



505.73

14

670
n.m.

THE
AMERICAN
JOURNAL OF SCIENCE.

EDITOR: EDWARD S. DANA.

ASSOCIATE EDITORS

PROFESSORS GEO. L. GOODALE, JOHN TROWBRIDGE,
W. G. FARLOW AND WM. M. DAVIS, OF CAMBRIDGE,

PROFESSORS A. E. VERRILL, HENRY S. WILLIAMS, AND
L. V. PIRSSON, OF NEW HAVEN,

PROFESSOR GEORGE F. BARKER, OF PHILADELPHIA,
MR. J. S. DILLER, OF WASHINGTON.

FOURTH SERIES.

VOL. XI—[WHOLE NUMBER, CLXI.]

WITH SEVEN PLATES.

NEW HAVEN, CONNECTICUT.
1901.



THE JOURNAL OF THE

AMERICAN SOCIETY OF
MUSICIANS

EDITED BY
WILLIAM T. HAYES

NEW YORK: THE TUTTLE, MOREHOUSE & TAYLOR CO.,
1900

THE TUTTLE, MOREHOUSE & TAYLOR CO.,
NEW HAVEN

NEW HAVEN, CONNECTICUT

1900



CONTENTS TO VOLUME XI.

Number 61.

	Page
ART. I.—Stereographic Projection and its Possibilities, from a Graphical Standpoint; by S. L. PENFIELD (With Plate I.)	1
II.—Mode of Occurrence of Topaz near Ouro Preto, Brazil; by O. A. DERBY	25
III.—Chemical Study of the Glaucophanes Schists; by H. S. WASHINGTON	35
IV.—Nature of the Metallic Veins of the Farmington Meteorite; by O. C. FARRINGTON	60
V.— <i>Erigenia bulbosa Nutt</i> ; by T. HOLM	63
VI.—New Species of <i>Merycochærus</i> in Montana, Part II; by E. DOUGLASS	73

SCIENTIFIC INTELLIGENCE.

Chemistry and Physics—Periodic Phenomena connected with the Solution of Chromium in Acids, W. OSTWALD, 84.—Krypton, LADENBURG and KRUEGEL, 85.—Combustion of Gases, S. TANTAR, 86.—Combustion of Acetylene in Air enriched with Oxygen. G. L. BOURGEREL: Inverse effect of a magnetic field upon an electric charge. M. V. CREMIEU: Electrical Convection, M. V. CREMIEU: Unipolar Induction, E. LECHER, 87.—Electron theory of metals, P. DRUDE: Simple modification of the Wehnelt interrupter, 88.

Geology and Mineralogy—Geological and Natural History Survey of Minnesota, Vol. V, N. H. WINCHELL and U. S. GRANT, 88.—Étude mineralogique et pétrographique des Roches gabbroïques de l'État de Minnesota, États Unis, et plus spécialement des Anorthosites, A. N. WINCHELL: Roches Éruptives des Environs de Ménerville, Algérie, L. DUPARC, F. PEARCE and E. RITTER: Charnockite Series, a group of Archean Hypersthene rocks in Peninsular India. T. H. HOLLAND: Geologische Skizze der Besitzung Jushno-Saoserk und des Berges Deneshkin Kamen in nordlichen Ural, F. LOEWINSON-LESSING, 89.—Some Principles controlling Deposition of Ores, C. R. VAN HISE: Physical Geography of the Texas Region, R. T. HILL, 90.—Field Operations of the Division of Soils, 1899, M. WHITNEY: Études sur les Minéraux de la Roumanie, P. PONI, 91.—Mineralogy, F. RUTLEY: Corundum and the Basic Magnesian Rocks of Western North Carolina, J. O. LEWIS, 92.

Botany—Maladies et les Ennemis des Caféiers, G. DELACROIX, 92.—Monographie und Iconographie der Oedogoniaceen, K. E. HIRN, 93.—Ueber *Sclerotinia cinerea* and *Sclerotinia fructigena*, M. WORONIN: *Platydorina*, a new Genus of the Family Volvocidae, from the Plankton of the Illinois River, C. A. KOFOD, 94.

Miscellaneous Scientific Intelligence—Velocity of Seismic Waves in the Ocean, C. DAVISON: Old Indian Village, J. A. UDDEN, 95.—Anleitung zur mikroskopischen Untersuchung der vegetabilischen Nahrungs- und Genussmittel, A. F. W. SCHIMPER, 96.

Number 62.

	Page
ART. VII.—Apparent Hysteresis in Torsional Magnetostriction, and its relation to Viscosity; by C. BARUS.....	97
VIII.—Dinosaurian Genus <i>Creosaurus</i> , Marsh; by S. W. WILLISTON.....	111
IX.—Stereographic Projection and its Possibilities, from a Graphical Standpoint; by S. L. PENFIELD. (With Plates II, III and IV.) ...	115
X.—Melting Point of Gold; by L. HOLBORN and A. L. DAY	145
XI.—New mineral occurrences in Canada; by G. C. HOFFMANN	149
XII.—Spectrum of the more Volatile Gases of Atmospheric Air, which are not Condensed at the Temperature of Liquid Hydrogen; by S. D. LIVEING and DEWAR	154

SCIENTIFIC INTELLIGENCE.

Chemistry and Physics—Diethyl Peroxide, BAEYER and VILLIGER, 162.—Ammonium Amalgam, A. COEHN: Hydrogen Telluride, ERNYEI, 163.—Conductivities of some Double Salts as Compared with the Conductivities of Mixtures of their Constituents, F. LINDSAY: Cause of the Loss in Weight of Commercial Platinum when Heated, R. W. HALL: Elementary Treatise on Qualitative Chemical Analysis, J. F. SELLERS, 164.—Bedeutung der Phasenlehre, H. W. B. ROOZEBOOM: Visibility of Hydrogen in Air, Lord RAYLEIGH: Wireless Telegraphy, SLABY and Count ARCO, 165.—Telegraphone, V. POULSEN: Properties of Argon and its Companions, W. RAMSAY and M. W. TRAVERS, 166—Studies from the Yale Psychological Laboratory, E. W. SCRIPTURE, 168.

Geology and Mineralogy—Periodic Variations of Glaciers, F. A. FOREL, 168.—Contributions to the Tertiary Fauna of Florida, W. H. DALL: Record of the Geology of Texas for the decade ending December 31, 1896, F. W. SIMMONS: Geological Survey of Canada, G. M. DAWSON: Report on the Geology and Natural Resources of the Country traversed by the Yellow Head Pass Route from Edmonton to Tête Jaune Cache, comprising portions of Alberta and British Columbia, J. McEVoy, 170.—Mesozoic Fossils, Vol. I, Pt. IV. On some additional or imperfectly understood fossils from the Cretaceous Rocks of the Queen Charlotte Islands, with a revised list of the species from these rocks, J. F. WHITEAVES: Geology of the Albuquerque Sheet, C. L. HERRICK and D. W. JOHNSON: I Vulcani dell' Italia Centrale. Parte I. Vulcano Laziale, V. SABITINI: Occurrence of Zoisite and Thulite near Baltimore, 171.

Miscellaneous Scientific Intelligence—Transcontinental Triangulation and the American Arc of the Parallel, C. A. SCHOTT, 172.—Astronomical Observatory of Harvard College, 173.—Norway; Official Publication of the Paris Exhibition, 1900: American Museum of Natural History: Principles of Mechanics: an Elementary Exposition for Students in Physics, F. SLATE: Knowledge Diary and Scientific Hand-book for 1901, 174.

Number 63.

	Page
ART. XIII.—Circular Magnetization and Magnetic Permeability; by J. TROWBRIDGE and E. P. ADAMS	175
XIV.—Notes on the Geology of Parts of the Seminole, Creek, Cherokee and Osage Nations; by C. N. GOULD	185
XV.—Names for the formations of the Ohio Coal-measures; by C. S. PROSSER	191
XVI.—New American Species of Amphicyon; by J. L. WORTMAN	200
XVII.—Studies in the Cyperaceæ, No. XV; by T. HOLM ..	205
XVIII.—Just Intonation Piano; by S. A. HAGEMAN	224
XIX.—Very on Atmospheric Radiation; by W. HALLOCK ..	230

SCIENTIFIC INTELLIGENCE.

- Chemistry and Physics*—Radio-active Lead, HOFMANN and STRAUSS: Physiological Action of Radium Rays, WALKHOFF: Chlorine Heptoxide, MICHAEL and CONN, 235.—Non-Existence of Trivalent Carbon, J. F. NORRIS: Diffusion of Gold in Solid Lead at Ordinary Temperature, W. C. ROBERTS-AUSTIN: Cerium, G. B. DROSSBACH: Method for Crystallizing Substances without the Formation of Crusts upon the Surface of the Liquid, A. WRÓBLEWSKI, 236.—Velocity of the ionized phosphorus emanation in the absence of electric field, C. BARUS: Thermo-chemistry of the alloys of copper and zinc, T. J. BAKER, 237.—Decrement of electrical oscillations in charging condensers, A. F. SUNDELL and H. J. TALLQUIST: Effect of a magnetic field on the discharges through a gas, R. S. WILLOW: Conductivity produced in gases by the motion of negatively charged ions, TOWNSEND, 238.—Recueil de Données Numériques publié par la Société Française de Physique, H. DUFET: One Thousand Problems in Physics, W. H. SNYDER and I. O. PALMER, 239.
- Geology and Mineralogy*—Maryland Geological Survey: Allegheny County, W. B. CLARK: U. S. Geological Survey, C. D. WALCOTT, 240.—Geological Survey of Michigan, A. C. LANE, 241.—Geological and Natural History Survey of Minnesota, N. H. WINCHELL: Pleistocene Geology of the South Central Sierra Nevada with especial reference to the Origin of Yosemite Valley, H. W. TURNER, 242.—Geologisches Centralblatt: Metasomatic Processes in Fissure Veins, W. LINDGREN, 243.—Some Iowa Dolomites, N. KNIGHT, 244.—Minerals of Ontario: Text-book of Important Minerals and Rocks, with tables on the determination of minerals, S. E. TILLMAN: Los Minerales, G. BODENBENDER, 246.
- Botany*—Monograph of the North American Umbelliferæ, J. M. COULTER and J. N. ROSE, 247.—Foundations of Botany, J. Y. BERGEN, 248.—Flora of Vermont: Catalogue of the African Plants collected by Dr. Friedrich Welwitsch in 1853–61. W. P. HIERN, 249.—Botany: an Elementary Text for Schools, L. H. BAILEY: Plant Life and Structure, E. DENNERT, 250.
- Miscellaneous Scientific Intelligence*—Comparative Physiology of the Brain and Comparative Psychology, J. LOEB: Microbes et Distillerie, L. LÉVY: Gesang der Vögel, seine anatomischen und biologischen Grundlagen, V. HACKER, 251.—O. S. U. Naturalist: Ostwald's Klassiker der Exakten Wissenschaften: Director-General of the Geological Survey of the United Kingdom, 252.

Number 64.

	Page
ART. XX.—Magnetic Theory of the Solar Corona; by F. H. BIGELOW	253
XXI.—Tertiary Springs of Western Kansas and Oklahoma; by C. N. GOULD	263
XXII.—Fundamental Propositions in the Theory of Elasticity: A study of primary or self-balancing stresses; by F. H. CILLEY	269
XXIII.—Boiling Point of Liquid Hydrogen, determined by Hydrogen and Helium Gas Thermometers; by J. DEWAR	291
XXIV.—Nature of Vowels; by E. W. SCRIPTURE	302
XXV.—Behavior of the Phosphorus Emanation in Spherical Condensers; by C. BARUS	310
XXVI.—Concretions of Ottawa County, Kansas; by W. T. BELL	315

SCIENTIFIC INTELLIGENCE.

- Chemistry and Physics*—Ammonium Bromide and the Atomic Weight of Nitrogen. A. SCOTT: Combustion of Gases, S. TANTAR, 317.—Peculiar Blue Color produced when Potassium and Sodium Sulphocyanides are Heated, W. B. GILES: Method of obtaining Crystals of difficultly Crystallizable Substances, A. RÜMLER: Elimination of Methane in the Atmosphere, V. URBAIN, 318.—Introduction to Modern Scientific Chemistry, LASSAR-COHN: Ausgewählte Methoden der Analytischen Chemie, A. CLASSEN, 319.—Radiation Law of Dark Bodies, F. PASCHEN: Unipolar Induction, E. HAGENBACH: Effect of Electricity on Bacteria, A. MACFADYN, 320.—Electric Convection, M. V. CREMIEU: Preservation of Photographic Records, W. J. S. LOCKYER: Eclipse Cyclone and the Diurnal Cyclone, H. H. CLAYTON, 321.—Attempt to show that the earth being a magnet draws ether with it, W. ROLLINS, 322.—Presence of Gallium in the Sun, W. N. HARTLEY and H. RAMAGE, 323.
- Geology*—Geology of the Boston Basin. W. O. CROSBY: University Geological Survey of Kansas, S. W. WILLISTON, 324.—Orange River Ground-Moraine, A. W. ROGERS and E. H. L. SCHWARZ, 325.—Founders of Geology, A. GEIKIE: Gesetz der Wüstenbildung in Gegenwart und Vorzeit, J. WALTHER, 326.
- Zoology*—Recent papers relating to the fauna of the Bermudas, 326.—Trans. Conn. Acad. Science: Zoological Results based on Material from New Britain, New Guinea, Loyalty Islands and elsewhere, A. WILLEY, 330.
- Miscellaneous Scientific Intelligence*—Leçons de Physiologie Expérimentale, R. DUBOIS et E. COUVREUR, 330.—Webster's International Dictionary, New Edition, 331.—The National Standardizing Bureau, 332.
- Obituary*—GEORGE MERCER DAWSON: CHARLES HERMITE: ADOLPHE CHATIN: J. C. AGARDH, 332.

Number 65.

	Page
ART. XXVII.—Studies of Eocene Mammalia in the Marsh Collection, Peabody Museum; by J. L. WORTMAN. With Plate V.	333
XXVIII.—Velocity of Chemical Reactions; by W. DUANE.	349
XXIX.—Transmission of Sound through porous materials; by F. L. TUFTS	357
XXX.—Yoke with intercepted Magnetic Circuit for measuring Hysteresis; by Z. CROOK	365
XXXI.—Mineralogical Notes; by C. H. WARREN	369
XXXII.—Expansion of Certain Metals at High Temperatures; by L. HOLBORN and A. L. DAY	374

SCIENTIFIC INTELLIGENCE.

Chemistry and Physics—Sulphur Hexafluoride, Thionyl Fluoride, and Sulphuryl Fluoride, MOISSAN and LEBEAU: Molecular Weight of Ozone, A. LADENBURG, 391.—Preparation of Chlorine from Sodium Chlorate, C. GRAEBE: New Alkaloids in Tobacco, PICTET and ROTSCHY, 392.—Hydrate of Sulphuryl Chloride, BAEYER and VILLIGER: Action of Hydrogen Peroxide upon Silver Oxide, BAEYER and VILLIGER, 393.—Action of Alcohol on Metals with which it comes in Contact, MALMÉJAC: Excitation and Measure of Sine Currents, M. WIEN: Metallic Reflection of Electrical Waves, K. F. LINDMAN: Light Transparency of Hydrogen, V. SCHUMANN, 394.—Measurement of the Röntgen Rays by means of Selenium, F. HIMSTEDT: Effect of the Röntgen Rays and the Becquerel Rays on the Eye, F. HIMSTEDT and W. A. NAGEL, 395.

Geology and Natural History—Eocene and Lower Oligocene Coral Faunas of the United States, T. W. VAUGHAN, 395.—Presence of a Limestone Conglomerate in the Lead region of St. Francis Co., Mo., F. L. NASON: New Species of Cambrian from Cape Breton, G. F. MATTHEW: Geological Survey of Western Australia, A. G. MATTLAND, 396.—Geology of Texas, F. W. SIMONDS: Concretions from the Champlain Clays of the Connecticut Valley, J. M. A. SHELDON: Study of the Gabbroid Rocks of Minnesota, A. N. WINCHELL: Flow of Marble under Pressure, ADAMS and NICOLSON, 397.—Flora of Cheshire, S. MOORE: Preliminary list of the Spermatophyta of North Dakota, H. L. BOLLEY and L. R. WALDRON, 398.

Miscellaneous Scientific Intelligence—New Star in Perseus, T. D. ANDERSON, 399.—National Academy of Sciences: Report of the Secretary of the Smithsonian Institution for the year ending June 30, 1900, 400.—Memorial of George Brown Goode: U. S. Coast and Geodetic Survey, 401.—La Navigation Sous-marine, M. GAGET: Geological Survey of Great Britain: Geological Survey of Canada, 402.

Obituary—Dr. HENRY A. ROWLAND: Professor GEORGE F. FITZGERALD: Professor CHRISTIAN F. LÜTKEN, 402.

Number 66.

	Page
ART. XXXIII.—The New Spectrum; by S. P. LANGLEY. With Plate VII	403
XXXIV.—Rival Theories of Cosmogony; by O. FISHER....	414
XXXV.—Study of some American Fossil Cycads. Part IV. Microsporangiate Fructification of Cycadeoidea; by G. R. WIELAND.....	423
XXXVI.—Studies of Eocene Mammalia in the Marsh Col- lection, Peabody Museum; by J. L. WORTMAN. With Plate VI	437
XXXVII.—Cæsium-Antimonious Fluorides and Some Other Double Halides of Antimony; by H. L. WELLS and F. J. METZGER.....	451
XXXVIII.—“Mohawkite”; by J. W. RICHARDS.....	457
Henry Augustus Rowland	459

SCIENTIFIC INTELLIGENCE.

Chemistry and Physics—Radio-active Lead, HOFMANN and STRAUSS: Zirconia of Euxenite from Brevig, HOFMANN and PRANDTL, 463.—Action of Radium Rays upon Selenium, E. BLOCH: Reducing-power of Magnesium and Aluminum, A. DUBOIN: Method of Determining Atomic Weights, Based upon the Transparency of Substances to the X-Rays, L. BENOIST, 464.—Presence of Platinum upon an Egyptian Hieroglyphic Inscription, BERTHELOT: Generalization from Trouton's Law, DE FORCAND, 465.—Wissenschaftliche Grundlagen der analytischen Chemie, W. OSTWALD: Spectrum of Carbon Compounds, A. SMITHELLS, 466.—Absorption of Gas in a Crookes Tube, R. S. WILLOW: Mechanical Movements of Wires produced by Electrical Discharges which also make these Movements luminous, O. VIOL: Band Spectrum of Oxides of Aluminum and Nitrogen, G. BERNDT: Électricité et Optique; La Lumière et les Théories Électrodynamiques, H. POINCARÉ, 467.

Geology and Natural History—U. S. Geological Survey, 21st Annual Report of the Director, C. D. WALCOTT, 468.—Physiography of Acadia, R. DALY: Carte Géologique du Massif du Mont Blanc, L. DUPARC and L. MRAZEC: Mineral constituents of dust and soot from various sources, W. N. HARTLEY and H. RAMAGE, 470.—Studies in Fossil Botany, D. H. SCOTT: Flora of Western Middle California, W. L. JEPSON, 471.—Grand Rapids Flora, E. J. COLE, 472.—Variations of a newly-arisen Species of Medusa, A. G. MAYER, 473.

Miscellaneous Scientific Intelligence—Annals of the Astrophysical Observatory of the Smithsonian Institution, S. P. LANGLEY and C. G. ABBOT, 473.—Report of the U. S. National Museum: Journal of Hygiene: Annals of the Astronomical Observatory of Harvard College, E. C. PICKERING and E. S. KING, 474.

E

Vi-
D.

it
er
ign,
o
it
e-
e,
al

ve
3-
n
n
t-
s
e
3-
g
e
-
y
e
t-
f
l
e

160

10
170

10
170

160

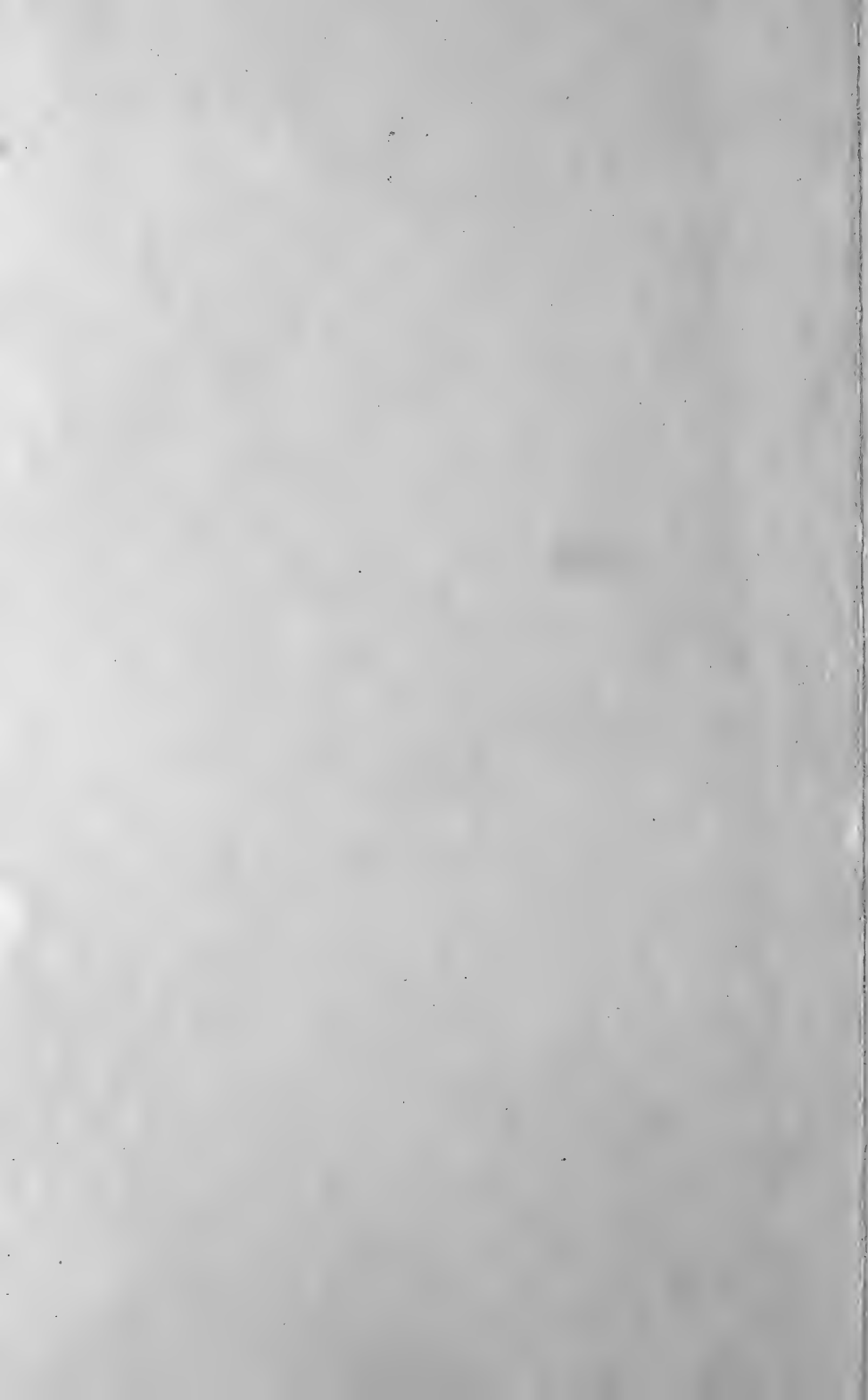

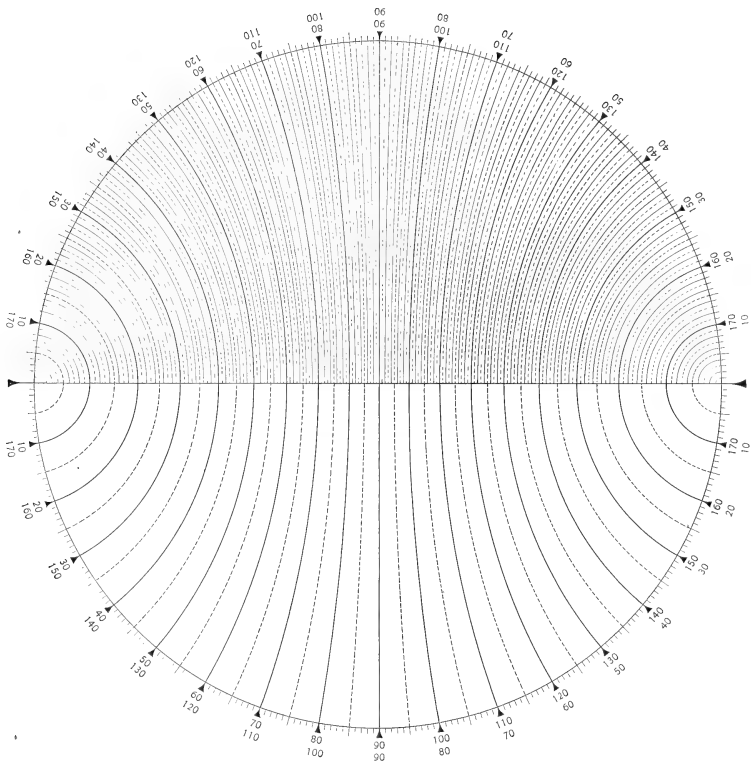

Patent applied for.

STEREOGRAPHIC PROTRACTOR NO. II, FOR MEASURING THE ARCS OF GREAT CIRCLES.

Printed from the original engine-divided plate.

v

A

X

X

X

X

X

H

c

c

l

I

THE

AMERICAN JOURNAL OF SCIENCE

[FOURTH SERIES.]

ART. I.—*The Stereographic Projection and its Possibilities, from a Graphical Standpoint*; by S. L. PENFIELD.
(With Plate I.)

Introduction.—The results which are given in the present paper are the outgrowth of a desire on the part of the writer to simplify some of the processes of plotting and determining crystal forms. The whole subject of stereographic projection, as it has gradually unfolded itself to him during the past two years, has revealed so many possibilities, and seems so important and of such general interest, that it has been decided to present first a paper treating of the stereographic projection alone, leaving for a later communication its applications to special problems of crystallography.

As far as the mathematical principles of the projection are concerned, the writer lays claim to no new facts. The projection is treated, in more or less detail (usually very briefly), in most text-books of crystallography, and instructions are given for making stereographic projections. The processes recommended, however, are generally tedious, and one of the objects of the present paper is to indicate how projections may be constructed easily and very accurately. Moreover, no mathematical formulas nor equations have been used in developing the subject, neither have tables been employed other than one of natural tangents for calculating a certain scale. The principles of the projection, as set forth in this article, are absolutely exact; while the errors involved in solving problems by graphical methods are dependent upon one's ability to locate points and read scales correctly, the errors generally diminishing as the size of the projection increases. It is also true of numerical calculations that the processes are limited. Given exact data, results accurate to the minute or to the second are

obtained according as four-place or seven-place logarithm tables are employed; while for some very exact geodetic computations, where small fractions of a second must be taken into consideration, ten-place logarithm tables are at times made use of. The advantages of graphical methods over numerical calculations are numerous, and are fully appreciated by engineers and others who deal extensively with measurements and practical results derived therefrom.

The writer would be one of the last to claim that numerical calculations can be dispensed with, yet he contends that, for a large number of problems, especially those where the data are not very exact, results obtained by graphical methods are in every way as serviceable as those secured by calculation. Then, too, it is possible to make computations by graphical methods wholly without the use of formulas and tables, and the processes can be carried out intelligently by persons who have had no special mathematical training, provided only that they have an appreciation of measurements expressed in terms of degrees and fractions. Many advantages to be derived from the use of the stereographic projection will naturally suggest themselves during the course of this paper. In subsequent paragraphs some of these advantages will be set forth, and results obtained by plotting will be given, in order that an idea of the accuracy of the method may be obtained.

General Principles of the Stereographic Projection.—In this method of projection all points and arcs on the surface of a sphere are projected on a flat surface (the plane of the projection) passing through the center of the sphere, the pole or point to which everything is projected being located on the surface of the sphere and at right angles to the plane of the projection. Often the equatorial plane is chosen as the plane of the projection, and the pole to which everything is then projected is the south pole. Under the foregoing conditions, it is also customary to represent only the features of the upper half of the sphere (the northern hemisphere) in the projection, although, as will be shown, the projection may be carried out beyond the equator so as to include the southern hemisphere as well. Projections are likewise frequently made upon a plane passing through some north and south meridian, in which case the pole of the projection will be located upon the equator, at right angles to the plane of the projection. As will be shown, projections can be made without difficulty upon any desired plane. A most important feature of the stereographic projection is that all angular distances and directions, which can be plotted and measured only with difficulty on a spherical surface, appear on the flat surface of the stereographic projection in such relations that they may be easily plotted and measured. This is true of no other method of projection.

Some essential features of the stereographic projection are illustrated in figure 1. The circle represents a vertical section

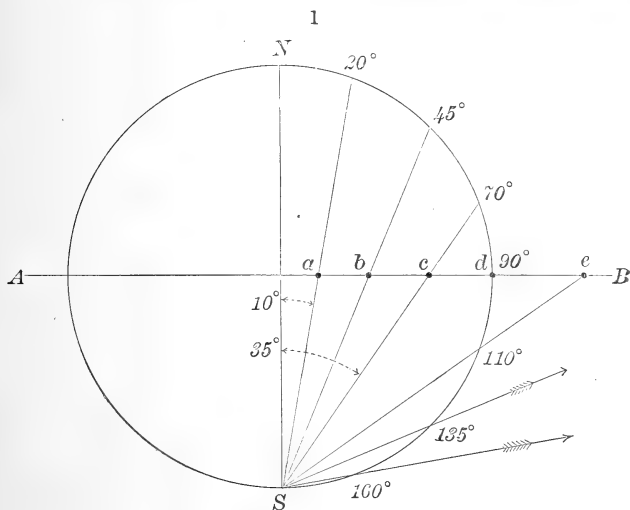

through a sphere, or a north and south meridian if considered as such. *N* and *S* are the north and south poles, respectively, and *AB* is the trace of the plane of the equator. Points on

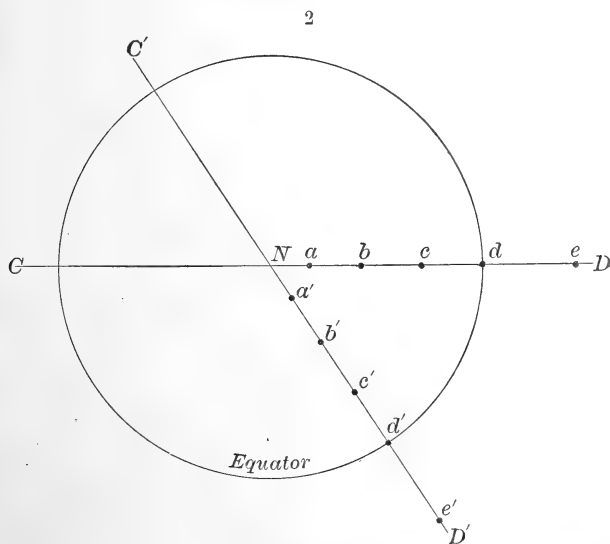

the meridian 20° , 45° , 70° , and 90° from *N*, when projected to the south pole, are seen upon the plane of the equator at *a*, *b*,

c, and *d*, respectively, while points more than 90° from *N* (110° , 135° , and 160° , for example), when projected to the south pole and continued along the lines of projection until they meet the plane of the equator, appear beyond the circle at *e*, and points still farther out as indicated by the direction of the arrows. In stereographic projection, figure 2, the equator appears as a circle, the north pole *N* occupies a position in the center, and a north and south meridian is projected upon the plane of the equator as a straight line corresponding to some diameter of the circle, it may be *CD*, or it may have some other direction, *C'D'* for example, depending, so to speak, upon the longitude of the meridian. Points 20° , 45° , 70° , 90° , and 110° from *N*, as measured on a north and south meridian, appear in stereographic projection, figure 2, at *a*, *b*, *c*, *d*, and *e*, or *a'*, *b'*, *c'*, *d'*, and *e'*, respectively, the distances of these points from *N* being equal to those of corresponding points from the center, figure 1, provided that the diameters of the two circles are the same. The diameter *CD*, figure 2, represents a stereographically projected north and south meridian, and the distances *N* to *a*, *b*, *c*, *d*, and *e*, indicate 20° , 45° , 70° , 90° , and 110° , respectively, as measured on the meridian. The true linear distances *N* to *a*, *b*, etc., are equal to the tangents of half the angles under consideration, the radius of the circle being regarded as unity. The foregoing tangent relation is well illustrated in figure 1, and depends upon an important principle of geometry; namely, that two lines within a circle meeting at the circumference (as any two lines meeting at *S*, figure 1) make an angle with one another which is measured by half the arc included between the lines at the circumference. The distances *N* to *a*, *c* to *d*, and *d* to *e*, each represent 20° in stereographic projection, and the relations of these distances should be carefully considered. Proceeding from the center, each stereographically projected degree is somewhat greater than the one just before it, hence the distance *c* to *d* just within the equator is nearly twice as great as *N* to *a* near the pole, and *d* to *e* just beyond the equator is more than twice as great as *N* to *a*.

From a consideration of figure 2, it is evident that, although any point on the stereographic projection (*a*, for example) which is 20° from the pole has a fixed relative distance from the center irrespective of the size of the circle, the absolute distance of 20° from the pole will vary with the size of the circle. Hence, the construction of stereographic projections can be greatly facilitated by adopting some definite size for the fundamental circle, and devising certain protractors and scales, by means of which points occupying known positions on the sphere may be quickly and accurately plotted. In

deciding upon an appropriate scale on which to make stereographic projections, it was necessary carefully to consider the two following points:

If the construction is too small, it is difficult to locate given points with sufficient accuracy, by means of a pencil and ordinary drawing instruments; while, on the other hand, if the construction is on too large a scale, the drawing becomes unwieldy and presents many difficulties, although the degree of accuracy is greatly increased. After some experimenting it was decided to make the projections on a circle of 14^{cm} diameter, and after nearly two years' experience, during which time almost all kinds of crystallographic problems have been under consideration, it may be stated that this scale has proved very satisfactory.

The Graduated Circle.—As one of the first aids for the quick and accurate construction of stereographic projections, a circle of 14^{cm} diameter, graduated into degrees, was engraved. Every tenth degree of the graduation is accentuated, so that it may be quickly caught by the eye, but it was thought best not to number the entire graduation, as degrees can be easily counted off. The exact center of the circle is indicated by a small cross. The circle was engraved by means of a dividing engine, which is equivalent to a guarantee of its accuracy. (See page 23.) The circle and some scales which will be described later are shown, much reduced and with only 5° graduation, in figure 3. They are printed together on large sheets of paper of excellent quality, the idea being that the sheets may be purchased at a trifling expense, and used for plotting all kinds of problems in stereographic projection.

Protractor No. I for plotting Stereographic Projections.—In order to facilitate the work of locating known points on a diameter of the graduated circle, a special protractor, designated as No. I, has been devised, which is shown without reduction in figure 4. The semicircle, divided into degrees, has a diameter of 14^{cm}, thus corresponding to the diameter of the graduated circle, figure 3, of the printed sheets. Holding the protractor in a vertical position, and regarding the upper 0°–90° point of the semicircle as the north pole, lines drawn from degree points on the semicircle to an imaginary south pole would cross the diameter at correspondingly numbered, *stereographically projected*, degree points. The distance from the center to each degree line of the graduation was determined by calculation, and the scale was then engraved by means of a dividing engine. The graduation has been numbered in both directions in order that angles given from either the pole or the equator can be conveniently located. The protractor is printed on cardboard and is inexpensive. It may be

3

DIVIDED CIRCLE AND SCALES FOR PLOTTING STEREOGRAPHIC PROJECTIONS.

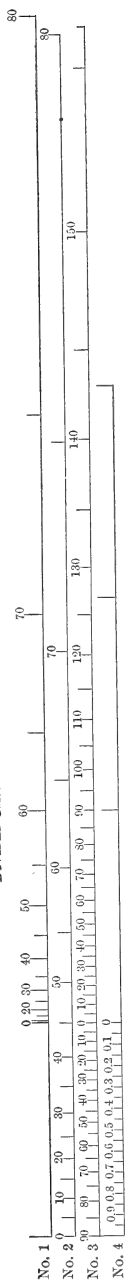

- No. 1 Radii of Stereographically projected arcs of great circles, degrees measured from the divided circle.
 No. 2 Radii of Stereographically projected arcs of small vertical circles, degrees measured from the divided circle.
 No. 3 Degrees of a vertical great circle stereographically projected on a diameter.
 No. 4 Decimal parts of the radius of the divided circle.

On the original engine-divided plate the circle has a diameter of 14^{cm} and is divided into degrees (compare plate I). The scales likewise are subdivided so as to give desired parts to degrees.

employed either in semicircular or rectangular form as an ordinary protractor for laying off and measuring plane angles.

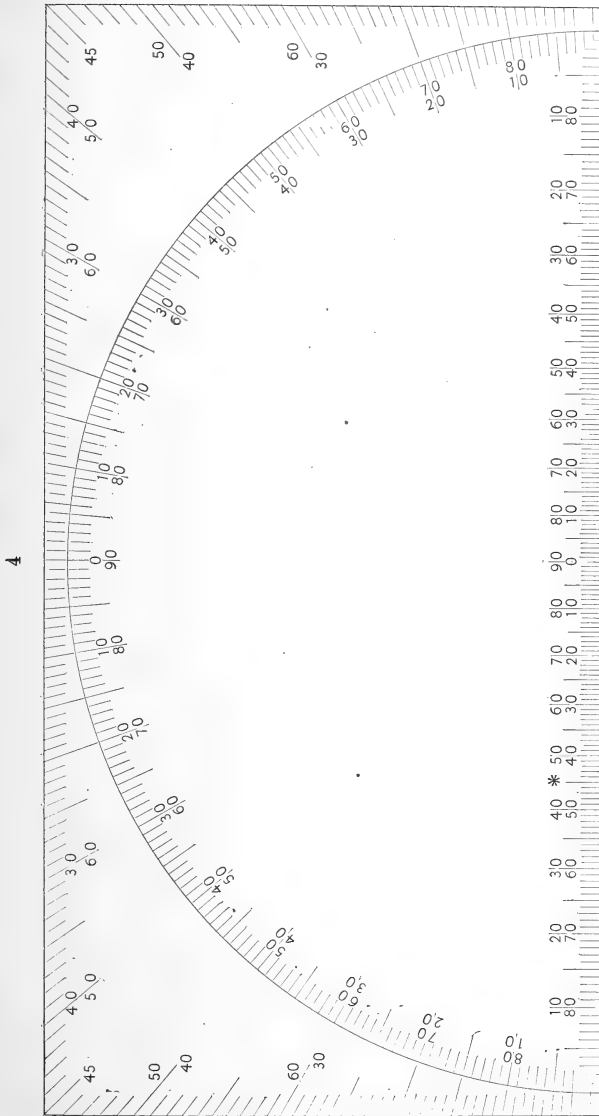

PROTRACTOR NO. 1, FOR PLOTTING STEREOGRAPHIC PROJECTIONS.

The graduation on the base line gives the stereographically projected degrees.
From * to 0 equals the chord of 90°.

Printed from the original engine-divided plate.

Scale No. 3, accompanying the graduated circle, figure 3, repeats the graduation of the base line of the protractor, and the graduation is further continued for arcs of more than 90°

from the pole. Thus, referring to figures 1 and 2, p. 3, the distances at which the lines of projection of arcs of 110° and 135° would meet the diameter can be taken directly from this scale. Various examples of the uses of scale No. 3 will appear during the course of this article.

Owing to the size of the sheets upon which the divided circle and scales are printed, there is a limit to the number of stereographically projected degrees which can be given. As seen in figure 3, the end of scale No. 3 indicates the 156th degree from the pole. Since in some operations it may be necessary to carry the projection beyond the limits of this scale, the distances from the pole to the remaining projected degrees are given in millimeters in the following table :

157°-344.1 ^{mm}	163°-468.4 ^{mm}	169°-727.0 ^{mm}	175°-1603.3 ^{mm}
158 -360.1	164 -498.1	170 -800.1	176 -2004.5
159 -377.7	165 -531.7	171 - 889.4	177 -2673.2
160 -397.0	166 -570.1	172 -1001.0	178 -4010.3
161 -418.3	167 -614.4	173 -1144.5	179 -8021.2
162 -442.0	168 -666.0	174 -1335.7	180 Infinity

The Possible Circles on a Spherical Surface.—About a point p located anywhere on the surface of a sphere, two kinds of circles may be described ; an indefinite number of *small circles*, whose distance from p is less than 90° , and one great circle, at a distance of 90° from p . If p is located at either the north or the south pole of a sphere, the small circles described about p correspond to the parallels of latitude of a terrestrial globe, and the great circle answers to the equator. If the sphere is oriented with its north and south poles in a vertical direction, and p is located on the equator, the small circles described about p will have a vertical position and will be referred to as *vertical small circles*. A *vertical great circle*, on the other hand, will pass through the north and south poles, and will thus correspond to some north and south meridian of a terrestrial globe. A great circle, whatever its position, corresponds to some circumference of a sphere, and, moreover, every great circle has this peculiarity, that it crosses the horizontal great circle, or equator, at two points which are antipodal.

The Stereographic Projection of Small Circles.—The upper portion A of figure 5 is intended to represent a vertical section through the center of a sphere ; hence, the graduated circle corresponds to some north and south meridian. XY is the trace of the plane of the equator, and N and S are the north and south poles, respectively ; p is some fixed point on the meridian, the figure representing it as 36° north of the equator. Around p , a small circle is supposed to be described,

every point of which is α° from p . In the figure, α is equal to 28° , hence the circle touches the north and south meridian at the points a and b , respectively at 8° , $=36^\circ - 28^\circ$, and 64° , $=36^\circ + 28^\circ$. It is evident that all possible lines of projection

5, A and B.

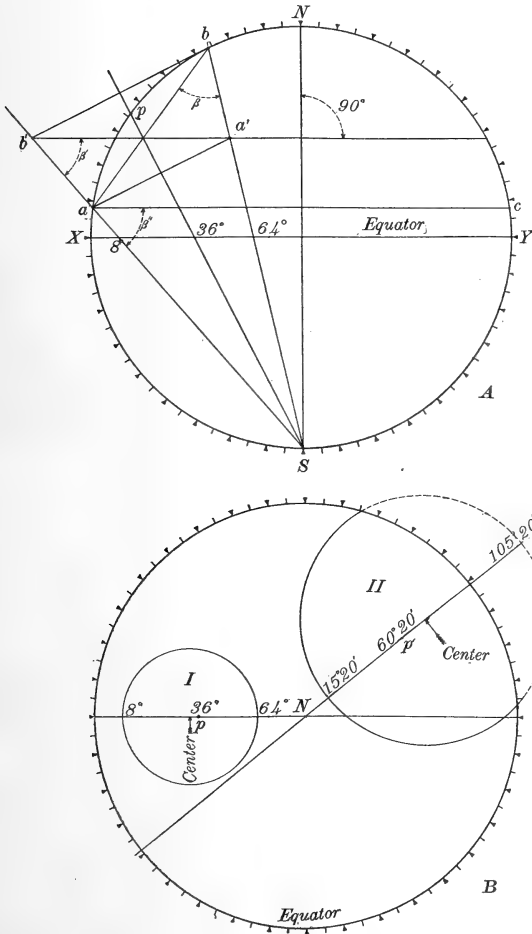

running from S to the small circle under consideration must be located upon the surface of an imaginary cone, with its apex at S and having a circular base touching the meridian at a and b . Such a cone is an *oblique cone*, and the plane abS is a symmetrical section through it. Continuing the line Sa , laying off a distance $Sb' = Sb$, and joining $b b'$

through the cone will be an ellipse, but it is not necessary for the present discussion to demonstrate this point. A line joining the center of $b b'$ and S , passes through p , bisects the angle of the cone at S , and may be regarded as an axis of the cone. Let it now be imagined that the cone $b b' S$ revolves about the axis $S p$. Since the section $b b'$ is an ellipse, and an ellipse is a figure of binary symmetry, the surface of the cone during the first quarter of the revolution will depart somewhat from its original position, and then on continued turning it will approach more and more to its original position until a revolution of 180° has been accomplished, when the correspondence of the conical surfaces will be complete. After the revolution of 180° , the points a and b of the cone in its original position will be transferred to a' and b' , respectively, and the section $a' b'$ must be a circle, because $a b$ was a circle. Figure 5, *A*, illustrates a most important feature of the stereographic projection; namely, *that no matter where p is located, if the pole of the projection is at S , all circular sections corresponding to $a' b'$ are horizontal and parallel to the plane of the equator; hence, the lines of projection running from S to the circle $a b$ or $a' b'$ intersect the plane of the equator in a circle.* Proof of this feature of the stereographic projection is very simple. The angles β and β' , figure 5, *A*, are equal, because they belong to the same cone before and after a revolution of 180° about the axis $S p$. Draw the line $a c$ parallel to $b' a'$, and β'' will equal β' because of the construction. The angle β (on the circumference of the circle at b) is measured by half the arc $S a$, and the angle β'' is measured by half the arc $S c$; therefore, since β and β'' are equal, the arcs $S a$ and $S c$ are equal. This being true $a c$ must be a chord, at right angles to a line joining the north and south poles, and hence *horizontal*, or parallel with the trace of the equator $X Y$. What holds good for a circle cutting the meridian at the points a and b , figure 5, *A*, holds good for a circle in any possible position on the sphere; hence, *all circles on the sphere will appear in stereographic projection as circles on the plane of the projection.*

Figure 5, *A*, further illustrates an interesting feature of conic sections; namely, that through an oblique cone circular sections are possible in two directions,—parallel to $a b$ and $a' b'$. All other sections are ellipses.

The construction of a small circle in stereographic projection corresponding to the problem of which, so to speak, an elevation has just been given in figure 5, *A*, becomes a very simple matter, and is illustrated in figure 5, *B*, case *I*. The divided circle here corresponds to the equator, and the north pole N is in the center. A north and south meridian would appear in the projection as a diameter of the circle, and the

pole p , 36° from the equator, is readily located on a diameter by means of protractor No. I, p. 7. On just what diameter it should be placed would depend upon some determining factor—for example, the longitude of the meridian. The small circle which is to be projected is $x^\circ = 28^\circ$ from p ; hence it would intersect the north and south meridian at points 8° and 64° from the equator, which points can be quickly located on the same diameter as p by means of protractor No. I. All that now remains to be done is to find the center point and construct the circle.

Another small circle in stereographic projection is illustrated by case II, figure 5, B . Here p' is some pole which may be located anywhere within the circle. Draw a diameter passing through p' , bring the base line of protractor No. I to correspond with the diameter, and note the position of p' . In the case under consideration, p' was found to be $60^\circ 20'$ from N . The small circle described about p' is distant 45° from p' ; hence it will touch the diameter at $15^\circ 20' = 60^\circ 20' - 45^\circ 0'$, and at $105^\circ 20' = 60^\circ 20' + 45^\circ 0'$. The two points $15^\circ 20'$ and $105^\circ 20'$ can be located on the diameter by means of scale No. 3, figure 3, and it then becomes an easy matter to find the center point and construct the circle. Numerous applications of the principles of the stereographic projection of small circles will appear during the course of this article.

The Stereographic Projection of Vertical Small Circles.—This is a problem deserving special consideration because of its very general application. The point p , figure 6, A , is located on the equator at the crossing of some meridian; hence the small circle described about it touches the north and south meridians, passing through p at points a and b , equally distant from p . The same demonstration that was employed on p. 9, figure 5, A , for illustrating that a small circle on the sphere is projected as a circle on the plane of the equator, holds good in the present case. Figures 5, A , and 6, A , are lettered alike, and the demonstration need not be repeated. In order to construct a vertical small circle in stereographic projection, figure 6, B , four points can be readily fixed upon. Two of these are the projection upon some diameter, xy , of the points a and b of the upper figure, the other two being points on the equator at the desired distance, x° , from p . To facilitate the projection of any desired vertical small circle, scale No. 2 of figure 3 has been constructed, from which the radius of the desired circle can be obtained. To construct, therefore, a small circle 36° from p , as represented by figure 6, B , draw a diameter xy through p , and upon it, by means of the scale on the base line of protractor No. I, locate a point 36° from p . Then set a pair of dividers so that their points

will span the distance from 0° to 36° on scale No. 2, figure 3, find the center point on the diameter xy , and draw the small circle, which will intersect the divided circle at 36° from p . Owing to the character of the stereographic projection, the greater part of projected vertical circles will always lie outside the divided circle.

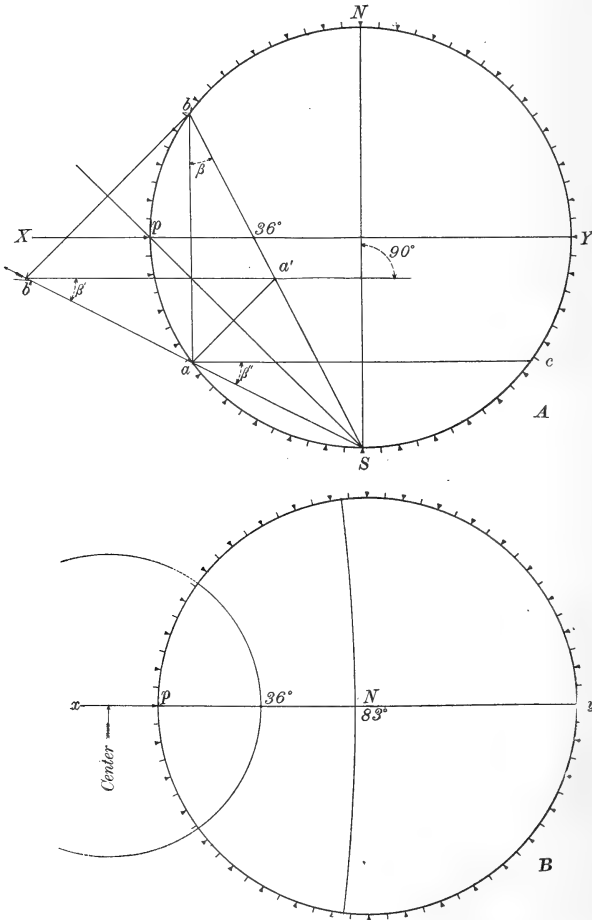
6, *A* and *B*.

Vertical circles nearly 90° from p have very long radii, and are best constructed by means of the curved ruler described later on. Thus, a vertical circle 83° from p , figure 6, *B*, must pass through two points 83° from p on the divided circle,

and also through the stereographically projected 83° point, as plotted on the diameter xy , by means of the graduation on the base line of protractor No. I.

7, A and B.

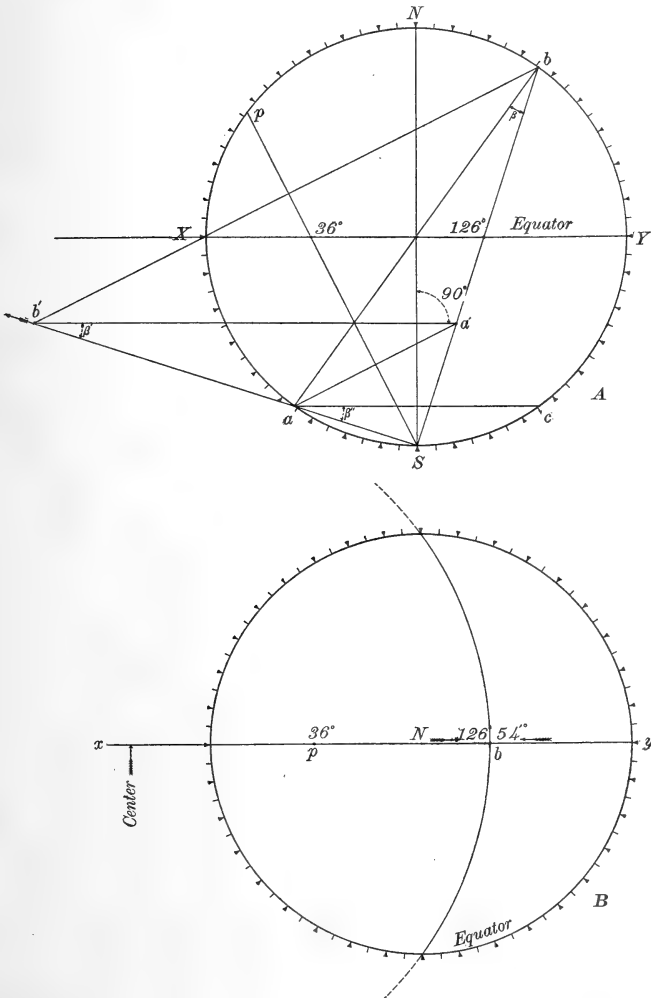

¶ The Stereographic Projection of Great Circles.—What was true of a small circle described about some point p as a center, holds true also for a great circle intersecting a north and south meridian, figure 7, A, at points a and b , 90° from p . In the special case illustrated by the figure, p being 36° from the

equator, the line of projection from S to b crosses the plane of the equator at 126° (stereographically projected) from the left-hand end of the diameter XY , or 54° from the right-hand end, while the line of projection from S to a would intersect the plane of the equator far out beyond the divided circle, as indicated by the arrow, at a point which could be determined by scale No. 3, figure 3, a being 144° from N . All possible lines of projection from S to the great circle ab are located on the surface of an imaginary oblique cone with its apex at S . Moreover, it could be proved, as was done in the case of the small circle illustrated by figure 5, A (the figures being lettered the same), that the intersection of the cone with the plane of the equator is in this case also a circle. The stereographic pro-

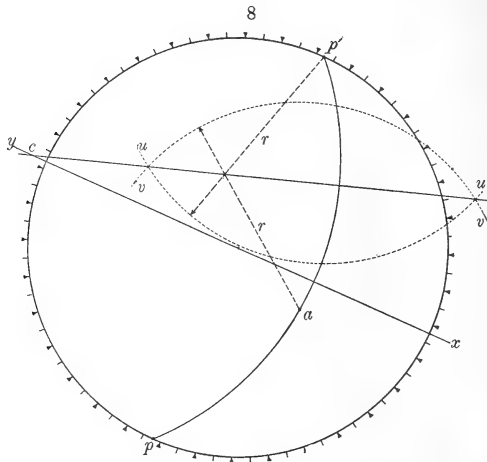

jection of a great circle is illustrated in figure 7, B . The projection of the point b , 54° from the equator on a north and south meridian, as shown by the upper figure, is quickly found on the diameter xy by means of the graduation on the base line of protractor No. I. A circular arc must then be found passing through b , and intersecting the divided circle at antipodal points at right angles to the diameter xy . To facilitate the construction of such circular arcs, scale No. 1 of figure 3 has been constructed, which gives the radii of possible great circles. As the arcs of projected great circles approach N (the center of the divided circle) they become flatter; hence they are best constructed by means of the curved ruler described later on. As seen from scale No. 1, figure 3, the shortest radius of any stereographically projected great circle is equal to the radius of the divided circle.

To draw the projected arc of a great circle through two points, one of which, p , figure 8, is on the divided circle and the other, a , within the circle, is a simple matter. The circular arc must intersect the divided circle at p' , antipodal to p , and its center must be on a line xy intersecting the divided circle at 90° from p and p' . The center c may be found by a few trials with a pair of dividers, or it may be determined analytically as follows: With dividers opened up to some convenient distance construct two circular arcs uu and vv , figure 8, having the same radius r , and draw a line through their intersections. The line thus drawn will be at right angles to the cen-

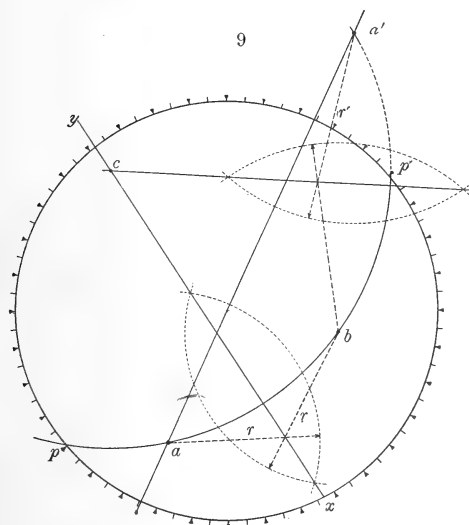

ter point of a line joining a and p' , and will intersect the line xy at c , which will be the center of the circular arc $pa p'$.

To draw the projected arc of a great circle through two points a and b , both of which are within the divided circle, the following principles may be used: That the great circle passing through a and b must also pass through points a' and b' , antipodal, respectively, to a and b ; also that the great circle must intersect the divided circle at antipodal points p and p' . If, therefore, there are two points, a and b , figure 9, anywhere within the circle, draw a diameter through one of them, a for example, and continue it beyond the circle. Apply the base line of protractor No. 1 to the diameter, determine the distance, in stereographically projected degrees, of a from the divided circle, and, making use of scale No. 3, figure 3, locate

a' just as many projected degrees beyond the divided circle as a is within it. Thus, as measured on a stereographically projected north and south meridian, a' is antipodal to a , and the problem of finding the center c and drawing a circular arc through a , b , and a' , which is fully illustrated by the figure, is too simple to need more detailed explanation. In some cases it may prove easier to plot a line xy , as illustrated by figure 9, and find upon it the point c by trial, for only one circular arc can be found, which, passing through a and b , intersects the divided circle at antipodal points p and p' . If the two points within the circle are so located that the projected great circle passing through them has a very long radius, the curved ruler described later on can be quickly adjusted so that a circular arc may be drawn passing through them and intersecting the divided circle at antipodal points.

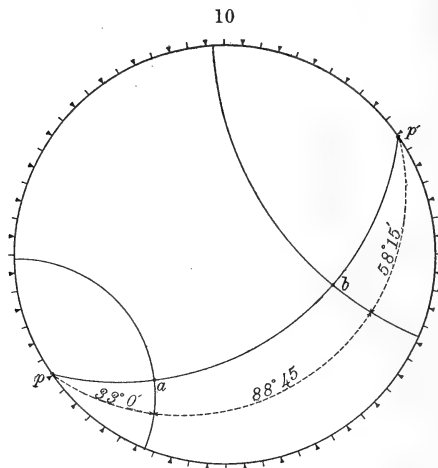

To measure the Angular Distance between any two points on a Stereographic Projection.—To measure the Side of a Spherical Triangle.—Let the two points a and b , be anywhere within the divided circle, figure 10. Since the angular distance between any two points on a sphere is measured in degrees along the arc of a great circle, it is first necessary to construct a great circle passing through a and b , and thus locate the antipodal points p and p' on the divided circle. It is now possible to find some projected vertical small circle described about p , which passes through a and serves as a measure of the angular distance p to a ; likewise a small circle described about p' and passing through b , which serves to measure the distance from p' to b . Knowing the angular distances p to a and p' to b , the distance a to b is readily determined. In fig-

ure 10, p to $a = 33^\circ 0'$ and p' to $b = 58^\circ 15'$; hence a to $b = 88^\circ 45'$, or the supplement of the sum of the two angles.

Without the aid of the special protractor described in the next paragraph, it is a laborious task to find the two projected vertical circles passing through a and b , figure 10; though by making use of the protractor No. I and scale No. 2, figure 3, they can be plotted without great difficulty.

Stereographic Protractor No. II.—To facilitate measurements of the angular distances between points on a stereographic projection, or measurements of the sides of spherical triangles, a special protractor has been devised which is represented in plate I, without reduction, and will be designated as the *Stereographic Protractor*, or *Protractor No. II*. The essential features of this protractor are as follows: The circle of 14^{cm} diameter, divided into degrees, corresponds with the divided circle shown, much reduced, in figure 3. On one-half of the circle, the projected arcs of vertical small circles, p. 11, have been constructed for every degree. Since on a 14^{cm}-circle the stereographically projected circles are very near together, the even degrees have been represented by full lines and the odd degrees by dashed lines; also the arcs of every fifth and tenth degree are engraved somewhat heavier than the others. These details, however, are not essential, but simply serve to make the use of the protractor somewhat easier. On the other half of the circle only the arcs of every fifth and tenth degree are represented. This half of the protractor is really superfluous, but for approximate measurements it will at times be found more convenient than the other half where the arcs are crowded. For convenience the protractor is numbered in two directions, from 0° to 180° . Further, in order to have the protractor really practical, it should be printed or engraved on some transparent material; transparent celluloid has been found to satisfy every requirement.

To use the protractor in finding the distance from a to b , figure 10, for example, lay it (best with the printed side down) on the drawing, and bring the 0° and 180° points to correspond with the antipodal points p and p' on the divided circle, then note the distances p to a and p to b in degrees and fractions, and the difference between the two readings will equal the angular distance from a to b .

To measure from any given point p on the divided circle to a point a within the circle, it is not necessary to go through the operation of constructing the arc of a great circle through p and a , as represented in figure 8, p. 14; merely place the protractor with its 0° and 180° points on p and p' , and then note on the protractor the projected arc which corresponds most nearly to a .

To measure the Angle made by the meeting of Two Great Circles.—To measure the Angle of a Spherical Triangle.—Just as the angle between two meridians at the north pole of a sphere is measured on the equator, so the angle between two great circles crossing at a point A , which may be anywhere within the divided circle, figure 11, is measured on the arc of a great circle at 90° from A . To make the measurement of the angle, draw a diameter of the divided circle through A , and, applying the base line of protractor No. I to the diameter, note the distance in projected degrees from N to A ; then locate a point B just as many degrees from the divided circle as A is from N . A and B are thus 90° apart, and, making use of

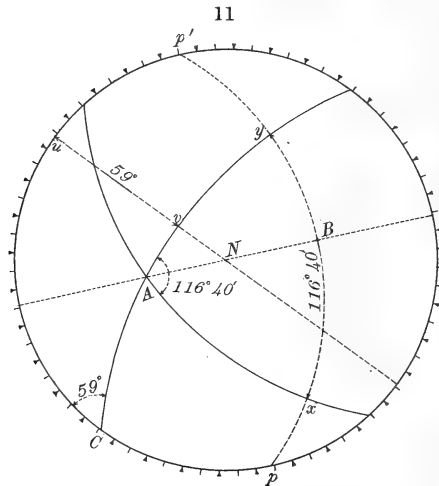

scale No. 1, figure 3, the arc of a great circle $p p'$, passing through B , can be easily drawn. All points on the great circle thus plotted, including the intersections x and y , are 90° from A , and the angle at A is equal to the distance in projected degrees between x and y , as measured with the stereographic protractor on the arc of the great circle $p p'$.

Provided an angle is located on the divided circle, as at C , all that is necessary to do is to draw a diameter of the divided circle at 90° from C , and measure the angle at C on the projected north and south meridian by means of the graduation on the base line of protractor No. I; for example, from u to $v = 59^\circ$.

Another method of measuring the angles of spherical triangles depends upon a well known and interesting peculiarity of the stereographic projection, to which the writer's attention was called by Prof. G. P. Starkweather of Yale University; namely, that the angle made by the crossing of two circles on

a sphere is preserved in the stereographic projection of the circles. The method of measuring is illustrated by figure 12. ABC is a right spherical triangle, and to measure the angle B , draw through B a tangent tt' ; the angle formed by tt' and the diameter CC' determines B . To draw accurately the tangent tt' , locate two points a and b , equally distant from B , on the great circle ABA' . A line joining ab would be a chord of the circular arc ABA' , and a line through B , parallel to ab , is a tangent to the circle. An ordinary protractor PP , preferably a transparent one,* centered at B by means of

12

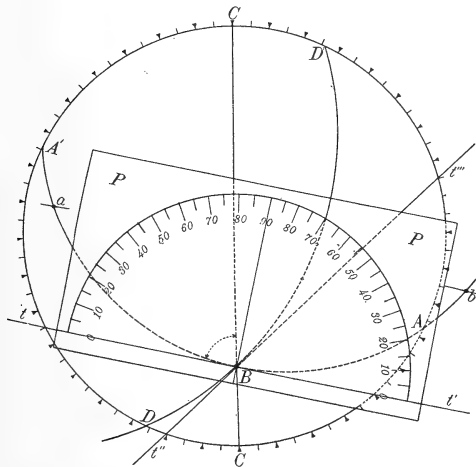

a needle, can be employed for measuring the angle. The $0^\circ-0^\circ$ line of the protractor is made to coincide with tt' , and the angle ($78^\circ 15'$ in the illustration) is determined from the graduation of the protractor. It is not necessary to construct the tangent tt' except when great accuracy is required; it is simply necessary to turn the protractor until the arc ABC intersects the circular arc of the protractor at equal distances from its two 0° points when its $0^\circ-0^\circ$ line will be tangent to the arc ABA' at B . In case the spherical triangle is an oblique one, ABD , to measure B draw two tangents, tt' and $t''t'''$, then measure the angle between them. Whether it is easier to construct tangents and measure with an ordinary protractor, as illustrated by figure 12, or to construct the arc of a great circle at 90° from B , as illustrated by figure 11, and measure by means of protractor No. II, plate I, is a matter which must be determined by experience. It is far simpler to

* Protractor No. II, plate I, which is printed on transparent celluloid and is divided at the periphery into degrees, can be employed.

measure the angles A and D , figure 12, by means of the graduation on the base line of protractor No. I, page 7, than by constructing tangents and measuring the plane angles.

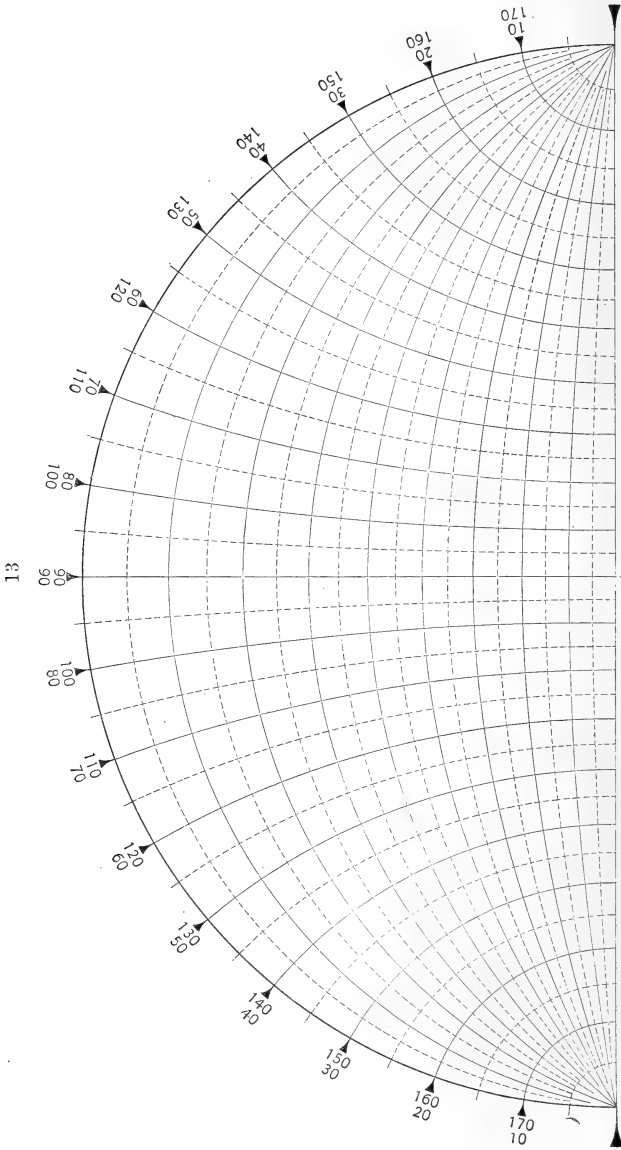

Patent applied for.

Stereographic Protractor No. III, with great and small circles for every fifth degree only.
Printed from the original engine-divided plate.

Supplementary Protractors.—Equipped with sheets containing the divided circle and scales, figure 3, and with protractors

I and II, figure 4 and plate I, practically all kinds of problems in spherical trigonometry can be plotted and solved by graphical methods. Two additional protractors, however, are so convenient that some space may be well devoted to them.

Protractor No. III, figure 13, is a combination of great and small circles on the same sheet. Every fifth degree only is given, the even degrees being indicated by full, and the odd degrees by dashed, lines. It is printed on transparent celluloid and is intended to be used for making an approximate measurement of the distance between any two points on a stereographic projection. At the center, there is a small hole, and if a sheet upon which a stereographic projection has been made is pierced at its center, the protractor can be quickly centered upon the sheet by means of a needle passed through the two holes. Thus centered, the protractor is turned until the two points, the distance between which is to be measured, fall either on an arc of a great circle or at proportionately equal distances between the arcs of two great circles. The distances of the two points from either zero point of the protractor is then noted, as indicated in degrees by the stereographically projected small circles, and the difference gives the distance between the points. Generally speaking, it is not essential to know upon what great circle the two points are located. They must be on some great circle, and the 0° and 180° points of the protractor locate approximately where this great circle intersects the divided circle. It is from the antipodal points thus ascertained that the readings of the protractor are made.

Given a chart or map in stereographic projection and a protractor, as just described, less than two minutes are required to shift the protractor to the proper position and measure the distance between any two points. Measurements thus made with a protractor graduated only to every fifth degree can be regarded as but approximately correct. They will seldom be more than a degree from the truth, and will average less than half a degree. For quick and approximate work, therefore, this protractor will be very serviceable.

The great circles for every fifth degree might well appear on that half of protractor No. II, plate I, on which the small circles for every fifth degree are engraved. The advantage, however, of having the two kinds of circles on the same protractor was not appreciated until after the plate for protractor No. II had been engraved.

Protractor No. IV.—In this protractor, figure 14, the great circles of every alternate degree (second, fourth, etc.) are represented. On the small scale adopted, it would bring the arcs too close together to represent every degree. The arcs are not numbered, but those corresponding to every tenth degree are represented by lines heavier than the rest, so that they may be

readily caught by the eye. The protractor is printed on transparent celluloid. At the center there is a small hole, and at

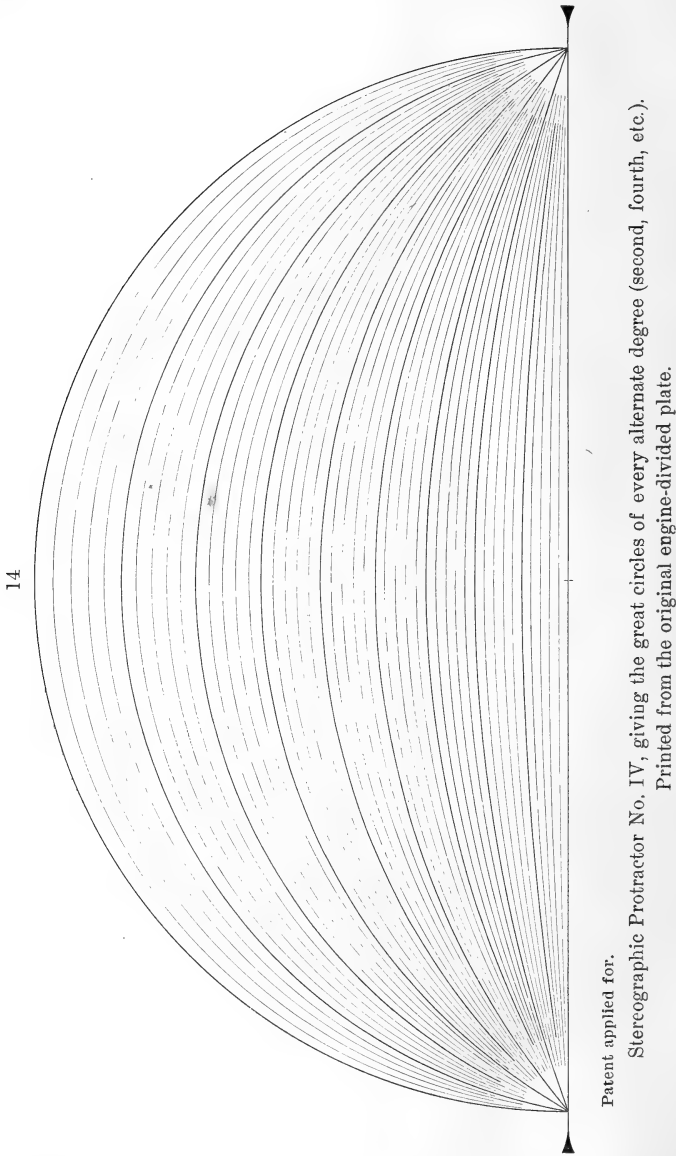

the ends of the semicircle the celluloid is cut away to the exact line of the diameter. The chief use of this protractor is to find the great circle which passes through any two given points

of a stereographic projection; more especially, however, to locate the antipodal points where the great circle crosses the divided circle. To perform this operation, the protractor is centered by means of a needle over a sheet upon which a stereographic projection has been made. It is then revolved until any two points of the projection are on, or proportionately distant from, the same great circle, when, by means of a pencil, marks are made on the drawing where the base line of the protractor crosses the divided circle. From the antipodal points thus located, measurements to the two points within the circle can be made by means of protractor No. II. In the majority of cases it is not necessary to draw the arc of a great circle passing through two points within the circle. To measure the distance between them, however, it is necessary to locate the antipodal points on the engraved circle. On page 15, figure 9, it was shown how a great circle passing through any two points within the circle of a stereographic projection may be plotted. Protractor No. IV furnishes a quick, though perhaps not quite so accurate a method of accomplishing the same result.

The Engraving of the Scales and Protractors.—It seems best to give a brief account of the methods employed in making the scales and protractors. The graduation of scale No. 3, figure 3, repeated in part on the base line of protractor No. I, figure 4, was calculated to a fraction of a millimeter by means of a simple tangent relation; for example, the distance of the 20° line from the center equals the radius of the circle multiplied by the natural tangent of 10° , page 4. The method of preparing scale No. 1, figure 3, may be illustrated by referring to figure 7, A, page 13. The distances (from the center) of the stereographically projected 126° point to the right and of the 144° point to the left, as determined by scale No. 3, are added, and their sum divided by two gives the radius of the great circle under consideration. Figure 6, A, page 12, illustrates how scale No. 2, figure 3, was derived from scale No. 3. From the distance (from the center) of the stereographically projected 126° point, that of the 36° point was subtracted, and the difference divided by two gives the radius of the small circle under consideration.

Scale No. 4 is not employed in the stereographic projection, but is used in crystallography. The data supplied for making scales 1, 2, and 3 was employed in the construction of the protractors. Scales and protractors were laid out and engraved by means of a dividing engine. The plates were made by the so-called wax process. In this process, a metal plate, covered with a wax preparation, is employed, and the engraving tools cut through the wax to the metal. Engine work on wax plates

should leave the engraver's hands practically perfect. An electrotype of the plates is next taken, and the copper depositing in the grooves made by the engraver's tools furnishes the relief from which impressions are taken. Finally, in order to prepare the electrotype for printing, the copper, stripped from the plate, is strengthened by casting some easily fusible metal upon the back of the electrotype. This casting causes a slight shrinkage of the plates, amounting to about 0.5^{mm} for a distance of 140^{mm} (the diameter of the protractors). It has been ascertained that the shrinkage is practically uniform and proportional in all the plates, so that no appreciable errors can arise from using engravings of this kind. Still, the plates are not absolutely perfect.

Copper or steel engravings would be preferable to engravings made by the wax process, but both the plates and impressions therefrom would be more expensive. If it is thought best to have another set of scales and protractors on a larger scale, the desirability of having them engraved on steel or copper should be carefully considered. Even impressions made from steel engravings might not be absolutely perfect, for paper changes somewhat under varying climatic conditions, and expansion and contraction are not always alike in every direction.

Another thing to be considered is that celluloid shrinks, and protractors printed from accurately engraved plates may become inaccurate in a few months. Except for its tendency to shrink, however, celluloid is exactly the kind of transparent material upon which to print the protractors, and a very simple correction serves to offset the slight shrinkage. For example, some impressions of protractor No. II, printed on newly purchased celluloid five months prior to the time of writing, have shrunk so that with a zero point of the protractor matched exactly at one end of a diameter of the divided circle, figure 3, the 180° point falls one-half a degree short of coincidence with the opposite end of the diameter. In other words, a distance of $179^{\circ} 30'$, stereographically projected upon a diameter of one of the engraved sheets, figure 3, is measured as 180° by means of the protractor; hence, from measurements made by the protractor, $5'$ should be deducted for every 30° , equivalent to $30'$ for 180° . It is believed that, in time, celluloid will become seasoned, so to speak, and that it will cease to shrink. Accordingly a rather large stock of this material has been purchased with the hope that in the course of a year or two it will be possible to print protractors which will not change.

Taking into consideration all imperfections of the plates, especially those due to shrinkage in casting, errors arising therefrom are quite insignificant when compared with the errors involved in plotting points and constructing arcs when the construction is based upon so small a scale as a 14^{cm} circle.

(To be continued.)

ART. II.—*On the Mode of Occurrence of Topaz near Ouro Preto, Brazil*; by ORVILLE A. DERBY.

THE current treatises on mineralogy, in the brief reference to the association of the yellow Brazilian topaz of the Ouro Preto district with talcose or chlorite schist, give an idea of a mode of occurrence quite different from that of any of the other known localities of the mineral. This statement is made on the authority of Eschwege, who in the early part of the century (1811–1822) spent a number of years at Ouro Preto and was very familiar with the mines during a period of active working. A fuller statement of Eschwege's observations, given in various writings, but most fully in his *Pluto Brasiliensis* published in 1833, is as follows. The topaz occurs in a narrow belt of country only a few hundred meters wide, extending for several kilometers from Saramenha, a suburb of Ouro Preto westward, in a nearly straight line for a distance of about 20 kilometers, by the mines of Boa Vista and José Correia to Capão de Lana,* with indications of a second less important belt a few kilometers to the northward. The topaz here occurs *in situ* and exclusively of a yellowish or rose color in contradistinction to the northern region near Minas Novas on the Jequitinhonha, where only white and blue stones occur exclusively in the state of rolled pebbles. The mineral, associated with quartz, specular iron, rutile and euclase, occurs in layers and nests of a fine scaly friable lithomarge, white or colored by iron oxide, all of these minerals being well crystallized but invariably broken at the base and irregularly mingled, as if kneaded into the lithomarge. The topaz-bearing nests and layers are enclosed in a decomposed unctuous schist which provisionally was called talc or chlorite schist, and which in turn are intercalated in the decomposed argillaceous schists of the region that were referred to the primary formation.

Mawe,† and Spix and Martius,‡ who visited the region about the same time gave descriptions of the mines in substantial accord with that of Eschwege, except that they refer the topaz to veins and the latter authors contest the classification of the enclosing schist as talcose, calling its characteristic mineral a modified mica.

No additional information of value regarding the topaz was given until 1882, when Gorceix§ described the principal mines

* Not Ulana nor Lane, as frequently given. Capão is the Indian name for an isolated group of trees or grove and Lana is probably the name of a former proprietor.

† Travels in the Interior of Brazil. London, 1812.

‡ Reise in Brasilien, Munich, 1831.

§ Annaes da Escola de Minas de Ouro Preto, No. 1.

and made analyses (reproduced in full in No. 57 of this Journal) proving that a great part at least of the unctuous schists of the region called talcose or chloritic by Eschwege and others are relatively poor in magnesia and rich in alkalis and are therefore essentially micaceous. Three of the schists analyzed were from the topaz mine of Boa Vista or its immediate vicinity, but it is almost certain that they represent what Eschwege called argillaceous schist (fibrous schist of Gorceix) rather than the topaz-bearing layers themselves, which are nowhere found in a sufficiently sound state to give satisfactory analyses. The lithomarge accompanying the topaz was also analyzed, giving: SiO_2 , 46.6 per cent, Al_2O_3 , 38 per cent, MgO 1 per cent, and loss on ignition 14.1 per cent—which is the composition of a true kaolin with a slight percentage of magnesia. The lithomarge is spoken of in one place as occurring in a vein occupying a line of fracture but in another as resulting from an alteration of the schist. The alignment of the principal mines noted by Eschwege was confirmed and somewhat extended by Gorceix and the existence of a second parallel line marked by the smaller workings of Caxambú and Fundão was affirmed.

In recent brief visits to the Ouro Preto region an attempt was made to resolve the doubts suggested by the above studies and to determine the original character and mode of origin of the topaz-bearing material. For this purpose the small mine of Caxambú was selected, as here the topaz bed was tolerably well exposed by recent workings, whereas in the larger mines it is now for the most part concealed and everywhere greatly obscured by landslides. A preliminary examination of these mines fully confirmed the opinion of Gorceix of their substantial identity with that of Caxambú, which may therefore be taken as typical of the topaz mines of the region. On account of the extreme decomposition of most of the material to be examined the problem presented was one of "mud geology"—the attempt to reconstruct from earthy materials the original rock types from which they were derived—and the solution here presented is necessarily largely hypothetical.

The mine is situated on the slope of a low col between the base of the high-rounded campo-covered knob called the Morro de Caxambú, and a lower knob a few score of meters to the southward. In both of these knobs on each side of the col sound rock is exposed in low bluffs. This is a sericitic phyllite heavily charged with fine hematite dust and on the southern side with a considerable amount of rather coarse quartz in scattered grains, which gives the rock the appearance of an iron-bearing quartzite (itabirite), though on examination it is seen to be more micaceous than quartzose. The rock from both of

these bluffs gives a small residue of rolled zircons, most abundant in the more quartzose one, and there can be no doubt that it is a metamorphosed clastic although from its essentially micaceous and ferruginous character, indicating a high percentage in alkalis and iron oxide, it may be suspected that it was not originally a perfectly normal sedimentary clay. On the slope of the col itself and only a few meters away from the mine on the line of strike there is a small exposure of a soft bluish black slate-pencil phyllite, which, in appearance, only differs from the rock of the bluffs on either side in its finer grain, and which is in all respects identical with the one of which an analysis was given in the September number of this Journal from a smaller topaz working in the immediate vicinity. This is a sericite schist free from quartz but heavily charged with iron, and in the paper above cited its low silica and high alkali contents were given as an argument for considering it as, possibly, a sheared eruptive. The absence of rolled zircons in its heavy residue (both the rock at Caxambú and the one analyzed) may be cited as a confirmation, though not an absolutely conclusive one, of this argument.

The mine itself, which is simply a small excavation in earthy material which when soaked with water has much the appearance and consistence of soft soap, exposes a zone some ten or dozen meters wide of bluish and yellowish clays which still distinctly show the nearly vertical lamination of the rocks from which they are derived. The predominant color is bluish but with streaks and patches of yellow which in part represent a more advanced stage of decay of the bluish material, in part, as will be seen farther on, a material of somewhat different structure and composition. The blue clay could be very satisfactorily traced into the slate-pencil phyllite above mentioned and on the other hand into a light yellow micaceous clay, or rather earth, that shows a change of color owing to the more complete hydration of the iron oxide. In the midst of this earthy material that, while still retaining its original form and structure, falls to pieces on the slightest movement, are bands from a few centimeters up to a meter or more in width of a different colored and more plastic earth, carrying oxide of manganese as well as of iron that gives it a darker yellow color passing to brown or black. The contacts between these two kinds of earth are perfectly sharp, like an eruptive contact, and are sometimes accentuated by a concentration of iron and manganese oxides, forming a black sahlband of about a centimeter's width that merges gradually into the general mass of the brownish or yellowish earth. In one case a band was observed having such a black sahlband on one side and on the other a

zone full of angular fragments of the blue phyllite, giving a brecciated appearance.

So far as could be observed, the topazes only occur in this darker-colored earth, and this is in accord with the descriptions given by Eschwege and Gorceix. This earth is evidently the decomposition product of an eruptive rock which though sheared is less perfectly laminated than the blue phyllite in which it is inclosed and which was evidently much more irregular in its composition and structure. This last difference is shown by a considerable variation, in streaks and patches, of the coloration and by the occurrence of nodular masses from the

1

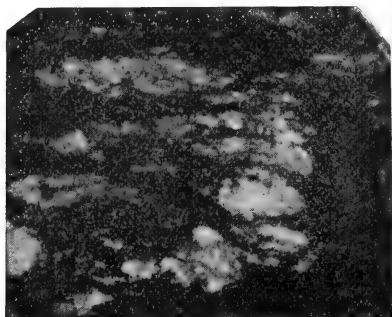

size of a pea up to that of the fist, or larger, of white kaolin, of a dark chocolate-colored earth, or of granular quartz, or of a mixture of these various elements. It is in these nodules that the topaz occurs though in a somewhat irregular manner, since a number of the smaller ones were washed without finding a trace of the mineral.

Of these nodular inclusions the most significant are those of kaolin. The small group exposed on a carefully-scraped face and shown of natural size in fig. 1 is very suggestive of an original porphyritic structure somewhat modified by shearing. The larger and more sheared group shown in fig. 2 exhibits a gneissoid aspect suggestive of the shearing of a granitic or syenitic nodule in a fine-grained rock as, for example in the phonolitic types of the Serras of Tinguá and of Caldas. The larger nodules of white or chocolate-colored earth and of quartz, in some but apparently not all of which the topaz occurs, are too friable to permit of satisfactory sections, but there can be little doubt that they are essentially of the same character. These frequently show a scale-like crust and irregular intercalations from a few millimeters to one or two centi-

meters thick of micaceous material that still retains a lithoid character and is composed almost exclusively of fine flakes of muscovite, which also occurs in considerable abundance and in larger flakes in the earthy and quartzose matter of the nodules.

Washings of the various phases of the topaz-bearing earth give a very abundant slime of earthy iron and manganese oxides and finely divided mica with a greater or less amount that is difficult to estimate of clay matter, leaving a comparatively insignificant residue of mica flakes and fine grains of scaly

2

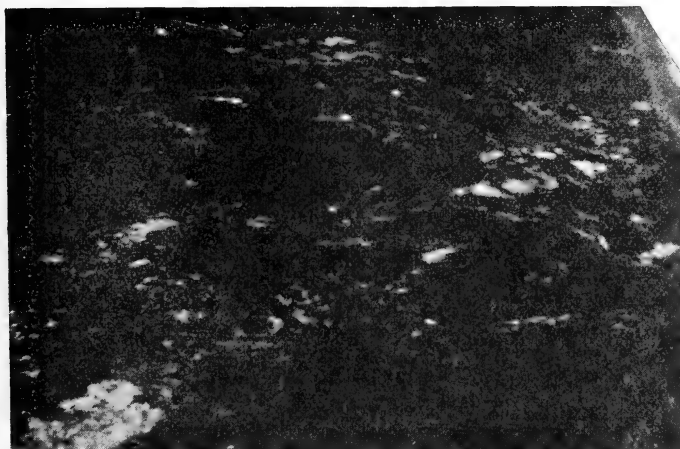

hematite. The normal earth free from visible kaolin of the specimen of fig. 2 gave 27.8 per cent soluble in hydrochloric acid, of which 3 per cent was manganese oxide, the rest being iron with a very perceptible trace of alumina. The darker earth of the brown clay nodules and that surrounding one of quartz gave about twice as much soluble constituents, that is to say of iron and manganese oxides. The residue after sliming is nearly free from quartz except when quartzose nodules occur. On removing the mica and iron a very slight heavy residue of minute grains and aggregates of rutile and needles of tourmaline remains with very rare and ill-formed grains of green anatase and a comparative abundance of a yellowish phosphatic mineral. The hematite grains are rare in the body of the earth but very abundant when the micaceous crusts above mentioned occur, and the tourmaline is distributed in a similar manner but is nowhere abundant. Rutile appears in all the washings, but is apparently more abundant in the main body

of the earth than in the nodules, while anatase only occurs sporadically. Zircon in extremely minute and usually ill-formed grains of difficult identification was found in the micaceous crusts but only sporadically in washings from other parts. The phosphatic mineral is usually in ill-formed aggregates that sink in the Klein solution, but a few rare crystals of rhombohedral form were detected. By microchemical and blowpipe tests (with the Florence bead) cerium was identified in these grains and this with the rhombohedral form and high specific gravity indicates that the mineral is the cerium-aluminum phosphate, florencite, recently described by Hussak and Prior. Topaz could only be found in some but not all of the nodular masses, but no trace of it could be detected in the main body of the earth free from inclusions. When found it was always in fragments of what had evidently been macroscopic crystals, no perfectly formed microscopic crystals being observed although they were carefully and confidently looked for.

The above observations afford a very insufficient basis for the determination of the original type of the topaz-bearing material, but in view of the interest of the subject and the slight probability of finding better preserved material for study, some hypothetical deductions may be hazarded. In this attempt at reconstructive geology two phases have to be considered, viz. the schistose one from which the earthy matter is directly derived by decomposition, and the original rock type from which this schist was derived by metamorphism accompanied by shearing.

In the schistose phase it is certain that the rock was essentially a micaceous schist, which, as the mica flakes, although minute, are for the most part well formed, can be designated as muscovite rather than as sericite schist. The mica contents of this schist must have varied from about 70 per cent in the normal parts free from segregations to about 30 per cent in the more basic and to almost nothing in the more acid of the latter. The iron and manganese contents varying in the inverse proportion are probably referable to original oxides* and in this case the schist must have been very similar in com-

* Probably but not certainly, as in the immediate vicinity there are extensive deposits of manganese ores that are residues from original carbonates and others that are presumed to be derived from original silicates, while examples of the complete replacement of an iron-bearing silicate (asbestiform amphibole) by limonite are frequent in the neighborhood. In the case in question, however, there are serious difficulties in the way of the hypothesis of the derivation of these hydrous oxides from either a carbonate or a silicate. The other conditions of the bed seem incompatible with the first, and the absence, at least apparent, of secondary silica in the vicinity gives a strong though not absolutely conclusive argument against the second.

position to the blue phyllite with which it is associated, differing principally in the presence of manganese and in the greater susceptibility to hydratization of the hematite grains, since in the residues only an insignificant amount of this mineral appears. This would give a muscovite schist normally free from quartz but heavily charged with metallic oxides and with scattered and more or less crushed crystals of feldspar and nodules of feldspar or quartz, or of mixed feldspar and quartz, with or without specular iron, rutile, topaz and muscovite. These nodules are frequently surrounded by a dark band more heavily charged with the metallic oxides than is the body of the schist and which may be either a primary or a secondary feature, most probably the former since nodules of a similar character and composition also occur. The accessory elements rutile, tourmaline, zircon (?) and florencite are common to both the normal schist and the nodules but are not prominent in either, while topaz, and probably euclase (not identified in any of the samples examined) appear to be confined to the latter. The larger undecomposed minerals of the nodules (quartz, topaz, specular iron, rutile and exceptionally euclase) usually show a certain amount of crushing which is in accord with the sheared condition of the rock as a whole and indicates that the nodular structure is a primary rather than a secondary feature. The circumstance noted by Eschwege and others that only very exceptionally do any of the minerals show double terminations probably indicates that the nodules were originally accompanied by drusy cavities that have doubtless disappeared in the shearing.

In a recent communication in this Journal I endeavored to show from the chemical and mineralogical characters of the schists of this region that many of them are probably sheared eruptives and suggested the hypothesis of decomposition and leaching prior to metamorphism to account for their peculiarities. One of the rocks there discussed is identical with the blue phyllite of the Caxambú mine and is from a topaz washing in the immediate vicinity, so that the arguments there presented are applicable to those here considered. The argument for an eruptive origin is somewhat weakened by the occurrence above noted of very similar, though more quartzose, rocks with clastic zircons on each side of the mine which perhaps may represent a mixture of eruptive and non-eruptive material. Be this as it may, the argument for decomposition and leaching, giving a concentration of iron oxide and alkalis necessary for the formation of a hematite-muscovite schist, still holds good and in this case the associated topaz schist may be presumed to have been similarly affected. An explanation is thus afforded for the peculiar composition of this rock, and with this hypothesis, that of a concentration during the leach-

ing of metallic oxides in certain nodules and about certain others becomes plausible. All things considered, however, it seems more probable that this last is rather due to an original and not a secondary feature.

The question of the original type from which, by shearing and metamorphism, this muscovite-iron-manganese schist was produced, is a more difficult one. Whether the blue phyllite was originally eruptive or not, there can be little doubt that the topaz-bearing schist enclosed in it was so. This is indicated by the character of its contacts, by the absence of clastic elements, by its manganese contents, and by its banded and nodular structure. Being eruptive, it must have been a rock without free quartz but with a comparative abundance of alumina-alkali silicates (feldspars or feldspathoids) and of iron and manganese minerals, which last, if in the state of silicates, must have been bisilicates containing lime and magnesia that have disappeared by leaching either in the recent decomposition, or, as seems more probable, before the metamorphism and shearing. The rock was probably porphyritic in structure (perhaps not necessarily so if an ancient period of decomposition be admitted) and full of segregated masses of both the more acid and the more basic constituents, in the former of which quartz, not a normal constituent of the rock, also appeared. These segregations must have been more or less drusy and in them several minerals, of which some were not normal to the rock, crystallized with one free termination.

The conditions above enumerated point to some member of the augite- or nepheline-syenite groups as the most probable original eruptive type. The rocks of these groups would afford the necessary alumina and alkalis to furnish the abundant mica free from quartz that characterizes the metamorphic schist, while their more or less basic phases would afford the metallic oxides as well, if the accompanying lime and magnesia can be supposed to have disappeared by leaching. Moreover these rocks are particularly subject to rapid alternations in texture or composition, or both, giving segregated masses, or *Schlieren*. In those known to me in various Brazilian localities both acid and basic segregations occur, and frequently one of the former character is surrounded by a zone more basic than the normal rock, thus giving the conditions noted in some of the topaz nests.

In this connection it is interesting to note that the study of the more normal schists of this and of the Diamantina region led to a similar conclusion, that rocks of the augite- or nepheline-syenite groups were probably represented among them, though in this case it seems necessary to admit that clastic as well as eruptive types occur. Combining the two series of observations, the hypothesis may be ventured of the existence in this

region (and various other similar ones in Brazil) of an ancient volcanic series represented by both massive and clastic types, characterized by soda-bearing rocks and ranging from soda-granite through augite- and nepheline-syenite to the extremely basic phases rich in metallic oxides that characterize these groups. In this regard the analyses by Gorceix of various schists from the Boa Vista topaz mine showing comparatively high soda contents are particularly significant. Perhaps the association, at least apparent, of iron and manganese ores with the schists here discussed, may be taken as an indication in the same direction, but a discussion of the matter must be deferred to another occasion. On this hypothesis the later phases of the eruptives may be supposed to have been characterized by topaz-bearing dikes.

Although topaz has not been recorded as occurring in rocks of the types above mentioned, there is no apparent reason why it should not be found, since the only element required for its formation that is not normally present in them is fluorine, which in the form of fluorite and fluo-silicates is quite frequent in their segregations and drusy cavities. It is worthy of note that its almost constant companions in the granitic rocks in which it has hitherto been found, cassiterite and tourmaline, are only represented by the latter in insignificantly small proportions. Its characteristic companion, if it can be said to have one, is euclase, containing the element glucinum, characteristic of a number of the rare minerals of the nepheline-syenite pegmatites of southern Norway. It may also be noted that in these last mentioned rocks cerium occurs in forms different from the common one of monazite, thus presenting a certain analogy with its occurrence as florencite in the topaz-bearing earth of the Ouro Preto district.*

Whether the above guess as to the original character of the topaz-bearing earth proves correct or not, it is certain that the occurrence of the topaz in the Ouro Preto district does not differ so materially from the other known ones as has hitherto been supposed. That is to say, the mineral does not occur in an essentially magnesian rock nor is its matrix of presumably sedimentary rather than of eruptive origin. On the other hand, the rock cannot be positively identified with any in which the mineral has hitherto been found. Of the known modes of occurrence the only one that offers a more or less remote analogy is that described by Cross in the lithophyses of a rhyolite of Colorado and Utah. As lithophyses are essentially drusy cavities of peculiar character and as rhyolites differ

*This mineral, which was first detected by Hussak in alluvial washings from Tripuby in the immediate vicinity of the topaz mines, has since been found in a number of diamond residues from the Diamantina district.

from acmite-trachytes and phonolites mainly in the higher proportion of silica, the analogy may be a closer one than at first sight appears.

Both Eschwege and Gorceix noted a linear arrangement of the topaz localities which is also suggestive of occurrence along one or more dikes. The older workings define quite clearly two such lines lying several kilometers apart, but recent prospecting in the soil cap shows that topaz occurs sporadically over much of the intervening belt.

Although the topaz is known to occur in other regions in Brazil, very little definite information can be obtained regarding it. Under the name of *pingos de agua* (water drops) rolled white and blue pebbles were for a long time an article of commerce at the little town of Minas Novas on the Jequitinhonha below Diamantina. This place was a center of trade in various gem stones, other than the diamond (aquamarine, chrysoberyl, tourmaline, spodumene, topaz and andalusite) coming from an extensive region lying between the Jequitinhonha and Doce, but for the most part, if not wholly, outside of the diamond region proper, where it is to be noted the minerals mentioned are extremely infrequent or wholly lacking in the miners residues that have been examined. Some years ago Dr. J. C. da Costa Sena of the Ouro Preto Mining School made a trip in this region and succeeded in finding most of these minerals both in gravel deposits and in the rocks but makes no mention of the topaz, from which it may be inferred that it does not occur in association with the minerals above named. The specimens from this region are often of considerable size, one in the National Museum of Rio de Janeiro being but little short of two kilograms in weight.

Some years ago a gentleman at Serro between Ouro Preto and Diamantina showed me some beautiful little doubly-terminated crystals of white topaz that had apparently been extracted from the original matrix and are presumed to be from somewhere in the vicinity, but I failed to learn the exact locality or conditions of finding. In the diamond region proper the topaz is a great rarity, although Gorceix reports having found it. Eschwege also reports it as occurring in a magnetite-bearing pegmatitic rock on the island of Pescaria near the little town of Sepitiba to the south of Rio de Janeiro. As there is a massif of augite- and nepheline-syenite near by, a detailed examination of this place may perhaps throw some light on the hypothesis above presented, but owing to quarantine restrictions it has not been possible to visit the place in time for the present paper.

ART. III.—*A Chemical Study of the Glauco-phane Schists*;
by HENRY S. WASHINGTON.

Introductory.—Among the metamorphic rocks the glaucophane schists are of special interest, on account of their peculiar mineralogical composition, as well as their comparative rarity. It is therefore somewhat remarkable that they have been only slightly investigated from a chemical point of view, especially as the characteristic mineral, glaucophane, has been analyzed from most of the localities. Indeed, as Rosenbusch* has remarked, our knowledge is far from sufficient for a proper understanding of their relations and origin. It is with the object of supplying partially this deficiency that the present chemical investigation has been undertaken. To supplement the analyses, some petrographical description is added, but the geological relationships will be only lightly touched upon, on account of the lack of opportunity for personal observations.

The material from Syra was collected by myself, several years ago, during a day's stay on the island. For the numerous specimens from the other localities I am deeply indebted to petrographers in different parts of the globe, and I gladly take this opportunity to express my hearty thanks to those mentioned in subsequent pages, in connection with the various specimens, for their kindness and generosity, which have made this investigation possible by supplying me with the requisite material.

Syra, Greece.

The glaucophane rocks of this island were first noticed by Virlet,† in 1833, who took the blue hornblende to be in part cyanite. Fiedler‡ in 1841, in a sketch of the geology and archaeology of the island, refers to this mineral as a hornblende, and mentions the abundance of epidote. Glauco-phane was indentified as a new mineral in these rocks by Hausmann§ in 1845. The rocks of the island were described by Luedecke¶ in 1876, from specimens collected by Fouqué and von

* Rosenbusch, *Elemente der Gesteinslehre*, 1898, p. 521; also *Sitzungsber. Akad. Wiss. Berlin*, 1898, p. 706.

† Virlet, *Expéd. Scient. de Morée*, vol. ii, p. 66, 1833.

‡ Fiedler, *Reise durch Griechenland*, vol. ii, p. 168, 1841.

§ Hausmann, *Gött. gel. Anzeigen.*, 1845, p. 193, Ref. in *Neues Jahrb.* 1845, p. 321.

¶ Luedecke, *Zeitschr. d. deutsch. geol. Gesellschaft.*, vol. xxviii, p. 248, 1876.

Fritsch, and later the geology, as well as the rocks, were described by von Foullon and Goldschmidt.*

While the glaucophane schists of Syra vary considerably in appearance and composition, yet, according to von Foullon and Goldschmidt, (with whose conclusions my own observations agree, as far as they go), they may be referred to two main types, epidote-glaucophane schist and mica (quartz)-glaucophane schist. These are not divided with absolute sharpness, as some transition forms are found, but, with only one or two exceptions all my specimens may be referred to these two. The more numerous divisions of Luedecke may also be put in one or the other of these two groups, or regarded as transition varieties.

In association with these are found various metamorphic rocks, such as gneiss and epidote schist (which are especially abundant, according to von Foullon and Goldschmidt), omphacite rocks and eclogites, and various augitic and hornblendic schists. All these occur in connection with and interbedded with metamorphosed limestones, but the relations of the different members of the complex are far too intricate and little known as yet to permit of discussion.

Epidote-Glaucophane Schist.—It would seem that the rocks belonging here are rather more abundant than those belonging to the other main group. They vary from coarsely crystalline forms, in which either the glaucophane or the epidote is porphyritic in quite large individuals, to fine-grained varieties, in which the epidote occurs as small patches in the mass of dark blue, silky prismatic glaucophane, forming specimens of great beauty. Garnet is present only to a small extent, and mica, quartz and feldspar are not abundant in the most typical representatives of this type.

The specimen chosen for analysis is from near Kyperusa, a small hamlet about $2\frac{1}{2}$ kilom. north of Hermoupolis, in the northeastern part of the island. It is fine-grained, and shows to the naked eye small prisms of pale greenish yellow epidote with some white flecks of calcite and quartz, lying in a dark blue, silky groundmass of minute glaucophane needles. Under the microscope all these minerals are seen, the glaucophane highly pleochroic, the epidote nearly colorless, together with some chlorite (which is apparently derived in great part from the glaucophane), a few small titanite and rutile crystals, and a little feldspar, which, with the quartz and calcite, is interstitial.

* von Foullon and Goldschmidt, *Jahrb. k. k. Geol. Reichsanst.*, vol. xxxvii, p. 1, 1887.

The analysis (No. I, below) shows a decidedly basic composition, with rather high Al_2O_3 and CaO , considerable Na_2O , and only a trace of K_2O . It will be seen later that it resembles the analyses of several other occurrences of these rocks.

As the mineralogical composition is quite simple, it may be calculated out quite readily as follows. The figures for glaucophane used here are those furnished by an analysis given further on, while those for epidote are based on the analysis by Luedecke.*

Glaucophane	37·2
Epidote	40·2
Chlorite	7·7
Quartz	6·1
Calcite	5·1
Feldspar	2·1
Titanite and rutile	1·6
	<hr/>
	100·0

In II there is given an analysis of another specimen from Syra, an omphacite-zoisite rock, composed of bright, grass-green omphacite (diallage) in blades and large crystals, white mica (paragonite), and granular zoisite, with a little interstitial quartz. The content of mica varies considerably, being fairly abundant in the specimen analyzed, and much less so in others.

This resembles I very closely, though Fe_2O_3 is considerably higher than FeO . TiO_2 was not determined, and is included in the Al_2O_3 . Even thus the latter is high, but is to be attributed to the abundant zoisite and paragonite. The mineral composition of this calculates out approximately ;

Omphacite	31·7
Zoisite	31·7
Paragonite	31·0
Quartz	5·6

Mica-Glaucophane Schist.—The rocks which may be referred to this group are not abundant, but vary considerably in character, and, through decrease in the amount of mica tend to become quartz-glaucophane schists. The specimen which was chosen for analysis seemed to be fairly typical. It came from near the Café Škarbeli, on the east coast, a short distance to the north of Hermoupolis on the east coast.

It is markedly schistose, and shows megascopically glaucophane, white mica, greenish epidote and diallage, and small

* Luedecke, op. cit., p. 262.

red garnets, the whole being rather fine-grained and traversed by veins of quartz, which were carefully avoided in the pieces chosen for analysis.

Under the microscope the glaucophane appears in long crystals, with fringed ends, of the normal gray-blue color and pleochroism, the blue being deeper at the borders. The epidote is slightly greenish yellow, in elongated crystals, and much broken. It is sometimes difficult to distinguish it from the diallage, which occurs in generally larger crystals and less green in color. The garnets are almost colorless and much cracked. The flakes of mica present the usual characters of muscovite, but they must be referred to the soda-mica paragonite, on account of the mere trace of K_2O which the analysis reveals. Apart from the veins, grains of quartz are fairly abundant, scattered through the other constituents and interstitial. Small brown titanites are seen here and there, a little chlorite is present, and also grains of an apparently alkaline feldspar.

Through the kindness of Prof. Lawson and Dr. Ransome, I have been enabled to study specimens and sections of the lawsonite-bearing schists of California, but have been unable to find any of this interesting mineral in the rocks of Syra.

The analysis (No. III, below) shows a much higher percentage of SiO_2 than the preceding, slightly lower Al_2O_3 and Fe_2O_3 , the same MgO and FeO and K_2O , with lower CaO and higher Na_2O . In nearly all respects, with the notable exception of the Na_2O , it is transitional between the analyses of the more basic rock and that of the quartz-glaucophane schist to be given presently, and this intermediate character is quite consonant with its complex and transitional mineral composition. In its general features it resembles the analyses of many diorites, and it may be mentioned here that this analysis is quite unique among the dozen or so given in this paper.

The mineral composition being so complex, any satisfactory calculation of the relative amounts of the component minerals is difficult, and would be arbitrary.

Quartz-glaucophane Schist.—It has already been said that von Fouchon and Goldschmidt divided the glaucophane schists of Syra into the two groups in which the blue hornblende was associated with either epidote or mica. While this is in general true, and in correspondence with the megascopical appearance of the rocks, yet it does not recognize fully enough the fact that the mica-glaucophane schists tend to become highly acid through the increase in quartz and decrease in mica. I have therefore referred some of my specimens to a third group of quartz-glaucophane schists, in which the mica, while present, and prominent in the hand specimen, yet is in

subordinate amount, and quartz very abundant. This division seems also to be in accordance with facts observed elsewhere.

Some of these schists resemble closely the preceding, and are rather bluish-gray, fine-grained, and highly schistose. The specimen taken for analysis differs from all these, and is a very striking rock, resembling (as far as can be told from the description) some of the quartz glaucophane schists of Angel Island, described by Ransome, to be mentioned later.

It is a highly schistose, shining white rock, from the north-west slope of Mt. Kappari. It is composed largely of quartz and less white mica, forming a fine-grained groundmass, through which are scattered blades of blue glaucophane, and some garnets about one cm. in diameter. Accessory epidote and apatite are also present in small amount.

The analysis (No. IV, below), it will be seen, differs radically from those of the other Syra rocks, being very acid, and with all other oxides much lower, except K_2O , which is quite high. In a general way it resembles those of the acid glaucophane schists of the Pacific coast.

	I.	II.	III.	IV.
SiO ₂	46.39	46.76	58.26	79.43
Al ₂ O ₃	17.34	22.65	16.21	12.68
Fe ₂ O ₃	6.32	4.35	3.44	1.10
FeO	4.62	1.74	4.63	1.86
MgO	4.93	3.93	4.99	0.48
CaO	13.07	14.43	3.82	1.40
NaO	2.95	2.36	5.36	1.61
K ₂ O	0.25	0.15	0.39	0.76
H ₂ O 110° + ..	1.48	2.87	0.98	1.03
H ₂ O 110° - ..	0.08	0.16	0.22	0.12
CO ₂	2.24	----	----	0.00
TiO ₂	0.85	not det.	1.37	0.17
MnO	trace	trace	trace	trace
	100.52	99.40	99.67	100.64

- I. Epidote-glaucophane schist. Kyperusa, Syra. Washington anal.
- II. Omphacite rock. Café Skarbéli, Hermoupolis, Syra. Washington anal.
- III. Mica-glaucophane schist. Café Skarbéli, Hermoupolis, Syra. Washington anal.
- IV. Quartz-glaucophane schist. N.W. slope of Mt. Kappari, Syra. Washington anal.

In connection with the glaucophane schists of Syra, it will be convenient to give the results of an analysis which I made of the glaucophane of the island. The mineral was very carefully separated by means of Thoulet's solution from a

rather coarse-grained specimen of quartz-mica-glaucophane schist, with a few accessory garnets. It just sank in a solution of sp. gr. 3.11, and was examined with the microscope and seen to be extremely pure.

My analysis (the mean of two) is shown in I, and for comparison are given the analyses of Luedecke (II) and Schnedermann (III), taken from the paper of Luedecke (p. 252), already cited. It is hoped to discuss this analysis, along with other new ones, in a subsequent paper.

	I.	II.	III.
SiO ₂	57.67	55.64	56.49
Al ₂ O ₃	11.07	15.11	12.23
Fe ₂ O ₃	3.20	3.08	----
FeO	9.68	6.85	10.91
MnO	0.06	0.56	0.50
MgO	9.85	7.80	7.97
CaO	0.95	2.40	2.25
Na ₂ O	6.80	9.34	9.28
K ₂ O	0.42	----	----
H ₂ O 110° +	0.36	----	----
H ₂ O 110° -	0.12	----	----
	<hr/>	<hr/>	<hr/>
	100.18	100.78	99.63

Attica.

The investigation of Lepsius* have shown that both the gabbros and the Cretaceous shales of Attica have been altered to glaucophane schists, through regional metamorphism.

	I.	II.
SiO ₂	48.00	45.97
Al ₂ O ₃	15.80	18.18
Fe ₂ O ₃	11.76	5.95
FeO	3.29	2.30
MgO	7.70	7.50
CaO	5.51	8.29
Na ₂ O	3.42	4.10
K ₂ O	0.46	0.75
H ₂ O	4.20	6.50
P ₂ O ₅	trace	trace
S	trace	----
MnO	trace	trace
	<hr/>	<hr/>
	100.14	99.54

- I. Gabbro. Kypriano, near Laurium. Lepsius anal., op. cit., p. 101.
 II. Gabbro. Malje Kuki, near Daskalio. Lepsius anal., op. cit., p. 102.

*Lepsius, Geologie von Attika, Berlin, 1893.

Unfortunately he gives no analyses of true glaucophane schists, but it seems worth while quoting the above two analyses of gabbros, which have partially undergone the transformation. Both are composed chiefly of plagioclase and diallage, which has been largely altered to fibrous green hornblende, with considerable glaucophane in needles. Chlorite and magnetite occur, but no olivine nor serpentine was seen.

Lepsius* also describes a blue gray, partially schistose rock, from west of Olimpos in Attica, composed of glaucophane needles lying in a groundmass of quartz and feldspar. A silica determination gave 87.43 per cent, and it is evident that this is a quartz-glaucophane schist, analogous to those of Syra, and, as will be seen later, of the Pacific Coast and elsewhere.

Croatia.

In 1887 Dr. Kišpatić† described a number of glaucophane schists, which occur chiefly as boulders or pebbles in various streams of Fruska Gora in Croatia. They vary to some extent, but it is of great interest to note that they may all be classed as either epidote-glaucophane schists, to which the majority belong, or as quartz-glaucophane schists, which are represented by only two occurrences. Garnet is sometimes present in abundance, sometimes quite wanting, and mica is rare, even in the more acid group.

I am indebted to Prof. Rosenbusch for one of Kišpatić's specimens from the Srnjevački Potok. It is of very simple composition, being composed chiefly of frayed, pleochroic glaucophane, and colorless or pale yellow epidote, in grains and prismatic crystals. Between these, but in very small amount is a colorless mineral, which occasionally shows multiple twinning lamellæ, and is referred to plagioclase. There are also rare rutile grains.

In thin section my specimen corresponds very well with Kišpatić's description. The rock is very fine-grained, composed of a pale glaucophane, in xenomorphic masses, with abundant grains and stout crystals of colorless or pale yellow epidote. A colorless mineral, apparently a plagioclase, as suggested by Kišpatić, is rare, in interstitial grains.

The analysis shows low SiO_2 , and resembles in a general way that of the Kyperusa rock. It differs, however, in having much higher MgO and lower CaO , as well as in the absence of CO_2 .

* Lepsius, op. cit., p. 104.

† Kišpatić, Jahrb. k. k. geol. Reichsanst., xxxvii, p. 35, 1887.

SiO ₂	47·36
Al ₂ O ₃	19·74
Fe ₂ O ₃	3·10
FeO	5·71
MgO	8·24
CaO	4·63
Na ₂ O	3·57
K ₂ O	0·51
H ₂ O 110° +	5·89
H ₂ O 110° -	0·16
CO ₂	trace
TiO ₂	1·36
MnO	trace

100·27

Epidote-glaucophane schist. Srnjevački Potok, Fruska Gora, Croatia. Washington anal.

Anglesey, Wales.

The occurrence of glaucophane schists on Anglesey was first observed by Blake* in 1888. The area is small and the composition apparently quite uniform, only epidote-glaucophane schist being mentioned. This occurs as local modifications of a hornblende schist which is probably derived from a diorite, which occurs in the vicinity.†

Through the kindness of Mr. Teall and Mr. E. B. Greenly I received specimens from the most typical locality, "The Monument," near Menai Bridge, on Anglesey, one of which was analyzed.

The specimens are very uniform, and are dense, compact, fibrous rather than foliated, schists, of a dark, blue-black color,

SiO ₂	47·47
Al ₂ O ₃	15·25
Fe ₂ O ₃	8·22
FeO	7·19
MgO	5·96
CaO	11·32
Na ₂ O	2·11
K ₂ O	0·56
H ₂ O 110° +	2·13
H ₂ O 110° -	0·04
TiO ₂	not det.
MnO	trace

100·25

Epidote-glaucophane schist. The Monument, Anglesey, Wales. Washington, anal.

* Blake, Geol. Mag., Decade III, vol. v, p. 125, 1888.

† Blake, Rep. Brit. Assoc. Adv. Sci., 1888, p. 406. Also op. cit., p. 125. Harker, Petrol. for Stud. 1897, p. 314.

and somewhat silky luster. Under the microscope they correspond with the plate given by Teall*, and are seen to be composed of a rather pale, prismatic glaucofane, with the normal pleochroism, rather less pale epidote, and small amounts of magnetite, quartz, mica and titanite. No calcite was seen.

Piedmont.

The occurrence of glaucofane schists in Piedmont is well known, and has been described by many geologists, but as I had no specimens from this region, I have passed it by in the preceding pages. Since they have been put in type, however, I have discovered an analysis of one of the rocks of this region, which is inserted here.

The occurrence of glaucofane schists and amphibolites ("prasinites") in the Val Maira, in southwestern Piedmont, is described by S. Franchi,† who also shows that they are both derived from diabases by metamorphism, apparently regional. The glaucofane schists are described as composed of glaucofane (gastaldite), with epidote and chlorite, and less albite, quartz, titanite and calcite. Analyses of this and of the amphibolite are given, and the very close correspondence between the two is evident. This is a strong point in favor of the view elsewhere expressed, that the formation of these two rocks is due, not to age distinctions, but to differences in conditions during metamorphism.

	I.	II.
SiO ₂	48·67	50·38
Al ₂ O ₃	18·36	17·65
Fe ₂ O ₃	10·30	10·02
FeO	-----	-----
MgO	5·49	4·77
CaO	11·03	10·95
Na ₂ O	1·12	2·52
K ₂ O	0·11	0·24
H ₂ O	4·20	2·52
TiO ₂	0·45	1·32
P ₂ O ₅	trace	trace
	99·75	100·37

- I. Glaucofane schist, Val Maira, Piedmont. Aichino anal. S. Franchi, *Boll. Com. Geol. Ital.*, xxvi, p. 199, 1895.
 II. Amphibolite ("Prasinite"), Valle del Sangone, Piedmont. Aichino anal. S. Franchi, *op. cit.*, p. 199.

Corsica.

For the sake of completeness there may be mentioned two glaucofane rocks of Corsica, which have been analyzed.

* Teall, *Brit. Petrog.* 1888, pl. xlvii, fig. 1.

† S. Franchi, *Boll. Com. Geol. Ital.*, vol. xxvi, p. 192, 1895.

One is a gray-green schist from the neighborhood of a large serpentine dike, at La Barchetta, near Bastia, of which, not having access to the original paper by Oels,* I can give no description. It is, however, possibly the same as that described by Oebekke† from the same locality, as composed of prismatic glaucophane, partly altered to chlorite, granular epidote, plagioclase, quartz and calcite.

The analysis (No. I, below) shows low SiO_2 and CaO , with very high alkalis, and Fe_2O_3 largely preponderating over FeO . It does not correspond with the description given by Oebekke, nor, in fact, as far as the iron oxides and alkalis are concerned, with any other analysis of a glaucophane schist.

The other is a glaucophane schist from the gneiss of Bastia,‡ a dark, fine-grained, tough rock, composed of "orthoclase, some oligoclase, needles and prisms of glaucophane, sahlite, iron mica and chlorite, with other secondary products."

The analysis, given in II below, is unsatisfactory, and of little value, as FeO , alkalis and H_2O have not been determined. As far as it goes it is rather anomalous for a glaucophane schist, and resembles most that of the rock from Caf  Skarbeli, in Syra.

	I.	II.
SiO_2	50.17	55.94
Al_2O_3	13.88	18.06
Fe_2O_3	7.80	12.17
FeO	1.69	
MgO	4.53	2.75
CaO	10.90	5.95
Na_2O	7.31	5.13 (difference)
K_2O	2.16	
H_2O	1.56	not. det.
Mn_3O_4	0.59	----
	100.59	100.00

I. Glauco-phane schist. La Barchetta. Bastia. Corsica. M. Oels anal. Ref. in Neu. Jahrb. 1896, i, p. 47.

II. Glauco-phane schist, near Bastia, Corsica. Busatti anal. Ref. in Neu. Jahrb., 1897, i, p. 281.

Japan.

Glaucophane schists are of quite common occurrence among the metamorphic rocks of Japan,§ and a number of them have been described by Kot . From him I received several specimens of typical material, two of which were analyzed.

* M. Oels, Inaug. Diss. Erlangen. 1894, Ref. in Neues Jahrb. 1896, J, p. 47.

† Oebekke, Zeitschr. d. deutsch. geol. Ges., vol. xxxviii, p. 647, 1886.

‡ Busatti, Atti Soc. Tosc. Sci. Nat., Mem. xiii, p. 1-19, 1894: Ref. in Neues Jahrb. 1897, i, p. 281.

§ Kot , Jour. of Sci. College, vol. i, Pt. i, p. 85, 1886. Harada, Die Japanischen Inseln, Berlin, 1890, pp. 54, 62.

Epidote-Glaucophane Schist.—One of these specimens is a rock of this character from Hongô, in Norimoto Village, Yana District, Province Mikawa. It is compact, of a rather dark, greenish gray color, and schistose with a silky luster. The specimen is traversed by a vein of calcite, which was avoided in the material chosen for analysis. The microscope, as well as the analysis, shows that this mineral is present throughout the rock to a considerable extent.

The structure of the rock as seen by the microscope differs from most of the other specimens examined, in the very finely fibrous character of the glaucophane, which is rather pale, but of the usual pleochroism. This forms streaks and bands through the rock, bringing out the schistose structure, and also occurs as a sort of felt. With it, but somewhat locally developed, is a pale green or bluish-green, not highly pleochroic, amphibole, also in needles, which seem to be an actinolite and to be derived from the glaucophane. A yellowish epidote occurs in small grains, chiefly intimately associated with the glaucophane.

Partly intermingled with these three, but generally forming the greater part of separate streaks, is a colorless mineral of rather high refraction and low birefringence, the polarization colors being grays and blue-grays. It is chiefly in long grains, not showing much cleavage, and is apparently orthorhombic. This must be referred to zoisite, as the low alkalies preclude the possibility of its being a feldspar. Calcite is quite common, and some grains of quartz are seen. Titanite is also present in small grains.

The analysis of this rock, given in I below, is that of a normal epidote-glaucophane schist, with high CaO. It calls for no special remark here.

A specimen of glaucophane schist from Otaki-san, near Tokushima, Shikoku Island, represents the rocks in which glaucophane was first discovered in Japan by Kotô, and which have been briefly described by him. The majority of them would seem to be epidote-glaucophane schist, some containing garnets, but the one in my possession is a quartz-glaucophane schist. Unfortunately it is seemingly so badly altered that no analysis was made of it, but a brief description may be of interest.

It is a highly fissile, schistose rock, of a general brownish color, glistening with mica scales, and with abundant dark blue glaucophane. Microscopically it is composed of stout prisms of dark glaucophane, white mica, and considerable interstitial quartz. Small crystals of colorless titanite, apatite and zircon (?) are numerous. Brown limonitic stains over all

the section indicate the decomposition of the specimen, but it is more fresh than the megascopic appearance would indicate.

“*Glaucophane Slate.*”—The second specimen which was chosen for analysis is one of a rock called by this name by the Japanese geologists. According to Kotô* they are extensively developed in the Paleozoic of Japan, and are really “schalsteins,” derived from diabase tuffs. The specimen in question, from Kamoi Kotan, Island of Hokkaido (Yesso), is a very fissile, slaty, fine-grained rock, of a general light, blue-gray color, but stained between the folia with limonite.

Under the microscope it is seen to be very fine-grained, and with the detrital, cataclastic structure of the original diabase tuff very well marked. There are irregular patches of a pale, fibrous glaucophane, with some rather large crystals and fragments of pyroxene, but the greater part is an indeterminate, very finely granular mass of colorless and yellow grains and fragments, mostly of augite, with some of glass, and possibly of plagioclase.

The analysis (No. II) resembles the preceding in many respects, but is lower in CaO, and higher in iron oxides, K_2O and $TiO_2 \cdot H_2O$ is high, but no CO_2 was found.

The analysis, on the whole, confirms the view that the rock is a metamorphosed diabase tuff, and for comparison, analyses of two of these are given in III and IV.

	I.	II.	III.	IV.
SiO ₂	47.89	48.88	47.25	49.13
Al ₂ O ₃	13.06	13.44	17.84	14.76
Fe ₂ O ₃	6.77	5.32	5.46	16.40
FeO	5.36	8.96	7.20	----
MgO	4.10	4.21	5.97	4.41
CaO	11.65	5.80	5.15	9.05
Na ₂ O	3.35	3.73	2.30	2.96
K ₂ O	0.57	1.71	0.29	1.81
H ₂ O 110° + ..	1.39	3.42	8.55	1.66
H ₂ O 110° - ..	0.12	0.36		
CO ₂	2.97	none	----	----
TiO ₂	2.14	3.90	in Al ₂ O ₃	----
MnO	0.09	----	0.14	----
	99.46	99.73	100.15	100.18

- I. Epidote-glaucophane schist. Norimoto, Yana Distr. Mikawa Prov. Japan.
- II. “Glaucophane slate.” Kamoi Kotan. Isl’d Hokkaido. Japan.
- III. “Schalstein.” Nogurizawa. Kanra Distr. Kozuke Prov. Japan. Harada anal. Harada. Die Jap. Inseln., p. 66.
- IV. “Schalstein.” Siebenhitz. NW of Hof. Bavaria. Schwager anal. Gümbel, Geogn. Beschr. Fichtelgeb. 1879, p. 227.

* Kotô, op. cit., p. 89.

California.

Coming to our own continent, we find glaucophane schists only in the extreme west, where they are extensively developed along the Pacific Coast, in California and Oregon, and possibly beyond these. They are very varied in character, and have been described in part by many geologists, but their relationships and origin are not yet fully understood. Some of them would seem to be the products of regional metamorphism, while in other cases they are due to contact metamorphism and are local in character.

They also vary widely in composition, but the researches already made by others, as well as the analyses given here, show that, just as in Syra, Croatia and Brittany, they belong to two groups, the basic and the acid. As the occurrences are somewhat widespread, they will be described under local headings.

Santa Catalina Island.—The geology of this island, which lies off the coast of Southern California, has been described by W. S. T. Smith.* It is composed largely of diorites and andesites, resting on a basement of quartzite and schists, in which also serpentine occurs.

Of the occurrence of the glaucophane schists he speaks as follows: "Besides the micaceous partings of the quartzites there were found at a number of points partings of blue amphibole, having frequently a silky luster. This amphibole also occurs in larger masses in a schistose condition. The occurrences of this rock are found particularly in the Little Harbor region, apparently confined to the neighborhood of areas of the amphibole, and talc-schists and serpentine. It is probable that here, as elsewhere in California, these blue amphibole schists are due to local contact metamorphism occasioned by the intrusion of basic eruptives."

Dr. Smith does not describe these rocks further, but in the petrographic collection of Yale University is a suite of rocks from Santa Catalina Island, collected by Prof. B. Silliman in 1867, among which are several specimens of the glaucophane schists from Little Harbor, on the west coast. I am indebted to Prof. Pirsson for the privilege of studying these, as well as material for analysis.

They all prove to be quartz-glaucophane schists, pale, blue-gray in color, rather ashy and dull, one fibrous, and the others (including the specimen analyzed), very schistose and fissile, though quite hard. One specimen shows thin bands of white quartz.

* W. S. T. Smith, Proc. Cal. Acad. Sci., (3), Geol., vol. i, p. 1, 1897.

Under the microscope the specimen analyzed shows a multitude of fine, pale blue glaucophane needles, and larger crystals fringing out into needles, embedded in granular quartz, with some minute zircons and a few grains of epidote. There is no carbonaceous matter present, but in another similar specimen this exists to a considerable extent, while a dark, compact rock, also from Little Harbor, is a black and apparently little altered, quartzose shale.

	I.	II.	III.
SiO ₂	74·48	80·21	74·16
Al ₂ O ₃	9·15	7·99	11·85
Fe ₂ O ₃	1·41		0·82
FeO	4·12	3·35	1·66
MgO	3·04	1·54	2·10
CaO	2·84	1·10	2·10
Na ₂ O	2·24	5·97	6·57
K ₂ O	0·43	0·22	0·15
H ₂ O 110° +	2·06	0·74	{ 0·52
H ₂ O 110° -	0·08		
CO ₂	---	---	0·09
TiO ₂	---	---	0·37
P ₂ O ₅	---	---	0·08
MnO	---	---	0·06
C	---	---	0·18
	99·85	101·12	100·76

- I. Quartz-glaucophane schist. Little Harbor, Santa Catalina Island, Cal. Washington anal.
- II. Quartz-glaucophane schist. Angel Island, Cal. Ransome anal. Bull. Dept. Geol. Univ. Cal., vol. i, p. 231.
- III. Adinole, Mansfield, Mich. Steiger anal. Clements. This Journal, vol. vii, p. 88, 1899.

The analysis shows that quartz is very abundant, more so indeed than the microscopical examination would have led one to suppose. It is possible, to judge from the amount of Al₂O₃, that sillimanite is present, since Smith speaks of it as occurring in the neighboring quartzite. None was seen in the sections, though the dense felt of glaucophane needles would make its identification difficult.

It may be inferred from the presence of carbonaceous matter in some of the specimens, and from the apparent gradation to true shale shown by them, that these schists are derived from shales of a quartzose character, or from the quartzites as Smith suggests, possibly through the contact metamorphism of intruded igneous rocks.

It may be mentioned that the analysis corresponds very well with that of an adinole (III above), derived from a clay slate

by contact metamorphism of a dolerite, at Mansfield, Michigan, described by Clements.* The adinole carries abundant albite, and actinolite instead of glaucophane. This difference may be connected with the higher Al_2O_3 and Na_2O and lower FeO in the adinole.

Angel Island, Cal.—The occurrence just described seems to be analogous with that at Angel Island, in San Francisco Bay, described by Ransome,† the similarity being also remarked on by Smith (p. 57). At the latter locality radiolarian cherts have been altered into quartz-glaucophane schists by the intrusion of fourchite and serpentine. They vary rather more in character, as some are composed essentially of glaucophane and albite,‡ while others are made up of glaucophane and quartz. Brown mica and garnet also occur. Analysis II above, by Ransome, shows the essentially general similar character of the two, though it was made evidently of an albitic schist.

It is of interest to note that, just as carbonaceous matter is preserved in the Santa Catalina schists, so in these from Angel Island the radiolarian remains are not entirely obliterated by the metamorphism.

Mount Diablo.—Among the metamorphic rocks of this locality glaucophane schists occur,§ but unfortunately detailed petrographic descriptions seem to be wanting. One of them, a boulder from Pine Canyon, has been analyzed by Melville.|| It is briefly described as bluish with streaks of green, with well marked schistose structure, and containing innumerable cinnamon garnets. It is composed presumably chiefly of glaucophane, epidote and garnet, with few accessories, and is probably closely similar to some of the glaucophane schist of Tupper Rock, Oregon, or a specimen from Tiburon Peninsula, sent me by Prof. Lawson. The analysis is given on the next page.

In a recent paper¶ Turner throws some doubt on the interpretation of these schists as the product of contact metamorphism by basic intrusions, but discussion of this problem is outside the scope of this article.

Sulphur Bank.—Glaucophane schists from this locality, which lies east of Clear Lake (north of the preceding locality), have been described by Becker.** They vary much, as elsewhere, some being quartz-mica-glaucophane schists, and others

* Clements, this Journal, IV, vol. vii, p. 88, 1899.

† Ransome, Bull. Dept. Geol. Univ. Cal., vol. i, p. 211, 1894.

‡ Turner (17th Ann. Rep. U. S. G. S., i, p. 728, 1896) suggests that they may be in reality dike rocks.

§ Turner, Bull. Geol. Soc. Amer., vol. ii, p. 384, 1891.

|| Melville, Bull. Geol. Soc. Amer., vol. ii, p. 413, 1891.

¶ Turner, Jour. Geol., vol. vi, p. 490, 1898.

** G. F. Becker, Mon. XIII, U. S. G. S., p. 102, 1888.

SiO ₂	47.84
Al ₂ O ₃	16.88
Fe ₂ O ₃	4.99
FeO	5.56
MgO	7.89
CaO	11.15
Na ₂ O	3.20
K ₂ O	0.46
H ₂ O 105° +	1.81
H ₂ O 105° -	0.17
P ₂ O ₅	0.14
MnO	0.56
	<hr/>
	100.65

Garnet-glaucophane Schist. Pine Canyon, Mount Diablo. Melville anal. Bull. Geol. Soc. Amer., vol. ii, p. 413, 1891.

zoisite-glaucophane schists. One of the last was analyzed, and is described by Becker as follows.

“It is a greenish-gray, schistose rock, consisting chiefly of glaucophane and zoisite. The latter occurs in imperfect prismatic crystals. The zoisite is distinctly dichroic and has a faint olive-green tint when the prisms are parallel to the principal section of the nicols. Sections perpendicular to the main axis are square, often with one truncated corner. The extinctions are normal and the colors of interference are gray to yellow in the prisms, but more vivid in granular aggregates. The angle of the optical axes appears to be large. Glauco-phane, in needles and long, imperfect, nearly parallel prisms, gives the rock its cleavage. Quartz, albite, muscovite and titanite are present.”

The occurrence of a purely zoisite-glaucophane schist, as described by Becker, is decidedly unusual, and the determination of all the supposed zoisite as such would seem to be somewhat problematical. It is true that some of the mineral was separated and analyzed,* the results corresponding fairly well with the determination as zoisite, but being not inconsistent with an epidote low in iron. The color and pleochroism are also unusual for zoisite. It would seem probable that both minerals exist in the rock, the granular form being probably especially referable to epidote.

Melville's analysis (I) shows a composition closely resembling the preceding one, and like other glaucophane schist analyses, with high CaO. It is of interest to compare with it an analysis of a diabase (Becker's pseudodiabase) from Mt. St. Helena, also by Melville. It will be seen that the two are almost identical.

* Becker, op. cit., p. 79.

	I.	II.
SiO ₂ -----	49·68	49·08
Al ₂ O ₃ -----	13·60	14·68
Fe ₂ O ₃ -----	1·86	1·95
FeO-----	8·61	9·63
MgO-----	6·27	6·69
CaO-----	10·97	10·09
Na ₂ O-----	3·09	4·60
K ₂ O-----	0·12	0·20
H ₂ O 100°+-----	} 3·84	} 1·18
H ₂ O 100°------		} 0·28
TiO ₂ -----	1·31	1·72
P ₂ O ₅ -----	0·21	0·23
MnO-----	0·04	0·15
	99·60	100·48

- I. Zoisite-glaucophane schist. Sulphur Bank. Melville anal. Becker, Mon. XIII U. S. G. S., p. 104, 1888.
- II. "Pseudodiabase." Mt. St. Helena. Melville anal. Becker, op. cit., p. 98.

While we are still in California, there may be quoted, for the sake of completeness, two analyses given by Rosenbusch. The first (I) is of a specimen sent him by Palache, of a "Grünschiefer with glaucophanes, further stage of altered tuff. Hills north of Berkeley." This is calculated from two partial analyses and an alkali determination.* It shows a composition very low in SiO₂ and MgO, probably high in iron, and high in CaO and Na₂O, differing materially from others only in the lower SiO₂.

The second† (II) is of the albite-crossite rock described by Palache,‡ and which Turner§ thinks may be a dike rock.

	I.	II.
SiO ₂ -----	42·59	65·2
Al ₂ O ₃ -----	} 31·00	} 15·8
Fe ₂ O ₃ -----		} 2·7
FeO-----		} 2·4
MgO-----	5·10	2·4
CaO-----	10·80	0·6
Na ₂ O-----	4·16	10·8
K ₂ O-----	1·01	0·1
H ₂ O, CO ₂ -----	5·34	----
	100·00	100·0

* Rosenbusch, Sitzungsber. Preuss. Akad., 1898, p. 716.
 † Rosenbusch, op. cit., p. 712.
 ‡ Palache, Bull. Dept. Geol. Univ. Cal., vol. i, p. 181, 1894.
 § Turner, 17th Ann. Rep. U. S. G. S., i, p. 728, 1896.

Rosenbusch calculated the rock composition from the specific gravities of the rock and of the two minerals, and their known chemical composition. He gives two limiting results, but, as they differ but little, that corresponding to the mineral mixture $Ab_{76}Cr_{25}$ is here given. As Rosenbusch remarks, this composition is quite anomalous, whether for eruptive or metamorphic rocks, and it is to be desired that an analysis of the rock itself were available.

Oregon.

Glaucophane schists, both acid and basic, occur along the coast in Oregon, and have been partially described by Diller,* who suggests that, as at Angel Island, they are the products of contact metamorphism. He very kindly sent me a number of typical specimens, three of which I have analyzed.

That from a ledge about one mile N.E. of Winston's bridge, near Roseburg, is a schistose, gray (scarcely blue) fine-grained rock, with many glistening flakes of white mica sprinkled through it. One specimen shows some small brown garnets. The other (analyzed) is wanting in them, and is composed of a felt of stout, rather short glaucophane crystals, with grains of epidote, some chlorite, a few irregular quartz grains, and phenocrysts of colorless mica.

Chemically (I) it is the most basic of all these rocks which have been analyzed with the exception of the one partially analyzed by Rosenbusch. It is also very high in iron, low in CaO , and, for these rocks, high in K_2O , which indicates that the mica is a muscovite and not a paragonite, as in the Syria rocks.

Glaucophane schists also occur southwest of Roseburg, in the neighborhood of Coos Bay. Those from Tupper Rock have been briefly described by Diller, and three specimens sent me indicate that they vary considerably in character. Two are composed essentially of glaucophane embedded in granular quartz, with some white mica, and a little epidote. The chemical composition of these must be closely similar to that from Four Mile Creek, described later. The other (III) is much more basic, composed of glaucophane with less granular epidote, or zoisite, in which lie many small garnets, around which are zones of white mica. This corresponds more nearly in chemical composition to the Mount Diablo occurrence.

The schist from Four Mile Creek, Coos County, is a rather coarser grained, schistose rock, of a general light gray color, showing considerable white mica and quartz. In general

* Diller, 17th Ann. Rep. U. S. G. S., i, p. 454, 1896; Geol. Atlas of U. S. Roseburg Folio, 1898.

appearance it is not unlike the intermediate mica-glaucophane schist from Cafe Skarbeli, Syra, already described. In thin section it is seen to be composed very largely of quartz, which shows clear evidence of crushing. In this lie well-formed glaucophane prisms, which are highly pleochroic, c blue, b violet, a pale yellow or colorless. With these, but in less amount, are thin flakes of colorless mica, which the analysis shows to be muscovite scales and plates of chlorite, and some small garnets.

The analysis (II) shows an exceedingly acid composition, being the highest in SiO_2 of any of the rocks so far examined by me. On calculation the mineral composition works out as follows:

Quartz	67.6
Glaucophane	14.2
Muscovite	10.4
Garnet	} 7.8
Chlorite	
100.0	

The relatively high K_2O in both these Oregon rocks is noteworthy, the nearest approach to them in this respect being the "glaucophane slate" of Kamoi Kotan in Japan.

	I.	II.	III.
SiO_2	46.07	82.53	49.15
Al_2O_3	15.35	6.88	15.87
Fe_2O_3	3.61	0.59	4.10
FeO	9.87	4.11	7.58
MgO	7.83	1.86	7.53
CaO	4.37	0.68	9.06
Na_2O	3.22	1.21	3.59
K_2O	2.68	1.24	0.54
$\text{H}_2\text{O } 110^\circ +$	4.25	1.35	1.07
$\text{H}_2\text{O } 110^\circ -$	0.16	0.07	0.16
CO_2	1.05	----	none
TiO_2	1.63	----	1.19
MnO	trace	trace	trace
	100.09	100.52	99.84

- I. Epidote-glaucophane schist. Near Winston's Bridge, Roseburg, Douglas Co., Oregon. Washington anal.
- II. Quartz-glaucophane schist. Four Mile Creek, Coos Co., Oregon. Washington anal.
- III. Garnet-glaucophane schist. Tupper Rock, near Brandon, Coos Co., Oregon. Washington anal.

General Conclusions.

It will be of interest to compare the foregoing analyses with each other, and for this purpose those which seem to be of most value are collected in the large table on page 55. It is at once evident that these rocks are divided into at least two main groups. One, the larger, is basic, with SiO_2 ranging only from 46 to 49.7, the other is very acid, with SiO_2 ranging from 74.5 to 82.5. These two seem to be very sharply separated, a possible third intermediate group being represented by only one analysis, with SiO_2 58.3.

Basic Group.—Taking up the basic group first, it is seen that they are of fairly uniform composition in most respects. Al_2O_3 in most of them is rather low, from 13 to 15, being higher only in II (17.34), III (19.74) and V (16.88) and VII (18.36). Iron oxides are high in all, and FeO uniformly surpasses Fe_2O_3 (molecularly), in two cases (I and X) very much so. MgO varies from 4.1 to 8.2, and there seems to be no correlation between it and any other oxide, though there are indications of a parallel variation of it and FeO.

CaO shows the most striking behavior, running from 4.4 to 5.8 in some, and then with a break from 11 to 13 in others. It would be natural to connect this behavior with some corresponding difference in mineral composition, but I have failed to find any trace of such. One would suppose that the rocks rich in CaO might be prone to carry garnets, but, while they are abundant in V and IX they are lacking in II, IV, VI and X. On the other hand they are quite wanting in I, III and VIII, in which CaO is low.

Na_2O remains very steady, varying only from 1.1 to 3.7, while K_2O is present, as a rule, only in traces, being above one per cent only in I (2.7) and VIII (1.7). H_2O is, of course, present in considerable, but varying, amount, and CO_2 likewise is irregular, being often quite absent, and again high. TiO_2 , when determined, is always high, a fact connected with the frequent occurrence of rutile and titanite as accessory minerals. P_2O_5 and MnO are present only in traces.

Acid Group.—Inasmuch as in this group SiO_2 constitutes 75 to 80 per cent of the rock, the distribution of the other oxides through the remaining 25 to 20 per cent allows of a comparatively small range in variation. It may be noted, however, that FeO is constantly higher than Fe_2O_3 , that MgO is rather high for such acid rocks, that CaO decreases regularly as SiO_2 increases, and that Na_2O is constantly higher than K_2O , which, except in XV, is present only in traces. The very high Na_2O in XIV is undoubtedly to be attributed to the presence of albite.

	I.	II.	III.	IV.	V.	VI.	VII.	VIII.	IX.	X.	XI.	XII.	XIII.	XIV.	XV.
SiO ₃	46.07	46.89	47.36	47.47	47.84	47.89	48.67	48.88	49.15	49.68	58.26	74.48	79.43	80.21	82.53
Al ₂ O ₃	15.35	17.34	19.74	15.25	16.88	13.06	18.36	13.44	15.87	13.60	16.21	9.15	12.68	7.99	6.88
Fe ₂ O ₃	3.61	6.32	3.10	8.22	4.99	6.77	10.30	5.32	4.10	1.86	3.44	1.41	1.10	---	0.59
FeO	9.87	4.62	5.71	7.19	5.56	5.36	---	8.96	7.58	8.61	4.63	4.12	1.86	3.35	4.11
MgO	7.83	4.93	8.24	5.96	7.89	4.10	5.49	4.21	7.53	6.26	4.99	3.04	0.48	1.54	1.86
CaO	4.37	13.07	4.63	11.32	11.15	11.65	11.03	5.80	9.06	10.97	3.82	2.84	1.40	1.10	0.68
Na ₂ O	3.22	2.95	3.57	2.11	3.20	3.35	1.12	3.73	3.59	3.09	5.36	2.24	1.61	5.97	1.21
K ₂ O	2.68	0.25	0.51	0.56	0.46	0.57	0.11	1.71	0.54	0.12	0.39	0.43	0.76	0.22	1.24
H ₂ O 110° +	4.25	1.48	5.89	2.13	1.81	1.39	4.20	3.42	1.07	3.84	0.98	2.06	1.03	0.74	1.35
H ₂ O 110° -	0.16	0.08	0.16	0.04	0.17	0.12		0.36	0.16		0.22	0.08	0.12		0.07
CO ₂	1.05	2.24	trace	---	---	2.97	0.45	none	none	---	1.37	---	none	---	---
TiO ₂	1.63	0.85	1.36	not det.	---	2.14	trace	3.90	1.19	0.21	---	---	0.17	---	---
P ₂ O ₅	---	---	---	---	0.14	---	---	---	---	0.04	trace	trace	---	---	---
MnO	---	---	---	trace	0.56	0.09	---	trace	trace	0.04	trace	trace	trace	---	trace
	100.09	100.52	100.27	100.25	100.65	99.46	99.73	99.73	99.84	99.59	99.67	99.85	100.64	101.12	100.52

- I. Epidote-glaucophane schist. Winston's Bridge, near Roseburg, Oregon. Washington anal.
- II. Epidote-glaucophane schist. Kyperusa, Syra. Washington anal.
- III. Epidote-glaucophaneschist. Srnjcovacki Potok, Fruska Gora Croatia. Washington anal.
- IV. Epidote-glaucophane schist. The Monument, Anglesey, Wales. Washington anal.
- V. Garnet-glaucophane schist. Pine Canyon, Mt. Diablo, Cal. Melville anal.
- VI. Epidote-glaucophane schist. Norimoto, Mikawa, Japan. Washington anal.
- VII. Epidote-glaucophane schist. Val Maira, Piedmont. Aichino anal.

VIII.

Glaucophane "Slate." Kamoi Kotan, Hokkaido, Japan. Washington anal.

IX. Garnet-glaucophane schist. Tupper Rock, Bandon, Coos Co., Oregon. Washington, anal.

X. Zoisite-glaucophane schist. Sulphur Bank, Cal. Melville anal.

XI. Mica-glaucophane schist. Cafe Skarbeli, Hermoupolis, Syra. Washington anal.

XII. Quartz-glaucophane schist. Santa Catalina Island, Cal. Washington, anal.

XIII. Quartz-glaucophane schist. Mt. Kappari, Syra. Washington anal.

XIV. Quartz-albite-glaucophane schist. Angel Island, Cal. Ransome anal.

XV. Quartz-glaucophane schist. Four Mile Creek, Coos Co., Oregon. Washington anal.

Comparisons with other rocks.—Rosenbusch* has already called attention to the fact that “certain glaucophane rocks are chemically identical with the igneous rocks belonging to the gabbro magmas, or their tuffs.” He bases this conclusion on the two analyses of Melville (Nos. V and X), admitting at the same time that it does not follow that all glaucophane rocks are so derived.

That this main conclusion is correct for the majority of glaucophane schists would seem to be borne out by the analyses in the table, and their comparison with typical analyses of diabase and gabbros quoted in the large works of Roth, Zirkel and Rosenbusch. It is undeniable that there is a remarkably close agreement between the two, and the conclusion is irresistible that a large part of the glaucophane schists are probably derived from diabases, gabbros or their tuffs.

That this is not true of all is rendered certain by the four analyses of acid glaucophane schists, which we have already seen are in all probability derived from cherts, quartzose shales or quartzites. The anomalous analysis No. XI corresponds with those of many rather acid diorites, and it is possible that it has been derived from a rock of this kind, though this is not certain.

Although outside the scope of this paper it will not be amiss to call attention to several cases which bear directly on the question of the derivation of some of the glaucophane schists from rocks of the gabbro family, and which are strongly confirmatory of this view.

Direct evidence of the change from undoubted igneous rocks was first given by Kotô† in the case of several Japanese occurrences, melaphyrs and diabase tuffs showing a gradual increase in the blue amphibole and final transition into true glaucophane schist, through “glaucophanization” of the diallage. Instances of the same thing are also mentioned by Harada.‡

Another instance is furnished in Greece by Lepsius, in his description of the metamorphic schist of Attica.§ He shows that some of the gabbros of this region, which have been intruded into the sedimentaries and have been subjected to the same regional metamorphism, contain glaucophane, often in large quantities, though there are apparently few instances of the final conversion into true glaucophane schist.

It may be noted that the gabbros from near the Isthmus of Corinth and from Argolis, according to Lepsius and my own observations, do not show any glaucophane, but are analogous

* Rosenbusch. op. cit., p. 711.

† Kotô op. cit.

‡ Harada, op. cit., p. 62.

§ Lepsius, Geologie von Attika. Berlin, 1893, p. 176.

to a more basic group of gabbros, also occurring in Attica, which furnish serpentine on alteration.*

The Attic Cretaceous shales, according to Lepsius,† also yield glaucophane schists as products of metamorphism. Unfortunately no analyses are given, but some of them, as that from Velaturi near Thoriko, must resemble closely the Kyperusa schist, being composed essentially of glaucophane and epidote. Others again are more acid and carry along with glaucophane abundant quartz, feldspar and white mica.

In this connection it is of interest to note that glaucophane schists are very common in the whole region of metamorphic rocks which runs along the eastern coast of Greece, and extends southward and eastward through the Archipelago. Rocks of this character have been described from Thessaly,‡ Enboea,§ Attica,|| Thermia,¶ Tinos,** Siphnos,†† Syra, Milos,‡‡ Samos,§§ Rhodes,||| and Smyrna.¶¶

We have already seen that the glaucophane schists of Anglesey are probably derived from diorite (possibly gabbro), since, according to Blake and Harker, gradual transitions are observed from massive diorite to hornblende schist, the glaucophane schist being locally developed. Serpentine also occurs on Anglesey, though not near the Monument, where diorite occurs.*** Though the whole district has been subject to regional metamorphism,††† it is uncertain whether the development of glaucophane schist is due to this or to contact metamorphism.

Another instance of derivation from basic igneous material is that given by Rosenbusch in the paper already cited. He describes specimens sent by Palache, labelled "altered tuff" from near Berkeley, Cal., and concludes that these diabase tuffs do in fact alter to true glaucophane schists.

In his monograph on the Quicksilver Deposits of the Pacific Slope Becker††† briefly describes the alteration of diabase to glaucophane schist, and also speaks of the glaucophane schists of Mt. Diablo passing over into slightly altered shales.

* Lepsius, op. cit., p. 86.

† Lepsius, op. cit., pp. 133 and 136 ff.

‡ F. Becke, *Min. Petr., Mitth.*, vol. ii, p. 49, 1879.

§ F. Becke, op. cit., p. 71.

|| Lepsius, op. cit.

¶ Oebekke, *Zeitschr. d. d. Geol. Ges.*, vol. xxxviii, p. 644, 1886.

** Von Foullon and Goldschmidt, op. cit., pp. 24 and 31.

†† K. Ehrenburg, *Inselgruppe von Milos*. Leipzig, 1889, p. 101.

‡‡ L. Chelussi, *Giorn. di Min.*, vol. iv, p. 34, 1893.

§§ Foullon, *Sitzber. Akad. Wiss. Wien*, vol. c, p. 176, 1891.

||| Oebekke, op. cit., p. 651.

*** Cf. Blake, *Q. J. G. S.*, vol. xlv, pl. xiii, 1888.

††† Sir A. Geikie, *Anc. Volc. of Gr. Brit.*, vol. i, pp. 128, 220, 1897.

††† Becker, op. cit., pp. 100 and 102.

Finally Barrois* regards the glaucophane schists of Île de Groix, in Brittany, as the product of the metamorphism of sedimentary rocks.

Comparison with amphibolites.—A point of some interest, already touched on by Rosenbusch,† is the general similarity in chemical composition between the basic glaucophane schists and many of the amphibolites, as may be seen on reference to the analyses of these last given by Roth, Zirkel and Rosenbusch. It was hoped that the present investigation would throw some light on this point, and possibly reveal some constant difference in chemical composition between the two, which would serve to explain the diverse mineralogic resultants of apparently identical metamorphic processes on similar original material.

The results are, on the whole, inconclusive, though as a rule, the amphibolites are higher in MgO , CaO and K_2O , and lower in Fe_2O_3 , than the glaucophane schists. The eclogites approach, as a class, much more closely to the glaucophane schists, especially in low K_2O , though they also are apt to be higher in MgO and lower in Fe_2O_3 .

As Rosenbusch remarks, the distinction between the amphibolites and the glaucophane schist lies in the fact that, while in the former the Na_2O has gone into feldspar, in the latter it has gone into glaucophane. He suggests that this may be connected with a difference in the age of the rocks.

With this view I cannot agree. It seems more reasonable to suppose that, just as in the consolidation of igneous magmas the eventual mineralogic composition of rocks derived from any given magma is chiefly dependent on the physical conditions of cooling, the presence of mineralizers, etc., so here physical or chemical conditions have determined whether the metamorphism of, for instance, a diabase tuff produces a normal amphibolite or an epidote-glaucophane schist.

This view is based partly on the general reasoning which has abolished the age distinction in igneous rocks, and partly on the following considerations:

In the first place, we find at many places, as Île de Groix, Greece, California, Anglesey, etc., amphibolites and glaucophane schists occurring together, the latter being often only locally developed.

In the next place glaucophane has been often developed at one locality by the metamorphism of such widely diverse original materials as cherts and diabase tuffs. This points clearly to the existence of some peculiar conditions, apart from

*Barrois, Ref. Neus Jahrb., 1884, ii, p. 72.

† Rosenbusch, op. cit., p. 711.

the composition of the original material, as necessary to the formation of the mineral.

Again we find glaucophane schists in the "Grundgebirge" or Lower Cambrian at Ile de Groix, Neocomian among the Pacific Coast, Post Cretaceous in Attica, and probably of other ages elsewhere. Similarly amphibolites are found of various ages.

Lastly, the fact that these rocks are not found generally distributed over the earth, as are the amphibolites, but occur in well-defined zones or regions of metamorphic rocks, points to the existence of some peculiarity in the conditions of the metamorphic processes involved. This occurrence in strongly marked regions is exemplified by their presence in Greece and the Archipelago, the Piedmont Region in Italy, Japan and along the Pacific Coast of this country.

Summary.—The glaucophane schists belong to two main groups, sharply separated from each other. The larger one is basic, composed chiefly of glaucophane and epidote, often with abundant garnet, zoisite, diallage, and sometimes smaller amounts of mica, feldspar and quartz, and rutile and titanite as frequent accessories. Chemically these closely resemble the composition of the rocks of the gabbro family, and are apparently divisible into two subgroups, one high in CaO, the other low in it. These are in most cases almost undoubtedly derived from such igneous rocks or their tuffs, but also possibly in rarer cases from sediments or slates of similar composition.

These basic glaucophane schists scarcely differ in chemical composition from the amphibolites and eclogites, and the difference in their formation is probably to be ascribed to differences in the conditions of metamorphism.

A smaller, but widely spread, group is acid in composition, and these are composed largely of quartz and glaucophane, with mica and sometimes albite. These are derived from cherts, quartzites or quartzose shales and sandstones.

The existence is indicated of a third, still smaller, group of intermediate mineralogical composition, and chemically like the diorites.

The glaucophane schists are apparently the result of both regional and of contact metamorphism, and in many regions they occur together. This last seems to be the rule in glaucophane schist areas of any size, and where only the one kind is found the area is apt to be small.

ART. IV. — *On the Nature of the Metallic Veins of the Farmington Meteorite*; by O. C. FARRINGTON.

IN notes on the Farmington, Kansas, meteorite published some years ago,* Preston described numerous metallic veins occurring in the mass of the meteorite, and made the following suggestion as to their origin: "That, as the meteor struck our atmosphere the concussion was so great that the mass was fractured in various places, of course extending from the surface inward, and the larger of these fissures or fractures were then filled by the metallic iron which was fused on the exterior surface of the mass, due to its velocity through the atmosphere and was thus forced in a molten state into its present position, thus forming the metallic veins." The explanation is ingenious and perhaps correctly states the origin of the veins, but a recent study of the matter by the writer has led him to a somewhat different conclusion.

A discussion of the point seems desirable in view of the light it may throw on the question as to whether the veins of meteorites are in general of terrestrial or pre-terrestrial origin. It should be first noted that the formation of fractures or fissures in a meteoric mass ought not probably to be ascribed to concussion from the meteor striking our atmosphere. The fact that such crumbly and friable meteorites as Orgueil, Warrenton, Allegan and others have reached the earth intact seems to argue against there being any particular force of concussion attending the meeting of a meteorite with the earth's atmosphere. The resistance of the atmosphere to the passage of a meteorite is probably rather a gradually increasing one. In the writer's view, therefore, expansion due to external heating of the mass while the interior remained cold is the cause of any fissures which may form in a meteorite during its passage to the earth. Granted, however, that such fissures may form the above quoted explanation of the metallic veins seems to be open to two objections: 1st. The interior of a meteoric mass of any considerable size is so cold that portions of molten metal would be chilled before penetrating to any appreciable distance. 2d. The metallic constituents of the Farmington meteorite are its least fusible ones. That the interior of a meteorite may remain intensely cold during its fall to the earth has been proved in at least two instances, that of the Dhurmsala meteorite, the fragments of which were so cold as to benumb the fingers of those who picked them up, being the

* This Journal, III, xliv, p. 399.

best known. The fact has already been urged by Tschermak* as proof that Reichenbach's view that the black veins of meteorites are formed by the flowing of fused material of the crust into fissures, cannot be correct, and he notes that in the Chantonay meteorite the fused matter of the crust only penetrated the fissures to a depth of 6^{mm} even though they were open some distance beyond this. Moreover the Farmington meteorite was not hot when dug up four hours after its fall.† The veins of other sections of the Farmington meteorite have less the appearance of leading in from the surface than those figured by Preston. In a section now in the Field Columbian Museum collection, shown in fig. 1, two veins cross one another nearly at right angles. One of these is continuous at intervals

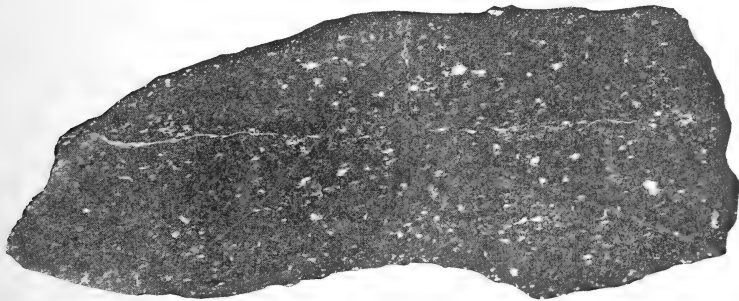

Farmington meteorite, natural size.

for a length of 90^{mm}. It is hard to conceive of such a system of fissures as this filling from the surface.

That the nickel-iron of the Farmington meteorite is more difficultly fusible than the stony constituents is proved by the fact that the former stands out in many places over the surface in prominent rounded beads. If any material had flowed into the fissures, therefore, it would probably have been fused silicates. If then the above theory of the origin of the metallic veins cannot be accepted, what is their nature? They do not appear to be of the nature of the *harnischflächen* of the Honolulu, Möcs, Pultusk and other meteorites, which when seen in cross section look like metallic veins but when cleft along the vein are plainly seen to be slickensided surfaces over which movement has flattened and drawn out the metallic grains. In the view of the present writer the veins of the Farmington meteorite are phases of structure of the metallic constituents of the mass. It is well known that the structure

* Sitzb. Wien. Akad., 1874, lxx, p. 467.

† Science, vol. xvi, p. 39.

of many of the siderolites is that of a metallic network enclosing grains of the silicates, while on the other hand the tendency of the metallic grains of many aerolites to a continuous arrangement has been noted by Reichenbach* and Newton.†

Between meteorites of the siderolite structure and those in which the metallic constituents occur only as isolated grains there are all gradations. Hence sheets or filaments of a continuous network might remain in some portion of a meteorite, while in the remainder the metallic constituents would be present only as isolated grains. Favorable cross sections of a continuous network would appear as veins. Metallic filaments which are undoubtedly of this character are to be seen in sections of the Crab Orchard (Rockwood) and Bluff meteorites now in the Field Museum collection. The nickel-iron appears in general in the sections in the form of isolated grains, but over a portion it appears as continuous filaments. These are the only sections in the collection which show such filaments but there is every reason to believe that the filaments could be found on sections of other meteorites if looked for. If the writer's view be correct, therefore, the term filament would describe these structures better than the term veins, since the latter term implies fissures filled subsequent to their origin.

* Pogg. Annalen, vol. cviii, pp. 291-311.

† This Journal, III, xlv, p. 152.

ART. V.—*Erigenia bulbosa* Nutt. A morphological and anatomical study; by THEO. HOLM. (With six figures in the text.)

WHILE not especially interesting in morphological respects, the *Umbelliferae*, nevertheless, possess types which have attracted some attention, though more by the structure of their flowers and inflorescence than by their vegetative organs. The seedling-stage, with the first development of rhizome and roots, has been studied in only a relatively small number of species by Bernhadi, Hegelmaier, Irmisch, Klebs, Lubbock, Winkler and others, and in regard to the mature plants, there are many species, which are so little known that it is altogether conjectural whether their underground organs represent roots or rhizomes; even in the "Revision of North American *Umbelliferae*"* the authors have made no attempt to draw the distinction between roots and rhizomes, but state simply: "We use roots here in the ordinary systematic way. Morphologically these tuberous roots are mostly subterranean stems." Considered from an anatomical view-point the order seems to be known much better, and we find in the literature several papers with accounts of the anatomy and some very comprehensive studies of the oil-ducts, which are particularly well developed in this order (*Umbelliferae*).

Thus it would appear as if there were a number of vacant spaces to be filled in the life-history of the order, and it is, therefore, our intention to present some brief notes as a contribution to the knowledge of one of its members, the "Harbinger of spring": *Erigenia bulbosa*.

It is a plant, which has, for a long time, attracted our attention on account of its globular underground part, by Nuttall correctly defined as a tuberous root. Having made a special study of similar plants with tuberous, underground parts, we have often desired to ascertain how far *Erigenia* possesses a true tuber or a tuberous root. It is, however, not always satisfactory to study plants of this nature only from adult specimens, and the publication of observations of this plant has been postponed for a considerable period until we succeeded in obtaining material in the seedling stage. The seedlings are, as a matter of fact, not easily found, and it was not until last spring that we detected some young plants, which proved to be the seedlings of *Erigenia*. Several years ago, in the early spring, we collected quite a number of seedling plants with only one cotyledon, just as we expected to find in *Erigenia*,

* For references consult the Bibliography appended to this article.

but an anatomical study of the specimens proved these to be seedlings of *Claytonia Virginica*, which germinates with a single cotyledon. But those of *Erigenia*, which we found last spring, did not only exhibit a single cotyledon, but they showed besides all the anatomical details, the characteristic oil-ducts for instance, as were familiar to us from the study of full-grown individuals; moreover these little seedlings showed a minute tuberous body at the base of the cotyledon.

Erigenia bulbosa seems to be rare in the vicinity of Washington, D. C., and has so far only been recorded from High Island and Plummer's Island; it is also found on the muddy river shore at Great Falls, Maryland, where we discovered it a few years ago. It prefers low, shaded grounds, and was found associated with such plants as *Dicentra*, *Trillium*, *Caulophyllum*, *Jeffersonia* and *Erythronium*. It may be found in bloom as early as the month of March or the beginning of April, and the seedlings appear at the same time. It is by no means acaulescent, but the stem is very low and bears a few stem-leaves and umbels, which are held in an erect position during anthesis. In the fruiting stage the stems bend down towards the ground, though without burying the fruits. These are said to fall off before maturity, a statement we cannot confirm, at least not according to our own observations. The seedlings are small, but occur in large numbers with the older plants, and the color of the cotyledonar leaf-blade is of the same deep green as the leaves of mature specimens. The blade of the cotyledon is held in a horizontal position, raised above the ground by a long, slender petiole (fig. 1). As already stated, a small light brown, tuberous body is to be noticed at the base of the cotyledon and this is the first indication of the globular root, which represents one of the characters of the genus, the monotypical *Erigenia*.

The tuber is at this stage about 2^{mm} in length, and tapers almost gradually into a filiform, unbranched root, covered by root-hairs, which are not very numerous, however. We observed, on the other hand, no root-hairs on the tuber itself and suspected, thus, that it represented the hypocotyl, but by examining its internal structure we felt convinced that it actually represents the basal portion of the primary root itself; the filiform part of the root does not grow out any further, but dies off during the first season. No other leaf than the cotyledon develops in the first year, and the plumule stays underground concealed in the sheathing base of the cotyledon. In the month of May the cotyledon had already faded away entirely, and the same was, also, the case with the leaves and stems of older specimens. In the second year after germination has taken place, the first proper leaf pushes up through

the ground (fig. 3) and shows a small, ternately decomposed blade with divisions of the same shape as those of mature leaves. This leaf has during the winter been surrounded by a small, membranaceous, scale-like leaf, which is still to be seen at this stage, but is, however, mostly decayed and not plainly visible. The tuber has increased in thickness, and the filiform part of the root below the tuber has died off altogether. A few (three or four) lateral roots, all filiform, have developed

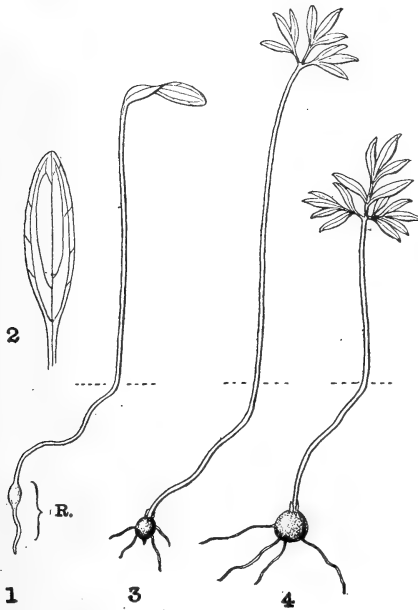

FIG. 1. Seedling of *Erigenia bulbosa* Nutt.; natural size. R = the primary root.

FIG. 2. Blade of the cotyledon, enlarged.

FIG. 3. Young plant in its second year; natural size. The filiform portion of the primary root has faded away, and four lateral roots have developed from the tuberous part. A small scale-like leaf is to be seen at the base of the petiole of the green leaf.

FIG. 4. Young plant in its third year; natural size. The dotted lines indicate the surface of the soil.

from the sides of the tuber, but otherwise the plant does not show much progress in growth since the first year. The third year's growth is not much advanced either (fig. 4), as only one green leaf is developed, though with a few additional divisions of the blade, and we find, also, at this stage a small scale-like leaf at the base of the larger, which has, thus, served as bud-scale during the winter. The tuber has only grown very little, retaining its globular shape and brown color, but no additional

lateral roots were observed at this stage. The depth of the tuber is, however, changed, and it seems as if it becomes buried deeper and deeper in the ground every season, not by means of contractile roots, but by continued deposits of sediment from the river during the winter, when the localities become inundated.

Erigenia thus germinates with only one cotyledon and the basal portion of the primary root shows a distinct swelling during the first year. This manner of germinating very much resembles that of *Carum Bulbocastanum*, which according to Irmisch's observations does not develop more than one cotyledon, the other one staying as rudimentary, but observable in the seed itself. Adventitious roots develop sometimes from the base of the cotyledonar petiole in this species of *Carum*, and similar roots have, also, been observed upon the underground portion of the hypocotyl in *Chærophyllum bulbosum*. In *Erigenia*, however, we found no seedlings, where such adventitious roots had developed from the base of the petiole. Some of the other *Umbelliferae* exhibit, also, a somewhat singular manner of germinating, viz: *Smyrniium olusatrum*, in which the hypocotyl is very short, while the cotyledonar petioles form a tube of 8–15^{mm} in length, which the plumule has to penetrate in order to reach the light. *Ferula Candellabrum* and *Tordylium Syriacum* illustrate a similar germination, but the cotyledonar tube is much shorter in these; *Ferulago*, *Prangos*, *Chærophyllum bulbosum* and *Smyrniium perfoliatum* possess also a cotyledonar tube, and the cotyledons are in the two last named the only assimilating organs of the plant during the first year.

In returning to *Erigenia*, there is, as we have stated above, a regular succession of scale-like and green leaves, which continues for about four years; after that time there may be developed two or three scale-like leaves, while at the same time the aerial leaf has attained the same size and shape as the later developed stem-leaves. The plant does not seem to reach its flowering stage until about six or seven years after the seed has germinated, and the flowering stem is in its bud-stage protected by about four scale-like leaves, tightly enclosing each other. When we, therefore, examine a flowering specimen of *Erigenia*, we find only scale-like leaves at the apex of the tuber, and the first green leaf at this stage is situated upon the stem some distance from the tuber, but close to the surface of the ground. The distance from the tuber to the first green leaf varies very much and depends of course upon the depth of the tuber in the ground; we observed specimens in which this stem-internode was only 1 or 2^{cm} in length, while in others it reached 13^{cm}. In most cases only a single stem is

developed during a season; this is terminal, but it is not unusual to find two or three more, which are lateral and developed from the axils of the scale-like leaves. Whether the plant produces flowers more than once is a question, which we have not been able to answer, since no traces of flowering stems from previous years were observed upon the large tubers, a fact that does not, however, exclude the possibility of the plant having bloomed before, inasmuch as the stems are so very weak and evidently fade away entirely. The tubers of fruiting specimens showed no signs of losing their vitality, but were, on the contrary, in perfectly healthy condition and still containing considerable deposits of starch: hence we suppose that *Erigenia* may be considered as a polycarpic plant.

While *Erigenia* is quite interesting at the seedling- and succeeding stages, when compared with the majority of the *Umbelliferae*, hitherto examined from this viewpoint, there are, furthermore, some peculiarities in its internal structure, which may be mentioned in connection therewith. Moreover it has not been possible from a mere superficial examination to decide whether the tuberous body is a true tuber: a stem-part, or simply a swollen root. The fact that we found no root-hairs on the tuberous part, but only on the filiform part, does not seem sufficient for separating them as morphologically distinct from each other, the former to represent a stem, for instance the hypocotyl, the latter a root. An anatomical study is necessary to decide this question, and since *Erigenia* does not appear to have been examined anatomically, it may be well to add some other details in regard to the position of its oil-ducts for instance, which are very distinct and well developed in this genus.

If we examine one of the filiform roots of a tuber in its third year, we find the following structure: Epidermis, this is almost without root-hairs, but many of the cells exhibit a slight extension of the outer wall, though not enough to form what is generally termed as "papillæ"; the cortical parenchyma is thin-walled and composed of a few (four or five) strata without deposits of starch, and, furthermore, neither lacunes or oil-ducts were observed in this tissue. The endodermis (E in fig. 5) is thin-walled and shows the dots very plainly; inside the endodermis is a pericambium of only one layer which surrounds the leptome and hadrome.

The hadrome constitutes a diametrical band of vessels, corresponding to two hadromatic rays of which the outermost (the first developed) are narrower than the inner. On each side of this single row of vessels is a group of leptome and separated from these by a stratum of thin-walled conjunctive tissue. Two, in transverse section, rhombic ducts (D) are

visible in the pericambium itself, just outside each of the two oldest vessels, hence diametrically opposite each other. The center of the root is occupied by a very wide vessel. If we compare this structure of a lateral root with that of the filiform, primary root of the seedling, we notice the same arrangement and development of tissues with the single exception that there is no central vessel in the primary root, but the two rows of vessels are separated from each other by conjunctive tissue. The primary and the lateral roots thus show the same principal structure and, as we have stated above, none of the tissues showed signs of contractility.

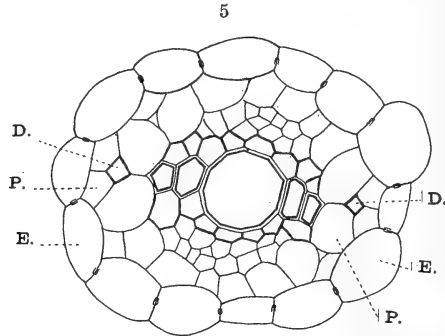

FIG. 5. Transverse section of the inner part of a lateral root of *Erigenia*. E = endodermis; P = pericambium; D = the ducts, developed in the pericambium. There is a group of leptome on each side of the diametrically arranged vessels, separated from these by a layer of conjunctive tissue. $\times 560$.

If we, now, examine a series of sections, taken from various parts of the tuber itself (the seedling-tuber), we observe the following modifications. In sections taken from a little above, where the filiform root begins, the structure is identical as far as concerns epidermis, cortex and endodermis, the two latter, however, containing deposits of starch. The pericambium, on the other hand, shows a number of cell-divisions and consists, thus, of several layers, surrounding the two rays of hadrome and the leptome, situated as described above. In other sections taken from the thickest part of the same tuber, the structure is still more different, but illustrates, nevertheless, a root-structure. Epidermis, cortex and endodermis are, still, preserved, but the endodermis surrounds now a mass of parenchyma, filled with starch, which borders inwards on several strata of cambium, which lies close to a central group of vessels, arranged in a line, just as we observed in the filiform root. There is no pith, and the leptome shows the same position as before, but is separated from the vessels by the cambium.

Several ducts, rhombic in transverse sections, occur inside the endodermis as a peripheral band around the central-cylinder. The increase in thickness, at this part of the seedling-tuber, is then due not only to the pericambium, which has now developed a broad parenchyma, a secondary bark, but also to the formation of a cambium between the leptome and hadrome. The tuber as it appears during the seedling-stage is thus to be considered as a swollen part of the primary root, of which the structure has been modified somewhat by the divisions of the pericambium and by the formation of cambial strata. The divisions of the pericambium have not, however, ceased at this moment, but continue during the further growth of the tuberous root-part. If we, for instance, examine another specimen in its third year, we notice that the epidermis, the cortex and endodermis have been thrown off, while the pericambium, by outward divisions has begun to develop a number of cork-layers at the same time as it continues the formation inwards of secondary cortex.

While thus the anatomical structure of the primary root is readily recognized as that of a true root in its entire length, in its tuberous and in its filiform part, and well comparable with that of a specimen in its third year, we find in fully matured specimens, such as have reached the flowering stage, a very different structure, which may have led to the belief that the so-called "globular tuber" is a stem and not a root; that is supposing a study of the seedling-stage to have been omitted. The mature tuberous root possesses a number of cork-layers, a secondary bark of very considerable width, filled with starch, and inside the bark is a band of collateral mestome-bundles with cambium between the leptome and hadrome and besides well defined strata of interfascicular cambium, while a broad pith occupies the central portion of the root, of which, however, the innermost part is broken down into a cavity; thus the principal features of the primary root are, almost, totally obliterated. Oil-ducts are quite numerous in the mature root; they are located in the same radii as the mestome-bundles and occur in four or five concentric bands. The innermost oil-ducts are to be seen in the leptome itself, the others some distance apart, the outermost being very near the periphery, though not in contact with the cork. It appears as if the ducts of the outermost two bands are mostly pentagonal in transverse sections, while those of the inner are rhombic and somewhat narrower in circumference.

Having thus described the root-system of *Erigenia*, we might, also, give a few notes on the structure of the other organs, as these are developed in the seedling and the mature plant. The petiole of the cotyledon exhibits the same pecu-

liarity as seems characteristic of the *Umbelliferae* in general, i. e., the mestome-bundles are separated from each other, and in this genus they are arranged in the form of an arch; there is no collenchyma; ducts with four special cells occur in the leptome besides that a larger duct with six special cells is to be observed beneath each of the three mestome-bundles on the leptome side. The leaf-blade of the cotyledon shows a bifacial structure with stomata on both faces, most numerous on the

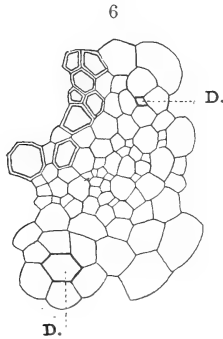

FIG. 6. Transverse section of a part of a mestome-bundle of the cotyledonary petiole of *Erigenia*. Two ducts (D) one with four, the other with six special cells. $\times 400$.

lower surface; a palisade-tissue of one stratum occupies the upper part of the blade, while an open pneumatic tissue occupies the lower. Large ducts with six special cells are visible above and below the mestome-bundles, but neither the smaller ducts, rhombic in transverse section, or collenchyma were found at this stage. In the petiole of a large leaf taken from a flowering specimen, there are five isolated mestome bundles forming an arch as in the cotyledon, and we noticed eleven oil-ducts, all of which were large and surrounded by five or seven special cells; these ducts are located in the cortical parenchyma, and mostly separated from the epidermis by a small group of collenchyma. The blade of the mature leaf has stomata only on the lower surface, and the cells of epidermis on the upper face are extended into minute, roundish papillæ, which along the margin attain the shape of pointed, thick-walled prickle-like projections. Otherwise the structure is like that of the cotyledon, and oil-ducts, were, also, found here above and below the mestome-bundles.

The stem above ground is obtusely triangular in transverse section and shows a rather weak structure with only moderately thick-walled collenchyma in small groups, inside of which we noticed the usual large ducts as in the petiole. But we found, also, the smaller ducts, and these occurred in the leptome, one on each side of this. Five mestome-bundles surround a thin-walled pith, of which the innermost portion is broken down, leaving a wide cavity in the middle of the internode. While oil-ducts are known to occur in the pith of several genera of this order, it seems as if they were lacking in *Erigenia*; we were, at least, unable to find any of these ducts in the pith in spite of very careful research.

The peduncle of the umbel is quadrangular in outline and the angles are rough from the presence of small prickle-like

projections from the epidermis, which is, here, distinctly thick-walled and covered by a wrinkled cuticle. There are four groups of collenchyma, one in each angle, corresponding to four mestome-bundles and four large oil-ducts, located in the bark, between the collenchyma and the mestome-bundles. The cortical parenchyma is somewhat open and consists only of about four or five layers, bordering on a thin-walled but solid pith. None of the smaller ducts with four special cells were observed in the peduncle, although we had expected to find such in the leptome, inasmuch as they were observed in the main stem.

In regard to the anatomical structure of the fruit, we observed that the carpophore is developed as a thick coating on the concave, ventral face of each mericarp and adnate to these. Thirty-eight oil ducts were noticed in each mericarp: twelve on the commissural side, one outside each of the five mestome-bundles and from five to six in the intervals between these. The statement by Coulter and Rose that the number of oil-ducts in the mericarp of *Erigenia* is only "one to three in the intervals and nine to eleven on the commissural side," is not correct; the same is also the case with the description of the ducts as being developed in "the inner epidermal layer itself." They are, according to our observations, developed in the mesophyll, but their location can only be ascertained by examining mericarps, which are not fully matured. We might furthermore, state that the mericarps are not glabrous, but hairy from numerous, short, unicellular, pointed hairs, which are readily seen to cover the entire dorsal face of these.

Brookland, D. C., May, 1900.

Bibliography.

- Coulter and Rose: Revision of North American Umbelliferæ. Crawfordsville, Indiana, 1888.
- Courchet: Etude anatomique sur les Ombellifères et sur les principales anomalies de structure que présentent leurs organes végétatifs. (Ann. d. sc. nat. Botanique, 6th series, vol. xvii, Paris, 1884, p. 107.)
- Hegelmaier, F.: Vergleichende Untersuchungen über dikotylen Keime. Stuttgart, 1878.
- Irmisch, Thilo.: *Carum Bulbocastanum* und *Chaerophyllum bulbosum* nach ihrer Keimung. (Abhdl. d. Naturf. Gesellsch. Halle, vol. 2, Halle, 1854, p. 47.)
- Klebs, Georg: Beiträge zur Morphologie und Biologie der Keimung. (Untersuch. a. d. Bot. Inst. Tübingen, vol. i, Leipzig, 1881-1885, p. 550 and 562.)
- Müller, Carl: Ueber phloëmständige Secretkanäle der Umbelliferen und Araliaceen. (Berichte d. Deutsch. Bot. Gesellsch., vol. vi, Berlin, 1888, p. 20.)

- Solereeder, Hans: Systematische Anatomie der Dicotyledonen. Stuttgart, 1899, p. 473.
- Van Tieghem, Ph.: Recherches sur la symétrie de structure des plantes vasculaires. (Ann. d. sc. Botanique, 5th series, vol. xiii, Paris, 1870-1871.)
- Van Tieghem, Ph.: Mémoire sur les canaux sécréteurs des plantes (ibidem 5th series, vol. xvi, Paris, 1872, p. 141).
- Van Tieghem, Ph.: Second mémoire sur les canaux sécréteurs des plantes (ibidem, 7th series, vol. i, Paris, 1885, p. 22).
- Winkler, A.: Anomale Keimungen. (Abhdl. d. Bot. Vereins Brandenburg, vol. xxxvi, p. 135.)

ART. VI.—New Species of *Merycochærus* in Montana.
Part II. By EARL DOUGLASS.*Merycochærus altiramus* n. sp.

THIS species, from the Madison Lake beds of the Loup Fork epoch, is represented by a right mandibular ramus which only lacks the posterior border and some other small fragments. The jaw is nearest like that of *M. laticeps*, but differs from it in several respects. In the present species the lower border slopes more uniformly downward and backward from the chin. From *pm 4* backward the jaw is deeper. I know of no other that is as deep in proportion to the length. The greatest depth, back of *m 3*, was very nearly $\frac{2}{3}$ the greatest length. The symphyseal border, at least the lower portion, was not concave and it forms a larger angle with the lower border of the jaw than in *M. laticeps*. The concavity under *pms 3* and *4* is less and the masseteric fossa is much deeper, being bounded in front by a high narrow ridge which dies out on the alveolar border under *m 3*. The lower border of the fossa is about on a line with this border. There is a small *foramen mentale* under the posterior part of *pm 3*.

Dentition.—A small portion of the bone in front of *pm 1* is lost, but the lower portions of the alveoli of the canine and first and second incisors are preserved. There is no trace of a first incisor and there probably was none. The inner border of the alveolus of *i2* is only about $1\frac{1}{2}$ millimeters from the symphysis. Separated by a still narrower ridge of bone is the alveolus of *i3*. One millimeter back of this is the three-sided canine alveolus with its rounded angles. The posterior side was the broadest and is close to *pm 1*. The canine was much smaller than the first premolar. The first premolar is set diagonally in the jaw. In cross-section it is nearly lenticular but the anterior inner side is concave, while the greater inner convexity is farther back than the outer one. Its transverse to its antero-posterior diameter is as 11 to 17. Its anterior and posterior edges are thin and sharp, and, though the tip is broken off it evidently ended in a sharp point. *Pm 2* is thin, compressed and trenchant and like the first is inserted diagonally but with two roots. It is almost unworn. The highest point and the convexity that descends from it are in the median line, but the posterior slope is steeper and longer. As seen from above the crest is sigmoid. In front of the highest point there is a hint of the anterior inner lobe that is quite prominent in *pms 3* and *4*. Back of this is a small groove. On the posterior inner side of the tooth is a slight concavity,

and another faint depression on the posterior outer surface. On the posterior margin the descending ridge divides, forming a little delta. In the third premolar these points are all more prominent and the posterior internal concavity has become quite a deep fossa bounded anteriorly by a prominent ridge. In *pm 4* the ridge has become a prominent element of the tooth, being separated from the other part by a large posterior fossa and the extension backward to meet it of the anterior interior fossa. In this tooth the posterior concavity above mentioned has become quite a deep trough and is more nearly central. The unworn and nearly perfect condition of the premolars gives an excellent opportunity for the study of their development and their conditions before wear. If worn to the same extent they would not differ so greatly from those of *M. laticeps*.

1

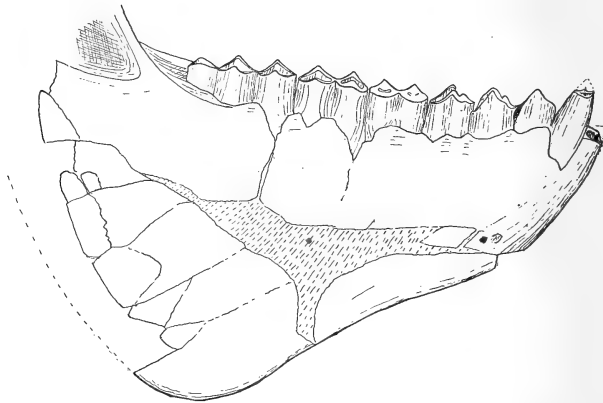
*Merycochærus altiramus*, $\times \frac{1}{3}$.*Measurements.*

	M.
Inferior dental series, length	·163
Molar-premolar series, length	·158
Molar series, length	·098
Premolar series, length	·060
First lower premolar, length, greatest	·018
First premolar, width, greatest	·011
Second lower premolar, length	·017
Second lower premolar, width	·008
Second lower premolar, height	·013
Third premolar, length	·019
Third premolar, height	·015
Fourth premolar, length	·019

	M.
Fourth premolar, width*	·0085
First molar, length	·0224
First molar, width*	·0126
First molar, height	·015
Second molar, length	·028
Second molar, width	·013
Second molar, height	·0245
Third molar, length	·0446
Third molar, width	·011
Depth of ramus beneath pm2	·042
Depth of ramus beneath pm 4, middle	·053
Depth of ramus beneath m1, middle	·063
Depth of ramus beneath m2, middle	·076
Depth of ramus beneath front part of m3	·098
Depth of ramus beneath back part	·125

Found by the writer in layer of sand at bottom of Loup Fork beds near top of White River beds in bluffs on eastern side of Lower Madison Valley about ten miles from Three Forks, Gallatin Co., Montana.

Merycochærus madisonius n. sp.

In my collection from the Madison bluffs is a lower jaw fragment with the anterior lobe of *m 3*, *m 2*, *m 1*, the roots of *pms 4* and *3* and of *pm 1*. It represents a somewhat older but smaller animal than the one described as *Merycochærus laticeps*, from which it differs in several particulars. The corresponding part of the ramus is much shorter. The anterior part has about the same depth. There is not that sudden descent under the interval separating *m 2* and *m 3*, to form the rounded angle. The *foramen mentale* is larger, narrower, and situated relatively farther back, being mostly under *pm 4*. The posterior part of the symphysis is farther back, being beneath the interval between *pm 4* and *m 1*. The ramus is much thicker near the lower border under *m 1*, the two being in the proportion of 19 to 24. The lower border is preserved to a point beneath the front lobe of *m 3*. Here it is much narrower than in *M. laticeps*, being $\frac{3}{4}$ the width. As nearly as I can determine the length of the premolar series and the first two molars in the present species is 8·8^{cm}; in *M. laticeps* it is 10·3^{cm}.

The length of the premolars and first two molars is about the same as in *M. rusticus*. The *foramen mentale* is about the

* The measurements of the width were taken at top of crown; as, to preserve the parts of the jaw in place, it was necessary to imbed it in plaster.

Some teeth overlap a little, so measurements of individual teeth do not quite coincide with the total.

The measurements of depth of jaw are taken from upper projections of bone between lobes of teeth.

same size and shape, but is farther back. The jaw is much deeper and not straight on the lower border back of the chin. It is broken in the region of the incisors, canine and second premolar, but the nearness of the first and third premolars and the position of the lower part of the alveolus of the outside root between these two teeth show that *pm 2* was probably small and closely crowded between them as in *M. compressidens*, to be described later.

On account of the thickness of the ramus and the narrowness laterally of the incisive region there is little curving inward of the inner part posterior to the symphysis.

2

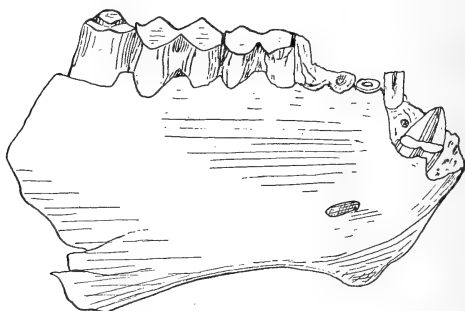

Merycochaerus madisonius, n. sp. $\times \frac{1}{2}$.

A low ridge or broad convexity begins just back of *pm 1*, sweeps downward and backward just above the *foramen mentale* to near the lower border of the ramus under *m 1*, then becoming a broad convexity sloping gently laterally it sweeps upward and backward towards the position formerly occupied by the last lobe of *m 3*. It was evidently continuous with the ridge forming the outer anterior border of the ascending ramus.

A cross-section of *pm 1* a little below the alveolar border is rather irregular. Its transverse is much greater than its antero-posterior diameter, the measurements being about 1.5 and .95^{cm} respectively. The enamel lakes have entirely disappeared in *ms 1* and *2*. In *m 1* the enamel is nearly worn away on the outside. There is only .4^{cm} left. On *m 2*, 1.25^{cm} of the crown remains, and on the anterior lobe of *m 3*, 2^{cm}. The outer lobes of *m 2* are united as if by a swelling, from each growing together, thus filling up the lower part of the space between them. On the last lobe of *m 2* and the first of *m 1*, the anterior and posterior faces are concave, making the outer lobes contracted in the middle.

Measurements.

Length of lower premolar series, estimated	·049
Length of m 1	·018
Width of m 1	·0155
Length of m 2	·023
Width of m 2	·0134
Depth of jaw at lower border of symphysis	·0585
Depth of jaw under pm 4	·051
Depth of jaw under m 1 middle	·055
Depth of jaw under m 2 middle	·057
Depth of jaw under m 3 anterior lobe	·061
Length of foramen mentale	·0096
Width of foramen mentale	·0026
Thickness of jaw under pm 4, greatest	·023
Thickness of jaw under m 3, anterior part	·0264

Found by myself in the Loup Fork Lake beds, Madison Valley, Montana.

Upper Jaw.—From the same beds as the above is a fragment of an upper jaw with the last three molars, which I refer provisionally to the same species. The part preserved differs from *M. laticeps* in the more posterior position of the inferior border of the anterior root of the zygomatic arch, the lowest part being opposite the anterior part of *m 1*, while in *M. laticeps* it is opposite the last lobe of *m 2*. In the present specimen the posterior border of this root, which forms the anterior border of the zygomatic foramen, is nearly vertical, while in the species above named it slopes backward. The small, short, malo-maxillary ridge extends forward horizontally, quickly dying out on the side of the face above the posterior part of *pm 4*. Above this the surface as far as seen is flat and looks forward and upward. Evidently the face contracted rapidly forward and upward, but its exact shape cannot be told. This sudden contracting would indicate a short skull to correspond with the shortening of the jaw in the type above described. The outer border of the palate next to the teeth is convex antero-posteriorly. The species was smaller than *M. laticeps*. The wearing of the teeth indicates a mature individual. There is a small posterior lobe on the last upper molar as in *M. proprius*, but the median external buttress extends more vertically outward. The other columns were evidently prominent, though they have disappeared.

Measurements.

Length of upper molar series	·072
Length of m 1	·0183
Width of m 1	·022
Length of m 2	·0215
Width of m 2	·021
Length of m 3	·032
Width of m 3	·0268

Merycochaerus elrodi n. sp.

Represented by part of the posterior portion of a left mandibular ramus with the last two molars. This, so far as they can be compared, most resembles *M. madisonius*, but I do not think they belong to the same species. The only portions common to the two are *m 2*, the anterior lobe of *m 3* and the portions of the rami beneath, and here there are no points of exact likeness. In the present species the crowns of the teeth are higher, though this is partly due to a less amount of wear. There is no bridge or buttress uniting the inner lobes in *m 2*. This tooth is longer and narrower in this specimen. There is a cingulum on the anterior face also on the front of *m 3*. The ramus is deeper but not so thick; the difference being more marked near the lower border. The lower border of the jaw is less flat and has an angular ridge near the outside border. The crescent-shaped convexity on the outer face is not seen but under *m 1* the jaw is nearly flat.

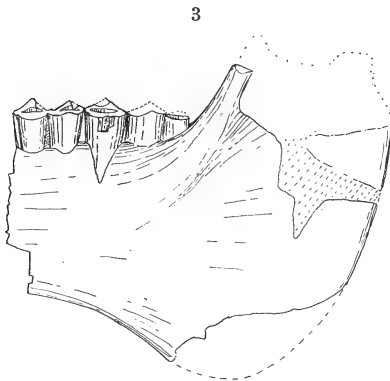
*Merycochaerus elrodi* $\times \frac{1}{3}$.

groove in *M. Laticeps* and *M. altiramus*.

The contour of the lower border of the jaw differs from that of *M. laticeps*. The descent to form the anterior part of the rounded angle is farther back, and the ramus does not become so deep. The masseteric fossa had evidently about the same position and shape as in *M. altiramus*. A shallow depression or groove extends downward and forward from it to the middle of the jaw under *m 2*. There are traces of a similar

Measurements.

M 2, length	M.
M 2, width	·027
M 3, length	·017
M 3, length	·041
M 3, width	·020
M 3, height, about	·030

The name is proposed in honor of my friend Prof. M. J. Elrod of the State University of Montana.

From fragment of indurated clay that had rolled from cliff near top of Big Round Top, east side of lower Madison Valley, about seven miles south of Logan, Montana. Found by the writer.

Merycochærus compressidens n. sp.

Represented by a left mandibular ramus extending back to beneath *m 3*. The premolars and first two molars are nearly perfect.

The most striking feature of this jaw is the close crowding of the premolars, in all of which there is an overlapping.

The form of the jaw is most like that of *M. proprius*. It differs from all those previously described in this paper, in the narrowness of the horizontal ramus, and from at least part of them in the presence of a first incisor. It agrees with these and differs from the *M. superbus* type including the so-called *M. montanus*, *M. macrostegus* and *M. leidyi* in the crowding with individual lengthening of the premolars, and the less relative length of the series as compared with that of the true molars.

4

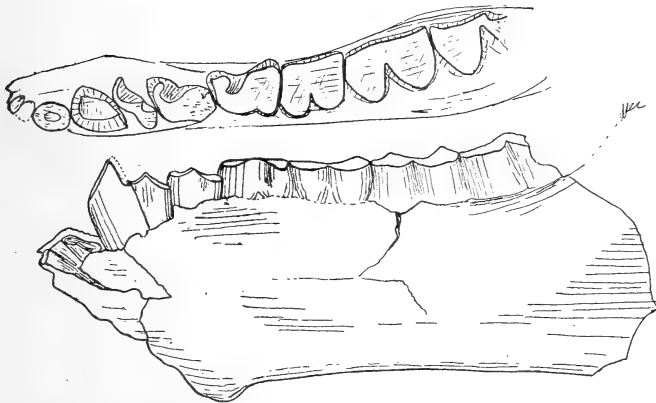

Merycochærus compressidens n. sp. $\times \frac{1}{2}$.

As the mandible is quite thick in the region of the chin, the symphysis is broad, especially the lower half. In *M. madisonius* the broadest part is near the top. Back of the chin the ramus is thinner, then it thickens under the last two molars, partly by the bellying inward on the inside, making a large convexity which stops short of the lower border of the jaw. This convexity is bounded infero-posteriorly by the inner fossa. The molar-premolar series is not straight, but somewhat sigmoid, there being a slight curve inward, outward and inward again in passing backward from *pm 1*. The last two molars form a slight angle with the premolars.

There is a broad protuberance at the angle of the chin. Back of this, the lower border is nearly straight, as far as preserved. The mental foramen is small and nearly round.

All of the teeth were closely crowded. The incisors were laterally compressed. The canine is nearly circular in section. *Pm 1* is quite large but not high. There is an anterior inner angle and a posterior outer one. Between these the tooth is broadly convex, being nearly semicircular in front, and less prominently convex behind. *Pm 2* is more nearly transverse than in a line with the dental series. While its longitudinal diameter is 1.6^{cm}, it occupies only one-half that amount of space on the alveolar border. *Pm 3* is also inserted diagonally but not so much so as *pm 2*. In *pm 4* the posterior part is proportionally broader than in *M. proprius*. The fold of enamel which separated the posterior lobes has by wear become an enamel lake. It occupied the same position as in *M. laticeps*. *Pm 2* has much the form of the corresponding tooth in *M. proprius* except that the anterior lobe has been twisted inward and backward. The same is true of *pm 3*, but on the posterior inner side a little rounded lobe has been added. This is true also of *pm 4* but the lobe is larger.

Measurements.

	M.
Length of ramus to second lobe of m 3128
Length of three lower incisors010
Length of premolars and first two molars092
Length of premolar series051
Length of ms 1 and 2 and anterior lobe of m 3055
Length of canine, about009
Width of canine009
Length of pm 1012
Width of pm 1014
Height of pm 1023
Length of pm 2016
Width of pm 2008
Height of pm 2, crown only0125
Length of pm 3017
Width of pm 3011
Height of pm 3011
Length of pm 4019
Width of pm 4014
Height of pm 4012
Length of m 1018
Width of m 10155
Height of m 1, crown on outside0054
Length of m 2024
Width of m 20187
Height of m 2015
Height of m 3, middle lobe, about020

From Loup Fork beds, on east side of Lower Madison Valley. Found by Earl Douglass.

Merycochærus? obliquidens?

In the collection from the Madison Lake beds are two portions of mandibles of a smaller animal than any of the preceding. One is part of a right ramus containing only one perfect tooth—the first molar. It seems to be much like the one described by Cope as *M. obliquidens*. The ramus is small, narrow and thick. *Pm 1* as indicated by the large abrupt bottom of the alveolus was robust. *Pm 2* was placed diagonally between *pms 1* and *3* as in *M. compressidens*, only more transversely as the alveoli are nearly at right angles to the long axis of the jaw. Evidently *pm 3* was also inserted obliquely, as the anterior root is near the inner margin while the posterior one invades the outer. *Pm 4* was in line with the long axis of the jaw. In the other specimen the fourth temporary premolar is preserved. It has three lobes of which the posterior is slightly the larger. *M 1* has a high, prismatic crown. All the premolars were large. The mental foramen and posterior of symphyseal suture occupy nearly the same place as in Cope's *M. obliquidens*. It is very doubtful whether this belongs to the genus *Merycochærus*.

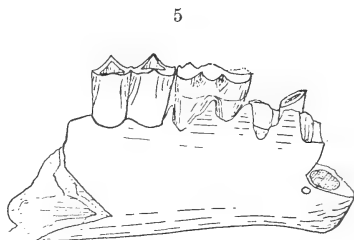

Merycochærus obliquidens?, $\times \frac{1}{2}$.
Last premolar from another specimen.

Measurements.

	M.
From posterior of pm 1 to anterior of m 10575
Length of pm 2 at alveolar border011
Shortest distance between pm 1 and pm 30055
Length of pm 3 alveolar measurement016
Length of pm 40217
Length of m 1019
Width of m 1015
Height of crown of m 1 outside015
Depth of ramus under pm 2 about032
Depth of ramus under m 1029

As the above described species are represented by portions of mandibles and the most striking differences are in the depths of the horizontal rami, I give below a table which will show the variation in this respect:

Species.	Depth of ramus under						
	Pm2	Pm3	Pm4	M1	M2	M3	
	M	M	M	M	M	ant. M	pos. M
<i>Merycochærus laticeps</i>	·043	·053	·050	·053	·067	·076	·109
<i>M. altiramus</i>	·043		·054	·063	·078	·098	·125
<i>M. madisonius</i>		·052	·051	·055	·057	·061	
<i>M. elrodi</i>					·062	·065	·90
<i>M. compressidens</i>	·050	·048	·045	·045	·044	·047	
<i>M.?</i> <i>obliquidens?</i>	·032	·030	·027	·029			

In the above table the measurements are taken as nearly as possible from the alveolar border at the middle of the last lobe of the tooth, except under *m3* which is taken beneath the anterior lobe, also the posterior one when present.

As previously stated, the discovery of a complete skull of *Merycochærus* shows that those previously described under that name must be divided into two genera, though at present the generic limits cannot be definitely defined. I include provisionally under the genus *Merycochærus*, of which *M. proprius* is the type, *M. rusticus*, *M. laticeps*, *M. madisonius*, *M. elrodi*, and perhaps *M. compressidens*, and *M. obliquidens*. Were the skulls of all these found, the genus might have to be divided again. The last two have a much slimmer ramus than the others and *M. compressidens* has a first incisor. With regard to *M. obliquidens*, which Cope does not mention in his "*Synopsis of the Oreodontidæ*," this is doubtful.

I have no wish to supply a generic name for the other species that have been included in this genus, as more experienced workers will, I hope, soon make a thorough study of all the data and material available. But for convenience I provisionally call the other members *Promerycochærus*, as all with the exception of *Promerycochærus montanus* are older, and some of the species are perhaps in the direct line of *Merycochærus*. Instead then of using the names *Merycochærus superbus*, *leidyi*, *chelydra*, *macrostegus*, and *montanus*, I will use provisionally the terms *Promerycochærus superbus*, *leidyi*, *chelydra*, *macrostegus* and *montanus* respectively.

Between these two groups as I have divided them there is an easily recognizable difference in the inferior dentition. In *P. montanus* and *macrostegus*; and, judging by the upper dentition in *P. superbus* and *chelydra*, the length of the premolar series nearly or quite equals that of the molar series. The molar series may be somewhat longer in *P. leidyi*. In *Merycochærus proprius*, *rusticus*, *laticeps*, *compressidens*, *altiramus*, and *madisonius*, the premolar series equals, or is slightly less than the length of the first two molars and the anterior lobe of *m3*. In the first species it is a trifle more and they decrease in

about the order mentioned. In the last the measurement does not fall short more than half the length of the anterior lobe of *m 3*. The measurements of the first two are taken from Leidy's illustrations.*

In all of these there is more or less crowding of the first three premolars, and *pm 2* is placed obliquely in the jaw. In other respects the mandibles vary so much that we may expect that farther discoveries will show that they do not all belong to the same genus.

With regard to a first incisor I have no proof that it was possessed by any but *M. compressidens*.

* Extinct Mammalian Fauna of Dakota and Nebraska.

SCIENTIFIC INTELLIGENCE.

I. CHEMISTRY AND PHYSICS.

1. *Periodic Phenomena connected with the Solution of Chromium in Acids.*—While experimenting upon the behavior of metallic chromium with acids, W. OSTWALD has found the action to be sometimes periodical. The evolution of hydrogen is at first slow, then it increases to a maximum, becomes slow again, again increases, and so on. The length of the periods from one maximum to the next is to a certain extent constant, as is also the rapidity of increase and decrease of gas evolution. The author was able to measure the rapidity of action by an apparatus analogous to those used in physiological laboratories for measuring changes in blood-pressure. In this apparatus the gas evolved in a flask was allowed to escape through a capillary tube, so that periodic changes of pressure occurred in the flask as the gas was formed more rapidly or more slowly than it escaped from the capillary tube. The periodic change of pressure is not due to a change in the solution, but to a change in the metal. When two pieces of chromium were placed beside one another, but without touching, in the same hydrochloric acid, the apparatus recorded a curve which was equivalent to the summation of two curves for single pieces. When the two pieces were placed in contact, however, the curve had a form like that produced by a single piece. This behavior is connected with the fact that passive chromium (*i. e.* that which does not dissolve in acids) is made active upon contact with active chromium, for in this apparatus contact with the piece which at the moment is giving off hydrogen more actively instantly causes the other to dissolve more rapidly. Different pieces of chromium did not behave uniformly, but gave curves of different forms. It is interesting to notice that only the chromium from a single fusion gave this periodic behavior. It was found that the addition of certain reducing agents, sometimes even in very small quantities had a very marked effect upon the form of the curves by retarding the action. The addition of a little potassium iodide has this effect, while cyanides, sulphocyanides and formaldehyde give still greater effects in the order in which they are mentioned. Other reagents, such as nitric acid, the lower oxides of nitrogen and bromic acid, accelerate the action, making the periods shorter. Hydrogen peroxide has a retarding action, like the reducing agents. Measurements of the electrical tension between the metal and the liquid showed that the metal is .1 volt more anodic while rapidly dissolving than while slow action is taking place. The variations in tension form a curve similar to that given by the pressure of hydrogen.

In a subsequent communication Ostwald has described further experiments upon this subject. He has succeeded in obtaining

another sample of chromium which showed fluctuations while dissolving, but in this case the periodic action took place only with particular acid solutions, while with other samples of acid of the same concentration a slow, uniform action occurred. It was finally discovered that the acid solutions which induced periodic action contained a trace of dextrin, derived from cloth bags that had been put into the liquids, and upon adding dextrin to other acids they also gave regular fluctuations. An examination of other carbohydrates and similar substances showed that their action is the more pronounced the higher their molecular weight is. The presence of .001 per cent of glycogen, .01 per cent of lichenin, .1 per cent of inulin, or 1 per cent of raffinose sufficed to produce the effect, while more concentrated solutions of cane sugar, milk sugar and dextrose gave a similar result. Certain kinds of chromium are "self-fluctuating," and an addition of dextrin to these produces irregularity in the hydrogen curve, which is more marked the greater the addition that is made.—*Zeitschr. physikal. Chem.*, xxv, 33; 204.

H. L. W.

2. On *Krypton*.—This rare constituent of the atmosphere, which was discovered by Ramsay and Travers, has been further studied by LADENBURG and KRUEGEL. They used for the purpose about three liters of residue left by the evaporation of the greater part of 850 liters of liquid air. Upon conversion into gas this residue occupied 2300 liters, and after oxygen and nitrogen had been removed in the usual manner about 3.5 liters of inactive gas were obtained. The latter was condensed by cooling with liquid air, when it formed a colorless liquid in which floated a small quantity of colorless crystals. The liquid was now raised to the boiling-point and fractions of gas were collected according to the boiling temperature, which rose quickly from -189° to -181.2 , where it became nearly constant while about 2.5 liters of gas consisting chiefly of argon were given off; then the temperature rose rapidly to -153° where the last portions of the liquid evaporated. At last there remained a crystalline residue which melted at about -147° , then quickly evaporated and was separately collected. This last fraction showed a strong krypton spectrum in which the lines D_4 , $589.9 \mu\mu$, and $558.1 \mu\mu$ were very brilliant, while many argon lines, including the whole of the violet end of the argon spectrum, were wholly wanting. It was therefore evident that the product contained very little argon, or only a constituent part of that gas. Compared with oxygen as 32, the density was found to be 58.81 and 58.67. These numbers correspond to the atomic weight if the gas is monatomic. Some of this gas was afterwards condensed by use of liquid air, when the tube containing it became covered with a crystalline layer, but no liquid was formed. A fraction of gas which evaporated last from the crystalline deposit gave a density of 59.01. Ramsay expected that the atomic weight of krypton would be about 80, although his density determination with gas which certainly contained much argon gave an atomic weight of

about 45. The authors believe that the new elements of the air should be placed before group I in the periodic system, so that helium = 4, argon = 39, and krypton = 59 come before lithium, potassium, and copper. It is their opinion that air contains less than 0.00002 per cent of krypton, but if this is so it is evident that the 750° of liquid air of Ramsay and Travers, in which they discovered the element, must have been previously subjected to a great amount of concentration by evaporation.—*Chem. News*, lxxxi, 205, and lxxxii, 209.

H. L. W.

3. *The Combustion of Gases.*—It is well known that sufficient dilution of an explosive mixture of gases with any other gas will prevent explosion. Thus Bunsen found that a mixture of 25.79 per cent of detonating gas (hydrogen and oxygen) with 74.21 per cent of carbon dioxide cannot be kindled, while 8.72 parts of detonating gas and 91.28 parts of oxygen behave in the same way. Such facts are satisfactorily explained by assuming that the dilution lowers the temperature of combustion below the kindling point. S. TANTAR calls attention to the fact that where the dilution is made with certain hydrocarbon gases the effect is caused by so little of the latter that the usual explanation is not sufficient to account for it. He found that 11–12 per cent of propylene, $\text{CH}_2 : \text{CH} \cdot \text{CH}_3$, or of trimethylene, $(\text{CH}_2)_3$, is sufficient to prevent the explosion of detonating gas, while methane, CH_4 , prevents the explosion when present in twice the amount, or 22–24 per cent. He found that when a mixture of 5° of propylene with 45° of detonating gas was exploded only a small change of volume, at most a diminution of 5°, took place instead of the expected disappearance of the detonating gas. If 5 to 15° more of detonating gas was taken than in the preceding experiment the contraction increased to the extent of this addition. An analysis of the resulting gases showed that propylene was no longer present, and that no noticeable amount of carbon dioxide was formed, particularly when the proportion of gases was such that the limit of combustibility was reached. The oxygen was completely used up in the combustion, so that the mixture of gases consisted essentially of carbon monoxide and hydrogen. It is remarkable that the combustion of propylene does not take place under these conditions until there is just enough oxygen present for its complete combustion to carbon monoxide and water, for 5° propylene require 15° oxygen or 45° detonating gas, which is the smallest amount that will cause an explosion. Methane requires half as much oxygen, and combustion actually takes place upon the addition of 25° of detonating mixture to 5° of the gas. The results show a remarkable selection which oxygen exhibits in combining with hydrocarbons in preference to hydrogen. Berthelot's thermochemical principle of greatest work does not apply here, for the reaction $6\text{H}_2 + 3\text{O}_2 = 6\text{H}_2\text{O}$ produces more heat than $\text{C}_3\text{H}_6 + 3\text{O}_2 = 3\text{CO} + 3\text{H}_2\text{O}$. It is the author's opinion that the only possible explanation of the phenomenon is that the rapidity of the action of oxygen with

hydrocarbons is much greater than with hydrogen. No satisfactory explanation is given for the curious fact that combustion does not take place at all until sufficient oxygen is present for the complete combustion of the hydrocarbon.—*Zeitschr. physikal. Chem.*, xxxv, 340. H. L. W.

4. *The Combustion of Acetylene in Air enriched with Oxygen.*—Having occasion to use high temperatures, G. L. BOURGEREL experimented with acetylene by using it in an ordinary blast-lamp. This gave a very high temperature by means of which nickel or pure gold could be melted with ease. Still higher temperatures being desired, the air used for the lamp was replaced by pure compressed oxygen from a cylinder. The result was surprising from the fact that the flame leaving the blowpipe was exceedingly brilliant. The gases did not mix, but burned only in contact with one another, then, little by little, there formed at the extremity of the central tube of the blowpipe a deposit of carbon which rapidly increased, taking the form of a truncated cone with the base outward. The carbon thus formed was very dense and that at the base of the flame was hard and sonorous, and in some instances sufficiently hard to scratch glass. When examined with a lens the carbon showed a cauliflower-like structure. The curious phenomenon was evidently due to the dissociation of acetylene. As the incomplete combustion when pure oxygen was used was unsatisfactory for the purpose of heating, mixtures of oxygen with air were tried with the result that very hot oxidizing or reducing flames could be produced.—*Moniteur Scientifique ; Chem. News*, lxxxii, 187. H. L. W.

5. *The inverse effect of a magnetic field upon an electric charge.*—M. G. Lippman, reasoning upon Maxwell's theory of electric convection, shows by the principle of the conservation of energy that variations in the strength of a magnetic field ought to produce a movement of an electrified body placed in such a field. M. V. CREMIEU has put this conclusion to the test of experiment. A charged aluminum disc is supported between the poles of an electro-magnet. The author calculates how much turning effect he should obtain on closing or breaking the circuit of the magnet. He did not obtain any effect, and he concludes therefore that this experiment taken in connection with his previous one on electrical convection (*Comptes Rendus*, cxxx, p. 1544, 1900) proves that the displacement of an electrified body does not produce a magnetic field along its trajectory.—*Comptes Rendus*, No. 15, p. 578, Oct. 8, 1900. J. T.

6. *Electrical Convection.*—M. V. CREMIEU returns to his attack on the experiments relating to the possibility of this effect. He has repeated those of Rowland and Himstet, and shows apparently that the effects observed are not due to the magnetic effect of moving charges, since they can be suppressed by the intervention of a metallic plate.—*Comptes Rendus*, Nov. 12, 1900. J. T.

7. *Unipolar Induction.*—E. LECHER continues his discussion with W. König on the question whether a magnetic pole can

revolve around a conductor carrying a current, and whether the well-known pieces of apparatus in physical cabinets which are supposed to illustrate the revolution represent a true phenomenon. He arrives at the conclusion that Biot and Savart's law, which is interpreted without reference to the position of the leading-in wires, is incorrect, and that the observed rotations are entirely due to the leading-in wires. It is impossible apparently to get rid of the effect of these wires in any of the pieces of apparatus which have been devised. There is however no theoretical ground for the existence of the rotation, since action and reaction are equal. H. Lorberg also discusses the point of contention between Lecher and König, and shows that in his *Lehrbuch der Physik* he arrived at Lecher's conclusion.—*Ann. der Physik*, No. 11, 1900, pp. 513-529. J. T.

8. *Electron theory of metals*.—The most important paper of the last issue of the *Annalen der Physik* is that of P. DRUDE on this subject. The author seeks to explain the electric current and its effects in the magnetic field by the hypothesis of the movement of electrons or corpuscles between the atoms of the metals of the conductors. He finds a sufficient amount of agreement with known facts to make the theory plausible, but he points out that it is highly desirable to collect together observations on the four transverse-galvanic and thermo-magnetic effects, together with the thermic, the electric conductivity and the Thomson effect in the same piece of metal, in order to prove his theory.—*Ann. der Physik*, No. 11, 1900, pp. 369-402. J. T.

9. *A simple modification of the Wehnelt interrupter*.—This consists in substituting a steel wire for the positive electrode while the negative electrode consists of a copper wire. Both wires are enclosed in glass tubes, except at the ends.—*Ann. der Physik*, No. 11, 1900, pp. 543-544. J. T.

II. GEOLOGY AND MINERALOGY.

- ✓ 1. *Geological and Natural History Survey of Minnesota, Vol. V. Structural and Petrographic Geology of the Taconic and Archean*; by N. H. WINCHELL, assisted by U. S. GRANT. 4°, pp. 1027, pl. 6, St. Paul, 1900.—It would be impossible in the limits of a brief mention like this to do much more than merely state that this volume contains an enormous mass of detailed observations on and descriptions of the rocks of Minnesota.

The first part, of some seventy-five pages, is by Prof. Winchell, and gives a résumé of his views on the general structure, age, origin, relationships and petrology of the rocks of the State.

The second part, by both authors, covers the detailed study of some three thousand thin sections from every part of the area. The occurrences are so numbered that the descriptions can be referred to their appropriate places in the earlier reports of the Survey. As is already well known, the great mass of this work relates to rocks of the gabbroid family.

The third part embraces such discussions and comparisons as to genesis and relationship as appear to be the result of the foregoing, and may be regarded as the petrographic geology of the State.

L. V. P.

2. *Étude mineralogique et pétrographique des Roches gabbroïques de l'État de Minnesota, États Unis, et plus spécialement des Anorthosites*; by A. N. WINCHELL. Inaug. Diss., Paris, 1900, 8°, pp. 164, pl. 8.—This work, which is being published in English in a journal devoted to geology, is a very careful, minute and painstaking petrographic examination of a series of the gabbroid rocks of Minnesota. It is accompanied by a series of analyses and a number of general conclusions upon the inter-relations of the gabbroid magmas are brought out. Especially noticeable is the detail and care with which the micro-mineralogy of the component minerals has been worked out.

L. V. P.

3. *Les Roches Éruptives des Environs de Ménerville, Algérie*; by L. DUPARC, F. PEARCE and E. RITTER. Mémoires de la Soc. de Phys. et d'Hist. Nat. de Genève, xxxiii, No. 2, 4°, pp. 142, pl. 8.—The region whose eruptive rocks have furnished the subject of this memoir lies about 40 miles east of the city of Algiers. There is an important massif of granite, and in the general neighborhood of this extensive areas of rhyolites (liparites), dacites and andesites. All these are carefully described from the petrographic point of view by the first two authors, with many appended analyses. The collection of the material and the geologic portion of the work is by the last-named author.

L. V. P.

4. *The Charnockite Series, a group of Archean Hypersthenic rocks in Peninsular India*; by T. H. HOLLAND. Memoirs Geol. Surv. India, vol. xxviii, pt. 2, pp. 130, pl. 8.—The author states that the name charnockite is intended for local use and convenience alone. Although these rocks are of great age, and have thus lost some of the distinctive features of igneous intrusions, they are nevertheless to be clearly regarded as such, and the author takes great pains to give the evidences on this point with fullness and detail. The nearest equivalents of these rocks among types previously described are found in the group of "pyroxene gneisses." The study of the field relations is supplemented by petrographical and chemical investigations.

L. V. P.

5. *Geologische Skizze der Besitzung Jushno-Saoserk und des Berges Deneshkin Kamen in nordlichen Ural*; by F. LOEWINSON-LESSING. 8°, pp. 257, pl. 9, Dorpat, 1900.—This volume is published in Russian, but a résumé of 87 pages in German will serve to greatly extend its readers among geologists. After a brief description of the region, the Devonian sediments and the gold-placer mines, the main body of the work is taken up with the petrography of the igneous rocks. Several varieties of these are described in detail, the chief interest centering in those rich in lime, iron and magnesia, a group of gabbros, norites, pyroxenites, dunites, etc. Analyses of these rocks are given and there is a general discussion of their magmatic relations.

L. V. P.

6. *Some Principles controlling Deposition of Ores*; by C. R. VAN HISE. Paper read before the American Institute of Mining Engineers, February, 1900. Author's edition.—Prof. Van Hise divides his paper into two parts, Part I being a consideration of the principles governing ore deposition, while Part II treats of their application to ore deposits. A brief outline of Part II follows. The outer zone of the lithosphere is a zone of fracture, a zone where the rocks under stress break into fissures, etc. The depth to which this zone extends depends upon the nature of the rocks and other considerations, but in no case exceeds 12,000 meters. Below this depth we have a zone of flowage, where rocks are deformed by flowage but do not fracture. The zone of fracture below the level of ground-water is everywhere permeated by water. This water is ever in more or less rapid circulation. Below the zone of fracture there can be practically no circulation. Therefore the first and fundamental premise of the paper is that the greater number of ore deposits are the result of the work of underground water. The second premise is that the material for ore deposits is derived from rocks within the zone of fracture. The chief cause of the circulation of underground water is gravimetric stress. The water descends through the smaller openings in the rocks, and continually seeking the easiest passages rises at last by means of the main fissures. Descending waters are in the main agents for solution; the ascending waters are in the main agents for deposition. After deposition, a second concentration and general enrichment of the upper parts of ore deposits is caused by descending oxidizing waters from the surface. Ore deposits which have their origin in deposition from solution may be of three kinds, (1) deposited by ascending waters alone, (2) deposited by descending waters alone, (3) deposited by ascending waters and concentrated by descending waters. Deposits of the last class are by far the most numerous.

W. E. F.

7. *Physical Geography of the Texas Region*; by ROBERT T. HILL. U. S. Geological Survey, Physiographic Folio No. 3.—The Physiographic folios “are designed chiefly as aids in the teaching and study of physical geography. Folios Nos. 1 and 2 contain general illustrations and descriptions. The present folio is descriptive of a large area which is particularly rich in distinctive physiographic types. The region is divided according to its geographic features—soil, climate, geologic structure, drainage, underground water, and environment for human culture—into six provinces. These provinces are described in detail, with special reference to the large and small topographic features represented. Plains are represented by the greatest variety, and an unfamiliar type—“Bolson Plains”—has many examples here. “Bolsos” are described as “apparently level valleys inclosed by mountains, ordinarily without drainage outlet—they are usually structural and floored with unconsolidated sediments” (page 8).

Ten sheets of “special illustrations” make the descriptions

doubly clear. They include charts showing drainage, rainfall, flora, mineral resources, distribution of population; photographs of valley, plain, cuesta, and mountain types; and 23 special contour maps of topographic features. This folio should be the text-book for the region it covers and a chapter in any general physiographic work.

H. E. G.

8. *Field Operations of the Division of Soils*, 1899; by MILTON WHITNEY. U. S. Department of Agriculture, Report 64; pp. 1-198, with 48 illustrations and 11 maps.—The plan of Prof. Whitney is to map the soils of the country on a scale of an inch to the mile and to give them distinctive local names. Mechanical and chemical analyses of the soils are then made in the field and in the laboratory. This information, taken in connection with the climatic conditions of a region, will determine the possibilities of successful cultivation of certain crops. After the character of the soil and the attitude of ground water is known, then the data are at hand for the study of methods to enrich the soil or to adapt it to particular plants. During 1899 field work was done on the alkali soils of the Pecos Valley, New Mexico, on the Salt Lake Valley of Utah, and on the Connecticut Valley soils of Massachusetts and Connecticut. The detail with which the work has been carried through is well shown by the fact that nine distinct soil types are mapped in the Connecticut Valley—each type suited to its own crops and demanding its own style of cultivation. The Agricultural Department considers this the most important agricultural investigation ever undertaken.

H. E. G.

9. *Études sur les Minéraux de la Roumanie*, par P. PONI. Pp. 1-137, Jassy, 1900 (Ann. Sci. Univ. Jassy).—Professor Poni has done a service to mineralogists in giving them this excellent summary of the little-known minerals of Roumania. It includes a catalogue of the species identified in the country, briefly characterized, and with a full account of the localities at which they occur. One of the most important of these lies in the crystalline schists of Broscéni in the district of Sucéva, where a considerable number of metallic species have been found. A number of these new analyses are given. Perhaps the most important pages are those devoted to the account of the rock salt deposits which occur on an enormous scale, although at present only developed at four points. The most important of these is at Slanic, where the amount delivered in ten years, down to 1897-8, was nearly half a million tons. The volume adds two new names to the literature of the mineralogy,—namely Badenite and Bros-tenite.

BADENITE is an arsenide of cobalt, nickel and iron, containing nearly 5 per cent of bismuth. It is found in the valley of Neguletzul, near the village of Badéni-Ungureni in the district of Muscel. It occurs massive with granular to fibrous structure; specific gravity = 7.104; color steel-gray, becoming dull on exposure to the air. An analysis gave:

As	S	Bi	Co	Ni	Fe
61.54	0.27	4.76	20.56	7.39	5.98 = 100.50

This gives a ratio of 2:3 nearly for (Co, Ni, Fe) : (As, Bi, S). The composition is somewhat analogous to that of rammelsbergite, but the latter has the ratio of about 1:2.

BROSTENITE is a hydrated manganite of iron and manganese, analogous to chalcophanite in composition. It occurs in large quantities in the crystalline schists of the region of Brosténi, district of Suceva. It is compact, friable; of a black color; luster semi-metallic on the fresh fracture but becoming dull on exposure to the air. Treated with hydrochloric acid, chlorine is freely evolved. Different samples yielded somewhat varying results upon analysis; that from the valley of Holda is interpreted as follows:

MnO ₂	MnO	FeO	CaO	H ₂ O	Gangue (SiO ₂)
52.40	6.16	11.47	3.05	11.97	14.75 = 99.80

The formula calculated from this is: $2\text{MnO}_2 \cdot \text{RO} + 2\text{H}_2\text{O}$, where R = Mn, Fe, Ca. For the mineral from Dorna, the formula $6\text{MnO}_2 \cdot 2\text{RO} + 3\text{H}_2\text{O}$ is calculated; and that from Dealul-Ferului, it is suggested, may be a mixture of these. The deposits of manganese oxides have probably been formed by the action of carbonated waters upon manganese carbonate.

10. *Mineralogy*; by FRANK RUTLEY. Twelfth edition, revised and corrected, pp. 240, 12mo. London, 1900 (Thomas Murby).—The fact that this little work is now in its twelfth edition is sufficient indication of the excellent way in which it fills the place for which it was written. Though necessarily brief in its treatment both of the theoretical and descriptive parts, a great deal of matter is brought together in a small space, and much good judgment is shown in the presentation of the whole.

11. *Corundum and the Basic Magnesian Rocks of Western North Carolina*; by JOSEPH OLNEY LEWIS (Bulletin No. 11, North Carolina Geological Survey). Pp. 107, Winston, 1896.—This Bulletin gives an interesting summary of the occurrence of corundum in North Carolina and the various types of rocks, peridotites, pyroxenites and amphibolites, with which it is associated.

III. BOTANY.

1. *Les Maladies et les Ennemis des Cafésiers*; by G. DELACROIX. Second edition, pp. 212, 8°, with 50 figures. Paris, Augustin Chollamel, 1900.—The first edition of this work formed a series of articles published in the *Revue des Cultures Coloniales* in 1898–99, which with numerous additions are now issued as a separate volume. Under the head of non-parasitic diseases are treated such subjects as changes due to excess of heat and moisture. By far the greater part of the volume is devoted to parasitic diseases, including both those due to fungi and those due to insects. Of the former the rust, *Hemileia vastatrix*, is the most widely spread and most injurious, and is treated at length by the author. According to Delacroix, the only parts of the world exempt from this disease are the west coast of Africa, New Caledonia and America, including the West Indies. He does not

accept the statement of Hennings' that the disease occurs in Guatemala, but believes that the trouble in that country is due to another cause. The disease known in Venezuela as Koleroga is due to an imperfectly known sooty fungus, *Pellicularia Koleroga*. There are several troublesome diseases of coffee known as leaf-spots, due to attacks of *Sphaerella coffeicola*, *Stilbum flavidum*, *Cercospora coffeicola* and *Gloeosporium coffeanum*. Other diseases in Java and Liberia are supposed to be due to Pyrenomycetous fungi, but their effect has not yet been studied in detail. A chapter is devoted to the action of the leaf-lichens belonging to the genus *Strigula* and the accompanying alga, *Cephaleuros virescens*. The phaenogamic parasites of the genera *Loranthus* and *Clusia* attack the coffee as well as other trees in the tropics, causing damage, but cannot be said to cause special diseases. The present volume is a very useful and convenient treatise which will be especially valuable in tropical countries, since the treatment as well as the origin of the various diseases is given in a way rarely found in works treating of diseases beyond the limits of Europe and North America.

W. G. F.

2. *Monographie und Iconographie der Oedogoniaceen*; by KARL E. HIRN. Acta Soc. Sci. Fennicae, xxvii, No. 1, pp. iv, 394, pl. 64. Helsingfors, 1900.—Our systematic knowledge of the Oedogoniaceae dates from Pringsheim's monograph in 1858, and this was followed by Wittrock's Prodomus in 1874. To the two genera *Oedogonium* and *Bulbochaete* treated by them a third genus, *Oedocladium*, with a single species, was added by Stahl in 1891. In the elaborate and thorough monograph of Dr. Hirn no less than 199 species of *Oedogonium* and 43 species of *Bulbochaete* are recognized besides the single species of *Oedocladium*. This large number of species is not due to the fact that Dr. Hirn is given to species making. On the contrary he is conservative in his treatment, and a comparatively small number of new species have been described and many species have been reduced to varieties. The monograph will be of great value to American geologists, since our species were in a chaotic condition, and Dr. Hirn, who has received material from several American sources, has been able to give us for the first time a clear and accurate account of our Oedogoniaceae. It is to be regretted that of the numerous American species described in Wolle's Fresh-Water Algae, so large a number cannot be recognized with certainty at the present time. *O. pungens* is an interesting new species collected by Ravenel in South Carolina, and *O. geniculatum* Hirn from California, described in Erythea, 1898, is figured for the first time. To *O. Martinicense* Hirn is referred a form included by Wolle in *O. crassum*, and an unnamed species of Wood is referred with doubt to *O. Margaritifera* Nordstedt and Hirn. Of the Wittrockian species not before recorded in America may be mentioned *O. Magnusii*, *O. nobile* and *O. nodulosum*. We should also mention that *O. acrosporum*, *O. Boscii*, *O. crispum* and *O. Wolleanum*, species much confused in American herbaria, are here clearly distinguished. An introduction,

giving an account of the structure and general character of the order and its literature, and good plates of the different species, give additional value to this admirable monograph. W. G. F.

3. *Ueber Sclerotinia cinerea und Sclerotinia fructigena*; by M. WORONIN, Mem. Acad. Imp. Sci. St. Petersburg, viii, Ser. x, No. 5, pp. 38, pl. 6, in part colored, 1900.—In the present sequel to the series of papers on Sclerotiniae by Woronin, the author gives a full account of his studies and experiments in relation to the two species to which is due the rotting of cherries, apples and other fruits of the order Rosaceae. The rotting in this case, however, is not the ordinary moist rot, but what may be called a dry wilting. In neither species was Woronin able to observe the cosporic stage, but he considers that they belong to the genus *Sclerotinia* since their conidia are those of that genus, although the disjunctive is less clearly marked. By some writers *S. cinerea* and *S. fructigena* have been considered forms of one species, but Woronin distinguishes the latter species by its larger conidia, which are yellowish and not gray. He withdraws his previously expressed opinion that the conidia are uninucleate, and states that they are multinucleate. *S. cinerea* is the species which has caused serious disease of cherries in many places, while *S. fructigena* causes a disease in apples and pears. These diseases are usually manifested in the fruit, but may attack twigs and leaves. Both species may occur on drupaceous as well as pomaceous fruits or may, at least, be made to grow on decoctions of them, but in nature Woronin believes that in all serious epidemics it is *S. cinerea* which affects cherries and stone fruits, while in the case of apples and other pomaceous fruits the fungus is *S. fructigena*.

W. G. F.

4. *On Platydorina, a new Genus of the Family Volvocidae, from the Plankton of the Illinois River*; by C. A. KOFOID. Bull. Illinois State Lab. Nat. Hist., V, 419-440, pl. 28. Dec. 28, 1899.—In this paper the writer supplements his previous notice of the genus *Pleodorina* by an account of another very interesting member of the *Volvoc* family discovered during his investigation of the plankton of the Illinois River. The new genus *Platydorina*, represented by the single species *P. caudata*, is one of the most peculiar members of this peculiar family, and is characterized by its horseshoe-shaped coenobium, composed of 16 or 32 cells with three or five prolongations or tails on the posterior end of the coenobium. The cells of the two sides of the compressed and flattened coenobium intercalate so that the flagella are found upon both faces on alternate cells. The different cells are, however, all similar, and the marked polarity of this genus is indicated by the general outlines of the coenobium rather than by a difference in the cells as in some other genera, as *Pleodorina*. Although the sexual reproduction was not seen, the non-sexual reproduction and the cell structure and arrangement are considered by the writer to indicate its near relationship to *Eudorina*. At the end of the paper is a key to the genera and species of *Volvocidae*.

W. G. F.

IV. MISCELLANEOUS SCIENTIFIC INTELLIGENCE.

1. *On the Velocity of Seismic Waves in the Ocean.*—Dr. CHARLES DAVISON has recently discussed the waves propagated by the Japanese earthquake of June 15th, 1896, the special object being to compare the observed velocity with that calculated from the usual formula, $v = \sqrt{gh}$, where h is the depth of the ocean taken as uniform, in which waves would travel with the same velocity as that of the seismic sea-waves. In this case, the epicenter was located some 240 km. east-south-east of Miyako, at a depth of 4,000 fathoms. The time of occurrence at Miyako and the surface velocity within the disturbed area being given, the approximate time at the epicenter is obtained, which is assumed to be correct within a minute.

The earthquake waves were observed at two stations, where self-recording tide gauges are established,—namely, at Honolulu, and at Sausalito in San Francisco Bay. In the case of Honolulu the first effect was observed after an interval of 7 hours 44 minutes, a small rise of three-quarters of an inch being noted. The disturbance continued for about 48 hours; at one time a group of seventeen small waves, with an average period of twenty-five and a-half minutes, was recorded. At Sausalito, the first crest reached the gauge after an interval of 10 hours and 34 minutes. Here there was a rise of 3.7 inches; later a series of thirty waves, with an average period of six minutes, and a mean distance between crest and hollow of 1.5 inches, were noted. The distance in the two cases was 3,591 and 4,787 miles respectively. From the time-intervals given, the mean velocity to Honolulu is calculated as 681 feet per second, and for Sausalito as 664 feet. The former would give a uniform depth to the ocean between the two points of 14,492 feet; the latter corresponds to 13,778. In the case of the Honolulu line, the depth is very variable, the Hawaiian Islands coming in between the two places; hence any comparison between the observed and calculated depth is more or less unsatisfactory. In the other case the shortest line joining the two points is free from islands, and cuts the sub-oceanic contour lines nearly at right angles. The mean depth along this line is more than 17,000 feet, so that the calculated depth of 13,778 feet is only about four-fifths of the measured value. This ratio is the same as that obtained by the author in an earlier discussion, where the calculated depth was 1900 fathoms and the true depth 2420.—*Phil. Mag.*, Dec. 1900, p. 579.

2. *An Old Indian Village.*—An exhaustive account has recently been published by JOHAN AUGUST UDDEN, of a series of mounds discovered on the west bank of Paint Creek, about a mile and a half south of Smoky Hill river, in McPherson county, Kansas.

It is noted that such prehistoric monuments are relatively rare west of the Mississippi, which is to be explained partly by the fact of the absence of powerful communities, such as were developed, for instance, in more fertile regions to the eastward as in the Ohio valley, and partly because the region has been thus far only imperfectly studied.

The locality here described includes a group of fifteen low mounds, averaging in most cases 125 feet apart or a multiple of this: they evidently represent the dwelling site of an aboriginal village. The mounds are circular in form, with a diameter of from 20 to 25 feet, and none more than three feet high. The locality was carefully searched and numerous relics, chiefly in the line of domestic utensils, bones of animals, etc., were found. There were no buried human remains discovered. A detailed account is given, with numerous excellent illustrations, of the different articles collected: including scrapers, which were very numerous; also pottery and other domestic utensils; arrow-points and spear-heads, also numerous; agricultural implements and tools; finally a few other articles, as catlinite pipes, etc. The most novel thing discovered was a piece of *chain mail*, presumably of European origin, which, it is suggested, may have been derived from the Spanish expedition of Coronado, which passed through this region in 1542.

In regard to the ethnic relations of the people who dwelt here, it seems probable that they were of agricultural habits and belonged to some tribe of the Siouan family. A certain mingling of northern, southern, and western features of primitive industry and art is noted.—*Augustana Library Publications*, No. 2, Rock Island, 1900.

3. *Anleitung zur mikroskopischen Untersuchung der vegetabilischen Nahrungs- und Genussmittel*; VON DR. A. F. W. SCHIMPER. II Auflage, mit 134 Abbildungen; pp. 158. Jena 1900 (Gustav Fischer).—The second edition of Prof. Schimper's "Anleitung" presents in somewhat systematic order the minute description of the more common vegetable foods and food accessories, with particular reference to their microscopical examination. The food analyst is yearly being confronted with the increased necessity of applying the microscope to the detection of adulterations in food; in fact, in many cases chemical methods absolutely fail to give a satisfactory answer to problems involving the purity of food materials. The book here reviewed is intended as a guide for the beginner, and presents the most recent improvements in technique, together with a large number of drawings for comparison with actual specimens. A brief introduction offers suggestions regarding the equipment of a laboratory adequate for the application of the directions contained in succeeding pages. The topics treated include the common varieties of starchy foods, pepper, tea, coffee, tobacco, mustard, cinnamon, vanilla, agar-agar, etc.

L. B. M.

THE

AMERICAN JOURNAL OF SCIENCE

[FOURTH SERIES.]

ART. VII.—*Apparent Hysteresis in Torsional Magnetostriction, and its relation to Viscosity*; by C. BARUS.

1. IN the present paper I shall describe a series of phenomena bearing on the permanence of torsional magnetostriction in iron and nickel magnetized by circular and by longitudinal fields, which have been encountered in different ways by others, but which appear here not only with greater clearness and in a more elementary form, but in a manner indicating a certain uniformity in the behavior of all metals. The phenomena are evoked by purely magnetic action. They are obtained by twisting the wire alternately back and forth over a definite angle within the elastic limits and examining the change of rigidity produced by circular or by longitudinal magnetization immediately after each new twist and after several repetitions of the magnetizations. The first magnetization succeeding any twist operates on the magnetic configurations surviving from the preceding twist and magnetizations; the remaining magnetizations (current alternately made and broken) for the same twist operate on the new configurations produced by the twist in question and the first magnetization applied to it. The results are very different as the following observations show. The former are viscous (temporary), the latter elastic (permanent) in character.

To explain the phenomena I shall make use of Maxwell's theory of viscosity in which (as I have ventured to interpret it) any deformation due to molecular instability is a viscous deformation. Now when the breakdown is gradual in character, which it must be if dependent on temporary local intensities in the distribution of heat motion, the deformation will be gradual as actually observed in ordinary viscous phenomena.

If, however, the breakdown is instantaneous, due for instance to the molecular shake-up accompanying magnetization or its withdrawal, then viscosity is instantaneously a minimum, the deformation sudden and the phenomenon "static." There seems to be no theoretical gap here.

2. The method of work is the same as that employed in preceding experiments.* The two identical wires to be compared, ab , cd , are fastened coaxially one above the other and a mirror, m , is attached between them. The top and the

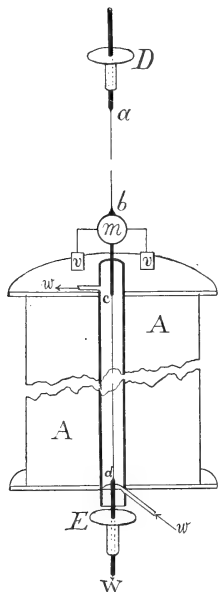

bottom of the system are soldered to corresponding torsion heads, D , E , and the wires are insulated from each other at the mirror. The lower wire is kept submerged in a tube of flowing water, ww , and the means† are at hand for passing an electric current through it without interfering with the torsional adjustment. Hence the lower wire is under the influence of a circular magnetic field and thermal discrepancies are reduced to a minimum. Again a helix, AA , is placed around the tube for a longitudinal field the water bath being retained.

As the two identical wires make a single system any degree of twist may be locked up in it and the change dn of rigidity n due to the magnetic field is $dn/n = d\theta/\theta$, nearly, where θ is the twist imparted and $d\theta$ the change of twist due to the action of the field and observed at the mirror.

In describing the experiments L will denote the length of each wire in centims., D their common diameter in centims., C the current passed either through the lower wire or through the helix in amperes.

3. The effect to be observed expresses itself in a shifting of the fiducial zero, i. e., the position of the spot of light on the scale when the magnetic field is nil. The amount of deflection obtained in the first and second magnetizations therefore differs because the zero is markedly changed and in the case of a circular field always in such a way as to diminish the deflection; in longitudinal fields on the contrary, in a way to increase the deflection.

* This Journal, [4] x, pp. 407-418, 1900.

† The vanes vv dipping in the salt solution contained in an annular trough (not shown), deaden vibrations and carry off the electric current for the circular field, entering at E . The weight W suitably stretches the system with the aid of a slot adjustment in the torsion head E .

In figure 1 for example (to begin with the circular fields) a nickel wire ($L = 41$, $D = .05$, $C = 4$) is twisted $+45^\circ$ and -45° alternately, as shown by the abscissas. The deflections observed are given by the ordinates in the order shown by the arrows. The two observations recorded at each twist correspond respectively to the first and the second (or succeeding) magnetizations. The deflection of the former is always the larger. The initial deflections or changes of rigidity due to circular magnetization lie along a line, a , the succeeding deflections along a line, b , of smaller slope. The fiducial zero in the successive twists suffers displacements due to the circular magnetization alone and would be represented by a zigzag line as will be more definitely instanced below.

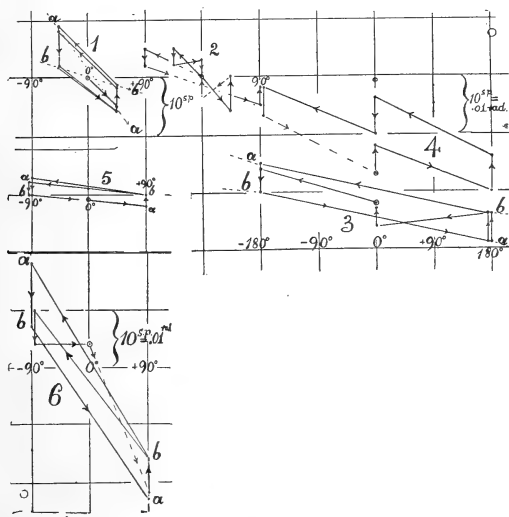

If the deflections are studied between three successive twists the result is even more striking as seen for example in figure 2, for twists successively 0° , -45° , 0° , $+45^\circ$, 0° . The lines for initial and final deflections might again be drawn but they would confuse the figure. The displacement of the zero is such as to indicate two successive displacements in the same direction.

The phenomena are independent of the direction of the current and a larger angle of twist does not magnify them in an easily discernable way.

The nickel wire being relatively thick and the current closed but a short time, no attention was paid to the heat produced in the wire by the current. In the following experi-

ments with a thinner wire of iron, this was kept submerged in the tube of flowing water specified. The residual diminutions of rigidity given by the line b in figure 1 may, therefore, be of thermal origin.

4. The decrement of rigidity due to the effect of circular magnetization on a submerged iron wire ($L = 41$, $D = .024$, $C = 3$) is so nearly like the above results for nickel, that a few sample curves will suffice to introduce the subject. The diameter being relatively small larger twists are admissible as lying well within the elastic limits.

In figure 3 the twists are alternately $+180^\circ$ and -180° , though the observations begin and end with zero. The arrows are a sufficient guide as to the sequence of results. The lines

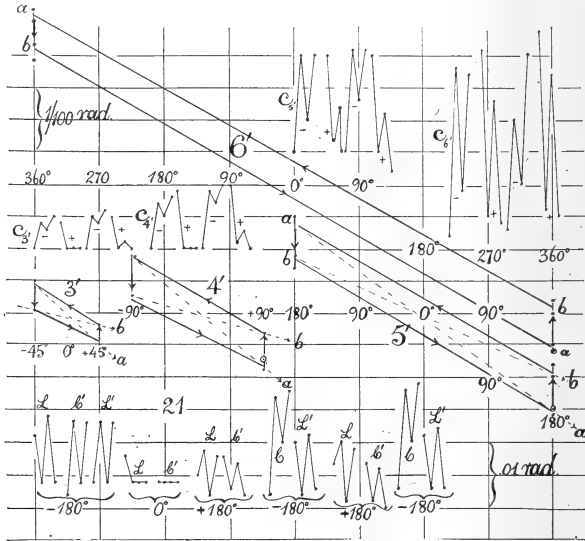

a and b show the decrement of rigidity due to the initial and subsequent circular magnetizations for each twist. In figure 4 three twists are successively applied. Lines corresponding to the initial and final magnetizations are omitted. An inspection of all the figures shows that the displacements of the zero due to twisting between two angles a and $-a$, is less than the aggregated displacements due to twisting from a to 0° and 0° to $-a$, under otherwise identical conditions. We have here also the key to certain results in a previous paper in which increasing positive twists return with larger positive displacements and increasing (absolutely) negative twists return with increasing negative displacements.

The curves given correspond to mean currents. The scale of the phenomenon increases with the strength of the current. For 1 ampere, figure 5, the decrements of rigidity due to the initial magnetizations line *aa* are still of marked value; the subsequent effects (line *bb*) lie within the errors of observation. For 6.5 amperes all decrements have been greatly magnified as seen in figure 6.

Finding that a more systematic series of results would facilitate the discussion below, I have added figures 3' to 6', for the same sample of (submerged) wire and a circular field (current 6.5 amperes), and for twists increasing from 45° to 360°, applied to each wire. These were 35 centims. long and .024 centims. in diameter. The cycles were many times repeated as the figures show at once. The striking feature of all these experiments is the remarkable constancy (for the same wire and current) of the slopes of the cycles, i. e., of lines connecting the means of initial and subsequent deflections. This slope shows no certain variation between 45° and 360° of twist. The marked contrast between the temporary slopes, *a*, due to the first magnetization and the permanent slopes, *b*, due to the ensuing magnetizations is sustained. All slopes are negative.

The displacements of the fiducial zeros or slips observed at the end of the cycles do not increase as fast as the twists. They show their chief increase between 45° and 90°. To better exhibit the displacement of the zero I have given the successive scale readings in the zigzag curves *c*, attached to each figure. The position of the spot is marked off vertically to scale, and the successive observations are charted at equal distances apart horizontally, for distinction, and joined by straight lines. The field is alternately made and broken beginning with no field. When the sign of the deflection (positive, up) and that of the twist (given by the attached sign) agree, rigidity is increased. The curves show that rigidity is diminished on closing the current and increased on breaking it. Moreover, after the first closing, the diminution of rigidity is enormously greater than on subsequently closing the current for the same twist. This is particularly true for small twists.

5. The endeavor must now be made to elucidate these phenomena. With regard to the relatively small decrement of rigidity obtained in the circular magnetizations succeeding the first (i. e., the permanent decrements), I have already shown (l. c.) that they may be reproduced in brass wire by the same means; and until specially refined experiments are made, they may be regarded as the mere result of the accession of heat. The phenomena are thermal and elastic in their nature. So much, therefore, for the slopes of the lines, *b*.

The interesting feature of the experiments are thus the lines, a , together with the corresponding displacements of the fiducial zeros given by the zigzags, c . These phenomena cannot be reproduced in brass* stressed within the elastic limits. Hence I infer that they are viscous in character and due to the breakdown of unstable magnetic configurations (in Maxwell's view) resulting from the new magnetization. For although the viscosity of a magnetic wire and of a non-magnetic wire are identical, the period of breakdown which follows the first magnetization must be rich in unstable configurations and, therefore, temporarily low in viscosity. I conclude, therefore, that the displacement of the zero is due to the molecular instability which accompanies the act of magnetization when first applied; that in subsequent magnetizations the molecular disturbance is less because the configurational effect of the first magnetization is largely permanent. Fixed configurations are merely deflected in their elements without being broken up anew. Further discussion would be of little value because of the heat discrepancy, occurring in spite of the submergence.† The essential data are to be incorporated with the remarks made for longitudinal fields.

6. After these results it seemed necessary to reconsider in detail the corresponding phenomena in a longitudinal field since here the *heat discrepancy* can be quite *eliminated*. This was done with the same precautions. The helix was supplied with currents of about 2, 4, and 8 amperes, respectively, evoking longitudinal fields of roughly 200, 400, and 800 c. g. s. units. The identical annealed iron wires were each of about 35 centims. long and .024^{cm} in diameter. They were insulated from each other so that a current could be passed through the lower alone, which was submerged in flowing water while the upper wire was suspended freely in air. Both wires were stretched in the same vertical line. Cf. figure above.

But one observation was made with the weak field for $C=2$ amperes, as shown in figure 7, the twists being alternately $+90^\circ$ and -90° . The interesting features are the directions a and b , corresponding respectively to the first and subsequent magnetizations, and, therefore, to the temporary and the persistent effects. Both are increments while in the above cases of circular magnetism they were decrements. The displacement of the zero, however, here and above has the same direction and corresponds to diminished viscosity (high molecular instability)

* I also tested the effect of a current on a submerged brass wire stressed a little beyond the elastic limits. The results showed that whereas the rigidity is decidedly modified by the presence of a current, the viscosity of the wire is not noticeably different in the two cases. The effects are due to heat.

† See preceding paper in this Journal, IV, x, p. 417, 1900.

of the magnetized wire in the initial magnetization. As this is the important result I will again record the successive scale readings as shown by the zigzag lines c , with the subscript referring to the figure. It is not necessary to give more than four observations for each twist since all subsequent elongations are like the second in magnitude. For the first and third points the field is off, for the second and fourth it is on.

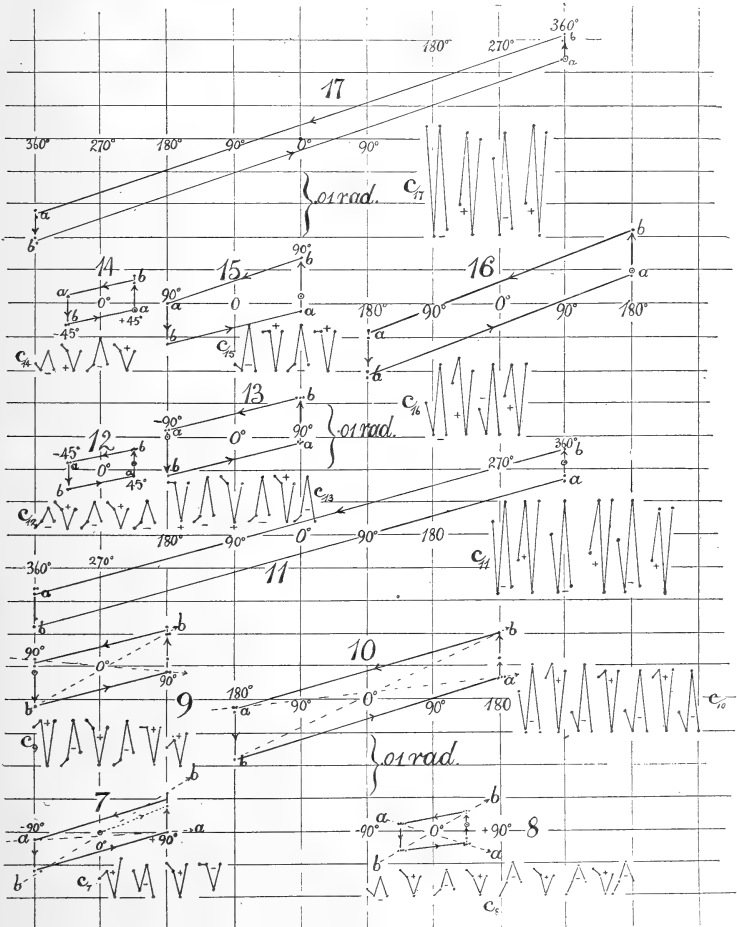

If the twist be positive (shown by the attached sign), an increased scale reading denotes increased rigidity of the magnetized wire, and vice versa.

It is preferable to discuss these results in connection with figures 8-11, for a larger field ($C=4$ amperes) and twists

respectively between 45° , 90° , 180° , and 360° both sides of 0° . In figure 8 the line *aa* shows that the initial magnetization has produced a decided decrement of rigidity; line *bb* that the persistent effect of longitudinal magnetization is an increment of rigidity. The series of zigzags *c* (except the first which is reached from zero or no apparent strain) bear this out very fully. The first magnetization produces a deflection in a direction opposite to the acting stress. On breaking the current this deflection is increased (rigidity further diminished). The second and subsequent magnetizations increase rigidity but the original reading is not again reached.

Figure 9 for twists between $+90^\circ$ and -90° is similarly explained. The original magnetizations are indecisive, sometimes corresponding to increase sometimes to decrease of rigidity. On the whole the initial slopes, *aa*, are nil. Slopes *bb* correspond to marked increase of rigidity as usual. Full account is given by the zigzags *c*.

Figures 10 and 11 apply for twists between $+180^\circ$ and -180° , and between $+360^\circ$ and -360° , respectively. Both the initial and the subsequent magnetizations produce marked increments of rigidity, as shown by the lines *aa* and *bb* for each case and by the lines *c*. The scale of the phenomenon increases as the limits of twisting increase. The displacements, however, do not increase; in other words the vertical breadth of the cycles is not much greater for 360° than for 45° . There appears to be a pronounced tendency for the displacements to pass through maxima of slip for intermediate angles. Finally, so far as can be discerned the slopes of the cycles are the same throughout, rather an unexpected result. This means that the mean increments of rigidity are proportional to the twists, *caet. par.*

Repetitions of the experiments with the same sample of wire and small angles reproduced the original results as shown for instance in figures 12 and 13.

In view of the small effects produced in fields for $C=2$, and $C=4$ amperes, respectively, it seemed advisable to investigate the effect of further doubling the strength of the longitudinal field. The data are given on the same plan as in §6, in figures 14, 15, 16, 17. The displacements (vertical width of the cycles) have remained about as large as before and tend to pass through a maximum for intermediate angles of twist. The slopes of the cycles have definitely increased, so that for mean values, rigidity increases proportional to twist at a faster rate in stronger fields.

A rough summary of the principal data will be in place here.

TABLE I.—Magnetostriction of soft iron in longitudinal fields.

Current Field.	Twist.	Slope <i>a</i> .	Slope <i>b</i> .	Cycle slope.	Displacement.
2 amp.	+90°	+0.5	+6.0	+3.0	+5.5
200					
4 amp.	+45	-3.0	+6.0	+1.5	+4.5
400	90	-1.0	5.5	3.0	6.0
	180	+1.0	5.0	3.0	7.5
	360	+2.0	3.5	2.5	5.0
4 amp.	45	-2.0	6.0	2.0	4.0
400	90	-1.0	6.0	2.5	7.0
					4.0
8 amp.	+45	-2.0	+6.0	2.0	4.0
800	90	-0.5	6.5	3.0	7.0
	180	+2.0	5.5	4.0	6.0
	360	+3.0	4.0	3.5	4.0

Length, 35^{cm}. Diam., .024^{cm}. Deflections in scale parts (.001 radian or .057°) per 90° of twist of each wire.

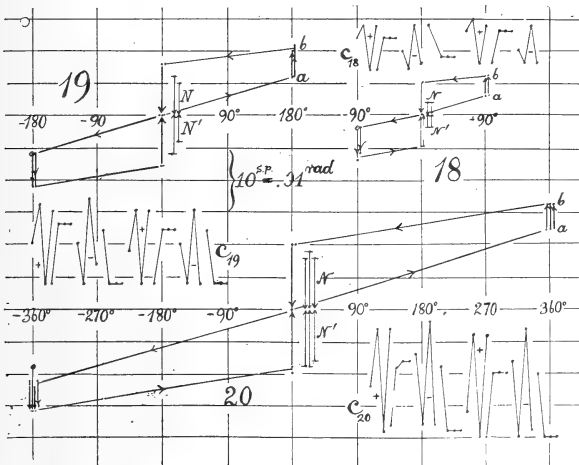

Hence with increasing twist the temporary deflection *a* and the permanent deflection *b* make respectively from large negative and from large positive values toward the same intermediate positive limit, which is larger for the larger field. The slopes of the cycles pass from small values rapidly into constant values as twist increases but they probably also pass through maxima as above. Finally the displacement of the zero for increasing twist marches through a definite maximum located at small angles of twist when the field is greater.

8. To obtain further relevant data it will next be necessary to twist between three angles, the middle one being zero and

the others equidistant from it. These results are shown in figures 18, 19, 20, the field corresponding to $C=8$ amperes. Soft iron wire ($L=35\text{cm}$, $D=.024\text{cm}$) was here used as above.

In figure 18 for instance, beginning with the twist -90° , the wire is magnetized twice, giving the temporary and the permanent effect: then untwisted and again magnetized twice giving the two corresponding effects; next twisted $+90^\circ$ and magnetized twice as the figure shows; finally untwisted again and magnetized twice, etc., for succeeding double cycles. In figure 19 the limits of twist are $\pm 180^\circ$; in figure 20, $\pm 360^\circ$.

The general characteristic of these figures is the very large zero displacement, or rather the large return displacements. In other words, the slip phenomenon is much larger on removing twist than on adding it, positively or negatively. The deflections are laid out on a larger scale for increasing twists and they are in general symmetrical. Temporary slopes a are usually negative and even at 360° not strongly positive. Permanent slopes are positive and about of the above values. The following data may be given. When the lines a and b are constructed either side of 0° , they are designated a' and b' .

TABLE III.—Magnetostriction of soft iron in longitudinal fields. Current, 8 amperes.
Field 800 c. g. s. units

Twist.	a .	b .	Cycle slope.	$+a'$.	$-a'$.	$+b'$.	$-b'$.	Displ. at 0° .	Displ. at elongation.	Displ. non-mag. at 0° .
$\pm 90^\circ$	+2.5	+6.3	+4.5	-2.0	-3.0	+6.0	+6.5	5	4.7	2.0
180	3.0	5.4	4.2	-1.0	-1.0	5.3	5.5	8	5.5	5.2
360	2.9	3.9	3.4	+0.5	+0.5	8.0	8.0	10	4.0	8.5

9. The next question at issue is the amount of displacement due to magnetization at the zero of twist, which may be produced by merely twisting the wire to different angles and back again to zero, *without magnetizing it when twisted*. These results are also inserted in figures 18, 19, 20, and marked N, N' . They increase rapidly as the twist (without magnetization) increases. At 360° it makes little difference whether the twisted wire is magnetized or not, so far as the displacement at the zero of twist is concerned; in all cases, however, magnetization at the elongation increases the slip at 0° .

Finally a perfectly fresh wire was adjusted, twisted to 360° without magnetization and then freed from twist. The result (amount of displacement due to magnetization at the zero of twist) did not differ essentially from the figure.

10. In conclusion a few words on the interpretation of the above phenomena may be added. The point of view taken has already been indicated in § 1. In Maxwell's sense any defor-

mation due to molecular instability is legitimately termed viscosity.

The initial longitudinal magnetization of the wire does two things: it increases its rigidity (see preceding paper, l. c.) in marked degree, and it decreases its viscosity during the act of magnetization. The subsequent magnetization merely increases rigidity without the accompanying viscous effect. The phenomenon now becomes purely elastic. Thus the first magnetization after any twist has been imparted is the one which reconstructs the magnetic configurations; the subsequent magnetizations (to refer to the mechanism of Ewing's theory) merely deflect the set molecular magnets.

It follows also that with each fresh twist molecular configurations are broken down. This is similar to what occurs in cases of the tempering of a glass-hard or hard drawn magnet. The prepondering amount of the magnetization is wiped out by the simultaneous decay of the hardness.*

Finally, whenever a wire is strained certain groups of molecules lag behind the stress: they may be gradually disintegrated by time (sæcular viscous deformation); more rapidly by rise of temperature (viscous deformation); or suddenly as in the present instances, by magnetization. It is not necessary to assume that the breakdown is identically the same even apart from time in all these instances. In other examples (tempering, etc.) whereas the decay of hardness wipes out magnetization, the decay of magnetization does not influence temper; but such cases are easily interpreted.

If we endeavor to follow the figures 7-11, 14-17, after the first magnetization, we encounter a case in which magnetically increased rigidity is to be imparted to a body of simultaneously decreased viscosity. The wire momentarily contains groups of unstable molecules and is thus in a condition to yield to the mechanical stress (torque) to which it has been subjected.

If now we consider the system of two wires and imagine these occurrences to be consecutive, the increment of rigidity would produce a deflection in the same direction as the twist, or work would be done by the magnetized wire upon the non-magnetic wire, against the existing torque. The yield of the wire due to the presence of unstable configurations would produce a deflection in the opposite direction to that of the twist; or work would be done by the non-magnetic wire upon the magnetized wire. After the first magnetization the greater of these effects will supervene. The result is uncertain as to sign. After subsequent magnetizations for the same twist the

* Barus and Strouhal. Bull. U. S. Geolog. Survey, No. 14, p. 154-5, 1885; cf. Wied. Ann., xx, p. 662, 1883.

viscous effect has vanished and the result is simply increased rigidity in definite amount during the continuance of each magnetization.

In figures 8, 9, and the corresponding figures 12, 13, 14, 15 (cf. the zigzag curves *c*), i. e., at low strains, 45° and 90° , the viscous effect preponderates. On first making the current after a fresh twist, rigidity is decreased; on breaking it rigidity is further decreased by a greater amount; on again making the current rigidity is increased definitely and the same occurs after all subsequent magnetizations.

In figures 10, 11, and 16, 17, the increased rigidity preponderates after the first magnetization. There is increased rigidity on first making the current, a numerically larger decrement on breaking, and thereafter definite increments of rigidity during the continuance of each subsequent making of the magnetizing current. Thus it follows that the magnetic increment of rigidity increases and decreases faster than the coexisting decrement of viscosity due to the first magnetization.

So understood, moreover, the observed hysteresis is a mechanical phenomenon and the magnetization acts as does ordinarily heat in producing the instabilities essential to viscous deformation. The molecular shake-up due to magnetic action is practically instantaneous, whereas the heat motion within the body is gradual in its action: hence the kaleidoscopic displacement of molecules in the one case seemingly without resistance, and the viscous displacement of molecules in the thermal case (seemingly with resistance). Again the displacement of the zero if due to viscosity should under like circumstances be of about the same order both in the cases of longitudinal and of circular magnetization (aside from the heat effect in the latter, which makes it larger). A comparison of figures 3' to 6', with the subsequent figures 7 to 17 show displacements of about the same order for both.

11. Simpler in its nature is the evidence contained in figures 18–20, for the displacement of the zero after the first magnetization. If the wire is twisted to say 360° and back again to zero, the resulting strain does not correspond to the zero of stress. Certain configurations lag behind in the direction of the twist which has last acted. The first magnetization, however, produces the necessary molecular shake-up to bring the strain back again to zero in correspondence with the stress. Hence the subsequent magnetizations produce no deflection since the wire is without twist. Residual strain has been wiped out.

Figures 18–20 show that the residual strain when stress is zero, increases with the preëxisting stress, being greater at

360° than at 90° , for instance: This is the natural explanation of the greater displacement corresponding to the greater stress and of the change of sign of the displacement with the pre-existing stress. Again the residual effect at zero is greater if the twist has been accompanied by magnetization before removal. Cf. N, N' . Combined magnetization and twist (say at 360° , for instance) correspond to a greater value of stress in the absence of magnetization; for the magnetization wipes out the lagging or unstable configurations, bringing the strain at 360° in correspondence with the stress.

Why, it may next be asked, is the displacement at zero after removal of twist 360° , greater than the displacement at 360° , for instance. We meet here, I think, the usual occurrence in viscous deformation.* For example, if a strained or hard metal is tempered at 100° C., it is then molecularly stable or shows no deformation or change of temper at temperatures below 100° or for smaller values of strain, even when the deformation at the original temperature (100°) and strain still continue.

If the wire is twisted to 360° (say) not only is strain stored up in the wire, but at the same time new instabilities are evoked by the process of twisting. When the stress is withdrawn or the wire untwisted to zero, instabilities are not encountered at nearly the same rate; for the preceding larger strain has wiped them out for the diminishing smaller strains. Hence the wire is less viscous when twisted and more viscous when untwisted for like stages or angles of twist. Now any twist no matter how small or within the elastic limits stores strain in the wire, which action possibly, is but another expression for the configurations broken during the process. This, as I understand it, is the explanation of figures 18–20, in which the slip at zero following a reduced strain is so much larger than the slip at 360° following a growing strain.

12. If the interpretation given be correct, then on shaking out a strain with longitudinal magnetization, the wire should be free from slip for circular magnetization; and vice versa. This is the case as shown in figure 21, p. 100, where the successive scale readings are given (vertically) at equal intervals (abscissas) apart, the current being alternately made and broken beginning with no field. L denotes a longitudinal field, C , a circular field if first in action; L' and C' , the corresponding fields if they succeed the action of other fields. The twist is alternately $+180^\circ$ and -180° . Mere inspection shows that from the cases L' and C' slip has practically been wiped out. It is markedly present in cases L and C , the first deflection being

* Barus and Strouhal, Bulletin U. S. Geolog. Survey, No. 14, p. 57, 1885; Wied. Ann., xi, p. 965, 1880.

respectively about half as large for L or twice as large for C as the second deflections due to the making of the field. Figure 21 also shows that if the residual strain or slip is wiped out for a longitudinal field it is also wiped out for a circular field. In cases L there is increase of rigidity and decrease of viscosity; in cases C decrease of both rigidity and viscosity. The differential and summational results are well given in the figure. In cases L' and C' there is increase and decrease of rigidity only with no viscous effect.

To sum up the argument it is briefly this: Magnetization is regarded as a means of shaking up the molecular mechanism and thus to produce temporary molecular instability or momentarily very low viscosity. Hence if mechanical strain has been stored up in the metal it will be instantly released and the metal will correspondingly yield to external stress. This view seems to give a good account of all the hysteresis-like phenomena met in torsional magnetostriction and makes it possible to describe the behavior of all paramagnetic metals in a single explanation.

The one quantity by which the experiments seem to be characterized is the cyclic slope, or the mean slope determined by the temporary (viscous) and the permanent (elastic) deflections, which increases (numerically) with the strength of the field and is nearly independent of the twist imparted, remembering that the remarks have no meaning beyond the elastic limits. It would seem, therefore, that in terms of this parameter the phenomena as a whole for any field or metal, may be simplified. Whether the slip constitutes a kind of molecular "back lash," and whether there is any meaning to its obvious analogy to the action of a "coherer" cannot here be answered.

Brown University, Providence, U. S. A.

ART. VIII.—*The Dinosaurian Genus Creosaurus, Marsh;*
by S. W. WILLISTON.

THE genus *Allosaurus* was proposed by Marsh in this Journal for November, 1877, for the type species, *A. fragilis*, from Colorado, presumably Cañon City. His description was as follows: "This genus may be distinguished from any known dinosaurs by the vertebræ, which are peculiarly modified to ensure lightness. Although apparently not pneumatic, they have the weight of the centra greatly reduced by deep excavations in their sides. Some of them have the centra hour-glass in form, the middle part being so diminished as to greatly reduce the strength. The vertebræ preserved are biconcave, with shallow cavities. The feet bones referred to this species are very slender. A lumbar vertebra has its centrum 105^{mm} in length, and 80^{mm} in least transverse diameter. An anterior caudal, 85^{mm} long, has its centrum so much constricted that its least transverse diameter is 38^{mm}, while its anterior face is 90^{mm} in transverse diameter."

In the following March, Marsh described in this Journal the genus *Creosaurus*, based chiefly, if not entirely, upon a left ilium collected by the present writer at Como, Wyoming. It will be observed that at the time of the erection of the genus, very little was known of the distinctive characters of *Allosaurus*, and, so far as the author of it knew there was no reason for referring the ilium and other bones there described to another genus—or at least Marsh gave no reason. In the following January number of this Journal, occurs the following passage by Marsh, which, taken in connection with subsequent changes, is a little remarkable:

"The genus *Allosaurus* is typical of the family [*Allosauridæ*, later merged into *Megalosauridæ*] which also includes *Creosaurus* and *Labrosaurus* [*Antrodemus* Leidy]. The first named genus presents some very interesting features in the vertebræ and pelvic arch. The vertebræ first described are remarkable for the reduction of the centrum by constriction, so that the necessary lightness is secured without cavities in the interior. This is shown in the lumbar vertebra represented in Plate X, figs. 3 and 4."

From this it would certainly be inferred that the vertebra figured was a type specimen, especially as it agrees in size and form quite with the lumbar vertebra first described, and upon which the genus and species *Allosaurus fragilis* practically rests. In a later paper (this Journal, xvii, Pl. XIV), however,

this same vertebra, used to typify Allosaurus, is figured as Creosaurus.

The interesting fact remains that the author of *Creosaurus* did not and apparently could not satisfactorily distinguish it from *Allosaurus*, and the name has remained in catalogues and text-books as a sort of floating wreckage, that will neither sink nor be cast up. The few characters Marsh gave for *Creosaurus*, it is readily seen are of very slight value. The ilium, it is true, is of somewhat different shape, as figured, but even this difference may be due to imperfect preservation, as Marsh himself suspected. The only other things mentioned by Marsh is the number of vertebræ in the sacrum, of very little value as already demonstrated in other genera of the Wealden dinosaurs; the position of the transverse processes, which I am confident will not prove distinctive; and the number of teeth in the premaxilla. In fact, then, nothing seems to be known as certainly belonging to *Creosaurus*, except the imperfectly preserved ilium first described.

In the Kansas University expedition to Wyoming in the summer of 1899, a number of bones of a carnivorous dinosaur were obtained from a deposit in the Freeze Out Mts., associated with remains of *Morosaurus*, *Diplodocus*, *Stegosaurus* and *Antrodemus*. These remains were at first unhesitatingly referred to *Allosaurus*, and it is possible that some of them may really belong with that genus. The numerous centra preserved certainly agree very closely with the description given of the *Allosaurus* vertebræ—but they also agree equally well with the vertebra referred to *Creosaurus*. Aside from the vertebræ, however, there were two scapulæ obtained that certainly show a generic distinction from *Allosaurus*, as I have convinced myself from inspection of the scapula referred by Marsh to that genus, and figured by him in various places. It remains to be seen, however, whether this scapula of Marsh indubitably belongs with the bones first referred by him to *Allosaurus*. I do not think that there is conclusive evidence of this. Associated with these scapulæ in our quarry, though not in immediate juxtaposition, were two coracoids, a humerus, radius, claw bones, etc., all of which belong I think with the same species, though from two animals. An ilium and femur, obtained later from the same deposit by the Field Columbian expedition, in all probability belong with one or the other of the two animals.

I give herewith a restoration of the shoulder girdle and arm, so far as the bones preserved permit. The portions outlined are reproduced from Marsh's restoration of the corresponding parts of *Allosaurus*.

The striking distinction from *Allosaurus*, at once seen, and clearly of generic value, is presented by the remarkably elongated and slender scapula. Its shape also is distinctively different in the proximal portion. The other bones preserved do not seem to differ very much from the corresponding bones of

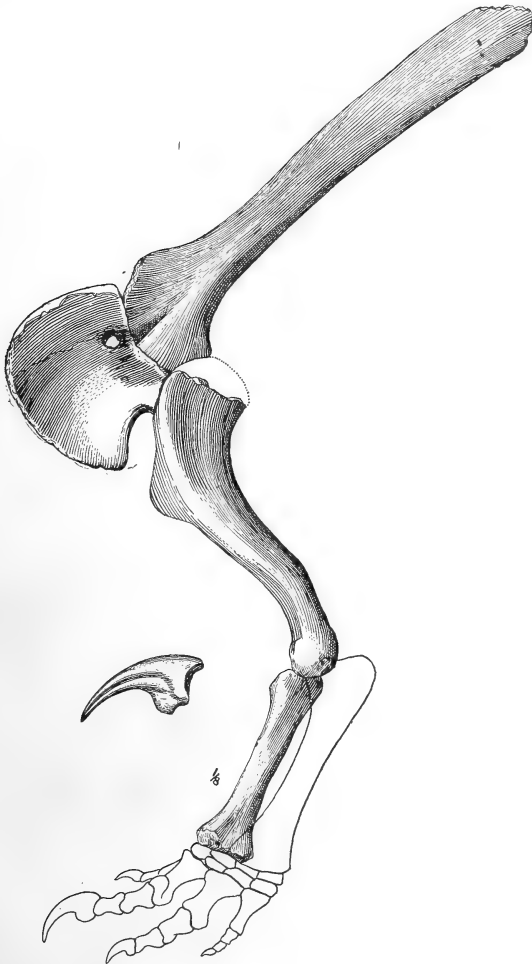

Allosaurus. The humerus appears to be somewhat more curved, the radius is stouter, and the hand is probably larger, relatively. This bird-like form of the scapulæ is a feature apparently unique among dinosaurs. Its shaft is of nearly equal width throughout or but slightly widened distally. The

upper half is much flattened, and the edges are thinned, while proximally it is more trihedral in cross-section, the posterior border rather sharp, the anterior one more rounded and the inner surface here more flattened. Longitudinally the external surface is convex, though less so, or nearly straight, in its middle portion.

The age of the beds whence these fossils are derived, the *Atlantosaurus Beds* of Marsh, I have no hesitancy in accepting as Lower Cretaceous. They were first referred to the Wealden by Marsh at the time of the discovery of the rich reptilian fauna in 1877, but afterwards wrongly placed by him in the Upper Jurassic. I have always doubted this reference, and their Cretaceous age it now seems to me to be sufficiently well proven to accept without question. The character of the reptilian forms present sufficient evidence, I believe, to refer them to beds equivalent to the Wealden of Europe, and the evidence from the invertebrates is still stronger: "The Wealden formation of England contains the greater part of the genera which occur in the *Atlantosaurus Beds* and is doubtless of the same age. The two formations have similar lithological characters, and four of the genera—*Unio*, *Valvata*, *Planorbis* and *Viviparus*—which are represented in the two formations by species having practically the same development, are not known from older formations."*

The name *Atlantosaurus Beds*, derived from a synonym, is not available for them, and must be replaced by *Como Beds* as proposed by Scott, unless indeed, the determination is sufficiently exact to allow the name Wealden to be substituted.

* Logan, Kans. Univ. Quart., ix, 132, 1900.

ART. IX.—*The Stereographic Projection and its Possibilities, from a Graphical Standpoint*; by S. L. PENFIELD.
(With Plates II, III and IV.)

(Continued from page 24.)

Some Results obtained from the Solution of Spherical Triangles by Graphical Methods.—In order to test the accuracy of the methods set forth in the foregoing pages, two right and five oblique-angled triangles were plotted and solved graphically. None of the parts of the triangles selected were given to exact degrees, so at the very beginning the points had to be approximately located between the degree graduations of the 14th divided circle and the scales derived therefrom.

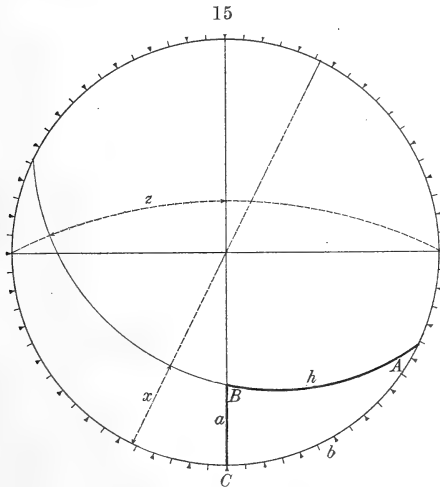

Case 1.—Given two sides, $a = 26^{\circ} 34'$ and $b = 63^{\circ} 26'$, of a right triangle, figure 15. At C construct a diameter, and, by means of protractor No. I, plot the side a , $26^{\circ} 34'$. Lay off the side b , $63^{\circ} 26'$, on the divided circle, and then construct a great circle passing through the points thus located, page 15. The angles A and B and the side h of the triangle are thus plotted. A is now measured on the diameter x (stereographically projected great circle) at 90° from A , by means of protractor No. I. B is measured on the great circle z , at 90° from B , by means of protractor No. II, page 18. The side h is measured by protractor No. II. The results of the work are as follows:

	Calculated.	Plotted.	Error.
$A =$	$29^{\circ} 12'$	$29^{\circ} 10'$	$2'$
$B =$	$77 24$	$77 30$	6
$h =$	$66 25$	$66 25$	0

Case 2.—Given an angle $A = 24^\circ 9'$ and a side $h = 70^\circ 14'$ of a right triangle, figure 16. On the diameter x , locate the point p $24^\circ 9'$ from the divided circle, using protractor No. I; then making use of scale No. 1, figure 3, construct the great circle $A p$. Likewise on the diameter y locate $p' 70^\circ 14'$ from

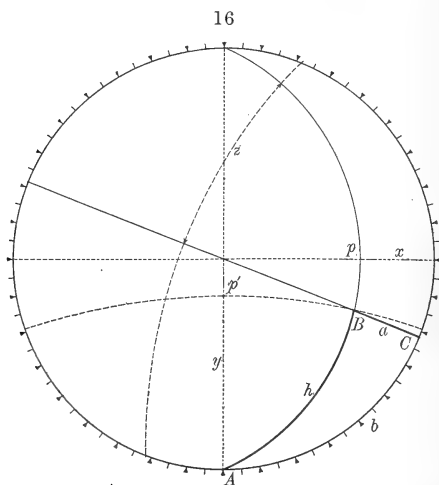

A , and making use of scale No. 2, figure 3, construct the small circle which intersects the great circle previously constructed at B . Through B draw a diameter, thus locating the right angle C , and completing the triangle. The side a is measured by protractor No. I, the side b by the graduation of the divided circle, and the angle B on the great circle z , by means of protractor No. II, page 18.

The results are as follows :

	Calculated.	Plotted.	Error.
$a =$	$22^\circ 39'$	$22^\circ 40'$	$1'$
$b =$	$68 \quad 30$	$68 \quad 25$	5
$B =$	$81 \quad 23$	$81 \quad 25$	2

Case 3.—Given the three sides of an oblique triangle, $a = 94^\circ 26'$, $b = 78^\circ 42'$, and $c = 72^\circ 36'$, figure 17. On the divided circle, lay off the side a , and thus locate the angles B and C . On the diameters x and y locate the points p and p' , respectively $78^\circ 42'$ and $72^\circ 36'$ from C and B , using protractor No. I. Now making use of scale No. 2, figure 3, construct small circles through p and p' , and their intersection locates the angle A . Construct the great circles through C and A , and B and A , and the sides a , b , and c , of the triangle are plotted. The angles B and C are measured on the diameter x' and y' , at 90° from B and C , respectively, using protractor

17

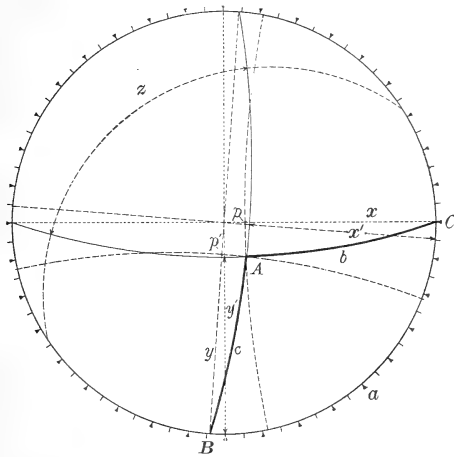

No. I. The angle A is measured on the great circle z , using protractor No. II, page 18.

The results are as follows:

	Calculated.	Plotted.	Error.
$A =$	$98^{\circ} 21'$	$98^{\circ} 30'$	$9'$
$B =$	$76 \quad 47$	$76 \quad 40$	7
$C =$	$71 \quad 16$	$71 \quad 15$	1

Case 4.—Given the two sides and the included angle of an oblique triangle, $a = 31^{\circ} 25'$, $b = 88^{\circ} 53'$, and $C = 97^{\circ} 13'$, figure 18. To plot the angle C , on the diameter x locate the point p $97^{\circ} 13'$ from the divided circle, and construct the great circle Cp . To plot the side a and thus locate B , on

18

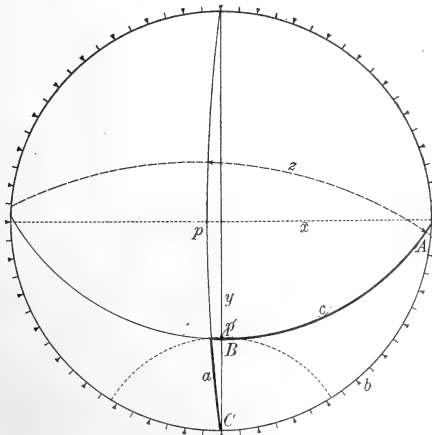

the diameter y locate the point p' $31^\circ 25'$ from C , and construct the small circle with radius given by scale No. 2, figure 3. Lay off b on the divided circle, and draw the great circle AB , thus completing the triangle. The side c is measured by protractor No. II. The angle A is measured on a diameter 90° from A , by means of protractor No. I. The supplement of the angle B is measured on the great circle z , using protractor No. II, page 18.

The results are as follows:

	Calculated.	Plotted.	Error.
$A =$	$31^\circ 11'$	$31^\circ 5'$	$6'$
$B =$	$83 \ 15$	$83 \ 0$	15
$c =$	$92 \ 48$	$92 \ 50$	2

Case 5.—Given two angles and the included side of an oblique triangle, $A = 59^\circ 3'$, $B = 53^\circ 34'$, and $c = 75^\circ 23'$, figure 19. Lay off the side c on the divided circle. Plot the

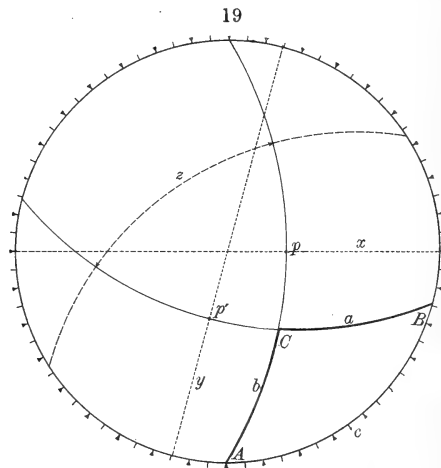

angles A and B by locating the points p and p' , on the diameters x and y , respectively, at 90° from A and B , the point p being $59^\circ 3'$ and the point p' $53^\circ 34'$ from the divided circle. Using scale No. 1, figure 3, construct the great circles through A and p , and B and p' , thus locating C and completing the triangle. The sides a and b are measured by protractor No. II, and the angle C also by protractor No. II on the great circle z , page 18.

The results are as follows:

	Calculated.	Plotted.	Error.
$a =$	$56^\circ 50'$	$56^\circ 45'$	$5'$
$b =$	$51 \ 45$	$51 \ 40$	5
$C =$	$97 \ 33$	$97 \ 35$	2

Case 6.—Given two sides and the angle opposite one of them of an oblique triangle, $a = 56^\circ 7'$, $b = 40^\circ 8'$, and $A = 93^\circ 39'$, figure 20. This problem has but one solution when a is greater than b , as in the present case. Lay off b on the divided

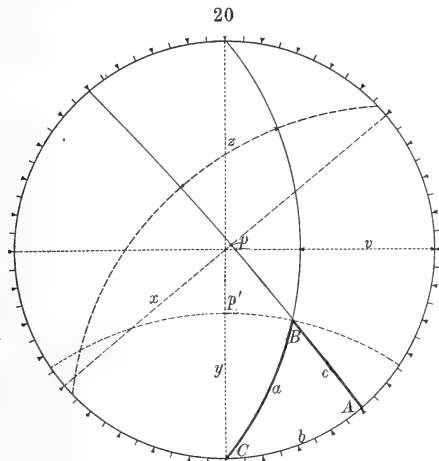

circle. On the diameter x , 90° from A , locate p $93^\circ 39'$ from the divided circle; and draw the great circle Ap . On the diameter y locate p' $56^\circ 7'$ from C , and construct the small circle which determines B . Through C and B draw a great circle, which completes the triangle. The angle C is measured on the diameter v , at 90° from C . The angle B is measured on the great circle z by protractor No. II, page 18. The side c is measured by protractor No. II.

The results are as follows:

	Calculated.	Plotted.	Error.
$B =$	$50^\circ 47'$	$50^\circ 55'$	$8'$
$C =$	$50 \quad 53$	$51 \quad 0$	7
$c =$	$40 \quad 12$	$40 \quad 25$	13

Case 7.—Given two sides and an angle opposite one of them of an oblique triangle, $a = 63^\circ 20'$, $b = 73^\circ 8'$, and $A = 55^\circ 10'$, figure 21. This problem is similar to the foregoing in the parts given, but has two solutions when a is less than b . On the diameter x , 90° from A , locate p $55^\circ 10'$ from the divided circle, and draw the great circle Ap . On the diameter y locate p' $63^\circ 20'$ from C , and construct the small circle which intersects the great circle Ap , previously drawn, at two points, B and B' . Thus two triangles are plotted, ABC and $AB'C$, determining the two solutions of this problem. The acute and obtuse angles at C are measured on the diameter v , at 90°

from C . The obtuse angle B is measured on the great circle z by protractor No. II, page 18. Likewise the acute angle B' is measured on the great circle z' , the portion between the arrow points giving the supplement of the angle. The sides c and c' , from A to B and from A to B' , are measured by protractor No. II.

The results are as follows :

	Calculated.	Plotted.	Error.		Calculated.	Plotted.	Error.
$B = 117^\circ 41'$	$117^\circ 37'$	$4'$	$B' = 62^\circ 19'$	$62^\circ 20'$	1		
$C = 20 17$	$20 11$	6	$C = 103 48$	$103 55$	7		
$c = 18 43$	$18 55$	12	$c = 116 1$	$115 55$	6		

21

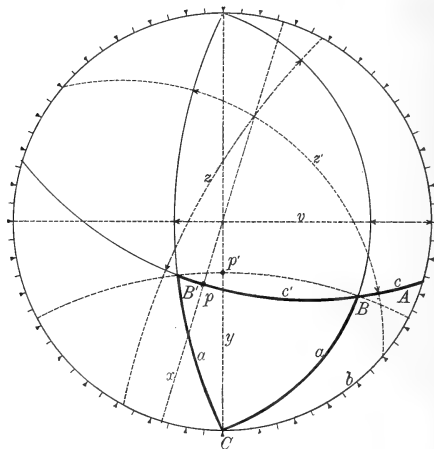

The solutions of the seven problems just given were made without knowledge of the calculated values; furthermore, the results are not a selection of best values, obtained from a number of solutions of the several problems. The results have been given exactly as they were obtained, and hence they serve to illustrate the probable degree of accuracy which may be secured. In solving the two right triangles the greatest error was $6'$, the average error less than $3'$. In solving the five oblique triangles the greatest error was $15'$, the average $7'$. It is evident that by increasing the size of the projection, and using more accurately engraved plates, the errors could be materially lessened.

One possible case has not been included in the foregoing list; namely, having three angles of a triangle given. Such a problem may be solved graphically, but, having no sides given, the problem is complicated. It may be done somewhat as follows: Referring to figure 19, the great circle Ap , determin-

ing the angle A , is first plotted. Then, taking protractor No. IV, page 22, the great circle corresponding most nearly to B is selected, and the protractor, centered on the drawing, is turned until the great circles $A p$ of the drawing and $B p'$ of the protractor cross at an angle approximating to C , which is told by means of an ordinary protractor, page 19. Thus an approximate solution may be quickly obtained.

Some Practical Applications of the Stereographic Projection.—Some mathematicians may contend, and justly, that the seven problems previously presented might be solved easier by numerical calculations than by plotting; and that by using four- or five-place logarithm tables the results would be correct to minutes, while those obtained by plotting are only approximately correct. In spite of the truth of this, graphical methods still have their advantages. Most persons who have occasion to make calculations, the writer included, use formulas and tables, as a rule, wholly in a mechanical way. With graphical methods, on the other hand, formulas and tables are not needed, and every operation is clearly understood, for graphical methods can scarcely be applied otherwise. In the majority of cases, numerical calculations are laborious, while graphical solutions appeal to one like pictures which, to a certain extent, tell their own story. Although it may be known that for some problems there are two solutions, it is safe to assume that of those persons who are accustomed to solve spherical triangles by the use of formulas, only a few could satisfactorily explain why two solutions apply to the conditions shown in figure 21 where a is less than b , while only one solution is possible when a is greater than b , figure 20. The two figures, however, being accurately constructed, not only show the point in question clearly, but present the problems in such a manner that desired parts can be measured.

Most persons have never studied spherical trigonometry, and those who have studied it usually regard the solution of a spherical triangle as at least a laborious, if not a difficult, matter. This is especially true of those who for a long time have not made numerical calculations, and who have thus lost their familiarity with the use of formulas and of logarithmic tables. Perhaps no one can appreciate the difficulties presented by the subject more than one who has had occasion to teach crystallography to advanced students. It is generally the case that students desiring to take up crystallography (chemists especially) have not made numerical calculations, other than very simple arithmetical ones, for a number of years. As a consequence, the problems in spherical trigonometry are regarded as a great trial. Mistakes of all kinds arise, and the only way to make absolutely sure of one's work is to check, either by

means of duplicate calculations or by applying formulas for checking. Professor Edward S. Dana, in preparing his "System of Mineralogy," had all the angles in the book recalculated, using as far as possible the fundamental angles of the original investigators. He has told the writer that the number of errors he detected was astonishing. Some of the errors had been made even before the axial relations of the crystals were determined, and whole tables of angles were, as a consequence, vitiated. Other mistakes had been made early in the century, and had been copied into all the leading text-books of mineralogy and crystallography.

By making use of the graphical stereographic methods, triangles can be plotted practically in exact proportions, and, by measuring the unknown parts, a check upon the results of numerical calculations can be made. The importance of having some simple method of checking can not be overestimated. In the matter of making numerical calculations persons differ greatly. Some have great facility and seldom make mistakes; others do the work with difficulty, especially, it would seem, if, like the writer, they are only occasionally called upon to make calculations. Some check, therefore, carried out graphically, is a great saving of nervous energy. In the writer's short experience in using graphical methods as applied to the stereographic projection, numerous errors in numerical calculations have been detected. At times the error has not amounted to 1° , yet it was evident that some mistake had been made. Then, too, in following out the graphical methods, a map or chart is prepared, which in crystallography, as doubtless also in other departments of science, is of importance.

In determining geographical distances, the stereographic projection possesses very great advantages. In physical geography, for instance, it is important to find the distance between two points on the earth's surface in order to determine the velocity of wind and ocean currents, seismic waves, tidal waves, etc. In navigation, at least in teaching it from an elementary standpoint, the distance between two points of given longitude and latitude must be determined. To indicate how easily this may be done, the problem of finding the distances of New York and Rio de Janeiro from Queenstown will be presented. The approximate longitudes and latitudes of the places, as taken from an atlas, are as follows:

Queenstown.	New York.	Rio de Janeiro.
$8^\circ 15' \text{ W.}$	$74^\circ 0' \text{ W.}$	$43^\circ 0' \text{ W.}$
$51^\circ 50' \text{ N.}$	$40^\circ 40' \text{ N.}$	$23^\circ 0' \text{ S.}$

In equatorial stereographic projection, figure 22, the meridian of Greenwich is drawn from the center to 0° . Queenstown is

located on the meridian $8^{\circ} 15' W.$, and by means of protractor No. I, at $51^{\circ} 50' N.$ In a similar manner, New York is located.

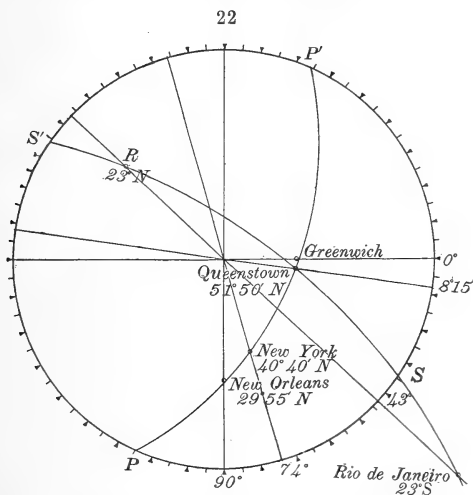

Rio de Janeiro being south of the equator falls beyond the engraved circle on the meridian $43^{\circ} W.$, but can be easily located by means of scale No. 3, figure 3. Instead of locating Rio de Janeiro, however, beyond the engraved circle, its antipodal point *R* can be located on the same meridian, at $23^{\circ} N.$ of the equator. Using now protractor No. IV, the points *P* and *P'*, and *S* and *S'* are located, where the great circles passing through Queenstown and New York, and Queenstown and Rio de Janeiro cut the equator; then using protractor No. II the distances are measured. From Queenstown to New York the distance, as plotted, was found to be $45^{\circ} 23'$, calculated $45^{\circ} 11'$. From Queenstown to *R* the distance as plotted was $99^{\circ} 20'$; hence to Rio de Janeiro is the supplement of this value, $80^{\circ} 40'$; while by calculation it is $80^{\circ} 47'$. The data for the calculations were the longitudes and latitudes as previously given.

An advantage is gained by using a meridian rather than an equatorial projection, since the method of measuring is simpler, and the plotting is done near the periphery of the divided circle, where the distances between the stereographically projected degrees are largest. Figure 23 illustrates this method. The divided circle represents the meridian passing through Queenstown, and a mark at $51^{\circ} 50'$ locates the place. On the stereographically projected equator, the intersections of the meridians of New York and Rio de Janeiro are plotted by means of the graduation on the base line of protractor No. I. The two meridians 74° and $43^{\circ} W$ of Greenwich are respec-

tively $65^{\circ} 45'$ and $34^{\circ} 45'$ West of the meridian of Queenstown. By taking the radii from scale No. 1, figure 3, the two meridians are quickly drawn. New York, being in latitude $40^{\circ} 40' N.$, is $49^{\circ} 20'$ south of the pole. Its position is determined by locating the point $40^{\circ} 40' N.$ on the central meridian, and constructing the small circle with radius $49^{\circ} 20'$ taken from scale No. 2, figure 3. In a similar manner, Rio de Janeiro is located. The figure also indicates another method of locat-

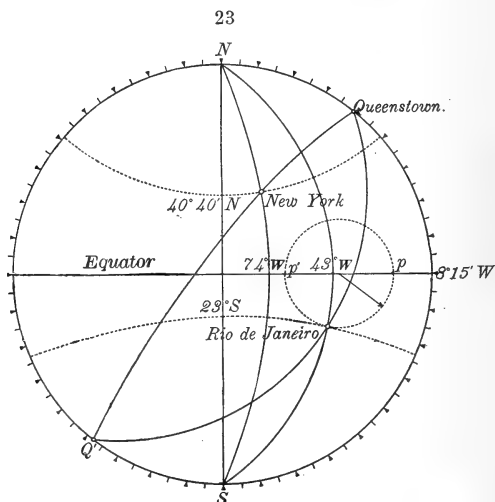

ing Rio de Janeiro. On the equator locate the points p and p' at 23° from the crossing of the meridian of Rio de Janeiro. The intersection of the meridian being $34^{\circ} 45'$ ($43^{\circ} - 8^{\circ} 15'$) from the divided circle, the points p and p' are respectively $11^{\circ} 45'$ and $57^{\circ} 45'$ from the divided circle. Now by finding the center and constructing the small circle, Rio de Janeiro is located. To measure the distances, match the zero point of protractor No. II with Queenstown, swing the protractor so that its center corresponds with that of the plate, and note the position of the points plotted. Thus plotted, the distances from Queenstown to New York and Rio de Janeiro were found to be respectively $45^{\circ} 15'$ and $80^{\circ} 52'$, calculated $45^{\circ} 11'$ and $80^{\circ} 47'$. Plotted in this way it is seldom that the error exceeds $6'$; the average error is less than $4'$. It is a decided advantage to be able to determine any distance by one reading of the protractor, rather than by two readings and a subtraction, as illustrated by figure 22.

It may be seen from the foregoing demonstrations that if there were maps of the northern and southern, and eastern and

western hemispheres accurately plotted in stereographic projection, and transparent protractors constructed on the same scale, such measurements could be made by simply shifting the protractors and noting the angles. Maps of this kind would be very serviceable, and the writer believes that they should and will be made. The most important continental features (promontories, mouths of rivers, lakes, etc.), the islands, and the principal ports and inland cities could be located with great accuracy on a map of 30^{cm} (nearly one foot) diameter, and it ought to be possible to measure distances between any two points within two or three minutes (two or three nautical miles) of the truth; while the maximum error ought not to exceed ten minutes. If there is an error of judgment in the foregoing statement, it favors greater, rather than less, exactness, for on the 14^{cm} circles a degree of accuracy can be obtained almost equal to that just expressed.

Without doubt geographers and physical geologists would find many uses for sheets printed from accurately engraved plates giving the meridians and parallels, in both equatorial and meridian stereographic projection, plates II and III. On such plates, points of given longitude and latitude could be quite accurately located (within half a degree), the outlines of continents sketched, wind and ocean currents noted, etc.; and, provided with protractor No. III, measurements sufficiently accurate for most purposes could be made in a very few minutes. The writer has not employed such sheets in crystallography,* but has had the plates prepared to conform with the protractors and scales described in this article, believing that they will prove very useful.

It is at times desired to shift a stereographic projection so as to bring some special point or pole to the center. By making use of scale No. 3, figure 3, this can be easily accomplished. Plate IV represents a projection thus shifted so as to bring longitude 75°, latitude 40° (practically the location of New York city), to the center. The north pole is shifted 50° from the center, and the equator is an arc of a great circle crossing the vertical diameter 50° from the divided circle. Cutting off scale No. 3, figure 3, from one of the engraved sheets, and matching it along the vertical diameter, the stereographically projected points 10°, 20°, etc., are laid off in both directions from the shifted north pole, and about the respective center points the parallels of latitude (small circles) are drawn. That parallel which is located by actual measurement exactly halfway between the stereographically projected north and south

* Impressions of an equatorial stereographic projection, essentially like plate II, have been recommended by Fedorow, especially for use with the two-circle or universal goniometer. *Zeitschr. für. Kryst.*, xxxii, p. 446, 1900.

poles (the parallel 40° South, plate IV) has an infinite radius, and appears as a straight line in the projection. Upon this straight line are located the centers of all the stereographically projected meridians, for they are all arcs of circles running through the north and south poles, hence having their centers on a line crossing the middle point of the N.S. diameter at 90° . The points of intersection of the meridians with the equator may be found by drawing an arc, with a radius like that of the equator, on an impression of protractor No. II, plate I. Then, by means of dividers, the points 5° , 15° , 25° , etc., from the 90° line of the protractor are transferred to the shifted equator. It took very little time to construct the parallels and meridians of plate IV, and, considering the size of the projection, they are accurately drawn. The outlines of the continents were sketched upon the chart by Mr. H. H. Robinson of Yale University.

Professor Andrew W. Phillips of Yale University has devised a machine consisting of jointed rods, by means of which the pole of any stereographic projection can be shifted to any desired position. Thus an equatorial projection, the easiest of all to make, can be transformed into a meridian projection, or into one like plate IV, having some desired point at the center. This machine was exhibited in 1884 before the British Association for the Advancement of Science, at their summer meeting in Montreal,* and is described by Professor Phillips in his geometry.†

Map Projection.—The method of projection almost universally employed by geographers for representing hemispherical surfaces is the so-called *Globular Projection*, invented in 1660 by the Italian Nicolosi.‡ In this method the equator is divided into equal parts, and the meridians are circular arcs uniting these points with the poles; the parallels are likewise circular arcs, dividing the extreme and central meridians into equal parts. Figure 24 shows the meridians and parallels in globular projection. Compare this figure with the stereographic projection of the meridians and parallels, plate III, and a marked difference is at once apparent. The stereographic projection is correct in every particular, the parallels intersect the meridians at right angles, as on a globe, and, as has been shown, distances and directions can be accurately measured and plotted on such a projection. In the globular representation, on the other hand, nothing is correct except the graduation of the outer circle and the directions of the two diameters; distances and directions can be neither measured nor plotted.

* Report of the British Association for the Advancement of Science, 1884, p. 649.

† Phillips and Fisher's Geometry, 1899, p. 510.

‡ Germain, *Traité de Projections des Cartes Géographiques*, p. 127, Paris, about 1865.

Strictly speaking, figure 24 is not a projection, for it does not correspond point for point with the surface of a sphere, according to some fixed law of projection. It is simply an arbitrary distribution of a series of curves. The only excuse for its continued use in map construction is that, having the distances on the equator and central meridian equally spaced, land and water areas are more uniformly distributed than in the stereographic

24

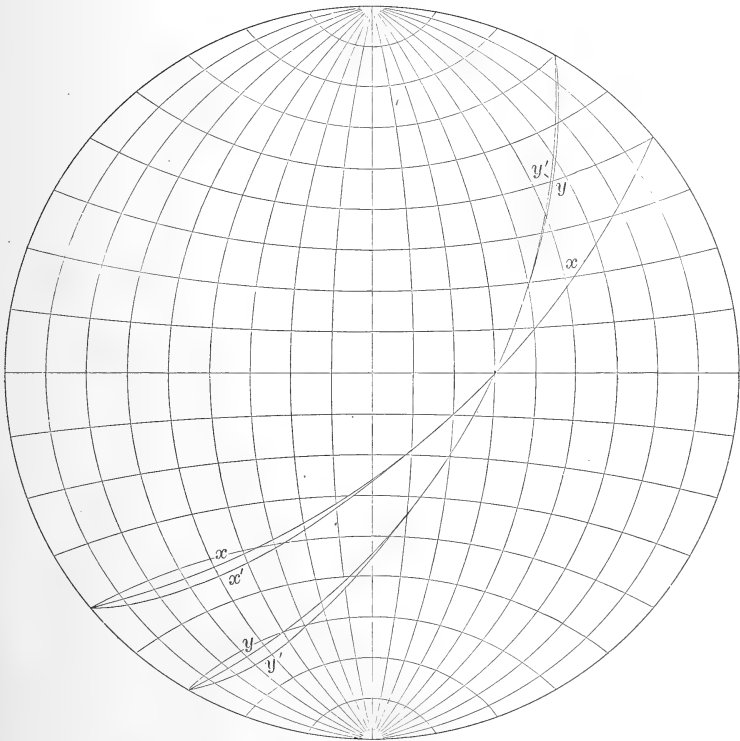

projection. In order to show still another defect of the globular representation, two circular arcs, x and y , have been drawn on figure 24, one running from 40° N. on the periphery to 60° W. on the equator, the other from 60° N. to 60° W. Circular arcs drawn from the same locations on plate III would represent stereographically projected great circles, agreeing in their intersections with the meridians and parallels point for point with corresponding great circles drawn on a sphere. Not so with the globular representation, however. The two great circles under consideration, if accurately plotted on the globular chart from their actual intersections with the meridians and parallels,

would appear not as circular arcs, but as the irregular curves x' and y' , figure 24, showing marked deviation from circular arcs in the lower left-hand portions of the chart.

It is impossible to represent the areal relations of a hemisphere upon a plane without sacrificing some features. In the stereographic projection, plates II and III, distances between the meridians and parallels become smaller as they approach the center. Distances and areas on stereographic maps must therefore be magnified in proportion as the distances between the meridians and parallels become smaller. The gradual contraction of areas, as the center of a stereographically projected hemisphere is approached, is not altogether a drawback, for it should be part of a person's education to understand that, in making a map on a flat surface, some contraction or magnification of areas must appear on certain portions of the map. Doubtless most geographical relations can be appreciated best by beginners by studying a sphere or globe. Serious difficulties, however, are encountered in making accurate drawings and measurements on a spherical surface; hence to be able to plot all the relations of a sphere easily, quickly, and accurately on a flat surface is a great advantage, an advantage, moreover, which the stereographic projection alone possesses.

It would seem as though the distorted and inaccurate globular representation, now universally employed by geographers, should give place to the accurate stereographic projection. It is safe to assume that few teachers in our academies and high-schools have exact ideas concerning the kinds of projection employed in map construction. By making use of comparatively simple wire models* it should be possible to give not alone to teachers, but to scholars of from twelve to sixteen years of age, a sufficient knowledge of the essential features of the stereographic projection to enable them to appreciate the meaning and significance of meridians and parallels as projected on a flat surface, plates II and III.

If scholars were supplied with stereographic charts, corresponding to plates II and III, and were taught to locate places from their longitudes and latitudes, the more skillful of them, at least, would soon be able to construct quite accurate maps, better than those now existing in our school geographies, and

* The writer has in mind models such as are used in teaching crystallography. Wire circles could be arranged and soldered so as to represent meridians, parallels, and arcs of circles in any desired position. It does not take many wire circles to give to such models the effect of a sphere. By running wires or threads from certain fixed points on the circles to the south pole, for example, the fundamental conception of the stereographic projection.—*the projection to a pole on the surface of a sphere*—can be demonstrated. Where the wires or threads intersect the plane of the equator, determine the position of the points in stereographic projection. Great and small circles could be thus projected, and if properly worked out with not too much detail, the models would be very effective.

ones which would be *correct* within certain limits, depending upon the size of the projection and the skill with which the drawing and plotting were done. Map-drawing is generally a feature of grammar-school education, and by making use of printed charts, showing stereographically projected meridians and parallels, it would be no more difficult to construct an accurate map than a mere sketch, and probably it would be easier. It would be at least more profitable and instructive.

Having demonstrated on a globe that the shortest distance between two points is along the arc of a great circle, the use of protractor No. IV, figure 14, could be explained, and by turning the protractor, the great circle passing through any two points could be easily and quickly found. It is probable that by making use of a suitable wire model, the principles underlying the construction of protractors II and III could be made clear. In any event, an intelligent person would soon learn to turn protractors II and III to the right position, and determine in degrees the distance between two stereographically projected points.

Students come to the universities with altogether too little knowledge of how to do things accurately, and the lack of proper training in this respect is a serious defect in their education. By applying to geography the mathematically correct principles of the stereographic projection, it would be possible to inculcate into pupils of high-school, possibly also of grammar-school, age, methods of absolute accuracy as pertaining to map construction. The essential features of the projection are so simple, that, if properly presented with the aid of a few models and diagrams, it should be possible to teach comparatively young pupils how to construct maps intelligently and to make geodetic measurements accurately. It seems to the writer that training of such a nature would be most beneficial, not alone because it is important to know how maps are constructed and geodetic measurements are made, but, in a broader sense, because of the advantages derived from that kind of training which teaches pupils how to do things and to do them correctly.

This opportunity will be taken to present a brief demonstration showing the advantages of the stereographic over the ordinary methods of map construction. In maps comprising small areas, it is possible to measure the distance between two points, in a straight line across the map, with considerable accuracy. Not so, however, for long, transcontinental distances, as such must be measured with reference to the curvature of the earth along arcs of great circles. Most persons have no means of determining the distance between distant points other than the very crude, and necessarily incorrect

method of applying a scale of miles in a straight-away direction across a map. For the sake of demonstration, the distance between New York, 74° W., $40^{\circ} 40'$ N., and New Orleans, $90^{\circ} 0'$ W., $29^{\circ} 55'$ N., was chosen. Making use of atlases, only those maps can be employed on which both New York and New Orleans appear on the same sheet, therefore maps of the whole United States must generally be used. On a number of such maps, varying in width from 14 to 26 inches, and accompanied in each case by a scale of miles, the following results were obtained: 1170, 1180, 1185, 1190, 1200, and 1210 statute miles. On all the maps, the position of the two places with reference to the meridians and parallels corresponded closely with the longitudes and latitudes as already given. By calculation from the longitudes and latitudes as given, the distance was found to be $16^{\circ} 52'$, or $1166\frac{1}{2}$ statute miles. By plotting in equatorial projection, and measuring with protractor No. II, the distance was found to be $16^{\circ} 53'$ (figure 22 shows both New York and New Orleans in equatorial projection). By plotting four different times in meridian projection, using the method shown in figure 23, page 124, the distance as measured by protractor No. II was found to be $16^{\circ} 53'$, $16^{\circ} 53'$, $16^{\circ} 53'$, and $16^{\circ} 58'$. It should be explained that in three cases (a zero point of the protractor being at New York) New Orleans fell just short of coincidence with the 17° line of the protractor; hence the position was recorded as $16^{\circ} 55'$. In one case it was on the 17° line. From these readings $2'$ were deducted to allow for the shrinkage of the celluloid protractor. It is in part accidental that four of these determinations, $16^{\circ} 53'$, came so close to the calculated value, $16^{\circ} 52'$; still it is seldom that an error of $6'$ is made in plotting and measuring on a meridian projection, and the average of measurements of a similar nature which the writer has made would be not over $4'$, probably not over $3'$, from the truth. Consider for a moment the discrepancies between measurements as made on ordinary maps and those made by means of the stereographic projection. On maps including the United States alone, and varying in width from 14 to 26 inches, the measurements ranged from 1170 to 1210 miles, a maximum error of 44 miles; while on a stereographic projection of 14 centimeters ($5\frac{1}{2}$ inches) diameter, comprising a whole hemisphere, the greatest error was less than seven miles, the average error being but two miles. To appreciate better the discrepancies of the two methods, compare the size of the whole North American continent, as shown on the stereographic map, plate IV, with an ordinary map of the United States. It seems to the writer that this example furnishes a strong argument for discarding the defective methods of map representation now in general use.

As pointed out on page 125 and shown in plate IV, it is an easy matter to shift a stereographic projection so as to bring any desired point to the center. Figure 25 shows the distribution of some of the meridians and parallels when the intersection of the 95th meridian and the 40th parallel is brought to the center of the stereographic projection. The point 95° W. 40° N. is about in the center of the United States. The map is not reduced,

25



but shows the actual size of the United States as it appears at the center of a stereographic projection, based upon a circle of 14^{cm} diameter. The distance from right to left across this map is 28^{mm} ($1\frac{1}{8}$ inches), and the distance from New York

26

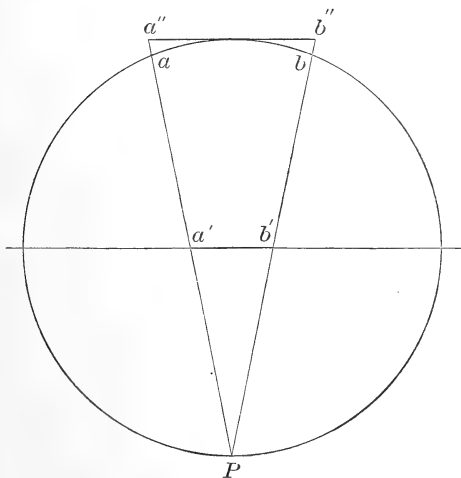

to New Orleans is $10\frac{1}{2}$ ^{mm}, but little over $\frac{3}{8}$ inch; yet in spite of the very small scale on which the map is made, and also of the fact that the United States is at the center of the hemisphere where it appears the smallest, measurements can be made with the stereographic protractors to within a fraction of a degree. For example, New York to New Orleans was measured by protractor No. II, after making a reduction for shrinkage, as $17^{\circ} 8'$, calculated $16^{\circ} 52'$, a difference of but $16'$, or about 18 statute miles.

There is but little distortion, due to the stereographic projection, provided a map does not cover an area larger than that of the United States. Measuring from right to left across the

center of the United States, figure 25, not from east to west along the 40th parallel, but on the arc of a great circle, the edges of the map are about 45° (one-eighth of a circumference) apart. An arc of 45° , $a b$, figure 26, appears in stereographic projection as a line $a' b'$. A stereographic projection, however, can be made on a tangent plane $a'' b''$, in which case the linear distance from a'' to b'' will be twice that of a' to b' , while the area on a tangent plane will be four times that of a plane passing through the center. As far as distortion is concerned, however, it makes no difference whether a map is made small on a central plane, or with four times the area on a tangent plane, the proportions of the two maps remain the same. Considering the radius of the circle, figure 26, as unity, the distance from a to b , 45° along the circumference, is 0.785, while from a'' to b'' it is 0.828, a difference of only 0.043. These figures indicate that the distortion resulting from the stereographic projection of a small portion of a sphere upon a plane, for example figure 25, can not be very great.

Figure 27 shows a stereographic protractor based upon a 14^{cm} circle, the same as that employed in making the map of the United States, figure 25, and sufficiently large to cover all portions of the map. The only great and small circles which

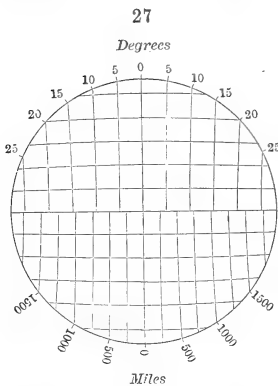

come into consideration are the ones near the center of protractors II and III, plate I and figure 13. The small circles on one half of the protractor indicate degrees, and on the other half statute miles. A semicircular protractor with the small circles indicating either degrees or miles would answer every purpose. Such a protractor would have to be centered on a map of the United States, corresponding to figure 25, at 95° W., 40° N.; that is, at the center of the projection. By turning the protractor, some great circle can be found running through any two points under consideration; and by noting the positions of the points with reference to the small circles, their distance apart may be determined, either in degrees or miles.

By increasing the width of the map of the United States, figure 25, sixteen times, an ordinary sized atlas sheet, eighteen inches in length, would result. In that case the projection would be based upon a fundamental circle of 224^{cm} (about $7\frac{1}{2}$ feet) diameter, and to plot the stereographically projected meridians and parallels on such a scale would present no difficulty. The

protractor also would have to be increased in like proportion. On such a scale the first degree of the protractor would be 9.8^{mm} (nearly a centimeter) from the center, and if the small circles of the protractor indicated tenths of a degree ($6'$), the graduation would be far coarser than that of protractor No. II, plate I. If the small circle graduation of the protractor indicated every fourth minute, the first line would be distant 0.652^{mm} from the center, while the first-degree line of protractor No. II, plate I, is 0.611^{mm} from the center. It will be at once evident to any one accustomed to reading scales, that, with divisions 0.65^{mm} apart, one quarter of the distance between such divisions may be easily estimated, and with care, perhaps, one eighth, which would be equivalent to half a mile on a map of corresponding scale. By making use of a dividing engine, it is possible to construct protractors of any size; and used in connection with carefully plotted maps, geodetic measurements can be made with almost any desired degree of accuracy.

For purposes of navigation of the North Atlantic, for example, it would seem that nothing could be simpler than a stereographic chart with 35° W., 45° N., at the center. On such a chart, 18 inches or more in diameter, all ports and lighthouses could be accurately located. If a navigator can determine his longitude and latitude correctly, which under favorable conditions he is supposed to do within a minute (nautical mile), all that remains to be done to find the distance from any desired point would be to locate his own position on the chart, shift a stereographic protractor so as to bring the two points on the same great circle, and note the position of the two points with reference to the small circles. The great circle, which it would not be necessary to draw upon the chart, would indicate the sailing direction. Compass bearings could be determined by means of an ordinary protractor, as indicated on page 19, figure 12. Calculations involving the use of tables and formulas would not be necessary. An 18-inch chart would probably be quite large enough for practical purposes. At all events, the errors in determining longitude and latitude would probably be as great as those resulting from locating the points on the chart and reading the protractor. The position of a ship from day to day being noted on a stereographic chart, the daily runs could be determined directly by means of a stereographic protractor. Without doubt, vessels have frequently been wrecked because of failure of the commanding officer to make his calculations correctly, but if ships were provided with suitable stereographic charts and protractors such accidents might be avoided. A navigator may make a mistake in locating his position, but, that having been correctly determined and located on a suitable chart, a stereographic protractor

would indicate not only the distance from any point of danger noted on the chart, but also the direction to any desired port. The possibilities of mistakes in calculation, other than those involved in determining the position of the vessel, would not have to be taken into consideration.

Still another method of projection which is in very general use is that of Mercator, invented in 1569.* In this, figure 28, the meridians appear as vertical straight lines equally spaced, and the parallels as horizontal lines so distributed that the

28

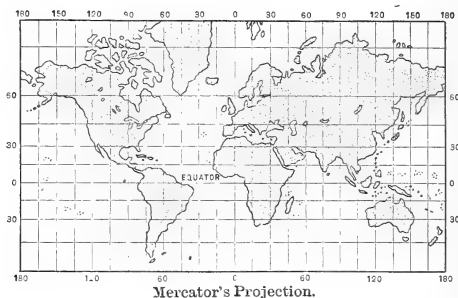

points of the compass preserve the same direction over all the map. In such a projection, areas are very much distorted, especially those near the poles, and distances can not be measured directly. Although the writer does not consider himself competent to pass judgment upon the relative merits of map projections as employed by navigators, he does see many advantages of the stereographic over all other kinds of projection.

It is interesting to note, for example, that the projection of Mercator, designed especially for use in navigation, does not give the navigator the information he most wishes to know, except in a few cases. A straight line drawn on the map from one point to another gives a possible sailing direction between the two points. If the direction is due north or south on any meridian, or east or west on the equator, the course is that of a great circle; hence the shortest possible. In all other cases, however, a course thus plotted as a straight line on the map, and sailed by compass without deviation from the direction indicated, will not correspond to the arc of a great circle; hence will not be the desired shortest possible route. Take as an illustration two ports on the same parallel, for example, Lisbon, $11^{\circ} 30' \text{ W.}, 38^{\circ} 30' \text{ N.}$, and the mouth of Delaware Bay, $75^{\circ} 0' \text{ W.}, 38^{\circ} 30' \text{ N.}$; how is a mariner to shape his course, provided that no account is taken of ocean currents? To one

* Germain, loc. cit., p. 205.

not accustomed to deal with spherical surfaces and their projections, it would seem, on looking at a map in Mercator's projection, that the course should be due west, and that an east wind would be most favorable. Steaming or sailing thus, however, one would be traveling along the arc of a small circle. In stereographic projection, figure 29, the small circle *S. C.*, crossing all

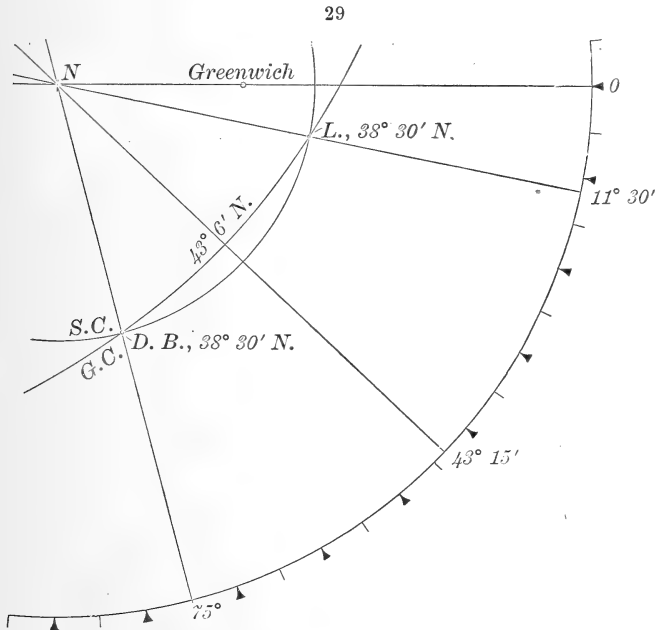

meridians at 90° , is drawn. The shortest course between Lisbon, *L.*, and Delaware Bay, *D. B.*, is, however, the great circle *G. C.*, passing as far north as $43^\circ 6'$. Sailing on this great circle, a vessel should be pointed $21^\circ 4'$ (plotted $20^\circ 57'$) north of west on leaving port, and should gradually change its course so as to cross the intermediate $43^\circ 15'$ meridian due west, and then proceed south of west. The distance traveled on the great circle is $48^\circ 38'$ (plotted $48^\circ 50'$), equal to 2,918 nautical miles, while the distance on the small circle is 2,982 nautical miles, a difference of 64 miles. It is not probable that a steady wind would be an east one swirling around the pole along the arc of a small circle, but, rather, it would be far more likely to travel along the arc of a great circle, crossing the different meridians at slightly different angles. It seems to the writer that these relations, as plotted in stereographic projection, must be far easier to comprehend than if plotted on any other projection.

A line plotted on a sphere so as to intersect all meridians at the same angle, and which appears as a straight line on a Mercator's projection, is known as a rhumb-line, and sailing with the same compass bearings from the place of departure to the place of destination is known as rhumb-sailing. A rhumb-line intersecting the meridians at an

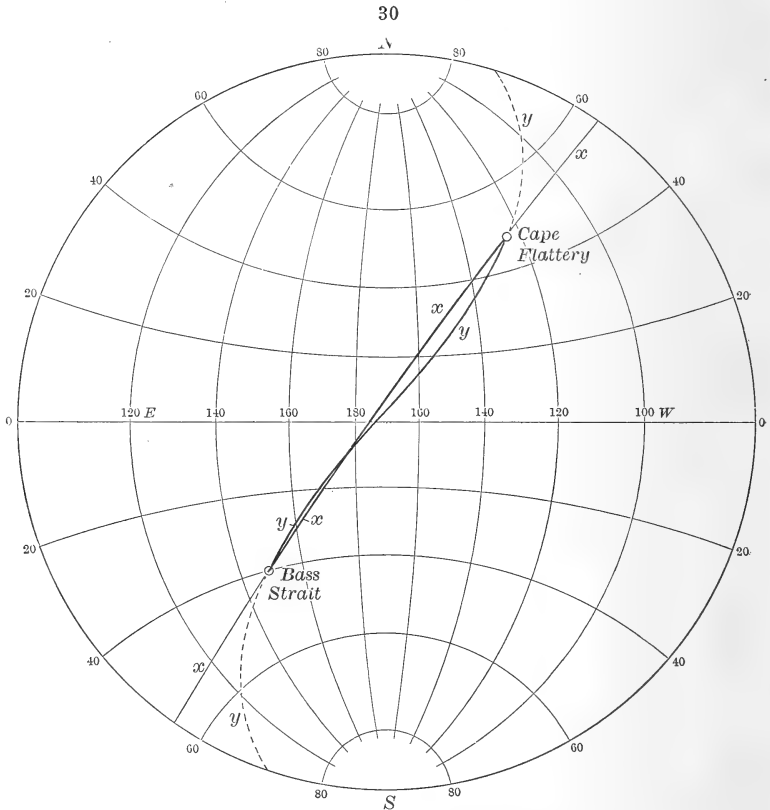

oblique angle (the condition which almost always comes into consideration) gives, when plotted on a sphere, a spiral curve with complex mathematical relations, known as a loxodromic curve. Figure 30 represents the meridians and parallels of a hemisphere in stereographic projection, and two possible sailing routes, from Cape Flattery, $124^{\circ} 45' W.$, $48^{\circ} 30' N.$, the extreme northwestern point of the State of Washington, to the entrance of Bass Strait, $148^{\circ} E.$, $40^{\circ} S.$, leading to Melbourne, South Australia. The shortest route is the great circle x , which, if followed, necessitates a slight change of compass

bearing, as one meridian after another is passed. The rhumb-course, which intersects all meridians at the same angle, hence maintains the same compass bearing ($41^{\circ} 20'$ West of South) throughout, is yy . It would be somewhat difficult to estimate the distance traveled in following the rhumb-course, but, judging from the figure, it would not be very much longer than that of the great circle. In regions near the equator the discrepancies between great-circle sailing and rhumb-sailing, both as regards distance and direction, would not be very great. As the polar regions are approached, however, discrepancies become greater. The rhumb-line from Cape Flattery to Bass Strait, figure 30, if continued toward the polar regions, as indicated by the dotted lines yy , deviates more and more from the great circle xx , and terminates eventually in two spirals, circling around the respective north and south poles, constantly nearing, yet, theoretically, never reaching them.

The problems presented by navigation are naturally complicated, and such factors as ocean currents and the probabilities of encountering favorable winds and weather during certain seasons of the year must be taken into consideration. Hence the route along which the *shortest and safest passage may be made* must be selected, rather than the shortest course. The main factor, however, in determining the shortest passage must be the shortest distance from point to point, which may be determined by a stereographic protractor giving great circles, figure 14. The direction of ocean currents and prevailing winds may be represented on a stereographic chart as well as on any other, and it must be a matter of judgment on the part of a navigator to shape his course so as to take advantage, as far as possible, of favorable and avoid unfavorable conditions.

Instruments needed for plotting Stereographic Projections.—For the most part, ordinary drafting instruments may be used. Pencils should be very hard and sharpened to a chisel-like edge, rather than to a point. For locating points very exactly, a fine needle, fastened in a suitable handle, is very useful. Although a puncture made by the needle point may be quite a fraction of a degree in diameter, its center may be regarded as indicating the exact location of any point; and in reading scales and protractors with reference to the puncture, the reading may be easily made from its center. An instrument which is not very generally used and is almost indispensable where great accuracy is required is a beam-compass. Ordinary dividers are not very satisfactory, and when used with an extension bar for constructing large circles the utmost pains must be taken in order to get good results.

For drawing very flat arcs the instrument shown one fourth natural size in figure 31, and designated as the *curved ruler*,

may be employed. The construction of the instrument is very simple. A strip of strong, straight-grained wood, $a a$, is bent by pressure applied in one direction at points $p p$, and in opposite direction at points $r r$. Pressure is applied by means of

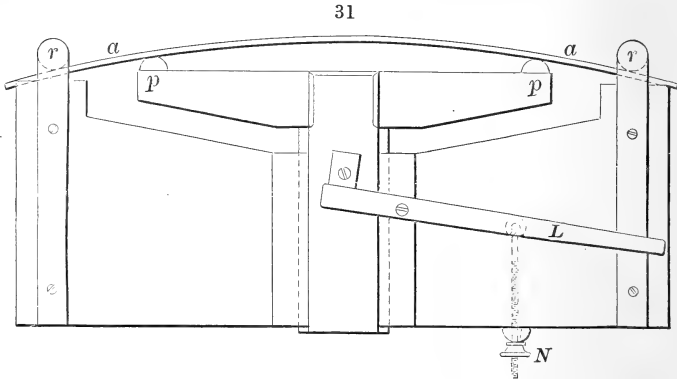

the lever L , which is held in any desired position by means of the nut N . The instrument may be quickly adjusted, and the curve between the points $a a$, even when the bending is considerable, corresponds exactly with the arc of a circle. It is no drawback that the wooden strip $a a$ becomes permanently bent when left for some time under pressure in the instrument. It is only necessary to withdraw the strip and reverse it, in order to draw a very flat arc, almost a straight line. A curved ruler, in principle like the one figured, but made of metal, was first described by Wulff.* Later Fedorow elaborated the instrument somewhat.† The writer has a metal instrument, made after the Fedorow model by Fuess of Steglitz, near Berlin, but has not found it as satisfactory as the one made of wood. This, however, is only because of certain minor defects. The metal strip in the Fuess instrument, corresponding to $a a$ of figure 31, is so high that it is difficult to use a pencil, and almost impossible to use a ruling-pen, in contact with it. Moreover, it is so highly polished that reflections from it are very annoying.

32

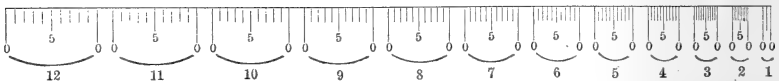

Figure 32, which may be designated as the *scale of decimal parts*, gives a series of spaces (millimeters as indicated by the

* Zeitschr. für Kryst., xxi, p. 253, 1892.

† Zeitschr. für Kryst., xxi, p. 618, 1893.

numbers), each divided into tenths, with the exception of the smallest space. It may be necessary to have spaces of millimeters and a half similarly subdivided, which must be determined by experience. For use, the *scale of decimal parts* will be printed on a card. It is to be used in locating points on charts corresponding to plates II and III, where the meridians and parallels are given for every tenth degree only. For example, to locate Queenstown, $8^{\circ} 15' W.$, $51^{\circ} 50' N.$, on plate II, its longitude is determined by the diam-

33

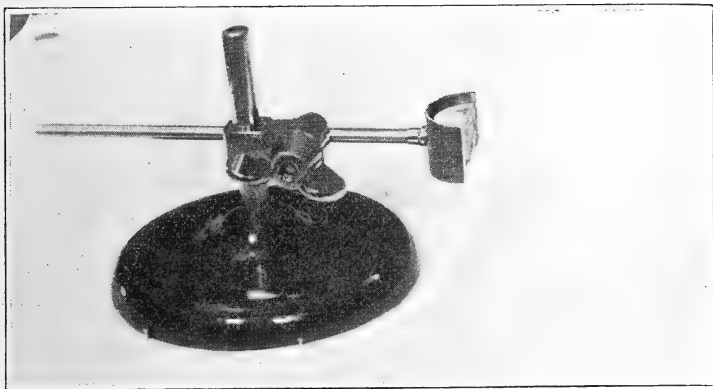

eter $8^{\circ} 15' W.$, and a short line on this diameter, drawn between the parallels 50° and $60^{\circ} N.$, locates the place in part. Making use of the *scale of decimal parts*, figure 32, one of the spaces (the 7^{mm} one) will approximate closely to the linear distance between the 50th and 60th parallels, and the location of Queenstown, nearly 2° north of 50° , can be determined with considerable accuracy. Similarly, on a meridian projection, plate III, the approximate location of any desired point between the ten-degree spaces of the meridians and parallels can be quickly ascertained.

Finally, in fixing locations exactly by means of a needle point, with reference either to the scale on the base line of protractor No. I, or to the scale of decimal parts, figure 32, it is convenient to use a lens of low magnifying power, for example, one of two-inch focus. A reading glass or pocket lens may be employed, but, still better, a lens cut in two and mounted on a stand, so that when placed upon the drawing or chart it will be at the proper distance above the paper and does not need to be held. By using only half a lens, the needle-point

holder can be held vertical, and, on a diameter or arc previously drawn, a puncture can be made which is centered very exactly with reference to the graduations of the scales and protractors. A cheap lens is trying to the eyes, as it distorts the lines of the scales, therefore persons making much use of the stereographic projection will find it greatly to their advantage to have a half-lens made from an aplanatic triplet. Figure 33 represents a half-lens made for the writer from a Hastings triplet, two-inch focus, by the Bausch and Lomb Company of Rochester, N. Y. This form of lens will doubtless be convenient for many kinds of work.

34

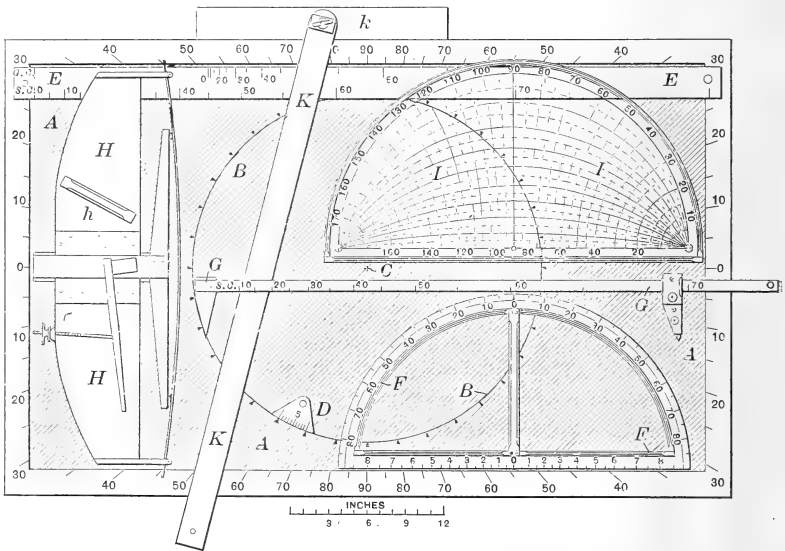

Black-board Demonstration of the Stereographic Projection.—In explaining the projection to an audience or class, it may be convenient to make use of a black-board, and with a few implements, demonstrations can be made very quickly and accurately.

Figure 34 represents the black-board equipment employed by the writer, in about one fourteenth its natural size. The black-board, *AAA*, is of slate, on which is scratched the circle *BB*, with center *C*. The circle has a radius of 35^{cm}, and its graduation gives every tenth degree. The circle and graduation marks need not be conspicuous, and they interfere in no way with the ordinary uses of the black-board. In case a permanent circle, scratched or painted on a black-board, is objectionable, a center point may be fixed, and degrees on any circle described about it may be taken from graduation marks

painted on the frame of the black-board, as shown. *D* is a scale, drawn on cardboard, which may be used for locating degrees between the ten-degree marks of the graduated circle. *E* is a ruler or straight-edge of light wood, on one side of which are the scales giving the radii of great circles, *G.C.* and vertical small circles, *S.C.*, as shown; while on the other side are the two scales corresponding to Nos. 3 and 4 of figure 3, page 6. For most operations a smaller ruler, which is not shown, is used. It is provided with the same scales as *E*. A semicircular protractor having the same radius as the circle is shown at *F*, with stereographically projected degree graduations upon its base line. A beam-compass is shown at *G*,* having one fixed arm ending in a metal point, and a sliding arm carrying a crayon. The sliding arm has two screw nuts, one for clamping the arm to the beam, the other for clamping the crayon. The beam may be graduated, the scale on one side giving the radii of vertical small circles, *S.C.*, as shown, while the scale giving the radii of great circles is on the other side. Another compass, exactly like the one shown, except having a shorter arm, is employed in most operations. A large curved ruler is shown at *H*, provided with a handle *h* for holding it in position against the black-board. A stereographic protractor, drawn with India ink on transparent celluloid, is shown at *I*. The face of the protractor is covered with a thin sheet of celluloid to protect the lines, and the two sheets are fastened by screws to a light semicircular frame of wood. *K* is a long, light blade of wood which may be clamped at any angle to the cross-piece *k* by means of a thumb-screw. With this instrument, lines of any desired inclination, taken from the graduation of the circle, may be drawn on any part of the black-board. Although the instrument is not needed for constructing stereographic projections, it has been included with the others in order to make the description of the black-board instruments complete. It is used for solving problems in crystallography by means of graphical methods which will be described in a later communication.

Although the black-board implements are graduated only to every fifth degree, quite accurate work can be done with them. For example, in solving the problems given on pages 115 to 120, the maximum error was 77', the average error 30'. In making such measurements as from Queenstown to New York or Rio

* A beam-compass of the form shown is an excellent instrument for black-board demonstrations, far superior to the black-board compasses ordinarily employed. If made with scales giving inches on one side of the beam and centimeters on the other, so that circles of any desired radius may be drawn, it would be a very useful instrument, not only in the school- or lecture-room, but in offices of architects and designers. Application has been made for a patent for this instrument.

de Janeiro, pages 123 and 124, results are often within a quarter of a degree of the truth, seldom more than half a degree out.

Conclusion.—Starting with the very simple idea of making a protractor with stereographically projected degrees upon its base line, one possibility after another has presented itself, involving, as stated at the outset, no new mathematical principles, but leading, as the writer believes, to very important results. The main features of this article are the development of the scales shown in figure 3, by means of which it is possible to make stereographic projections very quickly and accurately; and the discovery of the transparent stereographic protractors. The writer can not learn that any one has ever made use of such protractors, and accordingly has made application for patents to control their manufacture and sale. Up to the present time, protractors have been made to conform to a circle of 14^{cm} diameter only, but any demand for protractors and scales based on a larger circle can be easily satisfied. With accurately engraved stereographic plates and protractors, based on a circle of 12 or 18 inches diameter, for example, very accurate plotting and measuring could be done. Many have expressed surprise that on a circle of only 14^{cm} diameter, representing a whole hemisphere, such accurate measurements can be made as those cited in this article. It may be stated, however, that the method in itself is *absolutely exact*, and errors are wholly due to inability to work accurately on so small a scale as the one adopted, and with plates and protractors graduated to degrees only. Based on a circle of 14^{cm} diameter, a stereographically projected degree at the periphery and at the center is represented by distances of about 1.2 and 0.6^{mm}, respectively. Of these distances, one ought to be able to estimate about one tenth of the former and one quarter of the latter; hence, a point carefully located near the periphery ought not to be more than one tenth of a space, or six minutes, out of the way, and the chances are that it will be correct within three minutes, while near the center a point ought to be located at least within a quarter of a degree and probably within ten minutes of the truth. The possibilities as thus stated correspond closely with actual tests of the method. If the plotting is of a simple nature and made near the periphery, and especially if the measurement can be made with one reading of the protractor, the result is rarely more than 6' and averages less than 4' from the truth. If, on the other hand, the plotting is done near the center of the circle, and measurements necessitate two readings of the protractor, errors amounting to a quarter of a degree must be expected, but the average will be less than 10' from the truth.

The stereographic projection is admirably adapted for representing all kinds of relations pertaining to a sphere. It is very difficult, almost impossible, to plot and measure accurately on a spherical surface, and a sphere which may be used for such purposes is rarely at hand; hence, to be able to plot and measure accurately on a flat surface is a great advantage. The writer hopes, therefore, that as a result of this article the stereographic projection will become more widely known and appreciated, and that it will prove more generally useful. Crystallographers have employed the stereographic projection not only for indicating the distribution of crystal faces, but especially for showing zonal (great circle) relations and the spherical triangles which when solved determine the interfacial angles. The stereographic protractors will now give to the projection a new and far more important significance. Crystal forms being plotted according to some fixed scale, desired angles may be measured with sufficient accuracy for most purposes by the protractors. Protractor No. IV, page 22, will indicate zonal relations; and the solution of many other problems follow, which will form the basis of a later communication.

The application of the stereographic projection to astronomical problems are very numerous, and doubtless some astronomers will find their work simplified by using scales and protractors similar to the ones described in this article.

It would seem as though no course in spherical trigonometry could be quite complete without reference to the possibilities which the stereographic projection offers for the solution of all the problems presented.

Before closing this communication the writer takes pleasure in calling attention to a recent article by Professor E. von Fedorow of Petrowsko-Rasumowskoje, near Moscow, on a "*Universalgoniometer mit mehr als zwei Drehachsen und genaue graphische Rechnung.*"* In this communication, Professor Fedorow describes a modification of the two-circle goniometer, by means of which spherical triangles may be solved accurately by purely mechanical methods. This is accomplished by having two reflecting surfaces which may be set at any angle (*künstlicher Krystall*), and which take the place of a crystal on the instrument. By obtaining appropriate reflections from the surfaces, which necessitates the turning of certain circles, the problems are solved, the angles being read from verniers accompanying the graduations of the circles. Although it is shown that the instrument is capable of giving exact results, the applications of the Fedorow method of solv-

* Zeitschr. für Kryst., xxxii, p. 464, 1890.

ing triangles will probably be limited, since an expensive instrument must be procured, which not only must be kept in perfect adjustment, but can be used only by persons who thoroughly understand the workings of its several parts. Then, too, the instrument does not give a map or chart, which is such an important feature of the stereographic projection.

Although it is not customary for the writer of a scientific article to advertise, there are many who may wish to apply stereographic methods to the solution of problems in which they are especially interested, and therefore will find it convenient to make use of the printed sheets, scales, and protractors described herewith. Accordingly arrangements have been made to keep a supply of the necessary articles in stock, and, upon application either to the writer or to E. L. Washburn & Co. of New Haven, a price list will be sent.

If the method fulfills the writer's expectations, there will be in time a demand for scales and protractors of larger size and finer graduation, based, for example, on circles of 12 or 18 inches diameter. Moreover, with the experience already gained, there ought to be no serious difficulty in making them very accurately.

Sheffield Laboratory of Mineralogy and Petrography,
Yale University, New Haven, Conn., December, 1900.

A

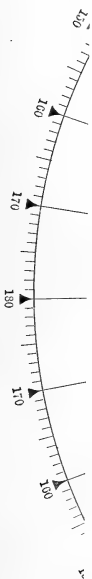



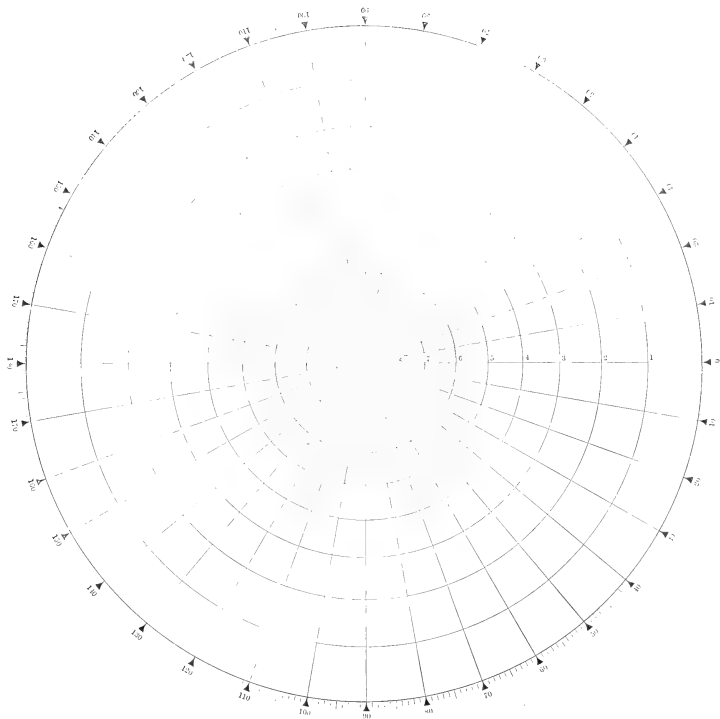

MERIDIANS AND PARALLELS IN STEREOGRAPHIC PROJECTION. EQUATORIAL PROJECTION.

Printed from the original engine-divided plate.

ing
ins
pe
the
Th
is

art
ste
the
ve
tor
ma
up
Co

in
fin
inc
the
acc
S





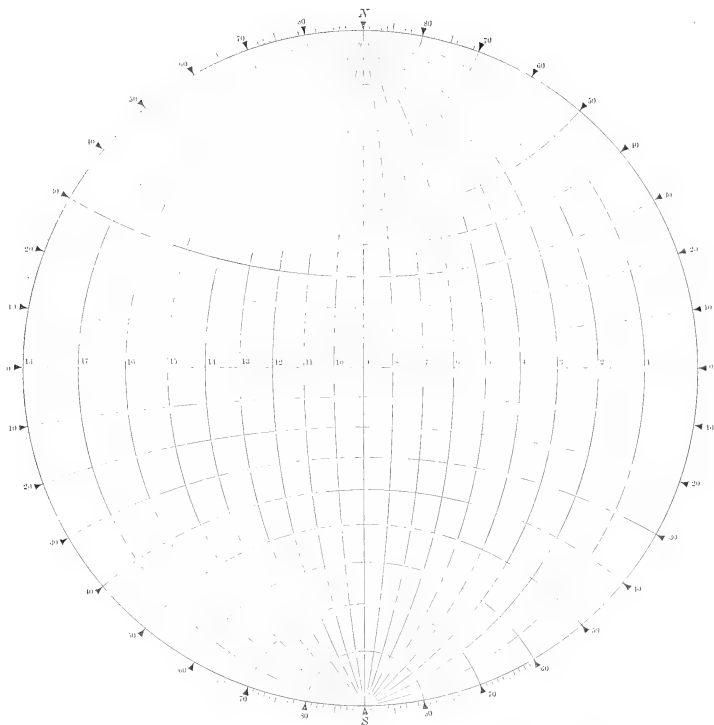

MERIDIANS AND PARALLELS IN STEREOGRAPHIC PROJECTION. MERIDIAN PROJECTION.

Printed from the original engine-divided plate.

1

i
i
F
t
l
i

e
s
t
v
t
r
l
(

i
f
i
f
:



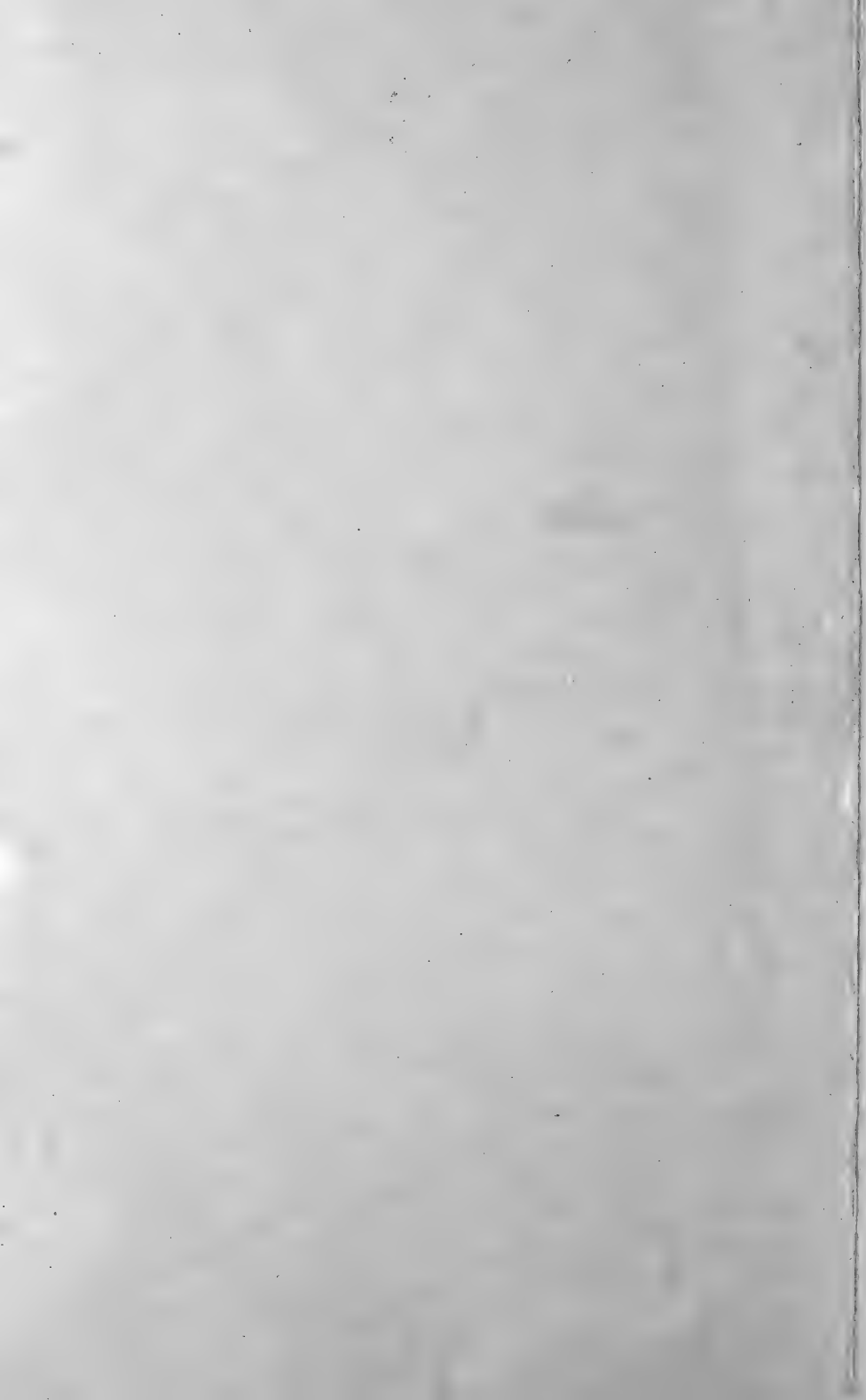



HEMISPHERE IN STEREOGRAPHIC PROJECTION,

With 75° W. 40° N. at the center.



ART. X.—*On the Melting Point of Gold*; by LUDWIG
HOLBORN and ARTHUR L. DAY.

[Communication from the *Physikalisch-Technische Reichsanstalt*, Charlottenburg, Germany.]

IN connection with the measurement of high temperatures with the gas thermometer,* the melting points of various metals lying between the temperatures 300° and 1100° were determined. The two methods employed were distinguished by the names "Wire Method" and "Crucible Method." The wire method consisted in inserting into the hot junction of the thermo-element about 1^{cm} of the wire whose melting point was to be determined, and observing the E.M.F. at the moment of melting and consequent interruption of the circuit; the crucible method, on the other hand, involved the introduction of a thermo-element properly protected by porcelain tubes into a comparatively large mass of the metal. The melting point of gold was determined at that time by the wire method only.

On account of the special importance which has been attached to the melting point of gold for comparing the temperature scales of various observers, it seemed to us advisable to make a further determination of this melting point by the crucible method as well, and at the same time to investigate whether the surrounding atmosphere exerts any influence on the melting temperature.

For this experiment some 450 gr. of pure gold were used, the purity being vouched for by the *Gold- und Silber-Scheidanstalt* at Frankfort-on-Main, where it was obtained. For the sake of certainty, however, a sample weighing 2 gr. was also analyzed in the chemical laboratory of the Reichsanstalt, but no impurities were found.

The gold was melted in the same oven which was described in the former paper, and measured with the same thermo-element which had served for the observations by the wire method.

Preliminary trials made with a smaller quantity of the metal (350 gr.) in a thin porcelain crucible yielded ill-defined "time curves" on account of the small latent heat of fusion, and also a difference between the melting and solidifying temperatures amounting to as much as 4°. Afterward, using 450 grams of gold and placing the light crucible in a larger one lined with asbestos, the distribution of heat was more even and excellent results were obtained. Crucibles of mixed graphite and clay with walls 5^{mm} in thickness also yielded satisfactory results, in fact we afterwards restricted ourselves to these

* Ludwig Holborn and Arthur L. Day, this Journal [4], vol. x, p. 171, 1900.

crucibles entirely, using old ones from which the graphite had been burned away where the reducing action was not needed.

The gold was melted under two different conditions, either in the reducing atmosphere of a graphite crucible, carbonic acid gas being also sometimes introduced, or in a double porcelain or thick clay crucible (graphite and clay from which the graphite had been burned away), in the presence of atmospheric air and later in an atmosphere of oxygen. The gas was introduced into the molten metal through a thin porcelain tube, as described in the experiments with silver (previous paper *loc. cit.*). Under these two conditions, both melting and solidifying points were observed.

TABLE I.

Date.	<i>i</i>	<i>t</i>		Mean.
		MV	Degrees.	
<i>Graphite Crucible.</i>				
June 21 -----	8.0	F	10194	1063.3
	9.2	M	10197	1063.6
	7.5	F	10194	1063.3
	8.8	M	10197	1063.6
July 9 -----	6.8	F	10197	1063.6
	8.3	M	10196	1063.5
	6.8	F	10197	1063.6
	8.2	M	10195	1063.4
<i>Graphite Crucible. Atmosphere of CO₂.</i>				
July 11 -----	7.2	F	10198	1063.6
	8.5	M	10198	1063.6
	7.0	F	10196	1063.5
	8.2	M	10199	1063.7
	6.8	F	10194	1063.3
	7.9	M	10196	1063.5
<i>Double Porcelain Crucible.</i>				
June 27 -----	8.0	F	10190	1063.0
	9.0	M	10198	1063.6
	7.5	F	10188	1062.8
	9.5	M	10197	1063.6
<i>Double Porcelain (or Clay) Crucible. Oxygen Atmosphere.</i>				
June 29 -----	7.3	F	10200	1063.8
	8.7	M	10199	1063.7
	7.0	F	10192	1063.1
	8.5	M	10199	1063.7
July 12 -----	6.7	F	10189	1062.9
	7.8	M	10195	1063.4
	6.5	F	10193	1063.2
July 13 -----	6.2	F	10198	1063.6
	7.5	M	10203	1064.1

Table I contains the temperature t (in microvolts and degrees) of the observed solidifying points F and melting points M . Under i is contained the number of amperes carried by the oven coil during the observations.

The various values of t show no systematic differences and the final mean is 1063.5° .

The forms of the time-curves, some of which are given in Table II, vary somewhat under the different conditions; the measurements in the oxygen atmosphere being especially conspicuous in this particular.

TABLE II.
"Time-Curves" (MV).

Min.	Gold in Graphite.		Gold in Graphite, Atmosphere of CO ₂ .		Gold Atmosphere of O.		Copper in Air.
	F	M	F	M	F	M	F
1	10331	10084	10402	10117	10366	10027	10590
2	10261	10150	10346	10166	10276	10074	10470
3	10209	10190	10298	10192	10223	10101	10352
4	10207	10194	10246	10195	10205	10144	10281
5	10203	10195	10200	10197	10201	10170	10217
6	10200	10195	10199	10194	10199	10198	10204
7	10199	10195	10199	10194	10199	10254	10212
8	10198	10195	10199	10194	10198	10238	10212
9	10197	10197	10198	10194	10196	10222	10212
10	10197	10199	10198	10196	10193	10205	10212
11	10197	10203	10198	10196	10194	10202	10212
12	10196	10212	10198	10197	10193	10201	10212
13	10196	10222	10198	10198	10194	10202	10212
14	10195	10231	10198	10199	10192	10203	10212
15	10194	10240	10197	10200	10191	10203	10212
16	10192	10248	10198	10201	10189	10203	10212
17	10188	10257	10197	10202	10186	10208	10211
18	10178	10272	10197	10205	10184	10216	10210
19	10070	10400	10197	10206	10184	10212	10208
20	9995	-----	10196	10205	10183	10222	10204
21	-----	-----	10196	10209	10174	10230	10195
22	-----	-----	10195	10204	10159	10360	10176
23	-----	-----	10195	10202	10065	-----	10027
24	-----	-----	10194	10214	-----	-----	-----
25	-----	-----	10192	10296	-----	-----	-----
26	-----	-----	10190	10400	-----	-----	-----
27	-----	-----	10186	-----	-----	-----	-----
28	-----	-----	10177	-----	-----	-----	-----
29	-----	-----	10083	-----	-----	-----	-----

The stationary temperature characteristic of the change of state is less well-defined in this case, the temperature in observations of the melting point often rising uninterruptedly to a

point somewhat above the melting point and coming back to it again afterward. The stirring produced by the gas bubbling through the molten metal is not the cause of this phenomenon, for the cases where carbonic acid was introduced under like conditions do not show it.

Furthermore, where the oxygen atmosphere was introduced the time-curves are always irregular and often even with ordinary air. This suggests the possibility that in these cases the melting metal takes on some oxygen. The effect of this irregularity upon the melting temperature, however, is small and scarcely exceeds the errors of observation.

From the same gold which had served for the measurements in the crucible, several grams were afterward drawn out into thin wire 0.25^{mm} in diameter, and used for a series of control observations by the wire method which it would be so desirable to be able to use in the case of gold. The same thermo-element was used for these also, and great care was taken that the two wires of the element enclosing the short gold wire be as free from strain as possible to avoid rupturing the gold before its proper melting point.

Five observations yielded the following values for the melting temperature:

Sept. 26.	10206 <i>MV</i>	1064.3°
	10197	1063.6
	10203	1064.1
	10199	1063.7
	10198	1063.6

The mean value, 1063.9°, differs only 0.4° from that obtained by the crucible method and only 0.1° from the earlier results obtained under the same conditions (see former paper, p. 190) in which other gold was used.

For the calibration of thermo-elements then, the determination of the melting point of gold by the wire method is perfectly trustworthy, and only about 0.03 gr. of gold are necessary for the determination.

If for any reason, however, the crucible method be preferred, the neighboring melting point of copper in air is well adapted for calibrations. Our determination of it was 1064.9. This point, aside from the diminished expense, is more convenient to determine than the gold-melting point by the crucible method, on account of the greater latent heat of copper.

Table II contains a time-curve for comparison with the gold, which was observed on Oct. 1 with 370 gr. of copper in a thin porcelain crucible. The current strength *i* in the heating coil amounted to 5.2 amp., and was smaller than in any experiment made with gold.

Charlottenburg, November, 1900.

ART. XI.—*On some new mineral occurrences in Canada;*
by G. CHR. HOFFMANN, of the Geological Survey of Canada.

[Communicated by permission of the Director.]

1. *Lepidolite.*

This species has been found to be a constituent of a coarse granite vein, of very considerable width, on the twenty-fifth lot of the seventh range of the township of Wakefield, Ottawa County, in the province of Quebec. The minerals composing this vein consist of white and light smoky-brown to brownish-black quartz, pinkish and light to dark verdigris-green microcline, a grayish albite having a fine bluish opalescence, and the mica in question, together with some aggregations of light purplish crystals of fluorite, and fine crystals of black and green tourmaline. The mica occurs in broad foliations having a rough, distorted hexagonal contour, and which in some instances have been found to measure fourteen by twenty-eight inches or more across. It has a pearly luster. In thin laminae it is transparent and colorless; in combinations of several laminae it exhibits, on a white surface, a fine, light purplish color; and in layers of about half an inch in thickness it has, by reflected light, a rich purplish brown color. Before the blowpipe, it fuses easily and with much intumescence to a light yellowish-brown glass, simultaneously coloring the flame intense carmine-red. Its specific gravity, employing the air-pump, at 15.5° C., was found by Mr. R. A. A. Johnston to be 2.858, and its analysis afforded him the following results:

Silica	47.89
Alumina	21.16
Ferric oxide.....	2.52
Manganous oxide.....	4.19
Potassa	10.73
Lithia	5.44
Soda	1.34
Magnesia.....	0.36
Water (direct estimation).....	1.90
Fluorine	7.41
	<hr/>
	102.94
Less oxygen, equivalent to fluorine.....	3.12
	<hr/>
	99.82

2. *Newberyite and Struvite.*

A material corresponding in composition to a mixture of these two minerals has recently been obtained from part-

ings resulting from the drying up of the soft material of the concentric rings of interglobular spaces in the ivory of the tusk of a mammoth which was found at a depth of some fifteen feet in a surface bed of dark frozen swamp-muck overlying stream-gravels on Quartz Creek, a tributary of Indian River which flows into the Yukon some twenty miles south of Dawson City, Yukon district, in the Northwest Territory.

The material occurred in the spaces in question in the form of readily removable plates of from one to two millimeters in thickness, which were at first colorless and transparent, but, on exposure to the air, became white and lost their transparency. In the closed tube it gives off water and ammonia and becomes opaque. When heated before the blowpipe it imparts a green color to the inner flame, and fuses at about 3 to a white enamel which, when moistened with a solution of cobalt nitrate and reheated, assumes a beautiful pink color. It is slightly soluble in water, and readily and completely so in cold, dilute hydrochloric, nitric or sulphuric acid.

Its analysis afforded Mr. R. A. A. Johnston the following results:

Phosphorus pentoxide	38.53
Magnesia	21.93
Ammonia	1.94
Water, by difference	37.18
Carbon dioxide	0.42
	100.00

These figures afford a ratio closely agreeing with the following formula:



3. *Schorlomite.*

A mineral which, as the result of an examination by Mr. F. G. Wait, proves to be this species, has been met with, in masses of considerable size, as an accessory constituent of the nepheline-syenite rocks of Ice River, a tributary of the Beaver-foot which flows into the Kicking Horse River, in the Rocky Mountains, province of British Columbia.

It is massive, without cleavage; the color is velvet-black, here and there tarnished blue, and occasionally with pavonine tints; that of the streak, hair-brown; the luster is vitreous; it is brittle; the fracture is irregular, occasionally subconchoidal; it is opaque; fuses quietly at 3 to a black enamel; has a hardness of 6.5, and a specific gravity, at 15.5° C., of 3.802. Its analysis afforded:

Silica	25·77
Titanic oxide	19·95
Alumina	3·21
Ferric oxide	9·69
Ferrous oxide	8·01
Manganous oxide	0·76
Lime	31·76
Magnesia	1·22
	100·37

These figures do not afford a rational formula. If, however, it be assumed that the iron represented as being present in the ferrous condition, does not exist in the mineral as such (as would appear to be justified by the fact that a very carefully conducted qualitative examination failed to afford more than the faintest reaction for ferrous iron), but that it resulted from an interaction between titanium and iron sesquioxides during the process of solution of the mineral (the titanous oxide being converted into titanic oxide at the expense of a portion of the oxygen of the ferric oxide, with simultaneous formation of ferrous oxide), and the above analysis be recalculated in accordance with this view, we obtain for the composition of the mineral:

Silica	25·77
Titanic oxide	10·83
Alumina	3·21
Ferric oxide	18·59
Titanous oxide	8·23
Manganous oxide	0·76
Lime	31·76
Magnesia	1·22
	100·37

which figures afford a formula closely analogous to that required for garnet, and according with that now generally accepted for schorlomite.

4. *Danalite.*

A few crystals of what has been identified by Mr. R. A. Johnston as the somewhat rare mineral danalite, have been observed by him scattered through the feldspar of a vein-stone composed of orthoclase, spodumene, and quartz, which was found by Mr. A. P. Low, cutting syenite, on Walrus Island, one of a group of islands lying off Paint Hill, east coast of James Bay, Ungava district, Northeast Territory.

The crystals are mostly minute, seldom exceeding a millimeter in diameter; one, however, was found,—and that the

only one of any appreciable dimensions in some twenty pounds of the rock, which measures fifteen millimeters across. It is a contact twin of two tetrahedrons, and on some of the faces is triangularly marked by successions of crystal growth. On some of the more minute crystals the rhombic dodecahedral plane—which is striated in the direction of the longer diagonal, is largely developed, sometimes obscuring the tetrahedral plane.

It has a faint yellowish orange-gray (faint yellowish-brown) color; is translucent; has a resinous luster; affords a yellowish white streak; is brittle, and breaks with a subconchoidal fracture. The hardness is 6, and the specific gravity, at 15.5° C., 3.25. Before the blowpipe, it fuses at about 5 to a black enamel. With soda on charcoal, it gives a slight coating of zinc oxide. It is perfectly decomposed by hydrochloric acid, with evolution of hydrogen sulphide and separation of gelatinous silica.

5. *Spodumene.*

This species has been identified by Mr. R. A. A. Johnston as being a prominent constituent of a micaless orthoclastic, granitic vein-stone found, by Mr. A. P. Low, in 1899 cutting syenite, on Walrus Island, one of a group of islands lying off Paint Hill, east coast of James Bay, Ungava district, Northeast Territory.

The mineral occurs in more or less well-individualized grayish green subtranslucent prisms, some of which measure more than ten centimeters in length and from eight to ten millimeters in diameter. It has one well-developed prismatic cleavage, the luster of which is pearly, while that of the cross-fracture, which is an uneven one, is vitreous. The hardness is nearly 7. Before the blowpipe, it swells up and fuses at about 4 to a white glass, imparting at the same time a bright purplish red color to the flame. The finely powdered mineral is not acted on by hydrochloric acid.

6. *Uranophane.*

A mineral which, on examination by Mr. R. A. A. Johnston, proved to be, as anticipated by the writer, uranophane, has been found, associated with gummite, uraninite, black tourmaline, white, light gray, pale olive-green and bluish green apatite, spessartite, monazite, and green and purple fluorite, in a coarse pegmatite vein—composed of white and light to dark smoky-brown quartz, microcline, albite and muscovite, which traverses a gray garnetiferous gneiss on the thirty-first lot of the first range of the township of Villeneuve, Ottawa County, in the province of Quebec.

The mineral which, in this instance, is evidently an alteration-product of gummite, occurs in small bright lemon-yellow fibrous masses, sometimes in immediate contact with the gummite found coating the uraninite or, per se, embedded in the albite immediately surrounding the tourmaline and often invading the latter. In the closed tube it blackens and gives off water. Before the blowpipe, it affords, with salt of phosphorus, in the oxidizing flame, a yellowish green bead, which, on reheating in the reducing flame, assumes a fine green color. Warm hydrochloric acid decomposes it, with separation of flocculent silica.

ART. XII.—*On the Spectrum of the more Volatile Gases of Atmospheric Air, which are not Condensed at the Temperature of Liquid Hydrogen.** Preliminary notice by Professor S. D. LIVEING, M.A., D.Sc., Professor of Chemistry University of Cambridge, and Professor DEWAR, M.A., LL.D., Fullerian Professor of Chemistry, Royal Institution, London.

[Read before the Royal Society of London Dec. 13, 1900.]

IN August last some tubes were filled at low pressure by an improved process with the more volatile gases of the atmosphere. The air was liquefied directly from that above the roof of the Royal Institution by contact at atmospheric pressure with the walls of a vessel cooled below -200° C. When about 200^{cc} of liquid had condensed, communication with the outer air was closed by a stop-cock. Subsequently, communication was opened, through another stop-cock, with a second vessel cooled by immersion in liquid hydrogen, and a part of the liquid from the first vessel, maintained at -210° , was allowed to distil into the second still colder vessel. When about 10^{cc} had condensed in the solid form in the second vessel, communication with the first vessel was cut off, and a manometer showed a pressure of gas of about 10 to 15^{mm} of mercury.

This mixture of gases was passed into tubes previously exhausted by a mercury pump, but before reaching the tubes it had to pass through a U-tube immersed in liquid hydrogen so as to condense less volatile gases, such as argon, nitrogen, oxygen, or carbonic oxide, which might be carried along by them. Previous trials with tubes filled in the same way, except that the U-tube in liquid hydrogen was omitted, showed that these tubes contained traces of nitrogen, argon, and compounds of carbon. The tubes filled with gas which had passed through the U-tube showed on sparking no spectrum of any of these last-mentioned gases, but showed the spectra of hydrogen, helium, and neon brilliantly, as well as a great many less brilliant rays of unknown origin. In addition, they showed at first the brightest rays of mercury, derived, no doubt, from the mercury pump by which they had been exhausted before the admission of the gases from the liquefied air. After some sparking the mercury rays disappeared, probably in consequence of absorption of the mercury by the electrodes, which were of aluminium.

In one experiment the mixture of gases in the second vessel into which a fraction of the liquefied air was distilled as above

* From an advance proof received from the authors.

described,—(the U-tube in liquid by Noyes having been dispensed with) was pumped out and examined. This mixture was found to contain 43 per cent of hydrogen, 6 per cent of oxygen, and 51 per cent of other gases—nitrogen, argon, neon, helium, etc.—and it was explosive when mixed with more oxygen. This shows conclusively that hydrogen in sensible proportion exists in the earth's atmosphere, and if the earth cannot retain hydrogen or originate it, then there must be a continued accession of hydrogen to the atmosphere (from interplanetary space), and we can hardly resist the conclusion that a similar interchange of other gases also must take place. The tubes containing the residue of atmospheric gases uncondensed at the temperature of liquid hydrogen we have examined spectroscopically.

On passing electric discharges through them, without any condenser in the circuit, they glow with a bright orange light, not only in the capillary part, but also at the poles, and at the negative pole in particular. The spectroscope shows that this light consists in the visible part of the spectrum chiefly of a succession of strong rays in the red, orange, and yellow, attributed to hydrogen, helium, and neon. Besides these, a vast number of rays, generally less brilliant, are distributed through the whole length of the visible spectrum. They are obscured in the spectrum of the capillary part of the tube by the greater strength of the second spectrum of hydrogen, but are easily seen in the spectrum of the negative pole, which does not include the second spectrum of hydrogen, or only faint traces of it. Putting a Leyden jar in the circuit, while it more or less completely obliterates the second spectrum of hydrogen, also has a similar effect on the greater part of these other rays of, as yet, unknown origin. The violet and ultra-violet part of the spectrum seems to rival in strength that of the red and yellow rays, if we may judge of it by the intensity of its impressions on photographic plates. We were surprised to find how vivid these impressions are up to a wave-length 314, notwithstanding the opacity of glass for rays in that part of the spectrum. The photographs were taken with a quartz-calcite train, but the rays had to pass through the glass of the tube containing the gases.

We have made approximate measurements of the wave-lengths of all the rays which are sufficiently strong to be seen easily or photographed with an exposure of thirty minutes, and give a list of them below. These wave-lengths are computed to Rowland's scale, and were deduced from the deviations produced by two prisms of white flint glass for the visible, and of calcite for the invisible, rays. The wave-lengths assigned to the helium lines are those given by Runge and Paschen, and

some of these lines were used as lines of reference. In general, the iron spark spectrum was the standard of reference.

The tubes when first examined showed the lines of the first spectrum of hydrogen vividly, and the earlier photographs of the spectrum of the negative pole contained not only the violet lines of hydrogen, but also the ultra-violet series as far up as λ 337. In order to get impressions of the fainter rays, exposures of half an hour or more were required, and a succession of photographs had to be taken so as to get different sections of the spectrum into the middle of the field, where measurement of the deviations would not be impeded by the double refraction of the calc spar. As the light of the negative pole only was required, the electric discharge was made continuously in one direction only, with the result that the hydrogen lines grow fainter in each successive photograph, and soon disappeared altogether. Along with the ultra-violet rays, the less refrangible rays of hydrogen also disappeared, so that no trace of the C or F line could be seen, nor yet of the second spectrum, so long as the current passed in the same direction as before. Reversal of the current soon made the F line show again, so that it seems that the whole of the hydrogen was driven by the current to the positive pole. The conditions under which this ultra-violet series shows itself are a matter of interest. It appears here in the midst of a brilliant spectrum due to gases other than hydrogen, and yet it is very difficult to obtain a photograph of it when no gas but hydrogen is known to be present, or, at least, to become luminous in the electric discharge.

We have had an opportunity of comparing the spectrum of the volatile residue of air with that of the more volatile part of gas from the Bath spring. The tube did not admit of the separate examination of the light from the negative pole, but was examined end on, so that the radiation probably included rays emitted from the neighborhood of the negative pole. The whole of the hydrogen had been removed from the Bath gas, but not all the argon. In the spectrum of this gas the rays of helium are dominant, decidedly stronger than those of neon, although the latter are very bright. In the spectrum of the residue of atmospheric air, the proportion of helium to neon seems reversed, for in this the yellow neon line is as much more brilliant than the yellow helium line as the latter is the more brilliant in the spectrum of Bath gas. All the prominent lines in the spectrum of the volatile residue of Bath gas were also in that of the residue of atmospheric air except the argon lines. There were, on the other hand, many lines in the latter not traceable in the former, some of them rather conspicuous, such as the ray at about λ 4664. It is, of course,

probable that such rays are the outcome of some material not contained in the Bath gas. A very conspicuous pair of lines appears in photographs of the spectrum of the air residue, at about λ 3587, which is not traceable in spectrum of Bath gas. The helium line, λ 3587.4, is seen in the latter spectrum, but is quite obscured in the former spectrum by the great intensity of the new pair. This helium ray is really a close double, with the less refrangible component much the weaker of the two, but the new pair are wider apart, and of nearly equal intensities; this character also distinguishes them from the strong argon line at λ 3588.6. They are, however, very much more intense at the negative pole than in the capillary, and it will require a good deal more study to determine whether these rays, and many others which we have not tabulated, are due to the peculiarity of the stimulus at the negative pole, or to the presence of a previously unrecognized material.

As our mixture of gases probably includes some of all such gases as pervade interplanetary and interstellar space, we early looked in their spectra for the prominent nebular, coronal, and auroral rays. Searching the spectrum about λ 5007 no indication of any ray of about that wave-length was visible in the spectrum of any one of the three tubes which had been filled as above described. Turning to the other green nebular line at about λ 4959 we found a weak, rather diffuse line to which our first measure assigned a wave-length 4958. The correctness of this wave-length was subsequently verified by measuring with a micrometer eye-piece the distances of the line from the helium lines λ 4922.1 and λ 5015.7 which were in the field of view at the same time. The position of the line was almost identical with that of the iron spark line λ 4957.8, and the conclusion arrived at was that the wave-length was a little less than 4958, and that it could not be the nebular line. There remained the ultra-violet line λ 3727. Our photographs showed a rather strong line very close to the iron spark line λ 3727.8, but slightly more refrangible. As the line is a tolerably strong one it could be photographed with a grating spectrograph along with the iron lines. This was done, and the wave-length deduced from measuring the photograph was 3727.4. This is too large by an amount which considerably exceeds the probable errors of observation, and we are forced to conclude that the nebular material is either absent from our tubes, or does not show itself under the treatment to which it has been subjected.

Although the residual gases of the atmosphere, uncondensed at the temperature of liquid hydrogen do not show the nebular lines, we found that another tube gave a ray very close indeed to the principal green nebular ray. This tube had been filled with gas prepared in the same way as the others, with the

exception that in passing from the vessel into which the first fraction of liquid air was distilled it was not passed through a U-tube immersed in liquid hydrogen on its way to the exhausted tube. In consequence it contained traces of nitrogen and argon, and when sparked showed the spectra of these elements as well as those of hydrogen, helium, etc. The nitrogen spectrum disappeared after some sparking, but the tube still shows rays of argon as well as those of the gases in the other tubes. On examining the spectrum of the negative pole in the neighborhood of the principal green ray, a weak ray was seen in addition to those given by the other tubes. It was found by comparison with the nitrogen rays λ 5002.7 and λ 5005.7 to be a little less refrangible than the latter of these rays, and by measuring its distance from the nitrogen rays and from the two helium rays 4932.1 and 5015.7.

With a micrometer eye-piece, the wave-length λ 5007.7 for the new ray was deduced. This looks as if we might find the substance which is luminous in nebulae to be really present in the earth's atmosphere, and we hope shortly to be able to verify the observation of it.

Turning to the coronal rays, our tubes emit a weak ray at about λ 5304. This is not far from the wave-length λ 5303.7 assigned by Sir N. Lockyer to the green coronal ray. It is, however, greater than that assigned by Campbell, namely, 5303.26.* Other lines observed by us near the places of coronal lines are at wave-lengths about 4687, 4358, 4570, 4323, 4232, 4220, 3985, 3800. These are all weak lines except that at λ 4232, which is of tolerable strength, and that at λ 4220 which is rather a strong line. The wave-lengths 4323, 4232, 4220, and 3800 come very close to those assigned to coronal rays, but the others hardly come within the limits of probable error. The ray 4220 seems too strong in proportion to the others, but the strength of that at 4232 seems to accord with the strength of the corresponding ray in the corona. It will be seen that the rays we enumerate above correspond approximately to the stronger rays in Sir N. Lockyer's list.† Further measures of the wave-lengths of the faint lines are needed before we can say definitely whether or no we have in our tubes a substance producing the coronal rays, or some of them.

As to the auroral rays, we have not seen any ray in the spectrum of our tubes near λ 5571.5, the green auroral ray. We have observed two weak rays at λ 4206 and λ 4198 which may possibly, one or both represent the auroral ray λ 420. The very strong ray of argon, λ 4200.8, would make it probable that argon was the origin of this auroral ray, if the other,

* *Astroph. J.*, vol. x, p. 190.

† *Roy. Soc. Proc.*, vol. lxvi, p. 191.

equally strong, argon rays in the same region of the spectrum were not absent from the aurora. Nor have we found in the spectrum of our tubes any line with the wave-length 3915, which is that of another strong auroral line. On the other hand it seems probable that the strong auroral line, λ 358, may be due to the material which gives us the very remarkable pair of lines at about the place of N of the solar spectrum, λ 3587, which are very strong in the spectrum of the negative pole, but only faint in that of the capillary part of our tubes. It may well be that the auroral discharge is analogous to that about the negative pole. We have also a fairly strong ray at λ 3700, which may be compared to the remaining strong ray observed in the aurora λ 3700. This, however, is a ray which is emitted from the capillary part of our tubes as well as from the negative pole, and is, moreover, emitted by Bath gas, and may very likely be a neon ray.

We hope to pursue the investigation of this interesting spectrum, and if possible to sort out the rays which may be ascribed to substances such as neon and those which are due to one or more other substances. The gas from Bath, even if primarily derived from the atmosphere—which is by no means sure—seems to have undergone some sifting which has affected the relative proportions of helium and neon, and a more thorough comparison of its spectrum with that of the residual atmospheric gases may probably lead to some disentanglement of the rays which originate from different materials. The arrangement of the rays in series, if that could be done, would be a step in the same direction.

We are indebted to Mr. Robert Lennox, F.C.S., for the great help he gave us in the complicated manipulation with liquid hydrogen required to fill the spectral tubes, and to Mr. J. W. Heath, F.C.S., for kind assistance.

List of Approximate Wave-lengths of the Rays, Visible and Ultra-violet, observed about the Negative Pole.

The rays of hydrogen and helium, and those attributed to neon by other observers are indicated by the chemical symbols of those substances:

A "b" prefixed to the number expressing the wave-length indicates that the ray is emitted by gas from the Bath spring as well as by that obtained from the atmosphere.

A "c" similarly prefixed indicates that the ray has been observed to be emitted from the capillary part of the tube as well as from about the negative pole.

A "w" indicates a weak line; "s" a strong one; "d" a diffuse one; "vw" a very weak; and "vs" a very strong one.

bc He	7281·8		5592	w	4628
	7247	b	5561	w	4616
	7174		5532	w	4589
bc He	7065·5	vwb	5503	w	4583
vw	7058	vw	5447		4576
bc Ne	7034	wb	5432	w	4570
bc Ne	6931	vw	5417		4540
bc Ne	6716	vwb	5409		4538
bc Ne	6678·4	b Ne	5400	w	4526
bc Ne	6601		5372	w	4523
sc He	6563		5360	w	4518
bc	6535		5355	w	4508
bc Ne	6508	bc Ne	5341 a pair	w	4500
vwb	6446	bc Ne	5330	w	4488
bc Ne	6404	w	5304	vs He	4471·6
bc Ne	6382	w	5298	vw	4460
bc Ne	6334		5234		4457
bc Ne	6304	b	5222	vw	4438
bc Ne	6266		5209	wb He	4437·7
bc	6244	b Ne	5204		4431
bc	6232	b	5192		4429
bc Ne	6217	b Ne	5188		4424
b	6183		5152		4422
bc	6176	b Ne	5145		4413
bc Ne	6163		5122		4409
bc Ne	6144	b Ne	5116		4398
vwb	6128	b Ne	5180		4392
b Ne	6097		5074	b He	4388·1
b Ne	6075	b He	5047·8		4380
b Ne	6031	sbc	5038	w	4370
b	6001		5031	vw	4365
b	5991	b He	5015·7	w	4363
wb	5987	wd	4958	w	4358
bc Ne	5976	b He	4922·1	vw	4347
wb	5964	vw	4884	s H	4340·7
sdb Ne	5945	sc H	4861·5	w	4334
w	5919	vwb	4838	vw	4322
w	5914	vw	4819	vw	4315
wb	5905	vwb	4811	vw	4306
bc	5882	wd	4791	w	4200
bc He	5875·9	wd	4754		4276
vsbc Ne	5852·7	b Ne	4715	w	4270
sb	5820	b Ne	4710	w	4261
sb	5804	b Ne	4704	w	4258
sbc	5763	w	4687		4251
bc	5747	w	4680		4241
bc	5718	wb	4657		4234
bc	5689	w	4647		4232
wbc	5662	wb	4640		4220
bc	5656	w	4636	w	4218

w	4206		3766	bc	3460
vw	4198		3754	w	3456
wc	4176		3751	bc	3454
wb He	4169·1	vw	3745	sbc He	3447·7
w	4151	w	3738	w	3429
b He	4143·9	? c	3735	w	3424
w	4134	? c	3728	sbc	3418
b	4131	w	3722	vw	3417
wb	4128	w	3721·5	w	3407
b He	4121	s	3713	w	3404
w	4112		3710	b	3393
sc H	4102	bc He	3705·2	b	3388
w	4099	w	3703	s	3378
vw	4086		3701	vw	3374
w	4080	s ? c	3694	w	3372
w	4063	c	3686	bc	3370
	4047	c	3683		3367
vw	4043	? c	3664	w	3363
vw	4037		3655	vw	3362
vsbc He	4026·3		3651		3360
b ? He	4009	w	3650		3358
w	3996		3644 a pair	b He	3354·7
vw	3985	sc ? He	3634 a pair	s	3345
vw	3980	vw	3628	w	3344
sc He	3970	bc He	3613·8	s	3335
s He	3964·9	w	3609		3329
vw	3933	bc ? He	3600		3327
? b ? He	3927	sbc	3593	s	3324
	3905	vs	3587·5 a pair	sb	3319
	3900		3575	w	3315
vsbc He	3888·8	w	3571	w	3313
wbc ? He	3872		3569	w	3311
bc He	3867·6	w	3561		3310
w	3866	w	3558	b ? He	3297
w	3862	vw b	3548	vw	3254
wc ?	3860		3543	wb	3250
w	3856	vscb	3521	s	3244
w	3842	bc	3515		3233
w	3840	wbc	3510	? pair	3230
c H	3836	w	3504		3225
b	3830	bc	3500	s	3218
sbc He	3819·75	bc ? He	3508		3214
wc ? He	3806		3482		3209
w	3800		3481		3199
c H	3798	sbc	3473	sb He	3187·8
	3777	bc	3467	w	3165
w H	3770	bc	3464	w	3142

SCIENTIFIC INTELLIGENCE.

I. CHEMISTRY AND PHYSICS.

1. *Diethyl Peroxide*.—BAEYER and VILLIGER have succeeded in preparing this interesting derivative of hydrogen peroxide by the action of the latter upon diethyl sulphate with the gradual addition of potassium hydroxide. The substance, $(C_2H_5)_2O_2$, is a colorless, mobile liquid, boiling at 65° , which does not solidify in a mixture of solid carbon dioxide and ether. It is difficultly soluble in water, but miscible with alcohol and ether. It has a faint odor resembling ethyl bromide, and its specific gravity at 15° compared with water at 4° is $\cdot 8273$. In its chemical behavior it is remarkably inactive for a peroxide. It does not react with permanganate, chromic acid or titanium sulphate. Acidified potassium iodide solution is not changed by it until after long standing. Metallic sodium has no action upon the pure substance, and sodium amalgam in the presence of water does not reduce it. Alkaline pyrogallate solution is not darkened by it until after long standing, when an intense color is produced and alcohol is formed. The substance, like all peroxides, is quickly reduced by the action of glacial acetic acid and zinc dust, the product being alcohol. The low kindling-point of the substance is very striking. If the bulb of a thermometer warmed to 250° is brought near the liquid, it ignites and burns very rapidly but noiselessly with a large, luminous flame. Carbon disulphide under the same conditions could not be kindled until a temperature of 300° was reached. If a hot copper wire is brought near the liquid for an instant in an atmosphere of carbon dioxide, the substance disappears very quickly after the wire is removed without producing sound or light, and without boiling. This is apparently a sort of slow explosion, which is almost magical in the impression made upon the observer. This internal combustion produces a large amount of formaldehyde, and, besides this, principally carbon monoxide and ethane. A mixture of the vapor of the substance with air explodes with violence, while with oxygen it explodes more strongly than detonating gas. The authors were unable to explode the liquid by the blow of a hammer even when fulminating silver was present, but it is their opinion that this apparently harmless substance may be very dangerous under certain conditions, just as acetylene is.

The properties of diethyl peroxide indicate that the older structural formula for hydrogen peroxide, $HO \cdot OH$ is more probable than a newer one that has been advanced, $H_2 : O : O$, in which one of the oxygen atoms is assumed to be quadrivalent. For, if the ethyl compound had a structure analogous to the latter it seems probable that its reduction product would be ethyl ether instead of alcohol; moreover it would be expected that $(C_2H_5)_2O : O$ would act upon alkaline pyrogallate as rapidly as molecular oxygen, $O : O$.

In preparing the compound that has been described the authors obtained a second substance which they had not yet been able to purify. They are convinced, however, that it is mono-ethylated hydrogen peroxide, $C_2H_5HO_2$. This substance is miscible with water, has an odor similar to chloride of lime, does not act upon acidified permanganate or dichromate solutions, but behaves like hydrogen peroxide with potassium iodide solution.—*Berichte*, xxxiii, 3387.

H. L. W.

2. *Ammonium Amalgam*.—It has been recently shown by ALFRED COEHN that this well known, curious substance, which swells up and gives off ammonia and hydrogen gases, is in all probability what its name implies. It was found that at about 0° the ammonium amalgam produced by electrolysis is comparatively stable, does not swell up, and presents a perfectly metallic appearance. When the amalgam under these conditions was allowed to act upon a cooled copper sulphate solution, the formation of metallic copper was readily seen, exactly as when potassium amalgam is used. It was possible also to reduce cadmium and even zinc from solutions of their sulphates by means of this amalgam. No such striking evidence of the fact that ammonium behaves like an alkali metal has been previously obtained, as similar experiments have failed at higher temperatures.—*Zeitschr. anorg. Chem.*, xxv, 430.

H. L. W.

3. *Hydrogen Telluride*.—This gas which was discovered by DAVY in 1810, has not heretofore been prepared in a pure condition, although its composition, corresponding to the formula TeH_2 , had been established by indirect means. ERNYEI has recently succeeded in preparing the pure substance. He first obtained the gas mixed with only a small quantity of hydrogen by means of electrolysis carried out at a temperature of -15 to -20° , using tellurium as a negative electrode in 50 per cent sulphuric acid with a current of 220 volts. By cooling the impure product with solid carbonic acid the hydrogen telluride solidified to lemon yellow needle-like crystals which melted at about -54° to a greenish-yellow liquid. Hydrogen telluride is a colorless gas possessing a very disagreeable odor and poisonous properties. In contact with air it decomposes at once, and even below 0° in a sealed tube it decomposes spontaneously into hydrogen and tellurium in a few days. It burns with a bright, blue flame, and is rather soluble in water. When passed into alkaline solutions it forms tellurides, but in solution of salts none are formed. The last statement corrects a generally accepted error. The vapor density of the pure substance determined by the method of Dumas gave the numbers 65.48 and 64.72 compared with hydrogen as unity, while theory requires 64.8. In making these determinations it was found that the liquid evaporated very slowly at 0° , but at 2 or 3° it went faster. The boiling point, therefore, is probably a little above 0° .—*Zeitschr. anorg. Chem.*, xxv, 311.

H. L. W.

4. *The Conductivities of some Double Salts as Compared with the Conductivities of Mixtures of their Constituents.*—F. LINDSAY has made a series of experiments from which he draws the conclusion that the conductivity of a double salt in concentrated solution is slightly less than that of a mixture of the constituents having the same concentration. In other words, he infers that it makes a difference in conductivity whether the constituents of a double salt have been in actual combination in the solid state or not before they are dissolved. The work, coming as it does from the laboratory of Professor H. C. Jones of Johns Hopkins University, deserves careful attention, but the conclusions are so incredible that it seems easier to assume that the results are due to experimental errors than that they are true. It must be admitted that the work was evidently done with great care, and that three different double salts gave differences in the same direction; but these differences are small, and the results, being entirely contrary to the modern ideas of equilibrium in solution, will hardly gain general acceptance without the most convincing confirmation.—*Am. Chem. Jour.*, xxv, 62.

H. L. W.

5. *Cause of the Loss in Weight of Commercial Platinum when Heated.*—Having observed unusual losses in the weights of platinum crucibles upon the introduction of blast from a blowing-engine into a new laboratory, R. W. HALL has made some important observations on the subject. He finds that strongly oxidizing flames greatly increase this loss. Where a crucible was placed high up in a blast-lamp flame the loss was 1.0 mg. per fifteen minutes, while lower down where the temperature was higher the loss was only one-fourth as great. The author does not find that the loss decreases after repeated ignition, as has been previously supposed, and various kinds of crucibles, old and new, of soft, comparatively pure platinum, and one of platinum-iridium alloy gave about the same results. Experiments were made by heating platinum wires by means of an electric current in a glass tube through which various gases were passed. Carbon monoxide, carbon dioxide and hydrogen gave little or no losses, while in air and oxygen the loss of platinum was very rapid, and mirrors were produced in the tube. An examination of one of the mirror-like deposits showed that the volatilized metal does not dissolve in aqua regia as rapidly as the original wire, hence it is inferred that certain elements are fractioned out of the impure platinum. As an explanation of the results, the suggestion is made that a volatile oxide of platinum is formed.—*Jour. Am. Chem. Soc.*, xxii, 494.

H. L. W.

6. *An Elementary Treatise on Qualitative Chemical Analysis*; by J. F. SELLERS. 12mo, pp. vii, 160, Boston, 1900 (Ginn & Company).—The author of this little book has aimed to avoid the two extremes of fullness and brevity. His objection to the latter in books where the material is condensed into "tables" and "schemes" is undoubtedly well founded, and these undesirable features are avoided. The practical part has been care-

fully worked out and is concise and brief enough for use in a very short course on the subject. Several "improved" methods have been introduced, some of which probably will not be as satisfactory to most teachers as those generally used. The introductory part of the book, comprising nearly half of it, seems to be somewhat overdone in fullness. It is difficult to believe that young pupils should study spectroscopy, including spark-spectra, before beginning qualitative analysis. The introduction of the "dissociation theory of solutions" is a step in the right direction, but the rather elaborate treatment here will certainly be far beyond the comprehension of the beginner who has no knowledge of analytical facts. The table of solubilities, which is also included in the introduction, contains a number of serious errors: for instance, lithium fluoride and phosphate are given as soluble in water.

H. L. W.

7. *Die Bedeutung der Phasenlehre*; by Dr. H. W. BAKHUIS ROOZEBOOM. 8vo, pp. 29. Leipsic, 1900 (Wilhelm Engelmann).—This lecture is a most excellent presentation of the Gibbs Phase Rule. Perhaps no one is better qualified to treat this subject than Roozeboom who has done so much experimental work on it. The application of the rule to various cases of equilibrium is taken up in a very clear elementary manner, with suggestions as to its possible future application in geology and physiology. The article is most heartily recommended to those who wish to take up the subject.

H. W. F.

8. *On the Visibility of Hydrogen in Air*.—Lord RAYLEIGH has resumed some experiments begun in 1897 on the presence of hydrogen in air, prompted by some late results obtained by M. Gautier who, working by chemical methods, finds that air normally contains about $\frac{2}{10,000}$ of hydrogen in addition to variable amounts of hydrocarbons. It appeared important to test these results by spectroscopic analysis and the author relates his experience in endeavoring to get rid of the hydrogen which came from the tubes and the drying materials employed. The visibility of the C line with ordinary air was not perceptibly diminished by the passage of the air over red hot cupric oxide. Lord Rayleigh had previously found that hydrogen introduced into nitrogen could be so far removed that the weight remained unaffected although $\frac{1}{10,000}$ of the residual hydrogen might be expected to manifest itself. Lord Rayleigh concludes that the experiments of Gautier are not above doubt, since it is not stated whether he properly estimated the gas which might have come from the walls of his apparatus. The paper also contains a method of showing the presence of argon at atmospheric pressure in very small quantities of air, and also a method of concentration of helium in the atmosphere.—*Phil. Mag.*, January, 1901, p. 100–105. J. T.

9. *Wireless Telegraphy*.—Professor SLABY and Count ARCO have lately conducted experiments on communicating with different stations at the same time, and believe that they have overcome previous difficulties. They have communicated with two

stations distant two miles and eight miles from the conference room of the General Electric Company in Berlin. Two instruments were used, both of which were connected to the lightning conductor in the neighborhood. One instrument syntonized with that in the laboratory of Charlottenburg, the other with that in the works at *Ober Schönweide*. The greater part of Berlin separated the conference room from one of the stations with which successful messages were exchanged.—*Nature*, Dec. 27, 1900.

J. T.

10. *The Telegraphone*.—V. POULSEN discusses with figures his very interesting invention. A small electromagnet connected with a microphone is moved along on an iron wire while a message is spoken into the microphone. Subsequently the microphone is removed and a telephone, having been substituted for it, the electromagnet not traversed by a current is again moved over the iron wire and the message is reproduced.—*Ann. der Physik*, No. 12, 1900, pp. 754-760.

J. T.

11. *On the properties of Argon and its Companions*.—In a paper read before the Royal Society on November 13, by W. RAMSAY and M. W. TRAVERS, after detailing the methods employed for obtaining a supply of the gases associated with argon, the authors give an interesting summary of their properties and with this a statement in regard to their place in the periodic scheme. We quote as follows:

“That these are all monatomic gases was proved by determination of the ratio of their specific heats by Kundt’s method; the physical properties which we have determined are the refractivities, the densities, the compressibilities at two temperatures, and of argon, krypton and xenon the vapor-pressures and the volumes of the liquids at their boiling points. The results are as follows —

	Helium.	Neon.	Argon.	Krypton.	Xenon
Refractivities (Air = 1)...	0.1238	0.2345	0.968	1.449	2.364
Densities of gases (O = 16)	1.98	9.97	19.96	40.88	64
Boiling-points at 760 mm	?	?	86.9°	121.33°	163.9°
			abs.	abs.	abs.
Critical temperatures	?	below 68°	155.6°	210.5°	287.7°
		abs.	abs.	abs.	abs.
Critical pressures	?	?	40.2	41.24	43.5
			meters	meters	meters
Vapor-pressure ratio	?	?	0.0350	0.0467	0.0675
Weight of 1 c.c. of liquid	?	?	1.212	2.155	3.52
			grams	grams	grams
Molecular volumes	?	?	32.92	37.84	36.40

The compressibilities of these gases also show interesting features. They were measured at two temperatures—11.2° and 237.3°; the value of PV for an ideal and perfect gas at 11.2° is 17,710 meter-cubic centimeters, and at 237.3° to 31,800. This is, of course, on the assumption that the product remains constant whatever be the variation in pressure. Now with hydrogen at 11.2° C. the product increases with the rise of pressure; with nitrogen, according to Amagat, it first decreases slightly and then

increases slightly. With helium the increase is more rapid than with hydrogen; with argon there is first a considerable decrease followed at very high pressures by a gentle increase, although the product does not reach the theoretical value at 100 atmospheres pressure; with krypton the change with rise of pressure is a still more marked decrease, and with xenon the decrease is very sudden. At the higher temperature the results are more difficult to interpret; while nitrogen maintains its nearly constant value for PV , helium decreases rapidly, then increases, and the same peculiarity is to be remarked with the other gases, although they do not give the product of PV coinciding with that calculable by assuming that the increase of PV is proportional to the rise of absolute temperature.

These last experiments must be taken as merely preliminary; but they show that further research in this direction would be productive of interesting results.

The spectra of these gases have been accurately measured by Mr. E. C. C. Baly, with a Rowland grating; the results of his measurements will shortly be published. It may be remarked, however, that the colour of a neon-tube is extremely brilliant and of an orange-pink hue; it resembles nothing so much as a flame, and it is characterized by a multitude of intense orange and yellow lines; that of krypton is pale violet; and that of xenon is sky-blue. The paper contains plates showing the most brilliant lines of the visible spectrum.

That the gases form a series in the periodic table, between that of fluorine and that of sodium, is proved by three lines of argument:

(1) The ratio between their specific heats at constant pressure and constant volume is 1.66.

(2) If the densities be regarded as identical with the atomic weights, as in the case with diatomic gases such as hydrogen, oxygen, and nitrogen, there is no place for those elements in the periodic table. The group of elements which includes them is:—*

Hydrogen.	Helium.	Lithium.	Beryllium.
1	4	7	9
Fluorine.	Neon.	Sodium.	Magnesium.
18	20	23	24
Chlorine.	Argon.	Potassium.	Calcium.
35.5	40	39	40
Bromine.	Krypton.	Rubidium.	Strontium.
80	82	85	87
Iodine.	Xenon.	Cæsium.	Barium.
127	128	133	137

(3) These elements exhibit gradations in properties such as refractive index, atomic volume, melting-point, and boiling-point, which find a fitting place on diagrams showing such periodic

* For arguments in favour of placing hydrogen at the head of the fluorine group of elements, see Orme Masson, *Chem. News*, vol. 73, 1896, p. 283.

relations. Some of these diagrams are reproduced in the original paper. Thus the refractive equivalents are found at the lower apices of the descending curves; the atomic volumes, on the ascending branches, in appropriate positions; and the melting and boiling points, like the refractivities, occupy positions at the lower apices.

Although, however, such regularity is to be noticed, similar to that which is found with other elements, we have entertained hopes that the simple nature of the molecules of the inactive gases might have thrown light on the puzzling incongruities of the periodic table. That hope has been disappointed. We have not been able to predict accurately any one of the properties of one of these gases from a knowledge of those of the others; an approximate guess is all that can be made. The conundrum of the periodic table has yet to be solved."—*Proc. Roy. Soc.*, No. 439.

12. *Studies from the Yale Psychological Laboratory*; edited by EDWARD W. SCRIPTURE, Ph.D., Director. Volume VII, 1899, pp. 1-108. Yale University, New Haven, Conn.—This volume, which is issued from the Yale Psychological Laboratory, contains an interesting paper by Dr. Scripture (pp. 1-101) giving the result of a first series of researches in experimental phonetics. The immediate question before the experimenter, as stated by him, was as to the possibility of using laboratory methods to settle the controversy in regard to the quantitative character of English verse. Records of verses in English poetry were made by means of a gramophone and were transcribed with great care by the use of delicate apparatus. The results are discussed in detail as to the character of the vowel- and consonant-sounds and their physiological explanation, also as to the nature of the rhythm. A second paper (pp. 102-108), also by Dr. Scripture, gives observations on rhythmic action.

II. GEOLOGY AND MINERALOGY.

1. *The Periodic Variations of Glaciers*.—Professor F. A. FOREL, in a lecture before the Helvetic Society of Sciences at Thuisin, in September, 1900, gave an interesting summary of his views in regard to the variations in length of glaciers, particularly as applied to those of Switzerland. He notes, in the first place, that the variation that takes place is really one of volume and not of form, though the observation of one dimension, as that of length, is usually sufficient in the discussion of the phenomenon. In regard to the changes that have taken place during the nineteenth century, he notes a decided phase of advance between 1816 and 1820; a maximum recognized everywhere in 1855, and a general recession from 1856 to the end of the century, with a small partial advance between 1875 and 1893. This is shown more definitely in the following table.

1800-1811	?
1811-1816 (1822)	Advance.
1818-1820	Grand maximum.
1820-1830	Slight recession, uncertain.
1830-1850	Contradictory movements.
1855	Maximum.
1856-1900	Recession.
1875-1892	Advance for some Swiss glaciers.
1890-1900	Same for some Austrian glaciers.

In regard to the duration of the periodic movement in general, there are to be recognized two distinct periods. First, the annual, caused by the fact that during the winter months no melting takes place, and the state of the glacier is stationary; the advance, consequently, continues, so that there is a temporary increase between October and April or May. During the summer months, however, the melting predominates and a decrease shows itself. This annual period causes in one case an acceleration, in another, a retardation, of the general variation going on, whatever that may be.

There is also a cyclic period, the duration of which is not easily established, but which the author connects with the thirty-five-year climatic period called the Cycle of Brückner. Thus, in 1889, after considering all the facts available, he arrived at the conclusion that the average value of the phase of increase was 10·5 years, that of decrease 27·4 years, or together 37·9 years for the entire period. This conclusion was also reached by E. Richter (1891) after discussing the observed maxima from 1600 down to 1840-50. Forel, however, is inclined to regard the actual periodic relations as much more complex. He would divide the Swiss glaciers for the nineteenth century into three classes. First, those with a single period, like that of the Aar, with a maximum about 1870; second, those of two periods, as the Rhône, maximums 1820, 1855; and finally, those of three periods, as the Trient and des Bossons, with maximums 1820, 1855, and 1892. While the glacial increase in general is due to an excess of precipitation, the period coinciding probably with the Brückner cycle, the actual advance must depend upon the length of time which the snow-fall requires in its journey from the upper névé regions to the glacial front, varying for glaciers of different length. The actual effect observed will be modified by the temperature conditions existing. The author adds that the minimum state is to be regarded as the normal magnitude for the glacier, the forward impulses being, as it were, accidents.—*Bibl. Univ.*, Nov. 15, 1900.

In this connection, attention may be called to the 5th Report (for 1899) on the periodic variations of glaciers by E. Richter, President of the International Commission of Glaciers (see this *Journal*, ix, 71). In this report (*Bibl. Univ.*, July 1900,) it is noted that for the Swiss glaciers the phase of advance which began about 1875, has spent its force, so that now, for 1899, only one glacier (Boveyre, Rhône) is certainly and only nine others probably advancing: which nineteen are certainly, and forty-four probably, retrograding.

2. *Contributions to the Tertiary Fauna of Florida*, with especial reference to the Silex Beds of Tampa and the Pliocene Beds of the Caloosahatchie River, including in many cases a complete revision of the Generic Groups treated of and their American Tertiary Species; by WILLIAM HEALEY DALL. Transactions of the Wagner Free Institute of Science of Philadelphia, vol. iii, Part v, pp. 949-1218; plates xxxvi-xlvii. Philadelphia, December, 1900.—The present Part, No. V, of Dr. Dall's important contributions to the Tertiary of Florida, includes the genera, from Solen to Diplodonta, of the order Teleodesmacea. It carries the whole so far on towards completion that it is expected that the entire work will be finished in another installment. This part has all the admirable characteristics in substance and method of presentation that have marked its predecessors. The careful and minute critical labor which is recorded here must serve to restore order in the case of a number of groups in which the nomenclature has been hitherto much confused. In addition to the description of the well-known species included within these limits, a very considerable number of new species are given. The illustrations given on the plates with which the part closes are worthy of the descriptive portion of the work and leave nothing to be desired.

3. *A record of the Geology of Texas for the decade ending December 31, 1896*; by FREDERIC W. SIMONDS. (Ex. Trans. Acad. Sci., Vol. III.) Pp. 1-280. 1900.—The value of this Index is greatly increased by the brief summary of contents of each of the volumes cited. It supplements Bulletin 45 of the U. S. Geological Survey (The Present Condition of Knowledge of the Geology of Texas, by Robert T. Hill, 1887), bringing the record down to the close of 1896. w.

4. *Geological Survey of Canada; G. M. DAWSON, Director. General index of the Reports of Progress, 1863 to 1884*, (compiled by D. B. Dowling). Pp. 1-475. 1900.—The Reports of the Geological Survey of Canada prior to 1863, were condensed and summarized in the Geology of Canada, 1863. The present index begins with this volume of 1863 and includes the volumes published up to the Reports of Progress for 1882, 1883, 1884, published in 1884. Its usefulness is apparent. Since 1884 "Annual Reports" have been published having their own indices. Special publications and paleontological and botanical reports of the Geological Survey are not indexed in this volume. w.

5. *Report on the Geology and Natural Resources of the Country traversed by the Yellow Head Pass Route from Edmonton to Tête Jaune Cache, comprising portions of Alberta and British Columbia*; by JAMES McEVOY. Pp. 1-44 D, Pl. I-II, figs. 1-2, 1 map. 1900.—In the region traversed by Mr. McEvoy the following formations were met with:

Tertiary	-----Paskapoo beds	} Laramie
Cretaceous	----- { Edmonton beds	
	----- { Pierre and Fox Hill	
Devono-Carboniferous		
Cambrian	----- { Castle Mt. Group	
	----- { Bow River Series	
Archean	-----Shuswap Series	w.

6. *Mesozoic Fossils, Vol. I, Pt. IV. On some additional or imperfectly understood fossils from the Cretaceous rocks of the Queen Charlotte Islands, with a revised list of the species from these rocks*; by J. F. WHITEAVES. Pp. 263-307, pl. 33-39. 1900.—In addition to making a thorough revision of the Cretaceous faunas of the Queen Charlotte Islands, the author particularly discusses the fauna of the “lower shales,” describing several new species. w.

7. *The Geology of the Albuquerque Sheet*; by C. L. HERRICK and D. W. JOHNSON. From the Bull. Sci. Lab., Denison University, Vol. xi, pp. 175-239, folded map and plates xxvii-lviii. June, 1900. Edited by W. G. TIGHT.)—The authors present in this paper a detailed account of their study of the Albuquerque region, as a sample of the geology of the Territory of New Mexico. They give descriptions of the species, some of which are new, and figures of the old species are reproduced from Bulletin 106, of U. S. Geological Survey. It furnishes a valuable summary of the local geology, correlated and compared with standard sections of other regions. H. S. W.

8. *I Vulcani dell' Italia Centrale. Parte I, Vulcano Laziale*; by V. SABATINI. Vol. X of Memorie descrittive della Carta Geologica Italiana. 8vo, pp. 392, pl. 11. Rome, 1900.—This, the first of a projected series of monographs on the volcanoes of central Italy, is a careful and detailed study of the complex of eruptive vents and the materials of which they have been built up. The author distinguishes five distinct craters, the oldest being the largest (Tusculan), and the latest that of Ariccia. The extensive deposits of tuff in the Roman Campagna are described at length, and the vexed question of their age and order of succession discussed. The earliest manifestations of activity appear to have been about the end of the Pliocene. Detailed petrographical descriptions are given of the tuffs and lavas, among the interesting features being the growth of leucite crystals and their alteration to feldspar. A few new analyses are given of the leucitites and leucite-tephrites, but it may be regretted that the author did not devote more space to a discussion of the relationships of these interesting rocks. A number of good phototypes and a colored plate of rock sections, together with a geological map on a scale of 1:75000, adorn the volume, which is an important addition to the literature of Italian geology. H. S. WASHINGTON.

9. *Occurrence of Zoisite and Thulite near Baltimore.**—These

* From notes by the late John W. Lee furnished by Prof. A. W. Bibbins of Baltimore.

minerals were found for the first time in Maryland in May, 1895, in a pegmatite dike, in the quarry of hornblende schist operated by Alphaeus H. Wright on Stony Run, east of Hampden. The gangue is white feldspar (oligoclase) together with mica, compact garnets in mass, talc, etc. They occur in the cracks and veins of the oligoclase as thin crusts, mostly in radiated crystals, isomorphous with epidote, with which it is intimately associated. The epidote has a brighter luster than the Jones Falls specimens in general.

The thulite is bright pink, shading off into light pink and light orange, clear and glassy. The crystalline form of the zoisite is identical with that of the thulite. It is gray, shading into the light and dark green of the epidote. There is room for question whether this should not also be regarded as thulite. Foliated, stellated and granular talc also occur, occasionally changing to deweylite. Bright iron pyrites is also often met with. The quartz has yielded a single crystal of beryl of good size and color—a rarity in Maryland.

Harris gneiss quarry on Jones Falls has yielded a large quantity of epidote but all of one color—dark bottle-green, but the slightest tint of pink or gray or intermediate colors has never appeared here, though the two localities are scarcely half a mile apart.

III. MISCELLANEOUS SCIENTIFIC INTELLIGENCE.

1. *The Transcontinental Triangulation and the American Arc of the Parallel*; by CHAS. A. SCHOTT, Chief of the Computing Division. Pp. 871, with 2 maps and 55 illustrations; 4to. Washington, 1900. (United States Coast and Geodetic Survey, Henry S. Pritchett, Superintendent. General Publication, No. 4).—The work of transcontinental triangulation began in 1871. Its completion in 1900 “marks an epoch not only in the scientific history of the United States but in the world’s Geodesy as well.” We have now a continuous triangulation along the 39th parallel from the Atlantic to the Pacific 2,625 miles in length. Its value to the sixteen states embraced by it need not be explained. Its value from a scientific standpoint consists in the great addition it offers to the data necessary for the accurate determination of the earth’s shape and size. No contribution to geodesy of equal magnitude has ever been made, that most nearly comparable being the measurement of the great Indian arc.

Its main result may be summarized in the statement that the curvature of the North American continent along the 39th parallel given by it is intermediate between that of the Bessel and the Clarke spheroids. The accuracy of this deduction is evidenced by the fact that the probable error in the measured length of the entire arc of 4,224 kilometers is 26 meters, while the difference on the spheroids of Clarke and Bessel for the same arc is 615 meters.

The entire triangulation is divided into three sections: the western of 1,047 miles characterized by the great altitude of its stations, many of them over 12,000 feet, and the unusual size of its triangles, many of the sides being over 100 miles long and not a few over 150 miles long; the central section of 756 miles from Colorado to St. Louis, with low stations and small triangles; and the eastern section of 822 miles, terminating at the Capes of the Delaware and marked by small but diversified hypsometric features. During the progress of this work, and in many cases resulting from it, new methods have been introduced and great gains have been achieved both in precision and rapidity of execution. Among the special problems met with may be mentioned the changed conditions in attractive and centrifugal force found at the great altitudes of the western stations, the variations in refraction between stations of very different altitudes, the development of new formulæ for spherical excess and the special treatment of geographical positions requisite in triangles whose sides are as long as 180 miles, as well as mechanical questions involved in mounting instruments 150 feet above the ground and erecting observing poles 275 feet high.

Most difficult of all and requiring the qualities of a great general is the orderly marshalling of the vast bulk of material of observation and the utilization of it to the best effect. The responsibility for this task has fallen chiefly on Mr. C. A. Schott, who has been in active service in the bureau for more than 50 years.

W. B.

2. *Astronomical Observatory of Harvard College.*—The Fifty-fifth Annual Report of the Director of the Harvard Astronomical Observatory, Prof. E. C. Pickering, in addition to the usual summary of work accomplished, gives an interesting statement of the present needs of the institution. It appears that the annual income of the Observatory is now nearly \$50,000, which puts it on an equal footing with the chief observatories of the world; but, notwithstanding, the shrinkage in interest rate makes an additional sum of \$200,000 necessary if the income of six years ago is to be secured permanently. Furthermore, new and fire-proof buildings at Cambridge are urgently needed; a large telescope mounted in the Southern Hemisphere would also prove a most valuable means of carrying on important work which cannot be provided for at present. Thus a sum of half a million dollars is needed to keep the Observatory in the foremost rank. Attention is also called to a considerable series of unpublished investigations which, if completed, would fill twenty-eight volumes, or two-thirds as many as have been published by the Observatory during its existence of the past fifty years. A moderate expenditure for additional computers would make prompt publication of this material practicable.

Volume xxxvii, Part I, of the Annals of the Observatory has recently been issued. It contains observations of circumpolar variable stars during the years 1889–1899, prepared for publication by Oliver C. Wendell, Assistant Professor of Astronomy.

3. *Norway ; Official Publication of the Paris Exhibition, 1900.* Pp. xxxiv, 626. Christiania, 1900.—This beautiful volume, prepared for the occasion of the Paris Exhibition of 1900, deserves a fuller notice than would be appropriate in this place. It contains a series of articles by able writers discussing this most interesting country in all its features, scientific, political, economic, educational, and artistic. These chapters are liberally illustrated by an abundance of excellent plates. An interesting though brief summary of the geology of the country, with a geological map, is given by Professor H. H. Reusch; other scientific papers are those on the climate by Axel Steen; on the plant life by H. H. Gran; on the animal life by James A. Grieg. The text has been translated into good English and the volume as a whole will be found to have permanent value as a useful book of reference.

4. *American Museum of Natural History.*—It has been recently announced that through the generosity of a donor whose name is for the present withheld, the collections of minerals and meteorites belonging to Mr. Clarence S. Bement of Philadelphia have become the property of the American Museum of Natural History in Central Park, New York City. Mineralogists are well aware of the very remarkable excellence of the Bement collections, representing as they do the earnest labors, extending over a period of many years, of a collector of indefatigable energy, keen eye and good judgment, and one who was always ready to purchase a specimen of unique beauty or interest even at a high price. It is a matter for congratulation that these collections are to be preserved unbroken for all time for the benefit of science and the public.

✓ 5. *The Principles of Mechanics: an Elementary Exposition for Students in Physics;* by FREDERICK SLATE, University of California. Part I. Pp. 299. New York, 1900 (The Macmillan Co.).—This book is intended for the use of students well grounded in experimental physics and the calculus. In connection with the analytical development much emphasis is laid on the fundamental notions of the science, which are broadly and philosophically presented, though with a degree of abstractness which would render it difficult for the beginner to grasp them firmly. A greater proportion of concrete exercises involving numerical computation would be desirable.

W. B.

Knowledge Diary and Scientific Hand-book for 1901. Pp. 120. London, 1900 (Knowledge Office, 326 High Holborn). The introduction to this volume contains an historic summary of the advance of science in the 19th century; astronomical notes and tables, with an account of the astronomical phenomena of the year; twelve star maps, showing the night sky for every month in the year, with full descriptive account of the visible constellations and principal stars; a calendar of notable events; photograph and detailed description of the gigantic telescope exhibited at the Exposition Universelle in Paris, with a table of principal observatories of the world and monthly astronomical ephemeris.

THE

AMERICAN JOURNAL OF SCIENCE

[FOURTH SERIES.]

ART. XIII.—*Circular Magnetization and Magnetic Permeability*; by JOHN TROWBRIDGE and E. P. ADAMS.

VERY little quantitative work appears to have been done upon the problem of the intensity of magnetization produced by an oscillatory current in an iron wire. Previous work of this kind has been done with oscillatory currents, either of very much higher frequency or of very much lower intensity than those used in the experiments about to be described.

In 1894, I. Klemencic* gave an account of some experiments on this problem. He studied the effects of the oscillatory currents induced in an iron wire by Hertz waves, reflected and received by parabolic mirrors. By comparing the heat produced in a short iron wire through the action of these oscillatory currents, with the heat produced in a similar non-magnetic wire, he was able to arrive at a value for the effective resistance of the iron wire to oscillatory currents. Then by making use of Lord Rayleigh's formula:

$$R' = \sqrt{\frac{1}{2}\mu l n R}$$

he calculated the value of the permeability of the iron. The heat produced in each case was compared by the use of a thermal junction held near the wire under investigation. In this way he arrived at the value 118 for the permeability of the iron to oscillatory currents, and estimated the maximum value of the field strength at 290. He reasoned that since this very large maximum field strength produced such feeble magnetization, the permeability of iron to oscillatory

* Wiedemann's *Annalen*, liii, p. 707.

currents was a constant. The frequency used by Klemencic was about 9×10^7 oscillations per second.

The experiments described below are with oscillatory currents of frequencies ranging from 600 to 3000, with maximum field strengths of higher values than those used by Klemencic. It appears from the results given below that with oscillatory currents of as low frequencies as this, the permeability is not a constant, but depends upon the strength of the magnetic field; that is, the iron behaves toward oscillatory currents in much the same manner as it does toward steady currents.

Similar results were brought out recently in an article by Marchant.* He showed that the same dependence of permeability to field strength holds in the case of oscillatory discharges as in the case of steady currents. No figures are given in his article by means of which a quantitative idea of this relationship may be obtained.

The arrangement of apparatus used in our investigation was as follows: B is a battery of 10,000 storage cells; C a con-

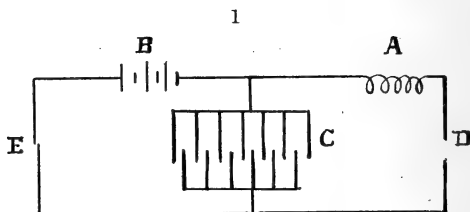

denser consisting of 300 glass plates, coated on both sides with tin-foil, the coated surface being 43×33 centimeters. The battery circuit was controlled by a switch at E. The discharge circuit, CADC, contained a spark-gap at D, of cadmium terminals. The self-induction of this circuit could be changed by placing coils of copper wire of different dimensions at A.

When the switch at E was closed the condenser was charged; it then discharged itself through the circuit CADC. This latter circuit was so proportioned that the discharge was always of an oscillatory character, that is, approximately, by the well-known theory, R^2 was less than $4L/C$, where R is the resistance, L the self-induction, and C the capacity of the circuit. The self-induction of A was large enough so that the self-induction of the rest of the circuit could be neglected; and the electrostatic capacity of the circuit could also be neglected in comparison with the capacity of the condenser.

* *Nature*, Aug. 30, 1900, p. 413.

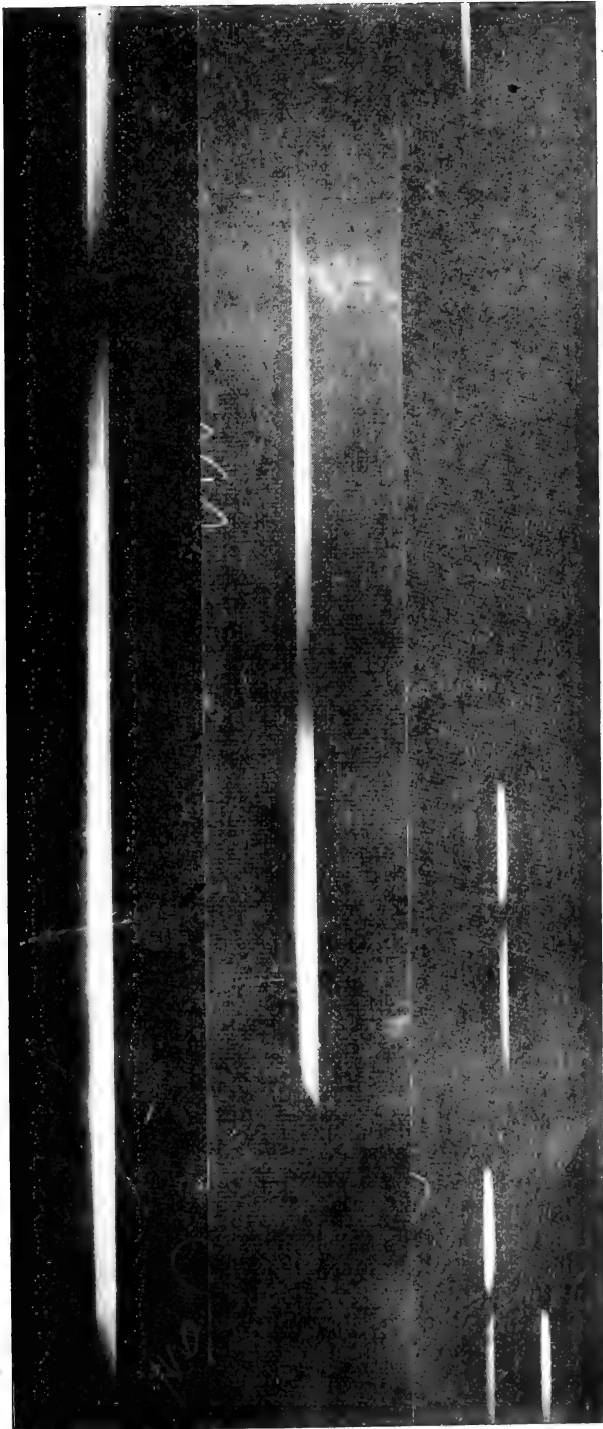

FIGURE 2.—Oscillatory Discharges of a Condenser, With periods 600 to 3,000.

In order to study the frequency of oscillation, the revolving mirror method was used. A concave mirror of about 300 centimeters focal distance was attached to the shaft of an electric motor. The image of the spark was reflected by the revolving mirror upon a photographic plate, and when the plate was developed the length of this image could be measured. Some typical photographs are shown in the accompanying cuts, fig. 2. The speed of the motor was obtained by means of a chronograph, the cylinder of which was directly attached to the shaft of the motor.

The formula connecting the periodic time of an oscillatory discharge, T , with the self-induction, L , and the capacity, C , of a circuit is :

$$T = \frac{2\pi}{\left\{ \frac{1}{LC} - \frac{R^2}{4L^2} \right\}^{\frac{1}{2}}}$$

or since $R^2/4L^2$ is very small compared with $1/LC$,

$$T = 2\pi\sqrt{LC}$$

In this formula T is known from the length of the spark on the photographic plate, the distance of the plate from the mirror, and the speed of rotation of the mirror.

C was determined by placing at A a coil of copper wire whose self-induction to steady currents could be accurately calculated. It was then assumed that for the low frequency used, the self-induction to oscillatory currents did not differ appreciably from its calculated value. That this was a legitimate assumption within the limits of experimental error, was shown by the close agreement that existed between this calculated value, and the value obtained by measuring the self-induction by means of Rayleigh's bridge, employing a frequency of about 700. Knowing thus L and T , C could be calculated by the above formula. The value of the capacity obtained for the lowest frequency used, viz: 1.85 micro-farads, agrees very closely with its value measured by comparison with a standard condenser.

Two different coils of copper wire, corresponding to frequencies, when alone in series with the condenser, of 633 and 1423 respectively, were used. For the higher of these two frequencies the capacity was about 5 per cent less than for the lower. Part of this change may have been due to the fact that the change of self-induction of the copper coil was neglected, but this latter was very small.

The iron wire, whose permeability was under investigation, was arranged in the form of a rectangle, around the four sides

of the Jefferson Physical Laboratory—200 feet long and 60 feet wide. The wire was the ordinary soft iron wire, 0.105 inches in diameter. This iron wire was arranged so that it could be put in series with either of the two copper coils, and also so that it could form practically the only self-induction in the discharge circuit.

The general method of procedure was as follows: As stated above, one of the copper coils was placed at A and the capacity of the condenser obtained. Next the iron wire was placed in series with the same copper coil. This of course changed the frequency of the discharge, but since the change was not large, it was assumed that the capacity of the condenser was not sensibly altered. Knowing the periodic time and the capacity, the self-induction of both copper coil and iron wire was given by the formula $T = 2\pi\sqrt{LC}$. Then the self-induction of the iron wire alone was obtained by subtracting from this combined self-induction, the calculated self-induction of the copper coil. Then by means of Lord Rayleigh's formula:

$$L' = l \left(A + \sqrt{\frac{\mu R}{2nl}} \right)$$

the permeability of the iron was obtained.

The same process was repeated using the other copper coil, and the permeability at this different frequency obtained in the same way. Finally the iron was placed alone in the discharge circuit, and the self-induction of this obtained directly from the formula: $T = 2\pi\sqrt{LC}$. In order to get the capacity of the condenser at this highest frequency, it was assumed that it had diminished by 5 per cent. This, of course, can only be regarded as a rough approximation.

The experimental data and calculations follow:

The self-induction of the two coils of copper wire was calculated by means of Maxwell's formula:

$$L = 4\pi n^2 a \left(\log \frac{8a}{R} - 2 \right) + 2l \left(\log \frac{D}{d} + 0.11835 \right)$$

where:

- n number of turns.
- a mean radius of coil.
- R geometric mean distance of cross-section of coil.
- l total length of wire.
- D diameter of insulated wire.
- d diameter of bare wire.

In these coils:

$$\begin{aligned} D & 0.3969^{\text{cm}} \\ d & 0.1241^{\text{cm}} \end{aligned}$$

For the larger coil:

$$\begin{aligned} a & 43.5558 \\ R & 2.1292 \\ n & 144. \\ L & 3.421 \times 10^7 \end{aligned}$$

For the smaller coil:

$$\begin{aligned} a & 40.2016 \\ R & 1.4194 \\ n & 64. \\ L & 7.125 \times 10^6 \end{aligned}$$

The iron wire was in the form of a rectangle, 200 feet long and 60 feet wide, the diameter of the wire being 0.105 inches. Rayleigh's formula for self-induction with alternating currents is:

$$L' = l \left(A + \sqrt{\frac{\mu R}{4\pi n l}} \right)$$

where:

- l length of wire.
- R resistance for steady currents.
- n number of alternations per second.
- μ permeability.

A is a constant, depending upon the geometric form of the circuit, and can be calculated from the self-induction of the circuit with steady currents. For steady currents, Rayleigh's formula becomes:

$$L = l \left(A + \frac{\mu}{2} \right)$$

Using Maxwell's formula for the self-induction of two parallel wires, and applying it to this case, we get for the self-induction of the iron wire to steady currents:

$$L = 4c \log \frac{b}{a} + 4b \log \frac{c}{a} + \mu(b+c)$$

Here

- c length of rectangle.
- b width “
- a radius of wire.
- l length of wire.

Hence

$$L = 311200 + 15860 \mu / 2$$

and

$$1A = 311200$$

The resistance of the iron wire to steady currents was measured by means of Wheatstone's Bridge, giving,

$$R = 4.3 \times 10^9$$

Thus Rayleigh's formula, for calculating the permeability, when we know the self-induction of the iron wire to alternating currents, becomes :

$$L' = 311200 + \sqrt{\frac{4.3 \times 10^9 \times 15860}{4\pi n}} \mu$$

Discharging the condenser through the larger coil, we had :

Length of half-oscillation	8.98 ^{cm}
Speed of mirror	3.0
Distance plate from mirror	300.9

From this we find the number of complete oscillations per second to be :

$$n = 633$$

Using this value of n , and the calculated value of the self-induction of the coil given above, we find for the capacity of the condenser :

$$C = 1.848 \text{ micro-farads.}$$

Discharging the condenser through the same coil and the iron wire in series we had :

Length of half-oscillation	6.91 ^{cm}
Speed of mirror	2.2
Distance plate from mirror	300.9

giving

$$n = 605$$

This gives for the combined self-induction of iron wire and copper coil :

$$L = 3.745 \times 10^7$$

Subtracting from this the self-induction of the coil, that of the iron wire becomes :

$$L' = 3.24 \times 10^6$$

Substituting this value in Rayleigh's formula we get for the permeability of the iron :

$$\mu = 327$$

Discharging the condenser through the smaller coil alone, we had :

Length of half-oscillation	7.42 ^{cm}
Speed of mirror	5.6
Distance plate from mirror	300.9

giving,

$$n = 1423$$

This value of n , with the calculated value of the self-induction of the coil, gives as the capacity of the condenser at this frequency :

$$C = 1.756 \text{ micro-farads.}$$

Discharging the condenser through the smaller coil and the iron wire in series, we had :

Length of half-oscillation	11.85 ^{cm}
Speed of mirror	8.0
Distance plate from mirror	300.9

giving

$$n = 1280$$

Using 1.756 as the capacity of the condenser, and this value of n , we get for the combined self-induction of coil and iron,

$$L = 8.805 \times 10^6$$

Subtracting the self-induction of the coil, that of the iron wire becomes :

$$L' = 1.68 \times 10^6$$

And by means of Rayleigh's formula,

$$\mu = 443$$

Discharging the condenser through the iron wire alone, we had :

Length of half-oscillation	2.42 ^{cm}
Speed of mirror	4.2
Distance of plate from mirror ...	300.9

giving

$$n = 3300$$

Assuming the capacity of the condenser to be 1.668 micro-farads, and using this value of the frequency, we get for the self-induction of the iron wire :

$$L' = 1.395 \times 10^6$$

By means of Rayleigh's formula,

$$\mu = 711$$

The values of the permeability so calculated are a kind of mean value for a single discharge of the condenser. The magnetic force is that due to the current in the wire, so that the iron becomes circularly magnetized. This magnetic force is 0 at the axis of the wire, and increases to the value $2i/a$ on the circumference, where i is the current and a the radius of the wire. Thus the magnetic force is not a constant over the cross-section of the wire; at any point in the wire its value is $2\pi ir/a^2$, where r is the distance of the point from the axis of

the wire. The mean value, found by integrating this expression over the cross-section of the wire, is :

$$H_{\text{mean}} = 4i/3a = 2/3 H_{\text{max.}}$$

The following values were obtained by Klemencic* for the susceptibility of iron wire to a steady circular magnetizing force. The last column gives the permeability as calculated from his results :

i (Amperes)	$H_{\text{max.}}$	H_{mean}	k	μ
·12	·23	·15	14·3	180
·23	·43	·29	16·7	210
·46	·87	·58	20·2	255
·85	1·62	1·08	28·7	362
1·26	2·40	1·60	46·8	590
1·45	2·77	1·85	61·2	771
2·39	4·56	3·04	103·5	1304
3·62	6·90	4·60	112·9	1423

These values of the permeability are thus seen not to differ very much from the average values of the permeability with longitudinal magnetization.

From the results of our experiment and the above table, it would seem that the oscillatory currents we employed were equivalent in their magnetizing effects upon the iron wire to steady currents varying in strength from about 0·8 to 1·4 amperes. We can easily get an approximate idea of what the maximum current strength was as follows. The images measured on the photographic plates were in every case the images of the first half-oscillation. Neglecting the damping during this first half-oscillation, which is small, the maximum current is given by the following expression :

$$I_{\text{max.}} = \frac{E}{\sqrt{R^2 + 4\pi^2 n^2 L^2}}$$

E is the potential to which the condenser was charged. The e.m.f. of each cell was very approximately 2 volts, giving as the total e.m.f.,

$$E = 20,000 \times 10^8$$

We can thus form the following table, making use of the maximum current strengths thus obtained, and the maximum magnetic field strengths :

$I_{\text{max.}}$ (Amperes)	Frequency.	$H_{\text{max.}}$	Permeability.
140	605	53	327
282	1280	106	443
742	3300	278	711

* Wied. Annalen, lvi, p. 585.

It might be supposed that we could have made a known change in the current by employing one-half the battery to charge the condenser. One-half, however, was not sufficient to charge the condenser to such a degree that sufficient light could be obtained in the spark. We believe that the following inference, however, is correct: the permeability is seen to increase with increasing field strength, in spite of the increase of frequency. But the increase of permeability with increase of field strength is seen to be much less rapid than in the case of steady currents. For, from the table of Klemencic, a permeability of 327 corresponds to a maximum current of about 0.8 amperes, while a permeability of 711 corresponds to a current of about 1.4 amperes. But in the case of an oscillatory discharge, these two values of the permeability correspond to maximum currents of 140 and 742 amperes respectively. This clearly shows the effect of period in diminishing the permeability; for the same change of permeability is produced by increasing the currents in the ratio 8:14 with steady currents as is produced by increasing the currents in the ratio 1:5 in the case of oscillatory currents.

Jefferson Physical Laboratory, Harvard University.

ART. XIV.—*Notes on the Geology of Parts of the Seminole, Creek, Cherokee and Osage Nations*; by CHARLES NEWTON GOULD.

DURING the month of August, 1900, while engaged in the Oklahoma Geological Survey, I was enabled to make a brief reconnaissance of the northwestern part of the Indian Territory and the Osage nation, Oklahoma. The trip was made by wagon and occupied in all about two weeks. I was accompanied by Mr. Paul J. White, botanist to the survey, and Mr. Roy Hadsell, general assistant. The route lay through Cleveland and Pottawotamie counties, Oklahoma, and the Seminole, Creek, Cherokee and Osage nations. The chief towns through which we passed were Shawnee, Keokuk Falls, Okmulgee, Sapulpa, Tulsa and Pawhuska.

The object of the trip was primarily to ascertain the general geological features of the region, and particularly to locate the eastern extremity of the Red-beds. Incidentally it was intended to locate the position of the heavy ledges of limestone which were supposed to extend southward from the Flint hills of southern Kansas into the western part of the Creek nation.

As is well known, the Flint hills or Permian mountains extend north and south across Kansas, reaching their culmination in Cowley, Butler, Chautauqua, Elk and Greenwood counties in the southeastern part of the State. For the most part these hills are composed of massive ledges of limestone containing great quantities of flint in the form of nodular concretions. Besides the limestones there are beds of green, blue and reddish shales of considerable thickness. The entire series is fossiliferous. The fossils of the lower part of the hills indicate that the rocks are of Upper Carboniferous age, while those from the summit are Permian. The Cottonwood Falls limestone, which lies near the point of division of these groups, is located near the top of the Flint hills.

Few ledges of sandstone are found except in the extreme southern part of the State. In the vicinity of Dexter, Cowley County, Kansas, a bed of arenaceous shale immediately beneath the Strong flint (Prosser) changes into a ledge of light brown sandstone. This ledge may be traced south past Maple City to the State line, and thence down Beaver creek to the vicinity of the Kaw agency. By this time, however, several other ledges of sandstone have come in. The section of a hill at the mouth of Beaver reveals the presence of six ledges of sandstone each from five to fifteen feet thick, alternating with limestone and shale.

This is intended to show that while the Flint hills in Kansas consist almost entirely of limestones and shales, still on the

southern line of the State sandstones have already begun to appear. To the south these conditions obtain more and more until the limestone is entirely replaced by sandstone. Even in Kansas the rock east of the Flint hills is sandstone and shale. To the west the limestones gradually thin out and give place to shales (the Marion and Wellington formations) which farther west are succeeded by the Red-beds. South of the State line the sandstones from the east and the Red-beds from the west begin to approach each other, while the limestone ledges become thinner and thinner and the flint less pronounced.

In Pawnee County, Oklahoma, there are still some heavy ledges of limestone, although even here sandstones greatly predominate. In eastern Payne County, fifty miles south of the Kansas line, the conditions have changed still more. The following section taken at Ingalls will illustrate the succession of the various rocks:

<i>Section at Ingalls, Oklahoma.</i>		Feet.
No.		
13.	Red clay and sandstone.....	20
12.	Red sandstone	2
11.	Red clay shale.....	20
10.	Two ledges of hard, flinty, fossiliferous limestone, 1 to 2 feet thick, separated by 1 foot of greenish clay---	5
9.	Red clay shale.....	50
8.	Sandstone	5
7.	Red and green shale.....	10
6.	Limestone	1
5.	Shales	10
4.	Limestone	1
3.	Greenish shale	5
2.	Limestone	1
1.	Shales.....	20
Total.....		150

No. 10 forms the cap of the noted Twin Mounds, seven miles east of Ingalls, as well as the tops of numerous bluffs and escarpments in the vicinity. It is the most pronounced ledge in the region and is the one that gives tone to the erosion forms. It will be observed, however, that of the 150 feet of strata represented but eight feet are limestones, the remainder being either sandstone or shale, with the latter predominating. Above the rocks represented in this section only shales and sandstones of the Red-beds are to be found. The gradation from the underlying Permian or Carboniferous to the superjacent Red-beds is so slow that when on the spot it is not easy to tell just where the one leaves off and the other begins. At

Ingalls, as shown above, there is a fifty foot ledge of red clay which may not be distinguished from typical Red-beds clay, below the thickest limestone ledge in the region. On the State line there are several hundred feet of blue and green shales between the upper limestone and the base of the Red-beds.

In general, however, it may be observed that in going eastward from a Red-beds region toward the Carboniferous the sandstones and shales, which have been of a deep brick-red color, become more and more brownish and grayish, and finally lose entirely their characteristic hue and take on that of the older formations. The lithology changes also, but so gradually that it is impracticable if not impossible to fix any but an arbitrary line of separation between the two groups.

With these facts in mind the reconnaissance was undertaken. In the absence of evidence to the contrary it was assumed that the limestones forming the southern extension of the Flint hills extended as far south as the Seminole nation. The plan, then, was to go east from Norman, Oklahoma, until these limestone ledges were encountered and then to follow them northward to the Kansas line. This object was not accomplished for the reason that on the eastern trip no limestones were found. As will be shown later, the only time when the party encountered the Flint hills was in the Osage nation, on the road from Pawhuska to Winfield. While the trip extended much farther east than had been planned, still this fact need not be regarded as an unmixed evil inasmuch as it enabled us to visit a region the geology of which has not been well understood.

From Norman to Shawnee the rock is prevailingly red. About the west line of the Seminole country the sandstones begin to lose their red color and are usually brown or even light gray. These ledges are frequently quite pronounced and in many localities form prominent escarpments or even hills of considerable size. Keokuk Falls of the North Canadian, on the north line of the Seminole reservation, is formed by one of these ledges. From Keokuk Falls to Okmulgee, a distance of fifty miles, only sandstones and shales appear. The sandstone ledges are often many feet thick and dip slightly to the west or southwest. The peculiar "stair-step arrangement" so noticeable in the Carboniferous of Kansas is observed throughout the region. Prominent ledges appear to the east as the escarpment of a bluff or hill. To the west these dip lower and lower and finally disappear beneath the bed of a stream, while they are succeeded above by other ledges.

These sandstones are not barren of fossils; the more common Carboniferous types being abundant in certain localities. Beds of coal are reported from the vicinity of Okmulgee. At Henry-

ville, a few miles south of Okmulgee, extensive beds have been located and are now being worked.

From Okmulgee to Sapulpa, thirty-five miles north, the same geological conditions obtain. Massive ledges of sandstone continue to give tone to the erosion forms. Two isolated buttes a few miles east of the "Frisco" railroad are so prominent as to have received the name of "Twin Hills." In the vicinity of these buttes the only ledge of limestone seen on the trip, except that in the Osage nation, was observed. The ledge is not to exceed two feet thick and is cut in a remarkable manner by joints running nearly at right angles. These joints are from twelve to twenty inches apart and in many cases extend the entire thickness of the ledge. As a result the limestone is cut into regular cubical blocks. In a number of places where the ledge is exposed in the bed of a stream these blocks have been pried out and used for foundations or stone walls. This rock requires very little dressing and will doubtless prove a source of considerable income.

In the region around Sapulpa and between that place and the Arkansas river at Tulsa, the sandstone ledges continue. Buttes and narrow ridges bordered by high and steep bluffs are frequent. Taneha mound, five miles east of Sapulpa, is perhaps the most typical of these. It is situated on the high prairie with its base 100 feet or more above the level of the Arkansas river at Tulsa. The sides of the hill are grass-covered and do not reveal the strata except the more prominent ledges of sandstone. The following section taken along the east slope illustrates the general rock structure of the country:

Taneha Mound Section.

No.		Feet.
10.	Sandstone forming cap of mound ----	10
9.	Slope -----	15
8.	Sandstone forming prominent terraces	5
7.	Slope -----	40
6.	Sandstone forming terraces -----	10
5.	Slope -----	30
4.	Sandstone forming a broad terrace... 5	
3.	Slope -----	20
2.	Sandstone -----	10
1.	Slope from level of prairie 100 feet above the level of the Arkansas... 50	
Total.....		195

Of this 195 feet of strata 40 feet consist of sandstone. The remainder, or 155 feet, is chiefly arenaceous shale. From the top of the mound a magnificent view of the surrounding country may be obtained. To the south especially is the scene

of particular geological interest. The dip of the sandstone ledges to the west is distinctly noticeable, and no fewer than five "stair steps" may be noticed from this point. Coal is found in several places in the vicinity. From what I was able to learn it occurs in at least two beds. On Coal creek, five miles east of the mound, a vein three feet thick is reported. Oil is also said to be present, although this can scarcely be authenticated as yet.

The most eastern point reached on the trip, and the lowest geologically, was the Dawson coal field in the west-southwest corner of the Cherokee nation. In the vicinity of Dawson the country is gently rolling. The coal is obtained by stripping. At present it is taken from a depth of from ten to fifteen feet. The rock dips quite strongly to the southwest. The following section shows the location of the vein:

Dawson Coal Field Section.

No.		Feet.
4.	Evenly laminated light brown shales with regular cleavage lines and some concretions.....	10
3.	Coal.....	2½
2.	Shales like No.4, grading upward from No.1	8
1.	Massive gray or yellowish sandstone, becoming shaly above and grading into No. 2.....	15
Total.....		35½

Other exposures of the same vein are found for several miles both north and south of Dawson. Outcrops are reported from numerous points along Bird creek all the way to Skiatook, a distance of more than twenty miles. This promises to become one of the most productive coal fields in the territory.

From Dawson to Pawhuska, a distance of 45 miles, the road lay up the valley of Bird creek. The hills are often steep and rugged and the bluffs are capped by ledges of massive or cross-bedded sandstone. Although no opportunity afforded to secure complete sections of the rocks of the region, the following (p. 190) is believed to present a fairly accurate provisional section from Skiatook to the top of the hill west of Pawhuska, or, in other words, from the upper coal beds to the base of the Flint hills. The dip of the rock continues to be to the west and southwest.

The three most noticeable features of the section are: 1st. The great predominance of sandstones and sandy shales. Of the entire section less than fifty feet consist of limestone. The three ledges of limestone are located near the center of the section and are well exposed on the bluffs below Lewis

Bird Creek Section.

No.		Feet.
9.	Massive sandstones and arenaceous shales extending from Lewis Rogers' place, thirty miles southwest of Pawhuska, to the top of the hill five miles west of Pawhuska	600
8.	Fossiliferous limestone	10
7.	Fossiliferous sandstone and shale	50
6.	Limestones with fossil shells and crinoids	5
5.	Sandstones and shales	100
4.	Massive fossiliferous limestone	20
3.	Arenaceous shales with ledges of sandstone	200
2.	Two thin ledges of limestone containing great quantities of fossil corals " <i>Camptophyllum torquium</i> " in ledges of sandy shale	25
1.	Sandstones and shales from Skiatook	100
	Total	1110

Rogers'. 2d. The strong and uniform dip of all the rocks to the west. This dip will average perhaps ten to fifteen feet per mile. 3d. The entire series is fossiliferous. This is the best fossil field in the territory that has come to my knowledge, and should be thoroughly studied. The ledges numbered 6, 7 and 8 particularly will reward investigation. All of these ledges are well exposed on the bluff back of Ben. Avant's farm, thirty-five miles southeast of Pawhuska.

From near Pawhuska to Winfield, Kansas, our route lay across the Flint hills. Massive ledges of limestone with flinty concretions, alternating with beds of calcareous shale, composed practically all the rock seen. The only sandstone noticed was on Beaver creek and near Maple City, spoken of above. The Flint hills have been too often described to require more than a passing mention in this place.

The results of this trip may be summarized as follows:

1. The Flint hills do not extend as far south as the Seminole country.

2. The sandstone, which is well developed in the eastern part of Chautauqua County, Kansas, continues uninterruptedly southward east of the Flint hills, beyond the North Canadian river.

3. The eastern limit of the Red-beds in southern Oklahoma is not far from the western part of the Seminole country.

4. A line of coal beds extends north and south near Bartlesville, Skiatook, Dawson, Tulsa, Okmulgee and Henryville. These beds vary much in thickness.

5. There is no reason to doubt that gas and oil will eventually be found near these coal beds.

ART. XV.—Names for the formations of the Ohio Coal-measures;* by CHARLES S. PROSSER.

FIELD work during the past three years has acquainted the writer with the formations composing the Coal-measures of southwestern Pennsylvania, Maryland and northern West Virginia. It was, therefore, quite natural in reviewing the classification of the Ohio formations that those of the Coal-measures should be among the first to be considered.

The Ohio Geological Reports contain a wealth of statements regarding the details of the formations and some that are conflicting. The writer makes no claim to have harmonized these various differences, but he has acquainted himself with the general nature and limits of the formations, so that he is able to compare the Ohio classification with that of the Appalachian.

Without attempting to trace the complete development, the more important features of the classification of the Appalachian Coal-measures may be briefly summarized.

Henry D. Rogers, in the final report of the First Geological Survey of Pennsylvania, proposed and defined the following divisions of the coal strata, or Seral series as he termed them, which are arranged in descending order:

- Upper Barren Coal-shales.
- Upper Productive Coal-measures.
- Lower Barren Coal-shales.
- Lower Productive Coal-measures.
- Seral conglomerate (or lowest division of the Coal-measures.)†

Under the description of the divisions the names are slightly modified and there is a lack of uniformity in the wording in the several places in which the names occur, but the following, omitting the conglomerate, is an approximation:

- Newer Coal-shales or Upper Barren group.
- Upper or Newer Coal-measures.
- Older Coal-shales or Lower Barren group.
- Older or Lower Coal-measures.‡

The Lower Barren group was defined as having "for its inferior limit the top of the Upper Freeport coal, and for its superior boundary the bottom of the great Pittsburg bed."§ This also fixed the top of the Lower Coal-measures, the base

* Presented to the tenth meeting of the Ohio State Academy of Science, Columbus, December 27, 1900.

† Geology Pennsylvania, vol. i, 1858, p. 109.

‡ Ibid., vol. ii, pt. 1, pp. 16-20.

§ Ibid., p. 19.

of which was not so sharply defined, although it was stated in general that it rested directly on the conglomerate; but in the anthracite region, where the two are closely united, Prof. Rogers reported that "considerations of convenience dictate that we place an arbitrary boundary at the bottom of the first or lowest considerable coal-seam."* The Upper or Newer Coal-measures were defined as extending "from the bottom of the Pittsburg coal to the top of the Waynesburg seam,"† and the Upper Barren group contained the remainder of the coal rocks which were found in the southwestern corner of the state.

From this classification has come the one in general use, which is stated as follows, by Dana, in the last edition of his Manual:

Upper Barren Measures.
Upper Productive Measures.
Lower Barren Measures.
Lower Productive Measures.‡

In 1872 Prof. Stevenson described the Coal-measure formations as shown in Monongalia and Marion counties, West Virginia, stating that he "thought it best to adopt the terms used in the Geology of Pennsylvania and the Virginia Reports, for, though they may not have been based on scientific grounds, they are most convenient for description, as the rocks are here developed."§ Under the descriptions of the formations, or groups as they were termed, names derived from geographical terms were used as synonyms for the Lower and Upper Coal groups, the limits of which differed somewhat from those fixed by Rogers.

The Lower Coal group or Allegheny river series extended from "the Great Conglomerate" to the top of the Mahoning sandstone.¶ The base of the formation was drawn at a lower horizon than has generally been the case in later classifications, for it included the Tionesta sandstone and coal (Coals Nos. 18 and 20 of the section), while the higher coal (No. 14 of the section) was correlated with the Brookville, which later has come to be regarded as very near the base of the Allegheny formation. The upper limit of the formation at the top of the Mahoning sandstone also differed from that of the Lower Coal-measures of Rogers, which was drawn at the top of the Upper Freeport coal at the base of the Mahoning sandstone.

The Upper Coal group or Monongahela river series extended from the base of the fire clay immediately underlying the Pittsburg coal to the top of the Waynesburg sandstone, which was given as from 31 to 55 feet above the top of the Waynesburg coal,¶ while the Upper Coal-measures of Rogers extended

* Geology Pennsylvania, vol. i, 1858, p. 17. † Ibid., p. 19.

‡ Manual of Geology, 4th ed., 1895, p. 648.

§ Trans. Am. Phil. Soc. Philadelphia, 2d Ser., vol. xv, p. 16.

¶ Ibid., pp. 27-30.

¶ Ibid., p. 17.

from the base of the Pittsburg to the top of the Waynesburg coal.

When the Second Geological Survey of Pennsylvania was organized Mr. Franklin Platt was engaged as Assistant Geologist to describe the bituminous coal fields of western Pennsylvania, and, as a result of his field work in 1874, the following year he published a table of Paleozoic formations in which geographical names were used for those of the Coal-measures with the exception of the Upper Barren Measures. The names of the formations under consideration are as follows:

		Upper Barren Measures.
Monongahela	{	M. Brownsville (Washington) coal.
		L. Waynesburg coal.
		K. Sewickley coal.
		J. Redstone coal.
Conemaugh	{	Middle Barren Measures.
		Mahoning sandstone.
Allegheny	{	E. Upper Freeport coal.
		Freeport limestone.
		D. Lower Freeport coal.
		Freeport sandstone.
		C. Kittanning coal.
		B' Ferriferous coal.
		Ferriferous limestone.
		B. Clarion coal.
		A. Brookville coal.

Conglomerate No. XII, (Seral).*

It will be seen from the above that the Allegheny formation extended from the base of the Brookville coal to the top of the Upper Freeport coal; the Conemaugh formation from the last mentioned horizon to the base of the Pittsburg coal, and the limits of the Monongahela formation differed from those of the Upper Coal-measures of Rogers in that they extended from the base of the Pittsburg coal to the top of the Washington coal, or the one succeeding the Waynesburg coal. The important point in connection with this classification is that geographical names were used for the three formations which compose the Coal-measures proper of Pennsylvania, and the terms based upon the presence or absence of valuable beds of coal abandoned, so that the classification was brought into harmony with the names used for the older Paleozoic formations. Modifications of this classification were published later by Pratt† and in 1877 he used the name Monongahela

* Second Geol. Surv. Penna., H, 1875, p. 8.

† Ibid., L, 1876, pp. 12, 17, 23; and H², 1877, pp. xxiii, xxiv.

River system to cover all the rocks from the highest Upper Barren Measures to the base of the Upper Productive Coal Measures, while those included between the horizon last mentioned and the top of the Pottsville conglomerate were called the Allegheny River system.

Lesley also in the same year divided the Carboniferous system into first the *Monongahela River Coal Series*, which included the rocks from the highest of the Upper Barren Measures to the base of the Upper Productive Coal-measures, and second the *Allegheny River Coal Series*, which apparently comprised all the rocks from the top of the Lower Barren Measures to the base of the Pocono sandstone.*

In some respects these modified classifications appear less desirable than the original one and, according to the practice of the U. S. Geological Survey which is now quite generally followed by American geologists, the names *Monongahela* and *Allegheny* having already been used for divisions of smaller rank, were not available as names for these two divisions.

In 1876 Prof. Stevenson divided the Upper Barren series into two groups, the upper one termed the Greene County group, which included all the rocks above the Upper Washington limestone; and the lower one, named the Washington County group, which extended from the top of the Washington limestone to the top of the Waynesburg sandstone, an horizon some 80 feet above the Waynesburg main coal.†

Professors Fontaine and I. C. White carefully studied the flora of the Upper Barren Measures and reached the conclusion that the "Upper Barrens of the Appalachian coal field are of Permian age."‡

In 1891 Dr. I. C. White published his excellent work on the "Stratigraphy of the bituminous coal fields of Pennsylvania, Ohio and West Virginia," in which he named the Upper Barren Measures the Dunkard Creek series,§ stating that "the rocks of this series begin with the roof shales of the Waynesburg coal and extend upward to the topmost beds of the Appalachian region."||

In 1896 Messrs. N. H. Darton and Joseph A. Taff published a description of the geological formations of the Piedmont folio, covering the southern part of the extreme western portion of Maryland and a larger area to the south of the North Branch of the Potomac river in the northern part of West Virginia. They gave new names to the Coal-measure formations derived from geographic names occurring in the Piedmont quadrangle, and in general the formations were not separated as they were

* Second Geol. Surv. Penna., H³, 1877, p. xxiii. † Ibid., K, p. 35.

‡ Ibid., Report PP, 1880, p. 119.

§ Bull. U. S. Geol. Surv., No. 65, p. 19. || Ibid., p. 20.

in the earlier classifications. Their list of names, beginning with the Conglomerate, is as follows :

1. The *Blackwater sandstone*, which represented the Pottsville conglomerate.

2. The *Savage formation*, which extended from the top of the Blackwater sandstone or conglomerate to the top of the Davis or Lower Kittanning coal and included nearly the lower half of the Allegheny formation.

3. The *Bayard formation*, which extended from the top of the Davis coal to the top of the sandstone overlying the Four-foot or Barton coal. This formation contained the upper half of the Allegheny and the lower part of the Conemaugh formation.

4. The *Fairfax formation*, which continued from the top of the Bayard formation to the base of the Elkgarden or Pittsburg coal and contained the remainder of the Conemaugh formation.

5. The *Elkgarden formation*, which contained the rocks above the base of the Pittsburg coal, all of which, with perhaps the exception of the highest, were in the Monongahela formation.*

Upon the organization of the Geological Survey of Ohio by Dr. Newberry a thorough study of the coal deposits of the state was undertaken and to the second report he contributed a "Sketch of the Structure of the Lower Coal Measures in Northeastern Ohio."† Dr. Newberry stated that "North of the National Road we have in Ohio, below the Barren Measures, from six to eight workable seams of coal, forming what is known as the lower coal series."‡ Beginning with the lowest seam, which was called Coal No. 1, they were described and given numbers, the highest one being Coal No. 7,§ which was stated to be "the highest workable seam of coal in Ohio below the Pittsburg bed. . . . It is overlaid by the great mass of colored shales which form the Barren Coal Measures."||

At a later date all the names proposed by Prof. Rogers for the Coal-measure formations of Pennsylvania were adopted for those of Ohio, as shown by a "Vertical section of the rocks of Ohio" published in 1873, on which the Coal-measures are composed of the following formations:

"Upper Coal Measures	}	1200 ft."¶
Barren Measures		
Lower Coal Measures		

*Geologic Atlas of the United States; Folio 28, pp. 3, 4, 6 and "Columnar Section."

† Geol. Surv. Ohio. Report Progress in 1870, 1871, p. 14.

‡ Ibid., p. 26. § Ibid., pp. 26-44. || Ibid., p. 43.

¶ Rept. Geol. Surv. Ohio, vol. 1, pt. 1, facing p. 89.

In the report which followed, Dr. Newberry gave a detailed account of the Carboniferous system of Ohio as then known, and to the list of formations of the former section he added the Upper Barren Measures with a thickness of 300 feet (?) and continued the numbering of the principal coal seams as far as 13 inclusive, of which No. 1 indicated the lowest coal.* In this classification, however, the base of the Lower Coal-measures was carried considerably lower than in Pennsylvania, so that the division contained a considerable part of Rogers' Seral Conglomerate, Coals Nos. 1, 2 and 3 belonging in the Conglomerate.

In 1884 the volume on Economic Geology appeared, containing Dr. Orton's exhaustive account of the Lower Coal-measures of Ohio. The classification of Rogers is quoted and explained,† but the greater part of the Conglomerate was included in the Lower Coal-measures, since this formation began with the lowest coal seam, as was the case in the earlier classification of Newberry. Dr. Orton stated that "In point of fact, there is no more marked separation between the highest coal seam of the Conglomerate series and the lowest of the Productive Measures than can be found between two coals of the latter subdivision."‡ It was shown, however, that Coal No. 4 of Newberry, occurring just below the Putnam Hill limestone, was probably equivalent to the Brookville Coal of Pennsylvania, which in that state occurs at about the base of the Lower Productive Measures or Allegheny formation.§

In 1888 the complete Rogers' classification of Pennsylvania, however, was adopted, as is shown in the following table :

"Upper Barren Coal Measures	500 feet
Upper Productive Coal Measures.....	200 feet
Lower Barren Coal Measures	500 feet
Lower Productive Coal Measures.....	250 feet
Conglomerate Group.....	250 feet"

Regarding the change in the classification for the two lower divisions from that of the preceding report, is the following explanation: "In the review in Vol. V, the Conglomerate series of Pennsylvania was included with the Lower Coal Measures, though the boundaries of each were shown to be clearly recognizable here. There are, however, less imperative grounds for the separation in Ohio than in Pennsylvania and

* Rept. Geol. Surv. Ohio, vol. ii, pt. i, 1874, "Section of the Carboniferous rocks of Ohio," facing p. 81.

† Rept. Geol. Surv., vol. v, pp. 1, 2.

‡ Ibid., p. 10. § Ibid., pp. 160, 230.

|| Ibid., vol. vi, p. 3; see also "Vertical section of the rocks of Ohio," facing p. 4.

the Virginias, and if only the Ohio series were to be classified, it is not probable that the divisions would have been made. But they stand for great and conspicuous facts elsewhere, and it probably would have been better to have maintained them in our territory also. The separation will be recognized in this review.”*

The same classification was used by Dr. Orton in his last report of the Ohio Survey,† which also contained a chapter on “The Coal Fields of Ohio” in which he described the coal seams of the Conglomerate Coal-measures, the Lower Coal-measures and the Upper Productive Measures.‡

The Maryland Geological Survey has carefully considered the Carboniferous formations and adopted the classification shown in the following table, which gives the approximate thickness and composition of the formations as exposed in Georges Creek valley in the western part of Allegany county:

Georges Creek, Md., Section of the Coal-measures and Permian.

Dunkard 400'.	{	400'	Mainly argillaceous shales, some thin limestones and sandstones and an occasional thin layer of coal.
		2'—	Waynesburg (Koontz) coal.
		116'±	Shales and limestones.
Monongahela 250'.	{	6'	Sewickley (Tyson) coal and shale.
		100'— 115'	Mainly argillaceous shales.
		14'±	Pittsburg (Elkgarden) or “Fourteen-foot” coal.
		144'	Black and gray shales and thin sandstones.
Conemaugh About 650'.	{	9'	Franklin (Dirty nine-foot) coal, partly shale.
		72'	Shales and sandstones.
		1'	About one foot of coal.

* Ibid., p. 43.

† Ibid., vol. vii, 1893, pp. 4, 36, 37 and “Geological Scale of Ohio” facing p. 4.

‡ Ibid., pp. 255-291.

Conemaugh About 650'.	}	187'	Sandy and bituminous shales and sandstones.
		4'	Barton (Four-foot) coal.
		112'	Shales, fire-clay and thin bedded sandstone.
		32'	Partly sandstone, (Upper Mahoning sandstone.)
		2'—	Mahoning coal.
		85'	Massive sandstone alternating with shales. Mahoning sandstone.
Allegheny 300'.	}	2'—3'	Upper Freeport (Thomas) coal.
		11'	Fire clay and shales.
		1'	Coal
		99'	Shales and sandstones.
		1¼'	Upper Kittanning (?) coal.
		55'	Shales and sandstones.
		6'	Lower Kittanning or Davis (Six-foot) coal.
		30'	Shales and sandstones.
		4'	Split Six-foot coal.
		96'	Fire clay, shales and thin bedded sandstones. In part of the field there is the massive Homewood or Piedmont sandstone at top of the Pottsville conglomerate.*

In Jennings and Braddock runs and on Dans Mountain there are two beds of coal near the base of the Allegheny formation which apparently do not occur in the lower part of Georges Creek valley in the vicinity of Westernport and Piedmont.

The section of the lower part of the Allegheny for this part of the field is approximately as follows:

* A more detailed account of these formations may be found in the report by the Maryland Geological Survey on Allegheny County, 1900, pp. 115-130, 166-180.

2'—2½'	Clarion (Parker) coal.
36'	Thin sandstones at top with drab argillaceous shales below. In some localities there is a coal seam 18' above the Bluebaugh coal.
2½'—7'	Brookville (Bluebaugh) coal. In the thickest deposit 16" of shale occurs, 1' below the top of the coal.
10'±	Homewood sandstone.*

The Maryland Geological Survey fully accepted the modern ruling that the name of a formation should refer to some locality at which the rocks are well exposed. For this reason the time-honored names of Rogers as Lower Productive Measures, etc., which referred to the presence or absence of workable seams of coal, were abandoned, and the names Allegheny, Conemaugh, Monongahela and Dunkard were adopted. With the exception of Dunkard these are the oldest names, derived from geographical terms, proposed for the formations. In regard to the Upper Barren Measures it was thought better to consider them as one formation, hence the name Dunkard of Dr. White, dropping the words "Creek series" as he originally published it, was used instead of the two earlier terms of Prof. Stevenson.

The names proposed by Messrs Darton and Taff were not used because it was considered that the Rogers-Platt classification, which also had priority, was a more satisfactory one.

In our review of the Coal-measure formations of Ohio we have shown that in the final classification their limits correspond to those of Pennsylvania, and, therefore, it is proposed that the names recently adopted for them by the Maryland Geological Survey be used for the same formations in Ohio. This will involve the following changes in the nomenclature of the Ohio formations:

<i>Present names.</i>	<i>Proposed names.</i>
Upper Barren Coal Measures	= Dunkard formation.
Upper Productive Coal Measures	= Monongahela formation.
Lower Barren Coal Measures	= Conemaugh formation.
Lower Productive Coal Measures	= Allegheny formation.

Columbus, O., December, 1900.

* This section of the Georges Creek valley is published with the permission of Dr. Wm. Bullock Clark, State Geologist of Maryland.

Some information concerning the lower part of the formation was obtained from Prof. James Hall's report regarding the north fork of Jennings's run as abstracted in Macfarlane's Coal-regions of America, 3d ed., 1877, p. 256.

ART. XVI.—*A New American Species of Amphicyon*; by
J. L. WORTMAN.

THE true genus *Amphicyon* has not hitherto been found in this country, notwithstanding the fact that Leidy, Cope, and Marsh have, at various times, referred certain specimens of extinct dogs, having three true molars in the upper jaw, to this group. Scott has satisfactorily shown that all the *Amphicyons* of the American Tertiary heretofore described, belong to genera quite different and distinct from the typical genus *Amphicyon* of Europe.

While recently engaged in the examination of some remains of extinct *Canidæ* in the Marsh Collection at the Peabody Museum, I came across a beautifully preserved palatal portion of a skull, from the Loup Fork Miocene deposits of Nebraska, which I do not hesitate to refer to this European genus. The specimen in question includes all the superior series of teeth with the exception of the incisors, a few premolars of the right side, and the last upper molar of the left side.

As compared with the best known European species, *Amphicyon giganteus* Laurill., from the Middle Miocene of France, great similarity of structure is at once apparent. Like all the *Amphicyons* the canines are unusually large and robust and are provided with prominent cutting edges, both anteriorly and posteriorly. The three anterior premolars are strikingly reduced in size, the two anterior being separated from each other and from the succeeding teeth by short diastemata. The first premolar is implanted by a single fang, the second and third by two. In comparison with the other teeth, the fourth premolar, or superior sectorial, displays about the same proportions as that of *A. giganteus*, but the internal cusp is less distinct; it appears as a low rounded swelling at the base of the crown, supported by an independent root, and is not so distinct as is usual in the *Canidæ*. The molars differ considerably from those of *A. giganteus* in that the external portion of the crown is less rounded, has a greater fore and aft extent and the internal less, giving to it a more distinctly triangular appearance, as in the true dogs. Another important difference is seen in the prominence and external position of the basal cusp at the antero-external angle of the first molar in the American species, in marked contrast with the internal position and more reduced character of this element in the European species. It may be remarked that in their general appearance the molars of the American form are decidedly more dog-like, while those of the European species more closely approach the structure displayed by the primitive bears.

After careful examination of the material at hand, I fail to find any characters which would warrant me in placing the present specimen in a genus distinct from *Amphicyon*, although the specific characters seem to be somewhat unusually accentuated. I propose, therefore, to refer to it under the name of *Amphicyon americanus*.

The chief interest in the *Amphicyon* group lies in the fact that it is through them that the ancestry of the modern bears has been traced directly to a canine origin, apparently by the most exact and satisfactory evidence. This evolution is supposed to have taken place in Europe, and the conclusion has been reached that from this exclusive area of origin they have gradually spread to nearly all parts of the world. However this may be, it is a matter of considerable interest to find one of the ancestral links of the phylum in this country, and one, moreover, which, so far as the superior molars are concerned, is the most primitive yet known.

It is desirable, therefore, to inquire further into the relationship between this *Amphicyon* and certain other extinct types of the *Canidæ* found in deposits of preceding age in this country. I am led to undertake this now for the sake of clearness, however brief and imperfect the results may be, pending a more complete study of the Eocene Carnivora which I hope soon to publish.

One of the prime essentials in the way of relationship which these earlier extinct *Canidæ* must exhibit, is the possession of three true molars in the upper jaw, as the disappearance of the last molar in any of them would certainly mean a two-molared successor. The possession of three superior molars is undoubtedly an archaic feature among the *Canidæ*, and this condition was retained by some of the phyla until comparatively late in their developmental history. Others again suffered an early reduction in the number of molars, particularly in the superior series, but in the great majority of instances this reduction has consisted in the disappearance of the last molar only. It is somewhat remarkable to find that the molar formula which characterizes the great bulk of the species of the *Canidæ* to-day was fixed at least as early as the Upper Eocene; and not only has the number, but the general form and proportions, of these teeth remained, up to the present time, unusually constant in that phylum from which the modern genus *Canis* was derived.

Of those types possessing three true molars in the superior series, *Paradaphænus*, a genus established by Matthew and myself,* is the only one which has thus far been found in the

* Bull. Amer. Mus. Nat. Hist., New York, June, 1899, p. 129.

Middle Miocene deposits of this country. It is represented by at least two species from the John Day beds of Oregon and is not uncommon. In the structure of the superior molars this genus agrees closely with *Amphicyon*, in that the crowns are symmetrical and much extended transversely; the last molar, moreover, is but little pushed inwards and the cusps and ridges are relatively high and prominent. There is no apparent reduction in the size of any of the premolars, a fact which would indicate that any species of *Paradaphænus* thus far known cannot be regarded as directly ancestral to *Amphicyon*.

In the underlying White River beds comes the genus *Daphænus* Leidy, represented by at least four well-marked species of rather common occurrence. In this group the ridges and cusps of the molars are characteristically low and blunt, the crowns of the upper molars are less symmetrical transversely, and the third molar is pushed inward on a line with the internal cusps. In any of the known species the premolars are not reduced in size to any very noticeable extent. It will be seen, therefore, that the genus is still further removed from *Amphicyon* in its dental anatomy, and on this account must be regarded as off the direct line of ancestry of *Amphicyon*. Next below the White River species is found the genus *Prodaphænus* W. and M.* from the Uinta or uppermost Eocene, and although but a single specimen consisting of a portion of a superior maxillary is known, yet it serves to indicate with certainty the existence of a three-molared type of the Canidæ in this horizon. This genus is again preceded in the Bridger beds by *Uintacyon* Leidy, which has numerous species reaching as far back as the Wasatch or Lower Eocene.

That which is of especial interest to us in this connection is the fact that certain species of *Uintacyon* and the only known species of *Prodaphænus* show a marked reduction in the size of the premolars, possessing at the same time a type of molar pattern which could have easily passed into that of *Amphicyon* and thence into the bears. The likeness is not confined to the upper molars, but extends to the lower molars and canines as well. While the materials now known are perhaps too fragmentary and scattering to hazard a definite opinion, yet the resemblances between *Amphicyon* and these Eocene forms are so striking that I cannot believe them altogether due to accident. If this surmise of genetic affinity is correct it will go far towards clearing up the origin of this peculiar and important group of the Canidæ.

* Bull. Amer. Mus. Nat. Hist., June, 1899, p. 115.

A

B

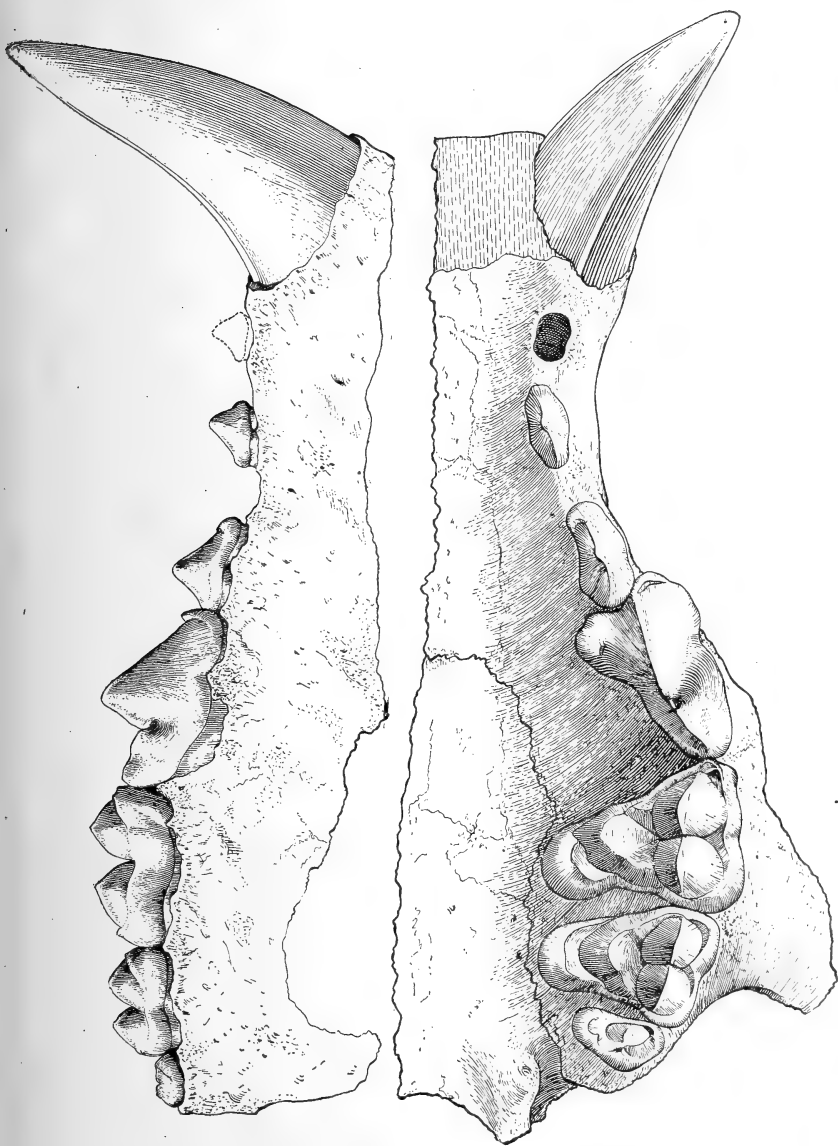

AMPHICYON AMERICANUS, Wortman.

Fig. A.—Left upper jaw, palatal view, natural size.

Fig. B.—Left upper jaw, side view, natural size.

Loup Fork beds, Niobrara River, Nebraska.

Type in Yale University Museum.

I give the following principal measurements :

	mm.
Length of superior tooth series including canine....	134
Antero-posterior diameter of canine at base	24
Length of true molar series	46
Transverse diameter of first superior molar	27
Antero-posterior diameter of superior sectorial....	27
Width of palate at first molar including crowns...	98

My best thanks are due to Prof. C. E. Beecher, Curator of the Geological Department of the Museum, for the opportunity of making the necessary studies and publishing the above results.

New Haven, Conn., Jan. 25.

ART. XVII.—*Studies in the Cyperaceæ*; by THEO. HOLM.
 XV. *Carices (Vigneæ) astrostachyæ*. (With five figures in the text.)

IN some previously published papers we have directed attention to the classification of the *Carices* in "*Vigneæ*," "*Vigneastræ*" and "*Carices genuinæ*" as the most natural method under which the species may be arranged in sections or "greges," as suggested by Drejer in his *Symbolæ Caricologicæ*. However, this author only treated some of "*Carices genuinæ*," although he fully recognized the stability of the "*Vigneæ*," while "*Vigneastræ*" did not appear to him as being separable from the paniculate *distigmaticæ*. While maintaining the *Vigneæ*, Drejer did not restrict this section to distigmatic species alone, but he considered, also, certain tristigmatic species, for instance *C. macrocephala*, as belonging to this section; he admitted at the same time a number of distigmatic heterostachyous species among the *Carices genuinæ*, even if he considered this section as consisting of typically tristigmatic species. The number of stigmata was, thus, of minor importance to Drejer in disposing of the species in "greges." We have already touched upon his views concerning the old section "*Psyllophoræ*," but hitherto we have not had an opportunity to discuss his ideas in regard to the arrangement of all the *Psyllophoræ* under *Carices genuinæ*, as "*formæ hebetatæ*" of these. It is, at least, the only way in which we can understand his remark (l. c., p. 8), "Constituunt ergo Psyllophoræ et Carices genuinæ unam maximeque naturalem sectionem, etc.," inasmuch as Drejer defined the *Psyllophoræ* as monostachyous, and the *Vigneæ* as possessing decomposed spikes (*spica composita præditas*). Moreover, in describing the various forms of perigynium, Drejer points out that, "omnes fere formæ perigyniorum, exceptis maxime evolutis, quæ apud Carices inveniuntur, inter *Psyllophoras* quoque occurrunt." He compares thus the perigynium of *C. polytrichoides* with that of *C. pallescens*, and of *C. Davalliana* with that of *C. sempervirens*, etc. Whatever his views were in respect to the lesser developed types of *Vigneæ*, Drejer does not seem to have considered any of these to be sought among the monostachyous species, formerly called "*Psyllophoræ*." But his work was left unfinished, and it is more than probable that he would have altered his views, had he prosecuted his studies further.

Tuckermann, whose system of *Carex* was published just one year earlier than Drejer's, adopted *Psyllophoræ* and *Vigneæ*

with the same distinction "spica unica" and "spiculæ plures"; further, he proposed "*Vigneastræ*," "*Leptantheræ*" and "*Legitimæ*," the last mentioned being identical with *Carices genuinæ*. This author, however, seems to have detected some affinity to exist between certain *Psyllophoræ* (*Dioicæ*) and *Vignæ* (*Stellulatæ*), since he makes the following statement about the former (*Dioicæ*), "Stellulatas referentes." In a lately published paper upon South American *Carices* Rev. G. Kükenthal accepts *Vignæ*, *Vigneastræ* and *Eucarex* (*Carices genuinæ*), and he recognizes five sections among the *Vignæ*: *Muricatæ* Fr., *Remotæ* Aschers, *Canescentes* Fr., *Alatæ* Kükenth. and *Capituligeræ* Kükenth. While this author refers certain *Psyllophoræ* (*Nardinæ* Fr.) to *Vignæ*, he does not suggest these to represent lesser developed types of any of the other sections, and the reason may be, that the South American *Capituligeræ*: *C. trichodes* Steud., *C. capitata* L. and *C. caduca* Boott, constitute a small and isolated group of species with no immediate relatives among the higher developed *Vignæ* of that region, the extratropical South America.

The systematic position of a number of monostachyous species of *Carex* thus remains to be decided upon, and it seems as if Tuckermann were the first author who felt warranted in referring some of these to *Vignæ*, the *Dioicæ* to the *Stellulatæ*, while both Drejer and Kükenthal considered several of these as "formæ hebetatæ of *Carices genuinæ*." It may be that the original type of *Carex* was diœcious and that it resembled our monostachyous species, and that both *Vignæ* and *Carices genuinæ* developed from such monostachyous forms as two parallel branches, a theory that has been discussed so excellently by a German author, August Schulz, in a paper upon the morphology of *Carices*. There would in this way hardly be any reason to object to the disposition of some of the monostachyous species among *Vignæ* as "formæ hebetatæ:" lesser developed types of which habit and structure might point towards the earliest fundamental forms of the genus.

In looking over the *Psyllophoræ* as this section is understood by Tuckermann, it is evident that several of these species have no other character in common than that taken from the structure of the inflorescence, being an almost simple spike, androgynous or sometimes diœcious. The purely staminate inflorescence and the staminate portion of the androgynous invariably represent true spikes, while the pistillate, as we have described in previously published papers, are always decomposed, though less so in these species than in others, where several pistillate spikelets may be united so as to form spicate, more or less ramified inflorescences. In the *Psyllo-*

phoræ the sectional character is thus: "spica unica simplicissima androgyna sive dioica," and Tuckermann divided these in nine subsections: *Dioicæ*, *Nardinæ*, *Pulicares*, *Paucifloræ*, *Filifoliæ*, *Scirpinæ*, *Obtusatæ*, *Polytrichoideæ* and *Rupestres*, of which the names readily indicate what species are comprised under these subsections. But on the other hand the characterization of these minor sections is in several cases well comparable with that of several of the *Vignæ* and *Carices genuinæ*, as defined by Tuckermann, with the only exception of the lesser decomposed inflorescence. We find among the *Dioicæ* such species enumerated as *C. dioeca*, etc., *C. exilis* and even *C. capitata* L., the last mentioned being followed by *C. nardina* Fr. (*Nardinæ*), and it seems strange that Tuckermann considered *C. capitata* as being such a close relative of *C. dioeca*, rather than placing it under *Nardinæ*. Elias Fries in enumerating the Scandinavian *Carices** has, also, the *Psyllophoræ* classified as his *Monostachyæ* distinct from his "*Homostachyæ*:" *Hyparrhenæ* and *Acroarrhenæ*, while Kunth only recognized *Vignæ* and *Carex*, the former containing all the species with bifid, the latter those with trifid style, thus each of these sections is represented by both mono-, homo- and hetero-stachyous species. The number of stigmata, however, is of little importance in classifying *Carices*, inasmuch as we have already pointed out, the number of stigmata being by no means a constant character in several species of *Vignæ* and *Carices genuinæ*.

In regard to the distribution of the sexes, diœcious forms are not restricted to the *Psyllophoræ* either, but occur among the *Vignæ*, e. g., *C. sterilis* Willd., *C. Douglasii* Boott, and occasionally among the *Carices genuinæ*: *C. Parryana* Dew., besides that *C. acuta* L. sometimes occurs with purely staminate spikes, the so-called variety *anomala* Lge., which has been found in Denmark. The very interesting *C. Bottiana* Benth. is only known as diœcious, but Boott† referred it nevertheless to *Carices genuinæ* on account of its close affinity to *C. Baltzelli* Chapm. However these cases of diœcism may well be considered as exceptional among *Vignæ* and *Carices genuinæ*, while there are typically diœcious species among the *Psyllophoræ*: *C. dioeca*, *C. parallela*, etc. The character "spica unica" as applied to all the *Psyllophoræ* is, on the other hand, not constant, and we remember for instance that in both *C. scirpoidea* and *C. exilis* additional, lateral spikes may be developed, consisting of several pistillate flowers. Drejer referred *C. scirpoidea* to his *Sphæridiophoræ*, and

* Fries Elias: Summa vegetabilium Scandinaviæ. Sectio prior. Upsala, 1846, p. 73.

† Boott, Francis: Illustrations of the genus Carex, vol. i, London, 1858, p. 16.

Boott* says of *C. exilis*: "The existence of these distinct spiculæ necessarily separate the species from the *Psyllophoræ*. It proves the correctness of the remark of Drejer, that that artificial group is to be considered as "formæ hebetatæ Caricum; monostachyæ incipiunt, evaduntque plioistachyæ. The evident affinity of *C. exilis* is with the *Stellulata*;" a similar suggestion was also made by Tuckermann, as mentioned above.

In looking over the *Vignæ* and *Carices genuinæ* monostachyous specimens are sometimes met with, especially among the latter, but such forms are hardly to be considered as typical, even if they may be quite common, for instance *C. typhina* and *C. squarrosa*, both of which abound in the vicinity of Washington, D. C., with a single gynæcandrous spike, subtended by several leaf-like bracts, indicating the suppression of the lateral spikes; these forms have, also, been found in many other places in the eastern United States, and seem to predominate, the typical plioistachyous forms being much less common in certain regions. It thus appears as if the *Psyllophoræ* in general exhibit some characters by which they may be distinguished from the other *Carices*: "spica unica simplicissima androgyna sive dioica," as indicated by Tuckermann, but beyond this distinction most of the species are readily noticed to be inseparable from *Vignæ* or *Carices genuinæ*. This becomes the more evident when we consider the structure of utriculus, which furnishes such excellent characters for distinguishing the species and even the "greges," and is of much greater importance than those characters, which are derived from the less decompound inflorescence, the number of stigmata and the separation of the sexes in some of the species. When speaking of utriculus, we must admit, however, that this exhibits a peculiarity which seems characteristic of a number of *Psyllophoræ* in contrast to the *Vignæ* and *Carices genuinæ* in general; and is evidently a sign of lesser development. This is to be noticed in the orifice of utriculus, which is unequally slit in the *Dioicæ*; thus the upper margin is almost entire on the ventral face, but cut down more or less deeply on the dorsal, the convex face. In the higher developed forms, *Vignæ* and *Carices genuinæ*, the beak is mostly bidentate or cut down equally on both faces, especially so in the latter. But this character, the unequally slit orifice of utriculus, is not peculiar to all the *Psyllophoræ* and is, moreover, to be observed in some of the *Carices genuinæ*, as pointed out by Drejer. But otherwise the utricles does not show any difference of importance, by which the *Psyllophoræ* may be distinguished from the other *Carices*,

* Ibidem, p. 17.

neither in regard to the mere outline, when considered in transverse section, or as to the minor details of the anatomical structure. The presence of a seta, which, as we have described in previously published papers, depends only upon the prolongation of rhacheola, has by some authors been considered as characteristic of *Psyllophoræ*, being especially well developed in *C. microglochis*, *C. Fraseri* and several others, but is, also, common to many species of *Carices genuinæ*. If we finally compare the position or rather the direction of utriculus in immature and mature specimens of the *Dioicæ*, we notice certain accordances with some of the other *Carices*. In *C. dioeca*, for instance, the utricles are erect during anthesis, but spreading, when the fruit is mature. This change of direction is, also, noticeable in the other species of *Dioicæ* (excluding *C. capitata*), but is, moreover, characteristic of a number of other *Carices* with the spikes squarrose at maturity (*C. echinata*, *C. flava*, *C. Pseudocyperus*, etc.), while in others the utricles maintain their original erect position, being more or less appressed to the rhachis as in *C. vulgaris*, *C. misandra*, *C. pratensis*, etc.

In summarizing these general characters, those that were formerly looked upon as being peculiar to the *Psyllophoræ*, and those which they have in common with the other *Carices*, we cannot consider these monostachyous species as constituting a section or grex distinct from the others, but we feel more inclined to accept them as lesser developed types and referable to the greges of *Vignæ* and *Carices genuinæ*, in the same way as we already outlined the *Stenocarpæ*, including *C. lejocarpa* and *C. circinata* as formæ hebetatæ of these. In the present paper, it is our intention to demonstrate the affinities of the *Dioicæ*, as understood by Tuckermann, although we have felt obliged to exclude *C. capitata* L., which, according to our opinion, is better placed among the *Nardinæ* Fr., as already suggested by Rev. G. Kükenthal. These diœcious species are as follows: *Carex dioeca* L., *C. gynocrates* Wormskj., *C. parallela* Læst., *C. Davalliana* Sm. and *C. exilis* Dew. However, monœcious forms are known of all these species and are so common in *C. gynocrates* and *C. exilis*, that it is difficult to say whether these two are typically diœcious or monœcious, and in regard to the former this was originally described as a monœcious species with androgynous spike, being the most prevalent form in Greenland. Since then the species has, also, been collected on the North American continent and in Kamtschatka as monœcious and diœcious, the latter being undoubtedly the most frequent form in this country. If Meyer's *C. Redowskyana* be identical with *C. gynocrates*, the plant from Kamtschatka is truly diœcious. To separate

these two forms, the monœcious from the diœcious, as distinct species would not be advisable, inasmuch as we have found no other distinction between these, neither morphological or anatomical, than the varied distribution of the sexes, a character that seems of little import, scarcely even of varietal value. *C. gynocrates* may be considered as being most frequently diœcious, and among the large number of specimens which we have examined from various parts of this country and from Greenland, there were c. 400 diœcious individuals against 76 with androgynous spike. *C. monosperma* Macoun is among these specimens, and we have failed to find any other distinction between this and *C. gynocrates* than the smaller number of pistillate flowers, often only one, at the base of the staminate spike. If we consider the geographical distribution of *C. gynocrates*, it seems as if the monœcious form is the most prevalent in the north, judging from the specimens we have examined, which were collected in Northern Labrador, Alaska and Greenland, where we found this species probably at its most northern limit, "Skarvefjæld," on the island Disco, above 69° N. lat., where it occurred only as monœcious.

In regard to *C. exilis*, this species represents a still more evolute stage, and occurs as diœcious or monœcious, mono- or plio-stachyous. A gynœcandrous spike is frequently met with in this species, besides that the female plant may possess several lateral spikes, from one to six, at the base of the terminal. *Carex Davalliana* exhibits a similar variation, possessing androgynous or gynœcandrous spikes besides purely staminate or pistillate, and, moreover, a few pistillate flowers may be found interspersed with staminate in the middle portion of the spike. Although the male plant is very abundant in Switzerland, Gaudin* states that the female is exceedingly rare. If we now examine the monœcious forms of *C. dioica* and *C. parallela*, we find these as being much rarer than in the species mentioned above. *Carex dioica* L. var. *isogyna* and *C. parallela* var. *androgyna* possess only from one to three pistillate flowers at the base of the otherwise staminate spike, but these forms are only known from a very few localities in Northern Europe. We have, thus, in the *Dioicæ* an analogous variation represented by all the species, but merely depending upon distribution of sexes, while in *C. exilis* the variation extends still further, the monostachyous inflorescence passing over into a plio-stachyous. The characterization formerly applied to these species "spica simplicissima androgyna sive dioica" is actually applicable to each of these, besides that one possesses occasionally a "spica composita" (*C. exilis*).

* Gaudin, I., Flora Helvetica, vol. vi, 1830. p. 27.

In regard to the general habit of these species, *C. Davalliana* and *C. exilis* possess a cespitose rhizome, while in the others the rhizome is stoloniferous; in *C. Davalliana* var. *Sieberiana* Opiz, by Fiegert considered as a hybrid between *C. dioeca* and *C. Davalliana*, the so-called *C. Fiegertii* Vollm.,† the rhizome is not so densely cespitose and often bears short stolons. A very slender and stoloniferous rhizome is observable in both the diœcious and monœcious forms of *C. gynocrates*. The leaves are very narrow in all the species, and the culm is terete and hollow in *C. dioeca*, *C. gynocrates*, *C. Davalliana*, pentagonal in *C. parallela* and obtusely triangular in *C. exilis*. The utricle is usually thickest at the base and tapers gradually into a beak, the orifice of which is cut down on the dorsal face so as to form a slit, but on the ventral side the upper margin is almost entire or slightly emarginate. In *C. exilis*, however, the beak is bidentate with erect teeth. In the last mentioned species, the utricle is, furthermore, a little winged and the margins are very scabrous, especially above, in which character it differs from the other species of the *Dioicæ*. In *C. dioeca* and *C. exilis* the ventral face of utriculus is flat in contrast to the dorsal, which is distinctly convex; in the other species both faces are convex, and the ventral often prominently so in *C. gynocrates*. Nerves are quite distinct on the dorsal face of all the species, less so on the ventral, and are very faint in *C. dioeca* and *C. parallela*. The base of utriculus is thick and spongy, especially after fecundation has taken place.

Another peculiarity common to the *Dioicæ* is the change of direction of the utricle when the achenia are mature. While thus utriculus is erect in these species during anthesis, it gradually bends down later on and occupies a horizontal position in *C. gynocrates*, *C. Davalliana* and *C. exilis*, or it becomes merely spreading (suberect) as in *C. dioeca* and *C. parallela*.

The scale-like bracts (squamæ) which subtend the pistillate spikelets are persistent in these species, while they are deciduous in some of the other *Monostachyæ*, e. g., *C. pulicaris*, *C. nigricans* and *C. pyrenaica*, in which the utricles show a similar change of direction after fecundation has taken place.

By possessing several morphological peculiarities in common, the *Dioicæ* may, thus, be considered as naturally allied species. However, we do not feel satisfied with the arrangement of these species as simply representing a section of their own and separated from *Vigneæ* and *Carices genuinæ* only on account of their lesser decomposed inflorescence and their frequent diœcism. It would seem more natural if these *Dioicæ* could

* Vollmann, Fr., Ein Beitrag zur Carex-Flora der Umgebung von Regensburg. (Denkschr. d. k. bot. Gesellsch. Regensburg, vol. vii; new series, vol. i, 1898.)

be arranged with some of the higher developed "greges," and the extreme forms of *C. exilis*, those which possess several lateral spikes at the base of the terminal, suggest some affinity with *C. echinata* Murr., as already observed by Tuckermann and Boott. In *C. echinata* and its allies the direction of utriculus undergoes the same change as we have described as characteristic of the *Dioicæ*, and, moreover, the structure itself of this little organ (utriculus) shows several analogies, which seem to indicate some affinity to exist between these species. We are, thus, more inclined to arrange the *Dioicæ* of Tuckermann (excluding *C. capitata*) under *Vigneæ* rather than under *Carices genuinæ*, and the reason is not so much because they are distigmatic, but on account of the structure of utriculus, which suggests affinities with *Vigneæ*, but not with the other *Carices*.

In regard to *C. echinata* Murr. a number of very diverse species (*C. loliacea*, *C. canescens*, etc.) have been considered as its nearest allies by writers of different periods, who have treated the genus. Nevertheless *C. sterilis* Willd.* is, beyond

* Having studied what Professor L. H. Bailey supposes to be "types" of various species of *Carex*, this author arrived at the conclusion that *C. echinata* Murr. from the Pacific slope appears to be the same as the European plant, but that the type does not occur in the Eastern United States. At that time (1889) Professor Bailey accepted *C. echinata* as an American species with some varieties, among which the var. *microstachys* Boeckl was considered identical with *C. sterilis* Willd. and *C. scirpoides* Schk. on the strength of some specimens preserved in the herbaria of Willdenow and Schkuhr. A few years later (1893) Prof. Bailey made still another disposition of the same species by eliminating *C. echinata* altogether from the North American flora, stating that Francis Boott many years ago "questioned if the American plant is the same as the European *C. echinata*." We are not aware that Boott made this statement in regard to this species in North America, but only so far as concerns specimens from "South of the British provinces" (Ill. genus *Carex*, vol. i, 56, 1858), which he could not satisfactorily refer to the European plant. While thus excluding *C. echinata* from this continent, Prof. Bailey adopts *C. sterilis* Willd. as a species and identical with *C. scirpoides* Schk., of which he claims to have seen the originals. Whether these specimens were the "original" or not, it must be borne in mind that the old botanists did not work with types, and in most cases, it is nothing but a mere guess whether this or that herbarium-sheet contains the specimen, or part of it, from which the original diagnosis was drawn. And it appears to us that this modern investigation of old specimens supposed to be types, arises from inability to faithfully comprehend the descriptions. If, for instance, the old specimens preserved of *C. sterilis* and *C. scirpoides* were "the types," and, moreover, identically the same species," one would necessarily expect to find the diagnoses equally uniform; but this is not the case, at least not as these species were understood by Willdenow. Let us, therefore, compare the most salient points in the diagnoses of these three species, *C. sterilis*, *C. scirpoides* and *C. echinata* as described by Willdenow with the one by Prof. Bailey, who has adopted *C. sterilis* as identical with *C. scirpoides*, and formerly even with *C. echinata*.

Willdenow.	Inflorescence.	Utriculus.	Squamæ.
<i>C. sterilis</i> .	Spicis dioicis sub- senis alternis ob- longis contiguis.	fruct. ovatis com- presso-triquetris- acuminatis, apice recurvis bicuspi- datis.	ovatæ acutæ capsulas sub- æquantés.

doubt, a close ally, and *C. elongata* L. and *C. læviculmis* Meins-
haus. show so many points in common with *C. echinata*, that
they may well be arranged in the same section; to these, we
think, may be added *C. remota* L., but only as a “forma des-
ciscens.” The central type of the section seems best illustrated
by *C. echinata* Murr., the *C. stellulata* Good., from which we
have derived the name “*astrostachyæ*” as being the most
appropriate for this new section, while the other species may
be classified as follows :

Carices (Vigneæ) astrostachyæ.

	}	<i>C. dioeca</i> L.
		<i>C. parallela</i> Læst.
hebetatæ		<i>C. gynocrates</i> Wormskj.
		<i>C. Davalliana</i> Sm.
		<i>C. exilis</i> Dew.
	}	<i>C. echinata</i> Murr.
centrales		<i>C. sterilis</i> Willd.
		<i>C. elongata</i> L.
		<i>C. læviculmis</i> Meinshaus.
desciscens.		<i>C. remota</i> L.

Further research will evidently prove that several other
species may be referable to this section, but we have not at
present been able to find any others in the very considerable
material of the genus which we have studied. It is readily
noticed from the above, that we have restricted the number of

Willdenow.	Inflorescence.	Utriculus.	Squamæ.
<i>C. echinata.</i>	Spica androgyna composita, spicu- lis subquaternis remotiusculis in- ferne masculis.	ovato-acuminatis bidentatis hori- zontalibus.	ovatis acutis
<i>C. scirpoides.</i>	Spica andr. comp, spiculis subquat. inferne masculis subapproximatis, ellipticis.	ovatis bidentatis compressis.	ellipticis obtusis.

Prof. Bailey :

<i>C. sterilis</i> Willd. incl. <i>C. scirpoides</i> Schk.	}	3 to 5 contiguous spikes of which the uppermost is usually conspicu- ously attenuated at base by the presence of stam- inate flowers.	thin and flat, con- spicuously con- tracted into a slender beak which is nearly or quite as long as the body.	-----
--	---	--	---	-------

It is readily seen from the above, that Willdenow had some reason for dis-
tinguishing these plants from each other, and that the collective diagnosis, as
presented by Prof. Bailey, is too vague to be considered.

allied species in a very considerable degree by omitting *C. canescens*, *C. loliacea*, *C. tenella*, *C. leporina* and several others, which, according to our opinion, do not seem to belong to this section, at least not when we consider the characters, drawn from inflorescence and utriculus. We have enumerated *Carex gynocrates* as a species distinct from *C. dioeca* L., and we have done so after a careful study of a large number of specimens from various regions, besides comparing these with the excellent diagnosis presented by Drejer in his "Revisio critica Caricum borealium." The habit of these two species is the same, but it appears as if the spikes, "squamæ and utriculi," of *C. gynocrates* are generally paler and of a more dull brown color than those of *C. dioeca*. Furthermore the utricles are merely spreading (subarrecti) in *C. dioeca*, but horizontal or sometimes almost reflexed in the other. Utriculus is plano-convex and drawn out into a long, flat and scabrous beak in *C. dioeca*, while in *C. gynocrates* this organ is nearly gibbous (biconvex) and the beak is shorter in proportion to the body, terete and a little curved. The scales (squamæ) are obtuse in *C. dioeca*, but more or less acute in the latter species. These morphological characters we consider much more important than those taken from the distribution of the sexes, inasmuch as androgynous spikes are, also, known in *C. dioeca*, as mentioned in the preceding pages. It might seem, however, as if these characters, possessed by *C. gynocrates*, are not sufficient for distinguishing it as a species, and that it simply represents a geographical variety of *C. dioeca*, a suggestion that has been made by both Mr. C. B. Clarke and by Rev. G. Kükenthal "in litteris."

If we examine the central forms, *C. echinata* and *C. sterilis* show a structure of utriculus which reminds us very much of that of *C. exilis*, with the only difference that the base is much broader in the former two species; otherwise the margins are distinctly winged, the beak scabrous and bidentate. In *C. elongata* and *C. læviculmis* the body of utriculus is narrower and tapers more gradually into the beak, which is also bidentate in these species, but less rough or nearly glabrous, besides that the margins are not winged. When the achenes are mature we notice in these species (*formæ centrales*) the same change of direction in the utricule as described as characteristic of the *Dioicæ* (*formæ hebetatæ*), and especially so in *C. echinata*. In regard to *C. remota* this species possesses a utricule of somewhat different structure, since the beak is not pronounced, but bidentate and scabrous; the margins are narrowly but plainly winged, and the base is somewhat thick and spongy as in all the others; at maturity the utricles are spreading, and the species *C. remota* appears to us as inseparable

from the section, even if the structure of utriculus leads us to consider it as a "forma desciscens."

In respect to the general habit the central forms and *C. remota* are all cespitose with long, narrow leaves and rather weak culms; the spikes are small and, the uppermost at least, gynæcandrous or purely pistillate; they are mostly contiguous but in *C. læviculmis* they are distant, and especially so in *C. remota*, in which, furthermore, the lower bracts, subtending the spikes, are developed into long leaves, more or less overtopping the inflorescence. The peculiar stellate appearance of the mature spikes is common to all and suggests the affinity with *C. exilis* and its allies among the formerly so-called *Dioicæ*. There are, however, among the other species of *Vignæ* several which possess similarly spreading or even horizontally directed utricles, but the shape of this organ, besides its internal structure, seems very distinct from what we have observed in the *Astrostachyæ*. The diagnosis of the section, derived from the central forms, is as follows :

Carices (Vignæ) astrostachyæ.

Spikes gynæcandrous or the lower ones purely pistillate, sessile. Bracts not sheathing, short and filiform. Utricles horizontally spreading at maturity, broad and spongy at the base, glabrous, nervose, tapering into a distinct beak with scabrous, winged margins and bidentate apex, the teeth erect; stigmas two. Mostly northern species with light-brown or greenish spikes. The lesser developed forms to be sought among the *Dioicæ*, of which *C. exilis*, especially, shows transition to *C. echinata*. *C. remota* may be considered as representing the limit of the section.

When considering the geographical distribution of these species, it appears as if only two are confined to this continent, *C. exilis* and *C. sterilis*, of which the first is a very local plant, only known from some localities in the northeastern section of this country, New Jersey, New Foundland and Eastern Canada; *C. læviculmis* is, also, quite rare, having been recorded from a few places in Kamtschatka, Alaska and Oregon, also from Idaho and Washington Territory, from where Mr. Kükenthal states (in litteris) that he has received some specimens; *C. gynocrates* is known from the west coast of Greenland and from a number of places on this continent especially in the northern and western sections, and also from the Rocky Mountains; it occurs, furthermore, in Alaska and extends from there to Kamtschatka and the Bajkal Mountains; *C. dioeca* and *C. parallela* are inhabitants of the northern countries of Europe and Asia, and the latter species is not infre-

quent in the Arctic region and the higher mountains of Norway; *C. Davalliana* is a more southern type distributed over Middle Europe and some parts of Asia, Altai for instance; *C. elongata* shows a corresponding distribution, but extends a little farther north, at least in Europe; *C. remota* accompanies *C. elongata*, but seems to be more frequent and is, moreover, known from Sikkim Himalaya, where it reaches an elevation of 12,000 feet;* it is, also, known from Japan. The widest geographical range is, however, exhibited by *C. echinata*, which is very abundant in Europe and Asia; besides it is, also, known from North America and New Zealand; *C. sterilis* has been reported only from this continent, from Canada to Carolina (fide Boott). While thus the diœcious *C. parallela* and *C. dioeca* appear to have their center of distribution farther north than any of the others, the monœcious *C. gynocrates*, although being much less frequent, exhibits a similar range in contrast to its diœcious form, which is more southern. *C. exilis* represents the most evolute stage of the "hebetatæ" and may be considered as a good illustration of the development of the section in this country with its herd of *C. echinata* and *C. sterilis* in a number of varieties, of which only the typical *C. echinata* is distributed in the old world. The nearest allies of *C. echinata* are, thus, to be sought in this country, where, moreover, *C. gynocrates* and *C. læviculmis* have their geographical center. *C. dioeca* and *C. parallela* are, no doubt, the oldest remnants of the section as this is preserved in recent time, and actually demonstrate a closer affinity to *C. exilis* than to *C. gynocrates* and *C. Davalliana*, even if *C. exilis* may be considered as younger than any of these. *C. elongata* and *C. remota* possess certain points in common with the others, and may represent the farthest developed types in the section. While thus, considered from a geographical viewpoint, the earlier types belong to the northern parts of the old world, the more modern forms are represented farther south, not only in Europe and Asia, but also in New Zealand and in this country. It might seem strange that the "formæ hebetatæ" of the section are so remote from each other as they really are: *C. dioeca* and *C. parallela* in Europe and Asia, *C. gynocrates* in this country, without being connected with each other by some circumpolar type; yet we must bear in mind that the development of the section and the migration of the species is not by any means to be fully explained by the present geographical range of a few old types, that are still in existence.

We have in the preceding pages given a brief account of the morphological characters of the *Astrostachyæ*, and we

* Clarke, C. B., *Cyperaceæ* in Hooker's Flora of British India, vol. vi, London, 1894, p. 699.

might append to these some observations upon the internal structure of the species in order to illustrate the section as completely as possible.

The root.

Having examined roots of a number of specimens from widely separated localities and of different age and development, we have, nevertheless, failed to detect any anatomical character of importance by which the "*formæ hebetatæ*" might be distinguished from each other or from their allies among the "*centrales*" and "*desciscentes*." Like most of the other *Carices* examined, the root possesses a hypoderm of a single layer inside the epidermis, and this tissue is thinwalled in all the species of *Astrostachyæ*. The cortex is differentiated into two zones, an outer and an inner, of which the former is distinctly thickwalled in contrast to the inner, which shows the usual tangential collapsing. The endodermis is more or less thickened, but as it seems constantly as an U-endodermis; it is very heavily thickened in *C. echinata*, less so in the other species. In *C. gynocrates* the endodermis showed only a very slight thickening of the inner cell-wall in specimens from arctic Greenland, while others from Canada, Alaska and Wyoming showed a very pronounced thickening of both the inner and radial cell-walls. The pericambium is usually thinwalled or moderately thickened as in *C. exilis*, *C. echinata*, *C. sterilis* and *C. læviculmis*; it was found to be interrupted by all the proto-hadrome vessels, without exception, in all the species of the *Astrostachyæ*. The leptome and hadrome is well developed, and the central portion of the root is occupied by conjunctive tissue, which is quite thickwalled in all the species, especially in *C. exilis*, *C. echinata* and *C. sterilis*.

In considering the development of the outer cortex, the endodermis and the conjunctive tissue, the roots of these species seem well supported in mechanical respect, and equally well in species from bogs or woodlands.

The rhizome.

The rhizome of the "*formæ hebetatæ*" is stoloniferous in *C. dioeca*, *C. gynocrates* and *C. parallela*, but cespitose in the other species. Epidermis is mostly thickwalled, and a hypoderm of a single stratum is noticeable inside the epidermis. The cortical parenchyma is, also here, differentiated into two zones, of which the outer is quite thickwalled. The endodermis shows the same manner of thickening as observed in the roots, and is especially thickwalled in *C. parallela* and *C. Davalliana*. The stereome occurs in *C. parallela* as a peripheral band of small isolated groups near epidermis, but is in the

other species only observable inside endodermis, where it forms a few strata around the mestome-bundles. The arrangement of the mestome-bundles is somewhat variable in these species; in *C. dioeca* and *C. gynocrates*, for instance, they form one very regular band, while two in *C. exilis*; three in *C. Davalliana*, and in *C. parallela* they seem scattered without order inside the endodermis; they occur mostly as collateral and bicollateral, perihadromatic, together, but in *C. gynocrates* we noticed only the collateral type in specimens from Greenland, Alaska and Canada, while in some rhizomes from Wyoming the mestome-bundles showed a tendency to become perihadromatic. Most of the mestome-bundles in *C. Davalliana* were observed to be bicollateral, while only a very few showed this structure in *C. exilis*. The pith occupies a very small portion of the central-cylinder in *C. parallela* and *C. Davalliana* and is solid in these species; in the others, on the contrary, the pith is larger and broken in the middle so as to form a wide central cavity.

The stem.

A triangular and solid stem is generally attributed to the *Cyperaceæ* in contrast to a cylindric and hollow culm in the *Gramineæ*. There are, however, many exceptions to this rule, and in both orders; we have, already, called attention to the outline of this organ in the "formæ hebetatæ" of *Arostachyæ* being mostly cylindric and hollow inside. *Carex exilis* is the only species of these in which the stem is triangular, though merely obtusely; but if we examine the higher developed types we find the stem to be triangular in all the species with the exception of *C. echinata*, in which it is almost regularly hexagonal; the pith seems invariably broken down in these species, as we, also, observed in the lesser developed types. The epidermis is quite thickwalled in all the species and nearly glabrous, the development of prickle-like projections being very scant except in *C. elongata*. The cortical parenchyma consists of short palisades radiating towards the center of the stem in the "hebetatæ," also in *C. echinata*, *C. sterilis* and *C. elongata*, while in *C. læviculmis* and *C. remota* the bark is composed of polyedric cells and no distinct palisades; intercellular spaces are very distinct in all the species, and lacunes are present, one between each two mestome-bundles; thus the cortical parenchyma does not represent any very firm or solid tissue in these species, and is especially open in *C. elongata*. Stereome occurs as hypodermal on the leptome-side of the larger mestome-bundles, besides that it is, also, developed on the hadrome-side of these, where it borders on the pith; at the smaller mestome-bundles there is less stere-

ome, and, with the exception of *C. laeviculmis* (fig. 1), this is here separated from the epidermis by strata of cortical parenchyma on the leptome side. It may be said about the stereome in these species, that it is generally well developed and seems to be especially thickwalled in *C. laeviculmis* and *C. remota*. In regard to the mestome-bundles, these are arranged in one peripheral band and represent larger, in transverse section oval, and smaller, which are nearly orbicular in outline; the parenchyma-sheath is thinwalled and the mestome-

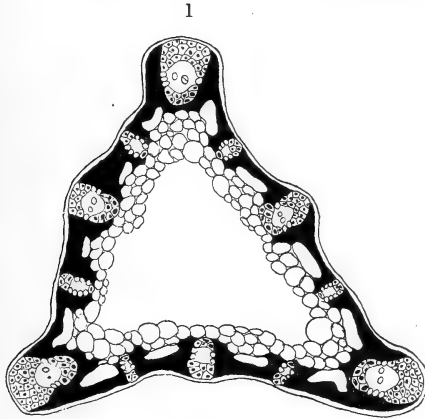

FIG. 1. Transverse section of the stem of *Carex laeviculmis* Meinshaus.

The cortex is painted black in the figure, lacunes are to be seen between the mestome-bundles, and the central portion of the pith is broken down into a wide cavity. $\times 75$.

sheath shows a distinct thickening of the inner cell-wall in all the species, and to the same extent. The mestome-bundles are thus of the same development as is usually observed in the genus, and we might state besides, that we found no trace of the inner chlorophyll-bearing sheath, which Haberlandt and Rikli detected in some of the other genera of the order.

The leaf.

This organ exhibits a much greater variation in these species than observed in the root, the rhizome and the stem. It is mostly hemicylindric in the "hebetatæ," at least in *C. dioeca*, *C. gynocrates* (fig. 2) and *C. exilis*, where this leaf-shape is characteristic of both the male and female plant, besides in monœcious specimens of *C. gynocrates*; in *C. parallela*, on the other hand, we noticed the leaf to be broader in the male than in the female plant, and in *C. Davalliana* the leaf is still broader and almost carinate. In the central forms as well as

in *C. remota* we find the leaves to be almost flat with a distinct keel as is characteristic of the majority of the higher developed *Vigneæ* and *Carices genuinæ*. In the "hebetatæ" the leaves are smooth and mostly glabrous, with the exception of *C. Davalliana*; in the others, "centrales and desciscentes," we find prickle-like projections to be quite abundant along the margins and the midrib, rendering the leaves more or less scabrous. Very characteristic in this respect is the leaf of

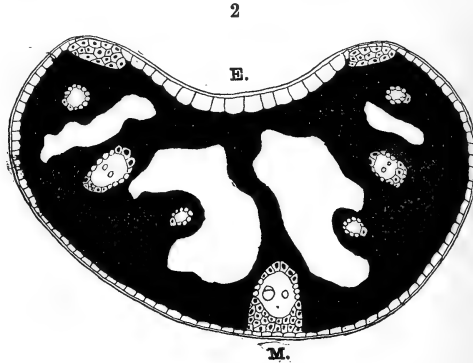

FIG. 2. *Carex gynocrates* Wormskj.; monœcious specimen from Wyoming; transverse section of leaf; mesophyll painted black; M.=midrib; E.=epidermis of upper face. $\times 120$.

C. læviculmis (fig. 4), of which both surfaces show the development of a number of obtuse papillæ. The cuticle is very distinct and smooth in all the species, and the epidermis shows relatively the same modifications as seen in most of the other *Carices*: the cells being generally larger on the upper face outside the mesophyll than on the lower. Bulliform cells are well developed as a single group above the midrib in all the central forms and in *C. remota*, besides that an additional group of these may be seen in *C. remota* (fig. 3) above one of the lateral mestome-bundles. The "hebetatæ" are mostly destitute of these bulliform cells, and it is only in the broader leaves of *C. parallela* (male specimens) and of *C. Davalliana* that some of the epidermal cells have attained such development, although in a much smaller degree than in the "formæ centrales." If we consider epidermis of the lower surface and outside the stereome, we notice the cells to be of a somewhat different size and shape than in the surrounding stomatiferous strata; the radial walls are less undulate and the cells often shorter and narrower than those adjoining. In *C. parallela* and in *C. exilis*, for instance, these epidermal cells outside the stereome are shorter than the others; in *C. Davalliana*, *C. sterilis*, *C. remota* and *C. læviculmis* they are much narrower.

but not shorter, while in *C. echinata* and *C. elongata* the same cells are not only much narrower, but also shorter than the others. The stomata are restricted to the lower surface of the leaf-blade outside the mesophyll; they are free in all species, even in *C. læviculmis* with its numerous papillæ, and the guard-cells are level epidermis in most of the species, with the exception of *C. parallela*, *C. sterilis*, *C. elongata* and *C. læviculmis*, in which they are slightly projecting.

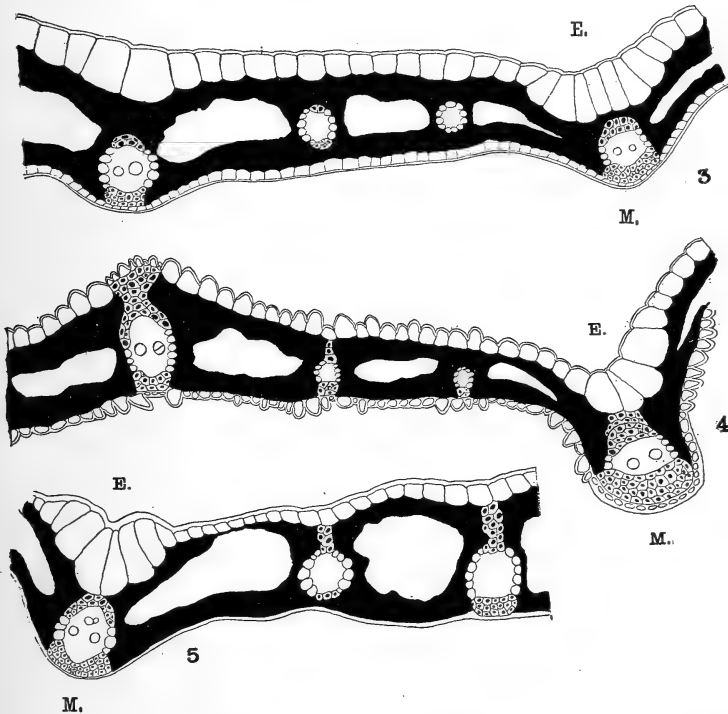

FIG. 3. *Carex remota* L.; fig. 4, *C. læviculmis* Meinshaus.; fig. 5, *C. echinata* Murr. Transverse sections of leaves; M.= midrib; E.= epidermis of upper face, developed in bulliform cells above the midrib; mesophyll painted black. $\times 120$.

The mesophyll consists mostly of a homogeneous tissue of short palisades vertical on the leaf-blade or radiating towards the center of the mestome-bundles as we observed in *C. Davalliana*; in *C. echinata*, *C. sterilis* and *C. læviculmis* the palisades are very short and often too irregular in shape to be called "palisades." In *C. remota* the mesophyll is differentiated into a ventral palisade- and dorsal pneumatic-tissue, this species being, thus, the only one of the section that possesses a typical bifacial leaf-blade. The cells of the mesophyll are

only occasionally closely packed in these species, and intercellular spaces are often not only numerous, but also quite wide; moreover, lacunes are observable in this tissue and are very broad in all the species, in the "hebetatæ," the "centrales" and in *C. remota* (fig. 3).

The stereome is thickwalled and occurs as hypodermal groups accompanying the mestome-bundles, or separated from the epidermis by the mesophyll, or as isolated groups in the leaf-margins. In the "hebetatæ" there is only hypodermal stereome on the leptome-side of the midrib, and also in the margins of the blade, while the smaller mestome-bundles are so deeply imbedded in the mesophyll that the stereome which supports these does not extend to epidermis. In the higher developed types ("centrales," etc.) there is usually hypodermal stereome above and below the larger mestome-bundles, especially well developed in *C. læviculmis* (fig. 4), where it is hypodermal on the lower surface at all the mestome-bundles, even at the smallest ones. Considering the mestome-bundles, these constitute only a single band in all the species, and are surrounded by a thinwalled parenchyma-sheath and a mestome-sheath, of which the inner wall is moderately thickened; the leptome and the hadrome exhibit the usual structure, and the bundles occur as oval (in transverse section) or as nearly orbicular.

The leaves of the *Astrostachyæ* exhibit certain modifications not only in respect to the outline of the leaf, but also in the development of epidermis as bulliform cells or as papillæ (*C. læviculmis*); moreover, the bifacial leaf of *C. remota* seems very exceptional, when we compare it with the nearly isolateral leaves of the other species. The structure of *C. exilis*, although this seems to represent the highest developed type of the "hebetatæ," at least morphologically, is actually identical with that of the lower forms: *C. dioeca* and *C. gynocrates*, while in both *C. Davalliana* and certain specimens of *C. parallela* the leaf shows some resemblance to that of the "centrales." A small leaf-surface is characteristic of the "hebetatæ" in contrast to the other types, in spite of the fact that several of these occupy the same kind of soil and live under the same climatological conditions; even in *C. gynocrates* and *C. parallela* from high northern latitudes the structure of such specimens agree very well with that of others from more southern latitudes or from subalpine regions.

When we finally compare the "hebetatæ" of *Astrostachyæ* with those of some other sections, we do not observe the leaf-blade uniformly narrow in all of these. We have described the relatively broad leaf of *C. lejocarpa* C. A. Mey. in contrast to that of *C. circinata*, both of the *Stenocarpæ*; further-

more in *C. pulicaris* the leaf is very narrow as in *C. pyrenaica*, but broad in *C. nigricans*, their nearest ally; a relatively broad blade is noticeable in the "hebetatæ" of *Sphæridiophoræ*, e. g., *C. scirpoidea* and *C. oreocharis*, and in *Lamprochlaenæ*: *C. rupestris* and *C. obtusata*.

Utriculus.

If it were not that this organ possesses such excellent morphological characters, by which our species of *Astrostachyæ* may be readily distinguished from each other, one would naturally suppose that the number of species were much smaller by examining the anatomical structure. The fact is, that when we examine the structure of utriculus, we do not find any points of importance by which these species may be distinguished anatomically. The differences are so slight and seem merely to depend upon a relative broader or narrower mesophyll and a larger or smaller number of isolated stereome-bundles, that none of these may be considered as being neither constant or of sufficient importance to be used as anatomical characters. Common to all is the broad mesophyll at the base of utriculus, and the presence of only two mestome-bundles; furthermore, the stereome is equally well developed in these species, not only as accompanying the mestome-bundles, but also by occurring as isolated, hypodermal groups between these. The number of these isolated stereome-bundles varies from 15 to 36, the strongest mechanical structure being possessed by *C. elongata*, *C. dioeca* and *C. gynocrates*. The outer epidermis is thickwalled in most of the species excepting *C. remota* and *C. læviculmis*.

When we finally compare the morphological and anatomical characters with each other, it seems as if our species may be naturally classified as representing a section of *Vignææ*. The transition from the "hebetatæ" to the "centrales" seems very gradual and as we have shown in the preceding, none of these species possess characters that stand as isolated among the others, neither in morphological or anatomical respects. If our disposition of these species, classified as "*Astrostachyæ*," may prove to be correct or at least quite natural, our observations have simply confirmed a suggestion, already proposed by both Tuckermann and Boott, whose remarks upon the affinities have been presented in the introduction to this paper.

Brookland, D. C., July, 1900.

ART. XVIII.—*A Just Intonation Piano*; by S. A. HAGEMAN.

THE problem of tuning and transposition and just intonation, the practical solution of which is the subject of this paper, is one which does not need to be restated for the readers to whom it will chiefly come. But for their convenience, and for the sake of logical completeness, the intervals of the two scales true and tempered are here given.

Taking, as is usual, the C scale for illustration, the letters designating the tones of a complete octave are given with the intervals between, and the fractions proportioned to the vibration numbers immediately below each letter.

$$\begin{array}{cccccccc} C & \frac{9}{8} & D & \frac{10}{9} & E & \frac{16}{15} & F & \frac{9}{8} & G & \frac{10}{9} & A & \frac{9}{8} & B & \frac{16}{15} & C \\ 1 & & \frac{9}{8} & & \frac{5}{4} & & \frac{4}{3} & & \frac{3}{1} & & \frac{5}{3} & & \frac{15}{8} & & 2 \end{array}$$

Chord lengths may be had by simply inverting the above fractions.

If, as is well known, we use, instead of these intervals, their logarithms, we have a set of numbers that may be compared by addition and subtraction and thus represent the actual magnitude of the intervals with a high degree of accuracy and convenience, especially for comparison with temperament.

The numbers 102, 91 and 56 are modified logarithms of the above fractions and may replace them—in which case 100 and 50 will respectively represent the two intervals of the tempered diatonic scale which is here given.

True scale	C	102	D	91	E	56	F	102	G	91	A	102	B	56	C
Tempered scale		100		100		50		100		100		100		50	

It is further desirable to append the complete duodene of C as the most complete exhibition of all the tones and semitones of the octave as used.

B \flat	D	F \sharp
E \flat	G	B
A \flat	C	E
D \flat	F	A

This is taken from the English translation of *Sensations of Tone* by Helmholtz.

It is not considered necessary to explain these anew further than to remark that, in this tabular arrangement of the complete diatonic and chromatic scale, the intervals along the vertical lines are pure fifths, and along horizontal lines pure thirds. Thus their exact mathematical values are clearly established.

During the past century a number of efforts have been made to construct keyboard instruments such as the organ so as to meet the requirements of just intonation.

The problem has been considered an extremely difficult one especially as regards the piano, and the unsatisfactory mechanism heretofore devised has, in every instance, been practically rejected by the musical public, though every true musician would willingly sacrifice much to regain the inestimable beauty and purity of just intervals.

Helmholtz, Blaserna, and Taylor and a long line of able and eminent writers, have appropriately set forth the defects of tempered intonation, its tendency to obscure theory, and its blighting effects upon the essential beauties of music. But no instrument has been brought forward that seemed so attractive as the piano, with the licentious freedom of its tempered scales—and not a few have even grown into a cultivated disregard of its really great defects. But the tempered piano does not quite take rank among the best musicians. It is denied a place in the orchestra, and the most eminent vocalists and violinists accept it reluctantly for purposes of accompaniment. One writer even contemplates its final abandonment, along with tempered intonation, apparently never dreaming that its faults were capable of being remedied. Had it not been that it was already installed in almost every household, it is quite probable that even the complicated and cumbersome just intonation organs, that have been offered, would have won the day, and tempered intonation, the reproach of music, would have been, at this moment, only an unpleasant memory.

It would be foreign to the scope and purpose of this paper to enter into any extended discussion of the merits or demerits of tempered intonation, but it is freely granted that—though through long and dreary years, while voice and violin and orchestra were alone struggling for truth—music has on the one hand certainly suffered from its use, it has at the same time, though in an imperfect manner, filled a gap of some two centuries of almost hopeless waiting for better things.

And yet it has been by the piano and organ that the priceless gems of musical masters from Bach to Wagner have been brought, though in unworthy attire, into our daily lives and made our common property. Their rehabilitation in fitting garb has been the cherished desire of the writer and the results attained are indicated in this paper.

It has been fully realized from the very first, that such a work as the construction of a just intonation piano must deal very gently with existing methods and mechanism. It must change nothing, take nothing away, impose little or no additional exertion upon the player, be free from mechanical

defects and intricacies,—and last but not least, make light demands upon the purse.

The ordinary piano has, therefore, been taken as a foundation for the new, and without taking from the player his familiar instrument, he is enabled to instantly substitute, for its tempered harmonies, mathematically just intonation in twelve keys based on the twelve tempered chromatic intervals of the octave.

The changes from one to the other of these twelve justly intoned keys (each having its own complete chromatic scale), or back to temper again, is under the instantaneous control of the left foot, so that the right is left free to operate the dampers as usual.

The absolute uniformity of the tempered scale with its twelve equal intervals makes it admirably suitable as a basis for the necessary corrections, and its adoption as such essentially simplified the problem.

The modification of the evenly tempered intervals, to make them conform to those of true intonation, is effected by a line of small metallic movable bridges.

Each unison has a separate bridge which is capable of being moved toward the center of the string, thus shortening the vibrating portion and raising the pitch, or, it may, by a contrary motion, cause a depression of the pitch. When the instrument stands in temper the bridges will occupy the usual line of the agraffe, which is set back far enough to make room for them. Mechanism for the proper control of these bridges is placed on the top of the wrest plank and at the back of the piano and is actuated by intonation pedals which pass beneath, at the left of the center. When an intonation pedal is pressed, every bridge is instantly set, so as to give the mathematical cord length for its tone in that key, in which position it remains until reset by the same means.

In the instrument as at first constructed, there were thirteen pedals, representing the twelve just keys and the even temper. A much simpler and better arrangement has been since adopted.

Description of Parts.—Fig. 1 is a vertical section of part of a piano adjacent to one of the movable bridges, showing side elevation of string, movable bridge and parts related.

Fig. 2 is also a vertical section taken on the line X, at right angles to the section of fig. 1, and is drawn to a larger scale.

The string, or group of strings forming one unison, is shown at *a*, passes over the movable bridge *b* and the agraffe *g* to the wrest pin *f*.

The extreme phases of vibration of the string are shown by the dotted lines *a'* *a''*. The rod *e* is attached to the bridge *b*,

passes through an opening in the agraffe and between the wrest pins, and connects with the horizontal arm of lever (not shown) at the top of the wrest plank.

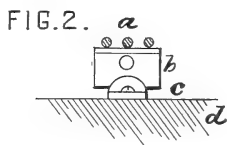
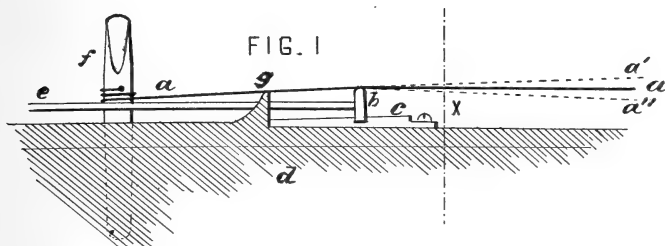

The movable bridge *b* has a concave bearing conforming to the convex surface of the slide, or way, *c*, so that the bridge may adjust itself to the plane of the strings constituting a unison and insure equal pressure of all the strings of the unison.

The slide *c*, upon which the bridge moves, has its upper surface parallel to the dotted line *a'*, thus equalizing the pressure of the string upon the bridge at all points and avoiding undue and unequal strain which would tend to put the piano out of tune.

At the top of the wrest plank is a series of lever arms actuating the bridges. By making these arms proportional to the strings to which they correspond, compensation is made for the varying lengths of the strings so that a given amount of motion (in arc) produces uniform change of pitch in all the strings.

These arms are attached to cylindrical rods which pass back to the rear of the piano where the other arm of each is attached at a right angle. The two arms and the connecting rod constitute a lever of which the cylindrical rod is the axis of motion.

The lever arms at the back are furnished with octave connections and on those pins are so placed that they are caught when a pedal is pressed and brought into that precise position that is required for the particular key that the pedal represents.

The entire just intonation mechanism including the eighty-eight bridges is made up of only two hundred and fifty movable parts, is not expensive nor difficult of construction, nor in any manner readily susceptible of derangement, but is durable and reliable to the last degree.

This construction is essentially different from all previous just intonation instruments in that *it acknowledges no tone cycles*, and consequently no compromise in intonation however small.

Each semitone of the tempered chromatic scale is in turn made the tonic or keynote of a separate just intonation scale of twelve tones to the octave, whose intervals correspond to those of the duodene given above.

This affords a complete and correct chromatic scale of just intervals besides a complete diatonic scale on the third below the tonic, whose seven tones bear the same relation to each other as those of the key itself. These same twelve tones comprise also four complete minor scales, founded respectively on the tonic, fourth, fifth and sixth, and having both the ascending and descending forms. Perfect triads, either major or minor, or both, are found upon all but one of the same twelve semitones, all without any change of intonation or use of pedals. But by using the pedals all these scales and chords may be duplicated on any one of the twelve tempered semitones as a tonic or key. Four dominant sept-chords, with resolutions on tonic triads a fifth below, should also be included in this estimate for each key. In addition to the twelve just keys as above, tempered intonation is always instantly available in response to pressure of a pedal.

These results summed up give one hundred and fifty-six tones to the octave, or eleven hundred and forty-four in the compass of seven and one-third octaves, against eight-eight in the ordinary piano.

The changes of tonality are practically instantaneous and can succeed each other in any order with great rapidity, if it were necessary, but the resources of a single key are so great that even in the most intricate music the pedal changes will be quite few. Many harmonies and progressions that would seem to involve foreign tones, do not require the use of the pedal at all but are found perfect and true, within the limits of the principal key in use at the time.

The way appears perfectly clear for the application of the same general principles to pipe and reed organs without increasing the number of pipes or reeds.

The result of familiarity with just intervals during the work of construction and since the satisfactory completion of the instruments now in use at my home in Cincinnati, fully confirms all that Helmholtz and others have said as to the inexpressible sweetness and beauty of pure harmonics.

Their clearness renders all music more intelligible as well as agreeable, the musical sense is rapidly rendered more acute, and tone perception and tone production matters of much

greater ease and precision, and as a natural consequence, tempered intonation, and errors of tuning generally, rendered more and more intolerable.

While any composition is greatly enhanced in beauty, there runs through all—even bits of melody, simple chords, or scales—a restful, satisfying effect that could hardly be conceived without the actual experience.

It is the profound conviction of the writer that just intonation in music is of the greatest importance.

Persons listening to the best orchestras often imagine that they are hearing it in its perfection. This is far from being true. Temperament has leavened it also, as is capable of abundant proof.

As Helmholtz remarks—few modern musicians have ever heard tone intonation, and consequently its superiority over temperament is greatly underrated.

Cincinnati, O.

ART. XIX.—*Very on Atmospheric Radiation*,* by WILLIAM HALLOCK.

IT will require no long consideration to recognize that the question of atmospheric radiation and absorption is one of fundamental importance in meteorology, and an equal reflection will convince any physicist of experience of the extreme complexity and difficulty of the search for its answer.

The problem is naturally divided into two parts: First, the absorption, transmission and re-radiation by the atmosphere of that energy which reaches it direct from the sun; that is, from a source at a very high temperature. Second, the absorption, transmission and re-radiation of the energy which comes to the atmosphere from terrestrial sources; that is, from a source at medium temperatures. The curve of distribution of energy with reference to wave length is radically different in the case of the two sources, the maximum for the sun lying in much shorter wave lengths than in that for the earth. Here at the outset is the difficult necessity of considering not only the total absorption or radiation, but its distribution as to wave length. Add to this the presence of water vapor in varying relative humidity, and absolute quantity, and of CO₂, and trouble enough is at once apparent.

Such a research as this is one properly suited to the resources of a Government Bureau, where a long series of exhaustive investigations may be carried on uninterruptedly by a competent physicist, with liberal provision for all money needed for expensive apparatus. In the present case the physicist alone with his zeal, and but little money, seems to have been relied upon to solve the riddle.

Prof. Very has carried out, with much skill and industry, a highly laborious piece of experimental work, and this, with his theoretical discussions, certainly constitute a most valuable contribution to this important subject. At the same time, no one better than he, can realize the still outstanding doubts which cluster about the subject, and which leave the final solution of the problem still indefinite.

Naturally the bolometer was chosen as the measuring instrument, since Prof. Very had already had such valuable experience with it. The Boys radio-micrometer or the Nichols radiometer would have been more sensitive, but too often added delicacy is purchased at the expense of serious disturbances and errors.

In "Method A," fig. 1, two masses of air at different temperatures, confined in long tubes with open ends, were alternately interposed between a concave mirror and the bolometer

* Atmospheric Radiation: a Research conducted at the Allegheny Observatory and at Providence, R. I.; submitted to Willis L. Moore, Chief U. S. Weather Bureau, by Frank W. Very. Pp. 134, 4to, Washington, 1900—Bulletin G, Weather Bureau, No. 221 (U. S. Dept. of Agriculture).

placed at its center of curvature. The concave mirror was of slightly larger angular aperture than the bolometer case and was kept at a constant temperature. The difficulties of manipulation and the comparatively small effect due to the differences of temperature of the air rendered this method unsatisfactory.

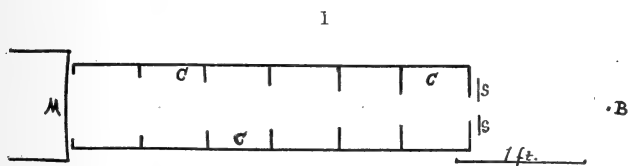

FIG. 1, diagram of "Method A." M is a concave spherical mirror, concentric with the bolometer strips at B. S S is the last screen in the opening of the bolometer case. C C C is one of the two air tubes interposed between the mirror and the bolometer.

Considerable valuable data was obtained by "Method B," where a vertical current of air of varying rectangular cross section and temperature was made to rise in front of the bolometer. The air current always subtended a greater angle than the aperture of the bolometer case. This method is similar to that used by Hutchins,* whose conclusion that "radiation only takes place when there is a fall of temperature within the limits of molecular action" appears to Prof. Very not altogether warranted. In this method the investigator is confronted with the question as to what extent a part of the radiating mass of air absorbs the radiations from another part. There can be no doubt that this takes place and that nothing is gained by increasing the thickness of the mass beyond a certain limit. It must not be forgotten, moreover, that this absorption is selective and does not affect all wave lengths equally (cf. fig. 4).

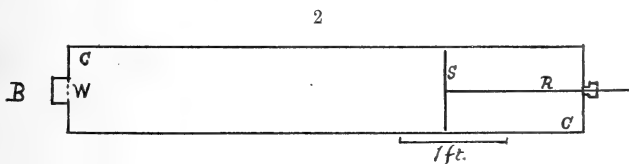

FIG. 2, diagram of "Method C." C C is the air-tight cylinder. S is the disk which can be moved near to, or far from, the rock-salt window W, by means of the rod R, which runs through a stuffing box. The bolometer is located at B.

Perhaps the most satisfactory contributions were made by "Method C," fig. 2. In this case an air-tight cylinder, five feet long and one foot in diameter, was provided with a rock-salt window at one end, and a stuffing box at the other. Through the latter ran a rod carrying a disk on its inner end which nearly

* This Journal, vol. xliii, p. 357, May, 1892.

filled the cross-section of the cylinder. This disk was supposed to remain at the same constant temperature as the gas, a greater or less thickness of which was allowed to radiate out the salt window, according as the disk was near to, or far from, that end of the cylinder. This apparatus, if it had been tight and provided with thoroughly satisfactory means of heating, would have given even better results than it did. By these means the effect of varying temperatures and pressures, relative humidities, and carbonic acid gas could be determined.

For example, it was found that for atmospheric pressure and temperatures to 100° C. excess, and a thickness of 141.8^{cm}, the ratio of radiation, air : CO₂ = 0.1885/0.1254 = 1.50. The radiation from steam was also tried, but the results were inconclusive. "Method D" used the above cylinder to store compressed gases, which after being heated in going through a hot brass tube were caused to pass in front of the bolometer. In this way the relative radiation of air and steam, and clear and smoky air, were studied. It appears that steam under certain conditions radiates at least four times as much as air, and that the presence of condensed particles of water does not seriously affect the results. A limited series of experiments seemed to show that the presence of fine particles in the air, as in smoke, did not affect its radiation.

It is manifestly impossible to refer ever so briefly to the mass of details and discussions; they must be studied in the original. When we consider how much material for study is here presented, and that too many government scientific publications are simply narrations of undigested details, without proper consolidation and abstraction, we must be grateful to Prof. Very for summarizing his work as well as its extreme complexity will admit. Nevertheless it will only be practicable to extract here a few sentences :

"The direct effect of the sun's rays is less on a normal surface in the tropics than in temperate regions, and less at sea level than upon a mountain top, owing to the difference in the aqueous component of the air; and the ability of the solar radiation to maintain a high temperature in the torrid zone or at sea level is due to the accumulation of the thermal energy imparted to the earth's surface by reason of the retention of the escaping radiation from that surface by a moist and highly absorbent atmosphere rather than to the direct power of the sunbeam." (P. 125.)

"Where the land is moist the changes in temperature are less than where it is dry or arid,' but it is the condition of the air and not that of the soil which makes the radiation possible or impossible." (P. 127.)

"Within moderate depths of only a few meters the radiation of dry air, purified from carbon dioxide, increases quite uniformly with the depth; the radiation of a 1-meter layer of purified air at 50° C. and near atmospheric pressure (735^{mm}) as compared with one at 0° C., is 0.00068 radim, representing a transformation and transfer of thermal energy of 0.00068 small calories every second through each square centimeter of limiting surface; the

radiation of a like depth of carbon dioxide at the same temperature is three and one-half times that of air, or 0.00238 radim,

3

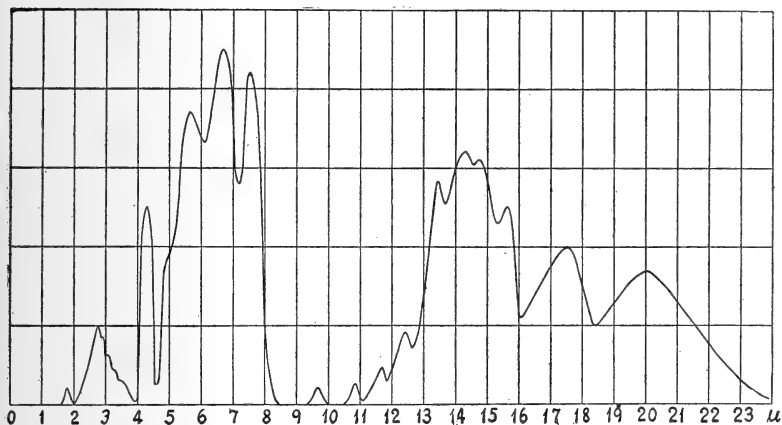

FIG. 3. Approximate spectral energy-curve of air radiation, for moist air at 50° C. Wave-lengths laid off as abscissæ.

4

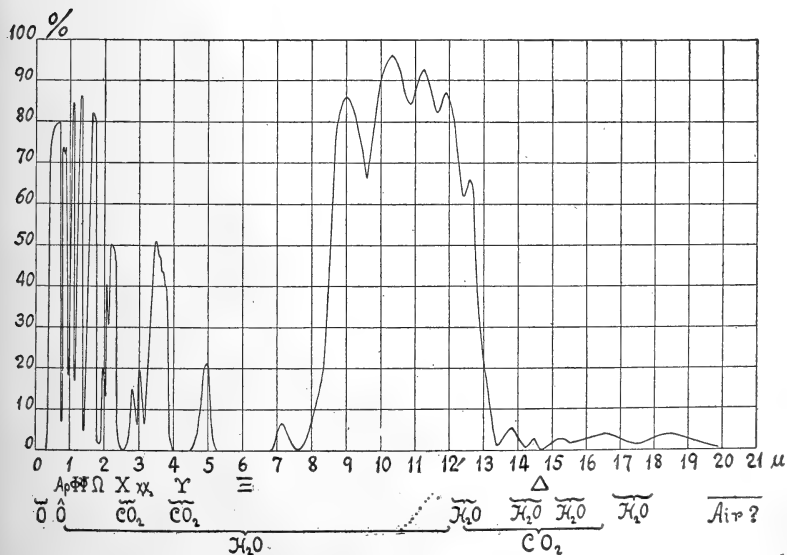

FIG. 4. Curve of transmission of radiation by the earth's atmosphere. Wave-lengths as abscissæ and percentage transmission as ordinates. The probable cause of the absorption band is indicated in each case.

which is very nearly a maximum for this temperature, further increase of the radiant depth being unattended by a corresponding addition of radiant energy, showing that equilibrium between radiation and emission has been almost reached at this depth; the radiation from a layer of steam five feet deep at one-sixth of atmospheric pressure is two and one-half times that from a like body of dry air at temperatures near the boiling point of water, and eight-tenths of the radiant emission from the black solid body; while for smaller depths the radiant power of water vapor is relatively greater." (P. 129.)

The accompanying diagrams, figs. 3 and 4, are reproduced from the summary. Fig. 3 is a provisional energy-curve of the radiation of moist air for the temperature $+50^{\circ}$ C. The positions of the bands (from observations by Paschen, Rubens and Aschkinass) relate to the emission from aqueous vapor and carbon dioxide with the exception of those of extreme wave length provisionally assigned to nitrogen, oxygen, etc., from observations by Hutchins of the absorption of air radiation by quartz. Fig. 4, the curve of transmission of radiation by the terrestrial atmosphere, relates to a vertical transmission through a clear air of moderate humidity, and shows the general fact of selective absorption scattering of short waves with the progressive strengthening of band absorption in the infra-red, due to the gases indicated (mainly water vapor), to finally a region of almost total absorption provisionally attributed to the permanent gases of the atmosphere.

In conclusion, it may not be amiss to call attention to the important bearing which recent investigations on electrification of gases, and their electrical behavior under the influence of violet, ultra-violet, Becquerel and X-rays, is sure to have upon the problems involved in meteorology.

Columbia University, Physical Laboratory.

SCIENTIFIC INTELLIGENCE.

I. CHEMISTRY AND PHYSICS.

1. *Radio-active Lead*.—Those substances that emit the remarkable rays discovered by Becquerel have heretofore been found associated with the uranium, thorium, barium, bismuth and titanium extracted from minerals containing uranium and thorium. HOFMANN and STRAUSS have recently found active properties in lead salts obtained from such minerals, viz., pitchblende, cleveite, bröggerite, uranium mica, samarskite and euxenite, and they believe that they have evidence of the existence of a new element which resembles lead in many ways, but is quite different from that metal in other respects. The substance, like lead, gives a sulphide which is insoluble in dilute acids and in ammonium sulphide, and a sulphate insoluble in dilute sulphuric acid. The chloride is more readily soluble than lead chloride in pure water. In the spark spectrum occurs a violet line which does not belong to lead. The equivalent weight of the substance is very different from that of lead, and the valency seems to be higher, since the sulphate liberates iodine from an acidified solution of potassium iodide. The authors think it probable that the element in question is bivalent and quadrivalent and has an atomic weight of over 260. The chloride and especially the sulphate fluoresce under the action of cathode rays, and they thus acquire the property of acting upon the photographic plate in the dark. It is only after some months that they lose this activity, which approaches in intensity that of the most active thorium or uranium preparations. The present communication is merely a preliminary notice, and further publications promised for the near future will be awaited with interest.—*Berichte*, xxxiv, 8.

H. L. W.

2. *Physiological Action of Radium Rays*.—It has been noticed by WALKHOFF that the rays of radio-active barium produce inflammation of the skin, similarly to Röntgen rays. This fact has been confirmed by GIESEL. The latter placed a double celluloid capsule containing .27 g. of active barium bromide for two hours in contact with the inner surface of the arm. At first there was only a slight reddening of the skin, but after three or four weeks a severe inflammation set in. Giesel found also that the radium rays exert a similar action upon the leaves of plants; the chlorophyll disappears, and the exposed part takes on the yellow or brown color of autumn.—*Berichte*, xxxiii, 3569.

H. L. W.

3. *Chlorine Heptoxide*.—This new substance, Cl_2O_7 , which is the anhydride of perchloric acid, has been prepared by MICHAEL and CONN by the action of phosphorus pentoxide upon pure perchloric acid. The reaction is a dangerous one on account of the explosive nature of the product, and must be carried out very gradually at a temperature of -10° . Chlorine heptoxide is a

colorless, very volatile oil, boiling at 82° . On standing a day it begins to turn yellow and after two or three days it is greenish yellow and gives off a greenish gas. When brought into contact with flame, or by a sharp percussion, it explodes with great violence, but in comparison with other oxides of chlorine it shows great stability, and it may be poured on paper, wood or similar organic matter with impunity, the oxide simply volatilizing in the air.—*Am. Chem. Jour.*, xxiii, 444. H. L. W.

4. *The Non-Existence of Trivalent Carbon.*—In a recent number of this Journal (vol. x, p. 458) mention was made of the supposed existence of triphenylmethyl, $(C_6H_5)_3C$, which would show the existence of trivalent carbon. J. F. NORRIS has now discovered facts which furnish an adequate explanation of Gomberg's results without the necessity of introducing any new principles. He believes that the compound formed by the action of zinc upon triphenylchloromethane is probably diphenylphenylenemethane, $(C_6H_5)_2C:C_6H_5$, an atom of hydrogen being removed along with the chlorine atom. In spite of this new aspect of the matter, Gomberg's results possess great interest. The trivalent carbon formula was advanced merely as a preliminary suggestion.—*Am. Chem. Jour.* xxv, 117. H. L. W.

5. *Diffusion of Gold in Solid Lead at Ordinary Temperature.*—By placing cylinders of solid lead upon disks of gold for a period of four years at a nearly constant temperature of about 18° , SIR W. C. ROBERTS-AUSTIN has found that gold passed into the lead. In the lowest layer of $.75^{mm}$ gold was present to the extent of 1 oz. 6 dwt. per ton, while in a slice 7^{mm} from the surface of contact there were found $1\frac{1}{2}$ dwt. per ton. It is calculated that the rate of diffusion is about $1/350,000$ of that in molten lead.—*Jour. Chem. Soc.*, lxxx, II, 9. H. L. W.

6. *On Cerium.*—The opinion expressed in recent literature that cerium consists of at least two elements, is shown to be in all probability without foundation by a careful investigation on the large scale by G. B. DROSSBACH. 250 kilograms of commercial cerium carbonate were subjected to a long series of operations in order to remove impurities, and finally double salts of cerous nitrate with ammonium nitrate were subjected to systematic fractional recrystallization. In the course of seven months more than two hundred crystallizations were made, and fractions widely separated from one another showed no differences from cerium preparations which could be obtained by the careful use of older methods of purification. The cerium dioxide obtained by igniting cerium nitrate in all cases showed a pale yellowish tint.—*Berichte*, xxxiii, 3506. H. L. W.

7. *A Method for Crystallizing Substances without the Formation of Crusts upon the Surface of the Liquid.*—When a substance is crystallized by the slow evaporation of its solution, crusts are often formed at the surface, and as evaporation continues from such crusts, any impurities that the liquid may contain are likely to be enclosed and thus contaminate the product.

A. WRÓBLEWSKI has devised a method of evaporation by which this difficulty is overcome. He places the solution from which crystals are to be obtained in a cylinder the bottom of which is closed with a parchment membrane, while the top is corked and provided with a water trap. Evaporation takes place through the membrane the lower side of which is exposed to air artificially dried with calcium chloride. In the case of readily diffusible salts a certain amount of dry crystals is formed upon the external surface of the membrane, but this does not take place with dilute solutions. Crystallization takes place within the cylindrical vessel without the formation of crusts. The method is particularly recommended for the crystallization of proteids.—*Zeitschr. physikal. Chem.*, xxxvi, 84.

H. L. W.

8. *On the velocity of the ionized phosphorus emanation in the absence of electric field*; by C. BARUS. (Communicated.)—In *Science* (Feb. 9, 1900) I communicated a series of data on the absorption of the emanation from phosphorus, in tubes of different diameter ($2r$) and material. I have since brought my results together and am now able to compute the velocity, k , of the ionized particle absolutely. I find $k = 2.65 (V/rx) \ln V/V_0$, where V and V_0 are the liters per minute of air saturated with phosphorus emanation needed to retain a field of constant color in the steam tube, for lengths x and zero, respectively, of the absorption tube of radius r .

The results are for tubing of gray rubber, $2r = .64^{\text{cm}}$, $k = .28^{\text{cm}}/\text{sec}$; pure rubber, $2r = .35^{\text{cm}}$, $k = .32^{\text{cm}}/\text{sec}$; lead, $2r = .63^{\text{cm}}$, $k = .25^{\text{cm}}/\text{sec}$; lead, $2r = .32^{\text{cm}}$, $k = .30^{\text{cm}}/\text{sec}$; glass, $2r = .29^{\text{cm}}$, $k = .27^{\text{cm}}/\text{sec}$. These data show no relation to diameter or material. I conclude that the ionized region is under a kind of osmotic pressure such that for highly saturated phosphorus emanation the velocity of particles is about 3 millimeters per second. This small velocity, it will be noticed, is associated with large viscous resistances, so that the pressures are not necessarily small.

9. *The Thermo-chemistry of the Alloys of Copper and Zinc*; by T. J. BAKER, B.Sc., King Edward's School, Birmingham. Read January 17, 1901, before the Royal Society of London.* (Abstract.)—The heats of formation of a number of alloys of copper and zinc, containing those metals in very diverse proportions, have been ascertained. The method consists in finding the difference between the heats of dissolution, in suitable solvents, of an alloy and of an equal weight of a mere mixture containing the metals in the same proportion.

The first series of experiments was made with an aqueous solution of chlorine as solvent. Its application was limited to those alloys containing less than 40 per cent of copper, as it was impossible to obtain those richer in copper in a sufficiently fine state of division to enable them to dissolve. The results, though not altogether satisfactory, showed that the heat of dissolution of an

* Advance proof from the author.

alloy was sensibly less than that of the merely mixed metals. Incidentally it was found that the equation $Cl_2.Aq = 2,600$ (Thomsen's "Thermochemische Untersuchungen") is erroneous and, on inquiry, Professor Thomsen gave a corrected value, 4,870. The author finds $Cl_2.Aq = 4,970$.

The most suitable solvents of the alloys are—

(a.) Mixture of ammonium chloride and ferric chloride solutions.

(b.) Mixture of ammonium chloride and cupric chloride solutions.

The chemical actions involved are simple reductions, and no gases are evolved.

Two series of experiments made on twenty-one alloys yielded very concordant results. They show that heat is evolved in the formation of every alloy of copper and zinc yet tested. A sharply defined maximum heat of formation is found in the alloy containing 32 per cent of copper, i. e., corresponding to the formula $CuZn_2$. It amounts to 52.5 calories per gram of alloy or 10,143 calories per gram-molecule. There is some evidence of a sub-maximum in the alloy nearly corresponding to $CuZn$. From these points there is a steady decrease in the heat of formation, both in the case of alloys containing less than 32 per cent of copper as the amount of copper decreases, and also in the case of those containing more than 50 per cent of copper as the quantity of copper increases.

The results, in general, confirm the existence of intermetallic compounds, and the values obtained are in accordance with those demanded by Lord Kelvin's calculation of the molecular dimensions of copper and zinc.

10. *On the decrement of electrical oscillations in charging condensers.*—This paper is the work of two authors. A. F. SUNDELL has worked out the theory and HJ. TALLQUIST the experimental appliances. It was found that after a relatively short time reckoned from the beginning of the charging the capacity of a mica condenser reached the same value under oscillatory charges as under direct charges. The method also give a means of determining self-induction.—*Ann. der Physik.*, No. 1, 1901, pp. 72–98. J. T.

11. *Effect of a magnetic field on the discharges through a gas.*—DR. R. S. WILLONS concludes from his experiments that at pressures below $.5^{mm}$ the magnetic field decreased the electric force near the cathode; this decrease depended upon the strength of the field and the current. At higher pressures the magnet increased the electric force. If the magnet caused the column to striate it also caused the electric force to show periodic striations. The magnet generally caused the electric force at the anode to increase.—*Phil. Mag.*, pp. 250–260, Feb. 1901. J. T.

12. *Conductivity produced in gases by the motion of negatively charged ions.*—Professor TOWNSEND, of Oxford, England, had previously shown that negatively charged ions moving through

a gas produce other ions, although the force acting on them is small compared with the force necessary to produce the ordinary vacuum discharge. (Nature, vol. lxii, Aug. 9, 1900.) In the present paper, he gives a more complete account of his investigations, and he is led to the conclusion that there is a great difference between the positive and the negative ions at low pressure, and that the negative ions are much smaller than molecules. There is not much difference between the rate of diffusion of the positive and negative ions. The slow rate of diffusion may be due to the negative ions being carried in groups of molecules, and the rates of diffusion of positive and negative ions would depend upon the size of such groups. When the current passes between two electrodes, one inside the other, the conductivity, when the electromotive force is small, is unaltered by reversing the current. When this force is large, the conductivity depends greatly on the direction of the force. The current obtained from the inner positive electrode may be five or ten times greater than that obtained when the inner electrode is negative. The reason appears to be due to collisions if we attribute the production of new ions to the negative ions. In order that new ions should be produced by collisions, it is necessary that negative ions should pass through the gas near the inner electrode where the force is large. When the inner electrode is positive, all the negative ions pass through this region, and a large conductivity is obtained. When the inner electrode is negative, only a few of the negative ions pass through the space where the force is large and the conductivity is much reduced. The increase in conductivity is due to the negative ions, and not to the positive ions. The positive and negative ions therefore possess different physical properties.—*Phil. Mag.*, pp. 198-227, Feb., 1901. I. T.

13. *Recueil de Données Numériques publié par la Société Française de Physique. Optique* par H. DUFET. Troisième Fascicule, pp. 787-1313, with volume title page and contents. Paris, 1900 (Gauthier-Villars).—This highly valuable compilation of physical data (see this Journal, vii, 472) has now reached its Third Part, which completes the volume on Optics. It contains the following tables: Table XVII, Rotary Power of Crystalline Bodies, including chiefly quartz and sodium chlorate; also other crystallized substances. Table XVIII, Rotary Powers of Bodies, liquid or dissolved; also those of vapors. Table XIX, Interference Colors, according to Newton, Wertheim, Quincke, and Rollet. These tables are complete to the close of 1898. A Supplement, pp. 1173-1305, brought down to the end of December, 1899, contains tables of wave-lengths; of refractive indices for gases, liquids, and various important solids, etc. The whole is printed with great clearness and full references are given to the original authors.

14. *One Thousand Problems in Physics*; by WILLIAM H. SNYDER and IRVING O. PALMER. Pp. 142. Boston, 1900: Ginn & Co.—This little volume contains well selected problems, especially suited to the use of teachers of Physics in the secondary schools.

II. GEOLOGY AND MINERALOGY.

1. *Maryland Geological Survey: Allegheny County*; WM. BULLOCK CLARK, State Geologist. Pp. 1-323, plate i-xxx, figures 1-15, with Folio Atlas, 1900.—“The present volume on Allegheny County inaugurates a new series of reports dealing with the physical features of the several counties of Maryland. Not only the geology and mineral resources of Allegheny County will be considered but also the physiography, soils, climate, hydrography, magnetic declination, forests and life characteristics.” This is a tempting program and will attract the interest of readers, as will the beautiful illustrations and fine appearance of the volume.

The following list of formation names is adopted and preliminary descriptions of them are given :

Cenozoic.	
Pleistocene	Alluvial, etc.
Paleozoic.	
Permian	Dunkard.
	{ Monongahela
	{ Conemaugh
	{ Allegheny
Carboniferous	{ Pottsville
	{ Mauch Chunk
	{ Greenbrier
	{ Pocono
	{ Hampshire
	{ Jennings
Devonian	{ Romney
	{ Oriskany
	{ Helderberg
	{ Salina
	{ Niagara
Silurian	{ Clinton
	{ Tuscarora
	{ Juniata

In the absence of paleontological evidence we shall watch with interest for the reasons for accepting the Niagara as one of the formations of the series in this State. And the geological reader will wonder on what basis the name Salina is applied to the rocks so described in the report, and also on what grounds the 400 feet of rocks “corresponding to the Tentaculite limestone of New York” are separated from the so-called Salina and included in the “Helderberg formation,” which is made the base of the Devonian.

2. *United States Geological Survey*. C. D. WALCOTT, Director.—The following publications of the Survey, bearing the date 1900 and for the most part not hitherto noticed, have been received, viz:

Monograph. XXIX. The Eocene and Lower Oligocene Coral Faunas of the United States, with Descriptions of a Few Doubtfully Cretaceous Species, by T. Wayland Vaughan. 263 pp., 24 pl. [To be noticed later.]

Bulletins—

163. Flora of the Montana formation, by Frank Hall Knowlton. 118 pp., 19 pl.
 164. Reconnaissance in the Rio Grande Coal Fields of Texas, by Thomas Wayland Vaughan, including a Report on Igneous Rocks from the San Carlos Coal Field, by E. C. E. Lord. 100 pp., 11 pl. and maps.
 165. Contributions to the Geology of Maine, by Henry S. Williams and Herbert E. Gregory. 212 pp., 14 pl.
 166. A Gazetteer of Utah, by Henry Gannett. 43 pp., 1 map.
 167. Contributions to Chemistry and Mineralogy from the Laboratory of the United States Geological Survey; Frank W. Clarke, Chief Chemist. 308 pp.
 168. Analyses of Rocks, Laboratory of the United States Geological Survey, 1880 to 1899, tabulated by F. W. Clarke, Chief Chemist. 308 pp.
 169. Altitudes in Alaska, by Henry Gannett. 13 pp.
 170. Survey of the Boundary Line between Idaho and Montana from the International Boundary to the Crest of the Bitterroot Mountains, by Richard Urquhart Goode. 67 pp., 14 pl.
 171. Boundaries of the United States and of the Several States and Territories, with an Outline of the History of all Important Changes of Territory (Second Edition), by Henry Gannett. 142 pp., 53 pl.
 172. Bibliography and Index of North American Geology, Paleontology, Petrology, and Mineralogy for the Year 1899, by Fred Boughton Weeks. 141 pp.
 173. Synopsis of American Fossil Bryozoa, including Bibliography and Synonymy, by John M. Nickles and Ray S. Bassler. 663 pp.
 174. Survey of the Northwestern Boundary of the United States, 1857-1861, by Marcus Baker. 78 pp., 1 pl.
 175. Triangulation and Spirit Leveling in Indian Territory, by C. H. Fitch. 141 pp., 1 pl.
 176. Some Principles and Methods of Rock Analysis, by W. F. Hillebrand. 114 pp.
3. *Geological Survey of Michigan.* ALFRED C. LANE, State Geologist. Vol. vii, Part III; *Geological report of Sanilac County, Michigan*; by C. H. GORDON. Pp. 1-34, 5 Plates, 2 figures. 1900.—The rocks met with in Sanilac County, together with those of Monroe and Huron Counties, described in parts I and II, represent all the formations of the lower Peninsula although these counties are situated in the southeast corner of the State. Part I, vol. viii; *Clays and Shales of Michigan, their Properties and Uses*; by H. RIES. Pp. 67, with four plates.

This volume, edited by the State geologist, Prof. Alfred C. Lane, contains the results reached by Dr. Ries in examining the clays of Michigan. An account is given of the various localities and also of the tests to which the clays from them have been subjected.

w.

4. *The Geological and Natural History Survey of Minnesota. The Twenty-fourth (and final) Annual Report for the years 1895-1898.* N. H. WINCHELL, State Geologist. 1899. Pp. 1-284.—The main body of this report consists of lists and notes of rock samples, record of the field work, and indices, but the introductory statement by the State Geologist is of special interest. A brief review of the history of the Survey during its 27 years is given. The Salt Spring lands of the State were early set apart to be used for the prosecution of the Survey. The State Geologist estimates that through the agency of the State Geologist, indemnity lands to the amount of 19,872 acres were discovered; these were transferred by the Legislature of 1885 to the Board of Regents for the purpose of a Geological and Natural History Survey. The Geological Survey of Minnesota has therefore been endowed by grants of land, 18,771 acres of the Salt Spring lands and 19,872 acres in 1885, making a total of 38,643 acres.

The total cost of the Survey from 1872 to July 31, 1899, is estimated to be \$146,357.27. "The total revenue to the State as shown in dollars that can be counted, in excess of the public good that may come from the Survey," is claimed to be \$132,609.26.

The State Geologist is to be congratulated that he can make so good a showing for his administration of the Survey of his State.

w.

5. *The Pleistocene Geology of the South Central Sierra Nevada with Especial Reference to the Origin of Yosemite Valley;* by HENRY WARD TURNER.—Proceedings of the California Academy of Sciences, 3d Series, Vol. i, No. 9, pp. 262-321, with 9 plates.—As an introduction to the discussion of the origin of Yosemite Valley, Mr. Turner reviews the orogenic movements of the Sierra Nevada region and describes three pleistocene periods, Sierran, Glacial and Recent. There is no common opinion regarding the importance of glacial work in the formation of the valleys of the Sierras. John Muir ascribes the topography of the entire mountain system from base to summit to the work of glacial ice. Prof. Whitney doubted the existence of any glaciation in the region. Other writers have held intermediate positions. Because of this wide variation in opinion, Turner has critically reexamined the evidence regarding the erosive power of ice, the origin of rock basins and glacial cirques with special reference to the Sierras. He concludes that "the theory that great canyons or even considerable ravines are formed by the gouging action of ice does not seem supported by the evidence," and that ice erosion has not been a controlling factor in the formation of Yosemite. That this valley is the result of a drop fault was held by Whitney, Reyer and Russell. The rocks, however, in general show no faulting

structures and it is quite improbable that a *graben* 4,000 feet deep would be so short and end so abruptly. Moreover, the steep walls which suggest faulting are satisfactorily explained by the system of vertical joints. Turner's investigations support the views of Becker and Branner that the Yosemite Valley "was formed by river erosion facilitated by strong jointing," just as are many other canyons of the Sierras. "That some faulting has occurred along the sheeted or jointed zones of granite about the Yosemite is probable, but it is thought that this has resulted rather in a more thorough shearing of the granite than in the dropping down of wedges. Along such a sheared zone, the streams would rapidly deepen their beds. Even where the rocks are not sheared, but merely intersected with vertical joints, it is easy to see how, as erosion progressed, the slabs would crumble or tumble off along the joint planes, leaving vertical faces. If now a tongue of ice should pass through the valley and clear out the talus and other detritus and round off the projecting shoulders and spurs, and as it retreats leave terminal moraines as barriers to form the valley floor, we seem to have sufficient means for the accomplishment of all we now see in Yosemite Valley." (Pp. 319-320.)

H. E. G.

6. *Geologisches Centralblatt; Anzeiger für Geologie, Petrographie, Palaeontologie, und verwandte Wissenschaften*; edited by K. KEILHACK. Vol. I, No. I, 32 pp., 8°. Leipzig (Gebrueder Borntraeger).—This new journal has for its object the prompt publication for those interested of brief abstracts of all important contributions in geology and its allied sciences. A special endeavor to accomplish this with the least possible delay is promised. The abstracts will appear in German, English and French. In addition to the editor-in-chief, the names of seventy-eight geologists, from all parts of the world, are given who will aid in conducting the journal. The numbers are to appear every two weeks. There can be no doubt that a publication of this kind, if well carried out, will prove highly useful, and we wish it all success.

L. V. P.

7. *Metasomatic Processes in Fissure Veins*; by WALDEMAR LINDGREN. (A paper read before the American Institute of Mining Engineers, Feb., 1900. Author's edition.)—The purpose of the paper, as expressed in the author's own words, is to collect the scattered data relating to the alteration of rocks near fissures, to indicate the principal active processes, to classify the veins, if possible, according to the different phases of alteration accompanying them, and finally to draw some conclusions from the facts thus grouped. In Part II of his paper Mr. Lindgren discusses the various minerals developed by metasomatic processes in mineral veins, giving the origin, mode of replacement, etc. In Part III he proposes fourteen different classes into which fissure veins may be divided, naming each class according to the principal metasomatic process found in it. Each class is discussed and examples cited. For instance, Class No. 8 is that of Sericitic

and Calcitic Gold Silver Veins, and is illustrated by the gold quartz veins of California. Some of the conclusions of the paper are as follows: Almost all fissure veins are bordered by altered zones, the character of the alteration differing widely in different veins; that the alteration usually consists in the loss of certain constituents and the introduction of new elements, chiefly CO_2 and S; that the processes are such as can only be explained by aqueous agencies acting under high pressure, temperature and concentration while ascending along the fissure; that these ascending waters are chiefly surface waters which after a circuitous underground route have found in a fissure an easy way to return to the surface; and that most fissure veins are genetically connected with bodies of intrusive rock which on cooling give off volatile compounds of the heavy metals which on sizing meet surface waters and are carried along by them and subsequently deposited by their aid in the veins.

W. E. F.

8. *Some Iowa Dolomites*; by NICHOLAS KNIGHT. (Communicated.)—The rocks herein described were analyzed in the chemical laboratory of Cornell College under the direction of the writer. The composition of the rocks varies from nearly typical dolomite to admixtures in different proportions of calcium carbonate and dolomite.

(1.) This is a bluish-drab saccharoidal rock, situated near the base of the Iowa Devonian series, at Rochester, Iowa. It is of special interest because locally believed to contain silver. A miner's shaft, thirty feet deep, has been sunk to it, and several analyses are said to have been made, showing a large amount of silver. Professor W. H. Norton, of the Iowa Geological Survey, was unable to authenticate any of the analyses. He found no geological grounds for the slightest suspicion of any precious metal in these beds. This analysis was made not to disprove the presence of silver, but to show the lithological change from the subjacent dolomites of the Silurian. The specimen was analyzed by Miss Minerva Herrinton, A.B.

CaCO_3	78.75	per cent
MgCO_3	20.16	"
Fe_2O_3 and Al_2O_3	0.10	"
SiO_2	0.4	"
MnO_2	0.2	"
	<hr/>	
	99.61	"

The rock varies widely from a true dolomite, which contains CaCO_3 54.35, MgCO_3 45.65.

(2.) The Coggon beds as described by Professor Norton in the Reports of the Iowa Geological Survey, overlie the Gower stage of the Silurian, and are immediately beneath the Otis beds of the Wapsipinnicon stage,—the lowest Devonian terrane recognized in Iowa. The lithological affinities of the Coggon are with the Niagara, but the very meager fauna inclines rather toward the Onondaga limestone of the Devonian. The specimen from

Bieler's quarry in Cedar County, Iowa, was analyzed by Miss Herrinton.

CaCO ₃ -----	58.2	per cent
MgCO ₃ -----	39.5	"
Fe ₂ O ₃ and Al ₂ O ₃ -----	0.9	"
SiO ₂ -----	1.2	"
	<hr/>	
	99.8	"

This is not a true dolomite but more nearly approaches it than the rock described in 1.

(3.) The Gower stage as defined by Professor Norton includes two distinct lithological types: a hard crystalline rock used extensively for lime and hitherto known as the Le Claire limestone; and a granular evenly-bedded rock which furnishes the best building stone in the State. This was, until recently, designated as the Anamosa beds, which have usually been assigned rank as a distinct geological formation; but the Iowa Geological Survey, in its recent reports, has taken them to be but a lithological phase of one formation. The name *Gower* has been assigned them from the township in Cedar County in which the important Bieler quarries are situated. Both types of rock are found in the Bieler quarries. The following specimen of the granular laminated building stone was analyzed by Miss Herrinton. It varies only slightly from a true dolomite.

CaCO ₃ -----	56.4	per cent
MgCO ₃ -----	42.6	"
Fe ₂ O ₃ and Al ₂ O ₃ -----	0.7	"
SiO ₂ -----	0.4	"
	<hr/>	
	100.1	"

(4.) Specimen of the Gower phase taken from the Mount Vernon quarry. It was analyzed by Mr. E. A. Rayner.

CaCO ₃ -----	54.02	per cent
MgCO ₃ -----	44.73	"
Fe ₂ O ₃ and Al ₂ O ₃ -----	0.61	"
SiO ₂ -----	0.29	"
	<hr/>	
	99.65	"

The rock is nearly a typical dolomite.

(5.) The rock at the Palisades, on the Cedar River, six miles distant from Mount Vernon, is similar in composition to the Mount Vernon rock. It is stratified but not granular. Building stone occupies layers adjacent to others which are burned for lime. The specimen was analyzed by Mr. G. R. Greaves.

CaCO ₃ -----	53.64	per cent
MgCO ₃ -----	43.89	"
Fe ₂ O and Al ₂ O ₃ -----	0.52	"
SiO ₂ -----	1.98	"
	<hr/>	
	100.03	"

(6.) This is of the same type as (3). It is a finely laminated building stone, but crystalline instead of granular. The specimen analyzed by Miss Herrinton is from the large quarries at Lime City, Iowa. It is nearly a dolomite in composition.

CaCO ₃	55.3	per cent
MgCO ₃	43.0	“
Fe ₂ O ₃ and Al ₂ O ₃	1.4	“
SiO ₂	0.6	“
	<hr/>	
	100.3	“

(7.) This is also a representative of the Gower limestone and of the Le Claire lithological phase. The specimen was taken from a ledge on Rock Creek, two and a half miles southwest of Tipton, Iowa. The ledge is notable for its exceptionally high dip, reaching 70°. It varies but little from true dolomite. The analysis was made by G. R. Greaves.

CaCO ₃	55.76	per cent
MgCO ₃	43.85	“
Fe ₂ O ₃ and Al ₂ O ₃	0.26	“
SiO ₂	0.12	“
	<hr/>	
	99.99	“

Each of the seven specimens examined is nearly pure calcium and magnesium carbonates. The admixtures of iron, alumina and silica are quite insignificant.

9. *Minerals of Ontario*.—Professor Willet G. Miller, of Kingston, has recently published in the Ninth Report of the Bureau of Mines, Ontario (pp. 192–212), a list of the minerals found in the Province of Ontario, with notes in regard to their occurrence and characters. This paper is accompanied by a large map of the mining district of Sudbury, with the location of the nickel deposits noted upon it. This gives an interesting representation of the mineral wealth of this region. As is well known, the ore is chiefly pyrrhotite, carrying some nickel. The average of several analyses for each of the five townships in the Sudbury district gives amounts varying from 1.94 to 2.99 p. c. Pentlandite and nickeliferous pyrite also occur in the region.

10. *A Text-book of Important Minerals and Rocks, with tables on the determination of minerals*; by S. E. TILLMAN. Pp. 176, 8vo, New York, 1900 (John Wiley & Sons).—This concise presentation of the principal facts of mineralogy, with brief accounts of the important species, will be found useful by teachers who do not want a more extended work. Some forty pages are devoted to determinative tables, and the closing part of the volume deals with common rocks of different types.

11. *Los Minerales*.—Su Descripción y Analisis con especialidad de los existentes en la República Argentina, por el Dr. GUILLERMO BODENBENDER. Pp. 306. Córdoba; 1899.—Dr. Bodenbender

has given here a brief description of the common mineral species with particular reference to their occurrence in the Argentine Republic. The volume is arranged so as to be suitable for purposes of instruction.

III. BOTANY.

1. *Monograph of the North American Umbelliferae*; by J. M. COULTER and J. N. ROSE. (Contributions from the U. S. National Herbarium, vii, 1-256, 8vo, Washington, December 31, 1900.)—It is more than twelve years since Messrs. Coulter and Rose published their useful Revision of the North American Umbelliferae. During this interval much new material has been accumulated toward the further clarification of this difficult group, and the present welcome publication has expanded to some 250 pages. Prefatory lists and tables show clearly the bibliography, statistics and generic synonymy of the family, careful attention having been devoted to the question of generic types. The generic key is artificial, but is based, as must be the case in this group, primarily upon fruit characters and inflorescence, much weight being ascribed to the number and arrangement of the oil-tubes. In the descriptive portion of the work the characterizations are mostly rather brief, greater space than usual having been given to the detailed citation of *exsiccatae*, a feature which will render the treatment—at least to the professional botanist—much clearer and more valuable than the introduction of fuller descriptions. There are a few habitat plates and many clear and excellent text-figures, mostly of the fruit.

Probably the most significant single change from the earlier treatment is the separation (as *Lomatium*) of the American plants hitherto referred to the genus *Peucedanum*, which is now regarded by the authors as strictly gerontogeous. It is to be regretted that the authors have felt it desirable to recast their nomenclature according to the Rochester Code, notwithstanding its serious defects, which have been often and clearly pointed out, and which render its general acceptance impossible. The geographic ranges assigned might, in some few instances, have been extended; thus *Leptocaulis echinatus* Nutt. occurs in Southern Missouri (Eggert). A few ranges are vaguely given which might with a little trouble have been made more definite; thus *Erigenia bulbosa* Nutt. is said to grow in the "United States and Canada east of the Great Plains," but it is lacking in New England and the maritime provinces. A more usual case seems to be the repetition of a compiled traditional range not fully borne out by the specimens examined. In this the authors appear to have been too conservative; for, considering the vast amount of material which they have studied—including all the larger public and many private herbaria—who can say better than they where a given American umbellifer occurs? It is, therefore, disappointing to find them still reluctant to relegate to

merited oblivion such venerable spooks as the New England *Thaspium aureum*. Surely it is not only the privilege but the duty of monographers to pass upon the validity of old and unsubstantiated reports.

In the interpretation of species the authors have on the whole been cautious, yet several are launched (e. g., *Hydrocotyle australis* and *H. cuneata*) which appear to rest upon fine technical characters unaccompanied by habitual differences of moment. While not prepared to challenge the validity of any of these species, we may say that they suggest the artificial category rather than species distinct in nature. Species with the opposite failing, in which distinctions of foliage and habit are unsubstantiated by satisfactory or constant differences in flower or fruit, are also found, as, for instance in the southern *Cicuta Curtissii*, which would be good enough provided the fruit maintained its orbicular form and never exceeded the assigned 2^{mm} of length, but unfortunately it is variable in these regards and the northern *C. maculata* sometimes has suborbicular fruit which falls short of its ascribed length of 4^{mm}. Similarly, a close scrutiny of the problematic *Sium Carsonii* Durand would have shown the authors that the supposed technical distinctions are, even in the original Pocono material, not invariably so strong as stated. Indeed, in a considerable suite of specimens it is difficult to draw a satisfactory line between this species and *C. cicutæfolium*, and it is known that under certain circumstances (changes of water-level) *S. cicutæfolium* transforms itself into states simulating so closely *S. Carsonii*, that, when so wide a variation is permitted to the former, it seems highly artificial to separate the latter upon trifling differences of degree.

In the successful elucidation of the Alaskan *Cœlopleurum Gmelini* Ledeb. and separation of the nearly allied *C. actæifolium* Coult. and Rose, of our northeastern flora, the authors have rendered a considerable service.

Genera in the Umbelliferæ are apt to appear technical rather than natural and this may be necessary in a group of such uniform floral structure and gradually varying habit, yet it is questionable whether technical subdivision is not carried too far when such habitually identical plants as *Leptocaulis patens* and *L. divaricatus*, with very similar fruit, are placed in separate genera owing to the different number of oil-tubes. The logic of such a course becomes still more doubtful when we see that the not very remote genus *Sanicula* is permitted to have as many or as few oil-tubes as it likes.

In several places the authors commit the common error of describing thick bodies, like the fruit of *Sanicula*, with such terms (of two dimensions) as *orbicular*, *elliptical*, or *oval*, instead of *globose*, *ovoid*, etc.

B. L. R.

2. *Foundations of Botany*; by JOSEPH Y. BERGEN. 8vo. Pp. xii, 669. Boston, 1901 (Ginn & Co.).—Under the above title Mr. Bergen has just issued what is virtually a revised edition of

his "Elements of Botany." Preserving all the valuable features which have made the "Elements" one of the most popular and useful text-books of the last decade, Mr. Bergen has added considerably to the laboratory exercises upon plant anatomy and physiology, increased the number of illustrations, replaced certain figures by much better ones and incorporated a fuller treatment of the cryptogams by Mr. A. B. Seymour. The work, which is the outcome of many years of practical experience in teaching botany, makes a pleasing impression throughout and at every point bears evidence of care and good judgment. Appended to the text-book is a partial flora, arranged in the sequence of Engler and Prantl's "Natürlichen Pflanzenfamilien," and including some seven hundred flowering plants selected from those most available in spring time in our northeastern and middle states. It is designed, of course, to familiarize the pupil with the common plants of his region and bridge the difficulty which must be encountered by a beginner in the immediate use of more complete and technical manuals. Whether such a simplified flora proves more helpful or misleading must depend largely upon the experience and good sense of the teacher,—qualities which even this well-nigh ideal text-book cannot wholly offset. B. L. R.

3. *Flora of Vermont, a List of Fern and Seed Plants growing without Cultivation*; prepared by E. BRAINERD, L. R. JONES, and W. W. EGGLESTON. (Reprinted from the Twentieth Vermont Agricultural Report; 8vo, 113 pp. Burlington, Vt.)—By its excellent arrangement, clear typography, and copious annotation, the recently issued catalogue of Vermont plants makes a favorable impression. It is evidently the outcome of much active exploration by the members of the Vermont Botanical Club, the results having been carefully verified and arranged by the editors. Each entry in the main catalogue rests upon plants personally examined by the compilers except in a few cases in which other authorities, usually well-known specialists, are cited. No attempt is made to swell the bulk of the flora by repeating second hand reports or unverified records. These, however, are appended in a sort of supplementary *limbo*, where without lessening the trustworthiness of the main catalogue, they will doubtless continue to stimulate renewed search. The arrangement of families is in accordance with the generally approved sequence of Engler and Prantl. The nomenclature is conservative and synonymy sufficient and well-selected. With one or two exceptions the editors have considerably avoided making new combinations, which they rightly regard out of place in local floras of composite authorship. B. L. R.

4. *Catalogue of the African Plants collected by Dr. Friedrich Welwitsch in 1853-61*. Dicotyledons, Part IV, Lentibulariaceæ to Ceratophylleæ; by WILLIAM PHILIP HIERN. Pp. 785-1035. London, 1900.—This catalogue of plants collected by Welwitsch in one of the most interesting parts of Africa forms one of the publications printed by order of the trustees of the British Museum, and is an especially important contribution to our

knowledge of the distribution of plants in Africa. Contrary to what one would have supposed, the Bignoniaceæ are represented by very few species. Acanthaceæ and Verbenaceæ are only fairly well represented and the same is true of Labiataæ, although a considerable number of new species of the last-named order are described. Of the Selagineæ, which are abundant at the Cape, none were known in West Tropical Africa previous to Welwitsch's discovery of three species, which are said to be among the most delightful of the plants of Huilla. "The negresses, who are in general but little susceptible to the beauties of nature, are in the habit of weaving in their head-dresses the flowering branches of the two species of Selago." The Proteaceæ, characteristic plants farther south, are represented only by *Leucadendron* with six species and *Faurea* with three species. The Loranthaceæ, which increase progressively from the sea coast towards the highlands of the interior and culminate in the mountainous forests of Pungo Andongo and Huilla at an elevation between 4,000 and 6,000 feet, are well represented by 28 species. The Euphorbiaceæ are numerous and those near the sea shore and on high plateaus have the cactus-like habit, while in the mountainous wooded region are found foliaceous climbing and arborescent species which resemble in habit orders like Convolvulaceæ, Urticacæ and Leguminosæ.

W. G. F.

5. *Botany: an Elementary Text for Schools*; by L. H. BAILEY. Pp. xiv + 355, with 500 figures. New York, 1900 (The Macmillan Company).—Two years ago, Professor Bailey published his "Lessons with Plants," which soon became favorably known to the botanical public. His new text is written in the same spirit but is rather more comprehensive in its scope. The book is divided into four parts: the first of these, occupying rather more than half the volume, deals with "the plant itself"; the second part treats "the plant in its environment"; the third gives a short account of "histology, or the minute structure of plants"; while the fourth, entitled "the kinds of plants," includes descriptions of a number of common wild and cultivated plants, with analytical keys to aid in their determination. The subject-matter, written in the author's usual style, requires little comment. One cannot help being surprised, however, at the admission of such topics as the "burst of spring" on page 40, and the "expressions of plants" on page 60. Possibly this is explained by the introductory statement that the book was written for the pupil rather than for the teacher. Although some of the half-tone figures are inferior in quality, the illustrations are, for the most part, satisfactory and well selected. Certain of them, however, might have been omitted without detracting from the value of the book, figures 347 and 380, for example, bringing out essentially the same points.

A. W. E.

6. *Plant Life and Structure*; by Dr. E. DENNERT, translated from the German by Clara E. Skeat. Pp. viii + 115, with 56 figures. London, 1900 (J. M. Dent).—This little volume is issued

as one of the Temple Primers. It gives a short account of the plant's various organs and of the work which they do. The topics treated are divided under three headings: the internal structure of plants (anatomy), the external organs of plants (morphology), and the life of the plant (physiology). The book is so concisely written that it is not always clear, and the general reader might easily gain from it incorrect ideas about some of the most important botanical facts.

A. W. E.

IV. MISCELLANEOUS SCIENTIFIC INTELLIGENCE.

1. *Comparative Physiology of the Brain and Comparative Psychology*; by JACQUES LOEB. 8vo, pp. x, 309. New York, 1900 (G. P. Putnam's Sons).—The motive of this very interesting work is well stated by the author in the following words of the preface: "It is the purpose of this book to serve as a short introduction to the comparative physiology of the brain and central nervous system. Physiology has thus far been essentially the physiology of vertebrates. I am convinced, however, that for the establishment of the laws of life-phenomena a broader basis is necessary. Such a basis can be furnished only by a comparative physiology which includes all classes of the animal kingdom." The nervous phenomena in medusæ, ascidians, actinians, echinoderms, worms, arthropods and mollusks are discussed in succession, and then those of vertebrates. Prof. Loeb is strongly anti-metaphysical, supposes all nervous and mental phenomena due to physico-chemical changes in cell protoplasm, and regards the dynamics of the process of association as the true problem of brain physiology. Whether its conclusions are accepted or not, the book will be useful and interesting to the student of biology as well as to the special student of physiology. The metaphysical psychologist also might find mental stimulus in it.

S. I. S.

2. *Microbes et Distillerie*; par LUCIEN LÉVY. 8vo, pp. vi, 323. Paris, 1900 (Carré et Naud).—The first and larger part of this manual, intended specially for the use of distillers, gives a concise account of the more important technique of microbiological investigation and a review of the biology of the organisms (here grouped under the general term microbes) which concern the brewer and distiller. The description of the various forms of yeast and their properties is of interest to the general biologist. The second part is devoted to the theory of the application of microbiology in the distillery. The book is fully illustrated with diagrammatic outline figures.

S. I. S.

3. *Der Gesang der Vögel, seine anatomischen und biologischen Grundlagen*; von VALENTIN HÄCKER. 8vo, pp. viii, 102. Jena, 1900 (Gustav Fischer).—In the first part of this memoir Prof. Häcker describes the structure of the vocal organs of birds and points out important sexual differences in the anatomy of the syrinx. In the larger and very interesting second part he dis-

cusses the singing and other sound-producing instincts and their significance in connection with wooing, pairing, etc. s. i. s.

✓ 4. *The O. S. U. Naturalist*, published by the Biological Club of the Ohio State University.—This new journal, commenced in November, 1900, and to be published monthly from November to June (50 cts. per year), is to be devoted especially to the Natural History of Ohio. The editor-in-chief is Prof. John H. Schaffner; he is aided by associate editors in five different departments. The numbers already issued contain, among others, several interesting botanical papers.

5. *Ostwald's Klassiker der Exakten Wissenschaften*. Leipzig, 1900 (Wilhelm Engelmann).—The following are recent additions to this series of Scientific Classics, which becomes continually more valuable as it gains more and more completeness.

Nr. 5. Allgemeine Flächentheorie (Disquisitiones Generales circa Superficies Curvas); von Carl Friedrich Gauss (1827). Pp. 64.

Nr. 114. Briefe über Thierische Elektrizität: von Alessandro Volta (1792). Pp. 161.

Nr. 115. Versuch über die Hygrometrie. I. Heft. I. Versuch Beschreibung eines neuen vergleichbaren Hygrometers. II. Versuch Theorie der Hygrometrie. von Horace Bénédict des Saussure. Pp. 168.

Nr. 116. Die Darstellung ganz willkürlicher Functionen durch Sinus- und Cosinusreihen; von Lejeune Dirichlet (1837) und Note über eine Eigenschaft der Reihen, welche discontinuirliche Functionen darstellung; von Philipp Ludwig Seidel (1847). Pp. 58.

Nr. 117. Darstellende Geometrie von Gaspard Monge. (1798) Übersetzt und herausgegeben von Robert Haussner. Pp. 217.

Nr. 118. Galvanismus und Entdeckung des Säulenapparates 1796 bis 1800. Von Alesandro Volta. Pp. 99.

6. *The Director-General of the Geological Survey of the United Kingdom*.—The announcement has just reached us (January 15th) that Sir Archibald Geikie has intimated his intention to retire from the post of Director-General of the Geological Survey of the United Kingdom, an office which he has so ably filled for the past twenty years, on March 1st next. In 1855, at the age of 20, Sir A. Geikie became an Assistant on the Geological Survey of Scotland, and he was made Director for Scotland in 1867. In 1881 he was appointed to succeed Sir Andrew Ramsay as Director-General of the Geological Survey of the United Kingdom. He has seen forty-six years' service, but is now only in his 66th year. We rejoice to learn that Sir A. Geikie has no intention of retiring from active participation in geological work, and that neither his hammer nor his pen are to be laid aside for some years to come.—*Geol. Mag.*, February, 1901.

THE

AMERICAN JOURNAL OF SCIENCE

[FOURTH SERIES.]

ART. XX.—*The Magnetic Theory of the Solar Corona*; by
FRANK H. BIGELOW.

THE hypothesis that the sun's corona is an appendage controlled by a magnetic field, whose base is in a central nucleus, and by an electric discharge radiation arising near the surface, which together interacting upon small particles of electrically charged matter arrange them in the observed curved rays, has been making progress in recent years towards a firm theory.* This view is so well known that we may pass at once to the review of certain results of research which tend to sustain, if not to confirm it. In my work, points were measured on photographs of the corona along the individual visible rays, and discussed by the formulæ applying to the lines of force surrounding a spherical magnet, modified to allow for projection on a plane passing through the center of the sun perpendicular to the line of sight from the earth. The invisible bases of the rays were located by tracing back their visible portions to the surface of the sun, and they were found to lie in narrow belts, one in each hemisphere, which were located about 30 degrees away from the poles, the polar zones themselves being denuded of rays. The equatorial and midlatitude zones were filled with an interlacing tangle of lines not subject to further magnetic classifications.

In the year 1892, Pupin† in America and Ebert‡ in Germany produced coronoidal discharges in poor vacua, by placing a small conducting body inside a glass globe covered with tin

* The Solar Corona, Smithsonian Institution, 1889; this Journal, Nov., 1890, July, 1891; Astron. Soc. Pac., No. 14, 1891, No. 16, 1891; Bulletin No. 21, U. S. Weather Bureau, 1898.

† This Journal, April and June, 1892.

‡ Chicago Congress, 1893.

foil and containing gas in a rarefied state, through which electric oscillating currents were made to pass. The electric discharge rays as formed by experiment bore a strong resemblance to the visible coronal rays, in regard to mutual repulsion, helical rolling of the individual streamers, color and instability, so that there was strong presumption in favor of pursuing this analogue to its conclusion. However, Lord Kelvin's presidential address* on "The Sun's Effect on Terrestrial Magnetism," came to the discouraging conclusion that the work required to be done by the sun to produce the observed terrestrial effects was too excessive to be considered practicable, and this brought the subject to a standstill in the minds of many for want of a convenient answer to this disconcerting result. But continued researches by Bigelow† and Ellis‡ on the sun spots and the terrestrial magnetic field, have demonstrated that Lord Kelvin's view cannot be maintained, and that there is in fact a continuous contact between the solar and terrestrial forces. It may be remarked in passing that the application of the formula for energy, from which the work expended was computed, namely,

$$E = \frac{1}{8\pi} \iiint \left(\frac{\partial V}{\partial x} \right)^2 + \left(\frac{\partial V}{\partial y} \right)^2 + \left(\frac{\partial V}{\partial z} \right)^2 = - \frac{1}{8\pi} \iint V \frac{dV}{dn} dS,$$

fails to take any account of secondary effects. Thus the solar forces may set in operation such processes as ionization, which modifies the magnetic field in the earth's atmosphere in proportion to some other factor than unity. The physics of the case is evidently too complex to be solved in so simple a manner as the above, and in the face of the well known continuous and unmistakable testimony of the observations it cannot be accepted as a barrier to further investigation.

The critical experiment has fortunately been made by H. Ebert§ which goes far to clear up the entire subject and put the theory on a working basis. I have made the following translation of his note: "For the explanation of the most important characteristics of the polar light phenomena, the following experiments were made: Spheres, disks and cylinders of iron and brass were exposed to the action of electromagnetic oscillations in spaces filled with rarefied gases; by this means their surroundings were made to glow, and the bodies mentioned were clothed with envelopes of light having a ray structure, whose color and appearance was different

* Nature, Dec. 1, 1892; Astrophysics, Jan., 1893.

† Bulletin No. 21, 1898;

‡ Proc. Roy. Soc., vol. lxiii.

§ Versammlung deutscher Naturforscher u. Aerzte zu Lübeck, 1895

according to the nature of the gas. *If these rays were then subjected to the lines of force of a strong magnetic field, the following phenomena were seen:*

(1). If the magnetic lines extended through the rarefied region, they illuminated the basal portions of the rays of light. If these disappeared, as when the gas was made too rarefied, they also appeared again when the field was strengthened.

(2). The rays of light are strongest in a field of medium strength.

(3). They follow the direction of the magnetic lines of force.

(4). When the lines of force are very dense and impinge at right angles to the surface of the iron body, the rays of light are thrust to one side. *The polar collar of the magnetized iron sphere, for example, was then entirely robbed of rays; the light structure surrounds the pole in the form of a ruffle, the inner boundary of which follows the same direction as the lines of force."*

Ebert makes an application of this valuable experiment to an explanation of the aurora borealis and the solar corona. It is evident that Pupin's experiment was incomplete, in that it lacked the organizing effect obtained by plunging the body emitting coronoidal electrical discharges into a magnetic field, and that the special phenomena observed in the corona of the sun are remarkably matched in all details by the forces produced through the combined action of electrical discharges in a magnetic field. My original result that the polar region of the sun is robbed of its rays, and that the coronal lines coincide in direction with the lines of magnetic force, is thus verified by experiment, and this is explained by the well known theory of the deflection of cathode rays in a vacuum tube under a magnetic field of force. The formula,* $\frac{m}{e} = \frac{H^2 r^2 Q}{2W}$,

involves the theory alluded to, as can be seen by consulting the references. The charged ions are deflected by a magnetic field, and also by an electrostatic field. This argument, which might be greatly expanded, carries with it the following conclusions, in my judgment:

(1) The photosphere of the sun is the seat of powerful electric discharges which ionize portions of its material, or at least set free minute particles of matter charged with electricity. These are repelled outward in a coronoidal radiation and give the forms seen in the disorganized streamers. (2) The nucleus of the sun must be the seat of a powerful magnetic field whose axis is near that of the sun's axis of rotation, and whose action upon the ions repels them from the polar zones, in

* J. J. Thomson, Phil. Mag., Oct., 1897; J. Henry, Phil. Mag., Nov., 1898, etc.

accordance with Ebert's experiment. (3) The equatorial regions of the sun usually show that there is a tendency to form a trumpet-shaped extension along the ecliptic, widening in proportion to the distance from the sun. This is another evidence of the fact of mutual electrical repulsion between the charged ions of like sign, since the spreading is similar to that of the cathode bundle in a vacuum tube. Hence we see that there is a tendency for the rays to diverge from the poles towards the equator, and for the equatorial rays to spread in opposite directions towards the poles, the former under magnetic and the latter under electrostatic forces of repulsion. The combined effect is to accumulate the ions in a quadrantal or synclinal structure near latitudes of 45 degrees, as is observed to be the case. The 11-year periodic change in the coronal structure is probably due to a variation of the balance between these two systems of forces, that of the magnetic polar structure dominating in minimum years, that of the electrostatic development in maximum years, and the quadrantal or compromise formation in the middle portions of the period. The polar rifts and the visible rays are to be referred to the same principles* as control the formation of striæ in the luminous vacuum tubes, that is to the variation of density in the number of the ions per unit volume. The rays are the places of recombinations of the ions under excessive density of their number, and the dark spaces are the loci of the ionization or dissociation, the former occurring at the places of maximum and the latter at places of minimum of the external impressed electric forces which produce the coronoidal discharge. The details of several experimental theories which are thus united for an explanation of the sun's corona, together with the promise of further developments along the same lines is very encouraging. The coronal pictures on a large scale taken in May, 1900, are entirely in accord with this theory; also Professor Wood's† comment on Abbott's measurement of the coronal heat, that the absence of heat rays is due to the smallness of the particles of matter in the corona, which emit little incandescent light, but reflect relatively more polarized light, may be understood to indicate that there exists in the sun a true form of cathode radiation, rather than the Röntgen or any other subform of radiation. The objection that the sun's high temperature is fatal to the hypothesis that it possesses a strong magnetic field is met in two ways. (1) The earth is very hot and yet carries a magnetic field depending upon the material of the interior; and (2) the great pressure in large bodies probably maintains

* J. J. Thomson, *Phil. Mag.*, March, 1899. J. H. Jeans, *Phil. Mag.*, March, 1900.

† Science, February 1, 1901; *Astrophysics*, January, 1891.

magnetization and high temperature in combination in the central portions.

Instructive as the preceding line of investigation has already become it will doubtless be much more profitable in further studies, such as it is possible to bestow whenever the minimum of the sun-spot period prevails. I hope to continue this research on the coronal photographs, as soon as the results of the eclipse of 1901 are in hand. The pictures of 1898, 1900 and 1901 may then be combined with the preceding computations, not only for a closer location of the coronal poles, but also for the period of revolution of the solar nucleus, as distinguished from that of the sun-spot belts, which are evidently an atmospheric drift over a more stable central body. We are not, however, limited to this single line of attack on the problem of the solar magnetic field, but possess at another place on the solar magnetic lines, namely, in the earth's atmosphere, an opening of equal validity, and apparently of a practical nature. This has been gradually built up, as in the preceding case, out of several different researches, at first independent of each other.

An example of the method employed for obtaining the deflecting vectors in the earth's magnetic field, which are observed to be impressed upon its normal field, is contained in "Solar and Terrestrial Magnetism," Chapter 3, Bulletin No. 21, W. B., 1898. The earth's field is disturbed from its normal form by the addition of forces whose direction in space, whatever may be their cause, can be computed mechanically by combining the residuals of the given rectangular coördinate vectors into a single resultant vector located by polar coördinates. Taking the available magnetic stations in different latitudes, 26 in number, and using the mean diurnal elements, the horizontal force, the declination, and the vertical force, so that no question of geographical longitude is involved, the conclusion is reached that the disturbing vectors are closely confined to north and south meridian planes; the lengths and angles that the vectors make with the surface at different latitudes are shown on Chart 10 of that chapter, which represents one of the meridian sections described. This is reproduced in the wave line of the adjacent diagram accompanying this paper, and it is indicated by the smooth inflexed full line. The vector directions are here omitted, as they can be readily explained by the theory of a permeable shell immersed in an external magnetic field. The peculiar curvature of the line that was found to bound the average length of these vectors is, however, one that has been difficult to account for, and has caused some students to doubt the reliability of my result. But, in fact, it is now believed to be a substantial

proof of the correctness of the research, and also of the theory by which it was interpreted. This curve has a minimum in latitude about 60° , and a maximum in latitudes of about 30° , speaking broadly; on the contrary, the magnetic theory of the distribution of force surrounding a permeable body in an external magnetic field, shows that there is a maximum in the

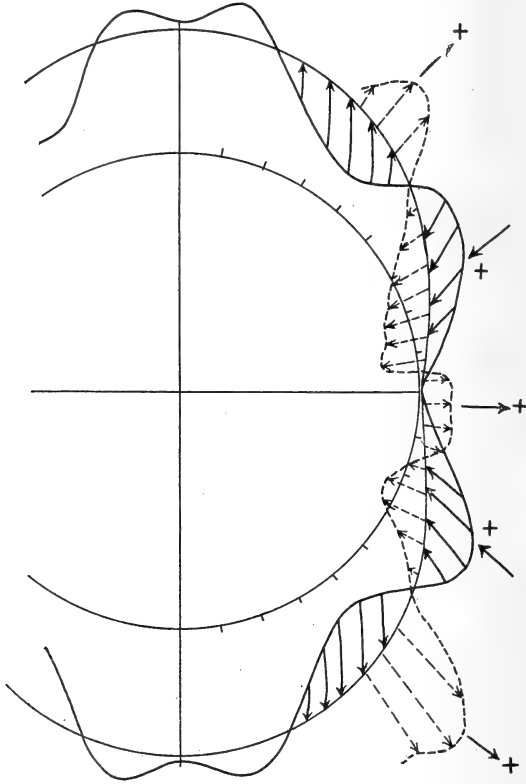

Comparison of the Magnetic and Electric Vectors in Latitude.

axis of the field and a minimum at the equator. This comes from the application of the formula for the normal component of the force, $F_n = \frac{8\pi}{3} I \cdot \cos \theta$, and for the tangential component, $F_t = \frac{4\pi}{3} I \cdot \sin \theta$, where I is the induced magnetization and θ the polar distance. The corresponding curve is drawn on the diagram, and it is the curve without inflexion from the pole to the equator. Therefore, we perceive that in the north mid-latitudes something occurs which adds a component to diminish the normal vector from an external magnetic field, and in the

south midlatitudes something which reinforces such vectors. If we can give an explanation of these secondary variations, then it follows that the undisturbed primary curve belongs to an external magnetic field, and by inference in this case to the solar field.

We turn for this purpose to a different research, which is important in this connection. Bauer* has computed the magnetic line integrals around the several parallels of latitude between 60° north and 60° south, and he found that instead of the summation being zero on each parallel there resulted a well defined variation which is distributed in latitude as shown by the dotted curve of the same diagram. This represents such residuals as would be accounted for by the existence of vertical currents of electricity in the atmosphere, downwards in the tropics and upwards in the higher latitudes as shown by the arrows for positive electrification. Although allowance must be made for the crude materials used in both the above investigations, arising out of the conditions of our scientific observations, which ought to be remedied as soon as practicable, the correlation of these two sets of forces is too striking to be overlooked. The idea is suggested that whatever accounts for one of them carries with it the explanation of the other as well. Meteorologists have already recognized the close connection that the electrical phenomenon has with the conditions known to prevail in the earth's atmosphere. Thus Trabert† refers to the mechanical transportation of electricity between the upper strata and the surface of the earth through convective currents in connection with precipitation. Elster and Geitel‡ refer the phenomenon of atmospheric electricity to the ionization of the atmosphere by solar radiation, and include Bauer's integration in its consequences. This theory may be summarized as follows, but the statement will be carried a step further than the authors referred to above have done. The electromagnetic energy of solar radiation is partly transformed in the atmospheric molecules and atoms, so that positive and negative ions are simultaneously given off; by more rapid diffusion the§ negative ions separate from the positive and produce the electrostatic strain potential observed to exist in the atmosphere. This is confirmed in many ways by Elster and Geitel's analysis. These processes occur chiefly in the latitudes which correspond with the Bauer diagram and are associated with the atmospheric motions of circulation, so that they may be adopted as a step in the right direction

* Vertical earth-air electric currents, *Terrestrial Magnetism*, March, 1897.

† *Meteorol. Zeitschrift*, November, 1898.

‡ *Terrestr. Mag.*, Dec., 1899; *Meteorol. Zeitschr.*, May, 1900.

§ John Zeleny, *Phil. Mag.*, July, 1898.

towards a solution of the problem. But these same ions are also vibrating and circulating electric charges, and hence they generate a magnetic field about them, so that they may be regarded as constituting minute magnets. Compare papers on the magnetic field caused by moving electric charges, as J. J. Thomson,* O. Heaviside,† H. M. Reese,‡ and others. The outcome of this theory is that the air is electrified and also magnetized *in situ* by the action of radiation on the atomic constituents of it. Thus the two secondary components of the above curves, namely the magnetic and the electric forces, are intelligible and can be attributed to one fundamental atmospheric process. Furthermore, it will be remembered that I have for several years insisted that sunlight acts upon the earth's magnetic field as if it were itself a magnetic field, and that to this action the diurnal deflection of the magnetic needle is to be attributed. This was, evidently, an imperfect statement for the theory of ionization recently established, which was not developed at the time of my writing, but it is now perceived that the fundamental basis of the conception is the same in each. This point is further illustrated in the International Cloud Report, Weather Bureau, 1898-99, page 476, where the diurnal wind components and the magnetic deflecting vectors, taken hour by hour, are shown to harmonize and point to one underlying system. The wind vectors are due to the heat contents produced by the radiation, and the magnetic vectors to the ionization of the air induced by the same cause. Thus the entire subject is placed on a working basis, and it can be carried to a definite end by perfecting our magnetic and electric observations of the atmosphere. This position is greatly strengthened, also, by what we know of the distribution of the components of the diurnal variations of the barometric pressure§ of the magnetic deflecting forces, and of the vapor tension of the atmosphere in latitude. Thus, the first component term of the barometric pressure is a maximum on the equator and disappears in latitudes 65° ; it also vanishes at a moderate altitude above the surface of the ground. The second term in the pressure breaks sharply at the same latitude, and shifts about ninety degrees in the polar regions. Likewise, the diurnal magnetic deflecting forces break abruptly at 65° in latitude,|| and reappear in the polar zone at right angles to their place in lower latitudes.

* Phil. Mag., July, 1889.

† O. Heaviside, Phil. Mag. (5), xxxix, 1889.

‡ H. M. Reese, Astrophysics, Sept., 1900.

§ International Cloud Report, Chapter 9, Weather Bureau Ann. Rep., 1898-99
Forthcoming Report on the Eclipse of May 28, 1900.

|| Bulletin No. 21, Chapter 4, 1898.

Now the distribution of the vapor tension is a function of the temperature of the air, such that it is large at temperatures of 100 degrees Fahrenheit and small below freezing; it, therefore, accumulates over the tropics and gradually diminishes to the poles so that the vapor pressure is very feeble beyond 65 degrees in latitude; at the same time, and for the same reason, it disappears at moderate elevations, highest over the equator, because the temperatures lower rapidly with the altitude. The vapor contents of the air, therefore, practically occur in a zone between 65 degrees of latitude, arching above the equator to the height of 2 or 3 miles. It is just in this region that the electric and magnetic effects in the air are found to take place, and in proportion to the vapor tension, which of course measures the vapor contents; and also it is in this region that principal terms of the diurnal barometric variation have their locus. Furthermore, it will be shown in the Eclipse Report, that the mean variation of the vapor tension in latitude has a representative curve with the same flexure as shown in the above diagram. It seems to me proper to infer that it is the ionization of the vapor contents of the atmosphere which is at once the cause of the phenomenon of the diurnal barometric wave, the atmospheric electric potential and the magnetic diurnal variations, which have, one and all, so long evaded the efforts of research to comprehend. The functional relations between pressure, electric current and voltage, and work energy have been somewhat elaborated by Ebert.* If it can be shown by experiment that a magnetic field is also produced at the same time as the other effects of ionization, then it will follow, not only that we have reached the correct point of view regarding these subjects, but that Terrestrial Magnetism as a science is distinctly and properly a *branch of Meteorology*, since its phenomena are produced by the sun's radiation acting on the constituents of the atmosphere *in situ*. This result will relieve magneticians of the impracticable task of trying to account for these effects by magnetic induction dependent upon electrical currents which are assumed to traverse the earth's atmosphere, as if it were a good conductor. The evidence is all against the existence of these electric currents in the lower atmosphere, because the air is a powerful non-conductor in these layers; if it be contended that in the rarefied high strata the air becomes a good conductor, then it is noted that the required magnetic and electrical effects are all located in the lower strata where the aqueous vapor contents are abundant. The fact that electrolytic action takes place readily

* Unsichtbare Vorgänge bei elektrischen Gasentladungen, Sitzungber. k. bayer. Akad. d. Wiss., 1898, Bd. xxviii, Heft IV.

in water solutions also points to the aqueous vapor as the true seat of the phenomenon of ionization rather than the adjacent dry air constituents.

This argument could be pursued to great length, but it is proper not to draw attention away from the main point of this paper. We have stated that the coronal effects at the sun are explained by a magnetic field in conjunction with an electric discharge radiation acting upon ionized products; that the earth is immersed in a true external magnetic field, and that the variations on the normal type are explained by the action of the ionization in the atmosphere, the ions being generated by the electromagnetic radiation. Other developments of this subject, which have already been published, merely enforce the theory that the earth is immersed in a magnetic field whose base is in the sun, and which rotates with it in space. Consequently the eleven-year period in the earth's magnetic and meteorological elements are caused by efficient internal solar processes; the 26·68-day period by the sun's axial rotation; the semi-annual inversion of the type curve by exposures to the solar lines at the earth in different aspects, such that oppositely directed couples are produced twice annually. It may be stated, finally, that the Weather Bureau is completing a rereduction of its barometric observations of the past 30 years to a homogeneous system, and that from this improved data we expect to obtain further developments along these lines.

Weather Bureau, Washington, D. C.

ART. XXI.—*Tertiary Springs of Western Kansas and Oklahoma*; by CHARLES NEWTON GOULD.

THE western third of Kansas and a good part of north-western Oklahoma are covered with the Tertiary formation. This rock consists for the most part of a white or yellowish clay with ledges and lenses of coarse sand and gravel interspersed between. Ordinarily this formation covers the level uplands of the region to the depth of from twenty to that of several hundred feet. The streams have in many cases cut their way through this rock into the underlying formations, usually the Cretaceous or Permian. In many instances the Tertiary may be recognized by one of two typical kind of rocks. Perhaps the most common of these consists of rather precipitous chalky-white cliffs, often known locally as gyp. cliffs (although there is no gypsum in their composition). These are typical in northern Clark County along the heads of Bluff, Bear and Sand Creeks. The other kind is that of a very coarse, pebbly sandstone conglomerate. This is often found along the bluffs of small streams and sand-draws throughout the region. The pebbles are of all sizes, shapes and colors, with white and pink predominating. They are usually smooth and water-worn, having been washed down from the Rocky Mountains during late geological time. It is these pebbles, set free from their matrix by the disintegration of the rock, that cover the slopes and form the gravelly points on so many of our western hillsides.

The two kinds of rock spoken of above will serve to illustrate the character of the entire formation. It consists of alternating layers of clay, sand and gravel. Perhaps the clay occupies the greater part of the thickness, but the two kinds of rock do not occupy a definite position with regard to each other. They are arranged in alternating layers one above the other, now the clay predominating, now almost the entire thickness being composed of sand and gravel. Sometimes wells will penetrate more than 100 feet without encountering gravel; again gravel and sand will be found all the way down.

Now it is well known that clay is impervious to water while sand (and much more readily gravel) permits the comparatively rapid flow of water through its particles. The rain water falling upon the surface of the soil will sink into the ground until it strikes a ledge of gravel when it slowly seeps through the porous material until it finds its way to a considerable depth. If a well penetrates this gravel bed, water will accumulate and furnish a supply relative to the thickness

of the bed and the amount of water it contains. But if the gravel bed extends to a considerable depth below the surface, the water, still seeking its lowest level, will continue to descend until in order to reach a steady flow wells must penetrate to a great depth. Happily on the plains this condition is not usually met with. The thickness of the Tertiary strata will perhaps average not more than fifty feet. In many places, it is true the rock is as much as 300 feet thick, but ordinarily this is not the case. The underlying stratum is usually either Cretaceous or Permian. In either case the lower rock is impervious to water. The water-bearing gravels lying on the impervious ledges soon become saturated and the water will often rise many feet in the bed, sometimes in fact nearly to the surface. A well, then, to reach a steady flow need only to penetrate to the saturated gravels. From this it follows that the wells throughout the region of the Tertiary have as a maximum depth the thickness of this formation, and as a minimum the distance to the saturated sand and gravels. The thickness to which the saturation extends depends upon a number of factors. Prominent among these are the slope of the beds, the regularity of the underlying strata, the amount of rainfall and the relative coarseness of the material which carries the water. Of course there are a number of others but they need not be considered in this connection.

The water that I have just been considering is the underflow or "sheet water" of popular phrase. Thousands of wells in western Kansas and Oklahoma obtain a never failing supply from this source. A popular but erroneous idea prevails in many localities that a subterranean lake is present or even that an underground river is flowing toward the sea. It is obvious that these explanations have no foundation in fact.

The statement was made above that many of the streams of the region have carved out a channel in the Tertiary and in many instances into the underlying formations. This is true at least in part for the following streams: Solomon, Sappa, Prairie Dog, Saline, Smoky Hill, Walnut, Pawnee, Arkansas, Ninnescah, Medicine, Bluff, Cimarron, Salt Fork, Beaver, Wolf, Canadian, Eagle Chief, and Red River, with their numerous tributaries. The greater part of these streams either take their rise in the Tertiary or else rising beyond, flow across this formation for a considerable distance. In almost every case they have cut down into the subjacent rocks, often having carved out canyon-like valleys in them. A person standing on the level Tertiary plain at a distance from the edge of the valley may often be able to look across to the plain beyond without being aware of the intervening valley. In other instances the valleys are broad and shallow, being nothing but

gentle depressions in the prairie through which the stream meanders across a sandy channel.

It is along these streams and usually at the point of contact of the Tertiary above and the Cretaceous and Red-beds beneath that the springs which form the title of this article are located. Ordinarily the spring has carved for itself a canyon, or at least is situated in one, often at its head. Sometimes, however, it bubbles up from the bottom of a sand-draw or, it may be, from the almost level prairie. Now it is a single bold spring issuing from a crevice in the rock and running off down the canyon; again, and perhaps more frequently, it takes the form of a number of seepage springs coming out along a line for a distance of perhaps 100 yards. In any case the water is very pure, and is clear, cold and soft. It is the best water found anywhere on the plains. In nearly every instance the site of a Tertiary spring is marked by the presence of trees and not infrequently they are the only trees anywhere in the country—the upland plains being in most places a treeless prairie. Some of the rarest bits of timber in all the plains country are along these spring-fed canyons.

But the springs have an economic value. This is one of the best cattle countries in the world. Grass grows luxuriantly. Cattle may be ranged the year round. But the question of water supply is always a vital one in a grazing country. It is often the first problem with which the stock man has to deal. The presence or absence of water on a range often determines whether or not it is a profitable grazing ground. There is a saying on the plains, "The man that controls the water controls the whole country." A single Tertiary spring often supplies the stock water for an area of several square miles, and thus renders this region profitable. If the spring is sufficiently strong to flow a steady stream no further notice need be taken of it, and the cattle are permitted to drink directly from the stream. If the spring is weak the water is often piped into tanks or reservoirs to which the cattle have free access. It frequently happens also that dwellings are located near a favorite spring. Occasionally the water from a spring will be piped through the kitchen, into the milk house, and from there into a tank in the barn lot, furnishing an ample supply for all purposes, and the surplus is then utilized to irrigate a small garden.

But Tertiary springs are utilized on a still larger scale. Camp Supply, a military post in northwestern Oklahoma, is situated on a flat prairie where Wolf and Beaver Creeks unite to form the North Canadian. The underlying formation consists of Red-beds in which the water is not only insufficient in quantity but also poor in quality. Some three miles distant

among the sand hills across Beaver Creek is a Tertiary spring. A reservoir was constructed just below this spring and a six-inch main laid to the fort. The supply has proven fully ample for the use of several hundreds of persons.

The city of Alva is located in the valley of Salt Fork. The wells furnish plenty of water, but so strongly impregnated with gypsum is it that it is unfit for use. The citizens are compelled to buy all the water used. The water is hauled in wagons from Elm Springs over two miles north, across the river. Recently the city has purchased Elm Spring and a ten-inch water main has been laid from it to the edge of town. It is thought that the supply will be more than adequate for the city.

Woodward in the valley of the North Canadian is similarly situated. The water is impure and many of the people prefer to pay for water that has been hauled from springs rather than to use that from the wells. The question of laying a main to some springs in the vicinity is being agitated and the project will doubtless eventually be accomplished.

A few of the Tertiary springs throughout the region that have come under my observation may be spoken of in this connection. They are nearly all located in the southern tier of counties in Kansas or the northern tier in Oklahoma, and are perhaps all within fifty miles of the State line.

At Belvidere, Kansas, near the head of the Medicine River, three creeks emptying into the river from the north are fed by Tertiary springs. These creeks are Soldier, Spring and Thompson. On Soldier Creek is located the celebrated Rockefeller horse ranch. One of the finest reservoirs in the west has been made on this ranch by throwing a dam across the creek. The water of Thompson Creek is turned into a ditch and utilized for irrigating several hundred acres of land on the Fullington ranch. Farther up the river, springs at Greenleaf's ranch and on Little Rocky canyon and Spring Creek furnish large quantities of water. Meals' Spring on Otter Creek is known for miles as are the springs in Abel's pasture on Walker Creek.

Mule Creek, a perennial stream in Comanche County, is fed by Tertiary Springs. The same is true of several creeks in Clark County. On Kiger Creek in the western part of the county a spring at the home of Wm. Funk supplies water for irrigating a small garden. This is near the famous St. Jacob's well and Big Basin. Still further west in Meade and Seward Counties the various branches of the Cimarron are fed by these springs.

The conditions in parts of northern Oklahoma do not differ from those in southern Kansas. All along the escarpments

where the highlands north of the streams break down into the valleys springs issue at irregular intervals. Elm Spring, mentioned above as supplying the water for Alva, is but one of scores on the north slope of Salt Fork. The same conditions obtain for the Cimarron. The famous Cleo springs in southern Woods County, near the mouth of Eagle Chief, consist of a number of small springs which issue at the point of contact of the Tertiary and Red-beds for a distance of a quarter of a mile along the bluff. There is nearly enough water at this place to turn a mill, if it were utilized. The water is very pure, but perhaps not more so than that from hundreds of similar springs. It only seems more pure in contrast with the water of the Red-beds of the Glass Mountains across the river, which being strongly impregnated with gypsum and other salts is unfit for drinking. Dozens of other springs along Eagle Chief are perhaps just as pure, but do not furnish as much water as those at Cleo.

Near the head of Bent's canyon, a southern tributary to the Cimarron at the Great Salt plain, there are a number of the finest springs in Oklahoma. The canyon in its upper part has been carved out of the high plains between the Cimarron and the North Canadian. The gorge is perhaps fifty feet deep and a quarter of a mile wide. As seen from a distance the course of the canyon is marked by a strip of green meandering across the brown sage brush plain. A dense growth of underbrush, with an occasional large cottonwood or elm interspersed here and there, with grape vines and Virginia creepers fills the canyon. This is one of the rarest bits of timber anywhere in western Oklahoma, the delight of a botanical collector. As is usual the bottom of the canyon is cut down into the Red-beds while the upper part is composed of Tertiary. The line of contact may often be seen. There are half a dozen or more springs within the distance of half a mile from each of which flows a stream half as large as a man's arm. In one case the spring issues from the side of a cliff fifteen feet above the stream. In another place the spring comes out in a little amphitheater up a small canyon an hundred yards or more from the main stream. A level bog covered with Monkey flower and other aquatic plants fills the basin. Still another spring a few rods further down stream supplies water for the Bird and Hawkins ranch house.

Along the North Canadian, besides the springs at Camp Supply and those near Woodward mentioned above, one of the most noted of the springs is the Osage Spring in eastern Woodward County. The tributaries to this river, particularly Beaver and Wolf Creeks, take their rise in the Tertiary farther west and are fed by springs from this formation. It is a

maxim on the plains that for steadiness of flow and purity of water the North Canadian excels all other streams of the region. The reasons are obvious.

Throughout a great part of Oklahoma and southern Kansas the water is not good. This region lies within the area of the great Red-beds of the plains. This formation is composed for the most part of reddish shales and clays containing great quantities of salt and gypsum. The water in many wells is so strongly impregnated with these minerals as to render it unfit for use. In a region of this character a spring of such soft water as those I have described constitutes a veritable oasis. Not infrequently families haul their water for household use for several miles. A whole neighborhood is often supplied from a single spring. Fortunately it is usually the case that the springs are located well up on the hills. As the country develops and the people can afford it the water from these springs will be carried to more and more towns and even to farm houses. In dozens of localities in the region the final solution of the now vexing problem of the water supply will be found in the presence of Tertiary springs.

University of Oklahoma, Oct. 12, 1900.

ART. XXII.—*Some Fundamental Propositions in the Theory of Elasticity. A study of primary or self-balancing stresses*; by FRANK H. CILLEY, S.B.*

LOOKING at two objects of precisely the same material, size, shape and general appearance, it would at first seem that one would be warranted in regarding them as precisely alike and applying to the one all conclusions which had been found to apply to the other. Yet a little reflection will show that this is by no means necessarily the case, and that, even where there is no hidden difference in structure, there still may exist a difference in internal condition which will have most important consequences.

Consider, for example, the specially prepared drop of glass with a long slender tail known as a "Prince Rupert drop" or "tear," and a precisely similar appearing drop of the same glass, prepared simply by melting and drawing out a tail followed by slow cooling. The two drops look just alike, yet we know that there is a very important difference in their conditions. For, break off the tail of the Prince Rupert drop and it will explode like a bomb, breaking into innumerable fragments, while the other not similarly prepared drop, if treated in the same way, does nothing at all.

Two lamp chimneys, identical in appearance, are put on two similar lamps. One breaks on the first lighting of the lamp, the other endures indefinitely.

On a cold winter's day as an electric car passes over a joint in the rails a sharp explosion is heard: the rail has broken at the joint. These joints had been firmly "welded" the previous summer, but the rails had contracted much more than the surrounding soil under the great fall in temperature.

After a spell of moist weather, windows, which ordinarily would open with ease, stick. The moisture has swelled the wood,—and frame and sash are wedged firmly together.

Two bicycle wheels look just alike. They are of the same material and construction. But if the spokes are gently struck we find, not only that no two spokes give forth the same sound but that the spokes of one wheel, on the whole, give forth a much higher sound than those of the other wheel. They have not been equally tightened, and one wheel is more ready to buckle and break than the other.

* The present article, read before the American Association for the Advancement of Science, Sec. D, New York, June, 1900, is based on an article prepared by the writer in March of 1897 but never published. The earlier article contained all the essential features of the present article, which is simply otherwise arranged, popularized and less brief and abstract than the original.

Two tennis raquets are seemingly the same. But one, when struck, emits a much higher tone than the other. It is strung tighter than the other.

A piece of wire has been bent repeatedly back and forth at one point. It looks much the same there as at other points, but we know it is much more ready to break there than elsewhere.

A sheet of brass has been run through between heavy rolls. It looks like another sheet that has not had this experience, but we know that it cannot be bent so sharply without breaking as the unrolled sheet.

So we could proceed, giving many other and familiar instances of things that look alike while actually in very different conditions. And if we consider in what the difference in condition consists we shall find in each instance that there was a straining of one part of the body against another, that there existed a condition of initial or, as I prefer to call it, "primary" strain.

Of the existence of these primary strains frequently evidence is only obtainable through the application of external force until injury ensues, for elastic action up to this point is usually practically unaffected by the presence of such strains. Only occasionally, as in the case of the bicycle wheels and the tennis raquets, is the contrary true and can non-injurious tests disclose and define these strains. In this case acoustic tests will perform this service; with glass, polarized light answers the same purpose.

Among the more prominent causes of these primary strains is sudden and unequal cooling from the molten state, the Prince Rupert drop furnishing a startling example of this but other cases being numerous, particularly among metal castings. The lamp chimneys are partly examples of this but partly examples of the consequences of sudden and unequal heating, of which thick bottles and tumblers, broken by suddenly filling them with hot water, are further examples. Then there are the consequences of the unequal expansion and contraction of different substances in contact. The breaking of the welded rail was due to this, it being put under great strain by contracting far more than the ground in which it lay. The same thing occurs in masonry and iron construction where the iron is firmly anchored to the masonry without any allowance for expansion and contraction. Wood and iron when united cause similar trouble, the swelling and shrinking of the wood from varying moisture adding a further factor. Cement and concrete in setting also make trouble, and many other instances could be found. And although this straining is usually objectionable, in some cases it is put to good use as in the balance

of a chronometer, where two metals of different expansibility in combination serve to correct the normal effects of change of temperature. As a parallel to the effects of unequal heating we have the effects of unequal swelling due to moisture. Sometimes, as in the case of the windows, different parts are differently affected; sometimes, as with wood and rope, the effect is different in different directions. Then we have the effects of the cold working of material, as the cold rolling of plates, the drawing of wire, the spinning of ductile metals, shearing, punching, bending and twisting. Most metals, if subjected to such operations and not relieved of the primary stresses thus engendered, by subsequently annealing them, are much less trustworthy under stress than before. And lastly we may note the consequences of straining up parts of built-up objects in their construction, as the tightening of nuts, screws and wedges. Frequently most serious and objectionable strains are thus introduced and added to all others.

When we have a body supporting,—resisting, applied forces,—loads; what we generally wish to know is how well able is that body to perform its duties, what are the actual stresses and strains within it? We know, if the body be at rest, that the stresses must be in equilibrium among themselves and with the bodily forces (as weight, magnetism, etc.) and the surface tractions. We know that on any complete section of the body the resultant must be equal and opposite to the resultant of the bodily forces and surface tractions acting on the part of the body cut off by the section. Thus, when the section becomes sufficiently small and circumscribes an elementary portion of the body, we obtain as consequence three general differential (interior) equations of equilibrium and three general ordinary (surface) equations of equilibrium.*

* Equations limiting actual stresses.

For interior points.

For surface points.

$$\left. \begin{aligned}
 \frac{\partial \bar{P}}{\partial x} + \frac{\partial \bar{U}}{\partial y} + \frac{\partial \bar{T}}{\partial z} &= -\rho X \\
 \frac{\partial \bar{U}}{\partial x} + \frac{\partial \bar{Q}}{\partial y} + \frac{\partial \bar{S}}{\partial z} &= -\rho Y \\
 \frac{\partial \bar{T}}{\partial x} + \frac{\partial \bar{S}}{\partial y} + \frac{\partial \bar{R}}{\partial z} &= -\rho Z
 \end{aligned} \right\} (1)$$

$$\left. \begin{aligned}
 l\bar{P} + m\bar{U} + n\bar{T} &= F \\
 l\bar{U} + m\bar{Q} + n\bar{S} &= G \\
 l\bar{T} + m\bar{S} + n\bar{R} &= H
 \end{aligned} \right\} (2)$$

where with a system of rectangular coördinates xyz the quantities $\bar{P}\bar{Q}\bar{R}$ are the *actually existing* and *complete* intensities of the normal components of the stress in the planes of x, y and z respectively; $\bar{S}\bar{T}\bar{U}$ are the intensities of the tangential components of the stress in the planes of y and z, z and x, x and y perpendicular to x, y and z respectively; ρ is the density and XYZ the bodily forces per unit volume at the point (xyz) ; lmn are the direction cosines of the perpendicular to the bounding surface at any point and FGH are the intensities of the surface tractions at that point in the directions x, y and z respectively.

These, the actual or total stresses in all bodies at rest, whether solid or liquid, whether elastic or inelastic, whether homogeneous or heterogeneous, whether æolotropic or isotropic, *must* satisfy. But these equations have precisely the same form as those for the *changes* in stress due to given applied forces.* This has erroneously led to the conclusion that the *changes* in stress are the total stresses, whereas actually the total stresses consist of two parts, one the *changes* in stress due to applied forces, the other the (often preëxisting) self-balancing or primary stresses. The latter are ordinarily and incorrectly neglected.

The primary stresses evidently must satisfy the condition that the resultant stresses on any complete section shall be zero. And in particular they must make the resultant stresses on any elementary portion of the body zero. This leads to three differential (interior) and three ordinary (surface) equations of equilibrium, which primary stresses must satisfy.† These are nothing (in form) but the ordinary general interior and surface equations of equilibrium with all bodily forces and surface tractions zero. It has incorrectly been assumed that these equations had no solutions other than zero, but since primary stresses are real quantities which must satisfy these equations it follows that other solutions than zero for these equations exist and have a real significance. Actually, as will later be seen, the solutions are innumerable.

Changes in stress due to applied forces—"the" stresses of the ordinary theory of elasticity,—we know, theoretically, are definitely determinable. This is rendered possible by these changes in stress being definitely related to changes in strain through stress-strain relations holding for the given body and material, and by the *changes* in strain, if elastic, being related to the displacements by certain geometrically necessary relations. Wherever the stress-strain relations are definitely known, this

* Equations limiting changes in stress.

For interior points.

$$\frac{\partial P}{\partial x} + \frac{\partial U}{\partial y} + \frac{\partial T}{\partial z} = -\rho X, \text{ etc. } (1')$$

For surface points.

$$lP + mU + nT = F, \text{ etc. } (2')$$

where *PQR* are the intensities of the normal components of the *changes* in stress or stresses due to the bodily forces *XYZ* and surface tractions *FGH* while *STU* are the intensities of the tangential components of these *changes*.

† Equations limiting primary stresses.

For interior points.

$$\frac{\partial(P)}{\partial x} + \frac{\partial(U)}{\partial y} + \frac{\partial(T)}{\partial z} = 0, \text{ etc. } (1'')$$

For surface points.

$$l(P) + m(U) + n(T) = 0, \text{ etc. } (2'')$$

where *(P)(Q)(R)* are the intensities of the normal components of the primary stresses and *(S)(T)(U)* are the intensities of the tangential components of the primary stresses.

results first in three differential (interior) and three ordinary (surface) equations between the *changes* in strain and the bodily forces and surface tractions, and thence in three differential (interior) and three ordinary (surface) equations between the displacements and the bodily forces and surface tractions, which equations then permit of definite solution. These equations for isotropic bodies subject to "Hooke's law" are particularly well known.* They are the subject of all the

* Here the strains are expressed in terms of the stresses through the relations

$$\left. \begin{aligned} e &= \frac{P}{E} - \sigma \frac{Q+R}{E} & a &= \frac{S}{\mu} \\ f &= \frac{Q}{E} - \sigma \frac{R+P}{E} & b &= \frac{T}{\mu} \\ g &= \frac{R}{E} - \sigma \frac{P+Q}{E} & c &= \frac{U}{\mu} \end{aligned} \right\} (3')$$

where *efg* are the *changes* in elongation per unit in the directions *x, y* and *z*; *abc* are the *changes* in the shears in the planes of *x, y* and *z*; *E* is "Young's modulus;" σ is the ratio of lateral contraction to longitudinal extension or "Poisson's ratio" and μ is the shearing modulus or modulus of rigidity. Between these quantities and two others, $-\kappa$ the modulus of volumetric change or bulk modulus and the coefficient $\lambda = \kappa - \frac{2}{3}\mu$ we have the relations

$$E = \frac{\mu(3\lambda + 2\mu)}{\lambda + \mu} = \frac{9\mu\kappa}{3\kappa + \mu} \quad (4) \quad \text{and} \quad \sigma = \frac{\lambda}{2(\lambda + \mu)} \quad (5)$$

whence denoting the sum $e+f+g$ by Δ (the change in the dilatation), we have the converse solutions of (3') giving stresses in terms of strains

$$\left. \begin{aligned} P &= \lambda\Delta + 2\mu e & S &= \mu a \\ Q &= \lambda\Delta + 2\mu f & T &= \mu b \\ R &= \lambda\Delta + 2\mu g & U &= \mu c \end{aligned} \right\} (6')$$

Introducing these converse solutions of the properties (3') into the equations (1') and (2') we deduce what are known as the equations of equilibrium of an isotropic elastic solid in terms of the strains (actually the *changes* in strain). These are

For interior points.	For surface points.
$\left. \begin{aligned} \lambda \frac{\partial \Delta}{\partial x} + \mu \left(2 \frac{\partial e}{\partial x} + \frac{\partial c}{\partial y} + \frac{\partial b}{\partial z} \right) &= -\rho X \\ \lambda \frac{\partial \Delta}{\partial y} + \mu \left(\frac{\partial c}{\partial x} + 2 \frac{\partial f}{\partial y} + \frac{\partial a}{\partial z} \right) &= -\rho Y \\ \lambda \frac{\partial \Delta}{\partial z} + \mu \left(\frac{\partial b}{\partial x} + \frac{\partial a}{\partial y} + 2 \frac{\partial g}{\partial z} \right) &= -\rho Z \end{aligned} \right\} (7')$	$\left. \begin{aligned} \lambda \Delta + \mu(2le + mc + nb) &= F \\ \lambda m \Delta + \mu(lc + 2mf + na) &= G \\ \lambda n \Delta + \mu(lb + ma + 2ng) &= H \end{aligned} \right\} (8')$

The *changes* in strain are related to the displacements by the equations

$$\left. \begin{aligned} e &= \frac{\partial u}{\partial x} & a &= \frac{\partial w}{\partial y} + \frac{\partial v}{\partial z} \\ f &= \frac{\partial v}{\partial y} & b &= \frac{\partial u}{\partial z} + \frac{\partial w}{\partial x} \\ g &= \frac{\partial w}{\partial z} & c &= \frac{\partial v}{\partial x} + \frac{\partial u}{\partial y} \end{aligned} \right\} (9')$$

usual operations and transformations of the general mathematical theory of elasticity. Only through their solution can the distortion of a body under given applied forces be correctly determined. Only through them may the *changes* in stress and strain due to these applied forces become accurately known. Except in certain cases of elastic instability their solutions are definite and single valued. The supposed relations of stress to strain being exact, they supply us with exact and definite results, but only as to *changes* in stress and strain, not as to actual or total stresses and strains.

In the case of primary stresses and strains, however, no such determination is possible. As with changes of stress due to applied forces the stress-strain relations determine from the differential (interior) and ordinary (surface) equations of equilibrium between the primary stresses, corresponding equations between the strains.* But there are no further strain-dis-

where u, v and w are the displacements in the directions of x, y and z respectively. Thus $\Delta = \frac{\partial u}{\partial x} + \frac{\partial v}{\partial y} + \frac{\partial w}{\partial z}$. Further denoting by $\omega_1, \omega_2, \omega_3$ the rates of angular rotation about the axes of x, y and z respectively, we have

$$\left. \begin{aligned} \omega_1 &= \frac{1}{2} \left(\frac{\partial w}{\partial y} - \frac{\partial v}{\partial z} \right) \\ \omega_2 &= \frac{1}{2} \left(\frac{\partial u}{\partial z} - \frac{\partial w}{\partial x} \right) \\ \omega_3 &= \frac{1}{2} \left(\frac{\partial v}{\partial x} - \frac{\partial u}{\partial y} \right) \end{aligned} \right\} (10')$$

Finally let ∇^2 denote the operation $\frac{\partial^2}{\partial x^2} + \frac{\partial^2}{\partial y^2} + \frac{\partial^2}{\partial z^2}$ and let $\delta n'$ be an element of the normal at the surface. Then we may write (7') and (8') in terms of the displacements in the forms

For interior points.	For surface points
$(\lambda + \mu) \frac{\partial \Delta}{\partial x} + \mu \nabla^2 u = -\rho X$	$\lambda l \Delta + 2\mu \left(\frac{\partial u}{\partial n'} + m \omega_3 - n \omega_2 \right) = F$
$(\lambda + \mu) \frac{\partial \Delta}{\partial y} + \mu \nabla^2 v = -\rho Y$	$\lambda m \Delta + 2\mu \left(\frac{\partial v}{\partial n'} + n \omega_1 - l \omega_3 \right) = G$
$(\lambda + \mu) \frac{\partial \Delta}{\partial z} + \mu \nabla^2 w = -\rho Z$	$\lambda n \Delta + 2\mu \left(\frac{\partial w}{\partial n'} + l \omega_2 - m \omega_1 \right) = H$

$\left. \begin{array}{l} \text{---} \\ \text{---} \\ \text{---} \end{array} \right\} (7' a) \quad \left. \begin{array}{l} \text{---} \\ \text{---} \\ \text{---} \end{array} \right\} (8' a)$

and these are the usual equations of the theory of elasticity for the determination of the displacements u, v and w and thence the *changes* in strain and the distortion and finally, through the stress-strain relations, the *changes* in stress in any isotropic elastic body, subject to Hooke's law. Too frequently, however, these latter are regarded as necessarily the actual or total stresses and strains.

* For elastic isotropic bodies subject to Hooke's law the primary strains in terms of the stresses are— and the primary stresses in terms of the primary strains are—

$$(e) = \frac{(P)}{E} - \sigma \frac{(Q) + (R)}{E} \quad (a) = \frac{(S)}{\mu}, \text{ etc. } (3'') \quad (P) = \lambda(\Delta) + 2\mu(e) \quad (S) = \mu(a), \text{ etc. } (6'')$$

placement relations in this case, for there are no displacements corresponding to the primary strains. Thus, since the equations of equilibrium alone are insufficient, primary stresses and strains are not mathematically determinable, a fact quite in accordance with our knowledge of their possibility of infinite variation. They are merely limited, not defined by the equations of equilibrium. They *must* satisfy these, they need satisfy no others. Any of the infinitude of solutions of these equations offer equally possible values (physical capacity for resistance apart).

Although they are not mathematically definable, primary stresses and strains may be physically defined. Primary stresses are those which, applied to a portion of a body when removed from the body, and at the same temperature, would reduce that portion of the body to the form and proportions it had when in the body, when the body was free from all bodily and external forces,—while primary strains are the corresponding strains. By cutting a body into more or less numerous pieces and measuring the changes in these pieces resulting from their release from the body, primary stresses and strains could be experimentally determined. But except where they have been systematically introduced or created, or can be determined by acoustic or optical methods, without such cutting up they must remain, in general, essentially undeterminable.

Since primary stresses and strains are not mathematically definable and actual stresses and strains have primary stresses and strains as one component,* actual stresses and strains are essentially mathematically indeterminate. *The theory of elasticity alone does not, can not define the actual state of stress and strain in any real body.*

where (e) (f) (g) (a) (b) (c) are the primary strains. Substituting from (6'') in (1'') and (2'') we obtain

For interior points.

For surface points.

$$\lambda \frac{\partial(\Delta)}{\partial x} + \mu \left(2 \frac{\partial(e)}{\partial x} + \frac{\partial(c)}{\partial y} + \frac{\partial(b)}{\partial z} \right) = 0, \text{ etc. (7'')} \quad \lambda \mu(\Delta) + \mu[2l(e) + m(c) + n(b)] = 0, \text{ etc. (8'')}$$

as the equations limiting the primary strains.

* Absolute stresses are the sum of primary stresses and the *changes* in stress due to applied forces, and absolute strains are the sum of the corresponding primary strains and *changes* in strain or

$$\bar{P} = (P) + P, \quad \bar{S} = (S) + S, \text{ etc. (11)} \quad \bar{e} = (e) + e, \quad \bar{a} = (a) + a, \text{ etc. (12)}$$

whence simply by addition of (7') and (7'') and of (8') and (8'') we get

For interior points.

For surface points.

$$\lambda \frac{\partial \bar{\Delta}}{\partial x} + \mu \left(2 \frac{\partial \bar{e}}{\partial x} + \frac{\partial \bar{c}}{\partial y} + \frac{\partial \bar{b}}{\partial z} \right) = -\rho X, \text{ etc. (7)} \quad \lambda \mu \bar{\Delta} + \mu(2l\bar{e} + m\bar{c} + n\bar{b}), = F, \text{ etc. (8)}$$

for the equations limiting the actual or total strains in elastic isotropic bodies subject to Hooke's law. No further limits may, in general, be set to them.

As in the case of primary stresses, we may define actual stresses as those which, applied to a portion of a body when removed from the body but still subject to the same bodily forces and at the same temperature, would reduce that portion of the body to the form and proportions it had when in the body when the body was subject to the given external and bodily forces,—and the actual strains will be the corresponding strains.

Actual stresses and strains are always real stresses and strains. But the corresponding primary stresses and strains may be fictitious because of such amount and character as to make their separate existence physically impossible. Such a state of affairs occurs when the removal of the bodily forces and surface tractions would result in so considerable *changes* in stresses and strains as to pass the elastic limits and lead to flow or even rupture. Release from excessive compression would involve such results, an illustration being found in the state of stress and strain in the earth's interior, which will be further considered presently. Certain states of stress and strain under certain forces, then, can not be deduced from any physically possible condition of the body when under other forces, notably when free from all bodily and external forces, through mere elastic distortion, but necessarily involve flow or even rupture of the material in the course of the transformation. This fact is one of the first importance in all attempts to apply the theory of elasticity to the explanation of cosmic phenomena.

In the practical treatment of the question of actual stresses and strains we are confronted with the facts that we are rarely able to determine the actual state of stress and strain by non-injurious observations, and that it is not permissible to cut the body to pieces in order to determine them. So we are obliged to make use of such knowledge as we possess of the history of the body, supplement it with such non-injurious observations as are possible and thence make the best guess we can as to the probable state of stress and strain in the body under some known condition as to outer and bodily forces. This guess must conform to the general equations of equilibrium for actual stresses and strains. Any state that satisfies them is, (except for physical limitations) a possible state, while any state not satisfying them can not possibly subsist as a state of equilibrium. These equations, then, serve simply as guides, furnishing criteria as to possible states of stress and strain. But beyond this they cannot help us.

Often it is reasonable to assume no stress and strain when there are no applied forces, and such is, consciously or unconsciously, the usual procedure. But in some cases we know that either under no applied forces there are certain fairly

definite stresses and strains, or else that under certain applied forces a certain condition of stress and strain exists. Or it may be that we merely wish to investigate the consequences of some supposed state of stress and strain. Whatever the basis, we must eventually have as the starting point for our strictly mathematical investigations a definitely given state of stress and strain under certain definite conditions as to temperature and applied forces. Thence, if we know the stress-strain relations that are true for the body and material under consideration, by the ordinary procedure of the theory of elasticity we may (theoretically) follow all subsequent elastic *changes* in the body's condition consequent on known *changes* in the applied forces and temperature, with perfect certainty. Here we are in the domain of exact analysis; cause and effect follow in unquestionable sequence. But the foundation on which the results are thus built, it must always be remembered, was one furnished by imperfect observations or mere assumptions, and we must never permit ourselves to fall into the error of attributing to our structure a security and certainty which its base never offered. We should be sure that our subsequent labors have introduced no further uncertainties, but never forget that those primarily existing must persist through our entire work.

Let us now consider some simple illustrations of the application of the principles of absolute and primary stresses and strains.

First let us consider how a simple and fairly definite state of primary stress and strain might be created. Imagine three bars of the same material, relatively broad for their thickness, relatively long for their breadth, practically the same in thickness and in breadth, but not quite of equal length, one being a trifle longer than the other two. Suppose the three bars were placed side by side, and lightly clamped together, their larger sides in contact and the longer bar in the middle; suppose there was applied to the ends of the longer bar such a compressive force that it was shortened to just the same length as that of the other two bars, and then that the three bars were firmly united by forcing some binding material between their adjacent faces. Now suppose the compressive force removed from the middle bar; it would expand, carrying with it the two adjacent bars, supposing the binding material sufficiently strong, and as a result we would have a composite bar built up of three layers of equal thickness, the two outer layers subject to tension, the middle layer to compression. It is evident that the force of compression of the middle layer would equal the sum of the tensions on the two side layers, that is, would be of intensity double that in the side layers. That is, the center

layer would be contracted twice as much as the side layers were extended. It follows that the compression in the center layer would be two-thirds its original compression, and the compressive force and intensity of compression in it therefore two-thirds that to which it was originally subjected. A little further consideration will show that, except near the ends, the binding material is subject to no appreciable shearing stress. Thus we have created a fairly definite state of primary stress and strain.

Now this state of primary stress and strain was derived from a certain known state of stress and strain,—that in which the middle layer was under a perfectly definite compressive stress, and the side layers wholly free from stress,—by the removal of the applied forces,—the compressive forces at the ends of the middle thirds of the composite bar. The resulting *changes* in stresses and strains would be those determined by the ordinary theory of elasticity for this case, regardless of the compound nature of the bar. Now, if the compressive forces had been uniformly distributed over the entire ends of the compound bar, their removal would simply have resulted in a uniform change in stress over all sections of the compound bar, equal in intensity (but opposite in kind) to the total compressive force divided by the total area. When the end pressures are concentrated on limited areas however, their removal does not result in such a uniform change in stress. But, as Saint Venant long since pointed out, in a body with relatively great dimensions in other directions, as in the present case, the effect of the local distribution of a force is purely local, and is inappreciable at a distance from it which is relatively considerable. So in this case, except near the ends, the consequences of the removal of the end pressures will be the same as though they had been uniformly distributed over the ends. This enables us to perceive very clearly what the primary stresses and strains must be and even to follow them to some extent where they lose their uniformity near the ends, and the binding material becomes subject to considerable shearing stress.

We might easily conceive much more complex but definitely strained built-up bodies, formed of numerous rods or of not quite flat discs or of rings. The latter construction is frequently employed in gun construction and its theory has received considerable attention. Let us examine an allied problem, a cylinder of uniform thickness, unlimited length and subject to a given internal pressure, but no (sensible) external pressure. We will suppose that the circular tension in the cylinder is uniform from inside to outside, that the axial stress is the same as if the tube were without stress when under no pressure, and that there are no shearing stresses on the princi-

pal sections. Under these circumstances we find by consideration of the equations of equilibrium* that the radial stress will fall off from the interior to the exterior according to a simple hyperbolic law. The ordinary solution of this problem, based on the supposition of no stress when there is no pressure on the tube, results in a circular stress much greater at the interior than at the exterior, a varying radial stress, and an axial stress constant at all distances.

If we examine the strains we find the actual strains† to be a circular extension decreasing from the inside out, a radial contraction decreasing from the inside out and an axial strain, changing from extension at the inside to contraction at the outside. The shearing strains are all zero.

* Let p_1 be the pressure inside the cylinder and \bar{Q} the circular or tangential stress constant at all distances from the axis. Let \bar{R} , the axial stress, be the same as the axial stress on the supposition of no primary stress, or $\bar{R} = R$ and let the shearing stresses $\bar{S} \bar{T} \bar{U}$ all be zero. Then the conditions of equilibrium simply require that the radial stress \bar{P} shall satisfy the differential equation (in circular coördinates)

$$\frac{\partial \bar{P}}{\partial r} + \frac{\bar{P} - \bar{Q}}{r} = 0 \text{ and the surface conditions } \begin{array}{l} P_1 = -p_1 \text{ (at inner surface)} \\ P_0 = 0 \text{ (at outer surface)} \end{array}$$

These yield at once the relation $\bar{P} = \bar{Q} \left(1 - \frac{r_0}{r} \right)$ (r_0 being the outer radius)

whence $\bar{P}_1 = -p_1 = \bar{Q} \left(1 - \frac{r_0}{r_1} \right)$ (r_1 being the inner radius) furnishes $\bar{Q} = p_1 \frac{r_1}{r_0 - r_1}$

and $\bar{P} = p_1 \frac{r_1(r - r_0)}{r(r_0 - r_1)}$. The ordinary solution for no primary stress (see Love,

Theo. of Elas., vol. I, art. 130)

is $e = \frac{\partial u}{\partial r} = \frac{r_1^2 p_1}{r_0^2 - r_1^2} \left(\frac{1}{2(\lambda + \mu)} - \frac{1}{2\mu} \frac{r_0^2}{r^2} \right)$ (radial strain—actually contraction)

$f = \frac{u}{r} = \frac{r_1^2 p_1}{r_0^2 - r_1^2} \left(\frac{1}{2(\lambda + \mu)} + \frac{1}{2\mu} \frac{r_0^2}{r^2} \right)$ (tangential strain—actually extension)

$g = 0$ (axial strain) $a = b = c = 0$ (shearing strains)

$\Delta = e + f + g = \frac{r_1^2 p_1}{r_0^2 - r_1^2} \frac{1}{\lambda + \mu}$ (dilatation—positive and constant)

$P = \lambda \Delta + 2\mu e = \frac{r_1^2 p_1}{r_0^2 - r_1^2} \left(1 - \frac{r_0^2}{r^2} \right)$ ($= -p_1$ at $r = r_1$ of course)

$Q = \lambda \Delta + 2\mu f = \frac{r_1^2 p_1}{r_0^2 - r_1^2} \left(1 + \frac{r_0^2}{r^2} \right)$

$R = \lambda \Delta + 2\mu g = \frac{r_1^2 p_1}{r_0^2 - r_1^2} \frac{\lambda}{\lambda + \mu} = 2\sigma \frac{r_1^2 p_1}{r_0^2 - r_1^2}$ (a constant tension)

† Our actual strains are—

$e = \frac{\bar{P}}{E} - \sigma \frac{\bar{Q} + \bar{R}}{E} = \frac{p_1}{E} \frac{r_1}{r_0 - r_1} \left(1 - \sigma - 2\sigma^2 \frac{r_1}{r_0 + r_1} - \frac{r_0}{r} \right)$ (radial strain—actually contraction)

If we compare these with the strains of the ordinary solution we will find them much more constant except for the axial strain which is zero in the ordinary solution. This will be most apparent if we consider the primary strains which, added to the strains of the ordinary solution, give the strains of our case.

We find that the primary stresses are* a radial compression diminishing from the interior layers of the ring in proceeding towards either surface, a circular stress, compression at the inner surface, tension at the outer surface and an axial stress

$$\bar{f} = \frac{\bar{Q}}{E} - \sigma \frac{\bar{R} + \bar{P}}{E} = \frac{p_1}{E} \frac{r_1}{r_0 - r_1} \left(1 - \sigma - 2\sigma^2 \frac{r_1}{r_0 + r_1} + \sigma \frac{r_0}{r} \right) \text{ tangential strain} \\ \text{— actually extension)}$$

$$\bar{g} = \frac{\bar{R}}{E} - \sigma \frac{\bar{P} + \bar{Q}}{E} = \sigma \frac{p_1}{E} \frac{r_1 r_0}{r_0^2 - r_1^2} \left(\frac{r_0 + r_1}{r} - 2 \right) \text{ (axial strain — varying from} \\ \text{extension to contraction)}$$

At the inner boundary $r = r_1$ these take the values

$$\bar{e}_1 = - \frac{p_1}{E} \left(1 + \sigma \frac{r_1}{r_0 - r_1} + 2\sigma^2 \frac{r_1^2}{r_0^2 - r_1^2} \right) \text{ (radial strain—actually contraction)}$$

$$\bar{f}_1 = \frac{p_1}{E} \left(\frac{r_1}{r_0 - r_1} + \sigma - 2\sigma^2 \frac{r_1^2}{r_0^2 - r_1^2} \right) \text{ (tangential strain—actually extension)}$$

$$\bar{g}_1 = \sigma \frac{p_1}{E} \frac{r_0}{r_0 + r_1} \text{ (axial strain—actually extension)}$$

At the outer boundary $r = r_0$ they take the values

$$\bar{e}_0 = - \frac{p_1}{E} \left(\sigma \frac{r_1}{r_0 - r_1} + 2\sigma^2 \frac{r_1^2}{r_0^2 - r_1^2} \right) \text{ (radial strain—actually contraction)}$$

$$\bar{f}_0 = \frac{p_1}{E} \left(\frac{r_1}{r_0 - r_1} - 2\sigma^2 \frac{r_1^2}{r_0^2 - r_1^2} \right) \text{ (tangential strain—actually extension)}$$

$$\bar{g}_0 = - \sigma \frac{p_1}{E} \frac{r_1}{r_0 + r_1} \text{ (axial strain—actually contraction)}$$

We see that the radial strain at the inner surface exceeds that at the outer surface by $-\frac{p_1}{E}$, the tangential strain at the inner surface exceeds that at the outer surface by $\sigma \frac{p_1}{E}$, and the axial strain at the inner surface exceeds that at

the outer surface by $\sigma \frac{p_1}{E}$, these latter being of opposite signs and nearly equal amount. This all corresponds to the fact that the difference in stresses at the inner and outer surfaces is simply the compression p_1 at the inner surface. The law of variation of these strains is in each case simply hyperbolic (varying as the reciprocal of the distance from the axis plus or minus a constant).

* The primary stresses are

$$(P) = \bar{P} - P = p_1 \frac{r_0 r_1 (r - r_0) (r - r_1)}{r^2 (r_0^2 - r_1^2)} \text{ (radial stress—always compression)}$$

$$(Q) = \bar{Q} - Q = p_1 \frac{r_0 r_1 (r^2 - r_0 r_1)}{r^2 (r_0^2 - r_1^2)} \text{ (tangential stress—is tension or compression} \\ \text{according as } r^2 \begin{matrix} > \\ < \end{matrix} r_0 r_1)$$

$$(R) = \bar{R} - R = 0 \text{ (axial stress—nothing).}$$

zero at all distances. The strains* are a circular (tangential) strain varying from contraction at the inner surface to a somewhat smaller extension at the outer surface, while the strains in the other two directions are simply the corresponding lateral strains at the inner and outer surfaces and intermediate values between. The primary stresses satisfy, as we should expect, the proper equations of equilibrium. The state of primary stress and strain will be very clear if we conceive it as similar to that which exists when an outer tube of a gun is shrunk onto an inner tube slightly too large to enter it when cold. But of course in the case just discussed there is no discontinuity such as would exist in the practical case mentioned above. As to the practical possibility of producing such a state of strain as has just been considered, nothing need here be said, for we are merely interested in considering the consequences of such a state of stress and strain could it be attained. It is of great interest to note however that a somewhat similar state of primary stress and strain with its consequent advantages in increased elastic resistance would be obtained by systematically and uniformly overstraining a tube by application of interior

* The primary strains are

$$(e) = \frac{(P)}{E} - \sigma \frac{(Q) + (R)}{E} = \frac{p_1}{E} \frac{r_0 r_1}{r^2(r_0^2 - r_1^2)} [(r - r_0)(r - r_1) - \sigma(r^2 - r_0 r_1)] \text{ (radial strain—extension inside changing to contraction outside)}$$

$$(f) = \frac{(Q)}{E} - \sigma \frac{(R) + (P)}{E} = \frac{p_1}{E} \frac{r_0 r_1}{r^2(r_0^2 - r_1^2)} [(r^2 - r_0 r_1) - \sigma(r - r_0)(r - r_1)] \text{ (tangential strain—contraction inside changing to extension outside)}$$

$$(g) = \frac{(R)}{E} - \sigma \frac{(P) + (Q)}{E} = \sigma \frac{p_1}{E} \frac{r_0 r_1}{r^2(r_0^2 - r_1^2)} \left[\frac{r_0 + r_1}{r} - 2 \right] \text{ (axial strain—extension inside changing to contraction outside)}$$

At the inner boundary $r = r_1$ they take the values

$$(P_1) = 0 \quad (e_1) = +\sigma \frac{p_1}{E} \frac{r_0}{r_0 + r_1} \text{ (radial strain—actually extension)}$$

$$(Q_1) = -\frac{p_1 r_0}{r_0 + r_1} \quad (f_1) = -\frac{p_1}{E} \frac{r_0}{r_0 + r_1} \text{ (tangential strain—actually contraction)}$$

$$(R_1) = 0 \quad (g_1) = +\sigma \frac{p_1}{E} \frac{r_0}{r_0 + r_1} \text{ (axial strain—actually extension)}$$

At the outer boundary $r = r_0$ they take the values

$$(P_0) = 0 \quad (e_0) = -\sigma \frac{p_1}{E} \frac{r_1}{r_0 + r_1} \text{ (radial strain—actually contraction)}$$

$$(Q_0) = +\frac{p_1 r_1}{r_0 + r_1} \quad (f_0) = +\frac{p_1}{E} \frac{r_1}{r_0 + r_1} \text{ (tangential strain—actually extension)}$$

$$(R_0) = 0 \quad (g_0) = -\sigma \frac{p_1}{E} \frac{r_1}{r_0 + r_1} \text{ (axial strain—actually contraction)}$$

We note that $\frac{\partial(P)}{\partial r} + \frac{(P)-(Q)}{r} = 0$ and that $\begin{pmatrix} P_1 \\ P_0 \end{pmatrix} = \begin{pmatrix} 0 \\ 0 \end{pmatrix}$ satisfying the equations of equilibrium.

pressure. Such a tube would evidently support much larger pressures without overstrain than would a tube not so prepared.

As another illustration let us consider a rectangular beam and let us suppose that on a cross section under a given bending moment the longitudinal fiber stresses do not vary simply as the distance from the neutral axis, as in the ordinary theory of beams, but that they vary according to a law which makes them at first increase very rapidly as we leave the neutral axis, but thereafter less and less rapidly, so that at last they are not increasing at all as the outer fibers are reached.* It will at once be seen that such a distribution would utilize the material of the beam in a particularly effective manner. Not only the outer fibers but the other fibers for some distance in would be acting with nearly their full effective strength, and so, with the same maximum fiber stress the moment resisted would be largely increased, or the same moment would be resisted with a considerably smaller maximum fiber stress. An increased resistance of from twenty to twenty-five per cent could be obtained from such a stress distribution, of course with a proportionally larger deflection. Such a stress distribution is similar to that which would result from systematically overstraining a beam. It would perhaps pay to roll beams curved,

* Let the beam be of depth $2a$ and of width $2b$ and resist at the section under consideration the moment M . Let the fiber stress vary with the departure from the neutral axis (central) according to the law

$$\bar{R} = \bar{R}_0 \frac{x}{2a} \left(3 - \frac{x^2}{a^2} \right) \text{ where } \bar{R}_0 = \bar{R} \text{ at } x = +a$$

This makes $\frac{\partial \bar{R}}{\partial x} = \bar{R}_0 \frac{1}{2a} \left(3 - \frac{3x^2}{a^2} \right)$ or zero at $x = \pm a$, that is it makes \bar{R} constant as the outer fibers are reached.

$$\text{We have } M = \int_{-a}^{+a} \bar{R}_0 \frac{x}{2a} \left(3 - \frac{x^2}{a^2} \right) b x dx = \frac{4}{3} \bar{R}_0 a^2 b$$

$$\text{whence } \bar{R}_0 = \frac{5M}{4a^2b} \text{ or } \bar{R} = \frac{5Mx}{8a^2b} \left(3 - \frac{x^2}{a^2} \right)$$

The stress by the ordinary solution involving no primary stress would be

$$R = R_0 \frac{x}{a} \text{ whence } M = \int_{-a}^{+a} R_0 \frac{x}{a} b x dx = \frac{2}{3} R_0 a^2 b \text{ and } R_0 = \frac{3}{2} \frac{M}{a^2 b} \text{ and } R = \frac{3Mx}{2a^2 b}$$

Thus the primary or self balancing stress which would remain if M were removed

$$\text{is } (R) = \bar{R} - R = \frac{Mx}{8a^2b} \left(3 - \frac{5x^2}{a^2} \right) \text{ which is zero at } x = \pm a \sqrt{\frac{3}{5}}, \text{ within this value}$$

has the same sign as \bar{R} and without has the opposite sign. We note that $\int_{-a}^{+a} b (R) dx = 0$ and $\int_{-a}^{+a} b (R) x dx = 0$ as they should. Under the distribution

of stress here considered the same moment is supported with a maximum fiber stress but five-sixths that for the beam without primary stress supporting the same moment.

systematically overstrain them to make them straight, then use them, having a care to keep the right side up.

A very similar but simpler case is that of a circular shaft subject to a twisting moment, in which the stress does not vary simply as the distance from the axis, as in the ordinary theory of torsion without primary stress, but in such a manner that, under a given twisting moment, the stress increases at first very rapidly as we leave the axis, but thereafter less and less rapidly, so that at last it is not increasing at all as the outer surface is reached.* Here again the distribution of stress imagined would considerably increase the resistance of the shaft, say ten to fifteen per cent. Such a distribution would result from systematically overstraining a shaft and suggests the preparation of shafts to be driven in one direction only, by such preliminary overstraining.

The three foregoing illustrations have not only shown us some solutions of the equations of equilibrium other than those ordinarily recognized, and their bearing on actual cases, but have further shown how it may be advantageous to introduce definite primary stresses in certain cases, and how these stresses may be produced. This has long been appreciated in gun construction but apparently not elsewhere. The illustrations explain to us, moreover, why, in part at least, the elastic limit

* Let the shaft be of radius r_0 and subject to the twisting moment M . Let the shear vary with the departure from the center according to the law

$$\bar{S} = \bar{S}_0 \frac{r}{2r_0} \left(3 - \frac{r^2}{r_0^2} \right) \text{ where } \bar{S}_0 \text{ is the shear at } r = r_0$$

This makes $\frac{\partial \bar{S}}{\partial r} = \bar{S}_0 \frac{1}{2r_0} \left(3 - \frac{3r^2}{r_0^2} \right)$ or zero at $r = r_0$, that is, makes \bar{S} constant as the outer surface is reached. We have

$$M = \int_0^{+r_0} r \bar{S}_0 \frac{r}{2r_0} \left(3 - \frac{r^2}{r_0^2} \right) 2\pi r dr = \frac{7}{12} \pi \bar{S}_0 r_0^3$$

whence $\bar{S}_0 = \frac{12M}{7\pi r_0^3}$, $\bar{S} = \frac{6Mr}{7\pi r_0^4} \left(3 - \frac{r^2}{r_0^2} \right)$. We may take M constant and $\bar{P} =$

$\bar{Q} = \bar{R} = 0$ $\bar{T} = \bar{U} = 0$. The ordinary solution has $S = S_0 \frac{r}{r_0}$

$$M = \int_0^{r_0} r S_0 \frac{r}{r_0} 2\pi r dr = \frac{1}{2} \pi S_0 r_0^3 \quad S_0 = \frac{2M}{\pi r_0^3} \quad S = \frac{2Mr}{\pi r_0^4}$$

The primary or self balancing shear which would remain if the moment M were removed is $(S) = \bar{S} - S = \frac{Mr}{7\pi r_0^4} \left(4 - 6 \frac{r^2}{r_0^2} \right)$ which is zero at $r = r_0 \sqrt{\frac{2}{3}}$, within

this has the same sign as \bar{S} and without has opposite sign. We note that

$\int_0^{r_0} r(S) 2\pi r dr = 0$ as it should. Under the distribution of stress here considered the same moment is supported with a maximum shear but six-sevenths that for a shaft without primary stress supporting the same moment.

is raised in certain cases by overstrain. Doubtless other factors are prominent also in this phenomenon, especially in the case of simple tension bars, although even there annular stresses thus engendered may play an important part. This part of the subject is pregnant with practical and valuable suggestions for the engineer.

It would be of great interest to enter into an analysis of some of the primary stresses engendered by temperature changes on the one hand, and those due to the tightening of parts in built-up constructions on the other hand. But the former in the case of stresses due to the unequal cooling of castings, is a very difficult subject, and in the case of ordinary temperature stresses due to unequal expansion, is already well known. As to the latter it presents many most interesting problems which present time and space unfortunately forbid our considering. It may be remarked however that in a majority of instances the primary stresses thus engendered are local, as is also true of most of the primary stresses due to cold working (shearing, punching, etc.) of metals. A case in which primary stresses introduced through construction are not local and are comparatively easy of consideration, is that of indeterminate frameworks. The writer has elsewhere* presented some special studies in this connection showing the desirability of avoiding constructions in which primary stresses may occur, and the necessity of considering these stresses where they may occur.

Probably few questions in structural engineering have caused more controversy than the theory of the masonry arch. Volumes have been written on the true position of the line of resistance, methods innumerable have been developed for its determination and the greatest diversity in practice and opinion still rules in this connection. Apparently the present best view tends to the treatment of the masonry arch on the same lines as the metal arch, that is as an elastic arch, but with this distinction, that the axial contraction be taken into consideration as well as the flexure, an addition necessitated by the usually considerable relative thickness of a masonry arch ring. This is excellent as far as it goes but it is not sufficient. From the manner of construction, flexibility of centers, employment of mortar, decentering, etc., primary stresses (horizontal component of reaction and moments at the abutments) of considerable importance are almost certain to be introduced. They should be studied and determined *by observation* as closely as possible. Nowhere is better exemplified the fact that the true

* "Some Fundamental Propositions Relating to the Design of Frameworks" in the *Technology Quarterly*, June, 1897, Boston, Mass.

"The Exact Design of Indeterminate Frameworks" in *Transactions of the American Society of Civil Engineers*, June, 1900, New York.

condition of stress and strain in a structure is not determinable purely from equations of elasticity. If we are considering an existing arch we can only know (since the arch stands) that the line of resistance lies within certain more or less well defined limits. On the other hand, because in a design we can pass a line of resistance within certain limits it does not follow that in the actual construction it will lie within those limits. This will depend on the nature of the materials and on how the construction is carried out. An arch designed "safe" by drawing a line of resistance within the middle third may in construction have that line pass without the middle third and fail. Consider the additional uncertainties introduced through masonry accessory to the arch band itself and through the manner of loading, and it will be seen that the problem actually is an exceedingly indeterminate, complex and at best uncertain one.

Turning from engineering applications to the domains of speculative science consider the application of the theory of elasticity to the study of the inner condition of the earth. A sphere of homogeneous, isotropic, elastic material, rigidly subject to Hooke's law, stressed only by its own gravitating force, would engender strains, contraction tangentially increasing from six at the surface to eleven at the center, and extension radially of four at the surface changing to contraction radially of eleven at the center. This is based on the value $\frac{1}{4}$ for the ratio of lateral contraction to elongation. But this solution* is inadmissible in the case of the earth, not merely because in its case the strains involved are far larger than those to which the ordinary theory of elasticity applies, but because the character of the strains at the surface, contraction in one direction, extension in that at right angles, would necessarily involve rupture in the case of such great strains. As a matter of fact no such stresses and strains are called for. We may have the stresses and strains actually not varying from those of fluid pressure (even though the material be exceedingly rigid) except in so far as variations in density and departures from the figure of equilibrium under the actual forces (including gravitation, centrifugal force and tidal forces of sun and moon) call for resistance. Thus the material of the earth need be called on only to have sufficient strength to resist the strains due to continental distribution, mountain elevations and tidal phenomena. If known materials have ample strength to resist these strains, as Prof. Darwin's investigations would indicate,† then it is shown that known materials are perfectly capable of

* See Love, Theory of Elasticity, Art. 127, vol. I.

† See various articles and also Thomson and Tait, Treatise on Natural Philosophy, vol. ii.

satisfying the demands of mechanics in this connection. It would be absurd to maintain in the face of known facts that the earth had arrived at its present condition simply through elastic distortion, and therefore that its condition could be deduced from consideration of the elastic distortions of a sphere originally free from all forces and all stresses and strains. Nothing is more certain than that innumerable flows and slips have occurred, and that, if the earth could be relieved of all gravitational force and could stand the resulting change of strains, it would then be found in a condition of great primary stress and strain. It has been assumed, to overcome the difficulties of the ordinary explanation which neglects these evident facts, that the moduli of elasticity are not constant, but are immensely greater under great stress than under the stresses with which we are familiar. This is quite possibly true and would greatly help out the old theory, but it certainly is not the only and complete explanation, in fact no explanation can be complete which does not take into consideration the possible differences between actual states of stress and strain and the *changes* in stress and strain under applied forces, at present alone considered by the theory of elasticity. This is also true of many other problems in speculative science which would take new shape and become comprehensible by aid of the idea of primary and actual states of stress and strain.

Here closing our illustrations, there still remain some special considerations worthy of attention, among which we may note the following.

Primary stresses and strains are in their essence no different from any other stresses and strains. They need be of no larger amounts, they no more involve consideration of the higher powers of the strains, than in the case of the *changes* in stress and strain produced by applied forces, and they are governed by the same stress-strain relations. These stress-strain relations are fixed purely by the physical constitution of the body at each point. The one peculiarity of the primary *stresses* is that they are not the concomitant of external forces, appearing and vanishing as these are applied and removed, and balanced against them, but on the contrary may exist independently of the external forces and are balanced among themselves. For this reason primary stresses may properly be characterized by the name "self-balancing stresses." And the peculiarity of primary *strains* is that they are not necessarily factors in the distortion of a piece under external forces, but may exist without any such forces and without any necessary relations to displacements such as the strain-displacement relations of the usual theory.

The fact that changes of stress and strain and therefore distortions due to applied forces are practically independent of pre-existing stresses and strains has previously been mentioned but not explained. The reason for this fact is very simple, being the linear character of the stress-strain relations, the consequences of Hooke's law,—“stress is proportional to strain.” Where Hooke's law closely holds, that is to say, within the elastic limits of most bodies to which it is attempted to apply the mathematical theory of elasticity, it makes no sensible difference in the elastic distortions due to applied forces whether primary stresses and strains exist or not. This probably explains their entire neglect by the theoretical elastician, for he has limited himself chiefly to investigations precisely within these limits of proportional stress and strain, with the determination of distortions consequent on the application of given forces, or the converse, as his one aim. Only when primary strains were very great, as possibly in some castings, would their presence noticeably affect distortions due to applied forces, for the unstrained lengths to which all strains are referred would then appreciably differ from the strained lengths. But with metals within the elastic limits this never becomes a very important factor. The real importance of the existence of primary strains is that they cause a body to become overstrained at a different time and place from what would ordinarily be expected.

The idea of innumerable possible solutions of the general stress or strain equations of equilibrium at first sight may seem contrary to Kirchhoff's celebrated demonstration of the uniqueness of solution of the equations of elasticity.* But a closer

* Kirchhoff's demonstration of the uniqueness of solution of the equations of elasticity as given in Love's Theory of Elasticity, vol. i, Art. 66 (e), pp. 123-4 is “(e). If either the surface displacements or the surface tractions be given the solution of the general equations of equilibrium is unique.

1°. Supposing the bodily forces and the surface tractions given, then, taking W a quadratic function of the six strains, we have

$$\frac{\delta W}{\delta e} = P$$

also the general equations of equilibrium are three such as

$$\frac{\delta P}{\delta x} + \frac{\delta U}{\delta y} + \frac{\delta T}{\delta z} + \rho X = 0 \quad (44)$$

and the boundary conditions are three such as

$$lP + mU + nT = F \quad (45)$$

If possible suppose there are two different solutions of these sets of equations, and that the corresponding displacements are $u_1 v_1 w_1$ and $u_2 v_2 w_2$ in the two solutions. Then, writing

$$u' = u_1 - u_2 \quad v' = v_1 - v_2 \quad w' = w_1 - w_2$$

we see that $u' v' w'$ are a set of displacements which satisfy three such differential equations as

examination shows that this is not the case, for we find the demonstration has reference only to *changes* in stress and strain due to applied forces, that it depends on suppositions applicable only to these changes, and therefore that it has no bearing on and in no wise limits actual or total stresses and strains. A misunderstanding among elasticians as to the scope of this theorem of Kirchhoff is probably one reason for their neglect to develop the general theory of primary stress and strain. We may note in this connection that the validity of Kirchhoff's demonstration (as here given) is limited to cases of relatively small displacements and to bodies subject to Hooke's law. It is not evident that the latter limitation is essential, for apparently the distortions of bodies not subject to Hooke's law, due to applied forces, are quite as singly determinate as those of bodies which are subject to that law. The former limitation is apparently quite necessary, for, where great displacements

$$\frac{\partial P'}{\partial x} + \frac{\partial U'}{\partial y} + \frac{\partial T'}{\partial z} = 0 \quad (46)$$

and three such boundary conditions as

$$lP' + mU' + nT' = 0 \quad (47)$$

where $P' \dots$ are the stresses corresponding to these displacements.

Now, by Green's transformation

$$\begin{aligned} & \iiint \left\{ u' \left(\frac{\partial P'}{\partial x} + \frac{\partial U'}{\partial y} + \frac{\partial T'}{\partial z} \right) + \dots + \dots \right\} dx dy dz \\ &= \iint \left\{ u'(lP' + mU' + nT') + \dots + \dots \right\} dS \\ & \quad - \iiint \left(e' \frac{\partial W'}{\partial e'} + f' \frac{\partial W'}{\partial f'} + \dots + c' \frac{\partial W'}{\partial c'} \right) dx dy dz \end{aligned}$$

where $e' \dots c'$ are the strains corresponding to the displacements $u' v' w'$. Hence

$$\iiint \left(e' \frac{\partial W'}{\partial e'} + f' \frac{\partial W'}{\partial f'} + \dots + c' \frac{\partial W'}{\partial c'} \right) dx dy dz = 0 \quad (48)$$

But from the form of W' as a positive quadratic function, we know that the expression under the integral sign is $2W'$ so that the integral is a sum of positive terms which can vanish only when $e' = f' = \dots = c' = 0$. Thus the displacements ($u' v' w'$) are such as are possible for a rigid body, and the solution is only indeterminate to the extent of such displacements.

2°. Supposing the bodily forces and surface displacements given, we take as before, two solutions $u_1 v_1 w_1, u_2 v_2 w_2$ and form their differences $u' v' w'$, then $u' v' w'$ satisfy stress equations like

$$\frac{\partial P'}{\partial x} + \frac{\partial U'}{\partial y} + \frac{\partial T'}{\partial z} = 0$$

and boundary conditions $u' = 0 \ v' = 0 \ w' = 0$ at the surface. Thus we find that

$$\iiint \left(e' \frac{\partial W'}{\partial e'} + f' \frac{\partial W'}{\partial f'} + \dots + c' \frac{\partial W'}{\partial c'} \right) dx dy dz = 0$$

and hence $e' = 0 \ f' = 0 \ \dots \ c' = 0$ and the displacements are only indeterminate to the extent of displacements possible for a rigid body. This indeterminate-

may occur, at any rate in certain cases of elastic instability, the possible states of equilibrium may be several.

Among the limiting conditions of *changes* in stresses and strains,—the ordinary stresses and strains of the theory of elasticity,—are what are known variously as the equations of compatibility or of continuity.* These simply state relations which must subsist between the strains in order that the sum of the products of the strains in a given direction with the distances, along any path whatsoever from one point to a second point, shall be a quantity independent of the path taken,—the displacement in the given direction of the one point with respect to the other. These equations have no reference to and do not apply to either primary or absolute strains, as will be found by attempting to apply them to the primary strains of the illustrations. The displacement of one point with respect to another accompanying the generation of primary strains involves flows or slips, and strain sums alone will not express it nor will they be equal along different paths between

ness is also removed, since uvw are given at the surface, and if three points of a rigid body be moved in a given manner the displacement of all points is determinate."

Examining the above demonstration, we note that it assumes that the stress equations of equilibrium have solutions in terms of displacements, which can only be true provided the stresses are functions of the displacements. So Kirchhoff's demonstration only applies to stresses that are functions of the displacements, that is to say to *changes* in stress due to applied forces. This is further confirmed by the use he makes of Green's transformation. If we integrate by parts we should simply get

$$\begin{aligned} & \iiint \left\{ u' \left(\frac{\partial P'}{\partial x} + \frac{\partial U'}{\partial y} + \frac{\partial T'}{\partial z} \right) + \dots + \dots \right\} dx dy dz \\ & = \iint \left\{ u' (lP' + mU' + nT') + \dots + \dots \right\} ds \\ & - \iiint \left\{ \frac{\partial u'}{\partial x} P' + \frac{\partial v'}{\partial y} Q' + \dots + \left\{ \left(\frac{\partial u'}{\partial y} + \frac{\partial v'}{\partial x} \right) U' \right\} \right\} dx dy dz \end{aligned}$$

and this last term only reduces to the form given by Kirchhoff providing that the strains $e' f' \dots c'$ are the derivatives $\frac{\partial u'}{\partial x} \frac{\partial v'}{\partial y} \dots \left(\frac{\partial w}{\partial y} + \frac{\partial v'}{\partial x} \right)$ of the dis-

placements and the stresses $P' \dots$ are the rates of change of the energy function W' with respect to *these* strains. This is not true of primary stresses and strains but only of *changes* in stress and strain due to applied forces.

* Love gives them in his Theory of Elasticity, Art. 66 (d), vol. I as follows:

$$\left. \begin{aligned} \frac{\partial^2 e}{\partial y^2} + \frac{\partial^2 f}{\partial x^2} &= \frac{\partial^2 c}{\partial x \partial y} & 2 \frac{\partial^2 e}{\partial y \partial z} + \frac{\partial^2 a}{\partial x^2} &= \frac{\partial^2 b}{\partial x \partial y} + \frac{\partial^2 c}{\partial z \partial x} \\ \frac{\partial^2 f}{\partial z^2} + \frac{\partial^2 g}{\partial y^2} &= \frac{\partial^2 a}{\partial y \partial z} & 2 \frac{\partial^2 f}{\partial z \partial x} + \frac{\partial^2 b}{\partial y^2} &= \frac{\partial^2 c}{\partial y \partial z} + \frac{\partial^2 a}{\partial x \partial y} \\ \frac{\partial^2 g}{\partial x^2} + \frac{\partial^2 e}{\partial z^2} &= \frac{\partial^2 b}{\partial z \partial x} & 2 \frac{\partial^2 g}{\partial x \partial y} + \frac{\partial^2 c}{\partial z^2} &= \frac{\partial^2 a}{\partial z \partial x} + \frac{\partial^2 b}{\partial y \partial z} \end{aligned} \right\} \begin{array}{l} (42) \\ (43) \end{array}$$

and these relations the *changes* in strain accompanying any elastic distortion must conform to.

the two points, for the flows or slips along these paths will in general have been different. Moreover, often if not generally, it would be very difficult to determine these flows or slips.

As a last consideration let us note that, while the circumstances that produce a condition of primary stress and strain frequently involve changes in the physical constitution of a body, such as a change from isotropy to æolotropy, the introduction of magnetism, polymorphism, and even chemical modifications, these are incidental and not necessary accompaniments of the existence of primary stress and strain.

We may conclude by stating that

Primary stresses are limited and limited only (capacity for physical resistance apart) to such as will satisfy the general differential and surface equations of equilibrium for the case of no surface tractions and bodily forces ;

Primary strains are limited and limited only by the equations resulting from these through the application to them of the stress-strain relations which are true for the material and body under consideration ;

Primary stresses and strains are not determinate purely by mathematics ;

True or actual stresses and strains (of which primary stresses and strains are a component) are limited but limited only and are not and can not be defined through the equations of the theory of elasticity alone.

ART. XXIII.—*The Boiling Point of Liquid Hydrogen, determined by Hydrogen and Helium Gas Thermometers*;* by JAMES DEWAR, M.A., LL.D., Professor of Chemistry at the Royal Institution.

[Read before the Royal Society of London, February 7, 1901.]

IN a former paper† it was shown that a platinum-resistance thermometer gave for the boiling point of hydrogen $-238^{\circ}.4$ C., or $34^{\circ}.6$ absolute. As this value depended on an empirical law correlating temperature and resistance which might break down at such an exceptional temperature, and was in any case deduced by a large extrapolation, it became necessary to have recourse to the gas thermometer.

In the present investigation the advantage claimed for the constant-pressure gas thermometer over the constant-volume thermometer is absent. The effect of high temperature combined with large increase of pressure does not occur in these experiments, where only very low temperatures and a maximum range of pressure of less than one atmosphere were encountered. At the same time, before dispensing with the effect of pressure upon the capacity of the reservoir of the thermometer, it was carefully estimated and found that it could not affect the volume of the reservoir by as much as $1/60,000$ th part. This being determined a particular advantage results from the use of the constant-volume form, because in its case it is unnecessary to know the actual volume of the reservoir, and of the "outside" space. It is only necessary to know the ratio of these two volumes, and as this ratio appears only in the small terms of the calculation it is not a serious factor in the estimation of such low temperatures.

Two constant-volume thermometers (called No. I and No. II) were employed, in each of which the volume of the reservoir was about 40 c.c., and the ratio of the outside space to the volume of the reservoir was $1/50$ and $1/115$ respectively. A figure of the apparatus is shown in fig. 1 (p. 293), where A is the thermometric bulb covered with a vacuum vessel to hold the liquid hydrogen, and be exhausted when necessary; B is the manometric arrangement for adjusting the mercury at C to constant volume, and D is the barometer. The readings were made on a fixed scale by means of a telescope with cross wires and lever attached. A similar telescope was permanently fixed on the mark to which the volume had to be adjusted. It was found convenient to use both telescopes on the same massive

* From an advance proof sent by the author

† On the Boiling Point of Liquid Hydrogen under Reduced Pressure, Roy. Soc. Proc., 1898.

stand and to read the barometer placed alongside simultaneously.

The formula of reduction used was that given by Chappuis in the *Travaux et Mémoires du Bureau International des Poids et Mesures*, vol. vi, p. 53, namely,

$$\left(V_0 + \frac{v}{1+at}\right)H_0 = \left(\frac{V_0(1+\delta T) + \beta h}{1+a\Gamma} + \frac{v}{1+at}\right)(H_0+h) \quad (1)$$

where V_0 is volume of reservoir at 0° C.

T , temperature of reservoir, measured from 0° C.

v , volume of "outside" space at the temperature of the room.

t , temperature of the room.

a , coefficient of expansion of the thermometric gas.

β , coefficient of alteration of volume of reservoir, due to change of pressure.

δ , coefficient of expansion of substance of reservoir.

H_0 , initial pressure (in these experiments always reduced to 0° C.).

H_0+h , pressure at temperature T , after all corrections have been made.

On putting $\beta = 0$ as already explained, equation (1), by algebraic transformation and without any approximation, was altered into the form.

$$\text{Where} \quad T = T_1 \frac{273+t+xT_1}{273+t-xT_1}, \text{ (say) } = T_1\theta \quad (2)$$

$$T_1 = \frac{P-P_0}{a\Gamma - \delta P} \quad (3)$$

in which P_0 and P replace H_0 and H_0+h and $x = \frac{v}{V_0(1+at)}$.

The gases used as thermometric substances were hydrogen, oxygen, helium, and carbonic acid. The values of a adopted in equation (3) were taken from Chappuis' memoir, and were 0.00366254 for the first three and 0.00371634 for carbonic acid. The reciprocals of these coefficients are 273.035 and 269.083. The number "273" which appears in θ is so nearly equal to the reciprocal of the former value for a that it was allowed to remain for the first three gases; but in dealing with carbonic acid it was replaced by 269.083.

In these experiments T_1 is always negative, and numerically less than 273, so that the value of θ is always greater than unity; nevertheless it differs from it but slightly, its value being unity when $T_1 = -273^\circ$ C., and rising to 1.02 when $T_1 = 0^\circ$ C. in the case of thermometer No. 1, where $x = 1/50$. It may be noted that when δ is neglected, T_1 is the usual value

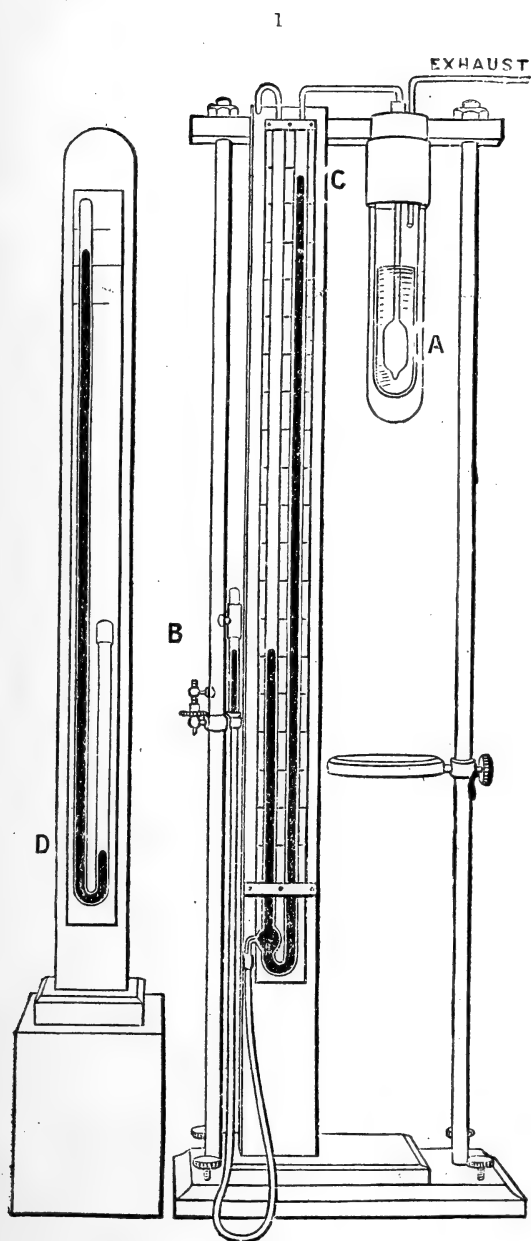

given by Boyle's law; there is a convenience, therefore, in this form of Chappuis' formula for approximation, because T_1 can quickly be calculated, and the correcting factor θ can be applied later if desired.

In the first experiment (No. 1 of subjoined Table I) thermometer No. 1 was filled with electrolytic hydrogen. The initial pressure, (the pressure at 0° C.) was almost three-eighths of an atmosphere, and was taken low in order to obviate any complication from condensation on the walls of the reservoir. Two other possible causes might abnormally reduce the pressure at very low temperatures; these were polymerisation and the presence as impurity of small quantities of gases liquefying above the boiling point of hydrogen. The measurement of the density of the gas at its boiling point showed that there was no polymerisation, and further proof of this was evident in the constancy of the value of the boiling point when different initial pressures were taken. To guard against the presence of gases with a higher boiling point than hydrogen, the electrolytic hydrogen was allowed to pass continuously for eighteen hours through the thermometric bulb before it was sealed off. It was further calculated that an impurity of oxygen necessary to reduce the boiling point of hydrogen by a degree would amount to 3 per cent, a quantity too large to escape detection. This experiment gave the boiling point of oxygen as $-182^\circ\cdot2$, and that of hydrogen as $-253^\circ\cdot0$.

In the second experiment (No. 2) a new thermometer, No. II, was constructed with a much smaller value of x , and as a further protection against the presence of impurities, palladium-hydrogen was employed as the source of the gas. A rod of palladium, weighing about 120 grams, kindly placed at my disposal by Mr. George Matthey, F.R.S., was charged with hydrogen in the manner described in my paper "On the Absorption of Hydrogen by Palladium at High Temperatures and Pressures,"* and subsequently used as the source of supply to fill the thermometer. The initial pressure was slightly less than that in the first experiment; the corresponding results were $-182^\circ\cdot67$ and $-253^\circ\cdot37$.†

The new thermometer was filled afresh (No. 4) with palladium-hydrogen at an initial pressure rather less than one atmosphere, and gave for the boiling point of hydrogen the temperature $-252^\circ\cdot8$. This result is a confirmation of the absence of polymerisation.

The next step was to compare these results with the results of similar experiments made upon another gas whose boiling point fell within the range of easily determined temperatures;

* Proc. Chem. Soc., 1897.

† This thermometer gave $99^\circ\cdot7$ for the boiling point of water.

and as a further precaution the gas used in the thermometer was the vapor rising from the liquefied gas whose boiling point was to be determined. The gas first selected was oxygen (No. 5), and as an additional condition to be noted, the initial pressure was made slightly more than an atmosphere, so that it would be in a Van der Waal's "corresponding" state with the hydrogen in the first two experiments, namely, the initial pressure in each case was about $1/50$ of the critical pressure. The critical pressure of oxygen was taken about 51 atmospheres, and that of the hydrogen about 18 atmospheres. There are good reasons for believing that the critical pressure of hydrogen is more likely to be about 11 or 12 atmospheres. In the event of the lower value being eventually found the more correct, the effect as between the oxygen thermometer and the hydrogen thermometer will be to make the boiling point of hydrogen a little too high. The result obtained from this experiment was to place the boiling point of oxygen at $-182^{\circ}29$, thus corroborating in a satisfactory manner the reliability of the method of determining the boiling point of hydrogen.

The question still remained, how far is a gas thermometer to be trusted at temperatures in the neighborhood of the boiling point of the gas with which it is filled? To answer this question the oxygen thermometer was used to determine the boiling point of liquid air (No. 7) in which a gold-resistance thermometer was simultaneously immersed. The gold thermometer had been previously tested and found to give correct indications of temperature down to temperatures not only well below the point in question, but lower than those obtainable by any other metal thermometer. In the result the oxygen thermometer gave $-189^{\circ}61$, and the gold thermometer $-189^{\circ}68$, as the temperature of that particular sample of air boiling at atmospheric pressure.

For another method of comparison this oxygen thermometer was practically discharged (No. 8) until its initial pressure was nearly the same as that in the first hydrogen thermometers. In this state it gave the boiling point of oxygen as $-182^{\circ}95$, establishing again the reliability of the method.

As an extreme test of the method, I charged the thermometer No. II with carbonic acid (No. 11) at an initial pressure again a little less than one atmosphere, and used it to determine the boiling point of dry CO_2 ; the result was $-78^{\circ}22$, which is the correct value.

Hence it appears that either a simple or a compound gas at an initial pressure somewhat less than one atmosphere may be relied on to determine temperatures down to its own boiling point.

Another thermometric substance at our disposal as suitable for determining the boiling point of hydrogen, as hydrogen had been in determining that of oxygen, is helium. The early experiments of Olszewski and my own later ones showed that pure helium is less condensible than hydrogen, and that the production of liquid or solid products by cooling Bath helium to the temperatures of boiling and solid hydrogen was only partial, and resulted from the presence of other gases undefined at the time the first experiments were made. The mode of separating the helium from the gases given off by the King's Well at Bath is fully described in my paper on "The Liquefaction of Air and the Detection of Impurities."*

If the neon, present as impurity in the Bath helium which was used, should reach its saturation pressure about the boiling point of hydrogen the values given by this thermometer of the boiling point of hydrogen would be too low. In order to avoid this, the crude helium extracted from the Bath gas was passed through a U-tube cooled by liquid hydrogen to condense out the known impurities, oxygen, nitrogen and argon. In my paper "On the Application of Liquid Hydrogen to the production of High Vacua,"† it was shown that at the temperature of boiling hydrogen, oxygen, nitrogen and argon have no measurable tension of vapor, and that the only known gases uncondensed in air after such cooling were hydrogen, helium, and neon. This same neon material occurs in the gas derived from the Bath wells. A sample of helium prepared as above described, which had been passed over red-hot oxide of copper to remove any hydrogen, was found by Lord Rayleigh to have a refractivity of 0.132. The refractivity of Ramsay's pure helium being 0.1238, and that of neon 0.2345, it results that my helium contained some 7.4 per cent of neon, according to the refractivity measurements. This would make the partial tension of the neon in the helium thermometer cooled in the liquid hydrogen to be about 4 mm., and this being taken as the saturation pressure the boiling point of neon is about 34° absolute. The initial pressure (No. 9) was taken rather less than an atmosphere, and the temperature of the boiling point of hydrogen was given by this thermometer as $-252^{\circ}68$. A further observation was taken on another occasion with the same thermometer, and the value was $-252^{\circ}84$. The fact that the boiling point of hydrogen, as determined by the helium thermometer, is in substantial agreement with the results obtained by the use of hydrogen itself is a conclusive proof that no partial condensation of the neon had occurred.

* Chem. Soc. Proc., 1897.

† Roy. Soc. Proc., 1898.

Of the remaining experiments in Table I, (No. 3) was made in order to show the effect of a very small initial pressure, one-sixth of an atmosphere. The results were unsatisfactory, owing to the sticking of the mercury giving uncertain readings. In this case an error in the reading of a low pressure has six times as great an effect as if the initial pressure had been about an atmosphere. If the temperature deduced for the boiling point of oxygen is corrected, and the same factor of correction applied to the observed liquid hydrogen boiling point, then it becomes $-251^{\circ}4$.

It is of particular moment to have some estimate of how far errors in the observed quantities employed in Chappuis' formula affect the final value of T .

In the case of an error in t , on differentiating equation (2) we get

$$dT = T_1 \frac{-x(273 + T_1)}{(273 + t - xT_1)^2} dt \quad (4)$$

If $x = 1/50$, $t = 13^{\circ}$, $T_1 = -180^{\circ}$; then $dT = 0.00339 dt$, or it would need an alteration of $2\frac{1}{2}^{\circ}$ in t to alter T by 1/100th of a degree at the boiling point of oxygen. In the same circumstances when $T_1 = -250$, $dT = 0.00136 dt$, so that an alteration of between 7° and 8° in the value of t would only affect the boiling point of hydrogen by 1/100th of a degree.

From equation (4) the error in T varies with x very nearly. This for the second thermometer where $x = 1/115$, a variation of t to the extent of 6° , would only affect the boiling point of oxygen by 1/100th of a degree; and it would require an alteration of 17° in t to affect the boiling point of hydrogen to the same extent.

In Table I the values of t enclosed in brackets are assumed values; this investigation shows that no serious error is involved in these assumptions.

In the case of an error in P_0 , a similar process gives

$$dT = \theta \frac{(a - \delta)P}{(aP_0 - \delta P)^2} - \frac{273 + t}{273 + t - xT_1} dP \quad (5)$$

If $x = 1/50$, $t = 13^{\circ}$. $P_0 = 760$ mm.; $T_1 = -180^{\circ}$; $dT = 0.3563 dP$, so that an error of 1 mm. in P would only alter the boiling point of oxygen by a third of a degree. In the same circumstances at -250° , $dT = 0.3516 dP$, which is practically the same result at the boiling point of hydrogen as at that of oxygen.

For the second thermometer these two equations become

$$\begin{aligned} \text{At } -180^{\circ}, dT &= 0.3575 dP. \\ \text{At } -250^{\circ}, dT &= 0.3548 dP. \end{aligned}$$

TABLE I.

Thermometer.	1	2	3	4	5	6	7	8	9	10	11
$x = \frac{7_0}{V_0}$	No. I. $\frac{5}{30}$	No. II. $\frac{11}{15}$	No. II. $\frac{11}{15}$	No. II. $\frac{11}{15}$	No. I. $\frac{1}{30}$	No. I. $\frac{1}{30}$	No. I. $\frac{1}{30}$	No. I. $\frac{1}{30}$	No. II. $\frac{11}{15}$	No. II. $\frac{11}{15}$	No. II. $\frac{11}{15}$
Substance.	Electrol. Hydrogen.	Palladium Hydrogen.	Palladium Hydrogen.	Palladium Hydrogen.	Oxygen.	Oxygen.	Oxygen.	Oxygen.	Helium (Bath).	Helium (Bath).	Helium (Bath).
Barometer	760.4	764.4	759.5	770.5	772.5	756.0	766.0	753.5	765.0	770.0	759.0
Temperature of Room ..	13° mm.	13° mm.	13° mm.	21° mm.	12° mm.	13° 6 mm.	12° mm.	13° 3 mm.	15° mm.	15° mm.	13° mm.
Pressures at 0° C.	286.6	269.8	127.0	739.0	806.0	806.0	807.0	290.5	728.0	728.0	619.0
B. P. of Carbonic Acid ..	204.3	193.6	91.0	—	—	—	—	—	—	—	441.0
“ Oxygen	97.0	90.2	43.0	—	272.5	269.0	—	95.5	—	—	—
“ Air	—	—	—	—	—	—	251.0	—	—	—	—
“ Hydrogen	21.5	19.7	10.7.	55.5	—	—	—	—	55.0	54.6	—
“ Hydrogen Solid	—	14.4	8.2	—	—	—	—	—	—	—	—
(30 to 40 mm.)	—	—	—	—	—	—	—	—	—	—	—
<i>Calculated Temperatures.</i>											
B. P. of Carbonic Acid ...	—	77° 95	78° 22	—	—	—	—	—	—	—	—78° 24†
“ Oxygen	—182° 20	—182° 67	—181° 52	—	—182° 29	—183° 46	—	—182° 95	—	—	—
“ Air	—	—	—	—	—	—	—	—	—	—	—
“ Hydrogen	—253° 03	—253° 31	—250° 81*	—252° 81	—	—	—	—	—252° 68	—252° 84	—
“ Hydrogen Solid	—	—258° 66	—255° 67†	—	—	—	—	—	—	—	—
(30 to 40 mm.)	—	—	—	—	—	—	—	—	—	—	—

* Corrected for Oxygen error —257°.1. † Corrected for Oxygen error —251°.8.
 ‡ Dry Carbonic Acid.
 No value is attached to second place of decimals.

In each of the last four results if $P_0 = \frac{1}{n} \times 760^{\text{mm}}$ the formulæ become respectively

$$\begin{aligned} dT &= n \times 0.3563 \, dP, \text{ and } dT = n \times 0.3516 \, dP, \\ dT &= n \times 0.3575 \, dP, \text{ and } dT = n \times 0.3548 \, dP; \end{aligned}$$

in other words, any error in reading P is magnified in its effect on T_1 directly in proportion as P_0 is diminished. This affords some explanation of the weakness of the results in Experiment (No. 3).

In like manner, from an error in P_0 , we get

$$dT = - \frac{P}{P_0} \frac{dT}{dP} dP_0. \quad (6)$$

Here if $x = 1/50$, $t = 13^\circ$, $P_0 = 760$ mm., $T_1 = -180^\circ$; $dT = -0.1188 \, dP_0$, or an error of 1 mm. in P_0 would only alter the boiling point of oxygen by a ninth of a degree; but with the same data at -250° , $dT = -0.0264 \, dP_0$, so that the boiling point of hydrogen would only be altered by a tenth of a degree for a change of 4 mm. on an initial pressure of about one atmosphere.

In this case also if $P_0 = \frac{1}{n} \times 760^{\text{mm}}$ we get similar results to those in the case of P , namely,

$$\begin{aligned} \text{For } x = 1/50, \quad dT &= -n \times 0.1188 \, dP_0 \text{ and } dT = -n \times 0.0264 \, dP_0. \\ \text{For } x = 1/115, \quad dT &= -n \times 0.1192 \, dP_0 \text{ and } dT = -n \times 0.0266 \, dP_0. \end{aligned}$$

The general results of an error in either P_0 or P is, that the more reliable experiments are those in which the initial pressure is as high as possible. Hence Nos. 4, 9, 10 are in this respect the most reliable for hydrogen. Also it is of much more importance that P should be accurate than that P_0 should be so; in fact, for hydrogen an error in P has 14 times as much effect as the same error in P_0 .

We can verify these results from Table I. In Experiment (No. 2), where $P_0 = \frac{1}{3} \times 760$ nearly, we have two readings—one at the boiling point, the other in solid hydrogen, namely, 19.7 mm. and 14.4 mm., whose difference is 5.3 mm. This corresponds to $dT = 3 \times 0.3516$ (-5.3) degrees, or $5^\circ.59$. The calculated temperatures for these pressures are $-253^\circ.37$ and $-258^\circ.66$, whose difference is $5^\circ.29$, a satisfactory agreement.

If we compare Experiments Nos. 4 and 9, in both of which the same value of a is used, we can pass from the former to the latter by the formula

$$dT = -0.0266 dP_0 + 0.3548 dP,$$

in which $dP_0 = -11$ mm. and $dP = -0.5$ mm. whence $dT = 0^\circ.152$; the observed result is $-252^\circ.683 + 252^\circ.806$ or $0^\circ.123$, which is also satisfactory and explains how so great a drop as 11 mm. in P_0 has, nevertheless, so slight an effect on the result.

An alteration in the value of x has but little relative effect on the results. As before we have

$$dT = T_1 \frac{(273+t)(273+T_1)}{(273+t-xT_1)^2} dx \quad (7)$$

If $x = 1/50$, $t = 13^\circ$, then

$$\begin{aligned} \text{At } T_1 = -180^\circ, & \quad dT = -57.085 dx, \\ \text{At } T_1 = -250^\circ, & \quad dT = -19.4205 dx, \end{aligned}$$

and for the second thermometer ($x = 1/115$) in like circumstances,

$$dT = -57.895 dx.$$

and

$$dT = -19.802 dx.$$

For instance, if x were altered from $1/50$ to $1/80$ the result would be to raise the boiling point of oxygen by $0^\circ.43$ and that of hydrogen by $0^\circ.15$.

Finally, the alteration of a for any particular gas being in any case small affects the value of T practically only in its main factor T_1 . To hundredths of a degree, therefore, the change in T is inversely proportional to the change in a , or, in other words, is directly proportional to the corresponding absolute zero.

For instance, in Experiment (No. 11) had we used the same value of a as for hydrogen the boiling point of dry CO_2 would have been $-79^\circ.35$.

The following table shows what alterations would be required for each of the thermometers, in the values of t , P , P_0 , and x to alter the boiling point of oxygen or that of hydrogen by $1/10$ or $1/100$ of a degree. The table is calculated for $t = 13^\circ$; and in the cases of P and P_0 the initial pressure is taken to be about $1/n$ th of an atmosphere.

Thus, for example, if the initial pressure in either thermometer were about half an atmosphere an error of $1/7$ mm. in reading P would alter T by a tenth of a degree.

If we take the average values given by these experiments as being the most probable, then the boiling point of oxygen is $-182^\circ.5$ and that of hydrogen is $-252^\circ.5$. The temperature found for the boiling point of oxygen agrees with the mean results of Wroblewski, Olszewski, and others. If the boiling point of oxygen is made -182° , which is the highest value it

TABLE II.

	Thermometer No. 1.	Thermometer No. 2.	Alteration of T.
t { at B.P. of O	$2\frac{1}{2}^{\circ}$	6°	$\frac{1}{100}^{\circ}$
{ at B.P. of H	$7\frac{1}{2}^{\circ}$	17°	
P { at B.P. of O	$\frac{0.280}{n}$ mm.	$\frac{0.280}{n}$ mm.	$\frac{1}{10}^{\circ}$
{ at B.P. of H	$\frac{0.285}{n}$ mm.	$\frac{0.282}{n}$ mm.	
P ₀ { at B.P. of O	$\frac{0.842}{n}$ mm.	$\frac{0.839}{n}$ mm.	$\frac{1}{10}^{\circ}$
{ at B.P. of H	$\frac{3.79}{n}$ mm.	$\frac{3.76}{n}$ mm.	
x { at B.P. of O	0.88 per cent.	2.00 per cent.	$\frac{1}{100}^{\circ}$
{ at B.P. of H	2.57 “	5.81 “	

can have then an equal addition to the hydrogen value must follow, making it then -252° or 21° absolute. In a future communication the temperature of solid hydrogen will be discussed.

I am indebted to Mr. J. D. H. Dickson, M.A., of St. Peter's College, Cambridge, for help in the theoretical discussion of the results, and to Mr. Robert Lennox, F.C.S., for able assistance in the conduct of the experiments.

ART. XXIV.—*On the Nature of Vowels*; by E. W. SCRIPTURE, Yale University.

THE speech curves, which are discussed in this paper, were traced off with great accuracy from several gramophone plates by a specially constructed apparatus. The method is essentially as follows: The rubber gramophone plate is slowly rotated (once in 5 hours) in such a way that the curve travels under a fine steel point. The point is thus deflected sidewise according to the vibrations in the speech curve; its movement is magnified by a system of levers and is recorded on a surface of smoked paper. An earlier form of this apparatus has already been described*; the present form will be described later.

The curves, shown in fig. 1, are from a plate containing the nursery rhyme of Cock Robin, spoken by an American. The equation beneath the figure indicates the relation between length and time.

The curve for *I* shows a series of vibrations in which each group resembles the neighboring one while there is a gradual change in character from a typical form for the *a* in the first part, to a typical form for the *i* in the second part, of the diphthong *ai* of which the pronoun *I* is composed. In the first portion there appears a succession of strong vibrations each followed by a series of weaker ones. These strong vibrations recur at periods of steadily decreasing length.

If we consider separately each group of vibrations beginning with a strong one, we find that it is, aside from minor details, the typical curve of a vibration initiated by a blow and dying away by friction, for which the equation is

$$y = a \cdot e^{-kt} \cdot \sin 2\pi \frac{t}{T},$$

where *y* is the elongation at the moment *t*, *a* the amplitude, *e* the basis of the natural series of logarithms, *k* a factor representing friction and *T* the periodic time.

The succeeding groups of vibrations following the first group are of the same form but of steadily increasing amplitude. They recur at steadily decreasing intervals. The formula for each group is approximately the same except for the difference in amplitude. The vibrations are evidently aroused by a series of blows of steadily increasing strength at steadily decreasing intervals.

* Studies from the Yale Psychological Laboratory, vol. vii.

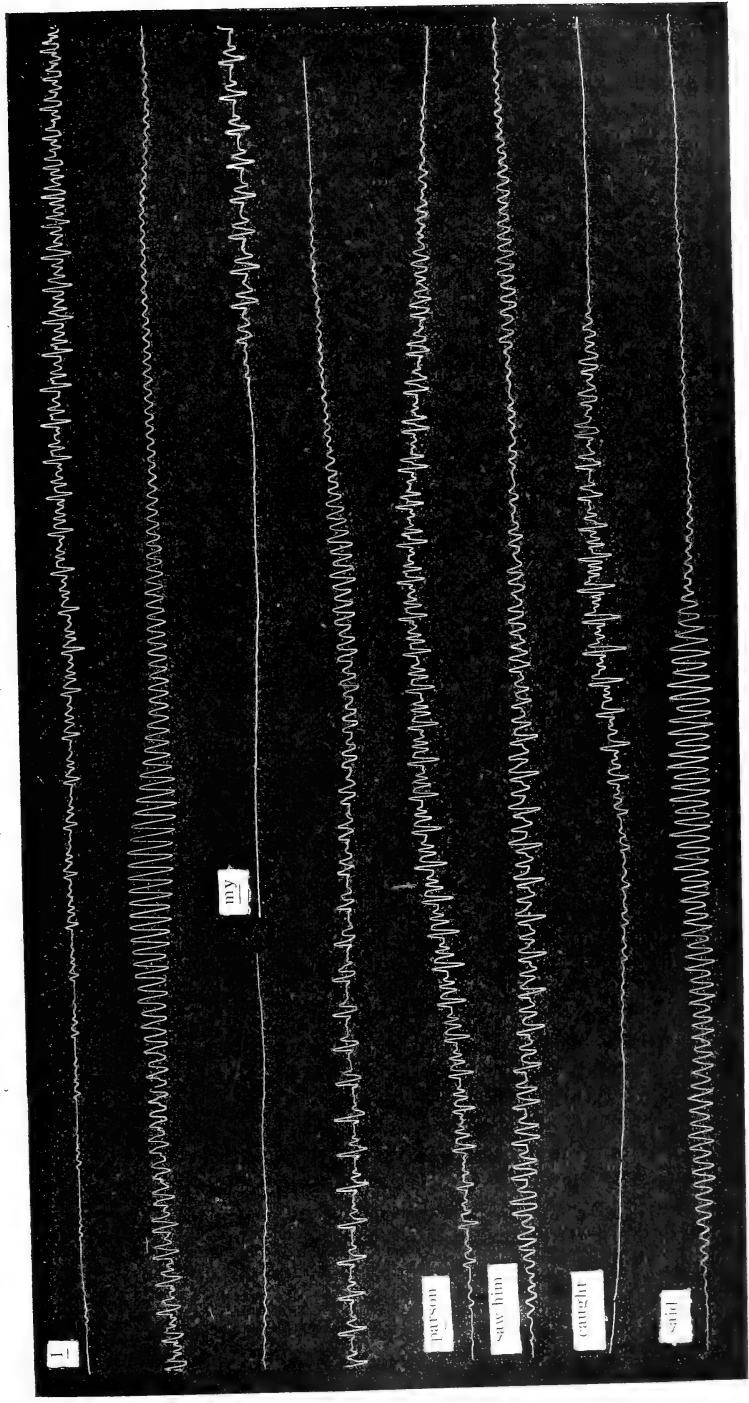

Fig. 1. ($1\text{ mm} = 0.001\text{G}^2$)

It seems clear that these vibrations represent the free vibrations of the air in the mouth cavity aroused by a series of sudden blows and that these sudden blows are due to explosive openings of the vocal cords. In spite of this fact it seems permissible to use the term "resonance vibrations" to include these free vibrations of a cavity aroused by a blow as well as the vibrations of a cavity impressed upon it by a source of continuous vibration.

The tone from the cords results from the succession of strong vibrations that mark off groups. The period of the tone from the vocal cords is represented by the distance from the strong vibration at the beginning of each group to the strong one at the beginning of the following group.

The complexities of the small vibrations indicate the presence of several partial tones. These complexities change steadily from the beginning of the vowel onward as the pitch rises in a way to indicate the presence of at least the following partials: 1, the fundamental cord tone consisting of a series of explosions rising from a period of 0.017^s (59, frequency) to one of 0.0052^s (192, frequency); 2, a constant resonance tone of 0.0034^s period (294, frequency); 3, a constant resonance tone of 0.0013^s period (769, frequency) and 4, higher resonance tones undergoing change.

The combined rise in pitch and in amplitude seen in the *a* is found in all cases of *I* that have been examined.

The minor complexities in the vibrations disappear at about one-third of the distance from the left on the second line in the figure. At the same time the amplitude is strongly increased. Shortly afterward the amplitude decreases and finally reaches zero. Throughout the whole latter half the curve has an entirely different character from that of the first half; we are probably quite safe in considering it the curve of *i* in the diphthong *ai*. Throughout the *i* the groups consist of two vibrations, one slightly stronger than the other. The period for a group 0.0052^s (192, frequency) remains constant till near the end, where it lengthens to about 0.0122^s (82, frequency). The resonance vibration forming half of each group remains constant at 0.0026^s (384, frequency) through nearly all of the *i*. Toward the close it still apparently remains at the same period, producing phenomena of interference as the group period is lengthened. The maintenance of pitch till near the end, in spite of the fall in amplitude, occurs in all the cases of *I* that have been examined.

From the curve for *i* it seems justifiable to conclude that the vocal cords emit explosions instead of sinusoid puffs of air here as well as in the *a*. The explosion produces a strong free vibration in the mouth cavity which is followed by another

of diminished amplitude. This would be followed by a third of still less amplitude, just as in *a*, but a new explosion from the cords occurs at just that moment. The coincidence of double the period of the resonance tone with the period of the cord explosions explains the rapid rise in amplitude when the cord tone rises sufficiently to produce the coincidence.

The maximum is followed by a relaxation in the force of breath, but the two tones maintain the same relation for a considerable time. As the sound finally dies away, the cords also relax, both breath and pitch falling together.

In *my* the *m* vibrations are too faint for accurate measurement. The *a* resembles somewhat but not closely the *a* of *I*. The period of the cord explosions remains constant at 0.0074^s (135, frequency) instead of decreasing. The lower resonance tone has a period in the neighborhood of 0.0022^s (455, frequency); it apparently undergoes a slow change from the beginning of the *a* to the *i*.

The last third of the curve somewhat resembles the *i* portion of *I*. There is, however, only a faint rise in amplitude, and the *i* portion is very brief. The vibrations in this portion are in groups of three; the groups have a period of 0.0074^s (135, frequency) constant to the end. The vibrations within the group have a period one-third that of the group itself, indicating a constant resonance tone of 0.0025^s (400, frequency).

In the *a* of *parson* the cord tone rises from a period of 0.0090^s (111, frequency) to one of 0.0072^s (139, frequency) and falls again to the pitch from which it started. There are indications of a constant resonance tone of 0.0022^s (455, frequency) and of higher tones with changing periods. In respect to the pitch of the lowest resonance tone there is more agreement of this *a* with that of *my*, yet the form of the curve resembles that of *a* in *I* more closely than that in *my*. The peculiarity of *my* seems to lie chiefly in the suddenness with which the vibrations within a group fall in amplitude after the initial strong vibration. In both *parson* and *I* the *a*-vibrations die away less quickly. Such differences may perhaps find their explanation either in the greater friction in the free vibratory movement in the mouth (less rigidity of the walls?) or in the sharper character of the cord explosions in the case of *my*.

The curve for *â* in *saw him* indicates a quite different vocal action from that present in *a*. Instead of a strong initial vibration followed by decreasing ones the earlier portion of the vowel shows groups that contain at least two strong vibrations. It is presumably the case that the cord explosions are of a more gradual character or else that the action of friction is much less. Even later in the vowel where there is appar-

ently only one very strong vibration in a group, this probably occurs because the lower portion of the second one is cut off by interference with another partial tone. In amplitude the vowel slowly increases and then decreases.

The cord tone starting with a period of 0.0072^s (139, frequency) remains at this pitch for a time and then falls to 0.0080^s in period (125, frequency.) A lower resonance tone with a period of 0.0026^s (385, frequency) is apparently present.

The last part of the line shows the vibrations for *i*, resembling those for *i* in *ai* of *I* and *my*. There is no *h* in the spoken sounds or in the record. The *m* is just begun where the record is cut off. The grouping in the *i* is in threes. The cord tone of *i* starts with a period of 0.0083^s (121, frequency) and steadily rises to one of 0.0072^s (139, frequency) in the *m*. The lower resonance tone has a period of about 0.0025^s (400, frequency).

The curve for the *â* of *caught* exhibits a decided difference from that for the *â* of *saw*, although both vowels are generally supposed to be the same. The *â* of *caught* shows a quick and strong increase in amplitude followed by a rather sudden decrease. Its pitch is approximately constant. The initial strong vibration of a group is followed by very much weaker vibrations; the vocal action resembles that in *a* rather than in the *â* of *saw*. Yet in the last few groups there is a marked change to a form indicating a condition between that of *â* in *saw* and that of *i*.

The cord tone rises from a period of 0.0074^s (135, frequency) to one of 0.0064^s (156, frequency) but falls again in the last few periods. The lower resonance tone seems to have a period of about 0.0024^s (417, frequency). Other tones of higher pitch are present.

In the *e* in *said* the vocal action is seen to differ essentially from that in *a* or *â* and to resemble somewhat closely that of *i*. There is much less indication of the explosive character of the cords. There are three resonance vibrations to each group. The pitch of the cord tone is nearly constant at 0.0072^s period (139, frequency); the lower resonance tone has a period of 0.0024^s (417, frequency). There are minor fluctuations in the curve that indicate higher resonance tones. The amplitude increases steadily until the vowel is ended rather abruptly by the change to *d*.

The preceding account gives in general the pitch of only the lowest resonance tone in each vowel. A determination for the higher tones would require more elaborate methods. It is probable that the higher tones are quite as important for the vowel characters as the lowest ones. The disagreement in the accounts of various investigators in regard to the tones found

in the vowels arises partly from finding different resonance tones.

The curves in fig. 1 furnish data concerning the physical characteristics of vowels that seem to justify the following conclusions:

1. The movement of the air in the mouth cavity is a free vibration and not a forced one. This is the theory first stated by Willis in 1830.* It was criticised by Wheatstone,† whose overtone theory developed by Helmholtz‡ has been almost universally accepted. This latter theory asserts that the mouth cavity acts as a resonator reinforcing one of the overtones of the vocal cords. The mouth tone must adjust itself constantly to one of the harmonics of the cord tone. The careful measurements of Hermann§ show clearly that the mouth tone remains constant for the same vowel sung on different notes. Hermann's curves were obtained with great care; they give results for sung vowels that are consistent only with the earlier theory. The curves of spoken vowels given in fig. 1 show that the mouth tone is constant even while the cord tone is steadily changing. It follows from these facts that the period of the mouth tone is independent of the period of the cord tone and that there is no necessary relation between the adjustment of the size of the mouth cavity and the tension of the vocal cords. If the period of the mouth vibration is independent, it must be the period of the free or natural vibration.

2. The cord movements in the vowels are of the nature of explosive openings and not of the usual vibratory form found in most musical instruments. According to Hermann, it is an essential of the vowel character that the cords should emit a series of puffs separated by intervals of silence. Such a series would be similar to that emitted by a siren with a series of holes passing before an air jet. This series of puffs is very evident in the first part of the *I* in fig. 1; there is no suggestion of a vibratory movement of the cords. This peculiarity has led to the queer statement that talking machines are deaf to the cord tones. The failure of vowel machines, like that of Helmholtz, to produce perfect vowels by adding simple tones together, and of harmonic curve tracers, like that of Preece and Stroh, to produce more than distant resemblances to vowel curves by compounding sine waves, is a natural one, if the cords do not make vibratory movements.

This view is also supported by the following facts. A vibratory body, whatever its natural period, when acted upon by a force varying harmonically, must itself vibrate with the period

* Trans. Camb. Phil. Soc.

† London and Westminster Review, 1837.

‡ Lehre v. d. Tonempfindungen.

§ Archiv f. d. ges. Physiol., vols. xlv, xlvii, xlvihi, liii, lviii, lxi.

of the impressed force. If the variations of the acting force are of the nature of a sum of harmonics, the period impressed will be that of one of them. If the cords acted like most musical instruments, their vibrations could be properly treated as the sum of a series of harmonics and the mouth tone would necessarily be one of them. "The *forced* vibrations of the mouth cavity can include only harmonic partials of the larynx note."*

It has been shown above that the mouth tone is inharmonic to the cord tone and that it is a *free* vibration. It follows that the cord vibrations are not of the nature of the sum of a series of harmonics. Hermann draws the conclusion that the vibrations of the cords must be of an explosive nature, to which a harmonic analysis is not applicable. To this it has been answered that when the mouth tone is high in relation to the cord tone, the treatment by analysis into a series of harmonics may not be applicable and that this may not disturb the usual views of resonance, but that, when the natural period of the mouth cavity is not distant from the cord period, the cavity must vibrate with a period that is harmonic to the cord period.† Rayleigh apparently does not regard the deductions of Hermann as conclusive. The issue seems clearly presented in the curves of the nature of those in fig. 1. In the first part of the vowel *a* in *I* the cord tone rises steadily till it is only about a duodecime below the mouth tone, and yet the mouth tone remains constant with no attempt at becoming one of the harmonics of the cord tone. Continuing along the curve, we find that beyond the middle the period of the mouth vibration is somewhat lengthened while that of the cord vibration continues to become shorter. In the latter third of the curve the vibrations are clearly in groups of twos, alternate ones being stronger. As the change from the *a* portion to the *i* portion is continuous without anything like a break that might indicate a sudden readjustment of the cords, each pair of waves in the *i* portion must belong to one cord vibration and each single wave must represent a mouth vibration. The mouth period is slightly less than half the cord period. Thus even when the two tones used in forming the vowel *i* are nearly in the relation of a simple musical interval, there is no accommodation of one to the other. It is to be noticed that the first vibration of each pair in the *i* is stronger than the second, just as in the *a* portion the first vibration is stronger than the following ones. It is worthy of remark that the relative strengths are not the same in the two cases and that the character of the explosion from the cords must differ to some extent in the two halves of *ai*. Similar conditions are found in the other vowels.

* Rayleigh, Theory of Sound, § 397.

† Rayleigh, § 397.

Such relations between the cord vibrations and the mouth vibrations are incompatible with the theoretical requirements on the supposition of the harmonic nature of the cord vibration. The conclusion seems quite justifiable that the cords emit a series of puffs, or explosions of air, instead of vibrating regularly back and forth.

These conclusions are apparently inconsistent with the treatment of the vocal apparatus as a reed pipe; various suggestions for a modified treatment are gathered into the following theory:

The vocal bands, including the vocal muscles (thyroarytenoid) and their ligamentous edges, vibrate by compression and not by movement in the axial direction of the larynx. Even acoustic strings set in action by a blast of air vibrate transversely to the current of air;* in the vocal bands this would result in a compression movement. The vibration of the vocal bands may be like that of a cushion struck by a billiard ball and not like that of a membrane. The possibility of such a cushion-action seems to have been first suggested by Ewald.† The suggestion is favored by the fact that the vocal bands are not of a nature and shape to readily vibrate transversely. The true shape is indicated in fig. 2; the usual diagrams in works outside those specially pertaining to laryngology give a quite erroneous idea of them. The vocal bands *aa* suggest a pair of cushions suitable for compression, and not a pair of membranes. When the bands are closed by the action of the cartilages, the air is retained behind them until the pressure is great enough to force them open, the pressure being regulated by the tension of the vocal muscles constituting the bands. When they have been forced apart to emit the puff of air, they close again and remain closed until the pressure is again sufficient for opening them.

The curious relation between the rise of pitch of the cord tone and the increase in the force of the puff, as shown in the first part of the *I* curve in fig. 1, would naturally result from a gradual tightening of the vocal muscles. In general, it may be said, there will be a relation between period and amplitude in a cord tone as long as the breathing pressure remains constant.

Such a theory would be in accord with the most carefully determined experimental results and there seem to be no serious objections to it from what is known of the action of vibrating bodies.



* Rayleigh, Phil. Mag., 1879, p. 161.

† Heymann's Handbuch d. Laryngologie u. Rhinologie, 180, Wien 1893

ART. XXV.—*Note on the Behavior of the Phosphorus Emanation in Spherical Condensers*; by C. BARUS.

1. IN my earlier experiments* it was assumed that conditions could be so chosen (swift air current, highly active ionizer, etc.), as to make the decay of ionization within the medium a negligible factor. Such an assumption is naturally precarious, and the following experiments with spherical condensers were planned with particular reference to the term ignored. In using this apparatus, moreover, no ions can escape, which is the case, for instance, with plate condensers.† The results show, I think, that decay due to the mutual destruction of the ions is not in evidence; that on the contrary, the enclosed air at a distance from the phosphorus grid behaves either as though it contains a greater number of ions than those which reach it from the source, or otherwise, as if in strong fields the number of ions is not as large as Ohm's law requires.

2. The closed spherical condenser was installed with its

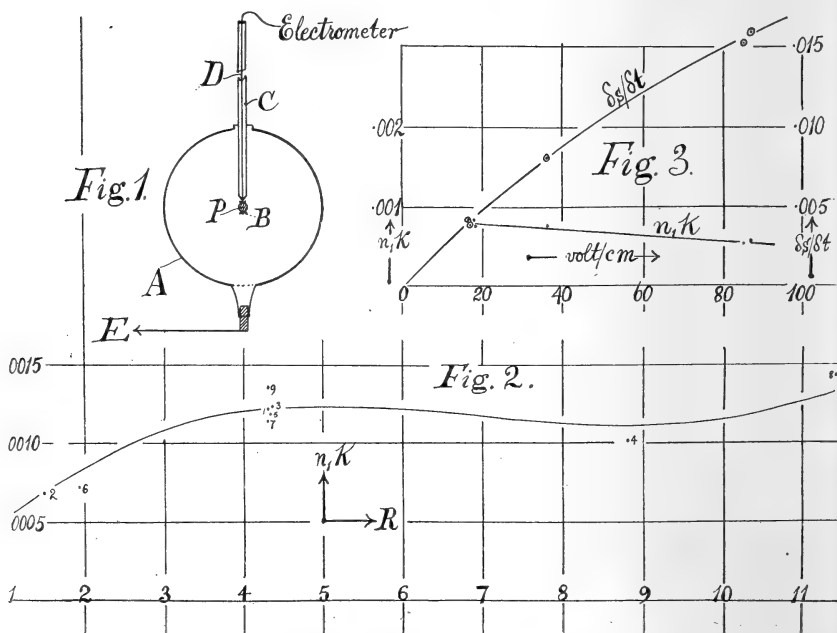

* Science, xi, 201, 1900; Phys. Review, x, p. 257, 1900; This Journal, March, 1901.
 † Science, March, 1901.

outer surface* permanently put to earth and its inner surface (always very small) in contact with the needle of a charged electrometer, the intervening space being air ionized by a piece of phosphorus about as large as a split pea, suspended at the center.

A series of König's resonators seemed very suitable for the purpose, as they were at hand in a large range of diameters, and fig. 1 shows the adjustment. *A* is the brass resonator, put to earth by the plug and wire *E*, *B* the curl of wire making the inner face of the condenser, and holding the spherule of phosphorus, *P*. *C* is an insulating glass tube about 30^{cm} long, through which the electrical charge is conveyed along a thin copper wire *D*, to be dissipated in the condenser. *B* is thus in contact with the electrometer, and the capacity of the latter, about 90^{cm}, is always large as compared with the condensers (less than 1^{cm}).

3. Leaving the results as a whole to be discussed elsewhere, I will merely instance the following example chosen at random from a large number. In order to estimate the variability of the ionizing source (due to temperature, environment and other conditions which I have not yet made out) condenser *K6* was treated as a standard and observations made with it before and after those for each of the other condensers. The observations for a single condenser consisted of 6 potential readings (scale parts suffice) taken at intervals of one minute. From these I computed the constants in the last column, to be presently explained.

4. If, as in my preceding experiments, the motion of the ion is supposedly independent of the potential difference, V , and of the concentration (n particles per cub. cm.), or if the effect of the potential gradient, V/R , is but a negligible contribution to the number of ions which are absorbed by the (outer) surface of the condenser distant from the emanating phosphorus, then the accumulation in an elementary spherical shell of radius r will be $4\pi k \cdot d(r^2 n) / dr \cdot dr$, per second. Here k is what I have called the absorption velocity; kn denotes the number of ions absorbed per square cm. per second. The decay within the element is per second, $k'n^2 4\pi r^2 dr$, if k' be the number vanishing per second per cub. cm., when $n = 1$. Hence $d(r^2 n) / dr = (k'/k)n^2 r$; or if n_1 be the number of ions at a distance 1 from the center, $r((k'/k)n_1(1-r) + r) = n_1/n$. If decay be ignored, $k' = 0$, and $n_1 = nr^2$, which as is otherwise clear, is independent of k also.

Now the electric conduction is dependent on the number of ions which reach the external shell ($r = R$), or $-dQ/dt = -CdV/dt = 4\pi R^2 U \cdot V/R \cdot ne$, where Q denotes the charge, C the

* In the present instance left open around the stem. The closed condenser is liable to introduce hurtful conduction where the stem enters.

TABLE.—Leakage of spherical condenser with a medium ionized by phosphorus. $V_0 = 40$ volts.

No. Radius R Field.	Time t .	Deflection s .	$10^5 \times n_1 k$.	No. Radius R Field.	Time t .	Deflection s .	$10^5 \times n_1 k$.	No. Radius R Field.	Time t .	Deflection s .	$10^5 \times n_1 k$.
K6 4.3 cm. 9.3 volt/cm.	29 ^m	6.60	117	K3 8.8 cm. 4.5 v/cm.	53 ^m	6.55	116	K6 11.7 cm. 3.4 v/cm.	76 ^m	6.60	116
	60	.40	121		60	.40	103		60	.40	78
	120	.15	124		120	.30	86		120	.20	144
	180	5.90			180	.20			180	5.90	
	240	.70			240	.10			240	.65	
300	.45		300	.05		300	.40				
K. 1.5 cm. 27 v/cm.	37 ^m	6.60	86	K6 4.3 cm. 9.3 v/cm.	61 ^m	6.65	104	K6 9.3 v/cm.	84 ^m	6.55	156
	60	.05	77		60	.45	120		60	.40	136
	120	5.60	75		120	.25	132		120	.30	137
	180	.20			180	.00			180	.20	
	240	4.90			240	5.75			240	.10	
300	.55		300	.50		300	.00				
K6 4.3 cm. 9.3 v/cm.	45 ^m	6.60	116	K17 1.95 cm. 20.5 v/cm.	69 ^m	6.60	77	K6 4.3 cm. 9.3 v/cm.	93 ^m	6.55	127
	60	.35	122		60	.20	69		60	.30	132
	120	.10	127		120	5.90	73		120	.10	146
	180	5.90			180	.60			180	5.80	
	240	.65			240	.35			240	.55	
300	.40		300	.05		300	.30				

capacity of the condenser, and where U is the mutual velocity of the ions and e the (average) charge of each. Since $n = n_1/r^2$, $-d(\log V)/dt = (4\pi e U/C)(n_1/R)$. Here the first term is obtainable from the observations directly, $4\pi e U/C = K$ is a constant, n_1 expresses the waning intensity of the ionizing phosphoric source, and R is the external radius of the condenser selected. The equation therefore admits of being tested. The integral value is $V = V_0 e^{-(4\pi e U n_1/CR)t}$, which in a general way suggests the observations. In the above table $n_1 K$ is computed for each case.

5. I have also represented the quantity $n_1 K$ graphically in the chart, fig. 2, to show the outstanding dependence on the radius R of the condenser, obtaining a curve which here as elsewhere is sinuous in outline but ascends from low values of the radii of the condensers. The situation is referable to the fluctuation of the intensity of the phosphorus ionizer, and to unavoidable conduction. To show this I have numbered the points in the order of measurement: thus point 8, which is too high, corresponds to a rise in the standard from point 7 to point 9; point 4 being too low, to a fall from point 3 to 5; etc., remembering that the standard affords a means of suggesting the reason of the discrepancy, not of eliminating it. Waiving further discussion, I will state my conclusion, that the quantity $n_1 K$ increases from the values for small condensers rapidly to constant values for larger condensers, attaining the latter when the radius exceeds 4 cm. Since $K = 4\pi e U/C$ contains no variables, it follows that n_1 , the number of ions at 1 cm. from the center is relatively greater for larger than for smaller condensers, though the limit is soon reached as stated. But as the initial potential difference, V_0 , is the same throughout (40 volts), the fields for the smaller condensers are greater. Hence without stopping to reconstruct the above theory, the general inference of §1 may be asserted. The experiments of the next paragraph, however, in which larger condensers are used and strong fields applied directly, showed me that in my smallest condensers the current may be 20 or 30 per cent too small. This is due to the easy access of air and the loss of ions around the stem (fig. 1), which with small condensers is necessarily a much more serious discrepancy than with large condensers. It follows that the initial parts of the curve, fig. 2, are considerably too low. Indeed it seems to me a more probable inference, that with an ideal adjustment and a constant ionizer this curve would become appreciably horizontal and $n_1 K$ constant throughout, compatibly with Ohm's law.

6. In addition to the above experiments with series of condensers, I completed a number of correlative tests by varying the potential difference of the same condenser from 20 to 300

volts. Three condensers (K2, $R = 11.7$; K4, $R = 6.5$; K8, $R = 3.5$ cm.) were treated in this way, admitting of electric fields from 2 to 90 volts/cm. The observations were made as above in sextuplets, and from these both the current, ds/dt , (arbitrarily in scale parts of the electrometer), and the constant, n_1K , were computed. The results however, owing to the variability of the phosphorus (whether due to this method of applying electric fields or to incidental causes, I do not know), are complicated, particularly in the case of weak fields. It will suffice therefore to give a graphic digest (fig. 3) of the data for K8, the smallest condenser selected, as this admits of the greatest variation of field. The curvature of the line ds/dt , shows that Ohm's law is not quite obeyed as the fields grow stronger; i.e., the number of ions is not indefinitely large†. Nevertheless the limit is as yet far off, showing that but a small part of the ions convey current even in fields of 100 volt/cm. It happens moreover, that the phosphorus for these experiments showed weak ionizing power. Usually the ionization was 50 per cent stronger and the curves more nearly straight. In case of K2 ($R = 11.7$ cm.), the line ds/dt , observed up to 20 volt/cm was quite straight, the condenser being the largest, admitting of best adjustment.

Corresponding with the values of ds/dt , the curve n_1K shows a downward slope and therefore a decreasing number of available ions (n_i) as the fields increase in intensity from 20 to 100 volts per cm. The value of n_1 computed from figure 2 ($n_1K = .00120$, whence $n_1 = 4 \times 10^4$ if U is about 1 cm/sec. and e about 2×10^{-19} coulombs) agrees very well with the value given in Science (March, 1900, $n_0 = 8 \times 10^4$) and obtained for plate condensers under the same limitations.

Brown University,
Providence, R. I.

* Science, xi, p. 4. 1900.

† In § 4 e is the average charge per particle. In reference to electrons a coefficient is thus implied; for all that I showed in my experiments with tubes is that the number of ions conveying current is proportional to the total number present.

ART. XXVI.—*The remarkable Concretions of Ottawa County, Kansas*; by W. T. BELL.

SITUATED on the side of a low hill, near Pawnee Gap, about three miles from Minneapolis, in Ottawa County, Kansas, is a group of curious rocks, that have excited the wonder of the ignorant and the speculations of many who call themselves geologists.

1



Locally, this deposit, consisting of more than fifty detached specimens, is known as "Rock City"; and scattered masses of the same formation may be seen at various places on the higher land in the neighborhood, especially at the locality known as The Cliff.

As will be seen from the illustrations, these rocks are for the most part nearly spherical in shape, and some of them are more than twelve feet in diameter.

They have been embedded in, and most of these specimens still rest on, a coarse soft sandstone, of a light color, which wearing away, has left these harder bodies exposed. In some cases the supporting sandstone has been so nearly removed as to allow the rocks to topple over; while other pieces have become fractured, and portions have fallen or slid from the part that still retains its upright position. These fractures are not on flat planes, but are conchoidal, and nearly all horizontal; the few that approach a vertical direction being zigzagged and interrupted.

In the sandstone under some of these masses is a band or layer five or six inches in thickness, of a dark reddish color,

resembling iron; and these saucer-like layers are separated from the spheres above by an interval of several inches, as shown in fig. 2, where a portion of the material that once filled this space has been removed.

These titanic marbles have been weathered to a dull gray color, and in their crevices several species of small ferns are growing; probably *Pelleas* and *Cheilanthes*.

Where freshly broken, these rocks are almost white, have a crystalline appearance, and by artificial light, when held in certain positions, reflect a silvery luster. Treated with hydro-

2

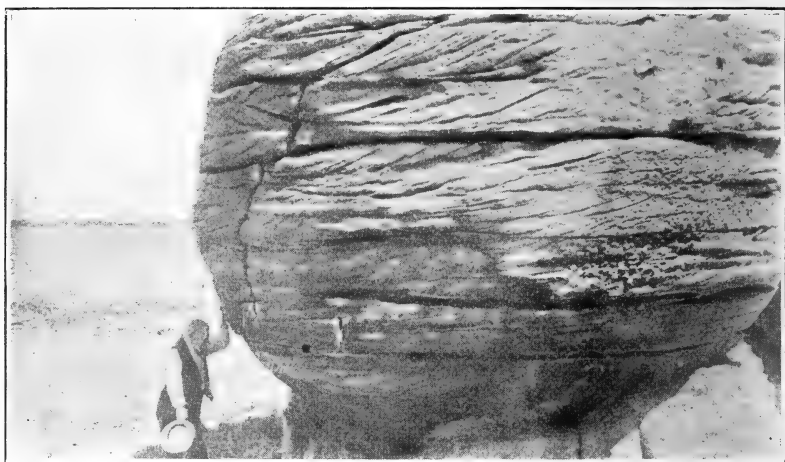

chloric acid in a test tube, fragments effervesce freely, staining the acid yellowish, and leaving only a few particles of what seems to be silica.

One writer claims that these are glacial boulders; but it seems unnecessary to make use of any argument to refute this view. A state geologist of Kansas has announced that they are corals but adduces no proofs; possibly for the reason that there are none. If he had visited The Cliff, and noted the hemispherical cavity near its top, from which one of these round masses had been dislodged, and had then gone below, and carefully examined the mass itself, and tested a portion of it, he would have found that it was identical with the larger pieces at Rock City; and a more rigid search there would have failed to show any coralline structure, but would have shown that they are concretionary masses of crystalline limestone, most of them still in place.

In Hitchcock's *Geology*, an illustration and brief notice is given of similar masses in shale, found near Muscatine, Iowa.

Franklin, Pa.

SCIENTIFIC INTELLIGENCE.

I. CHEMISTRY AND PHYSICS.

1. *Ammonium Bromide and the Atomic Weight of Nitrogen.*

—A portion of the classical work of Stas upon atomic weights has been repeated by ALEXANDER SCOTT at the Davy Faraday Research Laboratory of the Royal Institution in London. He has worked chiefly upon the ratio between the weights of silver and ammonium bromide. The materials used were prepared in various ways with the greatest care, and it seems that the silver and ammonium bromide used were even purer than the products employed by Stas. The equivalent of ammonium bromide, compared with silver as 107.93, from the average of a number of closely agreeing results, was found to be 97.995, while Stas found 98.023. The difference, amounting to about one part in 3000, is apparently most satisfactorily explained by supposing that Stas's ammonium bromide contained a little impurity, probably platinum. Scott has made also two determinations of the equivalent of ammonium chloride, and in this case also the result, 53.516, is slightly lower than that of Stas, 53.532. When the molecular weight of ammonium is calculated from Stas's value for ammonium bromide and ammonium chloride, the results, 18.077 and 18.075, agree extremely well, but from Scott's results the numbers, 18.059 and 18.040, show a much less satisfactory agreement. This discrepancy possibly points to the presence of an impurity in the silver used for the present investigation, but this supposition is not very probable because Scott's ratio of silver to bromine, as shown by the weight of silver bromide produced by a given weight of silver, agrees exactly with that found by Stas. Further work will be required to explain the matter.—*Jour. Chem. Soc.*, lxxix, 147.

H. L. W.

2. *The Combustion of Gases.*—The remarkable effect of small quantities of propylene and other hydrocarbons in preventing the explosion of detonating gas, which was observed by S. TANTAR, was mentioned in a recent number of this Journal (this vol. p. 86). The same author has now published some further observations upon the subject.

A mixture of 1500^{cc} of detonating gas ($2\text{H}_2 + \text{O}_2$) with 250^{cc} of propylene, C_3H_6 , was placed in a gas-holder. Upon allowing the mixture to escape, it burned quietly in the air with a luminous flame. When it was passed through a tube which was heated to redness at one spot, the gas was ignited at the hot place and the resulting flame moved slowly toward the inlet end of the tube and was extinguished at about 20^{cm} from the point of ignition. This was repeated again and again as unburnt gas arrived at the heated spot, but the phenomenon varied more or less according to the rate of flow of the gas and the length of the heated part of

the tube. The products escaping from the tube contained no carbon dioxide, but consisted chiefly of carbon monoxide and hydrogen, with a little propylene and oxygen. The original mixture of gases could not be exploded by an electric spark, but combustion gradually took place on continued sparking. When 28°C were thus treated until no further change in volume took place, there remained 25.15°C. The original gas contained 4°C of propylene, but only enough oxygen to burn 2.7°C to carbon monoxide and water according to the equation,

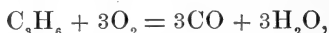

from which it is to be observed that, since the water is condensed, the contraction would correspond to the volume of the propylene thus burnt. The calculated contraction 2.7°C corresponds very closely with that actually observed, 2.85°C, so that it is evident that very little of the hydrogen in the mixture was oxidized.—*Zeitschr. physikal. Chem.*, xxxvi, 225. H. L. W.

3. *A Peculiar Blue Color produced when Potassium and Sodium Sulphocyanides are Heated.*—It has been noticed by W. B. GILES that the sulphocyanides under consideration become intensely blue when they are heated to low redness. Upon cooling, the color disappears, and it may be repeatedly produced with the same sample if care is taken not to decompose the substance to too great an extent. If the salts contain much alkaline carbonate or hydroxide as impurity, the color does not make its appearance. The author is unable to explain fully the cause of the reaction, but believes that it is in some way connected with the liberation of sulphur by the decomposition of the sulphocyanide. He finds, however, that the addition of an excess of the sulphur destroys the color.—*Chem. News*, lxxxiii, 61. H. L. W.

4. *A Method of obtaining Crystals of difficultly Crystallizable Substances.*—A. RÜMPLER gives the following method of crystallizing substances which are soluble in water, but insoluble in alcohol: The substance is dissolved in water, alcohol is added until a slight turbidity is produced, when the latter is removed by filtration or the addition of a few drops of water. The clear solution is then placed in a desiccator over quick-lime. Since the lime absorbs water, but not alcohol, the liquid becomes stronger in alcohol as evaporation goes on, instead of losing alcohol more rapidly than water, as would be the case in evaporating in the air or over sulphuric acid, this leads to the crystallization of the substance in case it is capable of forming crystals.—*Berichte*, xxxiii, 3474. H. L. W.

5. *The Elimination of Methane in the Atmosphere.*—It is well known that considerable quantities of methane, or marsh gas, are continually passing into the atmosphere, particularly from the fermentation in the absence of air of substances containing cellulose. Since there is no considerable accumulation of this gas in the air, it is evident that it must be removed therefrom in some manner. V. URBAIN has studied this matter and has found in the

first place that the gas is very slowly attacked by strongly ozonized air, so that the theory of oxidation by atmospheric ozone is very improbable. He has also examined the action of living plants upon air containing small quantities of the gas. The plants were hermetically sealed in glass vessels containing moistened sand for the roots and about 1300^{cc} of air mixed with a known volume of methane, which varied from $\frac{1}{50}$ to $\frac{1}{12}$ of the total volume. After exposures of from six to eleven days the methane remaining in the air was determined by combustion. It was found that from 20 to 82^{cc} of methane were absorbed by the plants, quantities which usually represented much more than half of the amounts taken. The author believes that he has demonstrated that it is vegetation which prevents the accumulation of methane in the atmosphere.—*Comptes rendus*, cxxxii, 334. H. L. W.

6. *An Introduction to Modern Scientific Chemistry*, by Dr. LASSAR-COHN. Translated from the second German Edition by M. M. PATTISON MUIR. 12 mo., pp. viii, 348. New York, 1901. (D. Van Nostrand Company.)—This book presents the subject in the form of popular lectures suited for university extension students and general readers. The difficult task of putting scientific elementary chemistry into an interesting form has been very satisfactorily accomplished, and the work will be useful, not only to beginners in chemistry, but also to teachers who are studying the methods of presenting the subject. A good feature is the introduction of a simple treatment of organic chemistry which is more comprehensive than is usual in works on elementary chemistry, and even such subjects as the isomeric benzene derivatives, the asymmetric carbon atom, and the alkaloids are briefly considered. The short discussion of agricultural chemistry is particularly well done, and there are many other excellent features. Where so much has been crowded into a small space, it is hardly fair to notice omissions, but it seems that the modern theories of solution should have received mention. Certain equations, however, that are given, for example,

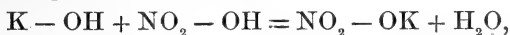

make it seem probable that the author is not in sympathy with the ionic hypothesis. Very few errors in regard to facts have been noticed, but a mistake is made where it is stated that in gun cotton, $C_6H_7N_3O_{11}$, there is plenty of oxygen to burn the carbon to carbon dioxide, and the hydrogen to water. The book is supplied with 58 illustrations by the author. Some of these show a little weakness in perspective, but they answer their purpose admirably and bring out clearly the important points.

H. L. W.

7. *Ausgewählte Methoden der Analytischen Chemie*, von Prof. Dr. A. CLASSEN. Erster Band. 8 vo, pp. xx, 940, Braunschweig, 1901, (Vieweg und Sohn). This work is intended as a guide for the practical analytical chemist. The present volume is upon the metals. It takes up their qualitative reactions as well as their

quantitative determination by gravimetric, volumetric and electrolytic methods. Special attention is given to cases of technical importance, and to a large number of rare elements. The book will be of great value to analytical chemists generally, as it contains descriptions of many processes that previously have not been readily accessible, and also gives much excellent advice in regard to the selection of methods. The author does not claim to include every reliable analytical method, as he has generally given preference to those with which he is familiar. It is surprising that the use of the Gooch crucible is not generally recommended in this book, for, in advising the use of tared filter papers for many things, and in neglecting the uses of this accurate method of weighing precipitates, the author, in common with most German chemists, is a quarter of a century behind the times.

H. L. W.

8. *Radiation Law of Dark Bodies.*—F. PASCHEN enters into a discussion of a theoretical law stated by Wien, which is deduced from thermo-dynamical considerations. Paschen's observations were made with prisms of fluor-spar, through which the rays were successively reflected by means of mirrors; and a bolometer was used to detect the heat rays. Wien's law is shown to hold within certain regions, and the analogous law of Planck, is found to hold more generally over the whole region of the observations. An article by Wien in the same number of the *Annalen* answers a criticism of Planck in regard to the fundamental assumptions of Wien.—*Ann. der Physik*, No. 2, 1901, pp. 277-298; pp. 422-424.

J. T.

9. *Unipolar Induction.*—Most physical cabinets contain an apparatus to illustrate the rotation of a magnet about a current which is conveyed axially through the magnet. This rotation is generally attributed to unipolar induction. A discussion of the reality of the existence of this inductive action has continued through the past two years. Lecher* maintained that the effect is due to the leading-in wires. E. HAGENBACH in a leading article of the *Annalen der Physik*, maintains that the rotation of the magnet is a true phenomenon and falls under Biot and Savart's law, which states that an infinitely long straight current acts upon a magnetic pole with a force which is proportional to the current strength and to the strength of the pole and is inversely proportional to the distance. Laplace proved that a stream element acts upon a magnetic pole with a force which is inversely proportional to the square of the distance, and Biot showed that it is proportional to the sine of the angle which the direction of the current makes with the line connecting both elements.

The author enters into a discussion of Ampère's laws, Grassman's law, and the Biot-Savart law in relation to this experiment.—*Ann. der Physik*, No. 2, 1901, pp. 233-276.

J. T.

10. *Effect of Electricity on Bacteria.*—In a lecture delivered at

* *Wied. Ann.*, lxi, p. 781, 1899.

the Royal Institution of Great Britain, by Dr. ALLAN MACFADYEN, Director of the Jenner Institute of Preventive Medicine, it is stated that there is little or no evidence that electricity has a direct effect upon bacterial life. The effects produced appear to be of an indirect character, due to the development of heat or to the products of electrolysis.—*Nature*, p. 359, Feb. 7, 1901.

J. T.

11. *Electric Convection*.—M. V. CREMIEU has repeated his original experiments with additional precautions, and believes that under the conditions of the experiments of Rowland and Himstedt, electric convection produces no magnetic effect.—*Comptes Rendus*, Feb. 11, 1901.

J. T.

12. *Preservation of Photographic Records*.—Dr. W. J. S. LOCKYER has called attention to the disappearance of feeble photographic impressions during the lapse of time, and speaks of various methods of intensification. Mr. Chapman Jones discusses the subject and shows that the photographic film should consist of pure silver in clean gelatine. Ammonia, ferrous oxalate, and potassium cyanide should not be used. Long washing is insisted upon. Acid fixing baths should not be used. The exposed photographic image should be protected from the air. Prints should be taken from the negatives as soon as possible: for deterioration probably goes on even if the above precautions are taken.—*Nature*, p. 373, Feb. 14, 1901.

J. T.

13. *The Eclipse Cyclone and the Diurnal Cyclone*. The latest publication of the *Annals of the Astronomical Observatory of Harvard College* (Vol. xliii, Part I) contains an interesting paper by Prof. H. HELM CLAYTON on the cyclonic disturbance produced at the time of the total eclipse of May 8th, 1900, as the result of the accompanying fall of air temperature. The circulation of the wind, blowing spirally outward from the center, and the form of the pressure-curve accompanying it, correspond closely to the type of *cold-air cyclone* developed by Ferrel. Special interest attaches to this eclipse cyclone because of the simplicity of the phenomena with which it is connected, the complication due to vapor condensation or conflicting air currents present in the ordinary cyclone being here entirely absent. The results show that a fall of temperature of a few degrees is capable of developing a typical cold-air cyclone in a wonderfully short time. Further, the eclipse cyclone showed no apparent lag due to the inertia of the air, but moved on continuously with the eclipse shadow at the rate of some two thousand miles an hour, being dissipated almost instantly in its rear. Hence the motion has a certain analogy to wave-motion, a given particle of air not moving more than five miles as a maximum during the passage of the eclipse.

In the light of this investigation, the author goes on to show that the double diurnal period long noted in the atmospheric pressure, is probably due to independent diurnal cyclones of the two types recognized by Ferrel, one developed by the cold of night and the other by the heat of day. This theory when closely

examined, furnishes an explanation for various attendant phenomena, for example, a third maximum of pressure in high latitudes in winter, the so-called inversion in the diurnal period near the pole, and other points.

14. *An attempt to show that the earth being a magnet drags ether with it;* by WILLIAM ROLLINS. (Communicated.)—The writer has carried on a series of experiments, designed to show

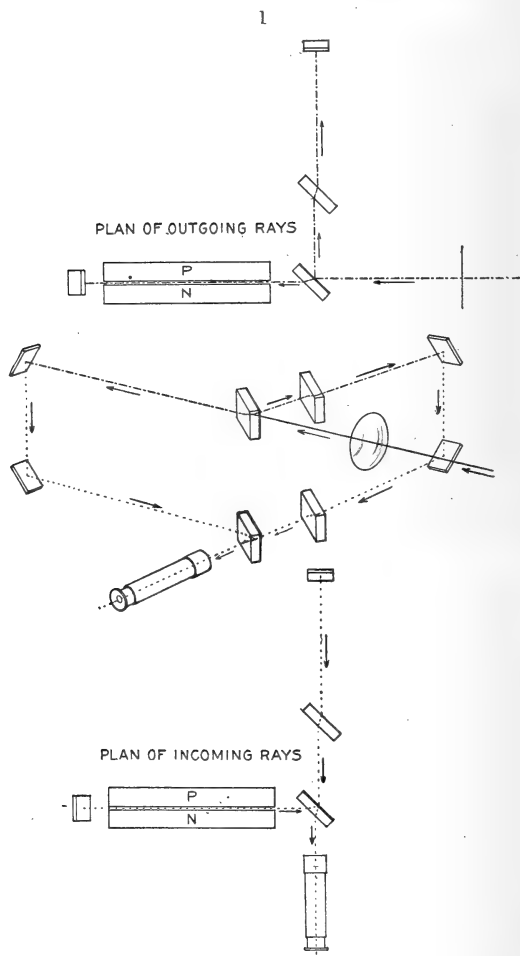

FIG. 1. Plan of Refractometer.

whether a revolving magnet, and hence the earth, drags ether with it. Although the results were not conclusive, one of the methods used is mentioned here, since the refractometer employed is likely

to be useful for other purposes, such as examining the passage of light through solutions at rest or in motion.

The apparatus, as shown in the accompanying figures, consisted of a refractometer in which each half-beam went out and back by different paths. The paths of one half-beam were between two iron disks one centimeter apart which could be rotated in either direction and magnetized by the observer while

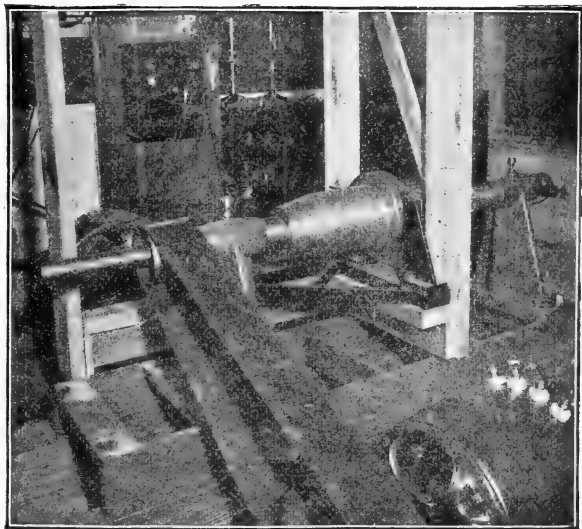

FIG. 2. Refractometer and Revolving Magnets.

examining the fringes in the telescope. A shift of the fringes was observed, but it was impossible to estimate how large a factor instrumental errors were in the result. It is proposed to repeat the experiments later with better apparatus.

15. *On the Presence of Gallium in the Sun.* An investigation has recently been published by W. N. HARTLEY and HUGH RAMAGE, in the Scientific Transactions of the Royal Dublin Society (Volume vii), on the wave-lengths of the principal lines of the spectrum of gallium. The values obtained for the two prominent lines are 4172.214 and 4033.125. These measurements were made on the reversed lines obtained with an arc spectrum of iron containing a large proportion of the residue from ignition of gallium ferrocyanide. After a minute examination of the solar spectrum, the conclusion is reached that this element, which has been shown by the same authors to be widely distributed in minute quantities in the crust of the earth, to be present in the pumice and volcanic dust from New Zealand and Krakatoa and associated with nickel and cobalt in iron meteorites, is also present in the sun. The solar lines determined

as 4172·122 and 4033·112 are probably identical with the gallium lines above noted. The proportion of the element present is probably small as compared with that of iron, the solar spectrum being fairly imitated by the arc spectrum of blast furnace iron containing one-thirty thousandth of its weight of gallium.

II. GEOLOGY.

1. *Geology of the Boston Basin*; by WILLIAM O. CROSBY. Vol. I, Part III. The Blue Hills Complex. Boston Society of Natural History. Occasional Papers IV; pp. 289-694, 24 plates and maps, 24 figures.—The Blue Hills Complex is an area of granitic rocks and Cambrian strata which constitutes the highest remnant of the New England peneplain to be found on the Atlantic Coast line south of New Hampshire. The Cambrian strata are calcareous slates and belong both to the Olenellus and the Paradoxides zone. At some time not later than the Devonian these Cambrian strata were invaded by igneous rocks. The igneous types include granitic phases of one parent batholite; intrusive diabases, quartz porphyries and felsites; extrusive apophyllites. The theory of formation of the Complex is given by Prof. Crosby as follows: The magma from which the granitic rocks were crystallized was produced by the fusion of the floor upon which the Cambrian strata were originally deposited. "This fusion, however, only extended up to a certain uneven surface, which surface now constitutes the demarcation between the granitic series and the Cambrian. Above this surface or upper limit of fusion the Cambrian formations retained their stratiform or bedded disposition and rested as a crust of hard and brittle rocks upon the magma, subject to its metamorphic influences. There is abundant evidence that while resting upon this plastic magma the crust was violently disturbed, folded, crumpled and in places shattered." The closing event in the development of the hard rocks of the Blue Hills Complex was the making of an extensive series of basic dikes.

In addition to the study of the petrography and general geology of the region (pp. 325-542), the surface geology has been mapped and described by Prof. Crosby (pp. 542-564) and a special paper is added by A. W. Grabau on "Lake Bouvé," an extinct glacial lake of large extent in the southern part of the Boston basin. The last chapter in the book is also by Dr. Grabau and deals with the paleontology of the Cambrian terranes of the Boston basin. The fossils are described in detail and figured (pp. 614-694). Unfortunately the book has been printed with no table of contents and no index. H. E. G.

2. *The University Geological Survey of Kansas. Conducted under authority of the Board of Regents of the University of Kansas.* Vol. VI. Paleontology. Part II. Carboniferous and Cretaceous. S. W. WILLISTON, Paleontologist. 1900. Pp. 1-516; plates I-LXXIII.—The following three papers are included in this

volume: Part I, "Carboniferous Invertebrates," by Mr. Joshua W. Beede, is a doctorate thesis, in which descriptions and figures of all the species in the writer's hands are given, none of which appear here for the first time. Several of the species were originally described by the author in vol. viii of the Kansas University Quarterly. The paper makes a satisfactory illustrated catalogue of part of the known Carboniferous species of the State.

In the second paper, Prof. Williston makes a definite contribution to our knowledge of the very unsatisfactory, but still important, group of Cretaceous teeth of Selachians and Pycnodonts.

The third paper, by Mr. Alban Stewart, is the report of a thorough investigation of a valuable collection of specimens representing the Teleosts of the Upper Cretaceous, in which detailed descriptions and measurements are given of the specimens in hand. At the close, the author has tabulated the known range of American Cretaceous genera of Teleosts, and, further, has presented a table of genera of Teleost fishes from the Upper Cretaceous of various parts of the world.

The volume is the sixth of the series of volumes prepared by the University Geological Survey of Kansas, which are intended to be manuals for the use of students and the people of Kansas, rather than pure records of new discoveries. w.

3. *The Orange River Ground-Moraine.*—The subject of the glaciation of South Africa by land ice is one which has been often discussed, and about which various opinions have been expressed. An important contribution has been recently made by A. W. ROGERS and E. H. L. SCHWARZ, in vol. xi of the Transactions of the Philosophical Society of South Africa (September, 1900). They describe a peculiar conglomerate which covers a wide area in the divisions of Prieska and Hopetown in the northern part of Cape Colony. This is regarded as probably continuous with the Dwyka conglomerate of the southern Carroo, which has been thought to be of glacial origin; their exact relation, however, is uncertain. The Prieska conglomerate has in part a distinct till-like character; in part it seems to be stratified, but it carries large numbers of scratched pebbles and boulders. The maximum thickness is estimated as some hundreds of feet, although the absence of sections at many localities leaves this in doubt. At one point the thickness beneath the shale exposed is only thirty feet; but the suggestion is made that the shale may have originally lain between two bands of conglomerate. The rocky surface underlying the conglomerate, usually quartzite or granite, shows at several localities an unmistakably glacial character, which is well brought out in a series of plates accompanying this article. The surface of the quartzite, for example, is smooth and rounded with distinct striæ having a general trend of N.N.E. to S.S.W.; this is on the gently inclined northern slopes of the mounds. The southern sides, on the other hand, which are like the roches moutonnées of Switzerland, are rough and

unscratched. The Prieska conglomerate passes under the so-called Kimberley shales or under the lowest sheets of dolerite at the bottom of the shales. No evidence was found to support the idea of Greene that the Kimberley shales rest upon the denuded surfaces of Dwyka and Ecca beds.

4. *The Founders of Geology*; by Sir ARCHIBALD GEIKIE. Pp. 297. Baltimore, 1901 (Johns Hopkins Press).—The highly interesting, and permanently valuable, course of lectures delivered by Sir Archibald Geikie at Baltimore in 1897 have recently been published in attractive form. As is well known, these lectures formed the first of the series of the George Huntington Williams Memorial Lectures on the Principles of Geology, established through the generosity of Mrs. Williams, under the auspices of the Geological Department of the Johns Hopkins University. A second series of lectures was delivered a year since, by Prof. W. C. Brögger (this Journal, June, 1900, p. 456).

5. *Das Gesetz der Wüstenbildung in Gegenwart und Vorzeit* von JOHANNES WALTHER. Pp. 175 with 50 illustrations. Berlin, 1900 (Dietrich Reimer).—Some years since, an interesting volume was published by the present author on Denudation in the Desert (this Journal, xlii, 177, 1891). He has now taken up the allied subject of the formation of desert regions both at present and in the past. He notes that the problem of the desert in general is involved in that of the history of regions having no drainage outlets; for although it is not true that every desert is without outlet, nor is every such region a desert, yet both phenomena are closely connected together. Of the entire land surface of the globe, estimated at 130,000,000 square kilometers, about one-fifth belongs to regions where the drainage is without outlet. Of these, 12,000,000 square kilometers belong to Asia, 7,000,000 to Australia, 4,000,000 to Africa, and 1.3 millions to America. If we go back in geological time, even as far as the Miocene, we find these areas largely increased; hence the importance of this aspect of the subject.

The special topics discussed by the author are the dry weathering due chiefly to change of temperature, deflation or the effect of winds, also the action of flowing waters. Other interesting chapters are those devoted to the deposition of gravel or mud, of lake loess and sand dunes; further the desert flora and fauna; the saline deposits, etc. The author has brought to the discussion of the subject a thorough knowledge of the various points, made more definite from his own personal observations; he has illustrated his text with excellent figures, and thus the volume as a whole is very suggestive from the scientific standpoint as well as being thoroughly readable.

III. ZOOLOGY.

1. *Recent papers relating to the fauna of the Bermudas*, with some corrections.—In the Trans. Conn. Acad. Sci., Vol. X, Part 2, are nine papers on this subject, viz:

(1) The Air-breathing Mollusks of the Bermudas. By Henry A. Pilsbry. Plate 62.

(2) Additions to the Ichthyological Fauna of the Bermudas, from the collections of the Yale Expedition of 1898. By Samuel Garman.

(3) Additions to the Marine Mollusca of the Bermudas. By A. E. Verrill and Katharine J. Bush. Plates 63-65.

(4) The Nudibranchs and naked Tectibranchs of the Bermudas. By A. E. Verrill. Plate 66.

(5) Additions to the Anthozoa and Hydrozoa of the Bermudas. By A. E. Verrill. Plates 67-69.

(6) Additions to the Crustacea and Pycnogonida of the Bermudas. By A. E. Verrill. Plate 70.

(7) Additions to the Echinoderms of the Bermudas. By A. E. Verrill.

(8) Additions to the Tunicata and Molluscoidea of the Bermudas. By A. E. Verrill. Plate 70.

(9) Additions to the Turbellaria, Nemertina and Annelida of the Bermudas, with Revisions of some New England genera and species. By A. E. Verrill. Plate 70.

Besides the above, Dr. W. M. Rankin has recently published "The Crustacea of the Bermuda Islands" (Annals N. York Acad., xii, p. 521, 1900), and Prof. H. L. Clark has published two papers on the Bermuda Echinoderms (op. cit., xi, p. 407, 1898, and vol. xii, p. 117, 1899).

The nine papers first mentioned are preliminary to a much fuller report on the Fauna of the Bermudas, now nearly completed by the writer, which is to be freely illustrated. It is intended to supply a want long felt by numerous students of zoölogy who annually visit the Bermudas, Bahamas, and other West Indian Islands. The marine fauna of the Bermudas is largely a colony from the West Indies.

These preliminary papers give, however, a much fuller idea of the character and extent of the Bermudian fauna than any previous works, relating to the same groups.

Mr. Pilsbry's paper on the terrestrial mollusks is complete, up to date. It includes 41 species. Of the truly terrestrial forms all except 15 species are supposed to have been introduced in comparatively modern times, and several quite recently. Six species: *Helicina convexa*, *Thysanophora hypolepta*, and *Pœcilonites* with four species, are endemic and not known elsewhere. The latter genus is the most remarkable, and its largest species (*P. Nelsoni*) is extinct, but it occurs abundantly in the æolian limestone, sometimes in strata exposed only at low tide, thus showing that it lived on the islands before their partial submergence, and indicating the comparatively great antiquity of the genus. Its nearest allies are now found in the eastern United States. The *Rumina decollata* is now the most abundant land shell. It was introduced accidentally, about 1876, probably on plants from Teneriffe or the Cape Verde Islands by Governor

Lefroy. It was first recorded by Bartram in 1879. A single specimen was found by J. M. Jones in the governor's grounds in 1877. It spread very gradually, at first, from Hamilton, as a center, until in a few years it became an important horticultural pest, for it has but few natural enemies in the islands. Mr. Garman describes three small rare fishes, dredged in shallow water. One of these is new (*Brosmophycis Verrillii*), another (*Gobius stigmaturus*) was previously known only from the original type, of which the origin was not known.

In the paper on Anthozoa, etc., several species of corals, gorgoniae and actinians are for the first time recorded from Bermuda. The most important additions to the reef corals are *Orbicella cavernosa*, *O. annularis*, and *Plesiastrea Goodei*, (sp. nov.), all large, massive species. The animal of *Madracis decactis* is described and figured for the first time. It has 20 tentacles. The current erroneous descriptions of the polyps of *Siderastrea* are corrected. Other genera are revised. Five new species of Actinaria are described. Seven gorgonians are added to the fauna, including *Muricea muricata* and one very large new species (*Eunicea grandis*).

In Dr. Rankin's paper on the Crustacea, 57 species of Malacostraca are enumerated.*

In the paper on Crustacea by the writer, 25 additional Malacostraca are recorded, not including a few that are synonymous with some in Dr. Rankin's list. Miss M. J. Rathbun has since sent me the names of a few additional species,† viz: *Scyllarides*

* This is exclusive of "*Pandalus tenuicornus*" (p. 544) introduced by an error, and *Alpheus Edwardsii*. A specimen of the latter sent to me by Dr. Rankin is the young of his *A. hippothoë*, var. *bahamensis*, which he also sent to me. This is apparently a form of *A. heterochelis* Say.

† Miss Rathbun has also determined some of those that were left doubtful in my list. The shrimp mentioned under Pontonidæ (p. 579) is *Gnathophyllum Americanum* (Guerin). The "*Paguristes*?" (p. 578) is a new species of hermit crab, viz: *Clibanarius Verrillii* Rathbun, sp. nov.

"The chelipeds are similar in shape but noticeably unequal, the propodus of the right being $\frac{2}{3}$ the length of the left. The distal margin of the carpus of both chelipeds is in line with the end of the eyes. The merus of the larger cheliped is two-thirds as high as long; its outer surface is marked by a few short, faint rugose lines; the upper margin is similarly rugose. The carpus is furnished with rough granules above and along the distal margin; there is a large tubercle on the outer surface. The palm is subrectangular, about equally long and high; upper margin convex. The margins are rough with granules; the outer surface is nearly smooth. Both fingers are stout and deflexed, and gape widely; the inner margins are very unevenly toothed; the upper margin of the dactylus is bordered by two rows of sharp granules. The fingers are excavated at the tips, which are white.

The smaller cheliped differs not only in being shorter and narrower but in having the upper margin of the carpus and propodus cut into stout spines increasing in size distally. A similar large spine is on the upper margin of the dactylus at the proximal third. The right cheliped is more hairy than the left, with long light hairs.

Colors.—In formalin a pinkish-white or yellowish-white ground-color with small roundish spots of bright yellowish-red or orange which are most numerous along the upper and distal margins of the segments of the legs, where they tend

latus and *S. sculptus* (U. S. Nat. Mus., coll. Dr. T. H. Bean); *Hippolyte acuminatus* (coll. Goode); and *Domecia hispida* (coll. Yale Exp., 1898). To these should be added *Hippolyte bidentata* Bate, making the total number of species 87, now known.*

Two new species of Pycnogonida, the only ones known in the region, are described and figured.

In the paper on the marine Mollusca a large number of species (about 80) are added to the fauna, and most of them are figured. Of these 25 species are described as new. This makes the total number about 350. In the article on Nudibranchs, etc., nine new species are described, including a very large *Aplysia* and a new genus (*Pleurobranchopsis*), allied to *Pleurobranchus*, but without a shell. In the three papers on echinoderms about 40 species are recorded, including numerous additions to the fauna, but no new species, except *Synapta acanthia*, described by Prof. Clark (1899, p. 134). Of Tunicata four new species are described, including a large and elegantly colored *Diazona* (*D. picta*), and three others are added to the fauna. The compound ascidians, which are numerous, have not been worked up. A small reddish brachiopod (*Cistella cistellula*) was found attached to the under side of corals in Harrington Sound. It agrees closely with specimens from Naples. Several Bryozoa are recorded for the first time, and two remarkable new species are described.† One of these (*Caulibugula armata*) is the type of a new genus, allied to *Bugula*, but it has an articulated stem; the other (*Barentsia timida*) is allied to *Pedicellina*.

In the ninth paper, two new planarians and two new nemerteans are described, and a previously known species of each group is recorded, both of which are found at Naples. These orders are sparsely represented at Bermuda and none had been recorded previously except the terrestrial *Tetrastemma agricola*. Of *Gephyræa* 4 species are recorded, two of which (*Aspidosiphon spinulosum* and *Golfingia elongata*) are new. Of Annelida 60 new species are described and at least 10 others are added to the fauna, which about trebles the known species. About 25 of the new species are Syllidæ. Several new genera are described and

to form irregular transverse bands. There are four bands on each of the pro-podal and terminal joints of the second and third pairs of legs; chelæ and eye-stalks spotted with red." (M. J. Rathbun.)

Total length about 40^{mm}. It becomes much larger.

Bermudas, 4 large and 1 small specimen (coll. Dr. F. V. Hamlin); Yale Mus. and U. S. Nat. Mus.

* The marine Isopoda have been worked out by Miss Richardson, who enumerates 23 species. About 25 species of Amphipoda were also collected by the Yale party. An undetermined fresh-water ostracode crustacean was found abundantly in a rain-water cistern at Bailey Bay.

† Another remarkable new bryozoan often occurs at Bermuda:

Amathia Goodei V., sp. nov. This forms large, intricately branched clusters, 4 or 5 inches high and broad, with the branches thick, soft, and flaccid, and more or less anastomosing, often 2 to 3^{mm} in diameter. The zooids are numerous, arranged in large, dense, elongated clusters, composed of several close rows, which often nearly or quite surround the stem, and extend for some distance below the nodes, but are scarcely at all spiral (coll. of G. Browne Goode).

other genera are revised, including certain New England genera and species. Several necessary changes in nomenclature are also made.

In this connection, it may be of interest to mention that a second Bermudian species of lizard, similar to, and perhaps identical with, the Blue-tailed Lizard of the eastern U. States, is in the Yale Museum. As preserved in alcohol, its body is green, without stripes; tail bluish green; head dark brown. Length about 5 inches.

A. E. V.

2. *Trans. Conn. Acad. Science*, Vol. X, Part 2, pp. 301-698. 1900. New Haven.—This part contains a Revision of certain West Indian Ophiurans with a Faunal Catalogue of all West Indian species, with their distribution (pp. 301-387, 2 plates), by A. E. Verrill; the Hawaiian Hepaticæ of the tribe Jubuloideæ, by Dr. A. W. Evans (pp. 387-463, 16 plates); Notes on some type-specimens of Myxomycetes in the New York State Museum, by W. C. Sturgis (pp. 463-491, pl. 62), and also nine papers relating to the fauna of the Bermudas, noticed below.

3. *Zoological Results based on Material from New Britain, New Guinea, Loyalty Islands and elsewhere*, collected during the years 1895, 1896, and 1897; by ARTHUR WILLEY. Part V (December, 1900). Pp. 531-690. Cambridge, 1899 (University Press).—Part V of this valuable series* contains the following papers: A description of the Entozoa collected by Dr. Willey during his sojourn in the Western Pacific, by Arthur E. Shipley; pp. 531-568, plates LIV-LVI. On some South Pacific Nemertines collected by Dr. Willey, by R. C. Punnett, pp. 569-584, plates LVII-LXI. On the young of the Robber Crab, by L. A. Borradaile; pp. 585-590, with figures in the text. Anatomy of *Neohelia porcellana* (Moseley), by Edith M. Pratt; pp. 591-602, plates LXII and LXIII. On a new blind snake from Lifu, Loyalty Islands, by G. A. Boulenger; pp. 603-605, with figures in the text. On Crustacea brought by Dr. Willey from the South Seas, by Rev. T. R. R. Stebbing; pp. 605-690, plates LXIV-LXXIV.

IV. MISCELLANEOUS SCIENTIFIC INTELLIGENCE.

1. *Leçons de Physiologie Expérimentale*, par R. DUBOIS et E. COUVREUR. Pp. 380, 303 gravures. Paris, 1900 (G. Carré et C. Naud).—With the increasing tendency to teach physiology as an experimental science has come the demand for manuals which will assist the student in his practical work. The volume under consideration is the outcome of the experience gained by the authors in directing the courses in experimental physiology at the University of Lyons. It differs from most of its predecessors in the detail with which the experimental technique peculiar to physiology has been presented. An acquaintance with the more important phenomena of living organisms is assumed, and the directions given are intended to be sufficiently explicit to guide the student in the laboratory. The diversity of topics considered, and more particularly the unusual mode of presentation

* See this Journal, vii, 79, 322; viii, 398; x, 89.

will make the book helpful to those who are interested in the investigation of physiological problems, as well as to the student of medicine.

The first part of the *Leçons* takes up the graphic method and its applications, together with a consideration of the chief forms of apparatus and instruments ordinarily employed in the physiological laboratory. This is followed by a study of the general properties of nerves, nervous centers and muscles, of respiration and the phenomena of the circulation. The parts on alimentation are treated largely from the standpoint of the physiological chemist, while the older methods for studying the more purely physiological functions of the digestive glands are also outlined at some length. The book concludes with a chapter on animal heat and calorimetry. Over three hundred figures and drawings illustrate the text; and like the methods and apparatus described, they are taken almost entirely from French sources. L. B. M.

2. *Webster's International Dictionary, New Edition, with a Supplement of 238 pages, containing 25,000 additional words and phrases.* Springfield, Mass. (G. C. Merriam & Co.), 1900.—This standard work has been very much improved and increased in value by the addition of large numbers of scientific and other terms that have come into more common use since the publication of the previous edition in 1890. These additional terms relate to every department of science and have been defined by numerous specialists. In general Biology, and in systematic and structural Botany and Zoölogy the number of additional words is particularly noticeable, in accordance with the recent rapid progress in these departments of science. In Zoölogy a large number of native or market names of West Indian, South African, Australian, and East Indian fishes, birds and other tropical forms, have been added, largely due to the recently increased interest, on the part of the English speaking peoples, in these tropical regions. Over sixty species of the fishes of Porto Rico, Jamaica, Cuba and the Bermudas are illustrated by cuts. There are over three hundred new zoölogical figures. A considerable part of these illustrate insects injurious to agricultural crops, or to fruit and shade trees in America. Most of these insects are grouped under the name of the tree or plant that they most damage, which will enable one unfamiliar with technical entomology to find and identify insects by the damage that they do. In too many dictionaries the insects, fishes, birds, etc., are placed under their technical scientific names, or else under improvised "book-names" that have never come into general use and are known only to specialists, which renders it very difficult for one not a specialist to find the information desired, even when it is contained in the book. In Botany the names of most of the orders and larger groups of plants have been introduced, with brief definitions. A considerable number of new Ethnological terms has been added, many of them relating to the races and tribes of the Philippines and other oriental countries. A large number of

new words in various departments, that are current in Australia, New Zealand, and in India, have been introduced, when they have found a place in English literature.

3. *The National Standardizing Bureau.*—Near the close of the last session of Congress, an act was passed establishing a "National Standardizing Bureau," the functions of which are stated as follows: "The custody of the standards; the comparison of the standards used in scientific investigations, engineering, manufacturing, commerce, and educational institutions with the standards adopted or recognized by the Government; the construction, when necessary, of standards, their multiples and sub-divisions; the testing and calibration of standard measuring apparatus; the solution of problems which arise in connection with standards; the determination of physical constants and the properties of materials, when such data are of great importance to scientific or manufacturing interests and are not to be obtained of sufficient accuracy elsewhere." The appropriation made in behalf of this end, both for officers and for buildings, is sufficiently liberal to insure the work being undertaken promptly and with satisfactory thoroughness. Prof. S. W. Stratton of the University of Chicago has been appointed Director of the Bureau; this choice meets with general approval.

OBITUARY.

DR. GEORGE MERCER DAWSON, Director of the Geological Survey of Canada, died on March 2, after a brief illness. He was the eldest son of Sir John William Dawson, who died in November, 1899. Dr. Dawson's contributions to the advancement of geology have been numerous and valuable. In the year 1875 his report on the "Geology and Resources of the 49th Parallel," at once established his position as a keen observer, an indefatigable investigator, and a man of more than ordinary powers of wide generalization. Upon the retirement of Mr. Selwyn, he became Director of the Survey in 1896, since which time he has conducted the Survey with great energy and administrative ability. The results of his latest investigations were summarized in his address upon "the Physical History of the Rocky Mountain region of Canada," delivered by him as President of the Geological Society of America, in December last; this address is published in the number of Science which recorded his death (vol. xiii, p. 401). Dr. Dawson's mastery of the geology of the northern part of the American continent makes the loss to American geology most deeply felt; and notwithstanding all he has accomplished, his sudden departure leaves his life work unfinished.

Professor CHARLES HERMITE, the eminent French mathematician, died in January last at the age of seventy-eight.

M. ADOLPHE CHATIN, the French botanist, died on January 13, at the age of eighty-seven.

Dr. J. C. AGARDH of Lund, the veteran Swedish botanist, well known for his work on marine Algæ, died on January 17 in his eighty-eighth year.

THE

AMERICAN JOURNAL OF SCIENCE

[FOURTH SERIES.]

ART. XXVII.—*Studies of Eocene Mammalia in the Marsh Collection, Peabody Museum*; by J. L. WORTMAN. With Plate V.

PART I. CARNIVORA.

INTRODUCTION.

IN pursuance of an understanding had with the late Professor Marsh shortly before his death, the writer has recently undertaken the study of the more important materials in the splendid collection of Eocene Mammalia in the Marsh Collection of the Peabody Museum, with the object of presenting a full account of the structure and relationship of those forms, as far as revealed by the remains at present known. This material was derived almost exclusively from the Bridger and Uinta Basins of Wyoming and Utah, but less extensive collections from the Eocene Basin of the San Juan of New Mexico are also included. The first collections of fossils from these localities were gathered in 1870, by the Yale Expedition into the Western Bad Lands, under the enthusiastic leadership of Professor Marsh himself. For four succeeding years, expeditions of a similar character were organized, equipped, and led into the fossil-bearing horizons of the West by this indefatigable student of paleontology, to whom the science is so deeply indebted. Later, for a number of years, Professor Marsh employed regularly trained collectors to search for fossils in the Bad Lands of these basins. The collections resulting from these sources have a richness and significance, perhaps unrivaled by any similar one in the world. The importance of the subject to the student of Mammalogy can scarcely be over-estimated, since these epochs witnessed the beginnings and branching off of many groups destined to play such a prominent part in

succeeding mammalian development. This fact was fully appreciated by Professor Marsh, and he spared neither pains nor expense in making the collections as complete as possible.

In 1871, he issued his first paper descriptive of these discoveries, in this Journal (vol. ii, August, 1871) and in succeeding years many publications in the same Journal were added. A few groups, Dinocerata, Coryphodontia, and Tillodontia, were described and illustrated *in extenso*, but by far the larger part of the collection has either not been studied or only a few specimens described in a brief preliminary way, mostly without illustration. For many years prior to his death, he had fully recognized the importance and desirability of having this subject, which the press of many matters had prevented his undertaking, finally and fully investigated for the sake of the advancement of the science. The Trustees of the Museum have, therefore, generously placed at my disposal this entire collection for study and publication, and it is to be earnestly hoped that the results obtained will prove commensurate with the importance of the undertaking. It is a source of the keenest regret to the author that the investigation could not have been made under the tutorship of the master whose ripe judgment and kindly advice would have proved so helpful and such a tower of strength in the preparation of the work. The subject will be considered group by group, omitting those that have been already fully published. The first of the series deals with the Carnivora, after which the Primates and other orders will follow. A consideration of the relationship of the horizons in which these fossils occur will be reserved for the latter part of the paper.

PART I. CARNIVORA.

In this group, I mean to include all those forms which are usually classified as the modern Carnivora, together with their extinct representatives commonly arranged under the ordinal group Creodonta. That all the modern Carnivores have arisen from and are directly traceable to what has been formerly known as the Creodonta is now coming to be so well established that from time to time it becomes necessary to modify our ideas of their classification and arrangement. According to the present state of evidence it seems probable that there were at least three if not more points of contact where the two groups actually unite. For this reason the distinction of one from the other becomes a more and more difficult task. I purpose, therefore, in the following treatise to consider the entire series as constituting a single homogeneous order, the origin of which dates back to Pretertiary times, along with the Edentates, Ungulates, and very probably, also, with the Insec-

tivores, Rodents, Primates, etc. There is as yet little or no evidence which throws any light upon their origin, and until the Cretaceous ancestors of the Monodelphs are more certainly known, the problem will of necessity remain obscure.

There appears to be a sort of vague belief that the Carnivora have arisen from the Insectivora, and one frequently hears the expression "Insectivore-creodont ancestors." Now, as a matter of fact, the Insectivora, as we at present know them, are not more primitive than a large majority of the Creodonts; but on the contrary, with very few exceptions, all the living Insectivores are considerably specialized, and even those that do exhibit a more or less generalized structure are far removed from the typical, ideal ancestor of the Carnivores. Nor do the few known fossil Insectivores help us much towards such a belief, for in all of them, as far as we know, the peculiar conformation of the anterior part of the skull is almost as strongly marked as it is in their living representatives. The very general enlargement of the premaxillæ and modification of the incisors, with the reduction or disappearance of the canine, constitute one of the striking osteological peculiarities by means of which they may nearly always be distinguished from any known Creodont or Carnassident.

It would appear from the present trend of the evidence that we shall be compelled eventually to return to the old idea of a direct Marsupial ancestry of all the Monodelphian orders. By this I do not mean to imply that the living Marsupials are these ancestors, for the reason that they have in all probability secondarily acquired a number of modernized features which remove them considerably from the hypothetical progenitors. Their peculiarities in the matter of the replacement of the teeth, the increased number of incisors in the carnivorous and insectivorous forms, and the inflection of the angle of the jaw, we may readily believe to have been acquired, and did not belong to their Mesozoic ancestors. In fact it has already been shown that the increased number of incisors is due to a development and partial retention of a first and second set.

Whatever may be said of the derivation of the other orders, the Mesozoic representatives of the carnivorous Marsupials are not far removed from the hypothetical forms, to which, it seems to me, the present evidence points with no doubtful signs, as the ancestors of the Carnivora. Although we know them from but a few fragments, yet the striking resemblances which these bear to the corresponding parts of the living carnivorous Marsupials, leave little doubt that their structure was very similar. If we subtract from the skeleton of some of the more typical living Marsupial Carnivores, such as the Sarcophiles, Dasyures, Thylacynes, and Opossums, those char-

acters which we may assume are specialized or secondarily acquired, we shall have left an assemblage of primitive features which must have certainly belonged to the ancestors of the Carnivores. These are especially seen in (1) the narrow more or less elongated type of skull, much constricted behind the orbits, (2) the stout, heavy zygomata, (3) the large lachrymal, spreading out upon the face, (4) the prominent sagittal crest terminating in a rather high, overhanging occiput, (5) the relatively large, downwardly projecting paroccipitals, (6) the double condyloid foramen, (7) the peculiar thickening of the posterior border of the palate, (8) the large hatchet-shaped neural spine of the axis, (9) the large size of the lumbar vertebræ as compared with the dorsals, and their tendency in some forms (Opossums) to develop the double tongue and groove articulations, (10) the large deltoid crest and characteristically broad distal end of the humerus, (11) the fusion of the scaphoid and centrale (Opossums, *Myrmecobius*, and *Dasyures*), (12) the subequal size of ulna and radius, (13) the large size of the lesser trochanter of the femur, (14) the large size of the fibula and its extensive articulation with the proximal surface of the astragalus instead of upon its outside, and (15) the very primitive form of the astragalus. To these may also be added, (16) the small size of the brain, (17) the dorso-lumbar vertebræ formula of 19, and (18) the posterior spreading of the nasals so as to exclude contact between frontals and maxillary in front. With respect to the forms of the teeth, they are with few exceptions primitive.

Now nearly all the foregoing characters are actually possessed in varying degrees by some members of the Creodonta, as far, at least, as we know them; and if the replacement of the dentition were complete instead of partial, and the so-called first molar of the carnivorous Marsupials, which is undoubtedly homologous with a persistent last milk molar of the diphyodont dentition, were replaced by a permanent simpler successor, as is invariably the case where its succession is accomplished, the analogy would then be complete and there would be no difficulties whatever in deriving the Creodonts from this source. In like manner the origin of the Insectivora would be traceable to a form similar to *Myrmecobius*. That the inflection of the angle of the jaw and the partial repression of the second set of teeth were secondarily acquired, is rendered probable from the recent discovery of Matthew* in which it would appear likely that both these characters have been acquired by the Mesonychidæ, among the Creodonts. Just what the Cretaceous Marsupials, when more fully known, will show with respect to these characters cannot now be predicted;

* Bull. Amer. Mus. Nat. Hist., January, 1901.

but we do know that such a type as *Didelphops* Marsh, in its dentition and palate, resembles the living carnivorous Marsupials, and it is to some such type in particular that I would refer the origin of the Creodonta.

The classification herein adopted with respect to the major divisions of the Carnivora is essentially that of Flower and Lyddeker in their work upon the Mammalia, with the exception that I have substituted for their name "Carnivora Vera" the subordinal term Carnassidentia. We shall then have the three suborders,—Creodonta, Carnassidentia, and Pinnipedia, but the difficulties of determining the limits and framing exact and satisfactory definitions for these groups, especially the two former, are just as great when considered as suborders as they are considered as orders. Two main features of their organization have hitherto been used to separate the Creodonts from the higher Carnivora or Carnassidentia, viz: the union of certain elements of the carpus and the modification of particular teeth into a sectorial or carnassial dentition. The relative importance of these two sets of characters in constructing the primary divisions of our classification is of course a matter upon which different opinions are held. Speaking for myself, I am convinced that the tooth characters are of greater moment in making these primary divisions than the union or non-union of certain carpal elements, for the reason that the ununited carpals are undoubtedly expressive of a generalized condition, which applied to all phyletic lines of this series in the early stages of their existence, and cannot, therefore, give the faintest hint of the breaking up into subordinate series. It is, moreover, largely dependent upon time, since later than a given epoch these carpals are united and earlier than this they are free, in any group belonging to the order.

If, on the other hand, we base our primary divisions upon the modifications of the teeth, we have from almost the earliest deposits in which we have knowledge of the remains of this group, many of the various phyla more or less distinctly outlined. Thus, as early as the Torrejon, we find representatives of the Viverravidæ, which not only have the teeth constructed upon the same identical pattern as that of certain living Carnassidentia, but the number is exactly the same. In the succeeding Wasatch, representatives of the modern Canids and Felids appeared, while the various lines of the Creodonta may be said to have been fully established by this time.

The one distinguishing feature of the dentition of the Carnassidentia is found in the fact that the fourth superior pre-molar and the first inferior molar have been exclusively developed into carnassial teeth. Some of the living representatives, such as the Bears and Raccoons, have largely lost the

more typical structure of these teeth, but the evidence is very strong in favor of their derivation from ancestors in which the carnassials were well developed.* In the Creodonta, on the other hand, if carnassial teeth are developed they are not confined to the fourth superior premolar and the first inferior molar, but usually consist of a varying number of molars in each series. In some of the older types there are no carnassials developed, the molars being intermediate in structure; while in others they are of a pronounced tubercular form. The three suborders would then be divided and defined as follows:

Suborder Creodonta.

Carnassial teeth present or absent; when present, not consisting exclusively of fourth superior premolar and first inferior molar. Scaphoid, lunar, and centrale of the carpus very generally free. Ungual phalanges broad, depressed and fissured, or laterally compressed and pointed. The following families are included: Oxyclænidae, Arctocyoniidae, Mesonychidae, Oxyænidae, and Hyænodontidae.

Suborder Carnassidentia.

Carnassial teeth present and always consisting of the fourth superior premolar and first inferior molar. Scaphoid, lunar, and centrale of the carpus, very generally united. Ungual phalanges compressed and pointed.

The following families are included: Viverravidae, Viverridae, Hyænidæ, Protelidæ, Palæonictidæ, Felidæ, Canidæ, Procyonidæ, Ursidæ, and Mustelidæ.

Suborder Pinnipedia.

Limbs modified for progression in the water; no carnassials; scaphoid, lunar, and centrale united. Ungual phalanges greatly modified by enormous development of subungual processes.

Families: Otariidae, Trichechidae, Phocidae.

SUBORDER CARNASSIDENTIA.

Family Canidæ.

The study of the Eocene Canidæ is attended with no little difficulty, owing in large measure to the insufficient and fragmentary materials upon which the types of the respective genera have been based. While fortunately these are not

* Matthew has (loc. cit., p. 17) quite recently discussed the relationship of the Arctocyoniidae, a family of the Creodonta from the Torrejon and Wasatch of this country and Europe, to the modern Bears. Arguing from the structure of the feet and teeth, he believes that they make certain distinctive approaches towards the Ursidæ and may have been ancestral to them. Had he taken the trouble to compare the feet of *Clænodon* with a living Opossum or a Dasyure, he would have found such a striking similarity of structure in every detail, with the possible exception of the astragalus, that he would have concluded that the Arctocyoniidae are much nearer to the Marsupials in these characters than to the Bears.

numerous, yet with such imperfect specimens it is not an easy matter to correctly determine their limits and relationships nor to refer other more complete material to them with certainty and exactness. Any attempt must, therefore, be regarded as tentative to a large extent, at least until such time as the acquisition of more complete specimens will throw additional light upon the structure and organization of the types.

The genera which have been proposed for these dogs are three in number, viz: *Vulpavus*, proposed by Marsh in 1871 upon a first superior molar tooth; *Uintacyon*, proposed by Leidy in 1872 upon an anomalous lower jaw, with the teeth considerably damaged, and *Miacis*, proposed by Cope in 1872 upon a fragment of a lower jaw bearing the penultimate molar. It will be seen, therefore, that in no case is there association of upper and lower teeth in one specimen, so that in the absence of any additional specimens which display characters exactly like the types, the reference of other more or less fragmentary material to them must, at best, be attended with an element of uncertainty.

In the matter of the synonymy of these generic names I have elsewhere expressed the opinion* that the type specimen of Cope's *Miacis* belongs to the same genus as that previously described by Marsh under the name of *Vulpavus*; but in the absence of superior molars in the former, this cannot be demonstrated with absolute certainty. After the study of a much wider range of specimens than were at my disposal when this conclusion was reached, I can see no reason to question the correctness of this view.

Fortunately the relationship of the type species of *Uintacyon* can now be determined with a reasonable degree of certainty and satisfaction. In the present collection a specimen in which there are upper and lower molars associated, shows that it is quite distinct from *Vulpavus*. While the number of superior molars cannot now be stated, they may nevertheless be assumed to be three; this assumption is based upon (1) the relative size of the second molar, the presence of which is indicated by its alveolus, and (2) upon its striking resemblance to the three-molared Oligocene *Daphænus* series, of which there can be little doubt that it was the forerunner. The main distinction between *Vulpavus* and *Uintacyon* has hitherto been supposed to rest upon the number of superior molars. *Vulpavus* was thought to have but two and *Uintacyon* three, but it now transpires that some of the species of *Vulpavus* have a third molar, and it is no doubt true of all of them; in fact it seems highly improbable that there are any species of Canids in the Bridger which had less than three superior molars. The dis-

* Bull. Amer. Mus. Nat. History, June 21, 1899, p. 110.

tinctions between the two genera are seen in the following characters: in *Vulpavus* the jaw is relatively slender, the heel of the inferior sectorial is comparatively small and basin-shaped, the second and third lower molars have sharp cusps, the main internal cusp of the first superior molar is large, lunate, and connected with the outer cusps by an anterior and posterior ridge upon which intermediates are developed, and there is a postero-internal cusp. In *Uintacyon*, on the other hand, the jaw is thicker and more robust, the heel of the inferior sectorial is small and cutting, the cusps of the succeeding molars are low and obtuse, the main internal cusp of the first superior molar is more conic and connected with the external cusps by a ridge in front only, and there is no posterior internal cusp.

A third group having the jaw characters of *Uintacyon*, as far as known, is represented by a few scattering fragments. In this group the premolars are much reduced in size and the canine is laterally flattened. Members of this latter group are found in the Wind River and Wasatch deposits, which carries them well back towards the base of the Eocene. That they represent a distinct and independent phylum there can be little doubt, and one, moreover, that is known to have left descendants in the succeeding Uinta beds.

If, upon further investigation, it should be found that the scaphoid, lunar, and centrale of the carpus are separate, which is not altogether improbable, the question will then arise as to whether they should be properly classed in the Canidæ or Viverravidæ or whether they should be placed in a distinct family by themselves. According to the previous and perhaps more common acceptation of the limits of the Creodonta they would without doubt be placed in this suborder, but I believe with Schlösser that they stand much nearer to the Carnassidentia and, as I will presently attempt to show, were the immediate progenitors of the two and probably three main branches of the canine phylum. If we range them with *Viverravus* in the Viverravidæ we shall fail to express by such a classification the distinctive and important positions which these two genera hold with respect to the canine and viverrine branches of the Carnassidentia. There now appears to be little doubt that when the evidence is more complete than it is at present, it will be found that the Canidæ and Viverravidæ were derived from a common ancestor. That the separation of these two genera took place, however, previous to the deposition of the Torrejon beds is evidenced by the fact that a species of *Viverravus*, with all the distinctive dental characteristics of this genus, is found therein, and we must therefore look to an earlier date for the

actual convergence of the two groups. If the Viverravidæ were the forerunners of the civets, which appears from present evidence to be exceedingly probable, then the dogs and civets have had a common origin, as has been so frequently insisted upon by Scott.

Vulpavus Marsh.

Vulpes, a fox; and *avus*, a grandfather. Amer. Jour. Sci., 3d ser., vol. xi, p. 124, Aug., 1871. *Miacis* Cope (in part). Paleont., Bull., No. 3, Aug. 7, 1872, p. 2; Proc. Amer. Philos. Soc., p. 470, 1872; Tertiary Vertebrata, 1884, p. 301. *Vulpavus* Wortman and Matthew, Bull. Amer. Mus. Nat. Hist., June, 1899, p. 118.

A group of small dogs limited in their vertical distribution, so far as at present known, to the Bridger Horizon. They are characterized by having the dental formula I. $\frac{3}{3}$, C. $\frac{1}{1}$, Pm. $\frac{4}{4}$, M. $\frac{3}{3}$, with the relative proportions of the lower molars nearly the same as in the modern genus *Canis*. The antero-external angle of the first superior, and to a less degree that of the second superior molar, is drawn out, and produced into more or less of a cutting blade. The external cusps are unequal in size, the anterior being the larger. The hind foot is pentadactyle, the astragalus little grooved, and the femur has a third trochanter. The humerus has a powerful deltoid crest and supinator ridge, and there is a large entepicondylar foramen. The articulations of the lumbar vertebræ are not complex as in some Creodonts but plane as in most Carnivores. The claws are compressed, sharp pointed, and unfissured. The carpus is unknown.

Vulpavus palustris Marsh.

Professor Marsh, in describing the remains upon which this genus and species were primarily established, included a portion of a right superior maxillary, carrying the fourth premolar and the roots of the three succeeding molars. Since this specimen agrees so perfectly in every respect with a species of the genus *Sinopa* Leidy, and differs in such important characters from the accompanying molar, it may be confidently excluded from any further consideration in this connection. The type, figure 1, consists of a first superior molar tooth of the right side, with the antero-external angle missing; otherwise the crown of the tooth is in a perfect state of preservation. The specimen indicates an animal considerably smaller than the common Red Fox with which Professor Marsh compared it in his original description. The composition of the tooth crown, and the arrangement of the component cusps and ridges indubitably stamp it as belonging to a mem-



FIGURE 1.—*Vulpavus palustris* Marsh; first superior molar; crown view; natural size. (Type.)

ber of the Canidæ, and the name *Vulpavus* was most happily chosen, since it is not only the forerunner of the foxes in name but is so in fact.

Like most of the Canidæ the crown is composed of two principal external cusps, a large lunate internal ridge enclosing a central depression or valley, together with a more internal and posterior ledge-like elevation arising from the cingulum. The external portion of the crown is very different from the corresponding part of this tooth in any of the Miocene, Pliocene, or modern species of dogs, but resembles that of the great majority of the older and contemporary Creodonts. This consists in its external expansion, and the formation of a relatively broad shelf-like area between the external margin of the crown and the two external cusps. Associated with this is the drawing out of the external angles, both anterior and posterior in this species, and the disposition to form cutting blades of these parts of the crown. While the antero-external part of the tooth is broken away in the type specimen, there can be little doubt, from its great similarity in structure to the nearly related species described below, that this angle was present and prominent.

Of the two external cusps, the anterior is by far the larger and more prominent, and as this character appears to be constant in all the species thus far known, it may be taken as of generic significance. The crescentic ridge thickens considerably at its internal angle into a low, stout, more or less trihedral cusp which forms its most prominent part. External to this the ridge is interrupted by two, less prominent, anterior and posterior intermediate cusps situated about midway of the tooth crown on the respective borders which they occupy. The postero-internal cingular cusp is unusually broad and thick for such an early species of the Canidæ, in fact almost equaling in this respect some of the modern species. The summit of this cusp is closely connected with the cingulum which is developed around the entire crown.

The locality of this specimen, which is the only one in the collection, is Grizzly Buttes. This locates it near the base of the horizon; it was found by Professor Marsh.

The following measurements are given:

	mm.
Transverse diameter of posterior part of crown	8
Antero-posterior diameter in middle of crown	4.5

Vulpavus Hargerii sp. nov. (Plate V.)

Two specimens of this species, which include a considerable part of the skeleton, are contained in the collection. From these a fairly accurate knowledge of a large part of the

osteology may be obtained. In one, which is here selected as the type, figures 2 and 3, the larger portion of the anterior moiety of the skull, together with a few fragments of other bones of the skeleton, are preserved, while in the other, parts of the skull, vertebræ, one hind limb complete, parts of fore limb, ribs, etc., are present in more or less perfect condition. There is one other specimen in which there are upper and lower teeth in association, and in this specimen the alveolus for the third superior molar is clearly shown.

Skull and Dentition.—The facial portion of the skull is sufficiently preserved to admit of description; this together with some fragments of the base of the skull and the larger part of the cranial vault serve to give a reasonably accurate idea of the skull. As compared with the Red Fox, the muzzle is shorter and less slender, resembling in this respect the Miocene *Cynodictis gregarius*, with which it agrees fairly well in size. The orbit is relatively larger than in this latter species, holding about the same proportions as that seen in the fox. Its anterior edge lies over the anterior half of the sectorial as in *Cynodictis*, while in the fox the orbit is more posterior. The infra-orbital foramen is larger and occupies its usual position on the side of the face; its posterior edge is a little more posterior than in *Cynodictis*, coinciding with the anterior border of the superior sectorial as in the fox. The skull is much constricted behind the orbits as in *Cynodictis*, in marked contrast with the relatively broad area of this region in the fox. There is a distinct postorbital process present, although it is small as in *Cynodictis*. The lachrymal has the same relative size and proportions in the three genera and is not spread out on the face; there is a small lachrymal tubercle present, which is less conspicuous in *Cynodictis* and absent in the fox. The two converging branches from the postorbital process unite just in front of the postorbital constriction to form a sagittal crest of moderate proportions just as in the case of the Miocene *Cynodictis*. In a large majority if not all the foxes, as is well known, these branches do not unite until near the lambdoidal crest, leaving a large lyrate area in this region of the skull. The development of this lyrate area is no doubt due to a progressive widening of the anterior part of the brain. In all modern species the postorbital constriction is very much less than in either the Miocene or Eocene forms. The zygomatic arches are well developed and display a somewhat greater degree of stoutness than that of *Cynodictis* and the fox.

A portion of a left squamosal exhibiting the glenoid fossa is sufficiently preserved to indicate the existence of an unusually broad postglenoid process; this is divided by a deep notch

into an external and an internal portion of which the external is the larger. The office of this notch, which appears to be a part of a foramen, is not altogether clear, but it is a matter of much interest to note that a similar arrangement is seen in the skull of the carnivorous Marsupials. Placed internal to and close to the edge of the fossa is seen the opening of the foramen ovale, much closer in fact than in any species of dog with which I am acquainted. This condition would seem to indicate a narrow brain case, which would be in keeping with the position of the species in the time scale. The position of the foramen is posterior to the fossa as in the Marsupials, and not anterior or opposite to it as in *Cynodictis* and the modern dogs. Posterior to the glenoid is seen the opening of a rather large postglenoid foramen.

The lower jaw, figure 2, is relatively a little stouter than that of *Cynodictis* and considerably more so than that of the fox; its inferior contour is like that of the typical dogs, being deepest in the region of the inferior sectorial, tapering thence forwards, and more or less curved posteriorly. The symphysis is short, extending to beneath the anterior border of the premolar as in *Cynodictis*. In the fox the symphysis is larger and more extended, reaching backward to beneath the anterior border of the third premolar. The angle is broken away in all the specimens of this species in the collection, but the base indicates that it was present and of apparently the same proportions as in *Cynodictis*. There is an appearance of a slight degree of inflection having been present. The masseteric fossa is relatively large and deep, occupying quite one-third the entire length of the jaw; it has about the same proportions as in *Cynodictis* but is considerably smaller in the fox. The coronoid is much damaged, but there is evidence of its goodly proportions, both as regards breadth and height. The condyle is somewhat heavier and of greater transverse extent than in either the Miocene or recent genera.

With the exception of the last superior molar and the superior incisors, the dentition can be fully described. The canines are of moderate size, more or less oval in cross-section at the base, and well pointed. Of the inferior premolars the first is small, single-rooted, with a somewhat conical crown, and separated from the canine and second premolar by short diastemata. The second has a flattened pointed crown, is implanted by two roots, and separated from the tooth in advance by a diastema. The third and fourth are larger two-rooted teeth with laterally compressed conical crowns having distinct anterior and posterior basal cusps. The third has in addition to these a faintly marked accessory cusp developed upon the posterior border of the crown.

The first molar, or sectorial, bears the unmistakable stamp of an early or primitive condition of this tooth in the Carnassidentia. This is particularly noticeable in the great elevation of the trigon above the heel, in the large size of the internal cusp and the arrangement of the cusps of the trigon in the form of an isosceles triangle, in the obliquity of the principal shear to the axis of the jaw, and the development of a posterior shear. In the sectorial of *Cynodictis* or of a modern dog, the trigon is less elevated, the principal shear is more in

2

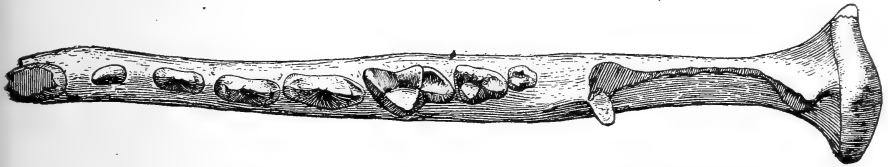

FIGURE 2.—Left lower jaw *Vulpavus Hargerii* Wortman; crown view; one and one-half natural size. (Type.)

line with the jaw axis, the internal cusp of the trigon is reduced, and the posterior shear has practically disappeared. Of the trigon the external or principal cusp is unusually high and prominent; it has a distinctly trihedral form, with the anterior cutting edge but little produced, in marked contrast with that of *Cynodictis* or the fox, in which the whole cusp is laterally flattened and the anterior edge drawn out into a cutting blade. The anterior cusp is prominent and relatively thick; its posterior edge is extended and forms the more important blade of the principal shear. The internal cusp is large and with the principal outer cusp forms a posterior, transverse shear of considerable efficiency, which bites against the anterior edge of the first superior molar. The heel or talon is proportionally small; it is made up of an inner basin-shaped and an outer vertically beveled part, divided from each other by an antero-posterior median ridge, which is terminated behind by a rounded cusp and continued forwards to the base of the trigon. The inner boundary of the basin is furnished by a ridge of moderate proportions which curves around posteriorly to join the median cusp, inclosing between it and the median ridge a concavity. The antero-posterior ridge joins the base of the trigon immediately posterior to and beneath the notch which separates the blades of the posterior or transverse shear. The extent to which this outer beveled portion of the heel is developed varies much in the different species of Canidæ; it has to do apparently with the pushing inwards of the principal external cusps of the first superior molar, for when they have

an internal position the beveled portion is large as in the present species, and when they have an external position the beveled portion is reduced and its position is taken by the basin-shaped part. Taking the present species as one extreme and the modern dogs as the other, the genus *Cynodictis* stands about midway between the two in this respect.

The second molar is a diminished copy of the sectorial with the exception that the trigon is much less in height, and there are less distinctive shears developed among the elements of the trigon. The cusps as well as the heel have approximately the same relations to each other. In *Cynodictis* and the modern dogs this tooth, as well as the succeeding one, has lost all traces of the sectorial structure. The third molar is still more reduced, being relatively as small as in the modern species; the crown, however, still retains traces of the tuberculo-sectorial pattern, although but faintly.

3

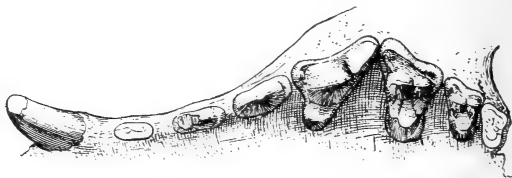

FIGURE 3.—Left upper jaw of *Vulpavus Hargerii* Wortman; crown view; one and one-half natural size. (Type.)

Of the superior dentition, figure 3, the canines are of moderate size and pointed, resembling those of the Miocene *Cynodictis*. The first premolar is a small single-rooted tooth placed close to the base of the canine; a short diastema intervenes between it and the second. The second and third are, as is usual among the Canidæ, two rooted, with laterally flattened, pointed crowns; the third has a posterior basal and accessory cusp like the corresponding tooth in *Cynodictis*. The superior sectorial displays the usual form seen in the Canidæ, although in some respects it is primitive. The two external cusps are large and modified into very efficient shearing blades. At the base of the large antero-external cusp is seen a small tubercle which recalls the structure of the superior sectorial among the carnivorous viverrines. In this latter group, however, it is larger and more distinct, while among the cats and hyænas it has been developed into a powerful third blade. The genus *Elurodon*, a dog-like mammal from the Loup Fork Miocene of America, likewise exhibits this cusp but in a less degree of development. The internal cusp is unusually large and has an anterior position, displaying about the same proportions as are

observable in *Herpestes* or *Viverriculus*. It is much larger than in the corresponding tooth of either *Cynodictis* or the fox.

The molars display the same generalized characters as those of the type species *V. palustris* already described, and, notwithstanding some minor specific differences, they are undoubtedly indicative of the same genus. The anterior border of the crown of the first molar is relatively much elongated in a transverse direction. The two external cusps, of which the anterior is the larger, are placed well inwards, and a considerable ledge-like area which is broadest in front intervenes between them and the external border. The postero-external angle is more or less rounded, and is not produced into a sharp crest as in the type species *V. palustris*. The large internal cusp is not as lunate in character as in the type species but is more pointed and distinctly separated from the rather large anterior intermediate, the posterior intermediate being small. The postero-internal cusp, which is so highly characteristic of nearly all species of the Canidæ, may be said to be practically absent; a rather strong development of the cingulum marks its position, however, but even this is somewhat variable in the several specimens in which it is shown. The almost total absence of this cusp is in marked contrast with its strong development in the type species. The crown of the second molar is almost an exact copy of that of the first; it is, however, smaller and all the cusps are less distinct. The third molar is not preserved, but its presence is indicated by the alveoli in the two specimens in which it is shown. It was small and vestigial in character.

Vertebræ.—There are comparatively few of the cervical or dorso-lumbar series of vertebræ preserved, so that it is impossible to give an account of either their number or characters. Some fragments of the lumbar, in which the zygapophyses are fairly perfect, indicate that their centra were large as in the early Carnivora and that their articulations were not complex as in many Creodonts. Some well-preserved caudals, figures 4 and 5, show that the tail was large and presumably of good length.

Scapula and Fore Limb.—The head of the scapula presents the same pyriform, cup-shaped glenoid cavity as that seen in

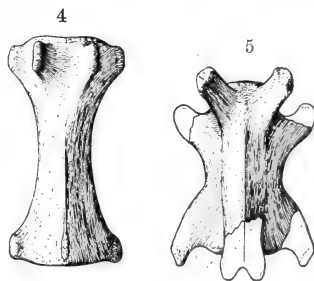

FIGURES 4, 5.—Caudal vertebræ of *Vulpavus Hargeri*; natural size. (Cotype.)

the fox, but the coracoid is larger and more elongate as in *Cynodictis*. The neck is short, the spine rises abruptly, close to the glenoid border, and terminates in an overhanging acromion and metacromion. There is not enough of the bone preserved to indicate the relations of the fossæ with certainty, but they were apparently like those of *Cynodictis* as described by Scott.*



FIGURE 6. — Left radius of *V. Hargeri* Wortman; natural size.

The humerus, figure 9, is broken in the region of its proximal third and does not give the character of the head of the bone. The most conspicuous feature of the shaft is the development on its anterior surface of the very large and prominent deltoid crest, which extends more than half way to the distal end. Associated with this are seen the unusually prominent supinator ridge and internal condyle, all of which serve to give to the bone a combination of characters hitherto completely unknown among the Canidæ. The entepicondylar foramen is present but there is no anconeal perforation. The anconeal and anticubital fossæ are distinct and the articular surface is of unusual transverse extent, as it is in the cats and viverrines, and very different from the modern dogs.

The radius, figure 6, resembles that of the civets much more than of the modern dogs. The shaft is slightly curved and moderately flattened. The head is cup-shaped and subcircular in outline, indicating power of complete pronation and supination; the tubercle for the insertion of the biceps is strong and that for the principal pronator of the fore arm is unusually well developed. The distal end is broken so as to destroy a considerable part of the articular surface for the carpus. Judging from what is preserved of this surface, however, there was apparently no division into separate scaphoid and lunar facets. This would seem to indicate a consolidated scapho-lunar, but this evidence is not altogether reliable.

* Trans. Philos. Soc. Phila., vol. ix, p. 381, 1898.

[To be continued.]

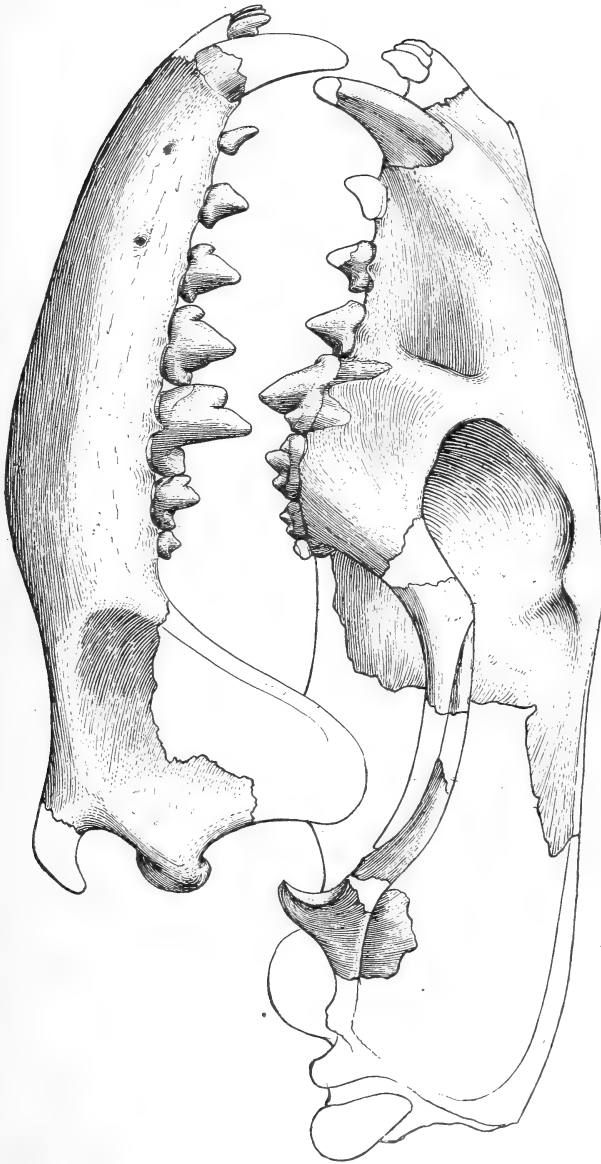

EXPLANATION OF PLATE V.

Skull of *Vulpavus Hargerii* Wortman; side view; one and one-half natural size (Type).



ART. XXVIII.—On the Velocity of Chemical Reactions; by
WILLIAM DUANE.

IN investigating the laws of physical chemistry it is expedient for the physicist to devise and develop the methods of measurement, and for the chemist to apply them. In the following pages are described two methods of measuring the velocity of chemical reactions. The velocity of a chemical reaction is the rate at which a chemical compound appears or disappears during that reaction. The changes in the quantity of this compound present during successive intervals of time are measured by the changes in some property of the chemical system during the intervals. This property is usually either a chemical or a physical one.

1



In the first of the following methods the basis of the measurement is the change in the index of refraction of the system, and in the second the change in its volume.

The first method is applicable to those chemical systems only that are transparent. It is substantially the following. Rays of light from an illuminated slit S (Fig. 1) passing through a long focus lens L and the tube $abcd$ form a distant image S_1 of S . The slit S is perpendicular to the plane of the diagram which represents a horizontal section of the apparatus. The tube $abcd$ has plane glass ends ab and cd ; and a plane glass plate ac divides it into two wedge-shaped compartments. The ends ab and cd are not quite parallel to each other, so that if the two compartments are filled with liquids having the same index of refraction there will be a slight resultant refraction of the light rays that pass through the tube. The rays of light that pass outside of the tube therefore will form an image S_2 a little to one side of S_1 . It is evident that if the liquid in one compartment (the wedge acd for instance) is undergoing a chemical change its index of refraction in general will vary and the image S_1 will move sideways. The distance that S_1 has moved will be a measure of the change that has taken place in the index of refraction and, therefore, of the amount of substance in acd , that has reacted. The displacements of S_1 can be determined by comparing its distances from S_2 which remains stationary.

In order to obtain a complete record of the position of S_1 a photographic plate S_1S_2 is placed in a vertical position at the images S_1 and S_2 and just in front of it a screen. A narrow horizontal slit cut in the screen allows a small part of the light only to pass through. At any instant of time, therefore, there will be two small spots of light on the plate at the intersections of the two images S_1 and S_2 with the projection of the slit on the plate. A system of cog-wheels allows the photographic plate to fall slowly during the reaction so that two lines are drawn on it, one of them straight due to the fixed image S_2 and the other curved due to the moving image S_1 . The curved line represents the reaction in that the abscissas are proportional to the intervals of time and the ordinates represent (but are not proportional to) the quantities of the substance that have reacted. After the reaction is completed the plate is drawn up and lowered again and the image S_1 traces a third line that is practically straight. This line may be taken as the zero line and the distances between it and the curved one are (at least in some cases) proportional to the amounts of the original compounds left in the solution.

2

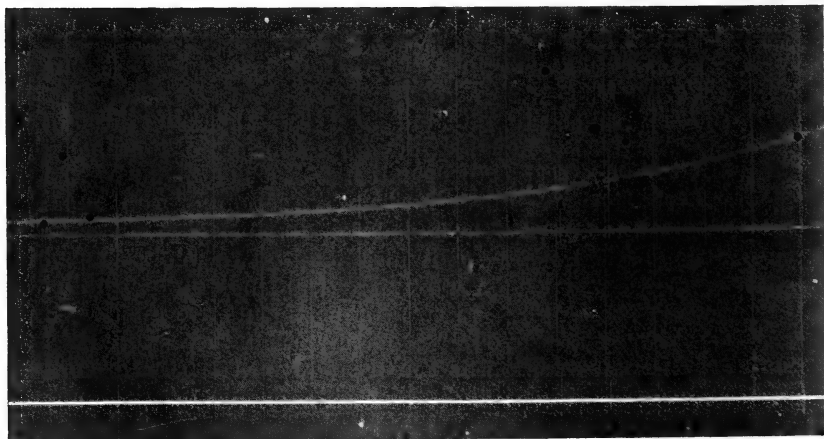

Fig. 2 is a reduced copy of a photograph representing the inversion of a 25 per cent solution of cane sugar, the inversion being accelerated by the addition of hydrochloric acid. The middle horizontal line represents the position of the image S_1 twenty-four hours after the reaction had started. The vertical lines were drawn with a dividing engine after the plate had been developed. The distance between two successive lines repre-

sents fifteen minutes. This distance was determined on a separate plate by lighting a magnesium burner for an instant every hour at some distance in front of the horizontal slit, and by measuring on the dividing engine the distance between the lines thus formed. A heavy vertical line to the extreme right of the plate (not seen in the copy) is a magnesium flash-light line and represents the instant at which the hydrochloric acid and sugar solution were mixed.

The photographic plate was fastened in a frame hung on a fine iron wire that was wrapped around a cylinder on the axle of one of the wheels in the works of a clock. The escapement of the clock was operated by an electro-magnet the circuit of which was made and broken by the swing of the pendulum of a standard clock. On account of the escapement the downward motion of the plate was by jerks, but as each jerk carried the plate only about $\frac{1}{20}$ th of a mm. this is not apparent from the photograph.

It is evident from the way in which the fifteen-minute lines are drawn that no correction need be made for the shrinkage of the gelatine films, for practically the same shrinkage takes place on one plate as on another. The shrinkage too reduces all the ordinates of the curve in the same proportion, and if the relative positions of the images are always determined by measurements on a photographic plate no correction need be applied to the ordinates.

The object of having two wedge-shaped compartments is to reduce the dispersion of the light passing through them as much as possible, indeed white light from an incandescent lamp can be used. The solution in the wedge $abcd$ is the same as that in acd except that in it the reaction has already taken place. Under these circumstances the indices of refraction in the two wedges are very nearly equal and a slow change of a few degrees in temperature does not displace the image S_1 since such a change affects the index of refraction in both solutions practically to the same extent.

In the above described experiment the dimensions of the apparatus were as follows: SL (Fig. 1) = 150cm ; LS_2 = 250cm ; $ab = 1\text{cm}$; $ad = 5.3\text{cm}$; $Lb = 15\text{cm}$, approximately. The breadth of the slit in front of the figure was $.2\text{mm}$, and its distance from the figure about $.3\text{cm}$.

That the distance of the image S_1 at any time from its final position after the reaction has been completed is very approximately proportional to the amount of cane sugar left in the solution at that time, may be seen from the following reasoning. The proof is based upon the assumptions that the density d and the specific index of refraction $\frac{n^2 - 1}{n^2 + 2} \cdot \frac{1}{d}$ of the solution

(where n is the ordinary index of refraction) are additive functions of the constituents (see Nernst, *Theoretische Chemie*). Granting these, it follows that the difference between the value of $\frac{n^2-1}{n^2+2}$ at any time and its final value must be proportional to the amount z of cane sugar remaining at that time. Denoting this difference by Δ we have

$$\Delta \frac{n^2-1}{n^2+2} = k z$$

Approximately for small changes

$$\Delta \frac{n^2-1}{n^2+2} = \frac{d}{dn} \left(\frac{n^2-1}{n^2+2} \right) \Delta n = \frac{6n}{(n^2+2)^2} \Delta n$$

Hence
$$\Delta n = \frac{(n^2+2)^2}{6n} k z$$

If n (Fig. 3) is the index of refraction of the already reacted solution

$$\begin{aligned} \frac{n_1}{n} &= \frac{\sin \beta}{\sin \alpha} = \frac{\sin (a + \Delta a)}{\sin a} \\ &= 1 - \cot a \sin \Delta a \end{aligned}$$

approximately, and therefore,

$$\cot a \sin \Delta a = 1 - \frac{n_1}{n} = \frac{\Delta n}{n}$$

or
$$\sin \Delta a = \frac{\Delta n}{n \cot a}$$

3

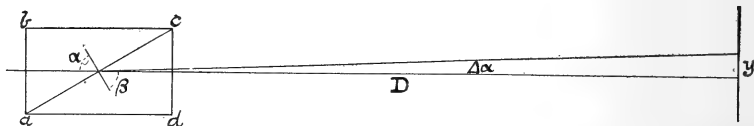

If D is the distance from the solution to the screen

$$\frac{y}{D} = \frac{\sin \Delta a}{\cos \Delta a}$$

$$\therefore y = D \sin \Delta a \text{ approximately}$$

Hence

$$y = \frac{D(n^2+2)^2}{n^2 \cot a} k z$$

n does not vary more than 1 per cent and if n lies between 1.3 and 1.4, which it usually does, the expression $\frac{(n^2+2)^2}{n^2}$ is practically constant.

Hence y is proportional to z , or the displacement of the image from its final position is proportional to the quantity of cane sugar in the solution.

Whether or not y is proportional to z in any particular case should and can be tested experimentally as follows. Take equal quantities by weight of a solution that has already reacted and of one that is just beginning to react. Mix them together and obtain a curve as above. This mixture is equivalent to a solution that has reacted half way, and the total change in the position of S_1 as indicated by the curve should be $\frac{1}{2}$ that in the case of the original solution. Such a curve photographed for the inversion of sugar proved the proportionality to within about $\frac{1}{2}$ of a per cent. If y is found not to be proportional to z a number of mixtures must be made with varying quantities of new and old solutions, and the relation between y and z determined.

The distances between the lines on the photographic plate corresponding to the different instants of time can be measured by means of a micrometer microscope of low power. I have found it more satisfactory, however, to place a glass scale over the plate and take the readings with a small lens, illuminating both scale and plate by means of a mirror below them.

The following table contains the results of such measurements on the plate representing the inversion of sugar. The first column contains the time t expressed in minutes; the second, the distances y in centimeters between the curve and the line drawn 24 hours later (the value of y for $t = 0$ being extrapolated), and the third, the percentage of cane sugar left in the solution.

t	y	% sugar	$\frac{k}{2.3026}$
0	25.5	25.	.00535
15	21.2	20.78	
30	17.9	17.54	.00490
45	15.4	15.09	.00463
60	13.25	12.99	.00454
75	11.3	11.07	.00455
70	9.75	9.56	.00449
105	8.5	8.33	.00441
120	7.4	7.25	.00435
135	6.4	6.27	.00433
150	5.55	5.44	.00431
165	4.85	4.75	.00427
180	4.3	4.22	.00419
195	3.95	3.87	.00405
210	3.6	3.53	.00395
225	3.3	3.23	.00385

According to Gouldberg and Waage's law the rate at which the cane sugar disappears should be proportional to the amount

left in the solution. Hence $\frac{dz}{dt} = -kz$

Or integrating between t_1 and t

$$k(t-t_1) = \log_e \frac{z_1}{z} = 2.3026 \log_{10} \frac{z_1}{z}$$

or
$$k = \frac{2.3026}{t-t_1} \log_{10} \frac{z_1}{z}$$

The third column in the table contains the values of $\frac{k}{2.3026}$ calculated by this formula, using the value $t_1 = 15$ minutes so as to avoid extrapolation. It appears that k as calculated above

4

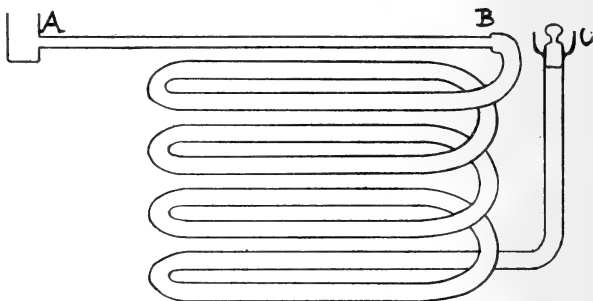

is not a constant. The decrease in its value indicates that the velocity of the reaction is greater at the beginning or less at the end than would be expected from Gouldberg and Waage's law. During the reaction, of course, the amount of water present changes perceptibly, but not enough to account for the large variation of k . The total change during the entire reaction is less than 2 per cent. The deviation from Gouldberg and Waage's law may be due to the relatively large quantity of hydrochloric acid in the solution. To decide whether it is or not will be the object of further investigation.

The second method is based upon the change in the volume of the chemical system during the reaction. In order to measure the change in volume the system is placed in a spiral glass tube (Fig. 4), on one end of which is sealed a capillary tube A B and on the other end a ground stopper and cup C. The reacting system may fill the entire spiral or only a part of it, the rest being filled with a liquid that does not combine with the given system. If the volume increases during the reaction, the cup A and most of the tube A B are filled with mercury. If the volume decreases, the cup and only a small part of the tube are filled. Evidently during the change of volume the mercury is drawn in or pushed out through the capillary tube and the positions of the end of the mercury column measure the amount of change.

The particular form represented (Fig. 4) was adopted, first, in order that the temperature of the system should remain that of a bath in which the spiral is immersed owing to the large surface presented to the bath; and second, in order that the tube might be filled, and the first reading of the position of the mercury column taken as soon after the reaction started as possible. The liquid is first poured in at C and allowed to fill the spiral, the tube A B and the cup A. Mercury is then poured into A and finally the stopper inserted at C. A little practice in manipulating the stopper and tilting the whole tube will enable one to set the dividing surface between the mercury and the other liquid at any desired point in the capillary tube. The tube A B is graduated or a graduated scale is fastened to it.

In most cases the change in the volume of a system is small. Hence, if the temperature of the apparatus varies during the reaction, even by a small amount, the consequent change in volume will be a large fraction perhaps of the change we wish to measure. It is, therefore, necessary to immerse the spiral tube in a delicate thermostat. In the following experiment on the inversion of a 25 per cent solution of cane sugar the electrical thermostat described by my assistant Mr. Lory and myself in this Journal for March, 1900, was used. The temperature of the bath did not vary as much as $\frac{1}{2000}$ th of a degree except once, and then the variation was only about $\frac{1}{1000}$ th of a degree.

In this experiment the spiral tube contained about 100^{cc} of the solution. The length of the capillary tube A B was 36^{cm}, and its cross section about 1^{sq mm}. The temperature was 25°·872 C.

The first two columns of the following table contain the readings of the end of the mercury column, on a metal scale attached to the capillary tube, together with the corresponding intervals of time *t* in minutes.

After allowing the apparatus to stand 24 hours and the reaction to become practically completed, the bath was heated up again to 25°·872 C., allowing all of the mercury which had been drawn into the spiral to run out. The end of the mercury column then stood at the mark ·20, which is the zero corresponding to zero quantity of cane sugar in the solution. The third column in the table contains the readings referred to this zero.

Under the assumption that the volume of the solution is an additive function of the constituents, these latter distances representing the changes in volume should be proportional to the quantities of cane sugar left in solution. The last column

contains the values of $\frac{k}{2.3026}$ calculated from the formula

$$\frac{k}{2.3026} = \frac{1}{t-t_1} \log_{10} \frac{z_1}{z}$$

<i>t</i>	cm.	cm.	$\frac{k}{2.3026}$
0			
20	34.55	34.35	
41	29.66	29.46	.00318
55	26.87	26.67	.00314
70	24.28	24.08	.00308
85	21.61	21.41	.00316
100	19.83	19.63	.00303
115	17.86	17.66	.00304
130	16.12	15.92	.00303
145	14.99	14.79	.00292
160	13.80	13.60	.00287
175	12.70	12.50	.00284
190	11.85	11.65	.00276
205	10.96	10.76	.00272
220	10.63	10.43	.00259
235	9.92	9.72	.00255
250	9.37	9.17	.00249
265	8.80	8.60	.00245

We see that *k* decreases, indicating as before that the velocity is less rapid at the end than would be expected from Gouldberg and Waage's law.

If desired, a complete record of the position of the mercury column could be obtained by any of the methods for recording the readings of a mercury thermometer.

The chief advantages of the above described methods are, first that the chemical system is not disturbed during the reaction; second, that no time is lost in titration or other chemical tests for the state of the system, thus making it possible to investigate rapid reactions; third, that it is not necessary for the experimenter to make observations during the reaction, which is a tedious piece of work if the velocity is very small; and fourth, the curves are drawn by purely mechanical processes, thus avoiding the influence of the personal equation.

A third method based upon the change in the index of refraction of the chemical system as measured by the motion of interference bands is being perfected.

In conclusion I wish to thank my assistant, Mr. F. C. Blake, for the care with which he has helped me obtain the above data. He and his brother, Mr. J. C. Blake, are at work applying the methods to hitherto uninvestigated reactions.

Hale Physical Laboratory,
University of Colorado.

ART. XXIX.—*The Transmission of Sound through porous materials*; by F. L. TUFTS, Ph.D.

A FEW years ago some experiments were made by the author for the purpose of determining the relative conductivities of different porous materials for sound waves. The methods employed at that time were comparatively crude, and while the data obtained could not be relied upon for great accuracy, they showed unmistakably that when two porous materials differ noticeably in the resistance offered to the transmission of sound, they also differ, in approximately the same way, in the resistance offered to the flow of a current of air through them.* When I attempted to obtain numerical results expressing the relative resistances offered by a number of different porous materials to the transmission of sound, I found that determinations made under different conditions gave results which varied to some extent. Some rather rough measurements of the relative resistances offered by these same materials to the transmission of air through them under different pressures, also showed variations greater than could be readily accounted for. It therefore seemed desirable to make a more careful comparison of the two phenomena.

For this purpose three different porous materials were selected, and in order not to introduce unnecessary complications, granular materials were chosen, the granules of which consisted of ordinary lead shot: a very considerable uniformity in the size and shape of the granules composing any one of the materials was thus obtained, and it was found that the packing of the material produced little or no difference in its conductivity. The coarsest material used consisted of a shot 4.37^{mm} in diameter. This will be referred to as material A; an intermediate material composed of a shot 2.79^{mm} in diameter will be designated by the letter B, and the material having the finest granules, a shot 1.22^{mm} in diameter, will be called C. When a cylindrical vessel was filled with any one of these materials, it was found that about 40 per cent of the volume of the vessel was still occupied by air, and this percentage was practically the same whether the coarsest material, A, or the finest, C, was used.

In the first part of this paper, I shall describe the experiments for determining the variations in the resistances offered by the three materials A, B, and C, to the flow of air through them under different pressures. In the second part the

* Science (N. S.) ix, 219-220, 1899

experiments for determining the variations in the resistances offered by these same materials to the to and fro motion of the air particles of a sound wave will be given.

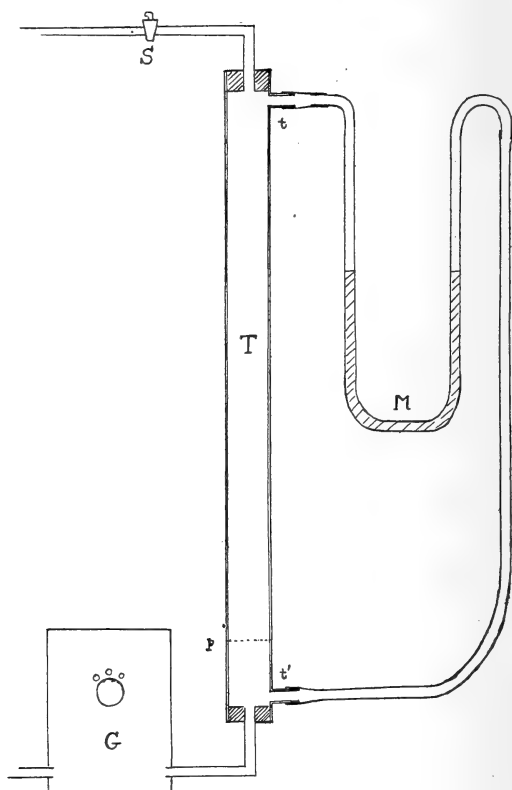

Fig. 1

Flow of air through granular materials.

The apparatus employed in studying the flow of air through the three sizes of shot is shown schematically in fig. 1. It consists essentially of a tube, T, about 75 centimeters long and 2.5 centimeters inside diameter, provided at *p* with a partition of wire gauze the meshes of which are fine enough to prevent the smallest shot from falling through. Near either end of this tube are connected side tubes, *t* and *t'*, to which are attached respectively the two arms of a water manometer, M. The upper end of the tube, T, is connected through a cock, S, with a source of compressed air, and the lower end of the tube is connected to a gas-meter, G. In

using the apparatus the tube, T, would be disconnected from the source of compressed air, and one of the sizes of shot, B for example, poured into it till the desired length of shot column had been added. The tube would then be reconnected to the compressed air-pipe, and the cock, S, turned till the manometer indicated the desired difference in air pressure between the two ends of the column of shot. The rate of flow of air through the shot would be measured by noting with a stop-watch the time required for a definite volume of air, usually one cubic foot, to pass through the meter. The data recorded would be the size of shot, A, B or C; the length in centimeters of the column of shot in the tube; the difference in pressure between the two ends of the column, given by the manometer in centimeters of water, and the time in seconds required for a given volume of air to flow through the shot.

The first experiments were for the purpose of ascertaining the relation between the resistance offered by a granular material to the flow of air and the length or thickness of the material used. The length of a column of shot, C for example, was made equal to 10, 20, 30, etc. centimeters successively, and the difference in pressure between the two ends of the column was made respectively 1, 2, 3, etc. centimeters of water. Under these conditions the times required for a given volume of air to flow through the different lengths of the material were found to be equal.

For convenience in stating the results of these experiments, the term *pressure-gradient* will be used to designate the quotient obtained by dividing the difference in pressure between the two ends of a column of shot by the length of the column. It represents the difference in pressure per unit length of the material. Using this term, the results of the above experiments may be stated as follows:

For a given size of shot and a given pressure-gradient, the rate of flow of air through the shot is independent of the length of column used. This is equivalent to the statement that, other things being equal, the resistance offered by one of these materials to the flow of air through it, is directly proportional to the length or thickness of the material used.

Experiments were conducted with pressure-gradients ranging from $\frac{1}{30}$ to about $\frac{1}{2}$ of a centimeter of water per centimeter length of material, and the columns of shot were varied in length from 5 to 70 centimeters. All three sizes of shot were experimented with, and no marked deviation from the above law was found within these limits.

The next experiments were for the purpose of studying the relation between the increase in difference of pressure between the two ends of a column of shot, and the increased flow of air

through it. The data given in Table I are typical of the results obtained.

The length of the column of shot used in this particular case was 69 centimeters. The successive differences in pressure between the two ends of the column are given in centimeters of water in the first column of the table headed M. The columns headed A, B and C, give the times in seconds required for a tenth of a cubic foot of air to flow through the materials A, B and C respectively, under the corresponding differences in pressure indicated in the first column. The next three columns of the table contain the products of the pressures into the corresponding times of flow through the three sizes of shot A, B and C respectively. An examination of these products shows

TABLE I.

M	A	B	C	M × A	M × B	M × C	C/A	C/B
1	48.5	101.0	484.0	48	101	484	10.0	4.8
2	31.5	59.0	283.0	63	118	566	8.9	4.8
4	19.1	31.1	150.0	76	124	600	7.8	4.8
8	13.6	20.6	79.0	105	165	632	5.8	3.8
16	8.1	13.1	39.0	130	210	624	4.8	2.9
26	6.4	9.7	24.0	166	252	624	3.7	2.4

that the times of flow through the different materials decreases less rapidly than the pressure-gradient increases. This difference in rates is much more marked for the coarse materials, A and B, than for the finer material C, and for all of the materials is more noticeable for the lower than for the higher pressure-gradients. As a result of this, the ratio of the time required for a given volume of air to flow through C to the time required to flow through A or B at the same pressure, given in the columns headed C/A and C/B respectively, is seen to be different for different pressures. A comparison of these ratios shows that they decrease in value as the pressure-gradient increases. The results of the experiments may be summed up in the following statement:

As the pressure-gradient for either of the materials A, B or C is increased, the rate of flow of air through the material increases less rapidly than the pressure-gradient, within the range of pressures investigated. This difference of ratio of increase is more noticeable for the coarse than for the fine shot, and as a result of this, the numbers expressing the relative rates of flow of air through A and B as compared to C, become smaller as the pressure-gradient increases. This is equivalent to the statement that the resistances offered by the three sizes of shot to the flow of air through them, become more nearly equal as the pressure-gradient increases. The pressure-gradients used varied from 0.01 to 0.60 of a centimeter of water per centimeter length of material.

Flow of sound through granular materials.

These experiments were undertaken for the purpose of ascertaining if there were any variations in the resistances offered by the materials A, B and C, to the transmission of sound through them, corresponding to the variations already detected in the case of air currents. A number of different forms of apparatus were used in studying the relation between the resistance offered by such materials to the transmission of sound and the thickness of the material used. The form of apparatus which seemed least subject to disturbing influences is shown schematically in fig. 2.

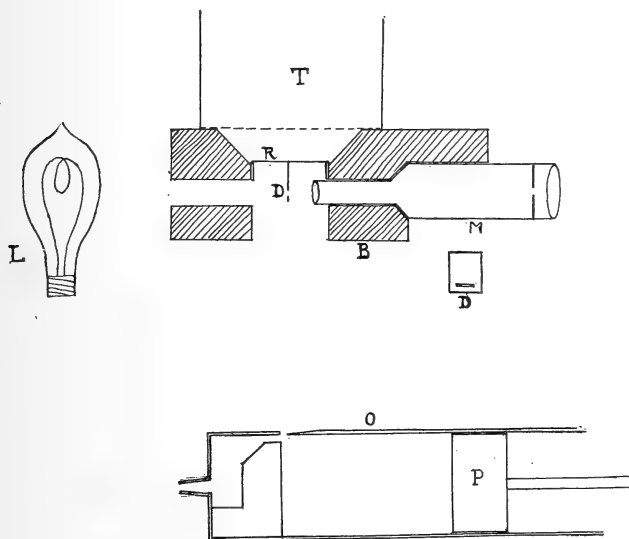

Fig. 2

It consists essentially of a thin rubber membrane R, stretched over a brass ring, which fits snugly in the opening through the block of wood, B. To the center of the membrane is attached a rectangular index of tinfoil, D, having a very narrow slit cut in it near its outer end. A microscope, M, provided with a micrometer ocular, is so mounted that it can be focused on the slit in the index, the slit being illuminated by a lamp, L. A tray, T, three centimeters deep, and about three centimeters in diameter, provided with a bottom of wire gauze, sits snugly on the block, directly over the membrane, and in it is placed the granular material under investigation. The application of a little cement around the edges of the tray makes an air-tight joint between it and the block, B. Thus the membrane together with the air in the tray above it forms

a single vibrating system, and any vibration of the membrane must be accompanied by a to and fro motion of the air in the tray. The block containing the membrane, microscope and tray was mounted on a suitable support, about fifty centimeters above an organ pipe, O, provided with a sliding piston, P, so that the effective length of the pipe could be varied, and the pipe thus brought in unison with the fundamental note of the apparatus above it. The organ-pipe was connected to a source of compressed air, and by means of a suitably placed stop-cock and manometer, the pressure at which the pipe was blown was kept constant. When the note emitted by the pipe was of about the same pitch with the fundamental note of the membrane, this would be set in quite violent vibration, and the amplitude of the vibration could be determined by measuring with the microscope the width of the band of light produced by the vibration of the slit, A.

A few preliminary experiments indicated that when the fundamental note of the membrane was as low as two hundred vibrations per second, no appreciable change in the fundamental note of the system, composed of the membrane and air in the tray above it, was produced by the gradual addition of shot to the tray. Under this condition, the diminution in the amplitude of vibration of the membrane, when shot is poured into the tray, is due chiefly to the increased resistance offered by the shot to the to and fro motion of the air particles, and only a very small amount is due to the slight change produced in the fundamental note of the system composed of the membrane and air in the tray.

In the experiments for the purpose of comparing the resistance of different thicknesses of the granular materials, the organ pipe was tuned to the vibrating system, R and T, and blown at a constant pressure. The amplitude of vibrations of the membrane was measured after each addition of a half centimeter thickness of shot. The differences between the reciprocals of these amplitudes should theoretically be proportional to the resistances offered by the various thicknesses of shot introduced. The data given in Table II are representative of the results obtained.

TABLE II.

T	A	B	C	A'	B'	C'	A'/T	B'/T	C'/T
0	60·0	60·0	60·0						
1	24·0	18·0	10·5	·0250	·0389	·0786	·0250	·0389	·0786
2	15·0	11·0	5·5	·0500	·0743	·1652	·0250	·0376	·0826
3	10·5	7·5	4·0	·0786	·1167	·2334	·0262	·0389	·0778
4	8·5	6·5	3·0	·1010	·1500	·3167	·0252	·0375	·0792
5	6·5	5·0	2·0	·1272	·1834	·4834	·0254	·0367	·0967
6	5·5	4·0	2·0	·1652	·2334	·4834	·0275	·0389	·0806

The note used in this particular case was about 150 vibrations per second. The numbers in the first column of the table headed T represent the thickness, in half centimeters, of the material in the tray. The next three columns, A, B and C respectively, contain the amplitudes of vibration of the membrane, in eightieths of a millimeter, after the addition to the tray of the corresponding thicknesses of the different materials A, B, and C respectively. The numbers given in the columns headed A', B', and C', are obtained by subtracting the reciprocal of the amplitude of vibration with the empty tray in place, from the reciprocals of the amplitudes of vibrations when 1, 2, 3, etc. half centimeters of one of the three sizes of shot A, B, or C, had been placed in the tray. These numbers should be, theoretically, proportional to the resistances offered by 1, 2, 3, etc. half centimeters of the different materials used. In the last three columns of the table, headed A'/T, B'/T and C'/T, are given the quotients obtained by dividing these numbers by the corresponding thickness of the material. An examination of these quotients shows them to be practically constant for a given size of shot. The variations are no greater than can be accounted for by experimental errors, since the amplitudes of vibration could not be read to a greater accuracy than two or three units in the first place of decimals, thus making the percentage error greater for small than for large amplitudes. Experiments with much modified forms of the apparatus indicated the same relation between resistance and thickness. This relation may be stated as follows: The resistance offered by granular materials to the to and fro motion of the air particles in a sound-wave is proportional to the thickness of the material, other things being equal. Hence the relation between resistance and thickness is the same as was found to hold for direct currents of air.

Observations were also made upon the transmission of sound and of direct currents of air through porous materials of a woven texture, such as cheese cloth, cambric and cotton flannel, and also through materials like felting and cotton batting. With such materials it was much more difficult to obtain consistent results than with shot, owing to variations in packing. By subjecting the materials always to the same pressure, the variation due to packing was almost eliminated, and the results then showed that the resistance which such materials offered to the transmission of sound and of direct currents of air, was directly proportional to the thickness or number of layers of the material used, as was the case with granular materials.

For practical purposes, it is quite important to know the comparative opacity of equal thicknesses of different substances to sound waves, that is, the relative resistances they oppose to the transmission of sound. Determinations of the relative resistances offered by different materials showed considerable variations, according to the conditions under which the materials were compared. For example: a comparison of the resistances offered by the two sizes of shot, A and C, to the transmission of sound, made in another set of experiments, showed that when the materials were placed near the node of a stationary sound-wave the finer shot, C, opposed only twice as much resistance to the to and fro motion of the air particles as the coarser material A, while if the comparison was made near a loop, C offered over ten times as much resistance as A. Experiments are now in progress for the purpose of studying the variations in the relative resistances of the three materials, A, B and C, to the transmission of sound. The resistances offered by equal thicknesses of the different materials have been compared at different positions, with respect to the nodes of a stationary sound-wave. The results so far obtained seem to warrant the conclusion that the relative resistance of C, as compared to either A or B, varies according to the distance of the material from the node of the stationary sound-wave. Diminishing the distance from the node has the same effect upon the relative resistances of the materials to the transmission of sound that increasing the pressure-gradient has upon the relative resistances of the same materials to the transmission of air currents.

Physical Laboratory of Columbia University,

Nov. 17, 1900.

ART. XXX.—*On a Yoke with intercepted Magnetic Circuit for measuring Hysteresis*; by ZENO CROOK, A.M., Fellow in Physics, University of Nebraska.

HOPKINSON'S bar and yoke method of studying the magnetic hysteresis in iron necessitates either breaking the continuity of the magnetic circuit in the specimen to be examined or using the "step up" method. In many instances it is impossible to break the magnetic circuit as in the first method, while the "step up" method cannot be used when it is desirable to determine the magnetic flux without varying the same. For example, if we wish to study the effect on the magnetic

1

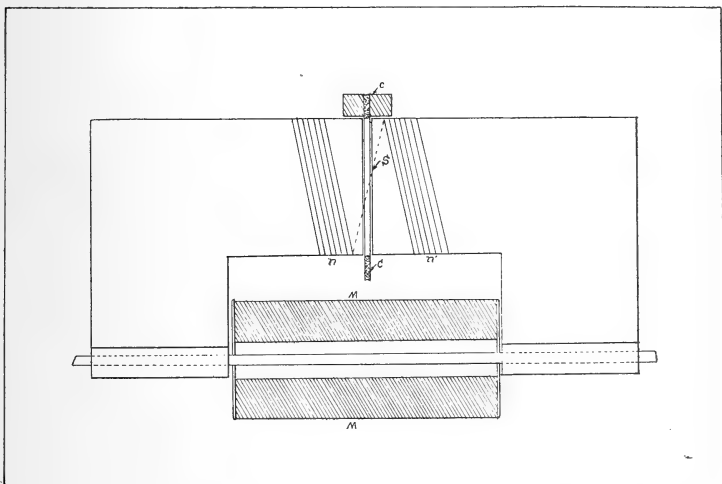

flux of an electric current it is impossible to break the magnetic circuit or vary the same during the observations. These difficulties may, however, be overcome by measuring the flux in the yoke itself. This method has been resorted to by Koepsel and others in direct-reading permeameters. In all these instruments, however, the air gap is so large that the reluctance of the circuit is very much increased.

These difficulties are overcome in a yoke designed by Professor D. B. Brace and constructed for him by Messrs. Siemens and Halske of Berlin. This yoke was forged from the best Norway iron and carefully annealed. Its cross-section is 100 \square cm. and the mean length of its magnetic circuit is 54^{cm}. It is divided into two like parts. The two halves, fig. 1, are mounted on a solid base and so arranged that the

slot S may be varied in width or be completely closed up at pleasure. Usually, however, the width is reduced to one or two-tenths of a millimeter. It was found that even within these narrow limits it was possible to use a test coil of sufficient number of turns to give accurate readings for weak fields. This coil C was constructed so that the total induction in the yoke would pass through it. It consisted of 125 turns of No. 46 double silk-covered wire between two thin sheets of mica. That part of the coil which had to pass through the slot was made of one layer of wire and the total thickness was such as to pass with perfect freedom through the slot when the latter was adjusted to a width not greater than $\cdot 025^{\text{cm}}$. Its resistance was approximately 1000 ohms.

2

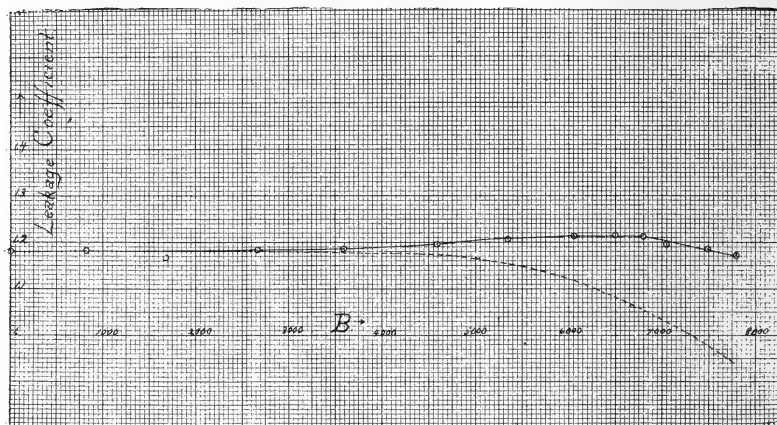

The specimens of iron or steel to be tested are shaped into cylindrical rods 40^{cm} long with a cross-section of $\cdot 28 \square^{\text{cm}}$. These fit into cylindrical grooves in the ends of the yoke and are clamped in place by iron covers and brass set screws. The magnetizing solenoid should be as small as possible. The solenoid which was used was constructed for another purpose and was much larger than necessary for bars of these dimensions. This solenoid "M" was 19^{cm} long and consisted of 1000 turns of No. 16 double covered copper wire. It was wound in nine layers on a brass spool, the inside diameter of which was $2\cdot 5^{\text{cm}}$. The rod when in position is coaxial with this coil.

The induction in the yoke is easily measured by jerking the test-coil from the slot and reading the deflection produced on the ballistic galvanometer. To determine the induction in

the rod it is necessary to know the leakage coefficient of the yoke, or the ratio of the induction in the rod to that in the yoke. A test of the leakage coefficient for different inductions is shown in fig. 2.

3

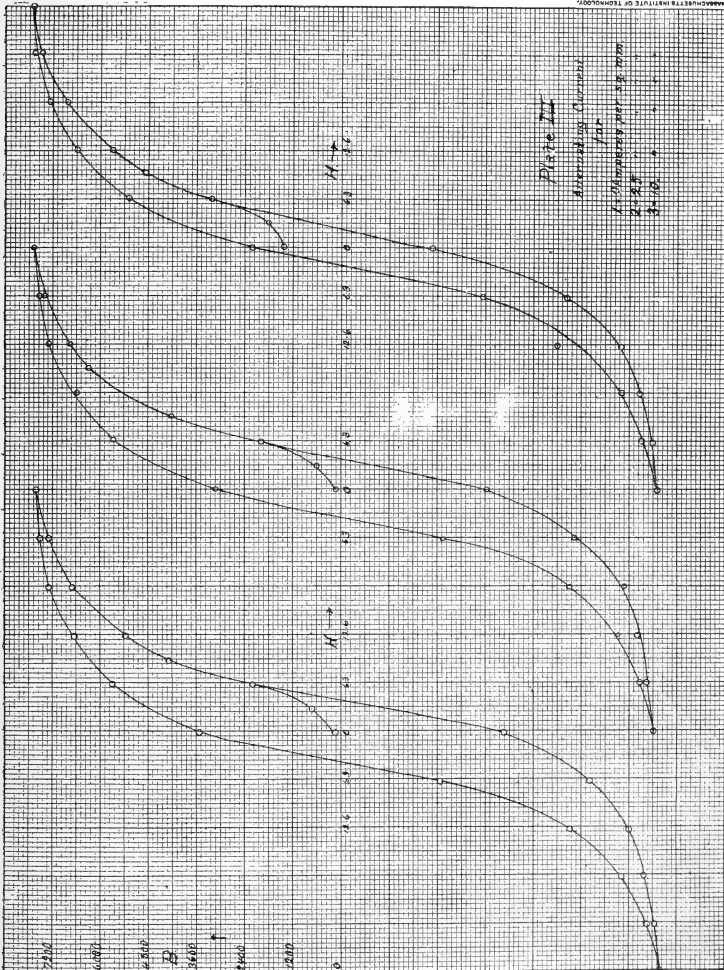

For observing its induction, a coil of fine wire was wound closely around the rod and the ends brought out and connected with a three-way switch, so that the induction for the same magnetizing current could be successively observed in the rod and in the yoke.

The first curve taken is represented by the dotted line. This shows that because of the large inside diameter of the magnetizing solenoid, as compared with the diameter of the rod, the induction in the yoke became greater than that in the rod when the rod approached saturation.

Compensating coils of a few turns were wound around the yoke, as shown by n and n' , and were connected in series with the magnetizing solenoid. As the current increases in them they tend to increase the leakage of the yoke, and when properly adjusted by a suitable number of turns gave the curve of leakage coefficients represented by the full line.

It is seen that this curve is almost a straight line and could be made more nearly so by a proper relation of the size of the iron rod and the magnetizing solenoid. If the rod were a little larger or the magnetizing solenoid a little smaller the dotted curve would not drop so rapidly and the full curve would be more nearly a straight line.

Even with the proportions used in this yoke the deviation from a constant value is so small that the error is negligible in taking the leakage coefficient constant. This form of yoke may thus be used for scientific measurements, as it gives, practically, a perfect hysteresis cycle. This is well shown in the curves in fig. 3, which were obtained by multiplying the inductions in the yoke by this coefficient. The use of the yoke for studying the demagnetizing action of electric currents, without interrupting the magnetic circuit or varying the same by means of the solenoid, is illustrated in these curves. The first one gives the cycle when no alternate current is passing through the rod, the second the cycle when the current density is 2.5 amperes per square millimeter and the third when the current density is 10 amperes per square millimeter. The convenience and accuracy of this method for this class of measurements indicate its general utility over the more common type of yokes.

Physical Laboratory, University of Nebraska, Lincoln.

ART. XXXI.—*Mineralogical Notes*; by C. H. WARREN.

THE minerals which are described in this paper were presented for the purpose of study to the Mineralogical Laboratory of the Sheffield Scientific School by the gentlemen whose names appear beyond, and to whom the writer takes pleasure in expressing his thanks. The materials were kindly placed at the writer's disposal by Prof. S. L. Penfield, and the investigations were made in the Sheffield Mineralogical Laboratory while the writer was connected with that institution.

Anorthite Crystals from Franklin Furnace, N. J.

The first specimens received, showing the anorthite crystals, were found by Mr. Wm. Niven, of New York City, in the limestone quarry near the railroad station, at Franklin, and later some of the same mineral was received from Mr. Hancock, of Burlington, N. J. The crystals are of a dull gray color, tabular in habit and vary in size from individuals a few millimeters in diameter to large flat tables, $1\frac{1}{2}$ cm long, 1 cm wide and 2 to 3 mm in thickness. They are few in number and are imbedded in the white crystalline limestone characteristic of that region. Flakes of graphite are plentifully sprinkled through the limestone and are plainly visible in the anorthite crystals themselves. As stated by Mr. Niven, the position in the quarry from which the specimens came was close to the contact of the limestone and the granite, and it is interesting to note here that anorthite has been noticed by Lacroix* as a contact mineral in limestones of the Pyrenees. It is probable that the Franklin mineral is of similar origin.

Although the faces of the crystals are dull and their solid angles and edges are somewhat rounded, sufficiently good reflections of the signal were obtained on some of the crystals to identify the following forms:

$$\begin{array}{llll} c & 001, & m & 110, & y & \bar{2}01, & o & \bar{1}\bar{1}1. \\ b & 010, & M & 1\bar{1}0, & p & \bar{1}11, & & \end{array}$$

Below are given the measured angles with the corresponding values calculated from the fundamentals established by Marignac.†

* Carte Géologique de la France, No. 61, vol. x, 1898-9.

† Kk., Min. Russl., iv, 200, 1862.

	Measured.	Calculated.
$c \wedge b = 001 \wedge 010 =$	86°	85° 50'
$c \wedge m = 001 \wedge 110 =$	66	65 53
$c \wedge M = 001 \wedge \bar{1}\bar{1}0 =$	69 31'	69 20
$c \wedge y = 001 \wedge \bar{2}01 =$	80 48	81 14
$c \wedge p = 001 \wedge \bar{1}11 =$	54 20	54 17
$c \wedge o = 001 \wedge \bar{1}\bar{1}1 =$	59 (poor)	57 52
$b \wedge m = 010 \wedge 110 =$	58 15	58 4
$b \wedge M = 010 \wedge \bar{1}\bar{1}0 =$	62 23	62 26½
$m \wedge M = 110 \wedge \bar{1}\bar{1}0 =$	59 32	59 29

The accompanying figures, 1 and 2, illustrate the habits of the crystals.

On the base of some of the better crystals a series of fine striations can be seen, due to twinning after the pericline law. The trace of the rhombic section can be seen in the striations on the faces, m , 110 , M , $\bar{1}\bar{1}0$, and b , 010 . A section cut from

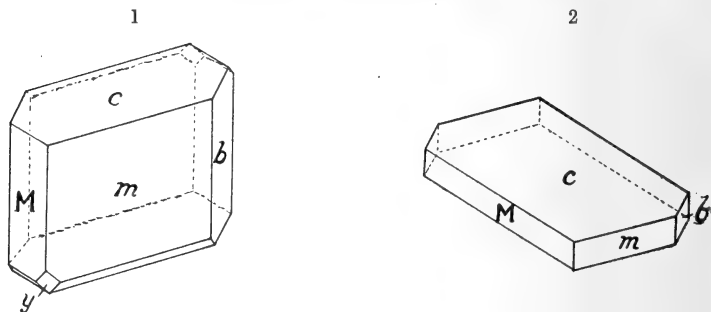

one of the crystals parallel to c , 001 , when examined under the microscope, showed a considerable amount of calcite and other inclusions in addition to the flakes of graphite already alluded to. Some of these inclusions are undoubtedly water, as is indicated by the strongly marked, dark borders and by the presence of a considerable amount of water in the mineral as shown by the analysis. The extinction measured on the base, 001 , using a Bertrand ocular and monochromatic light, was -40° .

A few of the smaller crystals were chosen for analysis. The included calcite was estimated by determining the amount of carbon dioxide evolved when the powdered mineral was treated with hydrochloric acid, and calculating from this the equivalent amount of calcium carbonate. After separating the silica in the usual manner it was dissolved in potassium hydroxide solution and thus separated from the small amount of graphite, which was afterwards weighed on a Gooch cru-

cible. The water was weighed directly by the method of Penfield.*

The results of the analysis are as follows:

			Mol. ratio.	
SiO ₂ -----	40·16%	÷ 60	=	·669 2·00
Al ₂ O ₃ -----	34·89	÷ 102	=	·342 1·02
CaO-----	18·26	÷ 56	=	·326 ·97
Na ₂ O-----	trace			
CaCO ₃ -----	5·30			
H ₂ O-----	1·69			
Graphite-----	·18			
	100·48			

The ratio of SiO₂: Al₂O₃: CaO is nearly 2:1:1 as required by the formula of anorthite, CaAl₂(SiO₄)₂.

Feldspar Crystals, from Raven Hill, Cripple Creek, Colorado.

The feldspar crystals were collected by Dr. Whitman Cross of Washington, D. C., while engaged in making the geological survey of the Cripple Creek region. They occur in considerable numbers imbedded in a rather soft, light gray rock, apparently of phonolytic character, the exact nature of which is unknown, no petrographical study of the rock having thus far been made. It is light gray in color, much altered in appearance and occurs, as we are informed by Dr. Cross, as a narrow dike cutting through the andesitic breccia of Raven Hill, Prospect Shaft, on the eastern slope above the Moose Mine.

The feldspar crystals, which vary in size from individuals 5^{mm} in length and 3^{mm} in diameter to those 15^{mm} in length, 10^{mm} in width and 8^{mm} in thickness, are of a light gray color like their matrix, and have undergone some alteration on their surface. The habit of the crystal is unusual in that the form $y, \bar{2}01$, is very prominent, while other forms $b, 010$; $c, 001$, and $m, 110$, are relatively small, fig. 3. Twinning after the Carlsbad law is common and gives rise to an appearance represented by fig. 4. In a large number of instances the crystals form peculiar aggregates, sometimes several crystals penetrating through each other. No simple twinning relations other than according to the Carlsbad law could be discovered.

The forms observed were: $c, 001$, $b, 010$, $m, 110$, and $y, \bar{2}01$, and below are the angles measured with a contact goniometer, also the calculated values.

* This Journal, *xlvi*, July, 1894.

		Measured.	Calculated.
$m \wedge m''' = 110$	$\wedge \bar{1}\bar{1}0 = 61^\circ$		$61^\circ 13'$
$m \wedge b = 110$	$\wedge 010 = 58\frac{1}{2}$		$59 23\frac{1}{2}$
$c \wedge m = 001$	$\wedge 110 = 67$		$67 47$
$c \wedge y = 001$	$\wedge \bar{2}01 = 80$		$80 18$

Sections parallel to both cleavages were prepared and showed on $b, 010$, an extinction of $+9^\circ$ to $+10^\circ$, and on $c, 001$, one approximately parallel to the a axis. Under crossed nicols the sections show a difference of shading or cloudiness, indicating that the crystals are not of homogeneous structure. Kaolinization has commenced to some extent and a small amount of a

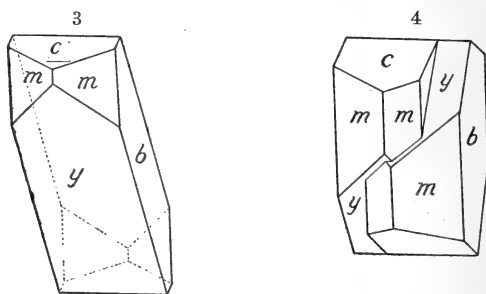

white lustrous mica can be seen. The large extinction-angle, $+9^\circ$ to $+10^\circ$ on 010 , would seem to indicate a soda-orthoclase.

Crystals of Iron Wolframite from South Dakota.

The Wolframite crystals were sent by Mr. W. M. Foote of Philadelphia, Pa., but the exact locality from which they were obtained could not be ascertained. The crystals, the largest of which are about 4^{mm} long and not over 1^{mm} in thickness, are found filling numerous small cavities in a highly siliceous rock. They are elongated in the direction of the ortho-axis, and, as the ortho-pinacoid and base are the most prominent forms, the crystals present the appearance of a nearly rectangular prism.

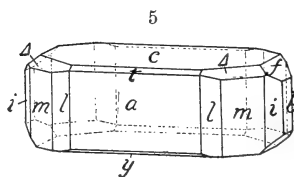

This prism is given a wedge-shaped termination by the development of the several prism faces, as can be seen from fig. 5. The majority of the crystals show a decided vicinal development of their faces and other irregularities. By using a strong illumination and the δ ocular

with a Fuess reflection goniometer satisfactory measurements were obtained from one of the smaller and more perfect crystals. The following forms were identified, of which the prism $i, 7\cdot11\cdot0$, is new:

a 100,	c 001,	s 210,	t 102,	f 011
b 010,	m 110,	i $7\cdot11\cdot0$,	y $\bar{1}02$,	Δ 112

The measured angles and their corresponding calculated values are given beyond, the later being taken from the fundamentals established by Des Cloiseaux* for wolframite :

	Measured.	Calculated.
$a \wedge c = 100 \wedge 001$	$= 89^{\circ} 25'$	$89^{\circ} 21'$
$m \wedge m' = 110 \wedge \bar{1}10$	$= 100 19$	$100 37$
$m \wedge b = 110 \wedge 010$	$= 50 22$	$50 18\frac{1}{2}$
$l \wedge l' = 210 \wedge \bar{2}10$	$= 134 45$	$134 55\frac{1}{2}$
$i \wedge i' = 7 \cdot 11 \cdot 0 \wedge \bar{7} \cdot 11 \cdot 0$	$= 74 51$	$74 59$
$a \wedge t = 100 \wedge 102$	$= 61 45$	$61 54$
$a' \wedge y = 100 \wedge \bar{1}02$	$= 63 8$	$62 54$
$a \wedge f = 100 \wedge 011$	$= 89 35$	$89 31$
$m \wedge \Delta = 110 \wedge 112$	$= 55 34$	$55 28$

Considering the character of the faces the foregoing measured and calculated values show a satisfactory agreement. The chief interest connected with this mineral is that it gives almost no reaction for manganese, indicating that its composition is very nearly that of an iron tungstate, FeWO_4 . So far as known to the writer, it is the first occurrence of a variety of this mineral free from manganese, and it is to be hoped that more may be learned of its place of occurrence.

Pseudomorphs of Wolframite after Scheelite from Trumbull, Conn.

Pseudomorphs of wolframite after scheelite have been known for some time to occur at Trumbull, Conn., where they are found in a highly siliceous vein associated with pyrite and a little native bismuth. The pseudomorphs attain a considerable size, sometimes measuring 3 or 4^{cm} in diameter, and usually present the habit of the simple pyramid common to scheelite, p , 111, often modified by the pyramid of the second order e , 101. The accompanying figure represents a somewhat more complicated habit and was drawn from a fine crystal kindly loaned by Mr. Lazard Cahn of New York. The most prominent form is e , 101, truncated by o , 102, and terminated by a basal plane c . The corners are modified by pyramids, of the first order p , 111, and of the third order s , 131. The angles of the crystal measured with a contact goniometer show a satisfactory agreement with the corresponding angles given for scheelite. A number of crystals showed, on breaking, a light colored core of scheelite still remaining within the black exterior of wolframite.

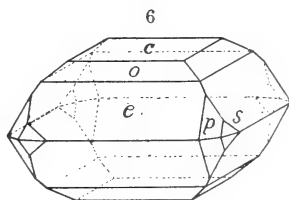

* Am. Ch. Phys., xix, 168, 1870.

ART. XXXII.—*On the Expansion of Certain Metals at High Temperatures*; by LUDWIG HOLBORN and ARTHUR L. DAY.

[Communication from the Physikalisch-Technische Reichsanstalt, Charlottenburg, Germany.]

THE expansion of bodies at high temperatures has been so little studied that the records are few and only indifferently accurate. We therefore devised a new method and applied it to the determination of the expansion of platin-iridium and of porcelain up to 1000° for use in our recent measurements with the gas thermometer and extended it afterward to various other metals. Platinum, palladium and nickel were investigated up to the same temperature, silver to near its melting point, constantan to 500° and finally a single sort each of iron and steel to 750° , these being of especial interest not only on account of their special magnetic properties, but on account of their wide technical application.

On account of the difficulty in heating considerable lengths of a metal uniformly, observations have usually been made heretofore upon short pieces with necessarily diminished accuracy, or the attempt at uniform heating has been entirely abandoned and the bar allowed to project out of the oven at both ends, these cold ends being provided with the marks upon which the expansion observations are made. In the latter case the mean temperature of the bar is determined with the gas thermometer or by an electrical resistance method.

This method has the disadvantage that the variation of the expansion with the temperature cannot be properly observed.

The arrangement of the apparatus in our experiments has been already described.* A bar one-half meter in length, of the metal to be investigated, is enclosed in an electrically heated porcelain tube considerably longer than the bar. In this way we obtained not only expansions of considerable magnitude (as much as 9^{mm} in some cases), but also a very uniform temperature along the bar, the exact distribution of which was measured and not merely a mean value.

Measurement of the Length.—The expansion was measured with the eye-piece micrometers of two fixed microscopes arranged to observe certain marks near the ends of the bar. The whole system was so solidly mounted upon a heavy stone pillar that after several days' observing no displacement of the microscopes could be observed equal in magnitude to the errors of observation. The differences observed between the

* Ludwig Holborn and Arthur L. Day, this Journal (IV), lvii, 171, 1900, also *Annalen der Physik*, ii, 505, 1900.

lengths of the various bars before and after heating consequently correspond to permanent variations in the lengths of the bars. This fact was also several times confirmed by measurements before and after heating, with a comparator.

An accidental disturbance of the adjustment is not wholly impossible however, and we therefore referred the expansion to the length of the cold bar as observed immediately before the heating rather than after, as the latter measurement could not be made until the following day after the oven had cooled down. The amounts of such slight differences as were observed are recorded in their proper places. The preliminary heating of the bar to remove mechanical strains and inhomogeneities in the metal is not taken into account of course in this connection. The permanent change in the length of a new bar after the first heating is often very considerable, hence each bar was always first subjected to a single preliminary heating to the highest temperature to be used in the subsequent measurements.

It may be further mentioned that the length represented by one turn of the micrometer screw was determined directly from the readings at the temperature of the room, the interval between the marks on the bar having been determined independently in advance upon the comparator.

The remaining details of the length measurement will appear from the example given in detail further on.

Measurement of the Temperature.—During the expansion observations the temperature of the middle of the bar alone was measured, a thermo-element whose bare hot junction lay upon the bar at its middle point being used for the purpose. The fall in the temperature toward the ends was determined separately by observations at points on each side of the center, the element being moved along the bar and the differences as compared with the center measured by direct comparison.

Two different oven tubes were used in the course of the series of observations here described. The first was wound with nickel wire 2^{mm} in diameter and proved fairly satisfactory, but in the hope of increasing the uniformity of temperature distribution a second tube was prepared with 1.2^{mm} wire in trifilar winding, which proved much better. We also tried rewinding the first coil with the heavier wire, but soon became convinced that although it is much more durable it is less well adapted to heating such a long and slender tube.

It is a matter of the greatest care to arrange the windings on such a tube so as to produce uniform temperature distribution. Some very painstaking trials yielded considerably poorer results than those here communicated. On the second tube mentioned, and the most successful one we obtained, the windings

are considerably nearer together toward the ends than in the center, but to compensate, the fall in temperature near the two openings through which the observations were made, is hardly possible without tremendously over-compensating the adjoining sections. The reason lies in the fact that one whole turn of wire is lost at the openings.

The presence of the bar also contributed something toward equalizing the temperature through its own conductivity. This was especially noticeable in the case of silver (6^{mm} in diameter) when compared with platinum and palladium (each 5^{mm} in diameter), for example.

Table I contains observations of the temperature distribution in the two tubes.

Nickel is included with this series for a special reason. Between the two measurements with nickel to 750° a considerable interval of time intervened, during which the oven was used for other purposes. These two series therefore show very clearly that the distribution of temperature suffers little from the oxidation of the oven coil with use.

Table I shows the differences of temperature in microvolts observed at eight points along the bar as compared with the middle. The relation between the thermo-electric force and the temperature for the element used is contained in Table XVI of the original investigation (*loc. cit.*, p. 186). The temperature gradient is then obtained graphically and the mean, Δ , algebraically added to the reading at the middle point to obtain the mean temperature of the bar.

The observations were always begun with a series of readings at the temperature of the room, which was measured by introducing a mercury thermometer into the oven tube, then at the points 250, 500, 750 and 1000° as nearly as the oven could be regulated. In certain cases the intermediate temperatures 375, 625 and 875° were also observed. No point below 250° was attempted on account of the diminished sensitiveness of the thermo-element at the lower temperatures. For observations in this region it would be better to substitute a bath for which the arrangement of the apparatus and the heating arrangements could be readily adapted. It would indeed be perfectly possible to carry on these observations in a niter bath to above 600° with a perfectly uniform distribution of temperature throughout the length of the bar by properly insulating the oven coil.

1. *Platinum.*

The platinum bar, as well as the two immediately following, were prepared from chemically pure material and placed at our disposal through the courtesy of the firm of Heräus in Hanau,

TABLE I.

Temperature Distribution in the Oven (in Microvolts).

From center of oven.	Platinum.							
	Oven Tube I.				Oven Tube II.			
	250°	500°	750°	1000°	250°	500°	750°	1000°
6 ^{cm} East	- 22	- 10	+ 17	0	+10	+ 35	+ 46	+ 77
12 "	- 33	- 23	+ 27	+ 25	+56	+125	+183	+227
19 "	-170	-230	-250	-443	+79	+157	+189	+171
23 "	-282	-310	-610	-900	-79	-196	-248	-411
6 ^{cm} West	+ 57	+170	+230	+335	- 5	+ 9	+ 49	+ 99
12 "	+ 73	+220	+315	+540	+38	+135	+238	+342
19 "	- 62	- 5	0	+ 53	+89	+227	+345	+398
23 "	-210	-250	-380	-480	-12	+ 42	- 9	-143
Δ	- 44	- 11	+ 4	+ 51	+25	+ 64	+116	+135

Temperature Distribution in the Oven (MV).

From center of oven.	Oven Tube II.							
	Palladium.				Silver.			
	250°	500°	750°	1000°	250°	500°	750°	875°
6 ^{cm} East	+ 13	+ 29	+ 55	+ 80	+ 3	+ 21	+ 35	+ 19
12 "	+ 59	+128	+180	+236	+47	+107	+150	+142
19 "	+ 80	+155	+188	+164	+78	+140	+163	+125
23 "	-100	-165	-210	-402	-84	-174	-220	-344
6 ^{cm} West	- 1	+ 12	+ 53	+ 94	+ 1	+ 15	+ 52	+ 20
12 "	+ 52	+148	+269	+356	+23	+ 82	+153	+177
19 "	+ 95	+233	+358	+399	+48	+133	+217	+223
23 "	+ 12	+ 34	- 3	-129	+ 3	+ 48	- 29	+ 11
Δ	+ 31	+ 77	+124	+135	+16	+ 49	+ 80	+ 62

From center of oven.	Oven Tube II.—Nickel.					
	250°	375°	500°	750°	750°	1000°
6 ^{cm} East	+16	+ 22	+ 27	+ 59	+ 57	+ 82
12 "	+64	+ 91	+124	+196	+191	+258
19 "	+89	+117	+147	+194	+168	+196
23 "	-87	-111	-150	-205	-226	-337
6 ^{cm} West	+ 4	+ 15	+ 26	+ 64	+ 75	+120
12 "	+55	+110	+163	+303	+333	+458
19 "	+99	+177	+248	+405	+445	+509
23 "	+13	+ 20	+ 21	- 29	- 26	-221
Δ	+38	+ 74	+109		+152	+185

Germany. Some 5^{mm} from the end of each bar plane surfaces were filed and polished upon it in the plane of the axis and upon these five fine divisions were ruled at millimeter intervals. The bar of platinum, which was 5^{mm} in thickness, was measured in both the oven tubes described.

By way of example, a full series of actual readings of the microscope is contained in Table Ia. The micrometer readings are represented by F and F' for the fixed wires, I, II, . . . V and I', II', . . . V' for the settings of the movable wires upon the ruled divisions on the two ends of the bar respectively. The temperatures in degrees or microvolts are contained under *t*.

At each temperature (20°, 250°, 500°, 750°, 1000° and then 19° after the oven had cooled down) two sets of readings were made each containing settings upon each division of the bar and the fixed microscope cross-wire in their proper succession—the first in the forward, the second in the backward direction of the micrometer screw. This symmetry served to minimize the effect of a slight creeping of the bar such as was often noticeable at the higher temperatures. The series also included five observations of the temperature at proper intervals.

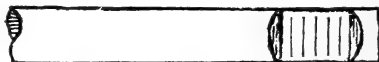

From the observations the displacement of the various divisions during the change of temperature from *t* to *t'* was calculated and is entered for each separately in Table Ib. A positive sign indicating that the displacement has taken place toward the end being read. The columns *M* and *M'* contain the intervals expressed in turns of the micrometer screw (*r* and *r'*) and the corresponding values reduced to millimeters, the sums being then brought together under Σ . For the remaining observations only the values of *M*, *M'* and Σ are given. Table Ic contains these values for the observations made upon the platinum bar which was heated in the first oven tube on the first two days and in the second on the remaining. It will be seen that the corresponding values of Σ agree extremely well.

The Σ values are then corrected slightly to correspond to the round numbers 0°, 250°, etc., by the use of an approximate formula for the expansion λ_s of the bar from which the required values of $\frac{d\lambda_s}{dt}$ were obtained.

The values of *t* observed at the middle point of the bar require to be corrected for the fall in temperature toward the ends as described above. These are contained in Table Id, in which only Σ' , the mean of each two corresponding values of Σ , is given.

TABLE I b.
Observations upon Platinum Bar, June 16, 1900.

<i>t</i>	<i>t'</i>	I	II	III	IV	V	Mean M		$\Sigma = M + M'$ mm.
							<i>r</i>	mm.	
20.3°	1813 MV	0.591	0.595	0.592	0.593	0.588	0.592	0.669	1.044
20.3	1823	0.589	0.590	0.592	0.594	0.594	0.592	0.669	1.044
1813 MV	4132	1.251	1.255	1.255	1.257	1.253	1.254	1.417	1.200
1822	4143	1.265	1.264	1.259	1.263	1.258	1.262	1.425	1.206
4132	6600	1.290	1.282	1.280	1.279	1.279	1.282	1.449	1.258
4143	6615	1.302	1.306	1.301	1.295	1.298	1.300	1.469	1.247
6600	9422	1.601	1.604	1.596	1.623	1.600	1.605	1.812	1.417
6615	9429	1.610	1.605	1.603	1.602	1.592	1.602	1.810	1.413
19.3°	20.3°	-0.430	-0.424	-0.419	-0.418	-0.421	-0.422	-0.477	0.008
19.3	20.3	-0.428	-0.420	-0.423	-0.417	-0.420	-0.422	-0.477	0.014
<i>t</i>	<i>t'</i>	I'	II'	III'	IV'	V'	Mean M'		
							<i>r'</i>	mm.	
20.3°	1813 MV	0.352	0.355	0.360	0.362	0.358	0.357	0.375	
20.3	1822	0.347	0.351	0.363	0.360	0.365	0.357	0.375	
1813 MV	4132	-0.221	-0.206	-0.210	-0.197	-0.200	-0.207	-0.217	
1822	4143	-0.212	-0.208	-0.215	-0.204	-0.204	-0.209	-0.219	
4132	6600	-0.176	-0.188	-0.186	-0.183	-0.178	-0.182	-0.191	
4143	6615	-0.220	-0.220	-0.211	-0.207	-0.204	-0.212	-0.222	
6600	9422	-0.386	-0.385	-0.379	-0.369	-0.368	-0.377	-0.395	
6615	9429	-0.369	-0.386	-0.381	-0.386	-0.371	-0.379	-0.397	
19.3°	20.3°	0.459	0.458	0.470	0.464	0.462	0.463	0.485	
19.3	20.3	0.463	0.468	0.475	0.464	0.473	0.468	0.491	

TABLE I c.
Platinum Bar.

	<i>t</i>	M (mm.)	M' (mm.)	Σ (mm.)	<i>t</i>	M (mm.)	M' (mm.)	Σ (mm.)
Feb. 24	19·9°				19·9°			
	1900 MV	0·799	0·249	1·048	1912 MV	0·799	0·257	1·056
	4255	0·680	0·541	1·221	4265	0·653	0·564	1·217
	6830	0·312	0·990	1·302	6838	0·294	0·985	1·279
	9649	1·143	0·239	1·382	9660	1·213	0·198	1·411
Feb. 27	17·8°				17·8°			
	1920 MV	0·794	0·275	1·069	1926 MV	0·798	0·280	1·078
	4250	0·548	0·664	1·212	4256	0·554	0·645	1·199
	6823	0·525	0·759	1·284	6823	0·498	0·786	1·284
	9639	1·022	0·345	1·367	9631	1·055	0·334	1·389
June 16	20·3°				20·3°			
	1813 MV	0·669	0·375	1·044	1822 MV	0·669	0·357	1·026
	4132	1·417	-0·217	1·200	4143	1·425	-0·219	1·206
	6600	1·449	-0·191	1·258	6615	1·469	-0·222	1·247
	9422	1·812	-0·395	1·417	9429	1·810	-0·397	1·413
June 20	20·1°				20·1°			
	4190 MV	2·634	-0·375	2·259	4200 MV	2·638	-0·379	2·259
	6564	1·381	-0·156	1·225	6570	1·403	-0·186	1·217
	9365	1·736	-0·328	1·408	9384	1·751	-0·343	1·408

TABLE I d.
Platinum Bar.

<i>t</i>	Σ' (mm.)		λ (mm.)			
	Oven Tube I. Feb. 24.	Oven Tube II. Feb. 27.	Oven Tube I. June 16.	Oven Tube II. June 20.	Observed.	Calculated.
0°					0	0
250	1·111	1·114	1·116	} 2·289	1·114	1·112
500	1·196	1·192	1·184		2·301	2·304
750	1·271	1·268	1·270	1·285	3·574	3·576
1000	1·344	1·334	1·386	1·377	4·934	4·928

In connection with this table it should be mentioned that the platinum bar was heated for the first time on Feb. 23, when $\lambda_s = 2·306^{\text{mm}}$ was observed at 500° and $\lambda_s = 4·986$ at 1000° . After cooling, an increase in the total length amounting to $0·084^{\text{mm}}$ was measured. These permanent changes in the length of the bar for the subsequent four days' observations contained in the table were $0·020$, $0·028$, $-0·007$ and $-0·004$ respectively.

The agreement in the observations up to 750° is most satisfactory throughout; in the interval between 750° and 1000° , however, a discrepancy appears between the observations in the two oven tubes amounting to 1 per cent of the total expansion. The expansion λ_s of the bar (in μ) may be expressed by the quadratic formula

$$\lambda_s = 4.288t + 0.000640t^2 \text{ (}\mu\text{)}$$

The mean distance between the marks on the two ends amounted to 483.5^{mm} at 0° , hence the expansion* of a unit bar would be

$$\lambda = \{8868t + 1.324t^2\} 10^{-9}$$

Benoît† obtained for the expansion of pure platinum measured between the temperatures 0° and 75° by Fizeau's method, the formula

$$\lambda = \{8901t + 1.21t^2\} 10^{-9}$$

The expansions obtained by extrapolation of this formula do not differ from ours by an amount equal to 1 per cent until 1000° is reached—a remarkable agreement considering the magnitude measured and the range of temperature involved.

2. Palladium.

The measurements upon palladium are contained in Tables IIa and IIb and were all made in the second oven tube except the preliminary heating at the beginning. For this, values of

TABLE IIa.
Palladium Bar.

	t	M (mm.)	M' (mm.)	Σ (mm.)	t	M (mm.)	M' (mm.)	Σ (mm.)
June 26	19.6°				19.6°			
	1810 MV	1.349	0.036	1.385	1819 MV	1.362	0.018	1.380
	4083	1.432	0.176	1.608	4098	1.434	0.177	1.611
	6571	1.197	0.526	1.723	6585	1.198	0.515	1.713
	9339	1.689	0.197	1.886	9343	1.718	0.172	1.888
June 28	18.8°				18.8°			
	1923 MV	1.212	0.239	1.451	1927 MV	1.199	0.252	1.451
	4072	1.305	0.224	1.529	4085	1.347	0.198	1.545
	6552	1.928	-0.205	1.723	6555	1.934	-0.222	1.712
	9345	2.313	-0.424	1.889	9348	2.322	-0.428	1.894

* The earlier formula published elsewhere (loc. cit., p. 174) was based upon the observations with the first oven tube only.

† Benoît, Trav. et Mem. du Bureau international, vi, 1, 1888.

TABLE II b.
Palladium Bar.

<i>t</i>	Σ' (mm.)		λ_s (mm.)	
	June 26.	June 28.	Observed.	Calculated.
0°			0	0
250	1·476	1·470	1·473	1·475
500	1·611	1·616	3·087	3·082
750	1·729	1·739	4·821	4·821
1000	1·878	1·858	6·689	6·692

the expansion at 250°, 500° and 750°, equal to 1·617, 1·720 and 1·840 respectively, were obtained. A permanent increase in length after the preliminary heating amounting to 0·024^{mm} was observed; the permanent changes after succeeding heatings in no case amounted to 0·01^{mm}.

The expansion of the bar employed may be represented by

$$\lambda_s = 5·636t + 0·00106t^2 (\mu)$$

Its length at 0° was 482·9, whence

$$\lambda = \{11670t + 2·187t^2\} 10^{-9}$$

3. *Platin-iridium* (80 Pt, 20 Ir).

The series of measurements upon the platin-iridium bar which are contained in the Tables III a and III b were all made

TABLE III a.
Platin-iridium Bar.

<i>t</i>	M	M'	Σ
	(mm.)	(mm.)	(mm.)
Jan. 19	16·9°		
	1810 MV	0·348	0·595
	4193	0·850	0·318
	6757	0·636	0·592
	9514	0·969	0·322
	9569	1·045	0·276
	9560	1·043	0·273
Jan. 24	17·9°		
	1862 MV	0·675	0·291
	4181	0·654	0·462
	6708	0·607	0·604
	9528	1·163	0·189
Jan. 26	18·8°		
	1843 MV	0·557	0·406
	4170	0·664	0·456
	6705	0·411	0·813
	9527	1·786	-0·450
	9539	1·797	-0·463

TABLE III b.

<i>t</i>	Σ' (mm.)			λ_s (mm.)	
	Jan. 19.	Jan. 24.	Jan. 26.	Observed.	Calculated.
0°	1.031	1.033	1.034	0	0
250	1.130	1.111	1.110	1.033	1.033
500	1.202	1.204	1.213	2.150	2.151
750	1.277	1.308	1.294	3.357	3.355
1000				1.280	1.287
	1.280				

in the first oven tube. Being the first observations made, the above described scheme was not exactly followed. For the temperatures below 1000° only a single set of measurements was made upon this bar; it had received a preliminary heating like the others however. The length at 0° was 483.1^{mm} and the formulæ are

$$\lambda_s = 3.960t + 0.000685t^2 (\mu)$$

$$\lambda = \{ 8198t + 1.418t^2 \} 10^{-9}$$

4. *Silver.*

The silver bar was 6^{mm} in thickness and carried seven divisions at each end, notwithstanding which the expansion was so great that not all the divisions were visible at all temperatures.

The preliminary heating was carried up to 900° and the permanent increase in the length which resulted amounted to 0.13^{mm}. The silver became very soft at this temperature and could with difficulty be prevented from sagging slightly. Partly for this reason probably, and partly because the permanent changes in the length after heating were larger than with any of the other bars, the observations at the higher temperatures disagree somewhat more widely among themselves. The last observation at 875° is not included in the calculation. The

TABLE IV a.
Silver Bar.

	<i>t</i>	M (mm.)	M' (mm.)	Σ (mm.)	<i>t</i>	M (mm.)	M' (mm.)	Σ (mm.)
June 22	20.2°				20.2°			
	1787 MV	1.216	0.945	2.161	1797 MV	1.252	0.929	2.181
	4088	2.254	0.386	2.640	4103	2.237	0.407	2.644
	6548	2.802	0.096	2.898	6548	2.815	0.073	2.888
June 23	20.2°				20.2°			
	1792 MV	0.149	2.325	2.176	1804 MV	0.111	2.304	2.193
	4116	1.905	0.771	2.676	4132	1.873	0.785	2.658
	6516	1.340	1.487	2.827	6581	1.394	1.456	2.850
	7937	1.049	0.603	1.652	7949	1.014	0.637	1.651

measurements upon the silver bar as well as upon all those following it were carried out in the second oven tube only.

Tables IVa and IVb contain the individual measurements.

TABLE IV b.

Silver Bar.

t	Σ' (mm.)		λ_s (mm.)	
	June 22.	June 23.	Observed.	Calculated.
0°			0	0
250	2·352	2·360	2·356	2·356
500	2·640	2·640	4·996	5·002
750	2·970	2·921	7·941	7·938
875	----	1·649	9·590	9·515

The first day's heating produced a permanent increase in the length amounting to 0·027^{mm}, the second 0·039^{mm}. The length at the close was 484·1^{mm} at 0°. The formulæ are

$$\lambda_s = 8.844t + 0.00232t^2(\mu)$$

$$\lambda = \{18270t + 4.793t^2\}10^{-9}$$

5. Nickel.

The nickel bar (6^{mm} in thickness) was at first ruled with five scale divisions on each end like the others and the observations only extended to 750°. In spite of the fact that the metal tarnished when heated, the divisions remained clear and sharp throughout until, at the close of the third series of observations, the temperature was carried up to 1000°. At this temperature not only did the divisions disappear but the surface and the contour lines of the bar could scarcely be distinguished from the oven background.

To remedy this a small thin platinum plate was prepared, some 5×5^{mm} in size and 0·5^{mm} thick and shoved into carefully filed dove-tail grooves in the bar so as to sit tightly in place with its polished surface in exactly the same position which the lost marks upon the nickel had occupied. Upon this platinum surface which of course also lay in the axis of the bar, new divisions were ruled and used in the two subsequent series of observations. If we assume from the ratio of the lengths that 1 per cent of the expansion is due to the platinum, the result will be influenced only 0·01(5·78 - 3·57) = 0·02^{mm} at 750°.

The length of the bar during the first observations was 482·6^{mm} at 0°; after the insertion of the platinum plates the new sets of divisions proved to be 0·2^{mm} further apart. The last observations are corrected for this increase in the length of the bar.

The nickel differed from the metals already described in that the permanent changes in the total length were in the opposite direction; the bar after cooling was always shorter than before—after the first two series, 0.024^{mm} and 0.018^{mm}, and after the last two, 0.016^{mm} and 0.035^{mm}, respectively.

The observations (Table Va and Vb) can be represented by a quadratic formula only above 375°. The measured expan-

TABLE Va.
Nickel Bar.

	<i>t</i>	M (mm.)	M' (mm.)	Σ (mm.)	<i>t</i>	M (mm.)	M' (mm.)	Σ (mm.)
June 30	19.1°				19.0°			
	1811 MV	1.354	0.227	1.581	1815 MV	1.377	0.218	1.595
	4072	1.548	0.407	1.955	4081	1.542	0.415	1.957
	6551	1.257	0.882	2.139	6561	1.261	0.865	2.126
July 2	19.8°				19.8°			
	1803 MV	1.102	0.469	1.571	1815 MV	1.142	0.463	1.605
	2914	0.953	0.038	0.991	2927	0.941	0.029	0.970
	4066	0.651	0.330	0.981	4075	0.639	0.343	0.982
	6551	1.286	0.863	2.149	6563	1.306	0.848	2.154
July 4	20.2°				20.2°			
	1793 MV	0.937	0.673	1.609	1799 MV	0.953	0.648	1.601
	4078	1.766	0.202	1.968	4083	1.753	0.218	1.971
	6552	1.314	0.822	2.136	6560	1.325	0.814	2.139
Sept. 18	17.7°				17.8°			
	6541 MV	5.674	-0.005	5.669	6537 MV	5.671	-0.013	5.658
	9356	2.591	-0.205	2.386	9358	2.612	-0.222	2.390
Sept. 19	18.4°				18.4°			
	6578 MV	5.942	-0.271	5.671	6578 MV	5.939	-0.275	5.664
	9332	2.495	-0.158	2.337	9330	2.505	-0.179	2.326

TABLE Vb.
Nickel Bar.

<i>t</i>	June 30.	July 2.	Σ' (mm.)		Sept. 18.	Sept. 19.	λ _s (mm.)	
			July 4.	Sept. 18.			Observed.	Calculated.
0°	1.670	1.678	1.708				0	0
250	} 1.957	} 0.975	} 1.953	} 5.770	} 5.748	} 5.748	1.685	(1.724)
375							2.660	2.661
500							3.643	3.648
750							5.782	5.772
1000	-----	-----	-----	2.313	2.313		8.095	8.096

sion at 250° falls out of the curve entirely as may be seen at once by calculating $\frac{\lambda}{t}$. This exceptional behavior was not unexpected, however, on account of the change which takes place in nickel in the neighborhood of 300° where its magnetic properties disappear.

Below this temperature therefore the formulæ

$$\begin{aligned}\lambda_s &= 6.496t + 0.00160t^2(\mu) \\ \lambda &= \{13460t + 3.315t^2\}10^{-9}\end{aligned}$$

do not apply: the term in the first power is there smaller while the quadratic term increases.

6. Constantan (60 Cu, 40 Ni).

The electrical conductivity as well as the thermo-electrical properties of constantan are peculiar, but in its expansion it differs little from other alloys. It has a coefficient corresponding to about the mean of those of the component metals.

The bar used was 6^{mm} in diameter and the scale divisions drawn upon the metal itself as with the earlier metals described, in consequence of which the marks grew fainter as the oxidation increased although the observations were only extended to 500° . The permanent changes in the total length reached a maximum value of about 0.01^{mm}. The length at 0° was 483.0^{mm}.

The results (Tables VIa and VIb) may be expressed by the following formulæ:

$$\begin{aligned}\lambda_s &= 7.156t + 0.00194t^2(\mu) \\ \lambda &= \{14810t + 4.024t^2\}10^{-9}\end{aligned}$$

TABLE VIa.
Constantan Bar.

	<i>t</i>	M [*] (mm)	M' (mm.)	Σ (mm.)	<i>t</i>	M (mm.)	M' (mm.)	Σ (mm.)
Sept. 24	17.9°	1.854	-0.023	1.831	17.9°	1.877	-0.057	1.820
	1818 MV	2.215	-0.125	2.090	1821 MV	2.187	-0.100	2.087
	4036				4036			
Sept. 25	17.9°	1.723	0.090	1.818	17.9°	1.750	0.052	1.802
	1815 MV	1.374	-0.348	1.026	1820 MV	1.366	-0.335	1.031
	2917	0.972	0.056	1.028	2927	0.956	0.063	1.019
	4007				4011			

TABLE VI *b*.
Constantan Bar.

<i>t</i>	Σ' (mm.)		λ_s (mm.)	
	Sept. 24.	Sept. 25.	Observed.	Calculated.
0°			0	0
250	1·916	1·903	1·910	1·910
375	2·159	1·040	2·950	2·956
500		1·106	4·063	4·063

7. *Wrought Iron.*

The bar of wrought iron as well as the steel bar described below were provided, before beginning the observations, with small platinum plates carrying the scale divisions, in the same way as the nickel bar above. One of the scale intervals at one end of the iron bar increased in length some 0·03^{mm} in consequence of the heating, nearly all of it occurring during the first day. None of the other divisions showed any noticeable change. The observations were not continued above 750° in order to avoid the permanent changes in the nature of metal such as occur in steel especially after long continued heating to high temperatures. The magnetic metals are known to

TABLE VII *a*.
Iron Bar.

	<i>t</i>	M (mm.)	M' (mm.)	Σ (mm.)	<i>t</i>	M (mm.)	M' (mm.)	Σ (mm.)
July 19	22·0°				22·0°			
	1841 MV	1·267	0·227	1·494	1847 MV	1·277	0·211	1·488
	4069	1·872	-0·030	1·842	4068	1·857	-0·024	1·833
	6564	1·823	0·170	1·993	6551	1·854	0·129	1·983
July 21	22·7°				22·7°			
	1816 MV	1·259	0·207	1·466	1823 MV	1·294	0·166	1·460
	2927	1·266	-0·364	0·902	2930	1·247	-0·349	0·898
	4077	0·987	-0·038	0·959	4077	0·966	-0·014	0·952
	6572	1·951	0·039	1·990	6567	2·004	-0·027	1·977
July 25	22·6°				22·6°			
	1803 MV	1·334	0·129	1·463	1807 MV	1·376	0·093	1·469
	4066	2·348	-0·473	1·875	4065	2·305	-0·453	1·852
	5248	0·963	0·016	0·979	5244	0·956	0·036	0·992
	6568	1·188	-0·188	1·000	6569	1·213	-0·211	1·002

TABLE VIIb.

Iron Bar.

t	Σ' (mm.)			λ_s (mm.)	
	July 19.	July 21.	July 25.	Observed.	Calculated.
0°				0	0
250	1.570	1.565	1.577	1.571	1.571
375		0.905		2.476	2.475
500	1.890	0.979	1.889	3.459	3.459
625		1.967		1.960	4.449
750			0.990		5.419
				0.964	

show an independent increase in length upon being magnetized, which must at least be considered here. We should expect with iron and steel in the weak field of the heating coil (at 250° H=30, at 500° H=42 at the middle point of the bar) a lengthening of the order of magnitude 5×10^{-6} of the length,* which for these measurements would be entirely negligible.

The iron bar (thickness 6^{mm}) was 482.7^{mm} long at 0° and showed a permanent change after the three heatings of 0.01, -0.025 and -0.025^{mm} respectively.

Tables VIIa and VIIb contain the measurements, which are very well represented by a parabola up to 500°.

The equations are

$$\lambda_s = 5.650t + 0.00254t^2 (\mu)$$

$$\lambda = \{11705t + 5.254t^2\} 10^{-9}$$

Above 500° the expansion increases less rapidly.

8. Steel.

In order that the difference in the nature of the material be as large as possible, a bar of steel with a high percentage of carbon was chosen.

The original length of the bar (thickness 6^{mm}) at 0° was 482.8^{mm} and decreased 0.10^{mm} during the first heating, but the subsequent changes did not exceed 0.04^{mm}.

The observations are contained in the Tables VIIIa and VIIIb.

If the curves

$$\lambda_s = 4.428t + 0.00402t^2 (\mu)$$

$$\lambda = \{9173t + 8.336t^2\} 10^{-9}$$

be laid out through the points 250° and 500° the observed value at 375° falls wide. The expansion of steel seems to be somewhat irregular even below 500°.

* Ewing, Induction in Iron, § 143.

TABLE VIII a.
Steel Bar.

	t	M (mm.)	M' (mm.)	Σ (mm.)	t	M (mm.)	M' (mm.)	Σ (mm.)
July 6	19.7°				19.7°			
	1801 MV	0.850	0.436	1.286	1809 MV	0.854	0.441	1.295
	4080	1.453	0.400	1.853	4088	1.463	0.397	1.860
	6535	1.431	0.140	1.571	6540	1.435	0.145	1.580
July 16	20.5°				20.5°			
	1824 MV	0.981	0.319	1.300	1828 MV	1.007	0.298	1.305
	2909	0.923	-0.047	0.876	2913	0.914	-0.041	0.873
	4150	0.628	0.394	1.022	4141	0.609	0.399	1.008
July 17	22.2°				22.2°			
	1813 MV	1.080	0.204	1.284	1817 MV	1.108	0.173	1.281
	4062	1.613	0.229	1.842	4060	1.595	0.236	1.831
	5274	0.555	0.445	1.000	5269	0.550	0.443	0.993
	6556	0.611	0.090	0.701		0.640	0.076	0.716

TABLE VIII b.

t	July 6.	Σ' (mm.)		July 17.	λ_s (mm.)		
		July 16.			Observed.	Calculated.	
0°		1.360		1.357	0	0	
250	} 1.866	0.896		} 1.871	1.359	(1.359)	
375		0.953			2.255	(2.227)	
500					0.979	3.221	(3.221)
625					0.704	4.200	(4.341)
750	} 1.582				4.904	(5.586)	

SCIENTIFIC INTELLIGENCE.

I. CHEMISTRY AND PHYSICS.

1. *Sulphur Hexafluoride, Thionyl Fluoride, and Sulphuryl Fluoride.*—MOISSAN and LEBEAU have recently described several new gases containing sulphur and fluorine. Sulphur hexafluoride, SF_6 , is produced when gaseous fluorine is brought into contact with sulphur. The sulphur immediately takes fire and burns with a bright flame. The gas thus produced is very remarkable for its great stability, as it has neither taste nor odor, and is not decomposed by water nor even by caustic potash solution. Although very rich in fluorine, the colorless gas, in its inertness, resembles nitrogen rather than the chlorides of sulphur. It is slightly soluble in water. At -55° it solidifies to a white crystalline mass which melts and then boils at a temperature a little above its point of solidification. It is not attacked by fused lead chromate, fused caustic potash nor by copper oxide at a low red heat. Sodium may be fused in contact with the gas without action taking place, but when the sodium is brought to the boiling point combination takes place with incandescence.

Thionyl fluoride, SOF_2 , is prepared by the action of fluorine upon thionyl chloride, and also by the reaction of arsenious fluoride with thionyl chloride. It is a colorless gas which fumes slightly in moist air, and which has a disagreeable, suffocating odor. It is decomposed by water at the ordinary temperature, with the formation of sulphur dioxide and hydrofluoric acid. In general it is much more active than sulphur hexafluoride.

Sulphuryl fluoride, SO_2F_2 , is most conveniently prepared by the combination of fluorine and sulphur dioxide. These gases burn when brought together if the combustion is started by means of a hot platinum wire. This is a remarkably stable gas, but it is not quite as inactive as SF_6 . It is colorless and odorless, does not act upon water even at 150° , but is decomposed by aqueous or alcoholic caustic potash with the formation of potassium fluoride and sulphate. It becomes liquid at -52° , solidifies when exposed to the temperature of liquid oxygen, and melts at -120° . It reacts with many substances at high temperatures.—*C. R.*, cxxx, 865, 1436; cxxii, 374.

H. L. W.

2. *The Molecular Weight of Ozone.*—The molecule O_3 is generally admitted to belong to ozone, but the facts upon which this assumption is based possibly leave some room for doubt in regard to the matter. A. LADENBURG, therefore, has devised a new method for determining the specific gravity of this gas. He weighed a glass globe filled with dry oxygen, then filled it with some of the same sample of oxygen after it had been ozonized and weighed again at the same temperature and pressure. After this he absorbed the ozone by means of oil of turpentine, and

thus determined the volume which it had occupied. These data sufficed for ascertaining the weight of ozone compared with that of oxygen, and several determinations made in this way served to confirm the accepted view in regard to the molecular weight of this substance.—*Berichte*, xxxiv, 631. H. L. W.

3. *The Preparation of Chlorine from Sodium Chlorate*.—Since sodium chlorate is now produced on the large scale as a very pure product, and since this salt is extremely soluble in water, C. GRAEBE recommends its use for preparing chlorine gas in the laboratory by allowing the concentrated solution to flow slowly into boiling dilute hydrochloric acid. This is a modification of the method recommended by Gooch and Kreider, in which warm hydrochloric acid is allowed to act upon lumps of previously fused potassium chlorate in a Kipp generator.

Graebe finds that his process yields chlorine containing only about 5 per cent of chlorine dioxide. For small quantities of the gas he uses hydrochloric acid of 1.10 specific gravity, while for larger quantities he prefers 1.12 acid. The acid can be used until the strength has fallen to 5 or 6 per cent. With 100° of 1.10 acid about 16 g. of chlorine can be obtained, and with the stronger acid, about 20 g. 1 g. of sodium chlorate yields about 2 g. of chlorine. The solution of this salt is made by dissolving 100 g. of it in 120 to 150° of hot water and afterwards diluting to 200°, so that 1° corresponds to a gram of chlorine. A special cylindrical, graduated dropping funnel is recommended, and the end of its stem should dip under the surface of the acid and be drawn out and bent upward.—*Berichte*, xxxiv, 645. H. L. W.

4. *New Alkaloids in Tobacco*.—Heretofore only a single alkaloid, nicotine, has been found in tobacco, although most other alkaloid-yielding plants have been found to contain a number of these bodies. PICTET and ROTSCHE have now shown that tobacco contains several alkaloids in addition to nicotine, and, consequently, that this plant is not an exception to the general rule. These chemists used the aqueous extract, concentrated in a vacuum, of 100 kg. of dried Kentucky tobacco. The liquid amounted to about 11.4 kg. and contained about 10 per cent of nicotine. After adding caustic soda and distilling with steam, both the residual liquid and the crude volatile alkaloid were examined for new bases. From the former, by extraction with ether and subsequent purification, two alkaloids were obtained. One of them, a liquid boiling at 266–268°, to which the name *Nicoteïne* is given, gave analytical results corresponding to the formula $C_{10}H_{12}N_2$. The other, called *Nicotelline*, was obtained as a solid from a higher-boiling fraction. This melts at 147–148°, and apparently has the formula $C_{10}H_8N_2$. By a somewhat intricate process a third alkaloid, called *Nicotimine*, was extracted from the large mass of crude nicotine. This base boils at about 250°, which is several degrees higher than the boiling-point of nicotine. It shows great similarity to the latter alkaloid and is believed to be isomeric with it.

The following formulæ are given for the alkaloids of tobacco :

Nicotine	$C_{10}H_{14}N_2$
Nicotimine	$C_{10}H_{14}N_2$
Nicoteïne	$C_{10}H_{12}N_2$
Nicotelline	$C_{10}H_8N_2$

The following table is given as a rough estimate of the quantities of these alkaloids in 10 kg. of the concentrated tobacco extract :

Nicotine	1000 g.
Nicoteïne	20 g.
Nicotimine	5 g.
Nicotelline	1 g.

Only one of the new alkaloids, nicoteïne, has been tested in regard to its physiological action. This appears to be even more poisonous than nicotine itself.—*Berichte*, xxxiv, 696. H. L. W.

5. *The Hydrate of Sulphuryl Chloride*.—BAEYER and VILLIGER have found that when sulphuryl chloride, SO_2Cl_2 is poured into ice-cold water a beautifully crystallized hydrate is formed, which, curiously enough, has not been previously noticed. The substance has the appearance of camphor, is only very slightly soluble in water at 0° , and in small quantities remains unchanged for hours under ice-cold water. When the hydrate is slightly warmed with water an oil separates which appears to be unchanged sulphuryl chloride, for the hydrate is formed again upon cooling. Analysis showed that the compound probably has the composition represented by the formula $SO_2Cl_2 \cdot 15H_2O$.—*Berichte*, xxxiv, 736. H. L. W.

6. *The Action of Hydrogen Peroxide upon Silver Oxide*.—According to Thenard these two substances reduce each other with the formation of oxygen, water and metallic silver. Berthelot advanced the view, however, that in this reaction only the extra oxygen of the hydrogen peroxide is evolved, while the oxygen given up by a part of the silver is retained by another part of it in the form of a higher oxide of that metal. BAEYER and VILLIGER have now shown clearly that Thenard's view is entirely correct, and that Berthelot was wrong in regard to this matter. Since finely divided metallic silver exerts a powerful catalytic action upon hydrogen peroxide, it is difficult to reduce silver oxide completely by means of a solution of this substance. By using about five times the theoretical quantity of hydrogen peroxide, however, and adding it slowly with thorough agitation, Baeyer and Villiger have obtained a practically complete reaction, and have found no evidence of the formation of a higher oxide of silver. They have shown also that more oxygen is always evolved when hydrogen peroxide acts upon silver oxide than when it acts upon a simple catalytic substance like finely divided platinum or silver, and that, under the proper conditions, the volume of oxygen given off corresponds to Thenard's theory.—*Berichte*, xxxiv, 749. H. L. W.

7. *Action of Alcohol on Metals with which it comes in Contact.*—After allowing pure 95 per cent alcohol to act upon several metals for a period of six months in corked flasks, Dr. MALMÉJAC has found that a considerable amount of action took place in several cases. With copper, there was no turbidity, and no residue was left upon evaporating some of the alcohol. With tin there was a decided turbidity, but the filtered alcohol gave a hardly observable residue. In the cases of zinc, lead, iron, and galvanized iron, there were considerable amounts of turbidity, and the filtered alcohol in each case left a decided residue, which was rather large in the case of lead. These experiments have an important bearing upon the choice of vessels used for the storage of alcohol.—*Chem. News*, lxxxiii, 115. H. L. W.

8. *On the Excitation and Measure of Sine Currents.*—One of the greatest needs in the subject of electrical measurements is an apparatus which will produce sine currents. The theory of periodic currents presupposes an accurate sinusoidal variation; but the instruments which are used to test the theory give in no case hitherto true sine waves. MAX WIEN describes in a leading article a method which seems to be a valuable one. The sine waves are produced by the revolution of a brass wheel in the periphery of which are numerous insertions of pieces of soft iron. This wheel is the analogue of the perforated disc of the syren in the subject of acoustics. The wheel revolves between stationary poles of an electromagnet, upon which are induction coils, in which the sinusoidal variations are produced. By means of a condenser the circuit is tuned to resonance, and accurate sine waves are produced, since by the tuning the harmonics are rendered weak, and only the fundamental tone of the circuit is preserved.—*Ann. der Physik.*, No. 3, 1901, pp. 427-458. J. T.

9. *Metallic Reflection of Electrical Waves.*—Righi has described an experiment in which he claimed to have observed elliptical polarization of electrical waves at metallic surfaces. KARL F. LINDMAN quotes the theoretical conclusion of Poincaré and of Drude, to prove the impossibility of this for waves certainly 10^{cm} in length. He concludes that this elliptical polarization does not exist, and he finds that the electrical waves are linear polarized. The results of Righi are attributed to some unexplained disturbance.—*Ann. der Physik.*, No. 3, 1901, pp. 617-637. J. T.

10. *The Light Transparency of Hydrogen.*—V. SCHUMANN, the author of the remarkable paper on very short wave-lengths of light in a vacuum, has shown that a layer of hydrogen gas is very transparent to light and allows the shortest waves to pass through it unabsorbed. He found, however, strange inconsistencies in his work, and in the present paper explains their cause. In the earlier experiments the gas was led into the apparatus through a rubber tube, and the use of this tube was found to lessen the transparency of the hydrogen. When it was dispensed with and great care was taken in preserving the hydrogen from

contamination, it was found that hydrogen transmits the shortest waves as well as a vacuum.—*Ann. der Physik*, No. 3, 1901, pp. 642-645. J. T.

11. *Measurement of the Röntgen Rays by means of Selenium.*—F. HIMSTEDT, in an investigation on the X-rays and the Becquerel rays, shows that these rays alter the resistance of selenium, and he hopes to devise a plan for the qualitative measurement of these rays.—*Ann. der Physik*, No. 3, 1901, pp. 531-536. J. T.

12. *The Effect of the Röntgen Rays and the Becquerel Rays on the Eye.*—Giesel has shown that a preparation of radium laid upon the eyelid gives a sensation as if the entire eye was filled with light. F. HIMSTEDT and W. A. NAGEL have made a careful examination of this phenomenon, and also of the effect of the X-rays on the eye. They show that a fluorescence is excited in the organs of the eye which produces the sensation of light. Their work confirms the investigations of previous observers and somewhat extends them.—*Ann. der Physik*, No. 3, pp. 537-552, 1901. J. T.

II. GEOLOGY AND NATURAL HISTORY.

1. *The Eocene and Lower Oligocene Coral Faunas of the United States*, with descriptions of a few doubtfully Cretaceous species; by T. WAYLAND VAUGHAN. Monograph, vol. xxxix, pp. 263, 24 pl. U. S. Geological Survey. Washington, 1900.—Upon taking up the study of the Tertiary corals, Mr. Vaughan set for himself the task of defining every species presenting good and identifiable figures, showing their stratigraphic range and geographic distribution; then, secondly, he sought to determine from the study of the corals, the bathymetric conditions under which they lived and were buried; and thirdly, to trace, so far as practicable, the affinities of the forms met with. He brought to the solution fine equipment and excellent collections, and has performed his task well. The descriptions and delineations of species appear to be all that could be wished for. The questions: what is a species? and how to classify corals? have been conscientiously met and judiciously handled, but the author, like other workers in this field, leaves the burden of proposing something better than the current system to those who will follow.

The study of the bathymetric distribution of the species on a basis of known depths at which corresponding genera are now living leads to the conclusion that the faunas of the Eocene and Oligocene under investigation lived at only moderate depth, not over 100 fathoms, and 18 out of 24 genera now live in water less than 50 fathoms deep. The author gives valuable statistics regarding the bathymetric values of the faunas of the several formations studied. An excellent account of the morphology of the Madreporarian coral skeleton is given, which will be helpful to students.

The volume is a distinct contribution to the systematic knowledge of Tertiary corals. w.

2. *On the presence of a Limestone Conglomerate in the Lead region of St. Francis Co., Missouri*; by FRANK L. NASON. (Communicated.)—For the past two months, the writer has been engaged in geological work in the disseminated lead fields in St. Francis County, Missouri. During the progress of the work a heavy bed (or beds) of limestone conglomerate has been discovered separating the St. Joseph, or Bonne Terre, limestones from the formation known as the Potosi. The interstitial filling of this conglomerate is a pure coarsely crystalline limestone, in sharp distinction to the magnesian limestone or dolomite which forms the pebbles. The interstitial part is filled with fragments of trilobites, brachiopods and possibly crinoid stems, all undetermined at present. I wish to announce now this discovery, which is of great importance geologically and promises to be of even greater importance economically in relation to the disseminated lead deposits of this section of Missouri. In a few weeks I hope to publish a geological section showing the relative position of the conglomerate with reference to the St. Joseph limestones and the Potosi.

3. *New Species of Cambrian fossils from Cape Breton*; by G. F. MATTHEW, Nat. Hist. Society of New Brunswick Bulletin, vol. iv, p. 219, with a plate. (Abstract by the author.)—In this paper on fossils from the Upper Cambrian of Cape Breton, nine new species and forms are described. These are referred to the several zones of *Parabolina*, *Peltura* and *Dictyonema*. The internal features of the valves of several of the Brachiopods are described and figured. An enlarged figure shows the complicated structure of the group of central muscles in *Lingulella*. A new *Schizambon* described is a minute orbicular form from the *Dictyonema* zone. This and a new *Acrotreta* have been found also in the Cambrian Basin at St. John, N. B., Canada.

The trilobites are of three genera, *Parabolina*, *Sphærophthalmus* and *Agnostus*. The first genus is represented by a species with a strongly arched front to the cephalic shield, but in other respects strongly resembles the European forms referred to this genus. The *Agnostus* is a fine example of *A. trisectus* of Salter, but differing in the markings of the surface of the shield and in having a tubercle at the back of the rhachis of the pygidium.

4. *Geological Survey of Western Australia*.—The Annual Report for the year 1899 has been recently issued. It contains an account of the Greenbushes tin fields, by the Government geologist, A. GIBB MAITLAND, with a detailed geological map; also of various gold fields, chiefly in the Coolgardie district, accompanied by geological maps. The mineralogist, Mr. Edward S. Simpson, gives results of assays of some twelve samples of native gold, in part nuggets, but chiefly from quartz reefs. Most of them show the presence of a considerable percentage of silver, from 3.5 to 10.5 p. c. The lowest specific gravity observed (14.66) is that of the "Bobby Dazzler" nugget, which yielded

gold 76·81, silver 23·04, copper and iron 0·15. The purest specimen was a sample of sponge gold from Boulder, East Coolgardie; this yielded gold 99·91, silver 0·09.

Some further information is given in regard to the problematic tantaloniobate from the tin-bearing gravels at Greenbushes, called by Goyder stibiotantalite. (Dana Min., App. I, p. 64.) This allows of a somewhat fuller description of the mineral than has been given before, and the hope is held out that material pure enough for complete analysis may be separated. Associated with this mineral, grains of metallic tin were identified. Cobaltiferous asbolite has been found at Norseman and Kanowna; it is associated with gold, at the latter place being often studded with minute crystals.

5. *Geology of Texas*.—The Transactions of the Texas Academy of Science for 1899, volume iii, contains a summary, prepared by Prof. F. W. SIMONDS, of publications on the Geology of Texas up to the end of 1896; a brief summary of the contents of each paper is given.

6. *Concretions from the Champlain Clays of the Connecticut Valley*; by J. M. ARMS SHELTON. With one hundred and sixty illustrations by Katharine Peirson Ramsay, L. R. Martin, and F. S. and M. E. Allen. Pp. 45, pl. I-XIV, 4to. Boston, 1900.—The author has given in this volume an interesting and exhaustive account of the concretions found in the Connecticut Valley clays. They were collected at different points between Dummerston, Vermont, and Deerfield, Massachusetts. The method of occurrence is fully described and the origin, chemical composition, and other points are discussed with all necessary detail. A considerable series of analyses shows a substantially uniform composition, differing somewhat for samples from different layers. The memoir closes with a full bibliography; it is illustrated by a series of fourteen admirable heliotype plates, which leave nothing to be desired in the way of presenting the varieties of form and structure.

7. *Study of the Gabbroid Rocks of Minnesota*.—The elaborate memoir by ALEXANDER N. WINCHELL, containing a mineralogical and petrographic study of the gabbroid rocks of Minnesota, and more particularly of the plagioclasyes, noticed on page 89 of this volume of the Journal and republished in the American Geologist (volume xxvi), has been recently issued in pamphlet form.

8. *On the Flow of Marble under Pressure*.—The full memoir by ADAMS and NICOLSON on this subject, of which an abstract was given in the number of this Journal for November last (p. 401), has recently been issued (pp. 363-401 of vol. cxcv, Pt. A of the Philosophical Transactions of Royal Society of London). The plates and other illustrations accompanying it add much to the clearness of the description and increase the general interest of the subject.

9. *The Flora of Cheshire* (400 pp., 8vo, Longmans, Green & Co.) is a carefully prepared work compiled by Mr. SPENCER MOORE from the manuscripts of the late Lord de Tabley. The extraordinary versatility of the author is well portrayed in an introductory biographical sketch. Chiefly known as a poet, dramatist, and novelist, Lord de Tabley found time to write seriously upon the federal coinage of Ancient Greece, produce a noteworthy work upon bookplates, and prepare the botanical manuscripts of remarkable detail from which the present posthumous work has been compiled. The Flora contains neither technical descriptions nor keys. There is a careful physico-botanical account of the different sections of the region covered, a list of and some notes upon the persons concerned in the past with Cheshire botany, an extensive list of works consulted, and finally the body of the catalogue, which is restricted to the spermatophytes, pteridophytes, and *Characeæ*. In looking over its pages one is impressed chiefly by the extraordinary minuteness and detail with which habitats and stations have been recorded. A single instance chosen at random will suffice to show the nature of the work in this regard. One of the meadow grasses is said to be "Plentiful in one spot on the shore of the Dee near Parkgate (destroyed in this locality, 1854); amongst shingle and at the base of the wall in the first field enclosure north of Parkgate; in the sandy tract commencing under the garden wall of the house at Old Quay a mile south of Parkgate; and seen now and again between the colliery and the gravel pit on that side of Benton Point, 1873." While all this may be of some interest to the local observer for whom, of course, it was primarily intended—if indeed the author ever expected that it would see light in print—yet, considered as a scientific publication, it runs far into the realm of the casual, if not the trivial. There is, furthermore, no synonymy, little bibliography except in relation to ranges, and finally a curious lack of those comparative or descriptive notes upon local varieties, in fact, of observations upon the plants themselves aside from their abundance and stations. In all these respects this stout volume is almost as barren as a mere list would be.

B. L. R.

10. *A preliminary list of the Spermatophyta of North Dakota*; by HENRY L. BOLLEY and LAWRENCE R. WALDRON (Bulletin No. 46 of the North Dakota Experiment Station).—No catalogue of the plants of North Dakota has heretofore been published and the present list is thus a piece of pioneering work. As such it will, notwithstanding its manifest and frankly confessed incompleteness, prove useful. It is furthermore of no small interest as showing for the first time in concise form the general nature of the vegetation in what is, as to its floral conditions, probably the most uniform of our larger states. A striking characteristic noticeable in the vegetation, as shown in this catalogue, is that nearly all of the species are those of wide range, endemic or truly local plants being almost unknown in the state. Another

feature of the flora which is noteworthy is the extreme paucity of species in certain usually well represented families; thus but 41 *Cyperaceæ* are recorded. This, it is true, may well be due largely to the difficulty of the group and the fact that many species present in the flora have yet to be discriminated and recorded. The same explanation, however, can hardly apply to the *Ericaceæ*, of which but one species, or to the ferns, of which only two species, *Cystopteris fragilis* and *Onoclea Struthiopteris*, are recorded for any part of the state.

B. L. R.

III. MISCELLANEOUS SCIENTIFIC INTELLIGENCE.

1. *The new Star in Perseus*.—As a culminating result of the vigilance with which Dr. THOMAS D. ANDERSON of Edinburgh, Scotland, has watched the northern heavens and which has furnished us with some two dozen new variable stars in the past few years, a new star in Perseus was discovered by him on February 21 at 14 hours 40 min. Greenwich mean time. It was then a little brighter than a third magnitude star and shone with a bluish-white light. The northern sky is now so extensively patrolled by photography that for the first time in the history of sudden apparitions of new stars we are able to say almost definitely when the outburst took place. A photograph taken at Harvard on February 19 shows no trace of the star, though stars to the eleventh magnitude are impressed, and a valuable plate secured by A. Stanley Williams, of Hove, Sussex, England, 28 hours before the discovery by Dr. Anderson, makes it certain that the new star must have then been fainter than a twelfth magnitude star. We are, therefore, able to time the occurrence within 14 hours.

The star continued to increase in brilliancy until February 23, when it was estimated at Harvard as of the magnitude 0.0, that is about a quarter magnitude, or about 25 per cent brighter than any star in the northern hemisphere, and only falling below Sirius and Canopus in the southern sky. This brilliancy has only been surpassed by temporary stars twice in historic records, once in 1572 and again in 1604, the two new stars described by Tycho and Kepler. On February 24 when the *nova* was first seen at the Yale Observatory, in broad daylight, it had already fallen to equality with Capella and diminished during the day fully half a magnitude. Since then the decline has been slow and steady with occasional fluctuations, and about April 1 it was of the fifth magnitude or 100 times fainter than at its maximum; and the color had gradually changed to an orange hue.

The most interesting and valuable features of the apparition will doubtless be found in the spectroscopic results. At present all the data have of course not been collated and discussed, but it seems certain that an earlier stage of development has been observed than on any previous new star. The first observations at Harvard, on February 22, show a spectrum quite unlike that of

other new stars, being continuous with a number of dark lines, and a few inconspicuous bright lines. By February 24, however, the star seems to have attained the stage observed in the new star in Auriga in 1892, as there appear two superposed and slightly separated spectra, one of dark and one of bright lines, either showing the presence of two bodies with enormous relative velocities or, more likely, some remarkable physical conditions in one body alone. The interpretation of the totality of the phenomena presented by this star will doubtless prove very valuable for our knowledge of the constitution and formation of the stellar universe.

W. L. E.

2. *National Academy of Sciences.*—The annual meeting of the National Academy was held in Washington, April 16–18th. The list of papers presented is given below. Professor Alexander Agassiz was elected President in place of Dr. Wolcott Gibbs, who resigned in April, 1900. Dr. Arnold Hague was elected Home Secretary and Professor Ira Remsen Foreign Secretary. The following gentlemen were made members of the Academy: Dr. George F. Becker of Washington, Prof. J. McK. Cattell and T. M. Prudden of New York, Prof. E. H. Moore of Chicago and Prof. E. F. Nichols of Ithaca. The titles of papers presented are as follows:

HENRY L. ABBOT: The climatology of the Isthmus of Panama.

R. S. WOODWARD: The effects of secular cooling and meteoric dust on the length of the terrestrial day.

ALPHEUS HYATT: The use of formulæ in demonstrating the relations of the life history of an individual to the evolution of its group.

E. B. WILSON: Artificial parthenogenesis and its relation to normal fertilization.

CARL BARUS: Simultaneous volumetric and electric graduation of the condensation tube.

W. O. ATWATER: Table of results of an experimental inquiry regarding the nutritive action of alcohol.

THEO. GILL: The significance of the dissimilar limbs of the Ornithopodous Dinosaurs.

J. W. POWELL: The place of Mind in Nature. The foundation of Mind.

ALEXANDER GRAHAM BELL: Conditions affecting the fertility of sheep and the sex of their offspring.

S. P. LANGLEY: The new spectrum.

3. *Report of the Secretary of the Smithsonian Institution for the year ending June 30th, 1900.* Pp. 117, with 18 plates. Washington, 1900.—Prof. Langley's annual report gives a summary of the year's work by the Smithsonian Institution in its many directions of useful activity. The appendixes which follow the formal report contain more detailed statements in regard to some of the departments; as, the National Museum, the Zoological Garden, the International Exchange Service, and the Astrophysical Observatory, etc. The last report, by Mr. C. G. Abbot, Aid-in-charge, is especially interesting, since it details, with numerous illustrations, the work done by the Smithsonian party at the total eclipse of May, 1900. Mr. Abbot gives the following summary of the work of the Observatory:

“The operations of the Astrophysical Observatory during the past year have been distinguished, first, by the publication of the first volume of its *Annals*, in which the infra-red solar spectrum is the main topic; second, by progress in the preparation of a highly sensitive, steady, and magnetically shielded galvanometer; third, by observations of the total solar eclipse, in which excellent large-scale photographs of the corona were secured, the coronal extensions photographed to upward of three diameters from the moon’s limb, the absence of intra-mercurial planets above the fourth magnitude made nearly certain and the presence of several such between the fifth and seventh magnitude rendered as probable as single photographs can do, and finally, in which the small but measurable intensity of the total radiations and the effectively low temperature of the inner corona were observed by the aid of the bolometer.”

4. *Memorial of George Brown Goode*.—Report of the U. S. National Museum, Part II. Pp. 515, with 109 plates. Washington, 1901 (Annual Report of the Smithsonian Institution for the year ending June 30th, 1897).—This volume is devoted to a Memorial of Dr. George Brown Goode, giving also a selection of his papers on Museums and the History of Science in America. It opens with an account of the memorial exercises held to commemorate the life and services of Dr. Goode, on February 13th, 1897, with the addresses by Prof. Langley and others, delivered at that time. A memoir by Prof. Langley follows (pp. 41–61). The remainder of the volume is devoted to the re-publication of some of the papers by Dr. Goode. Dr. Goode’s services to science were so important; his study of museums in general so thorough, and his labors in behalf of the one of which he was in charge so active and fruitful; his example as a man was so inspiring, that this volume must interest and benefit a large number of readers.

The opening paper discusses museum-history and gives an account of the older museums of the world. Another paper describes the origin and development of the U. S. National Museum; others are of general character and deal with museum administration and the progress of museums in the future. The discussions of the beginning of Natural History in America, and of American science in general, which are given in other papers, are most interesting, and bring together much material which it would be difficult to find in any other place. The volume is enriched by upwards of one hundred portraits of notable men, who, as scientists, explorers or statesmen, contributed to the advancement of science in this country.

5. *U. S. Coast and Geodetic Survey: Report of the Superintendent for the year from July 1st, 1898 to June 30th, 1899*. Pp. 964, 4to, with numerous plates and maps. Washington, 1900.—The annual volume of the U. S. Coast and Geodetic Survey contains the usual summary of the work, geodetic, hydrographic, magnetic, tidal, etc., which has been carried on in different parts of the country. This is followed by a series of

appendixes, one of which contains the statement of the progress made by the International Geodetic Association for the Measurement of the Earth. Another gives an exhaustive statement of work done in accurate leveling in the country with detailed observations. Still another describes the progress of the magnetic survey of North Carolina, recently inaugurated and conducted under the combined auspices of the Coast Survey and the State Geological Survey. This is accompanied by a declination map for the State. The concluding appendix, though brief, is particularly interesting as detailing the general magnetic work of the Survey, now under the charge of Dr. L. A. Bauer. Dr. Bauer has made a minute study of the earth's magnetism for a number of years, and the outlines given here of the investigations that it is proposed to carry on gives reason to hope that great progress may be made in this direction in the near future.

6. *La Navigation Sous-marine*; par MAURICE GAGET. Pp. 472, 12mo. Paris, 1901 (Librairie Polytechnique, Ch. Béranger).—This compact volume contains a full summary of the subject of sub-marine navigation. It treats first of its history; then the theory involved is elaborated, and finally detailed descriptions are given of the various more or less successful modern attempts to solve the difficult problems involved. In this department the French have accomplished much and this work will be read with interest by all those whom the subject concerns.

7. *Geological Survey of Great Britain*.—Mr. J. J. H. Teall, President of the Royal Geological Society, has been chosen Director-General of the Geological Survey of the United Kingdom (see p. 252).

8. *Geological Survey of Canada*.—The Directorship of the Geological Survey of Canada, left vacant by the death of Dr. George M. Dawson, has been filled by the appointment of Dr. Robert Bell.

OBITUARY.

DR. HENRY A. ROWLAND, Professor of Physics at the Johns Hopkins University and one of the Associate Editors of this Journal, died at his home in Baltimore on Tuesday, April 16th, at the age of fifty-two years. A notice is deferred until a later number.

PROFESSOR GEORGE F. FITZGERALD, of the University of Dublin, died on February 21 at the age of forty-nine. He occupied a high place among English physicists and his scientific papers were of great value though not very numerous; the most important of them is a memoir (1878) on the "electro-magnetic theory of the reflexion and refraction of light." A movement for the founding of a memorial to Prof. Fitzgerald has been inaugurated; it is proposed to give it the form of an endowment of research in physical science by advanced students.

PROFESSOR CHRISTIAN F. LÜTKEN, the able Danish zoologist, died on February 6 at the age of sixty-three years.

THE

AMERICAN JOURNAL OF SCIENCE

[FOURTH SERIES.]

ART. XXXIII.—*The New Spectrum*; by S. P. LANGLEY.
With Plate VII.

THE writer, (at the concluding meeting of the National Academy of Sciences on April 18th,) remarked on the disadvantages in the matter of interest of the work of the physicist, which he was about to show them, to that of the biologist, which was concerned with the ever absorbing problem of life. He had, however, something which seemed to him of interest even in this respect, to speak of, for it included some indications he believed to be new, pointing the way to future knowledge of the connection of terrestrial life with that physical creator of all life, the sun.

He had to present to the Academy a book embodying the labor of twenty years; though at this late hour he could scarcely more than show the volume with a mention of the leading captions of its subject. What he had to say, then, would be understood as only a sort of introductory description of the contents of the work in question, which was entitled "Volume I of the Annals of the Astrophysical Observatory of the Smithsonian Institution."

In illustration of a principal feature of this book, the Academy saw before them on the wall an extended solar spectrum,* only a small portion of the beginning of which, on the left, was the visible spectrum known to Sir Isaac Newton. This was the familiar visible colored spectrum which we all have seen and know something of, even if our special studies are in other fields.

* The references in this article are to the map in the present number (Plate VII).

It is chiefly this visible part, which has been hitherto the seat of prolonged spectroscopic investigation, from a little beyond the violet, at a wave-length of somewhat less than $0^{\mu}4$ down to the extreme red, which is generally considered to terminate at the almost invisible line A, whose wave-length is $0^{\mu}76$. On the scale of the actual wave-length of light, then, where the unit of measurement (1^{μ}) is $\frac{1}{10000}$ of a millimeter, the length of the visible spectrum is $0^{\mu}36$.

The undue importance which this visible region has assumed, not only in the eyes of the public but in the work of the spectroscopist, is easily intelligible, being due primarily to the evident fact that we all possess, as a gift from nature, a wonderful instrument for noting the sun's energy in this part, and in this part only.

While then this part alone can be *seen* by all, yet the idea of its undue importance is also owing to the circumstance that the operation of the ordinary prism gives an immensely extended linear depiction of the really small amount of energy in this visible part. There is also a region beyond the violet, most insignificant in energy and invisible to the eye, and the association of this linear extension due to the prism, with the accident that the salts of silver used in photography are extraordinarily sensitive to these short wave-length rays, so that they can depict them even through the most extreme enfeeblement of the energy involved in producing them, also makes this part have undue prominence. This action of the prism and of the photograph is local, then, and peculiar to the short wave-lengths; and owing to it, all but special students of the subject are, as a rule, under a wholly erroneous impression of the relative importance of what is visible and what is not. The spectrum has really no positive dimension, being extended at one end or the other according to the use of the prism or grating employed in producing it. Perhaps the only fair measurement for displaying a linear representation of the energy would be that of a special scheme, which the writer had proposed, in which the energy is everywhere the same;* but this presentation is unusual, and would not be generally intelligible without explanation.

The map before us will be intelligible when it is stated that it is, as to the infra-red, an exact representation of that part of the spectrum given by a rock-salt prism. The visible and ultra-violet spectrum given here is not exact, for the reason that it would take over a hundred *feet* of map to depict it on the prismatic scale, though this is caused by but a small fraction of the sun's energy; so monstrous is the exaggeration due to the dispersion of the prism.

* This Journal, III, xxvii, p. 169, 1884.

Looking then at the map; first, in the spectrum on the left and beyond $0^{\mu}4$ is the ultra-violet region, in fact almost invisibly small, but which in most photographs shows over a *hundred times larger than the whole infra-red*. It really contains much less than one-hundredth part of the total solar energy which exists. Beyond it is the visible spectrum, containing perhaps one-fifth the energy of the infra-red.

As the writer has elsewhere said, "the amount of energy, in any region of the spectrum, such as that in any color, or between any two specified limits, is a definite quantity, fixed by facts, which are independent of our choice, such as the nature of the radiant body or the absorption which the ray has undergone. Beyond this, Nature has no law which *must* govern us."

Everything in the linear presentation, then, depends on the scale adopted. In other words, if we have the lengths proportionable to the energies, the familiar prismatic representation enormously exaggerates the importance of the visible, and still more of the ultra-violet region, and similarly the grating spectrum exaggerates that of the infra-red region. Now he had given, on the map before them, and through the whole infra-red, the exact rock salt prismatic spectrum, but for the purpose of obtaining a length which represented (though insufficiently) that of the visible spectrum, he had laid the latter down on the *average* dispersion in the infra-red, which was perhaps as fair a plan as could be taken for showing the approximate relation of the two fields of energy in an intelligible way, though it gave the visible energy too small.

Let us recall, then, at the risk of iteration, that in spite of the familiar extended photographic spectra of the hundreds of lines shown in the ultra-violet, and in those of the colored spectrum, it is not here that the real creative energy of the sun is to be studied, but elsewhere, on the right of the drawing, in the infra-red. Looking to the spectrum as thus delineated, next to the invisible ultra-violet comes the visible or Newtonian spectrum, which is here somewhat insufficiently shown, and on the right extends the great invisible spectrum in which four-fifths of the solar energies are now known to exist.

Of this immense invisible region nothing was known until the year 1800,* when Sir William Herschel found heat there with the thermometer.

After that little was done† (except an ingenious experiment

* Philosophical Transactions, vol. xc, p. 284, 1800.

† It should, however, be mentioned that an important paper by Draper (London, Ed. Dublin Phil. Mag., May, 1843) was published in 1843 in which he appears to claim the discovery of the group here called $\rho\sigma\tau$ and which is now known to have

by Sir John Herschel* to show that the heat was not continuous) till the first drawing of the energy curve by Lamansky,† in 1871, which, on account of its great importance in the history of the subject, is given on the map. It consists of the energy curves of the visible spectrum, and beyond it, on the right, (and in illustration of what has just been said it will be seen how relatively small these latter appear) of three depressions indicating lapses of heat in the infra-red. It is almost impossible to tell what these lapses are meant for, without a scale of some kind (which he does not furnish), but they probably indicate something, going down to near a wave-length of 1^{μ} . It is obvious that the detail is of the very crudest, and yet this drawing of Lamansky's was remarkable as the first drawing of the energy spectrum. It attracted general attention, and was the immediate cause of the writer's taking up his researches in this direction.

It seems proper to state here that the true wave-lengths were at that time most imperfectly known, but that in 1884, and later in 1885,‡ they were completely determined by the writer as far as the end of what he has called "the new spectrum" at a wave-length of $5^{\mu}\cdot 3$.

The upper portion of the infra-red is quite accessible to photography, and the next important publication in this direction was that of Captain Abney,§ which gave the photographic spectrum down to about $1^{\mu}\cdot 1$, much beyond which photography has never gone since.

From the time of seeing Lamansky's drawing, the writer had grown interested in this work, but found the thermopile, the instrument of his predecessors, and the most delicate then known to science, insufficient in the feeble heat of the grating spectrum, and about 1880 he had invented the bolometer|| and was using it in that year for these researches. This may perhaps seem the place to speak of this instrument, though with the later developments which have made it what it is to-day,

a wave-length of less than 1^{μ} . (Its true wave-length was not determined till much later.) Later, Fizeau seems to have found further irregularities of this heat as long ago as 1847, and of its location, obtaining his wave-lengths by means of interference bands. His instrumental processes, though correct in theory, were not exact in practice; and yet it seems pretty clear that he obtained some sort of recognition of a something indicating heat, as far down as the great region immediately above Ω on our present charts. Mouton (Comptes Rendus, 1879) confirmed this observation of Fizeau's, and contrived to get at least an approximate wave-length of the point where the spectrum (to him) ended, at about $1^{\mu}\cdot 8$.

* Philosophical Transactions, vol. cxxx, p. 1, 1840.

† Monatsberichte der k. Akademie der Wissenschaften zu Berlin, Dec., 1871.

‡ This Journal, March, 1884, and August, 1886.

§ Philosophical Transactions, vol. clxxi, p. 653, 1880.

|| Actinic Balance, this Journal, 3d series, vol. xxi, p. 187, 1881.

it has grown to something very different from what it was then.

It has, in fact, since found very general acceptance among physicists, especially since it has lately reached a degree of accuracy, as well as of delicacy, which would have appeared impossible to the inventor himself in its early days.

It may be considered in several relations, but notably as to three: (1) its sensitiveness to small amounts of heat; (2) the accuracy of measurement of those small amounts; and (3) the accuracy of its measurements of the *position* of the source of heat.

As to the first, it is well known that the principle of the instrument depends on the forming of a Wheatstone bridge, by the means of two strips of platinum or other metal, of narrow width and still more limited thickness, one of which only is exposed to the radiation. In some bolometers in use, for instance, the strip is a tenth of a millimeter, or one two-hundred-and-fiftieth of an inch in width; and yet it is to be described as only a kind of tape, since its thickness is less than a tenth of this.

The use of the instrument is then based on the well-known fact that the heating of an ordinary metallic conductor increases its resistance, and this law is found to hold good in quantities so small that they approach the physically infinitesimal. In the actual bolometers, for instance, the two arms of a Wheatstone bridge are formed of two strips of platinum, side by side, one of which is exposed to the heat and the other sheltered. The warming of the exposed one increases its resistance and causes a deflection of the galvanometer.

It was considered to be remarkable twenty years ago that the change of temperature of one ten-thousandth of a degree Centigrade could be registered; it is believed at present that with the consecutive improvements of the original instrument and others, including those which Mr. Abbot, of the Smithsonian Institution Observatory, has lately introduced into its attendant galvanometer, that less than one *one-hundred-millionth* of a degree in the change of temperature of the strip can be registered. This indicates the sensitiveness of the instrument to heat.

As to the second relation, some measures have been made on the steadiest light source obtainable. With ordinary photometric measures of its intensity one might expect a probable error of about one per cent. The error with the bolometer was insensible by any means that could be applied to test it. It is at any rate less than $\frac{2}{1000}$ of one per cent. If we imagine an absolutely invisible spectrum, in which there nevertheless are interruptions of energy similar to those which the eye shows

us in the visible, then the bolometer, whose sensitive strip passes over a dark line in the spectrum, visible or invisible (since what is darkness to the eye is cold to it), gives a deflection on the side of cold, and in the warmer interval between two lines a deflection on the side of heat; these deflections being proportionate to the cause, within the degree of accuracy just stated.

The third quality, the accuracy of its measures of position, is better seen by a comparison and a statement, for if we look back to the indications of the lower part of Lamansky's drawing, we may see that at least a considerable fraction of a degree of error must exist there in such a vague delineation. Now in contrast with this early record, the bolometer has been brought to grope in the dark, and to thus feel the presence of narrow Fraunhofer-like lines by their cooler temperature alone, with an error of the order of that in refined astronomical measurement; that is to say, the probable error, in a mean of six observations of the relative position of one of these invisible lines, is less than one second of arc; a statement which the astronomer, perhaps, who knows what an illusive thing a second of arc is, can best appreciate.

The results of the writer's labors with the bolometer in the years 1880 and 1881, and in part of his expedition in the latter year to Mount Whitney, were given at the Southampton meeting of the British Association for the Advancement of Science in 1882.* During these two years, very many thousand galvanometer readings were taken by a most tryingly slow process, to give the twenty or more interruptions shown at that time, below the limit at $1''\cdot 1$ of Abney's photographs. The bolometer has been called an eye which sees in the dark, but at that time the "eye" was not fairly open, and having then not been brought to its present rapidity of use, the early results were attained only by such unlimited repetition, and almost infinite patience was needed till what was inaccurate was eliminated.

Several hundreds at least of galvanometer readings were then taken to establish the place of *each* of the above twenty lines during the two years when they were being hunted for, and this patience so far found its reward, that they have never required any material alteration since, but only additions such as the writer can now give. The part below $1''\cdot 1$ he then presented (at the Southampton meeting of the British Association) as having been mapped for the first time. Mouton had two years before obtained crude indications of heat as far as

* Report British Association, 1882. Nature xxvi, 1882.

1^μ.8, and Abney had, as stated, obtained relatively complete photographs of the upper infra-red extending to about this point (1^μ.1).

The writer had already determined for the first time by the bolometer, at Allegheny and on Mt. Whitney, the wave-lengths of some much remoter regions, including the region then first discovered by him and here called "the new spectrum," and was able to state that the terminal ray of the solar spectrum, whose presence had *then* been certainly felt by the bolometer, had a wave-length of about 2^μ.8 or nearly two octaves below the "great A" of Fraunhofer.

He stated in this communication of 1882, that the galvanometer then responded readily to changes of temperature in the bolometer strip of much less than one ten-thousandth of a degree Centigrade (as has just been said it now responds to changes of less than one one-hundred-millionth;) and he added "since it is one and the same solar energy whose manifestations are called 'light' or 'heat' according to the medium which interprets them, what is 'light' to the eye is 'heat' to the bolometer, and what is seen as a dark line by the eye is felt as a cold line by the sentient instrument. Accordingly if lines analogous to the dark 'Fraunhofer' lines exist in this invisible region, they will appear (if I may so speak) to the bolometer as cold bands, and this hair-like strip of platinum is moved along in the invisible part of the spectrum, till the galvanometer indicates the all but infinitesimal change of temperature caused by its contact with such a 'cold band.' The whole work, it will be seen, is necessarily very slow; it is in fact a long groping in the dark, and it demands extreme patience."

At that time it may be said to have been shown that these interruptions were due to the existence of something like dark lines or bands resembling what are known as the Fraunhofer lines in the upper spectrum, but apart from what the writer had done, no one then surmised how far this spectrum extended, nor perhaps what these explorations really meant. They may be compared to actual journeys into this dark continent, if it may be so called, which extended so far beyond those of previous explorers that the determination of positions by the writer, corresponding somewhat to longitudes determined by the terrestrial explorer in a new country, was by those who had not been so far, but had conceived an inadequate idea of the extent of the country, treated as erroneous and impossible.

A necessary limit to the farthest infra-red was in 1880 supposed to exist near the wave-length 1^μ. Doctor John Draper,*

* Proceedings of the American Academy, vol. xvi, p. 233, 1880.

for instance, announced in other terms that the extreme end of the invisible spectrum might from theoretical considerations be probably estimated at something less than the wave-length of $1^{\mu}0$, whence it followed that the above value of $1^{\mu}8$ was impossible, and still more that of $2^{\mu}8$. If in this connection we revert to our map, where the visible spectrum has an extent in wave-lengths of $0^{\mu}36$, then, on that same scale, the length of the entire possible spectrum, visible and invisible, was fixed by Draper at the point there shown near the band $\rho\sigma\tau$. In still other words, according to him, the very end of any spectrum at all would be less than 3 on a scale in which the visible spectrum was 1. Doctor Draper's authority was deservedly respected, and this citation of his remarks is made only to show the view then entertained by eminent men of science.

Now the writer had proved by actual measurement that it extended far beyond this point, and had announced, as the result of experiment, that it extended at any rate to about three times the utmost length then assigned from theoretical reasons, founded on the then universally accepted formula of Cauchy, which was later discredited by the direct experimental evidence given of its falsity by the bolometer.

The bolometer then, which is wholly independent of light as a sensation and notes it only as a manifestation of energy, first lays down the spectrum by curves of energy from which the linear spectrum is in turn derived.

There must now be explained, however, briefly, the way in which these energy curves, which are the basis of all, have actually been produced here.

In making the map of the energy curves it should be remembered that when an invisible band or line is suspected its presence is revealed by the change of temperature in the bolometer strips affecting the needle of the galvanometer, causing this needle to swing this way or that; let us suppose to the left if from cold, and the right if from heat. The writer's first method was to have one person to note the exposure; another to note the extent of the deflection, and a third to note the part of the spectrum in which it occurred. For reasons into which he does not enter, this old plan was, as he has already said, tedious in the extreme, and required as he has said hundreds of observations to fix with approximate accuracy the position in wave-length of one invisible line. It has been stated that only about twenty such lines had been mapped out in nearly two years of assiduous work prior to 1881, and if a thousand such lines existed, it was apparent that 50 years would be required to denote them.

The writer then devised a second apparatus to be used in connection with the bolometer. This apparatus was simple in

NOTE TO ARTICLE XXXIII, ON THE NEW SPECTRUM.—The portion of the energy curve in the plate immediately above the visible spectrum is given erroneously, through an oversight of the author's discovered **too late for** correction in the present number. The reader may suppose this part of the curve to be omitted, as it will be in subsequent plates.

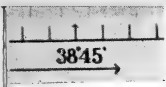



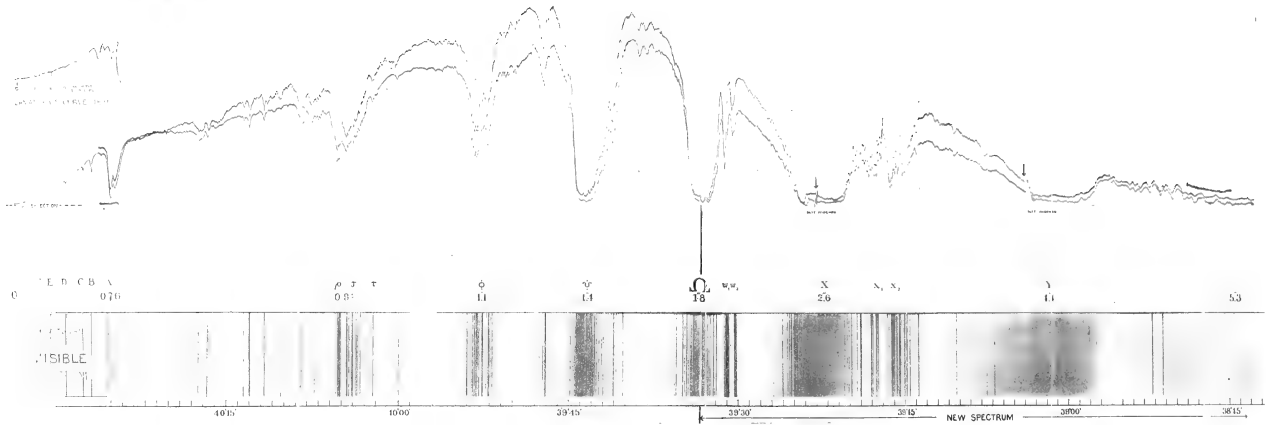

Reduction from Large Map of the Infra-red Solar Spectrum of a 60 Rock-Salt Prism. Energy Curves and Line Spectrum from Holographs of 1898
 Observations of S. P. Langley with the assistance of C. G. Abbot.



theory though it has taken a dozen years to make it work well in practice, but it is working at last, and with this the maps in this volume of the "Annals" and that before us have been chiefly made. It is almost entirely automatic, and as it is now used, a thousand inflections can be delineated in a single hour, much better than this could have been done in the half century of work just referred to.

Briefly, the method is this. A great rock salt prism (for a glass one would not transmit these lower rays nor could they easily be detected in the overlapping spectra of the grating) is obtained of such purity and accuracy of figure, and so well sheltered from moisture, that its clearness and its indications compare favorably, even in the visible spectrum, with those of the most perfect prism of glass, with the additional advantage that it is permeable to the extreme infra-red rays in question. This prism rests on a large azimuth circle turned by clockwork of the extremest precision, which causes the spectrum to move slowly along, and in one minute of time, for example, to move exactly one minute of arc of its length, before the strip of the bolometer, bringing this successively in contact with one invisible line and another. Since what is blackness to the eye is cold to the bolometer, the contact of the black lines chills the strip and increases the electric current. The bolometer is connected by a cable with the galvanometer, whose consequent swing to the right or the left is photographically registered on a plate which the same clockwork causes to move synchronously and uniformly up or down, by exactly one centimeter of space for the corresponding minute. By this means the energy curve of an invisible region, which directly is wholly inaccessible to photography, is photographed upon the plate.

Let it be noted that whatever the relation of the movement of the spectrum to that of the plate is, (and different ones might be adopted) it is absolutely synchronous,—at least to such a degree that an error in the position of one of these invisible lines can be determined, as has been stated, with the order of precision of the astronomical measurement of visible things.

The results were before them in the energy curves and the linear infra-red spectrum containing over seven hundred invisible lines. This is more than the number of visible ones in Kirchoff & Bunsen's charts. The position of each line is fixed from a mean of at least six independent determinations with the accuracy stated above.

The reader will perhaps gather a clearer idea of this action if he imagines the map before him hung up at right angles to its actual position, so that a rise in the energy curve given

would be seen to correspond to a deflection to the right, and a fall, to one to the left; for in this way the deflections were written down on the moving photographic plate from which this print has been made. The writer was now speaking of the refinements of the most recent practice; but there was something in this retrospect of the instrument's early use which brought up a personal reminiscence which he asked the Academy to indulge him in alluding to.

This was that of one day in 1881, nearly twenty years ago, when being near the summit of Mt. Whitney in the Sierra Nevada, at an altitude of 12,000 feet, he there with this newly invented instrument was working in this invisible spectrum. His previous experience had been that of most scientific men, that very few discoveries come with a surprise; and that they are usually the summation of the patient work of years.

In this case, almost the only one in his experience, he had the sensations of one who makes a discovery. He went down the spectrum, noting the evidence of invisible heat die out on the scale of the instrument, until he came to the apparent end even of the invisible, beyond which the most prolonged researches of investigators up to that time had shown nothing. There he watched the indications grow fainter and fainter until they too ceased at the point where the French investigators believed they had found the very end of the end. By some happy thought he pushed the indications of this delicate instrument into the region still beyond. In the still air of this lofty region, the sunbeams passed unimpeded by the mists of the lower earth, and the curve of heat, which had fallen to nothing, began to rise again. There was something there. For he found, suddenly and unexpectedly, a new spectrum of great extent, wholly unknown to science and whose presence was revealed by the new instrument, the bolometer.

This new spectrum is given on the map, where it will be observed that while the work of the photograph (much more detailed than that of the bolometer where it can be used at all) has been stated to extend, as far as regular mapping is concerned, to about $1^{\mu}1$: that everything beyond this is due to the bolometer, except that early French investigators had found evidence of heat extending to $1^{\mu}8$. Still beyond that *ultima thule*, this region, which he has ventured to call the "New Spectrum," extends. It will be found between wave-lengths $1^{\mu}8$ and $5^{\mu}3$ on the map.

The speaker had been much indebted to others for the perfection to which the apparatus, and especially the galvanometer, had been brought. He was under obligations particularly to Mr. Abbot, for assistance in many ways, which he had

tried to acknowledge in the volume; but before closing this most inadequate account of it, he would like to draw attention to one feature which was not represented in the spectrum map before them, although it would be found in the book.

During early years the impression had been made upon him that there were changes in the spectrum at different periods of the year. Some of these changes might be in the sun itself; the major portion of those he was immediately speaking of, he believed, were rather referable to absorptions in the earth's atmosphere.

Now these early impressions had been confirmed by the work of the observatory in recent years, and charts given in the volume would show that the sun, (being always supposed to be at about the same altitude, and its rays to traverse about the same absorbing quantity of the earth's atmosphere,) the energy spectrum was distinctly different in spring, in summer, in autumn, and in winter. The lateness of the hour prevented him from enlarging on this latter profoundly interesting subject. He would only briefly point out the direction of these changes, which were not perhaps to be called conspicuous, but which seemed to be very clearly brought out as certainly existing. With regard to them he would only observe, what all would probably agree to, that while it has long been known that all life upon the earth—without exception—is maintained by the sun, it is only recently that we seem to be coming by various paths, and among them by steps such as these, to look forward to the possibility of a knowledge which has yet been hidden to us, of the way in which the sun maintains it. We were hardly beginning to see yet how this could be done, but we were beginning to see that it might later be known, and to see how the seasons, which wrote their coming upon the records of the spectrum, might in the future have their effects upon the crops, prevised in ways somewhat similar to those previsions made day by day by the Weather Bureau, but in ways infinitely more far-reaching; and that these might be made from the direct study of the sun.

We are yet, it is true, far from able to prophesy as to coming years of plenty and of famine, but it is hardly too much to say that recent studies of others as well as of the writer strongly point in the direction of some such future power of prediction.

ART. XXXIV.—*On Rival Theories of Cosmogony*;* by the
Rev. O. FISHER, M.A., F.G.S.

THE nebular hypothesis of the origin of the earth has of late been brought into competition with a meteoric theory, which supposes that our globe has been built up out of the conglomeration of a swarm of meteorites gradually falling in; that it was never melted at its surface, and that it owes its internal high temperature to gravitational action upon the materials of which it is composed. Professor Chamberlin of Chicago† is of opinion that these meteorites formed "a swarm or belt revolving about the sun in the general neighborhood of the present orbit of the earth." If that was the case they did not belong to the class of meteorites which we still encounter in the shape of "stones" and "irons" that reach us from regions, as it is believed, beyond the solar system, although they may be supposed to have been petrologically similar.

Probably physicists would feel no difficulty in admitting that an earth so formed would continually assume the spheroidal shape appropriate to the speed of rotation, so that any objection on that score may be passed over.

It is not intended either to advocate or oppose the meteoric theory, but it may be useful to draw attention to some considerations which may help us to form an opinion upon its merits, as contrasted with the nebular hypothesis.

In the first place, if the meteorites were similarly constituted to those which sporadically reach us now, a difficulty, perhaps more apparent than real, arises in *limine*; because, although no elements occur in these which do not also occur in our rocks, nevertheless they differ greatly in the arrangement of these elements. For instance, free silica, which is one of the most abundant constituents of terrestrial rocks, is not known in that form in meteorites.‡ It may perhaps be conceded that a swarm of meteors, being as it were thrown into hotchpot, the minerals might emerge rearranged in such combinations as we find in the earth's crust, and that the deeper strata, which are concealed from us, might become proportionally poor in those common minerals, having by loss of them enriched the more superficial rocks which we can examine. The possibility of such a process involves considerations upon which we shall enter further on.

Ignorant as we are about the internal constitution of the

* Received from the Author.

† Journal of Geology, "On hypotheses bearing on climatic changes," 1897. Science, June 30th, 1899, "On Lord Kelvin's estimate of the age of the world."

‡ Sir Norman Lockyer, "The Meteoric Hypothesis," p. 23.

earth, there are two things about which we may feel tolerably certain, and these are, first, that the law of internal density is fairly represented by what is known as Laplace's law, which depends upon the assumption that the increase of the square of the density varies as the increase of the pressure. Hence we can decide approximately what the density will be at any given depth. The other fact, upon which we may feel assured, is the high internal temperature of the earth. It is proposed to enquire how these facts may severally be accounted for on the meteoric theory.

Let us consider first the question of densities. If the earth was built up of meteorites, these may be expected to have come in promiscuously—not all the heavy ones first and the lighter last. We may provisionally assume that their average density may have been nearly that of the present surface density, usually taken as 2.75. If this is too low, the arguments based upon it will not be affected in any great degree.

The high central densities may then be due to one of two causes, to compression, or to a higher intrinsic density owing to a rearrangement of the material. And first of compression.

In the Appendix to my "Physics of the Earth's Crust," I have said that, "In order to form an idea of the nature of the matter of the interior which would cause density to vary according to Laplace's law, let us suppose a globe unaffected by gravity composed of layers of varying compressibility, but of density everywhere the same as that of surface rock, and then suppose gravity to act upon it, and to reduce it to the size and density of the existing earth. This will give an idea of the law of compressibility of matter of surface density at various depths, which would be suitable to sustain the pressure, so as to bring the law of density into accordance with Laplace's law."*

Since the pressure and density at a given depth are fixed quantities, it follows that the compressibility at that depth must have a special value if the pressure there is to reduce matter of surface density to the required local density. For if the compressibility is too great the matter will become too dense, and if it is too small it will not become dense enough. The result which I obtained shows that the compressibility must decrease rapidly as the density increases, for, if the compressibility were to remain the same all the way down, the material in the lower depths would be very much more dense than, according to Laplace's formula, it actually is. My formula shows that in order to obtain this special compressibility measured in atmospheres per square foot at the depth where the density is ρ , we have merely to divide 3.6069×10^{-6} by the

* Appendix to "Physics of the Earth's Crust," p. 30, 1891.

value of ρ ($\rho + s$) using s for the surface density. Thus for instance at the depth of 400 miles, where by Laplace's law the density is 3.88, the compressibility would have to be $3.6069 \times 10^{-5} \div 3.88 \times (3.88 + 2.75)$, which makes it 1.4021×10^{-6} . This may be looked upon as a small compressibility, seeing that the compressibility of water similarly measured is 4.78×10^{-5} or nearly forty times as great. The condensation at this depth would be $(3.88 - 2.75) \div 3.88$ or about 0.29 and consequently the linear dimension would be reduced by about one tenth.

At the center the compressibility similarly measured would be very small, viz., 2.5×10^{-7} while the condensation would be large, viz., 0.744.

It appears, therefore, that if matter of the density of rock at the earth's surface can be reduced to the density matter has in the deep interior, it must at one and the same time be capable of being compressed into a much smaller volume than it originally occupied, and also it must be in a condition to require enormous pressure to effect that condensation. Now it does not seem probable that any solid substance would possess these properties, nor yet a liquid, but a hot gas would. Hence we seem driven to the alternative to enquire whether the deep interior consists of surface rock in the state of a heated gas, or whether it consists of matter such as iron or other metals intrinsically of the required density and either in a solid or a liquid state; because if the matter be gaseous, there would be no segregation of elements in it.

The above alternative when applied to the meteoric theory leads us to enquire in the first place whether rocky matter could by any amount of heat be reduced to the state of gas. The competing nebular hypothesis assumes that it can. Secondly, if that be the case, could the gas be compressed until it became more dense than the matter was in its solid state? It would be difficult to prove that it could not. Thirdly, would the necessary temperature be acquired under these circumstances? On this point I have made some calculations, and it appears that the temperatures produced by the condensation would be so inconceivably high that no substance capable of vaporisation could withstand them.

These calculations cannot of course pretend to any degree of accuracy, because they assume that the specific heat throughout the process of condensation continues as at first, although no increase of specific heat could alter the order of their magnitude; neither do they take account of the latent heat absorbed in passing from the solid to the fluid states. Nevertheless the results will be sufficient for the enquiry at hand. But before passing on to the question of temperatures, and

reverting to the expression for the compressibility, measured in atmospheres per square foot, which would reduce matter of the density of surface rock (s) to the density (ρ) which obtains at a given depth, it is as already stated $3.6069 \times 10^{-5} \div \rho(\rho + s)$. Now this gives a law of compressibility for all depths, and if we follow it up to the surface, giving to ρ the value s , we obtain the corresponding compressibility for surface rocks, viz.,

$$3.6069 \times 10^{-5} \div 2 (2.75)^2 \text{ or } 2.3847 \times 10^{-6}.$$

It will be interesting to enquire whether this value, which has been obtained without any reference to experiment, comes anywhere near the value of the compressibility of surface rock as determined by actual trial.

It does not appear that any direct measurements of the compressibility of rocks have been carried out; but the values of Young's modulus (M), and of the modulus of rigidity (n), have been obtained in some instances. From these the compressibility $1/k$ can be found by a known formula.* It is obvious that any experiment which gives $1/k$ negative must be set aside as fallacious.

All the estimates which have been made have been recorded in C. G. S. units. Dr. Knott† gives certain constants which he considers a "fair approximation" in the case of "fairly solid rocks." From these it is possible to calculate their compressibility by the formula, and it comes out 6.67×10^{-12} .

Dr. H. Nagaoka has also measured these constants for many rocks and has found for six different specimens of granite the following values of Young's modulus M , and the coefficient of rigidity n .‡

	1	2	3	4	5	6	
M	42.31	19.63	14.98	28.48	10.93	$\times 10^{10}$
n	18.43	13.99	6.89	5.05	4.47	4.43	$\times 10^{10}$

Since k must be positive No. 5 must be rejected. No. 2 is not complete. The values of $1/k$ (the compressibility) calculated for the remaining four are

	In C. G. S. units.	In atmospheres.
(1)	$1/k = 4.99 \times 10^{-12}$	5×10^{-6}
(3)	$1/k = 2.31 \times 10^{-12}$	3×10^{-6}
(4)	$1/k = 5.74 \times 10^{-12}$	7×10^{-6}
(6)	$1/k = 14.46 \times 10^{-12}$	14×10^{-6}
and Knott's	$1/k = 6.67 \times 10^{-12}$	8×10^{-6}

* It is $\frac{1}{k} = \frac{9}{M} - \frac{3}{n}$.

† Transactions Seismological Soc. of Japan, vol. xii, p. 119, 1888.

‡ See Publications of Earthquake Investigation Committee in Foreign Languages, vol. iv, p. 58. Tokio, 1900.

All these were measured in C. G. S. units, in which the unit of pressure is one dyne per square centimeter. To convert the value of the compressibility 2.3847×10^{-6} which we have obtained theoretically for atmospheric pressure into the same C. G. S. units, we must divide it by 1.014×10^6 and the result is

$$1/k = 2.352 \times 10^{-12}.$$

It is certainly not a little remarkable how closely this value ranges with those found by experiment. It is of the same order of magnitude but rather smaller than the average. But it will be noticed that Dr. Knott says of his experiments that they were made on "fairly solid rock" and our calculation clearly would refer to rocks thoroughly solid, for the specific gravity of surface rock which enters into our calculations has no reference to rigidity. We might, therefore, expect our value to be small.

We find here a somewhat strong presumption in favor of the view that the earth consists throughout of matter not very dissimilar from what we know at the surface, and that the internal densities are due rather to condensation than to the presence of heavier substances such as metals. But it is not a proof of this.

Let us next consider what the alternative view of the greater density towards the center being due to heavy metals involves. We may probably dismiss the supposition that these all fell in first, and only regard them as segregated from a uniform mass of some kind, and having gravitated towards the center. This implies a condition of liquidity. If the materials were solid this separation could not have occurred. Now the only force that we know of that could cause the denser materials to move by a kind of convection towards the center is gravity; and in a solid gravity would not have that effect. Moreover, it must not be forgotten that gravity continually diminishes as we go deeper into the earth, and that at the center bodies have actually no weight. It is greatest at the surface, and if not competent to segregate downwards the heavy particles of a rock at the surface, which we know it is not, still less could it have that effect near the earth's center.

Neither can we attribute this segregation to pressure; for pressures act equally upon the surface of heavy or light materials. If we had a layer of mixed shot and sand, no steady pressure laid upon it would force the shot to the bottom and bring the sand to the top.

It seems, therefore, that the view that the denser materials in the interior consist of heavy metals necessitates a condition of liquidity of the whole, which accords more readily with the nebular than with the meteoric theory of its origin. For we

may imagine that in a nebular mass cooling from the exterior, the first change from a nebulous or gaseous state would be the formation of a rain of condensed particles falling downwards, which would continue until the whole mass became liquid, and thus the heavier elements would begin to collect towards the center. In this case the highest possible interior temperature would be that at which the gaseous first assumed the liquid condition under the pressure at the depth.

Paradoxical as it appears, it is therefore possible that the temperature in the interior may have been rendered higher by a conglomeration of cold solid meteorites than by the cooling of a nebula.

We have no means of judging whether the meteorites would come in rapidly or slowly, but in either case if we take no account of the heat arising from impact, the amount produced by condensation would be the same; the only difference in the two cases being that it would be generated in a less or greater time. In the meanwhile a covering of a badly conducting material would concurrently accumulate, preventing the rapid escape of this heat, and at the same time increasing the pressure, the compression, and the heat.

To form an idea of the temperature which would be produced by the condensation of matter of surface density to the density now existing at any given depth within the earth, not taking into account its diffusion by conduction or otherwise, we require to know the work which has been expended upon it. Now we can estimate this in the following manner. Conceive the earth to have been built up of meteorites falling in, so that shell after shell accumulated until the globe attained its present size. Then, fixing the attention upon a particular unit volume, say a cubit foot, of the substance, and omitting atmospheric pressure, it would successively be subject to every degree of pressure from zero, when the shell of which it formed a part was not covered up, until the present pressure was reached, when it was buried to the depth at which it now lies. If then we know the relation between the pressure and the compression at every depth at the present moment, it will give us the relation between the pressure and the compression which that particular volume has obeyed during the course of ages; that is to say, we can judge how much compression any given pressure would have produced in the substance under the conditions involved.

Laplace's law of density being based upon the assumption that the increase of pressure within the earth is proportional to the increase of the square of the density, in terms of a pressure of one pound upon the square foot, this leads to the

result, that the pressure at the depth where the density is ρ is equal to $5.9 \times 10^7 (\rho^2 - s^2)$.

If we accept Laplace's law, this expresses a fact, whether the increase of density is due to condensation by pressure or to increased density in the intrinsic nature of the matter. But if we assume that the increase of density is caused solely by the pressure, then the above relation gives the amount of pressure which would reduce matter of density s to matter of density ρ under the circumstances existing within the earth. It will therefore remain true if the matter changes its state from solid to liquid, and from liquid to gas. If, for instance, we wished to apply a pressure which would reduce surface rock to the density 3, it ought to be $5.9 \times 10^7 (9 - 2.75^2) = 8.481 \times 10^7$ pounds per square foot, supposing no heat be allowed to escape. If the experiment could be made, it would afford a test of the truth or otherwise of the present hypothesis.

When we know the relation between the pressure and the condensation which it would produce, it is feasible to estimate the heat which would be generated, and also the temperature, provided we assume the specific heat of the substance, which for surface rock has been determined. For instance, at the depth of 0.1 of the radius, or about 400 miles deep, where the density would be 3.88, the temperature produced by condensation would be 1.2608×10^6 Fahr., or 7.0044×10^4 Cent., while at the center the figures would reach 2.7756×10^6 Fahr., or 1.0242×10^6 Cent. It seems at any rate that the meteoric theory would not fall short of accounting for temperatures as high as might be desired. It must at the same time be remembered that much of this heat would not be called into existence until the substance into which it was, as it were, being squeezed, had already been deeply buried under a badly conducting covering, so that the escape of the heat would not take place as fast as it was generated, as would probably be the case with heat generated at the surface by impacts. Thus the hypothesis that the present high internal temperatures are due to compression seems quite admissible.

We may compare the above named temperatures with some that are known. Acheson, for instance, obtains 6500° Fahr. in his Carborundum electric furnace, and 3300° Fahr. has been obtained by the oxyhydrogen flame. These temperatures are contemptible compared with those mentioned above. The Hon. Clarence King, prolonging Dr. Barus' line* for the melting point of diabase (which is 1170° C. at the earth's surface) to the earth's center, gives the temperature 76000° Cent., which is of the same order of magnitude as condensation would produce at only 400 miles depth.

* This Journal, Jan., 1893, p. 7.

But an observation of interest as bearing upon the present question was made by Professor Bartoli. He found that the temperature of the lava issuing from a subterranean outlet at Etna was 1060° C. or 1932° Fahr.

Now if we calculate the increase of density corresponding to the above temperature it comes out 0.120. The rate of increase of density near the surface is about 0.056 for 20 miles. Hence the depth, at which this lava temperature would according to the hypothesis be produced, would be about 43 miles. If we calculate the depth at which the same temperature might now be expected to occur with the commonly accepted gradient of 1° Fahr. for 60 feet, it appears to be 22 miles. It seems then that the hypothesis, that the internal densities are due to the condensation of matter of surface density, will not account for a temperature gradient originally as high as at present. Nevertheless the above observation upon the temperature of lava, and the comparatively small depth, 20 miles, at which condensation of rock would be capable of producing it, together with the small amount of condensation necessary, viz., 0.041, render it quite probable that fusion may have ensued in the deep interior without the necessity of a greater amount of condensation than such materials might be supposed capable of under the enormous pressure to which they would be subjected, even allowing for the increase of the melting point under pressure. In this case we might accept the second alternative, and attribute the high density of the more central parts to the accumulation of the heavier elements by gravitation. In this manner the materials of iron meteorites would fall toward the center. It will be noticed that a compression less than would be requisite of itself to produce the necessary density would be sufficient to produce the requisite temperature for fusion. But while any stratum was cooling by the conduction upwards of its own heat of compression, it would be receiving heat from regions below, where, so long as condensation was going on, the materials would grow hotter and hotter. It seems therefore possible that the upper layers, forming what we call the crust of the earth, may have received sufficient heat supplied from below to render the temperature gradient at the present time higher than it was originally, and that even those Archean rocks, which are by many thought to have been once melted, do not necessarily prove that the earth was not built of cold meteorites.

The presence of water upon the earth has to be accounted for, and the meteoric theory does not easily lend itself for this purpose. Not only is water present in the ocean and in the atmosphere, but also in a state of solution in the interior, as is testified by the enormous amount of steam emitted by vol-

canoes, and by cooling lava. It does not seem possible that molten rock can imbibe water from without, because it would be driven away instead of attracted, since the superficial tension of a substance diminishes as the temperature rises.* The writer has given his views (whatever they may be worth) upon this question in his *Physics of the Earth's Crust*† where he assumes the truth of the Nebular Hypothesis. He does not hold a brief for either theory. If the above remarks prove of any service in assisting in elucidating the question of the greater probability of either theory, his object will be gained. Astronomical considerations he leaves to astronomers, among whom there does not at present appear to be unanimity of opinion upon the subject.

* Maxwell's *Heat*, 5th ed., p. 294.

† 2d ed., p. 148.

Cambridge, England.

ART. XXXV.—*A Study of some American Fossil Cycads.*
 Part IV.* *On the Microsporangiate Fructification of*
Cycadeoidea†; by G. R. WIELAND.

IN this Journal for March, 1899, the writer presented in a preliminary manner the first definite knowledge of male fructification in the Bennettitaceæ.‡ This was done at some length, although the materials then studied represented only the beginnings of the great collections now available, while the nature of the preservation in the examples first selected for investigation somewhat obscured the characters of certain structures of fundamental importance. But these studies have now so far progressed that the writer feels that it is necessary to return to this topic. Its final consideration is, however, reserved for a monograph on the entire subject, at present actively in course of preparation.

In the contribution just mentioned, after describing the principal parts present in the pollen-bearing fructification of *Cycadeoidea ingens* Ward, the writer noted the archaic type of the sori, and distinctly stated their Marattiaceous character, together with the fact of the exceedingly clear additional testimony which these hitherto unknown fructifications offered in favor of the belief in the direct descent of the Cycads from such tree ferns as the Marattaceæ. Moreover, in describing the arrangement of the fundamental parts, the writer said :

“With regard to the homologies of these structures several facts are worthy of mention. The radial divisions occurring in the summit (of the fructification) are found to persist for a considerable distance downwards, and under the microscope are seen to consist in two lignified layers a single cell in thickness. They correspond to the twelve vertices of soral distribution mentioned above, and their presence is against the idea that the soriferal axis is derived from the fusion of the sporophylls of a male cone like that, for instance, of *Zamia integrifolia*. *Another and much more tenable hypothesis is that the soriferal (sorus-bearing) axis is a series of twelve fused leaves (or fronds) with their sorus-bearing pinnules turned inwards.*”

* Parts I-III of these studies appeared serially in this Journal for March, April, and May, 1899.

† It is deemed advisable to retain for the present the generic name *Cycadeoidea* Buckland, although it is, of course, certain that if *Bennettites* is to stand, as it probably must, there are well-marked American species of this genus. The writer will defer proposing any changes of generic or other names until making a final publication.

‡ A Study of some American Fossil Cycads, Part I. The Male Flower of *Cycadeoidea*, with Plates II-IV, pp. 219-226, Fourth Series, Vol. VII.

The above interpretation and conception of the male cycad inflorescences of the type then considered, I have now, from extended study of much additional material in a far superior state of preservation, confirmed as wholly correct and expressing their nature with precision. Defined in more detail, this unexpanded fructification or strobilus is a series of from twelve to twenty closely appressed fertile, morphologically Marattiacean fronds, of semicircinnate prefoliation (or better, inflexed prefloration), with twenty or more pairs each of simple and reduced synangia-bearing pinnules,—these fronds being inserted so closely as to appear on the same level, and *fusing basally* so as to form an hypogynous staminate disk enclosing

1

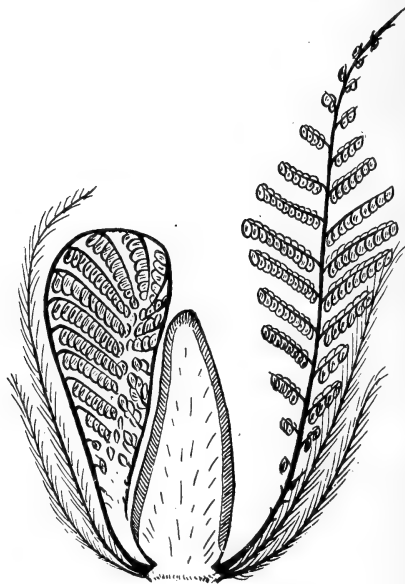

FIGURE 1.—*Cycadeoidea*. Diagrammatic sketch of longitudinal section through the bisporangiate strobilus. At the center is the apical cone closely invested by a zone of short-stalked abortive (?) ovules and interseminal scales. On the left is a single frond of the hypogynous staminate disk, with much reduced pinnules bearing densely crowded synangia. On the right a similar fertile frond is arbitrarily shown in an expanded position. Exterior to the fronds are the hairy bracts. About $\frac{1}{4}$ natural size.

a receptacle ending as a conical-shaped abortive (?) ovulate strobilus. The essential organs are surrounded and in the earlier stages enclosed by a series of acuminate and regularly imbricating hairy bracts, the entire inflorescence developing between the leaf bases, and later emerging, as in the case of the well known functionally ovulate strobili of *Cycadeoidea*

(*Bennettites*) *Gibsonianus* and *Morièrei*. See figure 1. Plates III and IV, given in Part I of these studies, may also be referred to.

In the inflorescence first studied there is, as was then mentioned, a large slightly conical central cavity with much chalcidized borders covered by a druse of quartz crystals, beneath which in just one small area about a millimeter in length and inside the innermost synangia, there was originally noticed a slight palisading which was at the time regarded as simply an accident of silicification. But as verified over and over since from material in the most wonderful degree of preservation and beautiful differentiation of tissues by a natural iron staining, this small area indicated a notable fact had we known how to interpret it. The central axis, or receptacle, bearing the fertile fronds with their petioles folded back once adaxially, terminates as a much elongated conical, and probably in most if not in all cases abortive, ovulate axis. This central and apical structure is preserved in several instances in such perfection of essential parts and bundle systems that notwithstanding its young and undeveloped condition, and the minuteness of its ovules, the most accurate comparisons can be made between it and obviously functional ovulate strobili. That these apical ovulate axes are of essentially the same structure as the more rotund to distinctly globular and much larger seed-bearing strobili borne on the same trunk in the case of such species as *Cycadeoidea dactotensis*, *Marshiana*, and some others, admits of no doubt. All the evidence in favor of the absence in these latter of fugacious organs of staminate character, and their solely feminine function, cannot now be conveniently given. But it led the writer to announce Cycadean Monœcism for the first time in this Journal for August, 1899 (vide page 164). The evidence which I have thus far been able to produce points well nigh indubitably in the case of the species just mentioned to a monœcious condition, the pollen-bearing axis being in this case morphologically but not functionally bisporangiate. The existence and importance of these bisporangiate axes was first announced by the present writer in the Yale Scientific Monthly for March, 1900, at which time somewhat extended study of them had already been made.

Before taking up the subject of what I here designate the staminate fronds, several remarks concerning data now considered in part may be recorded.

The presence on the same trunk of markedly different and much larger ovulate strobili surrounded, so far as my sections thus far completed show, by sterile bracts only, would indicate,

as just stated, that the ovulate portion of the microspore bearing axis is *abortive*. But that it was once not far previous in the history of these plants strictly functional, is scarcely to be questioned from the perfection with which it has persisted in the presence of similar but more robust seed-bearing axes which have failed to produce basally, fertile microspore bearing fronds. This bisporangiate axis is, therefore, very significant, though in a lesser degree paralleled by the even closer association of staminate and ovulate organs in *Welwitschia mirabilis*, or *Tumboa*, among the existing Gymnosperms. It also recalls the fact that, as suggested by Schimper (Zittel's Handbuch, Palaeophytologie II, page 247), *Cordaianthus Penjoni* may have borne apical ovulate structures after the manner of *Welwitschia*. My present view of the central axis is that it represents a synthesis of carpellary but not staminate leaves, as suggested in the case of *Williamsonia* by Saporta (Plantes Jurassiques), and that it may further be regarded as essentially a modified cone. The ovulate inflorescence of these Cycads, therefore, underwent far more evolution than the staminate organs by which it was surrounded, the latter retaining a quite primitive structure. Though as will be again noted, the case is in this respect exactly paralleled from the opposite side in the living *Cycas*, where the staminate organs are modified and arranged in conical order, while the carpels have retained a very primitive form and position. Although difficult hence to surmise whether the bisporangiate axis is the most primitive condition leading into the gymnosperms, it is at least clear that it occurs more frequently in the older forms, and that in this group the process of evolution has led away from such an axis by gradations of monœcism and finally diœcism.

It might be hastily said that these bisporangiate axes show no more essential relationship to angiospermous flowers than do the gymnosperm strobili hitherto known. And certainly the testimony of fundamental importance which they do offer has mainly to do with transitional stages between the Pteridophytes and the Gymnosperms. But this suggestion is here emphasized: *While the staminate disk surrounding the ovulate axis of Cycadeoidea indicates primarily an evolution terminating, so far as now possible to trace, in the Gymnosperms, the juxtaposition of parts is exceedingly suggestive of the possibility, if not the manner as well, of angiosperm development directly from pteridophytic forms.* For in these strobili the sporophylls are organized into a flower, as I justly applied the term in Part I of these studies, foreshadowing distinctly the characteristic angiospermous arrangement of stamens inserted on a shortened axis about an ovulate center, apical and sometimes strobilar as seen in *Liriodendron*. On

the basis of evidence afforded rather by the ovulate inflorescence, Saporta in his study of the French Bennettitaceæ given in his *Plantes Jurassiques*, has introduced for this group together with *Yuccites*, *Goniolina*, and several others, the name *proangiosperms*. And Scott has thus stated his opinion: "If by the name proangiosperms we simply mean to indicate plants with a near approach to angiospermous structure without implying any relationship to the class angiosperms as now existing, the Bennettitaceæ may well be called proangiosperms." This latter view is seen to be distinctly strengthened by the additional evidence here adduced.

The term staminate frond, as above introduced, will, however, certainly be found a necessary and convenient one, it being quite evident that the "male flowers" of *Gingko*, for instance, have also retained traces of frond structure characterizing forms ancestral to this genus, an intermediate stage of which is seen in *Baiera Münsteriana* Heer from the Rhät of Baireuth. These latter also recall the "stamens" of *Cordaites*.

Before more particularized deductions can, however, be attempted with any degree of safety whatever, this investigation must be carried much further. For while the plants from which the facts of the present contribution have been determined were not only preserved at such a critically important stage in their fructification, *but of their life history as well*, the very extent of the comparisons possible makes their completed study a prior necessity. While it is true that their prolific habit has greatly aided and simplified their investigation up to a certain point, a particular fructification as selected for study requires much comparison, as it represents a particular stage of development, as a rule one somewhat previous to that of maturity. Whereas the mature fruit represents, of course, the last stage in a series of changes certainly here requiring a year or more. It is hence necessary to bear in mind that in the case of very young stages of ovulate strobili certain structures may be undeveloped—to say nothing of the exigencies of silicification! Again in the maturer stages it is necessary to determine whether or not fugacious organs have earlier been present. The facts as announced are, therefore, the writer's present interpretation as based on observations which he hopes very greatly to extend before dealing with the subject finally, the entire arrangement of fructification as here described being, as the reader will have already noted, exactly the one most capable of variation and the most difficult to delimit. Happily at the same time the wealth of additional knowledge furnished by these structures promises to equal all that the most sanguine paleobotanist could have hoped for.

As now understood, however, in *Cycadeoidea dacotensis* Macbride, *C. Marshiana* Ward, and several other species, monœcism is indicated. In the series of species which includes *Cycadeoidea* (or *Bennettites*), *Gibsonianus*, *Morièrei*, and *Wielandi*, there is every probability of diœcism. While in the forms immediately ancestral to those under discussion, and as now seems possible, including *Cycadeoidea etrusca*, it is probable that the fructifications were potentially bisporangiate and had continued so from far back towards the time when ancestral Marattiaceæ attained heterospory. It is hence not unlikely that within the next few years all these forms of fructification will be found very definitely exhibited in cycadean forms of the Mesozoic.

The description of the expanded flowers with complete restorations of typical forms of these cycads in full leaf and fruit, all the details for which are now at hand, being reserved for the final publication, it remains to consider briefly the microsporophylls, or staminate fronds, and also to present certain general conclusions based upon their structure and strobilar association.

The Staminate Fronds.

As has been explained above, the most fundamental feature of the bisporangiate strobilus is a staminate or *pollen-bearing* frond. The petiole of each frond, as seen in unexpanded strobili which have begun to emerge from the surrounding leaf bases, and which bear approximately mature pollen, is about 10 centimeters in entire length as folded back once adaxially along the central ovulate axis. The pinnules inserted on all that portion of the petiole as seen to rise and then curve inwards to form a member of the still folded group, are simple, very thickly set with syngangia in nodes, and folded back in closely appressed drooping pairs towards the axis of the receptacle, between the ascending and descending segments of the petiole. (See figure 1.) But on the upper portions of the frond as seen in this infolded position, or inflexed prefloration, turned downward and lying closely appressed to the surface of the central ovulate cone, the pinnules lie in an outwardly and then more and more upwardly directed position, though of course becoming more and more inconspicuous towards the tip of the frond. And it is also a very interesting fact that the upper portion of the petiole is at first much compressed laterally, but as the tip is approached becomes expanded into a broad lamina much as in the ovulate fronds of *Cycas*. Of the pairs of simple pinnules there are about twenty, including the abortive and smaller ones near the base of the frond as well as those near the tip, the first and last fertile ones bearing but a single syngangium.

The largest pinnules are borne on the central portions of the frond. They are 1.5 centimeters in length and bear from twenty to thirty synangia attached to eight or ten closely set nodes. There is here seen, therefore, in the arrangement, form and pre-foliation a characteristic fern frond, although in the vascular bundles, the entire system of which is indicated by beautifully preserved xylem, there is an advance in the direction of the cycads, by the way, we venture to think of structures of cycadofilicinian type. The statement previously made that this frond is morphologically Marattiacean is however based more particularly on the histology of the synangia. Their resemblance to those of living Marattiaceæ is a striking one, and involves facts of far-reaching significance. In size, position, arrangement of the sporangia in two parallel rows extending the full length of the synangium, and in dehiscence, they resemble such species as *Marattia laevis*, or *cicutæfolia*, there being a tendency to greater breadth, a larger number of sporangia, and a slight variation in contour due to appression in interlocking series. But comparisons may be made quite final since the microscopic structure of these silicified synangia is preserved entire, bearing in mind that certain cell layers may have already broken down in life at the particular stages of development approaching maturity which most freely permit study. As a matter of convenience, I shall hence describe more fully than I have previously, the typical sorus, or better synangium, as seen in such representative species as *Cycadeoidea ingens*, upon which the first descriptions were based, and *C. dacotensis*, also briefly mentioned and figured in Part III of these studies. (This Journal, May, 1899, Plate X, figures 17 and 18, with text figures 3-16.)

The pendent synangia, as stated, are thickly set in nodes, being borne on very short stems. See figures 2 and 3.

Externally the synangium is covered by a layer of heavy walled palisaded cells a single cell in thickness, thickest near the base of the synangium, and thinning out somewhat as it approaches the apical median line, which is that of dehiscence. Just inside this outer palisaded tissue there is a layer of thin-walled hypodermal cells, also usually a single cell in thickness along the lateral wall of the synangium where the individual cells readily collapse, but growing smaller celled and firmer about the bases of the sporangial loculi, and widening out to form the principal ground tissue of the short stem of the synangium as it becomes confluent with the sporophyll. Next to the parenchyma layer lie the sporangial loculi, delimited by deeply iron-stained bands made up of wholly indistinct cell remnants apparently septal in character, with much collapsed pollen adhering. No other tissue than that indicated

by these bands separated the adjacent loculi. On the inner side of each row of loculi as thus delimited there is, finally, a

2

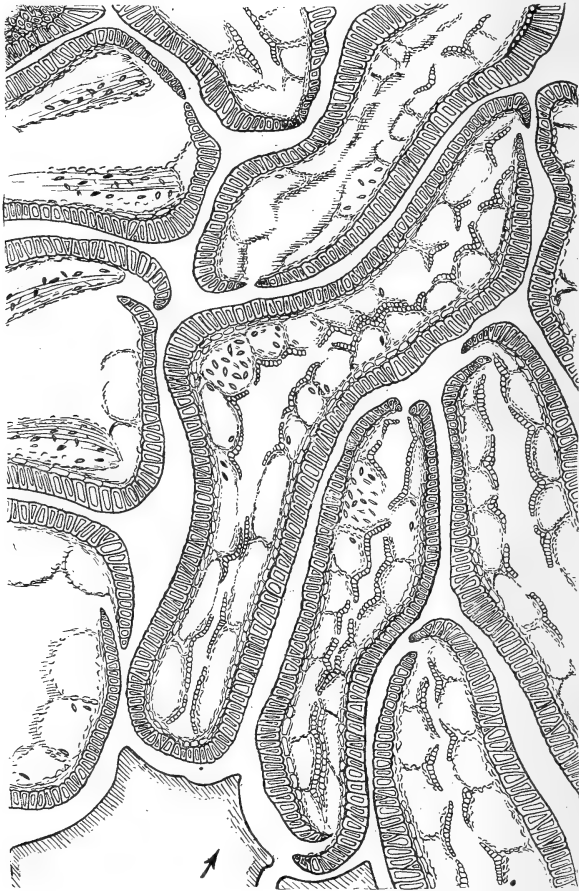

FIGURE 2.—*Cycadoidea dacotensis* Macbride. Transverse section of adjacent synangia. In the central synangium the outer covering of heavy walled prismatic cells is seen to be followed by a thin-walled layer. Adhering to this are the sporangial loculi closely ranged on each side of the synangium in two rows. Each loculus is delimited by bands of collapsed cells with adhering pollen grains, and each row of loculi is bounded on the inner side by well defined tissue a single cell in thickness, except between the angles of adjacent loculi, where there is a thickness of several cells. This layer thus bounds the two opposed inner faces of the synangium. It is usually split on the median line of the sporangia, and the striate appearance of its elongate cells when cut obliquely is indicated in several instances.

The tips of the three synangia on the left side of the figure are seen to be oriented nearly at right angles to the others, being cut very obliquely. At the lower left-hand corner portions of two transversely cut sporophylls are seen. $\times 30$. (Based on section figured in Part III of these studies, Plate X, figure 17.

well defined layer of small elongate cells, a single cell in thickness, or several cells in thickness between the angles formed by adjacent sporangia, and thus covering the entire inner face of the synangium, as early cleft down to the sporangial bases. (See figure 3.)

Along the inner middle surface of each sporangium this tissue weakens to form a well marked dehiscence line, along which splitting is frequently seen to have taken place in unexpanded stages of frond growth, though such premature dehiscence is probably due to the process of silicification.

Recapitulating, then, the principal features of the synangium are: First, the outer palisaded wall tissue; second, the delicate thin-walled layer usually collapsing or failing of well marked preservation; third, the sporangial loculi containing much well-preserved pollen but delimited only by desiccated pollen grains or collapsed remains of cells; and fourth, the thin elongate-celled layer bounding the sulcus between the two rows of sporangia:—dehiscence of the synangium taking place early along the median apical line, and of the sporangium, longitudinally along the inner median line, as in the genus *Marattia*, not *Danaë*.

Regarding the character of the tissue bounding the sporangial loculi a word remains to be said. The yellowish-brown iron-stained band, mentioned above, is more distinct in the less advanced stages observed thus far, but in all cases the collapsed remains of cells composing it so uniformly lack structure that it has not yet proven possible to determine the true character of the locular wall, as to whether wholly septal, or in part tapetal. It would appear, however, that it may have been two cells in thickness, rather than one, in this respect approaching the condition of the crushed double layer of wall cells observed by Lang in *Stangeria paradoxa*. See Lang, Studies in the Development and Morphology of Cycadean Sporangia, Plate XXII, figures 15 and 16. If by any chance the colored band represents a long persistent but finally crushed tapetum, the condition represented would be quite identical layer by layer

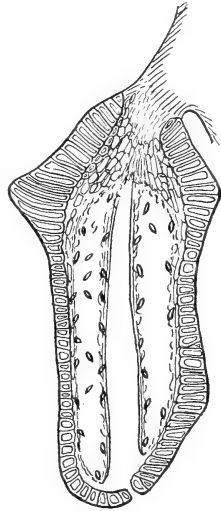

FIGURE 3.—*Cycadeoidea dacotensis* Macbride. Longitudinal transverse section through a synangium, showing attachment to the sporophyll, the several layers of the synangial wall, its dehiscence, the attachment of the sporangia, and the median sulcus or fissure between them. The basal buttressing of the outer wall is characteristic. $\times 37$.

of cells (in the transverse longitudinal section only) with that seen in a similar section of a nearly mature sporangium of *Angiopteris evecta* given by Campbell in his "Mosses and Ferns," fig. 143. The greatest difference would lie, of course, in the absence of a rudimentary annulus, and the strong development in the present forms of the outer prismatic layer with the projection of its two valves beyond the sporangia to meet lip-like on the line of dehiscence. It should be stated that it would appear from the investigations of Bower (Studies in the Morphology of Spore Producing Members) that the condition figured by Campbell is not the usual one observed in *Angiopteris*. If, however, it should approximate the condition seen in these fossil forms, we would then have indicated in them imperfect septation of the loculi carried to a high degree, an anomalous condition frequently noted in both *Danaë* and *Marattia* by Bower (loc. cit.).

While, then, these cycad synangia may recall or suggest other members of the living Marattiaceæ than *Marattia*, it is with this genus that they may most closely be compared, agreeing with it, as they do, in all essential structural details, as well as in dehiscence, and doubtless also in development plurilocularly from a single enclosed mass of sporogenous tissue. In fact the parallel to *Marattia* is seen to be so close that had the present structures been found isolated they might hitherto have been referred directly to this genus, no pollen being preserved, unless indeed the remarkably strong and uniform palisading of the outer layer, and its projection, as mentioned above, beyond the sporangia into two lips meeting over the sulcus between the two synangial halves, might have been considered characters of generic value. While it is quite possible that some little known Marattiacean forms may also show a stronger development of the outer layer, it is not probable, the heavy development seen in these cycads being apparently secondary, and mainly due to the necessity for resistant strength in the walls of the individual sporangia in their closely appressed position before the inflorescence emerged fully from the armor.

Among extinct members of the Marattiaceæ, *Scolecopteris elegans* Zenker of the Permian, long since so well and fully described by Strasburger (Jenaische Zeitschrift, viii, 1874), is likewise practically identical both in preservation and general structure, including the bundles of the sporophyll. The main distinction is, of course, in the lack of continuity in the outer synangial wall, and the reduced number of the sporangia. But as has been pointed out by Stur (Carbon Flora der Schatzlarer Schichten) and later further emphasized by Bower (loc. cit.), there is so much of transition in the amount of fusion

between the sporangia of even the living Marattiacean genera, as is seen on passing from the free sporangia of *Angiopteris* to the fused sporangia of *Marattia*, that in considering relationships, forms with free sporangia or with sporangia arranged circularly, must not be neglected as in the wider sense unrelated—a fact which it is well to bear in mind since it must now necessarily be extended to the cycadaceous forms as well.

One other observation in this connection I shall also make. As fully stated by Bower in his indispensable work just cited, while the evidence of development is in favor of the Marattian or Synangial type, developing from a single sporogenous mass, as being older than the *Angiopteris* type with free sporangia—an idea opposed to that of Stur (cited above), there has been hitherto no direct paleontological evidence either way. But now should the *Bennettitaceæ* and the living cycads not be polyphyletic, the latter have suffered a breaking up of the synangium which may well have been paralleled by a similar separation in the Marattiaceæ. In this category of pollen sac separation and reduction the Ginkgoaceæ may apparently be likewise included. The occasional occurrence of pollen sacs in groups of three in the living *Ginkgo*, as suggested by Thibaut (*Recherches sur l'appareil mâle des Gymnospermes*), may represent a primitive condition. And *Baiera Münsteriana* from the Rhät with asteriate groups of seven pollen sacs may certainly be regarded as still more primitive. There would therefore appear to have been, following an original soral septation, a more or less progressive separation of sporangia and reduction in their number in the Marattiaceæ, cycads, and Ginkgoaceæ. Certainly if the facts observed here cannot be construed as offering inferential testimony from the paleontological side in favor of Bower's supposition, they do not interpose any facts against it. In accordance with this view I incline to believe that the Bennettitean synangium is slightly more archaic in form than that of any of the living Marattian genera except perhaps *Danaë*, with which, as pointed out above, the comparison is not quite direct.

Now further as to forms presenting analogous synangia or sori. From the foregoing description it is clear that *Urnatopteris*, *Crossothea*, and especially *Calymmatothea* may be considered as distinctly related by reason of their synangial forms. But these are all dimorphic ferns as hitherto viewed, with reduced fertile pinnules suggesting those above described, and at once carrying the relationship of these Mesozoic cycads, themselves dimorphic as well, back to the Cycadofilices. Hence from the variations in form seen in the Marittiacean sorus, and no doubt also paralleled in the Cycads, at may be at once stated that so far as we may infer from isolated fructifica-

tions it must, until additional fortunate discoveries are made, as they doubtless will be, remain difficult to judge from isolated fruits of the Marattian type whether or not they belong to plants that have acquired the seed-bearing habit. When, however, preservation is unusually good the microspores may show either pollen or spore characters, as in the case respectively of the present forms and *Scolecopteris elegans*. At all events, an extraordinary interest will henceforth attach itself to fructifications of the Calymmatothecan, and Scolecopteran type, as well as to the possibility of accompanying macrosporophylls.

It is of importance to add that the presence, in these cycadaeous forms, of a central ovulate axis surrounded by an asteriate series of staminate fronds with basally adnate petioles, sheds a flood of clear light on the nature of *Williamsonia*,—a subject which has vexed paleobotany for thirty years. The axes which Williamson and Saporta have described as male (see Williamson, Trans. Lin. Soc., Vol. XXVI, Plate 52, and many figures in *Paleontologie Francaise, Plantes Jurassiques*, par Marquis de Saporta,) are doubtless mostly ovulate inflorescences around the bases of which were inserted the peculiar disks they have illustrated, which may be interpreted as staminate rather than "carpellary." Though that the central axis could terminate in an asteriate growth is not wholly impossible. Such growths could also be ovuliferous if apical and central, and calyxate if basal, there being here great possibility of variant structures.

However, in the writer's opinion the most important possibility suggested by the staminate fronds above described is as to the character of fructification in the Cycadofilices. If we are permitted to imagine, as we surely are, a plant vegetatively like *Lyginodendron*, and either monœcious or diœcious, with microsporophylls like those of the staminate fronds of *Cycad-eoidea*, and macrosporophylls like those of *Cycas*, do we not picture an ancestral form which almost beyond doubt existed and may any day be found? The existence of cones in the presence of both these simple types of micro- and macrosporophylls is from the preceding descriptions now manifestly possible. In the presence of such facts it is yet more patent that there are peculiar possibilities of structure of great interest in the case of such fructifications as that of *Cycadospadia Milleryensis*. (See Scott's *Studies in Fossil Botany*, p. 371.) Likewise, *Anomozamites minor* Brogn, from the Rhät of Scania, as restored by Nathorst, is seen to occupy a position of unique importance. It certainly becomes more than ever probable that the dimorphism of various paleozoic plants usually referred to the ferns is intimately connected with

forms of heterospory and the acquiring of the seed habit by types immediately ancestral to the cycads or other gymnosperms, if not also to the angiosperms.

It is, however, if we clearly apprehend the significance of the above described structures, as hitherto held, difficult to believe that the existing cycads could have been derived directly from the Bennettitaceæ. The evidence at present wholly favors the belief that the former represent a line of descent from an ancestral stock common to both, which underwent alteration of both macro- and microsporophylls on elongate axes resulting in true cones, with the exception of the macrosporophylls of *Cycas*, which have retained a quite primitive type and position. On the contrary, in the Bennettitaceæ, it is the microsporophylls which remain primitive, while the macrosporophylls have undergone an extreme of alteration and consolidation, albeit on ancient lines of development finding their nearest known analogy in *Cordaites*, and perhaps *Gingko*. It appears from the facts now at hand that both cycadean branches may not have passed through precisely the same evolutionary sequence of heterospory, bi- or monosporangiate, monœcious, and finally diœcious fructification.

It now becomes possible for the first time to consider the taxonomic position of the living and fossil cycads in the light of a clear knowledge of those structures and characters of fundamental importance in classification. It is quite evident that there is more resemblance between these two important groups than would be indicated by classification as the Cycadales and the Bennettitales. The lateral fructification of the latter group, while a distinctive feature, is not a profound difference. For if Williamson's restoration of *Zamia gigas* be correct, as now appears probable, this genus did not bear lateral fructifications, and is hence in this respect intermediate. Nor are the frequent adventitious buds and branches of certain living cycads to be overlooked.

On weighing the new evidence as carefully as possible, and bearing in mind that the staminate fronds of *Cycadeoidea* form a connecting link qualitatively of the same value as the carpophylls of *Cycas*, it becomes wholly clear that these fossils are true cycads and form an order, or perhaps preferably a sub-order, of equal rank with the living cycads. The classification already suggested by Professor Scott, I, therefore, believe to be a natural one. He says in his *Studies in Fossil Botany*, p. 474, "It appears then that there are at present known to us three distinct families of Cycadales. On the one hand the Zamieæ and the Cycadeæ, still existing, and together constituting the order Cycadaceæ; and on the other the Ben-

nettiteæ, wholly extinct, and so different as to merit ordinal rank.”

In their leaf structures these two orders are essentially similar. In trunk structure there is a well-marked minor difference affording a convenient means of separation,—the leaf traces (but not always the peduncle traces) of the Cycadaceæ arising as secondary cortical bundles, while those of the Bennettitaceæ are primary, passing out directly from the xylem zone.

In fructification the basis of separation rests on the fact that in the Cycadaceæ the microsporophylls are always organized into a distinct cone, while the macrosporophylls may retain primitive characters as carpellary leaves. In the Bennettitaceæ the opposite holds true. The microspores are borne on primitive pollinial leaves, while the macrospores are organized into an ancient type of cone.

It may be remarked that the gap between *Cycas* and the other living cycads is clearly lessened by the analogy afforded by the staminate fronds of the Bennettitaceæ. The living cycads may hence most conveniently be held as composed of two divisions of equal value, the Cycadeæ and Zamieæ.

Yale Museum, New Haven, Conn., April 20, 1901.

ART. XXXVI.—*Studies of Eocene Mammalia in the Marsh Collection, Peabody Museum*; by J. L. WORTMAN. With Plate VI.

[Continued from page 348.]

Pelvis and Hind Limb.—The pelvis is somewhat fragmentary and displays the character of the pelvic girdle in but an imperfect manner. An ischium and an anterior portion of an ilium are all that remain of it. The ischium is relatively much longer and more slender than that of either the ichneumon or fox and in this respect resembles *Cynodictis*. The ischial tuberosities are only slightly developed as in the civets and quite lack that broad characteristic expansion of the modern Canids. The obturator foramen was apparently longer than in either the fox or ichneumon and extended well forwards beneath the acetabulum as in the dogs, differing in this respect from the ichneumon, in which it is more posterior. The cotyloid notch of the acetabulum is wide as it is in both the viverrines and Canids. Only the anterior part of the ilium is preserved, and this, like that in *Cynodictis*, exhibits a narrow dorsal depression and a wider ventral cavity separated by a longitudinal ridge.

The femur, figure 7, has many peculiarities of its own, but on the whole it may be said to be much more dog-like than civet-like. The shaft is well rounded and has a slight backward curvature as in all the Canids and not perfectly straight as it is in the carnivorous civets in general. Of the proximal extremity the head is hemispherical and set upon the shaft by a rather short thick neck. The greater trochanter rises above the head and is of considerable fore and aft extent; the digital fossa is deep and roomy. The lesser trochanter is proportionally very large and placed upon the inner border of the shaft just below the head. According to Scott's description of *Cynodictis*, it is smaller and more external in this form. There is a distinct intertrochanteric line and a moderately well-developed third trochanter. The distal end of the bone exhibits well-developed condyles with the rotular groove, passing well up on the anterior border. The intercondylar notch is deep and the condyles project well backwards behind the axis of the shaft.

The tibia, figure 8, is a little shorter than the femur; the shaft is somewhat flattened in the proximal half of its extent and the cnemial crest is prolonged downwards, occupying quite one-third of the entire surface of the bone. This is in marked contrast with its shortness in the modern Canidæ. The head is relatively broad and overhangs the vertical axis of the shaft to a marked extent, the double tibial spine being rather indistinct. The lower portion of the shaft is subround in cross-section and dis-

plays upon its outer surface a well-marked interosseous ridge. The distal extremity has a large thickened internal malleolus, upon the internal and posterior surface of which is seen a deep tendinal sulcus. The articular surface shows but little grooving where it touches the astragalus.

The shaft of the fibula exhibits but little reduction when placed in comparison with the modern Canids. The head of the bone is relatively large with considerable fore and aft projections, and the proximal part of the shaft is sharply divided into three surfaces by as many distinct ridges; of these latter

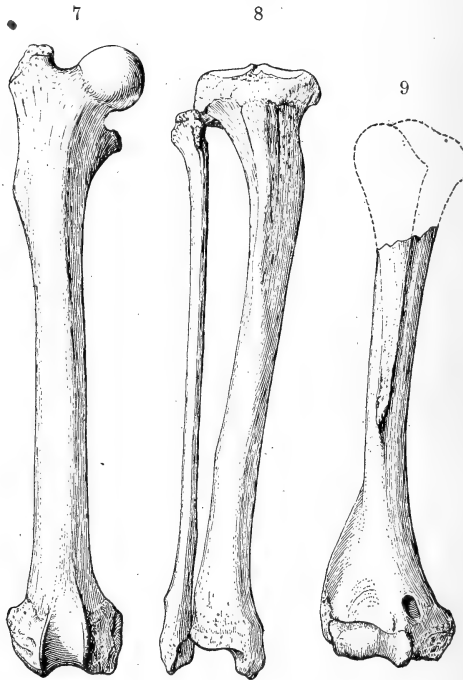

FIGURES 7, 8, 9.—Right femur, tibia, fibula, and humerus of *V. Hargeri* Wortman; three-fourths natural size. (Cotype.)

the anterior and posterior soon disappear below, but the internal is continued down the shaft as a sharp interosseous ridge. In keeping with the unreduced character of the bone, the distal end is large and prominent. The usual obliquely placed articular facet by which it touches the astragalus is present, but there is no evidence of a calcaneal facet. Behind and to the outer side is seen a prominent bony process which is deeply grooved for the passage of flexor-tendons.

The Pes.—The hind foot, of which there is an almost complete specimen preserved, figure 10, exhibits, as do the other bones of the hind limb, a wide departure from that of the modern Canids. The astragalus betrays the primitive character of the foot in the following important particulars: The tibial trochlea is little grooved; the head is proportionally large and has an oblique position; the transverse plane of the navicular facet coincides very nearly with that of the trochlear facet; and an astragalar foramen is present, though small. The calcaneal facet is rather wide and shallow, lacking the deep saddle-shape of that of the fox; the sustentacular facet is very convex from before backwards, is separated from the calcaneal facet by a wide shallow groove and is not continuous with the navicular articulation.

The calcaneum has a moderately elongated tuber of about the same proportions as seen in the fox; the astragalar facet is very convex but without the distinctly angular pattern of the recent Canids. The *sustentaculum tali* is relatively broad and has a shallow cup-shaped facet. The cuboid facet is much like that of the fox, and there is a large calcaneal tubercle present. The navicular differs quite considerably from that of the fox, in that it has a less vertical depth, and a squarish outline when viewed from above. It is, moreover, larger and broader, having the tubercle located at the postero-internal angle instead of on the posterior border as in the fox. Inasmuch as this character, in association with that of the head of the astragalus, has to do with the position of the foot in walking, it may be taken not only as an index of the inferior organization of the pes, but it may also be taken to indicate that if the

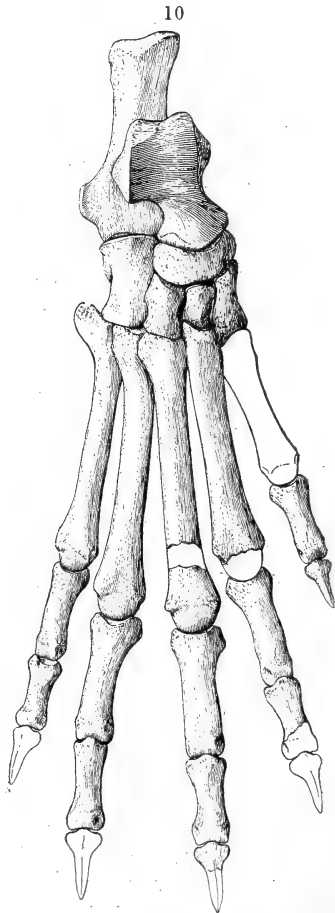

FIGURE 10.—Right hind foot of *V. Hargeri* Wortman; natural size. (Cotype.)

limb is carried in the fore and aft plane of the body, the outer edge of the sole of the foot touches the ground and the plantar surfaces are directed more or less inwards. This subject will be again referred to on a subsequent page. The remaining bones of the tarsus do not present any characters of especial interest. They resemble the corresponding bones of the fox with the exception of the internal cuneiform, which is large and functional for the support of the hallux. It has the same form as that of *Herpestes* but is proportionally broader and heavier, which would indicate a less degree of reduction for the hallux than in this species.

There are only four metatarsals of the foot preserved, that for the hallux being missing. When these bones are carefully articulated, they show that the toes were more spreading than those of *Herpestes* and somewhat less than those of the otter. They entirely lack that highly compressed form and closely interlocking arrangement seen in the fox. The distal ends are characteristically broad, with hemispherical heads and well-developed plantar keels. They resemble the corresponding bones of *Cynodictis* very closely in these particulars, and differ greatly from those of the fox, in which there is a distinctive "square-cut" appearance. The third metatarsal is slightly the longest and strongest bone of the series; the fourth is a little smaller and a trifle shorter; the second and fifth were apparently of about equal length, but the shaft of the second is considerably the stouter of the two. Their proportional length is much less than those of *Cynodictis*, in which the hind foot had already begun to assume the more compressed, elongated form of the modern dogs.

If we take the length of the ischium from the posterior border of the acetabulum, as a more or less fixed length and compare the length of the metatarsals with it, the hind foot of *Vulpavus* will be found to be as short as it is in *Herpestes*. Compared with this measurement, the following proportions of the different segments of the hind limb in several species are given herewith:

	Length of Ischium.	Length of Mt. IV.	Length of Tibia.	Length of Femur.
<i>Herpestes</i>	100	117	274	282
<i>Vulpavus</i>	100	117	314	326
<i>Cynodictis</i>	100	154	368	363
<i>Vulpes</i>	100	220	490	435

That is to say, taking the ischial length as 100, the metatarsal length in *Herpestes* is 117, the tibial length 274 and the femoral length 282 per cent of the ischial length, etc. I have been compelled to estimate the ischial length in *Cynodictis*, which when correctly ascertained may give slightly different percentages from those above recorded, but it may be assumed

that they are approximately correct. It will be seen from the above table that the relative proportions of the hind-limb bones and foot of *Vulpavus* place it much lower in the scale than *Cynodictis*. In this respect it is indeed the most primitive canine limb known.

The first phalanges are relatively short, rather broad proximally and much curved; this latter feature is as much or even more marked than it is in the felines, which is somewhat surprising. Were these bones found isolated, they would pass very readily for those of a cat. The middle or second phalanges are of moderate length and distally unsymmetrical like those of the cat, but not to such a marked extent. This undoubtedly indicates a certain degree of retractility of the claws which the animal in all probability possessed. There is a single claw or unguis phalanx preserved in nearly perfect condition, figure 11, and the base of a second much damaged; these show that they were compressed and pointed and not flattened and fissured as in many contemporary Creodonts.

11



FIGURE 11.—Unguis phalanx of *V. Hargeri* Wortman; natural size.

I give the following principal measurements :

	mm.
Length of superior dentition from anterior border of canine to posterior border of second molar	40·
Length of first and second molars	8·5
Antero-posterior diameter of first molar	5·5
Antero-posterior diameter of second molar	3·0
Length of superior sectorial, outside border	8·5
Length of premolar series including diastemata	17·5
Transverse diameter of superior sectorial	6·5
Transverse diameter of first molar	10·
Transverse diameter of second molar	5·5
Length of inferior dental series to anterior border of canine	45·00
Length of jaw from anterior border of canine to condyle	74·5
Length of inferior molars	15·5
Length of inferior premolars including diastemata	23·5
Depth of jaw at posterior border of sectorial	11·
Transverse diameter of distal end of humerus	23·5
Length of ischium from posterior border of acetabulum	34·
Length of femur	111·
Length of tibia	107·
Length of foot exclusive of unguis phalanx	106·
Width of tarsus	20·
Length of fourth metatarsal	40·
Length of first phalanx of third digit	18·
Length of second phalanx of third digit	12·5
Length of calcaneum	28·0
Length of astragalus	19·
Width of astragalus	12·5

Comparison with the Viverrines.

It will be observed from a consideration of the characters detailed above, that *Vulpavus* approaches the carnivorous civets quite closely in many of the more important features of its osteology. Indeed, it would appear that the interval between these ancient Canids and the civets is actually less than it is between *Vulpavus* and the fox. A comparison of *Vulpavus* with such a form as the living *Viverricula* or *Herpestes* reveals the following rather striking resemblances: (1) The postorbital constriction of the skull is considerable; (2) the superior molars display the same peculiar elongation of the anterior part of the crown and the internal cusp of the superior sectorial is large; (3) the principal shear of the inferior sectorial is very oblique and there is a distinct posterior shear present which bites against the anterior edge of the first superior molar; (4) the distal end of the humerus is broad, the supinator ridge is large, there is no intercondylar perforation, and an entepicondylar foramen is present; (5) the radius is short, the head circular, and there was power of complete pronation and supination; (6) the ischial tuberosities are small; (7) the limbs are not elongated; (8) the feet are pentadactyle; (9) the femur is longer than the tibia, the cnemial crest is elongate, and the fibula is little reduced and not applied to the tibia; (10) the head of the astragalus is placed obliquely upon the body, and the transverse plane of the navicular articulation coincides with the transverse plane of the trochlea; (11) the hallux is little reduced, the feet are relatively broad and the metapodials are not greatly appressed and interlocking.

These resemblances would undoubtedly be greatly augmented did we compare the Eocene ancestors of the viverrines with the species under consideration, but notwithstanding these similarities of structure, many of which may be looked upon as primitive characters more or less common to all the early Carnivořa, there yet remain certain unmistakable features which stamp it as belonging to the canine phylum. In the structure of the superior molars as has already been stated, there is a very decided tendency to the formation of a posterior internal cusp from the cingulum. Among the Carnivora this is exclusively dog-like and completely unknown in the Viverridæ. On the other hand, there is a distinct anterior basal cusp upon the superior sectorial of all the civets wherever this tooth displays the laniary structure, whereas, with one exception it is absent in all the Canidæ. The inferior molars are both in number and general structure much more dog-like than civet-like. No viverrine is known in which there

are three true molars in either the upper or lower jaw. Although the typical genus *Viverra* is known with reasonable certainty from the Upper Eocene deposits of Europe, the molar formula is remarkably persistent, being two above and below. The femur again shows in its incipient backward curvature, as well as in the lateral position of the lesser trochanter, that *Vulpavus* is more nearly allied to the dogs than to the civets.

But this evidence from the incomplete skeletal remains, while it is very strongly presumptive of canine relationship, is not at the same time absolutely conclusive. It, however, receives powerful additional support from a consideration of the forms intervening between it and *Cynodictis* of the Oligocene, of the canine affinities, of which there cannot be the slightest question. From the Washakie Beds, which appear to be somewhat later than the Bridger, comes the genus *Neovulpavus*, in which the superior molars had been reduced to two, giving the molar formula of the modern genus *Canis*. In the succeeding Uinta or Uppermost Eocene stage the genus *Procynodictis* furnishes a nearer approach in the structure of the molars, in that the two external cusps are subequal in size, are more widely separated and the antero-external angle is less prominent. In the carpus, the scaphoid, lunar, and centrale were fused into a scapholunar and the feet were much like those of *Cynodictis*. It will thus be seen that the evidence as far as it is obtainable points very strongly to a genetic relationship between *Vulpavus* and *Cynodictis*, and from this latter without doubt sprang a large number of the modern species of the Canidæ.

Progressive Modification of the Canidæ.

Regarding this, then, as the oldest and most primitive link in the true canine phylum that has yet been discovered, it is a matter of more than passing interest to examine into the bearing of its osteological structure upon the origin and evolution of the central group of the living dogs. The characters in which this group has shown evolution may be summarized as follows: The brain has increased greatly in size, both relatively and actually, having been especially widened in front; the superior molars have been modified in structure, in that they have largely lost that characteristic anterior transverse elongation so common to the Eocene types, but have, on the other hand, developed a large postero-internal cusp from the cingulum and a strong tendency to the formation of a second posterior internal cusp; the number of the superior molars has been reduced to two, the sectorial of the superior series

has developed a more perfect shearing apparatus and the internal cusp has been reduced; in the inferior series, the sectorial has been modified into a more perfect shearing organ by the enlargement and lateral flattening of the two external cusps of the trigon, by their more perfect alignment with the long axis of the jaw, with a concomitant reduction in size of the internal cusp, the disappearance of the posterior shear and the widening of the heel; the cusps of the posterior molars have been reduced and their tuberculo-sectorial pattern lost; in the atlas the alæ have increased in size and have developed a peculiar and characteristic arrangement of the foramina for the passage of the vertebral artery; the lumbar vertebræ have been greatly reduced in size in comparison with the dorsals; the ischial tuberosities have increased in size, the body of the ischium has become shortened and the obturator foramen reduced; the femur has been lengthened, the shaft has developed an antero-posterior curvature, the neck of the bone elongated, the lesser trochanter reduced in size and the third trochanter has disappeared; the tibia has been lengthened, the cnemial crest shortened and the distal trochlea deeply grooved; the shaft of the fibula has been reduced to a thin lamella of bone which has become applied to the shaft of the tibia for a large part of its extent; the hind foot has been compressed and greatly elongated, the astragalus deeply grooved, and the navicular narrowed; the metatarsals have become proximally flattened, closely appressed and have developed a characteristic "square-cut" appearance of the distal ends; the hallux has disappeared and the internal cuneiform has been reduced to a vestige; the phalanges have been slightly shortened and those of the middle row have largely lost their distal asymmetry; in the forelimb the humerus has been elongated, the deltoid crest and supinator ridge greatly reduced, the entepicondylar foramen has disappeared, the intercondylar perforation formed and the distal end of the bone greatly narrowed; the ulna and radius have been greatly elongated, and the head of the radius flattened so as to considerably restrict the power of pronation and supination.

The three species at present known may be distinguished as follows:

- | | |
|---|----------------------|
| Posterior external angle of first superior molar more or less extended and cutting; a strong postero-internal cusp | <i>V. palustris</i> |
| Posterior external angle of first superior molar rounded; postero-internal cusp small and consisting of no more than a cingulum | <i>V. Hargéri</i> |
| Species considerably smaller than the two preceding | <i>V. parvivorus</i> |

The above species is named in honor of the late Mr. Oscar Harger, whose work in connection with the early Yale Expeditions is so well and favorably known. The locality of the type and cotype is Henry's Fork, Bridger Basin, Wyoming, and the specimens were found by Messrs. Oscar Harger and F. S. Weeks of the Expedition of 1873. Two other fragmentary examples are from Point Gulch, near Henry's Fork.

Neovulpavus washakius, gen. et sp. nov.

Vulpavus palustris Wortman and Matthew, Bull. Amer. Mus. Nat. Hist., June, 1899, p. 118.

It is now evident that the species published by Dr. Matthew and myself, under the name *Vulpavus palustris*, is distinct from the typical representative of the genus above described. The difference consists in the loss of the third superior molar, and as this is in direct line of progressive modification towards *Cynodictis* and represents an intermediate step between *Pro-cynodictis* and *Vulpavus*, it may be regarded as a distinct genus, for which the above name is proposed. With the exception of the loss of the third molar, it agrees closely with *Vulpavus*. The type is from the Washakie Basin, and is preserved in the American Museum Collection; its catalogue number is 2305. It was fully described and figured in the Bulletin of the American Museum, 1899, p. 118.

Uintacyon Leidy.

Uinta, a local name; and *Cyon*, a dog. Proc. Acad. Nat. Sci., Phila., 1872, p. 277; Extinct Vertebrate Fauna of the Western Territories, 1873, p. 118. *Miacis* Cope (in part). Proc. Amer. Philos. Soc., 1872, p. 470; Tertiary Vertebrata, 1884. *Miacis* Scott. Jour. Phila. Acad., vol. i, 1886. *Uintacyon* Wortman and Matthew. Bull. Amer. Mus. Nat. Hist., 1899, p. 110.

Typically small or medium sized imperfectly known Canids, with dentition $I_{\bar{3}}$, $C_{\bar{1}}$, $Pm_{\bar{4}}$, $M_{\bar{3}}$, having an inferior sectorial with a disproportionately large trigon and small, low, cutting, or slightly basin-shaped heel; cusps of succeeding molars, low and blunt. First superior molar, in type species, with anterior border much elongated, the two external cusps unequal in size, and the internal cusp without posterior transverse lunate ridge. Jaw, either short and deep, or elongated and shallow. Premolars unreduced.

Uintacyon edax Leidy.

This species was established by Leidy upon an imperfect and anomalous lower jaw, in which there are five premolars instead of four. The sectorial is damaged in such a way as not to display satisfactorily the characters of the heel, but it seems highly probable that it was made up of a cutting ridge,

as mentioned above. There is a single specimen in the collection, which I refer to this species, and which, although a little smaller than the type, agrees with it so perfectly in other respects as to leave little doubt of the identity of the two. It consists of the anterior part of the right mandibular ramus, figure 12, carrying the canine and the alveoli for the incisors and first premolar, together with the posterior part of the jaw containing the first and second molars. Fortunately the first superior molars of both sides are present. The alveoli indicate the existence of three incisors, the second of which was pushed well back out of the transverse line, as in the *Canidæ* in general. The canine is of moderate size, oval in cross-section, and surrounded by a faint cingulum at its base. The first premolar is not preserved, but the alveolus shows that it was small, single-rooted, and placed a short distance behind the

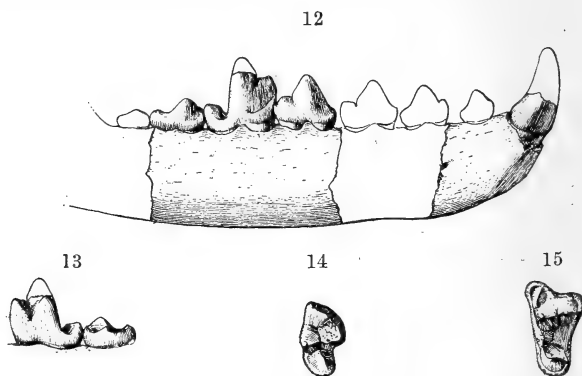

FIGURE 12.—Right ramus of *Urtacyon edax* Leidy; outside view.
 FIGURE 13.—First and second lower molars of same specimen; inside view.
 FIGURE 14.—First lower molar of same; crown view.
 FIGURE 15.—First left upper molar of same; crown view.
 All the figures are three halves natural size.

canine. The second and third premolars are missing; the fourth displays the usual pointed crown without an anterior basal cusp, but a strong posterior accessory cusp is developed. As compared with the corresponding tooth of *Vulpavus Hargerii*, the accessory cusp of this tooth is much stronger, but the heel is less prominent. It does not appear that the premolars were reduced in size, at least abnormally so, since those of the type are of the proportions usually seen in the *Canidæ*. The sectorial, figures 12–14, has a relatively smaller antero-posterior diameter than that of *Vulpavus*, the trigon having very much the same shape and disposition of its parts. The principal shear is very oblique and there is a well-developed posterior shear. In the structure of the heel, however, the two genera are very

different. In this species of *Uintacyon* the heel is smaller, and is composed of a single median cutting ridge, which is highest behind. On the inner border the cingulum is very slightly elevated, giving a faint indication of the basin of *Vulpavus*, but this is so inconsiderable that the heel may be said to be cutting. The second inferior molar, figures 12 and 13, may be described as having a very reduced trigon with the anterior cusp obsolete, a very small internal cusp and a cutting heel. As compared with that of *Vulpavus*, the cusps are much lower and more obtuse. The last molar is not preserved in the specimen under discussion, but judging from the type specimen it was small and single-rooted, with the cusps more or less vestigial.

The crown of the first superior molar, figure 15, in its external part, bears a very striking resemblance to that of *Vulpavus*, but internally, the two are quite distinct. As in that genus, the antero-external angle is produced and formed into a sharp cutting blade, separated from the antero-external cusp by a deep slit-like notch; this blade, together with the sharp anterior transverse ridge, bites effectively against the shears of the posterior cusps of the trigon. The postero-external angle is rounded. Between the base of the external cusps and the outer border of the crown is a relatively broad area, the outer edge of which is occupied by the cingulum. The external cusps have a flattened conical form, the edges of which are sharp, the anterior being the larger and more prominent of the two. The internal cusp is more or less conical and is somewhat extended posteriorly; it is connected with the antero-external cusp by a sharp transverse ridge, which is interrupted near its middle portion by a distinct anterior intermediate cusp. The posterior transverse ridge, which is very generally present in tritubercular teeth of this character is entirely absent. The cingulum, although more or less distinct upon the inner face of the crown, does not develop any postero-internal cusp.

The jaw is moderately long, rather shallow vertically, and of somewhat more than average thickness transversely. It has a distinctive breadth and "square-cut" appearance of the symphyseal region which is not shown in *Vulpavus*.

I give the following measurements:

	mm.
Length of Pm. ₃ , m. ₁ , ₂	15.5
Length of inferior sectorial	6.
Width of inferior sectorial	4.
Length of second molar	4.5
Depth of jaw at anterior border of sectorial	9.5
Depth of jaw at posterior border of Pm. ₁	8.
Thickness of jaw at posterior border of Pm. ₁	4.

The specimen is from the lower part of the Bridger Beds, and was found by R. E. Son.

A larger species, *U. vorax*, was established by Leidy, from the same horizon, upon a fragment of a lower jaw in which the heel of the sectorial and the penultimate molar are preserved.



FIGURE 16.—First superior molar of *Uintacyon vorax*(?); natural size.

The heel of the sectorial is not so trenchant as in the preceding species, but exhibits a more or less intermediate condition between the basin-shaped and cutting forms. Subsequently Scott described another species (*Miacis bathygnathus*) from the Bridger, in which the greater part of the lower jaws and some few fragments of the skeleton are preserved; but it would appear that it is not distinct from *U. vorax*. The jaws are short and deep, the symphyseal region abruptly rounded, and the premolars, as indicated by their alveoli, were not reduced in size below the normal; the canine, moreover, was more or less laterally compressed at its base. The few skeletal fragments exhibit characters of the early dogs. In this connection, I give a figure (figure 16) of a first superior molar, which probably belongs to this species. A third species from the Washakie, *U. pugnae*, displays the same jaw characters as *U. vorax*, but very little is known of it. A fourth species, *U. brevirostris*, was described by Cope from the Wind River Beds, and this species has also been identified from fragmentary remains from the Wasatch of the Big Horn Valley, clearly showing that the genus is of very ancient origin.

It now appears, even from this fragmentary evidence, that the direct connection between this group and the genus *Daphænus* of the White River Oligocene is so exceedingly probable, that it may be hypothetically assumed, notwithstanding the fact that the intermediate stages in the Uinta are as yet to a large extent wanting. The genus from this latter horizon, to which Matthew and myself gave the name *Prodaphænus*, is more probably a member of a line leading to *Amphicyon*. This is strongly suggested by the fact that the third superior premolar, and presumably the two anterior ones, are considerably reduced in size, a feature that does not occur in any known species of *Daphænus*, but does occur and constitutes one of the characteristic peculiarities of the genus *Amphicyon*.

The typical species of *Uintacyon*, *U. edax*, finds a highly probable successor in *Daphænus vetus*, in which the heel of the lower sectorial, as well as that of the second molar, are trenchant, and the lower jaw is slender and elongate, with marked traces of the characteristic abruptness of the mental region so

common in the Bridger species. I give in this connection (Plate VI) a drawing of a well-preserved skull of this species in the Marsh Collection, from the White River Bad Lands of Nebraska, on account of the apparently important position which it holds with reference to the origin of certain living species. It has been suggested by Matthew and myself,* that *Daphænus vetus* was the direct forerunner of *Temnocyon* of the John Day Miocene, which in turn passed by gradual transition into the living Dohles, or Red Dogs of India. If this chain of ancestry is correct, the evidence in favor of which seems to be very direct and positive, it establishes a long and eventful history for this phylum.

Daphænus Dodgei Scott, on the other hand, may be regarded as the successor of the short-jawed species of *Uin-tacyon*, of which *U. vorax* is a good type, and here again the characters, as far as we know them, fit with apparent accuracy. *Daphænus Dodgei* is known from a lower jaw only, and may, as suggested by Scott,* prove to be a distinct genus. Furthermore, it will not be surprising to find that it had already developed a reduced dentition, and was leading into the short-jawed dogs of the John Day, such as *Oligobunus*, *Enhydrocyon*, *Hyænocyon*, and thence through an unknown type, into the living Bush Dogs, *Icticyon*, of the South American tropics.

Prodaphænus Wortman and Matthew.

Prodaphænus Wortman and Matthew. Bull. Amer. Mus. Nat. Hist., 1899, p. 114.

In this group I arrange all those short-jawed dogs of the Eocene in which the size of the premolars, with the exception of the fourth superior, is much reduced. The dental formula is not fully known, but is very probably I. $\frac{3}{3}$, C. $\frac{1}{1}$ Pm. $\frac{4}{4}$, M. $\frac{3}{3}$. The canines are large and more or less laterally flattened, the heel of the inferior sectorial is basin-shaped, the anterior border of the superior molars extended transversely, the two external cusps are unequal in size and the postero-internal cingular cusp is small or absent.

The genus was established upon an incomplete superior dental series from the Uinta deposits and was unfortunately named. At the time, it was thought to be related to *Daphænus*, but it is now perfectly evident that it belongs to another line. The only other group of Canidæ thus far known in which this combination of characters occurs is the *Amphicyon* series; and as this begins abruptly in Europe in beds corresponding

* Loc. cit., p. 115.

† Notes on the Canidæ of the White River Oligocene. Trans. Amer. Philos. Soc., 1898.

in age to the American White River Oligocene or earlier, our Uinta species of this group may well have been their ancestors.

At least three species are known, the oldest of which, *P. promicrodon*, comes from the Wasatch of the Big Horn Valley. In this species the fourth lower premolar is not reduced but those anterior to it are quite small; the first premolar is single-rooted and the second and third are two-rooted. A second species, *P. canavus*, from the Wind River, shows the fourth premolar in the lower series reduced but the second premolar has two roots.

A fragment of a lower jaw in the collection, which I provisionally refer to the Uinta species *P. Scotti*, figure 17, shows the second premolar relatively very small and implanted by a single root.

It will thus be seen, from a consideration of what has already been said, that there were at least three, and probably four distinct lines of canine ancestry already established in the Bridger. One of these led from *Vulpavus* through *Neovulpavus* and *Procynodictis* directly into the Oligocene and Miocene *Cynodictis*, which without much doubt was the main axis from which all the living species of *Canis* have been derived. The second leads out through *Uintacyon edax*, *Daphænus vetus* and *Temnocyon*, into the living *Cyon* and possibly also into *Lycæon*. The third passes from *Prodaphænus* into *Amphicyon* and thence into the Bears. The fourth is more hypothetical, but was possibly split off from *Uintacyon*, passing into *Daphænus Dodgei* and thence into the succeeding short-jawed dogs of the Miocene and the living Bush Dogs.

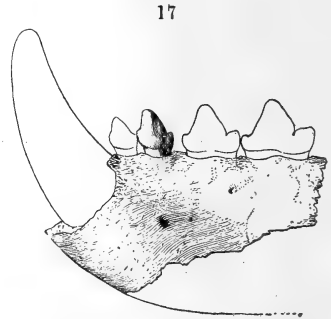
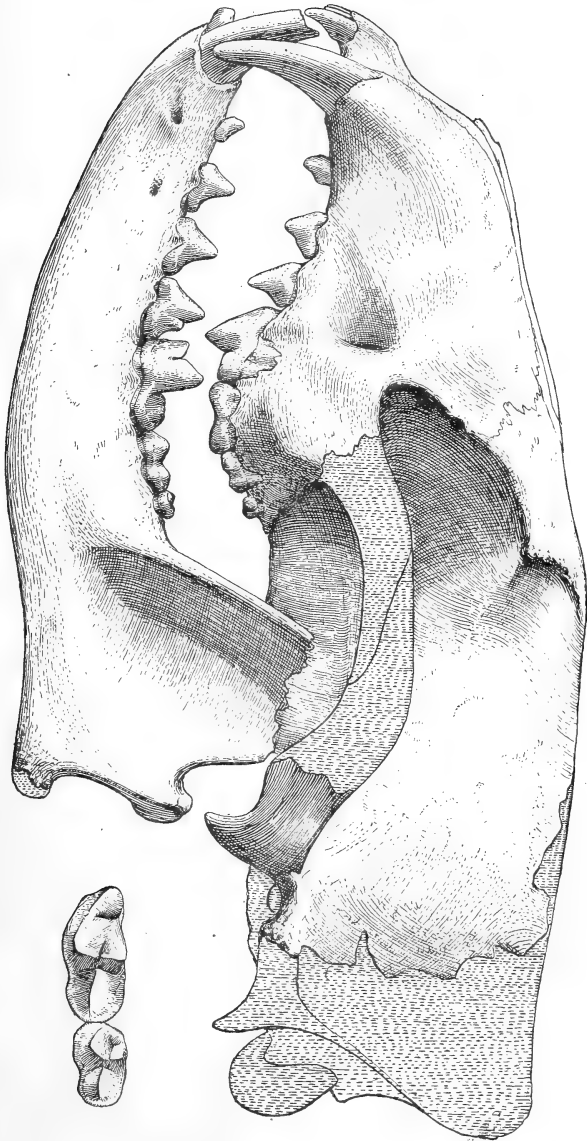

FIGURE 17.—Anterior portion of jaw of *Prodaphænus Scotti* (?); three halves natural size.



EXPLANATION OF PLATE VI.

Skull of *Daphænus vetus* Leidy; three-fourths natural size; side view and crown view of first and second lower molars; one and one-eighth natural size.



ART. XXXVII.—On the Cæsium-Antimonious Fluorides and Some Other Double Halides of Antimony; by H. L. WELLS and F. J. METZGER.

WE have made a thorough study of the double salts formed by cæsium fluoride and antimonious fluoride with the result that five compounds have been prepared. This is an unusual number for a series of double salts, and it gives a good illustration of the facility with which cæsium forms such compounds.

The salts to be described have the following formulæ :

Type.	
1 : 3	CsF·3SbF ₃
1 : 2	CsF·2SbF ₃
4 : 7	4CsF·7SbF ₃
1 : 1	CsF·SbF ₃
2 : 1	2CsF·SbF ₃

The previously described antimonious double fluorides, all of which were prepared by Flückiger,^a are as follows :

Type.			
1 : 1	KF·SbF ₃ ,		
2 : 1	2KF·SbF ₃ ,	2LiF·SbF ₃ ,	2NH ₄ F·SbF ₃ .
3 : 1	3NaF·SbF ₃ .		

The following chlorides, bromides and iodides have been described :

Type.				
1 : 2	RbCl·2SbCl ₃ .*			
3 : 4	3NH ₄ I·4SbI ₃ ·9H ₂ O.†			
1 : 1	NH ₄ Cl·SbCl ₃ ,‡	NH ₄ I·SbI ₃ ·2H ₂ O.§,	KI·SbI ₃ ·H ₂ O,§	RbCl·SbCl ₃ **
3 : 2	3KI·2SbI ₃ ·3H ₂ O,†	3NaI·2SbI ₃ ·12H ₂ O,†	3NH ₄ I·2SbI ₃ ·3H ₂ O,†	3RbCl·2SbCl ₃ *,
		3RbBr·2SbBr ₃ *,	3RbI·2SbI ₃ *,	
2 : 1	2NH ₄ Cl·SbCl ₃ ,‡	2NH ₄ Cl·SbCl ₃ ·H ₂ O,‡‡	2KCl·SbCl ₃ ,§§	3CsCl·2SbCl ₃ ,††
			2KCl·SbCl ₃ ·2H ₂ O.***	
7 : 3†††	7RbCl·3SbCl ₃ **	7RbBr·3SbBr ₃ *,	7KCl·3SbCl ₃ ,†††	7KBr·3SbBr ₃ ·8H ₂ O,†††
3 : 1	3NH ₄ Cl·SbCl ₃ ·½H ₂ O,‡‡	[3KCl·SbCl ₃ ,††],	3NaCl·SbCl ₃ ,‡‡	
4 : 1	4NH ₄ I·SbI ₃ ·3H ₂ O.†			

^a Pogg. Ann., lxxxvii, 245 [1852].

* Wheeler, this Journal (3), xlvii, 269. † Schäffer, Pogg. Ann., cix, 611.

‡ Deherain, C. r., lii, 734. § Nicklés, C. r., li, 1097.

** Remsen and Saunders, Am. Chem. Jour., xiv, 152.

†† Setterberg, Öfversigt K. Vetensk. Akad. Förhandl., 1882, 23; Remsen and Saunders, loc. cit.

‡‡ Poggiale, C. r., xx, 1180. It is probable according to Herty, Am. Chem. Jour., xv, 81, that 3KCl·SbCl₃ does not exist.

§§ Jacquelaine; Poggiale, loc. cit.; Benedict, Proc. Am. Acad., xxix, 212.

*** Benedict, loc. cit. ††† This type was described as 23 : 10; see Wells and Foote, this Journal, iii, 461. ‡‡‡ Herty, loc. cit.

Upon comparing the cæsium double fluorides with the salts already known, it is to be noticed that two types of the former, 1 : 3 and 4 : 7, do not occur among the latter, and that the 3 : 4, 3 : 2, 7 : 3, 3 : 1 and 4 : 1 types were not found among the cæsium-antimonious fluorides. The absence of a 3 : 2 fluoride is remarkable, since the salt $3\text{CsCl}\cdot 2\text{SbCl}_3$ is very sparingly soluble, and because this is a very prominent type among the chlorides, bromides, and iodides. It is evident that a close relation does not exist between the cæsium-antimonious fluorides and the other antimonious double halides, and that the types of the former could not have been predicted from a consideration of the latter. In range, the cæsium double fluorides extend farther at the antimony end than the others, while they do not extend as far at the alkali-metal end of the series of types.

When all the types of antimonious double halides are considered, they are remarkable for their large number, ten. This number is probably greater than is the case with any other negative element. The types, 1 : 3, 1 : 2, 4 : 7, 3 : 4, 1 : 1, 3 : 2, 2 : 1, 7 : 3, 3 : 1 and 4 : 1, with two or three exceptions, are the simplest that can exist in such number between the two extremes, and arithmetically they extend almost as far in one direction as the other.

Method of preparation.—Solutions of cæsium fluoride and antimonious fluoride were prepared by treating cæsium carbonate and antimonious oxide, each with an excess of pure hydrofluoric acid. To the antimonious solution the cæsium salt was gradually added in small quantities, and after each addition the liquid was evaporated and cooled until crystallization took place. If a homogeneous product was obtained a portion was removed for analysis, and the process was continued until finally the liquid contained a very large excess of cæsium fluoride. In every case the products were carefully inspected to make sure that they were not mixtures, and at least two crops of a salt were always prepared under somewhat different conditions, and were shown by analysis to be identical in composition before they were accepted as true compounds.

Method of analysis.—The crystals were carefully dried by pressing between filter papers, and the portions to be analyzed were preserved in glass weighing tubes which were coated within with a very thin layer of paraffine. For the determination of antimony and cæsium a portion was heated in a platinum crucible with concentrated sulphuric acid until all the hydrofluoric acid was removed, the residue was dissolved in hydrochloric acid, antimony was precipitated as sulphide, collected on a Gooch crucible and weighed after drying in a

small oven containing carbon dioxide. Cæsium was weighed as normal sulphate. Fluorine was determined by converting it into silicon fluoride, collecting the latter in water, and titrating with sodium hydroxide, according to a modification of Offermann's method. The results of these fluorine determinations were invariably somewhat too low, as we found by testing the method with pure potassium silicon fluoride; hence the chief value of these determinations consists in showing that the salts under investigation were not oxy-compounds.

1 : 2 *Cæsium-Antimonious Fluoride*, $\text{CsF} \cdot 2\text{SbF}_3$.—This salt was obtained in the form of beautiful, transparent needles by adding 2 or 2^s of cæsium fluoride to a solution of about 50^g of antimonious fluoride in somewhat dilute hydrofluoric acid solution, heating to boiling and cooling. Two separate crops gave the following results upon analysis:

	Calculated for	Found.	
	CsSb_2F_7 .	I.	II.
Cæsium	26·28	26·44	-----
Antimony	47·43	47·36	47·42
Fluorine	26·28	25·23	-----

1 : 3 *Cæsium-Antimonious Fluoride*, $\text{CsF} \cdot 3\text{SbF}_3$.—This salt crystallizes in the form of stout, transparent prisms. It was obtained by evaporating the mother-liquors from the preceding compound and cooling, or by the use of somewhat less cæsium fluoride in proportion to the antimonious fluoride in a more concentrated solution. Two crops gave the following results:

	Calculated for	Found.	
	$\text{CsSb}_3\text{F}_{10}$.	I.	II.
Cæsium	19·47	17·81	17·60
Antimony	52·71	52·95	53·89
Fluorine	27·82	27·01	26·84

The rather wide variation of the results from the calculated quantities is probably due to the fact that the crystals were taken from a very concentrated antimonious fluoride solution and were consequently not quite pure, even after careful drying on paper.

4 : 7 *Cæsium-Antimonious Fluoride*, $4\text{CsF} \cdot 7\text{SbF}_3$.—This salt crystallizes in transparent plates, and is formed in the presence of a little larger proportion of cæsium fluoride than the preceding compounds. It was obtained, for instance, upon adding about 4^g of cæsium fluoride to a mother-liquor from the last salt and crystallizing by cooling. Two crops gave the following results:

	Calculated for Cs ₄ Sb ₇ F ₂₅ .	Found.	
		I.	II.
Cæsium	28·80	28·99	-----
Antimony	45·47	46·02	46·03
Fluorine	25·73	24·58	24·61

We cannot say that we are absolutely sure about the formula of this apparently complicated double salt. It cannot be a 1 : 2 compound, for not only is it entirely distinct in appearance from CsF·2SbF₃, but coming as it does from a strong antimony solution, the results would naturally come too high rather than too low for antimony. The results vary too widely from a 2 : 3 ratio to make that probable, but they approach somewhat more closely the 3 : 5 ratio. The following calculations will show that we have selected the most probable formula :

Calculated for Cs ₂ Sb ₃ F ₁₁ .	Calculated for Cs ₃ Sb ₅ F ₁₈ .	Calculated for CsSb ₂ F ₇ .
31·86	29·75	26·28
43·11	44·75	47·43
25·03	25·50	26·28

1 : 1 Cæsium-Antimonious Fluoride, CsF·SbF₃.—In the presence of still greater proportions of cæsium fluoride this salt is produced by cooling the properly concentrated solution. It forms square prisms, the ends of which are not usually modified by any planes. Three crops gave the following analysis :

	Calculated for CsSbF ₄ .		Found.	
	I.	II.	III.	IV.
Cæsium	40·43	41·44	41·19	-----
Antimony	36·47	35·85	35·66	35·52
Fluorine	23·10	22·30	-----	-----

2 : 1 Cæsium-Antimonious Fluoride, 2CsF·SbF₃.—This salt is formed under a wide range of conditions when cæsium fluoride is present in large excess in comparison with the antimonious fluoride. It crystallizes in apparently rhombic prisms, which are often somewhat flattened. Four crops, made under very different conditions, gave the following results :

	Calculated for Cs ₂ SbF ₆ .		Found.		
	I.	II.	III.	IV.	
Cæsium	55·30	54·81	-----	-----	-----
Antimony	24·95	24·72	24·59	24·92	24·64
Fluorine	19·75	19·42	-----	-----	-----

By the use of very concentrated cæsium fluoride solutions with comparatively small amounts of antimonious fluoride, no

evidence was obtained of the existence of any double salt containing more caesium fluoride than the one just described.

Cæsium-Antimonious Iodide, $3\text{CsI}\cdot 2\text{SbI}_3$.—It appears that no compound of caesium iodide with antimonious iodide has been described. The sparingly soluble chloride, $3\text{CsCl}\cdot 2\text{SbCl}_3$ is well known, and this was the only double chloride that Remsen and Saunders* were able to prepare, although four rubidium-antimonious chlorides are known. It is evident that the slight solubility of caesium-antimonious chloride makes it impossible to prepare concentrated solutions of the component chlorides and consequently prevents the formation of salts of other types. We have found that an iodide which corresponds in composition to the chloride can be readily prepared. It is sparingly soluble in hydriodic acid solutions, and it exists in two distinct forms, one of which is brick-red and apparently octahedral in form, while the other is yellow and occurs in thin hexagonal plates. The octahedral salt was prepared by mixing antimonious iodide and caesium iodide in rather strong hydriodic acid solutions, while the yellow hexagonal salt was made in much less strongly acid solutions, particularly upon diluting them with water, boiling, and cooling. Two crops of each form were analyzed as follows:

	Calculated for $\text{Cs}_3\text{Sb}_2\text{I}_9$.	Found			
		Red salt.		Yellow salt.	
		I.	II.	I.	II.
Cæsium	22·39	23·46	22·15
Antimony	13·47	13·91	13·19	14·36	14·52
Iodine	64·14	62·98	63·03

This was the only double iodide that we were able to obtain.

There is little doubt that a corresponding bromide exists, for we observed, while engaged in work with another object in view, that a yellow precipitate is produced when the bromides of caesium and trivalent antimony are brought together in solution. Having overlooked the fact that the compound had not been described, we neglected to analyze the product.

Cæsium-Antimonic Halides.—So little is known concerning the double halides of quinquivalent elements that it seemed desirable to study the caesium-antimonic compounds. Setterberg† has described a single double chloride, $\text{CsCl}\cdot\text{SbCl}_5$, and we have confirmed his result, but by using widely varying conditions we have been unable to prepare any other compound. Setterberg's salt crystallizes in long, colorless, transparent needles. A crop of it gave the following results upon analysis:

* Loc. cit.

† Loc. cit.

	Calculated for CsSbCl ₆ .	Found.
Cæsium	28.54	29.14
Antimony	25.75	26.43
Chlorine	45.71	43.94

We have extended our investigation to antimonious fluoride and cæsium fluoride, but the results were disappointing from the fact that we were able to prepare but one double salt, while Marignac* has described two potassium antimonious fluorides. Either cæsium in this case unexpectedly fails to show as great a tendency to form double salts as does potassium, or else we have failed to find the proper conditions for producing them.

The salt obtained by us apparently contains hydroxyl, although prepared in strong hydrofluoric acid solutions, and has the formula CsF·SbF₄·OH. It crystallizes on cooling warm, rather concentrated solutions in the form of bundles of transparent needles. Two crops gave the following analyses:

	Calculated for CsSbF ₄ ·OH.	Found.	
		I.	II.
Cæsium	36.44	37.77	---
Antimony	32.87	31.82	31.72
Fluorine	26.03	25.54	26.18
Hydroxyl	4.66	[4.87]	---

Sheffield Scientific School, April, 1901.

* Liebig's Ann., cxlv, 237.

ART. XXXVIII.—"Mohawkite"; by JOSEPH W. RICHARDS.

DR. KOENIG has given the name Mohawkite to the nickeliferous and cobaltiferous variety of domeykite found at the Mohawk mine. He bases this on his analyses, corresponding to $(\text{Cu}, \text{Ni}, \text{Co})_3 \text{As}$.*

Dr. Ledoux published the results of an analysis of a mineral from the same mine,† which corresponded closely to $(\text{Cu}, \text{Ni}, \text{Co})_4 \text{As}$, and which he proposed should be called Mohawkite. Dr. Koenig, however, throws doubt upon the formula obtained by Ledoux; also claims that if $\text{Cu}_4 \text{As}$ does exist, a new name must be found for it, as he has preëmpted the name Mohawkite for his variety of domeykite. The object of this communication is to substantiate Ledoux's analysis and formula, and thereby prove the existence of the new species $(\text{Cu}, \text{Ni}, \text{Co})_4 \text{As}$.

Last autumn the writer received from Foote, of Philadelphia, a specimen from the Mohawk mine marked "Mohawkite?" Analysis of the material, completely freed from gangue, gave

Copper	70.8%
Cobalt	6.4
Nickel	trace
Iron	0.0
Arsenic (by difference)	22.8

100.0

The atomic ratios from the above are

Copper	$\frac{70.8}{63.4}$	=	1.117	}	1.225
Cobalt	$\frac{6.4}{59}$	=	0.108		
Arsenic	$\frac{22.8}{75}$	=	0.304		

Hence the atomic ratio..... $\frac{1.225}{0.304} = 4.003$ and the formula

$(\text{Cu}, \text{Co}, \text{Ni})_4 \text{As}$.

Dr. Ledoux's analysis, as calculated by Koenig, gives the corresponding atomic ratio $\frac{1.228}{0.302} = 4.066$. Koenig, however, makes a slight mistake in adding the basic valences, and the

* This Journal, December, 1900. Zeitschr. für Krystallographie und Mineralogie, xxxiv, 70 (1901).

† Engineering and Mining Journal, April 7, 1900.

correspondence is still closer. I have re-calculated Ledoux's results, as follows:

		Atomic ratios.	
Copper	68.6	1.082	} 1.218
Cobalt	1.2	0.020	
Nickel	6.55	0.112	
Iron	0.23	0.004	
Sulphur	0.53	0.017	
Arsenic	22.67		0.302

Assuming the sulphur to be present as RS, we subtract its ratio 0.017 from that of the bases, and there remains 1.201.

Ledoux's ratio is, therefore, $\frac{1.201}{0.302} = 3.98$.

I would propose the name *Ledouxite* for the compound Cu_4As , the existence of which no longer appears doubtful. It carries small percentages of cobalt and nickel and is similar in appearance to algodonite, with density 7.8 (Ledoux) or 8.07 (Richards). The latter was taken on clean material free from gangue.

Mineralogical Laboratory,
Lehigh University, April 5, 1901.

HENRY AUGUSTUS ROWLAND.

“A GREAT man has fallen in the ranks—great in talents, great in achievements, great in renown.” So spoke President Gilman to the faculty and students of the Johns Hopkins University assembled to do the last honors to their departed colleague and teacher; and the words awoke a sympathetic echo in every heart.

Henry Augustus Rowland was born at Honesdale, Pa., Nov. 27, 1848. He studied engineering at the Rensselaer Polytechnic Institute, in Troy, where he received the degree of C.E. in 1870. He spent a short time in railroad engineering, and became teacher of science for 1871–72 at Wooster College. The following year, 1872, he returned to Troy as instructor, and was soon made assistant professor, in which position he remained until 1875, when he was invited to Baltimore; but before taking up his duties there he spent some time in Europe. He had already published an important article on Magnetic Permeability, which brought him into notice. Professor Rowland sent this to Clerk-Maxwell, in Cambridge, England, who replied that he regretted the Royal Society was not in session, that he might present this work to them, but that he would do the next best thing, namely, send it to the Philosophical Magazine; and as Rowland was so far away, he would himself correct the proof sheets.

While in Europe Rowland went to Berlin and carried out one of his most important researches, proving that a moving charge of static electricity, like a current, sets up a magnetic field.

Returning to America, he became one of the little band of professors, already famous or soon to become so, who were brought together to form the Johns Hopkins University, and he remained at the head of the physical department until his death, April 16, 1901. His energies were given to research and to the instruction of his graduate students, but his influence was felt in the whole university, and even the undergraduates received a great stimulus in their studies by the example of his steady and successful work.

We shall not attempt here a close analysis of Professor Rowland's contributions to science, a list of the most important is given below ; as a man of unique genius his work will always remain, but at the present time we feel more drawn to speak of his personal character than of his achievements.

In two public addresses (before the American Association for the Advancement of Science in 1883, and before the American Physical Society in 1899) he set forth his ideas of what should be the aims and methods of the scientific man. Both breathe the same spirit—utter dissatisfaction with what is mediocre, and longing for what is great and important ; great contempt for sham, and high appreciation of the labors of those who have unselfishly devoted their lives to the advance of pure science.

In the first he speaks of American science as “a thing of the future” ; in the second he recognizes that some steps have been taken and that there are a number of students entirely given up to the pursuit of pure science ; and he points out the great problems awaiting solution.

Like all great men, he felt that the work he had undertaken was the most important work a man could do ; he spoke of physical science as “a science above all sciences, which deals with the foundation of the Universe, with the constitution of matter, . . . with the ether of space . . . ,” and he threw himself into it with all his heart and soul.

As a result he thoroughly mastered his subject and his native genius gave him a quick and sure insight into natural phenomena. This last gave him a confidence in his own conclusions and he bowed to no one but his peers.

During his connection with the University he held weekly conferences on the current literature of physical science, and it was probably on these occasions that he did most to help his students to broad and deep conceptions of physical laws. His criticisms were very severe, but they were not captious ; it was always his method to examine an investigation closely, to see what errors were committed and to show how such errors could be avoided. His own investigations fully show the result of this painstaking care.

He thoroughly appreciated the importance of organized

knowledge, and valued an experiment or research in proportion to the amount of light it threw on theory, and to the extent that it connected and unified other phenomena. I believe it was Maxwell's beautiful electromagnetic theory of light that so strongly attracted him to that subject, by showing a relation between phenomena apparently so independent as light and electricity. It is a fact that when he began his lectures on light in 1884 he developed the electromagnetic and elastic-solid theories side by side, pointing out their similarities and differences and noting the difficulties inherent in each.

He was not an experimentalist who experimented for its own sake, but he was a natural philosopher, seeking to solve the great problems of physical science, and he made use of all the means he could command to accomplish his purpose—experiment or pure reasoning, or more commonly the combination of the two. His absorption in research did not allow him to give very much time to his students; but the steadiness of his work, and the brilliant suggestions which he made from time to time, were more stimulating than greater personal attention would have been from a man of less genius.

As we look back over the last twenty-five years and see the change in the character of physical science in America, and consider the great influence Professor Rowland has had in effecting this change, we appreciate something of the work he has done and realize the great loss his death means to physical science in America and in the world.

Professor Rowland's work has received the recognition it deserved and he has been the recipient of many honors; he received the honorary degrees—Ph.D., Johns Hopkins University, 1880; LL.D., Yale University, 1895, Princeton University, 1896. He was an officer of the Legion of Honor of France; Rumford Medallist of the American Academy of Arts and Sciences; Draper Medallist of the National Academy of Sciences; Matteucci Medallist (Italian), and he received the prize of the Venetian Institute for his work on the "Mechanical Equivalent of Heat." Among the many learned bodies in which he was elected a member we will only mention the Royal Society of London; the Physical Society of London;

the French Academy of Sciences; the Royal Astronomical Society of England; the Royal Academy of Sciences, Berlin; the American Academy of Arts and Sciences, Boston; the National Academy of Sciences, Washington; and the American Physical Society, of which he was the first president.

HARRY FIELDING REID.

Johns Hopkins Univ., May 14, 1901.

The following is a list of Professor Rowland's most important papers:

On the magnetic permeability and the maximum of magnetisation of iron, steel and nickel; *Phil. Mag.*, xvi, August, 1873; reprinted in this Journal, December, 1873.

On the magnetic permeability and maximum of magnetisation of nickel and cobalt; *Phil. Mag.*, xlviii, 1874.

Studies on magnetic distribution; this Journal, x, 1875; *Phil. Mag.*, i, 1875.

On the magnetic effect of convection currents: Preliminary statements: *Sitzb. Akad. Berlin*, 1876; *Phil. Mag.*, ii, 1876; this Journal, xii, 1876; *Ann. Chim. Phys.*, xii, 1877. Full paper: this Journal, xv, 1878. Note: *Phil. Mag.*, vii, 1879.

Research on the absolute unit of electrical resistance; this Journal, xv, 1878; *Electr. techn. Ztschr.*, vi, 1885.

On electric absorption in crystals; *Am. Journ. Math.*, i, 1878.

Preliminary notes on Mr. Hall's recent discovery; *Am. Journ. Math.*, ii, 1879; *Phil. Mag.*, ix, 1880.

On the mechanical equivalent of heat, with subsidiary researches on the variations of the mercury from the air-thermometer and on the variation of the specific heat of water; *Proc. Am. Acad. Arts and Sci.*, xv, 1880; published separately, Boston, 1880; Prize essay of the Venetian Institute, 1881.

Electric absorption of crystals (with E. L. Nichols); *Phil. Mag.*, xi, 1881.

Preliminary notice of results accomplished in the manufacture and the theory of concave gratings for optical purposes; *Phil. Mag.*, xiii, 1882; *Johns Hopkins Univ. Circ.*, 20, 1882.

Article on the "Screw"; *Encycl. Brit.*, 1886.

Relative wave-lengths of the lines of the solar spectrum; this Journal, xxxiii, 1887; *Phil. Mag.*, xxiii, 1887.

Table of standard wave-lengths; *Johns Hopkins Univ. Circ.*, 73, 1889; *Phil. Mag.*, xxvii, 1889.

On the electro-magnetic effect of convection currents (with C. T. Hutchinson); *Phil. Mag.*, xxvii, 1889.

Gratings in theory and practice; *Astr. and Astr.-Phys.*, xii, 1893; *Phil. Mag.*, xxxv, 1893.

A new table of standard wave-lengths: *Astr. and Astr.-Phys.*, xii, 1893; *Phil. Mag.*, xxxvi, 1893; also *Johns Hopkins Univ. Circ.*, 106, 1893.

On a table of standard wave-lengths of the spectral lines; *Mem. of Amer. Acad.*, xii, 1896.

Electrical measurements by alternating currents; this Journal, iv, 1897; *Phil. Mag.*, xlv, 1898.

Some new methods for the measurement of self-inductance, mutual inductance and capacity (with T. D. Penniman); *Johns Hopkins Univ. Circ.*, vol. xvii, 1898; also this Journal, viii, 35, 1899.

SCIENTIFIC INTELLIGENCE.

I. CHEMISTRY AND PHYSICS.

1. *Radio-active Lead*.—It was recently mentioned in this Journal (this vol., p. 235) that HOFMANN and STRAUSS had obtained, according to the usual analytical methods, from the minerals pitchblende, bröggerite, uranium mica, and samarskite, a radio-active lead sulphate which loses its activity after several months, but regains it under the influence of cathode rays. These investigators have now published a description of a continuation of their work. In their previous article they mentioned the fact that by the fractional crystallization of the lead chloride prepared from the active sulphate a more soluble portion was obtained which appeared to contain a new radio-active element, but it now appears that while a substance with unusual chemical properties may thus be obtained from pitchblende (but not from bröggerite), this supposed new element has no radio-active properties. The authors believe, however, that there is another new element in the more soluble fractions obtained from lead chloride, but they admit that it approaches lead in its properties much more closely than the other one, and now they are not certain that this substance is the cause of the radio-activity. While the previous article raised the hope that a definite radio-active element would be obtained, the present article is disappointing in regard to the matter. As far as the supposed new elements are concerned, they would be interesting as such, even without possessing the power to emit Becquerel's rays; but so many mixtures have heretofore been brought forward as elements that one is inclined to be skeptical about such announcements.—*Berichte*, xxxiv, 907.

H. L. W.

2. *The Zirconia of Euxenite from Brevig*.—The discoveries of new elements are usually rare occurrences in the present period of chemical development, but now, in addition to the supposed new elements from pitchblende and bröggerite that have been mentioned in the preceding notice, an unknown element, or two, from euxenite is announced from the same laboratory in Munich. In extracting the small amount of lead from euxenite HOFMANN and PRANDTL treated the sulphuric acid residue with "basic" ammonium tartrate and obtained in solution not only lead, but titanium and zirconium. The latter possessed properties which made the presence of an unknown oxide seem probable, and by a series of operations an oxide was obtained which appeared to the investigators to be practically free from all previously known substances. It is distinguished from zirconia in being precipitated by an excess of ammonium carbonate and in giving no turmeric reaction. The authors say that it gives no precipitate with oxalic acid, "even when the mineral acid has been previously

neutralized with ammonia to the point of turbidity." If they always did this in applying the oxalic acid test, there is every reason to suppose that their new oxide is largely thoria, for they precipitated in the presence of ammonium oxalate in separating from the earths of the cerium and yttrium groups, and thorium oxalate is well known to be soluble in ammonium salts. There is a marked resemblance to thoria in the description of the properties and reactions of the earth, but it is evidently not pure thoria, for the equivalent found, 44.4, is much too low for that oxide. To the substance the name "Euxenerde" is given, which would probably correspond to euxenium for the metal. It may be mentioned that these authors have found another unknown substance in euxenite, which they think may be related to tantalum, but has a more marked basic character.—*Berichte*, xxxiii, 1064.

H. L. W.

3. *The Action of Radium Rays upon Selenium.*—EUGÈNE BLOCH has recently described some experiments upon the effect of the rays emitted from radio-active barium carbonate upon the electric conductivity of selenium. It has long been known that the action of light diminishes the resistance of this element, and it has been shown also that the Röntgen rays have a similar action. The experiments under consideration now show that Becquerel's rays produce the same effect, but apparently to a slighter degree. The investigation was made with a sample of barium carbonate which possessed an activity about 1000 times that of ordinary uranium.—*C. R.*, cxxii, 914.

H. L. W.

4. *The Reducing-power of Magnesium and Aluminum.*—A number of striking experiments, based upon the affinity of these metals for oxygen, are described by A. DUBOIN. One of these which seems to be novel, although extremely simple, consists in placing moistened magnesium or aluminum powder upon a scori-fier or porous plate, covering the mixture with dry magnesium and igniting. As soon as the combustion reaches the moistened part an exceedingly brilliant flame appears, which is due to the reaction of magnesium with water-vapor. The magnesia that is formed is left in long filaments. Another interesting experiment is the action of aluminum upon alumina. Four atoms of the metal to one molecule of the oxide are mixed, and upon ignition they react with vivid incandescence, forming, it is stated, the oxide Al_2O_3 .—*C. R.*, cxxxii, 826.

H. L. W.

5. *A Method of Determining Atomic Weights, Based upon the Transparency of Substances to the X-Rays.*—Soon after the discovery of the Röntgen rays it was recognized that the transparency of substances to them depended upon the atomic weights of the elements contained in the substances. L. BENOIST, who has made a study of this matter, has now applied this behavior to the determination of the atomic weight of indium. If this metal is bivalent its atomic weight is 75.6, but if trivalent it is 113.4. The higher valency is the more probable one. Using an organic compound of indium and the metal itself, Benoist has

compared their behavior with that of arsenic, silver and cadmium and their compounds and finds that the atomic weight of indium is near that of silver (108), and not similar to that of arsenic (75). This method supplies an interesting and novel means of confirming atomic weights.—*C. R.*, cxxxii, 772. H. L. W.

6. *The Presence of Platinum upon an Egyptian Hieroglyphic Inscription.*—In examining a metallic specimen covered with hieroglyphic characters, found at Thebes and probably belonging to a period corresponding to the seventh century of our era, BERTHELOT has found a small thin piece of hammered metal used in forming one of the characters, which, from its resistance to solvents and the nature of the solution obtained, was evidently an alloy of platinum with the closely related metals, such as is frequently found native. It is Berthelot's opinion that the Egyptians must have distinguished the difference between this substance and silver if it was often encountered, but it remains for future investigation to show whether they often used platinum or not. He is not aware that platinum has ever been found in Egypt or in other parts of Africa or in Arabia.—*C. R.*, xxxii, 732. H. L. W.

7. *A Generalization from Trouton's Law.*—An empirical relation between heat of vaporization, measured at the normal boiling point, and the absolute temperature of the boiling point of substances, was observed by Trouton in 1844. This is expressed by the formula,

$$\frac{L}{T} = K$$

and it was found that K varies from 20 to 26.

In 1887 Le Chatelier observed that the dissociable metallo-ammonia compounds yield for $\frac{Q}{T'}$ values (27.8, 28.7, 29.1) which are near the preceding; Q being the heat of fixation of the ammonia gas, and T' the absolute temperature at which the compound has a tension of 760^{mm}. Le Chatelier showed further that if one calculate $\frac{Q}{T'}$ for the following dissociable compounds, Pd_2H , CaCO_3 , IrO_3 , C_3N_3 , $\text{Ca}(\text{OH})_2$, which disengage gases other than ammonia, the values 23, 23.4, 24.3, 27.8 and 27.8 are obtained, which are almost identical with the preceding. Le Chatelier drew the conclusion that the equation

$$\frac{Q}{T'} = \frac{Q_1}{T'_1}$$

is a consequence of the laws of chemical equilibrium.

Recent investigations show that the higher values, in the neighborhood of 24 to 26, furnished by Trouton's relation, are given by liquids that have condensed molecules, while the non-polymerized, normal liquids give very constant values which are near 21 or 22. On the other hand, the quotient $\frac{Q}{T'}$ gives a value that is

quite constant, but higher, in the vicinity of 30 to 32. Since we have then a value for dissociation that is decidedly higher than that for vaporization, Le Chatelier's law appears no longer to be a generalization of Trouton's, but merely an analogous law.

Having presented this matter as abstracted above, DE FORCAND advances the belief that Le Chatelier's idea that the same statement applies without exception to all phenomena of vaporization, allotropic transformation and dissociation, ought to be retained in science, and we should have

$$\frac{L}{T} = \frac{L_1}{T_1} = \frac{Q}{T_1} = \frac{Q_1}{T_1},$$

but that the statement of the law and the value of L should be slightly modified.

In Trouton's formula, L is the heat of liquefaction of any gas; in Le Chatelier's, Q comprises three terms, L heat of liquefaction of a gaseous molecule, S heat of solidification of this liquid molecule, q heat of combination of this solid molecule with a solid body to form a solid compound without change of physical condition, or, in other words, supplementary heat of solidification.

The two terms $\frac{L}{T}$ and $\frac{L+S+q}{T'}$ are evidently not comparable, but they become so, and the values of the two will be almost constant at about 30, if we add in the first a term S representing the heat of solidification. We have then for all bodies,

$$\frac{L+S}{T} = \frac{L+S+q}{T'},$$

where q is always positive and T' always greater than T . The general law may be expressed as follows: "In all physical or chemical phenomena, the heat of solidification of any gas is proportional to its temperature of vaporization under atmospheric pressure."—*C. R.*, cxxxii, 879.

H. L. W.

8. *Die wissenschaftlichen Grundlagen der analytischen Chemie*, von W. OSTWALD. Dritte vermehrte Auflage. 8vo, pp. xii, 221. Leipsic, 1901 (Wilhelm Engelmann).—The influence that this book has exerted in causing the ionic theory to be accepted and practically applied by chemists generally has been very great, and the service that it has rendered to teachers and students of analytical chemistry, in explaining many facts that were well recognized but not understood, has been of the greatest importance. This third edition of the book in an enlarged and improved form, appearing within seven years after the first issue, is heartily welcomed.

H. L. W.

9. *Spectrum of Carbon Compounds*.—In view of the possible appearance of a new comet the paper of Professor A. SMITHELLS on the carbon spectra is of great interest. He discusses the spectra of cyanogen, of carbon disulphide, and the Swan spectrum, and points out the danger of drawing conclusions from spectra appearing in exhausted glass vessels which are due to contaminations from the constituents of the vessels.—*Phil. Mag.*, April 1901, pp. 476-503.

J. T.

10. *Absorption of Gas in a Crookes Tube.*—The anomalous behavior of X-ray tubes has been the subject of many investigations, and it is generally supposed that gases are occluded by the metallic terminals and by the glass tubes. In order to properly exhaust a tube it is necessary to subject it for a long time to electric discharges and to external heat. Mr. R. S. WILLOW has investigated this absorption of gases and concludes from experiment with electrodeless tubes that the absorption is largely due to the character of the glass employed. Jena glass absorbs hydrogen to only a small amount: soda glass to a large amount. The absorption is due to a chemical combination with the glass. In general hydrogen is absorbed less than air or nitrogen.—*Phil. Mag.*, April 1901, pp. 503-517. J. T.

11. *Mechanical Movements of Wires produced by Electrical Discharges which also make these Movements luminous.*—When oscillating discharges are sent over wires these become luminous under certain conditions and apparently show stationary electric waves. Various investigators have described this phenomenon and have measured wave-lengths, which they have considered true wave-lengths due to the capacity and self-induction of the circuit. O. VIOL, however, considers that these luminous effects are merely mechanical vibrations due to the electric spark of a much lower period than those which would arise from true electric oscillations, and that the nodes and ventral segments are rendered visible by a species of negative brush discharge along the vibrating wires.—*Ann. der Physik.*, No. 4, 1901, pp. 734-761. J. T.

12. *The Band Spectrum of Oxides of Aluminum and Nitrogen.*—Various authors have attributed the band spectrum observed in the spectrum of aluminum between wave-lengths 5162.05 and 4470.63 to aluminum. G. BERNDT finds, however, that this band spectrum disappears when the spectrum of aluminum is obtained in hydrogen gas, and becomes very strong when oxygen is substituted for hydrogen. He therefore attributes this band spectrum to oxides of aluminum. He also gives a very complete table of the wave-lengths of the constituents of the bands of nitrogen.—*Ann. der Physik.*, No. 4, 1901, pp. 788-793. J. T.

13. *Electricité et Optique. La Lumière et les Théories Électrodynamiques*, par H. POINCARÉ. Deuxième-édition, revue et complétée par J. BLONDIN et E. NÉCULCÉA. Pages x, 641. Paris 1901 (Georges Carré et C. Naud).—The first half of this remarkable book is nearly a repetition of the lectures given at the Sorbonne in 1888 and 1890, except for the suppression of the section relating to the experiments of Hertz, omitted because this subject is treated in detail in the author's work on Electric Oscillations, and for the addition of a little more than one hundred pages which extends the general discussion of electromagnetic theories of bodies at rest by including those of Ampère and of Weber. The latter half of the book, also divided into two parts, contains the lectures of 1899. These are devoted to a comparison of the different theories relative to the electrodynamics of

bodies in movement and of which the principles are those of Hertz, of Lorentz, and of Larmor.

Very interesting, as giving an insight into the intellectual attitude of the author, and well worth quoting, are the following paragraphs from his preface:—

“Although none of these theories seems to me entirely satisfactory, each of them contains without doubt a portion of truth and a comparison may be instructive.” . . . “Of all, that of Lorentz appears to me to correspond most nearly with the facts.”

He adds that it is possible that the recent investigations of Cremieu, should they be confirmed, may completely alter our ideas concerning the electrodynamics of bodies in movement.

Doubtless the instructed student of electricity will turn with the liveliest interest to Part Third of the book, which is given to the discussion of the merits and defects of the latest theories of electricity. It is quite impossible to give here even the barest outline of a review which occupies nearly three hundred pages of most acute criticism presented with almost unexampled clearness and with a mastery of analytical methods which few scholars will be able to fully comprehend without strenuous effort. The author's exposition of the various theories which he is about to submit to critical analysis is singularly lucid and satisfactory, and it offers unusual temptation for a reviewer to give numerous quotations, but selection from such a wealth of examples would be as difficult as to do justice in any translation.

Part Four, consisting of a little more than fifty pages, is given to a general discussion of points in electrical and optical theories suggested by the recent work of Larmor. The method of this part is somewhat different from that of the preceding portions being more discursive and of an obviously less final form; but there is a certain charm due to these very features which the reader would not willingly miss.

As a result of a careful inspection of this work, we are impelled to say that no book comparable with it as a source of intellectual stimulus to the qualified student of physics or so full of suggestiveness has appeared for a long time.

C. S. H.

II. GEOLOGY AND NATURAL HISTORY.

1. *United States Geological Survey, 21st Annual Report of the Director*; by CHARLES D. WALCOTT. Pp. 1-204, with 3 maps, 1 figure, 1900.—The total appropriations made for the fiscal year 1899-1900 for the work of the U. S. Geological Survey was \$834,240.89. The expenditure of this amount was distributed over a very large field of investigations, carried on in all parts of the country. The work accomplished during this year was, in general, a continuation of that of previous years and with substantially the same organization. The Director calls especial attention, in his report, to the following branches of the work, viz: The survey of the Forest Reserves, the explorations in

Alaska, the hydrographic work, the reorganization of the Geologic Branch, the division of Mines and Mining, the Insular surveys.

The reorganization of the Geological Branch of the Survey has become necessary on account of the growth and complexity of the work and the increased demands upon the director in administering the whole bureau. The several branches of the geologic work were placed in charge of specialists, who should supervise the scientific investigations of their several divisions.

The following divisions were made and officers placed in charge:

Division of Areal Geology: Bailey Willis, Geologist in charge.

Division of Pleistocene Geology: T. C. Chamberlin, Geologist in charge.

Division of Paleontology: T. W. Stanton, Paleontologist in charge.

Division of Pre-Cambrian and Metamorphic Geology: C. R. Van Hise, Geologist in charge.

Division of Mining and Mineral Resources: D. T. Day, Geologist in charge.

Division of Economic Geology: S. F. Emmons, Geologist in charge of section of Metalliferous Ores: C. W. Hayes, Geologist in charge of section of non-Metalliferous Economic Deposits, etc.

Division of Physical and Chemical Research: G. F. Becker, Geologist in charge.

The authority of these chiefs of division is restricted to the supervision of the scientific work, the administrative direction remaining in the hands of the director. At the same time the individual geologist is left free to make use of the facts observed within his own field.

The Director explains at some length the relation of the Government Survey to Mines and Mining, and urges the provision of means for more fully organizing and conducting a Division of Mines and Mining. He says, p. 45: "The establishment of a division of mines and mining within the survey would broaden the scope of its work and admit of a more direct application of the energies of the survey to the mining industry. In a general way such a division should be charged with the promotion of the mining industry of the country as a whole, as far as it can be done by a government organization, and in such way as not to interfere with the work of state organizations on the one hand or with the professional business of individuals on the other."

In response to a resolution passed by the Senate, the Director submitted a report to the Secretary of the Interior on the present condition of surveys in the islands now under the jurisdiction of the United States; together with recommendation of plans for furthering the topographic and geological surveys in Porto Rico, the Hawaiian Islands, the Philippines and Cuba.

The summary account of the detailed work of the Survey

shows a most satisfactory continuation and progress of the work of the survey in all its several departments.

At the close of the report is printed a biographic sketch, by Arnold Hague, of Othniel Charles Marsh, whose recent death interrupted the important investigations in vertebrate paleontology which he had been carrying on for the Survey, for many years.

2. *The Physiography of Acadia*; by REGINALD A. DALY. Bull. Museum Comp. Zool., vol. xxxviii; pp. 73-102, 11 plates.—Acadian land forms are shown to consist primarily of two planes of denudation which are essentially subaerial and referable to two cycles of geographic development. The topographic history of the region is believed by Dr. Daly to be closely similar to that of New England and the Southern Appalachians. H. E. G.

3. *Carte Géologique du Massif du Mont Blanc*; par L. DUPARC et L. MRAZEC. Comptoir Min. et Geol., Suisse, Genève.—This map is designed primarily to accompany the work of Duparc and Mrazec on Mount Blanc. The scale is 1/50,000, the relief is very clearly shown, and the glaciers with their morainal materials stand out almost as in a model. The map is a valuable addition to a laboratory outfit. H. E. G.

4. *The mineral constituents of dust and soot from various sources*.—A minute spectroscopic investigation has recently been carried on by W. N. HARTLEY and HUGH RAMAGE of samples of dust and soot from various sources. These included, for example, the solid matter which fell in a hail storm in April, 1897, at Dublin; similar matter collected in March, 1896; pumice from the Krakatoa eruption of 1883, etc. The examination was extended to sooty matter deposited from the air on the outskirts of Dublin in November, 1897; and also to soot and flue dust obtained direct from gas works and iron furnaces.

The *atmospheric dust* from the clouds was found to be somewhat regular in composition—each specimen appearing to contain the same proportions of iron, nickel, calcium, copper, potassium, and sodium; the proportion of carbonaceous matter was small. There was a very considerable difference between the dust from sleet, snow, and hail suddenly precipitated, the difference being in the proportion of lead, which, in the dust from sleet, is much larger than in the other specimens. The dust of November, 1897, which fell in a clear, calm night, was uniform in composition; it was magnetic, and its general similarity to meteorites made it reasonably clear that the material was to be regarded as of cosmic origin.

The examination of the spectra of specimens of *volcanic dust* proved that the heavy metals were, without exception, in comparatively small proportions—lead and iron, for example—while lime, magnesia, and the alkalis were the chief basic constituents.

Chimney soot from different sources was found to be characterized by the small proportion of iron in most specimens and of metals precipitated as hydroxides; its large proportion of lime

and the greater variability in the proportions of its different constituents distinguished it from other kinds of dust collected from the clouds or in the open air. The *flue dust* was found to contain, conspicuously, lead, silver and copper; also considerable quantities relatively of nickel and manganese; further, rubidium, gallium, indium, and thallium. The common presence of nickel shows that when found in dust from the clouds it is not proof of a source other than terrestrial. The authors call attention to the remarkably wide distribution of gallium. It occurs in all aluminous minerals, in many iron ores and in atmospheric and flue dust from various sources; the species bauxite contains it in larger proportion than any other mineral.—*Proc. Roy. Soc.*, Feb. 21, 1901.

5. *Studies in Fossil Botany*; by DUNKINFIELD HENRY SCOTT. Honorary Keeper of the Jodrell Laboratory, Royal Gardens, Kew, 533 pp., 12mo, with double page frontispiece and 152 illustrations in text. London, 1900.—In the fourteen lectures constituting Professor Scott's studies the statement is abundantly sustained that; "At the present day happily fossil botany is an eminently progressive branch of science." These lectures are not offered as a text, but rather as a general discussion of salient and fundamental facts with a taxonomic bearing. They are limited to the Pteridophytes and Gymnosperms, and even in the case of these the forms from the older formations, whence the beginnings of lines of descent are naturally to be expected, receive the more extended treatment, the object being, in the words of Count Solms-Laubach,—“to complete the natural system.”

This work is admirably suited to the general reader as well as the student. No writer on the subject excels Professor Scott in an easy clearness, while a particular excellence rests in his ability to state simply and give with precision the work of his *confreres*. The concluding paragraph finds a suitable place here:—"Only twelve years ago it was said that fossil botany had contributed little to our knowledge of the affinities of plants. Whether true or not at the time it was made, such a statement would not hold good now. Our whole conception of two at least of the great divisions of the vegetable kingdom—the Pteridophyta and the Gymnosperms—and of their mutual relations, is already profoundly influenced by the study of the ancient forms. Far greater results may be confidently expected from further research, but, by the work already accomplished, fossil botany has borne no small part in the advancement of our knowledge of the affinities of plants." This work is most earnestly recommended to the attention of all interested in this subject. G. R. W.

6. *Flora of Western Middle California*; by WILLIS LINN JEPSON, Ph.D. Pp. 625, 8vo. Encina Publishing Co., Berkeley, Calif., 1891.—Prof. Jepson's well-conceived and carefully executed flora is a welcome addition to the literature of American botany. It is the outcome of some ten years' intensive study of the flora of central California, during which the author has passed

repeatedly from close field observations to yet more detailed comparisons in the herbarium—an alternation of method by which alone a good manual can be made. Prof. Jepson has also taken pains to consult hundreds of types in the larger eastern herbaria, thereby adding much to the accuracy and authority of his work. The descriptions are full without such length as to obscure differential characteristics. Their greatest merit, however, is that they are based upon personal familiarity with the plants themselves, and the element of compilation, which cannot be entirely excluded from any such work, is here reduced to a minimum. There are also excellent and very complete keys which, to judge from cursory examination, are much clearer than in any work previously dealing with the flora of California. The common names assigned are in many cases unfamiliar at least to the Easterner and add a feature of interest from their originality and imaginative character. Owl's Clover (*Orthocarpus*), Pop-corn Flower (*Plagiobotrys*), Inside-out Flower (*Vancouveria*), Mule Fat (*Baccharis*), Hill Man Root (*Echinocystis*), and Milkmaids (*Dentaria*), are examples.

In the difficult matter of scientific nomenclature Prof. Jepson has been eclectic, adopting, on the whole, a course by which he has considerably avoided the making of new combinations or adding to the existing confusion. In the arrangement of the manual, the now generally approved sequence has been followed, which is determined primarily by the degree of connation, adnation, and irregularity of the floral parts. In this arrangement, however, it seems to us that the author is in error in placing in the ascending scale the Cichorieæ before the Asteroideæ and other groups of the Compositæ in which zygomorphy is much less pronounced. While it is easy to see how the strongly zygomorphic corollas of the dandelion, for instance, have resulted from the gradual modification of the tubular actinomorphic corolla, the reverse development seems highly improbable.

In no point does Prof. Jepson's work commend itself more highly than in the excellent judgment which he shows in the matter of specified limits and in conserving intact certain large and natural genera like *Oenothera*, *Mimulus*, etc., recently subjected to a technical splitting as unpractical as it is artificial.

B. L. R.

✓ 7. *Grand Rapids Flora*; by EMMA J. COLE. Pp. 17, royal 8vo, with map. Grand Rapids, Mich., 1891.—Miss Cole's recently issued catalogue of the flowering plants and ferns of Grand Rapids records 1290 species growing within an area 24 miles square. In the sequence of families Engler & Prantl's great work has been followed. In this respect, as in other matters, the catalogue exhibits advanced methods and possesses an up-to-date character. It is evident that no small care has been given to recent segregations of species since the results of such work are recorded with considerable discrimination. The scientific nomenclature is wisely conservative, without entire adherence to any

particular work. Considerable synonymy is given and also such vernacular names as are sanctioned by usage. Habitats, stations, frequency, and dates of flowering are concisely stated, and altogether the work is a model of its kind. The area covered presents considerable diversity and the flora is accordingly rather rich. It presents, as we should expect from its latitude and geological formation, an analogy to that of middle New England. There is, however, a more southern strain in the vegetation, as evinced by the presence of such plants as *Gymnocladus*, *Asimina*, *Jeffersonia*, *Cercis*, etc., several of which must here approach their northern limit. There is, of course, also a prairie element, shown in such genera as *Lepachys*, *Heliopsis*, *Amorpha*, etc., not found in New England. Several species are lacking in the Flora which may be sought in the region with considerable likelihood of success, as for instance, *Taraxacum erythrospermum*, *Goodyera tessellata*, *Helianthemum majus*, and *Camelina microcarpa*.

B. L. R.

8. *The Variations of a newly-arisen Species of Medusa*; by ALFRED GOLDSBOROUGH MAYER. Pp. 27, with two plates. The Macmillan Co. New York, 1901.—This memoir forms the first number of volume I of the Science Bulletins of the Museum of the Brooklyn Institute of Arts and Sciences.

III. MISCELLANEOUS SCIENTIFIC INTELLIGENCE.

1. *Annals of the Astrophysical Observatory of the Smithsonian Institution*, volume I; by S. P. LANGLEY, Director, aided by C. G. ABBOT. Large 4to; pp. 266, with 32 plates. Washington, 1901.—The publication of the first volume of the *Annals of the Astrophysical Observatory at Washington* is an event of no small importance, since it records the culmination of the investigations that have been carried on for so many years by Professor Langley and under his direction, in the study of the invisible infra-red solar spectrum. This work may be said to have had its beginning twenty years ago in connection with the author's study of the solar radiation with the bolometer—then a new instrument—on the summit of Mt. Whitney in California, at an altitude of 12,000 feet. Since 1890, observations have been carried on at Washington in the modest astrophysical observatory under the direction of the Secretary of the Smithsonian Institution at Washington. Since January, 1896, Mr. C. G. Abbot has been the Aid Acting in Charge, and by him many of the recent observations have been made.

Any extended review of this remarkable volume is made unnecessary here from the fact that a discussion of the results it contains is given by Professor Langley as the leading article of the present number. It will certainly be minutely studied, and with the greatest interest by all those concerned in this important department; its development of the subject, whether as regards description of instruments employed and methods of observation, discussion of measurements obtained, and the graphical presentation of the results, leaves nothing to be desired.

2. *Report of the U. S. National Museum.* Pp. xv, 598. Washington, 1901. (Annual Report of the Board of Regents of the Smithsonian Institution, showing the operations, expenditures, and condition of the institution for the year ending June 30, 1899.)—The report of the Secretary of the Smithsonian Institution for the year ending June 30th, 1899, was announced in the last number, p. 400. We have now the accompanying report of the U. S. National Museum giving the account of additions to the museum and other related points for the same period, by the Assistant Secretary, Mr. Richard Rathbun; to this are added also the reports of the Head Curators. Of the accompanying papers, forming Part II, the most extensive (pp. 153–483) is that by Mr. George P. Merrill, entitled a Guide to the Collections in the Section of Applied Geology in the National Museum; the Non-metallic Minerals. This paper, also published as a separate volume, contains much more that is interesting and of general value than might be anticipated from its title, since the author has brought together a large amount of material, much of which is new, particularly in regard to the occurrence of species described. Accompanying these descriptions are numerous plates showing quarry exposures, specimens of striking character, and other similar points. Two other interesting papers in the volume are by O. T. Mason on ethnological subjects.

3. *The Journal of Hygiene.* Edited by GEORGE H. F. NUTTALL in conjunction with JOHN S. HALDANE, and ARTHUR NEWSHOLME. Vol. i, No. 1, pp. 152. (University Press, Cambridge; price five shillings.)—This new journal, to be published quarterly in volumes of about 500 pages, has been established to fill the obvious need of an English publication containing original contributions on the subject of hygiene. It will embrace papers on all the different scientific lines which converge upon this department, and will also include discussions of administrative and practical questions. Of the papers contained in this number may be mentioned the following: two studies of the Anopheles and its distribution in England, in relation to malaria; another on pathogenic microbes in milk; on the artificial modifications of toxine with special reference to immunity; on the utility of isolated hospitals in the case of scarlet fever.

4. *Annals of the Astronomical Observatory of Harvard College.* Recent publications are the following:

Vol. XLV. A Photometric Durchmusterung, including all stars of the magnitude 7.5 and brighter, north of declination -40° , observed with the meridian photometer during the year 1895–98; by EDWARD C. PICKERING, Director of the Observatory. Pp. 1–330. 1901.

Volume XLI, No. 6. On the Forms and Images in Stellar Photography; by EDWARD S. KING. Pp. 153–187, with Plate vi.

INDEX TO VOLUME XI.*

A

- Academy of Sciences**, National, meeting at Washington, 400.
Acadia, Physiography of, Daly, 470.
Adams, E. P., circular magnetization and magnetic permeability, 175.
Air, spectrum of volatile gases in, Liveing and Dewar, 154; presence of hydrogen in, Rayleigh, 165.
Albuquerque Sheet, geology, Herrick and Johnson, 171.
American Museum of Natural History, gift to, 174.
Astronomical Observatory, Harvard University, annals 173, 474.
Astrophysical Observatory at Washington, work of, Abbot, 401; Langley, 403, 473.
Atmospheric air, see **Air**.
 — radiation, Very on, Hallock, 230.
Australia, Western, Geol. Survey, 396.

B

- Bailey, L. H.**, Elementary Botany, 250.
Barus, C., apparent hysteresis in torsional magnetostriction, 97; velocity of the ionized phosphorus emanation, 237; phosphorus emanation in spherical condensers, 310.
Becquerel rays, 395.
 — See **radio-active**.
Bell, W. T., concretions of Ottawa Co., Kansas, 315.
Bergen, J. Y., Foundations of Botany, 248.
Bermudas, fauna of, papers on, 326, 330.
Bigelow, F. H., magnetic theory of the Solar Corona, 253.
Birds, anatomy of, Häcker, 251.
Boston Basin, geology of, Crosby, 324.
Botany, elementary, Bailey, 250.
 — Foundations of, Bergen, 248.
 — Studies in Fossil, Scott, 471.

BOTANY.

- African plants collected by Dr. Welwitsch, Hiern, 249.
 Coffee plant, diseases and enemies, Delacroix, 92.
Cyperaceæ, studies in, xv, Holm, 205.
Erigena bulbosa, Holm, 63.
Flora of California, Jepson, 471.
 — of Cheshire, Moore, 398.
 — of Grand Rapids, Mich., Cole, 472.
 — of Vermont, Brainerd, Jones and Eggleston, 249.
Oedogoniaceæ, Hirn, 93.
Plant Life and Structure, Dennert, 250.
Platydorina, Kofoid, 94.
Sclerotinia, Woronin, 94.
Spermatophyta of North Dakota, Bolley and Waldron, 398.
Umbellifereæ, No. American, Coulter and Rose, 247.

C

- Canada**, Geological Survey, 402; general index, 170.
 — minerals of, Hoffmann, 149.
Carbon compounds, spectrum, Smithells, 466.
Chemical Analysis, Qualitative, Sellers, 164.
Chemistry, Analytical, Classen, 319; Ostwald, 466.
 — Introduction to Modern Scientific, Lassar-Cohn, 319.

CHEMISTRY.

- Acetylene, combustion in air with oxygen, Bourgerel, 87.
 Alcohol, action on metals, Malméjac, 394.
 Aluminum oxides, spectrum, 467.
 Ammonium amalgam, Coehn, 163.
 — bromide, Scott, 317.

* This Index contains the general heads, **BOTANY**, **CHEMISTRY** (incl. chem. physics), **GEOLOGY**, **MINERALS**, **OBITUARY**, **ROCKS**, and under each the titles of Articles referring thereto are mentioned.

CHEMISTRY.

Argon and its companions, Ramsay and Travers, 166.
 Atomic weights, method of determining, Benoist, 464.
 Cæsium-antimonious fluorides, Wells and Metzger, 451.
 Carbon compounds, spectrum, 466.
 — non-existence of trivalent, Norris, 236.
 Cerium, Drossbach, 236.
 Chemical reactions, velocity of, Duane, 349.
 Chlorine, preparation from sodium chlorate, Graebe, 392.
 — heptoxide, Michael and Conn, 235.
 Chromium in acids, phenomena connected with solution of, Ostwald, 84.
 Crystals, method for obtaining, Wróblewski, 236; Rümpler, 318.
 Diethyl peroxide, Baeyer and Villiger, 162.
 Gallium in the sun, Hartley and Ramage, 323.
 Gases in air, Liveing and Dewar, 154.
 — combustion of, Tantar, 86, 317.
 Gold, diffusion in solid lead, Roberts-Austin, 236.
 Helium, 166, 154.
 Hydrate of sulphuryl chloride, Baeyer and Villiger, 393.
 Hydrogen, boiling point of, Dewar, 291; in air, Rayleigh, 165.
 — peroxide, action upon silver oxide, Baeyer and Villiger, 393.
 — telluride, Ernyei, 163.
 Krypton, Ladenburg and Kruegel, 85, 166.
 Lead, radio-active, Hofmann and Strauss, 235, 463.
 Magnesium and aluminum, Duboin, 464.
 Methane elimination in the atmosphere, Urbain, 318.
 Neon, properties, 154, 166.
 Ozone, molecular weight, Ladenburg, 391.
 Phosphorus, emanation from, Barus, 237; in spherical condensers, 310.
 Platinum, loss of weight when heated, 164.
 — presence upon an Egyptian inscription, 465.
 Potassium and sodium sulphocyanides, color when heated, Giles, 318.
 Radium rays, action upon selenium, Bloch, 464.

Radium rays, physiological action, Walkhoff, 235.
 Sulphur hexafluoride, etc., Moissan and Lebeau, 391.
 Tobacco, new alkaloids in, Pictet and Rotschy, 392.
 Trouton's law, generalization from, 465.
 Xenon, properties, 166.
 Zirconia of euxenite, Hofmann and Prandtl, 463.
Cilley, F. H., theory of elasticity, 269.
Classen, A., Analytical Chemistry, 319.
Clayton, H. H., eclipse cyclone, 321.
Conductivities of double salts, Lindsay, 164.
Connecticut Academy of Sciences, 330.
Copper and Zinc, thermo-chemistry of alloys of, Baker, 237.
Corona, Solar, theory, Bigelow, 253.
Cosmogony, theories of, O. Fisher, 414.
Crook, Z., yoke with intercepted magnetic circuit, for measuring hysteresis, 365.
Crystals, method of obtaining, Rümpler, 318; Wroblewski, 236.
Cycads, American fossil, Wieland, 423.

D

Davison, C., velocity of seismic waves, 95.
Day, A. L., melting point of gold, 145; expansion of metals at high temperatures, 374.
Derby, O. A., occurrence of topaz, Ouro Preto, Brazil, 25.
Deserts, formation of, Walther, 326.
Dewar, J., spectrum of the volatile gases of atmospheric air, 154; boiling point of hydrogen, 291.
Douglass, E., new species of Merycochoerus in Montana, 73.
Duane, W., velocity of chemical reactions, 349.

E

Earth, theories of origin, Fisher, 414.
Earthquake waves in the ocean, 95.
Eclipse cyclone, Clayton, 321.
Elasticity, theory of, Cilley, 269.
Electric charge, effect of magnetic field upon, Cremieu, 87.
 — conductivity produced in gases, Townsend, 238; of double salts, Lindsay, 164.
 — convection, Cremieu, 87, 321.

Electric discharge, mechanical movements of wires, produced by, Viol, 467.
 — oscillations in charging condensers, Sundell and Tallquist, 238.
 — waves, metallic reflection, Lindman, 394.
Electricity effect on bacteria, Macfadyen, 320.
Electricity and Optics, Poincaré, 467.
Electron theory of metals, Drude, 88.
Ether, possible magnetic effect of earth on, Rollins, 322.

F

Farrington, O. C., metallic veins of the Farmington meteorite, 60.
Fauna of the Bermudas, papers relating to, 326.
Fisher, O., theories of cosmogony, 414.
Flora of West Middle California, Jepson, 471.
Florida, Tertiary fauna of, Dall, 170.
Fossil, see **GEOLOGY**.

G

Gas in a Crookes tube, absorption, Willow, 467.
Gases, present in air, 154, 165, 166.
Geikie, A., Founders of Geology, 326.
GEOLOGICAL REPORTS.
 Canada, 402; general index, Dowling, 170.
 Great Britain, 252, 402.
 Kansas, University Survey, 324.
 Maryland, 240.
 Michigan, vol. vii, pt. III., 241.
 Minnesota, vol. v, 88; 24th Annual Report, 242.
 United States, 240, 395; 21st Annual report, Walcott, 468.
 Western Australia, Maitland, 396.
Geologisches Centralblatt, Keilhack, 243.

GEOLOGY.

Albuquerque Sheet, Herrick and Johnson, 171.
 Amphicyon, new species, Wortman, 200.
 Boston Basin, geology, Crosby, 324.
 Cambrian fossils, new from Cape Breton, Matthew, 396.
 Concretions from clays of Connecticut Valley, Sheldon, 397.
 — of Ottawa County, Kansas, 315.
 Cosmogony, rival theories, Fisher, 414.

Creosaurus, Williston, 111.
 Cycads, American fossil, Wieland, 423.
 Deserts, law of the formation of, Walther, 326.
 Eocene and lower Oligocene coral faunas of U. S., Vaughan, 395.
 — Mammalia in the Marsh collection, Wortmann, 333, 437.
 Fossil Botany, Studies in, Scott, 471.
 Gabbroid rocks of Minnesota, Winchell, 89, 397.
 Glaciers, periodic variations, Forel, 168.
 Ground-Moraine, Orange River, So. Africa, Rogers and Schwarz, 325.
 Indian Territory, geology, etc., Gould, 185.
 Limestone conglomerate in the lead region of Missouri, Nason, 396.
 Marble, flow of under pressure, Adams and Nicolson, 397.
 Merycochærus in Montana, Douglass, 73.
 Mesozoic Fossils, vol. i, pt. IV., Whiteaves, 171.
 Metasomatic processes in fissure veins, Lindgren, 243.
 Ohio Coal-measures, Prosser, 191.
 Pleistocene geology of the Sierra Nevada, Turner, 242.
 Tertiary fauna of Florida, Dall, 170.
 — springs of West. Kansas and Oklahoma, Gould, 263.
 Texas, geolog. papers from 1886-1896, Simonds, 170.
 — region, physical geography, Hill, 90.
Geology, Founders of, Geikie, 326.
Glaciers, see **GEOLOGY**.
Gold, melting point of, Holborn and Day, 145.
Goode, George Brown, Memorial, 401.
Gould, C. N., geology of Indian Territory, etc., 185; Tertiary Springs of West. Kansas and Oklahoma, 263.

H

Hageman, S. A., a just intonation piano, 224.
Hallock, W., Very on atmospheric radiation, 230.
Harvard Astronomical Observatory, publications, 173, 474.
Hill, R. T., physical geography of the Texas region, 90.
Hoffman, G. C., new minerals in Canada, 149.

- Holborn, L.**, melting point of gold, 145; expansion of metals at high temperatures, 374.
Holm, T., *Erigenia bulbosa*, 63; studies in the Cyperaceae, xv, 205.
Hydrogen, boiling point, Dewar, 291; light transparency of, Schumann, 394; present in air, Rayleigh, 165.
Hygiene, Journal of, English, 474.
Hysteresis, apparent, in torsional magnetostriction, Barus, 97.
 — measurement of, Crook, 365.

I

- Indian Territory**, etc., geology, Gould, 185.
Indian village, old, Udden, 95.
Induction, unipolar, Lecher, 87; Hagenbach, 320.
Ions, producing conductivity, 238.
Italy, volcanoes of central, Sabatini, 171.

J

- Jepson, W. L.**, Flora of West Middle California, 471.

K

- Kansas**, University geological survey, 324.
Knight, N., Iowa dolomites, 244.

L

- Langley, S. P.**, the new spectrum, 403; annals of Astrophysical Observatory, 473.
Lassar-Cohn, Introduction to Modern Scientific Chemistry, 319.
Liveing, S. D., spectrum of the more volatile gases of atmospheric air, 154.

M

- Magnetic effect** of the earth on the ether, attempt to show, Rollins, 322.
 — field, effect on discharges through a gas, Willow, 238.
Magnetization, circular, and magnetic permeability, Trowbridge and Adams, 175.
Magnetostriction, Barus, 97.
Maryland Geological Survey, Clark, 240.
Matthew, G. F., new Cambrian fossils from Cape Breton, 396.
Mechanics, Slate, 174.
Metals, electron theory of, Drude, 88.
 — expansion at high temperatures, Holborn and Day, 374.

- Meteorite**, Farmington, Kansas, metallic veins, Farmington, 60.
Methane, elimination in the atmosphere, Urbain, 318.
Metzger, F. J., caesium-antimonium fluorides, 451.
Michigan Geol. Survey, vol. vii, pt. III, Lane, 241.
Microbes et Distillerie, Lévy, 251.
Mineral constituents of dust and soot, Hartley and Ramage, 470.
Mineralogy, Rutley, 92.

MINERALS.

- Anorthite crystals, New Jersey, 369.
 Badenite, Roumania, 91. Brostenite, Roumania, 92.
 Corundum, N. Carolina, Lewis, 92.
 Danalite, Canada, 151.
 Feldspar crystals, Colorado, 371.
 Iron wolframite, South Dakota, 372.
 Lepidolite, Quebec, 149. Ledouxite, 457.
 Mohawkite, 457.
 Newberyite, Yukon district, 149.
 Scheelite pseudomorphs, Connecticut, 373. Schorlomite, British Columbia, 150. Spodumene, Canada, 152. Struvite, Yukon district, 149.
 Thulite, Maryland, 171. Topaz, Brazil, 25.
 Uranophane, Quebec, 152.
 Wolframite, iron, So. Dakota, 372.
 Zoisite, Maryland, 171.
Minerals of the Argentine Republic, Bodenbender, 246.
 — and Rocks, Textbook of, Tillman, 246.
Minnesota, Geol. Survey, 88; 242.
 — study of gabbroid rocks, Winchell, 89, 397.

N

- Nason, F. L.**, limestone conglomerate in the lead region of Missouri, 396.
Navigation, Sub-Marine, Gaget, 402.
Norway, Official Publication of the Paris Exhibition, 174.

O

OBITUARY—

- Agardh, J. C., 332.
 Chatin, A., 332.
 Dawson, G. M., 332.
 Fitzgerald, George F., 402.
 Hermite, C., 332.
 Lütken, C. F., 402.
 Rowland, Henry A., 402.

Ohio State University Naturalist, 252.
 Ontario, minerals of, Miller, 246.
 Ores, deposition of, Van Hise, 90;
 Lindgren, 243.
 Ostwald, W., Analytical Chemistry,
 466.
 Ostwald's Klassiker der exakten
 Wissenschaften, 252.

P

Penfield, S. L., stereographic pro-
 jection, and its possibilities, 1, 115.
 Perseus, new star in, Anderson, 399.
 Piano, a just intonation, Hagemann,
 224.
 Phasenlehre, Roozeboom, 165.
 Phosphorus emanation, velocity of
 the ionized, Barus, 237; action in
 spherical condensers, 310.
 Photographic records, preservation
 of, Lockyer, 321.
 Physical data, compilation of, 239.
 Physics, Problems in, Snyder and
 Palmer, 239.
 Physiology of the Brain, Loeb, 251.
 — Experimental, Dubois and Cou-
 vreur, 330.
 Poincaré, H., Électricité et Optique,
 467.
 Projection, stereographic, Penfield,
 1, 115.
 Prosser, C. S., names of formations
 of Ohio Coal-measures, 191.

R

Radiation law of dark bodies,
 Paschen, 320.
 Radio-active lead, 235, 463; barium
 carbonate, 464.
 Reid, H. F., obituary notice of H.
 A. Rowland, 459.
 Richards, J. W., "Mohawkite" and
 Ledouxite, 457.
 Rollins, W., attempt to show the
 magnetic effect of the earth on the
 ether, 322.

ROCKS.

Charnockite series in Peninsular
 India, Holland, 89.
 Corundum-bearing, N. Carolina,
 Lewis, 92.
 Dolomites, Iowa, Knight, 244.
 Eruptive, about Ménerville, Algiers,
 Duparc, Pearce and Ritter, 89.
 Gabbroid, of Minnesota, Winchell,
 89, 397.

Glaucophaneschists, chemical study,
 Washington, 35.
 Marble, flow under pressure, Adams
 and Nicolson, 397.
 Röntgen rays, measured by means of
 selenium, Himstedt, 395.
 — and Becquerel rays, effect on the
 eye, Himstedt and Nagel, 395.
 Roumania, minerals, Poni, 91.
 Rowland, H. A., obituary notice,
 Reid, 459.
 Rutley, F., mineralogy, 92.

S

Schimper, microscopic investigation
 of foods, 96.
 Scott, D. H., Studies in Fossil Botany,
 471.
 Scripture, E. W., Yale Psychological
 laboratory, 168; nature of vowels,
 302.
 Seismic waves in the ocean, velocity,
 Davison, 95.
 Sellers, Chemical Analysis, 164.
 Sine currents, excitation and measure
 of, Wien, 394.
 Slate, F., Mechanics, 174.
 Smithsonian Institution, report, 400,
 473, 474.
 Soils, field operations of the division
 of, Whitney, 91.
 Solar Corona, magnetic theory, Bige-
 low, 253.
 Sound, transmission through porous
 material, Tufts, 357.
 Spectrum, the new, Langley, 403.
 — of aluminum and nitrogen oxides,
 467; of carbon compounds, 466.
 Standardizing Bureau, national, 332.
 Star, Nova Persei, Anderson, 399.
 Stereographic projection, Penfield,
 1, 115.
 Sun, see Solar.

T

Telegraphone, Poulsen, 166.
 Telegraphy, wireless, Slaby and
 Arco, 165.
 Texas, geology of, from 1886-1896,
 Simonds, 170.
 Tillman, S. E., Textbook of Min-
 erals and Rocks, 246.
 Transcontinental triangulation,
 Schott, 172.
 Trowbridge, J., circular magnetiza-
 tion and magnetic permeability,
 175.
 Tufts, F. L., transmission of sound
 through porous material, 357.

U

- Udden**, old Indian village, 95.
Unipolar induction, Lecker, 87;
 Hågenback, 320.
United States Coast Survey, 401.
 — Geological Survey, Walcott, 240,
 395, 468.
 — National Museum Report, 474.

V

- Van Hise, C. R.**, deposition of ores,
 90.
Veins, formation of fissure, Lind-
 gren, 243.
Velocity of seismic waves, Davison,
 95.
Very, atmospheric radiation, 230.
Volcanoes of central Italy, Sabatini,
 171.
Vowels, nature of, Scripture, 302.

W

- Walther, J.**, das Gesetz der Wüsten-
 bildung, 326.

Warren, C. H., mineralogical notes,
 369.

Washington, H. S., chemical study
 of glaucophane schists, 35.

Webster's International Dictionary,
 331.

Wehnelt interrupter, 88.

Wells, H. L., caesium-antimonious
 fluorides, 451.

Wieland, G. R., American fossil
 cycads, 423.

Williston, S. W., Dinosaurian genus
Creosaurus, 111.

Wortman, J. L., new American
 species of *Amphicyon*, 200; Eocene
 Mammalia in the Marsh collection,
 333, 437.

Y

Yale Psychological Laboratory, vol.
 vii, 168.

Z

Zoological results on material from
 Western Pacific, Willey, 330.

The American Journal of Science

ESTABLISHED BY BENJAMIN SILLIMAN IN 1818.

THE LEADING SCIENTIFIC JOURNAL IN THE UNITED STATES.

Devoted to the Physical and Natural Sciences, with special reference to Physics and Chemistry on the one hand, and to Geology and Mineralogy on the other.

Editor: EDWARD S. DANA.

Associate Editors: Professor GEORGE L. GOODALE, JOHN TROWBRIDGE, W. G. FARLOW and WM. M. DAVIS, of Cambridge; Professors A. E. VERRILL, HENRY S. WILLIAMS and L. V. PIRSSON, of New Haven; Professor G. F. BARKER, of Philadelphia; Professor HENRY A. ROWLAND, of Baltimore; Mr. J. S. DILLER, of Washington.

Two volumes annually, in **MONTHLY NUMBERS** of about 80 pages each.

This Journal ended its *first* series of 50 volumes as a quarterly in 1845; its *second* series of 50 volumes as a two-monthly in 1870; its *third* series as a monthly ended December, 1895. A **FOURTH SERIES** commenced in January, 1896.

CONTRIBUTORS should send their Articles two months before the time of issuing the number for which they are intended. The title of communications and the names of authors must be fully given. Notice is always to be given when communications offered have been, or are to be, published also in other Journals.

Thirty separate copies of each article will be furnished to the author free of cost and without previous notice from him. They will be provided with a plain cover (but with reference to volume and year). If the author orders separate copies, they will be understood to be in *addition* to the thirty mentioned above, and he will receive a bill for the extra expense involved, as also for that of a printed cover (with title, etc.), when this is *especially ordered*. These charges will conform to the following schedule; the rates will be somewhat increased if the article is accompanied by plates.

No. Copies.	50	100	200	300	500
8 pages -----	\$1.75	\$2.25	\$2.75	\$3.25	\$4.25
16 " -----	2.75	3.25	3.75	4.50	6.00
24 " -----	3.25	4.00	5.00	5.75	7.50
Cover -----	\$1.00	\$1.25	\$1.75	\$2.25	\$3.00

Subscription price \$6 per year, or 50 cents a number, postage prepaid in the United States; \$6 40 to foreign subscribers of countries in the Postal Union. A few sets on sale of the first, second and third series at reduced prices. *Ten-volume index numbers* on hand for the second and third series.

 Ten-volume Index, Vols. I-X, fourth series, price one dollar. Now ready.

Address,

THE AMERICAN JOURNAL OF SCIENCE,

New Haven, Conn.

NEW GEOTECTONIC MODELS

FOR THE ILLUSTRATION OF THE

ARCHITECTURE OF THE EARTH'S CRUST.

Constructed by Prof. Dr. L. DUPARC (Geneva), and by Prof. Dr. A. SCHMIDT (Bale).

These models, made of plaster, are constructed in such a manner as to show not only the geological features of the surface, but also on the sides diagrammatic sections illustrate the structure of the underlying crust. To each such model belongs a cap representing the masses of rocks, which are supposed to have been worn away by denudation, and showing the way in which the folding of the strata has taken place. The motives are taken from some of the most interesting parts of the Alps and the Jura Mts. in Switzerland. Among these are also two different representations of the renowned "*Glärner double fold with inversion and thrust-plane.*"

Price of the set of 8 models by Prof. Dr. L. Duparc, size about 40 x 20 x 10 cm., the Glärner double fold about 100 x 22 x 10 cm. \$100.00
Price of the Glärner-double-fold model by Prof. Dr. A. Schmidt, size about 100 x 22 x 10 cm. ----- 25.00
(An accurate description of these models will be sent free on application.)

New Collections of Rocks and Thin Sections.

Collection A. In addition to the well-known collection of 250 rocks and thin sections, according to Prof. Dr. Rosenbusch's book on Petrology, I have now arranged an extension of the same, consisting of 30 rocks and sections; most of them are very rare and interesting types of rocks which I was fortunate enough to collect during the last year.

(Such rocks as Monchiquite, Tinguaita, Leucitsyenite, Gautëite, Borolanite, Ijolithe, Jacupirangite, etc., etc.)

Collection B. This collection has been arranged according to Prof. Dr. H. Rosenbusch's book, "*Elemente der Petrographie,*" and contains only rocks and sections of the crystalline schists and sedimentary rocks, thus forming a

Supplement to the collection of 250 Specimens.

Price of collection A, 30 specimens, size 8½ : 11 cm. =-----	\$13.50
“ “ A, together with 30 thin sections =-----	23.50
“ “ B, 50 specimens, size 8½ : 11 cm. =-----	11.00
“ “ B, together with 50 thin sections =-----	27.50

Collections of Minerals, Fossils, Meteorites purchased for cash or exchanged.

DR. F. KRANTZ,

RHENISH MINERAL OFFICE,

BONN-ON-RHINE, GERMANY.

JANUARY, 1901.

Established by BENJAMIN SILLIMAN in 1818.

THE
AMERICAN
JOURNAL OF SCIENCE.

EDITOR: EDWARD S. DANA.

ASSOCIATE EDITORS

PROFESSORS GEO. L. GOODALE, JOHN TROWBRIDGE,
W. G. FARLOW AND WM. M. DAVIS, OF CAMBRIDGE,

PROFESSORS A. E. VERRILL, HENRY S. WILLIAMS, AND
L. V. PIRSSON, OF NEW HAVEN,

PROFESSOR GEORGE F. BARKER, OF PHILADELPHIA,

PROFESSOR H. A. ROWLAND, OF BALTIMORE,

MR. J. S. DILLER, OF WASHINGTON.

FOURTH SERIES.

VOL. XI—[WHOLE NUMBER, CLXI.]

No. 61.—JANUARY, 1901.

WITH PLATE I.

NEW HAVEN, CONNECTICUT.

1901.

THE TUTTLE, MOREHOUSE & TAYLOR CO., PRINTERS, 125 TEMPLE STREET.

Published monthly. Six dollars per year (postage prepaid). \$6.40 to foreign subscribers of countries in the Postal Union. Remittances should be made either by money orders, registered letters, or bank checks.

HOLIDAY HINTS

POLISHED SPECIMENS

A large and varied lot of minerals worked into neat ornamental pieces, polished on one side only, includes the following: Indigo blue Sodalite, fine Rose Quartz, Opalized Wood, Amazon Stone, translucent Green Opal, Variscite, Turquoise, Chrysoprase, Labradorite, Queensland Precious Opal in the rock, White Cliffs (N. S. W.), Precious Opal banded, Rutilated Quartz, Banded Malachite and Azurite, Perthite, Australian Malachite, Moss Agate, Agates various, Williamsite, etc., etc., at 50c. to \$3.00 each. A few wonderfully fine Opals at \$5.00 to \$15.00 each, including some desirable cut stones. Beautiful Rose Quartz and Rock Crystal Balls at \$1.50 to \$10.00 each. Hundreds of brilliantly colored crystallized minerals of equal decorative value, at similar prices.

MINERAL COLLECTIONS

Ranging from 75c. to \$9.10 and upwards. Handsome quartered oak cases with lifting trays, or the larger and more commodious drawer cabinets are included,—not only to make a better display, but to avoid confusion and mistakes. Careful preparation, combined with the “standard” quality of our educational material, have established a merited reputation for our collections, to sustain which no trouble or expense is spared.

POLYADELPHITE

A recent trip to Franklin Furnace furnished a large assortment of this yellow-brown variety of Garnet. Many of the groups are comparatively perfect, and development brought out the clear cut facial angles in fine contrast to the cream-colored Calcite. Specimens 2" by 3" to 3" by 4" and larger, 50c. to \$4.00.

Jeffersonite, Hornblende, Apatite, Tourmaline, the Zinc ores and associations are all well displayed. Leucophoenicite, Nasonite, Hardystonite and Hancockite. One specimen of Glaucochroite, \$25.00—and it's worth every cent of it! Two or three others, \$1.00 to \$6.00.

NICCOLITE

Interesting from a new locality—Tasmania. The find closely resembles the ore from Germany, but shows associations to better advantage, 50c. to \$3.00.

FOOTE MINERAL CO..

FORMERLY DR. A. E. FOOTE,

WARREN M. FOOTE, Manager.

ESTABLISHED 1876.

PHILADELPHIA,
1317 Arch Street.

PARIS,
24 Rue du Champ de Mars.

NINE NEW SPECIES FROM GREENLAND.

None of them ever before offered for sale in America.

**CORDYLITE, ANCYLITE, SPODIOPHYLLITE, LORENZENITE,
LEUCOSPHEENITE, NARSARSUKITE, EPISTOLITE,
BRITHOLITE, SCHIZOLITE.**



Also in the same consignment 5-Polyolithionite, 29 Steenstrupite. These minerals are now in the Custom House and will doubtless be on sale about January 1st. Their value is in the neighborhood of \$500.

SCANDINAVIAN MINERALS.

Just Arrived. An unusually good lot of Scandinavian minerals including Braunite xls, Homilite, Pyrochroite, Knopite, Native Lead, Linnaeite. Gadolinite xls, Cobaltite xls.

POLISHED SECTIONS OF QUARTZ ENCLOSING TOURMALINE.

We have cut a number of remarkably attractive sections from crystals of the Montana Tourmaline-Quartz. at right angles to the vertical axis. Each section is polished on both sides and shows many tufts of Tourmaline needles; some of them also show beautiful smoky phantoms, 50c. to \$1.50.

MATRIX TURQUOIS SPECIMENS.

A small lot of very choice matrix specimens of rich-blue Turquoise, also fragments suitable for cutting into gems. 10c. to \$2.50.

SUTTROP MILKY QUARTZ CRYSTALS.

300 uncommonly fine and large crystals, 5c. to 35c.

FLUORITE OCTAHEDRONS.

The recent work done at our Westmoreland, N. H. Fluorite Mine has enabled us to secure a new supply of magnificent cleavage octahedrons of emerald-green color, 10c. to \$1.50.

MINERALS FROM FRANKLIN FURNACE.

A new zinc-manganese variety of Wollastonite, of beautiful pink color; 10c. to \$1.50.

Leucophoenicite, good specimens, 25c. to \$2.00.

Rhodonite, cabinet size groups of crystals of good color, 50c. to \$3.50; also remarkably fine cleavages, 10c. to 50c.

Caswellite, excellent specimens, 10c. to \$2.00.

OTHER RECENT ADDITIONS.

Parisite, Montana. Excellent matrix specimens, showing one or more terminated or doubly-terminated crystals, $\frac{1}{2}$ to $\frac{3}{4}$ inch long; \$3.00 to \$10.00.

Datolite. A new find at West Paterson. Choice groups of brilliant crystals, 35c. to \$2.00.

Flexible Sandstone from India, remarkable (!) specimens, \$1.50 to \$3.00.

Deweyite, best ever seen, 10c. to \$1.00.

Covellite, superfine, 25c to \$5.00.

Actinolite, gemmy green crystals and groups, 10c. to \$2.00.

5000 Ohio *Selenites*. Powellite, Twin Sapphires, Roseite, Stibiodomeykite and other Mohawk Mine minerals, etc., etc.

124 pp. *Illustrated Catalogue*, giving Dana Species number, hardness, specific gravity, chemical composition and formula of every mineral, 25c in paper, 50c. in cloth.

44 pp. *Illustrated Price-Lists*, also *Bulletins* and *Circulars* free.

GEO. L. ENGLISH & CO., Mineralogists,

812 and 814 Greenwich Street (S. W. Corner of Jane Street), New York City.

INDEX TO VOLUMES I-X. Price One Dollar.

Now ready. Orders should be given at once, as the edition is limited.

CONTENTS.

	Page
ART. I.—Stereographic Projection and its Possibilities, from a Graphical Standpoint; by S. L. PENFIELD (With Plate I.)	1
II.—Mode of Occurrence of Topaz near Ouro Preto, Brazil; by O. A. DERBY	25
III.—Chemical Study of the Glaucophan Schists; by H. S. WASHINGTON	35
IV.—Nature of the Metallic Veins of the Farmington Meteorite; by O. C. FARRINGTON	60
V.— <i>Erigenia bulbosa Nutt</i> ; by T. HOLM	63
VI.—New Species of <i>Merycocherus</i> in Montana, Part II; by E. DOUGLASS	73

SCIENTIFIC INTELLIGENCE.

Chemistry and Physics—Periodic Phenomena connected with the Solution of Chromium in Acids, W. OSTWALD, 84.—Krypton, LADENBURG and KRUEGEL, 85.—Combustion of Gases, S. TANTAR, 86.—Combustion of Acetylene in Air enriched with Oxygen, G. L. BOURGEREL: Inverse effect of a magnetic field upon an electric charge, M. V. CREMIEU: Electrical Convection, M. V. CREMIEU: Unipolar Induction, E. LECHER, 87.—Electron theory of metals, P. DRUDE: Simple modification of the Wehnelt interrupter, 88.

Geology and Mineralogy—Geological and Natural History Survey of Minnesota, Vol. V, N. H. WINCHELL and U. S. GRANT, 88.—Étude mineralogique et pétrographique des Roches gabbroïques de l'État de Minnesota, États Unis, et plus spécialement des Anorthosites, A. N. WINCHELL: Roches Éruptives des Environs de Ménerville, Algérie, L. DUPARC, F. PEARCE and E. RITTER: Charnockite Series, a group of Archean Hypersthenic rocks in Peninsular India, T. H. HOLLAND: Geologische Skizze der Besitzung Jushno-Saoserk und des Berges Deneshkin Kamen in nordlichen Ural, F. LOEWINSON-LESSING, 89.—Some Principles controlling Deposition of Ores, C. R. VAN HISE: Physical Geography of the Texas Region, R. T. HILL, 90.—Field Operations of the Division of Soils, 1899, M. WHITNEY: Études sur les Minéraux de la Roumanie, P. PONI, 91.—Mineralogy, F. RUTLEY: Corundum and the Basic Magnesian Rocks of Western North Carolina, J. O. LEWIS, 92.

Botany—Maladies et les Ennemis des Caféiers, G. DELACROIX, 92.—Monographie und Iconographie der Oedogoniaceen, K. E. HIRN, 93.—Ueber *Sclerotinia cinerea* and *Sclerotinia fructigena*, M. WORONIN: *Platydorina*, a new Genus of the Family Volvocidae, from the Plankton of the Illinois River, C. A. KOFOD, 94.

Miscellaneous Scientific Intelligence—Velocity of Seismic Waves in the Ocean, C. DAVISON: Old Indian Village, J. A. UDDEN, 95.—Anleitung zur mikroskopischen Untersuchung der vegetabilischen Nahrungs- und Genussmittel, A. F. W. SCHIMPER, 96.

Established by BENJAMIN SILLIMAN in 1818.

THE
AMERICAN
JOURNAL OF SCIENCE.

EDITOR: EDWARD S. DANA.

ASSOCIATE EDITORS

PROFESSORS GEO. L. GOODALE, JOHN TROWBRIDGE,
W. G. FARLOW AND WM. M. DAVIS, OF CAMBRIDGE,

PROFESSORS A. E. VERRILL, HENRY S. WILLIAMS, AND
L. V. PIRSSON, OF NEW HAVEN,

PROFESSOR GEORGE F. BARKER, OF PHILADELPHIA,
PROFESSOR H. A. ROWLAND, OF BALTIMORE,
MR. J. S. DILLER, OF WASHINGTON.

FOURTH SERIES.

VOL. XI—[WHOLE NUMBER, CLXI.]

No. 62.—FEBRUARY, 1901.

WITH PLATES II-IV.

NEW HAVEN, CONNECTICUT.

1901.

THE TUTTLE, MOREHOUSE & TAYLOR CO., PRINTERS, 125 TEMPLE STREET.

FONTAINEBLEAU LIMESTONE

An unequalled assortment of groups and single crystals from the well-known locality above mentioned. A large stock was secured through our Paris house, an advance shipment of which has just reached us. They're too well known to need special description, and present prices will tend to make them even more so. Crystals, 25c. per dozen to 75c. each. Groups for cabinet purposes 50c. to \$2.00.

MENILITE

Also from France, representing an important variety of Opal. Sold in cabinet specimens at 50c. each, or for educational purposes at 50c. per pound. *Quartz after Gypsum* in curious rosette-like crystallizations, from Paris. Interesting specimens when considered individually, but more particularly so when associated with the rare Lutécite—an oxide of silicon—50c. to \$4.00.

CANADA ZIRCON

Twins and simple crystals of unusual lustre and perfection. Not a large lot and not even large crystals, but their quality is almost gemmy. Neatly trimmed with firm bases, 50c. to \$2.00.

NADORITE

Nearly 50 typical specimens of this rare lead and antimony compound, many crystallized in the thin tabular habit characteristic of the species. *Senarmontite* and *Valentinite*, also Algerian minerals containing antimony are well represented and reasonably priced. Cabinet specimens from 50c. to \$4.00.

CERUSSITE, SARDINIA

Clusters of columnar and acicular crystallizations, in fine reticulated masses of snow white and gray, sometimes on a brown limonite gangue. Beautiful specimens undoubtedly, but delicate and liable to fracture, unless mounted in our new glass-cover black boxes. They serve not only for protection, but as articles adding to the effectiveness of a drawer's display. Cabinet specimens so mounted—50c. to \$3.50.

Kermesite, Green Anglesite, Senarmontite, Valentinite, etc., etc., from the same locality.

OTHER NOTEWORTHY ARRIVALS.

Tetrahedrite, Hungary. A few neat cabinet specimens and one large group of particularly brilliant crystals at \$17.50.

Bornite, argentiferous from Tasmania. Beautifully iridescent and rich in silver. Typical examples 50c. each.

Covellite, Montana. Fine masses 2 by 3 to 6 by 8, wondrously lustrous, and of remarkable quality. \$2.00 per pound.

Cut Stones. Gem material recently secured yielded fine green, white, and pink Tourmalines, Golden Beryl, Aquamarine, Chrysoberyl (*Cats-eye*), Spessartite, Peridot, Hiddenite, Garnets various, and Opals in abundance. Prices the lowest.

"Twistem" crystal holders, fully nickeled, strong and of neat pattern. Holds the mineral securely and displays to the best advantage all crystal faces. Packed 12 in a box, 50c. per dozen.

FOOTE MINERAL CO..

FORMERLY DR. A. E. FOOTE,

WARREN M. FOOTE, Manager.

ESTABLISHED 1876.

PHILADELPHIA,
1317 Arch Street.

PARIS,
24 Rue du Champ de Mars.

AUSTRALIAN MINERALS.



A large and most important consignment has just reached us from Australia, embracing quite a number of minerals never before or but rarely offered for sale in America, besides many very choice specimens of the well-known Broken Hill minerals which were first prominently brought to the attention of mineral collectors in general by our large purchases a few years since. The shipment has been unpacked and inspected, but is not yet priced up and may not be on sale before February 16th. A partial list of the thousand or more specimens follows:

Atacamite; 240 good cabinet and museum size specimens, mostly well crystallized.

Cuprite; 25 matrix groups and 300 small groups and loose crystals, some exceedingly fine.

Copper; 35 small and cabinet size groups, many of remarkably well-formed crystals, others beautifully arborescent.

Cobaltite and **Smaltite**; 50 cabinet size specimens, including a number of excellent matrix groups of crystals.

Molybdenite; 40 showy specimens.

Sylvanite; 13 excellent specimens from the new find in West Australia.

Gold; 50 assorted specimens, a number very good.

Selenite; 10 good, lenticular crystals.

Cassiterite; 8 specimens, partly crystallized or in large rolled pebbles.

Azurite; a very few extra fine loose crystals and matrix specimens.

Chalcopyrite; 10 large interesting crystals and groups.

Pyromorphite; 20 brown groups, some of them extra fine.

Embolite and **Cerargyrite**; 60 specimens, large and small, many splendid crystallizations.

Iodyrite; 20 specimens, several extra fine.

Cerussite and **Anglesite**; 80 specimens, many of them in exceedingly fine crystals and groups.

Stolzite; 6 crystallized specimens.

Marshite; one large group.

Smithsonite; 10 excellently crystallized.

REMARKABLE MILLERITES FROM IOWA.

We now have on sale a most remarkable collection of specimens of matted needles of Millerite on crystallized Calcite, or enclosed in Calcite. Besides a show case full of museum-size specimens there are three drawers full of cabinet sizes. Prices very reasonable.

EXTRA CHOICE STILBITE AND CHABAZITE.

Just received; over a hundred extraordinarily beautiful red Chabazites, with excellent sheaves of richly-colored Stilbite; 10c. to 75c.

A NEW IMPORTATION OF SWISS MINERALS.

Rose Fluorite crystals on matrix, fine *Brookites*, *Heulandite*, *Smoky Quartz*, *Apatite*, etc. A small lot of extra good, little specimens.

OTHER RECENT ADDITIONS.

Nine new mineral species from Greenland; splendid matrix specimens of *Parisite* from Montana; many new species and interesting minerals from Franklin; beautiful, emerald-green cleavage octahedrons of *Fluorite*; splendid *Covellite*; choice groups of *Datolite*; polished sections of *Quartz enclosing Tourmaline* needles; choice polished *Williamsite*; remarkable *Flexible Sandstone*; and hosts of other desirable minerals.

124 pp. *Illustrated Catalogue*, giving Dana Species number, hardness, specific gravity, chemical composition and formula of every mineral, 25c. in paper, 50c. in cloth.

44 pp. *Illustrated Price-Lists*, also *Bulletins and Circulars* free.

GEO. L. ENGLISH & CO., Mineralogists,
812 and 814 Greenwich Street (S. W. Corner of Jane Street), New York City.

INDEX TO VOLUMES I-X. Price One Dollar.

Now ready. Orders should be given at once, as the edition is limited.

CONTENTS.

	Page
ART. VII.—Apparent Hysteresis in Torsional Magnetostriction, and its relation to Viscosity; by C. BARUS.....	97
VIII.—Dinosaurian Genus <i>Creosaurus</i> , Marsh; by S. W. WILLISTON.....	111
IX.—Stereographic Projection and its Possibilities, from a Graphical Standpoint; by S. L. PENFIELD. (With Plates II, III and IV.).....	115
X.—Melting Point of Gold; by L. HOLBORN and A. L. DAY.....	145
XI.—New mineral occurrences in Canada; by G. C. HOFFMANN.....	149
XII.—Spectrum of the more Volatile Gases of Atmospheric Air, which are not Condensed at the Temperature of Liquid Hydrogen; by S. D. LIVEING and DEWAR.....	154

SCIENTIFIC INTELLIGENCE.

- Chemistry and Physics*—Diethyl Peroxide, BAEYER and VILLIGER, 162.—Ammonium Amalgam, A. COEHN: Hydrogen Telluride, ERNYEL, 163.—Conductivities of some Double Salts as Compared with the Conductivities of Mixtures of their Constituents, F. LINDSAY: Cause of the Loss in Weight of Commercial Platinum when Heated, R. W. HALL: Elementary Treatise on Qualitative Chemical Analysis, J. F. SELLERS, 164.—Bedeutung der Phasenlehre, H. W. B. ROOZEBOOM: Visibility of Hydrogen in Air, Lord RAYLEIGH: Wireless Telegraphy, SLABY and Count ARCO, 165.—Telegraphone, V. POULSEN: Properties of Argon and its Companions, W. RAMSAY and M. W. TRAVERS, 166.—Studies from the Yale Psychological Laboratory, E. W. SCRIPTURE, 168.
- Geology and Mineralogy*—Periodic Variations of Glaciers, F. A. FOREL, 168.—Contributions to the Tertiary Fauna of Florida, W. H. DALL: Record of the Geology of Texas for the decade ending December 31, 1896, F. W. SIMONDS: Geological Survey of Canada, G. M. DAWSON: Report on the Geology and Natural Resources of the Country traversed by the Yellow Head Pass Route from Edmonton to Tête Jaune Cache, comprising portions of Alberta and British Columbia, J. McEVVOY, 170.—Mesozoic Fossils, Vol. I, Pt IV. On some additional or imperfectly understood fossils from the Cretaceous Rocks of the Queen Charlotte Islands, with a revised list of the species from these rocks, J. F. WHITEAVES: Geology of the Albuquerque Sheet, C. L. HERRICK and D. W. JOHNSON: I Vulcani dell' Italia Centrale. Parte I. Vulcano Laziale, V. SABITINI: Occurrence of Zoisite and Thulite near Baltimore, 171.
- Miscellaneous Scientific Intelligence*—Transcontinental Triangulation and the American Arc of the Parallel, C. A. SCHOTT, 172.—Astronomical Observatory of Harvard College, 173.—Norway; Official Publication of the Paris Exhibition, 1900: American Museum of Natural History: Principles of Mechanics: an Elementary Exposition for Students in Physics, F. SLATE: Knowledge Diary and Scientific Hand-book for 1901, 174.

Established by BENJAMIN SILLIMAN in 1818.

THE
AMERICAN
JOURNAL OF SCIENCE.

EDITOR: EDWARD S. DANA.

ASSOCIATE EDITORS

PROFESSORS GEO. L. GOODALE, JOHN TROWBRIDGE,
W. G. FARLOW AND WM. M. DAVIS, OF CAMBRIDGE,

PROFESSORS A. E. VERRILL, HENRY S. WILLIAMS, AND
L. V. PIRSSON, OF NEW HAVEN,

PROFESSOR GEORGE F. BARKER, OF PHILADELPHIA,

PROFESSOR H. A. ROWLAND, OF BALTIMORE,

MR. J. S. DILLER, OF WASHINGTON.

FOURTH SERIES.

VOL. XI—[WHOLE NUMBER, CLXI.]

No. 63.—MARCH, 1901.

NEW HAVEN, CONNECTICUT.

1901.

THE TUTTLE, MOREHOUSE & TAYLOR CO., PRINTERS, 125 TEMPLE STREET.

FOREIGN MINERALS AND RARE SPECIES

We take pleasure in calling to the notice of collectors numerous rare and attractive minerals contained in a shipment of twenty-one cases received by way of our Paris store. Mail orders will receive careful attention, and the privileges of our "approval system" are cheerfully extended to purchasers wishing to make personal selections. As yet we are not prepared to place more than a small portion of the entire consignment on sale, but enumerated among those most interesting are the following :-

STOLZITE.

One of the rarest of Australian minerals, which hitherto has been unobtainable in other than high priced specimens. The assortment offered from 50c. to \$2.00 is unrivalled—but of course we have finer crystallizations ranging from \$5.00 to \$15.00.

HESSITE WITH KARELINITE.

Both rare minerals of important composition. Material secured is small, representing however an interesting association. \$2.00 each.

BISMUTITE.

From Queensland. Typical examples, 50c. to \$7.00. A rarity from any locality,—doubly so from a new one.

OPAL REPLACING SHELL.

Curious alterations found at White Cliffs, N. S. W., show complete replacement of the shell by translucent Opal,—sometimes of gem quality. Original form is retained perfectly and only the opalescent lustre marks the distinction. A limited stock reasonably priced. 50c. to \$4.00.

TWINNED AMETHYST AND ROCK CRYSTAL.

Polished sections $\frac{1}{4}$ inch in thickness cut from a Brazilian crystal exhibit curious markings not unlike the Chiastolite figures. A dark colored Amethyst alternating with clear Rock Crystal forms a striking contrast. An interesting phenomenon. Six specimens, priced \$3.50 to \$5.00.

WOLFRAMITE.

Typical cleavage examples of the mineral from Argentine Republic. No crystallizations as yet, but we hope to secure them. 50c., 75c. and \$1.00.

A FEW OF THE RARE SPECIES.

Raspite, a twinned monoclinic occurrence of lead tungstate from Broken Hill; new form of **Mimetite** associated with **Gibbsite** from Tasmania; **Roepferite**, Broken Hill; **Mimetite**, Bolivia; **Thenardite**, Bolivia; **Beudantite** crystals; **Crookesite**, **Percylite**, **Schwartzembergite**, **Krennerite**, **Kalgoorlite**, **Calaverite** crystals, etc., etc.

EDUCATIONAL COLLECTIONS. LABORATORY MATERIAL.
GEMS AND PRECIOUS STONES.

FOOTE MINERAL CO..

FORMERLY DR. A. E. FOOTE,

WARREN M. FOOTE, Manager.

ESTABLISHED 1876.

PHILADELPHIA,
1317 Arch Street.

PARIS,
24 Rue du Champ de Mars.

REMOVAL.

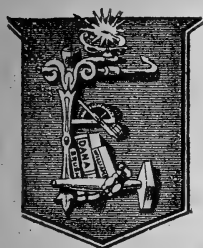

We take pleasure in announcing that we have removed to 3 and 5 WEST 18TH ST., first door West of Fifth Avenue, where with much more attractive salesrooms, many additions to our stock, and convenience of location, we hope to serve our customers much more acceptably in the future than in the past. The confusion incident to moving has delayed the placing on sale of many recent accessions, but we will have our salesrooms in order for our

SPRING OPENING

ON SATURDAY, MARCH 2d AT 1 P. M.

AUSTRALIAN MINERALS.

Our Australian shipment will then be placed on sale. Its many attractive specimens are described in our Spring Bulletin, to which and our announcements last month reference should be made.

NOVA SCOTIA ZEOLITES.

We now have in stock the most beautiful Nova Scotia Zeolites we have ever seen. Extraordinarily fine groups of salmon-colored Chabazite in $\frac{1}{4}$ to $\frac{3}{4}$ -inch crystals, 15c. to \$1.00. Stilbite in singularly choice sheaves of rich color, both alone and on salmon-colored Chabazite, 15c. to \$1.00. Also several hundred excellent student specimens at 5c. to 15c.

MOHAWKITE, STIBIODEMEYKITE AND WHITNEYITE.

Every specimen, before it is labeled, has been tested and the correctness of the determinations certified by Prof. G. A. Koenig.

Mohawkite, nearly pure, metallic masses, 35c. to \$3.50.

Stibiodomeykite, nearly pure, metallic masses, 25c. to \$2.50.

Domeykite and Whitneyite, equally good at same prices.

NEW COLORADO RHODOCHROSITE, HÜBNERITE, ETC.

Just received from a new locality, groups of delicate pink Rhodochrosite, some associated with green fluorite, very beautiful, 35c. to \$6.00.

Hübnerite, extra choice; 25c. to \$3.00.

Sphalerite, groups of fine, black crystals of rare forms, 25c. to \$2.00.

OUR SPRING BULLETIN

Is now in press and will be ready for distribution by March first. Its beautiful illustrations of the many minerals recently added to our stock, and the more than usually exact descriptions, will make it, we trust, of exceptional interest to mineralogists.

124-page *Illustrated Catalogue*, giving Dana Species number, hardness, specific gravity, chemical composition and formula of every mineral, 25c. in paper, 50c. in cloth.

44-page *Illustrated Price-Lists*, also *Bulletins and Circulars* free.

GEO. L. ENGLISH & CO., Mineralogists,

Dealers in Scientific Minerals,

Removed to 3 and 5 West 18th Street, First door west of Fifth Avenue, New York City.

INDEX TO VOLUMES I-X. Price One Dollar.

Now ready. Orders should be given at once, as the edition is limited.

CONTENTS.

	Page
ART. XIII.—Circular Magnetization and Magnetic Permeability; by J. TROWBRIDGE and E. P. ADAMS	175
XIV.—Notes on the Geology of Parts of the Seminole, Creek, Cherokee and Osage Nations; by C. N. GOULD ..	185
XV.—Names for the formations of the Ohio Coal-measures; by C. S. PROSSER	191
XVI.—New American Species of Amphicyon; by J. L. WORTMAN	200
XVII.—Studies in the Cyperaceæ, No. XV; by T. HOLM ..	205
XVIII.—Just Intonation Piano; by S. A. HAGEMAN	224
XIX.—Very on Atmospheric Radiation; by W. HALLOCK ..	230

SCIENTIFIC INTELLIGENCE.

Chemistry and Physics—Radio-active Lead, HOFFMANN and STRAUSS: Physiological Action of Radium Rays, WALKHOFF: Chlorine Heptoxide, MICHAEL and CONN, 235.—Non-Existence of Trivalent Carbon, J. F. NORRIS: Diffusion of Gold in Solid Lead at Ordinary Temperature, W. C. ROBERTS-AUSTIN: Cerium, G. B. DROSSBACH: Method for Crystallizing Substances without the Formation of Crusts upon the Surface of the Liquid, A. WRÓBLEWSKI, 236.—Velocity of the ionized phosphorus emanation in the absence of electric field, C. BARUS: Thermo-chemistry of the alloys of copper and zinc, T. J. BAKER, 237.—Decrement of electrical oscillations in charging condensers, A. F. SUNDELL and HJ. TALLQUIST: Effect of a magnetic field on the discharges through a gas, R. S. WILLONS: Conductivity produced in gases by the motion of negatively charged ions, TOWNSEND, 238.—Recueil de Données Numériques publié par la Société Française de Physique, H. DUFET: One Thousand Problems in Physics, W. H. SNYDER and I. O. PALMER, 239.

Geology and Mineralogy—Maryland Geological Survey: Allegheny County, W. B. CLARK: U. S. Geological Survey, C. D. WALCOTT, 240.—Geological Survey of Michigan, A. C. LANE, 241.—Geological and Natural History Survey of Minnesota, N. H. WINCHELL: Pleistocene Geology of the South Central Sierra Nevada with especial reference to the Origin of Yosemite Valley, H. W. TURNER, 242.—Geologisches Centralblatt: Metasomatic Processes in Fissure Veins, W. LINDGREN, 243.—Some Iowa Dolomites, N. KNIGHT, 244.—Minerals of Ontario: Text-book of Important Minerals and Rocks, with tables on the determination of minerals, S. E. TILLMAN: Los Minerales, G. BODENBENDER, 246.

Botany—Monograph of the North American Umbelliferae, J. M. COULTER and J. N. ROSE, 247.—Foundations of Botany, J. Y. BERGEN, 248.—Flora of Vermont: Catalogue of the African Plants collected by Dr. Friedrich Welwitsch in 1853-61, W. P. HIERN, 249.—Botany: an Elementary Text for Schools, L. H. BAILEY: Plant Life and Structure, E. DENNERT, 250.

Miscellaneous Scientific Intelligence—Comparative Physiology of the Brain and Comparative Psychology, J. LOEB: Microbes et Distillerie, L. LÉVY: Gesang der Vögel, seine anatomischen und biologischen Grundlagen, V. HACKER, 251.—O. S. U. Naturalist: Ostwald's Klassiker der Exakten Wissenschaften: Director-General of the Geological Survey of the United Kingdom, 252.

Established by BENJAMIN SILLIMAN in 1818.

THE
AMERICAN
JOURNAL OF SCIENCE.

EDITOR: EDWARD S. DANA.

ASSOCIATE EDITORS

PROFESSORS GEO. L. GOODALE, JOHN TROWBRIDGE,
W. G. FARLOW AND WM. M. DAVIS, OF CAMBRIDGE,

PROFESSORS A. E. VERRILL, HENRY S. WILLIAMS, AND
L. V. PIRSSON, OF NEW HAVEN,

PROFESSOR GEORGE F. BARKER, OF PHILADELPHIA,

PROFESSOR H. A. ROWLAND, OF BALTIMORE,

MR. J. S. DILLER, OF WASHINGTON.

FOURTH SERIES.

VOL. XI—[WHOLE NUMBER, CLXI.]

No. 64.—APRIL, 1901.

NEW HAVEN, CONNECTICUT.

1901.

THE TUTTLE, MOREHOUSE & TAYLOR CO., PRINTERS, 125 TEMPLE STREET.

Published monthly. Six dollars per year. \$6.40 to countries in the Postal Union. Remittances should be made either by money orders, registered letters, or bank checks (preferably on New York banks).

MORE FOREIGN MINERALS!

A consignment of several cases from our Paris house is expected early in April, and judging from lists received, we can then offer a full series of the newest European minerals at minimum rates. Many have been formerly represented in our stock, most of them are new, and *all* are deserving of special mention, though the list following is necessarily condensed:

HYDROCERUSSITE with native lead—a rarity frequently noticed on “desiderata” lists.

NARSARSUKITE, **CORDYLITE**, **EPISTOLITE**, **SCHIZOLITE**, etc., new Greenland minerals of unusual scientific interest.

CENOSITE, **PHENACITE**, **STEENSTRUPINE**, **LANTHANITE**, **PYROAURITE**, **ÆSCHYNITE**, **ELPIDITE**, **BARYSILITE**, **WÖHLERITE**, **BERZELIITE**, **ILVAITE**, **SCOLECITE**, **PINAKIOLITE**, **INESITE**, **MELANOTEKITE**, etc., etc.

TASMANIA.

Four cases packed in the chromate-yielding lead mines were delivered in Philadelphia about the middle of March, and by April first the material contained will be ready for examination. Advices from our Australian agent state that he, with the assistance of two laborers, worked one of the abandoned tunnels, and by stoping and extensive timbering opened a fresh deposit of Crocoite.

TYPES do not differ from those received in previous shipments, but the *quality* and *perfection of crystallization* place them far in advance of any hitherto offered from this store. Picture mentally, single crystals *three to five inches in length*; add if you can, perfect termination, rich color and translucent quality—and the idea conveyed will lack half the beauty of the original.

PRICES are uniformly reasonable. \$1.00 purchases a two-inch terminated crystal of fine quality, while \$5, \$10 or \$15 invested in Crocoites would furnish a series in which any collector would justly take pride. Send us one of the above sums and we will ship prepaid a selection on approval, with the certainty of your acceptance.

FOOTE MINERAL CO.,

FORMERLY DR. A. E. FOOTE,

WARREN M. FOOTE, Manager.

ESTABLISHED 1876.

PHILADELPHIA,
1317 Arch Street.

PARIS,
24 Rue du Champ de Mars.

NOVA SCOTIA ZEOLITES.



Possibly never before have we given the place of honor in our advertisements to Nova Scotia Zeolites. The remarkable beauty and real scientific merit of the specimens recently secured make it difficult to too highly honor them. Never before have we had in stock, never have we even seen, such exceedingly beautiful specimens of Stilbite and Chabazite as these. Fine groups of salmon-colored **Chabazite**, 1 x 1½ inches, 15c.; 2 x 2, 35c.; 2 x 3, 50c. to 75c.; larger sizes, \$1.00 to \$2.00. **Stilbite** in singularly fine sheaves, both alone and on salmon-colored Chabazite crystals, at same prices. **Gmelinite**, fine specimens, 15c. to \$1.50.

SUPERB SICILIAN SULPHURS.

Just received direct from the mine, a small consignment of very choice groups of highly lustrous sulphur crystals ranging from 3 x 4 inches up to 16 x 12 x 8 and in price from \$2.00 to \$25.00; also a small assortment of loose crystals and small groups at 5c. to 25c.

BEAUTIFUL COLEMANITE GEODES.

A few geodes of Colemanite in exceptionally brilliant crystals, \$1.00 to \$1.50.

CORUNDUM CRYSTALS.

An assortment of small Carolina corundum crystals exhibiting by parallel hexagons the lines of growth, 10c. to 35c.

POLISHED SECTIONS OF QUARTZ ENCLOSING TOURMALINE.

Some idea of the beauty of these sections may be obtained from the illustration given in our Spring Bulletin. We added to our stock during March sections of the largest crystals we have cut up, some of them being also exceptionally choice. Prices about 25c. per square inch, or 25c. to \$3.50.

MOHAWKITE, STIBIODOMEYKITE AND WHITNEYITE.

A new lot of over 40 nearly pure masses of those most desirable metallic minerals has been determined and is now on sale. See our Spring Bulletin. 35c. to \$3.50.

OUR SPRING BULLETIN ISSUED MARCH 1st,

24 pages, 29 illustrations, will be sent free to anyone desiring it. It describes many other recent additions to our stock and gives a complete list of Mineralogical Books.

124-page *Illustrated Catalogue*, giving Dana Species number, hardness, specific gravity, chemical composition and formula of every mineral, 25c. in paper.

44-page *Illustrated Price-Lists*, also *Bulletins and Circulars*, free.

GEO. L. ENGLISH & CO., Mineralogists,

Dealers in Scientific Minerals,

Removed to 3 and 5 West 18th Street, First door west of Fifth Avenue, New York City.

INDEX TO VOLUMES I-X. Price One Dollar.

Now ready. Orders should be given at once, as the edition is limited.

CONTENTS.

	Page
ART. XX.—Magnetic Theory of the Solar Corona; by F. H. BIGELOW	253
XXI.—Tertiary Springs of Western Kansas and Oklahoma; by C. N. GOULD	263
XXII.—Fundamental Propositions in the Theory of Elasticity: A study of primary or self-balancing stresses; by F. H. CILLEY	269
XXIII.—Boiling Point of Liquid Hydrogen, determined by Hydrogen and Helium Gas Thermometers; by J. DEWAR	291
XXIV.—Nature of Vowels; by E. W. SCRIPTURE	302
XXV.—Behavior of the Phosphorus Emanation in Spherical Condensers; by C. BARUS	310
XXVI.—Concretions of Ottawa County, Kansas; by W. T. BELL	315

SCIENTIFIC INTELLIGENCE.

Chemistry and Physics—Ammonium Bromide and the Atomic Weight of Nitrogen. A. SCOTT: Combustion of Gases, S. TANTAR, 317.—Peculiar Blue Color produced when Potassium and Sodium Sulphocyanides are Heated, W. B. GILES: Method of obtaining Crystals of difficultly Crystallizable Substances, A. RÜMPLER: Elimination of Methane in the Atmosphere, V. URBAIN, 318.—Introduction to Modern Scientific Chemistry, LASSAR-COHN: Ausgewählte Methoden der Analytischen Chemie, A. CLASSEN, 319.—Radiation Law of Dark Bodies, F. PASCHEN: Unipolar Induction, E. HAGENBACH: Effect of Electricity on Bacteria, A. MACFADYN, 320.—Electric Convection, M. V. CREMIEU: Preservation of Photographic Records, W. J. S. LOCKYER: Eclipse, Cyclone and the Diurnal Cyclone, H. H. CLAYTON, 321.—Attempt to show that the earth being a magnet draws ether with it, W. ROLLINS, 322.—Presence of Gallium in the Sun, W. N. HARTLEY and H. RAMAGE, 323.

Geology—Geology of the Boston Basin, W. O. CROSBY: University Geological Survey of Kansas, S. W. WILLISTON, 324.—Orange River Ground-Moraine, A. W. ROGERS and E. H. L. SCHWARZ, 325.—Founders of Geology, A. GEIKIE: Gesetz der Wüstenbildung in Gegenwart und Vorzeit, J. WALTHER, 326.

Zoology—Recent papers relating to the fauna of the Bermudas, 326.—Trans. Conn. Acad. Science: Zoological Results based on Material from New Britain, New Guinea, Loyalty Islands and elsewhere, A. WILLEY, 330.

Miscellaneous Scientific Intelligence—Leçons de Physiologie Expérimentale, R. DUBOIS et E. COUVREUR, 330.—Webster's International Dictionary, New Edition, 331.—The National Standardizing Bureau, 332.

Obituary—GEORGE MERCER DAWSON: CHARLES HERMITE: ADOLPHE CHATIN: J. C. AGARDE, 332.

Established by **BENJAMIN SILLIMAN** in 1818.

THE
AMERICAN
JOURNAL OF SCIENCE.

EDITOR: EDWARD S. DANA.

ASSOCIATE EDITORS

PROFESSORS GEO. L. GOODALE, JOHN TROWBRIDGE,
W. G. FARLOW AND WM. M. DAVIS, OF CAMBRIDGE,

PROFESSORS A. E. VERRILL, HENRY S. WILLIAMS, AND
L. V. PIRSSON, OF NEW HAVEN,

PROFESSOR GEORGE F. BARKER, OF PHILADELPHIA,
MR. J. S. DILLER, OF WASHINGTON.

FOURTH SERIES.

VOL. XI—[WHOLE NUMBER, CLXI.]

No. 65.—MAY, 1901.

WITH PLATE V.

NEW HAVEN, CONNECTICUT.

1901.

THE TUTTLE, MOREHOUSE & TAYLOR CO., PRINTERS, 125 TEMPLE STREET.

Published monthly. Six dollars per year. \$6.40 to countries in the Postal Union. Remittances should be made either by money orders, registered letters, or bank checks (preferably on New York banks).

HUNGARIAN MINERALS.

Only about a hundred specimens in all, but among them are some of the daintiest and most attractive groupings that we have handled for years. To move the lot quickly, we have priced each piece at a low figure—low even in comparison with our present scale of prices. That they will find ready purchasers we feel assured, and list a few of the most striking.

STIBNITE. Individuals and aggregates, brilliantly terminated. A variety of habits and associations shown, and each of convenient cabinet size. 50c. to \$4.00.

BARITE. Wonderfully transparent with brilliant faces and odd modifications. In quality they are much superior to our former stock, the penetrating crystals of Stibnite offering an association and inclusion of unusual interest. 50c. to \$3.00.

TETRAHEDRITE and **CHALCOPYRITE** from Kapnik. The types are well known, but some of the groups now on hand would be difficult to duplicate in any but the largest collections. \$1.50 to \$12.00.

RHODOCHROSITE. Quite an assortment, delicately tinted, and usually "inter-formed" with quartz crystals. 50c. to \$1.50.

SPHÆROSIDERITE, ORPIMENT, PSEUDOMORPHOUS MARCASITE, DOLOMITE, and two specimens of the rare "KENNGOTTITE" (MIARGYRITE).

ADDENDA

TO OUR ANNOUNCEMENT OF FOREIGN MINERALS IN THE APRIL NUMBER.

GALENOBISMUTITE. A few good examples of this interesting mineral. Characteristic specimens from 50c. to \$3.50.

CRYOLITE, THOMSENOLITE and **RALSTONITE** reasonably priced, yet first-class; brilliantly crystallized. 50c. to \$5.00.

STILBITE, HEULANDITE and **EPISTILBITE.** We offer many varieties and colorings sure to find ready purchasers. Iceland is the locality. 50c. to \$4.00.

SULVANITE

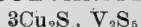

From Burra Burra, South Australia. Several specimens on sale, and it takes no glass to distinguish the mineral. Typical examples, \$1.00 to \$8.00 each.

FOOTE MINERAL CO.,

FORMERLY DR. A. E. FOOTE,

WARREN M. FOOTE, Manager.

ESTABLISHED 1876.

PHILADELPHIA,

1317 Arch Street.

PARIS,

24 Rue du Champ de Mars.

Extra Rare Selenium Minerals



Crookesite has always ranked as one of the rarest of rare minerals, being found sparingly in but one locality in Sweden. It is a selenide of copper, **Thallium** (!) and silver. We now have twenty good specimens at 50c. to \$20 00, some of them showing associated *Berzelianite*, another very rare selenide of copper. Several specimens of the rare selenide of copper and silver, *Eucairite*, are also in stock.

OTHER VERY RARE MINERALS.

A few other very rare minerals in stock just now are worthy of mention: *Livingstonite*, *Frieseite*, *Wapplerite*, *Tellurite*, *Cenosite*, *Marshite*, *Raspite*, *Pyroaurite*, *Aphthitalite*, *Connellite*, *Whe-wellite*, *Agularite*, *Sulfoborite*.

NATIVE LEAD FROM FRANKLIN.

A few specimens have just come in from Franklin Furnace.

LOOSE CRYSTALS OF SPHALERITE.

200 uncommonly good loose crystals of Sphalerite, 5c. to 25c.

A LARGE ENGLISH IMPORTATION.

The growing scarcity of all of the English minerals has persuaded us to lay in an abundant stock while yet it is possible to obtain them. Most of the English iron mines are now closed and the prospect is that the matchless *Fluorites*, *Barites*, *Calcites*, etc., for which they have so long been noted, will become as scarce as the fine Arizona red *Wulfenites*, once so abundant. Several thousand choice specimens have just arrived. The descriptions given in our Spring Bulletin apply in general to this importation.

SICILIAN SULPHURS.

Every specimen in the consignment advertised last month is sold.

SUTTROP MILKY QUARTZ CRYSTALS.

We now have on sale the best collection we have ever seen of these model-like crystals, a new lot having arrived during April. 5c. to 25c.

DOMEYKITE.

A \$12.50 specimen from any of the old localities is not as good as one at 75c. from the Mohawk Mine. Our stock is unrivaled.

Stibiodomeykite, a new antimonious variety, 35c. to \$2.50.

Mohawkite, a new arsenide of copper, nickel and cobalt, 50c. to \$3.50.

IRIDESCENT PYRITE CONCRETIONS.

Strikingly beautiful specimens, 25c. to \$2.00. A new find in New Jersey.

OUR SPRING BULLETIN.

24-pages, 29 illustrations, will be sent free to anyone desiring it. It describes many other recent additions to our stock and gives a complete list of Mineralogical Books.

124-page *Illustrated Catalogue*, giving Dana Species number, crystal system, hardness, specific gravity, chemical composition and formula of every mineral, 25c. in paper.

44-page *Illustrated Price-Lists*, also *Bulletins and Circulars*, free.

GEO. L. ENGLISH & CO., Mineralogists,

Dealers in Scientific Minerals,

Removed to 3 and 5 West 18th Street, First door west of Fifth Avenue, New York City.

INDEX TO VOLUMES I-X. Price One Dollar.

Now ready. Orders should be given at once, as the edition is limited.

CONTENTS.

	Page
ART. XXVII.—Studies of Eocene Mammalia in the Marsh Collection, Peabody Museum; by J. L. WORTMAN. With Plate V.....	333
XXVIII.—Velocity of Chemical Reactions; by W. DUANE.....	349
XXIX.—Transmission of Sound through porous materials; by F. L. TUFTS.....	357
XXX.—Yoke with intercepted Magnetic Circuit for measuring Hysteresis; by Z. CROOK.....	365
XXXI.—Mineralogical Notes; by C. H. WARREN.....	369
XXXII.—Expansion of Certain Metals at High Temperatures; by L. HOLBORN and A. L. DAY.....	374

SCIENTIFIC INTELLIGENCE.

Chemistry and Physics—Sulphur Hexafluoride, Thionyl Fluoride, and Sulphuryl Fluoride, MOISSAN and LEBEAU: Molecular Weight of Ozone, A. LADENBURG, 391.—Preparation of Chlorine from Sodium Chlorate, C. GRAEBE: New Alkaloids in Tobacco, PICTET and ROTSCHY, 392.—Hydrate of Sulphuryl Chloride, BAEYER and VILIGER: Action of Hydrogen Peroxide upon Silver Oxide, BAEYER and VILIGER, 393.—Action of Alcohol on Metals with which it comes in Contact, MALMÉJAC: Excitation and Measure of Sine Currents, M. WIEN: Metallic Reflection of Electrical Waves, K. F. LINDMAN: Light Transparency of Hydrogen, V. SCHUMANN, 394.—Measurement of the Röntgen Rays by means of Selenium, F. HIMSTEDT: Effect of the Röntgen Rays and the Becquerel Rays on the Eye, F. HIMSTEDT and W. A. NAGEL, 395.

Geology and Natural History—Eocene and Lower Oligocene Coral Faunas of the United States, T. W. VAUGHAN, 395.—Presence of a Limestone Conglomerate in the Lead region of St. Francis Co., Mo., F. L. NASON: New Species of Cambrian from Cape Breton, G. F. MATTHEW: Geological Survey of Western Australia, A. G. MANTLAND, 396.—Geology of Texas, F. W. SIMONDS: Concretions from the Champlain Clays of the Connecticut Valley, J. M. A. SHELDON: Study of the Gabbroid Rocks of Minnesota, A. N. WINCHELL: Flow of Marble under Pressure, ADAMS and NICOLSON, 397.—Flora of Cheshire, S. MOORE: Preliminary list of the Spermatophyta of North Dakota, H. L. BOLLEY and L. R. WALDRON, 398.

Miscellaneous Scientific Intelligence—New Star in Perseus, T. D. ANDERSON, 399.—National Academy of Sciences: Report of the Secretary of the Smithsonian Institution for the year ending June 30, 1900, 400.—Memorial of George Brown Goode: U. S. Coast and Geodetic Survey, 401.—La Navigation Sous-marine, M. GAGET: Geological Survey of Great Britain: Geological Survey of Canada, 402.

Obituary—Dr. HENRY A. ROWLAND: Professor GEORGE F. FITZGERALD: Professor CHRISTIAN F. LÜTKEN, 402.

VOL. XI.

JUNE, 1901.

Established by BENJAMIN SILLIMAN in 1818.

THE
AMERICAN
JOURNAL OF SCIENCE.

EDITOR: EDWARD S. DANA.

ASSOCIATE EDITORS

PROFESSORS GEO. L. GOODALE, JOHN TROWBRIDGE,
W. G. FARLOW AND WM. M. DAVIS, OF CAMBRIDGE,

PROFESSORS A. E. VERRILL, HENRY S. WILLIAMS, AND
L. V. PIRSSON, OF NEW HAVEN,

PROFESSOR GEORGE F. BARKER, OF PHILADELPHIA,
MR. J. S. DILLER, OF WASHINGTON.

FOURTH SERIES.

VOL. XI—[WHOLE NUMBER, CLXI.]

No. 66.—JUNE, 1901.

WITH PLATES VI-VII.

NEW HAVEN, CONNECTICUT.

1901.

THE TUTTLE, MOREHOUSE & TAYLOR CO., PRINTERS, 125 TEMPLE STREET.

Published monthly. Six dollars per year. \$6.40 to countries in the Postal Union. Remittances should be made either by money orders, registered letters, or bank checks (preferably on New York banks).



WE TAKE PLEASURE IN ANNOUNCING the completion of our "stock re-arrangement" and believe a few brief explanations of the changes will be of interest to our patrons. Much valuable time and a great deal of work have been liberally spent, but the results obtained amply repay the inconvenience of such an investment.

The "cabinet stock," including specimens valued at 50c. and upwards, is arranged in "Dana" order, each specimen plainly labeled and priced. Single crystals, 50c. each and over, are also included.

The "educational stock" comprises specimens below 50c. in value, and is arranged in a complete series *apart* from the cabinet material. Customers purchasing specimens in quantity for instruction or class use, will find this division particularly convenient.

The "crystal stock," divided under the six systems, includes single crystals 10c. per dozen to 30c. each. Thousands of crystals can be examined with dispatch, as every opportunity is offered to further rapid inspection.

A WORD CONCERNING PRICES.

Upon March 1, 1901, we undertook a series of reductions, principally affecting standard stock, though many minerals received direct from sources of supply were included. A thorough revision was given to prices upon European specimens, and we believe our stock will now compare favorably with that of most European dealers. Reductions from 20% to 50% frequently applied to an entire species. With such sweeping discounts our stock cannot fail to create a favorable impression upon the judicious purchaser, while our service we endeavor to make perfectly satisfactory. Prices, to which we strictly adhere, will be found uniform throughout the stock of both our Philadelphia and Paris houses.

We offer apologies to many of our customers for unavoidable delays in filling orders received during the past few months, but believe that increased facilities, combined with an earnest and intelligent desire to please, will render future service unrivaled.

Trial orders solicited. "Approval system" upon orders for cabinet material.

FOOTE MINERAL CO.,

FORMERLY DR. A. E. FOOTE,

WARREN M. FOOTE, Manager.

ESTABLISHED 1876.

PHILADELPHIA,

1317 Arch Street.

PARIS,

24 Rue du Champ de Mars.

Fine Molybdenite Crystals.



Choice crystals of Molybdenite have always been high priced and not at all common. We take pleasure, therefore, in announcing a lot of several hundred from a new locality in the far west which we are able to sell at the lowest prices ever known. 10c. to \$1.50. The crystals are well formed, one inch to four inches in diameter, and have low pyramids about 40° and 55°.

EXCELLENT FLEXIBLE SANDSTONE.

Mr. Williams recently visited North Carolina expressly for Flexible Sandstone. The result is that we have a large lot of splendid specimens and are able to sell them very cheaply. Pieces 3 x 1 inches, 5c.; 5 x 2 inches, 10c.; 7 x 2, 20c.; on up to 13 x 2 $\frac{1}{2}$, 75c., and even larger specimens. At these prices the mineral is not half as expensive as that from India. Every collector should have a specimen of this most curious mineral.

RARE MINERALS FROM AN OLD COLLECTION.

Several hundred specimens were recently purchased from an old collection, including Roepelite, Bementite, Pa. Amethyst, French Creek Chalcopyrite, Cubic Spinels, Japan Stibnites, Hungarian Opal, Siberian Emeralds and Beryl, Atlasite, Euchroite, Langite, Lettsomite, Serpierite, Connellite, Libethenite, Manganite, Dawsonite, Partzite, extra fine Cumberland Mimetite and Pyromorphite, etc.

CROOKESITE.

Twenty specimens of this excessively rare mineral were recently received, some associated with *Berzelianite* and *Eucairite*, 50c. to \$20.00.

OTHER IMPORTANT RECENT ADDITIONS.

Mohawkite, *Stibiodomeykite*, *Domeykite* from the Mohawk Mine, each piece tested.

Parisite, doubly terminated crystals in matrix.

Australian Atacamite, *Cerussite*, *Anglesite*, *Pyromorphite*, *Iodyrite*, *Embolite*, *Cuprite*, *Marshite*, *Stolzite*, etc.

New and rare species from Greenland.

Iridescent Pyrite from New Jersey, fine *Milky Quartz* crystals from Suttrop, *Lead* from Franklin, showy massive *Bornite*, *Millerite* in radiating needles from Antwerp, many fine *Barites*, *Calcites*, *Fluorites*, *Hematite* and *Quartz*, *Sphalerites*, etc., from England.

OUR SPRING BULLETIN.

24 pages, 29 illustrations, will be sent free to anyone desiring it. It describes many other recent additions to our stock and gives a complete list of Mineralogical Books.

124-page *Illustrated Catalogue*, giving Dana Species number, crystal system, hardness, specific gravity, chemical composition and formula of every mineral, 25c. in paper.

44-page *Illustrated Price-Lists*, also *Bulletins and Circulars*, free.

GEO. L. ENGLISH & CO., Mineralogists,

Dealers in Scientific Minerals,

3 and 5 West 18th Street, New York City.

INDEX TO VOLUMES I-X. Price One Dollar.

CONTENTS.

	Page
ART. XXXIII.—The New Spectrum; by S. P. LANGLEY. With Plate VII	403
XXXIV.—Rival Theories of Cosmogony; by O. FISHER ..	414
XXXV.—Study of some American Fossil Cycads. Part IV. Microsporangiate Fructification of Cycadeoidea; by G. R. WIELAND	423
XXXVI.—Studies of Eocene Mammalia in the Marsh Col- lection, Peabody Museum; by J. L. WORTMAN. With Plate VI	437
XXXVII.—Cæsium-Antimonious Fluorides and Some Other Double Halides of Antimony; by H. L. WELLS and F. J. METZGER	451
XXXVIII.—“Mohawkite”; by J. W. RICHARDS	457
—————	
Henry Augustus Rowland	459

SCIENTIFIC INTELLIGENCE.

Chemistry and Physics—Radio-active Lead, HOFMANN and STRAUSS: Zirconia of Euxenite from Brevig, HOFMANN and PRANDTL, 463.—Action of Radium Rays upon Selenium, E. BLOCH: Reducing-power of Magnesium and Aluminum, A. DUBOIN: Method of Determining Atomic Weights, Based upon the Transparency of Substances to the X-Rays, L. BENOIST, 464.—Presence of Platinum upon an Egyptian Hieroglyphic Inscription, BERTHELOT: Generalization from Trouton's Law, DE FORCAND, 465.—Wissenschaftliche Grundlagen der analytischen Chemie, W. OSTWALD: Spectrum of Carbon Compounds, A. SMITHELLS, 466.—Absorption of Gas in a Crookes Tube, R. S. WILLOW: Mechanical Movements of Wires produced by Electrical Discharges which also make these Movements luminous, O. VIOL: Band Spectrum of Oxides of Aluminum and Nitrogen, G. BERNDT: Électricité et Optique; La Lumière et les Théories Electro-dynamiques, H. POINCARÉ, 467.

Geology and Natural History—U. S. Geological Survey, 21st Annual Report of the Director, C. D. WALCOTT, 468.—Physiography of Acadia, R. DALY: Carte Géologique du Massif du Mont Blanc, L. DUPARC and L. MRAZEC: Mineral constituents of dust and soot from various sources, W. N. HARTLEY and H. RAMAGE, 470.—Studies in Fossil Botany, D. H. SCOTT: Flora of Western Middle California, W. L. JEPSON 471.—Grand Rapids Flora, E. J. COLE, 472.—Variations of a newly-arisen Species of Medusa, A. G. MAYER, 473.

Miscellaneous Scientific Intelligence—Annals of the Astrophysical Observatory of the Smithsonian Institution, S. P. LANGLEY and C. G. ABBOT, 473.—Report of the U. S. National Museum: Journal of Hygiene: Annals of the Astronomical Observatory of Harvard College, E. C. PICKERING and E. S. KING, 474.

INDEX TO VOLUME XI, 475.

313





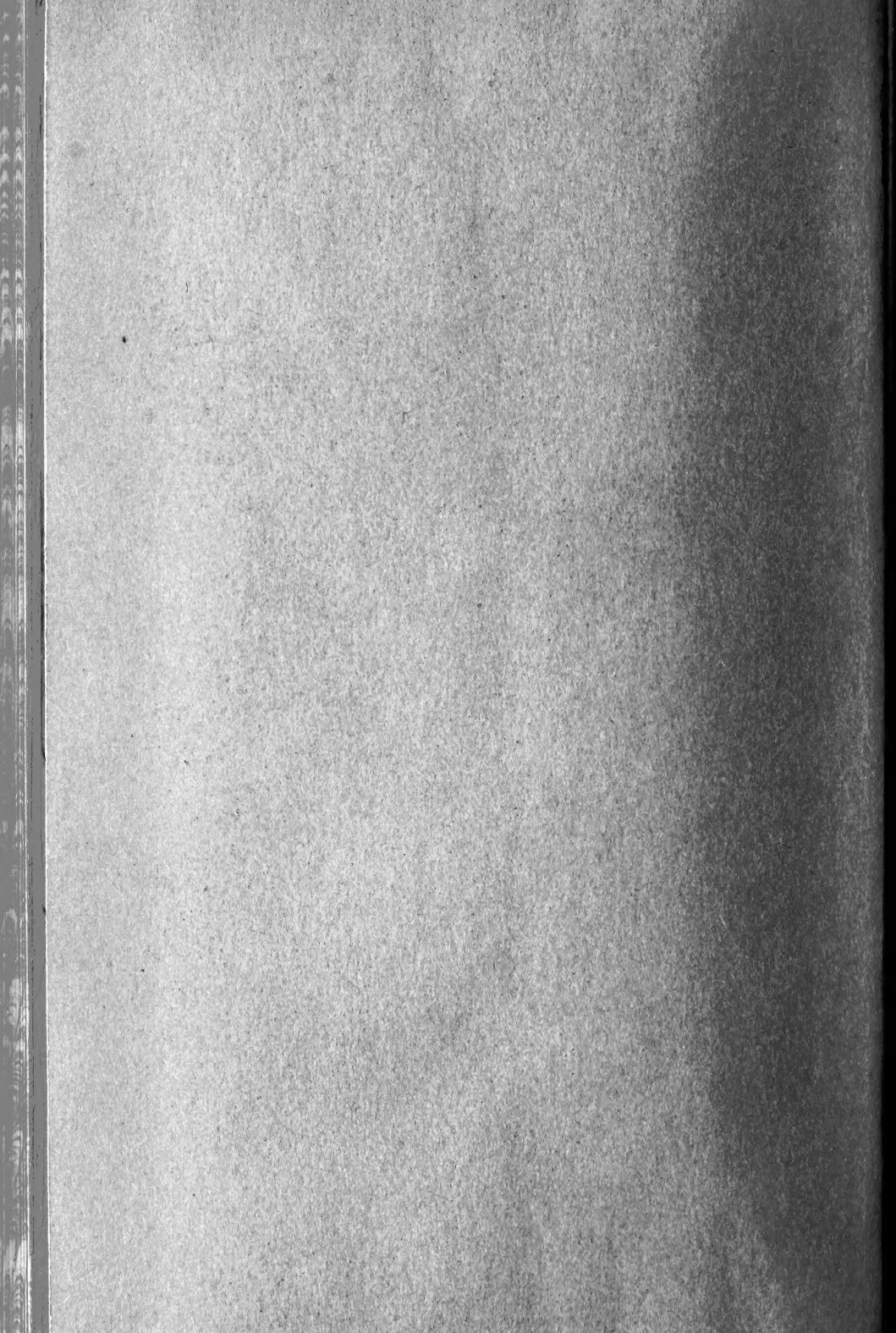



SMITHSONIAN INSTITUTION LIBRARIES



3 9088 01298 5628