

$\frac{8}{9}$

12714
5366

71.45

ANNALS

OF THE

NEW YORK ACADEMY OF SCIENCES.



506.73
N7N71

ANNALS

OF THE

NEW YORK ACADEMY OF SCIENCES,

LATE

LYCEUM OF NATURAL HISTORY.

VOLUME I.

New York:

PUBLISHED FOR THE ACADEMY.

1879.

GREGORY BROS.,
Printers, 34 Carmine Street,
NEW YORK.

OFFICERS OF THE ACADEMY.

1879.

President.

JOHN S. NEWBERRY.

Vice-Presidents.

T. EGLESTON.

BENJ. N. MARTIN.

Corresponding Secretary.

ALBERT R. LEEDS.

Recording Secretary.

OLIVER P. HUBBARD.

Treasurer . . .

JOHN H. HINTON.

Librarian.

LOUIS ELSBERG.

Committee of Publication.

DANIEL S. MARTIN.

JOHN S. NEWBERRY.

GEO. N. LAWRENCE.

ALBERT R. LEEDS.

W. P. TROWBRIDGE.

CONTENTS OF VOLUME I.

BY S. T. BARRETT.

PAGE.

- Descriptions of New Species of Fossils from the Upper Silurian Rocks of Port Jervis, N. Y. ; with Notes on the Occurrence of the Coralline Limestone at that Locality, (Art. IX)..... 121

BY W. G. BINNEY.

- On the Jaw and Lingual Dentition of certain Costa Rica Land Shells collected by the late Dr. William M. Gabb, (Art. XXIII)..... 257
On certain North American Species of Zonites, etc. (Art. XXVIII)... 355

BY H. CARRINGTON BOLTON.

- Application of Organic Acids to the Examination of Minerals, (Art. I) 1
Behavior of Natural Sulphides with Iodine and other Reagents, (Art. XV)..... 153

BY M. C. COOKE.

- The Fungi of Texas, (Art. XVIII)..... 177

BY LOUIS ELSBERG.

The Structure of Colored Blood-corpuscles, (Art. XXV).....	265
--	-----

BY HERMAN L. FAIRCHILD.

On the Structure of <i>Lepidodendron</i> and <i>Sigillaria</i>	41
No. 1; On the Variations of the Decorticated Leaf-scars of certain <i>Sigillariæ</i> , (Art. III).....	42
No. 2; The Variations of the Leaf-scars of <i>Lepidodendron aculeatum</i> , Sternberg, (Art. VII).....	77
No. 3; The Identity of certain Supposed Species of <i>Sigillaria</i> with <i>S. lepidodendrifolia</i> , Brongt., (Art. XII).....	129

BY EDWARD J. HALLOCK.

Index to the Literature of Titanium, 1783—1876 : (Art. VI).	
Part First, General Literature.....	53
Part Second, Minerals.....	65

BY DAVID S. JORDAN.

On the Distribution of Fresh-water Fishes of the United States, (Art. VIII).....	92
--	----

BY ALEXIS A. JULIEN.

On Spodumene and its Alterations, (Art. XXVII).....	318
---	-----

BY GEORGE N. LAWRENCE.

Descriptions of New Species of Birds from Dominica, (Art. IV).....	4
Descriptions of New Species of Birds of the Families Trochilidæ and Tetraonidæ, (Art. V).....	50
Description of a New Species of Parrot, of the genus <i>Chrysotis</i> , (Art. X)	125
Descriptions of New Species of Birds from St. Vincent, W. I., (Art. XIV).....	146
Descriptions of New Species of Birds from Grenada and Dominica, W. I., (Art. XVI).....	160
Description of a New Species of Cypselidæ, of the Genus <i>Chaetura</i> , (Art. XXII).....	255

Contents.

xi

BY ALBERT R. LEEDS.

Ozone and the Atmosphere, (Art. XX).....	193
Lines of Discovery in the History of Ozone, with an Index to its Literature, (Art. XXIX).....	363
The History of Antozone and Peroxide of Hydrogen, with an Index to the Literature of the latter, (Art. XXIX, Appendix).....	405

BY HENRY A. MOTT, JR.

Testing the Value of Guns by Firing under Water, (Art. XVII).....	164
---	-----

BY HENRY S. MUNROE.

Prehistoric Bronze Bells from Japan, (Art. II).....	35
---	----

BY JOHN S. NEWBERRY.

Descriptions of New Fossil Fishes from the Trias, (Art. XI).....	127
Descriptions of New Palaeozoic Fishes, (Art. XIX).....	188

BY G. JEWETT ROCKWELL.

Index to the Literature of Vanadium, (Art. XIII).....	133
---	-----

BY ISRAEL C. RUSSELL.

On the Physical History of the Triassic Formation in New Jersey and the Connecticut Valley, (Art. XXI).....	220
A New Form of Compass-Clinometer, (Art. XXIV).....	263

BY ROBERT E. C. STEARNS.

Description of a New Species or Variety of Land Snail from California, (Art. XXVI).....	316
---	-----

LIST OF PLATES, VOL. I.

PLATE I.

Micro-crystalline precipitates from the action of organic acids upon minerals.

- Figs. 1 to 6. Tartaric acid.
- 7 to 12. Hydro-calcium tartrate.
- 13. Hydro-barium tartrate.
- 14 to 16. Hydro-barium oxalate.
- 17, 18. The same, differently obtained.
- 19, 20. Hydro-strontium oxalate.
- 21. Ferrous oxalate.

For details, see pages 12 to 16 of text.

PLATE II.

Prehistoric bronze bells, exhumed in Japan.

PLATE III.

Variations of form and size in the leaf-scars of *Sigillaria reniformis*, Brongt., taken from a single specimen. See pages 43 and 44 of text.

PLATE IV.

Variations of form and size in the leaf-scars of *Sigillaria laevigata*, Brongt. See page 45 of text.

PLATE V.

Variations of form and proportions in the leaf-scars of *Lepidodendron aculeatum*, Sternb. See pages 77 to 91 of text.

PLATE VI.

The same.

PLATE VII.

The same.

PLATE VIII.

The same.

PLATE IX.

The same.

PLATE X.

Variations of leaf-scars in certain species of *Sigillaria*, probably all referable to *S. lepidodendrifolia*, Brongt. See pages 129 to 133 of text.

PLATE XI.

- Fig. A. *Velifera Gabbi*, animal in motion.
 B. " " shell.
 C. " " lingual dentition.
 D. " " caudal mucus-pore.
 E. The same (?) shell.
 F. " lingual dentition.
 G. Small species of *Helia*, lingual dentition (the extreme marginal on a larger scale).
 H. *Cryptostrakon Gabbi*, animal in motion.
 I. " " jaw.
 J. " " rudimentary shell.
 K. " " lingual dentition.
 L. *Bulimulus Irazuensis*, extreme lateral tooth.
 M. *Tebennophorus* sp., animal.
 N. " lingual dentition.
 O. *Linax semitechus* ? animal.
 P. " " jaw.
 Q. " " lingual dentition.

See page 262 of text.

PLATE XII.

Changes of form and structure in human red blood-corpuses.

- Fig. 1. *a.* Indentations and furrows.
b, c, d. "Rosette," "scalloped," and "stellate" forms.
e. Constrictions, etc.
 2. *a, b.* Protrusion and occasional separation of "knobs."
 3. Occasional coalescence into groups or chains.
 4. Internal vacuoles.
 5. Granular and "network" structure (also shown in fig. 3).
 6. Disappearance of the interior granular structure, and formation of "ghosts."

See pages 266 to 271 of text.

PLATE XIII.

Fig. 1. Cross-section of a crystal of Spodumene, partially altered to Cymatolite and Killinite. See page 329 of text.

Fig. 2. Magnified section of the line of contact (*a, a*) between Cymatolite (*c*) and Killinite (κ, κ), showing the blades of the former projecting into the latter. See page 346 of text.

PLATE XIV.

- Fig. A. *Vitrinizonites latissimus*, Lewis, animal.
 B. " " genitalia.
 C. *Zonites capnodes*, Binn., "
 D. " *Rugeli*, Binn., "
 E. *Mesodon Andrewsii*, Binn., "
 F. " " lingual membrane.
 G. " *dentifera*, Binn., genitalia.
 H. *Helix rariplicata*, Benson, dentition.
 I. *Rhytida vernicosa*, Kraus, "
 J. *Bulimimus Natalensis*, Kr., lingual membrane.
 K. *Helix globulus*, Müll., " "
 L. *Glandina*, dentition.

See page 362 of text.

PLATE XV.

- Fig. A. *Zonites placentula*, Shuttl., shell.
B. " *macilentus*, Shuttl., "
C. " *cuspidatus*, Lewis, "
D. " *Andrewsi*, Binn., "
E. " *lasmodon*, var. ? "
F. " *multidentatus*, Binn., "
G. " *significans*, Bland, "
H. " *Rugeli*, Binn., "
I. " Dentition of same.
J. " " " *Zonites subplanus*, Binn.
K. " " " *Stenopus? decoloratus*.
L. *Mesodon Andrewsi*, Binn., shell.
M. *Macrocyclus Hemphilli*, Binn., "
N. Dentition of *Spiraxis Dunkeri*, Pfr.

See page 362 of text.



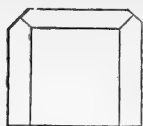

1



2



3



4



5



6



7



8

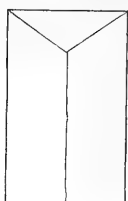

9

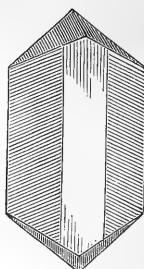

10

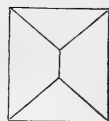

11

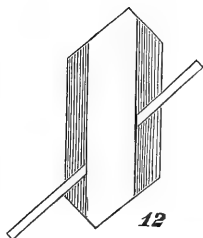

12

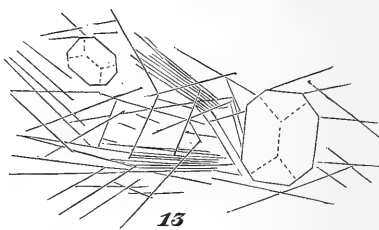

13



14

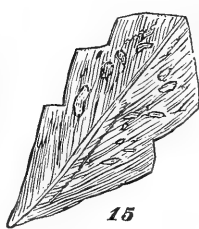

15

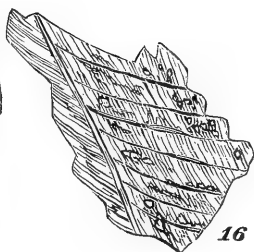

16

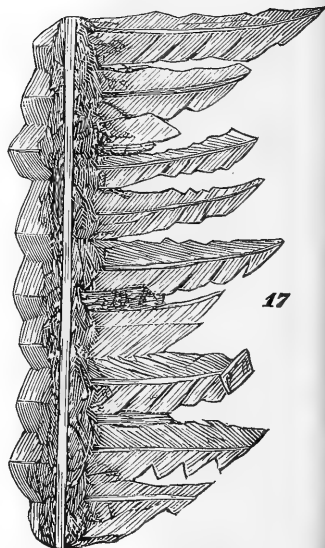

17

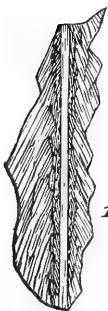

18

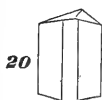

20



19

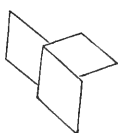

21

EXPLANATION OF PLATE I.

Micro-crystalline Precipitates, cf. pp. 14-18.

Figs. 1 to 6.....	Tartaric acid.
Figs. 7 to 12.....	Hydro-calcium tartrate.
Fig. 13.....	Hydro-barium tartrate.
Figs. 14 to 16.....	Hydro-barium oxalate, from witherite.
Figs. 17, 18.....	The same, from baryto-calcite.
Figs. 19, 20.....	Hydro-strontium oxalate.
Fig. 21.....	Ferrous oxalate.

NOTE.—These crystals vary in size, according to temperature and time of formation, and were not drawn by exact measurement. For the large crystals, figs. 14 to 18, a $1\frac{1}{2}$ inch objective was used; figs. 19, 20, and 21, required a $\frac{1}{2}$; the others were easily seen with a $\frac{3}{8}$.

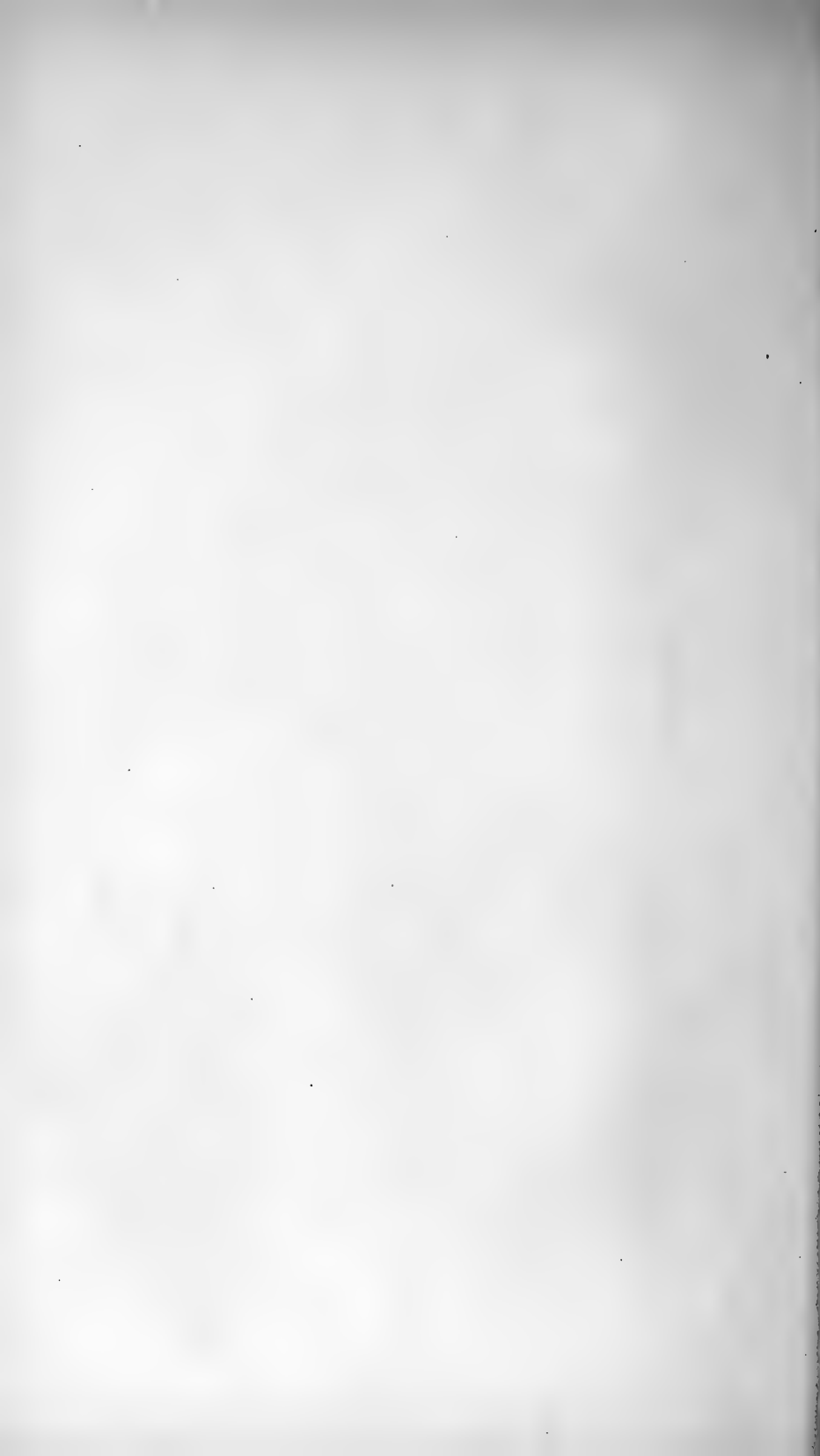

ANNALS
OF THE
NEW YORK ACADEMY OF SCIENCES.

VOLUME I.

[BEING A CONTINUATION OF THE ANNALS OF THE LYCEUM
OF NATURAL HISTORY.]

I.—*Application of Organic Acids to the Examination of Minerals.*
(With Plate I.)

BY H. CARRINGTON BOLTON, PH. D.

Read April 30th, 1877.

1. The organic acids have long been used in various operations of chemical analysis, but their direct application to the decomposition of minerals, with a view to the determination of the latter, appears to have been overlooked. Acetic acid finds frequent employment in quantitative analysis; tartaric and citric acids are used to hold ferric and aluminic hydrates in solution in the presence of alkalis, to dissolve antimonie oxide in mineral analysis and in blow-pipe tube reactions,* and in the preparation of Fehling's copper solution; ammonium citrate is used to dissolve so-called "reverted" calcium phosphate, and to separate lead sulphate from the sulphates of the alkaline earths; oxalic acid is used to dissolve sulphide of tin in the separation of this metal from antimony,† in volumetric analysis, in the determination of the metals of the magnesium

* Prof E. J. Chapman, Canadian Journal, Sept., 1865, p. 348.

† Prof F. W. Clark, American Journal of Science, [2] XLIX, 48.

group,* in the valuation of manganese ores, and in many other processes.

The behavior of minerals with the organic acids named has been only casually studied, and in but few instances; T. Sterry Hunt,† following Karsten, has made use of acetic acid in the proximate analysis of mixtures of calcite, dolomite, and magnesite, and in the separation of limestone and serpentine; ‡ J. Lawrence Smith§ has remarked the solubility of anglesite in ammonium citrate; calamine is sometimes distinguished from willemite by its gelatinizing with acetic acid; || and mineralogists often resort to the comparatively weak acetic acid for the purpose of "cleaning up" minerals associated with the easily soluble calcite. So far as we can learn, no systematic examination of the action of organic acids on minerals has previously been made; yet the field proves to be wide and fertile.

During a mineralogical excursion in the summer of 1876, among the rugged mountains of western North Carolina, the impracticability of transporting liquid mineral acids suggested to the writer an examination of the behavior of minerals with solutions of citric and tartaric acid, which are capable of being carried in the solid state. Subsequently a few preliminary trials established the fact that our preconceived notions of the weakness of organic acids as respects minerals were erroneous, and led to the investigation recorded in the following pages.

It became necessary at the very outset to collect a considerable number of minerals in a state of great purity and of normal physical condition: our own small collection supplied these in part, but we would have been embarrassed in this research without the kind assistance of Prof. Thomas Egleston, who generously placed the rich treasures of the School of Mines' mineralogical collection at our disposal, and to whom we tender our sincere thanks.

* W. Gould Levison, *American Journal of Science*, [2] I, 240.

† *American Journal of Science*, [2] XXVIII, 180, and XLII, 64.

‡ *Geol. Canada*, 1863, 609.

§ *American Journal of Science*, [2] XX, 244.

|| *Dana's System Min.*, 5th edition, p. 408.

Since the hardness, coherence, and solubility of minerals vary greatly in different specimens of a single species, the behavior of minerals with acids, whether inorganic or organic, depends in large measure upon the condition of the particular sample under examination. An absolutely thorough investigation, therefore, would embrace the reactions of several specimens of each mineral; as desirable as this would seem to be, it was found that on the whole so laborious an undertaking was superfluous, and for two reasons; first, the decomposing action of the acids on different samples of the same species differs in degree and not in kind; and, secondly, the behavior of different species nearly related is so similar that the observations made on each serve to mutually control.

2. The following list contains the names of the minerals which were submitted to the action of organic acids, their formulæ as given by Prof. Dana, the condition of the specimens, and the locality of each so far as could be ascertained. Where two or more specimens of a single species are named, they are numbered, for convenience of reference in subsequent pages.

Within the groups I, Carbonates; II, Sulphides; III, Oxides; IV, Sundries; V, Silicates, the minerals are given in the order, and with the formulas, which they have in Dana's System of Mineralogy.

I. CARBONATES.

MINERAL.	FORMULA.	DESCRIPTION.	LOCALITY.
Calcite, (1)	$\text{Ca } \ddot{\text{C}}$	fine-grained marble	Italy.
" (2)		transparent crystals.....	Bergen, N. J.
Dolomite, (1).....	$\text{Ca } \ddot{\text{C}} + \text{Mg } \ddot{\text{C}}$	coarse crystalline.....	Westchester Co., N.Y.
" (2).....		{ fine granular, with } { flakes of graphite, }	Amity, N. Y.
Gurhofite	$2\text{Ca } \ddot{\text{C}} + \text{Mg } \ddot{\text{C}}$	massive, subtransl.....	Montville, N. J.
Ankerite.....	$\text{Ca } \ddot{\text{C}} + (\text{Mg } \ddot{\text{C}} \text{ Fe } \ddot{\text{C}} \text{ Mn } \ddot{\text{C}})$	crystalline	Nova Scotia.
Magnesite, (1)....	$\text{Mg } \ddot{\text{C}}$	massive.....	Westchester, Pa.
" (2)....		compact.....	Piedmont.
Siderite, (1)	$\text{Fe } \ddot{\text{C}}$	massive	Roxbury, Conn.
" (2)....		massive.....	Dauphiny, France.
Rhodochrosite ...	$\text{Mn } \ddot{\text{C}}$	massive, pure.....	Austin, Nev.
Smithsonite.....	$\text{Zn } \ddot{\text{C}}$	earthy, massive.....	Sterling, N. J.

Witherite.....	$\text{Ba } \ddot{\text{C}}$	granular, massive.....England.
Strontianite.....	$\text{Sr } \ddot{\text{C}}$	granular Westphalia.
Cerussite.....	$\text{Pb } \ddot{\text{C}}$	crystallinePhoenixville, Pa.
Barytocalcite.....	$\text{Ba } \ddot{\text{C}} + \text{Ca } \ddot{\text{C}}$	massive and cryst.....Alston Moor, Eng.
Malachite.....	$\text{Cu } \ddot{\text{C}} + \text{Cu } \ddot{\text{H}}$	compact.....Russia.
Azurite.....	$2\text{Cu } \ddot{\text{C}} + \text{Cu } \ddot{\text{H}}$	massive, earthy.....Germany.

II. SULPHIDES

MINERAL.	FORMULA.	DESCRIPTION.	LOCALITY.
Stibnite.....	$\text{Sb}_2 \text{S}_3$	fibrous, massive	Arkansas.
Molybdenite.....	Mo S_2	scales.....	Germany.
Argentite, (1).....	Ag S	with PbS and SiO_2	Virginia City, Nev.
“ (2).....	“	massive, pure.....	Cornucopia, Nev.
Galenite.....	Pb S	cleavable, massive	Missouri.
Bornite, (1).....	$(\text{Cu Fe}) \text{S}$	massive	Acton, Canada.
“ (2) and (3) ...	“	two samples, very pure.	Harvey Hill, Can.
“ (4).....	“	massive.....	Germany.
Sphalerite.....	Zn S	massive	Friedensville, Pa.
Chalcocite, (1) and (3)	Cu S	massive.....	Chili. S. A.
“ (2).....	“	crystals	Bristol, Conn.
Cinnabar.....	Hg S	granular, massive.....	California.
Pyrrhotite, (1).....	$\text{Fe}_7 \text{S}_8$	granular, massive.....	North Carolina.
“ (2).....	“	granular, massive.....	Litchfield, Conn.
“ (3).....	“	massive	Anthony's Nose, N. Y.
Niccolite.....	Ni As	massive	Tangerhausen.
Smaltite.....	$(\text{Co Fe Ni}) \text{As}_2$	massive.....	Germany.
Pyrite, (1).....	Fe S_2	massive	Germany.
“ (2).....	“	massive.....	Freiberg, Saxony.
“ (3).....	“	massive	Colorado.
Chalcopyrite, (1).....	$\text{Cu S} . \text{Fe S} . \text{Fe S}_2$	massive	Acton, Can.
“ (2).....	“	massive	Harvey Hill, Can.
“ (3).....	“	massive	Colorado.
“ (4).....	“	massive	Ore Knob, N. C.
Ullmannite.....	$\text{Ni S}_2 + \text{Ni (Sb As)}_2$	Petersbach.
Marcasite.....	Fe S_2	crystalline	Germany.
Arsenopyrite.....	$\text{Fe S}_2 + \text{Fe As}_2$	massive	Norwalk, Conn.
Bournonite.....	$3 (\text{Cu Pb}) \text{S} + \text{Sb}_2 \text{S}_3$	massive	Germany.
Tetrahedrite.....	$4\text{Cu S} + \text{Sb}_2 \text{S}_3$	granular.....	Freiberg, Saxony.

III. OXIDES.

MINERAL.	FORMULA.	DESCRIPTION.	LOCALITY.
Cuprite	Cu	massive.....	Siberia.
Zincite	Zn	massive.....	Sterling, N. J.
Hematite, (1).....	Fe	micaceous.....	Michigan.
“ (2).....		red, massive	Missouri.
Magnetite, (1).....	Fe Fe	massive, granular.....	Canada.
“ (2).....		Saratoga Co., N. Y.
Limonite, (1)	Fe_2H_3	botryoidal.....	Salisbury, Conn.
“ (2).....		fibrous.....	Anniston, Ala.
Franklinite	$(\text{Fe Zn Mn})(\text{Fe Mn})$	massive	Franklin, N. J.
Chromite	Fe Cr	massive.....	California.
Uraninite	U U	massive.....	Bohemia.
Hausmannite.	$\text{Mn}_2 \text{Mn}$	crystalline.....	Thuringia.
Pyrolusite.....	Mn	massive, granular.....	New Brunswick. (?)
Manganite	Mn H	crystalline	Ilefeld, Hartz Mts.
Psilomelane.	$(\text{Ba Mn}) \text{Mn} + \text{Mn}$	massive.....	Germany.
Wad.....	$\text{R Mn} + \text{H}$	earthy.....	Saxony.
Brucite.....	Mg H	foliated	Texas, Pa.

IV. SUNDRIES.

MINERAL.	FORMULA.	DESCRIPTION.	LOCALITY.
Apatite	$\text{Ca}^3 \text{P} + \frac{1}{2} \text{Ca} (\text{Cl Fl})$	crystals	Mitchell Co., N. C.
Vivianite.....	$\text{Fe}^3 \text{P} + 8\text{H}$	radiated, fibrous.....	Mullica Hill, N. J.
Pyromorphite.....	$3\text{Pb}^3 \text{P} + \text{Pb Cl}$	crystalline.....	Bohemia.
Fluorite.....	Ca Fl	translucent, massive...	Muscalonge Lake, N. Y.
Cryolite.....	$3\text{Na Fl} + \text{Al}_2 \text{Fl}_3$	massive.....	Greenland.
Anglesite	Pb S	Phoenixville, Pa.
Gypsum.....	$\text{Ca S} + 2\text{H}$	crystals	Montmartre, France.
Samaraskite.....	$(\text{R}^3 \text{R} \text{R}^3)_2 \text{Ob}_3$	massive.....	Yancey Co., N. C.
Silver.....	Ag	pure silver.....	?
Copper.....	Cu	copper foil.....	?
Iron.....	Fe	iron wire.....	?
Zinc	Zn	granulated	Bethlehem, Pa.
Lead.....	Pb	test-lead	?
Tin	Sn	granulated	?
Aluminium	Al	foil.....	France.
Antimony.....	Sb	massive, crystalline....	?
Bismuth	Bi	massive, crystalline....	?

V. SILICATES.

MINERAL.	FORMULA.	DESCRIPTION.	LOCALITY.
Wollastonite...	Ca Si	fibrous.....	Natural Bridge, N. Y.
Diopside.....	$(\text{Ca Mg}) \ddot{\text{Si}}$	crystals.....	Tyrol.
Augite.....	$(\text{Ca Mg Fe}) (\ddot{\text{Si}} \ddot{\text{Al}}^3)$	crystals.....	Sicily.
Rhodonite.....	Mn Si	massive.....	Franklin, N. J.
Spodumene.....	$\text{R}^3 \ddot{\text{Si}}^3 + 4 \ddot{\text{Al}} \ddot{\text{Si}}^3$	crystals.....	Windham, Me.
Hornblende.....	$(\text{R R}) (\ddot{\text{Si}} \ddot{\text{Al}}^3)$	massive.....	New York City.
Chrysolite.....	$(\text{Mg Fe})^2 \ddot{\text{Si}}$	massive.....	North Carolina.
Olivine.....	$(\text{Mg Fe})^2 \ddot{\text{Si}}$	granular.....	Sandwich Islands.
Willemite.....	$\text{Zn}^2 \ddot{\text{Si}}$	massive.....	Franklin, N. J.
Almandite.....	$(\frac{1}{3} \text{Fe}^3 + \frac{1}{3} \ddot{\text{Al}})^2 \ddot{\text{Si}}^3$	crystals.....	Sterling, N. J.
Epidote.....	$[\frac{1}{3} \text{Ca}^3 + \frac{2}{3} (\text{Al Fe})] \ddot{\text{Si}}^3$	massive.....	Ducktown, Tenn.
Biotite.....	$\frac{1}{2} (\text{Mg K})^3 + \frac{1}{2} (\text{Al Fe})^2 \ddot{\text{Si}}^3$	laminae.....	Westchester Co., N. Y.
Muscovite.....	$(\text{R}^3 \ddot{\text{R}})_2 \ddot{\text{Si}}^3 + \frac{2}{3} \ddot{\text{Si}}$	laminae.....	North Carolina.
Wernerite.....	$[\frac{1}{3} (\text{Na Ca})^3 + \frac{2}{3} \ddot{\text{Al}}]^2 \ddot{\text{Si}}^3 + \ddot{\text{Si}}$	massive.....	Gouverneur, N. Y.
Labradorite.....	$[\frac{1}{2} (\text{Ca Na})^3 + \frac{1}{2} \ddot{\text{Al}}]^2 + \frac{2}{3} \ddot{\text{Si}}^3$	massive.....	Turin, N. Y.
Albite.....	$(\frac{1}{4} \text{Na}^3 + \frac{3}{4} \ddot{\text{Al}})^2 \ddot{\text{Si}}^3 + 6 \ddot{\text{Si}}$	massive.....	Yancey Co., N. C.
Orthoclase.....	$(\frac{1}{2} \text{K}^3 + \frac{3}{2} \ddot{\text{Al}})^2 \ddot{\text{Si}}^3 + 6 \ddot{\text{Si}}$	massive.....	New York City.
Chondrodite.....	$\text{Mg}^2 \ddot{\text{Si}}^3 \text{ [Fl]}$	crystals.....	Sparta, N. J.
Tourmaline.....	$(\text{R}^3 \ddot{\text{R}} \text{ B})^3 \ddot{\text{Si}}^3 \text{ [Fl]}$	black crystals....	New York City.
Kyanite.....	Al Si	crystals.....	Buncombe Co., N. C.
Datolite.....	$(\text{Ca}^2 \text{ H}^2 \text{ B}) \ddot{\text{Si}}$	crystals.....	Lake Superior.
Pectolite.....	$(\frac{2}{3} \text{Ca} + \frac{1}{3} \text{Na} + \frac{1}{3} \text{H}) \ddot{\text{Si}}$	crystals.....	Bergen, N. J.
Chrysocolla.....	$\text{Cu Si} + 2 \text{H}$	massive.....	Lake Superior.
Calamine.....	$\text{Zn}^2 \ddot{\text{Si}} + \text{H}$	crystalline.....	Friedensville, Pa.
Prehnite.....	$(\frac{1}{6} \text{H}^3 + \frac{2}{3} \text{Ca}^3 + \frac{1}{3} \ddot{\text{Al}})^2 \ddot{\text{Si}}^3$	uniform, massive....	Scotland.
Apophyllite.....	$[\frac{1}{2} \text{H} + \frac{1}{2} (\frac{1}{2} \text{K} + \frac{1}{2} \text{Ca})]^2 \ddot{\text{Si}} + \text{H} \ddot{\text{Si}}$	crystals.....	Bergen, N. J.
Natrolite, (1)...	$3 \ddot{\text{Si}}, \ddot{\text{Al}}, \text{Na}, 2 \text{H}$	dark, massive....	Württemberg.
“ (2)...		white, fibrous....	Bergen, N. J.
Analcite.....	$4 \ddot{\text{Si}}, \ddot{\text{Al}}, \text{Na}, 2 \text{H}$	fine crystals....	Lake Superior.
Chabazite.....	$4 \ddot{\text{Si}}, \ddot{\text{Al}} [\frac{1}{3} \text{Ca} + \frac{1}{3} (\text{Na K})] 6 \text{H}$	crystals.....	Nova Scotia.
Stilbite.....	$6 \ddot{\text{Si}}, \ddot{\text{Al}}, \text{Ca}, 6 \text{H}$	crystals.....	Nova Scotia.
Talc.....	$(\frac{1}{2} \text{H} + \frac{1}{2} \text{Mg}) \ddot{\text{Si}}$	massive.....	North Carolina.
Serpentine.....	$\text{Mg}_2 \ddot{\text{Si}} + \text{H}$	massive.....	Newburyport, Mass.
Retinalite.....	$\text{Mg}_2 \ddot{\text{Si}} + \text{H}$	waxy, transl.....	Montville, N. J.
Chrysothile.....	$\text{Mg}_2 \ddot{\text{Si}} + \text{H}$	silky, fibrous....	Montville, N. J.
Deweylite.....	$(\frac{1}{3} \text{Mg} + \frac{1}{3} \text{H})^2 \ddot{\text{Si}} + \frac{1}{3} \text{H}$	massive, transl....	Rye, N. Y.
Ripidolite.....	$8 (\frac{1}{2} \text{Mg}^3 + \frac{1}{2} \ddot{\text{Al}} \text{Fe}) 9 \ddot{\text{Si}}, 12 \text{H}$	laminae.....	North Carolina.

[Ninety Species, one hundred and twenty Specimens.]

3. The organic acids employed in this investigation were chiefly citric, tartaric, and oxalic; a few tests were made also with malic, formic, acetic, benzoic, pyrogallic, and picric acids. Of the solid acids, solutions saturated in the cold were used, unless otherwise specified; of the liquid acids, ordinary commercial products. The behavior of the minerals with these acids was studied in a very simple manner: the mineral to be examined was carefully freed from its associated gangue or mineral, finely pulverized in an agate mortar, and a portion placed in a test-tube; the solution of the acid was then added, and the resulting phenomena, in the cold and on boiling, carefully noted. Sometimes satisfactory conclusions were reached only by comparison of a number of tests under varying conditions, as to amount of acid, time of heating, etc. In some cases, to be mentioned in due course, the partial decomposition of the mineral was ascertained by filtering from the residue and testing the solution with an appropriate reagent; in others, by examining the disengaged gas with a suitable test-paper.

CARBONATES.

4. The natural carbonates dissolve with effervescence more or less readily in dilute and strong, cold and hot solutions of citric, tartaric, oxalic, malic, formic, benzoic, acetic, pyrogallic, and picric acids, the relative power of these acids being approximately in the order in which they are named. The behavior of the carbonates with citric acid may be summarized as follows:

(a) Calcite, gurhofite, witherite, strontianite, cerussite, baryto-calcite, and malachite dissolve rapidly in the cold.

(b) Dolomite, ankerite, rhodochrosite, smithsonite, and azurite are more feebly attacked in the cold.

(c) Magnesite and siderite are not attacked in the cold.

On heating, all the above carbonates dissolve very rapidly, except siderite, which is more slowly attacked. From strong, nearly neutral solutions of calcite, gurhofite, and some other calcium minerals, a white precipitate of calcium citrate forms on cooling; cerussite also deposits a white precipitate on cooling.

It is evident that a solution of citric acid effects the decomposition of mineral carbonates with sufficient ease to render it extremely useful where hydrochloric acid can not be conveniently employed. The organic acid acts, however, somewhat more slowly; in fact, time appears to be an important factor in studying these reactions. On some minerals the organic acid has at first no effect, and an appreciable time elapses before bubbles of carbonic anhydride appear, indicating the decomposition of the mineral; this is especially noticeable with dolomite and azurite. The time of incipient action varies also with the acid employed.*

Owing to the viscosity of a concentrated solution of citric acid, the liberated gas has difficulty in escaping, and often remains attached in bubbles to the powder until sufficiently large bubbles have formed to ascend through the syrupy liquid; this, of course, has reference to examinations made in the cold. Moreover, the precaution was observed of distinguishing between the escape of bubbles of air entangled by the powdered mineral and a true liberation of carbonic anhydride. These minute details are mentioned, because observation of them is necessary to obtain the same results as those recorded in the first part of this section. Magnesite and siderite were repeatedly tested, and always refused to effervesce with a cold solution of citric acid, a reaction which distinguishes them from other carbonates.

5. In making this investigation we have constantly borne in mind the possible employment of the methods in the field, and have conducted the tests in the simplest manner with that end in view. Since it is seldom convenient in field work to obtain the minerals in fine powder, an examination was made of the action of citric acid on the *massive* carbonates; and by

* The interesting subject of the Velocity of Chemical Reactions has recently been investigated in certain cases by Boguski and Kajander (Berichte d. deutschen Chem. Ges. Berlin, ix, 1646, and x, 34). They find that when nitric, hydrochloric, and hydrobromic acids, of the same concentration, act upon marble, the velocity of evolution of carbonic anhydride is inversely proportional to their molecular weights. Cf. American Journal of Science, [3] xii. p. 299. It will be interesting to ascertain whether this law holds good with organic acids.

way of comparison the behavior of the same with hydrochloric acid was also noted. The results may be summarized as follows: 1, signifying that the minerals effervesce quickly when the acid is dropped on their smooth surfaces; 2, that they are feebly and slowly attacked; 3, that they do not effervesce.

Mineral.	HCl. Sp. Gr. 1.055	Citric Acid.
Calcite.....	1	1
Dolomite.....	3	3
Gurhofite.....	1	1
Ankerite.....	2	3
Magnesite.....	3	3
Siderite.....	3	3
Rhodochrosite.....	3	3
Smithsonite.....	2	3
Witherite.....	1	2
Strontianite.....	1	2
Baryto-calcite.....	1	2
Malachite.....	1	2
Azurite.....	2	?

Porous minerals, and those having highly polished cleavage or crystalline surfaces, appear to resist the action of the acids, but for very different reasons; the former (smithsonite, for example) absorb the liquid and conceal its action within their pores; the latter (dolomite, siderite, etc.) seem to repel the liquid, or rather to prevent its actual contact. In the latter case the action of the acid may be rendered visible by scratching the surface with a knife and applying the acid liquid to the roughened surface or to the small amount of powder produced by the scraping. The observations above recorded were made on smooth surfaces.

In earthy minerals, the acid should be applied repeatedly at the same point until, the pores being filled, the action of the acid on the surface becomes apparent.

6. The mineral carbonates behave with a solution of tartaric acid much in the same manner as with citric acid, but the tartrates being in general a little less soluble than the citrates, crystalline precipitates form more readily on cooling the saturated solutions.

The results recorded below were obtained with a solution saturated in the cold :

(a) Calcite, gurhofite, witherite, strontianite, cerussite, and baryto-calcite dissolve readily in the cold ; on boiling, the action is increased, and the solutions deposit crystalline precipitates on cooling ; the precipitates of calcium tartrate and of barium tartrate form readily, and may be recognized with a little experience. (Cf. §10.)

(b) Dolomite, ankerite, rhodochrosite, smithsonite, malachite, and azurite effervesce feebly in the cold, and dissolve rapidly on heating. Dolomite and smithsonite deposit crystals on cooling the solutions ; malachite yields a bluish green precipitate ; azurite dissolves readily without residue.

(c) Magnesite and siderite are not attacked in the cold, but dissolve readily on heating. The specimen of siderite from Roxbury effervesced very slightly in the cold and appeared to be more soluble than the specimen from Dauphiny.

7. Oxalic acid decomposes the carbonates in a similar manner, forming, however, still more insoluble precipitates, which are in some cases characteristic of the bases contained in the minerals ; especially is this true of the white pulverulent calcium oxalate, the light yellow granular ferrous oxalate, the beautifully feathered crystals of barium oxalate, and the heavy white precipitate of lead oxalate. Ankerite contains enough ferrous carbonate to communicate a decided yellow color to the insoluble calcium salt, by the formation of ferrous oxalate. Baryto-calcite dissolves freely on boiling, with formation of insoluble calcium oxalate ; by decanting the supernatant liquid it deposits as it cools the feathered needles characteristic of acid barium oxalate, easily distinguishable from the stouter, lengthened, monoclinic prisms of oxalic acid which likewise form in concentrated solutions.

Magnesite, which resists the action of cold citric and tartaric acids, succumbs to oxalic acid. Siderite is also more readily decomposed. Malachite and azurite are feebly attacked in the cold, dissolve slowly on heating, and yield precipitates which are respectively grayish-green and bluish-white in color. Cerussite and smithsonite also furnish solutions which deposit crystalline precipitates on cooling.

8. Acetic acid does not act so energetically on the mineral carbonates as do the preceding; moreover, on boiling, the volatile acid distills off and the solution becomes weaker as the heating is continued; whereas with solutions of the solid acids, boiling increases their concentration and their decomposing power. We conjecture that experimenters in this direction have been deterred from further research by the unsatisfactory nature of the reactions with acetic acid. And yet, if we may trust the ancient chronicles of Rome, the behavior of minerals with this acid was investigated at a very early period; we refer to that much disputed tradition which represents the celebrated Carthaginian general, Hannibal, applying vinegar to the removal of rocks that obstructed his passage across the Alps, in his march on the Roman capital:

“Diducit scopulos et montem rumpit aceto.”*

Glacial acetic acid does not in the slightest degree dissolve calcite; even pure precipitated calcium carbonate does not effervesce when boiled with glacial acetic acid; but on adding one-fourth part of water, effervescence begins at once and the carbonate dissolves freely.

The behavior of carbonates with acetic acid may be summarized as follows (Sp. gr. of acid = 1.037).

(a) Calcite, gurhofite, witherite, cerussite, baryto-calcite, and strontianite effervesce freely in the cold and dissolve rapidly on heating.

(b) Dolomite, ankerite, smithsonite, and azurite effervesce slightly in the cold, the action being increased on boiling.

(c) Magnesite, siderite, rhodochrosite, and malachite are not attacked in the cold, and dissolve more or less readily on boiling.

9. Formic acid (Sp. gr. = 1.060) acts rather more powerfully than acetic; cerussite gives a peculiarly beautiful and characteristic deposit of lustrous white crystals. Malic acid also acts quite energetically; but the difficulty of obtaining it in a state of purity, and its high price, will prevent its use in this connection. It does not seem especially desirable to extend the list of organic acids; for though their number is legion,

* Juvenal, Satire X.

but few are commercial articles; some interest might be attached to a comparison of their decomposing power, but a practical application to the examination of minerals is very doubtful. To test the probabilities of their action, however, a few experiments were made with solutions of picric, benzoic, and pyrogallic acids.

A strong hot solution of picric acid (carefully freed from nitric acid by re-crystallization) decomposes calcite, dolomite, and witherite very readily. A moderately strong hot solution of benzoic acid dissolves calcite freely, and a crystalline precipitate falls on cooling. Dolomite dissolves on boiling. Pyrogallic acid attacks calcite in the cold, and dissolves it on boiling, with formation of a white precipitate, while the supernatant liquid turns dark in color through absorption of oxygen.

MICROSCOPICAL EXAMINATION OF THE CRYSTALLINE PRECIPITATES.

By JOHN H. CASWELL.

10. The crystalline precipitates obtained in these reactions are in some measure distinguishable by the naked eye, but microscopical examination of the varied forms develops interesting peculiarities. For this investigation we have had the good fortune to secure the skill, as well as the pencil, of our friend Mr. John H. Caswell, of the School of Mines, Columbia College, who places us under obligation by communicating the following results of his study.

The crystalline deposits were obtained by treatment of the different minerals named, with hot solutions of the acids, in test-tubes, and concentration of the solution when necessary. In addition to the crystalline forms of the acids themselves, tartaric and oxalic, the following substances were examined: Hydro-calcium tartrate, neutral calcium tartrate, hydro-barium tartrate, calcium oxalate, hydro-barium oxalate, hydro-strontium oxalate, ferrous oxalate, formate of lead, and calcium citrate. The precipitates resulting from treatment of the minerals were compared with similar precipitates formed from chemically pure material.

Tartaric Acid.—The most usual and characteristic forms

observed were triangular-shaped crystals, of very beautifully sharp and distinct outline. The smaller ones appeared to be without any modifications, as in Plate I, Fig. 4, but some of the larger and thicker ones had faces and planes on the angles and edges similar to those in Fig. 2. The same crystals viewed in a different position appeared as in Fig. 5, which forms were often grouped, together with the triangles, into stellate masses, Fig. 6. Flat, tabular crystals, apparently with domes and prismatic faces, were also observed. They were remarkable, owing to the terminations being different on the same crystal, thus occasioning a somewhat wedge-shaped form, as in Figs. 1-3. These tabular crystals are quite large, and often have inclosures of small acicular crystals and cavities. Very small needle-like crystals were also observed in the same slide as those already mentioned.

Hydro-calcium tartrate (Figs. 7 to 12).—From a solution of calcite in an excess of tartaric acid, crystals were obtained, strongly resembling orthorhombic or monoclinic forms, consisting of prism and dome, as shown in the figures. These crystals were quite small, but very beautifully sharp and distinct, and gave bright colors in polarized light. The figures show forms almost identical, but seen in different positions. The crystals were then twice boiled with water, to remove any excess of tartaric acid, the only effect being to mass the crystals in groups and to round their angles somewhat, although some good individuals were seen. The water solution was then evaporated and some very sharp and good crystals obtained, having the same characteristic face and angles as in the figure, but generally larger and sharper than those before observed. These forms, then, belong undoubtedly to hydro-calcium tartrate, tartaric acid being entirely too soluble to have furnished crystals in this way. Sometimes the crystals are in long, slender prisms, but always with the characteristic dome-like termination; and in some of the larger ones the pinacoid is present.

Gurhofite, treated with tartaric acid, gave the forms already described, and also some transparent masses of irregular shape, having no crystalline characteristics.

Dolomite, treated as above, also afforded some good crystals of hydro-calcium tartrate, very easily recognized among other irregular fragments or masses of no particular form.

Neutral calcium tartrate, obtained by treating a concentrated solution of tartaric acid with an excess of calcite, gave very minute needles, which in almost every case were grouped in small radiated circular masses, much resembling the spherulites of volcanic rocks. The outlines of these groups are sharp and distinct, always perfectly round, sometimes having the central part transparent, but no particular crystalline form could be made out.

Hydro-barium tartrate (Fig. 13), from witherite and tartaric acid, crystallizes in very delicate, long, almost capillary, acicular crystals, which are often grouped in bundles, the needles lying parallel to each other. A few characteristic crystals, probably hydro-calcium tartrate, having the form and faces (as previously mentioned) of prism and dome, were easily recognized; they doubtless proceeded from the calcium contained in the witherite. It is interesting to be able so easily, by the aid of the microscope, to distinguish a small percentage of calcium in the presence of a large quantity of barium. The needles of hydro-barium tartrate give fine colors in polarized light.

Oxalic acid forms long prismatic crystals, quite stout, and generally terminated with domes, similar to those faces in hydro-calcium tartrate; but apparently of much flatter angles. When carefully made, the crystals are sharp and distinct in outline and terminations, but the mass much oftener crystallizes in indistinctly radiated groups, in which the forms can scarcely be distinguished. Oxalic acid, as is well known, gives beautiful colors in polarized light.

Calcium oxalate is an amorphous powder, and, even under the microscope, appears to be in minute masses, almost opaque and with no distinguishable crystalline characteristics.

Hydro-barium oxalate, from witherite and oxalic acid (Figs. 14-16), crystallizes in large, beautiful forms, very characteristic, and different from anything before noticed. The crystals have the shape of a spear-head or arrow-head, being built up

of many small crystals arranged on a straight rib or spine somewhat like a feather. The spear-headed forms are deeply striated or furrowed, and inclose large fluid-cavities; they give beautiful colors also in polarized light. A few simple crystals, as in Fig. 14, are apparently monoclinic or triclinic; and the edges or sides of the feather-like forms generally terminate in similar small, distinctly outlined crystals, placed on the extremity of the lateral ribs.

Very striking were the forms (Figs. 17, 18) obtained from treating baryto-calcite with oxalic acid. They consisted, first, of the large spear-headed or feather-shaped crystal groups, as shown in the sketch, in which the mode of formation is very easily seen, especially the simple crystals terminating the lateral ribs. The latter are curved upward a little, but seem to be nearly at right angles to the main spine or axis. Besides these forms, amorphous calcium oxalate was observed, and also some long, columnar crystals of oxalic acid. By allowing the calcium oxalate to settle, and decanting and crystallizing the clear solution, the best and cleanest crystals of hydrobarium oxalate can be obtained, of tolerably large size.

Hydro-strontium oxalate (Figs. 19, 20), from strontianite and oxalic acid, gave very small crystals, somewhat resembling those of hydro-calcium tartrate, but apparently with much flatter angles. One form, Fig. 20, seemed to be made up of prism, pinacoid, and domes, probably orthorhombic or monoclinic. Other crystals, probably pyramidal, appeared to be minute rhombs (Fig. 19), sometimes in groups.

Ferrous oxalate (Fig. 21), from siderite and oxalic acid, gave yellow crystals, exceedingly minute, but nevertheless quite distinctly outlined. Their form was prismatic with a flat or basal termination.

The same crystals were abundantly obtained from ankerite also; but the crystalline mass was of a lighter yellow than that formed from siderite, owing to admixture of calcium oxalate.

Formate of lead, from cerussite and formic acid, crystallized in quite large acicular forms, sharp and transparent, but terminated with rounded faces, the exact nature of which

could not be determined. The crystals are generally comparatively short and stout, being quite different from the hydro-barium tartrate, which is almost capillary in character. Some of the larger crystals of formate of lead are thick and cloudy, apparently from the presence of microlites and fluid cavities.

Calcium citrate, from citric acid and calcite, had no crystalline appearance, being in the form of very minute masses, and is probably amorphous as thus obtained."

METALS AND ORGANIC ACIDS.

11. That citric and tartaric acids dissolve iron and zinc, with evolution of hydrogen gas, is a well-known fact, stated in many handbooks of chemistry.*

Crommydis has recently taken advantage of the solubility of zinc in oxalic acid to prepare glycollic acid ($H_2C_2H_2O_3$), a reaction in which nascent hydrogen plays an important part.†

In repeating and extending these experiments we have made the following observations: Iron, zinc, and magnesium dissolve readily in cold saturated solutions of citric, tartaric, oxalic, and malic acids, as well as with formic (Sp. Gr. = 1.060) and acetic acids (Sp. Gr. = 1.037), evolving hydrogen more or less freely; on heating, the action becomes violent. Magnesium is attacked by citric and other acids violently, the liquid becoming much heated.

A cold-saturated solution of citric acid, diluted with half its volume of water, attacks zinc slowly in the cold; on boiling, hydrogen comes off freely and continues to do so after cooling for a long time; the disengagement of gas being slow but steady, and under favorable conditions lasting for twenty-four hours. If the solution becomes very concentrated, an insoluble citrate of zinc precipitates, soluble, however, in water.

Tartaric acid acts on zinc feebly in the cold; on boiling, solution ensues, and at the same time the hot liquid becomes

* Cf. Handwörterbuch der Chemie, article "Citronsäure."

† Bull. soc. chim., xxvii, p. 3, 1877.

milky from the formation of an insoluble tartrate of zinc; on cooling, the solution becomes clear and a precipitate settles.

Oxalic acid in concentrated solution attacks zinc in the cold immediately; but the action soon ceases, owing to the surface of the zinc becoming coated with a quite insoluble zinc oxalate; on heating to boiling, the evolution of hydrogen is resumed, but is again arrested in a short time from the same cause. On cooling, a fine precipitate forms.*

SULPHIDES.

12. After experiencing the solvent power of organic acids described in the preceding section, we were prepared to discover many sulphides yielding to them, though we confess to surprise at finding this action taking place even in the cold. Such is the case with four out of the eighteen sulphides selected for examination, viz.: stibnite, galenite, sphalerite, and pyrrhotite. The tests were made as follows: the pulverized minerals were placed in test-tubes, a concentrated solution of citric acid was added, and a piece of paper moistened with plumbic acetate was suspended in each tube, which was then corked. After standing twelve hours at the ordinary temperature, the blackened test-papers gave evidence of the decomposition. Sphalerite seems to be the most readily decomposed, the sulphureted hydrogen coming off immediately. On heating, the disengagement of sulphureted hydrogen is very marked; with boiling citric acid, bornite and bournonite, in addition to those just mentioned, yield sulphureted hydrogen. One sample of argentite, containing mingled galenite, gave a reaction for sulphureted hydrogen; but

* Experiments were made to test the applicability of these methods of generating hydrogen to the detection of arsenic by Marsh's apparatus. If a solution containing arsenic be introduced into a flask in which hydrogen is evolved from the action of citric acid on zinc, the disengagement of gas is greatly augmented and arseneted hydrogen forms at once. Owing to the imperfect solubility of zinc citrate, the action soon ceases. With tartaric acid the same objection arises, while oxalic acid is out of the question. This difficulty does not apply to magnesium, which might be employed in an apparatus similar to that described by Dr. John C. Draper (*American Chemist*, II, 456). By using distilled magnesium and re-crystallized citric acid, the absence of arsenic in the materials used for toxicological researches could be placed beyond suspicion.

a purer specimen was not attacked. With bournonite the reaction is feeble.

Pyrite, marcasite, molybdenite, chalcocite, cinnabar, argentite, niccolite, smaltite, chalcopyrite, ullmannite, arsenopyrite, and tetrahedrite resist the action of citric acid. Tartaric and oxalic acids act in a similar manner, both in the cold and on boiling. A comparison of the behavior of nine organic acids with stibnite gave the following results:

(a) Stibnite heated with citric, tartaric, and oxalic acids yields sulphureted hydrogen freely and goes into solution.

(b) With malic, benzoic, and pyrogallic acids, sulphureted hydrogen comes off feebly and the mineral dissolves imperfectly.

(c) With formic and acetic acids no gas is evolved and the mineral is not dissolved.

(d) With picric acid no gas is evolved, but the mineral is partially dissolved.

It is noticeable that the *liquid* acids are powerless to effect decomposition. (§ 8.)

13. The action of the organic acids on mineral sulphides is not so decided as that of the mineral acids; but this is no disadvantage, since it affords additional means of determining them. On examining the reactions recorded in the preceding section, it will be found that bornite and pyrrhotite are decomposed by citric acid, while their kindred compounds, pyrite and chalcopyrite (as well as chalcocite) are not. In order to establish satisfactorily this difference of behavior, several specimens of each of these minerals, from various localities, were carefully tested.

(a) Four samples of bornite were heated with a concentrated solution of citric acid, and each gave a strong reaction for sulphureted hydrogen; of four specimens of chalcopyrite, treated in the same manner, two gave no traces of this gas, and two gave mere traces on long boiling; three samples of chalcocite yielded no traces of sulphureted hydrogen.

(b) Three specimens of pyrite heated with citric acid gave no traces of the gas, and three of pyrrhotite liberated it both in the cold and freely on boiling. On the other hand all the specimens named are decomposed by hydrochloric acid, except one specimen of pyrite (from Germany).

It is evident, then, that citric acid may be used to distin-

guish pyrrhotite from pyrite, and bornite from chalcocite or chalcopyrite. The presence of galenite in argentite may also be ascertained by this method, since the former yields H_2S even in the cold, while the latter is not decomposed on boiling.

OXIDES.

14. A few of the mineral oxides examined are attacked by the organic acids in the cold; brucite dissolves slowly, but to a considerable extent, in cold citric acid; the manganese oxides, hausmannite, pyrolusite, manganite, psilomelane, and wad, decompose the organic acid with evolution of carbonic anhydride; the reaction begins in the cold, and on applying heat proceeds rapidly, with a lively effervescence.



Manganite is not so soluble as the others, probably because the oxidizing power of the sesquioxide is less than that of manganese dioxide. The minerals are apparently more quickly and completely dissolved by oxalic acid than by citric acid.

Zincite, cuprite, and limonite are attacked by boiling citric acid, the latter but slightly. Hematite, magnetite, franklinite, and chromite are not attacked. In testing these minerals, conclusions were based on the reactions of the filtrates; in employing ferrocyanide of potassium to test the citric acid solutions of the iron oxides, we observed that the organic acid exerts a reducing action on the ferrocyanide, and produces a bluish precipitate proceeding from this reagent itself. This is especially noticeable on boiling, a light bluish-green precipitate forming abundantly. Tartaric and oxalic acids act similarly.

The oxides behave with tartaric acid in all respects as with citric.

SUNDRY MINERALS.

15. A few minerals not closely related were examined as to their behavior with citric acid. Gypsum appears to be somewhat more soluble in a concentrated solution of citric

acid than in water. Apatite is feebly attacked on boiling. Vivianite is readily soluble. Pyromorphite and anglesite are partly decomposed even in the cold, as shown by the behavior of the filtrates with hydrosulphuric acid.

Fluorite, cryolite, and samarskite are not attacked, as might be anticipated.

SILICATES.

16. Those silicates which are decomposed by hydrochloric acid, either with or without the formation of a jelly, are likewise attacked more or less strongly by a hot solution of citric acid. The minerals were examined as follows:—their behavior with strong hydrochloric acid was first ascertained, and they were then heated with a concentrated solution of citric acid; the solution becomes viscid by concentration, and the gelatinous silica is best seen by diluting with water and agitating. Very careful pulverization of the mineral is in most cases indispensable. The solubility of the mineral was also tested by filtering from the silica and undissolved material, and examining the solution with an appropriate reagent. Owing to the power possessed by citric acid (in common with other organic bodies) of preventing precipitation of salts which are otherwise insoluble, care was had to select those reagents which were least affected; in this we were aided by a table contained in Dr. Hermann Grothe's paper entitled, "Ueber das Verhalten der Metalloxydaufösungen gegen Alkalien bei Gegenwart nicht-flüchtiger organischer Substanzen und ueber den Nachweis der Metalloxyde in solchen Lösungen."*

So far as possible, color reactions were employed.

The results are summarized below:—1, signifying minerals which decompose readily; 2, those which are attacked with difficulty; 3, those which resist the acid. Minerals which yield gelatinous silica are marked G, and those which give slimy or pulverulent silica, S.

* Journal für prakt. Chemie, Vol. XCII, p. 175.

BEHAVIOR OF CERTAIN SILICATES WITH HCL AND WITH CITRIC ACID.

MINERAL.	HCl	C̄	MINERAL.	HCl	C̄
Wollastonite	1G	1S	Rhodonite.....	1	1
Chrysolite.....	1G	2	Natrolite.....	1G	1G
Olivine.....	1G	3	Analcite.....	1S	1S
Willemite.....	1G	1G	Chabazite.....	1S	1S
Wernerite.....	1-2	3	Stilbite.....	1	2
Chondrodite.....	1G	1-2 G	Serpentine.....	1S	1S
Datolite.....	1G	1G	Retinalite.....	1S	1S
Pectolite.....	1G	1G	Chrysotile.....	1S	2-3
Chrysocolla.....	1	1	Deweylite.....	1S	1S
Calamine.....	1G	1G	Talc.....	3	3
Prehnite.....	1	2	Epidote.....	3	3
Apophyllite.....	1S	2S	Orthoclase.....	3	3

In order to ascertain approximately the comparative decomposing power of the commoner organic acids with silicates, two which yield readily to citric acid and one which is attacked with difficulty were selected for treatment. The following are the results:

	Calamine.	Natrolite.	Prehnite.
Citric Acid	1G	1G	2
Tartaric "	1G	1G	3
Oxalic "	2	3	3
Formic "	1G*	1	3
Malic "	1G	1G	3
Acetic "	1G	2-3	3

* Very soluble.

Since calamine and willemite are sometimes distinguished by their behavior with acetic acid—the former gelatinizing and the latter giving slimy silica—it was thought of interest to examine their behavior with other organic acids. The results are given below:

	Calamine.	Willemite.
Citric Acid	1G	1G
Tartaric "	1G	1*
Oxalic "	2	2
Formic "	1G	1S
Malic "	1G	1
Acetic "	1G	1S

* Solution becomes very milky in appearance.

DECOMPOSITION OF MINERALS BY ORGANIC ACIDS AND
OXIDIZING AGENTS.

18. Desirous of extending the use of organic acids in attacking minerals, we tried the effect of adding oxidizing agents to the solution of the acid; the results were satisfactory and prompted the following investigation:

When potassium, sodium, or ammonium nitrate is added to a boiling solution of citric acid, on reaching a certain degree of concentration nitric acid is set free, and this immediately reacts upon the organic acid, decomposing it with evolution of gases. These gases proved on examination to consist of nitric oxide and carbonic anhydride; whether carbonic oxide is present was not determined. The reaction which takes place is very complex; it may possibly be expressed thus:—

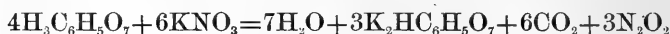

or admitting the formation of oxalic acid,* we may write:—

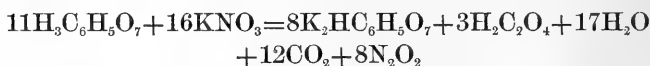

Potassium nitrite also decomposes citric acid in a somewhat similar manner, the action beginning in the cold and continuing with violence and a rise of temperature. The reaction may be expressed as follows:—

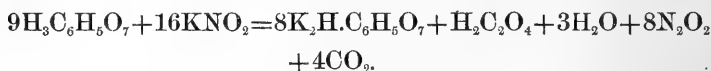

Or, abbreviating and disregarding the decomposition of the organic acid, we may have

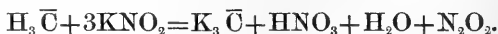

The nitric acid being then in a nascent condition, is prepared to effect oxidation in a most powerful manner.

When chlorate of potassium is substituted for the nitrate or nitrite, the decomposition begins on boiling down the solution to small bulk, and proceeds very vigorously, the carbonic

* Watts' Dictionary, I, 996.

anhydride disengaged being accompanied by a gas having an excessively irritating odor and exciting tears. This peculiar substance is probably the same as that obtained in 1847 by Plantamour,* by the action of chlorine on sodium citrate, and which was subsequently studied by Laurent, by Staedler, and by Cloez.† The latter showed the irritating body to be perchlorinated acetate of methyl, $C_3Cl_6O_2$, and explains its formation as follows:‡

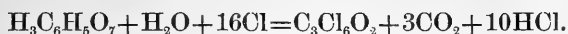

Precisely how the action proceeds with potassium chlorate and citric acid we have not determined; it is undoubtedly more complex than even the following equation indicates:—

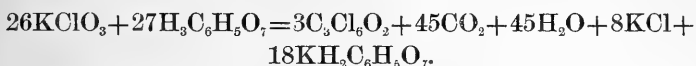

Tartaric acid behaves exactly like citric acid with the nitrate and the chlorate. Oxalic acid decomposes them in very concentrated solutions and attacks the nitrite very actively, probably in the following manner:



Acetic and formic acids do not decompose the nitrate nor the nitrite.

19. These interesting reactions enable us to attack many mineral sulphides with the greatest ease. With potassium nitrite and citric acid, they are decomposed in the cold; with the nitrate and chlorate, only on boiling. Pyrites, for example, in fine powder, is very quickly decomposed by these powerful agents, and completely dissolved, save a little sulphur. The solution contains ferric sulphate and hydropotassium citrate, while both nitric oxide and carbonic anhydride are evolved abundantly; the reaction then may be formulated as follows:—

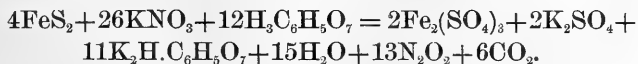

* Berzelius, Jahresbericht, Vol. xxvi, p. 428.

† Annals de Chimie et de Physique, (3) xvii, 297 and 311.

‡ Cf. Watts' Dictionary, I, 996.

Of the eighteen sulphides selected for examination, all but two, molybdenite and cinnabar, are readily decomposed by heating with citric acid and potassium nitrate; stibnite and bournonite yield clear and colorless solutions; argentite and galenite, turbid and colorless solutions; bornite, sphalerite, chalcocite, pyrrhotite, niccolite, smaltite, pyrite, chalcopyrite, ullmannite, marcasite, arsenopyrite, and tetrahedrite give colored solutions not particularly characteristic. The copper minerals, heated with a large proportion of the organic acid, give precipitates of red oxide of copper. The sulphur in these minerals is not completely oxidized by the potassium nitrate and a part floats in the solutions.

Parallel experiments with citric acid and potassium chlorate gave similar results, but the action of the chlorate is slower. Tartaric acid may be substituted for citric, and appears to differ little in its solvent power.

20. Although oxalic acid decomposes potassium nitrate, only in the most concentrated solutions, yet the presence of an oxidizable body like pyrites incites a reaction which effects complete decomposition of the sulphide, precisely as with citric acid. Potassium nitrate and oxalic acid heated together give the following reaction:—



and on the addition of pyrites we have:

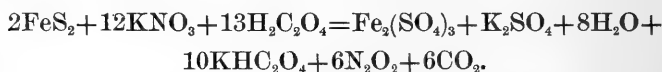

Since, however, the nitric oxide is evidently evolved in much greater proportion than the carbonic anhydride, the following equation probably expresses the actual reaction with greater accuracy:—

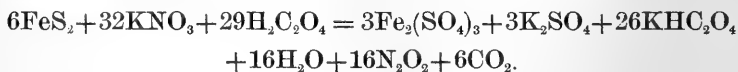

To decompose sulphides with oxalic acid and potassium nitrate, the best results are secured by boiling the two reagents together for a short time and then adding the finely pulverized

mineral; a violent action sets in immediately. In studying the rationale of the above-named decompositions, we discovered that many sulphides are attacked by an aqueous solution of potassium nitrate (and nitrite) without the addition of acid; this unexpected result explains satisfactorily the violence of the decomposition of the sulphides by the mixture of reagents, many forces being simultaneously brought into play; the organic acid, while able to decompose the potassium nitrate alone, acts at the same time as a solvent of the products resulting from the decomposition of the sulphide by the nitrate.

This explains also the fact that the comparatively weak acids—malic, acetic, and formic—which do not of themselves decompose potassium nitrate, are able to dissolve the sulphides in the presence of the latter reagents. We are now investigating the behavior of certain minerals with these and other saline solutions, and hope to present the results in a future paper.

We have applied this method of attack to several other classes of minerals, but without much advantage. The oxides of iron, magnetite and hematite, as well as franklinite and chromite, resist the combined action of the mixed reagents. The decomposition of silicates is not notably facilitated. Limonite is feebly attacked. Uraninite, however, dissolves completely and rapidly in this mixture of reagents.

The remarkable solvent power of a mixture of nitrate of potassium and citric acid is further demonstrated by the fact that metallic copper, silver, lead, tin, bismuth, and antimony, as well as magnesium, iron, and zinc, dissolve therein with more or less rapidity.

Aluminium resists this mixture of reagents:—the alchemists' dream of an *alcahest*, or universal solvent, is therefore only partly realized.

DECOMPOSITION OF SILICATES BY ORGANIC ACIDS AND AMMONIUM FLUORIDE.

21. A hot concentrated solution of citric acid decomposes ammonium fluoride, setting hydrofluoric acid free; and if

silicates are present, many of them dissolve with great facility. Those minerals which were hardly attacked by citric acid alone, viz. : olivine, wernerite, chondrodite, and prehnite, together with the following not previously examined, orthoclase, albite, labradorite, augite, diopside, hornblende, almandite, spodumene, kyanite, talc, and epidote, are more or less readily decomposed. Of the latter, albite, labradorite, and augite, dissolve quite freely, while epidote appears to be slightly attacked by citric acid alone.

That this method of attack must be conducted in platinum vessels, goes without saying; the silicon evolved as a fluoride may be detected by suspending a moistened glass rod in the vapors, causing a gelatinous precipitate. To obtain affirmative results, it is essential that the silicates should be in very fine powder; the common micas, muscovite and biotite, which are obtained in pulverulent form with great difficulty, appear to resist these reagents; and ripidolite is but slightly attacked, perhaps for the same reason.

Tourmaline decidedly resists the action of these reagents, as well as the fluorides, cryolite, and fluorite. Samarskite is not attacked.

It is hardly to be expected that this method of examining minerals will be serviceable in field work, but it may prove applicable to quantitative analysis.

SUMMARY OF RESULTS.

22. The results of this investigation establish the hitherto unrecorded fact that organic acids not only decompose a considerable number of minerals belonging to various groups, but they also possess a remarkable selective power as regards the degree of this decomposition; to make this selective property of citric acid evident, and at the same time to present a condensed recapitulation of its action on the ninety minerals examined, we have drawn up the annexed table (p. 30). This table shows that citric acid alone divides minerals into eight groups: A, those which dissolve in the cold without evolution of gas; B, those which dissolve in the cold with liberation of carbonic anhydride; C, those which are decomposed in the

cold with liberation of sulphureted hydrogen; D, those which dissolve in the hot acid without evolution of gas; E, those which dissolve in the hot acid with liberation of carbonic anhydride; F, those which dissolve in the boiling acid with liberation of sulphureted hydrogen; G, those which are decomposed on boiling, with formation of gelatinous silica; H, those which are decomposed on boiling, with separation of silica in a slimy or a pulverulent form. To these eight groups we may add three more: I, those which are decomposed by boiling with citric acid and potassium nitrate; K, those which are decomposed by heating with citric acid and ammonium fluoride; and L, those which are not attacked by any of the preceding methods.

Under E fall five minerals, hausmannite, manganite, psilomelane, pyrolusite, and wad, which dissolve rapidly in hot citric acid and decompose it with liberation of carbonic anhydride. Advantage is taken of this reaction in the quantitative analysis of manganese dioxides.

Notwithstanding the sharpness of the reactions by which many of the minerals are characterized, we do not regard the annexed table as a scheme for their determination, but merely as a general view of their behavior. The special cases in which minerals may be distinguished have been mentioned previously.

Under L are found thirteen of the ninety minerals examined; perhaps some of these will yield to these methods of attack by varying slightly the means of application. It is possible also that some of them may be decomposed by heating with citric acid solution in sealed tubes under pressure; but this process of course is not applicable to field work.

TABLE SHOWING THE BEHAVIOR OF CERTAIN MINERALS WITH CITRIC ACID, ALONE AND WITH REAGENTS.

DECOMPOSED (IN FINE POWDER) BY A SOLUTION OF CITRIC ACID.									
ON BOILING.									
IN THE COLD.									
A.	B.	C.	D.	E.	F.	G.	H.	I.	K.
Without evolution of gas.	With liberation of CO ₂ .	With liberation of H ₂ S.	Without evolution of gas.	With liberation of CO ₂ .	With liberation of H ₂ S.	With formation of a jelly (SiO ₂).	With separation of SiO ₂ .	Decomposed by boiling with C + KNO ₃ .	Decomposed by heating with C + NH ₄ Fl.
Brunite. Angetsite. Pyromorphite.* Vivianite.	Caicite. Dolomite.* Ankerite.* Gurhofite. Rhodochrosite.* Smithsonite.* Witherite. Strontianite. Baryocalcite. Cerussite. Malachite. Azurite.*	Stibnite. Galenite. Sphalerite. Pyrrhotite.	Zincite. Gypsum.* Apatite.* Cuprite. Limonite.*	Magnesite. Siderite. Pyrolusite. † Wad. † Hausmannite. † Manganite. † Psilometane. †	Fornite. Bournonite.*	Willemite. Datolite. Pectolite. Calamine. Natrolite.*	Wollastonite. Chrysolite. Chondroite.* Chrysocolla. Prehnite.* Apophyllite.* Rhodonite. Analcite. Chabazite. Stilbite. Serpentine. Chrysofille.* Retinalite. Deweyllite.	Argentite. Chalcocite. Pyrite. Marcasite. Niccolite. Smeltite. Chalcopyrite. Ullmannite. Arsenopyrite. Tetraedrite. Uraninite.	Olivine. Wernerite. Orthoclase. Albite. Lebadorite. Angite. Diopside. Hornblende. Kyanite. Talc.* Spodumene.* Almandite. Epidote.
			and those in A.	and those in B.	and those in C.			and those in F, and C.	and those in G, and H.

L.—Minerals not decomposed by the above reagents: Molybdenite, cinnabar; magnetite, hematite, chromite, frankinite; cryolite, fluorite; samarskite; muscovite, biotite, ripidolite, and tourmaline.

* Feebly attacked.

N. B.—The gases evolved are examined with acetate of lead test-paper; the solutions with appropriate reagents. † The CO₂ evolved is derived from the citric acid.

23. The applications of the methods of examining minerals detailed in the preceding pages are, we believe, numerous and important. Many of the reactions are simple, quickly applied, characteristic, and sensitive; they may be used, as we have seen, in distinguishing minerals nearly related, and probably in separating minerals mingled in one specimen. The methods will in all probability find useful application in quantitative analysis, a point which we propose to test at some future time. We have already employed a solution of citric acid in the analysis of limestones, for the determination of carbonic anhydride by loss. The evolution of gas proceeds regularly and the limestone is completely decomposed; citric acid possesses an advantage over hydrochloric acid in being non-volatile. Experiments to test the accuracy of the method were made with well-dried precipitated carbonate of calcium, and gave results differing by two or three tenths from the theoretical percentage.

By using the non-volatile organic acids in microscopic work whenever applicable, possible injury to the metallic mountings may be avoided, and in certain cases characteristic phenomena may be observed.

The importance of the application of these methods to the examination of minerals and rocks *in the field* is evident. The testimony of various persons as to the practicability of blow-pipe work and chemical work in the field differs greatly, some claiming that it is valuable and easily accomplished, and others that it is altogether impracticable. Professor Geikie, Director of the Geological Survey of Scotland, mentions as a valuable addition to the geologist's outfit, "a small bottle of weak hydrochloric acid, carried in a protecting wooden box or case, of use for testing carbonates;" and he quotes Sir William Logan as employing acid to test the material adhering to a "limestone spear," with which the underlying strata can be probed.*

We propose, therefore, the substitution of a stout paste-board box, containing solid citric (or tartaric) acid, for the

* Science Lectures at South Kensington: Outlines of Field Geology. 1877.

usual glass bottle of liquid hydrochloric acid, and the addition of potassium nitrite to the usual list of dry reagents contained in portable blow-pipe cases. Since citric acid solution decomposes potassium nitrite in the cold, we can carry nitric acid practically in a solid form; hydropotassium sulphate, already in use, furnishes sulphuric acid in a solid state; and it only remains, therefore, to provide for hydrochloric acid. Our experiments have as yet failed to solve this problem directly; ammonium, sodium, and potassium chlorides appear to resist the action of the organic acids. Iodine, on the other hand, while much less powerful than chlorine, possesses similar properties, and will form a valuable addition to the list of dry reagents; in aqueous solution it attacks many sulphides, and gives rise to characteristic phenomena. Iodine water was employed as early as 1858, by Professor Henry Wurtz, to separate pyrrhotite from pyrite;* but he did not extend its use to the determination of minerals, a question which we are now engaged in studying, and which has already yielded very interesting results.

Citric acid, potassium nitrite, and iodine, then, added to the reagents in common use,—borax, sodium-carbonate, potassium cyanide, ammonio-sodium phosphate, test-lead, tin, and an assortment of test-papers, including acetate of lead paper, together with as many of the solid reagents used in solutions as space will admit, would complete the outfit of *dry reagents* for *wet analysis* and for blow-piping.

A pocket case, made of lacquered tin, 20 cm. long, 5 cm. wide, and 2.3 cm. deep, containing pasteboard boxes (pill-boxes) of citric acid, potassium nitrate, dried borax, and sodium carbonate, together with a few simple requisites for blow-pipe work, has been used by the writer in short mineralogical excursions with great satisfaction. To carry on the examination with solutions, we are also provided with a pasteboard case, cylindrical in form, 14 cm. long, containing five stout test-tubes, fitting one within another, like a nest of beakers; the interior tube is open at both ends, a cork inserted

* American Journal of Science, (2) xxvi, 190.

tightly in the centre of the tube divides it into two compartments, one of which is filled with pulverized citric acid and the other with potassium nitrite, to be subsequently dissolved in water obtained in the field. This simple arrangement, greatly economizing space, will naturally suggest itself to all working mineralogists, and would scarcely be worth mentioning were not wet-analyses commonly regarded as impracticable in field work.

In proposing the use of organic acids in this connection, we are aware that they already occupy a place in the lists of "Special Reagents" contained in the larger treatises on Blow-pipe Analysis. Plattner* mentions tartaric acid, but limits its use to the separation of yttria and zirconia (by ammonium sulphide); and he names oxalic acid as employed in the precipitation of lime and in the separation of iron and uranium from yttrium, cerium, and lanthanum. To remove the organic acids from this restricted use, and to accord to them a more important position in the list of reagents, is our aim.

APPLICATION TO GEOLOGICAL PHENOMENA.

24. This newly developed power of the organic acids has undoubtedly an important bearing on the chemistry of geological changes: organic acids, resulting from the decomposition of vegetable and animal matter, demand recognition as powerful agents in the work of disintegration and consolidation.

Many of the results attributed to the imperfectly studied bodies, geic acid, $C_{20}H_{12}O_7$, humic acid, $C_{20}H_{12}O_6$, and ulmic acid, $C_{20}H_{14}O_6$ †—as well as the oxidation products, crenic and apocrenic acids—are perhaps the silent work of a higher class of organic acids.

That such acids constitute ingredients of the soil, is well established: "When the leaves of beets, tobacco, and other large-leaved plants, fall upon the soil, oxalic and malic acids

* Plattner's Manual, translated by Prof. H. B. Cornwall, third edition, pp. 53 and 54 1875.

† Mulder, *Ann. Chem. Pharm.*, xxxvi, 243, 1840. Detmer ascribes to humic acid the formula $C_{60}H_{54}O_{27}$, and regards humic and ulmic acid as identical in composition. Cf. *Watts' Dict.*, II Suppl., 642.

may pass into it in considerable quantity. Falling fruits may give it citric, malic, and tartaric acids." "Formic, propionic, acetic, and butyric acids, or rather their salts, have been detected by Jongbloed and others in garden-earth. The latter are common products of fermentation, a process that goes on in the juices of plants that have become a part of the soil or of a compost."*

How far these organic bodies assist in disintegrating rock material is largely a matter of conjecture; that they do exert considerable influence may be concluded from the existence in the soil of the ulmates, humates, apocrenates, and crenates of potash, soda, ammonia, lime, magnesia, iron, manganese, and alumina. We have, moreover, numerous instances of minerals containing organic acids in combination:

Berzelius and other chemists have remarked the occurrence in marshes of compounds of iron and organic acids, of undetermined composition. Prof. T. Sterry Hunt† describes limonites containing from 12.5 to 15 per cent. of humic acids; Dr. George A. Koenig,‡ in an investigation of the cause of the deep green coloration of amazon-stone from Pike's Peak, concludes that the coloring matter consists of some compound of iron with an organic acid, the nature of which he has not yet determined. Dr. Gideon E. Moore, in a paper on Cryptocallite, recently presented to the New York Academy of Sciences, refers to moresnetite containing iron combined with some organic acid. Forster§ conjectures that the color of smoky quartz is due to the presence of an organic substance containing carbon and nitrogen.

To these scattered notices may be added the small number of minerals, mentioned in Dana's System of Mineralogy, of which organic acids form constituents:

Whewellite, calcium oxalate, occurring in small crystals on calcite.

Thierschite, another calcium oxalate, forming an opaline incrustation on the marble of the Parthenon at Athens. Its origin is attributed to the action of vegetation on marble.

* Prof. S. W. Johnson in "How Crops Feed." New York. 1870.

† Geol. Canada, 1863, 510.

‡ Proc. Acad. Nat. Sci., Philadelphia, 1876, p. 155.

§ Pogg., Ann., cxliii, 173.

Humboldtine, hydrous ferrous oxalate, forming an incrustation on brown coal.

Succinite, or amber, containing $2\frac{1}{2}$ to 6 per cent. succinic acid.

Mellite, or hydrous mellitate of alumina, containing over 40 per cent. of the organic acid.

Pigotite, a salt of alumina and mudescous acid (Johnston). Formed on granite by the action of wet vegetation.

To these belong also the peculiar minerals grouped by Dana under the name Acid Hydrocarbons, found in peat-bogs and in brown coal, and containing the ill-defined bodies, geoceric, georetinic, and butyro-limnodic acids.

25. The manner in which silicates are decomposed and silica rendered soluble for the use of the vegetable world, has been a subject of much investigation. Friedel and Crafts,* in their remarkable researches on the ethers of silicic acid, and Friedel and Ladenburg,† in a paper on silico-propionic acid, have given a new insight into the functions of silica and its transformations in the organic kingdom. The reading of the latter paper before the French Academy of Sciences, June 27, 1870, excited a lively interest; the authors describe silico-propionic acid, $\text{Si C}_2\text{H}_5\text{O}_2\text{H}$, as a white amorphous body closely resembling silica, insoluble in water, and soluble in hot concentrated potassium hydrate. This communication drew from M. Paul Thénard‡ a remarkable announcement with respect to the solvent power of nitro-humic acid § on silica; he stated in substance that the dark-colored acids of the soil consist of a mixture of acids of the humic and nitro-humic series, which contain a notable amount of silica, the amount varying from 7.5 to 24 per cent.; and he conjectures that acids of the "nitro-humic series form spontaneously in the soil at the expense of the humic acid, the ammonia of rain-water, nitrogen of the air, and of the silica pre-existing in the soil."

Dr. J. S. Newberry, in a private communication to the writer, describes the peculiar manner in which quartz pebbles

* Bull. soc. chim., V, 174, 238 (1863).

† Comptes Rendus, LXX, 1407.

‡ Comptes Rendus, LXX, 1412.

§ In translating "*acide azhumique*" by the term "nitro-humic acid," we follow custom, but we are of the opinion that "azo-humic acid" would be more correct, since the word "nitro-humic" implies the existence of a "nitro" radical, NO_2 .

found at Keyport, N. J., in a clay very rich in carbonaceous matters, are eroded. All the sharp angles on these pebbles have been rounded, and the surfaces are more or less deeply pitted, as if by some solvent. He has also observed other phenomena of similar character, which he conjectures should be ascribed to the action of organic acids.

These references would be incomplete without mention of the generalizations of Prof. Henry Wurtz, whose "Scheme of the Geogonic Migrations of Silica throughout the Kingdoms of Life,"* shows thoughtful study and novel views.

Taken as a whole, the information respecting the part played by organic acids in the changes taking place on the earth's surface, is but small: are we not justified in the belief that some of the reactions disclosed by our researches may in the hands of chemical geologists furnish material for generalizations of no small value?

Finally, we are conscious of having treated but a very small number of minerals, compared with those which remain to be studied; our aim has been to place the methods of examination on record, rather than to exhaust the resources of mineralogy.

We take pleasure in acknowledging the services of Mr. Edward W. Martin, a student in the Chemical Course at the School of Mines, who has kindly assisted us in a portion of these researches.

*School of Mines, Columbia College,
New York.*

* American Chemist, I, 206.

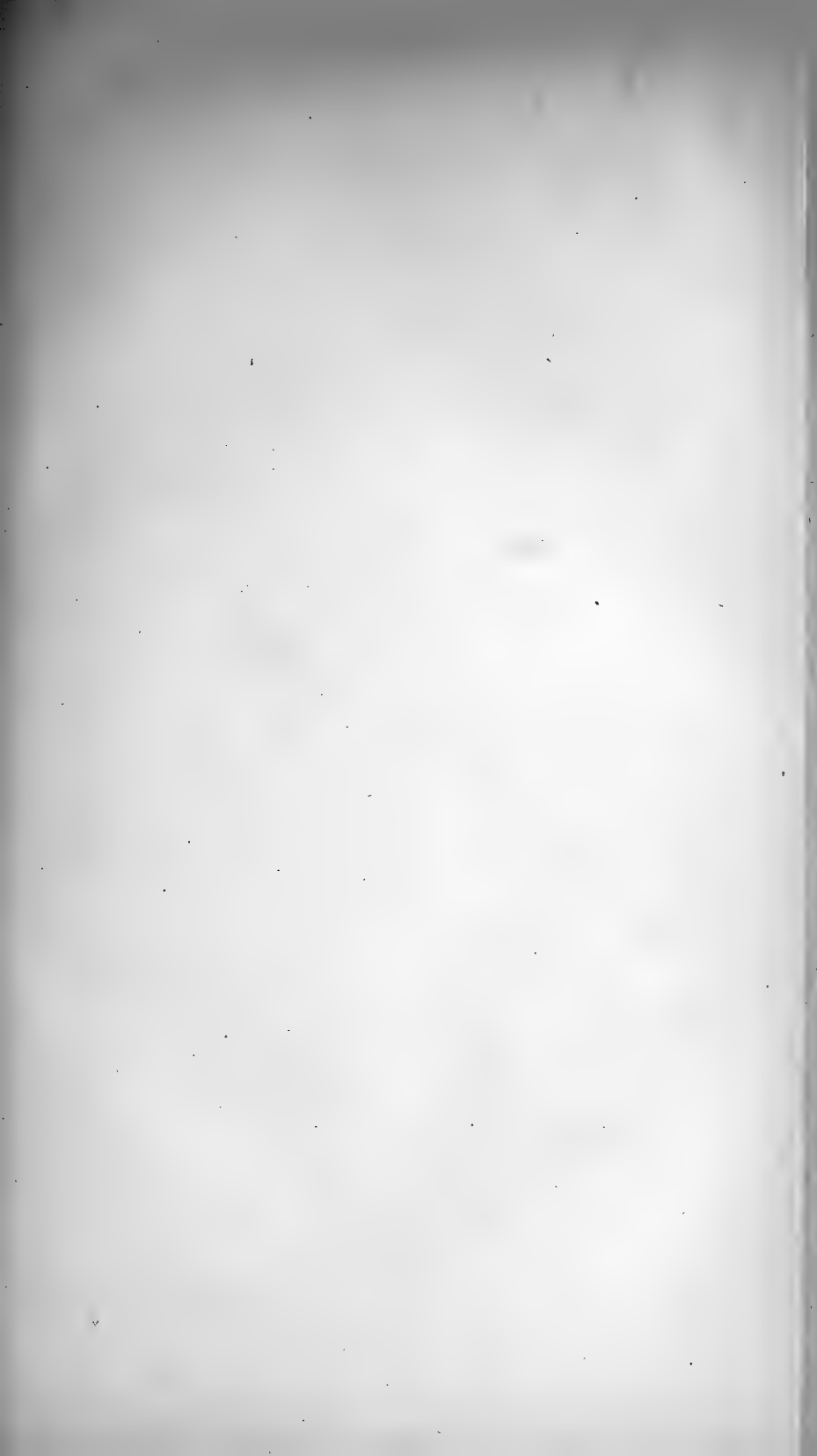

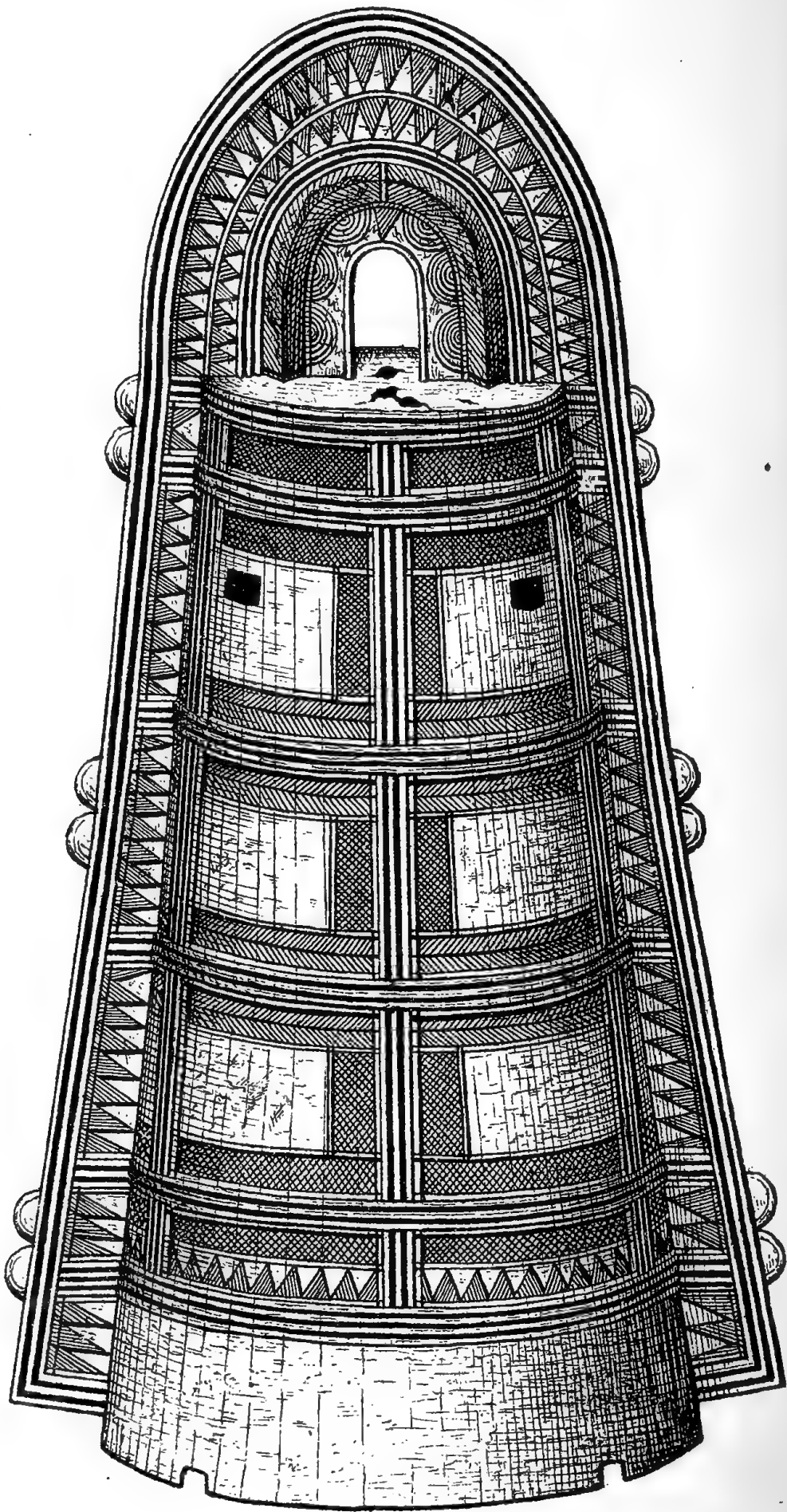

$\frac{1}{6}$ natural size.

E. Muhl, del.

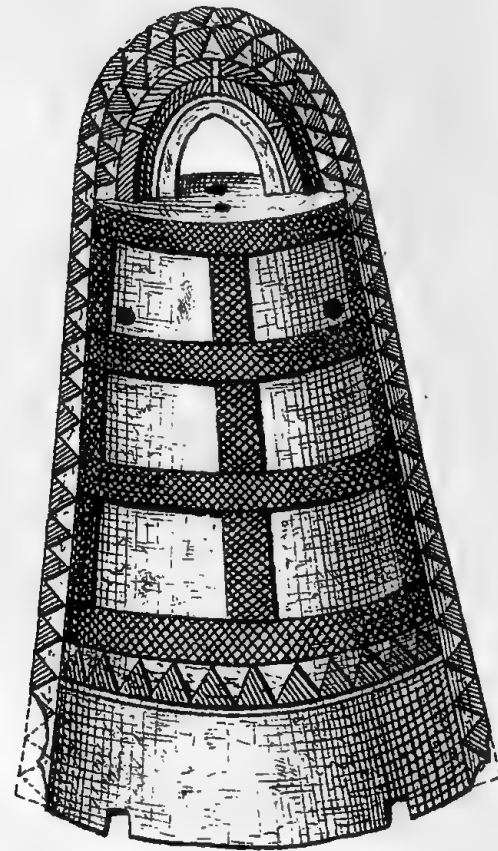
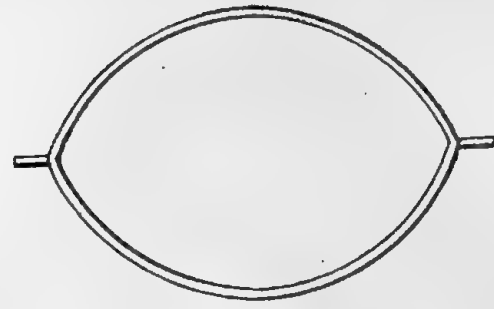

$\frac{1}{6}$ natural size.

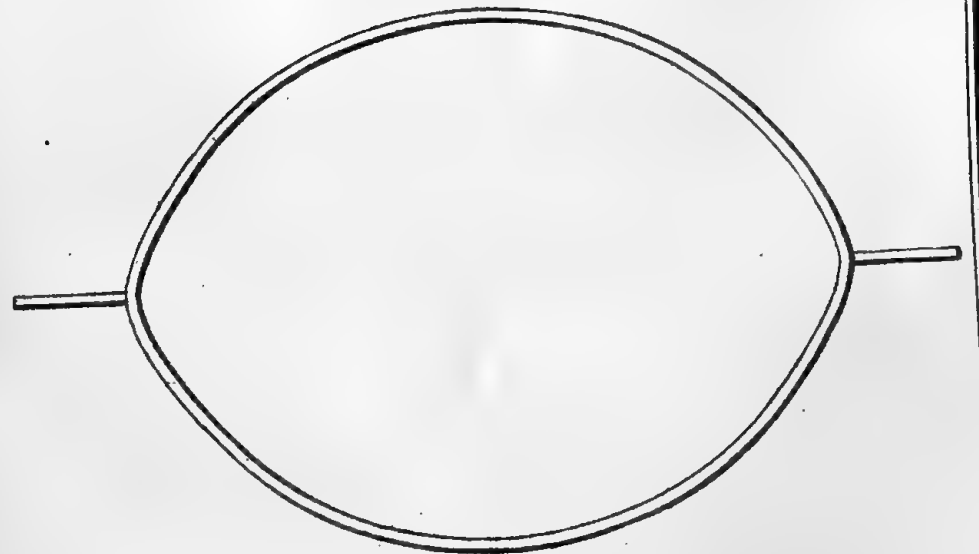

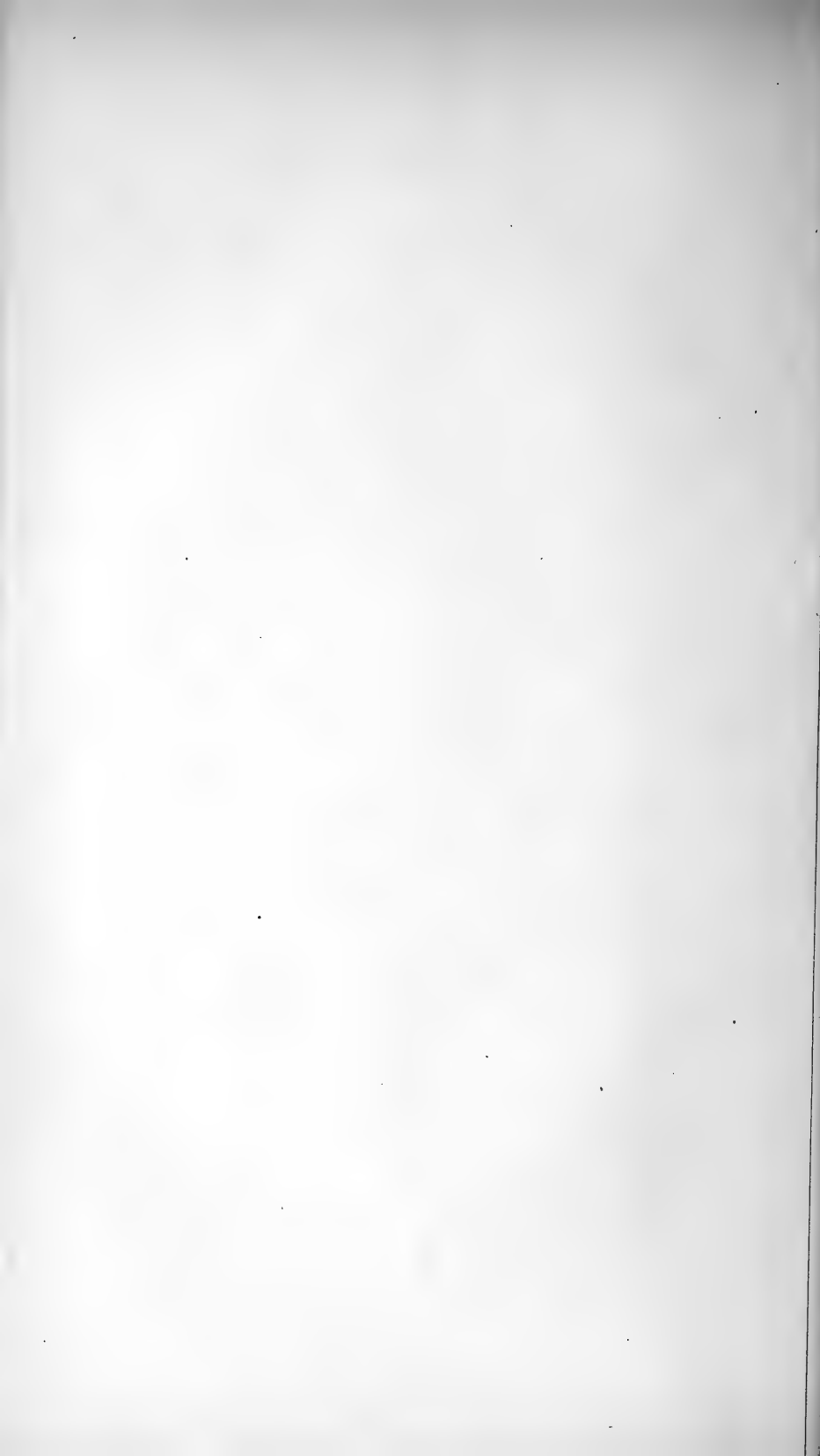

II.—*Prehistoric Bronze Bells from Japan.*

(With Plate II.)

By HENRY S. MUNROE, E.M.

Read February 5th, 1877.

In this paper I would bring to the notice of the members of the Academy, especially those interested in archæology, specimens of a peculiar form of bronze bell common in Japan. These bells are undoubtedly of very ancient origin; and it seems probable, from the statements of Japanese antiquarians, that they belong to a prehistoric bronze age.

My attention was first called to these peculiar bells by a communication from the Japanese Governor of Hiogo Ken, Mr. Kanda Takahira, addressed to Sir Harry Parkes, British Minister to Japan, and read by that gentleman at a meeting of the Asiatic Society of Japan, in October, 1875. Accompanying the letter was a bell, about a foot in height, similar in form and ornamentation to those figured in the accompanying plate.

Stone implements, pottery, and articles of copper and bronze, are frequently exhumed in Japan; and these relics have always been the object of much inquiry and speculation on the part of Japanese antiquarians. Among stone implements, I have seen, in the shops and museums of Tokio, arrow heads, axes, and cutting tools of various kinds, both wrought and polished; and of bronze articles, swords and spear heads of elaborate design, and numerous specimens of the peculiar form of bell which is the subject of the present paper.

Without further preface, I give herewith a copy of Governor Kanda's letter, taken from the columns of the *Japan Weekly Mail*:

GOVERNOR KANDA TO SIR HARRY PARKES.

These copper bells are all of a description that has frequently been dug out of the ground in Japan. There are no trustworthy traditions with regard to the use to which they were put in very ancient times. One report is to the effect that they were suspended from the corners of the roofs of

temples or pagodas, and this is the opinion that I myself hold; but still, the fact that upon the dragon-shaped handle there have not been left any marks of friction of some other metal fastening, affords ground for doubt. These copper bells have only been dug out of the earth, and there is no instance known of one having been handed down from olden days *above* the ground. The localities in which they have been found have mostly been to the west of Kawachi, Tôtômi, in the five Home Provinces, the Central Provinces, and in Shikoku. Nothing has been heard of their being discovered in the circuit to the east of the Hakoné Barrier, in the Hok'kaidô, or in Kiushiu. Their size, also, differs considerably. The very largest go so far as four or five feet, while the smallest are but one or two inches. Their apparent shape is for the most part similar, except that in some cases there may be slight differences in the pattern of the outer surface. These slightly different specimens are of greatly enhanced value in the eyes of Japanese antiquarians, the reason being that they are thus enabled to offer them as a basis for speculation regarding traces of very ancient times. The first instance of the discovery of a copper bell is of exceedingly old date. A short time ago I visited a friend of mine, Mr. Yokoyama Yoshikiyo, a widely read and well informed antiquarian, and questioned him on the subject, when I obtained from him a written reply that is of great importance. This I give below :

“In Vol. 5 of the ‘Fusô-riyak’ki’ it is stated that on the 17th day of the 1st month of the 7th year of the Emperor Tenji’s reign—corresponding to the year 669 A.D. of the foreign calendar—when the temple of Sô-fuku-ji was being erected in the Department of Shiga and province of Ômi, and the earth was preparatorily leveled, a strange and valuable bell was dug up from the ground. Its height was 5 ft. 5 in. There was also dug up a wonderful kind of white stone, 5 inches in length, which shone brightly at night.

“Again, in Vol. 6 of the ‘Nihonki,’ we find it said, that in the 7th month, in the autumn of the 6th year of the period Watô, corresponding to the year 714 A.D. of the foreign calendar, during the reign of the Emperor Gemmei, a person named Muragimi Adzumando—a *Taishôï no-jô* *—belonging to the village of Namisaka, in the Department of Uta and province of Yamato, found, in the uncultivated district of Nagaôka, a copper bell, which he accordingly offered up (to the Emperor). It was three feet in height, and measured one foot across the diameter of the mouth. Its style of manu-

* A title of rank.

facture differed from that ordinarily known, and its sound came under the *ritsu* and *riyo* tones. Orders were given by the Emperor to the officials to lay it up in the storehouse.

"In the 2d part of Vol. 11 of the 'Nihonkiryaku,' it is stated that in the 5th month of the 12th year of the period Kônin—corresponding to the year 822 A.D. of the foreign calendar—during the reign of the Emperor Saga—as a man in the province was digging in the ground he discovered a copper bell. It was 3 ft. 8 in. in height, and the diameter of the aperture was 1 ft. 2 in. The people styled it the Bell of King A-iku's* Pagoda.

"Again, in Vol. 11 of the 'Nihongôki,' we read that in the 6th month of the 9th year of Shôwa—corresponding to the year 843 A.D. of the foreign calendar—there was presented (to the Emperor), from the Province of Wakasa, a copper utensil that in shape very nearly resembled a bell, which had been dug up from out of the ground.

"In Vol. 4 of the 'Sandai Jitsuroku' it is stated that on the 14th day of the 8th month of the 2d year of Jôkan—corresponding to the year 861 A.D. of the foreign calendar—there was presented to the Emperor, from the Province of Mikawa, a copper bell. It was 3 ft. 4 in. in height, and one ft. 4 in. in diameter, and had been discovered in the hill called Muramatsu in the Department of Atsumi. It was observed by some one, 'This is a precious bell of King A-iku.'

"Apart from the above, there must also be other instances. The fact of King A-iku having in one single day erected 84,000 pagodas is mentioned in Vol. 4 of an old book called 'Konjaku Monogatari,' and in Vol. 13 of that called the 'Jinkaishô,' etc., etc. The first mention of him is made in Vol. 3 of 'Shokiyo Yôshiu,' but as this is a long affair, it is not fully given here.

“(Signed) YOKOYAMA YOSHIKIYO.”

Many years after the above, during the period of Tenshō (1573–92 A.D.), a copper bell was dug up in the Province of Yamato, and was presented to the Taikō Toyotami. The Taikō regarded this as an object of great value, but afterward conferred it, as a reward, upon a general who had achieved some great exploit. In the times of the Tokugawa family, during the period of tranquillity and peace, those bells that were dug up were very numerous. Sixty or seventy years ago there lived an antiquarian called Yashiro Tarô, who held the office of historian to the Bakufu. He was a man of profound knowledge and a lover of antiquities; and he collected

* Name of an Indian ruler, who erected many pagodas, v. *infra*.

together drawings of several tens of these copper bells, and made them into a volume, which he offered as a basis for speculation (about these bells). Unfortunately, however, these were not engraved on blocks, and so there are at present very few persons to whom (copies of) this volume have descended. Just now there is no lack of persons who are in possession of these copper bells. They are frequently sold at the old utensil shops in the three cities (Yedo, Kioto, and Osaka), and their price, too, is not excessively dear, which is a proof of the numbers that have been dug up. The articles that have been handed down from antiquity in my country (*i. e.*, Japan) are of three kinds,—stoneware, earthenware, and copper arms. The stone articles found are: *raifu*,* stone swords, flint arrow-heads, etc.; among the earthenware, sacred jars;† and among the copper ones, small round bells (*sudzu*), copper swords, and copper bells (like the present). Constant inquiry has from olden times been set on foot by Japanese literati with regard to these various articles, but still, down to the present time, there has not been found any one able to give clear explanations either as to their age, their owners, or the purposes for which they were used. My own opinion is that the one point to be investigated over and above these, is the single question as to whether such articles as these do or do not exist in countries beyond our own seas, and especially in China, Corea, Manchuria, etc. If inquiry be made into my reason for this, it is that supposing, in those other countries, there should exist similar articles, then this would afford a proof of the common origin of the ancestors of those nations and of our own. I have not, however, been able as yet to effect this search, and this is a matter for which I feel constant regret. I have heard that in Yokohama some learned foreign gentlemen have established a Society for the purpose of investigating Asiatic antiquities, and I think that some decisive conclusion may be arrived at by that Society with respect to the above three kinds of articles. I consequently now beg the kind offices of the English Minister, Sir Harry S. Parkes, and send to the Society a copper bell that has been kept in my possession for a long time, with the desire of inviting discussion thereon. Should the various gentlemen belonging to the Society hold any opinions on the subject, let them be so good as to make them known. If, in consequence of their exertions, it come to pass that we obtain some basis for ascertaining the place from which the ancestors of the Japanese people origin-

* Evidently a kind of axe.

† Apparently those used at Shintô festivals.

ally came, no small benefit will be conferred upon the land, and it will be a matter of rejoicing not to myself alone.

Written in Hiogo by

KANDA TAKAHIRA.*

May 10th, 1875.

On reading this letter before the Asiatic Society, Sir Harry Parkes remarked that, in accordance with the suggestions of Mr. Kanda, that similar bells may have been found in China, Manchuria, or Corea, he had sent the bell to Mr. Meadows, British Consul at Shanghai. From there it was sent to Dr. Bushell, of Peking, who had made the subject of bells a special study. Neither of these gentlemen could give any information. The disturbed state of Manchuria at the time rendered further investigation in that direction impracticable.

The following facts, brought out by Mr. Kanda's letter, are of great interest:—

1. These bells have been exhumed in large numbers in different parts of Japan, so that they are quite common in the shops of Tokio and other cities.

2. Among the large number of bells of this peculiar form, there is no instance in which one has been handed down from ancient times above the ground.

3. The bells are of a uniform shape, differing only in the ornamentation of the surface.

4. The fact that these bells are associated by Japanese antiquarians with stone implements, etc., is also significant. Whether any such prehistoric relics have been found buried with the bells, I am not able to say.

Another fact is interesting in this connection. According to Japanese historians, copper ore was first discovered in Japan in the year 684 A.D., and copper coins were not made till 706 A.D.; while according to Mr. Yokoyama the first of these bells was unearthed in the year 669 A.D.

As to these peculiar bells being common, I can myself testify; for in a few days' search in Tokio I found eight or ten specimens in different shops, and for sale at prices which made imitation seem improbable. On these eight or ten bells

* The Governor of Hiogo Ken.

there were apparently no signs, symbols, or written characters; the ornamentation in every case being of the simplest kind, similar to the geometrical designs on the specimens figured in the accompanying plate.

These bells evince considerable metallurgical skill on the part of the people of the bronze age in Japan. They show unmistakable signs of having been cast, apparently in moulds of sand. The metal is quite thin, averaging in the larger bells little more than one-eighth of an inch, but at the same time remarkably uniform and showing but few flaws. The lines of the pattern are clear and distinct.

I add the composition of the bronze of these bells, as determined by analyses made by students in the School of Mines, under the direction of Prof. H. C. Bolton. For comparison, I have placed in parallel columns analyses of some modern Japanese bronzes, etc.

	Prehistoric Bronzes.		Modern Bronzes.				Modern	
	Large Bell.	Small Bell.	"Old Bronze Vases and Ornaments."				Crude Copper.	
Copper..	94.30	79.75	85.30	83.70	71.00	73.48	Copper....	—
Tin.....	2.84	11.44	8.90	5.38	5.50	7.18	Silver.....	0.03
Lead....	2.40	7.32	4.70	7.80	20.35	13.07	Lead.....	0.46
Iron....	0.32	0.08	1.10	0.65	1.84	1.10	Iron.....	0.75
Arsenic	—	none.	traces.	traces.	—	traces.	Arsenic...	traces.
Zinc....	—	—	—	1.85	1.34	5.18	Antimony.	none.
Nickel..	—	0.92	—	—	—	—	Sulphur...	0.36
	99.86	99.51	100.00	99.38	100.03	100.01		—
Analyst	K. Nambu.	F. W. Taylor.	Dr. Geerts.				W. Gowland.	

A duplicate analysis of the large bell by Mr. N. Matsui gave results agreeing closely with those obtained by Mr. Nambu.* The composition of the small bell is the average of three analyses by Mr. Taylor.

* These gentlemen are Japanese students from the University of Tokio, now at the School of Mines of this city

From the analysis of Japanese copper, it would seem probable that the iron and the traces of arsenic in the bronzes are due to the crude copper used in making the alloy. The lead was purposely added, probably to make the alloy more fusible. Tin is found in Japan, but zinc and brass are obtained from abroad. The presence of zinc, therefore, is a distinguishing characteristic of the modern bronzes.

III. — On the Structure of *Lepidodendron* and *Sigillaria*.

By HERMAN L. FAIRCHILD.

The science of Palæontology has, up to the present time, been in what may be termed its analytical stage. The general tendency has been toward the separation of forms and the creation of new species. This is doubtless in the natural order of the development of the science; but in vegetable Palæontology the establishment of new species has certainly been carried to an extreme. It is admitted that Palæophytology is greatly confused; and, indeed, from the fragmentary character of fossil plants, much of this confusion is unavoidable. There is even yet a degree of uncertainty regarding the true specific and even generic character of several groups. But with all these causes of uncertainty, it is probable that species and even genera have been somewhat needlessly multiplied, by regarding as sufficient for distinction, variations so extremely slight that in living plants they would scarcely be noticed.

Probably no genus is involved in greater confusion, as regards the species, than either *Sigillaria* or *Lepidodendron*. In these genera the chief, and in nearly every species, the only feature upon which specific distinction can be based, is the scar or cicatrice left by the falling leaf. If we judge by living plants, and we are compelled to do so, these scars must vary more or less with age, position on the plant, rapidity of growth, leafiness, the degree of decortication, and many accidental circumstances. Only in very rare instances, however, have specimens of these gigantic palæozoic plants been found suffi-

ciently preserved to show the variation of the leaf scars in different individuals of the same species, or even upon different parts of the same individual. Yet the great majority of species have been constructed upon a few fragments, and many even from a single isolated fragment of bark, or its impression. It will doubtless be forever impossible to determine all the species accurately. But the means are constantly increasing, and ought now to be sufficient to permit the elimination of many of the false species. M. Schimper has already begun in this branch of Palæontology the synthetic phase. But as regards the fossil plants of America, the change is almost entirely yet to come.

It is the purpose of the writer to show, in a series of brief papers, the variations and relations of some of the common forms of *Lepidodendron* and *Sigillaria* that have come under his observation, with the object of helping, if possible, the determination of the true species.

The first of the present papers will relate to variations in the leaf-scars of certain common *Sigillariæ*; the second will endeavor to prove the identity of several so-called species of *Lepidodendron*.

No. 1.—On the Variations of the Decorticated Leaf-scars of certain *Sigillariæ*.

(With Plates III and IV.)

Read June 4, 1877.

The sub-cortical scars of *Sigillaria reniformis*, Brogniart, and of *S. laevigata*, Brgt., present remarkable variations in size and form, even upon small surfaces of the trunk. One strange form of *S. reniformis* has been described and figured by Prof. L. Lesquereux, in Rogers' Report of the Geology of Pennsylvania, as a distinct species, under the name of *S. discoidea*. After the description he comments as follows: " * * * Its place in the family of the *Sigillariæ* is scarcely acceptable. But as we could not obtain any good specimens for further examination, we have nothing else to say about its other characters; we mention it here till some better opportunity to study it is afforded."

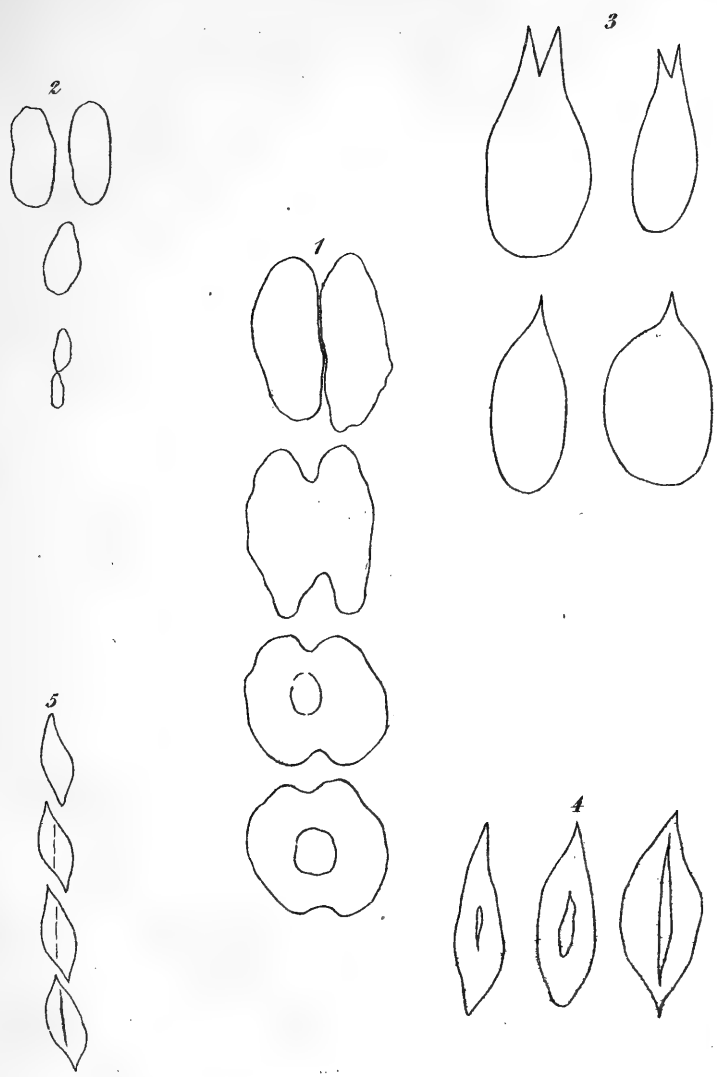

H. L. Fairchild, del.

Brett Lith. Co. N.Y.

Variations of *Sigillaria reniformis*, Brgt.

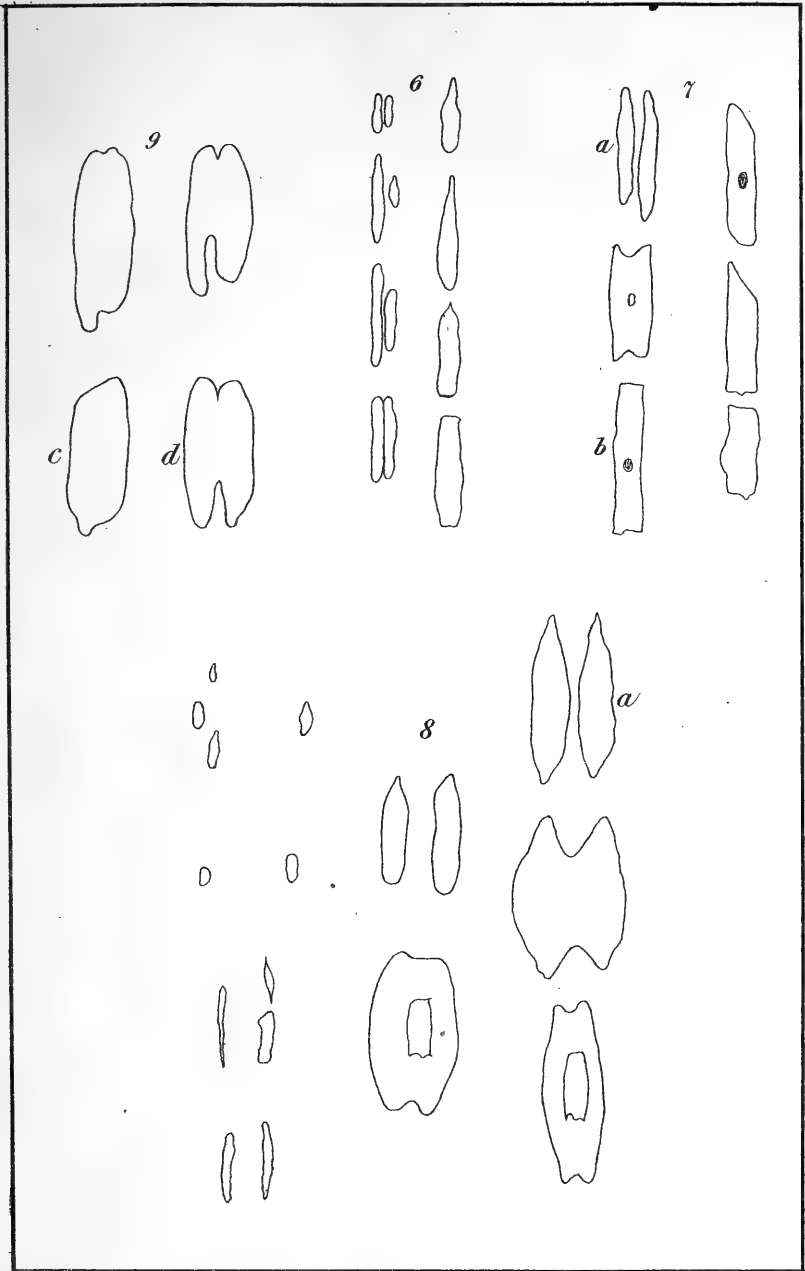

Variations of *Sigillaria laevigata*, Brgt...

That *S. discoidea*, Lesq., is simply one of the diverse forms produced by the union and distortion of the geminate vascular scars of *S. reniformis*, I have determined by examination of numerous specimens in several collections of coal plants. In the cabinet of Mr. Edward Jones, Olyphant, Pa., there are several remarkable specimens of decorticated *S. reniformis*, showing all phases of the transition from the geminate oval scars to the single orbicular scars described by Prof. Lesquereux. Two large slabs are especially worthy of mention. Each has ten rows of elevated disciform scars, four inches apart and twenty to twenty-four inches in length. The scars are one inch in diameter, almost touching, and are emarginate either above or below, as shown in Prof. Lesquereux's figure of *S. discoidea*. Many of them are emarginate on both the superior and inferior sides; and nearly all have an irregular depression in the centre, or a depressed line—the junction of the two vascular scars. Many of the discs are deeply lobed above and below, and some are entirely divided into two elliptical or oval scars. On one slab, the greater part of two rows thus clearly appear as *S. reniformis*. Fig. 1 (Plate III), shows four scars, from different portions of one of these slabs, which fairly represent the general character of the scars and their transition in form.

Other specimens showing the true nature of *S. discoidea*, so-called, may be seen in Professor J. S. Newberry's collection, New York; in the Museum of the Wyoming Historical and Geological Society, Wilkesbarre, Pa.; and in most large collections from the Wyoming basin.

Another specimen of *S. reniformis*, in Mr. Jones' cabinet, shows a great variation. The geminate oval scars on one side of the slab are one-half to three-fourths of an inch in length, and are separated by a space equal to one-half the breadth of either scar. But these diminish in size, and gradually coalesce to form single disciform scars, which continue to lessen in size until they become oval or elliptical and only one-fourth to one-eighth of an inch in length. The scars are crowded longitudinally. These rows are only twelve inches long, and every row presents a similar change. Fig. 2 repre-

sents the twin scars at one extremity of a row, two small scars at the opposite end, and one from the middle of the same row.

There are various diverse and peculiar forms produced by the union of the sub-cortical scars of this species. The scars illustrated in Fig. 3 are upon the same specimen. Other specimens show both ends acute or slenderly pointed. There is also great diversity in the breadth of these scars, as they vary from narrow elliptical to rotund. In some cases the transverse diameter is the greater. All of these forms may not, but they usually do, have a central depression, varying from rotund to oblong, or even linear, and frequently appearing only as a line or furrow, sometimes irregular or of varying width, extending the whole length of the scar. Fig. 4 shows three scars from one slab, illustrating these features. This, and also Fig. 3, are from specimens in Mr. Jones' collection. It will be readily understood how different in appearance are scars having peculiar combinations of the features above mentioned.

Another form of *S. reniformis* has oblique oval or elliptical scars, with ends acute and oppositely curved; length one-half inch; depression linear, width of ribs two inches. The scars are very close, and the oppositely curved ends of adjacent scars overlap like the cicatrices of *Lepidodendron*. This form evidently results from the twin vascular scars not uniting evenly end with end, but lapping over each other; caused doubtless by oblique distortion in the growth of the base of the leaf. Fig. 5 shows a portion of one row of scars. In this specimen the furrows between the rows are obsolete; and the rows are not continuous, but, as it were, broken and shifted laterally. The specimen is in my own collection, and is from the "Diamond" seam, Scranton, Pa. The other specimens already mentioned are said by the possessor to be from the "Hull" seam, Olyphant, Pa., the first above the "Diamond," in that locality.

Upon some decorticated slabs of *S. reniformis*, the fluting is very strong, while upon others it is entirely absent.

Since the preparation of the above matter, I find that, in

his *Traité de Paléontologie Végétale*, M. Schimper gives two figures (Plate 67, Fig. 8-9) showing the confluence of the decorticated geminate scars of *S. reniformis*.

The species *S. lævigata*, Brgt. is subject to a similar union of the geminate sub-cortical scars. The figures on Plate IV are from specimens in the collection of Prof. J. S. Newberry; locality, the Wyoming coal basin, probably the Lackawanna portion. Fig. 6 shows the variations upon a single slab: the scar *a* is the natural form. Fig. 7 shows scars from different parts of a large specimen. The greater number of scars have a distinct rectilinear form, like the one marked *b*. The rows are about two inches apart, but much broken and shifted. Upon one side of the slab, two broken rows are brought end to end, which belong to adjacent rows. The scars are very close longitudinally, and are much raised; furrows obsolete.

Fig. 8 represents the variation in two outside rows and the middle row of scars, upon a slab having five rows three inches apart. The furrows are obsolete. In the figure, the scars have their true relative positions, viz.: from the ends and middle of the rows. The left-hand row of scars is changed to an irregular row of very small scars; sometimes several to one leaf-base, and without regularity or order in any respect.

Another singular form is shown in Fig. 9. The scars are represented in this figure in their natural position; and they are a portion of a single row. The slab shows two rows of these double scars, with an intervening space of three inches; furrows obsolete. The geminate scars appear sub-geminate. Apparently we have in this figure only *two* leaf-scars; *c* and *d* constituting a single one. Whether such is the fact, or if the leaves were in double rows, I can not positively determine. It is very peculiar in either case.

Several of these forms are so different that, if studied separately, they might have furnished several species of *Sigillaria*. This is a good illustration of the difficulty in classifying isolated fragments of fossil plants, and of the consequent multiplication of species.

IV.—*Descriptions of New Species of Birds from the Island of Dominica.*

BY GEORGE N. LAWRENCE.

Read October 1, 1877.

An exploration of some of the least known of the West India islands, for the purpose of elucidating their natural history, has been undertaken by Mr. Fred. A. Ober, of Beverly, Massachusetts, under the auspices of the Smithsonian Institution. As yet, his investigations have been confined to Dominica, whence two collections of birds have been received, and sent to me for determination.

In his last letter (July 2d) he states that he intended leaving for Antigua, to remain about two months, and then return to Dominica, to conclude his exploration of that island during the hurricane months, when he expected to get the migrants that appeared at that season, and a few other resident species which he had heard of. When this collection is received, a list of the birds of that island will be published, together with the notes and observations made by Mr. Ober. He has already sent every species heretofore obtained in Dominica, with twenty-three additional ones. His first collection consists of 150 specimens, embracing thirty-one species, three of which I consider new and have described below. Of this collection he writes as follows: "The first collection was made in the mountains of the Caribbean side of Dominica, though it includes also birds of the lower hills and valleys, there seeming to be but few kinds of the low lands that do not ascend to the mountains; though there are many birds of the mountains and upper valleys that never descend into the low country near the coast."

Besides the three species of humming birds well known as inhabitants of the island, I was greatly surprised to find another species in the collection, viz., *Thalurania Wagleri*, of which there are seven specimens—all males. The only locality

heretofore given for it is Brazil, and it is considered rather rare; it looks now as if its headquarters were Dominica, yet it seems strange that none are recorded from any intermediate place. It would appear to be not uncommon, as more specimens were sent than of *Eulampis holosericeus* and *Orthorhynchus exilis*, which are abundant species. *Eulampis jugularis* was sent in large numbers. On the label of one of the examples of *T. Wagleri* is, "Sulphur lake, 2,300 feet above the sea."

The second collection was made on the eastern or Atlantic side of the island; it contains eighty-two specimens, and has in it ten additional species, but no novelties. There are two specimens of that fine and rare species of parrot, *Chrysotis augusta*.

1—Thryothorus rufescens.

MALE. Entire plumage rufous, much deeper in color above, of a lighter and brighter shade underneath; tail dark rufous, regularly and closely crossed with narrow bars of black; the coloring of the under part of the tail is duller, but is barred in a similar manner; inner webs of quills blackish-brown, outer webs and both webs of the innermost secondaries dark rufous, with distinct narrow bars of black; upper mandible dark brown, the under yellowish-white; feet pale brown.

Length, $4\frac{7}{8}$ in.; wing, $2\frac{5}{8}$; tail, $1\frac{5}{8}$; tarsus, $\frac{1}{2}$; bill from front, $\frac{3}{16}$; from rictus, $\frac{3}{4}$.

Type in National Museum, Washington.

Remarks. But a single specimen of this species was in the collection; it does not seem to require comparison with any other.

I have never seen *T. Martinicensis*, but, judging from its description, they are quite different.

2—Dendroeca plumbea.

MALE. The whole of the upper plumage is dark plumbeous; a narrow white line extends from the bill, over and beyond the eye, and there is a white mark on the lower eyelid; the lores are black; the under plumage is of a lighter plumbeous than that of the upper; the chin, middle of the throat and of the breast intermixed with white, centre of abdomen white; the two middle tail feathers, and the outer webs of the others, are like the

back in color, the inner webs are blackish slate color; on the inner web of the outer tail-feather, at the end, is a spot of white; on the next feather is a smaller one, and the next two have only a terminal edging of white; the middle and greater wing-coverts have their outer webs of the color of the back, and their inner webs black; they end conspicuously with white, forming two bars across the wings; quills with their outer webs like the back, and their inner blackish slate-color; under wing-coverts and axillars white; upper mandible black, the under light horn-color; tarsi and toes light brown.

Length (skin), $5\frac{1}{2}$ in.; wing, $2\frac{7}{16}$; tail, $2\frac{1}{2}$; tarsus, $\frac{3}{4}$; bill from front, $\frac{7}{16}$.

The female is above of a dark greenish olive; it has black lores, with a white stripe over the eye and on the lower eyelid, just as in the male; below it is of a much lighter or grayish-olive, the chin, middle of the throat and of the breast mixed with pale yellowish-white, the middle of the abdomen is pale yellow; the ends of the wing-coverts, the under wing-coverts and the axillars, are white, with just a tinge of yellow; the spots at the ends of the tail-feathers, as in the male, but less distinct; bill and feet of the same color as those of the male.

Types in National Museum, Washington.

Remarks. The contrast of color between the male and female brings to mind that which exists between the sexes of *D. caerulescens*. The coloring of the males of the two species, however, is quite different; but the females are in some respects singularly alike, as they agree in the color of the upper plumage, in having the white superciliary stripe and lower eyelids of that color, also in the dark lores, though they differ in the color of the under plumage and of the bill.

This would appear to be quite an abundant species, as there are eleven examples in the collection.

3—Myiarchus Oberi.

MALE. Pileum, nape and sides of the head dark umber-brown, upper plumage dark olive-brown, upper tail-coverts edged with dull ferruginous; two middle tail-feathers blackish-brown, the other feathers are colored the same, except on the outer two-thirds of the inner webs, where they are bright ferruginous; outer web of lateral feather and ends of the others, ash color; quills brownish black, the primaries narrowly edged with dark ferruginous; the outer secondaries are margined with very pale rufous, and the other secondaries with pale yellowish-white; wing-coverts dark brown, ending with pale ashy tinged with rufous; under wing-coverts pale, dull yellow, inner margins of quills light salmon-color; lores, throat

upper part of breast and sides clear bluish-gray, lower part of breast, abdomen and under tail-coverts pale yellow; bill and feet deep black.

Length, $8\frac{3}{8}$ in.; wing, $3\frac{3}{8}$; tail, $3\frac{3}{8}$, tarsus, $\frac{7}{8}$; bill from front, $1\frac{1}{8}$.

The female does not differ in plumage from the male.

Types in National Museum, Washington.

Remarks. This is a large species, exceeding *M. crinitus* in size; the fourth quill is longest, the third and fifth nearly as long and equal; the bill is large and strong, and of a deep black throughout; the upper plumage is dark, much like that of *M. tyrannulus*, but is even darker.

In the collection are seven specimens; they agree closely in plumage, two only differ from the type in the dimensions of the wing, one having it three and three-quarters, and the other four inches in length.

Mr. E. C. Taylor (Ibis, 1864) records a species of *Myiarchus* from Dominica, which was for a good while undetermined. In a List of Birds from St. Lucia, given by Mr. Selater (P. Z. S., 1871, p. 271), he refers it to *M. erythrocerus*.

I have a specimen of this species from Bahia (verified by Mr. Selater); on comparison I find the two birds to differ very decidedly.

M. erythrocerus is smaller; above it is of a lighter brown, more ochreous, especially on the crown; the bill is weaker and more depressed; they are somewhat alike in the coloration of the tail-feathers, but the line of contact of the two colors is more decided in *M. Oberi*.

I do not determine that this is the same as the species obtained by Mr. Taylor; possibly the two forms may exist in Dominica.

I have named this species in compliment to Mr. Fred. A. Ober, who has, thus far, so industriously worked up the avifauna of Dominica.

V.—*Descriptions of New Species of Birds of the Families
Trochilidæ and Tetraonidæ.*

By GEORGE N. LAWRENCE.

Read October 15, 1877.

1—*Sporadinus Bracei.*

MALE. Crown and gorget of a glittering pale green; back, upper tail-coverts, the two central and the next pair of tail-feathers, bronzed golden-green; the other tail-feathers are purplish-black, with their outer edges bronzed green; quills blackish-purple; breast and abdomen dull bronzy-green; under tail-coverts dark ash bordered with white; bill and feet black.

Length, $3\frac{3}{8}$ in.; wing, $1\frac{3}{4}$; tail, $1\frac{1}{8}$; bill, $\frac{3}{4}$.

Type in National Museum, Washington.

Habitat: Island of New Providence, Bahamas.

Remarks. The specimen is a mummy, and the outer two tail feathers are just being renewed, the length of these is important to determine its true generic position; but as it resembles *Sporadinus Ricordii* in other respects, I place it provisionally in the same genus. If the outer tail feathers were fully developed, they would doubtless increase the total length, as well as that of the tail. This species is nearly allied to *S. Ricordii* from Cuba, but differs from it in being smaller, with a longer bill; the green of the crown and throat is paler and more of a steely shade; the back is more bronzed, and the under plumage of a lighter green.

I have named this species in honor of L. J. K. Brace, Esq., who is now investigating the ornithology of New Providence, and recently sent this species, with a few others, to the Smithsonian Institution.

2—*Orthorhynchus emigrans.*

MALE. The basal half of the crest is of a shining emerald-green, the terminal half deep reddish-violet; the upper plumage is dark grass-green; tail-feathers blackish-purple, the two central ones washed with green; quills light purple; throat smoky-gray; breast and abdomen smoky-black; bill and feet black.

Length, $3\frac{1}{2}$ in.; wing, $1\frac{7}{8}$, tail, $1\frac{1}{8}$; bill from termination of frontal feathers, $\frac{7}{16}$.

A younger specimen, but with the crest fully developed, has the throat whitish-ash, and the outer two lateral feathers tipped with the same.

The female, as in the allied species, is without the brilliant crest.

Habitat: Venezuela. Type in my collection.

Remarks. This is a close ally of *O. cristatus* from Barbadoes; the two colors of the crest are equally divided in both, but they differ in shades of coloring; the green in the new species is without the strong golden tinge existing in the other, and the violet is rather deeper in color, which color it retains in all positions—whereas in some lights that of *O. cristatus* is greenish; the upper plumage of the latter is lighter and of a golden-green; the new species is also rather smaller, with a longer bill. They differ strikingly in the ends of the tail-feathers, these being obtusely pointed in the new species, and rounded in the other.

O. ornatus I have not seen, but judging from the description and plate of that species, a comparison with it is not necessary.

3—*Cyrtonyx Sumichrasti*.

In February of this year, Prof. Sumichrast sent me the description of a supposed new species of *Cyrtonyx*, obtained by him in the mountains of Santa Efigenia, with the request that I would investigate its claim to novelty. He promised to forward the specimen by the first opportunity; but so long a time having elapsed without its coming to hand, and being satisfied that it is a new species, I have concluded to give a translation of his description, which from his known capability may be relied on as correct.

“MALE. Head of a deep black, streaked with white, the feathers of the occiput forming a sort of loose tuft of pale ashy-brown; feathers of the back light leaden-gray, marked in the centre with a pale cinnamon-red stripe extending the entire length of the shaft, and with transverse black spots on each side; wing coverts pale ashy-gray, with a cinnamon-red stripe running the length of the shaft, and with black spots on each side; remiges brownish-black, spotted outwardly with white (on the primaries), and with reddish-white (on the secondaries); breast of a light red, the

feathers on the sides of a leaden-gray at their bases; upper part of the abdomen and flanks of a beautiful chestnut-red, the feathers of the flanks speckled with leaden-gray, and marked with transverse spots finely speckled with the same gray; belly, crissum, and under tail-coverts of a deep velvety-black; tail very short; bill with the upper mandible black, the under whitish; feet leaden-gray; iris deep brown.

"Length, 0m .20; wing, 0m .13; tarsus, 0m .025.

"This beautiful species, which I met with not long ago for the first time in the mountains of Santa Efigenia, closely resembles *C. Massena* in the white ornaments on deep black upon the head; but the size is less, the color of the breast and feet different, etc."

Habitat: Mountains of Santa Efigenia, Tehuantepec.

Remarks. In the markings of the head it closely resembles *C. Massena*, but differs in many particulars of color from that and also the other members of the genus. The different coloring and markings of the flanks of each species will readily distinguish them, in the new one being "chestnut-red speckled with leaden-gray," and in *C. Massena*, blackish-plumbeous with round white spots. *C. ocellatus* has the sides marked with large rufous spots, and *C. Sallei* has the flanks leaden-gray with chestnut spots and bars. I have conferred Prof. Sumichrast's name on this fine species, as a fitting tribute to his efficient aid in the cause of science.

Since the above was in press, I have received (Nov. 6th) a letter from Prof. Sumichrast, in which he says: "I hope to undertake in a few days an expedition to the mountains where I killed the *Cyrtonyx*. It is a region where no one, either white or Indian, has ever penetrated; and I flatter myself, unless some accident happens, to find some interesting species."

VI.—Index to the Literature of Titanium, 1783–1876.

By EDWARD J. HALLOCK.

Read December 11, 1876.

Part I, General Literature, 1791–1876; for Minerals, see Part II.*

1791	Wm. McGregor	Original Discovery	Crell's Ann. I, 40, 103. Journ. de Phys. LXXII, 152.
1791	Crell	Ménakanire	Ann. Ch. XII, 147.
1795	Klaproth	Researches on red schorl	Klapr., Beitr. I, 233. J. de M. II, 12, 45.
1797	Klaproth	Separation of Ti and Mn.	Klapr., Beitr. II, 236.
1798	Vauquelin	Researches	Ann. Ch. XXV, 30.
1798	Van Mons	Affinity of Ti	Ann. Ch. XXXVI, 91.
1799	Lampadius	Reduction of oxide	Scherer's J. IX, 72. Busch's Alman. III, 120. Phil. Mag. XVII, 95.
1799	Lowitz	Tests and reactions	Scherer's J. VI, 638. Crell's Ann. I, 183.
1800	Lowitz	Observations	Ann. Ch. XXXIV, 270.
1800	Humboldt	Crystals of Ti	Ann. Ch. XXXV, 106.
1801	Chevenix	Phosphide	Phil. Mag. XI, 88.
1803	Fourcroy and Vauquelin	Ti in platinum ore	Scherer's J. XI, 462. Ann. Ch. XLIX, 192. Schweigg., J. I, 364.
1807	Thomson	Ti in sand from the river Dee	Proc. Roy. Soc. Edinb. VI, 253. Phil. Mag. XXXV, 100. Repert. of Arts. (2), XVI, 100. Scherer's J. VII, 200.
1808	Gehlen	Not precip. by tannin	Ann. Ch. LXV, 187.
1812	Berzelius	Action of heat upon Ti O ₂	Schweigg., J. VI, 175.
1814	Laugier	Purification of Ti O ₂	Ann. Ch. LXXXIX, 306. Schweigg., J. XIX, 54.
1814	Berzelius	Oxide	Schweigg., J. XI, 201; XII, 40.
1816	E. D. Clarke	Before the blow-pipe	Gilb., Ann. LXII, 350. J. Roy. Inst. III, 104. Schweigg., J. XVIII, 241.
1816	Gadolin	Titanic acid	Alg. nord. Ann. Ch. II, 217. Mem. Ac. St. Petersb. VI, 1818.
1816	C. H. Pfaff	Ti in sulphuric acid	Schweigg., J. XVIII, 283.
1817		Separation of Ti and Zr.	Schweigg., J. XXI, 251.
1818	Berzelius	Atomic weight	Schweigg., J. XXII, 75.
1819	Stodart and Faraday	Attempt to reduce	Proc. Roy. Inst. IX. Gilb., Ann. LXVI, 188.
1820	Chevrenl	Difference between Ti and Zr.	Bull. Soc. Phil. 1820. Ann. Ch. Phys. (2), XIII, 247. Schweigg. XXIX, 146.

* This paper is prepared on the plan of Dr. H. C. Bolton's Indices to the Literature of Uranium and of Manganese, Annals of the Lyceum of Natural History, New York, vol. IX, p. 362, and vol. XI, p. 208.
E. J. H.

1821	H. Rose	Researches	Mem. Ac. Sci. Stockholm, 1821. Ann. Ch. Phys. (2), XXIII, 352.
1822	Wollaston	Ti in furnace slag	Gilb., Ann. LXXIII, 67, 129. Proc. Roy. Soc. 1822, 459. Lond. J. 1823. Phil. Mag. 1823. Ed. Phil. J. IX, 403. Trans. Phil. 1823. Gilb., Ann. LXXV, 220, 241. Ann. Ch. Phys. (2), XXV, 415 Am. J. Sci. VII, 192.
1824	Peschier	Researches	Bibl. Univ. XXVI, 43.
1824	Peschier	Estimation	Schweigg., J. XLII, 215. Ann. Ch. Phys. (2), XXVII, 281.
1824	Walchner	Ti metal	Schweigg., J. XLIV, 60.
1824	Wollaston	Ti is magnetic	Schweigg., J. XLI, 80. Phil. Mag. LXIII, 15. Schweigg., J. XLII, 236. Ed. Phil. J. X, 183.
1824	Du Métil	Separation of Ti	Schweigg., J. XLII, 56.
1824	Berzelius	Fluotitanates	Abh. Ak. Wiss. St. Pet. II, 1824. Pogg. IV, I.
1825	H. Rose	Separation of Ti and Fe	Pogg. III, 163.
1825	George	Chloride	Ann. Ch. Phys. (2), XXIX, 130. Ann. Phil. 1825, 18. Pogg. III, 171.
1825	Zinken	Ti in furnace slag	Schweigg., J. XLIV, 47.
1825	Walchner	Titanic cubes	Ann. des M. (1), XII, 208. Pogg. III, 175.
1825	Pfaff	Titanic acid	Schweigg., J. XLIV, 47.
1826	Berzelius	Separation of Ti and Zr.	Ed. Phil. J. XI, 410. Schweigg., J. XLV, 373.
1826	Unverdorben	Silicofluoride	Pogg. VI, 231.
1826	Dumas	Chloride Ti and B.	Berz., Jahreshb. 1826, 139. Pogg. VII, 320.
1826	Berzelius	Atomic weight	J. de Pharm. 1826, 300. Pogg. VII, 522.
1826	Walchner	Ti in slag	Pogg. VIII, 177.
1826	H. Rose	Ti O ₂	Ann. Ch. Phys. (2), XXXI, 331. Am. J. Sci. XII, 189.
1827	H. Rose	Phosphotitanic acid	Berz., Jahreshb. V, 137.
1827	Dumas	Atomic theory	Ann. des M. (1), XII, 300.
1827	Berzelius	Atomic weight	Pogg. IX, 47. Pogg. IX, 436.
1827	Wöhler	Chloride	Berz., Jahreshb. VII, 73. Pogg. X, 340.
1828	H. Rose	Preparation of Ti O ₂	Pogg. XI, 148. Pogg. XII, 479.
1829	H. Rose	Atomic weight	Ann. des M. (2), V, 141. Berz., Jahreshb. IX, 104. Pogg. XV, 145.
1829	H. Rose	Researches	Ann. Ch. Phys. (2), XLIV, 55.
1829	Greswolde	Ti in slag	Berz., Jahreshb. X, 106. Ann. des M. (3), I, 108.
1830	Persoz	Chloride	Pogg. XVI, 57. Ann. des M. (2), V, 316. Ann. Phil. Feb. 1828. Ann. Ch. Phys. XLIV, 57. Pogg. XX, 164.

1830	Wollaston	Metallic character of Ti	Bibl. Univ. Feb. 1830.
1831	Liebig and Wöhler	Titanic iron and Ca Cl_2	Pogg. XXI, 578.
1831	J. Liebig	Reduction of the metal	Ann. Ch. Phys. (2), XLVII, 108. Ann. des M. (3), II, 318. Berz., Jahresh. XI, 112.
1831	Liebig and Wöhler	Titanic iron	Ann. Ch. Phys. (2), XLVII, 259. Ann. des M. (3), II, 418.
1832	H. Rose	Chloride and P H_3	Pogg. XXIV, 141. Ann. des M. (3), I, 110.
1832	Becquerel	Prep. of Ti by electrolysis	Pharm. Centr. III, 527.
1832	Berthier	Preparation of Ti	Ann. Ch. Phys. (2), L, 362. Ann. Ch. Pharm. V, 246. Ann. des M. (3), V, 451.
1832	Lampadius	Titanium green	J. f. pr. und æk. Ch. XIII, 458; XVI, 345.
1833	Berzelius	Atomic weight	Pharm. Centr. IV, 3; V, 2.
1833	Zincken	Volatility of Ti	Pogg. XXVIII, 160. Ann. Ch. Pharm. XII, 222. Ann. J. Sci. XXVIII, 136. Berz., Jahresh. XIV, 120. Ann. des M. (4), V, 450. Ann. Ch. Pharm. V, 385. Berz., Jahresh. XIII, 103. Phil. Mag. V, 398. Dingl., J. LV, 436. Berz., Jahresh. XV, 457. Pogg. XXXIV, 5.
1833	Noeggerath	Metallic Ti	
1834	Rees	Ti in organic substances	
1835	G. Rose	Separation of Ti and Fe	
1835	Brett and Bird	Ti in Hessian crucibles	Dingl., J. LVII, 37. Phil. Mag. VI, 113. Pharm. Centr. VI, 411. J. pr. Ch. IV, 493. Pogg. XXXV, 527. Pharm. Centr. VI, 702. Berz., Jahresh. XVI, 105. Pharm. Centr. VI, 437. Pharm. Centr. VI, 445. Phil. Mag. VI, 201. J. pr. Ch. V, 134. Dingl., J. LV, 469. J. pr. Ch. VI, 387.
1835	Wöhler	Not in Hessian crucibles	
1835	Perso	Separation of Ti O_2	
1835	Rees	Ti in blood	Ann. J. Sci. XXVIII, 136. Ann. Ch. Phys. (2), LXII, 355, 385.
1835	Goebel	Ti O_2 and CO	Ann. des M. (3), IX, 350. J. des Pharm. XIV, 251.
1835	Peschier	Ti in primitive rocks	
1836	Regnault	Researches	Pogg. XLII, 527. Ann. Ch. Phys. LXX, 289. J. pr. Ch. XII, 229.
1836	Doebereiner	Cyanide	Ann. Ch. Pharm. XXII, 324. Ann. Ch. Pharm. XXII, 324. J. pr. Ch. XVI, 372. Pogg. XLV, 342.
1837	H. Rose	Action of Cl on Ti S_2	Pamph. ; J. pr. Ch. XVI, 212. Ann. Ch. Pharm. XXXII, 247. Bergwerksfreund, I, 303.
1837	Heller	Rhodizonate	
1837	Rees	Ti in human body	
1837	Marchand	Ti in human body	
1839	Werner	Prep. from slag	Ann. Ch. Pharm. XXXI, 123.
1839	Wöhler	Separation Ti and Ta	

1840	H. Rose	Precip. TiO_2 by H_2O	Pogg. XLVIII, 575. Pharm. Centr. XI, 98.
1841	Biewend	Reactions	Pharm. Centr. XII, 591. J. pr. Ch. XXIII, 251.
1841	Regnault	Specific heat	Ann. Ch. Pharm. XL, 164; LII, 172.
1842	Berzelius	Allotropism and isomorphism	Vetensk. Akad. Handl. 1842. Pogg. LXI, 10.
1843		Glowing of TiO_2 when heated	Pogg. LXIX, 479.
1843	Berthier	Separation from Fe by SO_2	Berz., Jahresb. XXIV, 39. Ann. Ch. Phys. (3), VII, 74. J. pr. Ch. XXIX, 77.
1844	Hankel	Thermo-electricity	Pharm. Centr. XIV, 382. Pogg. LXI, 291.
1844	H. Rose	Different states of TiO_2	Pharm. Centr. XV, 245. Pogg. LXI, 507; LXII, 119. Ber. Berl. Akad. 1844. J. pr. Ch. XXXII, 296. Ann. Ch. Phys. (3), XII, 176; XV, 290.
1844	Regnault	Sp. heat of $TiCl_4$ and TiO_2	Ann. des M. (3), VIII, 701. Berz., Jahresb. XXV, 155. Pogg. LXII, 70.
1845	v. Kobell	Test for Titanic iron and Sphene	Ann. Ch. Phys. (3), IX, 322. J. pr. Ch. XXXVI, 302.
1845	H. Rose	Researches	Anzeig. baier. Akad. No. 103, 166. Pogg. LXII, 119.
1845	Rogers	Ti in furnace	Ann. Ch. Phys. (3), XV, 290. Inst. No. 529, 60.
1846	Faraday	Magnetism of Ti	Ann. des M. (4), VIII, 700. Pogg. LXVII, 440; LXX, 32, 39.
1846	Playfair and Joule	Atomic volume	Phil. Trans. 1846, pt. 1.
1846	Elsner	Titanic green	Mem. and Proc. Ch. Soc. 1846, 62. Dingl., J. CV, 130. Preuss. Verhandl. 1846, 5 Lief.
1847	Pierre	Equivalent of Ti	Jahresb. I, 1058. L'Inst., Mar. 10, 1847. Ann. Ch. Pharm. LXIV, 220.
1847	Ebelmen	Researches	Ann. des M. (4), XV, 137. Am. J. Sci. (2), IV, 103. Ann. Ch. Phys. (3), XX, 385. Pharm. Centr. XVIII, 675. J. pr. Ch. XLII, 70. Ann. Ch. Pharm. LXIV, 169. J. Pharm. (3), XII, 437. L'Inst. 1846, 225.
1847	Hermann	Researches	Ann. des M. (4), XI, 473. Am. J. Sci. (2), VII, 106.
1848	Rammelsberg and Fischer	Ti in meteoric iron	Ann. des M. (4), XI, 476. Pogg. LXXIII, 585.
1848	Blumenau	Ti in slag	Pharm. Centr. XIX, 290. Ann. Ch. Pharm. LXVII, 122. Bergwerksfreund, XII, 815; I, 401, 938.
1848	H. Rose	Use of NH_4Cl in analysis	Ber. Berl. Akad. May, 1848. J. pr. Ch. XLV, 115; XLIV, 117. Pogg. LXXIII, 582; LXXIV, 562. L'Inst. 1848, 226, 377. Pharm. Centr. XIX, 261, 601.

1849	Depretz	Chloride	L'Inst. 1849, 401. C. R. XXIX, 48, 709. Jahresb. II, 36.
1849	Daubrée	Artificial Brookite	C. R. XXVII, 217. Am. J. Sci. (2), IX, 120.
1849	Wöhler	Metallic Ti	Nacht. k. Ges. Gøett., Nov. 12, 1849. Pharm. Centr. XX, 25, 822. J. pr. Ch. L, 22. Ann. Ch. Pharm. LXXIII, 47, 34. Ann. Ch. Phys. (3), XXIX, 166, 185. L'Inst. 1850, 46. Ann. des M. (4), XIX, 396. C. R. XXIX, 505. Ber. Berl. Akad. 1849, 244. Pogg. LXXVIII, 401. Ch. Gaz. 1850, 73.
1849	Wöhler	Preparation of Ti O ₂	Nacht. k. Ges. Gøett. Dec. 1849. Pharm. Centr. XXI, 25.
1849	Demoly	Researches	Revue Sci. XXXIV, 325. Ann. des M. (4), XIX, 394. Ann. Ch. Pharm. LXXII, 213. Jahresb. 1849, 269.
1849	Wöhler	Nitrocyanide	L'Inst. Nov. 7, 1849. Dingl., J. CXV, 75. C. R. XXIX, 505. L. E. and D., Phil. Mag. XXXVI, 69; XXXVII, 67.
1849	Breithaupt	Pleomorphism of Ti O ₂	Pogg. LXXVIII, 143.
1849	Depretz	Fusibility and volatility	C. R. XXIX, 545. Pharm. Centr. XXI, 22.
1850	Wöhler	Nitrocyanide and nitride	Ann. Ch. Pharm. LXXII, 134. Nacht. Wiss. Gøett. 1850, 15. Pharm. Centr. XXI, 81. J. Ch. Soc. II, 352. Ann. Ch. Pharm. LXXIII, 34, 219. Pogg. LXXIX, 327. J. pr. Ch. L, 233. Ann. Ch. Phys. (3), XXIX, 166. Kenng., Ueb. 204.
1850	Wöhler	Chloride and cyanide	Ann. Ch. Pharm. LXXIII, 226. Pharm. Centr. XXI, 81, 428. Ann. Ch. Phys. (3), XXIX, 184. J. Ch. Soc. III, 177.
1850	Wöhler	Note	Ann. Ch. Phys. (3), XXVIII, 382.
1850	Klein	Chloride and cyanide	Ann. Ch. Pharm. LXXIV, 84. Pharm. Centr. XXI, 588. Ch. Gaz. 1850, 313.
1850	Wöhler	Metal	Ann. Ch. Pharm. LXXIII, 34. Ann. Ch. Phys. (3), XXVIII, 382. J. Ch. Soc. III.
1850	Wöhler	Pure Ti O ₂	Ann. Ch. Pharm. LXXIV, 212. Ch. Gaz. 1850, 72.
1851	Ebelman	Dry crystallization	C. R. LXXII, 330, 713. Pharm. Centr. XXII, 294. Ann. Ch. Phys. XXXIII, 34. J. pr. Ch. LIV, 173, 143.
1851	Horstner	Ti in soil	J. pr. Ch. LIV, 129.
1851	Sandberger	Nitrocyanide	Pogg. LXXXIII, 596.

1852	Chapman	Blow-pipe reaction	Chem. Gaz. 1852, 297. J. pr. Ch. LVII, 269. Pharm. Centr. XXIV, 15.
1852	Ladrey	Crystallized Ti O ₂	C. R. XXXIV, 56.
1852	Mazade	Ti in waters of Neyrac	C. R. XXXIV, 952,
1853	Henry	Ti in waters of Neyrac	J. Pharm. (3), XXIV, 305. Phil. Mag. (4), VII, 149. J. pr. Ch. LXII, 29. Pharm. Centr. XXIV, 829.
1853	Junot de Bussy	Researches	C. R. XXXVI, 952. L'Inst. 1853, 97. Jahresb. 1853, 335.
1853	Wöhler	Optical properties	Phil. Mag. (4), VI, 265.
		Phosphide	Ann. Ch. Pharm. LXXXVII, 375.
1854	Daubrée	Artificial Brookite	C. R. XXXIX, 135. J. pr. Ch. LXIII, 4.
1855	St.-Claire Deville	Researches	C. R. XL, 1034. Ch. Gaz. 1855, 228. L'Inst. 1855, 150.
1855	Boedecker	Ti in sphærosiderite	Ann. Ch. Pharm. XCIV, 355. J. pr. Ch. LXVI, 190.
1856	Hofmann	Bromide	Pogg. XCVII, 510. C. R. XLII, 352.
1856	Kopp	Chloride	C. R. XLIV, 1347. Ch. Centr. I, 594.
1856	Duppa	Bromide	Proc. Roy. Soc. VIII, 42. Ch. Gaz. 1856, 138. Phil. Mag. (4), XII, 232. Ann. Ch. Phys. (3), XLVII, 164. C. R. XLII, 353. Ch. Centr. I, 290. J. pr. Ch. LXVIII, 253. L'Inst. 1856, 78, 414. Pogg. XCVII, 510. Arch. ph. nat. XXXI, 349; XXXII, 230. Ber. Berl. Akad. 1856, 154. Cimento, III, 153.
1856	Kopp	Note on Bromide	Ann. Ch. Phys. (3), XLVII, 166. Phil. Mag. (4), XII, 190. J. pr. Ch. LXVIII, 444. Ann. Ch. Pharm. XCVIII, 265. Ch. Centr. I, 565.
1857	Wöhler and Deville	Affinity for N.	L'Inst. 1857, 340. C. R. XLV, 480. Ann. Ch. Pharm. CIII, 230. Arch. Pharm. (2), XCII, 288. J. pr. Ch. LXXXIII, 104. Phil. Mag. XV, 109, Ann. Ch. Phys. (3), LII, 92. Ch. Centr. II, 772. Nacht. Wiss. Goett. 1857, 237. Ch. Gaz. 1857, 449.
1857	Warren	Titanates	Pogg. CII, 449. J. pr. Ch. LXXXV, 361.
1857	Delffs	Hydrated titanic acid	Jahresb. 1857, 174. N. Jahrb. Pharm. VII, 291.
1857		Ti in slag	Jern-Kontoret's Annaler, 1857, 135.

1858	Henke	Nitril compounds	Ann. Ch. Pharm. CVI, 272. Ch. Centr. III, 568.
1858	Wöhler	Prep. of nitride	Ann. Ch. Pharm. CV, 108. J. pr. Ch. LXXIII, 189.
1858	Deville and Caron	Artificial rutile	C. R. XLVI, 764. L'Inst. 1858, 133. Rép. Ch. pure. I, 16. Ann. Ch. Pharm. CVIII, 55. J. pr. Ch. LXXIV, 157. Dingl., J. CXLVIII, 372. Jahrb. Min. 1858, 578. Ann. Ch. Phys. (4), V, 109.
1858	J. P. W.	Formation of nitro-cyanide crystals	Dingl., J. CL, 316. Oest. Zeit. B. und H. 367. B. und H. Zeit. 1862, 375. Polyt. Centr. 1862, 955. W. Jahresb. V, 270.
1858	Elsner	Titanium green	Ch. Tech. Mitth. 1858-9, 40; 1859-60, 46. Ch. Centr. VI, 304. Polyt. Centr. 1861, 449. Dingl., J. CLX, 258. W. Jahresb. V, 270.
1859	Scheerer	Quant. determ. in silicates	Nacht. Gœtt. Univ. Aug. 8, 1859. J. pr. Ch. LXXVII, 314. Ann. Ch. Pharm. CXII, 178. Ch. Centr. V, 102.
1859	Mushet	Ti in steel	Ch. News, I, 143. Rep. Pat. Dec. 1859, 468; Feb. 1860, 116, 128, 131; Aug. 1862, 158. Polyt. Centr. 1860, 283, 475; 1862, 409, 1301. Dingl., J. CLV, 317; CLVI, 76; CLXIV, 74; CLXVI, 156. Tech. 1861, 66. Ch. News, I, 231, 276; IV 11. W. Jahresb. VI, 85. Ch. Centr. VII, 954.
1859	Harris and Stenson	Ti in steel	Ch. News, I, 274.
1859	Riley	Test for Ti	J. Ch. Soc. XII, 13. J. pr. Ch. LXXIX, 63. Ch. News, IV, 84.
1860	Stromeyer	Separ. of Ti and Zr. from iron	Ann. Ch. Pharm. CXIII, 127. Ch. Centr. V, 285.
1860	Wöhler	Silicide of Ti and Al.	J. pr. Ch. LXXX, 379. Ann. Ch. Pharm. CXIII, 248. J. pr. Ch. LXXX, 255. Ch. Centr. V, 408. Zeit. Ch. Pharm. III, 238. Rép. Ch. pure. II, 160.
1860	Michel	Silicide of Ti and Al.	Ann. Ch. Pharm. CXV, 102. J. pr. Ch. LXXXII, 273. Ch. Centr. V, 854. Phil. Mag. (4), XX, 377. Rép. Ch. pure. III, 49.
1860	Buff	Sp. heat of chloride	Ann. Ch. Pharm. CXV, 307.

1861	H. Rose	Separ. of Ti and Sn.	Pogg. CXII, 163. Rép. Ch. pure. III, 387. Zeitsch. Ch. Pharm. 1861, 231. Ch. News, V, 86.
1861	Deville	Blue oxide	Ann. Ch. Pharm. CXX, 182.
1861	Deville	Artificial rutile	Ann. Ch. Pharm. CXX, 181. N. J. f. Min. 1862, 79. C. R. LIII, 161. Ann. Ch. Phys. Ch. News, III, 226. Kengg., Ueb. IX, 236. Ann. Ch. Phys. LXI, 309.
1861	Deville	Detection of Ti	Ch. News, III, 309. Handb. met. Hütten. 1861, 795.
1861	Kerl	Ti in pig iron	J. Ch. Soc. XV, 311.
1862	Riley	Estimation of Ti in clay	Ch. Centr. VIII, 945. Zeit. anal. Ch. II, 70. Ch. News, V, 320.
1862	Riley	Researches	J. Ch. Soc. XV, 324.
1862	Graham	Dialysis of titanio acid	J. Ch. Soc. XV, 256. Ann. Ch. Pharm. CXXI, 54.
1862	Cahours	Ti ethyl	Ann. Ch. Pharm. CXXII, 63.
1862	Versmann	Ti pigment	Rép. Ch. appl. 1862, 84. W. Jahresb. 1862, 334.
1863		Action of Ti Cl ₄ on Sn diethyl	J. Ch. Soc. XVI, 23.
1863	Zinreck	Ti in steel	Zeitsch. f. Baukunst. 1863, 181.
1863		Ti in steel	Prac. Mech. J. XVI, 234.
1863	Riley	Ti in pig iron	J. Ch. Soc. XVI, 391. Ch. News, VII, 233. Am. J. Sci. (2), XXXVII, 26. Ch. Centr. VIII, 230. Min. and Smelt. Mag. IV, 193. Bull. Soc. Ch. (2), VII, 299. B. und H. Zeit. XXIII, 11. W. Jahresb. X, 56.
1863	Weber	Researches	Ber. Akad. Berlin. 1863, 458. Pogg. CXX, 120, 287. Ch. Centr. VIII, 707. J. pr. Ch. XC, 212. Bull. Soc. Ch. (2), VI, 184. L'Inst. 1863, 408. W. Jahresb. X, 284. Ch. Rép. 1863, 27. W. Jahresb. IX, 170.
1863	Welly	Ti bronze	Ann. Ch. Pharm. CXXVI, 43. J. pr. Ch. XC, 308.
1863	Hampe	N O ₂ and Ti Cl ₄	Bull. Soc. Ch. (2), V, 558. L'Inst. 1863, 226.
1863	Hautefeuille	Artificial minerals.	Ann. Ch. Pharm. CXXIX, 215. Ch. Centr. VIII, 193. C. R. LVII, 148. Les Mondes, 1863, July 28, 605. Am. J. Sci. XXXVIII, 424. J. pr. Ch. XCII; XCVI, 52.
1863	Buckton	Ti ethyl	J. Ch. Soc. XVI, 17. Ch. Centr. VII, 852.
1864	Rammelsberg	Ti in pig iron	Ch. Metallurgie, 1865, 140.
1864	Percy	Ti in pig iron	Iron and Steel, 1864, 164, 551, 570.
1864	Graham	Dialysed titanio acid	J. Ch. Soc. XVII, 325.

1864	Graham	Dialysed titanac acid	J. pr. Ch. XCIV, 354. Jahresb. 76. C. R. LIX, 174. Phil. Mag. (4), XXVIII, 314. Proc. Roy. Soc. XIII, 335. Pharm. J. Trans. (2), VI, 63. Ch. News, X, 97, 109. Pogg. CXXIII, 529. Ch. Centr. IX, 1105. Ann. Ch. Phys. (4), III, 121. Bull. Soc. Ch. (2), II, 178. N. Arch. ph. nat. XXII, 140. C. R. LIX, 188, 698, 732. L'Inst. 1864, 237, 346. Bull. Soc. Gh. (2), II, 194; III, 64, 66. Ann. Ch. Pharm. CXXIX, 215; CXXXIII, 194; CXXXIV, 23, 165. Ch. Centr. X, 10. N. Arch. ph. nat. XXI, 294. Am. J. Sci. (2), XXXVIII, 424. Ann. Ch. Phys. (4), IV 155. Keng., Ueb. IX, 232.
1864	Hautefeuille	Artificial minerals	C. R. LIX, 298. Bull. Soc. Ch. (2), II, 363. Ch. News, X, 218. Ch. Centr. X, 289. N. Arch. ph. nat. XXII, 343. J. pr. Ch. XCVII, 118. J. pr. Ch. XCI, 327. Ber. Akad. Berlin. 1865, 154. Ch. Centr. X, 621. J. pr. Ch. XCV, 147. Ann. Ch. Phys. (4), IV, 167. Ann. Ch. Pharm. CXXXIV, 166.
1864	Pisani	Estimation of Ti	Ch. News, XI, 144. Ch. News, XII, 308. J. Ch. Soc. XIX, 255. Ch. Centr. XI, 687. Ber. Akad. Berl. 1866, 148. J. pr. Ch. XCVIII, 94. Ann. Ch. Phys. XLIV, 319. Inaug. dissertation. J. pr. Ch. XCIX, 157. Ch. Centr. XII, 65. Zeitsch. Ch. 1867, 122. W. Jahresb. XIII, 305; XIV, 152.
1864	Werther	Analysis of silicates	J. pr. Ch. XCVII, 118.
1865	Werther	Selenacic chloride and Ti Cl ₄	J. pr. Ch. XCI, 327. Ber. Akad. Berlin. 1865, 154. Ch. Centr. X, 621. J. pr. Ch. XCV, 147. Ann. Ch. Phys. (4), IV, 167. Ann. Ch. Pharm. CXXXIV, 166.
1865	Hautefeuille	Titanates of Ca, Mg, Fe, and Mn.	Ch. News, XI, 144. Ch. News, XII, 308.
1865	Phipson	Ti H ₄	J. Ch. Soc. XIX, 255. Ch. Centr. XI, 687. Ber. Akad. Berl. 1866, 148. J. pr. Ch. XCVIII, 94. Ann. Ch. Phys. XLIV, 319. Inaug. dissertation. J. pr. Ch. XCIX, 157. Ch. Centr. XII, 65. Zeitsch. Ch. 1867, 122. W. Jahresb. XIII, 305; XIV, 152.
1865		Metallic Ti	J. pr. Ch. XCVII, 118. J. pr. Ch. XCVII, 338.
1866	Hofmann	Titanotriamine	Ann. Ch. Pharm. CXXXVIII, 289. Zeit. anal. Ch. V, 351. Phil. Mag. (4), XXXII, 81. N. Arch. ph. nat. XXVII, 25. Jahresb. 1866, 782.
1866	Persoz	Researches	Birmingham Min. J. Dingl., J. CLXXX, 326. Poly. Centr. 1866, 473. Deutsch. Ind. Zeit. 1866, 28. W. Jahresb. XII, 92.
1866	Merz	Researches	
1866	Hermann	Reaction	
1866	Hermann	Separ. Ti and Zr.	
1866	Bunsen	Flame reaction	
1866		Reduction by Na.	

1866	Marignac	Separation from Cb.	Ann. Ch. Phys. (4), VIII, 72. Bibl. Univ. Aug. 1867. Bull. Soc. Ch. (2), VIII, 182. Jr. pr. Ch. CII, 448.
1867	G. Rose	Reaction with borax	Ber. Akad. Berl. 1867, 450. Ch. Centr. XIII, 1. Pogg. CXXXII, 451.
1867	Weber	Chlorides, etc.	Bull. Soc. Ch. (2), VIII, 201.
1867	Hautefeuille	Iodide	Ch. Centr. XII, 878. C. R. LXIV, 608, 704. L'Inst. 1867, 90. Zeitsch. Ch. 1867, 303, 334. Ch. News, Am. repr. I, 154. Jahresb. 1867, 175.
1867	Kenngott	Titanite, alk. reaction	J. pr. Ch. CI, 4, 480; CIII, 304.
1867	G. Rose	Allotropic Ti O ₂	J. pr. Ch. CI, 217; CII, 385. Ber. Akad. Berl. 1867, 129, 450. Zeit. Ch. 1868, 122. Ch. Centr. XII, 433; XIII, 1. L'Inst. 1867, 351; 1868, 40. J. Ch. Soc. XX, 117. J. pr. Ch. CI, 377.
1867	Parkinson	Action of Mg on Ti O ₂	Ann. Ch. Pharm. CXLI, 111.
1867	Tüttschew	Researches	Bull. Soc. Ch. (2), VIII, 320. W. Jahresb. XIII, 289.
1867	Kletzinsky	Ti Bronze	Eng. Patent.
1867	Crawshaw and Thomas	In Metallurgy	B. H. Ztg. XXVII, 36; XXVIII, 331.
1867	Silva	Ti in iron	Rev. Univ. XII, 425. C. R. LXV, 207. Bull. Soc. Ch. (2), VIII, 418. Pogg. CXXXVI, 497.
1868	Schrauf	Optical properties	Z. S. G. XXI, 250.
1869	Rose	Blow-pipe tests	Engineering, V, 28, 275.
1869		Strength of Ti iron	Artizan, 1869, 27.
1869	Forbes	Estimation of Ti	Dingl., J. CXCI, 116. Zeit. Ch. V, 222. B. H. Z. XXIX, 208. Bull. Soc. Ch. (2), XII, 253. Zeit. anal. Ch. 1870, 387. Ch. News, XIX, 3. Mon. Scien. 1870, 71.
1869	Streit and Franz	Separ. from Fe and Zr.	Bull. Soc. Ch. (2), XIII, 507. J. pr. Ch. CVIII, 65. Ch. Centr. (3), I, 222, 339. Zeit. Ch. XIII, 256. Zeit. anal. Ch. 1870, 388. W. Jahresb. XVI, 249.
1869	Salet	Ti in the sun	Ann. Ch. Phys. (4), XVIII, 222.
1869	v. Monkhoven	Ti light	Phot. Mitth. 1869, 201. Poly. Centr. 1870, 212. W. Jahresb. XVI, 720. Ch. News. B. H. Ztg. XXVIII, 165.
1869	Hayes	Ti in pig iron	Zeit. anal. Ch. VIII, 380.
1869		Ti steel	Zeit. Ch. XIII, 279.
1869	Schönn	Preparation of Ti	Ber. d. d. Ch. Gesell. III, 680.
1870	Friedel and Crafts	Ti ethers	
1870	Wunder	Isotrimorphic Ti acid	J. pr. Ch. (2), II, 206. Ch. Centr. (3), I, 663. Zeit. Ch. XIV, 216.

1870	Stolba	Silico-fluoride before the blow-pipe	Dingl., J. CXCVIII, 178. Ch. Centr. (3), I, 740.
1870	Thomsen	Thermo-chem.	Pogg. CXXXIX, 212.
1870	Schöenn	Reaction with H_2O_2	Zeit. anal. Ch. IX, 41. Zeit. Ch. XIII, 446. Bull. Soc. Ch. (2), XIV, 42.
1870	Schöenn	Method of analysis	Zeit. anal. Ch. IX, 30. Bull. Soc. Ch. (2), XIV, 47.
1870	Mushet	Ti steel	Mech. Mag. 1870, 241. Poly. Centr. 1870, 741. W. Jahresb. XVI, 92.
1871	Burkart	In Metallurgy	Berggeist. 1871, 159, 165, 182.
1871	Rammelsberg	Separation from Cb.	J. Ch. Soc. XXV, 294. Ber. d. d. Ch. Gesell. IV, 874.
1871	Knop	Ti O_2 in P salt	Ann. Ch. Pharm. CLVIII, 363. Amer. Ch. I, 472. J. Ch. Soc. XXIV, 200, Zeit. Ch. XIV, 216. Bull. Soc. Ch. (2), XV, 190. C. R. LXXIII, 260. J. Ch. Soc. (2), IX, 1147.
1871	Troost and Hautefeuille	Spectrum	Bull. Soc. Ch. (2), XVI, 229.
1871	Wunder	Ti in pig iron	Engineering, XL, 374, 415.
1871	Wunder	Crystallizing Ti comp. from fluxes	J. pr. Ch. (2), IV, 339, 349. J. Ch. Soc. XXV, 121.
1872	Troost and Hautefeuille	Oxychloride	Ann. Ch. Pharm. CLXIII, 152. J. pr. Ch. (2), IV, 298.
1872	Akermann	Effects of Ti in the blast furnace	Jern-Kontoret's Annaler. B. H. Ztg. XXXII, 459.
1872	Kick and Gintl	Mushet's special steel	Tech. Blätter, 1872, IV, 122. Deut. Ind. Ztg. 1872, 346. W. Jahresb. 1872, 123.
1872	Riley	Special steel	Deut. Ind. Ztg. 1872, 448. W. Jahresb. 1873, 91.
1872	Forbes	Ti in metallurgy	J. Iron and Steel Inst. 1872, 158. B. H. Ztg. XXXI, 371.
1872	Hunt	Ti in metallurgy	Eng. and Min. J. XIII, 148. B. H. Ztg. XXXI, 418.
1872	Maynard	Ti in metallurgy	Eng. and Min. J. XIII, 275. B. H. Ztg. XXXIII, 71.
1872	Bell	C O and Ti O_2	Ch. News, XXIII, 267.
1873	Gruner	Special steel	Deut. Ind. Ztg. 1873, 97. Bull. Soc. d'Enc. 1873, 84. Ch. News, XXVII, 71. Dingl., J. CCVII, 316. B. H. Ztg. XXXII, 142. Poly. Centr. 1873, 374. W. Jahresb. XIX, 91.
1873	Roussel	Estimation of Ti in basalt	C. R. LXXVII, 1103. Ch. Centr. (3), IV, 776. Amer. Ch. IV, 354. J. Ch. Soc. XXVII, 137.
1873	Demarçay	Titanium ethers	Bull. Soc. Ch. (2), XXI, 71. C. R. LXXVI, 1414. J. Ch. Soc. XXVI, 1015.
1873	Wimmer	Ti in iron	Bull. Soc. Ch. XX, 127. B. H. Ztg. XXXI, 417. Ch. Centr. (2), III, 822. Bull. Soc. Ch. XIX, 137.

1873	Bettel	Estimation	Ch. News, XXVIII, 93. Bull. Soc. Ch. XX, 503; XXII, 273. Dingl., J. CCXII, 258. B. H. Ztg. XXXIII, 294. Ch. Centr. (3), IV, 633. J. Ch. Soc. XXVII, 93. Amer. Ch. IV, 340.
1873		Preparation of N H ₃ by means of Ti	J. de l'Eclair. du Gaz. 1873, No. 19. Amer. Ch. IV, 398.
1874	Friedel and Guerin	Researches	Bull. Soc. Ch. XXI, 145, 241; XXII, 482. Jahresb. Rein. Ch. II, 118. Ber. d. d. Ch. Gesell. VII, 187, 264. Ch. Centr. V, 315. J. Ch. Soc. XXVII, 1065. C. R. LXXXII, 509.
1874	Bogardus	Deportment of Ti in iron ore with P ₂ O ₅	Amer. J. Sci. (3), VIII, 334. Amer. Ch. V, 314.
1874		Alloy with iron	Poly. Centr. 1874, 315. B. H. Ztg. XXXIII, 166.
1874	Rammelsberg	Researches	Ber. Akad. Berlin. 1874, 490. Jahresb. Rein. Ch. II, 117.
1875	Akermann	Relations of Ti to iron	Iron, VI, 450. Dingl., J. CCXCIX, 86.
1875	Demarçay	Ti ethers	Les Mondes, XXXVI, 128. Ber. d. d. Ch. Gesell. VIII, 75. C. R. LXXX, 51. J. Ch. Soc. XXVIII, 441. Amer. Ch. VI, 276.
1875	Friedel and Guerin	Chloride, bromide, and nitride	Bull. Soc. Ch. XXIV, 531. Les Mondes, XXXVIII, 585. Ber. d. d. Ch. Gesell. VIII, 1292, 1566. Amer. Ch. VI, 398.
1875	Friedel	Separation from Fe	Bull. Soc. Ch. XXIII, 289. Ber. d. d. Ch. Gesell. VIII, 344.
1875	Mendelejeff	Supposed element	C. R. LXXXI, 969. J. Ch. Soc. XXVI, 521. F. Leslie's Newspaper, Nov. 1876.
1875	Bedson	Chloride of titanium ethers	Inaug. Dissert. Ann. Ch. Pharm. XLXXX, 236. Ch. News, XXXI, 65. Ber. d. d. Ch. Gesell. VIII, 188. J. Ch. Soc. XIV, 311. Amer. Ch. VI, 393.
1875	Bedson	Trichlorhydrin and Ti Cl ₄	Ann. Ch. Pharm. CLXXX, 236. J. Ch. Soc. XIV, 311.
1875	Schüller and Wartha	Metallic Ti	Ber. d. d. Ch. Gesell. VIII, 1015.
1875	Merz	Metallic Ti	Ibid. VIII, 1294, 1566.
1876	Kern	Metallic Ti	Ch. News, XXXIII, 57. J. Ch. Soc. VI, 882. Amer. Ch. VI, 435.
1876	Friedel and Guerin	Nitrides	C. R. April 24, 1876. Ch. News, XXXIII, 210.
1876	Glatzel	Non-compounds	Ber. d. d. Ch. Gesell. IX, 1829.
1876	König	Supposed new ele- ment	Proc. Phil. Ac. Science. 1876, 35.

Index to the Literature of Titanium.—(Continued.)

BY EDWARD J. HALLOCK.

Part II, Minerals. 1783–1876.

ABBREVIATIONS.

A = Anatase.	Oct = Octahedrite.	Sch = Schorlomite.
Æ = Æschynite.	O = Oisanite.	T = Titanite.
B = Brookite.	P = Perofskite.	Tsch = Tscheffkinit.
I = Ilmenite.	R = Rutile.	Y-T. = Yttrotitanite.
M = Menaccanite.	S = Spheue.	W = Warwickite.

1783	De Lisle	Schorl rouge	Crist. II, 421.
1783	Bournon	Schorl bleu indigo	De Lisle, Crist. II, 406.
1787	Pictet	Titanite	J. de Phys. XXXI, 368.
1787	Bournon	Schorl octaèdre rect.	J. de Phys. XXX, 386.
1790	v. Born	Schorl rouge	Cat. de Raab. I, 168.
1794	Kirwan	Red schorl	Kirw., Min. I, 271.
1795	Haüy	Crystals of T.	J. de M. III, 15, 27.
1795	Klaproth	Titanite	Klapr., Beitr. I, 245.
			Scherer's J. XIV, 467.
			J. de Min. II, 12, 45.
			Crell's Ann. 1705, I, 259.
1796	Saussure	Octaèdrite	Sauss., Voy. Alpes. § 1901.
1796	Kirwan	Titanite	Kirw., Min. II, 329.
1797	Vauquelin and Hecht	"A new mineral"	J. de M. III, 15, 10.
1797	Klaproth	Menakanite	Klapr., Beitr. II, 222.
1797	Delamétherie	Pictite, Oisanite, Crispite	Klapr., Beitr. II, 226.
			Delaméth. T. T. II, 282, 269, 333.
1797	Lampadius	Black garnet	Lamp., Samml. II, 119.
1797	Klaproth	Nigrine	Klapr., Beitr. II, 255.
1799	C. Haüy	Oisanite	J. de M. V, 273.
1799	Lowitz	Ti in Russian minerals	Scherer's J. II, 210.
			Crell's Ann. 1799, I, 183.
1799		Titanite	Ann. Ch. XXXII, 196.
1799	Lowitz	Titanic iron	Scherer's J. II, 210.
1799	Abilgard	Ti minerals	Scherer's J. II, 502.
1799	Haüy	Ti O ₂	J. de M. VI, (32), 614.
1800	Karsten	Nigrine	Karst., Tab. 56, 79.
1800	De Bellevue	Séméline	J. de Phys. LI, 443.
1800	Reuss	Rutile.	Scherer's J. IV, 541.
1801	Haüy	S., A., Titanic iron	Tr. Min. III, 101.
1801	Chevenix	Analysis of M.	Scherer's J. VIII, 403.
			Nich. J. V, 132.
			Phil. Mag. XI, 88.
1802	Vauquelin	Oisanite	Ann. Ch. XLII, 72.
			Gilb., Ann. XI, 240.
			J. de M. XI, (63), 425.
1803	Cordier	Analysis of S.	J. de M. XIII, (73), 67.
1803	Werner	Oct. and R.	Ludwig's Min. II, 218; I, 55.
1804	Thury	R. N. T.	J. de M. XV, (90), 401.
1804	Hassenfratz	Analysis of T.	J. de M. XV, (), 413.
1805	Tonnellier	Spheue	J. de M. XVII, (97), 79.
1805	Champeaux	Titanite	J. de M. XVIII, 105.
1805	Ekeberg	Ti minerals	Scherer's J. XIV, 348.

1805	Haily	Sphene	Scherer's J. XIV, 490. Bull. Sc. Soc. Phil. III, 206.
1805	Vauquelin	Analysis Ti iron	Scherer's J. XIV, 464. Ann. Mus. VI, 93.
1806	Vauquelin	Oisanite	J. d. M. XIX, (114), 478.
1807	Klaproth	Analysis of R.	Klapr., Beitr. IV, 153.
1807		Titanite	Leonh., Tasch. I, 306.
1807	De Morogues	Sphene	J. d. M. XXI, (125), 364.
1808	Karsten	Mænaken	Karst., Tab. 1808, 74.
1808	Lavater	Titan crucifié	Leonh., Tasch. II, 384
1808	Werner	Braun-Mänakerz	Min. Syst.
1810	Klaproth	Titanic iron	Klapr., Beitr. V, 210. Leonh., Tasch. V, 179.
1810	Klaproth	Iserine	Klapr., Beitr. V, 206.
1810		Spec. grav. of T.	Leonh., Tasch. IV, 231.
1811	Klaproth	Ti minerals	Leonh., Tasch. V, 163.
1813	Viviani	Ligurite	Mem. Ac. Sci., Genoa. III. J. de Phys. LXXVII, 236.
1813	Bournon	Craitonite	Bourn., Cat. 430.
1813	Zipser	R. and S.	Leonh., Tasch. VII, 480, 591.
1814	Gehlen	A. and R.	Schweigg., J. X, 138.
1814	Leonhard	Rutile	Leonh., Tasch. VIII, 268.
1816	Ekeberg	Titanium schorl	Leonh., Tasch. X, 515.
1817	Phillips	Angles of A.	Trans. Geol. Soc. IV. Ann. Ch. (2), VI, 62.
1817	Pausner	Titanium minerals	Leonh., Tasch. XI, 309.
1817	Pfaff	Ti garnet; R.	Schweigg., J. XXI, 240. Leonh., Tasch. XV, 496.
1818	Hitchcock	Red oxide	Am. J. Sci. I, 116, 134.
1818	Berzelius	R. and A.	Schweigg., J. XXII, 280.
1819	Eckel	Titanite	Leonh., Tasch. XIII, 250.
1819	Arfvedson	Rutile	Scherer's Ann. II, 117.
1819	H. Rose	Rutile	Gilb., Ann. LXIII, 67.
1819		Ti in Pt. ore	Schweigg. XXIV, 22.
1820	Berthier	Titanic iron	Ann. des M. V, 479.
1820	Porter	Red oxide	Am. J. Sci. II, 143; III, 228.
1820	Breithaupt	Iserine	Breith., Char. 51.
1821		Ti minerals	Scherer's Ann. VII, 200.
1821	Germar	Anatase	Leonh., Tasch. XV, 916.
1821	Peschier	Ti in mica	Ann. Ch. Phys. (2), XXI, 203; XXII, 67. Gilb., Ann. LXX, 315; LXXI, 18.
1822	G. Rose	Cryst. T. and S.	J. de Phys. 1821, Oct. Schweigg., J. XXXIV.
1822	Hayden	Red oxide	Leonh., Tasch. XVI, 393.
1822	Davey	Sphene	Am. J. Sci. IV, 55.
1823	Stromeyer	Ti in achmite	Am. J. Sci. IV, 276.
1823	Schweigger	Titanite	Schweigg., J. XXXVI, 213.
1823	Hitchcock	Red oxide	Schweigg., J. XXXIX, 245.
1824	Vauquelin	Ti in mica	Am. J. Sci. VI, 24. Ann. Ch. Phys. (2), XXVII, 67.
1824	H. Rose	Ti in mica	Schweigg., J. XLIV, 57. Ann. des M. (1), X, 255.
1824			Pogg. I, 77.
1824	Seybert	Ti in chrysoberyl.	Ann. Ch. Phys. (2), XXVIII, 105.
1824	Laugier	Analysis of minerals	Schweigg., J. XLII, 233. J. de Pharm. 1824, 414.
1825	Du Ménil	Ti in colophonite	Schweigg., J. XLII, 236. Ed. Phil. J. X, 183. Schweigg., J. XLIV, 55.

1825	Levy	Brookite	Ann. Phil. 1825, 140. Berz., Jahresb. VI, 213. Pogg. III, 163, 116.
1825	H. Rose	R. and Ilmenite	Ann. des M. (1), XII, 300. Ann. des M. (1), XIII, 214.
1826	Berthier	Anal. Titanic iron	Ann. des M. (1), XII, 301.
1826	Levy	Brookite	Pogg. IX, 286.
1827	G. Rose	Ilmenite	Karst., Arch. X, 1.
1837	Kupfer	Ilmenite	Phil. Mag. I, 221.
1827	Levy	Mohsite	Pogg. XV, 276
1829	H. Rose	Analysis Ti iron	Konigl. Vetensk. Acad. Handl. 1829, 200.
1829	Mosander	Analysis Ti iron	Ann. des M. (4), I, 433. Berz., Jahresb. X, 176. Pogg. XIX, 217.
1829	Clemson	Analysis Ti iron	Am. J. Sci. XVIII, 42.
1830	Breithaupt	Hystite	Breith., Uib. 64. Char. 236.
1831	Brooke	Mengite, J., and Æ .	Phil. Mag. X, 187. Pogg. XXIII, 360.
1832	v. Kobell	Titanic iron	Ann. Ch. Pharm. IV, 339. Schweigg., J. LXIV, 59, 245.
1832	Damour	Titanic iron	Ann. Ch. Phys. LI, 445.
1832	v. Kobell	Kibdelophan, M.	Schweigg., J. LXIV, 59, 145. Ann. Ch. Pharm. IV, 339.
1833	Berthier	Analysis Ti iron	Am. J. Sci. XXIV, 375. Ann. des M. (3), III, 39.
1834	v. Kobell	Titanic iron	J. pr. Ch. I, 87. Bayer. Ann. No. 110, 113.
1834	Berzelius, Frick, and Wöhler	Ti in Pt. sand	Pogg. XXXI, 674.
1835	G. Rose	Ti in diorite	Pogg. XXXIV, 5.
1835	Spessart	Titanic iron	Ann. Ch. Pharm. XVI, 241.
1836	Colquhoun	Anal. Ti iron	J. pr. Ch. VIII, 509.
1837	Dufrenoy	Ti iron in volcanic ash	Ann. Ch. Phys. LXVII, 251. Berz., Jahresb. XIX, 752.
1838	Shepard	Warwickite	Am. J. Sc. XXXIV, 313; XXXVI, 85.
1838	v. Kobell	Basanomelan	v. Kob., Grundr. 318.
1839	Mohs	Iserite	Mohs, Min. 436, 1839.
1839	G. Rose	Perofskite	Pogg. XLVIII, 558. Reis. Ural. II, 128.
1839	G. Rose	Tschoffkinite	Reis. Ural. II.
1840	Karsten	Blue slags	Pogg. XLIX, 229. Pharm. Centr. XI, 202, J. pr. Ch. XX, 373. Ann. des M. (3), XIX, 680.
1840	Karsten	Cause of blue color in natural and arti- ficial products	Pogg. L, 313.
1840	Dufrenoy	Greenovite	Ann. des M. (3), XVII, 529.
1840	Shepard	Lederite	Am. J. Sci. XXXIX, 357.
1841	Plantamour	Titanic iron	Bibl. Univ. 1841. 335. J. pr. Ch. XXIV, 302.
1841	Shepard	Washingtonite	Am. J. Sci. XLIII, 364.
1842	G. Rose	Mengite	Reis. Ural. II, 83.
1843	Fuchs	Analysis of T.	Ann. Ch. Pharm. XLVI, 319.
1843	Chapman	Titanioferite	Chap., Min.
1844	Hankel	Thermo-electricity	Pogg. LXI, 291. Pharm. Centr. XV, 245.

1844	Damour	Anal. A. and R.	Ann. Ch. Phys. (3), X, 414. Kenng., Ueb. 1844-9, 190, 193.
1844	Brooks	Analysis T.	Pogg. LXII, 253.
1844	Scheerer	Yttrotitanite	Kenng., Ueb. 1844-9, 185. Pogg. LXIII, 459.
1844	Rose	A., B., and R.	Kenng., Ueb. 1848-9, 186. Pogg. LXI, 516.
1844	Rose	Tscheffkinit	Jameson's J. XL, 383. Am. J. Sci. II, 416. Pogg. LXI, 591.
1844	Delesse	Greenovite and T.	Kenng., Ueb. 1844-9, 212. Ann. des M. (4), VI, 325.
1844	H. Rose	Perofskite	Kenng., Ueb. 1844-9, 186. Pogg. LXII, 596.
1844	Jacobsen	Analysis of P.	Kenng., Ueb. 1844-9, 187.
1844	Brooks	Analysis of P.	Kenng., Ueb. 1844-9, 188.
1844	A. Erdmann	Keilhanite	Kenng., Ueb. 1844-9, 188. Ak. H. Stockh. 1844, 355. Kenng., Ueb. 1844-9, 186.
1844	H. Rose	Titanic iron	Berz., Jahresb. XXV, 328. Pogg. LXII, 119.
1845	Scheerer	Titanic iron and tantalite	Kenng., Ueb. 1844-9, 203. Pogg. LXIV, 489.
1845	Rose	Analysis of T.	Kenng., Ueb. 1844-9, 204.
1845	Rose	Anal. A., B., R.	Ann. Ch. Pharm. LIII, 418.
1845	Scheerer	A. and R.	Ann. Ch. Pharm. LIII, 270. Kenng., Ueb. 1844-9, 189. Pogg. LXV, 276, 295.
1845	v. Kobell	Titanic iron	Ann. Ch. Phys. (3), XV, 320.
1845	Marignac	Titanic iron, T., Greenovite, Crichtonite, and Washingtonite	Ann. Ch. Phys. (3), XIV, 50. Kenng., Ueb. 1844-9, 187, 704.
1845	Berzelius	Greenovite	Berz., Jahresb. XXV, 368. Kenng., Ueb. 1844-9, 187.
1845	Descloizeaux	P. and R.	Ann. Ch. Phys. (3), XIII, 338, 496. Kenng., Ueb. 1844-9, 188, 190.
1846	Hunt	Enceladite	J. pr. Ch. XLII, 453. Am. J. Sci. (2), II, 30.
1846	Rogers	Native Ti	Kenng., Ueb. 1844-9, 193.
1846	Virlet	Rutile	Am. J. Sci. (2), II, 414. C. R. XXII, 505. Kenng., Ueb. 1844-9, 190.
1846	Karsten	Rutile	Leonh., J. 1849, 728. J. pr. Ch. XXXVII, 170.
1846	Shepard	Ar., B., and Sch.	Kenng., Ueb. 1844-9, 189.
1846	Fuchs	Titanite	Am. J. Sci. (2), II, 250. Leonh., J. 1846, 224.
1846	v. Kobell	Rutile	Kenng., Ueb. 1844-9, 185. Leonh., J. 1846, 72.
1847	Rhodius	Titanic iron	Kenng., Ueb. 1844-9, 190.
1847	Descloizeaux	Greenovite	Ann. Ch. Pharm. LXIII, 219. Jahresb. I, 1161.
1847	Städler	Pyrochlore	Ann. Ch. Phys. (3), XX, 84. Kenng., Ueb. 1844-9, 187.
1848	v. Kokscharow	Brookite	Pogg. LXX, 336. Kenng., Ueb. 1844-9, 188. Verh. Min. Ges. St. Pet. 1848-9 Am. J. Sci. (2), XIV, 274. Erd. Arch. VIII, 307. Kenng., Ueb. 1844-9, 191.

Literature of Titanium.

1848	Rose	A., B., and R.	Ann. Ch. Pharm. LXVIII, 163.
1848	Hankel	Electric poles of T.	Pogg. LXXIV, 238.
1848	Hermann	Titanic iron	J. pr. Ch. XLIII, 50.
1849	Damour	Brookite	Ann. des M. (4), XV, 447.
1849	Demoly	Rutile	Jahresb. 1849, 728. Kenng., Ueb. 1844-9, 190. C. R. XXVII, 325. Am. J. Sci. (2), XI, 228. Min. Unter. I, 10. Kenng., Ueb. 1844-9, 192.
1849	Kenngott	Arkansite	J. Nat. Hist. Bost. 1849, 42. Am. J. Sci. (2), VII, 433.
1849	Whitney	Anal. Sch. and Ark.	J. Nat. Hist. Bost. 1849, 132. Am. J. Sci. (2), VIII, 274.
1849	Teschemacher	Arkansite	Am. J. Sci. (2), VIII, 275. Jahresb. 1849, 729.
1849	Shepard	Brookite	Kenng., Ueb. 1844-9, 191. Pogg. LXXVII, 123.
1849	Shepard	Schorlomite	Kenng., Ueb. 1844-9, 185. C. R. XXIX, 229.
1849	Daubrée	Ti veins	Am. J. Sci. (2), IX, 122. L'Inst. 1849, 292. Arch. ph. nat. XII, 147. Ann. des M. (4), XVI, 129. Pharm. Centr. 1848, 821. Jahresb. II, 11. J. pr. Ch. XLVI, 401. Ramm., Handw. 40, 29. Kenng., Ueb. 1844-9, 190.
1849	Hermann	Brookite	Pogg. LXXVII, 302; LXXVIII, 143. Kenng., Ueb. 1344-9, 191, 192.
1849	Breithaupt	Arkansite	Phil. Mag. (3), XXXV, 75. Kenng., Ueb. 1844-9, 192.
1849	Miller	Arkansite	Pogg. LXXVII, 586. Kenng., Ueb. 1844-9, 192.
1849	Rammelsberg	Arkansite	Ann. des M. (4), XV, 447.
1849	Descloizeaux	Arkansite	Kenng., Ueb. 1844-9, 191.
1849	Alger	Rutilated quartz	Pharm. Centr. XXI, 744. Proc. Am. Assoc. 1849, 427. Am. J. Sci. (2), X, 72.
1850	Hermann	Identity of shepardite and brookite	J. pr. Ch. L, 200. Am. J. Sci. (2), XI, 229.
1850	Hunt	Titaniferous iron	Kenng., Ueb. 1850-1, 122. Logan's Rep. Geol. Canada; 1850, 105; 1863, 501. Am. J. Sci. XI, 231.
1850	Hawel	Anatase	Jahrb. G. Reich. I, 155.
1850	Shepard	Rutherfordite	Kenng., Ueb. 1850-1, 123. Proc. Amer. Assoc. IV, 311. Am. J. Sci. (2), XII, 209.
1850	Crossley	Schorlomite	Kenng., Ueb. 1850-1, 123. Dana's Min., 3d Ed. 692. Jahresb. 1850, 748.
1850	Vaux	Sphene	Kenng., Ueb. 1850-1, 121. Am. J. Sci. (2), IX, 430.
1850	Kutorga	Iwaarite	Kenng., Ueb. 1850-1, 121. Verh. Min. Ges. St. Pet. 1850-1, 327. Kenng., Ueb. 1852, 76. Verz. Finl. Min. 1851.

1850	v. Kokscharow	Brookite	Pogg. LXXIX, 454. Am. J. Sci. (2), XI, 528. Kenng., Ueb. 1850-1, 122.
1850	Hubbard	Rutilated quartz	Am. J. Sci. (2), X, 350. Kenng., Ueb. 1850-1, 122.
1851	A. A. Hayes	Rutilated quartz	Am. J. Sci. (2), XII, 389. Kenng., Ueb. 1750-1, 122.
1851	Shepard	Eumanite, Paracol- umbite, and Ruth- erfordite	Amer. Assoc. IV, 312. Am. J. Sci. (2), XII, 211, 209. Kenng., Ueb. 1852, 182.
1851	Smith	R. and I.	Am. J. Sci. (2), XI, 65. Ann. des M. XVIII, 305. Kenng., Ueb. 1852, 122, 128.
1851	Schmid	Titanic iron	Pogg. LXXXIV, 498. Am. J. Sci. (2), XIV, 275. Kenng., Ueb. 1852, 128. Pharm. Centr. XXIII, 92.
1851	Dana	Identity of Eumanite and B.	Kenng., Ueb. 1852, 122. Am. J. Sci. (2), XII, 397.
1851	A. A. Hayes	Rutile	Proc. N. Hist. Soc. Bost. 1851, 23. Am. J. Sci. (2), XII, 389. Kenng., Ueb. 1852, 122.
1851	Delesse	Sphene	Ann. des M. XX, 148. Kenng., Ueb. 1852, 121.
1851	Rammelsberg	Schorlomite	Pogg. LXXXIV, 301. Kenng., Ueb. 1853, 76.
1855	Hunt	Rutherfordite	Am. J. Sci. (2), XIV, 345. Kenng., Ueb. 4850-1, 121. Phil. Mag. III, 142.
1852	Chapman	Titanite	Pogg. LXXXVI, 157.
1852	Kopp	Expansion of R.	J. pr. Ch. LVIII, 183.
1852	Müller	Nigrine, R.	Jahrb. M. 1852, 367. Jahresb. 1852, 847. Kenng., Ueb. 1853, 76. Am. J. Sci. (2), XIII, 117. Kenng., Ueb. 1853, 77.
1852	Teschemacher	Eumanite. B.	Verh. Min. Ges. St. Pet. 1852-3, 44, 61. Kenng., Ueb. 1853, 77.
1852	v. Kokscharow	A., B., and R.	Min. Russl. 1853, 50. Jahresb. VI, 789.
1853	v. Kokscharow	Ilmenite cryst.	B. H. Ztg. XII, 444. Russ. Bergj. 1852, 356. Jahresb. VI, 787.
1853	Romanovsky	Brookite	Pogg. XCI, 154. L'Inst. 1854, 111. Min. Russl. 1853, 50. L'Inst. XXI, 78.
1853	v. Kokscharow	A. and R.	Kenng., Ueb. 1853, 107. B. H. Ztg. XII, 254. Am. J. Sci. XV, 442.
1853	Damour	A., B., and R.	Kenng., Ueb. 1853, 106. Jahrb. G. Reichs. IV, 695.
1853	Ulrich	Ti minerals in Harz	Kenng., Ueb. 1853, 106.
1853	Hunt	Analysis of T.	Leonh., Jahrb. 1853, 175. Kenng., Ueb. 1853, 106.
1853	Zepharovich	Cryst. of T.	Leonh., Jahrb. 1853, 680. Kenng., Ueb. 1853, 106.
1853	Ulrich	Titanite	Am. J. Sci. XVI, 96. Kenng., Ueb. 1853, 106.
1853	Gutberlet	Titanite	
1853	Dana	Isomorphism of S. with Euclase	

1853	Berlin	Anal. Mosandrite	Pogg. LXXXVIII, 166. Kenng., Ueb. 1853, 107.
1853	Smith	Enceladite	Jahresb. 1853, 853.
1854	Kokscharow	Perofskite	Verh. Min. Ges. St. Pet. 1854, 140. Kenng., Ueb. 1854, 110.
1854	Volger	Perofskite	Pogg. XCVII, 559. Kenng., Ueb. 1855, 85.
1854	Schmidt	Titanite	Mitth. mæhr. schl. G. Kenng., Ueb. 1854, 110.
1854	Zepharovich	Titanite	Jahresb. G. Reichs. VI, 466. Kenng., Ueb. 1855, 466.
1854	Dana	Silico-titanates	Am. J. Sci. (2), XVIII, 253.
1854	Dana	Homœomorphism of columbite and B.	Am. J. Sci. (2), XVII, 86.
1854	Igelstrom	Titanic iron	Cefv. Ak. Stockh. 1854, No. 3. J. pr. Ch. LXIV, 62.
1854	Kokscharow	Imenortile	Min. Russl. II, 352.
1854	Damour	Perofskite	Ann. des M. (5), VI, 512.
1855	Dauber	Crystals of A.	Pogg. XCIV, 407; XCII, 237. Am. J. Sci. (2), XXI, 195.
1855	Hunt	Analysis of W.	Am. J. Sci. (2), XIX, 369. Kenng., Ueb. 1855, 84.
1855	Edwards	Titanic iron	Rep. Brit. Assoc. 1855, 61. J. pr. Ch. LXXI, 124.
1855	Hunt	Anal. of I.	Phil. Mag. (4), IX, 358. J. pr. Ch. LXVI, 153.
1855	Forbes and Dahll	Anal. of Y.	J. pr. Ch. LXVI, 444.
1855	Hermann	Anal. of Ae.	Kenng., Ueb. 1855, 83. J. pr. Ch. LXV, 80.
1855	Forbes	Keilhauite	Kenng., Ueb. 1855, 84.
1855	Arppe	Analyses	Ed. N. Phil. J. II, 1, 62; III, 59.
1855	Damour	Ti in olivine.	Analysen af Finsk. min. 34.
1855	Dauber	Anatase	Ann. des M. (5), VIII, 90. Pogg. XCIV, 407.
1855	v. Kokscharow	Analysis of B.	Kenng., Ueb. 1855, 407. Am. J. Sci. (2), XXI, 197. Min. Russl. II, 79.
1856	Heusser	Rutile	Dana Suppl. Pogg. XCVII, 127.
1856	Hermann	Aeschynite	Kenng., Ueb. 1856-7, 130. J. pr. Ch. LXVIII, 97.
1856	Edwards	Titanic iron	Kenng., Ueb. 1856-7, 129. Pharm. J. Trans. XV, 232. J. Ch. Soc. VIII.
1856	Hessenberg	Crystals of R.	Leonh., Jahrb. 1857, 835. Kenng., Ueb. 1856-7, 145.
1856	Wiser	A., B., and R.	Jahresb. IX, 839. Kenng., Ueb. 1856-7, 131.
1856	Hesse	Titanic iron	Jahrb. Min. 1856, 15. Jahresb. IX, 839.
1856	Wiser	Titanite	Prog. Gewb. Sch. Chemn. 1856, 10. Jahresb. IX, 829. Kenng., Ueb. 1856-7, 14f.
1856	Daubrée	Titanite	Leonh., Jahrb. 1856, 13. Kenng., Ueb. 1856-7, 12f.
1856	Shepard	Xanthitan	L'Inst. XXV, 38. Kenng., Ueb. 1856-7, 12f.
			J. pr. Ch. LXX, 210. Am. J. Sci. XXII, 96. Kenng., Ueb. 1856-7, 128.

1856	Shepard	Sch., W., and Parathorite	Am. J. Sci. XXIV, 124. Kenng., Ueb. 1856-7, 129.
1856	Shepard	Pyromelane	J. pr. Ch. LXX, 210. Am. J. Sci. XXII, 96. Kenng., Ueb. 1856-7, 130.
1856	Zepharovich	Iserite	Wien. Ak. Ber. XIX, 350. Jahresb. IX, 839. Kenng., Ueb. 1856-7, 145.
1856	Vogel and Reischauer	Ti in magnetite	L'Inst. 1857, 82. Jahresb. IX, 839. Kenng., Ueb. 1856-7, 845.
1857	Damour	Analysis of I.	Ann. Ch. Phys. (3), LI, 445. Am. J. Sci. (2), XXV, 408.
1857	v. Kokscharow	Ilmeno-rutile	Min. Russl. II, 352. Am. J. Sci. (2), XXV, 412. Jahresb. X, 661. Kenng., Ueb. 1856-7, 131.
1857	v. Kokscharow	Brookite	Am. J. Sci. (2), 113. Min. Russl. II, 273.
1857	Damour	Titaniferous peridotite	C. R. XLI, 1151.
1857	Seneca	Perovskite	Ann. des M. (5), VIII, 90. Ann. d. Ch. u. Pharm. CIV, 317, 371.
1857	Sandberger	Rutile	Leonh., Jahrb. 1857, 808. Kenng., Ueb. 1856-7, 131.
1857	Hessenberg	T. and R.	Senk. naturf. Ges. Frankfurt, II, 252. Kenng., Ueb. 1858, 110.
1857	Hedde	Titanite cryst.	Phil. Mag. XV, 134. Kenng., Ueb. 1858, 110.
1857	Damour	A., B., and R	Jahresb. 1857, 661. Kenng., Ueb. 1858, 112.
1857	Grailich and Lang	Brookite	Bull. Géol. (2), XIII, 542. Wien. Ak. XXVII, 10. Kenng., Ueb. 1858, 113.
1858	Descloizeaux	Perovskite	Ann. des M. (5), XIV, 417. Kenng., Ueb. 1859, 88.
1858	Descloizeaux	Aeschynite	Ann. Ch. Phys. LIX, 379. Kenng., Ueb. 1860, 82.
1858	v. Kokscharow	Rutile	Min. Russl. III, 213. Kenng., Ueb. 1859, 88.
1858	Rammelsberg	Analyses of titaniferous iron	Pogg. CIV, 497. Ber. Ak. Berlin. 1858, 401. J. pr. Ch. LXXIV, 451. Ch. Centr. III, 662. Phil. Mag. (4), XVII, 497. Am. Jour. Sci. (2), XXVII, 127; XXVIII, 136. Min. Ch. 406.
1858	Dana	Note on titaniferous iron	Am. J. Sci. (2), XXVII, 423.
1858	Müller	Brookite	Am. J. Sci. (2), XXVI, 347. Verh. Nat. Ges. Basel. 1857, 578. Leonh., Jahrb. 1858, 313.
1858	Nordenskiöld	Iwaarite	Kenng., Ueb. 1858, 111.
1858	Scheerer and Breithaupt	Polykras, Polymignite, etc.	B. and H. Zeit. XVII, 62. Kenng., Ueb. 1858, 111.
1868	Hessenberg	Anatase	Abhandl. Senk. Ges. Frankfurt, III, 279. Kenng., Ueb. 1859, 89.

1858	Guiscardi	Guarinite	Z. S. G. X, 14. Leonh., Jahrb. 1858, 826. Kenng., Ueb. 1858, 111.
1858	Müller	Ilmenite	Ch. Centr. III, 702. Jahresb. 1859, 775. Vierteljahress. Pharm. VIII, 331. Am. J. Sci. (2), XXXIV, 213.
1859	Shepard	Rutile	Kenng., Ueb. 1860, 98. Am. Jour. Sci. (2), XXVII, 36; XXVIII, 144.
1859	Rammelsberg	Anal. Y-t.	Kenng., Ueb. 1859, 89. Pogg. CV, 296.
1859	Wiser	A. and T.	Kenng., Ueb. 1859, 86. Leonh., Jahrb. 1859, 425.
1859	Rube	Rutile	Kenng., Ueb. 1858, 207. Ann. der Ch. und Pharm. CXII, 179.
1860	Bunsen and Kirchhoff	Ca. in T., Tsch., etc.	Kenng., Ueb. 1859, 89. Pogg. CX, 181.
1860	v. Cotta	Ti iron	Kenng., Ueb. 1860, 82. B. H. Ztg. XIX, 124.
1860	Schrauf	Anatase	Kenng., Ueb. 1860, 97. Ber. Ak. Wien. XLII, 113. Pogg. CXII, 594.
1860	Wiser	Rutile	Kenng., Ueb. 1860, 83. Leonh., Jahrb. 1860, 784.
1860	Haidinger	Rutile	Kenng., Ueb. 1860, 83. Ber. Ak. Wien. XXXIX, 5. Am. J. Sci. (2), XXXI, 366. Min. Russl. IV, 26.
1860	Hunt	Ti iron	Kenng., Ueb. 1861, 102. Ch. News, II, 41. J. pr. Ch. LXXXII, 512. Rép. Ch. pure, II, 389.
1860	Zittel	Ti iron	Kenng., Ueb. 1861, 102. Leonh., Jahrb. 1860, 791.
1861	Hermann	Cb. in Ae.	Kenng., Ueb. 1860, 97. J. pr. Ch. LXXXIII, 108.
1861	Deville	V., Mo., and Sn. in R.	Kenng., Ueb. 1861, 93. Ann. Ch. Phys. (3), LXI, 342.
1861	v. Kokscharow	Rutile	Kenng., Ueb. 1861, 93. Bull. Ak. St. Pet. IV, 566. Z. S. Nat. XIX, 113. Jahresb. XIV, 977.
1861	Kenngott	Rutile	Kenng., Ueb. 1861, 93. Jahresb. XV, 715.
1861	Zepharovich	R. and A.	Leonh., Jahrb. 1861, 335. Jahrb. G. Reichs. XI, 59.
1861	Rømer	Rutile	Kenng., Ueb. 1861, 93. Leonh., Jahrb. 1861, 491.
1861	v. Rath	Cryst. Brookite	Z. S. G. XI, 583. Kenng., Ueb. 1861, 91. Pogg. CXIII, 430.
1862	v Rath	Cryst. T. and A.	Jahrb. Min. 1861, 849. Kenng., Ueb. 1861, 94. Pogg. CXV, 466, 482.
1862	G. Rose	Circular crystals of R.	Jahrb. Min. 1862, 726. Kenng., Ueb. 1861, 92. Pogg. CXV, 643. Kenng., Ueb. 1861, 94.

1862	Streng	Ti iron	Jahrb. Min. 1862, 952. Jahresb. XV, 717. Kenng., Ueb. 1862-5, 253.
1862	Scheerer	R. in furnace	B. H. Ztg. XXI, 98. Kenng., Ueb. 1862, 236.
1862	Damour	Tscheffkinites	Bull. G. Fr. XIX, 550. Kenng., Ueb. 1862, 234.
1862	Fischer	R. and P.	N. J. für Min. 1862, 432, 448. Kenng., Ueb. 1862, 235.
1862	Wappler	Rutile	B. H. Z. XXI, 272. Kenng., Ueb. 1863, 236.
1862	Websky	Ilmenite	Schl. Gesell. Vaterland. Cultur. XLIII, 30. Z. S. G. XVII, 567. Kenng., Ueb. 1862, 253.
1862	Descloizeaux	Effects of heat	Ann. des M. (6), II, 327. Pogg. CXIX, 491.
1863	Hessenberg	Rutile and T.	Abhandl. Senk. Ges. Frankfurt, IV, 205. Jahresb. XV, 801. Jahrb. Min. 1863, 593, 233.
1863	Wiser	Anatase	Jahrb. Min. 1863, 697.
1863	v. Kokscharow	R. pseudomorphs after A.	Bull. Ak. St. Pet. VI, 414. Jahresb. XV, 849.
1863	Fischer	Schorlomite	N. J. für Min. 1863, 559; 1865, 438. Natur. Ges. Freiberg in B. III, 13. Kenng., Ueb. 1863, 236.
1863	Wiser	Anatase	N. J. für Min. 1863, 679. Kenng., Ueb. 1862-5, 236.
1863	Gurlt	Ilmenite	Niederrhein. Gesell. 1863, Jan. 7. Kenng., Ueb. 1862-5, 253.
1863		Ti iron	Bergeist, 1863, 96.
1864	Pisani	Paracolumbite	Am. J. Sci. (2), XXXVII, 359. Kenng., Ueb. 1862-5, 263.
1864		Cb. in M.	Pogg. CXXII, 615.
1864	Wiser	T. and R.	N. J. für Min. 1864, 218. Kenng., Ueb. 1862-5, 234.
1864	Liebener and Vorhauser	Ilmenite	Kenng., Ueb. 1862-5, 236. Nacht. Min. Tyrol. 20.
1864	Brunel	Ti sand	Ch. News, XI, 9.
1864	Laspeyres	Anatase	Z. S. G. XVI, 454. Kenng., Ueb. 1862-5, 236.
1865	Klein	Titanite	Prager Sitzungsber. 1865, 2, 4. Kenng., Ueb. 1862-5, 234.
1865	v. Rath	A., B., R., and T.	Z. S. G. XIV, 413, 443. Kenng., Ueb. 1862-5, 234.
1865	Hermann	Aeschynite	J. pr. Ch. XCV, 78. Kenng., Ueb. 1862-5, 235.
1865	v. Kokscharow	Aeschynite	Min. Russl. IV, 53.
1865	Fischer	P. and Iserine	N. J. für Min. 1865, 439. Kenng., Ueb. 1862-5, 236, 253.
1865	Seeland	Rutile	Jahrb. G. Reichs. XV. Kenng., Ueb. 1862-5, 236.
1865	Wiser	Anatase	N. J. für Min. 1865, 725. Kenng., Ueb. 1862-5, 237.
1866	Breithaupt	T. and S.	B. H. Ztg. XXV, 107.
1866	Shepard	Rutile	Am. J. Sci. (2), XLII, 422.
1866	Hermann	Ae. and Ilmenium	J. pr. Ch. XCIX, 279.
1866	Forbes	Ti iron	Phil. Mag. (4), XXXII, 136.
1866	Breithaupt	Castellite	B. H. Ztg., XXV., 113.

1866	Mosler	Ti iron	Zeit. B. H. and S. Wesen, XIV, 102, B.
1866	Calberla	Ti iron sand	Sitzungsber. Isis, Dresden, 1866, 136. Jahrb. Min. 1867, 479.
1866	G. Rose and H. Rose	Tscheffkinite	Berz., Jahresb. XX, 209. Jahresb. XVIII, 943.
1866	Hermann	Tscheffkinite	J. pr. Ch. XCVII, 345. Zeit. Ch. 1866, 406. Jahrb. Min. 1866, 834.
1866	Fizeau	Expansion of R.	Bull. Soc. Ch. (2), VI, 392. C. R. LXXII, 1101, 1133. Pogg. CXXVIII, 586. Ann. Ch. Phys. (4), VIII, 358.
1866	Pfaff	Optical prop. of R.	Pogg. CXXVII, 156.
1866	Schrauf	Refractive power of R. and A.	Ber. Ak. Wien. Pogg. CXXIX, 624.
1866	Groth	Titanite	Jahrb. Min. 1866, 44.
1866	Smith	B., I., and R.	Am. J. Sci. (2), XLII, 92.
1866	Eddy	Anatase	J. Nat. Hist. Bost. X, 94. Am. J. Sci. (2), XLII, 272.
1867	Marignac	Aeschynite	J. pr. Ch. CI, 465.
1867	Wöhler	Anatase	Gel. Anz. Göttingen. 1867, 274. Jahrb. Min. 1868, 202.
1867	Silva	Ti iron sand	Jahrb. XIX, 980, C. R. LXV, 207. Bull. Soc. Ch. (2), VIII, 418.
1867	v. Hauer	Iserite	Ber. Ak. Wien. XIX, 350
1867	Forbes	Titanoferrite	Phil. Mag. (4), XXXIV, 344.
1868	Hermann	Anal. of Ae.	J. pr. Ch. CV, 327. Zeit. Ch. XII, 222.
1868	Forbes	Anal. of titaniferous iron	Ch. News, XVIII, 275. Dingl., J. CXCI, 220. B. H. Ztg. XXVIII, 102.
1869	Petersen	Ti in basalt	J. pr. Ch. CVI, 81.
1869	Hermann	Ti in Fergusonite	J. pr. Ch. CVIII, 132.
1869	Hermann	Ae. and Euxenite	J. pr. Ch. CVII, 153.
1870	Forbes	Titanic iron	Mon. Sci. 1870, 69.
1871	Sergeant	Titanic iron	Eng. and Min. J. XI, 136. B. H. Ztg. XXX, 231.
1873	Smith	Anal. of W.	U. S. R. R. and Min. Reg. C. R. LXXIX, 696. Jahresb. Rein. Ch. II, 119. Am. Chem. V, 349.
1873	Roussel	Ti in basalt	J. Ch. Soc. VI, 46. C. R. LXXVII, 1102. Ch. Centr. (3), IV, 776. Am. Chem. IV, 353.
1873	Apjohn	Ti in trap	J. Ch. Soc. XXVII, 137. Bull. Soc. Ch. XXI, 74 Ch. News, XXVI, 183.
1873	Hilger	Ti iron of abnormal comp.	Bull. Soc. Ch. XIX, 123. J. Ch. Soc. XXVII, 134.
1873		Conductivity of A. and R.	Jahrb. Min. 1873, 643.
1873	Von Gerichten	Ti iron of abnormal comp.	Ann. Ch. Phys. (4), XXVIII, 31. Annalen der Chemie und Pharm. CLXXI, 205. Am. Chem. V, 308. J. Appl. Chem. X, 73.

1874	Sandberger	Ti in dolerite	Jahrb. Min. 1874, 88. J. Ch. Soc. XXVII, 558.
1876	v. Rath	Brookite	Jahrb. Min. 1876, 201. Am. J. Sci. (3), XI, 234. J. Ch. Soc. 54.
1876	König	Hydrotitanite	Proc. Ac. Philadel. May 9, 1876. Foote's Cat. 10, 37.
1876	v. Rath	Anatase	Jahrb. Min. 1876, 64. J. Ch. Soc. VI, 887.
1876	Foote	R. in quartz	Sci. Amer. XXXV, 345.

NOTE.—The abbreviations employed are, in most cases, explained in the introduction to Dana's Mineralogy, edition of 1868. To these may be added the following:

Am. Chem. Ber. d. d. ch. Gesell.	American Chemist, New York. Berichte der deutschen chemischen Gesellschaft, Berlin.
Deut. I. Ztg. E. and M. J. W. Jahresb. Zeit. anal. Ch.	Deutsche Industrie Zeitung, Chemnitz. Engineering and Mining Journal, New York. Wagner's Jahresbericht, Leipzig. Zeitschrift analytische Chemie.



1.

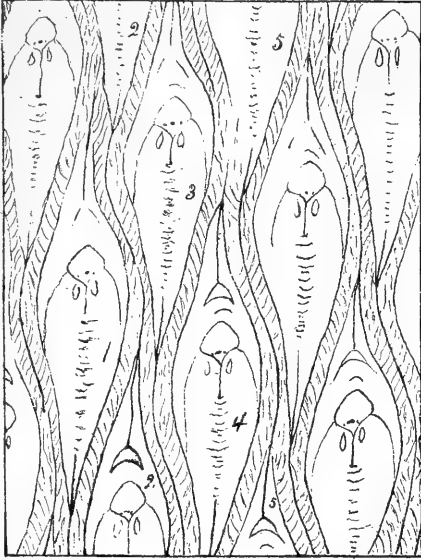

2.

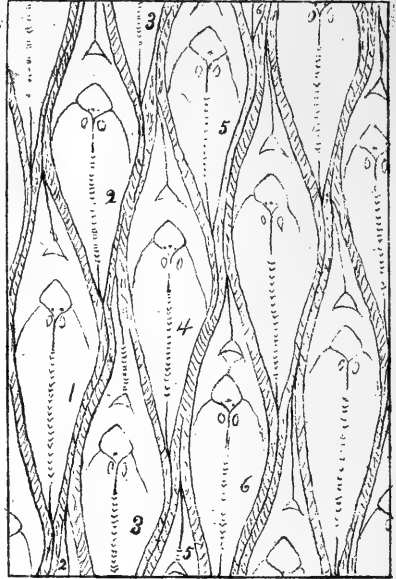

3.

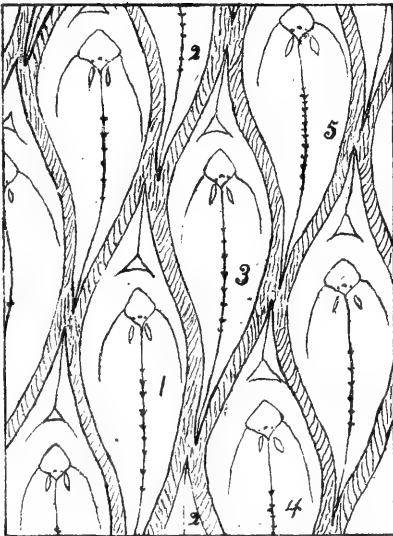

4.

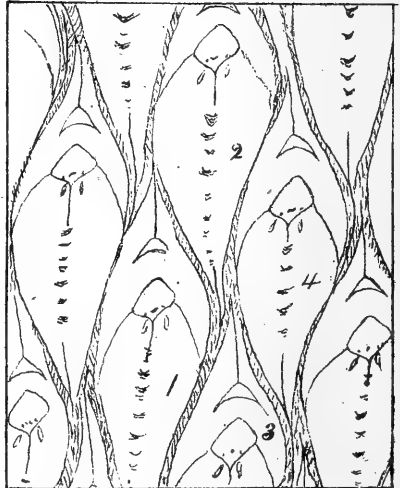



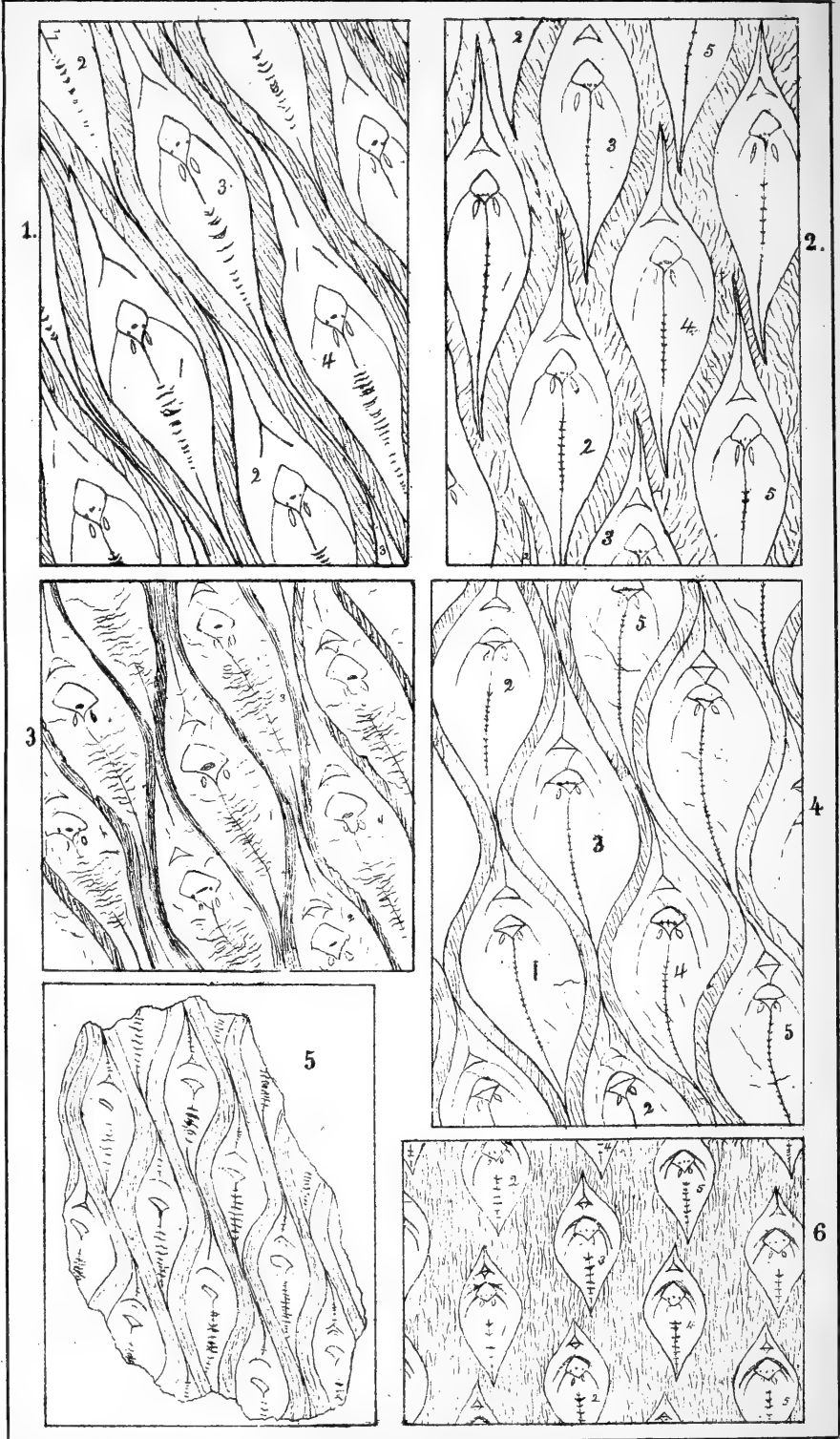

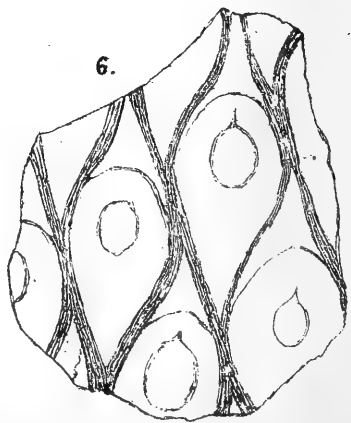
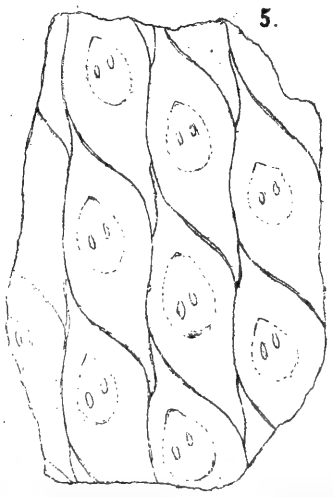
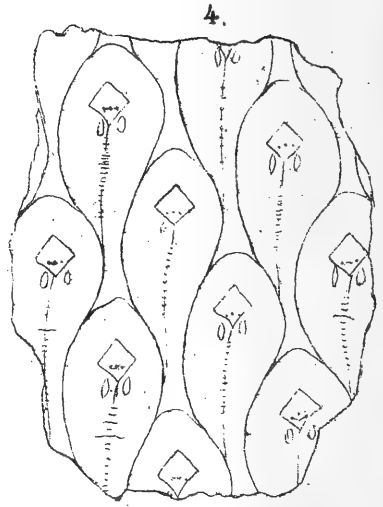
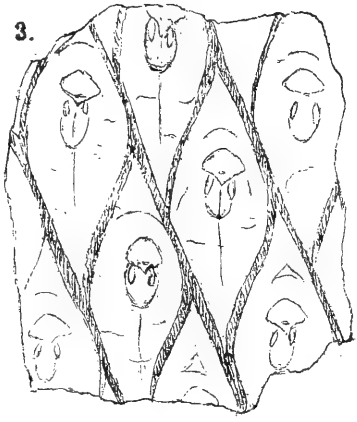
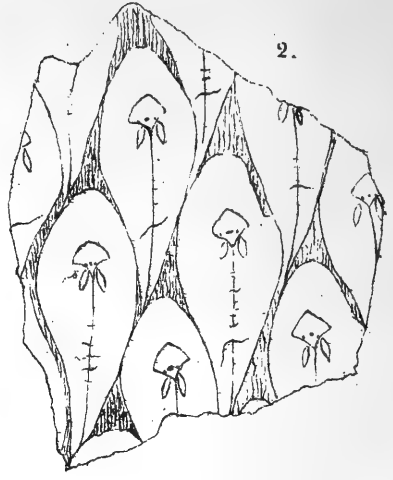
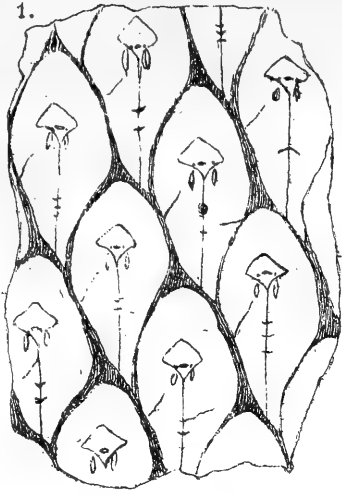

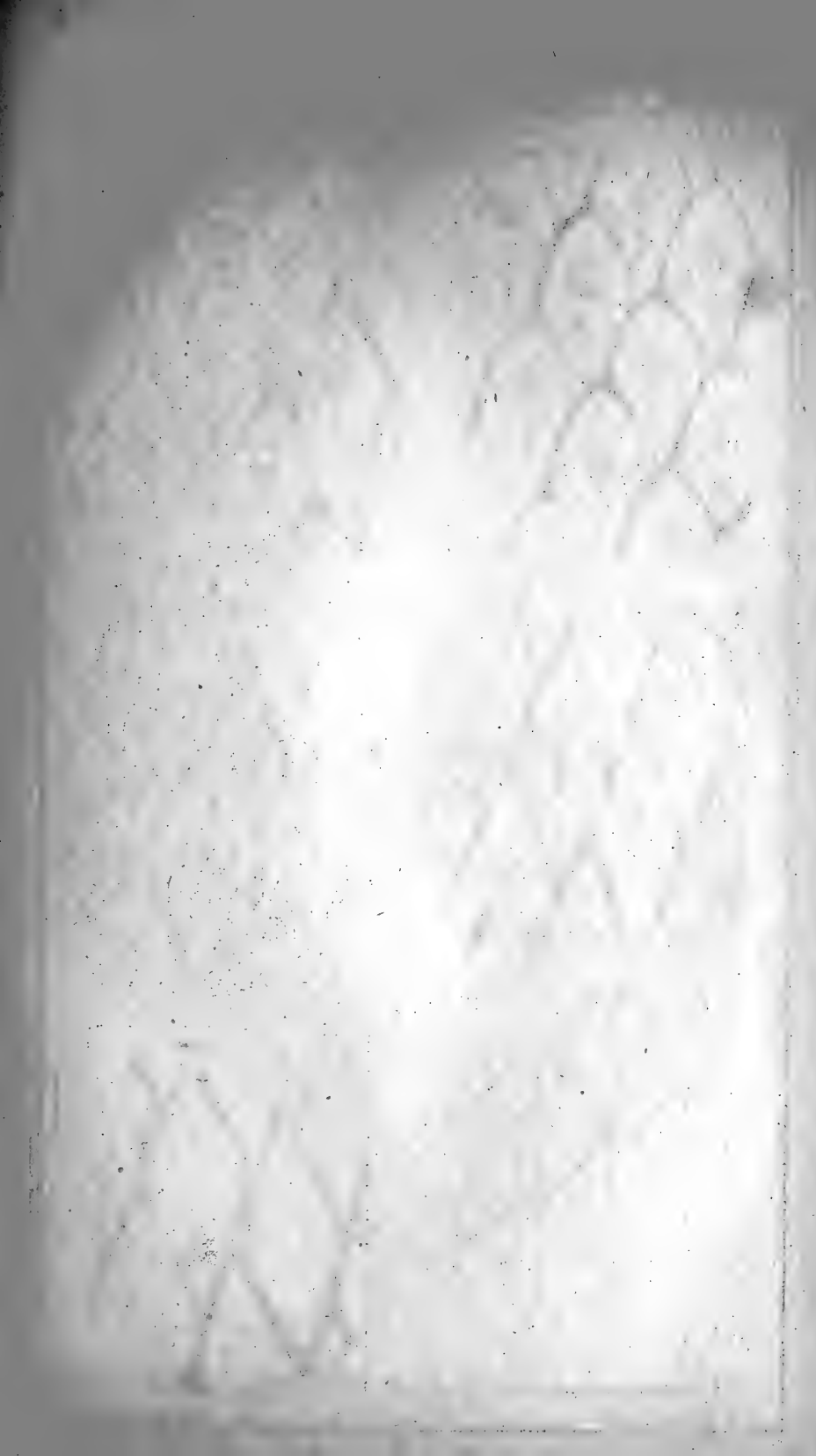

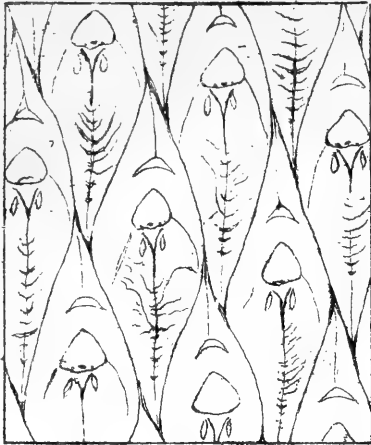

1.

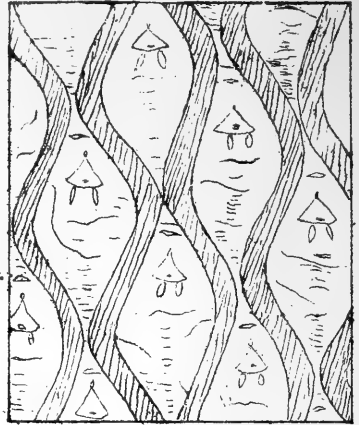

2.

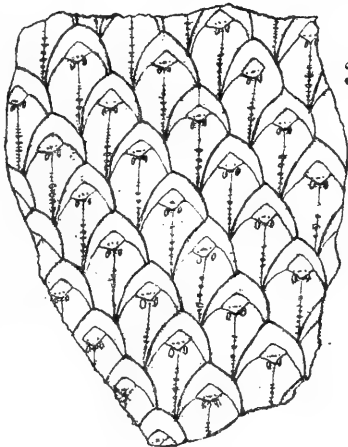

3.

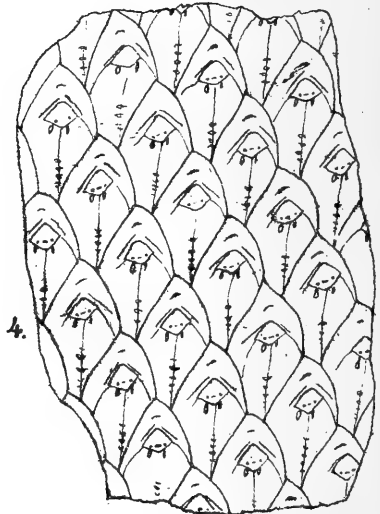

4.

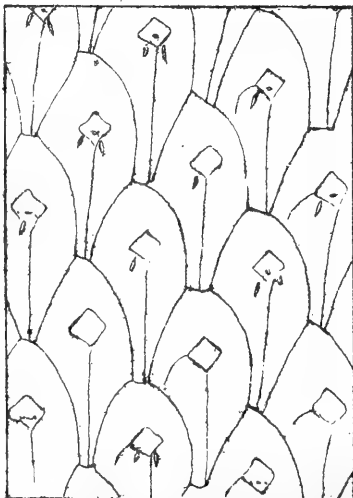

5.

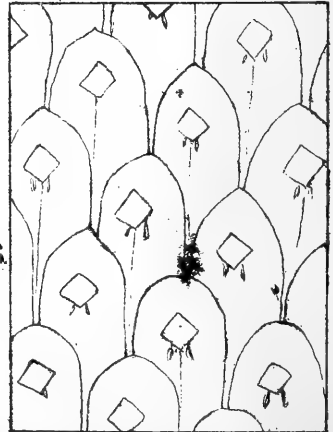

6.

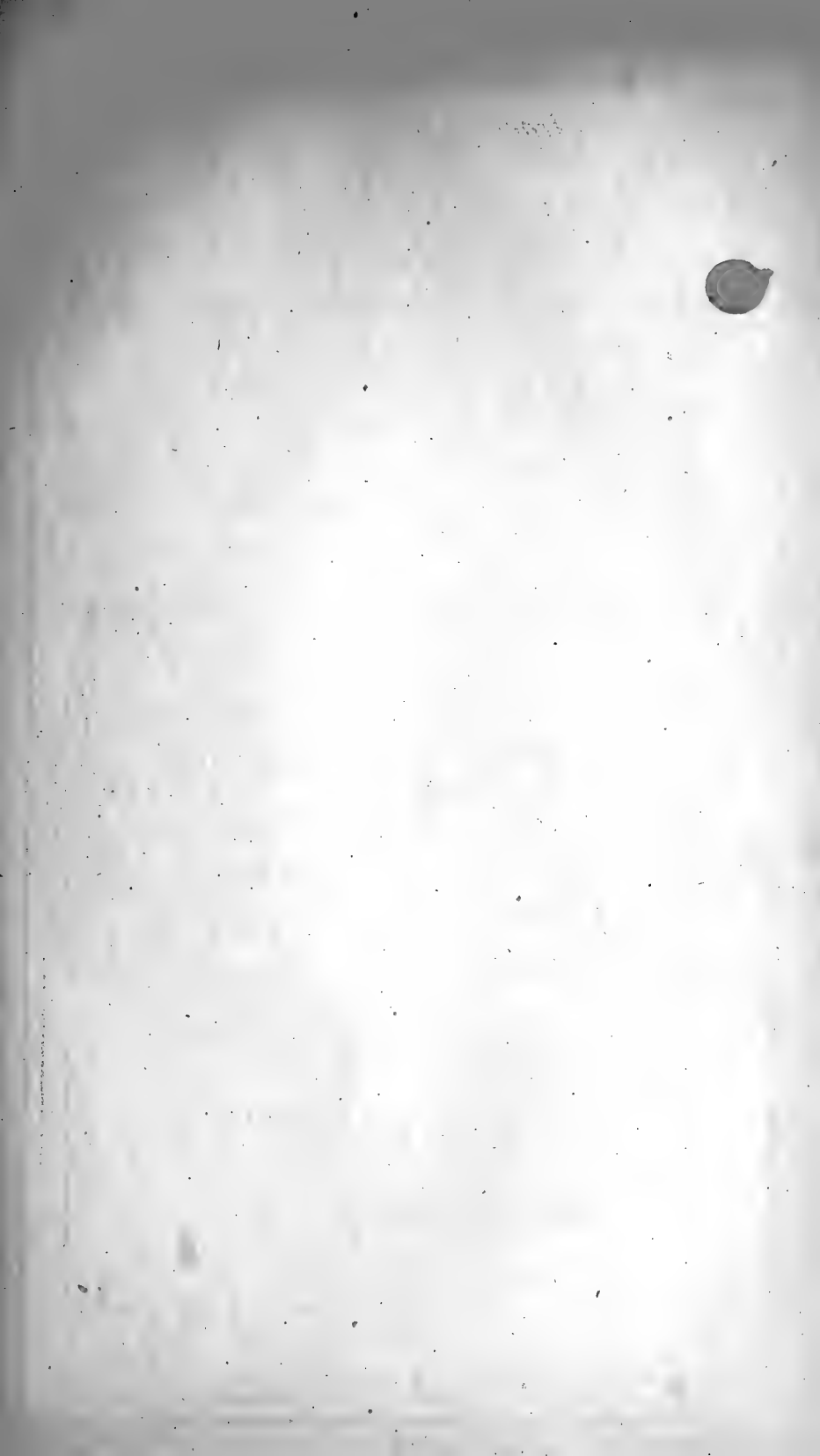

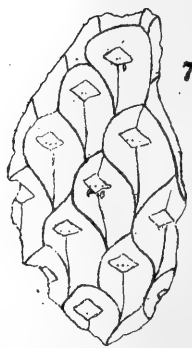
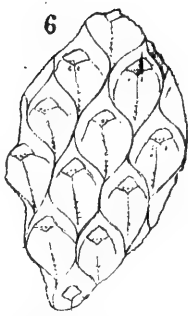
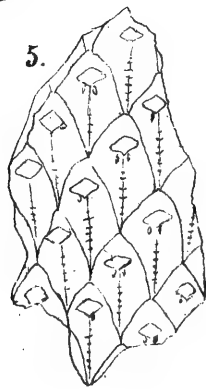
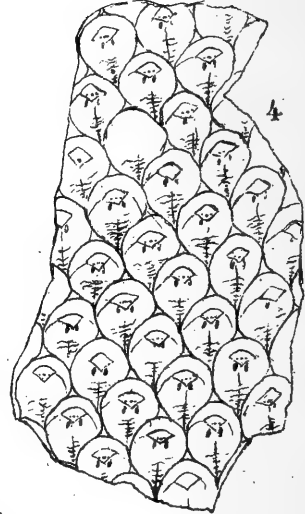
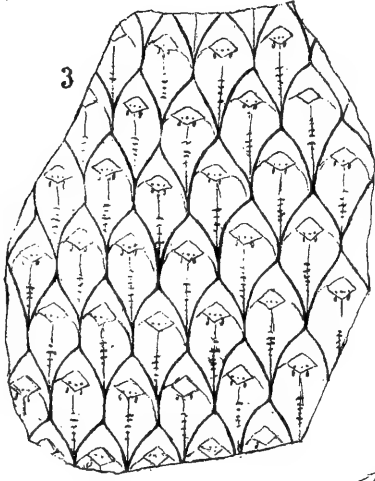
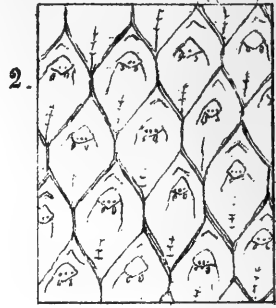
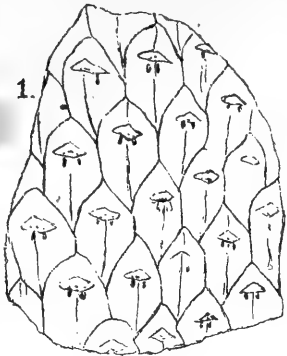

VII.—On the Structure of *Lepidodendron* and *Sigillaria*.

BY HERMAN L. FAIRCHILD.

No. 2.—The Variations of the Leaf Scars of *Lepidodendron Aculeatum*, Sternberg.

(With Plates V-IX.)

Read October 1, 1877.

The determination of species of *Lepidodendron* is a matter of extreme difficulty. Reasons lying in the fragmentary character of the fossils have already been mentioned. But this is not the only source of difficulty. The number of fragments would not be so great an obstacle, if they commonly presented recognizable characteristics, like animal remains, or were even as invariable as some other fossil plants. The chief source of trouble is the mutability of every feature or marking of the leaf scars that has been used to distinguish species. They are all alike unstable. Even the grouping of these features affords no sure basis. The close relationship of the species is another cause of difficulty, which perhaps produces the former. The species appear to blend or run into one another in a manner very discouraging to the student. M. Schimper's judgment, in his "Traité de Palæontologie Végétale," affords the best illustration I can give of the near affinity of the species and the blending of their various forms. Of *Lepidodendron* and identical genera, he mentions one hundred and nineteen names. Sixty of these he suppresses; uniting a large number with *L. Sternbergii*, Brgt. and *L. aculeatum*, Sternb., leaving only fifty-nine species. The majority of these he regards as closely allied to others; and several of them as founded on differences which he thinks of slight importance, or even worthless. Could he have examined our American species, there would probably be no occasion for publishing this article. After enumerating those described by Prof. Lesquereux, he says, "Il est fort probable qu'un examen fait sur les lieux mêmes réduirait ces huit espèces Pennsylvaniennes à deux ou trois." This sweeping

statement, and many of his remarks concerning American forms, fully agree with my observations of the fossils.

It is but just to say that my investigation was undertaken, and the results which are embodied in this paper were reached, independently and before I found access to Prof. Schimper's authoritative work, or had any knowledge of its contents. I shall simply quote his remarks upon the forms which I discuss.

In the Third Anthracite or Wyoming coal basin of Pennsylvania, it is not only impracticable, but to any important extent impossible, to study coal plants *in situ*. The conclusions herein contained have been reached by comparison of numerous specimens from many localities in that field. In this study, the partially obliterated, deformed, and anomalous specimens, that are usually neglected by collectors, but which are of great importance in tracing variations, have been carefully regarded. From peculiarities of form as distinct and important as some features that have been used as the basis of specific distinction, I could create new species. But I am convinced that such forms are connecting links between others already erected into species. Prof. L. Lesquereux's Memoir on the coal plants of the anthracite basins of Pennsylvania, contained in Rogers' report of the first Pennsylvania State Geological Survey, has of necessity been largely the basis of my work.

In what I regard as the typical form of *L. aculeatum*, Sternb. (Figs. 1, 2, Pl. V; Figs. 1, 5, Pl. VI), the medial line of the inferior half of each general leaf scar is continued as the medial line of the superior portion of another leaf scar. The general scars are thus directly connected in rows, or seriate. Frequently the attenuate extremities are much elongated, and sometimes the scars are confluent, as shown in two places in Fig. 1, Pl. VI. These variations of the typical form, together with somewhat similar derived forms hereafter described, furnished the species *Sag. confluens*, Sternb., *L. undulatum*, Sternb., *L. caudatum*, Ung., and others named by Sternberg, all of which M. Schimper has already united with *L. aculeatum*, Sternb. Each series of leaf scars is separated from its adjacent rows by an intervening furrow or band, called the mar-

gin. When the scars are connected by merely the extension of the keeled medial line, two margins are at intervals brought side by side, so that each leaf scar has double margins upon two opposite sides, if we regard the scar as a quadrilateral. Or to state the fact differently, in one oblique direction or spiral, the leaf scars are separated by double margins, produced by bringing scars adjacent which are members of alternate series. The expansion or increase in circumference of the cortex is effected by widening and consequent cracking of the margins. The direction of the fissures is usually obliquely across the margins, in consequence of being necessarily the resultant of the lines perpendicular to the directions of expansion, together with the flexuosity of the margins. It cannot be maintained that the margins, in the specimens furnishing the figures above referred to, are in any important degree produced by the widening of the cortex after the leaves attained their full size; because in that case, on account of the direction of the cracks, the fine keeled lines connecting the elevated leaf bases would be broken and obliterated by fissures extending across the double margins. This partly accounts for the rarity of the feature. Consequently we may affirm that this form is the natural typical relation of the leaf scars of this species, assumed when the leaves are not crowded, but have sufficient space upon the stem for their normal development. The proportions of the leaf scars vary, without obliteration or change of any character, from obovate to narrow elliptical, or the length from two to five times the breadth, not including the extension of the medial line. The extreme forms I have not figured. Any obliquity will, of course, make them rhombic or rhomboidal, which is slightly the condition in Figs. 1, 2, Pl. V, and more so in Fig. 5, Pl. VI. But if the leaf scars are somewhat obovate, the obliquity will make their trapeziform shape more prominent. These variations in shape are greater in the derived forms, which will be considered hereafter. Although the exact shape of the general cicatrix is in many descriptions made one of the distinctive characters of the particular species, in *L. aculeatum*, at least, the shape even of the typical

leaf scar can be correctly stated only in a general way, as ranging between wide and indefinite limits.

Excessive leafiness seems to have been very commonly, if not generally, the condition of these exuberant trees. Nearly all the fossils evidence more or less crowding of the leaf bases. See plates VIII and IX. For this reason the typical form and relation of the scars or foliar cushions must have been somewhat uncommon. It requires but slight crowding or mutual compression of the bases of the leaves, to obliterate the keeled line connecting them. This can frequently be seen upon fine specimens with mostly double margins, and is shown in three places in Fig. 2, Pl. V. But in this stage of compression the overlapping ends of adjacent scars will still be separated by a remaining portion of the margin, which has been mostly obliterated, or rather fused with the contiguous margin. This produces the form originally called *L. aculeatum*, Sternb. (Figs. 3, 4, Pl. V; Figs. 2, 3, Pl. VI; Fig. 1, Pl. VIII). In Figs. 1, 2, Pl. V, the ends of the leaf scars do not overlap in every instance; and Figs. 3, 4, Pl. V, show the resulting form of compression. But in Figs. 1, 5, Pl. VI, the ends overlap considerably; and Fig. 2, Pl. VI, shows the corresponding derived form. I use the expression "obliteration by compression," to cover two possible cases. First, a true destruction, by the crowding of the leaves, of certain features which actually existed with the young leaves; and second, the prevention or suppression of those features by the crowding and mutual pressure of the leaf bases from the time of starting. In specimens of full sized leaf scars, it is impossible to distinguish these causes, and in some cases it is likewise impossible to determine if the lines connecting the leaf scars have been obliterated by pressure or destroyed by expansion. Such a case is Fig. 2, Pl. VI. But from an examination of the whole specimen, I think it more probable that the connecting lines were obliterated by the coarctate condition of the leaves; the broad margins being produced by widening of the cortex after the leaves were fully grown. Upon the Plates V and VI, I have indicated the relation of the leaf scars by numerals; the same figure being applied to the scars that are connected

in one vertical rank, or which normally should be so connected. The breaks in the connecting lines on either side of scar number one, in Fig. 1, Pl. V, and also between scars four and two, in Fig. 2, have evidently been produced by expansion and consequent cracking. But between leaf scars four and six, and in two other places on the right side of Fig. 2, Pl. V, the lines were either destroyed or prevented from ever appearing by the crowding of the leaves.

If the compression of the leaf scars is still greater, the overlapping ends of the scars will be so shortened as merely to meet. This is the condition represented by *L. modulatum*, Lesq. Fig. 4, Pl. VI, is after the original figure. In this stage of compression, two scars belonging to adjacent series are brought end to end, and apparently connected; two naturally alternate margins are brought together; leaf scars which properly should be separated by two intervening series are brought side by side; and all the scars are consequently much shortened. Fig. 3, Pl. VI, is a form transitional between *aculeatum* and *modulatum*, showing the overlapping ends not entirely destroyed. In this coarctate form, the leaf scars are somewhat confluent. This condition is very common, much more so than the perfect *modulatum*.

It may be claimed that the relation of the leaf scars is essentially the same in *modulatum* as in Figs. 1, 5, Pl. VI, or Figs. 1, 2, Pl. V, and that the difference is only in the proportions of the scars and the length of the connecting line. This is true of some specimens; and yet the form is abnormal. The bases of the leaves assumed this form under compulsion; it is the second degree of compression of the typical form. There is a perfect transition from the typical form to *modulatum*, through the form first called *aculeatum*, by many minute gradations; and the positive proof is, that *aculeatum* is present in most specimens of the typical form, and *modulatum* is frequently shown on slabs of *aculeatum*. The form *modulatum* exists in the specimen from which Fig. 2, Pl. VI, is taken. Such examples are found in most collections. In many specimens of *modulatum*, the line joining the leaf scars is evidently not a continuation

of the medial line. The other apparent differences will be considered hereafter. Prof. Schimper observes that *L. modulatum* greatly resembles *L. aculeatum*. It could hardly be supposed that *modulatum* is the typical form; for it must be understood that the leaf scars are much more likely to be shortened by compression than lengthened. I can imagine no process of modification which could produce the form in Figs. 1, 2, Pl. V, from *modulatum*, or from any form in the plates. The resulting difference in form in the production of *modulatum* is not very striking, but it is the result of an interesting process.

The width of the margin bears no fixed relation to the size of the leaf scars. It represents either the space between the cushions of the growing leaves, or the amount of expansion of the cortex after the leaves attain their full growth. It cannot be thought that the leaves upon these rapidly growing plants should always be exactly the same relative distance apart, or the same relative size,—in other words, that the relation between the growth of the stem and of the leaves should be absolutely sustained. The rugosity of the margin usually increases with the breadth. But there is much variation; some very broad margins are finely wrinkled and plane, while narrow margins are sometimes exceedingly broken. The narrow margin is half round and depressed. On old stems, the delicate sculpturesque markings of the scars or cushions become obliterated by loss of the outer cortex; but well preserved specimens are found with the margins as broad as the scars. *L. distans*, Lesq. (Fig. 6, Pl. VI) is such an example. Here the leaf scars have precisely the same relation as in Fig. 2, Pl. VI. The only feature of *L. distans* that is in the least degree peculiar is the double appendages. The superior appendages are accessory and non-essential; they may be seen in Fig. 4, Pl. VIII, in a marginless specimen. I have rarely observed them on single leaf scars. But the same cause which produces a peculiarity on one leaf scar might likewise affect many of the neighboring ones, or all the scars over a large area. I shall hereafter explain the nature of the superior appendages. The size of the leaf scar in *distans* cannot be regarded as a specific charac-

ter. Prof. Lesquereux has said that his *L. oculatum*, which has much larger leaf scars, is perhaps *L. distans* in the decorticated state; and Prof. Schimper makes *oculatum* identical with *distans*, remarking that it differs only in size; thus implying that the size is not distinctive.

From this extreme width of margin, there is every lesser width down to its entire absence (Pl. VII). In some instances a broad margin is greatly narrowed in places. Sometimes the margins are quite suppressed upon two opposite sides of the leaf scars, regarding them as quadrilateral, while a fair breadth of the double margin appears on the other sides. In other instances the margin is very much narrowed, or entirely absent, for some distance along each side of the leaf scars, showing greater breadth at the ends of the scars (Fig. 4, Pl. V). The margin is certainly of little value as a specific character; though its presence may serve to distinguish a section.

In this species the acuminate ends of the leaf scars are sometimes blended with the margins, caused probably by a strong wrinkle of the medial line extending entirely across the point (Fig. 1, Pl. VII). The ends are thus abruptly or rounded obtuse. Sometimes a few leaf scars thus appear upon acuminate specimens. In other instances, the majority or all of the scars are so shortened. Usually only one end of the leaf scar is thus affected, but rarely both ends. When the superior end is shortened, the leaf scar is given more obovate proportions. *L. obtusum*, Lesq., is a very broad typical *aculeatum*, with the inferior part of the leaf scar narrowed and the end obtuse; thus bringing the vascular scar nearly to the middle of the leaf scar. The relative breadth of the leaf scars is not remarkable, even for the typical *aculeatum*; though it shows a crowding of the leaves lengthwise of the stem greater than usual. The wrinkle between the vascular scar and the crown is not peculiar to *obtusum*. The same may be found in Fig. 1, Pl. V. Prof. Schimper remarks of *L. obtusum*, Lesq.: "A Carbondale avec le *L. giganteum*, dont il pourrait bien représenter un rameau principal ou un individu moins adulte." And of *L. giganteum* he says: "Très-voisin du précédent" (*L. modulatum*), "les cicatrices sont plus large." It appears

to me that *L. giganteum* lacks several features that are common to the different forms of *L. aculeatum*. According to my observations thus far, it is identical with *L. clypeatum*, Lesq., and *L. tetragonum*, Sternb. But *L. tetragonum* may also be derived, I think, from *L. aculeatum*.

Fig. 2, Pl. VII, illustrates a specimen of marginless *aculeatum* with the leaf scars rounded above; and as the inferior ends of the same are acuminate, there are left triangular spaces of the cortex, which were not covered by the leaf bases. The superior ends of the leaf scars in Fig. 4 are rounded or arcuate, but the triangular spaces of Fig. 2 are in this specimen incorporated with the inferior ends of the leaf scars, making them fish-tailed in shape.

Upon plates VIII and IX, I have figured several remarkably compressed forms. Associated with those represented in Figs. 3, 5, 6, Pl. VIII, and Figs. 1, 3, 5, 7, Pl. IX, were found many specimens proving the derivation of these forms from *L. aculeatum*, and also the transition from that through these forms to *L. carinatum*, Lesq. (Fig. 2, Pl. IX). A careful study of these figures will show that the changes in the relative lengths of the corresponding sides of the leaf scars in the several specimens, are not due so largely to variation in the relative positions of the leaf scars (produced, one may imagine, by sliding the spiral ranks upon each other), as to mutual compression and consequent shortening of their overlapping ends. For example, the shortening of the ends in Fig. 1, Pl. VIII, first produces the four-sided leaf scar of Fig. 5, Pl. IX. Further crowding shortens the ends of the quadrilateral leaf scars still more, bringing other naturally separated scars into contact, and making them six-sided again, as in *carinatum* and all the remaining figures on Pl. IX. This latter change can be seen in Fig. 3, Pl. IX, passing from the right side to the left. Now, we have a third spiral of contiguous scars, and a relation of the scars the same as in *modulatum*. Indeed, it is young *modulatum*, of the kind having the line connecting the leaf scars an extension of the medial line; or it may, if the stem grows proportionately faster than the leaves, produce a broad typical *aculeatum*. The relation of the leaf scars in

Figs. 3, 4, Pl. VIII, is, at first sight, similar to that of Fig. 1, Pl. VIII. But it more closely resembles *carinatum*. The spirals are steeper, hence the length of the corresponding sides varies. Of course the moving or sliding of the spiral ranks upon each other would change the direction of the secondary spirals and the length of the sides of the scars; and if continued, it would change the scars from six-sided to four-sided, and back to six-sided, in constant recurrence. But this process would not shorten the ends of the leaf scars.

The proof of the identity of *carinatum* with *aculeatum* is by no means confined to the locality furnishing these specimens. The hexagonal form is sometimes the property of full-grown leaf scars. I have observed the change from *aculeatum* upon the same slab. Under mutual pressure, the inferior sides of the leaf bases seem usually to have given way to the superior sides, but sometimes the sides are all equally impressed.

Figs. 4, 6, Pl. IX, might be called *L. obovatum*, Sterub., which Prof. Schimper has identified with *L. Sternbergii*, Brongt. But on account of intermediate forms it is extremely difficult to separate them from *carinatum*. If *L. obovatum*, Sternb., is distinct from *L. aculeatum*, which yet admits of doubt, it is quite certain that the scars on young branches of old trees would frequently be indistinguishable.

Fig. 7, Pl. IX, shows great irregularity in the shape of the leaf scars. How much of the peculiarities of form in different specimens may be due to decortication, or to pressure in the rock, cannot be well determined. Figs. 5, 6, Pl. VIII, are from quite flat specimens. The absence of the more easily obliterated features may be due either to rock pressure or to decortication, or to both. But Figs. 3, 4, Pl. VIII, are from fossils having the foliar cushions in strong and clear relief.

The vascular scar, the cicatrix of the most vital part of the leaf base, is also subject to much variation. Its position is naturally somewhat above the center of the leaf scar; but by compression and distortion of the leaf bases, the distance may be either increased or diminished. The relative size of the vascular scar is variable, even on the same specimen, as the figures will attest. The shape varies from square to long

rhomboidal; it is usually described as rhomboidal. The figures on plates V and VI give the normal shape, which should be described as rhombic-trapezoidal, or what is perhaps more precise, rhombic-trapeziform. The greatest breadth may be either vertical or horizontal. In the perfect vascular scar, the inferior angle is always acute. But as regards the superior and lateral angles, there is so great variety that it is quite impossible to generalize. I refer the reader to the figures. The superior and lateral angles are very rarely, if ever, absolutely pointed, although they are frequently so figured. The shape of the vascular scar seems to be somewhat affected in the same manner as the general leaf scar containing it (Fig. 4, Pl. V; Figs. 1, 3, 4, 5, Pl. VI; Fig. 4, Pl. X).

The vascular bundles, proceeding from the vascular cylinder through the thick cortical layer to the leaves, gave to the vascular scars a firmer texture and more enduring character than is possessed by other portions of the general cicatrix. Consequently the vascular scars sometimes remain quite intact, while the remainder of the general scar becomes somewhat decorticated. *L. obscurum*, Lesq., described in the report of the Illinois State Geol. Survey, is probably a case of this kind. The same thing may very possibly occur in other species than *aculeatum*. Prof. Schimper unites *L. obscurum* with *L. diplogioides*, Lesq. Sometimes a part of the general leaf scar immediately beneath the vascular scar seems to partake of the permanence of the latter, and remains as an oval or subrotund convex elevation above the decorticated general surface (Figs. 3, 5, 6, Pl. VII). This is doubtless *L. mammillatum*, Lesq., occurring with *L. obscurum*.

It is not very rare to find the inferior angle of the vascular scar cut away or truncate, thus giving the vascular scar a conical form (Fig. 1, Pl. VIII). The angle that is cut off is sometimes wholly effaced; but in some instances it remains slightly separated from the main portion of the vascular scar. Prof. Lesquereux has called this distorted form *L. conicum* (Fig. 2, Pl. VIII), and remarks that, "though well marked and distinct, it may be a decorticated impression." Prof. Schimper says of it: "Je ne pense pas que cette espèce soit distincte du

L. modulatum." The specimen affording Fig. 1, Pl. VIII, has a portion of the vascular scars of normal shape and perfect.

The triangular or crescent-shaped cicatrix above the vascular scar, called the crown, is not often mentioned in descriptions of this species. But it certainly is as prominent and permanent as the appendages. The plates show its various modifications. The figures of *modulatum* and *distan*s are liable to give a wrong idea of the shape and character of this feature, to a person not familiar with the fossils. The inferior or concave side of the crown is depressed below the general surface of the leaf scar. In Figs. 4, 6, Pl. VI, the two lines between the crown and vascular scar, which give each crown the appearance of two triangles joined at their bases, only mark the boundaries of the triangular area between the depressed side of the crown and the superior angle of the elevated vascular scar. They are doubtless unduly prominent in the two figures; and they must be too prominent, if represented at all, in an outline drawing. Fig. 2, Pl. V, and Fig. 3, Pl. VI, show the same feature. Appendages to the crown are sometimes found on specimens with strong relief and sharp definition. The crown is easily obliterated.

The middle one of the three vascular points, which is elongated laterally, and is naturally larger than the punctiform lateral ones, is frequently much enlarged, while the lateral ones are obsolete (Fig. 3, Pl. VI; Figs. 1, 3, Pl. VII; Fig. 2, Pl. VIII). In some instances the lateral points are enlarged at the expense of the middle one (Fig. 4, Pl. VIII). It is not rare to find the three points united by an elevated line or wrinkle. *L. modulatum* is described as having the points united by a depressed line; but evidently the cast is described instead of the cortex, as the margin is said to be elevated. This line uniting the points, like many other passing features, is not sufficiently permanent to be of value.

The tubercles vary in shape from narrow elliptical to ovate, or even subrotund. They may be parallel or diverging. Sometimes they seem to be easily effaced, and at other times very enduring (Fig. 5, Pl. VII). In small or young scars they are often undeveloped.

The degree of rugosity of the medial line is extremely variable. The line is naturally smooth for some distance below the vascular scar, and again for some distance above the terminus of the leaf scar. But if the leaf scar is shortened, the rugosity may reach to the extreme point. The line extending from the superior point of the leaf scar to the crown is always quite smooth.

The appendages are easily effaced, and upon leaf scars having little relief they are either short or obsolete. Their direction is less variable.

Narrow portions of the surface of the leaf scars contiguous to the superior sides of the vascular scars, are rarely elevated with the latter. The lines bounding the superior sides of the narrow areas have the appearance of an extra pair of appendages, particularly when they proceed from the superior angle of the vascular scar. These lines are present in Fig. 4, Pl. VIII, and are doubtless the upper appendages in *distans* (Fig. 6, Pl. VI). It is scarcely necessary to add that they are of no importance as a specific character.

I suggest the possibility that the future thorough examination of these fossils will prove the identity of *L. aculeatum*, *L. Sternbergii*, Brongt., *L. crenatum*, Sternb., and other so-called species. I think this is not entirely contrary to Prof. Schimper. Of *L. aculeatum* he says: "Se rencontre avec le précédent, dont il n'est probablement pas autrement distinct que par les grandes cicatrices plus allongées vers le haut et vers le bas." But I judge there is considerable variation in the extremities of *Sternbergii*, as Prof. Schimper identifies with it *L. obovatum*, Sternb., and *L. rugosum*, Brongt.; the former of which was described as narrowed and acuminate below, and the latter, if I am not mistaken, as narrowed and acuminate at both ends. On the other hand, a large proportion of specimens of *aculeatum*, as I have endeavored to show, are by mutual pressure of the leaves in growth, much shortened at the ends. Prof. Schimper says of *L. crenatum*, Sternb.: "Cette espèce ne se distingue du *Lepid. Sternbergii*, que par les cicatrices un peu plus grandes et proportionnellement plus larges. Ce caractère me paraît peu important." Fig. 4, Pl. V, or Fig. 3,

Pl. VI, might be fairly called *crenatum*. So might *L. obtusum*, Lesq., as far as the vascular scars are concerned. This comparison could be greatly extended, and might result in closely interweaving many species. What was said in the beginning of this paper, regarding the blending of the species and the difficulty of separation, is pertinent just here. The certain determination of the species will require a thorough study of all the organs. If the fifty-nine species which Prof. Schimper preserves should ultimately be reduced one-half or more, it will not be an unexpected result. And that *L. aculeatum* should have been thus multiplied by even so eminent a palæontologist as Prof. Lesquereux, at a time when collections of coal plants were few, and opportunity for collection and study limited, is not in the least surprising. The number could very easily have been increased.

For the purpose of ready comparison, I have placed in tabular form the descriptions of the several species which I am confident are identical. If they are not identical, then consistently there is no alternative but to establish from the intermediate forms a great and indefinite number of new species. The description of *aculeatum* is Prof. Schimper's; the others are the originals.

To prevent possible misconception, I would mention that the figure of *L. aculeatum* in Dana's "Manual of Geology," p. 324, is extremely incorrect. It seems to have been taken from Fig. 8, Tab. VI, of Brown's "Lethæa Geognostica," and there called *L. obovatum*, Sternb. If the figure accurately represents the fossil, the latter is either very strangely distorted or an entirely distinct species. To find such a figure of *L. aculeatum* in the lately revised edition of this standard work, is an emphatic illustration of the uncertainty which still attends the specific characters of this genus.

The appended list of the figures gives the localities of the fossils as precisely as possible, and also the places where they are deposited. Besides the collections there named, the splendid cabinet of the Wyoming Historical and Geological Society contains material confirming my statements. It was impracticable to figure with this paper the large specimens which show conclusively the nature of the forms herein discussed.

NAME.	LEAF SCAR.	VASCULAR SCAR.	POINTS.	TUBERCLES.	APPENDAGES.	MEDIAL LINE.
<i>L. aculeatum</i> Sternb.	Cicatricibus truncato impositis magnis, longe rhomboidalibus, utraque extremitate longe productis, sensum opposito inflexis, tota longitudine centim. 8-9, latitudine media 2 mellefuitibus.	Cicatricula rhombea, superne obtusa.				Pulvinulo paulum ultra medium producto, ovato-clavato, in caudam decurrente, superne utroque latere carinae cicatriculae vascolari humilari vel verruciformi notato. (The original has <i>notata</i> ,—evidently an error.)
<i>L. modulatum</i> Lesq.	Oval, narrowed acuminate at both ends, curved at base, separated by broad, half-round, elevated, deeply-wrinkled margins; wrinkles undulate and parallel to scar.	Rhomboidal, obtuse arched above, narrow at base in long point, acute at both sides.	Three, transverse, unified by a depressed line.	Narrow	Double.	Deeply marked and transversely furrowed by deep short wrinkles.
<i>L. obtusum</i> Lesq.	Trapezoidal, acutely pointed above, slightly narrowed and abruptly obtuse below; margin broad, undulately striate and furrowed in their length.	Nearly placed in the middle, rhomboidal, obtuse above, acute below, angular on both sides.	Three, transverse.	Oval, diverging.	Irregular, distinct on one side only.	Wrinkled.
<i>L. distans</i> Lesq.	Oval, lengthened, acute or acuminate at both ends, margin very broad, striate, flat.	Rhomboidal square.	Three, transverse.	Small, diverging.	Two on each side.	Deep transversely cut by broad short wrinkles.
<i>L. carinatum</i> Lesq.	Oval, hexagonal, angular, acute at both ends; margins narrow, deep, keeled, smooth.	Rhomboidal, obtuse above, triangular below.		Small, oval.	Short, obsolete.	Obsolete, transversely wrinkled.
<i>L. conicum</i> Lesq.	Oval, acute, and narrowed at both ends; margins flat, broad, deeply wrinkled, parallel to scars.	Triangular, conical.	Single, oval in middle of scar.	Two, broad oval.	None.	Marked only by a row of long undulate transverse wrinkles.
<i>L. obscurum</i> Lesq.	Flat, rhomboidal, obscurely marked, distant and separated by longitudinal, deep, slightly undulate striae, becoming more and more marked, and forming deep furrows in the old part of the trees.	Central, round or oval, irregular.		None.	None.	
<i>L. mammillatum</i> Lesq.	Broadly oval, pointed at both ends, central scar round, mammillate or convex, notched at the top, or with irregularly undulate borders. Surface deeply irregularly grooved, the grooves passing in undulations between the cicatricies.	Oval, enlarged on the sides; beneath this an oval convex bolster, which is the only part left of the specimens when the surface is old or eroded.	Three, horizontal, medial one large, two lateral ones placed at the corners of the scar.			

LOCALITIES OF THE FIGURED FOSSILS, AND THEIR PLACES OF DEPOSIT.

PLATE V.

- Fig. 1. Mammoth Seam, Baltimore Quarries, Wilkesbarre, Pa.. Personal Collection.
- 2. Mammoth Seam, Baltimore Quarries, Wilkesbarre, Pa. Personal Collection.
- 3. Lackawanna Valley...Prof. J. S. Newberry's Coll.
- 4. Diamond Seam, Park Coal Co.'s Mine, Scranton, Pa.. Personal Collection.

PLATE VI.

- Fig. 1. Mammoth Seam, Baltimore Quarries, Wilkesbarre.....Personal Collection.
- 2. Lackawanna Valley...Prof. Newberry's Coll.
- 3. Mammoth Seam, Baltimore Quarries, Wilkesbarre.....Cornell University Coll.
- 4. After Lesquereux; from Rogers' Geology of Pennsylvania.
- 5. Mammoth Seam, Baltimore Quarries, Wilkesbarre.....Personal Collection.
- 6. After Lesquereux; from Rogers' Geology of Pennsylvania.

PLATE VII.

- Fig. 1. Sloan Shaft, Scranton.....Cornell University Coll.
- 2. Brisbin Shaft, Scranton.....Cornell University Coll.
- 3. Diamond Slope, Scranton.....Cornell University Coll.
- 4. Brisbin Shaft, Scranton.....Cornell University Coll.
- 5. Brisbin Shaft, Scranton.....Cornell University Coll.
- 6. Lackawanna Valley...Prof. Newberry's Coll.

PLATE VIII.

- Fig. 1. Mammoth Seam, Baltimore Quarries, Wilkesbarre.....Personal Collection.
- 2. After Lesquereux; from Rogers' Geology of Pennsylvania.
- 3. Brisbin Shaft, Scranton.....Personal Collection.
- 4. Lackawanna Valley...Personal Collection.
- 5. Brisbin Shaft, Scranton.....Cornell University Coll.
- 6. Brisbin Shaft, Scranton.....Cornell University Coll.

PLATE IX.

- Fig. 1. Brisbin Shaft, Scranton.....Cornell University Coll.
- 2. After Lesquereux; from Rogers' Geology of Pennsylvania.
- 3. Brisbin Shaft, Scranton.....Personal Collection.
- 4. Nanticoke, Pa.....Personal Collection.
- 5. Brisbin Shaft, Scranton.....Cornell University Coll.
- 6. Mammoth Seam, Baltimore Quarries, Wilkesbarre.....Cornell University Coll.
- 7. Brisbin Shaft, Scranton.....Cornell University Coll.

NOTE BY THE EDITOR.

It has been found impossible, from certain mechanical difficulties, to reproduce by photo-lithography the smoothness and elegance of the original drawings of these figures. They were prepared upon tracing-cloth, which under the powerful light requisite for photographing their details, imparted to the lines a roughness, which even great care in the process was unable to obviate. Their accuracy, however, may be relied upon.

VIII.—*On the Distribution of Fresh-Water Fishes of the United States.*

BY DAVID S. JORDAN, M.D.,

Butler University, Indianapolis, Ind.

Read, December 4, 1876.

THIS paper is designed solely as a contribution to our knowledge of the geographical distribution of our fresh-water fishes. It consists of a catalogue of (*a*) the fishes which have been collected by myself; (*b*) those sent me by correspondents; and (*c*) those *personally* examined by me in private collections, fish markets, and other places, *outside* of the great museums; accompanied by a list of the lakes and streams from which, or from tributaries of which, each species has been taken.

No species has been included which has not been personally identified, and no locality has been inserted from which I have not examined specimens, either in my own, or some other private collection.

It is, therefore, an original, and not a compiled record; and from such records the ichthyologists of the future must draw the material for generalizations concerning the problems of geographical distribution and variation. We know too little of our fish-fauna, as yet, for such generalizations to have much value, as is evinced by the errors which have thus far accompanied attempts at such work.

The material on which this paper is based is now chiefly deposited in the Museum of the Butler University, at Indianapolis, by the generous aid of which institution I have been enabled to explore several streams, of which the inhabitants are little known to science. It consists of collections made in Cayuga Lake, by Dr. B. G. Wilder and Instructor S. H. Gage; in Delaware River, by Prof. A. C. Apgar and Dr. C. C. Abbott; in Rock, Peckatonica, Baraboo, and Wisconsin Rivers, by Prof. H. E. Copeland, W. F. Bundy, and R. H. Struthers; in Northern Indiana, by the Indiana Geological Survey; in White River, Indiana, by Prof. Copeland, C. H. Gilbert, and myself; in Genesee River, by E. R. Beadle; in Lake Michi-

gan, by Dr. P. R. Hoy; in Illinois River, by Prof. S. A. Forbes; in various parts of Illinois and Maryland, by E. W. Nelson and A. W. Brayton; in Ohio River, in West Virginia, by Prof. John A. Myers; at the Falls of the Ohio, by Dr. John Sloan; in Salt River, Kentucky, by W. M. Linney; and my own collections in the Great Lakes, in the Genesee, Housatonic, Delaware, Youghiogeny, Potomac, and other Eastern rivers; in the Fox, Wolf, Suamico, Rock, and Peckatonica Rivers, Wisconsin; in White, Blue, Wabash, and other rivers, in Indiana; in the Ohio, at various points; in the Kentucky, Rock Castle, and Cumberland Rivers, in Kentucky; in the French Broad, and Powell Rivers, in Tennessee; in the Etowah, Oostanaula, and Coosa Rivers, in North-western Georgia; in the Chattahoochee River, near Atlanta, and in the South Fork of the Ocmulgee River, at Flat Rock, Georgia.

I have accompanied each species by a reference to one good description, usually in some generally accessible work. The nomenclature is that of Jordan's Manual of the Vertebrate Animals of the North-Eastern United States, Edition 2d, 1878.*

ETHEOSTOMATIDÆ.

1. AMMOCRYPTA BEANII, JORDAN.

Sand Diver.

JORDAN, Bull. U. S. Nat. Mus., 1877, 5.

Notalbany R., Louisiana.

2. PLEUROLEPIS PELLUCIDUS (BAIRD), AGASSIZ.

Sand Darter.

JORDAN, Man. Vert., 1876, 221.

White R., Mahoning R.

3. MICROPERCA PUNCTULATA, PUTNAM.

Least Darter.

JORDAN, Man. Vert., 1876, 218.

Fox R., Wolf R., Rock R., White R.

* This paper was originally written in 1876. In the winter of 1877 it was revised, and some additions made to the lists of localities. Since then, the nomenclature has been brought up to date, but no other additions of importance have been made.

4. *BOLEICHTHYS EOS*, JORDAN and COPELAND.

Red-Sided Darter.

JORDAN, Proc. Ac. Nat. Sci., Phila., 1877, 46.

Suamico R., Wolf R., Rock R., L. Mich., Wabash R., Kankakee R., St. Joseph's R., Maumee R.

5. *BOLEICHTHYS ELEGANS*, GIRARD.

Little Speck.

GIRARD, Proc. Phil. Ac. Sci., 1859, 103.

Etowah R.

6. *BOLEICHTHYS FUSIFORMIS* (GRD.), JOR.

Fusiform Darter.

GIRARD, Proc. Phil. Ac. Nat. Sci., 1854.

Charles R., Mass.

7. *ETHEOSTOMA FLABELLARE*, RAF.

Fan-tailed Darter.

Catnotus flabellatus, JORDAN, Man. Vert., 1876, 218.

Cumberland R., White R., Ohio R., Salt R., Rock Castle R.

8. *ETHEOSTOMA LINSLII*, H. R. STORER.

Brook Darter.

H. R. STORER, Proc. Bost. Soc. Nat. Hist., 1851, 37.

Cayuga L., Genesee R.

9. *ETHEOSTOMA LINEOLATUM* (AGASSIZ), JORDAN.

Lined Darter.

Catnotus lineolatus, JORDAN, Man. Vert., 1876, 218.

Rock R., Fox R., Wolf R., Baraboo R., Peckatonica R.

10. *PÆCILICHTHYS SPECTABILIS*, AGASSIZ.

Rainbow Darter.

JORDAN, Man. Vert., 1876, 220.

White R., L. Michigan, Rock R.

11. *PÆCILICHTHYS VARIATUS* (KIRTLAND), AG.

Blue Darter, Blue Johnny.

Pæcilichthys cæruleus, JORDAN, Man. Vert., 1876, 219.

Rock R., Baraboo R., White R., Mahoning R., Ohio R., Salt R.

12. *NOTHONOTUS CAMURUS* (COPE), JORDAN.

Trout Darter.

Nothonotus niger, JORDAN, Man. Vert., 1876, 219.

White R.

13. *NANOSTOMA ZONALE* (COPE), JORDAN.

Zoned Darter.

Pæcilichthys zonalis, COPE, Journ. Ac. Nat. Sci., Phil., 1868, 212.

Ohio R.

14. *BOLEOSOMA OLMSTEDI* (STORER), AGASSIZ.

Tesselated Darter.

Boleosoma tesselatum, DEKAY, Fishes N. Y., 1842, 20.

Delaware R., L. Michigan.

(b). VAR. *ATROMACULATUM* (GIRARD), JORDAN.

Scaly-necked Darter.

Estrella atromaculata, GIRARD, Proc. Phil. Ac. Sci., 1859, 64.

Cayuga L.

15. *BOLEOSOMA MACULATUM*, AGASSIZ.

Johnny, Slim Darter.

Boleosoma effulgens, JORDAN, Man. Vert., 1876, 222. (Not of Girard).

Suamico R., Fox R., Rock R., White R., Ohio R., Mahoning R., Illinois R., Salt R., Rock Castle R.

16. *ULOCENTRA STIGMÆA*, JORDAN.

Speck.

Boleosoma stigmæum, JORDAN, Ann. N. Y. Lyc. Nat. Hist., 1876, 311.

Etowah R., Alabama R., Notalbany R.

17. *DIPLESIMUM NEWMANI* (AGASSIZ), JORDAN.

Crawl-a-bottom.

Hyostoma Newmani, AGASSIZ, Amer. Journ. Sci. & Arts, 1854, XVIII, 303.

Tennessee R.

18. *DIPLESIMUM SIMOTERUM* (COPE), COPELAND.

Crawl-a-bottom.

Hyostoma simoterum, COPE, Journ. Phil. Ac. Sci., 1869, 215.

Rock Castle R., French Broad R.

19. *DIPLESIMUM BLENNIOIDES* (RAFINESQUE), JORDAN.

Green-sided Darter.

Hyostoma cymatogrammum, COPE, Jour. Phil. Ac. Sci., 1869, 214.

White R., Ohio R., Salt R.

(b). *RHEOCRYPTA COPELANDI*, JORDAN.

Copeland's Darter.

JORDAN, Bull. U. S. Nat. Mus., x, 1877, 9.

20. *IMOSTOMA SHUMARDII* (GIRARD), JORDAN.

Big-headed Darter.

JORDAN, Proc. Ac. Nat. Sci., Phila., 1877, 49.

Wabash R., Illinois R.

21. *ALVORDIUS MACULATUS*, GIRARD.

Black-sided Darter.

Etheostoma blennioides, JORDAN, Man. Vert., 1876, 222.

Wolf R., Peckatonica R., Baraboo R., White R., Rock Castle R., Cumberland R., French Broad R.

22. *ERICOSMA EVIDES*, JORDAN and COPELAND.

Orange-Barred Darter.

JORDAN, Bull. U. S. Nat. Mus., x, 1877, 8.

White R.

23. ALVORDIUS MACROCEPHALUS, COPE.
Long-headed Darter.

Etheostoma macrocephalum, COPE, Trans. Am. Phil. Soc., 1866.
Upper Ohio R.

24. ALVORDIUS PHOXOCEPHALUS (NELSON), COPE and JORDAN.
Taper-headed Darter.

JORDAN, Proc. Ac. Nat. Sci., Phila., 1877.
Wabash R., Illinois R., Kansas R.

25. HADROPTERUS NIGROFASCIATUS, AGASSIZ.
Crawl-a-bottom.

AGASSIZ, Amer. Journ. Sci. & Arts, 1854, XVII, 303.
Etowah R., Ocmulgee R., Tangipahoa R.

26. HADROPTERUS TESSELATUS, JORDAN.

JORDAN, Bull. U. S. Nat. Mus., H, 1877.
Foxburg, Pa. (Spec. in S. I. Mus.)

27. PERCINA CAPRODES (RAFINESQUE), GIRARD.
Hog Molly.

Pileoma semifasciatum, DEKAY, Fishes N. Y., 1842, 16.

L. Michigan, White R., Ohio R., Rock Castle R., Cumberland R., Etowah R.

28. PERCINA MANITOU, JORDAN.
Manitou Darter.

JORDAN, Proc. Ac. Nat. Sci., Phila., 1877.
Wabash R., Wisconsin R.

PERCID Æ.

29. PERCA AMERICANA, SCHRANCK.
Yellow Perch.

Perca flavescens, STORER, Fishes of Mass., 1855, 4.

L. Ontario, L. Erie, L. Michigan, Connecticut R., Genesee R., Cayuga L., Fox R., Rock R.

30. STIZOSTETHIUM VITREUM (MITCH.), JORDAN.

Pike Perch, Yellow Pike (Lakes); Black Salmon (Ohio R.); Dory (Green Bay); Wall-Eyed Pike, Glass Eye, Pickerel (L. Champlain); Blue Pike (L. Erie); Okaw or Horn Fish (British America).

Lucioperca americana, DEKAY, Fishes N. Y., 1842, 17.

L. Erie, L. Michigan, Fox R., Ohio R.

31. STIZOSTETHIUM SALMONEUM, RAFINESQUE.
White Salmon (Ohio R.); Salmon Trout (Georgia).

Perca salmonea, RAFIN., Ich. Oh., 1820, 21.

Ohio R., Rock Castle R., Tennessee R., Etowah R.

32. STIZOSTETHIUM CANADENSE (SMITH), JORDAN.

Sauger, Sand Pike.

Lucioperca grisea, DEKAY, Fishes N. Y., 1842, 18.

L. Michigan, L. Erie, Scioto R., Ohio R., St. Lawrence R., Missouri R.

LABRACIDÆ.

33. ROCCUS LINEATUS (BLOCH and SCHNEIDER), GILL.

Striped Bass, Rock Fish.

Labrax lineatus, STORER., Fishes Mass., 1855.

Delaware R., Potomac R., etc.

34. ROCCUS CHRYSOPS (RAF.), GILL.

White Bass, Cisco Bass (L. Winnebago).

Labrax albidus, DEKAY, Fishes N. Y., 13, 1842.

L. Erie, L. Michigan, Fox R., Mississippi R.

35. MORONE INTERRUPTA, GILL.

Short Striped Bass, Brassy Bass.

GILL, Ichthyology Simpson's Expedition, 1876.

Mississippi R.

36. MORONE AMERICANA (GMELIN), GILL.

White Perch.

Labrax rufus, STORER, Fishes Mass., 1855.

All East Coast streams examined.

CENTRARCHIDÆ.

37. POMOXYYS ANNULARIS, RAFINESQUE.

Crappie, Bachelor, New Light, Campbellite, Bank Lick Bass.

Pomoxys storerius, GILL, Proc. Ac. Nat. Sci., Phil., 1865, 64.

White R., Ohio R., Illinois R., Mississippi R., Rock Castle R., Cumberland R.

38. POMOXYYS NIGROMACULATUS (LE SUEUR), GIRARD.

Calico Bass, Grass Bass, Bar-fish.

Pomoxys hexacanthus, HOLBROOK, Ichthyology S. Car., 36, 1860.

Lake Erie, L. Michigan, Fox R., White R.

39. CENTRARCHUS IRIDEUS (LAC.), C. and V.

Shining Bass.

HOLBROOK, Ich. S. Car., 1860.

Mississippi R. (S. Ills.), Wabash R.

40. COPELANDIA ERIARCHA, JORDAN.

Large-finned Sunfish.

JORDAN, Proc. Phila. Ac. Nat. Sci., 1877.

Menomonee R. (near Milwaukee).

1877 . 7

ANN. N. Y. ACAD. SCI., VOL. I.

41. ENNEACANTHUS OBESUS (GRD.), GILL.
Nine-spined Sunfish.

JORDAN, Man. Vert., 1876.
Delaware R.

42. ENNEACANTHUS MARGAROTIS, GILL and JORDAN.
Blue-spotted Sunfish.

JORDAN, Bull. U. S. Nat. Mus., X, 1877.
Delaware R.

43. MESOGONISTIUS CHÆTODON (BAIRD), GILL.
Black-barred Sunfish.

Pomotis chætodon, BAIRD, Ninth Smithsonian Report, 1855, 324.
Delaware R.

44. XENOTIS PELTASTES (COPE), JORDAN.
Large-scaled Sunfish.

Lepomis peltastes, COPE, Proc. Am. Phila. Soc., 1870.
Illinois R.

45. XENOTIS INSCRIPTUS (AG.), JOR.
Inscribed Sunfish.

Ichthelis inscriptus, JORDAN, Man. Vert., 1876, 237.
White R., Mississippi R. (Ills.), Etowah R.

46. XENOTIS SANGUINOLENTUS (AG.), JOR.
Bloody Sunfish, Brim, Sun Peareh.

Pomotis sanguinolentus, AG., Am. Jour. Sci. and Arts, 1854.
Savannah R., Etowah R., Alabama R., Mississippi R. (La.)

47. XENOTIS MEGALOTIS (RAF.), JOR.
Long-eared Sunfish.

Ichthelis sanguinolentus, JORDAN, Man. Vert., 1876.
White R., Illinois R., Ohio R., Salt R., Wabash R., Kentucky R.

48. XENOTIS LYTHROCHLORIS, JORDAN.
Black-eared Sunfish.

Lepomis auritus, COPE, Journ. Phil. Ac. Nat. Sci., 1868.
White R.

49. EUPOMOTIS AUREUS (WALBAUM), GILL and JORDAN.
Common Sunfish.

Pomotis vulgaris, HOLBROOK, Ichthyology S. Car., 1860, 8.

Housatonic R., Genesee R., Cayuga L., Lake Ontario, L. Erie, L. Michigan, Fox R., Rock R., Wisconsin R., Illinois R., Delaware R., headwaters of Wabash R., Maumee R., Potomac R., etc.

50. EUPOMOTIS PALLIDUS (AG.), JORDAN.
White Sunfish.

Pomotis pallidus, AG., Am. Journ. Sci. Arts, 1854.
Mississippi R., Ohio R., Tennessee R., Alabama R.

51. XYSTROPLITES NOTATUS (AG.), JOR.
Spotted Sunfish.

Pomotis notatus, AG., Am. Journ. Sci. Arts, 1854.
Tennessee R.

52. XYSTROPLITES GILLI, JORDAN.
Gill's Sunfish.

JORDAN, Proc. Acad. Nat. Sci., Phila., 1877.
Garden Key, Fla. (Mus. S. I.)

53. LEPIOPOMUS ISCHYRUS, JORDAN and NELSON.
Stout Sunfish.

Ichthelis aquilensis, NELSON, Bull. Ills. Mus. Nat. Hist., 1876.
Illinois R.

54. LEPIOPOMUS OBSCURUS (AGASSIZ), JOR.
Dusky Sunfish, Brim, Coppery Bream (Ga.)

Pomotis obscurus, AGASSIZ, Am. Journ. Sci. Arts, 1854.
Etowah R.

55. LEPIOPOMUS PALLIDUS (MITCHILL), GILL and JORDAN.
Blue Sunfish, Copper-nose Sunfish.

Ichthelis incisor, HOLBROOK, Ichthyology S. Car., 1860, 12.

L. Erie, L. Michigan, Peckatonica R., White R., Illinois R., Mississippi R., Missouri R., Arkansas R., Tennessee R., Etowah R.

56. LEPIOPOMUS MACROCHIRUS, RAFINESQUE.
Chain Sunfish.

Lepomis nephelus, COPE, Journ. Ac. Nat. Sci., Phila., 1868, 222.
White R., Illinois R., Ohio R.

57. LEPIOPOMUS OCVLATUS, COPE.
Bright-eared Sunfish.

Bryttus oculatus, COPE, Proc. Phil. Ac. Nat. Sci., 1864.
L. Michigan.

58. LEPIOPOMUS ANAGALLINUS, COPE.
Orange-spotted Sunfish.

COPE, Journ. Ac. Nat. Sci. Phila., 1868, 221.
Salt R. (Ky.)

59. LEPIOPOMUS MINIATUS, JOR.
Scarlet Sunfish.

JORDAN, Proc. Phil. Ac. Nat. Sci., 1877.
Tangipahoa R. (La.)

60. LEPIOPOMUS AURITUS (L.), RAF.
Long-eared Pondfish, Red-tailed Bream.

Ichthelis rubricauda, HOLBROOK, Ich. S. Car., 1860, 15.
Ocmulgee R., Susquehanna R., Merrimac R., Delaware R., Potomac R.

61. APOMOTIS PHENAX, COPE and JORDAN.
New Jersey Sunfish.

JORDAN, Bull. U. S. Nat. Mus., 1877.

Beaseley's Point, New Jersey.

62. APOMOTIS CYANELLUS, RAF.
Blue-spotted Sunfish.

Lepomis mineopas, COPE, Journ. Ac. Nat. Sci., Phila., 1869, 224.

Illinois R., Ohio R., Kentucky R., Salt R., Rock R., Wisconsin R., White R., Mississippi R., Missouri R., Arkansas R., and all streams S. W.

63. ACANTHARCHUS POMOTIS (BAIRD), GILL.
Mud Sunfish.

Centrarchus pomotis, BAIRD, Ninth Smithsonian Report, 1855, 325.
Delaware R.

64. AMBLOPLITES RUPESTRIS (RAFINESQUE), GILL.
Rock Bass, Goggle-eye, Red-eye, Perch (Ga.)

Ambloplites œneus, GIRARD, Pac. R. R. Rep., 1859, 8.

L. Erie, L. Michigan, Fox R., Peckatonica R., Wisconsin R., Rock R., White R., Ohio R., Rock Castle R., Cumberland R., Powell's R., French Broad R., Etowah R., Red R. of the North (Mus. S. I.), Red R. (La.), Arkansas R., L. Champlain, etc.

65. CHÆNOBRYTTUS GULOSUS (C. and V.), JORDAN.
Toothed-tongue Sunfish.

Glossoplites melanops, JORDAN, Man. Vert., 1876, 317.

Alabama R., Illinois R., L. Michigan.

66. CHÆNOBRYTTUS VIRIDIS (C. and V.), JORDAN.
War-mouth.

Calliurus floridensis, HOLBROOK, Jour. Acad. Sci., Phil., 1855, 63.

Ocmulgee R.

67. MICROPTERUS PALLIDUS (RAF.), GILL and JORDAN.
Large-mouthed Black Bass, Oswego Bass (Lakes), Jumper (Ky.), Peach (Tenn.), Trout (Georgia), Moss Bass (Ind).

Micropterus nigricans, GILL, Proc. Am. Ass. Adv. Sci., 1873.

L. Erie, L. Michigan, Rock R., Wisconsin R., White R., Illinois R., Ohio R., Rock Castle R., Etowah R., St. John's R. (Fla.)

68. MICROPTERUS SALMOIDES (LACEPEDE), GILL.
Small-mouthed Black Bass, Jumper (Ky.), Peach (Tenn.), Trout (Ga.),
Mountain Trout (Ala.)

GILL, Proc. Am. Ass. Adv. Sci., 1873.

L. Ontario, L. Erie, L. Michigan, Fox R., Rock R., Illinois R., White R., Ohio R., Kentucky R., Rock Castle R., Cumberland R., Powell's R., French Broad R., Etowah R., Chattahoochee R., Ocmulgee R.

SCIÆNIDÆ.

69. HAPLOIDONOTUS GRUNNIENS (RAFINESQUE), GILL.
Sheepshead (Lakes), White Perch (Ohio R.), Grunting Perch, Drum.
(Southern States).
Corvina oscula, DEKAY, Fishes N. Y., 1842, 73.
Fox R., L. Michigan, Rock R., Ohio R., Cumberland R. ("lineatus"),
French Broad R., Etowah R.

ELASSOMIDÆ.

70. ELASSOMA ZONATUM, JORDAN.
Least Perch.
JORDAN, Bull. U. S. Nat. Mus., X, 1877.
Arkansas R., Streams of S. Ills.

APHODODERIDÆ.

71. APHODODERUS SAYANUS (GILLIAMS), DEKAY.
Pirate Perch.
DEKAY, Fishes N. Y., 1842, 35.
Delaware R., Neuse R., Mississippi R. in Louisiana, Flint R. (Ga.)
72. APHODODERUS ISOLEPIS (NELSON), JORDAN.
Nelson's Pirate Perch.
Sternotremia isolepis, NELSON, Bull. Ill. Mus. Nat. Hist., 1876.
Wabash R., Maumee R., Calumet R., Streams of S. Ill., Arkansas R.

COTTIDÆ.

73. URANIDEA GRACILIS (HECKEL), PUTNAM.
Miller's-thumb.
Cottus gracilis, GIRARD, Monograph Cottoids, 1850, 49.
Cayuga L., Susquehanna R. (W. N. Y.)
74. URANIDEA VISCOSA (HALDEMAN), COPE.
Slippery Miller's-thumb.
Cottus viscosus, GIRARD, Mon. Cott., 1850, 51.
Susquehanna R.
75. URANIDEA KUMLIENI, HOY.
JORDAN, Proc. Ac. Nat. Sci., Phil., 1877.
L. Michigan.
76. URANIDEA HOYI, PUTNAM.
Hoy's Bullhead.
JORDAN, Proc. Ac. Nat. Sci., Phil., 1877.
L. Michigan.

77. POTAMOCOTTUS CAROLINÆ, GILL.
Cave Bullhead, Goblin.

GILL, Proc. Bost. Soc. Nat. Hist., 1861, 41.

Near Wyandotte Cave, Lost R. (Ind.), Ohio R. (?), Powell's R.

78. POTAMOCOTTUS MERIDIONALIS, GILL.
Southern Bullhead.

Cottus meridionalis, GIRARD, Mon. Cott., 1850.

Youghiogheny R.

79. POTAMOCOTTUS ZOPHERUS, JORDAN.
Blob, Muffle-Jaw.

JORDAN, Ann. N. Y. Lyc. Nat. Hist., 1876.

Etowah R.

80. POTAMOCOTTUS ALVORDI (GRD.), GILL.
Alvord's Bullhead.

Cottus alvordii, GIRARD, Mon. Cott., 1850.

L. Michigan, Baraboo R., Wisconsin R.

81. POTAMOCOTTUS WILSONI (GRD.), GILL.
Wilson's Goblin.

Cottus wilsoni, GIRARD, Mon. Cott., 1850.

White R.

82. TAURIDEA SPILOTA (COPE), JORDAN and RICE.
Cow-faced Sculpin.

Cottopsis ricei, JORDAN, Proc. Phil. Ac. Nat. Sci., 1877.

L. Michigan.

GADIDÆ.

83. LOTA LACUSTRIS (WALBAUM), GILL.
Lake Lawyer, Ling, Burbot.

Lota maculosa, DEKAY, Fishes of N. Y., 1842, 284.

L. Michigan, Fox R., Rock R., Ohio R.

GASTEROSTEIDÆ.

84. EUCALIA INCONSTANS (KIRTLAND), JORDAN, 1840.
Brook Stickleback, Black Stickleback.

Gasterosteus inconstans, KIRTLAND, Bost. Journ. Nat. Hist., 1840, 273.

Suamico R., Fox R., Winnebago R., Wisconsin R., Rock R., Cuyahoga R.

(b.) VAR. CAYUGA, JORDAN, 1876:

JORDAN, Man. Vert., 1876.

Cayuga L.

ATHERINIDÆ.

85. LABIDESTHES SICCULUS, COPE, 1865.

Brook Silver-sides, Jack-fish, Skip-Jack.

Chirostoma sicculum, COPE, Proc. Am. Phil. Soc., 1870, 455.

L. Erie, Wisconsin R., White R., Illinois R., Ohio R., Cumberland R.

CYPRINODONTIDÆ.

86. FUNDULUS DIAPHANUS (LE SUEUR), AGASSIZ.

Mummichog, Spring Minnow.

Fundulus multifasciatus, STORER, Fishes of Mass., 1855, 296.

Cayuga L., Rock R., Illinois R.

87. FUNDULUS MENONA, JORDAN.

Hoy's Mummichog.

JORDAN, Proc. Phil. Ac. Nat. Sci., 1877.

Catfish R. (Wisconsin).

88. XENISMA STELLIFERUM, JORDAN.

Large-finned Stud-fish.

JORDAN, Ann. N. Y. Lyc. Nat. Hist., 1876.

Etowah R.

89. XENISMA CATENATUM (STORER), JORDAN.

Stud-fish, Studdy Pearch.

Fundulus catenatus, GUNTHER, Cat. of Fishes, VI, 322, 1866.

Powell's R., Clinch R.

90. ZYGONECTES NOTATUS (RAFINESQUE), JORDAN.

Top Minnow.

Haplochilus pulchellus, GUNTHER, Cat. of Fishes, VI, 314, 1866.

Rock R., White R., Ohio R., Mississippi R.

91. ZYGONECTES DISPAR, AGASSIZ.

Striped Top Minnow.

JORDAN, Proc. Phil. Ac. Nat. Sci., 1877.

Maumee R., Wabash R., Illinois R.

92. ZYGONECTES NOTTI, AGASSIZ.

Nott's Top Minnow.

AGASSIZ, Am. Journ. Sci. and Arts., 1854.

Mobile R.

UMBRIDÆ.

93. MELANURA LIMI (KIRTLAND), AGASSIZ.

Mud Dace, Mud Minnow, Dogfish, Black Chub.

Umbra limi, GUNTHER, Cat. of Fishes, VI, 232, 1866.

Suamico R., Fox R., Rock R., Wisconsin R., White R.

94. MELANURA PYGMÆA (DEKAY), BAIRD.

Eastern Mud Minnow.

JORDAN, Proc. Phil. Ac. Nat. Sci., 1877.

Delaware R.

ESOCIDÆ.

95. ESOX NOBILIOR, THOMPSON.

Muskallunge, Masquallonge.

Esox nobilior, COPE, Proc. Phil. Ac. Nat. Sci., 1865, 80.

L. Michigan, L. Huron, L. Erie.

96. ESOX LUCIUS, LINNÆUS.

Lake Pike, Pickerel (Wisconsin).

Esox lucius, COPE, Proc. Phil. Ac. Nat. Sci., 1865, 80.

L. Ontario, L. Erie, L. Michigan, Fox R., Rock R., Illinois R., Mississippi R.

97. ESOX RETICULATUS, LE SUEUR.

Pickerel.

STORER, Fishes of Mass., 1855, 311.

Westfield R., Delaware R., Ocmulgee R., Etowah R., Potomac R.

98. ESOX CYPHO, COPE.

Pickerel, Jack, Buffalo Pike.

COPE, Proc. Phil. Ac. Nat. Sci., 1865, 78.

Fox R. (Ill.)

99. ESOX AMERICANUS, GMELIN.

Trout Pickerel.

Esox ornatus, STORER, Fishes of Mass., 1855, 313.

Delaware R., Long Island.

100. ESOX SALMONEUS, RAFINESQUE.

Trout Pickerel.

Esox umbrosus, COPE, Trans. Am. Philos. Soc., 1866.

White R., Ohio R., L. Erie, Illinois R., Wabash R., Maumee R.

AMBLYOPSIDÆ.

101. AMBLYOPSIS SPELÆUS, DEKAY, 1842.

Larger Blind Fish.

PUTNAM, Mammoth Cave and its Inhabitants.

Mammoth Cave, Caves of S. Indiana.

102. TYPHLICHTHYS SUBTERRANEUS, GIRARD, 1859.

Smaller Blind Fish.

PUTNAM, Mammoth Cave, etc.

Mammoth Cave, Caves of S. Indiana.

PERCOPSIDÆ.

103. PERCOPSIS GUTTATUS, AGASSIZ, 1850.

Trout Perch.

AGASSIZ, Lake Superior, 1850, 286.

L. Erie, Fox R., L. Michigan, Ohio R. (Coll. Dr. Sloan), L. Superior.

SALMONIDÆ.

104. CRISTIVOMER NAMAYCUSH (WALBAUM), GILL and JORDAN.

Great Lake Trout, Mackinaw Trout.

Salmo namaycush, AGASSIZ, Lake Superior, 1850, 331.

L. Ontario, L. Erie, L. Huron, L. Superior, L. Michigan, Lakes of N. N. Y., Lake Champlain.

105. CRISTIVOMER SISCOWET (AGASSIZ), GILL and JORDAN.

Siscowet, Lake Superior Trout.

Salmo siscowet, AGASSIZ, Lake Superior, 1850, 333.

L. Superior.

106. SALVELINUS FONTINALIS (MITCHILL), GILL and JORDAN.

Brook Trout, Speckled Trout.

Salmo fontinalis, STOREY, Fishes of Mass., 1855, 322.

Westfield R., Housatonic R., Hudson R., Genesee R., Wisconsin R., Youghiogeny R., Susquehanna R.

107. SALVELINUS OQUASSA (GIRARD), GILL and JORDAN.

JORDAN, Man. Vert., Ed. 2, 1878.

Rangeley Lake, Maine.

108. THYMALLUS TRICOLOR, COPE, 1865.

MILNER, Rept. U. S. Fish Comm. for 1872-3, 739, 1874.

Jordan R. (N. Mich.)

109. COREGONUS ARTEDI, LE SUEUR.

Lake Herring, Michigan Herring.

Coregonus clupeiformis, DEKAY, Fishes N. Y., 1842, 248.

L. Ontario, Cayuga L., L. Erie, L. Huron, L. Michigan.

(b) VAR. SISCO, JORDAN.

Sisco of Lake Tippecanoe.

Argyrosomus sisco, JORDAN, Am. Naturalist, March, 1875, 135.

L. Tippecanoe and other lakes of N. Indiana, L. Geneva, L. Labelle, L. Oconomowoc, L. Kauchee, L. Nemahbin (Wis.)

110. COREGONUS NIGRIPINNIS (GILL), JORDAN.

Black-fin.

Argyrosomus nigripinnis, MILNER, Rept. Fish Commission, 1872-3 (pub. 1875), 87.

Lake Michigan.

106 *Fresh Water Fishes of the United States.*

111. COREGONUS HOYI (GILL), JORDAN.

Sisco of Lake Michigan, Lake Moon-eye.

Argyrosomus hoyi, MILNER, Rept. U. S. Fish Comm., 1872-3, 86.
Lake Michigan.

112. COREGONUS QUADRILATERALIS, RICHARDSON.

Menomonee White Fish.

GUNTHER, Cat. Fishes, VI, 176, 1866.

L. Michigan.

113. COREGONUS CLUPEIFORMIS (MITCHILL), MILNER.

White Fish of the Lakes.

Coregonus sapidissimus, AGASSIZ, Lake Superior, 1850, 344.

L. Ontario, L. Erie, L. Huron, L. Michigan, Cayuga L., Silver L.

HYODONTIDÆ.

114. HYODON TERGISUS, LE SUEUR.

Moon-eye, Toothed Herring, Spring Herring.

Coregonus quadrilateralis, GUNTHER, Catalogue of Fishes, VII, 375, 1868.

L. Erie, L. Michigan, Fox R., Rock R., Wisconsin R., Ohio R., Mississippi R.

DORYSOMATIDÆ.

115. DORYSOMA CEPEDIANUM (LE S.); VAR. HETERURUM (RAF.),

JORDAN.

Gizzard Shad.

Chatoessus ellipticus, KIRTLAND, Bost. Journ. Nat. Hist., IV, 235, 1844.

L. Erie, L. Michigan, Illinois R., Ohio R., Mississippi R., Alabama R.

CLUPEIDÆ.

116. POMOLOBUS CHRYSOCHLORIS, RAFINESQUE.

Skip-Jack.

JORDAN, Manual Vertebrates, 1876, 266.

Ohio R.

117. POMOLOBUS PSEUDOHARENGUS (WILSON); VAR. LACUSTRIS,

JORDAN.

Cayuga Lake Herring.

JORDAN, Man. Vertebrates, 1876, 265.

Cayuga L.

CYPRINIDÆ.

118. EXOGLOSSUM MAXILLILINGUA (LE SUEUR), HALDEMAN.
Day Chub, Nigger Chub.

COPE, Cyprinidæ of Penn., 1866, 360.
Susquehanna R. (Tioga Co., N. Y.)

119. CAMPOSTOMA ANOMALUM (RAFINESQUE), AGASSIZ.
Stone-roller, Steely-back Minnow.

JORDAN, Man. Vert., 1876, 275.

Rock R., Peckatonia R., White R., Ohio R., Kentucky R., Salt R., Rock
Castle R., Cumberland R., Powell's R., French Broad R., Etowah R.

120. PIMEPHALES PROMELAS, RAFINESQUE.
Fat-head, Black-head.

GUNTHER, Catalogue of Fishes, VII, 181, 1868.

Wisconsin R. ("*milesii*"), Peckatonia R., Ohio R. ("*promelas* and *agassizii*"), Kentucky R.

121. HYBORHYNCHUS NOTATUS (RAFINESQUE), AGASSIZ.

JORDAN, Man. Vert., 1876, 276.

L. Michigan, Fox R., Rock R., Wisconsin R., White R., Ohio R., Salt R.,
Rock Castle R.

122. HYBOGNATHUS NUCHALIS, AGASSIZ.
Blunt-jawed Chub.

AGASSIZ, Amer. Journ. Sci. and Arts, 1855, 224.

Wabash R., Illinois R.

123. HYBOGNATHUS ARGYRITIS, GIRARD.
Silvery Chub.

Hybognathus osmerinus, COPE, Proc. Am. Phil. Soc., 1870, 466.

Delaware R. ("*osmerinus*"), Ohio R., White R.

124. HYBOGNATHUS REGIUS, GIRARD.
Smelt (Potomac R.)

GIRARD, Proc. Phil. Ac. Nat. Sci., 1856, 209.

Potomac R.

125. ERICYMBA BUCCATA, COPE.
Silver-mouthed Chub.

COPE, Cyprinidæ Penn., 1866, 361.

White R., Kentucky R., Ohio R.

126. SEMOTILUS CORPORALIS (MITCHILL), PUTNAM.
Creek Chub, Horned Dace.

COPE, Cyprinidæ of Penn., 1866, 363.

Housatonic R., Hudson R., Cayuga L., Genesee R., Delaware R., L. Erie,
L. Michigan, Fox R., Rock R., Peckatonia R., Wisconsin R., Suamico R.,
White R., Illinois R., Ohio R., Kentucky R., Rock Castle R., Cumberland
R., Salt R., Powell's R., French Broad R., Etowah R., Ocmulgee R.

127. SEMOTILUS BULLARIS (RAF.), JORDAN.

Roach Dace, Fall Fish.

Cyprinus bullaris, RAF., Am. Monthly Mag., 1818.*Cheilonemus pulchellus*, STORER, Hist. Fishes Mass., 1856.*Semotilus rhotheus*, COPE, Cyprinidæ of Penn., 1866, 362.

Connecticut R., Delaware R., Susquehanna R.

128. CERATICHTHYS BIGUTTATUS (KIRTLAND), COPE.

Red-spotted Chub, River Chub.

COPE, Cyp. Penn., 1866, 366.

L. Michigan, Rock R., White R., Ohio R., Rock Castle R., Powell's R.,
Chattahoochee R.

129. CERATICHTHYS MILNERI, JORDAN.

Milner's Chub.

Nocomis milneri, JORDAN, Bull. U. S. Nat. Mus., X, 1878.

L. Superior (Milner Coll., S. I.)

130. CERATICHTHYS PROSTHEMIUS, COPE.

COPE, Cyp. Penn., 1866.

L. Michigan (S. I.)

131. CERATICHTHYS DISSIMILIS (KIRTLAND), COPE.

Long-nosed Chub.

COPE, Cyp. Penn., 1866, 368.

White R., Ohio R.

132. CERATICHTHYS AMBLOPS (RAF.), GIRARD.

Big-eyed Chub.

Ceratichtys hyalinus, JORDAN, Man. Vert., 1876, 279 (*nec* COPE).

Kentucky R., Mahoning R., Ohio R., White R., Salt R.

133. CERATICHTHYS GRACILIS (AGASSIZ), JORDAN.

White Chub.

Ceratichtys hyalinus, COPE, Journ. Phil. Ac. Sci., 1869, 226.

Powell's R., Etowah R.

134. CERATICHTHYS RUBRIFRONS, JORDAN.

Red-faced Chub.

JORDAN, Ann. N. Y. Lyc. Nat. Hist., 1876.

Ocmulgee R.

135. RHINICHTHYS CATARACTÆ (VALENCIENNES), JORDAN.

Long-nosed Dace.

Argyreus nasutus, STORER, Fishes of Mass., 1855, 289.

St. Lawrence R., Fox R., Susquehanna R.

136. RHINICHTHYS ATRONASUS (MITCHILL), AGASSIZ.

Black-nosed Dace.

Argyreus atronasmus, STORER, Fishes of Mass., 1855, 288.

Westfield R., Housatonic R., Genesee R., Cayuga L., Delaware R.

137. RHINICHTHYS OBTUSUS, AGASSIZ.

Blunt-nosed Dace.

Rhinichthys lunatus, COPE, Proc. Ac. Nat. Sci., Phil., 1864, 278.

L. Michigan, Etowah R., Rock R., Wisconsin R., Ohio R.

138. RHINICHTHYS MELEAGRIS, AGASSIZ.

Small Black-nosed Dace.

NELSON, Bull. Ills. Mus. Nat. Hist., 1876.

Illinois R.

139. PHENACOBIUS URANOPS, COPE.

Star-gazing Chub.

COPE, Proc. Phil. Ac. Sci., 1867, 96.

Rock Castle R., French Broad R.

140. PHENACOBIUS CATOSTOMUS, JORDAN.

Sucker-mouthed Chub.

JORDAN, Ann. N. Y. Lyc. Nat. Hist., 1876.

Etowah R.

141. ALBURNOPS HUDSONIUS (DEWITT CLINTON), JORDAN

Spawn-eater.

Hybopsis hudsonius, COPE, Cyp. Penn., 1866, 286.

Delaware R.

142. ALBURNOPS AMARUS (GIRARD), JORDAN.

White Minnow.

Hybopsis phaëna, COPE, Proc. Phil. Ac. Sci., 1864, 279.

Ocmulgee R., Potomac R.

143. ALBURNOPS VOLUCELLUS, COPE.

Large-finned Minnow.

Alburnops volucellus, COPE, Proc. Phil. Ac. Sci., 1864, 283.

Wisconsin R.

144. ALBURNOPS STRAMINEUS (COPE), JORDAN.

Insignificant Minnow.

Hybognathus stramineus, COPE, Proc. Phil. Ac. Sci., 1864, 283.

White R., Ohio R.

145. ALBURNOPS MICROSTOMUS (RAFINESQUE), JORDAN.

Small-mouthed Minnow.

Hybopsis microstomus, JORDAN, Man. Vert., 1876, 282.

Salt R.

146. ALBURNOPS HÆMATURUS (COPE), JORDAN.

Red-tailed Minnow.

Hybopsis hæmaturus, COPE, Cyp. Penn., 1866, 382.

Fox R.

147. ALBURNOPS XÆNOCEPHALUS, JORDAN.
Prickly-headed Minnow.

Hybopsis xænocephalus, JORDAN, Ann. N. Y. Lyc. Nat. Hist., 1876.
Etowah R.

148. ALBURNOPS CHROSOMUS, JORDAN.
Red-lined Minnow,

Hybopsis chrosomus, JORDAN, Ann. N. Y. Lyc. Nat. Hist., 1876.
Etowah R.

149. ALBURNOPS ROSEUS, JORDAN.
Rosy Shiner.

Luxilus roseus, JORDAN, Bull. U. S. Nat. Mus., X, 1877.
Louisiana (Bean Coll., S. I.)

150. LUXILUS SELENE, JORDAN.
Moon-eyed Shiner.

JORDAN, Bull. U. S. Nat. Mus., X, 1877.
L. Superior (Milner Coll., S. I.).

151. LUXILUS CORNUTUS (MITCHILL), JORDAN.
Shiner, Red-fin.

Hypsolepis cornutus, STOREY, Fishes of Mass., 1855.

Connecticut R., Cayuga L., Genesee R., L. Erie, L. Ontario, L. Superior,
L. Michigan, Fox R., Rock R., White R., Ohio R., Illinois R., Delaware R.,
Youghiogheny R., Kentucky R., Salt R., Powell's R., Rock Castle R., Cum-
berland R., French Broad R., Etowah R. (and in every other stream ex-
plored, except the Ocmulgee).

152. LUXILUS COCCOGENIS (COPE), JORDAN.
Red-cheeked Shiner.

Hypsolepis coccogenis, COPE, Proc. Phil. Ac. Sci., 1867, 160.
Powell's R.

153. LUXILUS GALACTURUS (COPE), JORDAN.
Milky-tailed Shiner.

Hypsolepis galacturus, COPE, Proc. Phil. Ac. Sci., 1867, 160.

White R., Ohio R., Rock Castle R., Cumberland R., Powell's R., French
Broad R.

154. LUXILUS ANALOSTANUS (GIRARD), JORDAN.
Silver-fin.

Hypsolepis kentuckiensis, COPE, Cyp. Penn., 1866, 371.
Cayuga L., L. Michigan, White R., Ohio R.

155. LUXILUS CALLIURUS, JORDAN.
Black-tailed Silver-fin.

Cyprinella calliura, JORDAN, Bull. U. S. Nat. Mus., 1877.
Alabama R., Tangipahoa R. (La.), (S. I.).

156. CODOMA EURYSTOMA, JORDAN.

Wide-mouthed Silver-fin.

Photogenis eurystomus, JORDAN, Ann. N. Y. Lyc. Nat. Hist., 1876.

Chattahoochee R.

157. CODOMA TRICHOISTIA, JORDAN and GILBERT.

Tri-colored Shiner.

JORDAN, Bull. U. S. Nat. Mus., XII, 1878.

Etowah R.

158. CODOMA STIGMATURA, JORDAN.

Spotted-tail.

Photogenis stigmaturus, JORDAN, Ann. N. Y. Lyc. Nat. Hist., 1876.

Etowah R.

159. CODOMA CALLISTIA, JORDAN.

Red Silver-fin.

Photogenis callistius, JORDAN, Ann. N. Y. Lyc. Nat. Hist., 1876.

Etowah R.

160. CODOMA CÆRULEA, JORDAN.

Blue Silver-fin.

Photogenis cæruleus, JORDAN, Ann. N. Y. Lyc. Nat. Hist., 1876.

Etowah R.

161. CODOMA XÆNURA, JORDAN.

Rough-tailed Silver-fin.

Minnilus xænurus, JORDAN, Proc. Ac. Nat. Sci., Phil., 1877.

Ocmulgee R.

162. CODOMA PYRRHOMELAS (COPE), JORDAN.

Crimson and Black Shiner.

Photogenis pyrrhomelas, COPE, Proc. Amer. Phil. Soc., 1870.

Neuse R. (Cope Coll).

163. CODOMA CALLISEMA, JORDAN.

Beautiful Silver-fin.

Episema callisema, JORDAN, Ann. N. Y. Lyc. Nat. Hist., 1876.

Ocmulgee R.

164. CODOMA GRANDIPINNIS, JORDAN.

Great-finned Shiner.

Photogenis grandipinnis, JORDAN, Bull. U. S. Nat. Mus., X, 1877.

Flint R., Ga.

b. CODOMA CHLORISTIA, JORDAN and BRAYTON.

Green-finned Shiner.

JORDAN and BRAYTON, Bull. U. S. Nat. Mus., XII, 1878.

Saluda R.

165. CLIOLA LEUCIODA (COPE), JORDAN.

Pearly Shiner.

Photogenis leuciodus, COPE, Proc. Phil. Ac. Sci., 1867, 164.

French Broad R.

166. CLIOLA ARIOMMA (COPE), JORDAN.

Big-eyed Shiner.

Photogenis ariommus, JORDAN, Man. Vert., 1876, 288.

White R., Green R. (Ky.) (S. I.)

167. CLIOLA SCABRICEPS (COPE), JORDAN.

Rough-headed Shiner.

Photogenis scabriceps, COPE, Proc. Phil. Ac. Sci., 1867, 166.

White R.

168. NOTROPIS PHOTOGENIS (COPE), JORDAN.

White-eyed Shiner.

Photogenis leucops, COPE, Proc. Ac. Nat. Sci., Phil., 1867, 167.

Ohio R.

169. NOTROPIS DINEMUS (RAFINESQUE), JORDAN.

Emerald Minnow.

Alburnellus jaculus, COPE, Cyp. Penn., 1866.

White R., Rock Castle R.

170. NOTROPIS ATHERINOIDES, RAFINESQUE.

Rosy Minnow.

Alburnus rubellus, AGASSIZ, Lake Superior, 1850, 364.

Fox R., Lake Michigan, White R.

171. NOTROPIS DILECTUS (GIRARD), JORDAN.

Delectable Minnow.

Alburnellus dilectus, GIRARD, Pac. R. R. Survey, 1859.

Ohio R.

172. NOTROPIS STILBIUS, JORDAN.

Shiny Minnow.

JORDAN, Ann. N. Y. Lyc. Nat. Hist., 1876.

Etowah R.

173. NOTROPIS RUBRIFRONS (COPE), JORDAN.

Rosy-faced Minnow.

Alburnellus rubrifrons, COPE, Cyp. Penn., 1866, 388.

White R.

174. NOTROPIS MICROPTERYX (COPE), JORDAN.

Small-finned Minnow.

Alburnellus micropteryx, COPE, Journ. Ac. Sci., Phil., 1869.

Rock Castle R., French Broad R.

175. NOTROPIS LIRUS, JORDAN.

Pale Red-fin.

Minnilus lirus, JORDAN, Ann. N. Y. Lyc. Nat. Hist., 1876.

Etowah R.

176. HEMITREMIA HETERODON, COPE.

Wisconsin Minnow.

Alburnops heterodon, COPE, Proc. Phil. Ac. Sci., 1864, 81.

Fox R., Rock R.

177. HEMITREMIA BIFRENATA, COPE.

Black-banded Minnow.

Hybopsis bifrenatus, COPE, Cyp. Penn., 1866, 384.

Connecticut R., Delaware R.

178. HEMITREMIA VITTATA, COPE.

Striped Minnow.

COPE, Proc. Am. Phil. Soc., 1870, 462.

Big Laurel R., Ky. (Rock Castle), Big Yellow Creek (Cumberland), Ky.

179. CHROSOMUS ERYTHROGASTER, RAFINESQUE.

Red-bellied Shiner.

Chrosomus erythrogaster, *pyrrhogaster*, and *eos*, JORDAN, Man. Vert., 1876, 284.

Peckatonica R. ("oreas"), Rock R., Wisconsin R., White R., Ohio R., Cumberland R., Rock Castle R.

180. PHOXINUS NEOGÆUS, COPE.

New World Minnow.

COPE, Cyprinidæ of Penn., 1866, 375.

Baraboo R.

181. GILA ELONGATA (KIRTLAND), JORDAN.

Long-jawed Shiner.

Clinostomus proriger, COPE, Cyprinidæ of Penn., 1866, 375.

Fox R., Rock R., Wisconsin R., Ohio R. (W. Va.)

182. GILA MARGARITA, COPE.

Pearly Shiner.

Clinostomus margarita, COPE, Cyp. Penn., 1866, 375.

Susquehanna R.

183. LYTHRURUS CYANOCEPHALUS, COPELAND.

Blue-headed Shiner.

JORDAN, Proc. Ac. Nat. Sci., Phila., 1877.

Root R. (Wis.), Rock R.

184. LYTHRURUS DIPLÆMIUS (RAFINESQUE), JORDAN.

Red-finned Shiner.

Hypsilepis diplæmius, COPE, Proc. Phil. Ac. Sci., 1867, 16.

Ohio R., Wabash R., White R., Illinois R.

1877.

8

ANN. N. Y. ACAD. SCI., VOL. I.

185. LYTHRURUS ARDENS (COPE) JORDAN.
Crimson Shiner.

Hypsilepis ardens, COPE, Proc. Ac. Nat. Sci., Phil., 1867, 16.
Cumberland R., Rock Castle R., French Broad R.

186. NOTEMIGONUS CHRYSOLEUCUS (MITCHILL), JORDAN.
Yellow Shiner, American Bream.

Stilbe americana, COPE, Cyp. Penn., 1866, 389.

Fox R., Rock R., Wisconsin R., White R., Illinois R., Ohio R., Delaware R., Potomac R., Etowah R.

187. NOTEMIGONUS AMERICANUS (LINNÆUS), JORDAN.
Thin-bodied Bream.

Notemigonus ischanus, JORDAN, Ann. N. Y. Lyc. Nat. Hist., 1876.
Ocmulgee R.

CATOSTOMIDÆ.

188. CATOSTOMUS LONGIROSTRIS, LE SUEUR.
Long-nosed Sucker.

Catostomus hudsonius, LE SUEUR, Journ. Phil. Ac. Nat. Sci., 1818.
L. Champlain, Illinois R., L. Michigan, Mississippi R.

189 CATOSTOMUS COMMERSONI (LACEPEDE), JORDAN.
Common Sucker, Brook Sucker.

Catostomus bostoniensis, STORER, Fishes of Mass., 1855, 290.

Housatonic R., Delaware R., Potomac R., Cayuga L., Genesee R., L. Ontario, L. Erie, L. Michigan, Fox R., Rock R., Wisconsin R., White R., Ohio R., Mississippi R., Youghiogheny R., Salt R., Kentucky R., Rock Castle R., Cumberland R.

190. CATOSTOMUS NIGRICANS, LE SUEUR.

Hog Molly, Stone Roller, Stone Lugger, Crawl-a-Bottom, Hog Sucker.

Hylomyzon nigricans, AGASSIZ, Amer. Journ. Sci. and Arts, 1854, 90.

Susquehanna R., Fox R., Rock R., White R., Powell's R., Rock Castle R., Cumberland R.

VAR. ETOWANUS, JORDAN.

JORDAN, Ann. N. Y. Lyc. Nat. Hist., 1876.
Etowah R.

191. ERIMYZON SUCETTA (LACEPEDE), JORDAN.
Creek Fish, Chub Sucker.

Moxostoma oblongum, AGASSIZ, Amer. Journ. Sci. and Arts, 1855, 86.

Delaware R., Potomac R., L. Michigan, Fox R., White R., Ohio R., Salt R., Cumberland R., Rock Castle R., French Broad R., Etowah R., Chattahoochee R., Ocmulgee R.

192. MINYTREMA MELANOPS (RAFINESQUE), JORDAN.

Spotted Sucker.

Moxostoma victoriae, GIRARD, U. S. and Mexican Bound. Surv., 35.

Erimyzon melanops, JORDAN, Man. Vert., 1876.

L. Erie, L. Michigan, L. Huron, Illinois R., Wabash R., White R., Ohio R., Etowah R.

193. MYXOSTOMA MACROLEPIDOTUM (LE SUEUR), JORDAN.

Long-scaled Sucker.

Ptychostomus macrolepidotus, COPE, Proc. Am. Phil. Soc., 1870.

Delaware R., Potomac R.

194. MYXOSTOMA DUQUESNII (LE SUEUR), JORDAN.

Red Horse.

Ptychostomus erythrurus, COPE, Proc. Am. Philos. Soc., 1870, 475.

White R., Ohio R., Wabash R., Kentucky R., Rock Castle R., French Broad R., Etowah R.

VAR. LACHRYMALE (COPE), JORDAN.

Southern Red Horse.

Ptychostomus lachrymalis, COPE, Proc. Am. Philos. Soc., 1870.

Etowah R.

195. MYXOSTOMA AUREOLUM (LE SUEUR), JORDAN.

Lake Red Horse, Great Mullet.

Ptychostomus aureolus, AGASSIZ, Amer. Journ. Sci. and Arts, 1855, 89.

L. Erie, L. Michigan, Fox R.

196. MYXOSTOMA EURYOPS, JORDAN.

Round-headed Mullet.

JORDAN, Ann. N. Y. Lyc. Nat. Hist., 1876.

Etowah R.

197. MYXOSTOMA ANISURUM (RAFINESQUE), JORDAN.

Short-headed Mullet.

Ptychostomus breviceps, COPE, Proc. Am. Philos. Soc., 1870.

Ohio R.

198. MYXOSTOMA CARPIO (CUVIER and VAL.), JORDAN.

Carp Mullet.

Moxostoma carpio, JORDAN, Man. of Vert., 1876, 296.

Fox R., Ohio R.

199. MYXOSTOMA VELATUM (COPE), JORDAN.

Small-mouthed Mullet.

Ptychostomus collapsus, COPE, Proc. Am. Philos. Soc., 1870.

L. Erie, L. Michigan, Ohio R., Illinois R.

200. MYXOSTOMA CERVINUM (COPE), JORDAN.
Slender Mullet.
Teretulus cervinus, COPE, Jour. Ac. Sci., Phil., 1868.
Ocmulgee R.
201. MYXOSTOMA PAPILLOSUM (COPE), JORDAN.
Papillose Mullet.
Ptychostomus papillosus, COPE, Proc. Am. Philos. Soc., 1870.
Ocmulgee R.
202. PLACOPHARYNX CARINATUS, COPE.
Cope's Sucker.
COPE, Proc. Am. Philos. Soc., 1870.
Detroit R. (S. I.), Ohio R., Wabash R., Scioto R., Illinois R.
203. QUASSILABIA LACERA, JORDAN and BRAYTON.
Hare-lip Sucker, Split-mouth Sucker.
Lagochila lacera, JORDAN and BRAYTON, Proc. Ac. Nat. Sci., Phila., 1877.
(*Lagochila* is preoccupied in conchology).
Chickamauga R., Elk R. (Tenn.)
204. CARPIODES VELIFER (RAFINESQUE), AGASSIZ.
Sailing Sucker, Quill-back, Skim-back, *Carp*.
COPE, Proc. Am. Philos. Soc., 1870, 482. Ohio R.
205. CARPIODES CUTIS-ANSERINUS, COPE.
Carp, Quill-back.
COPE, Proc. Am. Philos. Soc., 1870, 483. Ohio R.
206. CARPIODES DIFFORMIS, COPE.
Blunt-nosed Carp.
COPE, Proc. Am. Philos. Soc., 1870, 482. Wabash R.
207. CARPIODES CYPRINUS (LE S.), AG.
Eastern Carp Sucker.
COPE, Proc. Am. Philos. Soc., 1870. Susquehanna P.
208. CARPIODES THOMPSONI, AGASSIZ.
Thompson's Carp.
COPE, Proc. Am. Phil. Soc., 483, 1870. L. Erie, L. Michigan.
209. ICHTHYOBUS BUBALUS (RAFINESQUE), AGASSIZ.
Red-mouth Buffalo.
JORDAN, Man. Vert., 1876, 298.
Wabash R., Ohio R., Mississippi R., Illinois R.
210. BUBALICHTHYS URUS, AGASSIZ.
Large-mouthed Buffalo.
AGASSIZ, Am. Journ. Sci. and Arts, 1855.
Mississippi R. (Quincy, Ill.)

211. BUBALICHTHYS CYANELLUS, JORDAN.

Small-mouthed Buffalo.

Ichthyobus cyanellus, NELSON, Bull. Ills. Mus. Nat. Hist., 1876.

Catostomus bubalus, KIRTLAND, Bost. Journ. Nat. Hist., V, 266 (not of RAF.
= *Ichthyobus*).

Wabash R., Ohio R., Mississippi R. (Quincy), Illinois R.

212. CYCLEPTUS ELONGATUS (LE SUEUR), AGASSIZ.

Gourd-seed Sucker, Suckerel.

JORDAN, Man. Vert., 1876.

Ohio R., Mississippi R.

SILURIDÆ.

213. ICHTHÆLURUS PUNCTATUS (RAFINESQUE), JORDAN.

Channel Cat, Silver Cat, Blue Cat.

Ictalurus cærulescens, GILL, Proc. Bost. Soc. Nat. Hist., 1862, 42.

Illinois R., Wabash R., White R., Ohio R., French Broad R., Fox R., L.
Michigan, St. Lawrence R., Etowah R., Chattahoochee R., Ocmulgee R.

214. ICHTHÆLURUS ROBUSTUS, JORDAN.

Robust Channel Cat.

JORDAN, Bull. X, U. S. Nat. Mus., 1876.

Illinois R.

215. ICHTHÆLURUS FURCATUS (CUV. and VAL.), GILL.

Fork-tailed Cat.

Amiurus furcatus, GUNTHER, Cat. Fishes, 1864, V, 103.

Mississippi R., Ohio R.

216. AMIURUS NIGRICANS (LE SUEUR), GILL.

Great fork-tailed Cat, Mississippi Cat.

JORDAN, Man. Vert., 1876, 318.

Ohio R., Mississippi R., L. Michigan, Fox R. (Florida).

b. AMIURUS EREBENNUS, JORDAN.

Goode's Cat.

JORDAN, Bull. X, U. S. Nat. Mus.

St. John's R. (Fla.)

217. AMIURUS ALBIDUS, LE SUEUR.

Eastern fork-tailed Cat.

Pimelodus lynx, GIRARD, Proc. Phil. Ac. Sci., 1859, 160.

Potomac R.

218. AMIURUS LOPHIUS, COPE.

Big-mouthed Cat.

COPE, Proc. Am. Philos. Soc., 1870.

Potomac R.

219. AMIURUS NATALIS (LE SUEUR), GILL.

Coppery Cat.

JORDAN, Bull. U. S. Nat. Mus., X, 1877.

Illinois R., Ohio R., Mississippi R., Etowah R., L. Michigan

220. AMIURUS PULLUS (DEKAY), GILL.

Bull-head.

Pimelodus pullus, DEKAY, Fishes of N. Y., 1842, 184.

Genesee R., Cayuga L.

221. AMIURUS XANTHOCEPHALUS, RAFINESQUE.

Big-headed Cat.

Amiurus albidus, JORDAN, Man. Vert., 1876, 302 (not of GILL).

White R., Ohio R.

222. AMIURUS CATUS (LINNÆUS), GILL.

Bull-head, Cat Fish.

Pimelodus atrarius, STORER, Fishes of Mass., 1855.

L. Erie, L. Michigan, Westfield R., Delaware R., Potomac R.

223. AMIURUS MELAS, RAFINESQUE.

Chubby Cat.

Amiurus obesus, GILL, Ich. Capt. Simpson's Exploration, 1876.

Illinois R., Miami R., Ohio R.

224. AMIURUS VULGARIS (THOMPSON), NELSON.

Long-jawed Cat.

Pimelodus dekayi, GRD., Proc. Phil. Ac. Nat. Sci., 1859.

L. Erie, L. Michigan, Illinois R.

225. AMIURUS BRUNNEUS, JORDAN.

Brown Cat.

JORDAN, Ann. N. Y. Lyc. Nat. Hist., 1876.

Ocmulgee R.

226. PELODICHTHYS OLIVARIS (RAF.), GILL and JORDAN.

Mud Cat.

Hopladelus olivaris, GILL, Proc. Bost. Soc. Nat. Hist., 1862, 51.

Rock Castle R., French Broad R., Ohio R., Wabash R.

227. NOTURUS FLAVUS, RAFINESQUE.

Yellow Stone Cat.

Noturus occidentalis, GILL, Ich. Capt. Simpson's Explor., 1876.

Potomac R., Ohio R., St. Lawrence R., Missouri R. (S. I.)

228. NOTURUS INSIGNIS (RICHARDSON), GILL and JORDAN.

Margined Stone Cat.

Noturus occidentalis, GTHR., Cat. Fishes, Vol. V, 1854, 105 (not of GILL).

Susquehanna R.

229. NOTURUS EXILIS, NELSON.

Slender Stone Cat.

NELSON, Bull. Ills. Mus. Nat. Hist., 1876.

Wabash R., Illinois R., L. Michigan.

230. NOTURUS MIURUS, JORDAN.

Variegated Stone Cat.

JORDAN, Ann. N. Y. Lyc. Nat. Hist., 1876.

White R., Wabash R., Ohio R., Tangipahoa R. (S. I.).

231. NOTURUS SIALIS, JORDAN.

Chubby Stone Cat.

JORDAN, Man. Vert., ed. 2d, 1878.

Ohio R., White R., Wabash R., L. Michigan.

232. NOTURUS LEPTACANTHUS, JORDAN.

Small-spined Stone Cat.

JORDAN, Ann. N. Y. Lyc. Nat. Hist., 1876.

Etowah R.

ANGUILLIDÆ.

233. ANGUILLA VULGARIS, FLEMING.

Common Eel.

Anguilla bostoniensis, STORER, Fishes of Mass., 1855.

Cayuga L., Ohio R., Wabash R., Delaware R., Rock Castle R., Etowah R. and various coastwise streams.

AMIIDÆ.

234. AMIA CALVA, LINNÆUS.

Dog Fish, Lawyer.

JORDAN, Man. Vert., 1876, 306.

Cayuga L., L. Michigan, Fox R., Rock R., Illinois R., Maumee R., rivers in S. Carolina.

LEPIDOSTEIDÆ.

235. LEPIDOSTEUS OSSEUS (LINNÆUS), AGASSIZ.

Long-nosed Gar-pike.

JORDAN, Man. Vert., 1876, 308.

Fox R., Lake Michigan, Rock R., Illinois R., Mississippi R., Wabash R., White R., Ohio R., Etowah R., St. John's R. (Fla.)

236. LEPIDOSTEUS PLATYSTOMUS, RAFINESQUE.

Short-nosed Gar.

Cylindrosteus platystomus, JORDAN, Man. Vert., 1876, 308.

Fox R., Arkansas R.

237. LITHOLEPIS SPATULA (LAC.), JORDAN.

Alligator Gar.

Lepidosteus viridis, GUNTHER, Cat. Fishes, VIII, 1870, 329.

Mississippi R.

POLYODONTIDÆ.

238. POLYODON FOLIUM, LACEPEDE.

Paddle-fish, Spoonbill Cat, Duckbill Cat.

GUNTHER, Cat. Fishes, 1870, VIII, 346.

White R., Illinois R., Ohio R., Mississippi R., Arkansas R.

ACIPENSERIDÆ.

239. ACIPENSER RUBICUNDUS, LE SUEUR.

Red Sturgeon.

DEKAY, Fishes of N. Y., 1842.

Wolf R., Fox R., L. Michigan.

240. ACIPENSER MACULOSUS, LE SUEUR.

Rock Sturgeon.

GUNTHER, Cat. Fishes, VIII, 1870, 339.

Ohio R.

241. SCAPHIRHYNCHOPS PLATYRHYNCHUS (RAFINESQUE), GILL.

Shovel-nose Sturgeon.

Scaphirhynchus cataphractus, GUNTHER, Cat. Fishes, VIII, 1870, 345.

Ohio R.

PETROMYZONTIDÆ.

242. AMMOCETES FLUVIATILIS (LINNÆUS), JORDAN.

Small Eastern Lamprey.

Petromyzon nigricans, STORER, Fishes of Mass., 1855.

Cayuga L.

243. AMMOCETES NIGER (RAFINESQUE), JORDAN.

Black Lamprey.

Petromyzon niger, JORDAN, Man. Vert., 1876, 315.

Fox R., Peckatonia R., White R., Rock R., Wabash R.

244. AMMOCETEUS ARGENTEUS (KIRTLAND), JORDAN.

Silvery Lamprey.

Ichthyomyzon argenteus, Man. Vert., 1876, 315.

L. Erie, White R., Ohio R.

245. AMMOCETES HIRUDO (GRD.), JORDAN.

Leech Lamprey.

Ichthyomyzon hirudo, GRD., Pac. R. R. Survey, 1858.

L. Erie, L. Michigan, Mississippi R.

IX.—*Descriptions of New Species of Fossils, from the Upper Silurian Rocks of Port Jervis, N. Y.; with Notes on the occurrence of the Coralline Limestone at that Locality.*

By S. T. BARRETT.

Read January 28, 1878.

GENUS DISCINA, LAMARCK.

DISCINA JERVENSIS, New Species.

Shell obtusely oval in outline, extremities equal and broadly rounded; dorsal valve depressed convex; apex midway between the centre and the posterior margin, abruptly elevated behind and sloping gently forward, the lateral slopes ending in a broadly flattened margin; ventral valve slightly elevated in front of the foramen, and broadly concave between this elevation and the anterior margin. Foramen oval, about the same distance from the posterior border as the apex of the upper valve. The impression of the outer surface of the lower valve shows the imprint of fine raised concentric striæ, about seven of them to one-twelfth of an inch of the longer diameter near the front of the shell. The upper valve is similarly striated, and its cast has the apex divided by an impressed line, which is prolonged toward the front. Length of an average specimen, ten lines; greatest breadth, eight lines. Elevation of apex, 0.15 of an inch. The upper and lower valves of this shell are often found united, but with their surfaces so much injured by exfoliation that the external markings are only determinable by an examination of the matrices, which are generally covered with a thin portion of the shell.

This fossil is very abundant in a layer situated among the higher strata of the Oriskany group, at Port Jervis, N. Y., to which village the specific name refers.

GENUS TREMATIS, SHARP.

TREMATIS (SCHIZOCRANIA) SUPERINCRETA, New Species.

The upper valve of a patelliform shell, externally like the *Orbicula* (?) *filosa*, H., = *Trematis filosa*, H., = *Schizocrania filosa*, H. and W., is found, very rarely, in the Trilobite layers, or uppermost Lower Helderberg strata, of this village. It is twice or thrice as large as that shell, broadly ovate in general outline, convex, highest behind the middle, and widest anteriorly. Apex obtuse, marginal. Surface jet black, shining, radially marked by elevated filiform striæ, which are more or less arcuate toward the beak. Very fine concentric striæ cross these, preserving their full size over them, and imparting to them a sub-nodose or slightly moniliform appearance. Stronger concentric lines and laminations of growth are intermixed with these very fine concentric ones. Radiating striæ arising independently, rarely if at all bifurcating, ten to twelve in the width of one line over the rostral region, five to eight in the same space nearer the front. Length and width of valve sub-equal, from twelve to fifteen lines in the largest specimens yet seen. Lower valve, and internal markings of upper valve, unknown.

One or two valves have been seen attached to larger shells, precisely like specimens of *Schizocrania filosa*, from the Cincinnati Group. One was fixed upon a large *Strophomena*, its margin conforming to all the external inequalities of the larger shell, and spreading widely over its surface. It must have grown in that position, and have been, like the *Schizocrania* (?) *filosa*, parasitic. Other valves have been found in a similar position, but not with the spreading margin. In the absence of the lower valve, I can see no reason for not referring this shell to the same genus with the *Trematis* (*Schizocrania*) *filosa* H., and H. and W. It has been labeled *Trematis* by Prof. Hall, perhaps without being aware of its parasitic habit. But it seems to me to be very questionable, notwithstanding the eminent authorities upon the other side, whether parasitic habits alone can justify the erection of the new genus *Schizocrania*. I prefer, until its generic position is better established, to place it, provisionally at least, under

Sharp's genus, *Trematis*. The specific name refers to its mode of growth.

GENUS RECEPTACULITES, DE FRANCE.

RECEPTACULITES LATERITIUS, New Species.

Conoidal, basal margin narrowly rounded upward, base slightly concave, apex obtuse. Height and greatest breadth sub-equal, each about nine lines. The divisions of the exposed portions of the surface of this species agree with those of other species of this genus, but are finer than in most of them. The rhomboidal cells or casts of the inner surface of the ectorhin cover the upper two-thirds, and the quadrangular spaces or impressions of the inner surface of the ectorhin cover the lower third of the exposed side, portions not exposed being covered by the ectorhin itself. These divisions accord with those of the late Prof. Billings' excellent paper upon this genus, in *Palæozoic Fossils*, Vol. II. Rhomboidal spaces, 0.02×0.02 inch; quadrangular, 0.02×0.06 inch. The quadrangular spaces have a fanciful resemblance to a brick wall, to which aspect the specific name refers.

From the Delthyris Shale, Port Jervis, N. Y.

GENUS DIPHYPHYLLUM, LONSDALE.

DIPHYPHYLLUM INTEGUMENTUM, New Species.

A simple cylindrical coral belonging to the above genus is tolerably abundant in strata lying about forty to fifty feet below the Dark Blue Tentaculite Limestone, at Mr. William Nearpass' quarry, in the State of New Jersey, three miles south-west of Port Jervis. It has generally a dense epithelial covering; the vertical septa are strong, forty-four in the specimen were counted, springing from a broad peripheral rim, alternately longer and shorter, the longest ones reaching the centre. A thin, mounted, transverse section shows three divisions—an inner one, occupying about two-thirds of the diameter of the calicle, closely reticulated with dissepiments uniting the septa; a portion, occupying about half the remaining third of the diameter, entirely without dissepiments; and the peripheral rim. Weathered specimens show a tolerably deep cup at one end. Diameter of calicle, $\frac{2}{3}$ of

an inch. It is associated with *Cyathophyllum* (*Columnaria*) *inequale*, the (*Leptaena*) *Strophodonta*, figured without a specific name in Vol. II, Pal. of N. Y., pl. 74, figs. 3a and 3b, *Rhynchonella lamellata*, *R. nucleolata*, *Calymene camerata*, *Stromatopora constellata*, and some other species of the Coralline limestone, along with *Halysites catenulatus*, *H. agglomeratus*, *Callopora* and *Trematopora*, species not determined, *Cladopora seriata*, *Favosites* resembling the spheroidal forms figured in the same volume for the Niagara Group, *Rhynchonella pisa*, *Ambonychia acutirostra*, *Aulopora precius* (?), *Spirorbis inornatus*, *Caninia bilateralis*, *Streptelasma*, species not determined, *Proetus*, and some other forms not yet identified.

The association of some of the Niagara forms of the Ohio, Wisconsin, and Illinois palæontology with the coralline fossils of Schoharie, is very interesting. The Coralline, I think, is continuous from Schoharie along the Hudson to Rondout, and thence southwardly along the Appalachian folds to and beyond this village.

The forty feet of rock lying between the Coralline Limestone and the Dark Blue Tentaculite Limestone seems to agree very well with what is called the Water-lime group by some, and the Salina or Onondaga Salt group by others. At the top it has about ten feet of thinly laminated, much contorted, ashen-colored strata, with vertical sutures and an abundance of calcite in sheets, with the appearance, on the outside, of the *Lignilites* of Prof. Eaton. The contortion of this bed is all the more striking because there is none of it in the strata above or below. The rest of the rocky strata between this contorted slate and the Coralline Limestone may be generalized as consisting of two light-blue beds, weathering buff, with an intermediate limestone. The entire series from the Dark Blue to the Coralline is palæontologically connected with the Tentaculite Limestone, and I like best the division which makes the Water-lime an extension downward of that subdivision of the Lower Helderberg group.

This Coralline Limestone is in no way connected with or related to the ("Favosite Limestone") *Stromatopora* Limestone of my former paper.* The species are entirely different.

*Annals of the N. Y. Lyc. Nat. Hist., 1876, Art. 27.

*X.—Description of a New Species of Parrot of the Genus
Chrysotis.*

BY GEORGE N. LAWRENCE.

Read March 26, 1878.

Chrysotis lactifrons.

General plumage grass-green, darker on the back and lighter below; the flanks yellowish, the sides of the neck, jugulum, breast, and abdomen tinged with light verditer-blue; the feathers of the occiput, neck, back, breast, and upper part of abdomen margined with black, broader on the back and sides of the neck; front and lores milk-white; sinciput, ophthalmic region, cheeks, and upper part of throat clear gamboge yellow; the concealed bases of the yellow feathers are orange-red: upper tail coverts light-green; two central tail feathers very dark green, the next of the same color, except at the end, where it is light yellowish-green for the space of about an inch; the first lateral feather has the outer web blue for three-quarters its length, the inner web scarlet for the same extent, and terminating in yellowish-green, with a tinge of light-blue on the margin of the outer web; the next feather is scarlet for three-quarters its length, with the outer half of the outer web dark-green for the same extent, and a roundish spot of the same color on the inner web, just inside the termination of the red color, the end yellowish-green; the next two feathers are red on their inner webs for half their length, then dark-green, the outer webs also dark-green, both webs ending in yellowish-green: bend of wing gamboge-yellow; outer primary, black above and black underneath, except on the inner web, for three-quarters its length, where it is broadly margined with dull greenish-blue; the other large quills have their outer webs green above, with the inner webs, and the ends of some of the outer webs, black; underneath, they are colored much like the first primary; a speculum of scarlet occupies the central portion of the outer webs of the first four secondaries; the secondaries are dark-green above on their outer webs, terminating in deep-blue, with their inner webs black; underneath, both webs are dull greenish-blue; tertials dark-green on the upper surface, and light verditer-blue on the lower: under tail coverts, pale

yellowish-green, with a tinge of light-blue at their ends; wing coverts green, the small and middle ones like the back, the larger with a yellowish tinge; alula green, with the inner webs black for three-quarters their length; bill horn-white; tarsi and toes chestnut-brown.

Length, 12 in.; wing, $7\frac{1}{4}$; tail, $4\frac{1}{2}$.

Habitat, unknown.

Remarks.—The parrot described above I saw while alive in the Central Park Menagerie, New York, but was unable to determine the species. It died soon afterward, and was kindly sent me for examination by Mr. Wm. A. Conklin, Director of the Menagerie.

I requested Mr. Conklin to try to ascertain whence it came; he saw the person who deposited it in the Menagerie, and wrote me as follows: "The owner of the parrot says he purchased the four birds (deposited) in Bahia. Two of these are *Chrysotis amazonica*, and one is *C. vittata*. As the last was brought down the coast in some sailing vessel, the bird under consideration might have accompanied it, as there is always a demand in the South American ports for parrots."

C. amazonica inhabits northern South America; but *C. vittata* has only been found in Porto Rico.

It is, therefore, possible that this specimen may have been procured at some port in the West Indies.

I submitted the description, and a sketch of it, to my friend, Dr. Otto Finsch, of the Bremen Museum—the well-known authority on parrots. He writes me: "As to the parrot, there is no doubt, in my opinion, that it is an excellent new species, belonging among the small group of *C. sallæi*, *collaris*, and *albifrons*, distributed in the West Indies and Central America, and whereabouts I suspect its habitat will prove to be."

Having my determination of it thus fortified, I do not hesitate to publish it as new.

XI.—Descriptions of New Fossil Fishes from the Trias.

By J. S. NEWBERRY.

Read April 9, 1878.

DIPLURUS, Nov. Gen.

Cœlacanth ganoids of large size; body fusiform; head high behind, rapidly sloping to muzzle; cranial bones coarsely granulated; jugulars long-elliptical, their external surface covered with elongated tubercles; teeth conical acute. Paired fins lobate; fin-rays without spines; caudal fin broad and long; supplemental caudal relatively large, fan-shaped, distinctly separated from the caudal fin, composed of simple fluted rays, with bulbous bases, and, like those of the other medial fins, articulated throughout about half their length; scales small, exposed surface coarsely granulated.

This genus is closely allied to *Holophagus*, but differs in having the scales granulated, the rays of the median fins without spines, and the fin-rays articulated to a less degree. From *Cœlacanthus* it may be distinguished by its having granulated scales and bones, and fin-rays much more frequently articulated. From *Macropoma* it differs, in having the scales more distinctly granulated, and in not possessing spines on the fin-rays.

From the above description it will be seen that this great Triassic fish can not be placed in either of the Cœlacanth genera yet established; and it becomes necessary to give it a new generic name. It should be said, however, that the resemblance in structure in the whole group of Cœlacanths is so close, that if they had been found in the same formation, they would doubtless have been regarded as different species of the same genus. When the subject can be reviewed in the light of more material, it is not improbable that this conclusion will be reached.

DIPLURUS LONGICAUDATUS, Newb.

Fish large, having a length of three feet; body fusiform; exterior surface of cranial bones coarsely granulated; jugulars covered with elongated tubercles; dorsal fins large and strong; anterior dorsal supported by a large rounded plate of bone; paired fins lobate, and, like the anal and the posterior dorsal, based on forked or palmated bones; caudal fin long and large, with eleven or twelve rays on each side of the vertebral column at the extremity; supplemental caudal fin triangular, three inches in length and in breadth. Scales relatively small, exposed surface coarsely granulated.

Locality, Boonton, N. J.

PTYCHOLEPIS MARSHI, Newb.

Fish eight inches or more in length, by two and a quarter in breadth; fusiform, robust. Head pointed, contained four and a half times in the

entire length; all the bones of the head marked with strong raised lines, those of the upper surface somewhat radiate; on the opercula, maxillaries, mandibles, and gular plates, more or less undulately parallel and forked. The dorsal fin is of medium size, and placed near the centre of the back; the anal is set far back, reaching nearly to the caudal; caudal small, forked, the scales and vertebral column reaching distinctly into the upper lobe. The scales on the anterior portion of the body are twice or three times as long as high, and are marked with strong raised lines. In the middle and posterior portions, the scales are very long and narrow, five or six times as long as high, and traversed by a superficial furrow, which generally reaches from the anterior end half or two-thirds the length, and is again resumed on the posterior margin; by this the extremities of the scale are forked. On the anterior portion of the abdominal surface the scales are exceedingly narrow, acute, and spine-like. Vertebral column partially ossified.

On comparing our fish with the figure and description of *Pt. Bollensis*, Ag. (Poiss. Foss., Tom. 2, Tab. 85 b.), it will be seen that it differs from that species in the position of the dorsal fin, which is placed more anteriorly, in the details of the scale and head-markings, and in the greater degree to which the tail is vertebrated and the spinal column ossified. From *Pt. minor*, Egerton (Mem. Geol. Sur., Dec. VI, Pl. VIII), our species is easily distinguished by its much greater size, narrower scales, and more vertebrated tail. From *Pt. curtus*, Egerton (Mem. Geol. Sur., Dec. VIII, Pl. VIII), it differs in its more elongated form, in the plication of the scales, and the more heterocercal tail.

The discovery in our so-called Triassic rocks of a species of *Ptycholepis*—a genus before found only in the Lias of Europe—might seem to open up again the long-debated question of the age of the "New Red Sandstone" of the Atlantic States; but in fact it does not seriously invalidate the conclusion, based on other evidence, that this series of strata, though perhaps not strictly the equivalent of the Trias of Europe, and it may be covering with its upper beds a portion of the Jura, still is, on the whole, rather of Triassic than of later date; but the fish now described is a new species, and is more heterocercal, *i. e.*, has the vertebral column prolonged to a greater distance into the upper lobe of the tail, than its European Liassic representatives. Without attaching too much importance to this character, we may fairly infer that it indicates a little earlier date.

Locality, Durham, Conn.



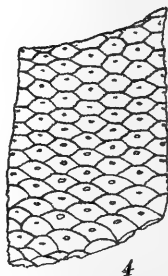
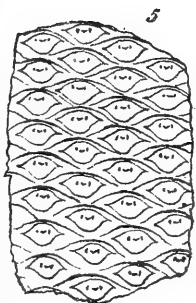
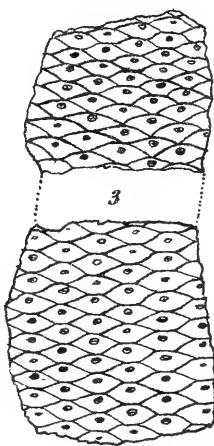
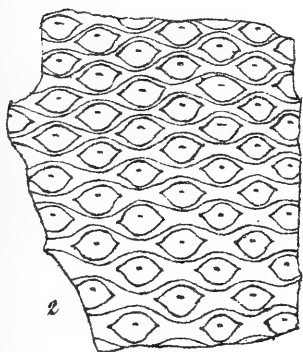
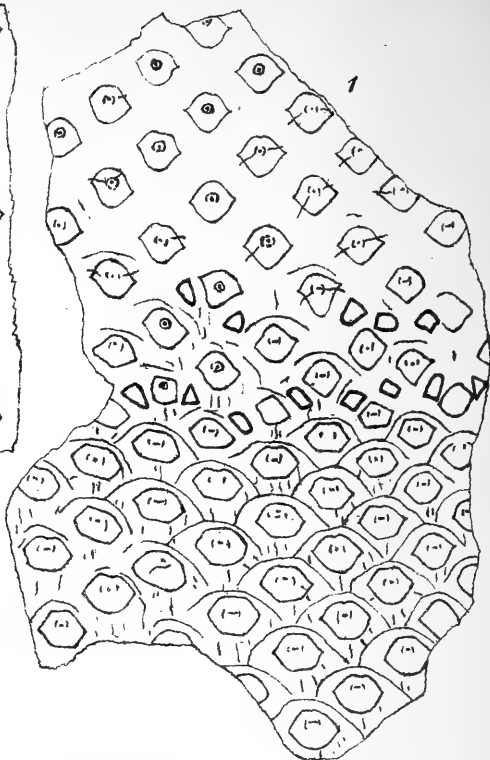
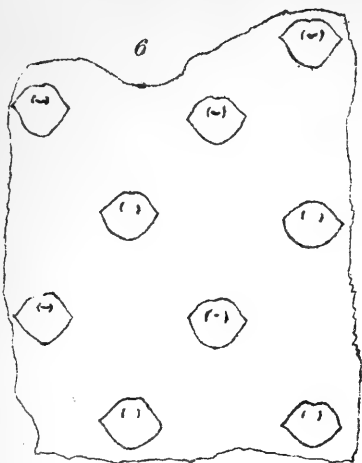

XII.—On the structure of *Lepidodendron* and *Sigillaria*.

BY HERMAN L. FAIRCHILD.

No. 3.—On the Identity of certain Supposed Species of *Sigillaria* with *S. lepidodendrifolia*, Brongt.

(With Plate X.)

Read April 1, 1878.

In the preceding paper of this series I attempted to show that several so-called species of *Lepidodendron* were but natural or accidental variations of growth of a single species. In this paper I propose to treat in a similar manner a number of forms of *Sigillaria*.

It is very rarely that a variation equal to that shown in Fig. 1, Pl. X, is found upon an equal amount of surface of a single fragment. And this specimen is the more remarkable, as evidently proving the specific identity of two forms of *Sigillaria*, widely diverse in appearance, and placed, by some writers, in different sections of the genus.

This fossil, and also the fragments represented in Figs. 2-4, were found in the "rock dump" of the Brisbin shaft, Scranton, Pa., and were derived from a horizon not below the mammoth, or E, seam of the Pennsylvania geologists.

These fragments, and several similar ones not figured, were split out of the same piece of rock with my own hands; and they were so intimately associated that, taken in connection with the fact that this block of roof-shale, as large as a man could easily roll, contained no other plant remains, it is almost certain that they are portions of one individual.

The specimen shown in Fig. 5 was presented to me by Mr. C. Farnham, of Scranton. Its locality was somewhere in the Lackawanna basin.

Fig. 6 represents a portion of a large slab of *S. lepidodendrifolia* Brongt., from the Hampton mine, Scranton; and, on the reliable authority of the superintendent, Mr. B. C. Green,

was derived from the roof of the "Diamond," or G, seam. These are casts; but I shall always speak of the reverse, or cortex. The scars and leaf-bases of Figs. 1 to 5, were elevated, with sharp relief; consequently, the forms are not due to flattening.

The fruit-scars, which are irregularly dispersed among the leaf-scars of Fig. 1, are slightly elevated, angular by compression, and without distinct markings. But a very similar specimen in Prof. J. S. Newberry's collection has the fruit-scars less angular, or even sub-rotund, and with elevated circular central area. They are similar to the fruit-scars of Prof. Dawson's *S. Lorwayana*, Geol. Sur. of Canada, Rep. on the Fossil Plants of the L. Carb. etc., 1873. And his remarks concerning the probability of those scars being the places of attachment of fruits like *Trigonocarpa*, single or in racemes, or like *Antholites*, and the impossibility of the fruits being the strobiles of Schimper, apply with equal force to these.

The production of the fruit apparently caused, or was accompanied by, a retardation of the upward, or vegetative growth of the branch, and a consequent crowding of the leaf-bases below the ring of fruiting.

The most natural of the forms upon Fig. 1 is that having the scars farthest apart, as thus affording free development and giving greater resemblance with the trunk. The upper half of Fig. 1 is certainly *S. lepidodendrifolia*. This I have determined fully by comparison with other undoubted specimens. The surface is not striated, but finely dotted or granulated, a not uncommon appearance. The cortex had not sufficiently expanded to produce the longitudinal furrowing seen on older specimens. However, the cracking of the bark had begun to obliterate the leaf-bases on the lower half of the same fragment. In this connection, I would observe that I found a specimen of typical *S. lepidodendrifolia* near these fossils. The rock of Fig. 6 is too coarse to preserve the striation of the bark.

It is quite as certain that the lower half of Fig. 1 is *S. Brardii*, Brongt; and that Figs. 3, 4, are *S. Menardi*, Brongt.

Figs. 2, 5, are intermediate forms. Prof. Schimper thinks that *S. Menardi* is a branch of *S. Brardii*. A comparison of specimens of these forms confirms in my mind their specific identity. But all the specimens of *S. Brardii*, which I have seen, are themselves fragments of branches, *S. lepidodendrifolia* being doubtless the trunk. The gradual obliteration of the leaf-bases of *S. Brardii*, and the blending of the form with *S. lepidodendrifolia*, can be traced in numerous specimens.

The vascular scars of *S. Brardii* are identical with those of *S. lepidodendrifolia*, the probable typical form being shown in Fig. 5.

S. Serlii, Brongt., is probably but another variation of this compressed form of *S. lepidodendrifolia*, as Prof. Schimper has suggested. Its chief peculiarity is the minuteness of the vascular scars; but these are a very variable and, with a few specimens, an unreliable feature.

If the scars of *S. Defranci*, Brongt., were somewhat smaller, I should affirm, without hesitation, that the figure is inverted, and the form identical with my Fig. 5. I am still very confident that this is the case. Scars of *S. Brardii* are frequently larger; and there can be no reason why scars slightly more compressed, and in a little different manner, should not be quite as large. The vascular scars of *S. Defranci* are represented as about in the middle of the leaf-scars, or, if we invert the figure, as sometimes slightly below the centre. It seems to me not impossible that this is an unconscious error of the draughtman's, produced by inverting the fossil, he knowing that the vascular scars are usually, if not always, more or less above the centre of the leaf-scar. However, the form as figured may be erect and still be compressed *S. Brardii*.*

S. rhomboidea, Brongt., and *S. obliqua*, Brongt., which

*Note: Since writing the above, I find that M. Grand'Eury, in his recent work, "Flore Carbonifère du département de la Loire et du centre de la France," makes *S. Defranci* a variety of *S. Brardii*.

In common with other palæontologists, he includes *S. Brardii* in the sub-genus *Clathraria*, and *S. lepidodendrifolia* in *Leioderma*; but admits that the types are connected by numerous transitional forms.

Prof. Schimper unites, are undoubtedly variations of *S. lepidodendrifolia*. *S. obliqua* was established upon Wilkesbarre specimens. *S. sculpta*, Lesq., in Rogers' Geol. of Pennsylvania, is probably another distorted form. Prof. Newberry's specimens of *S. lepidodendrifolia* show similar variations; and so does Brongniart's original figure.

I believe, also, that future comparison will prove the identity of *S. stellata*, Lesq., with *S. lepidodendrifolia*. All the characters of the leaf-scars of these two forms are precisely identical. Surely this is much more important, as a bond of union, than the difference in direction of the cracks between the scars is a reason for their separation. The striation or wrinkling is a cracking of the bark due to expansion; and the direction of the furrows is determined by the directions of expansion, which might be influenced by accidents of growth. For this reason, the peculiarity of wrinkling is not a reliable feature. I have observed upon *S. lepidodendrifolia* a slight tendency toward stellate wrinkling; yet, the radiation of the furrows of *S. stellata* is so very pronounced, that I am not confident of the unity of these forms. But, it may well be suggested that *S. stellata* is perhaps a peculiar expansion of a *Brardii* form which had the leaf-bases extremely elevated. A fine specimen of *S. stellata* in Prof. Newberry's collection shows very distinctly the contiguous hexagonal areas of the enlarged and still elevated leaf-bases. This peculiar form seems not to have occurred except in the anthracite fields of Pennsylvania, and is there extremely rare.

S. spinulosa, Germ., appears to agree, in the character of its leaf-scars, with *S. lepidodendrifolia*; and the markings which have been regarded as the points of attachment of succulent spines—whence the name—agree in shape with the fruit-scars of *S. lepidodendrifolia*; and also with those of *S. Lorwayana* Dawson. Prof. Schimper suggests that these marks are the scars of adventitious rootlets. He could not consider them the scars of strobile fruits. If they were the points of attachment of rootlets, we might expect some alteration of the

cortex, or of the appearance of the leaf-scars, neither of which is perceptible. It is probably *S. lepidodendrifolia*, with scattered fruits.

In conclusion, it appears to me extremely probable that the following forms, which are usually found associated, are specifically identical:

S. lepidodendrifolia, Brongniart.

S. rhomboidea and *obliqua*, Brongt.

S. sculpta, Lesq.

S. Brardii, Brongt.

S. Menardi, Brongt.

S. Serlii, Brongt.

S. Defranciai, Brongt.

With these, future investigation will perhaps unite,

S. stellata, Lesq.

S. spinulosa, Germ.

XIII. *Index to the Literature of Vanadium, 1801-1877.*

BY GEORGE J. ROCKWELL, M. A.,

Late Professor of Chemistry in the Imperial University of Tokio, Japan.

Read April 2, 1877.

I offer this "Index to the Literature of Vanadium" to chemists, with the hope that it may be of use to them in their researches respecting an element which is beginning to be of value in the arts, and has been the subject of much study during the past year. Dr. H. C. Bolton first suggested the idea of compiling indices to the literature of each of the elements, and has published two, on Uranium and on Manganese, in the Annals of this Society; while a third, on Titanium, has been prepared by Mr. E. J. Hallock.

G. J. R.

[For List of Abbreviations, see page 143.]

1801	Del Rio	Discovery of Erythronium in a lead-ore (Zimapan, Mexico)	Gilb., Ann., LXXI, 7. Gehlen's J., II, 695.
1805	Collet-Descotils	Declares erythronium to be impure Cr. (analysis of the Zimapan lead-ore)	Ann. d. Chimie, LIII, 260.
1830	Sefström	Discovery of Vanadium in bar-iron, and refinery slag of Taberg, Sweden	Vetensk. Acad. Handl., 1830 A. c. p., (2) XLVI, 105. Pogg., XXI, 43. Phil. Mag., (2) X, 151. Schweigg., LXII, 317 and 2. Am. J. Sci., (1) XX, 386.
1830	Berzelius	Letter announcing Sefström's discovery	A. c. p., (2) XLV, 332. Schweigg., LXII, 323. " LXII, 26.
1831	Berzelius	Researches (metal, at. wt., oxides, compounds with P and S, vanadates)	Abh. Schw. Acad. Wiss., 1831. Pogg., XXII, 1. Phil. Mag., (2) X, 321; XI, 7. Berz., Jahrb., XI, 97. Berz., Traité d. Chimie, IV, 642.
1831	Johnston	Vanadinite (Scotland)	Edinb. J. Sci., 1831. Schweigg., LXIII, 119.
1831	Wöhler	Occurrence of Vanadium in the Zimapan lead-ore	Pogg., XXI, 49.
1831	Prideaux	Ammonium vanadate and other compounds	Phil. Mag., (2) X, 209.
1831	Berzelius	Analysis of vanadinite (Zimapan, Mexico)	Berz., Jahrb., XI, 200.
1832	Johnson	Vanadinite (Scotland)	Edinb. J. Sci., V, 166, 318. Berz., Jahrb., XII 97, 171. Am. J. Sci., (1) XXVI, 386. Schweigg., LXIV, 88.
1832	Berzelius	Vanadium ink	J. c. T., 1860, 291, 817.
1833	Rose	Vanadinite (Beresowsk, Ural Mts.)	Pogg., XXIX, 455. A. C. P., XIV, 90. Berz., Jahrb., XIV, 196. Leonh., Jahrb., 1834, 231.
1836	Regnault	Action of vapor of water upon the metal	A. c. p., (2) LXII, 357.
1837	Damour	Lead vanadate containing Zn and Cu	Ann. d. M., (3) XI, 24. Ann. d. M., (3) XI, 161. J. pr. Ch., XI, 134. Berz., Jahrb., XVIII, 236.
1837	Thomson	Analysis of vanadinite (Wicklow, Ireland)	Thoms., Outlines, I, 574. Leonh., Jahrb., 1837, 332.
1838	Volborth and Hess	Volborthite	Petersb. Acad. Bull., IV, 22. J. pr. Ch., XIV, 52. A. C. P., XXVIII, 341. Berz., Jahrb., XIX, 296. Leonh., Jahrb., 1838, 423. Am. J. Sci., (1) XLII, 387.
1839	Schrötter	Occurrence of Vanadium in scoria from iron-works	Pogg., XLVI, 318. Berz., Jahrb., XX, 245.

1839	Svanberg	In hydrophite (analysis)	Vetensk. Acad. Handl., 1839. Pogg., LI, 538.
1840	Kersten	In cupriferos slate (Kupferschiefer)	Pogg., LI, 539. Leonh., Jahrb., 1842, 606. Berz., Jahresb., XXI, 114.
1841	Kersten	"Kupferschiefer" (analysis)	J. pr. Ch., XXII, 381.
1841	Kersten	Occurrence of Vanadium	J. pr. Ch., XXIV, 379.
1842	Wöhler	In uraninite (Bohemia)	A. C. P., XLI, 345.
1842	Bodemann	In siderite (Hartz Mts.)	Pogg., LV, 633.
1842	Ficinus	In uraninite	J. pr. Ch., XXVI, 35.
1842	Schultz	In iron-ore (Silesia)	Pharm. Centr., 1842, 372. Berz., Jahresb., XXIII, 120.
1843	Kersten	In iron-ore	Pogg., LIX, 121. Berz., Jahresb., XXIV, 115.
1843	Ficinus	In serpentine (Zöbletz)	J. pr. ch., XXIX, 491. Leonh., Jahrb., 1844, 360. Berz., Jahresb., XXIV, 115.
1844	Schafhäütl	Analysis of vanadin bronze (Bracco)	A. C. P., LI, 254. Berz., Jahresb., XXV, 362. Leonh., Jahrb., 1844, 721.
1846	Copper vanadate (Ural Mts.)	L'Institut, No. 525, 68. Berz., Jahresb., XXV, 333. Am. J. Sci., (2) II, 414.
1847	Plauer	Volborthite (occurrence)	Arch. wiss. Kunde Rus., VIII, 135. Gorny's Journ., 1847? Rammelsb., Min., 313.
1847	Thomson	Test for vanadic acid in minerals	Phil. Mag., (3) XXXI, 258. J. pr. Ch., XLII, 434. Jahresb., 1847, 965.
1848	Deck	Occurrence in refinery slag, (Staffordshire)	Chem. Gaz., 1848, 298. Pharm. Centr., 1848, 782. Jahresb., 1848, 413.
1848	Domeiko	Analysis of vanadinite and chileite (vanadinkupferbleierz)	Ann. d. M., (4) XIV, 145. Phil. Mag., (3) XXXIV, 395. Rammelsbg., Min., 314.
1848	Domeiko	Chileite (analysis)	Compt. rend., XXIV, 793. J. pr. Ch., XLIII, 312.
1849	Credner	Kalkvolborthit (contains analyses)	Pogg., LXXIV, 546. J. pr. Ch., XLVI, 409. Rammelsbg., Min., 314.
1849	Fritzsche	Konichalcite	Pogg., LXXVII, 140.
1850	Bergemann	Dechenite (determ. of vanadic acid, &c.)	Pogg., LXXX, 393. Arch. ph. nat., XV, 248. Phil. Mag., (4) I, 242. Jahresb., 1850, 752.
1850	Von Kobell	Aræoxene (bleizinkvanadat)	J. pr. Ch., L, 496. Jahresb., 1850, 753.
1850	Fritzsche	Occurrence and preparation of pure vanadic acid	Petersbg. Acad. Bull., IX, 195 A. C. P., LXXVIII, 338 Pharm. Centr., 1851, 375. J. pr. Ch., LIII, 90 Chem. Gaz., IX, 432. Jahresb., 1851, 350.
1851	Gisecke	Extraction from uraninite	Arch. Pharm., Feb., 1851, J. pr. Ch., LV, 445.
1851		Price of "Bohnerz," containing V ₂ O ₅ .	J. pr. Ch., LII, 320.

1851	Teschemacher	Vanadic ochre (Lake Superior)	Am. J. Sci., (2) XI, 233. Pharm. Centr., 1852, 73. Jahresb., 1851, 764. Leonh., Jahrb., 1856, 193.
1851	Wöhler	Extraction from pisolitic iron ore (Bohnerz)	A. C. P., LXXXVIII, 125. Jahresb., 1851, 349.
1852	Müller	Occurrence in "Bohnerz" (Württemberg)	J. pr. Ch., LVII, 124. Z. C. P., 1852, 22.
1853	Müller	Analysis of "Bohnerz" containing V ₂ O ₅	A. C. P., LXXXVI, 127. J. pr. Ch., LX, 63.
1853	Mohr?	Chileite	Mohs' Min., 28.
1854	Fischer and Nessler	Eusynchite	Ber. Ges. Freiburg, 1854, III, 33 Leonh. Jahrb., 1855, 570. Jahresb., 1855, 964.
1854	Damour	Descloizite (analysis, &c.)	A. c. p., (3) XLI, 72. J. pr. Ch., LXII, 246. Am. J. Sci., (2) XVII, 434. Pharm. Centr., 1854, 539. Arch. ph. nat., XXV, 78. Leonh. Jahrb., 1854, 346. Jahresb., 1854, 855. Rammelsb., Min., 312.
1854	Descloizeaux	Cryst. form of Descloizite	A. c. p., (3) XLI, 78.
1855	Genth	Volborthite	Am. J. Sci., (2) XIX, 23. Leonh., Jahrb., 1857, 439.
1855	Smith	Descloizite from Penn. (analysis:—occurrence of V ₂ O ₅ in red varieties of wulfenite)	Am. J. Sci., (2) XX, 246. J. pr. Ch., LXVI, 433. Pharm. centr., 1855, 850. Rammelsb., Min., 313. Jahresb., 1855, 964.
1855	Canaval	Vanadinite from Windischkappel, Carinthia, (cryst. form, sp. gr., &c.)	Jahrb. d. nat. Land., III, 171. Jahresb., 1855, 963. Leonh., Jahrb., 1857, 173.
1855	Bödeker	Vanadium and titanium in clay-ironstone	A. C. P., XCIV, 355. J. pr. Ch., LXVI, 190.
1856	Patara	Occurrence and separation of vanadium in uraninite (Joachimsthal)	Berg. Hüttenm. Ztg., 1856, No. 31 J. pr. Ch., LXIX, 118. Dingl. pol. J., CXLI, 375. Chem. Centr., 1856, 843.
1856	Von Hauer	Researches (sep. from Joachimsthaler uraninite; estim. of V ₂ O ₅ ; sep. from Pb. Ba, Sr; reactions of vanadates)	Wien. Acad. Ber., XX, 37. J. pr. Ch., LXIX, 118. Dingl. pol. J., CXLI, 375. Jahresb., 1856, 377, 744.
1856	Kenngott	Vanadinite	Pogg., XCIX, 95.
1856	Rammelsberg	Windischkappel vanadinite (cryst form, analysis, &c.)	Berl. Acad. Ber., 1856, 153. Pogg., XCVIII, 249. J. pr. Ch., LXVIII, 244. Chem. Centr., 1856, 374. Leonh. Jahrb., 1857, 716. Jahresb., 1856, 872.
1856	Von Hauer	Researches (NH ₄ , Na, Ba, Sr vanadates)	Wien. Acad. Ber., XXI, 333. J. pr. Ch., LXIX, 385.
1857	Schabus	Cryst. form of vanadinite	Pogg., C., 297.
1857	Bergemann	Analysis of arceoxene	Leonh., Jahrb., 1857, 397. Jahresb., 1857, 683.

1857	Struve	Vanadinite (Beresowsk)	Vehr. d. min. Ges. Petersbg., 1857, III, 42. Jahresb., 1859, 804.
1857	Brush	Dechenite, eusynchite, (presence of ZnO; identity of eusynchite and arceoxene with dechenite, &c.)	Am. Jour. Sci. (2) XXIV, 116. Jahresb., 1857, 685.
1857	Wöhler	Detection of vanadic acid in wulfenite	A. C. P., CII, 383. J. pr. Ch., LXXI, 447. Jahresb., 1857, 199.
1858	Uhrlaub	Compounds of vanadium with nitrogen	Pogg., CIII, 134. J. pr. Ch., LXXIII, 378. Chem. Centr., III, 166.
1858	Grailich	Cryst. form of vanadates	Kryst. Untersuch., 3.
1858	Schafarik	Researches (chlorides, metal, vanadic acids, &c)	Wien Acad. Ber., XXXIII, 3. A. C. P., CIX, 84. J. pr. Ch., LXXXVI, 142. Chem. Centr., 1859, 97. Rep. chim. pure, I, 292. A. C. P., (3) LV, 497. Jahresb., 1858, 166.
1858	Hallwachs and Schafarik	Action of ethyl iodide on vanadium	Wien Acad. Ber., XXXIII, 569. A. C. P., CIX, 206. Chem. Centr., 1859, 161. J. pr. Ch., LXXXVI, 140. N. Jahrb. Pharm., XI, 201. Rep. chim. pure, I, 334. Jahresb., 1859, 407.
1859	Von Hauer	Strontium trivanadate	J. pr. Ch., LXXXVI, 156. Jahresb., 1859, 177.
1859	Handl	Cryst. form of the above	Wien Acad. Ber., XXXVII, 391. Jahresb., 1859, 178.
1859	Buff	Electrolytic	A. C. P., CX, 257. Chem. Centr., 1859, 686. Phil. Mag., (4) XVII, 394. Jahresb., 1859, 34.
1859	Beauvallet	Occurrence in clay (Gentilly)	Compt. rend., XLIX, 301, Ann. d. M., (5) XVII, 20. Rep. chim. appl., I, 406. J. pr. Ch., LXXXIV, 256, Phil. Mag., (6) XVIII, 480.
1859	Von Hauer	Vanadates (NH ₄ , Na, Sr, Ba, Ca, Mg vanadates)	Wien Acad. Ber., XXXIX, 299, 448. J. pr. Ch., LXXX, 324. Chem. Centr., 1860, 439. Rep. chim. pure, II, 208. Chem. News, 1860, 59. Jahresb., 1860, 164.
1859	Hermann	Vanadium gummite	J. pr. Ch., LXXXVI, 328.
1860	Engelbach	V and Ti in brachydolerite and nepheline dolerite (Vogelsberg)	Jahresb., 1860, 810.
1860	Nordenskiöld	Vanadic acid (cryst. form, properties)	Oefv. Ak. Stockh., 1860. Pogg., CXII, 160. Jahresb., 1860, 164.

1860	Terreil	Occurrence in clays (Gentilly, Forges les-Eaux, and Dreux)	Comp. rend., LI, 94. Rep. chim. pure, II, 283. Chem. Centr., 1860, 896.
1861	Zippé	Rhombic vanadite	Wien Acad. Ber., XLIV, (I Abth.) 197. Leonh., Jahrb., 1852, 728. Jahresb., 1861, 1020.
1861	Tschermak	Analysis of rhombic vanadite	Wien Acad. Ber., XLIV, (II Abth.) 157. Leonh., Jahrb., 1862, 728. Jahresb., 1861, 1021.
1861	Werther	Delicate test for vanadic acid	J. pr. Ch., LXXXIII, 195. N. Arch. ph. nat., XI, 82. Z. anal. C., I, 72. Rep. chim. pure, IV, 57. Jahresb., 1861, 849.
1861	St. Claire Deville	Extraction from iron-ore (Baux)	Ann. d. M., (5) XVII, 19. Compt. rend., XLIX, 210. J. pr. Ch., LXXXIV, 255. Dingl. pol. J., CLXIII, 396. Pol. Notizbl., 1862, 64. J. c. T., 1862, 334.
1861	St. Claire Deville	Analysis of aluminous minerals containing V_2O_5 , (detection in cryolite, &c.)	A. c. p., (3) LXI, 309, 342. Chem. News; 1862, 103.
1862	Böttger	Extraction from "Bohnerz"	Jahres. des phys. Ver. zu Frankfurt, 1861-2, 70. J. pr. Ch., XC, 33. Dingl. pol. J., CLXVIII, 392. Bull. soc. chem., VI, 183. Chem. Centr., 1864, 416. Pol. Centr., 1863, 1100. Jahresb., 1863, 219.
1862	Schrauf	Zippé's vanadite compared with dechenite and descloizite	Pogg., CXVI, 355. Leonh., Jahrb., 1862, 1000. Jahresb., 1862, 754.
1862	Tschermak	Criticism on Schrauf.	Pogg., CXVII, 349. Jahresb., 1862, 754.
1862	Thompson	Argyllite or lead-sulphovanadate	London J. of Arts, N. S., XVI, 260.
1863	Schafarik	Researches (at. wt., oxides, compound with P and S, vanadium residues, &c.)	Wien Acad. Ber., XLVII, (II Abth.) 246. J. pr. Ch., XC, 1. Chem. Centr., 1863, 634. Z. C., 1863, 408. Bull. soc. chem., VI, 23. Jahresb., 1863, 15, 219.
1863	Phipson	Vanadic ochre (contains analyses of clays, bog-iron ores, &c., containing vanadic acid)	Compt. rend., LVII, 152. J. Chem. Soc., (2) I, 244. Chem. News, VII, 210. J. pr. Ch., XCI, 49; XCII, 63. Chem. Centr., 1863, 987. J. c. T., 1863, 376. Leonh. Jahrb., 1863, 861. Jahresb., 1863 219, 861.
1863	Thompson	Action of vanadium on iron	Le Technologiste, 1863, 450. Pol. Centr., 1863, 1172. Dingl. pol. J., CLXIX, 475.

1863	Thompson	Action of vanadium on iron	Berg. Hüttenm. Ztg., 1863, 380. J. c. T., 1863, 60.
1863	Czudnowicz	Researches (oxygen compounds: estim. of V_2O_5 , sep. from Zn: review of previous analyses of dechenite, vanadinite, arceoxene, eusynchite, &c)	Pogg., CXX, 17. Chem. Centr., 1864, 161. Jahresb., 1863, 221, 826. Leonh. Jahrb., 1864, 237. Z. anal. C., 1864, 377. J. c. T., 1864, 285. Am. J. Sci. (2) XXXVII, 270.
1863	Riley	Occurrence in gray pig-iron; and mode of extraction	J. Chem. Soc., (2) II, 21. Chem. News, 1863, 361, 277. Chem. Centr., 1864, 688. Bull. soc. chim. (2) II, 286. Pol. Notizbl., 1864. Jahresb., 1864, 232. Dingl. pol. J., CLXXV, 244. J. c. T., 1864, 58.
1864	Rammelsberg	Natural compounds of lead oxide and vanadic acid	Ber. Acad. Ber., 1864, 33. J. pr. Ch., XCI, 405. Chem. Centr., 1865, 23. Leonh. Jahrb., 1864, 844. Bull. soc. chim. (2) II, 344. J. Pharm., (3) XLVI, 70. Institut., 1864, 160. Jahresb., 1864, 855.
1864	Huber	Occurrence in psilomelane, (Krakow mine, Katzenellenbogen)	A. C. P., CXXX, 268, 371. Jahresb., 1863, 861.
1864	Rammelsberg	Occurrence in soda-lye	Berl. Acad. Ber., 1864, 680. J. pr. Ch., XCIV, 237. Chem. Centr., 1865, 1801. Z. C., 1865, 581. Pol. Centr., 1865, 1081. Jahresb., 1864, 185.
1865	Engelbach	Occurrence in basalt	A. C. P., CXXXV, 123. Z. C., 1865, 605. Chem. Centr., 1866, 367. A. c. p., (4) VI, 482. Jahresb., 1865, 219.
1865	Baumgarten	Occurrence in soda-lye	Z. C., 1865, 605. Chem. Centr., 1866, 367. Jahresb., 1865, 165, 219.
1866	Bunsen	Flame-reactions	A. C. P., CXXXVIII, 257. Z. anal. C., V, 351. Phil. Mag., (4) XXXII, 81. N. Arch. ph. nat., XXVII, 25. Jahresb., 1866, 782.
1867	Roscoe	Researches, Part I. (1) Occurrence in copper-bearing beds at Alderley Edge and Mottram St. Andrews, Cheshire, (2) sep., (3) at. wt., (4) estim., (5) oxides, (6) oxychlorides, (7) nitrides.)	Phil. Trans., 1868, 1. Proc. Roy. Soc., XVI, 220. Phil. Mag., (4) XXXV, 307. A. C. P., Suppl., VI, 77. Am. J. Sci., (2) XLV, 394. Chem. News, XVII, 135. Z. C., 1868, 417. N. Arch. ph. nat., XXXI, 331. A. c. p., (4) XIV, 438. J. pr. Ch., CIV, 429. Jahresb., 1867, 2 Dt. Ind. Ztg., 1

1868	Rammelsberg	Ammonium tungsto-vanadate $[(\text{NH}_4)_2\text{O}, 3\text{V}_2\text{O}_5, \text{WO}_3 + 6\text{H}_2\text{O}]$	D. C. Ges., 1868, 158. Z. C., 1868, 226. Chem. Centr., 1868, 652. Jahresb., 1868, 226.
1868	Thalén	Spectrum, giving wavelengths	Nova Acta Reg. Upsal., 1868, (3) VI. A. c. p., (4) XVIII, 243. Roscoe's Spect. Anal., 1873, 123.
1869	Roscoe	Researches. Part II. (1) metal, (2) chloride.	Phil. Trans., 1869, 679. Proc. Roy. Soc., XVIII, 37. Phil. Mag., (4) XXXIX, 146 Chem. News, XX, 37. Am. J. Sci., (2) XLVIII, 407. A. C. P. Suppl., VII, 1869, 70 J. pr. Ch., CVIII, 303. D. C. Ges., 1869, 424. Z. C., 1869, 553. Bull. soc. chim., XII, 447. Jahresb., 1869, 289.
1869	Smith	Descloizite (Penn.)	Am. J. Sci., (2) XLVIII, 137. Jahresb., 1869, 1231.
1869	Descloizeaux	Goniometric measurement of the above	Am. J. Sci., (2) XLVIII, 137.
1870	Roscoe	Researches. Part III. (1) metal, (2) V and I, (3) V. and Br., (4) vanadates, absorption of oxygen by vanadic acid; bleaching properties of same, &c.)	Phil. Trans., 1870, 317. Proc. Roy. Soc., XVIII, 316. Phil. Mag., (4) XL, 62. Am. J. Sci., (3) I, 374 Chem. News, XXI, 183. A. C. P. Suppl., 1870, VIII, 95 Z. C., 1870, 357. Chem. Centr., 1870, 644. D. C. Ges., 1870, 432. Bull. soc. chim., XIV, 208. Am. Chem., 1871, 435. Jahresb., 1870, 368, 1314. Bull. Soc. Imp. Moscow, XLII, 234.
1870	Hermann	Vanadiolite (association, analysis, &c.)	J. pr. Ch., (2) I, 442. Chem. Centr., 1870, 424. Am. J. Sci., (2) L, 273. Leonh., Jahrb., 1870, 780. Jahresb., 1870, 1287.
1870	Schrauf	Eosite, dechenite, descloizite, &c., (cryst. forms and relations of chromo-wulfenites, eosite, dechenite, &c.)	Wien. Acad. Ber., (1 Abth.) LXIII, 167. Proc. Roy. Soc., XIX, 451. Chem. News, XXIII, 230, 246. J. Chem. Soc., (2) IX, 500. Leonh., Jahrb., 1871, 163, 638. Jahresb., 1871, 1168.
1871	Roscoe	Estimation of vanadic acid	J. Chem. Soc., (2) IX, 28. Z. anal. C., X, 223. Bull. soc. chim., XVII, 43. Jahresb., 1871, 942.
1871	Roscoe	Orthovanadates	Z. anal. C., X, 224. Bull. soc. chim., XVII, 42.
1871	Lightfoot	Action of vanadium on aniline salts	Pamphlet, Manchester, 1871, 36 pp. Bull. Soc. Ind. d. Mulhouse, XLI, 285.

1871	Lightfoot	Action of vanadium on aniline salts	Textile Colorist, 1876, 130.
1871	Thorpe	Vanadyl-chlorides	Phil. Mag., (4) XLII, 305.
1871	Frenzel	Pucherite, a new mineral, (cryst. form, analyses, &c.)	J. pr. ch., (2) IV, 227, 353. Leonh., Jahrb., 1872, 97, 514, 939. Jahresb., 1871, 1168.
1871	Pinkney	Application of vanadium and uranium together, or in combination with nickel, for producing aniline black (patented Oct. 16)	Textile Colorist, 1876, 115, 131. Bull. soc. chim., XVIII, 47.
1871	Pinkney	Vanadium marking-ink, "Jetoline," (patented Oct. 16)	Textile Colorist, 1876 198.
1871	Thorpe	Vapor density of vanadyl-trichloride	Chem. News, XXIV, 287. Jahresb., 1871, 57.
1872	Maskelyne and Flight	Analysis of vanadinite, (S. Africa)	J. Chem. Soc., (2) X, 1053. Jahresb., 1872, 1129.
1872	Kenngott	Descloizite isomeric with lead sulphate	Zürich. naturf. G., (3) XVI, 137. Leonh., Jahrb., 1872, 535. Jahresb., 1872, 1129.
1872	Websky	Cryst. form of pucherite, (Schneeberg)	Leonh., Jahrb., 1873, 183. Jahresb., 1872, 1129.
1872	Böttger	Separation. Application of ammonium vanadate to making ink	Jahresb. des phys. Ver. zu Frankfurt, 1871-2, 18. Chem. Centr., IV, 514. Bull. soc. chim., XX, 501. Chem. News, XXIX, 62.
1872	Lasaulx	Ardennite (properties and analysis)	Leonh., Jahrb., 1872, 930.
1872	R. Apjohn	Occurrence and detection of vanadium in trap-rock	Chem. News, XXVI, 183. J. Chem. Soc., (2) X, 1116. Bull. soc. chim., XIX, 123. Jahresb., 1872, 916.
1872	E. Sonstadt	Occurrence in trap-rock	Chem. News, XXVI, 214.
1872	Lasaulx and Bettendorff	Occurrence in ardennite	Leonh., Jahrb., 1872, 930; 1873, 124. Pogg., CXLIX, 241.
1872	R. J. Hodges	Occurrence in iron-ore, (Antrim, Ireland)	Chem. News, XXVI, 238. Jahresb., 1872, 267.
1872	Carnelley	Thallium vanadates. Separation of vanadium from thallium	A. C. P., CLXVI, 155. J. Chem. Soc., (2) XI, 323. Bull. soc. chim., XIX, 502. Jahresb., 1873, 945.
1872	Pisani	Ardennite (analysis)	Compt. rend., 1872, No. 23.
1873	B. W. Gerland	Metavanadic acid	Chem. News, XXVII, 92. Bull. soc. chim., XIX, 501.
1873	Hautefeuille	Chloro-vanadates	Compt. rend., LXXVII, 896. Bull. soc. chim., XXI, 180.
1873	Patera	Preparation of salts	Bericht. Wien. Weltausstellung, 1873, III, (1. Abth.) 841. J. c. T., 1875, 615.
1873	V. Roussel	Occurrence in basalt, near Clermont-Ferrand. (Detect. of small quantities in silicates.)	Compt. rend., LXXVII, 1102. Bull. soc. chim., XXI, 71. Chem. News, XXVIII, 313. Jahresb., 1873, 944.

1873	R. Apjohn	Occurrence in meteorites	J. Chem. Soc. (2) XII, 104. Chem. News, XXVIII, 278. Am. Chemist, V, 29. Jahresb, 1874, 997, 1340.
1873	Norblad	Vanadium salts (sep. of vanadic acid from alkalis and alkaline earths)	Bull. soc. chim., XXIII, 64. D. C. Ges., VIII, 126. Z. anal. C., XIV, 344.
1874	Lasaulx	Presence of vanadium in ardenite	Leonh., Jahrb., 1874, 276.
1874	Jas. Gibbons	Photographic properties	Chem. News, XXX, 267. Les Mondes, 1875. XXXVI. Bull. soc. chim., XXIV, 368, Am. Chemist, VI, 277. Jahresb. 1874, 171.
1874	Sellon and Pinkney	Vanadium salts in conjunction with vegetable and animal coloring matter, for dyeing and printing (Pat. Dec. 4)	Textile Colorist, 1876, 86, 122, 131.
1875	A. A. Hayes	Wide diffusion of V compounds, associated with P in porphyritic and slate rocks, occurrence in natural waters, &c	Proc. Am. Acad. Sci., X, 300. Chem. News, XXXII, 34. Am. J. Sci., (3) X, 61.
1875	H. C. Bolton	Occurrence in uraninite	Am. Chemist, V, 363.
1875	H. Fresenius	Action of H ₂ SO ₄ on vanadic acid.	Z. anal. C., XIV, 193.
1875	Frenzel	Descloizite, vanadinite (analyses &c.)	Leonh., Jahrb., 1875, 673.
1875	Jno. Priestley	Physiological effect	Proc. Roy. Soc., XXIV, 40.
1875	P. Bedson	Compound of ether and vanadyltrichloride— (VOCl ₃ + C ₄ H ₁₀ O)	A. C. P., CLXXX, 935.
1876	R. Pinkney	Vanadium in production of aniline black	Moniteur de la Teinture, III, 208. Bull. soc. chim., XXV, 45.
1876	A. Guyard	Aniline black by means of vanadium salts	Bull. soc. chim., XXV, 58. Textile Colorist, 1876, 131, 284. Am. Chemist, VII, 114.
1876	M. A. Rosenstiehl,	Aniline black	Bull. soc. chim., XXV, 291.
1876	A. Guyard	Vanadium salts	Bull. soc. chim., XXV, 350.
1876	Von Zepharovich	Red vanadinite	Leonh., Jahrb., 1876, 561.
1876	B. W. Gerland	Sulphates; metavanadic acid	D. C. Ges., IX, 869. Bull. soc. chim., XXVII, 52.
1876	Rosenstiehl	Aniline black	v. c p., (2) VIII, 561.
1876	Lasaulx	Occurrence of vanadium in ardenite; analysis, &c.	Leonh., Jahrb., 1876, 363.
1876	G. A. Koenig.	Occurrence in schorlomite, perowskite, and other minerals from Arkansas	Proc. Phila. Acad. Sci. 1876, 37.
1876	I. Walz	Occurrence in American magnetites	Am. Chemist, VI, 453.

1876		Vanadium in dyeing and calico printing	Textile Colorist, 1876.
1876	F. A. Genth	Roscoelite, a vanadium mica	Am. Chemist, VII, 57. Am. J. Sci., (3) XI, July. Phil. Mag., (5) 11, 156.
1876	C. M. Stillwell	Occurrence in American hematites and other secondary iron ores	Am. Chemist, VII, 41.
1876	Witz, M. G.	Use of vanadium in preparing aniline black	Compt. rend., 1876. Am. Chemist, VII 61.
1876	Homme	Experiments upon the uses of aniline black in dyeing woolen and mixed tissues	Bull. Soc. Ind. Rouen, IV, 263. Textile Colorist, 1876. Am. Chemist, VII, 60.
1876	M. A. Rosenstiehl	Theory of the formation of aniline black	Bull. Soc. Ind. Mulhouse, 1876.
1876	Crow	Tetroxide	Am. Chemist, VII, 94.

EXPLANATION OF ABBREVIATIONS.

Abh. Schw. Acad. Wiss.	Abhandlungen der königlichen Schwedischen Academie der Wissenschaften, Stockholm.
A. c. p.	Annales de chimie et de physique, Paris,
A. C. P.	Annalen der Chemie and Pharmacie, Heidelberg.
Am. Chemist	American Chemist, C. F. and W. H. Chandler, New York.
Am. J. Sci.	American Journal of Science and Arts, Silliman and Dana, New Haven, Ct.
Ann. d. Chimie	Annales de Chimie, Paris.
Ann. d. M.	Annales des Mines, Paris.
Arch. Pharm.	Archiv der Pharmacie, Bley, Halle, etc.
Arch. ph. nat.	Archives des sciences physiques et naturelles, Genève.
Arch. wiss. Kunde Russ.	Archiv für wissenschaftliche Kunde von Russland, Berlin.
Ber. Acad. Ber.	Bericht über die zur Bekanntmachung geeigneten Verhandlungen der Königl. Preussische Academie der Wissenschaften zu Berlin.
Ber. Ges. Freiburg	Bericht d. Gesellsch. f. Naturwissenschaften zu Freiburg.
Ber. Wiener Weltausstellung	Bericht über die Wiener Weltausstellung von 1873, Braunschweig, 1875.
Berg Hüttenm. Ztg.	Berg-und Hüttenmannische Zeitung, Leipzig.
Berz., Jahresb.	Jahresbericht über die Fortschritte der Chemie. etc., Berzelius, Tübingen.
Berz., Traité d. chimie	Traité de chimie. Berzelius.
Bull. Sci. St. Petersb.	Bulletin Scientifique publié par l'Académie Imp. des Sciences de St. Petersburg.
Bull. soc. chim.	Bulletin de la Société chimique de Paris.
Bull. soc. Ind. Mulhouse	Bulletin de la Société Industrielle de Mulhouse.
Bull. soc. Ind. Rouen	Bulletin de la Société Industrielle de Rouen.
Bull. soc. Imp. Moscou	Bulletin de la Société Impériale des naturalistes de Moscou.

- Chem. Centr.
Chem. Gaz.
Chem. News.
Compt. rend.
- Dingl., pol. J.
D. C. Ges.
- Dt. Ind. Ztg.
Edinb. J. Sci.
Engineering.
Gehlen's J.
Gilb., Ann.
Institut.
- Jahrb. d. nat. Land.
- Jahresb.
- Jahres. des phys. Ver. zu
Frankfurt
J. c. T.
- J Chem. Soc.
J. pr. Ch.
J. Pharm.
Kryst. Untersuch.
- Les Mondes.
Le Technologiste
Leonh., Jahrb.
- London J. of Arts.
- Mohs' Min.
Monit. de la teinture
N. Arch. ph. nat.
- N. Jahrb. Pharm.
Nova Acta Reg. Upsal.
- Oefv. Ak. Stockh.
- Petersb. Acad. Bull.
- Pharm. Centr.
Phil. Mag.
- Phil. Trans.
- Pogg.
- Pol. Centr.
Pol. Notizbl.
Proc. Am. Acad. Sci.
- Proc. Phila. Acad. Sci.
- Proc. Roy. Soc.
Rammelsbg., Min.
- Chemisches Centralblatt, Knop; Leipzig.
Chemical Gazette, Francis and Croft, London.
Chemical News, Crookes, London.
Comtes rendus hebdomadaires des séances de
de l'académie des sciences, Paris.
Polytechnisches Journal, Dingler; Stuttgart.
Berichte der deutschen chemischen Gesellschaft
zu Berlin.
Deutsche Industrie Zeitung, Binder; Leipzig.
Edinburgh Journal of Science, Brewster.
Engineering, London.
Allgemeines Journal der Chemie, Gehlen; Berlin.
Annalen der Physik, Gilbert; Halle.
L'Institut; section des sciences mathématiques,
physiques et naturelles, Arnot, Paris.
Jahrbuch d. naturhist. Landmuseums von
Karnthen.
Jahresbericht über die Fortschritte der Chemie,
Giessen.
Jahresbericht des physikalischen Vereins zu
Frankfurt am Rhein.
Jahresbericht über die Fortschritte der chemi-
schen Technologie, Wagner; Leipzig.
Journal of the Chemical Society, London.
Journal für praktische Chemie, Erdmann.
Journal de Pharmacie et de Chimie, Paris.
Krystallographische Untersuchungen, Grailich;
Wien and Olmütz, 1858.
Les Mondes, Moigno; Paris.
Le Technologiste, Paris,
Jahrbuch für Mineralogie, Geognosie, etc., Leon-
hard; Heidelberg.
London Journal of Arts and Sciences, Newton;
London.
Grundriss der Mineralogie, Mohs.
Moniteur de la teinture, Paris.
Nouvelles archives des sciences physiques et
naturelles, Genève.
Neues Jahrbuch für Pharmacie, Speyer.
Nova Acta Reg. Soc. Sci. Upsal., Third Series,
Upsala, 1868.
Oefversigt af Kongl. Vetenskaps-Akademiens
Forhandlingar; Stockholm.
Bulletin de l'Académie des Sciences de St. Pe-
tersbourg.
Pharmaceutisches Centralblatt, Leipzig.
London, Edinburgh, and Dublin Philosophical
Magazine, London.
Philosophical Transactions of the Royal Society
of London.
Annalen der Physik and Chemie, Poggendorff;
Berlin.
Polytechnisches Centralblatt.
Polytechnisches Notizblatt.
Proceedings of the American Academy of Scien-
ces, Boston.
Proceedings of the Philadelphia Academy of
Natural Sciences, Philadelphia.
Proceedings of the Royal Society of London.
Handb. der Mineralchemie, Rammelsberg 1860,

Reimann's Färberzeitung	Reimann's Färberzeitung.
Rép. chim. appl.	Répertoire de chimie appliquée, Paris.
Rép. chim. pure.	Répertoire de chimie pure et appliquée, Paris
Roscoe's Spect. Anal.	Spectrum Analysis, H. E. Roscoe; Third Edition, 1873, London.
Schweigg.	Journal für Chemie und Physik, Schweigger; Nürnberg.
Textile Colorist.	Textile Colorist, Chas. O'Neill; Manchester.
Thoms., Outlines.	Outlines of Mineralogy, T. Thomson.
Verh. d. min. Ges. St. Petersburg.	Verhandlungen der Russisch-Kaiserlichen Mineralogischen Gesellschaft zu St. Petersburg.
Vetensk. Acad. Handl.	Kongl. Svenska Vetenskaps Academiens Handlingar, Stockholm.
Vierteljahres. Pharm.	Vierteljahresschrift für praktische Pharmacie, Wittstein; München.
Wien. Akad. Ber.	Sitzungsberichte der naturwissenschaftlichen Classe der Kaiserliche Academie der Wissenschaften zu Wien.
Z. C.	Zeitschrift für Chemie, Göttingen.
Z. C. P.	Zeitschrift für Chemie und Pharmacie, Erlangen.
Z. anal. C.	Zeitschrift für analytische Chemie, Fresenius; Wiesbaden.
Zürich naturf. G.	Vierteljahresschrift der naturforschenden Gesellschaft in Zurich, R. Wolf.

XIV.—*Descriptions of Seven New Species of Birds from the Island of St. Vincent, West Indies.*

BY GEORGE N. LAWRENCE.

Read May 13th, 1878.

When Mr. Ober had completed his investigations in Dominica, he proceeded to St. Vincent; but unfortunately, while there, he had two attacks of fever, one early in October, from which he soon recovered, but in December he had a relapse; by this he was completely prostrated, and it was not until the end of January, that he was convalescent.

There were also constant rains, and consequently his collecting was seriously interfered with. He thinks, however, that the specimens obtained, and the birds observed, complete quite thoroughly the avi-fauna of the island.

He left for the island of Grenada about the first of March, at which time he forwarded to the Smithsonian, the collection made in St. Vincent. This was received by me about the first of April. There are only 90 specimens, representing 35 species; seven of these I consider new to science, and their descriptions are given below. Besides the species sent, he enumerates 24 others, which he either saw, or had named to him as undoubtedly frequenting the island; making the total number 59. I expect soon to give a complete catalogue of them, together with his notes, which I now have.

1. *Turdus nigrirostris.*

FEMALE. Front, crown, and occiput dark warm brown, each feather of the crown and occiput with a shaft-stripe of dull pale rufous; upper plumage reddish olivaceous brown, deeper in color on the upper part of the back and on the wing coverts; the latter have their ends marked with small spots of bright rufous, which possibly may be an evidence of the example not being fully mature; the tail is of a dark warm brown, the shafts black; inner webs of quills blackish brown; the outer webs reddish brown, of the same color as the tail feathers; the shafts are glossy black; under lining of wings clear cinnamon red; under plumage light brownish ash, with the middle of the abdomen and the crissum white; on the upper part of the breast, a few feathers end with dark reddish

brown, forming an irregular narrow band; the throat unfortunately is soiled with blood, but as well as I can judge, it has stripes colored like the breast, and the feathers edged with whitish; the thighs are dull fulvous; the bill is large and strong, the upper mandible is black, the under also, but showing a brownish tinge; tarsi and toes dark brown.

Length (fresh), $9\frac{1}{4}$ in.; wing, $4\frac{1}{2}$; tail, $3\frac{1}{2}$; tarsus, $1\frac{1}{4}$; bill from front, $\frac{7}{8}$.

Type in National Museum, Washington.

Remarks. There is but one specimen in the collection; in the section (*Planesticus*) which this species comes under, the sexes do not differ.

In the distribution of colors on the under plumage, it is much like *T. albiventris*, but the color of the breast and sides is darker, and the upper plumage is of a much deeper and richer brown. The strong black bill is a striking feature.

Mr. Ober says: "Not abundant, obtained in Rutland Vale, January 25th, 1878."

2. *Myiadestes sibilans*.

The upper plumage is black; the front, lores, and sides of the head for a short distance under the eye, are intense black; the crown, occiput, hind neck and ear-coverts are deep black; the upper part of the back is not quite so deep in color, as it has a slight smoky tinge; the lower part of the back, rump, and upper tail-coverts, have a wash of dull olivaceous, the latter terminate with black; the ear-coverts have their shafts narrowly streaked with white, less striking than in *M. genibarbis*; the lower eye-lid is pure white; the chin and the anterior part of the rictal stripe are white, the posterior part of the latter is cinnamon-red; a very distinct black moustachial line starts from the under mandible, and joins the black of the side of the neck, separating the rictal stripe from the bright cinnamon-red color of the throat; the breast and upper part of the abdomen are of a clear plumbeous gray; the middle and lower part of the abdomen and the under tail coverts, are of a rather paler cinnamon-red than the throat; the thighs are blackish plumbeous, some of the feathers ending with light red; the quills are black, the edge of the wing and bases of the quill-feathers are white; the tail feathers, except the outer two, are brownish slate color, marked transversely with black bars, which are not very conspicuous; the first lateral feather has the inner web grayish-white, with a blackish diagonal mark at the base, the outer web is black for one quarter of its length from the base, the remaining part of a dusky ash color; the second feather is blackish, except that it has for half its length, on the inner web, an elongated white mark along the shaft, widening out to the end; the bill is black; tarsi and toes very pale yellow, claws black; "iris bright hazel."

Length (fresh), 7½ in.; wing, 3¾; tail, 3; tarsus, 1.

The sexes do not differ in plumage.

Types in National Museum, Washington.

Remarks. This differs from all the West India species in its black upper plumage. The color of the throat is much lighter than in *M. genibarbis* and *solitarius*; in both of these the color is of a deep chestnut red; it has the black moustachial line as in *M. genibarbis*, but it is more defined.

M. armillatus (according to the description and plate) differs in being of a lighter color above, slate-gray (gris ardoise); in having the red of the under plumage darker, brownish-red (brun roux); it has no moustachial line, and the eye is encircled with white; but it varies especially, in having the feathers of the thigh terminating in bright yellow.

Mr. Ober writes: "This bird has been an object of search for fifty years, and has so long eluded the vigilance of naturalists and visitors to the mountains, that it is called the 'invisible bird.' From being seen only on the Souffriere Mountain, it has acquired the name of the 'Souffriere bird.'"

Mr. Ober is entitled to great credit for unravelling the mystery connected with this bird. By his indomitable perseverance, and camping out on the top of the mountain for several days, he secured seven specimens.

3. *Thryothorus musicus*.

MALE. Above of a dark ferruginous, somewhat darker on the crown and brighter on the rump; lores, and a line running back from the eye, white tinged with rufous; the exposed portions of the wings are dark rufous, conspicuously barred with black; the inner webs of the primaries are blackish-brown; under wing-coverts white; the tail-feathers are dark rufous, barred with black; the entire back and upper tail-coverts are marked inconspicuously, with narrow transverse dusky lines; the feathers of the rump have concealed white shaft-stripes, which become wider towards the ends of the feathers; the feathers of the back also, have the basal portion of their shafts marked with white; the throat, breast, and middle of the abdomen are white, the latter tinged with rufous; the sides are light ferruginous; the under tail-coverts are rufous, each feather marked with a subterminal round black spot; upper mandible black; the under whitish, with the end dusky; tarsi and toes light brownish flesh color.

Length (fresh), $5\frac{1}{2}$ in.; wing, $2\frac{1}{2}$; tail, 1 13-16; tarsus, $\frac{3}{4}$.

There are three male specimens in the collection, but no female; one example is evidently not mature; in this, the white

dorsal and rump spots are wanting, and the crissum is immaculate; the sides are dull rufous, the under plumage is tinged with rufous, and marked with faint, narrow, dusky bars. This specimen was killed February, 1878.

Types in National Museum, Washington.

Remarks. In its white under-plumage, this species somewhat resembles *T. mesoleucus*, Sel. from St. Lucia; but it is bright rufous above, instead of earthy-brown, and the flanks are light ferruginous instead of fulvous; it is also of larger dimensions. The transverse markings on the back, and the round black spots on the crissum, are strong characteristics.

Mr. Ober states that it is common, and is known as the House Wren and Wall Bird, breeding in holes in houses and trees. He says: "The sweet warble of this lively little bird may be heard morning, noon, and night, about the houses and sugar mills, as well as far up the mountain-sides and valleys."

4. *Certhiola atrata.*

MALE. The entire plumage is black; on the head and throat it is of a deeper color; the breast, upper part of abdomen, and rump, on a side view, show a just perceptible tinge of greenish olive; bill and feet black.

Length (fresh), $4\frac{3}{4}$ in.; wing, $2\frac{3}{4}$; tail, $1\frac{3}{4}$; tarsus, $\frac{3}{4}$.

The female differs only in being smaller.

Length (fresh), 4 in.; wing, $2\frac{1}{4}$; tail, $1\frac{3}{8}$; tarsus, $\frac{3}{8}$.

Types in National Museum, Washington.

Remarks. This is certainly a remarkable departure from the regular pattern of coloration, which prevails so uniformly in this genus. Had there been only a single example, I should have considered it as probably a case of abnormal coloring; but it seems to be the representative form of the genus in this island. Mr. Ober says it is very abundant, and "seems to have almost entirely replaced the black and yellow one of Dominica, etc." He has sent four specimens, two of each sex. But what is surprising is, that there is likewise found in St. Vincent a species of the usual style of coloration, of which he sends but two specimens, stating that it is not abundant. This I have described as a new species also.

5. *Certhiola saccharina*.

FEMALE. Crown, occiput, lores, and sides of the head, glossy black; back of a dull grayish or smoky black; rump dull greenish-yellow; a very conspicuous white superciliary stripe runs from the bill to the hind neck; tail black, the first two lateral feathers have a small patch of dull white on their inner webs at the end, the third feather has the end narrowly white; wings black, with a white patch at the base of the primaries; these have their outer webs narrowly margined with white; edge of wing light yellow; under wing-coverts white; throat dark plumbeous, breast and upper part of abdomen, clear light yellow, the sides and lower part of the abdomen are light ashy olive, under tail-coverts yellowish-white, bill and feet black.

Length (fresh) $4\frac{1}{2}$ in.; wing, $2\frac{1}{2}$; tail, 1 9-16; tarsus, $\frac{5}{8}$. Two specimens are in the collection, one marked ♂, has the plumage greatly soiled; the other is marked as a ♀ with a ?; this I have taken for the type, the plumage being in a much better condition.

The male measures, length, $4\frac{3}{8}$ in.; wing, $2\frac{1}{2}$; tail, $1\frac{1}{4}$; tarsus, $\frac{3}{4}$.

Types in National Museum, Washington.

Remarks. This, in appearance, comes nearest to *C. Portoricensis*, but differs in the superciliary stripe being wider and extending farther back, in the throat being many shades darker in color, in having the flanks of a darker olive, and the yellow on the rump darker and duller.

The color of the breast and rump in *C. Portoricensis* is of a deeper yellow.

Mr. Ober says it is called the "molasses bird."

6. *Leucopeza Bishopi*.

MALE. The general plumage is smoky-black, rather darker on the head; the sides are blackish cinereous; a circle of pure white surrounds the eye; a large roundish spot on the middle of the throat, the upper part of the breast, and the middle of the abdomen, are dull white, somewhat mixed with blackish on the throat and with cinereous on the abdomen; a very small spot on the chin, and the tips of the feathers on the upper part of the throat, are dull white; the black on the upper part of the breast has the appearance of a broad band, separating the white of the throat from that of the lower part of the breast; the under tail-coverts are cinereous-black at base, ending largely with dull white; wings and tail black, the outer two tail-feathers have a small white spot, triangular in shape, on their inner webs at the end; bill black; tarsi and toes very pale yellowish-brown, perhaps much lighter colored in the living bird, nails also pale.

Length (fresh) $5\frac{1}{2}$ in.; wing, $2\frac{3}{4}$; tail, $2\frac{1}{2}$; tarsus, $\frac{7}{8}$.

Two specimens marked as females do not differ in plumage from the males.

Length (fresh) $5\frac{1}{2}$ in.; wing, $2\frac{3}{4}$; tail, $2\frac{3}{8}$; tarsus, $\frac{7}{8}$.

Another specimen, marked male, and of quite different colors, I have no doubt is the young of this species; though Mr. Ober in his notes says of it, (No. 428): "The quickest to respond to my call on the Souffriere, was this little bird. It seems an associate of the preceding species (*L. Bishopi*), though I never saw them closely together; yet in general shape and habits, especially in search for insects, they resembled one another. As I have got both male and female of the other, it precludes the possibility of its being the adult of the former. That there may be no doubt, I have preserved one in rum."

The color of this specimen (No. 428), is of a dark olive-brown above, lighter below, and where the white markings are in the adult, it is of a pale dull rufous; on the throat showing some white, and around the eye partially white; the marks on the ends of the tail-feathers are precisely as in the black specimens; the quills are dark brown; the tail-feathers are black. But what I consider conclusive evidence of its being the young of *L. Bishopi* is, that on the crown the black feathers are beginning to appear. Had it not been marked as a male, I should have taken it for the female of this species. But according to Mr. Ober, the sexes are alike.

Types in National Museum, Washington.

Remarks. This is a remarkable species, and at first I was at a loss where to place it properly; I determined it to be a *Sylvicolina* form, yet unlike any of that family in coloration. On comparing it with the description and plate of *Leucopezza Semperi*, Mr. Selater's new form from St. Lucia (P. Z. S., 1876, p 14), I determined it to be a second species of that peculiar genus, and, like that species, having long and light-colored tarsi.

Mr. Ober requested that I would bestow the name of our friend Mr. Nathaniel H. Bishop on some West India bird of his procuring, if the opportunity offered; and it gives me much pleasure to connect his name with so remarkable a species. Mr. Bishop has had much experience in West Indian exploration, and it was in a great measure due to his influence and representations, that Mr. Ober's visit to these islands was determined upon; he also contributed substantial aid, by the donation of instruments, and in other ways.

The habits of this bird would seem to be like those of the wren, as Mr. Ober has on the labels, "Wren?" He states that they are "very rare and very shy, and found in the crater and dark gorges of the Souffriere."

Three specimens were obtained in November, 1877, and one in February, 1878.

7. *Calliste versicolor*.

MALE. Front, crown, and occiput of a bright deep chestnut-red; upper plumage golden fawn-color, clearest on the sides of the neck and on the rump, in some positions showing a pale greenish silvery gloss; upper tail-coverts bluish-green; lores and partly under the eye black; sides of the head and ear-coverts dull dark green; tail-feathers black, except the two middle ones, which, with the outer margins of the others, are bluish green; quills black, conspicuously edged with bluish-green; wing coverts black, with their exposed portions bluish-green; under wing coverts of a light salmon-color; the under plumage is changeable according to position; viewed from the bill downwards it is of a light bluish-lilac, the blue color deepest on the lower part of the throat, and the upper part of the breast; on a side view, the abdomen is of a purplish-red; the feathers of the upper part of the throat are tipped with gray; the under tail-coverts are bright cinnamon color; upper mandible black; the under light brownish horn-color; tarsi and toes black.

Length, 6½ in.; wing, 3¾; tail, 2½; tarsus, 13-16.

The female differs in having the top of the head of a lighter chestnut color, and the upper plumage of a pale green; the under plumage has the same colors as the male, but much subdued; the abdomen, sides and under tail-coverts are of a light cinnamon-color; the wings and tail are black, but margined with a paler bluish-green; the markings about the head and on the throat, are similar to those of the male, "iris hazel."

Length, 6 in.; wing, 3¼; tail, 2½; tarsus, 13-16.

Types in National Museum, Washington.

Remarks. This fine, new species belongs to the group which contains *C. vitriolina*, *cayana*, *cyanolema* and *cucullata*; it somewhat resembles the latter, a species I have never seen, but according to the plate (Mon. of *Calliste*, Scl.), the colors of the present bird are generally darker, with no tendency to ochreous-yellow above, as in *C. cucullata*, and the abdomen is purple instead of reddish-ochreous; the crown is of a clearer and brighter chestnut red. It is larger than any of its allies; and a strikingly different character is its very large and stout bill, exceeding in size that of any of them I am acquainted with, being fully as large as the bill of *Tanagra cana*.

No species of *Calliste* appears to be on record before from any of the West India islands proper. There are five specimens in the collection, three ♂ and two ♀, procured in February, 1878. "Frequents the mountain ridges and valleys."

XV.—Behavior of Natural Sulphides with Iodine and other Reagents.

BY H. CARRINGTON BOLTON, PH.D.

Read March 18, 1878.

In a paper on the "Application of Organic Acids to the Examination of Minerals," presented to the Academy about a year ago,* we endeavored to show that citric (or tartaric) acid and potassium nitrite can be advantageously added to the usual list of dry reagents employed in the determination of minerals. Owing to the facility with which the latter reagent is decomposed by the former, nitric acid can be carried practically in the solid form; hydro-potassium sulphate, already in use†, furnishes sulphuric acid in a solid state; and it remains therefore to provide for hydrochloric acid, or chlorine. The alkaline chlorides, however, resist the action of organic acids; and a few experiments with easily decomposing sulphides yielded only negative results. Iodine, on the other hand, while less powerful than chlorine, possesses similar properties, and in aqueous solution it attacks many minerals, giving rise to characteristic phenomena.

The employment of bromine in analytical operations‡ has already demonstrated its power in decomposing natural sulphides; and it is precisely with these minerals that the most satisfactory results are obtained by the action of iodine.

The specimens named below are the same as those whose source and condition have been described in the paper referred to. The method of examination is exceedingly simple; the minerals in fine powder are placed in test tubes, a small quantity of pulverized iodine is added, and then water poured on; after standing in the cold for some hours (usually over

* *Annals N. Y. Acad. Sci.*, Vol. I, p. 1.

† Distinction of Natural Sulphides by Bisulphate of Potassa; E. Jannettaz (*Transl. from Comptes Rendus*). *Am. Chem.*, IV, 450.

‡ P. Waage; *Zeitschr. anal. Chem.*, 1871,

night), the results are noted; the contents of each tube are then heated to boiling, and the results again recorded. The solutions were tested by suitable reagents after expelling by heat the excess of iodine.

Stibnite, treated in the manner described, is strongly attacked; and with excess of iodine the solution turns deep brown-red. On boiling the red solution, it loses color as the iodine volatilizes, and after the latter is completely expelled, suitable reagents demonstrate the presence of sulphuric acid and of antimony. The decomposition of this mineral is complete.

Molybdenite is not attacked either in the cold or on boiling.

Argentite is attacked in the cold, yielding a red solution and a yellowish-white precipitate. If an excess of iodine be present, the mineral is completely decomposed in the cold.

Galenite is decomposed in the cold, the liquid being completely decolorized. Lustrous, yellow crystals of plumbic iodide form on the surface of the mineral. On heating, the action is increased; and the solution deposits, on cooling, large and abundant crystals.

Bornite is strongly attacked in the cold, the solution being brown-red and the residue yellowish-white. On heating, the decomposition is hastened, and a heavy precipitate of cuprous iodide forms.

Sphalerite is strongly attacked in the cold, the solution turning dark red and a crystalline precipitate forming. On heating, the decomposition is complete.

Chalcocite is strongly attacked in the cold, the solution with excess of iodine being brown-red. On the application of heat, the action is increased, but little (if any) cuprous iodide forms.

Cinnabar is feebly attacked in the cold. On heating, it is readily decomposed, with formation of small scarlet crystals of mercuric iodide.

Pyrrhotite is strongly attacked in the cold; the solution is not completely decolorized, and becomes darker on heating.

Pyrite is decidedly attacked in the cold; on boiling, the

action is increased, but the decomposition appears to be incomplete.

Niccolite is strongly attacked in the cold, yielding a green solution; which turns brown on heating with excess of iodine.

Smaltite is strongly attacked in the cold, forming a brown-red solution; heat increases the action.

*Chalcopyrite** yields a deep-red solution in the cold; the action is increased by boiling, but no precipitate forms.

Tetrahedrite, *ullmannite*, and *arsenopyrite* behave like chalcopyrite.

Bournonite yields a deep-red solution in the cold; and on heating, a heavy precipitate falls, which is evidently a mixture of plumbic iodide with yellowish-white cuprous iodide.

From the preceding notes, it appears that molybdenite is the only one of the seventeen sulphides examined which resists the action of an aqueous solution of iodine. The reactions of galenite and cinnabar are characteristic and beautiful; that of bournonite discloses its composition very satisfactorily. The difference of behavior between bornite and chalcocite is marked.

The results obtained with pyrite and pyrrhotite require some explanations. Professor Henry Wurtz,† in 1858, employed iodine-water to separate pyrrhotite from pyrite; he states that pulverized pyrite digested for 48 hours in the dark with a brown solution of iodine (pulverized and washed repeatedly to remove all free acid), "did not remove the brown color of the liquid, and the latter had dissolved but a trace of iron." We repeated this process, observing all the precautions mentioned, and found that pyrites (from Colorado, and from Saxony), was decidedly attacked. Possibly the discrepancy is only one of judgment as to the amount of decomposition which ensues, but under ordinary circumstances

* Meusel has studied the behavior of chalcopyrite with hydriodic acid; Ber. chem. Ges. III, 123; 1870.

† On some Improvements in the Preparation of Hard Minerals for Analysis, read before the A. A. S. at the Baltimore meeting. Am. J. Sci., [2] Vol. XXVI, p. 190.

we are confident that iodine (in excess) with water decomposes pyrite.

Besides the natural sulphides, we examined the behavior of a few minerals, belonging to various classes, with an aqueous solution of iodine. Limonite, hematite, magnetite, and the manganese oxides, as well as pyromorphite and calamine, are not attacked even on boiling the solution. Cuprite is completely decomposed in the cold, with formation of a bright green crystalline precipitate (CuIO_5 ?). Brucite, calcite, and natrolite, are decidedly attacked on boiling. Anglesite is feebly attacked in the cold, and strongly on heating; cerussite and vivianite appear to be slightly decomposed under the same circumstances. None of these reactions have special interest, except perhaps that of cuprite, which is quite characteristic.

Having continually in mind the possible application of methods to the examination of minerals in the field, and recognizing the impracticability of carrying iodine save in glass bottles, we were led to make another series of experiments with a view to providing iodine in a portable state. To this end, we took advantage of the ready decomposition of potassium iodide by organic acids. That even the weakest acids are able to set hydriodic acid free, in acting on the iodides of the alkaline metals, has been frequently noticed,* and we add the following observations:

When solid potassium iodide is added to strong acetic acid, in the cold, hydriodic acid is set free; and after standing for some time (24–48 hours), this acid decomposes, and the free iodine communicates to the solution a brownish-red color of varying intensity. With free access of air, the liberation of iodine begins at once, as shown by testing the mixture with carbon disulphide. This action is more marked in strong solutions than in weak.

* Dr. Rudolph Boehm, in his *Handbuch der Spec. Pathologie und Therapie*, vol. XV, p. 21, quotes Struve's discovery that even hydro-sodium carbonate decomposes potassium iodide in dilute aqueous solution. This power of carbonic acid has also been observed by Kammerer (*Virchow's Archiv*, LIX, 1874), and Binz (*ibid.*, LXII).

Tartaric and citric acids decompose potassium iodide in a similar manner.

A mixture of any of these organic acids with potassium iodide proves to be a powerful solvent of the natural sulphides. An examination of the seventeen sulphides already mentioned gave the following results:—

BEHAVIOR WITH POTASSIUM IODIDE AND CITRIC ACID.

Stibnite, *argentite*, *sphalerite*, *chalcocite*, *bornite*, and *ullmannite*, are attacked in the cold, with liberation of sulphuretted hydrogen; heat increases the action,—the gas coming off freely.

Galenite acts in the same manner, with formation of yellow crystalline flakes of plumbic iodide. On applying heat, the mineral is completely decomposed.

Cinnabar is also decomposed in the cold, with liberation of sulphuretted hydrogen. On boiling, the decomposition is complete, and crystals of mercuric iodide deposit on cooling,—provided no great excess of potassium iodide is present.

Arsenopyrite is decomposed in the cold, but no sulphuretted hydrogen appears to be set free. On boiling, the decomposition proceeds rapidly.

Pyrrhotite, *chalcopyrite*, and *bourbonite* yield no sulphuretted hydrogen in the cold, but freely on heating. The latter is but feebly attacked.

Pyrite, *niccolite* and *smaltite*, give no sulphuretted hydrogen, either cold or hot, though they are strongly attacked on boiling the liquid.

Tetrahedrite is attacked feebly in the cold; on heating, the action is increased.

Molybdenite resists the action of this mixture of reagents.

Similar results were observed with tartaric and oxalic acids, their decomposing power varying. *Cinnabar*, treated with a mixture of potassium iodide and oxalic acid, is decomposed with remarkable facility; the reaction sets in immediately and in the cold; on boiling, the decomposition continues with

violence; and on cooling, the solution deposits white crystals of hydro-potassium oxalate, mixed with scarlet crystals of mercuric iodide.

The probable nature of this reaction is shown in the following equation :

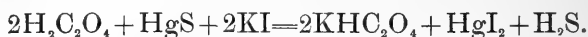

We examined the behavior of a few additional minerals with a mixture of potassium iodide and citric acid, with the results recorded below; but no special interest seems to be attached to this method of attack.

Magnetite is decidedly, and *franklinite* feebly, attacked in the cold, and strongly on heating. *Hematite* is feebly attacked, and *chromite* not at all.

Hausmannite, *pyrolusite*, and the other oxides of manganese, being attacked by citric acid alone, yield, as may be anticipated, deep brown-red solutions colored by the free iodine.

Anglesite and *pyromorphite* are completely decomposed in the cold, with formation of a yellow precipitate of plumbic iodide.

Cuprite is also completely decomposed in the cold, with formation of a yellowish-white precipitate of cuprous iodide, and a colorless solution. If, however, heat be applied at the outset, the same precipitate forms, while the solution is of a blue color.

We also examined the behavior of natural sulphides with a mixture of citric acid and potassium bromide. The latter does not, however, appear to be so easily decomposed as the iodide, and no characteristic phenomena were observed; nearly all the metallic bromides being soluble in water, no precipitates were obtained. In order to avoid repetition, we may briefly summarize the results by stating that, in general, the action of the bromide is less energetic than that of the iodide. Those minerals which yielded only with difficulty to the latter reagent, resist the former even on heating. Cinnabar, whose behavior with the iodide is so remarkable, is but fee-

bly attacked by the bromide. Argentite, galenite, sphalerite, chalcocite, pyrrhotite, pyrite, and chalcopyrite, are attacked in the cold, with or without liberation of sulphuretted hydrogen. Molybdenite resists this mixture of reagents, as well as the others previously mentioned.

In studying the behavior of minerals with organic acids, we obtained results which were embodied in a Table* exhibiting the eleven groups into which minerals are divided by the action of citric acid alone and with reagents. We are now able to add a twelfth group, viz: "minerals decomposed by heating with citric acid [and potassium iodide," and to transfer thereto, from the list of "minerals not decomposed by the above reagents," four species—cinnabar, magnetite, hematite, and franklinite.

Thus of the ninety minerals whose behavior with organic acids and reagents has been examined, only nine resist these methods of attack.

Trinity College, Hartford, Conn.

* Ann. N. Y. Acad. Sci., Vol. I, p. 30.

XVI.—*Descriptions of Supposed New Species of Birds from the Islands of Grenada and Dominica, West Indies.*

BY GEORGE N. LAWRENCE.

Read June 3d, 1878.

In a letter received from Mr. Ober, dated St. George's, Grenada, April 5th, 1878, he writes: "I have nearly completed Grenada; alas! Grenada has but little to complete. I send to the Smithsonian by the English ship 'Hermione,' a small box of birds, the result of my work here. I hope to get a few more in another part of the island, but take this chance to send them off."

The box was sent me from the Smithsonian, on its arrival, and contained 66 specimens, comprising 28 species; three of these I consider to be undescribed.

1. *Turdus Caribbæus.*

MALE. Upper plumage dark-olive, with the forehead dull reddish-brown; tail dark brownish olive; quills dark brown; lower part of throat, upper part of breast, and sides, clear ash; lower part of breast, middle of abdomen, and under tail-coverts white; upper part of throat white, with distinct narrow stripes of ashy-brown; the under wing-coverts are pale cinnamon; upper mandible blackish for two-thirds its length, the end yellow; the under is yellow, with the base black; tarsi and toes brown; "iris red, naked skin around the eye orange."

Length (fresh), 9 1-4 inches; wing, 5; tail, 4 1-2; tarsus, 1 3-16.

There are two specimens in the collection, both males; the length given of the other is 9 1-2 inches, the tarsi are blackish-brown.

Habitat, Grenada. Mr. Ober says; "rather numerous, but shy."

Type in National Museum, Washington.

Remarks. This species has a naked space around the eye, similar to that of *T. gymnophthalmus*; but it is of larger di-

mensions and differently colored from that species. The upper plumage of the new bird is clear deep olive, not at all brownish as in the other; the under plumage is of a lighter ash, and has a much greater extent of white; the striations on the throat are darker and more clearly defined.

2. *Thryothorus Grenadensis.*

FEMALE. Upper plumage of a rather bright ferruginous, a little inclining to brownish on the head and hind neck, and brighter on the rump; lores whitish tinged with rufous; a light rufous stripe extends over the eye to the hind neck; tail dull rufous, barred with black; the primary quills have their outer webs of a dull light rufous, with broad black bars; the inner webs are brownish-black; the wing-coverts and tertials are rufous with narrower black bars; under wing-coverts pale rufous; the throat is very pale rufous, inclining to whitish; the breast light rufous; the middle of the abdomen is of a rather paler shade; the sides and under tail-coverts are of a bright darker ferruginous; the upper mandible brownish-black; the under pale yellow, dusky at the tip; tarsi and toes hazel-brown.

Length (fresh), 4 3-4 inches; wing, 2 1-4; tail, 1 1-2; tarsus, 3-4; bill from front, 11-16.

There is also a specimen of the male, but as it was in poor condition, I chose the female as the type, from which it does not differ in plumage; its measure is given; length, 5 inches; wing, 2 1-4; tail, 1 1-2.

Habitat, Grenada. "Abundant."

Type in National Museum, Washington.

Remarks. This species differ from *T. rufescens*, from Dominica, in having the coloring lighter throughout, especially below, the entire under-plumage of *T. rufescens* being of a dark rufous; there are subterminal black markings on the under tail-coverts of *T. rufescens*, whereas those of the new species are immaculate.

T. musicus, from St. Vincent, is at once distinguished by its white under-plumage.

3. *Blacicus brunneicapillus.*

Blacicus Blancoi, Lawr., nec Gundlach.

MALE. The plumage above is of a clear olive-brown, assuming an ochreous cast on the rump; the crown is of a much darker brown, forming a decided cap; tail and quill-feathers brownish-black; the tertials are edged with very pale fulvous; the throat is gray with just a tinge of fulvous on the lower

part; middle of breast, abdomen, and under wing-coverts reddish-ochreous, under tail-coverts of the same color, but paler; sides of the breast olivaceous; upper mandible black, the under pale yellowish-white; tarsi and toes brownish-black.

Length (fresh), 5.3-4 inches; wing, 2.7-8; tail, 2.5-8; tarsus, 5-8.

Habitat, Dominica. Mr. Ober says; "everywhere abundant in the ravines and dark valleys of the mountains."

Type in National Museum, Washington.

Remarks. In "A Provisional List of the Birds of Dominica," published in 'Forest and Stream,' Dec. 6th, 1877, this bird was put as *Blacicus Blancoi*, Gundlach. Wishing to make a comparison with the type, I desired Dr. Gundlach to loan it to me for that purpose, with which request he kindly complied. The specimen was received quite recently; and I found that, though closely allied, the two birds are quite distinct.

B. Blancoi is from Porto Rico; the specimen sent is mounted, and is of somewhat smaller dimensions than the bird from Dominica; the wing measures 2.5-8 inches; the tail, 2.1-2; the tarsus, 9-16. The crown is olive-brown, which color gradually merges into the greenish-olive of the back and rump. In the new species the crown is deep brown, and the upper plumage olive-brown; it also differs in having the throat gray, which in the other is light fulvous; the color of the abdomen is rather paler than it is in *B. Blancoi*.

In another specimen of the new species, a female, "in young of the year plumage," the feathers of the wings and back are strongly marked with rufous, yet the upper plumage is as decidedly brown as in the adult, and the throat gray.

4. *Quiscalus luminosus*.

MALE.—The general plumage is of a lustrous dark bluish-violet; the upper and under tail coverts are dull dark green; tail dark glossy green; tertials, outer webs of larger quills, and the middle and larger wing-coverts, glossy green like the tail; the inner webs of the larger quills are black; smaller wing-coverts the color of the back; under wing-coverts black; the bill and feet are black; "iris yellow."

Length (fresh), 10.1-4 inches; wing, 5; tail, 4.1-2; tarsus, 1.1-4; bill, 1.1-4.

FEMALE.—Upper plumage of a fine dark brown, light on the crown, the

feathers of which are margined with dull pale rust-color; the tail is blackish-brown, with a wash of greenish; quills dark brown; the under plumage is dark brownish-ash, lighter on the throat and breast, and fuliginous on the flanks, lower part of abdomen, and under tail-coverts; on the lower part of the neck is a wash of dull rust color; bill and feet black; "iris yellow."

Length (fresh), 9 3-4 inches, wing 4 3-4; tail, 4; tarsus, 3-16; bill 1 1-8.

Habitat:—Grenada.

Types in National Museum, Washington.

Remarks. The male of this species, in dimensions and general appearance, somewhat resembles *Q. brachypterus* from Porto Rico, but is of a brighter and more uniform violet; it may be at once known by its upper and under tail-coverts being green, the other having the upper-coverts colored like the back, and the under ones black. The females are totally unlike,—that sex in *Q. brachypterus* being black like the male, only duller.

In all the West Indian species of this genus, with which I am acquainted, except the bird now described, both sexes are black.

XVII.—*Testing the Value of Guns by Firing under Water.*

BY HENRY A. MOTT, JR., PH. D., E. M.

Read May 13th, 1878.

While investigating the force of explosives under water, with the object of perfecting a counter-torpedo for Count Kolowrat, my attention was directed by Mr. Julius H. Striedinger, the well-known civil engineer, to some experiments conducted by Maj. Gen. Uchatius,* in Austria, in regard to firing under water.

Uchatius, when reading in Jules Verne's "Twenty Thousand Leagues under the Sea," how Captain Nemo, with his involuntary guests, sheltered in a diving-bell, devoted himself to the pleasures of hunting, and how with a pneumatic gun, at a depth of 10 meters, he shot an albatross while flying a meter above the surface of the sea, asked himself the question,—Is it possible, as a general thing, to shoot under water? And, if it be so, why are not divers provided with fire-arms for defense against large fishes? It is known, says Uchatius, that fishes, if they are not too deep under the surface of the water, can be shot from the land or from boats. But it is also known that the covering of a war-ship reaches at the most only 2 or 3 meters under the surface of the water, and below this depth the ship is considered invulnerable for the greatest hostile shots; since the latter can strike only under an angle of 20 to 30 degrees, and, consequently, before their contact with the unprotected part of the ship, must have passed through from 6 to 8 meters of water.

The subject appeared sufficiently interesting to Uchatius to prompt him to conduct a series of experiments.

Under a raft built of timber, he fastened a rejected Austrian service rifle, by means of iron spans, so that when the raft floated on the water, the gun was held from 0.5m. under the water in a horizontal position. The discharge was effected

* Mittheilungen über Gegenstände des Artillerie-und-Genie-Wesens, Vol. XIII, n. 54-53.

from the shore, by means of a string. An inch plank was used as a target, which was sunk vertically in the water at a given distance from the mouth of the gun. The results of Uchatius' experiments were as follows :

At a distance of 1.5m. (4.90 feet),	No impression.
“ “ “ 1.25m. (4.10 feet),	3 to 4 mm. deep.
“ “ “ 1m. (3.28 feet),	Pierced.

According to these experiments, a distance of .5m. decided whether there was to be any impression or whether the board was to be pierced.

These experiments being of so original a nature, and seeing in them a means of arriving at a number of important results, I determined to verify the same and elaborate upon them.

Having already constructed a tank twelve feet (3.6576m.) long by 9 feet (2.7432m.) wide by 3 feet high (.9144m.), capable of holding over ten tons (907.10528 kilogrammes) of water, I had the sides securely bolted together by large beams of wood, to prevent them from bursting out. I also had firmly constructed, within the tank, wooden rests for the guns to be used, so that there could be at least 15 inches of water over them, if so desired.

Being anxious to secure the best guns for experiments, I visited the office of the Remington Manufacturing Co., stated the object of my experiment, and Mr. Alford, the manager, kindly furnished me with guns and all the cartridges needed.

My first experiments were conducted on the 22nd of February, 1878, in the presence of Count Kolowrat, Lieutenant of the Austrian Army, Mr. Barnet Phillips of the *N. Y. Times*, and Mr. A. Alford of Remington's Sons.

Three breech-loading Remington rifles were used for the experiment :

I. THE NEW YORK STATE MODEL (OF U. S. model), used at Creedmoor by the National Guards; .50 inch caliber (or 12.7mm.) Barrel 35 1-8 inch (.9017m.) long. The cartridges used were composed as follows :

TABLE NO. 1.

PARTS.	NO. 1.		NO. 2.	
	Grains.	Grams.	Grains.	Grams.
Weight of cartridge.....	676 119	43 81	679 36	44 02
“ of powder.....	68 00	4 406	68 630	4 447
“ of bullet.....	450.380	29 170	450.489	29 190
“ of brass case.....	152.169	9 860	156 490	10.140
“ of paraffine.....	5 570	.374	3.751	.243
Total.....	676 119	43 81	679.36	44 02

II. THE SPRINGFIELD MODEL (or U. S. Army Rifle) .58 in. caliber (14.7mm). Barrel 39.1-8 in. (1.0033m.) long. The cartridges used were manufactured by the Winchester Co., being very inferior to those manufactured by Remington—at least one-half missed fire. The proportion of powder varied considerably, as the following table shows :

TABLE NO. 2.

PARTS.	No. 1.		No. 2.	
	Grains.	Grams.	Grains.	Grams.
Weight of cartridge.....	778 579	50.449	765 939	49 63
“ of powder.....	90.000	5 838	84 727	5 490
“ of bullet.....	542 627	35 225	542 006	35 120
“ of brass case.....	131.026	8 49	129 328	8 380
“ of filling* and paraffine.....	14.926	.896	18 565 1 313	1 555 085
Total.....	778.579	50.449	765 9.9	49 63

* The bullets were hollow to half their height—the cavity being filled with a substance resembling white lead or putty.

III. THE SPANISH MODEL—.433 in. caliber (11mm.). Barrel 35.1-8 in. (.9017m.) long.

TABLE NO. 3.

PARTS.	No. 1.		No. 2.	
	Grains.	Grams.	Grains.	Grams.
Weight of cartridge.....	605.127	39.21	612.69	39.7
“ of powder.....	72.4579	4.695	73.121	4.738
“ of bullet.....	384 8990	24.940	388 988	25.205
“ of brass case.....	144.6070	9.370	147 848	9.580
“ of paraffine.....	3 1639	.205	2.793	.177
Total.....	605.1279	39.21	612 69	39.7

The target consisted of a white-pine board 3 ft. high, 10 in.

Testing the Value of Guns by Firing under Water. 167

wide, and 1 in. thick ; and was securely nailed upright in the tank, by means of braces, so as to afford perfect resistance to the bullet. The temperature of the water was 4° C., sp. gr. 1.000.

The rifle was placed on the supports in the tank, was loaded under water, and fired by inserting the hand and pulling the trigger. In the first few experiments the trigger was pulled by a string at a respectful distance.

EXPERIMENTS WITH RIFLE No. I.

(U. S. Model Rifle)

TABLE No. 4.

NO OF SHOTS.	AT A DISTANCE OF	REMARKS.	HEIGHT OF WATER OVER RIFLE.
1	2 feet 0 inches.	The board was penetrated	8¾ inches.
2	2 " 6 "	" " " "	" "
3	3 " 0 "	" " " "	" "
4	3 " 6 "	" " " "	" "
5	3 " 9 "	" " " "	" "
6	3 " 10½ "	" " " "	" "
7	3 " 11 "	" " " "	" "
8	3 " 11¾ "	" " " "	12½ "
9	3 " 11½ "	" " " "	" "
10	3 " 11½ "	" " " "	" "
11	3 " 11¾ "	The bullet was imbedded	" "
12	3 " 11¾ "	" " " "	" "
13	4 " 0 "	¼ inch indentation	" "
14	4 " 0 "	" " " "	" "
15	4 " 8 "	½ " " "	" "
16	4 " 8½ "	" " " "	" "
17	4 " 10½ "	1-32 " " "	" "
18	4 " 11½ "	Indented	" "
19	4 " 11¾ "	No mark	" "
20	5 " 0 "	" " " "	" "

EXPERIMENTS WITH RIFLE No. II.

(U. S. Army Rifle).

TABLE No 5.

NO OF SHOTS.	AT A DISTANCE OF	REMARKS.	HEIGHT OF WATER OVER RIFLE.
1	3 feet 3 inches	The board was penetrated	5½ inches.
2	3 " 5 "	" " " "	" "
3	3 " 6 "	" " " "	7 "
4	3 " 9 "	" " " "	6 "
5	3 " 10 "	" " " "	" "
6	3 " 10½ "	" " " "	12¼ "
7	3 " 10½ "	" " " "	12¼ "
8	3 " 10¾ "	" " " "	12½ "
9	3 " 10¾ "	" " " "	" "
10	3 " 11 "	Bullet imbedded	" "
11	3 " 11 "	" " " "	6 "
12	4 " 0 "	" " " "	5¾ "
13	4 " 0 "	" " " "	" "

EXPERIMENTS WITH RIFLE No. III.

(Spanish Model Rifle).

TABLE No. 6.

NO OF SHOTS.	AT A DISTANCE OF	REMARKS.	HIGHT OF WATER OVER RIFLE.
1	3 feet 7 $\frac{3}{4}$ inches	The board was penetrated	5 $\frac{1}{2}$ inches.
2	3 " 9 $\frac{3}{4}$ "	" " " "	" "
3	3 " 10 "	" " " "	12 "
4	3 " 10 $\frac{1}{4}$ "	Bullet deeply imbedded.	" "
5	3 " 10 $\frac{1}{2}$ "	Imbedded	" "
6	3 " 10 $\frac{3}{4}$ "	" "	7 "
7	3 " 10 $\frac{3}{4}$ "	" "	" "
8	3 " 11 "	$\frac{3}{4}$ inch indentation	12 "
9	3 " 11 $\frac{1}{2}$ "	$\frac{1}{2}$ " " "	7 "
10	4 " 1 $\frac{1}{4}$ "	$\frac{1}{2}$ " " "	" "
11	4 " 1 $\frac{3}{4}$ "	$\frac{1}{2}$ " " "	" "
12	4 " 2 "	Slightly imbedded	12 "
13	4 " 3 $\frac{1}{2}$ "	$\frac{1}{2}$ inch indentation	" "
14	4 " 5 "	Slightly imbedded	" "
15	4 " 5 $\frac{1}{2}$ "	$\frac{1}{4}$ inch indentation	" "
16	4 " 5 $\frac{3}{4}$ "	$\frac{1}{8}$ inch indentation	" "
17	5 " 0 "	1-16 inch indentation	" "
18	5 " $\frac{1}{2}$ "	1-64 inch indentation	" "
19	5 " 2 "	No mark	" "

The principal points of the above tables may be presented in a condensed form as follows:

TABLE NO. 7.

NO. OF SHOTS.	RIFLE.	AT A DISTANCE OF	IN METERS	REMARKS.	DEPTH OF WATER.
9 & 10	U. S. Model.	3 feet 11 $\frac{1}{2}$ inches	1.2019	Board was penetrated	12 $\frac{1}{2}$ in
11 & 12	" "	3 " 11 $\frac{3}{4}$ "	1.2074	Bullet was imbedded	" "
19	" "	4 " 11 $\frac{3}{4}$ "	1.5122	No mark	" "
8 & 9	U. S. Army	3 " 10 $\frac{3}{4}$ "	1.1820	Board was penetrated	" "
10 & 11	" "	3 " 11 "	1.1894	Bullet was imbedded	" "
3	Spanish Model....	3 " 10 "	1.1644	Board was penetrated	12 "
4	" "	3 " 10 $\frac{1}{4}$ "	1.1704	Bullet was imbedded	" "
19	" "	5 " 2 "	1.5374	No mark	" "

From this table it would seem that the U. S. model is far superior to the other rifles. A board was penetrated with this rifle at 3 ft. 11 $\frac{1}{2}$ in., whilst with the U. S. Army rifle the board had to be $\frac{3}{4}$ inch nearer the rifle, or at 3 ft. 10 $\frac{3}{4}$ in., before it was penetrated; and when the Spanish model was used, the board had to be 1 $\frac{1}{2}$ in. nearer the rifle than in the first case, or at a distance of 3 ft. 10 in. This relation was true for the cartridges used, which were composed of 68 grains of powder and 450 of bullet for the U. S. model,—90 grains of powder and 542 of bullet for the U. S. Army rifle,—and 72

grains of powder and 384 of bullet for the Spanish model. The question naturally arose, what would be the relation if cartridges for each rifle were composed of the same proportions of powder and bullet. This I considered a very important problem, and I therefore submitted the proposition to prepare 25 cartridges for each rifle, to contain exactly 70 grains of powder and 450 grains of bullet each, to the Messrs. Remington's Sons, and they willingly volunteered to prepare them for me. It will be noticed from the above tables that a quarter of an inch determined in every case whether the bullet was to penetrate the board, or was to be imbedded. This may seem a very short distance, but when we consider that water is 770 times denser than the air, at 4° C., Bar. 29.922 in. (Pres. = 760 mm. of Hg.), one-quarter of an inch under water is equivalent to over 16 feet through the air. If a cartridge contains sufficient force to propel a bullet from a rifle through the air so that it will penetrate a board exactly 2400 feet away, if the board were placed 2416 feet, it would not be difficult to conceive, instead of the bullet passing through the board, of its being imbedded. Precisely the same thing happens under water; the force imparted to the bullet is quite sufficient to penetrate a board 3 feet 11 inches distant, when the U. S. Model Rifle is employed, but the force expended in travelling one-quarter of an inch farther deprives the bullet of the necessary amount of force to penetrate the board.

The preparing of the cartridges for further experiments, as I have already stated, was done for me by the Messrs. Remington. In making the cartridge for the U. S. Army Rifle, the shell, being made for 90 grains of powder, was too large for 60 grains, and consequently there would be an air-chamber between the bullet and the powder if wadding were not placed between. The first cartridges made for me contained this air chamber, but as I was of the opinion that the same amount of force would not be communicated to the bullet so effectually if the powder was in a loose state, as it would be if it were packed, the Messrs. Remington made me other cartridges with

170 *Testing the Value of Guns by Firing under Water.*

the powder packed with a paper wad, although Mr. Alford stated to me that it was the impression of sportsmen that there would be no difference. I decided therefore to test this point by actual experiment. To prepare cartridges for the Spanish model would have involved considerable extra expense; I therefore concluded to substitute a Sharp's Rifle of .50 in. caliber.

The cartridges were composed as follows:

TABLE NO. 8.
(SEE TABLES 1, 2, 3.)

PARTS.	I. CARTRIDGES FOR .50 CALIBER.		II. CARTRIDGES (air) FOR .58 CALIBER.		III. CARTRIDGES FOR .58 CALIBER.	
	Grains.	Grams.	Grains	Grams.	Grains.	Grams.
Weight of cartridge	648.03	41.99	669.94	43.41	695.43	45.061
“ of powder.....	70.22	4.55	69.91	4.53	70.19	4.548
“ of bullet.....	450.18	29.17	449.75	29.142	447.85	29.019
“ of shell.....	126.55	8.20	147.23	9.54	161.82	10.485
“ of paraffine.....	1.08	.07	3.05	.198	13.81 1.76	*.895 .114
Total.....	648.03	41.99	669.94	43.41	695.43	45.061

* Wad.

The following tables contain the report of my experiments conducted with the new cartridges, on May 4th.
Temperature of the water, 19° C., or 66.2 F.

EXPERIMENTS WITH THE U. S. ARMY RIFLE.

TABLE No. 9.
Height of water above the rifle, 11½ inches, in each case.

NO OF SHOTS.	CARTRIDGES WITH THE POWDER PACKED. DISTANCE.	CARTRIDGES WITH THE POWDER LOOSE. DISTANCE.	REMARKS.*
1	3 feet 10 inches.....	¼ inch indentation
2	3 feet 10 inches.....	
3	3 feet 9¾ inches.....	1-32 inch indentation Penetrated the board
4	3 feet 9⅝ inches }.....	
5	“ “ “ }.....	Imbedded
6	“ “ “ }.....	
7	3 feet 9¾ inches.....	Imbedded
8	3 feet 9¾ inches.....	
9	3 “ 9½ “.....	¼ inch indentation 1-32 inch indentation
10	3 “ 9⅝ “.....	
11	3 “ 9¼ “.....	Completely imbedded
12	
13	3 “ 9 “.....	Imbedded
14	3 “ 8¾ “.....	

* Quite a difference in effect will be noticed between the same cartridge in the second and third columns of the table, owing to the powder being loose.

EXPERIMENT WITH SHARP'S RIFLE.

Caliber .50 in., or 12.7 mm. Barrel 30 1-8 inches. The cartridges used have the composition in the above table, No. 8, first column.

TABLE NO. 10.

Height of water above the rifle, 11½ inches.

NO. OF SHOTS.	DISTANCE.	REMARKS.
1	3 feet 10 inches.	Penetrated the board.
2	3 " 11½ "	" " "
3	3 " 11¾ "	" " "
4	4 " ¾ inch.	" " "
5	4 " 1 "	" " "
6	4 " 1½ "	" " "
7	4 " 1¾ "	Deep indentation.
8	4 " 2¼ "	¼ in. indentation.

EXPERIMENTS WITH U. S. MODEL RIFLE I.

TABLE No. 11.

Height of water above the rifle, 11½ inches.

NO. OF SHOTS.	DISTANCE.	*REMARKS.
1	4 feet 0 inches	Penetrated the board.
2	4 " 1½ "	" " "
3	4 " 1¾ "	Imbedded.
4	4 " 2 "	"

*Same cartridge as used for the Sharp's Rifle.

Tabulating the principal points in the above tables, we find the results as follows :

TABLE No. 12.

The height of the water above the rifle in all cases 11½ inches.

NO. OF SHOTS.	RIFLE.	DISTANCE.	REMARKS.
3	U. S. Army Rifle	3 feet 9¾ inches	Powder packed.—Board penetrated.
6 and 7	" " "	3 " 9¾ "	Imbedded.
*	" " "	3 " 8¾ "	Powder loose.—Board penetrated.
14	" " "	3 " 8¾ "	Deeply imbedded.
6	Sharp Rifle	4 " 1½ "	Board was penetrated
7	" " "	4 " 1¾ "	Deeply indented.
2	U. S. Model	4 " 1½ "	Board was penetrated.
3	" " "	4 " 1¾ "	Imbedded.

*As the cartridges ran out, I was unable to try this experiment ; but as the bullet was almost through at 3 feet 8¾ inches, my experience indicates that at 3 feet 8½ inches, the bullet would have penetrated the board.

On carefully examining the figures in this table, it will be seen that when the U. S. Model rifle or Sharp's rifle is used exactly the same results are obtained; that is to say, the board would be penetrated at a distance of 4 feet 11-2 inches, while in the case of the U. S. Army rifle, with the packed cartridge, the board had to be 17-8 inches nearer the rifle, or at a distance of 3 feet 9 5-8 inches. One inch and seven-eighths through water is equivalent to 120.31 feet through the air; it *seems*, therefore, that the U. S. Army rifle is very inferior to the other two. Even with 90 grains of powder and 542+ grains of bullet, as shown by Table 7, it is greatly inferior to the U. S. Model.

On examining the shape of the bullets employed, I found that while the bullets used in the cartridges for both the U. S. Model and Sharp's rifles were conical, those employed in the cartridges for the army rifle were quite blunt, Fearing that the shape of the bullet offered some resistance to its progress, I carefully cut the bullet of the army rifle cartridges quite conical, but found in several experiments, that only a difference of 3-8 of an inch was made;—that is to say, that when the blunt bullet was used, the board was penetrated at 3 feet 9 5-8 inches, and when the conical bullet was used, at 3 feet 10 inches.

When cartridges were used containing the powder loose, by examining Table 12 it will be seen that the results are very variable, and that the board had to be 11-8 inch nearer the rifle, before it could be penetrated.

In the following table are given the results of the four rifles used for experiments, compared with the Austrian Service rifle.

TABLE 13.

NAME OF RIFLE.	PENETRATED THE TARGET AT	WEIGHT OF POWDER.	WEIGHT OF BULLET.	REMARKS.
U. S. Model.	3 ft. 11½ inches.	68 +grains.	450 grains.	See Table 7 & 1.
U. S. Model.	4 " 1½ "	70. "	450 "	" " 11 & 8.
Sharp's Rifle.	4 " 1½ "	70. "	450 "	" " 10 & 8.
U. S. Army Rifle.	3 " 10¾ "	90. "	542 "	" " 7 & 2.
U. S. Army Rifle.	3 " 9¾ "	70. "	450 "	" " 9 & 8.
Spanish Model.	3 " 10 "	72. + "	384 "	" " 7 & 3.
Austrian Rifle.	3 " 3¾ "			By Uchatius.

It will be seen from this table that the U. S. Model (N. Y. State Model) and Sharp's rifle come first; then the U. S. Army rifle; next the Spanish Model; and last the Austrian Service rifle. The experiments made by Uchatius with this last weapon were very limited; for example, he did not determine the distance that established the fact, whether the bullet is to penetrate the board or is to be imbedded; he consequently did not arrive at the true value of the rifle as regards penetration; and as the weight of powder and bullet were not given in his report, it is hardly fair to consider the Austrian rifle inferior to those that I tested, until more exact experiments are conducted with it.

It now becomes necessary to investigate also the cause of the variation between the different rifles experimented with. It will be remembered that in the first part of my paper I stated that my object was to verify the experiments of Uchatius. I therefore adopted as much as possible the conditions under which he worked. For instance, he says, "the distances were measured from the *mouth* of the gun." From the description given of the rifles used by me, it will be seen that the length of barrels differed; while in the U. S. Army rifle the barrel was 39 1-8 inches long, that of the U. S. Model and Spanish Model was 35 1-8 inches, while that of the Sharp's rifle was only 30 1-8 inches. It will be evident, as all my measurements were taken from the end of the barrel—instead of from the end of the cartridge,—that the bullet in the barrel of the greatest length had to travel through more water (in the barrel) than in a barrel of less length.

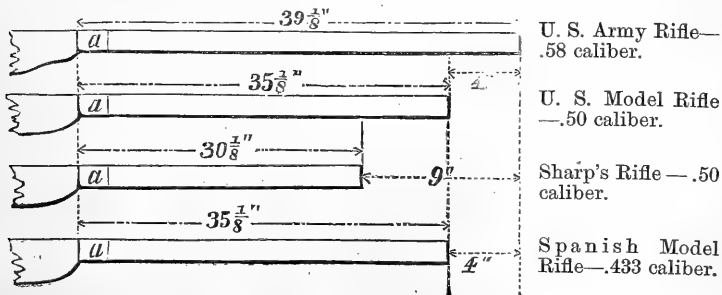

From the above illustration it will be seen, supposing the cartridges to be all of the same length, that the bullet in the U. S. Army rifle had to travel through (39 1-8—35 1-8) 4 inches more water than in the U. S. Model rifle, and that the bullet from the Sharp's rifle did not have to traverse as much water by (35 1-8—30 1-8) 5 inches, as the bullet of the U. S. Model rifle. Correction must therefore be made, before any true comparison of the rifles can be reached. With respect to the cartridges, also, some correction must be made, as they are not of the same length.

CARTRIDGES.

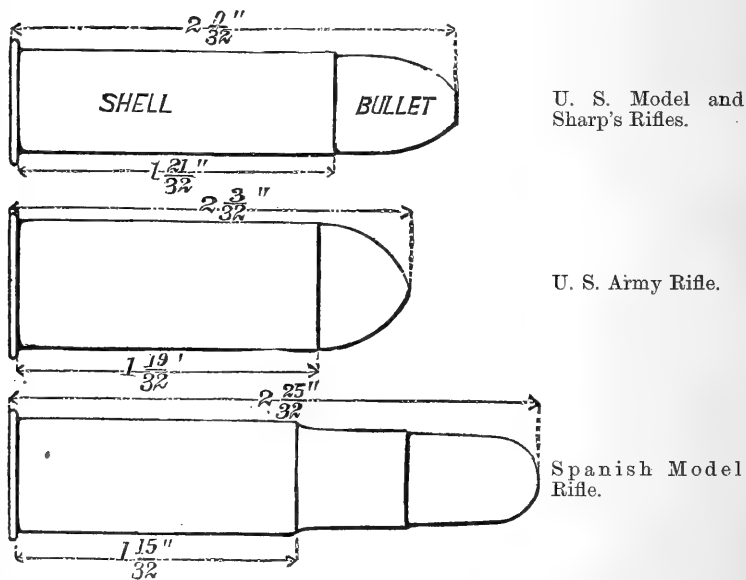

It is evident that if the measurements are taken from the cartridge, they must be from that part of it which fits the barrel, and not from the end of the bullet; as the bullet has a more or less conical shape, it is therefore surrounded by water when the rifle is submerged. In the cartridges for the U. S. Army, U. S. Model, and Sharp's rifles, the end of the metallic case is

the proper point for measurement. In the cartridge for the Spanish Model, the measurement must be from that point of the case just before it becomes bevelled to a smaller circumference. Regarding these points, we find from the above illustrations that the case of the U. S. Army cartridge is 2-32=1-16 inch less than the U. S. Model, and in the cartridge for the Spanish Model the point of measurement is 6-32=3-16 inches less than that of the U. S. Model. The proper correction then to make for the U. S. Army rifle, is 4 inches (39 1-8—35 1-8) for the barrel and 1-16 inch for the case, or in all 4 1-16 inches. For the Sharp's rifle, 5 inches (35 1 8—30 1-8) is the *total correction*, as the same cartridge is used for the U. S. Model.

For the Spanish Rifle, the barrel being the same as that of the U. S. Model, the only correction will be for the cartridge, or 3-16 inch—*total correction*. Making the above corrections in the results obtained with equal weight of powder and bullet for each rifle, measured from the mouth or nozzle of the gun, we obtain the true relation of one rifle to another, which will at once be seen to be quite different from the first results.

TABLE No. 14.

RIFLE.	FIRST DISTANCE.	CORRECTED DISTANCE.	REMARKS.
U. S. Army Rifle.....	3 ft. 9 $\frac{3}{4}$ inches	4 ft. 1 11-16 inches	Board was penetrated
" " ".....	3 ft. 9 $\frac{3}{4}$ "	4 ft. 1 13-16 "	Bullet was imbedded
U. S. Model Rifle.....	4 ft. 1 $\frac{1}{2}$ "	4 ft. 1 $\frac{1}{2}$ "	Board was penetrated
" " ".....	4 ft. 1 $\frac{1}{4}$ "	4 ft. 1 $\frac{1}{4}$ "	Bullet was imbedded
Sharp's Rifle.....	4 ft. 1 $\frac{1}{2}$ "	3 ft. 8 $\frac{1}{2}$ "	Board was penetrated
" " ".....	4 ft. 1 $\frac{3}{4}$ "	3 ft. 8 $\frac{3}{4}$ "	Bullet was imbedded
* Spanish Model.....	3 ft. 10 "	3 ft. 10 3-16 "	Board was penetrated
* " ".....	3 ft. 10 $\frac{1}{4}$ "	3 ft. 10 7-16 "	Bullet was imbedded

* The powder in this case was 72—73 grains; bullet 384—388 grains

By examining the corrected results in the third column of the above table, it will be seen that the *U. S. Army rifle* is superior, by 3-16 inch, to the U. S. Model rifle; and that this latter is 5 inches superior to the Sharp's rifle. Calculating for each rifle at what distance a board would be penetrated if the bullet passed through air instead of water, we find :

TABLE No. 15.

RIFLE.	DISTANCE THROUGH WATER.	DISTANCE THROUGH AIR.
U. S. Army Rifle.....	4 feet 1 11-16 inch.	3182 54 feet.
U. S. Model Rifle.....	4 feet 1½ inch.	3176.25 feet.
Sharp's Rifle.....	3 feet 8½ inch.	2855 41 feet.
Spanish Model.....	3 feet 10 3-16 inch.	2962 13 feet.

From this table it appears that the bullets from the U. S. Army rifle will penetrate a board through the air at 6.29 feet farther than when the U. S. model is used, and 327.13 feet farther than when the Sharp's rifle is used, with the same weight of powder and bullet.

In conclusion, I would remark that there can be no doubt, if the subject of firing submerged arms is understood and appreciated, that in the future, when an arm is to be tested, instead of firing in the air, it will be fired under water; and that as the editor of the 'Forest and Stream' says, "long ranges for testing rifles will be supplanted by water tanks." With respect to the tank, a word or two may be of advantage.

It should be about 12 feet long by 2 feet wide by 3 feet high; and if made of wood, the wood must be at least two inches thick, and the sides securely bolted together. As water is only very slightly compressible, it will readily be understood that, when the gun is fired, the force of the explosion is at once communicated to the sides of the tank, and unless they are securely bolted they will be readily broken apart. The tank could be made of iron, or could have heavy plate glass sides in an iron frame, when the bullet could be seen to drop.

By the use of this method, range and penetration can be arrived at with the greatest precision;—also the value of the numerous gunpowders in the market can be accurately ascertained, as well as the maximum effect from the minimum amount of powder. The best weight of bullet for a given weight of powder, the best length and bore of barrel for a given weight of powder and bullet, and the actual range of a given cartridge, —all these determinations can be made in a room less than twelve feet square.

The height of water over the rifle, according to my experiments, makes no difference, as the same results were obtained when the rifle was submerged five inches as when submerged 12 inches. This is not singular, when we consider the rapidity with which the bullet travels and the short time the column of water has to act on it. The cause of the limited range under water, then, is the fact of the motion of the bullet being opposed by a medium of much greater density than the atmosphere.

The variation between different rifles, from my experiments I have been led to believe, is due in part to differences in the length of barrel, in the size of bore, and in the internal structure of barrel; but more particularly to the fact that as a rule the amount of powder and bullet are not only in absurd relations to each other, but are not in correct proportions for the length and bore of barrels peculiar to different rifles. These facts only demonstrate that there is a large number of very important points yet to be examined.

XVIII.—*The Fungi of Texas.*

BY M. C. COOKE, M. A., LL. D.

Corresponding Member N. Y. Acad. Sci. Read May 27th, 1878.

The following is an enumeration of all the species of Fungi which, so far as I am aware, have hitherto been detected in Texas. In addition to the few collected by Wright and others, and mentioned in Berkeley's North American Fungi, a small collection of two hundred specimens, gathered a few years since by Mr. H. W. Ravenal, has been examined; and after the determination of these, the whole number of species does not exceed one hundred and fifty. This is a very poor catalogue for a State which is undoubtedly rich in these plants; but the enumeration will possess an interest and a

value, on account of its being the first and only attempt yet made to bring together the results of previous observers, and to present in a separate and distinct manner what is known of the mycologic flora of Texas.

1. *Agaricus (Collybia) Texensis*, Berk. and Curt., Ann. Nat. Hist., ser. II, vol. xii, pp. 418.
In woods. Wright (3162).
2. *Montagnites Candollei*, Fr., Ep., 241.
On sandy ground. Wright.
3. *Leutinus tigrinus*, Fr., Hym. Eur., p. 481.
On wood. Wright (3148).
4. *Strobilomyces strobilaceus*, Berk., Outl., p. 236.
On the ground. Wright (3889).
5. *Polyporus (Mesopus) arcularius*, Fr., Hym. Eur., 526.
On trunks. Wright (3142).
6. *Polyporus (Anoderma) Lindheimeri*, B. and C. in Grevillea, N. A. F., No. 130.
On sassafras. Lindheimer (3639).
7. *Polyporus (Inoderma) versicolor*, Fr., Hym. Eur., 568.
On stumps. Houston ; Rav. (287).
8. *Polyporus (Inoderma) barbatulus*, Fr., Nova Sym., 71.
On wood. Bigelow (6376).
9. *Polyporus (Resupinatus) contiguus*, Fr., Hym. Eur., 571.
On wood. Wright, (3906, 3907).
10. *Trametes hydnoides*, Fr., Ep., 490.
On wood. Wright (3093).
11. *Trametes Lindheimeri*, B. and C., Grevillea, No. 154.
On stumps. Wright (3764, 3919).
12. *Merulius Wrightii*, Berk., Grevillea, N. A. F., 164.
On wood. Wright (3144.)
13. *Irpex tabacinus*, B. and C., Grevillea, N. A. F., 198.
On bark. Wright (3152).
14. *Kneiffia setigera*, Fr., Hym. Eur., 628.
On trunks. Wright (3899). Ravenal (154).
15. *Thelephora cladonia*, Schwz., Car., No. 1068.
On the ground. Wright (3272).
16. *Stereum dissitum*, Berk., Grevillea, N. A. F., 241.
On dead wood. Wright (3903).
17. *Stereum Curtisii*, Berk., Grevillea, N. A. F., 239.
On oak. Houston ; Rav. (134, 160).

18. *Stereum pruinatum*, B. and Curt., Cuba, No. 409.
On living trees. Houston; Rav. (246).

19. *Stereum acerinum*, Fr., Hym. Eur., 645.
On trunks. Houston; Rav. (269).

20. *Corticium calceum*, Fr., Hym. Eur., 652.
On wood. Wright (3914).

21. *Corticium comedens*, Fr., Hym. Eur., 656.
On fallen limbs. Houston; Rav. (264).

22. *Corticium lactescens*, Fr., Hym. Eur., 650.
On fallen limbs. Houston; Rav. (271).

23. *Corticium carneum*, Berk. and Cooke. (n. s.)

Effused, somewhat membranaceous, ochraceous flesh colour, the margin whitish and fibrillose; hymenium thin, smooth and even to the naked eye, cracking when dry.

On logs. Houston; Rav. (78).

This is one of those species in which the hymenium is furnished with rough spindle-shaped cells, which project above the surface. It has been proposed to remove these species from *Corticium*, and place them in a genus intermediate between that and *Stereum*, under the name of *Peniophora*.

24. *Cyphella villosa*, Pers., Syn., 655, sub *Peziza*.
On twigs. Houston; Rav. (183).

25. *Cyphella convoluta*, Cooke. (n. s.)

Scattered, cupshaped, then flattened, 1 to 2 m m. wide, margin membranaceous, involute, externally white, internally fleshy-red: spores oblong (.007 m m. long.).

On trunks. Rav. (295).

Resembling a small sessile *Peziza*, such as *P. leucoloma*.

26. *Herneola auricula Judae*, Fr., Hym. Eur., 695.
On trunks. Wright (3143).

27. *Guepinia spathularia*, Fr., Epict., 566.
On branches. Wright (3146).

28. *Secotium Texense*, B. and C., Grevillea, N. A. F., 327.
On the ground. Pope (6375).

29. *Geaster hygrometricus*, Fr., Sym. Myc., iii, 19.
On the ground. Drummond.

30. *Tulostoma fimbritum*, Fr., Sym. Myc., iii, 43.
On the ground. Wright (3151).

31. *Bovista stuppea*, Berk., Grevillea, N. A. F., 330,
On the ground. Wright (3153).

32. *Scleroderma Texense*, Berk., Grevillea, N. A. F., 338.
On the ground. Drummond.
33. *Mitremyces lutescens*, Schwz., Car., t. 2, f. 1.
On the ground. Drummond.
34. *Physarum obrusseum*, B. and C., sub *Didymium*.
On leaves. Lindheimer.
35. *Licea Lindheimeri*, Berk., Grevillea, N. A. F., 369.
On dead bark. Lindheimer.
36. *Arcyria cinerea*, Fr., Sys. Myc., iii, 180.
On stumps. Lindheimer (3631).
37. *Phoma helvolum*, B. and C., Grevillea, N. A. F., 386.
On leaves. Wright (3901).
38. *Phoma hysteriiforme*, Cooke. (n. s.)
Gregarious. Perithecia elongated so as to resemble some *Hysterium*, flattened at the base. Spores elliptical, binucleate (.01—0.12 m m. long.), hyaline.
On herbaceous stems. Rav. (224).

Somewhat resembling the next species, but manifestly entirely distinct.

39. *Phoma hysteroideum*, B. and C., in Herb. Curt.
On reeds. Houston; Rav. (11).
40. *Phlyctæna smilacis*, Cooke. (n. s.)
Covered by the cuticle, minute, brown, collected in dense patches, slightly elevated. Spores filiform, curved at one extremity, and straight at the other, (.02—0.25 m m. long).
On Smilax. Rav. (208, 209).

Just the same kind of spores are described for an Australasian species of this genus, *P. dissepta*, Berk.

41. *Diplodia Zece*, Schwz., (sub *Sphaeria*).
On *Zea Mays*. Rav. (198).
42. *Hendersonia magna*, Cooke. (n. s.)
Erumpent, disposed in linear series. Perithecia black, subglobose, here and there connate, like a *Dothidea*, split irregularly. Spores cylindrical, obtuse, 3—5 septate. (.06—0.65x.01 m m.).
On herbaceous stems. Houston; Rav., (140).
43. *Discella leguminum*, Cooke. (n. s.)
Crowded together in irregular blackened spots, circumscribed with a definite line, pustules confluent. Spores elliptical or pear-shaped, uni-nucleate, hyaline, (.012—0.15x.006 m m.).
On legumes of *Prosopis*. Galveston.
44. *Discella angulata*, Cooke. (n. s.)
Gregarious, covered by the epidermis, which is split into irregular angular

fissures about the pustules. Spores elongated fusiform, hyaline, (.02x.004 m m.).

On limbs of trees. Galveston, Rav. (58).

45. *Melasmia acerina*, Lev., Ann. Sci. Nat., 1848, p. 252.

On leaves. Wright (3772).

46. *Septoria ampelina*, B. and C., Grevillea, Amer. Fungi, 440.

On leaves of *Vitis vulpina*. Wright (3885).

47. *Phyllosticta micropuncta*, Cooke. (n. s.)

Epiphyllous. Perithecia minute, black, crowded together in suborbicular spots. Spores minute, ovate, hyaline, (.003 m m. long).

On leaves of *Persea Carolinensis*. Ravenal, (235).

48. *Septoria Magnoliæ*, Cooke. (n. s.)

Epiphyllous. Perithecia black, half immersed in the leaf, crowded together in irregular brownish spots. Spores linear, nucleate, (.025—.03 m m. long).

On leaves of *Magnolia grandiflora*. Rav. (8).

49. *Septoria vestita*, B. and C., Grevillea, N. A. Fungi, 440*.

On gourds. Rav. (205).

50. *Septoria speculariæ*, B. and C., Grevillea, N. A. F., 439.

On *Specularia perfoliata*. Rav. (254).

51. *Torula quaternata*, B. and C., Grevillea, N. A. F., 507.

On leaves of *Dasydirion*. Wright (3768).

52. *Sporidesmium asteriscus*, B. and C., Grevillea, N. A. F., 534.

On *Pycnanthemum*. Rav. (289).

53. *Sporidesmium compactum*, B. and C., Grevillea, N. A. F., No. 523.

On carious wood. Rav. (49).

54. *Sporidesmium compositum*, B. and C., Grevillea, N. A. F., No. 525.

On oak rails. Rav. (248).

55. *Sporidesmium mundulum*, Cooke. (n. s.)

Effused in black patches. Spores nearly ovate, cellular, dark-brown, almost opaque; the spores adhere together for some time in a concatenate manner, the lower one being attenuated into a kind of short stem, (.015x.01 m m.).

On oak logs. Houston; Rav. (197.)

56. *Coryneum Kunzei*, Corda, Icon., IV, f. 131.

On oak twigs. Rav. (292).

57. *Phragmidium mucronatum*, Fr., S. M., iii, 497.

On leaves. Wright (3896).

58. *Triphragmium deglubens*, B. and C., Grevillea, N. A. F., 559.

On leaves. Wright (389).

59. *Puccinia prunorum*, Link., Sp., ii, 82.

On *Cerasus* and *Prunus*. Wright (3904).

60. *Puccinia lobata*, B. and C., Grevillea, N. A. F., 550.
On *Sida lepidota*. Wright (6400).
61. *Uromyces Texensis*, B. and C., Grevillea, N. A. F., 563.
On leaves of *Reuellia*. Wright (3879).
62. *Uromyces pulcherrimus*, B. and C., Grevillea, N. A. F., 565.
On leaves of *Abutilon*. Wright (3771).
63. *Uromyces solidus*, B. and C., Grevillea, N. A. F., 567.
On leaves of *Desmodium*. Wright (3882).
64. *Uromyces Phaseoli*, Strauss, Grevillea, N. A. F., 567.*
Probably the same as *Uromyces appendiculatus* P.
On *Phaseolus*. Wright (3888.)
65. *Uromyces Myristica*, B. and C., Grevillea, N. A. F., 568.
On leaves of *Euphorbium*. Wright (3890).
66. *Trichobasis rubigo-vera*, Lev., Ann. Sci. Nat.
On *Trichodium*. Rav. (285).
67. *Trichobasis Junci*, Strauss (sub *Uredo*).
On *Juncus*. Houston; Rav. (274).
68. *Graphiola Phœnicis* Poit., Ann. Sc. Nat., 1824, 473.
On *Chamærops*. Wright (4780.)
69. *Peridermium Ephedrae*, Cooke. (*Peridermium Pini*, var. *minor*, B and C., Grevillea, N. A. F., No. 576).
On *Ephedra*. Wright.
70. *Æcidium Orobi*, D. C., Grevillea, N. A. F., 583.*
On *Psoralea*. Pope (4844).
71. *Stilbum aleuriatum*, B. and C., Grevillea, N. A. F., 594.
On decayed wood of *Acer*. Wright (3782).
72. *Rhinotrichum Curtisii*, Berk., Grevillea, N. A. F., 657.
On wood. Wright (3892).
73. *Verticillium soorediatum*, B. and C., Grevillea, N. A. F., 670.
On dead wood. Wright (3777).
74. *Macrosporium compactum*, Cooke. (n. s.)
Black, effused in the form of a compact crust. Threads fasciculate, brown, septate, unbranched. Spores oval, obtuse at the ends, divided longitudinally and vertically into numerous cells, sooty-brown (.02—0.03x.012—0.014 mm.).
On stems of *Ricinus*. Rav. (272,273).
75. *Cercospora Altheana*, Sacc., *Michelia*, ii, 269.
On leaves of *Malva*. Rav. (229.)
76. *Cercospora Gnaphaliacea*, Cooke. (n. s.)
Amphigenous. Threads fasciculate, simple, collected in rounded brown spots. Spores robust, linear, 3—5 septate, hyaline (.04—0.07x.005 mm.),
On leaves of *Gnaphalium*. Rav. (283).

77. *Pilacre faginea*, B. and Br., Ann. Nat. Hist., No. 380.

On dead wood. Wright (3100).

Dr. Max. Cornu is of opinion not only that *Pilacre faginea* and *Pilacre Petersii* are forms of the same species, but that they are the conidia of another more highly developed fungus.

78. *Peziza (Cupulares) irrorata*, B. and C., Mycographia, fig. 254.

On soil. Wright (3138).

79. *Peziza (Humaria) melaloma*, A. and S., Mycographia, fig. 67.

On burnt soil. Wright (3137).

80. *Peziza (Sarcoscypha) pusio*, B. and C., Mycographia, fig. 106.

On the ground. Wright (3145).

81. *Peziza (Sarcoscypha) Texensis*, B. and C., Mycographia, fig. 145.

On the ground. Wright (3134).

82. *Peziza (Sarcoscypha) scutellata*, L., Mycographia, fig. 131.

On wood. Wright (3135).

83. *Peziza (Sarcoscypha) stercorea*, P., Mycographia, fig. 147.

On dung. Wright (3140).

84. *Peziza (Dasyscypha) virginea*, Batsch, El., 125.

On twigs. Wright (3136).

85. *Peziza (Mollisia) rubella*, Pers., Syn., p. 635.

On wood. Ravenal (103).

86. *Patellaria cyanea*, Cooke. (n. s.)

Scattered, dark-blue, almost black. Cups flattened, orbicular ($\frac{1}{2}$ —1 m m.) convex. Asci clavate, sessile. Sporidia clavate, or fusiform, 3—5 septate, rather constricted at the joints ($\cdot 03 \times \cdot 007$ m m.), the cells being nucleate. Paraphyses clavate, simple, or furcate, dark blue at the tips.

On herbaceous stems. Houston, Rav. (223).

Evidently allied to *Patellaria indigotica* C. and Pk., and, like that, with the gelatina hymenica coloured blue, so that a blue tint is suffused over the whole of the hymenium.

87. *Eustegia Magnoliæ*, B. and Rav., (stylosporous state).

On leaves of *Magnolia grandiflora*. Houston ; Rav. (236).

88. *Hysterium praelongum*, Schwz.

On wood. Wright (3894, 3916) ; Rav. (69).

89. *Hysterium (Glonium) lineare*, Fr., S. M., ii, 583.

On wood. Rav. (73).

90. *Hysterium (Glonium) medium* Cooke. (n. s.)

Perithecia elliptical or elongated, obtuse at both extremities, flattened above, black, densely gregarious or sometimes confluent. Asci cylindrical. Sporidia oval, at length uniseptate, hyaline, ($\cdot 008$ — $\cdot 01 \times \cdot 004$ m m.).

On decorticated *Berchemia*. Rav. (293).

Resembling *Glonium lineare* in many points, but differing in the contour and size of the sporidia.

91. *Hysterium (Lophodermium) xyloides*, Chev., in Duby.
On leaves. Rav. (182).
92. *Hysterium (Lophodermium) maculare*, Fr., S. M., ii, 592.
On leaves of *Persea*. Houston ; Rav. (234).
93. *Ailographum maculare*, B. and Br., Ann. N. H., No. 968.
On leaves of *Quercus aquatica*. Houston ; Rav. (101).
94. *Phacidium dentatum*, Fr., S. M., ii, 577.
On oak leaves. Wright (3909).
95. *Asterina Wrightii*, B. and C., Grevillea, N. A. F., 790.
On *Cucurbitaceæ*. Wright (3880).
96. *AcrospERMUM viridulum*, B. and C., Grevillea, N. A. F., 1001.
On leaves of *Quercus obtusiloba*. Houston ; Rav. (166).
97. *AcrospERMUM foliicolum*, B. and C., Grevillea, N. A. F., 1000.
On leaves of *Smilax*. Rav. (165).
98. *Torrubia Ravenalii*, B. and C., Grevillea, N. A. F., 799*.
On larvæ. Wright (3155).
99. *Xylaria Titan*, B. and C., Grevillea, N. A. F., 823.
On stumps. Lindheimer (2676).
100. *Xylaria clavulus*, B. and C., Grevillea, N. A. F., 825.
On dead grass. Wright (3150).
101. *Xylaria digitata*, Grev., Fl. Ed. 356.
On stumps. Lindheimer (3627).
102. *Xylaria rhopaloides*, Kze., Weig. Exs.
On stumps. Wright (3904).
103. *Poronia œdipus*, Mon. Syll., 209.
On dung. Wright (3778).
104. *Hypoxyton malleohis*, B. and Rav., Grevillea, N. A. F., 827.
On oak. Galveston Bay ; Rav. (26).
105. *Hypoxyton multiforme*, Fr., S. V. S., 384.
On branches. Houston ; Rav. (138).
106. *Hypoxyton rubiginosum*, Fr., S. V. S., 384.
On wood. Wright (3893).
107. *Hypoxyton argillaceum*, Fr., S. M., ii, 333.
On oak. Houston ; Rav. (108).
108. *Hypoxyton fuscum*, Fr., S. M., ii, 332.
On branches. Houston ; Rav. (132).
109. *Hypoxyton Sassafras*, Schwz., Syn., No. 87.
On *Persea* ; Rav. (211). On fallen limbs ; Rav. (110, 127).
110. *Hypoxyton annulatum*, Schwz., Fr. El., 264
On wood. Galveston Bay ; Rav. (39).

111. *Hypoxyylon investiens*, Schwz.

On oak rails. Rav. (249). Wright (3913).

112. *Eutypa limæformis*, Schwz., Syn., No. 86.

On dead logs. Houston; Rav. (238).

113. *Diatrype (Diatrypella) opaca*, Cooke. (n. s.)

Erumpent, suborbicular, dark brown. Ostiola depressed, sulcate, scarcely distinct. Asci clavate, much attenuated below. Sporidia sausage-shaped, very numerous, yellowish in the mass.

On *Ilex opaca*. Houston; Rav. (243).

Also received from Florida. Allied to *D. quercina*, but the pustules are smaller, and neater, the ostiola less prominent and smaller.

114. *Diatrype hypophleæ*, B. and Rav., Grevillea, N. A. F., 852.

On *Magnolia grandiflora*. Rav. (240).

115. *Diatrype atropunctata*, B. and C., Grevillea, N. A. F., 851*.

On branches. Rav. (168).

116. *Diatrype punctulata*, Berk. and Rav., Grevillea, N. A. F., 851*.

On oak. Galveston Bay; Rav. (35).

117. *Diatrype rumpens*, Cooke. (n. s.)

Elliptical, subconvex, at length casting off the cuticle, the fragments of which adhere around the margin. Ostiola scarcely prominent. Asci cylindrical. Sporidia broadly almond-shaped, dark-brown, opaque, (.015 x .009 m m.).

On bark. Galveston Bay; Rav. (63).

Scarcely an inch broad, rather convex. The same species has been received from South Carolina on ash. Rav. (1555).

118. *Diatrype dryophila*, Curr., Linn. Trans., xxii, p. 269.

On bark. Houston; Rav. (177).

119. *Diatrype exutans*, Cooke. (n. s.)

Broadly effused, black, produced beneath the cuticle, which is soon cast off. Ostiola punctiform, depressed. Asci cylindrical. Sporidia elliptical, attenuated towards each extremity, brown, with a single nucleus, (.014 x .008 m m.).

On bark. Galveston Bay; Rav. (76).

Two or three inches or more long, with an irregular outline, thinner than *D. rumpens*.

120. *Melogramma gyrosum*, Tul., Carp., ii, 87.

On *Liquidambar*: Rav. (241).

121. *Nectria episphaeria*, Fr., S. M., ii, 454.

On *Valsa stellulata*. Rav. (158).

122. *Valsa stellulata*, Fr., S. M., ii, 381.

On rotten logs. Rav. (68, 97, 133). Wright (3900).

123. *Valsa tetraploa*, B. and C., in Rav., Fungi Car.
On *Smilax*. Houston; Rav. (242). On bark. Houston; Rav. (102).
124. *Valsa Vitis*, Schwz., Syn. Car., No. 117.
On *Vitis*. Houston; Rav. (100, 180, 218).
125. *Valsa velata*, Pers., Syn., 32.
On fallen limbs. Houston; Rav. (194).
126. *Massaria Curreyi*, Tul., Carp., ii, 231.
On basswood. Houston; Rav. (297).
127. *Sphaeria (Byssisedæ) aquila*, Fr., S. M., ii, 442.
On wood. Galveston Bay; Rav. (79).
128. *Sphaeria (Byssisedæ) culcitella*, B. and Rav., in Rav., Exs. iv, 53.
On logs. Rav. (32).
129. *Sphaeria (Villosæ) canescens*, Pers., Syn., 448.
On *Carpinus*. Rav. (104, 215, 300).
130. *Sphaeria (Sordaria) macrospora*, Awd., in Hedw.
On rabbits' dung. Ravenal (230).
131. *Sphaeria (Sporormia) minima*, Awd., Hedw., 1868, p. 66.
On rabbits' dung. Ravenal (230).
132. *Sphaeria (Immersæ) livida*, Fr. S. M., ii, 479.
On naked wood. Wright (3781, 3902).
133. *Sphaeria (Immersæ) botulæspora*, Cooke. (n. s.)
Gregarious, immersed. Perithecia black, compressed laterally, pierced at the apex. Asci saccate. Sporidia cylindrical, straight, or slightly curved, obtuse at each extremity, uniseptate, the upper cell being twice the length of the lower, constricted at the septum, brownish, (.07—08 x .012 mm.).
On old oak rails. Houston; Rav. (202).
134. *Sphaeria (Immersæ) Texensis*, Cooke. (n. s.)
Scattered over greyish or bleached spots. Perithecia subglobose, immersed in the blackened wood, scarcely prominent. Asci cylindrical. Sporidia lanceolate, uniseptate, hyaline, (.015 x .006 mm.).
On old oak rails. Houston; Rav. (250).
135. *Sphaeria (Obtectæ) pertacta*, Cooke. (n. s.)
At first covered. Perithecia globose, black, at length exposed above, through elongated fissures of the cuticle, generally arranged in a linear series. Asci clavate, sessile. Sporidia biseriate, elliptical, attenuated towards each end, hyaline, (.02—023 x .01 mm.).
On fallen branches. Galveston Bay; Rav. (57).
136. *Sphaeria (Caulicolæ) torulæspora*, Cooke. (n. s.)
Gregarious. Perithecia black, of an obtusely conical form, flattened at the base, at length exposed. Sporidia linear, multiseptate, brown, resembling some forms of *Torula*, slightly constricted at the commissures, (.08 x .004 mm.).
On herbaceous stems. Rav. (60).

The specimens were in bad condition. No asci were really discovered, and therefore it has been described with some uncertainty.

137. *Sphaeria (Caulicolæ) uvæspora*, Cooke. (n. s.)
 Gregarious, covered by the cuticle. Perithecia almost globose, rather small, and not numerous, brown, pierced at the apex. Asci clavate. Sporidia shortly clavate, simple, hyaline, in form resembling grape-stones, (.012—015 x .005 mm.).
 On flower stalk of *Yucca*. Ravenal (18).
138. *Sphaeria (Caulicolæ) anguillida*, C. and E., in Grevillea.
 On herbaceous stems. Ravenal (199.)
139. *Sphaeria (Foliicolæ) appendiculosa*, B. and C., Grevillea, N. A. F., No. 967.
 On leaves of *Sapindus*. Wright (3887).
140. *Sphaeria (Foliicolæ) Janus*, B. and C. in Grevillea, N. A. F., No. 968.
 On leaves of *Quercus virens*. Wright (3908).
141. *Sphaerella exutans*, Cooke. (n. s.)
 Spots minute, dark brown. Perithecia few, immersed, at length casting off the cuticle above them in little operculoid discs. Asci clavate-cylindrical. Sporidia elongated, elliptical, unequally septate, hyaline, (.012 x .004 mm.).
 On the upper surface of leaves of *Persea*. Rav. (46).
142. *Sphaerella maculoæformis*, Fr., S. M., ii, 524.
 On leaves. Lindheimer (3642).
143. *Dothidea ilicis*, Cooke. (n. s.)
 Gregarious, erumpent. Pustules elliptical, black, the cells being inclosed in the stroma. Asci clavate. Sporidia elliptical, sometimes attenuated slightly towards each extremity, simple, hyaline, (.03 x .01 mm.).
 On bark of *Ilex opaca*. Rav. (284).
144. *Stigmatea gregaria*, Cooke. (n. s.)
 Epiphyllous. Perithecia gregarious, erumpent, black, globose, somewhat shining. Asci cylindrical. Sporidia subglobose, hyaline, (.01—012 x .009 mm.).
 On unknown leaves. Meskat Bay; Rav. (306).
145. *Microthyrium smilacis*, Not., Micro. Ital.
 On *Smilax*. Houston; Ravenal (220).
Phlyctæna smilacis, C. (No. 40) is probably the stylosporous condition of this species.
146. *Asterina orbicularis*, Berk. and C., Grevillea, N. A. F., No. 784.
 On leaves of *Ilex opaca*. Ravenal (164).
 Sporidia when mature strongly constricted, each cell nearly globose, scarcely equal in size, of a clear dark brown colour (.02 x .01 mm.).
147. *Asterina Wrightii*, B. and C., Grevillea, N. A. F., 790.
 On cactus. Ravenal (54).
148. *Perisporium Wrightii*, B. and C., Grevillea, N. A. F., No. 987.
 On *Opuntia*. Wright (3783.)
149. *Meliola amphitricha*, Fr., S. M., ii, 513.
 On *Garrya*, Lindheimer (3644).

XIX.—*Descriptions of new Palaeozoic Fishes.**

BY J. S. NEWBERRY.

Read April 9th, 1878.

Diplognathus. Nov. Gen.

Bones of cranium and body unknown. Dentary bones long and slender, rising anteriorly into points which diverge from the symphysis, giving a forked extremity to the lower jaw. Conical, incurved teeth, formed from the jaw tissue, are set along the upper margin of their divergent, triangular points.

The remarkable structure of the jaw on which the foregoing description is based, is without parallel, so far as known, in the animal kingdom. The dentary bones are produced forward into triangular divergent points, which are set with teeth on either margin; thus the extremity of the lower jaw forms a fork, set with strong recurved teeth. This would form a very effective instrument for catching slender slippery fishes like eels, and was doubtless used for that purpose. The danger of splitting this fork, which must have been considerable, was obviated by a strong ligament which united the mandibles at the symphysis.

One species only is known, *D. mirabilis*, *N.*, described below.

DIPLOGNATHUS MIRABILIS. (n. sp.)

Dentary bone of mandible about eighteen inches in length, by two inches in width at the widest portion, anterior half thickened as in *Dinichthys*, rising into a prominent point anteriorly, which diverges from its fellow of the opposite dentary bone, to form a forked extremity to the under jaw. Upper margin of the anterior half of the dentary bone set with strong, conical, smooth, acute, incurved teeth, which diminish in size as they ascend the elevated point. Four larger, conical, recurved teeth, are set on the inner side of the triangular extremity of the mandible, filling the space between the

*The species characterized in this paper will be described more fully, and figured, in the Report of the Geological Survey of Ohio. Vol. III, Palæontology.

point and the symphysis. A broad roughened depression or pit at the symphysis marks the place of attachment of a strong ligament, which united the mandibles, and prevented the splitting of the forked extremity of the jaw.

Only the anterior half of the mandible of this remarkable fish has yet been found. We therefore have but an imperfect knowledge of its structure and relations. It is evident, however, that it was allied to *Dinichthys*, since the general form of the mandible is similar; the posterior extremity was doubtless flattened and spatulate, the anterior third exposed, and this portion is thickened, and forms a segment of a circle by its lower outline, as in *Dinichthys*. The turned up extremities of the mandibles in *Dinichthys* are also divergent; and we have only to imagine the rows of teeth, which are set along the upper margin of the mandibles of *D. Hertzerei*, continued down the inner margins of the divergent extremities, to produce *Diplognathus*. A fragment of the mandible of *Diplognathus*, carrying a few teeth, was found some years ago, imbedded in the Huron shale at Sheffield, Ohio. This had evidently been broken from the jaw by violence, and is perhaps the record of an unequal contest between *Diplognathus* and *Dinichthys*. This fragment was referred to *Dinichthys Hertzerei*, and was regarded as evidence of the existence of that species, associated with *D. Terrelli*, in the last epoch of the Devonian age; but we now know that this reference was an error; and all the facts seem to indicate what was believed before the discovery of this fragment, that *Dinichthys Hertzerei* lived only in the earlier part of the Huron epoch, and that it was replaced, through modification or otherwise, by the *D. Terrelli* in the last portion of the period during which the Huron shale was being deposited.

From the Huron Shale, Sheffield, Loraine Co., Ohio.

Discovered by Mr. Jay Terrell.

GLYPTOPOMUS SAYREI. (n. sp.)

Fish fusiform, about two feet in length by five inches in diameter; head triangular in outline, five inches in length and breadth, cranial plates unknown. Under side of head covered with two large sigmoidally elliptical

jugular plates, bordered by five lateral jugulars, of which the anterior is linear, but broadest behind; the middle three are rhomboidal; and the posterior is spatulate and the largest of the series. Pectoral fins elliptical in outline, deeply lobed and scaled. Scales rhomboidal or quadrangular, smooth beneath, strongly marked on the outer surface with short curved vermicular furrows, divided by sinuous ridges.

Until the upper surface of the head of this fish can be found displayed, it cannot be asserted that it belongs to the genus *Glyptopomus*; and even with entire correspondence in the cranial bones, its jugular plates may be different; for it is not yet certain that *Glyptopomus* had lateral jugulars. The scales are, however, precisely those of *Glyptopomus*, and it wants the pectoral plates of *Glyptolemus*, although its lateral jugulars are similar. It has also more the general aspect of *Glyptopomus*, and it is therefore placed provisionally in that genus. Up to the present time, no other specimen of this fish has been found than that now described, and this is of special interest as indicating the former existence in America of another fish closely allied to those of the Upper Old Red Sandstone of Scotland.

From the Catskill Group, Wyoming Co., Penn.

Specimen presented by Mr. Sayre to the cabinet of Lehigh University, Bethlehem, Penn.

Archæobatis. Nov. Gen.

Dentition flat and pavement-like; teeth of large size, thick and massive, in several rows, the different series arched and increasing in size from behind forward; under surfaces somewhat excavated to fit the curvature of the cartilaginous jaw; upper third of teeth formed by a coat of enamel, transversely corrugated and punctate.

The teeth on which the above description is based have the general form of those of *Psammodus*, but they are many times larger, and are distinguishable from them by the beautifully regular transverse corrugation of the enameled surface, like that of the teeth of *Rhina*. A number of teeth, found in juxtaposition, show that the dentition was much like that of the living rays, especially *Myliobatis*; and there can be little

doubt that they represent the oldest and most gigantic member yet known of the ray family.

ARCHÆOBATIS GIGAS. (n. sp.)

Teeth numerous, nearly flat, forming rows from front to rear, and dimishing in size from the second backward; all quadrangular in form, with the longest diameter transverse; largest six inches wide by four inches from front to rear; thickness of the largest teeth, one inch and a half. The corrugation of the surface is strong and very regular, resembling that on the teeth of *Rhina ancylostomus*, and doubtless had the same function,—to prevent objects from slipping while being crushed.

From the Lower Carboniferous Limestone, (St. Louis Beds), Greencastle, Indiana.

Collected by Rev. H. Hertzner.

DINICHTHYS MINOR. (n. sp.)

Dorsal plate four to five inches long, shield-shaped, terminating anteriorly in an obtuse, posteriorly in an acute point; the sides, irregularly rounded, form a feather-edge, probably buried in the integument. Upper surface gently arched, marked by several obscure longitudinal striae, and by a peculiar transverse crape-like wrinkling. The under surface is uniformly excavated, and arched transversely on either side of the low and sharp central crest. This crest is prolonged into a narrow neck-like process, which projects forward and downward from the margin of the shield, and is excavated in a broad furrow on its upper surface.

The supra-occipital bone is wedge-shaped and truncated forward, rounded behind, with a low point at the center of the margin. The upper surface is marked with characteristic transverse, crape-like wrinkling; the under surface slopes backward from the middle, with a prominent ridge which forms the terminal point; anterior to this slope is a semi-elliptical excavation, divided at bottom in two by a longitudinal ridge.

An imperfect jaw found with the dorsal plate, and corresponding in size, is about four inches in length, posterior extremely spatulate and thin, the anterior portion polished without, and terminating above in a sharp edge; the anterior extremity is broken away.

From the Huron Shale, Sheffield, Loraine Co., Ohio.

Discovered by Jay Terrell, Esq.

CTENACANTHUS COMPRESSUS. (n. sp.)

Spine of medium size, perhaps six inches long, much compressed, by one inch and a half wide, strongly arched above; anterior margin smooth, posterior flattened, with a well-marked rounded ridge along the central line. Upper half of posterior face thickly set with conical recurved teeth.

Exposed portion wholly covered with fine longitudinal ribs, which are highly ornamented by closely approximated transverse lines. Pectination finest on middle and lower portion of sides.

Another spine of *Otenacanthus* has been found in the same stratum and place with that now described, but it is quite different. A figure and description of this (*O. vetustus*, N.) are given in Vol. I, Part II, p. 326, Pl. 35, Fig. 3, of the Report of the Geological Survey of Ohio; and by reference to these it will be seen that the spine before us is very much more compressed, and is ornamented by more numerous and finer longitudinal ridges on the sides.

From the Huron Shale, Sheffield, Loraine Co., Ohio.

Found by Mr. Jay Terrell.

RHYNCHODUS OCCIDENTALIS, (n. sp.)

Teeth of small size, much compressed. Anterior margin slightly curved but nearly vertical. Superior margin gently arched downward from the prominent anterior point, forming a much compressed triturating surface or edge. Posterior portion of upper margin acute-edged. Exterior lateral surface striated obliquely backward. Basal margin formed by the edges of external and internal laminae, of which the edges are broken and irregular.

From the Hamilton Limestone, Waverly, Iowa.

RHYNCHODUS EXCAVATUS, Newb.

R. excavatus, N., *Geol. Survey of Wisconsin*, Vol. 2, p. 396.

Tooth small; size, when entire, perhaps two and a half inches long by one and a quarter deep; the crown alone preserved. Of this, the external surface is marked vertically with vermicular furrows; superior margin sinuous, terminating anteriorly in a prominent point; the superior surface irregularly excavated and roughened, showing two prominent points or tubercles, one on the middle of the exterior margin and one near the anterior extremity. The inner surface of the tooth shows a prominent ridge running up to the anterior point.

This tooth is evidently fitted for trituration rather than cutting, and resembles in its general form *R. frangens* of the Corniferous limestone. It is, however, much smaller and thinner; and the tubercles of the upper surface are differently situated than in that species.

Hamilton Group, Brown Deer, Milwaukee Co., Wisconsin.
Collected by Prof. T. C. Chamberlain.

XX.—*Ozone and the Atmosphere.*

BY ALBERT R. LEEDS, PH.D.

Read April 9th, 1878.

In a paper entitled "Recent Progress in Sanitary Science,"* I endeavored to give a short resumé of the labors of European physicists upon the estimation of atmospheric oxygen and ozone. I had been unable to find a published analysis of the atmosphere at any locality in the United States, all our knowledge upon the composition of the atmosphere being derived from foreign sources. Moreover, few systematic observations upon ozone had been prosecuted, or if carried on, had rarely been published.

In making the oxygen estimations, Bunsen's methods were in most respects implicitly followed. The eudiometers employed were graduated by ourselves with great care. A gas room was fitted up, in which the thermometric readings rarely varied more than one half a degree during the periods of observation. The flasks employed to collect samples, were of thin glass, $2\frac{1}{2}$ c. m. in diam., 20 c. m. long, drawn out at one end into a tube about 15 c. m. in length. After cleansing and drying, a pellet of pure potassic hydrate was introduced and the tube sealed at a point about one-third from its extremity. When a sample was taken, the end of this tube was broken off with the aid of a file, the diameter of the tube near the flask narrowed down by heating in a lamp, the air in the interior completely changed by aspiration through a fine tube introduced until it nearly reached the bottom of the flask, which was then sealed with the flame. During the summer of 1876, numerous specimens of air were collected at Hoboken and vicinity, at the Centennial Exhibition, Philadelphia, and upon

* *Annals of the Lyceum of Natural History, N. Y., Vol. XI, November, 1876.*

various mountain tops and in many valleys of the Adirondacks, New York State. The temperature, barometer, wind, etc., were noted at the same time, although these meteorological data are not of much importance, except as part of a connected and simultaneous series of observations, conducted with a view of establishing a chemical climatology of the United States. At present, what is done in this direction can be looked upon merely as the beginning of a study, which will hereafter yield results of value to the agriculturist, the medical practitioner and the physicist. Suitable equipment of our observatories, so that they may yield not merely the meteorological, but also the requisite chemical data, is essential to advance in climatology. The following table contains some of the most interesting of the determinations heretofore made:

TABLE OF THE PERCENTAGE OF OXYGEN contained in the atmosphere at various localities in the United States, 1876.

LOCALITY.	DATE.	PER CENT.
Stevens Institute of Technology.....	July 4th, 12. M.	20.957
“ “ “	Aug. 2d, 1.20 P. M.	20.957
“ “ “	“ 11th, 1. P. M.	20.821
“ “ “	“ “ (duplicate)	20.843
“ “ “	“ 29th,	20.954
“ “ “	“ 30th, 9.30 A. M.	20.934
“ “ “	“ 31st, 5.20 P. M.	20.942
“ “ “	Sept. 1st, 10.30 A. M.	20.952
“ “ “	“ “ (duplicate)	20.957
“ “ “	“ 7th, 10. A. M.	20.932
“ “ “	“ “ (duplicate)	20.944
Horticultural Hall, Centennial	Aug. 15th, 3.40 P. M.	20.964
Machinery Hall. “	“ 21st, 5.15 P. M.	20.937
Main Building, “	“ 18th, 4. P. M.	20.868
Agricultural Hall, “	“ 22d, 3. P. M.	20.857
U. S. Building, “	“ 16th, 4. P. M.	20.878
Centennial Grounds. “	“ 15th, 6. P. M.	20.962
“ “ “	“ 18th, “ “	20.918
Stevens Institute of Technology.....	Sept. 26th, 10. A. M.	20.915
Keene Flats, Adirondacks.....	July 17th,	21.029
Mt. Marcy, Summit of.....	“ 21st, 3. P. M.	20.928
“ “ “ “	“ (duplicate).	20.926

ATMOSPHERIC OZONE.

In order to obtain some knowledge of the character of the results arrived at in testing for atmospheric ozone according to

customary methods, I prepared a number of ozonoscopic papers, with pure materials, after the formula of Osann, and during the summers of the years 1876 and 1877, in the Adirondacks, and during the rest of this period, in Hoboken, made regular observations. At Hoboken the results were negative, an ozone reaction being obtained on rare occasions only, and then in the most feeble and undecided manner. On the contrary, in Keene Flats, N. Y., the days were few in which the ozonoscopes were unaltered; usually they were decidedly affected, and sometimes to a degree most striking. The point in the Keene Flats, where the observations were conducted, was about 700 feet above sea-level, the surrounding vegetation mostly deciduous, the population and dwellings though scanty, not inconsiderable. Even more interesting were the results during the following summer, 1877, at a point near the upper end of Upper Saranac Lake. This was located at a much higher altitude than the foregoing, entirely isolated by miles of primitive forest from any other dwellings. The woods abounded in hemlocks, pines, larches, spruces, and were often redolent with odors of the balsam. Owing to a supposed virtue in these resinous-smelling woods, large numbers of patients, especially those suffering from pulmonary diseases, are sent by the physicians of New York and other large cities, to this portion of the Adirondacks. Bearing in mind that the beneficial effects are supposed to be due entirely to the atmosphere—not to any mineral waters, or peculiarities of regimen, exercise, or occupation—one of these sanitariums, like that on St. Regis Lake, would afford an opportunity of testing some disputed points concerning the effects of a varying constitution of the atmosphere on different diseases.

Certainly the intelligent selection of an appropriate sanitarium, is a duty frequently devolving upon the physician, but one which at the present time he can in many cases only imperfectly perform, from the lack of positive knowledge. Vague impressions or reports can never take the place of atmospheric analysis; they bear a similar relation to it with that which the ancient foretelling of the weather does to the

present signal service reports. It is to be hoped that the time is not far distant, when the Government may think it important to do as much for public hygiene as for commerce and agriculture.

Although in the light of subsequent experiments, little value I think can be attached to the following ozone observations, yet as illustrative of the variations in the amount of the so-called ozonic reaction, and of the apparent lack of connection between it and other meteorological phenomena, the accompanying table may be of interest :

Register of Ozone Observations,

Made at Upper Saranac Lake, Northern New York, altitude 1600 feet above the sea. Times of observation, 7 A. M. and 7 P. M. Season, Summer of 1877. Scale of 10.

DATE.	OZONE,	THERMOMETER.	BAROMETER.	WEATHER.			REMARKS.
				WIND.	RAIN.	CLOUDS.	
July 17..	5	74°	27.9	S.	Heavy.		Considerable lightning.
" 18..	2	70°	28	S.			
" 19..	2	71°	27.675	NE-SW	Much.		Great rain at night, and light'ng.
" 20..		70°	28.85	S.W.	Cirrus.	Air very clear—rain at a distance.
	2.5	73°	27.9	S.W.	Cum. (1)	
" 21..	2	62°	28	S.W.	Cum. (6)	
	1	64°	28.15	S.W.	Cum. (1)	Very pleasant day.
" 22..	0	67°	28.275	S.W.	Cum. (1)	Great cumulus clouds.
	0	72°	53.275	S.W.	Cum. (1)	Little air—not bracing.
" 23..	1	68°	28.35	S.W.	Nimb. (7)	" "
	0	72°	20.275	S.W.	Cum. (3)	
" 24..	1	66°	28.3	S.	Cirrus (5)	
	1				Cum. (1)	
" 25..	0	68°			Cum. (1)	
	1	80°	28.1		Cum. (2)	
" 26..	1	71°	28	S.W.	Stratus (3)	
	3		28.925	S.W.	" (1)	
" 27..	0	72°	28.125	S.W.	" (5)	Heavy rain at night, and light-
	1	80°	28.15	S.W.	Rain.	Nimb. (10)	ning—in morning cool and re-
" 28..	5	72°	28.1	S.W.	" (10)	freshing.
	1		28.05		Rain.	Nimb.	
" 29..	1	72°	28		Rain.	Cum. (2)	
	1	76°	27.925		Rain.	Nimb. (10)	
" 30..	3			N.	Cum.	
	3	78°	28.075	N.	Cum.	Very bright.
" 31..	0	64°	28.2	S.W.	Clear (0)	Exhilarating.
	6	72°	28.25	N.	Clear (0)	

DATE.	OZONE.	THERMOMETER.	BAROMETER.	WEATHER.			REMARKS.
				WIND.	RAIN.	CLOUDS.	
Aug. 1..	5	66°	28.325	Calm.	Clear (0)	No air stirring.
	4	75°	28.275	S.	Clear (0)	Exhilarating.
" 2..	3	68°	28.25	S.W.	Stratus (1)	
	4.5	72°	28.1	S.	" (3)	" Mackerel-sky."
" 3..	4.5	66°	28.025	S.	" (10)	
	2	72°	27.925	S.W.	Cum (1)	Clear and bright.
" 4..	4	64°	28.025	N.	Cum. (3)	Wind-storm at night.
	2.3	66°	28	N.	Cum. (5)	" " in afternoon.
" 5..	2	62°	27.95	S.	Cum. (1)	Opposing air-currents produc-
	3	64°	27.95	S.	Nimb. (10)	ing 5 storms.
" 6..	2	61°	27.925	N.	Cum. (1)	Brilliant atmosphere.
	1.2	66°	27.9	N.	Stratus (9)	Bright.
" 7..	7	68°	27.8	S.	Nimb. (10)	Heavy rain at night.
	6	72°	27.8	S.	Stratus (7)	Shifting clouds.
" 8..	7	76°	27.825	Calm	Clear (0)	Heavy rain and thunder during
	7	79°	27.825	N.E.	Much.	Cum. (5)	day.
9..	1	72°	27.825	S.W.	Fog (10)	Haze (smoke).
	3	74°	27.775	S.W.	Cum. (5)	Dull.
" 10..	3	72°	27.8	S.W.	Rain.	Cum. (1)	Haze. Little air.
	1.2	65°	27.35	S.W.	Cum. (2)	
" 11..	1	65°	27.975	S.W.	Strat's (10)	
	1	67°	28.075	S.W.	Nimb. (4)	Thunder storms.
" 12..	0	68°	28.05	S.	Clear (0)	Starlight night.
	2	65°	27.95	S.W.	Much.	Nimb (10)	Opposing winds.
" 13..	1	68°	27.95	S.W.	Much.	" (10)	
	2	70°	28	N.E.	Nimb. (9)	
" 14..	1		27.925	Calm.	Mist (5)	Heavy rain at night,
	1	65°	27.9	W.	Rain.	Nimb. (10)	
" 15..	1	67°	27.925	S.W.	Rain.	Cnm. (10)	
		67°	27.9	N.E.	Rain.	Nimb. (10)	
" 16..	5	64°	27.875	Calm.	Rain.	Cum (10)	
	1	66°	27.85	N.E.	Rain.	Nimb. (5)	

Examination of Methods in Ozonometry.

On resuming laboratory work in autumn, an inquiry, which seemed essential before making any further observations upon atmospheric ozone, was the deportment of the various tests under precise and varied conditions. It was desirable to experiment upon the most convenient method of preparing ozone, upon the precautions requisite for obtaining it in as pure and concentrated a form as possible, and upon the methods of estimating its percentage in an atmosphere of ozonized air or oxygen.

Preparation of Ozone by Electrolysis of Water containing Sulphuric Acid:—Electrolysis was not found a convenient method of preparing ozone in considerable quantities. But it is so important to demonstrate the formation of ozone, accord-

ing to the reaction which first attracted the attention of Schönbein, that the following novel experiment, which affords an impressive lecture illustration, is important.

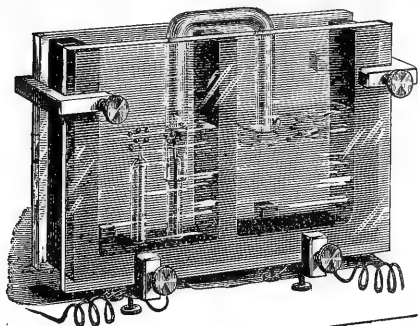

A glass tank is made, of thin sides of plate glass, and of less height and breadth than the diameter of a magic lantern condenser. These sides are held firmly against rubber walls of about 12 m. m. in thickness, cut out in such manner as to divide the tank into two cells. One is partly

filled with acidulated water,* the other with a 15 p. c. solution of potassium iodide.

The platinum electrodes from a battery of six Bunsen cells, rise from the bottom of the first compartment of the tank, covered, except at their ends, with glass tubes into which they have been previously sealed. A small bent glass delivery-tube is slipped over the electro-positive pole, its end just dipping beneath the surface of the potassium iodide solution. Decomposition begins as soon as the mixture of oxygen and ozone has displaced the air previously in the delivery-tube, and is made evident by the yellow color imparted by the liberated iodine. If, before projecting the image of the decomposition on the screen, a few drops of dilute starch have been added, the dark blue clouds, rolling away from the point of exit of the electrolytic ozone, are striking. A tincture of guaiacum, freshly prepared from the solid resin, shows the presence of ozone by a lighter blue coloration spreading across its surface in the tank; and an indigo solution is bleached. The last reaction is not so striking as the foregoing, since the bleaching is necessarily shown by a gradual, instead of an abrupt change of color. This tank is a modification of that manufactured by Messrs.

* According to L. Hoffman, a maximum liberation of ozone is obtained from a mixture of 1 part sulphuric acid and 5 parts water. (Pogg. 132, 607; Jahresb. der Chemie, 1867, 130). The mixture should be kept as cold as possible.

Wales and Co., which can also be employed to illustrate the effect of ozone upon the above mentioned solutions, the ozonized oxygen being in this case conducted by a glass tube from the ozonizer to the surface of the liquids in the tank.

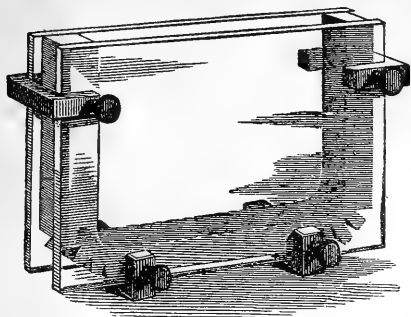

Preparation by Electricity.—The methods followed to submit the oxygen, in as dry and cold and condensed a condition as possible, to the action of electricity, will be given in a subsequent paper. A large Holtz machine, manufactured by Ruhmkorff, did not answer satisfactorily as a source of frictional electricity. Examination showed that the surface of the vulcanite supports was coated with a saline incrustation, which proved to be sulphates, probably formed by oxidation of the sulphur contained in the vulcanite, under the influence of ozone generated in the working of the machine. This saline matter being hygroscopic, attracted sufficient moisture to destroy insulation.*

The insulation might have been restored, by removing the coating; but in the remainder of the experiments I used the improved form of Holtz's machine, made by Messrs. Hall and Benjamin, (see wood-cut), and obtained excellent results. Various modifications of Siemens's apparatus, and the tube-ozonizer of Prof. Wright,† were employed for ozonizing.

* This difficulty had been previously noted by Prof. A. W. Wright, *Am. J. Sci.*, [3], vol. IV, p. 30.

† *Amer. Jour. Sci.*, *ib.*, p. 26.

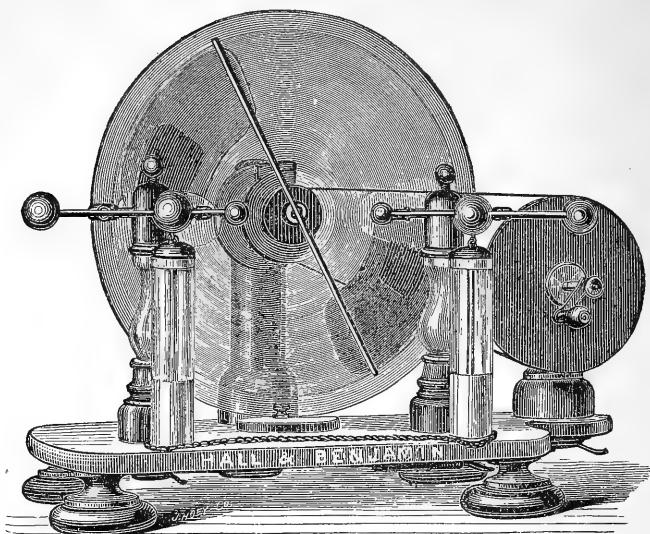

Does the Electric Spark Decompose Potassium Iodide?—One of the most interesting points to be determined in connection with the ozone tests, was whether the electric spark alone would decompose potassium iodide, or whether the decomposition was not due to the ozone produced whenever the electric spark is taken in the ordinary manner. To settle this question it was essential to submit the tests to the spark taken either *in vacuo*, or in an atmosphere of some gas which, under the influence of the spark, would neither suffer decomposition nor enter into combination. The first method was attended with insurmountable difficulties, for which reason the second was adopted, hydrogen being the gas selected.

The hydrogen was purified by permanganate of potash solution, as proposed by the author, in an article entitled "Contributions to the Chemistry of Hydrogen;" *American Ass'n Adv. Science*, Aug. 23d, 1876; *American Chemist*, Nov., 1876.* It was dried in the usual manner by sulphuric acid, and then passed over a length of 20 c. m. platinum sponge, which was kept heated at the middle. The farther end of this tube

* Later by Shobig, *Jour. pr. Chem.*, II., XIV, 289; Oct., 1876.

was filled with phosphoric anhydride, which gradually liquified, from absorption of moisture. To make sure that all traces of oxygen had been removed, by entering into combination with hydrogen under the influence of the platinum sponge in the first tube, a platinum sponge guard-tube was added, similar to the first, except that its anterior end, as well, was filled with phosphoric anhydride. In this guard-tube, no change occurred. The tests were contained in an apparatus constructed as follows:—A tube 25 c. m. long and 4 c. m. wide was drawn down at its ends and fitted very tightly with rubber corks covered with tin-foil. Through these corks glass tubes were passed, conveying platinum poles, the latter sealed to the tubes with only 5 m. m. of their free ends projecting. Two tubes were cemented on one side of the apparatus 6 c. m. from each end, and at the distance of 12 c. m., bent down at right angles. These tubes entered into small wash-bottles containing sulphuric acid, one acting as a seal at the entrance, the other at the exit, of the current of hydrogen.

In the first experiment, one specimen of each of the iodized papers was introduced into the apparatus. The hydrogen was then allowed to flow until all the air in the train of purifiers and driers had been displaced. Connection was made with the platinum sponge tubes and a slow current was allowed to flow for 3 hours. The object of continuing the current so long a time, was not so much with the view of displacing the air, as of thoroughly dessicating the papers. A stream of sparks was then passed between the poles, which were separated by an interval of 5 c. m.

The papers were pierced with numerous holes, but remained colorless. On opening the apparatus there was no smell of ozone, but an odor as of something burnt. The papers, on being moistened, developed faint blue stains at the points where pierced by sparks. The experiment was repeated with identical results. Either, then, it appeared, the sparks alone had decomposed potassium iodide, or ozone had been formed in the course of the experiment. That the hydrogen em-

ployed still contained oxygen, was negatived by the positive results obtained by the platinum sponge guard-tubes, and not less so by the absence of any smell of ozone, this last being in fact one of the most delicate tests which we possess. But the burnt smell noticed each time the apparatus was opened, rendered it extremely probable that the paper, containing, as it does, the elements of water, had undergone some decomposition.

To eliminate these sources of error, a tube was partially filled with pure potassium iodide, and hung upon the electrodes. After dessication in a current of hydrogen for many hours, sparks were passed through the iodide for a very long time. The magnificent color of the spark in hydrogen changed whenever the particles of potassium iodide were rendered incandescent. On testing the iodide afterwards, there was not the slightest indication of liberated iodine. From this it would appear that it is not the electric spark, but the ozone generated under its influence, which produces the chemical effects of decomposition in this and similar instances.

Collection and Preservation of Ozone.—A bottle with mouth partially covered, may be filled with ozonized oxygen by *displacement*. It is noticeable that even when the entrance-tube extends quite to the bottom of the bottle, the smell and iodo-starch reaction of ozone are obtained almost immediately, while quite an interval elapses before the air is so perfectly displaced that the issuing gas relights a spark at the orifice. Bottles so filled may be sealed with paraffine, and the contained ozone be preserved for hours. Great difficulty was encountered in making tight joints. It has been recommended to insert the ends of tubes to be joined, into a wider tube, and fill in with paraffine. But the adhesion of the paraffine is so slight, that such a joint easily comes apart. A better plan is, to take a strip of cotton cloth about $1\frac{1}{2}$ in. wide, and of suitable length, wrap it tightly round the tubes to be joined, fasten with soft flower or copper wire, and then render it impervious by melted paraffine applied with a feather or brush. Tubes of very different diameters, and vessels of various dimensions, can be joined by suitably modifying this plan,

The action upon India-rubber is very energetic, especially when under strain. This may be illustrated as follows: A piece of black rubber tubing is coiled tightly around a glass rod, and placed in a bottle through which a current of ozonized oxygen is allowed to flow, the gas entering at the bottom and escaping at the partially closed top. The black color disappears quickly, a dirty yellow following, and the surface becomes roughened. In a few minutes the edges are serrated, cracks open until the whole tube yields, and it falls into more or less ring-like fragments.

To determine more accurately the amount and kind of change produced in rubber, it was exposed to a slow current of ozonized oxygen (30 litres) for a number of hours. The gas, after passing over the rubber, was made to flow through a weighed sulphuric acid tube, then through a Liebig's bulb and sulphuric acid tube, then through another sulphuric acid tube acting as a guard, and finally through 3 Geissler bulbs, containing solutions of potassium iodide. The time and difficulty in making so many joints tight, by the aid of paraffine, were great. The results were as follows:

Porcelain boat + rubber after ozonizing	=	7.2523 grains.
“ “ + “ before “	=	7.2415 “
Increase due to action of ozone	=	0.0108 “
Sulphuric acid tube after ozonizing	=	12.745 “
“ “ “ before “	=	12.739 “
Increase (probably water)	=	0.006 “
Potash bulbs after ozonizing	=	14.620 “
“ “ before “	=	14.6094 “
Increase (probably carbonic acid)	=	0.0106 “

The first Geissler bulb was dark yellow, the second light yellow, the third colorless. The liberated iodine corresponded to 2.47 mgrm. ozone. The above experiment is far from being conclusive, and is given principally to show the need of investigation into the nature of the changes occurring in rubber and other organic bodies, under the action of ozone.

Preparation by Chemical Methods: The most noteworthy result arrived at in an examination of these methods, was the

discovery of a new method of generating ozone. When potassium permanganate and crystallized oxalic acid are pulverized together in a mortar, the heat developed is so considerable as to convert into steam much of the water formed during the course of the reaction. If the salts are introduced into a test-tube, and water added, the escape of gas at first is slow, but it rapidly increases with a corresponding elevation of temperature. Iodo-starch papers held at the mouth of the tube, show the presence of ozone in the escaping gases; so do those of guaiacum. Potassium iodide is little affected until the temperature is kept down by holding the test-tube in cold water, when the amount of ozone liberated is so considerable that the papers turn brown at once. Here, then, we have two solid substances, which may be kept together for any length of time without change, but on the addition of water liberate ozone. The practical as well as theoretical interest of this discovery is such that a careful study of this and similar reactions is now being made.

CRITICAL EXAMINATION OF OZONOSCOPES.

Potassium Iodide:—As the potassium iodide manufactured in this country, and sold for chemically pure, has presumably been employed in the preparation of ozone tests by American observers, it was important to examine into its purity. The principal manufacturers are four in number, and their goods were examined with the following results :

Analyses of C. P. Potassium Iodide manufactured in the United States.

SAMPLE.	REACTION.	CARBONATES.	SULPHATES.	CHLORIDES.	IODATES.	IODINE.
I.	Alkaline	Absent	Absent	Absent	Absent	Absent
II.	"	Present	Present	"	"	Present
III.	"	Absent	Absent	"	"	Absent
IV.	Neutral	"	"	Present	"	"

It will be seen from this table, that of the goods purchased at the time the analyses were made, those of but one manufacturer were free from foreign salts, and had a neutral reaction.

And as nothing is easier than the introduction of minute amounts of impurities into chemicals manufactured on a large scale, the necessity of analyzing each sample of potassium iodide employed in the making of ozonoscopes, is evident.

In order that no unnecessary element of uncertainty, however, should be introduced into the comparison of the various ozone tests employed in this investigation, the potassium iodide was especially made for the purpose. The following method was found convenient, and yielded excellent results :

36 grms. of iodine were introduced into a flat-bottomed half-litre flask, with 250 c. c. water, and then 12 grms. of clean piano-forte wire added in successive portions. The action at first was slow, but increased with the liberation of heat due to chemical combination, and at the close was accelerated by heating on a water-bath, until all brown color had disappeared. To the filtrate, which was of a greenish color, 12 grms. of iodine were added. Potassium carbonate, prepared by ignition of potassium bitartrate, was added, to decided alkaline reaction, and the flask heated on a water-bath, until the precipitate separated in the form of ferrosiferrous hydrate. This precipitate, after filtering, was evaporated to dryness, and washed out carefully to obtain the last portion of potassium iodide. The filtrates were evaporated, and two portions of crystals, amounting to 13.5 grms. and 11 grms., of pure potassium iodide obtained from them. The mother-liquor was then evaporated to dryness, alcohol of 85 per cent. added to dissolve out the iodide and get rid of excess of potassium carbonate, the potassium iodide crystallized from the alcoholic solution, and washed with absolute alcohol, yielding 29.5 grms. of the salt. The total yield was 54 grms. instead of 62, the theoretical amount.

Starch:—In order not to spend time unnecessarily in the examination of starches from various sources, a skillful pharmacist furnished me with arrow-root starch, which he had assured himself by microscopic examination contained no substances of organic origin other than the starch granules. This was washed with large excess of cold distilled water, until the

filtrates afforded no trace of saline matters, and then dried at the temperature of the air.

Paper:—A great variety of papers was examined, and all rejected for one reason or another, except the best Swedish filter-paper. This appeared to have no action on the tests, except possibly upon the thallium and the Moffat. The former, after keeping for some time, was minutely spotted with thallic oxide, and the latter turned brown on the edges. But it is probable that, in the latter case at least, the alteration of the ozonoscope was due to other causes than the paper. The paper might have been treated with dilute acid, and then repeatedly washed with distilled water, in order to remove all the impurities soluble in these menstrua; but this was not done for fear that the paper might be made too fragile to stand much subsequent handling. But fine cotton cloth, treated in this manner, might answer for certain of the tests, better than paper.

Classification of Ozonoscopes:—The most important ozonoscopes hitherto in use, may be conveniently grouped into five classes:

I. Those depending on the decomposition of a metallic iodide, the liberated iodine indicating the reaction. Under this head, the substance almost exclusively used is iodide of potassium. An examination of the tables given below, will show that it is the most sensitive of all the ozonoscopes examined. Unfortunately, the action of ozone does not stop with oxidation of the potassium, but extends to the iodine, so that a paper once brown from free iodine, may become quite colorless again, from the formation of potassium iodate. It is proposed to examine other haloid compounds, especially the iodides of the heavy metals.

II. Class No I, with starch added as an indicator. Very many tests, included in this class, have been proposed. They differ chiefly in the relative proportions of potassium iodide and starch. With some, the comparison is made when dry, in

others after moistening. Or the paper may contain potassium iodide only, the iodide of starch being formed subsequently, by moistening the papers, after exposure, with starch solution. We have added to this list, one new test, containing iodide of cadmium (as representative of the iodides of the heavy metals) and starch. It develops the characteristic blue color of iodide of starch very strongly and persistently on moistening, but is less sensitive than some of the other tests.

III. Those depending upon the alkaline reaction resulting from conversion of the electro-positive element into the form of oxide,—litmus or some similar coloring matter being added as indicator. It will be seen from experiments detailed below, that there are other bodies sometimes present in the atmosphere, which decompose potassium iodide, as well as ozone. But if this decomposition is attended with formation of caustic potash, only when ozone is the decomposing agent, the litmus-paper will be turned blue only in case of the presence of ozone. This was the ground taken by Houzeau, who proposed, and has strenuously advocated, tests of this character. He admits, however, that hydrogen proxide will likewise develop an alkaline reaction. The tables, above referred to, exhibit a similar result.

The best method of preparing these tests is to saturate papers with litmus solution containing about 1 centigramme of litmus in 1 c. c. The litmus must be brought with great care to that shade of wine-red at which it is most sensitive. After drying some of these papers are impregnated with a 1 p. c. solution of potassium iodide and again dried. Papers of both kinds, the plain and iodized litmus, are cut into slips and exposed in pairs. It is expedient to subject these tests to the action of artificially prepared ozone, to see that they are really sensitive. Great differences were found in this manner, between tests not apparently differing much in color. Even the best did not appear so sensitive as some of those in the first and second classes. (See tables.)

Two new tests were added to this class:—the alizarine and phenolphthalein potassium iodide tests, distinguished by the use

of alizarine or phenolphthalein in place of litmus. The alizarine was prepared by dissolving the crystals sublimed from commercial alizarine, in 80 p. c. alcohol.

Papers impregnated with this solution were dried, moistened with a 1 p. c. potassium iodide solution, and dried again. The latter were exposed in strips, along with non-iodized alizarine papers. The phenolphthalein was made by heating 3.3 grms. sublimed phthalic anhydride with 6.6 grms phenol and 1.5 grms. sulphuric acid at 120° — 130° C., for 3 hrs., thoroughly washing the brown resin obtained, which amounted to about 3 grms.,* and dissolving in alcohol.

The phenolphthalein potassium iodide tests were prepared in a manner similar to those of alizarine. It was found, however, that neither of these tests, especially the phenolphthalein, was as sensitive as that made with properly prepared litmus; and their use, after some trials, was therefore abandoned.

IV. Those depending upon the oxidation of a metal or metallic compound, with the development of a corresponding change of color.

The most important ozonoscopes in this class, which have previously been studied, are silver, thallos hydrate, manganous sulphate, and plumbic sulphide. Silver-leaf immersed in an atmosphere containing a sufficient percentage of ozone, is very slowly affected, if at all, except in the presence of moisture. Under these circumstances, its surface is energetically oxidized, with the formation of magnificent yellow, blue, and other films, passing into black at those points at which the formation of argentic oxide has reached a maximum.

Unfortunately, silver is not sufficiently sensitive to ozone. In a vessel containing in every litre of oxygen 1 mgrm. of ozone, the potassium iodide, the iodo-starch tests, the thallos oxide, Houzeau's, and some other tests were affected, before a notable change had occurred upon a moistened silver surface.† It is stated by Houzeau, that when a litre of oxygen containing about 1 centigramme of ozone was passed over silver, blacken-

* See Bayer, Ber. der Deutsch. Chem. Gesell., 1871, p. 658.

† See also Fremy, Compt. Rend., 61, 939.

ing took place, but when the same amount of ozone was diluted with 50 litres of oxygen, the silver was unaffected.* Even the latter mixture contains a far larger amount of ozone than is ordinarily present in the atmosphere, if we accept the determinations of Pless and Pierre,† who found, by titration of the iodine set free on the surface of potassium iodide paper, that 255 litres of air contained but 0.02 mgrms. ozone. Zenger found in 100 litres of air from 0.002 to 0.01 mgrm. ozone.‡

For the present, at least, silver is inapplicable as an atmospheric ozonoscope, not from want of reliability, but from lack of sensitiveness; and the desideratum is to find some ozonoscope which will be similar to silver in its reactions towards the compounds of the atmosphere, and at the same time of adequate sensibility.

The next most important reagent of this class is Thallous Hydrate.§ Small bars of metallic thallium were dissolved in dilute sulphuric acid, the reaction being hastened by the introduction of strips of platinum foil, and thallous sulphate crystallized out in brilliant prismatic needles. A solution of this salt was exactly neutralized with baryta, the filtrate from the barytic sulphate containing 10 p. c. of thallous hydrate. Strips of filtering paper, immersed in this filtrate, were dried over caustic potash under a bell-jar, so as to prevent them, as far as possible, from absorbing carbonic anhydride from the air.

When the ozonoscopes are compared dry, thallous hydrate occupies a very high position, sometimes the 4th or 3d place, but usually the 2nd position. After moistening, the papers of the first three classes exhibit a more striking appearance than the thallium peroxide. This result differs from that obtained by Huizinga, who thought that the thallous hydrate was more sensitive than the iodo-starch tests, when the papers were *freshly* prepared and the solution sufficiently concentrated.||

On examining into the behavior of thallous hydrate, when

* Comptes Rendus, Dec. 18, 1865.

† Jahresb. der Chemie, 1857, 79.

‡ Zenger, Wien. Akad. Ber., 24, 78.

§ Böttger, J. pr. Chem., 95, 311.

|| Huizinga, Journal für praktische Chemie, ci, 321.

exposed to the disturbing influences of the other bodies which may be present in the atmosphere, we found that it was unaffected by nitrous acid, if we except one trial in which the paper turned yellow. This was apparently due to some other cause than the formation of peroxide, which is of a brown color. This confirms the result previously arrived at by Böttger.*

In an atmosphere containing hydrogen peroxide, the thallos hydrate remained white, or if immersed, after having been turned brown by ozone, was bleached. Carbonic anhydride is rapidly absorbed by thallos hydrate, carbonate being formed, which is not decomposed with formation of peroxide in presence of ozone. Thallos hydrate is therefore not applicable to the detection of ozone in the atmosphere, though in the laboratory, to detect ozone in the presence of nitrous acid, it is of great service.†

Manganous sulphate is altogether inapplicable as an atmospheric ozonoscope, whether dry or moist; in the former condition it was scarcely affected at all, in the latter it occupied one of the lowest places in the scale. That there might be no error, from want of care in the preparation of the salt, the recrystallized sulphate was precipitated from its solution in alcohol, and used in making the tests. Thinking that the manganous oxide might be more easily converted into peroxide, if it were in combination with a feeble acid like acetic, some manganous acetate was prepared from the former salt by conversion into carbonate and then into acetate. Tests prepared with this salt did not appear more sensitive than those with manganous sulphate. They had the further disadvantage of being powerfully affected in a dilute atmosphere of nitrous acid, turning dirty brown, while the sulphate was little changed. They likewise became light brown in an atmosphere containing a trace of hydrogen peroxide. The manganous sulphate ozonoscopes contained 10 mgrms. of the salt in each square centimeter of surface. Of the manganous acetate papers, some were dipped in

* Böttger, Jour. pr. Chemie, 95, 311.

† See Lamy, Bull. Soc. Chim., [2], 11, 210; March, 1869.

a concentrated, others in a more dilute solution, but the results obtained with each were identical.

Similar remarks apply to the plumbic sulphide papers, which were so prepared that each square centimeter of surface contained about 10 mgrms. of the sulphide. They were not sensitive. Moreover, in an atmosphere of hydrogen peroxide or nitrous acid, they were bleached.

V. Those depending upon the oxidation of organic bodies, with the development of a characteristic change of color.

The only one of these substances particularly studied, was the resin of Guaiacum. It appeared essential to use this resin in the original masses, for if that which had been pulverized was used, even if it had not been exposed to light, the tincture made from it appeared deficient in sensitiveness. A tincture containing 8 p. c. of the resin was prepared with 90 p. c. alcohol. The papers so prepared had a slight yellow tinge. They were moderately sensitive, acquiring speedily when dry a faint blue color, and when moistened, occupying a position midway between the ozonoscopes most sensitive, and those least so, to the influence of ozone. They were rapidly turned greenish-blue by nitrous acid, and bluish-green by hydrogen peroxide. For these reasons, and on account of their deficient sensibility, they are objectionable as atmospheric ozonoscopes.*

- *Examination of Ozonoscopes under known conditions.* Having prepared pure materials, the following ozonoscopes were made, care being exercised to render them as nearly similar and uniform as the nature of the tests would permit. They were preserved in tightly-stoppered bottles, in the dark, and entirely removed from the laboratory odors. The potassium iodide papers were made with a solution containing 15 grms. of the salt. The proportion of iodide of potassium and starch in the iodo starch papers, is that recommended by the observers whose names they bear. The amount of water is the same in all, in order that the papers compared may be as nearly similar as possible.

* It is probable that the influence of light, as well, would be unfavorable to the employment of organic matters as ozonoscopes.

NAME OF OZONOSCOPE.	POTASSIUM IODIDE.	STARCH.	WATER.
Polli's	2. grms.	1 grm.	60 c. c.
Moffat's	0.4 "	1 "	"
Lowe's (with 0.03 grm. calcium carbonate)	0.2 "	1 "	"
Schönbein's	0.1 "	1.1 "	"
Osann's	0.1 "	1 "	"
Cadmium Iodide 1 grm		1 "	"

The preparation of the other tests is given elsewhere. The tests prepared with great excess of potassium iodide, as recommended by Dr. Polli, were not employed, since they turned brown while drying. The sensitiveness of these tests, as will be seen from the tables, increases, as a rule, with the percentage of potassium iodide. Those of Lowe, which occupy an intermediate position, and are not liable to change on drying, are perhaps to be preferred. Calcium carbonate was added in accordance with the recommendation of Mr. Lowe, in order to secure greater uniformity of action and prevent souring, but we were unable to perceive that the addition was of practical value.*

The tests were separately suspended in a capacious bell-jar, through which a current of ozonized oxygen, containing 1 mgrm. ozone in the litre, was caused to flow very slowly. No attempt was made to screen them from diffused light. In the first place, they were simultaneously exposed, while dry, for certain intervals. The effects were noted, and expressed by numbers, the ozonoscope which had experienced the most striking change, being placed first. They were then moistened, and the results indicated in like manner. Finally, in this moistened condition, they were allowed to remain in the vessel, and their changes noted at the expiration of times indicated in the tables. The effect upon silver is not given, because of its want of sensitiveness, and its inapplicability as an atmospheric ozonoscope.

* E. T. Lowe, Proc. Royal Soc., [12], p. 518.

FIRST SERIES OF COMPARISONS.

OZONOSCOPES.	DRY		MOISTENED		
	HALF AN HOUR.		AT ONCE.	ONE HOUR.	TWO HOURS.
K I.....	Dark Yellow		Brown	Brown	(1) Very brown
Cadmium.....		Lilac	Strong blue	(3) Dark blue
Moffat.....	Violet		Blue	Dark blue	(2) Black
Lowe.....		Faint blue	Dark blue	(4) Blackish blue
Osann.....	(not tried)	
Schönbein.....	"	
Houzeau.....	"	
Alizarine.....	"	
Thallium.....	"	
Manganese.....	(6) Brownish
Lead Sulphide.....
Guaiacum.....		Light blue	(5) Blue

SECOND SERIES.

THIRD SERIES.

OZONOSCOPES.	DRY		MOISTENED	DRY	MOISTENED
	5 MINUTES.	15 MINUTES.	AT ONCE.	15 MINUTES.	AT ONCE.
K I.....	Yellow	Brown (1)	(1)	Dark brown (1)	(1)
Cadmium.....	Yellow (5)	(6) (9)	(9)
Moffat.....	tr.	" (4)	(2)	Grey (5)	(2)
Lowe..... (6)	(3)	Greenish (7)	(3)
Osann.....	Lilac	Violet (2)	(5)	Lilac (6)	(4)
Schönbein.....	(8)	Faint lilac (8)	(5)
Houzeau.....	Blue (2)	(6)
Alizarine.....	(7)	Red (3)	(7)
Thallium.....	tr.	Brown (3)	(4)	Brown (4)	(8)
Manganese.....
Lead Sulphide.....
Guaiacum.....	(not tried)	(not tried)

FOURTH SERIES.

OZONOSCOPES.	DRY		MOISTENED	
	10 MINUTES.		AT ONCE.	HALF AN HOUR.
K I.....	Yellow (1)		Yellowish red (1)	Same as before (1)
Cadmium.....		Blue (6)	Darker blue (5)
Moffat.....	tr. (4)		Bark blue (2)	Same (2)
Lowe.....	tr. (5)		Blue (3)	Same (4)
Osann (not tried).....
Schönbein.....		tr. (7)	Blue (8)
Houzeau (not tried).....
Alizarine.....	Redn'd (3)		Same as before (5)	Same (8)
Thallium.....	Brown (2)		" " (4)	Same (6)
Manganese.....
Lead Sulphide.....
Guaiacum.....	Blue (7)

It will be noted that potassium iodide is the most sensitive test, changing rapidly while dry, using this term to apply to papers having only such hygroscopic moisture as had been attracted from the atmosphere. The thallium papers are also very sensitive. But when exposed for some time, in common with the other ozonoscopes, and then moistened, they fall behind the iodo-starch papers, which occupy an intermediate position between them and the potassium iodide test. The iodo-starch papers arrange themselves in an order corresponding to the amount of potassium iodide they contain, except the cadmium iodo-starch paper, which, unlike the other ozonoscopes of this class, does not, on moistening, after long exposure turn brown, but remains of a persistent blue. In some trials it fell below the thallium, alizarine, and Houzeau tests in sensitiveness. It is important to note that the alizarine and Houzeau tests, whatever may be their other merits, are less susceptible than the potassium iodide and iodo-starch tests; and the manganese and lead sulphide are evidently inapplicable as atmospheric ozonoscopes.

Influence upon Ozonoscopes of constituents of the Atmosphere other than ozone.

OZONOSCOPES WITH NITROUS FUMES (VISIBLE.)

OZONOSCOPES.	DRY.	WHEN MOISTENED BECAME.
K I.....	Brown	(1) Bleached (1)
Cadmium.....	Lower end lilac, upper brown	(2) Bluish-black (2)
Moffat.....	Brown	(5) Dark blue (3)
Lowe.....	Light brown	(6) " " (4)
Osann.....	Lilac	(7) Light blue (6)
Schönbein.....	Light brown	(9) Dark blue (5)
Houzeau.....	Red	(8) Red (8)
Alizarine (with K I).....	Brown }	(10) { Unaltered
" (no " ").....	Yellow }	
Thallium.....	Doubtful	
Manganese Acetate.....	Unaltered }	(11) Brown (7)
" Sulphate.....	" }	
Lead Sulphide.....	Bleached white	(4) " "
Guaiaacum.....	Dark blue	(3) " "

The air in the bell-jar, in which the tests affected as above were suspended, contained nitrous fumes in quantity just sufficient to give a recognizable color; in the following experi-

ment the amount was extremely small, and no fumes were apparent.

OZONOSCOPES WITH NITROUS FUMES (INVISIBLE).

OZONOSCOPES.	DRY.		MOISTENED.
	20 MINUTES	ONE HOUR	TURNUED AFTER 12 HOURS
K I.....	Yellow (1)		Brown
Cadmium	Unaltered	Unaltered	Dark blue
Moffat	Light brown (4)		(1) Dark brown
Lowe.....	Unaltered	Light brown (6)	(2) Brown
Osann	Light lilac (3)		(4) " "
Schönbein	Unaltered	Faint lilac (7)	(3) " "
Houzeau	Reddish (5)		Little changed
Alizarine (with K I).....	Unaltered		Reddened ?
" (no K I).....	"		
Thallium	Light brown		Brown
Manganese Acetate	Unaltered		
" Sulphate	"		
Lead Sulphide.....	"	Slightly bleached (8)	More bleached
Guaiacum	Greenish (2)		Greenish-blue

OZONOSCOPES WITH SULPHUROUS ANHYDRIDE.

OZONOSCOPES.	DRY	MOISTENED	SAME AFTER 12 HOURS
Houzeau	Red		
Alizarine.....	Yellow red		
Manganese Acetate		Turned brown ?	Became white
Lead Sulphide			A little bleached ?
The rest unaffected.....			

OZONOSCOPES (AFTER OZONIZING) WITH SULPHUROUS ANHYDRIDE.

- (1). Potassium iodide and all the iodo-starch papers bleached.
 - (2). Thallium, after having been ozonized to a dark-brown, is bleached.
 - (3). Manganese Sulphate and Acetate remain intensely brown.
 - (4). Guaiacum, Alizarine, and Houzeau test, little affected.
- Carbonic anhydride had no effect on the ozonoscopes, either before or after ozonizing.

OZONOSCOPES WITH HYDROGEN PEROXIDE.

OZONOSCOPES.	FIRST SERIES.	SECOND SERIES.
K I.....	Light yellow (7)	Yellow (10)
Cadmium.....	Faint lilac (8)	Intense blue (6)
Moffat.....	Light brown (2)	Very dark brown (1)
Lowe.....	" " (3)	Dark brown (2)
Osann.....	? (9)	Brown to blue (3)
Schönbein.....	Faint brown (4)	" " " (4)
Alizarine.....	Red (6)	Reddened (8)
Houzeau.....	—	Bluish (9)
Thallium.....	?	Unchanged
Manganese.....	Light brown (5)	(Not tried)
Lead Sulphide.....	Somewhat bleached (10)	Bleached to gray (7)
Guaiacum.....	Blue (fine color) (1)	Beautiful blue (5)

The hydrogen peroxide used in the first series was made from hydrated peroxide of barium, by decomposing with hydrochloric acid. The papers were suspended for about 15 hours over a solution containing 0.0044 grm. of the peroxide. Since the solution, prepared in this way, contained a little acid which had not been entirely removed, and this acid, by reacting with the peroxide, might liberate chlorine,—a second series of trials was instituted. In this, the solution had been prepared by decomposing with carbonic acid, and contained 0.5 p. c. of the peroxide. The ozonoscopes were exposed during a like interval.

In a third series, the papers being exposed for 48 hours during day and night, over a solution containing 0.2 p. c. hydrogen peroxide, Moffat's turned to a brown color, Osann's became brownish-blue, guaiacum a beautiful light blue, alizarine reddened, Houzeau's test apparently changed somewhat in the direction of blue and afterwards was partly bleached, cadmium test became dark-blue, potassium iodide quite white and damp, lead sulphide bleached to gray, silver was not affected. It is probable that the potassium iodide was decomposed, but became colorless again by conversion into iodate. This supposition was strengthened by the damp condition of the paper. The thallium test remained white, thallium peroxide undergoing reduction in contact with hydrogen peroxide,—water and oxygen being liberated.

Action of Ozone upon the Coloring Matter of Flowers:—
In connection with the use of organic coloring matters as ozonoscopes, experiments were made as to the action of ozone

upon flowers. It is well known that indigo solution, poured into a bottle filled with ozone, is instantly bleached. In this case the colorless modification of indigo is formed. But attempts hitherto made to destroy the coloring matters of plants by ozone, have yielded in our hands negative results. These results are striking as compared with those obtained by a reducing agent like sulphurous acid, or with chlorine.

A light red rose was exposed for three hours to a current of $3\frac{1}{2}$ litres of ozonized oxygen, containing a little more than 1 mgrm. ozone per litre. No effect was discernible on either leaves or flower. In sulphurous acid, it was bleached in the course of a few moments, though the chlorophyll of the leaves was unaffected. Returned to the ozone, the blanched petals reddened, showing that the sulphurous acid with which they were impregnated had been ozonized. The same effect was produced by dilute sulphuric acid.

An abutilon, a yellow and a blue pansy, cineraria, red geranium, fuchsia, hyacinth, pink, violet, and heliotrope, were exposed for 18 hours, in a quart bottle filled with ozone. On opening the bottle, no smell, except the perfume of the flowers, was apparent, and none of the flowers had changed except the violet and heliotrope. These had turned slightly brown, due probably to natural wilting. Other specimens of the same flowers were placed in an atmosphere containing sulphurous acid. The heliotrope began to change immediately, and in ten minutes its color had entirely disappeared. The hyacinth followed, and in the same length of time, only streaks of red remained. The bouvardia was nearly white; the fuchsia, japonica, geranium, and cineraria were somewhat bleached; the yellow pansy not noticeably affected. At the end of $3\frac{1}{2}$ hours, the darker portion of the fuchsia was nearly bleached, the geranium had become pink, the blue pansy was of a yellow color somewhat darker than the yellow pansy, the abutilon still unchanged. Flowers of *Salvia splendens*, *Camellia Japonica* (red), *Strelitzia regina*, *Abutilon venosum*, *Abutilon insigne*, *Inga pulcherrima*, *Ixia*, *Cineraria*, *Nasturtium*, *Azalea Indica*, and *Bouvardia*, were exposed for 36 hours to ozonized

oxygen, most of the time to a slow continuous current. A few light spots appeared on the azalea and nasturtium, and there was a slight discoloration of the camellia. Similar specimens, left for 3 hours in an atmosphere containing sulphurous acid, changed greatly: the camellia became lighter in spots and finally pink throughout, the azalea turned yellow and finally white, the *Abutilon venosum* saffron-yellow, the change beginning at the outer edge of the flower, the cineraria was somewhat lighter in color, the *Salvia splendens* white in spots, other portions red.

The *Ixia* had become white, the long ends of the mimosa (*Inga*) were also bleached, the reddish markings of the nasturtium had quite disappeared. The flowers of the *Bouvardia* were bleached at their outer edge; in the *Strelitzia*, neither flower nor leaf was affected. The same is true of the leaves of all the specimens.

After eighteen hours more of exposure, the yellow portion of the *Strelitzia* was not affected, but the blue had become quite white; the mimosa was a faint pink, the nasturtium a deep yellow throughout, and the *Salvia* bleached entirely. Even after this length of time, the chlorophyll of the leaves had undergone no change. When these same flowers were transferred from the sulphurous acid to a current of ozonized oxygen, the azalea turned red on the edges and colored somewhat throughout; the camellia reddened, so likewise the mimosa; the *Abutilon* became red along the veins, the petals of *Ixia* turned red at the edges, the nasturtiums reddened in places, the *Bouvardia* became brown, the *Strelitzia* did not change.

When similar flowers, which had been longer exposed to ozone without change, were placed in an atmosphere containing chlorine, the camellia became buff color, its leaf unaffected; the azalea turned yellow, then white, its leaves partly changing also; the *Ixia* and *Bouvardia* became perfectly white; *Salvia*, yellow-white, its leaves yellow. The red veins of the *Abutilon venosum* were not bleached, but its green calyx and part of the stem were. The leaf of the *Abutilon insigne* was bleached in spots; the leaf and stem of the nasturtium became entirely white. The blue portion of the *Stre-*

litzia was bleached, the yellow in part, the red leaf not affected. Corresponding changes took place in other specimens of these flowers which had not been previously exposed to ozone.

The action of ozone as a bleaching agent differs not only from that of sulphurous acid, as might be expected, but also from that of chlorine; and it is not improbable that its use has been proposed for bleaching in cases where its precise action has been unknown.

It is a striking fact in the economy of nature, that an agent like ozone, which operates as nature's purifier and disinfectant, and energetically destroys decomposing and putrescible organic substances, should have so little action upon the delicate coloring matters of flowers.

My thanks are due to my assistant, Dr. George A. Prochazka, for his co-operation in the experiments detailed above, and to the Rev. S. B. Dod for his aid in the study of flowers.

STEVENS INSTITUTE OF TECHNOLOGY, May, 1878.

XXI. On the Physical History of the Triassic Formation in New Jersey and the Connecticut Valley.

BY ISRAEL C. RUSSELL.

Read May 27th, 1878.

Beds of stratified rock, which have very generally been referred to the same age as the Triassic Formation of Europe, occur in a number of detached areas along the Atlantic border of our continent.

The most northerly of these is found in the Prince Edward Islands, which are formed almost entirely of soft red shales and sandstones, very similar in appearance to the corresponding rocks in New Jersey and the Connecticut Valley. The Triassic sandstones of these islands have yielded the bones of *Bathygnathus borealis*, one of the few relics that have come down to us of the abundant reptilian life of this period.

The rocks of this formation are again exposed on each side of the Bay of Fundy. In New Brunswick, the Triassic area is of small extent, covering but a few square miles in the neighborhood of Quaco Head, about thirty miles northeast of St. John. These beds consist likewise of soft red shales and sandstones, upon which rests a coarse conglomerate,—the whole series dipping towards the northeast at an angle of about thirty degrees. Beneath these rocks the unconformable limestones and conglomerates of the Carboniferous age are exposed.

Along the eastern shore of the Bay of Fundy, the Triassic beds are well shown for a distance of one hundred and twenty-five miles, and exhibit the association of sedimentary and igneous rocks, so frequent in this formation. The sedimentary beds are chiefly shales and sandstones; and the igneous rocks some of the many forms of trap, although at times varying greatly in structure and composition.

These two divisions of the formation seem to be conformable in dip, which, unlike that of the corresponding beds on the opposite shore of the bay, is towards the northwest at an angle of about sixteen degrees. The portions of this formation

which are shown along the sides of the Bay of Fundy, have, therefore, each an inclination towards the longer axis of the bay. This, as we hope to show farther on, is a matter of considerable significance. The eastern shore of the Bay of Fundy is composed of hard igneous rocks, sloping down to the water at an angle, as we have mentioned, of about sixteen degrees, and forming thus an inclined plane, against which the waves break with but little effect. This great ridge of trap, over a hundred and twenty miles in length, acts like a break-water, and has taken no inconsiderable part in protecting Acadia from the inroads of the sea. Where the waves have found a point of attack, on the sedimentary beds eastward of the trap, these have been rapidly eaten away. This may be seen at either end of the trap ridge, where the Basin of Minas has been formed at the northern extremity, and St. Mary's Bay at the southern. At Digby Gut, the break-water has been breached, and the sea, gaining access, has hollowed out the Annapolis Basin. This trap ridge is nowhere more than four or five miles in width, and seems to be the outcropping edge of an immense sheet of trap, conformable with the associated beds of sandstone and shale. Rising with a gentle slope from beneath the waters of the great bay, it attains in some places an elevation of four hundred feet, and usually presents a bold mural escarpment, facing the east. At its northern extremity it forms the picturesque promontory of Blomidon, which is surrounded by the finest coast scenery in Acadia.

To the eastward, the trap ridge is bordered by a narrow belt of Triassic beds, which form a fruitful and beautiful valley. The rocks underlying this valley are the usual red shales and sandstones of the Trias, which rest unconformably on the Carboniferous and crystalline rocks beneath.

In the Connecticut valley, rocks of this age extend northward from New Haven for a distance of one hundred and twenty-five miles, reaching entirely across the state of Connecticut and nearly to the northern boundary of Massachusetts, with a varying width of from five to twenty-five miles. Throughout this whole area the rocks present their usual

appearance of red shales and sandstones, with thick beds of intruded igneous rocks, the whole system dipping eastward at an angle averaging between 15 and 20 degrees.

We shall have more to say regarding the geological history of this area, in connection with the Trias of New Jersey.

The western bank of the Hudson River, from Jersey City northward to Stony Point in Rockland Co., New York, a distance of thirty miles, is composed of Triassic rocks. This is the beginning of a great extent of strata of this age, which stretch southward across the state of New Jersey, through Pennsylvania and Maryland, and far into Virginia,—a length of over three hundred and fifty miles. This belt has its greatest width on the Delaware, where it is thirty miles broad; it is six miles wide on the Susquehanna, and eight on the Potomac. Smaller detached areas of these rocks occur farther south in Virginia and North Carolina, in these states carrying the Richmond coal-beds, and those of Deep and Dan river. Throughout the whole distance from the Hudson to North Carolina, this formation is composed mainly of soft red shales and red and gray sandstones, together with extensive ridges of trap. In the northern portion of this area, the beds dip towards the northwest at an angle of from ten to fifteen degrees. In many cases, owing to local causes, the angle of inclination is much less than this, and sometimes much greater.* In North Carolina the inclination is toward the southwest at an angle of from 10 to 22 degrees.†

In New Jersey, the Triassic formation is separated into three natural divisions; (a) the first of these is a system of RED SHALES AND SANDSTONES, which compose the great bulk of the formation; (b) on the western border of these there occur several detached areas of COARSE VARIEGATED CONGLOMERATE; and both these beds of derivative origin are traversed by (c) dikes and sheets of ERUPTIVE ROCKS.

* See table of dips, Cook's Geology of N. J., p. 195.

† Emmons's Geol. Rep. N. Carolina, p. 231.

THE RED SHALES AND SANDSTONES.

The sandstone, so extensively developed in this formation, is well known to the citizens of New York and the neighboring cities as "brown stone," of which so many of both their public and private edifices are constructed. This reddish or brown sandstone almost invariably occurs interbedded with layers of soft crumbling shale. These are but varying deposits from the same waters, which at one time were charged with mud and deposited shale, and at another time spread out a layer of sand, which at length became consolidated into sandstone.

We can only notice at present a few of the localities where these shales and sandstones are unusually well exposed, referring our readers for greater detail to Prof. Cook's Geology of New Jersey, and to H. D. Rogers's reports on the geology of the same State. The first locality we will notice is on the line of the Montclair Midland Railroad, about four miles westward of Jersey City, and near the village of Arlington. Here the sandstone forms a line of bluffs, which border the Newark meadows on the west, and were doubtless at one time the shore-line. In these bluffs, a deep cut, made for the passage of the railroad, exhibits on its side an interesting section of the alternating layers of sandstone and shale, which, at this point, have an inclination of about fifteen degrees towards the northwest. As this excavation is more than a quarter of a mile in length, and has been cut down to a depth of 60 or 70 feet from the surface, it affords as fine a section of the Triassic rocks as is known to us.*

*Perhaps the most interesting feature in this section is the occurrence near the middle of the cut, of a great fissure which has parted the rocks in a nearly north and south direction, or parallel to their strike. This fissure is about five feet wide, and is filled in with debris from the red sandstone rocks; its walls are altered as if by the action of heat, and when broken are of a bright brick-red color. The fragments filling the fissure are small near the walls and imbedded in an earthy or shaly mass. They are nearly rounded, and show polished or "slickenside" surfaces. The centre of the fissure is filled with large angular masses of sandstone, which show more alteration both in texture and color than the walls, and also show slickenside surfaces.

A few miles southwest of Arlington occur the extensive Newark quarries, where these sedimentary rocks are again well exposed. Here the sandstones are more heavily bedded, the strata being in some cases fifteen or twenty feet thick, with the usual dip of 10 to 15 degrees toward the northwest. These quarries furnish great quantities of fine building-stone, largely used in the neighboring cities, which is composed of grains of quartz and felspar, cemented with oxide of iron and argillaceous material, and sometimes spangled with mica.

Again in Elizabeth, along the New Jersey Central railroad, the red shales and sandstones are well shown for a short distance, and exhibit a striking constancy both in the dip and in the uniform thickness of the strata.

Farther south, at New Brunswick, the red shales are beautifully displayed on the south bank of the Raritan river, about a mile westward of the town. They show their parallel planes of deposition, dipping with extreme regularity at an angle of 15 degrees toward the northwest. These layers are often but an inch or two thick, and very uniform in bedding.

On the Delaware, the Triassic area attains a width of thirty miles—the longest section in any portion of this belt. Throughout this whole distance the rocks present the well-known alternation of sandstones and shales, with the usual northwestward inclination. There are local exceptions, however, along this Delaware section, to the entire uniformity of dip which characterizes these beds in New Jersey,—due to the disturbance which some of the injected trap-sheets have effected in the arrangement of the sedimentary beds.

These few examples have been selected from a great number of exposures examined by the writer, and may be taken as representing the general geological characters of the red

The bedding of the sandstone and shale seems undisturbed where they approach the cleft. The metamorphic action is not confined to the immediate walls of the fracture, but extends at least 75 or 100 feet on either side. These facts seem strongly to indicate that the fissure, not far below, is filled with igneous rock, which reached near enough to the present surface to make its influence felt.

shales and sandstones of this formation in New Jersey, and in fact, save in the inclination of the beds, of all the Triassic areas along the Atlantic slope.

The dip of these strata, be it remembered, is *eastward in New England and northwestward in New Jersey; while in Virginia and North Carolina, two similar belts of Trias exist, with a like opposition in their dips.* [See note A, page 253.]

At many localities throughout the Trias of New Jersey, the beds of sandstone and shale exhibit a thinning out of the strata into wedge-shaped masses, known as current-bedding; this structure indicates the action of rapid and oft-changing currents of water during the deposition of the beds. The surfaces of the layers often exhibit peculiar markings, which aid greatly in determining the physical conditions under which these beds were accumulated.

At many points towards the western border of this formation, as at Plainfield, Bound Brook, Pompton, and Boonton, we have noticed *ripple-marks, sun-cracks, rain-drop impressions, and the foot-prints of animals.* These same occurrences have been recorded as likewise observed at Milford and Tumble Station, in the extreme southwest portion of this area.

When we attempt to gather these scattered pages of nature's records, we are struck with the fact that the markings just mentioned occur most abundantly along the western margin of the sandstone formation. Foot-prints have never been discovered eastward of the central portion. It is well known that ripple-marks on rocks indicate that they were deposited in shallow water, and that shrinkage-cracks, rain-drop impressions, and the foot-prints of animals, are formed where broad areas of muddy shore are exposed at low tide. From these considerations, it may be concluded that the rocks bearing these inscriptions were deposited in a body of water subject to high tides.

To arrive at comprehensive views as to the physical condition of the New Jersey and other Triassic areas, during the

time when these beds were accumulating, it is necessary, in accordance with the uniformitarian principle of geology, to make ourselves familiar with some region where similar sediments are forming at the present day.

Perhaps the very best locality that can be selected for such an examination is the Bay of Fundy. It has been my good fortune to spend a number of weeks on the shores of this interesting bay, during which time I learned many important facts which have been of value to me in studying the Trias.

If we approach the shore of the Bay of Fundy at high tide, we behold a broad expanse of rolling, intensely turbid waters, which fill all the creeks and inlets along the shore and come up to the verdure at our feet. If we return to the same scene at low water, especially if our visit is to some of the upper reaches of the bay, we see, instead of the turbid waters, a wide area of smooth glossy mud, extending far out from the shore, with a diminutive stream of muddy water flowing through the centre. During a warm day this exposed mud-flat sometimes becomes dried and cracked by the sun; or a passing shower will pit many acres of its surface with rain-drop impressions. The retreating waters frequently leave the expanse of mud covered with beautiful ripple-marks, from the nature of which we can sometimes judge of the character of the weather when they were produced. These same mud-flats are also trodden by large numbers of aquatic and shore-loving birds, and not unfrequently impressed by the feet of men and animals. When the next tide comes rushing in, sometimes with an *eagre* or *bore*, much of this surface which had not become sufficiently hardened, is torn up and washed away; but other portions, inscribed with all these records of surrounding conditions and of animal life, are covered with another layer of tenaceous mud, which in its turn is left exposed by the next retreat of the tide, with a smooth or ripple-marked surface ready to receive the records of another series of daily changes. Such, in brief, is the character of the accumulation of mud and sand, now forming on the shores of the Bay of

Fundy. In the deeper waters toward the center of the bay, it is evident that another kind of deposit would be spread out, more homogeneous in composition than the shore formation, although doubtless presenting sudden changes from sand to mud, caused by strong currents sweeping through the waters. These deposits would also differ from those along the shore, in the absence of rain-marks, sun-cracks, and foot-prints.

We may reasonably conclude, therefore, from the character of the deposits now forming, that wherever we find rocks bearing sun-cracks, rain-drop impressions, or the well-defined tracks of animals, that such beds were at one time soft and plastic, and were exposed above the water for at least a few hours. We can in all probability extend our conclusion, and consider that such deposits were formed in shallow water, along the shores of a bay or estuary, subject to high tides. Now, as we have seen, we find all these inscriptions on the Triassic rocks of New Jersey, and in many other portions of the Triassic areas above mentioned. I cannot resist the conclusion, therefore, that the red shales and sandstones of New Jersey were deposited under conditions very similar to those now in action in the Bay of Fundy, and indicate the position of a great land-locked bay in that region during Triassic times. This ancient bay must have been subject to high tides and strong currents, leaving great areas along its shores exposed as mud-flats during low tide; such being the case, we must conclude that a great subsidence occurred, to allow of the accumulation of shore deposits, or even mud-flats, throughout such a great thickness as is here indicated. A corresponding sinking of the bottom is now in progress in the Bay of Fundy, and in many other localities.

It is by no means certain, however, that no displacements occur in the area under consideration; yet none have been reported, and none have been observed by the writer—excepting three or four very small faults, with a displacement of a few inches each, at Boonton. It has occurred to me that the nearly parallel trap ridges that traverse these rocks in a

general north and south direction, may indicate the existence of lines of displacement. Until such faults have been shown to exist, however, we can only look upon these shales and sandstones as a continuous series of estuary deposits, slowly accumulated during long ages of subsidence. Admitting this view, we cannot estimate the thickness of these beds at less than twenty-five thousand feet. Such an immense deposit of sediments, bearing through a great part of their thickness the unquestionable evidence of shallow water and even mud-flat origin, cannot fail to strike with astonishment the student of the physical history of the Trias. Yet, after long study of this formation, and a residence of many years within its borders, we cannot arrive at any other conclusion. The only escape seems to be found in the possible existence of faults and displacements, as yet unrecognized.

Prof. Rogers* accounts for the accumulation of these beds of red sandstone and shale, and also for their inclined position, by assuming the existence, in the Triassic period, of a great river which, rising in North Carolina or Georgia and flowing northward, emptied into the ocean near the present mouth of the Raritan, in New Jersey. Prof. Rogers holds that the sediment forming the Triassic beds was brought by this river and deposited in its present inclined position, dipping, as we have seen, at an average angle of 10 or 15 degrees, but in some cases much more inclined. Such a supposition appears to us entirely contrary to the almost universal mode of deposition, which, especially for any considerable area, is always approximately horizontal. The thin even bedding of many of the layers of soft shale, which are frequently continu-

* The views advanced by Prof. Rogers (Final Report Geol. of N. J., 1840, pp. 163-171) are quoted in full by Prof. Mather in his report on the geology of the southern portion of New York (Geology of N. Y., Part I, pp. 289-293.) He agrees with Prof. Rogers in the main, but ascribes the deposition of the Triassic beds to the meeting of equatorial and polar oceanic currents: see page 192 of his report.

Prof. Rogers's theory is dissented from by Elisha Mitchell, in his book entitled "Elements of Geology, with an outline of the geology of North Carolina," p. 133.

ous for considerable distances, as near New Brunswick, also stands opposed to such a theory. The deposition of thin even layers of sediment, on surfaces inclined at an angle of from 10 to 40 degrees, has never been recorded as occurring at the present day. This theory, moreover, that these beds were deposited in an inclined position by a flowing river, does not allow for the formation of sun-cracks, rain-marks, foot-prints, etc., which occur so abundantly in these rocks. Again, the foot-prints which we have found at a number of localities in New Jersey, show no indications of having been impressed on a sloping surface.

We cannot avoid the conclusion that the sandstones and shales of this formation were spread out as nearly horizontal sheets of sand and mud, although their wedge-shaped bedding indicates that they must have been subjected to strong currents. As they are now inclined to the horizon at an angle of about 10 to 15 degrees toward the northwest, the only reasonable conclusion seems to be that they have been uplifted and tilted into their present position.

The trap-sheets in this formation, of which we will speak more fully further on, are beds of hard crystalline rock, usually conformable with the associated sandstones and shales. Owing to the denudation of these softer sedimentary beds, the more compact trap has been left as a series of hills, which have a gentle slope to the westward, corresponding to the dip of the sandstones and shales, and present steep mural escarpments to the eastward. In the valley of the Connecticut, we find this order reversed. The association there is the same as in New Jersey, viz, sandstones and shales bearing sun-cracks, rain-drop impressions, foot-prints, etc., and also traversed by sheets of trap. The whole system, however, is inclined to the eastward at an angle of from 5 up to 50 degrees.* The trap sheets in this valley, which usually conform in dip to the associated sedimentary beds, have their steep escarpments facing the west, and slope gently to the eastward.

* Hitchcock's *Ichnology of Mass.*, p. 10.

Between these two Triassic areas we find a belt of highly metamorphosed rocks, which appears at the surface in the southern part of New York and in the western portion of Connecticut. A section through this region would show the arrangement indicated in the following diagram:

FIG. 1. *Diagram showing the relation of the Triassic beds in New Jersey and Connecticut.*

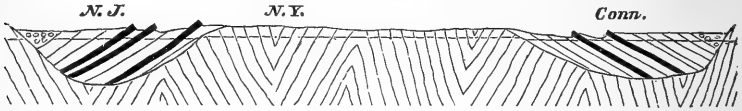

Applying to such a section—disregarding for the moment the thickness of the beds—the usual method of geological reasoning, the conclusion at once presents itself that the inclined Triassic beds in New Jersey and Connecticut are but the flanks of a great arch, the upper portion of which has been removed by denudation. The idea here advanced is that the red shales and sandstones of New Jersey and those of Connecticut, were once continuous, extending horizontally over the intervening region of crystalline rocks, and that they were afterwards elevated, the axis of upheaval passing southwestward through southern New York. We have reached this conclusion not only from observing the inclination of the beds under discussion, which has suggested the same idea to other geologists, but, also, from the study of the character of the sediments forming the flanks of this great arch.

Were it possible to make a section through the deposits now forming in the Bay of Fundy, we should find, at either end of the line, thin-bedded strata of mud and sand, bearing the familiar records of shallow water and mud-flat conditions. Between these shore-deposits, we should find a broad area of deep-water formation, more constant in composition, and lacking the peculiar markings of the shore deposits.

In studying the Trias in New Jersey, we have found that foot-prints, rain-drop impressions, etc., occur most abundantly along the western margin of the formation, and are seldom if

ever found in the eastern portion. Taking this as an estuary formation, it is evident that it is incomplete; that we cannot point out the deep-water accumulations of the central portion of the estuary, with its borders of shore deposits. We do find, however, abundant indications that the beds to the westward are shore deposits, which change imperceptibly into the deeper water formation to the eastward.

In the Valley of the Connecticut, the fact that foot-prints occur only along the eastern side of the Triassic area, was noticed by Prof. Hitchcock, who gives this as one of his reasons for dividing the red sandstone of that valley into two separate formations.* This fact is brought out on plate II of the above report, where it will be seen that all the foot-prints that have been discovered occur in the eastern portion of the formation. With these foot-prints, rain-drop impressions and sun-cracks are abundant, proving that the eastern border of this area was the low muddy shore of the estuary in which these rocks were accumulated. Hitchcock states † that "all along the west side of the valley, even to Long Island Sound, we find a coarse, thick-bedded sandstone * * * * It is rare to find interstratified shales or any other rock in this sandstone." We thus find that the Triassic area in the Connecticut Valley, like that in New Jersey, is an incomplete estuary deposit, the eastern shore of which is well-defined, while the beds along the western border indicate deeper water conditions.

In search of further information in this connection, we will pass on to the consideration of the

VARIEGATED CONGLOMERATE.

The name of the Variegated Calcareous Conglomerate was given by H. D. Rogers to a coarse conglomerate which occurs at a number of localities along the western border of the Triassic area in New Jersey. This rock is for the most part a peculiar coarse thick-bedded conglomerate, resting conformably upon the shales and sandstones beneath. The junction of

* *Technology of Mass.*, p. 19. † *Technology of Mass.*, p. 10.

this coarse deposit with the underlying beds may be studied at Pompton, at Boonton, and on the Delaware. The conglomerate is composed of angular as well as worn and rounded pebbles and boulders, derived mainly from the crystalline rocks to the westward, and in many cases of large size, frequently from sixty to a hundred pounds in weight. The geographical distribution of this deposit is given with some minuteness in Prof. Rogers's final report on the geology of New Jersey, to which we must refer our readers for further detail.

After describing the different localities where this conglomerate occurs, Prof. Rogers seeks to explain its origin by assuming* "a violent agitation of the whole belt of country, and the vertical rising of the bed of the red shale valley to a higher level, which would necessarily set into motion the entire body of its waters. These, rushing impetuously along the shattered strata of the base of the hills confining the current to the northwest, would quickly roll their fragments into that confused mass of coarse heterogeneous pebbles which we see, and strew them in the detached beds of conglomerate which they now form." "The protrusion of the trap, the formation and deposition of the conglomerate, and the elevation and final drainage of the whole red sandstone basin," are considered in this report as simultaneous events, and also that "the whole time occupied by these stupendous changes must have been extremely brief, compared with the period which produced the main mass of the materials of the basin."

After visiting several exposures of this interesting conglomerate, and studying its geological relations, it seems to us needless to call into play any of the cataclysmal forces so frequently appealed to in the early days of geological inquiry. To us, the beds of conglomerate skirting the western border of the Trias in New Jersey, have a history very similar to that of many other coarse conglomerates, differing but little in their mode of accumulation from the beds of pebbles and rounded stones found along many coasts at the present day.

*Rep. Geol. of N. J., 1840, p. 171.

If we examine the map which accompanies Prof. Rogers's report, on which the areas of conglomerate are delineated, we find that each patch of conglomerate occurs just where a stream leaves the highlands to the westward, which are composed of crystalline rocks, and becomes the broader and more quiet river of the sandstone country. In other words, these masses of conglomerate are situated opposite the extremities of valleys in the crystalline rocks, which must have been the mouths of rivers in the Triassic period.

At Pompton, where the Ringwood and Pequannock rivers leave the highlands, we find the most northerly of the patches of conglomerate mentioned by Prof. Rogers. At Boonton, at the mouth of the deep valley through which the Rockaway river flows, is another heavy bed of this deposit. In each of these cases, as we have mentioned, the coarse accumulation of stones and gravel rests conformably on the rocks beneath, which were deposited in more quiet waters. The next area of conglomerate to the southward is at the mouth of the Lamington river. Again, southward of this, where the Spruce Run and the South Branch of the Raritan leave the highlands, we find the conglomerate largely developed. The rocks in these southern areas hold a large amount of calcareous pebbles, and at times are cemented together by a calcareous cement. Specimens of this rock will sometimes take a good polish, and resemble closely the Potomac marble, which is, indeed, but another exposure of this same series of conglomerates, farther south on the Potomac. In the southwest corner of the State, we find the largest development of this conglomerate which occurs in New Jersey, just at the point where the Delaware leaves the crystalline rocks and begins its course through the beautiful pastoral valley which it has excavated through the red sandstone country. This same series occurs all along the western boundary of the Triassic formation in Pennsylvania,* and extending through Maryland, appears again, as we have mentioned, on the Potomac, and can thence be traced southward to the James River.

* H. D. Rogers's Rep. Geol. Penn., Vol. II, p. 681.

The extent of these several areas, moreover, and the coarseness of the conglomerate composing them, seem connected with the size of the valleys which traverse the crystalline rocks westward of each deposit. Thus, on the Delaware, the largest of the streams flowing down from these highlands, there is exposed for two miles along the bank of the river an immense deposit of this conglomerate, the stones composing it being in some instances a hundred pounds in weight.

From the above considerations, we conclude that these beds are shore deposits, derived chiefly from the accumulation of pebbles and rounded masses of rock, at the mouths of the rivers which drained the highlands of New Jersey in Triassic times.

These ancient rivers, like their modern representatives, must have been impetuous mountain streams, capable of pushing great quantities of rounded stones and other debris along their beds. The transportation of material in this manner is exemplified at the present time by the carrying power of the Rock-away river at Boonton. The slag from the iron works at this place, situated just within the border of the crystalline rocks, has for many years been thrown into the river, which has washed it away, and carried thousands of tons of this material for a distance of two or three miles down the stream. Where the waters become broader and less impetuous, upon entering the red sandstone country, the slag has been deposited in immense quantities, so as greatly to obstruct the flow of the stream and damage the adjacent meadows.

A swift river, upon flowing into more quiet waters or meeting the waves and currents of an estuary, would deposit the stones and gravel brought down from the valley through which it had flowed. Such an accumulation would have a fan-shaped form, with its greatest thickness near the mouth of the river, and becoming thinner and composed of finer material on its outer margin. Should the current of such a river vary with the seasons, or be affected by floods and drouths, the coarse material would be carried farther from shore when the river-current was swiftest. During seasons when the river was less energetic, the deposit of mud and sand, brought in by the waves and

currents, would overlap the beds of conglomerate, and thus an alternating series would be produced. This succession of beds of coarse river-debris and the finer sediments of still water, seems to have occurred at Boonton, where the evenly-bedded slates with sandstone, in some places so rich in the remains of Triassic fishes, occupy a position between two beds of coarse conglomerate. On the banks of the Delaware, beds of the conglomerate are separated by intervening beds of red shale.*

The original position of these conglomerate deposits is shown in the following diagram, where (a) represents the ancient shore-bluffs of crystalline rocks, (b) the wedge-shaped section of the beds of conglomerate brought down from the highlands, and (c) the sandstone and shale which are the ordinary shore and off-shore deposits.

FIG. 2.—*Showing relations of the Shore Conglomerate and the Red Shales and Sandstones—(looking north).*

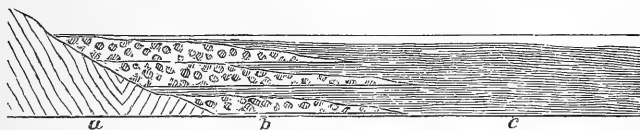

If such a series of beds were tilted up at an angle of 10 or 15 degrees, and the edges of the shale cut away by denudation to a horizontal surface, we might have a single bed of conglomerate exposed, resting conformably on a deposit of slates beneath, as in the section at Pompton; or if two beds of conglomerate came to the surface, with slates and sandstones between, it would present the conditions now to be seen at Boonton. If the accumulation was on a large scale and many alternations occurred, a section would be exposed like that along the banks of the Delaware, in describing which Prof. Cook says:† “A red shaly rock alternates with this conglomerate. The latter is generally in beds, from one to ten feet thick, and with less shale between them towards the northwest. The dip is 15°–20° N. 60° W. The conglomerate thins out in cer-

* Rogers's Geol. Rep. of N. J., 1840, p. 140.

† Geol. of N. J., page 209.

tain strata and the shale takes its place. * * * This conglomerate is seen along the river for a distance of two miles." Further on in the same description, Prof. Cook mentions that "The vertical section along the river exposes a thickness of between two hundred and three hundred feet of conglomerate and interstratified shales."

We cannot agree with some geologists who have held that this conglomerate is a peculiar and distinct deposit capping the red sandstone series. On the other hand, it seems very evident that it was formed contemporaneously with the beds of shale and sandstone with which it is associated, and may have accumulated at many distinct horizons in the Triassic series.

While examining the geology along the banks of Minnesongo Creek, in Rockland County, N. Y., I had an opportunity of testing these views in reference to the origin of the variegated conglomerate. Tracing this stream from where it empties into the Hudson near Stony Point, northwestward towards its source in the Highlands, I found it first flowing between banks of sand and clay, which form a terrace along the banks of the Hudson. Following up the stream, a fine exposure of the the Triassic shales is soon reached, near the little village of Stony Point. The banks are here about fifty feet high, and show interbedded layers of compact light-colored limestone, the most continuous of which is about fourteen inches in thickness. A few hundred yards above this, the stream comes down in a series of small cascades, which fact indicates at once that a change has occurred in the geology of its bed. On examination, I found that these rocks were unmistakably a portion of the series of variegated conglomerates, of which we have spoken. The nature of this deposit is beautifully shown, both in the bed of the stream and in the banks on either hand. The rock is a coarse breccia from 150 to 200 feet thick, composed of fragments of limestone and granite rock derived from beds in the upper portion of the valley, imbedded in a paste of red argillaceous material. Where this deposit is first met with in going up the stream, the red cementing material is more abundant than it is farther above, and the beds of conglomerate—breccia

in this case—are parted by seams of incoherent sand and shale. Beyond this, and abutting against the hornblende gneiss which composes the foot-hills of the Highlands, the conglomerate becomes more compact, with less shale and larger fragments of included rock. In every respect, even to minute details, this exposure exhibits the features which I had previously decided should occur when a stream like the Minnescongo Creek flows down from the highlands and enters the sandstone country. [See note B, page 254]

It may be gathered from the above that I look upon this variegated conglomerate as emphatically a *shore deposit*. If it is desired to trace the boundaries of the Triassic estuary in which these red shales and sandstones accumulated, it is evident that it can be done by noting the position of the coarse deposits that formed along its shores. The western shore-line is thus clearly defined, from Stony Point on the Hudson, all the way to the Potomac, and far into Virginia. In fact, a glance at the bold line of bluffs, composed of crystalline rocks, which rises to the westward of this belt of conglomerate, and stretches away in a series of blue receding headlands, leaves but little doubt that this was the ancient shore against which the waves broke and retreated millions of years ago.

When we go eastward in quest of the band of coarse shore deposits which should mark the eastern outline of the Triassic estuary, we can find no indications of such a deposit in New Jersey. All along the bank of the Hudson, from New York Bay to Stony Point,—the eastern boundary of the present area of this formation—the sedimentary strata are exposed in various places beneath the trap rocks of the Palisades, but always, with one exception, presenting their appearance of red shales and sandstones. This one exception is opposite New York city, under the heights of Weehawken, where the trap rests upon a coarse arkose, which sometimes contains pebbles an inch or more in diameter, together with angular fragments of felspar. This deposit, however, is of limited extent, and does not resemble the formation of which we are in search.

If we go farther eastward and cross the crystalline rocks

which separate the Trias in New Jersey from that in New England, we come first to the outlying mass of these beds in the towns of Southbury and Woodbury, Conn. There we find but the ordinary succession of shales and sandstones with trap rock, all inclined to the eastward. This little Southbury area is separated by fifteen miles of crystalline rocks from the Triassic region of the Connecticut Valley, where, it will be remembered, this formation extends northward from Long Island Sound for about 125 miles, the beds having a very constant inclination to the eastward. All along the western margin of this area, as we have already mentioned, are the ordinary shales with thick-bedded strata of sandstone. But on crossing the Triassic rocks in the Connecticut Valley, we find on the eastern margin a peculiar coarse conglomerate, corresponding with the one along the western border of the New Jersey Trias. In speaking of this deposit, Prof. Hitchcock says:* “Still farther east, on the very margin of the valley, we find a coarse conglomerate in a few places, of quite peculiar character. It is made up chiefly of fragments of slaty rock, argillaceous and silicious, such as we find in place farther north, among the metamorphic strata. The fragments are sometimes several feet in diameter, and the stratification of the rock is very obscure. It looks in fact like a consolidated mass of drift.”

In the geological report of Connecticut, † Mr. Percival speaks particularly of a “coarse conglomerate along the eastern border of the large secondary formation, which can be distinctly traced to different varieties in the adjoining Primary, frequently in the immediate vicinity;” and farther on, he mentions that “generally on the immediate border of the Eastern Primary, a coarse conglomerate occurs.”

The only conclusion which it seems possible to draw from these facts is that this line of conglomerate in Massachusetts and Connecticut marks out a portion of the eastern shore of the Triassic estuary whose western border we followed in New Jersey.

* *Ichnology of Mass.*, p. 11. † Page 428.

We have now concluded the examination of three distinct series of facts, and have arrived in each case at the same conclusion, viz, that the red sandstones and shales of New Jersey and of the Connecticut Valley are the marginal portions of one great Triassic estuary deposit. The several lines of proof which have brought us to this determination may be briefly stated as follows:

1st. That the rocks in the two areas dip in opposite directions, indicating that they are portions of one great anticlinal.

2d. That each area in itself is an incomplete estuary formation, possessing only one line of shore deposits.

3d. That the variegated conglomerate which borders the New Jersey area on the west, corresponds in character and position with the coarse conglomerate along the eastern edge of the Connecticut Valley portion, and thus maps out the eastern and western shores of the estuary in which the Triassic rocks were deposited.

4th. We must add to these considerations the occurrence of an outlying mass of Triassic beds in the towns of Southbury and Woodbury, Conn., which seems to be a remnant of the sedimentary rocks which once connected the Triassic areas of New Jersey and New England. This little isolated patch of Trias in the valley of the Housatonic, is but six or seven miles long, with a width of less than two miles.* Its escape from the destruction which removed the beds that once surrounded it, seems owing to its sheltered position and to the resistance offered to denudation by the sheets of trap that compose a great part of what remains. This oasis of Triassic rocks is separated from the corresponding formation in the Connecticut valley by a distance of fifteen miles, and from the New Jersey area by forty miles, of crystalline rocks. It seems to us probable that yet other patches of Trias may be discovered in the region between the two great areas of this formation, especially the remains of trap sheets or dykes which might have

* Percival's Geol. Rep. of Conn., 1842, p. 410.

been forced out in places far distant from the main outbursts.

5th. The line of mountains and bluffs, bordering the Trias on the west, may be traced as has been said, from the Potomac to the Hudson. It does not end here, however, but extends on far to the northeast. An observer standing on the Hook Mountains at Haverstraw, has a magnificent panorama spread like a map before him, the view toward the north and west being limited by a great range of rounded and truncated mountains. Starting far to the southwest, beyond the reach of vision, these highlands become more distinct and sharply outlined as their course is traced towards the Hudson, where the great Dunderberg towers up, but a few miles away; crossing the Hudson, the same line of headlands, with no change in its topographical features, stretches away towards the northeast as far as the eye can reach, becoming blue and misty in the distance. We know that the line of highlands on the left is the old Triassic shore; and it is impossible to deny the fact that the mountains to the east of the Hudson are but a continuation of the same range, and must also have been washed by the waters of the same estuary. If we wish to restore in fancy that broad landscape as it appeared in Triassic days, we have but to clothe those grey hills with a tropical growth of ferns, cycads, and conifers, and replace the level country at our feet with rolling turbid waters. I have but little doubt that this ancient coast-line can be traced far to the northward through Connecticut and Massachusetts, to where it must once have been connected with the other coast east of the Connecticut River. The banks of the streams that flow southward from these highlands, if closely examined, should reward the explorer with the discovery of some remnants of the formation which once covered this country; patches of the variegated conglomerate, especially, may be looked for just southward of this Triassic coast-line.

Before discussing the physical history of this formation, as given in the translations we have made from the records on the strata, we must pass to the consideration of the third great

division of the Triassic series in the State of New Jersey :

THE ERUPTIVE ROCKS.

In New Jersey the Triassic area is traversed by three main ridges of trap rocks, besides several much smaller detached hills and ridges of the same structure. Of these ridges, the first to claim our attention, and the largest of the series in the State, commences in the extreme northern extension of the Trias in Rockland Co., New York, and extends southward along the western shore of the Hudson as far as Jersey City. This is the outcropping edge of an immense sheet of crystalline rock which conforms in bedding to the associated sandstones and shales, and presenting an almost perpendicular face to the eastward, forms the picturesque Palisades which give to our noble river some of its most beautiful scenery. The height of this ridge is about one thousand feet at Haverstraw, and gradually diminishes southward, until at Bergen Point it is scarcely above low water. On Staten Island it appears again, but as we follow it southward it soon becomes covered with Cretaceous clays, and is no longer observable at the surface.

What seems to be the southern extension of this same trap-sheet, appears again south of New Brunswick, and extends to the Delaware River, and over into Pennsylvania. This immense sheet of eruptive rock, which traverses the entire length of the Triassic area in New Jersey, forms a great curve over seventy-five miles in length, with its convex side to the eastward and its ends bent sharply toward the west. It is remarkable that this peculiar curved outline can be traced, as we shall see, in almost all the trap ridges of the Trias. About nine miles westward of the central portion of the Palisade range, we find a second curved ridge of trap nearly parallel in outline with the first. This is known as the First Newark Mountain, which is about 40 miles in length, with an average height of three or four hundred feet. Like the Palisade range, it slopes gently westward, and presents a steep mural escarpment towards the east. Again, westward of this and concentric with it, we find the somewhat larger and broader range of the Second Newark Mountain. These two are separated by the

Washington Valley, in which the red sandstones and shales appear, with their usual dip toward the northwest. For further details of the geographical features of these trap ridges, we must again refer the reader to the geological reports of Professors Rogers and Cook.

In the Connecticut Valley, we find another series of trap hills traversing the Triassic formation of that section.* These ridges, like those in New Jersey, are usually sheets of igneous rock conformable with the associated sandstones and shales. As we have already seen, the sedimentary rocks in these two areas dip in opposite directions, and consequently the trap ridges slope gently to the eastward in the Connecticut Valley, and present steep mural escarpments facing the west. Like the ridges in New Jersey, also, those in the Connecticut Valley show a curved outline, but the convex side is towards the west, while the ends are bent sharply eastward, and like the New Jersey trap ridges, end abruptly when they approach the crystalline rocks. All these features are apparent at a glance upon examining a geological map of these regions; and we also see that the trap rocks are almost entirely confined to the area covered by the Triassic sedimentary beds.

The trap rocks of New Jersey and the Connecticut Valley are also nearly identical in their lithological peculiarities. They are usually composed of an intimate combination of hornblende with some form of felspar, forming different varieties of dolerite, diabase, etc. At times they are amygdaloidal, and contain quartz, calcite, and a great variety of zeolites, in their cavities. Again, they become basaltic in structure and form prismatic columns. Besides these indications that the trap rocks have cooled and consolidated from a state of fusion, we find also that in many cases where the shales and sandstones come in contact with these erupted rocks, the former have been changed from their normal condition and greatly metamorphosed both in color and structure. The occurrence of indurated shales associated with trap, is mentioned by Percival in

* For details see Hitchcock's Geol. Rep. of Mass., and Percival's Geol. Rep. of Conn., 1842.

his report on the geology of Connecticut, and may be observed at many points beneath the trap-sheets in the Connecticut Valley. In New Jersey, the proof that the trap rocks are truly intrusive in their nature, is abundant. In this connection the reader may refer to an article by the present writer, in the *American Journal of Science*,* from which we quote the following passage :

“It is not difficult to find the junction of these igneous rocks with the shales and sandstones that underlie them. In all such cases that have come under our notice, the stratified rocks have been found to be highly altered, and show very plainly that they have been exposed to intense heat. At a number of places beneath the trap rock forming the Palisades on the western shore of the Hudson, this change may be observed ; in some instances the sandstone beneath the trap has been metamorphosed into a compact vitreous quartzite. At the Falls of the Passaic, the junction of the igneous rocks with the altered sedimentary rocks beneath, is well exposed. We have also observed similar indications of the action of great heat at a number of places in the shales and sandstones beneath the trap rocks in the neighborhood of Plainfield, New Jersey.”

The proof that the shales and sandstone that rest upon the trap have been metamorphosed and greatly changed from their normal condition, is given in the same article. The observations prove definitely that the trap rock was forced out in a fluid state between the layers of the sedimentary beds, and altered the latter at the surface of contact, by the intense heat to which they were exposed. The trap in some instances appears as a true dike, breaking directly through the stratified rocks and showing at a glance its intrusive nature. An instance of this kind is described and illustrated in Professor Cook's geological report.†

Ever since we commenced the study of the physical history of this formation, we have been impressed with the manner in

* “On the Intrusive Nature of the Triassic Trap Sheets of New Jersey.”—*Amer. J. Sci., Third Series*, Vol. II, p. 277 (April, 1873).

† *Geology of N. J.*, 1868, p. 204.

which every fact, as it came to our notice, seemed to have had a place pre-arranged for it in the course of events which we are seeking to follow. We find this to be the case, also, with the Triassic traps. From their uniformity of structure and composition in both New Jersey and the Connecticut Valley, and from the striking analogy in their geological arrangement in the two areas, the decision seems inevitable that all these various sheets and dikes of trap must have a common history. This conclusion is especially indicated by the fact that the trap rocks are almost entirely confined within the borders of the red sandstone regions; and not only is this the case in the localities mentioned above, but also in every Triassic area along the Atlantic coast.

If we now return to our view of the previous condition of the Triassic sedimentary beds, viz., that they were spread out as horizontal layers of sediment at the bottom of an ancient estuary, we shall be able, I think, to find the place in the history to which the trap rocks should be referred. We have shown that the bottom of this ancient estuary must have been upheaved, in order to place the stratified rocks along its borders in the position which they now occupy. It may be that this upheaval was due to the formation of another anticlinal fold, like those of older date which form the Appalachian mountains to the westward. But it also seems as if, in addition to this folding of the strata, there must have been a force acting vertically upward. This movement was the reverse of the slow subsidence which had previously taken place, and which allowed the shallow-water deposit to attain such an immense thickness.

It is evident that when such a great movement of the earth's crust occurs, a time will come when the flexure of the rocks is no longer possible, and fracture must take place. The question arises as to where such fracturing will occur and what will be the direction of the fissures formed. We have, as the first condition of the problem, an immense basin-shaped depression in the crystalline rocks,—a hundred miles in its shorter diameter; the elevation of an area fifty to seventy miles wide takes place along its longer axis. The line of greatest strain will

evidently occur in the bottom of the smaller side-arches, which are bordered on one side by the rigid metamorphic rocks surrounding the basin, on the other side by the upheaved portion in the center. Such an upheaval, it appears to us, must result in the fracture of the rocks along the sides of the estuary in lines nearly parallel with the axis of upheaval. We know that elevations of the earth's crust are often due to the expansion of the igneous matter that exists beneath large portions of its surface. When a fracturing of the rocks occurs above these reservoirs of lava, the force that caused the upheaval is expended in driving the molten rock upwards, into or through the super-imposed strata.

This is what we conceive took place when the axis of crystalline rock was upheaved, which separates the Triassic areas in New Jersey and the Connecticut Valley. The trap, escaping through the fractures in the metamorphic rocks beneath, was forced upwards among the sandstone strata, sometimes opening their layers and forming sheets of injected matter, at other times traversing fissures that cut through the bedded rocks, and so forming trap dikes.

The protrusion of the trap could not have taken place until the upheaval had culminated. As we cannot but believe that the upheaval was gradual, and that the work of erosion must to some extent have kept pace with it, the relative elevation of the country would not have been much greater than it is at the present time. For this reason, the trap sheets could never have extended far beyond their present limits. Some of them, as we have seen, never reached the level of the present surface of the country. That these trap ridges have suffered considerable denudation, is shown by the vast amount of trap boulders that are strewn to the east and south of the exposures of this rock in the drift area, and by the fine light-colored earth and angular blocks of trap, that are found along their flanks in the driftless region to the southwest.

That the force which opened the layers of the sedimentary rocks and forced out the trap in a molten state, was sufficient, when confined beneath the surface, before the fractures in the metamorphic rocks occurred, to upheave the central por-

tion of the old estuary,—can be judged by the igneous rocks in the two areas under consideration. In New Jersey, the Palisade range is a hundred miles in length and several hundred feet high. The parallel concentric ranges in the central portion of the state, are each nearly fifty miles in length, and of great thickness. The outcropping edges alone of the trap sheets in New Jersey cover an area of 130 square miles. In the Connecticut Valley, the intrusive rocks are on an equally grand scale.

From our determinations, the outbursts of trap occurred after the sedimentary rocks had been consolidated and upheaved, and at the time when the elevation terminated. With this thought before us, we can understand the connection which plainly exists between the trap rocks of New Jersey and those in the Connecticut Valley, all of which must have been forced out from a common reservoir and have a corresponding history. Here, too, we find the reason why the trap sheets are confined to the red sandstone area, and are unconnected with any other system of eruptive rocks. The peculiar “canoe-shape,” which these trap ridges present, is only intelligible when we remember that the molten rock, after escaping through the fissures in the floor of the estuary, would find its way to the surface along the lines of least resistance, which are now projected on the surface by the ridges of trap.

GENERAL CONSIDERATIONS.

We are fully aware of the extent of the areas, the magnitude of the forces, and the great lapse of time, implied in such an interpretation as we have given of the Triassic history. As we have said before, the only way by which we can avoid these vast proportions, is the possible occurrence of faults in the Triassic rocks, which may have caused us to reckon the thickness of certain strata more than once. Until plausible reasons are shown, however, for suspecting such faults to exist, we are obliged to reckon the thickness of these rocks in the usual manner. From the dip of the beds and the breadth of country across

which they extend, it is evident that this formation cannot be less than 25,000 feet in vertical thickness. This is equivalent to saying that a mass of stratified shales and sandstone, at least 25,000 feet thick, has been removed by denudation from all the country which separates these two formations. This does not imply, however, that a mountain as high as the Himalayas once stood over the site of New York city.

As soon as the forces of upheaval had brought to the surface the bottom of the estuary in which these rocks were formed, the waves would begin to cut away the shore, and the rain, and perhaps the frost, to disintegrate and carry off the material exposed to atmospheric denudation. The degradation of the Triassic sandstones and shales, wherever exposed, must at all times have been rapid. The material which now forms the surface in these regions is very readily disintegrated. The layers of shale are usually so incoherent as to be easily picked to pieces with the fingers. It is evident that beds of this character cannot withstand for any considerable time the destructive action of the elements, before which even the most rugged mountains are constantly crumbling away.

Large portions of the country composed of Triassic rocks are scarcely above the level of high tide. The average elevation of the surface of this formation in New Jersey, exclusive of the trap ridges, is probably less than one hundred feet. Even at the present day, when the denudation is nearly at a minimum, all the rivers and brooks become turbid and loaded with sediment whenever a heavy shower passes over the country. The carrying power of these streams would be greatly increased were the country more elevated; and the degradation of their basins would be proportionately accelerated.

These rocks, however, which yield so readily to denudation at the present time, are the older and doubtless the more compact members of the Triassic series. The beds that composed the surface of this formation were probably much less compact, and when first upheaved could offer but little resistance to wear. The upper portion of the area upheaved, too, may have been fractured in a manner similar to that which took place in

the depressions along the sides, and the work of erosion may thus have been greatly aided. The fissure which we have described as occurring at Arlington, may be one of such a series. The suggestion also presents itself that the course of the Hudson might have been directed by this same means. When we remember that these beds have been exposed to denudation since the Triassic period, and have passed through the tremendous destruction caused by the glaciers and glacial rivers of the Ice Epoch, we cease to question the fact of their former great extent, but wonder, rather, that a vestige of them still remains.

It has been suggested as an objection to the extension of the Triassic beds over the southern part of New York and the western portion of Connecticut, that the crystalline rocks of this region show that they have suffered greatly from erosion, and must, therefore, have existed above the level of the ocean, and been subjected to degradation, for many ages. The view that this area has suffered denudation by the action of the elements, is without doubt correct. But that this erosion took place during the *Triassic* period, is far from having been proved. These crystalline rocks are supposed to belong to the Eozoic age, and, so far as we are now able to judge, existed as dry land throughout the Silurian, Devonian, and Carboniferous ages. During the Triassic period, however, if our views are correct, this surface was submerged, as already stated, and the Triassic beds deposited on the eroded surface of the crystalline rocks beneath. This ancient land surface was also again exposed to denudation, after the soft Triassic sediments had been removed.

In describing the extent of the degradation in the Uintah Mountains,* Major Powell states that the upheaval of these mountains began at the close of the Mesozoic age, and that the total amount of upheaval in the axial region was more than 30,000 feet. "Second, *pari passu* with upheaval, degradation progressed; and in some places along the axial portions of the region this degradation amounts to more than 25,000 feet, and the mean degradation is three and one-half miles; and from the entire area there has been a total degradation of 7095 cubic

* *Geology of the Uintah Mountains*, p. 201.

miles." It is to be remembered that this vast amount of material was removed *after the close of the Mesozoic age.*

Every geologist is familiar, from the writings of Lyell, Logan, and Dawson, if not from personal observation, with the wonderful "Section of the South Joggins," on the eastern shore of the northern portion of the Bay of Fundy. There the geological traveler may follow for a distance of ten miles a shore section of Carboniferous beds dipping uniformly towards the southwest, at an angle of 19 degrees. Included in the great number of strata that are exposed in these shore dips, there occur more than seventy seams of coal. The vertical thickness of these beds is given by Dawson as 14,000 feet.* Although this mass of sediment is less in thickness than the amount we have assigned to the Triassic beds, yet it represents a far greater period of time and a physical history that is full as interesting. While standing on this shore, which presents one of the finest geological sections in the world, and observing the cliffs composed of steeply inclined sedimentary beds, stretching away on either hand as far as the eye could reach, I attempted to restore in fancy the mighty arches of which the strata in the level-topped cliffs are a portion, but found it impossible to form even a dim idea of the magnitude and extent of the degradation which had there taken place.

The extent to which the surface of our country has yielded to the forces of denudation, has never been as fully studied and illustrated as it deserves to be. Sections drawn on a large scale, and having the same value for vertical as for horizontal distances, serve to bring out these features very forcibly. This method has been very successfully employed by Professor Ramsey, in his paper "On the Denudation of South Wales and the Adjacent Counties of England."† Although the sections obtained in Wales are not so extensive as many which our country affords, yet degradation is shown to have occurred there on the grandest scale. In speaking of the denudation in South Glamorganshire, Ramsey states that "it is not unlikely

* *Acañian Geology*, 1868, p. 151.

† *Mempirs of the Geol. Survey of Great Britain*, Vol. I, p. 297.

that, including all the rocks from the old red sandstone upwards, 9,000 feet is not the greatest vertical denudation which these rocks have suffered."

Examples like these, illustrating the tremendous waste which has affected nearly every portion of the earth exposed to atmospheric agencies, might be multiplied without limit. We only give those noticed above, in order to show that an immense denudation of the Triassic rocks of New Jersey and New England, is a necessary result of their upheaval.

We have, moreover, in the vast amount of material composing the Triassic beds themselves, another striking example of the extent of denudation. These strata, as we have seen, cover thousands of square miles over our country, and are many thousand feet in thickness, yet in the language of geology, they are derivative rocks, and owe their accumulation to the wear of pre-existing formations. To find the source from which this material was derived, it is only necessary to notice the region from which the Triassic estuary received the drainage. The country surrounding the Triassic area, on nearly all sides, is formed of granitic rocks, which, as is well known, are composed of the minerals quartz, felspar, and mica. The disintegration of this material furnished an abundance of quartz sand and mica, while the felspar sometimes appears as angular fragments, but is usually decomposed and affords the more earthy material of the shales. All these products of the disintegration of the land, upon being delivered to the estuary waters, would be rapidly assorted; the coarser material would be left near the shore, and the rest carried out by the current and deposited at various points, determined by its specific gravity, the strength of the currents, etc. We can also trace the large amount of iron which colors the greater portion of the Triassic beds, to the same source. Prof. A. A. Julien has shown, by a microscopical examination of the Triassic sandstones, that the iron which they contain was mainly derived from the decomposition of the hornblende and chlorite so abundant in the band of crystalline rocks surrounding the Triassic areas of New Jersey and the Connecticut Valley. This region is also

rich in mines of magnetic iron ore, which may have furnished some portion of the coloring matter spread so uniformly through the sandstones and shales.

From the coating of oxide of iron which covers so great a portion of the grains in the Triassic sandstones, it seems that they were deposited rapidly, and not subjected to a long washing on the beach, which would have removed the coloring matter, and left them light-colored like the ordinary beach-sand at the present day. The angular character of the grains of felspar which occur abundantly in the sandstones, points to the same conclusion.

A great extent of Triassic beds must be concealed beneath the more recent formations—the Cretaceous and Tertiary—of New Jersey, and also probably beneath the ocean. The land which separated the Triassic estuary from the open ocean, and yet admitted the free access of the tides, must have existed to the eastward of the present coast. The marine deposits which formed outside of this barrier in the Triassic period, are now submerged. These views, although incapable of direct proof, are strongly supported by the fact that the true border of the continent, as shown by the U. S. Coast Survey, lies at least 80 miles eastward of the present shore-line.

The Theory of Separate Basins.

In Le Conte's *Elements of Geology*, the inclination of the Triassic beds in the Connecticut Valley, is briefly accounted for by supposing that they were deposited horizontally in a basin of crystalline rocks, and that one side of this area was upheaved and the higher portion of the sedimentary beds cut away by denudation.* Such a supposition implies that each area of Triassic beds, as existing at present, represents about the extent of the basin in which it was deposited. We should find, were this the case, that each area would show the records of shallow water and mud-flat conditions along its sides, and of deeper-water accumulations through its center. This, as we

* Page 441, Fig. 695.

have seen, is not the case either in New Jersey or the Connecticut Valley. These views, also, fail to explain many of the peculiar relations that exist between the two separate portions of this formation. The little outlying mass of these rocks in the valley of the Housatonic, instead of being a remnant left by denudation, must be looked upon, in the light of this theory, as a distinct deposit formed in a isolated basin.

This view, moreover, requires as great an amount of subsidence and sedimentation as the one advanced in this paper, and as great an amount of vertical upheaval, which instead of occurring with a transverse axis a hundred miles in extent, must have been confined to the narrow limits of each separate valley. [See note C, page 254.]

As a synopsis of the views advanced in this paper, we may state briefly ;

1st. That the facts which we have gathered as to the physical history of the Triassic beds of New Jersey and the Connecticut Valley, tend strongly to show that these two areas are the borders of one great estuary deposit, the central portion of which was slowly upheaved, and then removed by denudation.

2d. That the trap-sheets were derived from a reservoir beneath the estuary deposits, and represent in part the force that caused the upheaval. The outburst of trap, as we have seen, must have been the closing event of the Triassic changes, and have occurred after the sedimentary beds had been upheaved and eroded.

3rd. The detached areas of Triassic rocks occurring along the Atlantic border from New England to North Carolina, seem fragments of one great estuary formation, now broken up and separated through the agency of upheaval and denudation.

These broad generalizations have been reached by simply following the path marked out by well-authenticated facts. Having two portions of an arch given, we have endeavored to reconstruct the curve.

Since reading this paper before the Academy, my attention has been called to the fact that Professor Kerx, in his report on

the geology of North Carolina,* has briefly described the relations of the Deep and Dan River Triassic areas in that State, and arrived at conclusions which are strikingly similar to those advanced in this paper. The two Triassic areas in North Carolina are separated by 75 to 100 miles of crystalline rocks. The Dan River beds, situated northwestward of the Deep River area, have an inclination of about 34° N. W.; while the Deep River beds dip 20° S. E. Prof. Kerr considers these two narrow areas of this formation as the fringing or marginal portions of an eroded and obliterated anticlinal. Curiously enough, it is stated that the original thickness of these beds could not have been less than 25,000 feet. This coincidence is very interesting to me, as my determination regarding the former extent of the New Jersey and Connecticut areas was reached before Prof. Kerr's account of the North Carolina section came under my notice.

NOTE A.—In the southern portion of the Trias, the dip is southwestward in the detached areas just east of the Blue Ridge, and extending southward from the Potomac to the Dan River in North Carolina. Eastward of this line, another series of Triassic beds is found, as in New England, with an inclination to the eastward. These extend from Mt. Vernon to Richmond, and occur also on the Deep River in North Carolina.

NOTE B.—The view here advanced as to the origin of the Variegated Conglomerate, receives still further support from the fact that most of the material composing these deposits agrees in its character with that of the rocks forming the ancient shore against which they rest and from which they must have been derived. Thus at Pompton and Boonton, the conglomerate contains a great many pebbles and boulders of gneiss and associated rocks corresponding with the material of the line of bluffs to the westward. On the Minnesongo Creek, however, we find this deposit largely composed of limestone pebbles, doubtless derived from the beds of the same nature just north of the old shore-line. This limestone formation appears on the Hudson in the conspicuous white cliffs a short distance above Stony Point. A similar identity between the material of the conglomerate and the rocks from which it must have been derived, may be observed also in New Jersey, where the conglomerate becomes highly calcareous, and on the Potomac,

* Rep. Geol. of North Carolina, Vol. 1, page 141.

where it forms a peculiar brecciated marble, used for the columns in the Capitol at Washington.

NOTE C.—There remains still another parallel between the deposits now forming in the Bay of Fundy and those laid down in the old Triassic estuary. At the northern end of the Bay of Fundy are the Tantra marshes, covering thousands of acres, and evidently produced by the filling up of that portion of the bay. The material forming these prairie-like marshes is in many places a carboniferous mud, fitted under the necessary conditions to form a carbonaceous shale or slate, in which vegetable impressions and the remains of animals now living would not be wanting. Such a swamp deposit, formed on the border of a great estuary subject to extremely high tides, would suffer many interruptions, and be less regular than the coal deposits of the great carboniferous marshes. We may reasonably infer that the geologist of future ages will find in the region now occupied by the Bay of Fundy a great formation of sandstone and shale fringed on either side by shore deposits, as already said, and at the northward passing into an irregular accumulation of carbonaceous shales, slates, and sandstones, in many places rich in fossils, and perhaps also carrying coal.

Turning now to the Trias, we recognize, as already shown, the deposits of the open estuary in Connecticut, New Jersey, etc., but far to the south, in Virginia and North Carolina, we find the swamp deposits of the same estuary in the coal fields near Richmond and those on the Deep and Dan Rivers. Here are conglomerate, carbonaceous sandstone, and shales, together with beds of coal which are sometimes of great, though irregular thickness. These deposits appear in rapidly changing successions, and were evidently formed in the swamps on the border of the Triassic estuary, where the shores were low and favorable to such conditions. These accumulations of carbonaceous material along the swampy shores, we consider synchronous with the beds of sand and mud found in the open waters of the same old estuary. This seems to us a very simple and natural explanation of the occurrence of coal only in the extreme southern end of the region of Triassic rocks, and of its absence in the northern areas. It is the reversal, as regards their relative position, of the swampy shore and open bay conditions now to be observed in the Bay of Fundy

The coal-bearing areas at the south, like the conglomerates fringing the borders of the Trias to the northward, must alike be classed as shore deposits. They enable us to trace still farther the outline of the ancient estuary in which these now detached remnants of Trias were deposited.

XXII. *Description of a New Species of Cypselidæ, of the Genus Chætura.*

BY GEORGE N. LAWRENCE.

Read November 11, 1878.

Chætura Dominicana.

Chætura poliura, Lawr. (nec Temm.), Proc. U. S. Nat. Museum, p. 62.

MALE. Upper plumage smoky-black; lores black; rump dark ash; upper tail-coverts brownish-black, just edged with whitish; tail glossy black, the spines fine and projecting for nearly a quarter of an inch; wings glossy black; throat dark grayish-ash; breast and abdomen of a warm smoky-brown; under tail-coverts brownish-black; bill black; feet yellowish-brown.

Length (fresh), 4 5-8 inches; wing, 4 1-2; tail, 1 5-8.

The female is similar to the male in plumage.

Habitat, Dominica.

Types in National Museum, Washington.

Remarks. In my Catalogue of the Birds of Dominica (Proc. U. S. Nat. Mus., 1878), I referred this species, provisionally to *C. poliura*, Temm., being partly induced to do so because that species was noted from Tobago, comparatively a not very distant point. I then stated that it agreed quite well with the measurements given of that species by Mr. Sclater, in his Notes of the Cypselidæ (Proc. Zool. Soc., 1865, p. 593), but that the wing was shorter. The measurement of 3 7-8 inches, given by me, was taken from Mr. Ober's note, and is clearly an error, as, in the four specimens sent, the wings of each measure 4 1-2 inches.

Quite lately I received a collection made in Tobago by Mr. Ober, and found in it an example of *C. brachyura*, Jard., which Mr. Sclater says, "Does not seem to be decidedly different from *C. poliura*, Temm., although the tail is rather shorter

and the upper coverts are much produced, so as to reach nearly to the end of the rectrices." In Mr. Ober's example from Tobago, the upper coverts reach quite to the end of the tail-feathers.

The species from Dominica is very distinct, and I think is undescribed. The Tobago bird is blacker above, and has the abdomen also black; it is at once distinguished by its light ashy upper tail-coverts.

The only other species requiring notice, if it really does, is the *Hirundo acuta*, Gm., from Martinique, which does not seem to be recognized by late writers, and is not noticed by Mr. Sclater in his Notes of the Cypselidæ. The locality given for it, viz., Martinique, is what has induced me to allude to it.

Gmelin's name is based upon the "Sharp-tailed Swallow" of Latham, who gives the size as that of a wren, "length three inches and eight lines;" he cites Buffon and Brisson. It is "L'Hirondelle noire acutipenne de la Martinique" of Buffon, Pl. Enl., No. 544. He describes it as being very small, the size of a wren, the length 3 inches and 8 lines; the whole upper part of the body without exception black, etc., the wings extending beyond the tail eight lines. Boddært refers this to *H. pelasgia*, Linn., but they do not agree in size or color.

It is "*Hirundo Martinicana*" of Brisson, who also gives its size as that of a wren, and its length 3 inches 8 lines; alar extent 8 inches; wings extending 8 lines beyond the tail; he names all the upper parts as being black, among them the uropygium.

The Dominica bird differs strikingly from this, the length being 4 7-8 inches; alar extent, 10 1-2 inches; the wings extending two inches beyond the tail, and the rump being ashy.

This Martinique species, if correctly described, remains yet to be rediscovered.



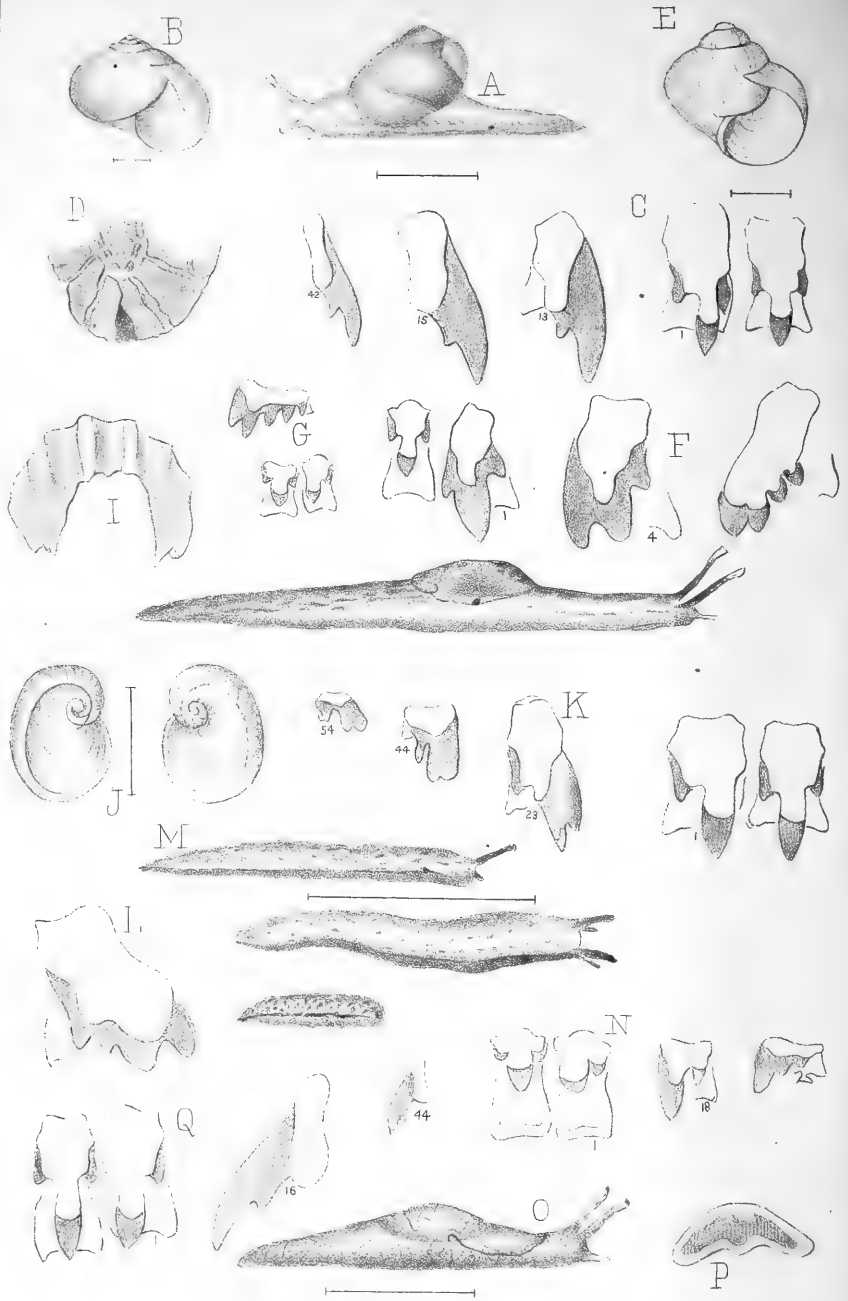

XXIII.—On the Jaw and Lingual Dentition of certain Costa Rica Land Shells collected by DR. WILLIAM M. GABB.

BY W. G. BINNEY.

(WITH PLATE XI.)

Read December 23d, 1878.

Among the specimens of land shells collected in Costa Rica by the lamented Dr. Gabb, were several preserved in spirits. These were submitted to me by him. I have examined the jaw and lingual dentition, and here offer the results of my examination. The original figures of the living animals, as drawn by Dr. Gabb, are also given, and his notes incorporated in the text. It will be seen that Dr. Gabb discovered two new genera.

*Velifera**, n. g.

Animal † (pl. xi, fig. A), heliciform, blunt before, tapering behind; mantle subcentral, thin, furnished with one or more ‡ accessory processes which cover most of the shell: respiratory, anal, and generative orifices,—?; a distinct locomotive disk: longitudinal furrows above the margin of the foot, meeting over a simple, longitudinal mucus-pore (pl. xi, fig. D.)

Shell (pl. xi, fig. B) imperforate, globose, very thin, polished; whorls few the last very large, scarcely falling at the aperture: aperture slightly oblique, large: peristome acute.

Jaw with smooth anterior surface and beak-like projection to the cutting edge.

Lingual membrane (pl. xi, fig. C) with the general arrangement of *Zonites*: the first laterals have an inner side cutting point: marginals aculeate, with side spur.

Although this animal does not combine the characters of any described genus, it is related to several by its separate characters. It has the caudal mucus-pore, and the jaw, of *Zonites*; but differs in having an appendiculate mantle. In

* Velum, a covering, a veil; fero.

† Animal heliciforme, antice obtusum, postice attenuatum, pallium tenue, subcentrale, appendiculatum, testam velans; apertura respiratoria, analis, et genitalis,—?; discus gressorius distinctus; porus mucosus caudalis.

Testa imperforata, globosa, tenuis, nitens, paucispira, anfr. ultimus globosus; peristoma acutum.

‡ As Dr. Gabb's figure gives the left of the animal, it is impossible to describe these processes correctly,

the latter character it also differs from *Vitrinoconus*. It has the shell, and probably, the appendiculate mantle, of *Helicarrion*; but that genus has a horn-shaped process over its caudal pore.

Its lingual membrane resembles that of *Limax agrestis* in having the inner, abnormal side cutting point to its first lateral teeth. All the marginals are bifid.

For geographical distribution see below, under *V. Gabbi*.

Velifera Gabbi, n. sp.

Animal (pl. xi, fig. A) blunt before, tapering behind: greenish, with a continuous black band above the margin of the foot, and a second band broader and a little higher up, broken by oblique light lines; median line of back nearly white: mantle apparently with two processes, one on the right, the other on the left, half enveloping the shell. It has the peculiarity, when distressed, as with the warmth of the hand, of throwing itself, like a worm, with vigorous blows of its tail. Caudal pore without overhanging process (plate xi, fig. D).

Shell (pl. xi, fig. B) imperforate, globose, very thin, pellucid, dark greenish brown; suture impressed; spire short, elevated; whorls 3; aperture rounded, slightly oblique: peristome simple, flexuose above, scarcely reflected below. Greater diam. 6, lesser 5, height 3 mill.

Locality, Flanks of Pico Blanco, 3000 feet.

For jaw and lingual dentition, see generic description.
Teeth, 30-12-1-12-30.

Plate xi, fig. E, represents a species very nearly allied to, if not identical with, *V. Gabbi*, from 3000-6000 feet elevation of Pico Blanco. It resembles in outline D'Orbigny's figure of *Helix progastor* (Voy. l'Amér. Merid., pl. xvii, fig. 12-15). I received a lingual membrane as belonging to this shell, and figure it on plate xi, fig. F; though I cannot help suspecting that it belongs to some species of *Bulimulus*. I did not myself extract it from the shell.

Cryptostrakon,* n. g.

Animal (pl. xi, fig. H, central figure) slug-like, cylindrical, attenuated behind; mantle slightly anterior, thin, small, oval, entirely covering the shell; distinct locomotive disk?; no caudal mucus pore; respiratory orifice on the

* *Κρυπτος, οστρακον*, concealed shell.

right of the mantle margin, slightly in advance of the centre: genital and anal orifices—? *

Shell internal (pl. xi, fig. J) rudimentary, unguiform, large, membranous, protected by an epidermis?, without distinct septa, a spiral arrangement, indicated above by depressed lines, below by raised ridges.

Jaw (pl. xi, fig. I) high, solid, decidedly arched, ends scarcely attenuated; anterior surface with a few stout ribs, denticulating the lower margin.

Lingual membrane (pl. xi, fig. K) as usual in *Polygyra*, *Stenotrema*, &c. Long and narrow. Central teeth tricuspid, laterals bicuspid; marginals quadrate, irregularly bicuspid, the inner cutting points the larger and bifid.

Known only by *C. Gabbi*, described below.

This curious slug may at once be distinguished from all others by its rudimentary shell, entirely concealed by the mantle, and of about similar size. The shell has no distinct whorls, but a spiral arrangement is indicated on the upper surface by impressed lines, on the lower surface by a raised spiral ridge. The edge of this ridge is reflected, in dried specimens, for about one-half whorl, giving a *Halotis*-like character to the shell. The shells of *Mariella*, *Gæotis*, and *Parmella* are somewhat similar to this, but those genera differ widely in their other characters, especially the jaw and lingual dentition. Indeed, there is no known slug combining all the generic characters of this, so that I am forced to suggest a generic name.

The dried animal reminds me of *Semper's* figure (Phil. Arch.) of dried *Vitrinopsis*, on account of the small size of the dried body compared to that of the shell.

* Animal limaciforme, subcylindricum, postice attenuatum. Pallium subcentrale, tenue, paululum anterior, parvum, ovatum, testam includens. Discus gressorius? Porus mucosus nullus. Apertura respiratoria ad dextram pallii in parte vix anteriori marginis. Apertura genitalis et analis—?

Testa interna, magna, membranacea, (epidermide protecta?) unguiformis paucispira.

Maxilla solida, valde arcuata, costis paucis validis exarata.

Lamina lingualis ut in *Polygyra*, *Stenotrema*, &c. Dentes centrales tricuspidatæ, laterales bicuspidatæ, marginales quadratæ, irregulariter bicuspidatæ, papillis internis majoribus, bifidis.

Cryptostrakon Gabbi, n. s.

(Pl. xi, fig. H.) Animal varying from black to shades of brown, and variously mottled with black or dark brown; usually a little greenish on the shell; darkest posteriorly. Length of dried specimens corresponding to size of Dr. Gabb's figure.

Internal shell (pl. xi, fig. J) rudimentary, about 14 mill. in greatest length; with concentric lines of growth; very membranous; about two whorls are indicated (see generic description).

Jaw strongly arcuate, ends blunt, but little attenuated; anterior surface with two stout decided ribs, denticulating either margin, and several other subobsolete ribs (pl. xi, fig I).

Lingual membrane (pl. xi, fig. K) long and narrow. Teeth 52-1-52, with 22 laterals, the 23d tooth having its inner cutting point bifid. Marginals low, wide, with one inner, long, wide, oblique, bluntly bifid cutting point, and one outer, short cutting point.

Locality, Flanks of Pico Blanco, 5000-7000 feet elevation.

Limax semitectus, Mörch ?

Plate xi, fig. O, is copied from an original drawing by Dr. Gabb, of a slug found by him on plantain leaves and stalks at Borubeta on the Uren, Costa Rica, altitude 2500 feet. From his notes it appears that the color is dark brownish-green; no spots; generally wrinkled. Length 0.7 inch. Head slender and projecting considerably beyond the mantle; tail very short, barely perceptible under the mantle. From dried specimens brought by Dr. Gabb, I am confident that the mantle and orifice of respiration are as given by me in fig. O. The size of the mantle suggests the identity of the slug with *Limax* (*Megapelta*) *semitectus*, Mörch, Jour. Conch., VI, p. 282, t. 10, f. 7. (*Limax*, *Krynickia*, *semitectus* of same author, 1857, l. c., p. 341). From the specimens preserved in spirits, I cannot detect the orifice of respiration, but evidently there is a locomotive disk, an internal shell like that of *Limax*, and the jaw of *Limax* (pl. xi, fig. P).

The lingual membrane (pl. xi, fig. Q) is long and narrow. There are 44-1-44 teeth. The centrals have side cusps and cutting points. The laterals, 12 in number on each side of the central, are bicuspid; the marginals are aculeate, all of them

are bifid by having the side spur often found on the side marginals in this genus. The 13th, 14th, and 15th teeth form the transition into the marginals.

Glandina (a large species not yet identified).

The lingual membrane is as usual in the genus. There are 33-1-33 teeth.

Helix (a small unidentified species).

Jaw not observed.

Lingual membrane (plate xi, fig. G), long and narrow. Teeth 15-1-15. Centrals with a base of attachment longer than wide, with lower lateral expansions; reflection large, decidedly tricuspid, each cusp surmounted by a cutting point. Laterals like the centrals, but asymmetrical and consequently bicuspid. Marginals low, wide, irregularly denticulated or serrate, the inner three cutting points being longer than the outer ones, of which there are several.

Locality, Upper Tirili River.

Tebennophorus.

There are several drawings of slugs of this genus, apparently all referable to one species. It may be that described by Mörch (Mal. Blatt., VI, 109) as *Costaricensis*.

Several of these figures are given in plate xi, fig. M.

The jaw of this is strongly arched, of equal width to its blunt extremities. There are subobsolete anterior ribs about the centre of the jaw, the ends of five of which denticulate the cutting margin.

The lingual dentition is figured on plate xi, fig. N. There are about 28-1-28 teeth. The centrals have a long base of attachment, with a strong line of reinforcement running parallel to its margin at the lower edge and for a short distance at the sides. The reflection is small, and bears a short, stout median cusp, and small stout side cusps, all three cusps bearing short, stout cutting points. The lateral teeth are like the centrals, but asymmetrical by the suppression of the inner cusp and cutting point and the inner lower expansion of the base of attachment. The marginals are but a modification of the laterals, the inner cutting point not becoming bifid, though

the outer one is so on the extreme marginals. There are hardly more than twelve perfect laterals. The change into marginals is very gradual.

Veronicella ———.

Jaw as usual in the genus: 30 to 40 ribs.

Lingual membrane as usual in the genus. See Terr. Moll. U. S., v, 240.

The species is unknown to me. Its body is long and narrow.

Bulimulus Irazuensis, Angas.*

Pl. XI. fig. L, represents an extreme lateral tooth of this species. The laterals are extremely numerous, reaching quite to the outer edge of the membrane, without changing into marginals. I could not detect the central or first lateral teeth.

The jaw is of the same type as that figured by me (Ann. Lyc. N. H. of N. Y., 1875, XI, pl. XVI, fig. A) of *B. limæoides*, Fèr. The median ribs in this species, however, are very oblique. In all there are about 32 ribs.

* Proc. Zool. Soc., Jan. 1878, 73, Pl. V, figs. 17-20.

EXPLANATION OF PLATE XI.

Fig. A	VELIFERA GABBI,.....	Animal in motion.
B	Shell.
C	Lingual Dentition.
D	Caudal mucus-pore.
E	same?.....	Shell.
F	Lingual Dentition.
G	Small species of Helix.....	Lingual Dentition. The extreme marginal on a larger scale.
H	Cryptostrakon Gabbi,.....	Animal in motion.
I	Jaw.
J	Rudimentary Shell.
K	Lingual Dentition
L	<i>Bulimulus Irazuensis</i> ,.....	Extreme lateral tooth.
M	<i>Tebennophorus</i>	Animal.
N	Lingual Dentition.
O	<i>Limax semitectus</i> ?.....	Animal.
P	Jaw.
Q	Lingual Dentition.

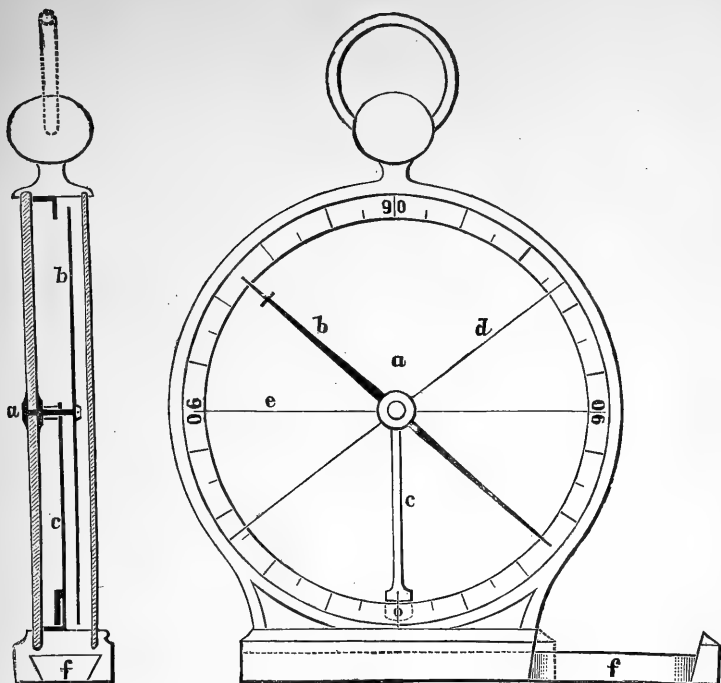

XXIV. A New Form of Compass-Clinometer.

BY ISRAEL C. RUSSELL.

Read June 10th. 1878.

In the accompanying figure, a vertical projection and section are given of a combination of clinometer and compass, recently constructed by Mr. William Gruno (the well-known instrument-maker at Columbia College, N. Y. City), after a drawing made by the writer. This instrument is watch-shaped in outline, with a base on which to place it, for the purpose of determining the inclination of surface. The sides are of glass, which enables the observer to look through the instrument in order to measure angles at a distance. The outer rim and base are of brass, cast in one piece, and accurately finished. One of the glass sides is securely fastened in its place, and, through

a hole in its center, supports the axis, *a*, which carries the compass-needle, *b*, and the clinometer pendulum, *c*. The other glass plate, with the line *d* drawn on its surface, admits of being revolved around its center, in the same manner as the faces of some aneroid barometers. The graduated circle, which answers for both compass and clinometer index, is secured between the glass plates, as shown in the section. This circle is divided from zero at the bottom, each way to ninety degrees, and then from zero to ninety degrees again. Between the ninety-degree points on each side, a cross-wire, *e*, is stretched, which is horizontal when the instrument is held so that the clinometer pendulum is at zero, and assists the eye in determining distant angles; or a line may be drawn on the fixed glass plate, which will answer the same purpose.

When the instrument is held before the eye, with the pendulum at zero, if the movable face is revolved so as to make the line on the glass coincide with the sloping surface of a mountain, for instance, the observer can at once read from the index the angle which such an object forms with the horizontal line.

When the inclination of a surface is required, the rod, *f*, is drawn out, so as to make the base as long as possible, thus securing greater accuracy, and the base of the instrument is then applied to the inclined surface. The clinometer pendulum will indicate the angle of dip. It is well to place a strip of board on the sloping surface beneath the instrument, in order to avoid errors arising from the unevenness of the rock-surface. If this precaution were always taken, the extension-rod in the base might be dispensed with. The bearings of objects, the strike of out-crops, etc., are obtained in the usual manner, with the aid of the magnetic needle.

Although this form of clinometer is more accurate when of large size, yet as a pocket-instrument, one of two and a-half inches in diameter answers every purpose. I have found this instrument of special service in measuring the dip of strata, the edges of which are exposed in inaccessible cliffs.

XXV.—*The Structure of Colored Blood-Corpuscles.*

BY LOUIS ELSBERG.

Read December 16th, 1878.

The discovery of red corpuscles in the blood was one of the first results of microscopical study, over two hundred years ago. Since that time no other constituent of the body has been more frequently examined. Nevertheless, the structure of colored blood-corpuscles has not heretofore been ascertained.

I.

The examination of a small drop of fresh human blood, mixed with a drop of a from 40 per cent. to 50 per cent. saturated solution of bichromate of potash, and highly magnified,¹ reveals in the course of a few hours the following:

Perhaps the first thing noticed, is that the colored corpuscles vary in size.

Having made a number of measurements,² I can state that in every person's blood that I have examined, there are some as small as, or smaller than, the $\frac{1}{3875}$, and in nearly every person's some as large as, or larger than, the $\frac{1}{2767}$ of an inch in diameter (*i. e.*, .00655 and .00917 Mm.), with transitional sizes between these. The extremes are sometimes not met with in

(1) My investigations were made with a 1-12 immersion objective, manufactured by Tolles of Boston, and a No. 12 immersion made by Véric of Paris, either of which, with the eye-piece that was used, magnifies about 1000 times. An exceedingly thin cover having been oiled near the edges, the drop of blood obtained from a pin-prick in the palm of the hand, and transferred on a slide, is mixed with a drop of the solution previously prepared, covered, and without delay placed on the microscope stage. By a 50 per cent. saturated solution, I mean a saturated solution diluted with an equal quantity of distilled water: by a 40 per cent., one containing three-fifths water; by a 60 per cent., one containing two-fifths water, etc.: I always prepare a saturated solution, and then dilute.

(2) I used with the Tolles' lens, and central illumination, in the eye-piece a micrometer-scale ruled with great exactness by Grunow of New York, each division of which was ascertained by the Standard Stage Micrometer of Rogers, N. S. No. 3, belonging to Mr. Fred'k Habirshaw, of New York, to measure, with the objective, eye-piece, and cover-adjustment employed, a 1-15,500, and each sub-division a 1-77,500 part of an inch.

each field of a drop, nor even in every drop of a person examined; but I have not found any adult of either sex, from whose blood the smaller extreme was absent, and only *very few* without the larger. I have repeated the measurements of blood-corpuscles without the addition of the reagent—both with and without oiling the edges of the covering glass, *i. e.*, with and without preventing the ordinarily rapid evaporation—with practically the same results; drying of course contracts blood-corpuscles, and corresponding variations are observed. Some of the disks are in outline not perfectly circular; by measuring the largest diameter of the largest, and the smallest diameter of the smallest disks, the extremes I have met with in one and the same specimen of human blood, are, as to the smallest, about the $\frac{1}{8000}$, and as to the largest, the $\frac{1}{2500}$ of an inch (*i. e.*, 0.00422 and 0.01016 Mm.). If the detached globules which I shall describe, be counted as blood-corpuscles, there are even still smaller ones. In each specimen of blood, the majority of red corpuscles, however, are of about one size, which differs in different specimens, but is most frequently between the $\frac{1}{3875}$ and the $\frac{1}{3100}$ of an inch (.00655.—00819 Mm.), or somewhere about the $\frac{1}{3370}$ of an inch (.0075 Mm.). The calculated average of the size of the red corpuscles in a drop, *i. e.*, the arithmetical mean of the measurements, is usually a little higher than the size of the majority of the corpuscles.

A very few, especially the smallest, but occurring exceptionally also among the larger, seem more or less globular; all others are bi-concave disks, the periphery being more shining and thick than the central portion.

So-called “rosette” and “thornapple” forms may be seen, either immediately or in the course of a little while. I have often watched the individual corpuscles while these forms, and many others, were being produced; and in Part III of this communication, I shall offer an explanation of their production.

Concentrating our attention upon the shape of the circular disks, we soon find that the round outline of a few (and the

same is at times also true of the smooth surface), begins to be made irregular at one or more points. This occurs in either of two ways, viz.: by indentation and by protrusion: sometimes the one, sometimes the other, first takes place; frequently both appear in different corpuscles, at about the same time; occasionally both are met with in the same corpuscles; in different preparations either the one or the other predominates.

Firstly:—In from fifteen minutes to an hour, a very slight indentation may appear, and gradually deepen, so that the corpuscle be nearly cleaved through; then the clefts may gradually become shallower, so that again a mere indentation is seen; finally, even this may disappear, and the corpuscle be rounded again (see fig. 1, a.). Division into two separating halves, I have never observed under these circumstances, although I have often watched for it. The furrow of every corpuscle that I have caught nearly cleaved through, either remained stationary, or usually, retrogressed to a greater or less extent. The retrogression may stop at any point, and the furrowing again increase; and this going and coming of a cleft, though taking place slowly, may continue for some time, and then stop at any stage of indentation. Sometimes indentations appear at two or more points of the same corpuscle, and in their progress give rise to a great variety of angular, regular and irregular “rosette,” “scolloped,” “crenated,” “thornapple,” and “stellate” forms (see fig. 1, b, c, d.). The sharp pointed ends seen in the last figure of d are the extremes met with and exceptional; usually the ends are plump and rounded). These forms, as well as those of single cleft, after changing backward and forward, either persist or become finally rounded off to a greater or less degree; in some cases constriction of portions more or less minute occurs, with separation following constriction (see fig. 1, e). Sometimes constricted portions remain attached for a long time by a more or less long and slender pedicle. Transitionally or permanently, in any of the cases mentioned, the most curious and

grotesque shapes may be met with. In the cases, too, of constriction and separation, the corpuscle, with the portions attached and unattached, sometimes gradually becomes rounded off so as to look like a parent globule surrounded by a number of little ones.

Secondly:—Usually in the course of half an hour, the protrusion of little round or roundish, more or less light colored knobs takes place. At first, only very few corpuscles show knobs, and the knobs are extremely small, and few in number, say only one, or at most two or three, on a corpuscle; but in the course of an hour or two, more corpuscles protrude knobs, more knobs are protruded from one corpuscle, and the knobs grow larger (fig. 2, a, Nos. 1 and 2). Occasionally a knob is drawn in again, and the former contour re-established. In some instances protrusion and retraction occur repeatedly, so that knobs appear and disappear, or become larger and smaller, very slowly, but repeatedly for some time. Occasionally a knob is pedunculated, and sometimes becomes detached from the corpuscle, while on the other hand some knobs are quite sessile (see fig. 2).

I have measured portions detached in either of the two ways described, and found them to vary from the $\frac{1}{30000}$ to the $\frac{1}{7500}$ of an inch (.00084–.00338 Mm.). All except the very largest may usually be seen in constant oscillatory (molecular) movement, and, unless entangled between larger stationary corpuscles, easily moving across the field (the latter probably caused by minute variation from absolute equilibrium level of the microscope stage).

In some dentated or so-called “mulberry” forms, knobs or small eminences protrude from the face of the disk, which may give to the inexperienced observer the impression of internal granules; but proper focussing corrects this impression, and shows the knobbed surface (fig. 2, b).

In addition to the protean changes in shape initiated by indentation and protrusion, there are still others occasionally met with, due to combination or coalescence of two or more

corpuscles. In the course of twenty-four hours or more—though this occurs in by far the smaller number of preparations of blood examined—two or more adjacent colored blood-corpuscles may, with a larger or smaller portion of their periphery, unite and form compound bodies, sometimes chains or other strange shapes (fig. 3).

Almost immediately on being ready for examination, a very few colored blood-corpuscles show a light central vacuole. In the course of the examination, a number of vacuoles, either of different sizes, or all of the same size, may appear in a corpuscle. Usually, a vacuole is round or roundish, but it may assume various irregular forms,—some of which, may perhaps have resulted from a union of several, and the breaking down of the separating walls, (see fig. 4. The three lower figures show appearance of vacuolized corpuscles seen on edge). Vacuoles sometimes persist and sometimes, after a longer or shorter continuance, suddenly disappear. They are either empty, or else contain one or more granules.

Soon after the corpuscles are studied, sometimes from the first, a difference is noticeable as to the intensity of their coloration: some are paler than others. Gradually a larger number of corpuscles becomes pale, and the degree of paleness, too, increases. There is a great difference in respect to the rapidity of “paling” of colored corpuscles, in blood taken from different persons, even in blood of the same person taken at different times, and with different strengths of the admixed solution of bichromate of potash.

Usually, in blood of healthy persons, examined as I have described, in about an hour from the time the drop of blood is placed on the slide, a few of the corpuscles that are least deeply colored appear to have become somewhat granular in their interior. Focussing shows that this is not the optical illusion alluded to in the case of knobiness of the surface.

Soon the granules or dots seem more distinct; short conical thorns, or more delicate spines, appear to issue from one or two of the largest of them; and, on close inspection and focussing, some appear to be connected by irregularly concentric filaments. In the course of five minutes more, a complete network is distinctly seen in the interior of one or more corpuscles, and what at first appeared to be granules, turn out to be thickened points of intersection of the threads forming this reticulum. These points or dots are irregularly shaped, and vary in size (see fig. 5). Radiary threads of the network terminate at the periphery of the corpuscle, either with thickened ends connected by threads—giving an appearance of unevenness to the outer boundary, as though it were constituted by a wreath of beads, each bead separated from its neighbors on the string—or, far more frequently, with terminal points lost in an encircling band of a uniform thickness, often greater than either the interior threads or most points of intersection (compare Nos. 5 and 2 of fig. 5). From this appearance, as well as that of the so-called “ghosts,” to be presently described, it is not to be wondered at that careful observers have ascribed to colored blood-corpuscles the possession of an investing membrane.

As the “paling” progresses, an increasing number of corpuscles shows the interior network, essentially as I have just described, and identical in construction with the network discovered by C. HEITZMANN in *Amœba*, colorless blood corpuscles, and other living matter of the body—(“*Bau des Protoplasmas*,” *Sitzungsberichte der Kaiserlichen Akademie der Wissenschaften zu Wien*, vol. 67, division III, p. 100. *Vorgelegt in der Sitzung am 17ten April, 1873*)—a discovery which I have communicated to the American Medical Association more than three years ago.¹

Gradually an interior network structure becomes visible, in nearly all the corpuscles in the field except the smallest, which appear more or less compact; and, occasionally a cor-

(1) “Notice of the Bioplaxion Doctrine.” *Transactions of the American Medical Association*, vol. XXVI (1875), p. 157.

puscle is met with having a central, or slightly excentric, dot of such relatively large size that it might be interpreted as a nucleus (see No. 1 of fig. 5).

Some movement takes place in the network; for sometimes the threads change in length, and perhaps in thickness, and the dots change their position and their size.¹

In the course of another half hour or hour, the network becomes less distinct in the palest corpuscles; and in these gradually fades away. Then, for some time, the network remains visible in nearly all corpuscles except those that are too pale or too small: vacuoles, one or more, appear in many of the latter; while the former occasionally show indications of irregularly massed matter in their interior, though usually nothing is seen of them but double-contoured rings which have been called their "ghosts" (see fig. 6). During this time, also, a quantity, sometimes rather large, of detritus accumulates.

It appears as though the network is most plain in corpuscles that have suffered either not at all, or but little, from detachment of a portion of their substance. The active changes of indentation and protrusion have usually disappeared in a large number of corpuscles, by the time "paling" has sufficiently progressed to render the interior structure visible. As before stated, some corpuscles permanently retain scalloped and knobbed forms, while the majority are finally more or less rounded off; but the play of changing shape of many corpuscles is going on at the same time that this network is seen.

After a while, further "paling" stops, and the network structure of all corpuscles which show it, remains visible indefinitely long.

Blood-corpuscles, from hemorrhage in the bladder, in the

(1) To make sure of the occurrence or non-occurrence of this movement, I used the micrometer scale, and having with great precaution as to entire rest of the microscope and the specimen, fixated by lines the position of the dots and length of the threads, the changes of position, size, and length became unmistakable.

urine of the late Dr. H****y, preserved with some bichromate of potash, still show the network after three years.

Specimens of blood taken from different individuals exhibited all the phenomena described, but with some slight differences among each other as to the order and time of appearance.

A 40 per cent. saturated solution of bichromate of potash, admixed with the blood, was found entirely satisfactory for the demonstration of all the phenomena; and some variation of strength, *i. é.* between the limits of a 35 per cent. and a 50 per cent. saturated solution, made no appreciable difference.

Of other solutions of bichromate of potash, it is sufficient to state the following:

With a 30 per cent. saturated solution, the phenomena are also to be seen, but appear more slowly, and quite a number of corpuscles usually remain more or less unpaled.

With a 20 per cent. saturated solution, the changes proceed still more slowly; comparatively few indentations occur; the network of the majority of corpuscles is visible after the lapse of 24 hours, but many remain entirely unaffected.

With a 10 per cent. saturated solution, vacuolization appears, also a little changing indentation and protrusion, but not sufficient "paling" to render the network visible even after several days.

With a 60 per cent. saturated solution, the majority of the corpuscles had already become pale by the time the specimen was in place for examination. Some showed interior network, some only double-contoured rings. Protrusions were seen, especially in the corpuscles not much paled; in one instance, a pale ring was also seen with a large pedunculated protrusion (fig. 6). During two hours, changes of scalloping and of knobs took place faster than is usual with blood mixed with a 40 per cent. or 50 per cent. saturated solution, but they could not be followed so distinctly. Extreme paling rapidly proceeded and much detritus filled the field, with only very few compact globules.

With a 90 per cent. saturated solution, the process of scal-

loping was completed in 20 minutes; and in 30 minutes a network was visible in a few roundish corpuscles, surrounded by masses of granular detritus. In addition, a large number of "ghosts" could be seen. Here and there a "ghost" would show a faint network.

With a saturated solution added undiluted, the network was after one hour visible in some corpuscles, but most of them were destroyed; of a few left intact, some looked homogeneous, and some vacuolized. The field was full of faint double-contoured rings, and a large quantity of granular detritus.

The network structure of colored blood-corpuscles is visible also in anatomical preparations which have been kept for a length of time in Müller's fluid (Bichromate of potash 100 parts, sulphate of soda 50 parts, and water 1000 parts).

In some of my examinations, especially the earlier, I used the heated stage; but as the phenomena described were seen at the ordinary temperature of a well-warmed room, I deem it best not to say anything here of variations of temperature.

I have made some micro-spectroscopic observations of blood, which I shall detail in another connection.

In this communication I omit the mention, also, of the remarkably varying amount of fibrine threads seen in different preparations of blood; nor do I enter at length into the question of "detritus formation," or as whatever else one may interpret the appearance in the field of an increasing number of free granules, and granular masses or plaques.¹ On both of these subjects, my Note-book relating to observations extending over two years, contains "minutes."

In addition to human colored blood-corpuscles, I have examined those of lower animals. Essentially the same intimate structure as that which I have described exists in all. As ex-

(1) Max Schultze, who saw some of these granules and granular plaques in healthy blood prefers the designation "granule formation," as being non-committal.—*Archiv für Mikroskopische Anatomie*, vol. 1, p. 38.

amples, I will quote from my Note-book a few words referring to the examination of the colored blood-corpuscles of the ox and the newt—the one an example of the unnucleated, the other of the nucleated corpuscles.

A drop of fresh ox blood, mixed with a 50 per cent. saturated solution of bichromate of potash, and highly magnified (Tolles' $\frac{1}{2}$ immersion) exhibited, within 20 minutes, vacuolization beginning in several red corpuscles. Within 40 minutes, knobs were protruded, though not copiously. In the course of an hour, "paling" proceeded regularly, so that the network became visible in some, and within two hours, in a large number, of the corpuscles. After three hours, the network, the Note-book says, was very distinct in many corpuscles, with some detritus and a few "ghosts." Twelve hours later, about one-half of the whole number of corpuscles showed the reticulum, while the other half were either vacuolized or unchanged. No further change was observable for two days. After the third day, some few corpuscles, perhaps, that had not shown the network structure before, now did; but the paled ones had become too pale to do so, except a very few which showed it finally. The rest had become "ghosts," with much detritus. A week later, nearly all the corpuscles that had exhibited the network had become "ghosts," only in a very few of which, faint traces of the reticulum could be made out. The rest were still unchanged, as on the first day and remained so as long as the specimen was kept.

The red blood-corpuscles of the newt, examined in a 50 per cent. saturated solution of bichromate of potash, into which a drop of the blood from the freshly cut tail had been allowed to fall, presented peculiar changes of shape, consisting mainly in contractions of the body around the nucleus.

The nuclei always exhibited the network structure, either perfect, and more distinct than in specimens unmixed with the solution, or, when the nucleus was swelled to double or treble its original size, with the network torn. Just as in the case of the colorless corpuscles, there were seen two kinds of

red corpuscles, finely granulated and coarse granular, the granules always being the points of intersection of the threads of the network. In both kinds the body as well as the nucleus exhibited the reticulum structure. The network of the body and that of the nucleus were connected by fine threads passing through the nuclear envelope. In many instances the body was reduced either to two polar flaps, bulging from each side of the nucleus, or to one flap, more or less colored, at the side of the nucleus; in other instances, it was uniformly contracted around the enlarged nucleus.

Many colored corpuscles contained vacuoles, in varying number, which were either empty or traversed by an exceedingly delicate, apparently stretched, reticulum, or else contained irregular accumulations of matter with remnants of the network.

II.

My observations as to amœboid movements of colored blood-corpuscles, as well as to varieties of size and shape,—observations which were really only incidental while investigating the structure, the main object of my researches,—have been anticipated by previous investigators. One saw and reported as an extraordinary finding, one or more forms or active form-changes like those I have described, another others; some a far greater number than I. "*Fehlt leider nur das geistige Band.*" The band which connects and explains the phenomena observed is the discovery of the structural arrangement.

In the following historical sketch of points bearing on my observations, I shall refer to a few only of the legion who have made colored blood-corpuscles the subject of their investigation.

More than a hundred years ago, *William Hewson*, after asserting that the red corpuscles are of different sizes in different animals, added; "I have likewise observed that they

are not all of the same size in the same animal, some being a little larger than others,"¹ etc. Hewson's editor, *Gulliver*, who has made a very large number of measurements of red blood-corpuscles of different animals, and is "our highest authority upon the subject," said of his own elaborate tables: "We are only speaking now of the average size, for they vary like other organisms; so that in a single drop of the same blood you may find corpuscles either a third larger or a third smaller than the mean size, and even still greater extremes;"² and more recently,³ "But as I have long since shown, the corpuscles in one species of the vertebrate class as seen in a single individual thereof, vary so much in size that their average dimensions cannot be determined with absolute precision; and were this fact kept in view much needless discussion might be spared."

Beale, also, long ago called attention to the fact that "corpuscles may be found which are not more than the fifth or sixth of the size of an ordinary blood-corpuscle."⁴ Again: "the red corpuscles vary in size, and more than is usually supposed,"⁵ and again: "It is generally stated that the red blood-corpuscles of an animal exhibit a certain definite size; but it will be found that they vary extremely, so that corpuscles exist of various dimensions."⁶

*Welcker*⁷ found in the blood of Dr. Schweigger-Seidel colored blood-corpuscles as small as .0051, and as large as

(1) Philosophical Transactions, vol. 63, Part 2, p. 320 (Read June 24, 1773). The works of William Hewson, F. R. S., Edited with an Introduction and Notes, by Geo. Gulliver, F. R. S. London. Published by the Sydenham Society, 1846: p. 234.

(2) "Lectures on the Blood of Vertebrata." *Medical Times and Gazette*, vol. II of 1862, p. 157.

(3) "Comparative photographs of blood-disks." *Monthly Microscopical Journal*, November, 1876, p. 240.

(4) Archives of Medicine, vol. II. (No. VIII.) p. 236, and *Quarterly Journal of Microscopical Science*, April-May, 1861; p. 249.

(5) "Observations upon the Nature of the Red Blood-Corpuscle." Transactions of the Microscopical Society of London (Read Dec. 9, 1863), vol. XII., N. S., p. 37. *Quarterly Journal of Microscopical Science*, Jan., 1864.

(6) The Microscope in its Application to the Practice of Medicine, 3d Edition. Republished in Philadelphia, 1867; p. 170.

(7) "Grösse, Volum und Oberfläche und Farbe der Blutkörperchen bei Menschen und bei Thieren." *Zeitschrift für rationelle Medicin*, S. III, vol. XX. (1863), p. 237.

.0085 Mm. Altogether, the minimum measurement recorded in his table is .0045 Mm., and the maximum, though not in the same specimen, .0097 Mm. He remarks: "I have always, both in animals and in man, found the transverse diameter of the blood-corpuscles of one and the same individual vary from $\frac{1}{4}$ to $\frac{1}{2}$ of the mean measurement; and it appears that all the sizes lying between the two extremes are present in tolerably equal numbers, with the exception of the smallest corpuscles, which occur for the most part singly and at intervals."¹

Max Schultze distinguished in his own and other persons' healthy blood two forms of colored corpuseles, viz.: globular and disk-like; the globular, few in number, vary from .005 to .006 Mm. in size; and from these there are gradual transitions to the ordinary disks, which measure from .008 to .010 Mm.²

The smallest colored corpuscles which *Klebs* reported³ having found in his own blood, varied from .0058 to .0066 Mm.; but in blood from the corpse of a leucæmic child he observed a few as small as .00416 Mm.

Woodward said: "The truth is that not only do the individual corpuscles in every drop of blood vary considerably in size, but as might be anticipated from this very fact, the average size obtained by measuring a limited number of corpuscles (50 to 175, still more in the case of but 10 to 50, as usually practiced) varies considerably, not only between different individuals, but also between different parts of the very same drop of blood." Both the maximum and the minimum which he found—viz.: the 396 millionths and the

¹ (1) Cited by *Woodward* "On the similarity between the Red Blood-Corpuscles of man and those of certain other animals, especially the dog; considered in connection with the diagnosis of Bloodstains in criminal cases." *American Journal of Medical Sciences*, Jan., 1875. *Monthly Microscopical Journal*, February 1, 1875, p. 69.

(2) "Ein heitzbarer Objecttisch und seine Verwendung bei Untersuchungen des Blutes." *Archiv für Mikroskopische Anatomie*, vol. I. (1865) p. 35.

(3) "Ueber die Kerne und Scheinkerne der rothen Blutkörperchen der Säugethiere." (Virchow's) *Archiv für pathologische Anatomie and Physiologie und für Klinische Medicin*: vol. XXXVIII, (1867), p. 195.

216 millionths of an inch, or .01005 and .00548 Mm.—were present in the same field of one drop.¹

*Berchon and Perrier*² state that the colored blood-corpuscles of the fœtus and the newly-born are on an average smaller than those of adults. The extremes given are minimum .0031 to .0062 Mm. and maximum .0091 to .0093 Mm.; but they do not mention that the extremes occurred in one and the same case. More recently, *Perrier*³ measured blood-corpuscles of 35 individuals of different ages, and found that those of .010 Mm. were very frequent in the first days after birth, while later they occurred much more rarely. After the first year, blood-corpuscles measuring .0093 Mm. were rarely present in greater proportion than 10 in a hundred; and in adults often absent. Such of .0043 Mm. occurred most often in the aged and in children. The diameter of the great mass at every age varies from .0050 to .0087 Mm.; within these limits, those of .0075 Mm. are most frequent and never absent. The form of the smaller is more or less globular; the larger are flattened.

According to *Hayem*,⁴ the red blood-corpuscles in the newly born are much less uniform in size than in adults; corpuscles larger than the largest and smaller than the smallest adult corpuscles occur comparatively often. The size varies between .00325 and .01025 Mm. *Hayem* also calls attention⁵ to the still smaller ones—measuring only .002 Mm.—which he considers young and growing blood-corpuscles, so called hæmatoblasts. He asserted having observed all transition sizes between these and the largest. He

(1) "The Application of Photography to Micrometry, with special reference to the micrometry of blood in criminal cases." *Transactions of the American Medical Association*, vol. XXVII. (1876), p. 303-315.

(2) "Note sur les globules du sang chez le fœtus." *Bordeaux médical.*, p. 123 and 237; *Canstadt's Jahresbericht* for 1875, I., p. 46.

(3) "Sur les variations du diamètre des globules rouges du sang dans l'espèce humaine, au point de vue de l'expertise légale." *Compt. rendus*, tom. 84 (1877), No. 24, p. 1404.

(4) *Des caractères anatomiques du sang chez le nouveau-né pendant les premiers jours de la vie.*" *Compt. rendus*, tom. 84 (1877), p. 1166.

(5) "Sur la nature et la signification des petits globules rouges du sang." *Ibid.*, No. 22 p. 1289.

found hæmatoblasts increased whenever under physiological or pathological conditions a reparation of blood occurs, *e. g.* he found them more abundant in children than in adults, and more abundant during menstruation, and after losses of blood, also during convalescence after acute diseases.¹

Netsvetzki reported² having found minute corpuscles moving in all directions, as constant constituents of normal human blood. [Although my observations as to the diversity of size of colored blood-corpuscles refer to healthy blood, I will not omit to mention here that *Vanlair* and *Masius*, having, in the blood of a patient who had symptoms of interstitial hepatitis, found a number of small globular corpuscles, gave them the name of microcytes, and called the patient's disease "microcythæmia," which they considered to be a peculiar alteration of the blood.³ Cases of so-called microcythemia have since been reported by *Litten*, in a tuberculous individual;⁴ by *Osler* in pernicious anemia⁵; and by *Lepine and Germont* in cases of cancer of the stomach. *Soerensen* distinguished in disease between Oligocythemia, in which the number of red blood-corpuscles is diminished, Achroicythemia, in which their richness in coloring matter is diminished, and Microcythemia, in which their size is diminished. In a case of chlorosis observed by him, the average size of the colored corpuscles was

(1) "Note sur l'évolution des globules rouges dans le sang des vertébrés ovipares." *Compt. rendus*, tom. 85, No. 20, p. 907-909. "Sur l'évolution des globules rouges dans le sang des animaux supérieurs (vertéb. ovipares) *Ibid.*, No. 27, p. 1285.

(2) "Zur Histologie des Menschenblutes. Kleine sich nach allen Richtungen hin bewegend Körperchen als constante Bestandtheile des normalen Menschenblutes." *Centralzeitung für die Medicinischen Wissenschaften*, 1873, No. 10.

(3) *De la Microcythemie*, Bruxelles, 1871; 101 pp.

(4) Aus der Klinik des Herrn Geh. Rath Prof. Frerichs "Ueber einige Veränderungen rother Blutkörperchen." *Berliner Klinische Wochenschrift*; 1877, No. 1.

(5) "Ueber die Entwicklung von Blutkörperchen in Knochenmark bei perniciöser Anæmie." *Centralblatt für die medicinischen Wissenschaften*; 1877, No. 28; 1878, No. 26.

(6) "Note sur la presence temporaire dans le sang humain d'un grand nombre de globules rouges tres petits (microcytes)." *Gazette medicale de Paris*; 1877, No. 18, pp. 218 and 219; and "Note relative a l'influence des saignées sur l'apparition dans le sang humain de petits globules rouges (microcytes)." *Id.* No. 24, p. 296.

found to be only .0045, instead of the normal .006 to .0075 Mm.¹

*Hicks*² found in the fluid from an ovarian cyst, small transparent colorless globular bodies which had been detached from red blood-corpuscles, and which were of a diameter of about the $\frac{1}{10000}$ of an inch.

Laptschinsky reported³ finding very small corpuscles, only $\frac{1}{3}$ as large as the normal ones, in conditions of the body accompanied with high fever, especially in infectious diseases.

Häyem has come to the conclusion⁴ that in anemia the blood-corpuscles are in general smaller than in normal conditions ; but that the extremes which are met with are greater, viz. .0022 and .010 to .014 Mm.

Piper found in a case of "ulcerated scrotum and inflamed testicle, with apparently tuberculous deposit in the gland," "on one and the same slide, specimens which measure $\frac{1}{4088}$ of an inch ; while on other parts of the same slide alike extensive fields of corpuscles which measure only a fraction less than the classic $\frac{1}{3200}$ of an inch."⁵

Ponfick,⁶ *Osler*,⁷ and *Obermeier*,⁸ have reported other abnormalities].

According to *Richardson*,⁹ the variations above and below the standard size of corpuscles from any particular animal are

(1) "Undersogelser om Antallet af rode og hoide Blodlegemer under forskjellige physiologiske og pathologiske Tilstande." Inaugural Dissertation, Kopenhagen ; 1876. 236 pp.

(2) "Observations on Pathological Changes in the Red Corpuscle." *Quarterly Journal of Microscopical Science*, vol. XII, (1872), p. 114.

(3) "Zur Pathologie des Blutes." *Centralblatt f. d. med. Wiss.*, 1874, No. 42, p. 658.

(4) "Des caractères anatomiques du sang dans les anémies." *Comptes rendus*, tome 83 (1876), pp. 82, 85, p. 152, p. 230.

(5) "Contraction of Blood-corpuscles through the action of Cold." *New York Medical Journal*, March, 1877, p. 246.

(6) "Ueber das Vorkommen abnormer Zellen im Blute von Recurrenkranken." *Centralblatt f. d. med. Wiss.* 1874, No. 25.

(7) "An account of certain organisms occurring in the liquor sanguinis." *Monthly Microscopical Journal*, Sept. 1874, p. 141.

(8) "Vorkommen feinsten, eine Eigenbewegung zeigender, Fäden im Blut von Recurrenkranken." *Centralblatt f. d. med. Wiss.*, 1873, No. 10. Confirmed by *Laptschinsky Id.*, 1875, No. 9, p. 84.

(9) "On the value of high powers in the diagnosis of blood-stains." *American Journal of the Medical Sciences*, July, 1874; and *London Monthly Microscopical Journal*, September, 1874, p. 135.

comparatively slight in fresh blood, as proved by the following experiments, made with his $\frac{1}{6}$ inch objective, which gives with the micrometer eye-piece an amplification of 3,700 diameters. When thus magnified, the human red blood disks appeared about one inch and one eighth in diameter, so that even slight differences in their size could be accurately measured. Among one hundred red corpuscles freshly drawn from five different persons, the maximum and minimum diameters in parts of an inch, were as follows:—

Twenty from a white male aged 30,	maximum	1-3231,	minimum	1-3500
“ “ “ “ “ 38,	“	1-3281,	“	1 3529
“ “ “ female “ 44,	“	1-3249,	“	1-3500
“ “ an African “ “ 50,	“	1-3182,	“	1-3559
“ “ a white male “ 8,	“	1-3231,	“	1-3500

Moreover, the smallest red disks of man, as usually met with in mechanically unaltered blood, whether dry or moist, are according to him larger than the largest corpuscles of an ox, and *a fortiori* of a sheep.

More recently,¹ he measured corpuscles of individuals of fourteen different nations, one hundred of each. Of the 1400 corpuscles measured, the average was $\frac{1}{3224}$ (.007878 mm.) the maximum $\frac{1}{2777}$ and the minimum $\frac{1}{4000}$ of an inch; 1158, or 83 per cent., measured between $\frac{1}{3448}$ and $\frac{1}{3030}$ of an inch in diameter, and consequently under a power of two hundred would appear about the same magnitude; the total number of corpuscles of minimum measure was only six, or less than one half of one per cent.; and the total number which measured the maximum was ten, or less than one per cent.

All this is very remarkable, unless he measured mainly the majority, or average sized corpuscles. He made some selection, for he tells us, “Instead of measuring all corpuscles, deformed or otherwise, in two directions, as proposed by Dr. Woodward, (*Phila. Medical Times*, vol. VI. p. 457), I prefer to determine the size of unaltered, *i. e.* circular corpuscles *only* :” and

(1) “On the Identity of the Red blood Corpuscles in different Races of Mankind.” *American Journal of the Medical Sciences*, January, 1877, p. 112.

further, "I cautiously avoided recording those which manifested even slight departures toward an oval form;" but, on the other hand, "to secure the most infallible accuracy for my deductions, as the preparation was moved along, I measured every isolated circular red disk which came into the field of the microscope."

In the year 1761, Padre *Jo. Maria de Turre*, of Naples, made a present to the Royal Society of London of four spherical glasses for the microscope, made by himself, of which the diameters and magnifying powers were said to be as follows :

DIAMETER.	MAGNIFYING POWER.
1. Near 2 Paris points.	640 times, and upward, in diameter.
2. 1 Paris point.	1,280 " "
3. 1 " "	1,280 " "
4. Half a Paris point, (1-144 of an inch.)	2,560 " "

Sir Francis Haskins Eyles Stiles, at the time in Naples, through whom the presentation was made, wrote several letters, in which he communicated Father de Turre's directions for the use of the glasses, as well as an account of some observations on the human blood, made by him, together with Turre, during July and August, 1761, and read before the Society during November, 1765. They saw in the blood globules the central depression, which had not theretofore been observed, and which carried with it so strongly the appearance of a perforation that they concluded the corpuscles to be rings. They also thought the rings to be articulated ("the transverse lines at the joints being very distinguishable").¹ As to their shape, "the figure of the rings, where they were free, and in their natural state, was circular; but where they were so crowded together as to compress one another in their passage, they assumed a variety of different figures, although they generally restored themselves to a circular figure again,"

1) "An Account of some Microscopic Observations on the Human Blood." *Philosophical Transactions*, vol. lv. 1765), p. 254.

unless broken by the compression, which frequently happened, and then the broken parts floated separately; or, if they opened at a single joint only, the whole of the ring would float along, varying its figure occasionally from that of a portion of a circle, which it would first assume, to a straight line, an undulated one, or some other accidental incurvature.")¹

Hewson² declared the so-called globules in the blood of man and all animals to be disks—"in reality, flat bodies," "as flat as a guinea." The dark spot in the middle, which Father di Torre had taken for a hole, he found "was not a perforation, and therefore that they were not annular." He denied that they were jointed, and inferred "they are not fluid, as they are commonly believed to be; but, on the contrary, are solid; because every fluid swimming in another, which is in larger quantity, if it be not soluble in that fluid, becomes globular." He also observed changes of shape; for, speaking of the blood-corpuscles of a lobster, he said: "But there is a curious change produced in their shape by being exposed to the air; for, soon after they are received on the glass, they are corrugated, or, from a flat shape, are changed into irregular spheres, as is represented in Plate XII, No. 12;"³ and on turning to the plate we find represented "angular," "rosette," and "stellated" forms. He was the first who likened the appearance of corpuscles, with their external surface corrugated, to that of small mulberries.

It would be impossible for me, as well as useless, to give a list of all those who have described changes of form in red blood-corpuscles since Hewson's time. Different shapes—and some of them far more curious and irregular than those I have described—have been observed, under many physiological and pathological conditions, as well as on subjecting the blood to the action of various chemical and physical agen-

(1) *Ibid.* p. 256.

(2) On the Figure and Composition of the Red Particles of the Blood, commonly called the Red Globules" *Philosophical Transactions*, Vol. I. XIII Part II (1773), p. 302-323.

(3) *Ibid.*, p. 321. *Opus posthumum*, p. 19, 20; *Collected Works*, edited by Gulliver, *op. cit.* 234.

cies. Text-books and monographs give sufficient information on this point, especially the article on the blood by *Alexander Rollett*, in Stricker's "*Handbuch der Lehre von den Geweben des Menschen und der Thiere*," which has been translated by Henry Power and published by the London New Sydenham Society, and which has been republished in this country.²

Since that article was written the following observations have been made :

Langhans,³ in experiments on rabbits, saw, in extravasated blood, red corpuscles with numerous fine projections, and, in pigeons' red blood-corpuscles, also, observed morphological changes.

*Lieberkühn*⁴ described remarkable form-changes in the red corpuscles of the blood of salamanders and of pikes.

*Wedl*⁵ observed changes of shape in human and frog's red blood-corpuscles on adding a drop of concentrated aqueous solution of pyrogallic acid to a drop of fresh blood.

*Ray Lankester*⁶ found in his own healthy blood, in addition to the ordinary biconcave forms, "thorn-apple" and "single and double watch-glass" forms. In the two latter there is, when the corpuscle is seen on edge, instead of a concavity, a convexity on either one or both sides. He also described and figured varieties of shape in both human and frog's colored blood-corpuscles subjected to the action of various reagents. Of these I shall cite, later on, the effects of very dilute ammonia gas and acetic acid vapor.

(1) *Ibid*, p. 313, etc.

(2) A Manual of Histology. By Prof. S. Stricker. American Translation edited by Albert H. Buck. New York: Wm. Wood & Co., 1872.

(3) "Beobachtungen über Resorption der Extravasate und Pigmentbildung in denselben." *Virchow's Archiv*, Vol. 49 (1870), p. 16-116.

(4) "Ueber Bewegungserscheinungen der Zellen." *Schriften der Gesellschaft zur Beförderung der gesammten Naturwissenschaften zu Marburg* Vol. IX (1870) p. 335

(5) "Histologische Mittheilungen: Ueber die Einwirkung der Pyrogallussäure auf die rothen Blutkörperchen." *Sitzungsberichte der Wiener Akademie der Wissenschaften*, Vol. 64 (1871), I Div., p. 405

(6) "Observations and Experiments on the Red Blood-corpuscle, chiefly with regard to the Action of Gases and Vapours." *Quarterly Journal of Microscopical Science*, October, 1871, p. 361-387.

*Braxton Hicks*¹ observed colored blood-corpuscles of various shapes in fluid from an ovarian cyst, and in blood in other pathological conditions.

*Huels*² described frog's red blood-corpuscles acted on by carbolic acid.

*Faber*³ observed, in the urine of a patient with Bright's disease, colored blood-corpuscles of a great variety of different shapes, some of which showed him phenomena of contractibility and amœboid movement, "very similar" to those of colorless blood corpuscles.

*Hüter*⁴ reported seeing in the capillaries of the frog lung a few red blood-corpuscles adhere to the sides by means of a drawn-out pedicle, with half the body on each side, having a saddle-bag like shape ("*zwergsackähnlich*").

Laptschinsky described and figured⁵ the effects of various reagents, among them aniline blue, magenta, and tannin, on the red blood-corpuscles of triton and man. He confirmed and enlarged the older observations of *Roberts*.⁶ *Laptschinsky*⁷ also described some variations of shape which he met with on examining human blood in different diseases.

*Arnold*⁸ in the course of his observations on diapedesis of colored blood-corpuscles after ligating the median vein of the frog's tongue, saw that in the various phases of transit these corpuscles assumed various shapes, sometimes pear-shaped, with slender stem, sometimes caudated, oval, etc. Similar shapes have under similar circumstances been described by others.

(1) Observations *cit.* Quart. Journ. Microsc. Science, vol. XII, (1872), p. 114.

(2) "Wirkung der Carbonsäure auf rothe Froschblutkörperchen." Inaug. Dissertation Greifswalde 1872 43 pp.

(3) "Ueber die rothen Blutkörperchen." Archiv der Heilkunde, 1873, XIV, p. 481-511.

(4) "Ueber den Kreislauf und die Kreislaufstörungen in der Froschlunge." Centralblatt für die Medicinischen Wissenschaften, 1873, No. 6 p. 82.

(5) "Ueber das Verhalten der rothen Blutkörperchen zu einigen Tinctionsmitteln und zur Gerbsäure." Sitzungsberichte der Wiener Akademie, Vol. 68 (1873) Div. III, p. 148.

(6) "On peculiar appearances exhibited by blood corpuscles under the influence of solution of magenta and tannin" Quarterly Journal of Microscopical Science, 1863 p. 170.

(7) "Zur Pathologie des Blutes," Centralblatt f. d. med. Wiss., 1874, No. 42, pp. 660 and 661.

(8) "Ueber Diapedesis." Virchow's Archiv, vol. 58 (1873), pp. 203-254.

*Hiller*¹ refuted the supposition of Hüter (II. Deutscher Chirurgen Congress, April 18, 1873), that the stellate and thorn-apple forms of red blood-corpuscles are due to immigration of monads into the substance of the corpuscles. He found such forms in blood during febrile and non-febrile diseases; they were absent in some cases in which large quantities of monads had been injected into the blood of animals; and he observed in many cases their development directly under the microscope.

Rommelaere,² observed in various diseases, changes of shape of the red blood corpuscles.

Landois,³ saw corpuscles assume, before their dissolution, a spherical form with exceedingly fine points.

Ebert,⁴ *Böttcher*,⁵ *Fuchs*,⁶ and *Schmidt*,⁷ have reported variations of the ordinary shape. The latter has also called attention to the fact that human red blood-corpuscles seen in exact profile, and closely examined, are represented by two straight and parallel lines connected at their extremities by two semicircular ones, and not showing merely their central concavity as usually represented.

The question whether or not colored blood-corpuscles possess an investing membrane, has been much discussed. *Hewson*, who, as I have already stated, showed that these corpuscles are not perforated, contended that the dark spot in the middle believed by Torre to be a perforation, "is a solid particle contained in a flat vesicle, whose middle only it fills, and

(1) "Ueber die Veränderungen der rothen Blutkörperchen nebst Bemerkungen über Microcyten." *Centralblatt f. d. med. Wiss.* 1874. Nos. 21-25.

(2) "De la deformation des globules rouges du sang." Bruxelles 1874. 47 pp.

(3) "Auflösung der rothen Blutzellen." *Centralblatt f. d. med. Wiss.* 1874 No 27. p. 419

(4) "Ueber Formveränderungen der rothen Blutkörperchen." Greifswald 1875.

(5) "Ueber einige Veränderungen welche die rothen Blutkörperchen in Extravasaten erleiden." *Virchow's Archiv*, vol 6, (1876), p. 295-307. Also in other articles which I quote in this review

(6) "Beitrag zur Kenntniss des Froschblutes und der Froschlymphe." *Virchow's Archiv*, vol. 71, (1877) p. 78-177

(7) "The structure of the colored Blood-corpuscles of *Amphiuma tridactylum*, the Frog and Man." *Journal of the Micr. Soc. of London*, May and July, 1878, pp. 66, 68, 110, etc.

whose edges are hollow, and either empty, or filled with a subtile fluid.”¹ He detailed the following experiments:—
“Take a drop of the blood of an animal that has large particles, as a frog, a fish, or what is still better, of a toad; put this blood on a thin piece of glass, as used in the former experiment, and add to it some water, first one drop, then a second, and a third, and so on, gradually increasing the quantity; and in proportion as water is added, the figure of the particle will be changed from a flat to a spherical shape,
* * * * * it will roll down the glass stage smoothly, without those phases which it had when turning over when it was flat; and, as it now rolls in its spherical shape, the solid middle particle can be distinctly seen to fall from side to side in the hollow vesicle, like a pea in a bladder.” He added: “From the greater thickness of the vesicles in the human subject, and from their being less transparent when made spherical by the addition of water, and likewise from their being so much smaller than those of fish or frogs, it is more difficult to get a sight of the middle particles rolling from side to side in the vesicle which has become round; but with a strong light (these experiments were all made with daylight, in clear weather), and a deep magnifier, I have distinctly seen it in the human subject, as well as in the frog, toad, or skate.” Another experiment he describes thus: “If a saturated solution of any of the common neutral salts be mixed with fresh blood, and the globules (as they have been called, but which for the future I shall call flat vesicles) be then examined in a microscope, the salt will then be found to have contracted or shriveled the vesicles, so that they appear quite solid, the vesicular substance being closely applied all around the central piece.” Furthermore, “the fixed vegetable alkali, and the volatile alkali, were tried in a

(1) “On the Figure and Composition of the Red Particles of the blood, commonly called the Red Globules.” *Philosophical Transactions* vol. 63, Part II. p. 310 *et seq.* (Read June 17th and 21st, 1773.) “A Description of the Red Particles of the Blood in the human subject and in other animals, being the remaining Part of the Observations and Experiments of the late Wm. Hewson.” By Magnus Falconer, London, 1777, p. 221 *et seq.*

pretty strong solution, and found to corrugate the vesicles.”

The vesicular nature of colored blood corpuscles, thus announced more than sixty years before the publications of Schleiden and Schwann, so perfectly fits into their cell-schema, that many suppose that they have originated this view of the constitution of the corpuscles. But in point of fact they have in this respect followed Hewson. According to Schwann,¹ the red blood-corpuscle is a cell and consists, like every other cell of the body, of a membranous envelope, a nucleus, and liquid contents; the credit of the observation of the “rolling around” of the nucleus is given by Schwann to C. H. Schultz, who, however, has only repeated and confirmed² the experiments of Hewson.

Although not accepted without some opposition, it was not until the year 1861 that the existence of a cell-wall was positively denied. Beale declared:³ “I have never succeeded in seeing the cell-wall said to exist, neither have I been able to confirm the oft-repeated assertions with regard to the passage of liquid into the interior of the corpuscle by endosmose, its bursting and the escape of its contents through the ruptured cell-wall. When placed in some liquids, many of the corpuscles swell up and disappear; but I have never seen the ruptured cell-walls.” He also published observations which he considered “fatal to the hypothesis that each corpuscle is composed of a closed membrane, with fluid contents.”⁴ Brücke expressed the opinion that the rolling around of the nucleus is illusory, that other phenomena do not conclusively prove the presence of a membrane, and that “the unanimity with which the vesicular nature of blood-corpuscles had for a long

(1) Mikroskopische Untersuchungen über die Uebereinstimmung in Structur und Wachsthum der thierischen und pflanzlichen Organismen. Berlin 1839 pp 74 und 75.

(2) Das System der Circulation. Stuttgart and Tübingen. 1 36. p 19 *et seq.*

(3) Lectures on the structure and growth of the tissues of the human body. Delivered at the Royal College of Physicians. Lecture III. April 22nd 1861.” Archives of Medicine vol. II. No. 8 (May, 1861). p 236 Re published in Quarterly Journal of Microscopical Science vol I N. S. (April-May, 1861) p. 240.

(4) Observations upon the nature of the red blood-corpuscle ” Transactions of the Micro Soc., vol. XII, N. S. p. 37. Quarterly Journal of Microscopical Science Jan., 1864.

time been taught, was owing more to the silence of the opponents than to the force of the arguments of the believers."¹ *Vintschgau*² and *Rollett*³ also argued against the existence of an investing membrane; and the opinion seemed doomed.

But before the end of the year in which Beale and Brücke contested the existence of an investing membrane, *Hensen* defended it.⁴ He reports having observed in the blood of frogs both in fresh preparations,—*i.e.*, in red corpuscles examined without the addition of any reagent,—and in corpuscles placed in various mixtures, especially a solution of sugar, that sometimes the membrane, as a distinct outer contour, is lifted up from the interior contents at one or more points of the circumference, these interior contents being retracted more or less densely upon the nucleus. A few years later⁵ *Hensen* reiterated his conviction as to the presence of a membrane; it is certain, therefore, that *Lankester*⁶ has misapprehended his meaning. *Kölliker*, who had previously asserted that the red blood-corpuscle possesses "a very delicate but nevertheless tolerably firm and at the same time elastic colorless cell-membrane, composed of a protein substance closely allied to fibrin,"⁷ continued to uphold their vesicular constitution.⁸ *Preyer* reported that the early observation of the rolling nucleus (erroneously ascribed by him, after *Schwann*, to *Schultz* instead of to *Hewson*), agreed with what

(1) "Die Elementarorganismen." Sitzungsberichte der Wiener Akademie, vol. 44, Div. II, p. 389 (Read Oct. 17th, 1861).

(2) "Sopra i corpusculi sanguigni della rana." Atti del Istituto Veneto, vol. VIII, Ser. III.

(3) "Versuche und Beobachtungen am Blute." Sitzungsberichte der Wiener Akademie, vol. 46 (1862), p. 65.

(4) "Untersuchungen zur Physiologie der Blutkörperchen sowie über die Zellennatur derselben." Zeitschrift für wissenschaftliche Zoologie, vol. XI, Heft 3 (Ausgegeben Dec. 23, 1861), pp. 253-278.

(5) In a foot note of an article entitled "Ueber das Auge einiger Cephalopoden." *Ibid.*, vol. XV, Heft 2 (April 1, 1865), p. 170.

(6) *Lankester*, in his article on the red blood-corpuscle in the *Quarterly Journal of Microscopical Science*, Oct., 1871, already cited, says, p. 366, that *Hensen* "distinguishes a layer of fluid protoplasm surrounding the colouring matter, by cadaveric alteration of which he believes the supposed membrane of the corpuscle to be formed."

(7) *Manual of Human Histology*. Translated and edited by Geo. Busk and Thos. Huxley, London, Sydenham Society, 1854. vol. II, p. 326.

(8) *Handbuch der Gewebelehre*, 1863, p. 627.

he himself had seen, and at least so far as red corpuscles of the blood of salamanders are concerned, positively declared a membrane normally to exist.¹ As proof of the existence of a membrane and of its taking no part in the formation of blood-crystals, *Bryanowski* refers to his success in demonstrating it by means of distilled water.² *Owsjannikow* says: "To prove with certainty the existence of the membrane is no easy task. Preparations occur which seem to be convincing that there is no membrane; but other preparations show it without the addition of any reagent. The interior contents retract away from it, so that between it and the yellowish colored contents an empty space remains. Still more distinctly than in pure blood is the membrane seen on the addition of a weak solution of sugar, either without or with admixture of a little alcohol. Then it appears in many or perhaps in most of the blood-corpuscles." Furthermore, he describes interior crystallization in which he has seen the membrane pushed out lengthwise by a crystal, and other cases in which "the membrane becomes very distinctly visible as it passes from nucleus to crystal." With high magnifying power, he says, human red blood-corpuscles not seldom show a very delicate membrane; and one of his conclusions is: "In the blood corpuscles of most animals an independent membrane can be proved to exist, which behaves toward serum, water, etc., differently than the cell contents and which occasionally possesses considerable firmness."³ *Richardson* argued⁴ in favor of the same view, mainly on account of experiments upon the gigantic blood disks of the *Menobanchus*, in which "crystals of hæmato-crystallin were seen to prop out a visible membranous capsule." More recently, *Richardson* exhibited before the members of the Section on

(1) "Ueber amoeboide Blutkörperchen." *Virchow's Archiv*, vol. 30 (1864), p. 437.

(2) "Beobachtungen über die Blutkrystalle." *Zeitschrift für wissenschaftliche Zoologie*, vol. XII, Heft 3 (Nov. 17, 1862), p. 317.

(3) "Zur Histologie der Blutkörperchen." *Bulletin de l'Academie des Sciences de St. Petersbourg*, t. VIII. (1835), pp. 564, 568, 569 and 570.

(4) "On the Cellular structure of the red blood-corpuscle." *Transactions of the American Medical Association for 1870*, pp. 259-271.

Biology of the International Medical Congress of Philadelphia, a slide with a colored blood-corpuscle of the *Amphiuma tridactylum*, of which it is reported that "the imperfectly crystallized cell-contents occupy the upper end, while the oval granular nucleus fills the inferior extremity, leaving the membranous capsule relaxed and wrinkled longitudinally, hanging like part of a half-flaccid balloon between them."¹ *Arloing*, as the result of his observations,² ascribed a membrane to red blood-corpuscles. *Kollmann*, after expressly declaring that when he uses the word membrane in relation to red blood-corpuscles, he means to speak of what may be called an "artefact," *i. e.* "that apparent membrane which is made visible by the action of reagents,"³ discusses the arguments pro and con, and concludes that "the adherents of a membrane have for their opinions, at least as many reasons as the opponents."⁴ He himself believes in "the existence of a membrane in the fresh condition, which can be made visible by the action of reagents by depriving the corpuscle of coloring matter, and which, when it does not become visible, has been destroyed by the reagent."⁵ According to *Böttcher*, the outer layer of the same blood-corpuscle is not the same at all times and under all circumstances. He seems to regard the appearance of a distinct membrane as an artificial production; but considers "the cortical layer as the result of a process of development which deprives the blood-cells more and more of their protoplasm, and finally converts them into homogeneous bodies." He, therefore, classes it "with the capsule of cartilage cells, and with the cellulose membrane of vegetable cells."⁶ *Fuchs* observed a membrane

(1) Transactions of the International Medical Congress of Philadelphia, held in 1876. Philadelphia, 1877, p. 488.

(2) "Recherches sur la nature du globule sanguin." *Compt. rendus*, t. 74 (1872), No. 19, pp. 1256-1 59.

(3) "Bau der rothen Blutkörperchen." *Zeitschrift für wissenschaftliche Zoologie*, vol. XXIII, Heft 3 (Nov. 18, 1873), p. 467.

(4) *Ibid.*, p. 482.

(5) *Ibid.*, p. 480.

(6) Compare "Neue Untersuchungen über die rothen Blutkörperchen," *Mémoires de l'Académie Impériale des Sciences de St. Petersburg*, VII Série, t. 22 (1876), No. 11, p. 8 :

of a certain power of resistance in frog's red blood-corpuscles after keeping them a few days on the slide without addition of any reagent, which membrane was particularly obvious when the nucleus made its exit out of the corpuscular mass.¹ According to *A. Bechamp*,² and *J. Bechamp and Baltus*,³ the red blood-corpuscles of mammals, birds and amphibia, possess a distinct membrane which can be thickened by adding a solution of starch to the blood and then becomes more resistant to the action of water.

It has even been supposed that blood-corpuscles had more than a single membrane; thus *Roberts* said⁴ his observations had led him "to the belief that the envelope of the vertebrate blood-disk is a duplicate membrane; in other words, that within the outer covering there exists an interior vesicle which encloses the colored contents, and in the ovipara, the nucleus." *Böttcher* has refuted this notion,⁵ and it is characterized by *Wedl*, too, as incorrect; according to *Wedl*, when the cortical layer becomes swelled and condensed, the double contour which is seen indicates its thickness—but he is "quite certain that whether it be called membrane or not, it is not simply an artificial product."⁶ *Lankester*, in his conclusions regarding the vertebrate red blood-corpuscle, says: its surface is differentiated somewhat from the underlying material, and forms a pellicle or membrane of great tenuity, not distinguishable with the highest powers (whilst the corpuscle is normal and living), and having no pronounced inner limitation."⁷ *Ranvier* thinks that the double contour

and the "Untersuchungen" in *Virchow's Archiv*, vol. 36, (1866), pp. 357, 383, 387-8, 389 and 404, with *Archiv für Mikroskopische Anatomie*, vol. XIV (1877), p. 93, or "On the minute structural relations of the red blood-corpuscles," (translated from the preceding in) *Quarterly Journal of Microscopical Science*, Oct., 1877, p. 392.

(1) "Beitrag zur Kenntniss des Froschbluts," etc., *l. c.*, p. 91.

(2) "Recherches sur la constitution physique du globule sanguin." *Compt. rendus t. 85*, (1878), No. 16, pp. 712-715.

(3) "Sur la structure du globule sanguin et la résistance de son enveloppe à l'action de l'eau." *Ibid.*, No. 17 p. 761.

(4) *L. c.*

(5) *Op. cit.* *Virchow's Archiv*, vol. 36, (1866), pp. 392-395.

(6) *L. c.*, p. 408.

(7) *L. c.*, p. 386.

—the effect of dilute alcohol—“proves the existence if not of a membrane, at least of a differentiated cortical layer.”¹

*Schmidt*² calls attention to the double contour as being “the only proof of the presence of a membrane, whether pre-existent or artificially produced.” In fresh blood of *Amphiuma* he has observed colored blood-corpuscles with a greenish border, indicating “the existence of a thin layer at the surface, differing if not in chemical composition at least in density from the substance of the disks.” He has frequently met with “specimens of blood-corpuscles, on which, by a contraction of the protoplasm representing the greater portion of the whole body, the pellicle in question appears separated from the latter.” Once he saw a fragment of a corpuscle on which “the membranous layer was seen projecting on the torn surface;” and at another time he found “a fresh blood-corpuscle of the *Amphiuma* on which the membranous layer had apparently burst and retracted, leaving a portion of the underlying material, the protoplasm, exposed.” He says: “The changes taking place in these blood-corpuscles, when treated with the solution of the hydrate of chloral, are very interesting and important; as they manifestly show the existence of the membranous layer of these bodies, such as I have described it. Thus, after the solution has been applied, the protoplasm of the blood-corpuscle, without much or any alteration of form, gradually contracts upon the nucleus. As the result of this contraction, it becomes entirely separated from the membranous layer, which manifests itself in the form of a delicate double contour. The interspace left between the contracted protoplasm and the double contour, representing the membranous layer, is very considerable, as will be seen from the drawings; and it seems to me

(1) “De l'emploi de l'alcool dilué en histologie.” *Archiv de physique*, 1874, pp. 790-793. And again, “Recherches sur les éléments du sang.” *Id.*, 2. Serie. vol. II, 1875, pp. 1-15.

(2) “The structure of the Colored Blood-corpuscles of *Amphiuma tridactylum*, the Frog and Man.” *Journal of the Royal Microscopical Society*; containing its Transactions and Proceedings, with other Microscopical Intelligence, London, Vol. I, No. 2 (May, 1878), pp. 57-73; No. 3 (July, 1878), pp. 67-120.

should be sufficient evidence to prove the existence of such a layer to an unbiassed mind." In the colored blood-corpuscles of the frog, he has also seen a distinct stratum, or membranous layer.

"The colored blood-corpuscles of man show a double contour under various circumstances and conditions, indicating the existence, if not of an enveloping membrane, at least of a membranous layer on its surface." As one proof, Schmidt recommends the experiment of pressing down, by means of the point of a forceps, a *small* round covering glass upon a very small drop of fresh human blood placed upon the slide, "with the object of compressing or crushing the blood-corpuscles as far as possible." "Carefully examined with a first-class objective of sufficient amplification, it will be found that they have not run into each other; but that, on the contrary, the outlines of almost every individual may be discerned, however distorted they may be."

Almost all investigators nowadays agree that the colored blood-corpuscles of birds, reptiles, amphibia, and fishes, have a nucleus; while in those of man and other mammalia, except in developmental forms, a nucleus does not occur. On this difference, *Gulliver* has founded his division of all vertebrate animals into Pyrenæmata and Apyrenæmata.¹ But the existence of a nucleus in living corpuscles of oviparous vertebrata has been denied on the one hand; while, on the other, the opinion has been advanced that the mammalian red corpuscles, as well as those of other vertebrata, are in reality nucleated.

Not to cite older authors, I will mention that *Funke*²

(1) "Lectures on the blood of vertebrata" *l. c.*; in "Journal of Anatomy and Physiology, vol. II; Proceedings of the Zoological Society of February 25, 1862; and Hunterian Oration, 1863, referred to in "Observations on the sizes and shapes of the red corpuscles of the blood of vertebrates, with drawings of them to a uniform scale, and extended and revised Tables of Measurements." Proceedings of the Zoological Society of London, for the year 1875. Part III, p. 479.

(2) *Lehrbuch der Physiologie*. Leipzig, 1863, vol. I, p. 17.

asserts that the nucleus of nucleated blood-corpuscles does not exist during life, but is a product of decomposition after death. Likewise *Savory*, in a paper¹ read before the London Royal Society, urged that "when living, no distinction of parts can be recognized; and the existence of a nucleus in the red corpuscles of ovipara is due to changes after death, or removal from the vessels;" and furthermore, "the shadowy substance seen in many of the smaller oviparous cells after they have been mounted for some time, is very like that seen under similar circumstances in some of the corpuscles of mammalia." But *Böttcher* has reported² seeing nucleated blood corpuscles in the capillaries of living frogs, and more recently *Hammond* saw a nucleus in the red blood-corpuscles of young trout, varying as to age from a day to three weeks, swimming in a cell full of water³; and, afterward, also in those of the tail of frog-embryos and in other animals⁴.

Böttcher has by numerous methods and for a long time sought to demonstrate the existence of a nucleus in mammalian red blood-corpuscles. In his first publication⁵ he gave a historical sketch of the literature of the subject, and described the effects of chloroform, magenta, tannin, and other reagents. He also treated corpuscles with serum of other blood; next⁶ he placed them in aqueous humor ("methods which alter the red blood-corpuscles as little and as slowly as possible"); afterward⁷ he treated them with alcohol and acetic acid, and

(1) "On the Structure of the Red Blood-corpuscle of Oviparous Vertebrata." *Proceedings of the Royal Society*, XVII, 1868, 1869. (Read March 18, 1869.) *Monthly Microscopical Journal*, April, 1869, p. 235.

(2) "Untersuchungen über die rothen Blutkörperchen der Wirbelthiere." *Virchow's Archiv*, vol. 36 (1866), (pp. 342-423), p. 351.

(3) "Observations on the structure of the red blood-corpuscles of a young trout." *Monthly Microscopical Journal*, June, 1876, pp. 282-283.

(4) "Observations on the structure of the red blood-corpuscles of living pyrenæmatous vertebrates." *Id.*, September, 1876, p. 147.

(5) The "Untersuchungen" just cited, pp. 359, 363, 367, etc., and 376.

(6) "Nachträgliche Mittheilung über die Entfärbung rother Blutkörperchen und über den Nachweis von Kernen in denselben." *Virchow's Archiv*, vol. 39 (1868), pp. 427-435.

(7) "Neue Untersuchungen über die rothen Blutkörperchen." *Mémoires de l'Acad. Imp. des Sci. de St. Petersburg*, VII Ser., t. 22, No. 11.

still more recently¹ by means of a concentrated alcoholic solution of corrosive sublimate (methods of "hardening the blood-corpuscles and then extracting the hæmatin from them"). *Freer*, using reflected instead of transmitted light (by means of Wales' Illuminator) affirmed² independently of *Böttcher*, the existence of a nucleus in human blood; and *Piper*³ seems very desirous to confirm *Freer*. *Brandt*, having⁴, in the red blood-corpuscles of living *Sipunculus*, occasionally found a nucleus, though usually there is none, thought that perhaps the nuclei are unstable formations which by slight influences are produced or made visible, and by others are destroyed or made invisible; on examining a drop of blood from his finger, on which he had before pricking placed a little fresh chicken albumen, he usually found in many red corpuscles what he was inclined to interpret as a central nucleus, in confirmation of the observations of *Böttcher*⁵. More recently *Stowell* has written a communication to corroborate *Böttcher*⁶. And *Stricker* has expressed the opinion that the nuclei of embryonal colored blood-corpuscles of mammals persist as circular thin disks; he argues that these "disks are so large that the body proper of the corpuscle appears on a surface view as only a narrow zone: and that, therefore, except with high powers, the existence of a nucleus is easily overlooked: and he asserts that, by means of objective No. 15, he has in the blood-corpuscles of man, dog, rabbit, and cat, seen the nucleus in both surface and profile views."⁷

(1) "Ueber die feineren Structurverhältnisse der rothen Blutkörperchen." *Archiv für Mikrosk. Anatomie*, vol. XIV (1877), pp. 73-93.

(2) "Discovery of a new anatomical feature in human blood-corpuscles." *Chicago Medical Journal*, May 15, 1868, and April 15, 1869.

(3) "Contraction of Blood-corpuscles through the action of Cold." *New York Medical Journal*, March, 1877, p. 244.

(4) "On the nucleus of red blood-corpuscles." *Arbeiten der St. Petersb. Gesellsch. d. Naturf.*, vol. VII (1876), p. 129. (In the Russian language.)

(5) "Bemerkungen über die Kerne der rothen Blutkörperchen," *Archiv. für Mikrosk. Anatomie*, XIII, 2 (1876), p. 392.

(6) "Structure of blood-corpuscles." *American Journal of Microscopy and Popular Science*, New York, June, 1873, p. 140.

(7) *Vorlesungen über allgemeine und experimentelle Pathologie*, II Abtheilung. Wien, 1878, p. 438.

On the other hand, *Schmidt* and *Schweigger-Seidel*, who repeated *Böttcher's* early methods, using especially chloroform as he had done, failed in finding nuclei, and suspected optical illusion¹. *Klebs* contradicted *Böttcher's* statements as to the presence of nuclei in normal mammalian red blood-corpuscles; but described the occurrence of nucleated red corpuscles in blood taken from the corpse of a child who had suffered from leucæmia, agreeing in so far with a like observation of *Böttcher*². *Brunn* said³ that he had convinced himself that the appearances produced by both of *Böttcher's* later methods are artificial and optical effects, due to action of the re-agents on the substance of the corpuscles. And, similarly, *Eberhardt* has come to the conclusion that the remains after the action of different decolorizing reagents, are not nuclei, but stromata deprived of coloring matter; and that a formation, unmistakably a nucleus, has not yet been demonstrated in adult human and mammalian red blood-corpuscles."⁴

Among other questions as to the red blood-corpuscle stated by Beale,⁵ he asks: "Is it a living corpuscle that distributes vitality to all parts of the organism, or is it simply a chemical compound which readily absorbs oxygen and carbonic acid gases and certain fluids? Is it composed of formative living matter, or does it consist of matter that is inanimate? Does it absorb nutrient matter, grow, divide, and thus give rise to other bodies like itself, or does it consist of passive material destitute of these wonderful powers and about to be dissolved into substances of simple composition and more nearly related to inorganic matter?"

(1) "Einige Bemerkungen über die rothen Blutkörperchen." Bericht der Königl. Sächsischen Gesellschaft der Wissenschaften, 1867. p. 190.

(2) "Ueber die Kerne und Scheinkerne der rothen Blutkörperchen der Säugethiere." Virchow's Archiv vol. 38 (1867), p. 290.

(3) "Ueber die den rothen Blutkörperchen der Säugethiere zugeschriebenen Kerne." Archiv für Mikroskopische Anatomie, vol. XIV, Heft 3 (1877), pp. 333-342.

(4) Ueber die Kerne der rothen Blutkörperchen der Säugethiere und des Menschen. Inaugural-Dissertation der medizinischen Fakultät zu Königsberg. April, 1877, p. 30.

(5) Observations upon the Nature of the Red Blood-corpuscle; *L. c.* p. 32.

He answers the first parts of these interrogatories in the negative, and holds that it is "not living, but results from changes occurring in colorless living matter, just as cuticle, or tendon, or cartilage, or the formed material of the liver-cell, results from changes occurring in the germinal matter of each of these cells." He says, "The colorless corpuscles, and those small corpuscles which are gradually undergoing conversion into red corpuscles, are living, but the old red corpuscles consist of inanimate matter. They are no more living than the cuticle or the hard horny substance of nail or hair is living."¹ He therefore denied the contractility and amœboid movement of colored blood-corpuscles.

Klebs was the first who accorded them life and contractility.² He did this because, on preventing evaporation and raising the temperature of blood, he noticed, aside from motion of the corpuscles, the protrusion and retraction of knobs, and the formation and disappearance of scallops. But, though the correctness of his observation was not doubted, his inferences were strenuously contradicted by *Rollett* and others.³ *Lankester* observed "amœboid figures" when colored blood-corpuscles had been subjected to the action of dilute ammonia and acetic acid, of which he says:⁴ "The behaviour of these corpuscles under alternate weak ammoniacal and acid vapors furnished a very curious parallel to the movements of amœboid protoplasm, and a careful consideration of the phenomena may throw some light on the nature of protoplasmic contractility." *Böttcher* admits the possibility of vital contractility, but thinks it cannot be compared to that of colorless blood-corpuscles.⁵ *Brücke*,⁶ also, admits cautiously this possibility. *Preyer*⁷ uses many qualifying expressions, such as "only in part," "under certain circumstances," "in some degree," "temporarily," "at certain times."

(1) *Idem.* p. 43.

(2) *Centralblatt für medizinische Wissensch.* 1863, No. 514, p. 851.

(3) For the views of *Rollett*, *Max Schultze*, *Kühne*, etc., see *Stricker's Handbuch, cit.*, Leipzig (1869) Edition, p. 297; American Reprint (1872), p. 286.

(4) *Op. c.*, p. 378.

(5) *Archiv für mikr. Anat.*, vol. XIV, *cit.* p. 91: translated in *Quart. Journ. of Microsc. Sci.*, Oct., 1877, p. 391.

(6) *L. c.*

(7) *Op. c.*, p. 417. *et seq.*

He observed active form-changes of red corpuscles in extravasated amphibian blood, examined in the moist chamber, which led him to the conclusion that "the substance of these corpuscles consists of dissolved coloring matter and a colorless material (protoplasma) which, both when still in connection with the coloring matter and when free from this, shows under certain circumstances phenomena of contractility similar to those observed in many lower organisms." He adds, "As a rule it evinces no contractility, and constitutes, as modified protoplasm, the stroma of amphibian blood-corpuscles."¹ *Max Schultze*, who denied the contractility of red blood-corpuscles of man and mammals, (although when subjected to a very high temperature—50 to 52° C., nearly enough to kill them—he saw protrusions and detachments of portions,) admitted that the red blood-corpuscles of very young chicken-embryos are contractile.² *Friedreich*³ observed in an enfeebled anæmic patient polymorphous red blood-corpuscles with active though very slow form-changes, which he could not but interpret as the result of contractility. In the *post-mortem* blood of a woman who had been leucæmic he saw similar polymorphous corpuscles; and in a case of albuminous urine he repeatedly observed colored blood-corpuscles from which minute portions became constricted and separated, as well as such which exhibited amœboid protrusion and retraction of short blunt projections, whereby a slow locomotion of the corpuscle was accomplished. He assumed that the contractility which the colorless corpuscles possess in so high a degree is preserved in undiminished strength in the red corpuscles in certain pathological cases. According to *Charlton Bastian*,⁴ red blood-corpuscles leave under certain circumstances the vessels by virtue of active amœboid movements; and he thinks it would be well if "the attention of future observers should be directed to these peculiarities, and to the particulars above mentioned, in order

(1) *Ibid.* p 440.

(2) Verhandlungen der Niederrheinischen Gesellschaft für Natur- und Heilkunde in Bonn, am 8 Juni, 1864: Berliner Klinische Wochenschrift, 1864 No 36, p. 358.

(3) "Ein Beitrag zur Lebensgeschichte der rothen Blutkörperchen;" *Virchow's Archiv*, vol. 41 (1867), p. 395.

(4) "Passage of the Red Blood-corpuscles through the walls of the Capillaries in Mechanical Congestion." *British Medical Journal* May 2, 1868 pp. 425, 426.

to determine more certainly than has yet been done how far amœboid movements and contractions do take place in the much-examined and much-written about red blood-corpuscles."

Lieberkühn observed in the red corpuscles of salamandra and pike's blood active protrusion and retraction of bead-like processes. He also saw movements of granules or small molecules in the interior of the red blood-corpuscles of living frog embryos.¹

Faber,² in addition to his own observations of contractility and spontaneous locomotion of colored blood-corpuscles in albuminous urine—phenomena which continued to be manifested for a longer time in colored than in colorless corpuscles—has given a rather complete account of the literature of these phenomena, including the reports of *diapedesis* observed by Virchow, Stricker, Cohnheim, Prussak and Hering. The observations of amœboid movements by *Bastian* (just cited), *Owsjannikow*,³ *Winkler*⁴ and *Brandt*,⁵ seem to have escaped him; *Arnold's* experiments concerning diapedesis,⁶ and *Belfield's* observation of emigration of certain small-sized red corpuscles of the frog,⁷ were published more recently. Since the publication of *Faber's* article, furthermore, *Rommelaere* has described amœboid movements of colored blood-corpuscles;⁸ *Brandt*⁹ has spoken of the peculiar forms of the red blood-corpuscles of *Sipunculus* and *Phascolosoma* referable to amœboid movements, and of the fact that occasionally in the temperature of an ordinarily warmed room considerable movements are accomplished; and *Schmidt* has observed spontaneous motion (expansion and contraction) in a fresh colored blood-corpuscle of *Amphiuma* in one instance,¹⁰ and

(1) "Ueber Bewegungserscheinungen der Zellen." Schriften der Gesellschaft zur Beförderung der gesammten Naturwissenschaften zu Marburg, vol. IX (1870), p. 335.

(2) "Ueber die rothen Blutkörperchen." Archiv der Heilkunde. XIV (1873), pp. 481–511.

(3) *Op. cit.*, p. 563.

(4) *Textur, Structur und Zelleben in den Adnexen des Menschlichen Eies.* Jena, 1870, p. 33.

(5) "Anatomisch-hist. Untersuchungen über d. *Sipunculus nudus*, L." Mémoires de l'Académie Impériale des Sciences de St. Petersbourg, VII. Serie, t. XVI, No. 8.

(6) *Loc. cit.*

(7) "Emigration in passive hyperæmia." American Quarterly Microscopical Journal, October, 1878, p. 39.

(8) *De la déformation des globules rouges du sang.* Bruxelles, 1874, p. 47.

(9) In a foot-note to his "Bemerkungen über die Kerne der rothen Blutkörperchen," *l. c.*, pp. 391, 392.

(10) *Op. cit.*, p. 67.

in those of man in a number of instances. He reports that he had witnessed the phenomenon in the colored blood-corpuscles of man as early as the summer of 1871. He says, "In examining a specimen of human blood, and whilst my attention was directed to the colored corpuscles as they were carried along by a moderate current of the liquor sanguinis under the covering glass, I noticed on some of them the projection and immediate withdrawal of minute, conical, thorn-like processes, whenever one blood-corpuscle came into the vicinity of another, without, however, actual contact. It seemed almost as if one corpuscle were attracting or drawing out the thorn-like process from the surface of the other. In other instances, however, I observed the shooting forth and quick withdrawal of these processes from the margins of corpuscles not in close vicinity to others. As these processes appeared at the marginal surfaces of the blood-corpuscles, before the latter had come in contact with other of their fellows, I naturally regarded the phenomenon as one of spontaneous motion, manifested by the colored blood-corpuscle. But as in most instances the phenomenon was observed in corpuscles passing near each other, I was inclined to attribute it to a certain power of mutual attraction, residing under certain conditions in the colored blood-corpuscles. Having taken the precaution of slightly warming the glass slide before putting the blood, quickly taken from the vessels of the skin of a vigorous young man, upon it, and the temperature of the surrounding air being 96° F., or even more at the time, I also considered a certain amount of heat, at least 98° F., as essential to the manifestation of the phenomenon. This view, however, proved to be erroneous, as I shall show directly. Although I have witnessed this phenomenon on blood-corpuscles when in a state of rest, it nevertheless is more frequently observed on blood-corpuscles in motion, as when they are carried along by a current, arising in the specimen under the covering glass, and resembling in character the current in the capillary vessels. With this view, the drop of blood should be thinly spread upon the glass slide, and quickly covered with the thin plate of glass. While the blood-corpuscle is projecting the thorn-like process, its body elongates, resembling a unipolar cell; but with the withdrawal of the process, generally assumes its original round form; bi-

polar or lemon-shaped corpuscles are also very frequently met with in specimens of human blood. The same process is also observed when the margins of two corpuscles actually touch each other very slightly, and then slowly separate again. While separating, the thorn-like processes will be drawn out at the exact place of contact, and either remain permanent or disappear again after the separation has taken place.

That the normal heat of the human blood is not essential to the manifestation of spontaneous motion in the colored corpuscles, I discovered during the past winter, while repeating my examinations of the structure of these bodies. I then witnessed the phenomenon above described, without having warmed the glass slide and covering glass, and at the temperature of a moderately warmed room. However, I observed a colored corpuscle of a constricted form, similar to a figure of eight, slowly expanding, and finally resuming its original round form.

From this we may conclude that the colored blood-corpuscle of man possesses not only a certain inherent power of contracting its body, but also of resuming its original form by a subsequent expansion, a characteristic property of the living protoplasm, enabling the colored corpuscle to manifest spontaneous motions, though not to so great an extent as is seen in the colorless."¹

In his "General Conclusions and Summary," *Lankester*² says, that the viscid mass constituting the red blood-corpuscles of the vertebrata "consists of (or rather *yields*, since the state of combination of the components is not known) a variety of albuminoid and other bodies, the most easily separable of which is hæmoglobin; secondly, the matter which segregates to form Robert's macula; and thirdly, a residuary stroma apparently homogeneous in the mammalia (excepting so far as the outer surface or pellicle may be of a different chemical nature), but containing in the other vertebrata a sharply definable nucleus; this nucleus being already differentiated, but not sharply delineated during life, and consisting of (or separable into) at

(1) *Op. cit.*, pp. 113, 114, 115.

(2) *Op. cit.*, p. 386.

least two components, one (paraglobulin) precipitable by CO_2 , and removable by the action of weak NH_3 ; the other pellucid and not granulated by acids."

A residuary stroma, such as Lankester here speaks of, seems to have been first recognized by *Nasse*, who said¹ that the red blood-corpuscle "consists of a basis tissue, insoluble in water, which is penetrated by a red substance, probably dissolved, or at least in water easily soluble (the red coloring matter of the blood), and some water, and within which there is an aggregation of solid granules not connected with the coloring matter." *Rollett*,² also, assumed that a stroma or matrix enters into the structure of the colored elastic extensible substance of the red blood-corpuscle, to which the form and the peculiar physical properties of the corpuscle are due. This stroma is, however, according to *Böttcher*, an artificial product, "nothing more than a residue of the colorless part of the red blood-corpuscles, varying much in form and extent, which remains after the dissolution of the original structural relations."³ *Brücke* considered the most probable interpretation of the forms of colored blood-corpuscles, based on their appearances after the addition of boracic acid, to be the existence of a porous mass of motionless, very soft, colorless, hyaline substance, which he calls œcoid, in the interspaces of which is imbedded the living body of the corpuscle; which body he calls zooid, and which consists of the nucleus (where that exists) and all the remaining part of the corpuscle containing the hæmoglobin.⁴ But *Rollett* insisted that the forms on which *Brücke* based this interpretation are products of decomposition.⁵ *Stricker* agrees with *Brücke* as to the existence of the œcoid, but separates, in oviparous

(1) "Blut." R. Wagner's Handwörterbuch der Physiologie. Braunschweig, 1842, vol. I, p. 89.

(2) "Versuche und Beobachtungen am Blute." Moleschott's Untersuchungen. IX; also, Sitzungsberichte der Wiener Akademie, vol. 46, Div. II (1862), pp. 65-98; and *Stricker's* Handbuch, cit. Leipzig Edition, 1869, p. 295; American, p. 284.

(3) *Op. cit.*, Archiv f. Mikrosk. Anatomie, p. 90, translated in Quarterly Journal of Microscopical Science, October, 1877, p. 390.

(4) Ueber den Bau der rothen Blutkörper; Sitzungsberichte der Wiener Akademie, vol 56. Div. II (1867), p. 79.

(5) "Ueber Zersetzungsbilder der rothen Blutkörperchen;" Untersuchungen aus dem Institute der Physiologie und Histologie in Graz. Leipzig, 1870, p. 1.

corpuscles, the remaining portion into nucleus and body.¹ Of the three views thus presented, Lankester gives, after Stricker, the following tabular statement:²

Red blood-corpuscles of ovipara, divisible into	{	Stroma.	}	According to Rollett.
		Coloring matter.		
		Æcoid=outer part of stroma.	}	According to Brücke.
		Zooid=rest of stroma plus hæmoglobin.		
		Membrane=æcoid.	}	According to Stricker.
		Body=zooid minus nucleus.		
		Nucleus=zooid minus body.		

If it had not been for the deserved eminence in other respects of the three investigators, Rollett, Brücke and Stricker, these notions of the structure of colored blood-corpuscles would probably never have attracted any attention.

*Laptschinsky*³ considered colored corpuscles to consist of two kinds of substance, viz., one which appears smooth, soft, extensible, assumes mostly a roundish form, and, altogether, possesses some if not all of the properties of the so-called stroma; the second, visible under the microscope only, when through the action of different re-agents it is precipitated, or swelled, or both. It is this second substance which, on staining, takes up the coloring matters, and, by separating in the interior of the corpuscle from the first substance, or protruding from it, gives rise to the various shapes observed. At present it cannot be determined in what relation these two substances stand to each other previous to the precipitation of the stainable portion. The separating the blood-corpuscles into the two substances mentioned, is brought about by various external influences.

In amphibian, *i. e.*, frog's and salamander's, red blood-corpuscles, *Hensen*, *Böttcher*, *Kollmann* and *Fuchs* have seen a network; and although they have failed to interpret it correctly—

(1) *Mikrochemische Untersuchungen der rothen Blutkörperchen;* Archiv für die gesammte Physiologie des Menschen und der Thiere (Pflüger's), vol. I (1868), p. 592.

(2) *Op. cit.* in a foot-note to p. 374.

(3) "Ueber das Verhalten der rothen Blutkörperchen;" *loc. cit.* pp. 173, 174.

as is evident from the context of their descriptions—I beg to call special attention to their observations.

Hensen ascribed to the corpuscle the possession of protoplasm accumulated at the nucleus and at the inner surface of the membrane; the two being connected by delicate radiating filaments, in the spaces between which the colored cell-liquid lies.¹

Böttcher, from his observations, “inferred that around the nucleus of the amphibian blood-corpuscles a mass of protoplasm is collected, which radiates in the form of filaments into the homogeneous red substance. * * * * The protoplasm appears sometimes collected uniformly round the nucleus, at other times it is accumulated more to one side of it. It is either provided with only a few processes, or is arranged round the nucleus in the shape of an elegant star, whose points extend to the margin of the corpuscle, or else it forms round the nucleus a peculiar lobed figure. Very often it appears beset on one or all sides with fine hair-like processes. Then, again, it may represent a sort of net-work, which either appears separated from the less darkly colored cortical layer and more contracted, or else it throws out into the cortex innumerable very fine radiating filaments, so that its processes approach the extreme periphery of the blood-corpuscles. In this case, therefore, the whole blood-corpuscle is permeated by a net-work of fine filaments.”²

According to Kollmann, the membrane encloses a net-work of delicate slightly granular albumen threads. These in their totality constitute the stroma, and in the small spaces between the threads of the stroma lies the hæmoglobin. The soft elastic albumen threads are stretched between membrane and nucleus. Only by a certain degree of their tension is the characteristic form of the blood-corpuscle possible. The hæmoglobin in the meshes counteracts excessive shortening of the threads.”³

Fuchs expresses himself similarly as to the net-work of fibers

(1) “*Untersuchungen*,” *l. c.*, p. 261.

(2) “On the Minute Structural Relations of the Red Blood-corpuscles,” *Quarterly Journal of Microscop. Science*, Oct., 1877, pp. 388, 389, 390.

(3) “*Bau der rothen Blutkörperchen*,” *l. c.*, p. 482.

emanating from the nucleus, and going to the periphery of the frog's red blood-corpuscle. He adds that the net-work gives the corpuscle its shape, and fixates the nucleus in the centre. Death of the corpuscle produces first coagulation, afterward liquefaction of the fibers of the net-work. Whenever the fibers are coagulated they are shortened, and produce indentations at the surface by drawing upon the points where they are attached; when the shortening proceeds too far, the fibers are torn off from the membrane, and in both cases of shortening there are places at the surface which look protruded. Liquefaction of the fibers is assumed when the corpuscle has a vesicular appearance, when it seems to contain a semifluid mass in which the nucleus may take any position, and from which it sometimes exudes, proving in exuding the existence of a membrane as already described.¹

Schmidt seems to have seen something like an arrangement of filaments, but if so, has misinterpreted it entirely. He has reported observing, in blood of amphiuma treated first with water under the microscope, and then with a very weak solution of chromic acid (strength not ascertained), "a series of fine lines, radiating from the periphery of the nucleus through the protoplasm to the inner surface of the membranous layer of the blood-corpuscle." He remarks: "Now this picture would almost seem to corroborate the theory of Hensen, as well as that of Kollmann; the fine double lines representing the filaments, which they suppose to radiate from the nucleus to the enveloping membrane. But this is not the case; for a closer examination reveals that these lines represent nothing but fissures in the protoplasm, which appears to have assumed some form of crystallization. This becomes more evident by observing some of these fissures, deviating from their course and giving rise to subordinate branches."² He has also reported a somewhat analogous appearance in the colored blood-corpuscles of the frog, both fresh and treated with the same reagents. This he explained by contraction of the interior mass. He says: "The protoplasm in such a case retracts upon the nucleus, which it

(1) *Op. cit.*, p. 95.

(2) *Op. cit.*, p. 72.

completely surrounds, while the membranous layer appears isolated, manifesting itself by a double contour. And again, if the same process should take place without entirely separating the protoplasm from the membranous layer, but leaving at certain small points a union between the two parts, the result must be the production of a number of filamentary processes, arising from the main bulk of the protoplasm, and passing to those points of the membranous layer."¹

Kneuttinger considered the two surfaces of the biconcave disk of blood-corpuscles to be connected at the place of the depression by protoplasmic threads; if these tear, the biscuit form changes to a sphere.²

According to *Krause*, the red blood-corpuscle consists of—1. A colorless stroma formed by a solid albuminous matter arranged into radial fibers, and—2. Hæmoglobin, which is a colored fluid albuminous matter lying in the interspaces of these fibers.³

Lieberkühn has found that the free nuclei of red blood-corpuscles of salamandra and tritons (the blood having been kept for some time in colored glass tubes) consists of two substances, of which one forms the envelope and septa or threads passing more or less regularly through the interior; the other being contained between these septa.⁴

In the nuclei of colored blood-corpuscles *Bütschli*, *W. Flemming* and *Klein* have reported the existence of a net-work, viz.:

In the nuclei of red blood-corpuscles of frog and newt, *Bütschli* observed fibrils, with granular thickenings, traversing the nucleus and passing to and connecting with its envelope.⁵

Flemming saw a very delicate and dense network of fibers pervading the interior of the nucleus, and attached to the nuclear membrane in many so-called cellular elements of the bladder of curarized salamandra maculata. He inferred that the net-work

(1) *Ibid.* p. 106.

(2) Zur Histologie des Blutes. Würzburg, 1865, p. 22.

(3) Allgemeine und Mikroskopische Anatomie, p. 325—334.

(4) *Loc. cit.*

(5) "Studien über die ersten Entwicklungsvorgänge der Eizelle, die Zelltheilung und die Cojugation der Infusorien." Abhandlungen der Senckenbergischen Naturforschenden Gesellschaft, vol. X, Heft 3, 4 (1876), p. 260.

is present also in the nuclei of the red blood-corpuscles, though he did not see it there.¹

Speaking of some capillary blood-vessels of a newt, Klein said: "Some such capillaries contained blood-corpuscles, and the nuclei of these showed a very distinct net-work."² Also, "The examination of the nuclei of fresh epithelium of frog, toad or newt, the nuclei of fresh colored corpuscles of these animals, especially of toad, with a Zeiss's F Lens, or a Hartnack's Immersion, No. 10, reveals fibrils in the nucleus, and also shows that the 'granules' are due to the twisted or bent condition of them."³

III.

The method employed in my investigation, viz.: treatment of fresh blood with solution of bichromate of potash, and examination with high magnifying power, has revealed certain appearances as the structural arrangements of colored blood-corpuscles. Do these arrangements exist in the living corpuscle, or are they artificial productions of the reagent?

Dilute solutions of bichromate of potash and Müller's fluid are known as the best preserving media for the most delicate animal structures: Nervous tissue, the eye, embryos, etc., are kept in them unchanged for any length of time. In the fecundated chicken-egg of only twenty hours, placed in such a solution, the heart, but just formed, has been known to continue for a time to beat. Rollett has investigated the influence of bichromate of potash on "protoplasm," and found that no alterations were produced. In my series of observations, the weakest solutions (10 *per cent.* saturated solution or less) produced no paling of the colored corpuscles; while, on increasing the strength up to a certain point, paling occurred in an increasing degree, and a morphological structure became visible at the same time that the manifestations of life (contraction and amœboid movement) continued.

(1) "Beobachtungen über die Beschaffenheit des Zellkernes." *Archiv für Mikroskopische Anatomie*, vol. XIII (1876), p. 693, *et seq.*

(2) "Observations on the Structure of Cells and Nuclei." *Quarterly Journal of Microscopical Science*, July, 1878, p. 337.

(3) *Ibid.* p. 332.

From this, we certainly may infer that the reagent has not altered, at all events not seriously impaired, the living matter; and when we find that the structural arrangements thus revealed are the same as those demonstrable without reagents in other living matter, the inference that they were pre-existing and not artificially produced by the reagent becomes a certainty.

The knowledge of the structure of colored blood-corpuscles will not enable us to solve all the problems regarding their nature; but some questions are answered pretty conclusively by my investigation.

The colored blood-corpuscle is not a cell in any proper sense of that word, but, like the colorless corpuscle, is an unattached portion of the living matter (bioplasson¹) of the body. Broadly speaking, the essential difference² between the two kinds of corpuscles is the presence of hæmoglobin, using this term to designate the substance or substances—no doubt chemically very complicated—constituting the coloring matter under all the varying physiological circumstances.

In size, human colored blood-corpuscles vary so much, that claims to be able to distinguish them by their size from certain other mammalian colored blood-corpuscles are inadmissible.

The colored blood-corpuscle has no separate investing membrane; nevertheless, the outer portion, essentially like the inner substance forming the net-work, may be considered to be differentiated from the latter, especially at the periphery of the disk, where it constitutes an encircling band of uniform thickness, or occasionally of a wreath-of-beads appearance. In the colored blood-corpuscles of the lower classes of vertebrate animals there is usually a nucleus to be seen, which is not the case as a rule in those of man and other mammals; but there is in the interior of these an accumulation of matter occasionally met with, which may be interpreted as a nucleus.

In the communication to the Vienna Academy, cited in Part I,

(1) I use the word bioplasson as synonymous with "living matter" in preference to the better known word "protoplasm," because the former is etymologically more correct, and also because the latter has been used with other meanings attached to it than the one alone intended here, viz., living matter.

(2) The differences in the possession of nuclei I shall discuss on another occasion.

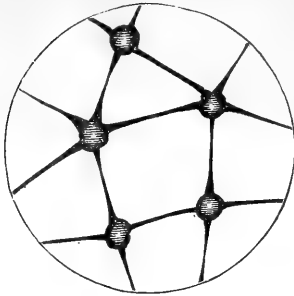

FIG. 7.

“the nucleolus, the nucleus, the granules with their threads, are the living contractile matter proper.”¹ Aside from some conditions which do not here concern us, he described, and illustrated by the accompanying schematic drawings, three states of the network, viz.: that of rest (fig. 7), that of contraction (fig. 8), and that of extension (fig. 9).

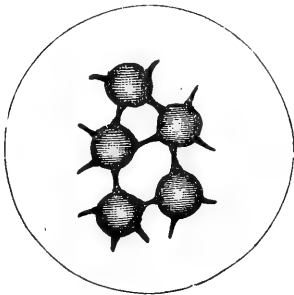

FIG. 8.

In the state of rest, the granules or points of intersection of the threads of the reticulum are in equilibrium, and the meshes holding the lifeless “protoplasmic fluid” are uniformly distributed. In the state of contraction, the granules increase in size at the expense of the length of the uniting threads; the granules approach each other, and as the meshes between them become smaller,

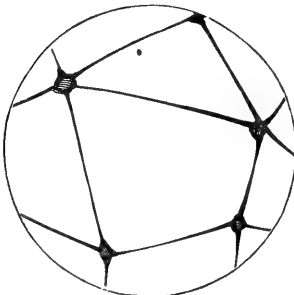

FIG. 9.

Heitzmann demonstrated the existence of a net-work in amœbæ, blood-corpuscles of astacus and of triton, human colorless blood-corpuscles and colostrum corpuscles; and, from direct observation of the changes in the reticulum during the contraction of the living body, announced that the substance constituting the net-work is itself the living matter or bioplaxion, *i. e.*,

“the nucleolus, the nucleus, the granules with their threads, are the living contractile matter proper.”¹ Aside from some conditions which do not here concern us, he described, and illustrated by the accompanying schematic drawings, three states of the network, viz.: that of rest (fig. 7), that of contraction (fig. 8), and that of extension (fig. 9).

In the state of rest, the granules or points of intersection of the threads of the reticulum are in equilibrium, and the meshes holding the lifeless “protoplasmic fluid” are uniformly distributed. In the state of contraction, the granules increase in size at the expense of the length of the uniting threads; the granules approach each other, and as the meshes between them become smaller, the fluid therein contained is forced toward the part not subjected to contraction. In the state of extension, the points of intersection decrease in size and move apart; the uniting threads become elongated, while the lifeless fluid is forced into the meshes from the contracting portion.

A fourth state of the living matter is assumed (hypothetically) by

(1) Sitzb. d. Wien. Akad., vol. 67, div. 3, p. 110.

the same investigator,¹ to account for the formation of a flat layer of living matter, such as forms the walls of a vacuole, the membrane of a nucleus, or the outer layer of the whole bioplasson mass; this is the protruding by a granule (which itself thereby loses its bulk and becomes flattened) of innumerable pseudopodia or offshoots, which unite laterally with each other, and with offshoots from neighboring granules. This is illustrated by Fig. 10.

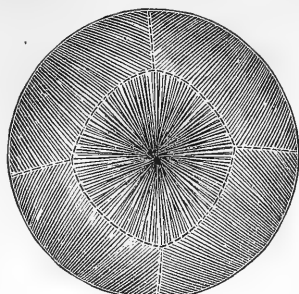

FIG. 10.

Heitzmann believes that each of these states may at any time change into the other, *i. e.*, that the network may from the condition of rest be transformed into that of contraction, or of extension, or of flattening, and from each of these into either of the others. At all events, there may arise in the bioplasson body a vacuole having a continuous thin wall, and containing lifeless fluid and detached particles of the living matter; the latter may send delicate offshoots to the wall of the vacuole, and suddenly the vacuole disappears and the network is re-established throughout the whole body. Or, a bioplasson mass may take into its interior foreign bodies by forming around them a *cul-de-sac*, which then opens toward the centre and closes at the periphery, and the network, rent during the process, re-establishes itself. Again, a bioplasson body, which by flap or knob protrusion and separation has lost a portion of its substance, as well as the portion detached, may become rounded off—the rupture at the place of detachment healing in each case without loss of life. And further, two bioplasson bodies may coalesce, and a portion of the periphery of each be transformed into the uniting net-work.

By adopting these views, and applying them to the living matter of colored blood-corpuscles, we may explain the changes which they have been observed to be subject to. What are the changes

(1) "The Cell-Doctrine in the light of recent investigations." New York Medical Journal, April, 1877.

that occur on the addition of a 40% saturated solution of bichromate of potash? I have described indentions and protrusions which either persist or are levelled again; protrusion of knobs, either pedunculated or sessile, which sometimes are so numerous that they surround the body of the corpuscle like a wreath; decrease of the size of the main body by detachment of knobs; appearance of net-work structure, most marked in the corpuscles which have not lost much of their substance; vacuolization of corpuscles, and transformation of many of the portions detached into vacuolized globules which increase in size; finally, change into faint, almost structureless disks, the so-called "ghosts."

The regular rosette, stellated, and thorn-apple shapes are caused by a uniform concentric contraction of the living matter;—the fluid in the interior, being pressed toward the outer layer between the points of attachment of the threads, will produce a bulging out at the periphery. Irregular contractions of the living matter will give rise to irregular flaps at the periphery.

An indentation is due to locally limited contraction of the net-work in the interior of the corpuscle. Contraction of the living matter at one part of the periphery will bring about a protrusion of a flap at another, the flap being bounded by the outer layer of the corpuscle.

Segmental contraction of the net-work will produce a rupture of the outer layer of the corpuscle, with projection of a pedunculated granule or knob, formerly a part of the interior net-work. Continued contraction will be followed by the rupture of the pedicle, and the production of either so-called detritus or small granules, or when the protruded knob is larger, or has become swelled, of a pale grayish disk.¹

Lastly, a large amount of the net-work having been separated

(1) The peculiar corpuscles believed to be characteristic of syphilis by Losterfer, and proved by Stricker, to be present in the blood of individuals broken down by that and various other diseases, are nothing but such disks, *i. e.*, portions of the colored blood-corpuscles protruded from the interior, detached and more or less swelled. As persons in low states of health have a relatively small amount of living matter in the same bulk, or, in other words, only a delicate network within the bioplason body or plastid (the so-called "cell"), such a network suspended in a relatively large amount of fluid can much more easily contract and bring about a rupture of the outer layer, than in the case of healthy persons within whose plastids there is relatively less room for contraction to take place.

from the parent body, the latter becomes transformed into a pale disk, in which no traces of a net-work, or but very indistinct ones, are visible, a so-called ghost.

At every stage of the protrusion of either flaps, or pedunculated knobs, or granules, the living matter may be overtaken by death, and the contraction become fixed by cadaveric rigidity. It may perhaps be worth while to notice that irregular contractions have a somewhat greater tendency to such permanency than regular ones; these more frequently yielding, by relaxation of the net-work, or re-establishment of the state of rest, at impending death. But in the blood-corpuscles kept for over two years in bichromate of potash, all the described forms can be observed just as well as in freshly made specimens.

The reason why the corpuscles of the smallest size do not change in the solution of bichromate of potash of medium concentration, is, perhaps, that, being compact masses of living matter in which the hæmoglobin is not as yet accumulated within meshes, the solution does not reach and cannot extract the hæmoglobin. These small globules are probably intermediate stages of development of colored blood-corpuscles, or the so-called hæmato-blasts of Heitzmann¹ and of Hayem.²

(1) "Studien am Knorpel und Knochen" Med. Jahrb., 1872.

(2) "Sur l'évolution des globules rouges dans le sang des vertébrés ovipares." Compt. rend. Acad. des Sci., Nov. 12, 1877; *Idem*, Soc. de Biologie, Nov. 24, 1877. "Sur l'évolution des globules rouges dans le sang des animaux supérieurs." Compt. rend. Acad. des Sci., Dec. 31, 1877.

THE STRUCTURE AND OTHER CHARACTERISTICS OF COLORED BLOOD-CORPUSCLES.

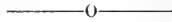

SYNOPSIS.

- Human colored blood-corpuscles vary so much in size, that it is not possible to distinguish them by their size from certain other mammalian colored blood-corpuscles:—Observations, p. 265. Literature, p. 275.
- Colored blood-corpuscles are portions of the living matter of the body, possessing contractility:—Observations, p. 267. Literature, p. 297.
- They assume various shapes:—Observations, p. 266. Literature, p. 282. Explanation, p. 312.
- They are vacuolized:—Observations, p. 269.
- They have no separate investing membrane; nevertheless the outer portion may be considered differentiated, especially at the periphery of the disk, where it constitutes an encircling band, occasionally of a wreath-of-beads appearance:—Observations, p. 270. Literature, p. 286.
- As a rule, human colored blood-corpuscles have no nucleus; but, occasionally, there is an accumulation of matter in the interior which may be interpreted as such:—Observation, p. 271. Literature, p. 294.
- The structure of colored blood-corpuscles is like that of other living matter (bioplasm), viz. : it constitutes a net-work such as was first described as the structure of protoplasm by Heitzmann. In the Pyrenæmata, the intranuclear net-work is in connection with the extranuclear:—Observations, p. 269 *et seq.* Literature, p. 302.
- Examination of specimens with various solutions of bichromate of potash:—p. 272.
- Examination of colored blood-corpuscles of ox and of newt:—p. 274. Conclusions, p. 308.

EXPLANATION OF ILLUSTRATIONS.

[Figs. 1 to 6 are included in Plate XII.]

- Fig. 1, exhibits shape-changes of colored blood-corpuscles by indentation.
- a*, progressing and retrogressing furrowing.
 - b*, indentations leading to irregular forms.
 - c*, indentations leading to more or less regular forms.
 - d*, instances of extreme and exceptional forms, especially the sharp-pointed stellated figure.
 - e*, four phases of form-change, observed in one corpuscle, with separation of a constricted portion.
- Fig. 2, shows knob-formation, principally by protrusion.
- a*, Nos. 1 and 2, progressive and retrogressive protrusion; No. 3, one pedunculated and three sessile knobs; No. 4, detachment of two knobs.

b, protrusion of knobs at the periphery and on the surface; in No. 3, the knobs surround the whole body of the corpuscle; and in No. 4, they are still more numerous.

Fig. 3, shows coalescence of two or more corpuscles, giving rise to chains and irregularly shaped compound bodies, with the net-work structure visible.

Fig. 4, represents vacuolized corpuscles.

In the upper line are seen three corpuscles, each with a differently sized central vacuole; in the middle line, the first figure shows three vacuoles in one corpuscle; these vacuoles are represented in the second figure to be close together, and in the third figure, the separating walls of apparently five vacuoles have broken down, and one irregularly shaped larger vacuole is seen. The lower line shows the appearance of vacuolized corpuscles seen on edge.

Fig. 5, shows the structure of five colored blood-corpuscles.

In the first, there is seen an encircling band of uniform thickness, in which are inserted numerous threads of a net-work; a number of knots are in the interior, which are seen to be the points of intersection of threads constituting a net-work; in the lower portion of the disk there is a larger knot, which may be called a nucleus. In the fifth corpuscle the complete net-work structure is best seen; in this corpuscle there is seen at the periphery, instead of an encircling band, a number of knots united by threads, having the appearance described as beads, each a little separated from its neighbors on the string. The second corpuscle shows the net-work and encircling band, as the majority of corpuscles show them. In the third, a lighter band is seen, and an irregular flap, produced by either indentation, or protrusion, or both. The fourth exhibits a large flap or knob at its lower portion, with a stretched or extended net-work.

Fig. 6, shows the final phases of colored blood-corpuscles treated with an appropriate solution of bichromate of potash.

In the upper left-hand figure there is a double-contoured ring, with irregularly massed matter and a central vacuole, showing traces of a net-work; in the lower right-hand figure this is less distinct; and in the two lower left-hand figures are represented two so-called "ghosts;" above these there is detritus, *i. e.*, two or three detached portions; and to the right-hand upper figure there is attached a mass, apparently extruded.

Fig. 7 (see p. 310), is a schematic drawing to illustrate the state of rest of the net-work; Fig. 8, the state of contraction; Fig. 9, that of extension; and Fig. 10 (see p. 311), that of layer-formation.

XXVI.—*Description of a New Species or Variety of Land Snail from California.*

BY ROBERT E. C. STEARNS.

Read October 20th, 1879.

***Helix*, variety *circumcarinata*, Stearns.**

Shell widely umbilicated, discoidal, flattened, angulated, with a peripheral keel; whorls six to six and a half, slightly tabulated near the sutures, which latter are deeply impressed; surface finely granulated, varying in different specimens; and otherwise sculptured by conspicuous subacute ribs parallel with the lines of growth both above and below, which meet, and sometimes cross, the peripheral keel; these ribs are more or less irregular and uneven, of varying prominence, and are also unequally spaced, being closely crowded in some places and farther apart in others. Aperture obliquely subangulate, semilunate; peristome moderately thickened, reflected somewhat, covering the open umbilicus, and made continuous by a connecting thin deposit of callus on the labium. Color, in some specimens, dingy white to white, in others a dingy reddish white, ornamented with a double revolving band,—the upper stripe being whitish, the lower reddish or light chestnut just above, and contiguous to the peripheral keel; the pinch or fold of the keel taking up what in *Helix Mormonum* is the third or lower stripe of white.

Number of specimens four, two adult and two immature, but nearly full grown.

Dimensions—Greater diameter,	.92 to 1.01 inch.
Lesser “	.75 to .86 “
Height,	.36 to .37 “

Animal not observed.

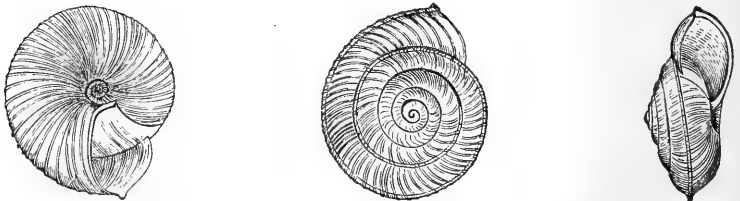

Helix, var. *circumcarinata*, Stearns.

Habitat, Stanislaus County, near Turloch, California.

For the specimens from which the above is written, I am indebted to Mr. A. W. Crawford, of Oakland, who has examples

in his collection; specimens are also contained in the typical collection of my friends Binney and Bland, and in my own museum.

Most authors would regard the above as a distinct and well-marked species; I regard it (as well as *H. Hillebrandi*, of Newcomb) as a varietal form of *Helix Mormonum*, to which it is a near neighbor, inhabiting the same region.

Binney, in his last volume on *The Terrestrial Air-breathing Mollusks of the United States, &c.*, in referring to *H. Mormonum* (on page 367), remarks: "The specimens lately received from California * * * are singularly granulated on the first one and a half apical whorls, and the epidermis of the next two or three whorls is sparingly ornamented with small but very distinct raised lines or points, something like prostrate hairs, being part of and same color as the epidermis." I have observed the same, but the points are not always epidermidal, but sometimes sculpture the shell as well, and the peculiarity Binney has detected is one of the connecting links between the three; as to the other links, and the special and general relations of the species or varieties cited, to others of our California land-snails, I propose to discuss the matter hereafter.

XXVIII.—*On Spodumene and its Alterations, from the granite-veins of Hampshire County, Mass.*

BY ALEXIS A. JULIEN.

Read June 10th and November 18th, 1878.

The mineral Spodumene is one of rather scanty occurrence, in regard both to abundance and to the number of its known localities. In Europe, it has been reported from only a half-dozen places in Scotland, Ireland, Sweden and the Tyrol; in this country, in only four localities outside of Massachusetts; but, in the eastern part of that State, it occurs at Sterling, and in crystals of remarkable size and perfection, at six localities, within Hampshire County in the western part. Here, as usual, it was found in coarse granite veins—huge lenticular masses of that rock, with sometimes great extension but little thickness—succeeding each other at intervals of several miles, along the strike and enclosed between the highly-tilted beds of the stratum of Staurolitic mica-schist. This is one of the lowest members of the group of crystalline schists of that region, consisting in descending order of the following series :

1—Chloritic, Hornblende, and Talc Schists, enclosing layer-veins of Magnetite, Rhodonite, Rutile, Zoisite, Emery (at Chester), Margarite, Diaspore, etc.

2—Micaceous grits, often slaty, fine-grained, siliceous, and arenaceous, with quartz-veins, mostly barren of minerals.

3—Ottrelitic Clay-slate, the well-known Phyllite of western Massachusetts : frequently intersected by heavy veins of milky-white quartz, of which the smaller sometimes carry blue Kyanite, Graphite, Cummingtonite, etc.

4—Staurolitic Mica-schist, rich in Garnets and more rarely Kyanite : everywhere marked by the intercalated layer-veins of coarse Orthoclase-granite, with Beryl. Several of these embrace secondary veins of albitic granite, containing a large variety of interesting minerals afterwards enumerated.

5—Granitoid gneiss, generally in heavy-bedded, coarse masses, rich in Orthoclase.

Localities of Occurrence.—The localities at which Spodumene has been found are as follows: All these veins, except II, were originally opened by E. Emmons, C. U. Shepard, and E. Hitchcock, many years ago.

I—In the northern part of the town of Goshen, on the Manning farm, over two miles north of the village of Goshen Center, on the road to Ashfield.

II—In the town of Goshen, on the farm of Levi Barrus, about one mile west of the preceding locality.

III—In the northwest corner of the town of Chesterfield, and two miles southeast of the village of East Cummington, at a granite ledge on the farm of A. Macomber. This small vein I first opened in the year 1870.

IV—At the village of Chesterfield Hollow, about two miles south of the last locality, in a ledge above the village, called "Isinglass Rock."

V—Four miles further south, in the town of Huntington (formerly Norwich), on Walnut Hill, in the vein celebrated for its remarkable crystals of Spodumene.

VI—In the town of Chester, about one mile north of Chester Village.

In the first locality mentioned, in the town of Goshen, the vein is not visible in place, but many large angular fragments and boulders, on the south-eastern slope of a low hill, indicate its close vicinity. The Spodumene here occurs in irregular and imperfect bladed crystals, sometimes two inches in diameter, and is much stained by films of Pyrolusite derived from the decomposition of the Garnet. With a little search, individuals were readily found in a partially altered condition, which had assumed a micaceous and radiated structure, and consisted of a soft and yellowish form of impure Cymatolite.

In the second of the Goshen localities referred to, on the Barrus farm, a heavy and coarse granite vein, accompanied in places with a contiguous vein of reddish-white quartz of corresponding size, forms the western wall of a low and somewhat marshy valley, thickly strewn with large and but little rounded granite boulders. In the visible portion of the vein, the only mineral of interest is Beryl, occurring in small and scattered green crystals. But, in the boulders, Spodumene has been of

frequent occurrence, mostly in rectangular prismatic masses, up to 18 inches in length, but occasionally in fair crystals, with good terminations, two or three inches long. The predominance of the planes $i-i$ and $i-i$, commonly results in the development of long square prisms. Its association is very interesting, and will be hereafter described. It was here that the same pseudomorphous mineral after Spodumene was originally discovered by C. U. Shepard, and announced in 1867, under the name of Cymatolite, by publication in Dana's "System of Mineralogy." His description and partial analysis, and a complete analysis by Burton, are embraced in that work under the species Pihlite, and the definite establishment of Shepard's species has apparently awaited the fuller investigation dependent upon a re-discovery of a purer material in sufficient supply.

At Chesterfield Hollow, in the mass of coarse Orthoclase-granite which forms the southern abutment of the hill above the village, I found a small and long-abandoned opening, and re-opened and excavated it during portions of three successive summers. The Spodumene was here found almost altogether in the form of well-defined crystals, often thickly grouped and traversing the smoky Quartz in every direction, and showing all the stages of alteration into Cymatolite, from a mere enveloping film, as an outer crust, and also dulling internally the lustre of its prominent cleavage-surfaces, to a pseudomorphous alteration of the entire crystal. Many of its crystals must have been of unprecedented and enormous size, as they were found, mostly in the altered condition, up to a length of 35 inches, actually measured while lying in the vein, and with a diameter which sometimes reached 10 or 11 inches. However they were, together with their quartz-gangue, so traversed by innumerable minute fissures, occupied but only feebly cemented by the films of Pyrolusite, that no perfect specimens could be extracted at all approaching these dimensions. On the other hand, acicular crystals were observed in abundance, penetrating the Quartz in an irregular and confused net-work; good single terminations were not uncommon; and even one or two short and doubly-terminated crystals were found in a partially pseudomorphous condition. Besides this form of alteration, several other pseudomorphs after Spodumene in various materials, Killinite, Quartz, Albite,

and Muscovite, were discovered, of which the description, and the nature of the process of alteration, will be discussed beyond.

The vein in Huntington has furnished the finest crystals of Spodumene for all mineralogical cabinets, sometimes 16 inches in length; as well as the material from that locality for the well-known and excellent analyses of Smith and Brush, and quite recently of Doelter.

The vein in the township of Chester was first discovered and opened by E. Emmons, and the Spodumene was found to be associated with Smoky Quartz, Muscovite, Cleavelandite, Indicolite, etc. In 1870, however, I could find no Spodumene remaining in a small vein of this general character, showing traces of blasting, which seemed to be the one opened by Emmons.

Analyses of Spodumene.—In the following table, I have now to present two analyses made on specimens of Spodumene from this region, probably almost unaltered.

In all analyses given in this paper, the material had been previously picked out under the loup, finely ground, and dried at 100° C.

I—Unaltered Spodumene from the Levi Barrus locality in Goshen. The material, carefully selected, was of a bright grayish-green color, high lustre, and translucent to sub-transparent.

II—Unaltered Spodumene from Chesterfield Hollow. The material was taken from the core of an enormous crystal, whose exterior was altered into a white crust of Cymatolite. It was of the same bright color and lustre as that of the preceding locality, and possessed remarkable translucency, dimmed in a hand-specimen by the numerous fissures, but with its constituent grains perfectly transparent.

III—Mean of analyses I and II. Also, for comparison, the following two analyses of the same mineral from the other Massachusetts localities (*Am. J. Sci.*, II, xvi, 372, 1853).

IV—Spodumene from Norwich (now called Huntington). Analysis by Smith and Brush.

V—Spodumene from Sterling (in eastern Massachusetts). Analysis by Smith and Brush.

ANALYSES OF SPODUMENE.

	I	II	III	IV	V
	Goshen (Julien.)	Chesterfid (Julien.)	Mean of I & II.	Norwich (Smith & Brush.)	Sterling (Smith & Brush.)
Silica,	63.27	61.86	62.57	64.04	64.50
Alumina,	23.73	23.43	23.58	27.84	25.30
Ferric Oxide,	1.17	2.73	1.95	.64	2.55
Manganous Oxide,	.64	1.04	.84	—	—
Magnesia,	2.02	1.55	1.78	trace.	.06
Lime,	.11	.79	.45	.34	.43
Lithia,	6.89	6.99	6.94	5.20	5.65
Soda,	.99	.50	.75	.66	} 1.10
Potassa,	1.45	1.33	1.39	.16	
Water,	.36	.46	.41	.50	.30
	100.63	100.68	100.66	99.38	99.89
Sp. Gr.	3.19	} 3.185 and 3.201		3.18	3.182

My own three S. G. determinations were made upon quantities of 7.9, 3.6, and 5.5 grammes of mineral, respectively, and show that the true Specific Gravity of *unaltered* Spodumene is a little higher than that hitherto accepted.

A considerable delay having occurred in the publication of this paper since its reading before the Academy, advantage has been taken of the opportunity to incorporate the latest results of other analysts.

Three good analyses of Spodumene have been recently published, on specimens from the following localities: so that I have been anticipated in the publication of the true composition of the mineral.

1. Norwich, Mass., by C. Doelter* (Min. u. petrog. Mittheil., 1878, New Ser., I, 517).

2. Brazil, by C. Doelter (*loc. cit.*).

3. Brazil, by F. Pisani (Compt. rend., 84, 1509: 1877).

The mineral from Brazil is transparent, yellowish-green, resembling Chrysoberyl, but differing in inferior hardness (7), and has a Sp. Gr.=3.16.

	SiO ²	Al ² O ³	FeO	MnO	MgO	CaO	Li ² O	Na ² O	K ² O
1. Norwich	63.79	27.03	.39	—	.21	.73	7.04	1.10	.12
2. Brazil	63.34	27.66	1.15	—	—	.69	7.09	.98	—
3. Brazil	63.80	27.93	1.05	.12	—	.46	6.75	.89	—

By these analyses, Na : Li :: 1 : 15.

In my analyses above given, the alkalis were separated by J. L. Smith's method (ignition with calcium carbonate). The residue of the three alkaline chlorides was carefully purified from adhering traces of magnesia, by repeated precipitation with barium hydrate. The excess of that reagent was removed from the filtrate as carbonate, the solution of the chlorides evaporated to dryness, and the Li Cl separated by digestion in the mixture of ether and alcohol. The lithia was then determined as sulphate, and afterwards, for precaution, as lithium-phosphate, Li³ PO⁴, by repeated precipitation and thorough washing in the usual way. However, the two methods did not produce accordant results, the latter yielding amounts of lithium-phosphate supposed to be pure, which in the two analyses were equivalent to the following per centages :

	I	II
Lithia,	7.43	7.62

The cause of these discrepancies has just been explained by Rammelsberg (Monatsber. der Berl. Akad., 613-631, 1878).

* In his determination of the formula of the mineral from Norwich, with the same result as my own given below, Doelter previously eliminates as impurities over three per cent. out of the percentage stated above, and yet finds an inaccuracy which he attributes to incipient decomposition. This deducted amount he assigns to Orthoclase and Hedenbergite, which have never been found as associates of Spodumene and are therefore of improbable occurrence as impurities. The detection of Killinite in masses, of which analyses are given beyond, explains the green tinge which Doelter naturally refers to Hedenbergite, on the ground of the isomorphous relationship of Augite and Spodumene.

He finds that the precipitate of $\text{Li}^3 \text{PO}^4$ carries down a small and variable amount of its analogue, $\text{Na}^3 \text{PO}^4$, which always renders the figure for estimated lithia too high.

The differences in these analyses of Spodumene, especially in the amount of oxide of iron, lithia, and the other alkalies, suggest that all the material employed has experienced, to a greater or less degree, incipient decomposition or alteration, attended by the chemical and physical effects already described. Even in my own material, this alteration may be indicated by the presence of water and the excess of alkalies, beyond the amount theoretically required for the protoxides.

Theoretical Constitution.—For the determination of the true theoretical constitution of this mineral, the elementary percentages and ratios have been calculated from the figures of the mean (column marked III), reckoning, Mn, Mg, Ca=2 R^I.

The microscopical examination of the material analyzed, afterwards explained, renders it highly probable that an incipient alteration into Pinite is indicated by the water present; and the proper correction has been made, taking as a basis the amount of water present, and the formula for the Pinite as deduced beyond.

		RATIOS.							
		Atomic.				Quantivalent.			
		Deduct for Pinite.							
Si	29.19	1043	37	1006	4	4	4024	6.3	
Al	12.55	459	30	429	1.8	2	1359	2.1	
Fe	1.36	24		24					
Mn	.65	12		12	2.2	2	631	1.	
Mg	1.07	45		45					
Ca	.32	8		8					
Li	3.24	463		463					
Na	.56	24		24					
K	1.15	29	15	14					
H	.045	45	45						
O	49.86	3116	150	2966	11.9	12			

Hitherto accepted.

R^I : Al : Si 2 : 1 : 4 1.5 : 1 : 3.75

R : Si 2 : 1 2 : 1

Na (K) : R^{II} (Mg, Ca) : Li 1 : 3: 12

It has been usual to consider the relation Na : Li, which is here 1 : 9, and, according to other analysts, 1 : 12, varying from 1 : 4 to 1 : 20 ; but it seems proper to group together all the replacing elements in R¹, i. e.

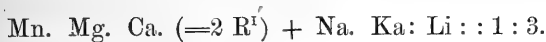

The corresponding ratio in Pisani's analysis of Spodumene from Brazil is 1 : 6, and it is therefore evident that no definite relationship holds in the replacements within R¹

Spodumene is thus shown to consist of one molecule of the normal silicate of aluminium, plus one molecule of the normal silicate of lithium, and its true formulas must be

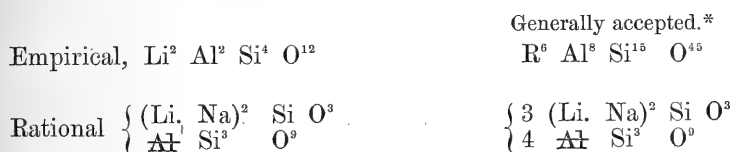

This may be graphically represented, but more simply than as given by Dr. K. Haushofer,† adopting the Augite-type, thus :

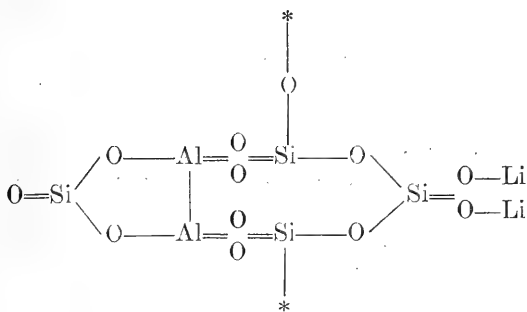

From my own analyses, the theoretical constitution of the American variety of this mineral may be calculated as follows:

* Rammelsberg (Handb. der Min. Chem., 423, 1875), Roth (Allgem. u. Chem. Geol., I, 382, 1879), etc.

† Die Const. der natürl. Silicate, 97 (1874).

			Percentages.*		
4	Si	112.	} equivalent to {	Silica	63.75
2	Al	54.6		Alumina	27.25
$\frac{3}{8}$	Mg $\frac{1}{2}$	4.5		Magnesia (or Lime)	1.99
$\frac{1}{8}$	Na	2.9		Soda	1.05
$1\frac{2}{8}$	Li	10.5		Lithia	5.96
12	O	192.			100.
		376.5			

In general, it appears that the alumina is sometimes replaced by ferric oxide; the magnesia by lime, ferrous oxide, or oxides of other dyads; the soda by potassa; and the lithia by variable amounts of all the preceding monad and dyad elements.

To recapitulate, it appears to me probable, that the duller color and the inferior lustre, translucency, hardness, and specific gravity of the specimens of the mineral from Norwich and other localities, which have hitherto supplied material for analysis, indicate that in most of these cases the mineral has been somewhat affected by weathering, facilitated both by the easy cleavage of the mineral and by the abundant rifts of the quartz matrix. The loss of a portion of its soluble protoxides—particularly the alkalis—has in most instances increased the content of both silica and alumina in the residue. This slight decomposition has naturally affected the physical characteristics by the differences already described. At both Goshen and Chesterfield the green transparent variety is uncommon, and at Norwich exceedingly rare; while the existence of this decomposition is confirmed by the corresponding effects upon the minerals associated with Spodumene, especially Garnet, Zircon, Triphylite, etc., and by the deposit upon the superficies of the Spodumene crystals, and within all interstices, of black Pyrolusite in delicate tracery, reddish-brown iron-ochre, scales of Autunite and uran-ochre, and a pink substance, the latter at Norwich acting as a characteristic coloring-film upon the Spodumene.

Microscopical characteristics.—On the microscopical examination of a thin section of the unaltered green Spodumene from

* These figures agree closely with those of Brush, (Am. J. Sci., II, x, 370, 1850).

Chesterfield, it appeared under low powers to be in large part clear and colorless, but with its transparency much clouded by a minute granulation (reminding the observer of Olivine) and by abundant cleavage-fissures, some very short and imperfectly parallel, belonging to the imperfect cleavage parallel to the orthodiagonal pyramid, but chiefly in the longer and parallel cleavages of the orthodiagonal and of the prismatic planes. Under a magnifying power of 270 diameters, the granulation is resolved into minute needles of the mineral, closely aggregated in the direction of the stronger cleavage; but foreign inclusions are rare, consisting merely of tiny orange-brown films and scales of ochre; of black opaque scales apparently of Hematite; and, especially along the wider fissures, of yellowish granules, scales, and slender threads of Killinite. Along the fissures, the yellowish material was found to be so abundant as to render the vicinity cloudy, even in a thin section of the purest Spodumene; this indicates an incipient alteration into Killinite, etc. Muscovite, also, is found either in crystals or clear lakes with sharp rounded outlines; but in some cases the Spodumene projects into the Muscovite in long fibres, some of which, associated with many ochreous particles, are also enclosed in the Muscovite. Between the crossed nicols, the mineral polarizes decidedly, with bright sheets of color passing into each other.

We have next to consider the interesting series of pseudomorphous minerals which accompany the Spodumene.

I—CYMATOLITE AFTER SPODUMENE.

An imperfect analysis of this material from Chesterfield was published in February, 1871 (*Am. Chem.*, I, 300), and that of Aglaite from Goshen, in May, 1879 (*Am. Jour. Sci.*, III, xvii, 398). The statement of the occurrence of this mineral at Norwich (Dana's *Syst. of Min.*, article "Pihlite") is probably a mistake, Prof. Shepard having informed me that he found Cymatolite only at the Barrus locality in Goshen. Profs. Brush and E. S. Dana have recently called attention to a new occurrence of the mineral at Fairfield, Conn. (*Am. Jour. Sci.*, III, xvi, 34, 1878), where they have found, along with "Spodumene in crystals weighing one to two hundred pounds, Cymatolite,

as a result of the decomposition of Spodumene-crystals, sometimes nine inches in width.”

Goshen Variety (Aglaite).—At the two Goshen localities, I obtained a small supply of a mineral, pseudomorphous after Spodumene, at once suggesting the Cymatolite of Shepard, but presenting some differences in physical character in the variety found on the Barrus farm. It there occurs only as the continuation of the imperfect square prisms of Spodumene (never as a crust upon them), in masses sometimes six or eight inches long, and from $\frac{1}{4}$ to $\frac{3}{4}$ inch square, with usually a sharp line of demarcation across the prism between the two minerals. The structure is micaceous, with the lamination *flat*, very rarely undulating, and always in the plane of the orthodiagonal cleavage of the original Spodumene crystal. The laminae are brittle, but the thinner scales are flexible, somewhat elastic, and transparent. The mineral is often more or less interlaminated with Muscovite and stained by Pyrolusite. Many of the laminae, both of Aglaite and Muscovite, project $\frac{1}{4}$ of an inch or more into the gangue at the sides of the crystals, so that the form of the prism is hardly retained in the pseudomorph. Lustre between that of silver and satin. Color, white. Feel, soft. Hardness=1.5. Sp. Gr.=2.753 (determined on 6 grammes).

The specific gravity in this case, as well as in all others subsequently given in this paper, was determined on the mineral in coarse powder, in distilled water at 62° F., generally after previous digestion on a steam-bath until the complete expulsion of all air-bubbles.

I am also indebted to the kindness of Prof. C. U. Shepard for a small fragment (0.7 gramme) from one of the specimens originally found, by him, which, besides presenting physical characteristics identical with those described above, was found to possess a specific gravity of 2.726.

Chesterfield Variety.—At the Chesterfield locality, this pseudomorphous material is far more abundant, and indeed predominates in quantity over that both of Spodumene and of all other products of alteration. The sizes of these pseudomorphs have been already described. Here the structure is intermediate be-

tween micaceous and fibrous, with a strong wavy tendency of the foliation, on the surface of fracture, especially in the thicker crusts with longer fibres. In the smaller crystals, the plane of foliation is usually at right angles to the faces of the Spodumene, and the folia therefore radiate from a central plane in those crystals which are completely altered; but in the larger ones, within a thin radiating crust of this kind, the folia of the pseudomorph generally and mainly conform to the central plane—that of the orthodiagonal cleavage of the Spodumene,—and a parallel foliation often results, with a complete disappearance of the wavy tendency along the axis of the pseudomorph. When a core remains in the smaller crystals, it is very often, if not generally, found to consist of the blackish-green Pinite (Killinite), while in the larger crystals the core consists of bright-green to greenish-white or white Spodumene, often with the dark Pinite within an inch or so of its termination, or forming a thin layer at various places next to the white pseudomorphous crust. Most of these phenomena are shown in Fig. 1, Plate XIII, a sketch (natural size) of the cross-fracture of one of the partially altered crystals. In this, a remnant of unaltered Spodumene is presented in the dark core, of a greenish-grey color, retaining the three cleavages indicated by the lines, and bordered, especially near the lower angle of the core, by a thin film of blackish-green Killinite. The whole is enveloped by the crust of wavy white Cymatolite, with satiny lustre, which also traverses the core in thin seams.

The greenish-yellow Muscovite, which abounds in the vein, is commonly intercrystallized in the larger pseudomorphs, in scales and films, sometimes so intimately that the two materials are indistinguishable by the eye, and a yellowish color is produced. The more slender of the pseudomorphous crystals are often found penetrating the coarse masses of Beryl, but the latter is never enclosed; while the black octahedra of Oerstedite are frequently found, not only implanted on the outer planes of these pseudomorphs, but often enclosed in the above yellow mixture. Many of the longer pseudomorphous prisms are found to be more or less flattened, distorted, twisted, or bent into decided arcs, or with their terminations squeezed into a wedge or bladed shape. At this locality there is a remarkable want of adherence

between the pseudomorphous crystals and the quartz-gangue, so that a slight blow of the hammer releases them in an uninjured condition.

Hardness, 1.5 to 2. Specific Gravity, 2.700 (determined on 5.7 grammes of coarse powder), 2.696 (determined on 5.5 grammes, in a lump, long digested to expel air). Lustre intermediate between silver and satin, but seeming to approach the latter, on account of the fibrous texture. Color, white to yellowish, also often stained by films of Ochre, or Pyrolusite. Laminae brittle, and only separable with difficulty, or not at all in the larger compact masses. Translucent on thinner edges. Feel, soft.

Pyrognostic Character.—In platinum forceps, it fuses on very thin edges (6), and the surface of the splinter becomes covered with a white and translucent blebby enamel. A fragment, moistened with solution of cobaltic nitrate, gives the alumina reaction without difficulty. In a matrass at high temperature, it yields a little water, and a small amount of ammonia, indicated by a feeble odor but distinct reactions with test papers, etc. In borax bead, it dissolves readily, with effervescence and in large quantity, to a clear bead, with the yellowish iron reaction while hot; gradually displays a siliceous skeleton; and at saturation becomes clouded by silica and bubbles. In phosphoros-salt, as in borax, but with immediate formation of the siliceous skeleton. Insoluble in acids.

Analyses of Cymatolite.—In the columns below are given the results of four analyses of the common wavy variety of this mineral, which was found in abundance at the Chesterfield locality.

VI and VII—Cymatolite from Chesterfield. Analysis in duplicate of the average material derived from a mixture of fragments of about forty different crystals, white and yellowish-white in color, taken at random.

VIII—Mean of the foregoing two analyses.

IX—Cymatolite from Chesterfield. Analysis of a slice across a complete pseudomorphous prism, of the radiated fibrous structure and white color, about an inch in diameter. Apparently it was completely altered to pure Cymatolite, but the increased amount of lithia in the analysis *may* indicate the presence of

over three per cent. of unaltered Spodumene, probably disseminated along the core.

X—Cymatolite from Chesterfield. Analysis of a fragment of the compact white variety, from a large pseudomorph about nine inches in diameter.

CYMATOLITE (CHESTERFIELD).

	VI	VII	VIII (Mean of VI & VII).	IX	X
Silica,	58.57	58.59	58.58	59.60	58.71
Alumina,	22.25	22.32	22.28	22.97	24.00
Ferric Oxide,	1.79	1.75	1.77	1.63	1.39
Manganous Oxide,	.15	.15	.15	.45	.11
Cobaltous Oxide,	.02	trace	—	trace.	—
Magnesia,	.49	.41	.45	.31	.27
Lime,	.95	.91	.93	.35	.51
Lithia,	.10	.09	.10	.26	.21
Soda,	9.17	8.99	9.08	7.83	7.38
Potassa,	4.48	4.47	4.48	5.14	4.67
Water,				1.73	1.80
Nitrogenous Organic Matter, }	2.04	2.12	2.08	.32	.62
	100.01	99.80	99.90	100.59	99.67

In IX, on the ignition of 8.65 grammes with soda-lime, the organic matter was found to yield 0.02 per cent. of ammonia (NH³). In this determination, as also in the similar one applied to Killinite, the possibility of absorption of the ammonia from laboratory vapors was eliminated by using specimens never so exposed, and a "blank analysis" carried on at the same time supplied the small correction necessary for ammonia introduced through the distilled water and reagents employed. It appeared to be a necessary precaution to select the variety of

material mentioned above, in order to establish its uniformity of composition, notwithstanding its pseudomorphous origin.

The following analyses were made upon materials from the two localities found in Goshen.

XI—Cymatolite from the more easterly locality, N. W. of Goshen Centre.

Common wavy and yellowish material, in part finely granular, in irregular pseudomorphous prisms, generally stained by Pyrolusite. The material was only with difficulty selected in sufficient purity for analysis. It resembled that of the Chesterfield locality.

XII—Cymatolite from the Barrus farm, west of the foregoing. The micaceous and brilliant rare white variety (Aglaite), in a perfectly pure state.

XIII—Cymatolite, average composition, as deduced from all my preceding analyses (VIII, IX, X, XI, and XII), on the material obtained from the three localities in Chesterfield and Goshen.

	XI Goshen. Wavy Yellow Cymatolite.	XII Goshen. Aglaite.	XIII Average of all analyses of Cymatolite.
Silica,	58.51	58.11	58.70
Alumina,	21.80	24.38	23.09
Ferric Oxide,	.85	1.66	1.46
Manganous Oxide,	.29	.18	.24
Cobaltous Oxide,	trace	—	—
Magnesia,	1.44	.75	.64
Lime,	.84	.48	.62
Lithia.	.19	.09	.17
Soda,	6.88	2.57	6.75
Potassa,	6.68	8.38	5.87
Nitrogenous Organic matter, }	.44	.43	.45
Water,	1.96	2.58	2.02
	<hr/> 99.88	<hr/> 99.61	<hr/> 100.01

In the determination of loss by ignition in Aglaite (XII), it was found that this micaceous and porous mineral obstinately retained some hygroscopic water above 100° C.

By long-continued heating, it lost—

At 110° C, 0.23 per cent (moisture).

At red heat, 3.01 “ “ (water of combination and organic matter).

The corresponding results, obtained on the fragment of original Cymatolite received from Prof. Shepard, were as follows :

At 110° C, 0.37 per cent (moisture).

At red heat, 3.28 “ “ (water of combination and organic matter).

The sum of the latter figures closely approaches the result reported by Prof. Burton (3.78 per cent.), which was obtained (as he has informed me) from the mineral dried at 100° C.

It may here be added, that the analytical figures given in my preliminary notice of the composition of this mineral (*Am. Chem.*, I, 300, 1871),* and there temporarily assigned to Pihlite in accordance with Dana's view (*Syst. of Min.*, 455, 1869), are too imperfect for further consideration.

Theoretical Constitution.—From the average composition of the mineral, given in column VII, the following elementary constitution and ratios may be deduced, reckoning

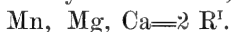

RATIOS

Percentages.		Atomic.		Quantivalent.		
Si	27.39		978	12.	3912	24. 8
Al	12.31	451	469	5.7	1407	8.6 3
Fe	1.02	18				
Mn	.19	3	481	5.9	481	3 1
Mg	.38	16				
Ca	.44	11				
Li	.08	11				
Na	5.01	218	163	2.	163	1 ½
K	4.88	125				
H	.23	67	163	2.	163	1 ½
O	47.63					

* Afterwards quoted in 2d App. to Dana's *Min.*, 44, 1875, and Roth's *Allg. u. Chem. Geol.*, I, 382.

To confirm the uniformity of these relationships, the atomic ratios have been further calculated in the same way from four of the individual analyses.

	VIII		X		XI		XII	
Si	976	12.2	987	12.1	975	12.2	969	12.
Al (Fe)	456	5.7	481	6.	436	5.5	496	6.1
Na (H, K)	474	6.	444	5.5	546	6.8	458	5.7
O	2954	37.	2980	37.	2956	37.	2988	37.
H (as aq.)	161	2.	161	2.	161	2.	161	2.

The atomic ratios of the elements which constitute R^I , in these analyses, are given in the following table.

	VIII		X		XI		XII	
Mg, Ca	60	3	34	2	110	5	62	3
Na	293	15	238	13	222	10	83	4
K, Li	102	5	113	6	155	7	184	10
H (basic)	19	1	59	3	59	2	129	7

From these figures, it may be inferred that the proportion of the several elements is somewhat indefinite and irregular, and that a sufficient complement of basic hydrogen is always present. The amount of sodium diminishes through the varieties to the lowest degree in Aglaite (XII), in which both potassium and hydrogen rise to the maximum; and that is the variety which possesses the physical characteristics most akin to those of the potash-bearing hydromicas.

From the atomic ratios

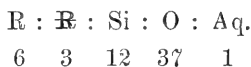

the formulas* of Cymatolite, empirical and rational, are found to be those of a normal silicate—

* According to the old system—

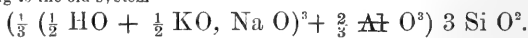

From my analysis of Aglaite, P. Groth (Zei's. f. Kryst. u. Min., 111, 1878) deduces the formula—

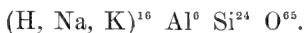

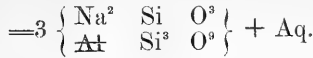
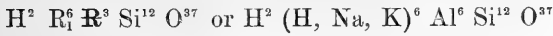

This yields the following calculation for the theoretical percentages in the constitution of the mineral.

				Calculated.	Found.		
12 Si	336	}	equivalent to	Silica	58.46	58.70	
6 Al	163.8			Alumina	24.99	24.55	
6 Na	138.			Soda	15.09	}	16.31
2 H	2.			Water	1.46		
37 O	592.						
1231.8				100.	99.56		

In view of the results obtained by so careful an analyst as Prof. Burton, and of the fact that his analysis and formula have been for over ten years associated with the name "Cymatolite," it seemed to me at first most judicious to attach a new name* to the new constitution of my own abundant material. However, since I have received from Prof. Shepard a fragment from an original specimen of his own collection, its identity with mine in all physical characteristics, seems to justify the application of the name, Cymatolite, to my own material as well. And yet it may be convenient to retain the name I proposed, *Aglaite*, (from ἀγλαός, brilliant) for the Barrus farm variety of Cymatolite. As already explained, this differs from the rest, both in the constitution of the protoxides, and in possessing a more brilliant silvery-white lustre and color, and generally a flat micaceous instead of a "wave-like" structure—a variety, therefore, to which the etymology of the name, Cymatolite, is not appropriate.

Cymatolite appears to be a hydrous bisilicate, which, excluding all but basic hydrogen, possesses the essential constitution of Spodumene. The character of the alteration may be simply stated.

In 3 molecules of Spodumene, the monad element has been

* Engineering and Mining Journal, April 7, 1877.

replaced by Na^2 , K^2 and H^2 , in various mutual proportions, and 1 molecule of aq. added, with the result :

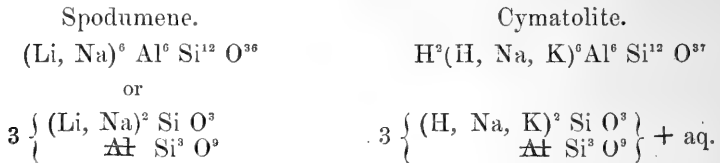

The latter formula may be represented graphically as follows, and consists, as will be seen, of a closed combination, saturated within itself.

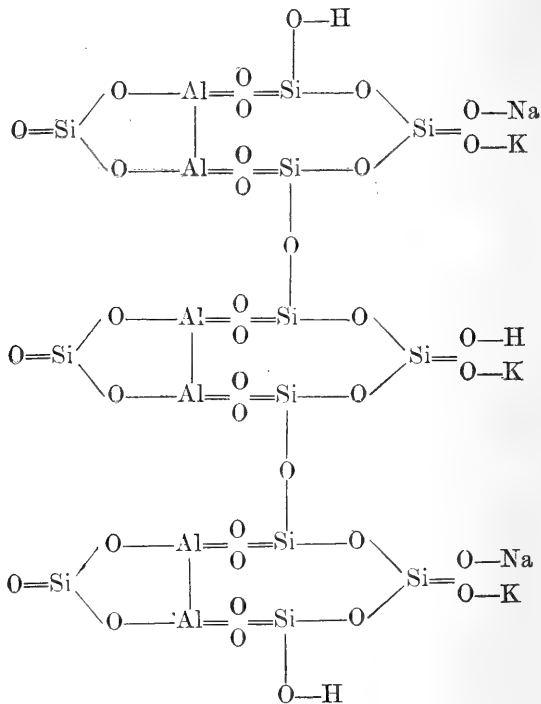

Microscopical Characteristics.—Under the microscope, the Aglaite of Goshen, instead of being made up of continuous sheets, as it appears to the eye, presents everywhere an irregular

fibrous network, an interwoven congeries of needles, scales, and blades, some of which have parallel sides, and are crossed obliquely by minute planes ($\times 175$), which suggest a cleavage structure. There are also here and there a few more distinctly crystallized blades of Muscovite, with parallel sides, which seem to lie across the general direction, but which never present good terminations. Among these blades are minute oblong bodies, often in groups, which under a sufficiently high power are also found to be perfect and doubly-terminated crystallized scales. Their length varies from 0.0019 to 0.0114 mm. Many are scattered through the material, having evidently crystallized between the laminae, and others are gathered in groups of considerable numbers. There are also numerous minute ochreous granules dispersed throughout. With strong illumination, interference fringes, with bright colors, are produced by the fine fibrous structure of the Aglaite. Between the crossed nicols of the polariscope, the mineral possesses a strong double refraction, with colors varying from brownish yellow, through purple, into bright blue.

The mineral from Chesterfield also presents a fine fibrous structure, somewhat curved, and without any interference fringes. Muscovite is occasionally distinguishable, either in rectangular blades or minute crystalline groups, sometimes 0.4 mm. in length: its presence, as well as that of occasional remnants of unaltered Spodumene in tiny fibres, seems to throw light on the excess of protoxides found in the analyses. Ochreous granules are not uncommon, and the existence of ferric oxide or hydrate in this accessory condition indicates at least that a portion of it should not have consideration in the formula.

The fibres of Cymatolite seem to spring from the terminal edges of those of the Spodumene, and form a continuation of their structure: so that it is evident that the process of alteration has most rapidly and favorably attacked the Spodumene from the ends of its fibres. Between the crossed nicols, the fibres present the usual strong double refraction and vivid colors, while the grains of unaltered Spodumene are feebly illuminated with colors varying on rotation from light brown to bluish gray. In a thin section made from a sliced cross-section of an entire pseudomorphous crystal, about an inch in diameter, of which the

core was composed partly of both Killinite and Spodumene, some further interesting observations were made. Near the outer margin of the section, the fibres of Cymatolite, lying at right angles to the contour of the crystal, were mostly parallel and undisturbed. But in approaching the core, sometimes the bundles of fibres were strongly curved, and sometimes completely dislocated into a confused mass of scales. Near the junction-line between the Cymatolite-crust and the core, the same curved bundles of fibrous blades were often observed. Outwardly they abutted perhaps against some one of the plates of Muscovite (which always have been formed and lie parallel to the axis of the Spodumene-crystal): in such a case the plates of Muscovite were seen to be partly dislocated, and their laminae shoved successively past each other *en echelon*. Inwardly their apices were directed against the yet unaltered core—like a forest of spears thrust against a fortress-wall. Some of these apices are seen to have been insinuated within the crevices of the Spodumene (or Killinite), apparently leaving a minute sieve-like passage between the serrated or drusy margin of the Cymatolite and the cracked surface of the Spodumene.

At first it had been concluded, from the many evidences of distortion which the pseudomorphs present, that these were merely the results of ordinary mechanical pressure, produced in this granite-vein—as certainly in many others tilted at high angles—by a settling of its contents in the direction of the dip of the vein, and by considerable internal motion. Greater familiarity with the latter phenomenon in other localities has called attention to its other accompanying results—such as slickensides, minute downward dislocation of crystals (as in long prisms of Beryl and Tourmaline), or folding of mica plates, by unequal or sudden pressure, etc.—*which appear to be completely wanting in this case.*

Now, the atomic volume of the triple molecule of Spodumene is about 355, but it rises to 451 in Cymatolite. It has therefore occurred to me that the pressure, which produced the bending, twisting and flattening of crystals, and the apparent squeezing or pinching of their terminations, may be possibly attributed to an entirely different cause. These facts may present a novel and interesting illustration, on a remarkably large

scale, of the phenomena of a crystallization attended by absorption of water and alkalis, and by great consequent expansion within a confined space. The volume of that part of the granite-vein at Chesterfield Hollow which has been excavated, comprises perhaps two or three hundred cubic yards of rock, and its original content of Spodumene must have amounted to several tons, a quantity sufficient, during alteration and expansion, to have produced an enormous pressure. On the one side, this mechanical force of expansion has hastened the process of alteration, both by the rupture of the superficies of the Spodumene, and by the production of the minute sieve-like space, which has apparently supplied the principal channel for the solutions which effected the pseudomorphous change. Outwardly, great pressure was at first exerted against the quartz-matrix, producing, as with the expansion of type-metal in a mould, a sharp impression upon the Cymatolite-crust—especially in the smaller prisms—of the finest lines of the cast of the Spodumene, and often, around the larger crystals, also crushing and rupturing the quartz, leaving it seamed by the present innumerable little rifts. This was probably followed by a subsequent contraction of the two materials, by loss of temperature and moisture, to which may be due the present slight adherence between the crystals and their gangue. Also, within the pseudomorphous crust, the same pressure brought about a bending of fibres and dislocation of scales, which resulted in the wavy structure to which Cymatolite owes its name, and which, being more than a mere accident, but in most localities essentially connected with the genesis of the mineral, imparts to that name a peculiar appropriateness.

The irregular transmission of pressure through the partially crushed and ruptured quartz-matrix, appears to have resulted in the bending, flattening, and common distortion of the crystals.

Again, in those crystals in which the more rapid process of alteration from a termination has progressed so far along the axes as to have produced blade-like cores, retaining the orthodiagonal cleavage of the parent Spodumene, the terminations are found to be flat or pointed, not merely in most cases by being pinched together by a pressure from without, but in many instances, perhaps, by the expansion and forcible protrusion of the bladed cores.

In the Goshen variety of the mineral, Aglaite, the pseudomorphous material was never formed as an enveloping crust, but entirely in the direction of the axes of the prisms. The density and toughness of the matrix would appear generally to have allowed the commencement of the attack only from the terminations; and the rapid progress of the alteration in the direction of the axis (as also in less degree along the cores of the Chesterfield prisms) seems to have been caused by the more ready wedging up of the Spodumene in its easiest plane of cleavage, the orthodiagonal, by the pointed ends of the Cymatolite blades. As fast as produced at the sharp alteration-line (marked in Fig. 2), the minute spiculæ and scales of Cymatolite hardly attained a length of a few hundredths of a millimetre before they were thrust aside in the same plane. The pressure was exerted mainly in that plane; laminæ were projected outwardly into the granitic gangue, perhaps somewhat plastic and yielding (resulting in the present lateral adherence of the altered prisms); and the laminæ thus retained the flatness, without crumpling, peculiar to Aglaite.

II—KILLINITE *after Spodumene.*

A second pseudomorphous material of the Pinite family, apparently Killinite, was found, frequently but in limited quantity at Chesterfield Hollow, and quite rarely in the Huntington vein. It sometimes occupies the entire core of some of the smallest Cymatolite pseudomorphs, in a dark mass, perhaps 1 to 2 inches in diameter. But ordinarily it constitutes only an outer layer of the Spodumene core, intermediate between that mineral and the enveloping crust of Cymatolite, in some of the larger crystals: in such cases it is rarely continuous, but usually occurs in isolated spots or sheets, presenting often a broken or wavy dark line along the fracture-section of the outer edge of the Spodumene-core. The contiguous portion of the Spodumene, though retaining its white color, is also found to show alteration, both by its yield of water, when heated in a closed tube, and by the exhibition under a pocket-lens, of very minute dark films of Killinite in a delicate net-work.

The purest Killinite presents the following characteristics.

Texture foliated, with the cleavages of Spodumene, but less perfect.

Hardness, 3.5. Specific Gravity, 2.623, (in coarse powder), 2.644, and 2.652 (in lumps).

Lustre, dull and greasy on irregular surfaces, to weak vitreous, or sometimes strongly vitreous, on the planes of orthodiagonal cleavage of the original Spodumene. Color, greenish-gray to olive-green, ranging, however, from greenish-black to greenish-white, the latter along the border next the unaltered Spodumene. Streak and powder white, slightly greenish. Opaque, only slightly translucent on thin edges. Fracture uneven, as in Spodumene. Feel, greasy. When breathed upon, it gives off a faint argillaceous odor.

Pyrognostics.—In the platinum forceps or on charcoal, it becomes snow-white and fuses along thin edges (fusibility 5.5), without visible intumescence, to a white and translucent blebby enamel. A fragment, whitened but not fused, and then moistened with cobaltic nitrate, yields a feeble alumina reaction. In matrass, it darkens to an ash-gray, in part reddish, and gives off immediately, at a low red-heat, much water and a decided odor of ammonia, with the usual reactions for that substance. With borax and phosphorus salt, it furnishes a slight effervescence, a feeble reaction for iron, and a siliceous skeleton.

Analysis of Killinite.—The chemical composition of Killinite is presented in the following analyses.

XIV—Olive-green Killinite, from Chesterfield Hollow, Mass. Analysis by myself. S. G.=2.623. Also, for comparison, selected out of many discordant analyses—

XV—Killinite from Killiney Bay, Ireland. Analysis by Lehunt & Blythe (Thomson's Min., I, 330). Different analysts report S. G.=2.56—2.71, in the Killinite from this locality, probably varying according to the intermixture of the unaltered Spodumene.

	XIV.	XV.
Silica,	46.80	47.93
Alumina,	32.52	31.04
Ferrous Oxide,	2.33	2.33
Manganous Oxide,	.04	1.26
Cobaltous Oxide,	.04	—
Magnesia,	.48	.46
Lime,	.77	.72
Lithia,	.32	—
Soda,	.78	—
Potassa,	7.24	6.06
Water,	7.66	10.
Nitrogenous Organic Matter,	1.14	—
	100.12	99.80

Also, on ignition of 2.79 grammes of the Pinite from Chesterfield with soda-lime, and on addition of platinic chloride to the distillate, 65 milligrammes of ammonium platino-chloride were obtained, which correspond to 0.18 per cent. of NH^3 , derived from the organic matter. The percentage of lithia in the above analysis, I think, certainly represents over four per cent. of Spodumene remaining unaltered: so that on making the proper reductions, the atomic ratios may be calculated as follows, reckoning Fe, Mn, Mg, Ca=2 R¹.

	Raised to 100 pr. ct.	Per cent.	Atomic Ratio.				
Si O ²	41.07	46.54	Si	21.72	776	5	5
Al ² O ³	31.35	33.10	Al	17.61	645	4.1	4
Fe O	2.30	2.43	Fe	1.89	34	}	
Mn O	.04	.04	Mn	.03	1		
Co O	.04	.05	Co	.04	1		
Mg O	.48	.51	Mg	.31	13		
Ca O	.77	.81	Ca	.58	15		
Na ² O	.76	.80	Na	.59	26		
K ² O	7.24	7.64	K	6.34	162	}	
H ² O	7.65	8.08	H	.89	890		
			O	50.	3125	20	20

Theoretical Constitution.—The following atomic relationships may be thence deduced, reckoning $R''=2 K$.

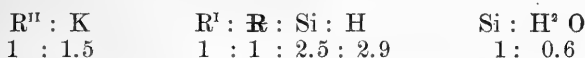

This corresponds to the formula for the half-silicate, which Rammelsberg writes—

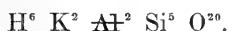

if all the hydrogen be basic. Or, after his other plan, with no basic hydrogen, it may be written—

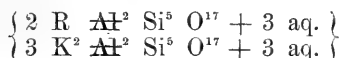

But in my opinion, for a reason stated beyond, it is probable that only one-third of the hydrogen is basic, and that the true empirical formula should read—

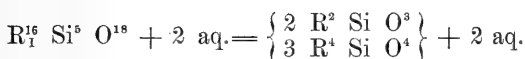
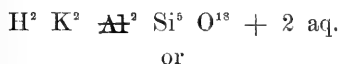

i. e., two molecules of the normal and three of the half-silicate, plus two of water.

Killinite thus appears to bear a close chemical relationship to Iolite in its forms altered by hydration, *e. g.* Fahlunite, Chlorophyllite, etc., and to possess the rational formula,

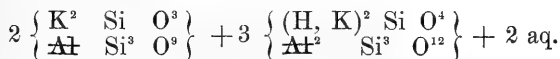

The theoretical percentage composition, calculated from the empirical formula, will be as follows:

5 Si	140.	}	equivalent to	{	Silica	45.92
4 Al	109.2				Alumina	31.40
2 K	78.2				Potassa	14.42
2 H (basic)	2.				Water (basic)	2.75
4 H	4.				" (aq.)	5.51
20 O	320.					
653.4					100.	

Its genetic relationship to Spodumene may be simply represented as follows. In two molecules of Spodumene,

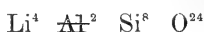

the four atoms of lithium have been replaced by ($\text{H}^2 \text{K}^2$), three molecules of silica, ($3 \text{Si} \text{O}^2$) have been removed, and two molecules of water of crystallization, ($2 \text{H}^2 \text{O}$), have been added by the solution of alteration: leaving that which therefore seems to me the true empirical formula for Killinite,



The following represents these changes graphically, the removed constituents being enclosed in brackets, and those added being put in heavy letters.

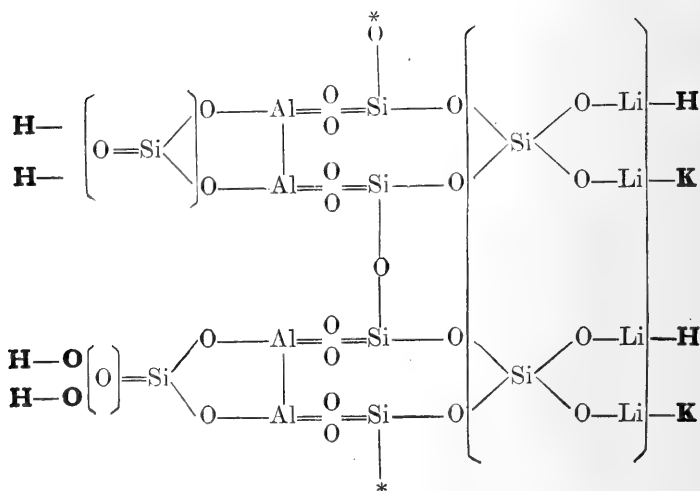

The foreign Killinite has only been found in Ireland, on the shores of Killiney Bay, at Killiney and Dalkey, near Dublin, in granite-veins traversing mica-schist, and with Spodumene, Garnet and Tourmaline as its associates. The imperfect crystallization of the Spodumene at that locality sufficiently accounts for the hesitation with which the theory of the derivation of the Killinite from that mineral has been gradually accepted. This new American occurrence, however, establishes the certainty of that mode of origin.

Microscopic Character.—On a microscopical examination of a thin section, under low powers, the Killinite of Chesterfield is found to present a slightly greenish-yellow color, with apparently the structure of Spodumene. Under higher powers, the Killinite appears to be largely concentrated as a vein-like material along the stronger cleavage-fissures of the pseudomorph, and exhibits a minute granulation and thready structure, sometimes with comb-like projections on each side along the other cleavage planes of the parent mineral. It is always rich in free Ochre, which substance serves *in the thin section* as a brownish-yellow coloring material. This, however, is often abundantly separated in nearly opaque reddish-brown flocks at the line of contact between the Cymatolite and Killinite.

This fact, and the presence of organic matter, suggest that the entire content of iron in this mineral may not exist in chemical combination in the main pseudomorphous substance present, and may not be essential, but may have been in part rejected, during the alteration of the Spodumene, in a ferrous combination with an organic acid. This seems to have been diffused as a greenish coloring material, subsequently oxidized during the artificial preparation of the thin section under examination. If this conclusion be true, a part of the atomic fraction of iron in the calculation of the ratio should have been disregarded; but, aside from replacing it by an equivalent of basic hydrogen, I think the calculation and formula would remain unaffected.

When the line of contact between the Killinite and Cymatolite is examined where it crosses the fibration both of the Killinite and of the Cymatolite (*i. e.*, transversely to the axis of the

prism), on the one side of it appear the rigid fibres of Killinite, straight and parallel, and, on the other, end to end, the curved needles and blades of the more flexible Cymatolite. But along that portion of the line, at the sides of the prism, where it runs parallel to the fibres of Spodumene or Killinite, it displays minute but abundant rounded indentations into the mass of the latter minerals, now occupied by the ends of Cymatolite-needles, in projecting bundles, or sometimes mixed in great disorder.

These indentations are also represented in the drawing (Fig. 2, Plate XIII): κ — κ is the Killinite, retaining the fibrous texture of the original Spodumene, c is the Cymatolite, and a — a the irregular line of contact between the two minerals. Along this line, many of the blades of Cymatolite display their terminations still perfect, being more recently formed and as yet sheltered from the pressure. The ends of many others are broken off bluntly or more or less obliquely, and the fragments appear here and there along the contact-line and even in the Killinite, as at b ; while several blades have been crushed up into a mass of irregular scales, at e , by a side-thrust from the left. The dark points scattered about are particles of ferric hydrate. The drawing was made under the microscope, and with the help of the camera lucida, upon a thin cross-section of an altered crystal, and at a magnifying power of 1002 diameters, (reduced to 617 at the size of the wood-cut). *

III.

ALBITIC GRANITE AFTER SPODUMENE.

The pseudomorphs most conspicuous by size, even more so than those of Cymatolite, consist of a vein-granite, made up of Muscovite, Albite, and Quartz, in varying proportions, even within the same pseudomorph, with Manganese-Garnet, Oerstedite, Beryl, etc., occasionally interspersed.

The large Cymatolite-columns generally pass at one end into mixtures of this character, and enormous masses of one or two hundred weight have thus been formed. They consist of an aggregation of perhaps only two or three pseudomorphs of this kind, rudely but in places distinctly shaped, each from several inches to nearly a foot in diameter, and from one to nearly three feet

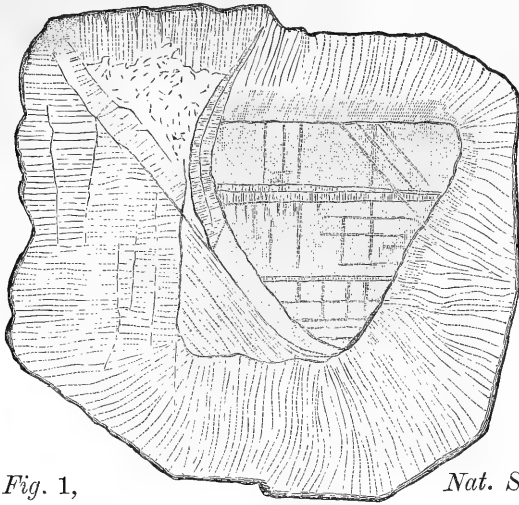
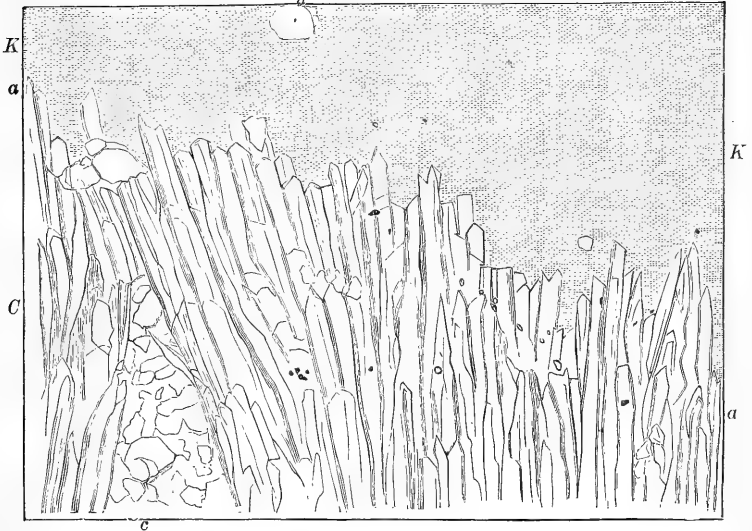

Fig. 1,

Nat. Size.

Fig. 2, $\times 617$ diam.



Hundredths.

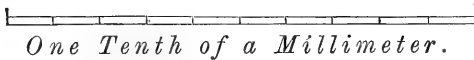

One Tenth of a Millimeter.

in length. Various transitions were observed in the disposition of these materials, such as huge pseudomorphs, of which a large core consisted of a coarse aggregate of mica-crystals, with an outer crust one or two inches thick, in some cases of Cymatolite, and in others of grayish-white Quartz.

IV.

MUSCOVITE AFTER SPODUMENE.

Many pseudomorphs were found in the Chesterfield vein, which consist in large part or entirely of a greenish-yellow Muscovite with peculiar greasy lustre. In fact all stages of intermixture with Cymatolite were observed, from the almost pure pseudomorphs in the latter mineral, in which Muscovite occurred only in minute or even microscopic scales, lying mostly parallel to the axis of the crystal—to others, in which the mica was so abundant as to have imparted a yellow or greenish color to the mixture—and at last to micaceous pseudomorphs, perfectly free from Cymatolite, retaining the form and superficial striation of the Spodumene even to the terminations, though the latter are in general more or less flattened in form and distorted. All these varieties of intermixture appear to be rather the results of intercrystallization than of alteration of either one of the pseudomorphous minerals into the other. The suddenness of the change of conditions which produced the one or other material is often illustrated by prisms, which consist of pure Cymatolite in one part of their length, and of Muscovite generally toward their terminations, with a sharp line of demarcation between the two.

Another kind of pseudomorph in Muscovite, less perfect in form, is a variety of those described under III, in which the mica may largely predominate over its associates. In the former kind, the mica tends to occur in continuous enveloping scales, parallel to the axis of the crystal; while in the latter the mass is always made up of imperfect crystals and flakes of mica, generally from one-half to two inches in diameter, lying confusedly in all planes, and producing a coarse granular structure. The former traverse the smoky quartz in slender and perfect prisms, sometimes six inches to a foot or more in length, and from one

or two inches down to one-eighth of an inch in diameter, but generally bent. The coarser pseudomorphs of the second kind are often of enormous size, as described under III.

At the Barrus locality in Goshen, the Aglaite and Muscovite are intercrystallized in similar ways. The laminae of the Muscovite also are continued into the gangue, and assist in producing the strong adherence of the latter to the altered prisms.

Genetic Relationships.—The nature of the chemical reactions connected with the genesis of the pseudomorphs in Muscovite and in Albite, may be understood from a consideration of the following published analyses of the minerals from this region :

XVI—Muscovite from Goshen. S. G. 2.859.

Analysis by C. F. Rammelsberg (Zs. G., xix, 400).

XVII—Muscovite from Goshen, rose-colored.

Analysis by Mallet (Am. J. Sci., II, xxiii, 180, 1857).

XVIII—Albite from Chesterfield.

Analysis by Stromeyer (Untersuch., 300).

XIX—Albite from Chesterfield.

Analysis by Laurent (Ann. Ch. Phys., lx). Both these Albites were *probably* the Cleavelandite from Clark's Ledge.

	Muscovite		Albite	
	XVI	XVII	XVIII	XIX
Fluorine,	.52			
Silica,	47.02		70.68	68.4
Alumina,	36.83		19.80	20.8
Ferric Oxide,	.51		Fe O,	.11
Manganous Oxide,	1.05			.1
Magnesia,	.26			
Lime,			.23	.2
Lithia,	} .30	.64		
Soda,		.99	9.06	10.5
Potassa,	9.80	9.08		
Water,	3.90			
	<hr/>		<hr/>	<hr/>
	100.19		99.88	100.

Atomic Ratios.

(Fe, Mn, Mg=2K)

H : K	1.6 : 1	
H, K: Al, Fe : Si	1.9 : 1 : 2.1	Na: Al : Si 2 : 1 : 6

The Muscovite from this locality is thus determined as a half-silicate,

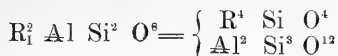

The Albite appears to be the sesqui-silicate—

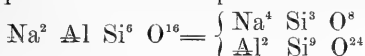

It is probable that there has commonly occurred a splitting up of two molecules of the bi-silicate, Spodumene, by a simple transference of two atoms of silica from one to the other, into one molecule of Muscovite and one of Albite, the lithium being replaced by potassium or sodium out of the solution during this change. This may be represented—

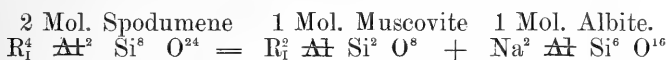

It is further possible that the formation of the great masses of Muscovite has been in large part due merely to the separation of two molecules of silica from a molecule of Spodumene, the silica thus isolated being deposited as quartz within many of the pseudomorphs.

Microscopic Structure.—In a thin section of Spodumene containing Muscovite, the latter appears under a low power as clear rounded glassy lakes; while in some cases the Spodumene is prolonged into slender threads, projecting into the mica parallel to the bladed laminæ of the latter.

V.

ALBITE AFTER SPODUMENE.

This form, generally intermixed with a little Muscovite and less quartz, is a mere variety of III, much rarer than IV, and always with rather indistinct outlines and terminal faces obliterated.

VI.

QUARTZ AFTER SPODUMENE.

The pseudomorphs in quartz are very rare, sometimes six to nine inches in length, with the original faces and striations of

the crystal sharply defined, but with the termination obliterated. They are more or less intermingled with scales of mica, or covered by it in a thin film, and often are only the continuations of those described under III, of which they are mere varieties.

PARAGENESIS OF SPODUMENE.

The paragenetic relationships between Spodumene and its *original* associates in these granite veins, previous to its alteration, will be more fully discussed in another paper; but the following brief statement will have a bearing on the present purpose.

In the two Goshen veins, they can be only imperfectly studied, from the partially concealed outcrops, though better from the abundant fragments. In the more easterly locality, the vein-stone consists mainly of a coarse aggregate of Albite, Indicolite, Garnet, and Spodumene, whose crowded and imperfectly outlined grains indicate a more rapid crystallization than in the other localities. In the Barrus vein, to the west, the mass of the vein seems to be represented in place by a coarse aggregation of white Quartz, Orthoclase, Muscovite, and occasionally greenish Beryl; while the scattered boulders of albitic granite appear to be fragments of a central band or secondary vein, whose slow crystallization is suggested by the beautiful aggregate of snow-white Cleavelandite and grayish-white Quartz, which forms the matrix of the rarer minerals. Of these, the most abundant are the Spodumene, whose habit has been already described, and Tourmaline, black, green, or blue-black (Indicolite), generally massive, but sometimes in good crystals. Less commonly were found Beryl, green, and white (Goshenite), in grains, or sometimes fairly crystallized with good terminations, Garnet, rose-colored Muscovite, and still more rarely Columbite and Cassiterite in minute crystals. Apparently there has been also, in parts of the vein, a final deposition of masses of smoky quartz, enveloping smaller crystals of these minerals, but particularly of green Beryl and Indicolite.

At Macomber's Ledge in Chesterfield, the coarse Orthoclase-granite of the main vein contains films of Margarodite and a few imperfect green Beryls; while in the secondary vein the succession appears to have been; first, Quartz, Muscovite, granu-

lar Albite, Tourmaline, and Spodumene: then Cleavelandite, Quartz, Manganese-Garnet, and Zircon: and finally smoky Quartz, with green and blue Tourmaline. The larger crystals of most of these minerals penetrate through all the layers, and their growth seems to have been continuous.

At Clark's Ledge, in Chesterfield, the main granite-vein is of the same general constitution as that just described, rarely showing a few large Beryls. In the secondary vein no Spodumene occurs, but the succession is in the same order. First, on either wall, a saccharoidal albitic granite, with little Quartz and Mica, and a few scattered imperfect black Tourmalines and Garnets: then coarse Cleavelandite, with blue, green, red, and rarely brown Tourmaline, and small quantities of the rarer minerals, Microlite, Columbite, Cassiterite, Zircon, Cookeite, and Lepidolite; all these, especially the Tourmaline, increase in quantity and development toward the centre of the vein, which is filled up by an irregular sheet of smoky Quartz.

At Chesterfield Hollow, the granite of the main vein is of the usual character, but shows no Beryl and little Mica. The successive deposition of minerals in the secondary vein is first Orthoclase, in huge crystals, large plates of Muscovite, sometimes 6 to 10 inches in diameter, and grayish-white Quartz. Within this comes an irregular mass of a coarse albitic granite, with green Muscovite, Spodumene, greenish-white Beryl, in masses sometimes ten to twenty-five pounds in weight, coarse Garnets, Columbite, in rudely-crystallized grains, up to half a pound in weight, and a Zircon rich in uranium, in minute double pyramids, rarely three-sixteenths of an inch in diameter. Usually this albitic granite passes gradually into a mixture of Quartz and Cleavelandite, in bunches of snow-white plates, enclosing less Muscovite,—Manganese-Garnets in large and abundant but imperfectly crystallized grains,—Zircon,—Spodumene,—and yellowish-white Beryl in irregular masses.

Finally, the core of the vein consists of an irregular sheet of smoky Quartz, penetrated by long prisms of Spodumene,—green Beryl in small and good crystals,—Muscovite, in hexagonal plates, often well crystallized, and up to two or three inches across, as well as in sheets, scattered scales, and wavy films, which in part seem to be altered to Margarodite,—Columbite and Zircon

in rare but perfect crystals. This succession of minerals in the secondary vein is not as regular as might be inferred from the foregoing description, in which it is intended to indicate only the general tendency toward a definite arrangement.

At Walnut Hill, in Huntington, the material of the main vein is similar to that of the preceding locality. In the secondary vein, the first deposit was found to be a very coarse albitic granite, rich in black Tourmaline, in huge masses, Muscovite and Garnet: then followed Cleavelandite, white Quartz, and Spodumene, in the well-known fine crystals, associated with black and blue Tourmaline, Triphylite, Cyrtolite, Garnet, Apatite, Muscovite, and greenish-white Beryl: and the central sheet of smoky Quartz received the terminations of the Spodumene-crystals, together with a little Beryl, Muscovite, and Cyrtolite.

The Spodumene, and in part its associates, in these veins, have been affected by two successive processes of alteration. The one, which may be denominated *Hydro-thermal*, occurred, perhaps before the folding of the strata, during subsidence to that depth below the surface at which they are known to be subjected to the long-continued action of alkaline solutions at a high temperature. The other, to which the term *Meteoric* may be applied, has been continued up to the recent period, with the strata in their present position, by solutions derived from the rain-water, soil, and the decomposed feldspars in the weathered superficies of the main granite-vein.

HYDRO-THERMAL ALTERATION.

The passage of heated solutions, rich in alkaline silicates, over the crystals of Spodumene, resulted at first in the simple substitution of the alkalis and of water, in various but definite proportions, for the protoxides in that mineral, by the modes of replacement already fully explained. The larger masses were in most cases only superficially altered, but in the smaller and slender crystals the process of substitution became complete.

The alteration first attacked the superficies of a crystal, was hastened by penetration along any existing fissures, and generally progressed most rapidly from the termination of a crystal along the plane of orthodiagonal cleavage. In the brittle, easily fis-

sured, and porous quartz-matrix of the Chesterfield vein, the crystals of Spodumene were thus attacked from all sides; but in the dense compact envelopment of the crystals of the Barrus locality in Goshen, the attack proceeded only in the direction of the longer axis of the prism along the orthodiagonal plane. The formation of the hydrous minerals was then gradually interrupted, and finally ceased, as new conditions of more rapid alteration came into existence, perhaps partly by greater saturation with alkaline and other salts, and partly by increase of temperature. The facts seem strongly to indicate that these conditions varied greatly and frequently, not only in time but in different parts of the vein, and of the same crystal, within even a few inches! Sometimes as the one or the other of the two main alkalies predominated in a percolating solution, alteration-pseudomorphs were produced,—of Albite, by addition of silica and substitution of soda for the more soluble lithium-silicate—and of Muscovite, by substitution of potassa and separation of an equivalent amount of silica in the form of free Quartz. The more rapid character of these processes naturally facilitated the production of displacement-pseudomorphs in Muscovite, Albite, and Quartz, by the complete removal and recombination of constituents.

METEORIC ALTERATION.

The subsequent process of alteration—or rather decomposition—and one which has continued up to the present time, upon the cores of Spodumene remaining unaltered by the preceding process, has been effected by ordinary meteoric waters, at times holding in solution the acids derived from the decomposition of humus. By ordinary carbonated waters, there has been a gradual removal of a part of the lithia and more soluble protoxides, almost universal, with the consequent effect upon the physical characteristics of the mineral, shown by the loss of weight, lustre, greenish color, and translucency. The channels for the passage of these solutions have been the increased number of fissures in the surrounding gangue, and in the altered crystals themselves, as well as the capillary vacuity along the contact-line between the core of each crystal and its alteration-crust.

In some points the oozing solution became charged from the surface with a content of organic acids and their ammoniacal salts—probably the “azo-humic acids” of Thénard*—combined with potassa derived from the superficial weathering of the granite-bed and decomposition of its Orthoclase. Here a new process of alteration into Killinite ensued, by the de-oxidation of the iron, the removal of the lithia and of a fourth part of the silica, and their partial replacement by potassa, water, and organic matter, with the great change in physical characteristics described under Killinite. The larger cores of Spodumene were affected chiefly at their terminations, and, in a smaller degree, along the sides next the crust of Cymatolite; but smaller crystals have been thus altered completely through. Saturation with this solution has further introduced into Cymatolite its present small content of nitrogenous organic matter.

In all these veins there has been a subsequent separation of other substances, through the decomposition of certain minerals by meteoric waters. The Zircons have absorbed water, and lost part of their uranium, which separated as Autunite, Torbernite and, by a further decomposition, Uran-ochre, and perhaps some other constituent, in the form of a pink mineral.

The Garnets, by decomposition, have afforded much ferric oxide in the form of ochre, and manganese in the form of the dendritic films of Pyrolusite which abound in all the veins. The Triphylite of Huntington, by absorption of water and higher oxidation of certain constituents, has assumed its present altered form, so that only small nuclei of the unaltered mineral may sometimes be detected in the heart of a crystal. The Spodumene, especially at Macomber's Ledge, has passed into a crumbling mass, or even an earthy powder, possibly kaolinic, which sometimes becomes a white clay when moist. The Cymatolite also has often become fissured and disintegrated into a clayey mass.

* Compt. Rend., LXX, 1412.

XXVIII.—On certain North American Species of *Zonites*, etc.

BY W. G. BINNEY.

(With Plates XIV and XV.)

Read October 20th, 1879.

Most of the following notes will serve as a supplement to "Terrestrial Mollusks and Shells of the United States," vol. V. The balance are furnished from specimens lately collected at Cape Town, South Africa, by Mr. J. S. Gibbons.

Spiraxis (Euspiraxis) Dunkeri, Pfr.

San Domingo, Mr. J. S. Gibbons.

No central teeth. (Pl. XV, Fig. N).

Glandina.

Mexico. Dr. Edward Palmer.

On pl. XIV, fig. L, I have figured the lingual dentition. There are about 32–1–32 teeth. The centrals are narrow, with a very slender cutting point.

Rhytida vernicosa, Krauss.

Cape Town, South Africa. Mr. J. S. Gibbons.

This species is placed by Von Martens in *Pella*, a subgenus of *Helix*. On examining the animal, however, I find it has no jaw, and that its lingual membrane presents the usual characters of *Rhytida*. Mr. Gibbons informs me "that the animal wants the characteristic labial palpi of the latter genus." There appears no central tooth. The rows of teeth are close together, not widely separated. There are about 14–14 teeth (Pl. XIV, Fig. I).

Stenopus? decoloratus.

Demerara. Mr. J. S. Gibbons.

This species is allied to *Zonites Cayennensis*, Pfr., of Cayenne, a species placed by Von Martens in *Mesomphix*. An examination of the jaw and lingual dentition leads me to consider it a *Stenopus* (see Morse, Ann. N. Y. Lyc., viii, 158, fig. 3). I

cannot judge of the character of the tail from the alcoholic specimens received.

The jaw is low, wide, slightly arcuate, ends blunt and but little attenuated; cutting edge without median projection.

Lingual membrane long: teeth, 23-1-23, the transverse rows arranged *en chevron*: centrals small, tricuspid: no lateral teeth: all the side teeth are aculeate marginals (Pl. XV, fig. K).

Macrocyclus Hemphilli, n. sp.

At Olympia, Oregon, Mr. H. Hemphill collected several specimens of a *Macrocyclus* (pl. XV, fig. M), which appears to be distinct from, though nearly allied to, *M. Vancouverensis*. It may be best described by saying that—

The umbilicus is narrower and not excavated so much—the termination of the last whorl not receding from the umbilicus as in all the forms of *Vancouverensis* and *concava*—in all, the whorls are more or less strongly striated within the umbilicus—often almost ribbed in *concava*; not so in this shell—the texture of the shell is glassy like *Hyalina*, and there is no trace of the microscopic spiral lines found in all the other forms;—beneath, the last whorl is proportionately wider. The greater diameter is 14 mill.; lesser, 10; height, 5.

The jaw and lingual dentition are as usual in the genus (See Terr. Moll. of U. S., vol. V, p. 88). I could not distinguish the characters of the central tooth in this species.

Vitrinizonites latissimus, Lewis.

I have already, in the Bulletin of the Museum of Comparative Zoology, vol. V, No. 16, p. 333, given a description of this genus and a figure of its lingual dentition. I here add a figure of the animal in motion (pl. XIV, fig. A), not fully extended. The caudal mucus-pore is circular, bordered with a narrow transversely grooved rim; and when closed is covered completely. When open the cover is raised along its longitudinal centre, into a sharp carina, leaving posteriorly when seen from behind, an erect triangular opening. It thus differs from the simple longitudinal slit found in most of the American species of *Zonites*, such as *friabilis*, *capnodes*, *fuliginosus*, *inornatus*, *demissus*, *ligerus*, *suppressus*, the last figured in Terr. Moll., V, fig. 47. *Z. laevigatus*, however, has a nearer approach to the circular pore of *Vitrinizonites*.

The lingual dentition (see Bull. Mus. C. Zool., l. c.) is nearer

to that of *Z. laevigatus* than any other American species. Like that, there are no perfect lateral teeth, but only decided transition teeth.

The genitalia are figured on plate XIV, fig. B. The ovary is very large (*ov*) and stout: the genital bladder (*g. b.*) is globular on a short, narrow duct: the penis-sac (*p. s.*) is very long, narrow, cylindrical, receiving the retractor muscle (*r.*) near its basal termination, and merging at its apex into the vas deferens (*v. d.*) The penis-sac has not the accessory process found in *Zonites capnodes*, *friabilis*, *laevigatus*, *inornatus*, *fuliginosus*, and *Rugeli*.

***Zonites capnodes*, W. G. B.**

Living specimens received from near Knoxville, Tenn., through the kindness of Mrs. G. Andrews, have enabled me to figure (pl. XIV, fig. C) the genitalia. The genital bladder (*g. b.*) is large, globular, on a short, narrow duct: the penis-sac (*p. s.*) has the same peculiar accessory process which I have (Terr. Moll., V) figured in those of *Z. laevigatus*, *friabilis* and *inornatus*.

It is in many individuals more easy to distinguish *capnodes* from *fuliginosus* by the genitalia and dentition than by the shell.

***Zonites subplanus*, Binn.**

Roan Mt., N. C. Mrs. G. Andrews.

I have already stated that the dentition of this species resembles that of *Z. inornatus*. I here give a figure of it on pl. XIV, fig. J.

***Zonites Rugeli*, n. sp.**

On Roan Mountain, Mitchell Co., N. C., Mrs. G. Andrews found numerous specimens of a *Zonites*, for which, proving new to science, I propose the name of its discoverer.

Shell (pl. XV, fig. H) depressed globose, perforated, thin, delicately wrinkled, the apical whorls sometimes striate, greenish horn-colored, dark smoky above; spire slightly elevated, apex flat; whorls 6, slightly rounded, the last globose, scarcely excavated at the perforation; aperture large, rounded, oblique; peristome simple, thin; ends slightly approaching; the columellar one scarcely broadened. Diam., larger 19; lesser 15; height 9 mill.

When first received, I believed this to be an extremely globose form of *Z. inornatus*, but an examination of the lingual dentition showed this to be impossible.

On pl. XIV, fig. D, I have given a figure of the genitalia. It will be seen that the accessory part of the penis-sac is in this species continued to a point beyond the retractor-muscle: otherwise the genitalia are very similar to those of *capnodes*, *friabilis*, *inornatus*, *laevigatus*, and *fuliginosus*. The last species I find to have this accessory process also, though it is not given in Leidy's figure.

Jaw as usual in the genus. Lingual membrane (pl. XV, fig. I) as usual: teeth 38-1-38. There are about 4 or 5 laterals; the 8th is a pure marginal on either side of the central line. It will be seen in Terr. Moll., V, that *inornatus*, *subplanus* and *laevigatus* are peculiar in having no perfect lateral teeth, but only transition teeth: *fuliginosus*, *capnodes*, and *friabilis*, as well as *Rugeli*, have well formed laterals, differing in number in the various species: thus the lingual dentition in this group is a good guide in distinguishing the species.

The animal is dark slate-colored: the caudal mucus-pore is a longitudinal slit as in *suppressus* (see Terr. Moll., V).

Some individuals have their apical whorls striate, as in *Z. subplanus*.

***Zonites placentula*, Shuttl.**

On pl. XV, fig. A, I give a figure of what appears to be the true *placentula* as described by Shuttleworth (whose description is translated in Moll., V, p. 124). The shell there figured, and also figured in this paper, pl. XV, fig. E, is either a distinct species, or an elevated edentate form of *lasmodon*.

***Zonites Andrewsii*, n. sp.**

On pl. XV, fig. D, is an illustration of a shell lately received from Mrs. G. Andrews, who collected it on Roan Mountain, Mitchell Co., N. C. It has the general appearance of *Z. significans*, *multidentatus*, and *lasmodon*, but differs so decidedly from each, that I propose to designate it by the name of its discoverer. A full specific description can be given later. Compared with

Z. lasmodon, it has fully 8 whorls, is $6\frac{1}{2}$ mill. in diameter, the umbilicus 1 mill. wide, whilst *lasmodon* with 7 whorls is 7 mill. in diameter, with an umbilicus 2 mill. wide: the Roan Mountain shell has also five parallel lamellæ, while *lasmodon* has only two, or at most three, and does not show the successive rows of lamellæ which are characteristic of *Andrewsi*, radiating from the centre.

From *Z. significans* it differs in its larger size, greater number of whorls, much wider umbilicus, and in the character of its internal denticles, which are long and winding on the wall of the whorl; while in *significans* the denticles are simply erect and conical, with broad base. The same differences distinguish it from *multidentatus*, which is still smaller than *significans*, and has a much narrower umbilicus.

***Zonites macilentus*, Shuttl.**

On pl. XV, fig. B, I give an illustration of what appears to be the true *macilentus* (see Terr. Moll., III, p. 20), which seems to be distinct from *lasmodon*, judging by specimens lately received.

***Zonites multidentatus*, Binn.**

For the sake of comparison with *Z. significans* and allied species, I give on pl. XV, fig. F, an enlarged view of this species, more satisfactory than that given in Terr. Moll. U. S., III.

***Zonites significans*, Bl.**

By an unfortunate oversight, another shell was used to illustrate this species in Terr. Moll., V, p. 132. I here figure (pl. XV, fig. G) an authentic specimen.

On pl. XIV, fig. F, I have given, for the sake of comparison, an illustration of *Z. multidentatus*, the nearly allied species.

***Zonites cuspidatus*, Lewis.**

In the Proceedings of the Academy of Natural Sciences of Philadelphia, 1875, p. 334, this is mentioned as probably a var. of *Z. cerinoideus*. I have received authentic specimens from

Dr. Lewis, and find them to be rather a variety of *gularis*—one of the many curious forms of that variable species. The internal tooth-like processes, strongly curved one towards the other, form almost an arched space. On pl. XV, fig. C, will be found a figure of this form. Dr. Lewis's specimens were from Munroe Co., Tenn. (Miss Law). I have also received it from Roan Mountain, N. C. (Mrs. G. Andrews).

Tebennophorus, —.

From Dr. W. Newcomb I have received a slug which, from its outward characters, jaw and lingual membrane, surely is a species of *Tebennophorus*. It is mentioned here, as the locality is new for the genus—Brazil, 300 miles up the river from Para.

Mesodon dentifera, Binn.

Vermont.

On pl. XIV, fig. G, I have figured the genitalia of this species, hitherto unknown.

The genital bladder (*g. b.*) is small, oval, on a short duct which is greatly swollen at a short distance below the bladder: the penis-sac (*p. s.*) is long, stout and contracted, at a short distance below its blunt end: the retractor is inserted in the vas deferens at about the middle of its length.

In another individual, the construction of the penis-sac was not so well developed.

Mesodon Andrewsii, n. sp.

At Roan Mountain, Mitchell Co., N. C., Mrs. Andrews collected numerous specimens of a *Mesodon* which cannot be referred to any known species.

Shell imperforate, globose, very thin, with delicate wrinkles of growth and microscopic revolving striæ; horn-color; spire elevated, conic, apex obtuse; whorls six, convex, the last greatly swollen; peristome white, thickened, slightly reflected, ends separated, the columellar one expanded. Greater diameter 25 mill., lesser 20; height 14 (Plate XV, Fig. L).

The absence of limestone on Roan Mountain accounts for the extreme thinness of the shell.

It can scarcely be said to resemble closely any known species

of *Mesodon*, though somewhat like a gigantic *M. Mitchelliana*.

The jaw has 16 ribs.

The lingual membrane (pl. XIV, fig. F) is long and narrow : teeth 64-1-64, with about 15 perfect laterals on either side of the central line. The central and lateral teeth have no side cusps or cutting points, and only on the extreme marginals does a side cutting point appear. The cutting point of the marginals is long. Thus the dentition is like that of *clausa* and *thyroides*.

The genitalia are figured on pl. XIV, fig. E. The genital bladder (*g. b.*) is large, oval, on a short, narrow duct : the penisac (*p. s.*) is long and stout, with a sub-central constriction : the prostate gland (*pr.*) is highly developed.

Helix (Dorcasia?) globulus, Müll.

Cape Town, South Africa, Mr. J. S. Gibbons.

Jaw low, wide, scarcely arcuate, ends not acuminate : no anterior ribs.

Lingual membrane wide, with about 40-1-40 teeth. Laterals as well as centrals tricuspid. Pl. XIV, fig. K, gives a central, with its adjacent lateral and several inner marginal teeth.

Both jaw and lingual membrane are quite different from those hitherto observed in *Dorcasia*, to which sub-genus Von Martens refers the species.

Mr. Gibbons informs me that the eggs of this species are of very large size. It lives on sandy flats close to the sea margin, burying itself in the sand by day.

Helix (Pella) rariplicata, Benson.

Cape Town, South Africa, Mr. J. S. Gibbons.

The jaw has ribs like those figured for *Microphysa Lansingi*, in Terr. Moll. U. S., V,—i. e., flat, crowded, wide, numerous.

The lingual membrane is long and narrow. There are about 16-1-16 teeth, with four laterals on either side of the central tooth. The central tooth has small detached side cusps and cutting points, as in *Strophia*, and the laterals are quite similar—a very unusual arrangement in the *Helicide*. The marginals are low, wide, with one inner, oblique, wide bifid cutting point.

The central, with its adjacent laterals and an inner marginal tooth, are given in pl. XIV, fig. H.

Buliminus Natalensis, Kr., var. **Draakensburgensis**, E. Smith.

Cape Town, South Africa, Mr. J. S. Gibbons.

The species is placed by Von Martens in the subgenus *Pachnodus* of *Buliminus*.

The jaw is very thin, slightly arched, low; ends blunt; scarcely attenuated; anterior surface with above forty ill-defined, flat, crowded ribs, scarcely denticulating either margin.

Lingual membrane (pl. XIV, fig. J) long and narrow. Central teeth tricuspid; laterals bicuspid; marginals quadrate, with one long, large, oblique inner cutting point, and one outer bifid cutting point. There are 54-1-54 teeth, with about 14 laterals on each side of the central line.

EXPLANATION OF PLATE XIV.

- Fig. A *Vitrinizonites latissimus*, animal in motion, not fully extended: drawn by Miss Emma Pringle.
 " B " " " genitalia.
 " C *Zonites capnodes*, genitalia.
 " D " *Rugeli*, "
 " E *Mesodon Andrews*, "
 " F " " " lingual membrane.
 " G *Mesodon dentifera*, genitalia.
 " H *Helix rariplicata*, central, adjacent laterals, and inner marginals.
 " I *Rhytida vernicosa*, Kraus, dentition.
 " J *Buliminus Natalensis*, lingual membrane.
 " K *Helix globulus*, lingual membrane.
 " L *Glandina*,—dentition (see p. 355).

EXPLANATION OF PLATE XV.

- Fig. A. *Zonites placentula*, Shuttl.
 " B " *macilentus*, Shuttl.
 " C " *cuspidatus*, Lewis.
 " D " *Andrews*.
 " E " *lasmodon*, var. ? (see. p. 358)
 " F " *multidentatus*, Binn.
 " G " *significans*, Bland.
 " H " *Rugeli*.
 " I Dentition of same.
 " J " " *Zonites subplanus*, Binn.
 " K " " *Stenopus ? decoloratus*
 " L *Mesodon Andrews*,
 " M *Macrocyclus Hemphilli*.
 " N *Spiraxis Dunkeri*, Pfr., dentition.

The figures of shells on this plate were drawn from nature by Mr. Arthur F. Gray, of Danversport, Mass.,—those of dentition by W. G. B.

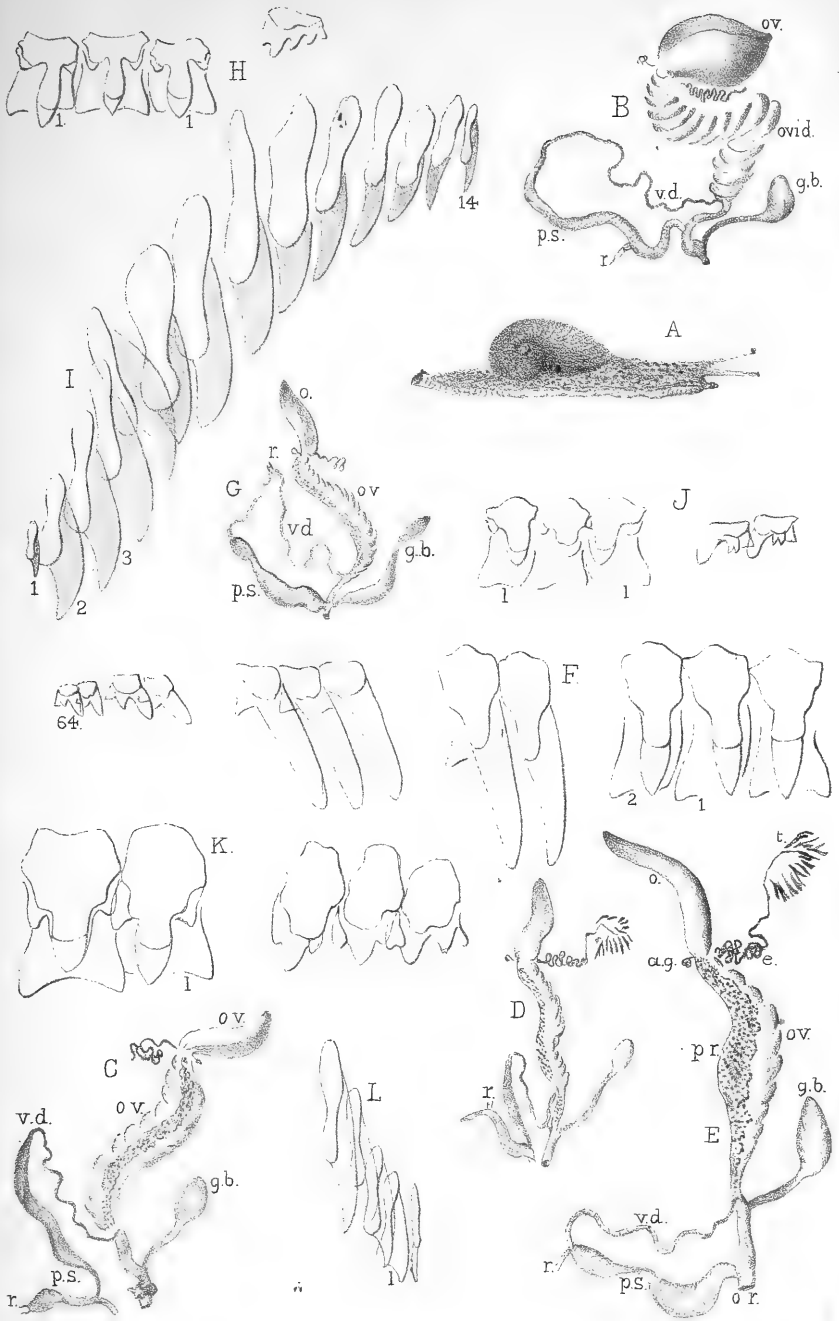

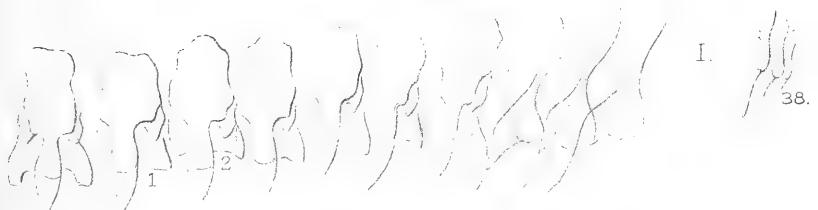
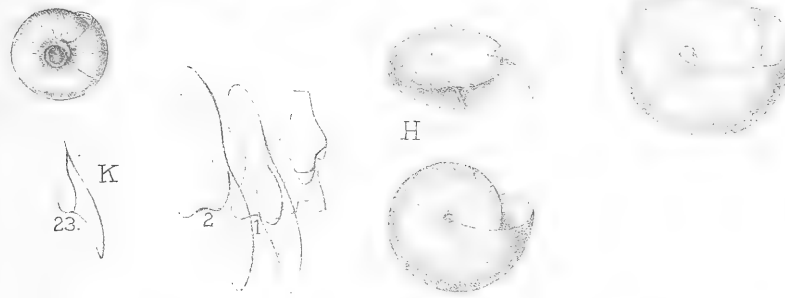
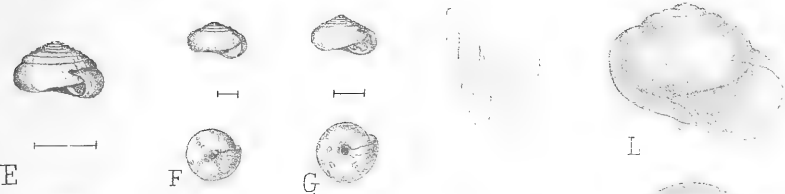
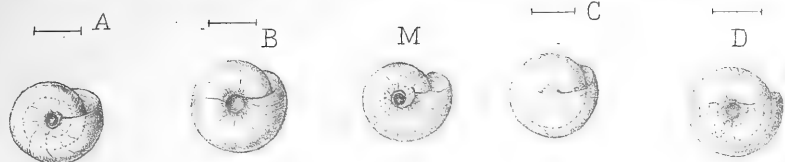

XXIX.—*Lines of Discovery in the History of Ozone, with an Index of its Literature, and an Appendix upon the Literature of Peroxide of Hydrogen.*

BY ALBERT R. LEEDS, PH.D.

Read January 12th, 1880.

LINES OF DISCOVERY IN THE HISTORY OF OZONE.

I.—ITS ORIGINAL DISCOVERY, SOURCES AND PROPERTIES.

The history of ozone begins with the clear apprehension, in the year 1840, by Schönbein, that in the odor given off in the electrolysis of water, and accompanying discharges of frictional electricity in air, he had to deal with a distinct and important phenomenon. Schönbein's discovery did not consist in noting the odor; that had been done by Van Marum, more than half a century before, but in first appreciating the importance and true meaning of the phenomenon. For while Van Marum, Cavallo, and others who followed them, connected the odor with the electricity, calling it the "electrical odor," or "aura electrica," and thus made it the property of an imponderable agent, Schönbein ascribed it to the peculiar form of matter operated upon.

The hypothesis of Van Marum necessarily remained barren of fruits; that of Schönbein speedily enriched chemical science with a host of acquisitions.

Clinging tenaciously to the doctrine that there could not be a variety of origin for one and the same odor, and that the kind of matter producing it in every case must be identical, Schönbein fixed his discovery by giving to that one and certain kind of matter, the name of Ozone. By adhering to this guiding clue, he added as a third source of ozone, the action of moist phosphorus upon air (1840-1843); and since that time, besides electrolysis, electrical influence, and the action of air upon moist phosphorus, no other sources of ozone of practical utility have been discovered.

The fact that Schönbein so stoutly insisted, and eventually so triumphantly established, the *identity* of the ozone from whatever

source derived, must not be lost sight of in any estimate of his merits as a discoverer. The earliest attack came from De la Rive, who attributed the odor to metallic oxides set free from the metals used as electrodes, or as terminals in electric discharges. But Schönbein pointed out, that besides the improbability of an odor arising from solid bodies, this hypothesis required that solid bodies should have the property of indefinite suspension in the atmosphere, instead of being deposited, or washed down by water (1840-1843).

The next attacks came from Fischer, who regarded Schönbein's ozone as probably peroxide of hydrogen, and from Williamson, who thought there were two kinds of ozone, one the ozone given off in electrolysis, and which he regarded as a higher oxide of hydrogen, differing from the previously well-known peroxide, and the other formed by the action of phosphorus on moist air. But Schönbein disposed of both objections;—of the first, by showing that the chemical and physical properties of ozone are not the properties of peroxide of hydrogen; and of the second, by demonstrating that, whatever might be the true nature of ozone, the gaseous matter obtained in the electrolysis of water, was in all respects identical with that formed by the action upon air of moist phosphorus (1844-1845).

During these first five years, Schönbein was busily engaged in ascertaining the properties of ozone. Since no peculiar methods were employed in the furtherance of these discoveries, they need not detain us here, further than briefly to summarize them, and to point out what corrections have been rendered necessary by the labors of subsequent investigators.

They are:—1st. Its eminent oxidizing powers, as shown by its ability to transform most metals into their higher oxides, and to raise the lower oxides into the condition of peroxides. Certain of the non-metals—phosphorus, chlorine, bromine, and iodine—are similarly oxidized. Schönbein's statement that it does not unite with nitrogen under ordinary circumstances, but enters into combination when alkali is present, has been abundantly disproved; among others, by Berthelot (1877), who has shown that no combination occurs, even when alkali is present. It oxidizes sulphites and nitrites into sulphates and nitrates,

and many sulphides into their corresponding sulphates. It destroys (as has since been more elaborately demonstrated by Houzeau, 1872) many gaseous compounds of hydrogen, like those with sulphur, selenium, phosphorus, iodine, arsenic, and antimony. It discharges vegetable colors and powerfully attacks many organic bodies. The nature of its action in the latter case has been more extensively studied by Gorup-Besanez (1863), and he has described the products of the reactions which occur when ozone is allowed to act upon organic substances, alone or in presence of alkali.

2d. According to Schönbein, ozone is insoluble in water. The observations of subsequent experimenters conflict on this point, but there appears to be much evidence to show that it is soluble in water, though only in small degree.

3d. Schönbein pointed out that atmospheric air strongly charged with ozone, acts powerfully on the mucous membranes, and produces symptoms of catarrh. This, and his analogous statement that ozone is present in the atmosphere and plays there a very important role, attracted to the subject not only great popular attention, but enlisted as observers a multitude of students of medicine the world over, who hailed the newly discovered body as an invaluable therapeutic agent, and rushed forward to establish, by sufficiently numerous observations, the relations between its presence or absence in the atmosphere, and the kind and prevalence of disease. Thirty years have passed away, and neither anticipation has been realized. Indeed, at the present hour, the possible value of ozone as a therapeutic agent, is obscured by its having fallen into the hands of empirics; and the multiplication of inexact observations, and the crude and hasty generalizations therefrom, have covered with a sort of scientific opprobrium the whole subject of Atmospheric Ozone.

What causes have led to these lamentable results in the past? what prospects are there that both subjects can be reinstated in good scientific standing in the future?

And first, with regard to ozone as a therapeutic agent. Without considering at present the unsettled questions of a medical

character, as to the proper mode or amount or propriety of application, we apprehend that there have been hitherto three grave instrumental difficulties. 1st. To obtain ozonized air or oxygen, of known strength and of adequate purity. 2d. It is doubtful whether in one form, in which the attempt has been made to employ ozone in medicine,—that of “ozonized water,”—any ozone whatever has been present. Such was the case with the “ozone water” of Krebs, Kroll & Co., in which Rammelsberg found *chlorine*. Since ozone is so slightly soluble in water at common temperatures, that it is extremely difficult to demonstrate the fact of solution, the proposition to employ “ozonized water” as a remedial agent opens a wide door to quackery. 3d. It is certain, that from the mixture of potassium permanganate and sulphuric acid, which has been and is recommended as a convenient source of ozone for medical use, no ozone, but merely chlorine and oxides of chlorine (due to impurities in the permanganate) are derived.

These errors have been exposed and the difficulties overcome. There is no obstacle to having in the office of the physician, the sick-room of the patient, or the wards of the hospital, ozonizers suitable to each place, and adequate to supply ozonized air or oxygen of known strength and purity. This being the case, it remains for the therapist to do his part of the work, and to discover when and how ozone is to be employed in legitimate practice.

Second, to detect the amount of ozone present at any time or place in the atmosphere, and the role this atmospheric ozone plays as a disease-excitant or prophylactic. The objections which vitiate the observations hitherto made, are two in number: 1st. The ozonoscopes hitherto employed, Houzeau's and the Thallium test included, are all affected by some one of the gaseous bodies possibly present in the atmosphere, as well as by ozone. 2d. The method of conducting the observations is in its nature inexact, and variations in wind, temperature, humidity, etc., are allowed to increase the resultant errors.

Advance in this direction is to be looked for, only when the methods at present in use are abandoned in favor of others more in harmony with those pursued in other branches of gas-analysis,

and when reagents are employed which will assign true values to the amount of ozone determined.

II. THE NATURE OF THE CONSTITUENT MATTER OF OZONE.

In his speculations upon the nature of ozone, Schönbein was far less fortunate than in his multiplied inquiries into its sources, properties and applications. The difficulty at that time of procuring air or oxygen containing more than a minute percentage of ozone, and of manipulating it when obtained, was very great, so that precise quantitative investigations were attended with formidable obstacles, and probably for that reason were rarely instituted by Schönbein. He brought forth a variety of hypotheses, thus introducing great uncertainty into a confessedly difficult subject, and necessitating the labors of chemists during nearly a quarter of a century for their complete overthrow.

His earliest hypothesis was, that ozone is a compound, consisting of hydrogen and oxygen. This, in 1844, he abandoned in favor of the theory, that ozone itself is elementary, and along with hydrogen enters into the composition of nitrogen, which is a compound substance.

The following year he reverted to his original hypothesis, and while maintaining strenuously that ozone is not peroxide of hydrogen, he nevertheless upheld the view that it is composed in certain unknown proportions of hydrogen and oxygen.

The second hypothesis was overthrown by the experiments of Marignac and De la Rive, who showed that ozone could not be derived from the decomposition of nitrogen, inasmuch as they obtained it by passing electric sparks through perfectly pure and dry oxygen. They proved the resultant body to be ozone, by causing it to react on moist silver and potassium iodide, with the formation of argentic peroxide and iodate of potassium. They explained these reactions by supposing that, under the influence of the electric discharge, the oxygen had acquired an electrified condition, with exalted chemical properties,—in other words, that ozone is oxygen and oxygen only, but oxygen in an electrified state. Plausible as was this explanation, there was nothing in the experiments, water having been present in the reaction upon silver and potassium iodide, to confute the different inter-

pretation brought forward by Schönbein : that ozone was oxygen, to which in some way was added the elements of water. Nor was this point settled by a more elaborate experiment of the same nature, instituted by Fremy and Becquerel in 1853, who demonstrated that when a certain volume of oxygen is confined over an aqueous solution of potassium iodide, moist silver or mercury, *all* of the oxygen undergoes absorption by the reagent, under the influence of a sufficiently prolonged series of electric sparks.

The first to abandon the theory that hydrogen is a constituent of ozone, was Schönbein himself (1849). He employed air, ozonized as strongly as possible by moist phosphorus, and afterwards dried by passage through a sulphuric acid drying-tube. That water was employed in the generation of the ozone, was not from Schönbein's point of view an essential element in the problem : it was whether this ozone, after drying, still contained the elements of water or hydrogen.

Three hundred liters of the desiccated air were passed through a narrow glass tube heated to redness, in order to decompose the ozone, and then through a second sulphuric acid drying-tube. Since the latter, in repeated experiments, showed no increase of weight, Schönbein regarded the absence of hydrogen in ozone as conclusively proven. At the same time he did not accept the views of Marignac and De la Rive, declaring that to him the existence of an allotropic modification of a gaseous body was inconceivable.

For a long time, however, the theory that ozone was a compound of hydrogen and oxygen prevailed. It derived great weight from the experiments, which had been made by Williamson in 1845. He prepared ozone by electrolysis, and to avoid obtaining along with the electrolytic oxygen any hydrogen, used oxide of copper dissolved in sulphuric acid as the electrolyte. The gas was dried over calcium chloride, and then passed over ignited copper turnings into a second drying tube. This uniformly showed an increase of weight. The copper previous to ignition had been reduced by carbonic oxide, and not by hydrogen, in order to prevent the possibility of any occluded hydrogen being given up, on ignition, to the stream of ozonized oxygen.

These views were apparently confirmed by Baumert's experi-

ments (1853). He passed the electrolytic oxygen evolved in such a manner as to exclude the presence of hydrogen, through a very long sulphuric acid drying tube, and thence into an absorption apparatus containing potassium iodide, and provided with a sulphuric acid bulb-apparatus, to condense evaporated water. In case the matter of ozone and oxygen were identical, the weight of oxygen equivalent to the weight of iodine set free by the ozone, should have been equivalent to the total gain in weight by the absorption apparatus. But, according to the experiments, this weight was less, and the numbers apparently assigned to electrolytic ozone, the formula $H_2 O_3$. And since Baumert found that ozone prepared by the electric charge, could not be made to yield up the elements of water on strong heating, while that prepared by electrolysis could, he regarded the two as different bodies, the former as allotropic oxygen, the latter as teroxide of hydrogen.

Thus, the old hypothesis, against which Schönbein had so long striven, that there were two (and possibly more) bodies of the nature of ozone, was rehabilitated. It was finally overthrown by Andrews (1856), who showed that the preceding experiments on electrolytic ozone had been vitiated by the presence of a small but appreciable quantity of carbonic acid, which, unless very great precautions be taken, is always present in the evolved gas. In very numerous experiments, he showed that the weight of active oxygen was equivalent to the weight of the iodine set free in the absorption apparatus, and therefore no hydrogen as well as could have been present; also, that the properties of electrolytic ozone, and that obtained by the action of the electrical spark on pure and dry oxygen, were identical. More especially, it was shown that both were converted into ordinary oxygen, at a temperature of about $237^{\circ}C.$; and from the whole investigation the author drew the conclusion, which was confirmed by the still more elaborate experiments of Soret, in 1863, and is now universally adopted, "that ozone, from whatever cause derived, is one and the same substance, and is not a compound body, but oxygen in an altered or allotropic condition."

III. THE EXACT NATURE OF THE RELATIONS EXISTING BETWEEN OZONE AND ORDINARY OXYGEN.

We have seen that Marignac and De la Rive, as the result of their experiments performed in 1845, had enunciated the view that ozone was oxygen, rendered allotropic by its passage into a peculiar electric state. They proposed to abandon the name "ozone," which assumed an independent chemical existence for this body, and to call it merely "electricized oxygen." This view of ozone was not readily susceptible of investigation by usual chemical methods. But the case was different with the hypothesis, which was shortly afterwards advanced by Dr. T. Sterry Hunt, in 1848. Since his intuition of a truth, not fully demonstrated until twenty years later, is of a very striking character, it will be interesting to quote it as originally announced. In a paper on the anomalies presented in the atomic volume of sulphur and nitrogen, Dr. Hunt says:—"In considering such combinations as $S O_2$ and SeO_2 , which contain three equivalents of the elements of the oxygen group, it was necessary to admit a normal species which should be a polymere of oxygen, and be represented by $O_3 = (OOO)$. The replacement of one equivalent of oxygen by one of sulphur, would yield sulphurous acid gas (OOS), and a complete metalepsis would give rise to (SSS). The first compound is probably the *ozone* of Schönbein, which the late researches of Marignac and De la Rive have shown to be in reality only oxygen in a peculiarly modified form," etc. The hypothesis herein stated, that ozone is triatomic oxygen, necessarily involved the assumption of a corresponding difference in density and other physical properties—differences admitting of exact quantitative proof or disproof. Such were the experimental difficulties in the way, however, that it was not until 1860, that an investigation was made into the volumetric relations of ozone to oxygen. The experiments of Profs. Andrews and Tait then resulted in establishing, that where perfectly pure and dry oxygen is converted into ozone, under the influence of the silent electric discharge, it becomes more dense, the amount of contraction being proportional to the quantity of ozone produced. Also, that when ozone, thus condensed, is exposed for a short

time to a temperature of 270° — 300° , it expands to its original volume. That the increase in density is exactly proportional to the amount of ozone formed, was proven by an analysis of the contracted gas by means of potassium iodide. The amount of iodine in every case set free, was precisely equivalent to the weight of a volume of oxygen equivalent to the volume of the contraction, which the oxygen had experienced in the process of ozonation. The same laws were demonstrated to hold good with regard to electrolytic ozone, not only by these authors (1860), but also by Von Babo and Claus, and by Soret (1863).

Andrews and Tait found great difficulty in reconciling the theory of the allotropism of ozone, with their experiments, inasmuch as the oxidation of a body like mercury, potassium iodide, etc., was effected without any diminution in the volume of the contracted gas. In other words, the density of the allotropic oxygen concerned in this oxidation was apparently infinite. They sought, therefore, to explain the origin of ozone by the assumption of a decomposition of the oxygen.

But in 1861, Odling put forth the interpretation, that ozone was a compound of oxygen with oxygen, the combination being attended by a contraction. Hence, if one portion of the combined or contracted oxygen were absorbed by an oxidizable body, the other portion would be set free, and by its liberation might expand to the initial volume. He likewise suggested that this contraction might consist in the condensation of three volumes of oxygen into two volumes, not because this ratio was the only one which would explain the volume and density relations, so far as then known, but because, on the hypothesis of the dual nature of oxygen, this was their simplest possible explanation.

Four years later, Soret discovered that a very remarkable reaction occurs when electrolytic ozone is allowed to act upon oil of turpentine. Its volume is diminished by a volume equivalent to twice that of the oxygen, corresponding to the iodine set free on passing the ozonized oxygen into a solution of iodide of potassium. The latter, it will be remembered, is the same as the diminution in volume, which the oxygen undergoes in ozonation, and may be called the contraction-volume. Hence the two volumes of ozonized oxygen, absorbed in Soret's experiments, contained not only their own volume of oxygen, but

also that contained in the contraction-volume, or, in all, three volumes of ordinary oxygen. The density of ozone, therefore, was to the density of oxygen, as three to two, or 1.6584; the density of ordinary oxygen being 1.1056.

Soret inferred rather than demonstrated these relations, inasmuch as in his first set of five experiments, the ratio of the total volume of ozonized oxygen absorbed by the turpentine, to the contraction-volume, was 2.4, and in his second set of seven experiments, 1.81; both of these results being far from 2, the theoretical number.

However, in 1872, Sir Benjamin Brodie, by the introduction of methods of exact volumetric character, supplied a rigorous experimental demonstration. He obtained in a set of eight concordant experiments made with oil of turpentine, for the ratio between the whole diminution in the volume of the original oxygen, to the diminution in volume of the ozonized oxygen, as a mean result, 3.02 to 2.02. Operating in the same manner with a neutral or slightly alkaline solution of sodium hyposulphite, he obtained as a mean result of 27 concordant experiments, the ratio 3.02 to 2.02. In these experiments, the actual weight of the oxygen absorbed, could not be determined otherwise than by calculation from the alterations in volume. But by the oxidation of stannous chloride, under proper conditions, he effected a direct determination, and found that the weight of the oxygen absorbed from the ozonized oxygen by the stannous chloride, was almost exactly three times the weight absorbed from the same gas by potassium iodide. At the same time the volume in the first case was almost exactly twice the contraction-volume, as determined by the latter reagent.

I N D E X

TO THE

Literature of Ozone.

1785	VanMarum	Quoted by Cahours, <i>Compt. Rend.</i> (1870), LXX, 369. "Report upon the labors of Houzeau relative to Ozone."	"Electrical Odor" acquired by oxygen through which electric sparks have been passed. Its chemical properties are also exalted, acquiring the property of oxidizing mercury at ordinary temperatures.
1840	Schönbein	Basel, Ber., IV, p. 66; <i>Bibl. Univ.</i> , XXVIII, p. 342; München, <i>Abhandl.</i> , 1837-1843, III, p. 265; <i>Pogg., Ann.</i> , L, p. 616; <i>Arch. de l'Elec.</i> , t. iv, p. 333. <i>Compt. Rend.</i> , X, p. 706; <i>Froriep. Notizen</i> , XIV, p. 292. <i>R. Soc. Proc.</i> , IV, p. 226.	Observations on the odor given off by the electrolysis of water and by ordinary electricity. Researches on the nature of the odor given off by certain chemical reactions. On the odor accompanying electricity and the probability of a new substance.
	De la Rive	<i>Pogg., Ann.</i> , LIV, p. 402.	Platinum, silver and copper as electrodes—their effects on evolved gases.
1841	Schönbein	Sturgeon, <i>Ann. Elec.</i> , VI, p. 108.	Research on the odor manifested by certain chemical reactions.
1843	"	<i>Pogg., Ann.</i> , LIX, p. 240; <i>Arch. de l'Elec.</i> , III, p. 295; München, <i>Abhandl.</i> , 1837-1843, p. 587.	On the odor accompanying the electrolysis of water and ordinary electricity. Opposes De la Rive's hypothesis that the odor arises from metallic oxides.
1844	"	<i>Arch. de l'Elec.</i> , IV, p. 333 and 454; <i>Atti Scienz. Ital.</i> , 1844, p. 167; <i>R. Soc. Proc.</i> , V, p. 507, 508, 565.	"Production of Ozone by chemical means." Regards nitrogen as a compound of hydrogen and ozone.
	"	<i>Pogg., Ann.</i> , LXIII, p. 520.	Ozone distinct from nitrous acid.

1844	Fischer	Berl. Jahrb. f. wissensch. Kritik, 1844.	Critique of Schonbein's pamphlet "Ueber die Erzeugung des Ozons auf chemischen Wege." Ozone produced by the action of electricity on pure oxygen.
1845	Schönbein	Arch. de l'Elec., V, p. 556; Chem. Soc. Mem., 1845, p. 62; Phil. Mag., XXVII, p. 336; Brit. Ass. Rep., p. 91; R. Soc. Proc., V, p. 565; Pogg., Ann., LXV, p. 69.	"On the nature of Ozone." Reverts to his original hypothesis that it is a compound of oxygen and hydrogen, and instead of nitrogen being essential, this body does not contribute in any way to the production of Ozone.
	Draper	Phil. Mag., 1845, p. 327; Am. J. Sci., XLIX, p. 346; Bibl. Univ., IX, p. 365.	Allotropic modifications of chlorine, etc.
	Schönbein	J. pr. Chem., XXXIV, p. 492; Pogg., Ann., LXV, p. 190.	Observations on Fischer's notice on the Ozone researches of Schönbein.
	"	Milano, Giorn., I, Lomb., VI, p. 200.	A new experiment on the production of Ozone.
	"	Pogg., Ann., LXV, p. 161.	Ozone in the atmosphere, and the role it plays.
	"	Pogg., Ann., LXV, p. 173; Phil. Mag., XXVII, p. 197.	Ozone compared with chlorine.
	"	Pogg., Ann., LXV, p. 196.	Action of Ozone on organic substances,
	"	Pogg., Ann., LXVI, p. 292; Phil. Mag., XXVII, p. 450.	Remarks on the Ozone researches of Williamson.
	"	Pogg., Ann., LXVII, p. 89.	Ozone as a means of oxidation.
	"	R. Soc. Proc., V, p. 543.	A new bleaching principle.
	"	Pogg. Ann., LXVII, p. 97; Bibl. Univ., LIX, p. 177.	Notice on guaiacum.
	"	J. pr. Chem., XXXIV, p. 42.	Some notes upon potassium iodide.
	"	R. Soc. Proc., V, p. 565.	Letter to Faraday on Ozone.
	"	Pogg., Ann., LXVI, p. 593.	Nature of Ozone.
	Fellenburg	Arch. de l'Electr., V, No. 17, 1845.	Reactions attributed to Ozone due in part to nitrous acid.
	Fischer	Schles. Gesel. Uebersicht, pp. 98 and 107; Pogg., Ann., LXVI, p. 163; J. pr. Chem., XXXV, p. 351.	On the Ozone discovered by Schönbein. Probably a peroxide of hydrogen.
	"	Pogg., Ann., LXVI, p. 168.	Reply to Schönbein in regard to Ozone. Ozone papers moistened with acid are turned blue in contact with ordinary air.

1845	Schönbein Marignac	J. pr. Chem., XXXIV, p. 492. Compt. Rend., XX, p. 808; Ann. de Chim., XIV, p. 252; Arch. de l' Elec., V, p. 5; J. de Phar., VII, p. 450.	Action of dilute acids on iodide of potassium. "The production and nature of Ozone." Criticism on Schönbein's theory of the elementary nature of Ozone and the compound nature of nitrogen. Shows that nitrogen is not concerned in the production of Ozone
	De la Rive and Marignac	Compt. Rend., XX, p. 1291.	Ozone produced by electric sparks from perfectly pure and dry oxygen.
	Williamson	Chem. Soc. Mem., II, p. 395; Liebig, Ann., LIV, p. 127; Phil. Mag., XXVII, p. 372; Compt. Rend., March.	Researches on Ozone. Its solubility in water. Supposes the ozone obtained by electrolysis and from phosphorus are different.
	Fischer	J. pr. Chem., XXXIV, p. 186.	Upon the property of various gaseous and vaporous bodies to polarize metals, and to bring about decomposition in potassium iodide. etc.
	Dulk	J. pr. Chem., XXXIV, p. 344.	Criticism on Schönbein's paper, "Some notes upon Potassium Iodide."
	Fischer	J. pr. Chem., XXXV, p. 342.	Upon the luminosity of Phosphorus: a consequence of oxidation.
	Schönbein	J. pr. Chem., XXXVI, p. 379.	Upon the luminosity of phosphorus. Reply to Fischer: connects it with the development of Ozone.
1846	Schönbein	Phil. Mag., XXVIII, p. 432; Pogg., Ann., LXVII, pp. 78 and 225.	The nature of Ozone, its similarity to hyponitric acid.
	"	J. pr. Chem., XXXVII, p. 129.	Some effects of Ozone and hydrogen dioxide compared.
	"	J. pr. Chem., XXXVIII, p. 59.	Remarks on Marignac's & De la Rive's experiments.
	"	Pogg., Ann., LXVII, p. 83.	Peculiar preparation of ferricyanide of potassium by means of Ozone.
	"	Pogg., Ann., LXVII, p. 89.	Ozone as an oxidizing agent.
	"	Basel, Bericht., VII, p. 23; Pogg., Ann., LXVIII, p. 42.	Behavior of Ozone to chlorine, bromine, iodine, and nitrous acid.

1846	Schönbein	J. pr. Chem., XXXVIII, p. 90.	Chemical Contributions. Formation of ferric phosphate in presence of Ozone.
	"	Stockholm, Ofersigt, III, p. 93.	Properties of Ozone.
	Marignac	Walker's Elec. Mag., II, p. 56.	Some properties of Ozone.
	Fischer	J. pr. Chem., XXXIX, p. 48.	Upon the luminosity of phosphorus. Thinks a compound of phosphoric and phosphorous acid is formed containing nitrogen.
	Williamson	Majocchi, Ann. Fis. Chim., XXI, p. 120.	Researches on Ozone.
	T. Sterry Hunt	Amer. J. Sci., II, p. 103.	On the substance called Ozone.
	Schönbein	Pogg., Ann., LXVII, pp. 78-99.	Different properties of Ozone.
	Marchand	Pogg., Ann., LXVII, p. 143.	Confirms De la Rive's experiments of making Ozone from oxygen. Also obtained from perfectly dry oxygen in contact with phosphorus.
1847	Schönbein	Basel, Bericht., VII, p. 4.	Behavior of Ozone to olefiant gas, to guaiacum and to nitrous acid.
	"	Brit. Ass. Rep., II, 57.	Peculiar formation of permanganic acid.
	"	J. pr. Chem., XLI, p. 225; Schweiz. Gesel. Verhandl., p. 68.	Various reactions of Ozone on peroxides.
	"	Pogg., Ann., LXXI, p. 517.	Various chemical conditions of oxygen.
	"	Pogg., Ann., LXXII, p. 466.	Ozone as a reagent for manganese.
	"	Pogg., Ann., LXXII, p. 450; Schweiz. Gesel. Verhandl., p. 73.	Action of Ozone, chlorine, and bromine on lead and manganese salts.
	"	Pogg., Ann., LXXVII, pp. 459, 462; Schweiz. Gesel. Verhandl., p. 81.	Peculiar formation of manganic acid, and new experiments on Ozone in the atmosphere.
	"	Pogg., Ann., LXXII, p. 457; Schweiz. Gesel. Verhandl. p. 89; Liebig, Ann., LXIV, p. 231.	Sympathetic ink and the use of manganese salts as reagent for nitrous and sulphurous acids.
	Williamson	Amer. J. Sci., IV, p. 320.	Properties of Ozone.
	Osann	J. de Phar., XI, p. 484.	Researches on Ozone.
		Pogg., Ann., LXXI, p. 458, and LXXII, p. 468.	Preparation of Ozone. Did not succeed in obtaining it by electrolysis.

1847	Schönbein	J. pr. Chem., XLII, p. 383; Phil. Mag., 1847, p. 176.	Letter to Faraday on the action of Ozone on manganese.
		J. pr. Chem., XL, p. 242.	Resumé from Berzelius's Jahresbericht.
	Williamson	Liebig, Ann., LXI, p. 13.	On the Ozone theory. Advises the use of little phosphorus and a slow current in the ozonation of air.
1848	Schönbein	Pogg., Ann., LXXIII, p. 489, and LXXV, p. 351.	Action of Ozone on guaiacum.
	T. Sterry Hunt	Amer. J. Sci., VI, 171.	Hypothesis advanced that Ozone is triatomic oxygen, with reasons drawn from its chemical relationships and physical characters.
	Schönbein	Pogg., Ann., LXXV, p. 361.	Ozone as a means to distinguish between antimony and arsenic stains.
	"	Pogg., Ann., LXXVI, p. 366.	Voluntary bleaching of manganese ink.
	"	Pogg., Ann., LXXV, p. 377.	Has phosphorus a smell?
		Schweiz. Gesel. Verhandl., p. 114; Pogg., Ann., LXXV, p. 367.	Production of Ozone by phosphorus from pure oxygen.
	Osann	Pogg., Ann., LXXV, p. 386.	On Ozone chemical and voltaic. Concentrated zinc sulphate solution is to be preferred as electrolyte for obtaining Ozone.
	Hoppe	Wunderlich's Archives, 1848.	Experiments on animals with ozonized turpentine.
1849	Schönbein	Basel, Bericht., VIII, p. 6.	Different chemical conditions of oxygen.
	"	Basel, Bericht., VIII, p. 8.	Action of Ozone, chlorine and bromine on lead and manganese salts.
	"	Henle and Pfeufer Zeitschrift, VII, p. 185.	Atmospheric Ozone.
	"	Schweiz. Gesel. Verhandl., p. 98; Pogg., Ann., LXXVII, p. 162.	Peroxide of lead compared with Ozone.
	Fischer	Pogg., Ann., LXXVI, p. 158.	Remarks on the production of Ozone from phosphorus.
	Osann	Pogg., Ann., LXXVII, p. 592.	Experiments with Ozone.
	"	Pogg., Ann., LXXVIII, p. 98.	Atomic weight of Ozone.
	Fischer	Pogg., Ann., LXXVI, p. 158.	Formation of Ozone from oxygen.
	Schönbein	Liebig, Ann., LXXII, p. 222.	Attempts to prove that Ozone is a compound of oxygen and hydrogen.

1850	Schönbein	Schweiz. Gesel. Verhandl., p. 126.	Oxidizing power of Ozone.
	"	Bibl. Univ., Arch. XV, p. 89; Schwz. Ges. Verhan. p. 44; J. pr. Chem., LI, p. 267.	Influence of the light on the chemical activity of oxygen.
	"	J. pr. Chem., LI, p. 321; J. de Pharm., XIX, p. 385.	On Ozone.
	"	Schweiz. Gesel. Verhandl., p. 120.	The slow oxidation of ether in the air and oxygen.
	Schwartzbach	Verhandl. der physik. med. Gesellsch. zu Würzburg, VI, p. 322.	Action of Ozone upon animals.
	Osann	J. pr. Chem., L, p. 209.	The nature of Ozone, its density and action.
	Becquerel	Compt. Rend., XXX, p. 13.	Schönbein on Ozone.
1851	Schönbein	J. pr. Chem., LIII, p. 321.	The equivalency of Ozone.
	"	J. pr. Chem., LIII, p. 501, and LV, p. 11; Basel, Bericht., X, p. 30.	Influence of phosphorus on the chemical power of ordinary oxygen.
	"	J. pr. Chem., LIV, p. 65; Basel, Bericht., X, p. 32.	Influence of the noble metals on the chemical power of oxygen.
	"	Phil. Mag., II, p. 32; J. de Pharm., XX, p. 258.	Influence of light and oxidizing substances on oxygen.
	"	Basel, Bericht., IX, p. 10.	The preparation of Ozone in pure oxygen by means of phosphorus.
	"	J. pr. Chem., LVII, p. 135.	Upon the peculiar behavior of ether and some etherial oils.
	"	Basel, Bericht., IX, p. 10.	Oxidation of silver and other noble metals by means of Ozone.
	"	J. pr. Chem., LIII, p. 72.	Decomposition of iodide of potassium in the dry way by Ozone; similarity of the peroxide of lead to Ozone; on nitrification and guaiacum.
	"	J. pr. Chem., LIII, p. 80.	Influence of light and oxidizing substances on the chemical power of oxygen.
	Osann	Pogg., Ann., LXXXII, p. 158.	Ozone in the atmosphere.
	"	Pogg., Ann., LXXXII, p. 531, and LXXXIII, p. 137.	On the nature of Ozone.
	"	Pogg., Ann., LXXXII, p. 537; J. pr. Chem., LIII, p. 51.	On Ozone-oxygen.
	Schönbein	J. pr. Chem., LIII, p. 248.	The atomic weight of Ozone.
1852	Schönbein	Basel, Bericht., X, p. 15.	Some properties of Ozone.

1852	Schönbein	Basel, Bericht., X, p. 50; J. pr. Chem., LV, p. 135.	Excited oxygen in iron oxide and nitrous acid.
	"	J. pr. Chem., LVI, p. 343; Basel, Bericht., X, p. 82. J. pr. Chem., LVI, p. 349.	On the name and nature of Ozone. Quantitative estimation of Ozone.
	"	Polli, Ann. di Chim., XIV, p. 276.	On Ozone.
	Osann	J. pr. Chem., LVII, p. 257; Würzburg Verhandl., II, p. 54.	On Ozone-oxygen.
	"	Würzburg Verhandl., III, p. 234; J. pr. Chem., LVIII, p. 92.	Description of an ozonometer.
	Fremy and Becquerel	J. pr. Chem., LVI, p. 124; Ann. d. Chem. u. Pharm., LXXXIV, p. 204; Ann. de Chim. et Phys. [3 S] XXXV, p. 62; J. de Pharm., XXI, p. 325.	On excited oxygen. Production of Ozone by means of the Ruhmkorff coil. Electro-chemical researches on the properties of electrified bodies.
	Faraday	Proc. R. Inst., Vol. I, 1851—1854, p. 94.	On Schönbein's Ozone.
1853	Schönbein	Neufchatel, Bull. III, p. 216.	Remarks on Ozone.
	Baumert	Breslau, Sches. Gesel. Verhandl. Uebersicht., 24; Ann. de Chim. et Phys., XXXIX, p. 477; J. pr. Chem., LIX, p. 350; J. de Pharm., XXIV, p. 381; Phil. Mag., VI, p. 51; Ann. d. Chem. u. Pharm. LXXXVIII, p. 221; Pogg., Ann., LXXXIX, p. 38.	A new oxide of hydrogen and its relation to Ozone.
	Leblanc	Compt. Rend., XXXVIII, p. 444.	On the electro-chemical decomposition of water.
	Clemens	Henle's Zeitschrift für die Staats arzneikunde, 1853.	Malaria and Ozone.
	Soret	Compt. Rend., XXXVIII, p. 445.	The development of Ozone at low temperature.
	Williamson	J. pr. Chem., LX, p. 254.	The ozonizing of turpentine and citron oils.
	"	J. pr. Chem., LIX, p. 504.	Action of Ozone on lead compounds.
	Fremy and Becquerel	Quar. Jour. Chem. Soc., V, p. 272; Compt. Rend., XXXIV, p. 399; J. de Pharm., XXXI, p. 321.	Electro-chemical researches on oxygen and the so-called principle Ozone. All of a certain volume of oxygen can be converted into Ozone, when a body like potassium iodide solution, moist mercury or silver, is present to absorb the Ozone formed.

1854	Schönbein	Ann. der Pharm., III, pp. 180 and 242; Ann. der Chem. und Pharm., LXXXIX, p. 257.	On Ozone and various conditions of oxygen.
	"		
	Soret	Bibl. Univ., XXV, p. 263; J. pr. Chem., LXXII, p. 40; Pogg. Ann., XCII, p. 304.	Production of Ozone at low temperature.
	Osann	J. pr. Chem., LXI, p. 500.	Active modifications of hydrogen and oxygen.
	"	J. de Pharm., XXVI, p. 68.	Carbon anodes, charged with electrolytic oxygen and immersed in potassium iodide solution, liberate iodine.
	Glaisher	Report on the Meteorology of London during the epidemic of cholera in 1854.	The occurrence of cholera is coincident with the absence or diminution of Ozone.
	Karlinsky	Pogg., Ann., XCIII, p. 627.	Ozone observations in Cracow.
	Schönbein	Pogg., Ann., XCI, p. 625.	First mention of Ozone.
	Baumert	Quar. J. Chem. Soc., VI, p. 169.	A new oxide of hydrogen and its relation to Ozone.
1855	Schönbein	Actes de la Soc. Helvetique, p. 214.	On various conditions of oxygen.
	"	J. pr. Chem., LXVI, p. 286; Basel, Verhandl., I, p. 252.	Ozonized oxygen.
	"	München, Gelehrte Anz., XLI, p. 108; J. pr. Chem., LXVI, p. 280.	Preparation of ozonized oxygen from peroxide of silver.
	"	J. pr. Chem., LXVI, p. 272; München, Gelehrte Anz. Bull., XIV, p. 115.	Behavior of ozonized turpentine oil and ether with antimony and arsenic.
	Houzeau	Compt. Rend., XL, p. 947; J. pr. Chem., LXV, p. 96.	Researches on nascent oxygen.
	"	J. pr. Chem., LXV, p. 499; J. de Pharm., XXVII, p. 413; Pogg., Ann., XCV, p. 484.	Its production from barium dioxide and sulphuric acid. The odorous gas thus obtained, different from the ozone of Schönbein, instantly converting ammonia into nitrate and nitrite, and being decomposed at a lower temperature.
	Wolf	Compt. Rend., XL, p. 419.	On the variations of Ozone in the atmosphere, considered relative to themselves and to the hygienic state of the place of observation.
	"	Compt. Rend., XL, p. 909.	Influence of Ozone on the health of man.
	Bineau	Compt. Rend., XL, p. 702.	Atmospheric Ozone.

1855	Berigny	Compt. Rend., XLI, p. 426.	Meteorological observations with ozone paper.
	Schönbein	J. pr. Chem., LXV, p. 96.	Existence of oxygen in two conditions.
	Osann	J. pr. Chem., LXVI, p. 105; Pogg. Ann., XCVI, p. 498; Würzburg Verhandl. VI.	Characteristics of the oxygen separated from water galvanometrically.
	Andrews	R. Soc. Proc., VII, p. 475.	On the constitution and properties of Ozone.
1856	Meidinger.	Quar. J. Chem. Soc., VII, p. 251.	On Ozone and hydrogen dioxide in the electrolysis of water.
	Robert	Gaz. Méd. de Strasbourg, Nov., 1855.	Relation between Ozone and epidemic of cholera at Neudorf.
	Pettenkoffer	Ueber die Cholera, 1855.	The Ozone does not fall below its summer minimum during epidemics of cholera.
	Schönbein	J. de Pharm., XXIX, p. 316.	Ozone, a means to distinguish between arsenic and antimony stains.
	"	Phil. Mag., XI, p. 137; J. pr. Chem., LXVII, p. 496.	Ozone and ozonic action in mushrooms.
	"	Ann. de Chim., XLVIII, p. 193; Pogg., Ann., XCIX, p. 473.	Ozone contained in acids formed by the slow oxidation of phosphorus in the air.
	Andrews	Phil. Trans., 1856, p. 1; R. Soc. Proc., VII, p. 475; Ann. de Chim., XLVII, p. 181; J. de Pharm., XXX, p. 3; Ann. der Chem. u. Pharm., XCVII, p. 371; Pogg., Ann., XCVIII, p. 435.	"Constitution and properties of Ozone." Ozone obtained by electrolysis does not contain hydrogen. It is identical in weight with the active oxygen present, and does not yield water on heating. Properties of Ozone the same from whatever sources derived.
	Baumert	Pogg., Ann., XCIX, p. 88.	The Ozone question. Reply to Andrews.
	Cloëz	Compt. Rend., XLIII, p. 38; Bull. Soc. Chim., [2] 3, 86; Ann. de Chim., L, p. 80.	Iodide of potassium as a reagent for Ozone. The presence of vapors of nitrous and nitric acids, etherial oils, and in moist air the light as well, can bring about the bluing of Ozone papers.
	Houzeau	Compt. Rend., XLIII, p. 34.	"Researches on nascent oxygen." It is identical with Ozone. Circumstances affecting production of Ozone by electrolysis.

1856	Houzeau	J. de Pharm., XXX, p. 342; Pogg., Ann., XCIX, p. 156.	Proves that Ozone is not a compound of oxygen with hydrogen, or with nitrogen.
	Osann	Pogg., Ann., XCVIII, p. 181.	On Ozone hydrogen.
	Dumas	Compt. Rend., XLIII, p. 38.	Remarks on Houzeau's article.
	Scoutetten	Compt. Rend., XLIII, pp. 93, 216, and 450.	Formation and sources of atmospheric Ozone.
	Brame	L'Institut, 1856, 282.	Plants as well as water furnish Ozone during day; not during night.
	Bineau, Cloez, and Scoutetten	Compt. Rend., XLIII, pp. 162, 762, and 863.	Remarks on Scoutetten's preceding article.
	Billiard	Compt. Rend., XLII, p. 885.	Source of organic Ozone.
	Scoutetten	Compt. Rend., XLII, pp. 941, 943.	Source of Ozone in the atmosphere.
	Wolf	Compt. Rend., XLII, p. 944.	Influence of Ozone on health.
	Berigny	Compt. Rend., XLII, p. 1115.	Observations at St. Cloud.
	Luca	Compt. Rend., XLIII, p. 865.	Oxygen given out by plants is ozoniferous.
	Andrews	J. pr. Chem., LXVII, p. 494	Composition of Ozone.
	Hiss	Virchow's Ann. der Phys. und Anatom., 1856, p. 348.	Relations of the Blood to active Oxygen.
	Campani	Cimento, IV, p. 112.	Influence of various bodies upon potassium iodide papers.
	Van der Willigen	Pogg., Ann., XCVIII, p. 511; Ann. de Chim., L, p. 126; Amsterdam, Verslag. Akad. IV, p. 280.	Formation of Ozone at positive pole of a platinum wire, rendered red-hot in an electric current.
	Bunsen	Quar. J. Chem. Soc., VIII, p. 232.	Volumetric estimation of Ozone.
1857	Schönbein	Basel, Verhandl., I, pp. 237, 246 and 252.	Behavior of ozonized ether and turpentine oil with antimony and arsenic, Ozone from dioxide of silver and ozonized oxygen.
	"	Basel, Verhandl., I, p. 3.	The excitation of oxygen by ferrous salts.
	"	Basel, Verhandl., I, p. 339.	Ozone in the vegetable kingdom.
	"	Basel, Verhandl., I, p. 355.	Influence of heat on the chemical activity of oxygen.
	"	München, Nat. Tech. Comm. Abhl., I, p. 173.	Relation of Ozone to practical chemistry.
	Andrews and Tait	R. Soc. Proc., VIII, p. 498; Ann. de Chim., LII, p. 333; Ann. der Chem. u. Pharm., CIV, p. 128; Chem. Gaz., p. 319; Pogg. Ann., CII, p. 625.	Density of Ozone.
	Baumert	Ann. der. Chem. u. Pharm., CI, p. 88.	Ozone developed by electricity.

1857 Houzeau	J. pr. Chem., LXX, p. 340; Compt. Rend., XLV, p. 873.	"Analytical method to detect and estimate nascent oxygen." Absorption by acid solution of potassium iodide, elimination of the iodine set free, and estimation of the potash produced.
Osann	J. pr. Chem., LXXI, p. 355; Würzburg, Verhandl., VII, p. 171.	Ozone-hydrogen.
Berigny	Compt. Rend., XLIV, p. 1104.	Researches on ozonometric papers.
Billiard	Compt. Rend., XLV, p. 1100.	Relation of Ozone to cholera.
Baumert	J. pr. Chem., LXX, p. 446.	Active oxygen.
Cloez	J. pr. Chem., LXX, p. 319; Ann. de Chim. et Phys., May, 1857.	Iodide of potassium as reagent for Ozone. Denies that oxygen evolved by plants in sunlight contains Ozone.
Erdmann	J. pr. Chem. XXI, p. 209.	Preparation of Isatin by the action of Ozone on the sulphate of indigo.
W. Siemens	Pogg., Ann., CII, p. 120.	An Ozonizer. Two glass tubes with an annular space between, and their inner and outer surfaces oppositely electrified.
—	Greenwich Observations, pp. CLXVI—CCX.	Influence of the sun's hour-angle on the production of Ozone.
Schönbein	Pogg., Ann., C, p. 4.	Various experiments with Ozone, its density, specific heat, &c., &c.
"	Pogg., Ann. C, p. 292.	Capability of ordinary oxygen to change nitrous to nitric acid.
"	J. pr. Chem., LXX, p. 129.	"A peculiar mode of preparing Nitrous Acid." Not only Ozone but platinum-sponge, agitated with oxygen, causes the oxidation of ammonia.
Neumann	J. pr. Chem., CII, p. 614.	Relation of atmospheric Ozone to pressure and electricity.
Baumert	Ann. der Chem. u. Pharm., CI, p. 88.	Review of Andrews' article on the composition of Ozone.
Andrews	Quar. J., Chem. Soc., IX, p. 168.	Constitution of Ozone.
Schönbein	J. pr. Chem., LXXV, p. 88.	Formation of peroxide of lead from the acetate by means of hydrogen dioxide or Ozone.

1858		Phil. Mag., XV, p. 24; XVI, p. 178.	Various conditions of oxygen.
	W. B. Rogers	Edinburgh New Philosophical Journal, January.	On Ozone observations. Does not think the oxygen evolved by growing plants is ozonized.
	Andrews & Tait	R. Soc. Proc., IX, p. 606.	Density of Ozone.
	Clausius	Pogg., Ann., CIII, p. 644; Bibl. Univ. Arch., II, p. 150; Phil. Mag., XVI, p. 45.	On the nature of Ozone.
	Houzeau	J. de Pharm., XXX, p. 115.	Method to discover nascent oxygen.
	"	Compt. Rend., XLV, p. 89; J. pr. Chem., LXXV, p. 110.	Proof of the presence of Ozone in the atmosphere.
	Houzeau and Zantedeschi	Firenze, Il Tempo, I, p. 181.	Scientific value of ozonometric observations.
	Osann	Würzburg, Verhandl., VIII, p. 180.	Ozone-hydrogen.
	Becquerel	Compt. Rend., XLVI, p. 670.	Report of a commission on Houzeau's communications on Ozone.
	Berigny	Compt. Rend., XLVI, p. 237.	On ozonometry.
	Billiard	Compt. Rend., XLVI, p. 98.	Relation of Ozone to hygiene.
	"	Compt. Rend., XLVI, p. 138.	The oxygen secreted by plants is not from Ozone.
	Berigny	Compt. Rend., XLVII, p. 947.	Ozonometrical observations in camp in the Crimea.
	Regnault	Compt. Rend., XLVI, p. 673.	On the term "Ozone."
	Schönbein	Pogg. Ann., CV, p. 258.	Researches on oxygen.
	"	J. pr. Chem., LXXIV, p. 329; Ann. der Pharm., CII, p. 129.	Oxidations occurring in the air due to the ozonization of oxygen.
	Tripe	Report of Council of Eng. Meteorological Society, 1858, pp. 7 and 36.	Air is deprived of Ozone by passing over densely populated towns.
1859	Schönbein	Amer. J. Sci., XXVII, p. 19.	Various conditions of oxygen.
	"	München, Gelehrte Anz., XLVIII, p. 73; J. pr. Chem., LXXVII, p. 257;	Chemical condition of the removable oxygen in ozonized turpentine oil.
	"	Pogg., Ann., CVI, p. 307. München, Gelehrte, Anz., XLVIII, p. 563; J. pr. Chem., LXXVII, p. 271.	Nascent oxygen.
	R. B. Smythe	Austral. Med. Jour., IV, p. 1.	Observations on Ozone.
	Gorup-Besanez	Ann. der Chem. u. Pharm., CX, p. 86; Erlangen, Mitt. Phys. Med. Soc., I, p. 13; J. de Pharm., XXXI, p. 65.	Action of Ozone on various organic compounds, as urea, uric acid, albumen, &c.
	Andrews & Tait	R. Soc. Proc., X, p. 427; Ann. der Chem. u. Pharm., CXII, p. 185.	The volumetric relations of Ozone.
	"	Ann. de Chim., LVI, p. 333.	Density of Ozone.
	Schafhäütl	J. pr. Chem., LXXVI, p. 129.	Upon the Wölsendorf Fluor Spar—cause of its odor.

1859	Houzeati	J. pr. Chem., LXXVI, p. 164	Method of discovering nascent oxygen.
	Osann	J. pr. Chem., LXXVI, p. 435, and LXXVIII, p. 93; Würzburg Verhandl., IX, p. 182.	Ozone-oxygen and ozone-hydrogen.
		Würzburg Verhandl., p. 197; Pogg., Ann., CVI, p. 326.	Reply to Magnus in regard to the preceding.
	Bérigny	Compt. Rend., XLIX, p. 391.	Ozonometric observations during the Aurora Borealis.
	Schönbein	Pogg., Ann., CVIII, p. 472.	Polarization of neutral oxygen by the slow oxidation of phosphorus and of ether.
	Löwenthal	J. pr. Chem., LXXIX, p. 473.	Change of inactive to active oxygen.
	Smith	Quar. J. Chem. Soc., XI, p. 208.	Absence of Ozone in the neighborhood of large towns.
1860	Schönbein	Basel, Verhandl., II, p. 139.	Chemical condition of the removable oxygen in ozonized turpentine oil.
	"	Basel, Verhandl., II, p. 155.	Nascent oxygen.
	"	München Gelehrte Anz., L, p. 446; J. pr. Chem., LXXX, p. 275.	Active positive oxygen.
	"	J. pr. Chem., LXXXI, p. 1.	Continuation of the contributions to a knowledge of oxygen.
	"	Basel, Verhandl., II, p. 9.	Formation of the peroxide of lead from the acetate by means of hydrogen dioxide or Ozone.
	Andrews and Tait	J. de Pharm. [1860], p. 161; J. Chem. Soc., XIII, p. 344; R. Soc. Proc., X, p. 427; Phil. Trans., p. 113.	Density of Ozone. Volumetric relations of Ozone.
	Weltzien	Ann. der Pharm., CXV, p. 121.	Polarization of oxygen: Ozonides and Antozonides.
	Houzeau	Pogg., Ann., CIX, p. 180.	Method of discovering nascent oxygen.
	"	Compt. Rend., L, p. 829; J. pr. Chem., LXXXI, p. 117.	Absence of free Ozone in terebenthine oxide.
	Schrötter	Pogg., Ann., CXI, p. 561.	Upon the occurrence of Ozone in the Mineral Kingdom.
	Osann	Pogg., Ann., CXI, p. 20; Würzburg Verhandl., X, p. 111; Würzburg Naturw. Zeitschr., I, p. 241.	Ozone-oxygen and ozone-hydrogen.
		Würzburg, Verhandl., X, p. 3.	Reply to Magnus.

1860	Gorup-Besanez	Chem. News, I, p. 38.	Action of Ozone on some organic substances.
	Andrews	Chem. News, I, p. 222.	Density of Ozone.
	Schrötter	Sitzung. der Acad. zu Wien, XII; Chem. News, II, p. 298.	Ozone in the Wölsendorf fluorspar.
	Lowe	R. Soc. Proc., X, p. 531.	A new Ozone box.
	Le Roux	Compt. Rend., L, p. 691.	Production of Ozone by a platinum wire rendered incandescent in the electric current.
	Bérigny	Compt. Rend., LI, p. 643.	Ozonometrical observations.
	Riche	Bull. Soc. Chim, 1860, 178.	Ozoniferous oxygen obtained by the action of concentrated sulphuric acid upon hydrogen peroxide.
	Mitchell	Edinburgh New Phil. Jour. [N. S], July, 1860.	"Remarks on Ozone." Bleaching of altered ozonoscopes independent of light and moisture
1861	Odling	Manual of Chemistry (publ. 1861), p. 94.	Phenomena consequent upon the contraction of oxygen in its conversion into ozone, explained upon the hypothesis that ozone is triatomic oxygen.
	St. Edme	Compt. Rend., LII, p. 408.	No ozone, but one of the higher oxides of nitrogen, formed at positive pole of a platinum wire ignited in electric current.
	Schönbein	J. pr. Chem., LXXXII, p. 231.	Behavior of oxygen to ammonia agitated in contact with oxides.
	"	München, Sitzungsbericht, p. 22; J. pr. Chem., LXXXII, p. 86.	Positive active Ozone.
	"	J. pr. Chem., LXXXIV, p. 193.	Chem. Contributions.—Behavior of the three modifications of oxygen to the nitrites.
	"	München, Sitzungsbericht, p. 546; Pogg., Ann., CXII, p. 281.	Behavior of Ozone, Antozone, and oxygen, with the nitrates.
	"	Phil. Mag., XXI, p. 88.	Insulation of Antozone.
	"	Presse Scient., II, p. 244.	Memoir on oxygen and Ozone.
	Gorup-Besanez	Ann. der Chem. u. Pharm., CXVIII, p. 232.	Action of Ozone on organic substances.
	Andrews	Pogg., Ann., CXII, p. 249.	Volumetric relations of Ozone.
	Houzeau	Ann de Chim., LXII, p. 129.	Researches on nascent oxygen.

1861	Osann	Chem. News, IV, p. 74.	Ozone-hydrogen.
	T. S. Hunt	Amer. J. Sci., XXXII, p. 109; Chem. News, IV, p. 193	Ozone, nitrous acid, and nitrogen.
	Eöttger	Chem. News, IV, p. 69; J. pr. Chem., LXXXVI, p. 377; Zeitschr. f. Chem. u. Phys., III, p. 718.	Ozone from sulphuric acid and permanganate of potash.
	Moffat	Chem. News, IV, p. 166.	Atmospheric Ozone.
	Gorup-Besanez	Chem. News, V, p. 110.	The removal of stains from engravings by means of Ozone.
	Andrews & Tait	Quar. J. Chem. Soc., XIII, p. 344.	Volumetric relations of Ozone.
	Sylvestri	Compt. Rend., LIII, p. 247; Pisa, Ann. Univ. Tosc. Cosm., V, p. 147.	Ozone observations of Pisa.
	Sauvage	Compt. Rend., LIII, p. 544.	Ozone a simple element.
1862	Schönbein	Basel, Verhandl., III, p. 155. München, Sitzungsbericht, p. 166; J. pr. Chem., LXXXVIII, p. 65.	Positive active oxygen. Allotropic condition of oxygen.
		J. pr. Chem., LXXXVI, p. 70; München, Sitzungsbericht, p. 171; Chem. News, V, p. 350; Phil. Mag., XIV.	Chemical preparation of Ozone.
	Moffat	Proc Meteor. Soc., June 18, 1862.	When ozone is most prevalent, phosphorus is most luminous, and <i>vice versa</i> .
	Heldt	Chem. Centr., 1862, pp. 695, 886.	Action of various bodies upon potassium iodide papers.
	Pfaff	Henle's Zeitschrift für die Staatsarzneikunde, 1862. No. 2.	Much atmospheric ozone unfavorable to diseases of the respiratory organs.
	von Babo	Freiburg, Ber., II, p. 331.	An apparatus to make Ozone,
	Lowe	Chem. News, VI, p. 186.	An Ozone-box.
	Böttger	Pogg., Ann., CXVII, p. 188; J. pr. Chem., LXXXVI, p. 377; Zeitsch. für Chem. und Pharm., III, p. 718.	Formation of Ozone from sulphuric acid and permanganate of potash.
	Lichtenstein	Compt. Rend., LIV, p. 1198.	Direct application of Ozone in medicine.
	Kosman	Compt. Rend., LV, p. 731.	Researches on Ozone given off by plants.
1863	Schönbein	J. pr. Chem., LXXXIV, p. 196; Basel, Verhandl., III, p. 196.	Behavior of Ozone and Antozone with the nitrates.
	"	Basel, Verhandl., III, p. 299.	Allotropic condition of oxygen.
	"	Basel, Verhandl., III, p. 305.	Chemical preparation of Ozone by means of $H_2SO_4 + KMO_4 + BaO_2$.

- | | | |
|-------------------------|--|--|
| 1863 Schönbein | Basel, Verhandl., III, p. 317; München, Sitzungsbericht, p. 181; J. pr. Chem., LXXXVI, p. 80; Phil. Mag., XXIII, p. 466. | Change of the allotropic condition of oxygen. |
| “ | München, Sitzungsbericht, p. 274; Basel, Verhandl., III, p. 408; J. pr. Chem., LXXXIX, p. 323. | Antozone in the Wölsendorf fluorspar. |
| Tyndall | “On Heat,” etc., London, 1863, p. 333. | Electrolytic oxygen has 136 times the capacity for absorption of the dark heat-rays, as ordinary oxygen. |
| Soret | Compt. Rend., LVI, p. 390; Bibl. Univ. Arch., XVI, p. 208; J. pr. Chem., XC, p. 216; Heidelberg, Verhandl. Nat. Med., III, p. 20; Ann. der Chem. u. Pharm., CXXVII, p. 38; Pogg., Ann., CXVIII, p. 623; Roma, Atti, XVI, p. 638. | Production of Ozone by electricity, and the nature of that body. |
| “ | Phil. Mag., XXV, p. 208; Chem. News, VII, p. 248. | Experiments on Ozone. Best methods of obtaining it by electrolysis. So prepared, it contains no hydrogen. |
| Lawes, Gilbert and Pugh | Jour. Chem. Soc., 1863, p. 100. | “On the Sources of the Nitrogen of Vegetation, etc.” Ozone near vegetation due to action of oxygen of the air upon hydrocarbons evolved by the plants, and not to any action within the cells. |
| Soret | Compt. Rend., LVII, p. 604; Chem. News, VIII, p. 191; Bibl. Univ. Arch., XVIII, p. 65; Heidelberg, Verhandl. Nat. Med., III, p. 82. | Volumetric relations of Ozone. |
| Meissner | Unters. über d. Sauerst., Hannover, 1863. | Water in contact with ozone acquires its properties. |
| Gorup-Besanez | Ann. der Pharm., CXXV, p. 207; Chem. News, VIII, p. 222. | Action of Ozone on some organic substances. |
| Morin | Compt. Rend., No. 18, 1863. | Pulverization of water always accompanied by development of ozone. |
| von Babo | Ann. der Pharm., Suppl., II, p. 265. | “Contributions to a knowledge of Ozone.” Influence of temperature, |

1863			pressure, electrical intensity. Contraction of volume. Maximum of ozonation.
	von Babo and Claus	Ann. der Chem. u. Pharm., Suppl. II, p. 297.	"Volumetric relations of Ozone." The amount of contraction is equal to the volume of oxygen corresponding to the iodine liberated from potassium iodide solution.
	Clausius	Zürich, Vierteljahrs., VIII, p. 345.	Difference between active and ordinary oxygen.
	Atkinson	Proc. Meteorological Soc., January, 1863.	Effect of light on ozonoscopes.
	Houzeau	Ann. de Chim., LXXVII, p. 466.	Method of determining nascent oxygen.
	Ireland	Chem. News, VII, p. 118 ; Edinburg, Med. Jour., VIII, p. 729.	Action of ozonized air on animals.
	De Luna	Chem. News, VIII, p. 39 ; Ann. de Chim. et Phys., [1863] p. 182.	Production of Ozone. States that hydrogen gas decolorizes ozonoscopes.
	Lawes et al.	Quar. J. Chem. Soc., I (N. S.), pp. 144 and 153.	Promotion of the formation of nitrogenous compounds in plants by Ozone.
	Lowe	R. Soc. Proc., XII, p 518.	Precautions in Ozone observations.
	Poey	Compt. Rend., LVII, p. 344.	Giving off of Ozone by plants.
	Bérigny	Compt. Rend., LVII, p. 846.	Influence of moisture on Ozone in air.
	Kosman	Compt. Rend., LVII, p. 979.	Researches on the relative quantity of Ozone in plants and atmosphere.
1864	Begeman	Arch. Pharm., CXIII, p. 1.	Action of various bodies on ozonoscopes.
	Meissner	Quar. J. of Science, IV, p. 670.	Ozone and Antozone; reply to von Babo.
	Kaiser	Brit. J. of Photography, 1864, p. 392.	Ozone said to possess the property of converting the insensitive variety of iodide of silver into one that is highly sensitive to light.
	M. Carey Lea	Amer. J. Sci. [2] XXXVII ; Quar. J. Science, III, pp. 509-523.	"On the influence of Ozone and some other Chemical Agents on germination and vegetation." Effects of respiring.

1864 M. Carey Lea	Quar. J. Science, I, p. 116.	Ozone from evaporation.
"	Quar. J. Science, I, p. 531.	Generation of Ozone from leaves of plants.
"	Quar. J. Science, I, p. 263.	Researches on Ozone.
Soret	Pogg, Ann., CXXI, p. 268.	On the volumetric deportment of Ozone.
Clausius	Compt. Rend., LVIII, p. 283.	Difference between ordinary and active oxygen.
Saintpierre	Compt. Rend., LVIII, p. 420.	Production of Ozone by the mechanical action of ventilation apparatus.
1865 Bérigny	Chem. News, XI, p. 224; Compt. Rend., LX, p. 903.	Ozonometrical observations during a period of nine years.
"	Compt. Rend., LXI, p. 937.	Ozonometrical observations.
—	Quar. J. Chem. Soc., [1865] p. 277.	Ozone researches.
Soret	Compt. Rend., LXI, p. 941; Chem. News, XII, p. 275.	Researches on the density of Ozone.
Jean	Compt. Rend., LXI, p. 995; Chem. News, XII, p. 288.	Preparation of Ozone. Decomposition of carbonic acid into carbonic oxide and Ozone, by electricity.
Houzeau	Chem. News, XIII, p. 5; Compt. Rend., LXI, p. 1113.	Remarks on atmospheric Ozone.
St. Claire-Deville	Compt. Rend., LXI, p. 1115.	Remarks on atmospheric Ozone.
Poey	Compt. Rend., LXI, p. 1107.	Ozonograph.
Fremy	Compt. Rend., LXI, p. 939.	Uncertainty of atmospheric ozonometry.
Schönbein	J. pr. Chem., XCIII, p. 25.	On Ozone and antozone.
"	J. pr. Chem., XCIII, p. 45.	Action on Pb and PbO.
"	J. pr. Chem., XCII, p. 154.	Ozone in contact with urine.
"	J. pr. Chem., XCIII, pp. 65 and 53.	Action of Ozone on cobalt and its hydrate: on nickel.
"	J. pr. Chem., XCIII, pp. 24, 25 and 35.	Formation of Ozone by slow oxidation of phosphorus and of turpentine oil in presence of Antozone.
"	J. pr. Chem., XCIII, p. 459.	Action of Ozone on photocyamin.
"	J. pr. Chem., XCII, p. 146.	Ozone in contact with H ₂ S.
"	J. pr. Chem., XCII, p. 165.	Formation of Ozone in urine.
Bérigny	Compt. Rend., May 1, 1865.	Ozone observations at Versailles Observatory for 1864.

1865	Osann	J. pr. Chem., XCII, pp. 20, 210 and 30.	Ozone - hydrogen and structure of Ozone.
	Soret	Ann. de Chim. et Phys., [4 S.] IV, p. 197, and VI, p. 235.	Density of Ozone and its mechanical energy.
	Andrews	Ann. de Chim. et Phys., [4 S.] VI, p. 245.	Influence of the seasons on the quantity of Ozone in the atmosphere.
	"	Ann. de Chim. et Phys., [4 S.] VI, p. 247.	Relation of Ozone in the atmosphere to the barometric height.
	St. Claire-Deville	Compt. Rend., LX, p. 909.	Remarks on atmospheric Ozone.
	Richardson	Chem. News, XII, p. 181; Brit. Assoc. Report, 1865.	Physiological experiments with Ozone. Its existence in the atmosphere discussed.
	Boeckel	Ann. de Chim. et de Phys., [3], VI, 235.	Ozone as an element in meteorology. The ozone-percentage of the air is greatest in spring.
	Moffat	Lancet, September 9, 1865.	Cholera is accompanied by a minimum quantity or complete absence of Ozone.
	Seitz	Catarrh and Influenza, 1865.	No relation observed during the cholera epidemic of 1854 in Munich, between it and the amount of Ozone.
1866	St. Edme	J. pr. Chem., XCIV, p. 507.	Production of Ozone by means of electricity.
	Lea	J. pr. Chem., XCV, p. 312.	Action of Ozone on the iodide and bromide of silver.
	Woods	J. pr. Chem., XCV, p. 311.	The action of Ozone on NO.
	Boussingault	J. pr. Chem., XCIV, p. 336.	Production of Ozone from phosphorus.
	Schönbein	J. pr. Chem., XCV, pp. 470 and 469; and XCIII, p. 36.	Action of Ozone on thallium and its oxide, and the influence of water on the chemical action of Ozone.
	"	Ann. de Chim. et Phys., [4 S.] VII, p. 103, and VIII, p. 465.	Action of platinum, iridium, and rhodium on ozonized oxygen,
	"	Ann. de Chim. et Phys., [4 S.] VII, p. 462; J. pr. Chem., XCV, p. 285.	Action of Ozone on cyanine.
	Gentele	J. pr. Chem., XCVI, p. 306.	Chemical structure of Ozone.
	Soret	Ann. de Chim. et Phys., [4 S.] VII, p. 113.	Density of Ozone.
	"	Ann. der Chem. u. Pharm., CXXXVIII, p. 45.	Volumetric relations of Ozone and its density.

1866 v Babo & Claus	Ann. der Chem. u. Pharm., CXL, p. 248.	Researches on the constitution of Ozone.
Daubeny	Paper read at meeting of English Chemical Society, Nov. 15, 1866.	At Torquay, ozonoscopes were most affected during S. W., W. and S. winds; least with N. winds.
"	Brit. Ass. Rep., 1866.	Atmospheric ozone due to the green parts of plants; but flowers do not generate ozone.
Houzeau	Compt. Rend., February 26, 1866.	Relation between the chemical activity of the air and certain atmospheric perturbations.
Böttger	J. pr. Chem., XCV, p. 311.	Recommended thallose oxide papers as ozonoscopes, since they were not affected by nitrous acid.
Weltzien	Compt. Rend., LXXII, pp. 640 and 757; Ann. der Chem. u. Pharm., CXXXVIII, p. 162; Chem. News, XIII, pp. 159 and 355.	Researches on Ozone and peroxide of hydrogen. Nitrogen and Ozone.
Montani	Compt. Rend., LXII, p. 538.	Ozone observations at Constantinople during the cholera.
Laborde	Compt. Rend., LXII, p. 307.	Diminution of Ozone during epidemics showing want of electricity.
Planté	Compt. Rend., LXIII, p. 181.	On the production of Ozone. Lead electrodes yield more ozone by electrolysis than those of platinum.
Hermay	Compt. Rend., LXIII, p. 645.	Study of Ozone in its relation to cholera.
Osann	J. pr. Chem., XCV, p. 55; Chem. News, XIII, p. 109.	On Antozone.
Poey	Chem. News, XIII, p. 5.	Ozonograph.
1867 Smythe	Compt. Rend., LXIV, p. 724.	Significance of atmospheric indications of Ozone.
Soret	Compt. Rend., LXIV., p. 904; Pogg., Ann., CXXXII, p. 165; Chem. News, XVI, 49.	Density of Ozone.
Poey	Compt. Rend., LXV, p. 708; Chem. News, XVI, p. 312.	Remarks on ozonoscopic observations.
Verrier	Compt. Rend., LXV, p. 711.	Remarks on the preceding.
Chevreur	Compt. Rend., LXV, p. 712.	Remarks on the preceding.
Bérigny	Compt. Rend., LXV, p. 982.	Reply to Poey.
Cossa	Chem. News, XVI, p. 37; Zeitsch. f. anal. Chem., VI, p. 24.	Ozonometry.

1867	W. F. Moffat	Brit. Ass. Report, 1867.	Amount of Ozone in different degrees of latitude and longitude at sea.
	Schönbein	J. pr. Chem., XCVIII, pp. 269 and 288.	Production of Ozone from camphene and by slow evaporation. Production of the same from phosphorus.
	"	J. pr. Chem., XCVIII, p. 83.	Action of Ozone on platinum black.
	"	J. pr. Chem., XCVIII, p. 71.	Hydrogen peroxide on the test paper for Ozone.
	Schmid	J. pr. Chem., XCVIII, p. 416.	Production of Ozone from phosphorus.
	Houzeau	Ann. de Chim. et Phys., 4 S., XII, p. 60.	Oxidation of thallium test paper.
	Weltzien	Ann. der Chem. u. Pharm., CXLII, p. 107.	Influence of pressure on the formation of Ozone. Bichromate of potash and sulphuric acid yield ozoniferous oxygen.
	Soret	Ann. der Chem. u. Pharm., Suppl. V, p. 148.	Density of Ozone.
	—	Quar. J. Science for 1867, p. 552.	Protoxide of thallium as test for Ozone.
	—	Quar. J. Science for 1867, p. 392.	Density of Ozone.
	Andrews	Pogg. Ann., CXXXI, p. 659.	The Ozone in the atmosphere.
	Hoffman	Pogg. Ann., CXXXII, p. 607.	Amounts of Ozone and antozone given off by the electrolysis of water.
	Daubeny	J. Chem. Soc. [2], V.	Influence of light on ozonoscopes.
1868	Schönbein	J. pr. Chem., C, p. 474.	Formation of Ozone from camphene.
	"	J. pr. Chem., CII, p. 154.	Action of Ozone on guaiaca resin, quinone, olefiant gas, and other organic substances.
	"	J. pr. Chem., C, p. 472.	Formation of Ozone from turpentine oil in presence of antozone.
	"	Ann. de Chim. et Phys., XIII, pp. 57 and 475.	Atmospheric Ozone.
	Andrews	Ann. de Chim. et Phys., XIII, p. 474; Ann. der Chem. u. Pharm., Suppl. VI, p. 125.	Identity of the body in the atmosphere that reacts on the starch papers, with Ozone.
	Wyrobouff	J. pr. Chem., C, p. 59.	Non-occurrence of Ozone in fluorspar.
	Soret	Ann. de Chim. et Phys., XIII, p. 257.	Determination of the density of Ozone by diffusion.
	Houzeau	Ann. de Chim. et Phys., XIV, p. 30.	H ₂ O ₂ not the cause of the turning of test paper in the atmosphere.

1868	Houzeau	Compt. Rend., LXVI, p. 1329.	Action of ether in contact with iodide of potassium.
	Denza	Compt. Rend., LXVI, p. 105; Chem. News, XVII, p. 70.	Power of electricity and Ozone during cholera.
	Blondlot	Compt. Rend., LXVI, p. 351.	Ozone and phosphoric acid produced by the slow combustion of phosphorus. Recommends temperature of 12° to 13°.
	Houzeau	Compt. Rend., LXVII., pp. 44, 314, and 491.	Method of collecting and examining small quantities of H ₂ O ₂ . Presence of Ozone in air.
	"	Compt. Rend., LXVII, p. 714.	Action of sulphuric acid on iodide of potassium.
	Sauvage	Compt. Rend., LXVII, p. 633.	The same.
	"	Compt. Rend., LXVII, p. 1138.	Reply to Houzeau.
	L'Hote and St. Edme	Compt. Rend., LXVII, p. 620.	Production of Ozone in air and oxygen influenced by the "spark of condensation" of an induction coil.
	Lippincott	Chem. News, XVII, p. 48.	Agreement between the iodized starch tests and those of moistened silver leaf.
	Andrews	Chem. News, XVII, p. 32.	Identity of the atmospheric body decomposing potassium iodide with Ozone.
	F. Wohler	Göttinger Nach. (1868), 139; Chem. News, XVIII, p. 189.	Formation of silver peroxide by Ozone in electrolysis.
	Hollman	Arch. neerland. des sciences ex. et nat., 3, 260.	1 gram. Ozone evolves 355.5 heat-units in its conversion into ordinary oxygen.
	Klebs	Bern. naturf. Verh., 1868, 13.	Many of the fluids of the human body are ozoniferous.
	—	Bulletin de Statistique Municipale, February, 1878.	Daily observations of ozone in Paris, 1866 and 1867.
	Jevons	Chem. News, XVIII, p. 245; Manchester, Lit and Phil. Soc., III, p. 11.	Remarks on Baxendell's laws of atmospheric Ozone.
1869	De la Sagro	Compt. Rend., LXVIII, p. 100.	The condensator as producer of Ozone.
	"	Zetsch. f. anal. Chem., VIII, p. 179.	Detection of Ozone in the atmosphere,
	Soret	Chem. News, XIX, p. 104.	Density of Ozone.
	Grotowski	Chem. News, XIX, p. 260.	Ozonation of hydrocarbon oils.
	Böttger	Ber. Bericht., II, p. 612.	Ozone ether is only ether containing H ₂ O ₂ .
	Andrews	J. pr. Chem., CIV, p. 55.	Ozone in the atmosphere.

1870	Beanes	Quar. J. Chem. Soc., VII (N. S.), p. 124.	The decolorization of sugar by Ozone.
	Schönbein	J. pr. Chem., CV, pp. 198 and 223.	Role Ozone plays in respiration. and on its production from camphene.
	Clausius	Pogg. Ann., CXXXVI, p. 102.	Odling's Ozone theory.
	Houzeau	Chem. News, XX, p. 35; Bull. Soc. Chim., p. 120.	Ozone in the atmosphere.
	Cook	Brit. Ass. Report, 1869.	Presence of cholera attended by a relative deficiency of Ozone.
	Dubrunfaut	Chem. News, XXI, p. 57; Compt. Rend., LXX, p. 159.	The nature of Ozone.
	Cahours	Compt. Rend., LXX, p. 369.	Report on the works of Houzeau relative to Ozone.
	Jougllet	Compt. Rend., LXX, p. 539; Chem. News, XXI, p. 136.	Action of Ozone on nitroglycerine, dynamite, and other explosives.
	Martin	Compt. Rend., LXX, p. 611; Chem. News, XXI, p. 154.	Electro-chemical studies on Ozone.
	Houzeau	Compt. Rend., LXX, p. 1286; Chem. News, XXI, p. 298.	Experiments on the electrifying of air or oxygen as a means of obtaining Ozone.
	"	Chem. News, XXI, p. 118; Compt. Rend., LXXI, p. 20.	First mention of Ozone by van Marum at Haarlem. Action of Ozone on mercury. Preparation from $H_2SO_4 + BaO_2$.
	Struve	J. pr. Chem., CVII, p. 503.	A review on Schönbein.
	Wolfenstein	Pogg., Ann., CXXXIX, p. 32.	On Ozone density by Soret.
	Soret	Pogg., Ann., CXLI, p. 294; Arch. des. Sci. Phys. et Nat. Suisse, XV, p. 5.	Reply to the preceding.
	"T. B."	Chem. News, XXI, p. 204.	Ozone found in bottles where nitrogen was formed during the slow oxidation of iron filings.
	Loew	Zeitsch. f. Chem. von Beilstein, VIII, pp. 13, 65; Chem. News, XXI, p. 107.	Formation of Ozone by blowing air through a Bunsen gas flame.
	"	Chem. News, XXI, p. 299; Zeitsch. f. Chem. von Beilstein, IX.	Reply to Böttger.
	"	Chem. News, XXII, p. 13; Am. J. Sci., XLIX, p. 369.	Formation of Ozone during rapid combustion.
	Böttger	Chem. Centr., 1870, 161.	Denial of Loew's statement, only ammonium carbonate and some hydrogen peroxide formed.
	Boeke	Chem. News, XXII, p. 57.	Reply to Loew.
	Than	Chem. News, XXII, p. 24; J. pr. Chem., [2] I, p. 415.	Formation of Ozone during rapid combustion of hydrogenous bodies.
	Engler & Nasse	Ann. der Chem. u. Pharm., May; Chem. News, XXII, p. 35.	Ozone and antozone.

	Moigno	Chem. News, XXII, p. 60; Les Mondes, VII, p. 7.	Explosion of picric acid in contact with Ozone.
1871	Tichborne	Chem. News, XXIII, p. 32; R. Irish Acad. Rep., IX, p. 1.	Formation of Ozone from resin under influence of air and light.
	Than	Quar. Jour. Chem. Soc., IX, (N. S.), p. 483; J. pr. Chem. (N. S.), I, p. 415; Zeitsch. f. Chem. [2] VII, p. 92.	Formation of Ozone during rapid combustion of hydrogenous bodies.
	Houzeau	Quar. J. Chem. Soc., IX (N. S.), p. 994.	Electrization of air and oxygen for the production of Ozone. A new apparatus.
	"	Compt. Rend., LXXIV, pp. 256 and 316.	Production of Ozone in a concentrated state.
	"	Compt. Rend., LXXIV, p. 712.	Ozone in the country and its origin.
	Soret	Ann. de Chim. et Phys., 4 S., XXII, p. 150.	Electrification of air or oxygen as a means of producing Ozone.
	"	Ann. de Chim. et Phys., 4 S., p. 152.	Continued production of Ozone in the air.
	Struve	Chem. News, XXIII, p. 203; Bull. de l'Acad. Imp. des Sci. de St. Petersburg, XV, No. 3.	Studies on Ozone, peroxide of hydrogen, and nitrite of ammonia.
	Debus	Proc. Chem. Soc., I, p. 6; Chem. News, XXIII, p. 272.	History of Ozone. Lecture delivered before the English Chemical Society.
	Ruhmkorff	Chem. News, XXIV, p. 252; Rev. Hebd. de Chim., Nov 9, 1871.	A new Ozone generator. Air ozonized under the action of a large number of electric sparks.
	Pincus	Pogg., Ann., CXLIV, p. 480.	Formation of Ozone by burning hydrogen in the air.
1872	Houzeau	Chem. News, XXV, p. 82; Compt. Rend., LXXV, p. 349.	A new ozonizer. Its powers. Decolorizing power of concentrated Ozone.
	"	J. Chem. Soc., N. S., X, p. 976; Chem. News, XXVI, p. 144; Ann. de Chim. et Phys., 4 S., XXVII, pp. 5, 29 and 59.	Atmospheric Ozone. New test papers, consisting of litmus + KI + starch.
	"	Compt. Rend., LXXIV, p. 256; J. Chem. Soc., N. S., X, p. 220; Chemisches Centralblatt, 1872, p. 242.	A new ozonizer.
	"	J. Chem. Soc., N. S., X, p. 465; Chem. News, XXV, p. 178	Proportion of Ozone in country air, and on its origin.
	"	Ber. Bericht., V, p. 217.	Ozonizer.
	"	Ber. Bericht., V, p. 827; Compt. Rend., LXXVI, p. 317; Chem. News, XXVI, p. 82.	Formation of hydrogen peroxide when Ozone acts on indigo.

1872	Brodie	Phil. Trans., Vol. 162, p. 435.	Action of electricity upon gases.
	Buchan	J. Scottish Meteor. Soc., Jan. and Apr., 1872.	"Report on Ozone Observations."
	Houzeau	Chem. News, XXV, p. 166; J. de Phar. et Chim., March, 1872.	Action of Ozone on silver, on organic bodies, on H_2S , H_3P , etc.
	Kingzett	Chem. News, XXV, p. 242; Ber. Bericht, V, p. 485.	Oxygen obtained from whatever source is always accompanied by Ozone.
	Croft	Chem. News, XXV, p. 87; Am. J. Sci., III, p. 466; Canadian Jour., XIII, No. 3.	Anomalous production of Ozone from crystallizing iodic acid.
	Gorup-Besanez	Ann. der Chem. u. Pharm., February and March; Chem. News, XXV, p. 202; J. Chem. Soc., N. S., X, p. 384; J. der Pharm., CLXI, p. 232.	Large amount of Ozone in the neighborhood of gradation machines of salt works.
	A. Frentz	Chem. News, XXV, p. 118; Rev. Hebd. de Chim. Scient. et Industr., Jan., 1872.	Mellowing alcohol drinks by Ozone.
	Bellucci	Chem. News, XXV, p. 118; Gaz. Chim. Ital., I, p. 687; J. Chem. Soc., N. S., X, p. 515.	Action of Ozone on plants.
	Pincus	Chem. News, XXV, p. 70.	Formation of Ozone from a fine jet of hydrogen burning in the air or in oxygen.
	Lies-Bodart	Chem. News, XXV, p. 205; Rev. Scientif. de la France et de l'Etranger, Sept., 1872.	Action of Ozone on the albumen of the blood, and on white albumen. Its disinfectant qualities.
	Carius	Chem. News, XXVI, p. 23; Ber. Bericht., V, p. 520; J. Chem. Soc., N. S., X, p. 785.	Absorption of Ozone in water.
	Thenard, A. and P.	Chem. News, XXVI, p. 105; Compt. Rend., LXXV, p. 458; J. Chem. Soc., N. S., X, p. 977; Ber. Bericht., V, p. 828.	Action of Ozone on sulphate of indigo and arsenious acid.
	Phipson	Compt. Rend., August 26, 1872.	The increased phosphorescence of Noctilucine during S. W. winds due to the large amounts of Ozone contained therein.
	Le Blanc	Chem. News, XXVI, p. 118; Compt. Rend., LXXV, p. 537.	Ozone and peroxide of hydrogen.

1872	Wideman	Chem. News, XXVI, p. 118; Compt. Rend., LXXV, p. 538.	Application of Ozone to remove fusel oil from whiskey.
	Wright	Chem. News, XXVI, p. 113; Amer. J. Sci. [3], IV, p. 29; J. Chem. Soc., N. S., X, p. 1072.	Apparatus to produce Ozone by electricity of high tension.
	P. Thenard	Chem. News, XXVI, p. 70; Compt. Rend., LXXV, p. 174; J. Chem. Soc., N. S., p. 921; Ber. Bericht., V, p. 824.	Process of estimation of Ozone by absorption in arsenious acid and titrating with permanganate of potash.
	A. Thenard	Compt. Rend., LXXV, p. 118.	An apparatus to subject vapors and gases to electricity.
	Odling	Chem. News, XXVI, pp. 281 and 294.	History of Ozone.
	Boillot	Chem. News, XXVI, p. 312; Compt. Rend., LXXV, pp. 214 and 1712; J. Chem. Soc., N. S., X, p. 879.	A new Ozonizer—A double tube filled with gas-carbon.
	Struve	J. Chem. Soc., N. S., X, p. 35.	Research on Ozone, hydrogen peroxide, and nitrite of ammonia.
	Chabrier	Compt. Rend., LXXV, p. 484.	Tendency of certain gases to acquire an active condition under influence of electricity.
	Becquerel	Comp. Rend., LXXV, p. 1735.	Report on A. Thenard's last article.
	Andrews	Ann. de Chim. et Phys., 4 S. XXVII, p. 31.	Influence of the seasons on the quantity of Ozone in the atmosphere.
	Wright	Pogg., Ann., CXLVI, p. 426.	Action of Ozone on vulcanized india rubber.
	P. Rumine	Ber. Bericht., V, p. 123.	An apparatus for Ozone production.
	B. J. Angell	Ber. Bericht., V, p. 543.	Seetang, as a means of obtaining Ozone.
	Loew	Ber. Bericht., V, p. 740.	Ozone obtained by blowing air through a Bunsen's burner.
	Moffat	Ber. Bericht., V, p. 814; Brit. Ass. Rep., 1872.	Tube ozonometer.
1873	Boillot	Chem. News, XXVII, p. 256; Compt. Rend., LXXVI, p. 1132; J. Chem. Soc., N. S., XI, p. 865.	Action of Ozone on absolute alcohol.
	"	Chem. News, XXVII, p. 208; Compt. Rend., LXXVI, p. 1712; J. Chem. Soc., N. S., XI, p. 724.	Production of Ozone from air and oxygen by electric action.

1873 Boeke	Chem. News, XXVII, p. 303; Berlin Bericht., VI, p. 1031; J. Chem. Soc., N. S., XI, p. 486.	Action of Ozone on pyrogallol.
"	Ber. Bericht., VI, p. 439; J. Chem. Soc., N. S., XI, p. 938.	Examination of various methods for the production of Ozone.
C. B. Fox	Chem. News, XXVII, p. 82; London, J. & A. Churchill.	Ozone and antozone, their nature and history.
Rammelsberg	Chem. News, XXVII, p. 322; Ber. Bericht., VI, p. 603; J. Chem. Soc., N. S., XI, p. 1103.	Insolubility of Ozone in water of ordinary temperature.
Carius	Chem. News, XXVIII, p. 84; Ber. Bericht., VI, p. 809.	Solubility of Ozone in water of 1°—2.5° C.
Houzeau and Renard	Chem. News, XXVII, p. 142; Compt. Rend., LXXVI, p. 572.	Concentrated Ozone as reagent for organic substances.
Houzeau	J. Chem. Soc., N. S., XI, p. 610; Ber. Bericht., VI, p. 267.	Concentrated Ozone as reagent for organic substances.
Bellucci	Chem. News, XXVII, p. 185; Gaz. Chim. Ital., Nos. 1 and 2 for 1873.	Alleged emission of Ozone from plants.
David	Chem. News, XXVII, p. 34; Rev. Hebd. de Chim. Scient. et Indust., Dec., 1872.	Bleaching cotton rags, etc., for paper making, by means of Ozone.
Wills	Ber. Bericht., VI, p. 769; Chem. News, XXVII, p. 292.	An improved ozonizer (Modification of Siemens's).
R. Lamont	Chem. News, XXVIII, p. 236.	Theory as to the formation of Ozone by the action of phosphorus.
1874 Schöne	Chem. News, XXIX, p. 37; Ber. Bericht., VI, pp. 1208 and 1224; J. Chem. Soc., N. S., XII, p. 222.	Reciprocal behavior of water and Ozone.
Kingzett	Chem. News, XXIX, p. 161; J. Chem. Soc., N. S., XII, p. 51.	Denies that the oxidation of turpentine in air yields Ozone.
Tommasi	Chem. News, XXIX, p. 284.	Estimation of Ozone in the presence of chlorine and nitric oxide.
Bellucci	Chem. News, XXIX, p. 145; Compt. Rend., LXXVIII, p. 362; J. Chem. Soc., N. S., XII, p. 596.	Supposed liberation of Ozone from plants.
Carius	Chem. News, XXX, p. 242; Ann. der Chem. und Pharm., Sept., 1874, Vol. CLXXIII, p. 1.	Behavior of Ozone towards water and nitrogen.
Böttger	Chem. Centralblatt, 1873, p. 497; J. Chem. Soc., N. S., XII, p. 653.	Formation of Ozone in the composition and decomposition of water.

1874	Wright	J. Chem. Soc., N. S., XII, p. 975; Amer. J. Sci. [3], VI, p. 184.	Ozone by electricity of high tension.
	Oppenheim	Amst. Ausstellungsab., p. 20; Wagner's Jahresbericht, 1874, p. 403.	Production of Ozone.
	Andrews	Nature, VIII, pp. 347 and 364; Pogg., Ann., CLII, p. 311.	History of Ozone.
	Ott	Wagner's Jahresbericht, 1874, p. 404; Dingl., Polyt. Jour., CCXIII, p. 306.	Loew's apparatus.
1875	Boillot	Chem. News, XXXI, p. 250; Compt. Rend., LXXX, p. 1167; J. Chem. Soc., N. S., XIII, p. 732.	Decolorizing properties of Ozone:—chlorine bleaches by its formation.
	Böttger	Chem. News, XXXI, p. 207; Centralblatt f. Agrik. Chem., Jan., 1875.	Formation of Ozone in the composition and decomposition of water.
	Pettenkofer & Wolffhügel	Chem. News, XXXII, p. 42; Centralblatt f. Agrik. Chem., 4 Heft, 1875.	Determination of the Ozone in the atmosphere.
	Carius	J. Chem. Soc., N. S., XIII, p. 40; Ann. der Chem. u. Pharm., CLXXIV, p. 1.	Solubility of Ozone.
	Giannetti and Volta	J. Chem. Soc., N. S., XIII, p. 607; Gaz. Chim. Ital., IV, p. 471.	Notes on Ozone. I, Want of delicacy in the starch KI papers; II, Influence of different electric discharges on the amount of Ozone.
	Loew	J. Chem. Soc., N. S., XIII, p. 108; Dingl., Polyt. Jour., CCXIII, p. 121.	Apparatus for the industrial preparation of Ozone.
	Maumené	Compt. Rend., LXXXI, p. 107.	Action of Ozone on sugarcane juice.
	Boillot	Compt. Rend., LXXXI, p. 1258.	Ozone as a preservative for flesh.
	Carvalho	Compt. Rend., LXXXII, p. 157.	Ozone apparatus for unhealthy regions.
	P. Thenard	Compt. Rend., LXXXII, p. 157.	Remarks on the foregoing:—considers Ozone as very unwholesome.
1876	Marie-Davy	Compt. Rend., LXXXII, p. 900.	Note on atmospheric Ozone.
	Berthelot	Compt. Rend., LXXXII, p. 128.	Thermic formation of Ozone.
	Giannetti and Volta	Ber. Bericht., IX, p. 84; Gaz. Chim. Ital., Jan., 1876.	Preparation of Ozone by means of the Holtz machine.
	Boillot	Ber. Bericht., IX, p. 190.	Action of Ozone on flesh:—prevents putrefaction.
	Reynose	Ber. Bericht. IX, p. 207.	Preparation of Ozone.
	Remsen and Southworth	Am. J. Sci., [3] XI, p. 136.	Action of Ozone on carbon monoxide.

1877	Menschutkin	Ber. Bericht., X, p. 2059.	Phosphorus-ozonator, constructed by Radulowitsch.
	Berthelot	Ber. Bericht., X, p. 233; Chem. News, XXXV, p. 44; Ann. de Chim. et Phys. (5 S.), X, p. 162, and XII, p. 440; Compt. Rend., LXXXVI, p. 71; J. Chem. Soc., XXXIV, p. 372.	Formation of nitrates by Ozone in presence of alkalis, not proved.
	Fautrat	Centralblatt f. Agrik. Chem., Heft I, 1877; Chem. News, XXXV, p. 146.	Scarcity of Ozone in forests of conifers.
	Levy	Chem. News, XXXVI, p. 54; Compt. Rend., July, 1877; J. Chem. Soc., December, p. 916.	Determination of the weight of atmospheric Ozone by means of arsenious acid and arsenite of soda.
	Ogier	Chem. News, XXXVI, p. 256; Compt. Rend., LXXXVI, p. 722; J. Chem. Soc., XXXIV, p. 469.	Formation of iodous acid by the action of Ozone upon iodine.
	Pellagri	Chem. News, XXXVI, p. 110; Gaz. Chim. Ital., July, 1877.	Action of carbonic acid and light upon iodide of potassium and water—liberates iodine.
	Papasogli	Ber. Bericht., X, p. 84.	Action of turpentine oil upon Ozone.
	Bartlett	Ber. Bericht., X, p. 904.	An Ozone apparatus (patent). Tubular vessels in which phosphorus is in contact with air and water.
1878	Jeremim	Ber. Bericht., XI, p. 988; J. Chem. Soc., 1879, p. 8.	Ozone is soluble in solution of oxalic acid. A cement prepared from pulv. pumice, paraffine, wax and colophonium withstands action of Ozone.
	Tomlinson	R. Soc. Proc., XXVII, p. 290.	Action of Ozone on nuclei.
	Berthelot	Ann. de Chim. et Phys. (5 S.), XIV, p. 361; Compt. Rend., LXXXVI, pp. 71-76.	Formation of Ozone, hydrogen peroxide, and persulphuric acid during the electrolysis of water.
	"	J. Chem. Soc., CLXXVI, May, 1878, p. 371; Compt. Rend., LXXXVI, p. 76; J. Chem. Soc., XXXIV, p. 371.	Stability of Ozone.
	Zoeller and Grete	Ber. Ber., X, p. 2144; J. Chem. Soc., CLXXXV, p. 372.	Production of ammonium nitrite.

- | | | | |
|------|------------|--|--|
| 1878 | Vulpius | Arch. Pharm. [3], XII, p. 534; J. Chem. Soc., XXXIV, p. 813. | Ozone-developer. Gives off no Ozone, but only a smell of resin and acetic ether. |
| | Leeds | Ann. N. Y. Acad. Sci., Vol. I, No. 6; Chem. News, XXXVIII, pp. 224, 235, 243, 249, 257. | Contributions towards a knowledge of the chemical constitution of the atmosphere; atmospheric Ozone: preparation of Ozone by electrolysis, frictional electricity and chemical methods: critical examination of ozonoscopes: action of Ozone upon the coloring matter of plants. |
| | Lévy | Compt. Rend., LXXXVI, p. 1263. | Ozone in atmospheric air. |
| | Darembert | Compt. Rend., LXXXVI, pp. 1203, 1346; Chem. News, XXXVIII, p. 9. | Ozone in atmospheric air. Ozonoscopic papers not reliable. |
| 1879 | Em. Schöne | Ann. der Chem., vol. 196, p. 58. | "Experimental Investigations upon Hydrogen Peroxide." This article includes a study of its action upon thallium ozonoscopes, which it turns brown. |
| | Gully | Compt. Rend., LXXXVII, p. 182. | Relation between the manifestations of ozone and the rotary movements of the atmosphere. |
| | Berthelot | Ann. de Chim. et de Phys. (5 S.), XVII, p. 142; Chem. News, XXXIX, p. 63; Ber. Bericht., XII, p. 377. | Researches upon Ozone and the electric silent discharge:—non-formation of water from a mixture of hydrogen and oxygen under its influence. |
| | Leeds | J. Am. Chem. Soc., Vol. I, p. 8; Ann. der Chem., vol. 198, p. 30; Chem. News, XL, p. 157; Ber. Bericht., XII, p. 2103. | "Relations between the Temperature and Volume in the Generation of Ozone, with description of a new form of Ozonator." |
| | " | Proc. Am. Chem. Soc., II, p. 153; J. Chem. Soc., 1879, p. 353. | Action of potassium permanganate upon sulphuric and oxalic acids:—no ozone formed. |
| | " | J. Am. Chem. Soc., I, p. 145; Ann. der Chem., CC, p. 286. | "Upon Ammonium Nitrite, and upon the By-products obtained in the Ozonation of Air by Moist Phosphorus." |
| | " | J. Am. Chem. Soc., I, p. 220; Proc. Amer. Ass. Adv. Science, 1879; Ber. Bericht., XII, p. 1831. | Solubility of Ozone in water. |

1879	Leeds	J. Am. Chem. Soc., I, p. 228 ; Chem. News, XL, p. 86 ; Proc. Amer. Ass. Adv. Science, 1879.	Action of Ozone upon the coloring matter of plants.
	"	J. Am. Chem. Soc., I, p. 229 ; Chem. News, XL, p. 86.	Bleaching of sugar syrups by Ozone.
	"	J. Am. Chem. Soc. I, p. 431 ; Chem. News, XL, pp. 246, 275.	Comparative results obtained with previous ozonizers, with description of a modified and and powerful form. Re-examination of certain chemical methods employed in generating Ozone. Non-production of Ozone in the crystallization of iodic acid. Action of Ozone upon organic substances (petroleum, etc.)
	McLeod	Chem. News, XL, p. 307.	"Note on the formation of Ozone during the slow oxidation of phosphorus." Thinks Ozone is formed, but no H_2O_2 .
	Leeds	Chem. News, XL, p. 257.	Non-production of Ozone in the crystallization of iodic acid.
	Kingzett	Chem. News, XL, p. 96.	"Is Ozone produced during the slow oxidation of phosphorus?" Says it is not, but only H_2O_2 .
	Bellucci	Annuario dell' Univ. di Pirugia ; Ber. Bericht., XII, p. 1699.	On the ozonizing powers of etherial oils, hydrocarbons, flowers, etc.
	Schiel	Ber. Bericht., XII, p. 507.	Formation of Ozone by hydrocarbons.

BIBLIOGRAPHY OF OZONE.

-
- 1844 Ueber die Erzeugung des Ozons auf Chemischen Wege. C. F. Schönbein. Basel.
- 1845 Ueber langsame Verbrennung in atmosphärischer Luft. C. F. Schönbein; Basel.
- 1850 Denkschrift über das Ozon. C. F. Schönbein; Basel.
- 1856 L'Ozone, ou Recherches Chimiques, Meteor., etc., sur l'Oxygène Electrisé. Scoutetten; Paris.
- De l'Ozone. Thesis by Dr. E. Boeckel, Strasburg.
- 1861 Die Fundamental eigenschaften des Sauerstoffes und Wasserstoffes. Dr. Wilh. Held; Berlin.
- 1864 Ozon (synopses and abstracts of publications prior to date.) Dr. G. Dachauer; Munich, E. H. Gummi.
- 1865 Die Jährliche period. Aenderung des atmos. Ozons, etc. Observations at Emden. Dresden.
- 1869 Neue Unbersuch. über den elektr. Sauerstoff. Meissner; Göttingen.
- 1869 Sull' Ozono, Note e Riflessioni. Prof. G. Bellucci; Prato. Giachetti; Figlio e C.
- 1871 Untersuch. über die elektr. Ozon erzeugung, etc. Meissner; (Reprint from Abhandl. der K. Gesell. der Wissenschaften zu Göttingen), Göttingen.
- 1872 Des atmosphärische Ozon, nach Messungen in Marienbad, Kissingen, etc. (Reprint from Göschen's "Deutsch. Klinik," No. 19, 1872.) Berlin.
- 1873 Das Ozon u. seine Wichtigkeit im Haushalte der Natur, etc. Dr. Johann Hammerschmied; Vienna. Gerold's Sohn.
- Ozone and Antozone. Their History and Nature, etc. C. B. Fox, M. D.; London, J. & A. Churchill.
- 1878 Ozone in relation to Health and Disease. Henry Day, M. D.; London, J. Churchill & Sons, 1878.
- 1879 Ozone and the Atmosphere, Albert R. Leeds, Ph. D.; New York. Munn & Co. Reprint from Scientific American Suppl.

The History of Antozone and Peroxide of Hydrogen.

(Read April 12th, 1880.)

I. ANTOZONE.

By far the most important fact in the long and perplexing history of Antozone, is the recent discovery that there is no Antozone. After giving rise to a very voluminous literature, filled with confused and contradictory statements, the mysterious body named by Schönbein Antozone, has disappeared from the pages of chemistry, and been added to that daily increasing host of defunct chemical elements, which, after a brief and troubled existence, have fallen into final oblivion. As it was, it never had a sturdy existence. It appeared to be a sort of chemical will-o-the-wisp, a matter of exhalations, connecting its existence with the formation and disappearance of clouds and similar phenomena, and ever resisting the attempts of the experimenter to obtain it in some tangible form. The ghost of Antozone, raised by Schönbein, and, together with its twin brother, Atmizone, expanded into great proportions by the labors of Meissner, was struck down by von Babo (in his Contributions towards a Knowledge of Ozone, 1863) and finally laid by the experiments of Nasse and Engler, on the phenomena attendant upon the action of oil of vitriol upon peroxide of barium (1870).

And when we consider for a moment the overwhelming host of acquisitions which are yearly made to our stores of veritable chemical knowledge, the mind experiences a sensation of actual relief in seeing so many questionable statements expunged from the history of chemistry, and in getting hold, so to speak, of an unexpected *tabula rasa* on which to write discoveries of permanent value. Such being the case, it would certainly be an unremunerated toil to weigh and ponder the great bulk of conflicting data concerning Antozone. The most we would feel willing to undertake would be, to inquire into the grounds upon which such mistaken views were originally built: further, into the experiments which appeared to confirm these views, and eventu-

ally to win for them the credence of philosophers in general: and finally, to examine narrowly into the validity of the experimental evidence, which is regarded as demonstrating conclusively the non-existence of Antozone.

The ground was prepared for the growth of a belief in the actual separate existence of Antozone, by the promulgation by Schönbein of his theory of Ozonides and Antozonides. Under the former class, he included the peroxides, which in their action upon other bodies manifested a strong likeness to Ozone, the typical body of this class being the Peroxide of Lead.

Without enumerating all the features in their deportment towards other bodies, an enumeration which would serve only to confuse us, it will be sufficient for our present purpose to note that the properties of ozonides that Schönbein regarded as most characteristic, were their power of liberating chlorine on contact with hydrochloric acid; of being reduced by peroxide of hydrogen to lower oxides (water and ordinary oxygen at the same time being generated), and of causing the tincture of the resin guaiacum to turn blue.

Antozonides, on the other hand, were those peroxides which under the circumstances detailed above, behaved in quite contrary fashion;—under no circumstances liberating chlorine from a chloride, not decomposing peroxide of hydrogen, and not turning guaiacum tincture blue. The typical body of this class was Peroxide of Barium.

And inasmuch as Schönbein thought he had demonstrated that ozone is electro-negative oxygen, and that the ozonides were combinations of a lower oxide with ozone, he accordingly regarded the antozonides as combinations of a lower oxide with electro-positive oxygen. This electro-positive oxygen, he appears to have named Antozone to distinguish it from Ozone, and to indicate the function it performed in antozonides, without claiming, at least at the outset, that it had been or could be isolated in a free condition. The fact that an ozonide and an antozonide could mutually decompose one another, and both at the same time undergo reduction to the state of lower oxides, with liberation of ordinary oxygen, was regarded as lending great probability to the view that the oxygen in the two compounds existed in two opposed electro-chemical conditions.

This hypothesis of Schönbein was evolved at that epoch when the electro-chemical theories of Berzelius reigned paramount, and has the same general objection which is urged against the dualistic theory in general, that instead of regarding a chemical compound as a new individual in which for the time being the specific identity of its components is lost, it assumes that these components, though unrecognisable for the time, nevertheless still exist. In other words, that in an ozonide there is ozone in combination with a lower oxide, and, in an antozonide, antozone. The validity of this reasoning is denied, on the ground that a compound body may yield up its constituents in one form or in another form, according to the reagents, or according to the circumstances, etc., by which its decomposition is brought about. So with the bodies under consideration. It was pointed out by Brodie (1863), that the chemical differences in the deportment of the ozonides and antozonides, were to be attributed to the nature of the substances with which in each class of bodies the oxygen was united, and to the nature of the substances taking part in the reactions, rather than to the existence in them of two different modifications of oxygen. For example, taking the evolution of chlorine when a chloride is brought into contact with an ozonide, as the most characteristic of its properties, as was done by Schönbein, we certainly should not anticipate that peroxide of barium, which is the typical antozonide, in contact with a chloride should evolve chlorine. But it was shown by Brodie (1861) that it did so or not according to circumstances, with concentrated hydrochloric acid yielding chlorine; with dilute, peroxide of hydrogen.

In the same direction tended the still earlier observations of Lenssen, that peroxide of hydrogen (an antozonide) could add oxygen to, or subtract oxygen from, an oxidizable body, according as the circumstances of the reaction, or as naturalists at the present time are fond of saying, "the environment," are favorable to the formation of a higher or a lower stage of oxidation. Thus in alkaline solution, it oxidizes oxide of chromium to chromic acid, while it reduces chromic acid to oxide in the acid solution.

The above facts are irreconcilable with the hypothesis that an ozonide contained ozone as such, and an antozonide, antozone.

Consequently, the hypothesis, and with it the terms employed, have been abandoned.

But the existence or non-existence of ozone is not only independent of the truth or falsity of any such hypothesis, but its properties have been studied with a minuteness, an exactitude, that render it in fact a much better known body than either sulphur or phosphorus. It is questionable whether or no sulphur and phosphorus are elementary bodies; but no one doubts that the substance-matter of ozone and ordinary oxygen is identical, and the relations existing between these allotropic conditions of one and the same elemental substance are clearly and sharply defined. How does the case stand with *antozone*?

It is manifest that the theoretical speculations of Schönbein upon the existence of electro-negative and of electro-positive oxygen, in a state of combination with lower oxides in ozonides and antozonides respectively, would strongly incline him to the possibility of obtaining in a free state antozone, corresponding to the previously obtained modification of oxygen, ozone. Accordingly, we find later that Schönbein thought that the gas set free by the action of oil of vitriol on barium peroxide contained antozone. He likewise formulated a number of characteristics by which the presence of antozone could be recognized. Without pausing to enumerate all of these, it will be of service to us in obtaining a clear notion of Schönbein's conception of antozone, to specify the three most salient. They are, 1st.—That antozone, such as is made from barium peroxide, combines with water to form peroxide of hydrogen. Ozone, on the contrary, cannot oxidize water to the form of peroxide. 2d.—It does not turn manganous salts brown, while ozone does, a higher oxide of manganese in the latter case being formed. 3d.—It bleaches paper saturated with manganous and lead salts, after they have previously been turned brown by ozone.

Unfortunately, these matters of distinction were open to sources of mistake in their verification. But had the antozone been odorless, or incapable of turning iodo-potassium-starch paper blue, Schönbein would have stated grounds of difference, which would have rendered it possible readily to distinguish between it and ozone. On the contrary, in these two most striking

points, according to Schönbein, antozone and ozone were nearly alike.

Perplexing as the subject was rendered by the numerous, and, not unfrequently, the contradictory statements of Schönbein, it was enveloped in a far more disheartening nebulosity, and, it is hardly exaggeration to say, buried beneath a dense fog, raised around it by the indefatigable life-long labors of Meissner. Witness the following samples of Meissner's modes of conceiving and stating the nature of the problems under study, and ask yourselves whether, as he stated them, the problems were not too vague to admit of precise thinking or of crucial experimentation. Antozone, says Meissner, is identical with the gas which is set free by the action of sulphuric acid upon peroxide of barium, except in the two respects, that unlike this gas it does not decompose iodide of potassium, and it does not smell (in other words, it is identical with a gas, from which it differs in two essential characters). But (note how the accompanying qualification tends to clarify our ideas) this gas likewise loses its smell, clouds at the same time being formed on coming into contact with moist air.

According to Meissner, ozone could not oxidize nitrogen, and probably antozone alone could not do so either, but both together could bring it about, in case moisture were present and other oxidizable bodies were absent. As the peculiarly distinguishing characteristic of ozone, Meissner rated its power of forming clouds in contact with water. When the water was abstracted from the clouds, by contact with dessicating bodies, the dried antozone could form ozone again by transmission through water.

Finally, in opposition to Schönbein, Meissner held that antozone was not absorbed or acted upon by potassium iodide, so that if a mixture of ozone and antozone is passed through a solution of iodide of potassium, the ozone is absorbed, while the antozone escapes and passes on free.

I have endeavored to present above the views entertained by Schönbein, Meissner, and others, concerning antozone, as lucidly as the contradictory and oftentimes vague statements made concerning it would allow, and have brought its history down to the time of the publication by von Babo of the memoir before alluded to (1863), in which the weakness of the experimental

evidence brought forth in support of a belief in its existence, was for the first time clearly set forth. For Meissner, it will be recollected, saw in its power of generating a cloud in contact with water, the distinguishing property of antozone. Von Babo discovered that the formation of a cloud is always to be noted when, in any manner whatever, ozone is decomposed, water being present. Meissner believed that the clouds could not be due to peroxide of hydrogen, because, according to him, the latter is not volatile. If, then, peroxide of hydrogen was not concerned in these phenomena, there was left as the only other alternative under the circumstances, the hypothesis of a peculiar modification of oxygen capable of giving rise to them, and to this modification, which again was necessarily different from ozone, Meissner gave the name of atmizone. Later he identified it with, and called it by the same name as Schönbein's antozone. Von Babo, on the contrary, found that the clouds were only peroxide of hydrogen diffused through vapor of water, and capable of being transported along with it, and even passing with it through aqueous solutions, for long distances, without being deposited or absorbed.

Unfortunately, these results of von Babo were encumbered with certain vague and doubtful speculations concerning the mode of genesis of the peroxide of hydrogen, through the interaction of ozone and water in the presence of an oxidizable substance. That they were in reality conclusive against the existence of the so-called antozone, was not generally recognised until the labors of Nasse and Engler (1870), upon the gas set free by the action of sulphuric acid upon peroxide of barium, had confirmed their truth and illuminated their proper bearings and significance. Nasse and Engler, by simple but trenchant experiments, demonstrated that the gas evolved in this case was a mixture, containing not only ozone, but also water and peroxide of hydrogen.

When the escaping gas was passed through a series of tubes surrounded with a freezing mixture, the latter underwent condensation, and the permanent gas which passed on was ozone. The condensed product, when subjected to appropriate tests, proved to be merely a solution of peroxide of hydrogen. Carry the simple explanation thus afforded with you, and see with

what a flood of light it illuminates all the hitherto hopelessly obscure passages in the history of antozone, and enables one to give readily a natural explanation to phenomena which at the time of their original discovery perplexed mightily their discoverers, and led them to form many ingenious, but in the end harmful hypotheses.

For instance, examine with the aid thus given, Schönbein's first distinguishing characteristic of antozone: *i. e.*, as made from barium peroxide, it combines with water to form peroxide of hydrogen. Since the gas given off in this reaction consists not only of ozone, but of peroxide of hydrogen, the peroxide of hydrogen which Schönbein thought was formed on its coming into contact with water, really pre-existed. Consider his second test: that antozone does not turn manganous salts brown, while ozone does. This difference is likewise true of peroxide of hydrogen as compared with ozone. The same remark applies to his third test:—that it bleaches papers saturated with manganous salts, after they have been turned brown by ozone. The same effect precisely is produced by peroxide of hydrogen. Is there any adequate explanation of these agreements, short of conceding that Schönbein's antozone is disguised peroxide of hydrogen?

But what shall we say of those numerous cases, in which Meissner thought that a mixture of ozone and antozone was present, and that on removing the former by passing the mixture through a solution of iodide of potassium, the latter went on alone attended with its characteristic white cloud? The explanation is that afforded by von Babo, *viz.*—that when ozone decomposes potassium iodide solution, there is found in addition to free iodine, iodate of potassium and potassium peroxide, *peroxide of hydrogen*. If any one doubts the adequacy of this explanation, let him try the following experiment. Strongly ozonize some *dry* oxygen by an electrical ozonizer, pass the ozonized gas through a sulphuric acid wash-bottle, and then allow it to descend upon a potassium iodide solution. The ozone will undergo complete absorption, the solution becoming deeply colored by the liberated iodine. Resting upon the surface will be seen a dense white cloud. This white cloud may now be aspirated through many wash-bottles containing water,

and even a solution of chromic acid, and may stand for hours over water before it completely disappears. But on examining the waters used in washing it, they will be found to contain peroxide of hydrogen. Apply the same mode of solving the other statements made by Meissner, remembering always that the peroxide of hydrogen which is formed when ozone is decomposed by an aqueous solution, is attended by a white cloud through which the peroxide of hydrogen has diffused itself,—a white cloud of such permanence that it may be transmitted through many solutions before undergoing absorption,—and their explanation will be found both natural and easy.

In conclusion, why not make an end of the matter by stating that antozone is peroxide of hydrogen? The objection to so doing is, that along with the term antozone there were attached many notions which are not true of peroxide of hydrogen, such as its being electro-positive oxygen, that it had the power of forming peroxide of hydrogen on coming into contact with water, etc.

Finally, the very name antozone implies a substance in its nature the opposite of ozone, and supposes the existence of a theory to account for the difference. For these reasons, I deem it more just to sum up the question by reaffirming the affirmation made at the beginning, that *there is not, and never was, antozone.*

II.—PEROXIDE OF HYDROGEN.

Though Peroxide of Hydrogen was discovered by Thénard more than half a century ago (1818), and has ever been a substance possessed of unusual interest in the eyes of chemists, yet the difficulties of its manufacture were so great, that only recently has it ceased to be a chemical curiosity and come into common use in the arts. Only a year ago a very dilute solution of the peroxide, imported from Europe, was sold in New York at the price of \$16 per gallon. But to-day a solution containing .8 per cent. is retailed at about \$1 per pound. At this high price, it is sold under fanciful names, and employed to bleach human hair. But there is much reason for believing that a

most important future is before it, and that alike in the chemist's laboratory and in the arts, as a most powerful oxidizing and reducing agent,—for it can act as both,—for bleaching purposes, etc., it is destined to play a great part. With its cheapening, many new uses will be found for it, and it is probable before very long, it will take its place, as Mr. G. C. Davis has strongly urged (*Chem. News*, XXXIX, p. 220), as an indispensable article upon the working-table of every chemist.

But it is not these considerations, which mainly interest us in connection with its scientific history. It is rather the accessions to our knowledge, which more especially of late have elucidated many obscure points connected with its sources and properties.

That the method of preparation from peroxide of barium and hydrochloric acid (Thénard, 1818), or from the same oxide and carbonic acid (Duprey, 1862 : Balard, 1862), is not used to obtain it on a commercial scale, is familiar to many,—the method of Pelouze, in which hydrofluoric or fluosilicic acid is used to effect the decomposition, being that employed in the arts.

That peroxide of hydrogen was formed in the electrolysis of water strongly acidulated with sulphuric acid, was stated by Meidinger (1853), and was apparently so well confirmed by the experiments of Bunsen (1854), C. Hoffmann (1867), and others, that until the researches of Berthelot (1878) were published, the production of peroxide of hydrogen in electrolysis was looked upon as a fully established fact. But the great French chemist showed that the body dissolved in the acid electrolyte, did not exhibit the reactions characteristic of peroxide of hydrogen: *i. e.*, it did not decompose potassium permanganate (Brodie's test), nor oxidize chromic to perchromic acid (Barreswil's test), nor convert calcium hydrate into an insoluble peroxide in alkaline solution (Berthelot's test?). He demonstrated that it contained in solution the same oxide of sulphur, which he had previously formed as a beautifully crystalline body by the long-continued exposure of dry ozone and dry sulphurous acid to the action of the silent electric discharge—Berthelot's persulphuric anhydride, $S^2 O^7$.

Finally, during the course of the year just passed, Schöne has demonstrated in his elaborate research upon the behavior of

peroxide of hydrogen towards the galvanic current (1879), that *in the electrolysis of water no hydrogen peroxide is formed.*

Will the same be found to be true of Schönbein's statement, that in the oxidation of phosphorus exposed to moist air, along with ozone, a by no means inconsiderable quantity of peroxide of hydrogen is formed? This point was investigated by the author in the course of a research into the by-products obtained in the ozonation of air by phosphorus, with the result of confirming Schönbein's observation. The amount of hydrogen peroxide was determined by analysis of the water employed in washing the ozonized gas, the iodine liberated by the washed gas being attributed entirely to the decomposition effected in a neutral solution of potassium iodide by the ozone. The proportion of hydrogen peroxide to the ozone, as determined by this method, was only one to four hundred. But later, the author has re-investigated the subject, estimating not only the hydrogen peroxide held back in solution, but the entire amount present in the ozonized gas, and has found that its proportion to that of the ozone may exceed one to three. The two substances, as Schöne has pointed out, may be present in the same vessel in quite a concentrated form for a long interval, without effecting a complete mutual decomposition, and when highly dilute, may co-exist for hours.

One question of very great interest still remains:—*is Peroxide of Hydrogen present in the atmosphere?* As yet, except as an inference from other meteoric phenomena, there is no evidence that it is. Meissner (1863), Schönbein (1868), Struve and Schmid (1869), and Goppelsröder (1871), believed that they had succeeded in demonstrating the presence of peroxide of hydrogen in rain. Houzeau, whose authority in matters of chemical climatology no one would feel disposed to question,—seeing that he gave a lifetime of arduous study to their elucidation,—made very numerous analyses of the atmospheric precipitates, at different seasons of the year, occurring in the vicinity of Rouen (1868). But he did not succeed in finding peroxide of hydrogen either in snow or rain-water, nor in natural or artificial dew.

But in the year 1874, Schöne made an elaborate investigation of the subject, and obtained results which established, that in that locality at least, and at the time his experiments were per-

formed, hydrogen peroxide was present in certain atmospheric precipitates. Of 130 samples of rain-water collected during the latter half of the year 1874, at Petrowskoje, near Moscow, he found only four in which hydrogen peroxide could not be detected. Of snow, of which 29 samples were examined, there were 12 in which the presence of hydrogen peroxide could not be proven. As to the amount, Schöne found that it varied in rain-water, between *one part in one million to one part in twenty-five millions*.

The problem, how to detect with scientific exactitude the presence of ozone, or peroxide of hydrogen, or of both, in the excessively dilute condition in which, if ordinarily they exist at all, they must be present in the earth's atmosphere, is still unsolved ; and while its importance, as a leading factor in chemical and medical climatology, is on all sides generally admitted, there appears to be scanty prospect of its speedy or satisfactory settlement.

I N D E X

TO THE

Literature of Peroxide of Hydrogen.

1818	Thenard	Ann. de Chim. et Phys., IX, pp. 314, 441; <i>Traité de Chim.</i> , 4me ed., IV, 2, 41; Paris, Mem. Acad. Sci., III, p. 385.	Discovery of oxygenated water (hydrogen dioxide), and experiments on some of its reactions.
1819	"	Ann. de Chim. et Phys., X, pp. 114, 335; and XI, pp. 85, 208; Brugnatelli, <i>Giornale</i> , II, pp. 82, 126, 206, 313; Thomson, <i>Ann. Phil.</i> , XIV, pp. 209, 274; <i>Phil. Mag. and Jour. Sci.</i> , LIII, pp. 21, 109, 147, 462, and LIV, p. 76; <i>Jour. de Phys.</i> , LXXXVIII, p. 455; Trommsdorf, <i>N. Jour. de Pharm.</i> , III, p. 378; <i>Compt. Rend.</i> , 1819.	Experiments on the reactions of H_2O_2 , with a method for its preparation from barium dioxide and sulphuric acid.
1820	"	Trommsdorf, <i>N. Jour. de Pharm.</i> , IV, p. 37; <i>Quar. Jour. Sci.</i> , VIII, pp. 114, 154.	Experiments on hydrogen dioxide.
	"	Gilbert, <i>Annal.</i> , LXIV, p. 1.	Liquid oxygen, or oxidized water.
1822	"	Thomson, <i>Ann. Phil.</i> , III, p. 41.	Memoir on the preparation of H_2O_2 .
1832	"	Ann. de Chim. et Phys., L, p. 80; Schweigger, <i>Jour.</i> , LXV, p. 439 (= <i>Jahrb.</i> V).	Preparation of H_2O_2 , and a study on some of its reactions.
	Pelouze	<i>Pogg.</i> , Ann., XXV, p. 508.	Preparation of H_2O_2 .
	Liebig	<i>Ann. der Chem. u. Pharm.</i> , II, p. 22.	Property of pulverulent or angular bodies to liberate oxygen from H_2O_2 .
1833	Thenard	<i>Phil. Mag. and Jour. Sci.</i> , II, p. 403.	Preparation of H_2O_2 .
1834	Vogel	<i>J. pr Chem.</i> , I, p. 448.	H_2O_2 from MnO_2 or PbO_2 with H_2SO_4 diluted with 8 times the quantity of water.
1836	Kirchner	<i>Ann. Chem. u. Phar.</i> , XVII, p. 40,	Peculiar formation of hydrogen dioxide from

1839	Lampadius	J. pr. Chem., XVII, p. 36.	chlorine held in a bladder in a moist atmosphere.
1843	Kirchner	J. pr. Chem., XXVIII, p. 250.	A solution bleaching litmus obtained from PbO_2 and dilute H_2SO_4 .
	Sondalo	Compt. Rend., XVII, p. 820.	Use of H_2O_2 to purify foul air in rooms, &c
	Barreswil	Compt. Rend., XVI, p. 1085.	Purification of foul air by means of H_2O_2 .
1845	Schönbein	Pogg., Ann., LXV, p. 161.	Conversion of chromic into perchromic acid by H_2O_2 .
1850	Brodie	Phil. Trans., XI, p. 759.	Electrolysis of H_2O_2 containing H_2SO_4 .
1851	Schönbein	J. Chem. Soc. (Memoirs), III, p. 358.	Decomposition of H_2O_2 as affected by the chemical polarity of the atoms.
1854	Bunsen	Pogg., Ann., XCI, p. 621.	Action of metallic oxides, metals, and charcoal on H_2O_2 .
	Wöhler and Geuther	Ann. der Chem. u. Pharm., XCIV, p. 127; J. pr. Chem., LXII, p. 250; Pharm. Centr. für 1854, p. 752.	Effect of heat on the formation of H_2O_2 in the electrolysis of acidulated water.
	Brodie	J. Chem. Soc., VII, p. 304; J. pr. Chem., LXIV, p. 474.	Equal amounts of oxygen are liberated from the MnO_2 and H_2O_2 by mutual decomposition in acid solution.
1858	Schönbein	Verhandl. der naturf. Gesell. in Basel, II, pp. 20, 113; J. pr. Chem., LXXV, p. 88; Chem. Centr., 1858, p. 951; Anzeige Philosophische Magazin, [4] XV, p. 24; Ann. der Chem. u. Pharm., CVIII, p. 157; Pogg., Ann., CV, p. 268; (See also Chem. Centr., 1859, pp. 19, 33); N. Arch. ph. nat., [4] XVI, p. 178; Amer. J. Sci., [2] XXVII, p. 19; Ann. Ch. Phys., [3] LV, p. 218.	Did not find the preceding to be the case.
	"	J. pr. Chem., LXVII, p. 263; Chem. Centr. für 1859, p. 741; Pogg., Ann., CVI, p. 313.	Behavior of H_2O_2 with plumbic acetate, ozone, potassium manganate, chromic acid, etc. Considers the O in H_2O_2 and KMnO_4 for example, to be in opposite electrical conditions; in the former, electro-positive, in the latter, electro-negative.
	"		H_2O_2 obtained from potassium, sodium, and barium peroxides on mixing with H_2O . Evolution of O on mixing H_2O_2 with perchlorates.

1859	Schönbein	J. pr. Chem., LXXVII, p. 276; N. Jahrb. Pharm., XII, p. 209; Chem. Centr. für 1859, p. 763.	Behavior of H_2O_2 to manganese and iron salts.
	"	Pogg., Ann., CVIII, p. 471; N. Jahrb. Pharm., XII, pp. 214, 281; J. pr. Chem., LXXXVIII, p. 63; See also Chem. Centr. für 1860, p. 33; Ann. Chim. Phys., [3] LVIII, p. 479.	Chemical polarity of oxygen. Formation of H_2O_2 by slow oxidation of phosphorus in contact with water.
	"	Verhandl. der naturf. Gesell. in Basel, 1859; N. Jahrb. Pharm., XII, p. 291; Pogg., Ann., CIX, p. 134.	Behavior of H_2O_2 with ether.
	"	Phil. Mag. [4], XVIII, p. 510; J. pr. Chem., LXXIX, pp. 65, 71, 285; Chem. News, I, p. 12.	Formation of H_2O_2 by slow oxidation of metals in moist air.
	"	Verhandl. naturf. Gesell. in Basel, 1859; N. Jahrb. Pharm., XII, p. 288.	Catalytic decomposition of H_2O_2 by platinum.
	F. H. Storer	Proc. Amer. Acad. Arts and Sciences, IV, p. 338; J. pr. Chem., LXXX, p. 44; Rep. chim. appliquée, II, p. 155.	Reaction for chromium by means of H_2O_2 .
1860	Böttger	J. pr. Chem., LXXX, p. 58.	Preparation of an ethereal solution of H_2O_2 .
	Schönbein	Verhandl. der naturf. Gesell. in Basel, II, p. 520; J. pr. Chem., LXXX, p. 280.	Preparation of H_2O_2 from $Ba O_2$ by means of hydrofluosilicic acid.
	"	Verhandl. der naturf. Gesell. in Basel, II, p. 455; J. pr. Chem., LXXX, p. 257; Rep. chim. pur., III, p. 36.	Behavior of chromic acid with H_2O_2 free from acid.
	"	Chem. News, II, p. 23.	Delicate tests for H_2O_2 ; 1st.—KI + starch + $Fe SO_4$; 2d.— $K_3 FeCy_6$ + a ferric salt; 3d.— $KMnO_4$; 4th.—Indigo + $Fe SO_4$; 5th.—Chromic acid.
	"	Ann. Chim. et Phys., LVIII, p. 486; Pogg., Ann., CIX, p. 130.	Catalytic decomposition of H_2O_2 by platinum, and the cause.
	"	Verhandl. der naturf. Gesell. in Basel, II, p. 507; J. pr. Chem., LXXXI, p. 265; Chem. Centr. für 1861, p. 165.	On the action of N_2O_4 on H_2O_2 .
	"	Pogg., Ann., CIX, p. 134.	Preparation of a mixture of H_2O_2 and ether, and its characteristics.

1860	Aschoff	J. pr. Chem., LXXXI, pp. 487, 401; Arch. Pharm., [2], CV, p. 129; Chem. Centr. für 1861, p. 234.	Chloride of lime with H_2O_2 in acid solution, gives off four atoms of oxygen. Action on chromic acid.
	Riche	Chem. News, II, p. 107; Pogg., Ann., CIX, p. 346; Bull. Soc. Chim., 1860, p. 178.	Action of H_2SO_4 on H_2O_2 in liberating ozone. Liberation of oxygen by the alkalies.
	Lenssen	J. pr. Chem., LXXXI, p. 276.	Iodine is changed by H_2O_2 into HI in presence of alkaline carbonate.
1861	Schönbein	Pogg. Ann., CXII, pp. 281, 287, 446,	Tests for H_2O_2 . Formation of H_2O_2 from H_2O and O in contact with Zn, Cd, Pb, Cu, and the other metals, except Au, Ag, Pt, etc., in a moist atmosphere.
	Brodie	R. Soc. Proc., XI, p. 442.	Action of H_2O_2 on oxygenated bodies in solution.
	Aschoff	Chem. News, V, p. 129; J. pr. Chem., LXXXI, p. 401.	Action of H_2O_2 on the higher oxides, and the formation of perchromic acid.
	Böttger	Chem. News, IV, p. 57; Wittsb. V. Schr., IX, p. 546.	Preparation of an ethereal solution of H_2O_2 .
1862	Osann	Chem. Centr., 1862, p. 97.	H_2O_2 made from K_2O_2 and hydrofluosillicic acid.
	Chevreul	Compt. Rend., LV, p. 737.	Bleaching power of H_2O_2 upon organic coloring matters.
	Duprey	Compt. Rend., LV, p. 736; Chem. News, VII, p. 301; Institut, 1862, p. 365; Dingl., Polyt. Jour., CLXVII, p. 38; J. pr. Chem., LXXXVIII, p. 440; Zeitsch. Chem. u. Pharm., 1862, p. 695.	Preparation of H_2O_2 from Ba_2O_2 , 8 H_2O and CO_2 .
	Balard	Compt. Rend., LV, p. 738.	Uses same method of preparation as Duprey.
	Brodie	Phil. Trans., p. 834.	Decomposition of H_2O_2 by $KMnO_4$, K_3FeCy_6 , $Ba(ClO)_2$ and H_2CrO_4 , and on the oxidation effected by H_2O_2 .
	von Babo	Ann. der Chem. u. Pharm., Suppl. II, p. 265.	Ozone forms H_2O_2 with water, only in presence of nitrogen or an oxidizable body.
	Schönbein	Zeitsch. anal. Chem., I, p. 440.	Action of H_2O_2 on plumbic acetate, etc.
1863	Brodie	J. Chem. Soc., XVI, p. 320.	Decomposition of H_2O_2 by $KMnO_4$, etc.

1863	Schönbein	Ann. Chem. u. Pharm., Suppl. II, p. 211; J. pr. Chem., LXXXVIII, p. 469; J. Pharm., [3] XLIV, p. 83; Bull. Soc. Chim., V, p. 442.	Action of H_2O_2 on bromine and chlorine.
	"	J. pr. Chem., LXXXIX, p. 22; Bull. Soc. Chim., V, p. 548.	Formation of H_2O_2 in the blood by respiration, and its behavior to the constituents of the blood.
1864	Schönbein	J. pr. Chem., XCIII, p. 24; Bull. Soc. Chim., [2] III, p. 179; Chem. News, XI, p. 25.	Formation of H_2O_2 by slow oxidation of lead.
	"	J. pr. Chem., XCIII, p. 60, and XCII, p. 150; Institute, 1864, p. 399.	Delicate tests for H_2O_2 by means of KI and indigo.
	"	J. pr. Chem., XCII, p. 168; Zeitsch. anal. Chem., III, p. 245; Bull. Soc. Chim., [2] III, p. 147; J. Pharm., [3] XLVI, p. 313.	Presence of H_2O_2 in urine.
1865	C. Hoffmann	Ann. der. Chem. u. Pharm., CXXXVI, p. 188; Chem. Centr. für 1865, p. 1119; Phil. Mag., [4] XXXI, p. 143.	H_2O_2 made from potassium peroxide and hydrofluosilicic or tartaric acid.
	Giannuzzi	Zeitschr. Chem., VIII, p. 749.	Action of H_2O_2 on myosin, fibrin, blood-serum, albumen, etc.
1866	Schönbein	J. pr. Chem., XCVIII, pp. 257, 280; Zeitsch. Chem. für 1866, p. 658; Bull. Soc. Chim., [2] VII, p. 238; J. Pharm., [4] IV, p. 308; J. pr. Chem., XCIX, pp. 11, 19; Zeitschr. Chem., für 1867, p. 93.	Formation of H_2O_2 by the slow oxidation of organic substances in the absence of water, as ether, alcohol, etc.
	"	J. pr. Chem., XCVII, p. 76; Ann. Chim. Phys., [4] VII, p. 103; J. Pharm., [4] IV, p. 395.	Catalytic decomposition of H_2O_2 by Pt, Ru, Ir, Rd, etc.
	"	J. pr. Chem., XCVIII, p. 270.	Delicate test for H_2O_2 —plumbic acetate, starch, potassium iodide or guaiacum and a solution of blood-corpuscles.
	"	J. pr. Chem., XCVIII, p. 65; N. Repert. Pharm., XVI, p. 6; Zeitsch. Chem. für 1866, p. 445; Zeitsch. anal. Chem., VI, p. 114; J. Pharm., [4] IV, p. 306; Chem. News, XV, p. 123.	Stability of H_2O_2 in aqueous solutions.

1866	Schönbein	Chem. News, XIV, p. 107; Bull. Soc. Chim., V, p. 547.	Concentration of H_2O_2 , and various reactions.
	Weltzien	Compt. Rend., LXII, p. 640; J. Pharm., [4] p. 254; Chem. News, XIII, p. 139, and XIV, pp. 1, 15, 39, 50.	Action on H_2O_2 of Fe, Al, ferrous salts, Mg, Tl, NH_3 , Ag NO_3 , KI, (KI + Fe SO_4), K Mn O_4 , K_4 Fe, Cy_6 , and K_3 Fe Cy_6 .
	"	Ann. der. Chem. u. Pharm., CXXXVIII, p. 129.	Concentration of H_2O_2 by evaporation at the boiling point, etc.
	"	Compt. Rend. LXII, p. 757; Chem. News, XIV, pp. 1, 15; Bull. Soc. Chim., [2] V, pp. 261, 322.	Theoretical consideration of H_2O_2 . Instability of the H in the molecule as compared with H_2O .
	Baudrimont Hoffmann	Compt. Rend., LXII, p. 829. Phil. Mag. & Jour. Sci., XXXI, p. 143.	Experiments in H_2O_2 . Preparation of H_2O_2 from K_2O_3 and fluosilicic acid; also from K_2O_3 and tartaric acid.
	Harcourt and Esson	Proc. Roy. Soc., XV, p. 262.	On the reaction of H_2O_2 and H O.
		Ann. Chim. et Phys., 4me S., VIII, p. 465.	Action of platinum, iridium, etc., on H_2O_2 .
1867	Schönbein	J. pr. Chem., CII, pp. 145, 155, 164; Zeitsch. Chem. für 1868, pp. 155, 178; N. Repert. Pharm., XVII, pp. 306, 321; J. pr. Chem., C, p. 469; Zeitsch. Chem., für 1867, p. 606; Bull. Soc. Chim., [2] IX, p. 74.	Formation of H_2O_2 from various substances, as in turpentine, alcohol, resins, etc.
	Harcourt and Esson	J. Chem. Soc., [2] V, p. 460.	Reaction of H_2O_2 and H I.
	Swiontowski	Zeitsch. Chem. für 1867, p. 179; Bull. Soc. Chim., [2] VIII, p. 404; Ann. der Chem. u. Pharm., CXLI, p. 205.	Action of H_2O_2 on potassium permanganate.
	Houzeau	Chem. News, XVII, p. 57; Compt. Rend., LXVI, p. 44.	Method of estimating quantitatively small amounts of H_2O_2 by means of KI and an acid.
	"	Compt. Rend., LXVI, p. 314,	Upon H_2O_2 , considered as the cause of the alterations in Houzeau's test papers.
	Schönbein	N. Repert. Pharm., 18, 364; J. pr. Chem., CVI, p. 270.	Occurrence of H_2O_2 in rain-water, air, etc.
	"	J. pr. Chem. CV, p. 219; Institute, 1869, p. 6.	H_2O_2 recognised by malt extract and guaiacum tincture.
	"	J. pr. Chem., CV, p. 241.	Stability of H_2O_2 on heating its aqueous solutions.

1868	Houzeau	Ann. Chim. Phys., [4] XIII, p. 111; Bull. Soc. Chem., [2] X, p. 242; J. Pharm., [4] VII, p. 268; Zeitsch. Chem. für 1868, p. 223; Zeitsch. anal. Chem., VII, p. 242; Chem. Centr., für 1868, p. 315.	Estimation of small quantities of H_2O_2 .
	"	Compt. Rend., LXVI, p. 314; Ann. Chim. Phys., [2] XIV, p. 305.	No H_2O_2 in the air.
	Parnell	J. Chem. Soc., [2] VI, p. 356; Zeitsch. Chem. für 1868, p. 714.	Reducing action of H_2O_2 in presence of C_6H_6O .
	Rundspaden	Ann. Chem. u. Pharm., CLI, p. 306.	H_2O_2 from electrolysis of water.
1869	Tomlinson (Harcourt, in discussion of Tomlinson's paper.)	J. Chem. Soc., [2] VII, p. 145.	Effect of the state of surface in the rate of decomposition of H_2O_2 .
	Struve	J. Pharm., [4] X, p. 356; Zeitsch. anal. Chem., VIII, p. 315; N. Rep. Pharm., XVIII, p. 753; Chem. Centr., für 1870, p. 148; Bull. Soc. Chim., [2] XIII, p. 39; Chem. News, XX, p. 23; Compt. Rend., LXVIII, p. 1551; J. pr. Chem., CVII, p. 503; Zeitsch. für Chem. von Beilstein, für 1869, p. 274.	Detection of H_2O_2 in rain, snow, &c., by means of KI, starch, and ammonio-ferrous sulphate.
	Schaer	Vierteljahrsschr. für pr. Pharm., XVIII, pp. 371, 497.	Action of H_2O_2 on emulsin and myrosin, spittle and milk.
	Schönbein	J. pr. Chem., CVI, p. 257; N. Rep. Pharm., XVIII, p. 28; Zeitsch. Chem. für 1869, p. 533; Zeitsch. anal. Chem., VIII, p. 81; Dingl., Polyt. Jour., CXCI, p. 499.	Behavior of H_2O_2 towards ferment.
	Schmid	J. pr. Chem., CVII, p. 60.	Occurrence of H_2O_2 in rain-water.
	Schonn	Zeitsch. anal. Chem., IX, p. 49; Zeitsch. Chem. für 1870, p. 446; Bull. Soc. Chim., [2] XIV, p. 42.	Action of H_2O_2 on molybdic acid and oxide, and upon titanous acid.
	Struve	N. Petersb., Acad. Bull., XV, p. 325.	Formation of H_2O_2 , ozone, and ammonium nitrite, in combustion of hydrogen.
	Houzeau	Compt. Rend., LXX, p. 519; Bull. Soc. Chim., [2] XIV, p. 372; Institute, 1870, p. 74; Zeitsch. Chem., [2] VI, p. 255.	Absence of H_2O_2 in the snow fallen at Rouen.

1871	Struve	Chem. News, XXIII, p. 203; Bull. Acad. Imp. Sci., XV.	Presence of H_2O_2 in air and in vital processes.
	F. Goppelsröder	J. Chem. Soc., XXIV, p. 356. J. pr. Chem. [2] IV, pp. 139, 383; Zeitsch. anal. Chem., X, p. 259; Moniteur Scientifique, [3] I, p. 912.	Reducing action of H_2O_2 and phenole. Presence and formation of H_2O_2 in the atmosphere.
1872	Struve	J. Chem. Soc., XXV, p. 35; Zeitsch. f. anal. Chem., X, p. 292.	Occurrence of H_2O_2 in combustion and in vital processes.
	Thenard	J. Chem. Soc., XXV, p. 921; Compt. Rend., LXXV, p. 177.	Action of KMO_4 on H_2O_2 under influence of a freezing mixture.
	Struve	J. Chem. Soc., XXV, p. 923; Zeitsch. f. anal. Chem., XI, p. 25.	Determination of H_2O_2 by means of indigo.
	LeBlanc	Compt. Rend., LXXV, p. 537.	Production of H_2O_2 in the electrolysis of H_2SO_4 .
	Thenard, A. and P.	Compt. Rend., LXXV, p. 458.	Formation of H_2O_2 by the action of ozone on sulphate of indigo.
	Houzeau	Compt. Rend., LXXV, p. 537.	The same.
1873	Al. Schmidt	J. Chem. Soc., XXVI, p. 186; Pflüger's Archiv., VI, pp. 413, 490; J. Chem. Soc., 1873, p. 180.	Decomposition of H_2O_2 by filter paper, ptyalin, and pepsin.
	LeBlanc	J. Chem. Soc., XXVI, p. 242.	Production of H_2O_2 in the electrolysis of sulphuric acid.
	Fudakowski	Ber. Bericht. VI, p. 107.	Presence of H_2O_2 in benzene.
	J. Thomsen	Pogg., Ann., CL, p. 31, and CLI, pp. 194, 225; Ber. Bericht., VI, pp. 223, 1434; Chem. Centr., 1873, p. 472.	Thermo-chemical researches on H_2O_2 .
	Böettger	Dingl., Polyt. Jour., CCIX, p. 157.	Stability of H_2O_2 .
	Struve	Wien. Akad. Ber., 2 Abth., LXVIII, p. 432.	Test for H_2O_2 by means of pyrogallic acid.
	Hamel	Compt. Rend., LXXVI, p. 1023.	Estimation of H_2O_2 by $KMnO_4$.
	Radenowitsch	Dingl., Polyt. J., CCX, p. 476; Ber. Bericht., VI, p. 1208; J. Chem. Soc., 1874, p. 433.	Formation of H_2O_2 in the slow oxidation of turpentine oil.
1874	Thomson	Dingl., Polyt. J., CCXI, p. 211; Ber. Bericht., VII, p. 73; J. Chem. Soc., 1873; p. 433.	Preparation of H_2O_2 .
	Weith & Weber	Ber. Bericht., VII, p. 1745.	H_2O_2 and NH_4O give nitrous acid.

1874	A. V. Schrotter Schöne	Ber. Bericht., VII, p. 983. Dingl., Polyt. Jour., CCX. p. 307; J. Chem. Soc., 1874. p. 601.	H ₂ O ₂ as a cosmetic. Tests for H ₂ O ₂ —titanic acid; cadmium iodide, starch, and ferrous sul- phate.
1875	Schöne Clermont Kingzett Thomsen Carius	Ber. Bericht., VII, p. 1693; J. Chem. Soc., 1875, p. 418. Compt. Rend., LXXX, p. 1591; J. Chem. Soc., 1875, p. 1216; Ber. Bericht., VII, p. 981. J. Chem. Soc., [2] XIII, p. 210; Moniteur Scientifique, [3] V, p. 1020. Pogg., Ann., CLI, p. 194; J. Chem. Soc., 1875, p. 223. Ann. der Chem. u. Pharm., CLXXIV, p. 31; J. Chem. Soc., 1875, p. 128; Ber. Bericht. 1874, p. 1481.	Atmospheric H ₂ O ₂ . Presence of H ₂ O ₂ in the sap of plants. Formation of H ₂ O ₂ from oxidation of turpentine. H ₂ O ₂ as an oxidizing agent (Thermo-chemical Re- searches). Formation in nature of ni- trous acid, nitric acid, and hydrogen peroxide.
1876	Cohné Kingzett Bellucci Griessmayer	Chem. News, XXXIV, p. 4; J. Chem. Soc., 1876, vol. II, p. 539. Report Brit. Assoc. for 1875 (2d Pt.), p. 43; Moniteur Scientifique, [3], VI, p. 197. Gazz. Chim. Italiana, V, p. 405; J. Chem. Soc., 1876, vol. I, p. 954. Ber. Bericht., IX, p. 835.	Formation of ozone by con- tact of plants with hydro- gen peroxide. Formation of H ₂ O ₂ by in- complete oxidation of terpenes. Presence of H ₂ O ₂ in the juice of plants. Connection of H ₂ O ₂ with the reduction of nitrates by bacteria, etc.
1877	Schaer Fairley Kingzett	Ber. Bericht., IX, p. 1068. J. Chem. Soc., 1877, vol. I, pp. 1. 125. Moniteur Scientifique, [3] VII, p. 715.	The same. H ₂ O ₂ and certain perox- ides. Disinfecting action of H ₂ O ₂ .
1878	Böttger E. Schöne Schöne Berthelot Boillot Berthelot	Chem. Centr., 1878, p. 574; J. Chem. Soc., 1879, p. 103. Ann. der Chem., Vol. 192, p. 257; J. Chem. Soc., 1878, p. 931. Ber. Bericht., XI, pp. 482, 561, 874, 1028; J. Chem. Soc., 1878, p. 552. Compt. Rend., LXXXVI, p. 71. Compt. Rend., LXXXVI, p. 123. Compt. Rend., LXXXVI, p. 277.	Formation of H ₂ O ₂ by ex- plosion of a mixture of oxygen and hydrogen. H ₂ O ₂ , its preparation, pro- ducts of. Atmospheric H ₂ O ₂ . Formation of hydrogen peroxide, ozone, and persulphuric acid during electrolysis. Effect produced by a low temperature upon a mix- ture of H ₂ O ₂ and H ₂ SO ₄ . New observations on the chemical reactions of the silent electrical dis- charge.

1878	Bellucci	Gazz. Chim. Ital., Fasc. VIII and IX, 1878; Chem. News, XXXIX, p. 149.	Alleged existence of H_2O_2 in the organism of plants.
	E. Schöne	Ann. der Chem., Vol. 195, p. 228; J. Chem. Soc., 1879, p. 353; J. Am. Chem. Soc., I, p. 250	H_2O_2 (3d paper). Behavior of H_2O_2 towards KI.
	"	Ann. der Chem., Vol. 196, p. 58; Chem. News, XXXIX, p. 164.	Behavior of H_2O_2 towards the oxygen compounds of thallium.
	"	Ann. der Chem., Vol. 196, p. 239.	Behavior of H_2O_2 towards ozone and chlorine.
	"	Ann. der Chem., Vol. 197, p. 137.	Behavior of H_2O_2 towards the galvanic current.
	Davis	Chem. News, XXXIX, p. 221.	Peroxide of hydrogen, its estimation, stability, and uses.
	Drechsel	J. pr. Chem., 2 S., XVIII, p. 303.	Catalytic decomposition of H_2O_2 by alkalies.
	Kern	Chem. News, XXXVII, p. 35.	H_2O_2 in the rain-water at St. Petersburg. Less in rain coming with north winds, than in that coming with south winds.
	Berthelot	Bull. Soc. Chim., XXXIII, pp 342, 249.	Decomposition of H_2O_2 in presence of alkalies. Action of iodide of potassium on H_2O_2 .

LIST OF ABBREVIATIONS.

Actes de la Soc. Helvétique.	Actes de la Société Helvétique des Sciences Naturelles,—Geneva.
Amer. J. Sci.	The American Journal of Science and Arts,—New Haven.
Ann. de Chim.	Annales de Chimie,—Paris.
Ann. der Chem. u. Pharm.	Annalen der Chemie und Pharmacie,—Leipzig and Heidelberg.
Ann. der Chem.	Justus Liebig's Annalen der Chemie,—Leipzig and Heidelberg.
Ann. of Pharm.	Annals of Pharmacy,—London.
Arch. de l' Elec.	Archives de l' Electricité,—Geneva.
Atti Scienz. Ital.	Reunione degli Scienziati Italiani.
Basel, Bericht.	Bericht über die Verhandlungen der Naturforschenden Gesellschaft in Basel.
Basel, Verhandl.	Verhandlungen der Schweizerischen Naturforschenden Gesellschaft bei ihrer Versammlung zu Basel.
Ber. Bericht.	Berichte der deutschen chemischen Gesellschaft,—Berlin.

Bibl. Univ.	Bibliothèque Universelle des Sciences, Belles-Lettres et Arts,—Geneva.
Bibl. Univ. Arch.	Supplément a la Bibl. Univ.,—Geneva.
Breslau, Schles. Gesell. Jahresb.	Jahresber. des Academischen Naturwissenschaftlichen Vereins zu Breslau.
Breslau, Schles. Gesell. Uebersicht.	Uebersicht der Arbeiten und Veränderungen der Schlesischen Gesellschaft für vaterländische Kultur,—Breslau.
Bull. Soc. Chim.	Bulletin de la Société Chimique de Paris.
Chem. News.	Chemical News,—London.
Compt. Rend.	Comptes Rendus Hebdomadaires des Séances de de l'Académie des Sciences,—Paris.
Dingl. Polytech. Journ.	Polytechnisches Journal von J. G. Dingler,—Stuttgart
Edinb. Med. Journ.	Edinburgh Medical Journal,—Edinburgh.
Erlangen, Abhandl.	Abhandlungen der Physikalisch-medicinischen Societät in Erlangen.
Erlangen, Mitt. Phys. Med. Soc.	Wissenschaftliche Mittheilungen der Physikalisch-medicinischen Societät zu Erlangen.
Freiburg, Bericht.	Berichte über die Verhandlungen der Naturforschenden Gesellschaft zu Freiburg in Breisgau.
Froriep, Notizen.	Notizen aus dem Gebiete der Natur- und Heilkunde, Erfurt
Gazz. Chim. Ital.	Gazzetta Chimica Italiana,—Palermo.
Heidelberg, Verhandl. Nat. Med. Ver.	Verhandlungen des Naturhistorisch-medicinischen Vereins zu Heidelberg.
Il Tempo.	Il Tempo, Giornale Italiano di Medicina, Firenze.
J. der Chem. u. Pharm.	Journal der Chemie und Pharmacie,—Heidelberg
J. pr. Chem.	Journal für praktische Chemie,—Leipzig.
J. de Pharm.	Journal de Pharmacie et des Sciences accessoires,—Paris.
J. Chem. Soc.	Journal of the Chemical Society,—London.
J. Amer. Chem. Soc.	Journal of the American Chemical Society,—New York.
Les Mondes.	Revue Hebdomadaire des Sciences et de leur Applications aux Arts et à l'Industrie,—Paris.
München, Gelehrte Anz.	Gelehrte Anzeigen,—München.
München, Sitzungsber.	Abhandlungen der Naturwissenschaftlich-technischen Commission bei der Königl. Baierischen Academie,—München.
Phil. Mag.	Philosophical Magazine,—London.
Pogg., Ann.	Annalen der Physik und Chemie,—Leipzig.
R. Soc. Proc.	Proceedings of the Royal Society,—London.
Roma Atti	Atti dell' Accademia Pontificia dei Nuovi Lincei,—Rome.
Schweiz. Gesell. Verhandl.	Verhandlungen der Schweizerischen Gesellschaft für die gesammten Naturwissenschaften,—Basel.
Stockholm, Ofversigt.	Ofversigt af Kongl. Vetenskaps Academiens Handlingar.
Würzburg Verhandl.	Verhandlungen der Physikalisch-medicinischen Gesellschaft in Würzburg.
Zeitsch. f. Anal. Chem.	Zeitschrift für analytische Chemie,—Wiesbaden.

GENERAL INDEX.

For all names in Botany and Zoology, see Index of Nomenclature, following the General Index.

For full titles of papers in this volume, and names of their authors, see Table of Contents.

	PAGE.		PAGE.
Acetic acid, <i>see</i> acid.		Acid, succinic	33
Achmite	66	sulphurous.	215, 217, 218 219, 370
Achroicythæmia	279	sulphuric.	30, 153, 197 209, 368
Acid, acetic.	1, 2, 7, 11, 18—25 32, 156, 210	tartaric, 1—24, 29, 31, 32, 157	
apocrenic.	31	titanic.	53—76
azohumic.	33, 354	ulmic.	31
benzoic.	7, 12, 18	vanadic	135—142
butyric.	32	Acid hydrocarbons.	33
butyro-limnodic.	33	Acids, organic, action of on min-	
carbonic.	156, 210, 216	erals.	1, 34, 156—158
chromic.	413	Adirondacks, ozone observa-	
citric, 1—10, 16—32, 157, 158		tions in.	195, 196, 197
crenic.	31	Aeschynite.	65, 75
fluosilicic.	413	Aglaite.	327, 328, 332—340, 348
formic.	7, 11, 15—25, 32	Air-samples, method of collect-	
geic.	31	ing.	193, 194
geocerit.	33	Albite.	6, 26, 28, 320, 346—353
georetinic	33	Albitic granite.	346, 351
humic.	31, 32, 33	Alcahest	25
hydriodic	156	Alizarine, as an ozone-test,	
hydrobromic.	8	207, 208, 211—216	
hydrochloric.	7, 8, 9, 29 30, 153, 216	Almandite.	6, 26, 28
hydrofluoric.	413	Alterations of Spodumene,—	
malic 7, 11, 16, 18, 21, 25, 32		to Albite.	346, 349, 353
metavanadic.	141, 142	to Cymatolite, 320, 327—340, 352	
mudescous	33	to Killinite.	340—346, 354
nitric.	22, 30, 153	to Muscovite.	347, 348, 349, 353
nitrohumic.	33	to Quartz.	349—353
nitrous.	210—214	Aluminium.	5, 25, 28
oxalic.	1, 7, 10—24, 31 157, 204	Amazon-stone	32
perchromic.	413	Ammonium citrate.	1
phosphotitanic.	54	Amœboid movements in blood-	
picric.	7, 12, 18	corpuscles.	275
pyrogallic.	7, 12, 18	Analcite.	6, 21, 28
silicic.	33	Analyses of bronzes.	40
silico-propionic	33	Anatase.	65—76
		Anglesite.	2, 5, 20, 28, 156, 158

PAGE.	PAGE.
Angular forms of blood-	Blood-corpuscles,
corpuscles 267, 283	ameboid movements of . . . 275
Aniline black 141, 142, 143	changes of form in
Ankerite 3, 7, 11, 28	266—268, 282—286, 312
Antimony 5, 25, 28	conclusions as to 308—314
Antozone, history of 405—412	“ghosts” of 270—274, 312
not a distinct substance,	“investing membrane”
405, 406, 412	of 286—294, 309, 314
probably the same as per-	literature of 275, 282
oxide of hydrogen, 411, 412	286, 294, 297, 302
Antozonides 406, 407	microscopical study of,
Apatite 5, 20, 28, 352	265, 282
Apocrenic acid 31	nucleus in 297—297, 314
Apophyllite 6, 21, 28	paling of 269—274
Apyrenæmata 294	preserving-agents for,
Aræoxene 135, 136, 137, 139	272, 273, 308
Ardennite 141, 142	sizes of 276—282
Argentite 4, 17—19, 24, 28, 154	vacuole in 269
157, 159	vitality of 297—302
Argyllite 138	Bohnerz 135, 136, 138
Arkansite 69	Bornite 4, 17—19, 24, 28, 154, 157
Arsenopyrite, 4, 18, 24, 28, 155, 157	Bournonite, 4, 17, 18, 24, 28, 155, 157
Artificial minerals 57—61	Brachydolerite 137
Atmizone 405	Brookite 65—76
Atmospheric Ozone 193—197	artificial 57, 58
365, 366	Bronze bells from Japan 35
Augite 6, 26, 28, 323, 325	Bronze, titanium 62
Austrian Service Rifle, 164, 172, 173	Bronzes, analyses of 40
Autunite 326, 354	Brucite 5, 19, 28, 156
Azo-humic acid 33, 354	Butyric acid 32
Azurite 4, 7—11, 28	Butyro-limnodic acid 33
Barium oxalate 10—14	Cadmium iodide, as an ozone-
Barytocalcite 4, 7—11, 15, 28	test 207, 212—216
Basan melan 67	Calamine 2, 6, 21, 28, 156
Bay of Fundy, geology of,	Calcite 2, 7—16, 28, 156
220, 221, 249, 254	Calcium oxalate 10—14
tides in 226, 227	Carbonates, action of organic
Benzoic acid 7, 12, 18	acids upon 7—12
Beryl 318, 319, 329, 338, 346	Carbonic acid 156, 210, 216
350—352	Cartridges 169, 170, 171, 174
Bibliography of Ozone 404	Cassiterite 350, 351
Bichromate of potash, as a pre-	Castellite 74
serving agent in studying	Cerussite 4, 7—11, 15, 28, 156
blood-corpuses, 272, 273, 308	Chabazite 6, 21, 28
Bioplasson 309, 310, 311, 314	Chalcocite, 4, 18, 19, 24, 28, 154
Biotite 6, 26, 28	157, 159
Birds of Dominica, W. I., 46, 50	Chalcopyrite, 4, 18, 19, 24, 28, 155
161, 162, 255, 256	157, 159
Grenada, W. I., 160, 161, 163	Chemical preparation of ozone,
New Providence, W. I., 50	203, 204
St. Vincent, W. I., 147—153	Chileite 135, 136
Tehuantepec 51, 51	Chlorinated acetate of methyl . . . 23
Venezuela 50, 51	Chlorine, action of upon flowers,
Bismuth 5, 25, 28	218, 219
Blood-corpuses, red, structure	Chlorophyllite 343
of 265—315	Chlorovanadates 141

PAGE.	PAGE.
Chondrodite.....	6, 21, 28
Chromic acid.....	413
Chromite.....	5, 19, 25, 28, 158
Chrysoberyl.....	66, 323
Chrysocolla.....	6, 21, 28
Chrysolite.....	6, 21, 28
Chrysotile.....	6, 21, 28
Cinnabar,	
4, 18, 24, 28, 154, 157, 158	
Citric acid.. 1—10, 16—32, 157, 158	
Citric acid in Marsh's apparatus, 17	
Cleavelandite, 321, 348, 350, 351, 352	
Clinometer, new form of... 263, 264	
Colophonite.....	66
Columbite.....	71, 350, 351
Comparative solubility of silicates in hydrochloric and citric acids.....	21
Compass-clinometer.....	263, 264
Connecticut, Trias of.....	220—254
Cookeite.....	351
Copper.....	5, 25, 28
Coralline Limestone.....	124
Craitonite.....	66
“Crenated” forms of blood-corpuscles.....	267
Crenic acid.....	31
Crichtonite.....	68
Crispite.....	65
Cryolite.....	5, 20, 26, 28, 138
Cryptocallite.....	32
Crystalline precipitates, microscopic examination of.....	12
Cummingtonite.....	318
Cuprite.....	5, 19, 28, 156, 158
Cymatolite.....	319—321, 327—329, 338, 345—354
analyses of.....	330, 331, 332
constitution of.....	333, 334, 335
microscopical characters of.....	336, 337, 340
Cyrtolite.....	352
Datolite.....	6, 21, 28
Dechenite... 135, 137, 138, 139, 140	
Decomposition of silicates by organic acids and ammonium fluoride.....	25
Decomposition of sulphides by citric acid and saltpetre....	23, 28
Decomposing power of organic acids compared.....	21
Delthyris Shale.....	123
Desclozite... 136, 138, 140, 141, 142	
Deweylite.....	6, 21, 28
Diaspore.....	318
Diopside.....	6, 26, 28
Distinction between calamine and willemite.....	2, 21
Dolomite.....	2, 7—14, 28
Dry reagents for wet analyses,	
30, 156, 157	
Electrical preparation of ozone, 199	
Electrolytic preparation of ozone.....	197, 198
Elsberg, Louis, on blood-corpuscles.....	265—315
Emery.....	318
Enceladite.....	68, 71
Eosite.....	140
Epidote.....	6, 21, 26, 28
Eruptive Rocks of the Trias,	
229, 241—246	
Erythronium.....	134
Euclase.....	70
Eunanite.....	70
Eusynchite.....	136, 137, 139
Euxenite.....	75
Fahlunite.....	343
Favosite Limestone.....	124
Fergusonite.....	75
Ferrous oxalate.....	10—15
Firing guns under water... 164, 176	
Fishes of the fresh waters of the U. S.....	92—120
Fishes, fossil, new species of,	
127, 128, 188—192	
Flowers, acted upon by chlorine.....	218, 219
by ozone.....	216—219
by sulphurous acid.....	217, 218, 219
Fluoride of ammonium and organic acids.....	25
Fluorite.....	5, 20, 26, 28
Fluosilicic acid.....	413
Fluotitanates.....	54
Foot-prints in the Trias... 225, 229	
230, 231	
Formate of lead.....	15
Formic acid.....	7, 11, 15—25, 32
Forms of red blood-corpuscles,	
266—268, 282—286, 312	
Fossils, new Upper Silurian,	
121—124	
Fossil fishes, new species of,	
127, 128, 188—192	
Fossil plants, leaf-scars of... 41—46	
77—92, 129, 130	
Franklinite.....	5, 19, 25, 28, 158

	PAGE.		PAGE.
Fresh-water fishes of the U. S.,	92—120	Hydro-strontium oxalate.....	15
Functions of silica in the soil...	33	Hydro-thermal alteration of	
Fungi of Texas.....	177—187	Spodumene.....	352
Galenite.....	4, 17—19, 24, 28, 154	Hydrotitanite.....	76
	157, 159	Hystite.....	67
Garnet.....	318, 319, 326, 345	Ilmenite.....	65—75
	350—354	Ilmenium.....	74
Geic acid.....	31	Ilmenorutile.....	71, 72
Geoceric acid.....	33	Indices to Chemical Literature,	
Geological work of organic		Ozone.....	373—403
acids.....	31—34	Peroxide of Hydrogen,	
Georetinic acid.....	33	416—426	
"Ghosts," of red blood-corpus-		Titanium.....	53—76
cles.....	270—274, 312	Vanadium.....	130—146
Glycollic acid.....	16	Indicolite.....	321, 350
Goshenite.....	350	"Investing membrane" of	
Graphite.....	318	blood-corpuscles 286—294, 309, 314	
Greenovite.....	67, 68	Iodides, as ozone-tests.....	204—216
Guarinite.....	73	Iodine, action of, on sulphides.	153
Guaiacum, as an ozone-test.....	198	Iolite.....	343
	211—216, 406	Iron.....	5, 16, 25, 28
Guns, tested by firing under		Iserine.....	66, 74
water.....	164—176	Iserite.....	67, 72, 75
Gurhofite.....	3, 7—11, 13, 28	Iwaarite.....	69, 72
Gypsum.....	5, 19, 28	Japanese antiquities.....	35, 38
Hæmoglobin.....	303—307, 309, 313	bronzes, analyses of.....	40
Hausmannite.....	5, 19, 27, 28, 158	Kalkvolborthite.....	135
Hedenbergite.....	323	Keilhauite.....	68, 71
Hematite, 5, 19, 25, 28, 143, 156	158, 327	Kibdelophan.....	67
History of Antozone.....	405—412	Killinite, 320, 323, 327, 329, 331, 338	340, 354
Ozone.....	363—372	analysis of.....	341, 342
Peroxide of hydrogen,		constitution of.....	343, 344
412—415		microscopical characters	
Hornblende.....	6, 26, 28	of.....	345, 346
Houzeau's tests for ozone, 207, 208	213—216	Konichalcite.....	135
Humboldtine.....	33	Kupferschiefer.....	135
Humic acid.....	31, 32, 33	Kyanite.....	6, 26, 28, 318
Hydriodic acid.....	156	Labradorite.....	6, 26, 28
Hydro-barium oxalate.....	14	Land Shells from	
tartrate.....	14	California.....	316, 317
Hydrobromic acid.....	8	Cape Town, S. A., 355, 361	362
Hydro-calcium tartrate.....	13	Costa Rica.....	257—262
Hydrochloric acid, 7, 8, 9, 29, 153	413	Demarara.....	355
Hydrofluoric acid.....	413	Oregon.....	356
Hydrogen peroxide, <i>see</i> peroxide		Roan Mountain, N. C., 357	
of hydrogen.		358, 360	
Hydrophite.....	135	Lead.....	5, 25, 28
Hydro-potassium oxalate.....	158	Lead oxalate.....	10
sulphate.....	30	Leaf-scars of fossil plants, 41—46	
Hydro-sodium carbonate.....	156	77—92, 129, 130	

PAGE.	PAGE.
Lederite..... 67	Mosandrite..... 71
Lepidolite..... 351	Mudescous acid..... 33
Lignilites..... 124	“Mulberry” forms of blood-
Ligurite..... 66	corpuscles..... 268, 283
Limonite..... 5, 19, 25, 28, 156	Muscovite, 6, 26, 28, 321, 327—329
Literature of Ozone..... 333—403	337, 338, 346—353
of Peroxide of Hydrogen,	
416—462	Natrolite..... 6, 21, 28, 156
of Titanium..... 53—76	Nepheline-dolerite..... 137
of Vanadium..... 133—145	New Jersey, Trias of..... 220—254
Litmus, as an ozone-test... 207, 208	New York Rifle..... 165
Lower Helderberg rocks..... 132	Niccolite..... 4, 18, 24, 28, 155, 157
Lowe’s test for ozone..... 212—216	Nigrine..... 65, 70
Mænakén..... 66	Nitric acid..... 22, 30, 153
Magnesite..... 2, 7—11, 28	Nitro-humic acid..... 33
Magnesium..... 5, 16, 25, 28	Nitrous acid..... 210—214
Magnetite, 5, 19, 25, 28, 142, 156	North Carolina, Trias of, 222, 253
158, 318	254
Malachite..... 4, 7—11, 28	Nucleus, in red blood-corpus-
Malic acid... 7, 11, 16, 18, 21, 25, 32	cles..... 294—297, 314
Mänakerz..... 66	Octahedrite..... 65
Manganes-garnet..... 346, 351	Oerstedite..... 329, 346
Manganite..... 5, 19, 27, 28	Oisanite..... 65, 66
Manganous salts, as ozone-tests,	Oligocythæmia..... 279
208—216, 408	Olivine..... 6, 21, 28, 71, 327
Marcasite..... 4, 18, 24, 28	Onondaga Salt Group..... 124
Margarite..... 318	Organic acids,
Margarodite..... 350, 351	action of on minerals... 1—30
Meissner, on antozone..... 405—414	and oxidizing agents... 22, 23
Mellite..... 33	comparative energy of... 21
Menaccanite..... 65—74	geological work of... 31—34
Mengite..... 67	354
Metals and organic acids..... 16	presence of in soils, 31, 32, 33
Metavanadic acid..... 141, 142	reactions with bromides
Meteoritic alteration of Spodu-	and iodides..... 153—159
mene..... 352, 353	Oriskany Group..... 121
Microcythæmia..... 279	Orthoclase, 6, 21, 28, 318, 323, 350
Microlite..... 351	351, 354
Microscope, in the study of	Orthoclase-granite..... 318, 320, 350
blood-corpuscles..... 265, 282	Orthovanadates..... 140
Microscopic study of crystalline	Ottrelitic clay-slate..... 318
precipitates..... 12	Oxalic acid... 1, 7, 10—24, 31, 157
Minerals, action of organic acids	Oxides, action of organic acids
upon..... 1—34	upon..... 5, 19, 28, 158
behavior with iodine... 153—159	Oxidizing agents and organic
behavior with organic	acids..... 22
acids and iodides, 157, 158	Oxygen, percentage of in the
Moffat’s test for ozone,..... 206	atmosphere..... 193, 194
212—216	relations of to ozone, 370—372
Mohsite..... 67	Ozone, action of upon flowers,
Mollusca, <i>see</i> Land Shells.	216—219
Molybdenite. 4, 18, 24, 28, 154, 157	atmospheric 193—197, 365, 366
159	bibliography of..... 404
Moresnetite..... 32	collection and preserva-
	tion of..... 202, 203

PAGE.	PAGE.
discovery, sources, and properties of.....	363—366
index to the literature of, 373—403	
nature of the matter com- posing.....	367—370
preparation of, 197—199, 203 204	
relations of to oxygen, 370—372	
tests for.....	204—216
therapeutic action of, 365, 366	
Ozonides.....	406, 407
Ozonized water.....	366
Ozonometry, examination of methods in.....	197—204
Ozonoscopes, classification of, 206—211	
critical examination of, 204—206	
materials for.....	204—211
relative efficiency of, 211—216	
uncertainties of.....	204—211, 214—216, 366
Paling of red blood-corpuscles, 269—274	
Palisades of the Hudson.....	241
Parathorite.....	72
Paragenesis of Spodumene, 350, 351	
Paracolumbite.....	70, 74
Pectolite.....	6, 21, 28
Perchromic acid.....	413
Peridote.....	72
Perovskite.....	65—74, 142
Peroxide of hydrogen, history of.....	412, 413
index to the literature of, 416—426	
influence of, on ozono- scopes... 207, 210, 211, 216	
not formed by electro- lysis.....	413, 414
presence of, in the air, 414, 415	
relations of, to ozone and antozone.....	408—412
Phenolphthalein, as an ozone- test.....	207, 208
Phosphotitanic acid.....	54
Phyllite.....	318
Picric acid.....	7, 12, 18
Pictite.....	65
Pigotite.....	33
Pihlrite.....	320, 327
Pinite.....	324, 329, 340, 342
Plumbic sulphide, as an ozone- test.....	208—216
Polli's test for ozone.....	212
Polykras.....	72
Polymignite.....	72
Port Jervis, N. Y., fossils of, 121—124	
Potassium bichromate, as a pre- serving agent for blood-cor- puscles.....	272, 273, 308
Potassium iodide, as an ozone- test.....	198—216, 367—370, 409
Potassium permanganate, as an ozone-test.....	366, 413
Potassium salts, action of, with organic acids, 22, 23, 156, 157, 158	
Prehistoric remains in Japan... 35, 38	
Prehistoric bronze bells.....	35
Prehnite.....	6, 21, 26, 28
Prince Edward Island.....	220
Pseudomorphs, <i>see</i> Alterations.	
Psilomelane.....	5, 19, 27, 28, 139
Pucherite.....	141
Pyrenæmata.....	294, 314
Pyrochlore.....	68
Pyrogallic acid.....	7, 12, 18
Pyrolusite... 5, 19, 27, 28, 158, 319 320, 326, 328, 330, 354	
Pyromelane.....	72
Pyromorphite... 5, 20, 28, 156, 158	
Pyrrhotite, 4, 17—19, 24, 28, 30, 154 155, 157, 159	
Pyrite, 4, 18, 19, 24, 28, 30, 154, 155 157, 159	
Pyrites, decomposition of by nitre and citric acid.....	24
Quartz.....	33, 320, 321, 346—353
Red Sandstones, Triassic... 223—231	
Remington Rifles.....	165
Retinalite.....	6, 21, 28
Rhodochrosite.....	3, 7—11, 28
Rhodonite.....	6, 21, 28, 318
Rifles.....	164—176
Ripidolite.....	6, 26, 28
"Rosette" forms in blood-cor- puscles.....	266, 267, 283, 312
Rutherfordite.....	69, 70
Rutilated quartz.....	69, 70
Rutile.....	65—75, 318
artificial.....	59, 60
Salina Group.....	124
Samarskite.....	5, 20, 26, 28
"Scalloped" forms of blood- corpuscles.....	267

PAGE.	PAGE.			
Schönbein, on antozone	405—414	Sulphide of lead, as an ozone-	test	208—216
on ozone	365—369	Sulphides, action of iodine	upon	153—157
ozone-test of	212—216	action of organic acids	upon	4, 17, 28
Schorl	65, 66	distinction of, by means	of citric acid	18
Schorlomite	65—74, 142	Sulphuric acid, 30, 153, 197, 368, 370		
Séméline	65	Sulphurous acid, action of upon	flowers	217, 218, 219
Serpentine	2, 6, 21, 28, 135	Talc		6, 21, 26—28
Sharp's Rifle	170—176	Tantra marshes		254
Shepardite	69	Tartaric acid		1—24, 29, 31, 32, 157
Siderite	3, 7—11, 15, 28, 135	Tentaculite Limestone		123, 124
Silica, functions of in the soil . .	33	Testing guns under water		164—176
Silicates, action of organic acids		Tests for Ozone		204—216
upon	6, 20, 25, 28	Tetrahedrite		4, 18, 24, 28, 155, 157
comparative solubility of,		Thallos hydrate, as an ozone-	test	208—210, 213—216
in acids	21	Thierschite		32
Silico-propionic acid	33	"Thorn-apple" forms, in blood-	corpuscles	266, 267, 284, 312
Silicotitanates	71	Tin		5, 25, 28
Silver	5, 25, 28	Titanates		53—76
Silver, as an ozone-test, 208, 209, 212		Titanic acid		53—61
Sizes of red blood-corpuscles,		Titanioferrite		67, 75
276—282		Titanite		65—75
Smaltite	4, 18, 24, 28, 155, 157	Titanium		53—76
Smithsonite	3, 7—11, 28	Titanotriamine		61
Solubility of metals in organic		Tourmaline, 6, 21, 26, 28, 338, 345		350, 351, 352
acids	16	Trap-sheets of the Trias		229
Souffriere Mountain	148, 151	241—246		
Sphaerosiderite	58	Trias of Eastern North Ame-		220, 254
Sphene	56, 65—75	rica		326, 352, 354
South Joggins, section at	249	Triphylite		65, 67, 68, 73, 74, 75
Spanish Model Rifle	166—176	Uintah Mountains		248
Sphalerite	4, 17, 18, 24, 28, 154	Ullmannite		4, 18, 24, 28, 155, 157
157, 159		Ulmic acid		31
Spodumene, action of organic		Uran-ochre		326, 354
acids upon	6, 26, 28	Uraninite, 5, 19, 25—28, 135, 136, 142		
alterations of	318, 324, 327	U. S. Army Rifle		166—176
340, 346—354		U. S. Model Rifle		165—176
analyses of	321, 322, 323	Vacuole, in blood-corpuscles . . .		269
constitution of	324, 325, 326	Vanadates		134—142
localities for	318, 319	Vanadic acid		135—142
microscopical characters		Vanadinite		134—142
of	326, 327	Vanadiolite		140
paragenesis of	350, 351	Vanadite		138
Springfield Rifle	166	Vanadium		133—143
Staurolitic schist	318	Variegated Conglomerate		231—240
Steel, titanium	62, 63			
"Stellate" forms of blood-cor-				
puscles	267, 283, 312			
Stibnite	4, 17, 18, 24, 28, 154, 157			
Stilbite	6, 21, 28			
Stone implements in Japan	35, 38			
Stromatopora Limestone	124			
Strontianite	4, 7—11, 15, 28			
Structure of blood-corpuscles,				
265—314				
Succinic acid	33			
Succinite	33			

	PAGE.		PAGE.
Velocity of chemical reactions	8	Willemite.....	2, 6, 21, 28
Virginia, Trias of	222, 254	Witherite.....	4, 7—14, 28
Vitality of red blood-corpuses,	297—302	Wollastonite.....	6, 21, 28
Vivianite.....	5, 20, 28, 156	Wulfenite.....	137
Volborthite.....	134, 135, 136	Xanthitan.....	71
Wad.....	5, 19, 27, 28	Yttrotitanite.....	65, 68, 71, 73
Warwickite.....	65, 67, 71, 72, 75	Zinc.....	5, 16, 17, 25, 28
Washingtonite.....	67, 68	Zincite.....	5, 19, 28
Water-lime Group.....	124	Zircon.....	326, 351, 354
Wernerite.....	6, 21, 26, 28	Zoisite.....	318
Whewellite.....	32		

INDEX OF NOMENCLATURE.

[The names of *new* species are printed in Roman letters; synonyms and species to which reference is made are in *Italics*; names of sub-families, families, or higher divisions, in SMALL CAPITALS.]

	PAGE.		PAGE.
Abutilon.....	182, 217	Amiurus <i>lophius</i>	117
<i>insigne</i>	217, 218	<i>melas</i>	118
<i>venosum</i>	217, 218	<i>natalis</i>	117
Acantharchus <i>pototis</i>	100	<i>nigricans</i>	117
Acer.....	182	<i>obesus</i>	118
Acipenser <i>maculosus</i>	120	<i>pullus</i>	118
<i>rubicundus</i>	120	<i>vulgaris</i>	118
ACIPENSERIDÆ.....	120	<i>xanthocephalus</i>	118
AcrospERMUM <i>foliicola</i>	184	Ammocetes <i>argenteus</i>	120
<i>viridulum</i>	184	<i>fluvialilis</i>	120
Agaricus <i>Texensis</i>	178	<i>hirudo</i>	120
Ailographum <i>maculare</i>	184	<i>niger</i>	120
Alburnellus <i>dilectus</i>	112	Ammocrypta <i>Beanii</i>	93
<i>jaculus</i>	112	Anguilla <i>Bostoniensis</i>	119
<i>micropteryx</i>	112	<i>vulgaris</i>	119
<i>rubrifrons</i>	112	ANGUILLIDÆ.....	119
Alburnops <i>amarus</i>	109	Anoderma <i>Lindheimeri</i>	178
<i>chrosomus</i>	110	Antholites.....	130
<i>haematurus</i>	109	APHODODERIDÆ.....	101
<i>heterodon</i>	113	Aphododerus <i>isolepis</i>	101
<i>Hudsonius</i>	109	<i>Sayanus</i>	101
<i>microstomus</i>	109	Apomotis <i>cyaneus</i>	100
<i>roseus</i>	110	<i>phenax</i>	100
<i>stramineus</i>	109	Archæobatis.....	190
<i>volucellus</i>	109	<i>gigas</i>	191
<i>xenôcephalus</i>	110	Arcyria <i>cinerea</i>	180
Alburnus <i>rubellus</i>	112	Argyreus <i>atronasus</i>	108
Alvordius <i>macrocephalus</i>	96	<i>nasutus</i>	108
<i>maculatus</i>	95	Argyrosomus <i>sisco</i>	105
<i>phoxocephalus</i>	96	Asterina <i>orbicularis</i>	187
Ambloplites <i>ceneus</i>	100	<i>Wrightii</i>	184, 187
<i>ripestris</i>	100	ATHERINIDÆ.....	103
AMBLYOPSIDÆ.....	104	Aulopora <i>precisus</i>	124
Amblyopsis <i>speiceus</i>	104	Azalea <i>Indica</i>	217, 218
Ambonychia <i>acutirostra</i>	124	Bathynathus <i>borealis</i>	220
Amia <i>calva</i>	119	Berchemia.....	183
AMIIDÆ.....	119	Blacicus <i>Blancoi</i>	161, 162
Amiurus <i>albidus</i>	117, 118	<i>brunneicapillus</i>	161
<i>brunneus</i>	118	Boleichthys <i>elegans</i>	94
<i>calus</i>	118	<i>Eos</i>	94
<i>erebennus</i>	117	<i>fusiformis</i>	94
<i>furcatus</i>	117		

	PAGE.		PAGE.
<i>Boleosoma atromaculatum</i>	95	<i>Ceraticthys Milneri</i>	108
<i>effulgens</i>	95	<i>prosthemiis</i>	108
<i>maculatum</i>	95	<i>rubrifrons</i>	108
<i>Ohmstedii</i>	95	<i>Cercospora altheana</i>	182
<i>stigmaeum</i>	95	<i>gnaphaliacea</i>	182
<i>tesselatum</i>	95	<i>Certhiola atrata</i>	149
<i>Bouvardia</i>	217, 218	<i>saccharina</i>	150
<i>Bovista stippea</i>	179	<i>Portoricensis</i>	150
<i>Bryttus oculatus</i>	99	<i>Chænobryttus gulosus</i>	100
<i>Bubalichthys cyanelhus</i>	117	<i>viridis</i>	100
<i>urus</i>	116	<i>Chætura brachyura</i>	255
<i>Buliminus</i>	362	<i>Dominicana</i>	255
<i>Natalensis</i> ,		<i>poliura</i>	255
var. <i>Draakensburgensis</i>	362	<i>Chamaerops</i>	182
<i>Bulimulus</i>	258	<i>Chatoessus ellipticus</i>	106
<i>Irazuensis</i>	262	<i>Cheilonemus pulchellus</i>	108
<i>linnaeoides</i>	262	<i>Chirostoma siccum</i>	103
<i>Byssisedæ</i>	186	<i>Chrosomus erythrogaster</i>	113
<i>Calliste cayana</i>	152	<i>pyrrhogaster</i>	113
<i>cucullata</i>	152	<i>Eos</i>	113
<i>cyanolarma</i>	152	<i>Chrysotis albifrons</i>	126
<i>versicolor</i>	152	<i>Amazonica</i>	126
<i>vitriolina</i>	152	<i>angusta</i>	47
<i>Calliurus Floridensis</i>	100	<i>collaris</i>	126
<i>Callopora</i>	124	<i>lactifrons</i>	125
<i>Calymene cannerata</i>	124	<i>Sallæi</i>	126
<i>Camellia Japonica</i>	217, 218	<i>vittata</i>	126
<i>Campostoma anomalum</i>	107	<i>Cineraria</i>	217, 218
<i>Caninia bilateralis</i>	124	<i>Cladopora seriata</i>	124
<i>Carpinus</i>	186	<i>Clathraria</i>	131
<i>Carpioles cutis-anserinus</i>	116	<i>Clinostomus margarita</i>	113
<i>cyprinus</i>	116	<i>proriger</i>	113
<i>difformis</i>	116	<i>Cliola arionnna</i>	112
<i>Thompsoni</i>	116	<i>leucioda</i>	112
<i>velifer</i>	116	<i>scalriceps</i>	112
<i>Catonotus flabellatus</i>	94	CLUPEIDÆ	106
<i>lineolatus</i>	94	<i>Codoma cærulea</i>	111
CATOSTOMIDÆ	114	<i>callisena</i>	111
<i>Catostomus Bostoniensis</i>	114	<i>callistia</i>	111
<i>bubalus</i>	117	<i>chloristia</i>	111
<i>Commersoni</i>	114	<i>eurystoma</i>	111
<i>Etowanus</i>	114	<i>grandipinnis</i>	111
<i>Hudsonius</i>	114	<i>pyrrhomelas</i>	111
<i>longirostris</i>	114	<i>stigmatura</i>	111
<i>nigricans</i>	114	<i>trichroistia</i>	111
<i>Caulicolæ</i>	186, 187	<i>xænura</i>	111
CENTRARCHIDÆ	97	<i>Cœlacanthus</i>	127
<i>Centrarchus irideus</i>	97	<i>Collybia Texensis</i>	178
<i>pomotis</i>	100	<i>Copelandia eriarcha</i>	97
<i>Cerasus</i>	181	<i>Coregonus Artedi</i>	105
<i>Ceraticthys amblops</i>	108	<i>chupeiformis</i>	105, 106
<i>biguttatus</i>	108	<i>Hoyi</i>	106
<i>dissimilis</i>	108	<i>nigripinnis</i>	105
<i>gracilis</i>	108	<i>quadrilateralis</i>	106
<i>hyalinus</i>	108	<i>sapidissimus</i>	106
		<i>sisco</i>	105

PAGE.		PAGE.	
Corticium <i>calceum</i>	179	<i>Esox ornatus</i>	104
<i>carneum</i>	179	<i>reticulatus</i>	104
<i>comedens</i>	179	<i>salmoneus</i>	104
<i>lactescens</i>	179	<i>umbrosus</i>	104
Dasydirion.....	181	<i>Estrella atromaculata</i>	95
Dasyscypha <i>virginea</i>	183	<i>Etheostoma blennioides</i>	95
Dendroeca <i>cærulescens</i>	48	<i>flabellare</i>	94
<i>plumbea</i>	47	<i>lineolatum</i>	94
Desmodium.....	182	<i>Linslii</i>	94
Diatrype <i>atropunctata</i>	185	<i>macrocephalum</i>	96
<i>dryophila</i>	185	ETHEOSTOMATIDÆ.....	93
<i>exutans</i>	185	<i>Eucalia Cayuga</i>	102
<i>hypophlœa</i>	185	<i>inconstans</i>	102
<i>opaca</i>	185	<i>Eulampis holosericeus</i>	47
<i>punctulata</i>	185	<i>jugularis</i>	47
<i>quercina</i>	185	<i>Euphorbium</i>	182
<i>rumpens</i>	185	<i>Eupomotis aureus</i>	98
Diatrypella <i>opaca</i>	185	<i>pallidus</i>	98
Didymium.....	180	<i>Euspiraxis</i>	355
Dinichthys.....	188, 189	<i>Eustegia magnoliæ</i>	183
<i>Hertzeri</i>	189	<i>Eutypa limæformis</i>	185
<i>minor</i>	191	<i>Exoglossum maxillilingua</i>	107
<i>Terrelli</i>	189	Favosites.....	124
Diphyphyllum <i>integumentum</i> ..	123	Foliicolæ.....	187
Diplesium <i>blennioides</i>	95	<i>Fundulus catenatus</i>	103
<i>Newmani</i>	95	<i>diaphanus</i>	103
<i>simoterum</i>	95	<i>menona</i>	103
Diplodia <i>Zœæ</i>	180	<i>multifasciatus</i>	103
Diplognathus.....	188, 189	GADIDÆ.....	102
<i>mirabilis</i>	188	Gæotis.....	259
Diplurus.....	127	Garrya.....	187
<i>longicaudatus</i>	127	GASTEROSTEIDÆ.....	102
Discella <i>angulata</i>	180	<i>Gasterosteus inconstans</i>	102
<i>leguminum</i>	180	<i>Geaster hygrometricus</i>	179
Discina <i>Jervensis</i>	121	<i>Gila elongata</i>	113
Dorysoma <i>cepedianum</i>	106	<i>margarita</i>	113
<i>heterurum</i>	106	<i>Glandina</i>	261, 355, 362
DORYSOMATIDÆ.....	106	<i>Glonium lineare</i>	183
Dothidea <i>ilicis</i>	187	<i>medium</i>	183
Elassoma <i>zonatum</i>	101	<i>Glossoplites melanops</i>	100
ELASSOMIDÆ.....	101	<i>Glyptolemus</i>	190
Enneacanthus <i>obesus</i>	98	<i>Glyptopomus</i>	189, 190
<i>margarotus</i>	98	<i>Sayrei</i>	189
Ephedra.....	182	<i>Gnaphalium</i>	182
Episema <i>callisema</i>	111	<i>Graphiola Phœnicis</i>	182
Ericosma <i>evides</i>	95	<i>Guepinia spathularia</i>	179
Ericymba <i>buccata</i>	107	<i>Hadropterus nigrofasciatus</i>	96
Erimyzon <i>melanops</i>	115	<i>tesselatus</i>	96
<i>sucetta</i>	114	<i>Halysites agglomeratus</i>	124
ESOCIDÆ.....	104	<i>catenulatus</i>	124
<i>Esox Americanus</i>	104	<i>Haplochilus pulchellus</i>	103
<i>cypho</i>	104	<i>Haploidonotus grunniens</i>	101
<i>lucius</i>	104	<i>Helicarium</i>	258
<i>nobilior</i>	104		

	PAGE.		PAGE.
HELICIDÆ.....	361	Hysterium <i>prælongum</i>	183
Helix...261, 262, 316, 317, 355,	361	<i>xyломoides</i>	184
<i>circumcarinata</i>	316	Ichthæolurus <i>furcatus</i>	117
<i>globulus</i>	361, 362	<i>punctatus</i>	117
<i>Hillebrandi</i>	317	<i>robustus</i>	117
<i>Mormonum</i>	316, 317	Ichthelis <i>aquilensis</i>	99
<i>progastor</i>	258	<i>incisor</i>	99
<i>rariPLICATA</i>	361, 362	<i>inscriptus</i>	98
Hemitremia <i>bifrenata</i>	113	<i>rubricauda</i>	99
<i>heterodon</i>	113	<i>sanguinolentus</i>	98
<i>vittata</i>	113	Ichthyolurus <i>bubalus</i>	116
Hendersonia <i>magna</i>	180	<i>cyaneellus</i>	117
Herneola <i>auricula-Judæ</i>	179	Ichthyomyzon <i>argenteus</i>	120
Hirundo <i>acuta</i>	256	<i>hirudo</i>	120
<i>Martinicana</i>	256	Ictalurus <i>cærulescens</i>	117
<i>pelasgia</i>	256	Ilex <i>opaca</i>	185, 187
Holophagus.....	127	Immersæ.....	186
Hopladelus <i>olivaris</i>	118	Imostoma <i>Shumardii</i>	95
Humaria <i>melalonna</i>	183	Inga <i>pulcherrima</i>	217, 218
Hyalina.....	356	Inoderma <i>barbatulum</i>	178
Hybognathus <i>argyritis</i>	107	<i>versicolor</i>	178
<i>nuchalis</i>	107	Irpex <i>tabacinus</i>	178
<i>osmerinus</i>	107	Ixia.....	217, 218
<i>regius</i>	107	Juncus.....	182
<i>stramineus</i>	109	Kneiffia <i>setigera</i>	178
Hybopsis <i>bifrenatus</i>	113	Krynickia.....	260
<i>chrosomus</i>	110	Labidesthes <i>sicculus</i>	103
<i>hæmaturus</i>	109	LABRACIDÆ.....	97
<i>Hudsonius</i>	109	Labrax <i>albidus</i>	97
<i>microstomus</i>	109	<i>lineatus</i>	97
<i>phaëna</i>	109	<i>rufus</i>	97
<i>ænocephalus</i>	110	Lagochila <i>lacera</i>	111
Hyborhynchus <i>notatus</i>	107	Leioderma.....	131
Hylomyzon <i>nigricans</i>	114	Lepidodendron, 41, 42, 44, 77, 129	
Hyodon <i>tergisus</i>	106	<i>aculeatum</i>	77—85, 88, 89, 90
HYODONTIDÆ.....	106	<i>carinatum</i>	84, 85, 90
Hyostoma <i>cymatogrammum</i>	95	<i>caudatum</i>	78
<i>Newmani</i>	95	<i>chypeatum</i>	84
<i>sinoterum</i>	95	<i>conicum</i>	86, 90
Hypoxylon <i>annulatum</i>	184	<i>crenatum</i>	88, 89
<i>argillaceum</i>	184	<i>diplotegioides</i>	86
<i>fuscum</i>	184	<i>distans</i>	82, 83, 87, 88, 90
<i>investiens</i>	185	<i>giganteum</i>	83, 84
<i>malleolus</i>	184	<i>mammillatum</i>	86, 90
<i>multiforme</i>	184	<i>modulatum</i>	81—84, 87, 90
<i>rubiginosum</i>	184	<i>obovatum</i>	85, 88, 89
<i>sassafras</i>	184	<i>obscurum</i>	86, 90
Hypsilepis <i>ardens</i>	114	<i>obtusum</i>	83, 89, 90
<i>coccogenis</i>	110	<i>oculatum</i>	83
<i>diplemis</i>	113	<i>rugosum</i>	88
<i>galacturus</i>	110	<i>Sternbergii</i>	77, 85, 88
<i>Kentuckiensis</i>	110	<i>tetragonum</i>	84
Hypsolepis <i>cornutus</i>	110		
Hysterium <i>lineare</i>	183		
<i>maculare</i>	184		
<i>medium</i>	183		

	PAGE.		PAGE.
Lepidodendron undulatum.....	78	Melanura pygmaea.....	104
LEPIDOSTEDÆ.....	119	Melasmia acerina.....	181
Lepidosteus osseus.....	119	Meliola amphitricha.....	187
platystomus.....	119	Melogramma gyrosum.....	185
viridis.....	119	Merulius Wrightii.....	178
Lepiopomus anagallinus.....	99	Mesodon.....	360, 361
auritus.....	99	Andrewsi.....	360, 362
ischyrus.....	99	clausa.....	361
obscurus.....	99	dentifera.....	360, 362
oculatus.....	99	Mitchelliana.....	361
macrochirus.....	99	thyroides.....	361
miniatus.....	99	Mesogonistius chætodon.....	98
pallidus.....	99	Mesomphix.....	355
Lepomis auritus.....	98	Mesopus arcularius.....	178
mineopas.....	100	Microperca punctulata.....	93
nephelus.....	99	Microphysa Lansingi.....	361
peltastes.....	98	Micropterus nigricans.....	100
Leptæna.....	124	pallidus.....	100
Leucopezæ Bishopi.....	150, 151	sabnoides.....	100
Senperi.....	151	Microthyrium Smilacis.....	187
Leutinus tigrinus.....	178	Minnilus æcenurus.....	111
Licea Lindheimeri.....	180	Minytrema melanops.....	115
Limax.....	260	Mitremyces lutescens.....	180
agrestis.....	258	Mollisia rubella.....	183
semitectus.....	260, 262	Montagnites Candollei.....	178
Liquidambar.....	185	Morone Americana.....	97
Litholepis spatula.....	119	interrupta.....	97
Lophodermium maculare.....	184	Moxostoma carpio.....	115
xylomoides.....	184	oblongum.....	115
Lota lacustris.....	102	Victoriae.....	115
maculosa.....	102	Myiadestes armillatus.....	148
Lutjoperca Americana.....	96	genibarbis.....	147, 148
grisea.....	97	sibilans.....	147
Luxilus analostanus.....	110	solitarius.....	148
calliurus.....	110	Myiarchus crinitus.....	49
coccogenis.....	110	erythrocercus.....	49
cornutus.....	110	Oberi.....	48, 49
galacturus.....	110	tyrannulus.....	49
roseus.....	110	Myliobatis.....	190
Selene.....	110	Myxostoma anisurum.....	115
Lythrurus ardens.....	114	aureolum.....	115
cyanocephalus.....	113	carpio.....	115
diplæmius.....	113	cervinum.....	116
Macrocyclus.....	356	Dugesnii.....	115
concava.....	356	euryops.....	115
Hemphilli.....	356, 362	lachrymale.....	115
Vancouverensis.....	356	macrolepidotum.....	115
Macropoma.....	127	papillosum.....	116
Macrosporium compactum.....	182	velatum.....	115
Magnoliâ grandiflora.....	181, 183, 185	Nanostoma zonale.....	94
Malva.....	182	Nasturtium.....	217, 218
Mariella.....	259	Nectria epispheeria.....	185
Massaria Curreyi.....	186	Nocomis Milneri.....	108
Megapelta.....	260	Notemigonon Americanus.....	114
Melanura limi.....	103	chrysoleucus.....	114

	PAGE.		PAGE.
<i>Notemigonus ischanus</i>	114	<i>Peziza stercorea</i>	183
<i>Nothonotus camurus</i>	94	<i>Texensis</i>	183
<i>niger</i>	94	<i>virginea</i>	183
<i>Notropis dilectus</i>	112	<i>Phacidium dentatum</i>	184
<i>dinemus</i>	112	<i>Phaseolus</i>	182
<i>lirus</i>	113	<i>Phenacobius catostomus</i>	109
<i>micropteryx</i>	112	<i>uranops</i>	108
<i>photogenis</i>	112	<i>Phlyctæna dissepta</i>	180
<i>rubellus</i>	112	<i>Smilacis</i>	180, 187
<i>rubrifrons</i>	112	<i>Phoma helvolum</i>	180
<i>stilbius</i>	112	<i>hysteriiforme</i>	180
<i>Noturus exilis</i>	118	<i>hysteroideum</i>	180
<i>fluvius</i>	118	<i>Photogenis aricomnus</i>	112
<i>insignis</i>	118	<i>cæruleus</i>	111
<i>leptacanthus</i>	119	<i>callistius</i>	111
<i>miurus</i>	119	<i>eurystomus</i>	111
<i>occidentalis</i>	118, 119	<i>grandipinnis</i>	111
<i>sialis</i>	119	<i>leuciodus</i>	112
<i>Obtectæ</i>	186	<i>leucops</i>	112
<i>Oecidium Orobi</i>	182	<i>pyrrhomelas</i>	111
<i>Opuntia</i>	187	<i>scabriceps</i>	112
<i>Orbicula filosa</i>	122	<i>stigmaturus</i>	111
<i>Orthorhynchus cristatus</i>	51	<i>Phoxinus neogæus</i>	113
<i>emigrans</i>	50	<i>Phragmidium mucronatum</i>	181
<i>exilis</i>	47	<i>Phyllosticta micropuncta</i>	181
<i>ornatus</i>	51	<i>Physarum obrusseum</i>	180
<i>Pachnodus</i>	362	<i>Pilacre faginea</i>	183
<i>Parmella</i>	259	<i>Petersii</i>	183
<i>Patellaria cyanea</i>	183	<i>Pileoma semifasciatum</i>	96
<i>indigolica</i>	183	<i>Pimelodus atrarius</i>	118
<i>Pella</i>	355, 361	<i>Dekayi</i>	118
<i>Pelodichthys olivaris</i>	118	<i>lyna</i>	119
<i>Peniophora</i>	179	<i>pultus</i>	118
<i>Perca Americana</i>	96	<i>Pimephales promelas</i>	107
<i>flavescens</i>	96	<i>Placopharynx carinatus</i>	116
<i>salmonæa</i>	96	<i>Planesticus</i>	147
PERCIDÆ	96	<i>Pleurolepis pellucidus</i>	93
<i>Percina caprodes</i>	96	<i>Pæcilichthys cæruleus</i>	94
<i>manitou</i>	96	<i>spectabilis</i>	94
PERCOPSIDÆ	105	<i>variatus</i>	94
<i>Percopsis guttatus</i>	125	<i>zonalis</i>	94
<i>Peridermium Ephedræ</i>	182	<i>Polygyra</i>	259
<i>Pini</i>	182	<i>Polyodon folium</i>	120
<i>Perisporium Wrightii</i>	187	POLYODONTIDÆ	120
<i>Persea</i>	181, 184, 187	<i>Polyporus arcularius</i>	178
<i>Petromyzon niger</i>	120	<i>barbatulus</i>	178
<i>nigricans</i>	120	<i>continguis</i>	178
PETROMYZONTIDÆ	120	<i>Lindheimeri</i>	178
<i>Peziza irrorata</i>	183	<i>versicolor</i>	178
<i>leucoloma</i>	180	<i>Pomolobus chrysochloris</i>	106
<i>melaloma</i>	183	<i>pseudoharengus</i>	106
<i>pusio</i>	183	<i>Pomotis chætodon</i>	98
<i>rubella</i>	183	<i>pallidus</i>	98
<i>scutellata</i>	183	<i>notatus</i>	99
		<i>obscurus</i>	99
		<i>sanguinolentus</i>	98

	PAGE.		PAGE.
<i>Pomotis vulgaris</i>	98	Rhytida	355
<i>Pomoxys annularis</i>	97	<i>vernica</i>	355, 362
<i>hexacanthus</i>	97	Ricinus	182
<i>nigromaculatus</i>	97	Roccius <i>chrysops</i>	97
<i>Storerius</i>	97	<i>lineatus</i>	97
<i>Poronia ædipus</i>	184	Sagenaria <i>confluens</i>	78
<i>Potamocottus Alvordii</i>	102	<i>Salmo fontinalis</i>	105
<i>Carolinæ</i>	102	<i>Namaycush</i>	105
<i>meridionalis</i>	102	<i>Siscowet</i>	105
<i>Wilsoni</i>	102	SALMONIDÆ	105
<i>zopherus</i>	102	<i>Salvelinus fontinalis</i>	105
Proetus	124	<i>Oquassa</i>	105
Prosopis	180	<i>Salvia splendens</i>	217, 218
Prunus	181	Sapindus	187
Psammodus	190	Sarcoscypha <i>pusio</i>	183
Psoralea	182	<i>scutellata</i>	183
<i>Ptycholepis Bollensis</i>	128	<i>stercorea</i>	183
<i>curtus</i>	128	<i>Texensis</i>	183
<i>Marshi</i>	127	Scaphirhynchops <i>platyrhynchus</i>	120
<i>minor</i>	128	Scaphirhynchus <i>cattaphractus</i>	120
<i>Ptychostomus aureolus</i>	115	SCIENIDÆ	101
<i>breviceps</i>	115	<i>Schizocrania filosa</i>	122
<i>collapsus</i>	115	Scleroderma <i>Texense</i>	180
<i>erythrorus</i>	115	Secotium <i>Texense</i>	179
<i>lachrymalis</i>	115	Semotilus <i>bullaris</i>	108
<i>macrolepidotus</i>	115	<i>corporalis</i>	107
<i>papillosus</i>	116	<i>rhotheus</i>	108
<i>Puccinia lobata</i>	182	Septoria <i>ampelina</i>	181
<i>prunorum</i>	181	<i>Magnoliæ</i>	181
<i>Pycnanthemum</i>	181	<i>Speculariæ</i>	181
<i>vestita</i>	181	Sida <i>lepidota</i>	182
<i>Quassilabia lacera</i>	116	Sigillaria	41—45, 77, 129
<i>Quercus aquatica</i>	184	<i>Brardii</i>	130, 131, 132, 133
<i>obtusiloba</i>	184	<i>Defrancii</i>	131, 133
<i>virens</i>	187	<i>discoidea</i>	42, 43
<i>Quiscalus brachypterus</i>	163	<i>laevigata</i>	42, 45
<i>luminosus</i>	162	<i>lepidodendrifolia</i>	129—133
<i>Receptaculites lateritius</i>	123	<i>Lorwayana</i>	130, 132
<i>Resupinatus contiguus</i>	178	<i>Menardi</i>	130, 131, 133
Reuellia	182	<i>obliqua</i>	131, 132, 133
<i>Rheocrypta Copelandi</i>	95	<i>reniformis</i>	42, 43, 44
Rhina	190	<i>rhomboidea</i>	131, 133
<i>ancylostomus</i>	191	<i>sculpta</i>	132, 133
<i>Rhinichthys atronasmus</i>	108	<i>Serlii</i>	131, 133
<i>cataractæ</i>	108	<i>spinulosa</i>	132, 133
<i>lunatus</i>	109	<i>stellata</i>	132, 133
<i>meleagris</i>	109	SILURIDÆ	117
<i>obtusus</i>	109	<i>Smilax</i>	180, 184, 186, 187
<i>Rhinotrichum Curtisii</i>	182	Sordaria	186
<i>Rhynchodus excavatus</i>	192	<i>Specularia perfoliata</i>	181
<i>frangens</i>	192	Sphærella <i>exutans</i>	187
<i>occidentalis</i>	192	<i>maculiformis</i>	187
<i>Rhynchonella lamellata</i>	124	<i>Sphæria anguillida</i>	187
<i>nucleolata</i>	124	<i>appendiculosa</i>	187
<i>pisa</i>	124		

	PAGE.		PAGE.
<i>Sphaeria aquila</i>	186	<i>Thymallus tricolor</i>	105
<i>botulæspora</i>	186	<i>Torrubia Ravenalii</i>	184
<i>canescens</i>	186	<i>Torula</i>	186
<i>culcitella</i>	186	<i>quaternata</i>	181
<i>Janus</i>	187	<i>Trametes hydnoides</i>	178
<i>livida</i>	186	<i>Lindheimeri</i>	178
<i>macrospora</i>	186	<i>Trematis superincretata</i>	122
<i>minima</i>	186	<i>filosa</i>	122
<i>pertacta</i>	186	<i>Trematopora</i>	124
<i>Texensis</i>	186	<i>Trichobasis Junci</i>	182
<i>torulæspora</i>	186	<i>rubigo-vera</i>	182
<i>uvæspora</i>	187	<i>Trichodium</i>	182
<i>Spiraxia Dunkeri</i>	355, 362	<i>Trigonocarpa</i>	130
<i>Spirorhis inornatus</i>	124	<i>Triphragmium deghubens</i>	181
<i>Sporadinus Bracei</i>	50	TROCHILIDÆ.....	50, 51
<i>Ricordii</i>	50	<i>Tulostoma fimbriatum</i>	179
<i>Sporidesmium asteriscus</i>	181	<i>Turdus albiventris</i>	147
<i>compactum</i>	181	<i>Caribbeus</i>	160
<i>compositum</i>	181	<i>gymnophthalmus</i>	160
<i>mundulum</i>	181	<i>nigrirostris</i>	146
<i>Sporormia</i>	186	<i>Typhlichthys subterraneus</i>	104
<i>Stenopus</i>	355	<i>Ulocentra stigmæa</i>	95
<i>Cayennensis</i>	355	<i>Umbra limi</i>	103
<i>decoloratus</i>	355, 362	UMBRIDÆ.....	103
<i>Stenotrema</i>	259	<i>Uranidea gracilis</i>	101
<i>Stereum acerinum</i>	179	<i>Hoyi</i>	101
<i>Curtisii</i>	178	<i>Kundienii</i>	101
<i>dissitum</i>	178	<i>viscosa</i>	101
<i>pruinatum</i>	179	<i>Uromyces appendiculatus</i>	182
<i>Sternotremia isolepis</i>	101	<i>myristica</i>	182
<i>Stigmatæa gregaria</i>	187	<i>Phaseoli</i>	182
<i>Stilbe Americana</i>	114	<i>pulcherrimus</i>	182
<i>Stilbum aleuriatum</i>	182	<i>sobibus</i>	182
<i>Stizostethium Canadense</i>	97	<i>Texensis</i>	182
<i>submoneum</i>	96	<i>Valsa stellulata</i>	185
<i>vitreum</i>	96	<i>tetraploa</i>	186
<i>Strelitzia regina</i>	217, 218	<i>velata</i>	186
<i>Streptelasma</i>	124	<i>vitis</i>	186
<i>Strobilomyces strobilaceus</i>	178	<i>Velifera</i>	257
<i>Stromatopora constellata</i>	124	<i>Gabbi</i>	258, 262
<i>Strophia</i>	361	<i>Veronicella</i>	262
<i>Strophodonta</i>	124	<i>Verticillium sorediatum</i>	182
<i>Tanagra cana</i>	152	<i>Villosæ</i>	186
<i>Tauridea spilota</i>	102	<i>Vitis</i>	181, 186
<i>Tebennophorus</i>	261, 360	<i>Vitriniconus</i>	258
<i>Costaricensis</i>	261, 262	<i>Vitrinizonites</i>	356
<i>Teretulus cervinus</i>	116	<i>latissimus</i>	356, 362
<i>TETRAONIDÆ</i>	50, 51	<i>Vitrinopsis</i>	259
<i>Thalurania Wagleri</i>	46, 47	<i>Xenisma catenata</i>	103
<i>Thelephora cladonia</i>	178	<i>stellifera</i>	103
<i>Thryothorus Grenadensis</i>	161	<i>Xenotis inscriptus</i>	98
<i>Martinicensis</i>	47	<i>lythrochloris</i>	98
<i>mesoleucus</i>	149	<i>megalotis</i>	98
<i>musicus</i>	148, 161		
<i>rufescens</i>	47, 161		

PAGE.		PAGE.	
Xenotis <i>pellastes</i>	98	Zonites <i>friabilis</i>	356
<i>sanguinolentus</i>	98	<i>fuliginosus</i>	356
Xylaria <i>clavulus</i>	184	<i>gularis</i>	360
<i>digitata</i>	184	<i>inornatus</i>	356
<i>rhopaloides</i>	184	<i>laevigatus</i>	356
<i>Titan</i>	184	<i>lasmodon</i>	358, 359, 362
Xystroplites <i>Gillii</i>	99	<i>ligerus</i>	356
<i>notatus</i>	99	<i>macilentus</i>	359, 362
Yucca	187	<i>multidentatus</i>	358, 359, 362
Zea <i>Mays</i>	180	<i>placentula</i>	358, 362
Zonites	257, 356	<i>Rugeli</i>	357, 358, 362
<i>Andrewsi</i>	258, 359, 362	<i>significans</i>	358, 359, 362
<i>capnodes</i>	356, 362	<i>subplanus</i>	357, 358, 362
<i>cerinoideus</i>	359	<i>suppressus</i>	356, 358
<i>cuspidatus</i>	359, 362	Zygonectes <i>dispar</i>	103
<i>demissus</i>	356	<i>notatus</i>	103
		<i>Nottii</i>	103

ERRATA.

Page 207, line 20 from the top, for 'proxide' read 'peroxide.'

Page 354, line 15 from the top, for 'dresent' read 'present.'

Page 366, line 13 from the top, for 'permangatnate' read 'permanganate.'

After the publication of his paper on "Testing the Value of Guns by Firing under Water" (Art. XVII), Dr. H. A. Mott, Jr., published a revision of the article, containing changes in a part of its results. These changes in no wise affect the principle involved, or the relative merits of the several weapons as tested; but by altering the calculation so as to include therein also the *common* length of the gun-barrels, the tables on pages 175 and 176 are materially modified, so as to give results as follows:—

	Board penetrated at total distance from Cartridge.	Board would be penetrated through Air at—
U. S. Army Rifle.....	6 feet, 11 $\frac{1}{32}$ inches.	5327.78 feet.
U. S. Model Rifle.....	6 " 10 $\frac{3}{4}$ "	5309.65 "
Sharp's Rifle.....	6 " 5 $\frac{3}{4}$ "	4988.95 "
Spanish Model Rifle...	6 " 6 $\frac{1}{2}$ "	5037.08 "

Bound covers at back.

Vol. I.

December, 1877.

Nos. 1-2.

ANNALS

OF THE

NEW YORK ACADEMY OF SCIENCES,

(LATE LYCEUM OF NATURAL HISTORY).

130610

New York:

PUBLISHED FOR THE ACADEMY.

1877.

MS. [unclear] [unclear]

GREGORY BROS., PRINTERS, 34 CARMINE STREET, N. Y.

OFFICERS OF THE ACADEMY.

1877.

President,

JOHN S. NEWBERRY.

Vice-Presidents,

T. EGLESTON. BENJ. N. MARTIN.

Corresponding Secretary,

ALBERT R. LEEDS.

Recording Secretary,

OLIVER P. HUBBARD.

Treasurer,

JOHN H. HINTON.

Librarian,

LOUIS ELSBERG.

Committee of Publication,

DANIEL S. MARTIN. JOHN S. NEWBERRY.

GEO. N. LAWRENCE. H. CARRINGTON BOLTON.

ANNALS
OF THE
NEW YORK ACADEMY OF SCIENCES.
VOLUME I.

The "Annals," published for over half a century by the late Lyceum of Natural History, are continued under the above name by the NEW YORK ACADEMY OF SCIENCES, beginning with the current year, 1877.

The present numbers, which have been delayed in passing through the press, will be soon followed by the other two numbers for 1877.

It is proposed, as before, to issue four numbers every year, each number to consist of not less than thirty-two pages (octavo), with or without plates. Price of Yearly Subscription, Two Dollars, payable in advance.

The Academy has for sale a number of back volumes of the Annals of the Lyceum, each containing twelve or more numbers; the price per volume is \$1.00 with uncolored plates, or \$5.00 with colored plates.

The Academy has established a Publication Fund, contributors to which, in the sum of \$100 at one time, are entitled to all the scientific publications of the Academy appearing subsequently to the payment of their contribution.

Communications should be addressed to

PROF. D. S. MARTIN,

Chairman of Publication Committee, 236 West Fourth St.

Or to

JOHN H. HINTON, M.D.,

Treasurer, 41 West Thirty-second St.

Any person residing within the United States, on sending the amount of his yearly subscription to the Treasurer, will receive the numbers as they appear, without further cost.

Agents in London, TRUBNER & CO.

In Leipzig, BERN HERMANN.

Special agents for the Academy,

NATURALISTS' AGENCY,



Salem, Mass.

NOTE.—The Index number (13)—the closing part of the last volume of the old series—will appear as speedily as the work upon it can be finished.



CONTENTS.

	PAGE
I. Application of Organic Acids to the Examination of Minerals. (With Plate I). By H. CARRINGTON BOLTON	1
II. Prehistoric Bronzé Bells from Japan. (With Plate II). By HENRY S. MUNROE	35
III. On the Structure of Lepidodendron and Sigillaria. No. 1.—On the Variations of the Decorticated Leaf-scars of certain Sigillariæ. (With Plates III and IV). By HERMAN L. FAIRCHILD	41
IV. Descriptions of New Species of Birds from Dominica. By GEORGE N. LAWRENCE	46
V. Descriptions of New Species of Birds of the Families Troch- ilidæ and Tetraonidæ. By GEORGE N. LAWRENCE	50
VI. Index to the Literature of Titanium; 1783-1876; Part I. By EDWARD J. HALLOCK	53



Vol. I.

April, 1878.

Nos. 3-4.

A N N A L S

OF THE

NEW YORK ACADEMY OF SCIENCES,

(LATE LYCEUM OF NATURAL HISTORY).

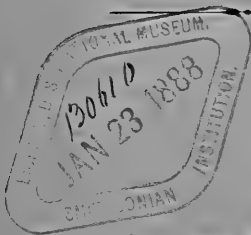

New York :

PUBLISHED FOR THE ACADEMY.

1877.

OFFICERS OF THE ACADEMY.

1877.

President,

JOHN S. NEWBERRY.

Vice-Presidents,

T. EGGLESTON.

BENJ. N. MARTIN.

Corresponding Secretary,

ALBERT R. LEEDS.

Recording Secretary,

OLIVER P. HUBBARD.

Treasurer,

JOHN H. HINTON.

Librarian,

LOUIS ELSBERG.

Committee of Publication,

DANIEL S. MARTIN.

JOHN S. NEWBERRY.

GEO. N. LAWRENCE.

H. CARRINGTON BOLTON.

ANNALS
OF THE
NEW YORK ACADEMY OF SCIENCES.
VOLUME I.

The "Annals," published for over half a century by the late Lyceum of Natural History, are continued under the above name by the NEW YORK ACADEMY OF SCIENCES, beginning with the year 1877.

It is proposed, as before, to issue four numbers every year, each number to consist of not less than thirty-two pages (octavo), with or without plates. Price of Yearly Subscription, Two Dollars, payable in advance.

The Academy has for sale a number of back volumes of the Annals of the Lyceum, each containing twelve or more numbers; the price per volume is \$4.00 with uncolored plates, or \$5.00 with colored plates.

The Academy has established a Publication Fund, contributors to which, in the sum of \$100 at one time, are entitled to all the scientific publications of the Academy appearing subsequently to the payment of their contribution.

Communications should be addressed to

PROF. D. S. MARTIN,

Chairman of Publication Committee, 236 West Fourth St.

Or to

JOHN H. HINTON, M.D.,

Treasurer, 41 West Thirty-second St.

Any person residing within the United States, on sending the amount of his yearly subscription to the Treasurer, will receive the numbers as they appear, without further cost.

Agents in London, TRÜBNER & CO.



In Leipzig, BERN. HERMANN.

Special agents for the Academy,

NATURALISTS' AGENCY,



Salem, Mass.

NOTE.—The Index number (13)—the closing part of the last volume of the old series—will appear as speedily as the work upon it can be finished.



CONTENTS.

	PAGE
VI. Index to the Literature of Titanium; 1783-1876; Part II, Minerals. By EDWARD J. HALLOCK.....	65
VII. On the Structure of <i>Lepidodendron</i> and <i>Sigillaria</i> . No. 2.—The Variations of the Leaf-scars of <i>Lepidodendron aculeatum</i> , Sternb. (With Plates V-IX.) By HERMAN L. FAIRCHILD.....	77
VIII. On the Distribution of Fresh-Water Fishes of the United States. By DAVID S. JORDAN.....	92
IX. Descriptions of New Species of Fossils, from the Upper Silurian Rocks of Port Jervis, N. Y.; with Notes on the Occurrence of the Coralline Limestone at that Locality. By S. T. BARRETT.....	121
X. Description of a New Species of Parrot of the Genus <i>Chrysolotis</i> . By GEORGE N. LAWRENCE.....	125
XI. Descriptions of New Fossil Fishes from the Trias. By J. S. NEWBERRY.....	127



Vol. 1. September—December, 1878.

Nos. 7-8.

ANNALS
OF THE
NEW YORK ACADEMY OF SCIENCES.

LATE
LYCEUM OF NATURAL HISTORY.

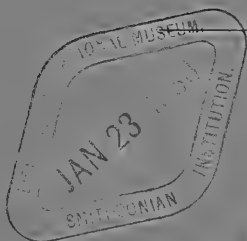

New York:

PUBLISHED FOR THE ACADEMY,

1878.

GREGORY BROS., PRINTER, 34 CARMINE STREET, N. Y.

ANNALS
OF THE
NEW YORK ACADEMY OF SCIENCES.
VOLUME 1.

The "Annals," published for over half a century by the late Lyceum of Natural History, are continued under the above name by the NEW YORK ACADEMY OF SCIENCES, beginning with the year 1877.

It is proposed, as before, to issue four numbers every year, each number to consist of not less than thirty-two pages (octavo), with or without plates. Price of Yearly Subscription, Two Dollars, payable in advance.

The Academy has for sale a number of back volumes of the Annals of the Lyceum, each containing twelve or more numbers; the price per volume is \$4.00 with uncolored plates, or \$5.00 with colored plates.

The Academy has established a Publication Fund, contributors to which, in the sum of \$100 at one time, are entitled to all the scientific publications of the Academy appearing subsequently to the payment of their contribution.

Communications should be addressed to

PROF. D. S. MARTIN;

Chairman of Publication Committee, 236 West Fourth St.

Or to

JOHN H. HINTON, M.D.,

Treasurer, 41 West Thirty-second St.

 Any person residing within the United States on sending the amount of his yearly subscription to the Treasurer, will receive the numbers as they appear, without further cost.



*Agents in London, TRUBNER & Co.
In Leipzig, BERN. HERMANN.*

Special agents for the Academy,

NATURALISTS' AGENCY,

Salem, Mass.



NOTE.—The Index number (13)—the closing part of the last volume of the old series—will appear as speedily as the work upon it can be finished.



CONTENTS.

XX. Ozone and the Atmosphere. By ALBERT R. LEEDS	193
XXI. The Physical History of the Trias of New Jersey and the Connecticut Valley. By ISRAEL C. RUSSELL.....	220
XXII.—Description of a new species of Bird of the Genus <i>Chatura</i> , By GEORGE N. LAWRENCE.....	255

111.



Vol. 1.

September, 1879.

No. 9.

ANNALS

OF THE

NEW YORK ACADEMY OF SCIENCES,

LATE

LYCEUM OF NATURAL HISTORY.

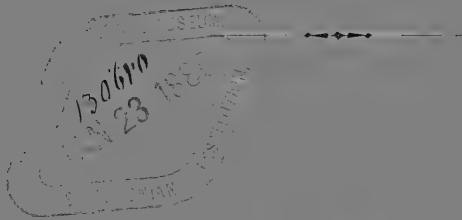

New York:

PUBLISHED FOR THE ACADEMY.

1879.

GREGORY PRCS., Printers, 24 Columbia Street, N. Y.

ANNALS

OF THE

NEW YORK ACADEMY OF SCIENCES.

VOLUME 1.—1879.

The "Annals," published for over half a century by the late Lyceum of Natural History, are continued under the above name by the NEW YORK ACADEMY OF SCIENCES, beginning with the year 1877.

It is proposed, as before, to issue four numbers every year, each number to consist of not less than thirty-two pages (octavo), with or without plates. Price of Yearly Subscription, Two Dollars, payable in advance.

The Academy has for sale a number of back volumes of the Annals of the Lyceum, each containing twelve or more numbers; the price per volume is \$1.00 with uncolored plates, or \$5.00 with colored plates.

The Academy has established a Publication Fund, contributors to which, in the sum of \$100 at one time, are entitled to all the scientific publications of the Academy appearing subsequently to the payment of their contribution.

Communications should be addressed to

PROF. D. S. MARTIN,

Chairman of Publication Committee, 236 West Fourth St.

Or to

JOHN H. HINTON, M.D.,

Treasurer, 41 West Thirty-second St.

Any person residing within the United States, on sending the amount of his yearly subscription to the Treasurer, will receive the numbers as they appear, without further cost.

Agents in London, TRUBNER & Co.

In Leipzig, BERN. HERMANN.

Special agents for the Academy,

NATURALISTS' AGENCY,

Salem, Mass.

NOTE.—The Index number (13)—the closing part of the last volume of the old series—will appear speedily



CONTENTS.

XXIII. — On the Jaw and Lingual Dentition of certain Costa Rica Land Shells collected by DR. WILLIAM M. GABB. (With Plate XI.) By W. G. BINNEY.....	257
XXIV. — A new Form of Compass-Clinometer. By ISRAEL C. RUSSELL.	263
XXV. — The Structure of Colored Blood Corpuscles. By LOUIS ELSEFEG.	265



Vol. I.

November, 1879.

No. 10.

ANNALS

OF THE

NEW YORK ACADEMY OF SCIENCES.

LATE

LYCEUM OF NATURAL HISTORY.



New York:

PUBLISHED FOR THE ACADEMY,

1879.

OFFICERS OF THE ACADEMY,
1879.

President,
JOHN S. NEWBERRY.

Vice-Presidents,
T. EGLESTON. BENJ. N. MARTIN.

Corresponding Secretary,
ALBERT R. LEEDS.

Recording Secretary,
OLIVER P. HUBBARD.

Treasurer,
JOHN H. HINTON.

Librarian,
LOUIS ELSBERG.

Committee of Publication,
DANIEL S. MARTIN. JOHN S. NEWBERRY.
GEORGE N. LAWRENCE. ALBERT R. LEEDS.
W. P. TROWBRIDGE.

ANNALS

OF THE

NEW YORK ACADEMY OF SCIENCES.

VOLUME 1.—1879.

The "Annals," published for over half a century by the late Lyceum of Natural History, are continued under the above name by the NEW YORK ACADEMY OF SCIENCES, beginning with the year 1877.

It is proposed, as before, to issue four numbers every year, each number to consist of not less than thirty-two pages (octavo), with or without plates. Price of Yearly Subscription, Two Dollars, payable in advance.

The Academy has for sale a number of back volumes of the Annals of the Lyceum, each containing twelve or more numbers; the price per volume is \$4.00 with uncolored plates; or \$5.00 with colored plates.

The Academy has established a Publication Fund, contributors to which, in the sum of \$100 at one time, are entitled to all the Scientific Publications of the Academy appearing subsequently to the payment of their contributions.

Communications should be addressed to

PROF. D. S. MARTIN,

Chairman of Publication Committee, 236 West Fourth St.

Or to

JOHN H. HINTON, M. D.,

Treasurer, 41 West Thirty-second St.

Any person residing within the United States on sending the amount of his yearly subscription to the Treasurer, will receive the numbers as they appear, without farther cost.

Agents in London, TRUBNER & Co.
In Leipzig, BERN. HERMANN.

Special agents for the Academy,

NATURALISTS' AGENCY,

Salem, Mass.

NOTE.—The Index number (13)—the closing part of the last volume of the old series—will speedily appear.

CONTENTS.

- XXV.—The Structure of Colored Blood-Corpuscles (*concluded*). By
LOUIS ELSBERG, (with Plate XII) 296
- XXVI.—Description of a New Species or Variety of Land-Snail from
California. By ROBERT E. C. STEARNS 316
- XXVII.—On Spodumene and its Alterations. By ALEXIS A. JULIEN.. 318

Vol. I.

March, 1880.

Nos. 11-12.

ANNALS

OF THE

NEW YORK ACADEMY OF SCIENCES.

LATE

LYCEUM OF NATURAL HISTORY.

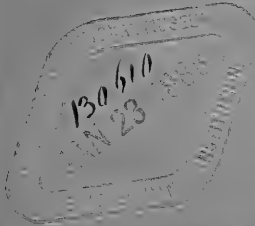

New York :

PUBLISHED FOR THE ACADEMY,

1880.

GREGORY BROS., PRINTERS, 34 CARMINE STREET, N. Y.

OFFICERS OF THE ACADEMY,
1879.

President,

JOHN S. NEWBERRY.

Vice-Presidents,

T. EGLESTON.

BENJ. N. MARTIN.

Corresponding Secretary,

ALBERT R. LEEDS.

Recording Secretary,

OLIVER P. HUBBARD.

Treasurer,

JOHN H. HINTON.

Librarian,

LOUIS ELSBERG.

Committee of Publication,

DANIEL S. MARTIN.

JOHN S. NEWBERRY.

GEORGE N. LAWRENCE.

ALBERT R. LEEDS.

W. P. TROWBRIDGE.

ANNALS
OF THE
NEW YORK ACADEMY OF SCIENCES.
VOLUME 1.—1879.

The "Annals," published for over half a century by the late Lyceum of Natural History, are continued under the above name by the NEW YORK ACADEMY OF SCIENCES, beginning with the year 1877.

It is proposed, as before, to issue four numbers every year, each number to consist of not less than thirty-two pages (octavo), with or without plates. Price of Yearly Subscription, Two Dollars, payable in advance.

The Academy has for sale a number of back volumes of the Annals of the Lyceum, each containing twelve or more numbers; the price per volume is \$4.00 with uncolored plates, or \$5.00 with colored plates.

The Academy has established a Publication Fund, contributors to which, in the sum of \$100 at one time, are entitled to all the Scientific Publications of the Academy appearing subsequently to the payment of their contributions.

Communications should be addressed to

PROF. D. S. MARTIN,

Chairman of Publication Committee, 236 West Fourth St.

Or to

JOHN H. HINTON, M. D.,

Treasurer, 41 West Thirty-second St.

Any person residing within the United States, on sending the amount of his yearly subscription to the Treasurer, will receive the numbers as they appear, without further cost.

Agents in London, TRÜBNER & Co.

In Leipzig, BERN. HERMANN.

Special agents for the Academy,

NATURALISTS' AGENCY,

Salem, Mass.

NOTE.—The Index number (13)—the closing part of the last volume of the old series—will speedily appear.

CONTENTS.

- XXVII.—On Spodumene and its Alterations (*concluded*). By
ALEXIS A. JULIEN, (with plate XIII) 329
- XXVIII.—On certain North American Species of Zonites, etc. By
W. G. BINNEY (with plates XIV and XV), 355
- XXIX.—Lines of Discovery in the History of Ozone, with an Index
of its Literature, and an Appendix upon the Literature
of Peroxide of Hydrogen. By ALBERT R. LEEDS 363

Vol. I.

April, 1880.

No. 13.

ANNALS

OF THE

NEW YORK ACADEMY OF SCIENCES,

LATE

LYCEUM OF NATURAL HISTORY.

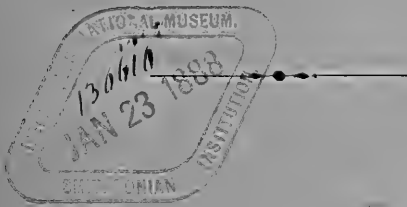

New York:

PUBLISHED FOR THE ACADEMY,

1880.

OFFICERS OF THE ACADEMY,
1879.

President,

JOHN S. NEWBERRY.

Vice-Presidents,

T. EGLESTON.

BENJ. N. MARTIN.

Corresponding Secretary,

ALBERT R. LEEDS.

Recording Secretary,

OLIVER P. HUBBARD.

Treasurer,

JOHN H. HINTON.

Librarian,

LOUIS ELSBERG.

Committee of Publication,

DANIEL S. MARTIN.

JOHN S. NEWBERRY.

GEORGE N. LAWRENCE.

ALBERT R. LEEDS.

W. P. TROWBRIDGE.

ANNALS

OF THE

NEW YORK ACADEMY OF SCIENCES.

VOLUME 1.—1879.

The "Annals," published for over half a century by the late Lyceum of Natural History, are continued under the above name by the New York ACADEMY OF SCIENCES, beginning with the year 1877.

It is proposed, as before, to issue four numbers every year, each number to consist of not less than thirty-two pages (octavo), with or without plates. Price of Yearly Subscription, Two Dollars, payable in advance.

The Academy has for sale a number of back volumes of the Annals of the Lyceum, each containing twelve or more numbers; the price per volume is \$4.00 with uncolored plates, or \$5.00 with colored plates.

The Academy has established a Publication Fund, contributors to which, in the sum of \$100 at one time, are entitled to all the Scientific Publications of the Academy appearing subsequently to the payment of their contributions.

Communications should be addressed to

PROF. D. S. MARTIN,

Chairman of Publication Committee, 236 West Fourth St.

Or to

JOHN H. HINTON, M. D.,

Treasurer, 41 West Thirty-second St.

Any person residing within the United States, on sending the amount of his yearly subscription to the Treasurer, will receive the numbers as they appear, without further cost.

Agents in London, TRUBNER & Co.

In Leipsic, BERN. HERMANN.

Special agents for the Academy,

NATURALISTS' AGENCY,

Salem, Mass.



CONTENTS.

XXIX.—Index to the Literature of Ozone (*concluded*), with an Appendix upon the History of Antozone and Peroxide of Hydrogen, and an Index to the Literature of the same.
By ALBERT R. LEEDS.

ANNALS
OF THE
NEW YORK ACADEMY OF SCIENCES.

VOLUME I, 1877—79.

The "Annals," published for over half a century by the late Lyceum of Natural History, are continued under the above name by the NEW YORK ACADEMY OF SCIENCES, beginning with the year 1877.

It is proposed, as before, to issue four numbers every year, each number to consist of not less than thirty-two pages (octavo), with or without plates. Price of Yearly Subscription, Two Dollars, payable in advance. Price of a single number, Fifty Cents; of a double number, One Dollar.

The Academy has for sale a number of back volumes of the Annals of the Lyceum, each containing twelve or more numbers; the price per volume is \$4.00 with uncolored plates, or \$5.00 with colored plates.

The Academy has established a Publication Fund, contributors to which, in the sum of \$100 at one time, are entitled to all the Scientific Publications of the Academy appearing subsequently to the payment of their contributions.

Communications should be addressed to

PROF. D. S. MARTIN,
Chairman of Publication Committee, 236 West Fourth Street.

Or to

JOHN H. HINTON, M. D.,
Treasurer, 41 West Thirty-second Street.

Any person residing within the United States, on sending the amount of his yearly subscription to the Treasurer, will receive the numbers as they appear, without further cost.

Agents in London, TRUBNER & Co.

Volume II will comprise the Annals for the years 1880—82.

CONTENTS.

Title, Contents, and List of Plates, Vol. I.....	i—xvi
General Index.....	427
Index of Nomenclature.....	435
Errata, etc.....	444

1
174680



SMITHSONIAN INSTITUTION LIBRARIES



3 9088 01302 0946