

EX LIBRIS

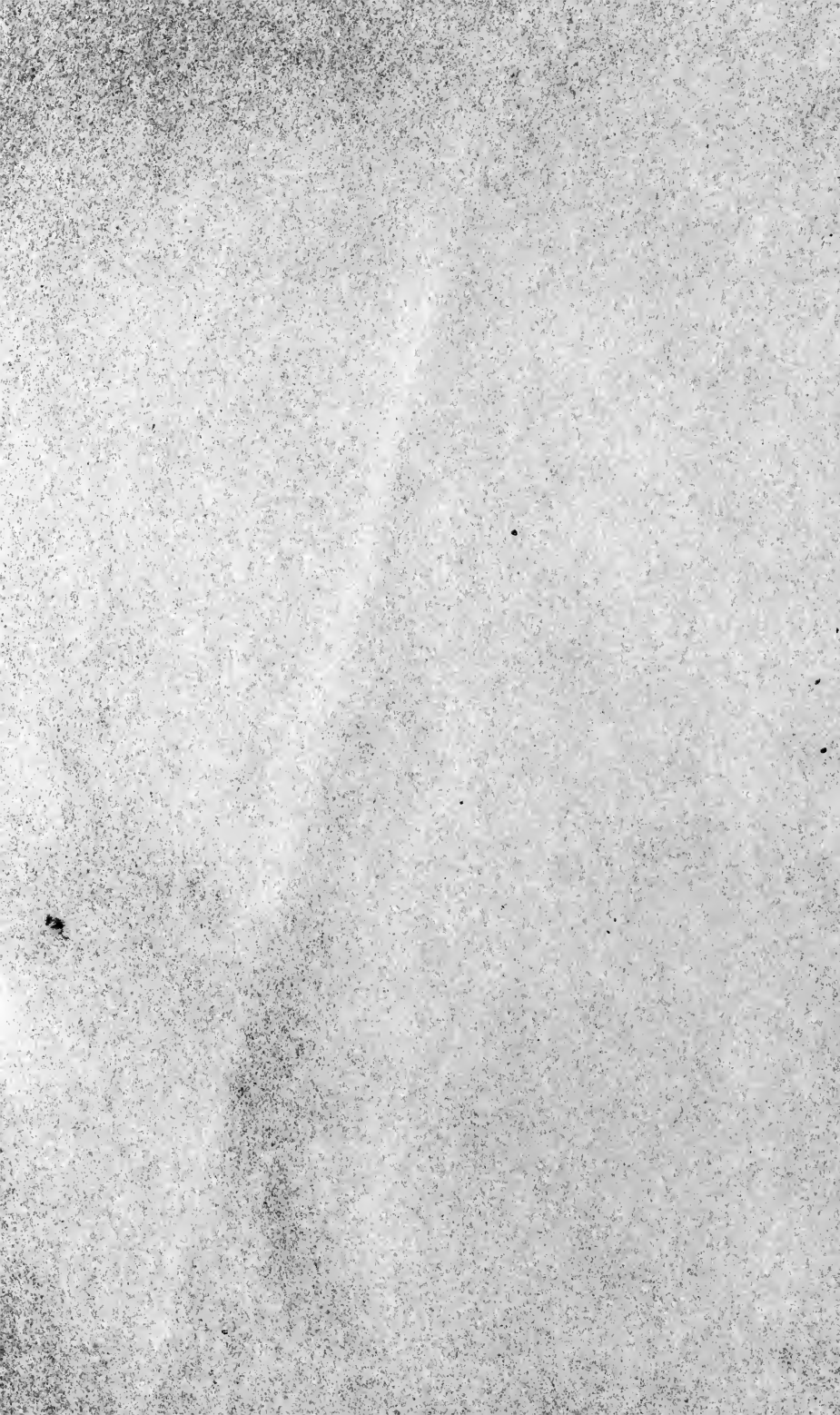

TA
350
P7

PREFACE

THIS text-book on Applied Mechanics is intended for use in the undergraduate courses in Mechanics in engineering schools. A knowledge of the principles of General Physics and the Calculus is assumed. The work in its present form grew out of the author's attempt to develop the basic principles of the subject in a way which the average student could easily follow and to present such illustrations as would show clearly the application of such principles to the solution of engineering problems.

Two features may be pointed out in which a departure from the usual procedure has been made which it is hoped will be advantageous to the student. One of these is the extended use which has been made of the graphic method of solution. It has been the author's experience that the graphic method is valuable not only on account of the ease and rapidity with which it may be applied to the solution of certain classes of problems, but also on account of the aid it gives in understanding the algebraic method. The principles underlying the two methods are developed coördinately in order to show their relation. The graphic method is used wherever its application tends to promote clearness.

The other special feature is the large number of illustrative examples which have been solved in detail to show the relation between the principle which has been developed and the problems to which it applies.

More problems are included than can usually be assigned if the book is to be completed in one semester. Those included in the articles should always be solved; the general problems at the end of each chapter may be used as the instructor prefers. The answers to all problems are given, since it has been found that the average student will work at a problem with more interest if he has the answer with which to check his result. Those instructors who

prefer no answers to be given may make suitable changes in the data of the problems.

In conclusion the author wishes to thank his colleague, Professor Richard G. Dukes, for his careful reading of the manuscript and for his helpful suggestions in regard to form and content.

A. P. POORMAN.

PURDUE UNIVERSITY,
March, 1917.

CONTENTS

	PAGE
PREFACE	v
GENERAL INTRODUCTION	1
ART.	
1. Definitions	1
2. Fundamental Quantities	1
3. Methods of Analysis of Problems in Mechanics	2
4. Vectors	2
5. Free-body Diagram	3
6. Newton's Three Laws of Motion	3
7. Classification of Forces	3
8. Transmissibility of Forces	4
9. Graphical Representation of Forces	4
10. Bow's Notation	4

PART I. STATICS

CHAPTER I. CONCURRENT FORCES

11. Definition	5
12. Resultant of Two Forces, Graphically	5
13. Resultant of Two Forces, Algebraically	6
14. Resolution of a Force into Components	7
15. Resultant of Three or More Forces in a Plane, Graphically	8
16. Resultant of Three or More Forces in a Plane, Algebraically	10
17. Resultant of Three or More Forces in Space, Graphically	13
18. Resolution of a Force into Three Components	14
19. Resultant of Three or More Forces in Space, Algebraically	15
20. Moment of a Force with Respect to a Point	17
21. Principle of Moments	17
22. Moment of a Force with Respect to a Line	18
General Problems	19

CHAPTER II. PARALLEL FORCES

23. Resultant of Two Parallel Forces, Graphically	23
24. Resultant of Two Parallel Forces, Algebraically	24
25. Resultant of Any Number of Parallel Forces, Graphically	26
26. Resultant of Any Number of Parallel Forces, Algebraically	27
27. Moment of a Couple	29

ART.	PAGE
28. Graphic Representation of a Couple.....	30
29. Composition of Couples.....	31
30. Resolution of a Force into a Force and a Couple.....	32
31. Coplanar Parallel Forces in Equilibrium, Algebraic Solution.....	32
32. Coplanar Parallel Forces in Equilibrium, Graphic Solution.....	34
33. Equilibrium of Parallel Forces in Space.....	35
General Problems.....	36

CHAPTER III. NONCONCURRENT, NONPARALLEL FORCES

34. Composition of Nonconcurrent, Nonparallel Forces in a Plane; Graphic Methods.....	39
35. Composition of Nonconcurrent, Nonparallel Forces in a Plane; Algebraic Method.....	40
36. Reduction of a System of Forces to a Force and a Couple.....	41
37. Two-force Members, Three-force Members, etc.....	42
38. Problems in Equilibrium; Forces in a Plane.....	44
39. Composition of Nonconcurrent, Nonparallel Forces in Space.....	49
40. Problems in Equilibrium; Forces in Space.....	50
41. Cord Loaded Uniformly Horizontally.....	53
42. The Catenary.....	56
General Problems.....	59

CHAPTER IV. CENTROIDS AND CENTER OF GRAVITY

43. Centroid of a System of Forces with Fixed Application Points.....	65
44. Centroids of Solids, Surfaces and Lines Defined.....	66
45. Moment with Respect to a Plane.....	66
46. Planes of Symmetry and Axes of Symmetry.....	67
47. Centroid of a System of Forces with Coplanar Application Points..	68
48. Centroids of Simple Solids and Surfaces.....	69
49. Centroids by Integration.....	70
50. Centroids of Surfaces and Solids of Revolution.....	73
51. Theorems of Pappus and Guldinus.....	74
52. Center of Gravity of Composite Body.....	75
53. Centroid of Irregular Plane Area.....	77
54. Center of Gravity by Experiment.....	77
General Problems.....	78

CHAPTER V. FRICTION

55. Static and Kinetic Friction.....	82
56. Coefficient of Friction.....	83
57. Laws of Friction.....	85
58. Determination of the Coefficient of Friction.....	85
59. Axle Friction and the Friction Circle.....	86
60. Least Pull and Cone of Friction.....	87

ART.	PAGE
61. Rolling Resistance.....	89
62. Friction of Brake on Wheel; Graphic Solution.....	90
63. Friction on Pivots.....	92
64. Friction of Belts.....	94
65. Summary of Principles of Friction.....	96
General Problems.....	96

CHAPTER VI. MOMENT OF INERTIA

66. Definition of Moment of Inertia of an Area.....	99
67. Radius of Gyration.....	100
68. Sign of Moment of Inertia.....	102
69. Relation Between Moments of Inertia with Respect to Two Parallel Axes in the Plane of the Area.....	102
70. Relation Between Moments of Inertia with Respect to Three Rectangular Axes.....	104
71. Relation Between Polar Moments of Inertia with Respect to Parallel Axes.....	104
72. Moment of Inertia of Composite Areas.....	105
73. Moment of Inertia with Respect to Inclined Axes.....	106
74. Product of Inertia.....	107
75. Relation Between Products of Inertia with Respect to Parallel Axes.....	108
76. Maximum and Minimum Moments of Inertia.....	110
77. Moment of Inertia of Mass.....	111
78. Relation Between Moments of Inertia of Mass with Respect to Parallel Axes.....	113
79. Determination of Moment of Inertia by Experiment.....	115
General Problems.....	116

PART II. KINETICS

CHAPTER VII. RECTILINEAR MOTION

80. Velocity and Speed.....	119
81. Acceleration.....	120
82. Constant Acceleration.....	121
83. Falling Bodies, Air Neglected.....	122
84. Relation Between Force, Mass and Acceleration.....	124
85. Effective Forces: D'Alembert's Principle.....	125
86. Composition and Resolution of Velocities and Accelerations.....	128
87. Acceleration Varying with Distance: Simple Harmonic Motion....	129
88. Acceleration Varying with Distance: Direct Solution.....	132
89. Motion in which Acceleration Varies Inversely as the Square of the Distance.....	133
90. Relative Motion.....	134
General Problems.....	137

CHAPTER VIII. CURVILINEAR MOTION	
ART.	PAGE
91. Velocity in Curvilinear Motion.....	140
92. Acceleration in Curvilinear Motion.....	140
93. Tangential Acceleration and Normal Acceleration.....	141
94. Uniform Motion in a Circle.....	142
95. Simple Circular Pendulum.....	145
96. Velocity of a Body in a Vertical Curve.....	147
97. Motion of Projectile, Air Resistance Neglected.....	149
General Problems.....	152

CHAPTER IX. ROTATION

98. Angular Displacement.....	154
99. Angular Velocity.....	154
100. Angular Acceleration.....	155
101. Simple Harmonic Motion: Auxiliary Circle Method.....	156
102. Constant Angular Acceleration.....	159
103. Variable Angular Acceleration.....	160
104. Effective Forces on a Rotating Body.....	160
105. Moment of Tangential Effective Forces.....	161
106. Resultant of Normal Effective Forces.....	164
107. Reactions of Supports of Rotating Bodies.....	166
108. Compound Pendulum.....	169
109. Center of Percussion.....	171
110. Centrifugal Tension in Flywheels.....	171
111. Weighted Conical Pendulum Governor.....	172
112. Balancing of Rotating Bodies.....	173
113. Balancing of Bodies in the Same Plane Normal to the Axis of Rotation.....	174
114. Balancing of Bodies in Different Normal Planes.....	175
General Problems.....	176

CHAPTER X. COMBINED TRANSLATION AND ROTATION

115. Any Plane Motion Equivalent to Combined Translation and Rotation.....	179
116. Resolution of Velocities in Any Plane Motion.....	180
117. Resolution of Accelerations in Any Plane Motion.....	181
118. Instantaneous Axis.....	182
119. Equations of Motion.....	183
120. Wheel Rolling on Horizontal Plane.....	185
121. Wheel Rolling on Inclined Plane.....	186
122. Connecting Rod of Engine. Graphic Solution.....	187
123. Kinetic Reactions on Connecting Rod.....	189
124. Kinetic Reactions on Side Rod.....	191
125. Kinetic Reaction on Unbalanced Wheel.....	192
126. Balancing Reciprocating Parts.....	193

CONTENTS

xi

ART.	PAGE
127. Balancing Both Rotating and Reciprocating Parts.....	195
128. Balancing of Locomotives.....	195
General Problems.....	197

CHAPTER XI. WORK AND ENERGY

129. Work.....	199
130. Graphical Representation of Work.....	201
131. Energy.....	202
132. Relation Between Work and Kinetic Energy.....	203
133. Kinetic Energy of Translation. Forces Constant.....	203
134. Kinetic Energy of Translation. Forces Variable.....	205
135. Kinetic Energy of Rotation.....	208
136. Kinetic Energy of Rotation and Translation.....	210
137. Work Lost in Friction.....	211
138. Braking of Trains.....	213
139. Power.....	215
140. Water Power.....	216
141. Steam Engine Indicator.....	216
142. Absorption Dynamometer.....	217
143. Band Brakes.....	219
General Problems.....	221

CHAPTER XII. IMPULSE, MOMENTUM AND IMPACT

144. Impulse and Momentum.....	223
145. Relation Between Impulse and Momentum.....	224
146. Conservation of Linear Momentum.....	225
147. Angular Impulse and Angular Momentum.....	226
148. Conservation of Angular Momentum.....	228
149. Resultant of Angular Momenta. Gyroscope.....	230
150. Reaction of a Jet of Water.....	233
151. Pressure Due to a Jet of Water on a Vane.....	233
152. Sudden Impulse or Impact.....	235
General Problems.....	238
INDEX.....	241

APPLIED MECHANICS.

GENERAL INTRODUCTION.

1. Definitions. *Mechanics* in general is the science which treats of the effects of forces upon bodies at rest or in motion. The complete subject includes many discussions which are of purely theoretical interest and others which are applicable only to extremely complex problems. All such discussions are considered to be beyond the scope of this work, which will include only those principles of mechanics which are applicable to the simpler problems of engineering.

Mechanics may be divided into *Statics* and *Kinetics*. *Statics* treats of bodies at rest or with uniform motion. *Kinetics* treats of bodies with variable motion. In this work the kinematic or pure motion discussion will be included in *Kinetics*.

2. Fundamental Quantities. *Space, time, force and mass* are the fundamental quantities used in mechanics. There are two systems of units in common use, the *centimeter-gram-second* (c.g.s.) system and the *foot-pound-second* (f.p.s.) system. The foot-pound-second system is used almost entirely by engineers in English-speaking countries, so will be the only one used in this book.

The units of *space* commonly used in engineering are the *foot* and the *inch*.

The unit of *time* commonly used is the *second*.

A *force* is an action of one body upon another which changes or tends to change the state of motion of the body acted upon. In our experience the most common force is the attraction of the earth for all bodies upon it. The measure of this attraction is called *weight* and is determined by means of the spring balance. Weight varies with the latitude and with the height above sea level. The unit of force commonly used is the *pound*.

The *mass* of a body is the quantity of matter in it, and is constant, regardless of position. Mass may be determined by means

of the lever arm balance, or since the acceleration of gravity g varies the same as the weight W , it may be determined from simultaneous values of W and g . The unit of mass commonly used in engineering is one containing g units of weight, or in symbols,

$$M = \frac{W}{g}.$$

Unless stated otherwise, the value of g will be taken as 32.2 ft. per second per second. It should be noted that the units of force and mass in engineering are g times the units used in pure physics. The reason for this will be explained later.

3. Methods of Analysis of Problems in Mechanics. A *problem* in mechanics, as in any other mathematical subject, consists of a statement of certain known quantities and relations from which certain other unknown quantities or relations are to be determined.

There are two methods of analysis of problems, *graphic* and *algebraic*. In the *graphic* method quantities are represented by corresponding lines or areas, the relations between them are represented by the relations of the parts of the figure and the solution is wholly by determination of the resulting lines or areas. In the *algebraic* method quantities are represented by symbols, the relations between them are shown by signs indicating operations, and solution is made by algebra and arithmetic. Both methods will be used in the solution of problems in this book and the student should soon be able to select the method which is the better suited to any given problem.

4. Vectors. A *vector quantity* is a quantity which has direction as well as amount. Force, velocity, momentum and acceleration are examples. Vector quantities are represented by lines called *vectors*, of definite length and with definite position and direction. The length of the vector represents to some scale the magnitude of the quantity, its position shows the line of

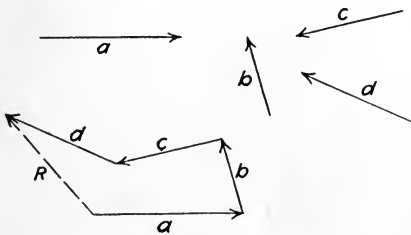

FIG. 1

action and an arrowhead shows the direction.

The sum of two or more vectors is found by laying them down

so as to follow each other in order; then the vector drawn from the beginning to the end of the system laid down is the sum or resultant vector. In Fig. 1 the sum of the vectors a , b , c and d is vector R . The line of action of vector R is not determined in this figure.

5. Free-body Diagram. The *free-body method* of analyzing problems will be used in this work. In applying this method, the whole body or some part of it is considered as isolated from the surrounding parts. This "free body" is represented diagrammatically, with the actions upon it of the parts removed indicated by vectors, known or unknown. From the conditions and forces known, the unknown relations and forces are determined.

For example, in Fig. 11(a), the 50-lb. block is to be considered as the free body. The block is represented diagrammatically by point A in Fig. 11(b). The attraction of the earth W , the normal resistance of the plane N , the tangential resistance of the plane F , and the pull P are represented by their corresponding vectors and are shown acting upon A . *The forces with which the free body acts upon the parts supposed to be removed are not considered.*

6. Newton's Three Laws of Motion. Sir Isaac Newton formulated the following *Laws of Motion*, generalized from observation.

1. Unless acted upon by some force, a body remains at rest or in uniform motion. This property is called *inertia*.

2. A body acted upon by a resultant force receives an acceleration in the direction of the force which is proportional to the force and inversely proportional to the mass of the body.

3. To every action there is an equal and opposite reaction.

7. Classification of Forces. A *distributed* force is one whose place of application is an area. A *concentrated* force is one whose place of application is so small that it may be considered to be a point. In many cases a distributed force may be considered as though it were a concentrated force acting at the center of the area of contact or at the center of the force system.

Forces are sometimes classified as *forces at a distance* and *forces by contact*. Magnetic, electrical and gravitational forces are examples of the first. Gravitational force, or the weight of bodies, is the chief one considered in mechanics. The pressure of steam in a cylinder and of the wheels of a locomotive on the supporting rails are examples of forces by contact.

8. Transmissibility of Forces. By common experience it has been found that the external effect of a force upon a rigid body is the same, no matter at what point of the body along the line of action the force is applied.

9. Graphical Representation of Forces. Since forces are vector quantities, they are represented graphically by vectors. For comparatively simple problems only one diagram is used, in which case each vector shows the line of action, direction and magnitude of the force represented, as in Fig. 2. For more com-

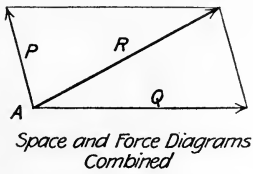

FIG. 2

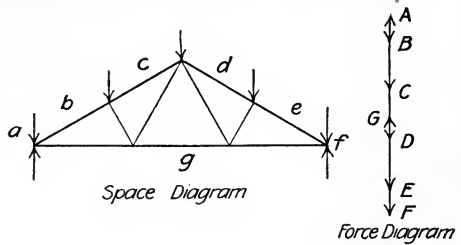

FIG. 3

plicated problems two diagrams are used, the space diagram showing the lines of action of the forces, and the force diagram showing the magnitude of the forces, as in Fig. 3. The direction of the forces may be shown in either diagram but is usually shown in both.

10. Bow's Notation. In the graphical work *Bow's Notation* will be used in all except very simple problems. In the space diagram each space from the line of action of one force to that of the next one is lettered with a lower case letter. The line of action bc in Fig. 3 is the line between space b and space c . The corresponding upper case letters are placed at the ends of the corresponding vector in the force diagram. Thus BC represents in amount the force acting along line bc in the space diagram.

PART I. STATICS.

CHAPTER I.

CONCURRENT FORCES.

11. Definition. A *concurrent system* of forces is one in which the lines of action of all the forces meet in a common point. If all of the forces in the system are in the same plane, it is called also a *coplanar system*.

12. Resultant of Two Forces, Graphically. *The Parallelogram Law.* If two concurrent forces are represented by their vectors, both of which are directed away from their point of intersection, the diagonal of the completed parallelogram drawn through their point of intersection represents their resultant.

In Fig. 4, let vectors MN and KL represent two forces whose lines of action intersect at O . By the principle of Art. 8 the forces may be transmitted along their lines of action until they are in the positions OA and OB .

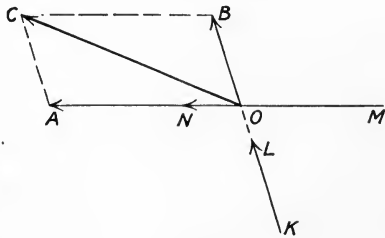

FIG. 4

Line AC is drawn parallel to OB and line BC parallel to OA , to complete the parallelogram $OACB$. The diagonal OC is the vector sum of the two vectors OA and OB and represents the resultant of the two forces.

If the two vectors had been placed so that they were both directed toward their point of intersection, their resultant vector would have been the same.

The Triangle Law. If two concurrent forces are represented by their vectors laid down in order as the two sides of a triangle, the third side of the triangle drawn from the initial point to the final point represents their resultant. Fig. 5

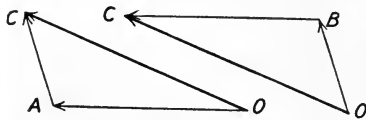

FIG. 5

shows the two possible solutions for obtaining the resultant of the

forces KL and MN of Fig. 4. In the lower triangle vectors OA and AC represent the two forces, and vector OC represents their resultant. In the upper triangle vectors OB and BC represent the two forces and vector OC represents their resultant as before.

These diagrams are *force diagrams only*. The line of action of the resultant must pass through the point of intersection of the two lines of action in the space diagram.

If two forces have the same line of action, the resultant is the algebraic sum of the two. If they are equal and opposite, their sum is zero and the two forces are said to be in equilibrium.

Conversely, if two forces are known to be in equilibrium, they must be equal, opposite and colinear.

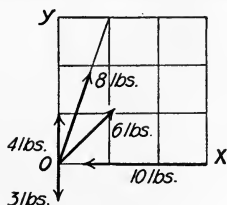

FIG. 6

Problem 1. Fig. 6 represents a body three feet square to which forces are applied as shown. Combine the 4-lb. force with each of the others

in turn by means of the parallelogram law.

Ans. With 8-lb. force, $R = 11.86$ lbs.; θ (with X) = $77^\circ 40'$.

With 6-lb. force, $R = 9.26$ lbs.; $\theta = 62^\circ 48'$.

With 10-lb. force, $R = 10.77$ lbs.; $\theta = 158^\circ 12'$.

With 3-lb. force, $R = 1$ lb.; $\theta = 90^\circ$.

Problem 2. Combine the 3-lb. force of Fig. 6 with each of the others in turn by means of the triangle law.

Ans. With 8-lb. force, $R = 5.25$ lbs.; $\theta = 61^\circ 02'$.

With 6-lb. force, $R = 4.42$ lbs.; $\theta = 16^\circ 20'$.

With 10-lb. force, $R = 10.44$ lbs.; $\theta = 196^\circ 40'$.

With 4-lb. force, $R = 1$ lb.; $\theta = 90^\circ$.

13. Resultant of Two Forces, Algebraically. From the trigonometry of Fig. 7,

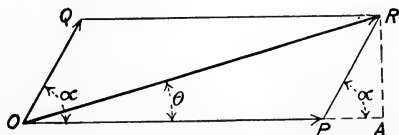

FIG. 7

$$\overline{OR}^2 = \overline{OP}^2 + \overline{OQ}^2 + 2\overline{OP} \times \overline{PQ} \cos \alpha,$$

$$\text{and} \quad \theta = \tan^{-1} \frac{\overline{AR}}{\overline{OA}} = \tan^{-1} \frac{\overline{OQ} \sin \alpha}{\overline{OP} + \overline{OQ} \cos \alpha}.$$

In the special cases when $\alpha = 0^\circ$, 90° or 180° , these expressions are much simplified.

For $\alpha = 0^\circ$, $\overline{OR} = \overline{OP} + \overline{OQ}$, and $\theta = 0^\circ$.

For $\alpha = 90^\circ$, $\overline{OR} = \sqrt{\overline{OP}^2 + \overline{OQ}^2}$, and $\theta = \tan^{-1} \frac{\overline{OQ}}{\overline{OP}}$.

For $\alpha = 180^\circ$, $\overline{OR} = \overline{OP} - \overline{OQ}$, and $\theta = 0^\circ$ or 180° .

Problem 1. Find the resultant of the 6-lb. force and the 4-lb. force of Fig. 6 by the method of this article.

Problem 2. Find the resultant of the 6-lb. force and the 10-lb. force of Fig. 6. *Ans.* $R = 7.15$ lbs.; θ with 6-lb. force = $98^\circ 36'$.

Problem 3. Find the resultant of the 4-lb. force and the 10-lb. force of Fig. 6. *Ans.* $R = 10.77$ lbs.; $\theta = 158^\circ 12'$.

14. Resolution of a Force into Components. By reversing the parallelogram law or the triangle law, any force may be resolved into two components. Let the vector AB in Fig. 8 represent the force. Through any point C draw the two lines AC and CB . The vectors AC and CB represent the components of AB . C may be any point, so any number of pairs of components may be obtained. The components usually desired are those parallel to certain given axes, such as AC_1 and C_1B , horizontal and vertical respectively.

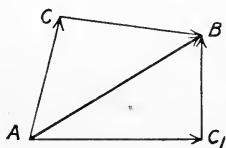

FIG. 8

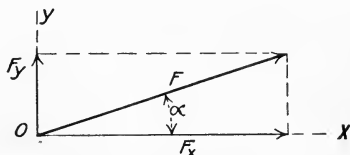

FIG. 9

In Fig. 9, let F be the force, F_x and F_y its components parallel to the X and Y axes respectively, and α the angle the force makes with the X axis.

By trigonometry,

$$F_x = F \cos \alpha \quad \text{and} \quad F_y = F \sin \alpha.$$

The components F_x and F_y are called the *projections* of the force F upon the X and Y axes.

A force may be resolved into its components at any point along its line of action.

Problem 1. In Fig. 9, let $F = 100$ lbs. and $\alpha = 30^\circ$. Determine F_x and F_y .

Ans. $F_x = 86.6$ lbs. $F_y = 50$ lbs.

Problem 2. Let $F = 40$ lbs. and $\alpha = 45^\circ$. Determine F_x and F_y .

Ans. $F_x = 28.28$ lbs. $F_y = 28.28$ lbs.

Problem 3. Let $F = 120$ lbs. and $\alpha = 110^\circ$. Determine F_x and F_y .

Ans. $F_x = -41.04$ lbs. $F_y = 112.8$ lbs.

Problem 4. Let $F = 500$ lbs. and $\alpha = 30^\circ$. Resolve F into two components, one horizontal, the other at an angle of 120° with the positive end of the X axis.

Ans. 577.3 lbs. horizontal. 288.7 lbs. at 120° .

15. Resultant of Three or More Forces in a Plane, Graphically. By an extension of the Triangle Law of Art. 12, the resultant of any number of concurrent forces may be found.

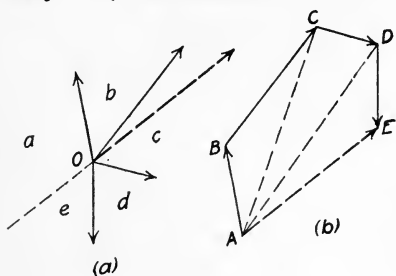

FIG. 10

In Fig. 10, AB and BC are combined into their resultant AC ; AC and CD are combined into their resultant AD ; and finally AD and DE are combined into their resultant AE , which is therefore the resultant of the entire system. Its line of action passes through O , the common point of the system.

It will be noticed that in making the solution, vectors AB , BC , CD and DE may be laid down in order, then the final resultant AE may be drawn without using the intermediate resultants AC and AD . Fig. 10(b) is called the *Force Polygon*. If the forces are taken in any other order, a different force polygon will be obtained, but the same resultant.

If the last force closes at the starting point, the resultant $R = 0$ and the system is in equilibrium. In any case, another force equal and opposite to R through the common point of the system will hold it in equilibrium.

Conversely, *If the force system is in equilibrium, the force polygon must close.*

In the special case of three forces in equilibrium, the following important principle also applies: *If a force system of three non-parallel forces is in equilibrium, they must meet in a common point.* For if any two of the forces are combined into their resultant, this resultant acts through their point of intersection. Then in order for the third force to balance this resultant and hence the other two forces, it must also pass through their point of intersection and be equal and opposite to their resultant.

These principles are used in the solution of problems in which the body and hence the force system acting upon it is known to be in equilibrium, but some of the forces are unknown.

EXAMPLE 1.

A block weighing 50 lbs. is lying on a plane inclined at an angle of 30° with the horizontal. If the friction of motion is 15 lbs., what force P parallel to the plane will be required to move the block uniformly up the plane?

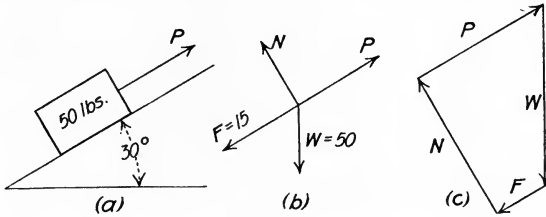

FIG. 11

Solution: — Fig. 11(a) shows the block resting upon the 30° plane with the force P acting upon it. In the free-body diagram, Fig. 11(b), the actions of all the surrounding parts upon the block as the free body are shown diagrammatically. The weight is a force of 50 lbs. vertically downward. The total reaction of the plane is resolved into two components, one, F , parallel to the plane (friction), the other, N , normal to the plane. The friction is a force of 15 lbs. downward along the plane. (Friction of the adjoining surfaces always opposes the motion of the free body.) N , the normal resistance of the plane, is unknown in amount and P is the unknown force asked for. Both N and P , however, are known in direction.

Since the body is in uniform motion, the forces are in equilibrium, so graphically the force polygon must close. This is drawn by laying down to scale vector W of the 50-lb. force and vector F of the 15-lb. force of friction, Fig. 11(c). Two other vectors, one parallel to N , Fig. 11(b), and one parallel to P , must close at the initial point. These are drawn and their lengths scaled. $N = 43.3$ lbs.; $P = 40$ lbs.

EXAMPLE 2.

A boom 30 ft. long, Fig. 12(a), weighs 1200 lbs. and is supported in a horizontal position by a cable BC at an angle of 30° with the horizontal. Determine the tension in the cable BC and the amount and direction of the hinge reaction at A .

Solution: — It is known that the boom is in equilibrium under the action of three forces, its weight vertically downward through the center of gravity D , the tension in the cable BC , and the hinge reaction through A . The line of action of the weight intersects BC at E . By the principle of Art. 15 the line of action of the hinge reaction at A must also pass through E , so its direction is determined, and is at an angle of 30° with the horizontal. The free-body

diagram for the boom is shown in Fig. 12(b) and the solution of the force triangle in Fig. 12(c). The tension in the cable and the hinge reaction at A scale 1200 lbs. each.

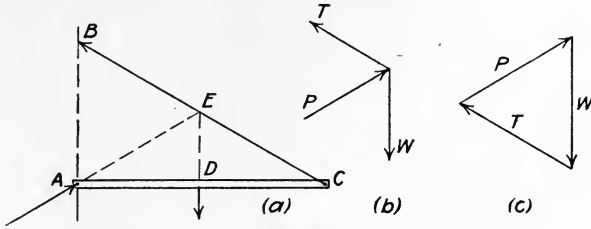

FIG. 12

It will be noticed that the force triangle formed of the vectors P , T and W is similar to the triangle AEB on the truss, since their sides are mutually parallel. As an alternative to drawing the force diagram accurately and scaling the values, the two unknown forces may be calculated from the proportionality of sides of the two similar triangles, since the dimensions of the triangle AEB are known.

$$\frac{P}{W} = \frac{AE}{AB}$$

$$P = 1200 \times \frac{17.32}{17.32} = 1200.$$

Problem 1. In Fig. 11(a), let P act horizontally and let the friction F be 20 lbs. Solve for the force P necessary to move the block uniformly up the plane.
Ans. $P = 52$ lbs.

Problem 2. In Problem 1 solve for the horizontal force P necessary to allow the block to move uniformly down the plane.
Ans. $P = 5.77$ lbs.

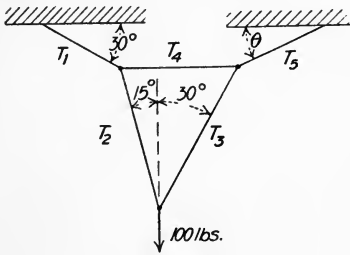

FIG. 13

Problem 3. A weight of 150 lbs. suspended by a cord is pulled to one side by a horizontal force of 40 lbs. What is the tension in the supporting cord and its angle with the vertical?
Ans. 155.2 lbs.; $\theta = 14^\circ 56'$.

Problem 4. Determine the tension in each cord and the value of the angle θ in the system of cords shown in Fig. 13.

Ans. $T_1 = 136.7$ lbs. $T_2 = 70.7$ lbs. $T_3 = 36.6$ lbs.
 $T_4 = 100$ lbs. $T_5 = 122.5$ lbs. $\theta = 15^\circ$.

16. Resultant of Three or More Forces in a Plane, Algebraically. As in the preceding article, the principles of Art. 13 may be extended to the case of three or more forces. Any two may be combined, then the resultant of these with a third and so on. This method is cumbersome and will be found of little use.

The principle of *resolution and recomposition* is more easily applied. By the principles of Art. 14 each force may be resolved at the common point of intersection into two forces along the two rectangular axes. All the X components may next be combined into one force called ΣF_x and all the Y components into one force called ΣF_y . These two forces may then be combined into the final resultant of the system R .

$$R = \sqrt{(\Sigma F_x)^2 + (\Sigma F_y)^2}.$$

A concurrent system of forces in a plane is in equilibrium if $R = 0$, which can be only if $\Sigma F_x = 0$ and $\Sigma F_y = 0$.

Conversely: *If a system of concurrent forces is in equilibrium, $\Sigma F_x = 0$ and $\Sigma F_y = 0$.*

This principle is used in the solution of problems in which a force system is known to be in equilibrium, but some of the forces are unknown.

EXAMPLE 1.

Determine the amount and direction of the resultant of the four forces represented in Fig. 14.

Solution:— Each force in order is replaced by its X and Y components, $F_x = F \cos \alpha$ and $F_y = F \sin \alpha$, as tabulated below.

F (lbs.)	$F_x = F \cos \alpha$	$F_y = F \sin \alpha$
$F_1 = 10$	$10 \times 0.866 = 8.66$	$10 \times 0.5 = 5$
$F_2 = 80$	$80 \times 0 = 0$	$80 \times 1 = 80$
$F_3 = 50$	$50 \times (-0.9848) = -49.24$	$50 \times (-0.1736) = -8.68$
$F_4 = 100$	$100 \times 0.707 = 70.7$	$100 \times (-0.707) = -70.7$
	$\Sigma F_x = +30.12$	$\Sigma F_y = +5.62$

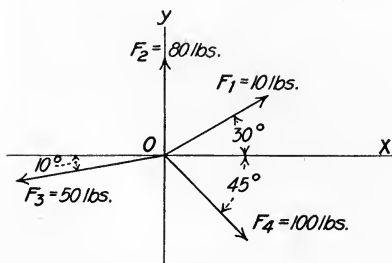

FIG. 14

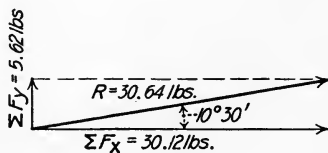

FIG. 15

The X components are added algebraically and give $+30.12$ lbs. for the resultant force along the X axis, ΣF_x . In the same way the Y components are added algebraically and give $+5.62$ lbs. for the resultant force along the Y axis, ΣF_y . The final resultant is obtained by taking the square root of the sum of the squares of the two rectangular components.

$R = \sqrt{30.12^2 + 5.62^2} = \sqrt{938.8} = 30.64$ lbs., as shown in Fig. 15. The angle θ with the X axis is given by the expression

$$\theta = \tan^{-1} \frac{\sum F_y}{\sum F_x} = \tan^{-1} \frac{5.62}{30.12} = 10^\circ 35'$$

EXAMPLE 2.

A cast iron sphere 1 ft. in diameter rests in an 8 in. \times 8 in. angle, one leg of which is at an angle of 30° with the horizontal, as shown in Fig. 16(a). What are the pressures at A and B ?

Solution:—The volume of a sphere = $\frac{4}{3}\pi r^3 = \frac{4}{3} \times \pi \times \frac{1}{8} = 0.5236$ cu. ft.

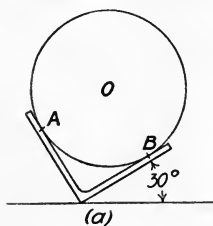
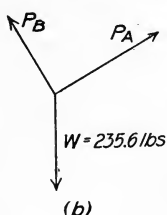

FIG. 16



Weight = $0.5236 \times 450 = 235.6$ lbs. Fig. 16(b) is the free-body diagram for the sphere. The weight is a force of 235.6 lbs. vertically downward, represented by vector W . Since there is no tendency for the sphere to move at the points of contact, the pressure of each side of the angle upon the sphere is normal to the

surface at that point. These pressures are represented by vectors P_A and P_B .

If the summation of horizontal forces in the free body diagram is equated to zero and the summation of vertical forces is equated to zero, each equation will contain two unknown quantities and the two must be solved simultaneously in order to determine the unknown quantities.

If the summation of forces parallel to P_A is equated to zero, the equation will contain only one unknown quantity which is immediately determined.

$$\begin{aligned} P_A - W \sin 30^\circ &= 0. \\ P_A &= 117.8 \text{ lbs.} \end{aligned}$$

Similarly, if the summation of forces parallel to P_B is equated to zero, P_B is determined.

$$\begin{aligned} P_B - W \cos 30^\circ &= 0. \\ P_B &= 204 \text{ lbs.} \end{aligned}$$

Problem 1. Check the results obtained for Example 1 above, using the line of action of the 100-lb. force as the X axis.

Problem 2. The system of forces shown in Fig. 17 is known to be in equilibrium. Determine the amounts of the unknown forces T_1 and T_2 .

Ans. $T_1 = 3010$ lbs. $T_2 = 985$ lbs.



FIG. 17

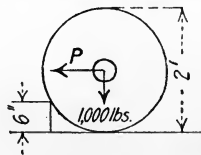

FIG. 18

Problem 3. A wheel 2 ft. in diameter carries a load of 1000 lbs. as shown in Fig. 18. What horizontal force P applied at the axle is necessary to start it over an obstacle 6 inches high? What force is necessary if the wheel is 4 ft. in diameter?

Ans. $P = 1732$ lbs. $P = 882$ lbs.

Problem 4. A boom P , Fig. 19, is held by a pin A at the wall CA , and a cable T fastened at the outer end and running up to the wall at an angle of 30° with the boom. A load of 1000 lbs. is carried at point B . Determine the compression in P and the tension in T .

Ans. $P = 1732$ lbs. $T = 2000$ lbs.

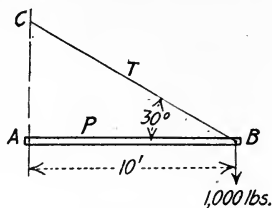

FIG. 19

Problem 5. Solve Example 2, Art. 15, by the method of this article.

17. Resultant of Three or More Forces in Space, Graphically.

Any number of concurrent forces in space may be combined graphically by a slight extension of the Triangle Law, Art. 12. Any two of the forces may be combined into their resultant, then this resultant may be combined with the third force, which in general will not be in the same plane with the first two, and so on until the final resultant is obtained. When the system consists of three forces mutually at right angles, the resultant is the diagonal of the rectangular parallelepiped constructed upon the three vectors. If the force polygon (in space) closes, the resultant is zero and the forces are in equilibrium.

Conversely: *If any system of concurrent forces in space is in equilibrium, the force polygon closes.*

Also, *If the force polygon in space closes, the projection of the force polygon on each of the three reference planes closes.*

In the solution of problems in equilibrium, the projection of the given system upon some reference plane is drawn and from the fact that the projection of the force polygon must close, the unknown forces are determined.

EXAMPLE.

A shear-legs crane has dimensions and load as shown in Fig. 20(a). Determine the stress in AE and the stress in AB .

Solution: — Take as the plane of projection the vertical plane AEF . The force system projected upon this plane is shown in Fig. 20(b), which may also be called the free-body diagram of point A . In this projection the forces BA and DA are superimposed. In Fig. 20(c) the graphical solution of this projected system is made. The vector T gives the stress in AE and scales

15,120 lbs. The vector P' gives the sum of the projected values of the stresses in BA and DA , 31,500 lbs.

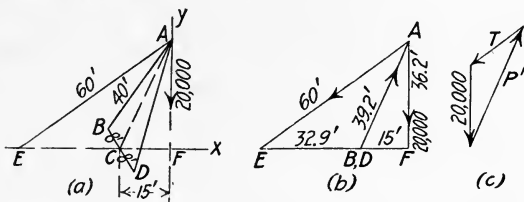

FIG. 20

In order to determine the stresses in BA and DA , a view in the plane ABD is taken, Fig. 21(a). Vector P' acts along CA and is really the resultant of the stresses in BA and DA . In order to determine these stresses, vector P' is laid down parallel to CA , as in Fig. 21(b). Through its initial point a line is drawn parallel to AB and through its final point a line is drawn parallel to AD . Their intersection determines the length of the vectors P, P , which represent the stresses in BA and DA . The scaled value of each is 15,400 lbs.

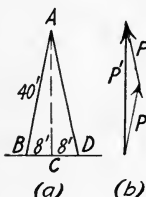

FIG. 21

Problem 1. A weight of 50 lbs. is hung from a horizontal ring 4 ft. in diameter by means of three cords each 4 ft. long. On the ring the cords are placed 120° apart. Find the tension in each cord.

Ans. 19.22 lbs.

Problem 2. Solve Problem 1 if two of the cords are 90° apart and the point of attachment of the third bisects the remaining arc.

Ans. 16.9 lbs. 16.9 lbs. 23.9 lbs.

18. Resolution of a Force into Three Components. The most common case of the resolution of a force into three components is that in which the components are parallel respectively to the three rectangular axes.

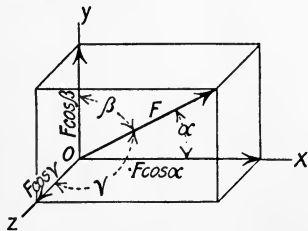

FIG. 22

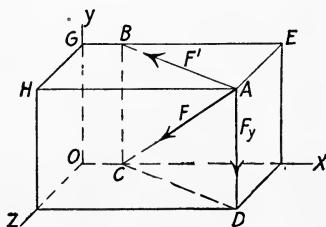

FIG. 23

If the angles between the force and the axes are given, α with X , β with Y and γ with Z , the algebraic method of resolution is more easily applied than the graphic method.

$$F_x = F \cos \alpha, \quad F_y = F \cos \beta \quad \text{and} \quad F_z = F \cos \gamma$$

are the rectangular components along the three axes, as shown in Fig. 22.

If the rectangular coördinates of two points on the line of action of the force are given instead of the angles α , β and γ , their cosines may be computed from the dimensions given and the resolution made algebraically. The graphic method, however, is very readily employed in this case.

Let the force be F , acting diagonally from A to C , Fig. 23. Pass a vertical plane $ABCD$ through the force. Fig. 24(a) shows

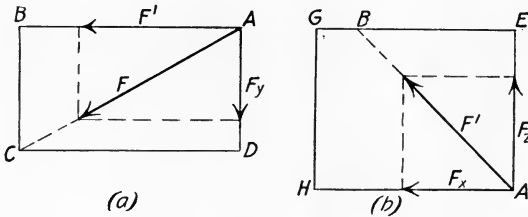

FIG. 24

the view normal to this plane, in which vector F is resolved into vector F' horizontal and F_y vertical. F_y is one of the components desired. In the horizontal plane $AEGH$, the top view of which is shown in Fig. 24(b), the force F' is resolved into its two components parallel to the other axes, F_x and F_z .

Problem 1. In Fig. 23, let $GE = 6$ ft., $GB = 3$ ft., $GH = 4$ ft., $GO = 4$ ft., and $F = 20$ lbs. Resolve force F into its three rectangular components, F_x , F_y and F_z .
Ans. -9.38 lbs. -12.5 lbs. -12.5 lbs.

Problem 2. If a force of 100 lbs. has line of action OA , Fig. 23, determine its three rectangular components, F_x , F_y and F_z .
Ans. 72.8 lbs. 48.5 lbs. 48.5 lbs.

Problem 3. In Fig. 22, $F = 1000$ lbs., $\alpha = 45^\circ$, $\beta = 64^\circ 50'$ and $\gamma = 55^\circ 30'$. Determine its three rectangular components, F_x , F_y and F_z .
Ans. 707 lbs. 425.3 lbs. 566.4 lbs.

19. Resultant of Three or More Forces in Space, Algebraically. If F_1 , F_2 , etc., Fig. 25, are the forces, at angles $(\alpha_1, \beta_1, \gamma_1)$ $(\alpha_2, \beta_2, \gamma_2)$, etc., with the X , Y and Z axes respectively, the resultant may be determined as follows:

At the common point of intersection each force may be resolved into its X , Y and Z components. The X components may be added algebraically into ΣF_x , the Y components into ΣF_y ,

and the Z components into ΣF_z . The final resultant of these three is,

$$R = \sqrt{(\Sigma F_x)^2 + (\Sigma F_y)^2 + (\Sigma F_z)^2}.$$

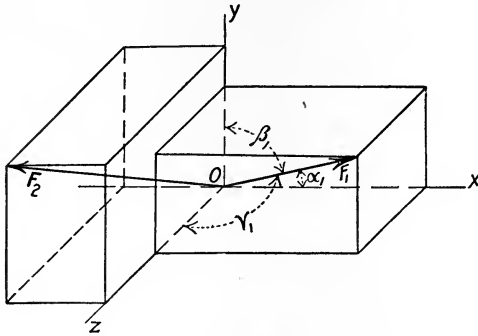

FIG. 25

The angles that R makes with the three axes are given by the following expressions:

$$\alpha = \cos^{-1} \frac{\Sigma F_x}{R}; \quad \beta = \cos^{-1} \frac{\Sigma F_y}{R}; \quad \gamma = \cos^{-1} \frac{\Sigma F_z}{R}.$$

If $R = 0$, $\Sigma F_x = 0$, $\Sigma F_y = 0$ and $\Sigma F_z = 0$, and the force system is in equilibrium.

Conversely, *If a system of concurrent forces is in equilibrium, the summation of forces along any line equals zero.*

Also, *The projection of any system of concurrent forces in equilibrium upon any plane constitutes a system in equilibrium.*

EXAMPLE.

Fig. 26 represents a hay stacking outfit. With a load of 1000 lbs. at the middle and a sag of 4 ft. below the horizontal, what are the stresses T_1 , T_2 and P ?

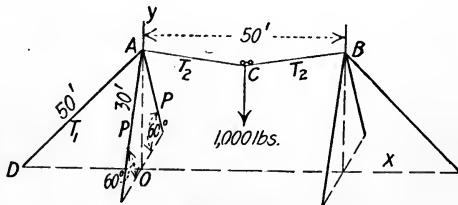

FIG. 26

Solution:— Consider first the cable ACB and the load as the free body. The stresses T_2 and the weight of the load constitute a coplanar system of

forces in equilibrium. With a sag of 4 ft. at C , the length $AC = 25.32$ ft. Equation $\Sigma F_y = 0$ gives

$$2 T_2 \frac{4}{25.2} = 1000.$$

$$T_2 = 3165 \text{ lbs.}$$

$$\text{Length } AO = 30 \sin 60^\circ = 25.98 \text{ ft.}$$

$$\text{Length } OD = \sqrt{50^2 - 25.98^2} = 42.7 \text{ ft.}$$

The four forces at A constitute a concurrent system in equilibrium. Equation $\Sigma F_x = 0$ gives

$$3165 \times \frac{25}{25.32} - \frac{42.7}{50} T_1 = 0,$$

$$T_1 = 3660 \text{ lbs.}$$

Equation $\Sigma F_y = 0$ gives

$$3660 \times \frac{25.98}{50} + 3165 \times \frac{4}{25.32} - 2P \times 0.866 = 0.$$

$$P = 1388 \text{ lbs.}$$

Problem 1. A tripod with legs 8 ft. long is set up on a level floor with each leg at the vertex of an equilateral triangle whose sides are each 4 ft. long. What are the stresses in the legs caused by a load of 100 lbs. on top?

Ans. 34.8 lbs. each.

Problem 2. Solve the Example in Art. 17 by the method of this article.

20. Moment of a Force with Respect to a Point. The moment of a force with respect to a point is the product of the force and the perpendicular distance from its line of action to the point. This perpendicular distance is called the *arm* of the force; the point is called the *center of moments*.

Let F , Fig. 27, be the force, d its arm and M_0 the moment of the force with respect to point O . Then

$$M_0 = Fd.$$

The *moment* of a force is the measure of its tendency to rotate the body upon which it acts around an axis through the center of moments, normal to the plane through the force and its arm.

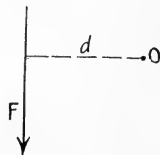

FIG. 27

Unit of Moment. Moment is measured in terms of the units of length and force used; as, foot-lbs., inch-lbs., inch-tons, etc.

Sign of Moment. Moments tending to produce rotation counter-clockwise are commonly called positive, those clockwise, negative. The opposite notation may be used if kept consistently throughout the problem.

21. Principle of Moments. *The algebraic sum of the moments of two concurrent forces with respect to a point in their plane is equal to the moment of their resultant with respect to the same point.*

Let P and Q , Fig. 28, be the forces concurrent at A , R their resultant and O any point in their plane. Draw AO and produce it to F . From the ends of P and R drop perpendiculars CE , DF and CG . Also drop perpendiculars p , q and r from O to the forces P , Q and R respectively. Let α , β and θ be the angles between the line AO and the forces P , Q and R respectively. Then

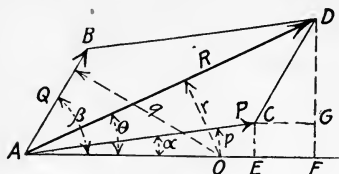

FIG. 28

Then

$$\overline{FD} = \overline{FG} + \overline{GD},$$

so

$$R \sin \theta = P \sin \alpha + Q \sin \beta.$$

This equation multiplied by \overline{OA} becomes

$$R \cdot \overline{OA} \sin \theta = P \cdot \overline{OA} \sin \alpha + Q \cdot \overline{OA} \sin \beta,$$

or

$$Rr = Pp + Qq.$$

The student should supply the proof when O is between P and R or between Q and R .

From the principle above, the moment of a force with respect to a point is equal to the sum of the moments of its X and Y components with respect to the same point. It is often simpler to compute this sum than the moment of the force itself.

This proof may be extended to the case of three or more concurrent forces. The statement of the general case, then, is as follows: *The moment of the resultant of any number of concurrent forces in a plane with respect to any point in that plane is equal to the algebraic sum of the moments of the forces with respect to the same point.*

The above demonstration is commonly called "Varignon's Theorem."

Problem 1. In Fig. 28, let $P = 100$ lbs.; $Q = 60$ lbs.; angle between P and $Q = 60^\circ$; angle $BAO = 80^\circ$; $OA = 4$ ft. Determine the resultant R and the moment of this resultant with respect to point O .

Ans. $R = 140$ lbs. $M_o = 373.2$ ft.-lbs.

22. Moment of a Force with Respect to a Line. The moment of a force with respect to a line parallel to it is zero, since there is no tendency for the force to rotate the body upon which it acts about that line as an axis. The moment of a force with respect to an

axis intersecting it is zero, since the moment arm is zero. The moment of a force with respect to an axis in a plane perpendicular to the force is equal to the product of the force and the perpendicular distance from the force to the axis.

If the axis is not in a plane perpendicular to the force, the force may be resolved at any point into two rectangular components, one parallel to the axis, the other perpendicular to a plane containing the axis. The moment of the original force with respect to the axis is equal to the moment of the perpendicular component alone, since the moment of the component parallel to the axis is zero.

Another method is to resolve the force into three mutually rectangular components, one of which is parallel to the axis and hence has no moment with respect to it. The sum of the moments of the other two components gives the moment of the original force.

Problem 1. In the force system shown in Fig. 29, determine the resultant moments with respect to the X , Y and Z axes. Each side of the parallelepiped is 3 ft. long.

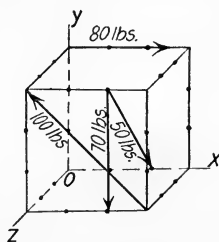

FIG. 29

Ans. $M_x = -2.1$ ft.-lbs. $M_y = -141.4$ ft.-lbs. $M_z = -238.6$ ft.-lbs.

GENERAL PROBLEMS.

Note. — In many cases in this and the following lists of general problems the student has a choice of methods of solution, so care should be taken to choose the method best adapted to the problem. If there is no figure to illustrate the problem, a sketch is a great help in the solution.

The free-body diagram should always be drawn.

Problem 1. A weight of 50 lbs is supported by two cords, one at an angle of 30° with the horizontal, the other at an angle of 45° with the horizontal. Find the tension in the cords.

Ans. 36.6 lbs. 44.8 lbs.

Problem 2. A slack wire performer weighing 150 lbs. stands in the middle of a wire 30 ft. long and depresses it 6 ft. What is the tension in the wire due to the man's weight?

Ans. 187.5 lbs.

Problem 3. A picture weighing 30 lbs. is hung by an endless wire passing over a hook at *A* and through screw rings at four points as shown in Fig. 30. What is the tension in the cord and the resultant pull on each screw?

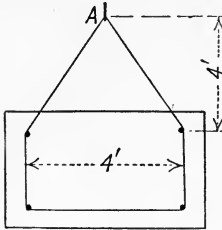

FIG. 30

Ans. Tension = 16.8 lbs. Top screws, 7.71 lbs. at $13^{\circ} 20'$ with horizontal. Bottom, 23.75 lbs. at 45° with horizontal.

Problem 4. Boatmen say that a mule can pull a heavier tow boat with a long hitch than with a short one, while teamsters claim that in their work the opposite is the case. Explain.

Problem 5. A force of 500 lbs. acts at an angle of 30° with the horizontal. Find its vertical and

horizontal components.

Solve also if the force acts at an angle of 15° with the horizontal.

Ans. 250 lbs. 433 lbs. 129.4 lbs. 483 lbs.

Problem 6. A horizontal force of 180 lbs. is pulling a body up a 20° plane. Find the components parallel to the plane and perpendicular to the plane.

Ans. 169.2 lbs. 61.6 lbs.

Problem 7. A guy wire to a smokestack makes an angle of 40° with the ground. When the tension in it is 10,000 lbs., what are its vertical and horizontal components?

The other two wires are at 120° with the first, but are at 45° and 50° with the ground. What is the tension in each and what vertical compression is caused in the stack by the three?

Ans. 6428 lbs. 7660 lbs. 10,830 lbs. 12,910 lbs. 23,228 lbs.

Problem 8. The upward reaction of the pedestal of a bridge upon the end pin is 8000 lbs., as shown in Fig. 31. Consider the actions of the end post and lower cord to be axial and determine the stress in each.

Ans. 9240 lbs. comp. in post. 4620 lbs. tens. in lower chord.

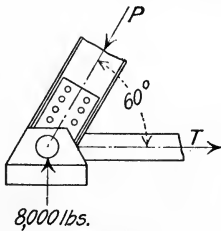

FIG. 31

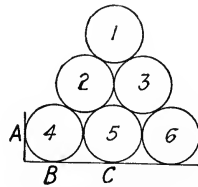

FIG. 32

Problem 9. Six cylinders of equal size, each weighing 1000 lbs., are piled up as shown in Fig. 32. Find the pressures at *A*, *B* and *C*.

Ans. 577 lbs. 2000 lbs. 2000 lbs.

Problem 10. Three uniform spheres, each weighing 12 lbs., just fit into a triangular box with vertical sides. A fourth sphere of the same size and weight is placed on top of the three. What pressure does each exert on the box at the three points of contact? *Ans.* 16 lbs. on bottom. 2.83 lbs. at each side.

Problem 11. A wheel 3 ft. in diameter carries a load of 500 lbs. What is the amount and direction of the least force P which will start it over an obstruction 6 inches high? *Ans.* 373 lbs. at $48^\circ 10'$ with the horizontal.

(*Note:* — Solve graphically. The weight is represented by a vector, known completely. The direction of the reaction of the obstruction is radial. The force P called for is given by the least vector which will close the triangle.)

Problem 12. One end of a horizontal rod 6 ft. long is pinned to a vertical wall and the other is supported by a cord passing up to the wall at a point 8 ft. above the pin. A load of 400 lbs. is hung at the outer end. What is the tension in the cord and the compression in the rod?

Ans. Tension = 500 lbs. Compression = 300 lbs.

Problem 13. If the weight is hung at the middle of the rod of Problem 12, what is the tension in the cord? What is the amount and direction of the pin pressure at the wall?

Ans. Tension = 250 lbs. $R = 250$ lbs.
 θ with hor. = $53^\circ 08'$.

Problem 14. Fig. 33 shows a simple derrick. What are the stresses in AB and AC ?

Ans. $AB = 2500$ lbs. tens. $AC = 2500$ lbs. comp.

Problem 15. In the crane shown in Fig. 34, determine the compression in BD and the amount and direction of the pin pressure at A .

Ans. 1300 lbs. 900 lbs. $43^\circ 50'$ with horizontal.

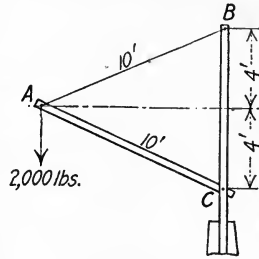

FIG. 33

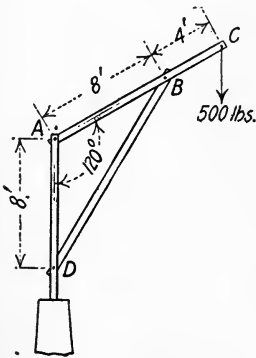

FIG. 34

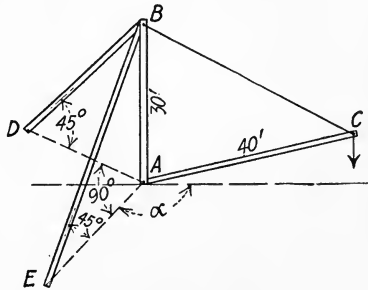

FIG. 35

Problem 16. The boom of the stiff-leg derrick shown in Fig. 35 has a range of position in a vertical plane from the horizontal to within 20° of the vertical. Determine the position of the boom for the maximum stress in BC . For this position of the boom in the vertical plane, determine the value of angle α for the maximum compression in BE . Same for the maximum tension. If the load at C is 2400 lbs., determine the maximum stresses in BC , AC , BE and BA .

Ans. $BC = 4000$ lbs. $AC = 3200$ lbs. $BE = 4525$ lbs. $BA = 6920$ lbs.

Problem 17. In the Example of Art. 17 resolve each force as there obtained into its X , Y and Z components.

Ans. For AE , $F_x = -12,080$ lbs. $F_y = -9120$ lbs. $F_z = 0$.

For AB , $F_x = 5790$ lbs. $F_y = 13,970$ lbs. $F_z = 3080$ lbs.

Problem 18. A shear legs crane is loaded as shown in Fig. 36. Find the stresses in AC and DC .

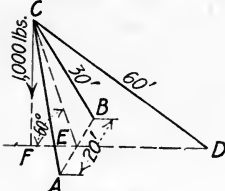

FIG. 36

Ans. $DC = 853$ lbs. tens. $AC = 825$ lbs. comp.

Problem 19. The pressure of the steam on the piston of an engine is 15,000 lbs. Neglecting friction, what is the pressure on the guide and the compression in the connecting rod when the connecting rod makes an angle of 15° with the direction of the piston rod?

Ans. 4020 lbs. 15,520 lbs.

Problem 20. What weight can be drawn up a smooth plane with a slope of 1 in 10, by a force of 50 lbs. acting parallel to the plane? How much by 50 lbs. acting horizontally?

Ans. 502.5 lbs. 500 lbs.

Problem 21. A tripod $ABCD$, Fig. 37, with vertex at A has leg AC 27.5 ft. long, leg AB 25 ft. long and leg AD 30 ft. long. It is placed on level ground with distance BC 20 ft., distance CD 30 ft. and distance BD 25 ft. With 6000 lbs. vertical load at A , what is the compressive stress in each leg? (Solve graphically.)

6000 lbs.

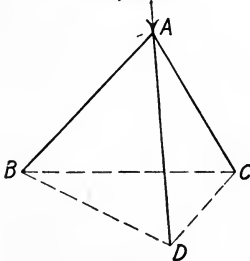

FIG. 37

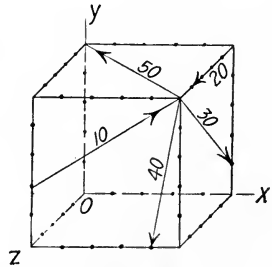

FIG. 38

Problem 22. Determine the resultant of the five forces shown in Fig. 38, both in amount and direction.

Ans. $R = 74.1$ lbs. $\alpha = 117^\circ 52'$. $\beta = 135^\circ 30'$. $\gamma = 121^\circ 30'$.

Problem 23. In the force system shown in Fig. 38, determine the moment of each force with respect to each axis. Each side of the cube is 5 ft. long.

<i>Ans.</i>	F	M_x	M_y	M_z
	(lbs.)	(ft.-lbs.)	(ft.-lbs.)	(ft.-lbs.)
	10	-25.75	+42.90	-17.15
	20	+100	-100	0
	30	-23.40	+117	-93.85
	40	+196	-39.25	-156.80
	50	-176.75	0	+176.75

CHAPTER II.

PARALLEL FORCES.

23. Resultant of Two Parallel Forces, Graphically. The graphic method of finding the resultant of forces, as used in Art. 12, must be modified in the case of parallel forces, since they do not intersect. By one method, one of the forces is resolved into two components, then the resulting system of three forces is combined into their resultant.

There are two cases, one in which the two forces are in the same direction, as in Fig. 39, the other in which they are in opposite

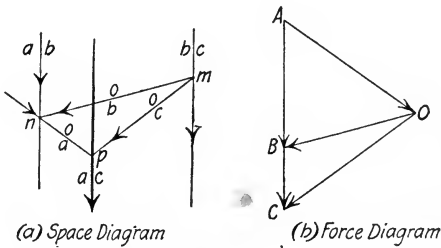

FIG. 39

directions, as in Fig. 40. The solution is simplified by using both the space and force diagrams. In either figure let AB and BC

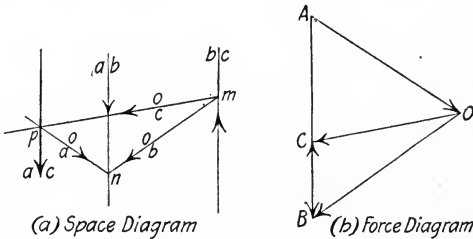

FIG. 40

represent the forces, acting along ab and bc . At any point n , resolve AB into any two convenient components, AO and OB , acting along ao and ob . Where ob intersects bc , at m , combine

OB and BC into their resultant OC acting along oc . The system now consists of forces AO and OC , concurrent at p in the space diagram. Combine these into their resultant AC which acts through the point of intersection p parallel to the original forces. The amount and the direction of the resultant are given by the algebraic sum of the original forces.

The original polygon in the force diagram is called the *force polygon*, point O is called the *pole* and the auxiliary lines OA , OB , etc., are called *rays*. The polygon in the space diagram is called the *funicular polygon*, and the component parts of it, oa , ob , etc., are called *strings*.

It will be noticed that in the case in which two parallel forces are oppositely directed, the resultant is not between the two, but is outside on the side of the larger force.

If the two forces are opposite in direction and equal in amount, the resultant is zero and point C , Fig. 40, falls at A in the force diagram. Then line oc will be parallel to oa , hence the forces OC and OA cannot be combined into a single force. Such a system is called a *couple* and will be discussed in Arts. 27–30.

Problem 1. In Fig. 39, find the amount and position of the resultant if force AB is 8000 lbs., force BC is 2000 lbs. and the distance between their lines of action is 5 ft.

Ans. $R = 10,000$ lbs., 1 ft. from ab .

Problem 2. Determine the amount and position of the resultant of the two wheel loads shown in Fig. 41.

Ans. $R = 2600$ lbs., 3.85 ft. from larger wheel.

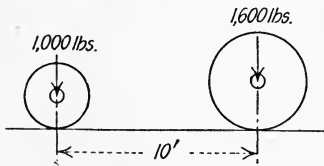

FIG. 41

Problem 3. In Fig. 40, find the amount and position of the resultant if force AB is 500 lbs., force BC is 300 lbs. and the distance between their lines of action is 3 inches.

Ans. $R = 200$ lbs. downward, 4.5 in. to the left of ab .

Problem 4. The horizontal pressures of the support upon the wheels of an elevator car are as shown in Fig. 42. Find the amount, direction and position of the resultant.

Ans. $R = 150$ lbs. to the right, 2.67 ft. below 250-lb. force.

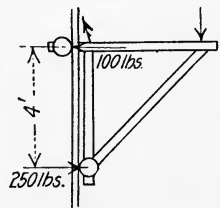

FIG. 42

24. Resultant of Two Parallel Forces, Algebraically. As stated in Art. 23, the resultant of two parallel forces is given in amount and direction by the algebraic sum of the component forces. It remains, then,

to find the position of the line of action. Let AB and BC , Fig. 43, be the two forces and ab and bc their lines of action. The position of the line of action ac of their resultant will now be determined with respect to ab .

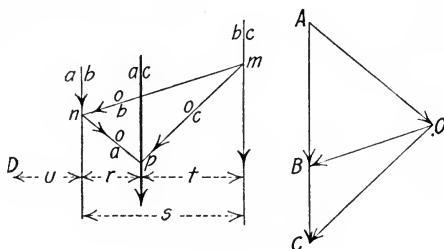

FIG. 43

By the principle of Art. 21, the moment of the resultant AC (acting along ac in the space diagram) with respect to point n is equal to the moment of its two concurrent components, AO and OC . But the moment of AO is zero, so

$$\text{Moment of } AC = \text{Moment of } OC.$$

Also, the moment of OC with respect to n is equal to the moment of its two concurrent components, OB and BC . Since the moment of OB is zero,

$$\text{Moment of } OC = \text{Moment of } BC,$$

$$\text{and} \quad \text{Moment of } AC = \text{Moment of } BC.$$

$$AC \times r = BC \times s.$$

Consider any point D , distant u from the line of action ab . Since $AC = AB + BC$,

$$AC \times u = AB \times u + BC \times u.$$

Add this equation to the one derived above. Then

$$AC(u + r) = AB \times u + BC(u + s).$$

The *Principle of Moments* for parallel forces may now be stated: *The algebraic sum of the moments of two parallel forces with respect to any point in their plane is equal to the moment of their resultant with respect to the same point.*

If the point D is taken on the line ac , the equation just derived becomes

$$AB \times r - BC \times t = 0,$$

$$\frac{t}{r} = \frac{AB}{BC},$$

or, the perpendicular distances of the resultant from the forces are to each other inversely as the forces.

Since by geometry three parallel lines divide any two intersecting straight lines in the same ratio, this principle holds true for any diagonal distances, also.

The graphical application of this principle is often very advantageous, so will be given here. If ab and bc , Fig. 44, are the two

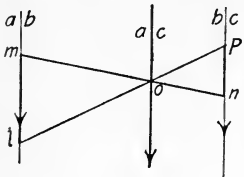

FIG. 44

forces, join their lines of action by any convenient straight line mn . From m lay off ml on ab equal by scale to force bc , and from n lay off np in the opposite direction on bc equal by scale to force ab . Join pl , cutting mn at o . The resultant passes through o .

Problem 1. Show that $\frac{t}{r} = \frac{AB}{BC}$ applies as well when AB and BC are in opposite directions.

Problem 2. Check the position of the resultant as found in Problems of Art. 23.

25. Resultant of Any Number of Parallel Forces, Graphically.

The graphical method of Art. 23 is readily extended to the case of three or more parallel forces in a plane. In Fig. 45, AB is resolved at any point m into AO and OB . OB is combined with BC into their resultant OC . OC is combined with CD into OD . OD is combined with DE into OE . AO and OE are now the only forces left, so they are combined into the final resultant of the system, AE , acting through point p . The order of solution is as follows:

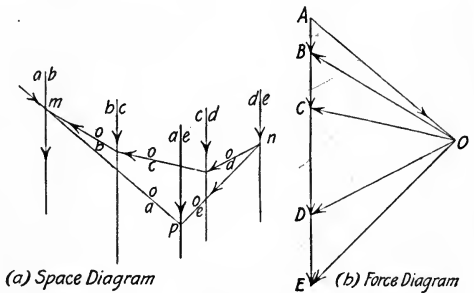

FIG. 45

system, AE , acting through point p . The order of solution is as follows:

- (1) Draw the space diagram.
- (2) Draw the force polygon, noting the resultant.
- (3) Choose any convenient pole O and draw the rays.
- (4) Parallel to the rays of the force diagram draw the corresponding strings of the funicular polygon in the space diagram.

(5) The intersection of the first and last strings determines the position of the resultant.

If Bow's notation is used, each string has its corresponding ray lettered similarly. For example, string ob is parallel to ray OB , and is drawn between the two lines which enclose the "b" space, ab and bc . When the solution is begun, string oa is "free" until intersected by the other free string to determine the line of action of the resultant.

If the final point of the force polygon coincides with the initial point so that the resultant $R = 0$ but the two "free" strings do not coincide, the resultant of the system is a couple, as will be discussed in Arts. 27-30.

In case the forces are not in the same plane, the graphical method is used by finding the resultant of any two forces in their plane, then the resultant of this with a third force in their separate plane, and so on.

Problem 1. Fig. 46 represents a body 4 ft. long with forces applied as shown. If $F_1 = 10$ lbs., $F_2 = 12$ lbs., $F_3 = 4$ lbs. and $F_5 = 16$ lbs., find the amount and position of the resultant.

Ans. 38 lbs., 2 ft. from the left end.

Problem 2. In Fig. 46, let $F_3 = 14$ lbs., $F_4 = 9$ lbs. and the other forces as in Problem 1. Determine the resultant.

Ans. 15 lbs. downward, 1.4 ft. from the left end.

Problem 3. Forces acting downward on the four vertical edges of a 3-ft. cube are in order, 10 lbs., 20 lbs., 25 lbs. and 15 lbs. Combine the four forces graphically.

Ans. $R = 70$ lbs., 1.07 ft. from 20-25 face, 1.29 ft. from 15-25 face.

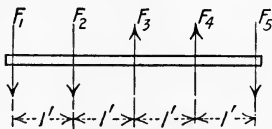

FIG. 46

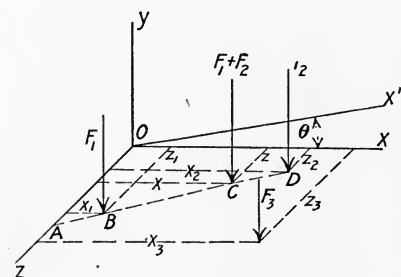

FIG. 47

26. Resultant of Any Number of Parallel Forces, Algebraically. In amount and direction the resultant R of any number of parallel forces is given by their algebraic sum. The method of locating the position of the resultant will now be shown.

Let F_1, F_2, F_3 , etc., Fig. 47, be any number of parallel forces and XOZ a plane of reference normal to them. Consider first the forces F_1 and F_2 whose lines of action pierce the plane of reference at B and D . Their result-

ant, $F_1 + F_2$, lies in their plane and, by Art. 24, pierces the reference plane at some point C such that

$$(F_1 + F_2)\overline{AC} = F_1 \times \overline{AB} + F_2 \times \overline{AD}.$$

If this equation is multiplied by $\sin BAO$, it becomes

$$(F_1 + F_2)x = F_1x_1 + F_2x_2.$$

If $(F_1 + F_2)$ is combined with F_3 in a similar manner, the resulting expression is

$$(F_1 + F_2 + F_3)x = F_1x_1 + F_2x_2 + F_3x_3.$$

By continuing until all of the forces of the system are combined into their resultant R , the final relation is obtained:

$$\begin{aligned} Rx &= F_1x_1 + F_2x_2 + F_3x_3 +, \text{ etc.}, \\ x &= \frac{F_1x_1 + F_2x_2 + F_3x_3 +, \text{ etc.}}{R} \end{aligned}$$

In a similar manner the distance z of the resultant from axis OX may be determined.

$$z = \frac{F_1z_1 + F_2z_2 + F_3z_3 +, \text{ etc.}}{R}$$

It will be noticed that the distance x of resultant R from the axis OZ is the same as the distance x of any point in the resultant from the plane ZOY . It follows, then, that the same moment equation would be obtained for any axis in the ZOY plane parallel to OZ . Since this is so, it is common to speak of the *moment of a force with respect to a plane parallel to it*, meaning thereby the moment of the force with respect to any axis in the given plane normal to the force.

It will now be shown that the expression derived above for locating the distance of the resultant from any axis in a plane normal to the force system holds true as well for any inclined axis. Let $X'OZ$ be a plane at an angle θ with the plane XOZ . Each force, at its point of intersection with the plane $X'OZ$, may be resolved into two rectangular components, $F \sin \theta$ in the plane $X'OZ$, and $F \cos \theta$ normal to it. The components $F \sin \theta$ in the plane $X'OZ$ have no moment with respect to the axis OX' , hence the moment of the normal components is equal to the moment of the original forces. From the preceding discussion the moment equation for the normal components becomes

$$R \cos \theta \cdot z = F_1 \cos \theta \cdot z_1 + F_2 \cos \theta \cdot z_2 +, \text{ etc.}$$

If this equation is divided through by $\cos \theta$, it becomes identical with that for axis OX or any axis in the plane XOY parallel to OX ,

$$Rz = F_1z_1 + F_2z_2 +, \text{ etc.}$$

It must be remembered that z is the mutual perpendicular between the force and the inclined axis OX' .

Since the axis OX may have any position in the plane normal to the forces, the axis OX' may have any position whatsoever; therefore *the algebraic sum of the moments of any number of parallel forces with respect to any axis is equal to the moment of their resultant with respect to the same axis.*

If the resultant R of a system of parallel forces is equal to zero, but the moment of the system with respect to any axis is not equal to zero, the system is equivalent to a couple, as will be discussed in Arts. 27-30.

Problem 1. Determine the position of the resultant of the three downward forces shown in Fig. 48.

Ans. 6.7 ft. from left end.

Problem 2. Determine the position of the resultant of the two upward forces shown in Fig. 48.

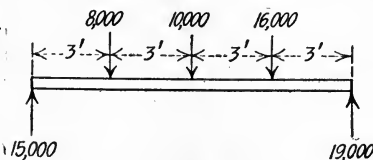

FIG. 48

Problem 3. A rectangular table 3 ft. wide and 4 ft. long has weights so placed that the downward pressures on the four legs in order around the table are as follows: $A = 20$ lbs.; $B = 26$ lbs.; $C = 30$ lbs.; $D = 24$ lbs. A and B are at one end. Solve for the amount and position of the resultant.

Ans. $R = 100$ lbs., 2.16 ft. from end AB , 1.32 ft. from side BC .

27. Moment of a Couple. Two parallel forces, equal in amount, opposite in direction and with different lines of action,

constitute a couple, as FF , Fig. 49. The perpendicular distance between them, f , is called the *arm* of the couple. The product of one force and the arm is called the *moment* of the couple, or

$$Mom. = Ff.$$

The moment of a couple is the same with respect to any point in its plane, as will be shown. Let O and O' be any two points in the plane of the couple, Fig. 49.

$$\Sigma M_0 = F \times \overline{OA} + F \times \overline{OB} = F \times \overline{AB} = Ff.$$

Also,
$$\Sigma M_{0'} = F \times \overline{O'A} - F \times \overline{O'B} = F \times \overline{AB} = Ff.$$

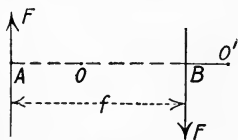

FIG. 49

Since the resultant R of a couple is zero, moment is the only effect of a couple. It follows, then, from the two preceding principles, that a couple may be transferred to any place in its plane or rotated through any angle and its effect will remain the same.

Since moment is the only effect of a couple, it follows also that any couple may be replaced by another of the same moment in the same plane. Thus the rotary effect of a couple composed of two forces of 8 lbs. each, acting 3 ft. apart, is the same as that of another in the same direction with forces of 4 lbs. each, acting 6 ft. apart.

No single force can balance a couple. Since the resultant R of the couple is zero, the resultant of the couple and another force could not be zero.

A couple may be transferred to any plane parallel to its original plane without change of effect. Since the moment of a couple with respect to any point O in its plane is the same as its moment with respect to an axis through O , perpendicular to its plane, the moment is independent of the location of the plane of the couple along the axis. For example, if a steam pipe is being screwed into a sleeve by means of two pipe wrenches (constituting a couple), the effect is the same, no difference at what point along the pipe they are applied.

28. Graphic Representation of a Couple. Since couples have no properties but *magnitude* and *direction*, they may be represented graphically by vectors. The length of the vector represents to some scale the magnitude of the couple, and the direction of the vector shows the direction of its plane and the direction of its rotation. The vector is drawn perpendicular to the plane of the couple. The convention commonly used with regard to the arrow is that in which, if the couple is viewed from the head end

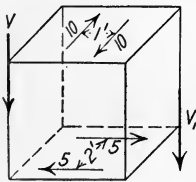

FIG. 50

of the vector, the rotation of the couple appears positive (counter-clockwise). Either of the vectors, V , V_1 , Fig. 50, 10 units long, vertical, with the arrow pointing downward, represents the moment (-10 ft.-lbs.) of either couple in the horizontal planes as shown.

The position of the vector is immaterial, since the moment of the couple is the same with respect to any axis perpendicular to its plane.

29. Composition of Couples. The moment of the resultant of any number of coplanar couples or of couples in parallel planes, is equal to the algebraic sum of the moments of the component couples.

By means of the principles of Art. 28, couples may be compounded by combining their vectors. Since the position of the vector is immaterial, the vectors of the couples may all be taken through any given point, then added graphically. The resultant vector represents completely the resultant couple.

Couples may also be combined directly. If the couples are in the same plane (or in parallel planes), they may all be reduced to couples having equal arms f , with the forces parallel. If these are superimposed, the forces F_1, F_2, F_3 , etc., combine into their resultant F in each case. Then $F_1f + F_2f + F_3f + \dots = Ff$.

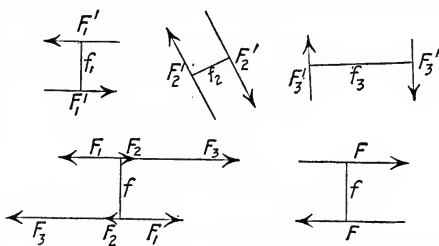

FIG. 51

In Fig. 51, couple $F_1'f_1$ reduces to couple F_1f .

Couples $F_2'f_2$ and $F_3'f_3$ reduce to F_2f and F_3f . Each set of forces, F_1, F_2, F_3 , gives the resultant force F , so the resultant couple is Ff .

If two couples to be combined are in intersecting planes, they may be reduced to couples whose forces are equal each to each. If the couples are then transferred, each in its own plane, so that

one force of each lies in the intersection of the two planes in opposite directions, as in Fig. 52, these two forces neutralize each other and may be removed from the system. This

leaves the couple with forces FF and arm f in the plane $ABCD$.

If ϕ is the angle of the two planes, and f_1, f_2 the arms of the original couples after being transposed, the arm f is given by

$$f^2 = f_1^2 + f_2^2 - 2f_1f_2 \cos \phi.$$

Problem 1. In Fig. 52, transfer the couple whose arm is f_1 downward in its plane until the upper force is at the intersection of the two planes and determine the resultant couple.

Ans. Forces $2F$ with arm $\frac{f}{2}$.

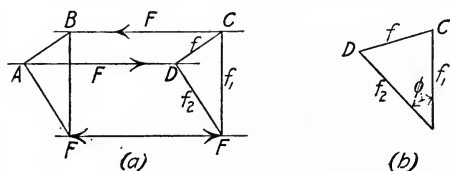

FIG. 52

Problem 2. Couples of 10 lbs. \times 4 ft., 3 lbs. \times 16 ft., and 20 lbs. \times 5 ft. are located in the same vertical plane, all rotating counter-clockwise. What is their resultant couple?
Ans. +188 ft.-lbs.

Problem 3. A couple of 10 lbs. \times 6 ft. in a vertical plane and one of 4 lbs. \times 20 ft. in a horizontal plane are to be combined. Both are negative, viewed from the angle between the planes. Determine the amount of the resultant couple and the slope of its plane.
Ans. -100 ft.-lbs. $\theta = 36^\circ 52'$ with the horizontal.

30. Resolution of a Force into a Force and a Couple. Any force may be resolved into a force through a given point and a couple. In Fig. 53, let F be the given force acting at A , and let O be the given point. At O introduce two opposite forces, F_1 and F_2 , each equal and parallel to F . Since they neutralize each other, they do not affect the system. Then F_1 and F constitute a couple with moment Ff , and may be transferred to any place in their plane, leaving force F_2 equal to the original force F , but acting at O .

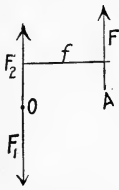

FIG. 53

Problem 1. Resolve the forces of Fig. 54 into a force at O and a couple. Each square is 1 ft. on each side.

Ans. $R = 263.25$ lbs. $\theta = 29^\circ 26'$ with hor. Couple = +329.3 ft.-lbs.

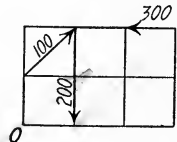

FIG. 54

Problem 2. Resolve the forces acting upon the 3-ft. cube in Fig. 55 into a force at O and a couple. *Note:*—Resolve each force into its X , Y and Z components first.

Ans. $R = 266$ lbs. $\alpha = 52^\circ 15'$. $\beta = 127^\circ$. $\gamma = 121^\circ$. Couple = 902 ft.-lbs. Direction of vector of couple is given by: $\alpha' = 85^\circ 30'$; $\beta' = 46^\circ$; $\gamma' = 136^\circ$.

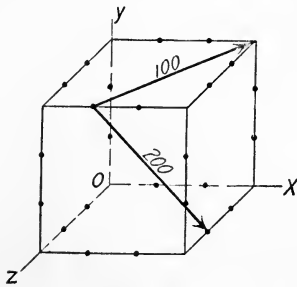

FIG. 55

31. Coplanar Parallel Forces in Equilibrium, Algebraic Solution. In general, any system of parallel forces in a plane may be reduced to a single force R and a couple with moment M .

If for any system both the resultant $R = 0$ and the moment $M = 0$, the system is in equilibrium.

Conversely: *If a system of coplanar parallel forces is in equilibrium, the resultant $R = 0$ and the moment M with respect to any axis = 0.*

If in a given system of forces which is known to be in equilibrium, some of the forces are unknown, they may be determined by

applying the conditions of equilibrium. The number of unknown forces, however, must not exceed the number of *independent* equations which can be written, two in this case.

EXAMPLE.

A beam 10 ft. long, supported at the ends, carries three loads spaced as shown in Fig. 56. What are the reactions at the supports, R_1 and R_2 , if the weight of the beam itself is neglected?

Solution: — The beam is at rest, so the force system acting upon it is in equilibrium. Application of the equation $\Sigma F = R = 0$, gives

$$R_1 + R_2 - 9000 = 0.$$

Equation $\Sigma M = 0$, with any point on R_1 as the center of moments, gives

$$10 R_2 - 6000 \times 2 - 1000 \times 5 - 2000 \times 9 = 0.$$

$$R_2 = 3500 \text{ lbs.}$$

By substitution of the value of R_2 in the equation above

$$R_1 = 5500 \text{ lbs.}$$

As a check, an independent solution for R_1 may be made by writing the equation of moments with respect to any point on R_2 .

When the loading on a beam is symmetrical, no equations need be written, since each reaction is one-half of the total load.

Problem 1. Solve for the reactions R_1 and R_2 of the beam shown in Fig. 57. Neglect the weight of the beam. *Ans.* $R_1 = 1917 \text{ lbs.}$ $R_2 = 583 \text{ lbs.}$

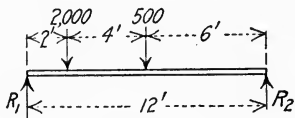

FIG. 57

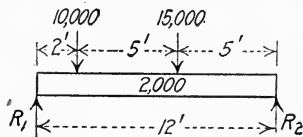

FIG. 58

Problem 2. Solve for the reactions R_1 and R_2 of the beam shown in Fig. 58. (*Note:* — The weight of the beam, 2000 lbs., is a uniformly distributed load with its centroid at the middle of the beam.)

$$\text{Ans. } R_1 = 15,580 \text{ lbs. } R_2 = 11,420 \text{ lbs.}$$

Problem 3. Solve for the reactions R_1 and R_2 of the beam shown in Fig. 59.

$$\text{Ans. } R_1 = 9833 \text{ lbs. } R_2 = 3167 \text{ lbs.}$$

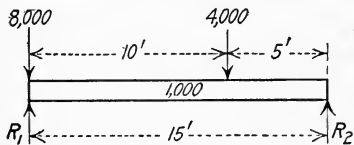

FIG. 59

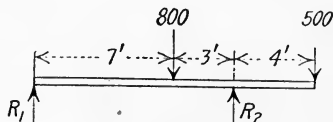

FIG. 60

Problem 4. Solve for the reactions R_1 and R_2 of the overhanging beam shown in Fig. 60. *Ans.* $R_1 = 40 \text{ lbs.}$ $R_2 = 1260 \text{ lbs.}$

32. Coplanar Parallel Forces in Equilibrium, Graphic Solution. The graphic relation corresponding to the principle of Art. 31 is as follows:

If a system of coplanar parallel forces is in equilibrium, the force polygon closes and the funicular polygon closes.

By the application of these two conditions of equilibrium, two unknown forces may be determined.

EXAMPLE.

Determine the reactions R_1 and R_2 of the beam shown in Fig. 61.

Solution: — The space diagram, Fig. 61(a), is drawn to scale. The force polygon, Fig. 61(b), is drawn to scale as far as known, AB, BC, CD . Since

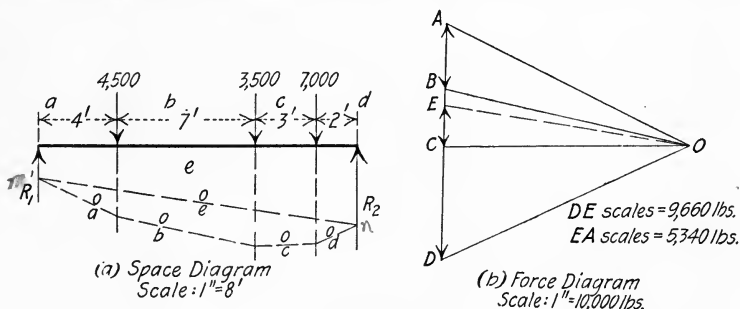

FIG. 61

the system is in equilibrium, point A must be the closing point, but point E is unknown. The location of point E is determined by the fact that the funicular polygon must close also. Any convenient pole O is selected and the rays OA, OB, OC and OD are drawn. The funicular polygon is begun at any convenient point on any one of the forces, as point m on force R_1 . String oa is drawn parallel to ray OA across the "a" space. From the point at which oa intersects ab , ob is drawn parallel to OB across the "b" space. Strings oc and od are drawn in a similar way. Since the funicular polygon must close, string oe must necessarily run from m to n . In the force diagram, ray OE must be parallel to string oe in the space diagram, so point E is determined. Vector DE represents the reaction R_2 to scale and vector EA represents the reaction R_1 .

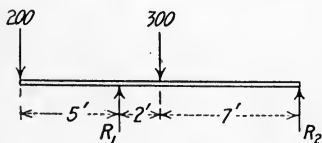

FIG. 62

Problem 1. A beam 13 ft. long, supported at the ends, has a load of 3000 lbs. 4 ft. from the left end and one of 1000 lbs. 3 ft. from the right end. Determine the reactions.

Ans. $R_1 = 2310 \text{ lbs.}$ $R_2 = 1690 \text{ lbs.}$

Problem 2. Solve for the reactions R_1

and R_2 of the overhanging beam shown in Fig. 62.

Ans. $R_1 = 544 \text{ lbs.}$ $R_2 = -44 \text{ lbs.}$

Problem 3. Solve for the reactions R_1 and R_2 of the cantilever beam shown in Fig. 63.

Ans. $R_1 = 1050$ lbs. $R_2 = 1200$ lbs.

33. Equilibrium of Parallel Forces in Space. In case all of the forces of a given system of parallel forces are not in the same plane, the principles of Arts. 31 and 32 must be slightly modified.

Algebraically. *If a system of parallel forces in space is in equilibrium, the resultant $R = 0$ and the moment $M = 0$ with respect to any axis in space.*

Graphically. *If a system of parallel forces in space is in equilibrium, the projection of the system upon any plane constitutes a coplanar system of parallel forces in equilibrium.*

Some problems of this kind may be simplified by replacing one or more pairs of forces by their resultant so as to reduce the system to a coplanar system.

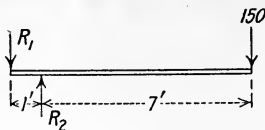

FIG. 63

EXAMPLE.

A horizontal equilateral triangular plate ABC , 3 ft. on a side, is supported at the vertices. What are the three reactions due to a load of 100 lbs. acting at a point on the median line 1 ft. from vertex A ?

Solution: — The altitude of the triangle is 2.6 ft. The distance from the base BC to the load is 1.6 ft. Equation $\Sigma M = 0$ for axis through the edge BC gives

$$100 \times 1.6 = 2.6 A.$$

$$A = 61.5 \text{ lbs.}$$

By symmetry, reaction $B =$ reaction C .

Equation $\Sigma F = 0$ gives

$$B + C + 61.5 = 100$$

$$B + C = 38.5$$

$$B = C = 19.25 \text{ lbs.}$$

Problem 1. A stick of timber 12 ft. long and of uniform cross section is to be carried by three men, one at the rear end, the others at the ends of a cross-bar under the stick. How far from the front end should it be placed in order that each man may carry the same weight. *Ans.* 3 ft.

Problem 2. A triangular flat plate ABC has side $AB = 8$ ft., $BC = 6$ ft. and $CA = 10$ ft. If the plate is placed horizontally and supported at the three corners, what are the three reactions due to a load of 100 lbs. resting on the plate at a point 1 ft. from side AB and 1 ft. from side BC ?

Ans. $A = 12.5$ lbs. $B = 60.83$ lbs. $C = 16.67$ lbs.

GENERAL PROBLEMS.

Problem 1. A beam 4 ft. long weighing 40 lbs. has a load of 100 lbs. at the left end and one of 30 lbs. at the right. At what point will it balance?

Ans. 1.176 ft. from left end.

Problem 2. A force P of 40 lbs. is acting vertically upward. Another force Q of 20 lbs. is acting vertically downward 2 ft. to the right of P . Determine the amount and position of their resultant.

Ans. 20 lbs. upward, 2 ft. to the left of P .

Problem 3. A cantilever truss has dead loads and wind loads acting upon it as shown in Fig. 64. Determine the amount and direction of the resultant of these loads.

Ans. 15,600 lbs. at $7^\circ 23'$ with the vertical, V .

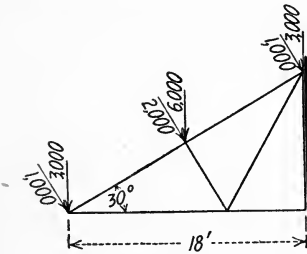

FIG. 64

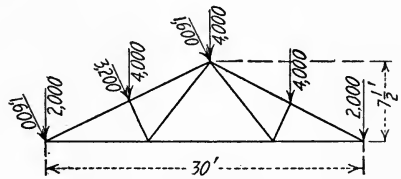

FIG. 65

Problem 4. Determine the amount, direction and position of the resultant of the wind and dead loads on the truss shown in Fig. 65.

Ans. 21,920 lbs. at $7^\circ 30'$ with V . Resultant cuts lower chord 1.5 ft. to left of middle.

Problem 5. Determine the amount, direction and position of the resultant of the wind forces on the truss shown in Fig. 66.

Ans. 4670 lbs. horizontal, 6.25 ft. below lower chord.

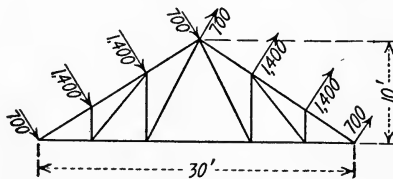

FIG. 66

Problem 6. If the total dead load of the truss shown in Fig. 66 is 12,000 lbs., find the resultant of all the loads.

Ans. 12,875 lbs. at $21^\circ 15'$ with V , cutting lower chord 2.43 ft. to left of middle.

Problem 7. A traction engine carries 15,000 lbs. weight on the two driving wheels and 4500 lbs. on the steering wheels. The distance between the front and rear axles is 11 ft. 8 in. Find the position of the resultant.

Ans. 2.69 ft. in front of drive wheels.

Problem 8. A beam 6 ft. long has forces acting upon it as follows: 100 lbs. downward at the left end; 200 lbs. upward 1 ft. from the left end; 400 lbs. downward at the middle; 300 lbs. upward at the right end. Determine the resultant.

Ans. The resultant is a couple of + 800 ft.-lbs. moment.

Problem 9. Forces parallel to the Z axis and all acting in the same direction are located as follows: 10 lbs. at (2', 4'); 20 lbs. at (1', 2'); 30 lbs. at (4', 1'). Determine the amount and position of the resultant.

Ans. 60 lbs. at (2.67', 1.83').

Problem 10. The sketch in Fig. 67 represents an A. T. & S. F. passenger locomotive. Dimensions are given to the nearest foot. The weight on the driving wheels is 147,400 lbs.; on the truck is 28,600 lbs.; on the trailers is 38,600 lbs. The weight of the tender is 135,400 lbs. Find the distance of the front wheel from the edge of a turntable 100 ft. in diameter for perfect balance.

Ans. 18.2 ft.

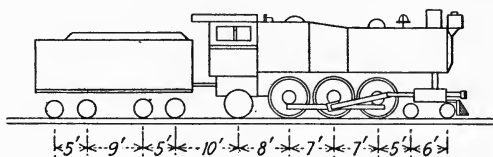

FIG. 67

Problem 11. A force of 100 lbs. is acting downward at each corner of a horizontal equilateral triangle ABC , 10 ft. on each side. Determine the position of the resultant.

Ans. 5.77 ft. from each vertex.

Problem 12. A counter-clockwise couple of 2 lbs. \times 2 ft. in the XY plane is to be combined with a counter-clockwise couple of 3 lbs. \times 1 ft. in the YZ plane. Find the magnitude and direction of the resultant couple.

Ans. +5 ft.-lbs. Its plane is parallel to the Y axis and is at an angle of $36^\circ 40'$ with the XY plane.

Problem 13. If a wagon is coupled too long for a platform scale to accommodate it, will the same result be obtained by weighing the front part and the rear part separately and adding the weights?

Problem 14. Reverse the force at vertex C in Problem 11 and solve.

Ans. 100 lbs., 8.66 ft. from AB .

Problem 15. Forces of 40 lbs., 60 lbs. and 80 lbs. act vertically downward at the corners A , B and C , respectively, of a horizontal equilateral triangle, 3 ft. on a side. Locate the resultant.

Ans. 1.156 ft. from AB ; 0.578 ft. from BC .

Problem 16. Equal parallel forces act downward at the corners of a horizontal triangle with sides of 6 ft., 8 ft. and 10 ft. Locate the resultant.

Ans. 2 ft. from the 8-ft. side; 2.67 ft. from the 6-ft. side.

Problem 17. A balance is slightly out of adjustment, one arm being longer than the other. Will it give accurate results by weighing first in one pan, then in the other, and averaging?

Problem 18. A workman closes a gate valve by exerting a pressure of 25 lbs. with each hand at opposite sides on the rim of a hand wheel 2 ft. in

diameter. At another time he thrusts a bar through the wheel and exerts the pressure at only one side, 3 ft. out from the center. What pressure must he exert? What is the difference in action in the two cases? *Ans.* $16\frac{2}{3}$ lbs.

Problem 19. The movable weight of a steelyard weighs 6 lbs. The short arm is 3 ins. long. How far apart must the pound graduations be placed?

Ans. $\frac{1}{2}$ inch.

Problem 20. One end of a bar 10 ft. long is hinged at the wall and the other rests on a smooth floor 6 ft. below. The bar carries a load of 200 lbs. at the middle. What are the reactions? (*Note:* — A smooth surface can exert only a normal reaction.)

Ans. 100 lbs. each.

CHAPTER III.

NONCONCURRENT, NONPARALLEL FORCES.

34. **Composition of Nonconcurrent, Nonparallel Forces in a Plane; Graphic Methods.** Let F_1, F_2, F_3 , etc., Fig. 68, be the forces to be combined. F_1 and F_2 are transferred along their lines of action until they intersect at m , where they are combined into their resultant R_1 . R_1 is transferred along its line of action until it intersects the line of action of F_3 , at n . F_3 is also transferred along its line of action until it is in the proper position, F_3' , where it is combined with R_1 into the resultant of all three forces R_2 . If there are other forces the same procedure may be followed until the final resultant is found.

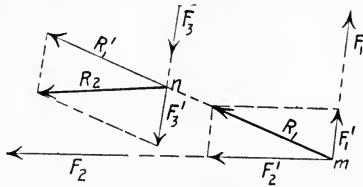

FIG. 68

If the forces are so nearly parallel that no intersection can be obtained, any one of the forces may be broken up into two components. Combination with the other forces may now be made as

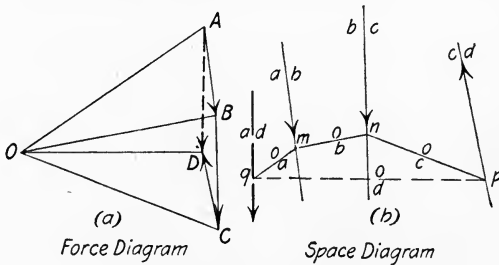

FIG. 69

above. As in the case of parallel forces, both space and force diagrams should be used. In Fig. 69, let the forces be AB, BC and CD , acting along ab, bc and cd respectively. At m , AB may be resolved into two components, AO and OB . OB and BC may be combined into their resultant OC at n . OC and CD may be com-

bined into their resultant OD at p . Finally, AO and OD may be combined into their resultant AD at q . AD is then the resultant of the entire system.

Another force, equal and opposite to the final resultant and colinear with it, will hold the system in equilibrium.

Also, conversely, *If a system of nonconcurrent forces in a plane is in equilibrium, the force polygon closes and the funicular polygon closes.*

If the force polygon closes but the funicular polygon does not close, the resultant is a couple. In Fig. 70, force vectors AB , BC and CD form a closed polygon, with point D coinciding with point A . These forces act along lines of action ab , bc and cd respectively in the space diagram. From any point O , rays OA , OB , OC and OD are drawn. In the space diagram the corresponding strings oa , ob , oc and od are drawn.

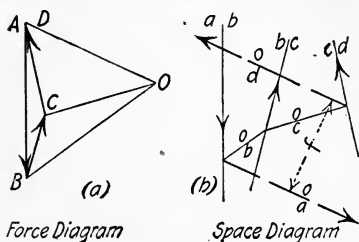

FIG. 70

Strings oa and od are parallel but not colinear, so the system is reduced to the two equal parallel forces AO and OD acting f distance apart.

Problem 1. Combine the wind and dead load forces acting upon the truss in Fig. 71 into their resultant, graphically

Ans 27,540 lbs. at $4^\circ 10'$ with V . R cuts AB 0.63 ft. to the left of the middle.

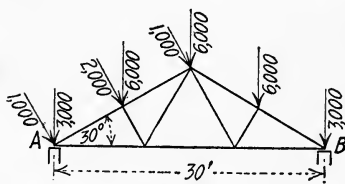

FIG. 71

35. Composition of Nonconcurrent, Nonparallel Forces in a Plane; Algebraic Method. The amount of the resultant R of any system of nonconcurrent, nonparallel forces in the same plane is given by the equation

$$R = \sqrt{(\Sigma F_x)^2 + (\Sigma F_y)^2}.$$

Its direction angle θ with the x axis is given by

$$\tan \theta = \frac{\Sigma F_y}{\Sigma F_x}.$$

As in the case of parallel forces, the theorem of moments is readily extended to this case:

For any system of forces in a plane, the moment of the resultant of the system with respect to any point is equal to the algebraic sum of the moments of the several forces with respect to the same point.

By means of this principle the position of the resultant R may be determined by writing the equation of moments with respect to any point. If the moment arm of the resultant is denoted by a , and the moment arms of the several forces by a_1, a_2 , etc.,

$$Ra = F_1a_1 + F_2a_2 + \dots, \text{ etc.}$$

Another force equal and opposite to R and colinear with it will hold the system in equilibrium.

EXAMPLE.

As an example, Problem 1 of Art. 34 will be solved by the method of this article. The vertical components of the wind forces in turn are 866, 1732 and 866. The horizontal components are in turn 500, 1000 and 500.

$$\Sigma F_x = 500 + 1000 + 500 = 2000.$$

$$\Sigma F_y = 866 + 1732 + 866 + 3000 + 6000 + 6000 + 3000 = 27,464.$$

$$R = \sqrt{(\Sigma F_x)^2 + (\Sigma F_y)^2} = 27,540 \text{ lbs.}$$

The angle θ with the horizontal is given by

$$\begin{aligned} \text{Tan } \theta &= \frac{\Sigma F_y}{\Sigma F_x} = \frac{27,464}{2000} = 13.732. \\ \theta &= 85^\circ 50'. \end{aligned}$$

To locate R , use point A as the center of moments.

$$\begin{aligned} 27,540 \times a &= 24,000 \times 15 + 4000 \times 8.66. \\ a &= 14.33 \text{ ft.} \end{aligned}$$

Problem 1. In Fig. 72, determine the resultant of the three forces in amount and direction. Determine also its perpendicular distance a from point A .

Ans. $R = 3228 \text{ lbs.}$ $\theta = 85^\circ 05'$ with H .
 $a = 9.54 \text{ ft.}$

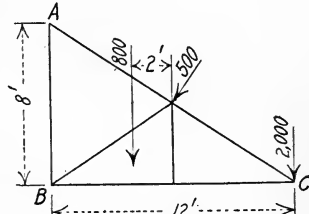

FIG. 72

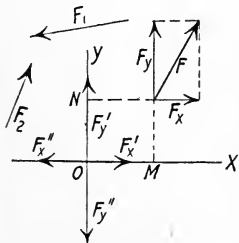

FIG. 73

36. Reduction of a System of Forces to a Force and a Couple. Any system of forces in a plane may be reduced to a force through any given point and a couple. Let F, F_1 , etc., Fig. 73, be the system of forces. At any point along its line of action, F may be resolved into its X and Y components, F_x and F_y . By Art. 30, force F_y may be resolved further into an equal force F_y' through O , and a couple $F_y \times \overline{OM}$. F_x may also

be resolved into an equal force through O , and a couple $F_x \times \overline{ON}$. Each force in turn may be resolved similarly. The resultant of the forces at O is

$$R = \sqrt{(\Sigma F_x)^2 + (\Sigma F_y)^2},$$

and the resultant of all the couples is a single couple ΣM .

For equilibrium of the system,

$$R = 0 \quad \text{and} \quad \Sigma M = 0.$$

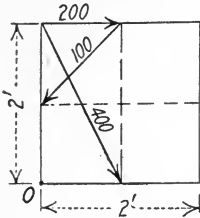

FIG. 74

Conversely, *If a system of nonconcurrent, nonparallel forces in a plane is in equilibrium, the algebraic sum of the forces along any line is zero and the moment with respect to any axis is zero.*

Problem 1. Reduce the force system shown in Fig. 74 to a force through point O and a couple.

Ans. $R = 527$ lbs. $M = -687$ ft.-lbs.

37. Two-force Members, Three-force Members, Etc. The student has doubtless already noticed that some members of structures have forces applied at only two points as for instance any member of a common bridge truss. (In this case, only the actions of the other members upon the member considered are taken into account, the weight of the member itself being neglected.) Such members of structures are called *Two-force Members*. In the crane shown in Fig. 75, the brace BE is a two-force

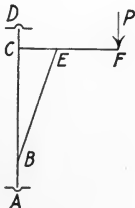

FIG. 75

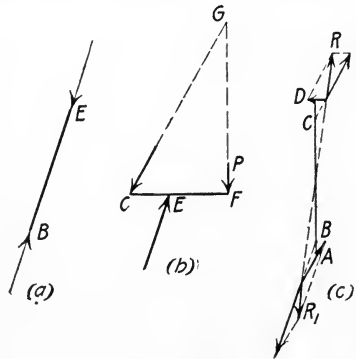

FIG. 76

member. Its free body diagram is shown in Fig. 76(a), in which the vectors at B and E represent the actions of the post and the boom respectively upon the free body. The forces acting upon

a two-force member are necessarily axial, producing direct compression or tension in the member, for if they were not axial they would not be colinear and could not hold the member in equilibrium. Since the internal stress in a two-force member is always axial, a section may be made through it in taking a free body.

If any member of a structure has forces applied at three or more points, it is called a *Three-force Member*. Since the stress is in general not axial, a section should not be made through a three-force member in taking a free body, but the entire member should be taken. If another three-force member joins the one considered as the free body, the X and Y components of the action of the other member upon the free body must be introduced if the direction of their resultant is not already known.

If a body is in equilibrium under the action of three forces, they must intersect in a common point or be parallel, and the resultant of any two must be equal and opposite to the third. The boom CEF , Fig. 75, is a three-force member, shown as a free body in Fig. 76(b). The force at F is the external load P . That at E is equal and opposite to the force at E on the brace EB . Since these two are known in direction, their intersection at G determines another point in the line of action of the force at C . Likewise, if the entire crane is considered as a free body, the direction of the reaction at A is determined by the intersection of the lines of action of force P and the horizontal reaction at D .

If a body is in equilibrium under the action of *four* forces, the resultant of any two must necessarily be equal and opposite to the resultant of the other two. If one of the four forces is wholly known and the directions of the others are known, the three unknown forces may be determined. This is illustrated in Fig. 76(c). The resultant of the forces at C and D must be equal and opposite to the resultant of the forces at A and B ; that is, R is equal and opposite to R_1 and is colinear with it.

The method of procedure in solution is to intersect the forces in pairs and join the two points of intersection. This gives the line of action of the resultant of each pair. With the force C known of the system C, D, R , the two unknown forces D and R may be determined. Resultant R is equal and opposite to R_1 , so the system R_1, A, B , can be solved.

If five or more forces are acting upon a body in equilibrium, two

or more can usually be combined so as to reduce the system to a four-force system, after which it can be solved as above.

38. Problems in Equilibrium; Forces in a Plane. The principles of Arts. 34–37 are useful in the solution of an important class of problems occurring in engineering work. The usual case is that in which a certain system of forces is known to be in equilibrium but some of the forces are unknown and are to be determined.

EXAMPLE 1.

The cantilever truss of Fig. 77(a) is loaded with roof or "dead" loads as shown. Determine the reactions at E and C by the algebraic method.

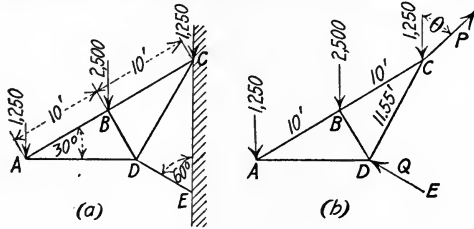

FIG. 77

Solution. — The reaction at E is the same as the stress in the strut or compression member DE . Since DE is a two-force member, its stress must be axial; so is known in direction. The reaction at C is unknown both in amount and direction, but must necessarily pass through point C . The free body diagram is shown in Fig. 77(b). Let the reaction at C be called P and let that at D be called Q . Also let the unknown angle between P and the vertical be called θ . Since the truss is in equilibrium,

$$\Sigma F_x = 0, \quad \Sigma F_y = 0 \quad \text{and} \quad \Sigma M = 0.$$

The first equation gives

$$Q \times 0.866 - P \sin \theta = 0.$$

The second equation gives

$$Q \times 0.5 + P \cos \theta - 5000 = 0.$$

The third, with C as center of moments, gives

$$1250 \times 17.32 + 2500 \times 8.66 = Q \times 11.5.$$

$$Q = 3750 \text{ lbs.}$$

By substitution of the value of Q in the equations above,

$$P \sin \theta = 3250.$$

$$P \cos \theta = 3125.$$

By division,

$$\tan \theta = 1.04.$$

$$\theta = 46^\circ 08'.$$

$$\sin 46^\circ 08' = 0.721.$$

$$P = \frac{3250}{\sin \theta} = \frac{3250}{0.721} = 4510 \text{ lbs.}$$

$P \sin \theta$ is really the X component of force P and $P \cos \theta$ is the Y component, so the solution would be practically the same if the unknown force P were replaced by P_x and P_y . Then

$$P = \sqrt{P_x^2 + P_y^2}.$$

With P_x and P_y replacing P , a simpler solution for the three unknown forces is made possible. By writing the equation $\Sigma M = 0$ with respect to the three points of intersection of the unknown forces in turn, only one unknown quantity occurs in each equation. Elimination between two equations is thus avoided. This method should be used if all distances are known or are easily obtained.

EXAMPLE 2.

Determine all the internal stresses in the members of the pin connected bridge truss shown in Fig. 78.

Solution:—The truss is symmetrical and the loading is symmetrical, so each reaction is one-half of the total load of 10,000 lbs.

$$R_1 = R_2 = 5000 \text{ lbs.}$$

All of the members are two-force members, so sections may be made through them as desired in taking a free body. Let a section be made through the truss at mn , and let the part at A be taken as the free body, as shown in Fig. 79(a).

The force F_1 is the internal stress in AB , acting now as an external force on the free body, and must be compression in order to balance R_1 . Simi-

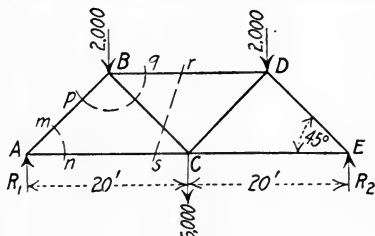

FIG. 78

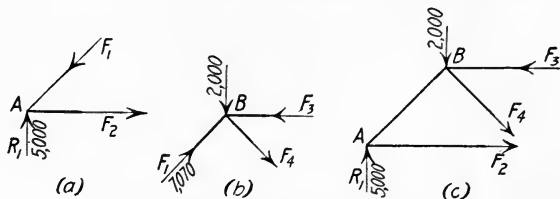

FIG. 79

larly the force F_2 is the internal stress in AC and must be tension in order to balance F_1 . Since this free body is in equilibrium, $\Sigma F_y = 0$ and $\Sigma F_x = 0$. Equation $\Sigma F_y = 0$ gives

$$5000 - F_1 \sin 45^\circ = 0.$$

$$F_1 = 7070 \text{ lbs. compression.}$$

Equation $\Sigma F_x = 0$ gives

$$F_2 - 7070 \cos 45^\circ = 0.$$

$$F_2 = 5000 \text{ lbs. tension.}$$

The next free body taken is the joint at B , enclosed by section pq . The free body diagram is shown in Fig. 79(b). There are two known forces acting on the free body, the load, 2000 lbs., and the stress in AB . The action of this

force on B must be equal in amount and opposite in direction to the force which AB exerts on A , so is 7070 lbs. acting as shown. Inspection of the known vertical forces acting at B shows that there is a larger force upward than downward. Therefore for equilibrium F_4 must have a component downward, so is tension as shown. For equilibrium horizontally, F_3 must be compression. Equation $\Sigma F_y = 0$ gives

$$7070 \sin 45^\circ - 2000 - F_4 \sin 45^\circ = 0.$$

$$F_4 = 4240 \text{ lbs. tension.}$$

Equation $\Sigma F_x = 0$ gives

$$7070 \cos 45^\circ + 4240 \cos 45^\circ - F_3 = 0.$$

$$F_3 = 8000 \text{ lbs. compression.}$$

It is not necessary that the true direction of the unknown stresses be determined before solution as above. If in either of the force diagrams the direction of an unknown force had been assumed incorrectly, the value obtained would have been the same numerically but negative in sign.

Since the truss and loading are both symmetrical, the stresses in corresponding members on the two sides of the truss are equal, so the solution need not be carried further unless it is desired to complete it as a check.

If the stress in only one member had been required as for instance that in BD , a shorter method would have been as follows: Let the section rs , Fig. 78, be passed through the truss and let all to the left of the section be taken as the free body. Fig. 79(c) shows the free body diagram. There are now three unknown forces, but they are not concurrent, so the problem can be solved. Equation $\Sigma M_C = 0$ gives

$$F_3 \times 10 - 5000 \times 20 + 2000 \times 10 = 0.$$

$$F_3 = 8000 \text{ lbs. compression.}$$

Stresses F_2 and F_4 can now be determined if desired.

Equation $\Sigma F_y = 0$ gives

$$F_4 \sin 45^\circ + 2000 - 5000 = 0.$$

$$F_4 = 4240 \text{ lbs.}$$

Equation $\Sigma M_B = 0$ gives

$$F_2 \times 10 - 5000 \times 10 = 0.$$

$$F_2 = 5000 \text{ lbs.}$$

The graphic method is especially well adapted to the solution of problems of this kind. Each joint in turn is taken as a free body and the unknown forces are determined by the principle that the force polygon for the free body in equilibrium must close.

In Fig. 80(a) is shown the truss of Fig. 78 with the same loading but with Bow's notation of lettering. The line of action of the 6000-lb. load is produced backward so that all of the loads are taken in order between the reactions. The force polygon for the first joint at the left, caf , is shown in Fig. 80(b), EA being the known reaction. $AF = 7070$ lbs. and $FE = 5000$ lbs. are determined by this polygon, and are the stresses in af and fe respectively. Since the force polygon must close, with the vectors following each other around the polygon, the arrows must be in the direction shown. The stress

AF is therefore downward toward the joint, compression, while the stress FE is away from the joint, tension. The sequence of the letters in the direction in which the polygon was drawn also indicates the direction of the stress. The

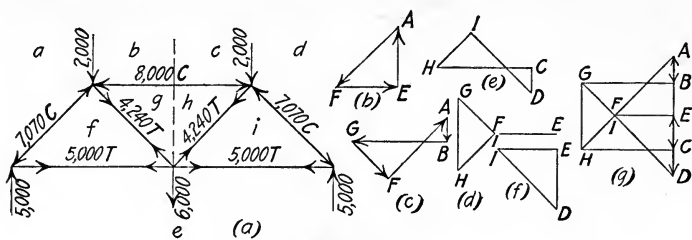

FIG. 80

arrows should be placed on the members in the space diagram as the direction of each stress is determined. The joint $fabg$ is the next free body, the two forces FA and AB being known. In Fig. 80(c) these are laid down in order and by the closing of the polygon, forces BG and GF are determined. It should be noted that in drawing the force polygon all of the known forces must be taken first. Also, less confusion results if the forces are always taken in the same order around the joints. The clockwise direction will usually be used, as in the preceding solution.

Fig. 80(d) shows the force polygon for the middle joint, HI and IE being the unknown forces determined. In this polygon point I coincides with point F and vectors EF and IE are superimposed. Fig. 80(e) shows the force polygon for joint $ihcd$, force ID being determined. This completes the solution, but the force polygon for the last joint may be drawn as a check, Fig. 80(f).

Since each of the internal stress vectors occurs twice, the force polygons may be superimposed as constructed, so as to form one complete diagram Fig. 80(g). The arrows on the stress diagram may be omitted but they should always be placed on the members in the space diagram.

EXAMPLE 3.

The A-frame shown in Fig. 81(a) supports a load of 8000 lbs. at the middle of member BD . Determine the pin reactions at B , C and D caused by this load, if the floor is considered to be smooth. Use the algebraic method.

Solution:— Since the floor is smooth, the reactions at A and E are necessarily vertical. The frame and loading are symmetrical, so each reaction is 4000 lbs. If either the frame or the loading were not symmetrical, the

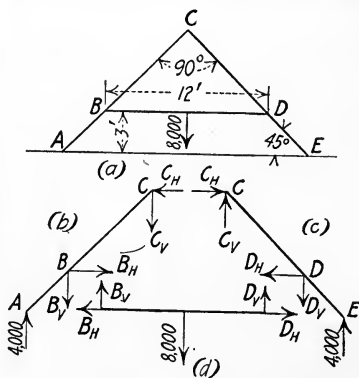

FIG. 81

moment equations for the entire frame as a free body would determine the

reactions. The structure consists entirely of three-force members, so each must be taken as a free body. The cross bar BD , Fig. 81(d), is considered first. The known force is 8000 lbs. downward at the middle. Since a three-force member joins it at B and another at D , the vertical and horizontal components of the reactions must be used. Either by moments or by symmetry

$$B_V = D_V = 4000 \text{ lbs.}$$

Equation $\Sigma F_x = 0$ gives $B_H = D_H$, but neither one can be evaluated from this free body. Member AC is next taken as the free body. Forces A and B_V are now known; forces B_H , C_H and C_V are unknown.

Equation $\Sigma F_y = 0$ gives

$$4000 - 4000 - C_V = 0.$$

$$C_V = 0.$$

Equation $\Sigma M_C = 0$ gives

$$B_H \times 6 + 4000 \times 6 - 4000 \times 9 = 0.$$

$$B_H = 2000 \text{ lbs.}$$

Since $B_H = D_H$, $D_H = 2000$ lbs.

Equation $\Sigma F_x = 0$ gives

$$B_H = C_H = 2000 \text{ lbs.}$$

The pin reaction at C is therefore 2000 lbs. horizontal.

The pin reactions at B and D are given by

$$B = D = \sqrt{2000^2 + 4000^2} = 4472 \text{ lbs.}$$

The angle θ with the horizontal is given by

$$\tan \theta = \frac{4000}{2000} = 2.$$

$$\theta = 63^\circ 28'.$$

Problem 1. Solve for the stresses in the members of the truss of Example 1.

Ans. $AB = 2500$ lbs. T. $BC = 3750$ lbs. T. $AD = 2165$ lbs. C. $BD = 2165$ lbs. C. $DC = 0$.

Problem 2. Consider the load at D , Fig. 78, to be changed to 4000 lbs. and solve for all stresses in the members.

Ans. $AB = 7780$ lbs. C. $AC = 5500$ lbs. T. $BC = 4950$ lbs. T. $BD = 9000$ lbs. C. $CD = 3540$ lbs. T. $CE = 6500$ lbs. T. $DE = 9200$ lbs. C.

Problem 3. The supporting cross bar AB of a platform is 6 ft. long and holds weights as shown in Fig. 82. The inner end is fastened to the wall by a hinge at A . A cable BC at an angle of 30° with the vertical supports the other end. Solve for the tension in the cable BC and the reaction at A in amount and direction.

Ans. $BC = 846$ lbs. $R = 630$ lbs. $\theta = 47^\circ 50'$ with H .

Problem 4. Consider each member of the A -frame in Example 3 to weigh 100 lbs. per linear foot and determine the pin reactions B , C and D .

Ans. $C = 3255$ lbs. horizontal. $B = D = 5635$ lbs. $\theta = 54^\circ 42'$ with H .

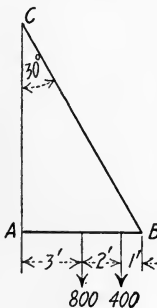

FIG. 82

39. Composition of Nonconcurrent, Nonparallel Forces in Space. A system of forces, F, F_1, F_2 , etc., not in the same plane, may be reduced to a single force through any given point and a couple. Let F , Fig. 83, be one of the forces of the system. Introduce at point O the opposite forces F' and F'' , each equal and parallel to F . This does not affect the system in any way, since they neutralize each other. Then F and F'' constitute a couple and the remaining force is F' equal to F , acting through point O .

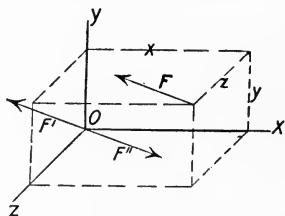

FIG. 83

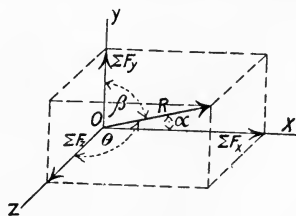

FIG. 84

This may be repeated with each force in turn. Each force of the concurrent system at O is then resolved into its X, Y and Z components and these are recombined, giving

$$R = \sqrt{(\Sigma F_x)^2 + (\Sigma F_y)^2 + (\Sigma F_z)^2}$$

as shown in Fig. 84. The direction cosines are given by

$$\cos \alpha = \frac{\Sigma F_x}{R}; \quad \cos \beta = \frac{\Sigma F_y}{R}; \quad \cos \theta = \frac{\Sigma F_z}{R}.$$

The couples may be combined by means of their vectors, exactly the same as the force vectors were combined above but a simpler method is the following. At any point along its line of action, each one of the original forces may be resolved into its X, Y and Z components. The algebraic sum of the moments of these components with respect to the X, Y and Z axes in turn gives M_x, M_y and M_z , which may be represented by their vectors. The vector of the resultant couple is given by

$$M = \sqrt{M_x^2 + M_y^2 + M_z^2}.$$

Also,

$$\cos \alpha_1 = \frac{M_x}{M}; \quad \cos \beta_1 = \frac{M_y}{M}; \quad \cos \theta_1 = \frac{M_z}{M}.$$

In general, then, a system of this kind tends to produce a translation of the body acted upon in the direction of R , and a rotation in the plane of the resultant couple M .

If $\Sigma F_x = 0$, $\Sigma F_y = 0$, $\Sigma F_z = 0$, $\Sigma M_x = 0$, $\Sigma M_y = 0$ and $\Sigma M_z = 0$, the force system is in equilibrium.

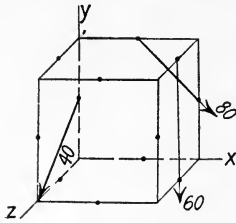

FIG. 85

Conversely, *If a body acted upon by a force system of this kind is in equilibrium, these six conditions are true.*

Problem 1. Combine the forces shown in Fig. 85 into a force at O and a couple. The sides of the cube are 2 ft. long.

Ans. $R = 150$ lbs. $\alpha = 67^\circ 50'$. $\beta = 153^\circ 30'$.
 $\theta = 76^\circ 13'$. $M = 305$ ft.-lbs. $\alpha_1 = 71^\circ 40'$.
 $\beta_1 = 90^\circ$. $\theta_1 = 161^\circ 40'$.

40. Problems in Equilibrium; Forces in Space. The conditions of equilibrium for nonconcurrent, nonparallel systems of forces in space as given in Art. 39 may be taken in sets of three, as follows:

$$\begin{aligned} \Sigma F_x &= 0, & \Sigma F_y &= 0, & \Sigma M_z &= 0. \\ \Sigma F_x &= 0, & \Sigma F_z &= 0, & \Sigma M_y &= 0. \\ \Sigma F_y &= 0, & \Sigma F_z &= 0, & \Sigma M_x &= 0. \end{aligned}$$

It will be seen that the first set gives the conditions necessary for equilibrium of a coplanar system of forces in the XY plane; the second set gives the conditions necessary for equilibrium of a coplanar system of forces in the XZ plane; the third set gives the conditions necessary for equilibrium of a coplanar system of forces in the YZ plane. Also, ΣF_x and ΣF_y are the X and Y components of the projections of the forces on the XY plane and ΣM_z is the moment of these forces in that plane. Then it follows:

If a syst m of nonconcurrent, nonparallel forces in space is in equilibrium, the proj ctions of these forces on any plane constitute a system of forces in equilibrium.

By means of these principles, unknown forces not to exceed the number of equations may be determined in any system which is known to be in equilibrium.

EXAMPLE 1.

Fig. 86 shows three views of a simple windlass. It is required to determine P , R' and R'' for the position shown, R' and R'' being the reactions at A and B respectively.

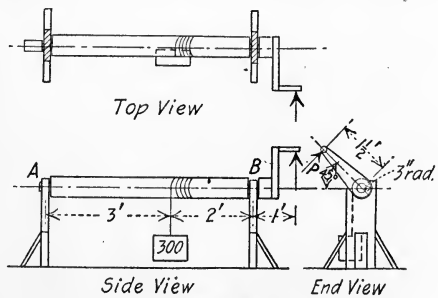

FIG. 86

Solution:—The free body diagram for the top view, the projection of the figure on the XZ plane, is shown in Fig. 87(a). That for the side view, the projection on the XY plane, is shown in Fig. 87(b). That for the end view,

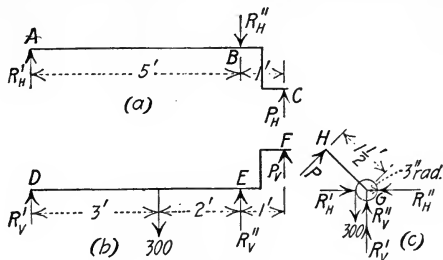

FIG. 87

the projection on the YZ plane, is shown in Fig. 87(c). In these diagrams R'_F is replaced by its horizontal and vertical components, $R_{H'}$ and $R_{V'}$. Also R''_F is replaced by its horizontal and vertical components, $R_{H''}$ and $R_{V''}$. The equation $\Sigma M_G = 0$ for Fig. 87(c) gives

$$P \times 18 = 300 \times 3.$$

$$P = 50 \text{ lbs.}$$

The four other unknown forces in this projection cannot be determined. With P known, the unknown forces in Fig. 87(a) can now be determined.

$$P_H = P \cos 45^\circ = 35.35 \text{ lbs.}$$

Equation $\Sigma M_A = 0$ gives

$$35.35 \times 6 = R_{H''} \times 5.$$

$$R_{H''} = 42.42 \text{ lbs.}$$

Equation $\Sigma M_B = 0$ gives

$$35.35 \times 1 = R_{H'} \times 5.$$

$$R_{H'} = 7.07 \text{ lbs.}$$

In Fig. 87(b), $P_V = P \sin 45^\circ = 35.35 \text{ lbs.}$

Equation $\Sigma M_D = 0$ gives

$$35.35 \times 6 + R_{V''} \times 5 = 300 \times 3.$$

$$R_{V''} = 137.6 \text{ lbs.}$$

Equation $\Sigma M_E = 0$ gives

$$35.35 \times 1 + 300 \times 2 = R_{V'} \times 5.$$

$$R_{V'} = 127.1 \text{ lbs.}$$

The amount and direction of R' and R'' may now be determined if desired.

EXAMPLE 2.

Fig. 88(a) shows the dimensions, position and loading of a derrick. Determine the external reactions due to a load of 1200 lbs.

Solution:—The external forces on the derrick constitute a nonconcurrent, nonparallel system in space, but by taking different parts of the derrick as free bodies in turn, only concurrent systems need be considered. The first free

body to be considered is the pulley at *A*, shown in its free body diagram in Fig. 88(b). If friction is neglected, the tension in any cable is constant throughout its length. Then equation $\Sigma F_y = 0$ gives

$$4T = 1200 \text{ (neglecting the slight angularity).}$$

$$T = 300 \text{ lbs.}$$

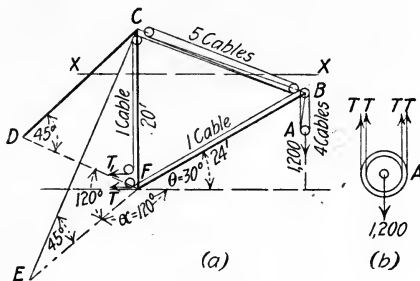

FIG. 88

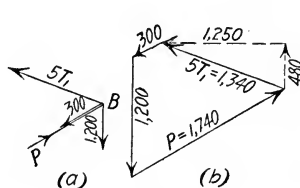

FIG. 89

The pin at *B* has forces acting upon it as shown in Fig. 89(a), forces T_1 and P being unknown. Fig. 89(b) shows the graphic solution, from which T_1 scales 268 lbs. and P scales 1740 lbs.

Consider next a section made by the horizontal plane $X - X$, Fig. 88(a), and let the part above the plane be taken as the free body. The system of forces acting on this free body is concurrent, but not coplanar. The horizontal projections of these forces, however, constitute a coplanar, concurrent system in equilibrium and so may readily be solved. From Fig. 89(b) the horizontal component of $5T_1$ is 1250 lbs. From Fig. 90(a) and (b) it is seen that the horizontal components of the stresses in CD and CE are each 1250 lbs. The stress in each, as shown in Fig. 90(c), is 1767 lbs.

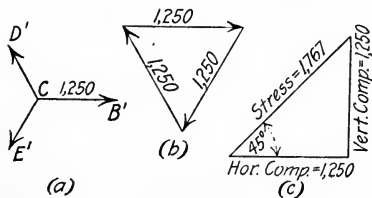

FIG. 90

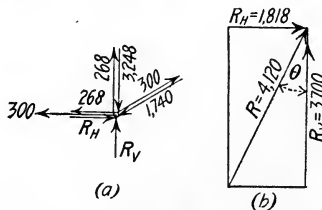

FIG. 91

The compression in the mast is determined by considering the vertical forces on the free body above plane $X - X$, Fig. 88(a). Let the compressive stress in the mast be called V . The vertical component of the stress in CB is 480 lbs., as shown in Fig. 89(b). The vertical component of the stress in CD is 1250 lbs. The vertical component of the stress in CE is 1250 lbs. as shown in Fig. 90(c). Equation $\Sigma F_y = 0$ gives

$$V - 1250 - 1250 - 268 - 480 = 0.$$

$$V = 3248 \text{ lbs.}$$

Next take the socket at F as the free body, Fig. 91(a). Equation $\Sigma F_y = 0$ gives

$$R_V = 3700 \text{ lbs.}$$

Equation $\Sigma F_x = 0$ gives

$$R_H = 1818 \text{ lbs.}$$

$$R = \sqrt{R_H^2 + R_V^2} = 4120 \text{ lbs.}$$

The angle with the vertical, $\theta = \tan^{-1} \frac{1818}{3700} = 26^\circ 10'$. See Fig. 91(b).

If framed members are inserted at DF and EF , they will carry the horizontal components of the stresses in CD and CE to the foot of the mast.

Problem 1. Determine the reactions and the force P on the windlass of Example 1 above, (1) when the handle is horizontal; (2) when the handle is vertical.

- Ans.* (1) $R_V' = 130$ lbs. $R_H' = 0$. $R_V'' = 120$ lbs. $R_H'' = 0$. $P = 50$ lbs.
 (2) $R_V' = 120$ lbs. $R_H' = 10$ lbs. $R_V'' = 180$ lbs. $R_H'' = 60$ lbs.
 $P = 50$ lbs.

Problem 2. In Example 2 above, consider the whole derrick as the free body and solve for the vertical and horizontal components of the reaction at the foot of the mast, and for the stresses in the legs.

Problem 3. Consider the boom of the derrick in Example 2 above to be lowered until it is in the horizontal position. Determine the value of angle α , (1) for maximum tension in EC ; (2) for maximum compression in EC . (Do not consider that the boom works in the smaller angle DFE , although it may be so used.) Solve for the stresses in the boom, the mast and the stiff legs for each position.

- Ans.* (1) 1740 lbs. C. 4065 lbs. C. 2350 lbs. T. in EC . 1175 lbs. T. in DC .
 (2) 1740 lbs. C. 135 lbs. C. 2040 lbs. C. in EC . 0 in DC .

41. Cord Loaded Uniformly Horizontally. A flexible cord suspended from two points forms a smooth curve. Two cases will be considered: First, that in which the cord carries a load which is uniformly distributed horizontally. Second, that in which the cord carries a load which is uniformly distributed along the cord. The second case will be discussed in Art. 42.

Fig. 92 represents a part of a cord carrying a load uniformly distributed horizontally. Let w be the weight carried per horizontal unit. Let O be the lowest point on the cord, B any other point, H the tension at O , P the tension at B , and x the horizontal distance between O and B . The total load on length OB is then wx , acting at $\frac{x}{2}$ distance from O . The part OB is in equilibrium under the action of the three forces, H , P and

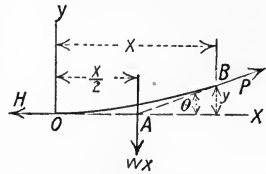

FIG. 92

w , which are therefore concurrent at A . The equation $\Sigma M_B = 0$ gives

$$wx^2 = 2Hy.$$

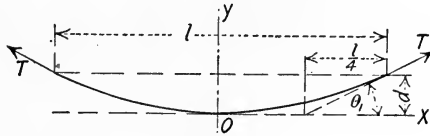

FIG. 93

This is the equation of a parabola with its origin at O and its axis vertical. If l is the total span and d is the sag at the middle, Fig. 93,

$$d = \frac{wl^2}{8H}.$$

$$H = \frac{wl^2}{8d}.$$

If T is the tension at the support, equations $\Sigma F_y = 0$ and $\Sigma F_x = 0$ give

$$T \sin \theta_1 = \frac{wl}{2}.$$

$$T \cos \theta_1 = H.$$

By squaring the two preceding equations, adding, and extracting the square root,

$$T = \sqrt{\left(\frac{wl}{2}\right)^2 + H^2}.$$

Also, from the figure,

$$\tan \theta_1 = \frac{4d}{l}.$$

Let s represent the length of the cord between the points of suspension. The value of s is given by a logarithmic equation derived in the calculus. This equation is accurate but is cumbersome to use. In order to obtain a simpler expression the logarithmic equation is expanded into a converging series, of which the third and succeeding terms are so small that they may be neglected without appreciable error. This gives

$$s = l + \frac{w^2 l^3}{24 H^2}. \quad (\text{Approx.})$$

In terms of l and d ,

$$s = l + \frac{8d^2}{3l}. \quad (\text{Approx.})$$

If s and H are given to find l , a cubic equation results. The second term is comparatively small, however, so that l may be replaced by s in it, giving

$$l = s - \frac{w^2 s^3}{24 H^2}. \quad (\text{Approx.})$$

A tightly stretched horizontal wire very closely approximates the condition of uniform loading horizontally, as do also the cables of a suspension bridge, Fig. 94, since the extra weight of the cables



FIG. 94

and hangers toward the ends is a small part of the total load carried. The lengths of the hangers in the so-called "catenary" trolley wire construction, Fig. 95, are really computed by the parabolic formulas of this article and not by the true catenary formulas. Allowance must be made for the elasticity of the material used.

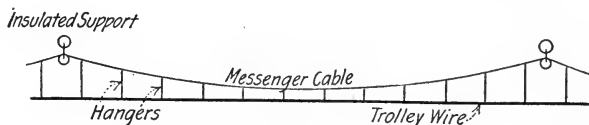

FIG. 95

For a wire with a sag of 1 per cent of the span, the error in H , T or d , compared with the value given by the correct catenary, is about $\frac{1}{24}$ of 1 per cent. For one with a sag of 10 per cent of the span, the error is about 2 per cent.

Problem 1. A steel wire weighing 0.04 lb. per foot has a span of 200 ft. and a tension at the lowest point of 300 lbs. What is the sag? What is the length of the wire? What is the amount and direction of the tension at the supports?

Ans. 8 in. 200.00592 ft. 300.027 lbs. $\theta = 0^\circ 46'$.

Problem 2. The cables of a suspension bridge have a span of 1200 ft., carry a load of 800 lbs. per linear foot per cable, and have a sag of 40 ft. at the middle. Determine the tension at the middle, the tension at the ends and the length of the cables.

Ans. $H = 3,600,000$ lbs. $T = 3,631,900$ lbs. $s = 1203.56$ ft.

Problem 3. A messenger cable for a "catenary" trolley system weighs 0.3 lb. per foot and is stretched between supports 100 ft. apart with a tension of 2300 lbs. What is the sag? (Assume $H = T$.)

Ans. 0.163 ft.

42. The Catenary. When the load on a cord is uniformly distributed along its length, the curve which the cord assumes is called the *catenary*. The equation of the catenary curve will now be derived.

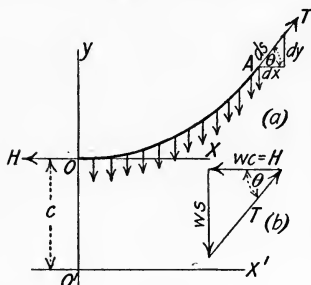

FIG. 96

Let w be the weight of the cord per unit length. Let O , Fig. 96, be the lowest point on the cord, A any other point, s the length of the cord from O to A , H the tension at O and T the tension at A . Also let H be represented by the weight of an imaginary length of the cord c , or $H = wc$. In Fig. 96(a) the length of cord s is shown as a free body in equilibrium. In Fig. 96(b) is shown the force triangle, from which the relation is obtained,

$$\frac{ws}{wc} = \tan \theta,$$

or

$$\frac{dy}{dx} = \frac{s}{c}.$$

$$dy^2 = ds^2 - dx^2,$$

so

$$\frac{s}{c} = \frac{\sqrt{ds^2 - dx^2}}{dx}.$$

By squaring and solving for dx ,

$$dx = \frac{c ds}{\sqrt{c^2 + s^2}},$$

or

$$\int_0^x dx = c \int_0^s \frac{ds}{\sqrt{c^2 + s^2}}.$$

By integration

$$x = c \log_e \frac{s + \sqrt{c^2 + s^2}}{c}. \quad (1)$$

The quantity e is the base of the Napierian system of logarithms, and its numerical value is 2.718,28. The reduction to common logarithms is made by the relation

$$0.4343 \log_e A = \log_{10} A.$$

Reduced to exponential form, equation (1) becomes

$$e^{\frac{x}{c}} = \frac{s + \sqrt{c^2 + s^2}}{c}.$$

Solution for s gives

$$s = \frac{c}{2} \left(e^{\frac{x}{c}} - e^{-\frac{x}{c}} \right). \quad (2)$$

If this value of s is substituted in the original equation, there is obtained the expression

$$dy = \frac{1}{2} \left(e^{\frac{x}{c}} - e^{-\frac{x}{c}} \right) dx.$$

If the origin is at O and dy is integrated between the limits 0 and y , a complicated expression results. A simpler expression is obtained by using O' as the origin. The integration of dy is then between the limits c and y .

$$\int_c^y dy = \frac{c}{2} \left(\int_0^x \frac{1}{c} e^{\frac{x}{c}} dx - \int_0^x \frac{1}{c} e^{-\frac{x}{c}} dx \right).$$

By integration,

$$y - c = \frac{c}{2} \left(e^{\frac{x}{c}} + e^{-\frac{x}{c}} \right) - c,$$

or

$$y = \frac{c}{2} \left(e^{\frac{x}{c}} + e^{-\frac{x}{c}} \right). \quad (3)$$

By squaring (2) and (3) and subtracting,

$$y^2 = s^2 + c^2. \quad (4)$$

From (1) and (4)

$$x = c \log_e \frac{s + y}{c}. \quad (5)$$

From the relation of the sides of the force triangle, Fig. 96(b),

$$T^2 = w^2 c^2 + w^2 s^2 = w^2 (s^2 + c^2) = w^2 y^2. \quad (6)$$

$$T = wy.$$

The related quantities are as follows:

Length	Unit Weight	Tension	Span	Deflection
$2s$	w	T	$2x_1 = l$	$y - c$

The most useful problems, those in which the *length*, *span* and *weight*, or the *deflection*, *span* and *weight* are given, can be solved for the unknown quantities only by trial, on account of the form of the logarithmic equation.

EXAMPLE 1

A cable 800 feet long, weighing 2 lbs. per foot, is stretched between two points on the same level with a tension of 1200 lbs. What is the sag and the span?

Solution: — $w = 2$ and $T = 1200$. Equation (6) gives

$$y = 600 \text{ ft.}$$

From equation (4)

$$c = 447.2 \text{ ft.}$$

The sag is $y - c = 152.8$ ft.

From equation (5) the span is $2x = 2 \times 447.2 \log_e \frac{1000}{447.2}$.

$$2x = 719.8 \text{ ft.}$$

EXAMPLE 2

If a cable weighing 2 lbs. per foot is stretched between points 800 feet apart and sags 100 feet, what is the tension and the length of the cable required?

Solution: — This problem can be solved only by trial.

$$y = c + 100.$$

From equation (4)

$$c^2 + 200c + 10,000 = s^2 + c^2.$$

$$s = 10\sqrt{2c + 100}.$$

From equation (5)

$$400 = c \log_e \frac{10\sqrt{2c + 100} + c + 100}{c}.$$

It is found by trial that $c = 810$ will nearly satisfy this equation. With this value of c ,

$$y = 910 \quad \text{and} \quad T = 1820.$$

From equation (4)

$$s^2 = y^2 - c^2.$$

$$s = 414.7 \text{ ft.}$$

Total length = $2s = 829.5$ ft.

Problem 1. A wire 300 feet long, weighing 0.01 lb. per foot, has a tension of 4 lbs. at each end. What is the span and the sag?

Ans. 292.7 ft. 29.2 ft.

Problem 2. A 1-inch cable, weighing 1.58 lbs. per foot, carries telephone cables and supporting cross pieces weighing 0.22 lb. per foot. The span between towers is 862 feet and the sag is 50 feet. Find the length of the cable and the tension.

Ans. 864.2 ft. 3408 lbs.

Problem 3. A chain 50 feet long, weighing 3 lbs. per foot, is stretched between two points on the same level 40 feet apart. What is the sag and the tension?

Ans. 13.3 ft. 90.5 lbs.

GENERAL PROBLEMS.

Problem 1. Fig. 97 represents a simple triangular truss.* Solve for the reactions and the stress in each member due to the load.

Ans. $R_1 = 202$ lbs. $R_2 = 298$ lbs. $AB = 456$ lbs. C. $BC = 505$ lbs. C. $AC = 408$ lbs. T.

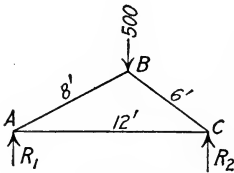

FIG. 97

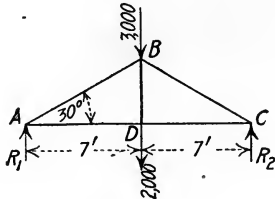

FIG. 98

Problem 2. Compute the reactions R_1 and R_2 and the stress in each member of the truss shown in Fig. 98.

Ans. $R_1 = R_2 = 2500$ lbs. $AB = 5000$ lbs. C. $AD = 4330$ lbs. T. $BD = 2000$ lbs. T.

Problem 3. The members of the truss shown in Fig. 99 weigh 100 lbs. per linear foot. Solve for the reactions and the pin pressure at B in amount and direction.

Ans. $R_1 = 929$ lbs. $R_2 = 871$ lbs. $B = 885$ lbs. at $8^\circ 20'$ with H.

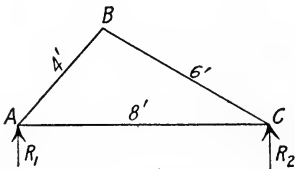

FIG. 99

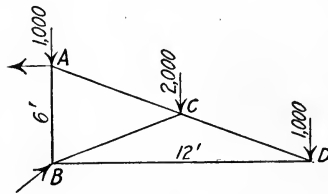

FIG. 100

Problem 4. Consider the reaction at A of the cantilever truss shown in Fig. 100 to be horizontal. Solve for the reactions and the internal stresses.

Ans. $A = 4000$ lbs. $B = 5656$ lbs. at 45° with H. $AB = 3000$ lbs. C. $AC = 4472$ lbs. T. $BC = 2236$ lbs. C. $CD = 2236$ lbs. T. $BD = 2000$ lbs. C.

Problem 5. If there is no member AB in the truss of Fig. 100, determine the amount and direction of the reactions at A and B .

Ans. $A = 5000$ lbs. at $36^\circ 50'$ with H. $B = 4120$ lbs. at 14° with H.

Problem 6. In the truss shown in Fig. 101 the reaction of the strut FB is horizontal. Determine the reactions and the internal stresses.

* Consider all trusses in this set of problems to be pin-connected at all joints.

Ans. $A = 2655$ lbs. at $57^\circ 20'$ with H. $B = 2433$ lbs. $AB = 827$ lbs. T. $AC = 1943$ lbs. T. $BC = 1654$ lbs. C. $BE = ED = 1000$ lbs. C. $CE = 500$ lbs. T. $CD = 866$ lbs. T.

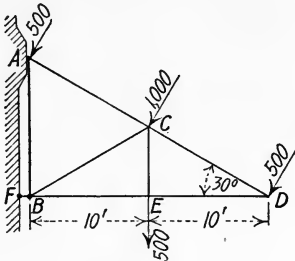

FIG. 101

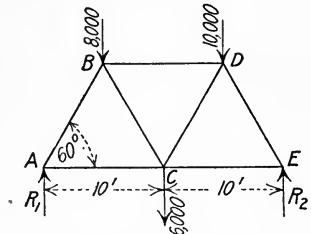

FIG. 102

Problem 7. Solve for the reactions and the stress in each member of the truss shown in Fig. 102.

Ans. $R_1 = 11,500$ lbs. $R_2 = 12,500$ lbs. $AB = 13,280$ lbs. C. $AC = 6640$ lbs. T. $BC = 4042$ lbs. T. $BD = 8660$ lbs. C. $CD = 2887$ lbs. T. $CE = 7216$ lbs. T. $DE = 14,433$ lbs. C.

Problem 8. The roof truss shown in Fig. 103 is held by a hinge at G and is supported on rollers at A . Solve for the reactions and the internal stresses caused by the wind loads shown.

Ans. $A = 2310$ lbs. $G_V = 1155$ lbs. $G_H = 2000$ lbs. $BD = AB = 2888$ lbs. C. $AC = CD = 2000$ lbs. T. $BC = 2000$ lbs. C. $DF = FG = 2310$ lbs. C. CE, DE, EF and EG all equal zero.

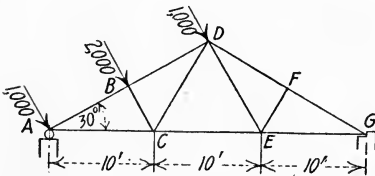

FIG. 103

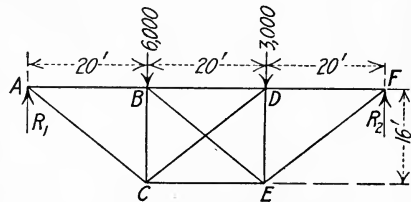

FIG. 104

Problem 9. The diagonals BE and CD of the truss shown in Fig. 104 can take only tensile stress. When the truss is loaded as shown, determine which diagonal is acting and the amount of the stress in it.

Ans. $CD = 1600$ lbs. T.

Problem 10. A cantilever frame is built up of members pinned together as shown in Fig. 105. Determine the amount and direction of the reactions at A and B and the amount of the stress in the diagonals due to the load of 100 lbs. at the end.

Ans. $A = 608$ lbs. at $9^\circ 25'$ with H. $B = 600$ lbs. hor. $CE = 424$ lbs. T. $DE = 424$ lbs. C.

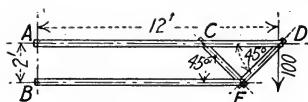

FIG. 105

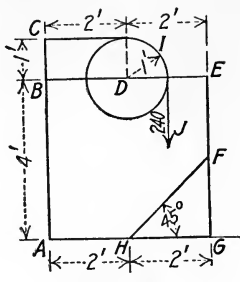

FIG. 106

Problem 11. Fig. 106 shows a frame supporting a 2-foot pulley. If the cord CIJ carrying a load of 240 lbs. is fastened at C , what is the stress in FH ?

Ans. 170 lbs. T.

Problem 12. Fig. 107 shows two views of a gin pole held by three equally spaced guy wires, each at an angle of 30° with the pole. If the force of the wind is 1000 lbs. acting at the middle of the pole at right angles to the vertical plane through guy wire OC , determine the stress in each wire caused by the wind.

Ans. $OA = 0$. $OB = 1154$ lbs. T. $OC = 577$ lbs. T.

Problem 13. A bar 10 feet long is held by a pin at the bottom end and rests at an angle of 45° against a smooth vertical wall. It carries loads of 100 lbs., 200 lbs. and 300 lbs. at 3 feet, 6 feet and 9 feet respectively from the lower end. What are the reactions?

Ans. Top, 420 lbs. hor. Bottom, 732 lbs. at 55° with H.

Problem 14. The A-frame shown in Fig. 108 is pinned at the joints B , C and D , and is supported by a smooth floor AE . Determine the pin reactions at B , C and D caused by the 4000 lbs. load.

Ans. $B = 1667$ lbs. at $53^\circ 10'$ with H. $C = 1024$ lbs. at $12^\circ 35'$ with H. $D = 2848$ lbs. at $69^\circ 30'$ with H.

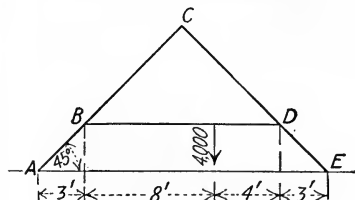

FIG. 108

Problem 15. Determine the stress in the brace BE of the crane shown in Fig. 109. Determine also the maximum tensile and compressive stresses in the stiff legs DH and DG as the boom rotates about the post.

Ans. $BE = 1618$ lbs. DH and DG max. tens. and comp. = 1455 lbs.

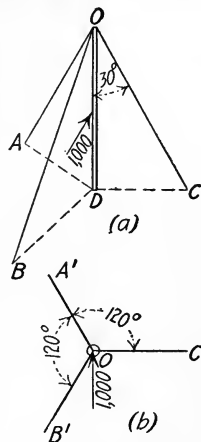

FIG. 107

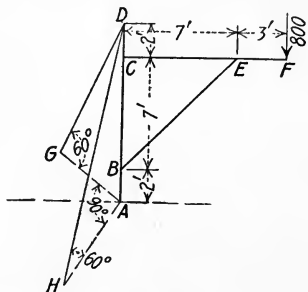

FIG. 109

Problem 16. The simple crane shown in Fig. 110 carries a load of 1000 lbs. at the end of the boom. The post AD weighs 600 lbs., the boom CF 400 lbs. and the brace BE 300 lbs. Determine the reactions at A and D and the pin pressures at B , C and E .

Ans. $A = 2528$ lbs. at $65^\circ 30'$ with H. $D = 1050$ lbs. H. $E = 2371$ lbs. at $42^\circ 35'$ with H. $B = 2584$ lbs. at $47^\circ 20'$ with H. $C = 1761$ lbs. at $6^\circ 30'$ with H.

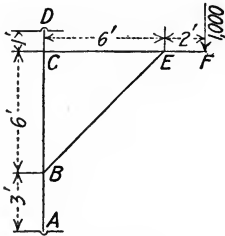

FIG. 110

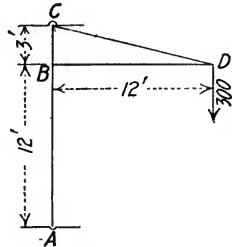

FIG. 111

Problem 17. Determine the stresses in CD and BD , and the reactions at A and C in the crane shown in Fig. 111. Neglect the weight of the crane itself.

Ans. $CD = 1237$ lbs. T. $BD = 1200$ lbs. C. $C = 240$ lbs. H. $A = 384$ lbs. at $51^\circ 20'$ with H.

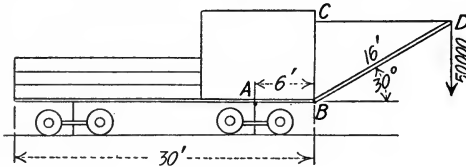

FIG. 112

Problem 18. In the crane shown in Fig. 112, solve for the stresses in BD and CD caused by the load of 50,000 lbs. at D . If the boom weighs 2000 lbs. and the weight on the car is uniformly distributed, what must the car weigh in order that it does not tip about point A ?

Ans. $BD = 100,000$ lbs. C. $CD = 86,600$ lbs. T. Wt. = 113,300 lbs.

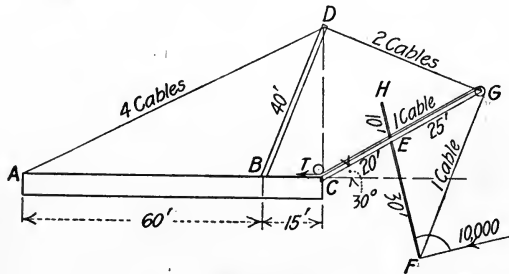

FIG. 113

Problem 19. Fig. 113 represents a dipper dredge with dimensions as shown. The boom CG weighs 40,000 lbs. The handle HF weighs 5,000 lbs.

and in the position shown is at an angle of 15° with the vertical. The dipper and load weigh 12,000 lbs. BD is an A-frame, 40 feet in altitude and spread 20 feet at the base. In the filling position consider the pressure to be 10,000 lbs. at right angles to the handle. Solve for the stresses in the cable FG , the cables DG and DA , the pin reactions at E and C and the compression in each member of DB .

Ans. $FG = 24,560$ lbs. $DG = 41,000$ lbs. $DA = 61,700$ lbs. $E = 4110$ lbs. at $62^\circ 30'$ with H . $C = 90,100$ lbs. at $39^\circ 40'$ with H . $DB = 23,240$ lbs. in each leg.

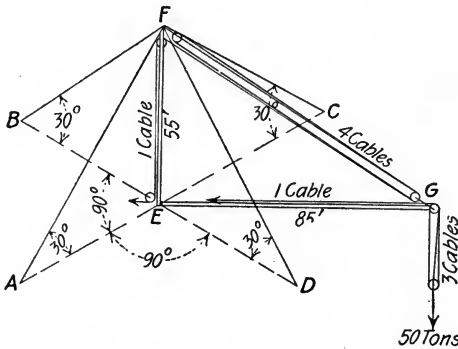

FIG. 114

Problem 20. In the derrick shown in Fig. 114, four guy cables, each at an angle of 30° with the ground, support a mast 55 ft. high. The boom is 85 feet long. When the boom is in the horizontal position and a load of 50 tons is being lifted, determine the stresses in the cables FG , cable EG and boom EG . Determine also the maximum stress that can come upon any one of the four guy cables as the boom is rotated horizontally.

Ans. $FG = 46,000$ lbs. in each cable. Cable $EG = 33,330$ lbs. Boom $EG = 187,880$ lbs. C. Max. in guy cable = 178,450 lbs. T.

Problem 21. The steam hoist represented in Fig. 115 is raising a weight of 800 lbs. When the crank is in the position shown, determine the stress in the connecting rod BD , the pressure of the guide on the cross-head N and the steam pressure P for uniform motion.

Ans. $BD = 1622$ lbs. $N = 270$ lbs. $P = 1600$ lbs.

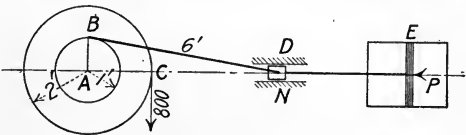

FIG. 115

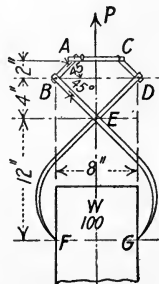

FIG. 116

Problem 22. Determine the stress in the link AB and the shear on the rivet E of the ice tongs shown in Fig. 116 when supporting a cake of ice weighing 100 lbs.

Ans. $AB = 70.7$ lbs. $E = 100$ lbs.

Problem 23. Determine the stresses in the members AD , DE , BD and BE of the simple wagon-jack shown in Fig. 117. The jack rests upon the ground at D and E .

Ans. $AD = 141$ lbs. T. $DE = 100$ lbs. T. $BD = 200$ lbs. C. $BE = 141$ lbs. C.

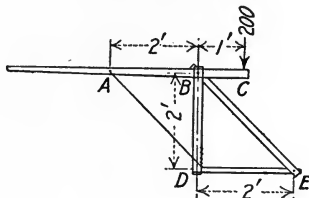

FIG. 117

Problem 24. The bridge shown in Fig. 118 has its lower chord in the shape of a parabola. The total weight of the bridge is 1500 tons. Find the stress in the lower chord at the piers and at the middle. (The bridge is like the suspension bridge inverted.)

Ans. 1,352,000 lbs. at pier. 1,125,000 lbs. at middle.

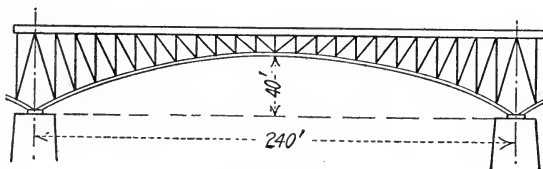

FIG. 118

Problem 25. A suspension foot bridge is 80 feet long, 4 feet wide and carries a load of 100 lbs. per square foot of floor area. It is supported by two cables which have 12 ft. of sag. What is the stress in each cable? What is the length of the cable between supports?

Ans. 15,530 lbs. 84.8 ft.

Problem 26. A wire can safely sustain 70 lbs. tension. Its weight per linear foot is 0.025 lb. If the allowable sag is 1.5 inches, what is the maximum spacing for posts? If 6 inches sag can be allowed, what is the spacing required?

Ans. 53 ft. 106 ft.

Problem 27. A cable weighing 0.3 lb. per linear foot is stretched between posts 160 ft. apart with tension at the middle of 500 lbs. What is the sag? What is the amount and direction of the tension at the end?

Ans. 1.92 ft. 500.58 lbs. $\theta = 2^\circ 45'$ with H.

Problem 28. A cable 800 feet long, weighing 0.5 lb. per foot, has 250 lbs. tension at each end. What is the sag? What is the distance between supports?

Ans. 200 ft. 660 ft. ($c = 300$ ft.)

CHAPTER IV.

CENTROIDS AND CENTER OF GRAVITY.

43. Centroid of a System of Forces with Fixed Application Points. In all of the previous discussions of forces applied to rigid bodies, it has been assumed that the force could be applied at any point along its line of action. In some cases forces are considered to be applied at certain definite points which remain fixed, no matter how the body is displaced or the system of forces rotated. Consider a system of particles, each of which is acted upon by a force proportional to its mass, and let these forces be parallel to each other. It is evident that if the system of particles is rotated while the forces remain fixed in direction, the result is the same as if the system of particles remained fixed in space and the force system were rotated, each force about its point of application.

Let such a force system be acting upon a system of particles in the direction of the Y axis. The distance of the resultant from the XY plane and also from the YZ plane may be determined by the theorem of moments. Then consider each force of the system to be rotated about its point of application until the system of forces is parallel to the X axis. The line of action of the resultant is necessarily at the same distance from the XY plane that it was before rotation. Also, its distance from the XZ plane may now be determined, and its point of intersection with the line of action of the resultant in its original position must necessarily be the point about which the resultant was rotated. Next, if from this position each force is rotated about its point of application until it is parallel to the Z axis, the line of action of the resultant is necessarily at a fixed distance from the XZ plane during the rotation.

Finally, if from this last position each force is rotated about its point of application back to its original position parallel to the Y axis, the line of action of the resultant remains at a fixed distance from the YZ plane and must necessarily return to its original position. In order for it to do this, the last two rotations must necessarily have been made about the same point as the first.

For if the second rotation had been made about a point on the resultant which had a different X coördinate from the first point of rotation, the final position of the resultant would have had a different X coördinate and therefore could not have coincided with the original position. Similarly if the third rotation had been made about a point which had a different Z coördinate from the first point of rotation, the final position of the resultant would have had a different Z coördinate and therefore could not have coincided with the original position. This point in the resultant is therefore the *one fixed point* in the system for any possible rotation, and is called the *centroid* of the system. Its coördinates are denoted by \bar{x} , \bar{y} , \bar{z} . (Called "gravity" x , etc.)

Each particle of a body is attracted by the earth, and the force of this attraction is proportional to the mass of the particle. It is obvious that the points of application of these forces remain unchanged for all positions of the body, and that the lines of action of the forces for bodies of the size considered in engineering problems are practically parallel. The resultant of all these attractive forces is called the *force of gravity*, or the *weight* of the body, and its fixed application point is called the *center of mass* or *center of gravity* of the body. Ordinarily it is only necessary to consider this resultant force.

44. Centroids of Solids, Surfaces and Lines Defined. The centroid of a geometric solid is that point which coincides with the center of mass of a homogeneous body occupying the same volume.

The centroid of a surface is the limiting position of the center of gravity of a homogeneous thin plate, one face of which coincides with the surface as the thickness of the plate approaches zero.

The centroid of a line is the limiting position of the center of gravity of a homogeneous thin rod whose axis coincides with the line as the cross-sectional area of the rod approaches zero.

45. Moment with Respect to a Plane. The moment of a force with respect to a plane parallel to its line of action is the product of the force and the perpendicular distance from the force to the plane, as discussed in Art. 26. By analogy, the moment of a solid, surface or line with respect to a plane is equal to the product of the solid, surface or line and the perpendicular distance from the plane to its centroid. Since solids, surfaces and lines are not vector quantities, the sign of the moment must be provided for

by assigning the plus sign to the ordinates on one side of the plane and the minus sign to those on the other.

By the principle of Art. 26, *the moment of the weight of a body with respect to a plane is equal to the sum of the moments of the weights of the several particles of the body with respect to the same plane.*

For the ZY plane, $W\bar{x} = \Sigma wx.$

For the XY plane, $W\bar{z} = \Sigma wz.$

For the XZ plane, $W\bar{y} = \Sigma wy.$

If the moment of the weight of a body with respect to a plane is zero, the center of gravity of the body is in that plane.

The moment of a solid, surface or line with respect to a plane is equal to the moment of its separate component parts with respect to the same plane. For if w is the unit weight of a homogeneous body and V is its volume, its total weight is $wV = W$. By the above principle,

$$wV\bar{x} = wv_1x_1 + wv_2x_2 + wv_3x_3 +, \text{ etc.,}$$

or
$$V\bar{x} = v_1x_1 + v_2x_2 + v_3x_3 +, \text{ etc.}$$

Similar propositions hold true for surfaces and lines.

If the moment of a solid, surface or line with respect to a plane is zero, the centroid is in that plane; and, conversely, if the centroid of a solid, surface or line is in a certain plane of reference, the moment with respect to that plane is zero.

46. Planes of Symmetry and Axes of Symmetry. If a solid, surface or line is symmetrical with respect to any plane, the centroid is in that plane.

If two or more planes of symmetry intersect in a line, this line is called an axis of symmetry and contains the centroid.

If three or more planes of symmetry intersect each other in a point, this point is the centroid.

Similar propositions are true for the center of gravity of a mass if homogeneous.

An observation of the planes of symmetry will enable the centroids of many geometrical figures to be located either partially or completely. The following are illustrations:

The centroid of a straight line is at its middle point.

The centroid of a circular arc is on the bisecting radius of the arc.

The centroid of a circle or its circumference is the center of the circle.

The centroid of a parallelogram or its perimeter is the inter-

section of the lines bisecting the pairs of opposite sides. It is likewise the intersection of the two diagonals.

The centroid of a sphere or of its surface is the center of the sphere.

The centroid of a cylinder or of its surface is the middle point of its axis.

The centroid of a right prism with parallel bases is the middle point of its axis.

The centroid of a right cone is on its axis.

The centroid of a thin plate is midway between the positions of the centroids of the faces.

47. Centroid of a System of Forces with Coplanar Application Points. In case the application points of the forces of a system are fixed and coplanar, two moment equations will be sufficient to locate the centroid if the axes are taken in the plane of the application points. By Art. 43, the centroid remains fixed for any rotation of the force system, so the forces may be assumed to be rotated until they are normal to the plane of the application points. Then, by the theorem of moments,

$$\bar{x} = \frac{\Sigma Fx}{\Sigma F},$$

$$\bar{y} = \frac{\Sigma Fy}{\Sigma F}.$$

The graphic method is readily applied to this case. Assume the system of forces to be rotated until the forces are in the plane of the application points, preferably parallel to one of the axes. The position of the resultant may be determined by the method of Art. 25. Again assume the system to be rotated through some angle in its plane, preferably until parallel to the other axis. The position of the resultant may be determined as before. The intersection of these two resultants is the position of the centroid.

Problem 1. Parallel forces of 10 lbs., 24 lbs., 30 lbs. and 16 lbs. have application points in the XY plane as follows: $(2'', 3'')$, $(4'', 1'')$, $(3'', 4'')$ and $(0'', 0'')$. Locate the centroid of the system if all of the forces are in the same direction.

Ans. 2.575'', 2.175''.

Problem 2. Solve Problem 1 if the first force is reversed in direction.

Ans. 2.767'', 1.90''.

Problem 3. Solve Problem 1 if both the first and second forces are reversed in direction.

Ans. - 2.17'', 5.50''.

48. Centroids of Simple Solids and Surfaces. For many simple surfaces and solids, enough planes or lines containing the centroid may be determined to locate the centroid completely.

Triangle. The centroid of a triangle is at the intersection of its medians.

Proof. In Fig. 119, the centroid of any elementary strip MN parallel to the base and of infinitesimal width is on the median AD , therefore the centroid of the triangle is on the median. Likewise it is on the median BE , and therefore is at their point of intersection O .

By geometry, $OD = \frac{1}{3} AD$. Therefore the centroid is on any median, at a distance of one-third its length from its intersection with the base.

The perpendicular distance from O to BC is one-third the altitude of the triangle; therefore, the centroid of a triangle is at the intersection of two lines drawn parallel respectively to two sides of the triangle and distant one-third of the altitude from the base.

Slant Area of Pyramid. The centroid of the slant area of a pyramid is on the axis of the surface, at a distance from the base equal to one-third of the altitude.

Proof. Consider the pyramid to be cut by planes parallel to the base and infinitesimal distances apart. The centroid of each infinitesimal area intercepted between two succeeding planes is on the axis, therefore the centroid of the total area is on the axis. The centroid of each of the triangular faces is in a plane distant one-third of the altitude from the base. Hence the centroid of the entire slant area is at the intersection of the axis with this plane.

Since the surface of a cone may be considered as the limit of the surface of a pyramid, the number of whose sides is increased to infinity, the same proposition holds true for a cone.

Oblique Prism. The centroid of an oblique prism with parallel bases is at the middle point of its axis.

Proof. Consider the prism to be cut into elementary plates parallel to the base. The centroid of each plate approaches coincidence with the centroid of its area as its thickness approaches zero. The straight line joining these centroids is the axis of the prism by definition, hence the centroid of the prism is on its axis. Again, consider the prism to be made up of elementary

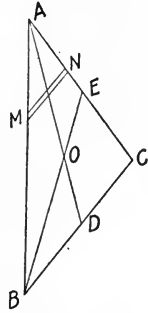

FIG. 119

rods parallel to the axis. The centroid of each rod is at its middle point, hence the centroid of the prism is in the plane passed through these middle points of the elementary rods parallel to the base.

Oblique Pyramid or Cone. The centroid of an oblique pyramid or cone is on its axis.

Proof. Consider the pyramid or cone to be cut into elementary plates parallel to the base. The centroid of each plate approaches coincidence with the centroid of its area as its thickness approaches zero. The surface of each plate is an area similar to the area of the base and its centroid is at a corresponding point in its area, hence on the axis. Therefore, since the centroids of all the elementary plates lie upon the axis, the centroid of the entire pyramid or cone is on the axis.

49. Centroids by Integration. *Lines, Plane Surfaces and Solids.* If a solid, surface or line be divided into its infinitesimal parts, the principle of moments, Art. 26, may be stated as follows:

For solid of volume V ,

$$\begin{aligned} V\bar{x} &= x_1 dV_1 + x_2 dV_2 + x_3 dV_3 + \text{etc.}, = \int x dV; \\ V\bar{y} &= \int y dV; \quad \int V\bar{z} = \int z dV. \end{aligned} \quad (1)$$

For surface of area A ,

$$A\bar{x} = \int x dA; \quad A\bar{y} = \int y dA; \quad A\bar{z} = \int z dA. \quad (2)$$

For line of length l ,

$$\bar{x} = \int x dl; \quad \bar{y} = \int y dl; \quad \bar{z} = \int z dl. \quad (3)$$

These expressions may be used when any given solid, surface or line cannot be divided into finite component parts whose centroids are known, but is of such form that the differential expression for the moment can be integrated.

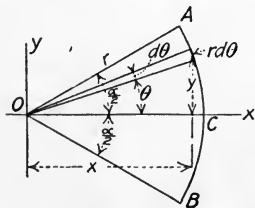

FIG. 120

EXAMPLE 1.

Locate the centroid of a circular arc.

Solution:— By symmetry the centroid is on the axis OC , Fig. 120, so $\bar{y} = 0$. To determine \bar{x} , use expression (3).

$$\bar{x} = \int x dl.$$

$$l = r\alpha; \quad x = r \cos \theta; \quad dl = r d\theta.$$

$$r\alpha\bar{x} = \int_{-\frac{\alpha}{2}}^{+\frac{\alpha}{2}} r^2 \cos \theta \, d\theta.$$

$$r\alpha\bar{x} = r^2 \sin \theta \Big]_{-\frac{\alpha}{2}}^{+\frac{\alpha}{2}}.$$

$$r\alpha\bar{x} = 2r^2 \sin \frac{\alpha}{2}.$$

$$\bar{x} = \frac{2r}{\alpha} \sin \frac{\alpha}{2}.$$

For $\alpha = 360^\circ$, $\sin \frac{\alpha}{2} = \sin 180^\circ = 0$. $\bar{x} = 0$.

For $\alpha = 180^\circ$, $\sin \frac{\alpha}{2} = \sin 90^\circ = 1$. $\bar{x} = \frac{2r}{\pi} = 0.637r$.

For $\alpha = 90^\circ$, $\sin \frac{\alpha}{2} = \sin 45^\circ = 0.707$. $\bar{x} = 0.707 \frac{4r}{\pi} = 0.901r$.

EXAMPLE 2.

Locate the centroid of the sector of a circle.

Solution: — Let the X axis bisect the angle of the sector, Fig. 121. Then

$$\bar{y} = 0.$$

To determine \bar{x} , use expression (2).

$$A\bar{x} = \int x \, dA.$$

$$A = \frac{1}{2}r^2\alpha; \, dA = \rho \, d\rho \, d\theta; \, x = \rho \cos \theta.$$

$$\frac{1}{2}r^2\alpha\bar{x} = \int_0^r \int_{-\frac{\alpha}{2}}^{+\frac{\alpha}{2}} \rho \cos \theta \, d\rho \, d\theta.$$

$$\bar{x} = \frac{4r}{3\alpha} \sin \frac{\alpha}{2}$$

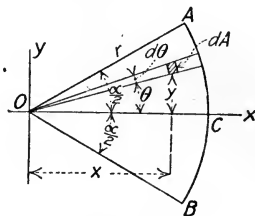

FIG. 121

EXAMPLE 3.

Locate the centroid of the area of a quadrant with respect to the limiting radius.

Solution: — By Example 2, $OA = \frac{8r}{3\pi} \sin 45^\circ$. See Fig. 122.

$$\bar{x} = BA = \overline{OA} \sin 45^\circ.$$

$$\bar{x} = \frac{4r}{3\pi}.$$

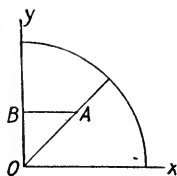

FIG. 122

EXAMPLE 4.

Locate the centroid of a pyramid or cone.

Solution: — By Art. 48 the centroid is on the axis, so it remains to determine its distance from a plane through the vertex parallel to the base. Let the

pyramid or cone be placed with its vertex at the origin O , Fig. 123, and its base MN normal to the X axis. Let A be the area of the base and let a be the area of any cross section parallel to the base at distance x from the vertex. Use expression (3).

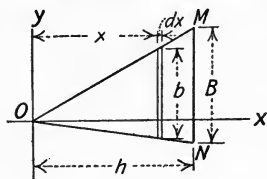

FIG. 123

By similar triangles,

$$\frac{b}{B} = \frac{x}{h}.$$

Also by the geometry of similar areas,

$$\frac{a}{A} = \frac{b^2}{B^2} = \frac{x^2}{h^2}.$$

Then

$$a = \frac{A}{h^2} x^2.$$

$$\frac{Ah}{3} \bar{x} = \frac{A}{h^2} \int_0^h x^3 dx.$$

$$\bar{x} = \frac{3}{4} h.$$

The distance of the centroid from the base is $\frac{1}{4}h$.

EXAMPLE 5.

Locate the centroid of a hemisphere.

Solution:— Let the axes be placed as shown in Fig. 124. By symmetry $\bar{y} = 0$ and $\bar{z} = 0$. To determine \bar{x} , use expression (1).

$$V\bar{x} = \int x dV.$$

$$V = \frac{2}{3}\pi r^3; dV = \text{volume of slice } AB = \pi y^2 dx.$$

$$\frac{2}{3}\pi r^3 \bar{x} = \int x \pi y^2 dx.$$

$$y^2 = r^2 - x^2.$$

$$\frac{2}{3}r^3 \bar{x} = \int_0^r r^2 x dx - \int_0^r x^3 dx.$$

$$\frac{2}{3}r^3 \bar{x} = \frac{r^4}{2} - \frac{r^4}{4}.$$

$$\bar{x} = \frac{3}{8} r.$$

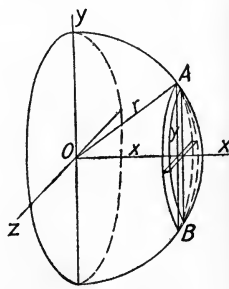

FIG. 124

Problem 1. Determine by integration the distance of the centroid of an arc of 90° from the radius at its end.

$$\text{Ans. } \frac{2r}{\pi}$$

Problem 2. Solve Example 2 above by using the elementary sector for dA .

Problem 3. In Example 2 above, use $dA = \rho \alpha d\rho$ as shown by the shaded part in Fig. 125, and solve.

Problem 4. Determine by integration the distance of the centroid of a quadrant from the limiting radius.

Problem 5. Locate the centroid of a parabolic segment of altitude a . The equation of the parabola is $y^2 = 4mx$. *Ans.* $\bar{x} = \frac{3}{8}a$.

Problem 6. Show by integration that the centroid of a triangle is distant one-third of the altitude from the base.

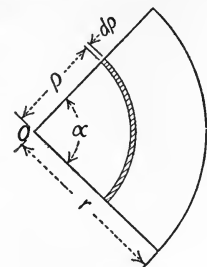

FIG. 125

50. Centroids of Surfaces and Solids of Revolution. The centroid of a surface of revolution generated by the rotation of a line about an axis in its plane is on the axis. In determining its position on the axis, the solution may be simplified by using for dA the area generated by the length ds of the generating line as shown by the shaded part in the two views in Fig. 126.

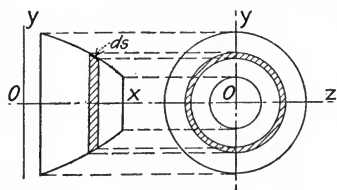

FIG. 126

The centroid of a solid of revolution generated by the rotation of an area about an axis in its plane is on the axis. In determining its position on the axis, the solution may be simplified by using as dV the volume generated by the element dA of the generating area.

EXAMPLE 1.

Locate the centroid of a hemispherical surface.

Solution:— Let the axes be placed as shown in Fig. 127. By symmetry $\bar{y} = 0$ and $\bar{z} = 0$.

$$A\bar{x} = \int x dA.$$

$$A = 2\pi r^2; \quad dA = 2\pi y ds; \quad x = r \cos \theta;$$

$$y = r \sin \theta; \quad ds = r d\theta.$$

$$2\pi r^2 \bar{x} = \int_0^{\pi/2} 2\pi r^3 \cos \theta \sin \theta d\theta.$$

$$\bar{x} = \frac{r}{2} \left[\sin^2 \theta \right]_0^{\pi/2}.$$

$$\bar{x} = \frac{r}{2}.$$

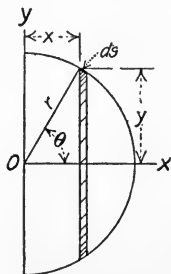

FIG. 127

EXAMPLE 2.

Locate the centroid of a spherical segment.

Solution:— Let the axes be placed as shown in Fig. 128. By symmetry $\bar{y} = 0$ and $\bar{z} = 0$.

$$V\bar{x} = \int x dV.$$

$$dV = \pi y^2 dx; \quad V = \int \pi y^2 dx; \quad x = r \cos \theta;$$

$$dx = -r \sin \theta d\theta; \quad y = r \sin \theta.$$

$$-\bar{x} \int_0^{\frac{\alpha}{2}} \pi r^3 \sin^3 \theta d\theta = - \int_0^{\frac{\alpha}{2}} \pi r^4 \cos \theta \sin^3 \theta d\theta.$$

$$\bar{x} = \frac{3}{4} r \frac{\sin^4 \frac{\alpha}{2}}{2 - 3 \cos \frac{\alpha}{2} + \cos^3 \frac{\alpha}{2}}.$$

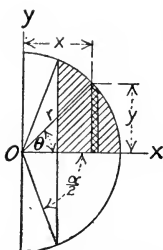

FIG. 128

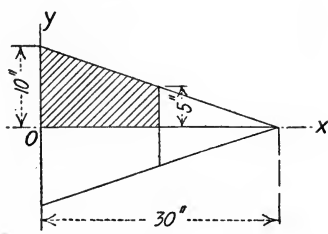

FIG. 129

Problem 1. Show by integration that the centroid of the curved surface of a cone is distant one-third of the altitude from the base.

Problem 2. Locate the centroid of the frustum of a cone which has dimensions as shown in Fig. 129. (Consider the frustum as generated by the revolution of the shaded trapezoid about the X axis.) *Ans.* $\bar{x} = 5.9$ in.

51. Theorems of Pappus and Guldinus.

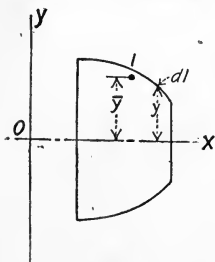

FIG. 130

I. *The area S of the surface generated by any plane curve revolved about a non-intersecting axis in its plane is equal to the product of the length of the curve and the length of the path traced by the centroid of the curve.*

Let l be the length of the curve as shown in Fig. 130.

$$l\bar{y} = \int y dl.$$

Also
$$S = 2\pi \int y \, dl.$$

By eliminating $\int y \, dl$,
$$S = 2\pi \bar{y}l.$$

II. *The volume V of the solid of revolution generated by a plane area revolved about a non-intersecting axis in its plane is equal to the product of the area and the length of the path traced by the centroid of the area.*

Let A , Fig. 131, be the generating area.

$$A\bar{y} = \int y \, dA.$$

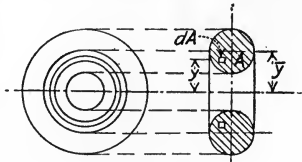

FIG. 131

The volume of the ring generated by the rotation of the differential area dA is dV and is equal to the product of the length of the ring and its cross section, $2\pi y \, dA$.

Total volume
$$V = 2\pi \int y \, dA.$$

By eliminating $\int y \, dA$,
$$V = 2\pi \bar{y}A.$$

Problem 1. Determine the area of a circle by means of Theorem I.

Problem 2. Determine the curved area and the volume of a cone with height h , radius of base r and slant height l .

Ans. Area = πrl . Vol. = $\frac{1}{3}\pi r^2 h$.

Problem 3. Determine the curved area and the volume of a cylinder with height h and radius of base r .

Problem 4. Given the volume of a sphere = $\frac{4}{3}\pi r^3$, show that the centroid of a semicircle is $\frac{4}{3\pi}r$ from the diameter.

52. Center of Gravity of Composite Body. If a body is composed of several simple parts whose centers of gravity are known, the principle of Art. 26 may be applied.

The moment of a body with respect to a plane is equal to the sum of the moments of the several parts with respect to the same plane.

$$W\bar{x} = w_1\bar{x}_1 + w_2\bar{x}_2 + w_3\bar{x}_3 + \dots, \text{ etc.}$$

Similar propositions hold true for \bar{y} and \bar{z} . If the body was originally of simple form with one or more simple parts taken away, a

modification of the preceding rule applies. The equation above may be written

$$w_1 \bar{x}_1 = W\bar{x} - w_2 \bar{x}_2 - w_3 \bar{x}_3 - , \text{ etc.}$$

That is, the moment of a part of a body with respect to a plane is equal to the moment of the whole body minus the moment of the parts taken away.

EXAMPLE 1.

Locate the center of gravity of a wire 12 inches long, bent as shown in Fig. 132.

Solution: — The weight is proportional to the length.

$$12 \bar{x} = 3 \times 0 + 4 \times 2 + 5 \times 5.25.$$

$$\bar{x} = 2.85 \text{ in.}$$

$$12 \bar{y} = 3 \times 1.5 + 4 \times 0 + 5 \times 2.165.$$

$$\bar{y} = 1.28 \text{ in.}$$

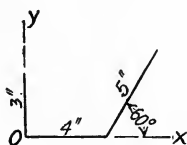

FIG. 132

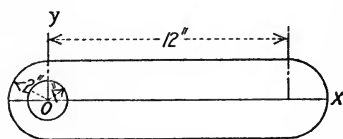

FIG. 133

EXAMPLE 2.

Locate the center of gravity of the plate shown in Fig. 133 with respect to the center of the hole at O .

Solution: — By symmetry, $\bar{y} = 0$. Total original area = 60.56 sq. in. Area of hole = 3.14 sq. in. Remaining area = 57.42 sq. in.

$$57.42 \bar{x} = 60.56 \times 6 - 3.14 \times 0.$$

$$\bar{x} = 6.34 \text{ in.}$$

Problem 1. Solve for \bar{x} , \bar{y} and \bar{z} of the wire shown in Fig. 132 if the 3-inch part of the wire is bent forward at right angles to the position shown.

Ans. $\bar{x} = 2.85 \text{ in.}$ $\bar{y} = 0.90 \text{ in.}$ $\bar{z} = 0.38 \text{ in.}$

Problem 2. Locate the centroid of the area shown in Fig. 134.

Ans. $\bar{x} = 3.58 \text{ in.}$ $\bar{y} = -4.07 \text{ in.}$

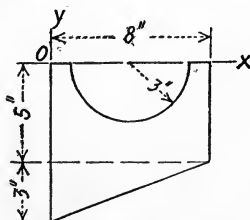

FIG. 134

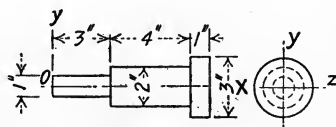

FIG. 135

Problem 3. Locate the center of gravity of the gear journal shown in Fig. 135.

Ans. $\bar{x} = 5.425 \text{ in.}$

53. Centroid of Irregular Plane Area. The centroid of any irregular plane area may be determined graphically. Consider the standard T-rail section, Fig. 136.

By symmetry, $\bar{x} = 0$; \bar{y} is to be determined. Only one-half of the area need be considered, that to the right of OY . Draw the axes EF and CD perpendicular to the Y axis and any distance y_1 apart. Locate as many controlling points on the bounding line FD as necessary. M and N are two such points. Determine the points M' ,

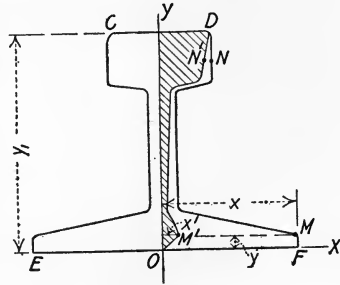

FIG. 136

N' , etc., such that $x' = \frac{y}{y_1} x$. Connect all of the points so obtained by a smooth curve. Let A be the half area of the rail and A' the shaded area between the Y axis and the curve $M'N'$.

$$A\bar{y} = \int y dA.$$

$$dA = x dy \text{ (horizontal strip).}$$

So
$$A\bar{y} = \int xy dy.$$

From the relation above, $xy = x'y_1$.

By the substitution of this in the preceding equation,

$$A\bar{y} = y_1 \int x' dy = y_1 A'.$$

Then
$$\bar{y} = \frac{A'}{A} y_1.$$

Areas should be measured with a planimeter.

Problem 1. Check the graphical method by solving for the location of the centroid of a rectangle: (1) using h for y_1 ; (2) using $2h$ for y_1 .

54. Center of Gravity by Experiment. The center of gravity of an irregular body may be determined by experiment. If the body is suspended freely, two intersecting vertical planes through the center of suspension may be marked on the body. Each of these planes contains the center of gravity, therefore it is in their line of intersection. If the body is then suspended in some other position, the intersection of any other vertical plane through the

center of support with the line of intersection of the other two planes determines the center of gravity.

If a body is of such form that it can easily be balanced across a knife edge, the position of the center of gravity may be determined readily. The body should be balanced perfectly in some position and the line of the supporting knife edge marked. The body should then be rotated and balanced and another line of support marked. The center of gravity is vertically above the intersection of the two lines.

GENERAL PROBLEMS.

Problem 1. Locate the centroid of the cross section of the T-bar shown in Fig. 137.

Ans. $\bar{y} = 1.125$ in.

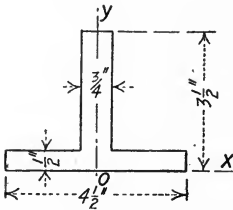

FIG. 137

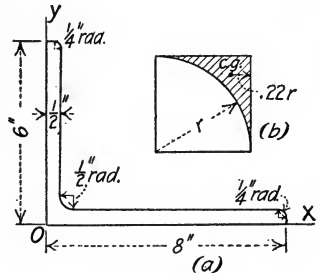

FIG. 138

Problem 2. Neglecting the fillet and rounded corners, locate the centroid of the angle section shown in Fig. 138. *Ans.* $\bar{x} = 2.47$ in. $\bar{y} = 1.47$ in.

Problem 3. Consider the fillet and rounded corners of the angle section of Problem 2 and solve for \bar{y} accurately. (c.g. of shaded area, Fig. 138(b), is $.22r$ from tangent.) *Ans.* $\bar{y} = 1.46$ in.

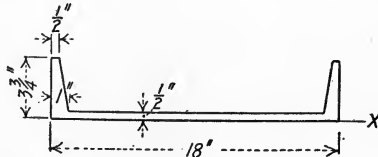

FIG. 139

Problem 4. Locate the centroid of the channel section shown in Fig. 139. *Ans.* $\bar{y} = 0.845$ in.

Problem 5. Locate the center of gravity of the governor ball and rod in the position shown in Fig. 140. The rod is steel and the ball is cast iron.

Ans. $\bar{x} = 10.62$ in. $\bar{y} = -10.62$ in.

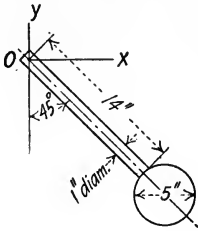

FIG. 140

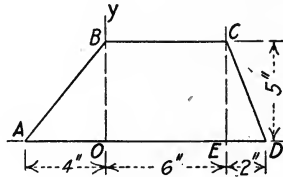

FIG. 141

Problem 6. Locate the center of gravity of the trapezoidal shaped piece of sheet iron shown in Fig. 141.

Ans. $\bar{x} = 2.44$ in. $\bar{y} = 2.22$ in.

Problem 7. If the triangular ends ABF and CED , Fig. 141, are bent forward at right angles to the remainder, determine \bar{x} , \bar{y} and \bar{z} .

Ans. $\bar{x} = 2.67$ in. $\bar{y} = 2.22$ in. $\bar{z} = 0.37$ in.

Problem 8. A controller magnet has dimensions as shown in Fig. 142. Locate the center of gravity.

Ans. $\bar{y} = 2.924$ in.

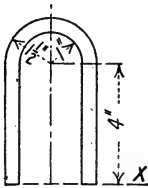

FIG. 142

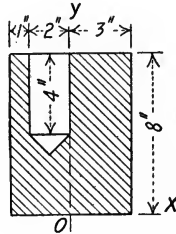

FIG. 143

Problem 9. An endless wire is bent into the form of an arc of 90° and its chord. Locate the center of gravity.

Ans. $0.808 r$ from center.

Problem 10. What is the distance from the chord of an arc of 60° to the centroid of the arc?

Ans. $0.0885 r$.

Problem 11. A cylinder 6 inches in diameter and 8 inches high has a cylindrical hole 2 inches in diameter and 4 inches deep bored into its top. Fig. 143 shows a cross section through the axis of the cylinder and the axis of the cylindrical hole. The bottom of the hole is conical, each element being at an angle of 45° with the axis. Locate the center of gravity.

Ans. $\bar{x} = 0.064$ in. $\bar{y} = 3.89$ in.

Problem 12. A 6-inch cube has cylindrical holes 1 inch in diameter and 2 inches deep drilled in the centers of the top, front and right-hand faces. Locate the center of gravity.

Ans. $\bar{x} = -0.0149$ in.

Problem 13. A telephone pole 14 inches in diameter at the bottom and 6 inches at the top is 30 feet long and tapers uniformly. It is loaded upon a wagon with 4 feet of the butt end projecting in front of the front axle. Where should the rear axle be placed so as to carry the same weight as the front axle?

Ans. 11.6 ft. from the top end.

Problem 14. A cast iron flywheel 3 feet in diameter has a rim with cross section as shown in Fig. 144. What is the weight of the rim? *Ans.* 280 lbs.

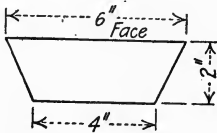

FIG. 144

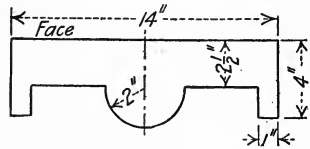

FIG. 145

Problem 15. A flywheel 12 feet in diameter has a rim with cross section as shown in Fig. 145. What is the volume of the rim? *Ans.* 19,600 cu. in.

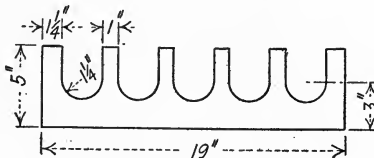

FIG. 146

Problem 16. An idler pulley for a rope drive is 2 feet in diameter and has a rim with cross section as shown in Fig. 146. The diameter is measured to the face of the groove. What is the volume of the rim? *Ans.* 4400 cu. in.

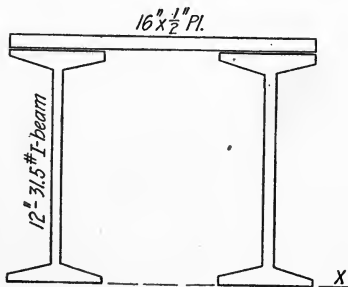

FIG. 147

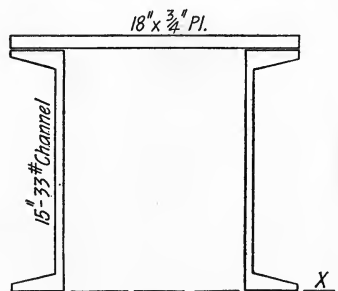

FIG. 148

Problem 17. Locate the centroid of the cross sectional area of the girder shown in Fig. 147. The area of one I-beam is 9.26 sq. in.

Ans. $\bar{y} = 7.89$ in.

Problem 18. The cross section of the end chord of a bridge is shown in Fig. 148. Determine the position of the centroidal axis parallel to the plate. The area of one channel is 9.9 sq. in. *Ans.* $\bar{y} = 10.7$ in.

Problem 19. Solve Problem 18, using a 12-in. by 1-in. plate and two 10-in. 20-lb. channels. The area of one channel is 5.88 sq. in. *Ans.* $\bar{y} = 7.78$ in.

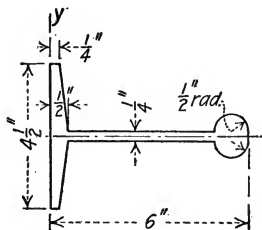

FIG. 149

Problem 20. Locate the centroid of the section of a bulb beam shown in Fig. 149. *Ans.* $\bar{x} = 2.35$ in.

CHAPTER V.

FRICTION.

55. Static and Kinetic Friction. If a block rests upon a horizontal supporting surface, the weight of the block and the resistance of the surface are the two forces acting upon the block. If these distributed forces are considered to be acting at their centroids, they may be represented by W and N , Fig. 150. If a small horizontal force P is applied to the block and it is still at rest, the force to balance P is the resistance of the supporting plane parallel to P , tangential to the surface, as shown in Fig. 151. This resistance is called *friction* and is denoted by F .

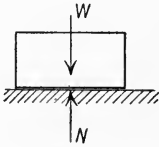

FIG. 150

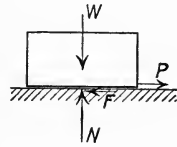

FIG. 151

If the force P is increased gradually, it will reach a certain value which the friction F can no longer balance and the block will move. While the block is at rest the friction is called *static friction*. The highest value of the static friction, that when motion is just impending, is called the *limiting friction* and will be denoted by F' . After motion begins the friction decreases and is called *kinetic friction*, or friction of motion. Friction is always a resisting force and opposes the motion or the tendency to move.

Adhesion must not be confused with friction. Adhesion is the attraction between two surfaces in contact. It depends upon the area in contact and is independent of the pressure. Friction is independent of the area and varies as the pressure. For nearly all problems in engineering, adhesion may be neglected.

If the two surfaces in contact are hard and well polished, the frictional resistance becomes very small but never reaches zero. For a perfectly smooth surface, then, the resistance would always

be normal to the surface. In many problems the friction is very small compared with the other forces acting and so may be neglected in the solution without appreciable error.

56. Coefficient of Friction. The ratio of the limiting friction F' to the normal pressure N is called the *coefficient of static friction*, and is denoted by f . In symbols,

$$f = \frac{F'}{N}.$$

The frictional force F and the normal reaction N acting on the block in Fig. 152(a) may be combined into their resultant R . It is evident that the resultant R must always lean from the normal in the direction to oppose motion or the tendency to move.

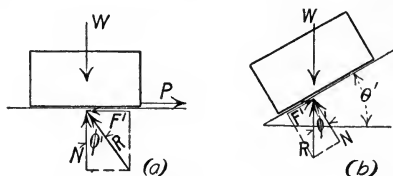

FIG. 152

If ϕ is the angle between the resultant reaction and the normal, it is plain from Fig. 152(a) that $\frac{F'}{N} = \tan \phi$. The maximum value of ϕ corresponding to F' is denoted by ϕ' and is called the *angle of friction*. It is evident that $f = \tan \phi'$.

If the surface upon which the block rests is inclined at an angle θ with the horizontal and no force but the pull of gravity and the reaction of the surface acts upon the block, the angle at which slipping is impending is θ' , the *angle of repose*. In Fig. 152(b), R is equal and opposite to W and acts at the angle ϕ' with the normal, since slipping impends. From the geometry of the figure, angle $\theta' = \text{angle } \phi'$.

If the value of the angle ϕ' for two given surfaces is known and slipping is impending, the resultant reaction becomes known in direction.

The *coefficient of kinetic friction* is the ratio of the kinetic friction F to the normal pressure N and is also denoted by f .

$$f = \frac{F}{N}.$$

EXAMPLE.

A block weighing 500 lbs. rests upon two wedges which in turn rest upon a horizontal plane surface. If the angle of the wedges is 10° and the coefficient of friction is 0.30, what are the forces P , P , required to force the wedges under the block?

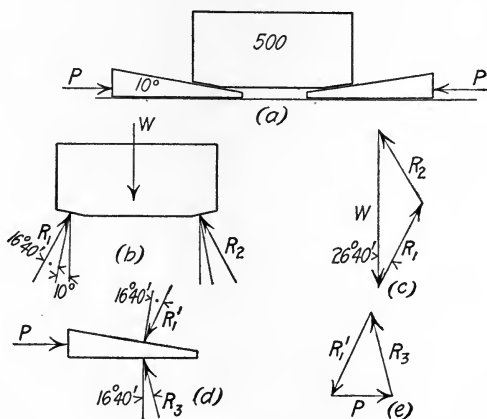

FIG. 153

Graphic Solution:—The angle $\phi' = \tan^{-1} 0.30 = 16^\circ 40'$. Fig. 153(b) shows the block as a free body. Since slipping is impending, the reactions R_1 and R_2 are acting at the angle $\phi' = 16^\circ 40'$ with the normal to the surface of contact, or at $26^\circ 40'$ with the vertical. The force triangle is shown in Fig. 153(c), from which R_1 and R_2 scale 280 lbs.

In Fig. 153(d) is shown the left wedge as a free body, with the known force R_1' equal and opposite to R_1 acting upon it. The unknown forces are P , horizontal, and R_3 acting to oppose motion at the angle $\phi' = 16^\circ 40'$ with the normal. The force triangle is shown in Fig. 153(e), from which P scales 200 lbs. and R_3 scales 260 lbs.

Algebraic Solution:—With the 500-lb. weight, Fig. 153(b), as the free body, equation $\Sigma F_x = 0$ gives

$$R_1 \sin 26^\circ 40' = R_2 \sin 26^\circ 40'.$$

$$R_1 = R_2.$$

Equation $\Sigma F_y = 0$ gives

$$2 R_1 \cos 26^\circ 40' = 500.$$

$$R_1 = 280 \text{ lbs.}$$

With the left wedge, Fig. 153(d), as the free body, $\Sigma F_y = 0$ gives

$$280 \cos 26^\circ 40' = R_3 \cos 16^\circ 40'.$$

$$R_3 = 261 \text{ lbs.}$$

Equation $\Sigma F_x = 0$ gives

$$P = 280 \sin 26^\circ 40' + 261 \sin 16^\circ 40'.$$

$$P = 126 + 75 = 201 \text{ lbs.}$$

Problem 1. In the example above, determine the horizontal force necessary to start the wedge out from under the block.

Ans. 104.1 lbs. in the reverse direction.

Problem 2. Solve Problem 1 if the coefficient of friction is reduced to 0.15 at all surfaces.

Ans. 30.9 lbs.

57. Laws of Friction. The laws of friction for dry surfaces were deduced chiefly from the experiments of Morin, Coulomb and Westinghouse. These may be stated as follows:

1. Friction varies directly as the normal pressure.
2. Limiting static friction is slightly greater than kinetic friction.
3. Ordinary changes of temperature affect friction only slightly.
4. At slow speeds, friction is independent of the speed. At high speeds, friction decreases as the speed increases, probably due to the fact that a film of air is drawn in and acts as a lubricant.
5. Kinetic friction decreases with the time.
6. Friction is increased by a reversal of motion.

The laws for lubricated surfaces are decidedly different from those for dry surfaces. For instance, friction is practically independent of the nature of the surfaces, due to the fact that the chief friction is between the different layers of the lubricant. Limiting static friction is much greater than kinetic friction, due to the fact that while at rest the film of lubricant is pressed out from between the surfaces. Ordinary changes of temperature make a decided difference in the character of many lubricants and therefore affect the amount of friction greatly. Heavy normal pressure tends to force out the lubricant and therefore increases the coefficient of friction. As the lubrication becomes poor, the laws approach those for dry surfaces.

58. Determination of the Coefficient of Friction. The coefficient of static friction for two surfaces may be determined experimentally by finding the pull P necessary to start a weight W on a horizontal plane, or by finding the angle of inclination of the plane at which motion is impending for the weight resting upon it, as explained in Art. 56.

The coefficient of kinetic friction may be determined by finding the pull P necessary to keep a weight W moving uniformly on a horizontal plane, or by finding the angle of inclination of the plane at which the motion of the weight upon it is uniform.

As would be expected, there are great variations in the values of the coefficients so obtained. The following table gives the range of values for the coefficient of static friction for a few materials.

The corresponding coefficients of kinetic friction are 20 per cent to 40 per cent less than the values for static friction.

SUBSTANCES	STATIC f
Wood on wood.....	0.30 to 0.70
Metal on metal.....	0.15 to 0.30
Wood on metal.....	0.20 to 0.60
Leather on wood.....	0.25 to 0.50
Leather on metal.....	0.30 to 0.60
Stone on stone.....	0.40 to 0.65

Problem 1. A wooden block weighing 4 lbs. rests upon a horizontal wooden table and is just started by a horizontal pull of 2.4 lbs. Determine f .

Ans. $f = 0.6$.

Problem 2. A block of cast iron starts to slide upon a steel plate when the plate is tilted at an angle of 15° with the horizontal. It still slides uniformly when the plate is lowered to an angle of 11° with the horizontal. What are the static and kinetic coefficients of friction?

Ans. Static $f = 0.268$. Kinetic $f = 0.194$.

59. Axle Friction and the Friction Circle. If a cylindrical axle of radius r rests in a bearing and is rotated, the axle will first roll from its position of rest until the resultant reaction of the bearing (resultant of N and F) acts at the angle of friction ϕ' with the radius at the point of contact, when slipping of the axle in the bearing takes place. The circle drawn concentric with the axle and tangent to the line of this reaction has a radius $r \sin \phi'$ and is called the *friction circle*.

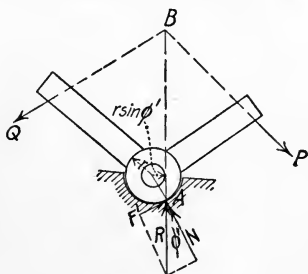

FIG. 154

The radius r and the angle ϕ' are usually known, so the friction circle may be used to locate the point of contact of the axle and the bearing. Its chief use is in the graphic solution. In Fig. 154, Q is the resistance and P is the working force. These intersect at B , so the resultant reaction of the bearing must also pass

through B . Since this resultant reaction must also be tangent to the friction circle, the point of contact of the axle and bearing is determined.

To determine the side of the friction circle at which the reaction is tangent, it is necessary to note the direction of pressure and the point of contact of the axle with the bearing. The reaction is tangent to the friction circle on that side toward which the axle rolls as it rotates.

Another rule is that friction, being a resistance, always shortens the lever arm of the working force and lengthens the lever arm of the resisting force.

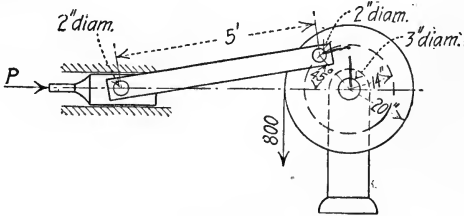

FIG. 155

Problem 1. Fig. 155 shows a simple steam hoist. Solve for the value of the force P necessary for uniform motion in the position shown, (1) if friction is neglected; (2) if friction is considered and $f = 0.15$ for all moving surfaces.

Ans. (1) $P = 1388$ lbs. (2) $P = 1500$ lbs.

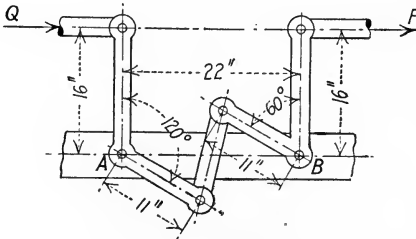

FIG. 156

Problem 2. Fig. 156 shows the standard compensator for interlocking signal systems in mean temperature position. Points A and B are fixed. All pins are 1 inch in diameter. Use $f = 0.10$ and determine the value of Q for $P = 50$ lbs.

Ans. $Q = 49$ lbs.

60. Least Pull and Cone of Friction.

If the force P , Fig. 157(a), acts horizontally on a body of weight W , and motion is impending, the force diagram is as shown in Fig. 157(b). If W and ϕ' are known, R and P can be determined, since for equilibrium the force polygon must close.

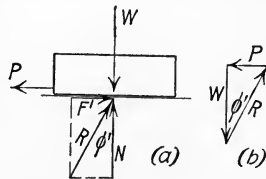

FIG. 157

If the force P is acting upward at the

angle θ with the horizontal, as in Fig. 158(a), N is decreased and therefore F' is decreased. Their ratio and the angle ϕ' remain constant. From the force diagram, Fig. 158(b), it is plain that with W constant and the direction of R constant, the minimum force P to close the force triangle must be acting at an angle of 90° with R . So with angle θ varying the least pull P to start

the block is given when $\theta = \phi'$.

This result may also be obtained by means of the calculus method.

If P is acting downward at the angle θ with the horizontal, N and F' are increased, as will be seen in Fig. 159(a) and (b). If the

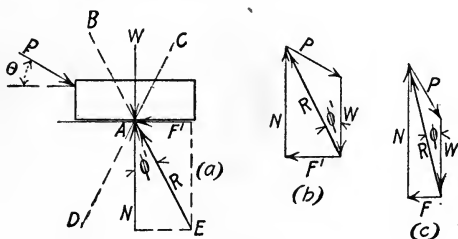

FIG. 159

body is free to move in any direction, the cone whose vertex is at A and whose axis is normal to the surface at A with angle of $2\phi'$ is called the cone of friction. If the resultant of P and W falls inside the cone of friction, it is evident that the reaction of the supporting plane falls within the angle DAE , that is, at an angle ϕ with the normal which is less than ϕ' , as shown in Fig. 159(c). The required frictional resistance F is less than the limiting value $F' = N \tan \phi'$, hence the plane will hold the body in equilibrium no matter how much P is increased.

Problem 1. A body weighing 100 lbs. rests upon a plane surface inclined at an angle of 10° with the horizontal as shown in Fig. 160. If $f = 0.25$, what is the friction under the body? What force P parallel to the plane will be necessary to start the body down the plane? What force P parallel to the plane will be necessary to start the body up the plane?

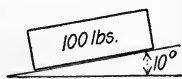

FIG. 160

Ans. $F = 17.4$ lbs. $P = 7.2$ lbs. down. $P = 42$ lbs. up.

Problem 2. What is the least pull P and its angle with the plane, to start the body of Problem 1 down the plane? Same for motion up the plane?
Ans. 7 lbs. at 14° with plane. 40.7 lbs. at 14° with plane.

Problem 3. In Problem 1, how many degrees each side of the vertical is the angle for which no motion is possible, no matter how large a downward force P is applied?
Ans. 4° above; 24° below.

61. Rolling Resistance. If the curved surface of a perfect cylinder touches a perfect plane, they are in contact only along a line. If a loaded wheel rests upon a rail or roadway, a deformation is caused so that there is an area of contact. If a horizontal pull P , Fig. 161, is applied to the axle to move the wheel forward uniformly, the resultant reaction R of the supporting surface acts at a point B in front of the vertical radius. Let the horizontal distance AB be called a . If motion is uniform and if the indentation is small, equation $\Sigma M_B = 0$ gives, approximately,

$$Pr = Wa.$$

$$P = \frac{Wa}{r}.$$

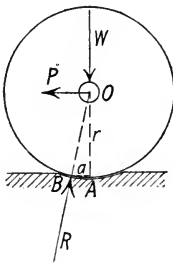

FIG. 161

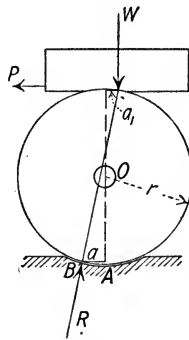

FIG. 162

If the load W is applied at the circumference of the wheel or roller, as in Fig. 162, and a force P is applied to move both load and roller forward uniformly, a similar relation is obtained. Let a be the distance from the point of application of the resultant to the vertical radius at the bottom of the roller and a_1 that at the top. Then the equation $\Sigma M_B = 0$ gives

$$2Pr = W(a_1 + a).$$

If $a_1 = a$,
$$P = \frac{Wa}{r} \text{ as before.}$$

If the weight W is carried by two or more rollers, $R_1 + R_2 +$, etc. = W (Approx.). Equation $\Sigma F_x = 0$ gives

$$P = (R_1 + R_2 +, \text{etc.}) \sin \phi,$$

if ϕ is the angle between R and the vertical. Then

$$P = W \sin \phi.$$

$$P = W \frac{a_1 + a}{2r}.$$

If $a_1 = a,$

$$P = \frac{Wa}{r}.$$

Experiments appear to show that the distance a is practically constant for the same materials, both for varying loads and varying radii, within reasonable limits. It is called the *coefficient of rolling friction*, or, preferably, the *coefficient of rolling resistance*. The experiments of Coulomb, Weisbach and Pambour give the following values for a in inches.

WHEEL	TRACK	a (in inches)
Elm.....	Oak	0.0327
Lignum-Vitæ	Oak	0.0195
Cast iron.....	Cast iron	0.0183
Cast iron or steel.....	Steel	0.007 to 0.020

Problem 1. If rolling resistance is 1 lb. per ton for a freight car, what is the value of the coefficient a for 33-inch wheels? *Ans.* $a = 0.00825$ in.

Problem 2. A cast iron engine frame weighing 1200 lbs. rests upon steel rollers one inch in diameter which in turn rest upon a pine floor. If the coefficient of rolling resistance for cast iron upon steel rollers is 0.01 inch, and that for steel rollers upon pine is 0.03 inch, what horizontal force P is necessary to move the frame forward uniformly? *Ans.* $P = 48$ lbs.

62. Friction of Brake on Wheel; Graphic Solution. In Fig. 163(a), the wheel of a car is considered as a free body, with the external forces acting upon it as shown. In this case the weight of the wheel is small compared with that of its load, so the force causing the negative acceleration of the wheel itself is not taken into account. The wheel is considered to be under static conditions. The normal reaction of the rail is N , equal to the weight of the wheel and its load; N_1 is the normal brake shoe pressure. Consider the wheel to be rolling, but let the brake shoe pressure be

large enough so that slipping of the wheel is impending. F' is the limiting static friction between the rail and the wheel, so R acts at the angle ϕ' with the normal. As discussed in Art. 56, ϕ' is the angle whose tangent is $\frac{F'}{N} = f$. (The coefficient of rolling resistance is comparatively small, and may be neglected.)

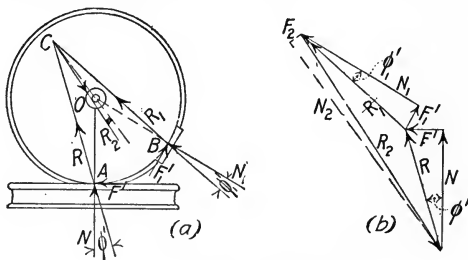

FIG. 163

At B , kinetic friction is acting, so $F_1' = f_1 N_1$, and R_1 acts at the angle ϕ_1' with the normal. These two forces meet at C , hence the reaction of the bearing on the axle must also pass through C . If the axle friction is neglected, reaction R_2 passes through the center of the axle at O . If axle friction is considered, the reaction passes tangent to the friction circle at O . The graphic solution for all of the unknown forces is shown in Fig. 163(b). N , ϕ' and ϕ_1' are supposed to be known.

The further discussion of the friction of brakes on car wheels and of friction dynamometers will be given in Chapter XI, Work and Energy.

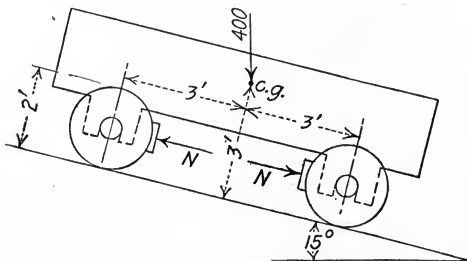

FIG. 164

Problem 1. Fig. 164 shows a car on an inclined track, the weight of 400 lbs. being carried by the two wheels on one side. Consider kinetic $f = 0.3$ (brake on wheel) and static $f = 0.4$ (wheel on rail). Neglect rolling resistance

and axle friction and determine the two equal and opposite normal brake shoe pressures, N , N , to allow uniform motion of the car down the plane.

Ans. 173 lbs.

63. Friction on Pivots. *Flat-end Pivot.* A flat-end pivot and its bearing are originally perfect planes, but they cannot remain so after wear begins. The unit pressure at first is constant over the whole surface but since the distance traveled over by any elementary area per revolution varies with its radial distance, the wear is greater at the outside. This reduces the pressure at the outside and increases it toward the middle. It is evident that after the pivot has run until conditions are uniform, the wear parallel to the axis on the pivot and bearing must be the same at all points. The wear on any unit area varies both with the distance traveled (or its radial distance) and with the normal pressure. Therefore, in order that the wear be uniform over the whole area, it is necessary that the product of the normal pressure on any unit area and the radial distance of the area shall be constant. If p is the variable unit pressure and ρ the distance of the unit area from the center, $p\rho$ must be constant, or

$$p\rho = K.$$

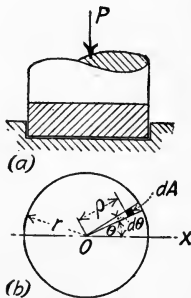

FIG. 165

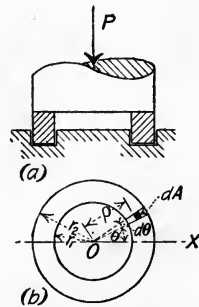

FIG. 166

Fig. 165 represents a solid flat-end pivot and Fig. 166 a hollow flat-end pivot. In either case, $dA = \rho d\rho d\theta$. The normal pressure on dA is $p\rho d\rho d\theta = K d\rho d\theta$. The frictional force on dA is $fK d\rho d\theta$, f being the coefficient of kinetic friction. The moment of this frictional force on dA about the center is $dM = fK\rho d\rho d\theta$. For the solid pivot of radius r , the total moment about the center is

$$M = fK \int_0^{2\pi} \int_0^r \rho d\rho d\theta = fKr^2\pi.$$

As given above, the normal pressure on dA is $K d\rho d\theta$. The total normal pressure is

$$P = K \int_0^r \int_0^{2\pi} d\rho d\theta = K 2\pi r.$$

From this,
$$K = \frac{P}{2\pi r}.$$

By substitution of this value in the expression for the moment above,

$$M = fP \frac{r}{2}.$$

This is seen to be a moment equivalent to the total frictional force fP acting at the mean radius $\frac{r}{2}$.

For the hollow pivot with inner radius r_1 and outer radius r_2 , the total moment of the frictional force about the center is

$$M = fK \int_{r_1}^{r_2} \int_0^{2\pi} \rho d\rho d\theta = fK\pi(r_2^2 - r_1^2).$$

The normal pressure on dA is $K d\rho d\theta$. The total normal pressure is

$$P = K \int_{r_1}^{r_2} \int_0^{2\pi} d\rho d\theta = K 2\pi(r_2 - r_1).$$

From this,
$$K = \frac{P}{2\pi(r_2 - r_1)}.$$

By substitution of this value in the expression for the moment,

$$M = fP \left(\frac{r_2 + r_1}{2} \right).$$

As before, this is seen to be a moment equivalent to the total frictional force fP acting at the mean radius $\left(\frac{r_2 + r_1}{2} \right)$.

The collar bearing, shown in Fig. 167, is the same as the hollow pivot. It has the advantage that it can be placed at any point along the shaft and also that several can be used on one shaft in order to obtain any desired amount of bearing area.

Conical Pivot. Fig. 168 represents a conical pivot under axial load P . Let dP be the load on area $dA = \rho d\rho d\theta$, and let dN

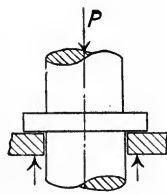

FIG. 167

be the normal pressure of the bearing on the slant area corresponding. Then since $\Sigma F_y = 0$,

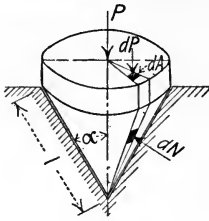

FIG. 168

$$dN \sin \alpha = dP,$$

or

$$dN = \frac{dP}{\sin \alpha}.$$

The friction caused by the normal pressure dN is $f dN = \frac{f dP}{\sin \alpha}$, and its moment about the

center is $dM = \frac{f \rho dP}{\sin \alpha}$. If p is the variable

unit pressure on the cross-sectional area, since the same conditions hold true as in the flat-end pivot,

$$dP = p \rho d\rho d\theta = K d\rho d\theta.$$

The total moment of the frictional forces about the center is

$$M = \int \frac{f \rho dP}{\sin \alpha} = \frac{fK}{\sin \alpha} \int_0^r \int_0^{2\pi} \rho d\rho d\theta = \frac{fK}{\sin \alpha} \pi r^2.$$

As in the flat-end pivot, $K = \frac{P}{2\pi r}$, so

$$M = \frac{fPr}{2 \sin \alpha}.$$

Since $\frac{r}{\sin \alpha} = l$, the length of an element of the cone of contact, the expression for the moment becomes

$$M = fP \frac{l}{2}.$$

It will be seen that the moment of the frictional force on a conical pivot is the same as that on a flat-end pivot whose radius is equal to the length of the element of the cone of contact.

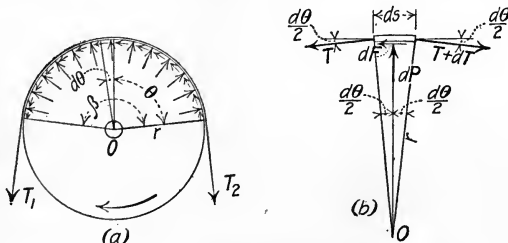

FIG. 169

64. Friction of Belts. If the belt shown in Fig. 169(a) is turning the pulley against some resistance, the tension T_2 on the

driving side is greater than the tension T_1 on the slack side. Consider a piece of the belt of ds length as a free body, Fig. 169(b). Let dP be the normal pressure of the pulley on the belt on ds length. Since the free body is in equilibrium under the action of the forces shown, equation $\Sigma M_0 = 0$ gives

$$\begin{aligned} r dF - r dT &= 0. \\ dF &= dT. \end{aligned}$$

By summing forces in the radial direction,

$$dP = T \sin \frac{d\theta}{2} + (T + dT) \sin \frac{d\theta}{2} = 2T \sin \frac{d\theta}{2} + dT \sin \frac{d\theta}{2}.$$

The term $dT \sin \frac{d\theta}{2}$ may be neglected since it is a differential of a higher order and $\sin \frac{d\theta}{2}$ may be replaced by $\frac{d\theta}{2}$.

Then
$$dP = T d\theta.$$

When slipping impends,

$$dF = f dP.$$

Therefore

$$dT = f dP = fT d\theta,$$

or

$$\int_{T_1}^{T_2} \frac{dT}{T} = f \int_0^\beta d\theta.$$

By integration,

$$\log_e \frac{T_2}{T_1} = f\beta.$$

In terms of common logarithms, this becomes

$$\log_{10} \frac{T_2}{T_1} = 0.4343 f\beta.$$

In the exponential form it becomes

$$\frac{T_2}{T_1} = e^{f\beta}.$$

The angle β is in radians. If the belt is slipping, the same relations hold true, f being the coefficient of kinetic friction. *These relations are not true if slipping is neither occurring nor impending.*

Problem 1. A belt runs between two pulleys of equal diameter for which $f = 0.5$. If the tension on the slack side of the belt is 100 lbs., what tension can be put upon the taut side before slipping is impending? *Ans.* 481 lbs.

Problem 2. A windlass has $2\frac{1}{2}$ turns of rope on the drum. $f = 0.4$ between the rope and the drum. If the load being pulled is 10,000 lbs., what tension must be exerted at the other end to prevent slipping? *Ans.* 13.7 lbs.

Problem 3. The tension in the free rope of a block and tackle is 300 lbs. It is held by being passed around a post for which $f = 0.3$. How many turns are required to hold it if the tension at the slack end is 5 lbs.?

Ans. 2.17 turns.

65. Summary of Principles of Friction. In the solution of problems involving friction, several principles are to be noted particularly.

(1) If friction is neglected, reactions are always normal to the surfaces.

(2) If the free body is in motion or tends to move, the friction of adjoining surfaces upon the free body opposes its motion.

(3) If the free body is at rest and the adjoining surfaces move or tend to move over it, the friction upon the free body is in the direction of the moving surface.

(4) The coefficient of static friction is used to determine the friction only when the body is at rest, *with slipping impending*. When slipping is not impending, static conditions determine the friction.

GENERAL PROBLEMS.

Problem 1. If the static coefficient of friction for cast iron wheels on steel rails is 0.20, what is the limiting slope down which cars can be run with uniform velocity? *Ans.* $11^\circ 20'$.

Problem 2. If the kinetic coefficient of friction for cast iron wheels on steel rails is 0.15 and the brakes are tightened so that the wheels skid, what is the unbalanced force down the limiting slope of Problem 1 for a car weighing 100,000 lbs.? *Ans.* 4940 lbs.

Problem 3. Fig. 170 shows a wedge of 20° angle which is forced under a weight of 200 lbs. held against a stop block *A*. If ϕ' for all surfaces is 15° , determine the force *P* necessary to start the wedge under the block.

Ans. 239 lbs.

Problem 4. Determine the value of the force P of Fig. 170 necessary for uniform motion of the wedge to the left. *Ans.* -35 lbs.

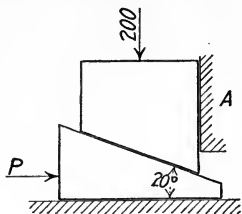

FIG. 170

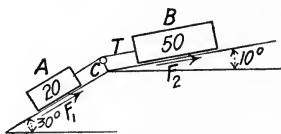

FIG. 171

Problem 5. In Fig. 171, A is a 20-lb. body on a 30° plane and B is a 50-lb. body on a 10° plane. The two are connected by a cord over a pulley at C . Will the system move if $f = \frac{1}{3}$ for both bodies? Determine F_1 , F_2 and T .

Ans. $F_1 = 5.77$ lbs. $F_2 = 12.92$ lbs. $T = 4.23$ lbs.

Problem 6. If $f = 0.3$ for the block shown in Fig. 172 and $\theta = 20^\circ$, what is the pressure P necessary to cause motion? *Ans.* 50 lbs.

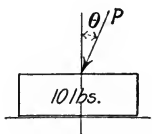

FIG. 172

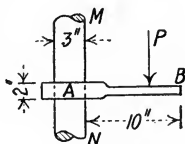

FIG. 173

Problem 7. If $f = 0.2$ for the hanger AB which slides up and down on the post MN , as shown in Fig. 173, determine how close to the post the load P can be placed without causing the hanger to slide down. *Ans.* 3.5 inches.

Problem 8. Use the smallest coefficient of friction for wood on wood as given in the table and determine the flattest slope a chute for unloading boxes may have for uniform motion. *Ans.* $16^\circ 40'$.

Problem 9. Determine the constant horizontal force necessary to move a block of ice weighing 100 lbs. uniformly up a wooden chute at an angle of 15° with the horizontal. Use $f = 0.05$. *Ans.* 32.2 lbs.

Problem 10. A plank 12 ft. long rests in a horizontal position upon two inclined planes, one at 60° , the other at 45° with the horizontal. If $\phi' = 20^\circ$ for each surface, determine the limits of the position where a load can be hung without causing motion. Neglect the weight of the plank.

Ans. 3.3 ft. from 60° plane. 1 ft. from 45° plane.

Problem 11. If the coefficient of rolling resistance $a = 0.01$ inch for the wheels of a freight car on steel rails, and $f = 0.03$ for axle friction, determine the horizontal pull necessary to keep a car weighing 100,000 lbs. in uniform motion on a level track. The wheels are 33 inches in diameter and the axles are 4 inches in diameter. Determine also the steepest grade on which the car would not start. *Ans.* 424 lbs. 0.424 per cent.

Problem 12. A white oak beam weighing 200 lbs. carries a load of 2400 lbs. and rests on elm rollers 6 inches in diameter. The rollers rest in turn on a horizontal oak track. What horizontal pull P is necessary to move the beam and its load?
Ans. 28.4 lbs.

Problem 13. A rectangular block of wood 1 ft. by 1 ft. by 2 ft., weighing 80 lbs., stands on end on a smooth floor. The coefficient of friction $f = 0.20$. If the block is acted upon by a horizontal force applied at the top of the block till motion ensues, will the block slide or tip? What is the amount of the force?
Ans. 16 lbs.

Problem 14. If the same block as in Problem 13 is placed on end on a plank which is gradually raised at one end, what is the least coefficient of friction which will make the block tip before sliding?
Ans. $f = 0.5$.

Problem 15. Find the least pull necessary to drag a stone weighing 250 lbs. along a horizontal floor for which $f = 0.6$.
Ans. 129 lbs.

Problem 16. A weight of 10,000 lbs. is being lowered into the hold of a vessel. The sustaining rope passes around a spar for which $f = 0.2$. How many turns around the spar must the rope have for uniform motion if the resistance at the other end of the rope is not to exceed 120 lbs.?
Ans. 3.52 turns.

Problem 17. A rope has $1\frac{1}{2}$ turns around the drum of a windlass. If $f = 0.4$ and the pull necessary to keep the rope from slipping is 40 lbs., what pull is being exerted at the other end of the rope?
Ans. 1730 lbs.

CHAPTER VI.

MOMENT OF INERTIA.

66. Definition of Moment of Inertia of an Area. Integral quantities in the form $\int x^2 dA$ occur in the study of mechanics of materials. In the expression $\int x^2 dA$, dA denotes any differential area, each part of which is the same distance x from the axis of reference, called the *inertia axis*. The sum of these differential areas equals the total area A . The quantity $\int x^2 dA$, integrated between the proper limits, is called the *Moment of Inertia** of the area A .

Defined in words, the *Moment of Inertia* of a plane area with respect to any axis is the sum of the products of each elementary area and the square of its distance from the inertia axis. Moment of inertia is denoted by I . If it is necessary to specify the axis of reference (inertia axis), a subscript letter is used, as I_X , I_G , etc.

The only axes used are those in the plane of the area and those

* The terms, *second moment of area*, *second moment of mass*, etc., would be preferable, but the term *moment of inertia* has been in use too long to be changed. In the case of areas the term is entirely misleading, for since an area has no inertia it can have no true *moment* of inertia.

The term was first used by Euler for second moments of mass, on account of the analogy between rotary and translatory motion.

$$\frac{\text{Force}}{\text{Mass (or Inertia)}} = \text{acceleration (translatory).}$$

$$\frac{\text{Moment of Force}}{\int r^2 dM \text{ (or Moment of Inertia)}} = \text{acceleration (rotary).}$$

According to modern definition, however, inertia is not synonymous with mass, but is only a property of matter, its amount being proportional to the mass. For lack of a better name the same term was applied to the expression

$\int x^2 dA$ for areas.

normal to it. The moment of inertia of an area with respect to an axis normal to its plane is called the *Polar Moment of Inertia*.

The expression $x^2 dA$ is the product of an area and a distance squared, hence the moment of inertia of an area is expressed in a dimension of length raised to the fourth power. In numerical computations the inch is commonly used as the unit length, and moment of inertia is, in units of "biquadratic inches," written in⁴.

67. Radius of Gyration. It is sometimes convenient to express a moment of inertia of an area in terms of the area and the square of a distance. Thus,

$$I = \int x^2 dA = k^2 A.$$

The quantity " k " is called the *radius of gyration*, and is the distance from the axis at which all the area could be considered as located and the moment of inertia remain the same. Stated in another way, k^2 is the mean value of x^2 for equal differential areas. As commonly determined,

$$k = \sqrt{\frac{I}{A}}.$$

EXAMPLE 1.

Derive the expressions for the moment of inertia and radius of gyration of a rectangle which has base b and altitude h , with respect to a centroidal axis parallel to the base.

Solution:—

$$I_X = \int y^2 dA.$$

$$dA = b dy. \text{ See Fig. 174.}$$

The limits of y are $-\frac{h}{2}$ and $+\frac{h}{2}$. So

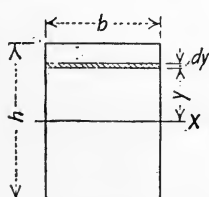

FIG. 174

$$I_X = \int_{-\frac{h}{2}}^{+\frac{h}{2}} by^2 dy.$$

$$I_X = \left[\frac{by^3}{3} \right]_{-\frac{h}{2}}^{+\frac{h}{2}} = \frac{1}{12}bh^3.$$

$$k = \sqrt{\frac{I}{A}} = \frac{h}{\sqrt{12}}.$$

EXAMPLE 2.

Derive the expressions for the moment of inertia and radius of gyration of a triangle which has base b and altitude h , with respect to its base.

Solution: —

$$I_X = \int y^2 dA.$$

$$dA = u dy. \text{ See Fig. 175.}$$

By similar triangles,

$$\frac{u}{b} = \frac{h-y}{h},$$

or

$$u = b - \frac{b}{h}y.$$

The limits of y are 0 and h . So

$$I_X = \int_0^h by^2 dy - \int_0^h \frac{b}{h} y^3 dy.$$

$$I_X = \frac{bh^3}{3} - \frac{bh^3}{4} = \frac{1}{12}bh^3.$$

$$k = \sqrt{\frac{I}{A}} = \frac{h}{\sqrt{6}}.$$

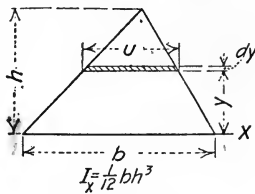

FIG. 175

EXAMPLE 3.

Derive the expressions for the moment of inertia and radius of gyration of a circle of radius r with respect to a diameter.

Solution: —

$$I_X = \int y^2 dA.$$

$$dA = \rho d\rho d\theta. \text{ See Fig. 176.}$$

$$y = \rho \sin \theta.$$

$$\begin{aligned} I_X &= \int_0^r \int_0^{2\pi} \rho^3 d\rho \sin^2 \theta d\theta, \\ &= \int_0^r \rho^3 d\rho \left[\frac{\theta}{2} - \frac{\sin 2\theta}{4} \right]_0^{2\pi} \\ &= \pi \int_0^r \rho^3 d\rho \\ &= \frac{1}{4} \pi r^4 \text{ or } \frac{1}{32} \pi d^4. \end{aligned}$$

$$k = \sqrt{\frac{I}{A}} = \frac{r}{2}.$$

EXAMPLE 4.

Derive the expressions for the polar moment of inertia and radius of gyration of a circle of radius r with respect to an axis through its center.

Solution: —

$$I_0 = \int \rho^2 dA.$$

$$dA = \rho d\rho d\theta. \text{ See Fig. 176.}$$

$$\begin{aligned} I_0 &= \int_0^r \int_0^{2\pi} \rho^3 d\rho d\theta \\ &= \frac{1}{2} \pi r^4 \text{ or } \frac{1}{32} \pi d^4. \end{aligned}$$

$$k = \sqrt{\frac{I}{A}} = \frac{r}{\sqrt{2}}.$$

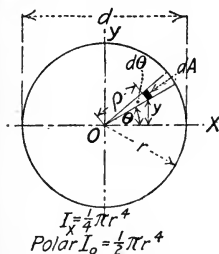

FIG. 176

Problem 1. Derive the expressions for the moment of inertia and radius of gyration of a rectangle with respect to its base.

$$\text{Ans. } I = \frac{1}{3} bh^3. \quad k = \frac{h}{\sqrt{3}}.$$

Problem 2. Derive the expressions for the moment of inertia and radius of gyration of a triangle with respect to its centroidal axis parallel to its base.

$$\text{Ans. } I = \frac{1}{36} bh^3. \quad k = \frac{h}{3\sqrt{2}}.$$

Problem 3. Derive the expressions for the moment of inertia and radius of gyration of a triangle with respect to an axis through the vertex parallel to the base.

$$\text{Ans. } I = \frac{1}{4} bh^3.$$

Problem 4. Derive the expressions for the polar moment of inertia and radius of gyration of a square with respect to an axis through its center.

$$\text{Ans. } I = \frac{1}{6} b^4.$$

Problem 5. Derive the expressions for the moment of inertia and radius of gyration of a sector of a circle with respect to its bounding radius.

$$\text{Ans. } I = \frac{r^4\theta}{8} - \frac{r^4 \sin 2\theta}{16}.$$

68. Sign of Moment of Inertia. Since the squares of both positive and negative quantities are positive and since areas are always positive, it follows that moments of inertia are always positive. In Fig. 177(a), I_X of the area M for which all of the values of y are positive is the same as I_X of the symmetrical area N for which all of the values of y are negative. Thus the moment of inertia of each half of a circular area is the same with respect to any diameter.

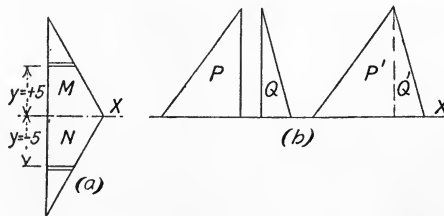

FIG. 177

The value of y does not depend upon the position of the area along the X axis. For example, I_X may be computed separately for the two triangles P and Q , Fig. 177(b), or the triangles may be considered to be shifted until they touch and form the one triangle $P'Q'$ for which I_X may be computed with one operation.

69. Relation Between Moments of Inertia with Respect to Two Parallel Axes in the Plane of the Area. If the moment of

inertia of an area with respect to an axis other than a centroidal axis is required, it may be obtained without integration if the moment of inertia with respect to the parallel centroidal axis is known. In Fig. 178 let X_0 be a centroidal axis and X_1 any other axis parallel to it, in the plane of the area, at a distance d from the centroidal axis.

$$I_{X_1} = \int y_1^2 dA.$$

$$y_1^2 = (y + d)^2 = y^2 + 2yd + d^2.$$

$$I_{X_1} = \int y^2 dA + 2d \int y dA + d^2 \int dA.$$

$$I_{X_1} = I_{X_0} + Ad^2.$$

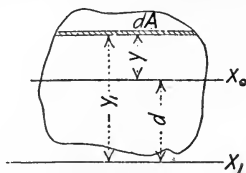

FIG. 178

$2d \int y dA = 0$ because $\int y dA = \bar{y}A$, and for the centroidal axis $\bar{y} = 0$.

Stated in words the equation above is as follows. *The moment of inertia of an area with respect to any axis in its plane is equal to its moment of inertia with respect to a parallel centroidal axis plus the product of the area and the square of the distance between the axes.*

This equation is commonly known as the *Transfer Formula*.

If both sides of the equation $I_{X_1} = I_{X_0} + Ad^2$ are divided by A , it becomes

$$\frac{I_{X_1}}{A} = \frac{I_{X_0}}{A} + d^2.$$

Hence

$$k_{X^2} = k_{X_0^2} + d^2,$$

or

$$k^2 = \bar{k}^2 + d^2.$$

Problem 1. Given I_{X_0} for a rectangle $= \frac{1}{12} bh^3$, derive the expression for I with respect to the base. *Ans.* $I = \frac{1}{3} bh^3$.

Problem 2. Determine the moment of inertia of a rectangle 20 in. by 1 in. with respect to an axis in its plane parallel to the 20-inch side and 10 inches from the centroidal axis. *Ans.* $I = 2001.67 \text{ in}^4$.

Problem 3. Given $I = \frac{1}{4} bh^3$ for a triangle with respect to an axis through the vertex parallel to the base, derive the expression for I (1) with respect to the base; (2) with respect to a centroidal axis parallel to the base.

$$\text{Ans. (1) } I = \frac{1}{12} bh^3. \quad (2) \ I = \frac{1}{36} bh^3.$$

Problem 4. Given I of a semicircle with respect to its bounding diameter, derive the expression for I_{X_0} with respect to a parallel centroidal axis.

$$\text{Ans. } I_{X_0} = \left(\frac{\pi}{8} - \frac{8}{9\pi} \right) r^4 = 0.11 r^4.$$

Problem 5. Derive the expression for I of a circle with respect to a tangent.

$$\text{Ans. } I = \frac{5}{4} \pi r^4.$$

70. Relation Between Moments of Inertia with Respect to Three Rectangular Axes. Let Fig. 179 represent any plane area and let Z be the polar axis through O .

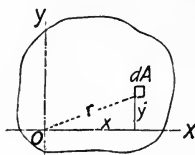

FIG. 179

Then

$$I_Z = \int r^2 dA.$$

$$r^2 = x^2 + y^2.$$

So

$$I_Z = \int (x^2 + y^2) dA$$

$$= \int x^2 dA + \int y^2 dA.$$

$$I_Z = I_Y + I_X.$$

The polar moment of inertia of an area with respect to any axis equals the sum of its moments of inertia with respect to any two rectangular axes in the area intersecting the polar axis.

Problem 1. Show that for a circle which has its center at the origin, $I_X = \frac{1}{2} I_Z$.

Problem 2. Derive the expression for the polar moment of inertia of a square with respect to an axis through one corner.

Problem 3. Prove that the moment of inertia of a square with respect to any centroidal axis in its plane is a constant.

Problem 4. Derive the expression for the moment of inertia of a circle with respect to a polar axis intersecting its circumference.

71. Relation Between Polar Moments of Inertia with Respect to Parallel Axes. The relation between the polar moment of inertia of an area with respect to a centroidal axis and that with respect to any parallel axis is similar to that between moments of inertia with respect to parallel axes in the plane of the area.

Let X_0 and Y_0 , Fig. 180, be the centroidal axes and X and Y any other parallel axes, all of them being in the plane of the area. By Art. 69,

$$I_X = I_{X_0} + Ad_1^2,$$

and

$$I_Y = I_{Y_0} + Ad_2^2.$$

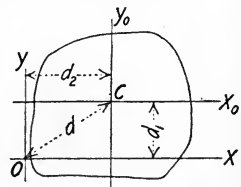

FIG. 180

Let Z be the axis through O perpendicular to X and Y and let Z_0 be the axis through C perpendicular to X_0 and Y_0 . By Art. 70,

$$I_Z = I_X + I_Y = I_{X_0} + I_{Y_0} + A(d_1^2 + d_2^2).$$

Since

$$I_{X_0} + I_{Y_0} = I_{Z_0}, \quad \text{and} \quad d_1^2 + d_2^2 = d^2,$$

$$I_Z = I_{Z_0} + Ad^2.$$

The polar moment of inertia of an area with respect to any axis is equal to its polar moment of inertia with respect to the centroidal axis plus the product of the area and the square of the distance between the two axes.

Problem 1. Solve Problem 4 of Art. 70 by the method of this Article.

Problem 2. Derive the expression for the polar moment of inertia of a square with respect to an axis bisecting a side. *Ans.* $I = \frac{1}{2} b^4$.

72. Moment of Inertia of Composite Areas. The moment of inertia of a composite area with respect to any axis equals the sum of the moments of inertia of the separate parts with respect to the same axis. For example, the moment of inertia of the trapezoid $ABCD$, Fig. 181, with respect to the base AD is the sum of the

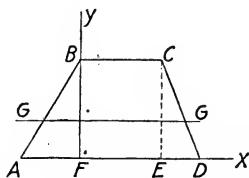

FIG. 181

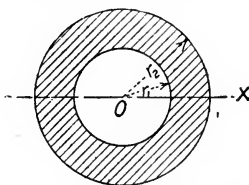

FIG. 182

moments of inertia of the rectangle $FBCE$ and the two triangles ABF and ECD with respect to AD . The moment of inertia of the annulus, Fig. 182, with respect to a diameter is equal to the moment of inertia of the larger circle minus the moment of inertia of the smaller circle with respect to the same axis.

$$I_X = \frac{1}{4} \pi r_2^4 - \frac{1}{4} \pi r_1^4.$$

Problem 1. In Fig. 181, let $BC = 4$ in., $BF = 5$ in., $AF = 3$ in. and $ED = 2$ in. Determine the moment of inertia of the trapezoid with respect to the base AD and transfer to its parallel centroidal axis GG .

Ans. $I_G = 64.25 \text{ in.}^4$. ($\bar{y} = 2.18 \text{ in.}$)

Problem 2. Solve for I_G of the trapezoid of Problem 1 by getting first the moment of inertia of each of the component parts with respect to its own centroidal axis parallel to the axis GG and then transferring to axis GG .

Problem 3. In Fig. 181 consider a semicircle of 2 inches radius with center at F cut out of the original trapezoid. Determine I_X and I_Y of the remaining area.

Ans. $I_X = 212.47 \text{ in.}^4$. $I_Y = 221.64 \text{ in.}^4$.

Problem 4. A wooden box girder is made of four 2 in. by 10 in. planks as shown in Fig. 183. Compute the moment of inertia of the cross section with respect to axis 1-1.

Ans. $I_{1-1} = 1786.67 \text{ in.}^4$.

Problem 5. Compute the moment of inertia of the cross section of half-pipe shown in Fig. 184, with respect to its centroidal axis GG parallel to the bounding diameter.

Ans. $I = 7210 \text{ in.}^4$. ($\bar{y} = 14.67 \text{ in.}$)

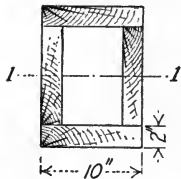

FIG. 183

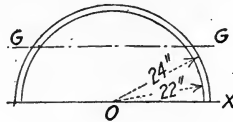

FIG. 184

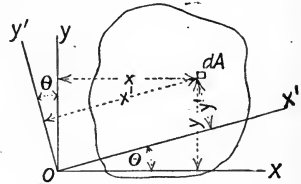

FIG. 185

73. Moment of Inertia with Respect to Inclined Axes. In Fig. 185, let X and Y be any two rectangular axes for which $I_X = \int y^2 dA$ and $I_Y = \int x^2 dA$. X' and Y' are axes at the angle θ with the original pair. Then

$$I_{X'} = \int (y')^2 dA \quad \text{and} \quad I_{Y'} = \int (x')^2 dA.$$

Also $y' = y \cos \theta - x \sin \theta$ and $x' = x \cos \theta + y \sin \theta$, from the geometry of the figure. By squaring these values and substituting above,

$$I_{X'} = \int y^2 \cos^2 \theta dA - 2 \int xy \cos \theta \sin \theta dA + \int x^2 \sin^2 \theta dA.$$

By integration,

$$I_{X'} = \cos^2 \theta \cdot I_X + \sin^2 \theta \cdot I_Y - 2 \cos \theta \sin \theta \int xy dA.$$

$$\cos^2 \theta = \frac{1 + \cos 2\theta}{2}, \quad \sin^2 \theta = \frac{1 - \cos 2\theta}{2}$$

and

$$2 \cos \theta \sin \theta = \sin 2\theta.$$

By substitution of these values the equation above becomes

$$I_{X'} = \frac{I_X + I_Y}{2} + \frac{I_X - I_Y}{2} \cos 2\theta - \sin 2\theta \int xy dA. \quad (1)$$

Similarly,

$$I_{Y'} = \frac{I_X + I_Y}{2} - \frac{I_X - I_Y}{2} \cos 2\theta + \sin 2\theta \int xy \, dA. \quad (2)$$

By adding these expressions for $I_{X'}$ and $I_{Y'}$ it is found that

$$I_{X'} + I_{Y'} = I_X + I_Y,$$

as shown in Art. 70.

Equations (1) and (2) simplify what would otherwise be a very tedious operation. If the moments of inertia of an area with respect to any two rectangular axes in the plane of the area are known, the moment of inertia with respect to any coplanar inclined axis passing through their point of intersection may be easily computed.

EXAMPLE.

Determine the moment of inertia of a rectangle 6 inches wide and 2 inches high with respect to an axis through the lower left-hand corner at an angle of 15° with the base, as in Fig. 186.

Solution:— $I_x = 16$. $I_y = 144$.

$$\int xy \, dA = \int_0^6 \int_0^2 x \, dx \, y \, dy = 36.$$

$$I_{X'} = 80 - 64 \cos 30^\circ - 36 \sin 30^\circ.$$

$$I_{X'} = 6.58 \text{ in.}^4.$$

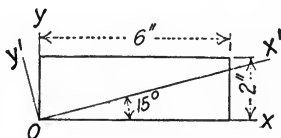

FIG. 186

Problem 1. Solve for $I_{Y'}$ of the rectangle of Fig. 186. *Ans.* 153.4 in.⁴.

Problem 2. Determine $I_{X'}$ of a 3-inch square with respect to a diagonal. *Ans.* 6.75 in.⁴.

Problem 3. Solve for $I_{X'}$ of the rectangle of Fig. 186 if $\theta = -15^\circ$. *Ans.* 42.6 in.⁴.

Problem 4. A rectangle 2 inches wide and 4 inches high is placed with the origin of coördinates 2 inches below the lower left-hand corner. Determine $I_{X'}$ for the axis through this origin at an angle of 15° with the horizontal.

Ans. 114.1 in.⁴.

74. Product of Inertia. By analogy with moment of inertia, the expression $\int xy \, dA$ is called the *Product of Inertia* of the area and is denoted by H . The form of the expression shows that product of inertia is always taken with respect to a pair of rectangular axes.

If either one of the axes is an axis of symmetry for the area, the product of inertia with respect to that pair of axes is zero.

Proof: — Let Fig. 187 be any area symmetrical with respect to the Y axis.

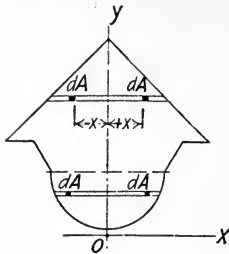

FIG. 187

$$H = \int xy \, dA.$$

In the summation of the products $xy \, dA$ it will be seen that for each term $(+x)y \, dA$ there is a numerically equal term $(-x)y \, dA$ to neutralize it. Hence for a figure symmetrical with respect to the Y axis,

$$H = \int xy \, dA = 0.$$

Similarly, $H = 0$ for a figure symmetrical with respect to the X axis.

75. Relation Between Products of Inertia with Respect to Parallel Axes. After the product of inertia is determined with respect to a pair of rectangular centroidal axes, it may be calculated easily with respect to any other pair of parallel axes.

In Fig. 188, OX and OY are any two rectangular centroidal axes, $O'X'$ and $O'Y'$ are any other pair of parallel axes in the same plane, (x, y) are the coördinates of dA with respect to the original axes and $(m + x, n + y)$ the coördinates of dA with respect to the new axes.

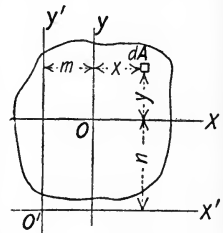

FIG. 188

$$H_0' = \int (m + x)(n + y) \, dA.$$

$$H_0' = \int mn \, dA + \int my \, dA + \int nx \, dA + \int xy \, dA.$$

$$H_0' = mnA + 0 + 0 + H_0.$$

H_0 is the product of inertia of the area with respect to the original axes.

This expression is similar to the transfer formula for moment of inertia, d^2 being replaced by mn .

The quantities m and n may be either positive or negative, so the term mnA may be either positive or negative. If the centroid of the area is in the first or third quadrant of the axes with respect to which H is taken, mnA is positive; if in the second or fourth quadrant it is negative.

As in the case of moment of inertia, the product of inertia of an area composed of several simple parts with respect to any pair of axes is equal to the algebraic sum of the products of inertia of the several parts with respect to the same axes. For example, if H_{XY} of the angle section of Fig. 189 is required, the area may be divided into the two rectangles M and N . Then H_{XY} of the angle section = H_{XY} of M + H_{XY} of N .

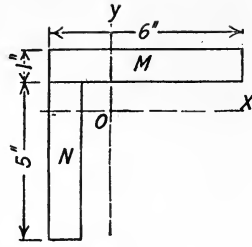

FIG. 189

EXAMPLE.

Determine the value of H_0' for the right triangle shown in Fig. 190.

$$\begin{aligned}
 H_0 &= \int xy \, dA \\
 &= \int_{-1}^{+2} \int_{-1}^{\frac{x}{2}+1} x \, dx \, y \, dy \\
 &= 4.5 \text{ in.}^4. \\
 H_0' &= H_0 + mnA \\
 &= +4.5 + 36 \\
 &= +40.5 \text{ in.}^4.
 \end{aligned}$$

In this case H_0' can be determined more easily by integrating directly than by the transfer method used above.

$$\begin{aligned}
 H_0' &= \int_0^6 \int_0^{\frac{x}{2}} x \, dx \, y \, dy \\
 &= +40.5 \text{ in.}^4.
 \end{aligned}$$

If $H_0 = 0$, as it does if either X or Y is an axis of symmetry, the transfer method is much simpler, for then

$$H_0' = mnA$$

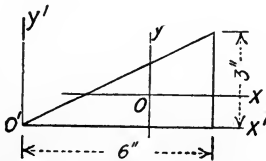

FIG. 190

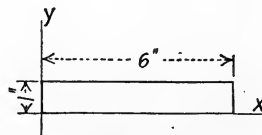

FIG. 191

Problem 1. Determine the product of inertia of the 6 in. by 1 in. rectangle shown in Fig. 191 with respect to the X and Y axes. Ans. +9 in.⁴.

Problem 2. Locate the centroidal axes parallel to the legs of the $6'' \times 6'' \times 1''$ angle section, Fig. 189, and calculate the product of inertia of the section with respect to these axes. *Ans.* $+20.44 \text{ in.}^4$.

Problem 3. Determine the product of inertia of a $4'' \times 3'' \times \frac{1}{2}''$ angle section with respect to the centroidal axes parallel to the legs.

Ans. $\pm 2.019 \text{ in.}^4$.

76. Maximum and Minimum Moments of Inertia. The moment of inertia of an area with respect to an axis at an angle θ with some original axis is given by Equation (1), Art. 73.

$$I_{X'} = \frac{I_X + I_Y}{2} + \frac{I_X - I_Y}{2} \cos 2\theta - H \sin 2\theta.$$

As θ varies the value of $I_{X'}$ varies. The values of θ for maximum and minimum values of $I_{X'}$ are determined by differentiating the expression for $I_{X'}$ and placing the first derivative equal to zero.

$$\frac{dI_{X'}}{d\theta} = (I_Y - I_X) \sin 2\theta - 2H \cos 2\theta.$$

For the maximum or minimum value of $I_{X'}$, $\frac{dI_{X'}}{d\theta} = 0$. Then

$$\tan 2\theta = \frac{2H}{I_Y - I_X}.$$

Two values of 2θ differing by 180° are obtained from the equation above, and therefore two values of θ differing by 90° . One value gives the angle for maximum $I_{X'}$, the other the value for minimum $I_{X'}$. The maximum and minimum moments of inertia are called the *principal moments of inertia*, and the corresponding axes the *principal axes*.

If either the X or Y axis is an axis of symmetry, $H = 0$, by Art. 74, therefore $\tan 2\theta = 0$. $2\theta = 0^\circ$ or 180° and $\theta = 0^\circ$ or 90° , so the X and Y axes are the principal axes.

Problem 1. Determine the maximum and minimum moments of inertia of the rectangle shown in Fig. 191 with respect to axes through the lower left-hand corner. *Ans.* Max. $I = 73.14 \text{ in.}^4$. Min. $I = 0.86 \text{ in.}^4$.

Problem 2. Determine the maximum and minimum moments of inertia of a $4'' \times 3'' \times \frac{1}{2}''$ angle section with respect to centroidal axes.

Ans. Max. $I = 6.14 \text{ in.}^4$. Min. $I = 1.33 \text{ in.}^4$.

Problem 3. Determine the maximum and minimum moments of inertia of a $6'' \times 6'' \times \frac{1}{2}''$ angle section with respect to centroidal axes.

Ans. Max. $I = 31.75 \text{ in.}^4$. Min. $I = 8.07 \text{ in.}^4$.

77. Moment of Inertia of Mass. The moment of inertia of a body with respect to any axis is the sum of the products of each elementary mass and the square of its distance from the axis.

The same notation is used for moment of inertia of masses as was used for moment of inertia of areas, with the addition of M for mass, V for volume and γ for mass per unit volume.

$$M = \gamma V \text{ and } dM = \gamma dV.$$

$$I = \int x^2 dM = \gamma \int x^2 dV.$$

Units of Moment of Inertia of Masses. The moment of inertia of a body is in terms of a length squared and a mass. Since the unit of mass commonly used in engineering is one containing g units of weight and g is usually given in units of feet per second per second, all dimensions should be in feet. No name has been given to the unit moment of inertia of mass.

EXAMPLE 1.

Show that for a right prism of altitude h , with respect to an axis perpendicular to the base,

$$I = \gamma h \times \text{Polar } I \text{ of Base.}$$

Solution:— In Fig. 192, let the Y axis be the inertia axis of the prism. The mass of the elementary prism whose altitude is h and base dA is $dM = \gamma h dA$.

$$I_Y = \int \rho^2 dM = \gamma h \int \rho^2 dA.$$

$$I_Y = \gamma h \times \text{Polar } I \text{ of Base.}$$

Right Circular Cylinder. Since the polar moment of inertia of a circle with respect to its center is $\frac{1}{2} \pi r^4$, the moment of inertia of a cylinder of radius r and altitude h with respect to its geometric axis is given by

$$I = \gamma h \times \frac{1}{2} \pi r^4 = \frac{1}{2} Mr^2.$$

$$k = \sqrt{\frac{I}{M}} = \frac{r}{\sqrt{2}}.$$

EXAMPLE 2.

Show that for a homogeneous sphere of radius r , with respect to a diameter,

$$I = \frac{2}{5} Mr^2 \text{ and } k = r \sqrt{\frac{2}{5}}.$$

Solution:— In Fig. 193 let the Y axis be the inertia axis. Let the sphere

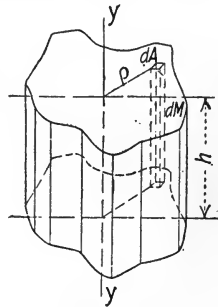

FIG. 192

be divided into thin plates by planes perpendicular to the Y axis, each of thickness dy and of radius r_1 . One plate is shown at A .

$$r_1^2 = r^2 - y^2,$$

and

$$dM = \gamma \pi r_1^2 dy = \gamma \pi (r^2 - y^2) dy.$$

By Example 1 the moment of inertia of this thin plate with respect to the Y axis is

$$I_Y = \frac{1}{2} dM r_1^2 = \frac{1}{2} \gamma \pi (r^2 - y^2)^2 dy.$$

If these differential moments of inertia are summed between the limits $-r$ and $+r$, the entire moment of inertia of the sphere is obtained.

$$I = \frac{1}{2} \gamma \pi \int_{-r}^{+r} (r^2 - y^2)^2 dy.$$

$$I = \frac{2}{5} Mr^2, \quad \text{since} \quad M = \gamma V = \gamma \frac{4}{3} \pi r^3.$$

$$k = \sqrt{\frac{I}{M}} = r \sqrt{\frac{2}{5}}.$$

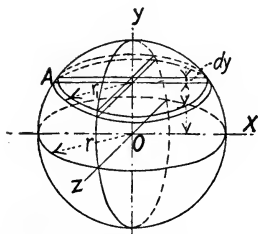

FIG. 193

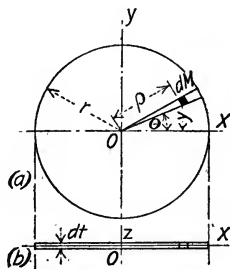

FIG. 194

EXAMPLE 3.

Derive the expression for the moment of inertia of a circular plate of radius r and thickness dt with respect to a centroidal diameter.

Solution: — Fig. 194(a) is a top view and Fig. 194(b) is an edge view of the plate. Let each dM be a prism of volume $\rho d\rho d\theta dt$ whose distance from the X axis is y .

$$dM = \gamma dV = \gamma \rho d\rho d\theta dt; \quad y = \rho \sin \theta.$$

$$I_X = \int y^2 dM = \int \rho^2 \sin^2 \theta \gamma \rho d\rho d\theta dt,$$

$$I_X = \gamma dt \int_0^{2\pi} \int_0^r \sin^2 \theta d\theta \rho^3 d\rho$$

$$= \frac{1}{4} \gamma \pi r^4 dt$$

$$= \frac{1}{4} Mr^2.$$

EXAMPLE 4.

Derive the expression for the moment of inertia of a slender rod with respect to an axis through one end.

Solution:— Let L be the length of the rod, Fig. 195, W its weight, M its mass, w its weight per linear unit and θ its angle with the Y axis.

$$I_Y = \int r^2 dM.$$

$$r^2 = l^2 \sin^2 \theta. \quad dM = \gamma dW = \gamma w dl.$$

Then
$$I_Y = \int l^2 \sin^2 \theta \gamma w dl = \gamma w \sin^2 \theta \int_0^L l^2 dl.$$

By integration,
$$I = \gamma w \sin^2 \theta \frac{L^3}{3} = \frac{1}{3} ML^2 \sin^2 \theta.$$

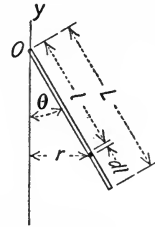

FIG. 195

If the axis is normal to the rod, $\theta = 90^\circ$ and $I = \frac{1}{3} ML^2$.

Problem 1. Derive the expressions for the moment of inertia and radius of gyration of a homogeneous parallelepiped whose sides are a , b and c , with respect to a geometric axis parallel to side c .

Ans. $I = \frac{M}{12} (a^2 + b^2).$

Problem 2. Derive the expressions for the moment of inertia and radius of gyration of a homogeneous right circular cone with respect to its geometric axis. The radius of the base is r and the altitude is h .

Ans. $I = \frac{3}{10} Mr^2.$

Problem 3. Determine the moment of inertia of a cast iron cylinder 2 feet in diameter and 6 inches high with respect to its geometric axis.

Ans. $I = 10.97.$

Problem 4. Determine the moment of inertia of a cast iron governor ball 4 inches in diameter with respect to its diameter.

Ans. $I = 0.00301.$

78. Relation Between Moments of Inertia of Mass with Respect to Parallel Axes.

The moment of inertia of a body with respect to any axis is equal to the moment of inertia with respect to a parallel centroidal axis plus the product of the mass of the body and the square of the distance between the axes.

In symbols,

$$I = I_G + Md^2.$$

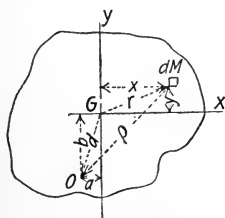

FIG. 196

Proof:— Fig. 196 represents a section of the body perpendicular to the inertia axis which passes through G . Let O be the point where any parallel axis cuts the section. Then with respect to the axis through O ,

$$I = \int \rho^2 dM.$$

From the figure,

$$\rho^2 = (x + a)^2 + (y + b)^2 = x^2 + y^2 + a^2 + b^2 + 2ax + 2by.$$

Then

$$\begin{aligned} I &= \int (x^2 + y^2) dM + \int (a^2 + b^2) dM + \int 2ax dM + \int 2by dM \\ &= I_G + Md^2 + 0 + 0. \quad (\text{See Arts. 69 and 70.}) \end{aligned}$$

By dividing by M ,

$$\frac{I}{M} = \frac{I_G}{M} + d^2,$$

or

$$k^2 = k_G^2 + d^2.$$

EXAMPLE.

Show that for a right circular cylinder with radius r and altitude h , the moment of inertia with respect to a centroidal axis parallel to the base is

$$I = M \left(\frac{r^2}{4} + \frac{h^2}{12} \right).$$

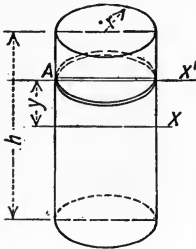

FIG. 197

Solution. — Consider the cylinder to be divided into circular plates, each of thickness dy , one of which is shown at A in Fig. 197. The moment of inertia of plate A with respect to its own central axis $X'-X'$ is $\frac{1}{4} dMr^2$, as shown in Art. 77, and with respect to axis X is $\frac{1}{4} dMr^2 + dMy^2$. $dM = \gamma\pi r^2 dy$, so the moment of inertia of all the plates, or the entire cylinder, with respect to axis X is

$$I_X = \frac{1}{4} \gamma\pi r^4 \int_{-\frac{h}{2}}^{+\frac{h}{2}} dy + \gamma\pi r^2 \int_{-\frac{h}{2}}^{+\frac{h}{2}} y^2 dy.$$

By integration,
$$I_X = M \left(\frac{r^2}{4} + \frac{h^2}{12} \right).$$

Problem 1. Derive the expression for the moment of inertia of a right circular cone of height h and radius of base r with respect to an axis through the vertex parallel to the base.

$$\text{Ans. } I = \frac{3}{5} M \left(\frac{r^2}{4} + h^2 \right).$$

Problem 2. A rectangular parallelepiped has sides a , b and c . Derive the expression for its moment of inertia with respect to the central axis in the ac face, parallel to c .

$$\text{Ans. } I = M \left(\frac{a^2}{12} + \frac{b^2}{3} \right).$$

Problem 3. Derive the expression for the moment of inertia of a sphere with respect to a tangent.

$$\text{Ans. } I = \frac{7}{5} Mr^2.$$

Problem 4. Derive the expressions for the moment of inertia and radius of gyration of a right circular cylinder with respect to a diameter of the base.

$$\text{Ans. } I = M \left(\frac{r^2}{4} + \frac{h^2}{3} \right).$$

Note: — If r^2 is negligible compared with h^2 , the expression for I becomes $\frac{1}{3} Mh^2$, as in Example 4, Art. 77.

Problem 5. Determine the moment of inertia of a steel cylinder 2 inches in diameter and 4 feet long with respect to a diameter of one end.

$$\text{Ans. } I = 7.08.$$

Problem 6. Determine the moment of inertia of a 3-inch cast iron governor ball with respect to an axis 8 inches from its center.

$$\text{Ans. } I = 0.0515.$$

79. Determination of Moment of Inertia by Experiment. If the form of a body is such that its moment of inertia cannot be computed readily by integration, it may be determined experimentally with a fair degree of accuracy. There are several methods but the one most readily applicable to problems occurring in engineering is the *pendulum method*. As will be shown in Art. 108, the radius of gyration of a compound pendulum is given by

$$k = \frac{T}{2\pi} \sqrt{gd},$$

in which T is the time of one complete oscillation, g is the acceleration of gravity and d is the distance from the axis of rotation to the parallel centroidal axis. The axis of rotation must be parallel to the axis for which the moment of inertia is required. If the body is vibrated and time T of one oscillation determined, k may be computed. Then $I_0 = Mk^2$, in which I_0 is the moment of inertia with respect to the axis of rotation. The moment of inertia with respect to the parallel centroidal axis is given by

$$I_G = I_0 - Md^2.$$

From this, if desired, the moment of inertia with respect to any parallel axis may be computed.

Problem 1. A pair of 33-inch cast iron freight car wheels and their connecting axle weighed 700 lbs. When suspended from knife edges 4 feet from the axis of the wheels they vibrated 100 times (complete oscillations) in 3 minutes and 43.7 seconds. Determine I and k with respect to their centroidal axis.

$$\text{Ans. } I = 6.99. \quad k = 0.568 \text{ ft.}$$

Problem 2. The connecting rod of a Corliss engine weighed 267 lbs. Its center of gravity was 48.5 inches from the crosshead pin. When suspended from the crosshead end it vibrated 40 times (complete oscillations) in 96 seconds. Determine I with respect to the axis of the crosshead pin.

$$\text{Ans. } I = 157.4.$$

GENERAL PROBLEMS.

Structural Steel Shapes and Built-up Sections.

Problem 1. Locate the position of the gravity axes parallel to the legs of a $6'' \times 3\frac{1}{2}'' \times \frac{3}{8}''$ angle section and compute the moment of inertia with respect to each axis.

$$\text{Ans. } I_{1-1} = 3.342 \text{ in.}^4, \quad I_{2-2} = 12.864 \text{ in.}^4.$$

Note: — Fillets and rounded corners are neglected.

Problem 2. The dimensions of a standard 12-in. 31.5-lb. I-beam are given in Fig. 198. Compute the moment of inertia and radius of gyration with respect to the centroidal axes 1-1 and 2-2.

$$\text{Ans. } I_{1-1} = 216.15 \text{ in.}^4, \quad I_{2-2} = 9.51 \text{ in.}^4.$$

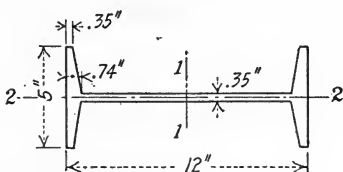

FIG. 198

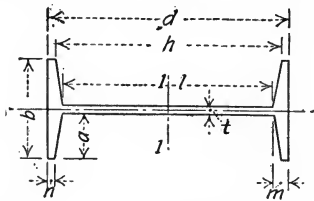

FIG. 199

Problem 3. Structural steel Handbooks give the following formula for the moment of inertia of an I-beam with respect to axis 1-1, Fig. 199.

$$I_{1-1} = \frac{1}{12} \left[bd^3 - \frac{a}{4(m-n)} (h^4 - l^4) \right].$$

Derive this formula.

Problem 4. Compute the moment of inertia of the symmetrical Z-bar shown in Fig. 200 with respect to axes 1-1 and 2-2.

$$\text{Ans. } I_{1-1} = 42.12 \text{ in.}^4, \quad I_{2-2} = 15.44 \text{ in.}^4.$$

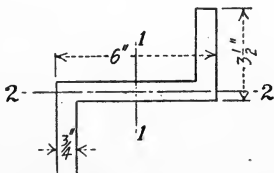

FIG. 200

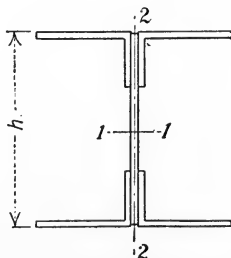

FIG. 201

Problem 5. The built-up I-section shown in Fig. 201 consists of four $6'' \times 3\frac{1}{2}'' \times \frac{3}{8}''$ flange angles and one 12 in. by $\frac{3}{8}$ in. web plate. Height $h' = 12\frac{1}{2}$ in. Compute the moment of inertia with respect to axes 1-1 and 2-2.

$$\text{Ans. } I_{1-1} = 456.7 \text{ in.}^4, \quad I_{2-2} = 119.3 \text{ in.}^4.$$

Problem 6. If a 14 in. by $\frac{1}{2}$ in. flange plate is added to each flange of the I-section of Problem 5, what is the moment of inertia of the section with respect to axis 1-1?
Ans. $I_{1-1} = 1026.0 \text{ in.}^4$.

Problem 7. In Problem 5, what difference is made if an 18 in. by $\frac{3}{8}$ in web plate is substituted for the 12 in. by $\frac{3}{8}$ in. plate? Height $h' = 18\frac{1}{2}$ in.

Ans. I_{1-1} is $2\frac{1}{2}$ times as much. I_{2-2} is changed only in the second decimal place.

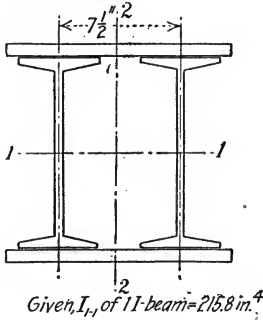

FIG. 202

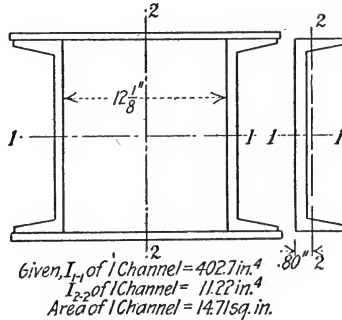

FIG. 203

Problem 8. Two standard 12-in. 31.5-lb. I-beams are used with two 14 in. by $\frac{3}{4}$ in. plates to form a box-girder, Fig. 202. Compute the moment of inertia of the section with respect to axis 1-1.
Ans. $I_{1-1} = 1286.6 \text{ in.}^4$.

Problem 9. A column is formed by two 15-in. 50-lb. channels and two 20 in. by $\frac{1}{2}$ in. plates, as shown in Fig. 203. Compute the moment of inertia of the section with respect to each axis.

Ans. $I_{1-1} = 2007.1 \text{ in.}^4$. $I_{2-2} = 2074.6 \text{ in.}^4$.

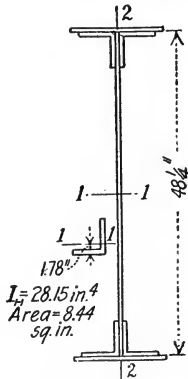

FIG. 204

Problem 10. The plate girder shown in Fig. 204 has a web plate 48 in. by $\frac{3}{8}$ in., flange angles $6'' \times 6'' \times \frac{3}{4}''$ and flange plates 14 in. by 1 in. Compute I_{1-1} .

Ans. $I_{1-1} = 37,406.6 \text{ in.}^4$.

Moment of Inertia of Masses.

Problem 11. A steel disk 30 inches in diameter and 3 inches thick has a cylindrical hole 4 inches in diameter at the center and another 2 inches in diameter 12 inches from the center. What is the moment of inertia with respect to the geometric axis?
Ans. 14.5016.

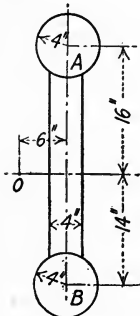

FIG. 205

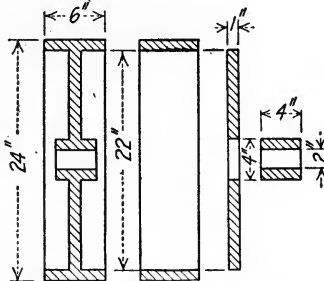

FIG. 206

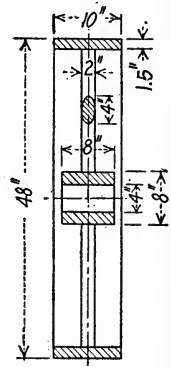

FIG. 207

Problem 12. A flywheel governor consists of a cast iron plate 4 in. by 1 in. by 22 in., Fig. 205, which connects the cast iron cylinders A and B. The cylinder at A is 8 inches in diameter and 2 inches thick. The one at B is 8 inches in diameter and 4 inches thick. Compute the moment of inertia of the governor with respect to an axis through O parallel to the axes of the cylinders.
Ans. $I_0 = 4.797$.

Problem 13. A cast iron pulley with a solid web has dimensions as shown in Fig. 206. Compute its moment of inertia with respect to the axis of rotation.
Ans. $I = 4.531$.

Problem 14. Compute the moment of inertia of the cast iron flywheel shown in Fig. 207. The wheel has six elliptical spokes which may be considered as slender rods.
Ans. $I = 74.67$.

PART II. KINETICS.

CHAPTER VII.

RECTILINEAR MOTION.

80. Velocity and Speed. The velocity of a particle is its rate of motion with respect to an assumed point of reference. (Any body which is small compared to its range of motion is considered to be a particle.) The point of reference usually assumed is some point which is at rest with respect to the surface of the earth. Motion is said to be *rectilinear* if the path of the particle is a straight line, and *curvilinear* if the path is a curved line. Curvilinear motion will be discussed in Chapter VIII.

If a particle in rectilinear motion traverses equal spaces in equal time intervals, its velocity is *uniform* and is equal to the ratio of any given space s to the time t in which it was traversed, or

$$v = \frac{s}{t}.$$

If a particle moves over unequal spaces in equal time intervals, its velocity is *variable*. In this case the ratio of any given space s to the time t in which it was traversed gives only the *average* velocity. As the space s is shortened until it becomes ds , this average velocity approaches the value of the instantaneous velocity at the point where ds is taken. This instantaneous velocity is

$$v = \frac{ds}{dt}.$$

Velocity has direction as well as magnitude. It is therefore a *vector* quantity and is represented graphically by a vector. *Speed* is the *scalar* or *quantity* part of velocity and is merely the rate of travel, irrespective of direction.

The *units* of velocity and speed are any units of length and time, as *feet per second*, *miles per hour*, etc.

Problem 1. Reduce velocity of 60 miles per hour to terms of feet per second.

Ans. 88 ft. per sec.

Problem 2. A man runs 100 yards in 10 seconds. What is his average speed in miles per hour?

Ans. 20.45 mi. per hr.

Problem 3. If in a certain motion of a body, $s = 4t^3$, s being in feet and t in seconds, what is the velocity of the body at the end of 4 seconds?

Ans. $v_4 = 192$ ft. per sec.

81. Acceleration. *Acceleration* is the rate of change of velocity. If the velocity is constant, the acceleration is of course zero. If the velocity is changed by equal amounts in equal time intervals, the acceleration is constant; if by unequal amounts in equal time intervals, it is variable. When the velocity increases, the acceleration is usually called positive; when the velocity decreases the acceleration is usually called negative.

If the acceleration is constant, it is the total change in velocity during unit time and its amount is obtained by dividing the total change in velocity by the time t in which the change was made. If a represents the acceleration, v_0 the initial velocity and v the final velocity,

$$a = \frac{v - v_0}{t}.$$

If $v_0 = 0$,

$$a = \frac{v}{t}.$$

If the acceleration is variable, its value at any instant is given by the ratio of the infinitesimal change in velocity dv to the corresponding time dt , or

$$a = \frac{dv}{dt} = \frac{d^2s}{dt^2}.$$

By eliminating dt between the equations $v = \frac{ds}{dt}$ and $a = \frac{dv}{dt}$, there is obtained the important relation,

$$v \, dv = a \, ds.$$

The units used are those of velocity and time. If the velocity of a body changes from 0 to 20 ft. per second in 4 seconds, its acceleration is a velocity change of 5 ft. per second in a second, or as commonly written, 5 ft. per sec. per sec. If the velocity of a body decreases from 40 miles per hour to 20 miles per hour in 10 seconds, the acceleration is -2 miles per hour per second.

Acceleration, like velocity, is a vector quantity and is represented graphically by a vector.

Problem 1. A street car attains a velocity of 10 miles per hour in 4 seconds. What is its average acceleration in feet per second per second?

Ans. $3\frac{3}{4}$ ft. per sec. per sec.

Problem 2. If the piston of a steam engine attains a velocity of 3 feet per second in $\frac{1}{10}$ of a second, what is its average acceleration? What is the space traversed if the acceleration is constant?

Ans. $a = 120$ ft. per sec. per sec. $s = 0.45$ inch.

Problem 3. If in a certain motion of a body $s = 4t^2$, s being in feet and t in seconds, what is the acceleration of the body at the end of 4 seconds?

Ans. $a_4 = 96$ ft. per sec. per sec.

82. Constant Acceleration. The integration of the differential expression $a = \frac{dv}{dt}$ between the proper limits gives the velocity in terms of the time. A second integration gives the distance in terms of the time.

$$a = \frac{dv}{dt}, \quad \text{or} \quad dv = a dt.$$

Let v_0 be the initial velocity. Then, if a is constant,

$$\int_{v_0}^v dv = a \int_0^t dt;$$

$$v - v_0 = at;$$

or

$$v = v_0 + at. \quad (1)$$

Since

$$v = \frac{ds}{dt}, \quad ds = v_0 dt + at dt.$$

$$\int_0^s ds = v_0 \int_0^t dt + a \int_0^t t dt.$$

$$s = v_0 t + \frac{1}{2} at^2. \quad (2)$$

The expression $v dv = a ds$ may be integrated in a similar manner.

$$\int_{v_0}^v v dv = a \int_0^s ds;$$

$$\frac{v^2}{2} - \frac{v_0^2}{2} = as;$$

or

$$v^2 = v_0^2 + 2as. \quad (3)$$

If

$$v_0 = 0, \quad v^2 = 2as.$$

Equations (1), (2) and (3) may be derived by simple algebra, as follows. If a particle gains a velocity of a during each unit of

time, in t units of time it will have gained at units of velocity. Its final velocity, then, will be the sum of its initial velocity v_0 , and the velocity it has gained, at .

$$v = v_0 + at. \quad (1)$$

The average velocity during time t will be the mean of its initial velocity v_0 and its final velocity $v_0 + at$. The average velocity is $\frac{v + v_0}{2} = v_0 + \frac{1}{2}at$. The space passed over will be given by the product of the average velocity and the time, or

$$s = \frac{v + v_0}{2} t = v_0 t + \frac{1}{2} at^2. \quad (2)$$

If t is eliminated from equations (1) and (2), the resulting equation is

$$v^2 = v_0^2 + 2as. \quad (3)$$

Problem 1. A car traveling at the rate of 40 feet per second is brought to rest in a distance of 100 feet. What is the average acceleration?

Ans. $a = -8$ ft. per sec. per sec.

Problem 2. A ball has an initial velocity of 10 feet per second and an acceleration of 4 feet per second per second. What is the velocity at the end of 4 seconds? At the end of 5 seconds? What is the space passed over during the 5th second? *Ans.* $v_4 = 26$ ft. per sec. $v_5 = 30$ ft. per sec. $s = 28$ ft.

83. Falling Bodies, Air Neglected. For comparatively short falls of bodies near the surface of the earth, the attraction of the earth may be considered constant; consequently, if the resistance of the air is neglected, the acceleration caused by this attraction may also be considered constant. This acceleration, denoted by g , is approximately 32.2 ft. per sec. per sec., and if no other value is given, this should be used in the solution of all problems. (The accurate value is given by

$$g = 32.0894 (1 + 0.0052375 \sin^2 l) (1 - 0.0000000957 h),$$

in which l is the latitude in degrees and h is the elevation above sea level, in feet.)

The equations of motion derived in the preceding article become, for falling bodies,

$$v = v_0 + gt. \quad (1)$$

$$h = v_0 t + \frac{1}{2} gt^2. \quad (2)$$

$$v^2 = v_0^2 + 2gh. \quad (3)$$

Space, velocity and acceleration are all positive downward. If the body falls from rest, $v_0 = 0$, hence $v = \sqrt{2gh}$. If the body is projected vertically upward, v_0 is negative. The body rises $t = \frac{v_0}{g}$ seconds through a distance $h = -\frac{v_0^2}{2g}$ where it comes to rest. It then falls from rest and passes the initial point with a velocity of $+v_0$ and continues downward from that point exactly as though projected downward with the same velocity.

EXAMPLE.

A ball is shot upward with a velocity of 30 ft. per sec. One second later another is shot upward with a velocity of 100 ft. per sec. Where and when do they pass?

Solution: — Let s_1 be the distance from the starting point to the point where they pass, t_1 the time elapsing after the first is discharged, and t_2 the time elapsing after the second is discharged.

Then

$$t_2 = t_1 - 1.$$

The initial velocity v_0 is negative in each case. After t_1 seconds the first ball will be a distance from the starting point, $s = v_0 t + \frac{1}{2} g t^2$, or $s_1 = -30 t_1 + 16.1 t_1^2$.

At the same instant the second ball, which has been traveling only $t_1 - 1$ seconds, will be a distance from the starting point, $s = v_0 t + \frac{1}{2} g t^2$, or

$$s_2 = -100 (t_1 - 1) + 16.1 (t_1 - 1)^2.$$

When the two balls pass, $s_1 = s_2$, so

$$-30 t_1 + 16.1 t_1^2 = -100 (t_1 - 1) + 16.1 (t_1 - 1)^2.$$

$$t_1 = 1.137 \text{ sec.}$$

$$s_1 = s_2 = -13.3 \text{ ft.}$$

It will be noticed that the first ball has reached the top point in its path in $\frac{30}{32.2}$ or 0.932 sec., and is therefore moving downward when they pass.

Problem 1. If a body falls freely from rest, what is its velocity 5 seconds later? How far has it fallen? *Ans.* $v = 161$ ft. per sec. $s = 402.5$ ft.

Problem 2. A body falls from a table to the floor, a distance of 3 feet. What is the velocity with which it strikes the floor? What is the time required? *Ans.* $v = 13.9$ ft. per sec. $t = 0.431$ sec.

Problem 3. The striking velocity of a pile driver hammer is to be 50 feet per second. From what height must it be dropped? *Ans.* 38.8 ft.

Problem 4. From a mine cage which is descending with a velocity of 20 feet per second, a body rolls off and falls 200 feet to the bottom of the shaft. With what velocity does it strike and what is the time required?

$$\text{Ans. } v = 115.2 \text{ ft. per sec. } t = 2.96 \text{ sec.}$$

Problem 5. In Problem 4, substitute "ascending" for "descending" and solve. *Ans.* $v = 115.2$ ft. per sec. $t = 4.20$ sec.

84. Relation Between Force, Mass and Acceleration. Newton's Second Law of Motion, Art. 6, states that the accelerations of bodies are directly proportional to the resultant forces acting and inversely proportional to the masses acted upon. Let F be the resultant force which acts upon mass M to produce acceleration a . Then a varies as $\frac{F}{m}$, or F varies as Ma .

$$F = KMa,$$

K being a constant, the value of which depends upon the units used. In American engineering practice the unit of force used is the pound and the unit of acceleration is the foot per second per second. In order to make the constant $K = 1$ and thus simplify the expression, the unit of mass used is that amount in which unit force produces unit acceleration. If a resultant force of one pound acts upon a quantity of matter weighing one pound, the acceleration produced is 32.2 feet per second per second as in the case of a falling body. If the quantity of matter is increased and the force remains constant, the acceleration will decrease proportionately, so if the quantity of matter weighs 32.2 pounds, the force of one pound will produce an acceleration of one foot per second per second. It is seen, then, that 32.2 pounds of matter is the unit of mass in which unit force produces unit acceleration and if this unit is used, $K = 1$. In order to obtain the number of mass units in a given quantity of matter, its weight in pounds must be divided by 32.2. That is, $M = \frac{W}{g}$. Then

$$F = Ma = \frac{W}{g}a.$$

In the equation $F = Ma$, M is a scalar quantity and F and a are vector quantities. If F_1 and F_2 are any two components into which the force F may be resolved, and a_1 and a_2 are the corresponding components of the acceleration, parallel respectively to F_1 and F_2 , it follows that

$$F_1 = Ma_1 \quad \text{and} \quad F_2 = Ma_2.$$

If the components are the rectangular components F_x and F_y ,

$$F_x = Ma_x \quad \text{and} \quad F_y = Ma_y.$$

EXAMPLE.

A horizontal force of 10 pounds is exerted upon a body whose weight is 100 pounds and which is resting upon a smooth horizontal surface. What is the velocity of the body at the end of 5 seconds, and what is the distance passed over?

$$\text{Solution: —} \quad F = Ma = \frac{W}{g} a.$$

$$10 = \frac{100}{32.2} a.$$

$$a = 3.22 \text{ ft. per sec. per sec.}$$

The force is constant, so the body has uniformly accelerated motion. Since the body starts from rest, the equations of motion are

$$v = at \quad \text{and} \quad s = \frac{1}{2} at^2.$$

$$v = 3.22 \times 5 = 16.1 \text{ ft. per sec.}$$

$$s = \frac{1}{2} \times 3.22 \times 25 = 40.25 \text{ ft.}$$

Problem 1. A resultant force of 50 pounds acts for 4 seconds upon a body weighing 200 pounds. What is the acceleration of the body and the space passed over during that time?

$$\text{Ans. } a = 8.05 \text{ ft. per sec. per sec.} \quad s = 64.4 \text{ ft.}$$

Problem 2. An elevator which weighs 1000 pounds starts from rest and in 2 seconds has attained a velocity of 10 feet per second upward, with uniform acceleration. What is the tension T in the supporting cables?

$$\text{Ans. Total } T = 1155 \text{ lbs.}$$

Problem 3. If in Problem 2 the tension is reduced to 900 pounds, in what time will the elevator come to rest?

$$\text{Ans. } 3.1 \text{ sec.}$$

Problem 4. A body weighing 10 pounds is projected down a smooth 45° plane with an initial velocity of 3 feet per second. How far will it move during the third second? If at the end of the third second a constant resisting force of 15 pounds begins to act, how long will it move before coming to rest?

$$\text{Ans. } s_3 = 59.91 \text{ ft.} \quad 2.8 \text{ sec.}$$

85. Effective Forces; D'Alembert's Principle. In general, any particle of a body considered free has a system of forces acting upon it, some of which may be external to the body as a whole and some of which are internal. The resultant of all these forces for the particle is called the *effective force* for the particle, and is equal to $dM \cdot a$, dM being the mass of the particle and a its acceleration. If the particles of the body were all made free of each other and each had its effective force acting, the motion of the system of particles would be the same as the actual motion of the body. The resultant of all these effective forces for all the particles of the body is called the *resultant effective force* for the body.

Since the internal forces between the particles of a rigid body are always mutual, that is, equal and opposite, their total resultant for the whole body is zero. It follows then that the *resultant effective force* for all the particles of a rigid body must be equivalent to the resultant of the *external* forces. If F is the resultant of the external forces,

$$F = \int dMa.$$

If the motion is translation, a is the same in amount and direction for all of the particles, so, for translation, $F = a \sum dM = Ma$.

Since each particle has a force equivalent to $dM \cdot a$ acting upon it and since each force is proportional to the mass of the particle, the *point of application of the resultant is necessarily the same as that of a system of particles acted upon by their own weights*. As shown in Art. 43, *this is the mass center of the body*.

If the system of effective forces were reversed and added to the external system of forces, the result would be equilibrium without changing any of the external forces.

This principle is called D'Alembert's Principle and is applicable to both rigid and non-rigid bodies, but only in the case of rigid bodies is it sufficient to determine the motion.

By this method a problem in kinetics is reduced to a simpler one in statics, for then all the equations of static equilibrium will apply; $\Sigma F_x = 0$, $\Sigma F_y = 0$ and $\Sigma Mom. = 0$. The student should keep in mind that this is only an *imaginary* force system, added to the actual system for the purposes of solution.



FIG. 208

This method of procedure does not conflict with the method of Art. 84, as will now be shown. In Fig. 208(a), let F be the resultant force acting upon mass M . From Art. 84, the force F produces an acceleration a in the mass M of such an amount that

$$F = Ma = \frac{W}{g} a.$$

In Fig. 208(b), F is the resultant force acting upon mass M . The

resultant effective force $\frac{W}{g} a$ is reversed and added to the system to produce a condition of equilibrium. Since the system of forces acting upon the mass M is now in equilibrium, $\Sigma F_x = 0$, so

$$F - \frac{W}{g} a = 0, \quad \text{or} \quad F = \frac{W}{g} a,$$

as before. The reversed effective force is sometimes called the inertia force of the body, since it may be considered as a force resisting the change in velocity.

In a problem of this kind, no advantage is gained by the use of this method. If the solution of a problem requires the use of a moment equation, however, the addition of the reversed effective force simplifies the solution very much, as will be shown in the following Example.

EXAMPLE.

A safe with weight and dimensions as shown in Fig. 209(a) is pulled along a horizontal track by a force of 100 pounds. A force of 60 pounds is sufficient to move it uniformly. Determine the normal components of the reactions at A and B.

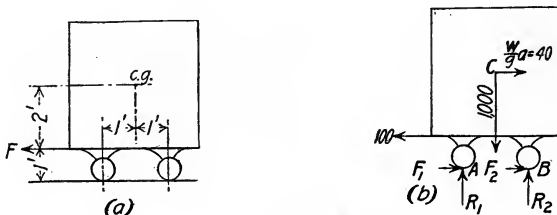

FIG. 209

Solution: — Fig. 209(b) shows the free body diagram, with all the external forces acting and in addition the *reversed effective force* $\frac{W}{g} a$, acting through the center of gravity. The free body now has a balanced system of forces acting and the equations of equilibrium are true.

Since 60 pounds will move the body uniformly, $F_1 + F_2 = 60$.

$$\Sigma F_x = \frac{W}{g} a.$$

$$100 - 60 = \frac{W}{g} a = 40.$$

The equation $\Sigma M_A = 0$ gives

$$100 \times 1 - 40 \times 3 - 1000 \times 1 + R_2 \times 2 = 0.$$

$$R_2 = 510 \text{ lbs.}$$

From the equation $\Sigma F_y = 0$,

$$R_1 = 490 \text{ lbs.}$$

Problem 1. In the example above, consider the 100-pound force to be removed while the resisting frictional forces F_1 and F_2 remain the same. Determine R_1 and R_2 while the safe is coming to rest.

$$\text{Ans. } R_1 = 590 \text{ lbs. } R_2 = 410 \text{ lbs.}$$

Problem 2. A 50-ton car moving with a speed of 30 miles per hour is brought to rest by means of the brakes in 6 seconds. The height of the center of gravity of the car above the track is 5 feet and the distance between the trucks is 30 feet. Find the pressure on each truck.

$$\text{Ans. } 53,793 \text{ lbs. on front. } 46,207 \text{ lbs. on rear.}$$

Problem 3. A rectangular block 1 foot square and 4 feet long stands on end on the flat surface of a car with its sides parallel to the motion of the car. What acceleration may be given to the car before the block tips if the friction is sufficient to prevent sliding?

$$\text{Ans. Limiting } a = 8.05 \text{ ft. per sec. per sec.}$$

86. Composition and Resolution of Velocities and Accelerations.

As stated previously, velocity and acceleration are vector quantities and can therefore be compounded or resolved the same as forces and displacements. (See Chapter I.) If a particle at point A , Fig. 210, is displaced first to B , then to D , its resultant displacement is AD . If the displacements were in the other order, the path would be ACD and the displacement would be AD as before. If the displacements occurred simultaneously, the path would be AD .

If AB represents a force acting upon a body at A , and AC represents another acting upon the same body, the resultant force, if they are simultaneous, is represented by AD .

The forces represented by AB and AC produce corresponding proportional accelerations, which to some scale are also represented by vectors AB and AC , and if the two are simultaneous, the resultant acceleration is given by the vector AD .

If the forces act during time t , each produces its corresponding velocity, $v = at$. If not simultaneous, the vectors AB and AC represent to some scale the velocities acquired. If they are simultaneous, the vector AD represents the resultant velocity.

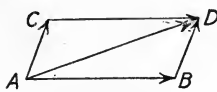

FIG. 210

In the discussion of some problems it is often much simpler to consider the velocity or acceleration as made up of certain components. Thus a velocity is often resolved into its x and y components, an acceleration into its normal and tangential components, etc.

Problem 1. A body has a velocity of 120 feet per second directed at an angle of 45° with the horizontal, as shown in Fig. 211. Resolve the velocity into horizontal and vertical components. Resolve into components parallel and perpendicular respectively to the 30° line, AB .

Ans. $v_x = v_y = 84.84$ ft. per sec. 115.90 ft. per sec. 31.06 ft. per sec.

Problem 2. A body has an acceleration vertically downward of 32.2 feet per second per second and an acceleration horizontally of 4 feet per second per second. What is the resultant acceleration of the body? What is the velocity of the body at the end of 0.3 of a second?

Ans. $a = 32.45$ ft. per sec. per sec. at $7^\circ 05'$ with vertical. $v = 9.74$ ft. per sec. at $7^\circ 05'$ with vertical.

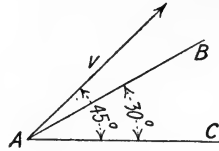

FIG. 211

87. Acceleration Varying with Distance; Simple Harmonic Motion. If the acceleration of a particle is variable, it may be given in terms of the velocity, of the time, or of the distance from some fixed point. In any case, it is necessary to analyze the motion by means of the equations,

$$v = \frac{ds}{dt}, \quad a = \frac{dv}{dt} = \frac{d^2s}{dt^2} \quad \text{and} \quad v dv = a ds.$$

If a particle has a motion along a straight line with an acceleration always directed toward a fixed point on the line and proportional to its displacement from that point in either direction, its motion is vibratory and is called *Simple Harmonic Motion*. Since the acceleration is always toward a fixed point in its path, it is necessarily directed oppositely to its displacement; that is, if the displacement is to the right or positive, the acceleration is to the left or negative.

In Fig. 212, let the particle be at A with displacement s from the fixed point O , and let it be moving to the right with velocity v and acceleration $-a$. The limiting values of s are $+s'$ and $-s'$, and the velocity of the particle at O is v_0 .

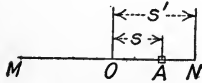

FIG. 212

From the definition,

$$a = -Ks,$$

K being a constant representing the acceleration at unit distance from O . Then

$$v \, dv = a \, ds = -Ks \, ds.$$

$$\int_{v_0}^v v \, dv = -K \int_0^s s \, ds.$$

$$v^2 - v_0^2 = -Ks^2.$$

$$v = \sqrt{v_0^2 - Ks^2}. \quad (1)$$

$$v = \frac{ds}{dt}, \quad \text{so} \quad \frac{ds}{dt} = \sqrt{v_0^2 - Ks^2}.$$

$$\int_0^t dt = \int_0^s \frac{ds}{\sqrt{v_0^2 - Ks^2}}.$$

$$t = \frac{1}{\sqrt{K}} \sin^{-1} \frac{\sqrt{K} s}{v_0}. \quad (2)$$

Solving for s ,

$$s = \frac{v_0}{\sqrt{K}} \sin t \sqrt{K}. \quad (3)$$

From equation (1), $s' = \pm \frac{v_0}{\sqrt{K}}$, since $v = 0$ when $s = s'$. The time for the particle to move from O to N is obtained from equation (2) by letting $s = s'$.

$$t_N = \frac{1}{\sqrt{K}} \sin^{-1} 1 = \frac{\pi}{2\sqrt{K}}.$$

The time for the particle to move from O to N and back to O again is obtained from equation (2) by placing $s = 0$.

$$t_0 = \frac{1}{\sqrt{K}} \sin^{-1} 0 = \frac{\pi}{\sqrt{K}}.$$

It is seen from the two expressions above that the time required for the particle to move from O to N is the same as that required for it to move from N to O . Also, motion to the left of O corresponds exactly to that to the right of O , so the time of one complete vibration is given by

$$T = 2t_0 = \frac{2\pi}{\sqrt{K}}. \quad (4)$$

The period is independent of the displacement. Equation (1) gives the velocity in terms of the distance and equation (2) gives

the time in terms of the distance. By eliminating s between these two equations, the relation between velocity and time is obtained.

$$\begin{aligned} v^2 &= v_0^2 (1 - \sin^2 t \sqrt{K}). \\ v &= v_0 \cos t \sqrt{K}. \end{aligned} \quad (5)$$

It will be seen from equation (5) that v_0 is the maximum value of v . Simple harmonic motion may be illustrated by means of a ball placed between two horizontal springs and supported by a smooth plane, as shown in Fig. 213. The ball is attached to both springs so that when it is displaced, one spring is compressed and the other is elongated. At the middle position O , neither spring is acting. If displaced a distance s' and then released, it will vibrate back and forth from $+s'$ to $-s'$. This motion would continue indefinitely if there were no friction of the supporting surface, the air and the springs.

EXAMPLE.

Let each spring in Fig. 213 be a 20-lb. spring and let the ball weigh 10 pounds. (A 20-lb. spring is one which is compressed or elongated 1 inch by a static load of 20 pounds.) If the ball is displaced $s' = +2$ inches and then released, what is the value of v_0 ? What is the period of vibration T ? Find the position, velocity and acceleration of the ball 0.25 of a second after release.



FIG. 213

Solution.—The constant K is the value of the acceleration when $s = 1$ ft. The force exerted by each spring is 240 times the displacement s in feet, so the total force exerted by the two springs would be 480 pounds when $s = 1$ foot.

$$F = \frac{W}{g} a, \quad \text{so} \quad a_1 = K = \frac{Fg}{W} = 1545.6.$$

From equation (4), period $T = \frac{2\pi}{\sqrt{K}} = 0.16$ sec.

Since $v = 0$ when $s = s'$, equation (1) gives

$$v_0 = \sqrt{K}s' = 39.3 \times \frac{1}{2} = 6.55 \text{ ft. per sec.}$$

In 0.25 of a second the ball has made one complete vibration, with 0.09 of a second remaining. Time is measured from the position O when the ball is moving to the right, so $t = 0.09 + 0.04 = 0.13$ sec.

$$\begin{aligned} s &= \frac{v_0}{\sqrt{K}} \sin t \sqrt{K} \\ &= \frac{6.55}{39.3} \sin (0.13 \times 39.3) \\ &= \frac{6.55}{39.3} \sin 292^\circ.8 \\ &= -0.1537 \text{ ft.} \end{aligned}$$

From equation (5) the velocity at the end of 0.25 of a second after release is

$$v = v_0 \cos 292^\circ.8.$$

$$v = 6.55 \times 0.388 = 2.54 \text{ ft. per sec.}$$

The acceleration at the end of 0.25 of a second after release is given by the equation

$$a = -Ks = -1545.6 \times (-0.1537) = 237 \text{ ft. per sec. per sec.}$$

Problem 1. If in the apparatus of Fig. 213 the ball is not attached to the springs, what will be its period of vibration? If $s' = +3$ inches, find v_0 and the position, velocity and acceleration $\frac{1}{2}$ second after release.

Ans. $T = 0.226$ sec. $v_0 = 6.95$ ft. per sec. $s = +0.0588$ ft. $v = -6.75$ ft. per sec. $a = -45.4$ ft. per sec. per sec.

88. Acceleration Varying with Distance: Direct Solution. If a body weighing W pounds rests upon a coil spring of scale Q , the spring will be compressed a distance $d = \frac{W}{12 Q}$ feet. This position is called the static position. If the body falls through a distance h and strikes the coil spring, the motion below the static position is simple harmonic motion, and if the body should become attached to the spring the total ensuing motion would be simple harmonic. In a case of this kind, however, it is simpler to integrate directly for the equations of motion, and use the initial position of the upper end of the unstressed spring as the origin.

EXAMPLE.

A ball weighing 100 pounds falls through a distance of 2 feet and strikes upon a 1000 lb. spring. See Fig. 214. Determine the compression of the spring, the total time to rest, the maximum velocity and the maximum acceleration.

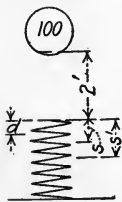

FIG. 214

Solution:— Since the scale of the spring is 1000 lbs. per inch, the resistance of the spring against the ball is 12,000 s , s being in feet. The total force acting upon the ball after it strikes the spring is $100 - 12,000 s$. From $F = \frac{W}{g} a$,

$$a = g - 120 gs.$$

$$v dv = a ds = g ds - 120 gs ds.$$

Let the velocity at the instant of striking be v_1 .

$$\int_{v_1}^v v dv = g \int_0^s ds - 120 g \int_0^s s ds.$$

$$\frac{v^2 - v_1^2}{2} = gs - 60 gs^2. \quad (1)$$

From the laws of falling bodies, $v_1 = \sqrt{2gh} = 11.35$ ft. per sec. At maximum compression, $v = 0$, so $s' = 0.1911$ ft. From equation (1),

$$v = \sqrt{v_1^2 + 2gs - 120gs^2}.$$

Since $v = \frac{ds}{dt}$,

$$\int_0^t dt = \int_0^s \frac{ds}{\sqrt{v_1^2 + 2gs - 120gs^2}}.$$

$$t = \frac{1}{\sqrt{120g}} \sin^{-1} \frac{240gs - 2g}{\sqrt{4g^2 + 480gv_1^2}} \Big|_0^s.$$

$$\text{For } s = s', \quad t = \frac{1}{\sqrt{120g}} \left[\sin^{-1} 1 - \sin^{-1} \left(-\frac{1}{2193} \right) \right] = 0.026 \text{ sec.}$$

From the equation $s = \frac{1}{2}gt^2$, the time t' to fall 2 feet = 0.352 sec., so the total time from release till it comes to rest at the bottom of its travel is $t + t' = 0.026 + 0.352 = 0.378$ sec.

In order to obtain the value of s for which the velocity is a maximum, $\frac{dv}{ds}$ from equation (1) is equated to zero. For maximum velocity, $s = \frac{1}{120} \frac{v_1^2}{g}$ ft.

Maximum $v = \sqrt{128.8 + \frac{2 \times 32.2}{120} - \frac{120 \times 32.2}{120 \times 120}} = 11.36$ ft. per sec. The maximum acceleration is at the bottom of its travel. From the equation for a given above, maximum $a = 32.2 - 120 \times 32.2 \times 0.191 = -706.2$ ft. per sec. per sec.

Problem 1. Solve the Example above by the equations of harmonic motion.

Problem 2. A 100,000-lb. freight car, equipped with an 80,000-lb. spring, strikes a bumping post while moving with a velocity of 2 miles per hour. Find the compression of the spring, assuming that it alone is deformed. (The equations derived above will not apply to this case but similar equations must be integrated.)

Ans. 2 inches.

89. Motion in which Acceleration Varies Inversely as the Square of the Distance.

If a body is at a distance s from the center of the earth, (s being appreciably larger than r , the radius of the earth), the force of attraction of the earth varies inversely as the square of the distance. Let Fig. 215 represent a diametral section of the earth with a body at point A , distant s from the center, and let a be its acceleration. Let the center of the earth be used as the origin and let distance, velocity and acceleration be considered positive outward.

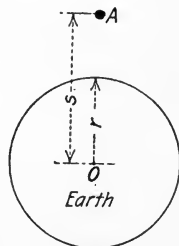

FIG. 215

Then $\frac{a}{g} = \frac{r^2}{s^2}$. Since the acceleration is negative toward the earth,

$$a = -\frac{gr^2}{s^2}$$

$$v dv = a ds = -g \frac{r^2}{s^2} ds.$$

$$\int_0^v v dv = -gr^2 \int_s^r s^{-2} ds.$$

$$\frac{v^2}{2} = gr^2 s^{-1} \Big|_s^r.$$

$$v^2 = 2gr^2 \left(\frac{1}{r} - \frac{1}{s} \right).$$

If $s = \infty$, $v = \sqrt{2gr}$, so if a body fell toward the earth from an infinite distance, its velocity would be $\sqrt{2gr} = 6.95$ miles per second for $r = 3960$ miles. If falling from any finite distance s , the velocity must be less than this. If projected outward with this velocity, the body would be carried to an infinite distance.

Problem 1. Find the velocity acquired by a body in falling 1000 miles to the surface of the earth. Use $r = 4000$ miles. *Ans.* 3.12 miles per sec.

90. Relative Motion. By *velocity of a body* is usually meant the velocity of the body with respect to the point on the earth from which the motion is observed. Although any point on the earth has several motions in space, it is considered to be at rest and the motion of any body relative to that point on the earth is called its *absolute velocity*. The velocity of one body with respect to another body is called its *relative velocity*.

Let A , Fig. 216, represent a car, top view, and B a body on the



FIG. 216

car. If the car A moves into the position A' in one second, BB_2 is the amount of its velocity and also its displacement. If the body B moves from the position B to B_1 relative to the car

while the car has moved from A to A' , the vector BB' , the resultant of BB_1 and BB_2 , gives the absolute velocity and displacement of B .

Similarly, if vector BB_2 represents to some scale the absolute acceleration of the car A , and vector BB_1 represents the relative

acceleration of B with respect to A , the vector BB' represents the absolute acceleration of B .

If either the absolute velocity or acceleration of A or the relative velocity or acceleration of B with respect to A is a variable, the absolute velocity or acceleration of B is given by the vector sum of the corresponding instantaneous values of the components.

This principle may be formulated as follows: The absolute displacement, velocity or acceleration of any body plus (vectorially) the relative displacement, velocity or acceleration of another body with respect to the first, equals the absolute displacement, velocity or acceleration respectively of the second. Stated more briefly,

The Absolute of A + the Relative of B to A = the Absolute of B .

If any two of these three quantities are known, the other may be found.

EXAMPLE 1.

A man swims across a stream which flows at the rate of 2 ft. per second. If he can swim at the rate of 3 feet per second, in what direction must he swim in order to land directly opposite? If the stream is 1000 feet wide, find the time to cross.

Solution:— If O , Fig. 217, is the point from which the swimmer starts, OC is the required direction of his absolute velocity. OA , 2 units to scale, represents the absolute velocity of the stream. Then OB , 3 units to scale, the vector representing the relative velocity of the swimmer with respect to the stream, must be at such an angle that their resultant lies along OC . The graphical construction gives angle $COB = 42^\circ$, or by trigonometry, $\sin COB$ must equal $\frac{2}{3}$, so $COB = 41^\circ 49'$.

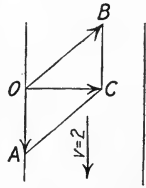

FIG. 217

Length OC is the absolute distance traveled by the swimmer in one second. $OC = \sqrt{5} = 2.236$ feet. The time to cross is $t = \frac{1000}{2.236} = 447$ sec. = 7 min. 27 sec.

EXAMPLE 2.

An ice boat runs due east with a velocity of 30 miles per hour. The wind blows from the northwest with a velocity of 20 miles per hour. How can the sail be set so that a forward pressure will be exerted?

Solution:— In this problem the two absolute velocities are given, to find the velocity of the wind relative to the boat. From O , Fig. 218, lay down the vectors representing the absolute velocities of the boat and the wind. Join the ends of the vectors with the line AB , and through O draw the vector OC , equal and parallel to AB . The vector OC represents to scale the velocity of the wind relative to the boat. Angle $COD = 41^\circ 40'$. If now the sail is set

in some such position as MN , at an angle with the axis of the boat less than $41^\circ 40'$, the wind striking it in the direction OC will exert a small forward thrust. If this thrust is equal to the frictional resistance, the velocity will be maintained, while if it is greater, the velocity will be still further increased. It is thus seen that an ice boat may travel faster than the wind which drives it, a fact which has often been proved experimentally.

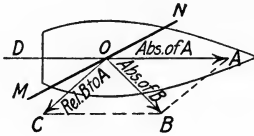

FIG. 218

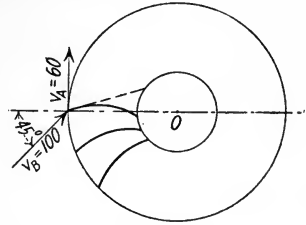

FIG. 219

Problem 1. Water enters an inward flow radial impulse turbine, Fig. 219, at an angle of 45° with the radius produced. If its velocity is 100 feet per second and the rim velocity of the wheel is 60 feet per second, what should be the angle of the outer edge of the vane in order that the water may enter smoothly? What is the initial relative velocity?

Ans. $8^\circ 35'$ with the radius. 71.5 ft. per sec.

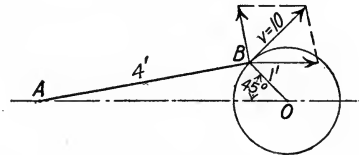

FIG. 220

Problem 2. In Fig. 220, AB is the connecting rod and BO the crank of a reciprocating engine. If the velocity of the crank pin B is 10 feet per second, what is the velocity of the crosshead A when the crank is at an angle of 45° with the horizontal? (The relative velocity of B with respect to A must necessarily be normal to AB , since AB is a rigid body.)

Ans. 8.36 ft. per sec.

GENERAL PROBLEMS.

Problem 1. In an elevator shaft 200 feet high an elevator is moving upward with a velocity of 10 feet per second. At the instant it is 6 feet from the bottom a ball drops from the top of the shaft. When and where will the ball and the elevator meet and with what relative velocity?

Ans. 3.17 sec. 37.74 ft. from bottom. Rel. $v = 112.2$ ft. per sec.

Problem 2. From the top of a tower 120 feet high a ball is dropped at the same instant that another is shot upward from the bottom with a velocity of 100 feet per second. How far from the bottom do they pass?

Ans. 96.82 ft.

Problem 3. A ball is shot upward with a velocity of 50 feet per second. One second later another is shot upward with a velocity of 100 feet per second. When and where will they pass and with what relative velocity? ✓

Ans. 1.412 sec. 38.5 ft. 82.2 ft. per sec.

Problem 4. A stone is dropped into a well and 3.2 seconds later the sound of the splash is heard. What is the depth of the well? (Use 1120 feet per second as the velocity of sound.)

Ans. 151 ft.

Problem 5. A pile-driver hammer weighing 800 lbs. drops 12 feet upon a pile. What is the velocity of striking? If the friction of the air and guides is assumed constant and equal to 50 lbs., what is the velocity of striking?

Ans. 27.8 ft. per sec. 26.92 ft. per sec.

Problem 6. The hammer of the pile driver in Problem 5 is drawn back up at a velocity of 4 feet per second. If this velocity is gained in 0.25 of a second by means of the clutch, what is the tension in the supporting cable?

Ans. 1198 lbs.

Problem 7. Fig. 221 represents a body weighing 30 pounds which rests upon a 45° plane, connected by a cord to another weighing 50 pounds which rests upon a 10° plane. If the coefficient of friction $f = 0.25$, determine if the bodies will move. Determine T , F_1 and F_2 .

Ans. $T = 11.25$ lbs. $F_1 = 5.3$ lbs. $F_2 = 12.31$ lbs.

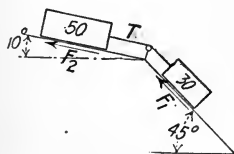

FIG. 221

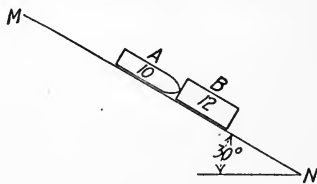

FIG. 222

Problem 8. Two blocks, A weighing 10 lbs. and B weighing 12 lbs., Fig. 222, slide down a 30° plane in contact. They start from M with an initial velocity of 5 feet per second and reach N , 100 feet from M , with a velocity of 50 feet per second. There is friction under B but none under A . Compute the coefficient of friction, the pressure between the blocks, the time to move from M to N and the velocity at the middle.

Ans. $f = 0.244$. $P = 1.15$ lbs. $t = 3.635$ sec. $v_{50} = 35.55$ ft. per sec.

Problem 9. A ball is dropped from the ceiling of an elevator 8 feet high. Find the time to drop to the floor (1) when the elevator is at rest; (2) when it

is moving upward with a uniform velocity of 10 feet per second; (3) when it is being accelerated upward at 10 feet per second per second; (4) when it is being accelerated downward at 10 feet per second per second; (5) when it is being accelerated downward at 32.2 feet per second per second.

Ans. (1) 0.704 sec. (3) 0.615 sec. (4) 0.849 sec.

Problem 10. Two blocks are connected by a cord as shown in Fig. 223. The friction of the cord over the curved surface at *A* is 10 pounds. The coefficient of friction under the 100-pound block is 0.1. Compute T_1 , T_2 , and the time required for the block to move 10 feet from rest.

Ans. $T_1 = 95.6$ lbs. $T_2 = 105.6$ lbs. $t_{10} = 3.93$ sec.

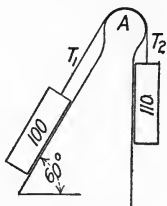

FIG. 223

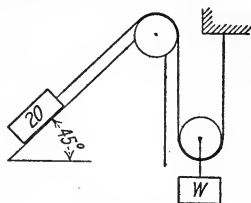

FIG. 224

Problem 11. In Fig. 224, find the weight W necessary to give the 20-pound body an acceleration of 12 feet per second per second if the coefficient of friction under it is 0.4. (Neglect the mass of the pulleys and cord.)

Ans. $W = 67$ lbs.

Problem 12. A car starts from rest on a 1 per cent grade and runs down under the influence of gravity for one mile. From there the track is level. Train resistance is assumed constant at $12\frac{1}{2}$ pounds per ton. Find the velocity of the car at the lower end of the grade, the time till it comes to rest and the total distance traveled.

Ans. $v = 35.7$ ft. per sec. $t_1 = 296$ sec. $t_2 = 177.5$ sec. $s = 8450$ ft.

Problem 13. In the apparatus of Fig. 225 the coefficient of friction under the blocks is 0.20. Find the acceleration of the blocks, the tension in the cord and the time to move 20 feet from rest.

Ans. $a = 9.22$ ft. per sec. per sec. $T = 96$ lbs. $t = 2.08$ sec.

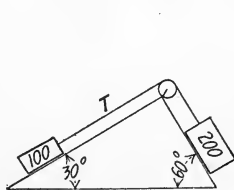

FIG. 225

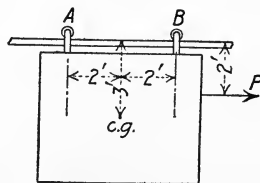

FIG. 226

Problem 14. The door shown in Fig. 226 weighs 200 pounds and is hung from a track by means of wheels at *A* and *B*. The wheel at *A* is broken and slides on the track, f being $\frac{1}{3}$. Find the amount of the force P applied as shown to give the door an acceleration of 8 feet per second per second. Find the reactions at *A* and *B*.

Ans. $P = 84.7$ lbs. $A_y = 105$ lbs. $A_x = 35$ lbs. $B = 95$ lbs.

Problem 15. A block 1 foot square and six feet long stands on end on a carriage with its sides parallel to the direction of motion. The coefficient of friction $f = \frac{1}{3}$. As the acceleration of the carriage is increased, will the block tip or slide first, and for what value of the acceleration?

Ans. $a = 5.36$ ft. per sec. per sec.

Problem 16. A small wooden beam is deflected 1 inch by a weight of $1\frac{1}{2}$ pounds. If a weight of 1 pound is placed on the beam and the beam is set in vibration, find the time of one complete vibration. *Ans.* $T = 0.261$ sec.

Problem 17. A weight of 5 pounds is supported by a cantilever beam spring, which is deflected 0.2 ft. below its neutral position. Find the time of one vibration. *Ans.* $T = 0.495$ sec.

Problem 18. A weight of 10 pounds hung from a spiral spring makes 107 vibrations per minute. What is the scale of the spring?

Ans. 3.25 lbs. per inch.

Problem 19. What must be the scale of a spring on an 80,000-lb. car so that if the car strikes a bumping post when moving with a velocity of 3 miles per hour, the spring will not be compressed more than 2 inches?

Ans. 144,200 lbs. per inch.

Problem 20. A river is a half mile wide and flows at the rate of 8 miles per hour. A motor boat which in still water could travel 12 miles per hour is headed straight across. Where will it strike the opposite bank? What time will be required? *Ans.* 1760 ft. below. $t = 2$ min. 30 sec.

Problem 21. In Problem 20, at what point would the boat strike if headed 30° up-stream? What time would be required?

Ans. 508 ft. below. $t = 2$ min. 53 sec.

Problem 22. A belt runs crossed between two 18-inch pulleys, 10 feet apart. Find the relative velocity of the two parts of the belt where they cross when the rim speed is 10 feet per second.

Ans. 19.77 ft. per sec. in direction of axes of pulleys.

Problem 23. A locomotive drive wheel is 6 feet in diameter and has a 15-inch crank. When the locomotive is running at 60 miles per hour and the piston is at the forward end of the stroke, what is the absolute velocity of the crank pin? What is its absolute velocity 90° farther on?

Ans. 95.25 ft. per sec., $22^\circ 40'$ below hor. 51.35 ft. per sec. hor. forward.

Problem 24. What is the absolute velocity of the top and bottom points on the rim of the drive wheel of Problem 23? What is their velocity relative to the frame of the locomotive?

Ans. 176 ft. per sec. 0. 88 ft. per sec. forward. 88 ft. per sec. backward.

Problem 25. The three bodies, A , B and C , Fig. 227, weigh 1 pound, 2 pounds and 3 pounds, respectively. If they are supported in the position shown and then released simultaneously, what will be the velocity of each body two seconds later? (Neglect mass of cords and pulleys.)

Ans. $v_1 = 26.4$ ft. per sec. upward. $v_2 = 19.0$ ft. per sec. downward. $v_3 = 3.8$ ft. per sec. downward.

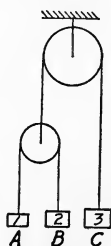

FIG. 227

CHAPTER VIII.

CURVILINEAR MOTION.

91. Velocity in Curvilinear Motion. The *velocity* of a particle is its rate of motion, or the time rate of change of its position in space. If the particle moves along a curved path, its motion is said to be *curvilinear*. In this chapter only *plane* curvilinear motion will be discussed.

If a particle moves along the curved path ABC , Fig. 228, its velocity at any point in its path, as at A or B , is in the direction of the path at that point. The velocity is therefore changing constantly in direction and may also be changing in amount. An approximate value of the velocity of the

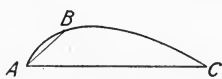

FIG. 228

particle at any point may be obtained by taking the average velocity over a small space which includes the point. If the arc AB is the distance traveled in Δt time, the vector AB is the displacement in Δt time. Then the ratio $\frac{AB}{\Delta t}$ gives the *average* velocity of the body

between A and B . If Δt becomes dt , approaching zero as a limit, point B will approach point A as a limit, so the limiting direction of the vector AB is the tangent at A , which gives the *direction* of the instantaneous velocity at A . As point B approaches point A the vector AB and the arc AB approach equality. If the length of the arc AB traversed in dt time is ds , $\frac{ds}{dt}$ is the *magnitude* of the instantaneous velocity, or the speed, at A .

92. Acceleration in Curvilinear Motion. Acceleration is the time rate of change of velocity. In curvilinear motion the velocity necessarily changes continually in direction and may also change in amount. Let the particle move along the curved path A_1A , Fig. 229(a), in time Δt , and let v_1 and v be the instantaneous velocities at A_1 and A , respectively. If from any point O , Fig.

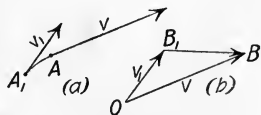

FIG. 229

229(b), vector OB_1 is laid off equal and parallel to v_1 , and vector

OB is laid off equal and parallel to v , vector B_1B represents the total change in velocity, and $\frac{B_1B}{\Delta t}$ gives the average rate of change of velocity, or acceleration, between A_1 and A . The limiting value of the average acceleration as Δt becomes dt is the *instantaneous acceleration* at A .

93. Tangential Acceleration and Normal Acceleration. It is seen from Art. 92 that in general the acceleration is not in the direction of the velocity of the particle. Since the direction of the velocity is usually the direction of reference, the resultant acceleration a is usually determined by means of its two components, a_t and a_n . The component a_t is the *tangential* component of the acceleration and is parallel to the direction of the velocity. The component a_n is the *normal* component of the acceleration and is perpendicular to the direction of the velocity.

If A_1 and A , Fig. 230(a), are consecutive points in the path of the particle, the distance A_1A being the distance ds which is traversed in time dt , then B_1B , Fig. 230(b), is the change in velocity in time dt . The average acceleration is $\frac{B_1B}{dt}$ and is the instantaneous acceleration at A since dt approaches zero as a limit.

The acceleration $\frac{B_1B}{dt}$ is resolved into its tangential and normal components, $\frac{DB}{dt} = a_t$, parallel to the direction of the velocity at A , and $\frac{B_1D}{dt} = a_n$, normal to the direction of the velocity at A . Since A_1 and A are consecutive points in the path, $DB = v - v_1 = dv$, so

$$a_t = \frac{dv}{dt}.$$

It will be seen that this is the rate of change of speed at point A .

In the limit,

$$B_1D = v_1 d\theta = v d\theta.$$

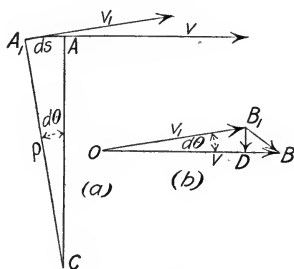

FIG. 230

Also,
$$d\theta = \frac{ds}{\rho} \quad \text{and} \quad \frac{ds}{dt} = v.$$

Then
$$a_n = \frac{B_1 D}{dt} = \frac{v d\theta}{dt} = \frac{v ds}{\rho dt} = \frac{v^2}{\rho}.$$

$$\mathbf{a}_n = \frac{\mathbf{v}^2}{\rho}.$$

The expressions $a_t = \frac{dv}{dt}$ and $a_n = \frac{v^2}{\rho}$ are important ones and should be kept carefully in mind.

From the discussion above and from the principle of effective force, Art. 85, it follows that if a particle of weight W is moving in a curved path and at any instant has a tangential acceleration $a_t = \frac{dv}{dt}$ and

a normal acceleration $a_n = \frac{v^2}{\rho}$, the effective force $\frac{W}{g} a$ must be the

resultant of the two components, $F_t = \frac{W}{g} \frac{dv}{dt}$ and $F_n = \frac{W}{g} \frac{v^2}{\rho}$.

94. Uniform Motion in a Circle. The discussion in Art. 93 will be understood better by considering its application to several typical problems. Consider first the case of a block sliding freely around a smooth groove, the plane of the groove being horizontal. The top view is shown in Fig. 231(a). Consider the block as the free body, as in Fig. 231(c). The pull of gravity W and the vertical reaction of the groove R are both normal to the path and

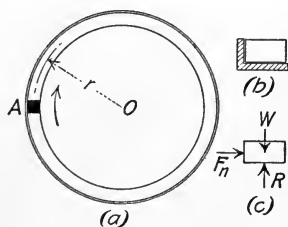

FIG. 231

balance each other, since there is no acceleration in the vertical direction. Since the block and groove are considered to be smooth, there is no tangential accelerating force, so the speed is constant and $a_t = 0$. In the direction of the normal to the path at each point there is an inward pressure F_n of the groove upon the block which

turns the block out of the straight path it would otherwise follow.

From Art. 93, this normal accelerating force $F_n = \frac{W}{g} a_n = \frac{W}{g} \frac{v^2}{r}$.

Since v and r are constant in amount, the accelerating force F_n is constant in amount and is always directed toward the center of the circle.

This normal force which the groove exerts upon the block is called the constraining or centripetal force and is the resultant of the external force system acting upon the body. The equal and opposite *inertia* force with which the body resists a change of direction of velocity is called the *centrifugal* force, since with respect to the groove the result is the same as if a real force were acting on the block. This inertia force is the *normal* reversed effective force, which, if added to the external system, will produce static conditions, since in this case there is no tangential acceleration. In Fig. 231(c), W and R are equal and balance. F_n is an unbalanced force and causes acceleration toward the center. If now, as in Art. 85, the reversed effective force, equal in amount to $\frac{W}{g} \frac{v^2}{r}$ and opposite in direction to the acceleration, be added to the system acting upon the free body, the body will be under static conditions and all static equations will apply.

The problem of the conical pendulum illustrates this method better. In Fig. 232(a), A is a small weight hung by a cord or light rod from the point O on a vertical axis about which it rotates in a horizontal plane. If the speed is constant, the angle θ is constant and there is no force in the direction of the motion. In Fig. 232(b), the weight is shown as a free body with all the external forces acting upon it, and in addition the *reversed effective* force $\frac{W}{g} \frac{v^2}{r}$, acting opposite to the ac-

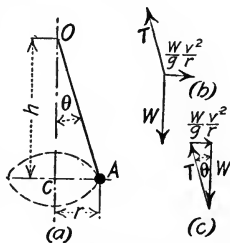

FIG. 232

celeration. The problem is now one in statics, and the equations $\Sigma F_x = 0$ and $\Sigma F_y = 0$ determine the unknown quantities. The moment equation, $\Sigma M_o = 0$, gives θ and h in terms of the velocity.

$$\frac{W}{g} \frac{v^2}{r} h - Wr = 0.$$

$$\tan \theta = \frac{r}{h} = \frac{v^2}{gr} \quad h = \frac{gr^2}{v^2}.$$

EXAMPLE 1.

In Fig. 232, let $l = 2$ feet and $W = 5$ pounds. What is the speed of the weight if $\theta = 30^\circ$? What is the tension in OA ?

Solution: — If $\theta = 30^\circ$ and $l = 2$ ft., $r = 1$ ft.

Equation $\Sigma F_y = 0$ gives

$$T \times 0.866 = 5.$$

$$T = 5.77 \text{ lbs.}$$

Equation $\Sigma F_x = 0$ gives

$$5.77 \times 0.5 = \frac{5 v^2}{32.2}.$$

$$v = 4.31 \text{ ft. per sec.}$$

Or, by using equation $\Sigma M_0 = 0$,

$$\frac{5 v^2}{32.2} \times 1.732 = 5 \times 1.$$

$v = 4.31 \text{ ft. per sec. as before.}$

EXAMPLE 2.

Find the superelevation e of the outer rail of a railroad track of gage G on a curve of radius r so that there is no resultant flange pressure when the car has a speed of v feet per second.

Solution:— In Fig. 233(a), R_1 and R_2 are the pressures of the rails on the wheels; R is their resultant; W is the weight of the car and r is the radius of curvature of the track. Since r is horizontal and the car is accelerated toward the center, the reversed effective force $\frac{W}{g} \frac{v^2}{r}$ must

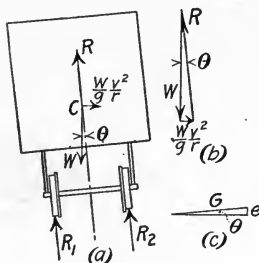

FIG. 233

act horizontally through the center of gravity. The conditions are now static conditions, so the three forces must be in equilibrium and can be made to form a closed triangle of forces, Fig. 233(b). Then $\frac{W}{g} \frac{v^2}{r} \div W = \tan \theta$, or $\tan \theta = \frac{v^2}{gr}$.

For small angles the sine and the tangent are approximately equal, so from Fig. 233(c),

$$e = G \tan \theta = \frac{v^2 G}{gr}.$$

If θ becomes large, so that the tangent and the sine cannot be considered equal, the superelevation e is determined from $e = G \sin \theta$.

Problem 1. With dimensions and weight the same as in Example 1 above, find the speed v necessary to keep the cord at an angle of 45° . What is the corresponding tension T ? Solve also for 60° .

Ans. $v = 6.75 \text{ ft. per sec.}$ $T = 7.07 \text{ lbs.}$ $v = 9.82 \text{ ft. per sec.}$ $T = 10 \text{ lbs.}$

Problem 2. Determine the superelevation of the outer rail of a track of gage $G = 4.9$ feet (center to center of rail) on a curve of radius $r = 2865$ feet to give zero resultant flange pressure at a speed of 30 miles per hour.

Ans. $e = 0.103 \text{ ft.}$

Problem 3. If a 100,000-lb. car has a speed of 60 miles per hour on the curve with superelevation as determined in Problem 2, what is the resultant flange pressure parallel to the ties? If the car is at rest on the curve, what is the resultant flange pressure parallel to the ties? *Ans.* 6290 lbs. 2100 lbs.

95. Simple Circular Pendulum. A *simple circular pendulum* consists of a particle vibrating in the arc of a vertical circle under the influence of gravity and some constraining radial force. The ideal simple circular pendulum may be closely approximated by means of a small heavy sphere at the end of a light cord.

Let A , Fig. 234, be such a body suspended by cord OA , of length l , and let distance along the arc be measured from C , positive to the right. The only force in the direction of motion is $-W \sin \theta$.

$$\text{From } F = \frac{W}{g} a,$$

$$a_t = -g \sin \theta.$$

$$v dv = a ds = -g \sin \theta ds.$$

The expression for t in terms of the integral of $\sin \theta ds$ is a complicated elliptic form, but an approximate solution is comparatively simple and for vibrations of small amplitude is very slightly in error. For small values of θ , $\sin \theta = \theta$, approximately, so the equations above become

$$a_t = -g\theta = -\frac{g}{l}s \quad \left(\text{since } \theta = \frac{s}{l}\right)$$

and

$$v dv = -\frac{g}{l}s ds.$$

Let v_0 be the velocity at C and v the velocity at A .

$$\text{Then } \int_{v_0}^v v dv = -\frac{g}{l} \int_0^s s ds.$$

$$v^2 - v_0^2 = -\frac{g}{l}s^2.$$

Since $v = 0$ when $s = s_B$,

$$v_0^2 = \frac{g}{l}s_B^2.$$

The insertion of this value of v_0^2 in the equation above gives

$$v^2 = \frac{g}{l}(s_B^2 - s^2).$$

$$v = \sqrt{\frac{g}{l}} \sqrt{s_B^2 - s^2}.$$

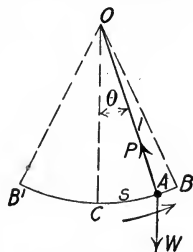

FIG. 234

Since $v = \frac{ds}{dt}$,

$$dt = \sqrt{\frac{l}{g}} \frac{ds}{\sqrt{s_B^2 - s^2}}.$$

If time is measured from the instant the pendulum is at C , moving to the right, this becomes

$$\int_0^t dt = \sqrt{\frac{l}{g}} \int_0^s \frac{ds}{\sqrt{s_B^2 - s^2}}.$$

$$t = \sqrt{\frac{l}{g}} \sin^{-1} \frac{s}{s_B}.$$

To get the time required for the pendulum to move from C to B , let $s = s_B$. Then

$$t_B = \frac{\pi}{2} \sqrt{\frac{l}{g}}.$$

To get the time required for the pendulum to move from C to B and back to C , let $s = 0$. Then

$$t_C = \pi \sqrt{\frac{l}{g}}.$$

The time required for the pendulum to move from C to B is therefore the same as that to move from B to C .

Motion to the left of C exactly corresponds to motion to the right of C , so the time of one complete period of vibration,

$$T = 2\pi \sqrt{\frac{l}{g}}.$$

This equation for T is independent of θ , so the time of vibration is independent of the amplitude for small values of θ .

It will be seen from the equation $a_t = -\frac{g}{l}s$, that for vibrations of small amplitude the acceleration is proportional to the displacement and so the motion is practically simple harmonic motion.

Since the ball of the pendulum is accelerated toward the center with an acceleration $\frac{v^2}{l}$, the summation of forces normal to the path gives

$$F_n = P - W \cos \theta = \frac{W}{g} \frac{v^2}{l},$$

P being the tension in the cord.

$$P = W \cos \theta + \frac{W}{g} \frac{v^2}{l}.$$

Problem 1. What is the length l of a simple pendulum which will vibrate from one side to the other (B' to B , Fig. 234) in 1 second? *Ans.* 2.26 ft.

Problem 2. A mine cage is suspended from a cable 500 feet long. What is the time of one complete oscillation? *Ans.* 24.75 sec.

Problem 3. A girder weighing 800 pounds is suspended from a cable 40 feet long. What horizontal force is necessary to pull it 6 feet out of its vertical position? What is the tension in the cable as the girder is allowed to swing back through its vertical position? *Ans.* 121 lbs. 818 lbs.

96. Velocity of a Body in a Vertical Curve. In Fig. 235, let A be a body of weight W moving along a smooth vertical curve under the influence of gravity, and let θ be the angle between the horizontal and the tangent to the curve at any point. The reaction N of the smooth surface is normal to the path, so if the resistance of the air is neglected the only force in the direction of the motion is $-W \sin \theta$, as in Art.

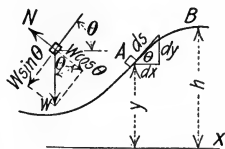

FIG. 235

95, and $a = \frac{F}{M} = -g \sin \theta$.

$$v \, dv = a \, ds = -g \sin \theta \, ds.$$

$$\sin \theta \, ds = dy,$$

so

$$v \, dv = -g \, dy.$$

Let v_0 be the velocity at point B . Then

$$\int_{v_0}^v v \, dv = -g \int_h^y dy.$$

$$v^2 - v_0^2 = 2g(h - y).$$

It will be seen from this equation that if a body moves along a frictionless path under the influence of gravity, the change in speed is the same as if it fell freely through the vertical distance between the two points. (See Equation 3, Art. 83.)

As in Art. 95, the normal constraining force P is given by

$$P = \pm W \cos \theta + \frac{W}{g} \frac{v^2}{r},$$

r being the radius of curvature of the path. The negative sign

is used if the body is above a horizontal line through the center of curvature.

EXAMPLE.

A body B weighing 2 pounds is rotating in a vertical circle at the end of a cord 1 foot long, as shown in Fig. 236. If its velocity at the bottom point is 15 feet per second, what is its velocity at the top point A ? What is the tension T in the cord at that point? What is the least velocity it can have at point A which will keep it in its circular path?

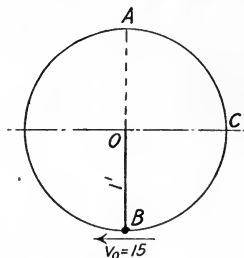

FIG. 236

Solution:— If the X axis is taken through B , the value of h in the equation above becomes zero. Then

$$v_A^2 = v_0^2 - 2gy = 225 - 128.8.$$

$$v_A^2 = 96.2$$

$$v_A = 9.81 \text{ ft. per sec.}$$

When the body is at point A , the only forces acting upon it are its weight and the tension in the cord, both downward. These produce the normal acceleration $a_n = \frac{v^2}{r} = 96.2$ ft. per sec. per sec.

From the equation $F = \frac{W}{g} a$,

$$T + 2 = \frac{2}{32.2} \times 96.2.$$

$$T = 3.98 \text{ lbs.}$$

Since the cord cannot have a compressive stress, the minimum value T can have is zero. When T is zero, equation $F = \frac{W}{g} \frac{v^2}{r}$ gives

$$2 = \frac{2}{32.2} \times \frac{v^2}{1}.$$

$$v = 5.67 \text{ ft. per sec.}$$

This is the least velocity which will keep the body in its circular path.

Problem 1. If the body in Fig. 236 starts from rest at point C , what is its velocity as it passes the 45° point? What is its velocity at the bottom point?

Ans. 6.75 ft. per sec. 8.03 ft. per sec.

Problem 2. If a body weighing 10 pounds is rotating in a vertical circle at the end of a cord 10 feet long, what is the least velocity at the bottom which will keep it in the circular path at the top? What is the tension in the cord when the body is at the bottom? When it is 60° from the top? When it is 30° from the bottom? *Ans.* 40.1 ft. per sec. 60 lbs. 15 lbs. 56 lbs.

Problem 3. A body is thrown from a cliff 2000 feet high with a velocity of 200 feet per second. What will be the amount of its velocity as it strikes the surface of the water below, if the air resistance is neglected?

Ans. 411 ft. per sec.

Problem 4. If in Fig. 237 the radius of the circle on the "loop the loop" is 6 feet, what must be the height h in order that the car will just pass the point A without leaving the track? Neglect frictional resistance.

Ans. $h = 15$ ft.

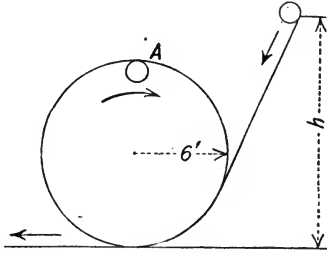

FIG. 237

97. Motion of Projectile, Air Resistance Neglected. If a body is impressed with an initial velocity and then moves freely through the air under the influence of gravity, it is called a projectile. In this discussion the resistance of the air will be neglected. For projectiles with high velocities the error is considerable.

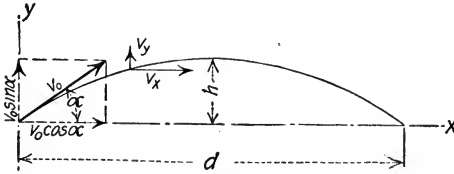

FIG. 238

Let the projectile be discharged with an initial velocity of v_0 at an angle α with the horizontal, as shown in Fig. 238. The initial velocity v_0 may be resolved into its horizontal and vertical components, $v_0 \cos \alpha$ and $v_0 \sin \alpha$, respectively. Since there is no horizontal force acting upon the body, the horizontal velocity remains unchanged throughout its motion.

$$a_x = 0, \quad v_x = v_0 \cos \alpha, \\ x = v_0 t \cos \alpha.$$

In the vertical direction the force of gravity is acting continuously, so the vertical component of the velocity is the same as that of a body projected upward with an initial velocity of $v_0 \sin \alpha$. See Art. 83.

$$a_y = -g, \quad v_y = v_0 \sin \alpha - gt, \\ y = v_0 t \sin \alpha - \frac{1}{2} gt^2.$$

To determine the time till the projectile reaches the highest point in its path, let $v_y = 0$; then $t = \frac{v_0 \sin \alpha}{g}$. The greatest height h will be found by putting this value of t in the expression for y . This gives

$$h = \frac{v_0^2 \sin^2 \alpha}{2g}.$$

For varying values of α , the maximum value of h is evidently given when $\sin^2 \alpha = 1$, so α for maximum $h = 90^\circ$.

The time the projectile is in the air until it reaches the same level again is obtained by letting $y = 0$. This gives

$$t = \frac{2v_0 \sin \alpha}{g},$$

which is twice the time required for it to reach the top point in its path.

The range d , the horizontal distance through which it travels until it reaches the same level again, is given by the product of the time t just obtained and the constant horizontal velocity

$$d = \frac{2v_0^2 \cos \alpha \sin \alpha}{g} = \frac{v_0^2}{g} \sin 2\alpha.$$

For varying values of α it is evident that d will be a maximum when $\sin 2\alpha = 1$. Then $2\alpha = 90^\circ$ and $\alpha = 45^\circ$.

The amount of the velocity at any point in the path is given by

$$v = \sqrt{v_x^2 + v_y^2} = \sqrt{v_0^2 - 2gy}.$$

The direction of the velocity at any point in the path is the same as the tangent to the path, and is given by

$$\tan \theta = \frac{v_y}{v_x},$$

θ being the angle the tangent to the curve makes with the horizontal.

The equation of the path in terms of x and y is obtained by eliminating t between the equations for x and y .

$$y = x \tan \alpha - \frac{gx^2}{2v_0^2 \cos^2 \alpha}.$$

This is the equation of a parabola with its axis vertical.

EXAMPLE 1.

A projectile is discharged with a velocity of 200 feet per second at an angle of 30° with the horizontal. Determine the maximum height, the time until it returns to the same level, and the range. Determine also the velocity at the end of 2 seconds.

Solution:—The vertical component of the velocity is $v_0 \sin \alpha = 100$ ft. per sec. The horizontal component of the velocity is $v_0 \cos \alpha = 173.2$ ft. per sec.

$$h = \frac{v_0^2 \sin^2 \alpha}{2g} = \frac{100 \times 100}{2 \times 32.2} = 155 \text{ ft.}$$

The time until it reaches the same level again is $\frac{2 v_0 \sin \alpha}{g} = \frac{200}{32.2} = 6.21$ sec.

The range d is given by the product of the horizontal velocity and the time.

$$d = 173.2 \times 6.21 = 1075 \text{ ft.}$$

The vertical component of the velocity at the end of 2 seconds is given by

$$v_y = v_0 \sin \alpha - gt = 100 - 64.4 = 35.6 \text{ ft. per sec.}$$

The horizontal velocity is constant, 173.2 ft. per sec. The resultant velocity $v = \sqrt{v_x^2 + v_y^2} = 176.8$ ft. per sec. The angle with the horizontal is given by its tangent

$$\frac{v_y}{v_x} = \frac{35.6}{173.2} = 0.2057. \quad \theta = 11^\circ 37'.$$

EXAMPLE 2.

From a tower 200 feet high a stone is thrown downward at an angle of 45° with the horizontal, with a velocity of 80 feet per second. How far away from the tower does it strike the ground and what is the time required?

Solution:—The horizontal component of the velocity is $v_0 \cos \alpha = 56.56$ ft. per sec. The vertical component of the velocity is $v_0 \sin \alpha = 56.56$ ft. per sec. downward. The vertical motion is the same as that of a body projected vertically downward with an initial velocity of 56.56 ft. per sec. From equation (2), Art. 83,

$$200 = 56.56 t + 16.1 t^2, \\ t = 2.18 \text{ sec.}$$

Since the horizontal velocity is constant the horizontal distance traveled in 2.18 seconds is

$$x_1 = 56.56 \times 2.18 = 123.4 \text{ ft.}$$

Problem 1. A shot is fired at an angle of 60° with the horizontal, with a velocity of 500 feet per second. Find the height and the range.

$$\text{Ans. } h = 2911 \text{ ft. } d = 6725 \text{ ft.}$$

Problem 2. What is the maximum height and the maximum range theoretically possible for a projectile with a muzzle velocity of 2000 feet per second?

$$\text{Ans. } h = 11.78 \text{ miles. } d = 23.56 \text{ miles.}$$

Problem 3. A gun with a barrel 3 feet long shoots a bullet with a muzzle velocity of 600 feet per second. When shooting at a target 1000 feet distant, to what height should the rear sight be raised?

$$\text{Ans. } 1.615 \text{ inches.}$$

GENERAL PROBLEMS.

Problem 1. A 10-pound weight at the end of a 3-foot cord revolves about a vertical axis as a conical pendulum. What is the tension in the cord and the speed of rotation if $\theta = 30^\circ$? *Ans.* $T = 11.55$ lbs. $v = 5.28$ ft. per sec.

Problem 2. A cast iron governor ball 4 inches in diameter has an arm 15 inches long. Neglecting the weight of the arm, find the tension and the speed if $\theta = 75^\circ$. *Ans.* $T = 33.76$ lbs. $v = 12.04$ ft. per sec.

Problem 3. A car is moving on a horizontal track around a curve of 600 feet radius with a speed of 30 miles per hour. A weight of 40 pounds is suspended from the ceiling by a cord 3 feet long. What is the tension in the cord, the angle with the vertical and the horizontal displacement?

Ans. 40.2 lbs. $5^\circ 42'$. 3.6 inches.

Problem 4. What superelevation of the outer rail would be necessary in Problem 3 in order to make the weight hang parallel to the sides of the car?

Ans. 5.88 in.

Problem 5. A standard gage interurban railway track has a curve of 100 feet radius. What should be the superelevation of the outer rail so that a car moving with a speed of 10 miles per hour will have zero resultant flange pressure?

Ans. 3.92 in.

Problem 6. In a fog, a car whose center of gravity was 6 feet above the track struck the curve of the preceding problem while moving with a speed of 30 miles per hour. What happened? (Solve graphically.)

Problem 7. At what angle must an automobile speedway be banked on a curve of 250 feet radius for a speed of 60 miles per hour so that there is no side thrust on the wheels?

Ans. $43^\circ 50'$.

Problem 8. If the coefficient of friction between the wheels and the track in Problem 7 is $\frac{1}{3}$, to what angle can the banking be reduced before the wheels skid on the curve?

Ans. $25^\circ 30'$.

Problem 9. A common swing 20 feet high is designed for a static load of 400 pounds with a factor of safety of 4. If two boys, each weighing 100 pounds, swing up to the horizontal on each side, what is the factor of safety?

Ans. $2\frac{2}{3}$.

Problem 10. If the swing of Problem 9 is vibrating 60° on each side of the vertical, what will be the total tension in the supporting ropes?

Ans. 400 lbs.

Problem 11. If the swing of Problem 9 vibrates through an angle of 10° , how many complete vibrations are made per minute?

Ans. 12.12.

Problem 12. A ball at the end of a cord 2 feet long is swinging in a complete vertical circle with just enough velocity to keep it in the circle at the top. If it is released from the cord when it is at the top point, where will it strike the ground 4 feet below the center of the circle?

Ans. 4.89 feet away.

Problem 13. If the ball of Problem 12 is released 45° later, where will it strike the ground?

Ans. 4.27 feet from vertical through center.

Problem 14. The muzzle velocity of a projectile is 1200 feet per second and the distance of the target is 3 miles. What must be the angle of elevation of the gun?

Ans. $10^\circ 22'$.

Problem 15. From a car moving with a speed of 60 miles per hour a stone is thrown horizontally at right angles to the direction of the car with a velocity

of 100 feet per second. Where will it strike the ground and with what velocity if the car is 10 feet above the level of the ground?

Ans. 78.8 ft. from track, 69.4 ft. forward, $v = 135.6$ ft. per sec.

Problem 16. A small block slides freely down the quadrant shown in Fig. 239. Determine the distance x_1 , the equation of the path BC and the velocity at C .

Ans. $x_1 = 10.95$ ft. $y = -0.0834 x^2$. $v_c = 28.9$ ft. per sec.

Problem 17. While blasting out a concrete foundation the most distant pieces fell 800 feet away. What was their initial velocity?

Ans. 160 ft. per sec.

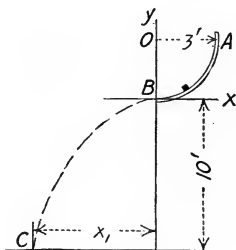

FIG. 239

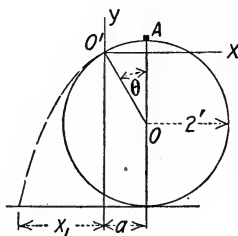

FIG. 240

Problem 18. If a target is 1000 feet distant horizontally and is 200 feet higher than the gun, what angle of elevation is necessary if the muzzle velocity is 800 feet per second?

Ans. $\alpha = 12^\circ 50'$.

Problem 19. A block starts from rest at the top of a sphere 4 feet in diameter, Fig. 240, and slides without friction to point O' where it leaves the surface of the sphere. Locate this point. Find also the equation of the path of the block after leaving the surface, and the distance from the sphere to the point where the block strikes the plane upon which the sphere is resting.

Ans. $\theta = 48^\circ 10'$. $y = 1.118 x - 0.843 x^2$. $a + x_1 = 2.92$ ft.

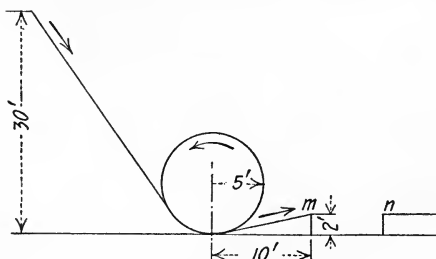

FIG. 241

Problem 20. The height of the starting point for the car on the "loop the loop," Fig. 241, is 30 feet above the bottom of the loop. What is the velocity of the car at the top of the loop? What is the pressure against the top if the man and car weigh 300 pounds?

Ans. 35.85 ft. per sec. 2100 lbs.

Problem 21. In Problem 20, if the track from the bottom of the loop to the right rises 2 feet in a distance of 10 feet, how wide a gap, mn , can be leaped?

Ans. 21.4 ft.

CHAPTER IX.

ROTATION.

98. Angular Displacement. If a particle describes a curvilinear motion with a constant radius r , the motion is called rotation and the angle described by the radius is called angular displacement. The unit of angular displacement is the *radian*. The radian is the angle at the center subtended by an arc equal in length to the radius. In Fig. 242, the length of the arc AB is equal to the radius r , so the angle AOB is one radian. Let the length of the arc ABC be s . Since any angle is proportional to its subtending arc,

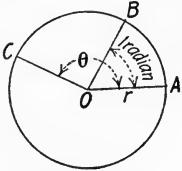

FIG. 242

$$\theta = \frac{s}{r} \text{ or}$$

$$s = r\theta.$$

There are 2π radians subtended by a complete circumference. Hence 2π radians = 360° and 1 radian = $\frac{360^\circ}{2\pi} = 57^\circ.3$. (More accurately $57^\circ.29578$.)

Angular displacement in the counterclockwise direction is considered to be positive, that in the clockwise direction negative.

Problem 1. Reduce to radians: 45° ; 100° ; 900° ; 4 revolutions.

Ans. 0.7854. 1.746. 15.71 25.13.

Problem 2. Reduce to degrees: 2 radians; π radians.

99. Angular Velocity. Angular velocity is the time rate of angular displacement. If equal angular displacements occur in equal intervals of time, the angular velocity is constant. Let ω represent the angular velocity in radians per second. Then if θ represents the angular displacement in time t , the rate of angular displacement, or angular velocity, is given by

$$\omega = \frac{\theta}{t}.$$

If the angular velocity varies, the *average* angular velocity for any small interval of time Δt is given by

$$\omega = \frac{\Delta\theta}{\Delta t}.$$

The instantaneous angular velocity is given by

$$\omega = \frac{d\theta}{dt}.$$

Angular velocity is commonly given in revolutions per minute (r.p.m.), which must usually be reduced to radians per second for the solution of problems.

$$1 \text{ r.p.m.} = \frac{1}{60} \text{ rev. per sec.} = \frac{2\pi}{60} \text{ rad. per sec.}$$

Since angular velocity involves only magnitude and direction, it is a vector quantity and may be represented graphically by a vector. In the same way as for vectors of couples, the vector is drawn parallel to the axis of rotation with the arrow pointing in the direction from which the rotation appears counterclockwise or positive. Vectors representing angular velocity may be combined graphically into their resultant vector which represents the resultant velocity. Conversely, the vector representing an angular velocity may be resolved into component vectors.

The relation between the linear and the angular velocities of a point moving in a circular path is obtained as follows.

By definition, $v = \frac{ds}{dt}$. Since $s = r\theta$, $v = \frac{rd\theta}{dt}$. But $\frac{d\theta}{dt} = \omega$, so

$$\mathbf{v} = r\boldsymbol{\omega}.$$

Problem 1. A pulley 40 inches in diameter rotates at 120 r.p.m. What is its angular velocity in radians per second and what is the speed of the belt in feet per second?
Ans. 12.57 rad. per sec. 20.94 ft. per sec.

Problem 2. The smaller of two friction wheels is 3 inches in diameter and the larger is 24 inches in diameter. If the smaller wheel rotates at 30 r.p.m., what is the angular velocity of the larger wheel? What is the speed of the rim?
Ans. $\omega = 0.3927$ rad. per sec. $v = 0.3927$ ft. per sec.

100. Angular Acceleration. Angular acceleration is the time rate of change of angular velocity. If the angular velocity is constant, the angular acceleration is zero. If the angular velocity changes by equal amounts in equal time intervals, the angular acceleration is constant. If the angular velocity changes by

unequal amounts in equal time intervals, the angular acceleration is variable.

If the angular acceleration is constant, its value may be obtained by dividing the total change in angular velocity by the time t in which the change was made. If α represents the angular acceleration and ω the change in angular velocity,

$$\alpha = \frac{\omega}{t}.$$

If the angular acceleration is variable, its instantaneous value at any point is given by

$$\alpha = \frac{d\omega}{dt} = \frac{d^2\theta}{dt^2}.$$

By eliminating dt from the two equations, $\omega = \frac{d\theta}{dt}$ and $\alpha = \frac{d\omega}{dt}$, there is obtained the equation

$$\omega \, d\omega = \alpha \, d\theta.$$

The unit of angular acceleration is the radian per second per second. Like angular velocity, angular acceleration is a vector quantity and may be represented graphically by a vector. Angular acceleration has sign, counterclockwise acceleration being usually taken as positive and clockwise acceleration negative.

The relation between tangential and angular acceleration is obtained as follows. By Art. 93, $a_t = \frac{dv}{dt}$. Since $v = r\omega$, $dv = r \, d\omega$ and $a_t = \frac{r \, d\omega}{dt}$. Since $\frac{d\omega}{dt} = \alpha$,

$$a_t = r\alpha.$$

By Art. 93, $a_n = \frac{v^2}{r}$. Since $v = r\omega$,

$$a_n = r\omega^2.$$

It is seen that the tangential acceleration varies directly with the radius and with the angular acceleration. The normal acceleration varies with the radius and with the square of the angular velocity. It is independent of the angular acceleration.

101. Simple Harmonic Motion: Auxiliary Circle Method. The equations of simple harmonic motion may be derived very easily by means of the *Auxiliary Circle*. If a point describes a circular motion with uniform speed, the motion of its projection upon a diameter is *simple harmonic motion*, as will be shown later.

Let P , Fig. 243, be the point, moving counterclockwise at ω radians per second with an angular displacement of θ from A . If time is measured from the instant when P is at point A , $\theta = \omega t$. Let the tangential velocity of the point P be v_0 . Let P' be the projection of P upon the horizontal diameter. The velocity of P' at O is evidently the same as that of P at A , since both are moving horizontally. At any point in its path, the velocity v of P' is equal to the horizontal component of the velocity of P in its corresponding position, or

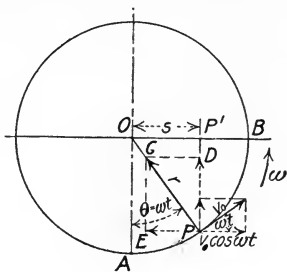

FIG. 243

$$v = v_0 \cos \omega t.$$

Since the point P is moving around the circle with uniform speed, its only acceleration is toward the center and is $a_n = r\omega^2$, represented by the vector PC . The acceleration a of the point P' is along its path and is equal to the horizontal component PE of the acceleration of point P . This horizontal component is equal to $a_n \sin \theta = r\omega^2 \times \frac{s}{r} = \omega^2 s$. The direction is negative, so

$$a = -\omega^2 s.$$

Since ω^2 is a constant, a is proportional to the displacement s , hence the motion of P' is simple harmonic motion.

By squaring the first equation above,

$$v^2 = v_0^2 \cos^2 \omega t.$$

Since $\cos^2 \omega t = 1 - \sin^2 \omega t = 1 - \frac{s^2}{r^2}$,

$$v^2 = v_0^2 \left(1 - \frac{s^2}{r^2} \right) = v_0^2 - \omega^2 s^2.$$

$$v = \sqrt{v_0^2 - \omega^2 s^2}.$$

From Fig. 243,

$$s = r \sin \omega t.$$

Solving for t ,

$$t = \frac{1}{\omega} \sin^{-1} \frac{s}{r}.$$

In these equations, t is the time from position O . From the last equation the time from O to B is evidently

$$t = \frac{1}{\omega} \sin^{-1} 1 = \frac{\pi}{2\omega}.$$

If K is substituted for ω^2 , the formulas of this article become identical with those of Art. 87, and as was there shown, the period is four times the time from O to B .

$$T = \frac{2\pi}{\omega}.$$

If the crank pin of a reciprocating engine rotated with uniform speed, the piston would have simple harmonic motion if the connecting rod were of infinite length, or if the slotted slider shown in Fig. 244 were used.

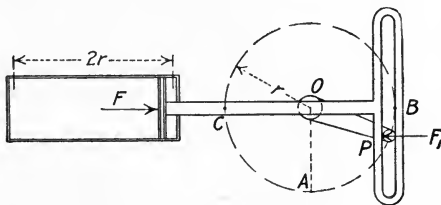

FIG. 244

EXAMPLE.

In the mechanism shown in Fig. 244, let $r = 1$ foot and let the crank pin be rotating at 120 r.p.m. Determine ω , T , v_0 and the maximum acceleration of the piston. If the weight of the piston and slider is 200 pounds and the steam pressure F is zero, what is the pressure F_1 of the crank pin on the slider when the piston is at its end piston?

Solution: — 120 r.p.m. = 2 rev. per sec. = 4π rad. per sec.

$$\omega = 4\pi = 12.57 \text{ rad. per sec.}$$

$$T = \frac{2\pi}{\omega} = \frac{1}{2} \text{ sec.}$$

$$v_0 = r\omega = 12.57 \text{ ft. per sec.}$$

Maximum

$$a = -\omega^2 r = -158 \text{ ft. per sec. per sec.}$$

At the end position the only force acting upon the piston and slider in the direction of its motion is the pressure of the crank pin F_1 . The acceleration is toward the left, so the force F_1 must act toward the left. From $F = Ma$,

$$F_1 = \frac{200}{32.2} \times 158 = 981 \text{ lbs.}$$

Problem 1. In Fig. 244 let the angle POA of the crank with the vertical radius OA be 30° and let all other data be the same as in the Example above. Determine the velocity and the acceleration of the piston. Determine the time since it was in its middle position. If the steam pressure $F = 500$ pounds, what is the crank pin pressure F_1 ?

Ans. $v = 10.88$ ft. per sec. $a = -79$ ft. per sec. per sec. $t = \frac{1}{4}$ sec. $F_1 = 991$ lbs.

Problem 2. With the same data as in the Example above, determine the velocity and acceleration of the piston and its distance from the right end of the cylinder 0.15 second after passing the middle position moving to the right. If the steam pressure is 1500 pounds (to the left), what is the crank pin pressure?

Ans. $v = 3.88$ ft. per sec. $a = 150.3$ ft. per sec. per sec. $F_1 = 566$ lbs. to right.

102. Constant Angular Acceleration. In Art. 82 the following expressions were derived for the linear motion of a particle with constant acceleration.

$$v = v_0 + at. \quad (1)$$

$$s = \frac{1}{2}(v + v_0)t = v_0t + \frac{1}{2}at^2. \quad (2)$$

$$v^2 = v_0^2 + 2as. \quad (3)$$

At any instant these equations apply also to the tangential motion of a particle moving in a circle with constant tangential acceleration. In the formulas above, a becomes a_t . From Arts. 98, 99 and 100,

$$\theta = \frac{s}{r}, \quad \omega = \frac{v}{r} \quad \text{and} \quad \alpha = \frac{a_t}{r}.$$

If equations (1) and (2) are divided by r and simplified, they become

$$\omega = \omega_0 + \alpha t. \quad (4)$$

$$\theta = \frac{1}{2}(\omega + \omega_0)t = \omega_0t + \frac{1}{2}\alpha t^2. \quad (5)$$

Similarly, if equation (3) is divided by r^2 , it becomes

$$\omega^2 = \omega_0^2 + 2\alpha\theta. \quad (6)$$

Problem 1. A flywheel is brought from rest up to a speed of 60 r.p.m. in $\frac{1}{2}$ minute. What is the average angular acceleration α , and the number of revolutions required? What is the velocity at the end of 15 seconds?

Ans. $\alpha = 0.2094$ rad. per sec. per sec. 15 rev. $\omega_{15} = 3.14$ rad. per sec. ~~✗~~ ?

Problem 2. If the flywheel of Problem 1 is 12 feet in diameter, what is the tangential velocity and acceleration of a point on the rim? What is the normal acceleration at the instant full speed is attained?

Ans. $v = 37.7$ ft. per sec. $a_t = 1.256$ ft. per sec. per sec. $a_n = 237$ ft. per sec. per sec.

Problem 3. A pulley which is rotating at 120 r.p.m. comes to rest under the action of friction in 3 minutes. What is the angular acceleration and the total number of revolutions made?

Ans. $\alpha = 0.0698$ rad. per sec. per sec. 180 rev.

Problem 4. The rim of a 33-inch wheel on a brake shoe testing machine has a speed of 60 miles per hour when the brake is dropped. It comes to rest when the rim has traveled a tangential distance of 440 feet. What is the angular acceleration and the number of revolutions?

Ans. $\alpha = 6.4$ rad. per sec. per sec. 50.9 rev.

103. Variable Angular Acceleration. If in a circular motion the angular acceleration α is variable, its law of variation must be known in order to obtain the equations of motion. In certain physical problems the acceleration is zero in the mid-position and increases directly with the angular displacement θ to either side of this position and is oppositely directed. Then $\alpha = -K\theta$, K being a constant. Let the angular velocity at the mid-position be ω_0 . Since $\omega d\omega = \alpha d\theta$,

$$\int_{\omega_0}^{\omega} \omega d\omega = -K \int_0^{\theta} \theta d\theta.$$

$$\omega = \sqrt{\omega_0^2 - K\theta^2}.$$

Since $\omega = \frac{d\theta}{dt}$, this equation becomes

$$dt = \frac{d\theta}{\sqrt{\omega_0^2 - K\theta^2}}.$$

If time is measured from the instant the body is in the mid-position moving positively, the limits of t are 0 and t , and of θ are 0 and θ .

$$\int_0^t dt = \int_0^{\theta} \frac{d\theta}{\sqrt{\omega_0^2 - K\theta^2}}.$$

$$t = \frac{1}{\sqrt{K}} \sin^{-1} \frac{\theta \sqrt{K}}{\omega_0}.$$

By transposing,

$$\theta = \frac{\omega_0}{\sqrt{K}} \sin \sqrt{K}t.$$

From the above equations it will be seen that the motion is periodic. (See Equation (2), Art. 87.) These equations apply to the motion of a torsion balance and approximately to that of a simple pendulum with vibrations of small amplitude.

Problem 1. The balance wheel of a watch is $\frac{1}{2}$ inch in diameter and oscillates 45° to either side of its mid-position. The time of one complete oscillation is $\frac{1}{2}$ second. What is its greatest angular acceleration, its greatest angular velocity, its greatest tangential acceleration and its greatest normal acceleration?

Ans. $\alpha = 124$ rad. per sec. per sec. $\omega_0 = 9.87$ rad. per sec. $a_t = 2.58$ ft. per sec. per sec. $a_n = 2.03$ ft. per sec. per sec.

104. Effective Forces on a Rotating Body. Let Fig. 245 represent any rotating body and P any particle of mass dM , at a

radial distance ρ from the axis of rotation, O . Then if the body has an angular velocity ω and an angular acceleration α , the tangential and normal components of the acceleration a are $a_t = \rho\alpha$ and $a_n = \rho\omega^2$ respectively for each dM . The effective force for each dM is given by its two components, $dM\rho\alpha$ tangential to its path and $dM\rho\omega^2$ normal to its path.

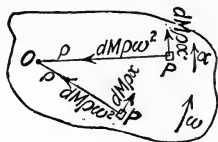

FIG. 245

It will be seen that for equal dM 's, these tangential and normal effective forces vary with the radius ρ , both in amount and direction. The tangential effective forces vary directly with ρ and are always at right angles to it in the direction of the angular acceleration. The normal effective forces vary directly with ρ and are always directed along the radius toward the axis.

105. Moment of Tangential Effective Forces. In Fig. 246 let O be the axis of rotation, C the center of gravity, F the resultant of all the external forces except the reaction at the axis O , and d the distance from the axis of rotation to the line of action of force F . P is any particle of mass dM , whose tangential effective force is $dM\rho\alpha$ as shown. (Since rotation alone is being considered, forces parallel to the axis of rotation are neglected.)

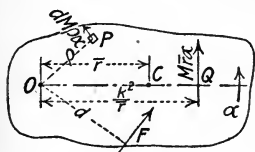

FIG. 246

By the principle of Art. 85 the impressed forces would be in equilibrium with the effective forces reversed. Since neither the normal effective forces (not shown) nor the reaction at O (not shown) have any moment about the axis O , the moment of the tangential effective forces must be equal to the moment of the impressed forces, or

$$Fd = \int dM\rho^2\alpha.$$

Since at any instant all particles of the body have the same value of α

$$Fd = \alpha \int dM\rho^2.$$

The value of $\int dM\rho^2$ if integrated between the proper limits is I , the moment of inertia of the body with respect to the axis of rotation. Then

$$Fd = I\alpha.$$

The analogy of this equation to the equation $F = Ma$ was discussed in the footnote to Art. 66.

It is convenient sometimes to consider the moment $I\alpha$ as equivalent to the moment of a single force $M\bar{r}\alpha$ (the total mass \times tangential acceleration of mass center). Its moment arm is given by

$$\frac{I\alpha}{M\bar{r}\alpha} = \frac{Mk^2\alpha}{M\bar{r}\alpha} = \frac{k^2}{\bar{r}}.$$

Then a force $M\bar{r}\alpha$ acting tangentially through point Q , Fig. 246, distant $\frac{k^2}{\bar{r}}$ from the axis has a moment about the axis equivalent to that of the actual tangential system of effective forces. It is evident from the discussion above that if the effective tangential force $M\bar{r}\alpha$ were reversed in direction and made to act tangentially through point Q , its moment would balance the accelerating moment of the external system of forces and would produce a static condition of rotation.

If a body rotates about its center of gravity so that points O and C coincide, $\bar{r} = 0$, so $\frac{k^2}{\bar{r}} = \text{infinity}$. This shows that in this case the equivalent moment can be given only by a couple of moment $I\alpha$, and not by a single force.

EXAMPLE 1.

A slender rod of length l is released from a horizontal position and allowed to rotate under the influence of gravity alone about a horizontal axis through one end, perpendicular to the axis of the rod. Determine the amount and position of the tangential effective force $M\bar{r}\alpha$ at the instant of starting.

Solution: — Let W be the weight of the rod. From the equation

$$\begin{aligned}Fd &= I\alpha, \\ \frac{Wl}{2} &= \frac{Wl^2}{g} \frac{\alpha}{3}, \\ \alpha &= \frac{3g}{2l}.\end{aligned}$$

$$M\bar{r}\alpha = \frac{W}{g} \times \frac{l}{2} \times \frac{3g}{2l} = \frac{3}{4}W.$$

$$\frac{k^2}{\bar{r}} = \frac{l^2}{3} \div \frac{l}{2} = \frac{2}{3}l.$$

EXAMPLE 2.

Fig. 247 represents a cast iron cylinder 3 feet in diameter and 6 inches thick, free to rotate about its geometric axis O . If a force of 10 pounds is

applied to a cord wrapped around the cylinder, what is the angular acceleration, the tangential acceleration, the angular velocity after 5 seconds and the number of revolutions it has turned? Neglect the axle friction.

Solution: — The forces acting upon the cylinder are its weight, the reactions of the supports at O , and the force F . The first two forces have no moment about the geometric axis, so the moment

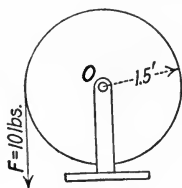

FIG. 247

$$Fd = 10 \times 1.5 = 15 \text{ ft. lbs.}$$

$$I_0 \text{ of the cylinder} = \frac{1}{2} Mr^2 = 55.6.$$

$$Fd = I\alpha.$$

$$15 = 55.6 \alpha.$$

$$\alpha = 0.27 \text{ rad. per sec. per sec.}$$

$$a_t = r\alpha = 0.405 \text{ ft. per sec. per sec.}$$

$$\omega = \alpha t, \text{ so } \omega_5 = 1.35 \text{ rad. per sec.}$$

$$\theta = \frac{1}{2} \alpha t^2 = 3.375 \text{ rad. in 5 sec.}$$

$$3.375 \div 2\pi = 0.537 \text{ rev. in 5 sec.}$$

EXAMPLE 3.

Instead of a force $F = 10$ lbs., let a weight of 10 lbs. be hung from the cord in Example 2. Determine the angular acceleration and the tension T in the cord.

Solution: — First, let the cylinder be considered as the free body.

The equation $Fd = I\alpha$ gives $T \times 1.5 = 55.6 \alpha$.

This equation contains two unknown quantities, so the equation of motion of the suspended weight must be written.

$$10 - T = \frac{10}{32.2} a.$$

Since a of the weight $= a_t$ of the rim of the cylinder, and $a_t = r\alpha$,

$$10 - T = \frac{10}{32.2} \times 1.5 \alpha.$$

$$\alpha = 0.266 \text{ rad. per sec. per sec.}$$

$$T = 9.86 \text{ lbs.}$$

Problem 1. A steel cylinder 2 feet in diameter and 2 inches thick is fastened firmly to an axle 2 inches in diameter. A weight of 50 pounds is hung from a cord wrapped around the axle. Find α and T , neglecting the mass of the protruding parts of the axle and also the axle friction.

Ans. $\alpha = 1.045$ rad. per sec. per sec. $T = 49.85$ lbs.

Problem 2. A cast iron flywheel 4 feet in diameter has a rim 2 inches thick and 12 inches wide. To its axle is fastened a 20-inch pulley around which a cord passes. If a 100-pound weight is hanging from the end of the cord, what is the angular acceleration of the flywheel and what is the tension in the cord? Neglect the mass of the axle, hub, spokes and small pulley, also axle friction.

Ans. $\alpha = 0.785$ rad. per sec. per sec. $T = 97.9$ lbs.

Problem 3. A cast iron cylinder 3 feet in diameter and 2 feet long is rotating at 360 r.p.m. A brake which rubs against the curved surface of the cylinder has a normal pressure on it of 500 pounds. The coefficient of friction between the brake and the cylinder is $f = 0.2$. If the friction on the shaft is neglected, what is the time required for the brake to bring the cylinder to rest? Through how many revolutions will it turn?

Ans. 56 sec. 168 rev.

106. Resultant of Normal Effective Forces. As stated in Art. 104 the normal effective forces for the particles of a rotating body at any instant are directly proportional to their radii and act toward the axis of rotation. (See Fig. 245.) In general, the resultant of these normal forces for the whole body is a force and a couple, as was shown in Art. 39. The solution of this problem in the general case is involved and difficult, for usually the resultant force does not act through the center of gravity, and the resultant couple is hard to obtain since it involves the product of inertia of the body. Fortunately, nearly all engineering problems in rotation come under a few special cases in which the value of the couple is zero or is easily obtained and the resultant force is easily located. Three of these cases will be discussed.

Case 1. *If a body has a plane of symmetry and rotates about any axis normal to this plane, the resultant normal effective force acts radially through the center of gravity and is equal to $M\bar{r}\omega^2$.*

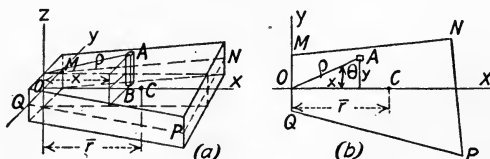

FIG. 248

Let Fig. 248(a) represent a body which has a plane of symmetry $QMNP$. Let the axis OZ normal to the plane of symmetry be the axis of rotation, and let the X axis be taken through the center of gravity C . Let AB be any elementary prism of mass dM , parallel to the axis OZ . Since each part of the prism has the same normal acceleration $a_n = \rho\omega^2$, the resultant of the normal effective forces for the prism AB is $dM\rho\omega^2$ acting in the plane of symmetry toward the axis OZ . Fig. 248(b) shows the section cut by the plane of symmetry. The X component of the force $dM\rho\omega^2$ is

$dM\rho\omega^2 \cos \theta = dM\rho\omega^2 \frac{x}{\rho} = dM\omega^2 x$, and for the entire body $\Sigma F_x =$

$\omega^2 \int dMx = M\bar{x}\omega^2 = M\bar{r}\omega^2$. The Y component of the force $dM\rho\omega^2$

is $dM\rho\omega^2 \sin \theta = dM\rho\omega^2 \frac{y}{\rho} = dM\omega^2 y$, and for the entire body, $\Sigma F_y =$

$\omega^2 \int dMy = M\bar{y}\omega^2 = 0$, since $\bar{y} = 0$. Hence the resultant of all

the normal effective forces is $M\bar{r}\omega^2$ acting in the plane of symmetry parallel to the X axis. Since the normal effective forces all pass through the axis OZ they have no moment about OZ ; hence their resultant can have no moment about OZ and must therefore lie in the axis OX through the center of gravity.

If the axis OZ passes through the center of gravity, $\bar{r} = 0$, so the resultant normal effective force $M\bar{r}\omega^2 = 0$.

Case 2. *If a body has a line of symmetry and rotates about an axis parallel to this line, the resultant normal effective force acts through the center of gravity and is equal to $M\bar{r}\omega^2$.*

In Fig. 249, let AB be a line of symmetry of the body shown and let the body be rotating about axis OZ parallel to AB . Consider

the plate EF of thickness dz and mass dM , whose plane is normal to the axis OZ . By Case 1, the resultant normal effective force on plate EF is $dM\bar{r}\omega^2$, acting through the center of gravity of the plate toward the axis OZ . On each similar plate there is a corresponding normal effective force directed from line AB normal to axis OZ , and each force is proportional to the mass of its plate. As

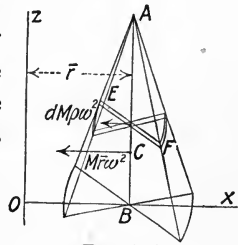

FIG. 249

shown in the last paragraph of Art. 43, the resultant of this system of parallel forces acts through the center of gravity of the body. Its amount is equal to $\Sigma dM\bar{r}\omega^2 = M\bar{r}\omega^2$, since \bar{r} and ω are constants.

If the axis OZ coincides with the line of symmetry, $\bar{r} = 0$ and the resultant normal effective force $M\bar{r}\omega^2 = 0$.

Case 3. *If a slender prismatic rod of length l is rotating about an axis through one end at any angle θ with the axis, the resultant normal effective force is equal to $M\bar{r}\omega^2$ and acts through a point distant $\frac{2}{3} l$ from the point of support.*

In Fig. 250, let OB be the rod of length l with its center of gravity at C , and let it be rotating about the axis OA with angular velocity ω . Let the rod be divided into equal elementary parts. The normal effective force on any elementary mass dm is equal to $dM\rho\omega^2$, ρ being the radial distance of the mass dM . These forces are proportional to the radial distances of the masses and are acting normal to the axis AO . Since ω^2 is the same for all elements, the resultant of all the effective forces becomes ω^2

$\int dM\rho = M\bar{r}\omega^2$ and acts at point Q , distant $\frac{2}{3}l$ from O . (See Art. 48.) If the axis does not pass through the end of the rod, the part on each side of the axis is treated independently.

Problem 1. A steel cone has the following dimensions: height $h = 4$ inches; radius of base $r = 2$ inches. If it is rotating at 200 r.p.m. about an axis parallel to its geometric axis and distant 6 inches from it, what is the resultant normal effective force? *Ans.* 32.4 lbs.

Problem 2. If the cone of Problem 1 is rotating about a diameter of the base at 120 r.p.m., what is the resultant normal effective force?

Ans. 1.94 lbs.

Problem 3. A cast iron disk 8 inches in diameter and 2 inches thick rotates about an element of the cylindrical surface. Compute the normal effective force for a speed of 60 r.p.m.

Ans. 10.7 lbs.

Problem 4. A steel rod 1 inch in diameter and 18 inches long is rotating about a vertical axis through one end. If it stands at an angle of 45° with the axis, at what speed is it rotating?

Ans. 64.5 r.p.m.

107. Reactions of Supports of Rotating Bodies. For any given problem in rotation, the unknown reactions of the supports may be determined by the principle of Art. 85. That is, if in addition to the actual impressed forces there be added the *reversed* effective forces, the body will be under static conditions and all static equations of equilibrium will be true. The method of solution is as follows: Draw the free body diagram and show all impressed forces, known and unknown. (Unknown reactions of supports are commonly replaced by axial, normal and tangential components.) Determine the angular acceleration and velocity from the given conditions. Determine the normal and tangential components of the effective force and apply these reversed. These components act through a point at a distance $\frac{k^2}{\bar{r}}$ from the axis.

Solve as many equations of equilibrium as are necessary to determine all of the unknown quantities.

If $\bar{r} = 0$, $M\bar{r}\omega^2 = 0$ and $M\bar{r}\alpha = 0$, so there are no *kinetic* reactions of the supports for Cases 1 and 2, but the reactions are the same as when the body is at rest. In Case 3, if the axis passes through the center of gravity of the rod the reaction of the support becomes a couple.

EXAMPLE 1.

Fig. 251(a) represents a steel disk 1 foot in diameter and 1 inch thick, free to rotate about an element through O . If it starts from rest with C vertically above O and rotates under the influence of gravity alone, find the normal and tangential components of the hinge reaction at O when $\theta = 90^\circ$.

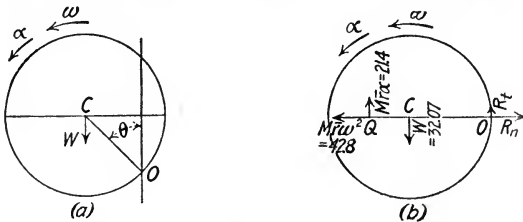

FIG. 251

Solution: — $\bar{r} = \frac{1}{2}$ ft.; $W = 32.07$ lbs.; $M = 0.995$; $I_c = \frac{1}{2} Mr^2 = 0.124$; $I_o = I_c + Mr^2 = 0.373$.

The equation of motion is

$$W\bar{r} \sin \theta = I_o \alpha.$$

When $\theta = 90^\circ$, $\sin \theta = 1$ and this equation becomes

$$32.07 \times 0.5 = 0.373 \alpha.$$

$$\alpha = 43 \text{ rad. per sec. per sec.}$$

To obtain ω , solve for α in the equation of motion and substitute its value in the expression $\alpha d\theta = \omega d\omega$ and integrate between the proper limits.

$$W\bar{r} - W\bar{r} \cos \theta = \frac{1}{2} I \omega^2.$$

When $\theta = 90^\circ$, $\cos \theta = 0$ and this equation becomes

$$32.07 \times 0.5 = 0.5 \times 0.373 \omega^2.$$

$$\omega = 9.27 \text{ rad. per sec.}$$

$$M\bar{r}\alpha = 0.995 \times 0.5 \times 43 = 21.4 \text{ lbs.}$$

$$M\bar{r}\omega^2 = 0.995 \times 0.5 \times 86 = 42.8 \text{ lbs.}$$

$$\frac{k^2}{\bar{r}} = \frac{I}{M\bar{r}} = 0.75 \text{ ft.} = \text{distance } OQ.$$

Fig. 251(b) shows the free body diagram in the position asked for, with the effective forces reversed, and the hinge reaction represented by its normal and tangential components. From the static equations of equilibrium,

$$\Sigma F_x = 0, \text{ so } R_n = 42.8 \text{ lbs.}$$

$$\Sigma F_y = 0, \text{ so } R_t = 32.07 - 21.4 = 10.67 \text{ lbs.}$$

EXAMPLE 2.

A vertical axle MN 4 feet long carries a horizontal arm AB 2 feet long which is attached to the axle 1 foot from the top as shown in Fig. 252. On the end of the horizontal arm is a cast iron sphere 6 inches in diameter. The axle is rotated positively by a pull of 10 lbs. on the cord which passes around the pulley C . If the sphere starts from rest in the XZ plane and the pull is parallel to the X axis, determine the reactions due to the sphere after one revolution.

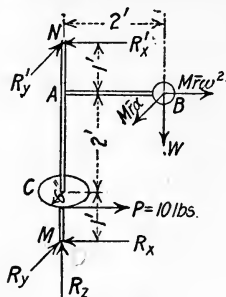

FIG. 252

$$\text{Solution: — } W = \frac{4}{3} \pi r^3 \times 450 = 29.45 \text{ lbs.}$$

$$M = 0.914. \quad I_{MN} = 3.679. \quad \frac{R^2}{r} = 2.013 \text{ ft.}$$

$$\theta = 2\pi \text{ radians} = 360^\circ.$$

$$\text{Equation } Pd = I\alpha \text{ gives}$$

$$10 \times 0.5 = 3.679 \alpha.$$

$$\alpha = 1.36 \text{ rad. per sec. per sec.}$$

Since the acceleration is constant,

$$\omega = \sqrt{2\alpha\theta} = 4.135 \text{ rad. per sec. after 1 revolution.}$$

$$M\bar{r}\alpha = 0.914 \times 2 \times 1.36 = 2.486 \text{ lbs.}$$

$$M\bar{r}\omega^2 = 0.914 \times 2 \times 17.1 = 31.25 \text{ lbs.}$$

The latter two forces are added reversed in Fig. 252, so the system as shown is in equilibrium.

$$\text{Equation } \Sigma F_z = 0 \text{ gives}$$

$$R_z = W = 29.45 \text{ lbs.}$$

$$\text{Equation } \Sigma M_{R_y} = 0 \text{ gives}$$

$$R_x' \times 4 - 29.45 \times 2 - 31.25 \times 3 - 10 \times 1 = 0.$$

$$R_x' = 40.66 \text{ lbs.}$$

$$\text{Equation } \Sigma F_x = 0 \text{ gives}$$

$$R_x = 0.59 \text{ lbs.}$$

$$\text{Equation } \Sigma M_{R_x} = 0 \text{ gives}$$

$$R_y' \times 4 - 2.486 \times 3 = 0.$$

$$R_y' = 1.86 \text{ lbs.}$$

$$\text{Equation } \Sigma F_y = 0 \text{ gives}$$

$$R_y = 0.62 \text{ lbs.}$$

Problem 1. With the same general data as in Example 1 above, compute the normal and tangential components of the reaction when $\theta = 45^\circ$.

$$\text{Ans. } R_n = 10.15 \text{ lbs. } R_t = 7.54 \text{ lbs.}$$

Problem 2. In Problem 1 compute the vertical and horizontal components of the reaction when $\theta = 135^\circ$.

$$\text{Ans. } R_y = 73 \text{ lbs. } R_x = 62.3 \text{ lbs.}$$

Problem 3. In Problem 1 compute the normal and tangential components of the reaction when $\theta = 180^\circ$.

$$\text{Ans. } R_n = 117.6 \text{ lbs. } R_t = 0.$$

Problem 4. With the same general data as in Example 2 above, compute the reactions when the sphere has rotated one-half revolution from rest.

$$\text{Ans. } R_x = 18.33 \text{ lbs. } R_x' = -23.93 \text{ lbs. } R_y = -0.62 \text{ lbs. } R_y' = -1.86 \text{ lbs.}$$

Problem 5. With the same general data as in Example 2 above, compute the reactions when the sphere has rotated one second from rest.

Ans. $\theta = 0.68$ rad. $R_x = -2.9$ lbs. $R_x' = 17.1$ lbs. $R_y = 9.2$ lbs. $R_y' = -9.44$ lbs.

108. Compound Pendulum. Any physical body suspended from a horizontal axis not passing through the center of gravity and free to rotate under the influence of gravity and the reaction of the support is called a *compound pendulum*. The student should refer again to Art. 95, Simple Circular Pendulum.

Let Fig. 253 represent a compound pendulum of weight W , suspended at O , and let C be its center of gravity. Let I be its moment of inertia with respect to the axis of rotation, k its radius of gyration, \bar{r} the distance from the support to the center of gravity and α the angular acceleration. The equation of moments about O gives

$$\Sigma M_0 = -W\bar{r} \sin \theta = I\alpha.$$

Since

$$I = Mk^2 = \frac{W}{g}k^2,$$

$$\alpha = -\frac{W\bar{r} \sin \theta}{\frac{W}{g}k^2} = -\frac{\bar{r}g \sin \theta}{k^2}.$$

The tangential acceleration a_t of point Q , at a distance l from the axis O , is

$$a_t = l\alpha = -\frac{\bar{r}lg \sin \theta}{k^2}.$$

If the length l be taken equal to $\frac{k^2}{\bar{r}}$, the tangential acceleration a_t of point Q will be

$$a_t = -g \sin \theta,$$

which is the same as the acceleration of the simple circular pendulum. It is seen from this that a simple circular pendulum of length $l = \frac{k^2}{\bar{r}}$ will vibrate in the same time as the compound pendulum.

The length $\frac{k^2}{\bar{r}}$ is called the *length of the compound pendulum*, and the point Q is called the *center of oscillation*.

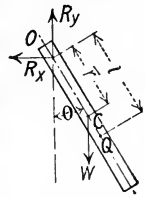

FIG. 253

Since $l = \frac{k^2}{\bar{r}}$, the time of one complete period becomes

$$T = 2\pi \sqrt{\frac{k^2}{g\bar{r}}}$$

Also,

$$k = \frac{T}{2\pi} \sqrt{g\bar{r}}$$

The point of suspension and the center of oscillation are interchangeable, as will now be shown. Let k_c be the radius of gyration of the pendulum with respect to the axis through the center of gravity C parallel to the axis of rotation. Since

$$k_c^2 = k^2 - \bar{r}^2 \quad \text{and} \quad k^2 = \bar{r}l,$$

$$k_c^2 = \bar{r}(l - \bar{r}) = OC \times QC.$$

Since k_c is a constant, regardless of the point of suspension, the product $OC \times QC$ must be a constant. If OC is made smaller, QC becomes proportionately larger, and *vice versa*.

Again, this equation would not be altered in any way if the position of O and Q were interchanged, hence if the pendulum is inverted and suspended from Q , point O must become the center of oscillation. Since the length l remains the same, the time of vibration is the same.

EXAMPLE.

A cylinder 2 inches in diameter and 12 inches long is hung from an axis through the diameter of one end. Find the time of oscillation. From what other point could it be suspended to vibrate in the same length of time?

Solution: — $k^2 = \frac{r^2}{4} + \frac{h^2}{3} = 0.335 \text{ ft.}^2$

$$T = 2\pi \sqrt{\frac{0.335}{32.2 \times 0.5}} = 0.905 \text{ sec.}$$

The center of oscillation is given by

$$\frac{k^2}{\bar{r}} = \frac{0.335}{0.5} = 0.67 \text{ ft.}$$

If the cylinder is suspended from the center of oscillation it will vibrate in the same length of time.

Problem 1. Find the time of oscillation and the center of oscillation for the cylinder of the Example above, if suspended from an axis through the cylinder 1 inch above the middle. *Ans.* $T = 1.16 \text{ sec.}$ $\frac{k^2}{\bar{r}} = 1.105 \text{ ft.}$

Problem 2. A bar 1 inch square is suspended from a central axis through one end parallel to the edges. What must be its length in order that it shall oscillate in 1 second. (Complete period.) *Ans.* $h = 1.225 \text{ ft.}$

Problem 3. Show that the bar of Problem 2 has four points of suspension for which its period of oscillation is 1 second. *Ans.* 0.408 ft. from the end.

109. Center of Percussion. Let P , Fig. 254, be an impulsive force or blow which causes angular acceleration of the body which is suspended from O . The force P is variable, but at any instant during the blow,

$$Pd = I\alpha.$$

By the principle of Art. 105, the resultant tangential effective force $M\bar{r}\alpha$ acts at point Q , distant $\frac{k^2}{r}$ from the point of support.

Let R_x be the tangential component of the reaction at O caused by P . If the effective force $M\bar{r}\alpha$ is applied reversed, the system shown will be in equilibrium. By using the equation $\Sigma M_Q = 0$, the value of R_x may be computed for any value and position of force P . It is evident that if force P is applied at point Q , $R_x = 0$. The point Q at which the body may be struck without producing any reaction parallel to the tangent is called the center of percussion. It is coincident with the center of oscillation of a pendulum. It follows, then, that the center of percussion and the point of suspension are interchangeable.

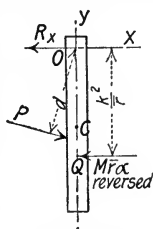

FIG. 254

Problem 1. A slender rod 2 feet long suspended in a vertical position from an axis through one end has a force of 100 lbs. applied normal to the rod at its middle point. What is the amount and direction of the horizontal kinetic reaction caused by the force? *Ans.* $R_x = 25$ lbs.

110. Centrifugal Tension in Flywheels. If the tension in the arms of a flywheel is neglected, the tensile stress in the rim due to rotation may be computed. For the half rim shown in Fig. 255 the normal effective force $M\bar{r}\omega^2$ acts through the center of gravity. Also, the effective force reversed as indicated would be in equilibrium with the two induced tensile forces, P, P . Then, if W is the weight of the half rim,

$$P = \frac{1}{2} \frac{W}{g} \bar{r}\omega^2.$$

If r is the mean radius of the rim, $\bar{r} = \frac{2}{\pi}r$ (approximately). The

unit stress $s = \frac{P}{A}$, A being the area of the cross section of the rim.

If the tension in the rim of the flywheel is neglected, the tensile stress in the arms may be computed. In Fig. 256, let AB be the part of the rim carried by one arm. Let W be the weight of this part and let r be the distance from O to its center of gravity. The induced tensile force caused by rotation is

$$P = \frac{W}{g} \bar{r} \omega^2.$$

The unit stress is $s = \frac{P}{A}$, A being the area of the cross section of the arm.

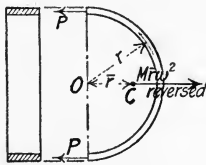

FIG. 255

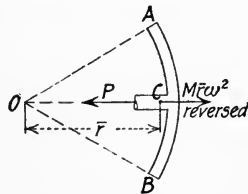

FIG. 256

Problem 1. Show that if the tension in the arms is neglected, the speed necessary to produce the same stress in the rims of flywheels varies inversely as their radii.

Problem 2. A cast iron flywheel 12 feet in diameter has a rim 2 inches thick and 12 inches wide. If the flywheel is rotating at 200 r.p.m., what is the unit centrifugal tensile stress in the rim if the tension in the arms is neglected?

Ans. 1490 lbs. per sq. in.

Problem 3. At what speed must a flywheel 1 foot in diameter be rotated to produce the same unit stress in the rim as in Problem 2?

Ans. 2400 r.p.m.

111. Weighted Conical Pendulum Governor. Fig. 257(a) represents a weighted conical pendulum governor which consists of two spheres, A, A , at the ends of arms BA , and a weight W_1 supported by the collar CC . Consider first the weight W_1 as the free body, Fig. 257(b), with the governor rotating uniformly. The body is under static conditions so equation $\Sigma F_y = 0$ gives

$$P = \frac{W_1}{2 \cos \theta_1}.$$

Consider next one of the spheres and its arm as the free body, Fig. 257(c). The impressed forces acting upon the free body are three in number, the weight W , the tension P and the pin reaction at B . If the effective force $M\bar{r}\omega^2$ is added to the system reversed

in direction, the free body will be under static conditions. Accurately, the force $M\bar{r}\omega^2$ should act through the center of oscillation of the sphere and its arm and the weight of the arm should be

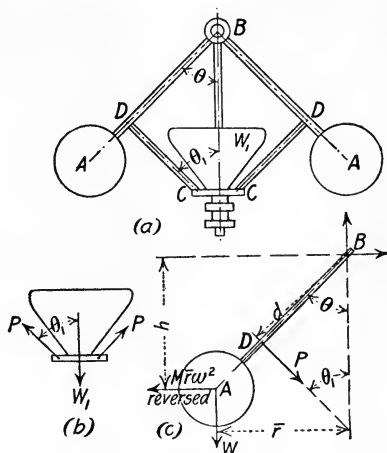

FIG. 257

considered, but the error is small if the weight of the rod be neglected and $M\bar{r}\omega^2$ be considered to act through the center of gravity of the sphere. The equation $\Sigma M_B = 0$ gives

$$Pd + W\bar{r} = M\bar{r}\omega^2 h.$$

Problem 1. In Fig. 257, let $BD = 12$ inches, $DA = 4$ inches, $W = 20$ lbs., $W_1 = 100$ lbs. and $\theta = \theta_1 = 45^\circ$ in the lowest position. At what speed will the governor begin to act?

Ans. 122 r.p.m.

Problem 2. If the governor described in Problem 1 has a spring which carries half of the weight W_1 when it is in its lowest position, at what speed will it begin to act?

Ans. 94.5 r.p.m.

112. Balancing of Rotating Bodies. It was seen in Art. 107 that if a body rotates about an axis not through its center of gravity, the bearing reactions have kinetic components. These continually change in direction and so cause destructive vibration.

Balancing consists in adding rotating parts in such a way that the effective forces for the entire system are in equilibrium and no kinetic reactions are induced. The static reactions due to gravity and any other constant impressed forces remain constant whether the body is at rest or in motion.

In the following discussion, only rotation at constant speed will be considered, and only rotation of bodies for which the resultant

normal effective force passes through the center of gravity. (See Art. 106.)

113. Balancing of Bodies in the Same Plane Normal to the Axis of Rotation. Let *A*, Fig. 258, be a body of weight W_1 , at a radial distance r_1 , rotating about the axis through *O* normal to *OA* with angular velocity ω . By its rotation it exerts upon the axis *O* a centrifugal pull equal to $\frac{W_1}{g} r_1 \omega^2$ which continually changes in direction and causes variable reactions at the supports. If, how-

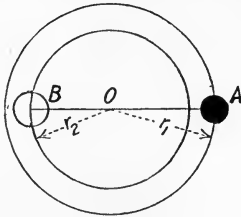

FIG. 258

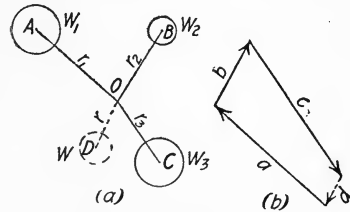

FIG. 259

ever, another body of weight W_2 be placed diametrically opposite in the plane of rotation at the end of radius r_2 , of such length that

$$\frac{W_2 r_2 \omega^2}{g} = \frac{W_1 r_1 \omega^2}{g},$$

the two bodies are in balance since the centrifugal pulls are equal and opposite. Since ω and g are constants, the condition above reduces to

$$W_2 r_2 = W_1 r_1.$$

It should be noted that the condition $W_2 r_2 = W_1 r_1$ is also the condition for static balance. In practice it is customary to determine the necessary value of $W_2 r_2$ by means of static balancing.

Fig. 259(a) represents a number of bodies, W_1 , W_2 , W_3 , at radial distances r_1 , r_2 , r_3 , in the same plane, rotating about the axis through *O* normal to their plane. These are to be balanced by a single weight W with radius r . If a vector polygon, Fig. 259(b), be drawn in which *a*, *b* and *c* represent $W_1 r_1$, $W_2 r_2$ and $W_3 r_3$ respectively in magnitude and direction, the closing line *d* will represent $W r$ in magnitude and direction. Either W or r may be assumed and the other computed.

Problem 1. A sphere weighing 40 lbs. at a radial distance of 10 inches from its axis of rotation is to be balanced by another of 60 lbs. weight. What must be its radial distance?
Ans. $6\frac{2}{3}$ in.

Problem 2. In Fig. 259, $W_1 = 10$ lbs., $W_2 = 5$ lbs., $W_3 = 20$ lbs., $r_1 = 24$ inches, $r_2 = 20$ inches, $r_3 = 16$ inches, angle $AOB = 45^\circ$ and angle $BOC = 90^\circ$. If r is to be 12 inches, what must be the weight W to balance the system? What is the angle DOA ? *Ans.* $W = 25.7$ lbs. $DOA = 105^\circ 50'$.

114. Balancing of Bodies in Different Normal Planes. In either Fig. 260(a) or 260(b) let W_1 be the body to be balanced, and OO the axis about which it rotates. Let planes through any two points B and C normal to the axis be the planes in which the balancing bodies are to lie. If W_1 is to be balanced by two bodies W_2 and W_3 , they must all lie in a plane containing the axis OO . It is also necessary that the sum of the moments of the normal effective forces about any point in this plane shall be equal to zero.

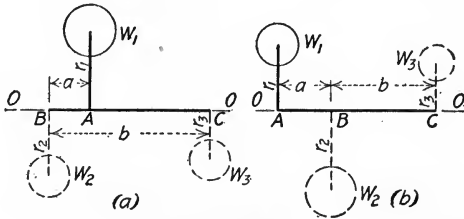

FIG. 260

Equation $\Sigma M_B = 0$ gives

$$\frac{W_3}{g} r_3 \omega^2 b = \frac{W_1}{g} r_1 \omega^2 a,$$

or

$$W_3 r_3 b = W_1 r_1 a.$$

In Fig. 260(a), equation $\Sigma M_C = 0$ gives

$$W_2 r_2 b = W_1 r_1 (b - a).$$

In Fig. 260(b), the same equation gives

$$W_2 r_2 b = W_1 r_1 (b + a).$$

From these equations the two unknown quantities, $W_2 r_2$ and $W_3 r_3$, may be determined.

Similarly, any other bodies W_1' , W_1'' , etc., in any other planes normal to the axis may be balanced by bodies W_2' , W_2'' , etc., in the plane through B , and bodies W_3' , W_3'' , etc., in the plane through C . Then finally all the bodies W_2 , W_2' , W_2'' , etc., in the normal plane through B may be replaced by a single body, and the bodies W_3 , W_3' , W_3'' , etc., in the normal plane through C may be replaced by a single body.

Problem 1. A shaft 6 feet long between bearings carries a steel disk 2 feet in diameter and 4 inches thick, 2 feet from the left bearing. The disk is keyed to the shaft and is eccentric 4 inches. What weights must be added in planes 6 inches from the bearings, at a radial distance of 1 foot, in order to balance the disk?
Ans. 119.7 lbs. at left. 51.3 lbs. at right.

Problem 2. If on the shaft described in Problem 1 another similar disk is placed 2 feet from the right end and 90° back of the first, what must be the balancing weights in order to balance both disks? At what angle with the position of the balancing weights in Problem 1 must they be placed?

Ans. Left, 130.1 lbs., at $23^\circ 10'$. Right, 130.1 lbs., at $66^\circ 50'$.

GENERAL PROBLEMS.

Problem 1. A pulley 2 feet in diameter rotating at 600 r.p.m. is brought to rest in 50 seconds by a constant force of friction on its shaft. How many revolutions does it make?
Ans. 250.

Problem 2. What is the tangential acceleration of a point on the rim of the pulley in Problem 1? What is the normal acceleration and the tangential velocity at the end of 10 seconds?

Ans. $a_t = 1.257$ ft. per sec. per sec. $a_n = 2528$ ft. per sec. per sec. $v = 50.3$ ft. per sec.

Problem 3. The drum of a hoisting engine for a mine cage is 50 inches in diameter. If the cage is to be lowered at the rate of 20 feet per second, how many r.p.m. must the drum make?
Ans. 91.7.

Problem 4. If the mine cage in Problem 3 weighs 500 lbs. and the moment of inertia of the drum is 120, during what time may the cage be allowed to drop freely before the given velocity is obtained?
Ans. 1.73 sec.

Problem 5. A flywheel weighing 200 lbs. has its axis of rotation $\frac{1}{8}$ inch from its geometric axis. If the wheel is midway between two bearings, what are the kinetic reactions at the bearings when the flywheel is rotating at 600 r.p.m.?
Ans. 128 lbs. on each.

Problem 6. If the axis of the flywheel in Problem 5 is horizontal, what speed would be necessary to cause each reaction to vary from zero to 200 lbs. during a half revolution?
Ans. 531 r.p.m.

Problem 7. A vertical shaft 6 feet long carries a weight of 100 lbs. 4 inches from its axis, 1 foot from the top support, and 50 lbs. 6 inches from the axis, 4 feet from the top support on the opposite side of the shaft. Find the normal,

tangential and axial components of each reaction when the shaft is rotating at 80 r.p.m.

Ans. At bottom, $R_n = 25.6$ lbs. $R_t = 0$. $R_v = 150$ lbs. At top, $R_n = 43.6$ lbs. $R_t = 0$. $R_v = 0$.

Problem 8. If the weighted shaft described in Problem 7 is brought to rest by a brake in 5 seconds, what are the tangential reactions?

Ans. $R_t = 0.58$ lb. at bottom. $R_t = 1.01$ lbs. at top.

Problem 9. A steel rod 1 inch in diameter and 10 feet long is supported on a horizontal axis through one end normal to the axis of the rod. Locate the center of oscillation. What is its period of oscillation if it is used as a pendulum with small amplitude?

Ans. 6.6668 ft. $T = 2.86$ sec.

Problem 10. If the rod described in Problem 9 is raised to the horizontal position and then released, what are the normal and tangential reactions at the instant of release? What are the normal and tangential reactions as it passes the vertical position?

Ans. $R_n = 0$. $R_t = 6.675$ lbs. $R_n = 66.8$ lbs. $R_t = 0$.

Problem 11. If the rod described in Problem 9 is released from the vertical position above the axis, what are the normal and tangential components of the reactions when it is 45° from the vertical? When in the horizontal position? When in the lower vertical position?

Ans. At 45° , $R_n = 7.11$ lbs. $R_t = 4.74$ lbs. At 90° , $R_n = 40.1$ lbs. $R_t = 6.675$ lbs. At 180° , $R_n = 106.8$ lbs. $R_t = 0$.

Problem 12. A cast iron flywheel rim weighs 4000 lbs. and is cast in two parts. The two sections are to be held together by six steel bolts at each joint. If the mean radius of the rim is 5 feet and the maximum speed is to be 240 r.p.m., compute the necessary area of each bolt at the root of the thread for an allowable unit tensile stress of 12,000 lbs. per sq. in.

Ans. 0.87 sq. in.

Problem 13. A solid cast iron flywheel rim is 4 inches wide, 3 inches deep and 24 inches outside diameter. If the tension in the arms is neglected, what is the unit tensile stress in the rim when the wheel is rotating at 1600 r.p.m.?

Ans. 2080 lbs. per sq. in.

Problem 14. A cast iron flywheel 10 feet in diameter has a rim 10 inches wide and 6 inches deep. If the ultimate tensile strength of cast iron is 25,000 lbs. per sq. in., what speed will rupture the wheel if the tension in the arms is neglected?

Ans. 1020 r.p.m.

Problem 15. The flywheel described in Problem 14 has a total weight of 8000 lbs. If the center of gravity is 1 inch from the axis of rotation and the wheel is midway between two supports, what is the variation in each reaction when the wheel is rotating at 60 r.p.m.?

Ans. 817 lbs.

Problem 16. The wheel of the Brennan monorail car gyroscope weighed 1000 lbs. and was rotated at 3000 r.p.m. on a horizontal shaft midway between bearings. If it had been eccentric 0.01 inch, what would have been the variation in each reaction?

Ans. From 1777 lbs. upward to 777 lbs. downward.

Problem 17. A 20-lb. governor ball on an arm 3 ft. long rotates at such a speed that the arm is kept at an angle of 45° with the axis. What is its speed? What is the tension in the arm?

Ans. 37.2 r.p.m. 28.3 lbs.

Problem 18. If the length of the arm of the governor ball described in Problem 17 is reduced to 2.5 feet and the governor is rotated at the same speed, what effect is produced on the angle with the axis and on the tension in the arm?
Ans. $\theta = 32^\circ$. $T = 23.5$ lbs.

Problem 19. Fig. 261 represents a weighted conical pendulum governor for which $W_1 = 40$ lbs. and $W = 10$ lbs. What speed will keep the governor in the position shown? What is the tension in each arm?
Ans. 158 r.p.m. 30.2 lbs. in lower. 45.2 lbs. in upper.

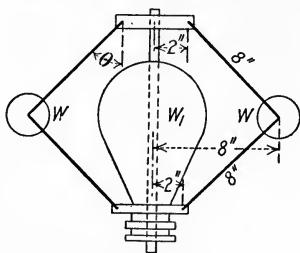

FIG. 261

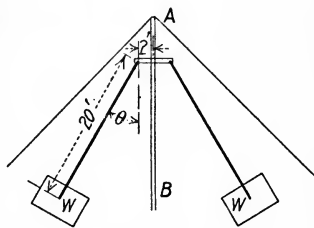

FIG. 262

Problem 20. If $\theta = 30^\circ$ when the governor shown in Fig. 261 is in its low position, at what speed will it begin to act?
Ans. 130 r.p.m.

Problem 21. In the swing shown in Fig. 262 each car weighs 1200 lbs. As the cars are rotated about the vertical axis AB they swing out from the vertical. If the maximum allowable value of θ is 45° , what is the maximum speed at which it may be run? What is the corresponding stress in the supporting cables?
Ans. 13.5 r.p.m. 1700 lbs.

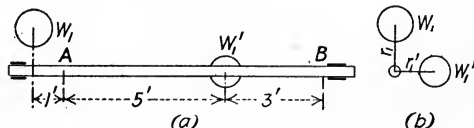

FIG. 263

Problem 22. Fig. 263(a) shows a side view and Fig. 263(b) an end view of a shaft to which two weights W_1 and W_1' are attached. If $W_1 = 100$ lbs., $r_1 = 18$ inches, $W_1' = 50$ lbs. and $r_1' = 15$ inches, what weights at A and B with radii of 12 inches will be necessary to balance the system? What is the angle of each radius with the horizontal plane?

Ans. $W_A = 170$ lbs. $\theta_A = 262^\circ 5'$. $W_B = 43.1$ lbs. $\theta_B = 154^\circ 10'$.

CHAPTER X.

COMBINED TRANSLATION AND ROTATION.

115. Any Plane Motion Equivalent to Combined Translation and Rotation. In a plane motion of a body, each point of the body remains at a constant distance from a fixed plane. This plane or any parallel plane may be called the *plane of motion* of the body. The plane of motion through the center of gravity of the body is commonly used for reference.

Any plane displacement of a body may be considered to be made up of a rotation about any point in the plane of motion and a corresponding translation. That is, the same result would have been obtained by the two simple motions as by the actual motion, whatever it may have been. In Fig. 264 let AB be a line in the plane of motion joining any two points of a body in their original position and let A_2B_2 be their position after any plane motion of the body. Let O be any point in the plane of motion. The displacement from AB to A_2B_2 may evidently be made by a rotation about O to the position A_1B_1 parallel to A_2B_2 , then a translation from A_1B_1 to A_2B_2 .

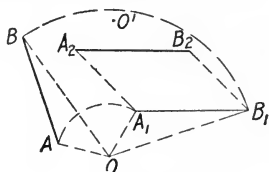

FIG. 264

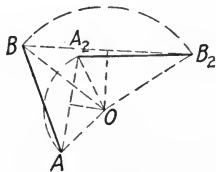

FIG. 265

Again, any plane displacement of a body is equivalent to a simple rotation about some fixed point in space. In order to locate this point, join AA_2 and BB_2 , Fig. 265. Erect perpendicular bisectors of AA_2 and BB_2 which intersect at O . The triangles AOB and A_2OB_2 are equal in all their parts. Therefore angle $AOA_2 =$ angle BOB_2 , since angle $AOB =$ angle A_2OB_2 . Hence it is plain that the displacement from AB to A_2B_2 is equivalent to simple rotation through angle AOA_2 about point O .

If AA_2 and BB_2 are parallel, the point O is at infinity and the motion is equivalent to pure translation.

Problem 1. In Fig. 264, resolve the displacement from AB to A_2B_2 into a rotation about O' and a corresponding translation. Do the same, using point A as a center. Do the same, using the point midway between A and B as a center.

Problem 2. A wheel rolls along a horizontal plane through one-fourth of a revolution. Find the center of equivalent rotation. Do the same for rotation through one-half of a revolution.

116. Resolution of Velocities in any Plane Motion. The absolute velocity of any point of a body which has any plane motion can usually be determined best by getting first its velocity relative to some special point of reference on the body and then the absolute velocity of the point of reference. By Art. 90 the absolute velocity of the given point is equal to the vector sum of the two velocities, its own velocity relative to some point of reference, and the absolute velocity of the point of reference.

Let B , Fig. 266, be any point of a rigid body and let A be the point of reference chosen. Let v_1 be the absolute velocity of A and v' the velocity of B relative to A . Since A and B are fixed points on the rigid body, the only velocity B can have relative to A is tangential. This is equal to $r\omega$, r being the length AB and ω the angular velocity. By the principle stated above, the absolute velocity of B is the vector sum of the two, or v .

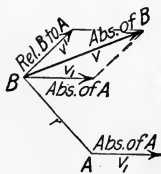

FIG. 266

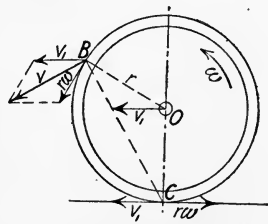

FIG. 267

Conversely, the absolute velocity of any point of a rigid body may be resolved into two components, one of which is equal and parallel to the absolute velocity of any chosen point of reference on the body, while the other is normal to the line joining the two points.

As an example consider the wheel shown in Fig. 267 which is rolling to the left on a horizontal plane. If the velocity of the

center of the wheel is v_1 and its angular velocity is ω , the velocity of any point on the rim with respect to the center is $r\omega = v_1$ for free rolling. The absolute velocity of any point is the vector sum of its velocity with respect to the center and the absolute velocity of the center, as shown at B . The absolute velocity of B is v , the vector sum of v_1 and $r\omega$. In the same way the absolute velocity of the bottom point C is the vector sum of its velocity with respect to O , which is $r\omega$, and the absolute velocity of O , which is v_1 . Since these are equal in amount and opposite in direction, the absolute velocity of point C is zero.

In discussing the motion of the rolling wheel, it is sometimes simpler to use point C as the point of reference. Since its absolute velocity is zero, the absolute velocity of any point, as B , is the same as its velocity relative to point C . Then $v_B = r_B\omega$, r_B being the distance BC .

Problem 1. In Fig. 266, v_1 is 20 feet per second horizontal to the right, r is 3 feet, ω is 5 radians per second clockwise and AB makes an angle of 30° with the horizontal. What is the absolute velocity of B ?

Ans. 30.4 ft. per sec. at $25^\circ 20'$ with hor.

Problem 2. A cylinder 1 foot in diameter is rolling to the right on a horizontal plane with a uniform velocity of 10 feet per second. Using the center as the point of reference, find the absolute velocity of a point on the rim in front, 45° above the horizontal through the center. Check by using the bottom point of the cylinder as the point of reference.

Ans. 18.46 ft. per sec. at $22^\circ 30'$ with hor.

117. Resolution of Accelerations in any Plane Motion. The principle of Art. 90, which was referred to in the preceding article, is true for accelerations as well as for velocities. That is, the absolute acceleration of any given point of a body is equal to the vector sum of the relative acceleration of the given point with respect to some chosen point of reference on the body and the absolute acceleration of the point of reference.

Let B , Fig. 268, be any point of a rigid body and let A be the point of reference whose absolute acceleration is a_1 . Let $AB = r$ and let the angular velocity and acceleration be ω and α respectively. The relative acceleration is most easily determined by means of its tangential and normal components. The tangential component is $r\alpha$ and the normal component is $r\omega^2$. These two combined give the relative acceleration a' , and finally a' and a_1 combined give vector $BC = a$, the absolute acceleration of B .

Conversely, the absolute acceleration of any point may be resolved into three components, one of which is equal and parallel to the absolute acceleration of any chosen point of reference on the body, another equal to $r\omega^2$ along the line joining the two points, and a third equal to $r\alpha$ perpendicular to this line.

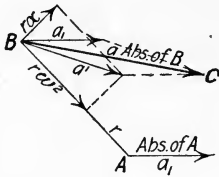

FIG. 268

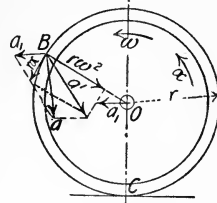

FIG. 269

As an example consider the wheel shown in Fig. 269, which is rolling to the left on a horizontal plane. Let the acceleration of the center of the wheel be a_1 , its angular acceleration α and its angular velocity ω . The tangential component of the acceleration of any point on the rim, as B , relative to the center is $r\alpha = a_1$ for free rolling. The normal component of the relative acceleration is $r\omega^2$. These two vectors combined give a' , the relative acceleration of B with respect to the center. The vector sum of a' and a_1 gives a , the absolute acceleration of point B .

Problem 1. In Fig. 268, a_1 is 50 feet per second per second horizontal to the right, AB is 3 feet long and is at an angle of 30° with the horizontal, ω is 5 radians per second clockwise and α is 20 radians per second per second clockwise. Determine the absolute acceleration of point B .

Ans. $a = 145.6$ ft. per sec. per sec., $5^\circ 45'$ above hor.

Problem 2. Solve for the absolute acceleration of the point described in Problem 2 of Art. 116, using the same two points of reference.

Ans. $a = 200$ ft. per sec. per sec. toward the center.

118. Instantaneous Axis. Let A and B , Fig. 270, be any two points of a rigid body having any plane motion. Let their velocities be in the directions of v_A and v_B as shown.

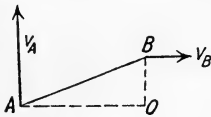

FIG. 270

At A erect AO perpendicular to v_A , and at B erect BO perpendicular to v_B . Since the absolute velocity of point A is normal to the line AO , it is equivalent to rotation about some point on AO . Similarly, since the absolute velocity of point B is normal to BO , it is equivalent to rotation about some point on BO . Since this point is on both

AO and BO , it must be at their point of intersection O . For the instant considered it is therefore the center of rotation of points A and B , and likewise of the rigid body upon which they are located. It is called the *instantaneous center* of the body and the axis through this point, normal to the plane of motion, is called the *instantaneous axis* of the body.

In general, the instantaneous center will be at a different point the following instant. Its path relative to the body is called the *body centrode* and its path in space is called the *space centrode*.

In instantaneous rotation, as in simple rotation, the relation $v = r\omega$ holds true. Then $v_B = \overline{OB}\omega$ and $v_A = \overline{OA}\omega$, ω being the angular velocity of the body at that instant.

Problem 1. AB in Fig. 270 is a uniform rod at an angle of 30° with the horizontal. The vector v_B is horizontal to the right and the vector v_A is vertical, upward. Locate the instantaneous center. If v_B is 100 feet per second and AB is 6 feet, what is v_A ? *Ans.* $v_A = 173.2$ ft. per sec.

Problem 2. In Problem 1, what is the normal acceleration of the center of gravity of the rod? *Ans.* $a_n = 3333$ ft. per sec.

Problem 3. Take two pieces of cardboard about 6 inches square and place one on top of the other with their edges coinciding. Let the bottom one remain stationary while the upper left-hand corner of the top one is moved downward along the left edge of the bottom one, and the lower left-hand corner of the top one is moved to the right along the lower edge of the bottom one. Locate on the upper card the instantaneous center for a number of positions and prick through into the lower card. Draw the body and space centrodes and cut the cards along these lines. Note that a straight line motion of the corners is obtained by rolling the body centrode upon the space centrode.

119. Equations of Motion. As shown in Art. 117, the absolute acceleration of any point of a rigid body having any plane motion may be resolved into three components, one equal and parallel to the acceleration of any chosen point of reference on the body, another equal to $r\omega^2$ acting along the line joining the two points, and a third equal to $r\alpha$ acting perpendicular to this line. If the mass of any particle is dM , the effective force for it is equal to the resultant of the three components, dMa , $dMr\omega^2$ and $dMr\alpha$.

In Fig. 271 let A be the point of reference and let the X axis coincide with a_1 , the absolute acceleration of A . Let ΣF be the resultant of all the external forces,

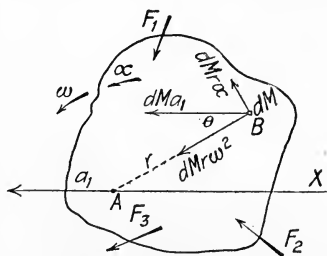

FIG. 271

and ΣF_x and ΣF_y the components of ΣF in the X and Y directions respectively. Since the external force system is equivalent to the effective force system for the whole body of mass M ,

$$\begin{aligned}\Sigma F_x &= \int dMa_1 + \int dMr\alpha \sin \theta + \int dMr\omega^2 \cos \theta \\ &= a_1 \int dM + \alpha \int dMy + \omega^2 \int dMx \\ &= Ma_1 + M\alpha\bar{y} + M\omega^2\bar{x}.\end{aligned}$$

$$\begin{aligned}\Sigma F_y &= \int dMr\alpha \cos \theta - \int dMr\omega^2 \sin \theta \\ &= \alpha \int dMx - \omega^2 \int dMy \\ &= M\alpha\bar{x} - M\omega^2\bar{y}.\end{aligned}$$

$$\begin{aligned}\Sigma M_A &= \int dMr^2\alpha + \int dMa_1r \sin \theta \\ &= \alpha \int r^2 dM + a_1 \int dMy \\ &= I_A\alpha + Ma_1\bar{y}.\end{aligned}$$

If the center of gravity is taken as the point of reference, as is usually the case, the three equations above become

$$\Sigma \mathbf{F}_x = \mathbf{M}\bar{\mathbf{a}}.$$

$$\Sigma \mathbf{F}_y = \mathbf{0}.$$

$$\Sigma \mathbf{M}_0 = \mathbf{I}_0\boldsymbol{\alpha}.$$

I_0 is the moment of inertia of the body with respect to the axis through the center of gravity.

The principles derived above may be stated as follows:—

1. *In any plane motion the center of gravity is accelerated the same as if the whole mass were concentrated at that point and acted upon by forces equal in amount and direction to the actual forces.*

2. *In any plane motion the angular acceleration about the center of gravity is the same as if that center were fixed and a couple of moment = ΣM_0 applied to the body.*

If the reversed effective forces are considered to be added to the free body with its actual impressed forces, the equations of equilibrium hold true. That is, if a force $M\bar{\mathbf{a}}$ be applied at the center of gravity in a direction opposite to its absolute acceleration and a couple $I_0\boldsymbol{\alpha}$ opposed in direction to the angular acceleration, the problem is reduced to static conditions.

120. Wheel Rolling on Horizontal Plane. Several illustrative examples of the last five articles will now be given. One of the simplest is that of a wheel rolling freely on a plane surface. The motion of the wheel is a combined rotation and translation.

If a horizontal force P , Fig. 272, acts at the center of the wheel to produce perfect rolling on a rough surface, a frictional force F is induced at the point of support. Then, by Art. 119,

$$\Sigma F_x = P - F = \frac{W}{g} a.$$

$$\text{Also} \quad \Sigma M_0 = Fr = I_0 \alpha.$$

$$\text{For perfect rolling,} \quad a = r\alpha.$$

From these three equations the acceleration and the frictional force may be determined. In the direction normal to the plane, static conditions hold true, so $W = N$.

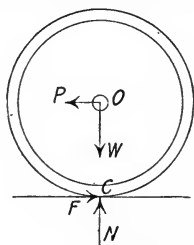

FIG. 272

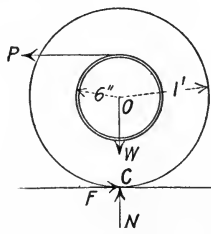

FIG. 273

EXAMPLE 1.

In Fig. 272, let the wheel be a cylinder 4 feet in diameter, let $W = 1000$ pounds and $P = 100$ pounds. Determine F , a and α .

Solution: — By summing horizontal forces

$$100 - F = \frac{1000}{32.2} a.$$

By moments about O ,

$$F \times 2 = \frac{1}{2} \frac{1000}{32.2} 4\alpha.$$

Also,

$$a = 2\alpha.$$

By solution of these three equations,

$$F = 33\frac{1}{2} \text{ lbs.}$$

$$a = 2.147 \text{ ft. per sec. per sec.}$$

$$\alpha = 1.073 \text{ rad. per sec. per sec.}$$

EXAMPLE 2.

Fig. 273 represents a cylinder 2 feet in diameter weighing 200 pounds resting on a horizontal plane surface. Attached to the cylinder and concentric with it is a hollow cylinder 1 foot in diameter, of negligible weight, around which a cord is wrapped. What horizontal force P applied to the cord as

shown will produce an acceleration of 20 feet per second per second? What is the frictional force F ? Assume free rolling.

Solution: — Equation $\Sigma F_x = Ma_x$ gives

$$P - F = \frac{200}{32.2} \times 20.$$

Equation $\Sigma M_0 = I_0\alpha$ gives

$$P \times 0.5 + F \times 1 = \frac{1}{2} \frac{200}{32.2} \times 1^2 \times \frac{20}{1}.$$

$$P = 124.1 \text{ lbs.}$$

$$F = 0.$$

If P is applied lower than the point indicated, a frictional force is induced in the direction opposite to P , while if it is applied above this point a frictional force is induced in the same direction.

Problem 1. Solve Example 2 above if the small cylinder is solid and weighs 50 pounds.

$$\text{Ans. } P = 147.5 \text{ lbs. } F = 7.7 \text{ lbs.}$$

Problem 2. A cast iron cylinder 1 foot in diameter and 1 foot long, free to roll on a horizontal plane, has a force of 5 pounds acting horizontally at the center normal to the geometric axis. Find the velocity and acceleration of a point on the rim behind, 30° above the horizontal through the center, 5 seconds from rest. What is the frictional force F ?

Ans. $v = 2.63$ ft. per sec. forward and upward, 30° with hor. $a = 4.87$ ft. per sec. per sec. forward and downward, $24^\circ 40'$ with hor. $F = 1.67$ lbs.

Problem 3. Solve Problem 2 if the 5-lb. force is acting horizontally at the top.

Ans. $v = 5.26$ ft. per sec. forward and upward, 30° with hor. $a = 18.88$ ft. per sec. per sec. forward and downward, $27^\circ 15'$ with hor. $F = 1.67$ lbs.

Problem 4. Solve Example 2 above if the diameter of the small cylinder is 1.5 feet.

$$\text{Ans. } P = 106.5 \text{ lbs. } F = 17.7 \text{ lbs.}$$

121. Wheel Rolling on Inclined Plane. Let Fig. 274 represent a wheel rolling on a plane inclined at an angle β with the horizontal.

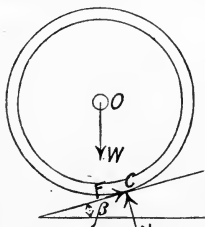

FIG. 274

The plane is considered to be rough enough so that free rolling takes place. If the wheel is released from rest at the top of the plane and allowed to roll down freely under the influence of gravity, there will be acting in addition to W , the normal reaction N and the frictional force F . The three equations of motion may be written as in the preceding article in order to determine F ,

N and the motion. Let the X axis be parallel to the plane. Then

$$\Sigma F_x = W \sin \beta - F = \frac{W}{g} a.$$

$$\Sigma F_y = W \cos \beta - N = 0.$$

$$Fr = I_0\alpha.$$

Also, $a = r\alpha$ for free rolling.

If the wheel is a cylinder, $I_0 = \frac{1}{2} \frac{W}{g} r^2$, so by solving for F ,

$$F = \frac{1}{3} W \sin \beta.$$

If f is the coefficient of static friction between the cylinder and the plane, and $F' = fN$ is the limiting value of the friction F ,

$$f = \frac{F'}{N} = \frac{\frac{1}{3} W \sin \beta}{W \cos \beta} = \frac{1}{3} \tan \beta.$$

This is the limiting value for free rolling. If in any case $\frac{1}{3} \tan \beta$ is greater than the coefficient of friction f , slipping will take place. If the cylinder slips, the friction is kinetic and a does not equal $r\alpha$. However, the force of friction becomes known, being fN (f is the coefficient of kinetic friction), so all values may be determined.

Problem 1. A steel disk 3 inches in diameter and 1 inch thick is released from rest on a 30° plane. If the coefficient of static friction is 0.25 and the coefficient of kinetic friction is 0.20, determine its linear and angular velocity when the disk has rolled 8 feet down the plane. What is the frictional force?

Ans. $v = 13.1$ ft. per sec. $\omega = 104.8$ rad. per sec. $F = 0.334$ lb.

Problem 2. Determine the motion of the disk in Problem 1 if the plane and disk are both smooth.

Ans. $v = 16.1$ ft. per sec. $\omega = 0$. $F = 0$.

Problem 3. Solve Problem 1 if the angle of the plane is changed to 45° .

Ans. $v = 17.08$ ft. per sec. $\omega = 68.2$ rad. per sec. $F = 0.283$ lb.

Problem 4. The steel disk described in Problem 1 is rolled up a 10° plane by means of a horizontal force P applied at the center. If there is no slipping and the acceleration is 2 feet per second per second, find the value of the force P , the normal pressure N and the friction F . If at the end of 5 seconds the force P is removed, how much farther up will the disk roll?

Ans. $P = 0.544$ lb. $N = 2.065$ lbs. $F = 0.062$ lb. 13.4 ft.

Problem 5. A steel sphere 2 inches in diameter starts from rest and rolls down a 15° plane. If the static coefficient of friction is 0.15 and the kinetic coefficient of friction is 0.10, what is the linear and angular velocity after one revolution? What is the force of friction?

Ans. $v = 2.49$ ft. per sec. $\omega = 29.9$ rad. per sec. $F = 0.088$ lb.

122. Connecting Rod of Engine. Graphic Solution. The principle of relative velocities and accelerations is especially well adapted to the solution of the problem of the connecting rod of a steam engine. In Fig. 275, A is the crosshead with velocity v and acceleration a , these being the same as the velocity and acceleration of the piston; AB is the connecting rod, of length l ; B is the crank pin with tangential velocity v_1 ; BO is the crank of length r ; O is the center of rotation of the flywheel. The flywheel is assumed to be heavy enough so that point B has a rotation

practically uniform, with angular velocity ω_1 . The angle ϕ between the connecting rod and the line AO increases to a maximum when B is at the top point in its circle, then decreases and changes to negative values.

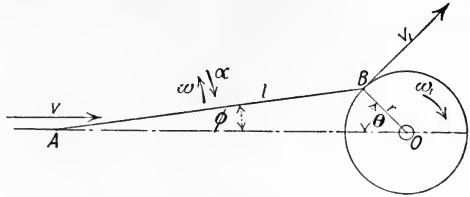

FIG. 275

The motion of the connecting rod is an oscillatory rotation with variable angular velocity ω about point A , which meanwhile has an oscillatory translation along the line AO . The absolute velocity of point B is $v_1 = r\omega_1$ normal to OB . By the principle of relative velocities, this is equal to the vector sum of the absolute velocity of A and the relative velocity of B with respect to A . Let v_2 be the velocity of B relative to A . It is known that its direction is normal to AB , since A and B are rigidly connected, and that the direction of v , the velocity of point A , is horizontal. The vector diagram, Fig. 276, completely determines the value of v_2 and v_1 . Since the motion of B relative to A is a rotation with radius l , $v_2 = l\omega$, or $\omega = \frac{v_2}{l}$. The linear velocity of A and the angular velocity of the rod with respect to A are thus completely determined, so the absolute velocity of any point on the rod may be found.

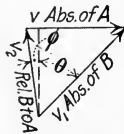

FIG. 276

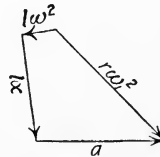

FIG. 277

In Fig. 277 the unknown accelerations are determined. Since point B , Fig. 275, is moving in a circle with uniform angular velocity ω_1 , its only acceleration is $r\omega_1^2$, toward the center O . This is drawn to scale in Fig. 277. The relative acceleration of B with respect to A and the absolute acceleration of A must have $r\omega_1^2$ as

their vector sum. The relative acceleration of B with respect to A is made up of two components, one wholly known, the other known only in direction. The normal component ω^2 is completely known, so is drawn first. The tangential component α is perpendicular to the direction of the connecting rod, and the absolute acceleration a of point A is horizontal and must close the polygon. This completely determines a and α , so the absolute acceleration of any point on the rod may be found.

Problem 1. The crank of an engine is 1 foot long and the connecting rod is 6 feet long. If $\omega_1 = 20$ radians per second, find the velocity and the acceleration of the crosshead when $\theta = 0^\circ$; when $\theta = 30^\circ$.

Ans. $v = 0$. $a = 467$ ft. per sec. per sec.

$v = 11.46$ ft. per sec. $a = 380$ ft. per sec. per sec.

Problem 2. Solve for the velocity and acceleration of the crosshead of Problem 1 when $\theta = 90^\circ$; when $\theta = 180^\circ$.

Ans. $v = 20$ ft. per sec. $a = -68$ ft. per sec. per sec.

$v = 0$. $a = -333\frac{1}{2}$ ft. per sec. per sec.

123. Kinetic Reactions on Connecting Rod. In order to determine the crank pin and crosshead pin pressures, the connecting rod is considered as a free body, Fig. 278. The impressed forces acting upon the rod consist of the following: its weight W vertically downward at its center of gravity; the pressure F from the piston rod through the crosshead; the normal pressure N_A from the crosshead; the crank pin reaction at B . The crank pin reaction is resolved into its two components, N along the rod and T perpendicular to the rod. Of these impressed forces, N , T and N_A are unknown.

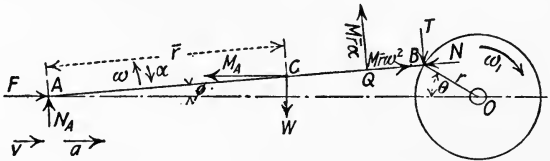

FIG. 278

Under the action of these impressed forces the rod is accelerated both in translation and rotation. By the method of Art. 122 the values of ω , α and a may be determined. If now the reversed effective forces be added to the free body, Fig. 278, it will be under static conditions as discussed in Art. 119. If ω_1 is clockwise and the value of θ between 0° and 90° , ω , α , v and a will be in the directions shown. The three components of the accelera-

tion of the center of gravity are a , horizontal to the right, $\bar{r}\alpha$ downward, normal to the rod, and $\bar{r}\omega^2$ along the rod toward A .

Then the *reversed effective* forces are (1) Ma horizontal to the left; (2) $M\bar{r}\omega^2$ outward away from A ; and (3) $M\bar{r}\alpha$ upward, normal to the rod. It will be remembered that $M\bar{r}\alpha$ acts through the point Q , distant $\frac{k^2}{\bar{r}}$ from A and not through the center of gravity. The force $M\bar{r}\omega^2$ acts through the center of gravity as shown in Case 1, Art. 106. Since all of the forces are known except N_A , N and T , these may be determined by the solution of the three equations of equilibrium.

In Fig. 278, equation $\Sigma F_x = 0$ gives

$$F - N \cos \phi + T \sin \phi - Ma + M\bar{r}\omega^2 \cos \phi - M\bar{y}\alpha = 0.$$

Equation $\Sigma F_y = 0$ gives

$$N_A - W + M\bar{x}\alpha + M\bar{r}\omega^2 \sin \phi - T \cos \phi - N \sin \phi = 0.$$

Equation $\Sigma M_A = 0$ gives

$$W\bar{x} - M\bar{a}\bar{y} - M\bar{r}\alpha \left(\frac{k^2}{\bar{r}} \right) + Tl = 0.$$

EXAMPLE.

In Fig. 278, let $r = 1$ foot, $l = 6$ feet, $W = 200$ pounds, $\bar{r} = 3.8$ feet, $F = 10,000$ pounds, $\omega_1 = 30$ radians per second, $\theta = 30^\circ$ and $I_A = 120$. Solve for N_A , N and T .

Solution: — $M = \frac{W}{g} = \frac{200}{32.2} = 6.21.$

$$\frac{k^2}{\bar{r}} = \frac{I}{M\bar{r}} = \frac{120}{6.21 \times 3.8} = 5.08 \text{ ft.}$$

$$\sin \phi = 0.0833; \cos \phi = 0.9965; \phi = 4^\circ 47'.$$

$$\bar{x} = 3.785 \text{ ft.}; \bar{y} = 0.316 \text{ ft.}$$

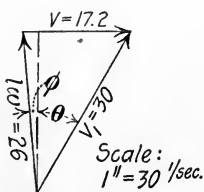

FIG. 279

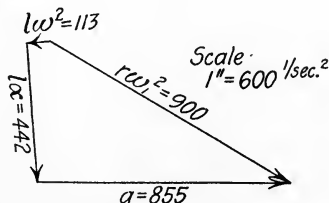

FIG. 280

The vector diagram for the velocities is shown in Fig. 279, from which by scale

$$v = 17.2 \text{ ft. per sec.,}$$

$$l\omega = 26.1 \text{ ft. per sec.,}$$

$$\omega = \frac{26.1}{6} = 4.35 \text{ rad. per sec.}$$

In order to determine the accelerations, their vector diagram is drawn, Fig. 280.

$$r\omega_1^2 = 900; \omega^2 = 6 \times 4.35^2 = 113.$$

Vector $l\alpha$ scales 442, from which $\alpha = 73.7$ rad. per sec. per sec.

Vector a scales 855 ft. per sec. per sec.

$$Ma = 6.21 \times 855 = 5310 \text{ lbs.}$$

$$Mr\alpha = 6.21 \times 3.8 \times 73.7 = 1740 \text{ lbs.}$$

$$M\bar{r}\omega^2 = 6.21 \times 3.8 \times 4.35^2 = 445 \text{ lbs.}$$

These are the three components of the effective force for the body, and if applied reversed, as shown in Fig. 278, are in equilibrium with the impressed forces.

Equation $\Sigma F_x = 0$ gives

$$10,000 - 5310 - 1740 \times 0.0833 + 445 \times 0.9965 + 0.0833 T - 0.9965 N = 0.$$

Equation $\Sigma F_y = 0$ gives

$$N_A - 200 + 1740 \times 0.9965 + 445 \times 0.0833 - 0.9965 T - 0.0833 N = 0.$$

Equation $\Sigma M_A = 0$ gives

$$5310 \times 0.316 - 200 \times 3.786 + 1740 \times 5.08 - 6 T = 0.$$

Solution of the last equation gives

$$T = 1627 \text{ lbs.}$$

This value substituted in the first equation gives

$$N = 5150 \text{ lbs.}$$

These two values substituted in the second equation give

$$N_A = 477 \text{ lbs.}$$

The resultant pressure of the crank pin is given by

$$\sqrt{N^2 + T^2} = 5400 \text{ lbs.}$$

Problem 1. The connecting rod described in Problem 2, Art. 79, is 6 feet long, the crank is 1 foot long, the horizontal pressure from the crosshead pin is 6000 pounds and the engine is running at 180 r.p.m. Find the pressure of the guide on the crosshead and the total pressure on the crank pin when $\theta = 45^\circ$.

Ans. $N_A = 414$ lbs. Crank pin pressure = 4190 lbs.

124. Kinetic Reactions on Side Rod. In the side or parallel rod of a locomotive, each particle of mass dM , as at D , Fig. 281,

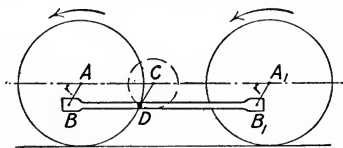

FIG. 281

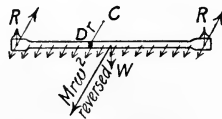

FIG. 282

has a motion of rotation about its own center, point C on the line AA_1 , and a translation the same as point C . If the linear velocity of the locomotive is constant, the absolute acceleration

of point D is $r\omega^2$ directed toward point C , ω being the angular velocity of the wheels. Since at any instant the accelerations of all the particles of the rod are the same in amount and direction, the resultant of all the elementary effective forces is equal to their sum, $Mr\omega^2$, and acts through their center of gravity.

Upon the rod as a free body, Fig. 282, the impressed forces acting are the two crank pin pressures and its weight W . The effective force $Mr\omega^2$ if added to the impressed forces reversed in direction will give static conditions. The crank pin pressures are most easily determined in terms of their two components, one vertically upward equal to $\frac{W}{2}$, the other radial equal to $\frac{Mr\omega^2}{2}$. It is evident that the resultant reaction is a maximum when the rod is at the bottom of its travel. At this point,

$$R = \frac{Mr\omega^2}{2} + \frac{W}{2}.$$

The reaction is a minimum when the rod is at the top, where

$$R = \frac{Mr\omega^2}{2} - \frac{W}{2}.$$

Problem 1. A side rod weighs 420 pounds, the drive wheels are 6 feet in diameter, the length of the crank is 16 inches and the locomotive is running at a speed of 70 miles per hour. What is the maximum pressure on each crank pin?
Ans. 10,390 lbs.

125. Kinetic Reaction on Unbalanced Wheel. If a wheel whose center of gravity does not coincide with its geometric center

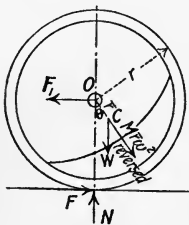

FIG. 283

rolls along a horizontal plane surface, the reaction of the surface is not constant in amount, but changes during each revolution from a value greater than the weight W to one less than W . Let the wheel be as shown in Fig. 283 with its center at O and its center of gravity at C , due to the added weight on one side. Let the speed of the center be constant toward the left and let its amount be v . Since the pull of gravity tends to retard the motion for values of θ from 0° to 180° and to accelerate it for values of θ from 180° to 360° , the forces F_1 and F are necessarily variable.

By the principle of relative motion, the absolute acceleration of point C is equal to the vector sum of the absolute acceleration of

the center, $r\alpha$, and the relative acceleration of C with respect to the center. The two components of the relative acceleration are $\bar{r}\alpha$ and $\bar{r}\omega^2$. Since α is zero, the acceleration of point C is $\bar{r}\omega^2$ toward the center O . If now the reversed effective force $M\bar{r}\omega^2$ be added, the wheel will be under static conditions and the equations of equilibrium may be written. Equation $\Sigma F_y = 0$ gives

$$N = W + M\bar{r}\omega^2 \cos \theta.$$

When θ is zero the value of N is a maximum and when θ is 180° it is a minimum.

Problem 1. In Fig. 283, let $r = 3$ feet and $\bar{r} = 6$ inches. At what speed will the reaction N be zero when C is directly above O ?

Ans. 24.06 ft. per sec.

Problem 2. A locomotive drive wheel 6 feet in diameter weighs 2000 pounds and carries an axle load of 13,000 pounds. When the side rod and the connecting rod are removed the center of gravity of the wheel is 0.6 of a foot from the center of the wheel due to the counterweight. If the locomotive is pulled by another at a speed of 30 miles per hour, what is the variation in the pressure on the track during one revolution?

Ans. 23,000 lbs. max. to 7000 lbs. min.

126. Balancing Reciprocating Parts. A simple illustration of the balancing of reciprocating parts is furnished by the slotted

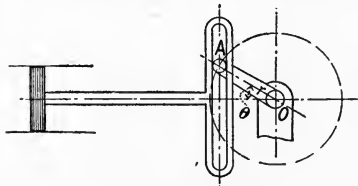

FIG. 284

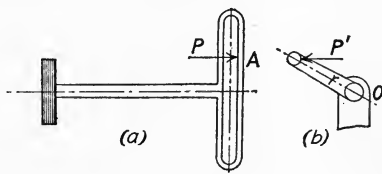

FIG. 285

slider apparatus driven by a crank rotating at constant speed, as shown in Fig. 284. Let W be the weight and $M = \frac{W}{g}$ be the mass of the slider and let friction be neglected. If the angular velocity of the crank AO is ω_1 , the acceleration of the crank pin is $r\omega_1^2$ toward the center. The slider has a variable horizontal acceleration $a = r\omega_1^2 \cos \theta$, and its motion is simple harmonic. The force to cause this acceleration is the variable pressure of the crank pin at A and is equal to

$$P = Ma = Mr\omega_1^2 \cos \theta,$$

as shown in Fig. 285(a). For values of θ between 90° and 270° the acceleration is toward the left, so the force P is acting toward

the left on the slider. The equal and opposite pressure of the slider on the crank pin is P' , as shown in Fig. 285(b), which is in turn transmitted to the support at O .

In order to balance the force P' on the crank pin, a mass M_1 at a distance r_1 may be added opposite to the crank, as shown in Fig. 286. If the values of M_1 and r_1 are such that

$$M_1 r_1 = Mr,$$

the force P' is completely balanced, since the mass M_1 is exerting a centrifugal force equal to $M_1 r_1 \omega_1^2$ in the direction OM_1 and this has a horizontal component of $M_1 r_1 \omega_1^2 \cos \theta$.

The vertical component $M_1 r_1 \omega_1^2 \sin \theta$ of the centrifugal force of M_1 is not balanced, however. This force is a maximum at the

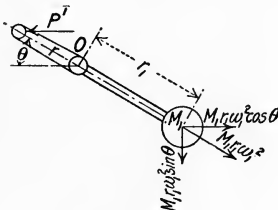

FIG. 286

top and bottom points, where it is equal to $M_1 r_1 \omega_1^2$. If the value of $M_1 r_1$ were half that of Mr , one-half of the horizontal force P' would be balanced and the vertical force at the top and bottom positions would be only $\frac{1}{2} M_1 r_1 \omega_1^2$. Since generally the horizontal force is more injurious to the

mechanism than the vertical, the usual

practice is to balance about two-thirds of the horizontal force. This leaves an unbalanced horizontal force of $\frac{1}{3} Mr \omega_1^2$, and gives an unbalanced vertical force of $\frac{2}{3} M_1 r_1 \omega_1^2$.

In the ordinary reciprocating engine with connecting rod the acceleration of the piston at the head end of the cylinder is greater than $r \omega_1^2$ by the amount $l \omega^2 = l \frac{v^2}{l^2} = \frac{r}{l} (r \omega_1^2)$, and at the crank end is less than $r \omega_1^2$ by the same amount, as may be shown by the method of Art. 122. The mean value is $r \omega_1^2$, so the reciprocating parts of such an engine are balanced in the same manner as those of the slotted slider.

Problem 1. The total weight of a single-cylinder horizontal engine is 20,000 pounds and the weight of the reciprocating parts is 1000 pounds. The crank is 1 foot long and the engine is running at 300 r.p.m. If the engine is perfectly free to move, what will be the approximate amplitude of oscillation of the frame and the magnitude of the displacing force at the end of the stroke? Assume that the reciprocating parts have simple harmonic motion.

Ans. 0.63 inch. 30,650 lbs.

Problem 2. If the engine of Problem 1 is balanced according to general practice, what will be the maximum vertical unbalanced force when running at 300 r.p.m.?

Ans. 20,430 lbs.

127. Balancing Both Rotating and Reciprocating Parts. In the usual type of engine with connecting rod, the rod has a combined rotation and translation. For the purposes of balancing, the small crosshead end of the rod and one-half of the plain part of the rod are considered to have a motion of translation with the crosshead, crosshead pin, piston rod and piston. The large crank end of the rod and the remaining half of the plain part of the rod are considered to have a motion of rotation with the crank and crank pin. In ordinary steam-engine construction the former is about one-third and the latter two-thirds of the weight of the rod.

If the moving parts are to be balanced in the plane of the crank, the following relation applies. Let W_t be the weight of the reciprocating parts, consisting of the piston, piston rod, crosshead and one-third of the connecting rod. Let W_r be the weight of the rotating parts, consisting of the crank, crank pin and two-thirds of the connecting rod. Let W be the weight of the counterbalance at radius r_1 and let r be the length of the crank. Then from Arts. 113 and 126,

$$Wr_1 = W_r r + \frac{2}{3} W_t r.$$

If there are two crank webs as shown in Fig. 287, half of W must be in the plane of each.

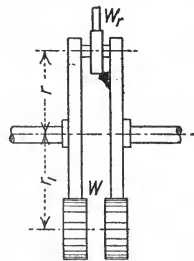

FIG. 287

Problem 1. A piston weighs 300 pounds, the piston rod weighs 100 pounds, the crosshead weighs 50 pounds, the connecting rod weighs 300 pounds and the crank pin weighs 30 pounds. Let $r_1 = r = 1$ foot, and let the arm of the counterweight balance the crank arm in each case. Determine the counterweight for each crank web, the construction being as shown in Fig. 287. If the cylinder is horizontal, what is the unbalanced vertical force if the engine is running at a speed of 180 r.p.m.?

Ans. 298.5 lbs. 4050 lbs.

128. Balancing of Locomotives. Fig. 288 shows a typical case in the balancing of locomotives, being that of an outside cylinder locomotive with six drive wheels. The crank is part of the middle drive wheel, and by means of the side rod the force from the connecting rod is transferred to the other two wheels.

The motion is one of combined translation and rotation, and the effects of the reciprocating and rotating parts upon the frame of the locomotive are the same as if it were running upon a stationary testing table. The conditions for balancing are the same as those

for the stationary engine discussed in Art. 127. For wheels 1 and 3, the rotating parts to be balanced consist of the crank pin and one-fourth of the side rod. For wheel 2 the rotating parts consist of the crank pin, one-half of the side rod and two-thirds of the connecting rod. The counterweight necessary to balance each may be computed as in Art. 113.

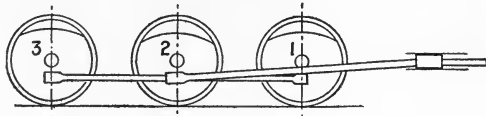

FIG. 288

The reciprocating parts consist of the piston, piston rod, cross-head and one-third of the connecting rod. As in the case of stationary engines it is customary to balance two-thirds of this reciprocating weight in locomotives. There are two methods of providing for the balancing of the reciprocating parts. One is to place all of the counterweight for the reciprocating parts upon wheel 2, combined with the counterweight for its rotating parts. The other is to divide the counterweight for the reciprocating parts equally among the three wheels. With the first method the large unbalanced vertical force due to the heavy counterweight on wheel 2 produces a heavy kinetic effect upon the track, so in general the second method is to be preferred.

Problem 1. For a locomotive of the type of Fig. 288, calculate the counterweights necessary to balance each wheel, given the following dimensions and weights:— wheel diameter, 72 inches; crank arm, 15 inches; weight of side rod, 500 pounds; weight of boss and crank pin on wheels 1 and 3, 120 pounds; weight of boss and crank pin on wheel 2, 150 pounds; weight of connecting rod, 300 pounds; weight of crosshead, 40 pounds; weight of piston rod, 80 pounds; weight of piston, 200 pounds. Use a radius of 28 inches for the counterweight in wheels 1 and 3, and 27 inches in wheel 2. Divide the counterweight for the reciprocating parts equally among the three wheels.

Ans. Wheels 1 and 3, $W = 181$ lbs. Wheel 2, $W = 387$ lbs.

Problem 2. What is the hammer blow on the track under each wheel of the locomotive of Problem 1 if it is running with a speed of 60 miles per hour?

Ans. 3100 lbs.

Problem 3. If the locomotive described in Problem 1, after being properly balanced, has the connecting rod taken off, but side rod left on, what is the hammer blow on the track when being pulled by another locomotive at a speed of 40 miles per hour? *Ans.* 1380 lbs. on 1 and 3. 4350 lbs. on 2.

GENERAL PROBLEMS.

Problem 1. The connecting rod shown in Fig. 289 is 5 feet long and the crank is 1 foot long. Begin at dead center with the connecting rod in the position AM and locate the position of the instantaneous center of the rod for each 30° of a half revolution.

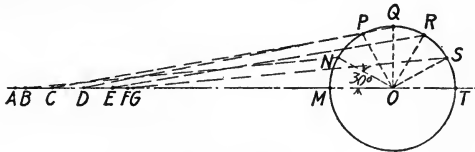

FIG. 289

Ans. AM , at A . BN , 3.37 ft. above B . CP , 9.39 ft. above C . DQ , infinity. ER , 7.66 ft. below E . FS , 2.37 ft. below F . GT , at G .

Problem 2. If the engine of Problem 1 is running at 100 r.p.m., find the velocity of the piston at each 30° point by means of the instantaneous center.

Ans. At A , $v = 0$. B , 6.15 ft. per sec. C , 10 ft. per sec. D , 10.47 ft. per sec. E , 8.15 ft. per sec. F , 4.32 ft. per sec. G , 0.

Problem 3. Check the results of Problem 2 by the graphic method.

Problem 4. The connecting rod described in Problem 1 weighs 300 pounds, its center of gravity is 3 feet from the crosshead end and its moment of inertia with respect to the axis of the crosshead pin is 107.8. What are the crank pin and guide reactions for the two positions, as follows:— (1) dead center at head end, horizontal pressure of crosshead pin 12,000 pounds; (2) at 60° from dead center, horizontal pressure of crosshead pin 8000 pounds?

Ans. (1) $N = 10,895$ lbs.; $T = 180$ lbs. upward; $N_A = 120$ lbs.

(2) $N = 7660$ lbs.; $T = 273$ lbs. downward; $N_A = 1377$ lbs.

Problem 5. A steel cylinder 8 inches in diameter and 3 feet long rests with each end on a horizontal rail normal to the direction of its axis, as shown in Fig. 290. If static $f = 0.25$ and kinetic $f = 0.20$, determine the motion if a force $P = 150$ pounds is applied vertically downward to a rope wrapped around the cylinder at its middle.

Ans. Cylinder rolls to right. Static $F = 100$ lbs. $a = 6.28$ ft. per sec. per sec.

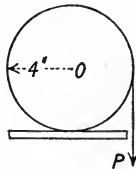

FIG. 290

Problem 6. Solve Problem 5 if the rope is wrapped through 180° more and the force is applied vertically upward.

Ans. Cylinder slides to right and rotates clockwise. Kinetic $F = 72.5$ lbs $a = 4.55$ ft. per sec. per sec. $\alpha = 29.2$ rad. per sec. per sec.

Problem 7. Solve Problem 5 if the force pulls horizontally to the left on the rope at the bottom of the cylinder.

Ans. Cylinder slides to left and rotates clockwise. Kinetic $F = 102.5$ lbs. $a = 2.98$ ft. per sec. per sec. $\alpha = 17.9$ rad. per sec. per sec.

Problem 8. A plane 10 feet long is inclined at an angle of 15° with the horizontal. Static $f = 0.15$ and kinetic $f = 0.12$. If a cylinder 4 inches in diameter starts from rest at the top and rolls down, determine the time required for it to reach the bottom and its linear and angular velocity at the bottom. *Ans.* $t = 1.865$ sec. $v = 10.7$ ft. per sec. $\omega = 64.2$ rad. per sec.

Problem 9. The plane described in Problem 8 is raised to an angle of 24° with the horizontal. Two similar cylinders are released from rest at the top. The one slides on its base, the other rolls freely. Find the time required for each cylinder to reach the bottom.

Ans. One slides in 1.44 sec. The other rolls in 1.51 sec.

Problem 10. A plane 20 feet long is inclined at an angle of 30° with the horizontal. Static $f = 0.25$ and kinetic $f = 0.20$. Two cylinders are released from rest at the top and allowed to roll down. One is solid, 6 inches in diameter; the other is hollow, 6 inches outside diameter and 5 inches inside diameter. Find the time for each to reach the bottom.

Ans. 1.93 sec. for solid cylinder. 2.14 sec. for hollow cylinder.

Problem 11. A cast iron cylinder 6 inches in diameter and 6 inches high rests on end on a horizontal plane whose coefficient of kinetic friction is 0.20. If a force of 20 pounds is applied horizontally to a cord wrapped around the cylinder, find the linear and angular accelerations.

Ans. $a = 8.15$ ft. per sec. per sec. $\alpha = 82.4$ rad. per sec. per sec.

Problem 12. Assume that in the engine described in Problem 1, Art. 127, the cranks are replaced by disks which need no balancing. Instead of the balance weights shown in Fig. 287, balancing is to be effected by adding one counterweight to the rim of a large flywheel 30 inches to the left of the plane of the connecting rod and another to the rim of a small flywheel 24 inches to the right of the plane of the connecting rod. If the radius of the counterweight in the large flywheel is 5 feet and in the small flywheel is 2 feet, find the weights necessary.

Ans. 53 lbs. 166 lbs.

Problem 13. The engine described in Problem 12 has two bearings, the center of each being 10 inches from the center of the connecting rod. What is the amount of variation in the vertical reaction of each when the engine is running at 180 r.p.m.?

Ans. 4050 lbs.

CHAPTER XI.

WORK AND ENERGY.

129. Work. The *work* done by a force is the product of the force and the distance through which the body upon which it acts moves in the direction of the force.

In Fig. 291, four forces, F_1 , W , N and F are shown acting upon a body resting upon a horizontal plane surface. Let the body move through a distance s to the right as shown.

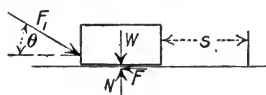

FIG. 291

Then forces W and N do no work upon the body, since the body does not move in the direction of either force. The work done by force F_1 is equal to $F_1 \times s \cos \theta$, since $s \cos \theta$ is the distance the body moves in the direction of the force F_1 .

Since $F_1 \times s \cos \theta = F_1 \cos \theta \times s$, and $F_1 \cos \theta$ is the component of F_1 in the direction of s , it may also be stated that the work done by a force is equal to the product of the distance moved through by the body and the component of the force in that direction.

If the displacement is in the same direction as the working component of the force, the work is positive, as in the case of F_1 above, and the work is said to be done *by the force*. If the displacement is in the direction opposite to the working component of the force, the work is negative, as in the case of the frictional force F above. The work is said to be done *against the force*, and is equal to $-Fs$.

If the force is variable, the work done in a small distance ds is $F \cos \theta ds$ as before, θ being the angle between the direction of the force and the direction of the motion. The total amount of the work done by the force is $\int F \cos \theta ds$. If the relation between F , θ and s is known, this expression can be integrated.

For a rotating body, $ds = r d\phi$, ϕ being the angle between the radius and a fixed axis through the center of rotation, hence

$$\text{Total Work} = \int F \cos \theta ds = \int F \cos \theta r d\phi.$$

But $F r \cos \theta$ is the torque M of the force F about the axis of rotation, θ being the angle between F and the tangent, so

$$\text{Total Work} = \int M d\phi.$$

If there are several forces producing rotation, M is the resultant torque. If the torque M is constant, this becomes

$$\text{Total Work} = M\phi,$$

ϕ being the total angle in radians described by the radius. The work done in one revolution is $2\pi M = 2\pi r F \cos \theta = 2\pi r F_t$, F_t being the tangential component of F . The normal component F_n does no work.

The work done on a body against gravity in raising it through any distance is equal to the product of the weight of the body and the *vertical* distance h through which it is raised, irrespective of its lateral motion. In Fig. 292, the body B is moved along the path ABC in a vertical plane. The work done against gravity in the distance ds is equal to $W ds \cos \theta$, and the total work is

$$W \int ds \cos \theta = W \int_0^h dy = Wh.$$

When a body is lowered, gravity does positive work upon it and the amount of the work is equal to the product of the weight of the body and its vertical displacement.

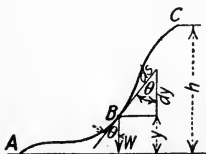

FIG. 292



FIG. 293

If a body of weight W is composed of any number of small parts with weights w_1, w_2, w_3 , etc., which are raised through different heights, the total amount of work done is equal to the product of the entire weight W and the distance \bar{H} through which the center of gravity is raised. In Fig. 293, let h_1, h_2, h_3 , etc., be the heights of w_1, w_2, w_3 , etc., above a chosen base line before they are lifted, and h_1', h_2', h_3' , etc., their heights above the same plane after being lifted. Then the total work is given by

$$\begin{aligned}
 &w_1(h_1' - h_1) + w_2(h_2' - h_2) + w_3(h_3' - h_3) + \text{etc.} \\
 &= (w_1h_1' + w_2h_2' + w_3h_3' + \text{etc.}) - (w_1h_1 + w_2h_2 + w_3h_3 + \text{etc.}) \\
 &= W\bar{h}' - W\bar{h} \\
 &= W\bar{H}.
 \end{aligned}$$

The *unit of work* is the work of one unit of force through one unit of distance. In the English system the *foot-pound* is the unit most generally used. In the c.g.s. system the unit is the *erg*, which is the work done by a force of 1 dyne acting through a distance of 1 centimeter.

Problem 1. In Fig. 291, $W = 1200$ pounds and $f = 0.30$. If $\theta = 30^\circ$ and $s = 1$ inch, find the amount of each force and the work done by it if the motion is uniform. *Ans.* $F_1 = 502$ lbs.; 36.3 ft.-lbs. $F = 435$ lbs.; -36.3 ft.-lbs.

Problem 2. What is the work done against gravity in pulling a 100,000-lb. car at uniform speed up a 2 per cent grade a distance of one mile? If train resistance is 6 pounds per ton, what is the total work done by the drawbar pull? *Ans.* 10,560,000 ft.-lbs. 12,144,000 ft.-lbs.

Problem 3. A vertical mine shaft 6 feet square is driven through 120 feet of clay, 80 feet of shale and 20 feet of sandstone. The material is raised 20 feet above the mouth of the shaft. If clay weighs 100 pounds per cubic foot, shale 120 pounds per cubic foot and sandstone 150 pounds per cubic foot, what is the total work done? *Ans.* 121,608,000 ft.-lbs.

Problem 4. A cable 200 feet long weighing 2 pounds per foot passes over a pulley with 50 feet hanging on one side and 150 feet on the other. What work is done against gravity as the pulley is rotated until the middle of the cable is at the pulley? *Ans.* 5000 ft.-lbs.

130. Graphical Representation of Work. Since work is the product of force and displacement, both of which are vector quantities, the graphical representation of work is made by means of an area. In Fig. 294, let AB represent the displacement s to some scale, and let AC represent the magnitude of the force to some scale. If the force is constant, the area $ABDC$ represents to scale the work done, since it is the product of AB and AC . If AB represents 4 feet and AC represents 3 pounds, the area of each small rectangle represents 1 foot-pound of work and the whole area represents 12 foot-pounds of work.

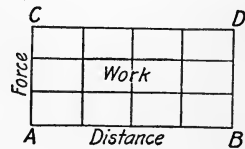

FIG. 294

If the force varies in magnitude, the ordinates will not be the same height, but the area will still give the work done. By calculus, the area under the curve which has abscissæ s and ordinates

F is equal to $\int F ds$. By Art. 129 this is the expression for the work done if the angle θ is zero. The simplest case is that in which the force varies as the distance, increasing from zero to a maximum or decreasing from an initial maximum to zero. The diagram for this case is a triangle, Fig. 295, in which the ordinate AB represents to some scale the maximum value of the force F , which has increased uniformly from zero. The work done is represented by the triangular area OBA , which is equal to $\frac{1}{2} AB \times OA$. In terms of the maximum force F_1 and the total distance s_1 ,

$$\text{Work} = \frac{1}{2} F_1 s_1.$$

If the relation between F and s is not known, as in the steam indicator diagram, Fig. 296, the area may be calculated approximately either by Simpson's One Third Rule or by dividing the area into a large number of narrow strips and considering each a trapezoid. An easy method and the one most commonly used is to measure the area with a planimeter.

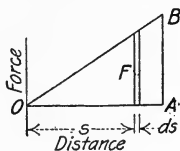

Fig. 295

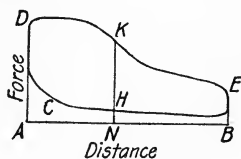

Fig. 296

Let AB , Fig. 296, be the atmosphere line. Then an ordinate to the top line, as NK , represents to scale the pressure in the cylinder when the piston was at that point in its travel moving to the right, so the area $ADEB$ represents the gross work of the steam. The ordinate to the lower line, as NH , represents the pressure on the same side of the piston at that point in the return stroke. This back pressure does negative work, represented by area $ADCHB$, so the net work is that done on the forward stroke, minus that done on the back stroke, represented by area $CDKEH$.

Problem 1. Draw the diagrams for the Problems of Art. 129.

Problem 2. A force is applied to a 20,000-pound spring to compress it $2\frac{1}{2}$ inches, then released $\frac{1}{8}$ inch. (A 20,000-pound spring is one which will be compressed 1 inch under a static load of 20,000 pounds.) Draw the diagram and from it compute the gross work, the negative work and the net work.

Ans. 50,625 in.-lbs. gross. 5469 in.-lbs. negative.

131. Energy. *Energy* is the capacity to do work. If a weight has capacity to do work on account of its position above a chosen

datum plane, its energy is called *potential energy*. If released from its support it may be made to do positive work in descending to its zero position. The steam in a boiler and a spring under compression are said to have potential energy, due to their stressed condition.

A moving body, by virtue of its velocity, has capacity to do work as it is brought to rest. This energy of motion is called *kinetic energy*.

In addition to these two forms of energy, sometimes called *mechanical energy*, several other forms may be classified. *Thermal energy* is the capacity to do work on account of the heat possessed by the body. *Chemical energy* is the capacity of substances to do work by combining chemically, as hydrogen and oxygen, which combine with an explosive force. *Electrical energy* is the capacity of a body to do work due to its electrical condition, as, for instance, a charged storage battery. These other forms of energy are in reality but different manifestations of kinetic energy, and all the forms mentioned are mutually convertible.

132. Relation Between Work and Kinetic Energy. Since kinetic energy is the capacity of a body to do work on account of its motion or velocity, the *amount* of its kinetic energy is necessarily equal to the amount of work done by the positive acting force or forces in producing that velocity. In Fig. 297 let F be the resultant force which acts upon a particle of mass m to produce the velocity v in the distance s .

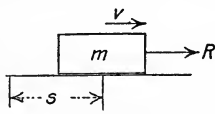

FIG. 297

Then the work done by the resultant force is equal to $\int_0^s F ds$. Since $F = Ma$ and $a ds = v dv$,

$$\text{Work} = \int_0^s F ds = \int_0^s ma ds = \int_0^v mv dv = \frac{1}{2} mv^2.$$

So in terms of the velocity the work done is equal to $\frac{1}{2} mv^2$, which is the *kinetic energy* of the particle.

133. Kinetic Energy of Translation. Forces Constant. The kinetic energy of a body at any instant is equal to the sum of the kinetic energies of the particles of which it is composed. In a motion of translation, each particle of the body has the same velocity at any instant, so the total kinetic energy is

$$K.E. = \Sigma \frac{1}{2} mv^2 = \frac{1}{2} v^2 \Sigma m = \frac{1}{2} Mv^2,$$

M being the mass of the whole body.

Let F , Fig. 298, be the resultant of all the working forces acting upon a body of mass M as it moves from A to B through the distance s . Let v_0 be its velocity at A and v its velocity at B .

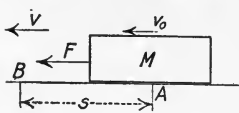

FIG. 298

Then

$$\text{Work} = \int_0^s F ds = \int_{v_0}^v Mv dv.$$

$$\int_0^s F ds = \frac{1}{2} Mv^2 - \frac{1}{2} Mv_0^2.$$

$\frac{1}{2} Mv_0^2$ is the kinetic energy of the body at A and $\frac{1}{2} Mv^2$ is its kinetic energy at B , so the following general statement may be made:—

In any motion of translation the positive work done by the resultant force is equal to the increase in kinetic energy.

If F is constant, $\int_0^s F ds = Fs$, so

$$Fs = \frac{1}{2} Mv^2 - \frac{1}{2} Mv_0^2.$$

It is usually simpler in any given problem to consider separately the work of the several forces acting upon the body instead of the work of their resultant. Let F_1, F_2 , etc., be the forces and F_1', F_2' , etc., their components in the direction of the motion of the body.

$$\text{Work} = \int F_1' ds + \int F_2' ds + \text{etc.}$$

If the forces are constant and act through distances s_1, s_2 , etc., respectively, in the direction of the motion of the body,

$$\text{Work} = F_1's_1 + F_2's_2 + \text{etc.}$$

If some of the forces are resistances, their work is negative.

In any motion of translation the work done by the positive forces minus the work done by the negative forces is equal to the increase in kinetic energy.

This may be written

$$\text{Positive Work} - \text{Negative Work} = \text{Final K.E.} - \text{Initial K.E.}$$

If the term $\frac{1}{2} Mv_0^2$ is transferred to the other side of the equation, it may be written

$$\text{Initial K.E.} + \text{Positive Work} - \text{Negative Work} = \text{Final K.E.}$$

EXAMPLE.

An 80,000-pound car is hauled up a 2 per cent incline by a constant drawbar pull of 1000 pounds. If the train resistance is 6 pounds per ton and the

initial velocity is 20 feet per second, how far up will it go before its velocity is reduced to 10 feet per second?

$$\text{Solution: — Initial K.E.} = \frac{1}{2} Mv_0^2 = \frac{1}{2} \frac{80,000}{32.2} \times 20^2 = 497,000 \text{ ft.-lbs.}$$

Positive work = 1000 s , if s is the distance in feet.

Negative work of train resistance = 240 s .

Negative work of gravity = $\frac{80,000}{50} s = 1600 s$.

$$\text{Final K.E.} = \frac{1}{2} Mv^2 = \frac{1}{2} \frac{80,000}{32.2} \times 10^2 = 124,200 \text{ ft.-lbs.}$$

$$\text{Then} \quad 497,000 + 1000 s - 240 s - 1600 s = 124,200.$$

$$840 s = 372,800.$$

$$s = 444 \text{ ft.}$$

Problem 1. A body weighing 100 pounds rests upon a horizontal plane for which the kinetic coefficient of friction $f = 0.10$. If a force of 15 pounds is applied horizontally, what is the velocity of the body 10 feet from the initial position?

Ans. 5.67 ft. per sec.

Problem 2. A body is released from rest at the top of a 45° plane 10 feet long for which kinetic $f = 0.25$. What is the velocity at the bottom?

Ans. 18.47 ft. per sec.

Problem 3. If a body is projected with a velocity of 20 feet per second along a horizontal plane for which kinetic $f = 0.15$, how far will it go?

Ans. 41.4 ft.

Problem 4. A piston, piston rod and one-third of connecting rod weigh 360 pounds. If the maximum velocity of the piston is 15 feet per second, what is its kinetic energy? Is this energy lost?

Ans. 1259 ft.-lbs.

Problem 5. If the drawbar pull on the car in the Example above is removed when the velocity is 10 feet per second, how much farther up the incline will it go? If then allowed to run back, with what velocity will it reach the bottom?

Ans. 67.6 ft. $v = 23.6$ ft. per sec.

134. Kinetic Energy of Translation. Forces Variable. If some of the forces acting upon a body during its motion are variable, the relation between work and change in kinetic energy becomes

$$\int F ds = \frac{1}{2} Mv^2 - \frac{1}{2} Mv_0^2.$$

If F varies with s , it must first be expressed in terms of s if the law of its variation is known, and then the expression integrated.

If a spring is deformed, the resistance it offers is proportional to the amount of its deformation. Hence, if a spring is the means of applying a force to a body, the amount of the force will be some

constant C multiplied by the distance deformed s , or $F = Cs$. The work done by the force is

$$\int_0^s Cs \, ds = \frac{Cs^2}{2} = \frac{F}{2} s.$$

This is the product of the average force and the distance.

If one of the forces is steam, working expansively, theoretically the absolute pressure varies inversely as the distance from the end of the cylinder, so the amount of the force during expansion is equal to some constant C_1 divided by the distance s from the end of the cylinder, or $F = \frac{C_1}{s}$. An example of each of the cases mentioned will better illustrate the method of solution.

EXAMPLE 1.

A body weighing 150 pounds falls 8 feet from rest and strikes a 2000-pound spring. What is the deformation of the spring?

Solution:—The body and spring are shown in Fig. 299. The body is at rest before starting to fall, hence has zero kinetic energy. When the spring has its maximum compression, the body is again at rest and has zero kinetic energy. The resistance of the spring is $2000 \times$ displacement in inches, or $24,000 \times$ displacement in feet. If s is the displacement in feet, the resistance of the spring is $24,000 s$. Then



$$150 \times 8 + 150 s - \int_0^s 24,000 s \, ds = 0.$$

$$1200 + 150 s = 12,000 s^2.$$

$$s = 0.3224 \text{ ft.} = 3.87 \text{ in.}$$

FIG. 299

The velocity at any point, as when the compression is 1 inch, may be found by equating the resultant work to the kinetic energy.

$$150 \times 8.083 - \int_0^{1/12} 24,000 s \, ds = \frac{1}{2} \frac{150}{32.2} v^2.$$

$$v = 22 \text{ ft. per sec.}$$

EXAMPLE 2.

Fig. 300(a) represents a steam hammer. The ram and piston weigh 500 pounds. The piston is forced downward by a steam pressure of 10,000 pounds against an air resistance of 1000 pounds. The stroke s_2 is 18 inches. Considering cut-off when $s_1 = 6$ inches, find the velocity of the hammer as it strikes the metal, assuming pressure \times volume = constant for steam after cut-off, and neglecting clearance volume and friction.

Solution: — The work of the positive forces minus the work of the resisting forces is equal to the increase in kinetic energy. The weight and the steam pressure are the positive forces, the atmospheric pressure is the resisting force and its total kinetic energy at striking is the increase in kinetic energy, since $v_0 = 0$.

In Fig. 300(b), ordinate DB represents the initial steam pressure P_1 , ordinate BA represents the force of gravity and ordinate AC represents the resisting force of the air. Then area $DCEFG$ represents the resultant work done on the hammer till the point of striking. The work of gravity = $500 \times 1\frac{1}{2} = 750$ ft.-lbs. The work of steam to cut-off = $P_1 s_1 = 10,000 \times \frac{1}{2} = 5000$ ft.-lbs.

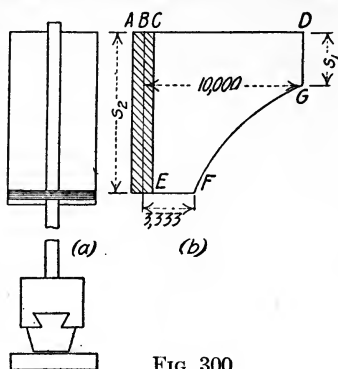

FIG. 300

The work of steam after cut-off = $\int_{s_1}^{s_2} P ds$, P being the variable pressure. Since the pressure varies inversely as the volume, it also varies inversely as the distance from the end of the cylinder, or

$$\frac{P}{P_1} = \frac{s_1}{s}$$

$$P = \frac{P_1 s_1}{s} = \frac{5000}{s}$$

Then work of steam after cut-off = $5000 \int_{0.5}^{1.5} \frac{ds}{s}$,
 $= 5000 \log_e \frac{1.5}{0.5}$
 $= 5000 \log_e 3$
 $= 5000 \times 2.3 \log_{10} 3$
 $= 5000 \times 2.3 \times 0.477$
 $= 5490$ ft.-lbs.

The negative work of atmospheric pressure = $1000 \times 1.5 = 1500$ ft.-lbs.

Work of gravity + work of steam — work of air = $\frac{1}{2} M v^2$.

$$750 + 5000 + 5490 - 1500 = \frac{1}{2} \frac{500}{32.2} v^2$$

$$v = 35.4 \text{ ft. per sec.}$$

Problem 1. A body weighing 800 pounds falls 2 inches and strikes upon a 3000-pound spring. What is the deformation? *Ans.* $1\frac{1}{3}$ inches.

Problem 2. A car weighing 80,000 pounds moving with a speed of 2 feet per second strikes a bumping post. Assuming the drawbar spring to take all the compression, what must be its strength in order that the compression shall not exceed 2 inches? *Ans.* 29,800-lb. spring.

Problem 3. A 100,000-pound car moving with a speed of 2 miles per hour strikes a bumping post. If equipped with a 40,000-pound spring, will all the shock be taken by the spring if the travel of the spring is 2.5 inches?

Ans. No, 2.83 in. required.

Problem 4. A steam hammer has the following dimensions: Weight of piston and ram, 2000 pounds; diameter of piston, 13 inches; diameter of piston rod, 2 inches; stroke, 36 inches; absolute steam pressure, 100 pounds per square inch; air pressure below piston, 15 pounds per square inch; cut-off at quarter stroke, expansion adiabatic. Neglecting clearance volume and friction, determine the velocity of striking.

Ans. 27.4 ft. per sec.

135. Kinetic Energy of Rotation. Let Fig. 301 represent any body rotating about axis O with angular velocity ω . The velocity of any particle of mass dM at a distance ρ from the axis is $\rho\omega$, and its kinetic energy is $\frac{1}{2} dM\rho^2\omega^2$. The total kinetic energy of the body is then $\int \frac{1}{2} dM\rho^2\omega^2$. Since ω^2 for all the particles at any instant is the same, and since $\int dM\rho^2 = I_0$,

$$\text{K.E. of rotation} = \frac{1}{2} I_0 \omega^2.$$

The value of I_0 may be computed by the regular methods of integration if the form of the rotating body is regular. If not, it may be determined by experiment, as in Art. 79.

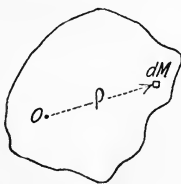

FIG. 301

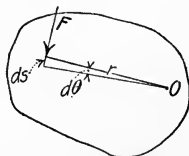

FIG. 302

In order to determine the relation between work and kinetic energy of rotation, the same principle is made use of as in the case of kinetic energy of translation, Art. 133. Let F , Fig. 302, acting at distance r from the fixed axis O be one of a system of forces producing rotation. Then the total work as shown in Art. 129 is

$$\int M d\theta.$$

Since $M = I\alpha$ (Art. 105) and $\alpha d\theta = \omega d\omega$ (Art. 100),

$$\int M d\theta = \int I\alpha d\theta = \int_{\omega_0}^{\omega} I\omega d\omega.$$

By integration,

$$\int M d\theta = \frac{1}{2} I \omega^2 - \frac{1}{2} I \omega_0^2.$$

This principle may be stated as follows:—

In any motion of rotation, the positive work is equal to the increase in kinetic energy.

EXAMPLE 1.

A flywheel and shaft weighing 1800 pounds are rotating in bearings at 80 r.p.m. The shaft is 3 inches in diameter and the radius of gyration of the shaft and wheel is $k = 2.5$ feet. If the coefficient of friction $f = 0.01$, how long will the wheel rotate?

Solution.—The only force is friction, a resisting force. In one revolution its work is $fN \times 2\pi r$, so in n revolutions its work is $0.01 \times 1800 \times 2\pi \times 0.125 n$, or $14.16 n$ ft.-lbs. The decrease in kinetic energy is the amount of the initial kinetic energy, or $\frac{1}{2} I \omega^2$.

$$I = Mk^2 = \frac{1800}{32.2} \times 6.25 = 349.$$

$$\omega = \frac{80 \times 2\pi}{60} = 8.39.$$

$$\omega^2 = 70.3.$$

$$\frac{1}{2} I \omega^2 = 12,280 \text{ ft.-lbs.}$$

Then $14.16 n = 12,280.$

$$n = 867 \text{ revolutions.}$$

Since its acceleration is constant, the average r.p.m. = 40. The time required for 867 revolutions is given by $867 \div 40 = 21$ min. 40 sec.

Problem 1. What is the kinetic energy of a steel cylinder 4 inches in diameter and 6 feet long when rotating at 240 r.p.m? *Ans.* 34.95 ft.-lbs.

Problem 2. Compute the kinetic energy of the flywheel shown in Fig. 207 when rotating at 120 r.p.m. *Ans.* 5896 ft.-lbs.

Problem 3. A cast iron cylinder 1 foot long and 1 foot in diameter is fastened to a horizontal shaft through its geometric axis. The shaft is 1 inch in diameter and rests in bearings for which the coefficient of friction $f = 0.015$. If a cord is wrapped around the cylinder and a force of 10 pounds is applied at the end of the cord during one revolution, what will be the speed of rotation of the cylinder? (Neglect the pull on the cord in computing the work of friction.)

Ans. 63.1 r.p.m.

Problem 4. Solve Problem 3 if the 10-pound force is replaced by a 10-pound weight. *Ans.* 61.5 r.p.m.

Problem 5. Fig. 303 represents a pulley 2 feet in diameter fastened to another 4 feet in diameter and free to rotate about their common geometric axis, O . Their combined weight is 200 pounds and their radius of gyration is 1.5 feet. If a weight of 300 pounds is hung from a cord wrapped around the smaller cylinder and another of 100 pounds to a cord wrapped around the larger cylinder in the opposite direction,

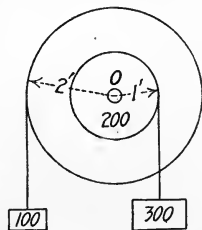

FIG. 303

find the speed of rotation after the 300-pound weight has moved 2 feet from rest. Neglect axle friction. *Ans.* 31.96 r.p.m.

Problem 6. A slender rod 5 feet long weighing 20 pounds is free to rotate about an axis normal to the rod one foot from the end. If the rod is released from rest in the vertical position with the center of gravity above the support, with what velocity will it pass through the horizontal position? What velocity will it have when it reaches its lowest position?

Ans. 4.72 rad. per sec. 6.68 rad. per sec.

136. Kinetic Energy of Rotation and Translation. A body which has a motion of combined rotation and translation may be considered at any instant to be rotating about its instantaneous axis. As in Art. 135, its kinetic energy at that instant is given by $\frac{1}{2} I\omega^2$, I being the moment of inertia with respect to the instantaneous axis. Since the instantaneous axis is not fixed in the body, it is in general difficult to determine I for the different instantaneous axes, so a transformation is made.

Since $I = I_o + M\bar{r}^2$ and $v = \bar{r}\omega$, I_o being the moment of inertia of the body with respect to the gravity axis parallel to the instantaneous axis, \bar{r} the distance between them and \bar{v} the absolute velocity of the center of gravity,

$$\begin{aligned} K.E. &= \frac{1}{2} I\omega^2 = \frac{1}{2} I_o\omega^2 + \frac{1}{2} M\bar{r}^2\omega^2 \\ &= \frac{1}{2} I_o\omega^2 + \frac{1}{2} M\bar{v}^2. \end{aligned}$$

The term $\frac{1}{2} M\bar{v}^2$ is the expression for the kinetic energy the body would have if moving in translation with velocity \bar{v} , and the term $\frac{1}{2} I_o\omega^2$ is the kinetic energy it would have if rotating about a fixed axis through the center of gravity parallel to the instantaneous axis. Hence the kinetic energy of a body with any plane motion is equal to the sum of the kinetic energies of translation and of rotation about the center of gravity.

EXAMPLE.

A wheel 2 feet in diameter weighing 100 pounds starts from rest and rolls freely down a 30° incline. If the plane is 10 feet long and the radius of gyration $k = 0.8$ foot, what is the velocity of the center of the wheel as it reaches the bottom? What is the kinetic energy of rotation? Of translation?

Solution:—The vertical height $h = 5$ feet, so the work of gravity is 100×5 ft.-lbs.

The frictional force F and the normal resistance N do no work, since their point of application is at rest.

$$\begin{aligned} I &= Mk^2, \text{ so} \\ 500 &= \frac{1}{2} M\bar{v}^2 + \frac{1}{2} Mk^2\omega^2. \end{aligned}$$

For free rolling, $\bar{v} = r\omega = \omega$; also $M = \frac{100}{32.2}$.

$$\bar{v} = 14.02 \text{ ft. per sec.}$$

$$\text{K.E. of rotation} = \frac{1}{2} Mk^2\omega^2 = 195 \text{ ft.-lbs.}$$

$$\text{K.E. of translation} = \frac{1}{2} M\bar{v}^2 = 305 \text{ ft.-lbs.}$$

Problem 1. Solve for the velocity of the disk in Problem 1, Art. 121, by the method of this article.

Problem 2. A solid sphere 2 feet in diameter weighing 100 pounds rolls freely down a 30° incline 10 feet long. Find its linear velocity at the bottom.

Ans. 15.16 ft. per sec.

Problem 3. What is the kinetic energy of a cast iron disk 2 feet in diameter and 4 inches thick which rolls along a level floor with a velocity of 10 feet per second?

Ans. 1098 ft.-lbs.

Problem 4. The connecting rod of Problem 2, Art. 79, and Problem 1, Art. 123, weighed 267 pounds and its center of gravity was 48.5 inches from the crosshead pin. By experiment, I with respect to the axis of the crosshead pin was found to be 157. The crosshead to which it was attached weighed 100 pounds, the piston rod weighed 70 pounds and the piston weighed 290 pounds. Find the total kinetic energy of the piston, piston rod, crosshead and connecting rod at dead center (head end), at 45° and at 90° .

Ans. 775 ft.-lbs. 2774 ft.-lbs. 4015 ft.-lbs.

Problem 5. A freight car weighing 80,000 pounds has four pairs of wheels like those described in Problem 1, Art. 79. Find the percentage of error if the rotational component of the kinetic energy of the wheels is neglected in computing the total kinetic energy of the car.

Ans. 0.59 of 1 per cent.

137. Work Lost in Friction. Friction is the great reducing agent by means of which kinetic energy is dissipated in the form of heat. When two surfaces move over each other the mutual friction reduces the total kinetic energy by an amount equal to the product of the frictional force and the relative motion. Let the crosshead of a locomotive have an average pressure on its guides of 500 pounds and let the coefficient of friction $f = 0.01$. If the crank is 1 foot long, the relative distance which the crosshead moves over the guides during the forward stroke is 2 feet. The work lost in friction between the crosshead and guides is then $0.01 \times 500 \times 2 = 10$ ft.-lbs. This cannot be recovered in the form of useful work in another part of the motion as in the case of the work required for accelerating the piston, for the friction changes direction and the same amount more is lost during the return stroke.

The brake shoe testing machine, Fig. 304, consists of a heavy drum A rigidly fastened to an axle O , to which is also fastened a car wheel B . By means of the levers C and D the weight P

applies a normal pressure to the rim of the wheel through the brake shoe E . The weights and dimensions are known, so the kinetic energy may be computed when the angular velocity is known. The weight of the rotating drum is 12,600 pounds, practically the

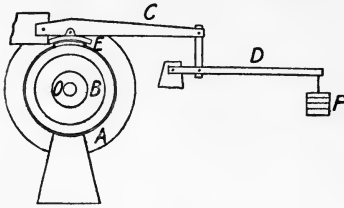

FIG. 304

same as $\frac{1}{3}$ of a 100,000-pound car, or the part supported by one wheel. The material is so arranged that its rotary kinetic energy is the same as the translatory kinetic energy of the same weight would be if it had the same speed as the rim of the wheel. The requirement for this is that $\frac{1}{2} I\omega^2 = \frac{1}{2} Mv^2$.

Since $I = Mk^2$ and $v = r\omega$, it is necessary that $k = r$, so the drum is built in such a way as to make $k = 1.375$ feet, the radius of the standard car wheel. The brake shoe on the testing machine is under the same conditions as in service.

The axle is connected to an engine by means of a clutch so that any desired speed may be given to it, after which the engine may be disconnected. The drum and wheel will then rotate freely until the weight of P is applied which presses the brake shoe E against the wheel. The arrangement of the levers is such that a weight P at the end of the lever produces a normal pressure of $24 P$ at E . In addition, the weight of the levers themselves produces a normal pressure of 1230 pounds. Let the total normal force be N . Then the frictional drag of the shoe upon the wheel is fN , f being the kinetic coefficient of friction, and the work of the frictional force is $fN\pi \frac{3}{2}$ ft.-lbs. in one revolution.

Some work is done also by the frictional force at the bearings. The pressure here is $12,600 + N$. The axle is 7 inches in diameter and if f_1 is the coefficient of friction the work lost in one revolution will be $f_1 (12,600 + N) \pi \frac{7}{2}$ ft.-lbs. The work of friction at the two points dissipates the kinetic energy of the drum and wheel. That at the brake shoe is, of course, much the larger. The kinetic energy is transformed into heat, sometimes making the surface of the shoe red hot.

If n is the number of revolutions of the wheel, the work-energy equation for the motion becomes

K.E. = work of friction.

$$\frac{1}{2} I\omega^2 = fN\pi n \times \frac{3}{2} + f_1 (12,600 + N) \pi n \times \frac{7}{2}$$

Problem 1. Use $f = 0.25$ and $f_1 = 0.005$ for the brake shoe machine described above. If the rim speed of the wheel is 60 miles per hour, what weight P will bring the wheel to rest in 100 revolutions? *Ans.* 237 lbs.

Problem 2. If the rim speed of the wheel on the testing machine is 75 miles per hour and with 300 pounds at P is brought to rest in 120 revolutions, what is the value of f ? Use the same value for f_1 as above. *Ans.* $f = 0.268$.

Problem 3. If force P in Problem 2 is 600 pounds, in what distance will the wheel be stopped when running with a rim speed of 90 miles per hour?

Ans. 809 ft.

138. Braking of Trains. A train which is running at a high rate of speed has a large amount of kinetic energy which has been given to it by the work of the steam in the cylinders, or if on a down grade, by gravity also. When the train is to be stopped, all

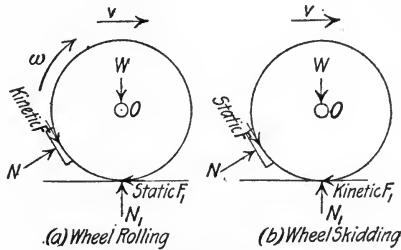

FIG. 305

this kinetic energy must be used up again in work. The usual method is to press brake shoes against the rims of the wheels and so transform the kinetic energy of the train into heat at the rubbing surfaces. The force of friction does work of retardation equal to fNs , f being the coefficient of friction, N the normal pressure of the brake shoe on the wheel and s the distance traveled by the rim of the wheel relative to the brake. The action is a tendency to check the rotation of the wheel, so that a backward static frictional force is developed at the point of contact of the wheel and the rail. This force of the rail on the wheel is the one which actually stops the train, but it does no work since its point of application does not move in the direction of the force. The maximum braking force is exerted when skidding of the wheel is impending, but the wheel is still rolling, as in Fig. 305(a), for then the limiting or maximum value of the static friction at the rail is induced. If the friction at the axle is neglected, the equation of moments about the axle shows that the two frictional forces F_1 and F are equal when the wheel is under static conditions.

If now the normal force on the brake shoe is slightly increased, the frictional force at the shoe will become slightly greater and the wheel will skid, as in Fig. 305(b). There is now kinetic friction between the wheel and the rail which is less than static friction, so resistance to motion is less. The work is being done at the point of contact of the wheel and the rail instead of at the surface of the brake shoe as before, while the brake shoe does no work and is not worn. Skidding of the wheels, besides being much less efficient in stopping the train, causes injurious flat spots to be worn on the wheel.

The coefficient of friction between brake shoes and car wheels is extremely variable on account of the following factors:— material of the shoe, material of the wheel, initial speed of the train, speed of the wheel at the time considered and weather conditions. Just before the wheel is stopped the coefficient is considerably higher than the average for the stop. At high speeds the coefficient is much less than at low speeds, due to the heating of the material at the rubbing surfaces.

The following table gives average results from some M. C. B. Association tests upon several different kinds of brake shoes, at two different speeds.

Speed (mi./hr.)	Average f	Final f
40	20.5	32.6
65	10.3	18.0

It is seen that both the average and the final values of f when the initial speed is 65 miles per hour are much less than they are when the initial speed is 40 miles per hour. This is due to the fact that at 65 miles per hour there is more than two and one-half times as much kinetic energy to be used up at the rubbing surfaces. The surfaces are heated more and their gripping qualities lessened. When stopping trains at high speeds it is customary to apply the brakes at first with a heavy pressure until the speed is partially reduced, then to release and apply again with a less pressure in order to avoid skidding as the train comes to rest.

Since the average value of the final kinetic coefficient of friction for low speeds is as high as the value of the static coefficient of friction between the wheel and the rail, the normal pressure on

the brake shoe should not be greater than the weight carried by the wheel if skidding of the wheel is to be avoided.

Problem 1. A wheel carries a load of 10,000 pounds. If the static coefficient of friction f_1 between the wheel and the rail is 0.30 and the maximum value of the kinetic coefficient of friction f between the wheel and the brake shoe is 0.40, what is the maximum allowable normal brake shoe pressure?

Ans. $N = 7500$ lbs.

Problem 2. A 1000-ton train while running at a speed of 30 miles per hour down a 0.5 per cent grade has brakes applied so that the train is brought to rest in 1200 feet. What is the total induced resisting force required, train resistance being 10 pounds per ton?

Ans. 50,000 lbs.

Problem 3. If the coefficient of static friction between wheel and rail is 0.25, what would be the shortest distance in which the train of Problem 2 could be stopped?

Ans. 123 ft.

139. Power. *Power* is the rate of doing work, or the amount of work done per unit of time. If a weight of 100 pounds is lifted 10 feet, the work done is the same whether it is lifted in 1 second or in 5 seconds. The power required, however, is different. In the first case the power is 1000 foot-pounds per second, while in the second it is 200 foot-pounds per second.

The *unit of power* is the unit of work developed in the unit of time. In the English system it is, therefore, the *foot-pound per second* (abbreviated ft.-lb. per sec.) This is too small a unit for some engineering work, so the larger unit of the *horsepower* is also used. The horsepower is 550 foot-pounds of work per second, or 33,000 foot-pounds of work per minute. In electrical work the unit of power commonly used is the *watt*, which is 10^7 ergs per second, or the *kilowatt*, which is 1000 watts. 1 h.p. = 0.746 kw., or approximately $\frac{3}{4}$ kw. If a force F moves through distance ds in dt time, its rate of doing work or its power is $F \frac{ds}{dt} = Fv$. So if F is in pounds and v in feet per second,

$$\text{Horsepower} = \frac{Fv}{550}.$$

Due to friction a certain amount of the energy supplied to a machine is lost, so the amount delivered by it, the output, is less than that delivered to it, the input. The ratio of the output to the input for a given length of time is called the *mechanical efficiency*.

$$\text{Efficiency} = \frac{\text{Output}}{\text{Input}}.$$

Problem 1. If a hoisting engine lifts a mine cage weighing 600 pounds 500 feet in one minute, what horsepower is expended? If an indicator shows that 10.5 horsepower is being developed, what is the efficiency of the engine and hoist?
Ans. 9.09 h.p. 86.5 per cent.

Problem 2. Find the amount of useful work done by a pump which discharges 300 gallons of water per minute into a tank 200 feet above the intake.
Ans. 15.22 h.p.

Problem 3. The driving side of a belt has 800 pounds tension and the slack side has 350 pounds. If the pulley is 2 feet in diameter and has a speed of 240 r.p.m., what horsepower is being transmitted? If it is driving a dynamo which has an efficiency of 85 per cent, how many kilowatts are being delivered?
Ans. 20.6 h.p. 13.08 kw.

Problem 4. An engine hoists 6 cubic feet of concrete and a 150-pound bucket 15 feet in 10 seconds. If concrete weighs 125 pounds per cubic foot, what horsepower is the engine delivering?
Ans. 2.46 h.p.

140. Water Power. If a stream of water has a cross-sectional area of A square feet and a velocity of v feet per second, the cubic feet of water flowing past any point in one second is Av and its weight is $62.5 Av$. Therefore, the kinetic energy per second, or power, is

$$\frac{1}{2} \frac{W}{g} v^2 = 0.97 Av^3 \text{ foot-pounds.}$$

If the velocity of the water as it reaches any certain point could be entirely destroyed in doing useful work, the horsepower generated would be $\frac{0.97 Av^3}{550}$.

If a flowing stream has a vertical fall of h feet and W is the weight of water flowing per second, the number of foot-pounds of work per second is Wh . Then $\text{h.p.} = \frac{Wh}{550}$.

Problem 1. A river has a cross-sectional area of 90 square feet and a velocity of 8 feet per second above a fall which has a drop of 6 feet. What is the theoretical horsepower that could be developed?
Ans. 572 h.p.

Problem 2. A 2-inch nozzle discharges water under a head of 1200 feet. The stream impinges upon a Pelton wheel which has an efficiency of 80 per cent, and the Pelton wheel is connected to generators which have an efficiency of 90 per cent. How many kilowatts can be delivered at the switchboard?
Ans. 444 kw.

Problem 3. If a volume of 300 cubic feet of water per second under a head of 40 feet flows through turbines which have an efficiency of 85 per cent, what horsepower will they deliver?
Ans. 1160 h.p.

141. Steam Engine Indicator. The steam engine indicator is an instrument for recording graphically the steam pressure and

piston travel of a steam engine. In Fig. 306, OX is the axis of zero absolute pressure. AB is the line showing atmospheric pressure, and its length represents to some scale the piston travel. The ordinate FA represents to some scale the steam pressure when the piston was at the corresponding point in its stroke. As shown in Art. 130, the area $GCDE$ represents the net work done by the steam. This area divided by the length AB will give the average ordinate, which multiplied by the scale of the spring will give the *mean effective pressure*. This is the pressure which, if exerted through the whole stroke, would have done the same amount of work.

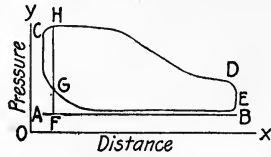

FIG. 306

Let P represent the mean effective pressure in pounds per square inch, l the length of the cylinder in feet, a the area of the piston in square inches and n the number of revolutions per minute made by the flywheel. Then Pa is the total pressure in pounds and Pla is the work done in one revolution by the steam on one side of the piston. $Plan$ is the work done in one minute and $\frac{Plan}{33,000}$ is the horsepower generated. This is called the *indicated horsepower* (I.H.P.). If the piston rod extends both ways from the piston so that the areas are the same and the mean effective pressures are the same, the total power generated in the cylinder is $\frac{2Plan}{33,000}$. If, as is commonly the case, the pressures and areas are different, the horsepowers of the two ends are computed separately and added.

Problem 1. The mean effective pressure of an engine is 80 pounds per square inch; the crank is 12 inches long; the cylinder is 7 inches in diameter; the piston rod is 1.5 inches in diameter and extends entirely through the cylinder. If the engine is running at 150 r.p.m., what is the indicated horsepower?
Ans. 53.4 h.p.

Problem 2. At the crank end of the cylinder of an engine the mean effective pressure is 115 pounds per square inch and at the head end is 110 pounds per square inch. The length of the crank is 1 foot, the diameter of the cylinder is 1 foot and the diameter of the piston rod is 2 inches. The piston rod extends only one way from the piston. If the speed of the engine is 90 r.p.m., what horsepower is it developing?
Ans. 137 h.p.

142. Absorption Dynamometer. An absorption dynamometer is an instrument for measuring the output of power of prime

movers, such as steam engines, electric motors and water wheels. It absorbs all the energy generated and transforms it into heat of friction. The most common form of absorption dynamometer

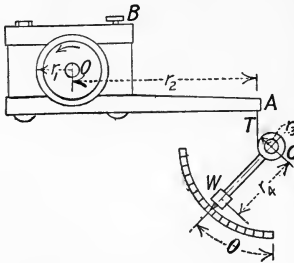

FIG. 307

is the Prony brake, Figs. 307 and 308. The simple construction of Fig. 307 is best for small, high-speed machines, as motors and small gas engines. By tightening the hand wheel *B*, the blocks of which the brake is composed are clamped against the wheel and the friction developed tends to turn the brake around with the wheel. This tendency is resisted by the pull of the weight *W*, hinged at *C*. The hand wheel *B* is tightened until all of the work done by the prime mover is used up in the heat of friction at the rim.

Let *F* be the total friction generated. Then the work absorbed in one revolution is $F \times 2\pi r_1$, and if *n* is the number of revolutions per minute the horsepower is given by

$$\text{h.p.} = \frac{F \times 2\pi r_1 n}{33,000}$$

But $F r_1 = T r_2$, by moments about *O*, and $T r_3 = W r_4 \sin \theta$ by moments about *C*, so

$$\text{h.p.} = \frac{2\pi n W r_2 r_4 \sin \theta}{33,000 r_3}$$

Instead of being graduated in degrees, the arc may be graduated to read *T* directly, or, more simply, the frictional force *F*.

The brake shown in Fig. 308 is used for larger sizes of flywheels.

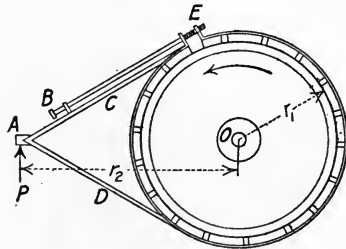

FIG. 308

It is composed of small blocks of wood fastened to a strap encircling the wheel and attached to a V-shaped lever arm, *CDA*. To

apply the brake, the ends of the band at E are drawn together by turning the hand wheel B . As before,

$$Fr_1 = Pr_2,$$

so
$$\text{h.p.} = \frac{2\pi nPr_2}{33,000}.$$

The force P is the net force due to friction alone after the weight of the brake arm has been balanced. It is usually measured by resting the lever arm on a platform scale, or by suspending it from a spring scale above.

Since some of the work done by the steam in the cylinder is used up in friction of the moving parts of the engine, the brake horsepower will necessarily be less than the indicated horsepower. The mechanical efficiency is the ratio of the brake horsepower to the indicated horsepower, or

$$\text{Efficiency} = \frac{B.H.P.}{I.H.P.}$$

Problem 1. In a brake of the style of Fig. 307, $r_1 = 3$ inches, $r_2 = 2$ feet, $r_3 = 3$ inches, $r_4 = 14$ inches and $W = 10$ pounds. If balanced so that the pointer is vertical with no load, at what angles should the calibration marks be placed for $F = 50$ pounds; $F = 100$ pounds; $F = 150$ pounds; $F = 200$ pounds?

Ans. $7^\circ 42'$; $15^\circ 33'$; $23^\circ 42'$; $32^\circ 25'$.

Problem 2. If a motor which is being tested by the brake described in Problem 1 is running at 500 r.p.m. and the pointer reads 170 pounds, what is the brake horsepower?

Ans. 4.05 h.p.

Problem 3. A brake of the style of Fig. 308 has the radius $r_1 = 2$ feet and $r_2 = 6$ feet. If when a certain engine is being tested $P = 410$ pounds and $n = 180$, what horsepower is being developed?

Ans. 84.3 h.p.

Problem 4. If the engine referred to in Problem 3 has a cylinder 16 inches in diameter, piston rod 3 inches in diameter (extending only one way from the piston), 24-inch stroke and mean effective pressure of 21 pounds per square inch, what is the mechanical efficiency of the engine? *Ans.* 93.2 per cent.

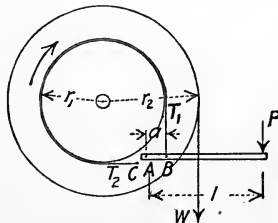

FIG. 309

143. Band Brakes. Fig. 309 shows a simple form of band brake, such as is used on hoisting engines. The band is attached

at C and passes around the wheel to the lever at B . The lever is hinged at A and if force is applied downward at the end, the band is tightened and the friction retards the motion of the wheel inside the band. If the weight W is to be lowered at a uniform rate of speed, the work done by gravity upon the weight must equal the work done by the frictional force $T_2 - T_1$ on the rim of the brake wheel, or

$$2\pi r_2 W = (T_2 - T_1) 2\pi r_1.$$

From Art. 64,

$$T_2 = T_1 e^{f\beta},$$

f being the kinetic coefficient of friction and β the angle of contact. By moments about point A ,

$$Pl = T_1 a.$$

From these three equations the force P required to lower the weight W may be determined.

The band brake with modifications is used on automobiles. If an automobile of weight W is moving with a speed of v , its kinetic energy is $\frac{1}{2} \frac{W}{g} v^2$. In bringing the automobile to rest in a short distance by means of the brakes, this kinetic energy is used up chiefly in the work of friction on the rubbing surfaces. If n is the number of revolutions the wheel makes until it is brought to rest, the relation between work and kinetic energy may be written

$$\frac{1}{2} \frac{W}{g} v^2 = (T_2 - T_1) 2\pi r_1 n.$$

T_2 and T_1 are the sums of the tensions on the tight and loose ends respectively of the two brakes.

Problem 1. In Fig. 309, $r_1 = 18$ inches, $r_2 = 24$ inches, $W = 1200$ pounds, $a = 5$ inches, $l = 48$ inches and $f = 0.15$. What force P is required in order that the weight may descend uniformly? *Ans.* 162 lbs.

Problem 2. If $P = 150$ pounds on the band brake of Problem 1, with what velocity will the weight W pass a point 50 feet below the starting point?

Ans. 15.54 ft. per sec.

Problem 3. If in Fig. 309 the rope sustaining W is wrapped the other way on the drum so that W descends on the left side, what force P will be required to allow it to descend uniformly? *Ans.* 329 lbs.

Problem 4. The weight of an automobile is 3000 pounds. The diameter of its wheels is 36 inches and that of its brake rims is 16 inches. If equipped with brakes similar to that of Fig. 309 for which $a = 1$ inch, $l = 6$ inches and $f = 0.40$, in what distance can it be brought to rest from a speed of 30 miles per hour by a total pressure $P = 40$ pounds if the wheels do not skid?

Ans. 151 ft.

GENERAL PROBLEMS.

Problem 1. Find the amount of work done in elevating the clay from a pit 30 feet in diameter and 50 feet deep if the clay weighs 100 pounds per cubic foot and is lifted 6 feet above the top of the pit. *Ans.* 109,563,000 ft.-lbs.

Problem 2. What is the work done against gravity in filling a standpipe 80 feet high and 16 feet in diameter if the water is drawn from deep wells whose average level is 120 feet below the base of the standpipe?

Ans. 160,848,000 ft.-lbs.

Problem 3. If the standpipe of Problem 2 is to be filled in 6 hours, no water being drawn out meanwhile, what horsepower must the engine develop?

Ans. 13.56 h.p.

Problem 4. A fire engine takes water from the surface of a lake 20 feet below its own level and delivers it from a nozzle 2 inches in diameter with a velocity of 100 feet per second. What horsepower is required?

Ans. 43.5 h.p.

Problem 5. A tank 8 feet long, 6 feet wide and 4 feet deep is half full of water. How many foot-pounds of work are required to raise all of the water over the top of the tank?

Ans. 18,000 ft.-lbs.

Problem 6. A block of granite 8 feet long, 3 feet wide and 3 feet high is lying on its side. How many foot-pounds of work are required to tip it up on end? (Granite weighs 160 lbs. per cu. ft.)

Ans. 31,960 ft.-lbs.

Problem 7. How much work is done in winding up a cable 500 feet long which weighs 2 pounds per foot?

Ans. 250,000 ft.-lbs.

Problem 8. A mine cage weighs 500 pounds, empty coal car weighs 200 pounds and the cable weighs 1 pound per foot. What work is done in raising 500 pounds of coal from the 200-foot level to the 50-foot level?

Ans. 198,750 ft.-lbs.

Problem 9. A 400-ton train is running at a speed of 60 miles per hour on a level track. If train resistance is 17 pounds per ton, what is the drawbar pull? What horsepower is the engine developing?

Ans. 6800 lbs. 1088 h.p.

Problem 10. A 1000-ton train attains a speed of 30 miles per hour in 1 mile on a level track with a constant drawbar pull. If train resistance is considered constant and equal to 8 pounds per ton, what is the drawbar pull? What is the horsepower developed when the speed is 30 miles per hour?

Ans. 19,390 lbs. 1550 h.p.

Problem 11. If the locomotive of Problem 10 is pulling the same train up a 0.25 per cent grade and is exerting the same drawbar pull, in what distance will it attain a speed of 30 miles per hour?

Ans. 9400 ft.

Problem 12. An ore car weighing 500 pounds is pulled up a 30° incline by means of a counterweight as shown in Fig. 310. If the counterweight weighs 600 pounds and the car resistance is 15 pounds, what velocity will the car have after moving 100 feet from rest?

Ans. 18.6 ft. per sec.

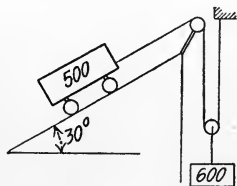

FIG. 310

Problem 13. A coal incline is 500 feet long and 30 feet high. A car weighing 60,000 pounds runs down the incline and out on level track. If car resistance is 6 pounds per ton, how far out on the level will it run?

Ans. 9500 ft.

Problem 14. If in a steam hammer of the same dimensions as given in Problem 4, Art. 134, the steam is cut off and released at the top end of the cylinder when the piston is at quarter stroke and at the same time is admitted at boiler pressure below the piston, how far down will the hammer move?

Ans. 1.83 ft.

Problem 15. In the hammer described in Problem 14, at what point must cut-off and release above, and admission below be made in order that the hammer just touches the anvil?

Ans. 1.23 ft.

Problem 16. If in the hammer described in Problem 14 the cut-off is made at quarter stroke but release above and admission below is made at half stroke, with what velocity will the hammer strike the anvil? *Ans.* 9.81 ft. per sec.

Problem 17. A Pelton wheel is driven by a jet of water 1 inch in diameter under a head of 280 feet. If the efficiency of the wheel is 80 per cent, what horsepower will be generated? If the wheel is directly connected to a generator which has 90 per cent efficiency, how many kilowatts will be delivered?

Ans. 18.64 h.p. 12.52 kw.

Problem 18. The steam indicator card for the head end of the cylinder of a steam engine had an area of 3.27 square inches and for the crank end 3.21 square inches. Length of atmosphere line was 3.25 inches; scale of the spring, 40 pounds per inch; length of stroke, 24 inches; diameter of piston, 10 inches; diameter of piston rod, 1.25 inches. If the engine is running at 120 r.p.m., what is the indicated horsepower?

Ans. 45.2 h.p.

Problem 19. A hoisting engine is lifting one ton of ore per minute from a steamer's hold 40 feet deep. If the efficiency of the hoisting apparatus is 75 per cent and that of the engine is 85 per cent, what is the indicated horsepower?

Ans. 3.8 h.p.

Problem 20. What horsepower is being developed if a 1000-ton train is being hauled up a 0.5 per cent grade at a speed of 30 miles per hour, the train resistance being 10 pounds per ton?

Ans. 1600 h.p.

Problem 21. If the train described in Problem 20 has the steam shut off and the brakes applied with their maximum effect ($f = 0.25$), how far will the train run?

Ans. 116 ft.

CHAPTER XII.

IMPULSE, MOMENTUM AND IMPACT.

144. Impulse and Momentum. The effect of a force may be given in terms of the product of *force* and *distance*, which is called *work*, or the product of *force* and *time*, which is called the *impulse* of the force. If a force F is constant both in magnitude and direction during time t , the impulse is Ft . If F varies in magnitude, the impulse for the infinitesimal time dt is $F dt$, and the impulse for any time t is given by $\int_0^t F dt$. If the relation of F and t is known, the integration may be performed. Sometimes, even though the relation between F and t is not known, the quantity $\int_0^t F dt$ can be eliminated between two simultaneous equations containing it.

Impulse, like force, is a *vector* quantity, and has the same direction and position as the force factor.

The resultant impulse of a force which varies in direction is the vector sum of the separate component impulses. Consider a resultant force F applied to a body for t seconds, then suddenly reversed and applied for a succeeding t seconds. It is evident that the vectorial sum of the impulses is zero, since they are of the same numerical value and of opposite sign.

If in the preceding case the force should be changed only through 90° , the resultant impulse would be $Ft \sqrt{2}$ in amount, at an angle of 45° with the direction of either component impulse. In any case in which the force varies in direction, $\int F dt$ must be vectorial.

The *momentum* of a body is the product of its mass and velocity, Mv . It is sometimes called the *quantity of motion*. Momentum, like velocity, is a vector quantity having definite direction and position. Like other vector quantities, both impulse and momentum may be resolved into components or combined into resultants.

The *unit of impulse* is the impulse of a unit force acting for a unit of time. In the English system this is the *pound-second*.

The *unit of momentum* is the momentum of a unit mass moving with unit velocity. In the English system the dimensions of this unit are obtained as follows. Since $M = \frac{W}{g}$, W being in pounds and g in $\frac{\text{feet}}{\text{seconds}^2}$, M is in units of $\frac{\text{pounds} \times \text{seconds}^2}{\text{feet}}$. Velocity v is in units of $\frac{\text{feet}}{\text{seconds}}$, so Mv is in units of $\frac{\text{pounds} \times \text{seconds}^2}{\text{feet}} \times \frac{\text{feet}}{\text{seconds}} = \text{pounds} \times \text{seconds}$. The dimensions of the unit of momentum are, therefore, the same as those of the unit of impulse.

145. Relation Between Impulse and Momentum. Let F be the resultant force acting upon a body of mass M to produce an acceleration a . Then $F = Ma$. If F is constant, a is constant and equals $\frac{v - v_0}{t}$. The equation then becomes

$$Ft = Mv - Mv_0.$$

If F varies in magnitude, $F = M \frac{dv}{dt}$, since $a = \frac{dv}{dt}$, and

$$F dt = M dv.$$

For time t , if v_0 is the velocity when $t = 0$ and v the velocity after time t ,

$$\int_0^t F dt = \int_{v_0}^v M dv.$$

$$\int_0^t F dt = Mv - Mv_0.$$

The general statement of this relation may be made as follows: *During any period of time the impulse of the resultant force acting upon a body is equal to its change in momentum.*

By means of the above relation, problems involving force, mass, velocity and time may be solved directly instead of with the double set of equations between force, mass and acceleration, and velocity, acceleration and time.

EXAMPLE 1.

A body falls freely for 3 seconds. What is its velocity if it started from rest?

Solution: — The force is the weight W , so the impulse is $3W$. The change in momentum is the same as the final momentum, or Mv .

Then

$$3W = \frac{W}{32.2}v.$$

$$v = 96.6 \text{ ft. per sec.}$$

EXAMPLE 2.

A 500-pound body initially at rest is acted upon for 10 seconds by a variable working force F which is equal to $100\sqrt{t}$, and also by a variable resisting frictional force F_1 which is approximately equal to $20 - t$ during that time. What is its velocity at the end of 10 seconds?

Solution: — Impulse = change in momentum.

$$\int_0^{10} 100 t^{\frac{1}{2}} dt - \int_0^{10} 20 dt + \int_0^{10} t dt = \frac{500}{32.2} v.$$

$$\frac{200}{3} t^{\frac{3}{2}} \Big|_0^{10} - 20 t \Big|_0^{10} + \frac{t^2}{2} \Big|_0^{10} = \frac{500}{32.2} v.$$

$$v = 126 \text{ ft. per sec.}$$

Problem 1. A body is projected downward with a velocity of 80 feet per second. What is its velocity 2 seconds later? *Ans.* 144.4 ft. per sec.

Problem 2. If a 100-pound weight on a level floor has a horizontal force of 15 pounds acting upon it for 10 seconds and a frictional force which is equal to $10 - t^{\frac{1}{2}}$ during that time, what will be its velocity if it starts from rest?

Ans. 21.3 ft. per sec.

146. Conservation of Linear Momentum. In any mutual action between two bodies or two parts of the same body, the mutual forces are always equal and opposite, by Newton's Third Law of Motion. Since the time of contact is necessarily the same, the impulses of the mutual forces are equal in value and opposite in direction, hence neutralize each other. Then if there is no resultant force acting which is external to the two bodies, the sum of the momenta before the action is equal to the sum of the momenta after the action, since for the whole system $\int F dt = 0$. If M_1 and M_2 are the masses of two bodies, v_1 and v_2 their velocities before contact and v_1' and v_2' their velocities after contact, then

$$M_1 v_1 + M_2 v_2 = M_1 v_1' + M_2 v_2'.$$

Though there is no loss of momentum in any mutual action between two bodies, there is always a loss in kinetic energy due to the heat generated at the point of contact.

The direction of v_1 should always be considered positive. If v_2 is in the opposite direction, it must be used as negative.

EXAMPLE.

A 50-pound shot is fired from a gun which weighs 20,000 pounds. If its muzzle velocity is 1200 feet per second, what is the initial backward velocity of the gun? If the recoil is against a constant force of 3000 pounds, how soon will the gun be brought to rest? What distance does it recoil? What is the kinetic energy of each?

Solution: — The momentum of the shot and the gun before the shot is fired is equal to zero, so the sum of the momenta after the shot is fired must also equal zero. Therefore,

Momentum of shot forward — momentum of gun backward = 0.

$$\frac{50}{32.2} \times 1200 = \frac{20,000}{32.2} v.$$

$$v = 3 \text{ ft. per sec.}$$

The impulse of the resisting force is equal to the momentum of the gun, so

$$\frac{20,000}{32.2} \times 3 = 3000 t.$$

$$t = 0.621 \text{ sec.}$$

Since the resisting force is constant, the motion is one with uniform acceleration and the distance is equal to the product of the average velocity and the time. The average velocity is $\frac{1}{2} \times 3 = 1.5$, so

$$s = 1.5 \times 0.621 = 0.932 \text{ ft.}$$

The kinetic energy of the shot is

$$\frac{1}{2} \frac{50}{32.2} \times 1200^2 = 1,120,000 \text{ ft.-lbs.}$$

The kinetic energy of the gun is

$$\frac{1}{2} \frac{20,000}{32.2} \times 3^2 = 2790 \text{ ft.-lbs.}$$

It will be noticed that though the momentum of the shot is numerically equal to that of the gun, its kinetic energy is 400 times as great.

Problem 1. A man weighing 150 pounds jumps with a velocity of 10 feet per second into a boat which weighs 120 pounds and which is at rest. What will be the initial velocity of the boat? What will be the loss in kinetic energy?

Ans. 5.55 ft. per sec. 104 ft.-lbs.

Problem 2. A gun weighing 160,000 pounds fires a projectile weighing 1000 pounds with a velocity of 1500 feet per second. With what initial velocity will the gun recoil? How far will it recoil if resisted by a nest of springs which would be compressed 1 inch by a force of 200,000 pounds? What is the kinetic energy of the projectile and of the gun respectively?

Ans. 9.37 ft. per sec. $5\frac{1}{8}$ inches. 35,000,000 ft.-lbs. 218,000 ft.-lbs.

147. Angular Impulse and Angular Momentum. In Fig. 311, let F be one of a system of forces acting upon the body shown, and let d be the perpendicular distance from O to the line of action of F . The impulse of the force F during time dt is $F dt$ and this

impulse is a vector quantity having direction and line of action as shown. The moment of this impulse about the axis O is $d \times F dt$ and the summation of these moments of impulse, $\int d \times F dt$, is called the *moment of impulse* or *angular impulse* of the force upon the body.

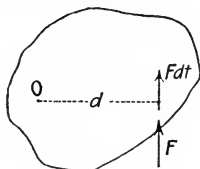

FIG. 311

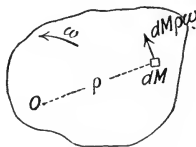

FIG. 312

In Fig. 312, let dM be the mass of any particle at distance ρ from the axis of revolution O . If the angular velocity of the body is ω , the tangential velocity of the mass dM is $\rho\omega$ and its momentum is $dM\rho\omega$. This momentum is a vector quantity whose position is through dM in the direction of the velocity of dM , normal to ρ . The moment of the elementary momentum about the axis O is $dM\rho^2\omega$ and is called the *moment of momentum* of the particle. The summation of all these elementary moments of momentum is called the *moment of momentum* or *angular momentum* of the body.

$$\int dM\rho^2\omega = \omega \int \rho^2 dM = I_0\omega.$$

From Art. 105,

$$Fd = I\alpha = I \frac{d\omega}{dt}.$$

$$\int d \times F dt = \int_{\omega_0}^{\omega} I d\omega.$$

$$\int d \times F dt = \int \mathbf{M} dt = \mathbf{I}\omega - \mathbf{I}\omega_0.$$

The statement of this relation is as follows:

In any motion of rotation, the sum of the angular impulses of the forces acting is equal to the increase in angular momentum.

Both angular impulse and angular momentum are vector quantities and are represented graphically by vectors parallel to their axes of rotation. The convention for sign is the same as that used in connection with couples, as explained in Art. 28. If viewed so that the rotation of the angular impulse or momentum

appears negative (clockwise), the vector points away from the observer. The vectors for Figs. 311 and 312 would be perpendicular to the plane of the figures, and the arrow would point toward the observer, since the rotation is counterclockwise. Like other vector quantities, angular impulse and angular momentum may be resolved into components or combined into resultants as desired.

EXAMPLE.

A flywheel weighs 3200 pounds and is rotating at 125 r.p.m. Its radius of gyration is 3.3 feet and its shaft is 6 inches in diameter. If the coefficient of friction f at the bearing is 0.02, how many revolutions will it make before coming to rest?

Solution: — Friction = $3200 \times 0.02 = 64$ lbs.

The impulse of the friction = $64 t$.

The angular impulse = $64 t \times \frac{1}{4} = 16 t$.

Angular impulse = change in angular momentum.

$$16 t = I\omega.$$

$$16 t = \frac{W}{g} k^2 \omega = \frac{3200}{32.2} \times 3.3^2 \times \frac{125}{60} \times 2\pi.$$

$$16 t = 14,180.$$

$$t = 885 \text{ sec.} = 14.75 \text{ min.}$$

The average speed of the flywheel is 62.5 r.p.m., so in 14.75 minutes it will turn through $62.5 \times 14.75 = 922$ revolutions.

Problem 1. When another lubricant was used, the wheel referred to in the Example above came to rest in 22 minutes, 13 seconds. What was the coefficient of friction? *Ans.* 0.0133.

Problem 2. A cast iron cylinder 1 foot in diameter and 4 inches long is supported in bearings by means of a shaft 2 inches in diameter. The coefficient of friction is 0.01. A force of 5.44 pounds vertically downward is applied to a cord wrapped around the cylinder. What is the rim velocity after 10 seconds if it starts from rest? *Ans.* 28.6 ft. per sec.

Problem 3. If in Problem 2 the force is released at the end of 10 seconds, how long will the cylinder rotate until the friction of the bearing brings it to rest? *Ans.* 4 min. 26 sec.

148. Conservation of Angular Momentum. If during any time t there is no external angular impulse on a body or system of bodies with respect to any given axis, the angular momentum with respect to that axis remains constant, irrespective of mutual actions and reactions between the bodies or parts of bodies. Since the internal forces always occur in pairs of equal and opposite forces during the same time t , the impulse of each pair, $\int F dt - \int F dt$,

reduces to zero. Since the angular impulse is zero, there can be no change in angular momentum.

Consider as an example two disks, *A* and *B*, Fig. 313, supported on a horizontal shaft. Let disk *A* be fastened to the shaft and be at rest, while disk *B* rotates upon the shaft with angular velocity ω . Let the moment of inertia of disk *B* be I , and the moment of inertia of the entire system be I' . Since disk *A* is at rest, the angular momentum of the system is equal to the angular momentum of *B*, or $I\omega$. If now by some means the two disks are fastened together, as by allowing a bolt in *B* to drop into a hole in *A*, the two will rotate together with a new angular velocity ω' . The angular momentum of the system is now $I'\omega'$, and since it has not been changed by the internal action and reaction of the bolt and the disks,

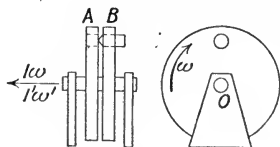

FIG. 313

$$I'\omega' = I\omega, \quad \text{so} \quad \omega' = \frac{I}{I'} \omega.$$

Both $I\omega$ and $I'\omega'$ are represented by the same vector as shown at the left of the figure.

As in the case of linear momentum, there is a loss of kinetic energy due to the mutual action between the two disks.

As another case, consider the two bodies *A* and *B*, Fig. 314, which may be moved along a horizontal axis and which are rotating with their support about a vertical axis with angular velocity ω . If I is their moment of inertia with respect to their axis of rotation, their angular momentum is $I\omega$. If now by some internal action the bodies are displaced, as to *A'* and *B'*, the moment of inertia of the system becomes I' . Then, as above, $\omega' = \frac{I}{I'} \omega$. Since I' is less than I , ω' must be correspondingly greater than ω .

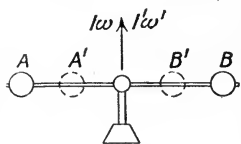

FIG. 314

Problem 1. In Fig. 313, the disks are steel, 18 inches in diameter. *B* is 2 inches thick and *A* is $\frac{1}{4}$ inch thick. If *B* is rotating originally at a speed of 60 r.p.m., what will be the speed of rotation after being connected? What is the loss in kinetic energy by the blow as they are connected?

Ans. 53.4 r.p.m. 2.77 ft.-lbs.

149. Resultant of Angular Momenta. Gyroscope. A gyroscope is a body which is rotating about an axis, called the *spin axis*, and is partially free to move in other directions. If the armature of a motor, Fig. 315, is suspended from a support and is rotating at a high rate of speed, it offers the same resistance to any translatory force or to any torque about the spin axis that it would if not rotating. If, however, a torque is applied to rotate it about any other axis, as the vertical, it will not rotate about the vertical axis, but will rotate or *precess* about a horizontal axis perpendicular to the other two axes. In Fig. 315, OX is the *spin axis*, OY is the *torque axis* and OZ , mutually perpendicular to these, is the *precession axis*.

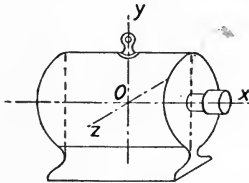

FIG. 315

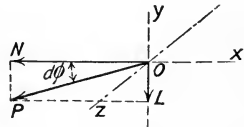

FIG. 316

The explanation of this precession is as follows. If I is the moment of inertia of the rotating part with respect to the axis of rotation and ω is its angular velocity, its angular momentum is $I\omega$, represented by vector ON , Fig. 316. The vector points to the left if the rotation is clockwise when viewed from the right end. If a torque M is applied to the frame which tends to rotate the motor about the axis OY in a clockwise direction viewed from above, this torque will have an angular impulse Mdt in dt time, and will produce an equal change in the angular momentum about axis OY . This is represented by vector OL . The resultant angular momentum of the body is represented in amount and direction by the resultant OP of the two angular momentum vectors, ON and OL , at an angle $d\phi$ with the vector ON . This is the new axis of spin and in order that it shall become so the body must rotate about axis OZ , the direction being counterclockwise viewed from the front. This motion is called *precession*, and ω' is the angular velocity of precession.

$$\frac{OL}{ON} = \tan d\phi = d\phi.$$

$$\frac{OL}{ON} = \frac{M dt}{I\omega}$$

$$d\phi = \frac{M dt}{I\omega}$$

$$\frac{d\phi}{dt} = \frac{M}{I\omega}$$

But $\frac{d\phi}{dt} = \omega'$, the angular velocity of precession about axis OZ , so

$$\omega' = \frac{M}{I\omega}$$

$$M = I\omega\omega'$$

If the torque about axis OY remains constant, the velocity ω' about axis OZ remains constant. Since there is no acceleration about axis OZ , M_z must equal zero.

Just as a torque about an axis normal to the spin axis causes a precession about a third axis normal to the two, a forced precession about an axis normal to the spin axis will cause a torque about the third rectangular axis. For example, if a uniform precession be caused about the axis OZ in a counterclockwise direction viewed from the front, a torque M about the axis OY is developed. This torque is in the clockwise direction, viewed from above, and is given by the axle reactions.

EXAMPLE.

The armature of the motor of an electric car weighs 600 pounds and rotates in the direction opposite to the rotation of the car wheels. The distance between bearings is 2 feet and the radius of gyration of the armature is 6 inches. The motor is geared so that it makes four revolutions to one revolution of the car wheels. The diameter of the car wheels is 33 inches. If the car is going forward around a curve of 100 feet radius with a velocity of 20 feet per second, what are the pressures on the bearings if the center of the curve is to the right?

Solution: — Fig. 317(a) is a top view and Fig. 317(b) is a rear view of the motor. OX is the spin axis, a vertical axis through the center of curvature of the track is the precession axis and any axis normal to these is the torque axis. Since the armature is being accelerated toward the center of the curve

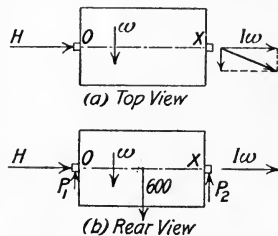

FIG. 317

with an acceleration $a = \frac{v^2}{r} = 4$ feet per sec. per sec., the horizontal pressure of the bearing,

$$H = \frac{600}{32.2} \times 4 = 74.5 \text{ lbs.}$$

This is due to the centrifugal force and would be the same if the motor were not rotating. Since there is no torque about the axis of precession, there are no horizontal components of the reactions at the ends of the armature normal to H .

Since the spin is backward, the angular momentum vector $I\omega$ points to the right. In order to combine with this momentum vector so as to produce precession to the right, the angular impulse vector must point backward along the track toward the observer. The torque to give the vector this direction is counterclockwise, so P_2 must be larger than P_1 .

Since $M = I\omega\omega'$, by moments about O ,

$$P_2 \times 2 - 600 \times 1 = I\omega\omega'$$

$$I = \frac{W}{g} k^2 = \frac{600}{32.2} \times \frac{1}{4} = 4.66.$$

The angular velocity of rotation of the car wheels is

$$\omega_1 = \frac{v}{r} = \frac{20}{1.375} = 14.55 \text{ rad. per sec.}$$

Since the gear ratio is 4 to 1, the angular velocity ω of the armature is

$$4 \times 14.55 = 58.2 \text{ rad. per sec.}$$

$$\omega' = \frac{v}{r} = \frac{20}{100} = 0.2 \text{ rad. per sec.}$$

$$2 P_2 - 600 = 4.66 \times 58.2 \times 0.2.$$

$$2 P_2 - 600 = 54.$$

$$P_2 = 327 \text{ lbs.}$$

Since $P_1 + P_2 = 600$, $P_1 = 273$ lbs.

It is seen that the pressure on the bearing on the inside of the curve is 27 lbs. heavier than if the motor were not rotating and the pressure on the outside is 27 lbs. lighter.

For a curve in the opposite direction the angular momentum vector would still point to the right, and the angular impulse vector would have to point forward in order that the two would combine to produce precession to the left. The torque is therefore of opposite sign, so the heavier pressure is again on the inside bearing.

For a motor geared so that it rotates in the same direction as the car wheels, the heavier pressure is on the bearing on the outside of the curve.

Upon the wheels themselves there is a like gyroscopic action, so that the pressure on the outer rail is greater and that on the inner rail is less than it would be with no rotation.

Problem 1. In Problem 1, Art. 79, it was found that a pair of 33-inch cast iron car wheels weighing 700 pounds had a moment of inertia of 6.99 with respect to the axis of rotation. If a car is running at a speed of 30 miles per

hour around a 10° curve, what is the extra pressure on the outer rail due to gyroscopic action? Use 4.9 feet as the distance from center to center of rail.

Ans. 3.54 lbs. for each pair of wheels.

Problem 2. Describe the gyroscopic action of the flywheel of an automobile engine when rounding a curve (1) to the right; (2) to the left.

Ans. (1) Heavier pressure on rear bearing.

Problem 3. If an ordinary top is rotating clockwise viewed from above and the upper end of the axis is pushed horizontally north, which way will it really lean? Explain.

Ans. East.

Problem 4. If an aeroplane which is coming down head on at a steep angle changes direction by a short curve into the horizontal, what will be the gyroscopic action if the propeller is rotating clockwise when viewed from the rear?

Ans. Left end will be thrown forward.

150. Reaction of a Jet of Water. If a jet of water of cross-sectional area A issues from the side of a vessel of water under head h , as shown in Fig. 318, it will have a velocity $v = \sqrt{2gh}$. The water before leaving the vessel is at rest, so the change in momentum in the direction of the jet is Mv per second, M being the mass of water flowing per second. $Mv = \frac{W}{g}v$, W being the

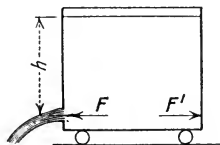

FIG. 318

weight of water flowing per second. If w is the weight of the unit volume of water, $W = wAv$. Then the change in momentum per second is $Mv = \frac{wAv^2}{g}$. The change in momentum in time t

is $\frac{wAv^2}{g}t$ and this must be caused by an impulse Ft . Then since

$$Ft = \frac{wAv^2}{g}t,$$

$$F = \frac{wAv^2}{g} = 2wAh.$$

F' is the equal and opposite reaction of the water upon the vessel. If the vessel is not held by some external force, it will move to the right under the action of force F' .

Problem 1. A cubical vessel 1 foot on each side, weighing 7.5 pounds is full of water and is suspended from a cord so that its center of gravity is 5 feet from the support. If a jet 1 square inch in area under a head of 1 foot is issuing from the side, how far from the vertical is the center of gravity displaced?

Ans. 0.745 in.

151. Pressure Due to a Jet of Water on a Vane. If a jet of water is discharged perpendicularly against a stationary flat vane,

as in Fig. 319, all of the velocity of the jet in the original direction is destroyed. If W is the weight of water flowing per second, the change in momentum in the direction of the jet is $\frac{W}{g}v$ per second.

The change in momentum in time t is $\frac{W}{g}vt$ and this must equal the impulse of the force F which supports the vane. Then

$$Ft = \frac{Wv}{g}t = \frac{wAv^2}{g}t.$$

$$F = \frac{Wv}{g} = \frac{wAv^2}{g} = 2wAh.$$

It will be noticed that the pressure P due to an impinging jet is twice as great as the static pressure $P' = wAh$ on the same area as the area of the jet, due to a head of water corresponding to the same velocity.

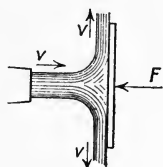

FIG. 319

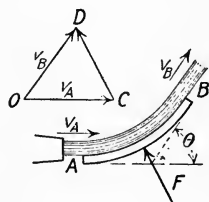

FIG. 320

If a jet of water strikes a curved vane tangentially, as shown in Fig. 320, and is turned through an angle θ , it will leave in a direction tangent to the vane at B with the same speed as that with which it enters at A neglecting friction. The vector OC may be drawn to represent to scale the velocity at A and OD to represent the velocity at B . Then CD is the vector change in the velocity of the jet. If W is the weight of water flowing per second, the vector change in momentum in time t is

$$\frac{W}{g} \overline{CD} t = \frac{W}{g} 2v \sin \frac{\theta}{2} t,$$

in the direction CD . This must equal Ft , since

$$\text{Impulse} = \text{change in momentum.}$$

The resultant pressure on the vane necessary to hold it against the jet is, therefore,

$$F = \frac{W}{g} 2v \sin \frac{\theta}{2}.$$

Problem 1. What pressure will be exerted upon a flat vane held normal to a jet of water 2 inches in diameter under a head of 60 feet? *Ans.* 164 lbs.

Problem 2. A fire stream from a nozzle 1.5 inches in diameter has a velocity of 120 feet per second. What pressure does it exert upon a wall at close range? *Ans.* 343 lbs.

Problem 3. What is the pressure in amount and direction exerted by a jet of water 2 inches in diameter under a head of 120 feet upon a curved vane for which $\theta = 90^\circ$? *Ans.* 463 lbs., 45° with initial v .

Problem 4. Solve Problem 3 if $\theta = 180^\circ$. *Ans.* 655 lbs. parallel to jet.

152. Sudden Impulse or Impact. The impulse of a force which acts for a very short time is called a *sudden impulse* or *impact*, as for example the blow of a hammer upon a nail, the collision of a projectile and its target, the impact of a bat upon a ball. If the mass centers of the two bodies before collision move along the same straight line and the form of the bodies is such that the pressure each exerts upon the other is also along this line, the impact is called *direct central impact*. All other impacts are oblique.

For simplicity assume the colliding bodies to be spheres, as in Fig. 321. The mass M_1 moving with velocity v_1 overtakes mass M_2 moving with velocity v_2 . When the bodies first touch, as in Fig. 321(a), the pressure between them is zero. For a short period of time, the centers approach each other and each is deformed by the pressure of the other. When the pressure becomes a maximum the deformation is a maximum, as shown in Fig. 321(b), and the bodies are moving with the same velocity v . If the bodies are inelastic, the pressure drops directly to zero, the deformation remains and the two bodies go on together with velocity v . By the principle of conservation of linear momentum, Art. 146,

$$M_1v_1 + M_2v_2 = M_1v + M_2v.$$

If the bodies are partially elastic, the pressure decreases gradually to zero, the original form is partially regained and the two bodies separate, M_1 moving with velocity v_1' and M_2 with velocity v_2' , as shown in Fig. 321(c). In this case also, by Art. 146,

$$M_1v + M_2v = M_1v_1' + M_2v_2'.$$

The first period of time is called the *period of compression*. The second period is called the *period of restitution*.

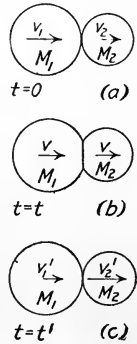

FIG. 321

From the two equations above the sum of the momenta before impact equals the sum of the momenta after impact.

$$\mathbf{M}_1\mathbf{v}_1 + \mathbf{M}_2\mathbf{v}_2 = \mathbf{M}_1\mathbf{v}_1' + \mathbf{M}_2\mathbf{v}_2'$$

The direction of v_1 should always be considered positive. If v_2 is in the opposite direction, it must be used as negative. The signs of v_1' and v_2' show their directions.

The relative velocity of the two bodies before impact is $v_1 - v_2$ and the relative velocity after impact is $v_2' - v_1'$. Due to the fact that physical bodies are not perfectly elastic, the relative velocity after impact is always less than that before impact, and the ratio of the two is called the *coefficient of restitution*, represented by e .

$$e = \frac{v_2' - v_1'}{v_1 - v_2}$$

This may be written

$$e(\mathbf{v}_1 - \mathbf{v}_2) = \mathbf{v}_2' - \mathbf{v}_1'$$

The value of e is zero for entirely inelastic bodies and would be unity for perfectly elastic bodies. The following table gives the values of e for several materials as determined by experiment.

Material	e
Glass.....	0.95
Ivory.....	0.89
Steel.....	0.55
Cast iron.....	0.50
Lead.....	0.15

The kinetic energy lost in heat of impact may be found by subtracting the final kinetic energy of the two bodies from their initial kinetic energy.

If the impact of two bodies is oblique, the velocity of each body may be resolved into two components, one along the line of centers, the other normal to the line of centers. The latter component of each is unchanged by the impact. The former is changed the same as in direct central impact and the final components are recombined to give the final velocities.

EXAMPLE 1.

An inelastic body weighing 5 pounds is moving with a velocity of 10 feet per second and collides with another weighing 2 pounds moving in the opposite direction with a velocity of 6 feet per second. What is the final velocity of the two bodies and the loss in kinetic energy due to the impact?

Solution: —

$$M_1 v_1 + M_2 v_2 = M_1 v + M_2 v.$$

$$\frac{5}{g} \times 10 - \frac{2}{g} \times 6 = \left(\frac{5}{g} + \frac{2}{g} \right) v.$$

$$v = 5.43 \text{ ft. per sec.}$$

$$\text{Initial K.E.} = \frac{1}{2} \frac{5}{32.2} \times 100 + \frac{1}{2} \frac{2}{32.2} \times 36 = 8.88 \text{ ft.-lbs.}$$

$$\text{Final K.E.} = \frac{1}{2} \frac{7}{32.2} \times 5.43^2 = 3.21 \text{ ft.-lbs.}$$

$$\text{Loss in K.E.} = 8.88 - 3.21 = 5.67 \text{ ft.-lbs.}$$

EXAMPLE 2.

A 10-pound steel ball at rest is struck horizontally by a hammer weighing 4 pounds with a velocity of 12 feet per second. What is the velocity of each after the impact and the loss in kinetic energy?

Solution: — The hammer is M_1 and the ball M_2 . From the table above, $e = 0.55$.

$$0.55(12 - 0) = v_2' - v_1' = 6.6.$$

$$48 + 0 = 4v_1' + 10v_2'.$$

$$v_1' = -1.29 \text{ ft. per sec.}$$

$$v_2' = 5.31 \text{ ft. per sec.}$$

The ball is driven in the direction the hammer was going originally; the hammer itself rebounds.

$$\text{Initial K.E.} = \frac{1}{2} \frac{4}{32.2} 144 = 8.95 \text{ ft.-lbs.}$$

$$\text{Final K.E. of hammer} = \frac{1}{2} \frac{4}{32.2} 1.29^2 = 0.10 \text{ ft.-lb.}$$

$$\text{Final K.E. of ball} = \frac{1}{2} \frac{10}{32.2} 5.31^2 = 4.39 \text{ ft.-lbs.}$$

$$\text{Loss in K.E.} = 8.95 - 4.49 = 4.46 \text{ ft.-lbs.}$$

Problem 1. An inelastic body weighing 10 pounds is moving with a velocity of 20 feet per second and overtakes another of 15 pounds weight moving in the same direction with a velocity of 15 feet per second. What is the final velocity and the loss in kinetic energy?

Ans. 17 ft. per sec. 2.4 ft.-lbs.

Problem 2. An inelastic ball of 30 pounds weight moving with a velocity of 100 feet per second strikes another of 30 pounds weight which is at rest. What is the final velocity and the loss in kinetic energy?

Ans. 50 ft. per sec. 2330 ft.-lbs.

Problem 3. A glass marble weighing 2 ounces drops 2 inches upon a heavy glass slab. To what height will it rebound? What is the loss in kinetic energy due to the impact?

Ans. 1.8 in. 0.002 ft.-lb.

Problem 4. A cast iron ball weighing 1 pound is moving with a speed of 10 feet per second and strikes another weighing 7.5 lbs. moving in the opposite direction with a speed of 3 feet per second. What are the final velocities?

Ans. $v_1' = -7.21$ ft. per sec. $v_2' = -0.71$ ft. per sec.

Problem 5. With what velocity must a 5-pound steel hammer strike a 1-pound steel ball at rest, in order to drive it with a velocity of 100 feet per second?

Ans. 77.5 ft. per sec.

GENERAL PROBLEMS.

Problem 1. A freight car weighing 40,000 pounds starts from rest and runs down a 2 per cent grade. If train resistance is 6 pounds per ton, what is its velocity at the end of one minute? *Ans.* 32.8 ft. per sec.

Problem 2. If the train resistance on the car described in Problem 1 is $6 + 0.1 t$ pounds per ton, t being in seconds, what is its velocity at the end of one minute? *Ans.* 30 ft. per sec.

Problem 3. If at the end of one minute brakes are applied so as to stop the car described in Problem 1 in 10 seconds, what is the braking force required? *Ans.* 4760 lbs.

Problem 4. A gun weighing 5 pounds shoots a bullet weighing 0.1 ounce with a muzzle velocity of 800 feet per second. What is the recoil velocity of the gun? *Ans.* 1 ft. per sec.

Problem 5. A push car weighing 300 pounds is moving with a uniform velocity of 15 feet per second. If a man weighing 150 pounds boards it from the side with no velocity in the direction it is moving, what is their velocity after the man comes to rest with respect to the car? *Ans.* $v = 10$ ft. per sec.

Problem 6. A mine cage weighs 800 pounds and the drum of the hoisting engine connected to it weighs 1000 pounds. If k is 1.5 feet, the diameter of the drum is 4 feet, the diameter of the shaft is 2 inches and the coefficient of friction at the bearings is 0.03, what velocity will the cage attain if allowed to fall for 5 seconds before the brake is applied? *Ans.* 94.3 ft. per sec.

Problem 7. Two cast iron spheres 4 inches in diameter connected by a slender rod with their centers 3 feet apart are rotating in a horizontal plane about an axis normal to the rod at its middle at a speed of 60 r.p.m. If by means of a spring joining them the two spheres are brought into contact at the middle, what will be their new speed of rotation? *Ans.* 3480 r.p.m.

Problem 8. If a spherical top 2 inches in diameter weighs 1 pound and is spinning at a speed of 800 r.p.m., what will be its time of precession if its point is 1.2 inches from the center of gravity and its axis is 15° from the vertical? *Ans.* 1.75 sec.

Problem 9. A gyroscope is composed of a circular rim weighing 10 pounds on a bicycle wheel 24 inches in diameter. The wheel is on the end of a horizontal axis 3 feet long, supported at its middle on a pivot so that it is free to rotate in any direction. If the wheel is rotating about its own axis with a speed of 600 r.p.m. clockwise when viewed from the pivot, in which direction will it precess and with what angular velocity?

Ans. Counterclockwise, viewed from above. $\omega' = 0.769$ rad. per sec.

Problem 10. Discuss the gyroscopic action of the propeller of a ship as the ship pitches fore and aft on the waves.

Problem 11. If the coefficient of restitution $e = 0.9$ for a rubber ball, how high will it rebound if dropped from a height of 10 feet? *Ans.* 8.1 ft.

Problem 12. A cast iron sphere 2 inches in diameter when dropped from a height of 12 inches upon a cast iron block rebounded 4 inches. Compute e and the loss in kinetic energy. *Ans.* $e = 0.577$. 0.727 ft.-lb.

Problem 13. A 100,000-pound railroad car moving with a speed of 5 miles per hour overtakes and collides with another weighing 90,000 pounds moving with a speed of 2 miles per hour. What is the loss in kinetic energy if $e = 0.20$?

Ans. 13,080 ft.-lbs.

Problem 14. From a point 5 feet above the ground a ball is thrown upward at an angle of 60° with the horizontal against a wall 20 feet distant. If its initial velocity is 60 feet per second and e for the ball is 0.50, where and with what velocity will the ball strike the ground?

Ans. 39.8 ft. from wall. $v = 86.7$ ft. per sec., 10° with vertical.

Problem 15. If the ball described in Problem 14 is thrown horizontally with the same velocity, but at an angle of 60° with the wall, where will it strike the wall? Where will it strike the ground and with what velocity?

Ans. 10 ft. along the wall, 2.61 ft. from ground. 15.13 ft. along the wall, 4.45 ft. from the wall. $v = 43.5$ ft. per sec. Angle with ground = $24^\circ 20'$. Angle with wall = 41° .

INDEX

- Absorption dynamometer, 217.
- Acceleration, 120.
angular, 155, 159, 160.
constant, 121.
in curvilinear motion, 140.
normal component of, 141.
tangential component of, 141.
variable, 132, 133.
- Accelerations, composition of, 128.
- Algebraic method of analysis, 2.
- Amplitude, 145, 160.
- Angle, of friction, 83.
of repose, 83.
- Angular, acceleration, 155, 159, 160.
displacement, 154.
impulse, 226.
momentum, 226.
velocity, 154.
- Area, centroid of, 66, 69.
moment of inertia of, 99.
- Auxiliary circle, 156.
- Axes of symmetry, 67.
- Axis, inertia, 99.
instantaneous, 182.
- Axle friction, 86.
- Balancing, 173, 174, 175.
of locomotives, 195.
reciprocating parts, 193.
both rotating and reciprocating parts, 195.
- Band brakes, 219.
- Belt friction, 94.
- Brake friction, 90.
- Braking of trains, 213.
- Brakes, band, 219
- Built-up sections, moment of inertia of, 116.
- Catenary, 56.
- Center, of oscillation, 169.
of percussion, 171.
- Center of gravity, 65.
of composite body, 75.
by experiment, 77.
- Centrifugal, force, 143.
tension in flywheels, 171.
- Centroid, of a force system, 65, 68.
of irregular plane area, 77.
of a line, 66.
of a solid, 66.
of a surface, 66.
- Centroids, 65.
by integration, 70.
of surfaces and solids of revolution, 73.
- Circle, friction, 86.
- Circular pendulum, 145.
- Coefficient, of kinetic friction, 83, 85.
of restitution, 236.
of rolling resistance, 90.
of static friction, 83, 85.
- Combined translation and rotation, 179.
- Composition, of accelerations, 128.
of couples, 31.
of forces, 39, 40, 49.
of velocities, 128.
- Compound pendulum, 169.
- Compression, period of, 235.
- Concurrent system of forces, 5.
- Cone of friction, 87.
- Conical pendulum governor, 172.
- Connecting rod of engine, 187.
- Conservation, of angular momentum, 228.
of linear momentum, 225.

- Cord loaded uniformly horizontally, 53.
- Couple, arm of, 29.
 graphic representation of, 30.
 moment of, 29.
- Couples, composition of, 31.
- Curvilinear motion, 140.
- D'Alembert's principle, 125.
- Direct central impact, 235.
- Dynamometer, absorption, 217.
- Effective forces, 125.
 on a rotating body, 143, 160.
 moment of tangential, 161.
 resultant of normal, 164.
- Efficiency, mechanical, 215, 219.
- Energy, 202.
 kinetic, 203.
- Equations of motion, 183.
- Equilibrium, of colinear forces, 6.
 of concurrent forces in space, 13, 16.
 of coplanar forces, 8, 11.
 of parallel forces, 32, 34.
 of parallel forces in space, 35.
 problems in, 44.
- Falling bodies, 122.
- Flywheels, centrifugal tension in, 171.
- Force, centrifugal, 143.
 concentrated, 3.
 definition of, 1.
 diagram, 4.
 distributed, 3.
 effect of, 124.
 moment of, 17, 18.
 polygon, 8, 24.
 projection of, 7.
 resolution into another force and a couple, 32.
 unit of, 1.
- Forces, composition of, 39, 49.
 concurrent system of, 5.
 effective, 125.
 effective, on a rotating body, 160.
 equilibrium of, 40, 41.
 graphical representation of, 4.
- Forces, moment of tangential effective, 161.
 parallel, 23.
 parallel in equilibrium, 32, 34, 35.
 reduction of a system to a force and a couple, 41.
 resolution and recomposition of, 11.
 resultant of normal effective, 164.
 transmissibility of, 4.
- Free-body diagram, 3.
- Friction, 82.
 angle of, 83.
 axle, 86.
 belt, 94.
 brake, 90.
 circle, 86.
 coefficient of, 83, 85.
 cone of, 87.
 kinetic, 82.
 laws of, 85.
 limiting, 82.
 pivot, 92.
 rolling, 90.
 static, 82.
 summary of principles of, 96.
- Funicular polygon, 24.
- Governor, weighted conical pendulum, 172.
- Graphic method of analysis, 2.
- Graphical representation, of acceleration, 121.
 of angular impulse, 227.
 of angular momentum, 227.
 of a couple, 30.
 of a force, 4.
 of impulse, 223.
 of momentum, 223.
 of velocity, 119.
 of work, 201.
- Gravity, center of, 65.
- Gyration, radius of, 100
- Gyroscope, 230.
- Harmonic motion, simple, 129, 156.
- Horsepower, 215.

- Impact, 235.
 direct central, 235.
 oblique, 235.
- Impulse, 223, 224.
 angular, 226.
- Indicator, steam engine, 216.
- Inertia, axis, 99.
 moment of, 99.
 product of, 107.
- Instantaneous axis, 182.
- Jet of water, 233.
- Kinematic discussion, 1.
- Kinetic energy, of rotation, 208.
 of rotation and translation, 210.
 of translation, 203.
- Kinetic friction, 82.
- Kinetic reaction on unbalanced wheel, 192.
- Kinetic reactions, on connecting rod, 189.
 on side rod, 191.
- Kinetics, 1, 119.
- Laws, of friction, 85.
 of motion, Newton's, 3.
- Line, centroid of, 66.
 moment of, with respect to a plane, 66.
- Mass, definition, 1.
 unit, 2.
- Mechanical efficiency, 215, 219.
- Mechanics, 1.
 divisions of, 1.
 fundamental quantities in, 1.
- Methods of analysis of problems, 2.
- Moment, of a couple, 29.
 of a force with respect to a line, 18.
 of a force with respect to a plane, 28.
 of a force with respect to a point, 17.
 of a solid, surface or line with respect to a plane, 66.
 of tangential effective forces, 161.
 sign of, 17.
- Moment, unit of, 17.
- Moment of inertia, of an area, 99.
 of an area, polar, 100.
 of an area, polar, with respect to parallel axes, 104.
 of built-up sections, 116.
 of composite area, 105.
 by experiment, 115.
 of mass, 111.
 maximum and minimum, 110.
 with respect to inclined axes, 106.
 with respect to parallel axes, 102.
 with respect to three rectangular axes, 104.
 sign of, 102.
- Moments, principle of, 17.
- Momentum, 223, 224.
 angular, 226.
- Motion, curvilinear, 140.
 equations of, 183.
 Newton's laws of, 3.
 rectilinear, 119.
 relative, 134.
 simple harmonic, 129, 156.
- Newton's laws of motion, 3.
- Normal, acceleration, 141.
 effective forces, 164.
- Oblique impact, 235.
- Oscillation, center of, 169.
- Pappus and Guldinus, theorems of, 74.
- Parallel forces, 23.
 in equilibrium, 32, 34, 35.
- Parallelogram law, 5.
- Pendulum, conical, 172.
 compound, 169.
 simple circular, 145.
- Percussion, center of, 171.
- Period, of compression, 235.
 of restitution, 235.
- Pivot friction, 92.
- Planes of symmetry, 67.
- Polar moment of inertia of an area, 100.
- Polygon of forces, 8, 24.

- Potential energy, 203.
 Power, 215.
 Pressure of water on a vane, 233.
 Principle of moments, 17, 25, 40.
 Principles of friction, summary of, 96.
 Problems in equilibrium, 44, 50.
 Product of inertia, 107.
 Projectile, 149.
 Projection, of a force, 7.
 of a force polygon, 13.
 of a force system, 16.
- Radius of gyration, of an area, 100.
 of mass, 111.
- Reactions of supports of rotating bodies, 166.
- Rectilinear motion, 119.
- Reference planes, 13.
- Relative motion, 134.
- Resistance, rolling, 89.
- Resolution, of accelerations, 128, 181.
 of a force into a force and a couple, 32.
 of a force into three components, 14.
 of a force into two components, 7.
 of velocities, 128, 180.
- Restitution, period of, 235.
 coefficient of, 236.
- Resultant, of angular momenta, 230.
 of normal effective forces, 164.
 of three or more forces, 8, 10, 13, 15.
 of three or more parallel forces, 26, 27.
 of two concurrent forces, 5, 6.
 of two parallel forces, 23, 24.
- Rolling resistance, 89.
 coefficient of, 90.
- Rotation, 154.
 kinetic energy of, 208.
 and translation combined, 179.
- Simple circular pendulum, 145.
 Simple harmonic motion, 129, 156.
- Solid, centroid of, 66, 69.
 moment of, with respect to a plane, 66.
- Space, diagram, 4.
 units of, 1.
- Speed, 119.
- Static friction, 82.
- Statics, 1.
- Steam engine indicator, 216.
- Surface, centroid of, 66, 69.
 moment of, with respect to a plane, 66.
- Symmetry, axes of, 67.
 planes of, 67.
- Tangential acceleration, 141.
- Three-force members, 42.
- Time, unit of, 1.
- Translation and rotation combined, 179.
- Triangle law, 5, 8.
- Two-force members, 42.
- Uniform, circular motion, 142.
 velocity, 119.
- Variable, acceleration, 120.
 velocity, 119.
- Varignon's theorem, 18.
- Vectors, 2.
- Velocities, composition of, 128.
- Velocity, 119.
 angular, 154.
 uniform, 119.
 variable, 119.
 in a vertical curve, 147.
- Water, jets, 233.
 power, 216.
- Weighted conical pendulum governor, 172.
- Work, 199.
 graphical representation of, 201.
 lost in friction, 211.





UNIVERSITY OF CALIFORNIA LIBRARY

This book is DUE on the last date stamped below.

Five cents on first day overdue

Ten cents on fourth day overdue

One dollar on seventh day overdue.

OCT 6 1947

DEC 8 1947

MAY 12 1948

JUN 4 1948

Dec 3 '48 RW

31 Jan 49 HI

26 Oct '59 GG

REC'D LD

OCT 27 1959

355451

17
250
17

THE UNIVERSITY OF CALIFORNIA LIBRARY

