



This is a digital copy of a book that was preserved for generations on library shelves before it was carefully scanned by Google as part of a project to make the world's books discoverable online.

It has survived long enough for the copyright to expire and the book to enter the public domain. A public domain book is one that was never subject to copyright or whose legal copyright term has expired. Whether a book is in the public domain may vary country to country. Public domain books are our gateways to the past, representing a wealth of history, culture and knowledge that's often difficult to discover.

Marks, notations and other marginalia present in the original volume will appear in this file - a reminder of this book's long journey from the publisher to a library and finally to you.

Usage guidelines

Google is proud to partner with libraries to digitize public domain materials and make them widely accessible. Public domain books belong to the public and we are merely their custodians. Nevertheless, this work is expensive, so in order to keep providing this resource, we have taken steps to prevent abuse by commercial parties, including placing technical restrictions on automated querying.

We also ask that you:

- + *Make non-commercial use of the files* We designed Google Book Search for use by individuals, and we request that you use these files for personal, non-commercial purposes.
- + *Refrain from automated querying* Do not send automated queries of any sort to Google's system: If you are conducting research on machine translation, optical character recognition or other areas where access to a large amount of text is helpful, please contact us. We encourage the use of public domain materials for these purposes and may be able to help.
- + *Maintain attribution* The Google "watermark" you see on each file is essential for informing people about this project and helping them find additional materials through Google Book Search. Please do not remove it.
- + *Keep it legal* Whatever your use, remember that you are responsible for ensuring that what you are doing is legal. Do not assume that just because we believe a book is in the public domain for users in the United States, that the work is also in the public domain for users in other countries. Whether a book is still in copyright varies from country to country, and we can't offer guidance on whether any specific use of any specific book is allowed. Please do not assume that a book's appearance in Google Book Search means it can be used in any manner anywhere in the world. Copyright infringement liability can be quite severe.

About Google Book Search

Google's mission is to organize the world's information and to make it universally accessible and useful. Google Book Search helps readers discover the world's books while helping authors and publishers reach new audiences. You can search through the full text of this book on the web at <http://books.google.com/>

COAL PETROLEUM
AND OTHER
DISTILLED OILS.

—
A. GESNER.

100-1
2 211
181

The Branner Geological Library



LELAND STANFORD JUNIOR UNIVERSITY



6069

Return - back side

CC

5/12/78

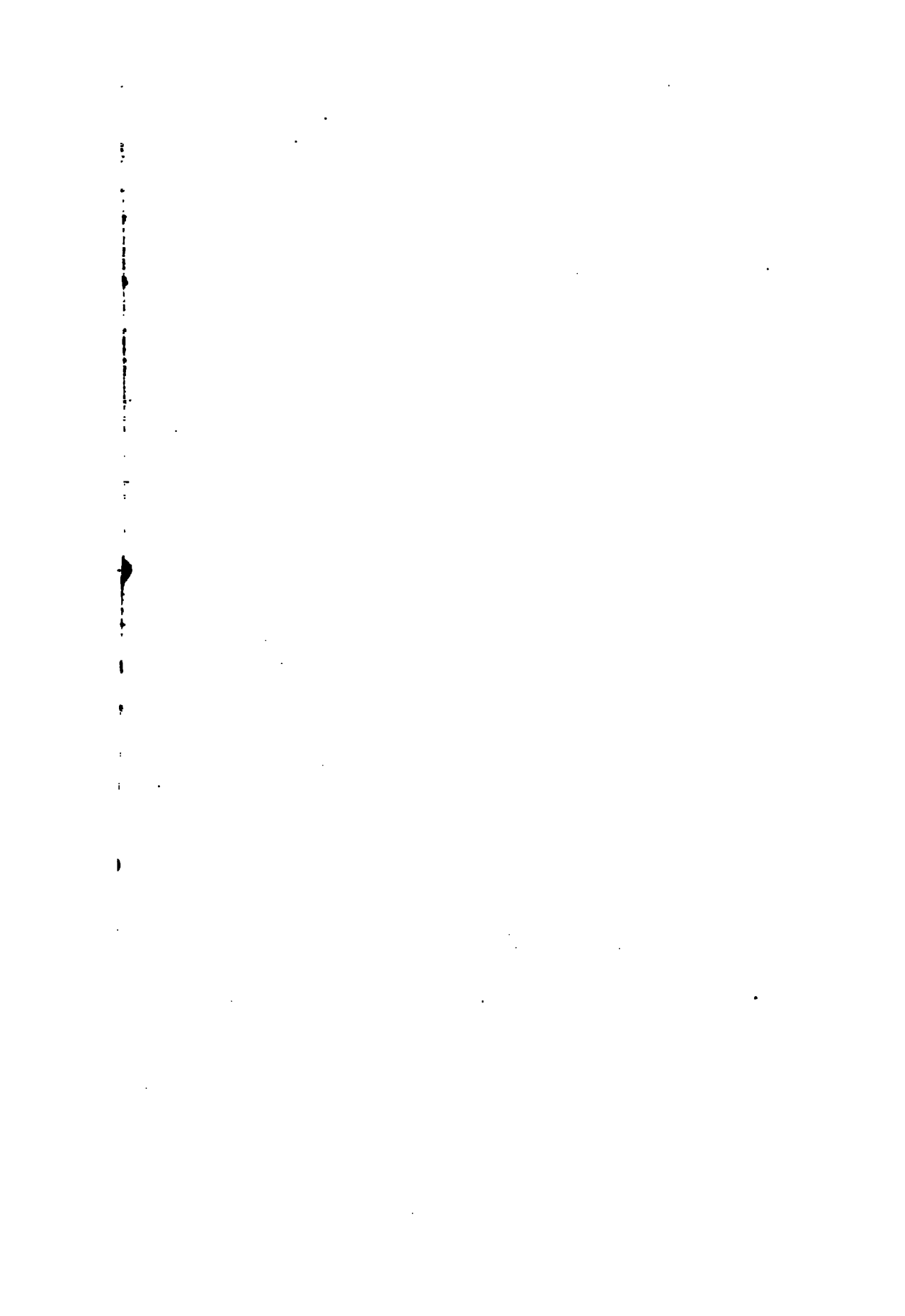





GREAT PITCH LAKE OF TRINIDAD, W. I.

From a Drawing by Capt. Goldsmith, R. N.

L. F. Beckham 11
J. C. Branner

A

PRACTICAL TREATISE
ON
COAL, PETROLEUM,
AND OTHER DISTILLED OILS.

By ABRAHAM GESNER, M.D., F.G.S.,
CONSULTING CHEMIST.
AUTHOR OF "INDUSTRIAL RESOURCES," "HISTORY OF NEW BRUNSWICK,"
"GEOLOGICAL REPORTS," &c., &c.



NEW YORK:
BAILLIÈRE BROTHERS, 440 BROADWAY.

London:
H. Baillière,
219 Regent Street.

Melbourne:
F. Baillière.

Paris:
J. B. Baillière et Fils,
Rue Hautefeuille.

Madrid:
C. Bailly-Baillière,
Calle del Principe.

1861.

+

213705

Entered according to Act of Congress in the year 1860, by
BAILLIERE BROTHERS,
In the Clerk's Office of the District Court of the United States, for the Southern District
of New York.

YSA98U: us07MAY2

E. CRAIGHEAD,
Printer, Stereotyper, and Electrotyper,
Carion Building,
21, 23, and 25 Centre Street.

CONTENTS.

CHAPTER I.

Early records and progress of the distillation of oils from coals and other bituminous substances.—Introduction of kerosene, patents, petroleum, varieties of coals; their origin and composition.—Effects produced upon coals by heat.—Variety of oils distilled from coals, bitumen, etc.—Products of common bituminous coals, etc., 7

CHAPTER II.

Materials employed for the production of oils.—Boghead coal.—Albert coal.—South Boghead coal.—Brown coal.—Bitumen of Trinidad, Cuba, United States, Canada, etc.—Extent of coal fields.—Petroleum springs.—Origin of petroleum.—Table of bituminous substances, etc., 20

CHAPTER III.

Nature of the Products distilled from Bituminous Substances.—Modes of obtaining Oils.—Retorts.—D-shaped Retorts.—Revolving Retorts.—Vertical Retorts.—Clay Retorts.—Brick Ovens.—Coke Ovens.—Stills.—Condensers.—Agitators, etc., 36

CHAPTER IV.

Products of the distillation of wood, coals, asphaltum, bitumen, petroleum, and other substances capable of yielding oils, 57

CHAPTER V.

Composition of distilled oils.—Homologous compounds.—Table of the same.—Compounds of Carbon and Hydrogen.—Gaseous compounds.—Homologues obtained from coal tar, coal, bitumen, caoutchouc, etc., 78

CHAPTER VI.

Purification of Oils.—Oxidation of the impurities in crude, hydro-carbon oils.—Action of acids, alkalies, and other agents. Sulphuric acid, nitric acid, permanganate of potash.—Extracts from Patents, etc., . . . 89

CHAPTER VII.

Buildings and Machinery.—Method of manufacturing and purifying the oils distilled from coals and other bituminous materials, and the products derived therefrom.—Distilling by steam.—Continual distillation.—Lamp oils, lubricating oils, Paraffine, etc.—Petroleum oils.—Refuse of oil factories, 108

P R E F A C E .

THE work before the reader has been prepared with a desire to aid the manufacturer of Oils in his avocation. It is more practical than theoretical.

A great deal of valuable information relating to the production of the hydro-carbon oils from bituminous minerals, is scattered throughout the French, German, and English scientific Journals, and numerous patents granted in those countries, to which the public have not convenient access. The information collected from those sources, that seemed applicable to the present treatise, has been carefully recorded therein.

The author has had much experience in the manufacture of the oils referred to, and during a period of several years, while he was engaged as a consulting chemist in the actual working of manufactories, he endeavored to discover and inscribe every useful fact having a bearing upon the subject. Those facts are communicated in the body of this work.

It is hoped that the professional chemist will find upon the pages of this volume, something to interest him, and especially as regards the homologous compounds of carbon and hydrogen.

The recent discoveries of vast reservoirs of petroleum in the Western and Southern States of the Union, have received a due share of attention; and the most accurate information regarding their supplies of oil, that could be obtained, has been recorded.

To assist the engineer and machinist, such drawings have been introduced as were called for in a work intended for general application in a most valuable and important branch of modern industry.

NEW YORK, Nov., 1860.

COAL, PETROLEUM, AND OTHER OILS.

CHAPTER I.

Early records and progress of the distillation of oils from coals and other bituminous substances.—Introduction of kerosene, patents, petroleum, varieties of coals; their origin and composition.—Effects produced upon coals by heat.—Variety of oils distilled from coals, bitumen, etc.—Products of common bituminous coals, etc.

IN a treatise devoted to the manufacture and purification of oils, it might be deemed proper to consider the oleaginous substances derived from the animal and vegetable kingdoms; but the present treatise is intended to give a descriptive account of the mineral oils only, and the modes by which they are manufactured and purified.

The rapid advances made during the last ten years in developing mineral oils, and their growing importance to the world for illuminating, and various other purposes, give them a value not rivalled by the whale fisheries of the Atlantic and Pacific Oceans.

The ancient inhabitants of different parts of the world, civilized and barbarous, were acquainted with those natural oils which flow from the earth, namely, mineral oil, or

naphtha, bitumen, etc. The Persians, Burmese, and other nations still continue to employ those substances in their crude state to give light, and for medicinal purposes. As early as 1694 Eeele, Hancock, and Portlock made "*pitch, tar, and oyle out of a kind of stone,*" and obtained patents therefor. In 1761 oils were distilled from black bituminous shale, and were employed in the cure of certain diseases, as stated in Lewis's *Materia Medica* for that year.

More than a century ago oils were obtained by the distillation of coals, but the purification of those oils, and their application to the common requirements of life, have been slow in their progress, and are not even now brought to perfection. The papers of the Royal Society of London, the *Philosophical Transactions*, and other European publications, give accounts of the distillation of oils from coals and other bituminous substances. In 1781 the Earl of Dundonald obtained oils from coals by submitting them to dry distillation in coke ovens, like those employed by some manufacturers of the present day for the same purpose. Laurent, Reichenbach, and others distilled the tars obtained from bituminous schists. These tars were purified in some degree by Selligue, and the oils subsequently obtained an extensive sale in Europe for burning in lamps, and for lubricating machinery. Many other chemists have from time to time contributed improvements in the purification of hydrocarbon oils.

The discovery of coal gas brought a new class of oils to the notice of the chemist, but the purification of those oils, and their application to useful purposes, have been but slowly advanced.

The first successful attempt to manufacture oils from coals in America was made by the author of this work. Oil from coal was made and consumed in lamps by him in

his public lectures at Prince Edward's Island, in August, 1846, and subsequently at Halifax, Nova Scotia, accounts of which are still extant. The patents afterwards obtained for his improvements were sold to the North American Kerosene Gas Light Company, and the oils are now manufactured and sold under the denomination of "Kerosene Oil."* Several patents, obtained by other persons at later dates, are but modifications of the modes of manufacture previously laid down, and contain but little that is new in principle.

Patents were granted in England, in 1847, to Charles Mansfield, for "an improvement in the manufacture and purification of spirituous substances and oils applicable to the purposes of artificial light," etc. Mr. Mansfield's operations appear to have been chiefly directed to the coal tar of gas works, from which he obtained benzole. He was perhaps the first to introduce the benzole or atmospheric light, which is described at length in his specifications.

James Young, of Manchester, secured a patent in England (Oct. 7, 1850), and subsequently in the United States (March 23, 1852), for "the obtaining of paraffine oil, or an oil containing paraffine, and paraffine from bituminous coals." These patents have been the subject of much discussion, and law proceedings have been instituted by Mr. Young against several oil companies for infringements of his alleged rights. The manufacture has nevertheless advanced rapidly, and has been extended to the chief cities of the Atlantic seaboard, and over the coal regions of the West. The claims of those patents extend to the distillation of coal in close vessels, and to the degree of heat employed for that purpose. The oils produced by Mr. Young's method are inferior in color, odor, and illumi-

* From κηρός, wax, and ελαιον, oil.

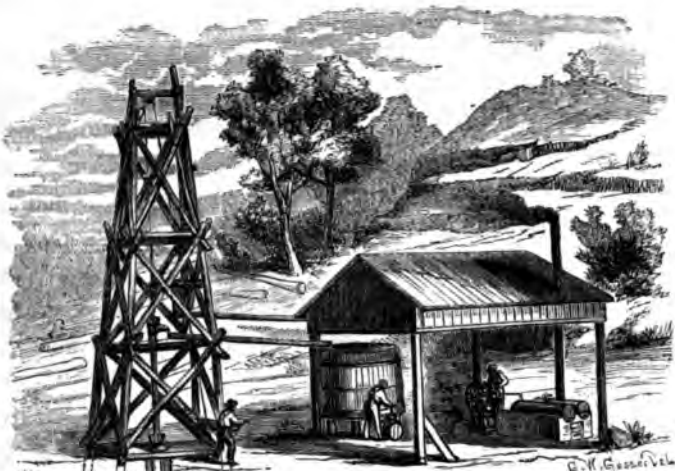

Water & 50 ft

PETROLEUM WELL.



nating properties to those now manufactured by other chemists, and as his claims are under the consideration of the legal authorities, with them the decision should be left, without the interference of public writers.

The progress of discovery in this case, as in others, has been slow and gradual. It has been carried on by the labors, not of one mind, but of many, so as to render it difficult to discover to whom the greatest credit is due. It is, notwithstanding, just to admit, that from the facts disclosed in the beforementioned patents, a spirit of inquiry was aroused, and experiments were multiplied. Almost all the patents that have recently been granted embrace the leading features of former discoveries, and some of them are characterized by a total lack of invention, and a desire to evade the claims of others.

The total number of patents granted, with inventions and improvements claimed for the manufacture and purification of oils from coals and other bituminous substances, since 1781, are more than one hundred in number, and upwards of forty patents have been granted for retorts, stills, and other apparatus connected with this branch of industry.*

Since the introduction of *kerosene* into the market, coal lands of every description within the limits of the United States have been explored, and bituminous clays, sands, and peat, have become objects of great interest. The products of those materials have been overrated, and the cost of manufacture underrated, by stockholders of *coal oil* companies.

During the past year numerous springs of petroleum have been opened in some of the Western States, and oils

* See Reports of Patent Inventions, European and American, also *The American Journal of Science and Arts*, vol. xxx. 1860.

are produced from them which are not inferior to those obtained from the most approved varieties of coal. A description of those oils, and the best practical methods for their purification, will be given in another part of this work, and if the above springs maintain their present supply, they will materially affect the distillation of oils from coals, bitumens, and other kindred materials.

Coal is evidently of vegetable origin, and consists chiefly of plants which have been subjected to great pressure, heat, and chemical agencies through vast periods of time. Its value to commerce, manufactures, machinery for warlike purposes, and for oils, is beyond computation.

The varieties of coal have heretofore been classed under the heads of

Anthracite, or Hard Coal,
Caking Coal,
Cherry Coal,
Splint Coal, and
Cannel Coal.

These five varieties have the following composition :—

| RICHARDSON. | | | THOMPSON. | | |
|-------------|--------------|--------------|--------------|--------------|-------|
| Anthracite. | Caking Coal. | Cherry Coal. | Splint Coal. | Cannel Coal. | |
| Carbon | 92.56 | 87.952 | 83.025 | 82.924 | 76.25 |
| Hydrogen | 3.33 | 5.239 | 5.250 | 5.491 | 5.50 |
| Nitrogen | " | " | " | " | 1.61 |
| Oxygen | 2.53 | 3.806 | 8.566 | 8.847 | 13.83 |
| Ashes | 1.58 | 1.393 | 1.549 | 1.128 | 2.81 |

Other varieties of combustibles have been arranged by Berthier in the following manner :—

| Composition in 100 parts. | Peat or Turf. | Lignite, or Brown Coal. | Bituminous Coal. | Anthracite, Pennsylvania. | Plumbago, or Graphite. |
|---------------------------|---------------|-------------------------|------------------|---------------------------|------------------------|
| Carbon | 38 | 54 | 73 | 94 | 95 |
| Hydrogen | " | 05 | 05 | 2.55 | " |
| Oxygen | " | 26 | 20 | 2.56 | " |
| Ashes | 17.4 | 14 | 02 | " | " |
| Volatile Matter } | 28 | " | " | " | " |
| Iron | " | " | " | " | 5 |

The names given to combustible substances have been applied with reference only to their common characters and uses. Frequently coals bear the names of the places where they are mined. Few of their appellations have any reference whatever to their chemical composition, and therefore in seeking for *oil coals* (if the term may be used) the manufacturer must be directed by an actual test of the material itself.

In the same coal field, the same series of strata, and in the same stratum, there are important differences of composition. It is as providential as wonderful that the carbonaceous material of the same deposit is adapted to different uses.

The varieties of coal may have been produced from the different kinds of plants from which the coal has been derived, and the peculiar conditions of the districts where those plants flourished before their downfall and inhumana-

tion, or submersion. The changes that have taken place in the original plants during their passage from woody fibre into coal, are ascribed to the evolution of a part of their carbon, hydrogen, and oxygen, as there is less of those elements in the coal than in wood. This will be observed by viewing the following table:—

| Composition of the Anthracites of the | Carbon. | Hydrogen. | Oxygen and Nitrogen. |
|--|---------|-----------|----------------------------|
| <i>Transition Rocks</i> | 90· | 2·40 | 3·69 |
| “ “ Bituminous Coal of the <i>Secondary Rocks</i> | 86· | 4·86 | 7·11 |
| “ “ Lignites of the <i>Tertiary Rocks</i> | 60·36 | 5·00 | 25·62 |
| Wood (recent) | 49·60 | 5·80 | 42·56 |

It will also be observed that the older the formation the greater the amount of carbon contained in its coal, the amount of hydrogen being diminished. This fact may be ascribed chiefly, or in part, to the greater degree of heat and pressure to which the lower and older coal strata have been, and still are subjected.

The gases of deep coal mines are very similar to those of gas manufactories, and such as are produced by a high temperature. The deeper the mine the greater is the discharge of carburetted hydrogen. It is to the internal heat of the earth, and other chemical agencies combined with causes of less force, that we must chiefly ascribe the transmutation of wood into coal. The similarity of the distilled products of wood and coals, and of charcoal and coke, should not be overlooked in seeking for proofs of the vegetable origin of coal. In mines of lignite and cannel coal carbonic acid or *choke damp* is almost the only gas present. In lower coal mines, or those that have been longer under

the influence of heating and other chemical agents, carburetted hydrogen or *fire damp* predominates.

Liebig has shown the great loss of oxygen, and increase of hydrogen and carbon in lignite and brown coal during their transition from a vegetable to a fossil state; still there is much that remains unexplained regarding other kinds of coal.

With a view to a proper arrangement of the subject, various materials capable of yielding oils by distillation will be considered in regular order. The chief of those materials, so far as present discoveries extend, are coals, bituminous shales, asphaltum, bitumen, bituminous sands and clays, petroleum, lignite, peat, caoutchouc, gutta percha, and the tars produced in the manufacture of stearine.

When organic bodies are exposed to heat, with the free admission of air, they undergo combustion. The greater part of the carbon is expelled in smoke, or in carbonic acid, the hydrogen in water, or carburetted hydrogen, and the nitrogen, if any be present, escapes in some compound of ammonia; but if those substances have heat applied to them in close vessels, there are new results, and a greater interchange of elements takes place.

In 1730 Hales distilled substances to discover if they contained air. In 1773 the same gentleman and Dr. Watson obtained gas from coals, and in 1786 Lord Dundonald burned the gas that arose from his coke ovens at the ends of iron pipes for the amusement of his friends. In 1792 Mr. Murdoch commenced lighting buildings with coal gas, and since that period gas lighting has been extended to every quarter of the globe. Besides the gas employed for illumination, it was thus early observed, that other gases and oils were produced by the distillation of coals. The

discovery of coal oils is therefore as old, if not older, than the discovery of coal gas, and cannot now be justly claimed by any living man.

When substances composed of carbon, hydrogen, and oxygen are submitted to dry distillation, the first effect is to remove oxygen from the body in the form of carbonic acid, or water. After the oxygen has been removed carbon and hydrogen escape, as carburetted hydrogen, or olefiant gas. If some of the acids are distilled they lose oxygen in the form of carbonic acid and water, and are converted into new acids. Organic acids distilled with strong bases part with the elements of carbonic acid, which uniting with the base and the acid, minus the carbonic acid, comes over in the form of a new product.

If a quantity of coals be placed in a suitable retort, with a condensing apparatus attached, and heat be gently and gradually applied thereto, the first result will be the escape of water in the form of vapor, or steam, and frequently mixed with an extremely light, volatile, and inflammable hydro-carbon, which is but partially condensable into a spirit, or oil. The hygroscopic water contained in the coal appears in the form of vapor, sometimes mixed with carbonic acid, and if the coal contained nitrogen ammonia is among the products. Then as the heat is increased a series of oils of different specific gravities are condensed, the lightest or first distilled having the character of a spirit rather than an oil; finally, when the heat has been raised to 750° or 800° Fah., gas, free carbon, and a number of pyrogenous substances appear, known as *dead oil*, which mixes mechanically with the aqueous products, and settles to the bottom of the receiving vessel. Throughout the distillation more or less water, formed by the oxygen and hydrogen present, continues to flow. Usually in proper

retorts the oils will all distil over at a temperature of 750° Fah. A higher degree of heat produces permanent gases from any volatile matter that may remain in the charge; but besides the elements before-mentioned, coal frequently contains sulphur and other minerals, which, by entering into new combinations during the distillation, yield other compounds, the *modus operandi* of whose formation is not well understood. In all these changes electricity plays an important part, and this remark will apply to all the products obtained by the distillation of bituminous and oleaginous materials. In the retort there remains a quantity of fixed carbon, or coke, united to the ash, which usually consists of silica, alumina, lime, and the oxides of manganese and iron.

The results here described are greatly modified by the kind of coals used, the degree of heat applied, and the mode by which the oleaginous vapors are condensed. The shape of the retort, the weight, or thickness of the charge, and the position and size of the discharge-pipe, also have an influence over the yield of oil, and the time required for its production.

In general, coals which yield the greatest amount of volatile matters, exclusive of hygroscopic moisture, afford the most oils, and estimates are often formed of their value by a simple test of the weight of matter expelled by the application of a moderate degree of heat. This test, however, is often delusive, as some coals expel much more free carbon during their distillation than others, and the sulphur contained in coal adds nothing to the oil, while it constitutes a part of its volatile products. Nor does such a test afford much information regarding the quality of the oils a given quantity of coal will supply. A long smoky flame is indicative of much free carbon, a shorter and more lumi-

nous flame denotes that there will be much fixed carbon in the coke. Some varieties of coals are peculiarly adapted to the manufacture of gas, as their chief products by heat are carburetted and bicarburetted hydrogen; such coals do not always contribute the most oils.

It is of the utmost consequence to the manufacturer of coal oils to know the quality as well as the quantity of the oils any one material will afford. For this the only reliable test is to submit the material to dry distillation, and the whole process by which coal oils are purified.

It will be seen hereafter that coals, coal shales, asphaltums, petroleums, and other bituminous substances, yield not one, two, or three oils; but series of homologous compounds. Some members of these series are of high specific gravity, some of low, or, as the oils are called, heavy and light; the light being eupion, or benzole, the heavy the oil pressed from paraffine, and, finally, the solid, as paraffine, naphthaline, etc.

These several series of hydrocarbons are greatly influenced by the heat employed in their distillations, the condensers, and, finally, their mode of treatment. Again, there are not two kinds of coal that will give the same products, even by the same modes of manufacture. Some yield much light, others much heavy oil; some send over much paraffine, and what are called by manufacturers impurities, namely, naphthaline, carbolic acid, copnomor, etc., ever attending the distillates. It is from ignorance of these facts, and of the chemistry of the above productions, that so much smoky and offensive oil is seen in the market.

Few common bituminous coals can be successfully employed in the oil manufactory; their distillates abound in creosote, or carbolic acid, and their purification is expen-

sive. Asphaltums, bitumens, bituminous shales and clays, and cannel coals, are the most productive of oils. A table setting forth the respective merits of a number of those substances will be appended to the next chapter. A few of them deserve particular notice.

CHAPTER II.

Materials employed for the production of oils.—Boghead coal.—Albert coal, —South Boghead coal.—Brown coal.—Bitumen of Trinidad, Cuba, United States, Canada, etc.—Extent of coal fields.—Petroleum springs.—Origin of petroleum.—Table of bituminous substances, etc.

BOGHEAD COAL, OR BITUMINOUS CLAY.

THIS peculiar mineral occurs at Torbane Hill, in the carboniferous limestone of the Frith of Forth, Scotland. It is the material from which Mr. Young obtains paraffine oil and paraffine, and his manufactory is in the immediate vicinity of the mines. It has been extensively shipped to the United States, and employed in the manufacture of kerosene at New York and Boston. During the year 1859 the North American Kerosene Gas Light Company imported upwards of 20,000 tons of this material for the supply of their works at Newtown Creek, Long Island, and at an average cost of eighteen dollars per ton. In consequence of the discovery of numerous strata of cannel coals in the Western States of this country, and of cheaper substances for the production of oils, the importation of the Torbane Hill mineral will doubtless be discontinued.

Although this mineral possesses few of the characteristics of a true coal, the term coal has been applied to it for commercial convenience. It has been the source of long-continued and expensive lawsuits. The point in dispute affected the ownership, whether it was coal, or not coal. Numbers of the most scientific men in Europe were arraigned before courts and juries to decide whether the so-called Boghead coal is coal, or bituminous clay. There

was a decided preponderance against the term "coal," and in favor of "bituminous clay." Finally the contending parties compromised, and the term coal was permitted to be applied, although the bitumen of the Great Pitch Lake of Trinidad has an equal right to that appellation.*

Boghead coal is among the most valuable minerals for the manufacture of oils. It has an uneven fracture, is of an earthy color, and burns with a long smoky flame. It yields 13,000 cubic feet of gas, of specific gravity 0.775, per ton. As it contains only traces of nitrogen, the quantity of ammonia given off is small. The following is the medium result of four trials in testing its qualities:—

| | | |
|-----------------|-----------|--------|
| Volatile matter | | 70.10 |
| Carbon in coke | | 10.30 |
| Ash | | 19.60 |
| | | 100.00 |

The ton of coal run in common retorts gives 120 gallons of crude oil, of which 65 gallons may be made into lamp oil, 7 gallons of paraffine oil, and 12 lbs. of pure paraffine. The coke is worthless, and the ash consists chiefly of silica and alumina. At a price of 11 dollars per ton for the coals, the cost of the oil is estimated at 63 cents per gallon.†

ALBERT COAL.

This bituminous mineral occurs at Hillsboro', Albert County, in the province of New Brunswick, and within four miles of the Peticodiac River. It is an injected vein, situated almost vertically in the earth, and from one to sixteen feet in thickness. It is associated with rocks highly charged with bitumen, and has neither roof, floor, under-

* *London Journal of Gas Lighting*, iii. 521. Young vs. White, and others.

† Report of the Committee North American Kerosene Gas Light Company. New York. 1860.

clay, nor stratum of *stigmaria*, nor other accompaniments which distinguish coal deposits from all others.*

The Albert coal, so called, is extremely brilliant, breaks with a conchoidal fracture, does not soil the fingers, and is strongly electric. It melts, and drops in the flame of a candle, and dissolves in naphtha and other solvents, forming a varnish. It has all the essential properties of asphaltum, while it is void of those which constitute true coal. Like the mineral of Torbane Hill, it has been the subject of disputes and lawsuits, the total cost of which has exceeded thirty thousand dollars. If the substance were coal, the coal was the property of one party; if asphaltum, the asphaltum belonged to another. Coal had been reserved by the Crown of Great Britain; but asphaltum was not mentioned in the grants of the land. In April, 1852, an intelligent jury, who analysed the mineral at Halifax, decided that it was asphaltum, and not coal. Another trial was held in the county where the so-called Albert coal is mined in July of the same year. It lasted eleven days. Chemists were summoned from every quarter, and under the most conflicting testimony, and with a jury of farmers, the advocates for coal obtained a verdict, and the asphaltum has since been called Albert coal. The composition of the Albert coal is as follows:—

| | | |
|------------------|------------------|---------|
| Carbon | 86.307 | 85.400 |
| Hydrogen | 8.962 | 9.200 |
| Nitrogen | 2.930 | 3.060 |
| Sulphur | traces | a trace |
| Oxygen | 1.971 | 2.220 |
| Ash | 0.100 | 0.120 |
| | 100.000 | 100.000 |
| | C. M. WETHERELL. | GESNER. |

* See Taylor on Coal, 2d edition, p. 516.

The average yield of crude oil by four trials in large retorts was 110 gallons per ton, and

| | |
|--------------------------------|---------|
| Volatile matters | 61.050 |
| Coke | 30.650 |
| Hygroscopic moisture | 0.860 |
| Ash | 7.440 |
| | <hr/> |
| | 100.000 |

Of the crude oil 70 per cent. may be made into lamp oil, 10 per cent. is heavy oil and paraffine. The coke is exceedingly brilliant and cellular; it burns rapidly, and gives a strong heat.

BRECKENRIDGE COAL.

The Alleghany, or Apalachian coal field of the United States has been estimated to embrace 63,000 square miles. Interstratified with the common bituminous coals, in this vast region there are very numerous strata of cannel coals, adapted to the manufacture of oils. In the numerous surveys and valuable reports made on the coal districts, cannel coals are seldom described as a distinct variety.

A peculiarity of the great Western coal field is, that the coal does not appear to be separated into basins, or lake-like depressions in the earth, as it is in Europe, and in the anthracite coal districts. The bituminous coal is found in the tops of hills, and even in the Alleghany Mountains, in beds nearly horizontal, and it displays the same peculiarity as it stretches away towards the Gulf of Mexico, the Canadian Lakes, and the Rocky Mountains.

Among the cannels that have been discovered Breckenridge coal holds an important place. This coal occurs in Breckenridge County, Kentucky. It is a rich variety of

cannel, three feet in thickness, and has already supplied a large amount of oil and paraffine. The lamp oil, when properly purified, is of good quality; although the oil heretofore sent from the manufactory near the mine to the New York market has been generally inferior in color and odor. At a red heat this coal yields—

| | |
|-------------------------------|--------|
| Volatile matters | 61.300 |
| Fixed carbon | 30.000 |
| Ash | 8.055 |
| Hygroscopic mixture | .645 |
| Sulphur, a trace | |

100.000

By the ordinary methods of working, this coal yields 130 gallons of crude oil per ton, of which 58 per cent. was manufactured into lamp oil, and 12 gallons into paraffine oil and paraffine. The quality of the coal is variable, and the products are very much influenced by the degree of heat applied to the retorts in the distillation.

CANDLE TAR.

The tar and pitch resulting from the manufacture of stearine have been employed for the production of oils. Large supplies have been imported from England into the United States, and sold under the names of "grease" and candle tar. The ordinary yield of crude oil from this material is 200 gallons per ton, of which 70 per cent. may be made into lamp oil, and 10 per cent. into lubricating oil. The oils are excellent in quality; but heretofore the first distillation of the tar has been attended with inconvenience, as it "foams up" in the retorts, and the coke adheres very firmly to their sides. The price has varied from 25 to 40 dollars per ton.

SOUTH BOGHEAD COAL.

Near Poole (England) there occurs a peculiar kind of shale, which has been sold as "South Boghead Coal." It abounds in the remains of fishes and *crustacea*. It gives out 42 per cent. of volatile matter, and therefore has offered an object of trial to oil-makers; but the oils made from this rock contain a greater number of the equivalents of carbon than those derived from coals, or bitumens, and with the ordinary density they smoke in the common lamp. It seems quite evident that the elements of the oil—carbon, hydrogen, oxygen, and nitrogen, now composing the shale, in part, have been derived from fishes and other marine animals, and not from the vegetable kingdom, as in the case of coal.

BROWN COAL.

Singular beds of brown coal have been discovered on the Ouachita River, Arkansas, and at other places in that quarter. They contain the remains of *sphagneous* plants and woody fibre. It appears that peat bogs have been overflowed, or otherwise saturated with petroleum, and hardened by time and oxidation. The oils distilled from this material abound in paraffine. It has the following composition in 100 parts:—

| | |
|---|--------|
| Volatile matters condensed into oils, and gas uncondensed | 60.10 |
| Fixed carbon | 32.85 |
| Ash | 7.05 |
| | <hr/> |
| | 100.00 |

Crude oil at the rate of 68 gallons per ton was obtained from it. It is semi-solid when the thermometer is at 80°. Fah., and, besides lamp and lubricating oils, it produces 143 lbs. of paraffine per ton.

BITUMEN OF TRINIDAD, CUBA, ETC.

The celebrated Pitch Lake of the Island of Trinidad* is upwards of three miles in circumference, and forms the head of La Brae harbor. At the time of the author's visit to the place, the bitumen, of the consistence of thin mortar, was flowing out from the side of a hill, and making its way outwards over more compact layers towards the sea. As the semi-solid and sulphureous mineral advances, and is exposed to the atmosphere, it becomes more solid; but ever continues to advance and encroach upon the water of the harbor. The surface of the bitumen is occupied by small ponds of water—clear and transparent, in which there are several kinds of beautiful fishes. The sea, near the shore, sends up considerable quantities of naphtha from submarine springs, and the water is often covered with oil, which reflects the colors of the rainbow. In the cliffs, along the shores, there are strata of lignite, in which it has been supposed by some the bitumen and naphtha had their origin.

It was from this bitumen the author first obtained kerosene, which differs in some degree from "coal oil." The bitumen is of a grey color, somewhat brittle, but still yielding, more or less, to the summer heat of the sun. A cargo of broken masses will consolidate itself in a ship's hold in such a manner as to require mining before it can be discharged. Its shipment has been refused under the belief that it strains the vessel. The following is the result of several trials made with reference to its application for the manufacture of oils:—

| | |
|---|------------|
| Specific gravity | 0.882 |
| Crude oil by first distillation | 71 gallons |
| Oils by second distillation per cent. | 62 " |
| Paraffine per cent. | 14 |

* See the frontispiece.

Of oil proper for lamps it gave 42 gallons per ton, and for lubrication 11 gallons. A bitumen yielding more than the above quantities of oils may be obtained in small quantities on the borders of the Great Lake. The odor of the oils obtained from Trinidad bitumen has heretofore been very offensive. It may, however, be removed by proper treatment.

There are several extensive mines of bitumen (chacapote) in the Island of Cuba, and springs of petroleum have been known to the Spaniards since the early settlement of Havana. The average product of crude oil obtained from this bitumen is 120 gallons per ton. It has recently been shipped to England for manufacturing purposes; but with all the skill that has been applied to them the oils retain their objectionable odor.

Central and South America abound in asphaltum, bitumen, petroleum, and bituminous clay, which have begun to draw the attention of enterprising Americans. The latter is an excellent article, and its oils are free from many of the impurities so often contained in coal oils.

Valuable deposits of bitumen have been discovered in California and Nicaragua. The asphaltum of Coxitambo, Peru, have long been known. Bitumen and petroleum also exist in Canada, in the county of Rambton, one hundred miles east of Detroit. The naphtha of Rangoon has been shipped from Burmah to England, and, after purification, to the New York market for sale. It yields three per cent. of paraffine, and much heavy oil. A vein has recently been discovered near Cairo, thirty miles east of Parkersburg, Virginia. It is represented as a perpendicular mass, jutting out from the side of a hill two hundred and ninety feet. The strata of the hill are nearly horizontal, and they are cut at right angles by the continuous vein of the bitu-

minous mineral, which is four feet eight inches in thickness. The position of the vein has been ascertained by the proprietors, who have sunk a shaft upon the line of the outcrop. A sensible description represents that it appears the hill has been split, a perpendicular chasm opened, and afterwards filled with asphaltum in a liquid state, and which has since hardened into a compact material. Coal never occurs in this manner; but is always interstratified with its associate sandstones, shales, and fire clays. In all its geological relations and character, the Cairo deposit is like the asphaltum of Albert County, New Brunswick. The bitumen veins of Cuba have similar positions in the earth. The Cairo asphalt will no doubt be found valuable for the manufacture of oils. But it is the oil resources of the United States that more particular descriptions are called for. The geology of bitumen and petroleum opens a wider range for investigation than this work is intended to take.

PETROLEUM SPRINGS AND BITUMEN OF THE UNITED STATES.

Among the number of natural productions adapted to the manufacture of oils within the limits of the United States, none appear at present to be of greater value than the petroleum of the coal region. The "Seneca or Genesee oil" has long been known, collected, and employed for medicinal purposes. It occurs in the State of New York, at Cuba, Cayuga Lake, in Cataraugus County, Syracuse, and other places. At Fredonia, Chautauque County, natural jets of carburetted hydrogen issue from the earth. The gas is collected in gasometers, and employed for lighting houses. Similar streams of gas have been found at

other localities.* These gas jets are evidently connected with the naphthalous springs, and are the result of decomposing agencies going forward in the earth.

It has been already stated that the Alleghany bituminous coal field occupies an area of 63,000 square miles.† The number of those square miles in each of eight different States has been set down in the following manner: ‡

| No. | STATES. | Area of the States. | Area of Bituminous Coal Strata therein. |
|-----|------------------|---------------------|---|
| | | Square Miles. | |
| 1 | Alabama | 51,770 | 4,300 |
| 2 | Georgia | 58,000 | 150 |
| 3 | Tennessee . . . | 45,000 | 4,300 |
| 4 | Kentucky | 40,500 | 9,000 |
| 5 | Virginia | 64,000 | 21,000 |
| 6 | Maryland | 18,950 | 550 |
| 7 | Ohio | 44,400 | 11,900 |
| 8 | Pennsylvania . . | 47,000 | 15,000 |
| | Total | 364,620 | 66,200 |

At numerous places, and throughout almost the whole extent of this coal region, reservoirs of petroleum, deep in the earth, and springs of the oil have been found to exist, and frequently associated with salt water, and doubtless salt itself.

* Vanuxim's first Annual Geological Report of the State of New York. 1837, p. 195.

† Transactions Asso. American Geologists and Naturalists, vol. i., p. 436.

‡ Taylor, Statistics of Coal, 2d ed., p. 271.

The original manufacture of kerosene, for which the public is much indebted to the New York Kerosene Gas Light Company, was followed by the manufacture of "coal oil." The celebrity the oil has obtained for illumination has led many to examine the earth, not only for coals, but for every mineral that will afford oil by distillation. The result has been remarkable. In some instances the borings made for salt water have given vent to petroleum in large supplies. In places where there have been indications of the mineral oil at the surface, the earth's crust has been perforated, and the petroleum is now pumped up, and constantly flowing from its deep subterranean cisterns.* What is the value, it may be asked, of 63,000 square miles of country which yields coal, iron, oil, and salt, beneath its fertile soil?!!! Here are the elements of strength, heat, light, food, and the giant steam opened at once to the science, skill, and untiring energy of an enterprising people.

Mineral oil, or petroleum was known to the ancients, and employed by them for various purposes. Herodotus treats of the wells of Zakanthus, now called Zante, which still yield bitumen. Plutarch describes the spectacle of a sea on fire, or lake of inflamed petroleum, near Ecbatana. The perpetual fires that burnt at the Pagan shrines are supposed

* To obtain the petroleum, holes of three and four inches diameter are drilled through the *debris* of the surface and the rocks beneath. When the oil is "*struck*" it is forced out by the pressure of the gas below, and flows for some time without the aid of a pump. An iron pipe is inserted into the hole, and so contrived that the surface water shall not enter the well. To the top of this pipe a pump is attached, and worked by hand, or by steam power. So great is the discharge of the petroleum, in some instances, that sufficient vessels cannot be obtained for its reception, and it runs in oily streams over the surface. Some springs yield 200 barrels per day. A reservoir of oil has been opened near Tideout, Erie County, Pennsylvania, at a depth of 170 feet, which yields 300 barrels per day.

to have been produced by springs of mineral oil inflamed at the surface. The springs of the United States were known to, and the oils used by the now dispersed tribes of Indians. Between the mouth of Oil Creek and Titusville, Pennsylvania, old vats are to be seen, and trees are now growing upon the earth thrown out in the sinking of pits to collect the naphtha of the surface.* At the present time the principal borings for oil are in Pennsylvania, Virginia, and Ohio. Explorations, and the sinking of pipes, have been commenced in Alabama, Georgia, Tennessee, Kentucky, and Maryland. The average depth at which oil is obtained has not yet far exceeded two hundred and fifty feet. Deeper sinkings may hereafter be found profitable. Carburetted hydrogen gas frequently escapes from the pipe when it is first let down into the earth, and sometimes salt water rises with the oil. Accurate records have not been kept of all the strata penetrated; but they appear to consist chiefly of limestone, sandstone, and shale. At the present time upwards of five hundred and fifty wells have been opened, or the borings are in progress. From the wells to which pumps had been applied, twenty-five thousand gallons of crude oil are raised daily, and the quantity is rapidly increasing. Before this report can go before the public, it is quite safe to state that the daily supply of petroleum will amount to thirty thousand gallons per day, for the supply of lamps, and to relieve the friction of machinery.† The

* As early as 1845, Lewis Peterson, Esq., of Alleghany County, Pennsylvania, opened two springs of petroleum while boring for salt water. In 1847 these springs gave from thirty to forty gallons per day. The oil was sold for medicinal purposes, and the supply from the springs has not abated.

† In Illinois the petroleum occurs in a porous limestone, through which the oil filters. This rock has been called the prairie gas stone, and is probably of great extent.

introduction of kerosene into the United States gave rise to poetical descriptions of the long and lasting holiday the whales of the sea would enjoy from the substitution of oils from coals for oils from animals. It now appears that the dreams of those who advocated peace with the marine mammalia are to be realized. The purified petroleums not only afford liquid oils, but also the solid paraffine, which for candles exceeds in beauty, and equals in light, the pure sperm taken from the heads of the finny monsters of the sea.

Besides the petroleums before-mentioned, a bed of bitumen has been discovered in Ritchie County, Virginia, as reported from that quarter. The samples received from this new mine are bright, glossy, and brittle. They are rich in oil, and yield at the rate of one hundred and seventy gallons per ton. This bitumen is evidently petroleum, which has at some remote period issued from the earth and been hardened by evaporation and exposure to the oxygen of the atmosphere. The oil springs frequently occur in the immediate vicinity of the coal. They are within the borders of the coal field, and there can be no doubt that the oil and the coal had one common origin. An idea has been thrown out that the petroleum has been distilled from the anthracites of Pennsylvania and bordering country, as those anthracites in general contain no bitumen. But the anthracite coal field is separated from the bituminous coal region, and the chief districts of the oil springs by the Alleghany mountains, and it is scarcely reasonable to believe that the bitumen derived from the anthracites ever penetrated through, or beneath lofty mountain masses of primary and metamorphic rocks.

The fact has been very clearly made out, that the slow and gradual passage of wood into coal is accompanied by

the escape of carbon and hydrogen in the form of carburetted hydrogen. The oils themselves are compounds of carbon and hydrogen. The one is a gas, the other a liquid, and the latter is condensed from the former.

It appears, therefore, that the conversion of vegetable matter into coal is still progressing in the bituminous Alleghany coal field, and that the oils and gases now flowing from the earth are only the results of those chemical operations going forward in Nature's laboratory, by which wood is transformed into coal, and coal into anthracite, and even into plumbago. Nor is this process very different from that employed by art, for by the distillation of wood and coals, charcoal, and coke, oils and gases are obtained, like those now being distilled in the ever-working retorts of the earth. In Alleghany County, Pennsylvania, and at other sites, the springs and coal occur in immediate proximity to each other.

Like the oils distilled from coals, the petroleums from different springs vary in their specific gravities from 0.820 to 0.880. This reality affords further evidence that the subterranean distillation has advanced more at some points than at others, for the lightest oils always distil first. From the foregoing facts and the reasons which may be deduced from them, it does not appear probable that the oil springs will soon fail, but will continue their supplies until all the chemical agencies operating upon the thick strata of coal beneath have subsided, and the once woody fibre of the coal has ceased to expel carburetted hydrogen.

A number of the most valuable materials for the production of oils having been treated of, some of the different kinds of coals and bitumens, and such as have been submitted to the test of working by the author, may be

| Locality. | Volatile Matters. | Coke. | Yield of Crude Oil per ton. |
|--|-------------------|-------|--------------------------------------|
| <i>England.</i> | | | |
| Derbyshire | 48.36 | 53 | 82 gallons. |
| Wigan Cannel | 44 | 56 | 74 |
| Liverpool " | 39 | 61 | 50 |
| Poole (Shale) | 42 | 58 | 50 |
| Newcastle | 35 | 65 | 48 |
| <i>Scotland.</i> | | | |
| Boghead | 70.10 | 29.90 | 120 |
| Scotch Cannel | 38 | 62 | 40 |
| Lesmahago | 51 | 49 | 96 |
| <i>Provincial.</i> | | | |
| Albert Coal, N. Brunswick | 61.050 | 30.65 | 110 |
| Asphalte Rock, " | 43 | 57 | 64 |
| Pictou Shale, Nova Scotia | 27 | 73 | 47 |
| <i>American.</i> | | | |
| Breckenridge | 61.30 | 38.55 | 130 |
| Erie Railroad | 35 | 65 | 47 |
| Newburg | 38 | 52 | 72 |
| Falling Rock | 50 | 50 | 80 |
| Pittsburg | 36 | 64 | 49 |
| Kanawha | 46 | 54 | 71 |
| Elk River | 41 | 59 | 60 |
| Cannelton | 34 | 66 | 86 |
| Coshocton, Ohio | 45 | 54 | 74 |
| <i>Bitumen, &c., United States.</i> | | | |
| Ouachita River, Arkansas | 60 | 40 | 64 |
| Ritchie County, Virginia | } | — | 170 gals. per ton. |
| Pennsylvania | | | — |
| Petroleum Springs, Alabama, Georgia, Tennessee, Kentucky, Virginia, Maryland, Ohio, Pennsylvania | } | } | From 70 to 90 per cent. of Lamp Oil. |
| | | | |
| <i>Cuba.</i> | | | |
| Bitumen | 71 | 29 | 120 |
| <i>Trinidad.</i> | | | |
| Bitumen | 38 | 52 | 70 |
| <i>Canada.</i> | | | |
| Bitumen | 70 | 30 | 118 |

noticed, and for convenience sake arranged in a table as on the preceding page, omitting the fractions of their products.

The foregoing table will afford some guide to the manufacturer, regarding the proportions that crude oil bears to the volatile matters of the material. The quality and specific gravity of the oils, and the quantities of paraffine, are not inserted, as they are ruled by the heat employed in the first dry or decomposing distillation, a knowledge of which is best acquired by experience.

CHAPTER III.

Nature of the Products distilled from Bituminous Substances.—Modes of obtaining Oils.—Retorts.—D-shaped Retorts.—Revolving Retorts.—Vertical Retorts.—Clay Retorts.—Brick Ovens.—Coke Ovens.—Stills.—Condensers.—Agitators, etc.

To obtain oils from coals and other dry bituminous materials, it is necessary in the first place that they shall be submitted to dry or decomposing distillation, by which oils are formed, the coke or fixed carbon remaining with the ash in the distilling vessel. The economy and perfection of this operation depend upon the kind of retort used, the degree of heat applied, and the efficiency of the condensing part of the apparatus. If a given quantity of coal be distilled in a retort or close vessel at a heat of $1,200^{\circ}$ or thereabouts, in the manner that coal gas is made, a large quantity of gas will be formed. The oily products will be small in quantity, and consist chiefly of benzole, naphtha, naphthaline, carbolic acid, piccamar, pittical, copnomor, and other hydrocarbons, which, so far as the oil manufacturers' objects are concerned, may be called impurities. They are not impurities; but in the progress of chemical science they may hereafter become valuable. Again, the crude oils obtained by such a heat contain more carbon than those produced by a lower heat, much of the hydrogen being driven off from the coal in carburetted gases. But if the heat to which the coals are exposed does not exceed 750° or 800° Fah., a different class of results follows. Instead of true benzole, eupion* will be formed,

* The composition of benzole is $C_{12} H_6$. That of eupion is $C_2 H_4$.

the naphthaline will be replaced by paraffine, the carbolic acid, piccamar, copnomor, etc., will be less in quantity, and there will be a great increase of the oils employed in lamps and for oiling machinery.

To obtain these results, not a little will depend upon the form of the retort, and the mode by which the oily vapors generated in it are condensed. The retort which will permit the charge of coal to be equally heated throughout, is best; for if the heat be strong on one part of the charge, and weak on another part, the former will produce permanent gas and impure oils, while the latter has, perhaps, a temperature too low to produce oils at all. It is on this account that revolving retorts, which keep the charge in constant motion, have been introduced.

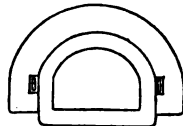

RETORT.—ELEVATION.

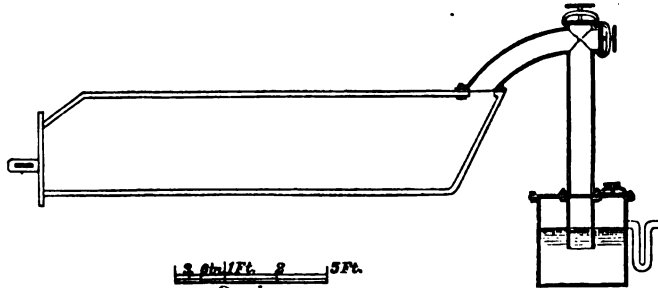

RETORT AND MAIN.—SECTION.

Full descriptions of all the retorts and ovens which have been experimented with, tried, patented, used, and in use, for distilling oils from coals, would not be interesting or

useful. For such descriptions it is necessary to refer to the American, English, and French records of patent inventions. Great as their number is, it is still increasing. Many persons besides chemists, who are concerned in this kind of manufacture, and tyros in the art, have a fancy for some novelty in which neither philosophy nor chemistry can discover any merit, and vast sums of money have been wasted in seeking the talisman that would convert everything into oil.

Horizontal D-shaped retorts, of large size, two or three being heated over one furnace, have proved satisfactory ;

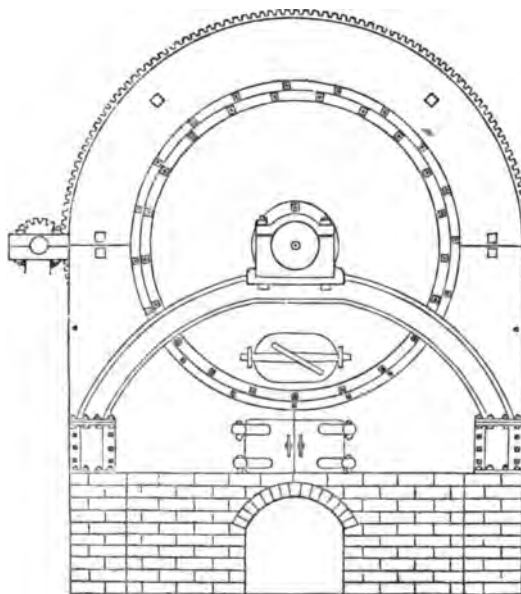

REVOLVING RETORT.—FRONT ELEVATION.

and in some instances they have taken the places of the revolving cylinders. They may be made of iron or clay. They are simple in construction, and readily charged

and discharged. They may be made from thirty to forty-five inches in width, and from eight to ten feet in length. The latter size will distil three charges of cannel coal, of 450lbs. each, in twenty-four hours, at a heat not exceeding 780° Fah. Forty of these retorts and more may discharge into one main, from which the gas is conveyed to a gasometer, to be afterwards used for fuel or for lighting. It is necessary that the discharge-pipes leading from these retorts to the main should not be less than eight inches in

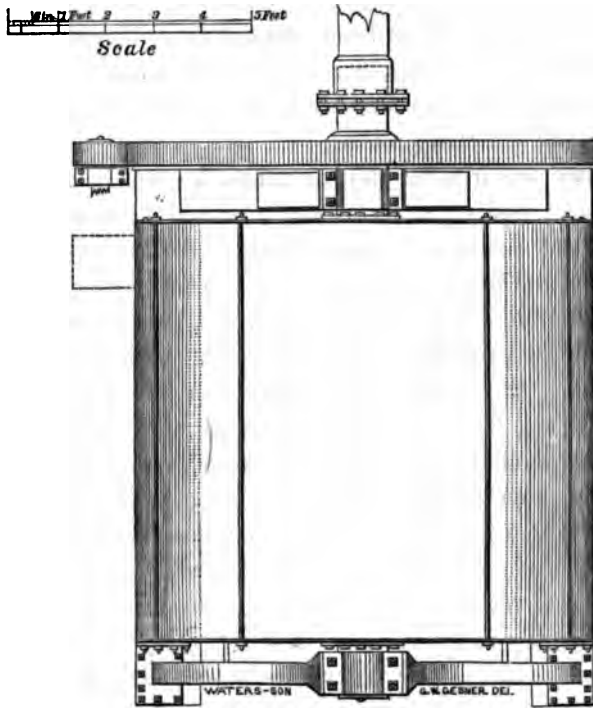

REVOLVING RETORT.—PLAN.

diameter, to prevent pressure and insure safety; and they should be inserted into the end of the retort opposite the

head and furnace, and upon a level with the upper part of the charge. The main itself should be three feet in diameter.

REVOLVING RETORTS.

Revolving retorts were employed by Gingembre, of France,* and by others, many years ago, in the manufacture of coal gas; but from their cost, and liability to get out of order, they were discarded. Since January, 1858, several patents have been granted in the United States for this kind of retort, as being adapted to the manufacture of oils from coals, shales, etc. In some establishments they are now in use; in others they have been replaced by large D-shaped stationary retorts.

They are iron or clay cylinders, frequently six feet in diameter and eight feet long, sustained upon an axle at each end, the vapors passing through the axle opposite the furnace, or head, where they are charged through a man-hole in the usual manner. They are kept in motion by machinery propelled by steam, making two or more revolutions per minute. The advantages of the revolving retort are, that the charge being constantly agitated by the motion of the cylinder, every part of the material is from time to time brought in contact with a heated surface, so that it is exhausted in much less time than it could be in a stationary retort; thus, also, there is a saving of fuel. A retort of the above dimensions will run six charges of one ton each, in twenty-four hours, of ordinary cannel coals. The objections urged against them, by those who have given them a trial, are their cost and liability to get out of order. They also grind the coal to a powder, which, by being carried along with the oily

* *Brevets d'Invention*, vol. ix., p. 235.

vapors, is apt to fill up the condensing worm; and its admixture with the oil increases the cost of purification. But the rapidity by which they distil the coal, and the saving of fuel, are certain results; and the ingenuity of numerous inventors may hereafter relieve them from the above drawbacks.

The revolving retort cannot be employed in the decomposition of Albert coal, nor any of the softer bitumens. These substances melt, and adhere to the iron closely, and therefore cannot be agitated like dry coals, when they are heated.

With the before-mentioned objects in view, namely, the agitation of the material while it is exposed to heat, oscillating retorts have been recommended and patented. Iron bars are fixed longitudinally in the cylinders, to prevent the charge from sliding, and to insure its rolling over.

BRICK OVENS.

Brick ovens have been introduced to decompose coals and produce oils. They are made of fire-brick, and laid in fire-clay. Their form is such, that the heat is distributed over a large surface. These ovens are incapable of resisting pressure, and they are apt to crack and grow leaky. If they are ever found to be economical, it will be in situations where coals and coal shales are cheap and plenty, and where the loss of vapor and fuel are not things of large account.

VERTICAL RETORTS.

In France, at Mehlam on the Rhine, and other places in Europe, upright retorts are used. They have been employed in Ireland for the distillation of peat. They are filled from above, and when the charge is exhausted it is

drawn from beneath. They require a great deal of fuel. The yield of oil is small and impure.

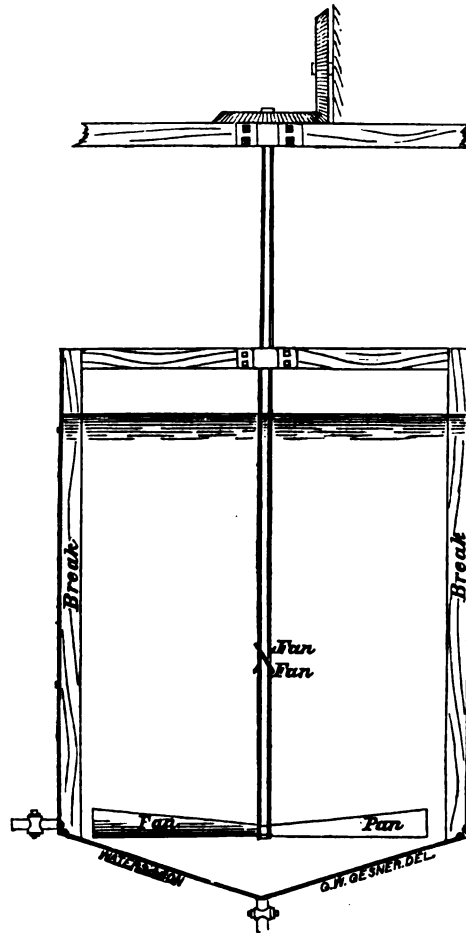

VERTICAL WASHER.—SECTION.

Patents have been granted in the United States for several vertical retorts, in which improvements are sup-

posed to have been made upon those used in the Old Country; but in none of these have the advantages sought

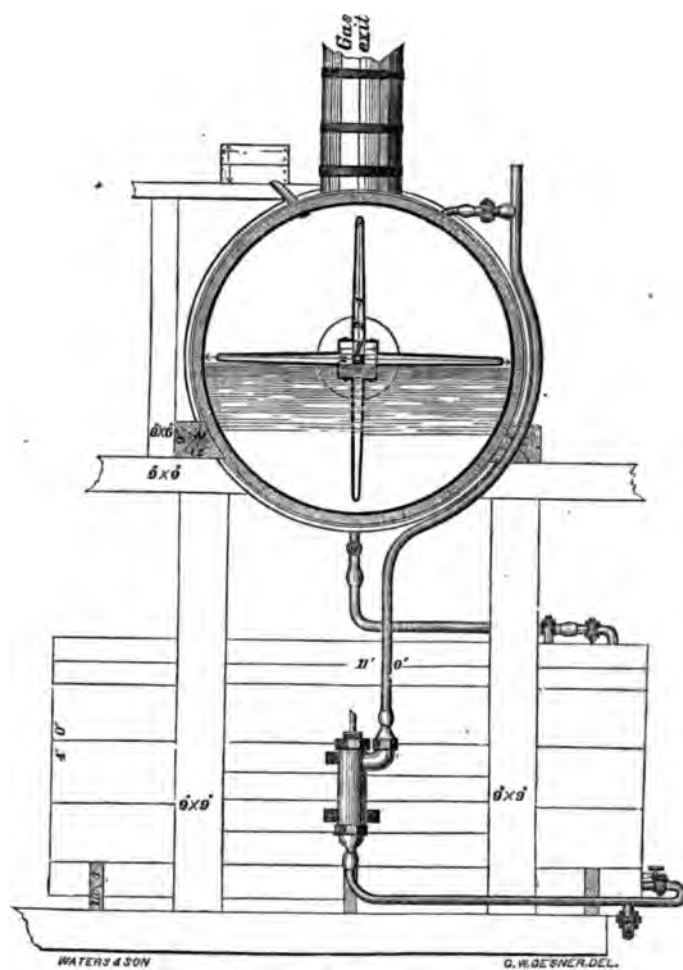

HORIZONTAL WASHER AND TANKS.—END ELEVATION AND SECTION.

for been obtained. It is obvious that the discharge of the gases from which the oils are condensed must take place

above the mass of the material in the retort. The sooner the oily vapor of the charge is removed from the retort

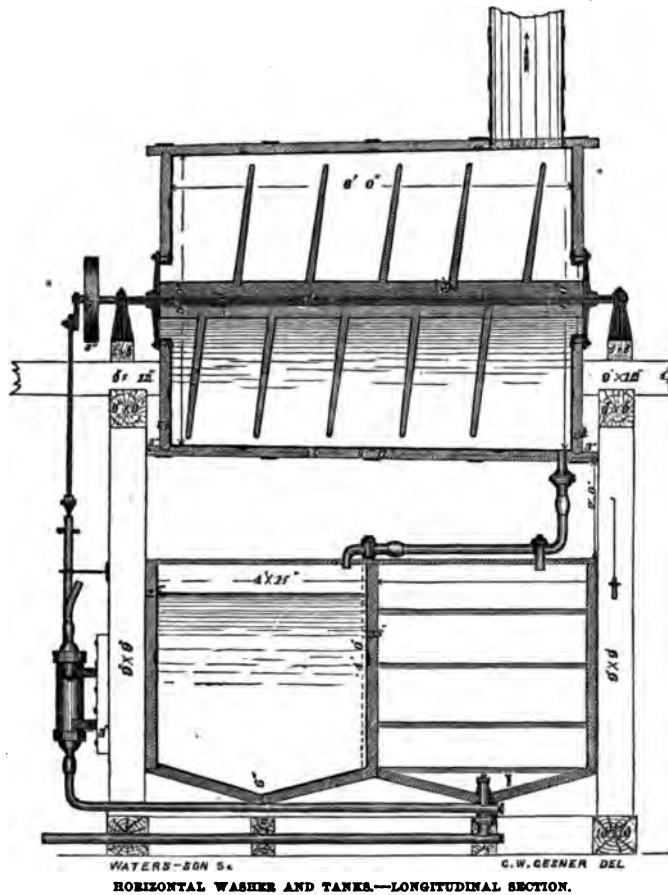

and condensed, the greater will be the amount of oil produced; for if that vapor is exposed to a heat equal to that by which it was first formed, it will itself be decomposed, and a part of it converted into permanent gases. Again,

the vapor first formed will be deprived of a part of its hydrogen, and there will be a diminution in the quantity of lamp oil.

Agitators, or stirrers in retorts, have been introduced for the purposes before-mentioned. Count de Hompesh patented and used an Archimedean screw nearly twenty years ago. By means of this screw the material was agitated, and finally discharged at the end of his retort. Several American patents have been granted for machinery to stir or agitate the charge of material, both in horizontal and upright retorts during its distillation. In situations where coal is abundant, the value of these inventions will be carefully weighed against the complexity of the machinery and its constant wear.

In order to apply a certain degree of heat to the substances undergoing distillation, baths of fusible metal have been placed in retorts and stills, the melting point of the metal being adjusted to the degree of heat required; but the experienced distiller calls for no such aid.

CLAY RETORTS.

Clay retorts were used in the manufacture of coal gas many years ago, and a contest has long been carried on between their advocates and those who prefer iron for that purpose. In Europe the clay retort is gradually coming into use. In Scotland the old iron cylinder is now seldom seen in gas works. The manufacturers of coal gas in the United States are yearly submitting clay to the test; but up to the present time, of all the retorts in operation, a very few are composed of that material. When the clay cylinder is first charged, gas escapes through the fine fissures opened by the baking of the substance. These openings, however, are soon closed with carbon, and the retort is

perfect. The chief advantage of the clay retort is its durability. In the distillation of coals for the production of oils, they are, doubtless, valuable, and the ordinary mechanic of the country understands the methods by which they are put in working order. In their use, it should always be understood that they will not withstand as much pressure as iron, and therefore their discharge-pipes should be large, and their condensing apparatus open and free.

Among the numerous means applied to the extraction of oils from coals, coke furnaces merit some attention. Charcoal has been known since the earliest ages. The coals mentioned in Isaiah liv. 16, seven hundred and twelve years before Christ, evidently refer to charcoal. The cutting and piling up of mounds of wood, covering them with earth, and firing them to obtain charcoal, is a process familiar to almost every one. In this operation all the volatile products of the wood escape in gas and smoke, and are lost. Within the past century charcoal furnaces have been invented by which those volatile products are collected, and the distillation of wood has produced a new class of substances; the chief of which are acetic acid, pyroxylic spirit, creasote, picamar, copnomor, paraffine, eupion, etc.

In China, Russia, and Sweden, the carbonization of wood is effected in pits, or furnaces not dissimilar to those for which patents have been recently granted in this country. The furnace is in the shape of an inverted cone, and the receptacle for the tar is at its side. Coal is converted into coke in a similar manner. In Europe coke has been extensively used in the manufacture of iron. In Great Britain it is burned on railways to avoid the smoke produced by coals, and coking furnaces are in constant use for its supply. In 1781 the Earl of Dundonald obtained oils by heat-

ing a quantity of coals in a coke furnace. The oils were condensed from the expelled vapors, and coke remained. The manufacture of coal gas now supplies vast quantities of coke, and the oils are called coal tar.

In August, 1853, two patents were granted in England for upright coking furnaces, the object being to obtain crude oils, and not coke. In these, and in other instances, the coals are produced in large perpendicular cones, or cylinders of masonry. A fire is lighted below, and as it advances upwards the volatile parts of the material are driven off by the heat produced by itself, and without the aid of any external heat. Discharge pipes are fixed at the top of the furnace, and communicate with a condenser in which the oils are formed.

The first objection that presents itself to this method of

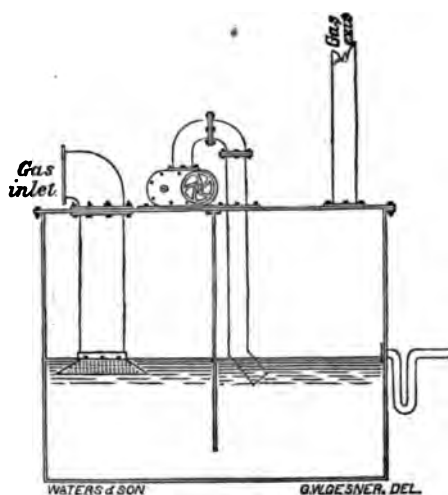

EXHAUST AND CONDENSER.—SECTION. SOALE OF COKE OVEN.—PLAN AND SECTION.

obtaining oils is the admission of air to the material, by which combustion rather than distillation is the result. To

afford a remedy for this difficulty Mr. Little obtained an English patent in 1854, the invention of which is to draw, or drive through the fire a blast of air, which is then said

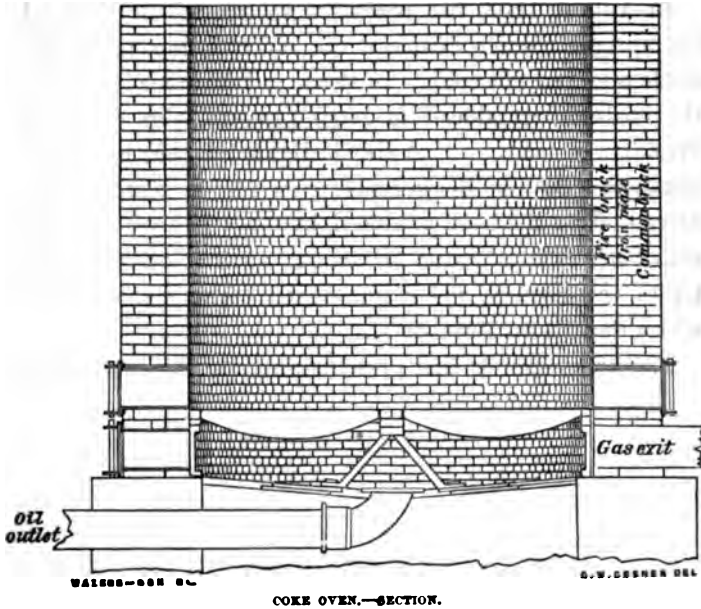

to be "burned," or deprived of its free oxygen, so that the combustion of the material is avoided, and the distillation carried on by the heat afforded by the gases emanating from the material itself. In this process the charge contained in the coking furnace is first fired at the bottom, then a current of air is drawn through the fire and the material in the furnace by an aspirator or exhausting pump, the oily vapors being drawn into condensing chambers, or worms, in the manner practised in ordinary distillations. An upward distillation has been opposed on the ground that the oil, which at first would be at the top of the fur-

nace, falls back, and undergoes repeated decompositions before its vapors finally escape. In practice this objection is groundless, for if the vapors from which the oils are

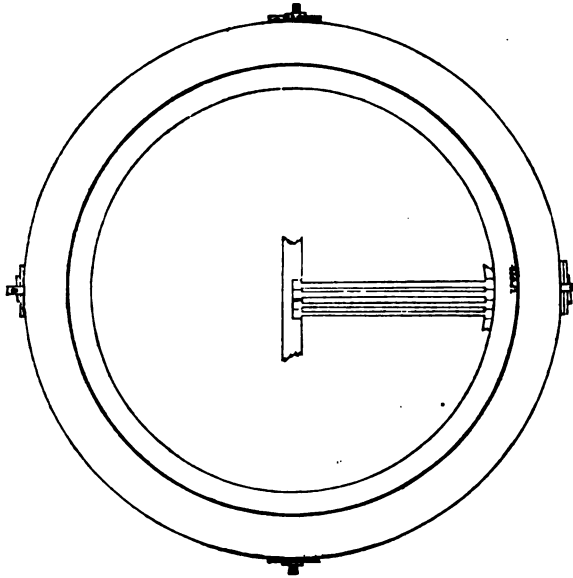

COKE OVEN—PLAN.

condensed are light, they make their exit immediately; if they are heavy, and condense in the furnace, their oils are improved by further decomposition.

Patents have been recently granted in the United States for similar coke furnaces. In one of these the current of air is directed downwards through the fire, material, and furnace, by a jet of steam thrown into the discharging pipe below. After a wood fire has been kindled at the top of

the furnace, and a stratum of hot coals is spread over the charge, a downward current of air is started, and continued until all the volatile matter is expelled from the material. It does not appear, however, that reversing the air current is a matter of any importance in the operation; the chief object being to force it through heated bodies, and thereby deprive it of a part of its oxygen before it reaches the charge. Ingenious as this method of distillation really is, its economy is doubtful, for sufficient heat cannot be applied to the charge in the furnace without the admission of oxygen, and that oxygen, when admitted, results in more or less actual combustion, which reduces the quantity of oils. This method has been extensively tested by the New York Kerosene Oil Company, who, according to their published reports, distilled only sixty-eight and one-seventh gallons of merchantable oils and paraffine from one ton of Boghead coal. By the large D-shaped retort seventy gallons of such oils can be obtained.

From what has been stated, this question presents itself—What is the cheapest, most efficient, and economical retort for manufactories of coal oils? Perhaps foremost in the reply stands the large horizontal D-shaped retort—next the revolving retort, which for running the greatest quantity of oil in the shortest space of time stands unrivalled.

Next in importance to the form and the mode of applying heat to the retorts is the condenser, or cooling apparatus, in which the gases and vapors of the material assume the liquid form. It may be laid down as a general rule, that the sooner the lighter vapors generated in the retort are withdrawn from it and cooled, the greater will be the yield of oil. The discharge pipes of the retorts employed in the manufacture of coal gas are upright cylinders, in which a part of the volatile products of the distilled coal

are condensed, and fall back into the retort, where they are decomposed, and the quantity of gas thereby increased.

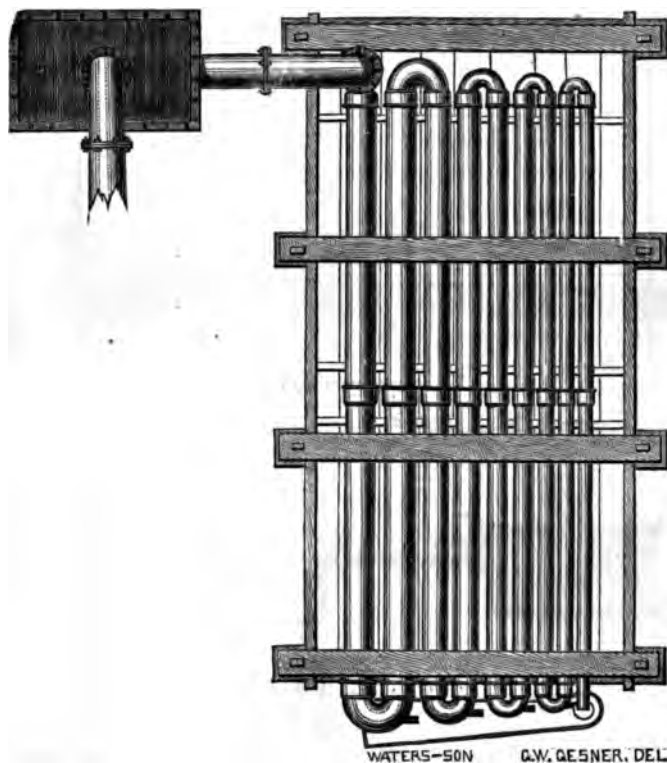

CRUDE OIL CONDENSER.—PLAN.

By this management the gas is made by the reduction of the hydrogen of the coal tar, which, consequently, contains much carbon, and is thereby rendered unfit for the manufacture of oils for lamps.* The exit, or discharge pipes, should therefore open outwards from the retort, as near to the charge undergoing decomposition as may be convenient.

* See table of homologous compounds.

Again, pressure upon the vapors generated, and the retort itself, should be avoided as much as possible. The

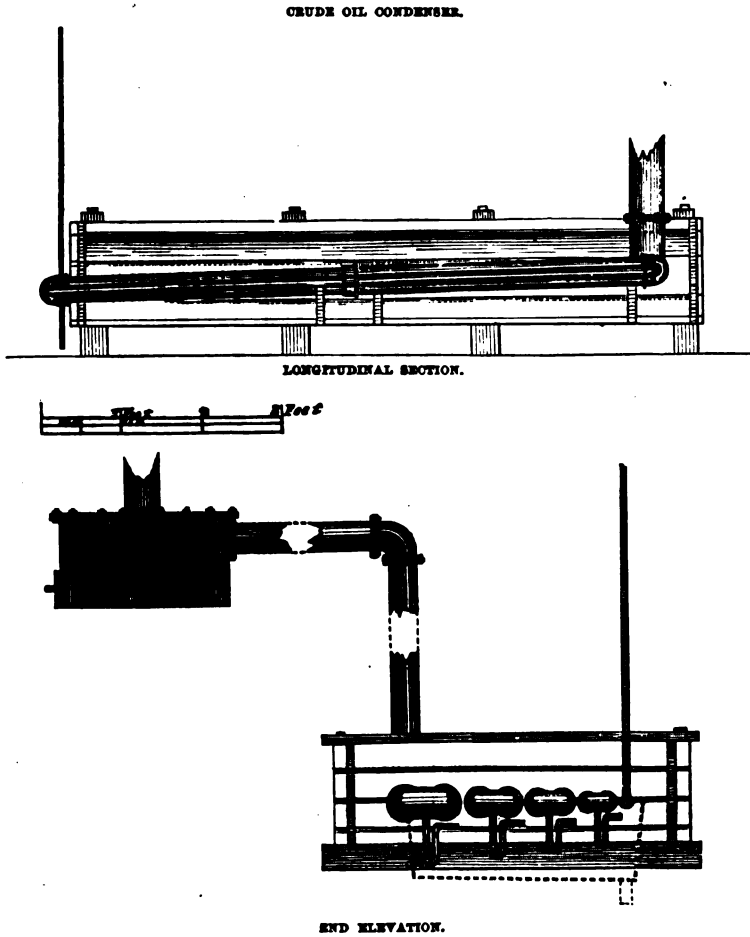

dipping of the discharge pipe in a main, to seal it against a return of gas, causes a pressure according to the extent of that dip. The greater the dip the greater the pressure, and

the quantity of oil will be diminished accordingly. It is on this account that exhausting pumps have been applied to the gas pipe leading from the main. The effect is to exhaust the charge in one half of the time usually required for that purpose, and with less heat in the furnace. But exhausting pumps are expensive, and, when employed as above, require to be kept constantly in motion. Therefore when the crude oil is made at the mouth of a coal mine their economy will afford matter for consideration.

The condenser may consist of the common worm generally used in distilleries—a serpentine pipe passing through a cistern of water, or an open chamber, all of which must be kept constantly cold by an influx of water.

But when much paraffine is present it is necessary to keep the water at a temperature of 70° or 80° to prevent the paraffine from cooling, and obstructing the apparatus. The gas that remains after the condensation has been completed may be collected in gasometers, and employed for illuminating purposes—to afford heat for the subsequent distillation of the oils, or to produce steam.

STILLS.

The variety of stills, and the contrivances applied to them, for the distillation of coal and other oils, equals that of retorts. Experience has led to the almost general adoption of cast iron stills for those purposes. They have been made with bottoms concave upwards and with hemispherical tops, with bottoms concave downwards and flat tops, some broad and flat, others high and cylindrical—some have been placed in steam jackets—many are exposed to the naked fire. The different opinions prevailing among the manufacturers prevent any settled form being established. Stills made of boiler-plate iron have been tried;

but when a high heat is required, and they are exposed to the direct action of the fire, they are soon destroyed, or commence leaking at the rivets. When the heat exceeds 560° , which is necessary in the distillation of the heavier oils and paraffine, they are in danger unless they are protected by the admission of steam, and guarded against the fire of the furnace. Whether the still be of cast or sheet iron, it is always unsafe to run the oil down so as to "coke" its bottom.

In order to facilitate the flow of oils, stirrers have been placed in the still to agitate the charge during its distillation. The effect of these stirrers will ever be to render the distillation more or less imperfect, by lifting the impurities upwards into the current of vapor rushing outwards into the worm. Stills with double necks have been tried, but without any real advantage. Some have preferred a large still, and they have been made to contain three thousand gallons. Such stills are more liable to accident, and dangerous in the event of fracture than smaller ones, and have no superiority in regard to time in working.

The first distillation of the oils may be carried on continuously by admitting into the still a small stream after the heat is up and the distillate begins to flow from the worm. But this mode requires more than an ordinary degree of heat to compensate for the caloric taken by the inflowing oil to bring it up to the distilling point. Simplicity of machinery and steadiness of operation are always desirable; on this account, for reasons already stated, and, from many actual trials, the author recommends that the largest stills, and those employed for distilling the crude oils as they come from the retorts or oil springs, shall not exceed in contents sixteen hundred gallons, and as there is generally a loss on the first distillation of ten or twelve per cent.

in carbon and impurities, the working contents of the refining stills need not exceed fourteen hundred gallons. The diameter of the largest stills may be eight feet six inches, with a height of four feet six inches. The crown should

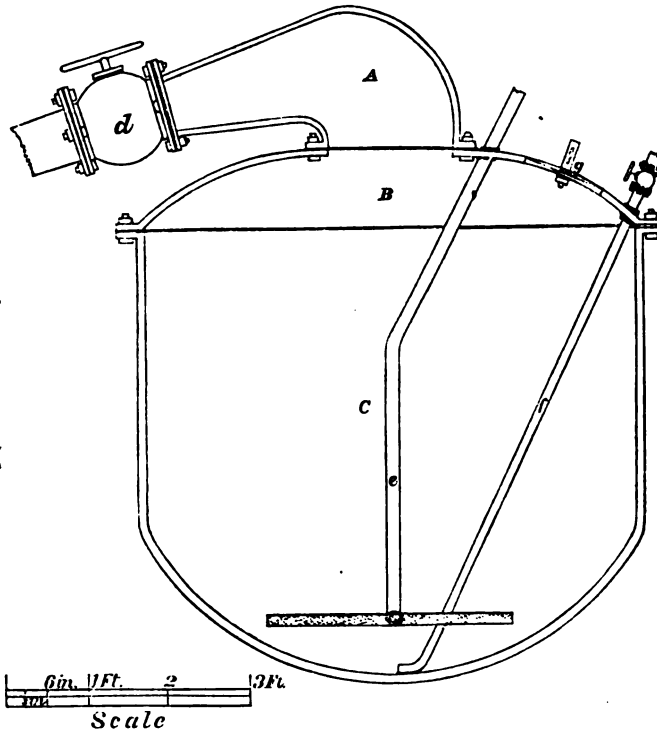

STILL.—SECTION.

References.

- | | |
|---------------------|------------------------------|
| <i>A</i> Gooseneck. | <i>d</i> Valve on gooseneck. |
| <i>B</i> Dome. | <i>e</i> Steam pipe. |
| <i>C</i> Kettle. | <i>f</i> Blow-off pipe. |
| | <i>g</i> Manhole. |

be moderately concave upwards to the neck. Those stills must be carefully protected against the direct action of the fire by arches of fire-brick. Common or superheated steam

may be introduced into them through large rose jets opening above, or into the charge. Steam always facilitates their operation.

CONDENSING WORMS.

The worms, or condensing tubes for the stills, should be one hundred feet in length, with a diameter of six inches where they leave the necks, and four inches throughout their middle parts, tapering down to two inches at the "*tail pipe*." The worms are surrounded by water, in a tank, where they are kept cool. But when the oil contains paraffine, the water must be allowed to heat up to 80° or 100° Fah. In cold water the paraffine would become solid, fill up the worm, and lead to the bursting of the still and all its dangerous results.

CHAPTER IV.

Products of the distillation of wood coals, asphaltum, bitumen, petroleum, and other substances capable of yielding oils.

PRODUCTS OF THE DISTILLATION OF WOOD.

THE products of wood distilled in close vessels are very numerous. The resinous woods give results different from those not resinous, and each kind affords some peculiar products. During distillation all yield more or less carbonic acid, carbonic oxide, and carburetted hydrogen. Charcoal remains in the retort. Some of the products are soluble in water, others are not. Of the products soluble in water and volatile, there are *acetic acid*, or *pyroligneous acid*. This is the most abundant liquid. It contains much creasote, and preserves meat, giving it at the same time a smoky taste and odor.

Pyroxylic spirit.—By distilling the crude pyroligneous acid a mixed liquid is obtained, known as pyroxylic spirit, or hydrated oxide of methyle. From this spirit Gmelin and Liebig derived lignone, xylite, xylitic acid, naphtha, xylitic oil, and resin, mesetine, methol, mesite, acetone, and other volatile liquids have been obtained, of which, up to the present time, there is but an imperfect knowledge existing.

PRODUCTS OILY AND VOLATILE.

Among these creasote is predominant. This is a clear neutral oil, with an odor of smoke, and hot pungent taste. It evaporates without residue, and is turned to a brown

color by being exposed to the light. It is soluble in ether alcohol, acetic acid, ammonia, and potash—is used as a styptic, and considered as a valuable remedy for the tooth-ache. Creasote has also remarkable antiseptic properties, and is employed in dyeing and tanning. A distinction between creasote and carbolic acid has not been clearly made out.

Picamar was discovered by Reichenbach, with creasote in the heavy oil of tar. With potash, it forms a crystalline compound. It is a colorless oil, having a hot, bitter taste. Its composition has not been clearly described.

Copnomor.—With the creasote and picamar the above chemist discovered copnomor, a limpid, colorless oil, highly refractive, with an aromatic odor and styptic taste. Nitric acid converts it into oxalic acid, nitro-picric acid, and other complex substances, of which little is known.

Eupion, another oily, or rather spirituous liquid, discovered by Reichenbach in the oil of tar, is $C_6 H_4$. It is readily purified by distillation, and has a specific gravity of 0.740. The author obtained it from the tar of candle manufactories, with a specific gravity of 0.640, and a boiling point of 112° . It is, therefore, among the lightest liquids known. It resists the action of the strongest sulphuric acid. With nitric acid it forms several new combinations analogous to those of benzole. It is perfectly colorless, evaporates rapidly, and to some persons it has an agreeable odor. This oil does not exist ready formed in the tars, but is produced by the action of strong acids and alkalis upon the distillates of crude oils. In the manufacture of hydro-carbon oils, eupion includes a number of the members of the homologous compounds of carbon and hydrogen. It is now frequently sold as benzole, and employed for making what is called the benzole or atmo-

spheric light, and for removing oil stains from clothes. A number of liquids have been classed under the denomination of eupion; they are all hydro-carbons, and their formula is C, H, or C₆ H₄, or some multiple of it.

Eupion may not only be distilled from wood, but also from other substances capable of yielding tars by distillation. It burns with a brilliant white flame, free from smoke; but it is extremely inflammable, and a dangerous liquid for lamps.

SOLID PRODUCTS OBTAINED FROM THE DISTILLATION OF WOOD.

Paraffine is the name of a white solid substance, or silvery scales resembling wax, discovered by Reichenbach. It is formed in large quantities from the petroleum of Rangoon, and the author has obtained it from the Ouachita coal of Arkansas, at the rate of 143 lbs. per ton. Coals, asphaltums, bitumens, petroleums, peat, and other substances, afford paraffine from one to five per cent. of their oils. It is most abundantly produced by the distillation of wax with lime.

Paraffine melts between 110° and 114°. Its specific gravity is 0.870, and according to Lewis its formula is C₂₀ H₂₁. It is readily made into candles, and in a wick it burns with a beautiful, clear, white light; and the candles are semi-transparent. It is indifferent to the strongest acids and alkalies. A number of compounds of carbon and hydrogen have been confounded with paraffine, such as methylene, ethylene, butylene, etc. It is remarkable that the paraffine produced by the distillation of different kinds of materials differs considerably on some points of comparison, some having a higher, and some a

lower melting point. These differences, however, may arise in some degree from the amount of heat by which they are produced, and their treatment to render them pure. The greatest obstacle to the application of paraffine for candles is its low melting point. It may be mixed with bleached wax, which does not fuse, in general, below 154°. The cup-like cavity around the wick of a pure paraffine candle is apt to yield to the heat, and the melted material overflows, and bears with it the name of "*slut*." Doubtless there are improvements to be made in the manufacture of this beautiful article. Paraffine does not exist in coal ready formed. It is one of the combinations resulting from the interchanges of the elements of bituminous and other bodies during their exposure to a high temperature. Paraffine burns well in the kerosene or common coal-oil lamp, when dissolved in hydro-carbon oils; but in cold weather it hardens, and will not then ascend the wick.

Cedriret is a volatile solid which forms red crystals in a solution of sulphate of iron. These crystals dissolve in sulphuric acid, and the red color is changed to blue. The blue tinge produced by reflected light of some of the coal oils in the market owes its origin in part to the presence of cedriret.

Pittical.—When heavy oil of tar is neutralized by potash, and barytic water is added, the solution is of a deep blue color, from the presence of pittical, which, when pure, is like indigo. Its color has been fixed on cloth, but its manufacture has not yet been brought to perfection.

Pyroxanthine is another volatile crystalline solid, first obtained by Scanlan from pyroligneous spirit. Its crystals are of a fine yellow color, easily fusible. Its composition is represented to be $C_{21} H_9 O_4$.

The foregoing are the principal products of the distil-

lates of wood. Besides these, there are others which are constantly engaging the investigations of chemists. They are important, and in time they will probably be applied to useful purposes. When the different kinds of wood, the different chemical changes produced by different degrees of heat, and the variable operations of re-agents are considered, it is not surprising that this division of chemical science should advance so slowly, and so little should be known of the changes matter undergoes by seemingly invisible agents. The identity of most of the before-mentioned products, with those resulting from the distillation of coals, affords much additional evidence that coal and bitumen, like wood and turpentine, have had one common origin.

PRODUCTS OF THE DISTILLATION OF COALS AT A HIGH HEAT, OR COAL TAR.

Certain specific spirits and oils have been obtained by chemists from coals and other bituminous bodies. These spirits and oils have been distinguished one from the other by their densities, boiling points, and other characters, and have received different and sometimes very inappropriate names. From coal tar Peckston distilled oil of tar and spirits of tar. Laurent, Reichenbach, Hoffman, and others, have given the composition of coal tar. Wagenman applied himself to the oils derivable from turf, brown coal, and bituminous slate, from which he obtained photogen, solar oil, and paraffine. From the slate near Bielefeld, Engelbach distilled light oil, heavy oil, butyric fat, and asphaltic fat.

Mansfield in his patent, registered in 1847, describes alliolo, benzole, tuluole, cumole, cymole, and mortuole,

products collected by him from the distillation of coal tar. Among the oily substances obtained by the distillation of coal tar the following have been described: *—

| | |
|--|-----------------|
| Benzole | $C_{12} H_6$ |
| Cumene, or cumole | $C_{10} H_{12}$ |
| Toluole, or toluene | $C_{14} H_6$ |
| Naphthaline | $C_{20} H_6$ |
| Anthracene, or paranaphthaline | $C_{30} H_{12}$ |
| Chrysene | $C_{12} H_4$ |
| Pyrene | $C_{16} H_2$ |
| Ampaline. | |

ACIDS.

| | |
|--------------------|------------------------|
| Carbolic | $C_{12} H_6 O_4 H_2 O$ |
| Rosalic. | |
| Brunolic. | |

BASES.

| | |
|-----------------------------------|-------------------|
| Ammonia | $N_2 H_4$ |
| Picoline, or odorine | $C_{12} H_7 N$ |
| Aniline | $C_{12} H_7 N$ |
| Leucoline, or quinoline | $C_{16} H_7 N$ |
| Parvoline | $C_{18} H_{13} N$ |
| Lutidine | $C_9 H_9 N$ |

and others not yet fully investigated.

Besides the foregoing compounds, derived from coal tar, phenyle, pyrrole, animine, olanine, cyanole, benzidam, etc., and others have been described. It has been usual to separate the coal tar of gas works into two parts, namely, naphtha and *dead oil*. The tar itself always contains much finely divided carbon, the quantity of which is augmented by a high heat. Both the naphtha and *dead oil* consist of a number of hydro-carbons. These cannot be considered as certain compounds, as they are liable to great variations. The nature of the coal, and the heat applied, as before remarked, have much to do with the quality of the tar, cannel

* See Gerhardt, *Chem. Organ.* vol. iv., p. 426.

coal being always more productive of spirits and oils than common bituminous coal. Besides these various and variable products, several of them, if not all, have many derivatives, formed by their combinations with other substances. For instance, by the action of chlorine on naphthaline, we have, according to the nomenclature of Laurent, *chlona-ptase*, *chlona-ptese*, *chlona-ptise*, etc. By the action of bromine, *brona-ptase*, *brona-ptese*, *brona-ptise*, etc. The derivatives of aniline are represented as chloranoline, dichloranoline, trichloranoline, bromanoline, dibromanoline, tribromanoline, nitrodibromanoline, etc., and thus pages might be filled with the names of these uncertain combinations, a systematic arrangement of which has not been completed. These discoveries mark the progress of chemical inquiry, although they have not, so far, added much to manufacturing or commercial interests.

When coal tar, and especially that obtained from cannel coal, is submitted to heat in a still connected with a proper condensing apparatus, it is resolved into water, benzole, naphtha, and various heavy hydro-carbonaceous oils—charcoal remaining in the still if the distillation has been carried on to dryness. In the meantime decomposition has taken place, and products present themselves that did not exist in the undistilled material. Of these products a part is volatile, and another and the largest part is dense and not volatile. The former may be advantageously distilled over by the aid of steam at the temperature of 212°, the latter by super-heated steam. Manufactories have been established where the coal tar is distilled down to a thick pitch, which is applied for roofing buildings; the dense oils are employed for fuel in glass works; the benzole and naphtha, after being rectified, are sold for dissolving gutta percha and india rubber, for varnish, and for producing the

benzole light. The heavy oils abound in naphthaline, which has not yet been extensively applied to any useful purpose. The last of the distillate frequently contains paraffine oil and paraffine.

Among the valuable derivatives of coal tar, is picric acid, Welter's bitter, carbozotic acid, or nitro-phenesic acid of some chemists. This acid was discovered by M. Guinon, of Lyons, and its composition is stated to be $C_{12} H_3 N_4 O_4$. This substance is obtained by acting upon coal tar, or coal tar naphtha, with strong nitric acid. It produces a beautiful yellow color, which is capable of being fixed on silks and woollen cloth. It is used in France and England as a dye. The yellow stain communicated to the skin by nitric acid, and which cannot be removed by washing, arises from the production of picric acid. Aniline also is converted into a violet-colored powder, which has been sold for \$250 per lb., on account of the beautiful red and purple dyes it communicates to silks. Its colors are permanent, and exceed in delicacy any before discovered.

Benzole ($C_{12} H_6$). *Bicarburet of hydrogen* (Faraday). *Benzine* (Mitscherlich).—This oil, so called, although it is rather a spirit, was discovered by Faraday, and by him condensed from oil gas. Mitscherlich obtained it by distilling benzoic acid with hydrate of lime, and it may be procured by passing the vapor of benzoic acid through a red hot tube. It exists in considerable quantities in coal tar naphtha, from which it may be separated by fractional distillation. It is readily purified, by first washing it with sulphuric acid, then with a solution of caustic potash, or soda, and final distillation over lime. Its specific gravity is 0.850, of its vapor 2.742, and it boils at 186°. Like other liquids distilled from coal tar, it is scarcely a distinct and separate product; but forms a member of a series to be noticed

hereafter. Benzole holds a medium position between alliole, so called, and naphtha. With chlorine it forms chlorobenzole $C_{12}H_6Cl_6$. Similar compounds are also formed with bromine, nitric and sulphuric acids. It is itself a starting point or type of a series of homologous compounds, the common difference at each step being C_2H_2 . These compounds all admit of their hydrogen being replaced by one, two, or three equivalents of chlorine, bromine, nitric acid, and amide; finally they give rise to bases, of which aniline or phenylamine is the type.*

It will be readily perceived how benzole differs from eupion. In both, the multiple, or increasing number of the hydrogen, is two; but as the benzole series starts with two equivalents of carbon to one of hydrogen and eupion, with one equivalent less of carbon than of hydrogen, the former series contains the most carbon throughout. In making the benzole, or atmospheric light,† the benzole requires to be diluted with alcohol, to prevent the flame from smoking. Again, eupion alone is found to be deficient in carbon for that purpose. A mixture may be made of the two liquids, in which the quantities of carbon and hydrogen may be so adjusted that the light will be brilliant and without smoke.

By adding benzole gradually to strong nitric acid, with

* Gregory, *Outlines of Organic Chemistry*. London, 1852. 3d ed., p. 128.

† The benzole, or atmospheric light, is made by passing a current of air through benzole, or other volatile liquid hydrocarbon. The air, by taking up a quantity of the liquid, burns freely, and is distributed in the manner of coal gas. Numerous machines have been invented for forcing a current of air through the fluid, and some of them are very efficient. But below a certain temperature the air will not convey vapor sufficient to afford a good light. In cold weather, also, the vapor of the benzole condenses in the pipes, and the liquid itself requires the application of heat. These difficulties have so far been insurmountable.

the aid of a gentle heat, a compound is formed which dissolves in the acid, and, on cooling, collects on the surface. On diluting the mixture with water, nitro-benzole is precipitated in the form of a yellow oil. This oil has a sweet taste, and the odor of the oil of bitter almonds. It is used in perfumery, and in the bakery. Benzole is employed for many useful purposes. It dissolves the gums, resins, and all fatty substances. It removes from cloth and silks spots of tar, grease, turpentine, etc., and for those purposes it has been imported from France in small bottles, which are sold at high prices. Its rapid evaporation renders it also a substitute for alcohol and turpentine in the preparation of paints and varnishes.

Cumole ($C_{10} H_{12}$), when treated like benzole, its homologues yield a crystalline solid, which is fusible and volatile.

Toluole ($C_{10} H_8$) is another oil, analogous to and homologous with benzole. It boils at 226° , and has a specific gravity of 0.870. When treated with nitric acid it yields two compounds, nitrotoluole and dinitrotoluole. Deville obtained a series of compounds from toluole, in which the hydrogen was replaced by chlorine.

Naphthaline.—This interesting and remarkable hydrocarbon exists in almost all kinds of tar. In coal tar it is very abundant. It does not exist ready-formed in coal, but results from a high heat in its distillation, and an interchange of elements during the decomposition of the bituminous mineral. Creasote, or carbolic acid, is its usual companion, and seems to add to its quantity. By the repeated distillations of coal tar, naphthaline will crystallize at the bottom of the receiving vessel, and may be separated from the oils that accompany it by simple draining and pressure. It is rendered pure by agitation first with sul-

phuric acid, then with a strong solution of caustic soda or potash, and final distillation and crystallization. When pure, naphthaline is colorless, and forms beautiful flat and needle-shaped crystals; it evaporates rapidly, like camphor, and gives out a peculiar odor, unpleasant to some persons, but agreeable to others. Its taste is hot and pungent, and it corrodes the skin. A soap made from it was considered beneficial to the complexion. It distils with water, and, like camphor, sublimes and crystallizes against the sides of the bottle in which it is contained, and opposite the light.

Chlorine and bromine combine with naphthaline, and lay the foundation of a great number of compounds, which are formed by the substitution of the chlorine and bromine for hydrogen. The labors of Laurent have been successfully applied to this inquiry, by which a new field of research has been opened, and the doctrine of substitution more clearly established. Sulphuric acid exerts itself upon naphthaline, forming *hyposulphonaphthalic*, *hyposulphonaphthic* acids, etc. Thus, also, with nitric acid; but the number of these combinations, and the great length of their names, render full descriptions of them unnecessary in a work intended to be practical. Naphthaline is worthy of a trial in medicine, and may hereafter prove itself to be valuable in the arts. In its unpurified state it adds to the offensive odor of the oils distilled from coals, and increases the cost of their treatment.

Paraffine has been already described under the solid products obtained from the distillation of wood. Its yield from the coal tar of cannel coals is seldom more than one-fourth per cent. of the tar, and it succeeds the naphthaline in the distillation.

Anthracene, or *paranaphthaline* ($C_{30}H_{12}$), is polymeric with naphthaline, and is obtained from the heavy distillates

of coal tar. It melts at 350° , distils at 398° , and crystallizes in thin, foliated plates. Like naphthaline, it is acted upon by nitric acid, which produces a series of compounds, oxygen taking the place of hydrogen. Thus we have hyponitrate of *ancethracenase*, bi-hyponitrate of *anthracenese*, etc.

Chrysene also is found to exist in the last divisions of the distillates of coal tar. It is a crystalline solid, of a yellow color, melting at 455° , and not soluble in many liquids.

Pyrene ($C_{10} H_2$) occurs with chrysene. It is acted upon by nitric acid, which produces a number of derivatives. Chemistry is mainly indebted to Laurent for the discovery and description of many of these combinations.

VOLATILE BASES IN COAL TAR.

Carbolic acid.—This is a colorless oil, which, in its general characters, resembles creasote; and by some it is believed to be only a modification of that compound. It also occurs in the heavy distillates of coal tar, and boils at 380° . Like creasote, it is very poisonous, and may be used as a remedy for toothache. If a piece of pine-wood be dipped in carbolic acid, and then in nitric acid, it will become blue, which finally changes into brown. This acid has an offensive odor, which it imparts to coal oils, and thereby increases the cost of their purification.

Picoline ($C_{12} H_7$) is a volatile, oily base, discovered in coal tar by Dr. Anderson. It boils at 272° , does not discolor pine-wood, and is probably the *odorine* of Unverdorben.

Analine has been termed *crystalline*, *cyanol*, *benzidam*, *phenylamine*, *phenamine*, *phenamide*, etc. This base occurs among the products distilled from coals, and those produced by the destructive distillation of animal matter. It is also described as having been obtained from indigo.

The author found it an abundant product in the tar of stearine manufactories, and the oils distilled from shales, which contain the remains of fishes and *crustacea*. Aniline is a highly refractive, colorless oil, of specific gravity 1.020. When pure, it has a hot, pungent taste, and pleasant smell. It does not act on turmeric, but turns purple to green. With bleaching powder, it produces a purple color. This color is frequently seen in the coal oils of the market.

Nitric acid combines with aniline, and forms nitrophenic (picric or nitro-picric acid). With chlorine, it forms *chlorophenic* and *chlorophenic* acids.

Leucoline, or *quinoline*.—This base is found to exist among the last and least volatile products of coal tar. It boils at 460°, has a disagreeable smell, and neutralizes acids.

Lutidine is another of these bases, the nature of which has been but imperfectly made out.

PRODUCTS OF THE DISTILLATION OF COALS AT A HEAT
OF 700° TO 800° FAH.

The oily products distilled from coals at a high heat, or those produced in coal gas manufactories, have been called tars. However incorrect this appellation may seem to the chemist, it will serve to distinguish those coal tars from the products distilled from bituminous substances at heats just sufficient to expel all the volatile matter they are capable of affording. These are oils. The same description of coals, distilled at the same temperature, and by the same mode, will always yield the same results. The principal products of the decomposition of coals at a gas-producing heat, have been already noticed; but in order to obtain the greatest amount of commercial oils, the heat

applied to the distilling vessel should not exceed 800° Fah., while for the production of illuminating gas a temperature of 1000° to 1200° will be required. Nevertheless, it should ever be remembered, that to make the greatest quantity and the purest oils, different coals require different heats, some of them yielding up their oily vapors more readily than others. Therefore, if the same coals which produce the before-mentioned compounds of carbon and hydrogen contained in coal tar, be dry-distilled at a heat not exceeding 750° or 800°, the products will be different in quality and quantity. Instead of benzole, there will be eupion; naphthaline will not be formed, and if formed, the quantity will be small; the quantity of paraffine will be greatly increased, and the amount of creasote or carboic acid reduced; so that the purification is less expensive. There will be, also, a great change in the quality of the oils. Instead of coal tar naphtha, which cannot be burnt in common lamps without smoke, on account of its being surcharged with carbon, there will be a large amount of oils, with fewer equivalents of carbon, and admirably adapted for illumination, and also denser oils for lubrication. The following are the results of one ton Newcastle cannel coal, distilled for gas and for oils:

| DISTILLED FOR GAS. | | DISTILLED FOR OILS. | |
|--------------------------------|----------------|-------------------------------|----------------|
| Products. | | Products. | |
| Coal gas, | 7'450 cub. ft. | Gas, | 1'400 cub. ft. |
| Coal tar, | 18½ gals. | Crude oil, | 68 gals. |
| Coke, | 1,200 lbs. | Coke, | 1,280 lbs. |
| Products of the Coal Tar. | | Products of the Crude Oil. | |
| Benzole, | 3 pints. | Eupion, | 2 gals. |
| Coal tar naphtha, | 3 gals. | Lamp oil, | 22'5 " |
| Heavy oil naphthaline, &c. 9 " | | Heavy oil and paraffine, 24 " | |
| Total, | 12¾ gals. | Total, | 48'5 gals. |

The product set down above as lamp oil consists of several oils combined, which will be noted hereafter.

PRODUCTS OF THE DISTILLATES OF ASPHALTUM, BITUMEN,
PETROLEUM, ETC.

The asphaltum of New Brunswick, now called Albert coal, is one of the richest materials ever discovered for the manufacture of oils. Seventy per cent. of the first distillate, after purification, may be brought up to a specific gravity of 0.820, and burned in the ordinary coal-oil lamp. The material contains nitrogen, and therefore yields ammonia. It melts in the retort, and the volatile parts escape at a lower heat than those of coal. This may account in some degree for its greater yield of oils, and their freedom from impurities. From it naphthaline is seldom produced; and although paraffine is found among its products, creasote and other compounds of its class exist but in small quantities, while the illuminating oils are abundant. The oils themselves belong to a series which contains less carbon than ordinary coal oils. They burn freely, and give a clear, white light. The asphalt, or bitumen, of the Dead Sea affords much oil, mixed with the impurities before noticed. There is present, also, a peculiar volatile oil, which gives even to its purest products an unpleasant smell. This might properly be called *odorine*, although it does not agree with the *odorine* of Unverdorben.

The bitumen of the Pitch Lake of Trinidad contains sulphur, and sulphuretted hydrogen issues from the pit where the semi-liquid mineral is discharged from the earth. By distillation it also yields a whole series of hydro-carbon

oils, some of which have been called naphtha, and represented as $C_6 H_6$; others $C_{20} H_{16}$. It is quite evident that bitumens and their distillates differ materially in their composition, and therefore their value for the manufacture of illuminating oils, or for gas, can only be ascertained by experiment. This bitumen yields 70 gallons of crude oil per ton of 2240 lbs. The impurities in its first distillate are numerous. Among its soluble parts pyroxilic spirit and other products of the distillation of wood have been detected, giving evidence of the vegetable origin of the pitch. All the oils distilled from this substance have a most forbidding smell, which arises from a volatile oil. This oil bids defiance to acids and alkalies, indeed the latter render it more persistent.

The bitumens of Cuba yield from 100 to 140 gallons per ton of the crude oil. These, when purified, are admirably adapted to lamps. A British company has recently shipped the bitumens (chapapote of the Spaniards) to England for the making of lamp and lubricating oils; but the odor has followed them, and presented an obstacle of significance. Few of the bitumens of Central and South America have been tested in reference to their composition, or value for hydro-carbon oils. Those of the United States and Canada are beginning to draw the attention of manufacturers in reference to their value in competition with cannel coals and petroleum.

The bitumen of Canada West contains decayed vegetables, and is no doubt the result of petroleum that has long been exposed to the air; 2,000 lbs. yielded 109 gallons of crude oils. From this crude product 64 gallons of lamp oils were distilled, and also 18 gallons of heavy oils suitable for lubricating machinery. It differs very essentially from the bitumens of the West India Islands, and the oils

require careful purification. The great diversity in the characters of these substances opens an extensive range for chemical research.

Bituminous sands and clays are found at many sites in Central and South America. These, when submitted to dry distillation, afford various quantities of gases and oils, which possess the ordinary characters of bitumen oils. Among those substances may be reckoned the "prairie gas stone" of Illinois, of which glowing descriptions have appeared in newspapers. This is a grey limestone, with pores and cells partially filled with bitumen. By distillation therefore the rock yields hydro-carbon oils, carburetted and bicarburetted hydrogen gases. One sample of the rock gave at the rate of 18 gallons of crude oils, per ton. The bituminous brown coal of Ouachita, Arkansas, has already been noticed.

All these oils, when purified, and when they are of a specific gravity less than 0.850, are extremely fluorescent. When freed from acids they appear yellow by transmitted light, and by reflected light blue. The beautiful hues of the rainbow are sometimes brought out by frequent distillations and the use of sulphuric acid and caustic alkalies, by which the illuminating oils are frequently injured. It is a peculiar feature of impure coal oils to change color by exposure to the air and light. Oils that come from the worm of the still perfectly colorless will turn yellow, then red, and in a few days a dark brown. Sometimes this change of color begins at the surface of the oil, and proceeds downwards until the whole mass is discolored. This arises from the oxidation of the impurities by the atmosphere. Changes of color also arise from the predominance of an acid or an alkali in the oil, which should be perfectly neutral. The purest oils, when exposed to the direct rays

of light, will vary in color, according as the day is bright or cloudy. They possess photographic properties not well understood.

Petroleum, or mineral naphtha, is generated in the earth, and issues from it at numerous places in the old world and in the new. The naphtha of Baku, near the Caspian Sea, is nearly colorless. The springs of the Burman Territory at Yananghoun, upon the Irawady, send up a brown naphtha. At this place 520 springs yield upwards of 120,000 gallons of petroleum yearly, and no diminution of the supply has been recorded. The Barbadoes petroleum, known as Barbadoes tar, the springs of which were visited by the author in 1818, still send forth their oily products, and the springs of other West India Islands and South America have not failed. All these tarry substances afford oils by distillation, some of greater and some of less value.

The petroleums of the great Alleghany coal field do not give the rank pungent smell of Southern naphthas, but a mawkish odor equally unpleasant. In general they are of a dark-brown color, and appear transparent when held against the light. They vary in their characters, and especially in their specific gravities, which extend from 0.814 to 0.930.* The modes by which they are to be refined must vary accordingly. The denser kinds yield much heavy carbonaceous matter unfit for illumination. When properly purified the oils are inoffensive, and burn with great brilliancy.

Some of the petroleums, when exposed to the air, evaporate rapidly down to a thick bitumen, others resist evaporation, and "skin over" like linseed oil. Their oils differ

* A sample of native petroleum received from Dr. Dale, of Alleghany County, Pa., and taken from a spring owned by Lewis Peterson, Esq., has a specific gravity of 0.814, and will yield ninety per cent. of pure lamp oil.

from those distilled from coals. They require a greater heat in their distillation, and their vapors are extremely inflammable. These petroleum oils usually commence to boil at 160° Fah., but sometimes at a still lower degree of heat. The lighter or spirituous parts of the charge then begin to distil off, and as the heat is increased the heavier portions come over in succession until the thermometer reaches 565°, when paraffine, if any be present, will begin to appear. It is therefore extremely difficult to obtain any one specific oil, of which the aggregate is compounded. A thermometer fixed in the still indicates the boiling or distilling point of the mass at the time of observation, and nothing more. Each of the oils composing the aggregate collection has a different number of the equivalents of carbon and hydrogen, with which the several boiling points doubtless agree; but the exact rate at which the boiling point does increase, according to the proportions of carbon and hydrogen present in the several oils, has not been accurately discovered.

Laurent has given the composition of some of the oils distilled from bituminous schists as follows:—

| Boiling Points. | Carbon. | Hydrogen. |
|-----------------|---------|-----------|
| 144° | 86 | 14.3 |
| 171° | 85 | 14.1 |
| 216° | 86.2 | 13.6 |
| 304° | 85.60 | 14.5 |

St. Evvre gives the following:—

| Boiling Points. | Carbon. | Hydrogen. |
|-------------------------|---------|-----------|
| 520° and 536° | 36 | 34 |
| 485° " 500° | 28 | 26 |
| 414° " 428° | 24 | 22 |
| 268° " 275° | 18 | 16 |

Candle Tar.—When the tar resulting from the manufacture of stearine is submitted to distillation, it sends over a series of oils, the chief number of which are good illuminators. Paraffine also appears in the latter part of the operation. Frequently there is the production of much aniline, the vapor of which produces a burning sensation in the throat and nostrils, and is very unhealthy. These oils are easily purified by alternate washings with sulphuric acid and solutions of the caustic alkalies, with final distillation. They are of a light orange color. The lighter oils are colorless, and by rectification they may be obtained of a specific gravity not exceeding 0·680. The denser oils are superior for lamps.

Caoutchene, or oil of caoutchouc, is produced by the distillation of India rubber, at a moderate heat. A series of light oils, easy of purification, is the result. The vapors are very heavy, and dissolve the resins, shellac, and amber. These oils have been represented as being *caoutchene*, which boils at 72°, Faradayine at 96°, eupione at 124°, and *caoutchine* at 330°.

Gutta Percha yields oils nearly allied to the above.

Peat has been extensively distilled for oils in Ireland, and also for its soluble products and paraffine. Its ordinary productions from a ton, when worked by Reecis' patent, are—

| | |
|-----------------------|-------|
| Ammonia | 0·289 |
| Acetic Acid | 0·207 |
| Naphtha | 0·140 |
| Oils | 1·059 |
| Paraffine | 0·125 |

The Irish Peat Company, in the County of Kildare, obtain from every ton of peat three lbs. of paraffine, two

gallons of lamp oil, and one gallon of lubricating oil. In America, where the materials for manufacturing those oils are rich and abundant, it is not probable that peat will ever be employed for such objects. The coke of peat affords fuel, and may be used in the decolorization of sugar.

CHAPTER V.

Composition of distilled oils.—Homologous compounds.—Table of the same.—Compounds of Carbon and Hydrogen.—Gaseous compounds.—Homologues obtained from coal tar, coal, bitumen, caoutchouc, etc.

OXYGEN OILS.

BEFORE entering upon a description of the methods employed for the purification of the before-mentioned oils, it is considered necessary to give some account of their component parts and their derivatives. Oxygen enters into the composition of all animal and vegetable oils, unless those oils have been submitted to distillation, which, in general, removes their oxygen and changes their characters. The oils distilled from plants with water are known as essences, or essential oils. They seldom contain oxygen, and are therefore called hydro-carbon oils. The volatile vegetable oils contain oxygen perhaps without an exception.

The oils distilled from the bituminous and oleaginous substances described in the preceding chapters contain no oxygen when they are pure; they are composed of carbon and hydrogen, and are therefore hydro-carbon oils. The greater the quantity of carbon, in proportion to the hydrogen any one of them contains, the greater is its specific gravity, the higher its boiling point, density of vapor, and tendency to smoke when employed for the purpose of illumination. An excess of carbon, however, does no harm to any oil designed for lubrication, but rather gives it consistency and durability. Regarding lamp oils, the greater the amount of carbon they contain the greater will be their

illuminating powers, and therefore that is the best lamp, which, when lighted, will decompose the greatest amount of carbon in the flame. It is to the equivalents of carbon and hydrogen contained in oils the attention turns as to a starting-point in this inquiry.

ORGANIC AND HOMOLOGOUS COMPOUNDS.

It is well understood that certain series of organic compounds occur, in which the quantities of carbon, hydrogen, oxygen, and nitrogen increase or decrease, rise or fall, in exact and certain quantities, or numbers of equivalents. Take, for example, twenty volatile acids, as given by Dr. Gregory, and with a general formula of $C_n H_{2n} O_4$ * as follows:--

| | |
|---------------------------------------|-----------------------|
| 1 Formic acid | = $C_1 H_2 O_4$ |
| 2 Acetic " | = $C_2 H_4 O_4$ |
| 3 Propylic acid | = $C_3 H_6 O_4$ |
| 4 Butyric " | = $C_4 H_8 O_4$ |
| 5 Valerianic acid | = $C_{10} H_{10} O_4$ |
| 6 Caproic " | = $C_{12} H_{12} O_4$ |
| 7 C Enanthylic " | = $C_{14} H_{14} O_4$ |
| 8 Caprylic " | = $C_{16} H_{16} O_4$ |
| 9 Pelargonic " | = $C_{18} H_{18} O_4$ |
| 10 Capric " | = $C_{20} H_{20} O_4$ |
| 11 Margaritic " | = $C_{22} H_{22} O_4$ |
| 12 Laurostearic " | = $C_{24} H_{24} O_4$ |
| 13 Cocinic " | = $C_{26} H_{26} O_4$ |
| 14 Myristic " | = $C_{28} H_{28} O_4$ |
| 15 Benic " | = $C_{30} H_{30} O_4$ |
| 16 Ethalic " | = $C_{32} H_{32} O_4$ |
| 17 Margonic " | = $C_{34} H_{34} O_4$ |

* *Handbook of Organic Chemistry*, 8d edition. By William Gregory. London, 1852.

| | | |
|---------------|-----------|--|
| 18 Basic acid | | = C ₂₈ H ₅₆ O ₄ |
| 19 Balenic " | | = C ₃₀ H ₆₀ O ₄ |
| 20 Behenic " | | = C ₃₂ H ₆₄ O ₄ |
| 21 Cerotic " | | = C ₃₄ H ₆₈ O ₄ |
| 22 Melissic " | | = C ₃₆ H ₇₂ O ₄ |

Here we see the quantities increased by the number 2, while the oxygen 4 is constant.

By his able and ingenious researches Laurent discovered a law of substitution by which one element is replaced by another, according to a perfect and harmonious system. The correctness of this doctrine received confirmation by Dumas, Dr. Hoffman, and Baron Liebig, and its opponents yielded up their views to its facts.

"Of fifteen elements, the equivalents of ten of them, or two-thirds, are represented by whole numbers, that is, they are exact multiples of that of hydrogen, the lightest of them all. They are—

| | | |
|------------|-----------|---------|
| " Hydrogen | | = 1·0 |
| Oxygen | | = 8·0 |
| Nitrogen | | = 14·0 |
| Sulphur | | = 16·0 |
| Bromine | | = 80·0 |
| Iodine | | = 125·0 |
| Fluorine | | = 19·0 |
| Phosphorus | | = 32·0 |
| Arsenic | | = 75·0 |
| Carbon | | = 6·0 |

"If only ten of these were known to us, the law would immediately be assumed that *the equivalents of the metalloidal elements are exact multiples of the equivalent of hydrogen.*"*

A series of types has therefore been discovered. Those types consist of different elements, and to which other

* *Elements of Chemistry.* By M. V. Regnault. Vol. i., p. 347.

simple substances may be added, or replaced while the original type is preserved. The series of volatile oily acids is only one of a number of such series already made out, and to which the oils distilled from oleaginous and bituminous bodies must be added. These series are homologous. Each member of them differs from the others by a certain number of the equivalents of carbon and hydrogen, or by a multiple of them. In their properties these compounds are perfectly analogous, and only differ in degree, and the difference is exactly in proportion to the amount of carbon and hydrogen they contain.

Taking the example given by Dr. Gregory—

| | |
|---------------------------------|---------------------|
| " Pyroxilic spirit is | $C_3 H_4 O_2$ |
| Alcohol is | $C_4 H_6 O_2$ |
| | $C_5 H_8 O_2$ |
| | $C_6 H_{10} O_2$ |
| Oil of potato is | $C_{10} H_{18} O_2$ |

Then the alcohol and pyroxilic spirit differ by $C_3 H_2$. The oil of potato and pyroxilic spirit differ by $4 C_3 H_2$. The compounds between the oil of potato and alcohol have not been discovered.

When a series of substances, especially if derived from the same source, is discovered to have analogous properties, it may be presumed that their compounds are homologous. Although some of the members of the group, or links in the chain, are undiscovered, they may yet be obtained, and the perfect series completed. It is only a few years since two of the acids obtained by the oxidation of alcohol—the formic ($C_2 H_2 O_3$) and acetic ($C_4 H_4 O_3$)—were known. Now recent discoveries have filled up the series to sixty equivalents of carbon.

The alcohols and ethers, and the acids of their different

series, differ by $C_2 H_4$, or multiples of one or both of these numbers. Still, in all the members of a group there is a family likeness. Here, also, the boiling point, and the density of the vapor, are governed by the proportion of carbon present. Ethyle, methyle, etc., have their derivatives. Each of these derivatives is the starting-point of a series of homologues. M. Dumas, Dr. Gregory, and others, have brought to notice the great analogy between the elementary groups—chlorine, bromine, iodine, potassium, sodium, lithium, etc., and homologous organic groups. Every organic compound belongs to some series in which each individual member of the elementary substances is increased or diminished by certain regular and fixed quantities. The fact may be again repeated, that the oils before described as resulting from the distillation of the different oleaginous and bituminous compounds, are not each a single oil of their kind, but consist of many members, which form a series of oils distinct one from the other. They have the same root, but differ in the branches. Each member of all their several groups contains a different number of the equivalents of carbon and hydrogen, forming chains which rise, step by step, from the solid to the liquid, and from a dense liquid to a light and extremely volatile spirit, and finally to a gas. Again, each of those members is capable of forming entirely new series of compounds, when combined with other elements. As regards the original oily groups, when their components of carbon and nitrogen are the same, their properties will be the same, irrespective of their origin. They will give the same amount of light when burned in lamps, and be equally applicable to useful purposes. This likeness can only be discovered by their specific gravity, boiling points, and, more important than all, by their ultimate analysis by the chemist. As all

those oils are capable of affording light, and the term "photogen" applies only to one of them, the appellation of hydro-carbon, or lamp oils, has been applied to all that are now consumed for illuminating purposes.

As the oils here treated of consist of carbon and hydrogen, some notice may be taken of those two elements. Carbon occurs abundantly in the animal, vegetable, and mineral kingdoms. In its pure and crystallized state it constitutes the diamond. It is the chief substance of plumbago, and frequently forms more than ninety per cent. of anthracite coal. It is essential to the organization of animals, and enters extensively into the composition of minerals, especially the varieties of coal, bitumen, petroleum, etc., and all substances of vegetable origin. Carbon appears also in the gases of coal mines, as carburetted hydrogen, or fire-damp, or carbonic acid, or choke-damp. When organic matter is heated in close vessels, volatile substances are expelled; these consist of carbon, hydrogen, nitrogen, and oxygen; the residue is carbon mixed with the ash—the minerals that enter into the composition of the wood. Carbon is without taste or smell, and insoluble. It resists decomposition, and, when buried in the earth, is imperishable.

Combined with oxygen, carbon forms two gaseous compounds, carbonic acid and carbonic oxide. Carbonic oxide may be considered a compound radical. It combines with chlorine, oxygen, and the metals. It is a transparent, colorless gas, without taste or smell, and, when inhaled, is fatal to animal life. This gas takes fire, and burns with a fine blue flame, which is often seen on the surface of coals burning in a grate.

Carbonic acid is formed by the respiration of animals,

and by vinous fermentation. It is a product of combustion, and is produced artificially by the action of acids upon carbonate of lime. It is a colorless gas, and so much heavier than air, that it may be contained in open vessels. The effervescing properties of wine, beer, soda-water, and some mineral waters, arise from the presence of this acid. It forms the food of growing plants, a part of which they retain in their structures. Another part is expelled, and is found in the atmosphere.

Hydrogen forms one-ninth part, by weight, of water, and exists in vegetable and animal substances. It has neither taste, color, nor smell, and is the lightest substance discovered in nature. It is nearly sixteen times lighter than oxygen, and fourteen and a half times lighter than air. It was, therefore, first employed in floating air balloons. A pressure of a thousand atmospheres has no sensible effect in the condensation of hydrogen gas. Sound moves with three times the velocity in hydrogen that it does in common air, and it refracts light with more power than any other gas. The greater the quantity of hydrogen present in any body, the less will be its weight, or specific gravity. It is thus with the hydro-carbon oils. Hydrogen is also the most inflammable substance in nature; it burns with an almost colorless flame, and great heat. The opinion is entertained by some, that hydrogen is a gaseous metal, as mercury is a liquid metal.

Carbon and hydrogen, hydro-carbons.—Carbon and hydrogen combine in a great number of proportions, and consequently produce numerous compounds; and as both elements are combustible, their compounds are also combustible and inflammable. By some these compounds are called carbo-hydrogens. At the ordinary temperatures, some of these are solid, such as paraffine, naphthaline, etc.;

others are liquid, as the oils of lemons, naphtha, etc. Two of them are gaseous, namely, light carburetted hydrogen gas, and olefiant gas, which are the roots of two, if not more, series of compounds. All these compounds are the products of vegetables, or they are produced from the decay or destructive distillation of organic matter.

Carburetted hydrogen (C, H_2) mixed with atmospheric air is the explosive fire-damp of coal mines, and it frequently issues from the earth through fissures connected with beds of coal, or collections of petroleum. When mixed with twice its volume of oxygen, it explodes with great violence. If mixed with about six times its volume of air, it also explodes. By this mixture gasometers have been blown up with terrible effect.

Bi-carburetted hydrogen, or olefiant gas (C_2, H_2), mixed with the above and other gases, occurs in coal mines. It is also transparent and colorless. It takes fire readily, and burns with a white flame, giving out much light. It is also the root of an extensive series of hydro-carbons. This gas and the preceding carburetted hydrogen, when pure, form what is known as coal gas, now extensively employed to light cities. Its value depends much upon the quantity of olefiant gas contained in the mixture.

The light produced by the combustion of the hydro-carbon oils is like that of coal gas. It is from gas in both instances. The oils are put in lamps, and inflamed; the gas is produced at the top of the wick, and decomposed instantaneously. In the other instance, the gas is made by heating the coals in retorts, and storing it in gasometers ready for use, and its distribution through pipes and burners. In the benzole, or atmospheric light, the vapor of the hydro-carbon is conveyed in the air to the burner, and there burned as coal gas. The fluctuations in the con-

densation of this vapor by changes of temperature are impediments to this mode of supplying artificial light.

Homologous series obtained from coal tar. The radical is $C_{10}H_4$; the multiple is C_2H_2 .

| | Bolling point. | Spec. grav. |
|-------------------------------|----------------|-------------|
| $C_{10}H_4$ | 135° | |
| $C_{12}H_6$ Benzole | 186° | 850 |
| $C_{14}H_8$ Toluene | 237° | 870 |
| $C_{16}H_{10}$ Xylole | 288° | |
| $C_{18}H_{12}$ Cumole | 339° | |
| $C_{20}H_{14}$ Cymole | 490** | |

It will be here observed that the boiling point rises 25.5° for every additional equivalent of carbon. By the action of chlorine, bromine, nitric acid, etc., each of the above hydro-carbons forms the root of other distinct and well-defined series.†

Homologous series obtained from the bitumen of Trinidad, distilled at a low heat:

| No. | Carbon. | Hydrog. | Spec. grav. | Bolling point. |
|-----|---------|---------|---|----------------|
| 1 | 4 | 3 | only partially condensed. | |
| 2 | 5 | 4 | 0.715 | 130° |
| 3 | 6 | 5 | 0.775 | 180° |
| 4 | 7 | 6 | | |
| 5 | 8 | 7 | | |
| 6 | 9 | 8 | | |
| 7 | 10 | 9 | | |
| 8 | 11 | 10 | | |
| 9 | 12 | 11 | Embracing the hydrocarbon oils suitable for lamps. Specific gravity of the whole when mixed, 0.819. | |
| 10 | 13 | 12 | | |
| 11 | 14 | 13 | | |
| 12 | 15 | 14 | | |
| 13 | 16 | 15 | | |
| 14 | 17 | 16 | | |
| 15 | 18 | 17 | | |
| 16 | 19 | 18 | | |
| 17 | 20 | 19 | | |
| 18 | 21 | 20 | | |
| 19 | 22 | 21 | Paraffine. | |

* Generally represented as $C_{20}H_{14}$.

† See Gregory's *Handbook of Organic Chemistry*, 3d edit., p. 129.

The bitumen of Cuba, Albert coal, bituminous shale of Albert county, the petroleum of Virginia, and candle tæx, produce the same series of hydro-carbons.

The series obtained from Breckenridge coal, distilled at an average heat of 780°, was as follows :

| No. | Carbon. | Hydrog. | |
|-----|---------|---------|---|
| 1 | 4 | 2 | Supposed to exist, but not condensed. |
| 2 | 6 | 4 | |
| 3 | 8 | 6 | Embracing the hydro-carbon oils suitable for lamps when mixed. Spec. grav. 0·816. |
| 4 | 10 | 8 | |
| 5 | 12 | 10 | |
| 6 | 14 | 12 | |
| 7 | 16 | 14 | |
| 8 | 18 | 16 | |
| 9 | 20 | 18 | Paraffine. |
| 10 | 22 | 20 | |

A coal from Kanawha, Virginia, when distilled at a heat of 900°, gave part of a series thus :

| No. | Carbon. | Hydrog. |
|-----|---------|---------|
| 1 | 8 | 4 |
| 2 | 12 | 8 |
| 3 | 16 | 12 |
| 4 | 18 | 16 |

Caoutchouc was distilled at a moderate heat, and the following was the series produced :

| No. | Carbon. | Hydrog. | Sp. grav. | Boiling point. |
|-----|---------|---------|-----------|----------------|
| 1 | 8 | 7 | 678 | 94 |
| 2 | 9 | 8 | | |
| 3 | 10 | 9 | | |
| 4 | 11 | 10 | | |
| 5 | 13 | 11 | | |
| 6 | 14 | 12 | | |

Other series of hydro-carbons might be laid down; but the foregoing are sufficient to demonstrate the existence of

a system which cannot be carried forward to perfection without great labor and research. This system is being gradually extended to every branch of chemistry, and is bringing the science into a beautiful harmony with mathematics, and its kindred study, astronomy.

To the manufacturer it is of the first importance. It teaches him that he has to deal with a great variety of compounds. An increase in the degree of heat employed in his operations will change the properties of his products, increase the proportions of carbon, and defeat him in his objects. A temperature too low will give results to disappoint him. He cannot fail to observe the different proofs at which his oils flow from the still, and the constant increase of heat required to produce them in the process of refining and purifying; and having obtained even an indistinct view of the point he would reach, his skill and experience will bring to him that knowledge of his art he desires.

CHAPTER VI.

Oxidation of the impurities contained in crude hydro-carbon oils.—Action of acids, alkalies, and other agents.—Sulphuric acid, nitric acid, permanganate of potash.—Methods of purification.—Extracts from patents, etc.

WHEN oils were first distilled from coals, few attempts were made to free them from their offensive odors, or remove their coloring matters. The only mode practised was fractional distillation, which is altogether quite ineffectual for that purpose. Although the oil made by the Earl of Dundonald in 1781 was burned in lamps, it does not appear that any process of purification was practised at that time. The earliest mode of purifying petroleum was simply to distil it with water, and this is more beneficial than some of the modes practised in the present day, by which the characters of the oils are changed and their illuminating powers deteriorated.

The great number of impurities contained in the oils distilled from coals, whether from coal tar or crude coal oil, renders their purification somewhat difficult, expensive, and uncertain. The varieties of coals and other substances employed to obtain hydro-carbon oils, the fluctuations of heat in distillation, and varying qualities of reagents, will ever require the care and skill of the practical chemist to overcome them. Much has been done in the purification of those oils, much is still to be performed before they are made perfect, namely, free from all offensive odor, and free from color. The great difference observed in the qualities of the oils in the market arises less from the different modes

90 ACIDS, ALKALIES, AND OTHER OXIDATING AGENTS.

by which these oils are treated, than from the properties of the coals from which they were distilled.

ACIDS, ALKALIES, AND OTHER OXIDATING AGENTS.

Acids, alkalies, peroxide of manganese, permanganate of potash, bichromate of potash, etc., have been unsparingly used in the purification of hydro-carbon oils, on account of their oxidating properties. The object of chemists has been to impart oxygen to the impurities, by which they separate themselves from the oils, and generally fall to the bottom of the vessel that contains them.

The oxidation of organic compounds takes place in several ways. In combustion atmospheric oxygen is aided by a high temperature. If the supply of air be deficient, as in the case of a burning lamp, the hydrogen, from a greater attraction for oxygen, is oxidated, and the carbon of the oil appears in smoke or soot. The decay of wood is produced by oxidation, and ulmine is the result. So also in some of the impurities in hydro-carbon oils; their combination with oxygen gives them new characters, by which they no longer remain with their native liquids. Reagents may be applied to oils that will not separate from them until exposed to the heat of distillation. By its oxidating properties permanganate of potash converts sugar into oxalic acid. Bichromate of potash diluted with sulphuric acid converts salicine into the hydruret of salicile, or oil of spirea.

Action of sulphuric acid.—In general, when sulphuric acid is applied to organic compounds (and such are the oils under consideration), it decomposes, or chars them. By the aid of heat its effects are more powerful, and it transmutes starch and lignine into grape sugar. Its action upon

naphthaline and other compounds of carbon and hydrogen has been before noticed. Paraffine is not sensibly affected, when boiled with sulphuric acid. For this reason it is employed in the purification of that substance, as it absolutely burns out all its impurities. Sulphuric acid, or oil of vitriol, is now universally used in the purification of coal oils, by which some of their impurities are converted into tar, or rendered soluble in water. The acid may be separated from the tar by distillation. This acid always decomposes a part of the oils in proportion to its strength and the quantity employed. It is a powerful purifier. It removes one kind of odor and substitutes another less disagreeable. How far it changes the characters of the oils has not been determined; but in some instances, when it is used in large quantities, there can be no doubt it produces what may be called *sulpho-oils*, which are unchangeable by the use of alkalis. Certain it is that these sulpho-oils are quite dissimilar to the natural oils obtained by the fractional distillation of coal oils, and are inferior to them for the purposes of illumination. The powerful effects of the before-mentioned acid in removing impurities from the distillates of coal, and its cheapness, have brought it into general use.*

Action of nitric acid.—The operations of nitric acid upon organic substances are very numerous. It usually, if not always, produces one or more acids. From gum there comes mucic acid; from indigo, indigotic and nitro-picric acids; from stearic acid, margaric acid, etc. Laurent has clearly described the action of nitric acid upon naphthaline.

Benzole admits of having its hydrogen replaced by one,

* The average specific gravity of commercial sulphuric acid is 1.800. It sometimes contains nitric acid.

two, or three equivalents of nitric acid. This remark applies equally to eupion and all the lighter products distilled from coals, petroleum, etc. All these compounds have an aromatic odor. As an instance, when benzole is saturated with fuming nitric acid, and water is added to the hot solution, nitro-benzole subsides as a yellow oil with the odor of cinnamon. It is sold as the oil of bitter almonds. Other light hydro-carbons give similar results, and a great number of oils, useful for perfumery and cookery, may be produced from them.

As an oxidator nitric acid is more powerful than sulphuric acid; but it exerts a greater action on the oils themselves, changing them into *nitro* oils, and removing them further away from the natural products of the material first employed.

Permanganate of potash must be included among the materials used for oxidating the impurities contained in distilled oils. Its effects are feeble when compared with those of sulphuric acid, and its price is too great a drawback on the profits of the manufacturer.

METHODS EMPLOYED FOR THE PURIFICATION OF HYDRO-CARBON OILS.

The earliest writers on the production of oils from coals and other analogous substances, did not describe any very satisfactory mode by which those oils could be purified. Selligie was perhaps the first to supply a method for this purpose; and it appears in the voluminous specification of his patent.* He commenced by agitating the oils with sulphuric, muriatic, or nitric acid. The agitation was con-

* Specification No. 10,726, English Patent Office. Translated by Du Buisson.

tinued for some time, so that every particle of the oil should be brought in contact with the acid, and a certain change of color had taken place. His agitators were of peculiar construction, and he has described them at length. After the oil and acid had been allowed time to separate, the former was decanted and washed with soap-maker's lye, proof 36° to 38° Baume. Thus a part of the coloring matter was precipitated, although some of the lye was subsequently permitted to go into the still with the oils. Fractional distillation was also resorted to, which with variations in the above mode enabled the chemist to produce oils of good quality. The specification of Selligie was written with great care; but his operations were complex and expensive. The alternate use of acids and alkalies forms the principal feature in the purification of those oils at the present time.

MANSFIELD'S PROCESS.

In 1847 C. B. Mansfield of Cambridge, England, obtained a patent for the "purification of spirituous substances and oils" derived from coal tar, &c. Of the products of coal tar he describes five, namely, alliole, benzole, toluole, camphole, mortuole, and nitro-benzole; for each of these classes he modified the treatment. To alliole and benzole, he applied diluted sulphuric or hydrochloric acid, and agitated the mixture, which was allowed to settle, when the acid and impurities were drawn off. The spirits and oils were then agitated with water, which was also afterwards removed, and the spirits and oils placed in a vessel of fresh burnt lime, and finally rectified by distillation. The toluole, etc., were purified by a similar method, except that stronger and greater quantities of the acids were employed, and the

number of distillations increased. The specification of this patent is also of great length, and directed to objects foreign to the purification of the oils derived from bituminous substances.

YOUNG'S PROCESS.

This alleged improvement consists in treating bituminous coals in such a manner as to obtain therefrom an oil containing paraffine, which is denominated paraffine oil, and from which Mr. Young obtains paraffine. He employs "Parrot coal," "cannel coal," and "gas coal." These are broken up to about the size of a hen's egg, and distilled in common gas retorts with worm pipes and the ordinary refrigerators of stills, the water in them being kept at a temperature of about 55° Fahr., by a stream of cold water entering the worm cistern. The retort is kept at a "low red heat," a higher heat will produce gas rather than oil. The retort is heated up gradually, and the product is an oil containing paraffine.

The crude oil is put into a cistern, and steam heat applied up to about 156°. This separates some of the impurities, and the oil is run off into another vessel, leaving the impurities behind. The oil is then distilled in an iron still with a worm pipe and refrigerator, the water in the latter being kept at 55° Fah. The oil thus distilled is then agitated with ten per cent. of oil of vitriol one hour. It is then allowed to settle twelve hours, when it is drawn off from the acid and impurities into an iron vessel, where it is again agitated with four per cent. of the solution of caustic soda of specific gravity 1.300. Six hours are again allowed for the alkali and impurities to settle, when the oil is again drawn off and distilled with half its bulk of water; water being

run into the still from time to time to supply the quantity distilled off. The lighter oil comes over with the steam, and is employed for illumination. The oil left in the still is carefully separated from all water and put into a leaden vessel, and there agitated with two per cent. of oil of vitriol. It is then allowed to settle twenty-four hours. This oil is then run into another vessel, and to every 100 gallons there are added twenty-eight pounds of chalk, ground up with water into a paste. The oil and chalk are agitated together until the oil is freed from acid. After it has remained a week at rest, it is used for lubricating machinery, and may be mixed with animal or vegetable oils for that purpose. To obtain the paraffine the oil containing it is brought down to a temperature of 80° Fah., when paraffine will crystallize and separate itself from the oil, or it may be filtered and finally submitted to pressure. Again it is agitated with its bulk of oil of vitriol, and the operation repeated until the acid ceases to be colored by the paraffine, which is kept melted during the operation.* Whatever may be the merits of this mode of obtaining lubricating, or paraffine oil, so called, the lamp oils are of a dark reddish-brown color, and of an unpleasant odor. They also incrust the wick of the lamp in burning. It is evident that the quantity of acid employed is too great, and by which a part of the oils are decomposed. In the purification of the paraffine the oils are charred, or burnt out. The paraffine alone resists its action.

KEROSENE PROCESS.

The specification describes the process for obtaining oils, denominated Kerosene, from "bitumen wherever found."

* Extracted from the patent of James Young.

water. They are then taken to a drying-furnace of the following construction: A space by preference of two hundred feet in length, and twenty feet in width, is intersected by walls of two feet high; at the distance of every four feet these walls are bound together by arches of one brick thick, and on these arches the coals and bituminous slate are spread.

“The space below the arches is filled up with the residue from the retorts.

“The coals or bituminous slate, when dried, is distilled in retorts, which are so far different from those used at the gas-works, that the pipes for letting out the produce of distillation are on the opposite ends to those where the doors are. Over each fire are two retorts, each by preference, of about eight feet long, and two feet wide, with an opening of five inches, to let out the produce of distillation. The fire runs below the retorts in a direction from front to back, the fire bars only extending part of the way. I prefer to arrange a stack consisting of eight fires and sixteen retorts around one chimney, by which means I am enabled to lead the flame from one fire to the others, and by that means to heat the retorts by a graduated heat.

“The products of distillation of the sixteen retorts meet together in one iron pipe about eighty feet long, and two feet diameter, which is surrounded by another, so that cold water can run between the two pipes for cooling. The gases, after having passed this pipe, enter in two cylinders, about twelve feet in height and four feet in diameter. These cylinders are filled with iron wire chips. The gases, after having passed the cylinders, pass through another iron pipe, forty feet high into the air, which pipe, to regulate the draught, is furnished with a regulator.

“It is important that the produce of distillation should

not be conducted so as to produce pressure in the retorts.

"The produce of distillation runs into a general reservoir, and the reservoir is so arranged that the condensed productions will have an average heat of 80° centigrade. The oils separate themselves here from the ammoniacal water. The ammoniacal water is thrown over the cooled residue of the drying furnaces, and mixed with it, which produces a very good manure. The tar, after being separated from ammonia, is distilled, and the product of distillation is cooled by the means of a lead pipe, standing in a cooling apparatus, the water for cooling being kept always lukewarm. The product of distillation is divided into three qualities: No. I. from the beginning of the distillation to 0.865 specific gravity. No. II. from 0.865–0.900 specific gravity. No. III. from 0.900–1.080 specific gravity.

"The produce No. I. is mixed with sulphuric acid and hydrochloric acid, at a temperature of 25° centigrade. Three hours afterwards the oil is taken off and washed with a solution of caustic soda, at 60° centigrade: it is left two hours, and then separated from the solution and distilled. In the still is mixed a concentrated solution of soda. After the distillation the oils are light yellow, and give an average weight of 0.815–0.825 specific gravity. To correct the smell I wash the oils again with sulphuric acid and hydrochloric acid, separate them from the solution, and wash with concentrated solution of soda.

"The oil No. II. is treated the same as No. I., but with different quantities of acids, and at a temperature of 85° centigrade. The product, after the distillation, is a lighter oil.

"The oil No. III. is the product for the preparation of the finest oil and paraffine candles. This oil is treated with sulphuric acid and hydrochloric acid, at a temperature of

33° centigrade, and allowed to stand; it is then separated from the acids, and washed with a solution of soda, at a temperature of 60° centigrade, and distilled. The oil contains paraffine, and is taken to a cool cellar at an average temperature of 12° centigrade, where it remains in iron butts for eight days. After this time the paraffine is separated from the oil by means of a centrifugal machine and cast in cakes, and pressed in a cold hydraulic press; afterwards melted and mixed with sulphuric acid, then separated and washed in water; it is then heated and cast in cakes, and again pressed by a heated press; afterwards again melted and mixed with sulphuric acid at a temperature of 70° centigrade; the acid is drawn off, and the paraffine is washed in water, after this it is melted with stearine."

In some instances the retorts are placed in a circle around the chimney, and two of them are heated by one furnace. The gaseous products of the distillation are conducted into a large iron pipe, upon which a stream of cold water plays constantly to produce the necessary condensation. The uncondensed gases escape at the end of the condensing pipe and are lost. The oils and other liquid products of the distillation flow into a cistern, whence they are pumped for purification.

Having been separated from the aqueous products the oils are submitted to the purifying process. Some chemists have the oils mixed with four per cent. of sulphate of iron, in cast iron cisterns, supplied with agitators worked by machinery. Next the charge of oil is distilled, and for this purpose various expedients have been resorted to. Some distil *in vacuo*, others employ common, or superheated steam. The latter obtains the preference, especially for the heavy oils.

The distillate is usually divided into two parts. The first is permitted to run from the still until the specific gravity comes up to 0.870. The second part embraces all the remainder of the distillate. The first part is then agitated four hours with six per cent. of concentrated sulphuric acid, one-eighth per cent. of bichromate of potash, and one-half per cent. of hydrochloric acid. The second part is treated in the same manner, except that the sulphuric acid is increased to eight per cent., with one-sixth per cent. of bichromate of potash, and one per cent. of hydrochloric acid. After the acid impurities, etc., have subsided they are drawn off and the oils are agitated two hours with lye and steam.

The oils are then distilled, great care being taken that they should not "boil over." By this mode lamp oils, heavy oils, and paraffine are produced. The paraffine is put in a cool place and allowed to crystallize in the usual manner.

At Bitterfield the coal is broken into small pieces and distilled in elliptical retorts eight feet in length. The discharge pipe is of large size and opposite the head of each retort. Pressure upon the material while it is undergoing distillation is avoided as much as possible. The purification consists in the alternate use of acids and solutions of caustic alkalis.

Dr. Vohl, of Bonn, commences the distillation of paper coal at a low heat, which is gradually raised up to a red heat, and he remarks that slates containing twenty-five per cent. of water yielded the largest amount of oil. The author has observed the same fact in the distillation of bituminous shales imported to New York from Pictou, Nova Scotia. When the retorts are first charged with those shales, steam is generated from the water contained in them.

With the steam some of the lighter oils are distilled over, and with it condense. The effect is quite similar to that produced by admitting steam into the retort at the commencement of the decomposing distillation. In both instances the quantity of oils is increased.

Brooman's Patent.—Among the lists of patents for the purification of hydro-carbon oils, this patent, which is dated London, February 28, 1856, has been overlooked, with several others of equal importance. The patent is for "improvements in treating bituminous shale, Boghead mineral, and other like schistose bodies, in order to obtain various commercial products therefrom."

The schistose bodies are first decomposed in common retorts. The receiver is placed at some distance from the retorts, and receives through pipes a part of the gas generated in them. Condensation is effected in refrigerating pipes kept cool by water. The oils are treated in agitators, or purifiers with sulphuric acid and caustic soda, and then distilled over again. The light oils are separated from the heavy for illuminating purposes by distilling them down to proof 32° (Gay Lussac's Areometer), all that remains is separated from the paraffine. For this purpose the heavy oil is placed in refrigerators with double bottoms and exposed to a low temperature, by which the paraffine is separated. The remainder is gathered into bags and subjected to pressure, to remove whatever oil it may contain.* The products represented as being obtained by this mode are—

- "1. Essential oil.
- "2. An oil for lighting purposes.
- "3. A fatty, unctuous oil, for lubricating machinery.
- "4. A liquid tar, for lubricating purposes.

* Journal of Gas Lighting (London), Sept. 16, 1856.

"5. A solid tar.

"6. A 'black,' which may be used in the manufacture of printers' ink.

"7. A 'black,' having the properties of animal black.

"8. Paraffine.

"9. Ammoniacal water, containing six per cent. of liquid ammonia."

There is some obscurity in the specification of this patent; still the practical manufacturer will readily understand, from the above, the nature of the process employed.

Bodmer's patent is dated London, February 4th, 1856.*

"Tars are taken which have been produced by the distillation of coal at a *high* temperature, such as are made in the manufacture of coal gas. This tar, being the cheapest at present, is therefore preferred; but tars produced in a similar manner, at a high temperature, from shale, peat, wood, and from bones, or other animal substances, will answer the purpose. These tars are placed in an ordinary still, into which the bulb of a thermometer is placed, and connected with a worm immersed in water; this water is kept regularly at a temperature of between 60° and 80° Fah., throughout all the distillations. The heat of the still is raised by fire; and when the thermometer in it rises to 300° Fah., the instrument is removed, and the products of distillation above 200° are run into another vessel, and kept separate from the products of distillation below 300°. The latter are rejected as unfit for the purpose. The tar is distilled to dryness, which is known to have taken place when products cease to run from the condenser, the heat being always kept up." "The oil obtained from the coal tar is purified as follows: This oil is put into a leaden tank, and to each five hundred gallons is added ten gallons

* *Journal of Gas-Lighting* (London).

of commercial brown sulphuric acid, of strength 140° Twaddle, or about 700 specific gravity, and they are well agitated together for one hour. The vitriol is allowed to subside, which will take place in ten or twelve hours, and is drawn off by a stop-cock placed at the bottom of the tank. Another ten gallons of brown sulphuric acid is then added to each five hundred gallons of the oil, and agitated for four hours. The oil, after subsidence, is removed to an iron vessel, and to each hundred gallons is added ten gallons of a solution of caustic soda, marking 70° Twaddle, or weighing 13½ lbs. to the gallon. These are agitated together thoroughly for ten or twelve hours; and it is preferred to keep the temperature of the oil in this tank up to 80° Fah., both during the agitation with the caustic soda and afterwards, for ten or twelve hours. The clear oil is then removed into a still, and to each hundred gallons is added about 20 lbs. of the soda ash of commerce, 20 lbs. of slaked lime, and four gallons of water, or 40 lbs. of caustic solution of soda, marking 70° Twaddle—or by measure, three gallons, weighing 13½ lbs. to the gallon, are taken for each hundred gallons of oil put into the still, and heat is applied. In general, no oil will come over until the heat of the still has reached 300° Fah.; but if any should come below this temperature, it is rejected. When about eighty per cent. of the oil put into the still has been obtained, the process is stopped. The product of distillation is the improved lubricating oil, which is named 'new tar oil.' It may be used either by itself or mixed with other oils, fats, greases, and soaps."

P. G. Barry places the oils in wooden tanks lined with lead. In these tanks the oils are agitated with five per cent. of their weight of sulphuric acid, during a period of three hours. After the acid and impurities have settled,

the oils are drawn off into a second purifying vessel, and there agitated with five per cent. of their weight of caustic alkali, or with lime water sufficient to remove all the acid present in them. After the alkaline mixture has subsided the oils are again distilled.

Bancroft obtained an English patent for the distillation of hydro-carbon oils from the petroleum of Burmah. He admits high pressure steam at fifty lbs. to the square inch into his stills, and places a fire beneath them until all the eupion is distilled over. This part of the distillate being removed, the fire beneath the still is increased, and the steam forced on, until about ninety per cent. of the charge is distilled off. At the close of the operation much paraffine appears, which renders it necessary that the condensing pipes should be kept at a temperature not less than 90° Fah. In several instances the cooling down of the condensing apparatus has led to the bursting of the still.

A process is recorded in *Le Genie Industriel*, and represented as being the invention of Messrs. Dumoulin & Cotelte, by which the heavy coal oils are made to burn in lamps without smoke or odor. In a close vessel they place one hundred lbs. of *crude* coal oil, twenty-five quarts of water, one lb. of the chloride of lime, and one half lb. oxide of manganese. The mixture is thoroughly agitated. After a repose of twenty-four hours the clear oil is decanted and distilled. Next the one hundred lbs. of coal oil are mixed with twenty-five lbs. of rosin oil, and this is considered the best part of their mode. This last mixture may be distilled if necessary. From the high per centage of carbon in the heavy coal oil, and also in the rosin oil, it will appear theoretically that this mixture cannot burn without smoking in any of the ordinary coal oil lamps, and this is found to be the fact in practice. In an argand lamp

with a short-topped wick, and a button over the inner air tube, or in the camphene lamp, the above oil will burn with a short flame and brilliant light, and so also will the rosin oil, or the heavy oil, mixed or unmixed; but those lamps are rapidly falling into disuse, being supplanted by the kerosene, or coal oil lamp.

It has been already stated that upwards of one hundred patents have been granted for alleged new methods of manufacturing and rectifying oils distilled from coals and other bituminous mineral substances; and upwards of forty patents have been issued for retorts and other apparatus connected with this branch of industry. A description of the various methods and similarities of operation, with the extraordinary and unphilosophical fancies set forth in some of those patents, would not interest the practical man nor the general reader. The extracts drawn from the foregoing patents have therefore been deemed sufficient for this brief technological treatise, and to direct the manufacturer of oils to the valuable discoveries now placed at his hand.

The preceding part of this chapter will have shown that upon a few leading, and, as it is supposed, essential operations, all the patentees appear to agree. Upon non-essentials they differ as widely as persons do in matters of far higher importance.

It is conceded at the present time—

1st, That the crude coal, or other material, must first be submitted to dry, or decomposing distillation, and that a moderate degree of heat will produce more and better oils than a high temperature.

2d, That the use of a strong acid is necessary in the purification of such oils.

3d, That the acid must be succeeded by the use of an alkali.

4th, That it is necessary to distil the oils after the use of the acid and alkali.

It will be perceived by the foregoing extracts, from patents for the manufacture and purification of oils, that distillation, acids, and alkalies, form the basis of every alleged invention; but upon the quantities, the modes of application, and the minor details of working, there is much disagreement; and persons unskilled in chemical science have frequently introduced some peculiar mode in the application of those agents, to give novelty to their patents, or to satisfy their employers of their superior skill.

The oils from different coals require different treatment. The oils of Albert coal (asphaltum), Boghead and Breckenridge coal are easily purified; while the oils from the ordinary American, English, and Scotch cannel, require more skill, and cost more to bring them up to a fair standard among the hydro-carbons sold in the market.

The author has made more than two thousand experiments in reference to the manufacture and purification of oils distilled from coal, petroleum, and other materials. From long practice, and the improvements introduced by others, he ventures to lay the following plan before his readers, as being generally applicable to the distilled oils of coal and bitumen. Petroleum will be noticed in the sequel. Regarding the purification of those oils, the present is the age of experiment. Improvements are constantly advancing, and some time may elapse before their manufacture is brought to perfection, and the distilled hydro-carbon oils attain that commercial and economic value they are destined to reach.

CHAPTER VII.

Buildings and Machinery.—Method of Manufacturing and Purifying the Oils distilled from Coals and other Bituminous Substances, and the Products derived therefrom.—Distilling by Steam.—Continual Distillation.—Paraffine.—Lubricating Oils.

DISTILLERY FOR COAL AND PETROLEUM OILS.

BEFORE any suggestions are made in reference to a proper mode of manufacturing and purifying the hydro-carbon oils, the construction and arrangement of the manufactory itself require some notice. It is very desirable, in all cases, that the buildings constituting the establishment should be constructed of stone or brick, with iron roofs. The occupation of wooden buildings is unsafe; when they are employed, great care is necessary. Every preservative against fire, by the use of non-combustible material and the command of water, should be planned for at the onset of construction.

When coal is to be distilled in retorts, the retort house should be separated from the distillery, or refining house, and all crude materials and marketable oils should be kept in separate stores, away from the operating part of the establishment. Receivers of the products of the retorts are advantageously situated underground. A steam pump, communicating with cisterns of water, and supplied with hose capable of reaching every building, should be always ready for action, while at the same time it performs the offices required by the manufactory.

Between the stills and the several worm-tanks and

receivers it is necessary to erect a strong brick or stone wall, through which the connecting pieces between the stills and the worms pass. It is also desirable to separate the stills one from the other by partition walls. During the distillation, and especially at its commencement, a light hydro-carbon vapor frequently escapes at the lower extremity of the condensing-pipe. This vapor is highly inflammable, as well as the lighter oils that accompany it. No fire should, therefore, ever be permitted in the body of the refinery.

The agitators should be placed at convenient heights to permit the oils to flow from the acid cisterns into the tanks where they are to be washed with the alkali, and to run thence into the stills. A good arrangement of the machinery is of much consequence; and, above all, the most rigid cleanliness should be observed in every operation connected with the manufactory. An abundant supply of clean, fresh water is absolutely necessary.

The plan and sections (pp. 110-111) represent approved arrangements of the building and apparatus of a coal oil or petroleum distillery.

Coals.—The crude oils distilled from coals differ greatly in yield and in quality. It will be observed in the table given in a preceding chapter, that a few varieties will produce over a hundred gallons per ton. Some cannels will not yield over fifty, and others thirty gallons per ton. The qualities of the crude oils also differ. Some afford large quantities of paraffine, or heavy oil, and but a small percentage of lamp oil. Others yield much eupion. In the purchase of coal lands, or coal for the manufacture of hydro-carbon oils, an accurate test of the coal is necessary. Coal oil works have been erected at coal mines, where the coal itself is almost worthless for oil-making.

110 DISTILLERY FOR COAL AND PETROLEUM OILS.

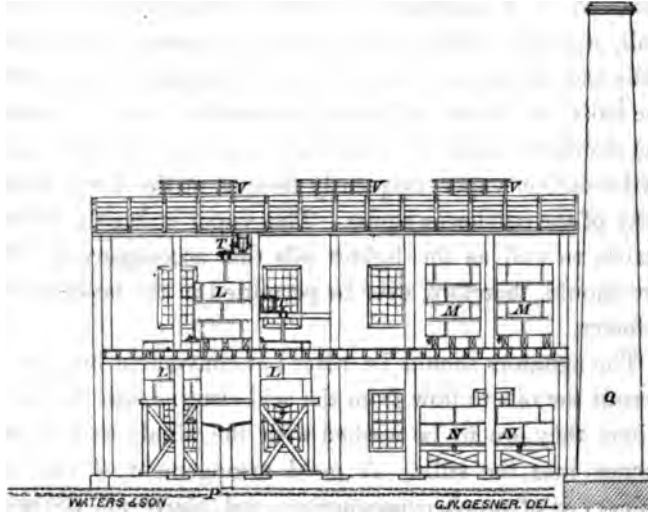

SECTION ON LINE C-D OF PLAN.

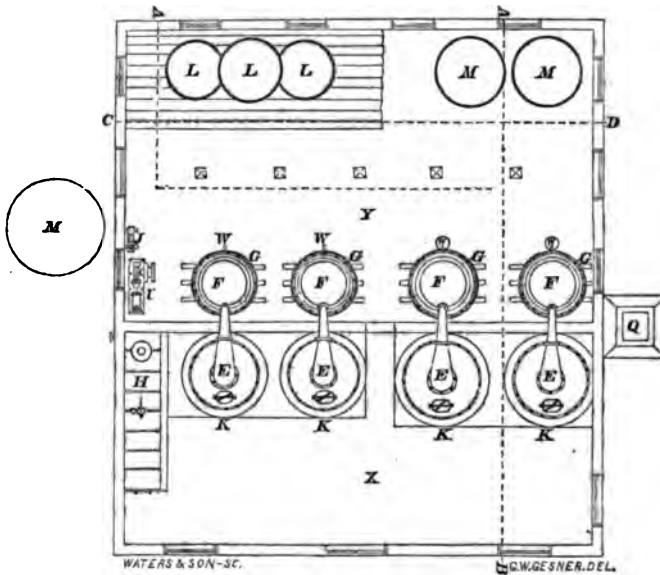

COAL OIL REFINERY PLAN.—600 GALS. CAPACITY PER DAY.

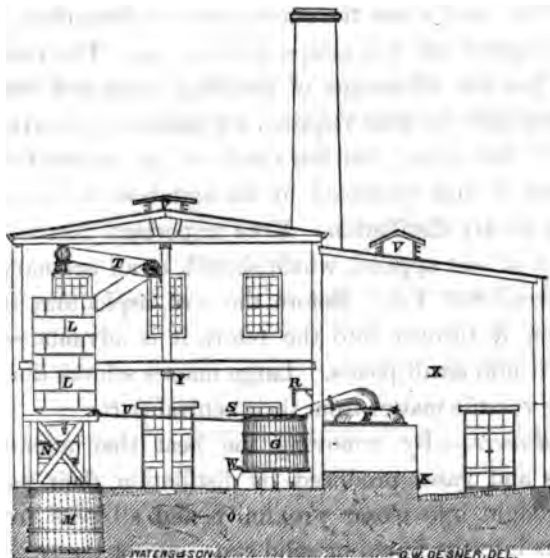

SECTION ON BROKEN LINE A-B OF PLAN.

REFERENCES.

- | | |
|---------------------------|-----------------------------------|
| E. Stills. | P. Drain. |
| F. Worms. | Q. Chimney. |
| G. Worm tanks. | R. Water pipe. |
| H. Boiler. | S. Steam pipe. |
| I. Engine. | T. Washer gearing. |
| J. Steam pump. | U. Pipe from agitators to stills. |
| K. Still furnace. | V. Ventilators. |
| L. Washers, or agitators. | W. Tall pipes. |
| M. Receivers. | X. Still house. |
| N. Market tank. | Y. Refinery. |
| O. Syphon of still pipe. | |

Bitumens.—The preceding remarks are also applicable to asphaltums and bitumens. The tars of candle manufactories also give different results, and yield some heavier and some lighter oils.

Retorts.—Different retorts also produce different results. When the discharge-pipe is high, there will be less crude oil; but the oil will be lighter and purer. Pressure upon the charge and its vapors during distillation will diminish

the yield; and where the condensation is imperfect, a part of the lighter oils will escape with the gas. The revolving retort has the advantage of distilling coals and shales in less than half the time required for stationary retorts. The yield is also large; but the crude oil is impure from the quantity of dust produced by the agitation of the material during its dry distillation. More important than all is the amount of heat applied, which should, as an ordinary rule, not exceed 800° Fah. Before the coal, asphaltum, or any bitumen is thrown into the retort, it is advantageous to break it into small pieces. Large masses seldom discharge all the volatile matter from their central parts.

Condensers.—By removing the heat that attends the vapors and gases produced by distillation, their particles are brought into closer proximity, and all pass from the gaseous into the liquid or solid state, except the permanent gas, which is incapable of condensation by ordinary means. Condensers are usually metallic worms immersed in water, which is kept at the desired temperature by the admission of cold water. It is quite immaterial whether the condenser is a long metallic pipe, a series of pipes, or an open chamber, if it be of sufficient dimensions, and kept at a low temperature.

Receivers—at coal oil manufactories—are tanks, usually sunk in the earth, to allow a descent of the oils from the condensers. They should be closely covered, to prevent the evaporation of the lighter oils, which, in warm weather, is very rapid. The gas which remains uncondensed should be conveyed to a gasometer, and there stored for fuel, or it may be purified in the manner of ordinary coal gas, and employed for lighting. In general the gas is allowed to escape, especially where fuel for the manufactory is cheap. It is admirably adapted to the distillation

of oils, and, with proper burners, a high degree of heat may be obtained.

Precipitation or settling.—With the crude oils that flow into the receiving tank there is always a quantity of water, or ammoniacal liquid combined with some carbonaceous matter and other impurities. When the coal, or other material distilled in the retorts, is very moist, the water in the receiver will sometimes amount to twenty per cent. of the distillate. To remove those impurities it is most advantageous to pump the whole into a second receiver, or tank, which should be elevated a little above the working level of the stills it is designed for.

The crude oils and their impurities should next be heated up, by means of a steam coil placed in the bottom of the tank, to 90° or 100° Fah. The ammoniacal water and the impurities soluble in water will then settle, and may be readily drawn off.

Ammonia.—When the ammonia present in the water is sufficient in quantity to pay the cost and a profit upon its separation, it may be neutralized by the application of sulphuric or muriatic acid, and the solution evaporated to obtain sulphate, or muriate of ammonia, or it may be profitably employed in combination with other manures for a fertilizer. The carbonaceous matter that forms a stratum between the crude oils and the water is worthless unless it be used in the preparation of artificial fuel.

TREATMENT OF THE CRUDE OILS.

The crude oils, being separated from their impurities, may at once be submitted to chemical treatment; but as a general rule, and especially when they are heavy and con-

tain much tar, they should be first distilled. This distillation is made in a common iron still, protected from the action of the fire by fire brick, which equalizes the heat, consequently the expansion of the metal, and lessens the risk of fracture.

DISTILLING BY THE AID OF STEAM.

The "charge" of oil prepared as above, may be run into the still and distilled without the use of steam. But when it has been "run off" to four fifths of the whole quantity, or when the part remaining in the still will be a thick pitch when cold, common steam should be gently let into the neck, or breast of the still. The steam immediately produces an outward current through the condensing apparatus and brings over all the remaining part of the oils, leaving a compact coke as the only residuum. Furthermore, it gradually diminishes the heat of the iron and prevents it from breaking. When the steam is thus let in, the fire is to be removed from beneath the still.

Common steam under moderate pressure has been introduced into stills, both above the charge and into it throughout the entire distillation. In the latter instance the steam soon becomes superheated after the lighter oils have been run off. Again, steam previously superheated is driven into the charge during the distillation, and for the distillation of the heavy oils and paraffine this mode has the preference; yet steam is advantageous however applied. When it is superheated the condensing apparatus should be extensive to meet the increased heat.

Continual Distillation.—In the first distillation of the crude oils, as they come from the retorts, and in subsequent ones, the oils may be slowly admitted into the still after it

has become sufficiently heated and the oils begin to flow freely from the worm, or condenser. By the adjustment of a cock, a stream of the crude product may be permitted to flow through an iron tube into the still while it is in operation. The tube should dip beneath the oil in the still, the in-flow of oil into which must not exceed the out-flow from the condenser. A greater amount of heat will be required for this operation than for the common method, as much of it is taken up by the cold oil constantly flowing inwards. By this mode a still working 1000 gallons may be made to run double that quantity without interruption, and steam may be applied in any manner before described.

The first distillate.—The first distillate of the crude oil should be separated into two parts, each of which requires somewhat different treatment. The first part is that which distils over from the commencement of the run until the oils in the receiver have a proof of 36° by hydrometer,* or a specific gravity of 0.843.

These light hydro-carbons and the eupion they contain form the lamp oil. The quantity produced will depend upon the quality of the coal, or other material, whence they have been derived. This part of the distillate being pumped from the receiving tank, or otherwise removed, the remainder, or second part, is allowed to flow on until it assumes a greenish color at the end of the worm pipe, when steam, if not previously employed, may be let into the still and continued until the whole distillation is completed; the fire in the furnace beneath the still being withdrawn. A quantity of coke will be found to remain, amounting to ten or fifteen per cent. of the whole charge. This coke is excellent fuel, and after all its volatile matter has been expelled it may be employed in the clarification of sugar.

* See note A, Appendix.

When steam is not employed the residuum in the still must not be run down lower than a thick pitch. Coking in the still without steam is unsafe and hazardous to the iron.

The first part is then to be placed in an iron cistern and therein thoroughly agitated from one to two hours, with from four to ten per cent. of sulphuric acid, the object being to bring every particle of the impurities in contact with the acid. The quantity of acid to be used depends upon the character of the oils and the coal, heat, &c., employed in the retorts.

If too much acid is applied the oils will be partially charred and discolored; if too little, the impurities will not be oxidated, and the oils will change color. After the agitation of the oil and acid is completed, the mixture must remain at rest from six to eight hours, when the acid, with the chief part of the impurities, will have settled to the bottom of the vessel. They are then to be drawn off, and the remaining oil to be washed with ten or twenty per cent. of water. The water removes a part of the remaining acid, and carries off the soluble impurities. The acid now appears in the form of tar, and may afterwards be separated from the impurities for further use. After the water is withdrawn the charge is to be agitated two hours with from five to ten per cent., by measure, of a solution of caustic potash, or soda of specific gravity 1.400. The hydrates of those alkalies may be used in the same manner; but the solution of caustic soda is generally preferred. Like the acid, the strength and quantity of the alkali must be varied according to the quality of the oils. After a repose of six hours or more, the alkali is to be withdrawn from the oil, and any further impurities rendered soluble, by its application, washed out with water. After the use of the water the oil should be perfectly neutral. When the water is

withdrawn from it, it is to be run into a still for final rectification. Should any acid still remain in the charge, it may be distilled over two or four per cent. of the alkaline solution, or an equivalent quantity of lime, or soda ash with or without water. During the whole of these operations the oils and the several washes applied to them are to be kept at a temperature not lower than 90° Fah. This is conveniently done by means of steam coils fixed at the bottoms of the tanks in which the agitations are made. The agitator employed may be of any kind, if its action is efficient. Finally the oil is to be carefully distilled, with or without steam. A small quantity of the lightest product or eupion, which comes first from the condensing worm, is usually discolored, and may therefore be transferred to the succeeding charge.

The last distillation should be made slowly and with care, avoiding all fluctuations produced by an unsteady heat. If desired, the eupion may be taken off at the commencement of the distillation. It should be at proof 60°, or specific gravity, 0.733, or it may be allowed to run in with the lamp oil. When the distillate has reached proof 40°, or specific gravity 0.819, the remainder is to be transferred to the next charge, or the heavy oil, as being too dense for illuminating purposes.

The mixed oils intended for lamps have their disagreeable odor chiefly removed by allowing them to remain in flat open cisterns over weak solutions of the alkalies during a period of some days. Light also improves their color. The alkalies employed in the foregoing treatment may be restored and used in subsequent purifications.

The oils of the second or heavy part of the first distillate are purified by the same means as described for the lighter oils, except that they require the application of

more acid and stronger alkalies. All the oils distilled from them at proof 40° are to be added to the lamp oils. At the close of each distillation, and as the oils acquire greater density, the color grows darker and changeable, finally they are partially charred, and especially when they have been distilled without steam. These dark-colored oils may always be renovated by the use of acids and alkalies, the permanganates of potash and soda, and, finally, by distillation. The color of the lamp oils should not exceed a tinge of greenish yellow, when viewed in a clear glass flask six inches in diameter. If by accident, carelessness, or negligence, the oils treated by the foregoing method should be impure, they must be submitted to washing and redistillation.

Paraffine.—In general all the oils below proof 35° contain more or less paraffine; below 30° the paraffine is still more abundant. When the whole process has been well conducted those oils are to be placed in tanks in cool situations (thermometer at 40° and lower); the paraffine will then crystallize on the sides of the tanks, in beautiful white silvery scales, from which the still liquid oils may be withdrawn. The paraffine, in a solid state, may then be removed, and submitted to powerful presses to get rid of a further portion of the oil. It is purified at last by agitating it while melted with one half or more of its weight of sulphuric acid. The acid is then washed out with hot water and solutions of the caustic alkalies. It is again pressed, and finally melted and cast into masses, or run into candles.* The heavy oils, and those which drain from the paraffine, are excellent lubricators. They may be mixed with animal oils when it is desirable to give them greater consistence. As they do not readily oxidate when exposed to

* See Knapp's *Applied Chemistry*. Vol. I, p. 382. London, 1855.

the air, they are peculiarly applicable as lubricants. The *gumming* complained of by machinists arises from the oxidation of the oils they have heretofore employed to relieve friction.

These heavy hydro-carbons, and even the solid paraffine itself, may be decarbonized and rendered suitable for lamps. Just in proportion to the amount, or number of the equivalents of carbon withdrawn from them, so are their boiling points lowered and their specific gravities diminished. The author is disposed to the belief that hydrogen is a volatile metal, of which the oils before described are carburets.

PURIFICATION OF PETROLEUM OILS.

An almost colorless naphtha arises from the earth at Baku, on the border of the Caspian Sea, accompanied by hydro-carbon vapors, which are collected and used for heating and lighting. It is also used in lamps in its natural state. A single distillation renders it quite pure. From the presence of paraffine the Rangoon petroleum is nearly of the consistence of butter at the ordinary temperature. It has been treated with sulphuric acid and the alkalies, in the manner recommended for coal oils. The paraffine, which was first discovered by Mr. Faraday, is also treated with the acids, and then submitted to pressure. Much of the Persian oil is colorless, and is consumed in lamps without purification.

The petroleums of South America and the West India Islands often contain much sulphur, and their odor is very offensive. In examining some of the now almost inactive and extinct volcanoes of the West Indies, the author observed that the petroleums of volcanic districts were

much more offensive than those of undisturbed localities. Boiling mud with steam issues from the earth on the shores of Trinidad, and raises itself into conical mounds, sometimes fifty feet high. The petroleum at those places has an intolerable odor, and contains sulphuretted hydrogen. Gold is immediately tarnished by the gases of these sulphurous districts. All these natural hydro-carbon oils require active treatment to render them unobjectionable for domestic purposes. The alternate use of acids and alkalies has been found the most effectual in their purification.

The petroleums of the United States, of which great quantities are now obtained, differ much in their densities or proofs. Some of the wells in Venango County, Pennsylvania, afford oils of specific gravity 0.800. In other parts of the oil region the petroleums have densities of 0.850, and even 0.900. Indeed these heavy semiliquid hydro-carbon compounds sometimes pass into compact bitumen, an example of which may be seen in Jackson County, Kentucky, and at other places.

These deposits of solid bitumen have probably been produced by the evaporation of the lighter hydro-carbons, and by the oxidation of those beds which now appear like the sites of ancient lakes. They are quite different in their origin and characters from the injected masses of solid asphalte discovered in Ritchie County, Virginia, and in Albert County, in the Province of New Brunswick.

From the great difference in the densities of those petroleums, there is a great difference in regard to their value and their treatment in the process of purification. Of the lighter oils ninety per cent. of pure oil for illuminating purposes may be obtained; but of the more dense varieties, and those which contain much tarry matter, not more than forty or fifty per cent. of lamp oil is at present produced.

The result has been the same as that in the manufacture of coal oils. Large quantities of the heavy oils, and impure paraffine, accumulate in the distilleries, and will continue to increase until a cheap and successful process is discovered for their decarbonization.

The methods practised by persons engaged in refining the American petroleums are as different as those in use for the purification of the oils distilled from coals. Some employ acids and alkalies in the manner previously described, others use alkalies alone, and steam is applied at various degrees of heat. Some of the oils produced by those means are of good quality, others are inferior, and do not ascend the wick of the lamp in sufficient quantities to afford a constant light. In others the illuminating principle, by some change effected on the carbon, is partially destroyed, and in almost all the odor is disagreeable. The oils from some of the wells contain traces of chloride of sodium, others carbonate of soda in quantities sufficient to affect their treatment. The denser oils, or those which contain too much carbon to admit of being consumed in lamps without smoke, are excellent lubricators, either mixed or unmixed with animal oils.

It will be perceived by the foregoing statement that it would be a difficult task to prescribe a mode of purification to meet the requirements of the oil refiners. Neither the petroleums, nor the oils distilled from them, contain creosote, or cabolic acid, and other impurities which contaminate the oils distilled from coals and coal shales; their purification is therefore simple and comparatively cheap.

When the proof of the oil is not below 38° , distillation with water, or by the use of steam, will most frequently render the lamp oil of good color, and its illuminating properties will be of the highest order. Before the heavy oils,

or those below proof 38°, are submitted to any treatment, it is necessary to give them a preliminary distillation, by the aid of common, or superheated steam, and the distillate should be separated into two parts, all below proof 38° being set aside to be treated for lubricating oil, and a farther portion to be added to the illuminating oil. Washing the lighter part of the charge with a solution of caustic potash, or soda of specific gravity not exceeding 1.400, is useful. A final distillation over a weak solution of either of those alkalies will generally render the oil pure. The heavy parts of the oil may require agitation with equal parts of sulphuric acid and water, followed by an alkaline wash and then distillation. It is only the most impure oils and those from the wells of certain localities that require the use of acids, which, like the strong alkalies when used in excess, greatly impair the illuminating properties of these hydro-carbons. The lighter the oils the lighter will be their color. At proof 45° they are colorless. At proof 42° coloring matter begins to appear in the distillate, and continues to increase until the charge is exhausted. In order to present the lamp oil of a light color some refiners have sent it to market at proof 45°; but it should be understood that such oils are much more inflammable and liable to explode than those at proof 40°. Color in this instance should be sacrificed to safety. The offensive odor of these oils is removed by the means laid down for the deodorization of coal oils. A valuable property of all the before-mentioned oils, consists in the fact, that they never become rancid nor ferment. Indeed they are improved by age, and gradually lose their unpleasant odor.

It is unnecessary to enlarge upon the national advantages which must evidently result from the manufacture of oils from mineral substances. Some of the uses to which those

oils may be applied have been noticed. Doubtless there are others to be discovered. The light afforded by the hydro-carbon oils is equal to that of gas, and in an economical point of view it is unrivalled.

REFUSE OF OIL MANUFACTORIES.

In the early operations of manufactories, and more especially when their chemists have not had the advantages of experience, residual and resultant products are frequently overlooked, attention being directed altogether to the staple articles called for in the market. This remark is peculiarly applicable to coal and petroleum oil manufactories. In the United States, at the present period, vast quantities of pitch, heavy oils, and other valuable refuse products are permitted to flow into creeks and rivers, being considered worthless. It is to those products the manufacturer should direct his care and attention. To their careful use he will have to look ere long for no small part of his gains. Competition will ultimately reduce the actual profits to be made upon the oils themselves within narrow limits, and success will only be awarded to economy and superior manufacturing skill.

The products here referred to are, *gas, coke, ashes, ammoniacal water, impure sulphuric acid, impure alkalies and pitch.*

Gas.—From the numerous coal oil works now in operation, thousands of cubic feet of carburetted hydrogen gas are daily evolved and wasted in the atmosphere which they contaminate. This gas might be collected and stored in gasometers for the supply of light to towns and villages. An exhausting pump placed between the main and the gasometer would relieve the pressure of the retorts and

readily force the gas in any required direction. Its purification could be made in the usual manner. It is to be admitted that this gas would be inferior for illumination to that usually supplied to cities; but its deficiency in quality could be made up in quantity, and the price at which it could be afforded would remove every objection to its use.

At situations where coal, or the supply of coke, is insufficient, the gas may be most advantageously employed for producing steam, and for all the distillations required in making and purifying the oils. For those purposes it is superior to any other kind of fuel, as the heat may be increased or diminished instantaneously at the will of the operator. For heating, the gas requires no purification, and recent improvements in producing heat by this agent will supply the highest temperature required.

Coke.—When the coal employed affords a good coke it is used for fuel; the coke of Boghead coal and the bituminous shales is of little value. Some of the asphaltums and bitumens afford a small residue of fuel.

Ashes.—Ashes collect around oil manufactories in large quantities, and they differ in their composition according to the nature of the coal consumed. In all cases where they contain any considerable percentage of lime, they will be found valuable fertilizing agents for certain soils.

Ammoniacal water.—Whenever nitrogen enters into the composition of the coal, shale, or other material distilled in the retorts, ammoniacal water will be one of the products, and upon it the lighter oils will repose in the receiving-vessels. The quantity of ammonia is often very considerable.

Sulphate of ammonia.—To prepare the sulphate of ammonia from the crude ammoniacal water, the latter is to be saturated with sulphuric acid, and evaporated in a cast-iron

boiler. The saturation may be made in a leaden vessel, and the evaporation performed by steam. When the liquid has attained a specific gravity of 1.400, or thereabouts, it should be run into a vessel lined with lead, and crystallized. Another mode consists of distilling the ammoniacal water, and conducting the distillate into a solution of sulphuric acid of spec. grav. 1.700. In this case the sulphate of ammonia is precipitated, and may be dipped out with ladles.

Chlorohydride of ammonia (sal ammoniac).—To form the sal ammoniac of commerce, the ammoniacal water is to be saturated with hydrochloric acid (muriatic acid). It is usually evaporated in vessels of lead, and then run into wooden coolers. The salt is then to be dried in stoves, and finally sublimed in iron pots with large domes. Some days are required to complete the last operation.

Sulphuric acid.—The sulphuric acid employed in the purification of coal and other distilled oils frequently contains half its bulk of impurities, oxidated and charred by the acid. This tarry liquid is now very generally discarded from the manufactories as a worthless and offensive article. Thousands of tons of acid that might be purified for further use are thus annually lost. After the acid has performed its office as a purifier, it should be placed in tanks lined with lead, where, by repose, from two to five per cent. of oil will rise to its surface, whence it may be removed and economized. The acid may be purified by distillation in glass, or platinum stills; but a cheaper and more convenient method of restoring it to its first state is worthy the attention of chemists.

Very great quantities of the solution of caustic alkalies are employed in purifying coal and petroleum oils. At present those washes, as they are called, are permitted to

run to waste. Frequently they are partially neutralized by the acid that preceded them in the purifying process. When these solutions are strongly alkaline, they may be submitted to evaporation and crystallization for further use, the impurities which float upon them being removed. If they have been nearly neutralized by the acid taken up from the oil, the neutralization should be completed by the addition of more acid, when they will form sulphate of soda, or sulphate of potash, as one or the other alkali has been employed. These alkalies are excellent fertilizers, when they are combined in compost with peat or other organic substances.

Pitch.—In the first distillation of the crude oil, and in subsequent ones, where steam is not employed, it is not convenient to run the charges down to dryness, whereby the stills are more or less endangered; and when the distillation of the paraffine is not considered important, the charges are run down to a thick pitch, which, when cold, is an artificial asphaltum. This pitch is very useful for many purposes. It may enter beneficially into the composition of waterproof cements, varnishes, and patent fuel. When evaporated down to a proper consistence, it is valuable for roofing. The roof is first covered with sheathing paper, and then with the melted pitch, upon which gravel or sand is thrown immediately, and finally all that remains loose is brushed off. The pitch may also be converted into lamp black, by burning it away from the air, by which the carbon is converted into lamp black, instead of carbonic acid, which would be the result if the air was freely admitted to the combustion.

APPENDIX.

NOTE a.

SCALE.

A TABLE OF SPECIFIC GRAVITIES OF OILS.

| | Degrees of Hydrometer, Therm. 60° Fah. | Specific Gravity. | Degrees of Hydrometer, Therm. 60° Fah. | Specific Gravity. | Degrees of Hydrometer, Therm. 60° Fah. | Specific Gravity. |
|----|--|-------------------|--|-------------------|--|-------------------|
| | GESSER. | | | | | |
| 70 | 0.696 | | 49 | 0.778 | 28 | 0.881 |
| 65 | 0.700 | | 48 | 0.782 | 27 | 0.886 |
| 60 | 0.704 | | 47 | 0.787 | 26 | 0.891 |
| 55 | 0.707 | | 46 | 0.791 | 25 | 0.898 |
| 50 | 0.711 | | 45 | 0.795 | 24 | 0.903 |
| 45 | 0.713 | | 44 | 0.800 | 23 | 0.909 |
| 40 | 0.718 | | 43 | 0.804 | 22 | 0.915 |
| 35 | 0.722 | | 42 | 0.808 | 21 | 0.921 |
| 30 | 0.725 | | 41 | 0.813 | 20 | 0.927 |
| 25 | 0.729 | | 40 | 0.819 | 19 | 0.933 |
| 20 | 0.733 | | 39 | 0.824 | 18 | 0.940 |
| 15 | 0.737 | | 38 | 0.828 | 17 | 0.946 |
| 10 | 0.741 | | 37 | 0.833 | 16 | 0.951 |
| | 0.745 | | 36 | 0.838 | 15 | 0.959 |
| | 0.749 | | 35 | 0.843 | 14 | 0.966 |
| | 0.753 | | 34 | 0.848 | 13 | 0.971 |
| | 0.757 | | 33 | 0.854 | 12 | 0.979 |
| | 0.761 | | 32 | 0.859 | 11 | 0.986 |
| | 0.765 | | 31 | 0.864 | 10 | 0.994 |
| | 0.769 | | 30 | 0.869 | | |
| | 0.773 | | 29 | 0.875 | | |

The difference between this scale and that of Baume is nearly five grains (omitting decimals) in the specific gravity of every proof given, or $\frac{4}{10}$ of a degree on the scale.

| Proof by Dr. GESNER'S SCALE. | BAUME'S SCALE. |
|------------------------------|----------------|
| 30° . . . | 29·6 |
| 40° . . . | 38·6 |
| 50° . . . | 47·6 |
| 60° . . . | 56·6 |
| 70° . . . | 65·6 |

and so on for all the other degrees.

| | | Spec. Gr. |
|-----------------------------------|-----|-----------|
| The proof of Eupion is fixed at . | 60° | 0·733 |
| “ Lamp oil . . . | 40° | 0·819 |
| “ Coal tar benzole . | 35° | 0·843 |
| “ Lubricating oil (light) | 28° | 0·881 |
| “ “ “ (heavy) | 20° | 0·927 |

Made by G. TAGLIABUE, 298 Pearl Street, New York.

NOTE b.

The following list comprises a number of the companies and firms manufacturing coal oil in the United States at the present period. There are also fifteen establishments where petroleum only is worked. Doubtless there are others whose names have not been reported:—

| | |
|-----------------------------------|---|
| Aladdin Co., Kiskiminitas, Pa. | Cornell & Co., Canfield, O. |
| Atlantic Co., New York. | Downer Co., Boston. |
| Adair & Veeder, Pittsburgh, Pa. | Dean, Cleveland, O. |
| Anderson, Darlington, Pa. | Empire State Co., New York. |
| Breckenridge Co., Cloverport, Ky. | Excelsior Co., New York. |
| Boston & Portland Co., Boston. | Eureka Co., New York. |
| Beloni & Co., New York. | East Cambridge Co., East Cambridge, Mass. |
| Brooks, Zanesville, O. | Enon Valley Co., Enon Valley, Pa. |
| Covington Co., Covington, Ky. | Franklin Co., New York. |
| Cox, Zanesville, O. | |
| Carbon Co., New York. | |

| | |
|---|--|
| Forest Hill Co., Kanawha, Va. | New York Coal Oil Co., New Galilee, Pa. |
| Falling Rock Co., Kanawha, Va. | Orion Co., N.Y. |
| Great Western Co., Newark, O. | Pinkham, Boston. |
| Greers, Kanawha, Va. | Peasley, Boston. |
| Great Kanawha Co., Kanawha, Va. | Page & Co., Boston. |
| Grasselli, Cincinnati. | Pictou Co., New York. |
| Glendon Co., Boston. | Palestine Co., Palestine, Pa. |
| Hartford Co., Hartford, Ct. | Phoenix Co., Cincinnati, O. |
| Himebaugh & Co., Coshocton, O. | Preston Co., Preston Co., Va. |
| Knickerbocker Co., New York. | Robinson & Co., Perry Co., O. |
| Kerosene Co., New York. | Ritchie Co. (bitumen), Ritchie Co., Va. |
| Preston Co., Va. | Sherwood, Canfield, O. |
| Long Island Co., New York. | Staunton, Kanawha, Va. |
| Lucesco Co., Kiskiminitas, Pa. | Stamford Co., Stamford, Ct. |
| Marion Co., Taylor Co., Va. | Union Co., Maysville, Ky. |
| North American Co., Kiskimini- tas, Pa. | White Day Co., Monongalia Co., Va. |
| New York and Wheeling Co., Wheeling, Va. | Western Co., Cincinnati, O. |
| New Bedford, New Bedford, Mass. | Zephyr Co., New York. |
| | Total, 56. |

NOTE c.

The following table, relating to the cost of Artificial Light, has been extracted from the statement of Dr. Charles M. Wetherill, and published in *The American Gas Light Journal*, May 1, 1860:—

| Illuminating Material. | Cost per lb. or gallon. | Consumption in four hours. | Cost of Light per hour. |
|-------------------------|-------------------------|----------------------------|-------------------------|
| Wax candles (red) | \$0 50 per lb. | 532 grains | 1·068 cts. |
| “ “ (green) | | 458 “ | |
| Paraffine candles, 6's. | 0 60 “ | 567 “ | 1·395 “ |
| Tallow “ 6's. | 0 15 “ | 563 “ | 0·324 “ |
| Sperm “ 4's. | 0 40 “ | 587 “ | 0·984 “ |
| Star “ | 0 25 “ | 636 “ | 0·688 “ |
| Lard oil | 1 20 per gallon | 12·61 ozs. fluid | 2·096 “ |
| Burning fluid | 0 75 “ | 5·09 “ | 0·746 “ |
| Kerosene | 1 20 “ | 3·89 “ | 0·912 “ |
| ADDENDA. | | | |
| Petroleum oil | 1 00 “ | 3·24 “ | 0·860 “ |
| New York coal gas . . | 2 50 per 1000 ft. | 4 feet burner. | 1·000 |

NOTE d.

Of kerosene, or coal oil lamps, there is a great variety in the market, and the weekly list of patents shows that the number is still increasing. A new lamp has just been brought to the notice of the public by HORATIO EAGLE, Esq., 126 Maiden Lane, New York. It produces a brilliant white light without the aid of a chimney.

INDEX.

| | PAGE |
|---|---------|
| Albert coal | 21, 71 |
| Aniline | 68 |
| Agitators | 45, 109 |
| Alleghany coal field | 29 |
| Acids | 90 |
| Alkalies | 90 |
| Action of Sulphuric acid | 90 |
| Action of Nitric acid | 91 |
| Acid, sulphuric, | 116 |
| Ammoniacal water | 124 |
| Ammonia | 113 |
| Anthracine | 67 |
| Ammonia, sulphate of, | 124 |
| Asphaltum | 22 |
| Ashes | 124 |
| Artificial Light, cost of, | 130 |
| Asphaltum, distillates of, | 71 |
| Bitumen of Trinid'ad | 26 |
| " " Cuba | 27 |
| " " Rangoon | 27 |
| " " South America | 27 |
| " " United States | 27 |
| " " Virginia | 32 |
| " " Oils of | 73 |
| " " West India Islands | 74 |
| Baku, Petroleum of, | 74 |
| Burman Territory, Petroleum of, | 74 |
| Bituminous schists | 75 |
| Bituminous Substances, table of products, | 34 |
| Brooman's Patent | 102 |
| Bodman's Patent | 103 |
| Bancroft's Patent | 105 |
| Buildings | 108 |
| Bicarburetted hydrogen | 85 |
| Benzole | 64, 92 |
| Brick ovens | 41 |
| Bituminous sands and clays | 73 |

| | PAGE |
|--|------------|
| Coke ovens | 48 |
| Coal, varieties of, | 12, 13 |
| " Composition of, | 14, 22 |
| " Effects of heat upon | 16, 18 |
| " Boghead | 20 |
| " Albert | 21, 71 |
| " Breckenridge | 23 |
| " Brown | 25 |
| " Table of products of | 34 |
| " Products of the distillation of | 61, 62, 69 |
| Coal field, Alleghany, | 29 |
| Coals distilled for gas and for oils | 70 |
| Candle tar | 24, 76 |
| Caoutchine | 76 |
| Cedriret | 60 |
| Carburetted hydrogen | 85 |
| Chlorohydride of ammonia | 125 |
| Caustic alkalies | 125 |
| Carbolic acid | 68 |
| Canada, bitumen of | 72 |
| Coal oil lamps | 130 |
| Choke damp | 113 |
| Coking furnaces | 47 |
| Crude oils | 109, 113 |
| Condensers | 51, 112 |
| Continual distillation | 114 |
| Copnomor | 58 |
| Coke | 124 |
| Cumole | 66 |
| Coal-tar, volatile bases in, | 61 |
| Coal-tar | 62 |
| Dundonald, Lord, | 8, 15 |
| Densities of Petroleum | 33 |
| Damoulin and Cotellet's method | 105 |
| Distillery | 108 |
| Distilling by steam | 114 |
| Distillation continual | 114 |
| Distillate, first, | 115 |
| Dead oil | 16 |
| Distillation of wood | 57 |
| Dead Sea, bitumen of, | 71 |
| Early records | 8 |
| Effects of heat | 18 |
| Eupion | 58 |
| Formula | 81 |
| Fire damp | 15 |
| Germany, oil manufactories in, | 97 |
| German methods | 101 |
| Gas | 123 |
| Gases of coal mines | 14 |
| Hydro-carbon oils | 83 |
| Hydro-carbons | 84 |

| | PAGE |
|---|---------|
| Hydrogen | 84 |
| Homologous series obtained from coal | 86 |
| " " " " Bitumen of Trinidad | 86 |
| " " " " " " Cuba | 87 |
| " " " " Kanawha coal | 87 |
| " " " " Caoutchouc | 87 |
| Hydrometers | 127 |
| Heat, effects of, | 16, 18 |
| Hales and Watson | 15 |
| Impurities in hydro-carbon oils | 89 |
| Kerosene, process of manufacture, | 94, 100 |
| Kerosene, A, B, and C, | 96 |
| Kerosene Oil Company | 9 |
| Leucoline | 69 |
| List of coal oil Companies | 127 |
| Laurent | 8 |
| Lutidine | 69 |
| Mansfield, Patent of, | 9 |
| Mansfield, Process of, | 92 |
| Naphtha | 119 |
| Nitric acid | 91 |
| Naphthaline | 66 |
| Ovens, brick | 41 |
| Odorine | 71 |
| Organic and homologous compounds | 79 |
| Oils, oxygen, | 78 |
| Oils, hydro-carbon, | 83 |
| Organic compounds, table of, | 79 |
| Oxidating agents | 90 |
| Oils, crude, from coals, | 109 |
| " " treatment of, | 113 |
| Picoline | 68 |
| Petroleums | 120 |
| Paranaphthaline | 67 |
| Petroleum well | 10 |
| Picamar | 58 |
| Patents | 9 |
| Pittical | 60 |
| Peat, products of, | 76 |
| Pyroxanthine | 66 |
| Petroleum of Baku | 74 |
| " Springs | 30 |
| " Density of | 33, 74 |
| Petroleums of the Alleghany coal field | 74 |
| Products of the distillation of wood | 57 |
| Process of Mansfield | 92 |
| " of Young | 95 |
| " for Kerosene | 96 |
| Patent of Wagenmann | 97 |
| Peat Company, Irish, | 76 |
| Permanganate of Potash | 92 |
| Pitch | 126 |

| | PAGE |
|--|----------|
| Precipitation | 113 |
| Paraffine, treatment of, | 118 |
| Purification of Petroleum oils | 119, 121 |
| Paraffine | 69, 67 |
| Receivers | 112 |
| Refuse of oil manufactories | 123 |
| Retorts | 111, 112 |
| Retort, Revolving, | 38 |
| " Vertical, | 41 |
| " Clay, | 45 |
| Reichenbach | 8 |
| Retorts, stationary, | 37 |
| Refinery for oils | 110 |
| Stills | 53 |
| Selligue, patent of, | 92 |
| Sulphate of ammonia | 124 |
| Sal ammoniac | 125 |
| Sulphuric acid | 125 |
| Steam, distillation by, | 114 |
| Toluole | 66 |
| Vohl's process | 101 |
| Volatile bases in coal tar | 68 |
| Wagenmann, patent of, | 97 |
| Washers | 43 |
| Worms, condensing, | 56 |
| Wood, products of the distillation of, | 57 |
| Young, James, patents of, | 9 |

BAILLIÈRE BROTHERS'

CATALOGUE

OF

CHEMICAL BOOKS.

A discount of 10 per cent. will be made off the prices of Books mentioned in this Catalogue on pages 1 to 14, if the amount is sent with the order.

[It is particularly requested that the manner in which books are to be forwarded should be specified on the order. If *by Mail*, ten per cent. must be *added* to the remittance, to cover the cost of postage, which the Post-Office regulations require to be prepaid.]

| | |
|--|-------|
| Accum. Treatise on the Art of Brewing. 12mo. London | 3 75 |
| — Treatise on Gas Lighting. Royal 8vo. London | 3 00 |
| Acken (A.) Arts and Manufactures, illustrated with historical and literary details. 8vo., half calf. London, 1831-45 | 8 00 |
| Aime, (Martin) Lettres a Sophie sur la Physique. 12mo. Paris, 1843 | 87 |
| Ajasson de Grandsagne. Nouveau Manuel complet de Chimie appliquee a la Medecine. 18mo. Paris, 1832 | 87 |
| Ajasson de Grandsagne et Fouche. Nouveau Manuel complet de Physique et de Meteorologie. 2d edit. 18mo. Paris, 1835 | 87 |
| An Explanatory Dictionary of the Apparatus and Instruments employed in the various operations of Philosophical and Experimental Chemistry. 17 Plates. 8vo. London, 1824 | 1 00 |
| Annales de Chimie , ou Recueil de Memoires concernant la Chimie et les Arts qui en dependent. Paris, 1789 to 1815 inclusive. 8vo., et 3 vols. de Tables. 3e Serie, 1816 to 1840, incl. 75 vols., 8vo. et 3 vols. de Tables. 3e Serie, 1841 to ——. Cette serie est en cours de publication. Prix par annee | 11 25 |
| Annuaire de Chimie , comprenant les applications de cette Science a la Medecine et a la Pharmacie, ou Repertoire des decouvertes et des nouveaux travaux en chimie faits dans les diverses parties de l'Europe. Par MM. E. Millon, J. Reiset. Avec la collaboration de MM. F. Hœfer et J. Nickles. 8vo. Paris, 1845-51. 7 vols. | 14 00 |
| Arago. Œuvres completes. — Meteorological Essays. With an Introduction by Humboldt. Edited by Col. Sabine. 8vo. London, 1855 | 5 50 |
| Archambault. Precis Elementaire de Physique. Premiere partie, comprenant la Pesanteur, l'Hydrostatique et la Chaleur, avec 98 gravures intercalees dans le texte. 1854. 12mo. | 1 00 |
| — Deuxieme partie, comprenant l'Electricite, le Magnetisme, le Galvanisme, l'Electro-dynamique, l'Acoustique et l'Optique, avec 142 gravures dans le texte. 1855. 12mo. | 1 80 |
| Arnott (A.) The Smokeless Fire-place, Chimney Valve, and other means, New and Old, of obtaining Healthful Warmth by Ventilation. 8vo. London, 1835 | 1 80 |
| Avogadro. Sul calor Speacico de Corpi Solidi e liquid. 4to. | 75 |
| Barreswil et Davanne. Chimie Photographique, contenant les elements de Chimie expliques par les manipulations Photographiques. Les procedes de Photographie sur Plaques, sur Papier sec ou humide, sur Verres au Collodion et a l'Albumine. La maniere de preparer soi meme, d'employer tous les reactifs et d'utiliser les residus. Les Recettes les plus nouvelles les derniers perfectionnements. La Gravure et la Lithographie. 8vo. 1854 | 1 00 |
| Barreswil et Sobrino. Appendice a tous les traites d'Analyse Chimique, recueil des observations publiees depuis 10 ans sur l'Analyse qualit. et quant. 1 vol., 8vo. Paris, 1842 | 1 75 |
| Barruel (G.) Traite de Chimie Technique appliquee aux Arts et a l'Industrie, a la Pharmacie et a l'Agriculture. Tome 1er. 8vo. Paris, 1856 | 1 75 |
| L'ouvrage aura 6 vols. | |
| Baudrimont (A.) Traite de Chimie Generale et Experimentale, avec les applications aux Arts, a la Medecine, a la Pharmacie, &c., accompagne de 200 planches intercalees dans le texte. 2 forts vol. in-8. Paris, 1844-46 | 4 80 |

| | |
|--|-------|
| Baudrimont (A.) Du sucre et de sa fabrication, suivi d'un précis de la législation qui regit cette industrie, par A. Trebuchet. 9vo., avec 21 fig. Paris, 1841 | 0 72 |
| Becquerel. Traite d'Electricite et de Magnetisme, et des Applications de ces Sciences a la Chimie, a la Physiologie et aux Arts. 3 vols. 8vo., plus planches. Paris, 1856 | 6 00 |
| Ouvrage termine. Il est l'expose des lecons qui sont faites au Museum d'histoire naturelle et au Conservatoire des arts et metiers sur l'electricite, le magnetisme et toutes leurs applications. Chaque volume renferme les applications relatives au sujet principal qui s'y trouve traite. Les figures, dessinees et gravees avec soin, sont intercalees dans le texte. | |
| — Traite de l'Electricite et du Magnetisme. 7 vols., 8vo., avec atlas in-fol. Paris, 1834 | 20 00 |
| — Traite complet du Magnetisme. 8vo. | 2 50 |
| — Elements d'Electro-Chimie Appliques aux Sciences Naturelles et aux Arts. 8vo. Paris, 1818 | 2 00 |
| Becquerel (M. A.) Des Applications de l'Electricite a la Pathologie. 8vo. Paris, 1856 | |
| Bernay (A. J.) First Lines in Chemistry: a Manual for Students. 12mo. London, 1855 | 2 12 |
| — Household Chemistry, or the Rudiments of the Science applied to every-day life. 12mo. London, 1852 | 1 12 |
| Berthier. Traite des Essais par la Voie Seche, ou des proprietes, de la composition et de l'essai des Substances Metalliques et des Combustibles. 2 vols., 8vo. 15 pl. Paris, 1848 | 8 00 |
| Berthollet. Art of Dyeing and Bleaching by Ure. 8vo. London | 3 60 |
| Berzelius. Traite complet de chimie minerale, vegetale et animale, seconde edition française, traduit, avec l'assentiment de l'auteur, par M. Esslinger et F. Hoefler. Paris, 1846-51. Vol. 1 to 6 | 18 00 |
| Ses Gerhardt. | |
| — Rapport annuel sur les progres de la chimie, presente le 30 mars de chaque annee, a l'Academie des Sciences de Stockholm, traduit du Suedois, par Plantamour, 8 vols. 8vo. Paris, 1841 to 1848 | 9 00 |
| — View of Animal Chemistry. 8vo. London | |
| — Use of the Blowpipe, translated by Children. 8vo. London. (Very scarce.) | |
| — Traite de Chimie. Nouv. edit., par B. Valerius. 4 vols., gr. 8vo., avec 8 planches. Half bound, cf. Bruxelles, 1841 to 1844 | 18 00 |
| — Lehrbuch der Chemie. Funfte auflage. Bds. 1-5. Dresden, 1842-48 | |
| Billard. Traite de la fabrication du Platine. 8vo., d'une feuille et quart. Paris, 1855 | 2 50 |
| Biot. Instructions pratiques sur l'observations et la mesure des proprietes optiques appelees rotatoires, avec l'expose succinct de leur application a la chimie medicale scientifique et industrielle. Paris, 1845 | 0 25 |
| — Precis elementaire de Physique. 2 vols., 8vo. Paris, 1825 | 5 00 |
| — Traite de Physique Experimentale. 4 vols., 8vo. Paris. (Very scarce.) | |
| — De la Polarisation de la Lumiere. 1 vol., 4to. Planches. (Scarce.) | |
| Hird (G.) Elements of Natural Philosophy, being an Experimental Introduction to the study of the Physical Sciences. 12mo., cloth | 3 75 |
| Bischoff. Elements of Chemical and Physical Geology. Translated by Paul and Drummond. 3 vols., 8vo. London, 1854-59 | 14 00 |
| Blanchiment. Nouveau Manuel complet du Blanchiment, du Blanchissage, Nettoyage et Degraissage des fils et Etoffes de Coton, Chanvre, Lin, Laine, Soie, etc. 3 vols., 12mo. Paris, 1855 | 1 50 |
| Black (W.) Practical Treatise on Brewing. 4th edit. 8vo. London, 1849 | 3 25 |
| Blanquart (Evrard.) Traite de Photographie sur Papier. 8vo. Paris, 1851 | 1 25 |
| Blowpipe. See SANDRAS, Dr. J. M. | |
| Bouchardat. Opuicules d'Economie Rurale. 8vo. Paris, 1851 | 1 00 |
| Bouquet (J. P.) Histoire Chimique des Eaux Minerales et Thermales de Vichy. Cusset, Vaise, Hauterive et Saint-Yorre; Analyses Chimiques des Eaux Minerales de Medague, Chateldon, Brugheas et Seuillet. 8vo., 3 cartes. Paris, 1855 | 1 75 |
| Boussingault. Rural Economy; in its Relations with Chemistry, Physics, and Meteorology. 2d edition, with notes carefully revised and corrected. 1 vol., 8vo., cloth, bds. London, 1845 | 4 50 |
| Boutet de Monvel. Cours de Chimie, redige conformement aux derniers programmes de l'Enseignement Scientifique dans les Lycees, et a celui du Baccalaureat des Sciences, avec 118 gravures intercalees dans le texte. 12mo. Paris, 1856 | 1 25 |
| Routigny. Base d'une Nouvelle Physique, l'etat Spheroidal. 8vo. 1848 | 1 25 |
| Bowman (J. E.) Introduction to Practical Chemistry. 2d edit. 12mo. | 2 00 |
| Brande. Tables of Chemical Equivalents. 8vo. London | 1 00 |
| — Dictionary of Science, Literature, and Art. 8vo. London | 7 50 |
| — Tables of Specific Gravity and Equivalents. 8vo. | 2 50 |
| — Lectures on Organic Chemistry, as applied to Manufactures, Dyeing, Tanning, &c., &c., arranged by Scoffern. 12mo. London | 2 25 |

| | |
|---|-------|
| Brande (W. T.) Manual of Chemistry. 2 vols., 8vo. London | 18 50 |
| Breisson (A. de). Nouvelle Methode Photographique sur collodion donnant des epreuves instantanees; traite complet des divers procedes. 8vo. Paris, 1853 | 1 00 |
| — Traite Complet de Photographie sur Collodion; repertoire de la plupart des Pro- cedes Connus. 8vo. Paris, 1855 | 1 00 |
| Brewster (Sir D.) A Treatise on Optics. 12mo. London, 1853 | 1 12 |
| — The Stereoscope; its History, Theory, and Construction, with its application to the fine and useful Arts and to Education. 13mo. London, 1856 | 1 62 |
| Brown (A.) The Philosophy of Physics, or Process of Creative Development. 8vo. New York, 1854 | 2 95 |
| Cabart (C.) Leçons de Physique et de Chimie. 8vo., avec 23 planches. Paris, 1854 | 2 30 |
| Cahours (A.) Leçons de Chimie Generale Elementaire, Professees a l'Ecole Centrale des Arts et Manufactures. Avec gravures sur bois intercalees dans le texte, et planches. 2 vols., 18mo. Paris, 1855 | 8 00 |
| Campbell. A practical Text-Book of Inorganic Chemistry, including the preparations of Substances, and their Qualitative and Quantitative Analyses, with Organic Analyses. 12mo. | 1 80 |
| Caoutchouc. Manuels-Roret. Nouveau Manuel complet du Fabricant d'Objets en Caoutchouc, en Gutta-Percha et en Gomme Factice; suivi de Documents Etendus sur la Fabrication des Tissus Impermeables, des Toiles Cirées et des Cuirs Vernis; par M. Pau- lin Desormeaux. 1 vol., 13mo., avec planches. Paris, 1855 | 1 00 |
| Cavendish Society's publications already published: | |
| GRAHAM'S Chemical Reports and Memoirs. Scarce. | |
| GMELINS. Handbook of Chemistry. Vols. 1 to 12, 8vo. | |
| LEHMAN'S Physiological Chemistry. 3 vols. and atlas. | |
| Life and Works of CAVENDISH. | |
| Life and Works of DALTON. | |
| BISCHOFF. Chemical Geology. 3 vols. | |
| Subscription, \$7 per annum. | |
| Chalmers (C.) Thoughts on Electricity, with notes of Experiments. 8vo., cloth. Edinburgh, 1851 | 1 80 |
| Chemical Technology; or Chemistry applied to the Arts and to Manufactures. By Professor Knapp and Drs. Ronolds and Richardson. 3 vols., 8vo. (vol. 1, 2nd edit.), illustrated with 776 woodcuts and 14 plates. London, 1843-55 | 18 00 |
| The vols. can be had separately. | |
| Vol. 1. Fuel and its Applications (Coal, Gas, Oil, Spermaceti, &c.), and their application to purposes of illumination, Lighthouses, &c., Resin, Wax, Turpentine, Peat, Wood, Stoves, &c., &c., in 2 parts, 8vo., with 438 engravings and 4 plates. Price \$9 00. | |
| Vol. 2. Glass, Alum, Earthenware, Cements, &c., &c., Manufacture. 8vo., with 214 engravings and one plate. Price \$4 00. | |
| Vol. 3. On those branches of Chemical Industry, including the production of Food, and related to Agriculture. (Bread, Milk, Tea, Coffee, Sugar, Tobacco, &c.) With 9 engravings and 129 woodcuts. Price \$5 00. | |
| Chemical Society, Quarterly Journal and Transactions of. Vols. 1 to 8, cloth | 19 00 |
| Vol. 9 to 13, Subscription price, \$8 00 per vol. | |
| Chemist (The), or Reporter of Chemical Discoveries and Improvements, and Protector of the Rights of the Chemist and Chemical Manufacturer. Edited by Charles and John Watt. 4 vols., 8vo., cloth. 1844-43 | 10 00 |
| — A Monthly Journal of Chemical and Physical Science. Commencing October, 1853. Price, per year or volume | 8 00 |
| Chertier (F. M.) Nouvelles Recherches sur les Feux d'Artifice. 2me edit., 8vo., avec gravures. Paris, 1854 | 2 25 |
| Chevalier. Recueil de Memoires et de procedes nouveaux contenant la Photographie sur plaques metalliques et sur papier. 8vo., half bound, calf. Paris, 1847 | 0 75 |
| Chevalier (C.) Photographie sur Papier, Verre, et Metal. Galvanoplastie. Catalogue universel explicatif et illustre des appareils perfectionnes. 8vo., avec 3 planches. Paris, 1856 | 0 62 |
| Chevallier. Dictionnaire des Alterations et Falsifications des Substances Alimentaires, Medicamenteuses et Commerciales, avec l'Indication des Moyens de les Reconnaître. 2me edition, 2 vols., 8vo. Paris, 1855 | 8 25 |
| Chevallier, Lamy, and Robiquet. Dictionnaire raisonne des denominations Chimiques et Pharmaceutiques, contenant tous les termes employes en Chimie, &c., &c. 2me edit., tome 1er. Paris, 1856 | 2 25 |
| Chevreul. De la Baguette divinatorie, du Pendule, dit Explorateur, et des Tables Tour- nantes, au point de vue d'Histoire, de la Critique et de la Methode Experimentale. 8vo. Paris, 1864 | 1 25 |
| — The Principles of Harmony and Contrast of Colors, and their Application to the Arts. 12mo., 2nd edition. London, 1855 | 8 75 |
| — De la loi du Contraste simultane des Couleurs et de ses Applications. 8vo., et 4to. Atlas. Paris, 1859 | 12 50 |
| Very scarce. | |

| | |
|---|-------|
| Claudet. Nouvelles Recherches sur la difference entre les Foyers Visuels et Photogeniques. 8vo. Paris, 1851 | 0 50 |
| Clegg (S.) Treatise on the Manufacture of Coal Gas. 4to. London | 9 50 |
| Codex. Pharmacopee Francaise, redigee par ordre du gouvernement, avec appendice therapeutique, par Cazenave. 8vo. Paris, 1857 | 2 50 |
| In half calf | 3 00 |
| Coloriste. Nouveau Manuel Complet du Coloriste, ou Instructions Simplifiees et elementaires pour l'enluminure, le lavis et la retouche des gravures. Nouvelle edition. 18mo., avec 3 planches. Paris, 1856 | 0 75 |
| Colles. Nouveau Manuel de la Fabrication des Colles, comprenant la Fabrication des Colles de Matieres Vegetales, par M. Malpeyre. 12mo. Paris, 1856 | 0 50 |
| Cooley (A. J.) Cyclopedia of Practical Receipts, and collateral information in the Arts, Manufactures, Professions, and Trades; including Medicine, Pharmacy, and Domestic Economy; designed as a comprehensive supplement to the Pharmacopoeia, and general book of reference for the Manufacturer, Tradesman, Amateur, and heads of Families. 3rd edition. 8vo. London, 1856 | 8 00 |
| Cooper (C.) Identities of Light and Heat; of Caloric and Electricity. 8vo. Philadelphia, 1848 | 0 75 |
| Cotte. Observations Meteorologiques. 4to. | 0 60 |
| Coulomb. Methode de determiner l'Inclinaison d'une Aiguille Aimantee. 4to. | 0 25 |
| Crabb (G. A.) Technical Dictionary; or a Dictionary explaining the terms used in all Arts and Sciences. 12mo. London, 1851 | 3 75 |
| Cumming, J. A Manual of Electro Dynamics. 8vo. London, 1827 | 1 50 |
| Cundall (J.) The Photographic Primer for the use of beginners in the Collodion process. Illustrated with a Photographic Picture. 2d edit. 12mo. London, 1856 | 0 31 |
| Cuvier. Analyse de ses Travaux sur la Physique et la Chimie. 4to. | 0 50 |
| Daguin (P. A.) Traite Elementaire de Physique Theorique et Experimentale, avec les Applications a la Meteorologie et aux Arts Industriels. 3 vols. Avec 300 gravures sur bois intercalees dans le texte. 8vo. Paris, 1856 | 6 00 |
| Dalton (John), Life and Scientific Researches of. By W. C. Henry. 8vo. London, 1854 | 3 50 |
| Chemical Philosophy. 2 vols., 8vo. London | 9 50 |
| Daniell (J. F.) An Introduction to the Study of Chemical Philosophy; being a preparatory view of the forces which concur to the production of Chemical Phenomena. 2nd edition. London, 1848 | 3 00 |
| Very scarce. | 7 21 |
| David (H.) Methode de Peinture appliquee uniquement a la Photographie de Portraits. 2nd edit., 8vo. Paris, 1856 | 0 50 |
| Davy (Sir H.) Chemical Philosophy. 8vo. London | 5 50 |
| Account of the Safety Lamp for Miners. 8vo. London | 1 50 |
| See KNAPP'S Technology. | |
| Delamotte (P.) The Practice of Photography: a Manual for Students and Amateurs. With a Calotype Frontispiece. 3d edition revised. 12mo. London, 1856 | 1 37 |
| The Oxymel Process in Photography. 12mo. London, 1856 | 0 30 |
| De la Rive (A.) A Treatise on Electricity in Theory and Practice. 3 vols., 8vo. London, 1858-6 | 23 00 |
| (A.—A.) Traite d'Electricite Theorique et appliquee. 3 vol., 8vo., avec 260 pl. intercalees dans le texte. Paris, 1858-1856 | 6 75 |
| Les nombreuses applications de l'electricite aux sciences et aux arts, les liens qui l'unissent a toutes les autres parties des sciences physiques, ont rendu son etude indispensable au chimiste aussi bien qu'au physicien, au geologue autant qu'au physiologiste, a l'ingenieur comme au medecin; tous sont appeles a rencontrer l'electricite sur leur route, tous ont besoin de se familiariser avec son etude. Personne mieux que M. de la Rive, dont le nom se rattache aux progres de cette belle science, ne pouvait presenter l'exposition des connaissances acquises en electricite et de ses nombreuses applications aux sciences et aux arts. | |
| Desains (P.) Leçons de Physique, a l'Usage des Aspirants aux Baccalaureats et aux Ecoles du Gouvernement. 3 vols. 12mo. Figures intercalees dans le texte | 2 50 |
| Deschamps. Art (l') de Formuler, contenant: les Principes Elementaires de Pharmacie, etc. 1 vol., 18mo., avec 19 figures intercalees dans le texte. Paris | 1 23 |
| Descloizeaux. Memoire sur la Cristallisation et la Structure Interieure du Quartz. 8vo., plus 4 pl. Paris, 1856 | |
| Desonges. Traite de Photographie sur Toile, dernier Perfectionnement. 8vo. Paris, 1855 | 0 75 |
| Disdéri. Manuel Operatoire de photographie sur collodion instantane. 8vo. Paris, 1854 | 0 75 |
| Renseignements Photographiques Indispensables a tous. 8vo., de 3 feuilles. Paris, 1855 | 1 25 |
| Dodd (G.) The Curiosities of Industry and the Applied Sciences. 8vo. London, 1854 | 1 00 |
| Dorure. Nouveau Manuel Complet de dorure et d'argenture par la methode electro-chimique et par simple immersion par M. M. Seimi, de Valecourt, Malpeyre, etc. Nouv. edit., tres augmentee, ornee de figures. 12mo. Paris, 1856 | 0 50 |

| | |
|--|------------|
| Dove (H. W.) The Distribution of Heat over the Surface of the Globe, illustrated by Isothermal, Thermic Isabnormal, and other Curves of Temperature. 4to., with map. London, 1858 | 5 00 |
| Du Bois-Reymond on Animal Electricity, by Bence Jones. 8vo. London, 1859 | 1 75 |
| Duhamel de Monceau. Traite de la Fabrique des Manœuvres pour les Vaisseaux ou l'art de la Cordierie perfectionne. 4to. Paris, 1747 | 3 00 |
| Dubrunfaut. Art of Distillation and Rectification. 12mo. London. (Very Scarce). | |
| Dumas and Boussingault. The Chemical and Physiological Balance of Organic Nature: an Essay. 12mo. | 1 00 |
| Du Moncel (Th.) Projection des Principaux Phenomenes de l'Optique a l'aide des appareils de M. Duboscq. 8vo. Paris, 1855 | 50 |
| — Expose des Applications de l'Electricite. Tome 1er. Notions Technologiques 2me edit. 8vo., avec 8 pl. Paris, 1856. (Cette edition aura deux vols peut-etre meme trois) | 1 25 |
| Dumas (J.) Essai de Statique Chimique des Etres Organises. 2me edit. Paris, 1842 | 1 00 |
| — Memoires de Chimie. Avec 7 Planches. 8vo. Paris, 1848 | 1 50 |
| — Traite de Chimie appliquee aux Arts. 8 vols. and 4to atlas. 8vo. Paris, 1828-46. | 50 00 |
| Very scarce | |
| — Edition de Bruxelles. 8 vols. and 4to atlas | 30 00 |
| Dunn (W.) History of the Steam Jet as applicable to the Ventilation of Coal Mines. 8vo. 0 75 | |
| Duplais (F.) Traite des Liqueurs et de la Distillation des Alcools, ou le Liqueuriste et le Distillateur Modernes, contenant, etc. 2 vols., 8vo. Versailles, 1859 | 3 75 |
| Durand (Fang.) Nouvelle Theorie Physique ou Etudes Analytiques sur la Physique et sur les actions Chimique fondamentales. 8vo. Paris, 1864 | 75 |
| Encres. Nouveau Manuel complet de la Fabrication des Encres, telles que Encres a Ecrire, Chine, de Couleur a Marquer le Linge &c. 18mo. Paris, 1855 | 1 00 |
| Etoffes imprimees. Nouveau Manuel Complet du fabricant d'Ettoffes Imprimees et du Fabricant des papiers peints, par L. S. le Normand. 18mo. Paris, 1856 | 75 |
| Exhibition of 1851 (Lectures on the Results of the Great,) delivered before the Society of Arts, Manufactures, and Commerce (Dr. Whewell, Professor Ansted, and others). 2 vols., post 8vo., each | 2 25 |
| Faraday (W.) Chemical Manipulations, being Instructions to Students in Chemistry. 8vo. London, 1827. (Very Scarce.) | about 7 50 |
| — Experimental Researches in Electricity. 3 vols., 8vo. London, 1849-55. | 18 50 |
| — The Subject-matter of a Course of Six Lectures on the Non-metallic Elements. 12mo., cloth. London, 1858, | 1 75 |
| Fau (J.) Douze lecons de Photographie. Description de procedes simples et faciles, au moyen desquels on obtient, presque infailliblement, des epreuves sur verre et papier. 18mo. | 0 75 |
| Fau et Chevallier. Manuel du Physicien preparateur, ou description d'un cabinet de Physique. 2 vols., 18mo., with an atlas of 98 plates. Paris, 1858 | 3 75 |
| Faucher (L.) Remarks on the Production of the Precious Metals, and on the Demonstration of Gold in Several Countries of Europe. 8vo. London, 1833, | 0 75 |
| Faure (J. J.) Analyse Chimique des Eaux du departement de la Gironde. 8vo. Bordeaux, 1858 | 0 75 |
| Figuer (L.) L'Alchimie et les Alchimistes ou Essai Historique et Critique sur la Philosophie Hermetique. 2d edit. 12mo. Paris, 1856 | 1 00 |
| Franccour (L. B.) Elements de Technologie ou Description des procedes des Arts. 8vo. | 1 25 |
| Francis (G. W.) The Dictionary of Practical Receipts; containing the Arcana of Trade and Manufacture, Domestic Economy, Pharmaceutical and Chemical Preparations, &c. 8vo. London, 1856 | 3 50 |
| Fresenius (Dr.) Instruction in Chemical Analysis. Quantitative. 8d edit. 8vo., cloth. 1860 | 4 50 |
| — Instructions in Chemical Analysis. Qualitative. 5th edit. 8vo., cloth. 1860 | 2 75 |
| Fresenius et Sacc. Precis d'Analyse Chimique quantitative. 18mo. Paris, 1845. (<i>Epuise.</i>) | |
| — Precis d'Analyse Chimique qualitative. 1 vol., 12mo., 8g. Paris, 1847. (<i>Epuise.</i>) | |
| Fyfe (A.) Elements of Chemistry. 8vo. London | 7 25 |
| — Manual of Chemistry. 12mo. London | 2 12 |
| Galloway (H.) The First Step in Chemistry: a New Method for Teaching the Elements of the Science. 2d edit. 12mo. London, 1865 | 1 50 |
| — Manual of Qualitative Analysis. 12mo., cloth | 1 12 |
| — Chemical Diagrams, on four large sheets | 1 75 |
| Galvanoplastie. Nouveau Manuel complet de Galvanoplastie, ou Elements d'Electrometallurgie; contenant l'Art de reduire les metaux a l'aide du fluide galvanique, etc., par Smee. Augmente d'apres MM. Jacoby, Spencer, Eisner, etc. Ouvrage publie par E. de Valenciennes. 2 vols., 18mo. | 1 25 |

| | |
|---|-------|
| Hardy (H. W. H.) Incidental Remarks on some principles of Light; being Part 3 of an Essay on Vision. 8vo. London, 1856 | 1 00 |
| Hardwich (T. F.) A Manual of Photographic Chemistry, including the Practice of the Collodion Process. 2d edition. 12mo, cloth. London | 2 00 |
| Harris (Sir W. S.) Rudimentary Treatise on Galvanism, and the general principles of Animal and Voltaic Electricity. 12mo., illustrated, cloth | 0 50 |
| Hassall (A. H.) Food and its Adulterations. With 150 Illustrations. 8vo. London, 1855 | 8 50 |
| Heath. Photography. A New Treatise, theoretical and practical, of the Processes and Manipulations on Paper and Glass. 8vo. New York, 1855 | 1 00 |
| Hedley (John). Practical Treatise on the Working and Ventilation of Coal Mines; with suggestions for Improvements in Mining. 8vo., cloth | 3 75 |
| Hennah (T. H.) The Collodion Process. 4th edition. 12mo. London, 1855 | 0 30 |
| Henry (W.) Elements of Experimental Chemistry. 3 vols., 8vo. London | 10 00 |
| Herling (A.) Traite de Photographie sur Collodion Sec. 2e edition. 12mo. Paris, 1856 | 0 50 |
| Highton. Treatise on the Electric Telegraph. 12mo. London, 1853 | 0 60 |
| Hinds (Dr. W.) The Harmonies of Physical Science in relation to the Higher Sentiments, with Observations on the Study of the Medical Sciences, and the Moral and Scientific Relations of Medical Life. 8vo. London, 1853 | 0 50 |
| Hofer (F.) Nomenclature et classification chimiques, suivies d'un lexique historique et synonymique comprenant les noms anciens, les formules, les noms nouveaux, le nom et la date de la decouverte des principaux produits de la chimie. 12mo., avec tableaux. Paris, 1845 | 0 75 |
| Hofer. Hist. de Chimie depuis les temps les plus recules jusqu'a nos jours. 3 vols., 8vo. Paris, 1842. (Very scarce.) | |
| Hood (C.) A Practical Treatise on Warming Buildings by Hot Water, on Ventilation, &c. 3d edition. 8vo. London, 1855 | 8 25 |
| Hopkins (T.) On the Atmospheric Changes which produce Rain and Wind. 2d edit. 8vo. | 1 50 |
| Hopkinson (J.) The Working of the Steam Engine Explained by the Use of the Indicator. 8vo. London, 1854 | 1 50 |
| Horsley (J. A.) A Catechism of Chemical Philosophy; being a familiar exposition of the Principles of Chemistry and Physics. 12mo. London, 1856 | 2 00 |
| Houzeau. Physique du Globe et Meteorologie. 18mo., with plates. Brussels, 1854 | 0 66 |
| Howard (Luke.) Seven Lectures on Meteorology. 12mo. London, 1843 | 1 00 |
| Howlett (R.) On the various methods of Printing Photographic Pictures upon paper, with suggestions for their preservation. 12mo. London, 1856 | 0 31 |
| Hunt (Robert). Researches on Light. 8vo. London, 1844 | 3 00 |
| Photography: a Treatise on the Chemical Changes produced by Solar Radiation, and the production of Pictures from Nature. 12mo., clo. London | 1 75 |
| Hur-aux. Histoire des Falsifications des Substances Alimentaires et Medicamenteuses, precedee d'une Instruction Elementaire sur l'Analyse, et suivie des Essais et Analyses Qualitatives pour Reconnaître Instantanement les produits Chimiques usites en Pharmacie, dans les Arts et dans l'Industrie. 1 vol., 8vo. Paris, 1855 | 1 75 |
| Inorganic Chemistry (First Outlines of). 12mo. London | 1 25 |
| Isadore Geoffroy Saint-Hilaire. Lettres sur les Substances Alimentaires et particulièrement sur la Viande de Cheval. 18mo. Paris, 1856 | 0 62 |
| Illustrated Standard Scientific Works (Library of), beautifully printed and illustrated. Original London editions at the price of the Reprints: | |
| Muller's Principles of Physics and Meteorology. With 530 woodcuts and 2 colored engravings. 8vo. | 4 00 |
| Weibach's Mechanics of Machinery and Engineering. Vols. 1 and 2, with 900 woodcuts | 7 50 |
| Technology: or, Chemistry applied to the Arts and to Manufactures. By Drs. KNAPP, ROWLANDS, & RICHARDSON. Splendidly illustrated. 3 vols., 8vo. | 13 00 |
| Quekett's Practical Treatise on the use of the Microscope. With Steel and Wood Engravings. 8vo. 3d edition, with additions | 5 00 |
| Graham's Elements of Chemistry, with its applications in the Arts. 3d edition, with innumerable woodcuts. 2 vols. | 10 00 |
| Fau's Anatomy of the External Forms of Man. For Artists. Edited by R. Knox, M.D. 8vo., and an atlas of 28 plates 4to. Plain, \$6 00. Colored, | 10 00 |
| Nichol's Architecture of the Heavens. 9th edition. Entirely revised. Steel Plates and Woodcuts | 3 50 |
| Mitchell (J.) Manual of Practical Assaying. 3d edition, much enlarged. 8vo. London, 1856 | 5 00 |
| Johnson (J. F. W.) Instructions for the Analysis of Soils, Limestones, and Manures. 2d edit. 12mo. Edinburgh, 1855 | 0 60 |
| The Chemistry of Common Life. 3 vols. 12mo. Edinburgh, 1855 | 3 00 |

| | |
|---|-------|
| Johnson (J. F. W.) Elements of Agricultural Chemistry and Geology. 6th edit. London, 1852 | 2 00 |
| Jourdain. Pharmacopoe Universelle, ou Conspectus de toutes les Pharmacopoes. 2 vols. in-8. 2 edit. Paris, 1840 | 6 25 |
| Joyce (Rev. J.) Scientific Dialogues intended for the instruction and entertainment of young people. 12mo. London, 1852 | 0 75 |
| — Dialogues on Chemistry. 2 vols. 12mo. | 2 75 |
| Jullien. Quelques points de Science dans l'Antiquite. Physique, Metrique, Musique. 8vo. Paris, 1854 | 2 00 |
| Kematz. A Complete Course of Meteorology. With additions by C. V. Walker. 1 vol., post 8vo., pp. 624, with 15 plates., cloth boards. 1845 | 8 00 |
| Kane (Sir Robert). Elements of Chemistry, theoretical and practical, including the most recent discoveries and applications of the Science to Medicine and Pharmacy, to Agriculture, and to Manufactures. Illustrated by 200 woodcuts. 8vo., cloth | 8 00 |
| Kemp (T. L.) The Phasis of Matter; being an Outline of the Discoveries and Applications of Modern Chemistry. 2 vols. 12mo. London, 1855 | 6 00 |
| — Agricultural Physiology Animal and Vegetable. For Practical Agriculturists. 12mo. Edinburgh, 1850 | 2 00 |
| Kerr (T.) A Practical Treatise on the cultivation of the Sugar Cane, and the Manufacturing of Sugar. 12mo., cloth | 1 50 |
| Knapp, RONOLDS, and Richardson. Chemistry in its application to the Arts and Manufactures: | |
| Vol. I.—Fuel and its Applications—Coal, Gas, Oil, Spermacet, &c., and their application to purposes of Illumination, Lighthouses, &c.—Resin, Wax, Peat, Wood, Stoves, &c., &c., in 2 Parts, 8vo., with 428 Engravings and 4 Plates | 9 00 |
| Vol. II.—Glass, Alum, Earthenware, Cements, &c., &c., manufacture. 8vo., with 214 Engravings and one Plate | 4 00 |
| Vol. III.—On those branches of Chemical Industry, including the Production of Food, and Related to Agriculture. (Bread, Milk, Tea, Coffee, Sugar, Tobacco, &c.) With 9 Engravings and 129 Woodcuts | 5 00 |
| Kobell. Sketches from the Mineral Kingdom. Post 8vo. London, 1858 | 1 50 |
| Vol. III., embracing sugar, coffee, tea, &c., with 7 folio coloured plates, | 5 00 |
| Knight. Dictionary of Arts, Commerce, and Manufactures. 8vo. London, | 2 50 |
| Kyan (J. H.) On the Elements of Light, and their identity with those of Matter, Radiant and Fixed. 8vo. London, 1838 | 2 00 |
| Laboulaye. Dictionnaire des Arts et Manufactures, de l'Agriculture, des Mines, &c. Ouvrage formant 2 tres forts volumes in 4to., et illustre de 8,000 gravures. Now complete | 15 00 |
| Lacambre. Fabrication de la Biere et Distillation des Alcools. Vol. 1 8vo. (For the 2 vols.) | 5 00 |
| Lacan (E.) Esquisses Photographique: a propos de l'Exposition Universelle et de la Guerre d'Orient. 12mo. Paris, 1856 | 0 75 |
| Lambert. Sur la Meteorologie. 4to. | 0 25 |
| Lame (G.) Cours de Physique de l'Ecole Polytechnique. 2 vols., en 8 Parties. 8vo., avec 17 planches. Paris, 1836-37. (Very Scarce.) | 5 00 |
| Lardner (D.) Handbook of Natural Philosophy. Hydrostatics, Pneumatics, and Heat. 12mo. London, 1855 | 1 50 |
| — The Museum of Science and Art. 10 vols., 12mo. Illustrated by engravings on wood | 6 25 |
| — Handbook of Natural Philosophy and Astronomy. Third Course—Meteorology; Astronomy. 8vo., with 87 lithographic plates and upwards of 200 illustrations on wood, cloth. London, 1853 | 5 00 |
| — A Treatise on Heat. 12mo. London, 1856 | 1 00 |
| Lassaigne. Dictionnaire des Reactifs Chimiques employes dans toutes les experiences. 8vo. 8g. Paris, 1839 | 2 50 |
| Laurent (W.) Precis de Cristallographie suivi d'une Methode Simple d'Analyse au chauxeau. 12mo. Paris | 0 37 |
| Laurent (Aug.) Methode de Chimie. Precedee d'un Avis au Lecteur, par M. Biot. 1 vol., 8vo., avec figures dans le texte. Paris, 1854 | 2 00 |
| Laurent (A.) Chemical Method, Notation, Classification and Nomenclature. Translated by Odling. London, 1855 | 3 50 |
| (Cavendish Society Publication.) | |
| Le Gray. Nouveau Traite de Photographie sur papier et sur verre. 8vo. Paris, 1851 | 0 75 |
| Lehmann. Physiological Chemistry. With Illustrations. 2 vols. 8vo. Philadelphia, 1856. | 6 00 |
| — Chemical Physiology. Translated by J. C. Morris. Philadelphia, 1856. | 2 25 |
| — Precis de Chimie Physiologique Animale. Traduction du Professeur Dron. Paris, 1855. 1 vol., gr. 18mo., avec fig. | 1 25 |

| | |
|---|-------|
| L'Heritier (S. D.) Traite de Chimie Pathologique ou Recherches chimiques sur les solides et les liquides du corps humain, dans leurs rapports avec la Physiologie et la Pathologie. 8vo. Paris, 1843 | 2 35 |
| Le Normand. L'art du distillateur des eaux-de-vie. 2 vols., 8vo. Paris, 1817 | 3 00 |
| Lerebours. A Treatise on Photography, by J. Egerton. 8vo. London, 1843 | 2 50 |
| Lerebours et Secretan. Traite de Photographie. 5e edit. 8vo. | 1 00 |
| Levesque. Art of Brewing and Malting. 4th edit. 8vo. London, 1847 | 7 00 |
| Liebig (J. V.) Chemistry and Physics, in relation to Physiology and Pathology. 2d edition. 8vo. | 0 75 |
| — Nouvelles Lettres sur la chimie, traduites par Charles Gerhardt. 12mo. Paris, 1853 | 0 75 |
| — Letters on Chemistry. 12mo. London | 2 00 |
| — Researches on the Chemistry of Food. 8vo. London | 1 00 |
| — Principles of Agricultural Chemistry, with special reference to the late researches made in England. 8vo. London, 1855 | 1 12 |
| — Handbook of Organic Analysis, containing a detailed account of the various methods used in determining the elementary composition of Organic Substances. Edited by Hoffman. Post 8vo., woodcuts. London, 1853 | 1 50 |
| Liebig and Kopp's Annual Report of the Progress of Chemistry, &c. 4 vols., cloth. 1858. (To be continued.) | 10 00 |
| Light: Its Nature, Sources, Effects, and Applications. Illustrated by a Photograph. 12mo. London, 1856 | 1 25 |
| Long (C. A.) Practical Photography on Glass and Paper. 2d edit. 12mo. Sewed. 1856. | 0 31 |
| Love (T.) The Art of Cleaning, Dyeing, and Scouring, &c. 12mo. London, 1854 | 2 25 |
| Low (David.) An Inquiry into the Nature of the Simple Bodies of Chemistry. 3d edit. 8vo. London, 1856 | 2 75 |
| Lowig. Principles of Organic and Physiological Chemistry, by D. Breed. 8vo. Philadelphia, 1853 | 3 50 |
| Mackenzie (C.) One Thousand Processes in Manufactures, and Experiments in Chemistry. 8vo. London, 1835. Half bd. | 3 50 |
| — Theory and Experiments in Chemistry. 8vo. London, | 6 50 |
| McGaughey (Rev. J. W.) Lectures on Natural Philosophy. 2 vols. 8vo. London, 1850. Half bd. | 5 00 |
| Malaguti (F.) Lecons de Chimie Agricole, Professees in 1847. 18mo. Paris, 1856 | 1 00 |
| — (J.) Lecons Elementaires de Chimie. 2 vols. 12mo., avec 104 figures intercalees dans le texte. Paris, 1853 | 2 50 |
| Marcet (W.) On the Composition of Food, and how it is Adulterated; with practical directions for its analysis. 8vo. London, 1856 | 2 00 |
| Martens. Esquisse d'une nouvelle classification Chimique des Corps. 4to. | 0 25 |
| — Combustion de la vapeur alcoolique et etheree, autour d'un fil de Platine. 4to. | 0 25 |
| — Sur la theorie Chimique de la Respiration et de la Chaleur Animal. 4to. | 0 50 |
| Martins (A.) Handbuch der Photographie. Dritte auflage. 8vo. Wien, 1859 | 2 3. |
| Mather (James). Coal Mines, their Dangers and Means of Safety. 8vo., woodcuts. London, 1853 | 1 12 |
| Mattonci. Cours Special sur l'Induction, le Magnetisme et sur les relations entre la Force Magnetique et les Actions Moleculaires. 8vo. Paris, 1854 | 1 50 |
| Matteucci et Savi. Traite des phenomenes Electro-Physiologiques des animaux. 8vo. Paris, 1841 | 2 00 |
| Matthews (W.) Compendium of Gas Lighting. 12mo. London | 1 25 |
| — Historical Sketch and Origin of Gas Lighting. 12mo. London | 2 25 |
| Memoires d'Agriculture, d'Economie Rurale et Domestique, publies et par la Societe Imperiale et Centrale d'Agriculture. Annee 1854. 1ere partie, 8vo. Paris, 1855 | 1 50 |
| Messler. Observations sur les grandes chaleurs, la Secheresse, etc., de la Seine a Paris, 4to. Pendant 1793 | 0 50 |
| Metcalf (S. T.) Caloric; its Mechanical, Chymical, and Vital Agencies in the Phenomena of Nature. 2 vols., 8vo. | |
| Mialhe. Chimie appliquee a la Physiologie et a la Therapeutique. 8vo. Paris, 1855 | 2 50 |
| Miller (W. A.) Elements of Chemistry, Theoretical and Practical, extensively Illustrated. 3 vols. 8vo. London, 1855-57 | 14 00 |
| Just Completed. | |
| Millar (James). Elements of Chemistry. 8vo. London | 2 75 |
| Miller (W.) (Cashier to the Bank of England.) Decimal Tables used at the Bank of England, for reducing Gross weight of Gold and Silver to Standard. 4to. London, 1854 | 1 25 |
| Millon (M. E.) Etudes de Chimie Organique faites en vue des Applications Physiologiques et Medicales. 8vo. Lille, 1849 | 0 75 |

| | |
|--|-------|
| Millon (W. E.) Des Phenomenes qui se produisent du contact de l'Eau et du Me et de leur Consequences, Industrielles. 8vo. Paris, 1854 | 0 60 |
| Mitchell (J.) Manual of Practical Assaying, intended for the use of Metallurgists, Captains of Mines, and Assayers in general. With a copious table, for the purpose of ascertaining in Assays of Gold and Silver the precise amount, in ounces, pennyweights, and grains, of noble metal contained in one ton of ore, from a given quantity. 1 vol., 8vo. 2nd edit. London, 1804 | 5 00 |
| — Treatise on the Adulterations of Food, and the Chemical means employed to detect them. Containing Water, Flour, Bread, Milk, Cream, Beer, Cider, Wines, Spirituous Liquors, Coffee, Tea, Chocolate, Sugar, Honey, Lozenges, Cheese, Vinegar, Pickles, Anchovy Sauce and Pasta, Catsup, Olive (Salad) Oil, Pepper, Mustard. 12mo. London, 1848 | 1 50 |
| Moligno. Traite de Telegraphie Electrique. 8vo., and atlas. Paris, 1852 | 3 75 |
| — Repertoire d'Optique. 4 vols., 8vo. Paris, 1849-50. (Very scarce.) | |
| Morehead (V.) Essay on Inebriating Liquors and Distillation. 8vo. London | 4 75 |
| Morfit (C.) A Treatise on Chemistry applied to the Manufacture of Soap and Candles. New edition. 8vo., woodcuts. Philadelphia, 1856 | 6 00 |
| Mulder (G. J.) The Chemistry of Vegetable and Animal Physiology, with introduction and notes by J. E. W. Johnston, and twenty illustrations, colored and plain. 8vo., cloth | 8 50 |
| Muller. Principles of Physics and Meteorology. Illustrated with 500 Woodcuts, and 2 colored plates. 8vo. London, 1847 | 4 00 |
| Murphy (Rev. H.) Elementary Principles of the Theories of Electricity, Heat, and Molecular Actions. Part I. 8vo. Cambridge (England), 1839 | 3 25 |
| Murphy (P.) Rudiments of the primary forces of Gravity, Magnetism, and Electricity in their Agency on the Heavenly Bodies. 8vo. London, 1830 | 4 00 |
| Murray. System of Chemistry, 4 vols., 8vo. London | 15 75 |
| — Sketch of Chemistry. 12mo. London | 3 25 |
| — Manual of Chemical Experiments. 12mo. London | 1 50 |
| — Chemical Tables and Diagrams. 8vo. London | 1 00 |
| — Elements of Chemistry. 4 vols., 8vo. London | 7 50 |
| Muspratt (Dr. S.) The Use of the Blowpipe, in the Qualitative and Quantitative Examination of Minerals, Ores, Furnace products, and other metallic combinations. By Platner. 8vo., cloth | 3 00 |
| — Chemistry Theoretical, Practical, and Analytical, as applied and relating to the Arts and Manufactures. Royal 8vo. 7 Div. 2. London, 1856. Each | 3 63 |
| Each division of this fine work contains 4 portraits (engraved on steel) of the most celebrated chemists. | |
| Napier (J.) Manual of Electro-Metallurgy. Post 8vo. 1858 | 1 00 |
| — A Manual of the Art of Dyeing. 8vo, with illustrations. London, 1853 | 2 25 |
| Webbs (J. C.) On Agricultural Chemistry, and the Nature and Properties of Peruvian Guano. 3d edition. 8vo. London, 1856 | 1 25 |
| Nisbet (W.) Dictionary of Chemistry. 12mo. London | 2 50 |
| Nicollet (H.) Atlas de Physique et de Meteorologie Agricoles. Grand in-fol., de 18 pl. col., avec tableaux et texte. Paris, 1855 | 13 50 |
| Wood (H. H.) A Manual of Electricity, including Galvanism, Magnetism, Diamagnetism, Electro-Dynamics, Magneto-Electricity, and the Electric-Telegraph. 4th edition, entirely rewritten. 2 vols. 8vo. London, 1856 | 7 20 |
| — Chemical Manipulation and Analysis Qualitative and Quantitative. With an introduction explanatory of the general principles of Chemical Nomenclature, &c. 8vo. London, 1853 | 3 00 |
| — Lectures on Chemistry. 8vo. London | 3 75 |
| Normandy. Commercial Handbook of Chemical Analysis. Post 8vo. London, 1850 | 3 75 |
| — A Practical Treatise on Chemical Analysis, Quantitative and Qualitative. By Rose. 2 vols., 8vo. London, 1848 | 10 25 |
| — An Introduction to ditto, 8vo. London | 2 75 |
| Orfila (M. P.) Elements of Modern Chemistry. 8vo. London | 3 25 |
| Ottley (W. C.) Dictionary of Chemistry and Mineralogy. 8vo. London | 4 00 |
| Paris (J. A.) Elements of Medical Chemistry. 8vo. London | 4 75 |
| Parnell. Treatise on Dyeing and Calico Printing. 8vo. London | 2 12 |
| — Elements of Chemical Analysis, Qualitative and Quantitative. 8vo. London, 1845. Reduced to | 2 75 |
| — Applied Chemistry in Manufactures. Vols. 1 and 2. 8vo. London. Each | 3 75 |
| Papen. Cours de Chimie Appliquee, professée a l'Ecole Centrale des Arts et Manufactures, et au Conservatoire des Arts et Metiers. Redige par Delisle et Poinot. 1re partie. Chimie Organique. 8vo., avec atlas folio de 60 planches. Paris, 1847 | 3 00 |

| | |
|---|--------|
| Payen. Précis de Chimie Industrielle, à l'usage des Ecoles préparatoires aux Professions Industrielles des fabricants, et des agriculteurs. 3 vols. 8vo., avec atlas de planches in 8vo. Paris, 1838. | 6 25 |
| Payen et Richard. Précis d'Agriculture théorique et pratique. 3 vols., 8vo. Paris, 1851. | 3 75 |
| Peckston (T. S.) Treatise on the Manufacture of Gas. 8vo. London | 7 75 |
| Peclet (E.) Traité élémentaire de Physique. 4me édition. 3 vols., 8vo., atlas, Paris, 1847 | 3 75 |
| — Traité de la Chaleur, considérée dans ses applications. Troisième édition entièrement refondue. Un atlas de 123 planches et un vol. de texte. Liège | 12 50 |
| Do., 3 vols., 4to., et atlas. Paris | 17 50 |
| — Le supplément séparément, 1853. 4to. | 9 25 |
| Pelouze. Traité de l'Eclairage au Gas tiré de la Houille, des Huiles, de Resines, etc. 1 vol., 8vo., et 24 pl. (Scarce.) | |
| Pelouze et Fremy. Traité de Chimie générale, comprenant les applications de cette Science à l'Analyse Chimique, à l'Industrie, à l'Agriculture, et à l'Histoire Naturelle. 2de édit. Tomes 1 à 5 et atlas. Paris, 1854-56 | 13 00 |
| Il y aura un 6e vol., qui sera donné gratis. | |
| — Abrégé de Chimie. Troisième édition, conforme aux nouveaux programmes de l'enseignement scientifique des Lycées. 8 vol., grand 18mo., avec 114 figures intercalées dans le texte. Paris, 1855 | |
| — Notions Générales de Chimie. Un beau volume imprimé avec luxe, accompagné d'un Atlas de 24 planches en couleur, cartonné. Paris, 1853 | 5 50 |
| Peltier (A.) Meteorologie. Observations et Recherches expérimentales. 8vo. Paris, 1840 | 3 00 |
| Perkins. Lectures on Polarised Light. Second edition, greatly enlarged from materials left by the author. Edited by Prof. Powells, of Oxford. 12mo., woodcuts. London, 1854 | 3 25 |
| Pernoz. Traité théorique et pratique de l'impression des tissus. 4 beaux vol., 8vo., avec 165 figures et 429 échantillons d'étoffes, intercalés dans le texte, et accompagnés d'un atlas de 10 pl. 4to., gravés en taille-douce, dont 4 sont colorées. Ouvrage auquel la société d'encouragement a accordé une médaille de 8,000 fr. Paris, 1846 | 17 00 |
| Pharmaceutical Journal and Transactions. Vols. 1 to 15. Half bound. London, 1841 to 1856 | 50 00 |
| Annual Subscription (published monthly) | 3 75 |
| Pharmacopœia. The New London, including also the Dublin and Edinburgh Pharmacopœias by J. B. Nevens, M.D. 8vo. London, 1851. | 5 00 |
| Phillips (J. A.) Gold Mining and Assaying; a Scientific Guide for Australian Emigrants. 12mo. With woodcuts, London, 1852. | 1 00 |
| — Manual of Metallurgy. Post 8vo. New edit. London, 1854. | 3 75 |
| Phillips (R.) A Million of Facts of correct data and elementary constants in the entire circle of the Sciences, and on all subjects of speculation and practice. New edit. 12mo. 1856. | 3 00 |
| Philosophical Transactions of the Royal Society of London, from 1685 to 1861, inclusive, forming 25 vols. 4to. Half bound in Russia | 130 00 |
| (Published price, £70 unbound.) | |
| Piesse (S.) The Art of Perfumery, and the Method of obtaining Odors of Plants; with instructions for the Manufacture of Perfumes for the Handkerchief, Scented Powders, Odorous Vinegars, Dentifrices, Pomatums, Cosmétiques, Perfumed Soap, &c. With appendix, &c. Crown 8vo., cloth. London, 1856. | 2 25 |
| Plattner (C. F.) Tableau de Caracteres que presentent au Chalumeau les alcalis, les terres et les oxydes métalliques, soit seuls, soit avec les reactifs. Traduit de l'Allemand par Sobrero, 4to. Paris, 1848 | 0 50 |
| — The Use of the Blowpipe in the Qualitative and Quantitative Examination of Minerals, Ores, furnace products, &c. 8vo. London, 1850 | 3 00 |
| Poisson (S. D.) Theorie Mathématique de la chaleur. 8vo. 1835 | 0 50 |
| Pouillet. Elements de Physique Experimentale et de meteorologie. 7me édition. 2 volumes, 8vo. de texte et un volume de 40 pl. 8vo., 4to. Paris, 1855 | 4 50 |
| Preuss (J. J.) Technologische Encyclopædie oder alphabetisches handbuch der Technologie der Technischen Chemie und des Maschinenwesens. Vols. 1 to 18. 8vo., and plates fol. | |
| Prideaux (T. S.) On Economy of Fuel, particularly with reference to Reverberatory Furnaces for the Manufacture of Iron, and to Steam Boilers. 12mo., cloth | 0 80 |
| Prout (W.) Treatise on Chemistry, Meteorology, etc. 8vo. London | 4 50 |
| Quetelet (A.) Positions de Physique. 3 vols. 18mo. Brussels, 1834 | 3 00 |
| Rammelsberg (C. F.) Lehrbuch der Stochiometrie und der Allgemeinen theoretischen Chemie. 8vo. Berlin, 1843 | 1 75 |
| — Anfangsgründe der quantitativen Mineralogisch, und Metallurgisch, analytischen Chemie durch Beispiele erläutert. 8vo. Berlin, 1845 | 1 75 |
| — Leitfaden für die Qualitative Chemische Analyse, mit besonderer Rücksicht auf H. Rose, Handb. der analyt. Chemie. 8vo. Berlin, 1843 | 0 75 |

| | |
|---|-------|
| Raspail (F. V.) Nouveau Systeme de Chimie Organique, fonde sur de nouvelles methodes d'observations, precede d'un Traite complet sur l'art d'observer, de manipuler en grand et en petit, dans le laboratoire et sur le porte-objet du microscope. Deuxieme edition, entierement refondue, accompagnee d'un atlas in-4 de 30 planches de figures dessinees d'apres nature, gravees et coloriees avec le plus grand soin. 3 vols., 8vo., atlas 4to. Paris, 1838 | 7 00 |
| — Nouveau Systeme de Physiologie vegetale et de Botanique, fonde sur les methodes d'observations developpees dans le nouveau systeme de chimie organique, accompagnee de 60 planches contenant pres de 1,000 figures d'analyse dessinees d'apres nature et gravees avec le plus grand soin. 2 forts vol., 8vo., et atlas de 60 planches. Paris, 1837 | 7 50 |
| — Le meme ouvrage, planches coloriees | 12 50 |
| Reech. Theorie Generale sur les Effets Dynamiques de la Chaleur. 4to., avec planche. 1854 | 3 00 |
| Regnault (M. H.) Cours Elementaire de Chimie, a l'usage des Facultes, des Etablissements d'Enseignement secondaire, des Ecoles Normales et des Ecoles Industrielles. 4 vols. 12mo. 4th edit. Paris, 1853-4 | 5 00 |
| — Elements of Chemistry. Translated by Betton and Taber. 2 vols. 8vo. 700 woodcuts. Philadelphia, 1853 | 7 50 |
| — Relations des Experiences entreprises pour determiner les principales lois et les donnees numeriques qui entrent dans le calcul des Machines a Vapeur. 4to. Paris, 1847. (Scarce.) | 10 00 |
| — Cours Elementaire de Physique. 4 vols., 18mo., anglais, avec figures dans le texte. Sous presse | |
| — An Elementary Treatise on Crystallography. Illustrated with 108 Wood Engravings, printed on black ground. 8vo. London, 1843 | 0 75 |
| — Premiers Elements de Chimie. 1 vol., 18mo., avec figures dans le texte. Paris, 1850 | 1 25 |
| Reichenbach (Baron Charles.) Physico-Physiological Researches on the Dynamics of Magnetism, Electricity, Heat, Light, Crystallisation, and Chemism, in their Relations to Vital Force. The complete work, from the German second edition, with additions, a preface, and critical notes, by John Ashburner, M.D. 8vo. With woodcuts and one plate. London, 1850 | 3 00 |
| Reid (D. H.) Illustrations of the Theory and Practice of Ventilation, with remarks on Warming, Exclusive Lighting, and the Communication of Sound. 8vo. London, 1844 | 4 80 |
| — Rudiments of Chemistry, with illustrations of the Chemistry of Daily Life. 4th edit. 12mo. London, 1851 | 0 75 |
| Repertoire de Pharmacie. 6 vols. 8vo. 1846-1850 | 7 50 |
| Richardson (C. J.) Popular Treatise on the Warming and Ventilation of Buildings. 18 plates. 8vo., hf. cf. London, 1831 | 2 00 |
| Rintoul (A. N.) A Guide to Painting Photographic Portraits, Draperies, Background, etc., in Water Color. With colored diagrams. 12mo. 1855 | 0 50 |
| Roberts (W. L.) Scottish Ale Brewer and Maltster. 8vo. London | 5 00 |
| Robertson (H.) A General View of the Natural History of the Atmosphere, &c. 2 vols., 8vo., cf. Edinburgh, 1809 | 2 00 |
| Rose (H.) Traite pratique d'analyse chimique, suivi de tables servant dans les analyses a calculer la quantite d'une substance d'apres celle qui a ete trouvee dans une autre substance; traduit de l'allemand sur la quatrieme edition par A. J. L. Jourdan. Nouvelle edition, avec des notes et additions, par M. Peligot, professeur de chimie au Conservatoire des arts et metiers. 2 vols., 8vo., fig. Paris, 1848 | |
| — Practical Treatise on Chemical Analysis, including Tables for calculations in Analysis. With notes and additions by A. Normandy. 2 vols., 8vo., cloth. London | 10 25 |
| — Analytical Manual of Chemistry, by Griffin. 8vo. London | 4 75 |
| — Ausführliches Handbuch der Analytisches Chemie. 2 vols., 8vo., hf. bound calf. Braunschweig, 1851 | 8 00 |
| Roseleur (A.) Manipulations Hydroplastiques. Guide pratique du doreur, de l'argenteur et du galvanoplaste (avec 90 figures en galvanoplastie intercalees dans le texte). 8vo. Paris, 1856 | 2 75 |
| Runge (F. F.) Chemistry of Dyeing. Part 1. 8vo. London | 1 50 |
| Ryland (A.) Treatise on Assay of Gold and Silver Wares. Post 8vo. London, 1833 | 1 75 |
| Sabine (E.) Magnetical Observations at Hobarton. Vol. 2, royal 4to. London, 1832 | 12 00 |
| Sacc (F.) Precis Elementaire de Chimie Agricole. 2e edit. 12mo. Paris, 1855 | 1 00 |
| Safety Lamps for Miners, etc. Knapp's Chemical Technology. Vol. 1. 1856 | 9 00 |
| Sanders (Dr. J. W.) Practical Manual on the Use of the Blowpipe Will be published in January, 1857. | |
| Santini. Teorica degli obiettivi acromatici. 4to | 0 50 |
| Scheerer (T.) An Introduction to the Use of the Blowpipe; together with a description of the Blowpipe, characters of the important minerals. Translated by H. L. Blanchard. 12mo. London, 1855 | 1 00 |

| | |
|---|--------------|
| Schrodler and Medlock. The Book of Nature; an elementary Introduction to the Sciences of Physics, Astronomy, Chemistry, &c., &c. 8vo. London, 1851 | 3 50 |
| Schroder (H.) Die Molecularvolumen der Chemischen Verbindungen im festen und flussigen Zustande. 8vo. Mannheim, 1848 | 1 00 |
| Scoffern. Chemistry of the Imponderable Agents; including the Principles of Light, Heat, Electricity, and Magnetism. 8vo. London, 1855 | 1 00 |
| — Manufacture of Sugar in the Colonies. 8vo. London | 3 25 |
| — Elementary Chemistry of the Imponderable Agents and of Inorganic Bodies. 8vo. London, 1855 | 1 50 |
| — Chemistry no Mystery. 12mo. London | 1 50 |
| Scoresby (W.) Magnetical Investigations. 3 vols., 8vo. London, 1838 | 3 00 |
| Sheir (Jehm). Directions for Testing Cane-Juice. 12mo., cloth | 0 87 |
| Smee (A.) Instinct and Reason; deduced from Electro-Biology. 8vo., cloth | 3 00 |
| — Elements of Electro-Metallurgy. Illustrated with woodcuts. 8vo., cloth | 1 50 |
| Smith (R. H.) Italian Irrigation; being a Report of the Agricultural Canals of Piedmont and Lombardy; addressed to the Directors of the East India Company. 2 vols. 8vo., and plates, folio, cloth. Edinburgh, 1855 | 9 00 |
| Smith (D.) Practical Dyer's Guide. 8vo. London | 19 00 |
| — Dyer's Instructor. 12mo., London | 6 50 |
| Solly (E.) Introduction to Rural Chemistry. 8vo. London | 1 50 |
| — Syllabus of Lectures on Chemistry. 8vo. London | 1 50 |
| Soubiran. Traite de Pharmacie theorique et pratique. 2e edition. 3 forts vol. 8vo., avec 68 fig. imprimees dans le texte. Paris, 1847 | 4 00 |
| — Precis elementaire de Physique. 2e edit., augmentee. 1 vol., 8vo., avec 18 planches 4to. Paris, 1844 | 1 25 |
| Sutton (T.) The Calotype Process: a Handbook of Photography on Paper. 8vo. London, 1855 | 75 |
| Swedenborg. Principles of Chemistry. 8vo. London | 3 00 |
| Tableaux generaux des Comptes Rendus des seances de l'Academie des Sciences, publies par MM. les secretaires perpetuels, conformement a une decision de l'Academie, en date du 13 juillet 1835. Tomes 1 a 31. 3 aout 1835 a 20 decembre 1850. 4to. Paris, 1854 | 6 00 |
| Tardieu (A.) Voities et cimetières. 8vo. Paris, 1853 | 1 00 |
| Tate (F.) The Little Philosopher; or, the Science of Familiar Things; in which the Principles of Nature and Experimental Philosophy are Systematically Developed from the Properties and Uses of Familiar Things. Vol. 1. 18mo. London, 1855 | 1 12 |
| — (C.) Theory and Experiments in Chemistry. 8vo. London | 6 50 |
| Thénard. Traite de Chimie elementaire. 6e edit. 5 vols. Paris, 1834-6 | Very scarce. |
| Thieme (F. W.) Die Physik in ihre Beziehung zur Chemie, oder diejenigen lehren der Physik, &c. 8vo. Leipzig, 1840 | 75 |
| Thomson (T.) Practical Dyer's Assistant. 12mo. London | 1 50 |
| — Chemistry of Organic Bodies—Vegetables. 1 large vol., 8vo., pp. 1092, boards. London, 1838 | 6 00 |
| — Heat and Electricity. 2d edition. 1 vol., 8vo. Illustrated with woodcuts London, 1839 | 4 00 |
| — Chemistry of Animal Bodies. 8vo., cloth | 4 00 |
| — History of Chemistry. 2 vols. 12mo. Scarce | 2 50 |
| — Treatise on Brewing and Distillation. 8vo. London | 1 00 |
| — Elements of Chemistry. 8vo. London | 3 25 |
| — First Principles of Chemistry. 2 vols., 8vo. London | 9 00 |
| — Outlines of Mineralogy, Geology, &c. 3 vols., 8vo. | 9 50 |
| — System of Inorganic Chemistry. 2 vols., 8vo. London | 12 50 |
| — System of Chemistry. 4 vols., 8vo. London | 18 00 |
| Thomson (E. D.) Cyclopædia of Chemistry, Practical and Theoretical, including the Application of the Science to the Arts, Mineralogy, and Physiology. 8vo., with illustrations. London, 1854 | 3 75 |
| Thornthwaite (W. H.) A Guide to Photography: Simple and Concise Directions for obtaining Views, Portraits, &c. 9th edit. 12mo. London, 1856 | 20 |
| Tizard (W. L.) Theory and Practice of Brewing. 2nd edit. 8vo. London, 1846 | 7 50 |
| — Brewer's Journal. London, 1854 | 3 25 |
| Tolhausen et Gardissal. Dictionnaire Technologique. Français-Anglais-Allemand. 3 vols., 12mo. Paris 1845 | 5 00 |
| Tomlinson (C.) Cyclopædia of Useful Arts, Mechanical and Chemical, Manufacturing, Mining and Engineering. 2 vols., 8vo., with splendid steel plates and woodcuts. London, 1854 | 13 00 |

| | |
|---|-------|
| Trosseau et Reveil. Traite de l'art de formuler, comprenant des notions de Pharmacie. 12mo. 1851. | 1 25 |
| Turner (F.) Elements of Chemistry, including the actual State and prevalent Doctrines of the Science. 8th edit. Edited by Baron Liebig and Dr. Gregory. 8vo. cloth | 9 00 |
| Ure (A.) A Dictionary of Arts, Manufactures, and Mines, containing a clear Exposition of their Principles and Practice. 5th edit., corrected and greatly enlarged. 8 vols., 8vo., and engravings on wood, cloth. London, 1839. | 24 00 |
| ——— Dictionary of Chemistry. 8vo. London | 6 50 |
| Van Mons. Sur les combinaisons faites par le Pyrophore. 4to. | 50 |
| Violette et Archambault. Dictionnaire des Analyses chimiques ou Repertoire alphabetique des Analyses de tous corps naturels et artificiels depuis la fondation de la chimie, avec l'indication des noms des auteurs et des recueils ou elles ont ete inserees. 2 vols., 8vo., a 2 col. Paris, 1851 | 4 00 |
| Or half calf | 5 00 |
| Walker (W.) The Magnetism of Ships and the Mariner's Compass: being a Rudimentary Exposition of the Induced Magnetism of Iron in Sea-going Vessels. 18mo. London, 1858 | 1 50 |
| ——— (C. V.) et Fau. Manipulations Electrotypiques, ou Traite de Galvanoplastie, contenant la Description des Procedes les plus Faciles pour Dorer, Argenter, Graver sur Cuivre et sur Acier, reproduire les Medailles et les Epreuves Daguerriennes, Metallisier les Statuettes de Platre, etc., au moyen du Galvanisme. 4me edition, 18mo. Paris, 1855 | 50 |
| Watson (H.) Chemical Essays. 5 vols., 18mo. London, 1800 | 2 50 |
| Webster (J.) Elements of Mechanical and Chemical Philosophy. 8vo. | 3 00 |
| Weeks (W. H.) A Memoir on the Universal Portable Eudiometer, an Apparatus designed for researches of Philosophical Chemistry. 4to., with plate. Sandwich, 1838 | 1 00 |
| Weldon (W.) Elements and Laws of Chemistry. 8vo. London | 2 75 |
| Wertheim. Theses presentees a la Faculte des sciences de Paris pour obtenir le grade de docteur de sciences physiques. Paris 1858 | |
| Theses de physique, de chimie et de mineralogie. | |
| Will et Liebig. Manuel Complet de Chimie Analytique, contenant des Notions sur les Manipulations Chimiques, les Elements d'Analyse Inorganique Qualitative et Quantitative, et des Principes de Chimie Organique. 2 vols. 18mo | 1 25 |
| Williams (C. W.) Treatise on the Combustion of Coal. 4to. London | 3 25 |
| Wittstein. Practical Pharmaceutical Chemistry, translated by S. Darley. London, 1858 | 1 88 |
| Wohler (F.) Handbook of Inorganic Analysis. Translated and edited by Hofmann. 12mo. London | 2 00 |
| Wolff (F. T.) Quellen-Litteratur der theoretisch-organischen Chemie, &c. 8vo. Halle, 1845 | 1 00 |
| Woodward (C.) A Familiar Introduction to the Study of Polarized Light. 2nd edit. 8vo. London, 1851 | 1 00 |

BAILLIÈRE BROTHERS beg leave to call the attention of Librarians of Colleges, Professors, and the Scientific World in general, to their unsurpassed facilities for the procuring of Books, Instruments, &c., with economy and dispatch, having houses in London, Paris, and Madrid, engaged in the same branch of the business. (Duty free for Public Institutions.) Their stock is always replete with the best and latest editions; from their great experience and knowledge of Scientific Works, and from their willingness and ability to give information about both old and new books, they are confident of being able to give entire satisfaction to all who favor them with their orders.

ALPHABETICAL INDEX

- Alchemy.** Figler, 5.
- Apparatus.** An Explanatory Dictionary, 1.
- Arts and Manufactures.** Acken, 1. Brande, 2; Dodd, 4; Exhibition Lectures, 5; Knight, 8; Laboulaye, 8; Mackenzie, 9; Muspratt, 10; Tomlinson, 13; Ure, 14.
- Assaying.** Berthier, 2; Mitchell, 10; Phillips, 11; Ryland, 12.
- Blowpipe.** Berzelius, 2; Griffin, 6; Muspratt, 10; Plattner, 11; SANDERS, 12; Sheerer, 12.
- Brewing.** Accum, 1; Black, 2; Lacambre, 9; Levesque, 9; Roberts, 12; Thomson, 12; Tissard, 12.
- Caoutchouc.** Manuel-Eoret, 2.
- Chemistry.** Brande, 2; Cavendish Society, 2; Chevallier (Dictionary), 3; Cuvier, 4; Dalton (Life), 4; Dumas (Statique), 5; Galloway (Diagram), 5; Griffith (Recreation), 6; Henry, 7; G. S. Hilaire, 7; Johnston, 7; Joyce, 8; Laurent, 8; Lehmann, S. L'Heritier, 9; Liebig, 9; Low, 9; Mackenzie, 9; Martens, 9; Messier, 9; Mulder, 10; Murray, 10; Orfila, 10; Paris, 10; Pelouse and Fremy, 11; Prout, 11; Rammelsberg, 11; Reid, 11; Schoedler & Medlock, 12; Scoffern, 12; Snee, 12; Swedenborg, 12; Tate, 12; Thomson, 12; Watson, 14.
- **Analysis.** Barreswill & Sobrino, 1; Fresenius, 5; Galloway, 5; Gerhaldt, 6; Johnson, 7; Liebig, 9; Noad, 10; Normandy, 10; Parnell, 10; Rose, 12; Violette et Archambault, 14; Will et Liebig, 14; Wohler, 14.
- **Animal.** Berzelius, 2; Thomson, 12.
- **Applied.** Ajasson de Grandsagne, 1; Annuaire de Chimie, 1; Barruel, 1; Bernay, 2; Knapp, 3; Daguin, 4; Dumas, 5; Francoeur, 5; Graham, 6; Kemp, 8; Miahle, 9; Morfit, 10; Muspratt, 10; Parnell, 10; Payen, 10; Thomson, 12.
- **Agricultural.** Johnson, 8; Kemp, 8; Liebig, 9; Malagutti, 9; Memoires, 9; Nesbit, 10; Payen et Richard, 10; Sacc, 12.
- **Catechism.** Graham, 6; Horsley, 7.
- **Cours et Lecons.** Boutet de Morvel, 2; Cybart, 3; Gerhardt, 6; Regnault, 11.
- Chemistry, Elements of.** Graham, 6; Kane, 8; Miller, 9; Murray, 10; Regnault, 12; Thomson, 12; Turner, 14; Weldon, 14.
- **Elementary.** Cahours, 3; Daguin, 4; Fyfe, 5; Glover, 6; Gregory, 6; Malagutti, 9; Regnault, 12; Thenard, 12.
- **First Steps.** Galloway, 5.
- **General.** Baudrimont, 1; Berzelius, 2; Pelouse & Fremy, 11.
- **Handbook.** Gmelin, 6.
- **History.** Hoefler, 7; Thomson, 12.
- **Inorganic.** Campbell, 8; Berzelius, 2; Gmelin, 6; Gregory, 6; Outlines of, 7; Thomson, 12.
- **Lectures.** Gurney, 6.
- **Manual.** Bernay, 2; Brande, 2; Fyfe, 5; Glover, 6.
- **Manipulation.** Faraday, 5; Noad, 10; Benoit.
- **Memoirs.** Dumas, 5; Graham, 6.
- **New-Metallic.** Faraday, 5.
- **Organic.** Brande, 2; Dumas, 5; Gerhardt, 6; Gmelin, 6; Gregory, 6; Lowig, 9; Millon, 9; Raspail, 12; Thomson, 12; Wolf, 14.
- **Philosophy.** Dalton, 4; Daniell, 4; Davy, 4; Webster, 14; Weekes, 14.
- **Practical.** Bowman, 2.
- **Progress of.** Berzelius, 2; Liebig and Kopp, 9.
- **Treatise.** Gregory, 6.
- Crystallography.** Desclotseaux, 4; Laurent, 8; Regnault, 12.
- Colors and Painting.** Chevreul, 6; Coloriste, 4.
- Cyclopaedia.** Cooley, 4; Francis, 5; Frecht, 11; Thomson, 1; Tomlinson, 12.
- Dictionary (Chemical, etc.)** Chevallier, 3; Crabb, 4; Hoefler, 7; Laboulaye, 8; Lassaigue, 8; Nesbit, 10; Outley, 10; Tollhausen, 12; Ure, 14.
- Distilling.** Dubrunfaut, 5; Duplais, 5; Lacambre, 8; Le Normand, 9; Morewood, 10.
- Dyeing and Staining.** Berthollet, 2; Blanchiment, 2; Brande, 2; Love, 2; Napier, 10; Parnell, 10; Parson, 11; Kunze, 12; Smith, 12; Thomson, 12.

- Electricity.** Becquerel, 2; Chalmers, 8; Cumming, 4; De la Rive, 4; De Bois Raymond, 4; Faraday, 5; Harris, 7; Matteucci, 9; Murphy, 10; Noad, 10.
- Electric-Telegraph.** Highton, 7; Moigno, 10.
- Electro-Metallurgy.** Dorure, 4; Galvanoplastic, 5; Gore, 6; Napier, 10; Roseleur, 12; Smee, 13; Walker et Fau, 14.
- Falsifications.** Chevallier, 3; Hassall, 7; Hureauux, 7; Marcet, 9; Mitchell, 10.
- Food.** See *Falsifications.*
- Gas.** Accum, 1; Clegg, 4; Knapp, 8; Journal of, 6; Matthews, 9; Fockston, 11; Pelouse, 11.
- Geological Chemistry.** Bischoff, 2.
- Glue.** Colles, 4.
- Heat.** Avogrado, 1; Cooper, 4; Dove, 5; Gavarret, 6; Lardner, 8; Metcalfe, 9; Peclet, 11; Poisson, 11; Prideaux, 11; Reech, 12; Regnault, 12; Thomson, 13; Williams, 14.
- Ink.** Encres, 4.
- Magnetism.** Becquerel, 2.
- Meteorology.** Arago, 1; Cotte, 4; Hopkins, 7; Housseau, 7; Howard, 7; Kaemts, 8; Lambert, 8; Nicollet, 10; Peltier, 11; Pouillet, 11; Prout, 11; Robertson, 12; Sabine, 12.
- Mineral Waters.** Bouquet, 2; Faure, 5.
- Optics and Light.** Biot, 2; Brewster, 8; Claudet, 4; Du Moncel, 5; Gorham, 6; Hardy, 7; Hunt, 7; Kyan, 8; Light, 9; Moigno, 10; Scantini, 12; Scoffern, 13.
- Perfumery.** Piesse, 11.
- Pharmacy.** Deschamps, 4; Goebel, 6; Guibourt, 6; Jourdain, 8; Pharmaceutical Journal, 11; Repertoire de, 12; Soubeiran, 12; Wittstein, 14.
- Pharmacopœia.** Codex, 4; New London, 11; Troussseau and Revell, 14.
- Photography.** Barreswil and Davanne, 1; Blanquart, 2; Brebisson, 3; Chevallier, 3; Cundall, 4; David, 4; Delamotte, 4; Desonges, 4; Disderi, 4; Fau, 5; Gaudin, 6; Hardwicke, 7; Heath, 7; Hennah, 7; Herling, 7; Howlett, 7; Hunt, 7; Lacan, 8; Legray, 8; Lerebours, 9; Long, 9; Martens, 9; Mintoul, 12; Sutton, 13; Thornthwaite, 13.
- Physics.** Aime Martin, 1; Ajasson de Grandsagne, 1; Archambault, 1; Biot, 2; Bird, 2; Boutigny, 2; Brown, 3; Cabart, 3; Coulomb, 4; Cuvier, 4; Daguin, 4; Desains, 4; Durand, 5; Fau and Chevallier, 5; Ganot, 5; Grove, 6; Gruyer, 6; Guitard, 6; Hinds, 7; Julien, 8; Lame, 8; Lardner, 8; Liebig, 9; McGauley, 9; Muller, 10; Peclet, 11; Pouillet, 11; Quetelet, 11; Regnault, 12; Reichenbach, 12; Scoffern, 13; Sooresby, 13; Soubeiran, 13; Thiemé, 13.
- Platina.** Billard, 2.
- Polarization.** Biot, 2; Pereira, 11; Woodward, 14.
- Precious Metals.** Faucher, 5.
- Pyrotechny.** Chertier, 3.
- Rural Economy.** Botchardat, 2; Bous-singault, 2.
- Safety Lamps for Miners.** Davy, 4; Knapp, 8.
- Sugar.** Baudrimont, 2; Kerr, 9; Scoffern, 13; Shier, 13.
- Ventilation.** Arnot, 1; Dunn, 5; Hedley, 7; Hood, 7; Mather, 8; Reid, 12; Richardson, 12.
- Weaving.** Coffes Imprimees, 5; Person, 11.

CHEMISTRY, ELECTRICITY, PHYSICS, METEOROLOGY, &c., &c.

[It is particularly requested that the manner in which books are to be forwarded should be specified on the order. If *by Mail, ten per cent.* must be *added* to the remittance, to cover the cost of postage, which the Post Office regulations require to be prepaid.]

| | |
|--|--------|
| Abel & Bioxam. Handbook of Chemistry. 2nd Edition. 8vo. London, 1858 . . . | \$4 00 |
| Agriculture, Hints on. By Cecil. London. 8vo. 1858 | 1 00 |
| Alcan (M.) Essai sur l'Industrie des matieres textiles comprenant le travail du coton, etc. 8vo. et atlas de 36 planches. Paris. 1859 | 8 00 |
| Allain. Elements de Chimie. 8vo. Paris. 1857 | 1 00 |
| Bakewell. Manual of Electricity. 3rd Edition. 12mo. 1859 | 1 00 |
| Barral (J.) Drainage des terres Arables. 2e Edition. Tomes 1, 2, 3. 12mo., avec nombreuses figures. Paris. 1856-57. L'ouvrage aura. 4 vols. | 4 50 |
| Barreswill et Davanne. Chimie Photographique, contenant les elements de Chimie expliqués par les manipulations Photographiques. 2e Edit. 8vo. Paris, 1858 | 2 00 |
| Barruel (A.) Traite de Chimie Technique appliquee aux arts et a l'Industrie, a la Pharmacie et a l'Agriculture. Tomes 1 a 4. 8vo. Paris, 1856-58. Chaque L'ouvrage aura 6 vols. | 1 50 |
| Basset (N.) Traite complet d'alcoolisation Generale. 2e Edit. 18mo. Paris, 1857 | 1 30 |
| ——— Traite de la fermentation. 18mo. Paris, 1857 | 1 50 |
| ——— Chimie de la ferme. Lecons familiares, etc. 12mo., figures. Paris, 1858 | 1 00 |
| Bequerel Resume de l'Histoire de l'electricite et du Magnetisme et des applications de ces sciences a la Chimie, aux sciences naturelles et a l'Industrie. 8vo. Paris, 1858 | 1 35 |
| ——— Suite au Traite de l'Electricite. 3 vols., 8vo. 5 40 | |
| Beer (A.) Introduction a la Haute optique, Traduit de l'allemand par Forthomme. 8vo., avec 2 planches et figures. Paris, 1858 | 2 70 |
| Billet (H.) Traite d'Optique Physique. 2 vols. 8vo., avec 14 planches. Paris, 1858 | 3 00 |
| Bischoff. Elements of Chemical and Physical Geology. Translated by Paul and Drummond. Vols. 1, 2, 3. 8vo. London, 1854-59. Published by the Cavendish Society | 11 50 |
| Blavier. Cours de Telegraphie Electrique. 12mo., avec planches et figures. Paris, 1857 | 1 50 |
| Boucherte. Memoire sur la conservation des Bois. 8vo. Paris, 1857 | 75 |
| Boulliet. Dictionnaire universelle des Sciences, des Lettres, et des Arts. 4eme. Edit. 8vo. Paris, 1858 | 5 00 |
| Bolley & Paul. Manual of Technical Analysis. 12mo. figures. London, 1857 | 1 35 |
| Boussingault. Rural Economy; in its Relation with Chemistry, Physics, and Meteorology. By J. B. Boussingault, Member of the Institute of France. 2nd Edition, with Notes, carefully revised and corrected. 8vo., cloth boards. London, 1845 | 4 50 |
| Boussingault. Memoires de Chimie Agricole et de Physiologie. 8vo. Paris, 1854 | 1 50 |
| Boutet de Monvel. Cours de Chimie. 4e Edit. 12mo., avec figures. Paris, 1859 | 1 15 |
| ——— Notions de Physique. 4eme Edit. 12mo., avec figures. Paris, 1859 | 1 00 |
| Boutigny (M. P. H.) Etudes sur les corps a l'etat spheroidal, nouvelle branche de physique. 3eme edition. Paris, 1857 | 1 50 |
| Bowman (J. H.) Introduction to Practical Chemistry. 3rd Edition. 12mo. London, 1858 | 1 00 |
| Branston. Cyclopedes of Practical Receipts. New edition. London, 1856 | 1 00 |
| ——— Handbook of Practical Receipts. 2nd edition. London, 1856 | 1 35 |

Baillere Brothers, 440 Broadway, N. Y.

| | |
|---|--------|
| Brettes (M. de) Appareils Chrono-Electriques a l'induction, applicables aux experiences ballistiques. 8vo., avec 4 planches. Paris, 1858 | \$2 00 |
| Brewster (Sir D.) Kaleidoscope; its history, theory and construction and application to the fine and useful arts. 2nd Edition. 12mo. London, 1858 | 1 50 |
| Brown (S.) Lectures on the Atomic Theory, with Essays. 2 vols., 12mo. London, 1857 | 4 00 |
| # Bunsen (R.) Methodes Gazometriques. Traduit par Schneider. 8vo., avec figures. Paris, 1858 | 1 80 |
| Bunsen. Gasometry; comprising the leading Chemical and Physical properties of Gases, together with the methods of Gas Analysis. 8vo., figures. London, 1857 | 2 25 |
| Burnett. Tillage, a substitute for Manure. 12mo. London, 1869 | 1 25 |
| CaIRD (J.) Prairie Farming in America; with Notes, by the way, on Canada and the United States. 12mo. London, 1859 | 1 00 |
| Cameron. Chemistry of Agriculture. 8vo. Dublin, 1857 | 1 00 |
| == Campbell. A Practical Text-Book of Inorganic Chemistry, including the preparation of Substances, and their Qualitative and Quantitative Analyses, with Organic Analyses. By Dugald Campbell, Demonstrator of Practical Chemistry to the University College. 12mo. London, 1849 | 1 62 |
| Castro (de.) L'Electricite et les Chemins de fer; description et examen de tous les systemes proposes pour eviter les accidents aux Chemins de fer, etc. 2 vols., 8vo. Paris, 1859 | 4 00 |
| Challeton (de Brughat.) De la Tourbe. Etudes sur les combustibles employes dans l'industrie. 8vo. Paris, 1858 | 1 50 |
| Chalmers (C.) Electro-Chemistry, with positive results; and Notes for inquiry on the Science of Geology and Astronomy, etc. 8vo., figures. London, 1858 | 1 00 |
| Chapman. A Brief Description of the Characters of Minerals; forming a familiar Introduction to the Science of Mineralogy. By Edward J. Chapman, Professor in the University of Toronto (Canada). 12mo., with 3 plates. London, 1844 | 1 25 |
| — Chapman. Practical Mineralogy; or, a Compendium of the distinguishing Characters of Minerals; by which the Name of any Species or Variety in the Mineral Kingdom may be speedily ascertained. By Edward J. Chapman. 8vo. with 13 engravings, showing 270 specimens. London, 1843 | 2 10 |
| Chapman. Tables for the Mutual Conversion of French and English Measures, including new and simple Methods of Approximation for general purposes. By Edward J. Chapman. No. 1, Measures of Length. On a card | 30 |
| — Chemical Society of London, Quarterly Journal and Transactions of. Vols. 1 to 9. 8vo. London. Reduced to Per vol. in Paris | 2 00 |
| Or in cloth | 2 50 |
| Annual subscription | 3 00 |
| Chemistry of Artificial Light. 12mo. London, 1856 | 50 |
| Chesnel (de.) Dictionnaire de Technologie, Etymologie et definitions des terms employes dans les Arts et Metiers. 2 vols. Gr. 8vo. Paris, 1858 | 3 25 |
| Chevalier. Methodes photographiques perfectionnees. Papier sec albumin, collodion sec, etc. Optique photographique et stereoscopique. 8vo. Paris, 1859 | 1 25 |
| — Chevalier. Dictionnaire des alterations et Falsifications des substances alimentaires, medicamentuses et commerciales, etc. 3e Edition. 2 vols. 8vo. Paris, 1857-58 | 3 37 |
| Chevrenil. Laws of Contrast of Color; and their application to the Arts. Translated by Spanton. New edition, with illustrations printed in colors. 12mo. London, 1859 | 1 25 |
| Clegg (S.) Practical treatise on the Manufacture of Coal Gas. 3rd Edition. 4to., illustrated. London, 1859 | 8 50 |
| Connington (E. T.) A Hand-Book of Chemical Analysis based on the 4th Edition of "Wills' Chem. Anal." 12mo. London, 1859 | 2 00 |
| — Tables for Qualitative Analysis to accompany the above. 12mo. London, 1859 | 67 |
| Coulvier (Gravier.) Recherches sur les Meteores et sur les lois qui les regissent. 8vo., et lithographies. Paris, 1859 | 2 70 |
| Crosse. Memorials, Scientific and Literary of Andrew Crosse, the Electrician. 12mo. London, 1857 | 2 25 |
| Daguin (P. A.) Traite elementaire de Physique Theorique et Experimentale avec les applications a la Meteorologie et aux Arts Industriels. 2 vols., 8vo., avec 300 gravures. Paris, 1855-58 | 6 00 |
| Damourette (J. P.) Resistance de la fonte de Fer a la compression. Colonnes en fonte de fer. 8vo., avec 3 planches. Paris, 1858 | 75 |
| Davy. Fragmentary Remains, Literary and Scientific, of Sir Humphrey Davy, Bart.; with a sketch of his life, etc., by his brother John Davy, M.D. 8vo. London, 1858 | 2 93 |
| De la Rive (A.) A Treatise on Electricity in Theory and Practice. 3 vols., 8vo., illustrated. London, 1853-58 | 10 80 |
| — (A) Traite d'Electricite Theorique et Applique. 3 vols., 8vo., avec gravures. Paris, 1853-58 | 6 00 |

Baillere Brothers, 440 Broadway, N. Y.

| | |
|---|--------|
| Desains (F.) Lecons de Physique. Tome 1er. 12mo., avec figures. Paris, 1857 | \$1 50 |
| Deschamps. Manuel Pratique d'Analyse Chimique. 2 vols., 8vo., avec figures. Paris, 1859 | 2 70 |
| Dessoye (J. B.) Etudes Theoriques et Pratique sur les Proprietes de l'Acier. 18mo., Paris, 1859 | 1 00 |
| Dickson. Unity of the Physical Sciences, Being an Enquiry into the Causes of Gravitation and Polarity. 8vo., London, 1859 | 1 10 |
| Dore. Lecons de Chimie Elementaire Appliquee aux arts industriels. 3 vols., avec figures, Paris, 1855-57 | 4 00 |
| D'Orvault. L'Officine ou Repertoire General de Pharmacie Pratique. 5eme. Edit. avec gravures, 8vo., Paris, 1858, demi relie | 3 37 |
| Dufrenoy. Traite Complet de Mineralogia. 4 vols., in 8vo., and Atlas de 260 planches. 2e Edition. Paris, 1858-59 | 12 00 |
| Dumas & Boussingault. The Chemical and Physiological Balance of Organic Nature; an Essay. By J. DUMAS and J. B. BOUSSINGAULT, Members of the Institute of France. 1 vol., 12mo. London, 1844 | 1 00 |
| Du Moncel (Th.) Expose des Applications de l'Electricite. 3 vols., 8vo., avec planches. Paris, 1856-57 | 5 85 |
| Du Moncel. Etude du Magnetisme et de l'Electro-Magnetisme au point de vue de la Construction des Electro-Aimants. 8vo., Paris, 1859 | 1 25 |
| Duplais (F.) Traite des Liqueurs et de la distillation des Alcools, ou le Liqueuriste et le distillateur Modernes, contenant, etc. 2e Edition. 2 vols., 8vo. Versailles, 1858 | 3 37 |
| Duplex (G.) Matter, its Forms and Governing Laws. 12mo. London, 1856 | 1 00 |
| Encyclopedie Britannica. 8th Edition. Vols. 1 to 14. 4to. London, 1853-59. Per vol. | 5 50 |
| Encyclopedie Partielle de l'Agriculture , publiee par F. Didot freres sous la direction de M. L. Moll. Tomes 1 et 2 in 8vo. Avec nombreuses gravures. Paris, 1859. Chaque volume | 1 58 |
| L'Ouvrage aura 16 vols. environ. | |
| English Encyclopedias.—Arts and Sciences. Vols. 1 and 2., R. 8vo., illustrated. London, 1859. Each vol. | 2 70 |
| Will be completed in 4 vols. | |
| Euler. Lettres a une Princesse d'Allemagne sur divers sujets de Physique et de Philosophie avec eloge d'Euler par Condorcet. 2 vols. 12mo., avec figures. Paris, 1859 | 1 58 |
| Faraday. Experimental Researches into Chemistry and Physics. 8vo. London, 1859 | 4 00 |
| Figulier (L.) Exposition et Histoire des Principales Decouvertes Scientifiques modernes. 5e Edit. 4 vols., 12mo., avec figures. Paris, 1858 | 3 15 |
| Figulier (L.) L'Année Scientifique et Industrielle. 1ere. Année, 12mo., Paris, 1857. Nouv. Edit. 1859 | 90 |
| 2eme Année. 2 vols., 12mo., Paris, 1858 | 1 58 |
| 3eme Année. 1 vol., 12mo., Paris, 1859 | 90 |
| Fontenelle et Malpeyre. Nouveau Manuel de physique amusante. Nouv. Edit. 12mo., avec planches. Paris, 1859 | 90 |
| Fownes. Manual of Elementary chemistry. 7th edit. 12mo. Illustrated. London, 1858 | 3 37 |
| Fresenius. Instructions in Chemical Analysis. Qualitative. 8th edit. London, 1859 | 2 43 |
| Galloway, R. Manual of Qualitative Analysis. 2nd edit. London, 1857 | 1 25 |
| Ganot. Cours de Physique purement experimentale à l'usage des Gens du Monde. 12mo. avec nombreuses figures. Paris, 1858 | 1 50 |
| Ganot, A. Traité élémentaire de Physique Experimentale et appliqué, et de Météorologie, avec un recueil de nombreux problèmes. 5eme edit. 12mo., avec nombreuses figures. Paris, 1858 | 1 58 |
| Gavarret, J. Traité de l'Electricité. 2 vols. 12mo., avec figures. Paris, 1857-58 | 3 00 |
| Gentillon, E. Traité complet sur la fabrication des étoffes de soie analysé degrés par degrés dans toutes les phases ou la soie a passée jusqu'à son entière execution en étoffe fabriquée. 4to., avec tableaux. Paris, 1859 | 2 25 |
| Gerhardt et Chancel. Précis d'analyse chimique quantitative, à l'usage des médecins, des pharmaciens, etc. 12mo., avec gravures. Paris, 1858 | 1 50 |
| — — — Précis d'analyse Qualitative. 12mo., avec gravures. Paris, 1855 | 1 13 |
| Gmelin, G. Handbook of Chemistry, translated by H. Watts. Published by Cavendish Society of London. London, 1848-59. | |
| Vol. 1, out of print, very scarce. | |
| Vol. 2 to 6 | 12 00 |
| Vol. 7, 8, 9, 10 | 14 00 |
| Vol. 11, 12 | 9 00 |
| Gossin (L.) L'Agriculture française. Principes d'agriculture appliqués aux diverses parties de la France. 4to., avec un carte et 225 planches. Paris, 1858 | 13 50 |

Bailliere Brothers, 440 Broadway, N. Y.

- Graham.** Elements of Chemistry; including the Application of the Science in the Arts. By T. Graham, F.R.S., L. & E., Master of the Mint, late Professor of Chemistry at University College, London. 2nd edition, revised and enlarged, copiously illustrated with wood-cuts. 2 vols. 8vo. 1860, 1857 \$10 00
 ——— Vol. II. edited by H. Watts, M.C.S., separately. 1857. 5 00
- Grassi.** Etudes comparative de deux systèmes de chauffage et ventilation à l'Hôpital la Ribolière. 8vo. Paris, 1856 50
 ——— Étude du système de chauffage et de ventilation établi par Van Hecke dans l'hôpital Beaujon. 8vo. Paris, 1857 50
 ——— Sur la construction et l'assainissement des latrines et fosses d'aisance. 8vo. avec planches. Paris, 1859 75
- Gregg.** Suggestions as to the employment of a Novum Organum Moraliū. 8vo. London, 1859 75
- Gregory, W.** Handbook of Inorganic Chemistry. For the use of Students. 4th edit. 12mo. London, 1857 1 80
 ——— Handbook of Organic Chemistry. For the use of Students. 4th. edit. 12mo London, 1857 3 24
- Griffin (F.W.)** A Compendium of Qualitative Analysis, from the Simplest to the most Complex Cases, arranged in a Series of Eight Tables. 4to. London, 1858 3 60
- Grove.** Correlation des forces Physiques, par Moigno. 8vo. Paris, 1855 1 80
- Grouvelle et Jaumez.**—Guide du chauffeur et du propriétaire de machines à vapeur 4e edit. 8vo., avec Atlas. 52 planches. Paris, 1859 2 25
- Hancock, T.** Personal narrative of the Origin of the Caoutchouc or India Rubber Manufacture in England. 8vo. With engravings. London, 1857 3 00
- Hardwich, T. F.** A manual of Photographic Chemistry. 5th Edit. London, 1859 2 00
- Harmonious Coloring of Photographs.** 12mo. London, 1859 75
- Henry, Ossian.** Traité pratique d'analyse chimique des eaux minérales potables et économiques avec leurs principales applications, etc. 8vo., avec figures. Paris, 1858 2 70
- Heuze, G.** Matières fertilisantes, engrais solides, liquides, naturels et artificiels. 3eme edit. Paris, 1859 2 00
- Hecker.** Dictionnaire de Chimie et de Physique. 3e edit. Paris, 1857 1 00
- Jamin, J.** Cours de Physique de l'Ecole Polytechnique. 8vo. vols 1 et 2, avec figures. Paris, 1858-59.
 L'ouvrage aura 3 vols., le 3eme volume payable à l'avance 6 10
- Jobert de Lamballe.** Des appareils électriques des poissons électriques. 8vo., avec Atlas de 11 planches in fol. Paris, 1856 2 25
- Johnson, G. W.** The Chemistry of the World; being a popular explanation of the Phenomena daily occurring in and around our persons, houses, etc. 12mo. London, 1859 1 62
- Johnson.** The Chemistry of Common Life. New edition. 2 vols. 12mo. London, 1859 3 15
 ——— Elements of agricultural Chemistry and Geology. 7th edit. 12mo. London, 1856 1 80
- Kœnigs, L. F.** Cours complet de Météorologie, traduit et annoté par Martins avec un appendice par Lalanné. 12mo., avec planches. Paris, 1858. 1 35
- Kœnigs.** A Complete Course of Meteorology. By L. F. Kœnigs, Professor of Physics at the University of Halle. With Notes by Charles Martins, and an Appendix by L. Lalanne. Translated with Additions, by C. V. Walker. 1 vol., post 8vo., pp. 624, with 15 plates, cloth boards. 1845 3 25
- Knapp, Ronalds, and Richardson.** Chemistry in its Application to the Arts and Manufactures. *Fuel and its Applications*, embracing Coal, its Structure and Products, Gas, Oil, Spermaceti, &c., and their Application to purposes of Illumination, Lighthouses, &c., Resin, Wax, Turpentine, Peat, Wood, Stoves, &c. By Drs. Ronalds and Richardson, 2 vols., 8vo., most fully illustrated with 433 engravings and 4 plates. (Being the 2nd Edition of Vol. I., in two parts, of Knapp's Technology.) 9 00
- The Authors of this Edition in their Preface say: "So rapid has been the growth, and so great the development of the branches of Manufacture more intimately connected with Fuel, that in preparing a Second Edition, we have found it necessary not only to re-write much of the original, but to extend so considerably the limits of the first group as to occupy the entire of this volume, which may therefore with far greater propriety be called a New Work than a Second Edition."*
- Vol. I. part III. Containing the Alkalies and Earth. By Richardson and H. Watts. *In the Press.*
- Knapp, Ronalds, and Richardson.** Vol. II. 8vo. Of Chemistry applied to the Arts and Manufactures, contains Glass, Alum, Potteries, Cement, Gypsum 4 00
- Knapp, Ronalds, and Richardson.** Vol. III. 8vo. Of Chemistry applied to the Arts and Manufactures, contains, Food generally, Bread, Cheese, Tea, Coffee, Tobacco, Milk, Sugar. Both these volumes are extensively illustrated with colored plates 5 00

Baillière Brothers, 440 Broadway, N. Y.

| | |
|---|-------|
| Kurr (J. G.) The Mineral Kingdom. 1 vol., folio, with 22 plates showing colored illustrations of the most important Minerals and Petrifications. Edinburgh, 1859 | 88 50 |
| — The same. French Edition. Paris, 1859 | 6 75 |
| Laboulaye. Essai sur l'Equivalent mecanique de la chaleur. 8vo. Paris, 1858 | 75 |
| Ladrey. Chimie appliquee à la viticulture. 12mo. Paris, 1857 | 1 53 |
| Landrin. Traité de l'acier. Théorie, metallurgie, travail pratiques, etc. 18mo. Paris, 1859 | 1 13 |
| — Du Plomb, de son état dans la nature. 12mo. Paris, 1857, | 1 13 |
| Lardner. Hand-book of Natural Philosophy. Vol. 4. Electricity, Magnetism, Acoustics. 12mo., with woodcuts. London, 1856 | 1 35 |
| Lardner (D.) Chemistry for Schools. 12mo., with 170 illustrations. London, 1859 | 1 00 |
| Latreille. Répertoire générale de Photographie. 12mo. Paris, 1858 | 1 00 |
| Laugel (A.) Etudes Scientifiques. 12mo. Paris, 1859 | 1 00 |
| Lebeaud et Julia Fontenelle. Nouv. Man. du distillateur et du liquoriste. Nouv. edit. 12mo. Paris, 1856 | 90 |
| Lefort (J.) Traité de Chimie Hydrologique; l'analyse chimique des eaux douces et des eaux minerales, etc. 8vo., avec figures. Paris, 1859 | 1 50 |
| Liebig (J.) Letters on modern agriculture. Edited by J. Blyth. 12mo. London, 1859 | 1 62 |
| — Familiar letters on Chemistry. 4th edit. 12mo. London, 1859 | 2 00 |
| — Chemistry and Physics, in Relation to Physiology and Pathology. By Baron Justus Liebig, Professor of Chemistry at the University of Giessen. 2nd edit. 8vo. London, 1847. | 75 |
| Lloyd (H.) Elementary treatise on the wave theory of Light. 2nd edit. 8vo. London, 1867 | 2 53 |
| Lorme (E.) Traité complet de la fabrication des savons contenant des notions sur les alcalis, etc. 18mo., avec 2 planches. Paris, 1859 | 90 |
| Love (G. H.) Des diverses resistances et autre propriétés de la fonte, du fer et de l'acier et de l'emploi de ces metaux dans les constructions. 8vo., avec 2 planches. Paris, 1859 | 2 25 |
| Magny. Méthode explicative des engrais déduite de la composition chimique des vegetaux, de celles des differents engrais usites, etc. 8vo. Auxerre, 1859 | 1 35 |
| Malaguti. Leçons élémentaires de chimie. 2eme edit. Tome 1er en 2 parties. 12mo., avec figures. Paris, 1858-59. Pour l'ouvrage complet en 2 vols. | 2 70 |
| Malaguti (F.) Leçons de Chimie Agricole, professes en 1857 en 1858 et 1859. 3 vols. 12mo. Paris. | 1 50 |
| Malaguti. Petit cours de Chimie Agricole. 12mo. Paris, 1857 | 90 |
| Martin (E.) Nouvelle école electro-chimique, ou chimie des corps imponderables et ponderables. Tome 1er, en 8vo. Paris, 1858 | 1 50 |
| L'ouvrage aura, 2 vols. | |
| Matteucci (C.) Course d'electro physiologie, professé à l'université de Pise en 1858 8vo., avec planches. Paris, 1858 | 90 |
| Memoires sur les Eaux de Paris. 1er Memoire 1854, 2eme Memoire 1855. 2 vols. 4to., avec 12 planches. Paris, 1855-59. | |
| Memoires of the Literary and Philosophical Society of Manchester. 2nd Series. Vols. 9-13, 8vo. with woodcuts and plates. London, 1851-1857. | 9 75 |
| Meunier (V.) Essais Scientifiques. Tomes 1, 2, 3. 12mo. Paris, 1851-58, chaque vol. | 37 |
| Mitchell (J.) Manual of Practical Assaying, intended for the use of Metallurgists, Captains of Mines, and Assayers in General. With copious Tables, for the purpose of ascertaining in Assays of Gold and Silver the precise amount, in Ounces, Pennyweights, and Grains, of noble metal contained in one ton of Ore from a given quantity. 2nd edit., 8vo., much enlarged, with 360 illustrations. London, 1854 | 5 00 |
| — Treatise on the Adulations of Food, and the Chemical means employed to detect them. Containing Water, Flour, Bread, Milk, Cream, Beer, Cider, Wines, Spirituous Liquors, Coffee, Tea, Chocolate, Sugar, Honey, Lozenges, Cheese, Vinegar, Pickles, Anchovy Sauce and Paste, Catsup, Olive (Salad) Oil, Pepper, Mustard. 12mo. London, 1848 | 1 50 |
| Mohr. Analyse chimique à l'aide des liqueurs titres, traduit de l'allemand par Forthomme. 8vo. Paris, 1858. | 1 50 |
| Moigno, l'abbé. Manuel de la Science. Annuaire du Cosmos. 1er Année en 2 parties. 12mo. Paris, 1859 | 1 00 |
| Monckhoven (D. Van.) Nouveau procede de Photographie sur plaques de fer etc. 8vo. Paris, 1858 | 1 35 |
| Monckhoven. Répertoire Général de Photographie pratique et theorique. 1 vol., et Atlas. 3eme edit. Paris, 1859 | 2 25 |
| Mortimer. Pyrotechny. 3rd edit. 12mo. London, 1856 | 1 00 |
| Mulder (G. J.) The Chemistry of Wine. Edited by H. B. Jones. 12mo. London, 1857 | 1 62 |

Bailliere Brothers, 440 Broadway, N. Y.

| | |
|--|--------|
| Muller. Principles of Physics and Meteorology. By J. Muller, M.D. Illustrated with 530 woodcuts and 2 colored plates. 8vo. London, 1847 | \$4 00 |
| Nadauld de Buffon. Cours d'agriculture et d'Hydraulique agricole. 3 vols. 8vo. avec figures et planches. Paris, 1859 | 9 00 |
| Napier. Manual of Electro-Metallurgy. 3rd edit. 12mo. figures. London, 1857 | 1 90 |
| Noad (H.M.) A manual of Electricity, including Galvanism, Magnetism, Magneto-Electricity, etc. 4th edit. 8vo. Illustrated. London, 1856-57, reduced to | 6 50 |
| Normandy (A.) The Chemical Atlas, or Tables; showing at a glance the operations of Qualitative Analysis etc., oblong folio. London, 1857 | 5 63 |
| — The Dictionaries to the Chemical Atlas; being a dictionary of simple substances, etc., and a dictionary of Tests and reagents. 12mo. London, 1857 | 2 00 |
| — Tableaux d'Analyse chimique. 4to., avec figures. Paris, 1858 | 5 63 |
| Northote and Church. A Manual or Chemical Analysis (Qualitative). 12mo. London, 1858 | 2 93 |
| Odart. Ampélographie universelle, ou Traite des cepages les plus estimés dans tous les vignobles de quelque renom. 4eme edit. Paris, 1859 | 1 80 |
| Orfila (L.) Leçons de Toxicologie. 8vo. Paris, 1858. | 75 |
| Orrs Circle of Sciences. Vol. 7. Practical Chemistry; including the theory and practice of electro-deposition; Photographic Art; the Chemistry of food, etc. 8vo. Illustrated. London, 1856 | 1 50 |
| Otte. Landscape Photography. New edit. 12mo. London, 1859 | 75 |
| Otto (J.) Manual of the Detection of Poisons by Medico Chemical Analysis. By J. Otto, Professor of Chemistry in Brunswick, Germany. Edited with Notes by W. Elderhorst. With illustrations. 12mo. New York, 1857 | 1 75 |
| Parkinson (S.) A treatise on Optics. 12mo., illustrated. London, 1859 | 3 00 |
| Payen. Précis de Chimie Industrielle, nouv. edit. Tome 1er et Atlas en 8vo. Paris, 1859 pour l'ouvrage complet en 2 vols. | 5 63 |
| Payen (A.) Traité complet de la distillation des principales substances qui peuvent fournir de l'alcool. 8vo., avec figures et planches. Paris 1858 | 1 80 |
| Peclet (E.) Traité de la chaleur considérée dans ses applications. 3eme edit. Tomes 1 et 2 e. 8vo., avec figures. Paris, 1859. Pour l'ouvrage complet en 3 vols. | 9 50 |
| Felouze. Traite de l'Eclairage au Gaz tire de la houille, des bitumes, des lignites, de la tourbe, etc. 8vo., et Atlas de 28 planches. Paris | 3 60 |
| — Fabrication du Coke et du Charbon de Tourbe. 8vo., avec 4 planches. Paris | 1 00 |
| Pelouze et Fremy. Traite de Chimie generale, comprenant les applications de cette Science a l'Analyse Chimique, a l'Industrie, a l'Agriculture et a l'Histoire Naturelle. 2eme Edition. 6 vols. et Atlas de planches in 8vo. Paris, 1854-57 | 10 80 |
| Pelouze et Fremy. Abrege de Chimie. 4e Edition. 18mo., illustrated. Paris, 1859 | 1 35 |
| Phillips. Principles of Agriculture, especially Tropical, and of Organic Chemistry. 8vo. London, 1859 | 2 00 |
| Philosophy in sport made Science in earnest. 8th Edition. London, 1857 | 2 50 |
| Photographic Art Annual for 1859. Folio. London, 1859 | 5 63 |
| Photograph. How to color a. 12mo. London, 1859 | 30 |
| Photography. A catechism of. 12mo. London, 1859 | 30 |
| Photographic News; a weekly record of the progress of Photography. Edited by W. Crookes. Vol. 1. 4to. London, 1859 | 2 25 |
| Pierre (J.) Chimie agricole; ou l'Agriculture consideree dans ses rapports principaux avec la Chimie. 2e Edition. 12mo. Paris, 1858 | 1 00 |
| Plesse (G. W.) Chymical, Natural, and Physical Magic. 12mo. London, 1859 | 1 00 |
| Plesse (S.) The art of Perfumery, and the method of obtaining odors of plants; with instructions for the Manufacture of perfumes for the Handkerchief, Dentifrices, Pomatums, etc. 2nd Edition. 12mo. London, 1857 | 2 25 |
| Pitt. How to brew good Beer. 12mo. London, 1859 | 1 25 |
| Poggiale (A. B.) Traite d'analyse chimique par la methode des volumes, comprenant l'analyse des gaz et des metaux, la chlorometrie, l'alcalimetrie, etc. 8vo., avec 171 figures. Paris, 1858 | 2 00 |
| Praumont (F. de) Manuel pratique d'essai par la voie seche, a l'usage des essayeurs. 12mo., avec une planche. Paris, 1858 | 75 |
| Prendeville. Photographic Fac-similes of Antique Gems, formerly possessed by the late Prince Poniatowsky. 1st Series. 4to. London, 1858 | 56 70 |
| Price (Lake.) A Manual of Photographic Manipulation, treating of the practice of the Art and its various applications to Nature. 12mo. London, 1858 | 1 80 |
| Redwood's Gray's Supplement to the Pharmacopoeia. 3rd Edition. 8vo. London, 1856 | 6 00 |

Bailliere Brothers, 440 Broadway, N. Y.

| | |
|--|-------|
| Regnault (M. H.) Cours elementaire de Chimie, a l'usage des facultes, etc. 5eme Edit. Tomes 1, 2, 3. 12mo. Paris, 1858. Pour l'ouvrage complet en 4 vols. | 84 50 |
| Regnault. An Elementary Treatise on Crystallography, illustrated with 108 wood engravings, printed on black ground. 8vo. London, 1848 | 75 |
| Reid. Rudiments of Chemistry, with Illustrations of the Chemistry of Daily Life, by D. B. Reid, M.D., Lecturer on Chemistry, formerly one of Her Majesty's Commissioners for the Health of Towns in England. 4th Edition, with 130 woodcuts. 12mo. 1850 | 62 |
| Rham (W. L.) The Dictionary of the Farm; revised and edited by H. Raybord. New Edition. 12mo. London, 1858 | 1 35 |
| Riffaud. Nouveau manuel du teinturier. Nouv. Edit. 12mo. avec 5 planches. Paris, 1859 | 90 |
| Rivot. Principes generaux du traitement des mineraux Metalliques. Tome 1er. Metallurgie du cuivre. 8vo., avec 4 planches. Paris, 1859 | 2 25 |
| Robiquet. Manuel theorique et pratique de Photographie sur colodeon et sur albumine. 18mo. Paris, 1859 | 1 25 |
| Rogers (S. B.) An Elementary Treatise on Iron Metallurgy, up to the Manufacture of Puddled Bars, &c., with Analytical Tables of Iron-making Materials. 8vo., with 20 4to. plates. 1857. | 6 00 |
| Rogers. Facts and fallacies of the sewerage of London and other large towns, with plans, elevations and sections. 8vo., with 8 plates. London, 1857 | 1 00 |
| Rohart (F.) Guide de la fabrication economique des engrais au moyen de tous les elements qui peuvent être avantageusement employés en Agriculture. 8vo. Paris, 1858 | 1 80 |
| Rose (H.) Traité complet de chimie analytique. Tome 1er. Analyse Qualitative. 8vo. Paris, 1859. | 2 70 |
| L'ouvrage aura 2 vols. | |
| Salvetat (A.) Leçons de ceramique profes-ées à l'ecole centrale des arts et manufactures. ou Technologie ceramique. 2 vols. 12mo. Paris, 1857 | 3 24 |
| Salvetat. Histoire et fabrication de la Porcelaine chinoise, traduit du chinois par S. Julien. Augmenté d'un mémoire sur la porcelaine du Japon traduit du Japon par J. Hoffman. 8vo., avec 14 planches. Paris, 1858 | 3 15 |
| Scoffern. Chemistry of Inorganic Bodies. 12mo., illustrated, London, 1856 | 1 00 |
| Scoffern, Truran and others. The useful metals and their alloys including Iron, Copper, Tin, Lead, Zinc, Antimony, etc. 8vo., illustrated. London, 1857. | 2 00 |
| Searesby (W.) Journal of a Voyage to Australia and round the world for magneetical research. 8vo. London, 1859 | 3 24 |
| Sherratt. A popular treatise on the origin nature and properties of Light. 12mo. London, 1853 | 60 |
| Sicard (A.) Monographie de la Canne à sucre de la Chine, dite Sorgho à sucre. 2eme edit. augmentée. Tome 1er. 8vo. Marseille, 1858 | 1 35 |
| L'ouvrage aura 2 vols. | |
| Simon (J. F.) Animal Chemistry, translated by Geo. E. Day. 2 vols. 8vo. London, | 4 20 |
| Solly (E.) Introduction to Rural Chemistry. 3rd edit. 12mo. London, 1860 | 1 50 |
| Somerville (M.) On the connection of the Physical Sciences. 9th edit., completely revised. London, 1859 | 2 43 |
| Soubefran. Traité de Pharmacie theorique et pratique. 5eme edit. 2 vols. 8vo., avec figures. Paris, 1857 | 3 83 |
| Sparling and Martin. Photographic Art, its theory and practice. Revised and corrected by Martin. 8vo. London, 1859 | 75 |
| St. Claire Deville. L'Aluminium. Ses propriétés, sa fabrication et ses applications. 8vo. Paris, 1859 | 1 00 |
| Steggall (J.) A medical manual for apothecaries' Hall and other Medical Boards. 12th. edit. 12mo. London, 1859 | 2 70 |
| Steggall (J.) First lines for chemists and druggists 2nd edit. 18mo. London, 1857 | 1 00 |
| Stereoscopic Magazine; a gallery of Landscape Scenery, Architecture, Antiquities and Natural History. Vol. 1. 8vo. London, 1859 | 12 34 |
| Sutton (T.) A Dictionary of Photography 8vo., illustrated. London, 1858 | 2 00 |
| Tennant and Mitchell. Mineralogy and Crystallography, being a classification of Crystals after their form and of minerals after their chemical composition. 12mo. London, 1857 | 90 |
| Tessier (P.) Chimie Pyrotechnique, ou traité pratique des feux colorés. Suivi d'un petit traité special pour la fabrication des pastilles simples et des pastilles diamants. 8vo. Paris, 1858 | 1 80 |
| Thomson. Chemistry of Organic Bodies—Vegetables. By Thomas Thomson, M.D., F.R.S. L. & E., Regius Professor of Chemistry in the University of Glasgow. 1 large vol. 8vo. pp. 1092, bds. London, 1838. | 6 00 |
| — Heat and Electricity. 2nd edit. 1 vol. 8vo., illustrated with woodcuts. London, 1859 | 3 75 |

Bailliere Brothers, 440 Broadway, N. Y.

| | |
|---|-------|
| Tissier (Ch. et A.) L'aluminium et les métaux alcalins. Recherches sur leurs propriétés, procédés d'extraction et leurs usages. 12mo., avec figures. Paris, 1858 . . . | 81 00 |
| Vernois et Grassl. Mémoires sur les appareils de ventilation et de chauffage établis à l'hôpital Necker. 8vo. Paris, 1859 . . . | 37 |
| Violette. Nouvelles manipulations chimiques simplifiées. Nouv. edit. 8vo., avec figures et une planche. Paris, 1858 . . . | 1 80 |
| Webster (W.) The recurring monthly Period and Periodic system of the atmospheric actions, with evidences of the transfer of Heat and Electricity. 8vo. London, 1857 . . . | 2 86 |
| Wilkie (G.) The manufacture of Iron in Great Britain; with remarks on the employment of capital in Iron-Works and collieries. 8vo. London, 1857 . . . | 2 02 |
| Wilkinson (J. G.) On color and on the necessity for the diffusion of taste among all classes; with remarks on laying out dressed or Geometrical Gardens. Examples of good and bad taste. 8vo. Illustrated by woodcuts and colored plates. London, 1858 . . . | 4 86 |
| Will (H.) Tables pour l'analyse chimique qualitative. Traduit de l'Allemand par J. Risler. 4to. Mulhouse, 1856 . . . | 1 00 |
| — Guide pour l'analyse chimique à l'usage des médecins pharmaciens, etc., traduit d'après la 3eme edit. Allemande par J. Risler. 8vo. Paris, 1857 . . . | 1 00 |
| Williams (C. W.) Treatise on Combustion of Coal and the prevention of smoke, chemically and practically considered. With an appendix containing report on the Newcastle Steam Coal. 12mo. London, 1858 . . . | 90 |
| Williams (C. G.) A Handbook of Chemical Manipulation. 8vo., illustrations. London, 1857 . . . | 4 00 |
| Wechler (F.) Eléments de chimie inorganique et organique. Traduit de l'Allemand par Grandeau. 8vo. Nancy, 1858 . . . | 1 80 |
| Zimmermann (W. F. A.) Les Phénomènes de la nature, leurs lois et leurs applications aux arts et à l'industrie. D'après l'Allemand de Valerius. 2 vols. gr. in 8vo., avec figures. Bruxelles, 1858 . . . | 8 60 |

NOTICE.

In order to facilitate the transaction of business, and to settle the question of discounts, we beg to remark that we have *reduced* our rates, and that the prices attached to the books in this List are the lowest that we will take. Our terms at such prices is *Cash with the Order*, and *positively no further discount will be allowed.*

. Persons having an *open account* with us will be charged at the old rates, or about 12 per cent. advance on these prices.

Books not in stock can be imported from London in about five weeks, and from Paris in about six weeks.

BAILLIERE BROTHERS,

440 Broadway, N. Y.

European Agencies:

LONDON: 219 Regent Street.

PARIS: 19 Rue Hautefeuille.

MADRID: 11 Calle del Principe.



