

AMERICAN MUSEUM *Novitates*

PUBLISHED BY THE AMERICAN MUSEUM OF NATURAL HISTORY
CENTRAL PARK WEST AT 79TH STREET, NEW YORK, N.Y. 10024
Number 2972, 35 pp., 7 figs., 3 tables
June 26, 1990

The Auditory Region of *Reithroparamys delicatissimus* (Mammalia, Rodentia) and its Systematic Implications

JIN MENG¹

ABSTRACT

The significance and phylogenetic position of the rodent subfamily Reithroparamyinae is controversial. This taxon has been included variously in Ischyromyidae (Paramyidae, infraorder Protrogomorpha) or in the infraorder Franimorpha. Its placement in the Franimorpha was based on an interpretation of the mandible as incipiently hystriognathous; reithroparamyines were therefore regarded by some workers as at least part of the ancestral stock of the Hystriognathi. Others considered the Reithroparamyinae to be the most primitive ischyromyids, giving rise to later North American forms. *Reithroparamys delicatissimus* discussed herein presents several derived features of the auditory region. These include: (1) inflated

bullae with internal septa, (2) apparent loss of the promontory artery, (3) the internal carotid artery crossing over the fenestra rotunda, (4) the presence of a meato-cochlear bridge, (5) a somewhat swollen promontorium, (6) bony tube for the stapedial artery and facial nerve partially formed, (7) fenestra ovalis large and tilted, and (8) epitympanic recess dorsally expanded. Analysis of these derived characters allows the ancestor-descendant relationship between reithroparamyines and hystriognathous rodents to be rejected. For the same reason, Reithroparamyines do not represent the most primitive ischyromyids; instead, a close relationship of reithroparamyines with sciurids, aplodontids, and glirids is proposed.

INTRODUCTION

The genus *Reithroparamys* was first proposed in 1920 by W. D. Matthew. Although Matthew designated AMNH 12561 the genotype of *Reithroparamys*, the type was in

fact *Paramys delicatissimus* (Leidy 1871) (Wood, 1962; Korth, 1984). Wood (1962) based a new subfamily, the Reithroparamyinae, on the genus and placed it in the family

¹ Graduate Student, Department of Vertebrate Paleontology, American Museum of Natural History; Department of Geology, Columbia University, New York, N.Y. 10027.

Paramyidae, superfamily Ischyromyoidea. Later, Black (1971) grouped the Reithroparamyinae, Ischyromyinae, Paramyinae and Prosciurinae in the family Ischyromyidae Alston (1876). Wood (1975) proposed a new infraorder, the Franimorpha, under the suborder Hystricognathi, and placed the Reithroparamyinae within it. Subsequent authors have either retained the Reithroparamyinae as a subfamily of the Paramyidae or Ischyromyidae (e.g., Korth, 1984) under the suborder Protrogomorpha or Sciuromorpha, or placed it as a subfamily or family in the infraorder Franimorpha under Hystricognathi (e.g., Chaline and Mein, 1979; Patterson and Wood, 1982).

It has long been argued that the North American protrogomorphs are the most primitive rodents. Their relationships with later groups remain problematic (e.g., Hartenberger, 1980: fig. 2; Wood, 1985: fig. 1), because few if any derive characters are known for these rodents. Among the North American protrogomorphous rodents, reithroparamyines play a crucial role in the reconstruction of rodent phylogeny. They are central to the debate on fundamental problems in the intraordinal relationships among rodents, such as the definition, composition, and origin of the Hystricognathi and the early divergence of rodents in North America and Asia. The controversial systematic position of the reithroparamyines has been more or less a direct result of divergent opinions about their mandible structure.

A major problem in the origin of hystricognaths is finding a temporal and geographic link between the Early Oligocene hystricognaths of Africa and South America, and the earliest Hystricidae from southern Asian Middle Miocene (Flynn et al., 1986). Wood (1974) presumed that Eocene reithroparamyines present in North America, and presumably present in Asia, provide the linkage, while Lavocat (1980) endorsed direct transoceanic dispersal of hystricognaths from Africa to South America. Recently, Korth (1984) proposed a hypothesis that reithroparamyines are the most primitive protrogomorphous stock in North America, and that they give rise to all other ischyromyids and later groups. Auditory features of *Reithroparamys*

delicatissimus described in this report present evidence that sheds new light on these problems.

Reithroparamys delicatissimus (AMNH 12561), the best and most completely preserved specimen of the subfamily, has been studied by many authors (most extensively by Wood, 1962). No agreement has been reached about the nature of the angular process of the mandible, and therefore its systematic position remains uncertain. Further preparation of this specimen, especially its ear region, has revealed morphological attributes previously unknown in *Reithroparamys* and known in few other paramyids.

ACKNOWLEDGMENTS

I am grateful to Dr. M. C. McKenna (American Museum of Natural History) for suggesting that I study this subject; he encouraged me throughout this study and incisively criticized an earlier version of this paper. I am also grateful to Dr. M. J. Novacek (AMNH) for patiently introducing mammalian auditory structures to me and for permitting me to study the specimens under his care. For further critical and detailed reading I thank Drs. P. Lockett (University Puerto Rico), L. Flynn (Peabody Museum), A. Wyss (AMNH) and M. Norell (AMNH); this paper is greatly improved and more readable with their valuable comments. I profited enormously from discussion with Dr. J. H. Wahlert (AMNH) on rodent anatomy and systematics. I have also benefited greatly from discussions with J. R. Wible (University Chicago) on the internal carotid complex in various groups of mammals. Thanks are given to Dr. C.-k. Li (Institute of Vertebrate Paleontology and Paleoanthropology, Beijing) for permitting me access to specimens under his care. J. Shumsky (AMNH) is gratefully acknowledged for ably preparing the specimen described here. I wish to express my deep appreciation to many people at the Department of Vertebrate Paleontology, AMNH, for their help in various ways. Finally, I thank my wife, Yu Liu, for her assistance in preparation of manuscripts. This work was supported by a faculty fellowship from Columbia University and by the Frick Laboratory Endowment Fund, AMNH.

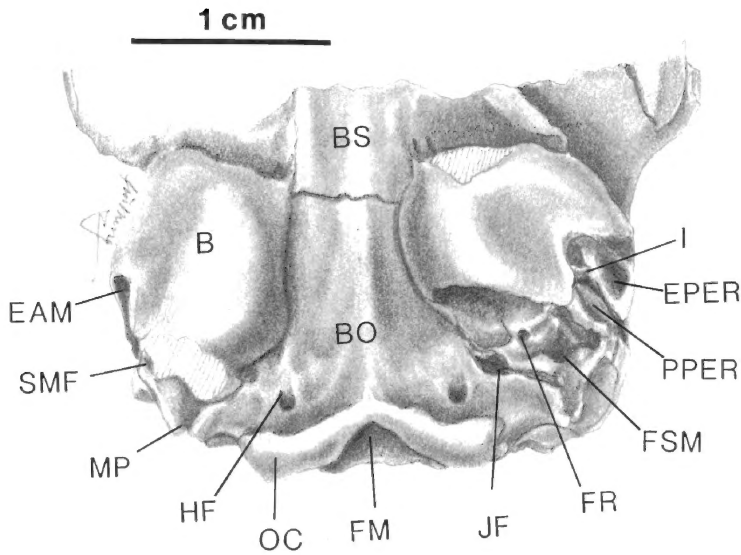

Fig. 1. Ventral view of the basicranial region of *Reithroparamys delicatissimus* (AMNH 12561). B, bulla; BO, basioccipital; BS, basisphenoid; EAM, external auditory meatus; EPER, ectotympanic part of the epitympanic recess; FM, foramen magnum; FR, fenestra rotunda; FSM, fossa for stapedius muscle; HF, hypoglossal foramen; I, incus; JF, jugular foramen; MP, mastoid process; OC, occipital condyle; PPER, petrosal part of the epitympanic recess; SMF, stylomastoid foramen.

DESCRIPTION OF THE EAR REGION OF *REITHROPARAMYS DELICATISSIMUS*

Reithroparamys delicatissimus (AMNH, 12561) is represented by an almost complete skull, articulated mandibles, and some postcranial skeleton (see Wood, 1962). The bullae on both sides of the skull are preserved although both are broken at their posterior end (fig. 1). The bullae are inflated and slightly flat lateroventrally, completely covering the tympanic cavity. The ectotympanic does not expand laterally to form an external auditory canal. The suture between the bulla and the surrounding cranial elements is distinct, indicating that the bulla is formed entirely by the ectotympanic. The bulla is tightly joined but not yet fused to the petrosal. The bullar wall is thin but gradually thickens toward the external auditory meatus. Internally a vertical bony septum is present at the anteromedial corner.

On the lateral side of the bulla, the contact between the ectotympanic and the squamosal is limited to the posterodorsal margin of the bulla. The squamosal is completely excluded

from the tympanic cavity by the ectotympanic. A marked imprint on the ventral margin of the squamosal indicates the overlapping of the dorsally expanded ectotympanic above the external auditory meatus (fig. 2). The anterolateral part of the bulla is separated from the squamosal by a narrow band of the petrosal (fig. 2). The medial side of the bulla is lacking foramina, fissures, or grooves that might be interpreted as an entrance or pathway for a medially placed internal carotid artery or even venous drainage. At the posteromedial end of the bulla, immediately ventral to the jugular foramen, is a foramen which was identified as the stapedial foramen by Wahlert (1974) because of its posterior position, but is herein referred to as the internal carotid foramen (see discussion below). The jugular and carotid foramina are separated by a narrowly exposed ridge of the petrosal. The carotid foramen is emarginated ventrally by the ectotympanic and dorsally by the petrosal. Breakage at the posterior end of the bulla has permitted removal of most of the matrix filling the tympanic cavity.

The internal carotid artery enters the tympanic cavity through the carotid foramen, and

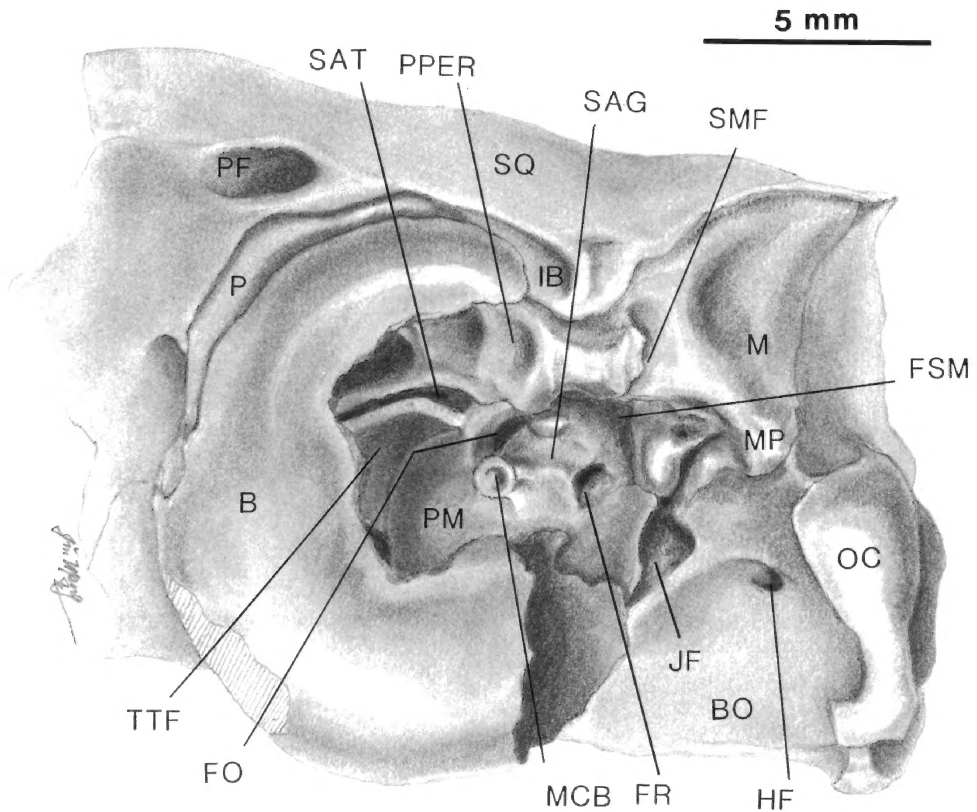

Fig. 2. Lateral (slightly posteroventral) view of the basicranial region, emphasizing the auditory region, of *R. delicatissimus*. B, bullae; BO, basioccipital; PPER, petrosal part of the epitympanic recess; FO, fenestra ovalis; FR, fenestra rotunda; FSM, fossa for the stapedius muscle; HF, hypoglossal foramen; IB, imprint left by dorsal extension of the bulla; JF, jugular foramen; M, mastoid; MCB, meato-cochlear bridge (only base preserved); MP, mastoid process; OC, occipital condyle; P, petrosal; PF, postglenoid foramen; PM, promontorium; SAG, groove left by the stapedial artery; SAT, tube for stapedial artery; SMF, stylomastoid foramen; SQ, squamosal; TTF, fossa for tensor tympani muscle.

runs in an open groove until it crosses the fenestra ovalis. The large size of the carotid foramen and associated groove suggest that the internal carotid and stapedial artery also may have been fairly large. The promontorium is somewhat inflated. There is no groove or any other trace on the surface of the promontorium to indicate the existence of a promontory artery. The fenestra rotundum is small and nearly circular. It is located at the posterior end of the promontorium and faces posteroventrally. The internal carotid artery runs laterally along the posterior end of the promontorium, shielding most of the fenestra rotundum. After passing the fenestra rotundum, the internal carotid artery continues as

the stapedial artery, while the promontory artery is assumed to have been lost (see character analysis section for more details). One of the most distinctive features of the tympanic cavity is the pathway of the stapedial artery. Lateral to the fenestra rotundum, a marked trough for the stapedial artery leads to the fenestra ovalis. In mammals where it is present, the stapedial artery normally travels along the ventral rim of the fenestra rotundum and approaches the fenestra ovalis from its ventral side. In this case, the long axis of the fenestra ovalis is usually oriented horizontally. The stapedial artery in *R. delicatissimus*, however, approaches the fenestra ovalis from its posterior rim. Therefore,

the fenestra ovalis is somewhat tilted so that the stapedial artery can easily run through the stapes so oriented. The fenestra ovalis is relatively large and its rim forms a slightly raised lip.

Another distinctive feature of the tympanic cavity is a prominent osseous process developed on the promontorium at the ventral rim of the fenestra ovalis. This process occupies the normal pathway of the stapedial artery. In the left tympanic cavity, this process is broken at its base, but on the right side it is a distinctly cone-shaped structure projecting posterolaterally. Due to breakage, it does not touch any other structure but in life the distal end of this process probably contacted the ectotympanic at the posterior end of the external auditory meatus. This structure is here referred to as the meato-cochlear bridge. The stapedial artery runs posterodorsal to this bridge. In ventral view, the fenestra ovalis is concealed by the osseous process. A small process posterior to the fenestra ovalis, but dorsal to the groove for the stapedial artery, is also developed. The stapedial artery is thus confined by the meato-cochlear bridge ventrally and this process dorsally before it passes over the fenestra ovalis.

After crossing the fenestra ovalis, the stapedial artery enters a bony canal. This canal is formed by the petrosal and is excavated ventrally in the tympanic roof. Its ventral side is cracked, indicating that either the canal was not completely formed in life or was broken in preservation. The canal extends anterolaterally, and the stapedial artery exited the tympanic cavity at its anterolateral corner. There is no indication of the bifurcation of the superior and inferior ramus of the stapedial artery within the tympanic cavity. Posterior to the fenestra ovalis, the lateral wall of this canal continues posteriorly to the stylomastoid foramen; the medial wall of the canal is incomplete so that it opens medially into the fossa assumed for the stapedius muscle. Thus, the facial nerve is exposed medially into the tympanic cavity after crossing the stapedial artery dorsally. In the right tympanic cavity, the bony tube for stapedial artery and facial nerve is not preserved; the tympanic aperture of the facial nerve is visible at the anterior end of the fenestra ovalis; and a groove originating from it runs poste-

riorly to the stylomastoid foramen. At the exit of the facial nerve on the right, the ectotympanic curves inward and covers the ventromedial side of the facial nerve. Because most of the posterior region of the bulla is broken, it is difficult to estimate the extent to which the facial nerve was covered by the ectotympanic. The posterior portion of the path for the facial nerve may have consisted of a bony tube formed by the petrosal laterally and the ectotympanic medially.

Posterior to the fenestra ovalis, a deep fossa, posteriorly bounded by a tubercle of the petrosal, is the fossa assumed for the stapedius muscle. In life this fossa would have been covered ventrally by the bulla, and the stapedius muscle would have been completely enclosed in the tympanic cavity. Posterior to the stapedius fossa, the mastoid process of the petrosal is small and not horizontally or ventrally expanded.

The epitympanic recess in *R. delicatissimus*, if examined through the external auditory meatus, lies between the tegmen tympani of the petrosal and the ectotympanic. The petrosal portion of the epitympanic recess is located on the lateral surface of the ventrally projecting tegmen tympani of the petrosal and is well separated from the fenestra ovalis. Immediately lateral to the petrosal portion of the epitympanic recess is the expanded ectotympanic portion of the epitympanic recess, which forms a distinct elliptical fossa in the ectotympanic. This fossa is situated dorsal to the external auditory meatus but is not distinctly separated from it.

Lateral to the stapedial canal and anterodorsal to the epitympanic recess, there is a deep depression roofed by the petrosal and medially bounded by the stapedial artery tube. This depression probably implies a dorsal expansion of the epitympanic recess. Because of this depression, the bony tube for the stapedial artery appears even more prominent. A tiny bone, possibly the displaced incus, lies within it. A broad depression assumed for the insertion of the tensor tympani muscle lies at the anterolateral side of the promontorium and medial to the stapedial tube. Anterior to this depression is a breakage which cannot be ascertained to be the piriform fenestra.

CHARACTER ANALYSIS

In this section, attention is given to the determination of character polarity. Focus centers on the derived auditory characters found in early rodents in reconstructing their phylogeny. Whether a character is primitive or derived depends on the systematic level being considered. Because *R. delicatissimus* has been regarded either as a member of the most primitive ischyromyids (Korth, 1984), or in the ancestral stock of the Hystricognathi (Wood, 1985), its derived auditory features are of special significance at the intraordinal level of rodents. In the following discussion, the *Reithroparamys* auditory region is compared with those of *Paramys*, *Sciuravus*, *Cocomys*, and the Theridomorpha. The ear regions of these groups are well known and generally accepted as representing the primitive morphotypes in rodents (Lavocat and Parent, 1985; Li et al., 1989). Comparison is also made between *Reithroparamys* and muroids, especially when characters are not available in early fossil forms due to fragmentary materials. This is because muroids are thought to have the most primitive auditory region among living rodents (Lavocat and Parent, 1985). The primitiveness of the auditory characters in the groups mentioned above is obtained through outgroup comparison (for instance, *Cocomys*, Li et al., 1989). The character polarity of *Reithroparamys* is basically determined by comparison with these rodent groups. However, when the polarity cannot be ascertained on comparison with these groups, or when the character states are unclear in these groups, other mammalian groups, especially those that may be closely related to rodents such as lagomorphs and macroscelidids (Novacek, 1985; Novacek and Wyss, 1986; Novacek et al. 1988) or primitive eutherians such as *Leptictis*, are employed to determine polarity.

ECTOTYMPANIC BULLA INFLATED WITH INTERNAL SEPTUM. Novacek (1977, 1980) pointed out that the primitive condition of the auditory bulla in eutherians was probably one similar to that of monotremes; there the bony bulla is not present and the ectotympanic rests at a low angle to the horizontal plane of the skull. An auditory bulla formed completely by the ectotympanic is present in

Rodentia and Lagomorpha. It is widely agreed that an ectotympanic bulla represents a derived condition in eutherians. In rodents a small ectotympanic bulla loosely attached to the petrosal, such as occurs in *Sciuravus* and *Cocomys*, is taken as the primitive condition.

In early rodents, an osseous bulla is not commonly found associated with the skull. An osseous bulla has not yet been found in Eocene ischyromyids except *Reithroparamys* (Korth, 1984). *Sciuravus* may have a poorly developed bulla, preserved in one specimen (USNM 22477) and illustrated in a reconstruction by Dawson (1961) and Wahlert (1974). The bulla of *Sciuravus* must have been loosely attached to the petrosal because no markings on the petrosal are detected. The bulla was not inflated and was completely confined to the ventral side of the skull. It even failed to cover the middle lacerate foramen. *Cocomys*, from the early Eocene of South China, displays a similar bullar condition (Li et al., 1989). A bulla co-ossified with the skull, like that of the *R. delicatissimus*, has been regarded as a derived condition in rodents. In *R. delicatissimus*, however, the bulla is not only co-ossified with the skull but also inflated to a considerable degree. The squamosal of *R. delicatissimus* is blocked, in ventral view, by the inflated bulla (fig. 1); the bulla was also tightly attached, though not completely fused, to the petrosal. Additionally, a vertical septum is present in the bulla of *R. delicatissimus*; this is definitely a derived condition. This condition is very much like that of sciurids, where a few septa are present in the bulla and one of them is always located at its anteromedial corner within the bulla.

A bony bulla is assumed to have been present in at least some paramyines (Wood, 1962). If such a bulla was present, it was probably similar to that of *Sciuravus* and *Cocomys*, and more primitive than that of *R. delicatissimus*. This may be inferred on two grounds. When viewing the lateral side of the *R. delicatissimus* skull, one can see a distinct imprint on the ventral margin of the squamosal (fig. 2), that accommodates the dorsal expansion of the ectotympanic. Such an imprint was not observed on any available skulls of *Paramys*. This implies that the lateral wall of the bulla in *Paramys*, if indeed the bulla

was present, must have been entirely confined to the ventral side the skull.

In addition, *Paramys* (AMNH 12508, for example) has a distinct tympanohyal, or a mastoid tubercle (which may be represented in part by an outgrowth of the mastoid and may fuse with the tympanohyal) (Novacek, 1986). The tympanohyal is the most cranial element of the hyoid bar, which often fuses to the petrosal in late developmental stages (van der Klaauw, 1931; De Beer, 1937; McDowell, 1958; MacPhee, 1981). Similar to the condition in *Leptictis*, there is a rounded fossa on the ventral surface of the tympanohyal in *Paramys*. A prominent tympanohyal is generally associated with a poorly developed bulla, as in marsupials, *Leptictis*, creodonts, and primitive carnivorans. In rodents where the bulla is considerably developed, the tympanohyal, or even the mastoid process where the tympanohyal is attached, fuses with the bullar wall so that a distinct tympanohyal is not usually present. If *Paramys* had a bulla, it was most likely very small and loosely attached to the petrosal. Lavocat and Parent (1985) claimed that the most primitive rodent auditory region is that of the Theridomorpha. Theridomorphs have a somewhat inflated bulla with the external auditory meatus slightly projected laterally (Lavocat, 1967, pl. 2). This bulla is clearly more derived than that of *Sciuravus* and *Comys*, and possibly that of paramyines.

LOSS OF THE PROMONTORY ARTERY (PA). The classic consideration of the primitive morphotype of the internal carotid artery (ICA) in eutherians is that the ICA system has two main trunks: the medial ICA courses medially to the tympanic cavity while the lateral ICA runs along the ventral surface of the promontorium and later gives off the stapedial artery (Matthew, 1909; Van Valen, 1965, 1966; McKenna, 1966; Szalay, 1975; Archibald, 1977; Parent, 1980, 1983). An internal carotid artery and stapedial artery can be traced back in various other tetrapods (Goodrich, 1930; Romer 1956; Romer et al., 1977). An alternative hypothesis about the ICA system has been proposed recently by several workers (Presley, 1979; Cartmill and MacPhee, 1980; MacPhee, 1981; Wible, 1983, 1986, 1987). Based on the observation of the auditory ontogeny and comparative

anatomy of living mammals, it is argued that there is only a single ICA trunk in all fossil and living mammals, and that the single ICA simply takes different positions in the tympanic region in different groups of mammals (fig. 3). The artery may be either in a medial or lateral position; there is no example in extant mammals showing the simultaneous presence of the ICA in both positions. This interpretation is followed in this paper, even though the more traditional position was taken by Lavocat and Parent (1985).

The terminology of the internal carotid artery system needs to be clarified because different terms have been used in the literature. Besides the usage in the two-trunk model of Matthew and others (see above), the internal carotid artery is regarded as the portion that terminates at the point where it bifurcates into stapedial and promontory arteries (Novacek, 1986). This portion is taken as equivalent to the lateral internal carotid artery by MacPhee (1981). In the usage of others (e.g., Bugge, 1985; Wible, 1986), the internal carotid artery includes the portion before the stapedial-promontory bifurcation and the promontory artery. In this paper (fig. 3), internal carotid artery system (ICAS) is used to indicate the proximal internal carotid artery, after it stems off the external carotid artery, and all its terminal branches including the stapedial artery. Proximal internal carotid artery (PICA) is used to indicate the portion before the stapedial-promontory bifurcation, while distal internal carotid artery (DICA) is used for the portion beyond the bifurcation point, no matter which position it is in. When DICA is in the promontory position, it is referred to as promontory artery (PA); when it is in the medial position, it is referred to as medial distal internal carotid artery (MDICA).

It is widely agreed that the reduction of the ICA system is a general evolutionary tendency in eutherians, apparently occurring independently, in various lineages. Similarly, it is a common evolutionary pattern in eutherian mammals that the stapedial artery was reduced and then lost while the MDICA or PICA may still exist. The final stage of this hypothesized transformation series is the complete loss of the ICA system, and its functional replacement by the external carotid

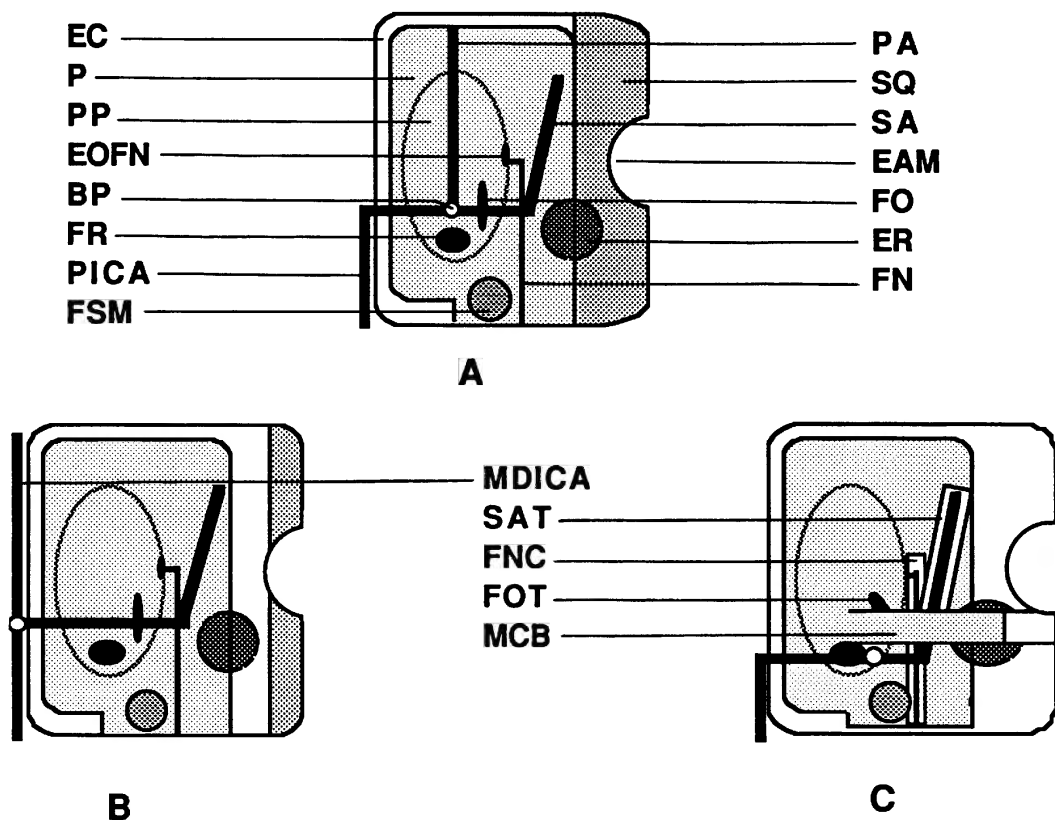

Fig. 3. Block diagrams showing character states in the ventral view of the tympanic cavity. **A**, Primitive eutherian condition; **B**, muroid condition; **C**, reithroparamyine condition. See text for details. Abbreviations: BP, branching point of SA and DICA; PA, promontory artery; EAM, external auditory meatus; EC, ectotympanic; EOFN, external opening of the facial nerve; ER, epitympanic recess; FN, facial nerve; FNC, facial nerve canal; FO, fenestra ovalis; FOT, fenestra ovalis tilted; FR, fenestra rotunda; FSM, fossa for stapedius muscle; MCB, meato-cochlear bridge; MDICA, medial distal internal carotid artery; P, petrosal; PICA, proximal internal carotid artery; PP, promontorium proper; SA, stapedia artery; SAT, tube for stapedia artery; SQ, squamosal.

system (e.g., Carnivora, Artiodactyla, and some Primates). Persistence of a functional stapedia artery while the promontory artery is completely absent is a rare occurrence in eutherians, recorded in some microchiropterans (Buchanan and Arata, 1969) and some rodents. A similar situation may (Szalay, 1975; MacPhee, 1981) or may not occur (Conroy and Wible, 1978) in lemurs.

In living rodents, muroids are the group that presents the most primitive ICA pattern, i.e., a MDICA and stapedia artery are both present (Bugge, 1974b, 1985) although the bifurcation of the DICA and stapedia artery is medial to the bulla (Goodrich, 1930; Wi-

ble, 1987), a rare condition in eutherians (fig. 3B). Among early rodents, sciuravids surely had a promontory and stapedia artery (Wahlert, 1974; personal obs. on AMNH 11614). Theridomorpha and some paramyines may have both arteries (Lavocat and Parent, 1985), but the promontory artery has not been clearly observed in *Paramys*. No matter which position the DICA is in, the condition in which both the distal internal carotid artery and the stapedia artery are present is primitive relative to the condition in which either is lost.

It may be asked from which condition, sciuravid-like or muroid-like, the *R. delicatis*-

simus condition was derived? If derived from the muroid condition, then the DICA would have been lost as a MDICA and the stapedial artery within the tympanic cavity would be homogeneous. If derived from the sciuravid condition, the vessel within the tympanic cavity is not completely the stapedial artery because its proximal end is the terminal end of the proximal internal carotid artery. It may further be asked which position of the internal carotid artery, PA or MDICA, is primitive for rodents? In answering this question, the single ICA hypothesis encounters some difficulty. Recently, Wible (1986) has attempted to clarify this problem. Several lines of evidence suggest that a promontory artery (i.e., an artery in the transpromontorial position) is more primitive than a medially placed distal internal carotid artery for placentals. Other workers argued a contrary view (e.g., Presley, 1979; Novacek, 1985, 1986). Wible's hypothesis is adopted here. The promontory artery is probably present in early rodents such as *Sciuravus*, *Cocomys* (Li et al., 1989), and possibly *Paramys*. The promontory artery is also present in macroscelids and possibly in early lagomorphs. Based on the present evidence, it seems likely that the promontory artery is primitive in rodents and the reithroparamyine condition is derived from an ICA system which had the distal internal carotid artery in the promontory position. Therefore, the proximal portion of the vessel in the tympanic cavity is part of the proximal internal carotid artery (fig. 3). In other words, the vessel in the tympanic cavity is not completely homologous to a stapedial artery and the foramen through which the artery enters the tympanic cavity is more precisely called the carotid foramen instead of the stapedial foramen.

Interestingly, it has been observed with in sciuroids (Tandler, 1899; Bugge, 1971b, 1974b; Wible, 1984) and gliroids (Bugge, 1971b, 1974b) the internal carotid artery does enter the tympanic cavity, as evidenced by its accompanying internal carotid nerve (Wible, 1984). In front of the cochlear fossula, the artery and nerve diverge: the artery (now the proximal stapedial artery) runs laterally toward the fenestra ovalis, and the nerve runs forward. Wible (1984) pointed out that Guthrie (1963) mistakenly identified the sciuroid

and gliroid internal carotid as the stapedial artery and the posterior carotid foramen as a stapedial foramen.

An extratympanic bifurcation of the DICA and stapedial artery has been poorly demonstrated (Ting and Li, 1984; Li and Ting, 1985) in the eurymylid *Rhombomylus*. The authors (Ting and Li, 1984: 98) stated: "the stapedial artery, after stemming from the external carotid artery, enters the tympanic cavity through the stapedial foramen at the posteromedial corner of the bulla." and "The ICA, after stemming from the external carotid artery, enters the cranial cavity through a fissure-like foramen at the anteromedial corner of the bulla (originally in Chinese)." The systematic implications of this feature are profound. In placental mammals, an extratympanic bifurcation of the DICA and stapedial artery is found only in some muroids (Wible, 1987) and probably in Heteromyidae (Bugge, 1974b, 1985; Lavocat and Parent, 1985). This means that these rodents may have evolved from an ancestor that had an ICA pattern similar to that of *Rhombomylus*. If this interpretation is further confirmed, it may serve as additional evidence for eurymylid-rodent relationship. Nevertheless, the condition as described in *Rhombomylus* by Ting and Li (1984, 1985) is questioned because the "internal carotid canal" seems too anteriorly located and too small to be a carotid foramen.

In the skull of *Paramys*, there is a very large canal between the petrosal and the basioccipital, that was interpreted by Lavocat and Parent (1985) as a possible course for the medial internal carotid artery. Moreover, none of the specimens of *Paramys* in the collection of the American Museum of Natural History displays a groove on the promontorium obviously branching from the groove for the stapedial artery to indicate the presence of the promontory artery. A medial canal is not present in *R. delicatissimus*. An internal carotid artery located between the petrosal and the basioccipital has never been recorded (Wible, 1983, 1984, personal commun.). The medial canal in *Paramys* likely housed the inferior petrosal sinus. It is possible that the promontory artery in *Paramys* was reduced or lost.

THE INTERNAL CAROTID ARTERY SHIELD-

ING THE FENESTRA ROTUNDA. An internal carotid artery with the stapedia artery has been reported in many groups of living and fossil mammals (Wible, 1987). Its shielding the fenestra rotunda is uncommon. The common and primitive condition is that the proximal internal carotid artery enters the tympanic cavity through the carotid foramen and then bifurcates into the promontory and stapedia arteries on the ventral surface of the promontorium. The promontory artery travels anteriorly while the stapedia artery runs laterally along the ventral rim of the fenestra rotundum toward the fenestra ovalis (fig. 3A). This pattern has been reported to be present in a few fossil mammals (MacIntyre, 1972; Szalay, 1975; Cifelli, 1982; Coombs and Coombs, 1982; Novacek, 1986), and in some early rodents (Wahlert, 1974; Parent, 1980; Bugge, 1974a; Lavocat and Parent, 1985; Li et al., 1989). Lavocat and Parent (1985) reported the stapedia artery of aplodontids as being lost, but in their character distribution chart (ibid., ch. 13, fig. 4), they coded the fenestra rotunda crossed by the stapedia artery. Nevertheless, the stapedia artery is present in some primitive aplodontids, such as prosciurines (Wahlert, 1974; Luckett and Hartenberger, 1985). In *Allomys nitens* (AMNH 6997) evidence of this vessel also exists: a bony tube partially crosses the fenestra rotunda, similar to the condition in sciurids. The proximal end of the stapedia artery is probably the distal end of the proximal internal carotid artery as postulated in this paper.

It has been reported that the lateral internal carotid artery (=PICA in this paper) shields the ventral part of the fenestra rotundum in a few placental groups. This condition is regarded as primitive in placentals (Szalay, 1972, 1975; Archibald, 1977). Novacek (1980, 1986), however, provided an alternative explanation for the shielding in certain groups. He argued that in many groups this shielding may result from specialized modifications including the marked enlargement of the stapedia artery or its enclosure in bony tubes or both. In *R. delicatissimus*, the shielding clearly results from the development of the meato-cochlear bridge (see below), and likely represents a derived condition. If the condition of the internal carotid artery in *R.*

delicatissimus is derived from a sciuravid pattern, the shielding is at least partly formed by the proximal internal carotid artery (fig. 3C).

THE OSSEOUS MEATO-COCHLEAR BRIDGE. This structure is very narrowly distributed in rodents; it is reported only in Sciuridae and Aplodontidae (Lavocat and Parent, 1985). No such condition has been observed in other mammalian groups. A similar structure may be formed by the fusion of the tympanohyal with the mastoid tubercle in some mammals. In the adult crania of some mammals, the proximal end of the tympanohyal fuses to the mastoid of the petrosal and its distal end may extend to the promontorium, ventrally arching over the exit groove of the facial nerve. In some cases, this process may touch or fuse to the promontorium, to form a bridge which looks superficially like the meato-cochlear bridge. These two conditions are clearly not homologous. The tympanohyal fuses with the mastoid and touches the promontorium at the ventral side of the fenestra rotundum as in the insectivore *Apternodus*, or at the posteroventral side of the fenestra ovalis as in some creodonts and primitive carnivorans. In all these cases, this osseous connection does not block the stapedia artery at the ventral side of the fenestra ovalis. The stapedia artery runs anteroventrally to the connection. If the meato-cochlear bridge is present, however, it joins the ectotympanic at the external auditory meatus and the stapedia artery runs posterodorsal to it (figs. 2, 3). Cifelli (1982) has proposed, alternatively, that in primitive carnivorans, the tympanohyal fuses to a ventromedial elongation of the squamosal. I have reexamined several specimens of primitive carnivorans and creodonts and found that specimens with clear sutures show a mastoid-tympanohyal connection instead of a squamosal-tympanohyal connection.

BONY TUBE FOR FACIAL NERVE AND STAPEDIA ARTERY. A bony tube for the stapedia and promontory artery has been reported in various groups of placentals and has been regarded as a derived condition (Szalay, 1975; Archibald, 1979; Novacek, 1980). The primitive condition is a sulcus or groove on the promontorium, i.e., the stapedia artery is exposed ventrally into the tympanic cavity.

As described by Lavocat and Parent (1985),

the stapedial artery, after passing the fenestra ovalis, enters the facial canal and exits the tympanic cavity by several possible routes. In fact, the stapedial artery does not enter the facial canal but just crosses it. In rodents where the stapedial tube is present, the facial nerve and the stapedial artery are enclosed in two separate tubes (fig. 3). The stapedial artery crosses the facial nerve ventrally in all eutherians, whether or not it is enclosed in a bony tube. The facial nerve runs posteriorly and usually parallel to the lateral side of the promontorium while the stapedial artery runs anterolaterally away from it. Their intersection occurs at a very short distance inside the tympanic cavity. If the bony tubes for the stapedial artery and facial nerve are present, they may be confluent with each other at the crossing point, but this does not mean the stapedial artery enters the facial canal.

After it exits the petrosal and enters the middle ear cavity posteriorly, the facial nerve is covered by a thin bony lamina for a short distance. The tensor tympani muscle usually inserts on the ventral surface of this bony lamina. Primitively, the course of the facial nerve in the tympanic cavity is open. In a more derived condition, however, the facial nerve is completely enclosed in a bony tube. In rodents most of this tube is formed by the petrosal, and only its posteromedial portion is formed by the ectotympanic. When the ectotympanic is well developed, it sinks dorsally into the tympanic cavity, and finally covers the stapedius muscle fossa and the ventromedial side of the facial nerve. When the ectotympanic fuses to the petrosal, the facial nerve is thus completely enclosed in a bony tube.

Similarly, the primitive condition of the stapedial artery in placentals is that the stapedial artery is conveyed in a sulcus and is thus exposed ventrally in the tympanic cavity. After it crosses the fenestra ovalis and then the facial nerve, the stapedial artery bifurcates into the ramus superior and ramus inferior within the tympanic cavity. In a few groups (rodents, lagomorphs, bats, and elephant shrews) the ramus superior/inferior bifurcation is within the cranial cavity, which is accepted as derived condition for Eutheria (Wible, 1986).

In primitive rodents, such as *Paramys*, *Sci-*

uravus, *Cocomys*, and *Theridomorpha*, the facial nerve, after coursing through the internal auditory meatus, appears in the tympanic cavity at an opening anterior or lateral to the fenestra ovalis. After passing the stapedial artery, the lateral side of the facial nerve is bounded by a bony wall formed by the petrosal until it exits the tympanic cavity through the stylomastoid foramen. Compared to the condition in *R. delicatissimus*, this wall in those forms is very short. In addition, the wall in the primitive forms is much lower so that the fenestra ovalis and the epitympanic recess is not significantly separated by it. In all these forms, then, the stapedial artery is completely exposed through the tympanic cavity. After passing by the fenestra ovalis, the proximal stapedial artery immediately pierces the petrosal and exits the tympanic cavity.

R. delicatissimus displays a more derived condition. Initially, the stapedial artery is exposed in the tympanic cavity as it courses over the fenestra rotundum, but after passing through the stapes it immediately runs into a bony tube. As in sciurids, the bony tube for the stapedial artery projects ventrally to a remarkable degree from the ventral roof of the tegmen tympani. The facial nerve enters the tympanic cavity after it passes the fenestra ovalis, but only its medial side is exposed. Before it exits the tympanic cavity, the facial nerve may well be enclosed medially by the ectotympanic. The lateral wall for the facial nerve projects so much that it separates the fenestra ovalis from the epitympanic recess as in sciurids.

ORIENTATION OF THE FENESTRA OVALIS. The orientation of the fenestra ovalis in rodents is generally classified as either vertical or horizontal (Parent, 1980, 1983; Lavocat and Parent, 1985). A vertical fenestra ovalis may refer to its vertical orientation relative to the frontal (horizontal) plane of the skull, while a horizontal fenestra ovalis is parallel to the frontal plane. The vertical fenestra ovalis is regarded as the primitive condition (ibid.). The orientation of the fenestra ovalis can also be described by the orientation of its long axis. The fenestra ovalis in mammals is more or less oval. A small and somewhat rounded fenestra ovalis occurs in some groups as a primitive condition (Archibald, 1979;

Prothero, 1983). Orientation of the long axis of the fenestra ovalis parallel to both frontal and sagittal planes is likely to be primitive. This condition is present in primitive eutherians and most living mammals, whether or not the fenestra ovalis is vertical or horizontal. *Paramys*, *Sciuravus*, and *Cocomys* have this condition. In *R. delicatissimus*, however, the fenestra ovalis is somewhat tilted to the frontal plane possibly because of the presence of the meato-cochlear bridge and the course of the stapedia artery approaching from its posterior side (figs. 2, 3A). In addition, the fenestra ovalis is larger than that in paramyines and sciuravids. A large fenestra ovalis is also believed to be a derived condition (Lavocat and Parent, 1985).

EXPANDED EPITYMPANIC RECESS. Unlike many mammals where the epitympanic recess is formed medially by the petrosal and laterally by the squamosal, the epitympanic recess in rodents is laterally bounded by the ectotympanic, which completely excludes the squamosal from the tympanic region (figs. 2, 3). Among living rodents, muroids retain a primitive ear region that compares closely with that of the Theridomorpha (Lavocat and Parent, 1985). The epitympanic recess in muroids is located primarily in the tegmen tympani of the petrosal and the ectotympanic contributes only a narrow process to the lateral wall of the recess. The recess is not expanded into the ectotympanic nor is it separated from the external auditory meatus. In other living rodents the ectotympanic, which makes up the lateral part of the epitympanic recess, is greatly excavated dorsally to form a deep fossa or notch. A bony lamina is also developed from the ectotympanic, separating the epitympanic recess from the external auditory meatus. In *R. delicatissimus* there is a very marked fossa in the ectotympanic (figs. 1, 3A). This fossa may function as the lateral part of the epitympanic recess. Primitively, however, it is confluent with the external auditory meatus. Anterodorsal to the epitympanic recess and lateral to the stapedia artery canal, a deep depression is formed in the petrosal. This depression provides the space for a further expansion of the epitympanic recess. In other primitive rodents such as *Paramys* and *Sciuravus*, a complete bulla is not known and the condition of the epitympanic

recess is difficult to ascertain. As discussed in the section on the bulla above, the ectotympanic bulla in these forms was possibly only poorly developed and not yet dorsally expanded, so that a deep epitympanic recess probably did not exist. In *Cocomys*, the epitympanic recess in the petrosal is distinct and there is no expanded fossa in the ectotympanic (Li et al., 1989). In other living rodents, the epitympanic recess in the tegmen tympani becomes less important while its ectotympanic part dominates. In addition, with the projecting facial canal, the epitympanic recess in the tegmen tympani is well separated from the fenestra ovalis.

INFLATION OF THE PROMONTORIUM. In primitive mammals, such as *Leptictis* (Novacek, 1986), *?Protungulatum* (MacIntyre, 1972), and marsupials (Clemens, 1966), the promontorium proper is generally low or flat. In most mammals, the elongated cochlea is coiled into a spiral; presumably this reflects a need for retaining an elongated labyrinth within the confined space of the ear region. Although monotremes have less than one cochlear turn (Griffiths, 1978), most mammals have at least one or two (MacIntyre, 1972). The shape of the promontorium probably reflects to some extent the number of cochlear coils and the orientation of the cochlea. However, there appears to be no direct relationship between the height of the cochlea and the number of half-turns in some mammals (Pye, 1979), nor such a relationship in rodents, although in general, the greater the cochlear height, the greater the number of half-turns in selected groups of rodents (Pye, 1977).

The cochlea coils around a central axis and this axis may point ventrally or anteriorly, indicating a rotation of the cochlear orientation. Generally, when the axis points anteriorly, the promontorium appears more inflated, while the promontorium looks low and flat when the axis points lateroventrally. The cochlear capsules undergo certain rotation and shift during ontogeny. Different groups of mammals present various patterns of rotation and shift (Zeller, 1987). The detailed knowledge of the cochlear rotation and shift during rodent ontogeny is unfortunately not yet available. Whether the cochlea coils tightly or loosely may also affect the shape of the

promontorium, such as in some rodents where the last part of the cochlea remains uncoiled (Lavocat and Parent, 1985). In fossil rodents, *Paramys*, *Sciuravus*, and *Cocomys* have a low and flat promontorium, while *R. delicatissimus* has a more inflated one. Nevertheless, we do not know whether or not the latter has more cochlear turns or has a more anteriorly pointed cochlear axis than the former, unless broken cochlear specimens are available.

THE STAPEDIUS MUSCLE. Lavocat and Parent (1985) believed that Paramyinae are somewhat derived in that the stapedius muscle lies completely within the bulla, and the ear region is located anteriorly in the skull. They considered *Sciuravus* and *Theridomorpha* to be more primitive because their ear region is located at the very posterior part of the skull and the stapedius muscle extends outside the tympanic cavity. The ear region is located less posteriorly in *Paramys* than in other rodents because its mastoid process is horizontally and posteriorly elongated. There is a distinct trough on the ventral side of the mastoid process. This condition is very similar to that of *Adelomys* (Lavocat, 1967: fig. 2; pl. 2), although in *Paramys* this trough is probably longer. A corresponding structure, for the insertion of the posterior belly of the digastric muscle, is present in *Leptictis* and such a trough was regarded as a primitive condition in various groups (Novacek, 1986). Early erinaceomorphs, such as *Pholidocercus hassiacus* and *Diacodon alticuspis*, have a similar trough on the ventral side of the mastoid process (MacPhee et al., 1988). This trough can also be found in early carnivorans and creodonts. In living rodents, the mastoid process is horizontally shortened or in some cases may be vertically protruded. When the mastoid process is reduced, the auditory region appears to be more posteriorly located. It is an open question whether the condition in *Paramys* is primitive or derived.

The stapedius muscle in *Paramys* likely extended outside the tympanic cavity. This is because the fossa for the stapedius muscle in *Paramys* is less restricted posteriorly than in *R. delicatissimus*, and the bulla is too small to completely cover the tympanic cavity. *R. delicatissimus* has a reduced mastoid process and the stapedius muscle is assumed to be within the tympanic cavity because the fossa

is deep and its posterior side is sharply bounded by a tubercle formed by the petrosal. In addition, the bulla is expanded posteriorly, covering the tympanic cavity and the stapedius muscle fossa.

OTHER CHARACTERS. There are some other characters that are basically primitive in *Reithroparamys* and will not be discussed in detail. Such discussions may be found in Parent (1980, 1983) and Lavocat and Parent (1985). These characters include small and circular fenestra rotundum, presence of the stapedia artery, the external auditory meatus not separated from the epitympanic recess, and tensor tympani muscle not covered.

METHODS AND RESULTS

Table 1 lists the auditory features considered in this analysis. Except for those pertaining to reithroparamyines, most features in other selected rodent groups have been taken from Parent (1980, 1983), Lavocat and Parent (1985), Wahlert (1974), Bugge (1985), George (1985), and Luckett (1985). The distribution of these characters in selected groups of rodents is listed in table 2. This data set was analyzed using both PAUP (3.0) provided by D. Swofford to M. Novacek and HENNIG 86 (version 1.5) by J. Farris. The McClade (2.87c) Test was used for data input and character tracing. Data were run on the heuristic and branch-and-bound searches in the PAUP and on *ie* calculations in HENNIG 86. The PAUP program is convenient in many aspects (see also Novacek, 1989), although its branch-and-bound search is slow in handling this particular data set. Calculation under the command *ie* in HENNIG 86 generates trees by implicit enumeration algorithms and the results are certain to be of minimal length (Farris, 1988; see Platnick, 1989, for more details).

Originally, most of the multistate characters have been coded as open, diagonally lined or solid squares for primitive, intermediately derived and derived conditions, respectively (Lavocat and Parent, 1985). The coding is replaced in this paper by 0, 1, and 2 for the purpose of calculation. Apparently, when an intermediately derived condition is specified, transformation of character states is assumed, i.e., from primitive to intermediately

TABLE 1
Selected Auditory Characters and Character
Polarity as Discussed in Text

1.	Bullae are small (0), moderately inflated (1), or inflated (2).
2.	Bulla-petrosal contact is very loose (0), tight (1), or fused (2).
3.	Promontorium proper is low (0), slightly expanded (1), or swollen (2).
4.	Epitympanic recess is a small and shallow fossa (0), or expanded dorsally into the ectotympanic (1).
5.	Epitympanic recess overlies the roof of external auditory meatus (0), or is separated from the external auditory meatus (1).
6.	Coils of cochlea are uniform (0), or its last part uncoiled (1).
7.	Cochlea is in a normal shape (0), slightly bent (1), or strongly bent (2).
8.	Internal septa of the bullae are absent (0), weakly developed (1), or well developed (2).
9.	Distal internal carotid artery is present (0), or absent (1).
10.	Stapedial artery is present (0), reduced (1), or absent (2).
11.	Fenestra ovalis is vertical (0), inclined (1), or horizontal (or tilted) (2).
12.	Fenestra ovalis is small (0), moderately large (1), or large (2).
13.	Fenestra rotunda is small (0), moderately large (1), or large (2).
14.	Fenestra rotunda is regular (rounded) (0), or twisted (1).
15.	Proximal internal carotid artery runs ventral to the fenestra rotunda (0), partially shielding (1), or greatly shielding the fenestra rotunda (2).
16.	Stapedius muscle is large (0), reduced (1), or absent (2).
17.	Stapedius muscle is exposed in the tympanic cavity (0), partially covered (1), or in a closed fossa (2).
18.	Posterior part of the stapedius muscle is outside the bulla (0), or completely inside the bulla.
19.	Tensor tympani muscle is uncovered (0), partially covered (1), or in a closed fossa (2).
20.	Facial nerve is exposed in the tympanic cavity (0), partially enclosed by bony element (1), or completely enclosed in a bony tube (2).
21.	Hypotympanic recess is absent (0), present but small (1), or large (2).
22.	Petrosal orientation is horizontal (0), tilted (1), or more vertical (2).
23.	Meato-cochlear bridge is absent (0), or present (1).
24.	Maleus and incus are separated (0), tightly jointed (1), or fused (2).
25.	Stapedial tube is absent (0), partially developed (1), or complete (2).

derived and then to derived state (or 0-1-2), although an intermediately derived state is more or less arbitrarily determined, such as the fenestra rotunda being small (0), moderately large (1), or large (2). Calculations are done based on two character-type sets: all characters unordered (nonadditive) and all characters ordered (additive). As an ordered character type, the character states are ordered as 0-1-2. When a character changes in a cladogram from state 0 to 2, or vice versa, it will be counted as two steps. In other words, the character must proceed progressively through state 1. However, there is no requirement that state 0 be the ancestral state (Swofford, 1989). As an unordered character type, any state is capable of transforming directly to any other state, and character state 1 in a multistate character is no longer treated as intermediately derived but simply a derived state. When a character transforms from state 0 to 2, or vice versa, it will be counted as only one step.

Figure 4 is the strict consensus (nelson) tree derived from six equally most parsimonious trees that result from a heuristic search of PAUP and *ie* algorithms of HENNIG 86, based on unordered (nonadditive) characters. Branch-and-bound search of PAUP is too slow to be completed in this particular data set. All the six trees have 77 steps of tree length and 0.56 overall consistency index. The consensus tree has 77 character changes, equal to the tree length.

Figure 5 is the most parsimonious tree from branch-and-bound search of PAUP and *ie* algorithms of HENNIG 86, based on ordered (additive) characters. It has 93 steps and 0.46 overall consistency index, but 81 character changes. Character changes are not equal to tree length because when a character changes from state 0 to 2, or vice versa, it is counted as two steps.

Figure 6 is the strict consensus of four equally most parsimonious trees from branch-and-bound search, based on irreversible characters of PAUP. The irreversible characters are equivalent to ordered characters with the additional constraint of irreversibility being imposed, i.e., transformations from a more derived state to a less derived state are prohibited. In this analysis, the "ir-

TABLE 2
Data Matrix of Auditory Features in Selected Rodent Groups
 [0 = primitive state; 1 and 2 = derived states (as unordered character type); 1 = intermediately derived in multistate characters
 (as ordered character type); ? = missing data.]

Taxa	Character																										
	1	2	3	4	5	6	7	8	9	10	11	12	13	14	15	16	17	18	19	20	21	22	23	24	25		
A Outgroup	0	0	0	0	0	0	0	0	0	0	0	0	0	0	0	0	0	0	0	0	0	0	0	0	0		
B Scuravidae	0	0	0	0	0	0	0	0	0	0	1	0	0	0	0	0	0	1	0	0	0	0	0	0	?	0	
C Theridomorpha	2	0	0	0	0	0	0	0	0	0	0	0	0	0	0	0	0	0	0	0	0	0	0	0	?	0	
D Paramyinae	0	0	0	0	0	0	0	0	0	0	0	0	0	0	0	0	0	0	0	0	0	0	0	?	0	0	
E Muroidea	1	0	0	0	0	0	0	0	0	0	0	0	0	0	0	0	0	0	1	0	0	0	0	0	0	0	
F Zapodidae	1	1	0	0	0	0	1	0	0	0	0	0	0	0	0	0	0	0	1	0	0	1	0	0	0	0	
G Heteromyidae	2	2	1	1	1	0	0	2	0	0	0	1	1	0	0	2	0	1	2	2	1	0	0	0	0	2	
H Castoridae	2	2	1	1	1	0	1	0	0	2	1	0	0	1	0	0	2	1	2	2	0	0	0	0	0	0	
I Sciuridae	2	1	2	1	1	1	2	2	1	0	1	2	1	1	2	2	0	1	0	2	0	0	1	0	2	0	
J Aplodontidae	2	2	2	1	1	1	2	2	1	1	2	2	1	1	1	2	0	1	0	2	0	0	1	0	1	0	
K Gliridae	2	1	2	1	1	1	2	2	1	0	2	2	1	0	2	0	1	0	1	2	2	0	0	0	0	2	
L Anomaluridae	2	1	2	1	1	1	2	0	0	2	0	1	0	1	0	1	0	1	1	0	0	2	0	0	0	0	
M Pedetidae	2	1	2	1	1	1	2	0	0	2	1	1	1	1	0	0	0	1	1	0	0	2	0	1	0	0	
N Ctenodactylidae	2	2	2	1	1	1	1	1	1	2	1	1	2	1	0	2	0	1	1	2	1	0	0	0	2	0	
O Thryonomysidae	2	2	2	1	1	1	2	1	1	2	1	1	1	0	0	1	0	1	0	1	2	0	0	0	2	0	
P Caviomorpha	2	2	2	1	1	1	2	1	1	2	2	2	2	2	0	0	1	0	1	2	2	1	0	0	2	0	
Q Reithroparamyinae	2	1	1	1	0	0	0	2	1	0	2	1	0	0	2	0	0	1	0	1	0	1	0	0	1	?	1

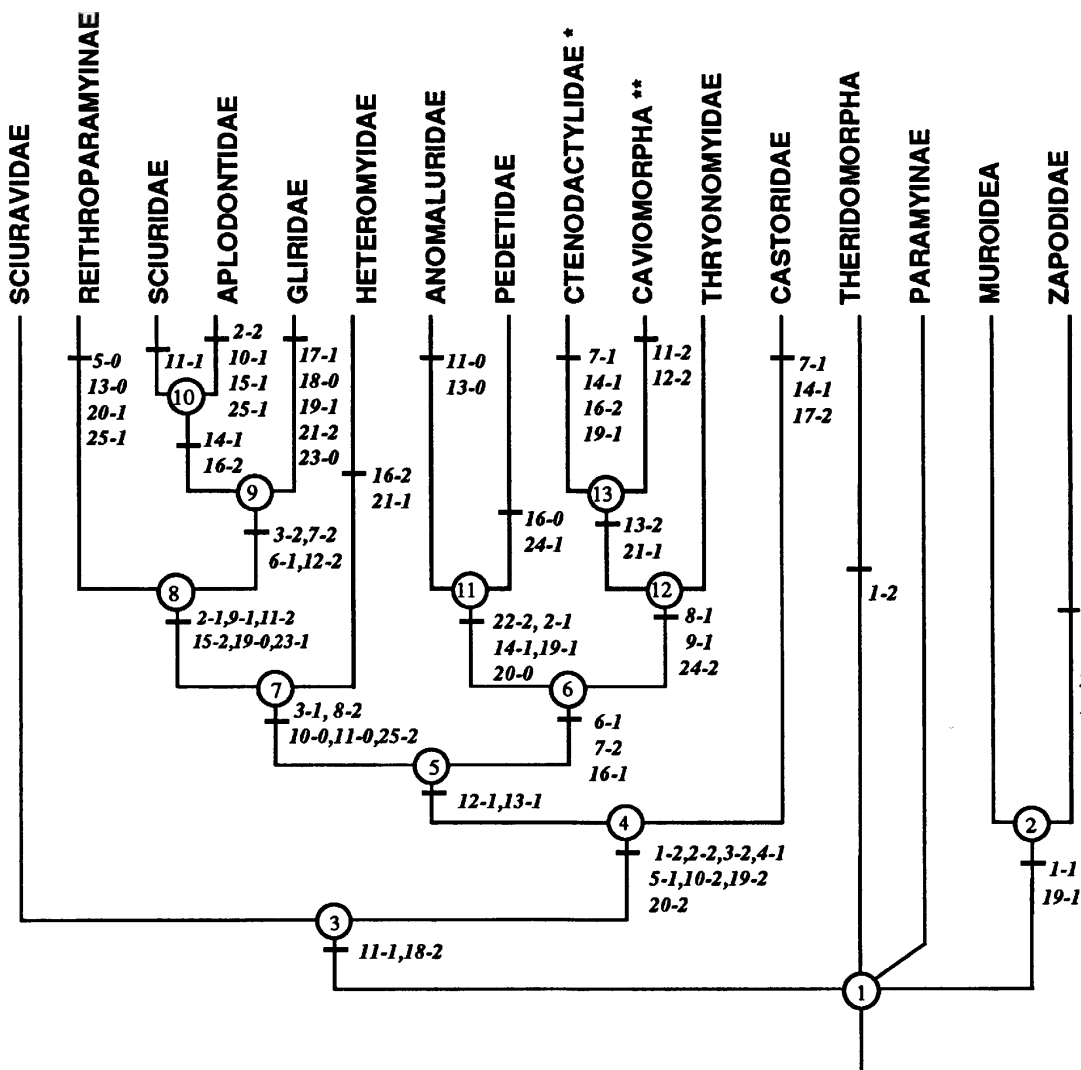

Fig. 4. Cladogram depicting the strict (nelson) consensus tree for selected rodent groups, derived from six equally most parsimonious trees resulting from heuristic search of PAUP and implicit enumeration algorithms of HENNIG 86. All characters unordered. Tree length = 77; overall consistency index = 0.56; character changes = 77. Character changes result from accelerated transformation (ACCTRAN) optimization of PAUP. Number preceding dash = character; number after dash = character state. *, only recent members of the family; **, Erethizontidae not included. See text for more details.

rev.up” command is used to specify that states higher in the symbols order are derived relative to states lower in the symbols order, such as state 2 being derived relative to state 1. The four trees have 102 steps and 0.42 overall consistency index. The consensus tree has 83 character changes.

The character changes in figures 4, 5, and 6 are also results of the accelerated transformation (ACCTRAN) optimization of PAUP.

If a derived state is not consistently present in all members of a given group, ACCTRAN prefers reversals over parallelisms whereas DELTRAN (delayed transformation) can be thought of as preferring parallelisms over reversals. Both optimizations produce cladograms with the same topography and equal tree length, but with different explanations of character changes. For example, as a result of ACCTRAN, the derived condition (2) of

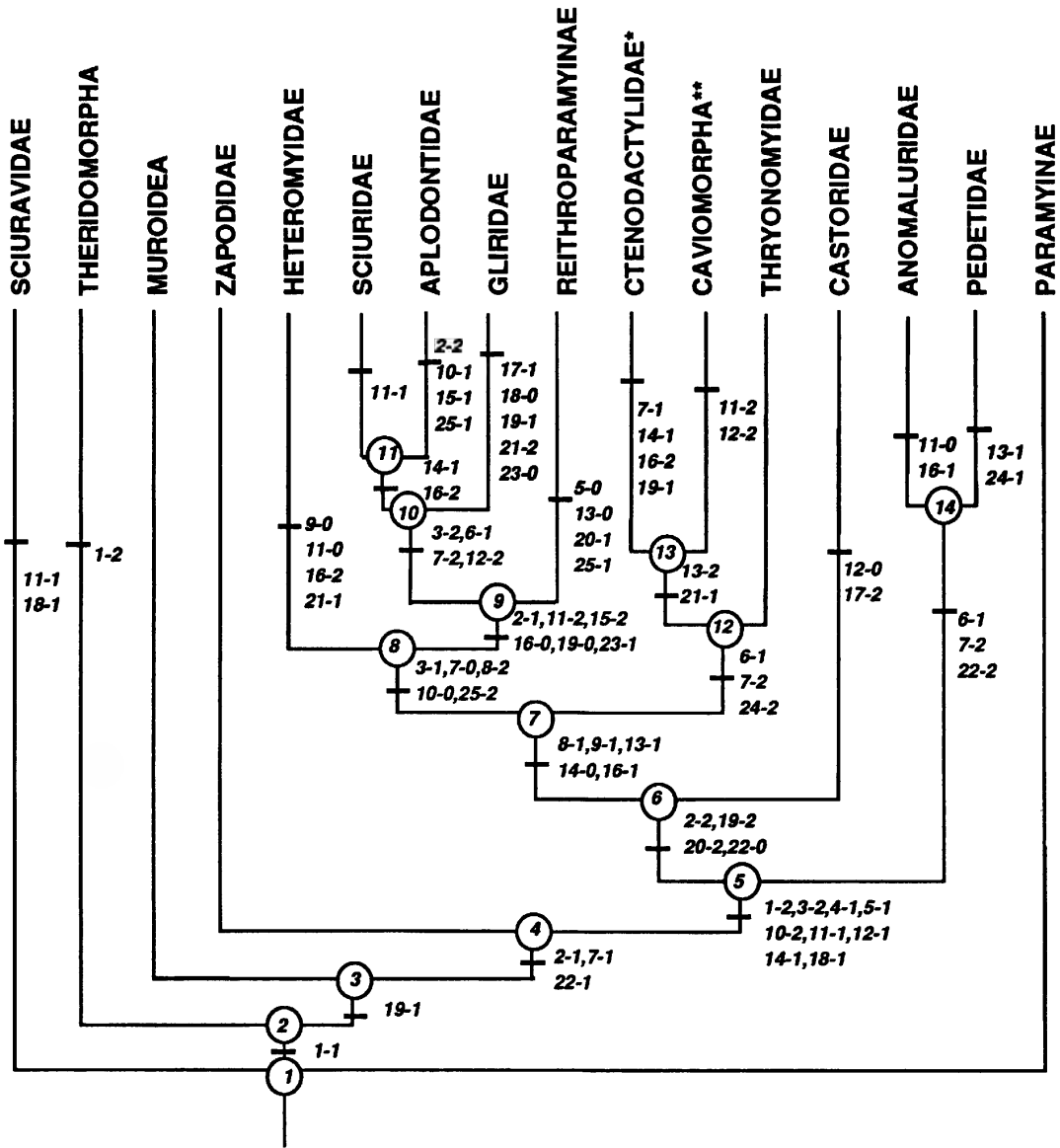

Fig. 5. Cladogram depicting the most parsimonious result from branch-and-bound searches of PAUP and implicit enumeration algorithms of HENNIG 86, based on ordered characters. Overall consistency index = 0.46; tree length = 93; character changes = 81. Character changes are not equal to the tree length because when a character changes from state 0 to 2, or vice versa, it is counted as two steps. Character changes are results of ACCTAN optimization of PAUP.

character 10 occurs at node 4 in figure 4, reverses to 10-0 at node 7, and then appears in Apodontidae as 10-1. As a result of DELTRAN, however, character state 10-2 will occur at node 6 and in Castoridae, and state 10-1 in Apodontidae. These character states can be interpreted as acquired independently

in these taxa and groups. Nonetheless, character 10 displays three steps of changes in both ACCTAN and DELTRAN optimizations. Because the results (the cladograms) are the same, only those of ACCTAN optimization are illustrated.

Table 3 lists the character consistency in-

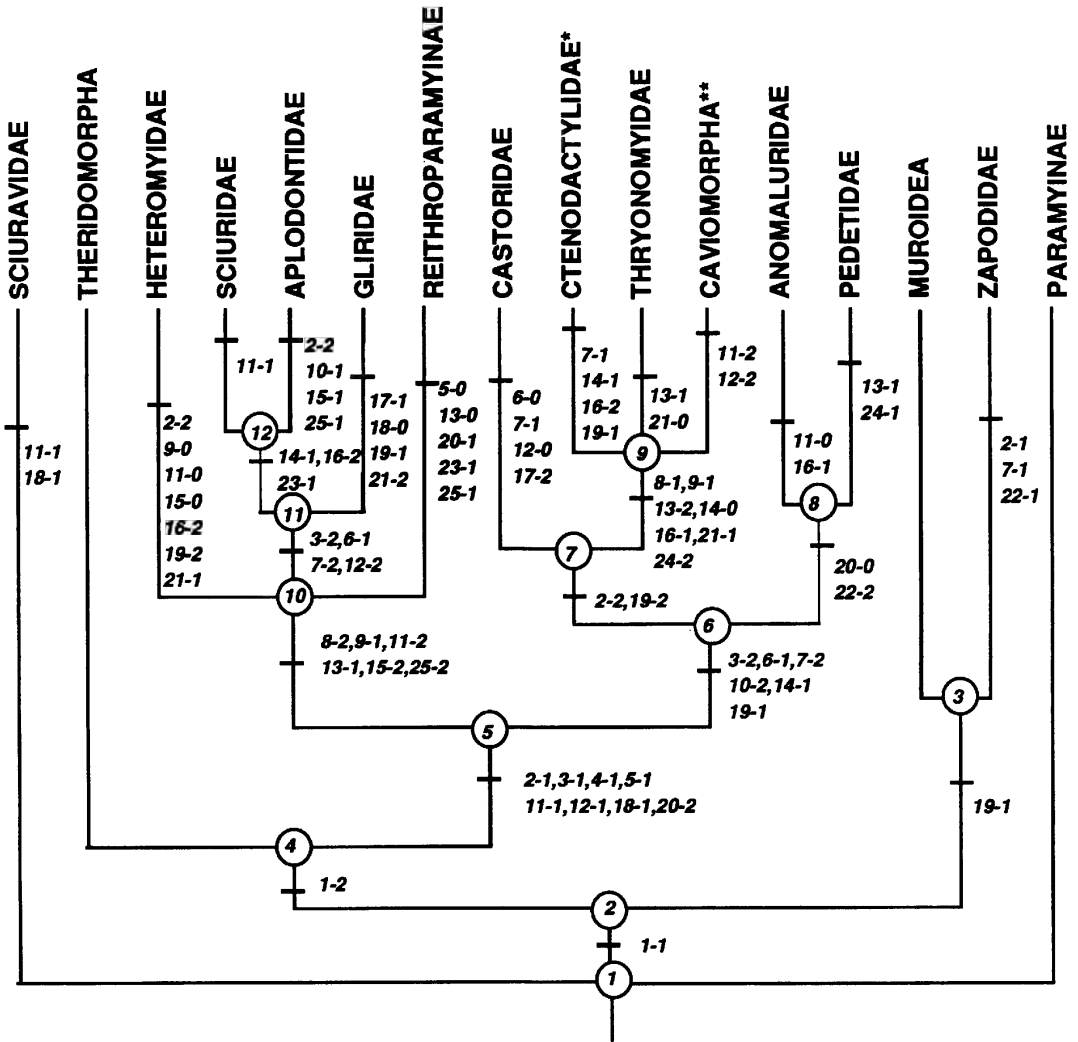

Fig. 6. Cladogram depicting the strict consensus tree derived from four equally most parsimonious trees. The four trees are obtained through branch-and-bound search based on irreversible characters of PAUP. Tree length = 102; overall consistency index = 0.42; character changes = 83.

dices for all characters in figures 4, 5, and 6. Some of these characters have very low consistency indices (CI), especially characters 7, 11, 14, 16, and 19. The CI of these characters are consistently lower than 0.5 in all the three algorithms. Figure 7 provides the consensus results of the most parsimonious trees resulting from the branch-and-bound searches of PAUP on unordered, ordered, and irreversible characters, respectively, with the above five characters excluded from the algorithms. Figure 7A is the consensus of 81 equally most parsimonious trees of un-

ordered characters. The branch-and-bound search of PAUP is possible in this case, although it took 20 hours to complete the calculation. The 81 trees have 51 steps tree length and 0.68 overall CI. Figure 7B is the strict consensus result from eight equally most parsimonious trees of ordered characters, each of them having 61 steps and 0.56 overall CI. Figure 7C is the strict consensus of four equally most parsimonious trees of irreversible characters. The four trees have the same 67 steps tree length and 5.07 overall CI.

As one can see, Figures 4-7 present similar

results. A few groups are stable in all these cladograms. These are Anomaluridae-Pedetidae, Ctenoactylidae-Thryonomyidae-Caviomorpha, and the group consisting of Sciuridae, Aplodontidae, Gliridae, Reithroparamyinae, and Heteromyidae. The occurrences of Anomaluridae-Pedetidae and Castoridae vary considerably in these cladograms, indicating uncertain systematic positions of these taxa (see discussion).

The auditory features do not contribute anything to the monophyly of Rodentia, i.e., no derived character appears at node 1 in figures 4, 5, and 6. Auditory features are only used to reconstruct the relationships within the group. Rodent monophyly is, however, recognized elsewhere by some other characters. In this analysis, Rodentia (ingroup) is assumed to be monophyletic and a hypothetical ancestor (outgroup) is employed for the purpose of analysis. This outgroup is not indicated in the cladograms but is implied by the rooted trees.

DISCUSSION

A cladistic analysis of rodent phylogeny based on the auditory features is attempted in this paper, although such an analysis is generally regarded as difficult, as cautioned by Wilson (1986), because parallelism is thought to be an important factor in rodent evolution. Character distribution in rodents is so inconsistent that it is almost impossible to obtain a single shortest cladogram on any data set by a manual procedure. This is probably why some workers (e.g., Parent, 1980; Lavocat and Parent, 1985) have provided a table of character distributions but failed to present a cladogram out of their distribution data.

I agree with Luckett and Hartenberger (1985) that those phylogenetic hypotheses corroborated by data from several different (and preferably unrelated) organ systems are more likely to reflect the true phylogeny of a group, than are those hypotheses corroborated by single character complexes. As has already been mentioned, previously proposed phylogenetic relationships of reithroparamyines to other groups of rodents have been based primarily on dental and a few cranial features. Data from the auditory re-

TABLE 3
Consistency Indices for Characters in figure 4 (CI-A), figure 5 (CI-B), figure 6 (CI-C)
(Asterisk indicates character that has CI consistently lower than 0.5 in all three algorithms)

Character	CI-A	CI-B	CI-C
1	0.667	0.667	1.000
2	0.400	0.500	0.400
3	0.667	0.500	0.667
4	1.000	1.000	1.000
5	0.500	0.500	0.500
6	0.500	0.333	0.333
7*	0.400	0.286	0.400
8	1.000	1.000	1.000
9	0.500	0.500	0.333
10	0.667	0.400	1.000
11*	0.333	0.286	0.296
12	0.667	0.500	0.500
13	0.500	0.500	0.400
14*	0.250	0.250	0.250
15	1.000	0.667	0.667
16*	0.400	0.286	0.400
17	1.000	0.667	1.000
18	0.500	0.333	0.333
19*	0.333	0.333	0.333
20	0.667	0.667	0.667
21	0.667	0.500	0.500
22	1.000	0.667	1.000
23	0.500	0.500	0.500
24	1.000	0.667	1.000
25	0.667	0.550	0.667

gion in major groups of rodents can be used to test previous hypotheses. Although most of these auditory features are known by some authors, a more explicit resolution of relationships based on these auditory features is provided in this paper. This data set in turn produces hypothetical relationships, which are open to further testing. The following discussion will focus on the phylogenetic position of reithroparamyines and related groups.

REITHROPARAMYINAE CONTROVERSY

The controversy about the relationship of reithroparamyines to other rodent groups began when they were implicated in the origin of the South American Caviomorpha. The Caviomorpha are first known from the Oligocene (Deseadan) of South America, and were already fully hystricognathous and hys-

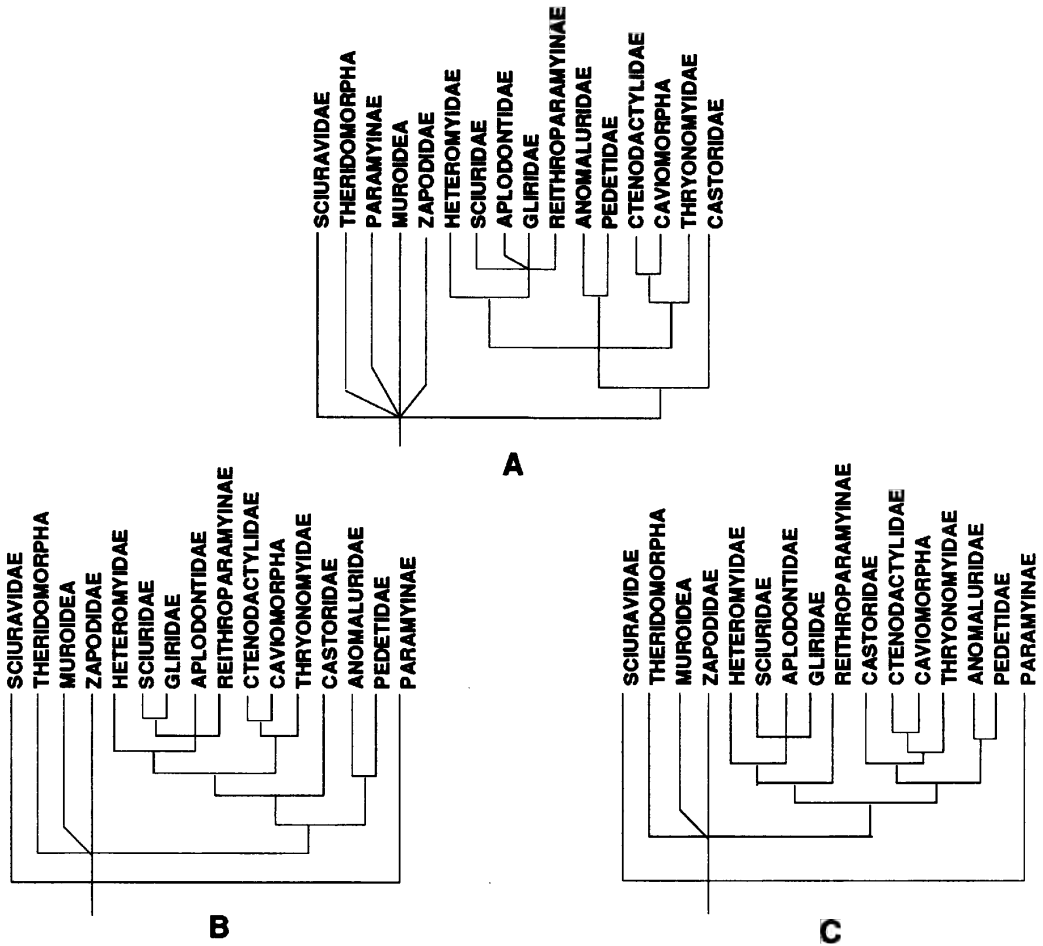

Fig. 7. Consensus results after characters 7, 11, 14, 16, and 19 are excluded (see table 3). All trees are obtained through branch-and-bound searches of PAUP. **A**, Strict consensus of 81 equally most parsimonious trees of unordered characters; tree length = 51; CI = 0.67. **B**, Strict consensus of 8 equally most parsimonious trees of ordered characters; tree length = 61; CI = 0.56. **C**, Strict consensus of 4 equally most parsimonious trees of irreversible characters; tree length = 67; CI = 5.07. A, B, and C are similar in configuration to figs. 4, 5, and 6, respectively, but with a higher overall consistency index.

tricomorphous (Wood, 1985). Two widely differing hypotheses concerning the origin of Caviomorpha are held by Wood and Lavocat. Views of these authors have been strongly and consistently expressed over the last quarter century. According to Lavocat (1973; 1974a, 1974b; 1976; 1980), caviomorphs originated from the African Phiomorpha, a hystricomorphous and hystricognathous group. Phiomorpha, in the usage of Lavocat, includes Old World hystricognaths but is restricted to the Thryonomyoidea by others (Patterson and Wood, 1982; Wood 1985). Lavocat's hypothesis is based largely on the

morphological similarities between Caviomorpha and Phiomorpha, particularly of the middle ear region (Lavocat, 1973, 1976; Parent, 1980, 1983; Lavocat and Parent, 1985). According to Wood (1974, 1975, 1977, 1980, 1981, 1983, 1984, 1985; Patterson and Wood, 1982), the South American caviomorphs are descended from the reithroparamyines or franimorphs, a North or Middle American group with incipient to full hystricognathy.

Beyond simply representing the ancestral stock of the Caviomorpha, Reithroparamyinae, included in Franimorpha, have also been

postulated as progenitors for all Hystricognathi. As early as 1975, Wood suggested that all the special similarities shared by the living hystricognaths that were absent in the Franimorpha must have evolved independently, by parallelism (except the incipient to full hystricognathy). He also believed that from Late Paleocene or early Eocene common ancestors similar to *Franimys*, the franimorphs evolved independently in both North America and Asia, and that the nearest approach to Eocene hystricognaths were the Reithroparamyinae. The New and Old World hystricognaths were regarded as independently derived from New and Old World subhystricognathous rodents, presumably all members of the Reithroparamyinae, that had reached North America and Asia by the Early Eocene. Furthermore, Patterson and Wood (1982: 453) stated: "The Order Rodentia was certainly of northern origin. Members of it first appear in the latest Paleocene of western North America. These forms, which had already acquired all the basic ordinal characters, are referable to two very closely related families, the sciurognathous Paramyidae and the incipiently hystricognathous Reithroparamyidae, the latter, in our opinion, the ancestral stock of all later members of the Hystricognathi."

Hystricognathi monophyly has been supported by evidence including blood vascular, reproductive, chromosomal, and skeletal features (George, 1985), fetal membranes and placenta (Luckett, 1980, 1985), internal carotid pattern (Bugge, 1985), and features at the molecular level (Sarich, 1985; Shoshani et al., 1985; Beintema, 1985; De Jong, 1985). As to the content of the suborder Hystricognathi, however, there are two different viewpoints. As defined by Wood (1975, 1985), Hystricognathi includes the Hystricidae, the Thyronomyoidea, the Bathyergoidea, the Caviomorpha, and the Eocene-Oligocene Franimorpha. Recently, Wood (1985) argued that the Hystricognathi are a natural group, but only if one includes the basic hystricognathous stock, the Franimorpha, in which many of the features secondarily associated with hystricognathy had not yet developed. In contrast to this, the inclusion of Franimorpha has been rejected by others (Korth, 1984; Luckett and Hartenberger, 1985).

Clearly, the grouping of franimorphs and

the transition of hystricognaths from franimorphs relies heavily on the dubious feature of incipient histricognathy which is believed to be present in reithroparamyines by Wood. That the condition seen in reithroparamyines is indeed incipient histricognathy has been questioned by others (e.g., Dawson, 1977) who regarded it instead as sciurognathy. Korth (1984) has even argued that none of the species included in the Franimorpha appears to have attained histricognathy as defined by Tullberg (1899), that the "incipient" histricognathous condition appears quite common among early rodents, and that it may in fact represent the primitive condition for rodents. Apparently, if this feature is disregarded, there remains little else to suggest that reithroparamyines are particularly closely related to other groups of rodents.

REITHROPARAMYIDAE AND HYSTRICOGNATHI

As introduced above, two views are held about the inclusion of reithroparamyines in the Hystricognathi, based on differing interpretations of mandible structure. Two questions addressing this problem may be posed: (1) are reithroparamyines the ancestral stock, or at least within the ancestral stock, of the histricognaths? (2) are franimorphs a monophyletic group? The answers in both cases appear to be no.

While the mandible of Reithroparamyinae can be viewed as either "incipiently" histricognathous or sciurognathous, derived features of the ear region of *Reithroparamys* clearly favor a closer relationship of reithroparamyines to sciurids, aplodontids, and glirids, shown in figures 4-7. In other words, reithroparamyines are more closely related to sciurognathous rodents than to the Hystricognathi. In figures 4-7, reithroparamyines are far distantly separated from histricognathous groups. There is no shared derived character in the auditory region demonstrating any close relationship between reithroparamyines and histricognaths. Based on the features of the auditory region, reithroparamyines as the ancestral stock of histricognathous rodents is rejected.

This raises the question of "Franimorpha" monophyly, particularly considering the fact that some of the members included in the

"Framimorpha" do develop typical hystricomorphy and histricognathy, but others have features typical of sciuromorphic and sciurognathous rodents. Framimorpha was proposed by Wood (1975) as an infraorder that first included Reithroparamyinae, *Prolapsus*, *Protoptychus*, and *Guanajuatomys*. Afterward, Wood (1980, 1985; Patterson and Wood, 1982) added Cylindrodontidae to this infraorder and the Reithroparamyinae was elevated to the family Reithroparamyidae. Among the "Framimorpha," the late Eocene *Protoptychus* (Scott, 1895; Wilson, 1937) is recognized as fully histricomorphous (Wahlert, 1973), although differing views have been published concerning its mandibular structure (Wood, 1975; Dawson, 1977; Korth, 1984). This may indicate that *Reithroparamys* and *Protoptychus* actually represent two different evolutionary lineages, i.e., *Protoptychus* evolved to a hystricomorph while the protrogomorphous *Reithroparamys* to a sciuromorph because the latter bears some derived characters only found in sciuromorphs.

Wood (1977, 1981) described the skull of *Prolapsus*, another member of "Framimorpha," as hystricomorphous. But Korth (1984) believed that the skull of *Prolapsus* was similar to that of the Bridgerian *Sciuravus* and that both are clearly protrogomorphous. Uncertainty also exists about the structure of the mandibles of *Prolapsus* and *Mysops*, although Flynn et al. (1986) thought that histricognathy occurs in the latter Eocene *Prolapsus*. Unfortunately, basicranial morphology in these forms is poorly known.

The ear region in cylindrodontids seems quite different from that of *Reithroparamys*. As described by Wahlert (1974), there is no stapedia artery in cylindrodontids but the internal carotid artery is probably present. The posterior opening of the carotid artery is very small and is separate from the jugular foramen. In reithroparamyines, as in sciurids, the carotid foramen occurs roughly in the same depression with the jugular foramen. The carotid canal, at least in *Ardynomys* and *Cylindrodon*, enters and runs anteriorly through the periotic. The circulation system indicates that *Reithroparamys* and cylindrodontids are widely divergent: the stapedia artery is retained but the DICA is lost in the former while the reverse is true of the latter. All these features suggest that Framimorpha

is not a monophyletic group, and there is not any shared and derived feature to support such a grouping. Korth (1984) has actually returned the Reithroparamyinae back to the Ischyromyidae and relegated other members of Framimorpha to various rodent groups.

Recently, a new genus, *Marfilomys*, from Central Mexico has been described by Ferrusquia-Villafranca (1989). According to the author, this new genus shows greatest resemblance to 7 groups among 27 rodent families compared: reithroparamyine ischyromyids, cylindrodontids, protoptychids, octodontids, cocomyids, yuomyids, and chapattimyine ctenodactylids. The author concluded that "the resemblances were interpreted as phylogenetically related in the case of the reithroparamyines, cylindrodontids, protoptychids, and the early octodontids, because these four taxa are both hystricognathous and histricomorphous (at least incipiently) and the first three, which are united as the Framimorpha, have an Eocene record and inhabit North and Middle America" (ibid., p. 114). Therefore, the discovery of *Marfilomys* in Middle America lends strong support to Wood's hypothesis that the framimorphs were essentially a Middle American group, and that from this group stemmed the ancestral caviomorphs. Apparently, the conclusion reached by the author is based on nothing but the same assumption provided by Wood that the Framimorpha are of at least incipient histricognathy and of Middle or North America distribution. Additionally, some of the characters believed to be shared by *Marfilomys* and framimorphs by the author (Ferrusquia-Villafranca, 1989: 112) may not be unique to these groups, but have a wide distribution in rodents (for instances: upper cheek teeth 1-0-2-3; deciduous premolars normally replaced; premaxillae forming a substantial part of the rostral dorsum, and meeting the frontals; and the relatively posteriorly set incisive foramina transected by the premaxillo-maxillary suture or being limited posteriorly by this suture).

REITHROPARAMYINAE AND OTHER ISCHYROMYIDS

Differentiating taxonomic groups is much easier than specifying their similarities, especially their synapomorphies. Recognizing

the Franimorpha as a nonmonophyletic group leaves open the question of reithroparamyine relationships to other groups. Although the family Reithroparamyidae has been included in the Franimorpha, many authors usually regard it as a subfamily within the Paramyidae (Wood, 1962) or Ischyromyidae (Black, 1971; Korth, 1984). In these cases, the associations have been based for the most part on primitive characters. The diagnosis of the Ischyromyidae proposed by Black (1971) and adopted by Korth (1984), illustrates this point: "Cheek teeth basically low-crowned and tritubercular with hypocone, when present, secondary in importance to protocone; lophate condition rare, found only in a few advanced forms; talonid basins generally large and undivided; infraorbital foramen generally small, rounded, not compressed; zygoma heavy; masseter arises from ventral surface of zygoma; skull quite narrow in postorbital region; nasals usually long; temporal fossa large; braincase small, not inflated; bulla co-ossified only in a few species; tibia and fibula separate; humerus with entepicondylar foramen."

Recently, it has become widely accepted that *Heomys* from the Middle or Late Paleocene of China is the mammal closest to the ancestry of the Rodentia and in particular to the early Eocene ctenodactyls (Li, 1977; Li and Ting, 1985; Li et al. 1987; Li et al. 1989; Korth, 1984; Flynn et al. 1986). Korth postulated that, if the ctenodactyls represent the primitive condition, then reithroparamyines are the most primitive ischyromyids because they maintain a hypocone on P4, a distinct hypoconulid on lower molars, and relatively larger hypocones on the upper molars than in paramyines. The simpler molar pattern in paramyines would be considered more derived. Korth (1984) has also considered four features of skull and mandible to be primitive for rodents: (1) nasal bones extended posteriorly to a level even with the posterior margin of the premaxillaries; (2) double mental foramen on the mandible; (3) posterior margin of the anterior root of the zygoma even with the posterior margin of P4; and (4) auditory bulla not ossified to the skull. Korth believed that the nasals extending farther posteriorly than the premaxillaries in the Paramyinae is a derived condition, because in several eurymylids (unknown in *Heomys*) the premaxillaries extend

farther posteriorly than the nasals. A similar situation, i.e., the premaxillaries extending to or beyond the posterior edge of the nasals, is present in reithroparamyines, pseudoparamyines, sciuravids, and early ctenodactyls. Therefore, Korth concluded that all paramyines could be derived from a primitive reithroparamyine stock by lengthening of the nasal bones and simplification of the occlusal pattern of the cheek teeth. In contrast, the ear region of *Reithroparamys delicatissimus* tells a very different story—that reithroparamyines are probably a more derived group than paramyines, as shown in figures 4–7.

It is to be noted that some members included in the genus *Acritoparamys* Korth, 1984, such as *A. atavus*, *A. atwateri*, and *A. francesi*, had been placed in *Paramys* by others (Jepsen, 1937; Wood, 1959, 1962; McKenna, 1961; Rose, 1981). *Acritoparamys* is included in Reithroparamyinae by Korth (1984), and therefore, reithroparamyine rodents become the earliest known in North America. As pointed out by Korth (ibid.), the most primitive paramyine is *Paramys taurus*, which possesses some of the primitive reithroparamyine characters such as a hypoconulid on the lower molars and hypocone on P4. This makes the separation of the two groups difficult.

Double mental foramina on the mandible are present in the *Heomys* and nearly all early ischyromyids and sciuravids and so are likely primitive. *R. delicatissimus* has only one mental foramen.

According to Korth (1984), the posterior margin of the anterior root of the zygoma in primitive eutherians is level with the posterior molars, and may even be farther posterior than M3. In *Heomys* it is level with the posterior margin of M1. In early ctenodactyls and most primitive paramyines, it is level with the posterior margin of P4, while in reithroparamyines it progressively moves forward until it is in line with the anterior margin of P4 as in *Microparamys* and *Apatosciuravus*. Reithroparamyines therefore have a more derived zygomatic condition. If paramyines were derived from reithroparamyines, one would have to assume a reversal in this character.

Among Eocene ischyromyids, a bulla co-ossified with the skull is only found in reithro-

paramyines. Korth suggested that this might bar the Reithroparamyinae from ancestry of paramyines, but that the earliest reithroparamyines may not have possessed this character. At least, it may not have developed in the Reithroparamyinae until the Paramyinae had already split off. This statement is a speculation for which there is no evidence, although the systematic position of *Reithroparamys* and *Acritoparamys* may be separate issues.

Among the four features of the skull and mandible listed by Korth, only the first seems to be primitive in reithroparamyines. However, whether the nasal bones extending posteriorly to a level with the posterior margin of the premaxillaries is primitive or derived remains an open question. First, "euromyloids" may have premaxillaries extending to or more posterior than the posterior margin of the nasals, but this does not necessarily imply a primitive condition for rodents because some euromyloids (*Rhombomylus*, for instance) are already too specialized (Li and Ting, 1984, 1985; Li et al., 1989) to present the primitive morphotype for rodents. Secondly, in *Cocomys lingchaensis*, the nasal bones extend more posteriorly than the posterior margin of the premaxillaries (Li et al., 1989). Thirdly, and most important, the conditions of a small premaxillary and the posterodorsal process of premaxillary not extending to the frontals are widely distributed in mammals and are generally regarded as primitive (Novacek, 1985, 1986; Li and Ting, 1985). In most mammalian groups, the premaxillary is a small element much less extended posteriorly than the nasal. It is more acceptable that a more posteriorly extended premaxillary in some rodents represents a derived condition.

Simplification of the occlusal pattern of the cheek teeth does not seem well defended. P3 in *Heomys* and *Cocomys* is relatively larger, with two cusps and two roots (at least in *Heomys*). The evolutionary tendency is more likely the simplification of this tooth, because in all ischyromyids the P3 is single-cusped and single-rooted. Comparatively, however, *Reithroparamys* has a more reduced P3 than does *Paramys*. As has been pointed out by various workers (Li, 1977; Li et al., 1989; Dawson et al., 1984), the P4 in both *Heomys* and *Cocomys* is nonmolariform, and the non-

molarized premolar, essential in pointing to the relationship between *Cocomys* and *Heomys*, is another important plesiomorphous feature. Such a P4 has only a single buccal cusp (paracone), and lacks a metacone and hypocone. Flynn (personal commun.) prefers to call the P4 of *Heomys* "submolariform." P4 is submolariform in Paramyinae and molariform in Reithroparamyinae (Korth, 1984). If Korth is correct, i.e., paramyines are derived from reithroparamyines, the transformation of P4 must be from non- or submolariform to molariform and then back to submolariform.

Several other features may also be more derived in reithroparamyines than in paramyines. In *Reithroparamys*, the masseteric fossa of the mandible is bounded by much heavier ridges and terminates more anteriorly. The postglenoid foramen in *Reithroparamys* is more reduced than in *Paramys*. In *Cocomys* this foramen is also very large (Li et al., 1989). The upper and lower incisors in *Reithroparamys* are more laterally compressed, and the anterior surface of the upper incisors is flat. The snout is shorter and more tapered than that of *Paramys*.

These features, plus the derived auditory region represented by *R. delicatissimus*, suggest that the reithroparamyines are more derived than the paramyines. The earliest ischyromyoids, such as *A. atavus* (or *P. atavus*), may truly represent the ancestral stock of the ischyromyoids, but there is little evidence to suggest their placement among reithroparamyines and therefore to suggest that reithroparamyines are ancestral to paramyines. Instead, a possible relationship that requires mention is that reithroparamyines may be derived from a morphotype similar to *Paramys*. Besides the characters discussed above, the possible absence of the promontory artery in *Paramys* may suggest such a possibility.

REITHROPARAMYINAE, SCIURIDAE, APLODONTIDAE, AND GLIRIDAE

As shown in the cladograms (figs. 4 and 5), one interesting grouping consists of Reithroparamyinae, Gliridae, Sciuridae, and Aplodontidae. A unique character at this node is character 15, i.e., the proximal internal carotid artery shields the fenestra rotunda. [Wahlert (personal commun.) considers that

this feature derives independently in glirids because it does not occur in all of them.] Characters supporting this grouping but also occurring in other groups are 2-1, 11-2, and 23-1.

Although aplodontids, sciurids, geomyoids, and castoroids were previously included in Sciuromorpha by Simpson (1945), not all these groups appear to be closely related (Wood, 1937, 1955, 1959; Stehlin and Schaub, 1951; Schaub, 1953; Lavocat 1956). An exception seems to be the Sciuridae and Aplodontidae, where a close sister-group relationship has been proposed by many researchers (Vianey-Liaud 1985; Wahlert, 1985b; Lavocat and Parent, 1985), based on the dental and cranial evidence of early fossils. This sister-group relationship is also supported by molecular evidence (Sarich, 1985), although both forms share the most primitive fetal membrane complex in rodents (Fisher and Mossman, 1969; Luckett, 1971, 1985; Luckett and Mossman, 1981). Moreover, Lavocat and Parent (1985) pointed out that these two groups share a few derived characters in the auditory region, including (1) cochlea bent; (2) meato-cochlear bridge; (3) fenestra rotunda twisted; (4) absence of the internal carotid artery, although some of these characters are also shared with other groups. These authors also believed that the auditory region of living Aplodontidae is more advanced than that of sciurids in two regards: loss of the stapedia artery, and loss of the stapedia bony tube crossing the fenestra rotunda (Lavocat and Parent, 1985). However, it has been noted by Luckett and Hartenberger (1985) that the stapedia artery is present in primitive prosciurine aplodontids as described by Wahlert (1974). As mentioned above, in a specimen of *Allomys nitens* (AMNH 6997), the ear region displays a very similar condition to that in *Palaeosciurus* and other sciurids. In this specimen, the stapedia is apparently present and enclosed in a bony tube along its entire course through the tympanic cavity. The pathway of this artery is similar to that of sciurids, i.e., the stapedia artery (probably the portion of the proximal internal carotid artery) partially crosses over the fenestra rotunda in a bony tube. This indicates that the other aplodontids may have their stapedia artery secondarily reduced from a condition present in *Allomys*. It is

likely that sciurids and aplodontids form a sister-group based on the known evidence.

Sciurids appeared in Europe immediately after the "Grande Coupure" (Lopez and Thaler, 1974; Vianey-Liaud, 1979, 1985; Hartenberger, 1983), and cannot have originated in Europe. Wilson (1949) suggested that the Aplodontidae, Sciuridae, and Castoroidea were derived directly from Eocene paramyines. Lavocat and Parent (1985) held that the Sciuroidea appeared simultaneously in the Oligocene of North America, Europe, and Asia, suggesting a previous Asiatic history, but information showing their connection to earlier forms is lacking. In general, sciurids and aplodontids have been regarded as derived from the Eocene protrogomorphous ischyromyids or sciuravids of North America (Korth, 1984; Vianey-Liaud, 1985), but no specific lineage has been proposed to support this.

Emry and Thorington (1982) described a specimen (USNM 243981), which they thought to be closely related to, if not conspecific with, *Protosciurus jeffersoni*. They regarded this specimen from the Oligocene White River Formation of Wyoming as not only the oldest fossil squirrel, but as almost certainly a tree squirrel. Although this specimen is basically protrogomorphous, the auditory region contains some derived features of modern sciurids: periotic and tympanic bulla fused into a single unit, bulla enlarged, transbullar septae present, and stapedia artery enclosed in a bony conduit through the middle ear. Vianey-Liaud (1985) pointed out these authors' failure to recognize the European sciurid *Palaeosciurus goti* (Vianey-Liaud, 1974a, 1974b, 1975), from Mas de Got, Quercy. This species is also known in the Early Oligocene locality of Aubrelog 1 (Quercy). Summarizing some of the dental, cranial, and postcranial features which define the family Sciuridae, Vianey-Liaud acknowledged that the earliest Oligocene European "squirrel" was clearly a sciuriformous sciurid and rejected *Protosciurus jeffersoni* as a sciurid.

Wood (1980b) held that the transition from protrogomorphy to sciuromorphy should mark the boundary between the Paramyidae and the Sciuridae; and this assumption was followed by Vianey-Liaud (1985). However, sciuromorphy as presently conceived is not

unique to Sciuridae, being independently attained in geomyoids and castorids (Emry and Thorington, 1982), although geomyoids may differ in some details, such as position of the infraorbital foramen. The specializations of the auditory region of sciurids could have taken place before the appearance of sciuriformity, and may represent a good diagnosis for the group. Lavocat and Parent (1985), based on characters of the ear region, proposed that the Sciuroidea (family Sciuridae) are monophyletic and recognizable by two rare auditory features that are always associated: (1) the stapedia artery (PICA used herein) crossing the middle part of the fenestra rotunda within a bony canal; and (2) a strong osseous bridge connecting the promontorium to the auditory meatus (osseous meato-cochlear bridge) and hiding the ossicles in ventral view. These two characters were also regarded as derived characters in Sciuridae by Vianey-Liaud. Whether or not the meato-cochlear bridge exists in *Protosciurus jeffersoni* was not mentioned by Emry and Thorington (1982).

It has been argued (Vianey-Liaud, 1985) that if the sciuriformity of sciurids were transformed from the protrogomorphy of North American rodents, there is no record of such a morphological transition. She admitted that if the sciuriform sciurids and the protrogomorphous aplodontids probably originated from primitive protrogomorphous rodents, it might be possible to find a protrogomorphous "squirrel." It seems that the sciuravids and paramyids have ear regions so primitive that they could be related to almost anything. It is impossible to trace relationships with later rodents by looking at these primitive characters. *Reithroparamys* is not sciuriform, but its auditory region displays conditions of typical sciurids, suggesting a divergence of at least some North American protrogomorphs toward the sciurid-aplodontid rodents. If Lavocat and Parent (1985) are correct, one can simply call *Reithroparamys* a "pro-sciurid" or a protrogomorphous "squirrel" as used by Vianey-Liaud (1985) because it has both a meato-cochlear bridge and the internal carotid artery crossing the fenestra rotunda, although the bony tube for the stapedia artery has not yet completely developed. This may lend

support to the assumption of Black and Sutton (1984) that sciurids certainly appear to be North American in origin.

The systematic position of Gliridae is also controversial. Glirids have been considered to be related to the muroid-dipodoid clade by some authors (e.g., Wahlert, 1978; 1985a, 1985b), based on zygomatic structure. Other authors (Wood, 1980a; Dawson and Krishnalka, 1984; Flynn et al., 1985; Vianey-Liaud, 1985) believed that muroids and glirids acquired these features independently and that glirids are not myomorphous. According to Vianey-Liaud, the "myomorphy" of glirids is only "pseudo-myomorphy," derived from a primitive protrogomorphy, in contrast to an ancestral state of histricomorphy for muroids. Auditory features provided by Lavocat and Parent (1985) and Bugge (1985) support the grouping of glirids and sciurids, although such a relationship is more dubious. This group is supported in the present analysis (figs. 4-7).

Interestingly, Reithroparamyinae has been grouped with Gliroidea based on the "gliroid" tooth pattern (Hartenberger, 1985). It was also shown that the glirids could have originated from the middle Eocene European *Microparamys* (Hartenberger, 1971); the latter was included in the subfamily Reithroparamyinae (Korth, 1984). In addition, reithroparamyines and glirids share the condition of the proximal internal carotid artery crossing the fenestra rotunda. This may hint at a special relationship of reithroparamyines and glirids. Moreover, because glirids likely acquired their "myomorphy" from a protrogomorphous condition, it is possible that *Reithroparamys* represents the ancestral morphotype of glirids, retaining protrogomorphy but sharing some derived characters with glirids.

SOME OTHER SELECTED GROUPS OF RODENTS

CASTORIDAE. The castorids are placed among the Sciuromorpha in Simpson's (1945) classification. Hartenberger (1985) maintained a similar view, considering the castorids and sciurids a monophyletic assem-

blage on the basis of sciuromorphy. A close relationship between castorids and sciurids has been rejected by others (e.g., Schaub, 1953; Wood, 1955). The affinities of castorids to other rodents still remain problematic (Wood, 1959; Wahlert, 1977; Bugge, 1985; Lavocat and Parent, 1985). Bugge emphasized the difference of the cephalic arterial system between castorids and sciurids and believed that a close relationship of these two groups is improbable. As demonstrated by Bugge, castorids retain the medial distal internal carotid artery but lose the stapedia artery while sciurids lose the promontory artery but retain the stapedia artery. Lockett and Hartenberger (1985) argued, citing Wahlert (1977), that the stapedia artery does occur in some fossil castoroids. However, the existence of the stapedia artery is a primitive character in rodents. In addition, the pathway of the stapedia artery in the castoroid *Eutypomys* (Wahlert, 1977) is primitive, coursing along the ventral rim of the fenestra rotunda, instead of across the fenestra rotunda as in sciurids. Therefore, if castorids share any affinity to sciurids and aplodontids, as suggested by Wilson (1949), they must have diverged well before the origin of reithroparamyines. In other words, castorids and sciurids, if related in some way, must have a very distant relationship. The presence of the medial distal internal carotid artery in castorids may turn out to be a clue for castorid phylogeny. It is more likely that castorids are derived from an ancestral stock giving rise to muroids than to sciurids. Nonetheless, the uncertain position of Castoridae is well reflected in figures 4-7.

CTENODACTYLOIDEA. The living Ctenodactylidae have remained until recently a group of uncertain position relative to other rodents (Simpson, 1945; Dawson et al., 1984; Li et al., 1989). On the other hand, Lockett (1980, 1985) and George (1985) suggested a sister-group relationship of recent ctenodactylids with hystricognathi. This relationship is strongly supported by auditory features as shown in figures 4-7, although this grouping may go too far by combining Ctenodactylidae with Caviomorpha as a sister group of Thryonomyidae (figs. 4, 5, and 7). However, I would like to see this as a sign for a more general scheme that Ctenodactylidae are

closely related to Hystricognathi as shown in figure 6. As an alternative view, Flynn et al. (1986) suggested that Ctenodactyloidea plus Pedetidae are the sister group of Hystricognathi.

Problems arise when early ctenodactylids are included. Fossil ctenodactylids have been extensively described from the Tertiary of Asia (Shevyreva, 1972; Dawson, 1977; Sahni and Srivastava, 1977; Hartenberger, 1977, 1980, 1982; Hussain et al., 1978; Li et al., 1979; Dasheveg, 1982; de Bruijn et al., 1982; Dawson et al., 1984). It has been noted that the early ctenodactylids are the rodents most similar to the eurymylid *Heomys*, the mammal which is closest to the direct ancestor to the rodents (Li, 1977; Gingerich and Gunnell, 1979; Chaline and Mein, 1979; Hartenberger, 1980; Dawson et al., 1984; Dawson and Krishtalka, 1984; Korth, 1984; Hartenberger, 1985; Li et al., 1987; Li et al., 1989).

Cocomys, the best preserved ctenodactylid, has almost all those primitive character conditions in its ear region, except for the stapedius muscle which was probably enclosed within the tympanic cavity and the facial nerve that is partially ossified (Li et al., 1989). Although theridomorphs also have primitive ear regions, they are not so primitive as *Cocomys*. For example, theridomorphs (*Adelomys*, for instance) have an inflated bulla (Lavocat, 1967: pl. 2), whereas *Cocomys* has only a small elliptical bulla which is completely confined to the ventral side of the skull. Because the bulla is very poorly developed, it is not impossible that the stapedius muscle in *Cocomys* was partly exposed at the posterior end of the tympanic cavity. Moreover, *Cocomys* possesses some primitive characters that are either present in the genus alone or retained from ancestral eutherian condition but never occur in other rodents (Li et al. 1989). Among these are two auditory features: large epitympanic wing of petrosal and large pyriform fenestra. *Cocomys* has perhaps the most primitive auditory region among rodents. When *Cocomys* (family Cocomyidae) and Ctenodactylidae are placed in the same superfamily Ctenodactyloidea, it becomes difficult to discuss the relationship of the superfamily to other rodents, because it contains the most primitive as well as some of more derived rodents. Re-

cently, Flynn et al. (1986) excluded *Cocomys* from Ctenodactyloidea because it is protrogomorphous and lacks hypolophids. Li et al. (1989) considered that *Cocomys* shares only a few cranial features (deep pterygoid fossa and palatal process of palatine extending more anteriorly) with later ctenodactylids, such as *Tataromys* and *Ctenodactylus*. They therefore conclude (ibid.) that this may be taken as evidence to support Wilson's assumption that "recent Ctenodactylidae are still rather much of an *incertae sedis*."

In considering the primitiveness of the *Cocomys* and the close relationship of the Ctenodactylidae with the Hystricognathi, an early dichotomy in rodent phylogeny between Asiatic cocomyids and North American-European paramyids (Hartenberger, 1980; Luckett and Hartenberger, 1985) appears to gain support. The cocomyids may have given rise to the later ctenodactylids in the Asiatic area, from which the Ctenodactylidae and the Hystricognathi were likely descended. The cocomyid stock also may have given rise to the ischyromyids, the basal stock for some later North American and European groups. Such a dichotomy emerges in figures 4–7, which can be compared to that of Luckett and Hartenberger (1985: fig. 2). *Cocomys* itself is probably too derived to be the direct ancestor of ischyromyids in at least one respect, the relatively larger infraorbital foramen. Vianey-Liaud (1985) termed this "pre-hystricomorphy" and believed that myomorphy is derived from this condition.

ANOMALURIDAE AND PEDETIDAE. These two families are grouped together in this analysis. This is consistent with the result derived from analysis of the arterial pattern (Bugge, 1974b, 1985; George, 1981). Affinities of pedetids and anomalurids are neither supported nor contradicted by fetal membrane data (Luckett, 1985). Hartenberger (1980) suggested a possible relationship of Pedetidae and Anomaluridae with Hystricognathi, but recently (1985) he provided a theridomyid-anomalurid grouping and placed Pedetidae as *incertae sedis*. Flynn et al. (1986) placed Pedetidae with Ctenodactyloidea. A close relationship of anomalurids and pedetids with Phiomorpha was suggested by Lavocat and Parent (1985), but Wood (1985) held that the

cheek-tooth patterns of anomalurids and pedetids have nothing in common and that there is no valid basis for assuming any relationships between the anomalurids and pedetids on the one hand and the Hystricognathi on the other. George (1985) distinguished a sciuromorph-myomorph clade and a ctenodactylid-hystricognath clade, and suggested that anomalurids and pedetids do not associate readily with either of them. Alternatively, Jaeger (1988) tentatively considered Anomaluridae as a sister group of the Theridomyidae. Auditory features support an anomalurid-pedetid sister group, but its relationships with other groups vary considerably (figs. 4–7).

MUROIDEA. A close relationship of Muroidea and Dipodoidea has been suggested on various grounds (Klingener, 1964; Bugge, 1971a; Emry, 1981; Vianey-Liaud, 1985; Flynn et al., 1985; Hartenberger, 1985; Luckett, 1985; Sarich, 1985). Due to their primitiveness, auditory features contribute little to the discussion of this proposed relationship. It has been argued that muroids may be derived from North American sciuravids (Wood, 1959; Korth, 1984). According to Luckett and Hartenberger (1985), however, the unique pattern of apparent "absence" of the medial internal carotid artery, and the occurrence of a promontory artery in sciuravids (Wahlert, 1974), would seem to contradict an ancestral-descendant relationship between sciuravids and muroids. The premise of this statement is that the classical consideration of the internal carotid system is correct (see above). If the internal carotid artery is but a single vessel and if its lateral placement is primitive in rodents, as assumed in this paper, then the ancestral-descendant relationship between sciuravids and muroids cannot be ruled out by this particular character.

An alternative relationship is one between ctenodactylids and muroids (Vianey-Liaud, 1985; Flynn et al., 1985). This is based on the observation that early muroids display a change of the infraorbital region from the hystricomorphous pattern to the typical myomorphous condition (Vianey-Liaud, 1979, 1985). Hystricomorphy (or pre-hystricomorphy) characterizes early ctenodactylids.

CONCLUSIONS

Some of the points discussed above are long-standing problems in rodent systematics. Features from the auditory region of *R. delicatissimus* may offer data to be incorporated in future discussion of rodent phylogenetics. The salient systematic conclusions may be summarized as follows.

1. "Framimorpha" is not a monophyletic group because no derived character supports such a group. The incipient hystricognathy of "Framimorpha" is ambiguous and not widely accepted. Even if this condition exists, it is probably not unique to "Framimorpha." On the other hand, reithroparamyines possess some shared derived characters with sciurids and aplodontids, such as the meato-cochlear bridge and the internal carotid artery over the fenestra rotundum. In addition, *Protoptycus* acquired hystricomorphy independently and *Cylindrodontidae* have an ear region that is derived in a different direction. These diverse morphologies indicate that these "franimorph" groups are more likely on different phylogenetic lines. Consequently, reithroparamyines can hardly be ancestral to hystricognaths nor can they be included in Hystricognathi.

2. Reithroparamyines are protrogomorphous rodents that have several derived features compared to paramyids and other ischyromyids and share only primitive characters with the latter. Little evidence supports the placement of Reithroparamyinae, as the ancestral stock, in *Paramyidae* or *Ischyromyidae*. Instead, reithroparamyines share derived characters with *Sciuridae*, *Aplodontidae*, and *Gliridae*. Although a revised classification is not attempted because the auditory features are only part of the total evidence, these features do reveal certain specialization in reithroparamyines. It is not impossible that reithroparamyines are included in a clade consisting of more derived groups such as *Sciuridae* and *Aplodontidae*, instead of in a grade of primitive protrogomorphs.

3. Finally, it is herein suggested that reithroparamyines be separated from ischyromyids and recognized as a family *Reithroparamyidae* (Patterson and Wood, 1982), including only the genera and most of the

species recognized by Korth (1984). This family may be defined as protrogomorphous rodents with some derived features: P3 reduced and P4 molariform; incisors more laterally compressed, with the anterior surface flat; masseteric fossa bounded by ridges and terminating more anteriorly on the side of the mandible; snout short and tapered; premaxillaries extended to or beyond the posterior margin of nasals; zygoma progressively moved forward until it is in line with anterior margin of P4; postglenoid foramen reduced; bulla co-ossified with skull, with internal septa formed; bony tube for stapedial artery and facial nerve partially formed; stapedial artery crossing fenestra rotunda; meato-cochlear bridge developed; epitympanic recess expanded in the ectotympanic.

REFERENCES

- Archibald, J. D.
 1977. Ectotympanic bone and internal carotid circulation of eutherians in reference to anthropoid origins. *J. Hum. Evol.* 6: 609-670.
 1979. Oldest known eutherian stapes and a marsupial petrosal bone from the Late Cretaceous of North America. *Nature* 281: 669-670.
- Beintema, J. J.
 1985. Amino acid sequence data and evolutionary relationships among histricognaths and other rodents. *In* W. P. Luckett and J.-L. Hartenberger (eds.), *Evolutionary relationships among rodents: a multidisciplinary analysis*, pp. 549-565. New York and London: Plenum Press.
- Black, C. C.
 1971. Paleontology and geology of the Badwater Creek area, central Wyoming. Part 7. Rodents of the Family Ischyromidae. *Ann. Carnegie Mus.* 43: 179-217.
- Black, C. C., and J. F. Sutton
 1984. Paleocene and Eocene rodents of North America. *Spec. Publ. Carnegie Mus. Nat. Hist.* 9: 67-84.
- Bruijn, H. de, S. T. Hussain, and J. J. M. Leinders
 1982. On some Early Eocene rodent remains from Barbara Banda, Kohat, Pakistan, and the early history of the order Rodentia. *Proc. Kon. Ned. Akad. Wetensch.*, ser. B, 85: 249-258.
- Buchanan, G. D., and A. A. Arata
 1969. Cranial vasculature of a neotropical

- fruit-eating bat, *Artibeus lituratus*. *Anat. Anz.* 124: 314–325.
- Bugge, J.
 1971a. The cephalic arterial system in mole-rats (Spalacidae) bamboo rats (Rhizomyidae), jumping mice and jerboas (Dipodoidea) and dormice (Gliroidea) with special reference to the systematic classification of rodents. *Acta Anat.* 79: 165–180.
 1971b. The cephalic arterial system in sciuriforms with special reference to the systematic classification of rodents. *Acta Anat.* 80: 336–361.
 1974a. The cephalic arteries of hystricomorph rodents. *Symp. Zool. Soc. London* 34: 61–78.
 1974b. The cephalic arterial system in insectivores, primates, rodents and lagomorphs, with special reference to the systematic classification. *Acta Anat.* 87 (Suppl. 62): 1–160.
 1985. Systematic value of the carotid arterial pattern in rodents. In W. P. Luckett and J.-L. Hartenberger (eds.), *Evolutionary relationships among rodents: a multidisciplinary analysis*, pp. 355–379. New York and London: Plenum Press.
- Cartmill, M., and R. D. E. MacPhee
 1980. Tupaiid affinities: the evidence of the carotid arteries and cranial skeleton. In W. P. Luckett (ed.), *Comparative biology and evolutionary relationships of tree shrews*, pp. 95–132. New York: Plenum Press.
- Chaline, J., and P. Mein
 1979. *Les Rongeurs et l'Evolution*. Doin Editeurs, Paris.
- Cifelli, R. L.
 1982. The petrosal structure of *Hyopsodus* with respect to that of some other ungulates, and its phylogenetic implications. *J. Paleontol.* 56: 795–805.
- Clemens, W.
 1966. Fossil mammals of the type Lance Formation, Wyoming. Part 2. Marsupialia. *Univ. California Publ. Geol. Sci.*, 62: 1–122.
- Conroy, G. C., and J. R. Wible
 1978. Middle ear morphology of *Lemus variegatus*, some implications for primate paleontology. *Folia Primatol.* 29(2): 81–85.
- Coombs, M. C., and W. P. Coombs
 1982. Anatomy of the ear region of four Eocene artiodactyls: *Gobiohyus*, *?Helohyus*, *Diacodexis* and *Homacodon*. *J. Vert. Paleontol.* 2: 219–236.
- Dashzeveg, D.
 1982. La faune de Mammiferes du Paleogene inferieur de Naran-Bulak (Asie Centrale) et ses correlations avec l'Europe et l'Amerique du Nord. *Bull. Soc. Geol. France*, ser. 7, 24(2): 275–281.
- Dawson, M. R.
 1961. The skull of *Sciuravus nitidus*, a middle Eocene rodent. *Postilla*, no. 53.
 1977. Late Eocene rodent radiations: North America, Europe and Asia. *Geobios Mem. Spec.* 1: 195–209.
- Dawson, M. R., and L. Krishtalka
 1984. Fossil history of the families of recent mammals. In S. Anderson and J. K. Jones, Jr. (eds.), *Orders and families of recent mammals of the world*, pp. 11–57. New York: Wiley.
- Dawson, M. R., C.-K. Li, and T. Qi
 1984. Eocene ctenodactylid rodents (Mammalia) of Eastern and Central Asia. *Carnegie Mus. Nat. Hist. Spec. Publ.* 9: 138–150.
- DeBeer, G. R.
 1937. *The development of the vertebrate skull*. Oxford: Clarendon Press, xxiv + 552 pp.
- De Jong, W. W.
 1985. Superordinal affinities of Rodentia studied by sequence analysis of eye lens protein. In W. P. Luckett and J.-L. Hartenberger (eds.), *Evolutionary relationships among rodents: a multidisciplinary analysis*, pp. 211–266. New York and London: Plenum Press.
- Emry, R. J.
 1981. New material of the Oligocene muroid rodent *Nonomys*, and its bearing on muroid origins. *Am. Mus. Novitates* 2712: 14 pp.
- Emry, R., and R. W. Thorington, Jr.
 1982. Descriptive and comparative osteology of the oldest fossil squirrel, *Protosciurus* (Rodentia, Sciuridae). *Smithsonian Contrib. Paleobiol.* 7: 1–35.
- Farris, J. S.
 1988. HENNIG 86 (version 1.5) Reference.
- Ferrusquia-Villafranca, I.
 1989. A new rodent genus from central Mexico and its bearing on the origin of the Caviomorpha. In C. C. Black and M. R. Dawson (eds.), *Papers on fossil rodents—in honor of Albert Elmer Wood*, pp. 92–117. Science Series no. 33, Nat. Hist. Mus. Los Angeles County.
- Fischer, T. V., and H. W. Mossman
 1969. The fetal membranes of *Pedetes capensis*, and their taxonomic significance. *Am. J. Anat.* 116: 29–68.

- Flynn, L. J., L. L. Jacobs, and I. U. Cheema
1986. Baluchimyinae, a new Ctenodactyloid rodent subfamily from the Miocene of Baluchistan. *Am. Mus. Novitates* 2841: 58 pp.
- Flynn, L. J., L. L. Jacobs, and E. H. Lindsay
1985. Problems in muroid phylogeny: relationship to other rodents and origin of major groups. *In* W. P. Luckett and J.-L. Hartenberger (eds.), *Evolutionary relationships among rodents: a multidisciplinary analysis*, pp. 589–616. New York and London: Plenum Press.
- George, W.
1981. Blood vascular patterns in rodents: Contributions to an analysis of rodent family relationships. *Zool. J. Linn. Soc.* 73: 287–306.
1985. Reproductive and chromosomal characters of ctenodactylids as a key to their evolutionary relationships. *In* W. P. Luckett and J.-L. Hartenberger (eds.), *Evolutionary relationships among rodents: a multidisciplinary analysis*, pp. 453–474. New York and London: Plenum Press.
- Gingerich, P. D., and G. F. Gunnell
1979. Systematics and evolution of the genus *Esthonyx* (Mammalia, Tillodontia) in the early Eocene of North America. *Contrib. Mus. Paleontol., Univ. Michigan* 25: 125–153.
- Goodrich, E.
1930. *Structure and development of the vertebrates*. London: MacMillan.
- Griffiths, M.
1978. *The biology of the monotremes*. New York: Academic Press.
- Guthrie, D. A.
1963. The carotid circulation in the Rodentia. *Bull. Mus. Comp. Zool. Harvard* 128: 445–481.
- Hartenberger, J.-L.
1971. Contribution à l'étude des genres *Gli-ravus* et *Microparamys* (Rodentia) de l'Eocene d'Europe. *Palaeovertebrata* 4: 97–135.
1977. A propos de l'origine des rongeurs. *Geobios, Mem. Spec.* 1: 183–193.
1980. Données et hypothèses sur la radiation initiale des rongeurs. *Palaeovertebrata Mem. Jubil. R. Lavocat*: 285–301.
1982. A review of the Eocene rodents of Pakistan. *Contrib. Mus. Paleontol., Univ. Michigan* 26(2): 19–35.
1983. La Grande Coupure. *Pour La Science* 67: 26–38.
1985. The Order Rodentia: Major questions on their evolutionary origin, relationships and suprafamilial systematics. *In* W. P. Luckett and J.-L. Hartenberger (eds.), *Evolutionary relationships among rodents: a multidisciplinary analysis*, pp. 1–33. New York and London: Plenum Press.
- Hussain, S. T., H. de Bruijn, and J. M. Leinders
1978. Middle Eocene rodents from the Kala Chitta Range (Punjab, Pakistan). *Proc. Kon. Ned. Akad. Wetensch., Amsterdam, ser. B*, 81: 74–112.
- Jaeger, J.-J.
1988. Rodent phylogeny: new data and old problems. *In* M. J. Benton (ed.), *The phylogeny and classification of the tetrapods, vol. 2: Mammals. Syst. Assoc. Spec. Vol. 35B*: 177–199.
- Jaeger, J.-J., C. Denys, and B. Coiffait
1985. New Phiomorpha and Anomaluridae from the Late Eocene of North-West Africa: phylogenetic implications. *In* W. P. Luckett and J.-L. Hartenberger (eds.), *Evolutionary relationships among rodents: a multidisciplinary analysis*, pp. 567–588. New York and London: Plenum Press.
- Jepsen, G. L.
1937. A Paleocene rodent, *Paramys alavus*. *Proc. Am. Philos. Soc.* 78: 291–301.
- Klaauw, C. J. van der
1931. The auditory bulla in some fossil mammals. *Bull. Am. Mus. Nat. Hist.* 62: 1–352.
- Klingener, D.
1964. The comparative myology of four dipodoid rodents (genera *Zapus*, *Napeozapus*, *Sicista*, and *Jaculus*). *Mus. Zool. Univ. Michigan Misc. Publ.* 124: 1–100.
- Korth, W. W.
1984. Earliest Tertiary evolution and radiation of rodents in North America. *Bull. Carnegie Mus.* 24: 1–71.
- Lavocat, R.
1956. Reflexions sur la classification des rongeurs. *Mammalia* 20: 49–56.
1967. Observations sur la région auditive des Rongeurs Théridomorphes. *Problemes actuels de Paleontologie, Colloque Internat. C.N.R.S.* 611: 491–501.
1973. Les Rongeurs du Miocène d'Afrique Orientale. I. Miocène inférieur. E.P.H.E., Inst. Montpellier, Mem. 1: 1–284.
1974a. The interrelationships between the African and South American rodents and their bearing on the problem of the origin of South American monkeys. *J. Hum. Evol.* 3: 323–326.

- 1974b. What is an hystriognath? Symp. Zool. Soc. London 34: 7–19.
1976. Rongeurs caviomorphes de l'Oligocène de Bolivie. II. Rongeurs du Bassin Desadien de Salla-Luribay. *Palaeovertebrata* 7: 15–90.
1980. The implications of rodent paleontology and biogeography to the geographical sources and origin of latyrrhine primates. In R. L. Ciochon and A. B. Chiarelli (eds.), *Evolutionary biology of the new world monkeys and continental drift*, pp. 93–102. New York: Plenum Press.
- Lavocat, R., and J.-P. Parent
1985. Phylogenetic analysis of middle ear features in fossil and living rodents. In W. P. Luckett and J.-L. Hartenberger (eds.), *Evolutionary relationships among rodents: a multidisciplinary analysis*, pp. 333–354. New York and London: Plenum Press.
- Li, C.-k.
1977. Paleocene eurymyloids (Anagalida, Mammalia) of Qianshan, Anhui. *Verbr. PalAsiat.* 15: 103–118.
- Li, C.-k., C.-s. Chiu, D.-f. Yan, and S.-m. Hsieh
1979. Notes on some Early Eocene mammalian fossils of Hengtong, Hunan. *Verbr. PalAsiat.* 17: 71–82.
- Li, C.-k., and S.-y. Ting
1984. The Paleogene mammals of China. *Bull. Carnegie Mus. Nat. Hist.* 21: 1–98.
1985. Possible phylogenetic relationship of Asiatic eurymylids and rodents, with comments on mimotonids. In W. P. Luckett and J.-L. Hartenberger (eds.), *Evolutionary relationships among rodents: a multidisciplinary analysis*, pp. 35–58. New York and London: Plenum Press.
- Li, C.-k., R. W. Wilson, M. R. Dawson, and L. Krishtalka
1987. The origin of rodents and lagomorphs. In H. H. Genoways (ed.), *Current mammalogy 1*, pp. 97–108. New York: Plenum Press.
- Li, C.-k., J.-j. Zheng, and S.-y. Ting
1989. The skull of *Cocomys lingchaensis*, an early Eocene ctenodactyloid rodent of Asia. In C. C. Black and M. R. Dawson (eds.), *Papers on fossil rodents—in honor of Albert Elmer Wood*, pp. 180–192. Science Series no. 33, Nat. Hist. Mus. Los Angeles County.
- Lopez, N., and L. Thaler
1974. Sur le plus ancien Lagomorphe européen et la “Grande Coupure” Oligocène de Stehlin. *Palaeovertebrata* 6: 243–251.
- Luckett, W. P.
1971. The development of the chorio-allantoic placenta of the African scaly-tailed squirrels (Family Anomaluridae). *Am. J. Anat.* 130: 159–178.
1980. Monophyletic or diphyletic origin of Anthroproidea and Hystriognathi: evidence of the fetal membranes. In R. L. Ciochon and A. B. Chiarelli (eds.), *Evolutionary biology of the new world monkeys and continental drift*, pp. 347–368. New York: Plenum Press.
1985. Superordinal and intraordinal affinities of rodents: developmental evidence from the dentition and placentation. In W. P. Luckett and J.-L. Hartenberger (eds.), *Evolutionary relationships among rodents: a multidisciplinary analysis*, pp. 227–276. New York and London: Plenum Press.
- Luckett, W. P., and J.-L. Hartenberger
1985. Evolutionary relationships among rodents: comments and conclusions. In W. P. Luckett and J.-L. Hartenberger (eds.), *Evolutionary relationships among rodents: a multidisciplinary analysis*, pp. 685–712. New York and London: Plenum Press.
- Luckett, W. P., and H. W. Mossman
1981. Development and phylogenetic significance of the fetal membranes and placenta of the African hystriognathous rodents *Bathyergus* and *Hystrix*. *Am. J. Anat.* 162: 265–285.
- Matthew, W. D.
1909. The Carnivora and Insectivora of The Bridger Basin, Middle Eocene. *Mem. Am. Mus. Nat. Hist.* 9: 289–567.
- MacIntyre, G. T.
1972. The trisulcate petrosal pattern of mammals. In T. Dobzhansky, M. K. Hecht, and W. Steere (eds.), *Evol. Biol.* 6: 275–303.
- MacPhee, R. D. E.
1981. Auditory regions of primates and eutherian insectivores. Morphology, ontogeny, and character analysis. In F. S. Szalay (ed.), *Contributions to primatology*, vol. 18. Basel: S. Karger, xii + 282 pp.
- MacPhee, R. D. E., M. J. Novacek, and G. Storch
1988. Basicranial morphology of early Tertiary erinaceomorphs and the origin of Primates. *Am. Mus. Novitates* 2921: 42 pp.
- McDowell, S. B.
1958. The Great Antillean insectivores. *Bull. Am. Mus. Nat. Hist.* 115: 113–214.

- McKenna, M. C.
 1961. A note on the origin of rodents. *Am. Mus. Novitates* 2037: 5 pp.
 1966. Paleontology and the origin of the primates. *Folia Primatol.* 4: 1–25.
- Novacek, M. J.
 1977. Aspects of the problem of variation, origin, and evolution of the eutherian auditory bulla. *Mammal Rev.*, 7: 131–149.
 1980. Cranioskeletal features in tupaiids and selected Eutheria as phylogenetic evidence. *In* W. P. Luckett, (ed.), *Comparative biology and evolutionary relationships of tree shrews*, pp. 35–93. New York: Plenum Press.
 1985. Cranial evidence for rodent affinities. *In* W. P. Luckett and J.-L. Hartenberger (eds.), *Evolutionary relationships among rodents: a multidisciplinary analysis*, pp. 59–81. New York and London: Plenum Press.
 1986. The skull of leptictid insectivorans and the higher-level classification of eutherian mammals. *Bull. Am. Mus. Nat. Hist.* 183(1): 1–111.
 1989. Higher mammal phylogeny: the morphological-molecular synthesis. *In* B. Fernholm, K. Bremer, and H. Jörnvall (eds.), *The hierarchy of life*, pp. 421–435. Elsevier Science Publishers B. V. (Biomedical Division).
- Novacek, M. J., and A. R. Wyss
 1986. Higher-level relationships of the recent eutherian orders: morphological evidence. *Cladistics* 2(3): 257–286.
- Novacek, M. J., A. R. Wyss, and M. C. McKenna
 1988. The major groups of eutherian mammals. *In* M. J. Benton (ed.), *The phylogeny and classification of the tetrapods*, vol. 2: *Mammals*. Syst. Assoc. Spec. Vol. no. 35B, pp. 31–71. Oxford: Clarendon Press.
- Parent, J.-P.
 1980. Recherches sur l'oreille moyenne des Rongeurs actuels et fossiles. *Anatomie. Valeur systématique*. Mém. Trav. E.P.H.E., Montpellier 11: 1–286.
 1983. Anatomie et valeur systématique de l'oreille moyenne des Rongeurs actuels et fossiles. *Mammalia* 47: 93–122.
- Patterson, B., and A. E. Wood
 1982. Rodents from the Deseadan Oligocene of Bolivia and the relationships of the Caviomorpha. *Bull. Mus. Comp. Zool.* 149: 371–543.
- Platnick, N. I.
 1989. An empirical comparison of microcomputer parsimony programs, II. *Cladistics* 5: 145–161.
- Presley, R.
 1979. The primitive course of the internal carotid artery in mammals. *Acta Anat.* 103: 138–144.
- Prothero, D. R.
 1983. The oldest mammalian petrosals from North America. *J. Paleontol.* 57: 1040–1046.
- Pye, A.
 1977. The structure of the cochlea in some myomorph and caviomorph rodents. *J. Zool. (London)* 182: 309–321.
 1979. The structure of the cochlea in some mammals. *J. Zool. (London)* 187: 39–53.
- Romer, A. S.
 1956. *Osteology of the reptiles*. Chicago: Univ. Chicago Press.
- Romer, A. S., and S. P. Thomas
 1977. *The vertebrate body*, 5th ed. Philadelphia: W. B. Saunders.
- Rose, K. D.
 1981. The Clarkforkian land-mammal age and mammalian faunal composition across the Paleocene-Eocene boundary. *Pap. Paleontol. Univ. Michigan* 26: 1–197.
- Sahni, A., and M. C. Srivastava
 1977. Eocene rodents of India: their palaeobiogeographic significance. *Geobios, Mem. Spec.* 1: 87–95.
- Sarich, V. M.
 1985. Rodent macromolecular systematics. *In* W. P. Luckett and J.-L. Hartenberger (eds.), *Evolutionary relationships among rodents: a multidisciplinary analysis*, pp. 423–452. New York and London: Plenum Press.
- Schaub, S.
 1953. Remarks on the distribution and classification of the "Hystricomorpha." *Verh. Naturforsch. Ges. Basel* 64: 389–400.
- Shevyreva, N.
 1972. New rodents in the Paleogene of Mongolia and Kazakhstan. *Paleontol. J. (Moscow)* 3: 134–145.
- Shoshani, J., M. Goodman, J. Czelusniak, and G. Braunitzer
 1985. A phylogeny of Rodentia and other eutherian orders: parsimony analysis utilizing amino acid sequences of alpha and beta hemoglobin chains. *In* W. P. Luckett and J.-L. Hartenberger (eds.), *Evolutionary relationships among rodents: a multidisciplinary analysis*, pp. 191–210. New York and London: Plenum Press.
- Simpson, G. G.
 1945. *The principles of classification and a*

- classification of mammals. *Bull. Am. Mus. Nat. Hist.* 85: 1-350.
- Stehlin, H. G., and S. Schaub
1951. Die trigonodontie der simplicidentaten Nager. *Schweiz. Palaeontol. Abh.* 67: 1-385.
- Swofford, D.
1989. *Phylogenetic Analysis Using Parsimony (PAUP)* (version 3.0) for Macintosh PC.
- Szalay F. S.
1972. Cranial morphology of the early Tertiary *Phenacolemur* and its bearing on primate phylogeny. *Am. J. Phys. Anthropol.* 36: 59-76.
1975. Phylogeny of primate higher taxa: the basicranial evidence. *In* W. P. Luckett and F. S. Szalay (eds.), *Phylogeny of the primates: a multidisciplinary approach*, pp. 91-125. New York: Plenum Press.
- Tandler, J.
1899. Zur vergleichenden anatomie der kopfarterien bei den Mammalia. *Denkschr. Acad. Wiss. (Wien)* 67: 677-784.
- Ting, S.-Y., and C.-k, Li
1984. The structure of the ear region of *Rhombomylus* (Anagalia, Mammalia). *Vertebr. Palasiat.* 22: 92-102.
1985. Possible phylogenetic relationship of Asiatic eurymylids and rodents, with comments on mimotonids. *In* W. P. Luckett and J.-L. Hartenberger (eds.), *Evolutionary relationships among rodents: a multidisciplinary analysis*, pp. 35-58. New York and London: Plenum Press.
- Tullberg, T.
1899. Uber das System der Nagethiere: eine phylogenetische Studie. *Nova Acta Reg. Soc. Scient. Uppsala*, ser. 3, 18: 1-514.
- Van Valen, L.
1965. Treeshrews, primates and fossils. *Evolution* 19: 137-151.
1966. Deltatheridia, a new order of mammals. *Bull. Am. Mus. Nat. Hist.* 132: 1-126.
- Vianey-Liaud, M.
1974a. *Palaeosciurus goti* nov. sp., écureuil terrestre de l'Oligocène moyen du Quercy. Données nouvelles sur l'apparition des Sciuridés en Europe. *Ann. Paleontol. Vertebr. (Paris)* 60: 103-122.
1974b. Les Rongeurs de l'Oligocène inférieur d'Escamps. *Palaeovertebrata* 6: 197-241.
1975. Caractéristiques évolutives des Rongeurs de l'Oligocène d'Europe Occidentale. *Coll. Internat. C.N.R.S., Paris* 218: 765-776.
1979. L'évolution des Rongeurs a l'Oligocène en Europe occidentale. *Paleontographica* 166: 136-236.
1985. Possible evolutionary relationships among Eocene and Lower Oligocene rodents of Asia, Europe and North America. *In* W. P. Luckett and J.-L. Hartenberger (eds.), *Evolutionary relationships among rodents: a multidisciplinary analysis*, pp. 277-309. New York and London: Plenum Press.
- Wahlert, J. H.
1973. *Protoptychus*, a hystricomorphous rodent from the late Eocene of North America. *Breviora* 419: 1-14.
1974. The cranial foramina of protrogomorphous rodents, an anatomical and phylogenetic study. *Bull. Mus. Comp. Zool.* 146: 363-410.
1977. Cranial foramina and relationships of *Eutypomys* (Rodentia, Eutypomyidae). *Am. Mus. Novitates* 2626: 8 pp.
1978. Cranial foramina and relationship of the Eomyoidea (Rodentia, Geomorpha). Skull and upper teeth of *Kansasimys*. *Am. Mus. Novitates* 2645: 16 pp.
1985a. Skull morphology and relationships of geomyoid rodents. *Am. Mus. Novitates* 2812: 20 pp.
1985b. Cranial foramina of rodents. *In* W. P. Luckett and J.-L. Hartenberger (eds.), *Evolutionary relationships among rodents: a multidisciplinary analysis*, pp. 311-332. New York and London: Plenum Press.
- Wible, J. R.
1983. The internal carotid artery in early eutherians. *Acta Palaeontol. Polonica* 28 (1, 2): 281-293.
1984. The ontogeny and phylogeny of the mammalian cranial arterial pattern. Ph.D. diss., Duke University, Durham, 705 pp.
1986. Transformation in the extracranial course of the internal carotid artery in mammalian phylogeny. *J. Vertebr. Paleontol.* 6(4): 313-325.
1987. The eutherian stapedia artery: character analysis and implications for superordinal relationships. *Zool. J. Linn. Soc.* 91: 107-135.
- Wilson, R. W.
1949. Early Tertiary rodents of North America. *Carnegie Inst. Washington Publ.* 584: 67-164.
1986. The Paleogene record of rodents: facts and interpretation. *In* K. M. Flanagan

- and J. A. Lillegraven (eds.), Vertebrates, phylogeny and philosophy. *Contrib. Geol.*, pp. 163–176. Univ. Wyoming.
- Wood, A. E.
1937. The mammalian fauna of the White River Oligocene. Part II. Rodentia. *Trans. Am. Philos. Soc.*, n. ser., 28: 155–269.
1955. A revised classification of the rodents. *J. Mammal.* 36: 165–187.
1959. Eocene radiation and phylogeny of the rodents. *Evolution* 13: 354–361.
1962. The early Tertiary rodents of the family Paramyidae. *Trans. Am. Philos. Soc.* 52: 1–261.
1973. Eocene rodents, Pruett Formation, southwest Texas; their pertinence to the origin of the South American Caviomorpha. *Texas Mem. Mus.*, Pearce-Sel-lards ser. 20: 1–40.
1974. The evolution of the Old World and New World histricomorphs. *Symp. Zool. Soc. London* 34: 21–60.
1975. The problem of the histricognathous rodents. *In* G. R. Smith and N. E. Friedland (eds.), *Studies on Cenozoic paleontology and stratigraphy in honor of Claude W. Hibbard Memorial Vol.*, 3. *Univ. Michigan Papers Paleontol.* 12: 75–80.
1977. The evolution of the rodent family Ctenodactylidae. *J. Palaeontol. Soc. India* 20: 120–137.
1980. The Oligocene rodents of North America. *Trans. Am. Philos. Soc.* 70: 1–68.
1981. The origin of the caviormorph rodents from a source in Middle America: a clue to the area of origin of the platyrrhine primates. *In* R. L. Ciochon and A. B. Chiarelli (eds.), *Evolutionary biology of the new world monkeys and continental drift*, pp. 79–91. New York: Plenum Press.
1983. The radiation of the Order Rodentia in the southern continents; the dates, numbers and sources of the invasions. *In* W.-D. Heinrich (ed.), *Wirbeltier-Evolution und Faunenwandel in Känozoicum*, pp. 381–393. *Schriftener. Geol. Wiss.* 19/20, Berlin.
1984. Hystricognathy in the North America Oligocene rodent *Cylindrodon* and the origin of the Caviomorpha. *In*: R. M. Mengel (ed.), *Papers in vertebrate paleontology honoring Robert Warren Wilson*, pp. 151–160, Carnegie Mus. Nat. Hist., Spec. Publ. 9, Pittsburgh.
1985. The relationships, origin and dispersal of the histricognathous rodents. *In* W. P. Luckett and J.-L. Hartenberger (eds.), *Evolutionary relationships among rodents: a multidisciplinary analysis*, pp. 475–513. New York and London: Plenum Press.
- Zeller, U.
1987. Morphogenesis of the mammalian skull with special reference to *Tupaia*. *In* H.-J. Kuhn and U. Zeller (eds.), *Morphogenesis of the mammalian skull. Mammalia Depicta*. Berlin: Verlag Paul Parey.

Recent issues of the *Novitates* may be purchased from the Museum. Lists of back issues of the *Novitates*, *Bulletin*, and *Anthropological Papers* published during the last five years are available free of charge. Address orders to: American Museum of Natural History Library, Department D, Central Park West at 79th St., New York, N.Y. 10024.

THIS PUBLICATION IS PRINTED ON ACID-FREE PAPER.