



The BEAGLE

*Records of the
Northern Territory Museum
of Arts and Sciences*

Volume 7

Number 1

July, 1990

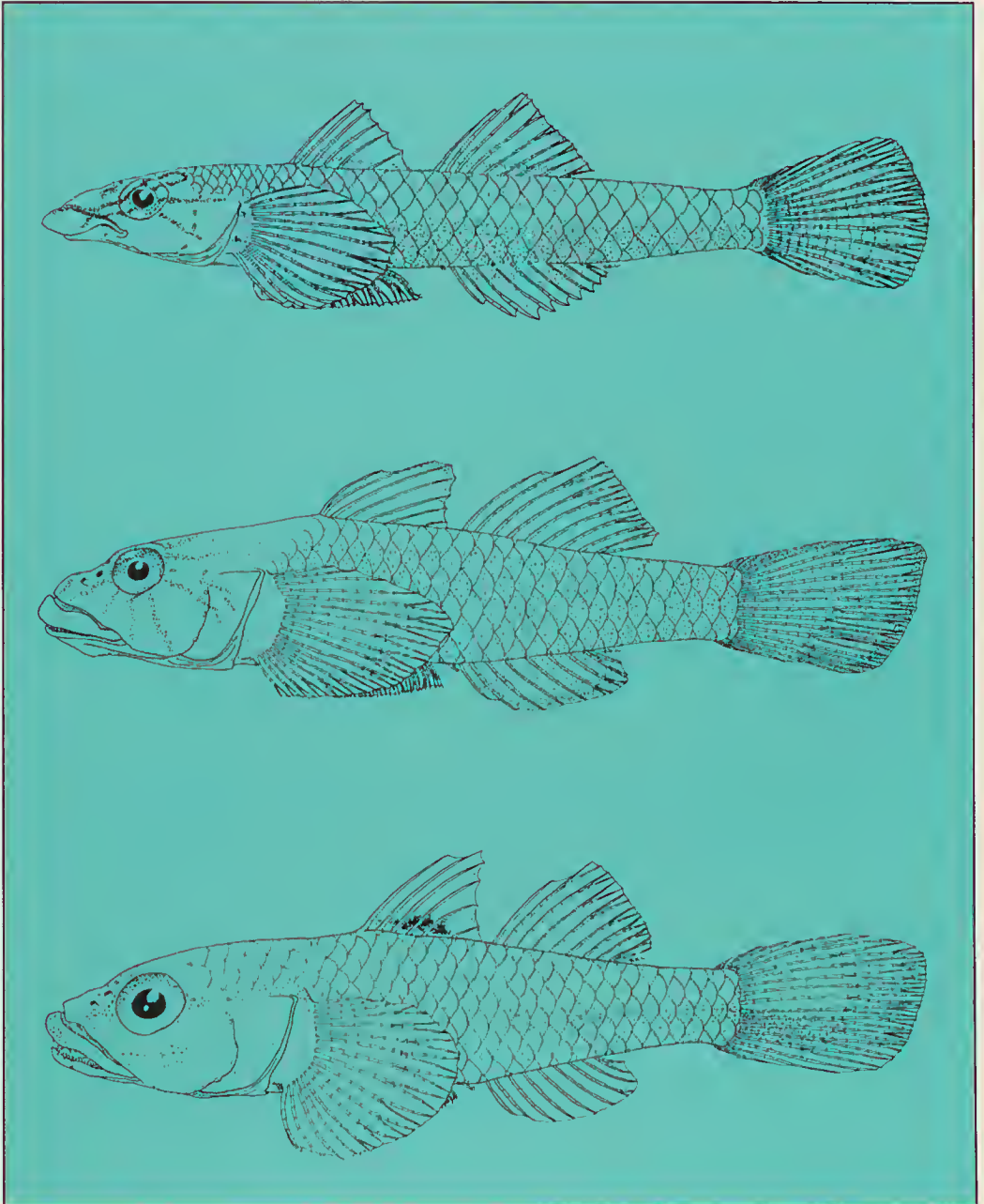

The BEAGLE, Records of the Northern Territory
Museum of Arts and Sciences
(formerly "Occasional Papers of")

ABSTRACTED IN ZOOLOGICAL RECORD AND BIOSIS

Editorial Board

J.N.A. Hooper	<i>Editor</i>	C. Jaek-Hinton
J.R. Hanley	<i>Associate Editor (Sciences)</i>	A.J. Bruce
J.J. Coe	<i>Associate Editor (Humanities)</i>	P.F. Murray
S. Gabrieli	<i>Assistant Editor</i>	U. Dasari <i>Distributions</i>

The Beagle is a refereed journal published by the Scientific Publications of the Northern Territory Museum to disseminate the results of research in the following areas:

- (i) Systematic and other studies of the terrestrial, marine and freshwater flora and fauna of the Northern Territory, tropical Australia, Southeast Asia and Oceania;
- (ii) Australian Aboriginal, Southeast Asian and Oceanic art, material culture and archaeology;
- (iii) Northern Territory and Indo-Pacific history, maritime history and archaeology;
- (iv) Museum conservation, display techniques, taxidermy, publication, public relations, communication and education.

The Beagle is published once or twice a year, depending upon the material available and budgetary considerations.

All contributions to *The Beagle* are peer reviewed by two referees, and where possible at least one international referee is selected by the Editorial board.

Whilst articles for *The Beagle* will normally be 10-30 pages in length, shorter communications and notes, Book Reviews and review articles may be acceptable also. Longer articles, significant works or substantial revisions, which form integral studies, may be considered for separate publication in the *Monograph Series of the Northern Territory Museum of Arts and Sciences*. The *Monograph Series* is distributed with the *Beagle*. Prospective authors should contact the Editor, Scientific Publications.

The Beagle may be obtained by subscription or by exchange. **Subscription rates for one year**, which include the *Beagle* and *Monograph Series* are: Individuals \$30.00, Institutions \$40.00. Postal charges, etc. In Australia only - \$5.00; overseas - \$10.00 (surface), \$20.00 (airmail). Cheques should be made payable to 'Northern Territory Museum'.

All subscriptions, back numbers and exchange enquiries should be addressed to the Librarian, Northern Territory Museum, P.O.Box 4646, Darwin, NT 0801, Australia.

AUTHORS OFFPRINTS

Twenty-five offprints are provided free for each published paper. Additional offprints may be ordered when returning proofs.

SUBMISSION OF MANUSCRIPTS

Contributions, including the original and two copies of each manuscript, a computer floppy disk if available, with copies of art work should be addressed to:

The Editor, Scientific Publications
Northern Territory Museum of Arts
and Sciences,
GPO Box 4646, Darwin NT 0801,
AUSTRALIA.

© Northern Territory Museum of Arts and Sciences, 1990.
ISSN 0811-3653

Cover: Gobiid fishes: top *Luposicya lupus*, middle *Pleurosicya muscarum*, bottom *P. mossambica*
Drawing by Helen Larson.



The BEAGLE

Volume 7

Number 1

July 1990

CONTENTS

SCIENCES

LARSON, H.K. - A revision of the commensal gobiid fish genera *Pleurosicya* and *Luposicya* (Gobiidae), with descriptions of eight new species of *Pleurosicya* and discussion of related genera 1

BRUCE, A.J. - *Periclimenes frankliui* sp. nov., a new deep-sea shrimp from the coral sea (Crustacea:Decapoda:Palaemonidae) 55

HOOPER, J.N.A. - A new species of *Rhabderemia* Topsent (Porifera:Demospongiae) from the Great Barrier Reef 65

GRIFFITHS, M., GREENSLADE, P.J.M., MILLER, L. AND KERLE, J.A. - The diet of the Spiny-anteater *Tachyglossus aculeatus acanthion* in tropical habitats in the Northern Territory 79

MURRAY, P. and MEGIRIAN, D. - Further observations on the morphology of *Wakaleo vanderleueri* (Marsupialia:Thylaeolconidae) from the mid-Miocene Camfield beds, Northern Territory 91

HUMANITIES

BURNINGHAM, N. - Stemless boats of Ende Bay 105

COE, J.J. - The 1989 Hat Yai Records 121

BOOK REVIEW

KING, M. - Kangaroos: their Ecology and Management in the Sheep Rangelands of Australia 137

SCIENCES

A REVISION OF THE COMMENSAL GOBIID FISH GENERA
PLEUROSICYA AND *LUPOSICYA* (GOBIIDAE),
WITH DESCRIPTIONS OF EIGHT NEW SPECIES OF
PLEUROSICYA AND DISCUSSION OF RELATED GENERA.

HELEN K. LARSON

Northern Territory Museum of Arts and Sciences
GPO Box 4646, Darwin NT 0801, Australia.

ABSTRACT

The tropical Indo-Pacific coral reef goby genera *Luposicya* Smith and *Pleurosicya* Weber are reviewed. *Luposicya* is represented by a single species, *L. lupus*, which is redescribed here. *Pleurosicya* is represented by 16 species of which eight (*P. annandalei* Hornell and Fowler, *P. bilobata* (Koumans), *P. holdinghi* Weber, *P. labiata* (Weber), *P. micheli* Fourmanoir, *P. mossambica* Smith, *P. muscarum* (Jordan and Seale) and *P. prognatha* Goren) were previously known and are redescribed here. Eight species of *Pleurosicya* are described as new (*P. australis*, *P. carolinensis*, *P. coerulea*, *P. elongata*, *P. fringilla*, *P. spongicola*, *P. occidentalis* and *P. plicata* spp nov.). The species of the genus can be distinguished from established taxa by a combination of characters which may include the amount of scallation, pectoral ray counts, extent of gill opening, jaw and tongue structure, tooth shape and arrangement, colour pattern, preferred host organism and specificity, and proportions of the head and body. All *Pleurosicya* species are commensal on a variety of invertebrates and plants, particularly sponges, corals, soft corals, gorgonians, seagrasses and algae, and several species are host specific. A key is given to the species of *Pleurosicya* and to differentiate the genus from allied genera (*Bryaninops*, *Lobulogobius*, *Luposicya* and *Phyllogobius*).

KEYWORDS: Gobiidae, taxonomy, new species, Indo-Pacific, commensals, corals, sponges, soft corals, gorgonians, invertebrates, *Bryaninops*, *Lobulogobius*, *Luposicya*, *Phyllogobius*, *Pleurosicya*.

INTRODUCTION

In 1913, Weber described the goby genus *Pleurosicya*, nominating *P. holdinghi* Weber, 1913 from New Guinea as the type species. Larson and Hoese (1980) redescribed *P. holdinghi* and *P. annandalei* Hornell and Fowler, 1922, and further defined the genus. In addition, they selected a lectotype for *P. bilobata* (Koumans, 1941), which was originally described from material consisting of two species. Additional *Pleurosicya* species have been described by Jordan and Seale (1906), Weber (1913), Smith (1959), Plessis and Fourmanoir (1966), Fourmanoir (1971) and Goren (1984). There are eleven nominal species in the genus, eight of which are considered here to be valid. Eight additional undescribed species have been found, from museum material and recent collections made by the author and colleagues, mostly in the western Pacific and northern Australia.

All of the species of *Pleurosicya* are commensal, mostly on alcyonarians (soft corals); they are found also on sponges, reef corals, tunicates, seagrasses and green algae. Hornell and Fowler (1922) were first to realise that commensalism occurred in the genus when they discovered *P. annandalei* living among the hollow branches of the gorgonian *Soleu-caulon tornosum*. However, in many museum collections examined by the author, fishes were collected from rotenone stations, with no record kept of any associated invertebrate. Some species are known to be species-specific as to host, whereas many others are specific only to the type of invertebrate host (e.g. found on soft corals but never on sponges). Several species are known only from a few specimens, with fresh colours and host organism unknown. Specimens of *Pleurosicya* and related genera are often overlooked by collectors and are not always well-represented in museum collections. Therefore the distribu-

tion presently known for many species largely reflects collecting effort, with species found from the Red Sea to Rapa Island in the South Pacific.

Smith (1959) described the genus *Luposicya* (with a single species, *L. lupus* Smith, 1959), distinguishing it from *Pleurosicya* by its restricted gill opening with "...1st gillslit closed by membrane, no outer rakers" and "different shape of head and mouth" (Smith 1959). *Luposicya* does have a unique shape of head and mouth, but the first gillslit is only partly closed, as in *Pleurosicya*. *Luposicya*, redescribed below, is retained here as a monotypic genus, with several characters separating it from *Pleurosicya* and related genera. It is known from the Red Sea to Fiji, with many apparent gaps in its distribution.

Luposicya and *Pleurosicya* are closely related to the genera *Bryaninops*, *Lobulogobius* and *Phyllogobius*; all genera share a similar pelvic fin form in which the usually cup-like fins have a fleshy, forwardly-folded frenum, and distinctive lobes around the pelvic fin spines. The Greek *sikyra* (feminine), an old word for a cupping-glass, aptly describes the cup-like pelvic fins of these fishes. A key to these genera is given below.

METHODS

Counts and measurements follow those in Larson and Hoese (1980). Measurements were taken to the nearest tenth of a millimetre; percentages have been rounded to the nearest whole number. Numbers in parentheses after counts represent sample size. A key to the species of *Pleurosicya* is given after the generic diagnosis. Species descriptions are presented in alphabetical order. Proportional measurements of specimens of *Luposicya* are given in Table 1. For each species of *Pleurosicya*, measurements are given for holotypes (Table 2), range of morphometrics of specimens examined (Table 3), frequency of dorsal and anal fin ray counts (Table 4), frequency of pectoral fin rays (Table 5), and number of unbranched pectoral rays (Table 6).

Abbreviations used throughout the text are as follows: BDA, body depth at anus; HL, head length; SL, standard length; TRB, transverse scale rows backward. Abbreviations of institutions: AMS, Australian Museum, Sydney; ANSP, Academy of Natural Sciences, Philadelphia; BPBM, Bernice P. Bishop Mu-

seum, Honolulu; CAS, California Academy of Sciences, San Francisco; IL, Ichthyology Laboratory, Pont de Briques; LIAIP, Laboratory of Ichthyology, Akasaka Imperial Palace, Tokyo; LON, Lembaga Oseanologie Nasional, Djakarta; MNHN, Muséum National d'Histoire Naturelle, Paris; NSMT, National Science Museum, Tokyo; NTM, Northern Territory Museum, Darwin; ROM, Royal Ontario Museum, Toronto; RMNH, Rijksmuseum van Natuurlijke Historie, Leiden; RUSI, J.B.L. Smith Institute of Ichthyology, Grahamstown; TAU, Tel-Aviv University, Tel-Aviv; UGM, University of Guam, Mangilao; URM, University of the Ryukyus, Naha; USNM, National Museum of Natural History, Washington; WAM, Western Australian Museum, Perth; YCM, Yokosuka City Museum, Kanagawa; ZMA, Zoologische Museum, Amsterdam; ZMH, Zoologische Museum, Hamburg; ZMUC, Zoologisk Museum, Copenhagen; ZSI, Zoological Survey of India, Calcutta.

SYSTEMATICS

Family Gobiidae Linnacus

Key to Genera Related to *Pleurosicya*

1. Interorbital canals separate; two anterior interorbital pores present 3
- 1A. Interorbital canals fused, forming one canal in narrow interorbit; one (rarely two) anterior interorbital pore present 2
2. Edges of lower lip fused to underside of head, lip free anteriorly at mandibular symphysis; lip at sides of lower jaw flared outward to accommodate diagonal row of long, curved, downward- and horizontally-directed teeth outside length of dentary ...
..... *Luposicya*
- 2A. Edge of lower lip free except at mandibular symphysis; sides of lower jaw not as above; usually with rows of short straight forwardly-pointing teeth present at front of lower jaw; if teeth rows extend onto outer face of dentary, the teeth short and restricted to front of jaw *Pleurosicya*
3. Pectoral rays all branched, lower rays not thickened distally (small specimens may have a few upper and lower rays unbranched); anal fin with one more soft ray than second dorsal; eyes quite small (6-7 times in head); deep-water species.....
..... *Lobulogobius*

- 3A. Pectoral rays with lower 2-6 rays unbranched and usually thickened distally; anal fin with same number of soft rays as second dorsal; eyes large (less than 5 times in head) 4
4. Gill opening wide, membranes fused into a free fold across isthmus; nape sealed; head broad and depressed; one species, commensal on flat-bladed sponges *Phyllogobius*
- 4A. Gill opening variable, membranes always attached to isthmus and never form a free fold; nape naked (rarely partly sealed in front of first dorsal); ten species, often commensal on gorgonians..... *Bryaninops*

Genus *Luposicya* Smith

Luposicya Smith, 1959:217 (type species *Luposicya lupus* Smith, 1959, by original designation, from Mozambique).

Luposicya - Goren 1984:81, fig. 5, from Tiran Island, Red Sea (erratum for *Luposicya*).

Diagnosis. Small, elongate goby (up to 28 mm SL), roughly rounded anteriorly and compressed posteriorly. Second dorsal fin rays 1,8; anal fin rays 1,8. Pectoral fin rays usually 14. Segmented caudal rays 17. Lateral scale count 26-32, TRB 8. Gill opening restricted. Snout long and rather pointed. Upper lip bound to head at top of snout. Edge of lower lip fused to sides of jaw, free only at chin. Dentary with row of long straight teeth with anteriorly-curved tips running diagonally across outer face of jaw toward lower surface of chin.

Osteology. (Based on one 18 mm male, NTM S.12717-001). Five branchiostegal rays; no posteleithrum; no mesopterygoid; metapterygoid slender, well separated from quadrate; no preopercular process connecting slender symplectic; ectopterygoid contacting anterior edge of quadrate; palatine slender, extending about half the length of ectopterygoid; hyomandibular in contact with dorsal process of preopercle; sphenotic reaching supraoccipital; epiotics narrowly separated by posterior process of supraoccipital; supraoccipital with crest posteriorly, and antero-lateral wings; basihyal spatulate; maxilla flattened and expanded antero-laterally; premaxilla curved, with articular process expanded and broad, ascending process very long and narrow, with a large foramen at base of each ascending process just above teeth; dentary deep, expanded ventro-medially to accommodate row

of large teeth that extends diagonally across outside of bone, elongate longitudinal foramen extends along most of dentary, separating inner and (diagonally) outer rows of teeth; scapula unossified; vertebrae 10 + 15 plus urostyle (= 26); dorsal ribs on first eight vertebrae (last two poorly ossified); ventral ribs on vertebrae three to ten; spinous dorsal pterygiophore formula (using Birdsong *et al.*'s 1988 formula) 3-22110; anteriorly-directed elongate ventral process of pelvic bones diverge at tips, forming a Y; pelvic spines nearly straight, pointed; caudal skeleton with lower hypural plate articulated with, but not fused, to urostyle; single epural with well-developed dorsal flange; upper hypural rod-like; parhypural free, with narrow ventral flange.

***Luposicya lupus* Smith**

(Figs 1-4; Pl. 1a)

Luposicya lupus Smith, 1959:217 (Pinda, Mozambique); Goren 1984:80-82 (Tiran Island, Red Sea); Winterbottom and Emery 1986:48 (Salomon, Chagos Archipelago).

Luposicya lupus - Goren 1984:81, fig. 5 (erratum for *Luposicya*).

Type material. HOLOTYPE - RUSI 266 (examined by D.F. Hoese (AMS) who made his notes available).

Additional material. QUEENSLAND - AMS I.29783-001: 3(17-18.5), Lizard Island, Research Station beach, from the sponge *Phyllospongia foliascens*, 2 m depth, 3 February 1975. BPBM 33932: 2(17-19), same data as previous, but from different sponge specimen. WAM P.30052-001: 21.5 mm male, same data as previous. CAS 68074: 29 mm male, same data as previous. NTM S.12664-001: 3(14-20), same data as previous. NTM S.12663-001: 24 mm male, Lizard Island, Mrs Watson's Bay, 3-5 m depth, 19 November 1975. NTM S.12662-001: 3(16.5-23.5), Lizard Island, reef by lagoon mangrove, 1-2 m depth, 29 Jan. 1975. AMS I.29784-001: 3(16-27.5), One Tree Island, small lagoon patch reef, 19 February 1974. AMS I.20208-028: 2(18.5-22.5), One Tree Island, largest lagoon, 27 September 1971. ANSP 165110: 3(20.5-25.5), Endeavour Reef, east of Cook wreck site, 14-20m depth, 11 November 1969. NTM S.12661-001: 10 mm juvenile, Rib Reef, windward side, 12 m depth, 4 December 1980. AMS I.22611-067, 11 mm juvenile, North Escape Reef, coral garden, 3-11 m depth, 31 October 1981. IRIAN JAYA - USNM 306880:

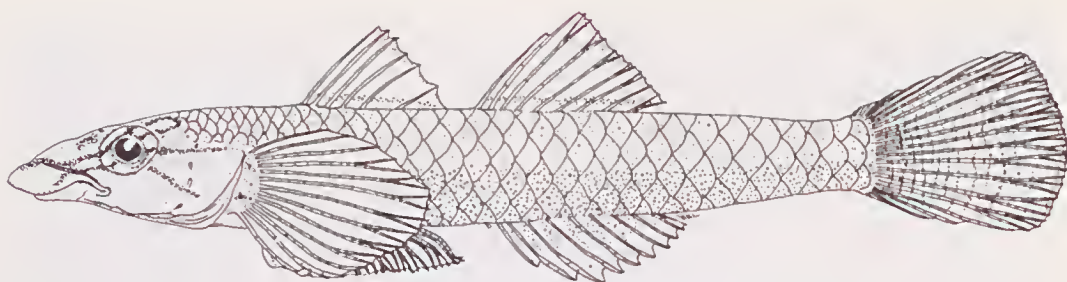

Fig. 1. 21.5 mm male *Luposicya lupus* (unregistered AMS) from Lizard Island, Queensland.

21 mm male, Batanta Island, CHAGOS ARCHIPELAGO - ROM 58020; 20 mm male, Salomon Island, 5-7 m depth, 20 March 1979. RED SEA - USNM 306881: Ethiopia, west of Harat Island, Sheikh el Abu, 0-4 m depth, 14 August 1969, 3(18-24), FIJI - ROM 58021: 3(10-22.5), Kandavu, Astrolabe Reef, Yanu Yanu Island, 10-16 m, among corals, sponges and gorgonians, A. Emery et al., 25 March 1983.

Diagnosis. As for genus.

Description. An asterisk indicates counts taken from the holotype. Based on 31 specimens, 10-27.5 mm SL. First dorsal VI (30)*. Second dorsal 1.7 (2); 1.8 (26)*; 1.9 (2). Anal 1.7 (1); 1.8 (27)*; 1.9 (2). Pectoral rays 13 (6), 14 (20), 15 (4)*; lowermost 3-6 rays unbranched, sometimes with skin surrounding unbranched rays thickened; specimens 10-14 mm or less with all rays unbranched. Branched caudal rays 11 (4). Longitudinal scale count 26-32, with mean of 29 (approximately 30 in holotype). TRB 8-10, mean of 9*. Gill rakers very reduced bumps, raker at angle of arch longest. Rakers on first arch 0+1+2 (2), 2+1+1 (1). Lower quarter of first arch bound by membrane to opercular wall. Vertebrae 10+16 (including urostyle) = 26 (1).

Head and body clongate (Fig. 1), roughly triangular in cross-section (apex dorsally) up to behind pectoral fins, rest of body compressed. Body depth at anus averages 14% (11-17%) of SL. Head length 29% (26-32%) of SL, head width greater than head depth. Snout long, 40% of head length. From above, snout elongate, pointed to rounded at tip. Anterior nostrils in short tube, posterior with low rim. Gill opening restricted, ranging from just past lower pectoral base to below preopercular margin. Upper jaw non-protrusible, skin of upper lip bound to head at top of snout. Eye 27% (23-31%) of head length, placed dorso-laterally. Interorbit usually very narrow, 7% (3-11%) of head length. Mouth subterminal,

upper jaw overhangs lower. Jaws reach to below anterior half or edge of eye. Males tend to have larger mouths (47% of HL versus 43% in females). Tongue wide at base, narrowing abruptly to thin pointed tip. Lower lip smoothly fused to underside of head except for short free fold behind mandibular symphysis (Fig. 2).

Teeth similar in both male and female. Upper jaw with band of small fine pointed teeth; band widest across front of jaw (about 5-6 rows deep), narrowing at sides to only one row of teeth toward edentulous gap at posterior part of jaw, with 2-3 teeth on downward-curving end of premaxilla. Outermost row consists of 5-10 large curved canines across front of jaw, with largest teeth toward side of jaw and smallest in centre. Lower jaw characterised by outermost row of long, generally straight teeth (Fig. 3), row begins on outer

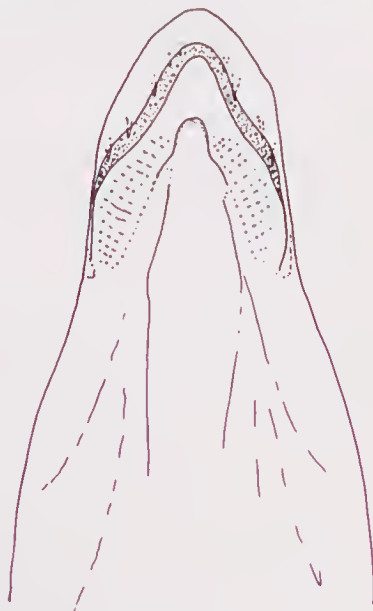

Fig. 2. Underside of head of male *Luposicya lupus* (WAM P.30052-001), showing lower lip fused to sides of jaw, and free anteriorly.

Table 1. Proportional measurements of *Luposicya lupus*, expressed as percentage of standard length (or head length where indicated).

	Males			Females		
	Range	Mean	N	Range	Mean	N
Standard length	18-27.5	22	16	14-24.5	19	9
Head length in SL	26-32	29	16	27.6-30.7	29	9
Head depth in SL	37.7-49.2	44	15	39.6-48.8	45	9
Head width in SL	44.6-57.8	52	15	47.5-60.4	53	9
Body depth at anus	11.4-16.7	14	15	13.2-15.6	14	9
Caudal length in SL	20.4-24.5	23	12	22.9-25	24	7
Pect. length in SL	16.2-20	18	16	16-19.3	18	6
Pelv. length in SL	18.6-22.5	21	16	19.2-24.2	21	9
Caud. ped. l. in SL	19.6-25.1	23	16	21.4-30	25	9
Caud. ped. d. in SL	7.1-10	9	16	7.9-10.3	9	9
Snout in HL	32.7-47.5	40	16	32.6-43.5	38	9
Eye in HL	23-31.1	28	16	24.5-30.4	27	9
Mouth in HL	40-62.1	47	16	39.3-45.7	43	9
Interorbit in HL	2.7-9.8	7	16	2.9-10.6	7	9

surface of dentary at inner corner of mouth, and runs diagonally downward and forward across outer face of bone to just below chin (by start of lower lip fold). Tips of teeth slightly bent anteriorly, especially those anteriormost. Innermost row of small, upright teeth extending up to symphysis, with one to three pairs of very large inwardly curved canines at symphysis. Innermost row of small teeth may consist of 2-3 rows of teeth at anterior half of jaw. A middle row of outward and downwardly directed straight teeth with curved tips, tips of teeth lie alongside outermost row of large teeth. No vomerine teeth.

Lateral line canals on head as in Figure 4. Anterior interorbital pore always single, usually in centre of interorbit. Three preopercular pores. Sensory papillae as in Figure 4, with suborbital and preopercular edges smooth, not scalloped or knobbed. Innermost row of mandibular papillae ends just above lower lip fold at chin.

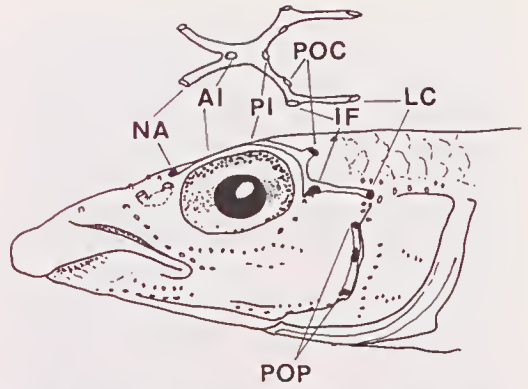
**Fig. 3.** Lateral view of teeth and jaws of *Luposicya lupus* (NTM S.12717-001).**Fig. 4.** Sensory papillae of *Luposicya lupus* (WAM P.30052-001), and diagrammatic dorsal view of canals and pores. NA, nasal pores, AI, anterior interorbital pore, PI, posterior interorbital pore, POC, postocular pores, IF, infraorbital pores, LC, lateral canal pores, POP, preopercular pores.

Scales on body extend on nape up to above preopercular edge in adults, nape naked in specimens 15mm SL or less. All scales ctenoid. Scales absent from pectoral base, breast and belly midline.

Pelvic fins long, reaching to or past anus when flattened, 21% of SL. Fin usually an elongated oval or flattened cup shape. Base of fifth pelvic ray slender, ray branched about three times. Lobes around pelvic spines flattened, rounded to pointed, and not usually particularly fleshy, fimbriate or folded. Frenum thin to somewhat fleshy, not usually fimbriate, and only folded forward slightly (occasionally not at all). Pelvic spines straight to very slightly curved inward. Pectoral fins short, reaching back to below sixth dorsal spine. First dorsal fin triangular, first spine about equal to greatest body depth. Second dorsal fin also somewhat triangular, equal in height to first dorsal anteriorly, and very low posteriorly. Dorsal rays branched in adults, may be unbranched in specimens 15 mm SL or less. Anal fin low, slightly higher anteriorly, all rays unbranched. Caudal fin truncate to rounded.

Genital papilla in females short, slightly flattened to bulbous, with fine fimbriate lobes in clump on each side of opening. Male genital papilla short, thin and flattened, with several fimbriate lobes across expanded tip.

Colour in life. Head and body transparent to translucent light greenish, with skin surface lightly covered with small dark brown speckles, including branchiostegal membranes.

Peritoneum silvery white to cream coloured, with three dark brown oblong blotches covering most of sides of abdominal cavity. Brain and vertebral column cream to whitish, with seven dark brown elongate internal blotches evenly spaced atop vertebral column, starting from just behind brain. First blotch appears on skin surface as dense dark brown streak at nape midline. Four short dark brown internal streaks over brain surface form "V" behind each eye, apex pointing to nape midline. "V" streaks may be irregular, but always present. Two dark brown lines extend forward from front of eye; uppermost running along snout to outer edge of upper lip, lowermost extends to middle of jaw and may extend onto upper lip. Bright golden patches may be present on snout between lines. Behind eye run two brown lines (continuations of snout markings); upper line extends across top of preopercle and fades out at upper opercular attachment, lower streak runs diagonally down across preopercle and ends on opercle (both lines may be quite diffuse). Eyeball light red gold to golden brown, iris pinkish gold marbled with brown, rim of eye red brown. Lines before and after eyes (including lowermost nape streak) continue onto iris as dark red brown diffuse lines. Two lines extend up from iris toward nape, meeting diffuse blotch in centre of narrow interorbit. Pectoral base often densely speckled with dark brown, and short distinct streak sometimes present (continuation of lower posterior eye line). Two or three bright white spots on upper pectoral base. Along midside of body, a fine dark brown line runs from pectoral base to base of caudal. Row of bright white spots placed evenly along line (as on vertebral column). Fine line may be reduced to diffuse spots, but bright white spots always visible. Dorsal midline with dark brown paired lines or spots along fin bases and nape. Both dorsals with diffuse brown line just above base of fin, and trailing edges of fins lightly dusted with brown. Anal fin speckled with dark brown, especially along base. Caudal fin barred, with about 10 narrow wavy brown vertical lines. Pectorals slightly dusky to transparent, and pelvics transparent.

Colour in alcohol. Fine dark brown speckles remain on head and body, including lips and branchiostegal membranes, but leaving breast, belly and isthmus unmarked. Brown pigment spots usually larger on lower half of body and head. Most conspicuous marking is

dense black or dark brown streak on midline of nape behind eyes (streak may equal eye length). More diffuse short streaks or spots present along each side of dorsal fin bases. First dorsal with dense dark stripe just above base; similar, but more diffuse, stripe on second dorsal. Other fins retain pattern shown when live. Eye lines and other head markings generally less distinct upon preservation. Sides of head usually densely speckled, with stripes across preopercle and opercle not visible. Irregular brown blotches present on centre of snout. "V"-shaped pattern behind eyes obscured by skin and surface musculature, but generally visible.

Comparisons. At first glance, *Luposicya* appears most like *Pleurosicya*, with its similar headpore arrangement, scaled nape and restricted gill opening. However, it differs from *Pleurosicya* by three main characters. These are: the lower lip free only behind the mandibular symphysis, the diagonal row of large teeth crossing the outer face of the dentary, and the premaxilla with a large foramen below the ascending process. *Luposicya* also has very rudimentary gill rakers on the first arch, often with none on the upper limb; unlike *Pleurosicya*, which has usually 1-3 small rakers on the upper limb, and up to 8 on the lower.

Remarks. *Luposicya* has an Indo-West Pacific distribution, previously recorded from South Africa (type locality), the Chagos Archipelago (Winterbottom and Emery 1986) and the Red Sea (Goren 1984). It occurs on the Great Barrier Reef from One Tree Island in the Capricorn Group north to Escape Reef. The record of *Luposicya* from Japan in Masuda *et al.* (1984) refers to a specimen of *Pleurosicya* (probably *P. labiatus*), apparently now lost. Despite reasonable collecting effort, *Luposicya* has not yet been found in Japan or the Philippines, and is known in Indonesia only from Batanta Island in Irian Jaya.

This species is commensal on sponges, although it has been collected together with its host only from Lizard Island, One Tree Island and Rib Reef, whereas all other records of the species have not included the host invertebrate. At Lizard Island, *Luposicya* has nearly always been found on *Phyllospongia foliascens* (Pallas) (*sensu* Bergquist 1969). This is typically a cup-shaped sponge, dull whitish with vermiculated grooves of greyish green (Pl. Ia). At Rib Reef, *Luposicya* was collected from upright, flat, thin, foliaceous purplish

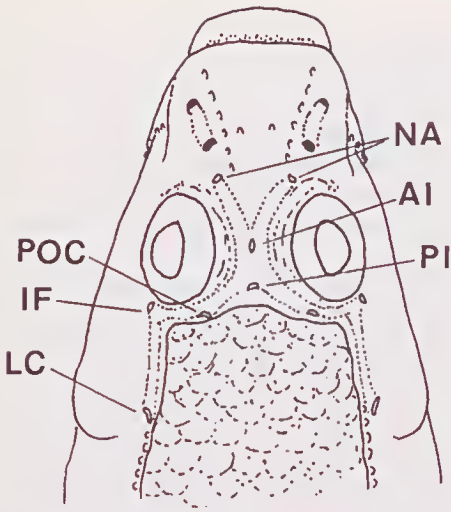

Fig. 5. Dorsal view of head of *Pleurosicya holdinhi* lectotype (ZMA 100.209), showing lateral canal pores and sealation. NA, nasal pores, AI, anterior interorbital pore, PI, posterior interorbital pore, POC, postocular pores, IF, infraorbital pores, LC, lateral canal pores.

brown sponges of another species of *Phyllospongia* (possibly *P. papyracea* (Esper), *sensu* Lendenfeld 1889). The flathead spongegoby, *Phyllogobius platycephalops* (Smith), is commensal on the same species of sponge at Rib Reef (and elsewhere), but the two fish species have not been collected together on the same sponge specimen. *Luposicya* and *Phyllospongia* have been found together in quite shallow lagoonal habitats (from less than 1 m to 6 m in depth), on coral sand and rubble substrates, often near rich coral cover.

Tyler and Bohlke (1972) and Gilbert and Burgess (1986) noted that there were no records of sponge-dwelling fishes from the Indo-Pacific. Larson (1985) described the first sponge-dwelling goby from the Pacific, *Bryaninops diannaee*, commensal on "a green sponge" from Fiji. The sponge has since been identified as *Haliclona* sp. (Larson 1987).

The gut contents of five adult *Luposicya* were examined. The gut form is simple, with a long, single-looped intestine. All guts were filled with soft elastic globular clumps of mucus, with a few sand grains, diatoms, algal fragments and several types of sponge spicules mixed in. Two fish had the gut quite tightly-packed with these mucus balls. It is assumed that the mucus came from the host sponge. The unusual dentition of this species is well-shaped for scooping up mucus (and embedded particles) from the host sponge

surface. I have not yet observed feeding behaviour in this species.

One large *Luposicya* specimen has been observed guarding a patch of eggs. The eggs were on the inside of a large cup-shaped sponge (probably *Phyllospongia*, but not verified), laid in a rounded patch about 3 cm in diameter. There were many specimens of *Luposicya* present on the sponge, but only one very large one, which sat on top of the egg patch, vibrating the pectorals and body very slightly. Despite my disturbing the sponge and its other inhabitants, by eating a large *Pleurosicya* which was also present, the *Luposicya* did not move from the egg patch.

Genus *Pleurosicya* Weber

Pleurosicya Weber, 1913:456-457 (type species *Pleurosicya holdinhi* Weber, 1913, by original designation, from New Guinea).

Cottogobius Koumans, 1941:253-254 (type species *Cottogobius bilobatus* Koumans, 1941, by original designation, from India).

Pleurosicyops Smith, 1959:217 (type species *Pleurosicyops timidus* Smith, 1959, by original designation, from Mozambique).

Pleurosicya Plessis and Fourmanoir, 1966:764 (erratum for *Pleurosicya*).

Diagnosis. Small gobies with fleshy lobes around the pelvic spines and forwardly-folded pelvic frenum. Eyes generally large and placed dorsolaterally. Interorbital narrow, often less than pupil diameter. Second dorsal rays I,7-9; anal rays 1,7-9. Segmented caudal rays 17. Lateral scales 20-28; TRB 7-10. Scales eteoid, absent from breast, pectoral base and belly; nape sealed to naked. Gill opening variable, may extend forward to below eye, or be restricted to pectoral base. Edge of lower lip free at sides, fused at chin. Rows of fine pointed teeth in both jaws, usually outermost row in lower jaw horizontal and moveable, outermost row across front of upper jaw usually larger and curved, and at least one pair of large curved teeth behind symphysis of lower jaw. Sensory papillae on head reduced. Head pores and canals present as in Figure 5: nasal pore close to rear of each posterior nostril, one median anterior (rarely two) interorbital pore in single interorbital canal, one median posterior interorbital pore, a postocular pore behind each eye, an infraorbital pore on each side of head at mid-eye level, and a lateral canal pore above preopercular margin (all connected by

canals, which may be open in small specimens); three preopercular pores usually present, connected by separate canal. Commensal on invertebrates such as corals, sponges, tunicates and bivalves, also on algae and seagrass.

Osteology. (Based upon one specimen each of *P. carolinensis* (from CAS 36875), *P. coerulea* (NTM unregistered FNQ 79-38), *P. fringilla* (NTM unregistered LZ 79-25), *P. mossambica* (NTM S.12642-001), *P. plicata* (CAS 36885), and *P. prognatha* (from AMS I.22631-055)). Five branchiostegal rays; small lower postcleithrum present; no mesopterygoid (endopterygoid); metapterygoid not meeting quadrate; preopercular process connecting process on symplectic in *P. fringilla* and *P. prognatha*, and nearly so in *P. carolinensis*; palatine extending half the length of ectopterygoid; ectopterygoid with flange (broad in *P. plicata*), and in contact with small quadrate; hyomandibular in contact with dorsal process of preopercle; sphenotic reaching supraoccipital; frontals separated from epioties; exoccipitals barely separated by rear of supraoccipital; supraoccipital with distinct crest and narrow antero-lateral wings; basihyal fan-shaped or spatulate; maxilla slender, flattened; premaxilla with articular and ascending processes well-separated except in *P. prognatha* and *P. fringilla*, in which they are very close and nearly fused in the former; dentary slender, slightly raised posteriorly in *P. plicata*, *P. fringilla*, and *P. prognatha*; scapula unossified (dorsal portion partly ossified in *P. mossambica*); vertebrae 10 + 15 plus urostyle (= 26); dorsal ribs on first eight to ten vertebrae; ventral ribs on first eight vertebrae; spinous dorsal pterygiophores (using formula of Birdsong *et al.* 1988) 3-22110; anteriorly-directed elongate ventral processes of pelvic bones diverge at tips, forming a Y; pelvic spines usually curved; caudal skeleton with upper hypural plate fused to, and lower articulated with, urostyle; single epural with broad dorsal flange; upper hypural rod-like; parhypural free, with flange; neural spine on preural vertebra (number 25) very short and broad.

Key to the Species of *Pleurosicya*

This is an artificial key, and not necessarily based on phylogenetic relationships between taxa. The key may not work with small juveniles 10-11 mm SL or less, and some specimens of *P. annandalei*, *P. micheli*, and *P.*

mossambica may be difficult to distinguish using the key alone.

1. Nape naked 2
 - 1A. Nape scaled up to behind eyes, or at least sides of nape scaled 10
2. Gill opening extends forward to below preopercle or nearly to eye 3
 - 2A. Gill opening restricted to pectoral base.. 4
3. Tongue trilobed (rarely blunt); male without black blotch at rear of soft dorsal; pelvic spine lobes usually long and folded; fish pale, without brown bars; commensal unknown; (Indo-West Pacific) *P. plicata*
- 3A. Tongue bilobed (occasionally blunt, rarely trilobed); male with black blotch at rear of soft dorsal; pelvic spine lobes usually not greatly expanded and folded; when live, fish green with about 12 narrow brown bars; commensal on seagrass; (Indo-West Pacific) *P. bilobata*
4. Tongue very small, usually narrow and pointed (sometimes blunt or rounded); upper lip with tip elongated and fleshy, giving a bird-like profile; no small canine tooth on each side of lower jaw 5
 - 4A. Tongue moderately broad, pointed, slightly trilobed, or round; upper lip may be fleshy, but never with elongated and pointed tip; small canine tooth may be present on each side of lower jaw 6
5. Tip of upper jaw narrow, with cartilaginous tooth-bearing projection present, covered by elongated pointed upper lip; often scales reach only to below gap between dorsals; no black spot on anal fin; (Red Sea, northern Australia) *P. prognatha*
- 5A. Tip of upper jaw without cartilaginous projection, upper lip may be elongated and fleshy; scales on body always reach to behind pectoral base; males with black spot on anal fin anteriorly; (Indo-West Pacific) *P. fringilla*
6. Enlarged teeth at sides of lower jaw (teeth may be reduced in females); which may be expanded outward at front 7
 - 6A. No enlarged teeth at sides of lower jaw; jaw may be triangular in shape, but is not expanded at front 8
7. One or more large curved teeth at middle of each side in the triangular lower jaw, which is expanded outward at front; body slender (BDA 14-18% of SL); (Western Caroline Islands) *P. carolinensis*

- 7A. One small to medium curved tooth at each side of lower jaw, which is triangular, but not expanded outward at front; body stocky (BDA 19-22% of SL); (Indonesia) *P. spongicola*
8. Mouth terminal, snout convex; eyes relatively small (average 25% of HL); five pairs of red lines on head radiating from eye when live (not always visible in preserved material); very few lower unbranched pectoral rays (1-7, average 2); commensal on soft corals; (Indo-West Pacific).. *P. muscarum*
- 8A. Mouth subterminal, with upper lip overhanging lower jaw; eyes moderate (averaging 29% of HL); lower unbranched pectoral rays 4-7 (average 6); probably only one pair of red or brown lines radiating from eye when live 9
9. Intense elongate black spot present on centre of nape; head width moderate (width averages 64% of HL), upper lip overhangs lower jaw, but not particularly fleshy; commensal unknown; (western Indian Ocean) *P. occidentalis*
- 9A. Central nape spot diffuse, not always present; head quite broad (average width 72% of HL), upper lip fleshy; commensal on *Heliopora coerulea*; (Indo-Pacific) *P. coerulea*
10. Second dorsal rays 1,7; anal rays 1,8; no melanophores visible on head, fins or body of preserved material; fish plain white when live, with thin red or pink stripes on head; commensal on deep-water soft corals; (Indo-West Pacific) *P. boldinghi*
- 10A. Second dorsal and anal rays usually 1,8 (rarely 1,7); body and fins variously pigmented (lateral stripe, or with blotch on pectoral base or first dorsal fin and at least part of body dusky) 11
11. Black blotch or streak (occasionally absent) on lower part of first dorsal fin; gill opening always wide (usually to posterior margin of eye) 12
- 11A. No black blotch or spotting on first dorsal fin; gill opening wide, or restricted to pectoral base 13.
12. Pectoral rays 17-19 (mean 18); BDA 15-19% of SL (mean 17%); nape midline naked in 68% of specimens; in coral reef habitats (1-24 m), commensal on many organisms such as soft corals and sponges; (Red Sea, Indo-West Pacific) *P. mossambica*
- 12A. Pectoral rays 19-20 (mean 19); BDA 15-22% of SL (mean 18%); nape midline always fully sealed; offshore dredge and trawl-depth habitats in 14-70 m; host unknown; (Indo-West Pacific) *P. annandalei*
13. Gill opening restricted to pectoral base; one or more large curved canines usually present at each side of lower jaw 14
- 13A. Gill opening extends forward to at least posterior margin of eye; no curved canines at each side of lower jaw 15
14. Symphyseal canines in lower jaw always present; nape usually scaled forward up to behind eyes; BDA 17% of SL; usually commensal on barrel-shaped sponges; (Western Pacific) *P. labiata*
- 14A. Symphyseal canines in lower jaw reduced or absent; nape scaled forward to above preopercle; BDA 14% of SL; usually commensal on fan-shaped sponges; (Timor Sea, Western Pacific) *P. elongata*
15. Body slender, BDA averages 16% of SL; first dorsal sometimes may have scattered dusky markings near base, lower half of body and caudal fin with brown streak; head triangular (mean HW 57% of HL), with eyes placed dorsolaterally; commensal on hard corals; (Indo-West Pacific, Hawaii) *P. micheli*
- 15A. Body stocky, BDA averages 20% of SL; first dorsal unpigmented, caudal fin base and lower half of fin with dark brown streak; head compressed (mean HW 53% of HL), with eyes placed laterally; commensal unknown; (Rapa and Mangareva) *P. australis*

Pleurosicya annandalei
Hornell and Fowler
 (Fig. 6)

Pleurosicya annandalei Hornell and Fowler, 1922:924 (Tuticorin, India); Larson and Hoese 1980:36 (off the coast of Somalia); Hoese, in Smith and Heemstra 1986:800 (Sodwana Bay, South Africa).

Type material. HOLOTYPE (examined by D.F. Hoese, who made his notes available to the author) - ANSP 51094: 25.1 mm SL (sex undetermined), Tuticorin, India, 14-16 m, from *Solenocaulon tortuosum*, 1922. PARALLECTOTYPES of *Pleurosicya boldinghi* - from ZMA 100.209: 2(17-24.5), West New Guinea, 32 m, "Siboga" station 164, 20 August 1899.

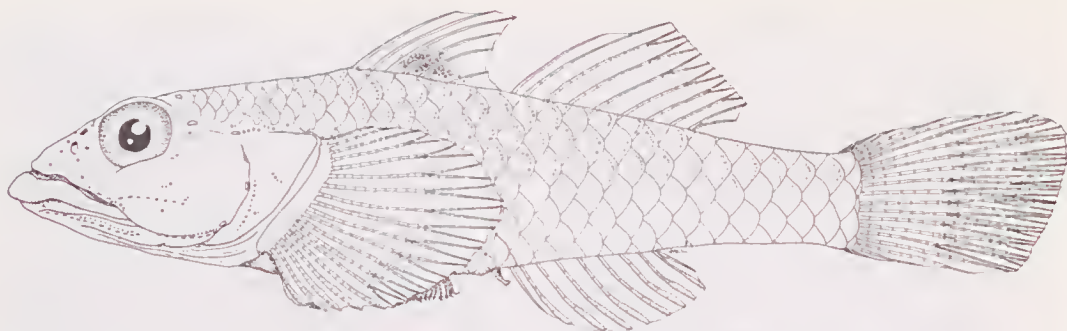

Fig. 6. *Pleurosicya amandalei* (RUSI 16091), 27 mm male, from off Mtentu, South Africa (scales mostly reconstructed).

Additional material. EAST AFRICA - AMS 1.21862-001: 23 mm SL male, off coast of Somalia, trawled from 41-70 m, "Meteor" station 122, 28 December 1964. ZMH 6144: 4(21.4-24.6), off coast of Somalia, trawled from 55-65 m, "Meteor" station 123, 28 December 1964. SOUTH AFRICA - RUSI 16091: 2(21.5-27), off Mtentu, Transkei, dredged from 50 m. A.D.Connell, 12 September 1981. WESTERN AUSTRALIA - NTM S.12660-001: 2(21-28), NW of Port Hedland, Taiwanese pair trawler BYME, 29 May 1983. CSIRO H.2256-01: 25 mm male, Northwest Shelf, FRV "Soela", 9 October 1986. CSIRO H.2257-01: 23.5 mm male, 19° 27.2' S, 118° 58.6' E, 36-46 m, epibenthic sled, FRV "Soela", 8 December 1982. CSIRO H.2258-01: 21.5 mm female, 19° 59' S, 117° 51.5' E, 42 m, beam trawl, FRV "Soela", 27 August 1983. CSIRO H.2259-01: 17 mm female, 19° 59' S, 117° 51' E, 42 m, beam trawl, FRV "Soela", 25 August 1983. CSIRO H.2260-01: 14.5 mm male, 19° 43.7' S, 117° 54.4' E, 52 m, beam trawl, FRV "Soela", 2 September 1983. NTM S.12691-001: 20 mm female, 19° 29.7' S, 118° 52.1' E, 38-39 m, beam trawl, FRV "Soela", 25 October 1983. NTM S.12692-001: 16.5 mm male, 19° 55.2' S, 117° 56' E, 40 m, beam trawl, FRV "Soela", 26 October 1983. PHILIPPINES - ZMUC P.781650-1659: 10(13.5-23), Jolo, Sulu Archipelago, 27 m, Mortensen Pacific Expedition, 21 March 1914.

Diagnosis. A relatively large *Pleurosicya* with a black blotch on the first dorsal fin. First dorsal rays 1,8; anal rays 1,8. Pectoral rays 17-20. Lateral scales 23, TRB 8. Nape scaled up to behind eyes, including nape midline. Gill opening wide, reaching to below posterior edge of eye. Tongue usually blunt. Small cirri or pointed bumps around rear of eye in some

specimens. Preferred host unknown; holotype commensal with gorgonian (*Solenocaulon*).

Description. An asterisk indicates counts of holotype. Based on 27 specimens, 13.5-28 mm SL. First dorsal VI (23)*. Second dorsal 1,7 (2); 1,8 (19)*; 1,9 (1). Anal 1,8 (21)*; 1,9 (2). Pectoral rays 17 (3), 18 (9), 19 (14), 20 (2)*. Lowermost 3-5 pectoral rays unbranched, with distal half thickened (damaged in holotype). Branched caudal rays 11 (2), 12 (1)*. Predorsal scales 7-14. Longitudinal scale count 20-25 (mean 23, 24 in holotype). TRB 6-9, mean 7 (9 in holotype). Gill rakers short, 2+1+4 (2). Lowermost third of first gill arch bound to inner face of opercle by membrane.

Head and anterior part of body triangular in cross-section, apex dorsally, with posterior part of body compressed. Body rather stocky. BDA averages 18% of SL (Fig. 6). Head length 32-39% of SL (mean 35%). Head width equal to or greater than head depth. Snout moderate, 24-33% of HL, rectangular in dorsal view, sometimes with bump in profile caused by ascending premaxillary process. Mouth terminal, jaws end at a point below mid-eye. Eyes moderate, averaging 27% of HL, set dorso-laterally. Nostrils in short tubes, anterior nostril tube often slightly longer; posterior nostril set near upper edge of eye, anterior nostril midway between eye and upper lip. Interorbital usually narrow, 3-11% of HL. Tongue blunt to concave, rarely weakly trilobed. Gill opening wide, reaching to below posterior margin of eye. Seven specimens (from South Africa and the Philippines) with tiny pointed bumps around the upper rear margin of eye, and sometimes in interorbital space; bumps often elongated as cirri.

First dorsal triangular, with third spine longest. Fins low, short. Anal rays unbranched. Pectoral fins rounded, reaching back to below

second dorsal fin origin or space between both dorsals. Caudal truncate to rounded. Pelvics oval, usually a flattened cup, when flattened reach to anus or slightly beyond. Frenum fleshy; pelvic spines curved inward, lobes folded and often bilobed.

Upper jaw teeth fine and pointed, arranged in band which is widest anteriorly, narrowing to two rows at sides. Outermost, six to eight large curved teeth across front of jaw, largest teeth at sides of jaw; these teeth protrude from lip. Lower jaw teeth small, sharp, in wide band of several across front of jaw, narrowing to two rows at sides; outermost row across front angle outward, movable. A large curved tooth at either side of symphysis, behind fine tooth band.

Lateral line canals as for genus. One specimen has no anterior interorbital pore.

Nape scales extend forward to behind eyes, scale rows always crossing nape midline, even in 13.5 mm specimen. Belly midline naked.

Male genital papilla small, slender and flattened, with tiny limbiate lobes at tip. Female genital papilla short, cylindrical, with several short lobes arranged about opening at tip.

Colour in Life. Hornell and Fowler (1922) record the live colour as being "pink over entire body" and do not report dark markings on any of the fins after preservation. No other information is available.

Colour in Alcohol. Most material is faded (and not in very good condition, as a result of being trawled), with a stripe from eye to tip of snout often faintly present. A broad blackish to brown stripe occupies the lower third of the first dorsal, sometimes this stripe reduced to a diffuse blotch between third and sixth spines. Two specimens from north-western Australia have only a few faint melanophores on the lower half of the first dorsal. Many specimens from this locality have scale margins outlined with dusky speckles, and the lower half of the body and caudal fin may be dusky. Three specimens from the Philippines have a dusky streak on the lower caudal fin (similar to *P. micheli* and *P. mossambica*).

Comparisons. This species is very close to *P. mossambica*. The two species differ from each other by pectoral ray count (mean rays 19 in *P. annandalei*, 18 in *P. mossambica*), average body depth in SL (18% in *P. annandalei*, 17% in *P. mossambica*), nape scalation (midline fully scaled in *P. annandalei*; in *P. mossambica* nape midline naked in 68% of

specimens, with scales on either side reaching to behind eyes, remaining 32% of specimens with nape midline fully scaled as in *P. annandalei*), and habitat (*P. annandalei* specimens obtained by trawl, epibenthic sled, or dredge from depths of 14-70 m, *P. mossambica* found in coral reef habitats from 1-24 m).

Remarks. The holotype was found as a commensal of *Solenocaulon tortuosum*, dredged from a sandy substrate at 14 to 16 m depth. Other material has come largely from trawl or dredge samples, with no indication of host invertebrate.

Pleurosicya australis sp. nov.
(Fig. 7)

Type material. HOLOTYPE - BPBM 17280: 25 mm SL female, reef at entrance Hauci Bay, Rapa, Tubuai Islands, 15-18 m, J. Randall & D. Cannoy, 10 February 1971. PARATYPES - BPBM 13593: 2(15-18), Gambier Islands, Mangareva, 1/4 mile E of Rikitea, patch reef, 3-11 m, J. Randall, D. Cannoy, J. Haywood, 14 December 1970. BPBM 17307: 21 mm SL female, Tubuai Islands, Rapa, S side of exposed reef at entrance to Haurei Bay, 2-6 m, J. Randall & D. Cannoy, 14 February 1971.

Diagnosis. A compressed *Pleurosicya* with large mouth, laterally-placed eyes, and blotch at lower caudal base and lower part of fin. Second dorsal rays 1.8; anal rays 1.8. Pectoral rays 17. Lateral scales 24-25, TRB 7-8. Head with scaled nape, midline usually naked at least anteriorly. Gill opening wide, reaching to below mid-eye. Tongue blunt to slightly concave. Lower half of caudal base with black blotch. Found only in French Polynesia, at Rapa and Mangareva Islands.

Description. An asterisk indicates counts of holotype. Based on four specimens, 15-25 mm SL. First dorsal fin VI (4)*. Second dorsal 1.8 (4)*. Anal 1.8 (4)*. Pectoral rays 17 (4)*. Lowermost 3-5 (4 in holotype) pectoral rays unbranched and thickened distally. Branched caudal rays 11 (2). Longitudinal scale count 24*-25. TRB 7*-8. Predorsal scales 9-14*. Gill rakers on outer face of first arch 3+1+6(1), rakers very small and thin; rakers on inner face of arch somewhat larger, with tiny spines at tips. Lowermost quarter of first gill arch bound by membrane to opercle.

Head and anterior half of body compressed, forming narrow triangle (apex dorsally), body

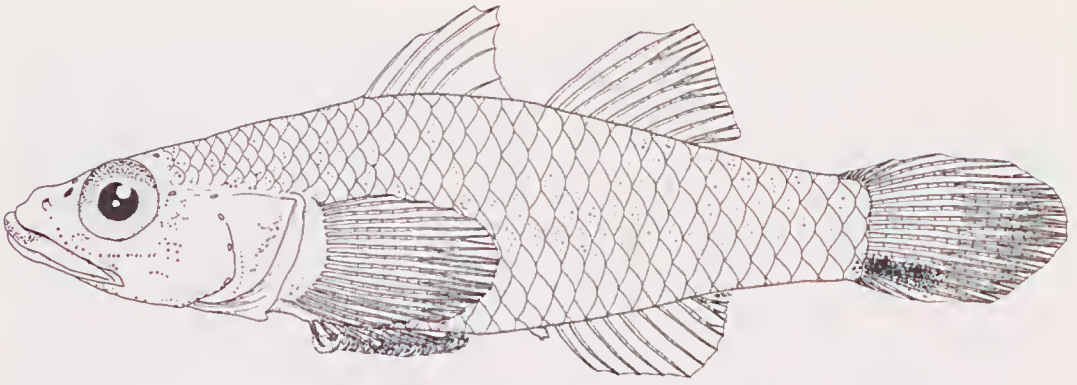

Fig. 7. *Pleurosicya australis* (BPBM 17280), 25 mm female holotype, from Rapa.

compressed posteriorly (Fig. 7). Body depth at anus averages 20% of SL. Body relatively short, mean head length 35% of SL. Head depth about equal to head width. Eyes moderate, 25-30% of HL, set laterally and high on sides of head. Snout pointed in profile, 26% of HL. Mouth terminal, large and oblique, reaching back to below mid-eye (mean jaw length 46% of HL). Interorbital moderate, 5-7% of HL. Nostrils close together; anterior nostril in short tube placed halfway between eye and upper lip, posterior nostril with low rim, close to rim of eye. Tongue large, blunt to slightly concave; specimens may show very slight protuberance at centre of tongue (enhanced when tongue folded inward). Gill opening wide, reaching up to below mid-eye (to posterior half of eye in one).

Dorsal fins short; first dorsal triangular, second dorsal higher than first anteriorly, quite low posteriorly. Anal fin moderate, rounded, posteriormost rays sometimes branched. Caudal fin bluntly rounded. Pectorals reach back to below end of depressed first dorsal. Pelvic fins rounded and cup-like, not reaching anus. Pelvic spine lobes rounded, folded in three largest specimens, and finely fimbriate (as is frenum and outer part of rays). Pelvic rays somewhat flattened near first branch point.

Upper lip narrow, not covering tip of lower jaw when jaws closed. Outermost in upper jaw, six or eight large curved teeth across front (mostly covered by lip); band of very tiny sharp teeth behind this row, band narrows posteriorly, outer teeth at sides larger and more upright. Lower jaw teeth small, sharp, in four or three rows (narrowing to two rows at sides); outermost teeth across front of jaw moveable, angled forward somewhat. Large

curved tooth on either side of lower jaw symphysis, behind rows of smaller teeth.

Lateral line canals of head as for genus.

Predorsal scaled up to behind eyes at sides, usually leaving triangular area on mid-line of nape naked. One specimen from Rapa with entire midline naked, slightly larger Rapa specimen has anterior half of nape midline naked.

Male genital papilla short, ovate, with finely fimbriate, expanded tip. Female genital papilla moderate, cylindrical, with two or three small lobes on either side of opening at tip.

Colour in Life. Randall's notes accompanying the 21 mm female read: "Translucent light red; a horizontal red band from snout to eye; blackish spot surrounded by dark red in lower part of caudal fin ... base".

Colour in Alcohol. Head and body pale brownish, with fine melanophores scattered over at least sides of body, and entire body in one specimen (lower half of head and belly unpigmented). Nape immediately behind eyes, top of snout, and lips usually with light scattering of brown pigment. Dorsals, anal, pectorals and pelvics hyaline. Distinct dark brown streak extends from lower caudal base to caudal margin; very little pigment on neighbouring caudal peduncle other than that covering body. Specimen from which Randall took colour notes has fine melanophores roughly following scale outlines on body, especially along mid-side. Diffuse brown stripe from each eye to tip of snout and upper lip, where stripes fuse; lips quite dusky.

Comparisons. This species looks like *P. mossambica*, but has an unpigmented first dorsal, a compressed head with eyes placed laterally (unlike *P. mossambica*'s distinctly

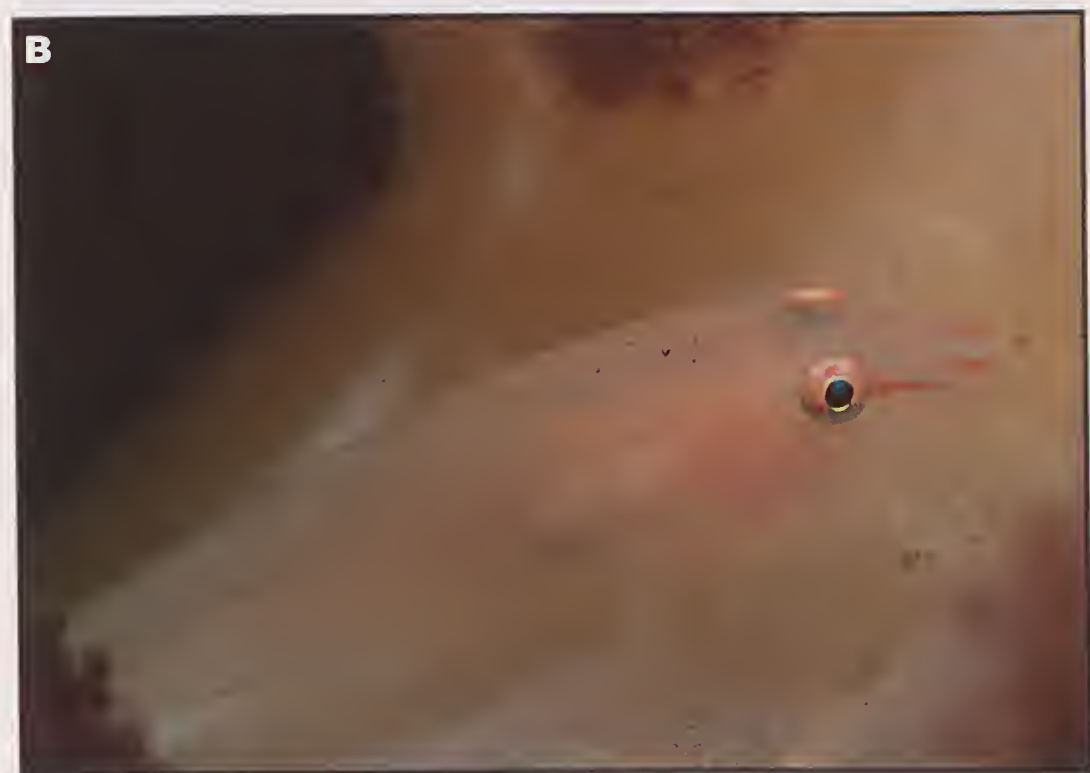

Plate I. a. Live *Luposicya lupus* on the sponge *Phyllospongia foliascens*, from Lizard Island, Queensland. Photo by Neville Coleman. b. *Pleurosicya boldingii* (one of LIAIP 1984172) living on the soft coral *Dendronephthya* sp. at Yokoshima, Ehime, Japan. Photo by Niimura.



triangular (in cross-section) head with dorso-laterally placed eyes), and a brown streak on the lower half of the caudal fin. The mean head width is 53% of HL, versus 64% in *P. mossambica*. Body depth may be slightly greater than that of *P. mossambica*.

Remarks. The lack of material available for this species probably reflects collecting effort, as its known distribution appears to be restricted to a few isolated islands in French Polynesia, an area which has not been well-sampled by collectors.

Etymology. The species name is taken from the Latin *australis* meaning "southern"; the Tubuai Island group (which includes Rapa) is also known as the Austral Islands.

Pleurosicya bilobata (Koumans)
(Figs 8-9)

Cottogobius bilobatus Koumans, 1941:253-254 (India); Koumans 1953:174-176 (India, Nicobar Islands, Celebes, Sulu Islands); Menon and Rao 1971:344 (Malikudu Island); Yoshino and Nishijima 1981:44 (Sesoko Island, Okinawa).

Pleurosicya taisnei Plessis and Fourmanoir, 1966:764-765 (Isle of Pines, New Caledonia).

Pleurosicya bilobatus - Larson and Hoese 1980:33-34 (Guam, Moluccas, Palau); Akihito, Hayashi and Yoshino, in Masuda *et al.* 1984:283 (Okinawa).

Type material. LECTOTYPE - USNM 203588: 19 mm SL male, Muthivaratu Paar, India, S.L. Hora, February 1911. PARALECTOTYPES - ZSI F.5451/2: 21 mm SL male, R.I.M.S. *Investigator* Station 615. ZSI 5452/2: 8.5 mm juvenile, R.I.M.S. *Investigator* Station 623. RMNH 16937: 22.5 mm male, Nicobar Islands, Expedition Harbour, west side near entrance, R.I.M.S. *Investigator* Station 627. HOLOTYPE of *Pleurosicya taisnei* - MNHN 1966-735: 16 mm SL male, Isle of Pines, New Caledonia, 30 m. from ascidian *Polycarpa aurata*, M.Taisne, August 1961.

Additional material. CARGADOS CARAJOS SHOALS - USNM 264920: 3(16-17.5), just NE of Siren Island, 17-21 m. V. Springer, 12 April 1976. INDONESIA - AMS I.18469-150: 17 mm SL male, Ceram, Marsegoe Bay, J. Paxton, 1 April 1975. PAPUA NEW GUINEA - USNM 260953: 22 mm male, Daru, W side of Daru Wharf, 0-10 m, T. Roberts, 10 October 1975; USNM unregist-

tered: Bootless Bay, Motupore Island, 0-1.8 m, B. Collette, 9 June 1979. ZMUC P.781660: 22.5 mm SL female, Bismarek Archipelago, N Manus Island, Lobahan village, in mangroves, Noona Dan Sta.48a, 19 June 1962. AMS I.17092-012: 18 mm SL female, Trobriand Islands, Kiriwinna Island, bay behind Kiriwinna Hotel, 0-1 m, B. Collette, 6 June 1970. AUSTRALIA, NEW SOUTH WALES - AMS unregistered: 16 mm SL female, Parsley Bay, Sydney Harbour, probably from *Halophila*, R. Kuitert, 15 February 1976. MARIANAS, GUAM - CAS 36861: 21 mm SL male, mudflats between Merizo village and Mamaon Channel, H.A.Fehlmann, 12 January 1959. UGM 5779, 15 mm female, Inarajan Pool, in *Enhalus* beds, R. Sanders, 29 December 1971. UGM 5778: 15 mm female, Inarajan Pool, in *Enhalus* beds, R.Sanders, 26 December 1971; UGM 5780, 6(12-19.5), 1/2 mile S of Inarajan village, *Enhalus* beds, 2 January 1972. MICRONESIA, PALAU - CAS 36869: 16.5 mm SL female, Koror Island, W end, R. Harry, F. Bayer, H.A. Fehlmann, 8 July 1955. CAS 36864: 15 mm SL female, Babelthup Island, by rocks between sea and mangrove swamp, Sumang, 3 November 1959. CAS 36892 - Babelthup Island, reef pool N of Toagel mid-passage, H.A. Fehlmann and Sumang, 23 June 1958. JAPAN - URM P.3573: 9(14-20), Okinawa, Onnason, on seagrass, H. Senou and K. Hatooka, 20 July 1982. URM P.3572: 5(13-16.5), same data as previous.

Diagnosis. An elongate *Pleurosicya* with 16-19 pectoral rays, second dorsal rays usually 1.8; anal rays 1.8-9. Lateral scales 23-29, TRB 5-7. Nape unsealed. Tongue usually bilobed, and wide gill opening reaching to at least below edge of eye. Body with narrow brown bands, head with diverging stripes, and in males, a characteristic black blotch posteriorly on the soft dorsal fin. Commensal on seagrasses such as *Enhalus*.

Description. An asterisk indicates counts of leetotype. Based on 31 specimens, 8.5 - 23 mm SL. First dorsal VI(31)*. Second dorsal 1,7(2); 1,8(29)*. Anal 1,7(2); 1,8(25)*; 1,9(4). Pectoral rays 16(12)*, 17(11), 18(5), 19(1). Lowermost 3-7 pectoral rays unbranched and thickened distally. Branched caudal rays 10(1), 11(3). No predorsal scales. Longitudinal scale count 23-29, with a mean of 24*. TRB 5-7, with a mean of 6*. Gill rakers on first arch very low, smooth; 1+1+4(1), 1+1+5(1),

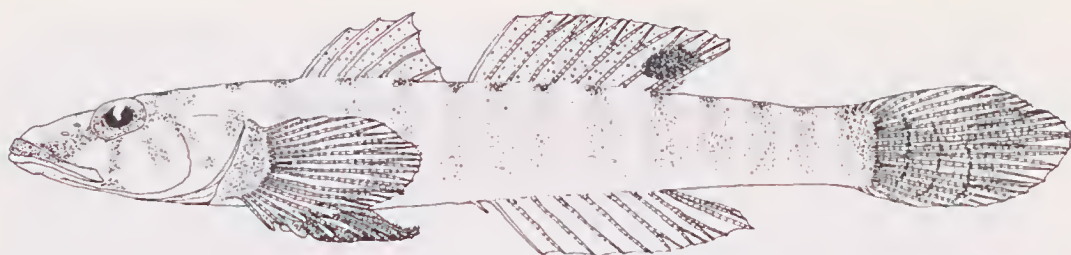

Fig. 8. *Pleurosicya bilobata* (CAS 36861), 22 mm SL male, from Guam (scales, sensory papillae and headpores omitted).

2+1+5(2). Rakers on inner face of arch with fine spines. Lowermost one-third of first gill arch bound by membrane to opercle.

Head and anterior half of body roughly triangular (apex dorsally), posterior half of body compressed. Body slender, body depth at anus averages 15% of SL (Fig. 8). Head length 26 - 36% of SL. Head width greater than head depth. Snout moderately long, 25-37% of HL. Mouth terminal, jaws ending approximately at a point below mid-eye. Eyes moderate, averaging 25% of HL, set dorso-laterally, and forming part of dorsal profile. Interorbital narrow, 3-8% of HL. Anterior nostril in tube, posterior nostril opening almost flush with skin surface. Tongue usually bilobed (blunt in 4, trilobed in 2). Gill opening wide, reaching from below posterior half of eye to not quite reaching eye (usually reaches posterior edge of eye).

Dorsal and anal fins quite low, first dorsal roughly triangular in shape. All anal rays usually unbranched except last, especially in Japanese material; other specimens may have last three or four rays branched at tips. Pectoral fins short, usually reaching back to below end of first dorsal at most. Pelvic fins round, short, not reaching anus. Pelvic spines curved inward. Frenum and lobes around pelvic spines somewhat thickened, lobes usually not greatly expanded and folded. Frenum, pelvic lobes, and inner edge of pelvic cup often finely fimbriate.

Upper jaw with band of small fine teeth, with outermost row of large curved teeth on anterior half of jaw (several of which may protrude from below lip). Lower jaw with an innermost irregular band of small fine teeth, and behind these, one or two large curved teeth on either side of lower jaw symphysis. Outermost row of slender slightly-curved teeth present, across anterior half of lower jaw; these teeth may angle outward somewhat.

Lateral line canals on head as for genus. Occasionally canals all open, with no distinct pores. Sensory papillae as in Figure 9.

Scales absent from head and nape, and not extending further forward than above pectoral base at most.

Male genital papilla flat, usually rather broad, and widest at base. Tip with several tiny lobes. Female papilla rounded and short, with several short lobes at tip.

Colour in Life. No detailed colour notes available. Living specimens translucent green to yellowish green, with brown to golden brown bands and markings on head and body. Eyes are marbled gold. Males with distinct black blotch on end of soft dorsal (blotch absent in females). A freshly-dead specimen is shown in colour in Masuda *et al.*, 1984 (Plate 255, J).

The Sydney Harbour specimen did not show any bars when live. It was noted as being translucent, the body surface covered evenly in red, black and (fewer) iridescent light blue chromatophores. Both dorsal fins were clear, with several red spots on each ray. The iris was red, with eyeball golden.

Colour in Alcohol. Most specimens have the anterior half of body pale, with about 12 narrow brownish bars across back and sides present. The first bar is mostly dorsal, just

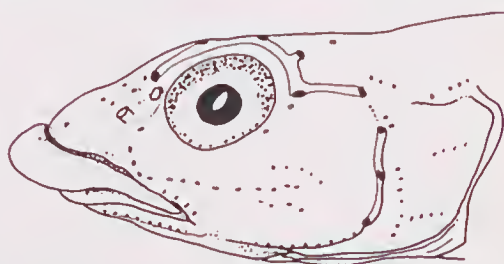

Fig. 9. Sensory papillae and lateral canals of *Pleurosicya bilobata* (URM P.3573), 18.5 mm SL male from Okinawa.

behind pectoral base and often only represented by a blotch (as may be second bar, at first dorsal origin). Bars most distinct on caudal peduncle. Body posterior to pectoral fin may be evenly dusky brown, with the 12 narrow bars across back and sides sometimes visible on upper half of body only. Head pale or light dusky, with three broad stripes from eye across sides of head. Rearmost stripe diffuse, crossing preopercle. Centre stripe more distinct, sometimes quite dark, extending from eye to end of jaws. Anteriormost stripe darkest, runs from eye below nostrils, to tip of lips and snout, but failing to meet counterpart at tip of lip. Entire upper lip may be dusky. Midline of nape above opercular margin with blotch (resembling body bar), which may be diffuse and dusky or distinct and nearly black. Pectoral base sometimes with brown diffuse bar, and upper corner of opercle sometimes with distinct brown blotch.

Both dorsal fins evenly dusky to lightly speckled, with distinct small brown to blackish blotches along their bases which correspond with body bars. Males with blackish elongate blotch on rear of soft dorsal, blotch lying between and partly over the last two rays. Caudal fin clear to dusky, with about four irregular (may form blotches) bands across centre and lower half of fin. Anal and pectorals clear to dusky. Pelvies translucent.

Comparisons. *Pleurosicya bilobata* is quite distinctive in form and colour pattern, especially when live or freshly-preserved. It superficially resembles *P. mossambica*, but is distinguished by its bilobed tongue, long snout, naked nape, relatively long caudal peduncle, specificity of host organism, and colour pattern.

Remarks. As Larson and Hoese (1980) pointed out, Koumans based his description of *Cottogobius bilobatus* on material consisting of two species, without specifying a holotype. Larson and Hoese (1980) designated a specimen from Muthivaratu Paar (USNM 203588) as lectotype. Menon and Rao (1971) refer to a specimen in the Zoological Survey of India's collection as being the holotype of *Cottogobius bilobatus* Koumans, giving the specimen's locality as "Malikudu Island (in small brackish salt water pools)", and also list five paratypes from the same locality. Koumans did not refer to any material from Malikudu Island in his description of *C. bilobatus*, therefore the specimens referred to by Menon and

Rao cannot be types. A short-bodied paralecotype (ZSI F.5450/2) of *C. bilobatus* may be *Pleurosicya coerulea* (in poor condition).

This species is commensal on seagrasses (usually broad-leaved types such as *Enhalus*). It clings to the leaf blades, and may seek refuge at the base of the plant. If pursued, *P. bilobata* tends to dart from one leaf to another. Fourmanoir (1966) reports that *P. taisuei* was collected from an ascidian, *Polycarpa aurata*, from 30 m depth. This is the only definite record of the species living on an organism other than seagrass. From my examination of the type, and from Fourmanoir's colour description, his species is the same as *P. bilobata*. Yoshino and Nishijima (1981) record *P. bilobata* as being found on "*Sarcophyton* spp.", but their record of this species is apparently confused with specimens of *P. muscarum* (which does live on *Sarcophyton*), as they give *P. bilobata* the common name of "umitake-haze", which is the common name for *P. muscarum* (*P. bilobata*'s Japanese common name is "umishobu-haze", "umishobu" meaning a kind of seagrass, "haze" meaning goby). The single specimen collected in Sydney Harbour (from *Halophila*) is the only record of this species known so far from Australia; however, seagrass habitats in northern Australia have not been widely sampled, and the species may be more widespread.

Pleurosicya bilobata does not use the seagrass as food, but as a platform for obtaining it. This species has a short gut and pointed teeth, and it picks small crustaceans such as copepods from the leaf blades, or as they float past in the current.

***Pleurosicya boldinghi* Weber**
(Figs 10-13; Pl. 1b)

Pleurosicya Boldinghi Weber, 1913:456-457 (New Guinea).

Pleurosicya boldinghi - Fowler 1928:402 (West New Guinea); Koumans 1953:237-238 (West New Guinea); Larson and Hoese 1980:34-36 (off the coast of Somalia, West New Guinea).

Type material. LECTOTYPE - ZMA 100.209: 26 mm SL male, West New Guinea, 32 m, "Siboga" station 164, 20 August 1899.

Additional material: EAST AFRICA - ZMH 6142: 27.5 female, off coast of Somalia, 55-65 m, "Meteor" station 123, 28 December 1964. ZMH 6153: 2(17-27), off coast of

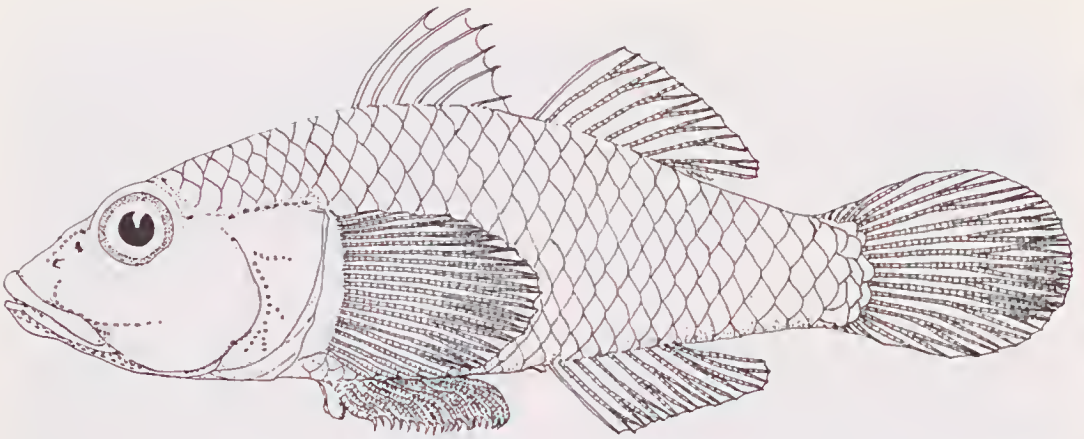

Fig. 10. *Pleurosicya boldinghi* (ZMH 6142), 27.5 mm female, from Somalia coast (scalation based on lectotype).

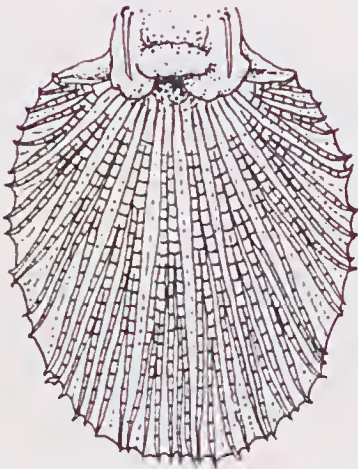

Fig. 11. Pelvic fin structure of *Pleurosicya boldinghi* (ZMH 6142).

Somalia, 41-71 m, "Meteor" station 122, 28 December 1964. NTM S.12659-01: 23 mm female. Kenya, Mombasa, about 2 km off Ras Iwetine, about 127 m, trawled, R. Lubbock, 9 May 1974. WESTERN AUSTRALIA - AMS 1.24799-002: 2(11-16), 80 nautical miles NNE of Port Hedland, 82 m, FRV "Soela", beam trawl, 23 October 1983. CSIRO H.2261-01: 17 mm male, 19° 29.6' S, 118° 52.2' E, 38-39 m, FRV "Soela", beam trawl, 30 August 1983. PAPUA NEW GUINEA - NTM S.12242-001: 12 mm female, Port Moresby, Horseshoe Bay, from seapen, 45 m, P.Colin, 16 April 1987. JAPAN - LIAIP 1984172: 4(21.5-27). Shikoku, Uwa Sea, Yokoshima Island, 24 m, Mr Niimura, 8 October 1984.

NTM S.11789-001: 5(13.5-27.5), Shikoku Island, Uwa Sea, near Yokoshima Island, 30 m, from large white *Dendronephthya* sp., H. Larson, 11 July 1985. URM P.8285: 21 mm female, Honshu, Izu Peninsula, Izu Oceanic Park, on *Dendronephthya* sp., 35 m, Mr. Ono, 1983. NTM S.12092-001: 11 mm juvenile, Shikoku, Uwa Sea, Shirahama Bay, off *Dendronephthya* sp., 35 m, H.Larson, 10 July 1985.

Diagnosis. Robust goby with relatively small eyes set high on sides of head. Second dorsal rays 1,7; anal rays 1,8. Pectoral rays usually 20. Lateral scales 23. TRB 9. Nape sealed, usually to behind eyes. Gill opening wide, reaching to at least below posterior edge of eye. Tongue blunt. Live colour white, with pale pink markings on head, and no black blotches anywhere. Commensal on soft corals (*Dendronephthya*).

Description. An asterisk indicates counts of lectotype. Based on 19 specimens, 11-27.5 mm SL. First dorsal fin VI(18)*, VII(1). Second dorsal 1,7(19)*. Anal 1,6 (1); 1,7(1); 1,8(17)*. Pectoral rays 18(1), 19(2), 20(12)*, 21(4). Lowermost 2-6 pectoral rays unbranched and thickened distally. Branched caudal rays 12(2). 13(2); caudal of lectotype broken. Predorsal scales 5-18 (10 in lectotype). Longitudinal scale count 22-25, with a mean of 23 (25 in lectotype). TRB 7-10*, with a mean of 9. Gill rakers on outer face of first arch low, rounded bumps; 1 + 1 + 3(2), 2 + 1 + 3(1), 2 + 1 + 4(1). Rakers on inner faces of arches more pointed, with tiny spines. Lowermost quarter to one half of first gill arch bound by membrane to opercle.



Fig. 12. A. Lateral view of teeth and jaws of *Pleurosicya boldinghi* (NTM S.11789-001), 28 mm SL male from Uwa Sea, Shikoku. B. Ventral view of upper jaw of same specimen.

Head and anterior half of body compressed or roughly triangular in cross-section (apex dorsally), posterior half of body compressed. Body stocky, body depth at anus 17-26% of SL (Fig. 10). Head length 30-41% of SL. Head depth approximately equal to head width, although mean depth is greater than mean width (as in lectotype). Snout moderate, averaging 31% of HL. Mouth terminal, slightly oblique, with jaws ending at point below anterior third of eye; jaw length 37-50% of HL. Eyes appear small, 20-29% of head length (mean 25%), set laterally, high on head, with a low supraorbital ridge present. Interorbital rather wide, 7-15% of head length (mean 10%). Anterior nostril in short tube, posterior nostril with low rim. Tongue blunt, occasionally weakly trilobed. Gill opening wide, reaching to at least posterior edge of eye in 6 specimens, nearly reaching eye in 6, and extending halfway between eye and preopercular edge in 7.

Fins low, first dorsal triangular in shape, caudal truncate to rounded. Anal rays variable, may be all branched, first two rays unbranched, or all unbranched. Pectoral fins reach back to below gap between dorsals. Pelvic fins rounded to oval, not reaching anus, fin rays branched many times, and rather flattened near first branch point (Fig. 11). Frenum and pelvic spine lobes thickened, fleshy and sometimes folded.

Both jaws with fine pointed teeth arranged in narrow bands (two to four rows), and a pair of large curved teeth behind lower jaw symphysis (Fig. 12A and B). Anterior half of upper jaw with outermost row of widely-spaced, large curved teeth. Anterior half of lower jaw with outermost band of small fine straight teeth. Outermost row or two of this band usually moveable, and may be directed upward or outward.

Lateral line canals on head as for genus. Sensory papillae as in Figure 13.

Scales extend up to behind eyes, with 5-18 rows predorsally (Fig. 5). Nape midline partly naked in some specimens (nape completely naked in 11 mm SL specimen), with scales extending forward on either side of nape midline to behind eyes.

Male genital papilla elongate, with several tiny lobes at slightly expanded tip. Female papilla short, thickened, and rounded, with group of tiny lobes across top.

Colour in Life. Body and fins translucent white, fins often transparent (Pl. 1b). Eye silver, overlaid with pink or orange marbling. Narrow red line extends from each eye to tip of upper lip, but lines do not meet. No black markings anywhere. One Japanese specimen had lower half of body light orange-pink, colour darker and more orange anteriorly. Pink colouration extended onto lower half of caudal fin. Edges of both dorsals outlined with faint dusky pigment. Eyes dark orange and snout stripe very pronounced. Two smaller Japanese fish had lower half of body light pink.

Colour in Alcohol. Preserved specimens show no colour pattern at all.

Comparisons. This species resembles *P. annandalei* in general body shape, having a scaled predorsal, wide gill opening, and high pectoral ray counts. It differs from that species (and all others) in having a second dorsal count of 1.7, and in colour pattern, with no black or dusky blotches anywhere on fins or body. The usually steep-profiled robust head with small eyes is distinctive. Japanese specimens look generally less stocky than those

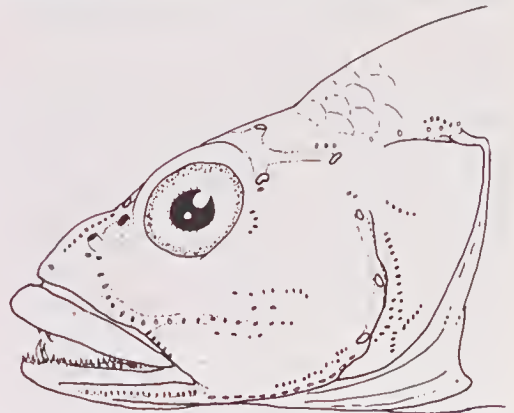

Fig. 13. Sensory papillae of 26 mm *Pleurosicya boldinghi* (one of LIAP 1984172).

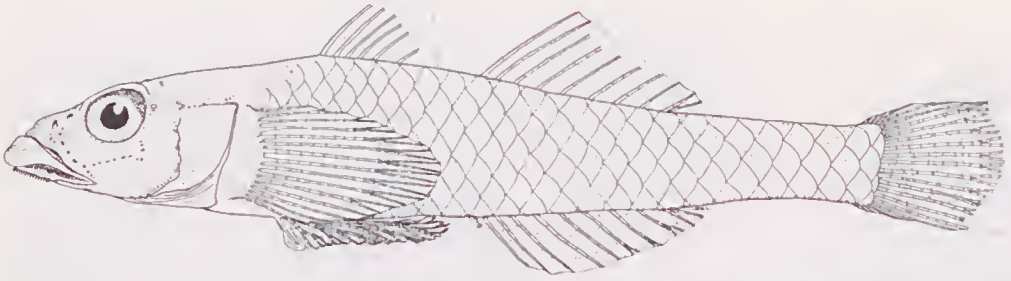

Fig. 14. Holotype of *Pleurosicya carolinensis* (CAS 36875), 25.5 mm male, from Palau. Fins partly reconstructed.

from other localities (body depth at anus averaging 20.6% of SL versus 23.5% of SL).

Remarks. *Pleurosicya holdingsi* was discussed by Larson and Hoese (1980), who also designated the lectotype. At that time, the invertebrate host was unknown for the species. Specimens since collected in Japan have been observed living on very large *Dendronephthya* (white with magenta polyps) of an unknown species, which grow at 20-40 m depths. One specimen from Port Moresby was collected from an unidentified species of sea pen. As most other specimens known have been trawled, the preferred host for these is still unknown.

Pleurosicya carolinensis sp. nov.
(Figs 14-15)

Type material. HOLOTYPE - CAS 36875: 25.5 mm SL male, reef flat in Iwayama Bay, S shore of island 11, Palau, Western Caroline Islands, H.A. Fehlmann & party, 28 August 1955. PARATYPES - CAS 36874: 18.5 mm SL male, Federated States Of Micronesia, Western Caroline Islands, Palau, Babelthup Island, Ngarehelong Peninsula, stream into lagoon at foot of Oktol Pier, H.A. Fehlmann and party, 22 August 1955. CAS 36873: 2(19.5-20), Micronesia, Western Caroline Islands, Palau, Auluaptagel Island, Iwayama Bay, in cove formed by W arm of Kogai-hento, H.A. Fehlmann and party, 28 July 1955. AMS I.29785-001: 2(14.5-17.5), Micronesia, Western Caroline Islands, Palau, E part Koror Island, small bay on W side Arappu Point in Iwayama Bay, H.A. Fehlmann and party, 23 July 1955. CAS 36868: 19 mm SL male, Micronesia, Western Caroline Islands, Palau, W end Koror island, sand flat enclosed by retaining wall parallel to Malakal Causeway, H.A. Fehlmann and party, 8 July 1955. USNM 306882: 2(15.5-19), Micronesia, Western

Caroline Islands, Palau, N tip of Auluaptagel Island and Malakal Causeway, H.A. Fehlmann and party, 7 November 1957. CAS 36871: 20 mm SL male, Micronesia, Western Caroline Islands, Palau, Auluaptagel Island, Iwayama Bay, in Geruherugairu Pass, between Kaibakku Island and Kogai-hento, H.A. Fehlmann and party, 22 July 1955. ANSP 165111: 5(17-22), same data as holotype. CAS 36858: 2(11-18.5), Micronesia, Western Caroline Islands, Yap, point jutting out into pass from Tomil Bay NW of Donitsch Island, H.A. Fehlmann and party, 4 July 1956. CAS 36860: 10(11.5-19.5), Micronesia, Western Caroline Islands, Yap, reef flat on W side Tarang Island, about 1 mile SW of Tomil Point, Sumang and party, 12 January 1960.

Diagnosis. An elongate *Pleurosicya* with distinctive triangular lower jaw, an enlarged curved tooth at each side of lower jaw, and row of downward-pointing teeth across front, and outside of, lower jaw. Soft dorsal and anal rays usually 1,8. Pectoral rays 14-15. Lateral scales 25, TRB 7. Nape naked. Pelvic spines lobes flattened and thin, and sometimes quite small. Gill opening restricted to pectoral base. Tongue blunt to rounded. Known only from Palau and Yap in the Western Caroline Islands, and possibly associated with seagrass.

Description. An asterisk indicates counts of holotype. Based on 24 specimens, 11 to 25.5 mm SL. First dorsal fin VI (23)*, VII (1). Second dorsal fin 1,8 (18)*; 1,9 (3). Anal fin 1,8 (19)*; 1,9 (1). Pectoral fin rays 14 (7), 15 (15)*, 16 (2). Lowermost 2-5 (mean 3, 4 in holotype) pectoral rays unbranched, occasionally thickened distally. Branched caudal rays 11, tips of rays broken in most material. Nape naked. Lateral scale count 23 - 27 (mean 25, 24 in holotype). TRB 6 - 8 (mean 7*). Gill rakers on outer face of first arch very low pointed stubs, 2+1+3 (1), 2+1+4 (2). Rakers on inner faces of arches longer, with spines at

tips. Lowermost quarter to third of first gill arch bound to opercle by membrane. Vertebrae 10 + 16 (including urostyle).

Head and anterior half of body rounded to roughly triangular in cross-section, compressed posteriorly (Fig. 14). Body elongate, body depth at anus 14-18% of SL (mean 16%)*. Head length 28-32% of SL (mean 30%). Head width always greater than head depth (mean width 58%, mean depth 50%, of HL). Snout medium, averaging 32% of HL, and rather broad from above. Mouth terminal, moderately large, 33-45% of HL. Jaws slightly oblique, ending at a point below anterior half of eye. Eyes medium, averaging 30% of HL, set dorsolaterally, and forming part of profile. Interorbital somewhat narrow, 3-9% of HL (mean 5%). Gill opening restricted to pectoral base. Anterior nostril closer to upper lip than eye, in slender tube, which may be expanded at tip. Posterior nostril in very short tube or with low rim only. Tongue broad, rounded to blunt (somewhat pointed in two specimens).

First dorsal triangular, equal to or greater than body depth. Second dorsal and anal low, rays highest anteriorly. Anal rays usually branched at tips, especially posteriormost few rays (rays often broken). Pectoral fins short, not reaching anus, and just reaching point below sixth dorsal spine base. Caudal truncate, upper rays longer than lower. Pelvic lobes flattened or slightly fleshy, round to pointed in shape, sometimes very reduced and thin (especially in the 10 specimens from Yap). Frenum narrowly folded forward; pelvic spines straight, tips not turned inward. Lobes and rays sometimes finely fimbriate. Fifth pelvic ray branched about six times, rays somewhat flattened near bases of lower branch points.

Teeth at sides of upper jaw pointed, upright, slender, arranged in single regular row, with one or two rows of smaller, fine pointed teeth behind (Fig. 15A). Front of jaw triangular, very small fine teeth arranged in broad band at each side of symphysis. Outside this band, eight to ten large curved teeth across front of jaw, mostly hidden by upper lip. Lower jaw with one or two rows of small, pointed, upright teeth along sides, and broad band of smaller fine teeth across front of jaw, and extending over front edge of jaw. Front of lower jaw expanded outward, with one or two medium-sized strongly curved canines at outermost

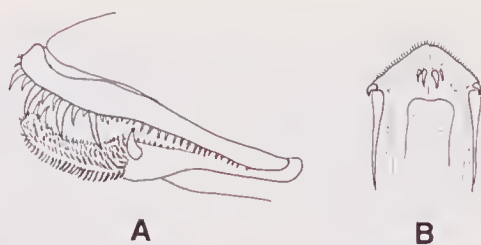

Fig. 15. A, Lateral view of teeth of male *Pleurosicya carolinensis* (CAS 36875), outline of upper lip indicated by dotted line. B, Dorsal view of lower jaw of same specimen, showing expanded sides of jaw by canines.

corners (Fig. 15B). Outermost row in lower jaw is of somewhat blunt, evenly curved, downward and outwardly-pointing teeth; row mostly separated from other teeth, clearly visible from below, and not covered by lips. Lower jaw symphysis raised, with two large curved canines present behind other tooth rows.

Lateral line canals of head as for genus.

Head and nape without scales, as is belly midline.

Male genital papilla slender, thin, narrowing toward tip, which is somewhat expanded and fimbriate. Female genital papilla short, cylindrical, with several slender lobes around opening.

Colour in Life. No information available.

Colour in Alcohol. All available specimens faded. Larger specimens evenly dusted with fine melanophores on sides, top and sides of head, and pectoral base, with pigment absent from breast, underside of head and belly. Occasionally several dusky blotches visible along dorsal midline, most obvious along dorsal bases. In some specimens, upper lip quite dusky, and indistinct dusky stripe present, from eye to tip of snout, and two diverging stripes from anterior interorbit to upper lip. Fins without obvious patterning. Both dorsals and anal covered with fine red-brown speckles, caudal lightly speckled with fine black melanophores. Pectorals with some speckling in some specimens. Pelvics hyaline.

Comparisons. *Pleurosicya carolinensis* can be distinguished from all other *Pleurosicya* by its tooth arrangement and lower jaw shape. This species is similar to *P. elongata* and *P. labiata* in body shape, pelvic fin form, and tooth arrangement (curved tooth at each side of lower jaw), but differs from both these species in that it does not have the tongue reduced, pointed and set back in the throat,

and in having a naked nape (versus scaled or at least partly so). It is similar to *P. fringilla* and *P. prognatha* in possessing a short process on the preopercle reaching toward a slight process on the symplectic (*P. fringilla* and *P. prognatha* have prominent preopercular processes which reach, or nearly reach, a distinct symplectic process).

Remarks. Palau and Yap appear to be the only localities from which this species is known. All the material examined was obtained during the George Vanderbilt Foundation Coral Fish Projects in the Western Carolines from 1955 to 1960. It is not known with what organism this species is commensal; however, most localities from which it was collected were shallow reef areas, often reef flats containing seagrass beds.

The gut is fairly long, and the guts of two specimens contained an amphipod, a few copepods, but were mostly packed with detritus consisting of many broken algal fragments, diatoms (many broken), and much unidentifiable flocculent material. The arrangement of the lower jaw teeth seems suitable for scraping the surface of whatever the fish is sitting on (possibly seagrass blades?).

Etymology. This species is named for its restricted distribution in the Caroline Islands.

Pleurosicya coerulea sp. nov.
(Fig. 16)

Pleurosicya HKL sp. 5 - Winterbottom and Emery 1986:54 (Eagle Island, Peros Banhos, and Salomon).

Type material. HOLOTYPE - NTM S.12658-001: 16 mm SL male, inter-island reef flat, Japtan Island, Enwetak, Marshall Islands, R. Johannes, May 1971, on *Heliopora coerulea*. PARATYPES - ANSP 165112: 23(8.5-17), Amirantes Islands, off E side D'Arros Island, 15-27 m depth, J. Bohlke and party, 5 March 1964. ROM 58022: 6(10.5-15.5), Chagos Archipelago, Great Chagos Bank, off N tip Eagle Island, 16 m, R. Winterbottom et al., 26 February 1979. ROM 58023: 9(11.5-15.5), Chagos Archipelago, Peros Banhos Atoll, lagoon side of Isle Mapua, 3-7 m, A. Emery et al., 6 March 1979. NTM S.12298-001: 2(14-17), Ashmore Reef, Territory of Australia, lagoon anchorage near West Islet, 10 m depth, off *Heliopora coerulea*, H. Larson, 14 September 1987. WAM P.29048-007: 11 mm SL female, Ashmore Reef, Territory of Australia, 12-13 m depth, G. Allen, T.

Knight. WAM P.28025-044, 36(9-16), Rowley Shoals, Western Australia, Clerke Reef, lagoon rim 1.5 km S of Bedwell Island, 1-2 m depth, G. Allen, R. Steene, 6 August 1983. AMS I.21318-058: 3(12-16), Western Australia, Scott Reef, South Lagoon, F. Talbot, 21 September 1979. USNM 209600: 27(7-17), Indonesia, Maluku, Haruku Island, point E of Tandjung Naira, in surge channel, 5 m depth, V. Springer, M. Gomon, 15 January 1973. URM P.11549: 4(15-20), Ryukyu Islands, Japan, Iriomote-jima, Shi-raho, off *Heliopora coerulea*, H. Senou, 28 April 1985. URM P.7518: 2(10.5-15), Ryukyu Islands, Japan, Iriomote-jima, Ohara, off *Heliopora coerulea*, H. Senou and Mr Toma, 30 June 1983. AMS I.20757-073: 2(12-14.5), Great Barrier Reef, Queensland, Escape Reef, AMS party, NTM S.12657-001, 15(7-15.5), Guam, near (Amanates?) Point, on *Heliopora coerulea*, R. Johannes, August 1971. USNM 306884: 13(12.5-18), Marshall Islands, Bikini Atoll, halfway between Bikini and Amen Islands, V. Brock and party, 21 July 1947. NTM S.12658-002: 4(15-15.5), same data as holotype. USNM 306883: 16.5 mm SL male, Marshall Islands, Rongelap Atoll, N end Kicshiechi Island, lagoon coral heads, 6 m depth, V. Brock and E. Herald, 24 July 1946. CAS 36853: 3(17-17.5), Marshall Islands, Kapingamarangi, Thoka-taman, coral head in centre of lagoon W of Hukuhenua Islet, R. Harry, 12 July 1954. AMS I.18045-033: 16(14.5-16), Kiribati, Abaiang Atoll, lagoon side of Teirio Islet, 1-2 m, D. Hoese and B. Goldman, 7 November 1973.

Additional material. ASHMORE REEF - NTM S.12328-053: 2(12-13), N of West Island, reef outside lagoon, 19-20 m depth, off *Heliopora*, H. Larson, 24 September 1987 (both heavily parasitised by copepods).

Diagnosis. A small *Pleurosicya* with broad head and snout, and eyes set dorsolaterally. Second dorsal and anal rays 1,8. Pectoral rays 15-18. Lateral scales 23, TRB 6. Nape naked. Pelvic fins rounded, cup-like, with fleshy, rounded pelvic spine lobes. Tongue round to rather pointed. Gill opening restricted to pectoral base, or only slightly forward. Gill membranes often form a fold over isthmus. Live colour translucent bluish to blue-green, with two reddish stripes on head, and dusky spot on nape midline. Commensal only on the blue coral *Heliopora coerulea*.

Description. An asterisk indicates counts and proportions of holotype. Based on 63

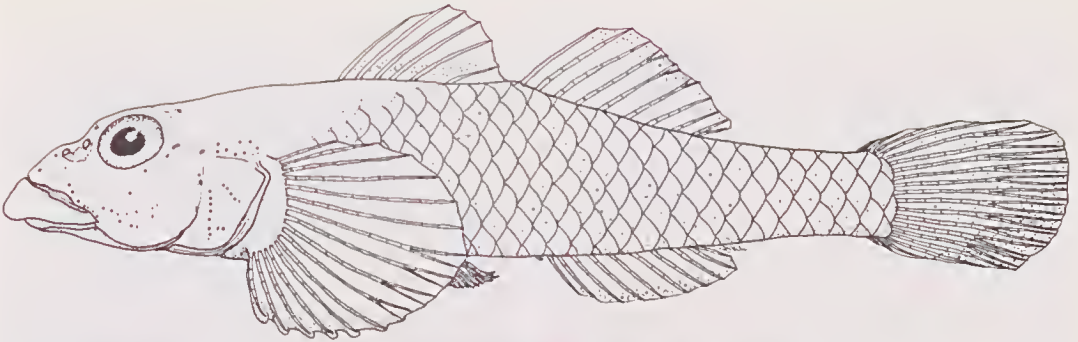

Fig. 16. Holotype of *Pleurosteya coerulea* (NTM S.12658-001), 16 mm male from Enewetak (first dorsal fin reconstructed).

specimens, 10.5 - 20 mm SL. First dorsal fin VI (56)*. Second dorsal 1,7(1); 1,8(55)*; 1,9(2). Anal fin 1,8(57)*; 1,9(1). Pectoral rays 15(1), 16(7)*, 17(36). 18(18). Lowermost 4-7 (mean 5, 6 in holotype) pectoral rays unbranched, at least tips (often half of ray) thickened distally. Branched caudal rays 11(5)*. Lateral scale count 22-25 (mean 23, 24 in holotype). TRB 5-7* (mean 6). Nape naked. Gill rakers on outer face of first arch 2+1+2 (1), 2+1+3 (1), 3+1+3 (1); rakers very tiny, first three to four rakers with fine spines at tips. Half, or nearly half, of lower limb of first arch bound to inner face of opercle by membrane.

Head and anterior half of body roughly triangular in cross-section (apex dorsally), posterior half of body compressed (Fig. 16). Body short, BDA 14.5-26% of SL (mean 17%). Head length 29-36% of SL (mean 32.5%). Head rather broad, width always greater than depth, cheeks sometimes expanded (mean HW 72% of HL, mean HD 55%). Snout moderate, rounded when viewed from above, averaging 35% of HL. Mouth straight, sub-terminal, jaws ending at point below anterior half of eye. Large upper lip overhangs mouth, especially anteriorly, concealing triangular lower jaw when mouth closed. Lower lip very narrow; near rictus, lip may have small rounded horizontal flap at each side. Eyes moderate, 24-43% of HL (mean 29%). Eyes set dorsolaterally, high on head. Interorbital narrow, 2-6.5% of HL (mean 4%). Anterior nostril in short tube, posterior nostril in shorter tube or low rim. Nostrils very close to upper edge of eye. Tongue rounded to slightly pointed (weakly trilobed in one specimen). Gill opening restricted to pectoral base (in 44), or forward to under opercle (in 15). Gill membranes usually form fold across isthmus

(just below level of preopercular edge), but are broadly joined to isthmus.

Fins low, first dorsal shorter than anterior rays of second dorsal. Anal rays unbranched. Caudal roughly rounded, upper rays longer than lower. Pectoral fins rounded, reach to below gap between dorsals. Pelvic fins round, cup-like, may just reach anus; fin rays broad and somewhat flattened near first branch point. Frenum and pelvic spine lobes fleshy and fimbriate, lobes rounded.

Upper jaw teeth very small, fine, and pointed; arranged in narrow band, broader anteriorly, narrowing at sides. Across front of upper jaw and mostly concealed by upper lip, eight to twelve enlarged, slender, curved teeth present. Lower jaw with band of very small, fine, pointed teeth across front; band extends over edge of jaw, so that outermost (sometimes slightly enlarged and curved) row of moveable teeth angle downward and outward. Innermost, an even row of upright, pointed teeth; and one or two large curved canine teeth at each side of jaw symphysis.

Lateral line canals as for genus. In three specimens, anterior interorbital pore paired; in one specimen pore absent.

Nape naked, scales on body extend up to just above pectoral base; naked strip below first dorsal fin. Belly midline naked; one specimen with several scales on belly just before anus.

Male genital papilla moderately long, flattened, with several tiny lobes at expanded, sometimes fimbriate, tip. Female genital papilla short, cylindrical to slightly flattened, with several small lobes on either side of tip.

Colour in Life. No colour notes available for living specimens. Freshly dead fish are translucent dull blue, with scale margins

slightly darker, and body covered with scattered pinkish to light brown speckles. Head and anterior half of abdominal cavity brighter blue than rest of body. Red brown stripe extends from each eye across snout to upper lip, stripes do not meet on lip. Iris silvery, with purple pigment dorsally. Unpaired fins covered with fine pinkish speckles (speckles on caudal fin darkest, nearly red); margins of dorsals, anal, caudal, and lowermost part of pectoral fins dusky, and anal fin rays outlined with dusky pigment.

Colour in Alcohol. Head and body generally pale, covered with fine black or brown melanophores. Melanophores generally absent from strip along bases of dorsals and posterior part of nape midline. Anterior half of nape, pectoral base and sides of body darkest, sides of head and snout usually lighter (pigment intensity variable). No trace of red snout stripes remain. Centre of nape sometimes with elongate diffuse blackish or brownish spot, darker than surrounding pigment. Belly and underside of head unpigmented.

Narrow brown streak on first dorsal fin, just above base. Free edge of first dorsal sometimes with narrow dusky margin. Second dorsal fin with broken brown line just above base of fin (line not always present); dusky margin sometimes present, usually more intense posteriorly; fin rays, especially anteriorly, may be dusky. Caudal fin with faint dusky band on rear edge, darkest dorsally. Pectorals and pelvics clear.

Comparisons. *Pleurosicya coerulea* is most like *P. muscarum* in general body form, but is distinguished by physiognomy (usually convex snout and terminal mouth in *P. muscarum* compared to *P. coerulea*'s overhanging upper jaw and usually flatter snout), mean eye size (29% of HL in *P. coerulea* and 25% in *P. muscarum*), colour pattern (five pairs of red lines on the head of *P. muscarum*, and only one pair of brown lines for *P. coerulea*), and host preference. It is also very close to *P. occidentalis* and is sympatric with this species at the Chagos Archipelago (see description of *P. occidentalis* for further distinguishing features).

Remarks. This species is commensal (parasite?) only upon the blue coral *Heliopora coerulea*, of the Order Helioporacea (i.e. not a true coral). The gut contents of five specimens were examined, as it was suspected that this species might feed upon its host's mucus and

epibiota. Three of the five guts were filled with clumps of white flocculent mucus; embedded within this were many diatoms, fine algal filaments, sponge spicules, tiny copepods, and a small amount of material which looked like yellowish plastic food wrap. The remaining two guts were filled with sheets of this "gladwrap" folded many times, and included mucus, diatoms, small copepods, sponge spicules, and algal fragments. The "gladwrap" has been identified as the cuticle or periderm of the *Heliopora*, a structure fairly recently described (Bouillon and Hovenaghel-Crevecœur 1970). So it would appear that *Pleurosicya coerulea* feeds upon its host directly, as well as obtaining shelter from it. The downward and outwardly-angled lower jaw teeth, though moveable, must be firm enough to dislodge the cuticle from the colony surface.

Etymology. The species name is derived from the Latin *coerulea* (blue), using an older spelling (nowadays *caerulea* is used) to echo the species name of the invertebrate host.

Pleurosicya elongata sp. nov.

(Fig. 17; Pl. IIa)

Type material. HOLOTYPE - NTM S.12654-001: 29 mm SL male, Bootless Bay, Buna Motu, Motupore Island, Port Moresby, Papua New Guinea, 10 m depth, off yellow sponge *Ianthella basta*, P. Colin, 15 September 1986. PARATYPES - NTM S.12310-001: 14.5 female, Ashmore Reef, E side of entrance to West Pass, 20 m depth, from yellow *Ianthella basta*, H. Larson, 18 September 1987. NTM S.12307-019: 2(15.5-16), Ashmore Reef, dropoff at entrance of West Pass, 18-20 m depth, host unknown, H. Larson, 16 September 1987. USNM 210068: 2(18-20), Indonesia, Maluku, Saparua, off Kampungmahu, 14-16 m depth, V. Springer & M. Gomon, 17 January 1973. NTM S.12654-002: 4(13.5-26), Papua New Guinea, same data as holotype. NTM S.12655-001: 8(13-28.5), same data as holotype but from different sponge specimen. WAMP.30053-001: 2(17.5-26.5), Papua New Guinea, Buna Motu, Motupore Island, Port Moresby, 12 m depth, from purple *Ianthella basta*, P. Colin, 14 September 1986. ROM 58024: 3(20.5-25.5), same data as holotype, but from different sponge specimen. AMS 1.29786-001: 2(17-21.5), same data as holotype but different sponge specimen. NTM S.12656-001: 3(14-25), reef slope, Papua New

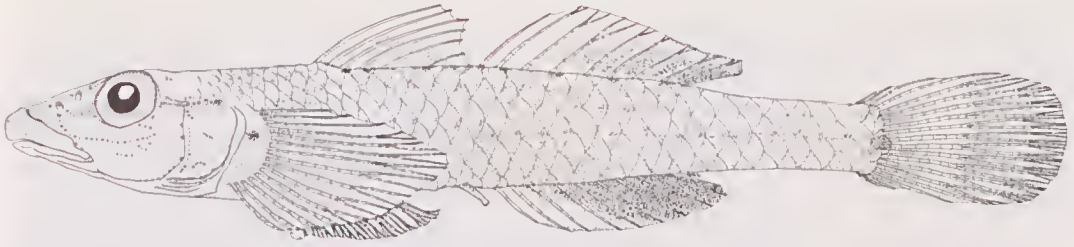

Fig. 17. Holotype of *Pleurosicya elongata* (NTM S.12654-001), 29 mm SL male.

Guinea, Lion Island, Port Moresby, 15 m depth, off fan-shaped sponges, P. Colin, 6 August 1986. AMS I.29888-001; 26.5 mm SL male, Papua New Guinea, Milne Bay. AMS I.22580-029, 21.5 mm SL male, Great Barrier Reef, Queensland, North Escape Reef, back reef, 37 m depth, AMS party, 28 October 1981.

Additional material. ZMUC unregistered: Mortensen Sta.40, 4(17-22), N of Doe Roe, Kci Islands, ca. 25 m depth, trawled from sand substrate, 25 April 1922 (in poor condition).

Diagnosis. A large *Pleurosicya* with long body and snout, and distinctive colour pattern. Dorsal and anal rays usually 1,8. Pectoral rays 15-17, usually 16. Lateral scales 25, TRB 8. Sides of nape scaled, scales rarely cross nape midline. Gill opening restricted to pectoral base. Tongue reduced, pointed, set far back in throat. Live colour translucent, matching colour of host, with dark internal markings along vertebral column and below dorsal midline, and brown stripe around snout. Commensal on the fan sponge *Ianthella basta*.

Description. An asterisk indicates counts of holotype. Based on 27 specimens, 13-29 mm SL. First dorsal VI (27)*. Second dorsal 1,8 (25)*; 1,9 (2). Anal 1,6 (1); 1,7 (1), 1,8 (23)*, 1,9 (2). Pectoral rays 15 (5)*, 16 (16), 17 (6). Lowermost 4-7 (mean 6) pectoral rays unbranched, often somewhat thickened distally. Branched caudal rays 11 (8)*. Sides of nape scaled, usually more scales present in larger specimens; midline naked (a few scales across midline of holotype, which is the largest specimen known). Lateral scale count 23-27, with mean of 25*. TRB 7-9, with mean of 8*. Gill rakers on outer face of first arch small, slender, 1+1+5 (1), 1+1+6 (1), 2+1+5 (3); rakers on inner faces of arches slender, with distinct tiny spines at tips. At least lowermost quarter of first arch bound by membrane to opercle.

Head and anterior half of body a rounded triangle in cross-section (apex dorsally), pos-

terior half of body quite compressed (Fig. 17). Body slender, body depth at anus 12-16% of SL (mean 14%). Head length 26-33% of SL (mean 29%). Head width greater than head depth (mean width 50%, and mean depth 57%, of HL). Snout relatively long, 25-52% of HL (mean 35%). Mouth moderate (30-41% of HL), terminal, parallel to body axis. Upper jaw slightly longer than lower, tip of upper lip fleshy. Lower jaw roughly rectangular. Jaws end below a point just in front of anterior edge of eye. Eyes relatively small, 24-36% of HL (mean of 30%), set dorsolaterally, forming part of profile. Interorbital narrow, 1-6% of HL (mean 3%). Anterior nostrils in short tube, posterior nostrils usually with low rim, which may be absent. Tongue narrow, pointed, set back in throat. Gill opening restricted to pectoral base.

First dorsal fin triangular, slightly shorter than anterior rays of second dorsal (about equal to BDA). Anal rays all unbranched. Caudal fin truncate to rounded, upper rays usually longest. Pectoral fins slightly pointed, reaching back to above anus. Pelvic fins oval to round, not reaching anus, forming shallow cup. Pelvic spine lobes flattened but fleshy, rounded, pointed or square in shape. Frenum long, with shallow fold at tips of pelvic spines. Pelvic rays not fleshy or fimbriate at tips, divided many times but not very flattened at first branch point.

Teeth at sides of upper jaw stout, backwardly-curved, arranged in single even row. On either side of upper jaw symphysis, a band of fine pointed upright teeth, with a large curved canine tooth where band meets single row at side. Outermost, at least one other slightly smaller canine at each side of symphysis. Teeth on sides of lower jaw similar to those of upper: backwardly - curved, sharp, in single even row, this row continues behind teeth across front of lower jaw. Front of jaw with band of straight sharp fine teeth at either side of symphysis, band angled outward across

front of jaw in larger specimens. At side where tooth band ends, an enlarged stout curved canine present, sometimes angled outward. An upright canine usually at either side of lower jaw symphysis in males. Females may have reduced, only one, or no lower jaw symphyseal canines.

Lateral line canals of head as for genus.

Body fully scaled, sides of head with scales extending forward to preopercle in large specimens, rest of head naked, as is breast and midline of belly. Holotype (largest specimen) with about 10 rows of scales on nape, scales cross nape midline (all other specimens with midline naked).

Male genital papilla small, narrow, slender, with expanded fimbriate tip (base of papilla may be pigmented). Female genital papilla short, rounded to rather flattened, with about three small lobes on either side of opening at tip.

Colour in Life. Colour description based mostly on slides of living specimens from Port Moresby, kindly provided by Pat Colin of Florida State University.

Head and body translucent pale green, yellow green, or purplish pink, depending on colour of host sponge (Pl. IIa). Scales on upper body with margins finely outlined with brown, lower half of body with very fine sprinkling of melanophores. Peritoneum silvery, with three oblong dark brown internal blotches across top, and series of smaller markings along its sides. Brain and vertebral column silvery white, with eight or nine internal elongate blotches of brown running along top of vertebral column, beginning at base of skull, with last blotch (on hypural fan) rounded. About eight internal brown blotches in line from rear of peritoneum to about end of anal fin. About 12 to 15 small brown to red - brown spots along dorsal midline of body, marking largely just below skin; spots may be joined (especially those below dorsal spines). Anterior-most two of these spots may form elongated marks on dorsal midline of nape. Two short red brown lines behind each eye on brain surface, lines forming "V", apexes nearly joined at nape midline. Relatively broad red to red brown line runs from front of eye to tip of upper lip, covering top of snout and anterior half of lip. A red to red brown line from rear of eye runs along top of opercle to opercular margin. Pupil surrounded by ring of bright orange to golden, rest of eye golden or golden

brown. Upper halves of opercle and preopercle with indistinct brown short lines and blotches, lower halves evenly spotted with fine brown speckles. Pectoral base with distinct brown spot (which may be double) near base of upper three to 10 rays, rest of base evenly covered with fine brown speckles (area above spot may be without pigment). Both dorsals with transparent membranes, spines and rays brownish to red brown. Anal apparently translucent, with whitish pigment on anteriormost rays. Caudal transparent, lower half of fin may be dusted with fine melanophores. Pectorals and pelvics transparent, rays light reddish or brownish.

A specimen from a yellow sponge was noted as having yellow (not brown) dorsal midline spots. Internal blotches and other dark markings pale reddish brown. Snout above red stripes, opercles, and lower half of pectoral base with yellow green iridescent pigment.

Colour in Alcohol. Brown and red brown markings of live colour generally remain as brown pigment. Head and body mostly fairly densely covered with melanophores, and scale margins on upper half of body (and nape) narrowly outlined with dark brown. Distinct unpigmented patch of skin nearly always present on nape behind eyes; rectangular block of brown pigment overlying brain may show through muscle tissue. Internal colour marks in body not visible, except for blotch on hypural fan. Dorsal midline paler than sides of body, and midline's dark brown spots and blotches are conspicuous, especially elongate marks on nape. Stripes behind and in front of eyes distinct, as is blotch or spot on pectoral base. Row of irregular small spots along mid-side of body, not always distinguishable from dark colouring of sides. Belly pale, unpigmented. Breast and branchiostegals often dusky, especially in larger specimens. Both dorsals and anal with pale pigment scattered over membranes, with dusky markings along bases of fins. Caudal fin covered with fine dusky melanophores, lower half of fin quite dark in some specimens. Pectoral and pelvic fins with membranes near bases dusky, rest of fins transparent.

Comparisons. This species resembles an elongated *P. labiata* in having similar physiognomy and colouration. It differs in that the nape is less scaled (scales usually extend up to behind eyes in *P. labiata*), the lower jaw is shaped differently (rectangular, and of moder-

ate size, not relatively short and triangular), the body is more slender (BDA 14% versus 17% in *labiata*), the pelvic fin form differs (cup-shaped with small slightly fleshy lobes, not flattened with flat folded lobes), and it prefers fan-shaped sponges (particularly *Ianthella basta*) as hosts (*P. labiata* prefers barrel-shaped sponges). One character that *P. elongata*, *P. labiata*, *P. fringilla* and *P. prognatha* all share is a similar tongue form (small, slender, and pointed, usually appearing to be anchored at the back of the throat). *Pleurosicya fringilla* and *P. prognatha* differ from the other two in morphology, host preference (staghorn corals), size, and jaw and teeth structure.

Luposicya lupus also resembles this fish when live, as there are many similarities in body form, colouration and host preference. Both species are sponge-dwellers, but *P. elongata* is found on different sponge species to *L. lupus*, and often at a greater depth. When preserved, they are easily distinguished by the characters given earlier for *L. lupus*.

Remarks. Apart from several specimens which were collected by trawl or rotenone, with hosts not observed, all other specimens of this species have been collected by hand from large fan-shaped sponges. These have been identified as *Ianthella basta* (Pallas, 1766), of the family Ianthellidae, a common sponge which has an Indo-Pacific distribution, and several colour forms. It seems likely that *P. elongata* is restricted to this sponge species.

Etymology. From the Latin *elongata* meaning prolonged, referring to the body length of this species.

Pleurosicya fringilla sp. nov.
(Fig. 18)

Pleurosicya HKL sp. 1 - Winterbottom and Emery 1986:54, Fig. 79 (lagoons at Peros Banhos and Salomon).

Pleurosicya 'sp. 1' - Allen and Russell 1986: 99 (Scott and Seringapatam Reefs).

Pleurosicya sp. 1 - Hoese, in Smith and Heemstra 1986:801 (Sodwana Bay, South Africa).

Type material. HOLOTYPE - USNM 242091: 15 mm SL male, Fiji, Lau Group, Yanutha Islet, lagoon side of barrier reef, V. Springer, 30 April 1982. PARATYPES - RUSI 9533: 11 mm SL male, South Africa, Sodwana, Zululand, P. Heemstra & party, 2 February 1979. CAS 68075: 2(10-14.5), Seychelles,

off S shore Beacon Island, 12-15 m, J. Bohlke and party, 3 February 1964. ANSP 165113: 3(17.5-18), Seychelles SE side Beacon Island, off Port Victoria, R. Rosenblatt and party, 5 February 1964. USNM 306887: 11 mm SL female, Madagascar, Nossi-Be, Pt Fievre, left of centre pier, J. Rudloe, 14 January 1964. ANSP 165114: 2(13.5-15), Seychelles, Mahe area, inner edge of reef just N of Anonyme Island, 0 - 3 m depth, J. Bohlke and party, 2 February 1964. ANSP 165115: 6(9.5-13), Seychelles, S side Praslin Island, just E of St Anne's Bay, 8 m depth, J. Bohlke and party, 22 February 1964. BPBM 16342: 18.5 mm SL female, Mauritius, west coast off Flic en Flac, in cave at 30 m depth, 20 November 1973, J. Randall. ROM 58025, 10(10-14), Chagos Archipelago, Peros Banhos Atoll, lagoon side of Isle Mapua, 3-7 m, A. Emery *et al.*, 6 March 1979. WAM P.27596-001: 2(13-14), Western Australia, Abrolhos Island, lagoon on W side Long Island, G. Allen and N. Cross, 19 April 1982. USNM 306885: 7(10.5-15.5), Fiji, same data as holotype. AMS 1.22631-055: 3(12-14.5), Great Barrier Reef, Escape Reef, AMS team. AMS 1.29787-001: 2(10-13), Queensland, Lizard Island, N side of South Island, on *Acropora* sp., 3 m, D. Hoese, 7 November 1975. NTM S.12653-001: 2(13.5-14.5), Queensland, Heron Island, P. Young, NTM S.12225-008, 5(11-13), Papua New Guinea, Port Moresby, Motupore Island, 3 m depth, from *Pocillopora eydouxi*, P. Colin, 3 October 1986. USNM 306886: 2(11.5-14.4), Papua New Guinea, along S edge of channel between Pelleluru and Ninigo Groups, V. Springer, 26 October 1978. NTM S.12652-001: 13 mm SL male, American Samoa, Tutuila Island, Taena Bank, 27 m depth, R. Wass, 11 November 1975. AMS 1.18051-078: 11(10.5-17), Kiribati, Abaiang Atoll, leeward reef off Bolton Point, 7-11 m, D. Hoese and B. Goldman, 10 November 1973. AMS 1.21915-077: 4(11-14), Philippines, Batangas Province, Sombrero Island, 6 m depth, D. Hoese, 24 April 1980. YCM 2760: 1 10.5 mm juvenile, Japan, Ryukyu Islands, mouth of Kabira Bay, Ishigaki-jima, M. Hayashi, April 1976. YCM 1758: 2(11-12), Japan, Ryukyu Islands, Kabira Bay, Ishigaki-jima, M. Hayashi and T. Ito, May 1975.

Additional material. GAMBIER ISLANDS - from BPBM 13593: 12.5 mm SL female, Mangareva, E of Rikitea, patch reef, 3-11 m depth, J. Randall and party, 14 Decem-

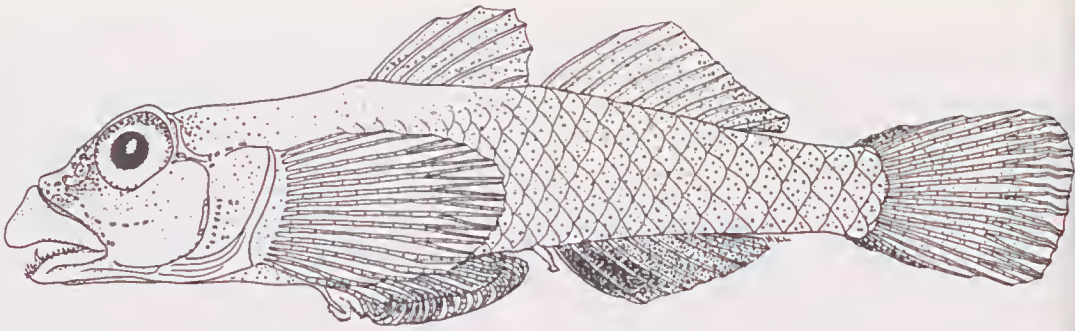

Fig. 18. Holotype of *Pleurosicya fringilla* (USNM 242091), 15 mm SL male from Fiji.

ber 1970. CORAL SEA - WAMP.28541-055: 3(10-12), Holmes Reef, 12-14 m depth. G. Allen, 20 November 1985.

Diagnosis. A small goby with large upper lip, long-snouted appearance, and eyes set relatively high on head. Second dorsal rays 1,8; anal rays 1,8. Pectoral rays 15-16. Lateral scales 27, TRB 8. Body fully scaled, head and nape naked. Gill opening restricted to pectoral base. Tongue small, pointed. Body and unpaired fins usually dusky, distinct black spot present over anterior rays of anal fin in males. Commensal on staghorn corals *Acropora* spp. and *Pocillopora eydouxi*.

Description. An asterisk indicates counts of the holotype. Based on 41 specimens, 10 - 18.5 mm SL. First dorsal fin VI (41)*. Second dorsal 1,7(2); 1,8(37); 1,9(2)*. Anal 1,7(3); 1,8(36)*; 1,9(2). Pectoral rays 14 (4), 15 (24), 16 (13)*. Lowermost 4-6 pectoral rays unbranched, and slightly thickened distally (sometimes no thickening). Branched caudal rays 11 (4)*. Longitudinal scale count 23-31 (24 in holotype), with a mean of 27. TRB 7-10, with a mean of 8*. Gill rakers on outer face of first arch reduced to rudiments; 1+1+1 (1), 1+1+2 (1), 1+1+3 (1), 2+1+4 (1). Lower quarter of first gill arch bound by membrane to opercular wall.

Head and anterior half of body varying from roughly triangular (apex dorsally) to compressed, posterior half of body compressed (Fig. 18). Body sometimes stocky, depth at anus 15-22% of SL (mean 18%). Head length 34% of SL. Head depth may be equal to head width, width usually slightly greater (as in holotype). Snout rather long and pointed, 28-43% of HL, (37% in holotype). Mouth terminal, nearly horizontal, with upper jaw slightly overhanging lower. Jaws end at a point below anterior half of eye. Eye medium in size, 24-35% of HL (mean 29%*). Eyes set laterally,

high on head and forming part of the dorsal profile. Interorbital very narrow, 2*-5% of HL (mean of 3%). Nostrils close to front of eye, anterior nostril in slender tube, posterior nostril with low rim. Tongue usually narrow, pointed, occasionally rounded. Gill opening restricted to pectoral base.

First dorsal low and rounded; unpaired fins rounded, including caudal. Second dorsal and anal fin rays all unbranched. Pectoral fins reach back to below tips of first dorsal spines, or nearly so, when depressed. Pelvic fins euplike, rounded, reaching past anus but not to anal fin origin. Pelvic rays multi-branched, flattened near first branch point. Pelvic spine lobes small, rounded to pointed. Lobes, folded frenum and outermost two-thirds of pelvic fins may be finely fimbriate.

Upper lip usually rather pointed, sometimes broad and fleshy, tending to overhang front of lower jaw. Upper jaw roughly square to pointed, teeth very small, even, pointed, arranged in broad band, widest anteriorly. Outermost, one or two larger curved pointed teeth present at sides of front of upper jaw (hidden by lip). Teeth of lower jaw small, even, pointed, in broad band, widest anteriorly. Outermost teeth at front of jaw often slightly longer, may form separate row, and are movable. Behind tooth band and widely set on either side of symphysis, are one or two large curved canine teeth.

Lateral line canals of head generally as for genus. Usually only two preopercular pores present, as in holotype (only one specimen with three pores on each preopercle).

Scales on body extend up to behind pectorals, leaving head and nape naked. In smaller specimens, scales do not reach upward to first dorsal or anterior half of second dorsal bases.

Male genital papilla somewhat elongated, broad at base, flattened, with slightly ex-

panded fimbriate tip (some specimens with papilla broad and relatively short). Female genital papilla short and rounded, with several small lobes at tip.

Colour in Life. A specimen collected from a brown staghorn *Acropora* at Lizard Island was transparent, with fine brown speckles over the entire peritoneum, the dorsal surface of which was silvery white and the rest yellowish (underneath the melanophores). A brown stripe ran from front of each eye to tip of snout, where it met its fellow from the other eye. Behind the eyes was yellowish orange, and indistinct brownish areas over the upper opercle. A brown stripe extended forward from origin of dorsal along nape midline to fade into the yellow colouring behind the eyes, and yellowish orange internal pigment was present below the stripe. Eyes silvery to golden. When observed in the field, this species appears translucent, with body colour matching the colour of the *Acropora* upon which it lives.

Colour in Alcohol. Body and posterior half of head evenly covered with light brown melanophores; belly, breast, and underside of head unpigmented. Interorbit, snout and sub-orbital region pale, with indistinct brown stripe from eye to tip of snout, meeting at middle of upper lip. Lower lip, and remainder of upper lip, unpigmented. Some specimens with top of snout from interorbit to lip dusky, which sometimes forms a distinct brown median stripe. Both dorsal fins transparent, with evenly scattered fine black melanophores present. Anal fin usually darker than dorsals, and in males the membrane between the first two or three rays is black (or darker than rest of fin), forming a distinct blotch. Caudal light brown. Pectorals and pelvics unpigmented, translucent.

Comparisons. This species resembles Goren's *P. prognatha*, and has been confused with that species. *Pleurosicya friugilla* differs in that it does not have an elongated upper jaw and lip forming a "beak", has a black blotch on the anterior rays of the anal fin in males, reaches a size of at least 18 mm SL (versus 15 mm SL), and is more common (in collections). *Pleurosicya friugilla* is also similar to *P. spougiicola*, which has higher pectoral ray counts, broad round tongue, steep head profile, and is so far known to be commensal on a sponge from trawl-depths.

Remarks. This species occurs where there are thick stands of large staghorn *Acropora*

corals, particularly *A. formosa* and *A. grandis*. *Pleurosicya friugilla* may be observed clinging to the underside of the *Acropora* branches; it will dart further into the thicket of branches if pursued. The species is sympatric with *P. prognatha*, but it is not known if both species live on the same coral colony together (which is likely, given the size of the colonies, and the behaviour of the group).

Both *P. prognatha* and *P. friugilla* share an osteological character which most other *Pleurosicya* examined do not possess: they have a somewhat bifurcate process on the preopercle reaching towards a process on the symplectic (*P. carolinensis* has a short preopercular process reaching toward a very small process on the symplectic).

Etymology. The species name comes from the Latin *friugilla*, meaning chaffinch (a finch), referring to the tiny bird-like appearance of this fish.

Pleurosicya labiata (Weber)
(Figs 19-20)

Rhinogobius labiatus Weber, 1913:470-471 (Flores, Indonesia).

(? *Fusigobius*) *labiatus* - Koumans 1953: 148 (Flores).

? *Luposicya lupus* - Yoshino, in Masuda *et al.* 1984:284, plate 255(O) (Kushimoto, Wakayama province).

Type material. SYNTYPE - ZMA 112.904: 18.5 mm SL female, Labuan Badjo (Badjo Bay), Flores, Indonesia, 17-35 m, sand bottom, "Siboga" station 50, 16-18 April 1899.

Additional material. INDONESIA - USNM 210333: reef off Kulur, Saparua, Moluccas, 6 m, V. Springer, M. Gomon, 20 January 1973. USNM 209995: 4(10.5-18), Saparua, off S side Ceram, 4-10m, isolated coral patch by mangrove shore, V. Springer, M. Gomon, 18 January 1973. USNM 306888: 17.5 mm SL female, Run Island, Banda Islands, "Alpha Helix" Moro cruise, 8 July 1979. USNM 210292: NE side of Ambon Island, about 2 km E of Sawa Telu, coral reef, V. Springer and M. Gomon, 8 January 1973. USNM 306889: 2(20.5-22.5), Tallabassi Bay, off NE tip Big Damalawa Islet, Kabaena Island, Sulawesi, vertical reef face and live and dead corals, 2-15 m, V. Springer *et al.*, 24 February 1974. PHILIPPINES - USNM 99579: 19.5 mm SL male, vicinity of Siasi, Sulu Archipelago, F.I.V. *Albatross* station D5147, 16 February 1908. USNM 243419:

19.5 mm SL female, Negros Oriental, Siquijor Island, 1 km W of Larena, 0-30 m, J. Libbey *et al.*, 15 May 1979. ANSP 165116: 25 mm SL female, SE side of Apo Island, 0-30 m. V. Springer and J. Libbey, 6 June 1978. CAS 68076: 20 mm SL male, off Bonbonon Point at S tip Oriental Negros, 0-18.5 m, V. Springer *et al.*, 13 May 1978. USNM 264925: 3(18.5-28), about 2 km W of Siquijor. Siquijor Island, 18.5-30 m, J. Libbey *et al.*, 14 May 1979. SRI LANKA - USNM 306890: 2(17.5-20), Trincomalee, sandy bottom with boulders and coral, 24 m, C.C. Koenig, 2 April 1970. GREAT BARRIER REEF- NTM S.12525-001: 19.5 mm SL female, off barrel sponge (probably *Xestospongia testudinaria*), Pandora Reef, 6 m, H. Larson, 8 Dec. 1980. NTM S.12524-001: 14 mm SL female, off large sponge, Linnet Reef, 6-15 m, D. Hoese, H. Larson, B. Russell, N. Coleman, 22 November 1980. ASHMORE REEF - NTMS.12230-003: 23 mm SL male, off large barrel sponge, reef slope at entrance to West Pass, 21 m, H. Larson, 25 September 1987.

Diagnosis. A long-bodied, robust *Pleurosicya* with small eyes and mouth. Second dorsal and anal rays 1,8. Pectoral rays usually 16. Lateral scales 25, TRB 8-9. Nape fully scaled. Pelvic fins generally flat, not cup-like, with lobes over pelvic spines thin, pointed or multilobed. Gill opening restricted to pectoral base. Tongue small, pointed. Lower jaw triangular, with large curved tooth at each side. Body speckled dark brown, with scales on upper body outlined with darker pigment, and red-brown stripe from eye to snout tip. Commensal with sponges.

Description. An asterisk indicates counts of syntype. Based on 22 specimens, 10.5-28 mm SL. First dorsal fin VI (18)*. Second dor-

sal fin 1,7(2); 1,8(15)*; 1,9(1). Anal fin 1,8(17)*; 1,9(1). Pectoral rays 15(2), 16(14)*, 17(3), 18(1). Lowermost 3-6 (mean 4) pectoral rays unbranched, occasionally with skin at tips thickened distally. Branched caudal rays 13(4). Predorsal scales 9-11*. Longitudinal scale count 24*-27, with a mean of 25. TRB 7-9*, with a mean of 8. Gill rakers on outer face of first arch very reduced, 1+3(1), 2+3(2), longest raker on upper arm of arch. Rakers on inner faces of arches somewhat larger, with few tiny spines at tips. Lowermost third to fourth of first gill arch bound to inner face of opercle by membrane.

Head and anterior half of body triangular in cross-section (apex dorsally), posterior half of body quite compressed. Body rather elongate, body depth at anus 13-20%, averaging about 17% of SL (Fig. 19). Head length to greater than head depth (mean width equal to or greater than head depth (mean width 60%, and mean depth 55%, of HL). Snout moderate, averaging 33% of HL. Mouth small, terminal, slightly oblique, with upper jaw overhanging lower. Lower jaw triangular, with pointed tip, and sides near large teeth angled outward. Mean jaw length 34% of HL (32-36%). Jaws end at a point below just in front of eye or below posterior nostril. Eyes relatively small, 23-31% of HL (mean of 27%), set dorsolaterally, high on sides of head. Interorbital narrow, 2-8% of HL, mean of 4%. Nostrils low, sometimes in short tubes (anterior nostril always longer), sometimes only with raised rims, particularly posterior nostril. Tongue reduced, pointed, and very short (set back in throat). Gill opening restricted, not reaching further forward than pectoral base.

First dorsal fin triangular. Second dorsal fin about equal in height to first. Anal fin rays

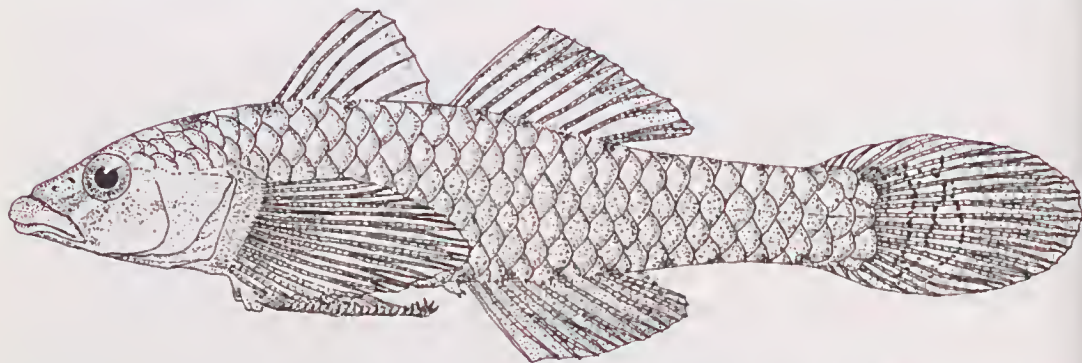

Fig. 19. *Pleurosicya labiata* (USNM 210333), 23 mm SL female, from Saparua, Moluccas (headpores and papillae omitted).

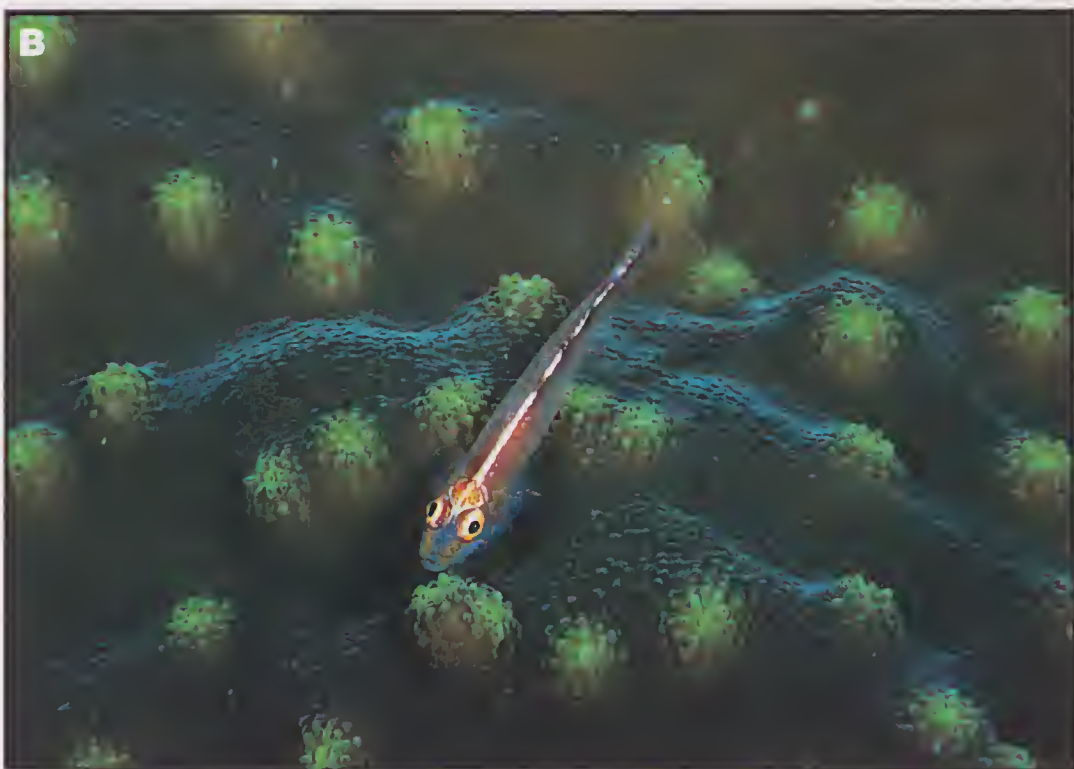
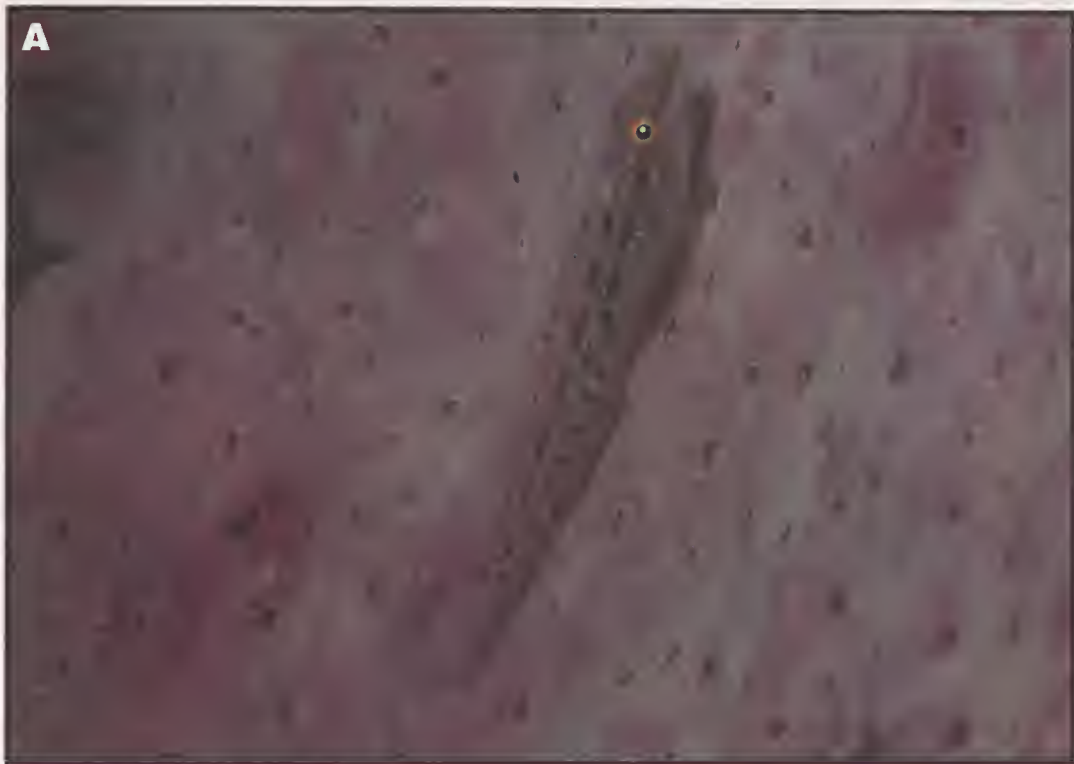

Plate II. a. *Pleurosicya elongata* (AMS I.29786-001) on the sponge *lanthella basta* at Buna Motu Island, Bootless Bay, New Guinea. Photo by Pat Colin. b. Live *Pleurosicya micheli* on the coral *Echinopora* sp., Flores, Indonesia. Photo by Rudie Kuiter.



Fig. 20. Sensory papillae of *Pleurosicya labiata* (USNM 210333).

mostly branched. Caudal fin truncate to rounded. Pectoral fins, when flattened, usually reach back to below folded dorsal spine tips. Pelvic fins flattened, not cup-like, with thickened skin present only around pelvic spines and frenum. Pelvic spine lobes flat, not thick or fleshy, may be lobed, folded, pointed, or rounded. Fold in frenum may be quite shallow. Pelvic rays divided many times, but not much flattened near first branch point.

Teeth on sides of jaws small, backwardly curved, and in single row. Teeth across front of upper jaw tiny, straight, pointed, arranged in broad band, with a large curved canine at each side of band. Teeth in lower jaw similar, but most are movable; innermost somewhat curved and upright, with outermost straight and nearly horizontal. One or two large curved outward-angled canines present on each side of band, and sides of jaw angled outward below these teeth. Large pair of curved teeth behind symphysis of lower jaw.

Lateral line canals on head as for genus. Sensory papillae as in Figure 20.

Head and nape usually fully scaled, with scales extending up to behind eyes, in 9-11 rows. In five specimens the nape midline is naked, with scales extending forward on either side to behind eyes. Belly midline and breast naked.

Genital papilla in male elongate, flattened, wide at base and narrow at tip. Tip with about three tiny lobes present. Female genital papilla short, thick and cylindrical, with two large and several smaller lobes at tip.

Colour in Life. The Ashmore Reef specimen was recorded as being entirely (body and fins) speckled with dark brown, with six internal blocks of yellowish pigment arranged along the vertebral column. The eye was

golden brown. A red-brown stripe ran from each eye to snout tip (but did not meet at tip), and two similar stripes began at anterior interorbit, each running to anterior nostril region.

Colour in Alcohol. Head and body evenly covered with melanophores, with most pigment on upper half of body. Scales on upper half of body with edges usually distinctly outlined, forming reticulated pattern. Nape usually with elongate blackish spot on midline, behind eyes. Side of head with broad whitish stripe from eye to rictus and upper jaw; above this is brown stripe from eye to middle of upper jaw (stripe runs just below nostrils). Two indistinct brown stripes extend from interorbit to snout (above nostrils); these stripes not always distinguishable. Lips not heavily pigmented, often pale.

Rays of both dorsals dusky, with some scattered melanophores across membranes. Anal fin light dusky, but rays not heavily pigmented. Pectoral fins dusky basally, and rays often dusky. Pelvic fins usually hyaline to transparent. Caudal fin dusky.

Comparisons. This is a distinctive species, and is closest to *P. elongata* and *P. carolinensis*, the three forming a close-knit group. *Pleurosicya elongata* is most similar to *P. labiata*, but has the lower jaw symphyseal canines either reduced or absent, scales usually present on the sides of the nape only, is commensal on the fan sponge *lanthella basta*, and is more slender (BDA 14% of SL, versus 17% in *P. labiata*). *Pleurosicya carolinensis* has the nape naked, pectoral rays usually 14, not 16, the tongue rounded, not pointed, and different teeth (outermost row in lower jaw exposed, pointing outward and downward).

Remarks. The species was originally described from two specimens, 22 and 24 mm total length, of which only one remains. The other has not been located (H. Nijssen, personal communication) and is presumed to be lost.

The specimen (which is also apparently lost) illustrated in Masuda *et al.* (1984; Plate 255, O) as *Luposicya lupus* is probably this species. The photograph, counts and description fit *P. labiata*, although the locality is the furthest north known for the species, and the invertebrate host reported (*Junceella juncea*) usually supports *Bryaninops amplus*, not *Pleurosicya* (Larson 1985). *Luposicya* has not yet been found in Japan, but several species of *Pleurosicya* and *Bryaninops* occur there.

Pleurosicya labiata is usually commensal on large barrel-shaped sponges. the Pandora Reef specimen having been identified as probably *Xestospongia testudinaria* (J. Hooper, personal communication).

***Pleurosicya micheli* Fourmanoir**
(Fig. 21; Pl. 11b)

Pleurosicya micheli Fourmanoir, 1971: 499-500, Fig. 8 (Lifou, Loyalty Islands) [type lost].

Pleurosicya HKL sp.15? - Winterbottom and Emery 1986:55 (drop-off at Peros Banhos).

Type material. NEOTYPE - out of AMS 1.21918-069: 17.5 mm SL female, Caban Island, Philippines. D. Hoese, 1980.

Additional material. SEYCHELLES - ANSP 165117: 5(8.5-13.5), Amirantes Islands, SW of Ressource Island, 24-30 m, J. Bohlke and party, 7 March 1964. SOUTHERN TAIWAN - NTM S.12160-004: 18 mm SL female, Wang-li-tun, 10 m, K.T. Shao, 1986. NTM S.12160-006: 20 mm SL male, same data as previous. OKINAWA, JAPAN - URM P. 2154: 2(13-15.5), Amurojima, Kerama Islands, 20 m, on *Pachyseris* sp., K. Shimada, 15 July 1980. URM P.2198: 14.5 mm SL male, Gahi, Kerama Islands, 20 m, on *Pachyseris* sp., K. Shimada, 14 July 1980. URM P.2149: 2(15-16.5), Agenashiki, Kerama Islands, 20 m, off *Pachyseris* sp., T. Yoshino, 16 July 1980. PALAU, MICRONESIA - AMS 1.17936-001: 16.5 mm SL female, Bairakaseru Island, coral cliff, 38-53 m, G. Allen, W. Starck. PHILIPPINES - AMS 1.21918-069: 4(13.5-17.5), Caban Island, D. Hoese, 1980. AMS 1.21908-016: 16.5 mm SL female, Sombrero Island, Batangas Province, 1-34 m, D. Hoese and party, 23 April 1980. USNM 264928: 18 mm SL male, Mindanao, Zamboanga del Norte, W side Selinog Island, 21 m, L. Knapp, 3 May 1979. USNM 264918: 6(16.5-20), Negros Oriental, about 2 km W of Siquijor, Siquijor Island, 24-30 m, J. Libbey and party, 14 May 1979. USNM 306891: 17 mm SL male, Palawan, Cuyo Island on W side Cocoro Island, 0-21 m, V. Springer and party, 26 May 1978. HAWAII - BPBM 28712: 12(14-18), off Kona, P. Lobel, March 1982. BPBM 28736: 34(11-17), Ke'ci, Kona coast, on *Porites lobata* heads and ledges beneath, 24 m, P. Lobel and J. Randall, 11 August 1982.

NTM S.12651-001: 2(14.5-20), Napoopoo Bay, among corals, 15 m, P. Lobel, 1982. FIJI - USNM 242085: 3(11.5-17), Ono-Ilau, outside barrier reef on NW side of island, 0-42 m, V. Springer and party, 1 May 1982. USNM 242087: 11 mm SL female, Viti Levu, S corner of Toberua Passage entrance, 0-36 m, V. Springer and party, 30 May 1982. USNM 241785: 14.5 mm SL male, NW corner of barrier reef, Navutu Ira Island, Lau Islands, Fiji, rocks and sand, 30-36 m, V. Springer *et al.*, 3 May 1982. TONGA - BPBM 28864: 16.5 mm SL male, Tongatapu, off NW corner Manima Island, 17 m, J. Randall, 9 March 1983.

Diagnosis. A small *Pleurosicya* with wide gill opening and dark stripe along lower half of body and caudal fin. Second dorsal and anal fins 1,8. Pectoral rays 16-19. Lateral scales 25, TRB 7-8. Sides of nape scaled up to behind eyes, midline naked. Gill opening wide, at least to below posterior edge of eye. Tongue blunt to weakly trilobed. First dorsal fin may have scattered dusky markings; lower half of body dusky, intensified posteriorly to form blackish stripe on caudal peduncle and fin. Commensal on lobed or foliose hard corals such as *Pachyseris* and *Porites*.

Description. An asterisk indicates counts of neotype. Description based on 34 specimens, 11.5 - 20.5 mm SL. First dorsal fin VI (33)*. Second dorsal 1,7 (3); 1,8 (31)*. Anal 1,7 (2); 1,8 (30)*; 1,9 (2). Pectoral rays 16 (2), 17 (20), 18 (11)*, 19 (1). Lowermost 2-5 (4 in neotype) pectoral rays unbranched, tips usually thickened distally. Branched caudal rays 11 (4). Scale rows on sides of nape 8-12. Longitudinal scale count 22-28, with mean of 25. TRB 6-9, mean 7. Gill rakers reduced to tiny stumps, on first arch 2+1+5 (3). Lower quarter of first gill arch bound to inner face of opercle by membrane.

Head and anterior half of body triangular (apex dorsally), posterior half of body compressed. Body usually slender, depth at anus 14-21%, mean depth 16% of SL (Fig. 21). Head length averages 33% of SL. Head width always greater than head depth. Snout moderate, rectangular in shape from dorsal view, 21-30% of HL. Mouth terminal, slightly oblique, with narrow lips. Jaws 38-48% of HL, end at point below anterior half of eye or mid-eye. Eyes moderate, placed dorsolaterally on head, 25-35% of HL. Interorbital narrow, 2-5% of

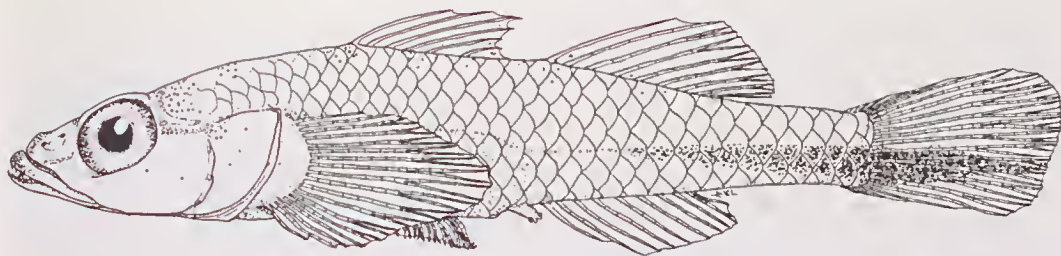

Fig. 21. Neotype of *Pleurosicya micheli* (out of AMS 1.21918-069), 17.5 mm female from Caban Island, Philippines. Scales reconstructed, based on average scale counts, and sensory papillae omitted.

HL (mean 4%). Nostrils close together, posterior nostril in low rim, placed close to anterior upper edge of eye, anterior nostril in short tube, placed halfway between edge of eye and upper lip. Tongue blunt to weakly trilobed. Gill opening wide, reaching forward to at least posterior edge of eye.

First dorsal fin low and rounded; second dorsal fin roughly triangular, taller than first dorsal anteriorly, quite low posteriorly. Anal fin rounded, about equal to first dorsal in height; anal rays unbranched. Caudal truncate, upper lobe usually slightly longer than lower. Pectorals reach back to below gap between dorsals. Pelvics round, when flattened reaching to anus; pelvic spine lobes irregular and folded several times, often forming several smaller lobes; lobes finely fimbriate, as may be surface of pelvic cup. Fifth pelvic ray not flattened. Frenum fimbriate, often elongated fimbriate lobe present posteriorly on frenum.

Teeth in upper jaw with band of fine sharp teeth, wide anteriorly, narrowing to two rows at sides, outermost teeth at sides slightly larger than inner; outermost row of larger curved teeth across front of jaw only, largest teeth at end of row. Lower jaw teeth small, sharp, arranged in broad band anteriorly, innermost row becomes single row at sides of jaw (teeth in single row somewhat larger and more upright); outermost teeth at front of jaw very small, usually moveable. Single large curved canine tooth at each side of lower jaw symphysis, behind bands of small teeth.

Lateral line canals as for genus.

Scales on body extend up onto sides of nape in adults, in some specimens scales on head only extend forward to over opercle; scales usually reach to eyes or close behind eyes. Nape midline naked; one specimen from Okinawa has two scales at first dorsal origin and rest of nape naked.

Genital papilla in males slender and flattened, with several tiny lobes at barely-expanded tip, often one slightly longer central lobe at rear of tip. Female genital papilla short, rounded, with several, sometimes elongate, lobes around opening at tip.

Colour in Life. Transparent with red or red-brown internal pigment extending over pharynx and upper half of peritoneum, then forms streak which runs just below entire length of vertebral column (Pl. IIb). Brain and vertebral column bright white, silvery white, or silvery pink, with four to six blocks of red colour internally extending from red streak up over white vertebral column (giving it red and white banded appearance). Peritoneum white. Red streak below vertebral column darkens posteriorly to brown. On surface of body, beginning approximately behind abdominal cavity, a brown stripe follows internal streak onto caudal base, and usually extends onto lower half of caudal fin (brown stripe may be very dense, or black, on caudal base itself).

Iris light golden to silver, with broad outer margin of red brown pigment (often dark brown dorsally); bright white or light golden pigment present; either as broad stripe above pupil, or as round spot on upper rear of eye. Surface of brain sometimes with scattered brown or red rounded blotches. Sides of head may be tinged with brown or red pigment. Red or orange stripe extends forward from each eye to snout and upper lip; stripes do not meet. Upper lip dusky, with orange or red pigment where eye-snout stripes end. Base of first dorsal fin with narrow red or brown streak, second dorsal fin tinged with light red, other fins (other than caudal) transparent. Caudal fin with upper half clear, lower half with red brown streak reaching from base to margin. Narrow brown or pink line sometimes visible on dorsal midline, extending from origin of first dorsal fin to caudal base.

Colour in Alcohol. Internal markings no longer visible; fish appear pale with dusky streak extending from midbody along lower sides then onto caudal fin. Streak often quite dark above anal fin base, and on lower lobe of caudal fin, and may form a blackish blotch on caudal base. First dorsal fin sometimes with faint dusky stripe near base, or scattered dusky markings (usually unpigmented). Entire lower lobe of caudal fin may be dark brown, or only light dusky streak present. Stripe from eye to upper lip dusky, usually observable. Some dusky pigment may be visible along lower half of head and body; some specimens with entire body lightly dusted with melanophores, and streak on lower side indistinguishable.

Comparisons. This species is similar to *P. mossambica*, possessing a moderately wide gill opening, and it has the sides of the nape scaled. *Pleurosicya micheli* can be distinguished by its lacking a black blotch on the first dorsal (scattered dusky, not black, markings may be present), in having the nape midline naked (a few scales on midline just in front of first dorsal in one specimen), distinctive live colour, and in using hard corals as host invertebrate. *Pleurosicya mossambica* may sometimes have a dusky stripe along the side of the caudal peduncle, but is a much larger, robust species, and the lateral stripe is more diffuse. It also prefers soft corals and sponges as hosts (just over half the specimens recorded), with only 18% being found on hard corals.

Remarks. The type of *P. micheli* appears to be lost. The holotype was not found at MNHN during a visit there in 1988 and despite Fourmanoir's statement in the original description, the specimen was never deposited at MNHN (Bauchot *et al.* in press). Fourmanoir's brief description and figure greatly resemble the coral-commensal species referred to as *Pleurosicya* sp. 15? in Winterbottom and Emery (1986). Although Fourmanoir's description is short, and does not give the position of the gill opening, his colour description and figure indicate that his *P. micheli* is more than likely the same as the present material. No additional material is known from the Loyalty Islands (the type locality). The neotype was chosen from Philippine material, rather than from Fiji or Tonga (closer to the type locality), because of its size, reasonable condition, and typical colouring.

This species appears to be commensal on hard corals. Fourmanoir's specimen was collected from a coral and alcyonarian substrate. Most specimens are from rotenone stations, and their hosts thus unknown. The Japanese specimens, collected by hand, came from *Pachyseris*, a foliose, plate-like coral. The hand-collected Hawaiian specimens came from *Porites lobata* and small ledges surrounding the coral colonics. Colour slides of living fish in Hawaii, Tonga, Port Moresby, Rabaul, and Flores show the fish perched on *Psammocora*, *Porites*, *Turbinaria*, *Platygyra sinuosa* and *Echinopora* respectively. *Pleurosicya micheli* is relatively conspicuous when live (transparent with banded red and white internal markings) and may be observed perched on corals in a similar manner to the red and white striped tripterygiid *Helcogramma striata*. The obvious colour and behaviour of this species is probably why it is the species of the genus most often photographed.

A copepod parasitising the gill chamber of a specimen from the Philippines was identified as *Pharodes bayunlensis* by Dr. Z. Kabata of the Pacific Biological Station, British Columbia.

Pleurosicya mossambica Smith
(Fig. 22; Pl. IIa-b)

Pleurosicya mossambica Smith, 1959:218, Fig. 37 (Baixo Pinda); Allen *et al.* 1976:431 (Lord Howe Island); Goren 1984:72-74, Fig. 1 (Marsa Barecha, southern Sinai Peninsula); Hoese, in Smith and Heemstra 1986:800 (Sodwana Bay, Mozambique, Seychelles, and tropical Indo-West Pacific).

Pleurosicya sinaia Goren, 1984:74-76, Fig. 2 (Marsa Barecha, southern Sinai Peninsula).

Pleurosicya HKL sp. 2 - Winterbottom and Emery 1986:54, Fig. 80 (Peros Banhos and Salomon).

Type material. HOLOTYPE of *Pleurosicya mossambica* - RUSI 227: 18 mm SL male, Baixo Pinda, Mozambique, South Africa, M.M. Smith. HOLOTYPE of *Pleurosicya sinaia* - TAU 6415: 16 mm SL male, Marsa Barecha, southern Sinai Peninsula, M. Goren, 16 October 1979. PARATYPE of *Pleurosicya sinaia* - TAU 6414: 17.5 mm SL male, 15 km S of Eilat, A. Avidor, October 1976.

Additional material. SOUTH AFRICA - RUSI 76-8: 17 mm SL male, reef off Sodwana,

- Kwazulu. SEYCHELLES - ANSP 165118: 17 mm SL male, off S shore Faon Island, 12-15 m, R. Rosenblatt and party, 28 January 1964. ANSP 165119: 2(17-20), W of N tip of Anonyme Island, 10.5-15 m, J. Bohlke and party, 11 February 1964. WESTERN AUSTRALIA - WAM P. 30054-001: 22 mm SL female, Monte Bello Islands, near Alpha Island, off *Turbinaria* coral, 3-9 m, H. Larson, 22 April 1983. NTM S.12650-001: 24 mm SL male, from flat sponge, otherwise same data as previous. NTM S.10805-050: 3(16-25), Monte Bello Island, near Alpha Island, on sponges and *Turbinaria* coral, H. Larson and R. Williams, 22 April 1983. NORTHERN TERRITORY - NTM S.10591-005: 17 mm SL male, off E side New Year Island, 10-12 m, from *Nephtya* sp., H. Larson, R. Williams, 14 October 1982. GREAT BARRIER REEF, QUEENSLAND - AMS I.207010-002: 3(20.5-22), One Tree Island, off sponge, D. Hoese, 1972. AMS I.29788-001: 12.5 mm SL female, Lizard Island lagoon entrance channel, off *Simularia peculiaris*, 2-6 m, H. Larson, 12 December 1978. AMS I.29789-001: 15 mm SL female, Wistari Reef, 15 m, D. Fisk, 20 September 1976. NTM S.12649-001: 2(17-21), Wistari Reef, 10-11 m, off *Leunalia africana*, H. Larson, 27 October 1978. NTM S.12648-001: 20 mm SL male, off bowl-shaped coral, otherwise same data as previous. AMS DFH 75-444: 21.5 mm SL male, Lizard Island, Mrs Watson's Bay, 4 m, from mantle of *Tridacna gigas*, N. Coleman, 29 November 1975. NTM S.12647-001: 7(12.5-18), Lizard Island, Mrs Watson's Bay, 6 m, off *Millepora* sp., H. Larson, 12 February 1977. AMS I.29790-001: 22 mm SL male, Mrs Watson's Beach, 17 m, off feathery angiosperm, R. Kuitert, 6 November 1975. AMS I.29791-001: 12 mm SL female, Mrs Watson's Beach, 15 m, off alga *Avrauvillea* sp., N. Coleman, 9 November 1975. NTM S.12646-001: 5(18-24), Lizard Island, between South and Palfrey Islands, 5-10m, off *Simularia flexibilis*, H. Larson, 10 February 1977. NTM S.12645-001: 6(15-21), off *Simularia* sp., otherwise same data as previous. AMS I.22579-068: 19 mm SL male, Escape Reef North, baek reef flat, 1-4 m, 28 October 1981. NEW SOUTH WALES - AMS I.29792-001: 18.5 mm SL female, Sydney Harbour, Parsley Bay, R. Kuitert, on grey sponge, 8 February 1976. AMS I.29794-001: 17 mm SL male, Sydney Harbour, Watson's Bay, R. Kuitert, on orange sponge, 8 February 1976. AMS I.29793-001: 7(10.5-19.5), Sydney Harbour, Parsley Bay, R. Kuitert, on several species of sponge, 15 February 1976. AMS unregistered: JP 77-10: 4(12.5-15), North Solitary Island, H. Larson, 1977. PAPUA NEW GUINEA - NTM S.12228-003: 3(13.5-17), Loloata Island, off Port Moresby, 6 m, P. Colin, off *Millepora* sp., 7 November 1986. FIJI - USNM 260062: 2(17.5-18.5), lee side of South Minerva Reef, 0-24 m, G. Preston and party, 1 October 1982. NEW CALEDONIA - AMS unregistered: 27 mm SL male, "from aleyonarian", Fourma-noir, 14 June 19???. MARSHALL ISLANDS - USNM 306892: 18.5 mm SL male, Bikini Island, in lagoon, K. Emory, 11 May 1946. PHILIPPINES - LIAIP 1983.364: 2(18-19.5), El Nido, western Palawan, H. Masuda, 6-25 March 1983. JAPAN - YCM 9243: 2(13.5-15), Himejima, near Okinoshima Island, Hakata, Kochi Prefecture, 20 m, M. Hayashi, 17 August 1981. YCM 9244: 2(16-17), same data as previous. LIAIP 1984.171: 18 mm SL male, Shirahama, Nishiumi-eho, Ehime Prefecture, 28 m, Mr Niimura, 23 August 1984. LIAIP 1984.173: 13.5 mm female, Kyokojima, Nishiumi-eho, Ehime Prefecture, on red *Dendronephthya* sp., 9 October 1984.
- Diagnosis.** A robust *Pleurosicya* with black blotch on the first dorsal fin, and sealed nape. Second dorsal and anal rays 1.8. Pectoral rays 17-19. Lateral scales 20-27. TRB 6-8. Nape fully sealed to behind eyes, or with nape sides sealed and midline naked. Gill opening wide, to below posterior half of eye. Pelvies round. Tongue usually blunt. Lower half of first dorsal with distinct black blotch or streak; sometimes entire body dusky. Commensal on a wide range of organisms (including plants), chiefly soft corals and sponges.
- Description.** An asterisk indicates counts of holotype. Based on 67 specimens 10.5-27 mm SL. First dorsal fin V (2), VI(62)*. Second dorsal fin 1.6(1); 1.7(4); 1.8(58)*. Anal fin 1.7(1); 1.8(60)*; 1.9(3). Pectoral rays 16(1), 17(24)*, 18(30), 19(11), 20(1). Lowermost 3-8 (mean 5.4 in holotype) pectoral rays unbranched, thickened distally. Branched caudal rays 11*. Predorsal scales 6-13. Nape sealed up to behind eyes in adults, with 6-13 predorsal scales. Nape midline naked in 43 specimens, midline partly to fully sealed in 20 specimens. Belly in front of anus may be sealed. Longitu-

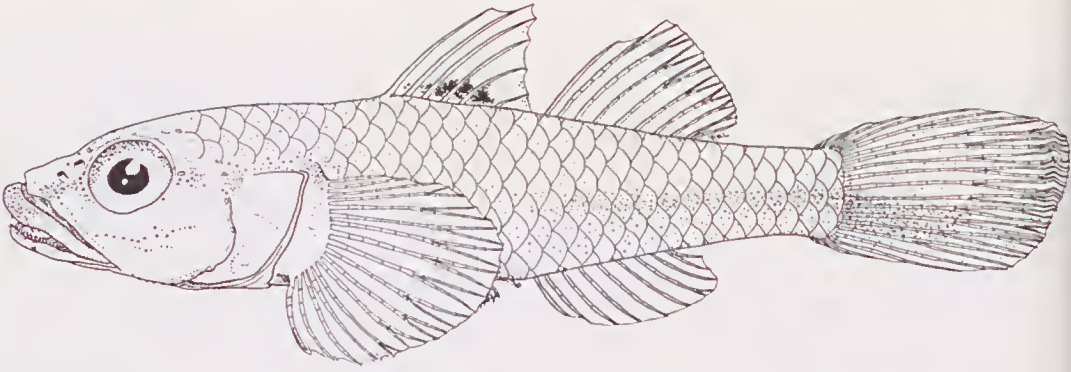

Fig. 22. *Pleurosicya mossambica* (21 mm SL), from Wistari Reef, Queensland, NTM S.12649-001.

dinal scales 20-27 (mean 24, 23 in holotype). TRB 6-8 (mean 7, 7 in holotype). Gill rakers very short. 1+1+6 (1), 2+1+6 (3). Lowermost quarter or third of first gill arch bound by membrane to inner face of opercle.

Head and anterior half of body triangular, apex dorsally; posterior half of body compressed (Fig. 22). Body usually stocky, BDA 15-19% of SL (mean 17%). Head length 30-38% of SL. Head width nearly always greater than head depth (mean width 64%, and mean depth 55%, of HL). Snout moderate, averaging 28% of HL, rounded to (usually) rectangular from dorsal view, profile rather pointed. Mouth terminal, sometimes barely subterminal, slightly oblique, with jaws ending at point below anterior half of eye; mean jaw length 45% of HL. Eyes moderate, 23-34% of HL, set dorsolaterally high on head. Interorbital relatively narrow, 3-7% of HL. Anterior nostril in short tube, slightly closer to edge of eye than upper lip; posterior nostril with low rim and placed close to edge of eye. Tongue usually blunt, can be slightly trilobed or concave. Gill opening wide, reaching forward to below mid-eye, or at least posterior edge of eye. Two specimens from Japan possess tiny cirri around rear rim of eye (similar to those in some specimens of *P. annandalei*).

Fins low, first dorsal roughly triangular, shorter than anterior rays of second dorsal, which is quite low posteriorly. Anal fin low, rounded; rays either unbranched, or only tips of posteriormost few rays branched. Caudal truncate, upper half slightly longer than lower. Pectoral fins reach back to below gap between dorsals. Pelvies round, cup-like, usually reach anus; rays not broad and flattened before first branch point (rather flattened between first and second branch points). Pelvic spine lobes

triangular, each lobe usually divided and folded somewhat; lobes and frenum usually fimbriate.

Outermost in upper jaw, six to eight curved canine teeth across front of jaw only, teeth mostly covered by upper lip and only tips of teeth visible; behind these teeth a band of tiny sharp teeth composed of about five rows, this band narrows to three or two rows at rear sides of jaw. Lower jaw teeth with similar band of tiny sharp teeth, innermost row of teeth slightly larger, more upright than others, and only this row remains at rear sides of jaw; outermost rows across front of jaw moveable, may be oriented nearly horizontally. One or two large curved canine teeth on either side of lower jaw symphysis, behind other rows. Males have larger teeth than females.

Lateral line canals as for genus. Sensory papillae and lateral canals as in Figure 22. In three specimens, anterior interorbital pore close to, and partly fused with, posterior interorbital pore.

Nape sealed up to behind eyes in adults, with 6-13 predorsal scales. Nape midline naked in 43 specimens (including holotype), midline partly to fully scaled in 20 specimens. Belly in front of anus may be scaled in large specimens.

Male genital papilla small, elongate, and flattened, slightly wider at base than towards tip; tip expanded, with several tiny lobes and one somewhat longer lobe at centre rear of tip. Female genital papilla short, rounded, with group of small lobes around opening at tip.

Colour in Life. The colour of this species is variable, and generally depends on host colouration (Pl. IIIa-b). Head and body transparent, or translucent light grey green, pale pink, or dull yellow (depending on basic colour of

host). Brain, vertebral column and peritoneum usually visible, coloured white or light pink or golden. Lower half of head and body with internal reddish or light brown pigment; posterior lower half of body may have reddish stripe on surface, extending toward caudal peduncle. In some (usually transparent) specimens, the vertebral column is evenly blotched with internal red pigment (six or seven small blocks of red), and a red brown diffuse streak extends from behind each eye along body, on either side of vertebral column. Of six specimens off a single *Simularia* colony, three were generally greenish blue, one grey green, and two dull yellow ochre (all with dusky black spot on base of first dorsal).

Snout and jaws may be yellow, or dusky pink. Distinct pink, red brown, or red stripe extends from each eye to tip of upper lip, each stripe usually meeting its counterpart at lip; upper lip usually pink or red. Two stripes may be present, at upper and lower anterior margins of eye, stripes join by nostrils to form single stripe. Indistinct markings sometimes form a diffuse pink or red-brown stripe from rear of eye across opercle. Top of head behind eyes directly over brain usually with clusters of brown, black or orange spots or blotches (subcutaneous pigment may be yellow or whitish). Iris bright silvery or golden, margin of eye rimmed with red, orange, or brown marbling. Fins transparent; lower half of first dorsal with black blotch or streak. A specimen from New Caledonia was noted as having lower half of first dorsal red, with a black streak from the third to fifth rays, and upper half of fin clear with red margin.

A specimen photographed on a bright orange sponge is not only translucent orange but also densely covered with fine melanophores over head and body (fins plain orange). A large specimen photographed on *Halimeda* sp. at Lizard Island was a nearly opaque yellow (almost lemon yellow), with about eight bright white irregular patches across the back, and on upper pectoral base. The body colour extended onto the lower half of the caudal fin, where the lowermost rays were quite reddish. The irises and eye/snout stripes were orange red (the stripes indistinct). The Sydney Harbour specimens were noted as being quite variable in colour. They were translucent, covered with black and red chromatophores in varying proportions, giving them a pale grey to pink col-

our. The peritoneum was light yellow, with two to six broad dark orange bands of internal pigment crossing the abdominal cavity. Four specimens from bright orange sponges were translucent pale yellow (internally), covered with black, yellow and orange chromatophores over the body surface. Fins varied from pink to orange, similar to the fish's body colour. Both dorsal fins had about three red blotches along each ray, and the caudal fin showed some red bars.

Colour in Alcohol. The black blotch on the first dorsal fin remains as the most distinctive marking. In some specimens, and in most juveniles, the blotch is very faint or reduced in size. Usually the blotch occupies at least the lower third of the fin, and is most intense between the third and sixth spines. Sometimes the dorsal fin blotch is larger in males than in females; but this is not consistent. Very little may remain of the rest of the colour pattern, as all internal pigment is obscured by the body wall. The snout/eye stripe, irregular dusky markings on the nape, and possibly a diffuse streak along lower caudal peduncle may be all that is visible. The lower half of the caudal fin may be dusky; other fins translucent.

Some specimens are very dark, with dusky pigment arranged evenly over the head and body, and the scale margins are often distinctly outlined. The first dorsal fin blotch is still present, but is not as conspicuous against the dark body (most of these dark specimens come from rotenone stations, so it is not known if the colour is linked to a particular host; the dark brown Northern Territory specimen was collected from a *Nephthea* sp.). Still other specimens may show very little to no black or brown markings on the first dorsal fin, although these fish may have been collected along with others which do show black blotches (these differences cannot be linked to sexual dimorphism with certainty).

Comparisons. The combination of characters such as a wide gill opening, usually fully scaled nape and a black blotch on the first dorsal fin serves to distinguish this species from other *Pleurosicya*, except for *P. amandalei* and *P. micheli*. *Pleurosicya mossambica* and *P. amandalei* are very similar, but can be differentiated by pectoral ray counts, habitat, and nape scalation. These differences are discussed under *P. amandalei*. *Pleurosicya mossambica* differs from *P. micheli* in that *P.*

micheli has the nape midline naked, has no or very little dusky markings on the first dorsal, is generally smaller (largest specimen known so far is 20.5 mm SL), distinctive live colour (some specimens of *P. mossambica* may have similar colouring, but with black blotch on first dorsal; if brown streak present on side of body, it is not as prominent as in *P. micheli*), and is usually associated with hard corals (only 20 out of 111 *P. mossambica* collected were from hard corals).

This species not only varies in colour, but shows some variation in physiognomy and scalation. The variation in nape scalation does not seem to depend on sex, commensal host, or geographic region. In a number of cases, several specimens, collected at the same time from the same host, showed considerable variation in scalation (some fully sealed, some with nape midline variably unsealed). Some specimens have the nape naked, but with an isolated patch of scales over the opercle (three or four rows of one or two scales).

Physiognomy and proportions are variable. The 12 specimens from New South Wales are particularly variable, both in colour and in head shape. The larger specimens have black markings on the first dorsal fin, whereas the smaller (less than 16 mm) do not. In addition, seven specimens have snouts which are shorter than usually found in the species, and these are round when viewed from above (usually roughly rectangular). A 15 mm female specimen from Wistari Reef has the shortest snout and largest eyes of all *P. mossambica* specimens examined, as well as rather small teeth, and thus does not resemble a typical *P. mossambica*, although it has a sealed nape, wide gill opening, dark markings on the lower part of the first dorsal fin and was commensal on an unidentified gorgonian. A 12.5 mm female from Lizard Island, commensal on *Simularia peculiaris*, closely resembles this specimen in head proportions, as do the female specimens among a batch of seven specimens collected from *Millepora* sp. (the single male being "typical" in proportions, with longer, less rounded snout). Usually, however, males and females have similar head shape and proportions.

Remarks. Goren (1984) described *P. sinaia* as being different from all other *Pleurosicya* in having a low dorsal ray count (1,6, with

most *Pleurosicya* having 1,8). The holotype of *P. sinaia* has the last (eighth) dorsal soft ray broken close to the base, and must have been overlooked by Goren; so must have the last (eighth) dorsal ray of the paratype, which is undamaged. The paratype is in slightly better condition than the holotype (which has been somewhat squashed sideways). The fish are rather compressed, but otherwise appear to be *P. mossambica*.

This species has the widest distribution and widest range of host organisms of all *Pleurosicya* species. It often occurs on soft corals of the families Aleyoniidae (known from *Lobophytum batarum*, *Simularia* sp., *S. flexibilis*, *S. peculiaris*, *Sarcophyton crassocaule*, and *S. trocheliophorum*) and Nephtheidae (*Lemnalia africana*, *L. carnosa*, *Lemnalia* sp., *Nephtea chabrolii*, *N. gracillima*, *N. legiopolypa*, and *Nephtea* sp.) and is the only gobiid known to live on nephtheids. In addition, the hydroid *Millepora* sp., the giant bivalve *Tridacna gigas*, the corals *Dendrophyllia* sp. and *Turbinaria* sp., at least four sponge species from Sydney Harbour, several unidentified Great Barrier Reef sponges, the green algae *Caulerpa* sp., *Halimeda* sp., and *Avranvillea* sp., and the angiosperm *Halophila* sp. have all been observed as hosts to *P. mossambica*. Several small juveniles of what are probably *P. mossambica* have been collected from the coral *Parahalomitra* sp., and unidentified holothurians and tunicates from Lizard Island. The Sydney Harbour specimens were collected from four species of sponge (but no record was kept of which fish came from which sponge). The sponges are *Crella incrustans* (family Crellidae), *Spirastrella* sp. (family Spirastrellidae), *Callyspongia* sp. (family Callyspongiidae), and an unidentified sponge of the family Tedaniidae.

Among 111 specimens collected of which the hosts were known, 37 were found on soft corals, 27 on sponges, 20 on stony corals, 12 on *Millepora* sp., and a scattering of specimens on other organisms (five on tunicates, three on *Halophila* sp., two on algae and 1 each on *Tridacna* sp., *Antipatharia* sp., *Isis hippuris*, a holothurian, and an unidentified gorgonian). On a number of these hosts, other gobiids have been present with *P. mossambica* (*Luposicya lupus* on sponges, *Bryaninops erythropis* on *Millepora*, *B. isis* on *Isis hippuris*, and *B. tigris* on *Antipatharia*).

Pleurosicya muscarum (Jordan and Seale)
(Fig. 23)

Rhinogobius muscarum Jordan and Seale, 1906:401 (Pago Pago).

Glossogobius biocellatus (in part) - Schultz 1943:231 (based on syntypes of *Rhinogobius muscarum*).

Pleurosicyops timidus Smith 1959:217 (Baixo Pinda, Mozambique).

Pleurosicya timidus - Hoese and Winterbottom 1979:5 (South Africa).

Pleurosicya muscarum - Wass 1984:28 (American Samoa); Hoese, in Smith and Hemstra 1986:800 (Mozambique, Seychelles).

Pleurosicya sp. - Yoshino, in Masuda *et al.* 1984:283-4 (Ryukyu Islands).

Pleurosicya HKL sp.8 - Winterbottom and Emery 1986:54 (Salomon).

Type material. SYNTYPES of *Pleurosicya muscarum* - USNM 51782: 2(11-13), Pago Pago, Samoa. HOLOTYPE of *Pleurosicya timidus* - RUSI 228: 17 mm SL male, Baixo Pinda, Mozambique. J.L.B. Smith, 1956. PARATYPE of *Pleurosicya timidus* - RUSI 696: 18 mm SL female, Baixo Pinda, Mozambique, 10 August 1951.

Additional material. OMAN - ROM 39903: 14.5 mm SL female, Gulf of Oman, Sur, B. Simm, 4 November 1981. SEYCHELLES - ANSP 165120: 19 mm SL male, off S shore Faon Island, 12-15 m depth, J. Tyler and party, 28 January 1964. SOUTH AFRICA - RUSI 76-9: 18 mm SL female, Kwazulu, reef off Sodwana. CHAGOS ARCHIPELAGO - ROM 58026: 15 mm SL male, Great Chagos Bank, in Three Brothers lagoon, 7 m, large patch reef, A. Emery *et al.*, 28 February 1979. ROM 58027: 2(12.5-13), Salomon Atoll, drop-off on E side Isle Poulc, 18-25 m, seafans, corals and sponges, A. Emery *et al.*, 22 March 1979. ROM 58028: 16.5 mm SL male, Peros Banhos Atoll, S end of Isle de Bain, 7 m. *Acropora* bommie, R. Winterbottom *et al.*, 6 February 1979. WESTERN AUSTRALIA - NTM S.10814-050: 12 mm SL male, Dampier Archipelago, Rosemary Island, 3-4 m depth, H. Larson and R. Williams, 26 April 1983. GREAT BARRIER REEF, QUEENSLAND - ANSP 165121: 10(13-18.5), Endeavour Reef, 3/4 mile NW of Cook wreck site, 2-5 m depth, J. Tyler and party, 16 January 1969. AMS 1.29795-001: 17 mm female, Lizard Island, on *Sinularia flexibilis*, H. Larson. NTM S.11447-

016: 11(12-16), Lizard Island, H. Larson, 19 September 1981. AMS 1.29796-001: 15.5 mm SL female, Lizard Island, research station beach, off *Lobophytum crassospiculatum*, H. Larson, 3 February 1975. AMS 1.22733-003: 9(14-18.5), Lizard Island, Osprey Island, 21 September 1981. AMS unregistered LZ 81-3: 2(16.5-20.5), Turtle Beach, N of Mrs Watson's Bay, off *Sinularia flexibilis*, 4 m depth, H. Larson, 16 September 1981. NTM S.12644-001: 3(15-20), Pandora Reef, 6 m depth, off *Sarcophyton* sp., H. Larson, 8 December 1980. NTM S.12643-001: 2(15.5-21.5), Heron Island, reef flat S of boat channel, off *Cladiella steineri*, 1-2 m depth, H. Larson, 25 October 1978. JAPAN - YCM 12921: 2(13-18), Yaeyama Islands, Aragusuku Island, M. Hayashi, 25 July 1984. YCM 12922: 15 mm SL female, same data as preceding. URM P.8281: 20 mm SL male, Okinawa, Sesoko Island, 2 m depth, on *Sarcophyton* sp., T. Yoshino, 21 August 1974. URM P.10342: 5(10-16), Okinawa, Zampa Cape, off *Lobophytum crassum*?, 17 November 1984. NTM S.12117-001: 18.5 mm SL male, Iriomote-jima, Sakiyama Bay, on *Sarcophyton* sp., H. Larson, 12 August 1985. URM P.8279: 18 mm SL, Ishigaki-jima, Sukuji, K. Shimada, 26 July 1980. PHILIPPINES - USNM 306894: 3(16-20), Palawan Province, W side Tagauayan Island, 0-14 m depth, USNM team, 25 May 1978. GUAM - CAS 36862: 15.5 mm SL male, Agana Bay, lagoon just N of Alupat Island, A. Fehlmann and party, 26 April 1959. MICRONESIA - NSMT P.22981: 16 mm SL male, Truk, SE coast Moen Island, K. Matsuura, 26 June 1982. CAS 68077: 15 mm SL male, Caroline Islands, Kapingamarangi Atoll, Thokataman, coral head in centre of lagoon W of Hukuhenua Islet, 12 July 1954. USNM 223056: 16 mm SL male, Caroline Islands, Ponape, Nan Madol, 0-2 m depth, V. Springer, 3 September 1980. AMERICAN SAMOA - AMS 1.21390-001: 8(12-16), Tutuila, Pago Pago Bay, 2 m depth, off soft coral, R. Wass, 24 May 1979. FIJI - USNM 241704: 5(14-18), Lau Group, Matuku Island, N side of main harbour, 0-1 m depth, V. Springer and party, 23 April 1982.

Diagnosis. A relatively large *Pleurosicya*, with distinctive convex-nosed profile, and pattern of red lines on head when live. Second dorsal and anal rays 1,8. Pectoral rays usually 17-18. Lateral scales 23, TRB 6. Head and nape naked. Gill opening to pectoral base,

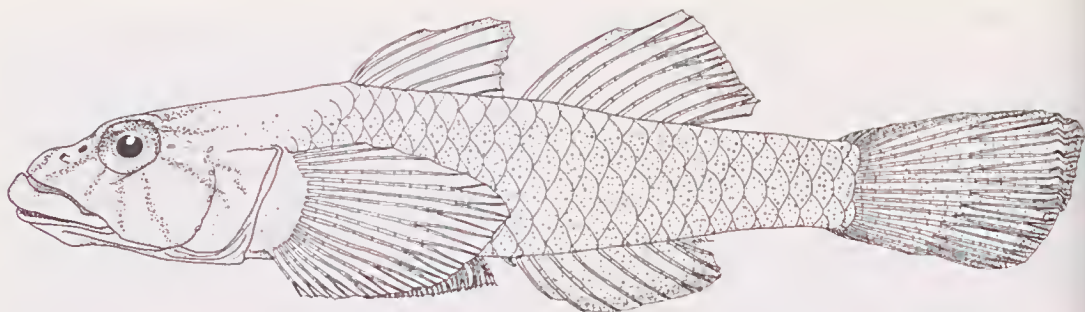

Fig. 23. *Pleurosicya muscarum*, 20.5 mm SL male (AMS unregistered), from Lizard Island, Queensland (papillae omitted). Note deformed anterior first dorsal fin spine.

sometimes slightly further forward. Tongue blunt or rounded. Live colour translucent greyish blue or green, with several thin red lines radiating from eye over sides of head and snout. Commensal only with alcyonarian soft corals.

Description. Based on 45 specimens, 11–21.5 mm SL. First dorsal rays VI (45). Second dorsal I,7 (5); I,8 (40). Anal I,7 (4); I,8 (39); I,9 (2). Pectoral rays 16 (1), 17 (21), 18 (16), 19 (7). Lowermost 1–7 pectoral rays unbranched, somewhat thickened distally, as may be lower 3–5 branched rays if number of unbranched rays is low. Fifteen specimens with only one unbranched ray, and six with all unbranched (mean 2). Branched caudal rays 11 (7). Lateral scale count 21–25, with a mean of 23. TRB 5–7, mean of 6. Gill rakers on first arch rudimentary stubs, 1+1+4 (1), 2+1+2 (1), 2+1+5 (3). One third to less than one quarter of first arch bound by membrane to opercle.

Head roughly triangular (apex dorsally), 29–36% of SL. Body compressed, especially posteriorly, body depth at anus 14–21% of SL (Fig. 23). Head width always greater than head depth (mean depth 53% of HL, mean width 61% of HL). Snout moderately long, 23–38% of HL (mean of 31%), with convex profile, more pronounced in larger specimens. Mouth large, terminal, slightly oblique, with jaws ending at a point below middle of eye. Upper lip fairly wide, covering teeth of upper jaw, and overhanging tip of lower jaw in some specimens. Eye relatively small, 20–31% of HL (mean of 25%), set high on sides of head. Interorbital narrow, 2–7% of HL (mean 4%). Anterior nostril in short tube, posterior with low rim; both nostrils close to eye. Tongue usually blunt to rounded; weakly trilobed in the paratype of *Pleurosicyps timidus*, and two other specimens. Gill opening restricted

to pectoral base, reaching further forward to (or nearly to) preopercular edge in five specimens. Vertebrae of syntypes both 10 + 16.

First dorsal fin triangular, about equal to body depth. Second dorsal with anterior rays highest, taller than first dorsal, posterior rays shorter. Last three to four anal rays may be branched in large specimens. Caudal fin rounded, upper rays somewhat longer than lower. Pectoral fins reach nearly to second dorsal fin origin. Pelvic fins rounded to oval, average 19% of SL, and do not always reach anus. Pelvic spine lobes usually rather narrow, pointed to rounded, fleshy, and may be slightly folded. Lobes and frenum usually finely fimbriate. Fifth pelvic ray broad and flattened near first branch point.

Innermost upper jaw teeth very small, sharp, in single row on sides, and forming moderate band across front of jaw (two to five closely-packed rows). Across front of jaw, an outer row of larger somewhat curved canines, largest teeth towards sides. Lower jaw teeth with innermost row of moderately stout pointed teeth evenly spaced. Two large curved canines present behind lower jaw symphysis, often an additional smaller canine beside each tooth. Outermost teeth very fine, pointed, and movable, forming a band from middle of side of jaw to symphysis, and sometimes partly covered by mucus. Teeth of females smaller than males, particularly the canines.

Lateral line canals on head as for genus. In some specimens, underside of head and anterior part of breast covered with fine papillae (as described for *Phyllogobius platycephalops* by Larson 1986), which are differentiated from sensory papillae by their smaller size.

Head and nape naked, body scales may not always extend forward over pectoral base.

Male genital papilla of moderate length, flattened, widest at base, tip finely fimbriate. Female genital papilla short, rather rounded, with several small lobes on either side of tip. Females are not as large as males.

Colour in Life. This species was usually recorded (in my notes) as being a transparent bluish to greenish grey, sometimes with yellow snout, and always with at least five pink lines on the head, and one (internal) on each side of peritoneum. The following is the usual arrangement. The posteriormost line on head runs from rear edge of eye along top of opercle, but not reaching edge. The next extends from lower rear edge of eye across top of preopercle then diagonally across opercle, but does not reach lower angle. The next line, from rear lower edge of eye, extends towards angle of preopercle, but does not quite reach it. The next line forward is from lower edge of eye to corner of mouth. The anteriormost line runs from front of eye to tip of snout, where it bends to join its fellow from the opposite side, and extends somewhat onto upper lip. A short pink line extends from anterior part of interorbit to each nostril, forming a "V". A short pink line sometimes visible behind each eye on temporal region. Internally, the oesophageal area is pink, and a distinct pink line extends from this region to either side of top of peritoneum ending approximately above anus (pink lines visible from above). The margins of both dorsals and anal fins are outlined by dusky black, and the entire caudal is evenly dark grey. The iris is silver or golden. A freshly dead specimen is shown in colour in Masuda *et al.*, 1984 (Plate 255. K).

A Heron Island (Queensland) specimen was noted as being basically similar to the above, with the lines being more red than pink, the iris silver, and all fins pink, with no dusky margin present. It was kept alive in a small container for some time with a second smaller specimen being added later. Upon seeing the smaller fish, the larger fish immediately changed colour: its head became translucent yellow, the lips intensified their pinkish red colouration, and the entire body darkened. Accompanying these colour changes was an aggressive display (the fish inflated its branchiostegal rays, its pectorals were spread wide and vibrated, and it hopped sideways toward the smaller fish).

Colour in Alcohol. When initially preserved, pink or red lines fade to orange or

brownish, and body scales (except for lower half of body) may show as outlined in orange. After some time in alcohol, very little trace may remain of red lines.

Body (including belly but not breast in larger fish) evenly covered with melanophores, giving fish a pale brownish appearance, with pale head and dorsal midline. Posterior half of body may be more heavily pigmented than anterior half. Nape, top of head and opercle usually dusky, with pale areas interspersed with dusky stripes representing remains of red stripes sometimes present. Tip of snout, upper lip, and sometimes chin, dusky. Preorbital usually without pigmentation. Both dorsals and anal transparent, with distinct dusky margins, and a scattering of melanophores over rest of membranes. Caudal fin dusky; sometimes fairly dark, with melanophores arranged in close-set wavy vertical rows (giving a fine-banded appearance). One very dark specimen from Ponape has dusky streak on caudal fin. Pectoral and pelvic fins generally translucent to hyaline, pectoral fin may have outer part of membrane speckled with melanophores.

Comparisons. This is a fairly distinctive *Pleurosicya*, characterised by a moderately long body, convex snout profile, small eyes set high on head, live colouring, low number of unbranched pectoral rays, and a host distribution restricted to only soft corals. The species is easy to distinguish from *P. mossambica*, which also may inhabit soft corals (the two species may be found in neighbouring corals, but so far they have never been recorded on the same coral). *Pleurosicya mossambica* has a black blotch on the base of the first dorsal, larger and more dorso-laterally placed eyes, wide gill opening, and a sealed nape.

Remarks. *Pleurosicya muscarum* was originally described from six specimens, however, only two syntypes have been found. They are not in good condition and have damaged fins and bodies. Both specimens, especially the male, show the characteristic longish convex-profiled snout and evenly scattered pigmentation on the body, which is illustrated in Jordan and Seale's (1906) figure. Schultz (1943) included *P. muscarum* in his synonymy of *Glossogobius biocellatus*, which was apparently based on his observation of the syntypes' gill openings, which are torn (and thus wide) in both.

This species is commensal only on soft corals of the family Alcyoniidae, preferring species of the genera *Siularia* and *Lobophytum*. It has been found on *Cladiella steineri* (only at Heron Island, Queensland), *Lobophytum crassospiculatum*, *L. crassum*?, *L. robustum*, *L. choedei*?, *Sarcophyton ehrenbergi*, *Siularia flexibilis*, *S. leptocladus*, *S. polydactyla*, and *S. robusta*. The fish live in small groups among the branches and base of the coral. Unfortunately it is often difficult to collect all specimens from a particular soft coral by hand, since the fish may hide in crevices at the base of the colony, and thus the sex ratios are indeterminate. In addition, males are larger and thus more conspicuous than females (males reaching 23.5 mm SL, females 18 mm SL), and they are more easily caught by hand. It appears that there may be at least two males (possibly more) and several females and juveniles on a moderate sized soft coral colony.

Pleurosicya occidentalis sp. nov.
(Fig. 24)

Pleurosicya HKL sp. 3 - Winterbottom and Emery 1986:54 (Eagle Island, Peros Banhos, Salomon, and Three Brothers).

Type material. HOLOTYPE - USNM 264746: 18 mm SL male, Cargados Carajos Shoals, 0-2 m. V. Springer and party, 30 March 1976. PARATYPES - USNM 264749: 11(14-18), Cargados Carajos Shoals, about 2 miles E of Raphael Island, inside reef edge, 0-1 m. V. Springer and party, 3 April 1976. USNM 261968: 20 mm SL male, Cargados Carajos Shoals, just NE of Siren Island, 17-21 m. V. Springer and party, 12 April 1976. USNM 306895: 14(12.5-20), same data as holotype. RUSI 74-304, 7(11-14), St Brandon's Shoals. ROM 58029: 30(10.5-16), Chagos Archipelago, Great Chagos Bank, lagoon at Eagle Island, among corals, *Heliopora* sp., and *Millepora* sp., 0-0.5 m. R. Winterbottom *et al.*, 26 February 1979. ROM 58030: 2(14-15), Chagos Archipelago, Salomon Atoll, Isle Boddam lagoon, caves in side of flat-top bommie, 0-3 m. A. Emery *et al.*, 19 March 1979.

Additional material (not examined). SEYCHELLES - ANSP unregistered Station F-59: 8(13.5-18.5), Praslin Island, S shore just E of St Anne's Bay, 7.5 m. J. Bohlke and party, 22 February 1964.

Diagnosis. A somewhat slender *Pleurosicya* with a dense black spot on nape centre, and known only from the western Indian Ocean (Chagos Archipelago, Cargados Carajos Shoals, and Seychelles). Second dorsal and anal rays 1.8. Pectoral rays 16-18. Lateral scales 24, TRB 5-6. Nape naked. Pelvic fins rounded, usually cup-like, with rounded lobes. Gill opening restricted to pectoral base. Tongue rounded, with pointed centre. Preserved colour includes dark stripe along bases of dorsal and anal fins, pectoral base dusky, and elongate, dense, black spot on centre of nape. Invertebrate host unknown.

Description. An asterisk indicates counts of holotype. Based on 33 specimens, 11.5-20 mm SL. First dorsal fin V(1), VI(31)*. Second dorsal fin 1.6(1); 1.7(1); 1.8(29)*; 1.9(1). Anal fin 1.7(1); 1.8(20)*; 1.9(1). Pectoral rays 16(7), 17(24)*, 18(2). Lowermost 4-7 (mean 6)* pectoral rays unbranched, and sometimes thickened. Branched caudal rays 11(4)*. Nape naked. Longitudinal scale count 21-27, with mean of 24 (23 in holotype). TRB 5-7*, with mean of 6. Rakers on inner face of first gill arch very small, sometimes a few spines present, 1+1+4, 2+1+1, 2+0+3, 3+0+4. Lowermost third of first gill arch bound by membrane to inner face of opercle.

Head and anterior half of body triangular in cross-section (apex dorsally), body quite compressed posteriorly (Fig. 24). Body relatively elongate, BDA 14-19% of SL (mean 16%). Head length 30-35%, averaging 32% of SL. Head width always greater than head depth (mean width 63.8%, and mean depth 54% of HL). Snout moderate, averaging 32% of HL. Mouth relatively large, slightly oblique or horizontal, upper jaw and lip slightly overhanging lower. Jaws end at a point below anterior half of eye, mean jaw length 40% of HL. Eye relatively small, 24-32% of HL (mean 29%), set dorsolaterally. Interorbital narrow, 2-5% of HL, averaging 3%. Nostrils close together near eye, anterior nostril in tube, posterior nostril in shorter tube or with very low rim. Tongue pointed, or bluntly rounded with pointed centre. Gill opening restricted to pectoral base (slightly further forward in three specimens).

First dorsal fin triangular, shorter than body depth. Second dorsal anteriorly nearly as tall as first. Anal rays unbranched. Caudal rounded, upper rays longer than lower. Pecto-

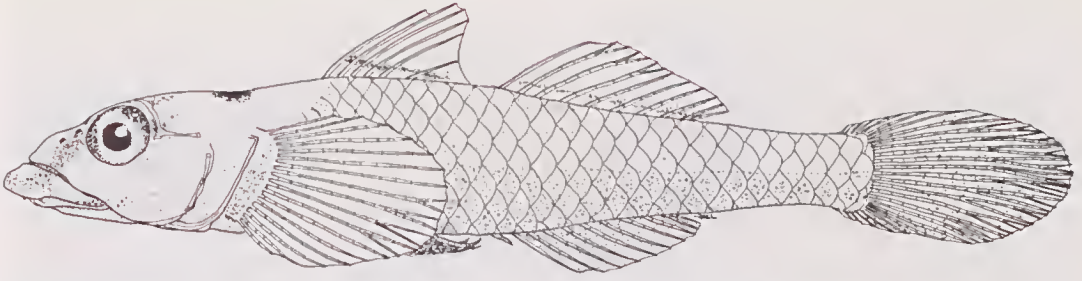

Fig. 24. *Pleurosicya occidentalis* holotype (USNM 264746), 18 mm male, from St. Brandon's Shoals.

ral rays reach to below sixth dorsal spine or nearly to gap between dorsals. Pelvic fins rounded, sometimes somewhat oval, but usually cup-shaped. Pelvic spine lobes usually round, not very fleshy, sometimes thin and slightly folded. Lobes and frenum often finely fimbriate. Fifth pelvic ray rather flattened near first branch point.

Upper jaw teeth very small, fine, and pointed; arranged in narrow band, broader anteriorly, narrowing at sides. Across front of upper jaw and mostly concealed by upper lip, eight to twelve enlarged, slender, curved teeth present; four to six anteriormost of these smaller than rest; posteriormost tooth on each side largest. Lower jaw with band of very small, fine, pointed teeth across front; band extends over edge of jaw, so that outermost (sometimes slightly enlarged and curved) row of moveable teeth angles downward and outward. Innermost, an even row of upright, pointed teeth; and one or two large curved canine teeth at each side of jaw symphysis.

Lateral line canals as for genus; canals on head may be open in smaller specimens.

Scales on sides of body extend up to behind pectoral base, but do not extend over base. Head and nape naked.

Male genital papilla flattened, slender, wider at base, narrowing toward tip. Tip usually slightly expanded, bearing several tiny lobes. Female genital papilla short, cylindrical, with several lobes at each side of opening at tip.

Colour in Life. No information available.

Colour in Alcohol. Body and head pale, with sides and pectoral base covered with brown melanophores. Head often lightly pigmented. Nape and dorsal midline areas with no or very little dusting of melanophores. Under-side of head and belly unpigmented. Most conspicuous mark is an elongate dense black blotch on central midline of nape. Narrow

brown streak on lower bases of dorsals and anal fins. First dorsal fin with dusky margin, sometimes absent. Second dorsal and anal fins often covered with brown pigment. Caudal fin with tiny spots forming about eight vertical lines, and posterior margin of fin with broad dusky band (which blends into the pattern of lines).

Comparisons. *Pleurosicya occidentalis* is very like *P. coerulea*, but the head is narrower (averaging 64% of HL for *occidentalis*, and 72% for *P. coerulea*), the snout is shorter on the average (32% of HL for *P. occidentalis* and 35% for *P. coerulea*), and the black nape spot is very intense (not diffuse or absent as in *P. coerulea*). *Pleurosicya coerulea* appears to have a slightly broader, more fleshy upper lip than does *P. occidentalis*, but this was not quantified. The two species are sympatric, and have been collected together at the same rotenone station (ROM WE 79-40, in the Chagos Archipelago).

Remarks. Unfortunately, no information is available as to this species' preferred commensal organism. All specimens were obtained from rotenone stations in relatively shallow water (0-25 m), with the exception of those from RUSI (collection data unknown).

The gut of one damaged specimen was examined. It was simple, with a single loop as in *P. coerulea*, and it contained a few copepods and a little flocculent material.

Etymology. The species name is derived from the Latin, meaning "western", referring to the western Indian Ocean distribution of this species.

Pleurosicya plicata sp. nov.
(Figs 25-26)

Pleurosicya HKL sp. 12 - Winterbottom and Emery 1986:55, Fig. 81 (primarily lagoons at Peros Banhos, Salomon, and Three Brothers).

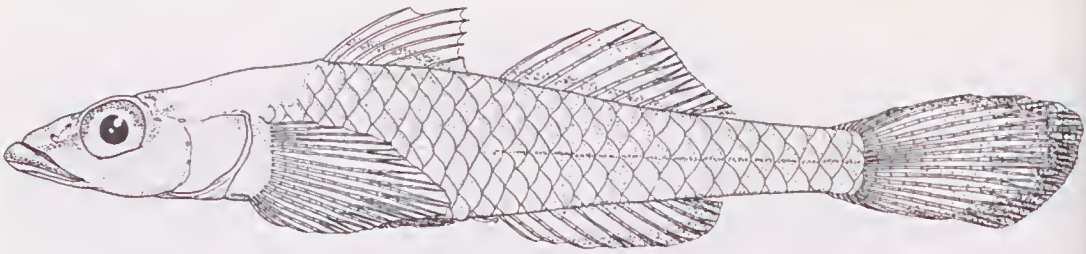

Fig. 25. *Pleurosicya plicata* holotype (ROM 58031). 19 mm male, from Salomon Atoll, Chagos Archipelago.

Pleurosicya 'sp. 12' - Allen and Russell 1986:99 (Rowley Shoals).

Type material. HOLOTYPE - ROM 58031, 19 mm SL male, Chagos Archipelago, Salomon Atoll, N of jetty off Isle Boddam, 10-15 m, coral heads on sand, R. Winterbottom *et al.*, 15 March 1979. PARATYPES - ZMUC P.781661: 18 mm SL male, Mauritius, Tombeau Bay, sand and coral, 12 m, 8 October 1929, T. Mortensen Station 38. ROM 58032: 9(15-19.5), Chagos Archipelago, Peros Banhos, off S end Isle Montepatre, knoll of *Acropora* and *Microdictyon* algae, 32 m. A. Emery *et al.*, 2 March 1979. ROM 58033: 23(8-19), same data as holotype. ROM 58034: 2(11-19.5), Chagos Archipelago, Peros Banhos, Isle de Coin, 25 m, small coral knoll, A. Emery *et al.*, 3 March 1979. ROM 58035: 6(11.5-18), Chagos Archipelago, lagoon side of Isle Poule, coral and sand patch reef, sheet *Acropora* dominant, 21-30 m, R. Winterbottom and A. Emery, 12 February 1979. WAM P.27666-027: 22 mm SL male, Western Australia, Rowley Shoals, Mermaid Reef, E side of lagoon, 15-18 m, 26 July 1982, G.R. Allen. NTM S.11388-021: 21 mm SL male, Western Australia, Seringapatam Reef, B.C. Russell, 12 September 1984. USNM 306896: 15.5 mm SL male, Papua New Guinea, Hermit Island, E side of Jalun Island, 0-33 m, 2 November 1978, V. Springer and party. USNM 306897: 16.5 mm SL male, Papua New Guinea, Kranket Island, lagoon on NW side, 0-20 m. 7 November 1978, V. Springer and party. USNM 225001: 17 mm SL male, Western Caroline Islands, Ponape, reef just S of Param Island, 0-14 m, V. Springer and party, 6 September 1980. CAS 68078: 22.5 mm SL male, Western Caroline Islands, Palau, W end of Koror Island, sand flat enclosed by retaining wall, 8 July 1955, H. Fehlmann and party. CAS 36870: 19 mm SL male, Western Caroline Islands, Palau, N side Urukthapel Island, shallow pass S of Butottoribo Island, H.

Fehlmann and party, 20 July 1955. CAS 36889: 20 mm SL female, Western Caroline Islands, Palau, Iwayama Bay, off SE point of Sanryo Island, H. DeWitt and party, 18 November 1957. CAS 36883: 6(15-18.5), Western Caroline Islands, Palau, Babelthuap Island, in Gongolungel Strait, H. DeWitt and party, 25 September 1957. AMS 1.21939-005: 19 mm SL male, Philippines, Apo Island, 27 m, C. Ferraris, 1980.

Diagnosis. A slender *Pleurosicya* with naked nape, wide gill opening, and trilobed tongue. Soft dorsal and anal rays 1,8. Pectoral rays 15-17. Lateral scales 25, TRB 7. Nape naked. Pelvic fins long and flat, with pelvic spine lobes usually long, thin and folded inward. Gill opening relatively wide, to below preopercle or nearly reaching eye. Tongue trilobed. Pale fish, with lower half of body dusky, upper half with scale margins faintly outlined, nape with light dusky blotches, stripe usually visible from each eye to snout tip, no black markings present. Commensal invertebrate host unknown.

Description. An asterisk indicates counts of holotype. Based on 36 specimens, 11-22.5 mm SL. First dorsal fin VI(36)*. Second dorsal fin 1,7(2); 1,8(33)*. Anal fin 1,7(1); 1,8(33); 1,9(1)*. Pectoral rays 15(11), 16(16), 17(7)*, 18(1). Lowermost 2-4 (mean 3*) pectoral rays unbranched, skin at tips of rays sometimes thickened. Branched caudal rays 11(4). No scales on sides of nape or predorsal. Longitudinal scales 22-26 (mean 25, 24 in holotype). TRB 6-8 (mean 7*). Gill rakers on first arch very reduced stubs, without spines, 1+1+5 (1), 2+0+5 (1), 2+1+5 (1), 2+0+6 (1). Rakers on inner faces short, with tiny spines. Lowermost quarter or third of first arch bound by membrane to inner face of opercle.

Head and anterior half of body rounded to roughly triangular in cross-section, posterior half of body quite compressed (Fig. 25). Body rather elongate, BDA 14-19% of SL (mean

16%). Head length 30-39% of SL (mean 33%). Head width greater than head depth, with mean width 53% and mean depth 45% of HL. Snout moderate to long, greater than eye, averaging 30% of HL, almost rectangular in shape from above. Mouth moderate, terminal, and slightly oblique, reaching to below at least anterior margin of eye. Lips narrow, not fleshy. Jaw length 33-45% of HL (mean 37%). Eyes equal to or less than snout, set dorsolaterally, and averaging 27% of HL. Interorbital narrow, 3-7% of SL (mean 4%). Anterior nostril in short tube, set halfway between eye and upper lip; posterior nostril with low rim. Tongue trilobed or weakly trilobed, blunt in two specimens. Gill opening reaches to at least below preopercular edge, nearly reaching eye in two specimens.

First dorsal fin triangular, second dorsal fin higher than first anteriorly. First three or four anal fin rays unbranched. Caudal fin truncate, upper rays slightly longer than lower. Pectoral fins nearly reach to below gap between dorsals. Pelvic fins equal to pectorals in length, usually reach anus, forming an oval flattened cup. Pelvic spines straight, and pelvic spine lobes long, flat and folded (Fig. 26). Lobes and frenum may be smooth or fimbriate (nine

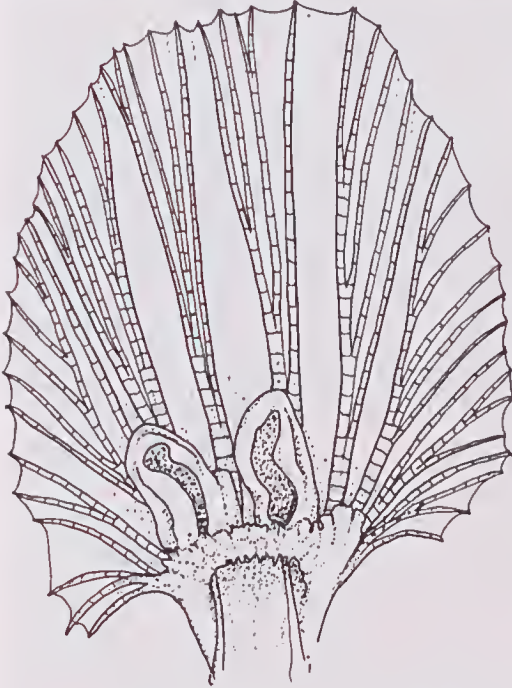

Fig. 26. Pelvic fins of *Pleurosicya plicata* (one of CAS 36883), showing elongated pelvic spine lobes.

specimens from Chagos with lobes and frenum very thin and reduced).

Teeth in outermost row of upper jaw enlarged, especially anteriormost 10 or 12, which are curved and sharp, and spaced apart from each other; rest of teeth smaller and less curved (almost straight at rear of jaw). Innermost two to three rows of upper jaw teeth composed of very small sharp teeth forming band (widest anteriorly). Lower jaw with innermost row of relatively stout sharp teeth (largest at sides of jaw). Outside this row, a band, formed by crowded rows of tiny sharp teeth, which widens anteriorly; outermost teeth straight, pointing outward or horizontally, and moveable. Innermost, a large stout curved tooth on either side of lower jaw symphysis.

Lateral line canals as for genus.

Scales on body reach up to behind pectoral base, but do not extend over base. Head, nape, belly midline and breast naked.

Male genital papilla moderately elongate, broad and flattened, with tip expanded and finely fimbriate. Female genital papilla short and round, with at least two pairs of tiny lobes at each side of opening at tip; tip sometimes fimbriate.

Colour in Life. Freshly dead colour based on three slides of ROM paratypes, including the specimen illustrated in Figure 81 in Winterbottom and Emery (1986). Head and body pale pink to reddish orange. Scale margins narrowly outlined in darker red. Nape and upper back up to gap between dorsals with scattered melanophores. Snout, head behind eyes, upper preopercle, and opercle orange to reddish, darker than body, with narrow dark red stripe from eye to tip of snout. Tip of upper lip orange, not red, and lower margin of upper lip dark red, especially so posteriorly, where colour extends variably onto lower margin of preopercle. Lower jaw whitish or translucent. Cheek from below eye to upper jaw without pigment. Iris pale golden, with orange red pigment before and behind iris, also usually on dorsal half of eye. Fins damaged, but unpaired fins appear dusky with red markings. Caudal fin pale with irregular vertical bands of reddish spots and speckles near base. First dorsal with diffuse black line along posterior half of base, line continued anteriorly as red, somewhat diagonal, line. Second dorsal with line just above base, line formed by mixture of red

and black speckles; rest of fin dusky, fin margin probably reddish. Anal fin dusky, with red streak along base and margin. Pectoral fin translucent, rays faint reddish. Pelvic fins white.

Colour in Alcohol. In most specimens, body usually pale, with no black blotches. Sides of body with some sprinkling of melanophores. Upper pectoral base with faint dusky blotch in some specimens. Opercle often with dusky patch dorsally. Usually, indistinct dusky patches and spots present behind eyes and on nape. Diffuse stripe of dusky pigment runs from eye below nostrils to upper lip; stripes do not meet each other at lip. Upper lip faintly dusky. In otherwise pale specimen from Seringapatam Reef, iris silvery, dark dorsally. Fins hyaline, first dorsal often with light brown speckles posteriorly, and on margin. Caudal may have faint dusky rear margin.

Specimens from Chagos Archipelago similar to the above, but fins and sides of body show more pigmentation. Lower half of body light dusky, margins of scales on upper half distinctly dusky. Both dorsal fins with thin brown stripe just above bases, stripe extending length of fins. Second dorsal may have faint, narrow dusky margin as does first dorsal. Lips often quite dusky; nape with narrow brown line along midline in more heavily pigmented specimens.

Comparisons. This species is similar in body proportions to *P. bilobata*, but can be distinguished by having the tongue trilobed (versus bilobed), and by colour pattern (scale margins on upper body outlined in dusky pigment and no black blotches, versus 12 brown bars and a black blotch on the soft dorsal fin in males). Other slender species of *Pleurosicya* (such as *P. carolinensis* and *P. elongata*) have the gill opening restricted to the pectoral base. Of these, *P. carolinensis* is the most similar, but has a blunt to round tongue, and a large curved tooth at each side of the triangular lower jaw.

Remarks. There is no information available as to this species's preferred host invertebrate. It has been collected in moderately deep water, in both lagoon and reef channel habitats.

Etymology. The species name is from the Latin *plicata*, meaning folded, referring to the folding of the narrow pelvic fin lobes.

Pleurosicya prognatha Goren
(Figs 27-28)

Pleurosicya prognatha Goren, 1984:76-78 (Marsa Bareeha, southern Sinai Peninsula).

Type material. HOLOTYPE - TAU P.6478: 14.4 mm SL male, Marsa Bareeha, southern Sinai Peninsula, 16 October 1979. PARATYPES - TAU P.6416: 3(8-11), same data as holotype. TAU P.6478: 11.5 mm SL male, Elat, Red Sea, 20 m, 26 June 1983.

Additional material. RED SEA - USNM 306898: 10.5 mm female, reef near road at Marsa Muqabita, NW coast Gulf of Aqaba, V. Springer, 17 July 1969. USNM 306899: 11.5 mm female, Bay at El Himeira, NW coast Aqaba, 0-16 m, V. Springer, 16 July 1969. IL.428-018: 13 mm male, Dorale Reef, near Djibouti, 1 m, J.-M. Rose, 18 January 1981. GREAT BARRIER REEF - AMS I.22578-093: 9(9-12.5), Escape Reef, Australian Museum coll., 28 October 1981. AMS I.22618-001: 2(11-14), Escape Reef. AMS I.22631-073: 3(11-15), Escape Reef. WESTERN AUSTRALIA - AMS I.21316-001: 9(6-11.5), Scott Reef, south reef lagoon, large staghorn beds on sand, 7-10 m. F. Talbot, 20 September 1979. WAM P.28030-040: 10(8-14), Rowley Shoals, Clerke Reef, central lagoon basin, 3-5 M, G. Allen, R. Steene, 11 August 1983.

Diagnosis. A very small *Pleurosicya* with the tip of the upper jaw and lip extremely elongated, giving it the appearance of a curved beak. Second dorsal and anal rays 1,8. Pectoral rays usually 15. Sealation reduced, anterior third of body mostly naked. Lateral scales 20, TRB about 5. Gill opening restricted to pectoral base. Tongue small, pointed or rounded. Colour generally pale in females, males evenly dusky; no black blotches on fins. Commensal with large *Acropora* spp.

Description. An asterisk indicates counts of holotype. Based on 29 specimens, 8-15 mm SL. First dorsal fin VI(28)*. Second dorsal I,8*(26); I,9 (2). Anal I,8 (27); I,9* (holotype only). Pectoral rays 14 (1), 15* (21), 16(6). Pectoral rays all unbranched in nine specimens; 19 specimens have lowermost 1-8 rays (mean 5)* unbranched and sometimes slightly thickened. Branched caudal rays 11 (7), 12*. Head naked, as is anterior half of body. Lateral scale count 15-27 (mean 21, 22 in holotype). TRB 1-10 (mean 5, 7 in holotype). Gill rakers



Plate III. a. *Pleurosicya mossambica* on the calcareous alga *Halimeda* sp., Mrs Watson's Bay, Lizard Island, Queensland. Photo by Rudie Kuiter. b. *Pleurosicya mossambica* on an orange sponge from Watson's Bay, Sydney Harbour, New South Wales. Photo by Rudie Kuiter.

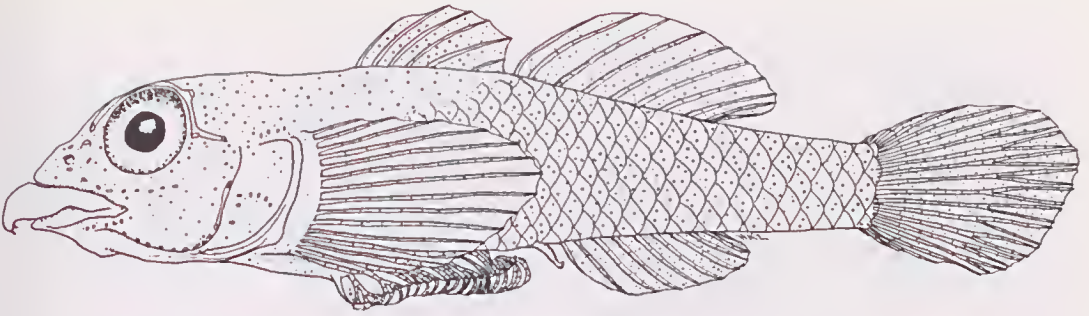

Fig. 27. *Pleurosicya prognatha* (one of WAM P.28030-040), composite based on two males from Rowley Shoals, Western Australia.

on outer face of first arch consist of tiny bumps: 1+4 (1), 2+4 (1), with lower quarter of arch bound by membrane to opercle.

Head and body somewhat compressed, especially posteriorly. Body short but slender, depth at anus 18% (14-24%) of SL (Fig. 27). Head relatively long, 35% (32-41%) of SL. Head depth (mean 59%) usually greater than head width (mean 56%). Snout rather concave in profile, long (33-44% of HL, mean 39%), with tip of upper lip elongated, fleshy, and usually pointed, turning downwards over front of mouth, giving fish unmistakable parrot-like profile. Mouth terminal, nearly horizontal, with jaws ending at point below margin or anterior half of eye. Tip of upper jaw narrow, with cartilaginous tooth-bearing projection (slightly expanded anteriorly) present, as long or longer than upper lip. Eyes large, lateral, averaging 31% of HL, and usually forming part of profile. Interorbital narrow, 5% of HL. Anterior nostrils in slender tube, posterior with low rim. Tongue short and small, pointed to rounded, and absent in two specimens. Gill opening restricted to pectoral base.

Both dorsals low and rounded, first dorsal not much taller than second. Anal rays all unbranched. Caudal truncate to rounded. Pectorals reach to below gap between dorsals. Pelvic fins rounded and cup-like, usually reaching to past anus. Pelvic spine lobes rounded in shape. Skin of lobes and frenum thickened, fimbriate, and distal third to half of pelvic rays usually fimbriate also. Fifth pelvic ray quite flattened at first branch point.

Upper jaw narrow, with one to two rows of tiny, slightly curved, pointed teeth, and a curved canine tooth on either side of cartilaginous projection (Fig. 28A). A patch of tiny, curved, sharp teeth at tip of projection, which may protrude outside upper lip (Fig. 28B).

Lower jaw with one row of backwardly curved pointed teeth along sides, and band of fine pointed teeth across front of jaw (largest teeth outermost). A pair of stout curved canines behind tooth bands at symphysis.

Lateral line canals of head generally as for genus, but only two preopercular pores usually present (three pores on right preopercle in holotype).

Scales on mid-side of body usually reach to below gap between dorsals, with one to several rows (which may consist of isolated scales only) continuing forward to behind pectoral fin. Six specimens (including holotype) have body nearly fully scaled to up behind pectoral fin.

Male genital papilla elongate, wide at base and narrowing towards tip, which is expanded, bearing many tiny villi. Female genital papilla short, round, with many small lobes at tip.

Colour in Life. Goren (1984) records *P. prognatha* as being transparent when live, with "black pigmentation around the eyes and a light yellow shade around the viscera". No

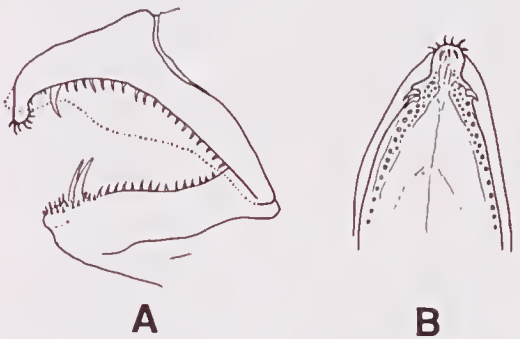

Fig. 28. A. Lateral view of teeth and jaws of male *Pleurosicya prognatha* (one of WAM P.28030-040), outline of upper lip indicated by dotted line. B. Ventral view of upper jaw of same specimen, showing cartilaginous projection.

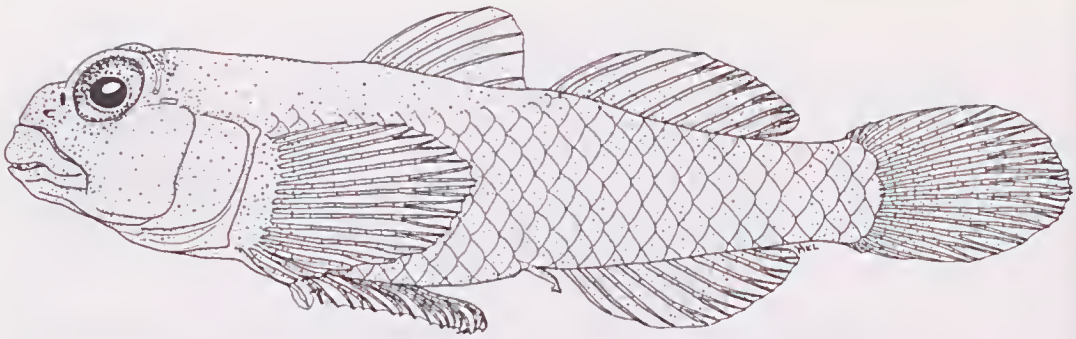

Fig. 29. Holotype of *Pleurosicya spongicola* (NTM S.11355-001), 13.5 mm male from Lombok.

further colour notes are available. Examination of freshly preserved material shows the iris to be silvery pink to rose coloured, and the body and fins of males to be quite dusky. No distinct black spots.

Colour in Alcohol. Females are plain hyaline, with the peritoneum speckled lightly with melanophores, usually showing through the body wall. At least distal third to half of soft dorsal, anal, and usually part of caudal fins scattered with melanophores; other fins transparent. No distinct blotches or spots. Several specimens from Clerke Reef with tiny brown or blackish spot on edge of preopercle near lower preopercular pore. Small males similar. Adult males evenly dusky over head, body and unpaired fins. Dorsals and caudal sometimes dark brown. Pectorals and pelvies unpigmented. One relatively large (14 mm SL) male had a lighter-coloured broad band across the side between the dorsals, and the head and nape abruptly paler (from first dorsal origin forward).

Comparisons. This species and *P. fringilla* are very similar in appearance. *Pleurosicya prognatha* can be distinguished by the elongation of the upper jaw and lip, in lacking a black blotch on the anterior rays of the anal fin as present in male *P. fringilla*, and in tending to be smaller than *P. fringilla*. Both species are distinguished from most other members of the genus in having a process extending from the preopercle towards the symplectic process (and nearly meeting). Also, these fish are found in similar lagoon habitats (staghorn coral thickets), and may occur together. *Pleurosicya fringilla* is more common than *P. prognatha*.

Remarks. The flap on the upper margin of the eye mentioned by Goren (1984) is an arte-

fact of preservation, a fold of skin on the eye of the holotype, which is slightly dehydrated.

This species inhabits large staghorn coral thickets (probably *Acropora formosa* and/or *Acropora grandis*), which grow on shallow to deep lagoonal habitats. They probably cling to the underside of the branches as does *P. fringilla*.

Pleurosicya spongicola sp. nov.
(Fig. 29)

Type material. HOLOTYPE - NTM S.11355-001; 13.5 mm SL male, Indonesia, Lombok Strait, off SW coast of Lombok, 40 m depth, from inside sponge. B. Russell, 24 August 1984. PARATYPES - NTM S.11355-002; 13 mm SL female, same data as holotype. LON unregistered; 13 mm SL male, same data as preceding.

Diagnosis. A small, stocky *Pleurosicya* with small eyes and steep snout. Second dorsal rays 1,8; anal rays 1,8. Pectoral rays 16-17. Lateral scales 25, TRB 8. Body fully scaled, head and nape naked. Small canine tooth present at side of lower jaw. Tongue broad and round. Gill opening restricted to pectoral base. Body and fins evenly dark brown. Commensal on sponges, in trawl-depth water.

Description. Based on three specimens, 13-13.5 mm SL. First dorsal fin VI (3). Second dorsal 1,8 (3). Anal 1,8 (3). Pectoral rays 16 (1), 17 (2). Lowermost 5 pectoral rays unbranched, and thickened distally. Branched caudal rays 11(2), 10(1). Longitudinal scale count 25 (3). TRB 8 (3). Gill rakers on outer face of first arch almost absent, 1+1+1 (in 1), tiny thin bumps only; rakers on rear of arches very small, without spines. Lower quarter of first gill arch bound by membrane to opercular wall.

Head roughly triangular, blunt apex dorsally. Body compressed, somewhat rounded anteriorly. Body stocky, depth at anus 19-22% of SL (Fig. 29). Head length 32-35% of SL. Head depth less than, but almost equal to, head width. Snout short, steep, 30-36% of SL. Mouth horizontal, barely sub-terminal, upper jaw slightly overhanging lower. Jaws 35% of HL, end at point below anterior half of eye. Eyes small, lateral, set high on head and forming part of dorsal profile, 27-31% of HL. Interorbital moderate, 5-9% of HL. Anterior nostril in short slender tube, halfway between lip and rim of eye; posterior nostril round, flat, placed close to anterior edge of eye. Tongue medium-sized, broad and rounded. Gill opening restricted to pectoral base.

First dorsal fin low, rounded; unpaired fins rounded, including caudal. Posteriormost three to five anal fin rays branched in two largest specimens. Pectorals short, reach back to below sixth dorsal spine origin. Pelvies oval, when flattened reach anus in all specimens; pelvic spine lobes short, round; frenum low, short. Pelvic rays slender, first branch point of fifth ray close to base.

Upper lip broad, slightly overhangs front of lower jaw in two specimens. Upper jaw with band of tiny sharp teeth, broadest anteriorly, narrowing to one row at sides, and four to six large curved teeth outermost across front of jaw. Lower jaw roughly triangular, with band of tiny upright sharp teeth, broad anteriorly, narrowing to one row at sides posteriorly. Outermost teeth across front of lower jaw slightly larger than inner teeth. Small curved canine at side of lower jaw, at point where band of teeth becomes one row; canine larger in males, reduced but present in female specimen. Large curved tooth present on either side of lower jaw symphysis, behind rows of teeth.

Lateral line canals of head generally as for genus; anterior and posterior interorbital pores in two specimens fused together in one large opening in centre of interorbital space, and lateral canals very short. No preopercular pores in same two specimens, two preopercular pores on each side in remaining specimen.

In all specimens, scales on body extend up to behind pectoral fin, absent from head and nape.

Genital papilla in male moderate, wide at base and flattened, with group of tiny lobes at slightly expanded tip. Female papilla short,

rounded but not bulbous, with several small lobes at either side of opening at tip.

Colour in Life. No live colour information available.

Colour in Alcohol. Head and body evenly covered with brown pigment, lighter on belly and underside of head. Nape immediately behind eyes, and interorbital region, quite dark brown. Midline of nape behind eyes with very dark brown line, extending from point above preopercular edge to end of opercle. Dark brown stripe from front of eye to tip of snout, and a second such stripe visible on female from just above rear nostril to upper lip. Upper lip darker than lower. Both dorsals, anal, and caudal covered by dense brown speckles. Pectoral fin similar in female; in males (roughly) proximal half of pectoral pigmented. Pelvies hyaline.

Comparisons. This fish is very similar to *P. fringilla*, but has a broad, rounded tongue (instead of small, narrow, pointed tongue at back of throat), a higher pectoral ray count (16-17, versus 15-16 in *fringilla*), very steep, short snout; small canine at each side of lower jaws (absent in *fringilla*), and a different invertebrate host (*P. spongicola* lives on a sponge, whereas *P. fringilla* lives among *Acropora* corals). So far this species is known only from three specimens. *Pleurosicya fringilla*, which greatly resembles this species, has not been collected from depths greater than 27 m, and its depth distribution is undoubtedly linked to that of its host corals (which generally prefer lagoon conditions).

Remarks. *Pleurosicya spongicola* is known from three specimens, which were obtained by trawling in 40 metres of water. The sponge in which the specimens were found was broken up on deck (unfortunately none of the sponge was retained).

Etymology. The species name *spongicola* refers to its association with a sponge host, from the Latin.

DISCUSSION

There are differences in proportions and physiognomy among species of *Luposicya* and *Pleurosicya*, and in some species these differences are of use in their identification. Consequently, small juveniles are sometimes difficult (or impossible) to identify to species with any certainty, and this is especially true if they

are not in good condition. In contrast, there are very few differences between the species in their meristics. *Pleurosicya boldinghi* stands apart in having different dorsal ray counts, and in having the highest pectoral ray count (Tables 3 and 4). *Pleurosicya carolinensis*, *P. fringilla*, and *P. prognatha* all have low pectoral ray counts, with an average of 15 rays (Table 4). Most species have the lowermost four or five pectoral rays unbranched (Table 5), but *P. muscarum* has very few, averaging only two unbranched rays (*P. carolinensis* has three, the next lowest).

There appear to be several species-groups within *Pleurosicya*: one group consisting of five species, three groups with species-pairs, and another five single species groups which do not share any distinguishing characters. The first group of five species consists of the relatively generalised *P. amandalei*, *P. australis*, *P. boldinghi*, *P. micheli* and *P. mossambica*. These are species with similar teeth arrangements, scaled predorsal regions and wide gill openings. The second to fourth groups are the species-pairs: (a) *P. elongata* and *P. labiata* (which share jaw, teeth, and tongue structure), (b) *P. coerulea* and *P. occidentalis* (with naked predorsal and similar morphology), and (c) the most specialised pair *P. fringilla* and *P. prognatha* (sharing body proportions, tongue morphology, and preopercular osteology). The remaining five species without any obvious affinities with other groups are: *P. bilobata*, *P. carolinensis*, *P. spongicola*, *P. muscarum*, and *P. plicata*. *Pleurosicya carolinensis* resembles *P. elongata* and *P. labiatus*, but with different tongue shape; *P. plicata* differs from any of the others; *P. spongicola* is similar to *P. fringilla* and *P. prognatha* but with a different tongue shape; and both *P. bilobata* and *P. muscarum* are similar to the *P. mossambica* group, but with naked predorsals and different physiognomies.

Pleurosicya and the four genera to which it is related (*Bryaniops*, *Lobulogobius*, *Luposicya*, *Phyllogobius*) form a close-knit group characterised by the unique form of the pelvic frenum and pelvic spine lobes. The forwardly-folded frenum and flattened rounded lobes around the spines somewhat resemble those of the freshwater-dwelling sicydiine gobies, which prompted some earlier workers (e.g. Koumans 1953) to include the *Pleurosicya* group with the sicydiines. However,

sicydiines have specialised teeth, lips, and osteology, separating them from gobiines such as *Pleurosicya* (Hoese 1984). Characters separating *Pleurosicya* and *Bryaniops* have been discussed elsewhere (Larson 1985).

Phyllogobius at first sight resembles an extremely flattened *Pleurosicya* (it is a sponge-commensal, unlike most *Bryaniops* and *Lobulogobius* species). Larson (1986) pointed out the differences and similarities between *Pleurosicya* and *Phyllogobius*.

Lobulogobius also resembles *Pleurosicya*; *L. omanensis* more so than *L. morigu*. *Lobulogobius* differs in its unrestricted gill opening, wide interorbital with anterior interorbital pores paired (and often one of these is absent), in having all pectoral rays branched (in adults), and in having one more anal ray than soft dorsal rays. This latter character sets *Lobulogobius* apart from the other genera of this group, which all have the number of anal rays equal to that of the soft dorsal rays. *Lobulogobius omanensis* also has unique large slitlike nasal pores, unlike any *Pleurosicya* species.

All these fishes are considered to be commensals, in the broad sense of sharing a common food source with their hosts (zooplankton, in part), and in the fish's specificity to the host invertebrate. Of the 16 *Pleurosicya* species, eight are known to be host-specific commensals. They are: *P. bilobata* on broad-bladed scagrasses, *P. fringilla* and *P. prognatha* on large *Acropora* thickets, *P. coerulea* on *Heliopora coerulea*, *P. muscarum* on alcyonarians, *P. micheli* on hard corals, *P. labiata* on barrel-sponges (species uncertain but possibly *Xestospongia testudinaria*), and *P. elongata* on *lanthella basta*. Only two of these are so far known to be quite species-specific in their host relationship (*P. coerulea* and *P. elongata*). *Pleurosicya mossambica* is commensal on such a variety of organisms that it is possible only to say that it is most often found on soft corals and sponges. Large *Deudronephthya*-sp. (Japan) and a seapen (New Guinea) are the known hosts for *P. boldinghi*, and *P. spongicola* is known from an unidentified sponge. Further fieldwork may discover hosts for the other species (*P. amandalei*, *P. australis*, *P. carolinensis*, *P. occidentalis*, and *P. plicata*), but we presently know very little about these.

In the related genus *Bryaniops*, only three out of the 10 species are known to be definitely

Table 2. Counts and measurements of primary type specimens of the species of *Pleuroscia* (measurements in mm).

	Holotype ANSP 51094	Holotype BPRM 17280	Holotype USNM 203588	Lectotype ZMA 100.209	Holotype CAS 36875	Holotype NTM S.12658-001	Holotype NTM S.12654-001	Holotype USNM 242091	Lectotype ZMA 112.904	Neotype out of AMS 1.21918-069	Holotype RUSI 227	Syntype USNM 51782	Holotype USNM 264746	Holotype ROM 58031	Holotype TAU P.6478	Holotype NTM S.11355-001
	<i>annandalei</i>	<i>australis</i>	<i>bilabata</i>	<i>baldingi</i>	<i>carolinensis</i>	<i>coerulea</i>	<i>elongata</i>	<i>fringilla</i>	<i>labiata</i>	<i>micheli</i>	<i>mossambica</i>	<i>muscarum</i>	<i>occidentalis</i>	<i>plicata</i>	<i>pragnatha</i>	<i>spangicola</i>
First dorsal	VI	VI	VI	VI	VI	VI	VI	-	VI	VI	VI	VI	VI	VI	VI	VI
Second dorsal	1.8	1.8	1.8	1.7	1.8	1.8	1.8	1.9	1.8	1.8	1.8	1.7	1.8	1.8	1.8	1.8
Anal	1.8	1.8	1.8	1.8	1.8	1.8	1.8	1.8	1.8	1.8	1.8	1.8	1.8	1.9	1.9	1.8
Pectoral	20	17	16	20	15	16	15	16	16	18	17	17	17	17	15	15
Unbranched rays	-	4	5	-	4	6	4	5	-	4	4	-	6	3	5	5
Lateral line	24	24	24	25	24	24	25	24	24	-	23	-	23	24	22	25
Transverse scales																
backward	9	7	6	10	7	7	8	8	9	7	-	7	7	7	8	8
Standard length	25	25	19	26	26	16	29	15	19	17.5	18	13	18	19	15	14
Head length	8.7	8.7	6.0	9.7	7.5	5.3	8.2	5.2	5.4	5.6	5.8	4.3	5.7	5.9	4.7	4.7
Head depth	-	4.7	2.5	6.7	3.9	3.0	4.4	3.0	3.2	3.0	3.3	2.3	3.0	2.7	2.9	3.3
Head width	-	4.9	3.8	6.3	4.1	4.2	4.9	3.2	3.3	3.2	3.6	2.5	3.8	3.2	2.5	3.6
Body depth at anus	5.4	5.2	2.5	6.8	4.1	2.9	4.2	2.4	3.4	3.0	3.2	2.4	2.9	3.2	3.0	2.9
Caudal length	-	5.6	3.8	-	-	3.6	6.4	3.3	3.5	4.1	3.6	-	4.1	4.4	-	3.3
Pectoral length	-	5.0	3.5	-	4.7	3.0	5.7	3.2	-	3.5	3.6	-	3.6	4.0	3.4	2.9
Pelvic length	-	4.9	2.9	4.8	4.4	3.1	5.2	3.2	5.1	3.3	3.6	1.9	3.8	3.8	2.9	3.3
Caudal ped. length	-	5.2	4.1	5.0	6.3	3.8	7.7	3.0	4.1	4.0	4.0	2.9	4.1	3.9	2.9	2.2
Caudal ped. width	-	2.3	1.7	3.6	2.2	1.6	2.5	1.4	2.1	1.6	1.7	1.1	1.5	1.8	1.5	1.7
Snout	-	2.4	2.2	3.3	2.7	2.2	3.2	1.9	1.8	1.4	1.8	1.4	2.1	1.8	1.8	1.5
Eye	-	2.4	1.4	2.2	1.9	1.4	2.3	1.5	1.5	1.6	1.7	1.2	1.5	1.5	1.4	1.3
Mouth	4.7	4.0	2.5	4.8	3.2	2.3	3.4	2.0	1.8	2.3	2.9	1.9	2.4	2.1	1.9	1.6
Interorbit	-	0.3	0.5	0.7	0.6	0.2	0.5	0.1	0.2	0.2	0.2	0.3	0.2	0.2	0.2	0.4

Table 3. Range of morphometrics in *Pleurostictus* species examined. Mean and range (in parentheses) are given for each species, as percentages of HL or SL (as indicated)

	<i>annandalei</i>	<i>australis</i>	<i>bilobata</i>	<i>boldingi</i>	<i>carolinensis</i>	<i>coerulea</i>	<i>elongata</i>	<i>fringilla</i>	<i>labiata</i>	<i>michele</i>	<i>mosambica</i>	<i>muscarum</i>	<i>occidentalis</i>	<i>plicata</i>	<i>prognathia</i>	<i>spongicola</i>
Standard length	21.1 (13.5-28)	19.7 (15-25)	17.3 (8.5-23)	20.7 (11-27.5)	17.8 (11-25.5)	14.8 (10.5-20)	20.7 (13-29)	13.8 (10-18.5)	19.9 (14-28)	16.4 (11-20.5)	18.0 (10.5-27)	16.5 (11-21.5)	15.4 (11.5-20)	17.5 (14-22.5)	12.0 (10-15)	13.0 (13-13.5)
Head length in SL	35 (32-39)	35 (25-37)	33 (26-36)	36 (30-41)	30 (28-32)	32 (29-36)	29 (26-33)	34 (31-36)	29 (26-31)	33 (31-37)	34 (30-38)	32 (29-36)	32 (30-35)	33 (30-39)	35 (32-41)	34 (32-35)
Head depth in HL	53 (48-60)	54 (51-56)	44 (36-50)	61 (56-68)	50 (46-64)	55 (49-60)	61 (44-58)	61 (52-67)	55 (46-62)	50 (44-57)	55 (48-74)	53 (45-64)	54 (48-64)	45 (41-50)	59 (53-71)	66 (64-70)
Head width in HL	59 (48-67)	53 (47-56)	58 (50-65)	57 (53-68)	58 (53-68)	72 (56-88)	57 (48-64)	64 (51-75)	6 (55-66)	57 (50-62)	64 (53-75)	61 (48-76)	64 (55-73)	53 (48-58)	56 (46-66)	74 (69-77)
Body depth at anus in SL	18 (15-22)	20 (19-20)	15 (11-16)	22 (17-26)	16 (14-18)	17 (15-26)	14 (12-16)	18 (15-22)	1 (13-20)	16 (14-21)	17 (15-19)	17 (14-21)	16 (14-19)	16 (14-19)	18 (14-24)	20 (19-22)
Caudal length in SL	24 (20-27)	22 (22-22)	22 (19-24)	18 (21-27)	22 (19-25)	22 (18-25)	23 (20-26)	23 (21-25)	2 (19-25)	24 (21-27)	24 (20-28)	25 (23-30)	23 (20-25)	25 (22-31)	23 (21-26)	24 (23-25)
Pectoral length in SL	21 (19-24)	20 (19-22)	18 (14-20)	19 (18-26)	19 (16-21)	20 (17-24)	20 (18-24)	23 (21-28)	2 (20-23)	21 (19-24)	20 (18-24)	22 (19-25)	20 (16-22)	21 (18-27)	23 (19-27)	23 (22-24)
Pelvic length in SL	23 (20-26)	21 (20-22)	16 (21-21)	20 (18-24)	21 (17-24)	20 (17-23)	19 (17-23)	23 (17-28)	24 (21-28)	21 (19-24)	21 (18-26)	19 (15-25)	20 (18-24)	21 (18-24)	22 (19-26)	26 (24-29)
Caud. ped. length in SL	21 (20-23)	21 (21-22)	21 (18-24)	19 (18-22)	23 (20-25)	21 (18-25)	25 (23-29)	21 (18-25)	24 (21-28)	23 (19-29)	21 (19-25)	23 (18-28)	22 (20-26)	23 (20-27)	20 (17-22)	18 (16-20)
Caud. ped. width in SL	10 (8-11)	10 (9-11)	8 (7-10)	13 (11-14)	9 (8-9)	9 (8-10)	8 (7-10)	10 (7-12)	10 (8-11)	9 (8-11)	10 (8-11)	10 (8-12)	9 (8-10)	9 (8-14)	10 (8-12)	12 (12-12)
Snout in HL	29 (24-33)	26 (24-28)	31 (25-37)	30 (26-37)	32 (25-37)	35 (28-42)	35 (25-52)	36 (28-43)	33 (27-38)	26 (21-30)	28 (21-34)	31 (23-38)	32 (26-39)	30 (27-36)	39 (33-34)	32 (30-36)
Eye in HL	27 (22-33)	28 (25-31)	25 (21-31)	25 (20-29)	29 (25-35)	29 (24-43)	30 (24-36)	29 (24-35)	27 (23-31)	30 (25-35)	28 (23-34)	25 (20-31)	29 (24-32)	27 (22-31)	31 (27-36)	29 (27-31)
Mouth in HL	47 (39-54)	46 (44-50)	42 (36-47)	43 (37-50)	40 (33-45)	42 (37-57)	36 (30-42)	37 (30-07)	34 (32-36)	42 (38-48)	45 (38-51)	43 (38-48)	40 (32-46)	37 (33-45)	38 (35-43)	35 (33-36)
Interorbit in HL	6 (3-11)	6 (5-7)	5 (3-8)	10 (7-15)	5 (3-9)	4 (2-7)	3 (1-6)	4 (2-5)	4 (2-8)	4 (2-5)	5 (3-7)	4 (2-7)	3 (2-5)	4 (3-7)	5 (3-8)	7 (5-9)

Table 4. Frequency of pectoral rays in *Pleurosicya* species.

Species	Number of pectoral rays								
	14	15	16	17	18	19	20	21	Mean
<i>annandalei</i>	-	-	-	3	6	15	3	-	19
<i>australis</i>	-	-	-	4	-	-	-	-	17
<i>bilobata</i>	-	-	12	11	5	1	-	-	17
<i>holdingi</i>	-	-	-	-	1	2	12	4	20
<i>carolinensis</i>	7	15	2	-	-	-	-	-	15
<i>coerulea</i>	-	1	7	36	20	-	-	-	17
<i>elongata</i>	-	5	16	6	-	-	-	-	16
<i>fringilla</i>	4	24	13	-	-	-	-	-	15
<i>labiata</i>	-	3	12	3	1	-	-	-	16
<i>micheli</i>	-	-	2	20	11	1	-	-	17
<i>mossambica</i>	-	-	1	20	22	9	1	-	18
<i>muscarum</i>	-	-	1	21	16	7	-	-	18
<i>occidentalis</i>	-	-	7	24	1	-	-	-	17
<i>plicata</i>	-	11	14	6	1	-	-	-	16
<i>prognatha</i>	1	18	4	-	-	-	-	-	15
<i>spongicola</i>	-	-	1	2	-	-	-	-	17

Table 5. Frequency of unbranched lower pectoral rays in *Pleurosicya* species.

Species	Number of unbranched rays								
	1	2	3	4	5	6	7	8	Mean
<i>annandalei</i>	-	-	3	12	10	-	-	-	4
<i>australis</i>	-	-	2	1	1	-	-	-	4
<i>bilobata</i>	-	-	1	6	7	5	3	-	5
<i>holdingi</i>	-	3	6	3	4	2	-	-	4
<i>carolinensis</i>	-	3	8	5	1	-	-	-	3
<i>coerulea</i>	-	-	-	5	30	21	2	-	5
<i>elongata</i>	-	-	-	3	8	13	3	-	6
<i>fringilla</i>	-	-	-	2	27	13	-	-	5
<i>labiata</i>	-	-	5	8	2	3	-	-	4
<i>micheli</i>	-	2	7	13	8	-	-	-	4
<i>mossambica</i>	-	-	3	11	30	5	2	1	5
<i>muscarum</i>	13	15	8	-	-	1	1	-	2
<i>occidentalis</i>	-	-	-	3	12	11	4	-	6
<i>plicata</i>	-	3	20	6	-	-	-	-	3
<i>prognatha</i>	1	-	-	1	7	4	1	1	5
<i>spongicola</i>	-	-	-	-	3	-	-	-	5

species-specific in host choice (*B. isis* on *Isis hippuris*, *B. tigris* on *Antipathes* sp., and *B. yongei* on *Cirripathes anguina*). The other species are more generally host-specific: e.g. *B. erythroptus* and *B. nexis* occur on several *Millepora* and *Porites* spp, and *B. amplius* lives on several species of the seawhips *Junceella* and *Ellisella* (although usually only on *Junceella fragilis*).

Part of the problem of verifying species-specificity for all these fishes is the reliable identification of the host invertebrate, as the taxonomy of many, such as the sponges and gorgonians, is far from resolved. Another consideration is the question of whether all

these fishes are truly commensal. The definition of commensalism assumes that both host and commensal share the same food source to some extent, but this varies among the *Pleurosicya* species, as has been shown above (although in most cases food habits are not known). It is not known if the food items selected by a *Pleurosicya* inhabiting a soft coral are the same types of items the coral would utilise, or whether the fish is using quite a different food source to its host, and therefore only using the host for protection and access to food. Morton (1988) defined the term "aegism" for the association in which the "commensal" mainly derives protection from the "host", which may also include access to a food source. However, this term does not adequately cover the behaviour of these fishes either, whereas the broad concept of "commensalism" seems to best fit these small gobies.

Pleurosicya mossambica, four species of *Bryaninops*, and *Luposicya lupus* have recently been confirmed as protogynous hermaphrodites (Fishelson 1989), and it is likely that most species of the group have this form of reproduction. This reproductive strategy, previously suspected to occur in the group by Larson (1985), is common among small, obligatory invertebrate commensal gobies such as *Gobiodon*, *Paragobiodon* and the Atlantic genus *Gobiosoma*. This has been discussed in detail by Fishelson (1989).

Table 6. Frequency of dorsal and anal ray counts in *Pleurosicya* species.

Species	Dorsal rays					Anal rays				
	1,6	1,7	1,8	1,9	Mean	1,6	1,7	1,8	1,9	Mean
<i>annandalei</i>	-	2	19	1	1,8	-	-	20	2	1,8
<i>australis</i>	-	4	-	-	1,9	-	-	4	-	1,8
<i>bilobata</i>	-	2	29	-	1,8	-	2	25	4	1,8
<i>holdingi</i>	-	19	-	-	1,7	1	1	17	-	1,8
<i>carolinensis</i>	-	-	18	3	1,8	-	-	19	1	1,8
<i>coerulea</i>	-	1	55	2	1,8	-	-	57	1	1,8
<i>elongata</i>	-	-	25	2	1,8	1	1	23	2	1,8
<i>fringilla</i>	-	2	37	2	1,8	-	3	36	2	1,8
<i>labiata</i>	-	2	15	1	1,8	-	-	17	1	1,8
<i>micheli</i>	-	3	31	-	1,8	-	1	31	2	1,8
<i>mossambica</i>	1	4	48	-	1,8	-	1	49	3	1,8
<i>muscarum</i>	-	5	40	-	1,8	-	4	39	2	1,8
<i>occidentalis</i>	1	1	29	1	1,8	-	1	20	1	1,8
<i>plicata</i>	-	2	33	-	1,8	-	1	33	1	1,8
<i>prognatha</i>	-	-	26	2	1,8	-	-	27	1	1,8
<i>spongicola</i>	-	-	3	-	1,8	-	-	3	-	1,8

ACKNOWLEDGEMENTS

Many thanks in particular to the following, who provided fresh specimens and/or colour photographs of *Pleurosicya*: Neville Coleman, Patrick Colin, Masayoshi Hayashi, Doug Hoese, Bob Johannes, Rudie Kuitert, Phil Lobel, Jack Randall, Roger Steene and Rick Winterbottom. Additional preserved material and information were kindly made available by G. Allen, M.-L. Bauchot, W. Eschmeyer, D. Fisk, S. Jewett, K. Meguro, H. Nijssen, K.T. Shao, K. Shimada, W. Smith-Vaniz, V. Springer, and T. Yoshino.

Thanks are also due to the late J. Verseveldt of Zwolle, The Netherlands, for identifying many soft corals from rather small pieces; Phil Alderslade of NTM, for identifying additional soft corals and the peculiar cuticle of *Helio-pora*; John Hooper of NTM, for identification of sponges; and to Ian Skinner, for Sydney Harbour sponge identifications.

REFERENCES

- Allen, G.R., Hoese, D.F., Paxton, J.R., Randall, J.E., Russell, B.C., Starek, W.A. II, Talbot, F.H. and Whitley, G.P. 1976. Annotated checklist of the fishes of Lord Howe Island. *Records of the Australian Museum* 30(15):365-454.
- Allen, G.R. and Russell, B.C. 1986. Fishes. *Records of the Western Australian Museum, Supplement* 25:75-103.
- Bauchot, M.L., Desoutter, M., Hoese, D.F., and Larson, H.K. In press. Catalogue critique des types de poissons du Muséum National d'Histoire Naturelle. (Suite) Sous-ordre des Gobioidei. *Bulletin du Muséum National d'Histoire Naturelle* in press.
- Bergquist, P.R. 1969. Shallow water Demospongiae from Heron Island. *University of Queensland Papers Department of Zoology* 1(4):63-72.
- Birdsong, R.S., Murdy, E.O. and Pezold, F.L. 1988. A study of the vertebral column and median fin osteology in gobioid fishes with comments on gobioid relationships. *Bulletin of Marine Science* 42(2):174-214.
- Bouillon, J. and Houvenaghel-Crevcoeur, N. 1970. Etude monographique du genre *Helio-pora* De Blainville (Coenothecalia - Aleyonaria - Coelenterata). *Annales Musée Royal de l'Afrique Centrale - Tervuren Belgique, Serie In 8. Sciences Zoologiques* 178:1-83.
- Fishelson, L. 1989. Bisexuality and pedogenesis in gobies (Gobiidae: Teleostei) and other fish, or, why so many little fish in tropical seas? *Senckenbergiana Maritima* 20(3/4):147-169.
- Fowler, H.W. 1928. The fishes of Oceania. *Memoirs of the Bernice P. Bishop Museum* 10:1-540.
- Fourmanoir, P. 1971. Notes ichthyologiques (IV). *Cahiers ORSTOM. Série Oceanographie* 9(4):491-500.
- Gilbert, C.R. and Burgess, G.H. 1986. Variation in western Atlantic gobioid fishes of the genus *Evermannichthys*. *Copeia* 1:157-165.
- Goren, M. 1984. Three new species and two new records for the Red Sea of invertebrate associated gobies (Gobiidae, Pisces). *Cybium* 8(1): 71-82.
- Hoese, D.F. and Winterbottom, R. 1979. A new species of *Lioteres* (Pisces, Gobiidae) from Kwazulu, with a revised checklist of South African gobies and comments on the generic relationships and endemism of western Indian Ocean gobioids. *Royal Ontario Museum Life Sciences Occasional Papers* 31:1-13.
- Hoese, D.F. 1984. Gobioidae: relationships. pp. 588-591. In: H.G. Moser (ed.) *Ontogeny and systematics of fishes*. Based on an international symposium dedicated to the memory of Ehlbert Halvor Ahlstrom. American Society of Ichthyologists and Herpetologists: Gainesville.
- Hornell, J. and Fowler, H.W. 1922. Description of a new gobioid fish from Tuticorin. *Journal of the Bombay Natural History Society* 28(3-4):924-925.
- Jordan, D.S. and Seale, A. 1906. The fishes of Samoa. *Bulletin of the Bureau of Fisheries* 25:173-488.
- Koumans, F.P. 1941. Gobioid fishes of India. *Memoirs of the Indian Museum* 13:205-329.
- Koumans, F.P. 1953. *Gobioidae. The fishes of the Indo-Australian Archipelago*. Volume 10: 423pp. E.J. Brill: Leiden.
- Larson, H.K. 1985. A revision of the gobioid genus *Bryaninops* (Pisces), with a description of six new species. *The Beagle, Occasional Papers of the Northern Territory Museum of Arts and Sciences* 2(1):57-93.
- Larson, H.K. 1986. *Phyllogobius*, a new generic name for *Cottogobius platycephalops* Smith (Pisces:Gobiidae), and a redescription of the species. *The Beagle, Occasional Papers of the Northern Territory Museum of Arts and Sciences* 3(1):131-136.
- Larson, H.K. 1987. A new species of *Bryaninops* (Pisces: Gobiidae) with notes on new records of three species of the genus. *The Beagle, Records of the Northern Territory Museum of Arts and Sciences* 4(1):139-145.
- Larson, H.K. and Hoese, D.F. 1980. Gobiidae. *Fische des Indischen Ozeans. "Meteor" Forschungs-Ergebnisse Volume* 32:33-43.

- Lendenfeld, R. von 1889. *A monograph of the horny sponges*. Royal Society, Trübner and Co.: London.
- Masuda, H., Amaoka, K., Araga, C., Uyeno, T. and Yoshino, T., (eds) 1984. *The Fishes of the Japanese Archipelago*. Volumes 1-2: 437 pp, 370 pls. Tokai University Press: Tokai.
- Morton, B. 1988. *Partnerships in the sea: Hong Kong's marine symbioses*. Hong Kong University Press: Hong Kong.
- Plessis, Y. and Fourmanoir, P. 1966. *Pleurosycia taisnei*, nouvelle espèce de Gobiidae de Nouvelle-Calédonie. *Bulletin du Muséum National d'Histoire Naturelle* **37**(5):764-765.
- Smith, J.L.B. 1959. Gobioid fishes of the families Gobiidae, Periophthalmidae, Trypauchenidae, Taenioiidae, and Kraemeriidae of the Western Indian Ocean. *Rhodes University Bulletin of the J.L.B. Smith Institute of Ichthyology* **13**:185-225.
- Smith, M.M. and Heemstra, P.C. 1986. *Smith's sea fishes*. 1047 pp. Macmillan: Johannesburg.
- Tyler, J. and Bohlke, J. 1972. Records of sponge-dwelling fishes, primarily of the Caribbean. *Bulletin of Marine Science* **22**(3):601-642.
- Wass, R.C. An annotated checklist of the fishes of Samoa. *NOAA Technical Report NMFS SSRF*(781). 43 pp.
- Weber, M. 1913. Siboga expedition. Die Fische der Siboga - Expedition. pp 1-170. Leiden.
- Winterbottom, R. and Emery, A.R. 1986. Review of the gobioid fishes of the Chagos Archipelago, central Indian Ocean. *Royal Ontario Museum Life Sciences Contributions* **142**:1-82.
- Yoshino, T. and Nishijima, S. 1981. A list of fishes found around Sesoko Island, Okinawa. *Sesoko Marine Laboratory Technical Report* **8**:19-87.

Accepted 14 June 1990

PERICLIMENES FRANKLINI SP. NOV., A NEW DEEP-SEA SHRIMP
FROM THE CORAL SEA
(CRUSTACEA:DECAPODA:PALAEMONIDAE).

A.J. BRUCE

Northern Territory Museum of Arts and Sciences,
GPO Box 4646, Darwin NT 0801, Australia.

ABSTRACT

A new species of pontonine shrimp, *Periclimenes franklini*, from 300 m in the Coral Sea, is described and illustrated. The new species occupies an isolated systematic position in the genus *Periclimenes* as the carapace lacks an antennal spine, and is closely related only to *P. gorgonicola* Bruce, from which it differs in the presence of large articulated postrostral spines. Both species suggest that the genus *Mesopontonia* Bruce, is more closely related to the genus *Periclimenes*, rather than other genera that lack an exopod in the third maxilliped. *Periclimenes franklini* is probably also a gorgonian associate.

KEYWORDS: Crustacea, Decapoda, Palaemonidae, *Periclimenes*, new species, deep-sea, Coral Sea.

INTRODUCTION

Although Australian seas are provided with a high diversity of pontonine shrimps, particularly of the genus *Periclimenes*, very few species have been reported from deeper waters, over 100 m. *Periclimenes alcocki* Kemp, 1922, has been reported from off Bateman's Bay, New South Wales, at 330 m (Bruce 1983). *P. hertwigi* Balss, 1913, on *Araeosoma thetidis*, off Mooloolaba, Queensland, at 500 m (Bruce 1983), and *Mesopontonia gorgoniophila* Bruce, 1967, from 26° 27'S. 153° 51'E., at 270 m (Bruce 1983). The addition of a single new deep-water species is therefore of interest. Recent studies, with suitable small mesh gear, in New Caledonian waters (Bruce 1990) have indicated that a moderately rich pontonine fauna is present in deep water in other regions of the Coral Sea and it is likely that suitable studies would provide an equally rich fauna from Australian waters.

Carapace length refers to the postorbital carapace length. Abbreviations used in the text: NTM, Northern Territory Museum, Darwin; QM, Queensland Museum, Northern Branch, Townsville.

SYSTEMATICS

Periclimenes franklini sp. nov.
(Figs 1-5)

Type material. 1 male, 2 females (1 ovig.) - CIDARIS 1, R.V. *Franklin*, Stn. 42-2, 17°

21.7'S. 146° 48.52'E, 296-302m depth, modified Ockelman-Pichon sledge, 15 May 1986, (ref. NW 145). The ovigerous female (W.13234) is designated as the holotype and the single male (W.13235) as allotype, and both are deposited in the collections of the QM. The non-ovigerous female paratype is dissected and deposited in the NTM (Cr. 006789).

Description. A medium sized shrimp, of slender, subcylindrical body form.

Carapace smooth, glabrous, with rostrum well developed, about 0.85 of carapace length in female, 0.97 in male, distinctly exceeding antennular peduncle, reaching to about level of tip of scaphocerite lateral tooth. compressed, very feebly up-curved, slender, acute; dorsal carina well developed, with seven long, acute, slender teeth, of decreasing size anteriorly, anterior to the posterior orbital margin, anteriormost tooth small, sub-apical in female, larger, post-apical in male; lateral carinae distinct, narrow, not posteriorly expanded; ventral carina well developed, with three acute teeth in female, four in male; supraorbital spines lacking, postorbital rostral carina well developed, with two large articulated spines, at about 0.70 and 0.90 of carapace length; orbital notch distinct, inferior orbital angle feebly produced, subacute, with reflected lower inner flange, antennal spine absent, hepatic spine large, slender, acute, laterally projecting, not reaching anterior margin of carapace,

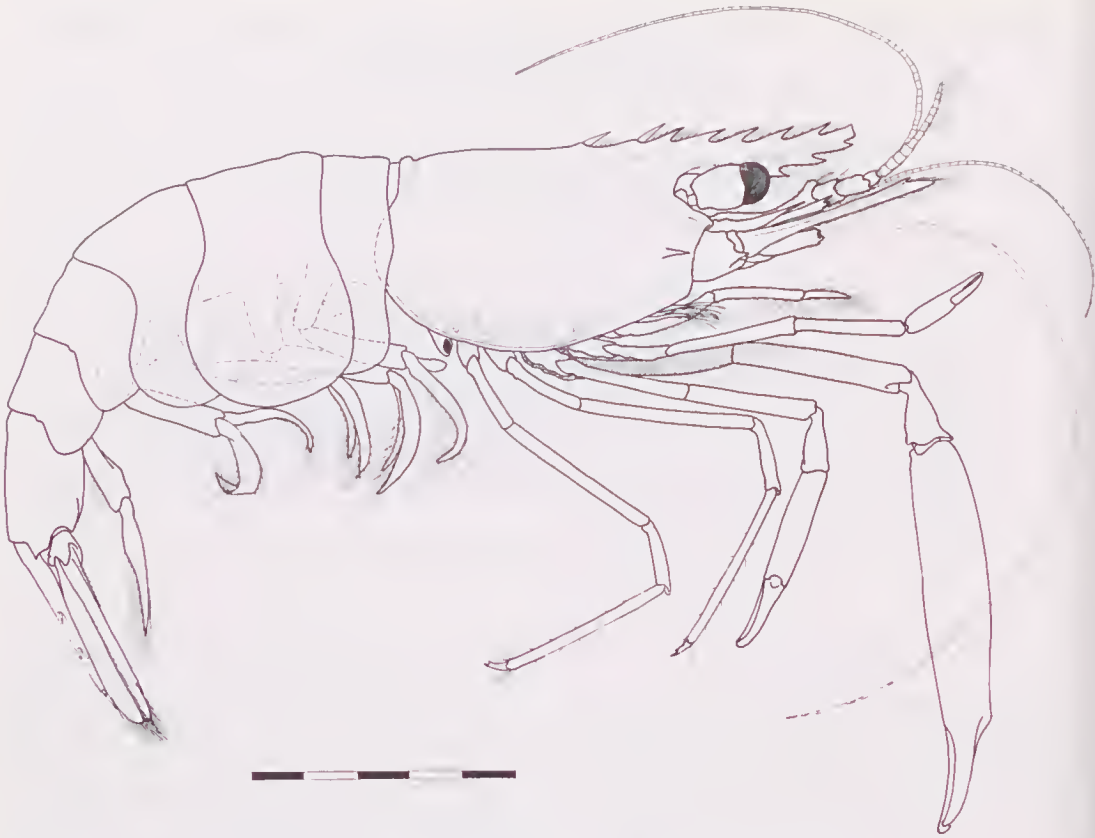

Fig. 1. *Periclimenes franklini* sp. nov., holotype female, Coral Sea. Scale bar in millimetres.

anterolateral branchiostegite not produced, bluntly angular.

Abdomen smooth, glabrous, third segment not posterodorsally produced, fifth segment about 0.66 of sixth segment length, sixth segment compressed, 1.5 times longer than central depth, posterolateral angle strongly produced, acute, posteroventral angle smaller, less acute, first three pleura bluntly rounded, enlarged in females, fourth and fifth feebly produced, posteriorly rounded. Telson slender, about 1.4 times sixth segment length, 4.0 times longer than anterior width, lateral margins straight, posteriorly convergent, slightly contracted proximally, with two pairs of large, subequal dorsolateral dorsal spines, about 0.65 of dorsal length, at about 0.45 and 0.7 of telson length, posterior margin subangular, with small median point, about 0.4 of anterior width, with three pairs of posterior spines, lateral spines shorter than dorsal spines, intermediate spines long, slender, about 9.0 times longer than basal width, 0.2 of telson length, submedian spines slender, setulose, 0.5 of intermediate spine length.

Eye well developed, with large, globular, well pigmented, slightly oblique cornea, with distinct small dorsal accessory pigment spot; stalk about as long as wide, slightly compressed.

Antennule with peduncle distinctly shorter than sephoecrite: proximal segment almost 2.0 times longer than proximal width, feebly tapering distally, with strong, acute, ventromedial tooth, distolateral margin produced, with rounded medial lobe, long slender lateral tooth, reaching to about 0.6 of intermediate segment length, styloecrite long, slender, reaching to about 0.8 of proximal segment length; statoecyst normal, with granular statolith; intermediate segment short, about 0.25 of proximal segment length, slightly narrower than dorsal length, with small setose lateral lobe, obliquely articulated with distal segment; distal segment about 1.1 times intermediate segment length, 1.7 times longer than wide; upper flagellum biramous, with proximal four segments of rami fused, shorter free ramus about 2.0 times fused portion length, with eight segments, about 13 groups of aes-

thetascus, longer ramus slender, filiform, about 1.75 times carapace length; lower flagellum slender, filiform, about 1.1 times carapace length, about 0.6 of longer upper ramus length, with about 30 segments.

Antenna with stout basicerite, with strong, acute lateral tooth; ischiocerite, merocerite normal; carpocerite short, stout, about 2.8 times longer than central width, slightly compressed, reaching to about distal margin of proximal segment of antennular peduncle, flagellum well developed, about 2.5 times carapace length; scaphocerite large, distinctly exceeding rostrum, about 3.3 times longer than broad, greatest width at about 0.3 of length, feebly tapered distally, distal end broadly, bluntly angular, far exceeding tip of stout distolateral tooth.

Ophthalmic somite without bec ocellaire; epistome unarmed; first three thoracic sternites moderately broad, unarmed; fourth with feebly bilobed transverse plate, without slender median process; fifth narrow, sixth to eighth broadening posteriorly, unarmed.

Mandible (right) with corpus normal, without palp; molar process robust, obliquely truncate distally, with six blunt marginal teeth, with small tuft of setae distoventrally; incisor process well developed, tapering distally, distal margin oblique, with three acute teeth, central tooth smaller, disto-medial margin with six minute denticles. Maxillula with bilobed palp, lower lobe slightly larger than upper, with small hooked seta ventrally; upper lacinia broad, with about 10 short, stout, simple spines distally; lower lacinia short, tapering, blunt, with numerous simple, spiniform setae. Maxilla with short stout, tapering palp, with few short plumose setae proximolaterally; basal endite deeply bilobed, lobes subequal, elongate, with about 11 slender, simple setae distally, proximal medial margin with single slender, simple seta; coxal endite obsolete, medial margin convex, glabrous; scaphognathite well developed, about 2.75 times longer than broad, posterior lobe about 1.4 times longer than broad, anterior lobe about 1.4 times longer than wide, medial margin concave. First maxilliped with elongate, subcylindrical, tapering, pointed, non-setose palp, exceeding distal margin of basis; basal endite large, broadly rounded, distal and medial margins with numerous slender, feebly setulose setae; coxal endite small, separated

from basal endite by small medial notch, sparsely setose; exopod well developed with large caridean lobe, flagellum slender, with five plumose distal setae; epipod large, triangular, feebly bilobed. Second maxilliped with normal endopod; dactylar segment about 3.25 times longer than wide, medial border with numerous short, stout, densely serrate spines and larger, slender serrulate setae; propodal segment broad, distomedially expanded, margin with six stout, feebly serrulate spines; carpus with distomedial angle acutely produced; ischiomerus without special features; basis elongate, feebly excavate medially; exopod well developed, flagellum with five plumose distal setae; coxa with small medial process, with simple setae; epipod subrectangular, without podobranch. Third maxilliped with endopod exceeding carpocerite by about 0.5 of distal segment; ischiomerus almost fully fused to basis, compressed, bowed and twisted, about 6.5 times longer than proximal width, expanded distomedially, distolateral margin feebly setose, with two small spines distally, ventrolateral margin with long finely setulose, spiniform setae, medial margin more densely setose, with numerous long spiniform setae, particularly distally, with 12 short, plumose, submarginal setae along proximal 0.5 of ventral border; penultimate segment subcylindrical, about 5.0 times longer than wide, feebly tapering distally, with groups of paired long, feebly setulose, spiniform setae medially, six long, spiniform setae laterally; distal segment about 0.5 of ischiomerus length, about 3.3 times longer than proximal width, tapering distally, lateral margin with 7-8 long spiniform setae, medial margin with about 10 groups of serrulate spines and longer spiniform setae; basis feebly angular medially, with few simple setae; exopod with slender flagellum, with five plumose distal setae; coxa feebly produced medially, with large suboval, distally angulate, lateral plate; with small quadrilamellar arthrobranch.

First pereopod exceeds carpocerite by chela and half carpus, and scaphocerite by finger of chela; chela with palm subcylindrical, feebly compressed, about 2.7 times longer than deep, with six transverse rows of short serrulate setae proximolaterally; dactyl about 0.75 of palm length, 4.0 times longer than proximal depth, tapering distally to strongly hooked tip, with sharp, entire edge over distal 0.75 of



Fig. 2. *Periclimenes franklini* sp. nov., paratype female. A, carapace, eye, antennal peduncles. B, anterior carapace, eye, antennal peduncles, dorsal view. C, anterior carapace and rostrum. D, antennule. E, antenna. F, eye. G, telson. H, same, posterior spines; inset, dorsal spine. I, uropod. J, same, distolateral exopod.

cutting edge; fixed finger similar, about 4.5 times longer than proximal depth; carpus about 1.1 times length of chela, 5.0 times

longer than distal width, tapered proximally, with numerous serrulate setae along distomedial margin; merus slender, subcylindrical,

about 1.1 times carpus length, about 8.5 times longer than wide; ischium about 0.6 of merus length, about 3.75 times longer than greatest

depth, narrowed proximally, distoventrally feebly carinate, setose; basis about 0.5 of merus length, 2.5 times longer than deep, dis-

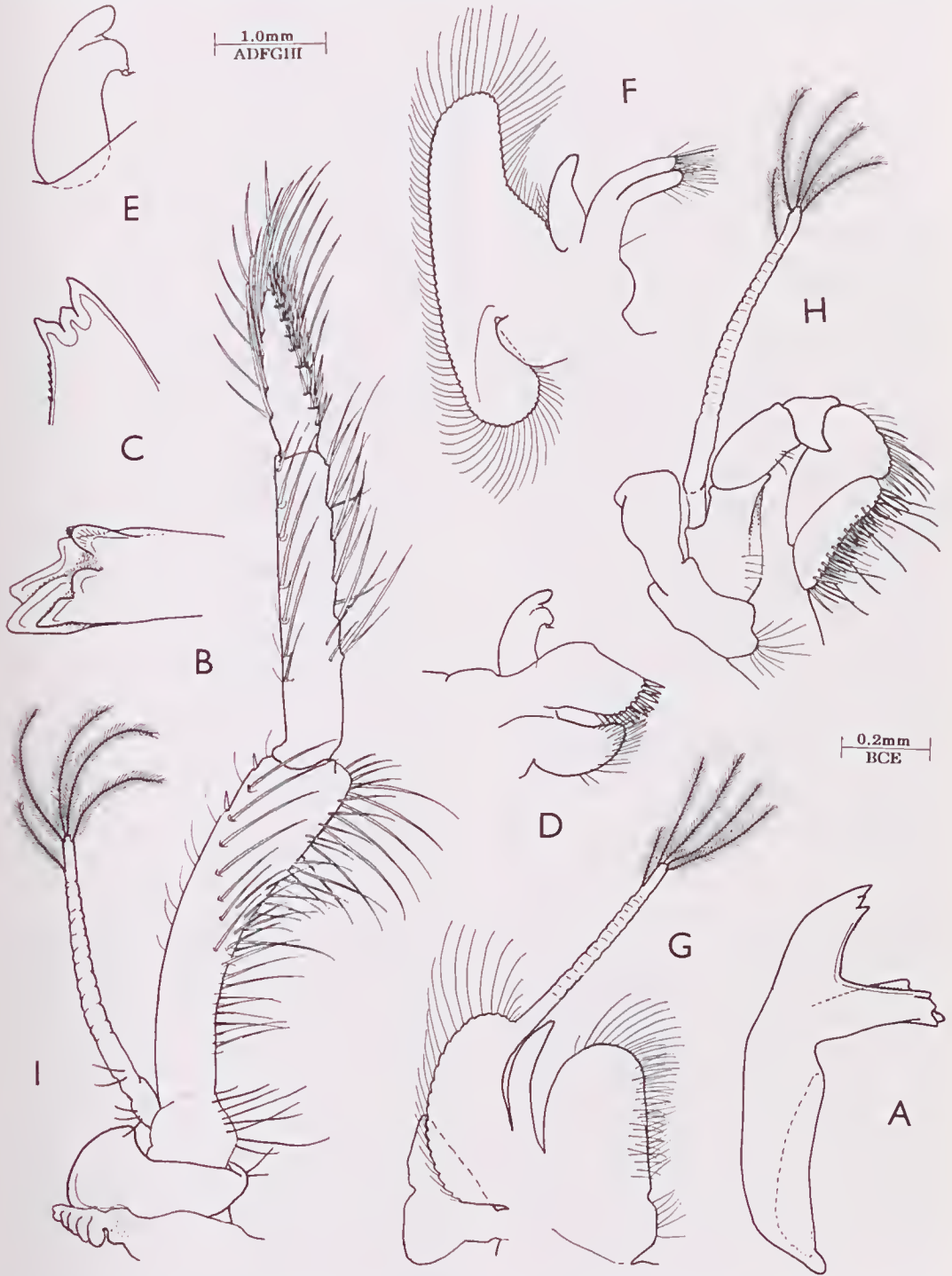

Fig. 3. *Periclimenes franklini* sp. nov., paratype female. A, mandible. B, same, molar process. C, same, incisor process. D, maxillula. E, same, palp. F, maxilla. G, first maxilliped. H, second maxilliped. I, third maxilliped.

toventrally feebly earinate, with small distoventral process. feebly setose; coxa robust, with small, setose, distoventral process.

Second pereopods well developed, markedly unequal; major chela (female) with merus reaching to about distal end of antennular peduncle, distal scaphocerite exceeded by 0.5 of carpal length, chela about 1.5 times earapace length, with palm very minutely tuberculate, subcylindrical, slightly swollen proximally, feebly compressed, about 4.0 times longer than deep; dactyl about 0.45 of palm length, about 4.0 times longer than proximal depth, with strongly hooked, acute tip, without lateral flange, cutting edge distally with feeble cutting edge, proximally with two large, robust, acute teeth, distal slightly larger than proximal, separated by U-shaped notch, with thick rimmed fossa proximally; fixed finger similar, with low acute tooth opposing U-shaped notch on dactyl, with low tricuspid tooth proximally; carpus about 0.3 of palm length, 1.5 times longer than distal width, distally expanded, unarmed; merus about 0.86 of palm length, 5.0 times longer than distal width, feebly tapered proximally, unarmed, without distoventral tooth; ischium subequal to merus length, more slender, about 6.5 times longer than distal width, feebly tapering proximally; basis and coxa normal, without special features. Minor second pereopod (female) about 0.73 of earapace length chela about 0.5 of major chela length, reaching to about 0.33 of the major chela palm length, exceeding carapocrite by distal half of carpus; chela with palm smooth, about 3.75 times longer than deep, slightly swollen proximally; fingers about 0.6 of palm length, slender, with strongly hooked tips, distal half with sharp cutting edge, proximal half with pair of low, subacute teeth, slightly smaller on fixed finger; carpus about 0.5 of palm length, 2.5 times longer than distal width, distally feebly excavate, unarmed; merus 2.0 times carpus length, 0.9 of palm length, 6.5 times longer than distal width, unarmed; ischium subequal to meral length, about 6.6 times longer than distal width, unarmed; basis and coxa normal, slender. Male specimen lacking major second pereopod, minor pereopod as in female; chela about 1.09 times earapace length.

Ambulatory pereopods slender; third exceeding scaphocerite by dactyl and distal fourth of propod, dactyl with corpus com-

pressed, about 2.4 times longer than proximal width, feebly tapering distally, ventral margin concave, with pair of distolateral setae, unguis feebly demarcated, acute, about 0.5 of dorsal length of corpus, 4.0 times longer than proximal width, slightly curved; distoventral accessory tooth stout, 0.5 of unguis length, 1.8 times longer than proximal width, gaping widely from unguis; propod about 6.4 times longer than dactyl, about 0.65 of earapace length, 12.0 times longer than deep, with long terminal and preterminal pairs of ventral spines, four single ventral spines, of decreasing size proximally, with numerous long simple setae, distally and along dorsal margin; carpus 0.4 of propod length, with distodorsal lobe, unarmed; merus about 0.95 of propod length, 11.0 times longer than wide, unarmed; ischium about 0.5 of merus length, 4.7 times longer than distal width, tapering proximally, unarmed; basis and coxa normal. Fourth pereopod similar to third, propod subequal to third propod length. Fifth pereopod similar to third, propod longer and more slender, about 1.1 of third propod length, 14.0 times longer than proximal width, with single distoventral spine, with two transverse distolateral rows of simple setae, ventral margin with one pair of spines, with five isolated ventral spines, distinctly smaller than third propod spines.

Male first pleopod with basipodite 2.0 times longer than broad, exopod about 1.2 times basipodite length, 5.0 times longer than central width; endopod about 0.5 of exopod length, about 3.0 times longer than wide, slightly expanded centrally, with small distomedial lobe, distolateral margin with 11 short feebly plumose setae, proximal third of medial margin with three long plumose setae proximally, four very short simple curved spines distally. Male second pleopod with basipodite about 2.1 times longer than broad, 1.2 times first pleopod basipodite length, exopod about 4.6 times longer than broad, 1.2 times basipodite length, endopod 0.93 of exopod length, 6.0 times longer than broad, with appendices at 0.27 of medial margin length; appendix masculina with corpus subcylindrical, tapered proximally, about 6.5 times longer than distal width, reaching to about 0.5 of endopod length, with three simple distal spines, two long, one short, dorsolateral margin with four simple spines, three long, proximal spine short; appendix interna slen-

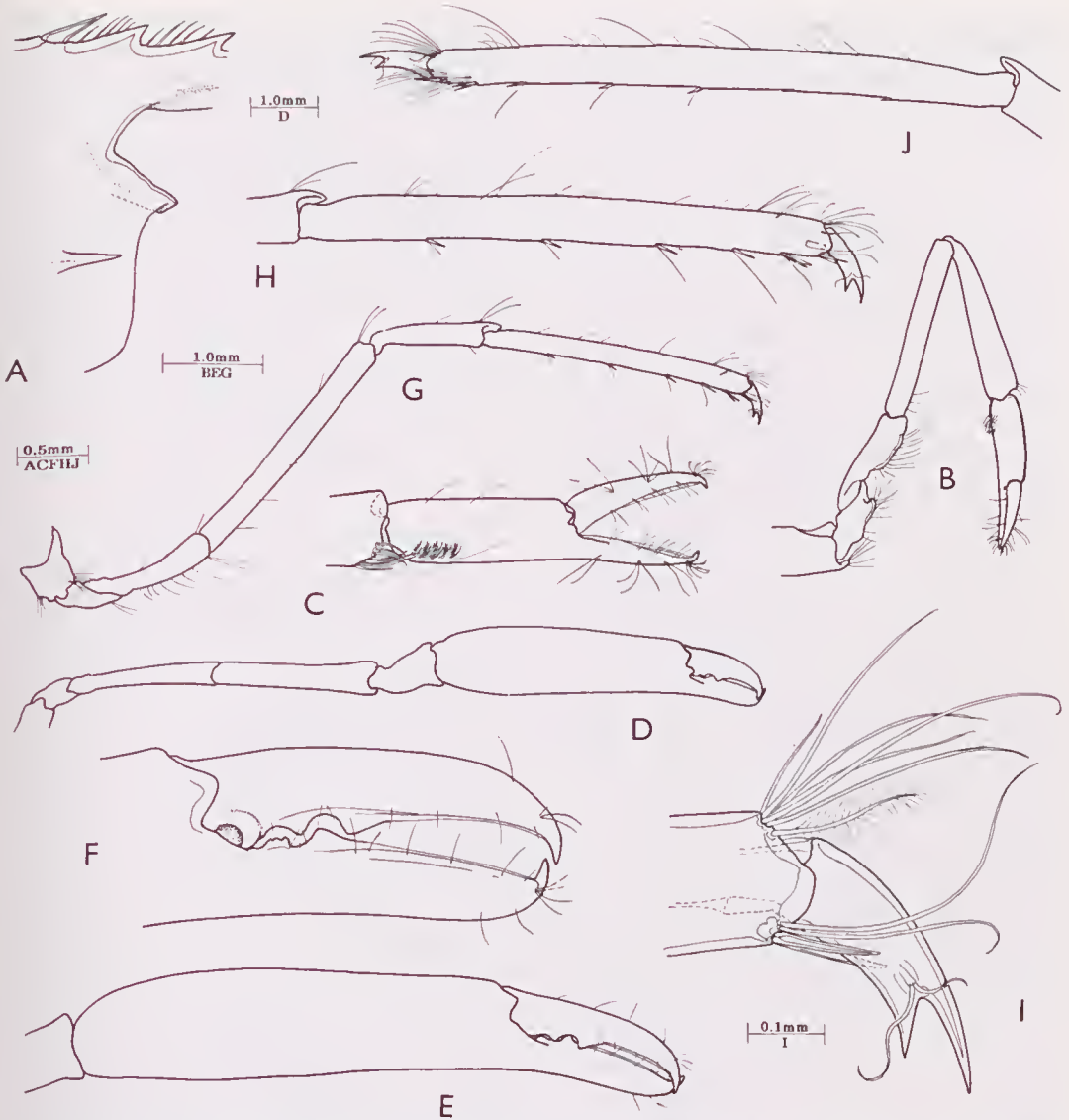

Fig. 4. *Periclimeses franklini* sp. nov., paratype female. A, orbital region, lateral. B, first pereiopod. C, same, chela. D, major second pereiopod. E, same, chela. F, same, fingers. G, third pereiopod. H, same, propod and dactyl. I, same, dactyl. J, fifth pereiopod, propod and dactyl.

der, slightly swollen distally, with few cincinnuli, distinctly exceeding corpus of appendix masculina.

Uropod with protopodite short, with blunt posterolateral lobe; exopod broad, subequal to telson length, 3.0 times longer than wide, greatest width at 0.6 of length, lateral margin feebly convex with large, acute distolateral tooth, with longer, slender, mobile spine medially, distal lamella broad, separated by distinct diaeresis; endopod 0.92 of exopod length, 3.6 times longer than broad, greatest width at 0.3 of length.

Ova small, single ovigerous female with only three undeveloped ova.

Measurements (mm). Holotype female: carapace length, 5.25, carapace and rostrum, 8.84; total length (approx.) 22.0+; major chela, 8.6; minor chela, 3.75. Allotype male: carapace length, 4.0; carapace and rostrum, 8.0; total length (approx.), 19.5; minor chela, 4.35. Paratype female: carapace length, 4.6; carapace and rostrum, 8.4; total length (approx.), 21.0; major chela, 6.15. Length of ovum, 0.75.

Colouration and host. Unknown.

Systematic position. *Periclimenes franklini* is most closely related, amongst Indo-West Pacific species of *Periclimenes*, only to

P. gorgonicola Bruce, 1969, which is the only other species so far described lacking an antennal spine. These two species are closely similar in their general morphology, but *P.*

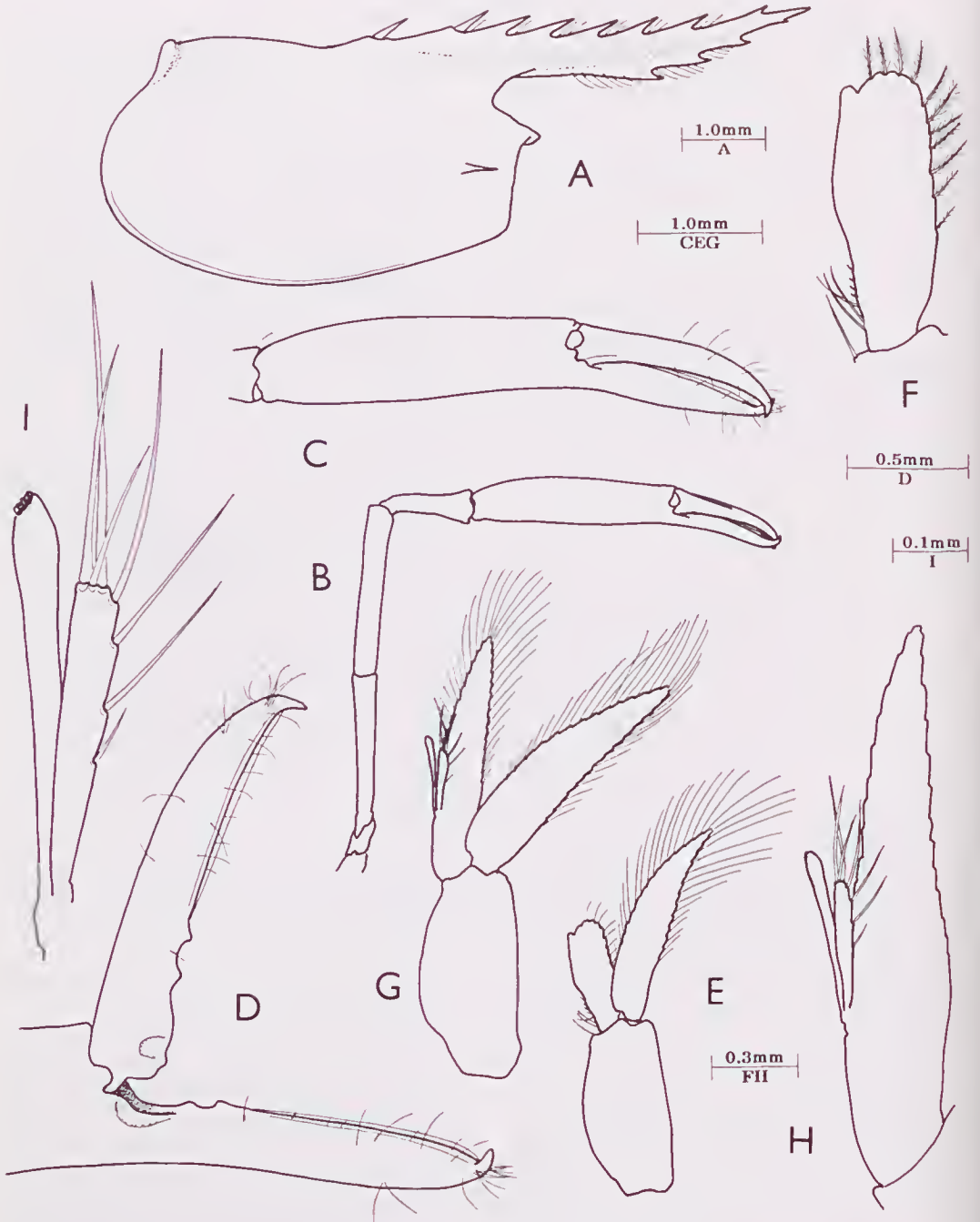

Fig. 5. *Periclimenes franklini* sp. nov., allotype male. A, carapace and rostrum. B, minor second pereiopod. C, same, chela. D, same, fingers. E, first pleopod. F, same, endopod. G, second pleopod. H, same, endopod. I, same, appendix masculina and appendix interna.

franklini may be readily distinguished from *P. gorgonicola* by the presence of the two large, articulated postrostral spines on the carapace, which are replaced by smaller, non-articulate teeth in the latter species, in which the stylocerite is also less elongate, reaching only to the middle of the length of the proximal segment of the antennular peduncle. In *P. gorgonicola*, the morphology of the inferior orbital angle is identical, and the fourth thoracic sternite also has a notched, transverse plate, exactly as in *P. franklini*.

Etymology. The specific epithet is given in recognition of the contribution of the CSIRO Research Vessel 'Franklin' to knowledge of Australia's benthic deep-sea fauna.

DISCUSSION

Periclimenes franklini, together with *P. gorgonicola*, appears to occupy an isolated position in the genus *Periclimenes*, although closely related to some of the other deep-water species. They do not appear to be closely related to *P. longicaudatus* (Stimpson, 1860) a Caribbean-west Atlantic species that also lacks an antennal spine. The systematic importance of the antennal spine appears to be considered less important than that of the hepatic spine, and supraorbital and epigastric spines may be present or absent in the genus *Periclimenes*. The loss of the hepatic spine would indicate a position in some other genus, such as *Philarius* Holthuis. Re-evaluation of the genus *Mesopontonia* Bruce, 1969, shows that it is closely related to species of *Periclimenes*, particularly *P. franklini* and *P. gorgonicola*. *Mesopontonia gorgonioplila* closely resembles *P. franklini* in its general morphology, particularly in the orbital region, and the postrostral carina also has two articulated spines instead of fixed teeth. Indeed, the genus *Mesopontonia* could readily have evolved from a *Periclimenes* species, such as *P. franklini* by the simple loss of the exopod of the third maxilliped. *Mesopontonia* appears much less closely related to the other genera that lack the third maxilliped exopod, such as *Pontonides* in the Indo-West Pacific, and numerous Atlantic-Mediterranean genera. *Periclimenes franklini* does show slight but significant reduction in the size of the exopod of the third maxilliped, when compared with those of some other deep-sea *Periclimenes* species. In *P. foresti* Bruce, 1981, for ex-

ample, the exopod reaches to the distal margin of the merus of the endopod, is broader, with numerous plumose setae distally. In both *P. foresti* and *P. foveolatus* Bruce, 1981, the antennal spine is small and marginal, in comparison with many other *Periclimenes* species, suggesting a process of obsolescence.

Periclimenes longicaudatus (Stimpson) appears to be a member of the *P. aesopius* species group, and records of its occurrence in the Indian Ocean should probably be referred to *P. holthuisi* Bruce, 1969, or related species. Its inferior orbital angle is more strongly produced and knob-like; the rostrum, which has the upper margin convex, with a dentition of 1 + 6-8/(0) 1-2; second pereopods with chelae subequal, similar, and ambulatory dactyls long and slender, so that it is readily distinguishable from both *P. franklini* and *P. gorgonicola*.

Periclimenes gorgonicola is a known associate of gorgonians of the genera *Melithea* and *Acabaria*. *Mesopontonia* has been found in association with the same genera, both in the northern South China Sea (Bruce 1979), which suggests that *P. franklini* may be involved with similar coelenterate associations.

A key for the identification of the deep-water Indo-West Pacific species of the genus *Periclimenes* has been provided by Bruce (1990). *Periclimenes franklini* can be readily included in this key by the insertion of the following modification. The addition of *P. franklini* raises to 21 the number of Indo-West Pacific *Periclimenes* species known to occur in depths of 100 m or more.

1. Antennal spine present 1a
- Antennal spine absent 1b
- 1a. First and second postrostral teeth acute and non-articulate; R. 2+ 8/4
 *P. gorgonicola* Bruce, 1969
- First and second postrostral teeth replaced by large, slender, articulated spines; R. 2 + 6-7/ 3-4*P. franklini* sp. nov.

ACKNOWLEDGEMENTS

I am most grateful to Dr. M. Pichon, for the opportunity to report on these specimens from the R.V. *Franklin* CIDARIS Expedition.

REFERENCES

- Balss, H. 1913. Diagnosen neuer ostasiatischer Macruren. *Zoologischer Anzeiger* 42:234-239.

- Bruce, A.J. 1967. Notes on some Indo-Pacific Pontoniinae. III - IX. Descriptions of some new genera and species from the western Indian Ocean and the South China Sea. *Zoologische Verhandelingen (Leiden)* 87:1-73.
- Bruce, A.J. 1969. Preliminary descriptions of sixteen new species of the genus *Periclimenes* Costa, 1844 (Crustacea, Decapoda Natantia, Pontoniinae). *Zoologische Mededelingen (Leiden)* 43(20):253-278.
- Bruce, A.J. 1979. Records of some pontoniine shrimps from the South China Sea. *Cahiers de l'Indo-Pacifique* 1(2):215-248.
- Bruce, A.J. 1981. Decapod Crustacea: Pontoniinae. Résultats du Campagnes MUSORSTOM. 1. Philippines (18-21 mars 1976) 1(8). *Mémoires ORSTOM* 91:189-215.
- Bruce, A.J. 1983. The pontoniine shrimp fauna of Australia. *Australia Museum Sydney Memoirs* 18:195-218.
- Bruce A.J. 1990. Crustacea: Decapoda: Palaeomonoidca; Deep-Sea Shrimps from New Caledonian Waters. Résultats des Campagnes MUSORSTOM 6. *Mémoires du Muséum National d'Histoire Naturelle (A)* 145:149-215.
- Kemp, S. 1922. Notes on Crustacea Decapoda in the Indian Museum. XV. Pontoniinae. *Records Indian Museum* 24:112-288, pls 3-9.
- Stimpson, W. 1860. Prodrromus descriptionis animalium evertebratorum quae in Expeditione ad Oceanum Pacificum Septentrionalem a Republica, Federato missa, C. Ringgold et J. Rogers Ducibus, Observavit et descripsit. *Proceedings of the Academy of Natural Sciences of Philadelphia* 1860: 22-48.

Accepted 17 November 1989

A NEW SPECIES OF *RHABDEREMIA* TOPSENT (PORIFERA: DEMOSPONGIAE) FROM THE GREAT BARRIER REEF

JOHN N.A. HOOPER

*Northern Territory Museum of Arts and Sciences
GPO Box 4646, Darwin NT 0801, Australia.*

ABSTRACT

A new species of *Rhabderemia* is described from a fringing coral reef habitat in the Whitsunday Islands Group, Great Barrier Reef, bringing the total number of species known for the genus to 16, although this is only the second record of the genus in Australian waters. The genera *Rhabderemia* Topsent, *Rhabdosigma* Hallmann, and *Nisibaris* de Laubenfels are merged, and the family Rhabderemiidae is defined in the order Poecilosclerida. A key and synonymy of the described species is given, and preliminary phylogenetic and zoogeographic analyses of species are made. Two groups of species are indicated, differentiated by skeletal construction (hymedesmoid-plumose and reticulate skeletons), and there also appears to be two zoogeographically disjunct groups of species separated into the Atlantic and Indo-Pacific systems.

KEYWORDS: Porifera, Demospongiae, Poecilosclerida, Rhabderemiidae, *Rhabderemia*, new species, coral reef, Great Barrier Reef, taxonomy, cladistics, zoogeography.

INTRODUCTION

Recent collections throughout Australian shallow coastal waters by the Australian Institute of Marine Science Bioactivity Unit, Townsville, discovered a species of sponge new to science, inhabiting a fringing coral reef in the Whitsunday Islands, Queensland. This new species is only the second record for the genus *Rhabderemia* Topsent in Australia, and brings the total number of species known for the genus to 16. The species is described and illustrated below, and a key to species is also given. A preliminary investigation on the zoogeography and phylogenetic relationships between species is made, based mostly on descriptions from the literature.

Methods of spicule preparation for light and scanning electron microscopy are described elsewhere (Hooper 1986). A phylogenetic analysis of species was produced using the computer-generated cladistic routine (PAUP; Swofford 1985), which produced minimum length trees under the principle of maximum parsimony, inferring plesiomorphy by out-

group comparisons. A taxonomic key was constructed using ordered binary and multistate characters utilizing the DELTA computer system (Dallwitz and Paine 1986). Abbreviations used in the text and in Appendix 1 are as follows: AIMS, Australian Institute of Marine Science, Townsville; AM, Australian Museum, Sydney; BMNH, British Museum (Natural History), London; CMFRI, Central Marine Fisheries Research Institute, Mandapam Camp, India; ICZN, International Code of Zoological Nomenclature; IM, Indian Museum, Calcutta; MNHN, Muséum National d'Histoire Naturelle, Paris; MOM, Musée Océanographique de Monaco, Monaco; NCI, National Cancer Institute of the United States, Shallow Water Marine Organism Contract, Australian Institute of Marine Science Bioactivity Unit, Townsville; NM, Natal Museum, Pietermaritzburg; NMNZ, National Museum of New Zealand, Wellington; NTM, Northern Territory Museum, Darwin; SM, Musée Zoologique, Strasbourg; SMF, Natur-Museum und Forschungsinstitut Senckenberg, Frankfurt.

SYSTEMATICS

Order Poecilosclerida Topsent
Family Rhabderemiidae Topsent

Rhabderemiidae Topsent, 1928:64, 309.

Diagnosis. Poecilosclerida with monoactinal choanosomal rhabdostyles forming hymedesmoid, microcionid-plumose, or plumoreticulate skeletal structures usually with poorly developed spongin fibres. Microscleres include toxiform, sigmoid and microstylote spicules.

Remarks. The definition of Rhabderemiidae given above is from contemporary authors (Lévi 1973; Bergquist 1978; Hartman 1982). The family shows some similarities with the Bubaridae (e.g. *Bubaris* Gray), but it may be most closely related to the Raspailiidae (e.g. *Hemectyonilla* Burton). The rhabderemiids are excluded from the Raspailiidae in having sigmoid, toxiform and microstylote microscleres, whereas most raspailiids lack microscleres, or when present they consist only of raphides. Rhabderemiids also lack any evidence of an extra-axial skeleton, but this feature is not always obvious in many raspailiids either (Hooper, in press). Although typical raspailiids such as *Raspailia* Nardo have well differentiated axial and extra-axial skeletons, others such as *Echinodictyum* Ridley have simply reticulate skeletons, but generally in the Raspailiidae there is always at least some remnants of an extra-axial skeleton. Although some degree of relationship is inferred between these two families, with vague similarities appearing in skeletal architecture and the presence of rhabdostyles in genera of both (e.g. *Rhabderemia* and *Heterectya* Hallmann, respectively), the status of this monogeneric family is uncertain. The spined microscleres discovered in the new species described below are quite unusual, but it is quite likely that they may occur in other species of *Rhabderemia*, and these may eventually be found through extensive SEM studies of other material.

Rhabderemiidae is currently assigned to the polyphyletic order Axinellida, although in the past it has been included with both the Poecilosclerida (e.g. Topsent 1928) and Hadromerida (in the family Spirastrellidae) (de Laubenfels 1936; Bergquist 1968). The family is returned here to the Poecilosclerida on the basis of its

monoactinal choanosomal megascleres and the diversity and geometry of microscleres.

Genus *Rhabderemia* Topsent

Rhabderemia Topsent, 1890:28; Topsent 1892a:115; Dendy 1905:180; Topsent 1928:309; de Laubenfels 1936:144; Lévi 1973:606.

Rhabdosigma Hallmann, 1916:520; Hallmann 1917:398; Topsent 1928:312; de Laubenfels 1936:144 [type species *Sigmavinnella mammillata* Whitelegge, 1907:512, by original designation].

Nisibaris de Laubenfels, 1936:144 [type species *Hallmannia spirophora* Burton, 1931:352, by original designation].

Hallmannia, in part, Burton, 1930:352.

Not *Hallmannia* Burton, 1930:519 [type species *Bienna aruensis* Hentschel, 1912:352, by monotypy].

Type species. *Microciona pusilla* Carter, 1876:239, by subsequent designation (Dendy 1905:180).

Diagnosis. Encrusting, massive or lobate-branching sponges. Choanosomal architecture varies from hymedesmoid, to plumose, to reticulate. Spongin fibres are typically poorly developed and cored by diverging tracts of rhabdostyles. Rhabdostyles may have spined or smooth shafts, or both, and if present spines usually occur at the distal end of spicules. Microscleres include sigmoid spicules (either contort sigmas or true sigmas), microstyles (including both true forms and toxa-like thraustoxeas), and true toxas, all of which may be smooth or microspined.

Remarks. Topsent (1892a) initially created *Rhabderemia* for encrusting species which had smooth (*s.s.*) or microspined rhabdostyles producing erect-hymedesmoid or plumose-microcionid skeletal columns, and diverse microscleres consisting of contort sigmas, thraustoxeas (spined spicules which are doubly-bent in the middle or centrotylote), smooth or spined microstyles, and toxas. A number of other species were subsequently described with similar characteristics, differing mainly in the size and spination of megascleres, and the presence or absence of particular categories of microscleres. Hallmann (1916) established *Rhabdosigma* for a species which closely resembled *Rhabderemia*, but had an erect growth form, a reticulate spongin skeleton, a plumoreticulate spicule skeleton in

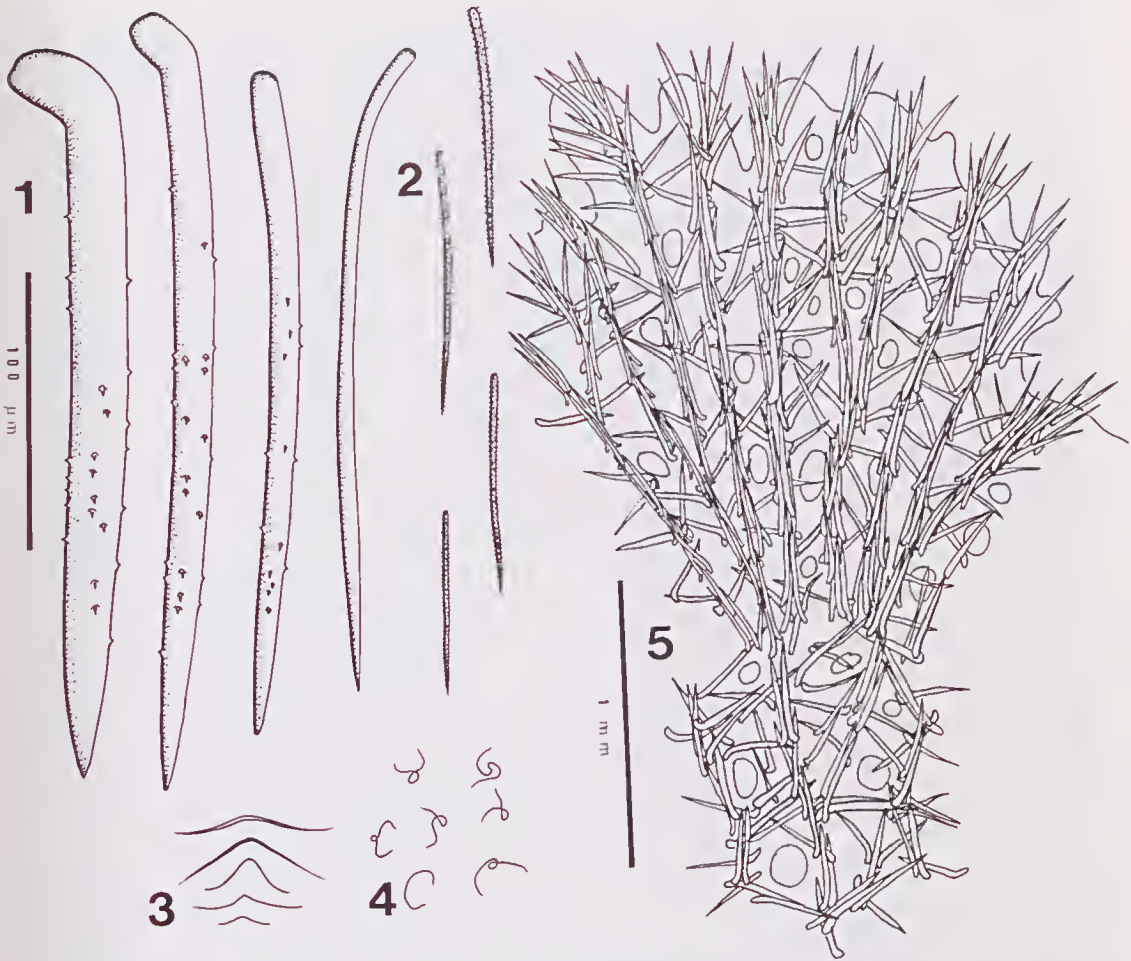

Figs 1-5. *Rhabderemia sorokinae*: 1, rhabdostyles; 2, microspined microstyles; 3, toxas; 4, contort sigmas with rare non-contort forms; 5, section through peripheral skeleton.

which rhabdostyles cored spongin fibres in diverging plumose brushes (not echinating fibres as indicated by Hallmann), and with true (not contort) sigmas as the only microseleres. These sigmas appear to be smooth under light microscopy, but like the species described below it is possible that they too are minutely microspined. Until SEM studies of this species are completed the genus is used in the sense of Hallmann (1916).

Topsent (1928) discounted the differences in skeletal structure between *Rhabderemia* and *Rhabdosigma* as unimportant, and he suggested that they were probably merely related to variations in growth form. But he also suggested that the latter genus could be differentiated from *Rhabderemia* s.s. in lacking microstyles, thraustoxeas and toxas. However,

this system is not accepted here, as the loss of one or more categories of microseleres can be construed as a simple reduction. Similarly, several species of *Rhabderemia* have since been described with reticulate architecture and with typical microseleres. Thus the only character which can reliably separate the two genera is the possession of contort versus true sigmas.

Burton (1930) established the genus *Hallmannia* for *Biemna arnensis* from the Arafura Sea, but then again (1931:352) he re-designated the type species as *H. spirophora*. De Laubenfels (1936) noted correctly that such an action was invalid under the terms of the (then existing) ICZN, and as such he renamed Burton's (1931) genus *Nisibaris*. *Hallmannia* in the strict sense is a lipochelous *Mycale* (*B.*

aruensis, holotype SMF 958, has subdermal rosettes of microstyles, a fistulose growth form, and longitudinal tracts of subtylostyles), whereas *Hallmannia* in the sense of Burton (1931) (= *Nisibaris*) is a clear synonym of *Rhabdermia*. Burton (1931) also suggested that *H. spirophora* was most closely related to the Trachyeladiidae, because both had contort, spined sigmoid-like spicules, but this comparison may be inappropriate. Sigmoid microscleres in *Trachycladus* are vermiform and true sigmaspires, and they appear to be quite different from the contort sigmas of *Rhabdermia*.

The type species designation of *Rhabdermia* is still slightly confused, and requires brief discussion. Topsent (1892a) assigned three species to the genus upon its conception, one of which was described by him as new, but he did not nominate a type species. Dendy (1905) subsequently designated the first-named species of Topsent, *R. pusilla*, as the type of the genus, which thus invalidates de Laubenfels's (1936:144) subsequent designation of *R. guernei*. However, Dendy (1905) also notes that Carter did not originally intend to propose the name *R. pusilla* for this species, but rather he intended to use the name *R. minutula* (Carter 1876:p.239 cf. p.479), and Carter (1880:44) formally emends the species name. This is interpreted as a justified emendation (ICZN Article 19, 33bii), and the type species of *Rhabdermia* is therefore correctly cited as *R. minutula*. Subsequent references to *R. pusilla* (e.g. Hallmann 1917; Dendy 1922; Thomas 1968; van Soest 1984) are erroneous.

***Rhabdermia sorokiniae* sp.nov.**
(Figs 1-12, Plate 1a-b, Table 1)

Type material. HOLOTYPE - NTM Z3580: northern end of Deloraine Island, Whitsunday Is, Great Barrier Reef, Qld. 20° 09'S, 149° 04.5'E, 20 m depth, 15 October 1987, coll. S. Sorokin and NCI (NCI Q66C-0811-V).

Habitat. Found in a crevice on a dead coral head of a fringing coral reef, on the edge of a steep drop-off (Plate 1A).

Description. Shape: Thickly encrusting clump, approximately 22 x 10 cm, composed of lobate-bulbs scattered over the dead coral surface (Plate 1A).

Oscula: Large oscula are raised above the surface of the sponge on conical membrane-

ous pedicels, and these appear to be confined to the upper external surfaces of lobes (Plate 1B). Minute ostia (<0.5 mm diameter) are numerous and evenly distributed over the upper (exposed) surface of lobes, with a few slightly larger examples situated within shallow exhalant drainage canals (Plate 1B).

Colour: Live colouration is yellow-brown alive (Munsell 2.5Y 8/6; Plate 1B) and slightly darker in ethanol.

Texture: Sponge consistency is relatively soft, easily compressible and easily torn.

Surface: The surface is macroscopically even *in situ*, but minutely hispid, even shaggy in places in preserved material, produced by the terminal choanosomal spicule brushes. Scattered over lobes are evenly rounded bumps and bulbs, and the sponge appears insubstantial due to the numerous small oscula

Table 1. Comparison between published records of all described species of *Rhabdermia*, showing extreme ranges of spicule dimensions denoted as length x width (where known). All measurements are given in micrometres. Refer to Appendix 1 for sources of information. Key to symbols: e=encrusting, l=lobedigitate, b=lobate-bulbous, * denotes that measurements were taken from the material examined (otherwise they were taken from the literature).

SPECIES	CHARACTER					
	Growth form	Rhabdostyles	Microstyles	Thraustoxeas	Toxas	Sigmas
<i>R. acanthostyla</i>	e	1:84-258 x2-4 11:109-315 x6-12	absent	absent	absent	12-25
<i>R. bistylifera</i> *	e	120-317 x2-5.5	1:30-40x0.2 x0.5-1 11:110-130 x0.5-1.5	absent	absent	5-12 x1-1.5
<i>R. coralloides</i>	l	340 x34	40 x2	32 x2.6	absent	8
<i>R. fascicularis</i> *	e	122-358 x8-17	absent	28-73 x1.5-3.5	absent	9-17
<i>R. guernei</i> *	e	183-473 x5-15	65-112 x1-2	45-75 x2.5-4	absent	18-32 x1-2
<i>R. indica</i>	e	230-315 x3.5-10.5	42-49 x0.7-2	absent	absent	6.3-12
<i>R. intexta</i> *	e	150-350 x9-14	absent x0.5-1	absent	absent	1:6-16 11:28-60 x1-2
<i>R. mammillata</i> *	l	126-302 x5-8.5	absent	absent	absent	1:9-13 x1-2 11:24-42 x1.5-4 x0.5-1.5
<i>R. minutula</i> *	e	1:45-75 x4-6 11:170-480 x10-17	1:30-55 x0.5-1 11:88-177 x1-3	absent	absent	8-16.4 x0.5-1.5
<i>R. mutans</i> *	l	190-306 x14-28	32-88 x1-2	37-79 x1-2	absent	10-13 x1-2
<i>R. prolifera</i>	e	90-210 x4-8.2	82-147 x1-2	absent	absent	12-12.3
<i>R. sorokiniae</i> *	b	178-283 x3-22	53-96 x0.8-2	absent	18-72 x0.4-1.2	6-15 x0.5-1.2
<i>R. spinosa</i> *	e	134-327 x4-15	20-35 x0.5-1.5	27-39 x1.5-4	absent	6-13 x0.5-1
<i>R. spirophora</i> *	b	215-288 x5-9	32-51 x1-2	absent	absent	3-8 x0.5-1
<i>R. stellata</i>	e	200-356 x12-23	36-48 x3-4.3	absent	absent	10.6-17
<i>R. toxigera</i> *	e	225-407 x7-11	53-63 x1-2	absent	37-57 x1-2.5	5-11 x0.5-2

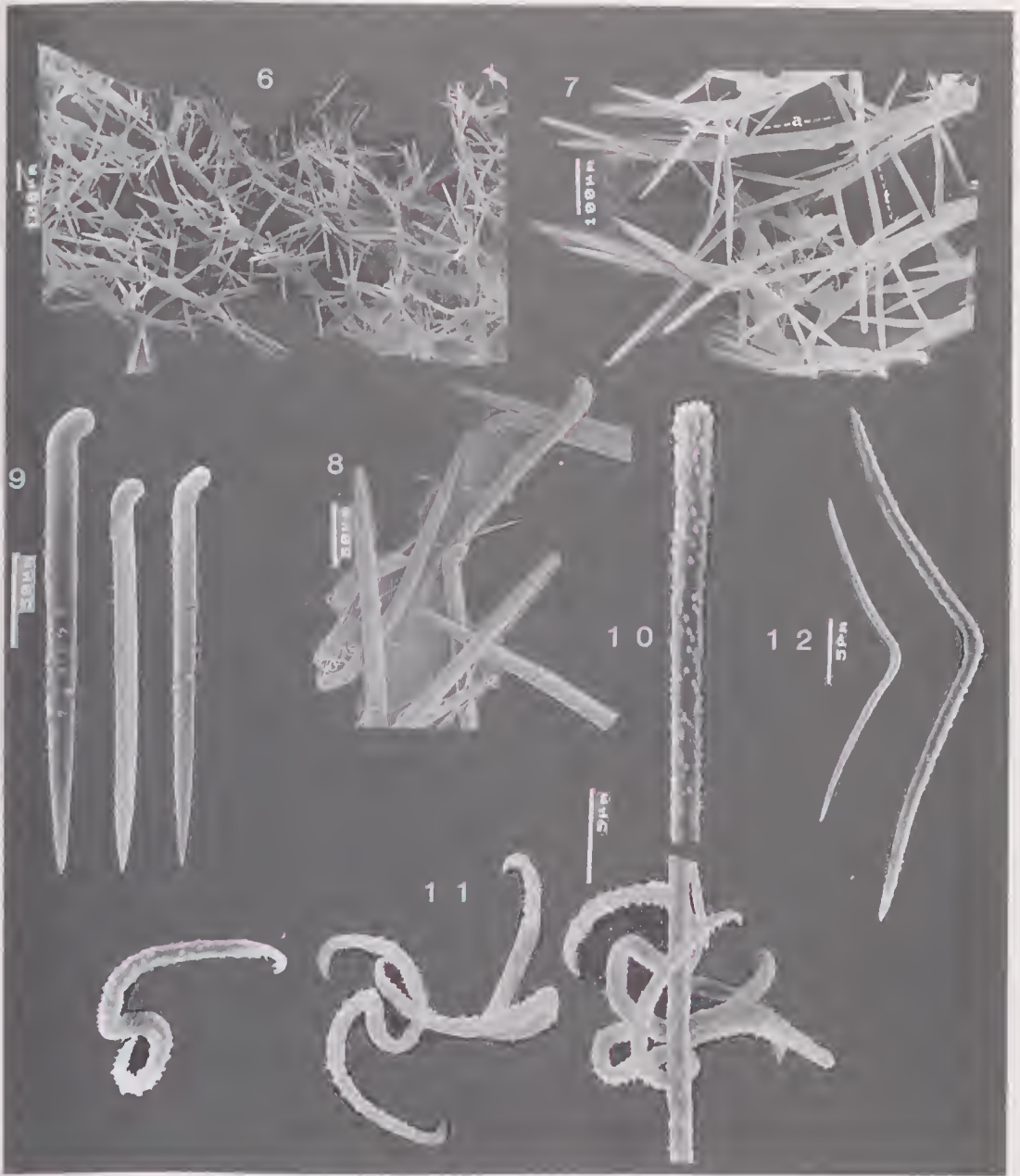

Figs 6-12. Scanning electron micrographs of the skeleton of *Rhabdermia sorokinae*: 6, plumo-reticulate skeletal structure; 7, plumose ascending multispicular tracts (a), and transverse unispicular tracts (t), forming isodictyal meshes; 8, groups of rhabdostyles, microstyles, toxas and sigmas; 9, rhabdostyles; 10, spined microstyles; 11, spined sigmas; 12, sparsely spined toxas.

scattered over the surface. Most bulbous lobes are excavated by one or more shallow drainage canals. Membraneous pedicels on which oscula are raised, seen in live material (Plate 1b), collapse upon preservation.

Ectosome: The ectosomal skeleton is membraneous, without any specialized spiculation, but a prominent feature of this region is

the protruding spicule brushes from the primary choanosomal tracts (Fig. 6). These tracts of rhabdostyles diverge near the surface, becoming increasingly plumose, and spicule brushes may extend for up to 400 µm from the surface. Spicule brushes of the peripheral skeleton are loosely bound together with heavy granular type B spongin. This ectosomal

spongin contains numerous irregularly scattered microstyles, but these also occur in equally heavy concentrations elsewhere in the skeleton.

Choanosome: The choanosomal skeleton is plumo-reticulate. There is no trace of axial compression of the skeleton, but in the centre of each lobate bulb the spicule tracts form regular or irregularly reticulate, triangular or square isodictyal meshes, up to 180 μm in diameter, bounded on all sides by uni-, pauci- or multispicular tracts of rhabdostyles (Fig. 7). Spongin fibres are poorly invested in type A spongin, but spicule tracts also have heavy deposits of spongin B surrounding them, and these deposits are particularly heavy in the axis of the skeleton. In the extra-axial region of the choanosomal skeleton, towards the periphery, spicule tracts become clearly separated into primary ascending multispicular tracts, with 3-6 spicules in each row, and secondary transverse unispicular components, one or two spicules in length. Transverse spicules and spicule tracts diverge from the ascending fibres at angles of 30-90°, and these could be interpreted as echinating spicules (c.g. Hallmann 1917). However, most of these transverse secondary spicule tracts in the extra-axial skeleton interconnect with the adjacent primary ascending fibres, producing a vaguely isodictyal reticulation, whereas at the periphery they are clearly plumose, so the term "echinating" may be misleading. Choanocyte chambers are oval, 150-260 μm in diameter. The mesohyl matrix is very heavily invested with dark brown type B spongin, which contains numerous microscleres.

Megascleres: Choanosomal rhabdostyles are relatively robust, thick, with rhabdose bases bent at between 35-70° from the shaft, evenly rounded, unspined, and never contort; occasionally styles are seen without rhabdose bases, but these are rare. The apex varies from fusiform sharply pointed in smaller spicules to hastate-pointed in larger examples, and the shaft usually contains a sparse scattering of small spines in the distal two-thirds of the spicule (Fig. 9): 178-(235.1)-283 x 3-(14.0)-22 μm .

Microscleres: Microstyles are relatively long, thin, sometimes straight but usually with a flexuous bend near the middle, with a slightly subtylote base, tapering to sharp raphidiform

points. Microstyles have prominent microspination over their shafts and rounded bases, like other members of the genus, but these spines appear only as a slight roughening of the surface under light microscopy, whereas higher magnification clearly shows individual spines (Fig. 10): 53-(82.4)-96 x 0.8-(1.5) 2.0 μm .

Toxas are sparsely microspined (Fig. 12), small, thin, ranging from v-shaped to forms with a gentle central curvature and reflexed arms: 18-(39.4)-72 x 0.4-(0.9)-1.2 μm .

Sigmas are small, thin, contort, usually with a central curl, but occasionally they are regularly c-shaped. Sigmas are shown to be smooth under light microscopy, but higher magnification reveals prominent microspination, as for microstyles and toxas (Fig. 11): 6-(12.2)-15 x 0.5-(0.8)-1.2 μm .

Etymology. This species is named in honour of Shirley Sorokin, marine biologist with the NCI shallow-water collection project, Australian Institute of Marine Science Bioactivity Unit, who was the original collector of the species, and in encouragement to continue working on Porifera.

Remarks. The discovery of this species from the Great Barrier Reef is only the second record for the genus in Australian waters. The new species also shows some affinities with the other Australian representative, *R. mammillata*. These apparent affinities are based on the presence of similar skeletal architecture, similar geometry and size of rhabdostyles. Growth form is also similar, with *R. mammillata* being an erect lobodigitate sponge with a short stalk, whereas *R. sorokiniae* has a lobate-bulbous shape, but microscleres are quite different. *Rhabderemia mammillata* has two size categories of and normally formed c- and s-shaped sigmas, whereas those of *R. sorokiniae* are microspined, predominantly contort with very few normally-formed ones, and the new species also has microspined microstyles and toxas. The only other species with true toxa microscleres is *R. toxigera* from the Mediterranean, but that species is encrusting, the toxas and microstyles appear to be smooth (under light microscopy at least), and it has entirely smooth and much larger rhabdostyles (Table 1). The presence of microspined sigmas and toxas in *R. sorokiniae* are new characters for the genus *Rhabderemia*. However, these features are not over-emphasized here

since it is probable that other studies in electron microscopy may discover their occurrence in other species.

In growth form, skeletal structure and some aspects of spiculation *R. sorokinae* also shows close affinities with *R. coralloides*. The latter species consists of irregular, subcylindrical lobate digits, and it too has a membranous skin-like dermis which covers a prominently sculptured surface excavated by subdermal drainage canals. Choanosomal skeletal architecture is a compact isodictyal reticulation of fibres and spicules, with differentiated primary ascending and transverse secondary lines. In these features the two species are closely related, but they may be differentiated by their respective spicule dimensions (Table 1), and in the presence of toxas in *R. sorokinae* and thraustoxeas in *R. coralloides*. A key to the described forms of the genus is given below.

Key to the species of *Rhabderemia*.

- 1(0) Thraustoxea microscleres are present .. 2
 Thraustoxea microscleres are absent5
- 2(1) Microstyle microscleres are roughened (onychaete-like) or microspined3
 Microstyle microscleres are entirely smooth4
 Microstyle microscleres are absent
*R. fascicularis* Topsent
- 3(2) Skeletal architecture is irregularly plumoreticulate, without fibres
*R. mutans* Topsent
 Skeletal architecture is a compact isodictyal reticulation*R. coralloides* Dendy
- 4(2) Rhabdostyle megascleres are spined in the distal half*R. spinosa* Topsent
 Rhabdostyle megascleres are entirely smooth*R. guernei* Topsent
- 5(1) True toxa microscleres are present6
 True toxa microscleres are absent7
- 6(5) Rhabdostyle megascleres are spined in the distal half*R. sorokinae* sp.nov.
 Rhabdostyle megascleres are entirely smooth*R. toxigera* Topsent
- 7(5) Sigmoid microscleres consist of true sigmas8
 Sigmoid microscleres are contort sigmas9

- 8(7) Skeletal architecture is plumose microcionid*R. intexta* (Carter)
 Skeletal architecture is plumoreticulate, with well developed fibres
*R. mammillata* (Whitelegge)
- 9(7) Microstyle microscleres are roughened (onychaete-like) or microspined10
 Microstyle microscleres consist of both microspined and smooth varieties
*R. minutula* (Carter)
 Microstyle microscleres are entirely smooth11
 Microstyle microscleres are absent
*R. acanthostyla* Thomas
- 10(9) Skeletal architecture is erect hymedesmoid*R. bistylifera* Lévi
 Skeletal architecture is plumose microcionid, with unispicular connecting tracts*R. stellata* Bergquist
 Skeletal architecture is irregularly plumoreticulate, without fibres
*R. indica* Dendy
- 11(9) Skeletal architecture is erect hymedesmoid*R. prolifera* Annandale
 Skeletal architecture is a compact isodictyal reticulation*R. spirophora* (Burton)

DISCUSSION

The 16 species currently known for the genus *Rhabderemia* are not well differentiated by their morphological characters, with species showing minor differences in the diversity, geometry, and the presence or absence of spination on their microscleres. Other characters such as megasclere spination, growth form and skeletal architecture may also be useful in determining relationships between species, and these are investigated using eladistics techniques below. This analysis relies heavily on descriptions from the literature, since most of the type material seen (listed in Appendix 1) consisted only of microscopie slide preparations of spicules, and consequently it must be considered to be somewhat preliminary. It is possible that some of the species recognized today may be only extreme forms of the more variable species, and these may be eventually merged.

Skeleton: Species of *Rhabderemia* are either encrusting or lobate-digitate, including bulbous forms; the encrusting growth form is considered here to be the plesiomorphic con-

Table 2. Characters used to investigate phylogenetic relationships between species of *Rhabderemia*. Criteria for judging apomorphy are discussed in the text.

PLESIOMORPHIC STATE		APOMORPHIC STATE	
1A	Skeletal architecture is erect hymedesmoid.	1C	Plumose with unispicular connecting tracts.
1B	Plumose microcionid.	1D	Irregularly plumoreticulate, without fibres.
1E	Plumoreticulate, with well developed fibres.	1F	Compact isodictyal reticulation.
2A	Choanosomal megascleres are isolated rhabdostyles erect on the substrate	2D	Multispicular ascending plumose columns inter-connected by unispicular tracts of rhabdostyles.
2B	Isolated and diverging plumose bundles of rhabdostyles.	2E	Paucispicular isodictyal reticulation of rhabdostyles.
2C	Multispicular ascending plumose columns of rhabdostyles.		
3A	Ectosomal skeleton is simply membranous.	3B	Dermal crust of microstyles.
4A	Growth form is encrusting.	4B	Lobodigitate.
5A	Rhabdostyle megascleres are spined in the distal half.	5B	Both smooth and spined forms.
		5C	Entirely smooth.
6A	Microstyle microscleres are microspined.	6B	Consist of both microspined and smooth forms.
6C	Entirely smooth.	6D	Absent.
7A	Thraustoxea microscleres are present.	7B	Absent.
8A	True toxa microscleres are present.	8B	Absent.
9A	Sigmoid microscleres consist of true sigmas.	9B	Contort sigmas.

dition (see Hooper 1987). To a greater or lesser extent skeletal architecture is related to growth form, whereby thinly encrusting species only have erect-hymedesmoid or plumose-microcionid choanosomal skeletons, whereas lobodigitate species are usually reticulate or plumoreticulate. The latter feature is apomorphic. The distribution of megascleres within fibres is linked to choanosomal skeletal architecture, ranging from the plesiomorphic condition which consists of isolated rhabdostyles embedded in basal spongin and erect on the substrate (i.e. a hymedesmoid skeleton) or with multispicular plumose columns of rhabdostyles (i.e. a microcionid skeleton), to plumoreticulate multispicular tracts or regularly formed paucispicular isodictyal tracts of rhabdostyles. There are no specialized ectosomal megascleres in this genus, but in two species microstyles are aggregated on the surface producing a dermal skeleton. This is considered to be a derived character, whereas plesiomorphy is simply a membranous ectosome (although in these cases spicules derived from the primary ascending tracts may protrude through the surface).

Spicules: In all species the only megascleres are rhabdostyles, which is an apomorphy for the genus. These spicules vary between species in being either smooth (the

derived condition), or with both smooth and spined forms, or with spines occurring on all spicules, usually dispersed over the distal portions of spicules (plesiomorphy). This determination is consistent with the conclusions of van Soest (1984), Hooper (1987) and Hieemstra and Hooper (1990). Microscleres are of four kinds. Microstyles range from microspined (onychaete-like) to entirely smooth forms, and the latter condition is considered here to be apomorphic. One species has examples of both, and in several species these spicules are absent entirely, which is interpreted as a secondary loss, and both conditions are derived. Thraustoxeas, which are thought to be derived forms of microstyles (Topsent 1928:311), occur in about half the number of species, and these are usually spined and contort with double central bends or centrotyle. Similarly, true toxas are present in two species, and these have straight or slightly reflexed arms and slight central curvature. Species which possess thraustoxeas do



Fig. 13. Cladogram of the hypothesized relationships between species of *Rhabderemia*, with indication of two species groups. Each number and letter on the cladogram corresponds to a character and character state, respectively, summarized in Table 2, and represents an evolutionary change from a relatively plesiomorphic to a relatively apomorphic state (consensus information = 0.528).

Fig. 14. Distribution of nominal *Rhabderemia* species. Conspecificity is assumed from the literature. Refer to Appendix 1 for sources of information. Key to species: a, *R. minutula* (Carter); b, *R. guernei* Topsent; c, *R. fascicularis* Topsent; d, *R. mutans* Topsent; e, *R. intexta* (Carter); f, *R. toxigera* Topsent; g, *R. spinosa* Topsent; h, *R. prolifera* Amandale; i, *R. bistylifera* Lévi; j, *R. indica* Dendy; k, *R. sorokinai* sp.nov.; l, *R. mamillata* (Whitelegge); m, *R. stellata* Bergquist; n, *R. coralloides* Dendy; o, *R. acanthostyla* Thomas; p, *R. spiriphora* (Burton).

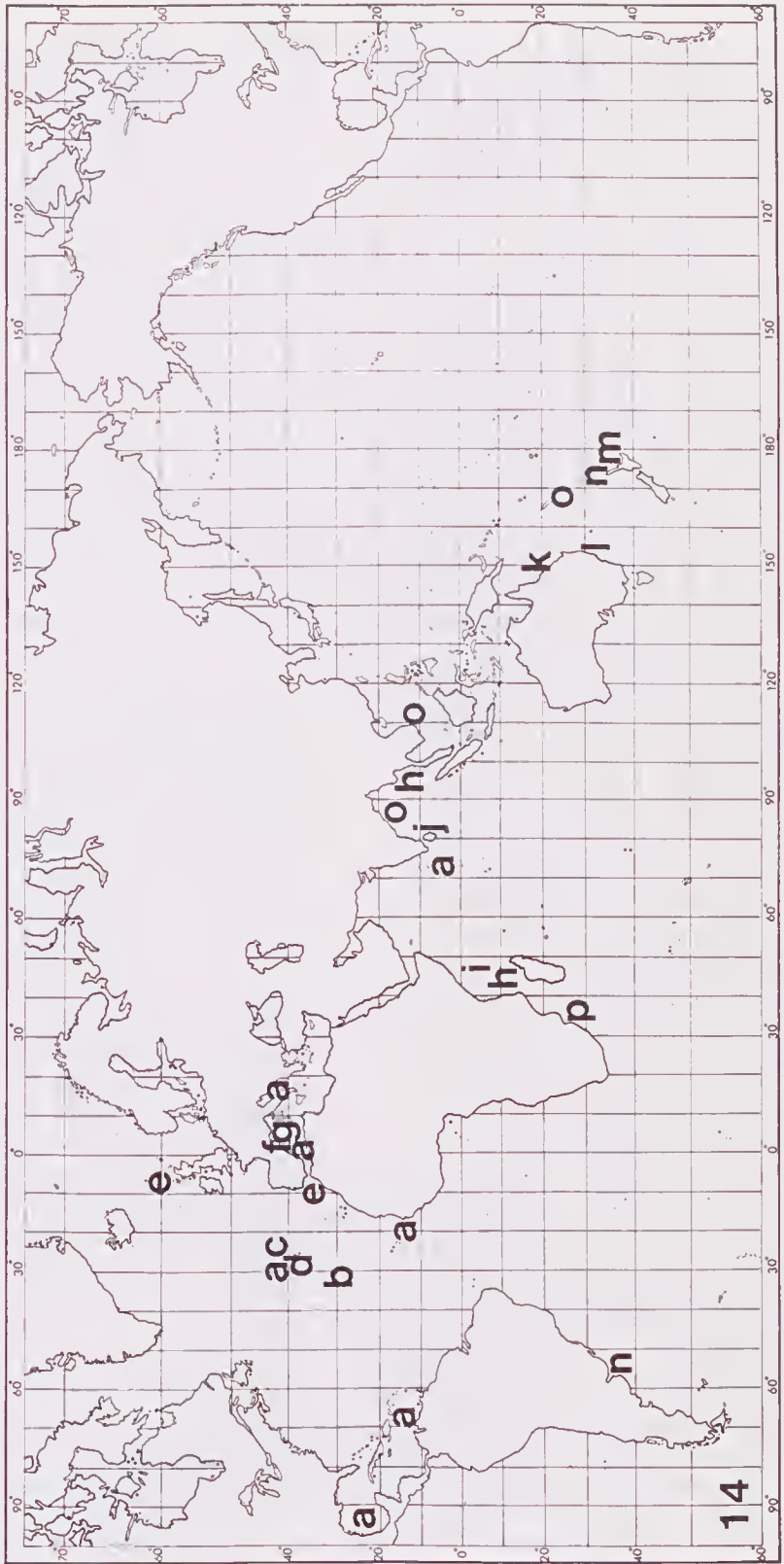

not have toxas, and the converse is also true. All species of *Rhabderemia* have some sort of sigmoid microscleres, and these are apomorphic for the genus in general. But sigmas vary from normal forms with c- and s-shapes, which are possessed by only two members of the group and interpreted here as the plesiomorphic condition, to derived contort forms, sometimes referred to as sigmaspires by authors (e.g. Lévi 1961). In this genus the contort sigmas appear to be derived from normal forms, and the application of the term sigmaspire, coined by Sollas for spiraster-derived microscleres, may be inappropriate. Thus, the differentiation of these two groups of species into two genera, *Rhabdosigma* and *Rhabderemia*, with either normal or contort sigmas, respectively, is artificial and not recognized here. This interpretation is supported by the distribution of other characters amongst the species (hymedesmoid-plumose versus reticulate skeleton types, spination of rhabdostyles), and the occurrence of both contort and (rare) normal sigmas in *R. sorokinae*. The presence of the newly discovered characters of spines on sigmas and toxas in *R. sorokinae* is not included in these analyses, since electron microscopic examination of all species is required to verify the presence or absence of this feature amongst other species.

Postulated relationships between species of *Rhabderemia* were investigated using a numerical computer method for inferring phylogenies (PAUP, Swofford 1985). This analysis utilizes the Wagner method, taking the preferred phylogenetic tree as the most parsimonious one, i.e. the one with the fewest number of evolutionary steps. Data used in this analysis were derived from a binary and an unordered multistate character set, and the criteria for judging apomorphy are discussed above and summarized in Table 2. Outgroups chosen were from the family Raspailiidae, and these included species from the genera *Anlospongia* (*A. tubulatus* (Bowerbank)) and *Hemecyonilla* (*H. involutum* (Kirkpatrick)). A consensus tree, produced from 28 minimum length trees, is depicted in Figure 13. Levels of homoplasy within this classification are quite high, as indicated by the number of characters which reoccur throughout the tree. The construction of a phylogeny for this group is quite difficult because the most unusual features in most species are the diversity and geometry of microscleres, but these appear amongst spe-

cies in all combinations, and they are rarely concordant with the distribution of other features. Nevertheless, this cladogram does represent a phylogeny in which there are fewest convergences, and Figure 13 suggests that the genus can be subdivided into two major groups, with emphasis placed on the characters of choanosomal architecture and spination on rhabdostyles.

The first group is predominantly encrusting and has skeletal structure ranging from hymedesmoid to plumose-microcionid. It is united only by these plesiomorphic features, and includes 9 species: *R. intexta*, *R. acanthostyla*, *R. spinosa*, *R. fascicularis*, *R. bistylifera*, *R. guernei*, *R. prolifera*, *R. minutula* and *R. toxigera*. The second group of *Rhabderemia* is predominantly lobodigitate in growth form, with a reticulate skeletal architecture. It contains seven species: *R. sorokinae*, *R. mutans*, *R. coralloides*, *R. mamillata*, *R. stellata*, *R. indica* and *R. spirophora*. Both groups of species may be further split into subgroups based on the presence or absence of spination on rhabdostyles.

Although relying heavily on the literature to assume conspecificity, a plot of species' distributions (Fig. 14) shows that with the exception of two anomalies there are two zoogeographical groups: one in the Atlantic system and the other in the Indo-Pacific. The Atlantic fauna (Caribbean, North Atlantic, Mediterranean) consists of seven species: (a) *R. minutula*, (b) *R. guernei*, (c) *R. fascicularis*, (d) *R. mutans*, (e) *R. intexta*, (f) *R. toxigera*, and (g) *R. spinosa*. Most of these species are known from only one or two isolated records, and most of these were described by Topsent (1892 *et seq.*), whereas *R. minutula* is relatively widely distributed, extending from the Gulf of Mexico into the Mediterranean, with a single (and possibly aberrant) record from the central Indian Ocean (Salomon, Chagos Archipelago; Dendy 1922). Confirmation of the distribution of this species into the Indian Ocean requires corroboration from a comparison between Dendy's (1922) specimen in the BMNH and the holotype (BMNH 1902.11.16.32), which may reveal hitherto undetected cryptic differences. The Indo-Pacific fauna consists of nine species: (h) *R. prolifera* from both sides of the Indian Ocean, (i) *R. bistylifera*, (j) *R. indica*, (k) *R. sorokinae*, (l) *R. mamillata*, (m) *R. stellata*, (n) *R. coralloides*, (o) *R. acanthostyla*, and (p) *R.*

spirophora. Most of these species are known only from single records, but the New Zealand species *R. coralloides* is also apparently present in the South Atlantic, off the coast of Uruguay (Burton 1940). This record may be anomalous, or it is possible that this species is austral (antiboreal) in distribution. Similarly, an examination of unpublished material collected by Claude Lévi and housed in the MNHN Paris (see Appendix 1) also extends the known distribution of *R. acanthostyla* considerably. The species was originally recorded from Galaxea Reef in the Gulf of Manaar, whereas MNHN specimens are reportedly from Vietnam and New Caledonia.

There is no correlation between the two species groups determined from phylogenetic relationships, shown in Figure 13, and the two groups indicated by their zoogeographic distributions in Figure 14. The former groups of species appear to be distributed between the Atlantic and Indo-Pacific systems.

ACKNOWLEDGEMENTS

This paper benefited greatly from the suggestions provided by two anonymous referees, for which I am most grateful. I thank Dr Peter Murphy, Ms Shirley Sorokin, and other members of the NCI Bioactivity project in Townsville (AIMS) for providing the specimen and photographs of this new species. NCI is also acknowledged for permission to publish colour photographs of this new species (Plate 1). I thank Prof. Claude Lévi (MNHN), Miss Shirley Stone (BMNH), Dr Manfred Grasshoff (SMF) and Dr Frank Rowe (AM) for providing access to their respective collections. The author acknowledges the research funding support from the Sir Winston Churchill Memorial Trust, Canberra, the Australian Bureau of Flora and Fauna, Canberra, and the Muséum National d'Histoire Naturelle, Paris, which enabled first-hand access to European museum collections.

REFERENCES

- Annandale, N. 1915. Some sponges parasitic on Clionidae, with further notes on that family. *Records of the Indian Museum* 1915:457-478.
- Bergquist, P.R. 1961. A collection of Porifera from Northern New Zealand with Descriptions of seventeen new species. *Pacific Science* 25(1):33-48.
- Bergquist, P.R. 1968. The Marine Fauna of New Zealand Porifera. Demospongiae. Part 1. (Tetraetnomorpha and Lithisiida). *Bulletin of the New Zealand Department of Scientific and Industrial Research. Memoirs of the New Zealand Oceanographic Institute* 37(188):1-106. pls 1-15.
- Bergquist, P.R. 1978. *Sponges*. Hutchinson: London.
- Bibloni, M.A. and Gili, J.M. 1982. Primera aportación al conocimiento de las cuevas submarinas de la isla de Mallorca. *Oecologia Aquatica* (6):227-234.
- Boury-Esnault, N. 1971. Spongiaires de la zone rocheuse de Banyuls-sur-mer. II. - Systématique. *Vie Milieu* (B) 22(2):287-350.
- Burton, M. 1930. Norwegian sponges from the Norman collection. *Proceedings of the Zoological Society of London* 2:487-546, pls 1-2.
- Burton, M. 1931. On a collection of marine sponges mostly from the Natal coast. *Annals of the Natal Museum* 6(3):337-358, pl.23.
- Burton, M. 1940. Las Esponjas Marinas del Museo Argentino de Ciencias Naturales. *Anales Museo Argentino de Ciencias Naturales "Bernardino Rivadavia"* 40:95-121, pls 1-8.
- Carter, H.J. 1876. Descriptions and Figures of Deep-Sea Sponges and their Spicules, from the Atlantic Ocean, dredged up on board H.M.S. 'Porcupine', chiefly in 1862 (concluded). *Annals and Magazine of Natural History* (4) 18:226-240, 307-324, 388-410, 458-473, pls 12-16.
- Carter, H.J. 1880. Report on specimens dredged up from the Gulf of Manaar and presented to the Liverpool Free Museum by Capt. W.H. Cawne Warren. *Annals and Magazine of Natural History* (5) 6:35-61, 129-156, pls 4-6.
- Dallwitz, M.J. and Paine, T.A. 1986. *User's guide to the DELTA system. A general system for processing taxonomic descriptions*. Third Edition. CSIRO Division of Entomology Report No. 13:1-106. Commonwealth Scientific and Industrial Research Organization: Canberra.
- Dendy, A. 1905. Report on the sponges collected by Professor Herdman, at Ceylon, in 1902. In: Herdman, W.A. (ed.) *Report to the Government of Ceylon on the pearl oyster Fisheries of the Gulf of Manaar*. Volume 3, Supplement 18:57-246. Royal Society: London.
- Dendy, A. 1922. Report on the Sigmatotetaxonida collected by H.M.S. "Sealark" in the Indian Ocean. In: Reports of the Percy Sladen Trust Expedition to the Indian Ocean in 1905, Volume 7. *Transactions of the Linnean Society of London, Zoology* 18:1-164, pls 1-18.
- Dendy, A. 1924. Porifera. Part I. Non-Antarctic sponges. In: British Antarctic ('Terra Nova')

- Expedition, 1910. Natural history report. Volume 6 Number 3:269-392, pls 1-15. British Museum (Natural History): London.
- Hallmann, E.F. 1916. A revision of the genera with microscleres included, or provisionally included, in the Family Axinellidae, with descriptions of some Australian species. Part ii. (Porifera). *Proceedings of the Linnean Society of New South Wales* **41**(3):495-552, pls 29-38.
- Hallmann, E.F. 1917. On the genera *Echinaxia* and *Rhabdosigma* [Porifera]. *Proceedings of the Linnean Society of New South Wales* **42**(2):391-405, pls 21-22.
- Hartman, W.D. 1982. Porifera. In: S.P. Parker (ed.) *Synopsis and Classification of Living Organisms*. Volume 1: 640-66. McGraw-Hill: New York.
- Hiemstra, F. and Hooper, J.N.A. 1990. Additions to the Indo-Australian representatives of *Acarinus* Gray (Porifera: Demospongiae: Poecilosclerida), with description of a new species. *Memoirs of the Queensland Museum*: in press.
- Hooper, J.N.A. 1986. Revision of the marine sponge genus *Axos* Gray (Demospongiae: Axinellida) from northwest Australia. *The Beagle, Occasional Papers of the Northern Territory Museum of Arts and Sciences* **3**(1):167-189.
- Hooper, J.N.A. 1987. New Records of *Acarinus* Gray (Porifera: Demospongiae: Poecilosclerida) from Australia, with a synopsis of the genus. *Memoirs of the Queensland Museum* **25**(1):71-105.
- Hooper, J.N.A. In press. Revision of Raspailiidae (Porifera: Demospongiae), with description of Australian species. *Invertebrate Taxonomy*: in press.
- Laubenfels, M.W. de 1936. A discussion of the sponge fauna of the Dry Tortugas in particular, and the West Indies in general, with material for a revision of the families and orders of the Porifera. *Carnegie Institute of Washington Publication Number 467. Papers of the Tortugas Laboratory* **30**:1-225, pls 1-22.
- Lévi, C. 1956. Spongiaires de la région de Dakar. *Bulletin de l'Institut Fondamental d'Afrique Noire* **18**:391-405.
- Lévi, C. 1961. Résultats scientifique des campagnes de la "Calypso" Fascicule V. XIV. Campagne 1954 dans l'Océan Indien. 2. Les spongiaires de l'île Aldabra. Campagne Océanographique de la "Calypso" (May-Juin 1954). *Annales de l'Institut Océanographique, Monaco* **39**:1-31, pls 1-2.
- Lévi, C. 1973. Systématique de la classe des Demospongiaria (Démospouges). In: P. Brien, C. Lévi, M. Sarà, O. Tuzet and J. Vacelet (eds) *Spongiaires. Traité de Zoologie, Anatomie, Systématique, Biologie*. Volume 3(1):577-631. Masson et Cie: Paris.
- Pulitzer-Finali, G. 1983. A collection of Mediterranean Demospongiae (Porifera) with, in appendix, a list of the Demospongiae hitherto recorded from the Mediterranean Sea. *Annali del Museo Civico di Storia Naturale di Genova* **84**:445-621.
- Sarà, M. 1961. La fauna di Poriferi delle grotte delle isole Tremiti. Studio ecologico e sistematico. *Archivio Zoologico Italiano, Napoli* **46**:1-59.
- Shaw, M.E. 1927. On a collection of sponges from Maria Island, Tasmania. *Proceedings of the Zoological Society of London* **18**:419-439, pl. 1.
- Soest, R.W.M. van 1984. Marine Sponges from Curaçao and other Caribbean Localities. Part III. Poecilosclerida. *Studies on the Fauna of Curaçao and other Caribbean Islands* (199):1-167, pls 1-10.
- Swofford, D.L. 1985. *PAUP. Phylogenetic analysis using parsimony*. Version 2.4. Illinois Natural History Survey: Champaign.
- Thomas, P.A. 1968. Studies on Indian sponges - I. Two new species of silicious sponges belonging to the genera *Echinodictyum* Ridley and *Rhabderemia* Topsent (class: Demospongiae Sollas, order: Poecilosclerida Topsent). *Journal of the Marine Biological Association of India* **10**(2):245-249.
- Thomas, P.A. 1979. Studies on sponges of the Mozambique Channel. I.-Sponges of Inhaca Island. II.-Sponges of Mambonc and Paradise Islands. *Annales de Musée Royal de l'Afrique Centrale, Sciences Zoologiques* (227):1-73, pls 1-3.
- Topsent, E. 1889. Quelques Spongiaires du Banc de Campêche et de la Pointe-a-Pître. *Mémoires de la Société Zoologique de France* **2**:30-52.
- Topsent, E. 1890. Notice préliminaire sur les Spongiaires recueillis durant les Campagnes de l'"Hirondelle" (1886-1887-8881 [sic.]). *Bulletin de la Société Zoologique de France* **15**:26-32, 65-71.
- Topsent, E. 1892a. Contribution à l'étude des Spongiaires de l'Atlantique Nord. *Résultats des Campagnes Scientifiques Accomplies sur son Yacht par Albert Ier Prince Souverain de Monaco* **2**:1-165, pls 1-11.
- Topsent, E. 1892b. Diagnoses d'éponges nouvelles de la Méditerranée et plus particulièrement de Banyuls. *Archives de Zoologie Experimentale et Générale, Notes et Revue* **1892**:17-30.
- Topsent, E. 1896. Matériaux pour servir à l'étude de la faune des Spongiaires de France. *Mémoires de la Société Zoologique de France* **9**:113-133.
- Topsent, E. 1904. Spongiaires des Açores. *Résultats des Campagnes Scientifiques Accomplies sur son Yacht par Albert Ier Prince Souverain de Monaco* **25**:1-280, pls 1-18.

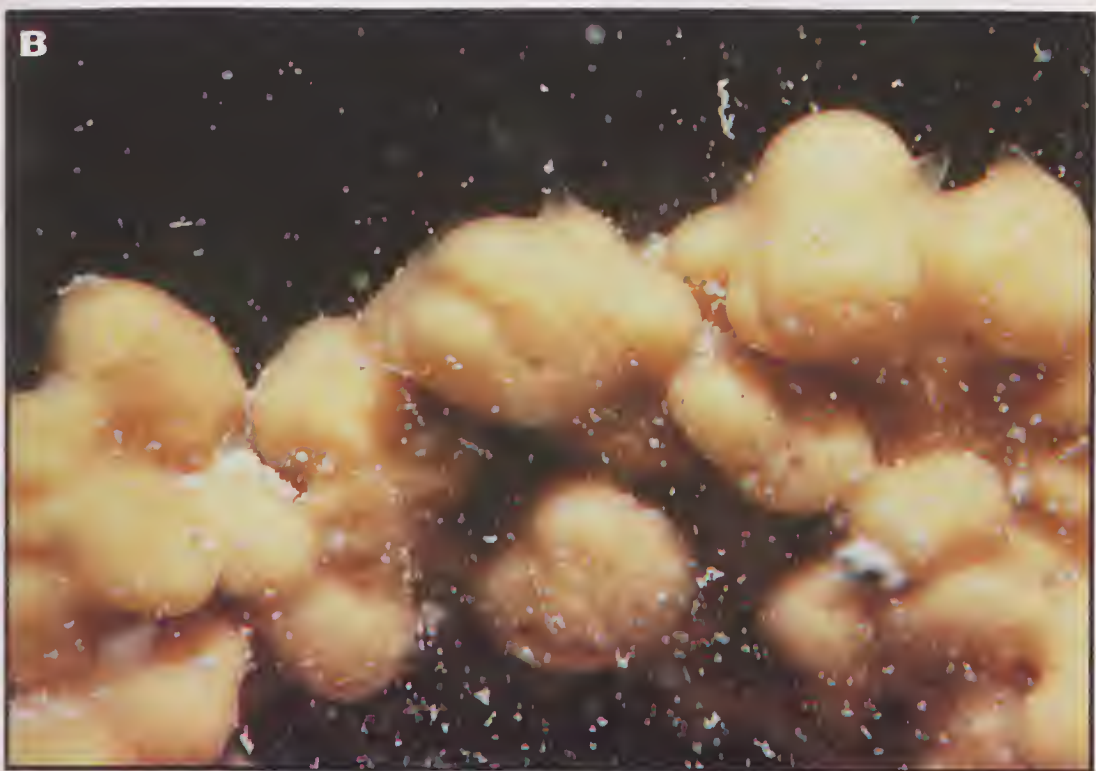

Plate I. *Rhabderemia sorokinae* sp.nov.; A, holotype *in situ*, Whitsunday Islands, Great Barrier Reef, 20 m depth; B, close-up of the same, showing individual lobate bulbs with evenly dispersed small ostia, surface drainage canals, and larger oscula surmounted on conical membraneous pedicels at the apex of lobes. Photos NCI.

- Topsent, E. 1927. Diagnoses d'Éponges nouvelles recueillies par le Prince Albert Ier de Monaco. *Bulletin de l'Institut Océanographique Monaco* 502:1-19.
- Topsent, E. 1928. Spongiaires de l'Atlantique et de la Méditerranée provenant des croisières du Prince Albert Ier de Monaco. *Résultats des Campagnes Scientifiques Accomplies sur son Yacht par Albert Ier Prince Souverain de Monaco* 74:1-376, pls 1-11.
- Vosmaer, G.C.J. 1935. In: Vosmaer-Röell, C.S. and Burton, M. (eds) *The Sponges of the Bay of Naples. Porifera Incalcaria with Analyses of Genera and Studies in the Variations of Species*. Volume 2:457-828. Martinus Nijhoff: The Hague.
- Whitelegge, T. 1907. Sponges. Part I. - Addenda. Part 2. Monaxonida continued. In: Scientific Results of the Trawling Expedition of H.M.C.S. "Thetis" Off the Coast of New South Wales in February and March, 1898. *Memoirs of the Australian Museum* 4(10):487-515, pls 45-46.

Accepted 9 May 1990

APPENDIX 1

Synonymy of described *Rhabderemia* species, including the known distribution of each and repository of the holotype (where known. Those specimens marked with an asterisk denote material seen by the author). Although 16 species are presently recognized, it is possible that some of these may eventually be merged into other taxa.

- Rhabderemia acanthostyla* Thomas**
Rhabderemia acanthostyla Thomas, 1968: 247-248, pl. 2, figs 4-5.
"Rhabdosigma foreipula" MS name ["paratype" MNHN LBIM DCL3243*].
"Rhabdosigma conulosa" MS name [attributed to Lévi 1961, but apparently unpublished; specimen MNHN LBIM DCL1560*].
Distribution: Galaxea Reef, Gulf of Manaar (Thomas 1968); New Caledonia region (MUSORSTOM stn. 2) (Lévi, unpublished data); Nha Trang, Vietnam (Lévi, unpublished data).
Holotype: CMFRI 131.
- Rhabderemia bistylifera* Lévi**
Rhabderemia bistylifera Lévi, 1961:15, text-fig. 18.
Distribution: Aldabra, W.Indian Ocean.
Holotype: MNHN DCL358*.
- Rhabderemia coralloides* Dendy**
Rhabderemia coralloides Dendy, 1924: 357, pl. 12, fig. 3, pl. 15, figs 1-4; Topsent 1928:65; Burton 1940:116; Bergquist 1968:19.
Distribution: North Cape, New Zealand and Maldonado, Uruguay.
Holotype: BMNH number unknown.
- Rhabderemia fascicularis* Topsent**
Rhabderemia fascicularis Topsent, 1927: 18; Topsent 1928:310, pl. 10, fig. 25.
Distribution: Azores, North Atlantic.
Holotype: ? MOM; slide MNHN DT1244*.
- Rhabderemia gnernei* Topsent**
Rhabderemia guernei Topsent, 1890:29; Topsent 1892a:116, pl. 11, fig. 7; Hallmann 1917:399; Topsent 1928:312, pl. 10, fig. 24.
Distribution: North Atlantic.
Holotype: ? SM; slide MNHN DT956*.
- Rhabderemia indica* Dendy**
Rhabderemia indica Dendy, 1905:180, pl. 12, fig. 10; Topsent 1928:310.
Distribution: Ceylon, Indian Ocean.
Holotype: BMNH number unknown.
- Rhabderemia intexta* (Carter)**
Microciona intexta Carter, 1876:238, pl. 15, fig. 43a-e; Vosmaer 1935:607.
Rhabderemia intexta - Topsent 1892a:116; Topsent 1904:152; Hallmann 1916:520; Hallmann 1917:399.
Rhabdosigma intexta - Topsent 1928:313, pl. 10, figs 29-30.
Distribution: Hebrides and Morocco, North Atlantic.
Holotype: BMNH 1890.4.10.12*.
- Rhabderemia mammillata* (Whitelegge)**
Sigmaxinella mammillata Whitelegge, 1907:512.
Rhabdosigma mammillata - Hallmann 1916:520; Hallmann 1917:399, pl. 21, figs 1-2, text-fig. 2; Shaw 1927:427.
Distribution: Norah Head, New South Wales, and Maria I., Tasmania, Australia.
Holotype: AM G4356*.
- Rhabderemia minutula* (Carter)**
Microciona minutula Carter, 1876:479, pl.

- 16 [emend.]; Carter 1880:44; Vosmaer 1935:608.
Rhabderemia minutula - Topsent 1904: 152-153, pl. 1, fig. 10, pl. 13, fig. 13; Lévi 1956:393, fig. 2; Boury-Esnault 1971:306; Biblioni and Gili 1982:231; Pulitzer-Finali 1983:533, text-fig. 51.
Microciona pusilla Carter, 1876:239, pl. 16, figs 51a-d; Carter 1880:437; Topsent 1889:41, text-fig. 7.
Rhabderemia pusilla - Topsent 1892a:116; Hallmann 1917:399; Dendy 1922:85; van Soest 1984:108.
Rhabderemia indica - in part, Sarà 1961: 44, text-fig. 8; Pulitzer-Finali 1983:534.
Distribution: Gulf of Mexico and Antilles, Caribbean, Azores and Dakar, North Atlantic, Mallorca and Adriatic Sea, Mediterranean, and Chagos Archipelago, Indian Ocean.
Holotype: BMNH 1902.11.16.32*.
10. *Rhabderemia mutans* Topsent
Rhabderemia mutans Topsent, 1927:17; Topsent 1928:310, pl. 2, fig. 2, pl. 10, fig. 21.
Distribution: Azores, North Atlantic.
Holotype: ? MOM; slide MNHN DT1236*.
11. *Rhabderemia prolifera* Annandale
Rhabderemia prolifera Annandale, 1915:464, pl. 34, fig. 3, text-fig. 3; Hallmann 1917:399; Thomas 1979:26, pl. 1, fig. 19
Distribution: Andaman Islands, E. Indian Ocean, and Mozambique Channel, W. Indian Ocean.
Holotype: IM 6420/7 ZEV.
12. *Rhabderemia sorokiniae* sp.nov.
13. *Rhabderemia spinosa* Topsent
Rhabderemia spinosa Topsent, 1896:121; Hallmann 1917:399; Topsent 1928:310, pl. 10, fig. 22.
Distribution: Banyuls, Mediterranean.
Holotype: ? MOM; slide MNHN DT2379*.
14. *Rhabderemia spirophora* (Burton)
Hallmannia spirophora Burton, 1931:352, pl. 23, fig. 12, text-fig. 8.
Nisibaris spirophora - de Laubenfels 1936: 144, 152.
Distribution: Natal, South Africa.
Holotype: NM 1254; slide BMNH 1928.10.19.18*.
15. *Rhabderemia stellata* Bergquist
Rhabderemia stellata Bergquist, 1961:41, fig. 13a-e; Bergquist 1968:19, pl. 1e, fig. 11h, text-fig. 3
Distribution: Bay of Plenty, New Zealand.
Holotype: NMNZ unnumbered.
16. *Rhabderemia toxigera* Topsent
Rhabderemia toxigera Topsent, 1892b:25; Hallmann 1917:399; Topsent 1928:310, pl. 10, fig. 23.
Distribution: Banyuls, Mediterranean.
Holotype: ? SM; slide MNHN DT2380*.

THE DIET OF THE SPINY-ANTEATER *TACHYGLOSSUS ACULEATUS ACANTHION* IN TROPICAL HABITATS IN THE NORTHERN TERRITORY

MERVYN GRIFFITHS¹, P.J.M. GREENSLADE², L. MILLER³ AND J.A. KERLE⁴.

¹CSIRO Division of Wildlife and Ecology, PO Box 84, Lyneham, ACT 2602, Australia.

²CSIRO Division of Soils, GPO Box 639, Canberra, ACT 2601, Australia.

³CSIRO Division of Entomology, GPO Box 1700, Canberra, ACT 2601, Australia.

⁴51 Larapinta Drive, Alice Springs, NT, 0870, Australia.

ABSTRACT

The diet of the Northern Territory "Top-End" echidna, *Tachyglossus aculeatus acanthion*, living in tropical habitats, consists, on average, of about 50% ants and 50% termites as judged by frequency of occurrence in scats. However, at times a majority of ants is eaten, and at other times termites are the predominant food items. Data from a small number of samples gave no indication of change of diet with season. Of 11 genera and 35 species of termites collected in the habitat, 9 genera and 21 species were identified in scats. Of 34 genera and 105 species of ant "identified", 23 genera were found in both scats and collections, but the echidnas consumed six other genera not present in the habitat collections. In one multiple sample 55 species of ant were identified but the overall mean was 14 species per sample. It is concluded that *T. a. acanthion* in a tropical habitat forages opportunistically so that the diet is largely a straight-forward reflection of the composition of the ground-layer ant and termite fauna.

KEYWORDS: Kakadu, echidnas, ants, termites.

INTRODUCTION

The echidna or spiny-anteater, *Tachyglossus aculeatus*, has an Australian-wide distribution including Tasmania and Kangaroo Island. It is found in a variety of habitats ranging from the Simpson Desert to Mt. Kosiusko.

Of the five recognised sub-species of *Tachyglossus aculeatus* (see Griffiths 1978) *T. a. acanthion* is the one found in arid parts of Australia and the Top End of the Northern Territory. This echidna is adapted to the climates of such habitats in that it has very little hair, its pelage being made up largely of stout spines interspersed with a few bristles. Thus it has high conductance (Auger 1978a) enabling it to radiate heat efficiently from its body. However, this is not sufficient to protect it from heat apoplexy if ambient temperatures exceeding 38°C are encountered. The echidna then has to retreat to shady, relatively cool refuges until temperatures fall in the evening allowing it to forage for its prey.

The food of echidnas in southern and central mainland Australia consists almost exclu-

sively of ants and termites, the proportions eaten varying with habitats (Griffiths 1968, 1978, 1989; Abensperg-Traun 1988). Very occasionally moth larvae and small beetles may be eaten. Smith *et al.* (1989), however, have found that the New England Tableland echidna ingests scarab beetle larvae which at times account for 37% of the biomass intake, the rest being ants and termites.

Echidnas capture their ants and termites by the protrusion of a long sticky vermiform tongue, to which prey adheres. The tongue also serves to grind the prey into fragments by the reciprocal action of a toothed pad located on the dorsal surface of the posterior end of the tongue. Only the soft parts are digested and the fragmented chitinous exoskeletons of the prey pass out in the faeces, which also contain dirt and sand ingested with the insects. The scats so formed set hard, in a characteristic cylindrical shape, and resist weathering. Most of the chitinous fragments in the scats can be identified under the microscope down to family level and some to genus and species so that estimates of proportions ingested can be made

(Griffiths 1968, 1978; Abensperg-Traun 1988).

The diet of echidnas living in tropical Australia is unknown and since a preliminary survey showed that seats could be collected in sufficient numbers in Kakadu National Park it was decided to carry out a study of the diet of tropical *Tachyglossus aculeatus acanthion* in that region.

STUDY SITES

Kakadu National Park comprises a region upwards of 20,000 square kilometres through which passes a major portion of the South Alligator River (Fig. 1) and to a lesser extent the East Alligator River. Land forms (Christian and Aldrick 1977) consist of woodlands, tributary creeks of the rivers and associated flood plains, a portion of the Arnhem Land escarpment, large outliers of the escarpment and small isolated rain-forest patches.

The dominant feature of the climate is the occurrence of two very different seasons the "wet" and the "dry" (Christian and Aldrick 1977). The wet lasts from November to April. About 80% of the annual rain falls during this period (annual mean recorded at Oenpelli, 1343mm), January to March being the wettest months. The period May to October is one of drought. High ambient temperatures are another feature of the climate and these are sustained throughout the year; the range between mean monthly temperatures is only 5.6°C. October and November are the hottest months exhibiting a mean maximum of about 38°C. The coldest month is July exhibiting a mean minimum of 17°C. Echidnas can cope quite well with cold weather (Augee 1978b) so the mild minimum temperatures of Kakadu's winter would impose no restrictions on foraging activity during that season.

METHODS

Seats were collected over the period 20 February 1980 to 15 October 1981 from four widely separated areas in the Park (Fig. 1): (1) Monsoon rainforest at the edge of the East Alligator River flood plain (Fig. 1, location A) and at Radon Creek (location G). (2) Cannon Hill, Hawk Dreaming, Obiri Rock and outliers at East Alligator Ranger Headquarters (locations B, C, D and E respectively). (3) Djawamba Massif and associated rock outliers,

Table 1. Termites collected at the eastern portions of Kakadu National Park in monsoon rainforest and escarpment. Data from Braithwaite *et al.* (1985, 1988). + Present, - Absent.

	Rainforest	Escarpment
MASTOTERMITIDAE		
<i>Mastotermes darwiniensis</i> Froggatt	+	-
RHINOTERMITIDAE		
<i>Copiotermes acinaciformis</i> Froggatt	+	+
<i>Heterotermes vagus</i> (Hill)	+	-
<i>Heterotermes validus</i> Hill	+	-
<i>Heterotermes venustus</i> (Hill)	+	-
<i>Schedorhinotermes actuosus</i> (Hill)	+	+
<i>Schedorhinotermes breinli</i> (Hill)	+	+
TERMITIDAE		
<i>Amitermes laurensis</i> (Mjöberg)	-	+
<i>Amitermes perelegans</i> (Hill)	-	+
<i>Amitermes</i> sp. A	-	+
<i>Amitermes</i> sp. B	-	+
<i>Australitermes perlevis</i> (Hill)	-	+
<i>Drepanotermes septentrionalis</i> Hill	-	+
<i>Microcerotermes boreus</i> Hill	+	+
<i>Microcerotermes nanus</i> (Hill)	+	-
<i>Microcerotermes nervosus</i> Hill	+	+
<i>Microcerotermes seriatius</i> (Froggatt)	+	+
<i>Microcerotermes</i> sp.	-	+
<i>Nasutitermes eucalypti</i> (Mjöberg)	+	+
<i>Nasutitermes graveolus</i> (Hill)	+	+
<i>Nasutitermes longipennis</i> (Hill)	-	+
<i>Nasutitermes</i> sp. A	-	+
<i>Nasutitermes</i> sp. B	-	+
<i>Nasutitermes</i> sp. C	-	+
<i>Occultitermes occultus</i> (Hill)	+	+
<i>Termes froggatti</i> (Hill)	+	+
<i>Termes melvillensis</i> (Hill)	+	+
<i>Termes quadratus</i> (Hill)	+	+
<i>Termes xunteri</i> (Hill)	+	+
<i>Termes taylori</i> (Hill)	-	+
<i>Termes</i> sp. A	-	+
<i>Termes</i> sp. B	-	+
<i>Termes</i> sp. C	+	+
<i>Termes</i> sp. D	-	+
<i>Termes</i> sp. F	-	+

(location F - F). This collection area was some 20 kilometres long and 23 samples were taken at 10 different places. Kerle and Burgmann (1984) have described this part of the study area in detail; it consists principally of dry escarpment and woodland. (4) Jim Jim Falls, H. and U.D.P. Falls, I. The distance from location A to I is 130 kilometres. Area 2 has been described as woodland and dry escarpment by Braithwaite *et al.* (1985) and area 4 as wet escarpment and rainforest. The species of termite occurring in those habitats and monsoon rainforest have also been given by those authors (Table 1). A collection of termites made by us at Djawamba Massif differed in no way from their escarpment collection.

Some background information is available on the ant fauna of Kakadu. In January 1983 ants were sampled with pitfall traps and using cracked-wheat and sardine baits, the latter placed on the trunks of trees and on the ground in a selection of habitats including monsoon forest, open forest, and woodland plots (described by Braithwaite and Dudzinsky 1983); these results are summarized by Greenslade

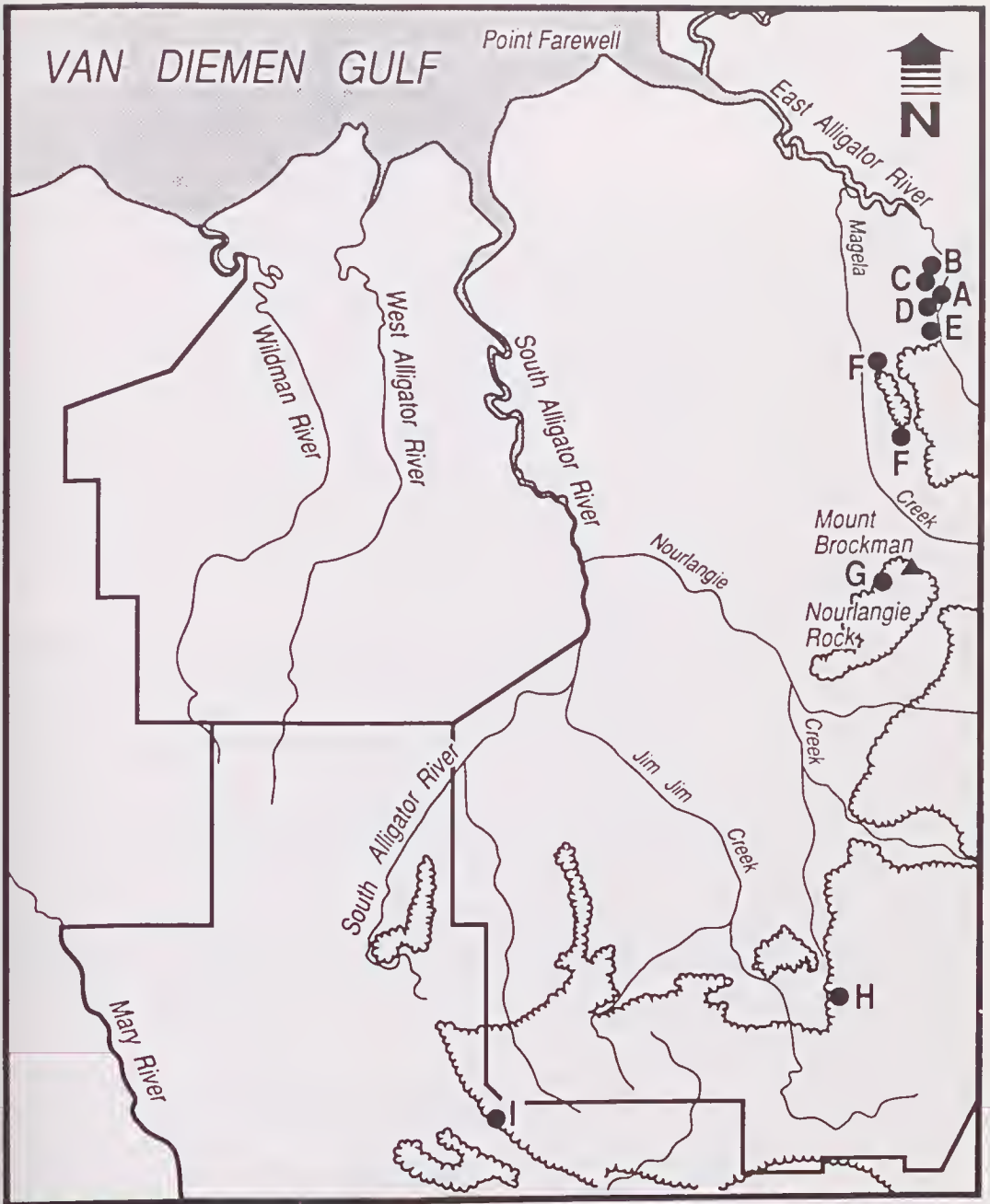

Fig. 1. Map of the Alligator Rivers Region showing the nine localities where echidna scats were collected.

(1985). In May 1983 this sampling routine was repeated. Additional material also came from limited hand collections and Tullgren-funnel extraction of soil and litter (Greenslade, unpublished results). Only a fraction of the ants that were collected can be given specific names but in the January collection 105 species were 'identified', if only by code numbers

within genera. A plot of eumulative species against eumulative samples rises steeply to a possible asymptote indicating a tally of 200 species for the region (Greenslade 1985). More recent studies suggest that this is a very conservative figure (A.N. Anderson, personal communication). A list of the genera found is given in Table 7.

Table 2. Frequency of termites and ants in echidna scats collected at the four areas (see text) in the Park.

Collection Area	Number of samples analysed in duplicate	% Termites	% Ants
1. Rain Forest	12	59	41
2. Dry Escarpment	18	56	44
3. Dry Escarpment	23	49	51
4. Wet Escarpment	3	75	25

The scats were found in a variety of places: in the monsoon forest, in exposed areas of escarpment and rock outliers, on sand amongst spinifex clumps on those outliers and in eaves and overhangs of the outliers. Some of these scats were quite fresh, being soft, dark and exhibiting a faecal odour, whereas others were of indeterminate age. Scats were between 1.5-6.0 centimetres long.

Most of the samples were of one or two pieces of scat, however, some were multiple samples containing 7-35 pieces. In all, a total of some 170 scats were collected. For dietary analyses these were freed of dirt and sand by trituration with a glass rod in water in a litre Erlenmeyer flask. The flask was then vigorously shaken and immediately filled with water. The chitinous parts floated to the top of the neck of the flask and were removed with a spoon and transferred to 80% alcohol. This procedure was repeated until no more chitin could be obtained. Duplicate aliquots of well-stirred suspensions of the samples in alcohol were transferred to 75 x 100 mm microscope slides, the chitinous parts being spread thinly and evenly as possible. They were then allowed to dry, covered with Canada Balsam and baked in an oven at 50°C. The frequency

Table 3. Frequency of termites and ants in fresh scats collected at various times of the year at the four areas in the park.

Collection Area	Time of Year	% Termites	% Ants
1	16 September	68	32
	16 September	54	46
	6 November	58	42
2	28 February	40	60
	19 August	65	35
	19 September	74	26
	19 September	73	27
	29 November	47	53
3	28 July	28	72
	24 August	77	23
	26 August	75	25
	4 September	17	83
	22 September	57	43
	26 September	34	66
4	30 March	83	17
	15 October	75	25
	13 November	67	33

of ants and termites in the samples was determined by counting the chitinous parts along carefully defined transects of the slides. The parts counted were the head capsules of ants, rostra of nasutitermitine soldiers, jaws of other termite soldiers and jaws of termite workers, the counts of the jaws being divided by two. The choice of these entities for determination of numbers was determined by the observation that the head capsules of the ants and nasute soldiers almost always remained intact whereas the soft head capsules of the other termite castes were crushed by the echidna's grinding pad leading to separation of the jaws which are relatively indestructible. For determination of the ratio of ants to termites ingested, the number of identifications made varied from 88 to 430 per slide depending on the size of the sample available, i.e. about 180-800 identifications per sample. The counts of the duplicates expressed as percentages agreed very well, the average difference being only $4.9\% \pm 4.7\%$.

The different kinds of termites in aliquots of the samples were identifiable only to subfamily level as judged by the morphology of nasutes, worker and soldier jaws on a quantitative basis (i.e. frequency). Where possible genus and species were identified but no quantitative estimates could be made. Determinations of frequencies of termites were also made in duplicate, a hundred identifications being made each time.

A procedure different from the one described above was adopted for the ant moiety of the diet in view of the very large number of different species that were ingested and which could be 'identified' to species level.

Ants were recorded from aliquots of 30 of the samples, mainly from the single scat samples of Area 3, and from some composite multi-scat samples. Each sample was examined under low magnification in approximately 10ml lots. Two procedures were carried out: firstly in each scat and composite sample all ants were identified to genus and sorted to species within genera from whatever fragments were present, from single mandibles to entire bodies. This provides frequency data: the sum of species per genus per scat or composite sample. Secondly a quarter of each 10ml sub-sample was examined in a gridded dish identifying and counting individual head capsules to genus and, where possible to species giving minimum relative abundance

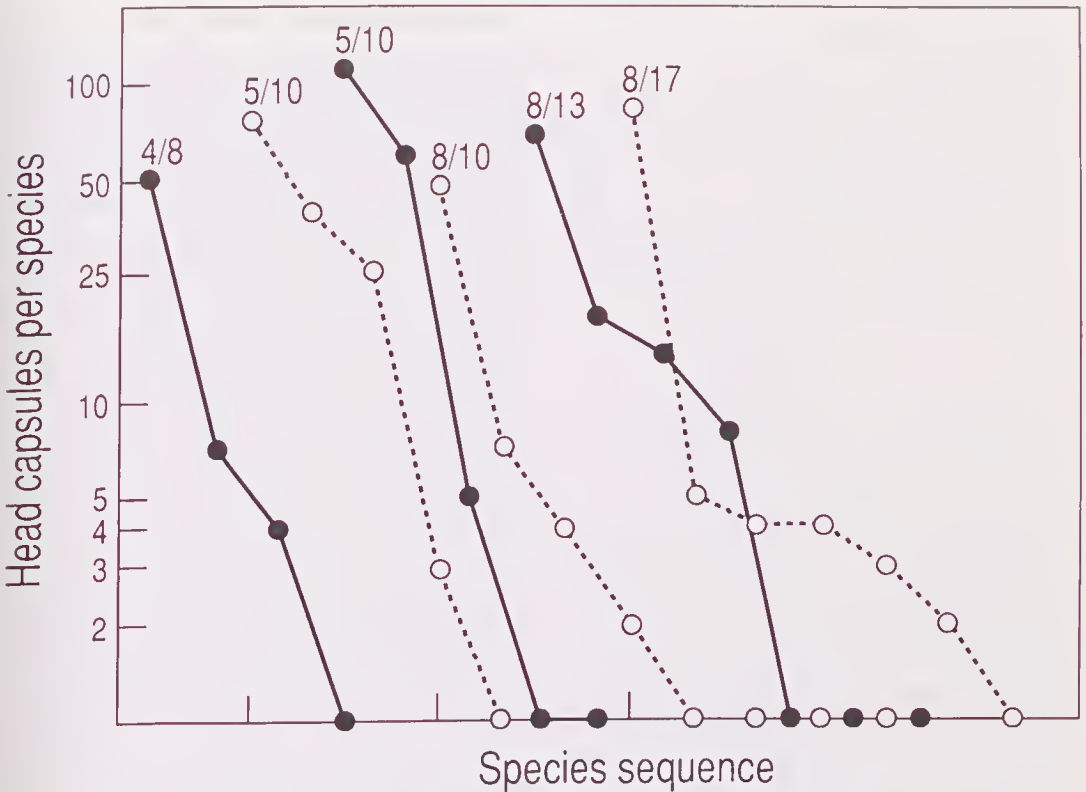

Fig. 2. Statistical distributions of the relative abundances (from head capsule counts) of individual ant species in six echidna seats. Fractions represent: total species in head capsule counts/total species recognized in the sample.

data. This involved 550 species records and counts of 3684 head capsules, averaging 18 species and 120 head capsules per seat or composite sample.

Significance of differences between means was determined by Peritz's F test for multiple comparisons using the computer program written by Harper (1984).

RESULTS

Kinds of food items ingested. Along with a total count of 15,000 ants only 15 individual arthropods, including 8 scarab larvae, were encountered in the samples. All other items were termites. Consequently the Kakadu echidna is overwhelmingly an ant and termite eater.

Ratio of termites to ants ingested. The proportions of ants and termites occurring in the seats from the four areas are shown in Table 2. From this it is apparent that in all areas except Jim Jim - U.D.P. Falls the Kakadu echidna eats roughly equal proportions of ants and termites. The apparent preference for termites in Area 4 is very likely due to the small

sample size ($n = 3$). This is borne out by the wide variation in the type of intake in areas where the sample size was adequate. For example, in Area 3 on eight occasions the frequency of ants exceeded 70% and on the same number of occasions the frequency of termites exceeded 70%. Equally large variations were also found in Area 2 seats. The point is further emphasized in Table 3 in which the results from examination of the fresh seats are given. From these data one can say it is just as likely that the echidnas will be eating more ants than termites or vice versa. Furthermore, there is no evidence from analysis of this small number of fresh samples that there are any seasonal changes in diet.

Termites. Large differences in the kinds of termites ingested are apparent. From the data in Tables 4 and 5 it can be seen that in all the study areas many more Termitidae than Rhinotermitidae were eaten. In areas 1, 2 and 3, where the numbers of samples permitted statistical analysis, the differences between the mean frequencies of Termitidae and Rhinotermitidae were significant ($P < 0.0001$).

Table 4. Frequency of termite families identified in scats from monsoon rainforest and wet escarpment habitats.

a. Radon Creek Rainforest			
Number of samples	Frequency of each termite family		
	Rhinotermitidae ¹	Termitidae ²	Mastotermitidae
10	24.1%	75.9%	Nil
[Termitidae comprising: <i>Amitermes</i> -group (5.8%), <i>Termes</i> -group (45.1%), and Nasutitermitinae ³ (25.0%)]			
¹ Rhinotermitidae species identified:	<i>Coptotermes acinaciformis</i> <i>Schedorhinotermes actuosus</i> <i>S. breinli</i>		
² Termitidae species identified:	<i>Microcertermes serratus</i> <i>M. nervosus</i> <i>M. nanus</i> <i>M. boreus</i> <i>Termes orbus</i> <i>T. melvillensis</i> <i>T. sunteri</i>		
³ Nasutitermitinae:	No remains identified beyond subfamily level.		

b. Edge of East Alligator River Flood Plain Rainforest			
Number of samples	Frequency of each termite family		
	Rhinotermitidae ¹	Termitidae ²	Mastotermitidae
2	3.0%	97.0%	Nil
[Termitidae comprising: <i>Amitermes</i> -group (18.6%), <i>Termes</i> -group (26.0%), Nasutitermitinae ³ (51.5%)]			
¹ Rhinotermitidae species identified:	<i>Heterotermes</i> sp. <i>Coptotermes</i> sp.		
² Termitidae species identified:	<i>Microcertermes nervosus</i>		
³ Nasutitermitinae:	No remains identified beyond subfamily level.		

c. Jim Jim and U.D.P. Falls Wet Escarpment			
Number of samples	Frequency of each termite family		
	Rhinotermitidae ¹	Termitidae ²	Mastotermitidae
3	20.1%	79.9%	Nil
Termitidae comprising: <i>Amitermes</i> -group (11.0%), <i>Termes</i> -group (20.2%), Nasutitermitinae ³ (48.7%)			
¹ Rhinotermitidae species identified:	<i>Coptotermes acinaciformis</i> <i>Schedorhinotermes actuosus</i> <i>S. breinli</i>		
² Termitidae species identified:	<i>Amitermes</i> sp. <i>Microcertermes</i> sp. <i>Drepanotermes</i> sp.		
³ Nasutitermitinae:	No remains identified beyond subfamily level.		

Since species composition of Termitidae in rainforest differed from that of escarpment (Table 1) it was to be expected that differences within that group would be found in scats from the different areas: in Area 1 (Radon Creek) significantly more *Termes*-group termites and Nasutitermitinae were caught than *Amitermes*-group ($P < 0.0001$ in both instances). It is noteworthy, however, that the echidnas' diet here contained a small percentage of *Amitermes*-group termites whereas Braithwaite *et al.* failed to collect them. The difference between consumption of *Termes*-group termites and Nasutitermitinae was barely significant ($P = 0.016$).

On the other hand in Areas 2 (Cannon Hill etc.) and 3 (Djawawba Massif) many more

Nasutitermitinae than either *Amitermes*- and *Termes*-group termites were eaten; these differences between the mean frequencies of the *Amitermes*-group and the *Termes*-group in Areas 2 and 3 were not significant.

Ants. The scats proved to be remarkable for the very wide range of ants that they contained, 55 different species being recognisable in one composite sample. The number of species in individual scats, however, varied from 2-36 (Table 6) with an overall mean of 14.0 species. Given the relative number of scats from different areas or habitats there is no significant departure, as shown by the standard deviations in Table 6, from this overall mean.

Figure 2 shows the distribution of abundances of individual species in a small number

Table 5. Frequency of termite families identified in scats from dry escarpment habitats.

a. Cannon Hill, Hawk Dreaming, Ohiri Rock, East Alligator River Ranger's Head Quarters.			
Number of samples	Frequency of each termite family		
	Rhinotermitidae ¹	Termitidae ²	Mastotermitidae ³
18	9.1%	90.4%	0.5%
[Termitidae comprising: <i>Amitermes</i> -group (21.5%), <i>Termes</i> -group (16.8%), Nasutitermitinae ⁴ (52.1%)]			
¹ Rhinotermitidae species identified:	<i>Coptotermes acinaciformis</i> <i>Coptotermes</i> sp. <i>Schedorhinotermes actuosus</i> <i>S. breinli</i> <i>Heterotermes validus</i>		
² Termitidae species identified:	<i>Amitermes</i> sp. <i>Drepanotermes</i> sp. <i>Microcertermes boreus</i> <i>M. nervosus</i> <i>M. serratus</i> <i>Microcertermes</i> sp. <i>Termes quadratus</i> <i>Termes</i> sp.		
³ <i>M. darwiniensis</i> in 3 scats only			
⁴ Nasutitermitinae: No remains identified beyond subfamily level, except <i>Tumulitermes</i> sp.			

b. Djawawba Massif			
Number of samples	Frequency of each termite family		
	Rhinotermitidae ¹	Termitidae ²	Mastotermitidae ³
23	15.2%	84.6%	0.2%
[Termitidae comprising: <i>Amitermes</i> -group (22.2%), <i>Termes</i> -group (17.7%), Nasutitermitinae ⁴ (44.7%)]			
¹ Rhinotermitidae species identified:	<i>Coptotermes acinaciformis</i> <i>Schedorhinotermes actuosus</i> <i>S. breinli</i> <i>Heterotermes</i> sp. <i>Heterotermes venustus</i>		
² Termitidae species identified:	<i>Amitermes</i> sp. <i>Drepanotermes</i> sp. <i>Microcertermes serratus</i> <i>M. boreus</i> <i>M. nanus</i> <i>M. nervosus</i> <i>Termes melvillensis</i>		
³ <i>M. darwiniensis</i> is 2 scats only			
⁴ Nasutitermitinae: No remains identified beyond subfamily level, except <i>Tumulitermes pastinator</i> .			

of scats in which all species could be distinguished unequivocally from their head capsules. The general pattern consists of a curve in which a large proportion, 50-80%, of the total number of individuals are contributed by one or a few ant species, with a variable tail of infrequent species. Some nest aggregations are certainly included in the diet judging by this abundance distribution and the occasional presence of dealate queens and alate sexuals.

Table 7 describes the faunal composition of ants recognised in scats in comparison with what little we know of the regional ant fauna of the Alligator Rivers - Kakadu area.

Despite the fact that most echidna seats came from dry escarpment and woodland, while most information on the ant fauna comes from collections made in open forest and woodland, Table 7, shows a close correspondence at generic level between the two sets of data: of the 34 genera in Table 7, 23 were represented in both. However, five of the genera collected in 1983 were not found in the scats and six were found only in scats. Also the frequencies of three important genera *Iridomyrmex*, *Oecophylla* and *Crematogaster* were lower in scats than would be predicted from the 1983 data. Reasons for these apparent anomalies are discussed below. With these exceptions in taxonomic composition, therefore, the ant component of the diet as shown by the data in this Table seems to be a fair sample of the regional ant fauna, apart from the absence of exclusively arboreal ants. This is supported by the relationship between the frequency of genera in the 1983 collections and their frequency in scats, shown in Figure 3.

However, arboreal species that do forage on the ground as well as on vegetation, notably

Table 6. Summary of echidna seats sorted for ants.

	Area of Collection				Totals
	Monsoon Rainforest 1	Dry Escarpment 2	3	Wet Escarpment 4	
Total Samples	6	6	15	3	30
Total Seats	3	5	15	3	26
Total Species records	164	110	234	42	550
Total abundance	1,004	586	1,762	368	3,720
Mean no. (and range) of species per scat	9.0 (7-12)	12.2 (2-18)	15.6 (5-36)	14.3 (9-21)	14.0 (2-36)
± S.D.	2.16	5.71	8.55	4.99	7.54

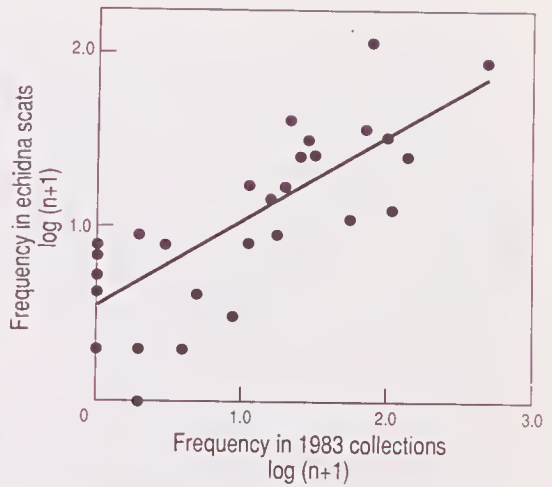

Fig. 3. Relationship between frequency of ant genera in 1983 collection samples and frequency in echidna seats (data double logarithmically transformed); ($r = 0.8$, $P < 0.001$, $y = 0.53 + 0.49x$).

Oecophylla smaragdina, are taken and must be captured as individual workers on the soil surface. In fact these arboreal species were more prominent in seats than strictly cryptic species: per cent frequency/per cent relative abundance for cryptic species was 5/2, and for the arboreal species it was 11/4. There is also a close relationship between frequency in seats and frequency in the 1983 collections (Fig. 3 and see Table 7).

When relative abundance in seats was plotted against frequency of occurrence (Fig. 4a) a disproportionately high abundance of *Pheidole* and *Paratrechina* and low abundance of *Rhytidoponera* became apparent. Considering all genera, there is a significant frequency-abundance relationship (Fig. 4a), although with a wide scatter of points for the numerically least important and infrequently represented genera. *Pheidole*, *Paratrechina* and *Rhytidoponera* ranked 1, 3, and 5 in frequency, respectively. If these are excluded there is a very close frequency-abundance correlation for the remaining genera (Fig. 4b) which emphasizes the outlying position of *Pheidole*, *Paratrechina* and *Rhytidoponera* (see Discussion).

Habitat-area distributions of some major ant taxa are shown in Figure 5, although it should be noted that only a small number of seats were examined from some areas (area 4 in particular, Table 6). These data suggest that there is no wide variation at the generic level in the ants taken by the echidnas, regardless of

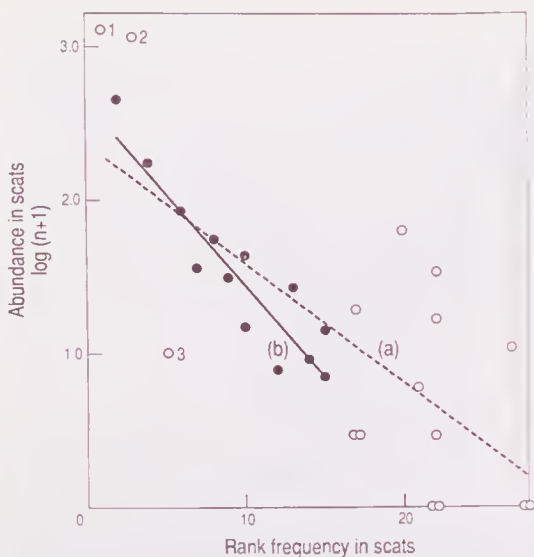

Fig. 4. Relationship between rank frequency of genera in scats and relative abundance (head capsule counts, $\log(n+1)$). (a) open circles, broken regression line : all genera ($r = 0.76, P < 0.001, y = 2.46 - 0.08x$); (b) solid circles, solid regression line : more frequent genera (up to rank 15) excluding points 1, *Pheidole*, 2, *Paratrechina*, and 3, *Rhytidoponera* (see text) ($r = -0.92, P < 0.001, y = 2.68 - 0.12x$).

which area scats were obtained, with the exceptions of the leading "dominants" *Oecophylla smaragdina* and *Iridomyrmex sanguineus* (Greenslade 1985). Both of these occurred infrequently and at low abundance. An explanation of this is offered below.

DISCUSSION

In agreement with the findings of Griffiths (1968, 1978, 1989) and Abensperg-Traun (1988) on the diet of echidnas living in arid and southern parts of Australia, the Kakadu echidna is an ant and termite eater. In this respect it is unlike the echidna *T. a. aculeatus* living in the New England tablelands, a significant proportion of whose diet is scarab larvae (Smith *et al.* 1989). This is not surprising since the habitats of the two kinds of echidna are quite different: that of the New England echidna consists of large areas of improved arable pasture infested with scarabs.

The results on the determination of the ratios of ants to termites eaten indicate that the Kakadu echidna is an opportunistic feeder ingesting ants and termites as it encounters them. Whereas some scats show that these echidnas ate a preponderance of ants, others

Table 7. Ants recorded from the Alligator River region from monsoon rainforest, open forest and woodland in January 1983 (Greenslade 1985), with later additions May 1983, and in echidna scats from Area 1, 2, 3 and 4. A, genera containing arboreal nesting species. C, cryptic genera consisting of species entirely or almost entirely restricted to soil and litter. The genus *Cheloner* is provisionally retained despite synonymisation with *Monomorium* (Bolton 1987).

Taxon	January 1983 (species/ frequency)	January+May 1983 (Total species)	Echidna Scats (Frequency/ relative abundance)
PONERINAE			
<i>Anochetus</i>	-	-	7/2
<i>Bothroponera</i>	1/1	3	3/-
<i>Brachyponera</i> C	-	-	1/-
<i>Cerapachys</i>	2/2	3	7/19
<i>Discothyrea</i> C	-	1	-/1
<i>Hypoponera</i> C	-	2	3/-
<i>Leptogenys</i>	1/1	2	8/6
<i>Odontomachus</i>	2/54	2	10/8
<i>Rhytidoponera</i>	7/99	10	32/0
DORYLINAE			
<i>Aenictus</i>	-	-	7/61
PSEUDOMYRMICINAE			
<i>Tetraponera</i> A	-	1	-/-
MYRMICINAE			
<i>Cardiocondyla</i>	1/1	2	-/-
" <i>Cheloner</i> "	3/10	9	7/2
<i>Crematogaster</i> A	4/136	5	26/88
<i>Glamyromyrmex</i> C	-	1	-/-
<i>Meranoplus</i>	8/17	15	8/13
<i>Monomorium</i>	15/72	17	34/177
<i>Oligomyrmex</i> C	1/8	1	2/25
<i>Podomyrma</i>	-	1	-/-
<i>Pheidole</i>	12/76	17	110/1462
<i>Quadristruma</i> C	1/1	1	1/-
<i>Solenopsis</i> C	1/10	2	16/43
<i>Strumigenys</i> C	-	-	4/5
<i>Tetramorium</i>	6/15	7	13/9
DOLICHODERINAE			
<i>Iridomyrmex</i>	9/368	11	88/469
<i>Tapinoma</i>	1/4	1	3/34
FORMICINAE			
<i>Camponotus</i>	10/32	13	25/36
<i>Melophorus</i>	8/24	14	24/55
<i>Oecophylla</i> A	1/110	1	12/26
<i>Opisthopsis</i>	3/19	3	17/14
<i>Paratrechina</i>	4/20	7	38/1203
? <i>Plagiolepis</i>	-	-	3/16
<i>Polyrhachis</i> A	3/28	5	21/31
<i>Stigmatoceros</i>	-	-	-
3/2			
TOTALS	104/118	156	550/3720

show the opposite, but most scat analyses show that it eats equal numbers of ants and termites. Furthermore, although the data are limited, the results from examination of fresh scats show nothing to indicate that there is any seasonal change in diet.

Of the 11 genera and 34 species of termite known to occur in the region (listed in Table 1), all genera except *Occultitermes* and *Australitermes*, and 21 of these species were identified in the echidna scats. The absence of *Occultitermes* from the diet can be attributed to the fact that it is a minute termite which nests in soil. Similarly, *Australitermes perlevis* is quite rare in both wet and dry seasons (Braithwaite *et al.* 1988). These data again

suggest that the Kakadu echidna forages opportunistically, ingesting termites as it encounters them.

In contrast, the results of a detailed analysis of the termite moiety in the scats revealed a different picture, whereby far more Termitidae than Rhinotermitidae were ingested. It might be argued that this is due to the relative scarcity of rhinotermitid termites, but from data listed in Table 8 it is apparent that the abundance of rhinotermitid species found in the escarpment is greater than that of the Nasutitermitinae, which were favoured by the echidnas living in that habitat. A likely explanation for this is that rhinotermitid species were shunned by echidnas, as opposed to the alternative explanation that Termitidae were preferred, since the former have very well-developed chemical defence mechanisms producing a variety of particularly noxious alkanes and ketones (Deligne *et al.* 1981; Moore 1968). Nasutitermitinae also produce defensive secretions but, in anthropocentric terms, the odours of those of *Schedorhinotermes actuosus* and *S. breinli* are revolting, whereas those of Nasutitermitinae are quite pleasant. Although these noxious chemicals are used for the defence of colonies, foraging workers and so on against ants and other invertebrate predators, Deligne *et al.* (1981) remark that "It is conceivable that some of the termite defensive compounds have been evolved as specific vertebrate deterrents. Such a development would ensure that these secretions would be highly adaptive because of their simultaneous deterrence to both predatory invertebrates and termite-phagous vertebrates". Since echidnas have well-developed organs of taste and olfaction (Griffiths 1968), and in view of all the above, we conclude that the Kakadu echidna actively shuns Rhinotermitidae because of the unpalatable nature of their defensive chemicals. In support of this notion is the fact that *T. a. acanthion* in an entirely different

part of the continent (the wheatbelt of Western Australia) also shuns Rhinotermitidae in spite of a prevailing abundance of *Coptotermes acinaciformis* (Abensperg-Traun 1988).

The high diversity of species of ants found in the samples (mean of 14 per scat and a maximum of 55 from a composite sample) again suggests that the Kakadu echidna feeds opportunistically. In further support of this notion is that there is no evidence from our data on the distribution and abundance curves of individual species in the scats (Fig. 2) of any directed search by echidnas for, or concentration on, particularly rewarding nests, colonies or foraging workers.

It has already been noted that the ant component of the diet represents a fair sample of the regional ant fauna, with the exception of five genera which are absent: *Discothyrea* (Ponerinae), *Tetraponera* (Pseudomyrmecinae), *Cardiocondyla* (2 spp), *Glamyromyrme* and *Podomyrma* (Myrmecinae). *Tetraponera* and *Podomyrma* have arboreal nests and rarely forage on the ground and so are not generally available to echidnas. Similarly, one of the *Cardiocondyla* species, forages at high temperatures, at a time when echidnas have retired to refuges. It was recorded only once in the January 1983 collection and has a localized distribution in the area (A.N. Andersen, personal communication). The remaining three species (*Discothyrea*, and *Glamyromyrme* and the second *Cardiocondyla*) all appear to be uncommon inhabitants of forest litter.

The six genera found only in scats but not in the general habitat collections were *Auochetus* and *Brachyponera* (Ponerinae), *Aenictus* (Dorylinae), *Strumigenys* (Myrmicinae), *Plagirolepis* and *Stigmacros* (Formicinae). Of these *Brachyponera* cf. *lutea* (identified from a single damaged head capsule) occurs in the Alligator Rivers region (A.N. Andersen, personal communication) but probably only occurs on sandy soils that were not studied in 1983; *Plagirolepis* was very tentatively identified from head capsules - the genus has not been recorded from the area and the specimens closely resembled the head capsules of, and indeed may be, *Crematogaster* species; *Strumigenys* inhabits forest litter which has yet to be intensively sampled; *Aenictus*, *Auochetus* and *Stigmacros* species, although not rare, are only found sporadically and locally (A.N. Andersen, personal communication).

Table 8. Relative abundance of Rhinotermitidae and Nasutitermitinae at various places on the Kakadu escarpment during the dry and wet seasons. Data from Braithwaite *et al.* (1985)

Species	Average Abundance Index	
	Wet	Dry
Rhinotermitidae (<i>Schedorhinotermes actuosus</i> , <i>Schedorhinotermes Breinli</i> , <i>Coptotermes acinaciformis</i>)	1.33	0.58
Nasutitermitinae (<i>N. eucalypti</i> , <i>N. graveolus</i> , <i>N. longipennis</i> , <i>N. spp</i> A, B, C)	0.46	0.30

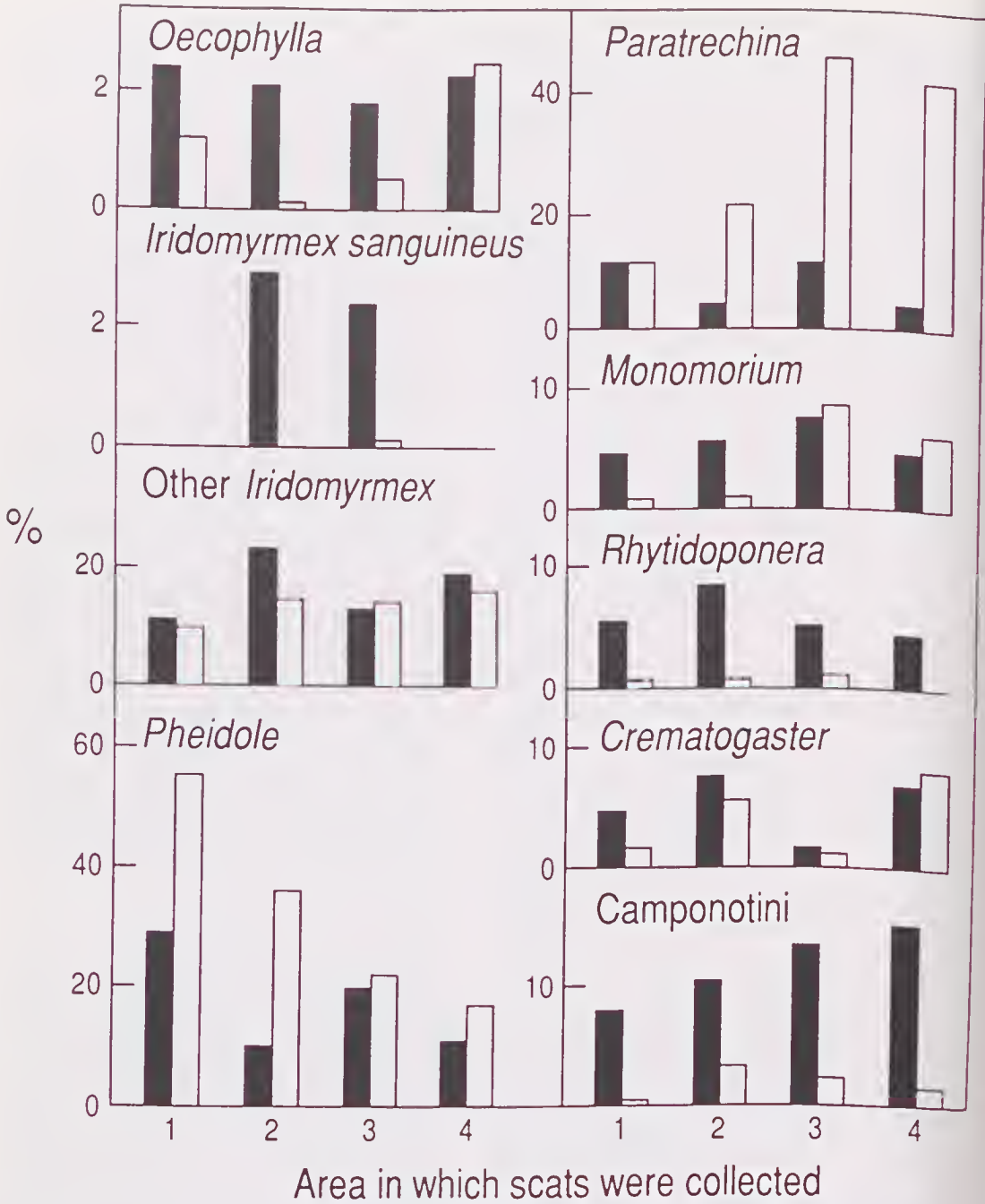

Fig. 5. Distribution (% frequency, solid bars, and % relative abundance, open bars) of some major ant taxa in scats according to area and habitat. Area 1 is monsoon forest, Areas 2 and 3 are dry escarpment, Area 4 is wet escarpment. Note variation of scale of the abscissa. The Camponotini comprised the genera *Camponotus*, *Opisthopsis* and *Polyrhachis*.

The low abundance of *Rhytidoponera* in relation to the apparently high abundances of *Pheidole* and *Paratrechina* in scats (Fig. 4) is accounted for by the fact that the *Rhytidoponera* workers are solitary rather than group-

or column-foragers, the echidnas apparently picking up single workers on the soil surface. *Pheidole* and *Paratrechina* are both common genera especially in habitats where the diversity of the rest of the ant fauna is reduced.

They occur in disturbed areas (both genera), on water-logged sites (*Paratrechina*) and on the floor of monsoon rainforest, from which many ants seem to be excluded by shade and low maximum temperatures. An alternative explanation for the high relative abundances of *Pheidole* and *Paratrechina* demonstrated in Figure 4 is that these are a consequence of a relatively low abundance in the echidna's diet of the genus *Iridomyrmex*, even though this is the second-most frequent genus in scats. This does not quite seem to fit the pattern of opportunistic foraging. This applies equally to two other important genera: *Oecophylla* and *Crematogaster*.

The frequencies of these three genera in scats (Table 7, Fig. 5) were lower than would be predicted from the 1983 data, which may be an artefact of the sampling method. Members of these genera are, or include, dominant and strongly territorial species that are frequent at, and monopolize, sardine baits, especially those on trees. Thus, as a measure of importance in the ground layer their frequencies were over estimated by the sampling methods in January 1983. Another contributing factor is that *Oecophylla* and some species of *Creमतogaster* are arboreal nesting ants. Consequently, most of these anomalous data are artefacts of sampling.

Despite the fact that *Oecophylla* and the meat-ant, *Iridomyrmex sanguineus* are "dominants" in the Alligator River-Kakadu region, and both exhibit populous colonies and have large-sized workers (Greenslade 1985), both ants were not prevalent and occurred only in low abundance in these scats (Fig. 5). *Iridomyrmex sanguineus* was not present at all in scats from Area I, which is monsoon rainforest where the meat ant is not found (Greenslade 1985). In other habitats *I. sanguineus* and *Oecophylla* have mutually exclusive distributions at the colony level: *Oecophylla* was most abundant in the areas in which meat ants were not present in the scats. The infrequency and low abundance of *O. smaragdina* and *I. sanguineus* can be related to the former's primarily arboreal habit, whereas for the latter actual avoidance may be indicated since *I. sanguineus* is a particularly ferocious ant, attacking in large numbers any intruder at the colony. The mound colonies of a closely related and equally ferocious meat-ant, *Iridomyrmex purpureus* (formerly *I. detectus*) are, however, attacked by echidnas

during August-October in southern parts of Australia (Griffiths and Simpson 1966), whereas during the rest of the year the colonies are avoided. However, these echidnas at that time are emerging from torpidity or hibernation, and consequently they require energy-rich food. This is supplied by the fat-bodies of the enormous (2 cm body length) virgin queens which come to the surface of the mound at that time of the year. Since this behaviour is a matter of necessity, the echidnas must endure the torment of the bites of the workers to get at the queens (Griffiths and Simpson 1966). This phenomenon would not apply to the Kakadu echidna since ambient temperatures never fall low enough to induce torpor, and consequently the necessity to seek out energy-rich meat-ants does not arise. In all probability the low frequency and abundance of meat-ants in the Kakadu scats can be related to their ferocity.

Another instance of possible avoidance of an ant by echidnas is the fact that the genus *Calomyrmex* occurs at Kakadu, although not abundantly (A.N. Andersen, personal communication), yet it was not recognised in scats. This genus produces a secretion from its mandibular gland which has been shown to be distasteful to, and to repel a number of insectivorous vertebrates (Brough 1978).

CONCLUSION

Abensperg-Traun (1988) found that *T. a. acanthion* living in the wheatbelt of Western Australia forages opportunistically, ingesting its prey - ants and termites - in proportions as encountered. Our study shows that *T. a. acanthion* in tropical habitats likewise forages opportunistically, so that its diet is largely a straightforward reflection of the composition of the ground-layer ant and termite-fauna.

ACKNOWLEDGEMENTS

We are grateful to Dr. A.N. Andersen for comments on the ant fauna of Kakadu; to Dr. Graham Brown for statistical analyses; to Dr. Richard Braithwaite, Mrs. Billie Gill and Messrs. Andrew Griffiths and John Wombey for assistance in collecting scats and termites.

REFERENCES

- Abensperg-Traun, M.A. 1988. Food preferences of the echidna; *Tachyglossus aculeatus* (Monotremata: Tachyglossidae) in the wheat-belt of

- Western Australia. *Australian Mammalogy* **11**: 117-123.
- Augee, M.L. 1978a. Metabolic consequences of subspecific pelage variations in the echidna. *The Australian Zoologist* **20**: 105-109.
- Augee, M.L. 1978b. Monotremes and the evolution of homeothermy. *The Australian Zoologist* **20**: 111-119.
- Bolton, B. 1987. A revision of the *Solenopsis* genus-group and revision of Afro-tropical *Monomorium* Mayr (Hymenoptera: Formicidae). *Bulletin of the British Museum (Natural History), Entomology* **54**: 263-452.
- Braithwaite, R.W. and Dudzinski, M.L. (unpublished). Kakadu Fauna Survey interim Report to Australian National Parks and Wildlife Service, January 1983. CSIRO Division of Wildlife and Rangelands Research.
- Braithwaite, R.W., Miller, L. and Wood, J.T. (unpublished). The ecological role of termites in Kakadu National Park. In: *Kakadu Fauna Survey Final Report*. Volume 2: 389-429, with Appendix VII. Volume 4.
- Braithwaite, R.W., Miller, L. and Wood, J.T. 1988. The structure of termite communities in the Australian tropics. *Australian Journal of Ecology* **13**: 374-391.
- Brough, E.J. 1978. The multifunctional role of the mandibular gland secretion of the Australian desert ant, *Calomyrmex* (Hymenoptera: Formicidae). *Zeitschrift für Tierpsychologie* **46**: 279-297.
- Christian, C.S. and Aldrick, J.M. 1977. *Alligator Rivers Study. A review Report of the Alligator Rivers Region Environmental Fact-finding Study*. Australian Government Publishing Service: Canberra.
- Deligne, J., Quennedey, A. and Blum, M.S. 1981. The Enemies and Defence Mechanisms of Termites. In: H.R. Hermann (ed.) *Social Insects* Volume 2: 1-76. Academic Press: New York.
- Greenslade, P.J.M. 1985. Preliminary observations on ants (Hymenoptera:Formicidae) of forests and woodlands of the Alligator Rivers regions, N.T. *Proceedings of the Ecological Society of Australia* **13**: 153-160.
- Griffiths, M. 1968. *Echidnas*. Pergamon Press: Oxford, New York, Paris.
- Griffiths, M. 1978. *The Biology of the Monotremes*. Academic Press: New York.
- Griffiths, M. 1989. Tachyglossidae. In: B.J. Richardson and D. Walton (eds) *Fauna of Australia*. Volume 1B. Australian Government Publishing Service: Canberra.
- Griffiths, M. and Simpson, K.G. 1966. A seasonal habit of spiny ant-eaters. *Commonwealth Scientific and Industrial Research Organisation Wildlife Research* **11**: 137-143.
- Harper, J.F. 1984. Peritz's F. test, BASIC program of a robust multiple comparison test for statistical analysis of all differences among group means. *Computing in Biology and Medicine* **14**: 437-445.
- Kerle, J.A. and Burgman, M.A. 1984. Some aspects of the ecology of the mammal fauna of the Jabuluka area, Northern Territory. *Australian Wildlife Research* **11**: 207-222.
- Moore, B. 1968. Studies on the chemical composition and function of the cephalic gland secretion in Australian termites. *Journal of Insect Physiology* **14**: 33-39.
- Smith, A.P., Wellham, C.S. and Green, S.W. 1989. Seasonal foraging activity and micro-habitat selection by echidnas (*Tachyglossus aculeatus*) on the New England Tablelands. *Australian Journal of Ecology* **14**: 457-466.

Accepted 1 May 1990

FURTHER OBSERVATIONS ON THE MORPHOLOGY OF
WAKALEO VANDERLEUERI (MARSUPIALIA:THYLACOLEONIDAE)
FROM THE MID-MIOCENE CAMFIELD BEDS,
NORTHERN TERRITORY

PETER MURRAY¹ AND DIRK MEGIRIAN²

¹Northern Territory Museum of Arts and Sciences,
GPO Box 2109, Alice Springs NT 0871, Australia.

²Northern Territory Museum of Arts and Sciences,
GPO Box 4646, Darwin NT 0801, Australia.

ABSTRACT

We describe new *Wakaleo vanderleurei* material from the Bullock Creek Local Fauna that gives an improved estimation of the range of variability of the species. The morphological bases for the discrimination of the species *W. vanderleurei* from *W. oldfieldi* are not as consistent as previously thought, but the distinction could continue to be retained as a chronospecies designation. The Late Miocene *Wakaleo alcootaensis* shows no tendency to overlap with *W. vanderleurei* at the large end of the morphocline. A distal radius fragment assigned to *Wakaleo* is described. The wrist joint of *Wakaleo* was less mobile than that of *Priscileo* Rauscher, 1987. A brief review of the phylogenetic relationships of the Thylacoleonidae and a consideration of the position of the wakaleonines based on the described material is given.

KEYWORDS: Thylacoleonidae, *Wakaleo* species, biochronology, systematics, morphology.

INTRODUCTION

The Thylacoleonid species *Wakaleo vanderleurei* (Clemens and Plane, 1974) was based on a dentary fragment containing M_2 and the empty alveoli for the remaining cheek teeth. *Wakaleo vanderleurei* was distinguished from *W. oldfieldi* (Clemens and Plane, 1974) on the basis of larger molars and dentary size and strong anterior and labial ridges descending from the apical cusp of M_2 . Additional diagnostic characters were given as: P_3 absolutely and relatively larger than in *W. oldfieldi* and the M_2 talonid basin of subrectangular, as opposed to oval, outline. On the basis of the close similarity of the species, Clemens and Plane (1974) considered *W. oldfieldi* to be directly ancestral to *W. vanderleurei*.

Megirian (1986) compared an almost complete *W. vanderleurei* dentary with the *W. oldfieldi* holotype, attributing differences in the dentary shape to evolutionary trends within the lineage. The cranium of *W. vanderleurei* was described by Murray *et al.* (1987).

Existing cranial material of *W. cf. oldfieldi* (Archer *et al.* 1989) has not been described. Subsequently recovered *Wakaleo* material from the Bullock Creek Local Fauna has resulted in a small collection of four well-preserved dentaries, a fragment of maxilla and a few examples of possible wakaleonine postcranial material, including a distal radius showing some features of possible functional significance.

At present, the geochronology of depositionally isolated Tertiary aged vertebrate sites in Australia is determined by the stage of evolution of a small suite of diprotodontoid marsupials (Woodburne *et al.* 1985). Consequently it is important to document the range of variation of significant chronospecies from various localities. The apparent gradual, linear evolution of *Wakaleo* species combined with the increasing evidence that they are not especially rare fossils, may indicate that the wakaleonines are at least as useful for stage-of-evolution geochronology as the zygomatic diprotodontids. The morphological overlap in *Wakaleo* and other chronospecies

(e.g. *Neohelos tirarensis*) from Miocene-aged localities in Australia offers the possibility of a refined geochronological faunal calibration, assuming that the trends are time-related.

Abbreviations used in the text are as follows: CPC, Commonwealth Palaeontological Collection, Canberra; NTM, Northern Territory Museum, Darwin; SAM, South Australian Museum, Adelaide; UCMP, University of California Museum of Paleontology, Berkeley.

SYSTEMATICS

Family Thylacoleonidae

Wakaleo vanderleueri Clemens and Plane

Wakaleo vanderleueri Clemens and Plane, 1974: 656-660, pl. 1, text-fig. 2.

Material. NTM P87108-6, left dentary with P_3 - M_3 ; NTM P87108-5, left dentary with I_1 - M_3 ; NTM P8695-97, right dentary fragment with $M_{3,4}$; NTM P87103-9, left maxilla retain-

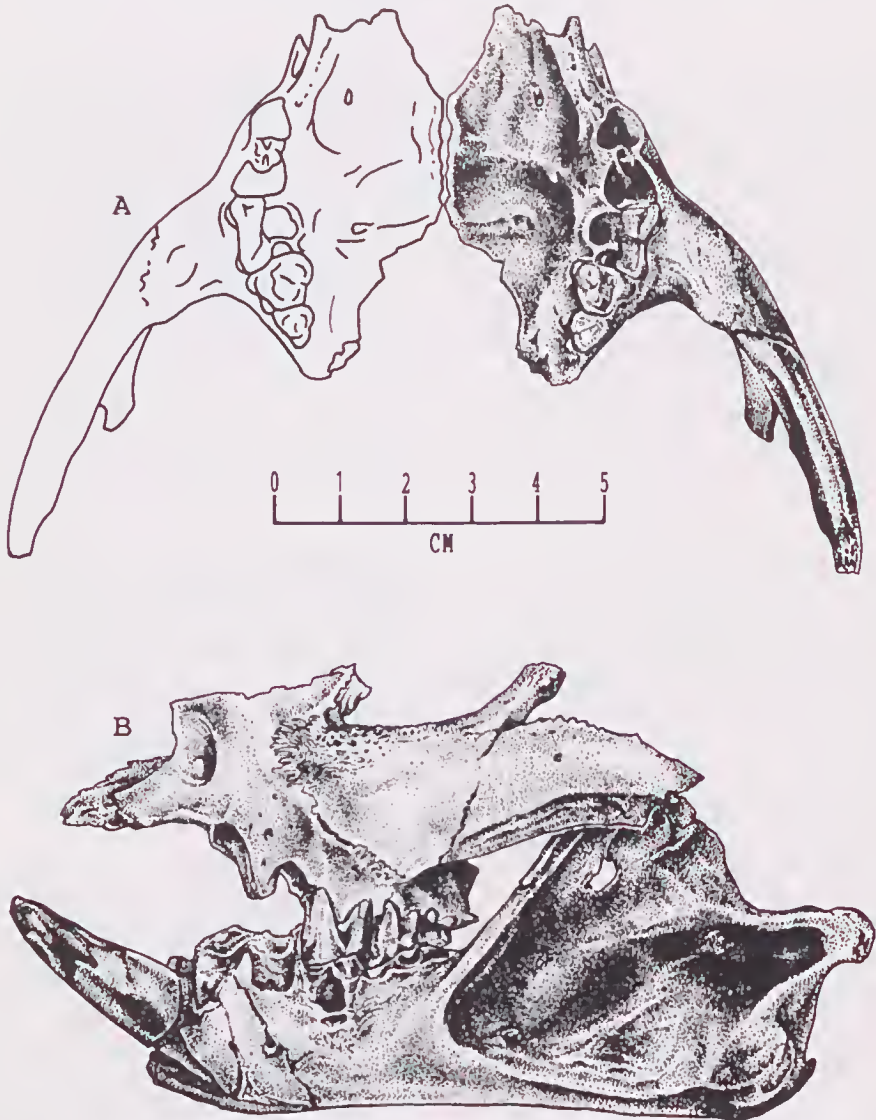

Fig. 1. Newly recovered acetic acid prepared *Wakaleo vanderleueri* cranial material from the mid-Miocene Bullock Creek Local Fauna. A, Ventral aspect of left maxilla (NTM P87103-9) depicted as a mirror-image restoration; B, partial restoration of *W. vanderleueri* skull in lateral aspect combining maxilla (NTM P87103-9) with left dentary (NTM P87108-5). Note heavily worn incisor, eroded alveolar bone below M_2 in dentary NTM P87108-5, complex maxillo-jugal suture and characteristic rugosity of the bone below the orbit in NTM P87103-9.

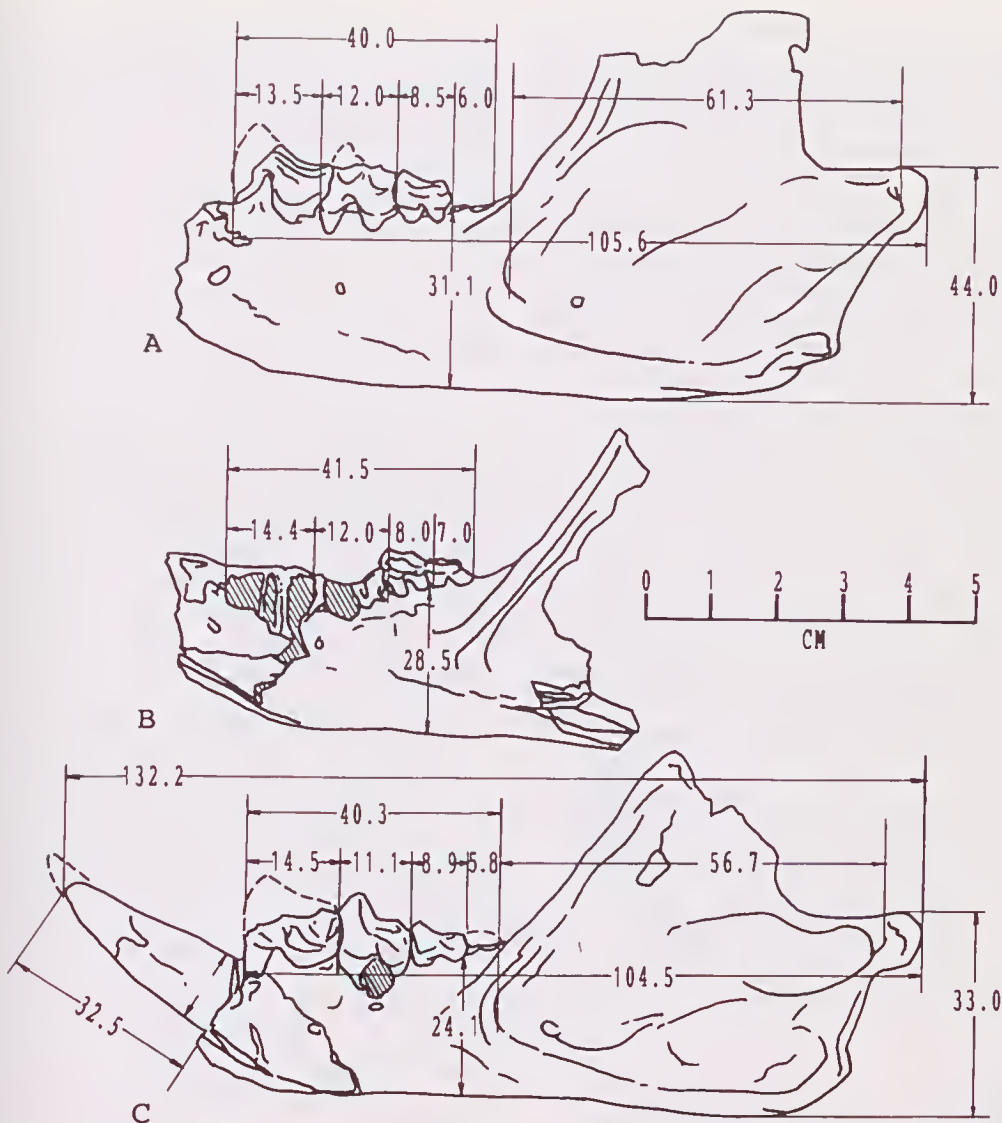

Fig. 2. Variations in size and shape of three *W. vanderleuerei* dentaries from the Bullock Creek Local Fauna. A, left dentary NTM P87108-6; B, right dentary NTM P8695-97 (reversed for comparison); C, NTM P87108-5, left dentary resembling the type specimen of *W. oldfieldi* (SAM P17925). Measurements of the teeth give the dimensions of the alveoli, not the tooth crowns, and are not intended to be equated with the crown measurements given in Table 1.

ing M_{2-4} ; NTM P8695-95, distal fragment of left radius; NTM P8695-96, isolated left M_4 .

Age. The Bullock Creek Local Fauna is estimated to be mid-Miocene age (Serravalian Stage); post-Kutjamarpu/ pre-Alcoota (Clemens and Plane 1974).

Description. Maxilla: The maxilla of *W. vanderleuerei* has been described by Murray *et al.* (1987). NTM P87103-9 is very similar to CPC 26604. It differs from the previously described specimen in lacking an alveolus for

the P_2 , in having a slightly longer diastema and a smaller canine alveolus (Fig. 1A, B).

Dentaries: The dentary morphology of *Wakaleo* species has already been described in detail by Clemens and Plane (1974) and Megirian (1986). The recently discovered Bullock Creek *Wakaleo* specimens will therefore be considered on a comparative basis by reference to Figures 1B, 2A-C, 3A-C, 4A, B and Tables 1-2. NTM P87108-6 (Fig. 2A) is a robust specimen with a deep horizontal ramus,

shallow masseteric fossa and a weakly developed anteecondylar fossa, a thumb-print sized depression situated within the masseteric fossa, immediately anterior to the condyle. In shape and proportions it strongly resembles the isolated left dentary (NTM P85553-4) described by Megirian (1986), but is distinctive in having a deep anteecondylar fossa and sharply delineated crests surrounding the masseteric fossa. NTM P87108-5 (Fig. 2B) has a much shallower horizontal ramus than either of the above specimens. It is otherwise quite thick, with a marked convexity to its lateral surface. NTM P87108-5 (Figs 1A, 2C, 6C) is remarkable for its gracility, and except for its slightly larger size (about 10%) it is nearly identical to the holotype of *W. oldfieldi* (SAM P17925). It departs from *W. oldfieldi* in having a deep anteecondylar fossa, though other *W. vanderleuerei* specimens indicate that this is a variable feature (Fig. 2A; Table 2).

Lower incisor: NTM P87108 (Fig. 3A-C) retains the I_1 , which was previously unknown for the species *W. vanderleuerei*. Although very worn at the tip, the incisor is much like that of *W. oldfieldi*. The enamel crown envelopes the entire apical portion of the tooth. The incisor has a flattened, asymmetrically elongated, oval section. The distinctly triangular shape of the lower incisor crown of *Thylacoleo carnifex* is scarcely, if at all, apparent in *W. van-*

derleuerei. The ventral contour of the tooth is a smooth arc, that if projected beyond the worn tip of the crown, would result in the slightly hooked caniniform shape, distinctive in *W. oldfieldi*. This assumption is also supported by the orientation of the breached nerve canal. The dorsolabial enamel flange that was apparently present is entirely worn away in the specimen. The lingual surface of the tooth is flat and presents a well-developed interproximal wear facet over the distal third of the tooth. This indicates considerable mobility of the dentaries at the symphysis.

The extensive wear on the crown of the incisor of NTM P87108-5 indicates that *Wakaleo* dentitions were involved in more than puncturing wounds, breaching the hides of their prey and slicing off chunks of flesh. The crown is deeply worn dorsally exposing a considerable length of the cementum, dentine and nerve canal. The wear continues around the apex of the crown extending along its ventral surface for at least 5.0 mm.

Lower cheek teeth: The condition of the lower cheek teeth of *W. vanderleuerei* also seems to indicate extremely hard usage, which is not restricted to observations of considerable P_3 crown attrition. Two of the four examples have apical abscesses around the P_3 roots. NTM P8695-97 appears to have had a condition similar to "lumpy-jaw". These

Table 1. Dimensions of the cheek dentitions of *Wakaleo* spp (in millimetres). Data is taken from Clemens and Plane (1974), Megirian (1986), Murray *et al.* (1987), and Archer and Rich (1982). Brackets indicate estimated dimensions.

SPECIES/NUMBER	CHEEK DENTITION - LOWER											
	P_3			M_2			M_3			M_4		
	L	AW	PW	L	AW	PW	L	AW	PW	L	AW	PW
<i>W. oldfieldi</i> SAM P17925 UCMP 102677	12.4	6.2	7.8	10.4	8.7	7.2	7.5	6.3	6.1			
<i>W. vanderleuerei</i> NTM P87108-6 NTM P8695-97 NTM P87108-5 NTM P8695-96 CPC 13527 NTM P85553-4	[14.2]	6.3	7.6	11.3	[8.5]	7.7	9.4	6.3	6.8	6.0	4.2	4.7
	[14.5]	5.7	7.2	12.0	8.2	7.4	9.8	6.3	6.1	5.8	4.1	4.0
	13.9	-	[7.1]	11.7	7.9	7.7	7.6	5.5	5.2			
				9.6	-	[6.5]						
	CHEEK DENTITION - UPPER											
	P_3		M_2		M_3		M_4					
	L	W	L	W	L	W	L	W	L	W		
<i>W. vanderleuerei</i> CPC 26604 NTM P87103-9	17.9	9.2	11.2	11.0	7.0	9.5	5.0	5.5	5.6	5.8		
					7.5	8.4						
<i>W. alcootaensis</i> NTM P1	24.4	9.9	14.7	15.7	7.2	9.0						

Table 2. Summary of character expressions in *Wakaleo* spp. Symbols used: +, present; -, absent; ?, unknown.

CHARACTER	SPECIES		
	<i>W. oldfieldi</i>	<i>W. vanderleuerei</i>	<i>W. alcootaensis</i>
Small P_3	+	-	?
Cheek teeth wide	+	-	?
Crest on m_2	-	+?	?
Oval talonid basin	+	++	?
Antecondylar fossa	-	+-	?
Masseteric crests	+	++	?
Subcondylar fossa	-	+	?
Gonial angle	-	+-	?
Dentary depth	-	+-	?
Pterygoid fossa	-	+-	?
Posterior strut	-	+	?
P_2	+	+-	-

pathological signs were probably caused by impactions of bone splinters and extreme occlusal forces being exerted on the roots.

The dimensions of *W. vanderleuerei* cheek teeth vary, (Table 1) and in some instances closely approximate or overlap with those of *W. oldfieldi*. Although no complete *W. vanderleuerei* P_3 is available, the NTM P85553-4 example is at least 1.5 mm longer than that of the *W. oldfieldi* type. The estimated lengths of the other two *W. vanderleuerei* P_3 's support the observation that a longer P_3 is consistent for the species. The differences between the *W. oldfieldi* holotype and our sample of *W. vanderleuerei* can be accentuated somewhat by comparing proportional differences between cheek tooth lengths and widths (McGirian 1986) but even here, the distinction is relatively minor (Fig. 4A, B). Such a difference could be attributed to individual variation, to allometry or could relate to sexual dimorphism. The overall differences between the two species in evidence so far could be duplicated in contemporaneous geographic morphs in many widespread mammalian species, eg. among geographic races of *Trichosurus vulpecula*.

Other possible distinctions between *W. oldfieldi* and *W. vanderleuerei*, the subrectangular talonid basin and strong anterior and labial ridges on the apical cusp of M_2 are not supported by the additional material. Due to wear, the existence of a consistent labial ridge on the M_2 of any specimens other than on that of CPC 13527 (Clemens and Plane 1974) has not been verified. The subrectangular talonid basin observed in CPC 13527 is a variable feature: both NTM P87108-6 and NTM P87108-5 have oval talonid basins, as in *W. oldfieldi*.

Distal radius fragment: The postcranial skeleton of *Wakaleo* species is largely un-

known. Foot elements of thylacoleonids have been recovered from the Alcoota Local Fauna that probably represent *Wakaleo alcootaensis*. The only material of a distinctive nature that can be confidently assigned to *Wakaleo vanderleuerei* is a radius fragment (NTM P8695-95). We describe this specimen because it appears to express some functional contrasts with both *Priscileo* and *Thylacoleo*.

The specimen consists of approximately one-third of the distal end of a left radius within the size range expected for an animal with a skull the size of *Wakaleo* (Fig. 5A-C). Its distinctive thylacoleonid features include a broad, flattened distal diaphysis, anteroposteriorly compressed, shallow scapholunar articular surface, prominent, pointed styloid process and prominent ulnar process (DeVis 1900).

The crests and surfaces for muscle and connective tissue attachments on the fragment are interpreted in relation to Barbour (1963) for the brushtailed possum (*Trichosurus vulpecula*) and Rauscher's (1987) interpretation of *Priscileo*. The anterior surface of the

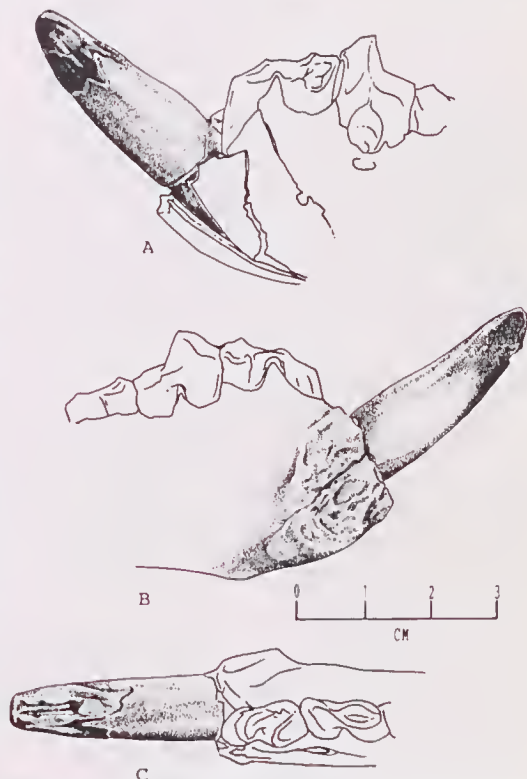

Fig. 3. Left I_1 of *Wakaleo vanderleuerei*. A, labial aspect; B, lingual (interproximal) aspect; C, dorsal aspect.

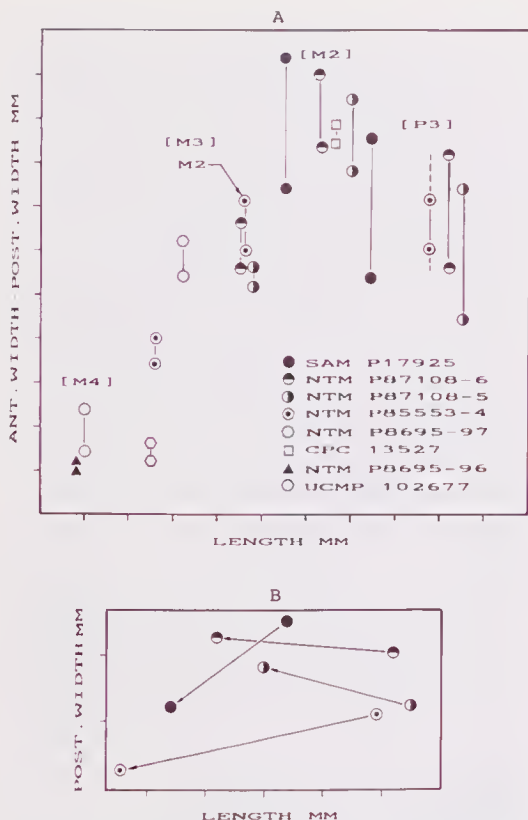

Fig. 4. Scatter diagrams of lower check tooth dimensions in *Wakaleo* spp. A, Linear plot of tooth-length by anterior width and posterior width, the latter two dimensions being depicted by connecting them with a vertical line - species designations of specimens listed by accession numbers are given in Table 2; B, log-linear plot of P_3 and M_2 - arrow draws attention to the trending relationship of length to width ratio of P_3 to M_2 for each specimen. Symbols correspond to the key for graph A. Because many of the teeth are imperfect, the graph depends upon estimates. These are designated in Table 1 by brackets.

fragment is slightly convex. On the ulnar side of a low crest, a broad, shallow concavity is present for the extensor carpi radialis and extensor digitorum communis tendons. The fragment preserves a groove for the attachment of the abductor pollicis longus and extensor pollicis brevis tendon anterodorsal to the styloid process.

The styloid process is triangular with its apex directed posteriorly. The posterior surface of the styloid process bears a triangular facet which participates in the formation of a shallow, shelf-like crest dorsally for the attachment of the radiocarpal ligaments. The crest for the radiocarpal ligaments ("posterior crest" of Rauscher 1987) is robust and extends across the epiphysis in a shallow arc.

Immediately dorsal to the styloid process, a tuberosity, apparently for restraining the abductor pollicis tendon is conspicuously developed (Fig. 5C, apl. br?). Its degree of development suggests that the brachioradialis probably inserted on the dorsal surface of the tuberosity rather than on the dorsal aspect of the scaphoid. The ulnar articular surface is

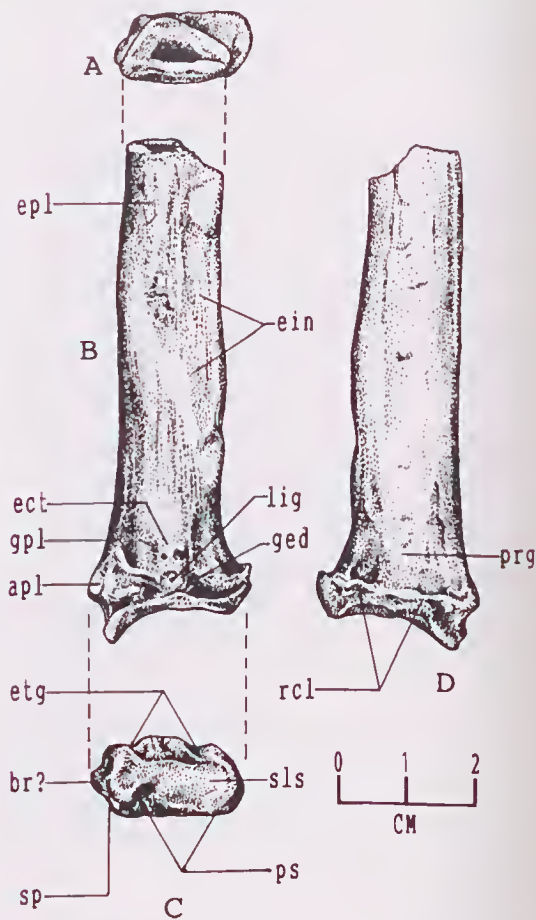

Fig. 5. Distal left radius fragment (NTM P8695-95) considered by the authors to represent *Wakaleo vanderleueri*. A, section viewed from the proximal end of the fragment; B, extensor side; C, distal aspect showing scapholunar articular surface; D, flexor side. Abbreviations relating to inferred muscle and ligamentous scars: epl, extensor pollicis longus; ect, extensor carpi tendons; apl, abductor pollicis longus and extensor pollicis brevis (extensor ossi carpi pollicis); etg, grooves for extensor tendons; br?, probable insertion of the brachioradialis muscle (as in anthropoid primates?); sp, styloid process; sls, scapholunar surface; ged, groove for extensor digitorum communis tendon; lig, ligamentous scar; ein, scar of extensor indicis or extensor pollicis (brevis?); prg, groove for the pronator muscle; rcl, crest for the radiocarpal ligaments; ps, posterior shelf; gpl, groove for extensor pollicis longus.

smooth and convex and not directed obliquely posteriorly. A flattened area of the anterior diaphysis about 25.0mm from the articular

surface appears to represent the distal origin of the extensor pollicis. A low crest divides this surface, implying the incipient differentiation

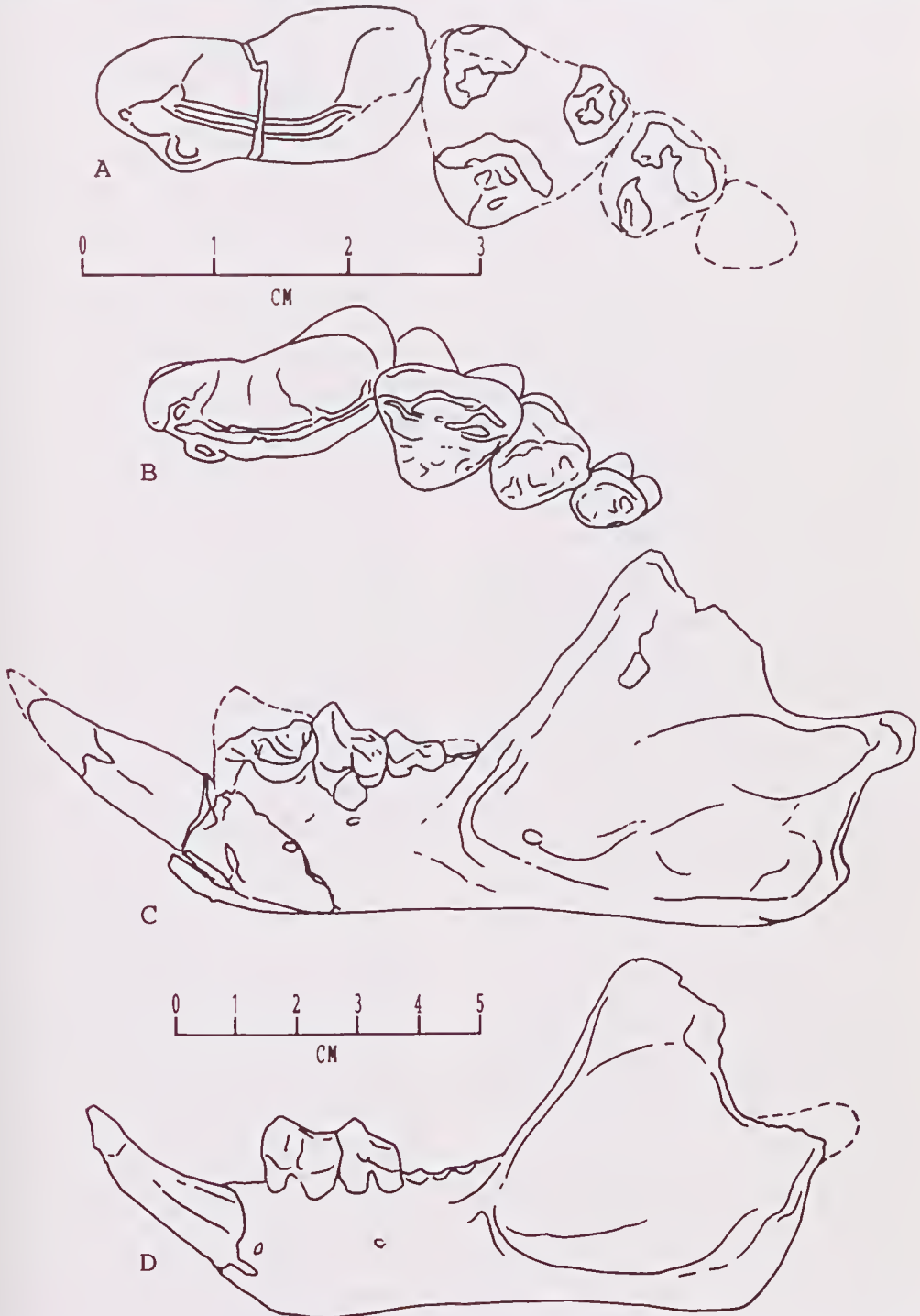

Fig. 6. Sealed outline sketches of the three *Wakaleo* species. A, upper cheek teeth of *W. alcootaensis*, (after Archer and Rieh 1982); B, upper cheek teeth of *W. vanderleueri*, CPC 26604, (after Murray *et al.* 1987); C, dentary of *W. vanderleueri*, NTM P87108-5; D, dentary of *W. oldfieldi*, SAM P17925.

of the pollical extensors as observed by Rauscher (1987) for *Priscileo*. The thin, flange-like expansion on the mesial border of the fragment represents the area of attachment of the interosseous membrane.

Comparing the three known thylacoleonid genera; the distal articular surfaces show increasing anteroposterior compression in the order: *Priscileo*, *Wakaleo*, *Thylacoleo*. This is largely due to the reduction of the posterior crest of Rauscher (1987) and appears to be related to the range of movements of the wrist joint, determined in part, by the radiocarpal ligaments.

The broader, arcing radiocarpal ligamentous attachment in *Priscileo* appears to have provided strong resistance to tensional forces on the wrist joint over a wide range of radiocarpal postures, indicating considerable wrist mobility. Tensional resistance combined with mobility is also reflected in the more elongated and robust styloid process for the attachment of the radiocollateral ligaments.

The radiocarpal articulation is more hinge-like in *Thylacoleo* than in the other two genera, the *Wakaleo* specimen being intermediate. We conclude that *Wakaleo* was less agile than *Priscileo*, but this does not exclude the possibility that *Wakaleo* was arboreal: its wrist joint places it well within the range of a scansorial climber, but might reasonably exclude it from the terminal branch gymnastics that *Priscileo* would have been capable of.

Remarks. Megirian (1986) supported Clemens and Plane's (1974) species diagnosis of *W. vanderleuerei* by confirming the presence of a relative and absolute enlargement of the P_3 compared to M_2 in the second, more complete Bullock Creek specimen (NTM P85553-4) from the Northern Territory Camfield Beds. The Camfield specimen failed to confirm Clemens and Plane's (1974) observation of the presence of a subrectangular as opposed to oval talonid basin and the presence of strong anterior and labial ridges descending from the apical cusp of M_2 .

The specimen, moreover, exhibited a suite of characters that seemed to enhance the proposed specific designation. These additional, potentially diagnostic characters include the elaboration of the masseteric fossa by a deep oval depression anterior to the condyle and a conspicuous oval depression immediately below the condyle. Megirian (1986) related

these details to a proportionally enlarged adductor complex and a capacity for increased gape. The combination of these and other features resulted in a strongly contrasting visual impression of the two specimens and there seemed to be little doubt that the two species could be consistently distinguished by comparative inspection.

The new Bullock Creek dentary specimens of *Wakaleo vanderleuerei* indicate that the distinctions from *W. oldfieldi* are more subtle and probably less reliable than originally thought. Specimen NTM P87108-5 exhibits the slender horizontal ramus, steeper gonial angle and overall proportioning of the *W. oldfieldi* holotype as faithfully as might be expected of any conspecific (Figs 1B, 3C, 6D). It differs only in being slightly larger, on the order of about 10% overall, although like NTM P85553-4 (Megirian 1986; Fig. 1) it possesses a deep antecondylar fossa. However, a larger, more robust *W. vanderleuerei* specimen (NTM P87108-6), similar to NTM P85553-4 has a poorly developed antecondylar fossa, no more conspicuous than that of SAM P17925, the *W. oldfieldi* holotype.

Other characters found to merge between the two species include the expression of an oval talonid basin in the M_2 of *W. vanderleuerei* and the variable relative proportions of the cheek dentitions (Table 1). Although our Bullock Creek sample is too small for probability testing, the considerable morphological variability of the population is readily apparent. The combined *Wakaleo* spp. show a similar range of variation to some other taxa from these Miocene localities, particularly the widespread zygomatic diprotodontid *Neohelos tirarensis*. The larger *Neohelos* from the Bullock Creek Local Fauna was initially thought to be specifically distinct from the Tirari, Wipajiri and Riversleigh populations. Re-examination of these populations demonstrates that the variations within a local fauna are about as great as the differences between local faunas. In the absence of any discrete morphological criteria upon which to base a specific differentiation, we conclude that *W. vanderleuerei* represents a slightly larger and perhaps younger extreme of the chronocline of *W. oldfieldi* populations.

Wakaleo alcootaensis (Archer and Rich 1982) is also a very similar species (Fig. 6a). Unfortunately, no lower dentitions have been

recovered. The maxillary fragment is morphologically similar to *Wakaleo vanderleueri* but is about 25% larger. The ratio of P_3 to M_2 length is the same as in *W. vanderleueri* and the width to length proportions of the P_3 are almost identical. Judging from what is available for comparison, *Wakaleo alcootaensis* retains all the essential features of the smaller *Wakaleo* species while revealing no characters that would suggest an ancestral relationship to any other thylacoleonid taxa, nor any significant morphological difference, other than larger size that would indicate any deviation from the adaptive zone of its ancestral population. Archer and Rich (1982) observed that $P_{1,2}$ are absent in the Alcoota specimen. *Wakaleo vanderleueri* shows that the presence or absence of the P_2 is variable by virtue of its absence in a newly acquired specimen (NTM P87103-9) and the presence of the tooth in CPC 266904 (Murray *et al.* 1987); (Table 2). Thus the grounds for discriminating *W. alcootaensis* from *W. vanderleueri* rest predominately, if not entirely upon its larger size and the inference of its younger geological age.

The absence of a clear morphological distinction other than size among these species is by no means an unusual situation in the Australian marsupial fossil record, where the phenomenon of "morphic" speciation is a familiar theme in later Tertiary assemblages. In Quaternary faunas, a consistent size difference of about 25% or more between two otherwise morphologically identical populations has, more often than not, resulted in the designation of separate species (for example see Bartholomai 1975 for a discussion of the differences among *Macropus giganteus*, *M. titan* and *M. birdselli*).

On the basis of the available evidence we consider that the priority designation *Wakaleo oldfieldi* (Clemens and Planc, 1974) is the systematically valid species, whereas *W. vanderleueri* represents a chronospecies, the discrimination of which will ultimately depend upon arbitrations of the morphocline extending to *W. alcootaensis*.

In the case of *W. alcootaensis*, a poorly preserved specimen, there is some reservation in equating the degree of molar reduction relative to the premolar with that of *W. oldfieldi* and there is substantial evidence in support of its significantly younger geological age (probably two to three million years younger

than Bullock Creek), whereas an age difference between the Wipajiri Formation and the Camfield Beds is difficult to demonstrate other than by the minor differences implied by comparable elements of their respective faunas.

We recognize the utility of formally designating chronospecies in palaeontology and support the need for making such discriminations, but draw attention to the problematic genetic and phylogenetic implications, and more importantly, the assumption that geographic distance and crudely interpolated geological age differences provide a sufficient basis for a species separation. In this particular case, the subtle differences between the Bullock Creek and Wipajiri specimens give the impression of a gradually evolving form and thus, the basic idea put forth by Clemens and Planc (1974) will probably be supported by new evidence. The problems arise when *Wakaleo* material, particularly in the form of isolated fragments, is eventually recovered in a new locality and the geochronology of the site becomes founded on the basis of little more than the size of a tooth.

Wakaleo cf. oldfieldi is also known from the Carl creek Limestone at Riversleigh, Queensland. Archer *et al.* (1989) consider their specimens to be intermediate between the Wipajiri and Etadunna equivalents. A possible earlier *Wakaleo* sp. specimen has been recently recovered from Riversleigh (Mike Archer, personal communication). It is among the earlier forms of *Wakaleo* that we might anticipate some significant morphological distinctions, perhaps with connections to *Priscileo* or *Thylacoleo*.

DISCUSSION

Wakaleo phylogeny. Although *Wakaleo*'s check dentition is more derived than that of *Priscileo* Rauscher 1987, the retention of an alisphenoid tympanic wing in *Wakaleo* indicates that its basicranium is the least derived of the known thylacoleonids and moreover, leaves the question open as to a possible phalangeridan affinity for the group (Murray *et al.* 1987). Thylacoleonids are clearly an ancient group, with no especially close affinities to any of the living Australian marsupials. Since the time of Owen, the overall similarity of the thylacoleonids to various phalangeridan

groups (burramyids, petaurids and phalangerids in particular) has been recorded.

It is therefore with some trepidation that Aplin and Archer (1987) placed the thylacoleonids within the Vombatimorphia, explaining that the essential phalangerid characters of thylacoleonids are either plesiomorphic or parallel conditions. In fact, there are few unequivocal vombatimorphian synapomorphies in evidence in *Wakaleo*, whereas *Thylacoleo carnifex* supports their observations remarkably well (Murray *et al.* 1987).

Speculating on what is known so far of the group, it can be assumed that the ancestral thylacoleonids were about the size of brush-tailed possums and basically similar in appearance. They were arboreal, based on the morphology of the limb fragments of the small mid-Miocene *Priscileo pitikantensis* (Rauscher, 1987) and the proportions of complete skeletons of the derived Pleistocene form *Thylacoleo carnifex* (Wells and Nichol, 1977; Finch 1982). Our current knowledge of the family commences in the lower to mid Miocene, when both *Priscileo* and *Wakaleo* were present in the tropical forests of northern Australia.

Speculations on predaceous macropodoids aside, the medium to large bodied marsupial carnivore guild in Australia had not elaborated to the extent seen among placental mammals of equivalent age. In the mid-Miocene, the thylacoleonids are represented by the two genera, *Wakaleo* and *Priscileo*; The genus *Thylacoleo* is not yet in evidence. Our examination of the wrist joint of *Wakaleo* suggests a possible partitioning of the two genera, with *Priscileo* being an arboreal form. The heavily worn dentitions and root trauma in *Wakaleo*, suggestive of scavenging, might be taken as evidence of a terrestrial adaptation.

Other mid Miocene terrestrial carnivores include a minor radiation of small thylacinids, among them, the genus *Nimbacinus* Archer *et al.*, 1989. There appears to have been therefore, a simple carnivore guild spanning the arboreal and terrestrial adaptive zones in the predominately forested environments postulated for the mid Miocene of Australia. As these once coterminous forests became increasingly dissected by invading savanna grasslands in the later part of the Miocene, the partitioning of the carnivorous marsupial genera was accentuated. A fox-like forest

thylacinid gave rise to the larger, cursorial, savanna adapted genus *Thylacinus* which makes its appearance in the late Miocene Alcoota Local Fauna. The genus *Wakaleo* retained its progressively diminishing forest-edge adaptation, while *Priscileo* retreated with the forests to eventually become extinct, though not before giving rise (vicariantly) to a scansorial, semiterrestrial descendant, similar to *Wakaleo*. This mid- to late-Miocene thylacoleonid was the ancestor of *Thylacoleo carnifex*.

The first representatives of *Thylacoleo* (*Thylacoleo*) *hilli* Pledge, 1977 were about the same size as *Wakaleo alcootaensis* and may have been contemporaneous. As *Thylacoleo* species developed a stronghold in the forested east of Australia, *Wakaleo* may have become trapped in a diminished and deteriorating habitat by early Pliocene times and being unable to take refuge elsewhere due to competition from *Thylacoleo*, became extinct.

Assuming that our geochronological assessments of the relative ages of the Miocene Local Faunas are correct, *Wakaleo* appears to retain the same adaptive zone throughout its existence. It appears to be a slowly evolving form in which its primary modification is enlargement. A similar pattern is evident in certain other Miocene genera such as *Neohelos* and *Palorchestes*.

SUMMARY AND CONCLUSIONS

The Miocene genus *Wakaleo* contains three species of which one, *W. vanderleueri* shows few unequivocal distinctions from the nominal species *W. oldfieldi*. Because of the uncertainty of the geological ages of local faunas from which these forms were recovered, the assumption that the slightly larger *W. vanderleueri* represents a different species on chronological and geographic grounds alone is unsupported. The increased sample size of *W. vanderleueri* from the Bullock Creek Local Fauna points to a full morphological overlap with the Wipajiri specimen, analogous to the continuity observed in certain other species such as *Neohelos tirarensis*.

Wakaleo alcootaensis is too fragmentary to place under the same scrutiny. Its only distinction other than larger size from the Bullock Creek *Wakaleo* was the absence of P₂. Agensis of the P₂ is also found in the Bullock Creek

sample. There is abundant evidence however, to indicate that the Alcoota Local Fauna is significantly younger than either the Camfield Beds or the Wipajiri Formation. Moreover, the Alcoota species is about 25% larger than the largest Bullock Creek *Wakaleo*, a degree of difference often used to distinguish species of Pleistocene "giant" marsupials from their living counterparts (eg. *Macropus titan* from *Macropus giganteus*; *Sarcophilus harrisi* from *Sarcophilus lanianus*). The character of the Alcoota Local Fauna differs from all of the other Miocene local faunas in showing a marked increase in body size among many of its species, particularly in the case of the thylacines and the zygomaturine diprotodontids. Descendants of mid Miocene lineages from Alcoota also show morphological distinctions more appropriately designated as being generic.

The *Wakaleo* sample now at hand suggests a population continuity over a geologically significant period of time. Within the genus, there is a general conservatism of morphological features, with possibly only average size varying significantly through time. A fossil population showing monotonic variation of a single character or a restricted suite of characters is more realistically described as a single chronospecies rather than a number of species distinguished by provenance and arbitrary subdivisions of a morphocline. Nevertheless, the designation of chronospecies has utility in biochronology. Clemens and Plane (1974) recognized the probable population continuity of *W. vanderleueri*, which we recognize, together with *W. alcootaensis* as chronospecies, but only *W. oldfieldi* has phylogenetic validity.

Observations on the radius fragment assigned to *Wakaleo* indicate that its radiocarpal ligaments restricted the wrist mobility of *Wakaleo* more than in *Priscileo*. *Thylacoleo* shows a greater restriction of wrist movement than either of the other genera. The wear on the incisor and evidence of damage to the gums and alveoli of *Wakaleo* suggest that it was as much a scavenger as a predator. This pattern may indicate an at least partially terrestrial adaptation.

Speculation on the evolution of *Wakaleo* raised the possibility of wakaleonines being the more plesiomorphic members of the family and that *Thylacoleo* may have arisen vicari-

antly from *Priscileo* as it retreated eastwards with the diminishing forest cover of later mid Miocene central Australia.

ACKNOWLEDGEMENTS

We thank Dr Rod Wells of Flinders University for his comments on the manuscript and for verification of our assignment of thylacoleonid postcranial material. The fieldwork and preparation of the Camfield material is supported by a Northern Territory Heritage Grant.

REFERENCES

- Aplin, K. and Archer, M. 1987. Recent advances in marsupial systematics with a new syncretic classification. In: M. Archer (ed.) *Possums and Oppossums: Studies in Evolution*. pp. xv-lxxii. Surrey Beatty and Sons and the Royal Zoological Society of New South Wales: Sydney.
- Archer, M., Godthelp, H., Hand, S. and Megirian, D., 1989. Fossil Mammals of Riversleigh, Northwest Queensland: preliminary overview of biostratigraphy, correlation and environmental change. *Australian Zoologist* 25(2):29-65.
- Archer, M. and Rich, T., 1982. Results of the Ray E. Lemley Expeditions. *Wakaleo alcootaensis* n. sp. (Thylacoleonidae, Marsupialia), a new marsupial lion from the Miocene of the Northern Territory with a consideration of early radiation in the Family. In: M. Archer (ed.) *Carnivorous Marsupials*. pp. 495-502. Royal Zoological Society of New South Wales: Sydney.
- Barbour, R. 1963. The musculature and limb plexuses of *Trichosurus vulpecula*. *Australian Journal of Zoology* 11(4):488-610.
- Bartholomai, A. 1975. The genus *Macropus* Shaw (Marsupialia: Macropodidae) in the Upper Cainozoic deposits of Queensland. *Memoirs of the Queensland Museum* 17(2):195-235.
- Clemens, W. and Plane, M. 1974. Mid-Tertiary Thylacoleonidae (Marsupialia, Mammalia). *Journal of Paleontology* 48(4):652-660.
- De Vis, C. W. 1900. Bones and diet of *Thylacoleo*. *Annals of the Queensland Museum* 1900:7-11.
- Finch, E. 1982. The discovery and interpretation of *Thylacoleo carnifex* (Thylacoleonidae, Marsupialia) In: M. Archer (ed.) *Carnivorous Marsupials*. pp. 537-51. Royal Zoological Society of New South Wales: Sydney.
- Megirian, D. 1986. The dentary of *Wakaleo vanderleueri* (Thylacoleonidae: Marsupialia). *The Beagle, Occasional Papers of the Northern Territory Museum of Arts and Sciences* 3(1):71-79.

- Murray, P., Wells, R. and Plane, M. 1987. The cranium of the Miocene thylacoleonid, *Wakaleo vanderleneri*: click go the shears - a fresh bite at thylacoleonid systematics. In: M. Archer (ed.) *Possums and Opossums: Studies in evolution*. pp. 433-466. Surrey Beatty and Sons and the Royal Zoological Society of New South Wales: Sydney.
- Pledge, N. 1977. A new species of *Thylacoleo* (Marsupialia: Thylacoleonidae) with notes on the occurrences of Thylacoleonidae in South Australia. *Records of the South Australian Museum* 17:277-283.
- Rauscher, B. 1987. *Priscileo pitikantensis*, a new genus and species of thylacoleonid marsupial (Marsupialia: Thylacoleonidae) from the Miocene Etadunna Formation, South Australia. In: M. Archer (ed.) *Possums and Opossums: Studies in Evolution*. pp. 423-32. Surrey Beatty and Sons and the Royal Zoological Society of New South Wales: Sydney.
- Wells, R. and Nichol, B. 1977. On the manus and pes of *Thylacoleo carnifex* Owen (Marsupialia). *Transactions of the Royal Society of South Australia* 101(6):139-146.
- Woodburne, M., Tedford, R., Archer, M., Turnbull, W., Plane, M. and Lundelius, E. 1985. Biochronology of the continental mammal record of Australia and New Guinea. *Special Publication of the South Australian Department of Mines and Energy* 5:347-363.

Accepted 20 March 1990

HUMANITIES

STEMLESS BOATS OF ENDE BAY

NICK BURNINGHAM

*Northern Territory Museum of Arts and Sciences,
GPO Box 4646, Darwin NT 0801, Australia.*

ABSTRACT

This paper presents lines and construction details of the various types of stemless water craft from Ende Bay, Flores in the lesser Sunda islands of Indonesia. The structures and characteristic styles of these vessels were formerly more widely distributed. Elements of the structures and of the styles can still be traced elsewhere in the archipelago in the constructions of planked vessels built with stems and in the styling of dugout canoes. The boats of Ende are an interesting remnant of an indigenous boat building tradition.

KEYWORDS: Perahu, maritime technology, Indonesia, Flores, sailing vessels.

INTRODUCTION

This paper presents data collected by the author during a week spent in Ende, Flores (8° 50'S, 121° 40'E) in February 1989.

The spelling of indigenous nautical terms, such as the names of boat types, is the spelling supplied, or agreed to, by the majority of local informants at Ende. For this reason the spelling *sope* differs from *soppe*, *sopé* and *sopek* collected in other areas and used in previous papers (Burningham 1989a,b). Modern Indonesian orthography is used for Indonesian words and place names (e.g. Makassar) but the old spelling Macassar is given in historical context and the term *Macassan* is used as defined by Macknight (1976:1-2).

Ende Bay is on the south coast of Flores, a coast which is largely steep to, and open to the Indian Ocean swell, and therefore lacks harbours and maritime activity. Ende Bay is an exception: in the wide bay there are a number of anchorages; fishing villages line the shore and small boat building is practised in the villages of Ende Bay and also Ipih Bay close to the east. Larger cargo carrying *perahus* are built and operated from the island, Pulau Ende, which is in the bay; the best of these are fine examples of motor-sailing *perahu* (*perahu layar motor* or P.L.M.) with the *lambo* hull form.

The Dutch ethnographer Nootboom was attracted to Ende in the 1930's and wrote a description of the boats of Ende (Nootboom 1936; Horridge and Snoek unpublished). Some of the boat types described by Nootboom still exist at Ende and they have been briefly described by Horridge (1986:56-57). They are planked boats which are notable for their stemless structure. Planked boats with this stemless structure were formerly more widely distributed in Indonesia (Van Kampen 1909:32-33) but are now found in only a few places. These are discussed below. A simple version of this structure is still often seen on built-up dugout canoes especially in the area formed by the Sulu Sea, Makassar Strait and South Sulawesi. In this type of structure, specially shaped pieces form each side of the bow and stern and they are fastened together at the ends without a stem or sternpost.

Physically the Endenese, along with the other ethnic groups of central and eastern Flores, are mixed and have a considerable proportion of papuan and melanesian features (Lebar 1972:86; Bellwood 1985:75). The coastal, maritime oriented people of Ende have noticeably more malay features though they speak the same local language (bahasa Ende). The maritime people are almost exclusively Moslem and the non-maritime people are predominantly Christian. The coastal

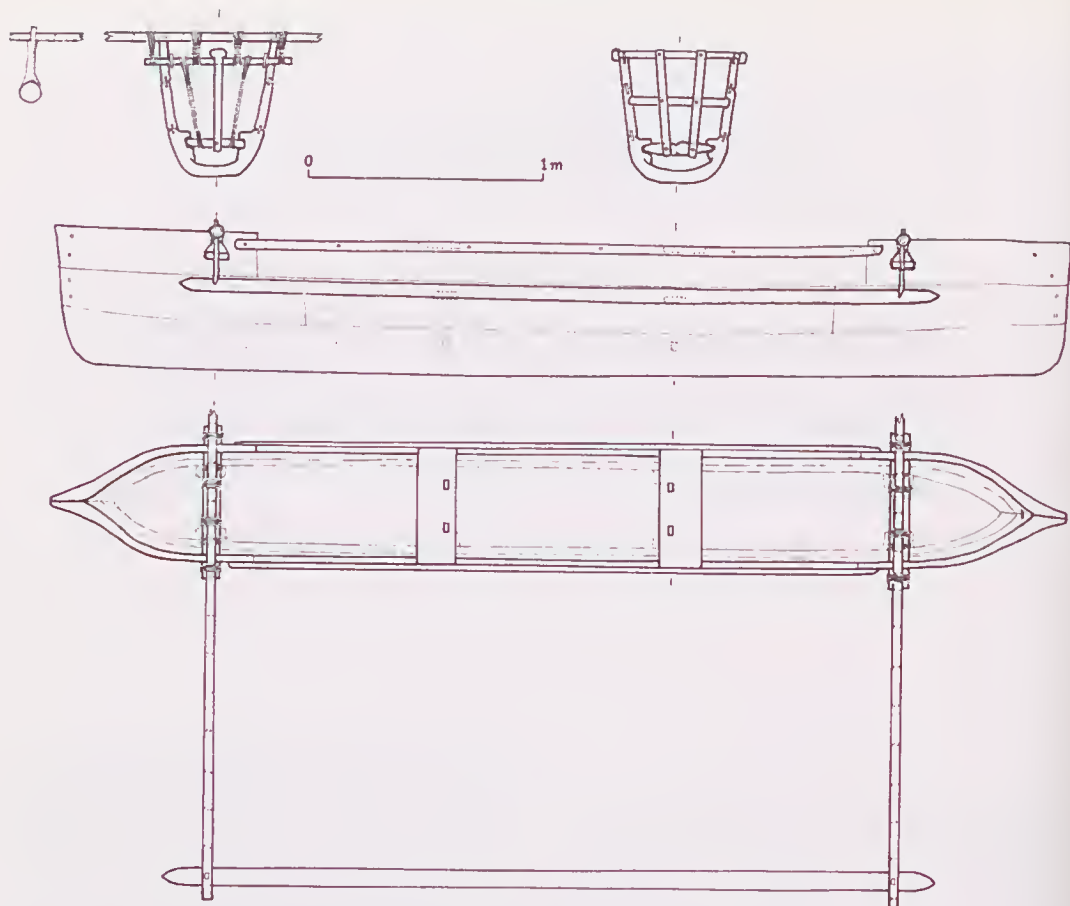

Fig. 1. A *Kova Navi* showing the two types of *kamukaro* and other structural detail.

Moslems regard the Christian communities as mountain people; but some of the mountain people do, in fact build, own and use boats called *kova navi*.

THE KOVA NAVI

These boats of the mountain people are usually built in villages some distance from the sea and then carried down to the sea when they are complete. They are double-outrigger canoes, the hulls are built-up dugouts of functional but rather unsophisticated design. Their dugout base, called *una*, is shallow and flat bottomed with a considerable thickness of timber which makes them rather heavy. The sides are raised by two fairly wide straits which are edge-dowelled together and to the *una*. The long straight planks which build up the sides of the canoe are called *fi*: short curved pieces which form each side of the bow and stern are called *to'bo*. The *to'bo* meet at

the ends of the hull where they are fastened together with treenails.

There are no frames fitted in the hull of a *kova navi* but there are beams let into the dugout and into the planks and these beams are connected to each other by struts and lashings (Fig. 1). These structures which hold the hull together are called *kamukaro*. There are four of them: one in the bow and one in the stern are used to secure the outrigger booms (*samang*). The connection of the outrigger booms to the hull is an interesting combination of the two main systems found in Indonesia (Hornell 1920). There is a narrow thwart a short distance below the boom which projects through the hull so that the boom can be lashed to the thwart both inside and outside the hull: this system is common on canoes from the region of Ujung Pandang (formerly called Macassar) in South Sulawesi, (Hornell 1920:88). In the case of the Ende *kova navi* the thwart is secured to a beam or brace below it which is held

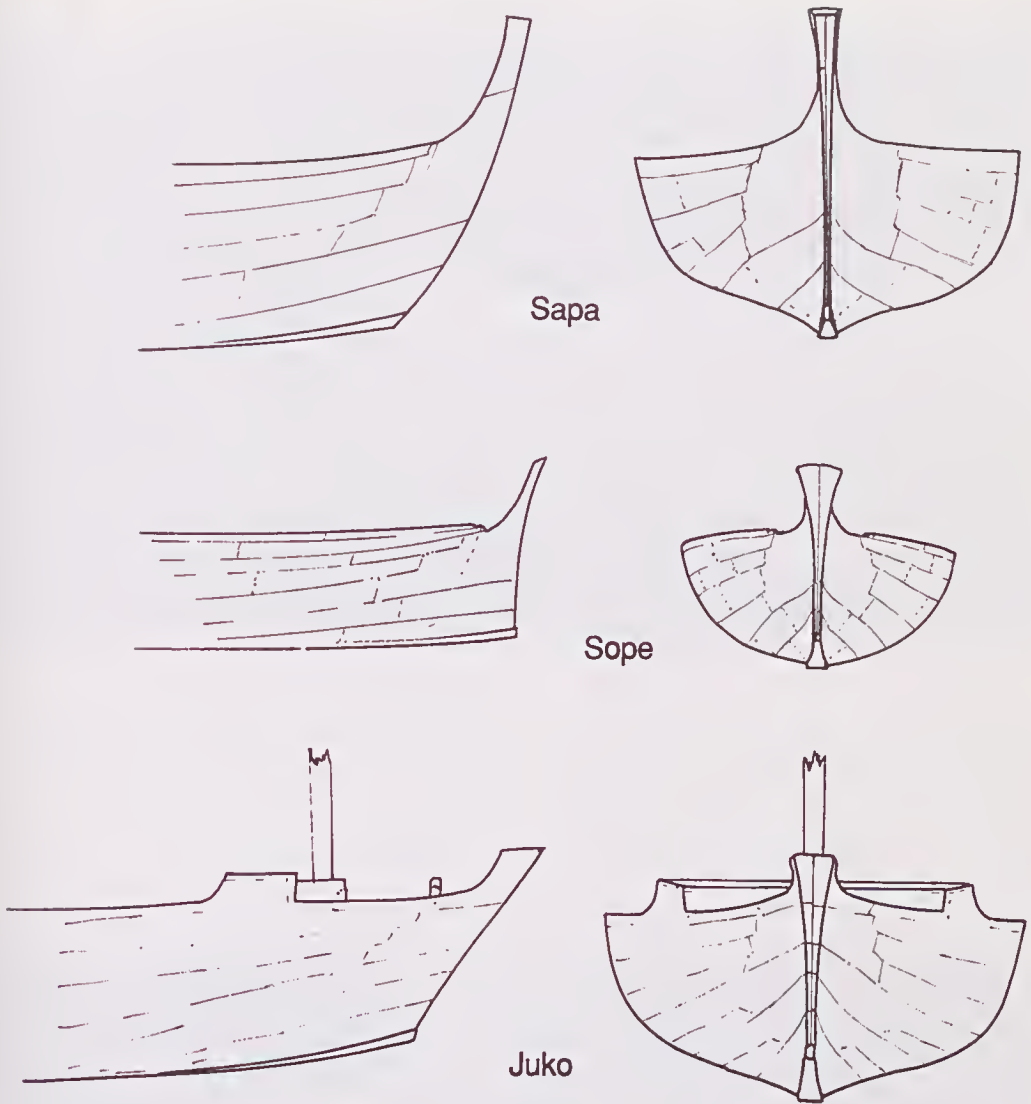

Fig. 2. Profiles and bow-on views of three styles of stemless boat from Ende Bay.

by cleats low in the hull: in most Indonesian outrigger canoes the outrigger boom is secured directly to this beam (Hornell 1920:figs 36,41,52; Hornell 1936:11).

The outrigger connectives which are slightly forked at the bottom and straddle the outrigger are of a type not classified by Hornell (1920) or Haddon and Hornell (1938). Nootboom (1936) noted that the aft connectives were let through the outrigger and this design was observed on one *kova navi* in 1989, however, the owner stated that it was a temporary and incorrect arrangement.

Kova navi are simple functional craft, the bow and stern are identical and there is no

styling or ornamentation. They are used mainly for tending basket fish traps (*vuvu*) and they are usually propelled by paddles. Occasionally a small sail is set from a temporary mast which is lashed to the forward *kamukaro*.

SMALL CRAFT OF THE MARITIME PEOPLE

The coastal communities around the town of Ende believe themselves to be descendants of mercenaries who came to fight for neighbouring clans against the *raja* of Ende. They do not use *kova navi* or any other outrigger canoes but they employ a variety of small craft

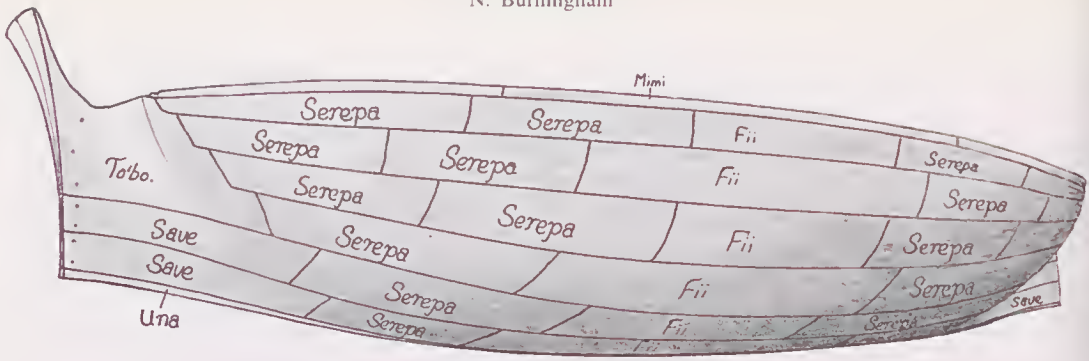

Fig. 3. Plank pattern of a *sapa savé dua* with the names of planks, bow pieces and keel.

which are generically known as *sapa*. The name *sapa* is applied to vessels less than about five or six metres length.

There are a few simple dugouts in use, they are called *sapa monda*: *monda* means rounded. A *sapa monda* is considered to be a canoe carved from a single tree trunk with no planks added but some do have a small plank let in to repair or raise a low part of the rail. If there is a complete run of planks forming a straik, so that the canoe is a built-up dugout, then it can be called a *kova* or sometimes a *sapa sangge*: *sangge* is actually the name of a type of sea shell and also a spiral or scroll motif which resembles the shell. The *sangge* motif is sometimes used to decorate the bow and stern of some types of *sapa* and it seems that the name *sapa sangge* is now used by some people for

certain types of *sapa* with a rounded, cutaway forefoot whether or not they are decorated with a *sangge*.

Neither *sapa monda* nor built-up *kova* type canoes are common in the area of Ende. Small planked boats are much more popular. These planked *sapa* range in size from about 3.5 m in length up to an undefined size too large to be called *sapa*. There are three distinct styles of planked *sapa*, these styles are usually called *sope*, *juko* and *sangge*, but for the reason given above the name *sangge* is not really appropriate and the third type is also simply called *sapa* (Fig. 2). They are all constructed in the same way.

Nearly all planked *sapa* are built up from a small, shallow, rockered keel but a few have a wider, dugout keel piece. It is said that the



Fig. 4. Internal view of the bow of a *sapa*.

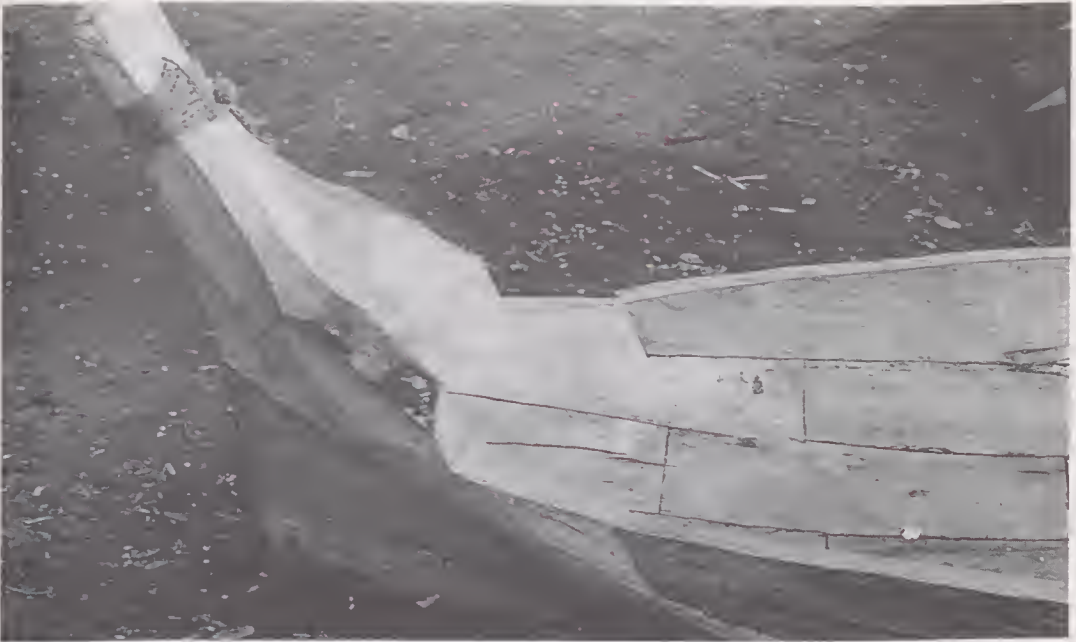

Fig. 5. The bow of a *sapa* under construction showing the roughly shaped *to'bo*.

dugout base was formerly more common but a true keel is now preferred because it can be fashioned from a hard durable timber whereas the dugout would be fashioned from a lighter timber, more easily worked but not so durable. The best timber available locally is called *kayu bafu* or *bapo* (*Vitex* sp., probably *pubescens*). A dugout would usually be *kayu waru* (*Hibiscus tiliaceus*) which is moderately durable if sufficiently mature but it has soft, rot-prone sap wood.

A keel or a dugout base is called *una*, the same name is used for the dugout base of the *kova navi*. Before any planks are fitted to the *una* of a *sapa* a small hole is drilled into one side of the *una* and a little gold is placed in the hole to ensure good fortune. The hole is considered to be the vessel's navel.

The planking which is edge-dowelled together can be made from a variety of timbers and frequently there is a variety of timbers used on one *sapa*. The best *sapa* are built entirely of *kayu bafu* although this makes them rather heavy. *Kayu waru* is often used and *kayu kajuwai* (*Callophyllum iuophyllum*) is a good timber which is locally available and not as heavy or as difficult to work as *kayu bafu*. The planks at the midsection are called *fii* as on the *kova navi* but the plank pattern is more complicated (Fig. 3). Extending each *fii* to-

wards the bow and the stern are planks called *serepa*, and forming the ends of the lower straits are planks called *save*.

The upper straits do not have *save* and do not reach the bow or stern: they run out on large pieces called *to'bo* which form each side of the bow and stern. The name *to'bo* is the same as for the bow and stern pieces of the *kova navi* but the *to'bo* of the planked *sapa* are larger and much more complex in shape. They are stepped to take the ends of at least three straits and they form the distinctive shapes of the bows and stern with projecting prows and stern finials. The two *to'bo* that form each end of the hull are pinned together with a small number (two or three usually) of treenails made of a remarkably strong timber known as *kayu usu*. Crawford (1856:138) says that *usu* is *sapan* (*Caesalpinia sappan*) but local boat builders at Ende in 1989 stated that *usu* is different from, and stronger than *sapan*. Since *usu* can also mean treenail in *bahasa* Ende perhaps the name could be applied to any timber suitable for making treenails, for instance *Miuusop elengi*, *Dichrostachys cinerea* or *Sindora supa*. One of the treenails that fastens together the *to'bo* is positioned so that its middle portion is exposed where it passes between the converging port and starboard *to'bo*. Short strops are spliced on to these



Fig. 6. The plank shell of a *sapa* nearly complete; the planks have been reduced in thickness and smoothed.

treenails to be used for carrying or dragging the *sapa* up and down the beach (Fig. 4). One might expect the treenail to snap under such load but apparently it never does. A similarly positioned treenail is usually found in the bow

and stern of built up dugout canoes in the Sulu Sea and South Sulawesi area.

The planking of a *sapa* is finished with a narrow sheer strake called *mimi* which terminates either with a step or runs out smoothly on

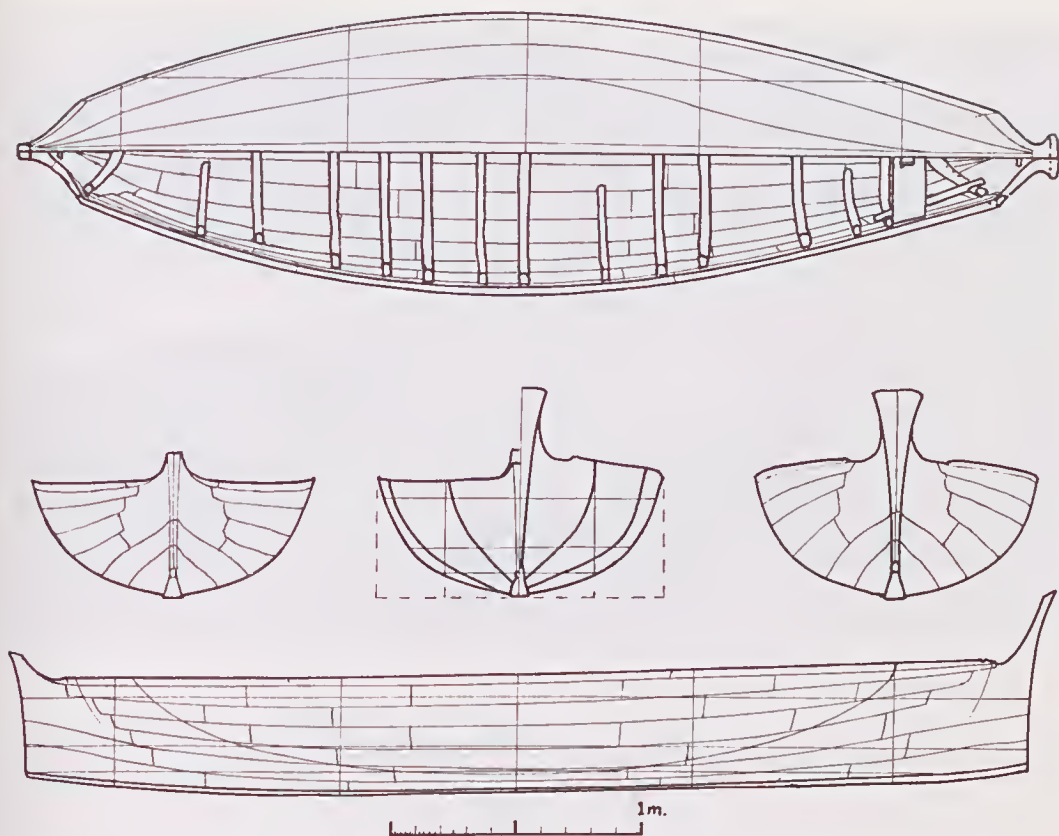

Fig. 7. Lines, plank pattern and rib placement of a small sapa from Kelurahan Ruku Lima.

top of the *to'bo*. The plank shell is assembled with the planks thick and rather rough hewn but the seams are carefully worked and tight (Fig. 5). Fibre scraped from the ribs of the *enau* palm frond (*Arenga saccharifera*) is used as luting (*du'du*) placed in the seams during assembly. When the plank shell is complete it is carefully smoothed and reduced in thickness (Fig. 6). The best *sapa* which are built of *kayu bafu* are given a fine polished finish to the plank shell both inside and outside before the frames are fitted.

Usually the first frames fitted are the forked timbers which fit into the bow and stern and function rather like bow and stern aprons. They are called *eko ika*, the name is equivalent to *ekor ikan* in *bahasa Indonesia*, meaning fish tail. The *eko ika* are raked into the bow and stern and in some cases the bottom end of the forward *eko ika* curves aft along the top of the keel to form the mast step.

Rib patterns vary: at Ende town the most common pattern is full frames alternated with half frames. Further west around the bay there are well built *sapa* with all frames made as full

frames and very long scarphs joining the timbers which compose the frames. In many cases a more-or-less arbitrary or random arrangement of floors, full frames with floors and half frames is determined by the availability of suitably shaped timbers.

The three styles of *sapa* shown in Figure 2 are each favoured in certain villages. In the villages on the south side of Ende town the *sope* style is popular, while on Pulau Ende the *juko* is more popular. The *sapa sangge* decorated with the *sangge* motif seems to have entirely disappeared but there are *sapa* with a curved forefoot and high prow and a matching stern profile which some people call *sapa sangge*, these are mainly at *Kampung Keraro* on the western side of Ende town. Both at *Kampung Keraro* and at *Ipoh Bay* to the east it was said that this type, derived from or related to the *sapa sangge*, was the oldest type.

The smallest *sapa* of any type will have only one straik below the *to'bo*. That straik will terminate at the bow and the stern with the planks called *save*. Such a boat can be called *sapa save satu* ("one *save* boat"). Larger



Fig. 8. A new *sope* styled *sapa* at Ruku Lima.

sapa are *save dua* (two *save*) *save tiga* (three *save*) etc. There are always at least three straits which terminate on the *to'bo* and a sheer strait (*nimi*), so the minimum number of straits is five.

The plank pattern and lines of a small *sope* styled *sapa save dua* are shown in Figure 7. This *sapa* from *kelurahan* Ruku Lima at the southern end of Ende town, is typical of the small *sapa* built with a mast step but intended mainly to be paddled. There is little rocker to the keel, little freeboard and flat sheer. The midsection shows a sleek bilge turning gradually from the keel to the rail. Many *sapa* of only slightly greater size have relatively greater freeboard, more rocker of the keel and a slightly firmer turn of the bilge; they are designed to sail well and go further out to sea (Fig. 8). The length beam ratio of 4:1 is typical for small *sapa* whether or not they are designed to sail well. They have to be handled with skill and agility to avoid capsizing in gusty conditions. Larger *sapa* have relatively greater beam which confers greater stability. Figures 9 and 10 show the lines, some construction detail and sail plan of a larger *sapa* of the *juko* type from *kampung* Raporendu, about 20 km west of Ende. A *sapa* of this size is expected to sail well and would only be paddled when setting nets or in a calm. The midsection shows moderate deadrise with a little hollow, the turn

of the bilge is firmer and the topsides more vertical than on the smaller craft. The single spritsail has a high peak and considerable area. In heavy conditions the sprit would be taken down and the peak brought down to the taek to reduce sail area. All *sapa* carry a single sprit sail.

A boat of this size is not always considered to be a *sapa*. A *sope* style boat of this size could be called a *sapa* or a *sope bajo* at Ende (Fig. 11). This name reflects the belief that the *sope* style was introduced by Bajo people (Bajau or "Sea Gypsy") which might be true but curiously the *Bajo* people at Labuan Bajo, at the western end of Flores now call the *sope* style *sope Ende*.

The coaming in the bow and mast partner structure shown in Figure 8 are found on all *sope* and *juko* of this size and larger. The *to'bo* is a relatively small part of the whole structure. In the case of the *juko* illustrated, the three *save* also function rather like *to'bo* because there are two straits running into each *save*.

Only one quarter-mounted rudder is carried on a *sapa* and it is only effective when carried on the lee side so it must be shifted over the stern when the vessel changes tack. The rudder shown in Figure 9 is strongly raked and curved aft, this is typical for a *sapa*. The rudder mounting structure is a type found in South Sulawesi, mainly but not exclusively on

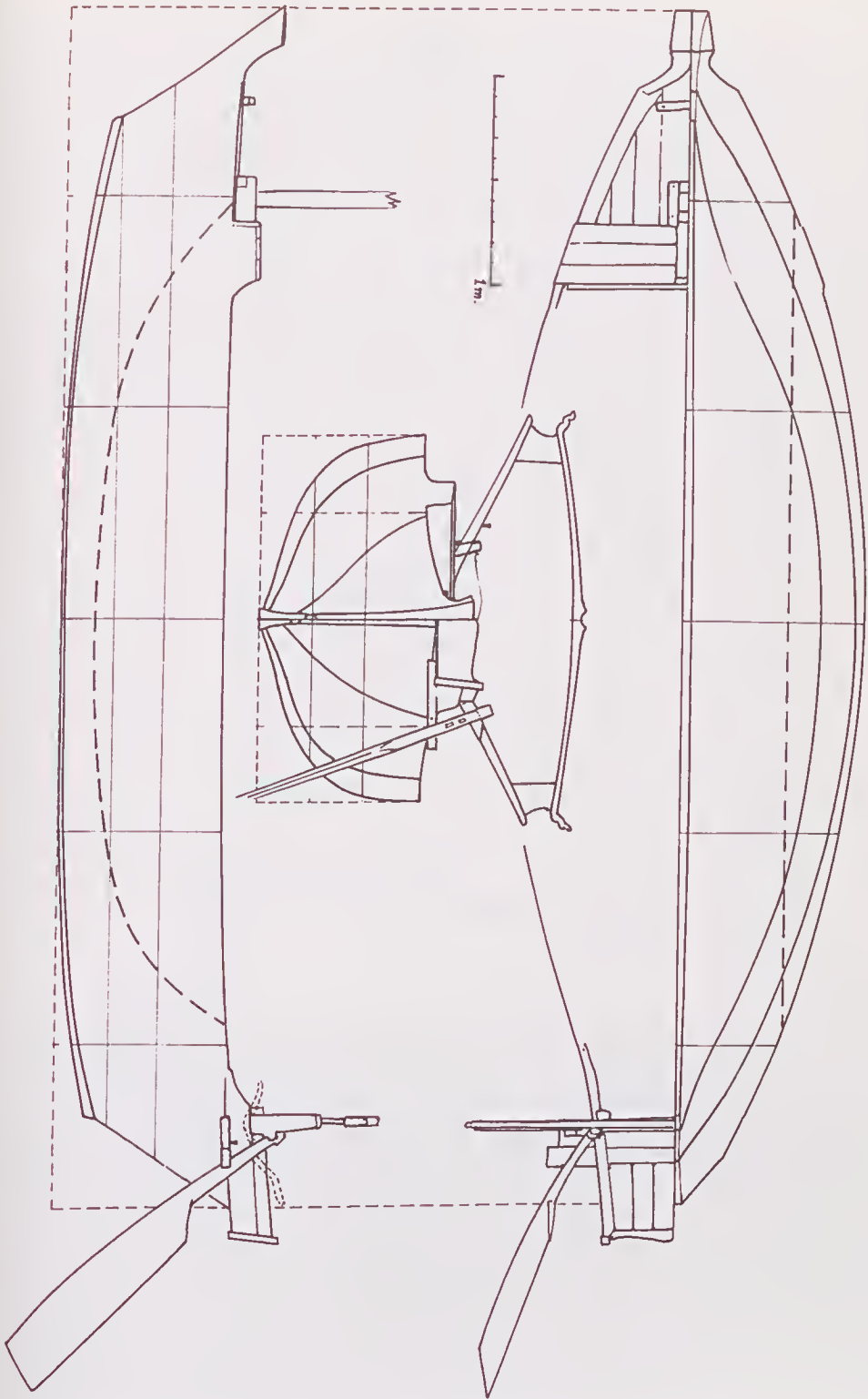

Fig. 9. Lines of a larger *juko* style *sapa* from *Kampung Raporendu*.

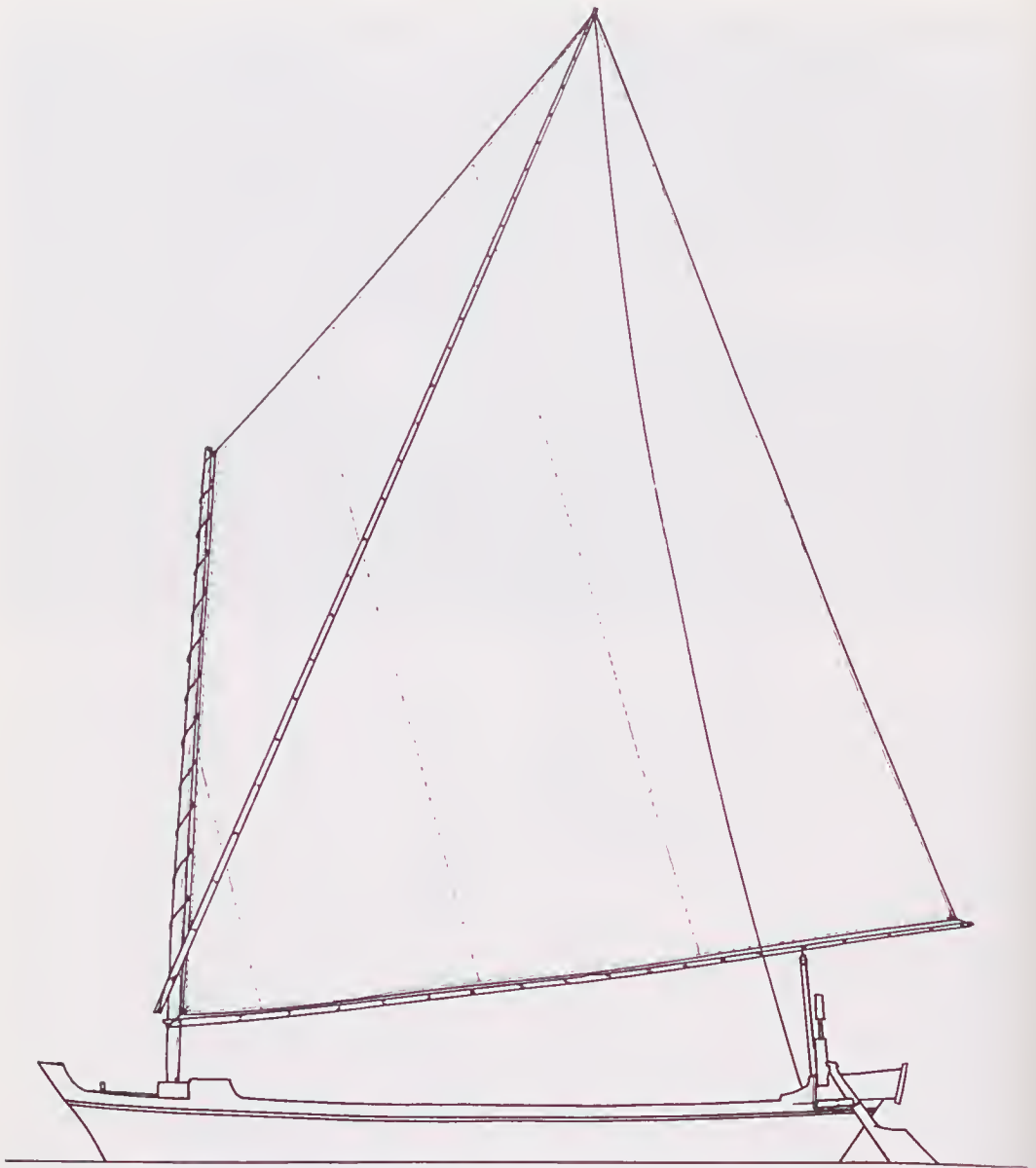

Fig. 10. Sail plan of the *sapa juko* from Raporendu.

Mandar and Bajo canoes. The strong rake and curve aft of the *sapa's* rudder would be unusual in South Sulawesi.

Sapa with their large spritsails and easy lines sail well, especially if they are not too heavily built. Some are rather heavily constructed but others are carefully finished with adze until the plank shell is reduced to less than 20mm thickness in the topsides.

Fishing techniques. *Sapa* are used mainly for fishing. A number of techniques are used. At night kerosene pressure lanterns are used to attract fish and squid for hand netting.

Purse seine nets are set from larger *sapa*. Hand line fishing is practiced at certain times of the year. Fish and crayfish are caught in basket traps. Rays, sailfish and sharks are sometimes taken with harpoons.

Many *sapa* are equipped for fishing in an apparently unique system. The equipment called *bando* consists of a float made from a segment of very large bamboo with a long fishing line attached, usually about 200 metres of 200 kilogram line with one or two large (No. 5) hooks on wire trace. The hooks are baited with small fish. A single unpainted

bando can be seen in the stern of the *sapa* in Figure 8.

A *sapa* will usually set about 25 to 30 *bando*. Each *sapa* has its *bando* painted with a distinguishing colour scheme and pattern: usually the *sapa* has a similar colour scheme. If the *bando* is taken by a fish it may be towed a considerable distance. Any fisherman who spots a *bando* with a fish on the line will retrieve it and land the fish. The fisherman will know from the colour scheme of the *bando* who owns it so he can return it with the fish; the fisherman who lands the fish and returns it is entitled to a quarter of the fish or its cash value. Apparently the system works well because everyone involved is scrupulous in observing the mutual responsibilities.

LARGER STEMLESS VESSELS FROM ENDE BAY

The larger cargo-carrying stemless boats are mainly from Pulau Ende and the others are from the mainland coast opposite the northern end of Pulau Ende. They are built in the *sope* and *juko* styles and are called *sope* or *juko* according to their style. Their hulls are fully enclosed by decks and cabins and they carry a tall gunter cat rig instead of the spritsail cat rig of the *sapa* and the intermediate sized *sope bajo*. They are equipped with two rudders, one carried on each quarter mounted on parallel rudder mounting beams (*sangkalang*) in the same manner as on larger traditional Makas-

sarese and Buginese vessels of South Sulawesi.

There are quite distinct differences between the midsection and hull form of a typical large *sope* and a typical large *juko*. Generally the large *sope* have more moulded depth, less beam, a firmer turn of the bilge and nearly vertical topsides (Fig. 12), while the large *juko* have sleek bilges and very flared topsides giving great beam at the level of the rail (Fig. 13). The largest *juko* can carry about 7000-8000 kg (7-8 tonnes) while the largest *sope* were built to carry about 5000 kg (5 tonnes), but in February 1989 there were said to be none of this size still in use: large *juko* were always much more common.

The coaming seen on the foredeck of large *sapa* is built into the cabin of the *sope* and *juko*. Cargo carrying *juko* and *sope* are most commonly employed carrying salt and rice from Bima, Sumbawa to Ende and other places on the south coast of Flores. They are generally acknowledged as fast and weatherly but they have the disadvantage that they will not come about or fall off on a new tack without at least one crew member working an oar: some traditional western cat rigged boats had the same problem.

Virtually all of the large *juko* and *sope* at Ende in February 1989 had auxiliary motors; most had only small auxiliaries and retained their gunter rig intact or only very slightly cut down. Some had their decorative mast finial with tufts of *ijok* palm fibre cut off flat to



Fig. 11. *Sope bajo* with masts unstepped.



Fig. 12. The stern of a large *sopé* showing a typical midsection.



Fig. 13. Large *juko* with a shallow, beamy midsection.

indicate that they were auxiliaries but the sail area was apparently unaltered.

STEMLESS DESIGNS IN OTHER PARTS OF INDONESIA

The *sopé* and other stemless designs were formerly more common and widely distrib-

uted in Indonesia. Large *sopé*, often with *tanja* rig (tilted rectangular rig), could be found in many places in eastern Indonesia until the 1970's. A fine *sopé* of this type was drawn in East Lombok in 1904 by W.O.J. Neiuwenkamp and it appears reproduced in Horridge (1985:61). Another stemless *sopé* seen dere-

liet near Pare Pare, Sulawesi in 1979 is presented in Horridge (1985:57).

A few *lete* (Indonesian lateen) rigged *sope* still exist in South Roti (Fig. 14) along with a larger number of similarly rigged open boats which have similar hull form but have a stem.

The Rotinese *sope* in Figure 14 has a stem fitted externally above the first *save*. It has a coaming on the foredeck like an Ende *sope* but the lines are much heavier. During the 1970's there were a few small *lete* rigged *sope* with finer lines at Oe laba, a community composed



Fig. 14. A *sope* from Roti; a stem has been added but it does not reach the keel.



Fig. 15. A small *sope* type boat with a light stem at Namo Sain near Kupang, Timor.

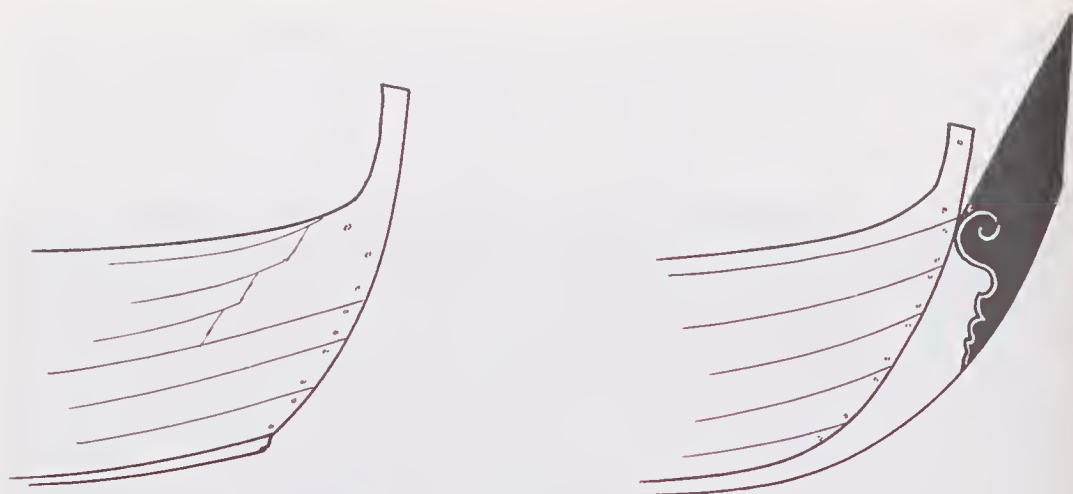

Fig. 16. The bow of a *sapa* compared with the bow of a *perahu lete* which has a large stem added.

mainly of Butonese and Bajo on Roti. Virtually identical small *lete* rigged *sope* could be found in the Tukang Besi islands, southeast of Buton especially at the Bajo community Pantai Mola on Wangi Wangi. These attractive small craft still exist in both places but they are now built or rebuilt with a stem and stern post fitted (Fig. 15). The stem and stern post are usually light and have little structural function because they are fitted on to the butt ends of the planks. Inspection of small craft in many places in Indonesia reveals that they are built with a stem simply butted on to the end of the planking and often bolted to an apron after the plank shell is completed. In the case of the *sope* type boats the stem seems to have been adopted as a new means of producing the typical *sope* prow profile in a way which is easier and uses less timber than carving the prow as part of the *to'bo*.

The *juko* and *sangge* or *sapa* style of stemless planked boats are found only at Ende but the features of these styles can be found on the bows and sterns of dugout canoes throughout much of Indonesia along with the *sope* style. On Roti for instance, all three styles exist: a *juko*-style dugout is called *jurung jurung*, a *sope* style dugout is called *jukung* and the rounded *sapa* style is simply called *sampan* which is a general name for small water craft.

The rounded profile is relatively uncommon at Ende and it is not much favoured by Buginese, Makassarese or Butonese maritime people of Sulawesi but it is the distinctive style of the sophisticated built up canoes of the

Mandar people which are called *sande* and *pangkur* (Horridge 1985:pls 7.8.9). With a tall stem added it is also the style of the large planked *perahu lete lete* (Fig. 16) from the islands east of Madura which have mixed Mandar and Madurese populations.

It is possible that the curved profile was once more common. A drawing executed in 1839 by L. Le Breton of Macassan trepangers at Raffles Bay in northern Australia (reproduced in Macknight 1976:pl. 10) shows the Macassans using small planked outriggerless boats of the *sapa sangge*-style. It should be noted however that Le Breton was not always a meticulous observer of native craft.

In West Java, around Indramayu there exist stemless planked boats called *jegongan* which are styled much like stemless *sope* but have a different structure with only four broad straits (Burningham 1989). The *jegongan* might have developed independently of the stemless *sope* type or it could be another remnant of a once predominant style and tradition of Indonesian boat building.

ACKNOWLEDGMENTS

My thanks to the people of Ende Bay who were generous, patient and enthusiastic in giving me the data for this paper especially the men of Ruku Lima and Raporendu who made the measuring of their *sapa* so easy and pleasant a task. Thanks to Adrian Horridge who gave me a copy of his and Chris Snock's translation of C. Nootboom's work on boats

at Ende. Thanks to Dr Colin Jack-Hinton, the Director of the Museum and Art Galleries of the Northern Territory, who encouraged my field work at Ende. And thanks to Chris Haigh and Lorna Watt who have typed several drafts of this paper.

REFERENCES

- Bellwood, P. 1985. *Prehistory of the Indo-Malaysian Archipelago*. Academic Press : Sydney.
- Burningham, N. 1989a. Four double-ended Perahu Lambo. *The Beagle, Records of the Northern Territory Museum of Arts and Sciences* 6(1):179-194.
- Burningham, N. 1989b. The Structure of Javanese Perahus. *The Beagle, Records of the Northern Territory Museum of Arts and Sciences* 6(1):195-220.
- Crawford, J. 1856. *A Descriptive Dictionary of the Indian Islands and Adjacent Countries*: Bradbury & Evans: London.
- Haddon, A.C. and Hornell J. 1938. *Canoes of Oceania, Vol.3. Definition of Terms, General Survey, and Conclusions*. Bernice P. Bishop Musueum: Honolulu.
- Hornell, J. 1920. The outrigger Canoes of Indonesia. *Madras Fisheries Bulletin*. 12:43-114.
- Hornell, J. 1936. *Canoes of Oceania, Vol 1 the Canoes of Polynesia, Fiji, and Micronesia*. Bernice P. Bishop Muscum: Honolulu.
- Horridge, A. 1985. *The Prahu Traditional Sailing Boat of Indonesia*. 2nd edition. Oxford U.P: Singapore.
- Horridge, A. 1986. *Sailing Craft of Indonesia*. Oxford U.P.: Kuala Lumpur.
- Horridge, A. and Snock, C. Unpublished. *Boats at Ende by C. Nootboom, Translated and Summarised with Notes*. (Personal communication to the author).
- Lebar, F.M. 1972. *Ethnic Groups of Insular Southeast Asia, Vol. 1. Human Relation Area Files Press: New Haven*.
- MacKnight, C.C. 1976. *The Voyage to Marege*. Melbourne University Press: Carlton.
- Nootboom, C. 1936. Vaartuigen van Ende. *Tijdschrift Voor Indische Taal-Land-en Volkenkunde* 76:97-126.
- Van kampen, P.N. 1909. *De Hulpmiddelen Der Zeevisscherij, op Java en Madoera in gebruik*. G. Kolff & Co.: Batavia.

Accepted 17 November 1989

THE 1989 HAT YAI ACCORDS

JOHN J. COE

*Northern Territory Museum of Arts and Sciences
GPO Box 4646, Darwin NT 0801, Australia.*

ABSTRACT

This research paper reviews the background to and the impact of the 1989 Accords between the Communist Party of Malaya and the Government of Malaysia and the Communist Party of Malaya and the Kingdom of Thailand. The writer was an Observer at the signing of the Agreement.

KEYWORDS: Hat Yai, Malaysia, Thailand, Communist Party of Malaya, CPM, Accords, Chin Peng, Chaovalit, Kittii.

PREAMBLE

At a press conference in southern Thailand on 30 November 1989, Secretary General Chin Peng of the Communist Party of Malaya (CPM), confirmed his intention to sign a peace agreement with the Governments of Malaysia and Thailand. On 2 December 1989, before an audience of some 350 dignitaries and press representatives, Chin Peng, with the Chairman of the Communist Party of Malaya, Abdullah C.D. and long time Central Committee member, Rashid Midin, formally abandoned their long standing armed challenge to power in Malaysia. Under the terms of the joint communique issued at the peace agreement:

Former members of the disbanded armed units led by the Communist Party of Malaya have given their pledge to Thailand and Malaysia to respect the laws of these two countries and to participate in the socio-economic development for the benefit of the people (Joint Communique by the Government of the Kingdom of Thailand, the Government of Malaysia, The Communist Party of Malaya, 2.12.89, Hat Yai).

The Agreement (hereafter described as the 'Accords') marked the end of an era. In light of the general *denouement* of international Communism, it is appropriate that the CPM's decision to enter into a negotiated settlement be subjected to analysis.

INTRODUCTION

South East Asia's oldest insurgency came to an end almost as abruptly as it began. At 1040hrs on a sultry and rain sodden Saturday,

the 12th floor ballroom of the Lee Gardens Hotel in Hat Yai erupted in applause as signatories from Thailand, Malaysia and the CPM signed, countersigned and lifted glasses of champagne to each other's health.

Thus concluded an insurgency that commenced in 1948 - the year of the Berlin airlift, predating by six years the French defeat at Dien Bien Phu.

In that year the Malayan Communist Party launched its revolution against the British in Malaya. After a decade of bitter fighting, political manoeuvring and the inevitable civilian casualties, the Communists were defeated and politically discredited. Beaten but unbowed, the remnants of the Communist army moved into the border sanctuary of the Betong salient in southern Thailand. Here the Party regrouped and planned its return.

Contemporary history deemed this was not to be. Despite several attempts to infiltrate back into the peninsula, the Party was unable to regain either the political or military initiative integral to successful revolution. Thus was the revolution contained.

The Communist thrust for power was distinguished by paradox. The armed and political struggle was conducted by the Communist Party of *Malaya* (emphasis added) against the sovereign states of Malaysia and Singapore, directed from sanctuaries in southern Thailand by an enigmatic leader resident in China.

Despite the Communist claims to be in the vanguard of the peoples of Malaya, the Party enjoyed the distinction of being in effective exile since 1953 from the homeland it purported to be liberating. The question of liberating who from whom remained vexatious.

The simple ceremony that signalled the end of hostilities was in itself a curious paradox. The spectacle of a Government treating with a political party it did not recognise at a conference hosted by another state at whose behest the parties foregathered, clearly appealed to the imagination of a large contingent of the South East Asian press corps.

Notwithstanding, the occasion was an unqualified triumph of diplomatic nuance and a media event *par excellence*.

On reflection, the Accords marked the end of an era. The insurgency remained an embarrassing legacy of a colonial era, an unwelcome spectre of racial and social divisions; it remained a knot in the political psyche of two generations of Malaysians and Singaporeans and a constant irritant in the bilateral relations between Thailand and Malaysia.

Within the broader geopolitical setting, the decision by the CPM to abandon the armed struggle must be seen in the context of the changing nature of international Communism and the shifts in China's 'westpolitik'.

This paper will review the background to the agreement; it will describe the nature and content of the press conferences and the official signing ceremony and it will discuss some of the ramifications of the Accords. It will provide, as appendices, extracts as recorded by the writer from the two press conferences; the text of the Joint Communiqué; a list of Signatories to the Agreement and a copy of Secretary General Chin Peng's speech at the signing ceremony.

BACKGROUND

The Communist Party of Malaya is the oldest political movement in Malaysia and Singapore. Formally established in 1930 by the Comintern under the tutelage of the Communist Party of China (CCP), its origins can be traced to the Comintern activities in the region in the early 1920's.

In its formative years the Party was subject to the uncertainties of the power plays between the Comintern and the CCP that were to presage the Sino-Soviet split two decades later. In the course of its history the CPM initiated several successful industrial campaigns and, basking in the prestige of controlling a successful resistance army against the Japanese, it earned for itself a brief period of respectability. A crippling leadership crisis

helped precipitate the Party into a period of political violence better known to students of contemporary military affairs as 'the Malayan Emergency'. Following its defeat in the field, the Party suffered a series of 'rectification' campaigns, ideological traumas, internecine feuds and finally a major split.

The final chapter in the history of the movement opened in 1970. In September of that year, the 8th Regiment broke away from the Party to form the Communist Party of Malaya (Revolutionary Faction). After ongoing and fractious debate, on 1 August 1974, the Second Military Zone broke away to form the Communist Party of Malaya (Marxist-Leninist Faction). The original Chin Peng faction became known as the CPM (Orthodox Faction.) On 5 December 1983, the Marxist-Leninist and Revolutionary factions merged to form the Communist Party of Malaysia. (Coe 1988a:170)

The presence of the Party tri-partite in Thailand in the 1980's became an embarrassment to the Thais. Drawing upon their own extensive counter-insurgency experience and the highly successful Civil-Police-Military techniques developed by General Saiyud Kerdphol under Order 66/23 (Saiyud 1986), the Thai Fourth Army launched a dual military and civil offensive to draw the CPM out of the jungle.

In the opening weeks of 1987 the Communist Party of Malaysia, through its military arm, the Second Military Zone of the Malaysian People's Liberation Army, entered into a negotiated settlement with the Thai Fourth Army. The substance of this agreement required the former to abandon its armed struggle and place itself in the hands of the Thai military authorities. This agreement was conditional, however, on a guarantee that members of the former Liberation Army would not be repatriated involuntarily to Malaysia and that they would be given the opportunity to participate in the civil reconstruction of Thailand, through a resettlement programme (Anonymous 1987a). In accordance with the terms of this historic agreement, on 28 April 1987 some 542 guerrillas emerged from the jungle, laid down their arms and equipment and attended a reconciliation ceremony in a remote jungle clearing near Betong attended by the Commander of the Fourth Army and other Thai military and civil dignitaries.

ให้ทั้งสามฝ่ายหยุดทุก ๆ ด้าน ลงระงับแต่ความรุนแรง ความวุ่นวาย ๆ ขึ้นไป กับขอให้
สันติภาพที่พวกเราได้ร่วมกันสร้างขึ้นมาในอดีตนี้ จงลดศัตรวยุติกันไว้กับศรั
และนำมาซึ่งสันติสุข ความสามัคคี และความเจริญรุ่งเรือง และความเข้าใจอันดีของ
ประชาชนทุกหมู่เหล่า และทุกเชื้อชาติในภูมิภาคนี้สืบไป ขอขอบคุณ

JOINT COMMUNIQUE

BY

**THE GOVERNMENT OF THE KINGDOM OF THAILAND
THE GOVERNMENT OF MALAYSIA,
THE COMMUNIST PARTY OF MALAYA**

1. THE GOVERNMENT OF THE KINGDOM OF THAILAND, THE GOVERNMENT OF MALAYSIA, AND THE COMMUNIST PARTY OF MALAYA, CONSISTANT WITH THEIR COMMON DESIRE FOR RECONCILIATION AND PEACE, HAVE REACHED THE MUTUAL AGREEMENTS, ONE BETWEEN THE GOVERNMENT OF MALAYSIA AND THE COMMUNIST PARTY OF MALAYA AND THE OTHER BETWEEN THE INTERNAL SECURITY OPERATIONS COMMAND REGION 4 OF THE KINGDOM OF THAILAND AND THE COMMUNIST PARTY OF MALAYA TO TERMINATE ALL ARMED ACTIVITIES AND BRING PEACE TO THE ENTIRE THAI-MALAYSIA BORDER REGION AND MALAYSIA.

2. FORMER MEMBERS OF THE DISBANDED ARMED UNITS LED BY THE COMMUNIST PARTY OF MALAYA HAVE GIVEN THEIR PLEDGE TO THAILAND AND MALAYSIA TO RESPECT THE LAWS OF THESE TWO COUNTRIES AND TO PARTICIPATE IN SOCIO-ECONOMIC DEVELOPMENT FOR THE BENEFIT OF THE PEOPLE. THAILAND AND MALAYSIA WILL PROVIDE FAIR TREATMENT TO THESE MEMBERS. THE GOVERNMENT OF MALAYSIA WILL IN DUE COURSE ALLOW FORMER MEMBERS OF THE DISBANDED ARMED UNITS LED BY THE COMMUNIST PARTY OF MALAYA WHO ARE MALAYSIAN CITIZENS OR WHO HAVE BECOME MALAYSIAN CITIZENS TO FREELY PARTICIPATE IN POLITICAL ACTIVITIES WITHIN FRAMEWORK OF THE FEDERAL CONSTITUTION AND THE LAWS OF MALAYSIA.

3. ALL THREE PARTIES RECOGNISE THAT THIS HONOURABLE SETTLEMENT WILL BRING PROSPERITY, STABILITY AND SECURITY TO THE THAI-MALAYSIAN BORDER REGION AND MALAYSIAN.

4. THE GOVERNMENT OF MALAYSIA AND THE COMMUNIST PARTY OF MALAYA EXPRESS THEIR HEARTFELT GRATITUDE TO THE GOVERNMENT OF THE KINGDOM OF THAILAND FOR ITS EFFORTS IN PROVIDING FACILITIES FOR THE HOLDING OF THE TRIPARTITE PEACE TALKS AND IN BRINGING ABOUT THE SUCCESSFUL CONCLUSION OF THE PEACE TALKS.

**ผู้ร่วมลงนามความตกลงสันติภาพ 3 ฝ่าย
SIGNATORS IN PEACE AGREEMENT**

ฝ่ายไทย THAI SIDE

- | | | |
|-----------------------------|--------------------|---|
| 1. พล.อ.ชาลิต ยงใจยุทธ | รอง ผบ.ปท. | DEPUTY DIRECTOR OF THE INTERNAL SECURITY OPERATIONS COMMAND |
| GEN. CHAVALIT YONGCHAIYUDH | | |
| 2. พล.อ. ยุทธนา เข็มตันหู่ | ผบ.ปท.ภาค 4 | DIRECTOR, INTERNAL SECURITY OPERATION COMMAND REGION #4 |
| LT. GEN. YOODHANA YAMPUNDHU | | |
| 3. พล.ท.อ.แสวง ธีระสวัสดิ์ | อธิบดีกรมตำรวจ | DIRECTOR GENERAL OF THE ROYAL THAI POLICE DEPT. |
| POL. GEN. SAWANG THERASAWAT | | |
| 4. นายเอก สิทธีประศาสน์ | ปลัดกระทรวงมหาดไทย | PERMANENT SECRETARY OF THE INTERIOR MINISTRY |
| MR. ANEK SITHIPRASASANA | | |

ฝ่ายมาเลเซีย MALAYSIA SIDE

- | | | |
|---|--------------------|---|
| 1. ดาโต๊ะ ฮาจิวัน ซิดีก บิน ฮาจิวัน อับดุลรามาน | ปลัดกระทรวงมหาดไทย | SECRETARY GENERAL MINISTRY OF HOME AFFAIR |
| DATO' HAJI WAN SIDIK BIN HAJI WAN ABDUL RAHMAN | | |
| 2. พล.ต.พันตรี ฮัสซิม โมฮัมหมัด อาลี | ผ.สูงสุต | CHIEF OF DEFENCE FORCE |
| GEN. TAN SRI HASHIM MOHAMAD ALI | | |
| 3. พันตรี โมฮัมหมัด ฮานีฟ บิน โอมาร์ | อธิบดีกรมตำรวจ | INSPECTOR GENERAL OF ROYAL MALAYSIAN POLICE |
| TANSRI MOHAMAD HANIFF BIN OMAR | | |

ฝ่ายพม. CPM. SIDE

- | | | |
|--------------------|------------------|----------------------------|
| 1. จีนเฟิง | เลขาธิการพม. | GENERAL SECRETARY OF CPM. |
| CHIN FENG | | |
| 2. อับดุลลาฮ์ ฮิดี | ประธานพม. | CHAIRMAN OF CPM. |
| ABDULLAH C.D. | | |
| 3. ราซิด มิดิน | ผู้แทน จมทรม 10, | REPRESENTATIVE OF THE CPM. |
| RASHID MIDIN | | |

As part of the resettlement programme, the former guerrillas were split up into five resettlement villages, four of which are dispersed along the Betong - Yala road and the fifth near Sa Dao. The objective of the programme is that each village will develop as a self sustaining community in the 'swords into ploughshares' tradition. (Coe 1988b)

Despite reservations held in some quarters, the Thai initiative in treating with the Second Military Zone was a radical and apparently effective solution to a military problem. Nonetheless, in attempting to find this solution, the Thais were faced with a delicate dilemma, namely, how to treat with a political entity of a friendly country that was actively trying to subvert by force of arms the duly

constituted government of that country, without alienating the country concerned.

The solution was straightforward. The Thai authorities did not deal with the party but rather with its military arm, viz the Second Military Zone. Because the negotiations were maintained at a strictly military level, the problematical question of political recognition and legitimacy of the CPM was obviated. Under the terms of the Press Communique issued by the Headquarters of the Second Military Zone on the Agreement:

In mid April 1987, delegates of the Second Military Zone of the People's Liberation Army of Malaysia and delegates of the Thai government held several rounds of negotiation on the question of terminating peacefully

OFFICIAL PROGRAMME FOR THE SIGNING CEREMONY
ON 2ND DECEMBER 1989 AT LEE GARDENS HOTEL,
(12TH FLOOR) HAADYAI

- 08.30 ARRIVAL OF MASS MEDIA
- 09.00 BRIEFING FOR MASS MEDIA BY CHIEF OF STAFF ISOC. 4
AT SIAM ROOM, GROUND FLOOR, LEE GARDENS HOTEL.
HAADYAI, REPORTERS TO SUBMIT WRITTEN QUESTIONS WHICH
WILL BE SCREENED BY THE THAIS BEFOREHAND. DURING THE
BRIEFING THE THAIS WILL DISTRIBUTE COPIES OF THE
JOINT COMMUNIQUE TO THE PRESS.
- 09.30 GUESTS TO BE SEATED AT SIGNING CEREMONY HALL, LEE
GARDENS HOTEL
- 09.40 ARRIVAL OF THAI CHAIRMAN AT HAADYAI AIRPORT
- 10.10 ARRIVAL OF VIPS AT LEE GARDENS HOTEL.
- 10.15 ARRIVAL OF THAI CHAIRMAN, GEN. CHAVALIT AT CEREMONY
HALL, LEE GARDENS HOTEL
- 10.30 COMMENCEMENT OF SIGNING CEREMONY
- 10.45 THAI CHAIRMAN'S SPEECH AND JOINT COMMUNIQUE
- SPEECH BY HEAD OF MALAYSIAN DELEGATION
- SPEECH BY GENERAL SECRETARY OF CPM
- TOAST - SIGNATORIES ONLY
- INTERVIEW BY THE PRESS
- 12.00 LUNCH FOR OFFICIALS AND GUESTS AT HONG KONG
RESTAURANT, 2ND FLOOR, LEE GARDENS HOTEL

LUNCH FOR REPORTERS AT SIAM HALL, GROUND FLOOR, LEE
GARDENS HOTEL.
- 13.00 THAI CHAIRMAN DEPART FOR HAADYAI AIRPORT
- 19.30 THANK YOU PARTY AT 12TH FLOOR, LEE GARDENS HOTEL
HOSTED BY ISOC 4 DIRECTOR, LT GEN. YOODHANA YAMPUNDHU
- ONLY FOR OFFICIALS OF THE 3 PARTIES.
- 20.00 OPENING ADDRESS AT PARTY BY ISOC 4 DEPUTY DIRECTOR,
MAJ GEN, KITTI RATTANAJAYA,
- SPEECH BY ISOC 4 DIRECTOR
- SPEECH BY REPRESENTATIVE OF MALAYSIA
- SPEECH BY REPRESENTATIVE OF CPM
- CULTURAL SHOW
- 21.30 CLOSE

our Army's armed activities in Thai territory
...both sides reached an agreement of total
peace on 11 of April 1987 (Anonymous
1987a).

To summarise, the salient points of the 1987
Agreement are that it was an internal and
bilateral agreement between the Thai authori-
ties and the Second Military Zone without the
overt participation of the Malaysian authori-
ties with very clear, albeit limited, conditions
and obligations on both parties.

By contrast, the 1989 Accords were to present
a new set of constraints and intricate ques-
tions.

THE 1989 ACCORDS

'This a historic day. Mr Chin Peng, you may
sign now.'

Proposed by this memorable understatement
of the Thai master of ceremonies, 41

years of armed struggle were relegated to the
pages of history.

The signing was the consummation of a
drama that had opened two evenings before.

At 8pm on the evening of Thursday 30th
November, Major General Kitti Rattanachaya,
Deputy Commander, Fourth Army Region,
chaired a press conference at the Combined
Task Force Head-quarters in Senanarong
Army Barracks, Hat Yai. His guest of honour
was Chin Peng.

The 80 journalists and photographers at-
tending were collected by a fleet of buses from
the Lee Gardens Hotel and crowded into the
Operations Room under the watchful if be-
mused eyes of the Thai military police. The
arrival of the Chairman and his guest caused
momentary confusion as photographers
scrambled atop desks and chairs to capture on
film the first public appearance of the elusive
guerrilla leader in 34 years.

Smiling, alternately diffident and confident
but always relaxed, Chin Peng looked
punchy, prosperous and healthy. Impeccable
in a blue grey suit and sober tie, his dress and
demeanour gave every appearance of a benign
Hong Kong towkay. This writer was vividly
and immediately reminded of Tunku Abdul
Rahman's description of Chin Peng at Baling,
'... he looked too clean to be a revolutionary,
he looked more like a businessman' (Tunku
Abdul Rahman, personal communication, Pe-
nang, 18.3.87).

Chin Peng entered the conference accompa-
nied by his personal secretary whom he cour-
teously introduced as Miss Huang Hui Her, a
Singaporean.

Commencing the conference, Major Gen-
eral Kitti explained that Chin Peng would
confine his political comment and discussion
about the Agreement to after the signing cer-
emony on the 2nd December. Subsequently,
Chin Peng fielded delicate questions with a
polite '...I would rather answer that on the
2nd...'

He was tri-lingual, (Malay, Chinese and
English), often repeating in each language his
comments and answers. Although little was
said of substance, of significance was Chin
Peng's comment on the dissolution of the army
but not the Party. This point was keenly
grasped by the Singaporean and Malaysian
journalists and given prominence by the press
coverage in those countries. The significance

of this point is that the Accords indicate a military rather than a political settlement.

Chin Peng was scrupulous in avoiding any ambiguous comment on Malaysian politics *except*, when asked his reaction to the Tunku's comments about him, he pulled a wry face and smiled:

Q. Any comment for Tunku Abdul Rahman, who said you cannot be trusted?

A. I don't think I shall reply to that at this moment.

Q. Once a Communist always a Communist. Are you always a Communist?

A. This is his impression. Not my words.

Q. What is your word?

A. I think I shall wait until the 2nd.

Of equal significance was Chin Peng's response to the question as to whether he had expected the outcome of the struggle to be like this. He replied that he had expected it for several years.

Chin Peng was effusive in his praise for the Thai authorities and in particular for Maj. Gen Kitti, whom he described as his '...good friend'.

Afterwards, on the steps of the darkened Headquarters, Chin Peng held an impromptu autograph signing session under the glare of the camera lights. He signed in both Roman and Chinese script.

Immediately before stepping into his Mercedes limousine, he clasped his hands together above his head, turned around to the crowd and said, 'I shake hands with all of you'.

Despite its lack of substance, the evening proved to be a well orchestrated and highly successful media exercise during which the protagonist was feted like a returnee from exile. Chin Peng's polished performance, together with the ample and deliberate photo opportunities he and the occasion provided, indicate a good deal of preparation for the event. Chin Peng obviously relished the sense of occasion his presence generated and the press responded warmly to his *empressment*, with the notable exasperation of one Thai reporter who asked him heatedly in English why he did not speak in Thai!

Given the significance of the occasion it was disappointing that no European journalists attended this conference. Their insouciance doubtless reflected the priorities and attitudes of their markets. The significance of the evening was, however, not lost on the members of regional press. To witness at first hand

the appearance of one of the legends of contemporary South East Asia was to be a participant in history.

In stark contrast to the restrained intimacy of Thursday evening was Saturday morning. By 8am the lobby of the Lee Gardens was a veritable farrago. The arrival of the Bangkok press corps, specially flown in by the Thai airforce, swelled the growing number of journalists and photographers to over 250 (some estimates said 300). The press bloc now included a small contingent of Europeans which had gathered on the Friday and Saturday morning.

Significantly, at the press briefing on Saturday morning, the Thai briefing officer was specific in his request that the press be discreet in their questions to Chin Peng and to avoid any use of the term 'surrender', stressing the negotiated nature of the Agreement.

Given the sheer volume of press representatives it is hardly surprising that the details of the signing ceremony were admirably covered in all the regional papers which, in the main, devoted several pages to the occasion. Suffice to say, the security and protocol arrangements totally collapsed under the weight of the obdurate press phalanx which pushed, jostled, climbed and harried for a view of the top table to the total exclusion of the seated dignitaries. One seasoned English journalist exclaimed to this writer that he had not witnessed such enthusiasm since the OPEC conferences of the early seventies.

Distributed at the ceremony was a pink brochure containing the text of the Joint Communique issued by the concerned parties in both Thai and English, together with the details of the signatories (*sic.*) to the Agreement. The dignitaries seated along the front rows comprised the Malaysian, Thai and CPM delegations.

The official Thai signatories arrived shortly after 1015 led by General Chaovalit Yongchaiyudh, Deputy Director of the Internal Security Operations Command, followed by the Malaysian delegation led by Dato Haji Wan Sidek Bin Abdul Rahman, the Secretary General of the Ministry of Home Affairs. The CPM delegation entered last, much to the excitement of the assembly.

Mustering as much dignity as the conditions would allow, the parties, with the aid of military police and Thai officials, forced their way



Fig. 1. Chin Peng, 30 November 1989 (photo author).

through the throng of waiting photographers who totally disregarded the harassed Master of Ceremonies' plea for calm and order. It is apposite to point out that, in spite of the apparent confusion, the Thai authorities maintained their characteristic *sang-froid* in dealing with the situation.

Thence followed a series of short speeches by each delegation leader. These ran to script and contained few surprises. Each was fulsome in its praise for the efforts of either side to end the hostilities. All expressed their sincerity in the quest for peace. General Chaovalit, as Chairman, spoke first in Thai, followed by Dato Haji Wan Sidek Bin Abdul Rahman who, speaking in English, acknowledged and greeted the leader of the CPM delegation as 'Mr Ong Boon Hwa' to the good humour of the audience ('Chin Peng' is an alias).

Chin Peng's response, in Bahasa, acknowledged that as Malaysian citizens '...we pledge our loyalty to his Majesty the Yang di-Pertuan Agong and the country'. His speech also made

oblique reference to the '...current historical trend where people of the whole world are striving for peace and democracy ...' but contained no hint as to the future of the Party, stressing instead the cessation of military activities.

The scheduled press conference followed the toasts. The Thai and Malaysian delegations left the room leaving the CPM delegation of Chin Peng, Abdullah C.D., Rashid Midin and Miss Huang Hui Her to face the press. Chin Peng alone answered questions.

In a carefully scripted performance Chin Peng, despite his promises of Thursday, said little of consequence, avoiding reference to his future plans, his past or the future of the Party. He was effusive once again for the efforts of the Thai authorities in their part behind the negotiated settlement.

It should be noted that immediately preceding the conference Chin Peng stated in English:

I would prefer to answer questions in my national language - Bahasa.

SPEECH BY CHIN PENG, SECRETARY-GENERAL OF
THE COMMUNIST PARTY OF MALAYA
AT THE SIGNING CEREMONY OF
THE PEACE AGREEMENTS

(2nd December, 1989)

Your Excellency ^{Tan Sri} General Chaovalit Yongchaiyuth,

The Honourable Datuk Wan Sidek bin Wan Abdul Rahman,

Honourable Members of the Delegation of the Government of the Kingdom of Thailand,

Honourable Members of the Delegation of the Government of Malaysia,

Respected Ladies and Gentlemen!

The delegations of the GOVERNMENT OF THE KINGDOM OF THAILAND, the GOVERNMENT OF MALAYSIA and the COMMUNIST PARTY OF MALAYA have held a series of peace talks and reached a successful conclusion as evidenced by the signing of the two peace agreements. We are pleased with the outcome of these talks.

The agreements that have just been signed are in keeping with our party's policy for the realization of peace. Besides, they are also consistent with the current historical trend where the peoples of the whole world are striving for peace and democracy as well as consistent with the interests of the peoples of our two countries -- Malaysia and Thailand.

We deem both the agreements to terminate the armed activities that have been going on for 41 years through peace negotiations an honourable settlement. Without doubt, this settlement which is just and reasonable to all parties concerned has been achieved in the spirit of mutual understanding and accommodation.

We believe that the signing of these agreements will mark a new chapter in the history of our motherland and will contribute significantly to the realization of prosperity and stability in Malaysia and in the Thai-Malaysian border region.

As Malaysian citizens, we pledge our loyalty to His Majesty the Yang di-Pertuan Agong and the country.

As one of the signatories, we promise to carry out the agreements to the letter. We shall disband our armed units and destroy our weapons to show our sincerity to terminate the armed struggle.

Last but not least, please allow me, on behalf of the delegation of the COMMUNIST PARTY OF MALAYA, to express our heartfelt gratitude to the GOVERNMENT OF THE KINGDOM OF THAILAND for providing valuable assistance for the tripartite peace talks and acting as witness to the peace agreement between the GOVERNMENT OF MALAYSIA and the COMMUNIST PARTY OF MALAYA as well as playing host to this historic signing ceremony. I also would like to convey our special appreciation to ^{Tan Sri} General Chaovalit Yongchaiyuth for his far-sightedness and to Major-General Kitti Ratanachaya for his efforts in making the peace negotiations a success.

Thank you.

He then continued in faultless and fluent modern Malay using his personal secretary Miss Huang to interpret for him. Following discussions with Malay journalists after the conference the general opinion was that Chin Peng acquitted himself well in Bahasa, surprising for one supposedly so distant and 'out of touch' with contemporary developments in the country. 'Maybe he reads the *Utusan Malaysia* regularly' quipped one Malaysian journalist impressed with Chin Peng's familiarity with the language (*The Straits Times*, December 4, 1989).

Chin Peng was generous in his praise of the Malaysian authorities, suggesting that their understanding and compromise was a major factor in the peace discussions:

Because of this spirit, we ended the peace talks successfully (*Sunday Star*, December 3, 1989).

Chin Peng was explicit in his denial of the press rumours that he was to take part in the next Malaysian general election. Although, as indicated, he was not to be drawn as to his political future.

With reference to the composition of his forces he revealed that some 1100 CPM members were to come out of the jungle shortly. Of these some 30-40 were Singaporeans and, to the detailed attention of Japanese consular officials and press, two were Japanese from the Second World War. He indicated that these were to be sent home after the signing if they so wished. They were later identified as Shigeyuki Hashimoto, 71, and Kiyooki Tanaka, 77. The pair were the only survivors of 15 Japanese who joined the CPM in 1945. They emerged from the jungle in early January to a reunion with relatives and were repatriated to Japan (*Bangkok Post* January 11, 1990).

Chin Peng denied that the events in Europe and China had any bearing on the CPM's decision to negotiate and denied any pressure from China. Almost as if to underscore the point, he was swift and explicit in his admission to still being a Marxist-Leninist. He was later to add '...I want to qualify my comment on being a Marxist-Leninist. I am not a dogmatic Marxist' (Discussion between the author and Stephen Vines of *The Observer*, 2.12.89).

Towards the end of the conference Chin Peng admitted that he had had no direct involvement in the military affairs of the CPM

but had given 'political guidance' only. He declined to elaborate on this point. His comments raise an interesting question as to the nexus between the military command structure and the Politburo. The answers to this and many other questions will doubtless have to await the Secretary General's convenience - he promised to answer some of these questions in 'books and articles' shortly.

Saturday's press conference was a far more formal affair than the preceding Thursday evening. Understandably, Chin Peng was not quite as relaxed, relying upon set-piece answers to foil sensitive questions. Notwithstanding, his performance was impressive and gave every indication of his formidable negotiating skills. Despite his seemingly accommodating nature and charm he gave very little away and it is not difficult to conceive of a tight bargaining schedule to achieve the Accords.

The delegates and signatories to the Accords were scheduled to leave the hotel after lunch. Outside, on the street, a small patient crowd had been waiting all morning. An unkempt and pock marked Chinese 'businessman' struck up an amiable conversation with the writer. From this communicative source it became readily apparent that the crowd comprised CPM members and supporters waiting to catch a glimpse of their leader. On Chin Peng's appearance from the hotel they broke into discreet applause. Acknowledging their support he momentarily paused on the steps, waved in salute and, pursued by photographers, climbed into his car. Following his departure the writer turned to resume discussion with his Puckish acquaintance, only to find that both he and his companions had spirited away. The pavement was deserted.

Chin Peng, together with selected CPM executives, made one more appearance later that evening at the hotel for a dinner hosted by the Thais, after which he left for destinations unknown. The show was over.

The aftermath of a media event is always anti-climactic. After three days of anticipation and activity, the lobby of the Lee Gardens Hotel seemed unnaturally deserted on Sunday morning, a reminder that a new chapter in the history of the region had opened.

DISCUSSION

The fanfare that surrounded the Accords belies the complex negotiations that necessar-

ily preceded their signing and the regional implications that were to succeed them.

An indication of the negotiation complexities were the speculative press reports leading up to the Accords. Evidence the following headlines:

Malaysia is not negotiating with CPM: Mahathir (*The Straits Times*, November 18, 1989).

Chin Peng 'to sign Bangkok pact on Dec 5' (*The Straits Times*, November 21, 1989).

330 Reds 'will return to Malaysia after Dec 2 pact' They will be allowed to take part in politics, say Thai officials (*The Sunday Times*, November 26, 1989).

Malaysia to legalise Communists (*The Australian*, November 27, 1989).

KL pledges legitimate political role for CPM (*Bangkok Post*, December 2, 1989).

From these and other newsprint reports during this period, a picture of dissimulation emerges. Given their success in concluding negotiations with the CPM (Malaysia faction) it was inevitable that the Thais would be cast in the role of honest brokers. Their diplomatic endeavours would appear to be very much in evidence in the number of attributable comments by senior Thai sources, mainly military, in the aforementioned reports. In the time honoured tradition of diplomatic manoeuvring, these comments appear timed and designed to exert appropriate pressure on the various parties.

To appreciate further the complexities of the tri-lateral negotiations is to appreciate the disparity of the respective positions of the parties. Based on previous position statements, the likely *sine qua non* of the parties might be summarised as follows -

From the Thai perspective, the objectives of the negotiations would have been straightforward, namely, to terminate hostilities, thereby obviating an embarrassing diplomatic problem with Malaysia and freeing capital and resources for development in the region. From the Thai standpoint, both the CPM and the Malaysian delegation ought to accept in principle equal responsibility for the resolution of the conflict; that Malaysia address the issue of citizenship by allowing responsible and fair repatriation to Malaysia of CPM members of Malaysian origin and that the CPM accede to total demobilisation.

The Malaysian position was more complex. Although the CPM no longer represented a direct military threat, its presence in the Be-

tong salient provided reason enough for the deployment of a sizeable security force along the border. Given that much of the Malaysian security planning has, for three decades, been preoccupied with the idea of counter-insurgency, both the civil and military arms of the security forces held deep rooted suspicions of CPM motives. The question of Trojan Horse tactics by the CPM was apposite as also was the concomitant potential for racial and political tensions. The Malaysian negotiating team would doubtless have been briefed to extract from the CPM an unequivocal commitment to abandon the armed struggle and a clear statement of the position and intentions of the Party with a view to its dissolution. In addition, the CPM members would be expected to accede to detailed debriefing and re-orientation before the granting of full citizenship rights whilst providing a firm undertaking not to engage in any subversive or pro-Communist activities in Malaysia.

The CPM came to the talks from an apparent position of weakness. Conceived in the colonial era, matured in the Cold War and out of step in a world demonstrating a marked decline of enthusiasm for Communism, the CPM appeared to have little choice but to sue for peace. Notwithstanding, Chin Peng admitted to controlling a guerrilla force of 1100. This represented something approximating one fifth of the original army of revolution of 1948. Given the civil, political and military commitment required to counter a determined insurgency, simple arithmetic illustrates the potential for tragedy had the CPM opted for a Quixotic military solution. Given that the CPM was well established in the Betong salient, having successfully resisted previous Thai efforts to dislodge them and given that it maintained a civilian support system in Malaysia, the Party could well have opted to remain a formidable irritant. The optimum gambit by the CPM would likely have included therefore, an armistice, a recognition by the Malaysians of the CPM, leading ultimately to its legalisation and a policy of unrestricted return to Malaysia by all CPM members who so desired.

In all probability, the discussions would have been reduced to and centred around the nature of the cessation of hostilities, the vexatious question of repatriation and resettlement, the measure of political activity allowed by the returnees and the shape and format of the



Fig. 2. Chin Peng (left), Miss Her (centre), Maj. Gen. Kitti (right) (photo author).

signing ceremony. The net result was one of cautious compromise.

The diffuseness of the Joint Communique indicates the nature of this compromise. The future of the CPM and the details concerning the repatriation and resettlement of the returnees remained in question.

The resettlement and repatriation question had long been a point of contention between the three parties. The CPM consistently claimed citizenship rights for its members in both Thailand and Malaysia dependent upon country of birth. Malaysia consistently put the view that by resorting to arms the insurgents forfeited their citizenship (Federal Constitution Article 25) and the Thai authorities have been chary of granting automatic citizenship rights to all, including Malaysian born, returnees. Thus CPM members have been effectively stateless for decades.

To further complicate the issue both countries had differing rehabilitation policies for returnees.

The Thais, as part of their counter-insurgency programme, use the promise of commu-

nal resettlement as an inducement for insurgent groups to abandon hostilities. This programme was used to effect in countering the Communist Party of Thailand's insurgency and, of immediate interest, the CPM (Malaysia) were settled in Friendship Villages in the southern border region.

By contrast, the Malaysian government demonstrated caution in its rehabilitation programme, requiring returnees to undertake a variable programme of assessment and re-orientation. Exemplifying this caution was Deputy Home Minister, Datuk Megat Junid Megat Ayob who, during the negotiations, offered another perspective as to why Malaysia could not follow Thailand's lead in resettling the Communist 'cadres':

We must take into consideration that the Communists had killed many of our citizens whose families cannot forget their grief. The lives of the Communists will be in danger if we allow them to resettle freely in Malaysia (*The Straits Times*, November 11, 1989).

However, a Malaysian report the day after the signing quoted Prime Minister Datuk Seri

Dr. Mahathir as saying that the Government had yet to decide whether its rehabilitation programme was to continue (*Sunday Star*, December 3, 1989).

Significantly, a Thai report suggested that the Thai authorities would provide settlements for the former guerrillas in Sukhirin district of Narathiwat province and Bang Lang, Betong and Yaha in Yala province (*Bangkok Post*, December 3, 1989). Should this report be correct, the new resettled communities, taken together with the Friendship Villages, will add an interesting dimension to the social and political character of the border region.

The question as to the future of the Party fuelled a familiar debate in Malaysia.

The negotiations and the Accords raised considerable disquiet in some circles in Malaysia, notably elder statesman, Tunku Abdul Rahman and retired psychological-warfare expert, Tan Sri C.C. Too. The imprecise commitment by Chin Peng about the future of the Party drew a rash of press speculation in Malaysia and Singapore, typical of which is the editorial of the *New Sunday Times* commenting on the Accords:

The ideological and revolutionary conflicts of the Fifties have become musty and irrelevant. The peoples of Eastern Europe are creating a different kind of revolution, having had enough of the inefficiencies and failures of Communist regimes. The CPM has renounced its armed struggle, but it is still vague about its ideological intent and bent. It is hoped the party will honour the accords, and if its members still want to make a point, that they will do so via democratic processes (*New Sunday Times*, December 3, 1989).

The Party remains proscribed in Malaysia and press reports indicate that the Government has no intention of reversing its policy. Commenting on Chin Peng's statement that the Accords dissolved the army but not the Party, Mahathir said that the Government would act if any returnee continued to promote Communism, however:

If they persist with their ideals but are not involved in any action, then nothing will happen (*Sunday Star*, December 3, 1989).

The debate about the future of the Party raises an interesting question of semantics. Under the 1987 formula the problematical question about the Party was neatly resolved in that emphasis was placed on the peace agreement between the Thai Fourth Army and

the Second Military Zone and, aside from casual reference that the Party was now finished, no details were made available as to its formal status (Coe 1988c:21). The 1989 Accords were, however, substantially different in that an agreement was reached between two sovereign states and the Communist Party of Malaya. Given that the CPM is proscribed in Malaysia, the political and legal nature of the agreement is abstruse. The notion of an 'Accord' is therefore an accurate description of the agreement in that it implies a military rather than a political settlement. It is little wonder that the future of the CPM remains under the shadow of doubt.

Relative to these diplomatic niceties was the format of the official ceremony. It is significant to note that, unlike the Malayan Peoples Anti-Japanese Army in 1945 and indeed, the Second Military Zone in 1987, the CPM did not have a public ceremonial parade and official demobilisation. The writer understands that both the Malaysian and CPM delegations opted for a low key ceremony lest the Accords be misinterpreted by the media. Chin Peng was concerned that the Accords were not to be construed as a form of surrender. The public handing over of arms could well be interpreted thus. The Malaysians, by contrast, were chary of such a public ceremony lest it be interpreted as providing legitimacy and public recognition to the armed struggle and the 'Malayan National Liberation Army'.

Quoting 'Thai officials', the *Bangkok Post* hinted however, that a formal military ceremony might be scheduled within 75 days (16 February 1990) with attendance restricted to military and para-military representatives from the three parties. The report continued by suggesting that the armed units would take at least six months to disband (*Bangkok Post*, December 3, 1989).

Possibly the most curious paradox in this political composition is the exclusion of Singapore from the Accords. Given the CPM's previous position over the question of Singapore, together with the numbers of Singaporeans in the armed units, it could reasonably be assumed that the Singapore authorities would have had more than a passing interest in the settlement. The reason for the exclusion will have to await the release of appropriate documentation on the subject. Sufficient to say that the official comment from Singapore has been cautious, typical of

which was Brigadier-General Lee Hsien Loong's view:

It would be oversanguine to think that this *de facto* abandonment of the armed struggle by the CPM marks the end of the Marxist threat, or that subversion and insurgency will no longer be problems in Malaysia and Singapore (Lee 1990).

The Accords will have a direct bearing upon the future strategic shape of the region. Aside from relieving both Thailand and Malaysia of an expensive military burden, the cessation of hostilities should allow both countries to concentrate and re-deploy available resources more appropriate to contemporary demands. For example, Major General Kitti revealed that Thailand spent 40-60 million baht annually on security operations against the CPM (*The Straits Times*, December 2, 1989).

An intermediate consequence of the Accords will be the releasing of military resources for possible redeployment on Thailand's northern and western borders. However, in the immediate future the *Bangkok Post* raised a real fear in that the Accords will leave a power vacuum in the southern border region that could be filled by the increasingly militant and violent Muslim separatists previously countered by the CPM (*Bangkok Post*, December 3, 1989).

It is more likely however, that following the removal of the CPM's armed units, the full weight of the Fourth Army can be turned upon the separatists. This will test again the efficacy of the Thai counter-insurgency methods. Doubtless the Thais will be looking forward to the active co-operation of the Malaysians on this issue.

From the Malaysian standpoint, the Accords have had the immediate effect of easing military restrictions and the lifting of curfews in the northern states and along the East-West Highway. In the longer term, the removal of the CPM guerrillas removes the requirement for the large scale deployment of specialist counter insurgency units along the border. Indication of a new direction in defence training and emphasis was given substance in a news report which reported Prime Minister Mahathir as commenting that the direction of the Malaysian armed forces would be aimed at ensuring the security of the country's land and sea areas, especially the exclusive economic zone (*The Sunday Times*, December 3, 1989). The means by which Malaysia projects its

presence over its regional interests, which presumably includes the disputed Spratly Islands, will doubtless be of interest to regional defence observers.

Finally, the geopolitical factors that might have contributed to the CPM decision to seek a negotiated settlement are worthy of comment. Germane to these are two points made by Chin Peng in his press conferences, namely, that he had expected the armed struggle to end like this for several years and his protestations that neither China nor the international situation had any bearing on the CPM's decision.

His first comment alludes directly to the inevitability of ending the armed struggle; his second, to its timing.

In both cases the China question, as ever, is material. The CPM has been a long standing client party of Beijing and, in part, a willing instrument of China's foreign policy. However, since the mid 1970's, the CPM has suffered from a state of profound disorientation. Splits and schisms notwithstanding, the comfortable certitudes of the fifties and sixties began to fall away with the Nixon visit to China in 1972 and the Beijing-Kuala Lumpur rapprochement of 1974. Contrast, for example, the CPM's 'Voice of the Malayan Revolution' (25 May 1974) commentary on Prime Minister Razak's visit to China:

China also has achieved brilliant success in socialist revolution and construction. As a impregnable revolutionary bastion, China is now making an increasingly important contribution to world revolution (Doc.240, Jain 1984:211).

with the *Peoples Daily* editorial on the friendly relations between China and Malaysia of 28 May 1974:

It is our consistent stand to establish and develop relations with other countries on the basis of the Five Principles of Peaceful Co-existence ... the affairs of a country should be handled by the people of that country themselves. The social system of each country can be chosen and determined only by the people of that country themselves, and no interference by external force is allowed (Doc.242, Jain 1984:216-217).

Momentarily out of step with its patron, for the Communists of Malaya the contradictions in the Byzantine world of China's 'westpolitik' must, at times, have seemed insuperable.

The subsequent period of history was a watershed in international affairs in which the CPM found itself drawn towards the inevita-



Fig. 3. Datuk Wan Sidek Abdul Rahman (left), Gen. Chaovalit (centre), Chin Peng (right) (photo courtesy of Sin Chew Jit Poh).

bility of reaching some measure of concord in the region. The decision by the rival faction to abandon the armed struggle, based partly on an appraisal of the international situation. (Anonymous 1987b), must have left the CPM with an uneasy feeling that history was overtaking them.

Given that the CPM's history consistently reflected the shifts and fortunes of international Communism it is reasonable to assume that its decision to negotiate a settlement would have been taken with some reference to the international situation. Ironically, the CPM found itself at the vanguard of the sweeping changes besetting the Communist parties in Europe and the Accords provided the means by which it was able to come in from the cold without the ignominy facing its Eastern Bloc counterparts.

CONCLUSION

The CPM's armed struggle was a conflict that had long been overtaken by the war in Indo-China and other regional developments. Nonetheless, it remained a very private and very real war for both the guerrillas and those members of the Malaysian and Thai security forces on duty in sandbagged observation posts along the lonely and mountainous border. It became a stalemated war, of increasing irrelevance to the political shape of the region. After 41 years, it was difficult to see just

where it could go. Direction came unexpectedly.

The Hat Yai Accords represented a major diplomatic breakthrough bringing to a dramatic close a chapter of Malaysian and Singaporean history and, in line with the international situation, marking the end of militant Communism in the region. Not since the unsuccessful 1955 Baling Talks had the peoples of the region the opportunity to seriously contemplate the prospect of peace.

But Baling was another age, beset by other problems and tensions. Held under the world spotlight, the Talks left neither side room to manoeuvre. Expectations were unbounded and unrealistic. In the event, it would have been surprising indeed had the Talks ended any other way. Although the Accords lacked the drama of Baling, the press and observers were invited to the party rather than the working sessions, thereby allowing participants maximum negotiating flexibility.

Comparisons are always invidious but it is worth remembering that the Baling Talks stumbled over the questions of 'surrender', the recognition of the CPM and the twin issues of the repatriation and rehabilitation of the guerrillas (Anonymous 1956:41-47). These questions, in part, still remain, but the fact that an Accord has been achieved notwithstanding bears testimony to the good faith of all parties concerned.

The undoubted star of the show was the

enigmatic Secretary General of the CPM, Chin Peng. Elsewhere the writer has described Chin Peng as the Rusa Merah, the embodiment of the *Jinggi*, the guardian spirit of the deer (Coe 1988a). The elusiveness of his namesake was never more apparent than at the Accords. True to his reputation he materialised, charmed his audiences, said little of consequence and disappeared, leaving as many unanswered questions and a trail of rumours behind him.

It was, however, wholly appropriate that Chin Peng, having steered the Party into the jungle should, as an act of reconciliation, lead his remaining followers out of the wilderness.

In so doing it is moot to reflect whether, whilst negotiating the Accords, he recalled his lines at Baling:

I am not coming here to argue questions of ideology, but if questions of peace are to be discussed, we are fully prepared to do so. Peace is the common demand of all people. We also hope that peace will be realised early so that the misery of the people can be reduced. War is War. War will certainly bring misery to the people and will also bring hatred (Anonymous 1956:5).

In 1989 peace, as always, was uppermost in the minds of the people. The tragedy is, that it took so long to achieve.

ACKNOWLEDGEMENTS

I should like to take the opportunity of acknowledging the generous assistance of the Thai and Australian Foreign Affairs Departments, the Thai Fourth Army, and Mr Tony Hill, ABC correspondent in Bangkok. I would also like to thank Sin Chew Jit Poh for permission to publish figure 3, and the NT Museum for its ongoing support for my research

APPENDIX 1

The following selected transcripts are extracted from the two press conferences as recorded by the writer.

Press Conference 1

Combined Task Force Head Quarters
Senanarong Army Barracks, Hat Yai.

Chairman, Major General Kitti
Rattanachaya, Deputy Commander,
Fourth Army Region.

2000hrs-2020hrs 30 November 1989

Q. Since when have you been here?

A. I will tell you after the 2nd.

REFERENCES

- Anonymous, 1956. *Record of the Baling Talks*. TOP SECRET, Kuala Lumpur. Copy No. 16, PRO London CO1030/29 159706.
- Anonymous, 1986. *Malaysia: Federal Constitution*. Kuala Lumpur, MDC Sdn. Bhd..
- Anonymous, 1987a. Press Communique by the Headquarters of the Second Military Zone of the People's Liberation Army of Malaysia on the Agreement reached in Peace Negotiations between Delegates of the Second Military Zone of the People's Liberation Army of Malaysia and Delegates of the Thai Government. April 11, 1987
- Anonymous, 1987b. Speech made by the Sokesman of the Second Military Zone of the Malaysian People's Liberation Army in News Conference concerning the Peace Negotiations. Betong, May 5.
- Coe, J. 1988a. The Rusa Merah: Reflections on a Revolutionary. *The Beagle, Records of the Northern Territory Museum of Arts and Sciences* 5(1):163-173.
- Coe, J. 1988b. Friendship Village No. 1 Betong, South Thailand. *Kajian Malaysia, Journal of Malaysian Studies* 1(2):86-95.
- Coe, J. 1988c. *Working paper No. 2*. 'An Analysis of Interviews Conducted with CPM (Malaysia) Returnees at Friendship Village No. 1, Betong, Thailand Between 1-4 December, 1987. Darwin: in litt.
- Coe, J. 1989. Unpublished Interview Tapes and Field Notebooks of Press conferences (30.11.1989 and 2.12.1989) [see Appendices].
- Jain, R. 1984. *China and Malaysia 1949-1983*. Humanities Press: New Jersey.
- Lee, Hsien Loong 1990. The View From Singapore. *Pacific Defence Reporter* XVI(8):23.
- Saiyud, Kerdphol 1986 *The Struggle for Thailand: Counter-insurgency 1965-1985*. S. Research Centre: Bangkok.

Accepted 21 May 1990

Q. How many Singaporeans are there?

A. I cannot reply the actual number now. Wait and I will give you the number.

Q. Are you taking your people back to Malaysia?

A. Sorry.

Q. Will you go back to Malaysia to raise a new political party there?

A. I think that after the signing I will reply.

Q. Any comment for Tunku Abdul Rahman, who said you cannot be trusted?

A. I don't think I shall reply to that at this moment.

Q. Once a Communist always a Communist. Are you always a Communist?

A. This is his impression. Not my words.

- Q. What is your word?
A. I think I shall wait until the 2nd.
- Q. Have you got any comments on the developments in International Communism in light of what is happening in Europe and the Peoples Republic of China?
A. This is a big question. I prefer to answer you on the 2nd.
- Q. You look very happy tonight. Do you really feel so and did you expect this moment to come? Did you expect this moment some years ago?
A. I am very happy actually. I think I expected this to happen, earlier or later.
- Q. Many years ago?
A. Some years ago.
- Q. Can you comment on the Thai Government?
A. Yes, I think I must express our gratitude to the Thai Government for all they have done. Without their assistance this peace agreement would be impossible and I would like to express my gratitude to the Thai Government, especially to General Chaovalit and Major General Kittii, my friend here.
- Q. What do you think about the ex-CPM members about two years ago that dissolved their army?
A. We are going to dissolve our army yes, but not the CPM.
- Q. They will join you in Malaysia?
A. That will be mentioned in the Joint Communique.
- Q. You are going to dissolve the army but not the Party?
A. Yes, we are going to dissolve the army, disband the army.
- Q. But the Party remains?
A. No, I think this is delicate, better wait until the 2nd.
- Q. Is this tantamount to accepting the amnesty and the agreement you were supposed to sign in 1955?
A. I think this is a very long story to tell.
- C.P. Thank you General Chaovalit, thank you Major General Kittii. So the peace talks have come to a successful conclusion.
- A. 1100 CPM members to come out shortly.
Q. What about the two Japanese?
A. After the signing we shall try to send them home to Japan.
Q. Does the CPM still exist?
A. The Joint Communique explains clearly about this.
Q. How many Singaporeans are in the CPM?
A. In the armed units only around 30 -40.
Q. If you are going to establish a party, under which platform will you operate?
A. Our Party Committee is still to discuss this.
Q. Was your decision influenced by what is happening in the socialist world?
A. We do not interfere in the affairs of other Communist Parties. I cannot comment because I had no time to study the developments in these countries. We did not have the information on these socialist countries beyond what we read in the newspapers.
Q. What is China's stand on the agreement?
A. I don't know what China's position is. That is a matter for China.
Q. Do you regard yourself as a Marxist-Leninist?
A. Yes. (Significantly, he was to later qualify this comment to Mr Stephen Vines of *The Observer*... I want to qualify my comment on being a Marxist-Leninist. I am not a dogmatic Marxist'.
Q. When did you return to China and what have you been doing since then?
A. No comment. (In English)
Q. What have you achieved?
A. Too long to answer here.
Q. Do you regret it?
A. I will answer that later. (Chin Peng also promised to answer this question in books or articles)
Q. Were you in day to day command of military matters?
A. No. I gave political guidance only.
Q. Do you recognise the independence of Singapore.
A. Yes, certainly.

Press Conference 2

Lee Gardens Hotel, Hat Yai
1100hrs. 2.12.89.

- C.P. I want to correct reports in the press about my participation in the next general election.
Q. How many armed members are in the jungle?

Note: In the foyer after lunch Chin Peng stopped to ask of Stephen Vines, the correspondent from *The Observer*, as to the health of his old friends and Force 136 comrades, John Davis and Richard Broomc.

BOOK REVIEW

Kangaroos: Their Ecology and Management in the Sheep Rangelands of Australia.

Edited by Graeme Caughley, Neil Shepherd and Jeff Short.

Cambridge University Press, 1987
ISBN 0 521 303443, 253 pages, Hardback.

This most excellent volume is the product of a joint research project carried out by CSIRO Division of Wildlife Research and N.S.W. National Parks and Wildlife Service. The five year study examined the relationship between high kangaroo densities and vegetation in the Kinchega National Park and compared this to a nearby grazing property 'Tandou'.

The essence of this study is to examine two adjoining and similar ecosystems, both of which are grazed by red and grey kangaroos and one of which is also grazed by sheep. The product is an assessment of how kangaroos may best be managed in national parks and rangelands.

The book is subdivided into a preface and 11 chapters, an author index and a subject index. Each of these contributions is by an author or group of authors expert in that particular aspect of ecology.

Graeme Caughley's first chapter, "Introduction to the sheep rangelands", chronicles the introduction of man, his domesticated animals and his practices to Australia, and catalogues their impact on the marsupial population. The ten illustrations and single table show the main protagonists in the conflict (sheep and kangaroos), in terms of their distributions and densities, and sets the scene for what follows.

Robertson, Short and Wellard's second chapter, "The environment of the Australian sheep rangelands", then gives an overview of the sheep rangelands environment and provides a detailed assessment of the two study areas, Kinchega and Tandou. Climate, landforms, soil, vegetation and fauna are described in some detail. The chapter includes 12 figures (line drawings and photographs) and four tables of data. The impact of the introduction of sheep and rabbits, together with the effects of massive overgrazing and land management techniques are described. The resultant extinction of 32% of marsupial species in sheep

rangelands is laid bare. The only minor fault which stood out in this chapter was the failure to include the European hare in the list of European mammals introduced to Australia.

Whereas the first two chapters set the scene and catalogue the effects of past events and current conditions, the third chapter, "The effect of weather and soil moisture and plant growth in the arid arca", is a straight research report and is marked by a change in format to that of Introduction, Methods, Results, Discussion and Conclusion - with which we are all so familiar. Greg Wellard's study involves the analysis of two animal enclosure areas on different soil types in Kinchega (floodplain and sandplain). He attempts to determine the relationships between rainfall and soil moisture and asks if these can be used to predict changes in pasture growth biomass. The data analyses and findings are illustrated with six line drawings and five sets of tables. As we might have expected, growth was correlated with rainfall over the previous month or so and biomass was equally related to rainfall, but over a longer time period, and could be predicted. The findings were unremarkable, but the contribution undoubtedly necessary for this volume.

Robertson's fourth chapter, "Plant dynamics", returned to the less traditional format. In this study biomass and species composition were measured at several hundred sites at Kinchega and Tandou. Comparisons were made on caged and uncaged plots to measure the effects of kangaroo, sheep and rabbit grazing, trampling and digback. Biomass and species composition were estimated. The results are illustrated with 12 figures (line drawings and photographs) and a single table. The conclusions are significant in showing that not only rainfall but grazing are determinants of plant biomass, although rainfall, or more precisely its absence, overrides all. Grazing by mammalian herbivores removed 70% of the

pasture biomass, kangaroos and sheep differed in that the latter browse blue bush heavily in drought periods.

Chapter 5 forms an interesting contrast with Chapter 4. Barker approaches "The diet of herbivores in the sheep rangelands" from a different perspective; that is, by analysing faecal, rectal and stomach samples. Three tables and six illustrations and photographs assist in presenting the data. They show that red kangaroos ate blue bush, whereas greys are not particularly fond of it, and when the grass ran out would tend to eat prickly wattle. Reds and greys tend to eat much the same things when food is abundant. It would seem that reds and sheep eat similar plants during times of stress and greys do not. Eastern and western greys also have a very different diet. The chapter is well written and presented.

In Chapter 6 Jeff Short examines "Factors affecting food intake of rangelands herbivores". He analyses grazing trials of sheep, rabbits and kangaroos. The feeding trials were at Kinchega for red and western grey kangaroos and rabbits, and utilised published data from other areas for sheep. It appears that there is minimal competition between species when biomasses are above 300 kg/ha. But lower than this and the interactions start. Food quality affects the amount of intake. Not surprisingly the rates of increases of these herbivores are constrained by food availability. Sheep, red kangaroos and rabbits, because of their grazing efficiency and predilection for seedlings, have the capacity to greatly modify rangelands and wipe out plants such as blue bush. Western grey kangaroos appear to be less efficient feeders than are reds, or for that matter sheep and rabbits.

Whereas Chapters 3 to 6 discussed the utilisation of food resources by kangaroos in Kinchega and Tandou, Chapters 7, 8 and 9 discuss their population dynamics, home range condition and reproductive condition.

In Chapter 7, "The mobility and habitat utilisation of kangaroos", David Priddel presents his results of mark - recapture - release, telemetry and habitat utilisation studies which were made on red and western grey kangaroos in both study areas. The results presented demolish some of the oft repeated furrphies about the migration of hordes of kangaroos. Few kangaroos do move considerable distances, but Priddel has convincingly shown

that the great majority of animals live and die within their home ranges which are less than 8 km². This paper is well illustrated with seven plates and figures and the data is presented in four tables. Population sample sizes are quite adequate for the conclusions reached within those study areas. Clearly, they would be expected to be larger if multiple sites were investigated.

Peter Baylis's chapter on "Kangaroo dynamics" concentrates on the use of aerial spotting to determine the relationship between the dynamics of red and western grey populations and their food supply on Kinchega, Tandou and other adjoining properties. The situation is interesting although anomalous in that reds and western greys are found in a ratio of approximately three to one in both areas, yet the population is twice as large in the national park when compared to the sheep station. Most significantly Bayliss found that the difference in density was due to sheep reducing the amount of food available for kangaroos. In terms of the ratios of the two kangaroo species, Bayliss found that if one species increased the other decreased and *vice versa*. This is well illustrated with five plates and figures and a single table.

The ninth chapter, "Conditions and recruitment of kangaroos", by Neil Shepherd is blood and guts zoology in its simplest form. Three monthly samples of red and western grey kangaroos from Kinchega and Tandou (only reds) were shot and the animals were dissected to assess body and reproductive condition. The data are presented in eight tables and five line drawings. It appears that body condition is a useful summary of a kangaroo's response to its environment. This would seem to be hardly surprising, nor is the fact that it correlated best with food supply! Naturally, all are linked with rainfall. Shepherd also found that reds and western grey kangaroos have different reproductive strategies. Reds mature earlier in good conditions and have a higher production rate. Whereas, western greys have a longer pouch life and suckle longer than reds.

Graeme Caughley synthesises the findings of this suite of studies in Chapter 10, "Ecological relationships". This large chapter of 28 pages (three tables and five figures), is subdivided into main sections on "relationships" and "what regulates kangaroo popula-

tions?", ecological questions to be answered and a large conclusion section. It is seldom that a working ecologist has such a fine suite of contributions to utilise in an overview of two discrete study areas. Caughley does this expertly and succinctly. The elements of the system are identified (the 'pasture - biomass loop' and the 'plant-herbivore loop'), and then the behaviour of the system is described.

In the last chapter Shepherd and Caughley make an exhaustive assessment on the "Options for management of kangaroos". The approach taken is to introduce the kangaroo "problem" in a historical/legalistic mode; eventually acknowledging the fact that the kangaroo populations are often very large and a harvestable resource. They have clearly attempted to produce a balanced and unbiased account and have done so in considerable detail. Nevertheless, while providing reasonable options they appear commercially directed and a little dismissive. I found it somewhat ironic that the animal liberationists (p. 212) arguments were dismissed along with recreational hunters (p. 213). "Recreational hunters are unlikely to have much effect on numbers because most do not class kangaroos as game animals" (p. 213). I found this a little odd since the recent N.S.W. state elections demonstrated that there are a large number of recreational hunters in that state. These hunt-

ers do not normally have the legal opportunity to hunt kangaroos, a fact which makes me wonder where the authors found their information. It seems to me a true misuse of public resources to find that some 13,000 kangaroos should starve to death at Kinchega in 1983, when many could well have been harvested by recreational hunters paying a per-animal-fee. But then, since when has game management had anything to do with logic.

Caughley, Shepherd and Short have edited what is one of the most significant Australian ecological and management analyses produced. This in-depth study of one of Australia's most visible environmental issues, the kangaroo, has flattened the extremist views of pastoralists on one hand and animal liberationists on the other. It has exposed the lack of an effective management plan for Australia's most prominent animals and has given the N.S.W. Government options on which to act. This most excellent volume is a landmark study and a must for all Australian ecologists. Indeed, it should also be a necessity for all informed graziers and pastoralists.

MAX KING
Northern Territory Museum
GPO Box 4646
Darwin NT 0801, Australia.

GUIDE TO AUTHORS

Authors are advised to follow the layout and style in the most recent issue of *The Beagle*.

Three copies of typewritten manuscripts should be submitted. Manuscripts should be in English, double-spaced throughout and have a margin of at least 4cm on the left-hand side. Text should be on one side of good quality A4 bond paper. If available, a computer file of the manuscript (on 5" or 3" MS/IBM DOS floppy disk) should be submitted together with the printed version. Where appropriate, articles should conform to the sequence: Title, Abstract, Keywords, Introduction, Materials and Methods, Text, Discussion, Acknowledgements, References.

The Title should be concise and informative. An abridged title (not exceeding 50 letter spaces) should be included for use as a running head.

The Abstract should not exceed 150 words, and should state concisely the scope of the work and give the principal findings.

Keywords, to facilitate information retrieval, of up to 15 in number should be chosen to outline the main subjects covered.

The Introduction, including a review of literature, should not exceed what is necessary to indicate the reason for the work and the essential background. Abbreviations used throughout the text may be explained at the end of the introductory material, or placed separately in the Materials and Methods section.

Footnotes are to be avoided, wherever possible, except in papers dealing with historical subjects.

The International System of units should be used.

In the descriptive text numbers from one to nine should be spelt out and figures used for numbers over nine. For associated groups, figures should be used consistently, e.g. 5 to 10, not five to 10.

Systematic papers must conform with the International Code of Zoological Nomenclature and, wherever possible, with their recommendations.

Synonymies should be given in the short form (*taxon* author, date:page) and the full reference cited at the end of the paper. Full citations of taxa used in the text (i.e. *taxon* author, date) must also be included in the references, whereas the short citation (i.e. *taxon* author) need not be included. Subsequent citations of taxa given in synonymies should be separated from bibliographical details by a dash (-).

TABLES

Tables should be numbered with arabic numerals and accompanied by a title. Horizontal rules are inserted only above and below column headings and at the foot of the table. Footnotes on tables should be kept to a minimum and be reserved for specific items in columns. All other explanatory material should be incorporated with the title.

ILLUSTRATIONS

Line drawings, maps, graphs and photographs are generally regarded as "figures" and are to be numbered consecutively for interspersing through the text. Drawings must be on drafting film or good quality board with appropriate lettering inserted. Black and white photographs must be sharp, of high contrast on glossy paper, and mounted on board. The author's name, title of paper and figure number must be indicated on the reverse side of all illustrations. Captions or legends should be typed together on pages at the end of the text.

Colour illustrations may be accepted for larger papers, such as substantial revisions, and only where colour contributes significantly to the descriptive or scientific merit of the paper.

CITATIONS AND REFERENCES

Citations of sources within the body of the text should include the author, year of publication and page reference (where appropriate), e.g. Roth (1896); (Roth 1896); (Roth 1896, 1898); (Roth 1896; Smith 1915). Note that commas are not used to separate bibliographical citations (e.g. Roth 1896), whereas they should be included for taxonomic citations; for the original citation (e.g. *Dasyurus* Geoffroy, 1796), but not for subsequent citations (e.g. *Dasyurus* - Gould 1842).

References should be arranged alphabetically and chronologically at the end of the paper. Titles of all references must be given in full and wherever possible citations given in BIOSIS format. Where an author has published more than one work referred to in the same year, the references should be appended with the letter (a), (b), etc. The following examples show the style to be followed:

Brake, B., McNeish, J. and Simmons, D. 1979. *Art of the Pacific*. Oxford University Press: Wellington.

Cogger, H.G. 1981. A Biogeographic Study of the Arnhem Land Herpetofauna. In: *Proceedings of the Melbourne Herpetological Symposium*: 148-155. Zoological Board of Victoria: Melbourne.

Kaepler, A.L. 1963. Ceremonial Masks: a Melanesian art style. *Journal of the Polynesian Society* 72(2):118-138.

Roth, H.L. 1896. *The natives of Sarawak and British North Borneo*. 2 volumes. Truslove and Hanson: London [Textual reference: Roth 1896 (II):22-26].

Skwarko, S.K. 1968. Mesozoic. In: *Geology of the Katherine-Darwin Region, Northern Territory*. *Bureau of Mineral Resources, Geology and Geophysics Bulletin* 82:105-116.

The BEAGLE, Records of the Northern Territory
Museum of Arts and Sciences

Volume 7

Number 1

July, 1990

CONTENTS

SCIENCES

- LARSON, H.K. – A revision of the commensal gobiid fish genera *Pleurosicya* and *Luposicya* (Gobiidae), with descriptions of eight new species of *Pleurosicya* and discussion of related genera 1
- BRUCE, A.J. – *Periclimenes franklini* sp. nov., a new deep-sea shrimp from the coral sea (Crustacea:Decapoda:Palaemonidae) 55
- HOOPER, J.N.A. – A new species of *Rhabderemia* Topsent (Porifera:Demospongiae) from the Great Barrier Reef 65
- GRIFFITHS, M., GREENSLADE, P.J.M., MILLER, L. AND KERLE, J.A. – The diet of the Spiny-anteater *Tachyglossus aculeatus acanthion* in tropical habitats in the Northern Territory 79
- MURRAY, P. and MEGIRIAN, D. – Further observations on the morphology of *Wakaleo vanderleueri* (Marsupialia:Thylacoleonidae) from the mid-Miocene Camfield beds, Northern Territory 91

HUMANITIES

- BURNINGHAM, N. – Stemless boats of Ende Bay 105
- COE, J.J. – The 1989 Hat Yai Accords 121

BOOK REVIEW

- KING, M. – Kangaroos: their Ecology and Management in the Sheep Rangelands of Australia 137