

*

UMASS/AMHERST

*



312066 0333 2756 0

LIBRARY

OF THE



MA

TTS

A

2AL

PER
SF
521
B47

SOURCE

unds...

1898

v. 11

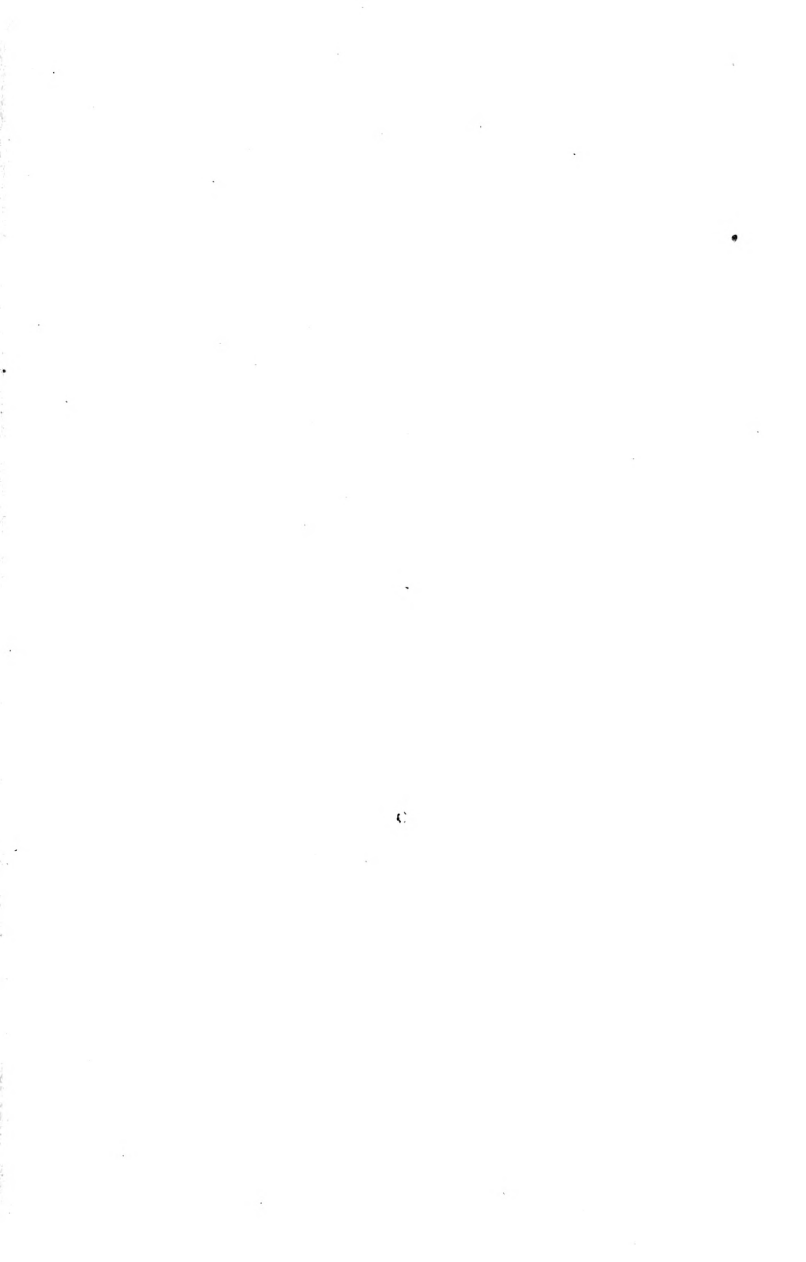





The Progressive Bee-Keeper

Is a 28-page monthly bee journal published at Higginsville, Mo.; price, 50c per year. With the year of 1898, we begin the eighth volume; hence it is past the experimental stage. **R. B. Leahy** and **G. M. Doolittle**, editors. Some of the features of 1898 will be a continuation of **Wayside Fragments**, by **Sommambulist**. **Experience and its Lessons**, by **R. C. Aikin**. This series of articles will be reviewed by Mr. Doolittle, which is practically giving *his* experience with its lessons. "Experience" and its lessons, as reviewed, will be a gold mine for beginners and advantageous to those more advanced in bee culture. The **Sommambulist** articles are written in a pleasing style, as none but **Sommy** could write them. They are highly entertaining and instructive. **Dr. C. C. Miller**, and other popular writers also contribute to its columns. The **PROGRESSIVE** is a popular journal at a popular price. Printed in the highest art, on beautiful paper. Fearless in its character, newsy in its contents, and artistic in its make-up. Remember the **PROGRESSIVE BEE-KEEPER** is but 50c per year. The **PROGRESSIVE** and that "one only" book for beginners, the **Amateur Bee-Keeper**, by **Prof. J. W. Rouse**, both for 65c. A sample copy of the **PROGRESSIVE** for your name, and a beautiful illustrated catalogue of apianian supplies for the asking. Address,

Leahy Mfg. Co., Higginsville, Mo.

Bees Scooped!

I have at last succeeded in buying all the bees within 2½ miles of my home apiary. This practically gives me a clear field for breeding pure Italian queens. I have had over twenty years' experience in breeding and experimenting with Italian queens and bees, and I now breed "for business" from my own importations. Poor stock is costly as a gift.

One colony of Italians in single story, 8-frame, D. T. hive, \$6 00; 5 colonies, \$27.50; 10 colonies, \$50 00; one frame nucleus, \$1.00; two frame, \$1.75. Select the queen wanted and add price to the above. During March and April, one tested queen, 2.00. Select tested queen, \$3 00. After May 1st, one tested queen, \$1 50; 3 for \$4 00; 6 for \$7 50; select tested, \$2 50. Untested queens as early as the season will permit of their being reared, one for \$1 00; 3 for \$2.25; 6 for \$1 00; 12 for \$6.75.

JOHN M. DAVIS,

2-95 12

Spring Hill, Maury Co., Tenn.

Please mention the Review

Muth's HONEY EXTRACTOR PERFECTION Cold-Blast Smokers

Square Glass Honey Jars, Etc.

For Circulars, apply to CHAS. F. MUTH & SON
Cor. Freeman & Central Aves., Cincinnati, O.
Send 10c. for Practical Hints to Bee-Keepers.

1-97-1f

Please mention the Review.

The No-Drip

SHIPPING CASES,

when crated for shipment, reach the market in that dry, clean, tidy condition so attractive to buyers. Not to use them is penny wise and pound foolish. Write for prices. Cash paid for beeswax.

M. H. HUNT,

8-97-1f

Bell Branch, Mich.

Please mention the Review

Violin for Sale.

I am advertising for the well known manufacturers of musical instruments, Jno. F. Stratton & Son, of New York, and taking my pay in musical merchandise. I have now on hand a fine violin outfit consisting of violin, bow and case. The violin is a "Stradivarius," Red, French finish, high polish, and real ebony trimmings, price \$14.00. The bow is of the finest snakewood, ebony frog, lined, inlaid (pearl lined dot) pearl lined slide, German silver shield, ebony screw-head, German silver ferules, and pearl dot in the end, price \$2.50. The case is wood with curved top, varnished, full-lined, with pockets, and furnished with brass hooks, and handles and lock, price \$3.50. This makes the entire outfit worth an even \$20.00. It is exactly the same kind of an outfit that my daughter has been using the past year with the best of satisfaction to herself and teachers. Her violin has a more powerful, rich tone than some instruments here that cost several times as much. I wish to sell this outfit, and would accept one-half nice, white extracted honey in payment, the balance cash. It will be sent on a five days' trial, and if not entirely satisfactory can be returned and the purchase money will be refunded.

W. Z. HUTCHINSON, Flint, Mich.

G. M. LONG, Cedar Mines, Iowa, manufacturer of and dealer in Apiarian Supplies. Send for circular. 1-96-6

Please mention the Review

START IN BUSINESS!



HATCH THOUSANDS
WITH THE PRAIRIE STATE
INCUBATOR
200 FIRST PREMIUMS.
PRAIRIE STATE INC. CO.
HOMER CITY, PA.

SEND FOR CATALOG.

Please mention the Review

WRITE US

Before ordering your sections and we will give you **BOTTOM PRICES** on the

"BOSS" ONE-PIECE SECTIONS,



Also D. T. DIVES, SHIPPING CRATES and other Supplies.

We have everything in tip top order, and can fill orders on short notice. Let us hear from you for prices.

J. FORNCROOK & CO.,

Jan. 1st, 1894.

Watertown, Wis.

Please mention the Review.

Make Your Own Hives.

Bee-Keepers
Will save money by
using our Foot Power
Saw in making
their hives, sections
and boxes.

Machines on trial.
Send for Catalogue.

W. F. & J. D. BARNES CO.,

384 Ruby St.,

Rockford, Ills.

2-96 12

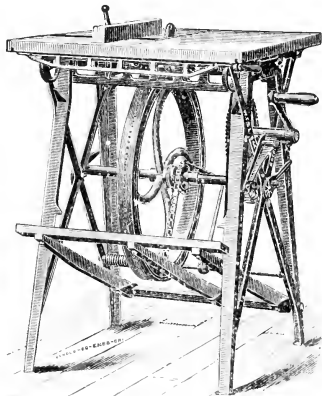

The "Higginsville" Smoker.

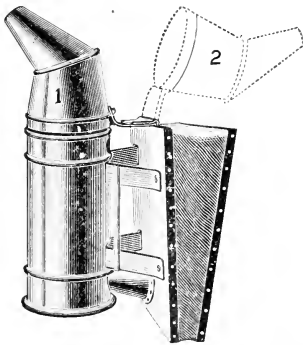

The above cut shows the "HIGGINSVILLE" Smoker. Fig. 2 shows the nozzle thrown back for filling. This Smoker is made of the best material, is strong and well made, will burn any kind of fuel, and has a very strong draft.

The "Higginsville" Smoker is a dandy with a big D. J. M. Morse, Holden, Mo.

Price of smokers, 75c; 3 for \$1.80; by mail add 25c each for postage. Send for catalog of other supplies.

The Amateur Bee-Keeper, a book for Beginners, 25c each; by mail, 28c.

LEAHY MFG. CO., Higginsville, Mo.

Please mention the Review

— If you wish the best, low priced —

TYPE - WRITER.

Write to the editor of the REVIEW. He has an Odell, taken in payment for advertising, and he would be pleased to send descriptive circulars or to correspond with any one thinking of buying such a machine.

FINE FOUNDATION.

My foundation is made by a peculiar process (no dipping boards used) which results in a superior article—one that can't be surpassed. The best goods are none too good, and the lowest prices none too low for these times, and I can furnish both, not only in foundation but a full line of bee keepers' supplies.

SUPPLIES.

Send for a catalogue and be your own judge. Wax wanted at 26 c cash or 29 c in trade, delivered. **AUGUST WEISS,** Hortonville, Wis. 4-97-10-t

Dovetailed Hives,

Sections, Smokers, Queen Cages, and everything needed in the apiary. Warranted Italian queens 75 cts. each. Two frame nucleus, with a queen, \$2.60. Send for catalog.

DEANES & MINER, Ronda, N. C.

— If you are going to —

BUY A BUZZ-SAW,

write to the editor of the REVIEW. He has a new Barnes saw to sell and would be glad to make you happy by telling you the price at which he would sell it.

Page & Lyon

MFG. CO.

New London, Wis.

Nearness to pine and basswood forests, the possession of a saw mill and factory equipped with the best of machinery, and years of experience, all combine to enable this firm to furnish the best goods at lowest prices. Send for circular, and see the prices on a full line of supplies. 1-97-tf

The Cheapest

FALCON POLISHED SECTIONS are superior to all others.

HIVES AND FIXTURES of all kinds kept in stock or made to order.

LARGE ILLUSTRATED CATALOGUE and copy of *The American*

Bee-Keeper (now in its 7th year) for the asking. Address

W. T. Falconer Mfg Co., Jamestown, N. Y.

is not always the best, in Bee-keepers' Supplies as well as other things. We make the best goods and they are as cheap as any.

We are the People

Who can turn out *Fences* (Cleated Separators) and *Plain Sections* (Sections Without Insets)

— For 1898. —

Having special appliances and machinery, we can make them right. Nothing in late years has seemed to stir up such a furor in the Bee-Keeping World as these new goods. If you don't know about them, send to

The A. I. ROOT CO., Medina, Ohio.

New 1898 Catalog, largely re-written, now out.



4-97-12

Our Prices are worth looking at. We are making the new

Champion Chaff Hive

with dovetailed body and supers and a full line other Supplies, and we are selling them CHEAP. A postal sent for a price list may save you \$ \$ \$ \$.

R. H. SCHMIDT & CO.,

Box 187 Sheboygan, Wis.

Please mention the Review.

JOHN PATTERSON, England, Pa., is an American, 23 years of age, has had three years experience in the apiary, and would like to secure a position the coming season in an apiary or on a fruit farm. Is teaching school at present, but will be free by March 1st. Can give references.

Please mention the Review.

Bee-keepers in the

Northwest

Can save money and freight by getting their supplies from the Minn. Bee-keepers' Supply Mfg. Co., Nicollet Island Power Building, Minneapolis, Minn. They have all the latest and most improved machinery and manufacture and handle a full line of supplies. Send for catalogue before ordering.

Please mention the Review.

QUEENS,

Either Golden or Imported, by return mail. Untested, 75c; tested, \$1.00; breeders, \$2.00.

6-97-tf

W. H. LAWS, Lavaca, Ark.

Sweet Clover Seed.

We have about 3,000 lbs. of sweet clover seed, (of the white variety) that we offer for sale at the following prices :

25 lbs., \$2.25; 50 lbs., \$4.00; 100 lbs., \$7.50.

BERTSCH & FLEEMAN, Holland, Mich.

COMB



FOUNDATION

WHOLESALE AND RETAIL.

Working wax into foundation, for cash, a specialty. Reduced prices during winter. My foundation will speak for itself, and prices are O. K. Don't fail to write for catalogue containing prices and samples. Beeswax taken in exchange for foundation or other supplies.

GUS. DITTMER,

10-97-12t

Augusta, Wis.

Please mention the Review.

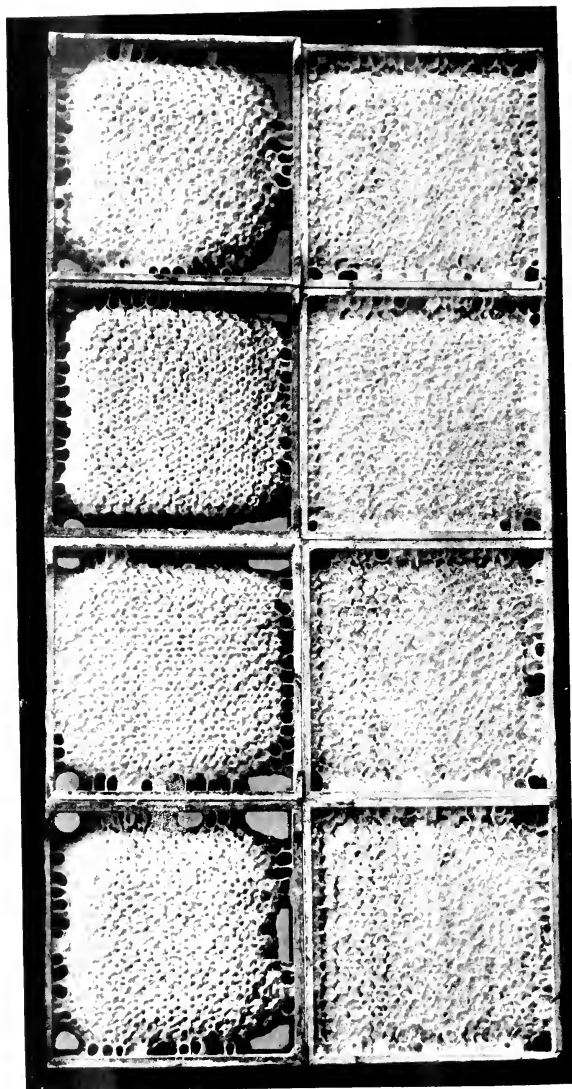

An Object-Lesson in Comb-Building—Plain, and Old-Style Sections.

The Bee-Keepers' Review.

A MONTHLY JOURNAL

Devoted to the Interests of Honey Producers.

\$1.00 A YEAR.

W. Z. HUTCHINSON, Editor and Proprietor.

VOL. XI. FLINT, MICHIGAN, JAN. 10, 1898. NO. 1.

THE PLAIN OR SIMPLE SECTION.

A Fair Consideration of its Merits and Demerits. A Novel Method of Changing the Old Style to the Simple After Being Filled.

J. E. CRANE.

"If thy right hand offend thee, cut it off and cast it from thee."—BIBLE.



MENTION has been made in our bee-journals of what is called the "No-bee-way Sections;" a very clumsy name for one of the neatest sections ever made; a section where the top, bottom, and sides are of the same width. It seems to me that the word "simple" would be a better name, as this is more simple in construction than those where the sides project an eighth of an inch beyond the top and bottom.

It is claimed that these sections, when used in connection with what is called

a "fence" which is simply a separator made of narrow strips of thin wood with passageways between them for bees, will be better filled with much handsomer combs, that will grade higher, and sell for one or two cents a pound more than honey in the old style of sections. These sections can also be more easily cleaned, and will hold more honey for their size, etc. Now, if these claims are all true, the adoption of them marks a new departure in bee-keeping.

If such honey would sell as is claimed for an extra cent per pound more than in ordinary sections this would have made a difference with me in the last two years of several hundreds of dollars—an item of no small importance, and I have felt the subject should be most carefully investigated, as it would cost me several hundred dollars to make the change in sections, separators, and clamps.

That these sections when well filled look nice, no one who has handled them can deny; but will it pay the cost of changes for the bee-keeper who is now well supplied with clamps, separators, etc.? This is the great question with me.

Right here I may as well say that there are one or two disadvantages in this style of sections. My experience has

been that they require more careful handling than ordinary sections, or they will be marred and set to leaking. The projecting sides of a section are a great protection to the comb, even though it be but $\frac{1}{8}$ of an inch. As most of the honey in this State is sent to market in paper cartons, if the paper box is made to fit the well-filled new style of section it will be much more likely to be injured by handling, as most persons who take up a box will do so with the thumb on one side, and fingers on the other, and thus press the comb and set it to leaking. Where paper boxes are not used this last objection will not hold. In shipping these simple sections to market I have found it a saving of $16\frac{2}{3}$ per cent in packing-cases—quite an item in their favor.

It has been a great query with me whether the new style of separator, or "fence," was not of much more value than the simple *section*. I have long wished for a perforated separator that was cheap and practical. The one I now use is three and one-half inches wide, giving the bees free communication with the sections on each side, both at the top and below, and seems to answer very well, the bees entering promptly in spring and storing as long as the harvest lasts.

How much honey is lost by compelling the bees to build their comb in small compartments is one of the unsolved problems. I have sometimes thought perhaps one-tenth, or more; but as the small packages sell for considerably more than large ones, it has seemed about an even thing. If, now, instead of the separator we have an open fence between sections, so open that the whole surplus chamber shall seem to the bees to be as one large receptacle, there is reason to believe that the sections will be better and more handsomely filled than with present arrangements, and also more honey stored. And yet, as I frequently find colonies at the close of the harvest that have stored nearly or quite all of their honey in the sections, leaving almost

none in the brood-chamber, I have wondered if they would have done better or stored more had I used twenty-pound boxes instead of one-pound sections.

Again, I have wondered if the very favorable season has not had something to do with the fine appearance of combs where the open separator was used. Combs are likely to look well where the more common sections and separators are used, in such seasons. But it can not be denied that the simple section with the same amount of honey in it looks better than the section with its projecting sides.

And now let me tell the reader how the ordinary section can be made into a simple section after it is filled with honey, for there are many, like myself, who can not readily make the change at once from one kind to the other, even if it proves to be all that is claimed for it. For many years I have taken a part of my honey and put it in this shape for market. I select the heaviest clamps and put them on a Barnes saw, and slice off the projecting edges, and then pack in shipping-crates with one or both sides of glass.

Sawing the edges off brings the honey within about $\frac{1}{16}$ of an inch of the glass, and the appearance is better than in any other way it can be packed.

I have now arranged an arbor for a Barnes saw-table so I can put on two saws just one and nine-sixteenth, inches apart. Now, it will be readily seen that by having a gauge just right, I have only to run the four sides of the section through and all the edges are left clean and white—in fact, much neater than they could be made by hand scraping. By this process we not only get rid of the side projection of the section but clean it at the same time—clean it by machinery, if you please. The saw or saws should be set so as to come just $\frac{1}{8}$ inch above the saw-table, or just through the section, as, if it goes much higher, it is liable to injure the comb.

I do not know how many tons of honey I have put up in this way; but I do

know it has always proved a success, so far as neatness and appearance are concerned. I have never kept a close account of the time spent in this cutting or sawing down edges of sections, but think a strong man could saw down about as many in a day as he would clean of propolis, perhaps more.

But have I realized a cent more per pound for this honey than that in the more common section? I think I hear some one ask. I am sorry to say I have not. Perhaps if I had sold direct to the retailer I might have realized more; but it was sent to the city, and sold at the same price as honey of the same grade in the ordinary section. But I might add that it has really sold *more promptly*, and on a falling market this would sometimes amount to a cent a pound. Nevertheless, as honey is more attractive put up in this way I believe all beginners, at least, should carefully investigate its merits when deciding on what style of section to use.

MIDDLEBURY, Vt. Dec. 10, 1897.



DIFFERENT STYLES OF SECTIONS.

Something in Favor of the One-Bee-Space Section and Paraffine Paper.

S. D. MATTHEWS.

I HAVE used sections with a bee-space on both sides, also sections with no bee-space, with cleated separators, but I prefer the one-space section for more reasons than one. The no-bee-space section will not crate well, as it is a well-known fact that there will be occasionally sections with comb built out to the separator; besides, they look too lean; but they sell well, and, as I make honey for money, I prefer the section that sells best.

In my apiaries of over 200 colonies I find the best work done in the sections having *one* bee-space. They have fewer

sections with comb built to the separators. The 4 x 5 one bee-space Danzenbaker section, with the cleated separator and paraffine paper, has less propolis than any other I ever used, and takes less work, and I have tried most of the different kinds in my 15 years of bee-keeping.

I beg to differ with the editorial in the Canadian Bee Journal for Nov., stating that no bee-keeper anxious to produce first-class honey in sections, and willing to master that business, should use such paper, and that the best-filled sections can not be secured without a bee-space above the sections. I have produced some as fine honey as I ever saw with paraffine paper and no bee-space above, and so does Mr. Miles Morton, of N. Y., and many others. In Gleanings for Nov. 15, page 815, will be seen a cut taken from sections of honey produced with no bee-space and paraffine paper alone, which will prove to the contrary of our Canadian brother's assertions.

HAMILTON, N. C. Nov. 26, 1897.



EMPTY COMBS.

How and Where to Keep Them.

M. M. BALDRIDGE.

"All nature feels the renovating force of winter." THOMSON



THE very best place I have found to keep and preserve empty combs is in the hives, and right out of doors, no matter whether under cover, in the shade, or directly in the sun!

At least, that is the way I keep my empty combs, and the plan I have pursued for a number of

years. "But," says the reader, "do not the moth-worms destroy the combs in hot weather when left out of doors?" No, not if *wintered* out of doors, or where combs will *freeze*, and the hives containing them are piled up in such a way that the moths can not get into them after the combs have been frozen.

I keep not less than two sets of surplus combs for each colony I extract from. When done extracting, these combs are set back in the top stories and then placed *under* the brood-nest, so that the bees may remove the honey that remains in them, and they remain thus during the autumn, or until about the time to pack the bees for winter, or to take them into winter quarters. These bottom stories full of empty combs are then piled up out of doors to freeze during the winter, and there they remain until wanted again for surplus honey, whether the next season or later on. I never find any worms in or among such combs when thus treated—not even when they touch each other. In fact, I have often packed the top stories with empty combs as close together as I could get them, at the beginning of winter, and have left them in that way through the following summer, and without finding any worms among them. But I prefer to remove one or two combs from each set and then place the others in the hive about an equal distance apart.

Of course, the reason the worms do not destroy such combs, when treated as indicated, is simply because the eggs that produce them have been destroyed by the winter freezes. This plan of preserving the empty combs will not work, of course, except in cold latitudes, or where the freezings are sufficiently severe to destroy the bee-moth.

Another advantage I find in keeping the empty combs outdoors the year round, aside from the labor of taking them indoors and providing extra room for them—is, that they remain bright, and free from mold, when in hives properly constructed.

ST. CHARLES, ILL. Dec. 21, 1897.

COMB FOUNDATION.

Some of the Advantages and Disadvantages of

No-Wall Foundation.

L. A. ASPINWALL.

By viewing Nature Nature's handmaid, art,
Makes mighty things from small beginnings
grow.—DRYDEN.



THE changed condition of wax after being subjected to a melting heat, rendering it tough and leathery, becomes an objectional feature in comb foundation; and only through precaution in

maintaining the limit of heat necessary in melting is the objection minimized. In addition to this objection, and coupled with it, is impurity. This latter, however, is chiefly propolis, and can be almost entirely eliminated in rendering by using the solar extractor.

Its being soluble in hot water at once commends to us the superiority of sun rendering over either water or steam; the latter, however, is less objectionable, although the high temperature (212° at least), together with the attendant condensation, naturally tends to dissolve the propolis, and contaminate the wax. Being soluble in hot water, particles infinitely small become incorporated with the wax; the presence of which may be recognized by the greenish shade; which also is proportionate with the amount it contains. The contrast is wonderful when compared with the beautiful yellow product of the sun extractor, as is also its texture, which is rendered hard and brittle in the same ratio.

Inasmuch as wax melts at a temperature varying from 150 to 160° according to its purity, I would caution all against

excessive heat, even in sun rendering. With a temperature over 212° the tendency to soften propolis whereby it becomes more or less incorporated with the wax, is much increased. Instead of painting the extractor black, which is a severe strain upon the wood, being subjected as it is to extreme expansion and consequent contraction, I use white paint both inside and out, obtaining the most satisfactory results.

Although other impurities, such as pollen and that which naturally results from old brood-combs are found, their elimination is comparatively easy. However, in justice to the manufacturers of comb foundation, I will state that the use of sulphuric acid serves a useful purpose in separating the impurities from wax; still, a means of prevention is always preferable to a cure. Then, again, cleanliness in all the work of sun rendering is a matter worthy of our consideration; and, being done outside, saves much inconvenience to the inmates of our homes.

The changed condition of wax, to say nothing of impurities, has necessitated much effort on the part of foundation-makers, not only to restore its original color, but the softness of its texture. While much progress has been made in this respect, far more satisfactory results have been obtained by reducing the quantity of wax in each lineal foot of foundation.

Although foundation as first made was heavy, with but little projection or cell-walls above the base, and, in many instances, none, Mr. T. F. Bingham suggested to the Michigan bee-keepers, in session last year at Mt. Pleasant, the possibility of producing a very light foundation without the cell-walls. Of course, the changed condition of wax after being melted, whereby it is rendered hard, was duly considered as being objectionable, and the use of a minimum quantity advised, hence, a return to the primitive design.

But the state of the art had advanced—the methods of manufacture had been

improved, as well as the foundation itself. An exceedingly thin septum being the result of continued experimenting for years seemed an opportune time for the aforesaid change—not unlike the development of our improved section, in which the plain style, although first made, is only now being popularized.

The members of the Michigan convention being willing to try the experiment suggested by Mr. Bingham, unitedly paid the amount necessary to procure a mill engraved expressly for the purpose.

In due time Mr. Bingham announced that the mill had been completed, and those desirous of testing the product could do so by procuring the foundation through him; whereupon I ordered some three or four pounds. Upon receiving and examining the foundation I was agreeably surprised to find the product so thin and delicate. However, owing to its smooth angular surface, which was minus the cell-walls, I was somewhat skeptical as to its acceptance by the bees. I expected to see much of it torn down, or transformed into drone comb. In this respect I was agreeably surprised, it being readily accepted by the bees, and not a single section was found to contain drone comb.

But the finished product was far more interesting and satisfactory. The daily test by both Mrs. Aspinwall and myself led us to give it the preference. It requires an expert to detect any difference between it and natural comb. Although I remarked to friend Hutchinson when at our home that it was about equal to the natural product, I also mentioned the tendency to warp, which is quite an objection. In some instances the foundation warped to such an extent that little or no cell room was left between the septum and separator at the lower edge or bottom of the section, necessitating elongated cells on the opposite side. Although the objection is apparently slight, still such combs are never fastened to the bottom of the sections; consequently they lack the plump, well-filled appearance, as well as

the requisite strength necessary in transportation.

If we carefully examine the process of comb-building, the added knowledge will enable us to understand why a foundation without cell-walls so closely approximates natural comb in the finished product.

During comb building small particles of wax are constantly being welded to the edges of new comb, which is also true of foundation with rudimentary cell-walls. Bees invariably attach the plastic material to the edges, which are previously reduced to a like condition, in order that the work may be homogeneous throughout. As a natural consequence, the base or septum is scarcely touched during a good honey yield. With foundation having no cell-walls, the angular bases must first be operated upon by the bees, and rendered sufficiently plastic to retain the new particles of wax. This process practically renews the entire base, inasmuch as the angles of both sides necessitate much closer work than we would naturally expect.

While this process of renewal or rendering the angular surface plastic is productive of comb equaled only by the natural, it also causes the warping already alluded to, especially when the sides are operated upon unequally.

In all lines of progress, however, with a point gained we are likely to encounter a corresponding evil. But inventors wear them away. By fastening the foundation on three sides, the objection would be overcome, although a lesser one (that of fastening) would present itself.

Although I do not like divided sections, which, by clamping, secure the foundation, still I think some method should be devised to supersede the use of hot plates or melted wax if possible.

In all probability, we shall not experience a honey yield for some time which will fully equal that of last season. Under the circumstances of a poor yield, the Michigan foundation might prove a failure. Certainly, 1897 was exceptionally

favorable to the acceptance of any artificial base. During times of failure, bees, like individuals, are wont to be employed, and will tear down the artifice of men's hands rather than remain idle.

JACKSON, Mich. Dec. 29, 1897.



PLAIN SECTIONS.

The Combs in Them are Easily Damaged, and
They are a Failure from an Artistic
Standpoint.

T. F. BINGHAM.



THE bee-keepers who are thinking of adopting this style of section can well ask themselves, what advantages have these sections over those now in use? Dis-

advantages ought also to be considered. New separators must be procured, and either more expensive, or more perfect, shipping-cases used. Then the merchants and the clerks must be taught to lift honey carefully from the no-drip case. And right here please emphasize the *no-drip* feature. With the old-style of sections, having projecting edges, this caution was unnecessary. With the plain sections in which the honey comes out to the edge of the wood, there can be no question as to the constant danger. Every move will be a risk; and soon the retailer will find a drip and a loss previously unknown. Neither will the trouble stop in the shipping-case, but the section must be wrapped up and tied with a piece of twine, and the twine broken after it is tied. Does any one familiar with comb honey doubt the con-

stant and increased danger of handling such combs? The very thought of such sections is a thought of danger. Either the shipping-cases will have to be more perfect, or the one-piece section abandoned. Sections that are not square will creep into or against one another in shipment, and no method now in use will prevent it. The least side-shake will be a menace, and separators between the rows will be as indispensable in the shipping-case as in the super.

There is also a touch of art in the matter. Any one familiar with architecture knows the beauty of projecting edges and borders. Do the advocates of this formless "chunk-honey" realize how thin, meager and lean it will look? Take away the projecting edge from a section of honey, and we see sweetness without ornament.

The plain sections will cause the bee-keeper extra expense, the shipper extra danger, the merchant extra care, and will be a violation of the accepted lines of art and beauty.

If they possess any advantages it will be desirable to hear from those who have used them and can speak of their virtues, before we make any changes.

FARWELL, Mich. Jan. 8, 1898.



WELL-RIPENED HONEY.

Its Superiority to that Just Sealed Over.
A Pointer in Wax-Rendering.

ARTHUR C. MILLER.

The following is a private letter, but I obtain permission to print it.—Ed.

MY dear Mr. Hutchinson, The Review of the 10th ult. is at hand and I take your general request personally, as in the past. I agree with you fully in regard to the improved appearance of the paper

in type and paper as well as make-up. For several years past I have not been so situated that I could take an active interest in bee culture, although I have at no time been entirely without them. The matter which occurs to me at present most forcibly, and which is most likely to be of interest to you, was suggested by the remarks of Mr. Hasty in regard to the consumption of poor honey and particularly of comb honey, which is taken off the moment the sections are sealed. The whole matter of honey consumption, as with many other issues of the present time, calls for a campaign of education; it is slow, I know, and its results are often apparently very slight. I have, for some years, been educating my acquaintances in the purchase of box honey in the markets; telling them to pick out the yellowest combs, being careful to make a distinction between dark *combs* and dark *honey*. It has been but little words dropped now and then, here and there, but I have found they have produced marked results. Friends who have, as you say, become tired of honey, have taken it up again on my suggestions, and have expressed themselves as again acquiring a liking for it.

I am very glad to see that you and Mr. Aspinwall are forcing the matter of smooth sections (without entrance spaces) on the attention of your readers. While I have not been a very extensive experimenter in these lines, I have done enough to prove most of your statements. Mr. Aspinwall has succeeded in perfecting a section case such as I have long desired; as often happens, where people are working along in the same lines, I have very closely on several occasions approached his invention, but just far enough off to miss its perfection. But I know from my own experience that his is bound to be satisfactory.

In your general request for notes and information I fear you did not fully consider what you were calling down upon yourself. Doubtless, you will get plenty of replies; but I am sorry for you in en-

deavoring to sift the wheat from the chaff, although you are generally very successful at this.

As is usual with me each winter, I am building air castles in regard to the coming season's work, but whether they will be more than air castles, only the future will tell. One more thing which occurs to me in regard to the securing of bright yellow wax. I have found from careful experiments that many a lot of fine wax has been spoiled or very much darkened by allowing the water in which it is melted to boil together with the wax. What chemical change this produces is beyond me, but that it *does* make a difference is beyond dispute.

PROVIDENCE, R. I. Jan. 1, 1898.



PLAIN SECTIONS AND SLAT-SEPARATORS.

They are Severely Condemned by one who
has tried Them by the Thousands.

JAMES HEDDON.

To Truth's house there is a single door,
Which is Experience.—BAYARD TAYLOR.

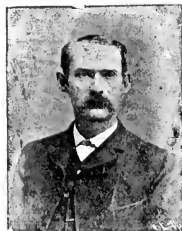

IN this paper for October, and more conspicuously in Gleanings for November 15, we find cuts and descriptions of two claimed steps in advance, which I have been taught in my experience, are radical steps *backward*. I refer to sections without spaces, and cleated separators, called "fences." Having been one of the original inventors of sections (whether prior or not, I

don't know) I thoroughly tested, as I believe, the spaceless sections. One year, I used 5000 of them, opening the spaces with thick separators, and I have relics of them yet about my home apiary. They became things of the past, wholly because sections with bee-spaces, that is, with tops and bottoms narrower than the up-rights, are much superior to them, at every step, from the surplus case to the consumer.

Bro. Root tells us that he believes these two features are improvements, although tried and laid aside by several foremost honey producers. He says that the times were not right for them, but he doesn't take the time to tell *why*. He cites us to electric railway inventions in an early day, and their later adoption, after said inventions had been perfected and made practical, and public conditions had changed, while no change of conditions has taken place to make the worthless, spaceless section of 20 years ago, a thing of beauty and joy forever to day. Mr. Root declares that he is sincere in his convictions, even if the change is specially adapted to large supply houses with special machinery. (We now refer to the cleated separators.) I call this cleated separator a miserable glue-trap that will vex the bee-keeper beyond all other implements of the apiary. I am not without some early-day experience with that also.

It seems too simple to discourse upon the reasons *why*; it is inconceivable to me that there can live any practical honey-producer who can not see a dozen reasons at a glance.

Spaceless sections are a nuisance in the case, in the shipping crate, and every other place. And cleated separators are worse, if possible, as compared with the standard varieties of to day; and I am willing—yes, anxious—to stake my reputation as a bee-keeper, upon that fact.

It seems to me that these costly errors grow out of the fact that there is nothing of any special worth to write about, that has not been chewed over and over again, hence, the old errors must be taken up so

that we can begin back about 25 years ago.

DOWAGIAC, Mich. Dec. 31, 1897.

[Mr. Heddon complains because Bro. Root does not give reasons why plain sections and slatted separators are superior, and then falls into the same fault himself. It is so seldom that I disagree with Mr. Heddon that it is almost a pleasure to find myself on the opposite side of the fence from him. I do not mean that I am unchangeably convinced that plain sections and slat-separators are superior to the ordinary style. I mean that I believe that Bro. Root *has* given reasons why he considers these styles of goods superior, while Mr. Heddon has simply *asserted* to the contrary, giving his experience as a base for his assertions. His nearest approach to a reason is the calling of the separator a "glue-trap." But what do we care for the daubing of propolis on the separator? that is, upon the slats, there is no necessity for cleaning it off. Where the sections touch the separators, propolis will be deposited, but this is true of every style of separator. I must admit, however, that it seems to me that the slatted style of separator will be more difficult to clean, where the sections do touch it, than is the case with the plain smooth separator, that can be scraped its whole length at "one fell swoop."

Now, friend Heddon, have patience. You must remember that some of us are thick-headed. We not only have to be told things in plain English before we can comprehend them, but sometimes our heads are so thick that it is actually necessary to pound in the ideas. Now, if you will write another article, and go carefully over the ground, pointing out all of the objections that you found against the plain section and the slatted separator, just as though you were writing for real common folks, instead of the unusually bright ones, I shall be very glad to print it.—ED.]

NOTES FROM FOREIGN BEE JOURNALS.

F. L. THOMPSON.

As cold waters to a thirsty soul, so is good news from a far country.—BIBLE.

WHENEVER "potasche" is called for on pages 261 and 262 of the October Review, in the recipes for making cake, carbonate of potash is to be used, so says a German baker of Denver; and Pastor Fleischmann has just written the same. It may be procured at any drugstore.

THE BEE-KEEPERS' RECORD.—Mr. Brice's experience with some Caucasian queens imported from Russia was so unfavorable that he finally killed them. They are very unprolific, and their colonies-lazy and weak, so that he had to keep their strength up by additions from other hives.

In a general way, says Wm. McNally, it takes several years to establish a private honey market. In his experience, there is no readier or quicker method of accomplishing that end than by competing on the show-bench.

GRAVENHORST'S ILLUSTRIRTE BIENENZEITUNG.—Gravenhorst, who has had much experience in transporting bees by wagon and rail, now invariably uses cloths made of loosely woven jute, instead of wire cloth. This material is very cheap, if bought second hand after having been used for packing purposes. It prevents the light from exciting the bees, while it lets air pass through. The regular entrances are plugged tight.

One way to prevent swarming, says he, is to unqueen about the end of April or middle of May, according to circumstances. In raising a young queen under such conditions, the colony hardly ever swarms, but destroys the remaining queen-cells, and later on is not apt to swarm, especially if population is kept down by removing brood at the proper time. (evidently local conditions must decide whether such a plan is advisable).

Von Rauschenfels introduces queens "never-faillingly" by using a wax cage, which he makes by warming a piece of foundation (doubled if thin) $2\frac{3}{4}$ inches long and a suitable width, and wrapping it around a lead pencil. The upper end is closed by pinching so as to terminate in a round form; then the pencil is withdrawn, and two or three little holes made with the point in the rounded end, so as to give the queen air and allow the bees to feed her. The queen is then made to crawl in head first. When she has reached the upper end, the lower part is pinched nearly an inch from the lower end, bent at right angles at that point, and the cage fastened to a top-bar or in a comb aperture in the center of the brood-nest, and the next comb carefully brought up close.

B. Rietsche has invented a cheap little spirit-lamp for fastening foundation by melted wax, which is ready for use in half a minute after lighting, and melts only just enough wax for the purpose. Sheets so fastened never separate at their junction with the wood.

According to N. Ludwig, royal jelly is nothing more than a nutriment, which can not possibly be the cause of such extreme differences as exist between a queen and a worker. It has not the slightest effect, for example, on the drone larva. (But Dr. Murdock, of Florida, would say it has just such an effect, since he attributes part of his success in rearing large bees to the fact that his drones were fed with royal jelly in their larval state.) Herr Ludwig puts forth three propositions. First, every fertilized egg has two "rudiments" (*Anlagen*—a word troublesome to translate, much used in German biology), i. e., two arrangements pre-established by nature, by which it is made possible that sometimes a complete worker is developed, sometimes a complete queen. Second, the "rudiment" of the worker is such that the natural development of the egg, without the presence of food, results in a worker larva. Third, the "rudiment" of the

queen remains latent until called forth by the stimulant of royal food, which can act only on the hatched larva. The royal jelly only excites what is already present. He denies having said that an egg in a queen-cell can not be developed into a worker, but does contend that, when once the rudiment of a queen is aroused to activity in a larva (which can take place at any period of the larval existence, from the first to the sixth day), such a larva can never develop into a worker, however brief may have been the action of the food which is the subordinate cause. His theory is disputed by several. (If true, it would be incorrect to speak of queens reared from old worker larvae as "about half workers"—they would be simply runt queens.)

In a subsequent issue, Herr Reepen points out that the theory is not original with Ludwig, but has always been expressly stated and applied to the bee by Weismann, the well-known biologist; with whom, however, most other biologists do not agree.

Dr. Langer's determination of the constituent parts of a bee's poison-sac results thus: 1. Formic acid (not the poison); 2. A volatile body, the cause of the aromatic odor; 3. Inorganic substances (muriatic acid, phosphoric acid, carbonate of soda, lime); 4. Albumen in solution (about 30 per cent); 5. The specific poison, closely resembling that of vipers and rattlesnakes. (Compare the alcohol cure for injurious results of bee-stings, given in Nov. issue.) Major Beck, who gives this information, suggests that an antidote to the occasionally serious results of a bee-sting might be procured in the same manner as the French investigator Cahette procured a blood-serum which is an antidote for snake-bites, by systematically poisoning rabbits.

DENVER, Colo. Nov. 24, 1897.

Next month's Review will contain an excellent article on out-apiaries, by a new contributor; and the frontispiece will show one of his out-apiaries—a beautiful view.

Bee-Keepers' Review.

PUBLISHED MONTHLY.

W. Z. HUTCHINSON, Editor and Proprietor.

TERMS:—\$1.00 a year in advance. Two copies \$1.90; three for \$2.70; five for \$4.00; ten or more, 75 cents each. If it is desired to have the REVIEW stopped at the expiration of the time paid for, please say so when subscribing, otherwise, it will be continued.

FLINT, MICHIGAN, JAN. 10, 1892.

"A CORNSTALK FIDDLE," writes Mr. W. H. Pridgen, "will beat Bro. Hasty's nickel clock in imitating the piping of a queen. If he did not make them for amusement when a boy, and does not know how it is done, I will send him one for the asking. Who knows but this might open a road to the 'tiny machine' wanted on page 296 of Nov. Review?"

LENGTH OF TONGUE in bees is something that has been discussed somewhat in the journals, but I have just read of the first successful attempt in that line. Mr. J. M. Rankin, who now has charge of the Michigan Experiment Apiary, writes to the American Bee-Keeper that, by actual measurement, he has increased the length of tongue of one strain of bees two-tenths millimeter the past season. This was done by crossing.

SHIPPING-CASES are rather expensive "out West," judging from the way Mr. F. L. Thompson writes. Here is what he says:

"Thin, 24-lb., single tier, cases cost 17³/₄ cts., and weigh 5 lbs. each. Best honey is, only \$1.75 per case in Denver, and freight one cent a pound. Just gaze on those figures, and see if you don't think there is some reason for getting restive? Couldn't you start some suggestion for getting rid of cases altogether?"

THE SOUTHLAND QUEEN is now, I believe, printed by the Atchleys without the assistance of a professional printer, and they got out a holiday number that was almost as bright as a rainbow. That is,

a few pages were printed in green, a few in red, a few in brown, and then a few in black, etc. This making of an effort to be enterprising is commendable, but I hope Bro. Atchley will pardon me for saying that, in my opinion, the reading pages of a magazine can never be neater than when printed with black ink on white paper.

THE AMERICAN BEE JOURNAL comes out with a new front heading, also new Department headings, and it must be prospering, for its editor wrote me not long ago that he never before had so busy a December as the last one. I can say the same. Never before did I see so urgently the need of there being "two of me." I had hoped to "catch up" a little on the Review this month, but it was simply impossible. Some days I was busy from daylight until dark simply attending to the mail that came in.

SWARMING-TROUBLES.

The trials of swarming-time have not commenced yet for this year, but Mr. J. T. Hariston of Salina, Indian Territory, so graphically describes his of last year that I can not forbear telling what he wrote. I beg his pardon for "telling," if any is needed. He says:

"As I was anxious to have the bees swarm I began feeding early in the spring for stimulation. The first swarm came the 19th of April, and the swarms continued to swarm, two or three a day, until all had swarmed. I had clipped the queens, so had no trouble in living the swarms, and I was happy. About this time second swarms began to come forth. Then they swarmed some more. I began to get enough of it. I had used up one order of twenty-five hives, and hurried off another order for thirty more. Still they swarmed. As long as the old clipped queens were leading out swarms, everything was lovely, but when swarms with virgin queens began settling in the tops of those rough black-jacks and hickories it wasn't so lovely. I began to hunt up all of the articles on swarming that I could find. I had to do this at night, as the bees kept me in the trees all day. If ever a poor mortal was in trouble it was myself. I tried every plan that I could

read of to stop those pets from swarming, but without success. I don't aim to stimulate this spring."

As Mr. Hairston increased ten colonies to forty-five, and secured 600 pounds of extracted honey and seventy-five of comb, I presume he does not feel like complaining, even if he did have to "stay in the trees" a few days.

BOOK-LEARNING IS GOOD, BUT IT ISN'T EVERYTHING.

I honestly believe that many bee-keepers who are well-versed in their business, and could give us valuable facts, hesitate to do so because they fear that their spelling, or penmanship, or grammar, is not good enough. I occasionally get glimpses of this feeling in the letters that come to me. For instance, at the end of a nice, long letter that now lies before me, I find the following:

You will readily see that I am no scholar. I was raised an orphan, without the advantages of schooling. What little I know I got at night by a brush fire, without so much as a candle or lamp. I am still studying.

I believe that I enjoy beautiful penmanship, correct spelling and well-constructed sentences, as well as any one does, but above all these come honesty, integrity and the real mind or spirit shown by the writer. When I get a letter in which the handwriting is cramped and crooked, the words mis-spelled, and the rules of grammar and rhetoric violated, if the *spirit* is right, I can easily overlook these shortcomings, and there comes over me a desire to grasp the untrained fingers that have with so much effort tried to comfort, cheer, encourage, instruct, or advise their friend. I hope no one will ever hesitate one moment about writing me because of a lack of book-learning.

THE "GOLDEN" SECTION - HONEY CLEANER.

Cleaning sections of propolis by the use of some sort of a machine will probably be the next step. Mr. Aspinwall

illustrated such a machine in the December Review, and Mr. J. A. Golden of Reinersville, Ohio, does the same thing in the American Journal, from which I borrow the following description and the cut. He says:—

"Having an old sewing-machine table, I nailed some boards together and cut out a wheel, which is 36 inches in circumference, and has a 4-inch face. I attached it on the old table, covered the face of the wheel with medium-fine sand-paper, by gluing it on, and arranging a cover so that the face of the wheel protruded from 1-16 to 1/4 inch, as shown by the picture, where Flora is in the act of passing a section over the wheel. (Just as I was ready to take the view, Flora turned her head and said, 'Tell Mr. York that I am just pretending to clean this section'—when I touched the button and caught her and her smile.)

"It will be observed that there is plenty of room for a full super of sections to be placed on the table at a time.

"Now as to how the machine works. Well, it was just fun to clean sections with it, and so clean and bright that no one could tell by looking at them afterwards, that they ever had propolis on them, excepting at the scallops, which have to be scraped out. But if the plain, no-bee-way section is used, a knife will never be brought into use, as the machine does it all, and very speedily.

"I had intened to send a picture and explanation of this device last summer, but having quite a serious time in a financial way, caused by dishonest persons (but thanks to my bees, every dollar has been canceled), the matter was forgotten until I received the December Review, where I was suprised to see that L. A. Aspinwall of Michigan, had invented nearly the same arrangement.

"In conclusion, let me add: Bread and table knives, pen-knives, scissors, or any small edge-tools, can be quickly ground on this wheel the same as on an emery wheel, so our woman-folks will now have no excuse for not having sharp knives, as any one who can run a sewing-machine can run this section-cleaner."

Mr. E. H. Schaeffle, of California, writes me that he was very much interested in Mr. Aspinwall's article, but that if he were going to construct a machine for this purpose he would use a fourth-inch, planer-bit, set so as to project about one-eighth of an inch above the

table. He fears that the sand-paper on a mandrel would soon gum up. Neither Mr. Aspinwall nor Mr. Golden mention this trouble. I presume, of course, that the work is done when the propolis is stiff and cold, and that it crumbles freely instead of sticking.

arising from their sexuality, to give their views. Since that matter was put in type, this very point has been brought out in the Query Department of the American Bee Journal, and some of the men who answer queries take the ground that more energy is shown by colonies having



THE "GOLDEN" SECTION CLEANER.

ARE THE WORKERS MORE ENERGETIC
WHEN DRONES ARE PRESENT?

In the Extracted Department is an article by Mr. Dadant in which he condemns the practice of allowing large numbers of drones in each colony. At the close of that extract, I ask all who think that drones are of any benefit, aside from that

drones. Mr. Aspinwall has also written me, taking the same ground. Most of you are aware that Mr. Aspinwall has experimented a great deal with wooden combs in which it was impossible for the bees to rear drones, and has thus had exceptionally good opportunities for observation along this line; that is, if the wooden combs themselves were not a discour-

aging factor. It is possible, of course, that the presence of drones may act as a spur to industry. I remember telling a friend once, that, no matter how hard a time I had to get along, I always went to my work with a brave heart and real happiness in my soul. "Yes," he replied, "but, you have some one who stands ready to pat you on the back when you start out." As his home-life was not exactly the happiest in the world, I thought that there might be more than a little in what he said—in fact, I know that there was much in it. Now then, the drones may not "pat the workers on the back" as they start out in the morning, but their presence is an indication that there may be swarming ahead, and there is a necessity for labor. Without drones there is little prospect of swarming; hence, not so much necessity, not so much incentive, for labor. All this is theory, and may or may not be true, but, if it is true, there is no necessity for an excessively large number of drones in each colony. Two or three hundred in each colony, if they are anyways smart drones at all, ought to be able to give the workers all of the "patting on the back" that is necessary.



HOW THE REVIEW IS REGARDED BY ITS READERS.

The readers of the Review are very responsive, and I am glad of it. I am thankful, indeed, to those who have so kindly written and expressed their opinion in regard to the Review, and especially to those who have made suggestions as to its improvement. Quite a number in writing took occasion to criticise some of the other journals, and did it with a freedom that, to me, would have been delightful if it had only been the Review that was under criticism. Perhaps I ought not to expect it, but I do most earnestly wish that my readers could be brought to the point of criticising my views and methods with the same freedom that they commend them. It would be

an easy matter to fill one issue of the Review with the letters of congratulation that have come in since the issue of the December number, but I must content myself with the giving of a few extracts. As the letters from which these extracts are taken were not intended for publication, the names are withheld. Each paragraph is a separate extract.

"Now, as to the Review: Some things about it I like, and some I don't. First, I like the kind, gentlemanly and whole-souled spirit of its editor, so free from jealousy. And right here let me say that, of all men on earth engaged in a common business, bee-keepers seem to have the best fraternal feeling; there seems to be something in the pursuit that sweetens the disposition of men and makes them more kind to one another. I have sometimes had a fancy that perhaps honey was destined to revolutionize this world of wicked humanity, and make us all one universal brotherhood. I like the Review very well in all of its make-up; as they say out here on the coast, "it's a dandy." Now, what *don't* I like? Well, that's harder. Not that I feel you would be offended if I did find fault, but, to tell the truth, I feel very much as did the young bridegroom about his bride. She was so nice and so neat, and so clean and so sweet, that he could find only one fault, and that was that she was so *small*. If there had only been more of her he would have been better pleased. Now, if there were more of the Review, and it came oftener, I would like it better."

"Hasty's and Thompson's reviews give the cream of the other journals, and your other correspondents compare favorably with the correspondents of the other journals, but I wish to say right here, and I assure you it isn't flattery, either, that I read the editorials first, and if you will give us more of them I am sure no one will grumble."

"You deserve much credit for bringing out such a magazine as the Review. It is difficult to say which feature of it I like

best, but Mr. Hasty's "condensations," giving the cream of all the bee journals, is surely excellent. I can not suggest any improvements, but then, I am not one of those persons who knows how to run a paper better than the editor does."

"Say, W. Z., do you know that as I read that little item about your consigning the old type to that old box, and bidding it a final farewell, the tears moistened my eyes, and my voice faltered as I read the last sentence. It was not so much on account of the old type as it was the flood of sympathy that went out in your behalf."

"In design and beauty of finish the Review compares favorably with the magazines of immense circulation. When we recall the bee-keeping of forty-five years ago, who would have thought it possible to attain such a high standard of literature?"

"When I first saw the December Review it was strutting along holding up its nice new dress so it wouldn't get in the mud. Whew, how nice! Why, it's *awfully* nice! Well, without any joking, it is better. Your man Taylor has given us the best thing on foul brood that I ever read."

"I like the Review for its type, so comforting to the eyes, for being so well-stuffed with a solid stuffin', for its Hasty puddin' so well-seasoned with good will toward all men and the rest of the world, and because the editor does not shut himself up in a glass house and doesn't go on stilts, and I like it because it's your baby. I don't like it because it hasn't more ads. —I don't want any of my friends to go to the poor house. This is strictly confidential, and not to be mentioned outside of the family—of the Review."

"The Review in its new dress was welcomed to day, and had so much of interest in it that, being brought in at dinner time, my dinner was cold when at last I sat down to the table."

"We take about all of the best magazines, and think that the Review is now the equal of any of them. If there is

any criticism to make it is that the writers in the Review seem to feel their dignity, or their responsibility, and are so very staid. Can't you get them to limber up, so that your subscribers will feel that they are listening to some of their own numbers instead of to scientists?"

"The December Review seems a great improvement. My eyes are not strong, and I appreciate the clearer type. The added pages, somehow, seem pleasing. A small man be just as strong or intellectual as a larger specimen, but, for the life of me, I always feel sorry for him. It is a luxury to have a journal so full of good reading with so little, or none, that is not worth reading. I saw only one thing to criticise, and that is the ad. on page 335, of patent medicine. While it may be all right in itself, it belongs to a class that is decidedly objectionable. Having been much of an invalid during my life I have come to know something of these advertisements. The one before us appears to be all right, as it offers to send a sample bottle free by mail. But, alas! That sample bottle is the decoy that is to get our money, and perhaps health and morals, too. Most of these medicines contain a large percentage of alcohol, and not always of the best quality, either, which is quite likely to make most persons in poor health feel 'improved,' especially if not accustomed to its use. Other poisons will produce the same effect for a time. Hold on, now, I guess I have said enough; but, don't you think the Review would look better without it?"

Perhaps the criticism that did me the most good, or that will do the Review the most good, came from an old friend that is proof reader on a prosperous journal. I presume that most of you are aware that I have had only a common school education, neither was I brought up in a printing office, but picked up my knowledge of the business since beginning the publication of the Review, hence the suggestions of this friend in regard to the use of rules, hints about the spacing out of lines, the use of punctuation marks,

abbreviations, etc., were very welcome; and then the tone in which these suggestions were given, the evident fear that *possibly* I might take offense, made the letter very pleasant reading. I don't suppose that this friend realized what he was bringing down upon his head, as I have been sending him some proofs since then and asking him to correct them that I might be broken of some of my bad tricks. One of them came back pretty "speckled" with corrections, and on the back was written: "And I do not claim to have got all of 'em, as the woman said to the boy when she put up the fine comb."

Then, a great many have written about themselves, their families, their bees, etc., and I have enjoyed these letters immensely. I believe that a teacher, a preacher, or an editor, can not do so much good if he holds himself aloof from the members of his flock. He must get close to them, and look at things from their standpoint. I doubt if the readers of a bee journal realize how much they can do towards the improvement of said journal. If I could get such a batch of letters each month as I have received the past month, I think I am safe in saying that the value of the Review would be doubled. Write to me often. Your letters will always be welcome.



THE PLAIN SECTION.

This issue of the Review comes very near being an old-fashioned, special-topic number on the subject of plain sections and slat-separators. To begin with the frontispiece, it is a fair representation of the honey built in the two classes of sections, viz., the old-style and the plain. At least, it is a fair representation of such honey that I have seen produced in the two classes of sections. I am aware that much more perfect combs have been produced in the old style of sections than the ones I have shown in the engraving, for I have produced them myself. In fact, I have produced just as perfect combs in the old style of sections as it is *possible* to produce; that is, I have produced a *few*

such sections, but in the honey produced by Mr. Aspinwall and by Mr. Danzenbaker and by Barnet Taylor, the *majority* of the sections were filled out plump and full in the corners and next the wood, just as shown in the illustration. By taking pains in selecting I could have secured some better sections of comb that were built in the old style of sections, and, in the same way, I could have found more perfect faces of comb in the plain sections, or I could have found less perfect ones. What I have aimed to do is to show a fair representation of both classes.

Just why the bees should build more perfect combs in the plain sections, I am unable to understand. Mr. Crane suggests that it may not be the result of the sections themselves, but of the use of slat or slotted separators, and I think that this point is worth considering. For the life of me, I can not see why there need be any difference whether the upright edges of the sections project far enough to reach the separator, or if the edges are met half way by projections fastened to the side of the separator; but it is very evident that there is *something*, either in this style of section or in the slat-separator, that produces a more perfect filling of the section.

The danger that combs in this style of section will have to brave, are, I think, overdrawn. They do not quite reach the edge of the section. They lack a little, perhaps one-twelfth of an inch, and in this case, as many others, "a miss is as good as a mile." I had three cases of such sections, filled with honey, with me at the fairs last fall, and they were opened and the sections taken out and pulled about and handled and exhibited and then put back—this at five fairs—and not a scratch was there made on the combs. If the combs do not touch one another in the case, what more is needed? Mr. T. F. Bingham, at the late Michigan [convention], said that it might be all right in ordinary seasons and with ordinary management, but if the bees are crowded in a full flow they will lengthen out the cells, getting

down on their very "knees" to squeeze through between the ends of the cells and the separator. In such a case, he says that there will be trouble. He also says that these same conditions will produce ridged, or "washboardy" honey when the "fence" style of separator is used. I noticed that Mr. Danzenbaker's honey *did* have a slight "washboardy" appearance if it were held so the light struck it just right. Mr. Aspinwall's honey shows nothing of the kind, but then, his separator is not of the "fence" style. He writes me, however, that he has heard from several, and some report ridged combs, in some instances, from the use of "fence" separators.

I think that Mr. Bingham's point in regard to the artistic appearance of "borders" would be much stronger if the wide edge of the section *entirely surrounded* the comb, but, as it is on only *two* sides, it reminds me of a picture that has a frame on only two sides.

That the combs would be more likely to be injured in their journey from the retailer's case to the consumer's kitchen, I think looks reasonable. That projecting edge is quite a protection against injury to the comb. Let us be honest about these things.

When I was coming home from the Michigan convention, I stopped a few hours at Saginaw, with Mr. O. J. Hetherington; and I found him rigging a few cases with the "fence" style of separator and the plain sections. He is going to give them a trial in a small way; and I honestly believe that that is the best way for all bee-keepers to do. Never mind if you *do* believe these things are a "snare and a delusion," try them *yourself* in a small way. On the other hand, no matter how certain you may be that they are of superior merit, don't throw away your old fixtures and go to many dollars of expense in adopting the new until you have first tried a few and seen how they "pan out."

Those who are using T supers can try the plain sections with no other expense than that for "fence" separators.

THE NO-WALL FOUNDATION.

Some of my readers will remember that at the meeting of the Michigan State Bee-Keepers' Association, held in 1896, Mr. Bingham so strongly advocated what he considered the advantages of a very thin foundation having no side-walls, that sufficient money was contributed to pay for the expense of making a mill upon which such foundation could be manufactured. Some of this foundation, running about sixteen feet to the pound, was sent out to the different members; some of them using as much as ten pounds of it. Unfortunately, however, so far as a report was concerned, Mr. Bingham was about the only one present who had given the foundation much of a test. I produced no comb honey in my own apiary last year, and Mr. Aspinwall was detained at home by company.

Mr. Bingham produced a nice little crop of comb honey in 1897, using this style of foundation exclusively, if I remember aright, and he was delighted with it.

It will be remembered that Mr. Aspinwall had previously reported in the Review that he was pleased with it so far as the eating quality of the honey was concerned, but that it curled too much to suit him. He farther expresses himself on the subject in this issue of the Review. His only objection is that of curling. To show how little trouble *he* had from curling, Mr. Bingham brought along to the convention a super full of partly finished sections just as they came from the hive. The foundation had been drawn out, or partly drawn out, and filled with honey, and, as this was at the end of the season, when, as all experienced bee-keepers know, there will be curled combs if at any time, the exhibition of that super, just as it came from the hive, was a pretty good proof that the foundation will not curl in *some* places where it might be expected that it would. Of course, no one doubts that it *did* curl with Mr. Aspinwall, but, of course, there must have been some reason for it—something in his management, locality, or *something*.

Mr. Bingham's supers are small; I think that two are required to cover the top of his hive, and that one super holds fifteen sections. Some boys got hold of two of the best-filled sections, and "gouged" them so badly that they were valueless for pictorial purposes, but I rescued the other baker's dozen, and brought them home, and had them photographed; first taking one side from all but two of them. From the photograph I had a half-tone

more inclined to gnaw it down when no honey was coming in, than they were other kinds, but, as in many other things, actual experiment under various conditions is needed. The quality of the finished product is certainly very fine; the nearest approach to that of natural comb of anything I have seen.

In working out the ordinary, flat-bottom foundation, the bees do change over the base to the lozenge-shaped style,

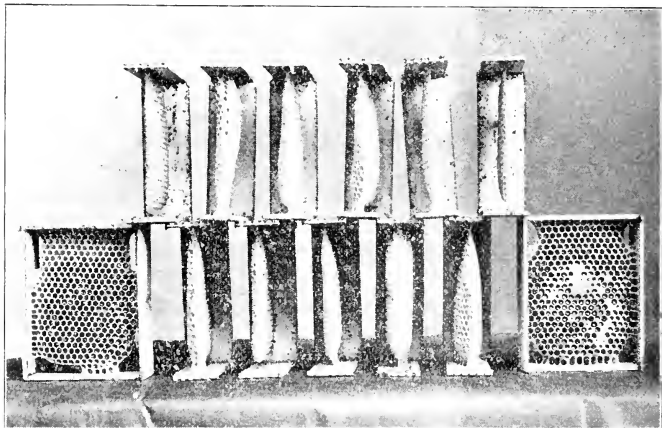

UNFINISHED COMBS BUILT FROM NO-WALL FOUNDATION.

made which is shown herewith. I did this to show how straight are the combs that are built under circumstances where curled combs would be expected. Mr. Bingham says that this was not a selected super, and to show that the sections were not selected, he brought the super just as taken from the hive, with the sections all stuck together with propolis, so that it was necessary to pry them loose with a knife in order to get them out.

I honestly believe that this thin, no-wall foundation is worthy of a most thorough trial. The fault of curling has been urged against it, and some complaints were made that the bees were

There are no side-walls on in the way, and it is possible for them to make this change. With the deep-cell, or Weed, style of foundation, the bottoms of the cells are so securely braced by the three deep walls that center upon each cell-bottom, that it is impossible for the bees to "budge" the bottoms of the cells. Not only this, but the side-walls are in the bees' way, and prevent their getting at the bottoms of the cells to make changes. Even with the ordinary, or lozenge-shaped base, the bees make some changes in working out the foundation. Mr. Bingham had with him a piece of the no-wall foundation which had been

partly drawn out in a stripe down through the center. Some of the cells were, perhaps, one-fourth of an inch in depth, and shaded off until there could be seen only a few "scratches" that the bees had made on the surface of the wax. About the first thing that the bees do, judging from the appearance of this specimen, is to make the bottom of a cell rounding, like the bottom of a pressed-tin wash basin. Then, as the side-walls are started, the lozenge-shaped character begins to appear in the base. It is much the same in natural comb-building. Get a piece of natural-built comb having a wedge-shaped edge of cells that are not complete. Look right down close to the edge, where the bases and side-walls are being started. You will see that there is a stage in the proceedings when each base, or bottom, to a cell is rounding instead of being formed of lozenge-shaped pieces. As the side-walls are laid out and started, the lozenge-shaped base appears.

What is the point to all this? Well, it is probably that we will never be able to make such foundation that the bees will accept it without change, and be satisfied with it, any more than we can make a nest that would suit a robin, but let us get just as near to it as we can.

Mr. Bingham has brought out the best style of smoker, and the best style of honey-knife, and it is possible that he has struck upon the best style of foundation for use in the sections.

A Condensed View of Current Bee Writings.

E. E. HASTY.

Blame where you must, be candid where you can,
And be each critic the Good-natured Man.

GOLDSMITH.

THAT closing onslaught of R. L. Taylor's on page 316 of the Review was a sickener for the brethren who believe that foul brood is caused by chilling. I

think he served the interests of truth by his keen thrust—that is, I don't believe the United States ever had, or ever will have, a case of the dread disorder in any other way than by the presence of the germs from some previous case of foul brood. It is time, however, for us to comprehend the fact that there are *two* companies of folks who believe that foul brood develops *de novo*, and one of these companies has a position just as scientific as ours. Sensible folks owe it to themselves to understand a position before they do very much laughing at it.

No length of time we have to deal with can suffice to make one species of living creature out of another, or out of nothing; but a moderate number of generations of almost any creature may establish a new *breed*. Now, bacilli breed so rapidly (a number of generations within one day's time if I have the right) that a new breed can be established in but a few days. This is not a barren fact but a very fruitful and live one. Most of the world's great physicians are eagerly at work taking advantage of it. The present appearance is that every deadly bacillus can be bred down to comparative harmlessness. Next the degenerate breed is used to immunize the human system against the deadly breed; for, strange to say, immunizing power is not lost in breeding down. Sometimes the degenerate breed is propagated in the human system to head off the deadly breed, but oftener some animal is powerfully immunized, and then the serum of its blood is injected into the human blood. In this way it is hoped that cholera and yellow fever and nearly every deadly plague may soon be brought under a measure of control—for nearly every one is the work of some particular bacillus.

For some reason, breeding *up* seems more difficult than breeding *down*; but manifestly it can be done. Both breeding *up* and breeding *down* are apparently going on in nature's domain outside of man's control. Whenever a bacillus too feeble to hold its own in the human body

breeds up to a degree of vigor and virulence that the defenses of the human body can not stand against, then a new disease starts out and goes round the world. Several have so done within the memory of the present generation. It is as if a pair of bull pugs, too sleepy and too small to be dangerous, should breed up to an army of 200-pound bull dogs, with a disposition to jump at every man's throat.

Now for the theory that we have been wading toward. The bull-pug breed of *Bacillus alvei* is supposed to be scattered around everywhere, and to be doing no particular harm. A hive full of frozen brood is supposed to offer so peculiarly stimulating a nidus for development that (sometimes, not always) the harmless pug of *Bacillus alvei* breeds up to the destroying bull-dog breed of *B. illius alvei*. Now, not everything actually takes place which one considers imaginable and rational. I, for one, don't believe this theory has an actual counterpart in fact. But if some brother just as good a naturalist as I thinks that it does, I have no business to call him a ninny.

In the same article Mr. Taylor says he has proved by a hundred cases that it is entirely unnecessary to put foul-broody colonies, that are being cured, on clean sheets of foundation the second time. Here he is getting a little too "hot." That experience is not proof. It is a cheering *indication* that proof may eventually be complete. Only by experiments in different years, and under many different circumstances, and in wide-apart localities, can there be proof of the maximum persistence of such a variable thing as a bacillus disease.

A change of our standard section in the air, eh? See Review, 325. Important—and I'm afraid also it is true—but I rather wish it were not. Our present section is good enough; and I, like good old Job, was expecting to "die in my nest." The work and expense of getting out of it and into a new nest is not a pleasant

prospect to me. And lots of old fogies will sympathize with me, methinks. When the market gets fully supplied with a kind slightly more popular than ours we may be driven to move; but we'uns are not going to lead the grand march—you hear me shouting!

When moth-worms are tumbled down upon the bottom-board by bees they are apt to find a bottom-bar so near the board that they can just squeeze under; and then the bees can not dislodge them. Square bottom-bars, *set angle down*, make this kind of refuge impossible. Strong score in favor of square bottom-bars, if they are otherwise satisfactory; and it is claimed that comb is built down better to the upward angle than to a flat surface. A. L. Boyden, Gleanings, 661. But J. O. Grimley says in Gleanings, 732, that small, square bottom-bars, in his experience, cause a bad mess of burr-comb to be built around them as soon as they are put into the extracting-super. This is a heavy weight on the outer side.

W. W. Eagerty, Gleanings, 666, says spread sections on thick soft green grass under a dense shade, instead of wetting them before folding. Who knows but that would be a handy and winning scheme sometimes? I should fear, however, that they would curl up like sticks of cinnamon, unless you mowed some of the green grass and sprinkled it on top of them.

In Gleanings, 683, J. A. Johnston claims to have been trying for twelve years without success to exterminate sweet clover from a pasture and some fence-corners where he had sowed it.

So it seems that Gravenhorst, one of the weightiest of German authorities, favors living swarms on starters rather than on full sheets of foundation. Straw, Gleanings, 730. Chance for the foundation folks to trot out a Ronald to meet this Oliver—but let them not revile the starter-using folks much till they have downed him.

Both Ernest Root and Dr. Miller think cross bees can be influenced for the bet-

ter by the mere presence among them of a new queen of gentle stock. Gleanings, 730. May it not be that *all* bees immediately after requeening haul in their horns a bit, and feel as if home were hardly worth fighting for? Experiments with a cannibal queen given to gentle bees would solve that question.

"I have often worked in my study until the weariness was overpowering, and went forth to work in the apiary, when shortly I had forgotten that I was weary, and went back to my study able to do what would have been otherwise quite impossible except for the restful pleasure received in the apiary." A. J. Cook, *Gleaning*, 731s.

T. S. Ford, in *Gleanings*, 733, says he has caught the southern whip-poor-will at the regular business of gormandizing on his bees in the evening. Big fellow whose opened mouth measured $1\frac{3}{4}$ inches wide and $2\frac{3}{4}$ inches gape. By the way, is not the southern species of whip-poor-will more properly called the chuck-wills-widow? Let us "beware of the widders," of course; but I don't want a crusade against our cheery little northern whip-poor-will inaugurated. Let us wait for at least some evidence that he is in it. Probably the other only occasionally learns the bad trick, and therefore the few individual culprits, and not the whole species indiscriminately should be shot.

In *Gleanings*, 734, F. L. Thompson thinks that paraffine paper on the sections wastes too much time, and makes too large demands on the bee-man's patience (with a sample of how near he came to being betrayed into "cuss words.")

In *Gleanings*, 738, W. H. Eagerty calls for a machine that will shave a cake of wax into scales the size bees secrete themselves. These artificial scales are to be put on the bottom of the brood-chamber, a place bees are accustomed to run to for thrown-away scales, and other odds and ends of wax. The editor blows cold on the idea. I should say, may be there's something in it. He that first gives thorough trial to furnishing wax in this form, and reports, doeth well. For one experiment, blacken some wax, and pre-

sent it to them in the super, in a wax-feeder sized and shaped like a section, and see if they use any of it for comb-building in the sections adjacent. Of course, if they will use it freely the whitest virgin wax should be used there.

In *Gleanings*, 738, A. E. Trussler reports house-apiary bees from a portion painted white returning in considerable numbers to another white portion which was empty and 24 feet away. Other colors existed, both in empty and occupied parts of the house, but no other color drew the bees astray nearly as badly as white. Possibly it is worth while to remember here that white and greenish-white flowers are a little more apt to be honey-bearing than yellows, reds, and blues. And were not these bees working on white flowers at the time, so that the habit of steering for white influenced them somewhat? When bees are working strong on golden rod or dandelion, somebody observe if yellow empty spaces in house-apiaries do not excel in the number of stray bees.

John Craycraft thinks slightly damp corn-husks the best fuel for smokers. *Gleanings*, 739. If this is so, many of us can get them readily enough.

In the *American Bee Journal*, 419, I. W. Beckwith gets a just whack at Mr. Doolittle for his assertion that bees learn nothing. Wild bees learn where the bee-hunter has his bait, and where to look for it when he moves it. He put a long bee-escape on his honey-house, which worked at first, but bees learned to get in. He plugged it temporarily, hoping that it would serve the purpose again after awhile; but, no, they remembered as well as learned. I would add that it is a matter of common notoriety that bees learn to follow us about when we open many hives in times of honey famine. And if we work very early in the morning or very late at night they are apt learners to gradually get on to our tricks and be on hand.

In A. B. J., 657, Chas. F. Muth calmly admits that he went into importation from Cuba, with a first shipment of 87,000

pounds, and brought down the price of extracted honey two cents a pound. Guess it's all right—only way to keep the New York importers from ousting him from his markets—but it's hard on we'uns. Perhaps it's a feather in his cap that he frankly tells us about it instead of keeping shady. At present we are not supposed to have any Cuban honey to carry, unless there are remnants left yet of ship-load lots received in New York before the Cuban rebellion.

In A. B. J., 659, E. S. Lovesy says he has visited over 2000 colonies having the new bee-disease, pickled brood. He still thinks abundance of salt sprinkled over them a good remedy. This is *similia similibus curantur*, isn't it—using salt for pickles? And what a long list of bad diseases apiculture is getting! First foul brood; second, paralysis; third, evaporation; fourth, pickled brood. The last, though generally milder than the rest, is said to spread the most rapidly of all.

A. B. J.'s Boiler, page 661, quotes McIntyre as saying that extracting partially stops the income of honey for a day or two—bees supposedly employed licking the cells dry and mending their ragged tops.

Fred. Bechly got two laying queens, heavy with eggs, to fight, small-dog fashion, on the top of a hive. Both were killed. A. B. J., 677. This is a slight warning to us that our prevalent habit of letting surplus queens fight it out is not exactly safe. But then, one would have survived in this case if he had not interfered. One got on the other's back at the first onset, and he made them quit and come together again fair and square.

Leaving all honey to be extracted at the close of the season can not always be practiced without losing a material part of the later crop. What can be done about the raw nectar in the combs? O. O. Poppleton says, put the honey in tall cans, let it stand for a day or two, then turn the too liquid portion off. A. B. J., 690. I never had to practice what follows

—locality not rich enough—but I should say have your extracting-super in two apartments or stories, one not in use till the other is half full; then extract only the chock-full apartment, and let alone the apartment having raw nectar in the combs—except that, if it's an upper story, the combs should be put below. Or a single ten-frame super can be managed *as if* it were two apartments, without any shutting off. Put in at the outset five good combs on one side and five frames with only starters on the other—with intent to take the started frames out later, and replace them with five good empty combs.

C. P. Dadant is more of a humorist than he thinks. He says Deacon makes too many assertions that are without *foundation*. A. B. J., 601. Allee same, when C. P. gets to laying down his own foundation he lays it wisely and well—at least, some of it. When starters of foundation are used in brood-frames bees often bend off their construction to one side, and get over to the next frame. With only a line or strip of wax to guide them the evil occurs more frequently.

Potassium permanganate for stings. Wet the wound and rub it on. Revue Internationale quoted by A. B. J., 695. On this I want to speak with my mouth just a little, as our German friends say. Get the best. Quite possibly the above may be the best *chemical* remedy, but for most bee-keepers the best remedy is to think of something else and let alone. A sting is like a fire, and nerve force is like a poker to the fire. You can not think, think, think of a sting continually without turning so much nerve energy loose upon the spot that it will poke up more blaze than your remedy suppresses. The best, in cases where letting alone is not altogether sufficient, is a piece of tissue paper two inches square put on with strong mucilage. This simply excludes oxygen, which would otherwise get in by way of the pores of the skin. A sting is again like a fire, in that both must have oxygen before they can

blaze much. But paper is hardly available about nostrils and lips, a locality to which bees generally incline to direct very pointed attentions. As an oxygen-excluder there, the best is to daub around the thickest honey that can be got hold of, and to patiently tolerate the daub for a long time. If by chance the eyes get swelled shut the best way to reduce the swelling is to make four pretty moist mud pies (but not sticky) weighing, say, half a pound each. Lie down upon the back and place one on each eye. As soon as they get warm, lay them off to cool, and put on the cool ones—and continue to alternate them *ad libitum*.

RICHARDS, Ohio, Jan. 5, 1898.

EXTRACTED.

CELLAR WINTERING OF BEES.

Something about the Temperature, and how it may be Modified.

Mr. C. P. Dadant has an article in the American Bee Journal on the cellar wintering of bees, and from it I extract the two closing paragraphs. They read as follows:—

An ordinary house-cellar is sufficient, if the portion reserved to the bees is partitioned off in some manner to make it dark, and if the temperature can be kept without much trouble at the proper degree. From 40° to 45° is the best temperature. We have heard it said, by men who claimed to know, that a moist cellar could be kept at a much higher temperature, and that the bees would winter well in it. We have even heard a bee-keeper assert that bees would remain quiet in a cellar with a temperature of 60° or 80°; but we afterward found out that this man did not have a thermometer in his cellar, and was "just guessing" at the degree. This is wrong. What is worth doing at all is worth doing well, and the cost of a thermometer is not so great that a practical man should winter his bees on a guess.

In ordinary winters, we find it less difficult to keep the temperature above the limit mentioned than below it. Fifty

or 100 colonies of bees, grouped together in a cellar that will usually keep fruits or potatoes, will be found to raise the temperature very rapidly, if no outside current tempers it. We must remember that the bees are warm-bodied insects, and keep their cluster at blood heat. This, of course, must necessarily act upon the air of a closed apartment, materially increasing the degree of heat. So we find it quite indispensable to keep the cellar-windows partly open, with a shutter that excludes the light. The quantity of air given is measured according to the atmospheric condition and the warmth of the cellar. Many of our good bee-keepers pay daily attention to their bees, and find it as necessary to do so when they are housed up as at any other time. It is certain that only by such watchfulness can bee-culture be made a success. The bee-business, as Mr. Heddon said, is altogether a "business of details."

DRONES.

Are They of any use Except for Fertilizing Queens?

A while ago there appeared in the American Bee Journal, in the Question-Box Department, some queries about drones. The idea was intimated by the query that bee-keepers were making a mistake in keeping the drone comb out of their hives; in other words, that there is some unknown or unseen advantage in having a lot of drones in a hive, "just as Nature does it." I believe that others, even so good a man as brother Hasty, have hinted that we'd better let the drones alone. Here are the views of C. P. Dadant, as given the American Bee Journal:

The writer of the query thinks that Nature has provided the drones for a certain purpose. Yes, indeed, it has, and the great number of drones in a hive, in natural circumstances, is another evidence of the correctness of the theory of natural selection, or of the "survival of the fittest," as it has aptly been called by the leading men of science, and by Darwin in particular. In a state of nature the bees do not exist in very great numbers in any one place; and when hives are several miles apart it becomes necessary that a great number of drones be hatched in

each colony, in order that a sufficient number of them be found in the fields to render the queen's bridal flight successful. In other words, there must be enough drones reared in each hive to make it almost an absolute certainty that the queen of this hive, or of any other, for several miles, be sure to find one in the few minutes, or hours, at the most, that she spends in the air. Upon her life, the life of the colony depends, as there are often no other means left for the continuance of reproduction. All bee-keepers of experience know what little chance there is for a colony whose queen is lost in her wedding-flight, if young brood is not given it by the attentive owner.

But under domestication the conditions are changed; the colonies being congregated together in large numbers, it is quite evident that the drones of one or two hives will serve the same purpose that they would have served if those two hives were the only ones within the bees' range. It is, therefore, useless to rear such a number of drones in all the hives.

The querist desires to know what would be, approximately, the difference in amount of surplus honey harvested, if colonies are incapacitated from rearing drones. Before answering that question we should like to inquire what advantage the writer has found in the rearing of drones. They do not work; they eat honey in the hive, never out on the blossoms, and their rearing decreases the number of workers reared. Are not these facts sufficient to incite the bee-keepers to prevent their production in numbers limited only by natural proficiency? Is it necessary to theorize on the profit, and the approximate amount saved by their suppression? If we had to compute it we would place this amount at a very high figure.

In a square inch of comb about 55 workers may be reared, while the same space will furnish room for only 36 drones, both sides of the comb being taken, as a matter of course. Thus in a square foot of comb, where 5000 drones could be hatched, you may rear nearly 8000 workers, in round numbers. It looks reasonable that the same amount of feed will rear either brood, since it occupies the same space. And when they have been hatched, you have a small swarm of workers, instead of a heap of useless, bothersome gounmands that do nothing but loaf, but are sure to come home to eat. So if you have allowed your colony to rear them at a great expense you soon become convinced that they are in the way, and that they daily

decrease your profits, and you perhaps go to work and provide a drone-trap—a nuisance—to try to get rid of them! Better not rear them at all! If you have taken pains to make sure of a sufficient number in one or two of your best colonies, why go upon some imaginary idea to permit their production in every hive? If you try ever so hard to get rid of the drone comb, you will still find more drones than you want when summer comes. But you will do well, and find it pays, if you, at least, get rid of the biggest patches of drone comb in all your hives but the breeders, as mentioned before.

What good did any one ever claim the drones do? "They kept the brood warm," some one says. But before they keep the brood warm, *they* have to be first kept warm, and they hatch only in the warm season, when there is but little danger of the brood getting cold; and when night comes, do not all the bees return to the hive and keep it warm? and is it not true that, during the time when the drones are plentiful, the bees are rather too warm in the hive? Is not this the time when they cluster on the outside, because it is too warm inside? And you want the drones to keep them warm? Better have the drones reared for winter, then!

It seems to us that the advantages from removing the drone combs and replacing them with worker combs are sufficiently apparent to make the matter a question of very serious consideration among practical bee-keepers; and unless some better arguments are brought to bear to convince us of our error, we shall continue to advise our friends to remove the drone combs, and do it ourselves, whenever opportunity offers. We are only sorry that we did not do it more carefully in former years.

Now let those who think that the drones are of some use, aside from the function arising from their sexuality, say of *what* use. For my part I think that Mr. Dant has told the truth and told it well, but if others think or know differently, let us hear from them. The truth is what is wanted.



A New Companion Every Week.

Fifty-two times a year THE YOUTH'S COMPANION goes into the homes of every one of its subscribers. Fifty-two times a year it brings to the fireside the best thoughts of the best minds in Europe and America. Coming every week, there is a delightful freshness and timeliness to

its contents. THE COMPANION keeps always in touch with current events. Its editorial utterances and its notes on new topics of interest in nature and science are always abreast of the times. Fifty-two numbers are scarcely sufficient to contain all the stories, special articles, and other reading already provided for COMPANION readers during 1898.

Among the eminent writers for the new volume whose contributions are already in hand are Mr Gladstone, Lord Dufferin, Speaker Reed, the Duke of Argyll, Senator Hoar, Senator Lodge, Justin McCarthy, Shaler, John Burroughs, Percival Lowell, Rodney Kipling, W. D. Howells, Mary E. Wilkins, Captain Mahan and Lieutenant Peary.

Present readers of THE COMPANION who renew their subscriptions, and new subscribers will receive free a beautiful gold-embossed calendar, printed in twelve colors. It is one of the richest and costliest calendars ever printed. Those who subscribe now will receive THE COMPANION every week from the time the subscription is received until January 1899. A handsome illustrated announcement of THE COMPANION'S contents for 1898 will be sent free to anyone addressing THE YOUTH'S COMPANION,

Boston, Mass.

Honey Quotations.

The following rules for grading honey were adopted by the North American Bee-Keepers' Association, at its Washington meeting, and, so far as possible, quotations are made according to these rules:

FANCY.—All sections to be well filled; combs straight, of even thickness, and firmly attached to all four sides; both wood and comb unsoiled by travel-stain, or otherwise; all the cells sealed except the row of cells next the wood.

No. 1.—All sections well filled, but combs uneven or crooked, detached at the bottom, or with but few cells unsealed; both wood and comb unsoiled by travel stain or otherwise.

In addition to this the honey is to be classified according to color, using the terms white, amber and dark. That is, there will be "fancy white," "No. 1 dark," etc.

CHICAGO, Ill.—Demand slow for comb. Extracted sells promptly. We quote as follows: Fancy white, 11; No. 1 white, 10; No. 1 Amber, 8 to 9; No. 1 dark, 5 to 7; White, extracted, 5 to 6; Amber and dark, 4 to 4½; Beeswax, 27.

S. T. FISH & CO.,

Jan. 6. 189 So. Water St., Chicago, Ill.

CLEVELAND, OHIO.—We quote as follows: Fancy white 12 to 13. No. 1 white, 11 to 12; fancy amber 9 to 10; No. 1 amber 8 to 9; Fancy dark, 7 to 8; white, extracted, 6½; amber 5½; beeswax, 28.

A. B. WILLIAMS & CO.,

Nov. 22. 80 & 82 Broadway, Cleveland, O.

CHICAGO, Ill.—We quote as follows: Fancy white, 11; No. 1, 9 to 10; Fancy Amber, 8; No. 1, Amber, 7; White, extracted, 5 to 6; Amber, 4 to 5; Dark, 4; Beeswax, 26 to 27.

R. A. BURNETT & CO.,

Jan. 7. 163 So. Water St., Chicago, Ill.

KANSAS CITY.—We quote as follows: Fancy White 10 to 11; No. 1 white, 10; Fancy Amber, 9 to 10; No. 1 Amber, 9; No. 1, Dark, 8; White, extracted, 5½ to 6; Amber, 5 to 5½; Dark, 4 to 4½; Beeswax, 20 to 22.

C. C. CLEMONS CO.,

Jan. 7. 521 Walnut St., Kansas City, Mo.

BUFFALO, N. Y.—Very little fancy honey here and some could be sold at prices quoted. Common grade and extracted can be sold also by crowding hard. We quote as follows: Fancy white, 10 to 11; No. 1 white, 9 to 10; Fancy amber, 7 to 8; No. 1 amber, 7 to 7½; Fancy dark, 6 to 7; White, extracted, 5 to 6; Dark, 4 to 4½; Beeswax, 25 to 27.

BATTERSON & CO.,

Jan. 6. 167 & 169 Scott St., Buffalo, N. Y.

NEW YORK, N. Y.—Demand for comb honey is rather slow, especially for all grades, white and dark, and, as we have a large stock of these would not advise shipping for the near future. Our stock of fancy white is light and such would find ready sale at quotations. Our market for extracted buckwheat will open up shortly and we would advise bee-keepers to ship this along now. Beeswax steady. We quote as follows: Fancy white, 11 to 12; No. 1, White, 10; Fancy Amber, 8; No. 1, Amber, 8; Fancy Dark, 7; No. 1, Dark, 6; White, extracted, 5 to 5½; Amber, 4½ to 4¾; Dark, 4 to 4¼; Beeswax, 26 to 28.

HILDRETH BROS. & SEGELKEN,

Jan. 7. 120 & 122 West Broadway New York.

NEW YORK.—Our market is rather quiet on Comb Honey, though fancy white would find a ready sale at full prices. We have a good stock of fair and mixed honey and in making sales have to shade quotations some. Extracted honey is selling very well. Fancy white clover and bass wood would find ready sale. We quote as follows: White Comb, Fancy, 11½ to 12½; Fair grades, 9 to 10; Buckwheat and mixed, 6½ to 7; Extracted Calif., white, 5 to 5½; Amber, 4½ to 4¾; White clover and basswood 5¼ to 5½; Buckwheat, 4 to 4½; Southern, 50 to 55 per gallon, in demand; Beeswax, 26 to 27; finds ready sale.

FRANCIS H. LEGGETT & CO.,

Jan. 7. W. Broadway, Franklin & Varick Sts.

WM. A. SELSER,

10 VINE ST., PHILA., PENN.

White Clover Honey Specialist.

Now is the time to order your supplies, bee-hives, sections, foundation, smokers, and everything that is needed in the Apiary at prices that are right. Send for circular.

W. H. BRIGHT, Mazepa, Wabasha county, Minn.

JOHN F. STRATTON'S CELEBRATED



MANDOLINS,

Importers of and Wholesale Dealers in all kinds of
MUSICAL MERCHANDISE,
811, 813, 815, 817 East 9th St., New York.

Bee keepers should send for our

'97 CATALOG.

We furnish a full line of supplies at regular prices. Our specialty is Cook's Complete hive.

J. H. COOK, 62 Cortland St., N. Y. City

"BEE-KEEPER'S REVIEW"

Franklin House DETROIT, MICH.

Cor. Bates and Larned sts. Very central. Elevator service, steam heat, electric lights, tile floors, etc. Rates \$1.50 to \$2 per day. H. H. JAMES & SONS, Props.

The Land of Honey, The Italy of America!

Send for a copy of the *PACIFIC BEE*

JOURNAL: 365 E. 2nd St., Los Angeles, California.

BUY NORTHERN GROWN SEEDS

FARM SEEDS

Salzer's Seeds are Warranted to Produce.

E. Water, Leffersville, Pa., astonished the world by growing 250 bushels Salzer's corn; J. Breider, Mishicot, Wis., 173 bush. barley, and P. Sinnott, Randolph, Iowa, by growing 196 bush. Salzer's oats per acre. If you doubt, write them. We wish to gain 150,000 new customers. *Write!* Will send on trial

10 DOLLARS WORTH FOR 10c.

If price of rare farm seeds, Hog Pea, Sand Vetch, "Doc" Wheat, Sheep Rape, Jerusalem Corn, etc., including our mammoth seed catalogue, telling all about the \$100 gold prizes for best name for our new marvelous corn and oats, "Prodigies," also sample of same, all mail 1 you upon receipt of but 10c. postage, positively worth \$10 to get a start. 100,000 lbs. Seed Potatoes, at \$1.50 a bid, 50 pkgs. earliest vegetable seeds, \$1.00.

Please send this adv. along.

Catalog alone, 5c.
No. 86

JOHN A. SALZER SEED CO. LACROSSE WIS.

SCRIBNER'S MAGAZINE FOR 1898 A Great Programme.

The Story of the Revolution by Senator Henry Clay Lodge, to run throughout the year. For the first time all the modern art and resources will be brought to bear upon the Revolution. Howard Pyle and a corps of artists are making over 100 paintings and drawings expressly for this great work.

Captain A. T. Mahan's "The American Navy in the Revolution," to be illustrated by Carlton T. Cha'man, the marine artist; Harry Penn, and others.

Thomas Nelson Page's First Long Novel, "Red Rock—A Chronicle of Re-considers." Mr. Page has devoted four years to the story, and he considers it his best work. (Illustrated by B. West Chinedinst.)

Rudyard Kipling, Richard Harding Davis, Joel Chandler Harris, George W. Cable, and others, are under engagement to contribute stories during 1898.

Robert Grant's "Search-Light Letters"—replies to various letters that came in consequence of his "Reflections of a Married Man" and "The Opinions of a Philosopher."

"The Workers" in a new field—Walter A. Werkoff, the college man who became a laborer, will tell about his experience with sweat-shop laborers and anarchists in Chicago. (Illustrated from life by W. R. Leigh.)

The Theatre. The Mine, etc., will be treated in "The Conduct of Great Businesses" series (as were "The Wheat Farm," "The Newspaper," etc., in 1897), with numerous illustrations.

Life at Girl's Colleges—like the articles on Undergraduate Life at Harvard, Princeton and Yale, and as richly illustrated.

Political Reminiscences by Senator Hoar, who has been in public life for forty-five years.

C. D. Gibson will contribute two serial sets of drawings during 1898, "A New York Day," and "The Seven Ages of American Woman."

The full prospectus for 1898 in small book form (21 pages), printed in two colors, with three original illustrations (cover and decorations by Maxfield Parrish), will be sent upon application. Postage paid.

PRICE, \$3.00 A YEAR, 25 CENTS A NUMBER.
CHARLES SCRIBNER'S SONS, NEW YORK.

JAPAN PLUM TREES! Large stock of best varieties at lowest rates. Full assortment of fruit and Ornamental trees and plants. Correspondence solicited from parties who intend planting large orchards. Get our prices before ordering elsewhere. We can save you money. Send for our new Spring Catalogue—it is free. Established 1869. Over 150 Ac. es.

Address **THE GEO. A. SWEET NURSERY CO., Box 1165 Iansville, N. Y.**

DADANT'S FOUNDATION

BY THE NEW WEED PROCESS

Has no superior because it is made in the best possible manner, upon the best machines, and from the best wax—that from which all foreign substances, such as pollen, bee glue, dirt, iron from boilers, burnt wax and soot have been removed; and that, too, without the use of acids. These foreign matters make the foundation offensive to the bees and decrease its tenacity. Every inch of foundation is guaranteed to be equal to the sample which will be sent upon application.

LANGSTROTH ON THE HONEY BEE, Revised, Smokers, Sections, Tin Pails, and other Supplies. Send for Circular. **CHAS. DADANT & SON, Hamilton, Ills.**

4-96-12t

Please mention the Review.



See That Wink?

Bee Supplies. Root's goods at Root's prices. **POUDER'S HONEY JARS** Prompt service. Low freight rates. Catalog free. **WALTER S. POUDER**, 162 Mass. Ave., Indianapolis, Ind., the only exclusive bee supply house in Indiana.

Farm Bee-Keeping.

The only bee paper in the United States edited in the interests of the farmer-bee-keeper and the beginner is the **Busy Bee**, published by **EMERSON T. ABBOTT**, St. Joseph, Mo. Send for free sample copy NOW.

CLOVER SEED

Largest growers of Grass and Clover Seeds in America. 5000 acres. Our Grass Mixtures last a lifetime. Meadows sown in April will give a rousing crop in July. Prices dirt cheap. Mammoth catalogue and 11 pkgs. Grass and Grains free for but 1 c. postage. Catalogue alone 5c. **JOHN A. SALZER SEED CO., La Crosse, Wis.**

BEESWAX EXTRACTORS.

The only extractor in the world that will extract all of the wax from old combs rapidly by steam. Send for descriptive, illustrated catalogue to **C. G. FERRIS**, 4-96-tf South Columbia, N. Y.

THE MONITOR PAPER FILE

Binds securely and neatly all periodicals. Preserve your papers, magazines, pamphlets, bulletins, music &c., by binding them together as you get them. Each new number filed quickly and easily. Will bind 52 numbers of any periodical aggregating 1000 or fewer pages. All lengths from 6 to 28 inches. Light and handsome. **PRICE**.—All sizes 12 inches and under 12 cents; over 12 inches one cent per inch. When wanted by mail add one cent for each 5 inches or fraction thereof.

For sale by the Publisher of this paper.

PATENT. WIRED, COMB FOUNDATION

HAS NO SAG IN BROOD FRAMES.

Thin, Flat Bottom Foundation

HAS NO FISHBONE IN SURPLUS HONEY.

Being the cleanest, it is usually worked quicker than any fdn. made.

J. VAN DEUSEN & SONS,
(SOLE MANUFACTURERS),

1-93-tf Sprout Brook, Mont. Co., N. Y.



Please mention the Review.

Best on Earth. 19 Years Without a Complaint.



	Dozen	Each
Smoke Engine (largest smoker made) 4 inch stove...	\$13.00—mail,	\$1.50
Doctor	3.00—	1.10
Conqueror	6.50—	1.00
Large	5.00—	90
Plain	4.75—	70
Little Wonder (wt. 10 oz.)	4.50—	60
Honey Knife	6.00—	80

For further description, send for circular.

T. F. BINGHAM, Farwell, Michigan.

Sections!

We make millions of them yearly; workmanship, smoothness and finish can't be better. The basswood grows right here. If you want some good **Shipping Cases**, you can get them of us. A full line of **Bee Supplies** on hand. Write for illustrated catalogue and price list, free.

Marshfield Mfg. Co., Marshfield, Wis.

1898 Queens 1898 Camera for Sale.

For Business—Queens for Strong Colonies—Queens for large surplus. Competition in Quality, but not in price.

If you want queens, nuclei or supplies at bottom prices, send for my illustrated price list. 12-97-tr

J. P. H. BROWN, Augusta, Ga.

I have several hundred

QUEEN CAGES

of different styles and sizes, made by C. W. Costellow, and I should be pleased to send samples and prices to any intending to buy cages.

W. Z. HUTCHINSON, Flint, Mich.

By the way of a "dicker" I have come into possession of a most excellent 5x8 camera and the accompanying outfit, that I would like to sell. The following is a list of the articles and what they cost when new.

Camera and Lens	\$25 00
Tripod	3 00
Plate holders (three at \$1.50)	4 50
Pneumatic Shutter	4 50
Focusing Cloth	35
Developing Tray	75
Inside Kit for making 4x5's	25
The following book:-	
Pictorial Effect in Photography	\$1.50
Photographic Instructor	1 50
Picture Making by Photography	1 00
Total	\$42 35

Everything is in strictly first class condition, just exactly as good as new, but I got the outfit at a bargain, and am willing to sell it at the same, if I can get it into cash. **\$20.00** will buy the entire outfit. I have used the instrument enough to know that it will do excellent work—in fact, I will send a sample of the work to anyone who really wishes to buy.

W. Z. HUTCHINSON, FLINT, MICH.

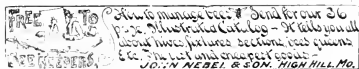

Our basswood lumber is *white as snow*, our machinery *up to date*, and we can furnish the *finest*

One - Piece Sections

in the market. Price list and sample section free. Special prices on large quantities. **ONE-PIECE SECTION CO.,**

PRAIRIE DU CHIEN, WIS.

The Progressive Bee-Keeper

Is a 28-page monthly bee journal published at Higginsville, Mo.; price, 50c per year. With the year of 1898, we begin the eighth volume; hence it is past the experimental stage. **R. B. Leahy** and **G. M. Doolittle**, editors. Some of the features of 1898 will be a continuation of **Wayside Fragments**, by **Sommambulist**. **Experience and its Lessons**, by **R. C. Aikin**. This series of articles will be reviewed by Mr. Doolittle, which is practically giving *his* experience with its lessons. "Experience" and its lessons, as reviewed, will be a gold mine for beginners and advantageous to those more advanced in bee culture. The **Sommambulist** articles are written in a pleasing style, as none but **Sammy** could write them. They are highly entertaining and instructive. **Dr. C. C. Miller**, and other popular writers also contribute to its columns. The **PROGRESSIVE** is a popular journal at a popular price. Printed in the highest art, on beautiful paper. Fearless in its character, newsy in its contents, and artistic in its make-up. Remember the **PROGRESSIVE BEE-KEEPER** is but 50c per year. The **PROGRESSIVE** and that "one only" book for beginners, the **Amateur Bee-Keeper**, by **Prof. J. W. Rouse**, both for 65c. A sample copy of the **PROGRESSIVE** for your name, and a beautiful illustrated catalogue of apianian supplies for the asking. Address,

Leahy Mfg. Co., Higginsville, Mo.

Bees Scooped!

I have at last succeeded in buying all the bees within 2½ miles of my home apiary. This practically gives me a clear field for breeding pure Italian queens. I have had over twenty years' experience in breeding and experimenting with Italian queens and bees, and I now breed "for business" from my own importations. Poor stock is costly as a gift.

One colony of Italians in single story, 8-frame, D. T. hive, \$6.00; 5 colonies, \$27.50; 10 colonies, \$50.00; one frame nucleus, \$1.50; two frame, \$1.75. Select the queen wanted and add price to the above. During March and April, one tested queen, 2.00; select tested queen, \$3.00. After May 1st, one tested queen, \$1.50; 3 for \$4.00; 6 for \$7.50; select tested, \$2.50. Untested queens as early as the season will permit of their being reared, one for \$1.00; 3 for \$2.25; 6 for \$4.00; 12 for \$6.75.

JOHN M. DAVIS,

2-95 12 Spring Hill, Maury Co., Tenn.

Please

to

Muth's HONEY EXTRACTOR PERFECTION Cold-Blast Smokers

Square Glass Honey Jars, Etc.

For Circulares apply to CHAS. F. MUTH & SON
Cor. Freeman & Central Aves., Cincinnati, O.
Send 10c. for Practical Hints to Bee Keepers.

1898

Please mention the Review

Good Queens,

Either three-banded or golden—sent promptly. Two different yards. Circular free. Am a member of the National Queen Breeders' Union. 2-9S-1f

J. B. CASE, Port Orange, Fla.

Please mention the Review

Violin for Sale.

I am advertising for the well known manufacturers of musical instruments, JACO. F. Stratton & Son, of New York, and taking my pay in musical merchandise. I have now on hand a fine violin outfit consisting of violin, bow and case. The violin is a "Stradivarius," Red, French finish, high polish, and real ebony trimmings, price \$14.90. The bow is of the finest snakewood, ebony frog, lined, inlaid (pearl lined dot) pearl lined slide, German silver shield, ebony screw-head, German silver ferules, and pearl dot in the end, price \$2.50. The case is wood with curved top, varnished, full-lined, with pockets, and furnished with brass hooks, and handles and lock, price \$3.50. This makes the entire outfit worth an even \$20.00. It is exactly the same kind of an outfit that my daughter has been using the past year with the best of satisfaction to herself and teachers. Her violin has a more powerful, rich tone than some instruments here that cost several times as much. I wish to sell this outfit, and would accept one-half nice, white extracted honey in payment, the balance cash. It will be sent on a five days' trial, and if not entirely satisfactory can be returned and the purchase money will be refunded.

W. Z. HUTCHINSON, Flint, Mich.

G. M. LONG, Cedar Mines, Iowa, manufacturer of and dealer in Apiarian Supplies. Send for circular. 1-96-6

Please mention the Review

START IN BUSINESS!
HATCH THOUSANDS
WITH THE PRAIRIE STATE
INCUBATOR
200 FIRST PREMIUMS.
PRAIRIE STATE INC. CO.
HOMER CITY, PA.



END FOR CATALOG.

Please mention the Review

WRITE US

Before ordering your sections and we will give you **BOTTOM PRICES** on the

"BOSS" ONE-PIECE SECTIONS,



Also D. T. HIVES, SHIPPING CRATES and other Supplies.

We have everything in tip-top order, and can fill orders on short notice. Let us hear from you for prices.

J. FORNCROOK & CO.,

Jan. 1st, 1894.

Watertown, Wis.

Please mention the Review

Make Your Own Hives.

Bee-Keepers
Will save money by
using our Foot Power
Saw in making
their hives, sections
and boxes.

Machines on trial.
Send for Catalogue.

W. F. & JNO. BARNES CO.,

384 Ruby St.,

Rockford, Ills.

2-96-12

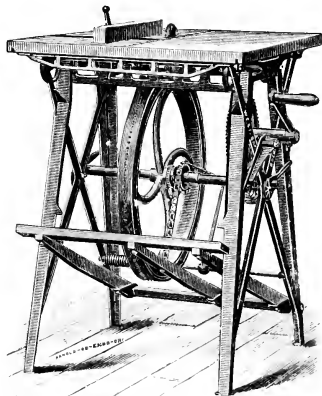

The "Higginsville" Smoker.

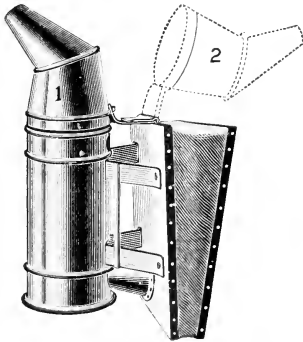

The above cut shows the "HIGGINSVILLE" Smoker. Fig. 2 shows the nozzle thrown back for filling. This Smoker is made of the best material, is strong and well made, will burn any kind of fuel, and has a very strong draft.

☞ "The 'Higginsville' Smoker is a dandy with a big D." J. M. Morse, Holden, Mo.
☞ Price of smokers, 75c; 3 for \$1.80; by mail add 25c each for postage. Send for catalog of other supplies.

The Amateur Bee-Keeper, a book for Beginners, 25c each; by mail, 28c.

LEAHY MFG. CO., Higginsville, Mo.

Please mention *The Review*

— If you wish the best, low-priced —

TYPE - WRITER.

Write to the editor of the REVIEW. He has an Odell, taken in payment for advertising, and he would be pleased to send descriptive circulars or to correspond with any one thinking of buying such a machine.

FINE FOUNDATION

My foundation is made by a peculiar process (no dipping boards used) which results in a superior article one that can't be surpassed. The best goods are none too good, and the lowest prices none too low for these times, and I can furnish both, not only in foundation but a full line of bee keepers'

SUPPLIES.

Send for a catalogue and be your own judge. Wax wanted at 26c cash or 29c in trade, delivered. **AUGUST WEISS,**
497-1st St. Hortonville, Wis.

Dovetailed Hives,

Sections, Smokers, Queen Cages, and everything needed in the apiary. Warranted Italian queens 75 cts. each. Two frame nucleus, with a queen, \$2.60. Send for catalog.

DEANES & MINER, Ronda, N. C.

If you are going to

BUY A BUZZ-SAW,

write to the editor of the REVIEW. He has a new Barnes saw to sell and would be glad to make you happy by telling you the price at which he would sell it.

Page & Lyon

MFG. CO.

New London, Wis.

Nearness to pine and basswood forests, the possession of a saw mill and factory equipped with the best of machinery, and years of experience, all combine to enable this firm to furnish the best goods at lowest prices.

Send for circular, and see the prices on a full line of supplies. 1-97-1f

The Cheapest

FALCON POLISHED SECTIONS are superior to all others.

HIVES AND FIXTURES of all kinds kept in stock or made to order.

LARGE ILLUSTRATED CATALOGUE and copy of *The American*

Bee-Keeper (now in its 7th year) for the asking. Address

W. T. Falconer Mfg Co., Jamestown, N. Y.

is not always the best, in Bee-keepers' Supplies as well as other things. We make the best goods and they are as cheap as any.

We are the People

Who can turn out *Fences* (Cleated Separators) and *Plain Sections* (Sections Without Insets)

— For 1898. —

Having special appliances and machinery, we can make them right. Nothing in late years has seemed to stir up such a furor in the Bee-Keeping World as these new goods. If you don't know about them, send to

The A. I. ROOT CO., Medina, Ohio.

New 1898 Catalog, largely re-written, now out.



Our Prices are worth looking at. We are making the new

Champion Chaff Hive

with dovetailed body and supers and a full line other Supplies, and we are selling them **CHEAP**. A postal sent for a price list may save you \$ \$ \$ \$.

R. H. SCHMIDT & CO.,
Box 187 Sheboygan, Wis

1-97 12

Please mention the Review.

JOHN PATTERSON, England, Pa., is an American, 23 years of age, has had three years experience in the apiary, and would like to secure a position the coming season in an apiary or on a fruit farm. Is teaching school at present, but will be free by March 1st. Can give references.

Please mention the Review.



\$100

Given as **Bounties** to purchasers of the improved Danz. Hives and Sections. See schedule in my bee-book "Facts About Bees." Tells

how to produce honey that sells for the most money. Free for 2c in stamps. Address

THE A. I. ROOT CO., Medina, Ohio,
OF F. DANZENBAKER, Box 466, Washington, D. C.

Please mention the Review.

QUEENS,

Either Golden or Imported, by return mail. Untested, 75c; tested, \$1.00; breeders, \$2.00.

6-97-tf

W. H. LAWS, Lavaca, Ark.

Sweet Clover Seed.

We have about 3,000 lbs. of sweet clover seed, (of the white variety) that we offer for sale at the following prices:

25 lbs., \$2.25; 50 lbs., \$4.00; 100 lbs., \$7.50.

BERTSCH & FLIEMAN, Holland, Mich.

COMB

FOUNDATION

WHOLESALE AND RETAIL.

Working wax into foundation, for cash, a specialty. Reduced prices during winter. My foundation will speak for itself, and prices are O. K. Don't fail to write for catalogue containing prices and samples. Beeswax taken in exchange for foundation or other supplies.

GUS. DITTMER,

10-97-12t

Augusta, Wis.

Please mention the Review.

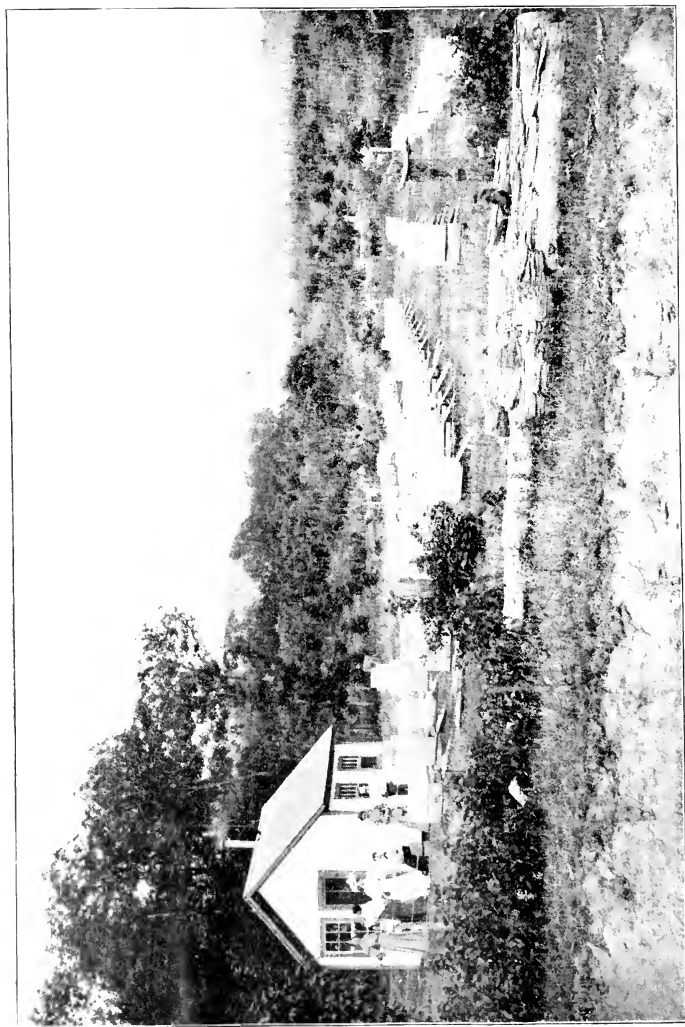

"Linden Valley Apiary;" an Out-Apiary Belonging to E. D. Ochsner of Wisconsin.

The Bee-Keepers' Review

A MONTHLY JOURNAL

Devoted to the Interests of Honey Producers.

\$1.00 A YEAR.

W. Z. HUTCHINSON, Editor and Proprietor.

VOL. XI. FLINT, MICHIGAN, FEB. 10, 1898 NO. 2.

OUT-APIARIES.

Reasons for their Establishment; Selecting the Locations; Moving the Bees; Buildings; Summer-Management; Wintering; Etc.

E. D. OCHSNER.

Things out of hope are compass'd oft with venturing.—SHAKESPEARE.



IN the year 1884, our home-apiary, situated in the village of Prairie du Sac, became too large; and we began looking for some way out of the difficulty. Another inducement to move

the bees lay in the fact that we had a good neighbor (if you don't care what you say) who said that the bees spotted their clothes all through the summer; and one day he told father, in my presence, that if we did not move our bees out of town, *he* would move them for us. Father told him to go ahead and move

them if he wished to pay damages. From that day on, we heard no more from him; as he learned that father was a member of the Union. I would advise every bee-keeper to join the Union, and thus see that we are not cramped upon. It is the only way that we can hold our rights.

Finally, we rented half an acre of land seven miles west of the home-apiary, and near a large stream called Honey creek. This was a fine location, being a fertile country westward, but sandy on the east, or we would not have gone so far from home. To this location we took about half of our home-apiary. The first summer our out-apiary produced 6,000 pounds of fine, No. 1, white honey; mostly bass-wood, but some goldenrod and horse-mint. This we thought was very good for our first year's experience. Next year we enlarged the out-apiary and things went fine.

Being so well-pleased with two year's experience, we started a second yard, the following spring, four miles below the first one, on the same creek, and five miles from home, at a place called Honey-flats; being mostly marsh and bottom-lands, but not so fertile a country as the first location. This yard we call Indian-mound apiary; and there is where we have a very fine bee-cave, 24 x 8 and 8 feet

high, with two roofs; one covered first with sand, and next with dry leaves, and then the second roof. There are two ventilators; one in the entry and the other in the cellar.

This cellar is in the north side of the hill where the yard stands; so we don't carry the bees far when taken in and out of the cellar; but I will not dwell on this subject any longer, but go on with out-apiaries.

Until the spring of 1894, we ran only three apiaries; then we saw a fine location eight miles north of the home-yard; a drive over as good a farming country as there is Wisconsin; not one hill, simply a level, fertile prairie. This is Linden valley apiary, and is shown in the frontispiece. It was named after a large ravine that runs up back of the yard; the timber being mostly Linden. The range of bluffs back of the apiary is over 1000 feet above sea-level; and heavily wooded with all varieties of wood, and in all depressions are plenty of lindens.

Deer are quite plentiful throughout the range. On the front side of the yard is the prairie I mentioned before; and here is where I get my white clover honey; so you see I have picked a fine location. Good water is there in plenty. A spring just back of the yard is so large that I can dip a full pail at a time, and is a fine watering place for the bees. The bees in this yard are wintered on their summer-stands; in Champion chaff hives made by the G. B. Lewis Co., of Watertown, Wisconsin. These are fine hives, with loose bottom boards. Those boards in front of the hives are for the bees to drop on when they come home heavily laden. I raise the hives because they are cooler in summer; also, so that I can mow the grass to better advantage. The stands are just the size of the hives, and six inches from the ground, and have a slant of two inches. The hives stand eight feet apart each way.

This yard is run for comb honey, and is managed by myself, except when I exchange to get the other yards in working

order. We rent the land, about an acre or less, for five dollars a year. This, of course, is land that is not under cultivation.

The four apiaries are run with two horses, and three helpers, besides myself. Father runs the yard west of town. This is run for extracted honey, and wintered on summer-stands; my younger brother, who is quite young, runs the Indian mound apiary; and mother attends to the swarming at home; so, you see, the expense is not so large as one would think.

The home-yard was bettered a great deal by removing part of it, for the location is nothing extra. I would never think of overstocking an apiary again. It takes a good location for a hundred colonies. I thought thieves would eat up all the profit, but I have had very little loss so far. This winter a chaff hive was opened; and two full frames of honey taken out; but it did not injure the colony. The best plan is to invite your neighbors in and give them all that they can eat, and some to take home to their families, and you will have no trouble unless you are located in a "hard nation."

If you can get farmers to sow alsike clover it will pay you to buy them the seed the first year.

If there are no old buildings in the right place, it is the best way to put up a shanty of ship-lapp, 12 x 16, for ten or fifteen dollars. An old stove can be got for a dollar or two; and then, with a cot and two or three pieces of bedding, you can stay a few days if you wish. A "bike" is very handy when there is nothing to carry; but I prefer a horse, so that I can go when I please. I drive to my farthest yard in one hour. Don't be afraid of stock coming too near; for, if you have a good fence, there will be no trouble. In seventeen years of bee keeping, we never had a mishap from stings.

By all means, don't locate nearer than one mile from a sorgum mill. The further away the better.

All bees must be moved before they commence to store honey. Give plenty

of air and use a spring wagon to haul them. The best way is to get your load on the night before, so as to get an early start, then you can let them out before the sun gets too hot. In dandelion bloom is a good time to do this work; then they will go right to working when they are set at liberty, instead of robbing. By careful loading, you can take twenty colonies at a load.

To work for extracted honey in out-apiaries is the best. Have everything ready at the yard so as not to be forced to haul supplies in swarming season.

In the fall of 1897 we put about four hundred colonies into winter quarters, all in good condition.

My company, which you see in the picture, consists of my wife, my sister, and three cousins which were here.

PRAIRIE DU SAC, Wis. Jan. 16, 1898.



THE TREATMENT OF FOUL BROOD.

It may be Safer in Some Instances to Com-
pel the Bees to Build Some Comb Before
Giving them Foundation.

F. A. GEMMILL, *

I'll make assurance doubly sure.—SHAKESPEARE.



THE December issue of the Review, on its 10th birthday, is a gem. The appearance is greatly improved, owing to the new face with which it came before its readers, and the contents

are certainly of great value to the bee-keeping fraternity.

The beautiful frontispiece of that detestable disease, foul brood, caught my eye *instantly*, because of its correctness and life-like appearance.

I have seen hundreds, yes, I may say several thousands, of just such combs during the past seven or eight years, some of which existed in my own apiary, but the greater portion, however, having come under my observation since becoming associated with Mr. McEvoy as assistant inspector of apiaries.

Thanks to legislation, and the desire of the more progressive class of apiarists, there is not now, nor need there be, the great fear that at one time existed regarding it; as the scourge is becoming more generally understood. I am now living in the hope that the future will not reveal so much of disease, which, unfortunately, in Canada, at least, has been disseminated through ignorance, neglect, and, in some instances, lack of principle and regard for the rights of others.

It is not now my intention to write a lengthy article on the above pretty-well-thrashed-out subject; but, if you will kindly allow me space, I should like to refer to the excellent articles by Messrs. Taylor and Babridge in the December Review. In the main my experience corroborates their views regarding its treatment.

Mr. Taylor has handled the subject well. His description of this disease, and how to find it, is exceedingly definite—so much so that a mere novice can detect the symptoms if he chooses; and I doubt not that the means advocated, if employed by *himself*, will always, as he states, result in a cure; viz., by merely shaking or hiving bees directly upon foundation, and that it is unnecessary to first put the bees on starters for four days, as some recommend, and then give foundation afterwards. This latter statement is one that Mr. McEvoy, myself, and some others in Canada, and elsewhere, possibly, cannot conscientiously recommend at all times and under all circumstances; although, in even the worst cases, I would not always insist upon four days, as two days, and, sometimes, even one day, is sufficient.

If I understand Mr. Taylor aright, he concedes that, at times, the disease as-

sumes a virulent or more contagious type or form, while, later, it may have spent, to some degree, its force; and I can only conclude that, under some such circumstances, the foundation cure alone may be quite sufficient, but not in *all cases*; and, until more experience teaches me otherwise, I cannot recommend or justify its adoption in *toto*. Past experiments prompt me in stating that it is better to be sure than sorry—as in many instances the amount of infected honey carried with the bees was so great that odd cells would show diseased larvæ, if this honey were deposited in the *brood chamber*.

If I mistake not, some of the California apiarists agree with me in this matter; as, during my late visit there, I understood the practice with some of those who happened to have the "good luck" to find a stray swarm in or near their own apiary was to hive it on starters for a few days, and then, afterwards, give foundation; fearing that the visitors might have brought with them a gift other than sound honey.

I must confess that Mr. Baldrige's article was a pleasant surprise to me. Treating foul broody colonies by his method is novel, and yet savors so much of possibilities that I can but express my delight with the information it contained. The great difficulty, heretofore, has been to secure a good crop of honey from a colony having the disease, and at the same time cure it with as little time, labor, and expense as possible.

The plan outlined prevents increase, of course, but that is no detriment; at least, ought not to be to any one possessing either few or many hives. More explicit directions for carrying out the cure could scarcely have been given; so that failure can scarcely follow if a pains-taking bee-keeper undertakes the remedy. I wish that assurance possessed my soul to such an extent that all would succeed who tried it; but that would almost be expecting too much, for there are those who, unfortunately, bungle anything they undertake.

No objection can be offered at present by me to his treatment. At the same time, it will be tried, as soon as an opportunity presents itself, and results duly reported.

One thing, of probably minor importance, is the boring of a hole in the front of the hive, for the purpose of attaching a cone for the exit of the bees from the diseased colony. I just would not bore that hole in the hive, but, instead, would use an attachment containing a cone (a double cone preferred) which can be adjusted in a second to the front of any hive, without altogether closing the entrance proper, thus affording freer ventilation to the practically imprisoned bees. Such an arrangement is quite simple; and has been in use for seven or eight years, or more, by Mr. J. B. Hall, one of our best comb honey producers. I have used it myself some five or six years for the prevention of after-swarms, by transferring the bees from the parent colony to the swarm until the young queen is ready for fertilization, when the old hive can be removed to a new stand, or disposed of as seems best.

Of course, there are numerous ways of curing foul brood, but time, nor space, I fear, are sufficient to enlarge on them here; so I will, therefore, in *conclusion*, congratulate the editor on having secured so many other good contributions which are highly appreciated, but can be more profitably commented upon by others than by your humble servant; and I will simply add that some experiments which Mr. McEvoy and myself have been carrying out of late had to be abandoned for the present for lack of time. I mention this fact, as I had occasion to refer to such in corresponding with you some few months ago.

STRATFORD, Canada, Jan. 15, 1898.

[I think Mr. Taylor has never positively asserted that foul brood could be gotten rid of in all cases by simply shaking the bees off upon sheets of foundation, but that such had been *his* experience without a single failure.—ED.]

PROMPTNESS AND EXACTNESS.

Also Some of the Points to be Observed in
Using Plain Sections.

L. A. ASPENWALL.

"Early begin and end your toil."



THE present
age of develop-
ment, with its
machinery and
appliances, is
compulsory. The
man who follows
the beaten path
will soon find
himself "fishing
behind the net." But, viewing the

mass of humanity in its onward trend, we behold the impulsive, the cautious, and the conservative. Not a few belong to the first-named class. Those who profit by the bitter experience of the impulsive are—cautious. They constitute the largest class; although, in this progressive age and land, many are compelled to become conservative through lack of means, largely due to the centralization of capital.

In bee culture, the developments compare favorably with those of other lines. The improvement in sections is most prominently before us at present. Comb honey stored in plain sections not only commands the highest price, but sells more readily than in the old style. So the dollars-and-cents end naturally makes its adoption compulsory. All together, the plain section brings added complication; in other words, it necessitates the observance of technicalities. The use of special separators with projections or cleats $\frac{1}{8}$ of an inch high allows the elongation of cells an equal distance nearer the section edges. As a consequence, the bees will occasionally overstep the prescribed limit, capping a few cells beyond the wood. To lessen this tendency we

are compelled to observe more accurate measurements in their construction. The space above and at the sides, where vertical passages are used, should not be more than $\frac{1}{4}$ of an inch; and, at the bottom, not more than $\frac{3}{16}$ of an inch. Even then, with insufficient storage room, a little bulging will occur. Furthermore, through any neglect to remove the supers as soon as well filled, the tendency will be increased and burr-combs constructed even in the narrowest bee-spaces throughout the hive. Let me state, parenthetically, although we construct hives with $\frac{1}{4}$ -inch bee-spaces between and above the top-bars, still, burr-combs will be constructed when insufficient storage room is given. So the necessity of removing supers as soon as well filled, becomes imperative in order to prevent bulged edges. But, in so doing, we obtain an added compensation—honey in its extreme whiteness and beauty—a product which will attract the most fastidious purchaser.

Furthermore, greater care must be exercised in handling and crating. If any sections with bulged edges are found, only one or two, at most, should be put into a case. If placed near the center no abrasion of the cappings need occur when removing them, the first row being the most difficult to remove.

I fear we shall have some complaints in the matter of bulged edges the coming season, especially where imperfectly constructed separators are used.

The plain section will undoubtedly necessitate some changes in shipping-cases. Each section getting closely against the adjoining ones, will prevent much if not all drip below, which may possibly prove objectionable, as the honey would be likely to run through an entire row in the event of a single breakage. Even with veneering or heavy paper separators, each one would be swamped in its own leakage. But the plain section, with its many points of excellence, will more than balance the slight objections presented. With well filled sections and proper handling, no serious breakage need occur. However,

I expect to use less expensive cases another season by leaving out the supporting cleats and paper, as well as making other slight changes. In the meantime I trust our supply manufacturers will anticipate all these things. In a letter from Mr. F. L. Thompson, my attention was called to this requirement. In consideration of low prices we must have cheaper shipping-cases.

Although having described my separator in the December Review, there are one or two essentials which I will further explain in detail. First. The verticals, or transverse openings, or passage-ways, for the bees afford access to the sections not only laterally, to each adjoining row, but longitudinally through each individual row. This practically makes the sections accessible from all sides; which would be impossible if cleats were used instead of the short metal projections. I regard the vertical openings, in combination with the short metal projections, as essential to a perfect separator. Secondly. A tin separator is sufficiently strong to support the sections without end-pieces; and adapted to hold sections of any desired width.

The item of cleaning is also important. To scrape propolis from a thousand separators is no small task. But with a large kettle of boiling water, a thousand or more made of tin may be cleaned in fifteen or twenty minutes.

Technical observance is also necessary in hive construction and appliances. The best results can be obtained only when our colonies are unrestricted in their workings. This is true both winter and summer. Unrestricted flight is a prime requisite in successful wintering. It is even so regarded by those who are advocates of cellar wintering, some of whom occasionally remove their colonies during a warm spell in winter for a cleansing flight.

Queen-excluding zinc is objectionable, not only in restricting the passage of laden bees to the supers, but it induces the building of burr-combs. The thin edges,

like cell-walls of comb, naturally invite the bees to build thereon. Unless the queen is impeded in her work of laying, by over-crowded combs, she will confine herself to the brood apartment. In my hives, dummy combs lessen the crowded condition to such an extent that queens seldom venture above. The present season I found only three sections containing any brood. They were from a single super provided with drawn combs. As edges invite comb-building, so drawn-combs invite the queen to laying, and the workers to deposit pollen. Taking all into consideration, I regard perforated zinc as worse than useless. I know of no place in which it serves a useful purpose, and I have an abhorrence for it when used in the form of a drone-trap. Not only does it restrict the passage-way to such an extent that much pollen is lost, but it is a cruel and filthy method of eliminating the drones. The traps are frequently daubed to such an extent as to render them actually filthy. I can not understand how any one can tolerate the torture inflicted upon creatures so harmless and defenseless.

"Let each living creature share thy warm love
and be thy care,
Let what'er thine eyes may see form a link
'twixt heaven a'nd thee"

Let us accept the oft-advised plan of removing all excess of drone comb during the early spring; substituting worker comb for it.

In 1865 Mr. Quinby stated, "Bees will store more honey in a barrel, box, or hollow log, just large enough to hold all that is gathered, than in any patent fixture ever presented for the purpose."—Quinby's Bee-Keeping, 2nd edition, page 49. For correct and accurate conclusions, I think no writer on the subject of bee-keeping equaled Mr. Quinby during the decades from 1850 to 1870, unless it was L. L. Langstroth. I believe he was correct when the above statement was made; but we are advancing in knowledge, and developments are taking place in bee culture, which, according to my judgment, render the above statement obsolete. I

have discovered that a crowded condition is unfavorable to the most rapid storage of honey, which interference induces preparations for swarming. The use of dummy combs not only tends to distribute the bees over an increased area, but furnishes additional surface for travel to the supers. In other words, they afford unrestricted travel to the supers. In contrast with a few colonies having no dummy combs, also with my neighbor's bees, the storage of honey was much greater by colonies provided with dummies. I have often wondered how bees managed to travel from the entrance to a super over crowded combs, naturally interfering with the nurses and queen, as well as those returning from the super. Can we expect anything less than preparation for swarming under such circumstances?

From the foregoing experience I believe more honey will be stored in a properly constructed and arranged hive than in a mere hollow receptacle.

JACKSON, Mich., Jan. 28, 1898.



ITALIAN VERSUS BLACK BEES.

A Fair-Minded Champion of the Dark Race

J. E. CRANE.

"Handsome is as hand one does."



It is with particular pleasure that I sit down to compare the merits of Italian and black bees as honey-gatherers, and weigh them in an even balance. My excuse for so doing

is that I do not now remember of ever reading an accurate statement of the rel-

ative value of the two races. Such may have been written; but, if so, it has now escaped me.

Just here I may as well say that I have no "ax to grind," no queens to sell, and nothing to gain or lose, except the good opinion of my brother bee-keepers, and I fear I may offend some of them if I am true to myself and my subject.

It is now nearly or quite forty years since I first read of the Italian bees, which were described, or I imagined them as so described, as being nearly or quite as large as "bumble-bees," as gentle as flies, and vastly better honey-gatherers than the common bee ever thought of being.

In the latter part of the winter of 1865-66 I bought my first Italian bees; and, in the spring, with this one weak colony of pure Italians, and another of hybrid, or grade bees, costing, altogether, forty dollars, and two strong colonies of black bees, which cost twelve dollars, my brother and I began bee-keeping with all the customary enthusiasm.

The colony of pure Italian bees were quite weak in the spring, and yet, notwithstanding the season was very unfavorable, it filled its hive with honey, having to build some new comb in order to do so. The hybrid colony, although much stronger, did not gather as much honey; and the two black stocks, although very strong, did not either of them make half enough to winter on.

At the close of the season I thought I knew all about Italian bees; and, if not quite as large as they had been reported, they would certainly gather two or three times as much honey, in proportion to their numbers, as would the black bees.

For some years following, every black swarm bought was relieved of its queen, and an Italian queen given at the first opportunity.

During the summer of 1867 there appeared to be quite a difference in the amount of honey gathered, even among colonies of pure Italian bees.

In the fall of 1868, to make sure that we had pure stock, we bought an imported queen of the late Moses Quinby, paying twenty dollars for her.

The season of 1869 proved, in this section, an unusually good one. My brother and I had taken our father in as a partner; and, altogether, we began the season with about seventy hives of bees. I gave up my time in caring for them; and, in addition to quite an increase, we secured some three thousand pounds of very handsome honey, mostly in glass boxes. Such a crop of honey, from one apiary, had never before been heard of in Western Vermont; and the newspapers commented on it from one end of the State to the other. I was not puffed up with our success, as I supposed it largely due to our having *Italian* bees and movable-frame hives.

I was now so well satisfied with the Italian bees that I had no desire to try the black bees; as they were likely to hybridize my yellow bees; and, besides, there was no question as to their great inferiority; as I had already tested both races when I first began bee-keeping.

During the winter of 1881-82 I moved to my present home; and, to fill out my yard here, I bought in some black bees which, for some reason, I did not at once Italianize. The following summer proved very favorable for honey; yet these black bees that I had bought filled their hives better, and gave more surplus than my pure Italian colonies. I tried, as best I could, to excuse my handsome yellow bees for not doing better. I thought it might be owing to the more crooked combs in the hives of black bees; or because their combs had not been handled so much.

The following winter I lost an unusual number of colonies in two yards. The greater loss was in the yard where the black bees were; and, by figuring up carefully, I found that a larger per cent of black colonies had died than Italian; and, without taking into consideration the fact

that they were in a more exposed position, I tried to make myself believe that they were less hardy; even if they did sometimes gather more honey.

The next spring, to fill up my silent hives, in part, I bought over fifty colonies of black bees. The spring was followed by one of the best honey seasons I have ever known; and, much to my surprise, from some of these black colonies, that I had bought and transferred, and robbed of a large amount of brood to help up my weak colonies of yellow bees, I secured more finished sections, (from them and their increase,) than I had ever taken from a colony of pure Italian bees, and its increase. To say that I was surprised is putting it very mildly. But then, we had read that black bees would do very well in an extra good year, when honey was as plentiful as water after a shower. Still, if they would do better in an extra good year, and in a very poor year, as the previous one had been, why would they not do well in other years? Much of my prejudice was gone; and I was willing to keep both races side by side, in my different yards, and watch their behavior; which I have done, with a good deal of interest, during the past fifteen years. At present I have comparatively few of either race absolutely pure.

G. M. Doolittle, one of the most careful and conscientious writers in our ranks, says of the Italian race that "When we have a light yield of honey, * * * they work right on untiringly, storing a little honey in the sections every day, at times when hybrids and other bees are scarcely getting a living," and I believe he stated the exact truth, so far as he saw it; and I might say, I have had them behave in exactly the same way. I have in some years thought I could almost tell the purity of any colony of bees if I knew the amount of surplus honey it had stored. In other years the difference was not marked; and in some years, as in 1897, almost exactly the reverse has been true; and I have found, as a rule, that my col-

onies with the darkest bees, or bees with the most black blood, giving me the most surplus honey. I wish it were otherwise; for I like those beautiful yellow bees; so quiet on their combs, and so gentle that they will not hurt you if you don't hurt them; but when I found them idling away their time, and the dark bees filling their hives, it set me to thinking very fast; and I wondered if they had not degenerated by removing them to this country. But, if they *have* degenerated in thirty years, what of the blacks that were imported two hundred years ago? Guess that theory won't work.

One of the great drawbacks to these yellow bees is their disposition to swarm—much worse in some seasons and in some locations than in others. In one of my yards they are very much worse than in the others; and in '97 they swarmed before they had a bit of honey in the supers; and but little even in the brood chamber. In some cases not even an ounce of honey was left in the brood chamber! But will not these early swarms fill up their hives and give lots of surplus? They will perhaps fill them up with honey and brood; and a start may be made in surplus sections, when, out they pour again, as though they meant to do their full share in fulfilling the Divine injunction to "Multiply and replenish the earth."—and so the season is frittered away, and the harvest is past and the summer is ended and my boxes only half finished.

Mrs. Tupper and others have said that a colony would not swarm if a laying queen of the present season were given it before preparations for swarming were commenced. But, alas! my Italians have not the slightest regard for what Mrs. Tupper said; or the age of their queens, either. Swarm, swarm, *swarm*, they will; until I have become so disgusted that I have thought I would use black queens only, until every vestige of Italian blood was wiped out. But over-swarming is not their only fault; for in some yards, the past summer, as in other years, where

there was but little swarming, the dark bees were ahead. Why was that? It seems to me that the solution of the problem is just here: The black bees are not nearly so fastidious as to the honey they gather, as are the Italians; and in such a year as 1897, in this section, when even clover honey is of "off-quality," they have greatly the advantage, or manage to get the advantage, before the end of the season; and far surpass their more genteel neighbors; who will have the best or none, or but very little. It is true, the surplus honey gathered by the blacks would not, in such instances, average quite as white, perhaps, as that gathered by the other bees; but, as I used to console myself last summer, so I can say now, honey a little dark is better than none; which was just about the amount some of my handsomest yellow bees gave me; while the dark bees gave me a fine yield of surplus.

A few years ago, I received a letter from a gentleman, living in a section where their surplus honey was principally buckwheat, asking why his Italian bees did not give him as much surplus as his black bees. He had been much disappointed in the result of introducing Italians into his apiary. The stupid fastidiousness of the Italian race in not gathering dark honey, when there was no light honey to be had, was my only explanation.

In drawing this discussion to a close, I will say that I fully believe that in those sections of country where the majority of flowers yield dark honey, or honey with flavor a little "off," the dark bees will be found much the more profitable. The same is likely to be true where, during only a part of the season, such honey is gathered; while, in those sections of country where there is rarely much dark honey gathered, and the clovers and basswood abound, one can not do better than to use Italian bees.

MIDDLEBURY, Vt., Dec. 11, 1897.

BEES HAVE NOTIONS.

Some Views Concerning the No-Wall Foundation.

T. F. BINGHAM.

To build, to plant, whatever you intend,
To rear the column, or the arch to bend,
To swell the terrace, or to sink the grot,
In all, let nature never be forgot. — OPE



FROM the lack of reports, at the Michigan bee convention, regarding the use of the no-wall foundation, it would appear that any foundation is good enough—if we are only in the habit of using it. While several bee-keepers used this thin foundation, none of them found it *too* thin, or that it did not give as good satisfaction as any foundation. It is a significant fact that no one failed—all succeeded. The lack of reports can be accounted for on the theory that while bee-keepers take notice of the honey produced, they pay very little attention to the peculiar methods pursued by the bees in storing the honey.

In my observance I have learned that no foundation yet produced exactly meets the artistic notions of my bees. While it would seem that it is as perfect as the bees can make it, yet they hold opinions of their own; and, strange to say, those opinions clash with all of the different makes of foundation. I have used all of the styles, except the Given, and it is the same with them all. The thick has to be changed—on what theory, I am unable to say. Why the bees should object to beeswax by the pound, provided it is in exactly the form in which they need it, is incomprehensible to me. They must see, or feel, a difference, as no foundation has yet been made that they do not change.

These unsatisfied notions of theirs have led to the promulgation of a great many theories. I thought, and said, last year, at the Michigan convention, that I believed that foundation with the least possible wax in it, with sharp angles but no walls, would be accepted and would result in the least objectionable septum. Since then my experience has fully demonstrated that fact. The thinner the foundation, the more quickly it is accepted, and the less work is required in remodeling it.

Perhaps the shiny, pressed surface of foundation is objectionable to the bees. At any rate, they do not build combs with shiny walls; and when the no-wall foundation is changed to comb and ready to be filled with honey, it can not be distinguished from the thinnest natural comb. The shine has disappeared, and it has the soft, downy look of natural comb.

FARWELL, MICH., Feb. 8, 1898.



MANAGING SWARMS FOR COMB HONEY

Also Something About the Advantages of Side-Passageways in Hives.

J. A. GOLDEN.



MR. Doolittle and others have told how the field bees give the honey to the nurse bees, and the latter store it in the cells. My bees, as a rule, do not follow that practice. I

know this to be true, as I have spent a great deal of time sprinkling bees with flour, and then watching them through the glass as they pass up and deposit their loads of nectar in the sections.

To save the bees the trouble and time of pushing up through a crowded brood-nest to the supers, I have a close-fitting division board at each side of the hive. It stands out $\frac{3}{8}$ of an inch from the side of the hive and extends up to $\frac{1}{4}$ inch of the top of the hive. Of course there is a space between it and the bottom board large enough to allow the bees to pass in behind it. The great mass of field-bees use these passage-ways in going at once to the supers. It is something on the plan of raising the hive up in front and thus throwing the bees to the sides, *a la* Pettit.

When a colony swarms I hive it on the old stand in two supers containing sections filled with foundation. The queen is caught and caged in a section containing a partly finished comb. The section is made into a cage by tacking wire cloth on both sides. The section containing the queen is placed in the upper super. On top of these supers is placed the old hive and its contents. If the bees were working in a super when they swarmed, the super is left on top of the old hive.

In five or six days, I shake the bees from the brood combs, and cut out all of the queen-cells, unless I wish to supersede the old queen, when I leave one cell and destroy the old queen. The hive is then placed on the bottom-board, all the supers put on top, and the old queen released at the entrance, accompanied by two or three puffs of smoke. The bees must now be given plenty of room, by tiering up.

By this method all of the vim of a newly hived swarm is employed in putting honey into the sections.

REINERSVILLE, Ohio, Jan. 18, 1898.

The next frontispiece will be a scene in the sugar-maple forest of Michigan, from a photograph taken by the editor; and he will write a little about the value of the maple as a honey producer in early spring—perhaps give a few reminiscences of his boyhood among these grandest of forest-trees.

NOTES FROM FOREIGN BEE JOURNALS.

F. L. THOMPSON.

As cold waters to a thirsty soul, so is good news from a far country.—BIBLE.

RHEINISCHE BIENENZEITUNG.—Herr Gudden prevents waste of candied honey in the brood-chamber by putting candied combs in warm water for a day, thus liquefying the honey in the comb.

New combs, says Herr Kiel, may be extracted from without danger of breaking, if drawn gradually apart while being built, so that the bees make the cells long and the comb thick.

Heath honey is too thick to extract by ordinary methods, but Herr Gruen writes that for a number of years a neighbor of his has been extracting it without difficulty by first inserting into the cells, after uncapping, a sort of comb, each tooth of which penetrates to the bottom of a cell.

Objects set up in the yard for swarms to alight on, says Herr Flohe, should be placed in position in early spring, to get the bees accustomed to them. In his experience, the advantage in doing so was quite perceptible.

Herr Kiel thinks queens should not be held responsible for all the differences in the yield of colonies otherwise alike. The best colony, with too much unsealed brood on a cold or stormy day, may lose a number of bees in gathering pollen or water, and thus be disabled from furnishing as much surplus as in other circumstances. A swarm coming off six days before the opening of the main flow will have brood to feed when the flow comes, and will yield less than a swarm no better, but coming at the beginning of the flow.

Six judges instead of three ought to be appointed for a large number of exhibits, says Herr Cremer. If possible they should finish their work before the opening of the show or exposition, or as soon as possible after beginning, in order that novi-

ces in bee-culture, and buyers and sellers of honey, many of whom are present during only the first day, may get the benefit of the decisions. Especially desirable is it that uniform score-cards are adopted for the whole country. He proposes also a score-card for judging colonies of live bees.

Sugar-honey, a product of German sugar-factories, with which bees have nothing to do, is often sold for heath honey, and, strange to say, is said to be incapable of being detected by chemists. A case arose in which a bee-keeper was prosecuted by a dealer in the article, because the former, Herr Guhler, had declared it an adulteration. He was acquitted, and the plaintiff condemned to pay the costs and the defendant's expenses. The government chemist was unable to declare it adulterated; but the testimony of six bee-keepers and one of the largest manufacturers of honey-cakes was accepted, to the effect that the taste and smell showed that it was not honey.

BIENENWIRTSCHAFTLICHES CENTRAL-BLATT.—"A colony that is to be stimulated by feeding, must, besides the feed, have so much stores on hand that it would get along without feed until the beginning of the flow. The Hannoverian bee-keepers are masters in stimulative feeding, and know by experience that real results are to be attained only by the use of pure honey; so they pay especial attention to the preparation of a good feed-honey; not allowing, for example, a single open cell of honey to come into the feed-cask."—P. Neumann. The bee-keepers referred to commonly select for stimulative feeding such honey-combs as also contain plenty of pollen. These are put in a cask and mashed up with a stick. Hence the name "stampfhonig," or pounded honey.

H. Niemeyer contends that May sickness, or paralysis, is caused by a lack of pollen in connection with ensuing abundance. If while the bees are gathering plenty of pollen, a number of days of bad weather ensue, followed by fair weather

and abundance of pollen again, the disease appears in from 3 to 8 days after the cessation of the bad weather. A few days only of bad weather do no harm. The violence of the disease is in proportion to the length of bad weather, to the suddenness of the change to good weather again, and to the strength of the colony; the strong ones suffering most. Colonies which are not affected, he has found, are those which have a reserved supply of pollen. Colonies in sunny and sheltered situations have it worse. The disease can occur at any time in the year, though most likely to do so in Spring. As a remedy, he proposes to feed liberally during the spells of bad weather with the "pounded honey" referred to above; or with cakes of sugar and flour in connection with thin honey.

Bee-keeping, according to Herr Lehzen, is a profession in the province of Hannover, and most bee-keepers there are masters in their trade, though they rarely write or speak about it. They rent apiaries of about sixty colonies each, of the farmers. If a farmer's apiary falls behind others in like circumstances, he looks around for another bee-keeper. To get a position, it is necessary to have served an apprenticeship of two years with another bee-keeper. The management is peculiarly adapted to the locality and the local strain of bees, the heath-bee, which has the swarming tendency well developed. In a moderate flow it is inferior to the Italian bee; but when nectar is plenty it surpasses all other races. The bee-keepers are thorough believers in the superiority of a few strong colonies to a number of weak ones. After-swarms are united or added to the least populous of the prime swarms. When it is desired to stop an old colony from swarming further, it is put into an empty hive over night. The next morning the combs are cleared of queen-cells and drone-comb, and the bees returned, which, meanwhile, have killed all but one of the young queens with them. Often, 20 colonies are thus treated in one

evening and the next morning. Drumming, it seems, is a very quick operation with the straw hives universally used in the province. Doubtless, too, the bees are peculiarly adapted to it, in leaving their combs quickly. If left to themselves, the prime swarms would swarm again in about four weeks. To prevent this, an equal number of nuclei, of a handful of bees and a young queen each, are formed. When a prime swarm makes swarming-preparations, it and a nucleus are drummed out and put in each other's hives, which exchange places, so that the bees have their old locations, but new hives and combs. As the nucleus has done but little comb-building, the prime swarm finds plenty to do in filling up the hive, and does not swarm, while the nucleus builds up by means of the brood and stores which the prime swarm had provided. Swarms are always put on the stands of the old colonies, and a laying queen frequently given to the old colony three days after swarming. Queen-rearing nuclei are a part of the apiary. Migratory bee-keeping is much practiced. A characteristic of Hannoverian bee-keeping is that though strong colonies are required, yet increase is the rule. They go on the principle that three, four or five colonies produce more than one colony. To attain these apparently contradictory objects, migration is practiced, and stimulative feeding with "pounded" honey is the invariable rule whenever no surplus honey is coming in, until all chance of surplus is over in the fall. The combs must always be "sharp." Only young queens are wintered, and new comb is preferred for wintering.

R. Dathe thinks old combs are excellent for wintering, but that the colony develops better in the spring on new combs.

He does not recommend equalizing the force of colonies by exchanging places, for the queen of the weaker colony is too likely to be killed.

An old bee-keeper claims that a sure and speedy cure for robbing is to shut up

and remove the hive, put an empty one in its place, and burn something in it, such as a piece of turf, which will keep it continually filled with smoke. When the robbers give up the matter, the original hive is set back. He says that by this method neighboring hives are not attacked.

To prevent honey in earthen vessels from cracking when the honey granulates, says P. Neumann, push a stick to the bottom of the vessel while the honey is still soft, and withdraw when the honey has become firm. Another plan is to simply turn the vessels upside down.

The Mecklenburg foul-brood law, which has proved of much benefit, would never have become a law, says P. Neumann, had not the Mecklenburg association been for years in the habit of gathering statistics of bee-culture, so that at the proper time it was able to give complete information to the authorities of the extent of bee-culture and the income resulting from it, hence its importance.

The same authority refers to two cases of foul brood in which the cause was "with certainty" traced to the use of foundation made from wax rendered from diseased combs. He does not give the details.

According to the observation of a certain Casiki, all nectars are colorless; and the various tints of honey are due to the action of the fluids of the honey-stomach on the different nectars.

Baron Bela Ambrozy, a Hungarian authority, has always found that the honey-sac of a fanning or "roaring" bee contains thin honey; an indication that the condensation of honey is carried on in the body of the bee.

Dr. Dzierzon thinks that individual bees have no fixed temperature of body; and that it is a waste of time to try to establish it. Unless the outside temperature is high, a bee is dependent upon the cluster for the warmth necessary to its existence; when deprived of that for any great length of time, it perishes.

DENVER, Colo., Dec. 20, 1897.

Bee-Keepers' Review.

PUBLISHED MONTHLY.

W. Z. HUTCHINSON, Editor and Proprietor.

TERMS: - \$1.00 a year in advance. Two copies \$1.90; three for \$2.70; five for \$4.00; ten or more, 75 cents each. If it is desired to have the REVIEW stopped at the expiration of the time paid for, please say so when subscribing otherwise, it will be continued.

FLINT, MICHIGAN. FEB. 10, 1898.

"SOMETHING WITH ITS EARS CUT OFF," is the way Bro. Leahy describes the appearance of the plain section.

SECTION-CLEANERS having a *disk* covered with sand paper, such as E. R. Root says he now has "in his head," are decidedly faulty, writes Mr. Aspinwall; and he promises to tell all about it in the next Review.

T. S. FORD, of Scranton, Mississippi, died last November; as I have just learned by a letter from his son. Mr. Ford was a very pleasant writer, and gave us some of the best articles that have been written on bee paralysis.

AS A WRITER of descriptive prose, especially in regard to travels, I used to think that Mr. Root stood at the head of the bee-keeping editors; and I am still inclined to that opinion; but he must look to his laurels now that Bro. Leahy has started in on that line.

A PURE FOOD CONGRESS is to be held in Washington, on March 2nd. The Bee-Keepers' Union is entitled to send three delegates. It is quite likely that the General Manager will go and probably one or two other members, but at this writing it is not definitely settled as to who will go. The object of this congress is to discuss the need of legislation on the adulteration of foods, and how best to secure it.

MR. J. E. CRANE has a most excellent and readable article in this issue regarding the comparative merits of Italian and black bees. I have only one comment to make, and that is, if the Italians are not superior, how does it happen that they have been so universally adopted and held in such high esteem for so many years?

CONSOLIDATING THE TWO BEE-KEEPERS' UNIONS.

There is an old saying that no question is ever really settled until it is settled *right*; and this saying is well illustrated by this matter of the amalgamation of the two Unions. This matter has been under consideration now for some three or four years, and I believe that it has been earnestly desired by the well informed rank and file of both organizations. This is shown by the vote taken at the last meeting of the California bee-keepers. California is now really the home of the old Union; yet, at the vote just mentioned, forty-three members voted to have the old Union absorbed by the new, and not one voted against it. At the Buffalo meeting the vote in favor of amalgamation was also unanimous. I feel sure that if the matter could now be put to vote, that amalgamation would be carried unanimously. What is there to hinder such a vote being taken now?

"RATHER EXCLUSIVE," is the criticism that one good brother makes on the Review. Then he modifies it by saying that it has "*seemingly* been rather exclusive." He does not think that this has been intentional on my part, and finally closes by saying, "I doubt not but that it is a difficult matter for one to aim at a high standard, and avoid this."

How difficult it is to see ourselves as others see us. This is the last criticism that I should have thought of as being deserved by the Review. My only thought has been to secure the best possible mat-

ter, regardless of persons or whereabouts; and I wish bee-keepers *everywhere* to feel that they have only to send in items of interest to the Review to have them meet a warm welcome. My warmest thanks are extended to the brother who has thus had the kindness, courage and candor to speak his mind—may there be more like him.

MR. ARTHUR L. BOYDEN and Miss Constance M. Root were married February the first, at Medina, Ohio. Miss Root, better known, through Gleanings, as "blue eyes," is a daughter of Mr. A. I. Root; and Mr. Boyden was a Michigan man until he went to work for the A. I. Root Co., several years ago as the right-hand-man of Mr. J. T. Calvert, the business manager. He has been my competitor at several fairs, and I know him as a right royal, good hearted, worthy young man. This is the second daughter of Mr. Root who has been won by a business manager. These young men from the North who go down to Medina and secure positions as business managers, seem to be pretty good managers in more ways than one. I believe Bro. Root has still another daughter, and I sincerely hope that he may so prosper in business as to eventually need another business manager. Joking aside, I wish the young couple every happiness.

MR. DAZENBAKER writes that the slightly ridged appearance of his comb honey came from having the openings in the separators too large. They were 5-16 of an inch. This year they will be only 1-6; and he anticipates no trouble from this source. By the way, Mr. Niver says in Gleanings that he saw Mr. Dazzenbaker have *one* section that had no pop holes in the corners. I know that Mr. Dazzenbaker had one such section *outside* of his case at Buffalo, and it is probable that that is the one Mr. Niver saw, but he had a whole case full of just as nice ones as the one outside. I ought to know, as I bought it of him and carried it around

and exhibited it at all the fairs, and then sold it for 20 cents a pound. There were no pop holes in any of the sections in the case. Mr. Dazzenbaker closes his letter by saying: "I have always considered the Review an excellent journal, but in the last two issues it has fairly surpassed itself. The frontispiece in the January number is worth the price of the paper for a year—it is a chapter in itself."

MR. M. H. HUNT once told me that he could have any section completely filled with comb—no pop holes—by simply fastening the section in the super in such a manner that the bees could pass *all around it*, on every side. I believe that the whole secret, of getting sections completely filled with comb, lies in this one idea—free communication between and among the sections. It is the bees' instinct to have passage-ways among their combs. If man furnishes these passage-ways the bees do not need to leave them around in the corners of the sections. If he does not furnish them, then the bees leave holes where they can pop through.

SHALL WE PRAISE A MAN TO HIS FACE?

Seems to me there is an old saying about praise to the face being open disgrace; and I wish to enter my protest against this sentiment; that probably owes its birth to flattery. When a man has worked hard and accomplished something that is really worthy of praise, I see nothing objectionable, and there may be much good, in letting him know that his work is appreciated. Some people have the happy faculty of bestowing praise in a delicate, tactful way, in a way so "pat" as to add greatly to the enjoyment; as did the little boy who asked a young lady if her eyes were new, and when asked why, replied "because they are so bright." But even if we are not blessed with the happy faculty of saying things in a bright, poetical way, that need not prevent our bestowing praise and encouraging words where we think they are deserved. We

little know how much good a kind or encouraging word may do some fellow mortal. I was led to this train of thought by the following paragraph that I found in a letter recently received from Ernest Root:—

The Review was never quite equal to what it is now. As soon as it came I grabbed it up eagerly, and, although I was busy, I read it clear through before dropping it. I was too interested to let it go. Father picked it off my desk and read it clear through, same as I, and his opinion is the same as mine.

I know that some of us bee-keeping editors have been accused of belonging to a mutual admiration society; which, being translated, means, I suppose, that we admire one another because it is to our *advantage* to do so. I do not believe it. I doubt if any bee-keeping editor ever praised a brother editor upon the principle of "you tickle me and I'll tickle you."

When a man dies we forget his faults, and remember his virtues, and cover his coffin with flowers; let us not withhold our flowers and appreciative words until eyes and ears have passed beyond rejoicing.

WELL FILLED SECTIONS THE RESULT OF
FREE COMMUNICATION RATHER
THAN OF PLAIN SECTIONS.

Last month I expressed my inability to understand *why* more perfect combs should be built in plain sections, but I was satisfied that some factor brought in to use by their adoption did result in the more perfect filling of the sections. Since the January Review has been mailed I have received several letters and articles bearing upon this point. I have an article from a bee-keeper now in Florida, a man who has produced 100,000 pounds of honey in his life time, although all of it has not been comb honey, and he attributes the difference to the free communication established when plain sections are used—but I must not steal his thunder, as I expect to print his article next month. I also have an article from Mr. Doolittle taking still differ-

ent grounds, and actually defending the upper row of sections in the January frontispiece—but I won't "give him away" as I have the Florida man; but, instead, give his article next month. Then I have a letter from a Mr. C. G. Ferris, of New York, that I would like to print, but he expressly said I must not—I have hopes, however, of inducing him to change his mind. But I think I can make room for a portion of a letter just received from Mr. J. E. Crane. It reads as follows:—

The December Review was so fine that I was afraid you would scarcely be able to keep it up to that standard through the year of 1898, but I believe the January number is even better than the December. Perhaps, after all, it is because I am so much interested in the principal subject treated. I have been very much interested in the plain section; and more especially in open separators. I have material on hand for 2,000 plain sections, and 500 open separators; so I can give the subject a careful study and test the coming season. I feel satisfied in my mind that the gain comes principally in the separators being so open that the bees feel as though all the sections in a row are a single comb; or, at any rate, a more desirable place to store their surplus than in the small cubby-holes usually given them.

At our State convention I asked an old bee-keeper, who is a very candid man, and who once used shallow frames, without separators, over the brood-chamber, what he thought the difference in amount of surplus honey would be, or had been with him, between the open surplus clamp and the small sections with separators. He thought the bees stored almost twice as much in the open frames as now in small sections. I guess he over-estimated; but there is evidently a point here of considerable importance. I therefore propose to test the matter quite fully; and shall make a part of my separators in such a way as to give the bees still greater freedom than will the fence with cleats. I shall drive little pins through the slats, in the middle, so as to project enough for a bee-space, and thus keep the sections in place and give the bees a passage-way around the edges of each section; so that four sections will be as a frame extending clear across the clamp. After all, different hives of bees, and different seasons will produce different results. The

frontispiece in the January Review is one of the strongest arguments I have ever seen in favor of the open separator.

By the way, what *splendid* pictures those are in both the December and January numbers—the best I think I have ever seen. That one of foul brood was just *perfect*.—I could almost smell it.

It is now my opinion, that when we get clear down to the bottom facts in this matter, that we shall find that the well filled sections come from the freer communication that is brought in when the plain sections are used. As Mr. Crane puts it, the bees are led to feel that one row of sections is only one continuous comb. But, supposing that it *should* turn out that the securing of these fine combs are the result of the freer communication, I fail to see why the plain section should not be adopted. To my mind it has advantages over the old-style.

A Condensed View of Current Bee Writings

E. E. HASTY.

Blame where you must, be kind where you can,
And be each critic the Good-natured Man.

G. LDSMITH.

NO-O-O, friend Miller, I won't fight it out about assorting those sections at the same time they are being scraped. If Doolittle and Miss Wilson are both to pitch at me at once I'm going to haul off for repairs.

But about eating honey mixed with bits of propolis, that's different. I know in my bones that there are others besides myself that lick fingers and knives when they get to dripping with choice honey. A bee-man's fingers are always encased with propolis, except when he has just been laboriously cleaning them off. He can no more lick his fingers without getting propolis than a sailor could lick his without getting tar. To the world's people, propolis looks dirty; but bee-keepers know very well that it is clean dirt.

Thus it comes about that bee-keepers take within a certain amount of propolis—in addition to one's normal peck of dirt. Propolis has not very much taste—at least what taste it has is not very bad. It seems to be a strong diuretic, and one may easily suspect it of other properties. I only set up a *perhaps* that it bore some part in destroying the honey relish—and guess I won't run away from that perhaps just yet. Whoever doth that boot displace must meet Bombastes face to face.

Chance shots are sometimes very lucky. Once a Syrian common soldier shot an arrow without shooting at anything in particular, and killed the king of Israel. Dr. Miller fires in Gleanings, 79 and 876, to the effect that January brooding is because, the colder it is outside, the more the bees take pains to heat up the inside and so the colder the outside the warmer the inside. Ernest thinks there is something in it; and it certainly does look like a good explanation of a point previously unexplained, why cellar bees sometimes breed less than those out doors. On the whole, perhaps this is nearer to being a well-reasoned-at proposition than a mere chance shot.

Machines to clean off sections are in the wind. I have rather slender faith that any machine which works with sand-paper will keep itself in good working order long enough to pay for the time spent in putting on a new paper. Pulverized propolis is great at gumming up, or cementing up, everything it touches. I find it some trouble to keep a case-knife clean enough to see what it's made of while scraping. And, at its best estate, I have some doubt about the wheel being *very much* quicker than the knife. It will freshen up the surface of the wood, which the knife can not do, and so do a much better looking job than the knife, providing the first difficulty mentioned does not spoil everything.

Yes, brother Bridgen, I made corn-stalk fiddles in my boyhood—no necessity of shipping 'em here from the Carolinas. And now you want me to crouch by a

hive and spend the whole night fiddling for a company that don't want to dance—that perchance they might consent to dance the next day, to escape being fiddled to death. My indolence gets the better of me,—don't believe I'll do it. Say, lets locate a colony by a tiny waterfall, and have a water-wheel geared to fiddle while we sleep. To come out in the morning rubbing my eyes, and find 'em all ready to swarm would be more to my mind. Then I'd be less inclined (or more) to say, "Oh fiddle!" Aside from jokes, perhaps Mr. Pridgen's suggestion, that a cornstalk fiddle gives the *tone* of the queen's piping, may be of value. But I rather think that a tiny cog-wheel wrestling with a tiny splinter would hit the tone more exactly, take less space, and require much less motive power.

That opening photograph in last Review nearly knocks the breath out of me. Almost inclined to take back what I said about the old section being good enough. At first glance I cried out that those four sections up top were not a fair selection, and ran to my old stack of sections for proof. Still think they are a *little* below average; but they're too near it. May be by next month I shall get my second wind enough to "argie;" but just now I shall gasp for breath. Alas, a photo is a tough antagonist to argue against, don't you mind?

PACIFIC BEE JOURNAL.

The Pacific of late has been a monthly paper instead of a quarterly, and a very beautiful little paper too. Still more recently it seems to have had its shawl and kombi blown away by breezes of adversity or something. But breezes do not last forever; and we'll hope that the aforesaid outer integument and inner light will be recovered all right at no distant day. The Pacific has not ceased to be a live paper, as to its internal spirit. The apicultural novelets which were so in evidence the last time the Pacific's turn came in this View have subsided; in fact, they seem to have gone below the bee-

keeping horizon everywhere. May the dew have plenty of time to fall before they rise again.

Editor Bennett thinks three nouns bother our craft very greatly—selfishness—bigotry—pride. The first objects to every move lest somebody not in the ring might get a share of the benefits. The second, on broad general principles, objects to every move whatsoever. The third won't let us live within our incomes—nor retail our own honey—lest we appear too much like the "peddling German Jew." Says he practices what he preaches, drops off the boughten luxuries, and eats honey. Wants all bee men to go and do likewise—be missionaries, first under their own roofs, second to their next neighbors, and then "go ye into all the world, and preach the honey gospel to every creature." All right friend Bennett; reckon I'm with you, if not a little ahead. A chronic half invalid, I'm just now trying desperately to recover the many, many hours that go to waste (or worse) from bodily and mental off-the-track-ness. Concluding that poor digestion is at the bottom of most of it, I am experimenting with several food regimens—and withdrawing from the family table entirely, for greater convenience in taking only just what I decide to take, and especially to get more *time* at meals than current table customs will allow. One of these regimens calls for two meals a day, each to consist of two ounces of granola (made up with half a cup of milk) three ounces crackers, and six ounces candied honey. Another regimen in which *dates* take the place of the granola, and of most of the honey too, shows some signs of coming out a neck ahead. Both seem beneficial; and at present I alternate, first three days of one and then three days of the other. As to the benefit I am getting, I can now read till eleven o'clock in the evening if I want to, instead of speedily falling asleep in my chair.

The first thing I tried was a modification of the Salisbury system—lean flesh and nothing else. In some respects it

helped me evidently; but my weight went down frightfully, nine pounds in six days, and I got so weak that it was soon the alternative, quit or not have strength enough to get around and do necessary chores. Presumably that regimen hit me extra hard because I have been an entire vegetarian for a good many years. Mean to try some more things before I get through.

California has had a bee-keeper in jail for 25 days, for keeping bees where they were not welcome—rather a shock to our free-country nerves. But then he "riled up the animals" by advertising in a newspaper that he would pay ten cents for every colony temporarily brought to the spot. *Pacific Bee Journal*, page 13, January.

Like the Michigan law, the California law, also gives no opportunity to cure foul brood; nothing but compulsory destruction the next night after being discovered. The act has been on the books (and apparently not often visible except on the books) for 15 years. P. B. J., Page 6, December.

On page 12, August number, the editor grows righteously savage over the report, freshly brought in, that one of their California apiarists had produced a crop of six tons without using a knife upon it at all—every pound of it green and uncapped. Advises that such people be arrested on charge of offering for sale a food commodity unfit for human food. Possibly he has set his plane a little too rank to dress the board; but I shouldn't wonder if in the sweet by and by naughty boards would be planed with just that kind of plane. Being a liberal consumer of honey himself, he mentions three recent purchases of his own. Doubtless he exercised some discrimination in buying; but only one lot out of the three came up to his ideal of what honey ought to be.

THE GENERAL ROUND-UP.

It seems that in reviewing the *Busy Bee* (November Review) I made the rath-

er stupid blunder of corraling as editorials some ifs and doubts about sweet clover which were not editorial, but at variance with the editor's opinions. When I get around to the *Busy Bee* again, friend Abbott, better I eat an extra pound of honey to clear my upper story cobwebs out.

I see in Review 27 that our editor mentions me as one of those not favoring an anti-drone crusade. Perhaps I had better state my position a little more clearly. No doubt drones eat ravenously; and the dictum, the more drones the less honey, has good support *on one side*. No doubt the colony is better without drones so long as they *voluntarily* refrain from rearing them. Also I have small hopes that any occult good influence exists whereby the drone benefits the hive. He is an indispensable element of breeding, and not much else. The trouble is, if I understand it, that when the bees take a notion to desire his presence in the hive they positively *won't* feel satisfied without him—won't send out each day the full *new addition* to the honey gathering ranks. The bees that should make their first trip for honey stay at home and devote themselves rather frantically to futile efforts to rear drones—while their keeper devotes himself to futile efforts to prevent the rearing of drones. So I would amend the dictum given above into, "The more of that 'kill my dog and I'll kill your cat' spirit that gets in between bees and keeper the less honey for market." One of the worst results of this unprofitable contest is that the queen will be right into the sections, if she can possibly get there, in search of drone-comb to lay in; and the bees will be more than willing to get it ready for her. I don't want to be compelled to put perforated zinc between brood and sections; and many of our craft are like minded. I don't want to be compelled to fill every section entirely full of foundation. Not so many of the brethren are with me in that, yet quite a sprinkle of them. With my present practice the amount of brood

in sections is so small that the damage can easily be endured. If I followed the orthodox practice in regard to drones I should directly have to do one of those things which I don't want to do at all. Those who raise a great horde of drones score a heavy loss; and those who try to avoid having any drones I accuse of scoring a heavy loss. Where then is the proper middle ground? Mr. Doolittle says leave in the brood chamber 4 to 6 square inches of drone comb. I want quite a bit more than that. Both Mr. Doolittle and myself, I believe, would have all the drone comb in the two outside frames—so there will be no special temptation to rear drones till drones are earnestly wanted.

O. O. Poppleton, A. B. J. 708, found the freight on honey from Cuba to New York 15 cents a hundred, from Florida to New York 85 cents a hundred. Also he hired a very good man in Cuba for 8 dollars a month; to get as good a one in Florida cost 25 dollars a month. In the same article he assails the doctrine, current from Virgil's time till now, that bees store more honey by being kept closely robbed of it. Store fully as much when the hive is nearly full, he thinks. Guess I'll continue to stand in with the old view a while longer. Full hive and extra force of field bees are apt to be found together; and of course that combination can beat any empty hive that Florida or Cuba or any other where can show.

In A. B. J., 722, that good authority, Dr. Brown, goes over the main points of queen rearing. He remarks that the details of the matter are so numerous that no book on the subject can enumerate all. There just must be a man at the job with readiness of tact, and good sense. And the more experience the better of course.

On the next page Prof. Cook answers questions about the wax moth. He feels sure that the moth does not lay on the anthers of flowers—never seen lurking around flowers; always lurking as near combs as possible, in or out of the hive. I find it hard to give this up, because it

is so very often that a solitary cell of pollen in a section of honey hatches out a larva. It is difficult to understand how the moth got there to place the egg; but if bees sometimes gather eggs and pollen together, then what we see is just what we ought to expect. No doubt the usual effort of the moth is to get directly at combs; but I think the professor should allow that possibly sometimes it may accept a big floral anther with ripe pollen as a good enough nidus.

One of the best suggestions yet made as to what to do with an obstinate fertile worker colony is contributed by Bevins in A. B. J., 724. Set a nucleus having a good laying queen close by; and gradually pull the old colony down, and build up the nucleus with the proceeds.

R. L. Taylor put paper bags on hundreds of clusters of grapes to find out about the cracking of grapes in and out of shelter, and also about the hand our beestake in the affair. With the kinds that crack worst the loss was much greater inside the bags than out. The juice from the cracks wrought mischief and decay on surrounding berries inside the bags. Evidently the bees in gathering the juice did less harm than the juice un-gathered did. A. B. J., 758. Perhaps it would be still better to have the wind dry up the escaping juice, and the bees let things alone.

S. A. Niver says about the plain section, and its wonderful no-hole characteristic, that Danzenbaker had *one* with no holes. Niver never saw a second one, and is apparently inclined to hint that nobody else ever did. Gleanings, 81.

Gleanings has a bran new set of department heads throughout, just to keep things looking fresh and bright. Hardly do for me to say the American Bee Journal has a new face. The public might object to such belated news as that. Say, if I get my View so it is somewhere near up to date you may think my food regimens are succeeding; if not, then you may conclude they don't amount to very much.

RICHARDS, Ohio, Feb. 11, 1898.

EXTRACTED.

MANAGING SWARMS FOR COMB HONEY.

Some Comments on the Golden Method.

In this issue of the Review appears an article from Mr. J. A. Golden on his method of managing swarms so as to secure a large crop of comb honey and at the same time prevent any increase. In the American Bee Journal, for February 3, appears a criticism on that plan. It is written by Mr. W. W. McNeal of Ohio, and reads as follows:—

How do you manage to keep pollen out of this double super during the first five days after the swarm is hived? Just why the bees should fill these sections with such choice honey and leave no pollen is decidedly a wrinkle I fail to see. My experience is that bees are inclined to place themselves and their brood between the entrance and the stores. Now, pollen being something that cannot be so easily carried away, is often given a place close to the entrance. This is more noticeable in early spring, and especially so if the frames run parallel with the entrance. The runways provided at the sides of the super may have something to do with it; but why the field-bees, upon their return to the hive, would run up through these to the brood-combs above, and there leave the pollen, returning to the sections below with the honey, is the query with me.

Of the two evils, honey stored in comb built the previous season, and that which is stored in combs built the present season, but containing more or less pollen, I would choose the former for two reasons: 1st. The average consumer of honey would hardly detect the harshness of the comb at all if the precaution had been taken to break away the varnished face of the combs before giving them to the bees. 2nd. But they would detect pollen were it there, and so would the little wax weevil. It is a rare thing to find pollen in sections placed over the brood-combs, save in hives where such room is limited, and when a case of partly filled sections has been given to a swarm newly hived on frames with only starters in them.

I have tried to get a swarm to build comb under nearly the same conditions

that Mr. Golden outlines, but failed in every instance. My hives were prepared thus: If a colony run for extracted honey cast a swarm, I took its surplus cases and placed them over an empty brood-chamber—with starters—with a queen-excluder between the two apartments. Now, if there chanced to be any uncapped brood in these upper cases the bees would sulk until they could cap over some kind of a cell and call it a queen, when the swarm would abscond. Should there be nothing but honey in the combs, they will continue to sulk until something happens. The queen being caged, and the excluder removed, may cause the bees to behave in a vastly different manner, though like a great many other things it does look that way.

Still, I can not see why a colony that does not swarm shouldn't store as much honey as though it did. Of course, if the swarm issues early, and the season be prolonged, then the two may exceed what the one would have done. If we can gain for the colony without its having to swarm, that which is gained by swarming, then wherein does Mr. Golden's method have any advantage? I mean the desire and ability to build comb. Nothing so incites a colony to good work as does the presence of newly-built comb in the hive. To obtain this vantage ground, a frame of comb foundation can be hung in the brood-chamber some little time previous to the giving of the supers, providing the strength of the colony and the state of the weather will permit. Place the frame of foundation between two combs of brood, and in due time follow this up with a super alternated with frames of comb and frames of foundation or starters. A half-depth case is always preferable for the first one given. Sometimes it works better to give a complete case of combs until they been coaxed above, when this can be lifted and a section super placed between. It is always well to look to it that the queen be not in the upper case when raising it, for her presence there would work disastrously; in that the capacity of the small frames would not be equal to the ability of the queen; which would tend to dissatisfaction; and her absence from the combs below would cause queen-cells to be started, and swarming would result. Arranged in this way, a colony can be run for both comb and extracted honey with the incumbrance of a queen-excluding honey-board.

The queen will not pass the section-super to again occupy the upper one, although the queen-cells in this upper case

must be taken away or destroyed as soon as they reach the proper age, or swarming may result just the same as though they had been built below. But how much easier done in the shallow case than in the deep brood-combs, heavy with brood and honey.

You may say, "Why not put on the excluder at the time the combs are given to the bees, and thus prevent the queen ever going there at all?" Well, the point is to get the workers there as quickly as possible; and you all know that if the queen goes there, honey will not be long in finding its way there. So, when the case is raised and an empty one placed beneath it, the presence of brood tends to draw the *hive-force* away from the brood-combs, and lessens the tension there. The field-force will then get a hustle on themselves that tells you something is going to be done. O how they—the *hive force*—then need air! Give it to them, plenty of it, and always from below. Nothing so causes the upward march of the bees to roll back upon the brood-combs as does the giving of cooling drafts of air from above.

I think that when thus managed bees will store as much honey as they will by the Golden method; and without the great danger (so it seems to me) of getting pollen in the sections.

I will here admit that I have never tried Mr. Golden's way, as he arranges and describes, but I intend to do so. Mr. Golden must use a small brood-chamber, and certainly his bees were not started off properly or they would not swarm with but one super partly filled.

I do not see it exactly, that by having a swarm in a double super you get such a large amount of honey that the bees otherwise would have used in building combs for the new hive and storing the same after they are constructed. Let's see. We will suppose a swarm is issuing, or has just issued; I need a few more extracting-combs, or that some I now have are crooked or contain more or less drone-comb, all of which is tolerably new. I cut the comb out, save an inch or so the next the top-bar. These frames are put into a shallow extracting-case, which case is then placed over a similar one though empty; and the two constitute the brood-chamber to the hive the swarm is to occupy. On this I place a slatted queen-excluding honey-board, and then place the section-cases that were on the parent hive. The swarm is to occupy the old stand, the old hive is given a new location, but before doing this, a portion of the yet remaining bees are to be driven

out with smoke. This so weakens them that there is little danger of second swarms. Contract the entrance, and shade the hive well. Now, see here, the presence of the empty super gives sufficient room till the fever subsides; the absence of old brood-combs causes the bees to gather less pollen for the first few days after being hived, and what they do bring in, the narrow strips of drawn comb will catch the most of it by the aid of the honey-board, for a bee can not easily pass through the perforations with pollen on her legs. The brood-chamber is thus left for about a week, when the empty case is to be taken away, the other now being placed on the bottom-board. The hive may now remain until the honey season is over, or the colony may be re-united with the parent colony about the time the extracting-combs are completed.

All this has been done with only supers for a hive, the increase has been kept down, the extracting-combs have been secured, a few choice queens reared, and I think with as much really *marketable* honey as if the swarm had been treated according to Mr. Golden's method. However, I am open to conviction. If it can be shown that the bees *do not* store pollen in the section-comb while the super sits beneath the brood-chamber, then perhaps there is no quicker, nor more profitable way of disposing of a swarm.

It seems to me that others have tried plans similar to that used by Mr. Golden, and that they have abandoned them, but just why I do not recall. I wish that those who have tried this plan or something like it, would report as to their success. The plan followed by Mr. McNeal is practically the one that I follow and advise in *Advanced Bee Culture*.

"FACING" COMB HONEY.

Is Putting the Best Side out, in Crating Comb Honey, a Dishonest or Undesirable Practice?

by outward show let's not be cheated.—647.

Down in eastern New York lives an honest bee-keeper. His name is Aaron Snyder, and his dwelling place Kingston. He has an article in *Gleanings* on "put-

ting the best side out," or "the best foot forward," or whatever it may be called. Putting it mildly, he thinks that this practice is carried too far by many bee-keepers in crating honey for market—but here is what he says:—

I have been buying and selling honey for many years, and can come to no other conclusion, after repeatedly seeing positive evidence, than that bee-keepers who produce comb honey (I will nothing about extracted-honey producers), and crate and market the same, are dishonest. Let me tell you why I have come to this conclusion. Almost every case of comb honey I ever bought has been "faced"—that is, the outside row of sections, next the glass, was nicer than the rows in the middle of the case filled up with inferior quality, and that very act alone, done, too, by the producers themselves, has caused more mischief and done more to lower prices than all other evils combined as regards the standard of comb-honey production.

A few days ago I went into a store in this city to sell some extracted honey. The lady who manages the store used very plain language in telling me that all honey-men were frauds. I tried to convince her my honey was pure and all right, which it was; but she would not listen to me. She then called my attention to a case of comb honey she had lately bought, saying: "Just look at that case of honey over there on the counter;" and added that if we bee-keepers would cheat in comb honey we would cheat in extracted honey too, and gave me to understand that she wished me to leave the store. This lady had bought what she supposed to be a case of nice honey. The outside rows were very nice, but the middle ones were very inferior. She said she would never buy any more honey of that house, meaning commission man; but don't you see the commission man was not so very much to blame? Most likely he had never opened the case, supposing it was put up honestly, and *knowing* that it should have been; and now don't you realize the whole blame rests on the man who crated the honey? He was dishonest. Grocers the world over are finding fault with us bee-keepers for putting up honey as we do. They call us frauds, dishonest, slick article, and the like. It is a shame that we as a great army of men must be looked upon as frauds, humbings, dead beats, etc.; but there is no one to blame but ourselves. We deserve just what we are getting, and shall, so long as we continue to practice fraud and de-

ception in trying to pull the wool over our neighbors' eyes in order that we may get a few more cents than honestly belong to us, while, in fact, we are getting less and less all the time, just because honey-buyers can not trust us. It's on the same principle of the farmer putting up apples when he puts a few nice ones in the bottom of the barrel then fills it up about two-thirds with little ones, then tops it off with the very best. Don't you see? Then he laughs to himself to think how nicely he has cheated some one; but, instead he has cheated himself.

I know a farmer who several years ago had a lot of poor bog hay, and conceived the idea that he would bale it up in such a way that it would sell for first quality; so he engaged a man to "fix it up" by wrapping good hay all around the poor bog hay when baling it, putting the bogs entirely out of sight. This man shipped the hay to New York for sale, and in a few days had to pay a very nice sum as damages in order to avoid being arrested for fraud. It served him just right. He ruined his reputation as a man, and just so we bee-keepers are ruining our reputations as men. Away with such business!

I should like to mention one more case. Not long ago I drove out of town to a bee-keeper's place to buy some comb honey. I got a few cases picked out, then, looking up, saw a case on a shelf that looked very nice, and asked if I could have that. He said, "No. That is some very nice sections I have assorted out to face up with." Now, brother bee-keepers, what do you think of this kind of business? I won't mention this man's name, but he lives eleven miles north of Kingston, N. Y.; and if he should see this in print it might do him good.

Kingston, N. Y.

The editor of *Gleanings* gives expression to his views in the following language:—

[Mr. Snyder's arraignment of bee-keepers seems a little severe. I can not think that even a majority of our fraternity are guilty of some of the things that he so justly condemns. However that may be, I am afraid there is truth in much that he says—seldom smoke without some fire. It is certainly true that commission men are not entirely to blame for some of the difficulties that arise between them and bee-keepers.

It is easy—oh, so easy!—to face cases of comb honey. I do not think bee-keepers have any intention whatever of deceiving when they unconsciously, on seeing a nice box of honey, put it next to the glass. They do not put it there because

they wish to convey the impression that all the honey which shows is of that character, *but* because the honey is beautiful, and they wish to put it where its *beauty* can show. We have had several lots of comb honey shipped us lately from different bee-keepers from widely separate localities, but I do not think there was any evidence of "facing" in any of the lots that were sent to us.

If bee-keepers are guilty of this one sin they are no worse than farmers. A year or so ago I was in one of our large commission houses when a carload of apples was received and opened. As a lid was lifted off I remarked, "My! what beauties!"

"Oh! they will not look like that all the way down," said the clerk with a smile.

"Why not?" said I.

"Because they never are," he replied.

"But don't your customers soon learn that, and find fault?"

"Not a bit. They *expect* it."

"I do not see how that can be," I said.

"If I were buying apples that stood in front of your store, I should want to know how they would run *clear through* the barrel; and I should expect the *center* of the barrel to average with the *top*."

"You do not understand," said the clerk. "Our customers chiefly are grocers, or at least those who buy to sell again. They *want* their barrels faced."

I did not say any thing further; but upon a moment's reflection I made up my mind that some one somewhere at the end of the route made "a kick" at such a species of dishonesty, or that even the consumer had learned to expect (because he had to) that the apples in the center of the barrel he buys are poorer than those at the top, or "facing," by about 25 or 50 per cent.

I wonder if it is possible that commission men *expect* to have their cases of comb honey faced. I wonder, too, if it is also possible that their customers, their grocery trade, also demand it. I can hardly credit it, for the great majority of comb-honey buyers pull out a section or two at random, and by these *random sections* the valuation of the honey is gauged, rather than by the "facing" behind the glass.

It seems to me it would do no harm to have this subject aired out a little. If we bee-keepers are culpable, let's hold up our hands, and confess. If we are not, then let us know the exact condition of things, both from the commission man's standpoint and that of the bee-keeper. It is a sort of family affair, you know, and we might just as well talk plainly among

ourselves if the talk will result in good, as I have every reason to believe it will. —ED.]

I have visited few places that I enjoyed more than South Water street, Chicago. The profusion of products, and the neat, attractive and tempting manner in which they are put up and displayed, challenge the admiration. I have seen those same barrels of apples that Bro. Root mentions. The apples all of good size, laid exactly the same side up, and in circles. If I had been buying one of those barrels of apples, I should not have expected that *all* of the apples in the barrel were as nice as those on top. I did not suppose that *any* one expected such results. But I should expect *fair* fruit. I look at it about like this: After the apples have been sorted, and the culls thrown out, let a barrel of apples then be placed on a table, or other convenient spot, and then the nicest ones *in that barrel* may be picked out and placed at the ends. I think that this is *about* what is done. For a man to go through his crop of apples and sort out the very best, and use these for "facing" his barrels of culls, would not only be dishonest, but also very foolish. It would certainly bring him trouble, as did the marsh hay in the center of the bales bring trouble to the man who put it there.

On many of the street corners of Chicago may be found fruit stands. At these places we will find the apples polished until they shine, and the *rosy* side of the apple is *always* placed uppermost. Not only this, but some kinds of fruit are covered with some kind of thin fabric, something like mosquito-netting, and care is taken to choose just the right color to heighten the effect of the natural beauty of the fruit. If we go into a butcher-shop we will see pieces of meat lying on the table, and they are all so turned as to show a nice, clean, *lean* side. Pick up one and turn it over, and we may find that the other side is about all fat, or half bone. But there is no use of multiplying examples. The whole world has been putting the best side out so long that i

is no longer a deception. Perhaps I am not competent to say whether it is right or wrong. I will say this much: I do it, and if I thought it were wrong I would not do it. As I said about the apples, so I say about the honey. It ought to be graded, and graded honestly. I think there ought to be three grades; fancy, No. 1, and culls. Now, let us suppose that the honey is graded, and we are crating the fancy. We take out enough sections to fill a case. Now I believe that it is perfectly right, legitimate and honest, to select from *that case* of sections, those that are the best, and put them next the glass—yes, and turn the best sides out at that. But to face No. 1, or culls, with fancy, I believe not only wrong, but very unbusiness-like. In fact, I believe that whatever is wrong or dishonest, is a very foolish thing to do, even from a business standpoint. If there are any of my readers who do not agree agree with me, now is their chance.

Honey Quotations.

The following rules for grading honey were adopted by the North American Bee Keepers' Association, at its Washington meeting, and, so far as possible, quotations are made according to these rules:

FANCY. All sections to be well filled; combs straight, of even thickness, and firmly attached to all four sides; both wood and comb unsoiled by travel-stain, or otherwise; all the cells sealed except the row of cells next the wood.

No. 1.—All sections well filled, but combs un- even or crooked, detached at the bottom, or with but few cells unsealed; both wood and comb unsoiled by travel stain or otherwise.

In addition to this the honey is to be classified according to color, using the terms white, amber and dark. That is, there will be "fancy white," "No. 1 dark," etc.

CHICAGO, Ill.—Demand slow for comb. Extracted sells promptly. We quote as follows: Fancy white, 11; No. 1 white, 10; No. 1 Amber, 8 to 9; No. 1 dark, 5 to 7; White, extracted, 5 to 6; Amber and dark, 4 to 4½; Beeswax, 27.

S. T. FISH & CO.,
Jan. 6. 189 So. Water St., Chicago, Ill.

CLEVELAND, OHIO. We quote as follows: Fancy white 12 to 13. No. 1 white, 11 to 12; fancy amber 9 to 10; No. 1 amber 8 to 9; Fancy dark, 7 to 8; white, extracted, 6½; amber 5½; beeswax, 28.

A. B. WILLIAMS & CO.,
Nov. 22. 80 & 82 Broadway, Cleveland, O.

CHICAGO, Ill.—We quote as follows: Fancy white, 11; No. 1, 9 to 10; Fancy Amber, 8; No. 1, Amber, 7; White, extracted, 5 to 6; Amber, 4 to 5; Dark, 4; Beeswax, 26 to 27.

R. A. BURNETT & CO.,
Jan. 7. 163 So. Water St., Chicago, Ill.

KANSAS CITY.—The supply of both comb and extracted honey is large, and the demand light. We quote as follows: Fancy white 10; No. 1 white, 9; Fancy amber, 8; No. 1 amber 7; white, extracted, 5 to 5½; amber, 4 to 5; dark, 4; beeswax, 20 to 22.

C. C. CLEMONS CO.,
Feb. 10. 521 Walnut St., Kansas City, Mo.

BUFFALO, N. Y. There is quite a good trade in strictly fancy, 1-lb. sections; but other grades are very quiet and require pushing, and the cutting of prices, to move them; but they can be sold as quoted. We quote follows: Fancy white, 10 to 11; No. 1, white, 9 to 10; fancy amber, 7 to 8; No. 1 amber, 6 to 7; fancy dark 6 to 7; No. 1 dark, 5 to 6; white extracted, 5½ to 6; amber, 4½ to 5; dark, 4 to 4½; beeswax, 27 to 28.

BATTERSON & CO.,
Jan. 10. 167 & 169 Scott St., Buffalo, N. Y.

NEW YORK. We have had a good trade in comb honey the past week. Fancy white is in demand. Our stock of fair and mixed honey is working down very well. Extracted honey is selling well. Fancy white clover and basswood find ready sale. We quote as follows: fancy comb honey, 11½ to 13½; fair grades, 9 to 10; buckwheat and mixed, 6½ to 7; Extracted, California, white, 5 to 5½; amber, 4¾ to 5; white clover and basswood, 5¼ to 5½; buckwheat, 4 to 4½; southern, 50 to 55 per gal.; beeswax finds ready sale at 27 to 28.

FRANCIS H. LEGGETT & CO.,
Jan. 21. W. Broadway, Franklin & Varick Sts.

NEW YORK, N. Y. Demand for comb honey is rather slow, especially for off grades, white and dark; and, as we have a large stock of these we do not advise shipping for the near future. Our stock of fancy white is light and such would find ready sale at quotations. Our market for extracted buckwheat will open up shortly and we would advise bee-keepers to ship this along now. Beeswax steady. We quote as follows: Fancy white, 11 to 12; No. 1, White, 10; Fancy Amber, 9; No. 1, Amber, 8; Fancy Dark, 7; No. 1 Dark, 6; White, extracted, 5 to 5½; Amber, 4½ to 4¾; Dark, 4 to 4½; Beeswax, 26 to 28.

HILDRETH BROS. & SEGELKEN,
Jan. 7. 120 & 122 West Broadway New York

WM. A. SELSER,
10 VINE ST., PHILA., PENN.

White Clover Honey Specialist.

Root's make, **Section Machine** and Grooving Machine, complete, for sale at a bargain. GEO. RALL MFG. CO.,
2-98-11 Galesville, Wis.



Bee-keepers in the Northwest

Can save money and freight by getting their supplies from the Minn. Bee-keepers' Supply Mfg. Co., Nicollet Island Power Building, Minneapolis, Minn. They have all the latest and most improved machinery and manufacture and handle a full line of supplies. Send for catalogue before ordering.

Please mention the Review.

Extracted

Honey Wanted.

If you have any extracted honey for sale, send sample and price to W. D. SOPER, 2 98-tf Jackson, Mich.

Please mention the Review.

Root's Goods,

At wholesale and retail. Honey is cheap, and, to be successful, goods must be bought at the lowest possible price. I can help you in this. Try it, by sending a list of what you want—you will get prices by return mail. Large, Illustrated Catalog, full of information, free. Bees-wax wanted in exchange for goods, or cash, at best prices. 2-98-tf

M. H. HUNT, Bell Branch, Mich.

Please mention the Review

Now is the time to order your supplies, bee-hives, sections, foundation, smokers, and everything that is needed in the Apiary at prices that are right. Send for circular W. H. BRIGGET, Mazeppa, Wabasha county, Minn.

Please mention the Review

To stick things, use MAJOR'S CEMENT. Beware!!! Take no substitute. 2 98-12t

JOHN F. STRATTON'S CELEBRATED



MANDOLINS,

Importers of and Wholesale Dealers in all kinds of MUSICAL MERCHANDISE, 811, 813, 815, 817 East 9th St., New York

Bee keepers should send for our

'97 CATALOG.

We furnish a full line of supplies at regular prices. Our specialty is Cook's Complete hive. J. H. M COOK, 62 Cortland St., N. Y. City

Franklin House DETROIT, MICH.

Cor Bates and Larned sts Very central. Elevator service steam heat, electric lights, tile floors, etc. Rates \$1.50 to \$2 per day H.H. JAMES & SONS, Props.

The Land of Honey, The Italy of America!

Send for a copy of the PACIFIC BEE JOURNAL: 365 E. 2nd St., Los Angeles, California.

Please mention the Review

Advertisement for John A. Salzer Seed Co. featuring a man pointing and a list of seeds for 14 cents. Includes prices for various seed varieties like Early Spring Turnips, Earliest Red Beets, Bismarck Cucumber, Queen Victoria Lettuce, Landyke Melon, Jubilo Giant Onion, and Brilliant Flower Seeds.

JAPAN PLUM TREES! Large stock of best varieties at lowest rates. Full assortment of Fruit and Ornamental Trees and plants. Correspondence solicited from parties who intend planting large orchards. Get our prices before ordering elsewhere. We can save you money. Send for our new Spring Catalogue it is free. Established 1869. Over 150 Ac-es. Address THE GEO. A. SWEET NURSERY CO. Box 1165 Dansville, N. Y

DADANT'S FOUNDATION

BY THE NEW WEED PROCESS

Has no superior because it is made in the best possible manner, upon the best machines, and from the best wax—that from which all foreign substances, such as pollen, bee glue, dirt, iron from boilers, burnt wax and soot have been removed; and that, too, without the use of acids. These foreign matters make the foundation offensive to the bees and decrease its tenacity. Every inch of foundation is guaranteed to be equal to the sample which will be sent upon application.

LANGSTROTH ON THE HONEY BEE, Revised, Smokers, Sections, Tin Pails, and other Supplies. Send for Circular. CHAS. DADANT & SO., Hamilton, Ills.

4-96-12t

Please mention the Review



See That Wink?

Bee Supplies. Root's goods at Root's prices. **POUNDER'S HONEY JARS**. Prompt service. Low freight rates. Catalog free. **WALTER S. POWDER**, 162 M 88 Ave., Indianapolis, Ind., the only exclusive bee supply house in Indiana.

"WORTH POWDER'S AD"

Farm Bee - Keeping.

The only bee paper in the United States edited in the interests of the farmer-bee-keeper and the beginner is the **Busy Bee**, published by **EMERSON T. ABBOTT**, St. Joseph, Mo. Send for free sample copy NOW.

CLOVER SEED

Largest growers of Grass and Clover Seeds in America. 5000 acres. Our Grass Mixtures last a lifetime. Meadows sown in April will give a rousing crop in July. Prices dirt cheap. Mammoth catalogue and 11 pkgs. Grass and Grains free for but 1 cc. postage. Catalogue alone, c.

JOHN H. SALZER SEED CO., La Crosse, Wis

BEESWAX EXTRACTORS.

The only extractor in the world that will extract all of the wax from old combs rapidly by steam. Send for descriptive, illustrated catalogue to **C. G. FERRIS**.

4-96-tf

South Columbia, N. Y.

THE MONITOR PAPER FILE

Binds securely and neatly all periodicals. Preserve your papers, magazines, pamphlets, bulletins, music &c., by binding them together as you get them. Each new number filed quickly and easily. Will bind 52 numbers of any periodical aggregating 1000 or fewer pages. All lengths from 6 to 28 inches. Light and handsome. **PRICE.**—All sizes 12 inches and under 12 cents; over 12 inches one cent per inch. When wanted by mail add one cent for each 5 inches or fraction thereof.

For sale by the Publisher of this paper

PATENT WIRED, COMB FOUNDATION

HAS NO SAG IN BROOD FRAMES.

Thin, Flat Bottom Foundation

HAS NO FISHBONE IN SURPLUS HONEY.

Being the cleanest, it is usually worked quicker than any fdn. made.

J. VAN DEUSEN & SONS,
(SOLE MANUFACTURERS),

1-93-tf Sprout Brook, Mont. Co., N. Y.



Please mention the Review.

Best on Earth. 19 Years Without a Complaint.



	largest smoker made	4 inch stove	Dozen	Each
Smoke Engine			\$63.00—	mail, \$1.50
Doctor	3 1/2	"	9.00—	" 1.10
Congregator	3	"	6.50—	" 1.00
Large	2 1/2	"	5.00—	" .80
Plain	2	"	4.75—	" .70
Little Wonder (wt. 10 oz.)	2	"	4.50—	" .60
Honey Knife			6.00—	" .80

For further description, send for circular.

T. F. BINGHAM, Farwell, Michigan.

Sections!

We make millions of them yearly; workmanship, smoothness and finish can't be better. The basswood grows right here. If you want some good *Shipping Cases*, you can get them of us. A full line of *Bee Supplies* on hand. Write for illustrated catalogue and price list, free.

Marshfield Mfg. Co., *Marshfield, Wis.*

1898 Queens 1898 Camera for Sale.

For Business—Queens for Strong Colonies. Queens for large surplus. Competition in Quality, but not in price.

If you want queens, nuclei or supplies at bottom prices, send for my illustrated price list. 12-97-tt

J. P. H. BROWN, *Augusta, Ga.*

I have several hundred

QUEEN CAGES

of different styles and sizes, made by C. W. Costello, and I should be pleased to send samples and prices to any intending to buy cages.

W. Z. HUTCHINSON, *Flint, Mich.*

By the way of a "dicker" I have come into possession of a most excellent 5x8 camera and the accompanying outfit, that I would like to sell. The following is a list of the articles and what they cost when new.

Camera and Lens	\$25.00
Tripod	3.00
Plate holders (three at \$1.50)	4.50
Pneumatic Shutter	4.50
Focusing Cloth35
Developing Tray75
Inside Kit for making 4x5's25
The following books:	
Pictorial Effect in Photography	\$1.50
Photographic Instructor	1.50
Picture Making by Photography	1.00
Total	\$42.35

Everything is in strictly first class condition, just exactly as good as new, but I got the outfit at a bargain, and am willing to sell it at the same, if I can get it into cash. **\$20.00** will buy the entire outfit. I have used the instrument enough to know that it will do excellent work—in fact, I will send a sample of the work to anyone who really wishes to buy.

W. Z. HUTCHINSON, *Flint, Mich.*

How to manage bees? Send for our 26
Illustrated Catalog - It tells you all
about hives, frames, sections, feed queens,
&c. The best and cheapest goods -
JOHN NEBEL & SON, HIGH HILL, MO.

Our basswood lumber is *white as snow*, our machinery *up to date*, and we can furnish the *finest*

One - Piece Sections

in the market, Price list and sample section free. Special prices on large quantities. **ONE-PIECE SECTION CO.,**

PRAIRIE DU CHIEN, WIS.

The Progressive Bee-Keeper

Is a 28-page monthly bee journal published at Higginsville, Mo.; price, 50c per year. With the year of 1898, we begin the eighth volume; hence it is past the experimental stage. **R. B. Leahy** and **G. M. Doolittle**, editors. Some of the features of 1898 will be a continuation of **Wayside Fragments**, by **Sommambulist**. **Experience and its Lessons**, by **R. C. Aikin**. This series of articles will be reviewed by Mr. Doolittle, which is practically giving *his* experience with its lessons. "Experience" and its lessons, as reviewed, will be a gold mine for beginners and advantageous to those more advanced in bee culture. The **Sommambulist** articles are written in a pleasing style, as none but **Sommy** could write them. They are highly entertaining and instructive. **Dr. C. C. Miller**, and other popular writers also contribute to its columns. The **PROGRESSIVE** is a popular journal at a popular price. Printed in the highest art, on beautiful paper. Fearless in its character, newsy in its contents, and artistic in its make-up. Remember the **PROGRESSIVE BEE-KEEPER** is but 50c per year. The **PROGRESSIVE** and that "one only" book for beginners, the **Amateur Bee-Keeper**, by **Prof. J. W. Rouse**, both for 65c. A sample copy of the **PROGRESSIVE** for your name, and a beautiful illustrated catalogue of apianian supplies for the asking. Address,

Leahy Mfg. Co., Higginsville, Mo.

Bees Scooped!

I have at last succeeded in buying all the bees within 2½ miles of my home apiary. This practically gives me a clear field for breeding pure Italian queens. I have had over twenty years' experience in breeding and experimenting with Italian queens and bees, and I now breed "for business" from my own importations. Poor stock is costly as a gift.

One colony of Italians in single story, 8-frame, D. T. hive, \$6.00; 5 colonies, \$27.50; 10 colonies, \$50.00; one frame nucleus, \$1.00; two frame, \$1.75. Select the queen wanted and add price to the above. During March and April, one tested queen, 2.00. Select tested queen, \$3.00. After May 1st, one tested queen, \$1.50; 3 for \$4.00; 6 for \$7.50; select tested, \$2.50. Untested queens as early as the season will permit of their being reared, one for \$1.00; 3 for \$2.25; 6 for \$4.00; 12 for \$6.75.

JOHN M. DAVIS,

2-95 12

Spring Hill, Maury Co., Tenn.

Please mention the Review

Muth's HONEY EXTRACTOR PERFECTION Cold-Blast Smokers

Square Glass Honey Jars, Etc.

For Circulars, apply to CHAS. F. MUTH & SON, Cor. Freeman & Central Aves., Cincinnati, O. Send 10c. for Practical Hints to Bee Keepers.

1 57-11

Please mention the Review.

Good Queens,

Either three-banded or golden sent promptly. Two different yards. Circular free. Am a member of the National Queen Breeders' Union. 2-95-11

J. B. CASE, Port Orange, Fla.

Please mention the Review

Violin for Sale.

I am advertising for the well known manufacturers of musical instruments, Jno. F. Stratton & Son, of New York, and taking my pay in musical merchandise. I have now on hand a fine violin outfit consisting of violin, bow and case. The violin is a "Stradivarius," Red, French finish, high polish, and real ebony trimmings, price \$14.00. The bow is of the finest snakewood, ebony frog, lined, inlaid (pearl lined dot) pearl lined slide, German silver shield, ebony screw-head, German silver ferules, and pearl dot in the end, price \$2.50. The case is wood with curved top, varnished, full-lined, with pockets, and furnished with brass hooks, and handles and lock, price \$3.50. This makes the entire outfit worth an even \$20.00. It is exactly the same kind of an outfit that my daughter has been using the past year with the best of satisfaction to herself and teachers. Her violin has a more powerful, rich tone than some instruments here that cost several times as much. I wish to sell this on fit, and would accept one-half nice, white extracted honey in payment, the balance cash. It will be sent on a five days' trial, and if not entirely satisfactory can be returned and the purchase money will be refunded.

W. Z. HUTCHINSON, Flint, Mich.

G. M. LONG, Cedar Mines, Iowa, manufacturer of and dealer in Apiarian Supplies. Send for circular. 1-96-6

Please mention the Review

START IN BUSINESS!

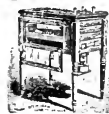

HATCH THOUSANDS
WITH THE PRAIRIE STATE

INCUBATOR

200 FIRST PREMIUMS.

PRAIRIE STATE INC. CO.
HOMER CITY, PA.

SEND FOR CATALOG.

Please mention the Review

WRITE US

Before ordering your sections and we will give you **BOTTOM PRICES** on the

"BOSS" ONE-PIECE SECTIONS,



Also D. T. HIVES, SHIPPING CRATES and other Supplies.

We have everything in tip-top order, and can fill orders on short notice. Let us hear from you for prices.

J. FORNCROOK & CO.,

Jan. 1st, 1894.

Watertown, Wis.

Please mention the Review

Make Your Own Hives.

Bee-Keepers

Will save money by using our Foot Power Saw in making their hives, sections and boxes.

Machines on trial.
Send for Catalogue.

W. F. & JNO. BARNES CO.,

384 Ruby St.,

Rockford, Ills.

2-96-12

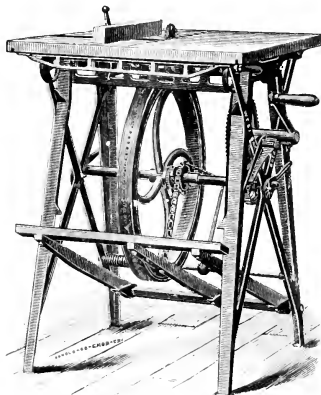



Bee-keepers in the

Northwest

Can save money and freight by getting their supplies from the Minn. Bee-Keepers' Supply Mfg. Co., Nicollet Island Power Building, Minneapolis, Minn. They have all the latest and most improved machinery and manufacture and handle a full line of supplies. Send for catalogue before ordering.

Please mention the Review.

Root's Bee-Supplies,

Shipped from Jackson at Root's prices. Honey bought and sold. White, Plymouth Rock chicks and eggs for sale. Send for prices.

W. D. SOPER, Box 565
Jackson, Mich.

2-98-tf

Root's Goods,

At wholesale and retail. Honey is cheap, and, to be successful, goods must be bought at the lowest possible price. I can help you in this. Try it, by sending a list of what you want—you will get prices by return mail. Large, Illustrated Catalog, full of information, free. Bees-wax wanted in exchange for goods, or cash, at best prices.

2-98-tf

M. H. HUNT, Bell Branch, Mich.

Please mention the Review.

Now is the time to order your supplies, bee-hives, sections, foundation, smokers, and everything that is needed in the Apiary at prices that are right. Send for circular W. H. BRIGHT, Mazeppa, Wabasha county, Minn.

Please mention the Review.

To stick things, use MAJOR'S CEMENT. Beware!!! Take no substitute.

2-98-12t

JAPAN PLUM TREES! Large stock of best varieties at lowest rates. Full assortment of Fruit and Ornamental Trees and plants. Correspondence solicited from parties who intend planting large orchards. Get our prices before ordering elsewhere. We can save you money. Send for our new Spring Catalogue—it is free. Established 1869. Over 150 Ac. es.

Address **THE GEO. A. SWEET NURSERY CO.** Box 1165 Iansville, N. Y.

JOHN F. STRATTON'S CELEBRATED



MANDOLINS,

Importers of and Wholesale Dealers in all kinds of
MUSICAL MERCHANDISE,
811, 813, 815, 817 East 9th St., New York

Bee keepers should send for our

'97 CATALOG.

We furnish a full line of supplies at regular prices. Our specialty is Cook's Complete hive.
J. H. M. COOK, 62 Cortland St., N. Y. City

Franklin House DETROIT, MICH.

Cor. Bates and Larned sts. Very central. Elevator service, steam heat, electric lights, tile floors, etc. Rates \$1.50 to \$2. per day. H. H. JAMES & SONS, Props.

The Land of Honey. The Italy of America!

Send for a copy of the **PACIFIC BEE JOURNAL**: 365 E. 2nd St., Los Angeles, California.

BUY NORTHERN GROWN SEEDS

FARM SEEDS

Salzer's Seeds are Warranted to Produce.

E. Walter, Le Roy, Pa., astonished the world by growing 250 bushels Salzer's corn; J. Bredler, Mishkott, Wis., 173 bush. barley, and P. Sinnok, Randolph, Iowa, by growing 196 bush. Salzer's oats per acre. If you doubt, write them. We wish to gain 100,000 new customers. Hence we send on trial

10 DOLLARS WORTH FOR 10c.

11 pkgs. of rare farm seeds, Hog Pea, Sand Vetch, etc. Wheat, Sheep Rape, Jerusalem Corn, etc., including our mammoth Seed Catalogue, telling all about the \$500 gold prizes for best income for our new marvelous corn and oats, "Prodigies," also sample of same, all mailed you upon receipt of but 10c. postage, positively worth \$10. to get a start. 100,000 bbls.

Seed Potatoes at \$1.50 a bbl.
3 pkgs. earliest vegetable seeds. \$1.00.

Please send this adv. along.

JOHN A. SALZER SEED CO. LACROSSE WIS.

Catalog alone, 6c. No. 86

We are the People

Who can turn out *Fences* (Cleated Separators) and *Plain Sections* (Sections Without Insets)

— For 1898. —

Having special appliances and machinery, we can make them right. Nothing in late years has seemed to stir up such a furor in the Bee-Keeping World as these new goods. If you don't know about them, send to

The A. I. ROOT CO., Medina, Ohio.

New 1898 Catalog, largely re-written, now out.

Our Prices are worth looking at. We are making the new

Champion Chaff Hive

with dovetailed body and supers and a full line other Supplies, and we are selling them **CHEAP**. A postal sent for a price list may save you \$ \$ \$ \$.

R. H. SCHMIDT & CO.,
Box 187 Sheboygan, Wis.

Please mention the Review.



4-97 12

JOHN PATTERSON, England, Pa., is an American, 23 years of age, has had three years experience in the apiary, and would like to secure a position the coming season in an apiary or on a fruit farm. Is teaching school at present, but will be free by March 1st. Can give references.

Please mention the Review.



\$100

Given as **Bounties** to purchasers of the improved Danz. Hives and Sections. See schedule in my bee-book "Facts About Bees." Tells

how to produce honey that sells for the most money. Free for 2c in stamps. Address

THE A. I. ROOT CO., Medina, Ohio,
or F. DANZENBAKER, Box 466, Washington, D. C.

Please mention the Review.

QUEENS

Either Golden or Imported, by return mail. Untested, 75c; tested, \$1.00; breeders, \$2.00.

6-97-1f

W. H. LAWS, Lavaca, Ark.

Sweet Clover Seed.

We have about 3,000 lbs. of sweet clover seed, (of the white variety) that we offer for sale at the following prices:

25 lbs. \$2.25; 50 lbs., \$4.00; 100 lbs., \$7.50.

BERFCH & FLIEMAN, Holland, Mich.

COMB

FOUNDATION

WHOLESALE AND RETAIL.

Working wax into foundation, for cash, a specialty. Hives, Sections, and a full line of Supplies. The best of everything. Write for Catalog, with prices, and samples of Foundation and Sections. Beeswax always wanted for cash or trade.

GUS. DITTMER,

10-97-12f

Augusta, Wis.

The A. I. Root Co.'s Goods, WHOLESALE AND RETAIL.



A Grove of Sugar - Maples in Full Bloom.

The Bee-Keepers' Review.

A MONTHLY JOURNAL

Devoted to the Interests of Honey Producers.

\$1.00 A YEAR.

W. Z. HUTCHINSON, Editor and Proprietor.

VOL. XI. FLINT, MICHIGAN, MAR. 10, 1898. NO 3.

THE SUGAR-MAPLE.

Its Value as a Honey Producer; Also Some Reminiscences of the Editor that Cling About this Beautiful Tree.

W. Z. HUTCHINSON.

All the air is full of spring,
Full of warblers on the wing—WARMAN.



"W. Z." at 18.

of bees on the wing, we bee-keepers know that activity has commenced again in the hive; that the workers are bringing water, and foraging far and near that they may bring home the few grains of pollen that will show that spring is really here. By the way, is there a more cheering

sight to a bee-keeper than the first bee that he sees in the spring loaded with pollen, as it pushes its way energetically into the hive—a beautiful harbinger of spring.

The dainty white clover and the gorgeous basswood furnish us our great crops of surplus honey; but they might bloom in vain, so far as profit to us is concerned, were it not for the flowers that bloom in the spring and thus lay the foundation for the great army of workers that gather the harvest in June and July. In many localities there is no early honey-flow greater than that from the sugar-maple. I well remember the first bees that I kept twenty-two years ago. They were in box hives—four colonies—and we transferred them in our kitchen, when the sugar-maples were in bloom. I can remember how well the combs were filled with a bright golden honey—much of it unsealed. I can remember a few other things. For instance, that we began the work of transferring at ten o'clock and finished at four, that there was a very much mussed up kitchen and two very tired folks. The old hives and odds and ends were carried off several rods, and left for the bees to clean them up, but they paid very little attention to them—the yield from the maple was so good. Fruit bloom came from ten days to two

weeks later, but the yield was not to be compared to that from the maple.

The sugar-maple, with its clean, thrifty look, graceful proportions, and soft gray, corrugated bark, is always a beautiful tree; but it is doubly so when in bloom. The blossoms hang from long golden threads; and a tree in full bloom looks as though each twig were a festoon of silken floss as bright in color as a canary's wing.

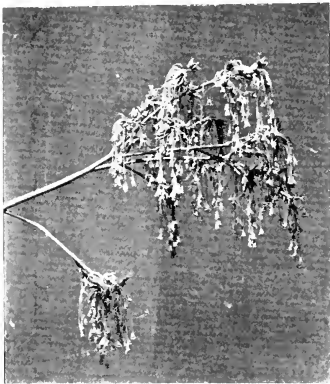

A MAPLE SPRIG IN BLOOM—ONE-FOURTH NATURAL SIZE.

Shortly after the appearance of my bee-keeping article in the *Cosmopolitan*, in 1895, Mr. J. E. Crane suggested that I write another article about the honey resources of the country; illustrating it with photographs of the plants and trees while in bloom. Since then I have been making photographs with this object in view. When it came to getting a photograph of sugar-maple, I had no difficulty in deciding upon what spot it should be taken. Of course, there were plenty of maples near by, a whole row of them right in front of my home, but I wanted a typical "sugar-bush," and I remembered a point on the "river-road" to Flushing (a town where a certain young lady lived years ago) where the road passed through a

piece of woods in which nearly all of the trees were maples. The picture as taken appears as a frontispiece to this issue of the *Review*.

I remember the morning when a photographic friend (is that a correct expression? I'll risk it any way) and myself drove out to take the picture. The grass was beginning to show green by the roadside, farmers were busy with their plowing, young lambs frisked by the side of their sedate mothers, and children were on their way to the school house on the hill overlooking the river, while my companion, whose mind is of a scientific, philosophical, speculative bent, enjoyed himself weaving theories to an appreciative listener.

I once showed this picture to a compositor in the *Review* office, a young man who had worked more or less in Flushing, and he at once exclaimed: "Why I know that piece of woods. That's Schram's sugar-bush. It's about two miles this side of Flushing."

The picture would lead one to believe that the trees were in leaf; but such is not the case. An occasional tree may have a few leaves that are just beginning to show, but the great mass of what appears like foliage is simply bloom.

Among my earliest recollections is that of standing at the window of a log house about which the forest stretched away for miles, and seeing my father chop down the sugar-maples. As the years went by, the forest receded before the strokes of this same relentless ax; but I literally grew up in the most excellent company of these grand old trees, and learned how to lay them low with the best of them; although my first attempts caused my father some amusement—he said that the trees looked as though the beavers had gnawed them down. By the way, chopping is no mean accomplishment. To swing the ax around, away up above your head, and bring it down with all of your might, with ever increasing speed, with all of its accumulated force, in *exactly* the desired spot, to do this not only

once, but to continue to do this from morning until night, is not only a fine test of acquired skill but of physical endurance. To do this the woodsman must be thoroughly acquainted with his ax and its "helve," or handle. He could not do it with the ax of a companion—not until he had become accustomed to it. The successful chopper is not only expert with the ax, but long experience enables him to decide, almost unconsciously, exactly where to plant each stroke to accomplish the greatest results.

There is one more recollection connected with the maple that is probably sweeter to me than all others. Let me picture it for you. Trees all gray and bare, branches sharply out-lined against the blue of the sky, ground carpeted with the brown of fallen leaves, with here and there a patch of snow in some sheltered nook, crows cawing from the withered branch of a neighboring pine, spring sunshine over all, and two boys, scarcely in their teens, with arms full of household dishes, pans, baking-tins, butter-bowl, and what not, going from tree to tree, boring holes and driving in the home-made "spiles." How it all comes back to me. I can almost hear the sharp, quick d-r-r-rip of the sap, as, having filled the cavity bored in the tree, it comes rushing down the spile and tumbles into the pan below. Then comes the gathering of the sap, the fire, by the side of a big log, over which hung kettles that I now have reasons for thinking a mother sometimes needed quite badly in her cooking, and, finally, the triumphant carrying home in the twilight of a heavy pail of thick syrup.

One more picture and I am done; and I shall not paint it myself, as I find it already drawn by a master-hand, that of my old friend, Prof. Cook, in his admirable little book, "The Sugar-Bush." He says:

"The glory of an autumnal landscape, where maples are thickly interspersed, is utterly indescribable. The intermingling of varied tints of orange with all the shades of red, from flaming scarlet to richest crimson, and all encircled by the

deep green foliage yet unchanged, presents a picture such as no hand except that of the great loving master Artist can ever paint."

FLINT, Mich. Mar. 2, 1898.



PLAIN SECTIONS VS. STRAIN OF BEES.

The Craze for new Things; Is the Extra-Well-Filled Section Really Desirable?

G. M. DOOLITTLE.



I WISH to thank Mr. T. F. Bingham for his timely article in the Review for January, 1898. Every now and then there seems to be a "craze" come over the bee-keepers of the

United States for something *different* from what they have been using. To make the change will cost the great mass of bee-keepers up into the hundreds and thousands of dollars, if not into the millions. And all for what? Just that we may have things a *little different* from what we are now using, is all that I can see in the matter. No matter if the thing compels those under our care to scrimp and economize in the necessities of life, we must have this *new* thing. How easy it seems to be for the apiarists to drift from their moorings, and the one who raises his voice against such drifting, as has Mr. Bingham, should have the gratitude of every right thinking person.

Now, I wish every reader of this article to turn to that photograph of those eight sections found just before the reading matter in the January Review, and ask themselves which is really the *one* section, out of the eight, the *most* to be desired by any lover of a beau-

tiful white comb of honey, to set upon the table in a form to tempt some invited friends we may chance to have at dinner, or tea. I was not a second in deciding which section that *one* was; but for fear I might look through a distorted vision, I passed the picture to Mrs. Doolittle and asked her which would be *her* choice out of those eight sections; providing all were alike as to quality and whiteness of capping. Without a moment's hesitation, she chose the same one I did; which was the second one from the right in the top tier. I asked her *why* she chose that section in preference to any of those on the lower tier, or row. Her reply was that it could be cut from the section without marring the comb containing the honey, except a very few cells at the bottom, and, when the section was lifted off, instead of having all the cells on the sides "dauby" with running honey, these side cells would show the honey through them in such a transparent way that it would set the mouth of any person to "watering" for a taste of it. "Then" she continued, "after cutting the honey out of any one of the sections on the lower tier, there would be a troublesome scraping of the section to save all the honey; or else there would be a dauby, dripping thing to dispose of in some way; liable to take another plate, which must be washed, yes, and steps used to get it, or else run the risk of having honey dripped or daubed on the table cloth, floor, or somewhere which would tend to ruffle the feelings of any person who cared how their house looked. Then, by the time the company was ready for the honey, the nice comb of honey would be 'swimming,' so to speak, in the drip from the broken cells at the sides; thus giving it much the appearance of a little comb honey swimming in glucose, as seen in cans of honey on the market." This might be enlarged upon, but it is enough to show, that there are some at least who do not agree that *fullness* of section is the great desideratum some would have us believe; and this fullness

of section, and a consequent theory that it looks better and will sell better on that account, is the chief argument advanced in its favor, by its advocates. As I consider this fallacious, and as I realize to some extent what a general change from the "fixings" now in use, to those necessary to use with the plain sections will cost, I feel that I must add my testimony to that of friend Bingham, and call a halt; a halt long enough, at least, so that we might ask ourselves "where we are at."

Then, another thing, Mr. Editor, were I a betting man, I would venture a "cookie" that the same "strain" of bees which built the comb in the lower tier of sections did not build the comb in the upper ones. And I would wager my old straw hat, pictured in Gleanings, that had the bees which finished up the lower tier, been given the upper tier, and *vice versa*, that the bee-way sections would have been the full ones, and the plain sections had the "peep holes" in them. That is, providing that picture is a true representation of the combs which stood before the camera, which I suppose it must be. No one at all familiar with the difference in the comb building of different varieties of bees, can look at that picture and think otherwise. The bees building the comb in the lower tier of sections had enough Italian blood in them so that, when they commenced on a section they expected to *fill it*, without stopping to ask, "Will not the honey yield fail before we can complete these sections?" The bees building the comb in the upper tier of sections had enough black blood in them to cause them to ask each other, "Had we not better go a little slow on this thing for fear the honey-flow may be cut short just when we have a great big job mapped out?" And so the latter hesitated, and went along from "hand to mouth," as it were, in the matter, while the former moved the whole thing out "bodily" to its completion. Do you see the rounded, nearly smooth, cappings to the cells in the upper tier, and the drawing in of the combs at the

bottom and sides? That speaks for the *bees* which built them, and not for the "fence" or plain sections. Then, do you see the general flatness of the capping to the cells of those in the lower tier, together with the "lattice work" of raised wax, or ridges on them? That speaks for the kind of bees that fill sections *full clear to the wood*, every time, fence or no fence, plain sections or bee-way sections, providing that the secretion of nectar holds out till they can complete the work laid out. If this secretion does not hold out, then we have sections which are unsealed throughout, instead of sections having cells filled and sealed at the top and down through the middle, while at the sides and bottom the combs are "dubbed" off and empty of honey, as is the case with bees that finish sections like those in the upper tier. Don't give the credit belonging to the bees to plain sections and the "fence."

In conclusion, allow me to say, let those who wish to try the different things that come up from time to time, of a different nature from what they have been using, *heed well* the advice given by editor Hutchinson, in his last two paragraphs on this matter, found on page 21 of the January Review, rather than heed those who are pushing the matter of plain sections and other new (?) things, without having stopped to fully analyze what will be the ultimate outcome to the *masses*, by such a course.

BORODINO, N. Y. Feb. 11, 1898.

[The man who furnishes the American Bee Journal with pithy, pointed, paragraphs, under the heading of "Beedom Boiled down," says, in referring to that picture of the two styles of sections, as it appeared in the frontispiece of the January Review, "It would have been much more to the point if the editor could have said 'These sections were produced by the same bees at the same time in the same super.'"

There may be a point here. I don't deny it; nor wish to deny it. I have no ax to grind in this matter. Italian bees

built the combs in the plain sections. I wish that it were true that they *always* built such combs. I can not say positively in regard to the strain of bees that built the combs in the old style of sections. The apiary in which they were built contained no black bees, but there were some hybrids. Most of the bees in the apiary were pure Italians, but there is no way of knowing whether they built these combs. It is quite likely that the coming season will decide some of these disputed points.

I agree perfectly with Mr. Doolittle in that, for my own use, I should prefer the sections in the upper row for the reasons he gives, but, to *ship* and *sell*, those in the lower row are *away ahead*. When discussing the square versus the oblong section, Dr. Miller once said he thought that the square section looked better on the plate on the table than was the case with the oblong section. This may be true, although I am not yet ready to admit it, but the time when we, as producers and sellers of honey, wish a section to look the most attractive, is when it sits on the counter and there is a man with 15 cents in his pocket standing in front of it and trying to decide whether it is best to have the money and the honey change places.

Then there is another point that is *very important*, and that is the matter of safety in shipping. Of course, it is easier for the housewife to remove the comb from the section if the former is not fastened in very securely; but we don't wish it to be so insecurely fastened that it will be knocked out before it reaches her, or even the grocer who is to sell it to her. If we were going to buy honey for our own use, and have it shipped to us over several different lines of railroad, we would, in that case, probably choose the well filled sections. There are some delicious varieties of fruits and vegetables that a man may raise for his own use, that are complete failures for shipping purposes. It is the same way with sections of honey. However, I very much doubt

if we will ever find consumers complaining because our sections are so well filled out! The complaint is more likely to be because they are *not* well filled. They have not reached the point occupied by Bro. Doolittle and myself, and it will be a long while before they do—if ever.—[ED.]



A FOUL BROOD LAW THAT IS PERFECT.

It has been Secured by Wisconsin, and Ought to be Passed by Every State. Some Views of Ontario's Foul Brood Inspector.

WM. M'EVROY.

Law's the wi-dom of all ages,
And managed by the oldest sages

BUTLE^o.

FRIEND Hutchinson—Your card is received. It reads as follows: "I wish that you would send me a copy of the foul brood law of Ontario, and tell me briefly about what course you pursue in putting it in force, what the results have been, etc. Tell me if the law is what you think it ought to be; that is, would you suggest any changes."

I would with the greatest of pleasure mail you a copy of the foul brood law of Ontario, if I had one; but, as I have not, I will send you a copy of the foul brood law of Wisconsin, which is *perfect*. It was framed by an expert bee-keeper, Mr. N. E. France, of Platteville, Wisconsin. It is by far the best in the world; and every State and Province should have a foul brood law exactly like it. It reads as follows:—

CHAPTER 150.

AN ACT for the suppression of foul brood among bees in Wisconsin.

The people of the State of Wisconsin, represented in Senate and Assembly, do enact as follows:

APPOINTMENT.

SECTION 1. Upon the recommendation of a majority vote of the members of

the bee-keepers' societies of Wisconsin, the governor shall appoint for a term of two years a State inspector of apiaries, who shall, if required, produce a certificate from the governor that he has been so appointed.

DUTIES.

SECTION 2. The inspector shall, when notified, examine all reported apiaries, and all others in the same locality not reported, and ascertain whether or not the disease known as foul brood exists in such apiaries; and if satisfied of the existence of foul brood, he shall give the owners or caretakers of the diseased apiaries full instructions how to treat said cases, as in the inspector's judgment seems best.

DESTRUCTION OF BEES.

SECTION 3. The inspector, who shall shall be the sole judge, shall visit all diseased apiaries a second time, and if need be, burn all colonies of bees and combs that he may find not cured of foul brood.

VIOLATIONS.

SECTION 4. If the owner of a diseased apiary, honey, or appliances, shall sell, barter, or give away, any bees, honey, or appliances, or expose other bees to the danger of said disease, or refuse to allow said inspector to inspect such apiary, honey, or appliances, said owner shall, on conviction before a justice of the peace, be liable to a fine of not less than fifty dollars nor more than one hundred, or not less than one month's imprisonment in the county jail, nor more than two months' imprisonment.

ANNUAL REPORT.

SECTION 5. The inspector of apiaries shall make an annual report to the governor of Wisconsin, giving the number of apiaries visited, the number of diseased apiaries found, the number of colonies treated, also the number of colonies destroyed by fire and his expenses.

EXPENSES.

SECTION 6. There is hereby appropriated out of any moneys in the State treasury, not otherwise appropriated, a sum not exceeding five hundred dollars per year, for the suppression of foul brood among bees in Wisconsin. Said inspector shall receive four dollars per day, and travelling expenses, for actual time served, which sum shall not exceed the moneys hereby appropriated, to be paid by the State treasurer, upon warrants drawn and approved by the governor.

SECTION 6. This act shall take effect and be in force from and after its passage and publication.

Approved April 1, 1897.

As you have asked me to briefly explain the course I pursue in enforcing our foul brood law, and what the results have been, I will try and comply with your request. I go in for wholesale curing at all times, and in all places, and have not only succeeded in getting thousands of colonies cured of foul brood, but have made a great success of turning almost ruined apiaries into great paying ones.

For years past, many foul broody colonies have been sold through the Province of Ontario without either the seller or buyer knowing that they *were* diseased. Many of the buyers paid spot cash, while others gave notes of from \$50. to \$240. I always gave such cases very prompt attention; and worked for and secured peaceful settlements and justice to both buyers and sellers.

I have always asserted, and do yet, that foul brood can and does *sometimes* originate from the rotting of uncared for brood; and believing that to be a fact, I have warned bee-keepers everywhere against the dangerous and horridly filthy practice of putting combs containing decayed brood into their colonies for the bees to clean out. Many a fine apiary has been ruined through the owner putting combs of foul brood into his colonies for his bees to clean out; he supposing it, at the time, to be only chilled brood. I have saved many a bee-keeper from loss, and prevented the spread of a great deal of foul brood, by my repeated warnings to keep all combs with dead brood in out of their colonies.

In the honey flow several bee-keepers, whose apiaries had got into a *very bad state with foul brood*, tried the "short cut" by filling up the hives with foundation just as soon as they took out the old combs and then expected a cure. When I examined these colonies in the fall I found about one-half of them cured, while the others had cells of foul brood scattered all through the brood-nest.

Of course, these beautiful white combs had to be destroyed, and these colonies treated over again. I felt sorry for the owners, but it was no fault of mine in their not carrying out my first orders.

Mr. D. A. Jones, of Beeton, Ontario, found the dumping of bees off foul broody combs upon full sheets of foundation, a failure; and before he could get his colonies cured he had to resort to starvation, starving his bees almost to death before he put them on foundation.

If Ontario had been left until now without a foul brood law, most of the bees in our Province would have been swept out of existence by this time.

Mr. F. A. Gemmill, of Stratford, one of Canada's best bee-keepers, took hold and worked very hard in securing the passage of the foul brood Act, and to him belongs the credit for the work that has been done.

WOODBURN, Ont. Feb. 16, 1898.



VARIATION IN BEES.

It is Fully as Great as Among Other Domestic Animals, and is Valuable.

J. E. CRANE.

Nature, through all her works, in great degree, borrows a blessing from variety. CHURCHILL



HERE are a few persons living in the country who do not readily recognize the great variations or individual characteristics, among horses and other domestic animal. Indeed,

we never find two exactly alike. There is a difference in size, build or form, disposition, temperament, constitution, etc.

Yet few persons seem to think that each colony of bees vary from the others in the same way. Most persons may admit that different varieties of bees are quite different in character, yet these persons would be greatly surprised to be told that there is as much difference between different colonies of the same variety as the average difference between different varieties.

Any one who has had even a little experience with bees will readily admit that some colonies are more vicious than others. I remember one such colony. It was with the greatest difficulty that the hive could be opened and the combs lifted out, and this trait remained permanently until a new queen was given.

Differences in comb-building were very marked before the advent of comb foundation. Some colonies would build their combs straight and handsome; while others would build combs so crooked as to be almost worthless.

In the surplus boxes some colonies would build their combs slowly, perhaps, but every available bit of space would be occupied; while other equally strong colonies would build their combs, and perhaps leave them with the edges but poorly attached to the sides of the box or section.

Some colonies would gather much more propolis than others, to the disgust of their keeper, daubing the inside of their hive with it until it would run down the sides. They leave the legitimate pursuit of honey-gathering to daub the inside of their surplus boxes and half-finished combs with a coat of bee glue.

The business thrift of other colonies is very marked. With a far less number of bees than some of their neighbors, they make the most of their condition. At the end of the season they will have much more to show for their summer's toil than will colonies that were more populous in early spring.

Some colonies are most uncomfortably shiftless or actually *lazy*, like some families of the *genus homo*. No matter how much we try to help them up, they are

always behind and in need of all we can bestow.

Some colonies gather much more pollen than others; apparently leaving the more laborious employment of gathering nectar, because it *is* laborious, thus filling their brood combs, crowding the mother-bee for room, and even spoiling their surplus honey by filling with pollen many cells in almost every section.

The combs in some hives can be handled with the greatest ease, with or without smoke, while it requires great care to handle them in other colonies.

The swarming passion, or impulse, or instinct, seems feeble in some colonies, while it is very strong in others; so much so that unless you let them have their way, or do *something* to satisfy them, they will sulk and do little or nothing.

Some colonies will work earlier in the morning, or later in the evening, or gather honey from some kind of flowers that others neglect.

I remember one colony, a few years ago, that had the peculiar habit of tearing out its brood-combs in early spring. I never could quite understand their object, as their combs were comparatively new and clean and free from anything that I should expect would annoy them. The first time I found them in this condition I supposed it the work of mice; and I spliced or fitted in quite a large amount of comb to fill up the places that had been gnawed out. The next spring the same thing was repeated; when I became satisfied it was the work of the bees and not of mice. If I remember rightly, the process was repeated the third spring; when I put a stop to it by removing the queen and introducing one whose progeny would spend their time and strength at something more useful than tearing down their combs.

Then we have more or less variation in color, size, shape and other traits of character that I have not time to mention.

Of course, we bee-keepers understand that all these various traits of character are represented in the queen of the colo-

ny; and that we may treat each colony as one individual; and that the character of our colonies will depend upon that of the queen and drone with which she has mated. Aside from the characteristics of her offspring, the queen has traits peculiar to herself; as her size, her willingness to remain on the comb and continue her egg-laying when the comb is removed from the hive; and, more important than all others, her ability to lay eggs.

Here we see the necessity of having our hives stocked with the best queens, that have mated with the best drones to be had.

Again, the variation in our queens and their progeny should not be looked upon altogether a disadvantage, but rather as the sure promise of great improvements in bees in the near future. Already, I believe better queens of the Italian race can be found in this country than in Italy.

But I am digressing. If we look around us we will find in both plants and animals of the same species a disposition to vary more or less from the common type.

Some years ago I planted a dozen or more Norway spruce. Not one of these proved to be exactly like the others. There was a difference, either in form, or foliage, or growth. There is a much greater tendency to vary in some species than in others. In some there is none at all. A celebrated horticulturist of Europe raised some 60,000 seedlings of a certain wild plum, without observing the slightest variation in either fruit or tree; and gave up its improvement as almost hopeless. In other species of plants we see great variations as they grow wild; as, for instance, some species of our American wild grapes; more especially that one known as *Vitis Labrusca*, or fox grape.

It may be stated as a rule that the greater the variation found in plants or animals in a wild state, the more rapidly can they be improved under cultivation or domestication. For instance, fifty years ago, not a half dozen native

grapes were known to nurserymen as worthy of cultivation; to day there is almost an endless variety, of all colors, and many of them of most excellent quality, well adapted to our harsh, changeable climate.

May we not then prize this disposition to vary among bees as something of great value to intelligent and progressive bee-keepers?

MIDDLEBURY, Vt. Dec. 10, 1897.



MAKING EXHIBITS AT FAIRS.

They have Little Effect Upon the Sale of Honey; Old Exhibitors Know this, and go for the Premiums. How to Sell Honey.

J. H. MARTIN.



FRIEND II—
Your description of swinging around the circle of the fairs reminds me of my own experiences in that line back in York State some years ago. I have also been reading

something on exhibits in a recent issue of *Gleanings*, and I am inclined to put in a few words if your circle of contributors will allow me to squeeze in and get my foot on the fender with them. I know that you Eastern fellows must have a comfortable fire and need it. Eastern papers give us hints of cold north winds, whirling snow and frosty windows, while here, on the last day of the old year, the thermometer registers 82 degrees in the shade; we have roses in bloom, now and then a barefooted urchin, and bees working busily on the gum trees. How often we forget that this is called winter, and act-

ually get lost respecting the seasons. But to the point:

It seems that the same conditions rule you at the fairs as I experienced ten years ago. In arranging my exhibit I had in mind the philanthropic idea of educating the public respecting the habits of the honey bee; also with the selfish motive of finding a market for my honey, and found myself, after a few year's trial, working for premiums and attending fairs where the management gave the highest awards.

From an educational point of view, an exhibit at a fair is a failure; not a *total* failure, for there are a few people in every crowd who can absorb and remember all about interesting exhibits.

The observatory hive with its queen bee is always a center of attraction; and for the four or five days of the fair our bees, our honey, and our appliances excite as much notice, comment and questioning as any other fine exhibit.

But now let us follow the crowd and see how the educational feature works. There are, perhaps, 25,000 people on the fair grounds; our exhibit is in the agricultural or domestic building with a passage six feet wide on one side of it for the surging crowd; now, out of a crowd of a thousand that march before our exhibit, there are 250 that are doing the fair so fast that they only get a bird's eye view of the entire contents of the hall, and could not the next day, for the life of them, remember a single thing they saw in that building. Then there are about 500 who will remember what most interests them; while there may be a score that will go away with more or less of an impression of our honey exhibit. About a week after the fair a very few of this score will think enough of the exhibit to hunt up the bee-keeper's card and order a case of honey. There *may be* a few permanent customers.

The dear people are not to blame for not taking hold of the sweets stronger; they attend the fair to have a good time; and, generally, they have it. There is too much to absorb; and, by the time they

have been through all of the buildings, taken in the cattle show, horse trot, side-shows, and listened to the fakirs, the thousand and one things to be seen and heard the result is a confused idea of what they have seen, outside of some *special* object in which they are directly interested. Therefore, the premium, if generous, is the best thing to work for at a great or small fair.

Where the educational effect is desired more can be accomplished in a community through the means recently inaugurated by Mr. Weed and described in a recent issue of *Gleanings*. When the subject of honey and its production is described to the patrons of a grocer's store, and backed up by a honey leaflet, the education is permanent. There are a very few grocers, though, who take enough interest in the disposal of honey to push the sale as they do some other lines of goods. When it is pushed a larger sale results.

The selling of honey requires a great amount of talking and even downright argument; prejudice has been excited through what has been written about the adulteration of honey, and there are many people who really believe that they have seen and eaten artificial comb honey.

Another educational factor through which much honey can be sold, both at wholesale and retail, is to have hustling agents on the road to drum up trade. The California Bee Keepers' Exchange has had the service of two such men, by way of experiment, and the result is highly satisfactory.

If we had enough of the right kind of men, the entire honey crop of California could be disposed of in a few months. It is really pleasing to see movements inaugurated that have for their object the proper dissemination of our honey. Our methods of production are well nigh perfection; and now the other end of the equation should be brought up to it; and the latter end can be accomplished better through organization than any other way. Let us work for organization.

LOS ANGELES, Calif. Dec. 31, 1897.

[My experience as an exhibitor for a dozen or more years, leads me to agree with the views of my friend Martin. I believe that honey is more or less popularized by its exhibition at fairs, but not to the extent that some of us have imagined. I think these exhibitions *might* be so conducted as to accomplish more in this direction, but the same amount of time, money, and energy expended in other channels, like those mentioned by Mr. Martin, for instance, will accomplish ten times as much; and for the reasons he gives.—Ed.]



SOME COMMENTS ON THE REVIEW.

A few Encouraging Words. A Glimpse of Southern Bee-Keeping. Editorial Comments.

DR. A. T. PEETE.

EDITOR REVIEW—I enclose \$1.00 as subscription for the current year. The new make-up of the Review came as a surprise, and a most pleasant one. Paper, print and illustrations are high-class. There is also a marked improvement in the matter of late.

The most valuable part of the matter is likely to be the editorial department. I am firmly convinced that editorial comments are of more value than anything except occasionally some rare article. Everybody wants the editor's judgment on passing topics, new methods, or appliances.

I have never seen anything objectionable in the Review excepting in the January number; where appears a familiar advertisement. If those people are square, which I doubt, they should be made to change the wording of their ad.

Like your other readers, I felt deep sympathy on learning of the great trouble which came upon you last year. Words do nothing in the way of help, in such cases, yet, as I am writing, I may as well

deliver my message to you. Having been in the past "acquainted with grief," I can say this: Early happiness never lasts. When it departs it never returns. It is, perhaps, a stimulus needed in youth, while we grow strong for future burdens. But when there comes in its place *peace*, which is better, because it is enduring, these outrageous wounds are healed in time, and leave only scars which give almost no pain. To endure bravely and to do one's duty steadfastly is the noblest thing in life.

As you say you take interest in our bee-keeping affairs, here are a few details. There are vast numbers of colonies of bees in this State kept in box hives and cypress logs. The number of movable frame hives is surprisingly small. I have been a missionary in introducing modern hives and Italian bees into this section. Have instructed numerous pupils and written many articles for the leading newspapers of the State. Professional work leaves me time for attending to only a few colonies; so I generally have no more than forty. Surplus honey is made here almost exclusively from flowering trees and shrubs; such as black gum, holly, locust, persimmon, magnolia, huckleberry, gallberry, etc. The harvest begins about April 15, and lasts four to six weeks. Cotton, cow-peas, etc., give a little honey to fill the hives for winter. The fall-flow seldom amounts to much. Our white honey (limited in amount) is, in my judgment, equal to any in the country.

My bees commenced to carry in pollen January 10. There is plenty of brood and young bees in the hives now. Fruit bloom is close at hand.

When our farmers learn to plant the clovers (something needed here) this State should rank well for honey producing. We have very little cold weather (bees fly all the year), no winter problem, no bee-diseases of any kind, no laws to interfere with us, and no cantankerous neighbors to give trouble.

This rambling talk is going to unreasonable lengths, and I will end by wishing

you and the Review renewed success with a prosperous future.

BRANCHVILLE, S. C. Jan. 10, 1898.

[The foregoing is a private letter, but I have obtained permission to print it. It contains one thought upon which I wish to say a few words; and that is in regard to the importance of and interest in editorials. I know that, as a rule, I find myself reading the editorials of the other journals first, and I have sometimes wondered wherein lay their attractiveness or charm. I used to think that, perhaps, it was because an editor, having so much experience in writing, had learned to put things in a pleasing, interesting way; and I am still somewhat inclined to that view; but my own experience leads me to place above that the fact that there is continually passing through his hands a stream of correspondence; and in this way he is led to *look at things from various points of view*. Let a beekeeper attend a convention and hear a thorough discussion of some topic, and he can go home and tell a neighboring bee-keeper some very interesting things on this subject; and do it in *a very few words*. Well, an editor is continually in a convention, so to speak, and is thus continually absorbing knowledge; and when he comes to express himself he is full and running over.

Readers, the fuller you fill your editor with facts and ideas, the stronger and better will be the "overflow."—ED.]

Bee-Keepers' Review.

PUBLISHED MONTHLY.

W. Z. HUTCHINSON, Editor and Proprietor.

TERMS:—\$1.00 a year in advance. Two copies \$1.50; three for \$2.75; five for \$4.00; ten or more, 75 cents each. If it is desired to have the REVIEW stopped at the expiration of the time paid for, please say so when subscribing, otherwise, it will be continued.

FLINT, MICHIGAN MAR. 10, 1898.

CALIFORNIA bee-keepers do not consider the prospects very bright for a crop of honey the coming season.

THE UNITED STATES BEE-KEEPERS' UNION now has over 300 members.

A GERMAN TEXT BOOK for bee-keepers has been written by Mr. J. F. Eggers, of Grand Island, Nebraska; and it is the intention to have it out before the opening of the approaching season.

MR. ASPINWALL'S article came so late this month, on account of a little sick spell on his part, that, in order to use it, other matter already in type would have to be thrown out, and I thought best to let it run over until the next issue.

THE INFLUENCE OF A DAZZLING WHITE COLOR UPON A BEE'S VISION.

Mr. W. H. Pridgen of North Carolina, writes as follows:

On page 25, Bro. Hasty suggests that the bees from a portion of a house painted white may have been influenced, by working on white flowers at the time, to return to an empty white portion; intimating that they can not distinguish the side of a house from a flower of the same color; and then he justifies Mr. Beckwith in his "whack at Mr. Doolittle for his assertion that bees learn nothing." Say, Bro. H., "Where are you at?"

I rather guess that those bees were taking their first exercise on the wing, and had never seen a flower; also that the sun was shining on that portion of the house, and they were attracted by the the dazzling whiteness.

On leaving a newly painted, white hive, facing so that the sun shines brightly on it above the entrance, bees often act as though they were magnetized; and hob along up like a fly on a window pane, apparently making a great effort to escape.

SECTIONS in which the insets extend not only the whole length of the top and bottom bars, but also a short distance upon the uprights, are advocated by Mr. A. F. Brown of Florida and Mr. W. H. Norton, of Maine. I have articles from

both of these gentlemen, and expected to print them in this issue of the Review, but, as there are so many other things that I wish to give, and this is the main point of their articles, I shall have to put them over, at least, for the present.

Of course, the making of sections in this style is not new, but the idea is advanced that the freer communication thus established results in a better filling of the sections.

THE AMERICAN BEE-KEEPER'S NEW
EDITOR.

When a new member is added to the apicultural-editorial family, we naturally wish to know something about him, and how he looks. Such a state of affairs has now been brought about because the proprietors of the American Bee Keeper, realizing that a real live editor can do more for a journal than pages and pages of "boiler plate matter," have wisely dropped the latter and picked up the former in the shape



H. E. HILL.

of Mr. Harry E. Hill, of Titusville, Pennsylvania; who began life in Canada about 33 years ago. As a youngster he was always interested in bees; and, after various experiences with bees, he passed one season in the employ of Mr. J. B. Hall of Canada; and one very proud moment of his life was when he received a certificate of his ability as an apiarist from Canada's comb-honey king. A year or two later he passed a season in Cuba in charge of a large apiary. Three or four years later he passed a season in California where he had charge of several apiaries owned by Wheeler & Hunt. He returned to Pennsylvania and tried his hand at running a job printing

office, and publishing a newspaper. After two years of this work he sold his interest in the printing business, and went to Florida in the interests of the "South Florida Apiary Company;" and so managed as to be there at the proper time to get the full benefit of the freeze in 1894. There are probably few men who have seen bee-keeping under more diversified conditions than has Bro. Hill. And now the Falconer Co. has caught him; and his thorough knowledge of bee-keeping, coupled with the little dip that he has had in to journalism and printing, give promise that the American Bee-Keeper will now make some long strides towards the front. Mr. Hill has a wife, and one little boy about five years old; and there is "no man whom he envies."

NEEDED CHANGES IN FOUL BROOD LAWS.

Years ago, when Prof. Cook drafted our Michigan foul brood law, it probably fitted existing conditions. Foul brood was considered practically incurable. At least, that the attempt to save anything from diseased colonies was likely to "cost more than it would come to." In those days it is quite likely that the complete destruction by fire of diseased colonies was the best thing that could be done. With the knowledge that we now possess on the subject there is no necessity for the destruction of any part of a diseased colony. The bees can be put into a new hive and freed from the disease. The brood allowed to hatch and the bees saved. The hive disinfected and used. The honey extracted and boiled and used. The combs melted into wax. According to *lata*, no one has a right to even attempt to thus save his property—it must be destroyed by fire. I believe California has a law that is similar both in age and unreasonableness. I believe, also, that these laws have never been put in force—have never been used. At least, I have never known of a case of their enforcement. It is possible that these laws may have been used as a club to hold over the head of

some obstinate bee-keeper who could not otherwise be induced to get rid of foul brood. In this way the laws may have done good.

At the late Michigan State bee-keepers' convention, at Mt. Pleasant, the above objection was urged against the Michigan law. Still other faults were urged against it. For instance, considerable work is necessary to put the law in operation. If a bee-keeper has reasons for thinking that foul brood exists in his neighborhood, he must get other bee-keepers to join with him in petitioning the judge of probate for the appointment of a foul brood commissioner. After he is appointed then complaint must be made against the bee-keeper upon whose premises the existence of foul brood is suspected. If it proves upon examination that his suspicions were unfounded, the cost of the examination is thrown upon the one making the complaint. The necessity for the exercise of all these efforts, and the risk of incurring what may prove a useless or needless expense, deters many from taking the necessary steps to put the law in force. If there were a State commissioner already appointed to whom any one could simply send word that the existence of foul brood was suspected, in such and such an apiary, complaints would always be sent in whenever foul brood was suspected.

Then again, it would often be the case that a competent man could not be found in some county to be appointed to the commissionership. This is really an important point. Not only should a commissioner be able to detect foul brood with unerring certainty, and to know, from *actual practice*, how to best get rid of the disease, but he should be a man of mature years and judgment possess an ability for handling men as well as bees and foul brood; and stand high in the estimation of bee-keepers. Such a man could probably be found in each State; but to find one for each county would not be possible.

Ontario's foul brood inspector, a man who has had much experience in curing

foul brood *according to law*, says that the Wisconsin law is *perfect*; and I can see no fault with it; and with such a man as Mr. N. E. France for commissioner I shall look for good results in Wisconsin. If we had such a law in Michigan with R. L. Taylor for commissioner, I should have hopes of the suppression of foul brood.

At the Michigan convention it was suggested that possibly our Live Stock Commissioner, in the absence of any laws upon foul brood, might take steps for its suppression. I wrote to the head man of our Live Stock Commission, and he said that, as bees came under the head of live stock, that he supposed the Commission could be employed in the suppression of any contagious disease among bees. He sent me a copy of the law, but, upon reading it, I find that it would have to be changed somewhat, or a very liberal construction placed upon its meaning, to enable the Commission to cope with foul brood. I think a law and a commissioner such as there is in Wisconsin and Ontario are far superior to anything else.

A Condensed View of Current Bee Writings.

E. E. HASTY.

Blame where you must, be candid where you can,
And be each critic the Good-natured Man.

GOLDSMITH.

SURE enough, brother Hutchinson, I have got over gasping for breath, and want to argue a little—and rip and snort—in opposition to that inevitable plain section. Look here, the wood of the section is not brought to the table to be admired. Basswood small lumber *au naturel* is not eaten by my lady and her guests at tea—no more than the coat and buttons of our ship's officer is eaten by the cannibals. The cannibals aforesaid can not be fooled with pretty coat and buttons. If they have any choice in the matter they are going to choose the man

who looks plumpest and most promising after the buttons "and sich" are taken off. It is the section that looks best on the plate, and not the section that looks best on the counter, that will finally win. The more or less awkward problem of getting the tender comb out of its integument of wood has got to be surmounted before it can shine as the choicest ornament of the tea-table. This work *usually* has to be done by persons with very little dexterity in that particular line. Let Bridget take one of the plain sections from that "blooming" photograph of yours, and with a case-knife in an unsteady hand proceed to cut out the honey. What is the result? Half the time the knife wanders away from the wood. Besides the main square, several thin slices of comb have to be stacked on one side of the plate, to the serious detriment of looks. Now, let Bridget take one of the sections from the upper tier—say the right center section. There is comparatively little cutting to do. The knife can be put through without ramming it through. Even a child can see right where to cut. *The edges of the cake are all nicely rounded off to start with*, and will remain so. The matter when duly shaken seems to resolve itself into this: Plain sections will look best in the grocer's window, while the other kind will look best on the table. Good looks on the table are all our customers are willing to pay for *when once their minds are directed to the matter*. And those of us who sell largely to consumers are likely to do some missionary work right in that spot.

The American Bee-Keeper has shed off its "patent," boiler-plate other half, and is now content to be just like folks. It has also quit the attempt to run editorially on a few odd minutes of an overworked good man's time, and has taken to itself an editor who will devote to it a material part of his hours. The new editor is H. E. Hill. Success to him.

I was greatly interested in friend Crane's experiences with black and Italian bees. Review, 43. He has reached about the same goal as I. He has few of

either race pure now, and I have none at all. Each of us once had a spasm of seeking to exterminate the Italian blood altogether, and got better of it.

As to your question on page 50, dear editor, suppose we should meet it by asking another of the same sort. How came the Italians to be so long held in general esteem? A colony of bees is like an army; what it accomplishes depends very largely on its tactics. The tactics of the two races are quite different; and sometimes the one and sometimes the other eventuates best. And we "poor critters" mostly remember the successes of our favorite bees, and fail to remember the successes of the others.

A. I. Root's department-head in Gleanings shows palm trees, the pyramids, the sphynx, a camel, and the Nile. Going to Egypt next, eh?

Gleanings says that when the new Union was organized the old one got on an extra hustle. Perhaps if somebody would start a third Union we should then have two hustling ones.

Ernest in his question department, Gleanings 55, says the section holder with two rows of sections has been almost entirely abandoned. Wonder if he isn't a little astray there. The eight-section holder shows no signs of turning up its toes in my apiary. With hybrid bees and proper management, it's nonsense to say that there is any trouble to get storing begun, when there is anything to store. With pure Italians quite likely one-tier arrangements score a decided gain during the early days of honey flow. It is even possible that occasionally very obstinate Italians would swarm under a two-tiered super when they would start at storing all right under a single tier.

Mrs. Axtell is a daring sister. Had the audacity to ask the ladies' church society to come and scrape honey for her. Twenty came, and cleaned up 1,500 pounds. Paid them two dollars and their dinner. And actually the damages they wrought upon the honey were no more extensive than in case of one woman hired for the

purpose. Gleanings, 54. At my shanty taking honey from the hives, taking it out of its holders, and the final task of weighing and marking it, seems to me to constitute the *work*. The mere removal of the propolis strikes me rather as a rest or play spell, almost too soon over with. Should hardly wish to hire anybody to do just that alone. But then that's mainly owing to my usual mental condition—enjoy light routine work that I don't have to *think* much about.

Doolittle says that apple and dandelion honey need more heat and ventilation to ripen them up than clover and basswood do. Gleanings, 52. Also he says that honey of any kind should never be stacked directly on the floor of a room. (That's where my stack stands this minute; but don't do as I do, do as I tell you.) And he would have strips put in the stack between each tier of sections. I would add the remark that no amount of care in stacking counts quite as much as to have the honey *thoroughly* ripened before it is taken from the hive.

Rambler figures that the people of Los Angeles use 2 pounds of honey per capita (If so that's better than most of our towns.) Wants a plan for pushing consumption up to 20 pounds per capita. (Start 'em on a honey-eating health regimen.) He also sends in what seems to be an excellent anti-ant invention by Mr. Tilton of Newhall. Disks of turned chalk are put under each hive just as the tin pans are put under a corn crib; and standards, preferably of metal, come up underneath. Also he tells more than I have noticed elsewhere about the alcohol test for glucose. Pour alcohol on pure honey, and there is no movement or agitation whatever. Pour it on a glucose mixture and little balloons and threads directly begin to push up into it. Gleanings, 50.

Proof like Holy Writ—

"Why, the summer that father died, our bees all died except this one swarm; and I suppose they too would have died, only that they were once grandfathers." Gleanings, 45.

Dr. Miller worked on the eight hour system last season—eight hours in the

forenoon and eight hours in the afternoon. But to atone for it came 17,150 lbs. of sections to 293 ten-hour days of work. Five dollars a day, Gleanings lumps it off. Gleanings, 41.

L'Apiculteur's figures for France in Straw 41. Colonies, 1,615,061: Honey, 17,621,692 pounds: Wax, 4,867,219 pounds—"Hold your hosses thar!" That wax crop gives the whole thing away. No considerable country realizes three pounds of wax per colony, nor anywhere near that. Apparently, the French guess at leading elements of their sheet, and sling figures around just like we'uns.

Mrs. Atchley of the Southland Queen has, we are sorry to hear, been sick this three months, near to death's door much of the time—slowly recovering at latest accounts.

Doolittle advises having every colony that that is strong enough on ten frames in mid spring, and just before the harvest taking out all the frames the queen is not occupying, filling the space with boards and dummies. American Bee Journal, 49. Guess it's all right for those who have the time and the get-up-and-git to do the very best possible for each individual colony. My colonies begin on seven frames; and when I meditate reducing one to six frames, or five, I find the frames to be taken out such a mass of fresh pollen that I doubt the policy of sacrificing so much of the colony's hard work—and I let them alone. Wouldn't it be more practical to give three more frames to the extra-prolific queens, just at the right time, than it is to get away frames already in use? As to size of hives mine will all hold ten frames, or more.

In the same article he says that whether the old colony or the swarm stores the more surplus depends on the dates of swarm and harvest respectively. When a swarm comes out *during* harvest give it everything you can; for it will make the surplus if there is any made. But in case the swarm comes ten days before harvest, then favor the old colony, for it will give you the larger returns

—in case it can be kept from swarming any more.

Mc Evoy says, don't buy combs from an apiary where the bees have all died out. Buy foundation instead. A. B. J., 50.

Dr. Gallup says he lost five queen cells out of eight last summer in the West wire protector. Too much cold metal for California cool nights. Saw Wellhausen use cell protectors in the long, long, ago, before frame hives came. Those protectors were made of hollow milkweed stems, and wouldn't chill the babies inside. A. B. J., 50. In some things we may not have gotten ahead as far as we think we have.

A. B. J., on page 51, starts the plan of having half a dozen of the question respondents go over some point of a question again at greater length, in reply to a correspondent who don't feel satisfied yet. Good idea.

My fondness for guessing gets the start of me again. A questioner, A. B. J., 54, wants to know why more runaway swarms go west than other directions. (Hardly true at my apiary.) Dr. Miller rather thinks it is so, but gives up. Well, one of the possible causes of running away is scant forage at home coupled with a *smell of abundance* coming on the breezes. Now it stands to reason that even bees can't smell dinner seven miles, or three miles, against the wind. As our prevailing wind is west, the larger share of swarms that desert *from that cause* will go west.

The Northwesterners think that queens reared in cells hanging down from the bottom of the comb are not quite so apt to be good ones as when reared up in the center of the colony. Not always immersed in bees cool nights, and sometimes chilled to death outright. A. B. J., 58.

Friend Golden has a new section cleaning machine in which sand paper on a horizontally revolving disc does the work—apparently quite an improvement on previous machines. I suspect that really the right way to proceed is to first take off the propolis with the knife, and then take off the *stain* with the machine.

C. P. Dadant goes Dr. Miller two better, and figures out a profit of seven dollars a day for bee-keepers' work—and that not an occasional season but on the average. A. B. J., 33. If that is so some of us had better be letting our apiaries out at the halves.

Even veteran bee-keepers do not always find estimates and actual weights to correspond. C. Davenport confesses to going over a yard in mid season to decide how much honey was then in the supers. He did this for a prospective purchaser, and both set figures; one at 2,500 pounds and the other at 2,100. And the whole crop at the end of the season was about 1,300. This is made to do service against the journalistic enterprise of getting early reports of what the year's crop is going to be. A. B. J., 35.

The limb of a tree in George S. Wheeler's yard was (it is alleged) the resting place of hundreds of swarms, and always at the same place on the limb. A. B. J., 17. I can't quite see that fly, but I can hear it step—in this fashion. One single tree, of the numerous trees around my apiary, has the habit of catching about half of the entire multitude of swarms—that is for frequent and considerable spells of time. *Sometimes* nearly all go elsewhere for quite awhile.

On page 22, A. B. J., Dr. Miller says— "If there is not enough pollen floating in honey to start the queen laying in the spring." I think if he will take a microscope and examine different samples of honey until he has found even one single grain of pollen he will thenceforth discontinue that strain of speech. I once started out to familiarize myself with all the different species of pollen usually involved, in order that I might tell by a glance in the microscope the origin of any sample of honey—as to whether clover, or mixed, or golden rod, or sumach, or what not. After spending much time and a good many dollars of money I concluded I had been awfully fooled by current bee-keepers' language (like the above) not founded on

facts. Prof. Cook, in A. B. J., page 2, describes an apparatus in the bee's honey-stomach made on purpose to get pollen out of the nectar.

There's been a funny Donnybrook fair in the British Bee Journal over the question, What species of plant is the genuine Irish shamrock? The Irish themselves can't agree. It is essential that it "grow on Irish ground," and that it bear a trifoliate leaf such as could serve for the historic object-lesson sermon of St. Patrick; but beyond this all seems to be at sea. Some would have it an *Oxalis*, some a *Trifolium*, and some would fly to some other botanical genus. But, let me see, how does this get under the head of apiculture anyway?

Most of us knew that iron utensils were forbidden to render wax in; but now it seems some cry out against tin and copper as also discoloring wax to some extent. They would leave us only wood and earthenware. Or is zinc still unchallenged?

Beedom Boiled Down, as A. B. J.'s Boiler does it, shows such careful reading and discriminating selection that I am getting jealous—And first I know I'll be accused of egotism for even putting my head up that high.

As one of the important points in the important matter of swarming (and a point not generally kept in mind) Doolittle says young queens are much slower in getting to laying if after-swarming is interfered with by the keeper. Seven to eleven days if entirely let alone, twelve to sixteen days if meddled with. A. B. J., page 3.

Same article says eggs often appear in drone comb and still no swarm issues; but no swarm issues till eggs in drone comb first—not even among crazy Italians that swarm before queen cells are built.

What to do with a bunch of lost young bees that gather in the honey house, Mrs. Axtell dips them in warm water, and then lays them in front of some weak colony. A. B. J., 2. Not a bad plan.

RICHARDS, Ohio, March 2, 1898.

EXTRACTED.

DISTURBING BEES IN WINTER.

It may do Harm, and it may not, and it may be Necessary.

It is seldom that I find myself disagreeing with my friend, C. P. Dadant; but, if I do not differ from him in regard to the disturbing of bees in winter, as expressed in an article in the February Busy Bee, I certainly do not feel certain that he is correct. Here is what he says:—

I once heard an old bee-keeper say that he examined his bees at all times of the year and in all kinds of weather, and that it never did them any harm. I do not see how one can seriously consider such an assertion. During the spring and summer, when the bees are able to fly, a little disturbance is not injurious and it is quite probable that in most cases it is beneficial, if there are no robbers prowling about to pounce upon their stores, for if the apiarist is thoroughly informed of the condition of his bees, he can better attend to their needs. But in cold weather, the novice cannot be too much warned against the ill effects of a disturbance of colonies; whether they be in the cellar or in the open air. The bees at this time are closely clustered together in as compact a shape as the combs will allow, and so as to be as near the honey as possible. If you carefully open a hive you will notice that their heads are all turned towards the center, and that they move but little, all their efforts seemingly tending to gain access to the warmest spot. A disturbance often induces a certain number of them to leave the cluster, to ascertain the danger, and their vigilance becomes the cause of their death, as they become numb and perish before they have realized that the temperature is beyond their endurance.

In a cellar, the disturbances cause still more trouble, for they are more on the alert in a temperate atmosphere, and a shock, or jar, sometimes induces hundreds of bees to roam about and leave the hive, through any aperture, and the least ray of light attracts them. Thus, quietude is indispensable; and if the novice must satisfy his curiosity, he must do it at the peril of the bees. If food has not been supplied before winter for each colony

it is a difficult thing to supply it then, without risk. The proper time to feed is just before the beginning of cold weather.

Aside from the loss of those bees that leave the cluster and cannot return, the disturbing of hives in cold weather has another objection. Whenever they are disturbed, if the disturbance is continued for a certain length of time, for instance, in transporting a hive from one place to another, the bees become frightened and load themselves with honey. When the disturbance ceases they again unload it, into the cells; but this excitement has caused them to consume more of the honey than they would have needed, and there is consequently greater amount of dejections produced. As they can not discharge these in the hive without injuring the health of the colony, they become restive and are more prone to succumb.

There is, however, a time, in winter, when it may prove very advisable to disturb a colony of bees. It is, when a warm day comes, and for some reason they have not become aware of it, either because their hive is in a shady spot, or because it is too thick, and the heat has not had time to pierce its walls. Chaff hives are often guilty of this inconvenience and that is the main reason why they are not more popular. It takes a long time for a chaff hive to become cold, it takes too long to warm it up. We have used some 80 hives with thick double walls filled with chaff or saw dust, and we have often had to wake up the bees on a warm day when all the other hives were having a good cleansing flight. The single, one-inch walls are quickly warmed by the rays of the sun, and unless the bees are shut in by the dead bodies piled at the entrance, or the hive is too well sheltered, they are very prompt to take advantage of a mild day.

But if from one of these causes they remain quiet they should be disturbed. The bees that have the greatest number of winter flights in cold, hard winters, are those that come out in the best shape. It is for this reason that we object to a Northern exposure, when wintering on summer stands, and for the same cause, we do not think the shade of an evergreen is advisable.

The topic taken up for special discussion in the very first issue of the Review was that of "Disturbance of Bees in Winter," and, almost without exception, such men as R. L. Taylor, James Heddon, F.

Boomhower, Eugene Secor, and others, expressed doubts as to the injury arising from disturbance. Many instances were given where bees had been repeatedly disturbed during the winter, where they had been moved from one part of the country to another locality, hives were opened in the cellar, bees fed, etc. and no harm resulted. Some admitted that if the food were bad, or there were other unfavorable circumstances, disturbance might aggravate these troubles. I think that I will reproduce Mr. R. L. Taylor's article as one that covers the ground in the most comprehensive manner. He said:

We bee-keepers are prone to draw hasty and consequently erroneous conclusions; perhaps we are not more likely to do so than other classes, though it often seems so.

In the paper I read before the N. A. B. K. convention at Chicago I argued that the successful wintering of bees turned principally upon their being supplied with stores of a good quality, and used some facts gathered from my experience in feeding bees sugar syrup, solely to aid in establishing that point, but many present rushed to the conclusion that I was advising the using of sugar stores for wintering, a matter upon which I had not so much as touched. Now, if anything I shall say in this article should seem to show that the disturbing of bees in winter does no harm, I protest in advance against the assumption that I advise such disturbance.

So also it seems a matter worthy of consideration whether it is not a hasty conclusion we have so generally held that this disturbance of bees in winter is injurious.

We know that bees not wintering well are in a disturbed state generally; are we, therefore, warranted in holding that the result of a disturbed state is ill wintering? Can we legitimately say that ill wintering is the cause of the disturbance, and that the disturbance is the cause of ill wintering? May each condition properly be said to be the cause of the other?

It may plausibly be argued that disturbance causes the bees to consume greater quantities of food and induces the rearing of brood, and there are some facts that seem to warrant such a view; nevertheless, though such may be the result during their season of activity may we

safely, therefore, conclude that the same result follows during their season of rest?

From the time I began to keep bees I have fallen in more or less with the popular notion, though with ever increasing doubt, for, as the interest I took in knowing their condition in winter well nigh overpowered any fear I had of doing them injury, I have always handled them more or less during the winter without as yet any ill effects.

The first winter after I had learned anything about bees, I had fifteen colonies wintering out of doors. Like a child with a new toy, I was intensely interested in them, and was anxious both to know how they were doing and to learn more about them, and so examined them frequently and in all kinds of weather, and not only could I see no harm come of it, but I know that none did, for all wintered perfectly and so drowsy were some of them in April that it seemed necessary to arouse them to begin the season's operations.

My faith in the doctrine concerning the ill effects of winter disturbance suffered, and since that time I have felt no compunction in examining a colony whenever I felt inclined.

Having had bees in my cellar for the last six winters it has been my custom to visit them two or three times a week with a lamp, lifting covers freely, and not infrequently examining the combs. This disturbance was generally confined to certain hives convenient for the purpose, and in the spring I could never see that they had wintered better or worse than those not treated. I have now and then fed a colony or two in the winter with no indication that such feeding was necessarily injurious.

In two cases I have gone through all the hives in the cellar moving and opening them and adding or exchanging combs. In one case the bees came out in the spring in as good condition as could be desired, in the other they did not winter well, but that they would not was quite evident before the manipulation, and in neither case could I discover that handling did in any way affect their welfare.

Again, having been troubled considerably two winters with mice, I have seen several colonies that wintered admirably with mice living in nests on the top of the frames and in the combs at the side of the cluster, and I do not now remember of seeing one thus trespassed upon that did not winter well.

However, I would not jump to the conclusion that bees will in no case be injured by disturbance in the winter, though

I feel certain that colonies with perfectly sound stores would endure without injury almost any degree and almost any kind of it with full daylight added. But in the case of bees with unsound stores I am not so certain. It seems reasonable, and it may be the case, that disturbance hastens the effects of bad food, but this is a point very difficult to determine.

There is one more point in friend Dardant's article to which I wish to call attention; that of disturbing bees to cause them to fly when the temperature is such that they may do so with safety. This is one of those points upon which I do not feel sure. I think that Wm. F. Clarke, of Canada, was nearer right than some of us thought when he advanced his "hibernation" theory a few years ago. Of course, bees do not hibernate as in the case of the woodchuck, but they do sink into a quiet state where they exercise but little and consume only a little food; and when they have successfully reached this state, and food and other conditions are all right, they seem to be able to hold it for months with no discomfort—this is what might be called perfect wintering. When bees are in this condition, I doubt the necessity of stirring them up and breaking the spell, even for the sake of giving them a flight. This very point was once under discussion in the Review, viz., that bees well protected by thick packing were not aroused in time to take a winter's flight, while those in thin hives would be roused in time, and Mr. Bingham, I think it was, said "I know that bees so protected don't fly at such times, but they *don't have to*." It is possible that bees that are not wintering perfectly would be so much benefited by a flight that it might be advisable to go to some pains to induce them to fly if the temperature is high enough. Just a word here about packing. A populous colony will generate sufficient heat to make itself comfortable, provided that heat is retained by means of some non-conductor. In this case, thick packing is all right; but in the case of a weak colony there is not sufficient heat generated, and the thick packing shuts off that from the sun

that occasionally gives a respite. In short, a warm cellar is about the only place in which a weak colony stands much chance of living through the winter.

Just a word more about disturbance: It is not reasonable to suppose that it does the bees any *good*, and it is possible that in some cases it may do harm; but the probabilities that it does harm are so slight that no needed attention should be withheld for fear that a disturbance may work an injury.

♦ ♦ ♦

MIGRATORY BEE-KEEPING.

Some Excellent Hints in Regard to Preparing Bees for Shipment.

There are only a few bee-keepers who practice migratory bee-keeping; but there are quite a number who ship bees, or have occasion to move them; and, to such, the experience of Mr. A. F. Brown, of Florida, will be valuable. Mr. Brown has, for years, been moving bees in large quantities and for long distances, and has learned a great many points upon which success is dependent; and he has put them into a long article that was published last fall in the *American Bee Journal*. No one who has occasion to move bees can afford to miss reading it; and those who are interested in migratory bee-keeping will find it of especial value to them. Here is the article:—

I am asked by the editor to give a few items on the above subject, touching especially upon the small details connected with such line—those brought out in the everyday life of one following the production of paying crops of honey by moving the colonies from place to place as seasons and blossoms offer inducements.

The subject is well worthy the attention and careful consideration of every thoughtful honey-producer, especially to those who live in localities that are more or less uncertain, and at the same time are within reach by a short move of some locality that furnishes a surplus from some other source, or at a different season of the year than at the home location.

My experience in migratory bee-keeping covers about five years' active work in moving from 150 to 250 colonies, three or four times each year, and covering distances of from 20 to 200 miles at each move. Most of my moves were of distances of 50 to 150 miles.

In this State (Florida) there are several classes of soils, the timber growth and flora of each being quite distinct. In some the surplus honey-flow comes early in the spring, in others it may be a couple of months later, or at midsummer, and still others in the fall or midwinter, consequently to one informed on the localities it becomes quite apparent that by being in position to move from one locality to another makes the success of securing a crop just so much more sure.

With the exception of a very few short moves, I have used the railroads, and places accessible by water transportation, for all of my movings. In going long distances I prefer the railroad, for the saving of time, as well as expenses. For distances under 25 miles I have found teams the most satisfactory. Transportation by water on boats disturbs the bees least of all, yet the actual gain therefrom is small.

After the colonies are once *properly packed* and ready for a move, *the greatest point of success lies in getting them to their destination and opened for a "flight" at the earliest moment possible.* In my experience I have found colonies to stand three or four days' bumping and jolting over roads and railroads better than they withstand a week's confinement on board a "lighter" towed by a steam tug-boat. I find it is the long confinement that tells on the *vitality* of the bees. Colonies given *plenty of room, plenty of ventilation, and space to cluster off from* (and away from) *the combs of brood*, with ample provision of honey and water, will stand transportation during our hottest weather by hauling with teams or on railroads, providing you do not keep them confined more than four or five days. I endeavor to accomplish my moves in a space not exceeding three days' confinement for the bees, and only once have I lost any number of colonies. In fact, I seldom lose any colonies. A few old bees in nearly all colonies will die, but I think it is only about the actual number that die each day when in their normal condition.

Covering about 20 moves in five years, I have never kept bees more than four months at a time in one locality, generally about two months, and I was off for some other pasture, frequently 150 or 200 miles distant.

When I first commenced moving bees, I knew very little of the requirements for success. My first heavy losses were from loss of *unsealed brood*. To overcome this I found *water* almost an absolute necessity. Give each colony two combs (about two quarts) of water placed next the side of the hive, and the loss of brood will be greatly lessened. To fill the combs with water, lay them in the bottom of a tub or barrel (barrel is best), and pour water from a dipper held three feet above. When one side is full turn it over and fill the reverse side. One Langstroth frame will hold about a quart of water.

Ample ventilation is another big item in successful moving of bees. I find a rim three inches deep, the same size as hive, covered with wire-cloth, the proper thing. Put one of these on the bottom and one on the top, and securely fasten. I have tried many kinds of fastenings, and find common-place laths cut the right length to reach from the bottom screen to the top one, four to each hive, one nailed at each corner, is the simplest and *best*—the *most secure* method of fastening screens and hive bodies solid.

In the front end of half of the screens have a $\frac{3}{4}$ -inch hole bored. This allows an entrance for the bees, and you can put on the screens several days in advance of the day of moving, and when all is ready to move, a cork or plug fastens the entrance-hole.

Frames should be securely fastened in the hives, so they will not slide together or swing. As I use, and have used for years, the Hoffman style of frame, which is, as most are aware, self-spacing, I have no bother about this item.

In the few instances when I have had occasion to move colonies in loose hanging-frame hives, I have fastened them securely by means of two small slats nailed one at each end on top of the end-bars down through and into the ends of the hive, then tip the hive up on its end, and stuff old newspapers in the bee-space between the end of the frames and the end of the hive. This fastened them securely.

If colonies have more than 20 or 25 pounds of honey in their combs, extract it, or enough to leave only this amount, for heavy combs of honey are liable to be jarred loose and be broken down.

The upper story of extracting-combs is left on, but all surplus arrangements in connection with comb honey should be removed, or the bees "stain" them badly, and render them unsightly for future use. Also, their clustering on the foun-

dation starters will generally result in their coming down, and being lost, with the need of putting more in to take their place.

In loading bees in cars (try always to secure cattle cars) you need a number of 1 x 2 inch strips to lay several on the floor to raise the first tier of hives off from the floor, to allow ventilation; then lay more on top of the first tier to raise the second tier, and thus all the way throughout the car.

I find that 250 colonies in two-story hives make a very comfortable carload, though more can be put in if care is used. Be sure the end ventilators of the car are open, and then leave the doors wide open so that when the train is in motion a strong current of air rushes through and among the bees. If the car has ventilators on top, turn the "hood" so as to carry a current of air down into the car, and thus help to keep things cool. But whenever possible secure open cattle cars, for these are the finest self-ventilators out. It should be needless to say, yet it is well-worth repeating, to load all colonies on cars with combs running lengthwise of the car, parallel with the iron rails of the track, never crosswise. In hauling on wagons load, where practical, so the combs stand crosswise of the wagon and road. I have used common, heavy farm-wagons without springs, and in all my hauling, of hundreds of colonies, from a few hundred yards to 20 miles, I have seldom had a comb to break down—certainly not one out of five hundred—and I have traveled over some very rough roads; but, as I have said above, my combs are principally in Hoffman frames, and most have three horizontal wires to the frame.

When arriving at the destination open the hives as soon as possible, so the bees can have a flight. If there is honey coming in the bees will be at work within an hour—in fact, in less time frequently.

To one moving around all over the country, a model, systematically arranged apiary is a thing not likely to be kept up long. When we can secure a field or open spot, order can be observed in arrangements; still, I have found most of my locations were in the woods, and the hives were scattered around about as they would happen to be shot out of a cannon, the hive-entrances facing every point of the compass.

As soon as possible after getting the hives placed and opened, I set each hive up on a couple of sticks of stovewood; this raises them about four inches from the ground, and is all the hive-stand I

use nowadays. Two or three seasons I dispensed with alighting-boards, using the screen as a bottom-board, or removing it entirely and allowing the bees free access to come and go from the whole bottom of the hives.

Half way up on the front of the hives I had two $1\frac{1}{2}$ -inch auger holes bored, with a $1\frac{3}{8}$ -inch space between them. At the center of this space was screwed a button $1\frac{3}{8}$ inches wide and $1\frac{3}{4}$ inches long; by turning it, the size of the entrances was enlarged the full width, or closed to only a single bee-space. These I found to be fine entrances, and the bees preferred them to the bottom entrance. I had 200 colonies arranged thus, and I liked the arrangement very much indeed. My hives at that time were all the 8-frame size, but now I would prefer for a general purpose hive the 10-frame size. In honey-flows I used the 8-frame size tiered three high. The big colonies gave good results, and I then made and put into use 50 16-frame hives, with the upper story in two parts of 8 frames each. In fact, I used 8-frame bodies for the upper stories. These hives I gave the name of "Jumbo." They have proved "Jumbo" in more than one way. With two queens in the lower story and 16 extracting combs above, one gets "a right smart bit" (as our Florida Crackers express it) of honey from one single colony. For extracted honey these "Jumbo" hives have many advantages, but are rather cumbersome for the "migrator."

For comb honey a hive that is shallow and square rather than oblong, and capable of expansion and contraction, is the hive of all hives. Then use the Capt. Hetherington tall section, and large yields of comb honey can be produced.

But comb honey cannot be produced to advantage by a man following migratory bee-keeping, his business lies solely in extracted honey. The 10-frame two-story Langstroth hive is the hive he will find the most advantageous. Outside of his hives and screens, his only tools needed are two or three tents, a good extractor, a couple of honey-knives, and two or three good smokers. Let the thousand and one odd traps "stop home." His handiest honey-package is a barrel. One of these with a screen half way up inside, and a 1×1 inch bar of wood across the top will make his uncapping-can. A small solar wax-extractor might be carried, but what is more practical in the line of his business is a square, double-tank galvanized-iron boiler. I have one 14 inches wide, 20 inches deep, and 30 inches long inside the tank; a little small-

er at the bottom than at the top. There is a one-inch space between the two at the bottom. They cost about \$5.00; one is worth a dozen solar extractors where there is any amount of wax to be rendered. Have two or three pails of water in the outside tank, and the same in the inside one. Then put in the comb and keep adding more. When thoroughly melted, let stand till cool, then turn out the cake of wax, scrap off the residues on the bottom, and it is ready for market.

Mr. Nebel, of High Hill, Missouri, once wrote an article for the Review on this subject of preparing bees for shipment; and, among other things, he placed considerable stress upon the importance of ridding a colony of those old bees that will die anyway if the colony is to be confined several days on a journey. These bees will not bear confinement so well as will the young bees. They become impatient and uneasy, and stir up a flurry, and worry themselves to death, and in so doing excite and annoy the other bees. His advice was that a colony that was to be shipped a long distance should be set to one side, given a new stand, for a few hours before shipment, and thus rid it of these old workers whose days are nearly ended, and who cause trouble when confined. A nucleus may be set on the old stand to catch these old bees, and thus all of the good be gotten out of them that is possible. Perhaps the man who is buying bees might object to such proceedings; but I can tell him that, unless the bees are to be confined only two or three days, that it will be to his advantage to have this very thing done.

While this matter of moving bees is being considered, I might mention that Mr. E. A. Wander, of Connecticut, told me, last fall, at the Buffalo convention, that bees might be moved short distances without even so much as stopping up the entrances. Give them a little smoking, and after they are really subdued, put them in the wagon and drive off with them. Naturally, one would think that many of them would leave the hive and go away, but he says not—that only a very few bees will leave the hive.

Honey Quotations.

The following rules for grading honey were adopted by the North American Bee-Keepers' Association, at its Washington meeting, and, so far as possible, quotations are made according to these rules:

FANCY.—All sections to be well filled; combs straight, of even thickness, and firmly attached to all four sides; both wood and comb unsoiled by travel-stain, or otherwise; all the cells sealed except the row of cells next the wood.

No. 1.—All sections well filled, but combs uneven or crooked, detached at the bottom, or with but few cells unsealed; both wood and comb unsoiled by travel-stain or otherwise.

In addition to this the honey is to be classified according to color, using the terms white, amber and dark. That is, there will be "fancy white," N, o. 1 dark," etc.

CHICAGO, ILL.—Demand slow for comb. Extracted sells promptly. We quote as follows: Fancy white, 11; No. 1 white, 10; No. 1 Amber, 8 to 9; No. 1 dark, 5 to 7; White, extracted, 5 to 6; Amber and dark, 4 to 4½; Beeswax, 27.

S. T. FISH & CO.,
Jan. 6. 189 So. Water St., Chicago, Ill.

CLEVELAND, OHIO.—We quote as follows: Fancy white 12 to 13. No. 1 white, 11 to 12; fancy amber 9 to 10; No. 1 amber 8 to 9; Fancy dark, 7 to 8; white, extracted, 6½; amber 5½; beeswax, 28.

A. B. WILLIAMS & CO.,
Nov. 22. 80 & 82 Broadway, Cleveland, O.

CHICAGO, ILL.—We quote as follows: Fancy white, 11; No. 1, 9 to 10; Fancy Amber, 8; No. 1 Amber, 7; White, extracted, 5 to 6; Amber, 4 to 5; Dark, 4; Beeswax, 26 to 27.

R. A. BURNETT & CO.,
Jan. 7. 163 So. Water St., Chicago, Ill.

KANSAS CITY.—The supply of both comb and extracted honey is large, and the demand light. We quote as follows: Fancy white 10; No. 1 white, 9; Fancy amber, 8; No. 1 amber 7; white, extracted, 5 to 5½; amber, 4 to 5; dark, 4; beeswax, 20 to 22.

C. C. CLEMONS CO.,
Feb. 10. 521 Walnut St., Kansas City, Mo.

BUFFALO, N. Y.—There is quite a good trade in strictly fancy, 1-lb. sections; but other grades are very quiet and require pushing, and the cutting of prices, to move them; but they can be sold as quoted. We quote follows: Fancy white, 10 to 11; No. 1, white, 9 to 10; fancy amber, 7 to 8; No. 1 amber, 6 to 7; Fancy dark, 6 to 7; No. 1 dark, 5 to 6; white extracted, 5½ to 6; amber, 4½ to 5; dark, 4 to 4½; beeswax, 27 to 28.

BATTERSON & CO.,
Jan. 10. 167 & 169 Scott St., Buffalo, N. Y.

NEW YORK.—We have had a good trade in comb honey the past week. Fancy white is in demand. Our stock of fair and mixed honey is working down very well. Extracted honey is selling well. Fancy white clover and basswood find ready sale. We quote as follows: fancy comb honey, 11½ to 12½; fair grades, 9 to 10; buckwheat and mixed, 6½ to 7; Extracted, Cali-

fornia, white, 5 to 5½; amber, 4¾ to 5; white clover and basswood, 5¼ to 5½; buckwheat, 4 to 4½; southern, 50 to 55 per gal.; beeswax finds ready sale at 27 to 28.

FRANCIS H. LEGGETT & CO.,
Jan. 24. W. Broadway, Franklin & Varick Sts.

NEW YORK, N. Y.—Demand for comb honey is rather slow, especially for off grades, white and dark, and, as we have a large stock of these would not advise shipping for the near future. Our stock of fancy white is light and such would find ready sale at quotations. Our market for extracted buckwheat will open up shortly and we would advise bee-keepers to ship this along now. Beeswax steady. We quote as follows: Fancy white, 11 to 12; No. 1, White, 10; Fancy Amber, 9; No. 1 Amber, 8; Fancy Dark, 7; No. 1 Dark, 6; White, extracted, 5 to 5½; Amber, 4½ to 4¾; Dark, 4 to 4¼; Beeswax, 26 to 28.

HILDRETH BROS. & SEGELKEN,
Jan. 7. 120 & 122 West Broadway New York.

WM. A. SELSER,

10 VINE ST., PHILA., PENN.

White Clover Honey Specialist.

Michigan Headquarters for the G. B. Lewis Company's

SUPPLIES,

Dadant's foundation, and everything needed in the apiary. Send for price-list to L. C. WOODMAN,

3-98-61 Grand Rapids, Mich.

GOLDEN Queens

The best that knowledge and ten years' of experience can produce.

Untested Queens.	One	Six	Twelve.
In June, July and August,	.75	\$4.25	\$8.00
All other months,	1.00	5.00	9.00
Tested Queens,	1.50	8.00	15.00

Nuclei, in Mar., Apr. and May.	One	Two	Three	Six	Twelve.
	One L. frame,	.90	\$1.60	\$2.25	\$4.25
Two " frames,	1.50	2.75	4.00	7.50	14.00
Three "	1.80	3.25	4.50	8.50	16.00

These prices are for nuclei without queens, and a discount of ten per cent. will be given on the NUCLEI if queens at the above prices are ordered sent with them. Bees by the pound at the same price as nuclei. File your order for six or more queens 30 days before you want them shipped, and get ten per cent discount from above prices.

E. R. JONES,
3-98-121 Milano, Texas.

Sections!

We make millions of them yearly; workmanship, smoothness and finish can't be better. The basswood grows right here. If you want some good **Shipping Cases**, you can get them of us. A full line of **Bee Supplies** on hand. Write for illustrated catalogue and price list, free.

Marshfield Mfg. Co., *Marshfield, Wis.*

1898 Queens 1898 Camera for Sale.

For Business—Queens for Strong Colonies
Queens for large surplus. Competition in Quality,
but not in price.

If you want queens, nuclei or supplies at
bottom prices, send for my illustrated price
list. 12-97-11

J. P. H. BROWN, Augusta, Ga.

I have several hundred

QUEEN CAGES

of different styles and sizes, made by C. W.
Costellow, and I should be pleased to send sam-
ples and prices to any intending to buy cages.

W. Z. HUTCHINSON, Flint, Mich.

By the way of a "dicker" I have come into
possession of a most excellent 5x8 camera and
the accompanying outfit, that I would like to
sell. The following is a list of the articles and
what they cost when new

Camera and Lens	\$25.00
Tripod	3.00
Plate holders (three at \$1.50)	4.50
Pneumatic Shutter	1.50
Focusing Cloth35
Developing Tray75
Inside Kit for making 1x5's25

The following books:		
Pictorial Effect in Photography	\$1.50
Photographic Instructor	1.50
Picture Making by Photography	1.00

Total \$42.35

Everything is in strictly first class condition,
just exactly as good as new, but I got the outfit
at a bargain, and am willing to sell it at the
same, if I can get it into cash. **\$20.00** will
buy the entire outfit. I have used the instru-
ment enough to know that it will do excellent
work. In fact, I will send a sample of the work
to anyone who really wishes to buy.

W. Z. HUTCHINSON, FLINT, MICH.

FREE TO BEE KEEPERS. How to manage bees? Send for our 36 page Illustrated Catalog - It tells you all about hive fixtures, sections, bee queens &c. The best and cheapest goods - **JOHN NEBEL & SON, HIGH HILL MO.**

Our basswood lumber is *white as snow*, our machinery
up to date, and we can furnish the *finest*

One - Piece Sections

in the market. Price list and sample section free. Special
prices on large quantities. **ONE-PIECE SECTION CO.,**

PRAIRIE DU CHIEN, WIS.

The "Higginville" Smoker.

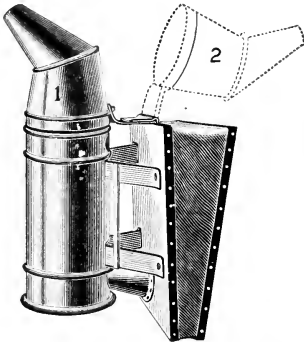

The above cut shows the "HIGGINVILLE" Smoker. Fig. 2 shows the nozzle thrown back for filling. This Smoker is made of the best material, is strong and well made, will burn any kind of fuel, and has a very strong draft.

☛ "The 'Higginville' Smoker is a dandy with a big D" J. M. Morse, Holden, Mo.

☛ Price of smokers, 75c; 3 for \$1.80; by mail add 25c each for postage. Send for catalog of other supplies.

The Amateur Bee-Keeper, a book for Beginners, 25c each; by mail, 28c.

LEAHY MFG. CO., Higginville, Mo.

Please mention the Review

— If you wish the best, low-priced —

TYPE - WRITER.

Write to the editor of the REVIEW. He has an Odell, taken in payment for advertising, and he would be pleased to send descriptive circulars or to correspond with any one thinking of buying such a machine.

FINE FOUNDATION

My foundation is made by a peculiar process (no dipping boards used) which results in a superior article—one that can't be surpassed. The best goods are none too good, and the lowest prices none too low for these times, and I can furnish both, not only in foundation but a full line of bee-keepers'

SUPPLIES.

Send for a catalogue and be your own judge. Wax wanted at 26c cash or 29c in trade, delivered. **AUGUST WEISS,**
4-97-10-t Hortonville, Wis.

Dovetailed Hives,

Sections, Smokers, Queen Cages, and everything needed in the apiary. Warranted Italian queens 75 cts. each. Two frame nucleus, with a queen, \$2.60. Send for catalog.

DEANES & MINER, Ronda, N. C.

— If you are going to—

BUY A BUZZ-SAW,

write to the editor of the REVIEW. He has a new Barnes saw to sell and would be glad to make you happy by telling you the price at which he would sell it.

Page & Lyon
MFG. CO.
New London, Wis

Nearness to pine and basswood forests, the possession of a saw mill and factory equipped with the best of machinery, and years of experience, all combine to enable this firm to furnish the best goods at lowest prices. Send for circular, and see the prices on a full line of supplies. 1-97-1f

A Talk About Comb Foundation.

We can now furnish the very best that can be made from pure wax. Our new process of milling enables us to surpass the previous efforts of ourselves in the manufacture of comb foundation. It is always pure and sweet. It is the kind that does not sag. It is the kind you want. If you once try it you will have no other. Samples furnished free. Large, illustrated catalogue of bee-keeper's supplies, and a copy of the *American Bee-Keeper* sent upon application.

W. T. Falconer Mfg Co., Jamestown, N. Y.

DADANT'S FOUNDATION

BY THE NEW WEED PROCESS

Has no superior because it is made in the best possible manner, upon the best machines, and from the best wax—that from which all foreign substances, such as pollen, bee glue, dirt, iron from boilers, burnt wax and soot have been removed; and that, too, without the use of acids. These foreign matters make the foundation offensive to the bees and decrease its tenacity. Every inch of foundation is guaranteed to be equal to the sample which will be sent upon application.

LANGSTROTH ON THE HONEY BEE, Revised, Smokers, Sections, Tin Pails, and other Supplies. Send for Circular. **CHAS. DADANT & SON, Hamilton, Ills.**

4-96-12t

Please mention the Review.

See That Wink!



Walter DOUDERS' AD.

Bee Supplies. Root's goods at Root's prices. **POUDER'S HONEY JARS** Prompt service. Low freight rates. Catalog free. **WALTER S. POUDER**, 162 Mass. Ave., Indianapolis, Ind., the only exclusive bee supply house in Indiana.

Farm Bee - Keeping.

The only bee paper in the United States edited in the interests of the farmer-bee-keeper and the beginner is the **Busy Bee**, published by **EMERSON T. ABBOTT**, St. Joseph, Mo. Send for free sample copy NOW.

POTATOES \$1.50 a Bbl.

Largest Seed POTATO growers in America. The "Rural New-Yorker" gives Salzer's Early Wisconsin a yield of 738 bushels per acre. Prices dirt cheap. Our great Seed Book, 11 Farm Seed Samples, worth \$10 to get a start, for 10c. postage. **JOHN A. SALZER SEED CO.**, LaCrosse, Wis.

BEESWAX EXTRACTORS.

The only extractor in the world that will extract all of the wax from old combs rapidly by steam. Send for descriptive, illustrated catalogue to **C. G. FERRIS**, 4-96-tf South Columbia, N. Y.

THE MONITOR PAPER FILE

Binds securely and neatly all periodicals. Preserve your papers, magazines, pamphlets, bulletins, music, &c., by binding them together as you get them. Each new number filed quickly and easily. Will bind 52 numbers of any periodical aggregating 1000 or fewer pages. All lengths from 6 to 28 inches. Light and handsome. **PRICE.**—All sizes 12 inches and under 12 cents; over 12 inches one cent per inch. When wanted by mail add one cent for each 5 inches or fraction thereof.

For sale by the Publisher of this paper

PATENT WIRED, COMB FOUNDATION

HAS NO SAG IN BROOD FRAMES.
Thin, Flat Bottom Foundation
HAS NO FISHBONE IN SURPLUS HONEY.
Being the cleanest, it is usually worked quicker than any fdn. made.
J. VAN DEUSEN & SONS,
(SOLE MANUFACTURERS),
1-94-tf Sprout Brook, Mont. Co., N.Y.



Please mention the Review.

Best on Earth. 19 Years Without a Complaint.



		Dozen	Each
Smoke Engine (largest smoker made)	4 inch stove	\$13.00—mail,	\$1.50
Doctor	3 1/2	9.00	1.10
Conqueror	3	6.50	1.00
Large	2 1/2	5.50	.90
Plain	2	4.75	.70
Little Wonder (wt. 10 oz.)	2	4.50	.60
Honey Knife		6.00	.80

For further description, send for circular.

T. F. BINGHAM, Farwell, Michigan.

A Benefit to all Three.

MY Dear Subscriber—I have in mind a plan by which you and I and some other bee-keeper may all be benefitted. It may require a little explanation, but, in the end, I will show that I am correct.

To begin with, let me quote from the editor of that phenomenal success, the Ladies' Home Journal. He says: "The way to succeed in journalism is to make a good journal, one that the people want, and then let them know about it."

But, advertising is expensive. I believe that the advertising done in securing subscribers often costs about as much as these same subscribers pay for their first year's subscription. In other words, a publisher might, perhaps, send his paper free to new subscribers, the first year, if he could thereby dispense with advertising.

I do not propose to drop my advertising; but, in addition to it, I wish to enlist the services of my present subscribers; and to pay them well for their work. To any subscriber of the Review, I will send, absolutely free of charge, a fine, tested, Italian queen for each *new* subscriber he will get me. I can furnish either the golden, or those bred from imported mothers—each reared in a separate apiary. Orders will be filled in rotation—first come, first served.

Not only will I give this liberal pay, but I will assist my friends, in every way possible, in their work of getting subscribers. I will furnish them all of the sample copies that are needed; and, in addition, if desired, copies will be mailed direct to the addresses of any bee-keepers they will send me; and a notice will also be sent announcing that, "For the copy of the Review sent, you are indebted to the courtesy of Mr. _____, (here the name of the sender of the list will be

put in) who would be pleased to obtain your subscription for the same." Then, for three or four months, at least, samples of the Review will be sent, each month, to these addresses. During this time it will probably be possible to meet these bee-keepers, speak a good word for the Review, and ask them to subscribe.

There is no time of the year when it is easier to induce bee-keepers to subscribe for a journal than when the bees, having passed the rigors of winter, are filling with music the soft air of spring, and the bee-keeper's heart is jubilant with hope. It is none too soon now to begin sowing seed, in the shape of sample copies of the Review.

Reader, don't you know of at least *one* bee-keeper that you might influence to become a subscriber? If you can do this, I shall be glad to send you a nice queen.

In carrying out this plan I shall not make one cent of profit, *the present year*; but if only 75 per cent. of the readers thus obtained remain as permanent subscribers, there will be a good profit in the end. This year not more than *one* per cent. has dropped out.

If you send me a new subscriber on these terms you will get a fine queen, I will get a new subscriber that, in all probability, will stay with me for years, and the new subscriber will get information that will be worth to him ten times its cost. As in all genuine "bargains," all the parties to it are benefitted. There is one other point: the larger subscription list that a paper has, the better it can be made, and in this way subscribers are benefitted.

If *you* can help in this way, let me know in what way *I* can help *you*.

W. Z. Hutchinson, Flint, Mich.

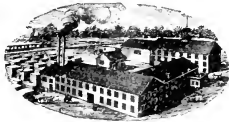

Bee-Supplies

We have the best equipped factory in the West. Capacity, one carload a day. We carry the largest stock and greatest variety of everything needed in the apiary, assuring *Best Goods* at the *Lowest Prices*, and prompt shipment. Illustrated catalogue, 72 pages, free.

We also manufacture tanks of either wood or galvanized steel, all sizes, any form, and for all purposes. Price list free. Address

E. Kretzmer, Red Oak, Ia.

Page & Lyon,

Mfg. Co.

New London, Wis.

Nearness to pine and bass-wood forests, the possession of a saw-mill and factory fully equipped with the best of machinery, and years of experience, all combine to enable this firm to furnish the best goods at lowest prices. Send for circular, and see the prices on a full line of supplies.

ROOT'S GOODS,

At wholesale and retail. Honey is cheap, and, to be successful, goods must be bought at the lowest possible price. I can help you in this. Try it by sending a list of what you want—you will get prices by return mail. Large Illustrated Catalogue, full of information, free. Beeswax wanted in exchange for goods, or cash, at best prices.

M. H. HUNT,

BELL BRANCH, MICH.

COMB Foundation.

We can now furnish the very best that can be made from pure wax. Our new process of milling enables us to surpass our previous efforts in the manufacture of foundation. It is always pure and sweet. It does not sag. It is the kind that you want. If you once try it you will have no other. Samples furnished free. Large, illustrated catalogue of bee-keepers' supplies, and a copy of the *American Bee-Keeper* sent upon application.

W. T. Falconer Mfg Co.

JAMESTOWN, N. Y.

Violin for Sale.

I am advertising for the well known manufacturers of musical instruments, Jno. F. Stratton & Son, of New York, and taking my pay in musical merchandise. I have now on hand a fine violin outfit consisting of violin, bow and case. The violin is a "Stradivarius," Red, French finish, high polish, and real ebony trimmings, price \$14.00. The bow is of the finest snakewood, ebony frog, lined, inlaid (pearl lined dot) pearl lined slide, German silver shield, ebony screw-head, German silver ferules, and pearl dot in the end, price \$2.50. The case is wood with curved top, varnished, full-lined, with pockets, and furnished with brass hooks, and handles and lock, price \$3.50. This makes the entire outfit worth an even \$20.00. It is exactly the same kind of an outfit that my daughter has been using the past year with the best of satisfaction to herself and teachers. Her violin has a more powerful, rich tone than some instruments here that cost several times as much. I wish to sell this outfit, and would accept one-half nice, white extracted honey in payment, the balance cash. It will be sent on a five days' trial, and if not entirely satisfactory can be returned and the purchase money will be refunded.

W. Z. HUTCHINSON, Flint, Mich.

G. M. LONG, Cedar Mines, Iowa, manufacturer of and dealer in Apiarian Supplies. Send for circular. 1-96-6

Please mention the Review.

START IN BUSINESS!

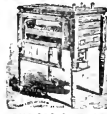

HATCH THOUSANDS
WITH THE PRAIRIE STATE

INCUBATOR

200 FIRST PREMIUMS.

PRAIRIE STATE INC. CO.
HOMER CITY, PA.

SEND FOR CATALOG.

Please mention the Review

WRITE US

Before ordering your sections and we will give you **BOTTOM PRICES** on the

"BOSS" ONE-PIECE SECTIONS,



Also D. T. HIVES, SHIPPING CRATES and other Supplies.

We have everything in tip-top order, and can fill orders on short notice. Let us hear from you for prices.

J. FORNCROOK & CO.,

Jan. 1st, 1894.

Watertown, Wis.

Please mention the Review.

Make Your Own Hives.

Bee-Keepers

Will save money by using our Foot Power Saw in making their hives, sections and boxes.

Machines on trial.
Send for Catalogue.

W. F. & JNO. BARNES CO.,

384 Ruby St.,

Rockford, Ills.

2-96-12

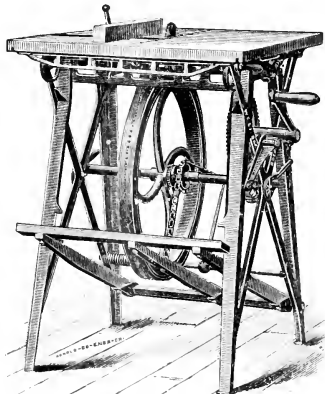

Two Special Offers.

As explained in former ads., publishers can afford to put forth extra efforts in securing *new* subscribers; as the majority remain, once they become subscribers to a *good* journal. It is from this point of view that I make the following offers:—

Offer No. 1.

To any one not a subscriber to the Review who will send me \$3.00 I will send the Review for 1898, and 1,000 strictly first-class, snow-white, one-piece sections. After accepting this offer, if any one wishes to buy more sections, I will furnish them at the following prices: 1,000 for \$2.75; 2,000 for \$5.25; 3,000 for \$7.50; 5,000 for \$12.00. Sections will be shipped from any of the following points. Flint, Mich.; Chicago, Ill.; Medina, Ohio.; Jamestown, N. Y.; Higginsville, Mo. or Omaha, Neb.

Offer No. 2.

To any one not a subscriber to the Review, who will send me \$1.50, I will send the Review one year and a fine, TESTED Italian queen. Purchasers may have either the bright golden strain, or the dark leather-colored reared from imported mothers. After accepting this offer, if any one wishes more queens, they will be furnished at the following prices: single queen, 90 cts.; 3 for \$2.65; 6 for \$5.00; 12 or more at 75 cts. each. Orders will be filled in rotation, and safe arrival guaranteed.

Unless otherwise ordered, subscriptions will begin with the Jan. issue; and the Dec., 1897, number will also be sent, free.

W. Z. Hutchinson, Flint, Mich.

A Bargain in Bees. Large Apicultural Establishment.

I have made a trade with Mr. A. W. Gardner, of Centerville, Michigan, whereby I have come into possession of some colonies of bees that I can sell at an exceptionally low price. They are in *two-story*, eight-frame hives, and in fine condition, yet I will sell them \$5.00 per colony. Mr. Gardner is an experienced bee-keeper, has taken the Review for years, and I have every confidence in him. Any one in Southwestern Michigan, or in that vicinity, and being in need of bees, can not do better than to take advantage of this offer. Send the orders to me, and I will have the bees shipped to you by Mr. Gardner.

W. Z. HUTCHINSON, Flint, Mich.

(Established in 1860.)
For the Rearing and Export of Pure, Selected Italian Queen Bees. Price list: March, April, and May, 1 tested queen, \$1.75; 6 for \$9.25; 12 for \$18.00. June, July, and August, one queen, \$1.25, 6 for \$7.00; 12 for \$14.00. September, October and November, 1 queen, \$1.00; 6 for \$5.75; 12 for \$10.00. Orders must be prepaid and accompanied by Post Office Money Order. Please state names, addresses and railway stations in a legible manner. Should a queen bee die during the journey, the same must be returned accompanied by a Post Certificate, and another queen bee will be sent immediately.

CAV. PROF. PIETRO PILATI,
Via. Mazzini No. 70, Bologna (Italy.)

I have several hundred

QUEEN CAGES

of different styles and sizes, made by C. W. Costellow, and I should be pleased to send samples and prices to any intending to buy cages.

W. Z. HUTCHINSON, Flint, Mich.

We are the People

Who can turn out *Fences* (Cleated Separators) and *Plain Sections* (Sections Without Insets)

— For 1898. —

Having special appliances and machinery, we can make them right. Nothing in late years has seemed to stir up such a furor in the Bee-Keeping World as these new goods. If you don't know about them, send to

The A. I. ROOT CO., Medina, Ohio.

New 1898 Catalog, largely re-written, now out.



497-12

Our Prices are worth looking at. We are making the new

Champion Chaff Hive

with dovetailed body and supers and a full line other Supplies, and we are selling them CHEAP. A postal sent for a price list may save you \$ \$ \$ \$.

R. H. SCHMIDT & CO.,
Box 187 Sheboygan, Wis.

Please mention the Review.

JOHN PATTERSON, England, Pa., is an American, 23 years of age, has had three years experience in the apiary, and would like to secure a position the coming season in an apiary or on a fruit farm. Is teaching school at present, but will be free by March 1st. Can give references.

Please mention the Review.



\$100

Given as **Bounties** to purchasers of the improved Danz. Hives and Sections. See schedule in my bee-book "Facts About Bees." Tells

how to produce honey that sells for the most money. Free for 2c in stamps. Address

THE A. I. ROOT CO., Medina, Ohio,
or F. DANZENBAKER, Box 466, Washington, D. C.

Please mention the Review.

QUEENS,

Either Golden or Imported, by return mail. Untested, 75c; tested, \$1.00; breeders, \$2.00.

6-97-tf

W. H. LAWS, Lavaca, Ark.

Sweet Clover Seed.

We have about 3,000 lbs. of sweet clover seed, (of the white variety) that we offer for sale at the following prices:

25 lbs., \$2.25; 50 lbs., \$4.00; 100 lbs., \$7.50.

BERTSCH & FLIEMAN, Holland, Mich.

COMB

FOUNDATION

WHOLESALE AND RETAIL.

Working wax into foundation, for cash, a specialty. Hives, Sections, and a full line of Supplies. The best of everything. Write for Catalog, with prices, and samples of Foundation and Sections. Beeswax always wanted for cash or trade.

GUS. DITTMER,

10-97-12t

Augusta, Wis.

The A. I. Root Co.'s Goods, WHOLESALE AND RETAIL.

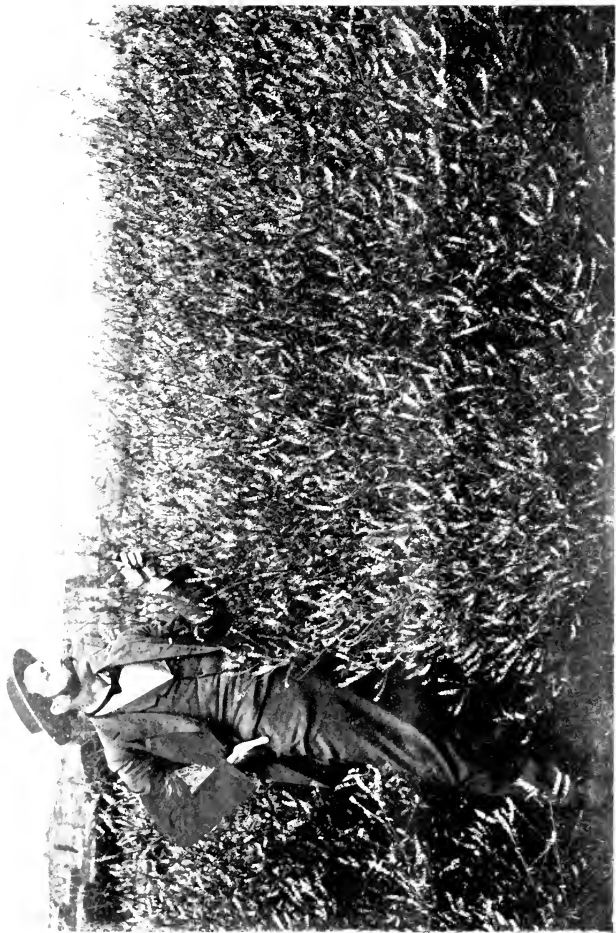

Editor of the Review Admiring a Luxuriant Growth of Sweet Clover.

The Bee-Keepers' Review

A MONTHLY JOURNAL

Devoted to the Interests of Honey Producers.

\$1.00 A YEAR.

W. Z. HUTCHINSON, Editor and Proprietor.

VOL. XI. FLINT, MICHIGAN, APRIL 10, 1899. NO 4.

SWEET CLOVER, OR MELILOTUS.

Why it Sometimes Fails to Grow; A Success
on Lime Soils; How it Fertilizes the Soil.

M. M. BALDRIDGE.



"SWEET clover is an excellent honey-plant. The amount and quality of honey from it is rarely surpassed. I have grown the plant in Michigan for bee-feed for years; but I have never

been able to get my cows or horses to eat it. I think the plant is worthless except for bees."—Prof. Cook.

Several of my correspondents have written me that sweet clover does not grow very well in their locality; or upon certain kinds of soil. They do not know why this should be the case. But others write me that they have discovered the reason why. I think Mr. Heddon once wrote me that the plant with him does not make a satisfactory growth—especially on sandy

soil. Well, one of the objects of this article is to throw more or less light on the subject as to the *reason why*.

Jeff Welborn, a well known writer on agricultural topics in the South, and now a resident of Arkansas, wrote me in February, 1896, substantially as follows:

"Sweet clover failed to grow on the sandy soil of east Texas where I lived for a number of years. It also failed to grow here in Lonoke county on the swamp lands last year. This is without doubt owing to lack of *lime* in the soil. It grows with success and is a grand plant on all the lime lands of the South. There is no doubt of the great value of the plant on the proper kind of soil. It is a wonderful plant for enriching the soil; and this is mainly owing to its dense shade."

I must differ from the scientists and many others as to where the fertilizing from sweet clover and other leguminous plants comes from. Many think, as all scientific men teach us, that the roots of these plants do all the work. I say it is mainly the dense shade through the summer. Like alfalfa, sweet clover has the propensity of stooling; and this enables the plant to shade the surface very quickly in the spring, or after cutting. This shade protects the earth from the sun's heat, and attracts moisture which, by

cooling the earth, attracts whatever is soluble in the atmosphere.

Now, why does sweet clover prefer lime lands? Because lime is an alkali earth and contains a superabundance of phosphate of lime. Then, to make a perfect soil, nothing is needed but nitric acid; which our scientific men, with one accord, now agree is gathered from the atmosphere in abundance by leguminous plants; such as peas, beans, sweet clover, alfalfa, the other clovers, etc.

A few years ago scientific men told us that these plants collected this free nitrogen through the pores in the leaves; but now they tell us that this free nitrogen is converted into nitrates, or plant food, by microbes, bacteria or insect life. One is as absurd as the other; and either is worse than the moon-signs, or hollow-horn theory they make so much fun of.

Now, if it were possible for sweet clover and other legumes to take in these elements through the leaves it would be impossible for them to depart and get into the earth until the plant dies; because nothing ever passes from a living plant back into the earth through the roots unless the latter are cut or broken. Then if we remove the plant from the soil we take all the gathered nitrogen with it. It can not come from the decaying roots, for these shade or leguminous plants have fewer roots than the non-shade plants. We know that sorghum has many times more roots than cowpeas; corn more roots than cotton; and millet more roots than clover; and yet, these shade crops gather nitrogen, whereas the non-shade crops exhaust the nitrogen with their great mass of roots.

Again, these same scientific men tell us that the roots of leguminous plants have the power to crush stones and bones containing alkali or phosphate; when the truth is, that the shade therefrom gathers the moisture and acids from the atmosphere; and these dissolve the bones or rocks and form the alkalis and the phosphatic acids into nitrates and phosphates. This loosens the soil and causes

it to become dark and fertile thus enabling the roots to penetrate the soil and push up thrifty plants.

Scientific men also tell us that all lime is the petrified remains of salt water animals. The phosphate rock comes from the same source. The phosphoric acid in these rocks or bones is made soluble by treatment with sulphuric acid. Nitric acid produces the same effect; and this can be produced by shading the soil with sweet clover or other leguminous plants.

Cotton seed contains a large amount of nitric acid. Years ago some hogs died in Texas with cholera; and the owner buried them in a large pile of cotton seed. After a few weeks had gone by he found, on examination, that the hogs were entirely eaten up, bones and all; the only exception being the vegetable matter found in the intestines. The bones looked like meal. Since then he has collected all the bones he could and buried them in cotton seed kept moist with water. In this way he has made his cotton seed net him 25 cents per bushel. Now if the nitric acid in cotton seed will dissolve bones so perfectly it will surely also dissolve lime rock. And the nitrogen in the atmosphere, converted into nitrates by combining with the mineral elements in the soil, will have the same effect as the nitrogen in the cotton seed. And there is no doubt that this is collected by the dense shading of the soil with sweet clover and other leguminous plants.

The following was written in December, 1896, by one of my sweet clover correspondents in eastern Mississippi. The writer, Edwin Montgomery is an extensively known writer on Southern agriculture of an agricultural periodical and is a rural topic. He says:—

"I have now growing on my farm from 15 to 20 acres of sweet clover, or melilotus. The plant is doing well, and stock are getting a good bite from it to-day, December 14. I shall sow more in February, as this is probably the best month in which to sow sweet clover in this section. My neighbor who wrote you that

he had seeded 1,000 acres to sweet clover, in narrow strips, has had poor success in securing a good stand. Much of his seed was sown on land utterly unsuited to the plant—being destitute of lime. On such land the plant is always a failure. Sweet clover is truly a lime plant, and there is no use in trying to make it grow on any land not strongly impregnated with lime. In lime soils the plant here is always a grand success; and our drouths, however severe, never kill it after it has become well rooted. I think it is only a question of time when the northern prejudice against sweet clover will die out and its merits will be properly appreciated. Alsike clover is also a success here in average seasons; but a deal of it was killed by the last summer's drouth. Still, in some places the stand is fairly good."

Mr. Montgomery is a breeder of choice Jersey cattle; keeps a fine dairy; uses a cream-separator; and lives where sweet clover has been grown quite extensively for hay and pasturage for live stock for about 20 years.

Sweet clover is also grown as a fertilizing plant. At first it was, perhaps, grown more for this purpose than any other. As no special attention has been given to bee culture by the growers of sweet clover in eastern Mississippi, it can not therefore be charged that the plant is grown mainly for honey purposes, or by bee-keeping lunatics.

Alfalfa, red clover and alsike clover, as well as many other forage plants, also grow with success in eastern Mississippi. In fact, alsike clover produces two crops of seed in good seasons there, which is seldom or never the case in the Northern States.

Having now shown why sweet clover does not grow profitably or successfully on certain kinds of soil, I will now conclude by stating that, in my opinion, it can be made to grow upon any soil by a proper supply of lime applied thereto, artificially. My plan would be to plant the sweet clover in hills, or drills, the same as corn, and then use a cup full, a

pint, or possibly a quart of fresh slacked lime to each hill. I would use a hoe to make a depression to receive the seed, then cover with lime, and finish with soil. The seed will come up if covered two inches deep, more or less. No one need be afraid to use even a quart of slacked lime, if thought best, to each hill, for it is my belief that the sweet clover plant will grow and thrive in *lime alone*, and without a particle of soil! My experience along that line seems to corroborate that statement. Three to five seeds to each hill will be ample, for if but one of them germinates, the plant will make a stool large enough to shade the entire plat of ground; even if not closer than three feet apart each way.

ST. CHARLES, ILL., March 18, 1898.



TESTS OF COMB FOUNDATION.

Deep-Cell Foundation 37 per cent. Thicker than Natural Comb; Some Makes of Thin Foundation Thinner than Natural Comb No-Wall Foundation Thinnest of all.

R. L. TAYLOR.

He could distinguish and divide
A hair 'twixt south and south-west side. BUTLER.



So great is the importance to bee-keepers in my estimation of securing the best possible quality in comb foundation that I again made an effort the past season (1897) to test several spec-

imens from different sources. These consisted of two from the A. I. Root Co. of Medina, Ohio, thin and extra thin, two

from a maker in Lansing, Iowa or Minn., (whose name and exact address has been mislaid,) thin and extra thin; one from T. F. Bingham, Farwell, Mich. and one known as drawn foundation having very deep cells from the A. I. Root Co. For comparison each of these was used in connection with foundation made on a Given press as in former experiments.

The weight of the several kinds was as follows:

A. I. Root's extra thin,	12.1	ft. to the lb.
" " "	10.3	" "
" drawn fdn.,	6.25	" "
Bingham's no-wall,	11.3	" "
Lansing extra thin,	14.8	" "
" " "	12.7	" "
Given,	7.4	" "

The drawn foundation is a very good imitation of new comb just as it begins to be occupied by brood or honey except that it is of a decidedly yellower color and the top of the cell walls is sharp as in the case of natural comb when the surface has been shaved off as in uncapping. The several kinds of foundation were all well made, but, owing to the wax from which they were made, some were very yellow—an undesirable characteristic it seems to me in foundation to be used in sections for comb honey. In making comparative tests of foundations it appears to me there are three questions of paramount importance, viz., Which do the bees work the more readily? Into which will the bees put the most honey in the same time under like circumstances? And which will they draw out thinnest or most like natural comb? The first must be answered by inspection, the second by weighing sections of honey filled under the same circumstances, and the third by measuring with a proper instrument the thickness of the bases of the cells of the resulting comb.

To secure these answers, fourteen sections were filled with foundation of each kind except the Given and the drawn foundation, then with each lot was put a

set of fourteen sections filled with Given foundation, and each lot of twenty eight sections thus made up was put into a case by itself, the two kinds alternating throughout, thus making the Given sections occupy a position in the case corresponding exactly with that of the other kinds with which they were placed. Of the drawn foundation I had only sufficient to fill six sections; so the six thus filled were placed alternately with Given sections in a case, as near the center as possible, and the filling of the case completed with other sections. Each of the cases thus prepared was placed on a colony of bees during the honey season and all the sections were worked more or less, but not sufficiently so that the test by weighing could be made with any satisfaction. By inspection, however, the preferences of the bees were readily discovered. In this respect the case of drawn foundation was curious and worthy of consideration by all who contemplate making any use of this sort. It was used at once, almost, for storing honey, and it appeared then that it would be ahead of the plain foundation at the time of capping in point of weight, but such did not prove to be the case. At the end of the honey flow, when the centre sections were beginning to be capped, a drawn foundation section right in the center of the case weighed only 70 per cent. as much as the Given section standing next it. It seems probable that this unexpected result was due either to the fact that the bees were dissatisfied with this imitation of comb and used it only for the reception of honey until they could provide other receptacles, or else to the fact that having only the six sections capable of holding honey at once they put so much thin honey in them at the outset as to delay the process of evaporation to such an extent that these sections in the end appeared at a disadvantage. If this result was owing to the dissatisfaction of the bees, this sort of foundation must apparently be condemned; but if owing to the other ground given, condemnation would not necessarily fol-

low for if it were in regular use there would be twenty eight sections instead of six in which to distribute the incoming nectar, and it might well be that this greatly increased surface would enable the bees to cure the honey as rapidly as necessary. This is a point that touches the use of drawn comb in sections; which, on account of this drawback, probably, has sometimes been condemned. Naturally, more nectar is gathered when the comb is ready for its reception; and it occurs to me that the num-

were taken; and in case of the Root thin, of which but three were taken. Allowance ought to be made these on this account, for, in making up the table given herewith, showing the results, I have made use of the three lowest measurements in each case, as showing best the thinness to which the bees work each. The reason is here: As the bases approach the points where the side walls are attached, they naturally become much thicker, and, evidently, measurements in many cases were taken at or near this point. The num-

TABLE SHOWING THE THICKNESS, IN THOUSANDTHS OF INCHES, OF THE SEPTUM IN COMB BUILT ON DIFFERENT FOUNDATIONS.

	A. I. Root Co. extra thin.		Lansing.		A. I. Root Co. Given.		Lansing, extra thin.		Bingham, or no-wall.		Deep-cell.		Root, of 1896.		Dadant, 1896.		Hunt, 1896.		Natural comb.	
Three lowest measurements.	5	3	55	4	85	5	5	5	4	4	8	5	6	5	4	6	4	6	6	6
	6	6	5	5	95	3	5	5	5	5	9	8	6	6	5	5	5	5	7	7
	6	6	5	5	127	8	5	5	5	5	10	7.5	8	6	6	6	6	6	7	7
Average thickness.	5.67 5		6.5		4.67 9.67		6.33		5.33 6		4.33 4.67		9.16 7.83 7		5.67 5		6.67		6.67	

ber of sections given a colony under such circumstances should be increased accordingly. As to the other sorts of foundation, the two Root samples were worked at about equal pace with the Given—the kind called “thin” perhaps a little more rapidly. The Lansing “thin” was behind the Given in that respect; and the Bingham and the Lansing extra thin were behind in a more marked degree. To determine the thinness to which the bees worked these foundations, pieces of the comb made from them were cleaned and sent to Dr. Beal of the Agricultural College for measurement. I also sent pieces of comb from foundation used in my experiments in 1896, and a piece of natural comb. From five to twelve measurements were taken from each piece, generally. Exceptions are found in the case of the Lansing thin, of which but two

ber of measurements, and the largest one in each case, are as follows:

Kind of foundation	Number of measurements	Largest measurement
Root extra thin,	7	9
Given,	22	15
Lansing thin,	2	8
Given,	8	7
Root thin,	3	12
Given,	8	15
Lansing extra thin,	6	8
Given extra thin,	3	7
Bingham,	16	10
Given,	6	7
Drawn foundation,	7	20
Given,	6	9
Root '96,	4	12
Dadant '96,	5	9
Hunt,	5	8
Natural comb,	6	10

All the measurements are in thousandths of an inch. Dr. Beal writes that the measurements are correct; but that too much stress ought not to be put on them on account of the variations in the thickness of the bases; and I agree that they are not to be relied upon unless there is assurance that they are taken at points not affected by the junction of the side walls.

The following salient points in this experiment are to be noted: 1. The average of all the foundations tested, exclusive of the drawn foundation, appear by the measurements to have bases about eleven per cent thinner than those of the natural comb tested; which had every appearance of being an average specimen. 2. In point of thinness the Bingham foundation decidedly surpassed all others. 3. Making due allowance for the Root "thin," as suggested, the base of the drawn foundation was much the heaviest of any; exceeding that of the natural comb thirty seven per cent; indeed the difference was clearly perceptible to the naked eye on comparing the cut edges of the several septa.

It will be remembered that two or three years since I made some incidental experiments with foul brood, one by introducing a queen from a badly diseased colony to a healthy one, and another by giving a healthy colony a comb of honey from a diseased colony. The comb was the outside one in the brood chamber, and probably had never contained brood; at least no diseased brood. The colonies thus experimented upon continued to be healthy up to and through the season of '97 and it is safe to say that no disease was conveyed by the operation in either case. But though it proved harmless in these cases, it is not to be understood that it is to be recommended as a safe thing to do in the present state of our knowledge. The experiments were made as a step in the direction of increased knowledge of the powers and limitations of the foul brood scourge.

LAPER, Mich. Feb. 16, 1898.

SWEET CLOVER.

When to sow it and how Cattle may be led to eat it.

DAVID BERTSCH.

I HAVE had six years' experience with sweet clover, and find that it will flourish in any place where alsike or white clover will thrive; but it will not grow on "blow-sand."

I begin sowing it in the fall at the time that the seed is ripe, and continue until corn-planting time; sowing on the high land first and finishing up on low swamp land. I sow it in waste-places, old slashings and pasture lots. In the fall of 1894 I seeled down ten acres of land that had just been cleared and burned over. I sowed timothy, alsike and sweet clover and went over it lightly with a drag. The following year I turned in seven cows. They did not touch the sweet clover until it was about two feet high, picking out the other grass that grew among it, then, as the hot dry weather came on, they took to the sweet clover and ate it to the ground, allowing the other grass to grow up and blossom. The cows remained in good health and gave good messes of rich milk.

HOLLAND, Mich. Dec. 11, 1897.



SWEET CLOVER.

It Makes good Pasture, Especially in a dry Time, and can be Easily Eradicated.

A. A. ALVERSON.

I HAVE sowed sweet clover upon pastures and waste places for the last six years, and can say that it has filled the bill for stock; especially in dry seasons when other clovers and grasses are literally dried up. It is a mistake to say that stock will not eat it; as, after tasting it a

few times, they give it a preference. Last summer I saw a pasture of seventeen acres in which sweet clover was eaten down close to the ground, while alsike, timothy and white clover went to seed in the same lot. Just over the fence, in another lot, the sweet clover grew seven feet high and so thick that one could scarcely pass through it.

It is called a weed by some, but this is not the case. Of course, if sown upon waste lands, such as swamps, open woodlands, clearings, etc., it will take the place of thistles and ragweed, and hold its own, but, as it dies root and branch the second year, there is no trouble getting rid of it. Not only this, but it leaves the ground full of richness that it has brought up from the lower depths.

HOLLAND; Mich. Jan. 13, 1898.



PLAIN SECTIONS AND SECTION CLEANERS.

Mr. Aspinwall and his Friend Discuss the Finer Points of these Innovations.

L. A. ASPINWALL.

"A little nonsense now and then,
Is relished by the wisest men."

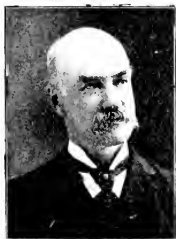

MR. A.—Good morning friend Weatherbee where have you been all summer?

Mr. W.—On the farm.

Mr. A.—On the barn?

Mr. W.—No, I said on the *farm*.

Mr. A.—Oh,

beg your pardon, it *would* be a queer place to spend the summer, come to think. Friend Weatherbee, you see I'm at it as usual, so please excuse this suit of clothes; my apiary, as you know, is a veritable

experiment station; and much of the work is ruinous to clothing. But you seem to be wearing a better suit than usual; haven't held up a clothing house lately have you?

Mr. W.—I see you are the same old boy you were twenty-five years ago, friend A.; and just as full of fun. But I must tell you about that suit of clothes. My good wife advised me to try the plain sections the past season; and, as a result, my crop of honey brought from a cent to two cents a pound more than if it had been in the old-style of sections. My crop of 5,000 lbs. netted me at least \$50. more than it would otherwise have done; so I told my wife to purchase the best dress she could find. Of course, woman-like, she agreed to it; but said I should appear her equal, in dress, at least, (which was a slight insinuation), and I, woman-like; agreed to it also. Say, friend A., my wife came very near calling me honey that day.

Mr. A.—Why? What did she say?

Mr. W.—She called me old beeswax.

Mr. A.—Friend W., don't you think it would be a good plan to get a sun extractor instead of rendering wax the old way, daubing up everything as well as your clothing? By the way, my wife asked me last week, if I knew the difference between a honey comb and a honey moon. I replied, that there could be no difference in one sense, as both were exceedingly sweet. She said, however, there was a great difference; whereupon, I became interested to learn just what it was, and requested her to explain. Well, friend W., what do you think it is?

Mr. W.—You don't want me to guess it do you?

Mr. A.—Certainly, if you can.

Mr. W.—Certainly I can't, what is the difference?

Mr. A.—I'll tell you. One is composed of a lot of little cells, and the other is one great big sell.

Mr. W.—Ha! Ha! I'm going straight home and give that conundrum.

Mr. A.—Hold on friend Weatherbee, I've lots to say about plain sections. The

technicalities are worth looking after. I refer to the supers and all work included until the honey is sold.

Mr. W.—All right; I am interested in all that's progressive pertaining to our pursuit; for I consider it the most profitable, as well as the most instructive and elevating branch of farming. There are lessons to be learned from the bee, setting forth the highest order of government. They are practically a theocracy—self-governed, and working for the general welfare of all. Then, again, we may learn lessons from their industry—the instinct, which, above all else, characterizes their nature. And, as artisans, can we find anything in Nature comparable to them?

Mr. A.—That is true friend W., we may learn lessons from the bee.

Mr. W.—Well, friend A., what were you going to present in the matter of plain sections?

Mr. A.—You know that one improvement in any line necessitates or opens the way to others; for example, the plain section has opened the way for machine-cleaning; and now that machine-work is an assured success, I propose to facilitate its work in every way possible. The market here in Jackson, having had machine-cleaned sections, will not be satisfied with anything less in the future. As you know, my super has no slats under the sections; hence, more or less propolis will be plastered there. Now, I intend to construct forty or fifty sets of section holders similar to friend Root's. Having used them with my super, I find they work admirably; any number may be used to expand or contract the size as desired; and you know the advantages of an elastic super.

Mr. W.—But didn't you tell me last Spring they were too fussy?

Mr. A.—Yes; but, as I said before, the section cleaner has already necessitated it. Furthermore, I think that I shall be enabled to cheapen my tin separators enough to balance the cost of holders. Like dummy combs, although a little

fussy, I am satisfied they will be a paying investment. Movable frames are fussy compared with box hives; and had the plain sections and separators been introduced beside the primitive honey-box forty-five years ago, they would have been considered very fussy indeed. But we are progressing toward a perfect system of bee-culture and the requisite appliances must naturally constitute a part of the system. By the way, how do you prevent pop-holes or passage-ways in the section corners?

Mr. W.—Simply by filling the sections with foundation close to the sides, and giving the equivalent of room for travel by using a thoroughly open separator. This is fully illustrated by the old style of sections, with their closed corners, which afford insufficient communication; hence, an opening is left in the corners of filled sections. Separator cleats likewise form an obstruction compelling a line of travel up and down; which interferes with the comb builders, and prevents the sections from being well filled next to the wood. Plain sections, (having no closed corners), although better filled even with a cleated separator, will be almost solid with honey if a thoroughly open separator is used.

Mr. A.—Your experience is mine to a dot.

In view of this fact, I intend, as an experiment, to fill a number of sections full to the corners with foundation, cutting an inverted V-shaped opening at the bottom, extending to the corners, about $\frac{1}{2}$ an inch deep at the center, which will afford a passage-way for the bees, where it will most likely be filled at the finish.

Mr. W.—I believe that will help; still, they are filled well enough for all practical purposes. Taking the extra work into consideration I doubt as to its paying. Do you leave a space above the sections?

Mr. A.—I do not unless the supers are tiered. With a thoroughly open separator, it is unnecessary; furthermore, the sections are not exposed to propolizing. As already stated, that is my reason for

using the section holder in combination with an open separator.

Mr. W.—Speaking of shipping cases, I intend to leave out the supporting cleats, and paper, also return to the two-row, which will be a saving of 30 per cent. in glass. I shall also try a few cases with a single row of sections, which will save another 30 per cent. of glass. Such a case can be constructed of narrow pieces of cull lumber 23 inches long to hold fifteen sections. Furthermore, I shall make a groove on each side for a sliding cover, as nailing or screwing the covers down is objectional for home marketing. The opening of a sample case is too slow where nails are used; besides, the covers are often broken.

Mr. A.—I believe you are right. Experiencing the same difficulty, I have been using a single nail in one end of the cover, and a double pointed tack in each opposite corner, driven in the end grain of sides and cover. They are easily removed, when the cover may be turned one side for removal of sections. Of course, a single-row case would be odd looking, yet it could never be set on end.

Mr. W.—Speaking of section cleaners, I would like to know something about their workings. What do you think of the disk plan suggested by friend E. R. Root?

Mr. A.—While I don't know it all, I can say there is one inherent objection to all disk or belt cleaners which cannot be overcome. While they answer very well for the outside or surface, the grindings or fine particles of propolis mingled with woody fiber can not escape when a disk is applied to the section edges. As a consequence, both comb and inside edges of the sections are often dusted to an extent which would render them quite unsalable. With an outside row of cells unsealed, much dust will be thrown into the honey, making the objection untenable. My experience thus far teaches that a small cylinder is the correct principle. A small point of contact with the section edges leaves abundant space for the downward

escape of dust, which is assisted by a current of air induced by rapid rotation, and gradually thrown off by centrifugal force. Not a few difficulties present themselves in the construction of a perfect section cleaner; the most serious being the tendency to gum or clog the cylinder. Sandpaper I regard as the poorest material that can be used. Aside from the tendency to gum, it must be glued to the cylinder, otherwise it will become torn; and, as a consequence, injure the honey cappings. Emery cloth is decidedly preferable. It can be quickly secured to the cylinder and roughly used without the slightest danger of being torn. Still, it will become thoroughly gummed in cleaning 25 or 30 sections, according to temperature and amount of propolis.

Mr. W.—How about a planer-bit as suggested by Friend Schaeffle of California?

Mr. A.—Having tried cylinders with cutting and scraping surfaces, I am convinced that nothing so fragile as a section can withstand such violent action; and that propolis can be removed only by a grinding surface. In view of the tendency to gum or clog, and knowing the effect of boiling water upon propolis, I substituted a cylinder of solid emery for the cloth. You will see, Friend W., that another step in advance was then made in securing something *durable*, although a little more expensive at the outset. Still, I am not satisfied yet; something must be forthcoming that will prevent all gumming in order to economize every moment of time, and insure rapid work.

Mr. W.—Well, Friend A., I am surprised to learn that so many difficulties were encountered; certainly your experiments have involved much time and expense. But will not the cost of such a machine be a serious objection to its general introduction?

Mr. A.—I think not. The present machine will be somewhat simplified. Taking all into consideration, I think the coming section cleaner can be sold for about \$5.00. Having cleaned about one thousand sections with mine the past sea-

son, I would willingly give that sum rather than return to hand-work.

Mr. W.—Friend A., I am glad I called on you this morning. I have certainly enjoyed a pleasant and profitable visit.

Mr. A.—Thank you, Friend W., it is mutual. I have also enjoyed the call exceedingly, and profited by your experience, and hope you will come again very soon.

Mr. W.—Thank you, I will. Good morning, Friend A.

Mr. A.—Good morning, Friend W.

JACKSON, Mich. Feb. 4, 1898.



COMB HONEY.

Our Modern Improvements (?) are Robbing
it of its Delicate Deliciousness.

C. G. FERRIS.

I AM thoroughly disgusted with the way that producers of comb honey are going *backward* instead of improving their product. About twelve years ago we had a two-pound section box of good size, that could be glassed, so as to protect it in handling, also to keep out the ants and vermin. The starter was of natural comb; and honey stored in this manner was profitable to the producer, and a lasting joy to lovers of comb honey. My mouth waters for some now. Who was it that gave to the customer the idea of smaller packages? Bee keepers, themselves. Who was it that put a piece of artificial comb in each box? Bee-keepers. It looked nice, this artificial comb did, the cells were regular and even, and it was a pleasure to handle it in small square pieces, for the boxes; besides, it makes the honey tough to handle, and it stood shipment better; but it was just as *tough* to those who ate it. Say, when you get a chance, I wish you would suggest to foundation makers, to put in some of Primley's, pepsin, to help digest the wax.

Perhaps, by so doing, some of the objections may be overcome.

Again, I ask, who is it doing this retrograde work? *Bee-keepers*. Smaller and smaller has grown the box. Narrower and narrower goes the section. If this thing goes on we will have a hard rib of foundation with perhaps a little honey to offer as an inducement to get rid of it. It will be right in line, at present, for bee-keepers to do *something* to keep up the reputation of honey.

As a bee-keeper of 22 years' experience, I have always tried to have every comb, every hive, and everything so made as to protect itself in some simple way. Sections made with wider sides than ends protect the combs in handling. When those familiar with the handling of them will occasionally give them a dig, what can be expected of the novice? A very vivid illustration of this arises in my mind. Seeing a crate of honey of *modern style*, upon a counter in a Southern store, I asked the proprietor if he sold much of it. He said no; it went awfully slow. But I thought it was going quite fast; as the ants had found it and were going and coming in a long continuous stream. The sections had been palled out, as the finger marks on each side of them clearly showed. Honey was running, and a sad mess it was.

About the new fangled "glue-traps," as Heddon calls them, just go back twenty years and look in Quinby's *New Bee Keeping*, where he is describing sections, and see something new, perhaps, to some young bee-men. This separator is without doubt the most practical of any thing ever used, as the bees have access on all four sides. If I should ever use boxes again to any extent I would not ask for anything better. Say, I like Heddon's article, it smacks of practice. I feel like shaking him by the hand. No fine-spun theories there. I wrote him the other day in regard to fixing him up a wax extractor; about what kind he would want; one of the single-basket, or with two. I know now. He will want one with *busi-*

ness in it; and that is what he will get. Should I ever meet him I know I will like him.

Well, I have blowed enough about the absurdness of tampering with what should be the most *delicate* and *delicious* of food until one thing and another has disgusted every lover of it.

The second year I kept bees I had charge of 60 colonies; increased to 100 and averaged 200 pounds to the colony. Honey sold for 25 cents a pound, and I got the cash in my fist. Those were the golden days, and *foundation was not known*.

So, COLUMBIA, N. Y. Feb. 7, 1898.



INFLUENCE OF TYPOGRAPHICAL BEAUTY.

Some Praises of the Review that bring a Flush
to its Editor's Cheek.

E. E. DACUTT.

For praise that's due does give no more
To worth, than what it had before, BUTLER.



OUR ever welcome friend, the Review, always neat, attractive and well gotten up, came out in December with a new dress, and better than ever; showing evident signs of prosper-

ity. I am very fond of good books, magazines and papers; and, although those gotten up in plain style will answer, I much prefer those gotten up in the highest style of the art; when it is appropriate to do so. How much more readable and enjoyable they are when printed on fine paper—preferably white—with clear bold type, and embellished with clear, beautiful engravings and suitable decorations.

While it would not be proper to get up every publication in the higher style of the publisher's art, there is no reason why a publication worth publishing at all should not be gotten up reasonably well; especially as to quality of paper and type. There are publications that are well enough, as to quality of contents, but are meanly gotten up otherwise. What is worth doing at all, is worth doing well. As companions either elevate or degrade, so the publications we take into our homes do the same. The reading matter is the most important, but the character of the publication, in regard to the kind and style of art displayed, is also important in its elevating and refining influence.

When the Review came to hand, looking so neat and beautiful, I was pleased; and the issues since have maintained the same high character. Often have I taken up the magazine and looked at the frontispieces of the December and January numbers; especially of the latter. How natural they look; almost I do not know whether I ought to say *almost* or not; if not quite as natural as the real.

Certain things have a peculiar attraction for some people. I presume that every reader of the Review has felt the peculiar attraction of bee-keeping. It is so strong that if it once gets a fair hold of a person it is difficult to get out of its grasp. I have noticed that if a person once keeps bees that he or she is apt to continue to keep them, although "they are going to sell them," the bees somehow seem to stay on.

It is, no doubt, this influence that causes the fraternal spirit that exists among bee-keepers. There may be a difference now and then between two members of the pursuit; but the fraternal spirit will in time smooth over all such. I know of no business or profession that possesses so much fraternal feeling among its members. It has been said that it is due to contact with Nature; but such an explanation is not satisfactory, for we come in contact with Nature in other things, but we do not

feel such an influence. Farmers come in contact with Nature more than any other class, yet the fraternal spirit of a common pursuit can be scarcely said to exist among them at all.

Being under the influence of such a spirit, it is no wonder that the readers of the Review have so highly appreciated the improvements in it; and said so many nice things about it and its editor; and that he has appreciated the same by suitable expressions of appreciation. Since the editor of the Review has made such a success of apicultural journalism, I regret that the apicultural world is too small for a man to fully expand in. The agricultural world is large and wide and in it there has long been a want for an agricultural journal of the highest type—national in character and gotten up in the highest style of the art of publishing. Such a journal should be in every rural home; and its influence to elevate, refine, and ennoble would be great. Where is the man that will do as well in agricultural journalism as friend Hutchinson has done in apicultural journalism?

As to further improvements in the Review, I would state that it seems to me friend Hutchinson is fully equal to the task of improvement, even without help from his readers. Still, since he has asked for opinions in the matter, I will give some ideas in relation to it that may be of interest; hoping that I will not be considered too critical and over particular.

Too much sameness is tiresome to the eye and mind; hence, changes in the make-up of a magazine, in certain respects, should be made at the proper time. Witness how much better the cover of the Review looks by the mere change in the color. Even so small a change as the rearrangement of headings of articles or changes in the type of the same, has its effect. Of course, the changes I have reference to need to be made only at certain intervals, determined by whether they would be of advantage or not.

The cover is an important feature of a magazine; and if properly gotten up adds

much to its attractiveness. It should be neatly and tastily, but not extravagantly, decorated; and the same should be the case with the other parts of a magazine. I am no friend of the slipshod, tumble-down-fence style of decoration. Some artists seem to think that they are doing a fine thing when they picture a countryman as a crude looking affair, with long, disheveled hair, over-loose, ill-fitting clothes and coarse looking features. If they illustrate a nice country residence they are almost sure to spoil the picture by having a worm fence, or a tumble-down fence, or some other rude affair as a part of the surroundings. They do not seem to know that true art is not distortion, but is purely natural.

The title page, or rather the first page of the reading matter, the upper part of which answers to a title page, affords a good chance for display of decorative art; and even so simple a thing as the title at the top of each page can be improved by simple decoration, which I have seen done. Right here let me ask why is it that the word "the" is put in front of the name of a magazine or paper as is often done? I do not suppose that such a thing is ever thought of when the name is put on a ship or locomotive, or probably anything else. It always seems curious to me. I prefer a rule between the columns of the printed page. It takes away the bare appearance of the vacant space. Compare the second page of the cover with the pages of reading matter. I think a suitable border around each page would be an improvement. Notice how much more attractive those advertisements look that have decorative borders. Even a line around the page with decorative corners, would, I think, be an improvement.

Engravings add greatly to the value of a publication, and I hope the editor of the Review will continue to make them a prominent feature of his magazine. I very much admire the beautiful half tone engravings, and am glad that the process of producing them has been so far improved that they can be printed by fast work-

ing presses. Good engravings make a publication more readable and enjoyable and have an elevating and refining influence. Although I did not like, at first, to have *my* likeness at the head of my writings in the Review, and it got there only by a certain manœuvre of the editor, I now think the idea of putting the likeness of the writers of the Review at the head of their writings a good one. When we listen to a speaker we instinctively look at him; because his gestures and the expressions of his countenance are a part of his language. When we read the writings of a person we do not have the advantages we have when we listen to a speech; but by having the likeness of a writer at the head of his articles, we can see how the writer looks and get the expression of his face, which is an advantage. Mr. Hasty has been writing for the Review for years; and not having had the pleasure of meeting him, I would like to see how he looks; especially since the composer of the music for the beautiful gospel hymn "Seeking for Me," bears the name of E. E. Hasty. I wish there were some way to get Mr. Hasty to allow his likeness to be at the head of his writings in the Review.

The editorial department of a magazine or newspaper should be one of its chief features. We naturally wish to know what the editor's opinions are in regard to things of importance within the sphere of his own journal. Where is there a better place for an editor to make use of his powers and talents than in the columns of his own journal? I wish the editor of the Review would write editorials for each number as newspaper editors do for their journals; and not put them after the editorial notes, as if they were of minor importance, but put them first—the *best* forward. The likeness of the editor should be at the head of the editorial department; and it could be nicely blended with the editorial heading.

Whatever friend Hutchinson does with the Review, I hope he will always keep it a monthly. It is proper to publish *news-papers* frequently; for they are devoted to

giving the news, and it should be fresh, but our bee-journals are not mere newspapers, and are best as monthlies. Then they are in compact form and can be taken up at leisure and their contents given proper consideration; which is not so likely to be the case if published oftener. As monthlies they can be gotten up and published more cheaply; and a better journal can be given in consequence for the same cost.

The Review possesses a most important advantage in not being connected with the bee-keepers' supply business; and, therefore, does not have the caste of an advertising pamphlet, and its correspondents have a freedom of criticism and discussion that they would not otherwise possess. May it continue to prosper and improve.

*WHITE HOUSE STA., N. J. Mar. 8, 1898.



FEEDING WAX TO BEES.

It may be Done at a Profit—But Read the Following Article.

J. E. CRANE.



MR. EDITOR, will you just say to that Hasty fellow, who writes with a diamond pointed pen that always sparkles, that the feeding of wax to bees, (see Jan. Review, page 25, bottom of first column,) is just as easy as rolling off a log. It is not necessary to blacken the wax, nor to color it red nor blue, nor green. Yellow will answer every purpose. Just take a jack knife, if you have one, or a butcher knife, or a piece of glass, and scrape some thin shavings from the top of a cake of bright yellow wax, and

put them over sections nearly full, or that the bees are capping, and cover them with a bell-glass, or glass-box, with free communication below, and see how quickly the bees will pounce upon them and lug them down. Then, in a day or so, just lift some of the sections and observe their mottled white and yellow. I have a comb in my honey room illustrating just this point, and wish you could see it. It is a fact that bees will take wax, when they need it, just as readily as they will honey.

Now, where is the inventive genius who can give us a wax-feeding annex to a moth-trap? Price, \$2.50; five for \$10.00. For, don't you see, oh, ignoramus! wax is worth but twenty-five cts. per pound, and honey ten cents, and if it takes seventeen and one-half pounds of honey to make one of wax, that is worth \$1.75, don't you see a clear saving of \$1.50 on every pound of wax needed if you only have a wax-feeder? Besides, you can feed extracted honey and keep the bees building combs all summer at a profit; and if you haven't extracted honey you can feed—but, "*Where am I at!*" as the drunken Congressman observed to the Speaker.

P. S. After some experiments in feeding wax, I prefer to feed it in thin sheets—some call it foundation.

MIDDLEBURY, Vt. Feb. 19, 1898.



EDITORIAL Offerings.

MR. DAGGITT is to be praised or blamed, as the case may be, for this new editorial heading. See his article on another page, and you will understand what is meant.

THIS ISSUE of the Review goes to a large number of bee-keepers who are not subscribers; and, for this reason, I have used considerable space in describing the Review and its characteristics.

MY BEES are still in the cellar this 7th day of April. They are nicely clustered and quiet, and I am not worrying.

A JOURNAL that is bright, wide-awake, vigorous, up to date, and full of ideas that help and arouse the reader to better deeds, can be forgiven almost any failing.

TWELVE HUNDRED NUCLEI, is the number that Mr. H. G. Quirin, of Bellevue, Ohio, proposes to run the coming season. It would seem as though there need be no waiting there in filling orders. Wouldn't I like to work in such a yard. Whoop-e-e!

DR. J. P. H. BROWN, of Augusta, Georgia, has written and published a neat book especially designed for beginners in bee-keeping; pains being taken to adapt it particularly to the requirements of the South. Its title is "Bee-Keeping for Beginners," and the price is fifty cents.

CRITICISM of the right kind, that which is fair and fearless, can do much good; and the Review expects to soon have a department devoted entirely to that branch of apicultural journalism. The critic will be none other than our old-time correspondent, R. L. Taylor, of Lapeer, Michigan. His first batch of criticisms will probably appear in the May Review.

THE FRONTISPIECE in this issue of the Review was made from a photograph taken within half a mile of the Review-office. It is on the flats of Flint river. By looking closely a glimpse of the river can be seen in the shape of a light streak near the top of the clover. Part of a lumber-yard belonging to a saw-mill can also be seen in the background.

I sent a copy of the picture to Mrs. Hutchinson, and she wrote "That growth of clover is fine; and the picture of yourself is *just you*; it is as natural as any picture of you that I ever saw."

HOW TO REPORT CROOKED OR SHAKY FIRMS.

Quite a little is now being said in some of the journals regarding the difficulty of reporting commission firms who deal in honey, but are not desirable houses—that is, they may be slow pay, or something like that, even if not downright dishonest. The difficulty is that if we say such or such a firm is dishonest, we at once lay ourselves liable to prosecution for libel. We may know to a moral certainty that a certain firm is not honest, or has some other very undesirable trait, but to *prove* it in a court of law might be very difficult—certainly very expensive. For this reason a publisher has to be very careful what he says about a dealer. Under these circumstances some publishers have been hinting at the "local habitation and name" of a dishonest firm. Such hints as these do very little good. If we can't tell the *name* of a crooked firm we might about as well keep still. Let the *name* of the firm be given, and then do the hinting in regard to its undesirable traits. Of course, this would have to be done very cautiously, but it *can be done*. To illustrate: there is a paper published at St. Paul, Minnesota, under the title of the Publisher's Guide, that makes a specialty of looking after the standing and character of advertisers, and reporting the same in its columns for the benefit of publishers. The firm-name is *always* given; and then, by reading between the lines, the publisher must be dull, indeed, who can not draw a correct conclusion. This company has representatives in all of the large cities, or sends them wherever it is necessary, and these representatives report in regard to all suspicious-looking firms. A publisher would lay himself open to the charge of libel if he should say that a certain firm was to be avoided because it was dishonest, or because it was lacking in capital, or because its methods were undesirable, etc., but a representative of the paper can call at the firm's place of business and tell *exactly* what he sees, and in the tell-

ing can convey a *correct* impression, yet there will be nothing in his report that can be constructed as libel. I call to mind one case, and will give it as an illustration. Some firm was advertising with a great spread. The representative of the Publisher's Guide found the office up several flights of stairs, in the back part of the building. There was an old desk, a few old chairs and tables and some girls busy mailing circulars. The representative told *exactly* what he saw, and then added "but, of course, all this does not prevent a man from paying his bills." There is nothing in all this that could give a chance for prosecution, but where is the publisher that would give credit to this firm after reading this report? The Guide frequently calls attention to the fact that, owing to the libel-laws, the utmost caution must be employed in reporting all firms; but if its readers will use good common sense and a little bit of shrewdness, there is little danger of being caught by a fake advertiser. I am satisfied that a similar course might be followed by our bee-journals. Let them give the *name* of a dishonest firm, and then say something that may be understood by reading between the lines.

HOW TO MAKE MONEY PRODUCING

HONEY.

There. Isn't that an attractive title? That's what we all wish to know about. If I can do justice to the title, I am all right. I'll tell you what put me in mind of it. It was reading in Gleanings the account of E. R. Root's trip down East last fall. Among other bee-keepers whom he visited was Mr. W. L. Coggs hall. He did a good thing for Gleanings when he visited Mr. Coggs hall and wrote of what he saw. I have had the pleasure of meeting Mr. Coggs hall a few times at conventions; and he has always impressed me as being one of the shrewdest of shrewd men. He is genial and companionable, and all that, but it has always seemed to

me that the fellow who attempted to "put up a job" on Mr. Coggshall would better look out. Whether or not my estimate of his character is correct, he has certainly been shrewd enough to recognize that time, or labor, is the most expensive factor that enters into the cost of producing honey. Bees cost less than labor; so Mr. Coggshall keeps lots of them; and then puts into practice all the short cuts and "lightning" methods that his bright brain can devise. To illustrate; if extracting when robbers are troublesome, instead of going to the expense of making a building bee-proof, he goes on with his work regardless of the robbers. Of course, they dive into the extractor and are knocked down into the honey; but they rise to the top, and the honey beneath them can be drawn off free from bees. "Bees are cheaper than tight buildings," says Mr. Coggshall. "I can raise them for fifty cents a colony, and probably not more than a colony is lost in this way." When he is through extracting, the supers or hives of empty comb are left in the old buildings for the bees to clean up; even if they do have a general *melée* at it. His apiaries are isolated, and if the bees do go on a "tear," no one is injured thereby. Mr. Coggshall is one of the fortunate few in this country who have really made quite a little money in bee-keeping.

I was once talking with Mr. Heddon about the advisability of covering a little spot of ground with a coating of cement, or with something like the asphalt pavement for each hive. There would then be no more rotting of hive-stands, and the grass would be kept down. He exclaimed: "Oh, Hutchinson, we couldn't do anything like that when we are raising ten-cent honey!"

Speaking of ten-cent honey reminds me that my friend Koeppe was in to see me a few days ago. He had been to Detroit to sell some honey, and found that the finest white comb honey could be bought for only ten cents a pound. He said: "Of course, there is a profit in it at

that figure; but I tell you, a fellow has got to raise a lot at that price to make anything."

That is the point exactly. The man who makes his fortune in the keeping of bees must now keep a lot of them; scatter them around in out apiaries, and then adopt such implements and methods as will enable him to secure the honey with the least possible labor. It is not a question of how can I secure the most honey per colony; but, of how can I make the greatest profits? This is the broad sense in which bee-keeping must be viewed if we are to reach the highest commercial success.



KEEP COMB HONEY UP TO A HIGH STANDARD.

There are two articles in this issue of the Review bearing upon this point. One is by Mr. R. L. Taylor; in which he shows the different thicknesses of different foundations after they have been worked by the bees. The other is by Mr. C. G. Ferris. This is really a more important subject than many bee-keepers realize. Comb honey, as built naturally by the bees, is a morsel of unsurpassably delicious sweetness. The use of comb foundation has enabled bee-keepers to produce more honey—much more—and to produce straight, even combs with less care; but it has robbed honey of some of its deliciousness. For my own eating, I would willingly pay a cent a pound more for honey in which there was no foundation. In the gradual breaking down of those flaky walls of virgin whiteness, there comes to the palate a delicious sweetness and pleasure that is largely absent when a piece of tough, leathery, yellow wax takes the place of those brittle flakes of comb. Not only this, but the cell-walls themselves are often largely made up of the wax that is taken from the foundation; and are thus more tough and leathery than those built from flakes of virgin wax. I know that I have written before upon this point, but it needs line upon

line until bee-keepers *realize where they are drifting*. Consumers may not understand exactly *why* they do not like honey so well as they did once; but that makes no difference to us so long as the *fact* remains. I say it in all kindness of spirit, but the greatest blessing that has come to bee-keepers of late was the failure of the deep-cell foundation.

I know that the advantages of foundation are so great that it is not likely that it will ever be dispensed with in comb honey; but let it be of the very lightest and thinnest possible. Mr. Taylor's experiments show that the no-wall foundation is even thinner than natural comb. This foundation will certainly come the nearest to giving us comb honey that is a near approach to natural comb. If some one like the Roots, for instance, would take hold of this no-wall foundation and "boom" it in their characteristic way, it would be a blessing to the fraternity. So far, there has been only one objection urged against it, and that is that it warps; but Mr. Dadant, who is the man that makes it, says, in the American Bee-Journal, that this can be easily overcome by making the merest rudimentary walls upon one side; so that it will stick to one roll when it comes from the mill. He says that when foundation sticks to first one roll and then the other and thus warps and twists about while being rolled, it will always give trouble in the hive; and that this is what the no-wall does; and that it can be remedied as he suggests.

Comb honey is a luxury. Argue as we will, the fact remains. Let us not forget it; and, let us, as its producers, see that it never loses one whit of its delicate deliciousness.

Since the above was put in type I have received a letter from Mr. E. R. Root in which he says that he has sent me a sample of their latest product in the foundation line—a foundation running 18 feet to the pound. By reducing the wall it can be made even thinner. I am very glad indeed to note the "change of base" on the part of our enterprising Medina folks.

A Condensed View of Current Bee Writings.

E. E. HASTY.

"And I also claim that there is nothing out of the way, if any one chooses to do so, in shipping cases of honey having XXX facers and XX or X honey inside, ON COMMISSION. Yea, more, I claim that there would be nothing DISHONEST in filling the center of the case with buckwheat honey, the same having XXX white honey facers, providing it was SHIPPED ON COMMISSION, every case alike, and the producer thought it to his interest to do so." Doolittle in *Gleanings*, 175.

Dr. Miller intimates in a recent straw that he expects me, from my known opinions, to pitch into you, friend W. Z., for your frank admissions in Review 61. I have chosen the above, however, as smelling the strongest of brimstone of anything on this topic I have seen lately, put out by a leading bee man. Besides, Mr. D. is the foremost of practical bee-keepers, and also stands high as a Christian; and the scriptural maxim that judgment should begin at the house of God applies in his case.

Who wants the task of arguing Mr. Doolittle down on the quotation given above? Not I. The job is "to let." Nevertheless, my heart is so deeply stirred that I shall talk around the outside of the tent quite a bit.

It sometimes happens that a girl casts off the restraints of propriety and good form, speaks to every nice looking young man she sees, and takes twilight walks with well known libertines, and does all such desperate capers. She says she has not the slightest intention of doing anything wrong, but only a heroic determination to claim and maintain her freedom from unnecessary and unendurable chains. Who wants the task of arguing her out that position? But, on the other hand, who is willing to insure her a decent future?

There is a rumor (to say the very least) that a certain business company paid its transportation bills, and then reasoned the carriers to paying back part of the bills—that this went on till it became the usual thing—that the company grew

great, and the carriers at length did not *dare* to refuse it rebate money—that this company's policy eventuated in the destruction of nearly every other company in that branch of trade, and gave it a monopoly embracing more continents than one. Who wants the task of proving to *that company's satisfaction* that their policy was wicked? On the other hand, if Mars or Venus, or the best planet of Alpha Centauri, were open for settlement, who would consent to stay on earth, should a couple dozen equally big and bad monopolies get footing?

A certain rich man (it is also rumored) got on by making some hundreds of employers work without any wages, and take their pay out of money contributed by the sleeping-car public. Beggary is the plain English of it. Reported also that this man at length came to make his employers give him a percentage of the proceeds of their beggary, besides working for nothing. Who wants the task of proving to the like of this man that his course was anything worse than a nice little business arrangement all round? Boss beggar piling up the money; subordinate beggars securing enough to make them objects of envy to wage-earners outside; public generally indifferent, else shaking with laughter. Who cares for a few reformers who won't be satisfied with anything? O Devil, thou art indeed a most wonderful Devil! O sleek, sly, wonderful spirit, whose words from Eden to Uz, and from Uz to Quirrantania sound! to weak man's ears just like the simple truth!

Now it is not supposed that Mr. Doo-little in saying the above realized that he was doing anything discreditable to a good man. But I hope he'll be able to say "Faithful are the wounds of a friend" when I tell him he was so doing. I say that the quotation at the head of this View is not laying at the s'ceek and wonderful Devil with the sword of the Spirit—it is not laying at him with the kick of an honest man—it is just gently stroking him down the back. One almost listens

to hear his majesty purr. Every trickster will feel bolder after reading that quotation; and general petty trickiness in business doings is a greater obstacle to making this world what it ought to be than either of the evils I have brought out in the three paragraphs just preceeding. True and innate modesty is not so rare, and does not need such careful culture and support on absolutely every side, as the desire to deal truly and fairly by one's customers. The greatest monopoly on earth is not so hard to tackle as covetousness in the heart of man. (I know, for I've put honey in case, and have said to myself "There, I may lose pennies on that honey, but I can stand it, and will." and then, first you know, you'd see me looking for pretty faces to put outside.) The meanest man that ever carried on beggary by proxy and called it business is not so mean as any one of us will get to be if we only yield to the spirit of the world, and take little short steps, all in the covetous direction, and keep on taking them long enough. "All our people do so" is the Congo cannibal's argument—does it prove anything? The fact that schemes to deceive purchasers are almost universal is only a peremptory call to arms for all those who have been listening to the Man of Nazareth. The true question is not "Can this or that be sustained logically?" But "Does this reflect a heart tremendously in earnest against the evils of a world crammed full of wickedness?" If we believe in warfare against the world the flesh and the Devil we must not be talking "armistice" all the while.

AMERICAN BEE JOURNAL.

The American Bee Journal is so much in evidence all the time that the coming around of its regular turn does not amount to much—nevertheless I give it its line of caps, and range its citations together underneath. No great change since last time—unless it is to sell all its "departments" to the rag man, retaining only the old and long tried ones—and the new broom of Beedom Boiled Down.

Dr. Gallup says, in A. B. J., 68, that the cold wet-sheet pack is the best remedy when life is in danger by reason of a multitude of stings. For a horse the same. Strap on wet blankets, and keep them wet with more cold water.

C. B. Elliott of Colorado had a case where a pint of bees with a young queen, just beginning to lay Oct. 5, built up steadily all winter, became extra strong in June, and then made one of the best honey records of the apiary. A. B. J., 68.

As is well known, bees have two kinds of eyes; three ocelli, or simple eyes, and two compound ones, which are the usual eyes of insects. It seems the question has been raised by Henry W. Brice whether one kind of eye may not use X-rays, or something similar, instead of light. If so, the queen may see the eggs she has laid on the other side of the comb, and that's why she gets them so correctly opposite. A. B. J., 71, from B. B. J. I would add that the seeming absurdity of having little eyes located in a mat of hair would mainly disappear if said eyes used rays to which the hairs were transparent. And do the mole's eyes use X-rays too, penetrating through hair and dirt too, to betray his enemies above ground?

It would seem from A. B. J., 87, that it's all right for hot water to get into the boiler, but still the Boiler don't like to get into hot water. I'm going to throw some hot water onto the outside of him because he does not give the page of the passages he refers to. I get disgruntled in mind when I try to refer to the original passage and can't find it.

A little further down the same column we find him at Dr. Miller and the Germans about a half-and-half cross changing in process of Nature and mathematics to a two-thirds cross. This is a queer matter, not without importance. Put colonies with pure Italian virgin queens, and a supply of black drones, in an isolated location, and the next year all your drones will be pure Italian and all your young queens half Italian. This would seem to indicate bees three-quarters Ital-

ian and one quarter black. The third year, however, backslide one-half—with the ultimate result of bees two-thirds Italian and one third black.

RICHARDS, OHIO, Mar. 31, 1898.

EXTRACTED.

SUCCESS.

A Journal That is Devoted to That Weighty Problem—Success in Life.

Of all the newer ventures in journalism I think none found a place ready and waiting for it to a greater extent than did the one that has chosen for its title that one word: "Success." It claims to be an up-to-date journal of inspiration, progress, self-help, self-respect, self reliance, self-culture and self-control; and, in my judgment it is all that it claims to be. It is only four months old, but it is going ahead and gaining subscribers at a wonderful rate. Probably more of us fail because of getting discouraged and giving up than from any other cause; and here is what Success has to say on this point:—

Persistency is characteristic of all men who have accomplished anything great. They may lack in some other particular, may have many weaknesses and eccentricities, but the quality of persistence is never absent in a successful man. No matter what opposition he meets, or what discouragements overtake him, he is always persistent. Drudgery can not disgust him, labor can not weary him. He will persist, no matter what comes or what goes; it is a part of his nature; he could almost as easily stop breathing. It is not so much brilliancy of intellect or fertility of resource as persistency of effort, constancy of purpose, that gives success. Persistency always inspires confidence. Everybody believes in the man who persists. He may meet misfortunes, sorrows and reverses, but everybody believes that he will ultimately triumph, because they know there is no keeping him down. "Does he keep at it,—is he persistent?" This is the question which the world asks about a man. Even a man with small ability will often succeed if he has the

quality of persistence, where a genius without it would fail.

What would be the value of such an item to a man lacking in persistency if he would read and heed it? This extract is only a sample of what may be found in *Success*. It is a nicely printed and illustrated journal of about the size of the *Ladies' Home Journal*. The price is \$1.00 a year. I wish that all of my readers could become subscribers to *Success*. I will club it with the *Review* at \$1.75; although, in so doing, I am not making one cent of profit. *Success* is published by the Success Publishing Co., Cooper Union, New York City. Single copy 10 cents. This is not a paid advertisement. I am giving this notice without the publishers knowing anything about it—doing it because I think I shall do good by spreading this journal.

THE BEST BEES.

Mr. Doolittle Explains Which are the Best Kind of Bees for Certain Kinds of Work.

In a recent article Mr. J. E. Crane gave his experience and views regarding the black and Italian varieties of bees; and, in so doing he referred to the views of Mr. Doolittle. Since the publication of that article in the *Review*, Mr. Doolittle has given his views more in detail in *Gleanings*. Some one wrote and asked him if he were breeding especially for honey-gathering purposes, which he would prefer—the golden Italians, dark ones, or hybrids? If he preferred hybrids, how he would breed for the best results. His reply is as follows:—

Volumes have been written on this subject, and the matter is not fully settled in the minds of many at the present time. Some of our very best bee-keepers tell me that they do not know which is the best; but from my standpoint a true solution depends upon which we are producing—comb or extracted honey. If I were producing extracted honey altogether, I think I would select the darker Italian, or those produced from queens reared from an imported mother, allowing these queens to mate with whatever drones

there were in and about the apiary, paying no attention as to whether these drones were from Italian, hybrids, or black stock. If I were working for comb honey exclusively, then I would procure a good queen of the golden variety, rearing all queens from her, and allow them to mate with any drones they might chance to meet, the most of which, without doubt, would be from an entirely different "blood" from themselves, which would give a direct cross. Such direct cross always give the greatest vigor, and, as the question is asked, I should not care one cent whether my yellow queens mated with drones from black or hybrid stock, as all my experience goes to prove that thoroughbred golden Italian queens; mated to drones of either black or hybrid stock give bees equal to the very best for comb-honey purposes. But if I could conveniently hinder the thing I should prefer not to have these queens meet drones from young queens reared from imported mothers—not because they would not give bees just as vigorous, and of just as good honey-gathering qualities, but for the reason that, as a rule, workers having much imported "blood" in them do not cap their honey nearly so nice and captivating to the eye as do those having more of the golden, hybrid, or German "blood" in them.

To sum up I would say, first have your queens mate with drones as distantly related to your queens as possible; second, use queens as closely related to imported Italian stock as possible, where working for extracted honey, for there are no bees in the world, in my opinion, that excel those one generation from imported stock, for honey-gathering. Third, where white capping of combs becomes one of the great objects to work for, as is the case when working for comb honey, then choose the golden Italians, on account of their qualities in that direction; while at the same time they are in no way second to Italians from imported stock, as to their honey-gathering qualities.

SWEET CLOVER.

Its Value as a Forage and Honey Plant.

With the dry seasons that seem to have formed the habit of coming quite frequently of late, it behooves farmers to turn their attention to some forage plant that can withstand the dry weather—one that sends its roots down to such a depth as

to be well nigh independent of the drouth. Such a crop we have in sweet-clover—at least, it seems so from the reports of reliable men. When we consider that it is of real value, too, as a honey producer, it is worth while for bee-keeping farmers to consider the advisability of giving it a fair trial. I have recently been looking over the articles on this subject that appeared in the October issue of the *Busy Bee*, for 1897. This issue is a special topic number, devoted to a consideration of the characteristics of sweet clover. Of all the contributions I thought none seemed more fair and reasonable than that of that conservative bee-keeper, Mr. H. R. Boardman, of East Townsend, Ohio. The article appeared originally in *Gleanings*, in 1894. Here is what Mr. Boardman says:—

I am surprised that any bee-keeper of experience, who has had a reasonable opportunity of observing, should report sweet clover anything less than a first-class honey-plant; and yet I am aware that there are a few adverse reports coming from very reliable sources.

I am quite sure—yes, I think I know from my own experience and observations with this plant, extending through a period of a dozen years or more—that it is unsurpassed, and equaled only by the noted alfalfa; and these convictions are supported by the opinions of some of the most practical and reliable bee-men of my acquaintance.

The last season was the first for several years when white clover alone yielded me any surplus, and this, too, with the fields white with its bloom in every direction as far as bees could fly; and yet I should not be warranted in claiming that white clover was not a good honey-plant. It has a world wide reputation that is unimpeachable. If it were no more abundant than its cousin it would hardly have gained this enviable reputation—certainly not in the last few years.

I think it has been generally conceded by practical bee-keepers that it will not pay to plant for honey alone. This conclusion is undoubtedly a safe one. We must, then, look for some other value besides that of honey, in order to recommend sweet clover as a field crop.

I once supposed, as most people do now, that sweet clover was entirely worthless as a forage plant for stock—that nothing would eat it; but I have demonstrat-

ed to my own satisfaction that horses, cattle and sheep, will not only learn to eat it, but will thrive upon it, both as pasture and dried as hay, and that hogs are fond of it in the green state. I say, they learn to eat it, because most stock have to acquire a taste for it, not taking readily to it at first. I gave it a fair trial last summer. My horses and family cow fed upon it almost entirely during the dry part of the season. They became fat and sleek, without the help of grain or other feed. The milk and butter from the cow showed no objectionable flavor. The amount of feed furnished was something surprising. It has a habit of continually throwing out or renewing its foliage and its bloom; also, when cut or fed back, it keeps it constantly fresh. After gaining a growth of four or five feet in height in dense masses in my pasture it was fed down entirely, even the coarse stalks, so that at the close of the season, nothing was left. The seeding was, of course, destroyed; but in my desire to put to a severe test the feed value of the crop, this was lost sight of.

Sweet clover, like the alfalfa, sends its great roots deep down into the hardest, driest soils, thus enabling it to withstand severe drouths as no other plant can. This gives it great value as a fertilizer; and growing as it does upon the hardest, poorest soils, it recommends itself for reclaiming soils too poor for raising other crops. It has a habit of taking possession of vacant lots and roadsides, which has caused some alarm with those unacquainted with its habits, fearing it would spread over the fields and prove a pest. I can assure you it will do no such thing. In all my acquaintance with it I have never seen it spread into cultivated or occupied fields to any extent. I have been very reckless with the seed about my own premises; and if there had been any danger in that direction I should have found it out long ago.

Some time during the latter part of last summer I made a trip through a part of the state where a severe drouth prevailed. The cattle and sheep looked gaunt and hungry, and were roaming over pastures that were dry, scorched and dead. Fire had run over the farms here and there, adding still further to the look of desolation. In places the cows had been turned into the growing corn, the only green forage in sight. I wondered again and again how it was possible for the stock to escape entire starvation. A field of sweet clover, with its dark green foliage, would have made a refreshing picture amidst this desolation. It would have been more

than a picture. It would have supplied a place where it would have been most heartily welcomed and appreciated in this trying emergency. I think it will recommend itself and come to be appreciated soon in times of severe drouth. It makes a slender growth the first year. It is this crop that is the most valuable for hay, and cutting it will not interfere with the second year's growth. The second year it grows coarser; blossoms, seeds and dies root and branch. If cut for hay in the second year it should be cut just as it is beginning to bloom. A second crop may be cut late in the season. It should be well dried, and it requires good weather to do it in. If cut for seed it may be thrashed and hulled with a machine, like red clover, or the seed may be sown without hulling.

Now don't be induced by the bright picture I have drawn to seed your whole farm to sweet clover, for it would result in an unprofitable failure, I am sure. But if you desire to test its value, do it on a small scale, with an acre or two, and do it thoroughly. I have found it no easy thing to succeed in making it grow as a field crop, and I would advise sparing no pains in getting it started. When once it gets possession of the ground it will stay if allowed to ripen a late crop of seed. Sow with winter wheat or rye in the spring, the same as other clover. Please don't write me for seed. I have none to spare.

Honey Quotations.

The following rules for grading honey were adopted by the North American Bee-Keepers' Association, at its Washington meeting, and, so far as possible, quotations are made according to these rules:

FANCY.—All sections to be well filled; combs straight, of even thickness, and firmly attached to all four sides; both wood and comb unsoiled by travel-stain, or otherwise; all the cells sealed except the row of cells next the wood.

No. 1.—All sections well filled, but combs uneven or crooked, detached at the bottom, or with but few cells unsealed; both wood and comb unsoiled by travel stain or otherwise.

In addition to this the honey is to be classified according to color, using the terms white, amber and dark. That is, there will be "fancy white," "No. 1 dark," etc.

CLEVELAND, OHIO. We quote as follows: Fancy white 12 to 13. No. 1 white, 11 to 12; fancy amber 9 to 10; No. 1 amber 8 to 9; Fancy dark, 7 to 8; white, extracted, 6½; amber 5½; beeswax, 25.

A. B. WILLIAMS & CO.,
Nov. 22, 80 & 82 Broadway, Cleveland, O.

CHICAGO, Ill.—There is a good demand for fancy white comb honey. This grade would sell for 11 cts—possibly higher. Considerable Amber and dark on the market—selling anywhere from 5 to 8. Extracted White sells at 5½ to 6; Amber 4½ to 5; dark, 4. Beeswax, 27.

S. T. FISH & CO.,
Mar. 24, 189 So. Water St., Chicago, Ill.

CHICAGO, Ill.—The season for the sale of comb honey will close with this month. A little is sold in April, but so small as to fail in changing prices. We quote as follows: Fancy White, 10; No. 1, white, 8 to 9; Fancy Amber, 7 to 8; No. 1, Amber, 7; Fancy dark, 7 to 8; No. 1, dark, 7; White, Extracted, 5 to 6; Dark, 4; Beeswax, 27.

R. A. BURNETT & CO.,
Mar. 24, 163 So. Water St., Chicago, Ill.

KANSAS CITY.—The supply of both comb and extracted honey is large, and the demand light. We quote as follows: Fancy white 10; No. 1 white, 9; Fancy amber, 8; No. 1 amber 7; white, extracted, 5 to 5½; amber, 4 to 5; dark, 4; beeswax, 20 to 22.

C. C. CLEMONS CO.,
Feb. 10, 521 Walnut St., Kansas City, Mo.

BUFFALO, N. Y.—Really fancy honey moves well but other grades require pushing and enticing to move. We quote as follows: Fancy White, 10 to 11; No. 1, white 9 to 10; Fancy Amber, 8 to 9; No. 1, Amber, 7 to 8; Fancy dark, 6 to 7; White, Extracted 5 to 6; Amber, 4½ to 5; Dark, 4 to 4½; Beeswax, 24 to 28.

BATTERSON & CO.,
Mar. 24, 167 & 169 Scott St., Buffalo, N. Y.

NEW YORK.—We have had a good trade in comb honey the past week. Fancy white is in demand. Our stock of fair and mixed honey is working down very well. Extracted honey is selling well. Fancy white clover and basswood find ready sale. We quote as follows: fancy comb honey, 11¼ to 12½; fair grades, 9 to 10; buckwheat and mixed, 6½ to 7; Extracted, California, white, 5 to 5½; amber, 4¾ to 5; white clover and basswood, 5¼ to 5½; buckwheat, 4 to 4½; southern, 50 to 55 per gal.; beeswax finds ready sale at 27 to 28.

FRANCIS H. LEGGETT & CO.,
Jan. 24, W. Broadway, Franklin & Varick Sts.

NEW YORK, N. Y.—Demand for comb honey is rather slow, especially for off grades, white and dark, and, as we have a large stock of these we did not advise shipping for the near future. Our stock of fancy white is light and such would find ready sale at quotations. Our market for extracted buckwheat will open up shortly and we would advise bee-keepers to ship this along now. Beeswax steady. We quote as follows: Fancy white, 11 to 12; No. 1, White, 10; Fancy Amber, 9; No. 1, Amber, 8; Fancy Dark, 7; No. 1 Dark, 6; White, extracted, 5 to 5½; Amber, 4½ to 4¾; Dark, 4 to 4¼; Bee-wax, 26 to 28.

HILDRETH BROS. & SEGELKEN,
Jan. 7, 120 & 122 West Broadway New York.

WM. A. SELSER,
10 VINE ST., PHILA., PENN.

White Clover Honey Specialist.

—If you are going to—

BUY A BUZZ-SAW,

write to the editor of the REVIEW. He has a new Barnes saw to sell and would be glad to make you happy by telling you the price at which he would sell it.



See That Wink?

Bee Supplies. Root's goods at Root's prices. POWDER'S HONEY JARS Prompt service. Low freight rates. Catalog free. WALTER S. POWDER, 162 Mass. Ave., Indianapolis, Ind., the only exclusive bee supply house in Indiana.

Please mention the Review

Farm Bee - Keeping.

The only bee paper in the United States edited in the interests of the farmer-bee-keeper and the beginner is the **Busy Bee**, published by EMERSON T. ABBOTT, St. Joseph, Mo.

Send for free sample copy NOW.

Please mention the Review.

Michigan Headquarters for the G. B. Lewis Company's

SUPPLIES,

Dadant's foundation, and everything needed in the apiary. Send for price-list to **L. C. WOODMAN,** 3-18-6t Grand Rapids, Mich.

Please mention the Review

FINE FOUNDATION:

My foundation is made by a peculiar process (no dipping boards used) which results in a superior article—one that can't be surpassed. The best goods are none too good, and the lowest prices none too low for these times, and I can furnish both, not only in foundation but a full line of bee keepers'

SUPPLIES.

Send for a catalogue and be your own judge. Wax wanted at 26 c cash or 29 c in trade, delivered. **AUGUST WEISS,** 4-97-10-t Hortonville, Wis.

Please mention the Review.

THE MONITOR PAPER FILE

Binds securely and neatly all periodicals. Preserve your papers, magazines, pamphlets, bulletins, music &c., by binding them together as you get them. Each new number filed quickly and easily. Will bind 52 numbers of any periodical aggregating 1000 or fewer pages. All lengths from 6 to 28 inches. Light and handsome.

PRICE.—All sizes 12 inches and under 12 cents; over 12 inches one cent per inch. When wanted by mail add one cent for each 5 inches or fraction thereof.

For sale by the Publisher of this paper

Dovetailed Hives,

Sections, Smokers, Queen Cages, and everything needed in the apiary. Warranted Italian queens 75 cts. each. Two-frame nucleus, with a queen, \$2.60. Send for catalog.

DEANES & MINER, Ronda, N. C.

Good Queens,

Either three-banded or golden-send promptly. Two different yards. Circular free. Am a member of the National Queen Breeders' Union. 2-98-tf

J. B. CASE, Port Orange, Fla.

GOLDEN Queens

The best that knowledge and ten years' of experience can produce.

Untested Queens.	One	Six	Twelve.		
In June, July and August.	.75	\$1.25	\$8.00		
All other months.	1.00	5.00	9.00		
Tested Queens.	1.50	8.00	15.00		
Nuclei, in Mar., Apr. and May.					
	One	Two	Three	Six	Twelve.
One L. frame,	.90	\$1.60	\$2.25	\$4.25	\$8.00
Two " frames,	1.50	2.75	4.00	7.50	14.00
Three "	1.80	3.25	4.50	8.50	16.00

These prices are for nuclei without queens, and a discount of ten per cent. will be given on the NUCLEI if queens at the above prices are ordered sent with them. Bees by the pound at the same price as nuclei. File your order for six or more queens 30 days before you want them shipped, and get ten per cent discount from above prices.

E. R. JONES,

3-98-12t

Milano, Texas.

Beeswax Extractor.

The only Bees Wax Extractor in the world that will extract all the wax from old combs rapidly by steam. Send for descriptive illustrated catalogue.

C. G. FERRIS,
South Columbia, N. Y.

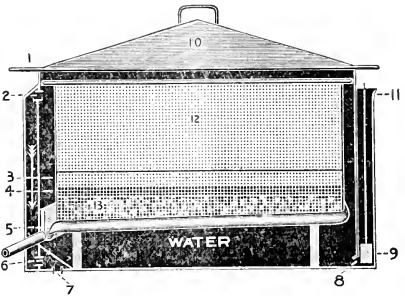

Take the big 4.

- Beautiful Golden Italian Queens,
- Choice seed Potatoes at living prices,
- Prize winning seed corn, 4-9S-tf
- Business Plymouth eggs. Catalog free.

J. F. MICHAEL, Greenville, Ohio.

PATENT. WIRED, COMB FOUNDATION



HAS NO SAG IN BROOD FRAMES.
Thin, Flat Bottom Foundation
HAS NO FISHBONE IN SURPLUS HONEY.
Being the cleanest, it is usually worked quicker than any fdn. made.
J. VAN DEUSEN & SONS,
(SOLE MANUFACTURERS),
1-93-tf Sprout Brook, Mont. Co., N.Y.

— If you wish the best, low-priced —

TYPE - WRITER.

Write to the editor of the REVIEW. He has an Odell, taken in payment for advertising, and he would be pleased to send descriptive circulars or to correspond with any one thinking of buying such a machine.

1898 Queens 1898

For Business—Queens for Strong Colonies—Queens for large surplus. Competition in Quality, but not in price.

If you want queens, nuclei or supplies at bottom prices, send for my illustrated price list. 12-97-tr

J. P. H. BROWN, Augusta, Ga.

Please mention the Review.

We are headquarters for the

Albino Bees,

the best in the world. If you are looking for the bees that gather the most honey, and are the gentlest of all bees to handle, buy the Albino. I can furnish the Italian, but orders stand 50 to 1 in favor of the Albino. I manufacture and furnish supplies generally. Send for circular.

S. VALENTINE,

4-98 2t

Hagerstown, Md.

How to manage bees? Send for our 36 page Illustrated Catalog - It tells you all you need to know about bees, queens, etc. - the best and cheapest goods - JOHN NEBEL & SON, HIGH HILL, MO.

Best on Earth. 19 Years Without a Complaint.



	Dozen	Each
Smoke Engine (largest smoker made) 4 inch stove...	\$13.00 - mail,	\$1.50
Doctor	9.00 - "	1.10
Conqueror	6.50 - "	1.00
Large	5.00 - "	90
Plain	4.75 - "	70
Little Wonder (wt. 10 oz.)	4.50 - "	60
Honey Knife	6.00 - "	80

For further description, send for circular.

T. F. BINGHAM, Farwell, Michigan.



Bee-keepers in the

Northwest

Can save money and freight by getting their supplies from the Minn. Bee-Keepers' Supply Mfg. Co., Nicollet Island Power Building, Minneapolis, Minn. They have all the latest and most improved machinery and manufacture and handle a full line of supplies. Send for catalogue before ordering.

Please mention the Review.

Root's Bee-Supplies,

Shipped from Jackson at Root's prices. Honey bought and sold. White, Plymouth Rock chicks and eggs for sale. Send for prices

2-98-tf

W. D. SOPER, Box 565
Jackson, Mich.

Bees For Sale.

Owing to failing health I wish to avoid establishing more than one new apiary this spring; hence I offer for sale from 75 to 100 colonies of Italian bees in two-story, New Heddon hives, all complete, in lots of ten colonies at \$5.00 per colony. Single-story colonies, in lots of ten, at \$2.50 per colony. The bees are in good condition, have young queens, and the hives, combs, etc., are all strictly first-class, and I guarantee that they will give the best of satisfaction. As to make my reliability I can refer to the editor of the Review. I would exchange bees for good timber, or for timbered land in Michigan.

O. H. TOWNSEND,
Otsego, Mich.

Now is the time to order your supplies, bee-hives, sections, foundation, smokers, and everything that is needed in the Apiary at prices that are right. Send for circular.

W. H. BRIGHT, Mazepa,
Wabasha county,
Minn.

Please mention the Review.

To stick things, use **MAJOR'S CEMENT.**
Beware !!! Take no substitute. 2-98-12t

JOHN F. STRATTON'S CELEBRATED



MANDOLINS,

Importers of and Wholesale Dealers in all kinds of
MUSICAL MERCHANDISE,
941, 813, 815, 817 East 9th St., New York.

Bee keepers should send for our

'97 CATALOG.

We furnish a full line of supplies at regular prices. Our specialty is Cook's Complete hive.
J. H. M. COOK, 62 Cortland St., N. Y. City

Please mention the Review.

Franklin House DETROIT, MICH.

Cor. Bates and Larned sts. Very central. Elevator service—steam heat, electric lights, tile floors, etc. Rates \$1.50 to \$2 per day. H. H. JAMES & SONS, Props.

Please mention the Review.

The Land of Honey. The Italy of America!

Send for a copy of the **PACIFIC BEE JOURNAL**; 365 E. 2nd St., Los Angeles, California.

Please mention the Review

FOR 14 CENTS

We wish to gain 100,000 new customers, and hence offer

1 Pkg. 1 Day Radish,	10c
1 Pkg. Early Spring Turnip,	10c
1 " Earliest Red Beet,	10c
1 " Bismarck Cucumber,	10c
1 " Queen Victoria Lettuce,	15c
1 " Klondyke Melon,	15c
1 " Jumbo Giant Onion,	1c
3 " Brilliant Flower Seeds,	15c

Worth \$1.00, for 14 cents.

Above 10 pkgs. worth \$1.00, we will mail you free, together with our great Plant and Seed Catalogue upon receipt of this notice and 4c postage. We invite your trade and know when you once try Salzer's seeds you will never get along without them. **Potatoes at \$1.50 a Bbl.** Catalogue 5c. No. 83

JOHN A. SALZER SEED CO., LA CROSSE, WIS.

Please mention the Review.

JAPAN PLUM TREES! Large stock of best varieties at lowest rates. Full assortment of Fruit and Ornamental Trees and plants. Correspondence solicited from parties who intend planting large orchards. Get our prices before ordering elsewhere. We can save you money. Send for our new Spring Catalogue—it is free. Established 1869. Over 150 Ac. es.

Address **THE GEO. A. SWEET NURSERY CO.** Box 1165 Danville, N. Y.

Character of the Review.

Reviewing

Current apicultural literature is, as indicated by its name, one of the distinctive features of the REVIEW. Errors and fallacious ideas are faithfully, but courteously and kindly pointed out, while nothing of value is allowed to escape unnoticed. But few articles are copied entire, but the ideas are extracted, given in the fewest words possible, and commented upon when thought advisable.

It is Practical

In its character. It does not waste columns in the discussion of fine-spun theories, and those numerous phrases of bee-keeping that may be interesting, but have no practical bearing upon the bread and butter side of the business. It aims to publish only such matter as will aid in making bee-keeping a more safe, pleasant and profitable pursuit.

No Side-Issues

Are tolerated in the REVIEW. It may not publish so much matter as some of the other Bee-Journals, but in the amount of practical, valuable, helpful bee-keeping information furnished, it is behind none of its competitors. It is not so much a question of how large is the journal, or how often does it come, *but what information does it bring when it does come?*

Its Correspondents

Are successful, practical bee-keepers, most of whom have numbered their colonies by the hundred, and sent honey to market by the ton, and who can write, from experience, articles containing information of some real benefit to honey producers.

The Editor

Has been a practical bee-keeper for more than twenty years, and is thus in a position to choose wisely in selecting matter for his journal, and is also able to write from the standpoint of actual experience upon all subjects pertaining to practical bee-keeping—to criticise, if necessary, the views of correspondents.

No Supply Trade

Is run in connection with the REVIEW, and for this reason the price must be such that there is a profit in its publication, but it leaves its editor free from even an unconscious bias, and his views in regard to hives, implements, methods, and devices are wholly disinterested.

Neat Typography

Is one of the features of which the REVIEW may be proud. Good paper, type, ink and rollers, and a good pressman, are employed, and engravings used when words can not so clearly describe. This neatness may not add to the value of the information given, but it does add to the comfort and enjoyment of those who read it.

In Conclusion.

The REVIEW gives monthly criticisms by R. L. Taylor upon what he finds in the other journals deserving of the same. It gives Hasty's monthly three-page review of the other American Bee Journals; and F. L. Thompson's review of the Foreign Bee Journals; as well as the extracts and short editorial comments; and when there is occasion for it, some topic is made the subject of special discussion; in which the views of leading bee-keepers are gathered together in one issue, thus allowing a close comparison of views.



A. B. MASON,
Auburndale, Ohio.



T. F. BINGHAM,
Aubonia, Mich.



E. D. OCHISNER,
Prairie du Sac, Wis.



ISAAC LUNDY,
Wilsonville, Ont.



J. A. GOLDEN,
Reinersville, Ohio.

Men Who Make the Review.

THE success and usefulness of a periodical are largely dependent upon the men chosen by the editor as correspondents; hence it is worth while to notice who are the REVIEW-correspondents and how they were secured.

During the past eighteen years the editor of the REVIEW has attended nearly every bee-keepers' convention of a national character; has visited scores and scores of bee-keepers in their own homes, and received and answered thousands and thousands and thousands of letters; in short, he has enjoyed, and still enjoys, a personal acquaintance with most of the leading bee-keepers of the country. When he wishes for information upon some special topic he knows *exactly* where to find it. He knows who is posted on this point, who on that—who rides this hobby, who that and this wide acquaintance has enabled him to choose, as his principal correspondents, successful, practical men, most of whom have numbered their colonies by the hundred and sent honey to market by the ton, and who can write, from experience, articles containing information of real benefit to honey producers.



G. M. DOOLITTLE,
Borodino, N. Y.



R. M'KNIGHT,
Owen Sound, Ont.



G. E. BOLTON,
Fremont, Mich.



J. E. CRANE,
Middlebury, Vt.



F. A. GEMMILL,
Stratford, Ont.



H. R. BOARDMAN,
E. Townsend, O.



W. F. CLARKE,
Guelph, Ont.

COMB HONEY

Is profitably produced only when several important factors are combined. First, we must have the right kind of bees. We all know that there is not only a vast difference between the different varieties, but also a variation in strains of the same variety. Just which are the best bees for producing comb honey, *why* they are best, and how to secure them, is told in one of the chapters of *ADVANCED BEE-CULTURE*.

When bees of the right kind have been secured, then comes the matter of using the right kind of hives, fixtures, sections, etc., to secure the best results with the least labor; and *ADVANCED BEE - CULTURE* has a chapter on "Hives and their Characteristics;" and another on "Sections and their Adjustment on the Hives."

Bees may gather large quantities of white honey, and yet be so managed as to put very little of it in the sections; or they may be so managed that nearly all of it will go into the sections; all of which is explained in one of the chapters of *ADVANCED BEE - CULTURE*.

Comb foundation costs money. Notwithstanding this, its use is very profitable at some times and in some places. Under other conditions it is worse than wasted. Read *ADVANCED BEE - CULTURE* and learn *why*.

ADVANCED BEE - CULTURE is a book of 32 chapters, describing the most advanced methods of bee - keeping from the beginning of the year through the entire season.

Fifty cents is the price of the book; or it and the *REVIEW* for one year will be sent for \$1.25.

W. Z. Hutchinson, Flint, Mich.



Bee-Supplies

We have the best equipped factory in the West. Capacity, one carload a day. We carry the

largest stock and greatest variety of everything needed in the apiary, assuring **Best Goods** at the **Lowest Prices**, and prompt shipment. Illustrated catalogue, 72 pages, free.

We also manufacture tanks of either wood or galvanized steel, all sizes, any form, and for all purposes. Price list free. Address

E Kratchmer, Red Oak, Iowa

Page & Lyon,

Mfg. Co

New London, Wis.

Nearness to pine and bass-wood forests, the possession of a saw-mill and factory fully equipped with the best of machinery, and years of experience, all combine to enable this firm to furnish the best goods at lowest prices. Send for circular, and see the prices on a full line of supplies.

TESTED QUEENS,

At \$1.00 each. As usual, I am requesting my apiary this spring with young queens from the South, and, that the tested queens that are removed may move off quickly, I offer them at \$1.00; or six for \$5.00. These queens are fine Italians of last year's rearing, and right in their prime. The Review one year and one of these queens for only \$1.75.

W. Z. Hutchinson,
FLINT, MICHIGAN.

No Fish-Bone

Is apparent in comb honey when the Van Deusen, flat-bottom foundation is used. This style of foundation allows the making of a more uniform article, having a *very thin* base, with the surplus wax in the side-walls, where it can be utilized by the bees. Then the bees, in changing the base of the cells to the natural shape, work over the wax to a certain extent; and the result is a comb that can scarcely be distinguished from that built wholly by the bees. Being so thin, one pound will fill a large number of sections.

All the Trouble of wiring brood frames can be avoided by using the Van Deusen *wired*.

Send for circular; price list, and samples of foundation.

J. VAN CEUSEN

SPROUT BROOK, N. Y.

Violin for Sale.

I am advertising for the well known manufacturers of musical instruments, Jno. F. Stratton & Son, of New York, and taking my pay in musical merchandise. I have now on hand a fine violin outfit consisting of violin, bow and case. The violin is a "Stradivarius," Red, French finish, high polish, and real ebony trimmings, price \$14.00. The bow is of the finest snakewood, ebony frog, lined, inlaid (pearl lined dot) pearl lined slide, German silver shield, ebony screw-head, German silver ferules, and pearl dot in the end, price \$2.50. The case is wood, with curved top, varnished, full-lined, with pockets, and furnished with brass hooks, and handles and lock, price \$3.50. This makes the entire outfit worth an even \$20.00. It is exactly the same kind of an outfit that my daughter has been using the past year with the best of satisfaction to herself and teachers. Her violin has a more powerful, rich tone than some instruments here that cost several times as much. I wish to sell this outfit, and would accept one-half nice, white extracted honey in payment, the balance cash. It will be sent on a five days' trial, and if not entirely satisfactory can be returned and the purchase money will be refunded.

W. Z. HUTCHINSON, Flint, Mich.

G. M. LONG, Cedar Mines, Iowa, manufacturer of and dealer in Apianian Supplies. Send for circular. 1-96-6

Please mention the Review.

START IN BUSINESS!

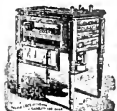

HATCH THOUSANDS
WITH THE PRAIRIE STATE
INCUBATOR

200 FIRST PREMIUMS.

PRAIRIE STATE INC. CO.
HOMER CITY, PA.

SEND FOR CATALOG.

Please mention the Review.

WRITE US

Before ordering your sections and we will give you **BOTTOM PRICES** on them.

"BOSS" ONE-PIECE SECTIONS,



Also D. T. HIVES, SHIPPING CRATES and other Supplies.

We have everything in tip top order, and can fill orders on short notice. Let us hear from you for prices.

J. FORNCROOK & CO.,

Jan. 1st, 1894.

Watertown, Wis.

Please mention the Review.

Make Your Own Hives.

Bee-Keepers

Will save money by using our Foot Power Saw in making their hives, sections and boxes.

Machines on trial.

Send for Catalogue.

W. F. & JNO. BARNES CO.,

381 Ruby St.,

Rockford, Ills.

2-96 12

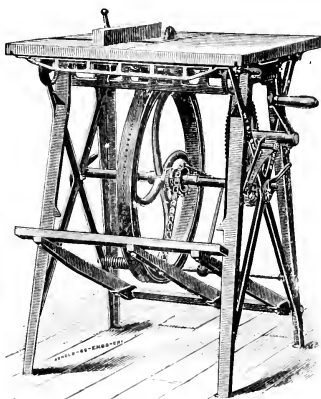

ROOT'S GOODS,

At wholesale and retail. Honey is cheap, and, to be successful, goods must be bought at the lowest possible price. I can help you in this. Try it by sending a list of what you want—you will get prices by return mail. Large Illustrated Catalogue, full of information, free. Beeswax wanted in exchange for goods, or cash, at best prices.

M. H. HUNT,

BELL BRANCH, MICH.

If the REVIEW

Is mentioned when answering an advertisement in its columns a favor is conferred upon both the publisher and the advertiser. It helps the former by raising his journal in the estimation of the advertiser, and it enables the latter to decide as to which advertising mediums are most profitable. If you would help the Review, be sure and say "I saw your advertisement in the Review," when writing to advertisers.

SUGGEST

Is one of the most pleasant experiences with which a man can meet. If this is what you would like to meet, but are a little doubtful as to which road to follow, take the advice of one who has met success, and can tell you all about it. Few men have met with greater success in bee-keeping than has Mr. Jas. Heddon, of Dowagiac, Mich.; and the paths that he has trod are clearly mapped out in a book which he has published, and which is very appropriately called "SUCCESS IN BEE-CULTURE." The price is 50 cents. The foregoing is given as the honest opinion of the editor of the Review.

COMB Foundation.

We can now furnish the very best that can be made from pure wax. Our new process of milling enables us to surpass our previous efforts in the manufacture of foundation. It is always pure and sweet. It does not sag. It is the kind that you want. If you once try it you will have no other. Samples furnished free. Large, illustrated catalogue of bee-keepers' supplies, and a copy of the *American Bee-Keeper* sent upon application.

W. T. Falconer Mfg. Co.,
JAMESTOWN, N. Y.

Dovetailed Hives.
 Cowan Extractors.
 Danzenbaker Hives.
 Porter Bee - Escapes.
 No-Drip Shipping Cases.
 Gleanings in Bee-Culture.

Root's Goods.

OUR SPECIALTIES.

The Fence and Plain Sections.
 Weed New Process Foundation.

Catalog of goods and sample of Gleanings sent for your name on a postal.

The A. I. ROOT CO., Medina, Ohio.

Branch Offices :

118 Michigan St., Chicago, Ill. 1024 Mississippi St., St. Paul, Minn.
 1635 W. Genesee St, Syracuse. 10 Vine St., Philadelphia. Mechanic Falls, Me.



Our Prices are worth looking at. We are making the new **Champion Chaff Hive** with dovetailed body and supers and a full line other Supplies, and we are selling them **CHEAP**. A postal sent for a price list may save you \$ \$ \$ \$.
 R. H. SCHMIDT & CO.,
 Box 187 Sheboygan, Wis

4-98-4f

Please mention the Review.

ALBIRO QUEENS

For sale. Best bees in existence. Untested, in May, \$1 00; after June 1st, 75 c.
 5-98-3t J. D. GIVENS, Lisbon, Texas.

Please mention the Review.



\$100

Given as Bounties to purchasers of the improved Danz. Hives and Sections See schedule in my bee-book "Facts About Bees." Tells how to produce honey that sells for the most money. Free for 2c in stamps. Address
THE A. I. ROOT CO., Medina, Ohio,
 or F. DANZENBAKER, Box 466, Washington, D. C.

how to produce honey that sells for the most money. Free for 2c in stamps. Address
THE A. I. ROOT CO., Medina, Ohio,
 or F. DANZENBAKER, Box 466, Washington, D. C.

Please mention the Review.

QUEENS, Untested, 75 c; 6 for \$4.00; tested, \$1.00; 6 for \$5.00; breeders, \$2.00. The best stock, imported or golden. W. H. LAWS, Lavaca, Ark.

Sweet Clover Seed.

We have about 3,000 lbs. of sweet clover seed, (of the white variety) that we offer for sale at the following prices :

25 lbs., \$2.25; 50 lbs., \$4.00; 100 lbs., \$7.50.

BERTSCH & FLIEMAN, Holland, Mich.

COMB

FOUNDATION

WHOLESALE AND RETAIL.

Working wax into foundation, for cash, a specialty. Hives, Sections, and a full line of Supplies. The best of everything. Write for Catalog, with prices, and samples of Foundation and Sections. Beeswax always wanted for cash or trade.

GUS. DITTMER,

10-97-12t

Augusta, Wis.

The A. I. Root Co.'s Goods, **WHOLESALE AND RETAIL.**

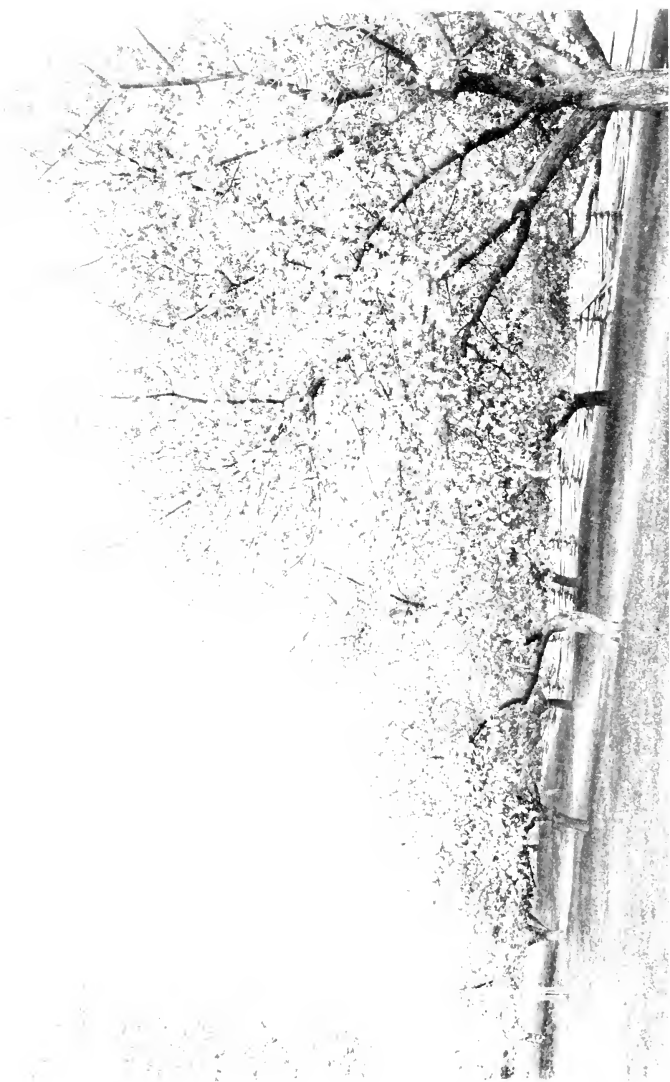

A Michigan Apple Orchard in Full Bloom.

The Bee-Keepers' Review.

A MONTHLY JOURNAL

Devoted to the Interests of Honey Producers.

\$1.00 A YEAR.

W. Z. HUTCHINSON, Editor and Proprietor.

VOL. XI. FLINT, MICHIGAN, MAY 10, 1898. NO. 5.

BEES AND APPLE BLOSSOMS.

The Importance of These Early Honey-Flows
in Building up Colonies for the Main
Harvests. An Esthetical View
of the Subject.

G. M. DOOLITTLE.

Sweet is the air with the budding haws, and
the valley stretching for miles below
is white with blossoming apple-trees, as if just
covered with lightest snow.—LONGFELLOW.



It was with much interest that I read the first article in the March Review on "The Sugar-Maple" and the relation it bore to our friends, the bees, in getting them in shape so that

they could, by the "great army of workers" produced through the stimulation of maple bloom, gather for us the tons of honey from white clover and basswood; which is exchanged for the things which make the pursuit of bee-keeping one of profit. The same line of reasoning which

Bro. Hutchinson applies to the sugar-maple, holds doubly good in regard to apple bloom. There is nothing in the line of early honey that so stimulates brood rearing as does that which comes from the pink and white blossoms of the apple trees. In fact, it has always been a proverb in this section of the country, "as goes apple bloom, so goes the season," as to honey.

More than a third of a century ago, the hand of the lamented M. Quinby penned these words: "In good weather, a gain of 20 pounds is sometimes added to the hives during the period of apple blossoms. But we are seldom fortunate enough to have continuous good weather, as it is often rainy, cloudy, cool or windy, all of which are very detrimental. A frost will sometimes destroy all, and the gain of our bees is reversed; that is, their stores are lighter at the end than at the beginning of this season of flowers. Yet this season often decides the prosperity of the bees for the summer. If there is good weather now, we expect our first swarms about June first; if not, no subsequent yield of honey will make up the deficiency."

Never were truer words uttered, as applied to central New York, and what applies to this locality will apply quite

generally to the Northern States. Hence we see that the apple tree bears no mean relation to the person interested in bee-keeping; outside of the fruit it yields.

In 1877 we had the best yield of honey from apple bloom that I ever knew; and the result from the apiary that year was the highest ever obtained by the writer; which was 166 $\frac{2}{3}$ pounds of honey on an average from each old colony in the spring; the most of which was comb honey.

In 1870, the second year of my bee-keeping life, we had a yield from this source nearly as good as in 1877; and at that time I tried a guessing experiment by counting the bees which came in at the entrance loaded with this delicious nectar obtained from the apple trees. It was about eight o'clock in the morning when the bees began to come in steadily with their loads; and, taking out my watch, I counted for one minute, the bees as they dropped on the alighting board. This first count showed 42; the second count, 46; the third, 41; and the fourth, 44. At 10 o'clock I counted again; and the average at that time was 49 to the minute, on five counts, while at one o'clock the average was 51 per minute; and at five o'clock the number of loaded bees entering the hive proved to be nearly the same as the first count of the morning. I figured that each bee carried a drop of nectar; then estimated the number of drops it would take for a pound, (calling nine pounds as the weight of a gallon of this nectar) as it came in from the fields; then I struck an average to get the number of bees per minute for the whole day, and multiplied this number by the number of minutes worked, and decided that the result of that day's work would be 7 $\frac{1}{2}$ pounds. I had weighed the hive in the morning, before any bees went to work, and the evening weight showed a gain of eight pounds and two ounces in excess of that of the morning; so I had guessed within 10 ounces of what had really come in that day. The next morning the hive was weighed again,

which showed a gain of nearly five lbs. over the morning previous; thus giving 3 lbs. 2 ounces as the loss by evaporation during one night; this showing that the nectar, as it is brought in from the apple bloom, is very thin.

I consider the great value of nectar from apple bloom to lie in its stimulating quality, toward plentiful brood rearing, and in producing stores to tide over the period of scarcity which immediately follows this bloom for a time approximating two weeks.

Apple blossom honey is rank and strong when first gathered, but after staying on the hive till thoroughly ripened, it assumes a nice spicy flavor; though when at its best it can hardly be said to equal that from clover or basswood.

I believe that if we had the same number of bees in the hive in apple bloom that we do in basswood, and if the weather could be equally good, the yield from this source would be nearly or quite as good while the bloom lasted; but the trouble is that the bloom comes so soon after cold weather that we do not have the bees; and, still worse, the weather is usually such that the bees do not have an opportunity, oftener than one year in four, to work on the bloom more than enough to encourage brood rearing; hence I doubt the advisability of trying to work the colonies up to an unusual strength, with the hopes of securing a surplus from this source.

That bees are a great help to the fruit grower is proven by the abundant secretion of nectar in the bloom of the apple tree; for I am satisfied, from 30 years of observation, that a greater secretion of nectar proves a greater need, in such bloom, for insects to secure the proper pollenization. Nearly all are familiar with that bit of history where bees were banished from a certain township, because they were charged with injuring the apple crop by taking away the honey from the blossoms. The next year after their banishment there was scarcely an apple in the interior of that township;

although there was ample bloom for a full crop. And as the trees on the outskirts of the township gave their usual supply of apples, the fruit growers willingly acknowledged their mistake, and humbly begged that the bees be brought back again.

So far I have touched only on the practical, or dollar-and-cent side of this matter. There is another side which we, as bee-keepers, look after so seldom that we grow poor, and, to a certain extent ugly, in our "ever-lasting" hustle after that which shall pour mammon into the home treasury; and, we go about having continually, a look on our faces which says to every passer by that we consider "Time is Money." He who sees in the bees, the apple blossoms and the ripened fruit only that which shall put money into his pocket, lives in a poor, half-furnished house. He who obtains from them only what he can sell, gathers but a meager crop. If I find something besides dollars and cents with my bees and on the apple trees, shall I not take it? If I find in these things more than can be sent to the dining-table or the commission merchant I feel that I have a right to put out my hand to gather it. Such a matter-of-fact tree as the apple makes some attempt to embellish its life with ornament, and in May the bees will prove, to any right thinking person, that joy and happiness may be gotten from its branches. Indeed, apple trees, during each year, are like some people we know. In their young and blossoming days, they are sweet and pink-hued, and then they grow acid, pale and hard; but, in the ripened experience of later life they may become sweet again; and more enchanting by their ministering to the calls of humanity. So if any of us have become acid, pale and hard, in our eager grasping after the "almighty dollar" part, which may come from the bees and the apple trees, let us once more return to the joy and sweetness we had in the springtime of life which may again come into our lives, as the deep richness of

color comes to the ripened fruit of the apple trees in autumn. If we have allowed our grasping disposition to get the better of our inner being, something as apples led to the loss of Paradise, is it not about time that we begin to reconstruct a bit of Eden, by once more listening to that better nature, which will, if we will let it, lead us once more under the blossom laden boughs, made pleasant with their perfume and the joyful hum of the bees? Nature might have contented herself by allowing the apple trees to bear seeds only, but she accompanied such prosaic action with fragrant flowers and delicious fruit. And it would be well for us to remember, in the ordinary courtesies of life, that our lives may convey some blessing and happiness to those about us.

BORODINO, N. Y. April 9, 1898.



CHANGES IN PLANTS AND ANIMALS.

How They are Brought About by Selection and Domestication.

J. E. CRANE.

And thy young glories,—leaf, and bud, and flower,
Change cometh over them with every hour.

GALLAGHER.



CONSIDERING the tendency of bees to vary, and the faults of both Italian and black bees as pointed out in previous papers, it will be seen that we have no thoroughbred variety of bees

that is altogether satisfactory; unless it might be for some peculiar regions, or localities. It will appear that we need, or, at least I need, a variety that will not

cause me so much vexation, trouble, and actual loss, by swarming; or by refusing to work upon some honey-yielding flowers not to their fancy, even when no others are in bloom.

The kinds of bees we now have are really only so many different varieties, produced by climate conditions and surroundings, and, perhaps, to some extent, by the management they have received at the hands of man. There is reason to believe, however, that bees have been less influenced or changed by man than has other animal life that has been long under domestication.

The invention of the movable comb hive threw a flood of light upon the development of the queen; and has opened a new era in both the theory and practice of bee-keeping; and the time seems opportune to look the situation over and see if more may not be done to improve our bees than has heretofore been attempted.

Improving present types or varieties of animals, or plants, or producing new ones of greater value than those now known, is one of the most fascinating pursuits of man. No wonder Doolittle thinks his business pays as he goes about his queen rearing; although the pecuniary value in dollars and cents may not be large.

In speaking of these improvements in domestic animals and plants, Darwin says: "One of the most remarkable features in our domestic races is that we see in them adaptation, not indeed to the animal's or plant's own good, but to man's use or fancy" * * * "Breeders habitually speak of an animal's organization as something plastic; which they can model as they please!"

If we look at the various breeds of domestic pigeons, so unlike in form, plumage and habits, the delicate fantail, with its great development of tail feathers, the elongated body of the pouter, the strange habits of the tumbler, the great size of the runt, with the great strength and endurance of the carrier, and other

varieties that I will not stop to mention, we shall find it hard to believe that they all sprang from *one common ancestry*; and have been changed to their present forms by the *cunning hand of man*, yet naturalists tell us that such is the case.

Take our domestic fowls, as another illustration; and see what changes have been made. Some are valued for their great size and gentleness; others for their diminutiveness and gracefulness; some for color, others for their laying qualities, and several for their indisposition to incubate—they sometimes being called "everlasting layers." May we not get a hint here? Does not the desire to incubate and lead out into the bright sunny world, in springtime, a brood of chicks, correspond quite closely to the swarming fever in bees? I certainly know that where fowls are kept for their eggs alone, and bees for their honey, the desire to incubate and the desire to swarm are equally *provoking*. If the desire to incubate has been so nearly bred out of some breeds of fowls, why may we not breed out the disposition in bees to swarm? I believe it can be done; and with far less labor and time than the desire in fowls to incubate has been eradicated.

If we compare the ponderous draft horse with the dwarfish breeds adapted to cold climates and sterile soils, or with the nervous race horse, so delicately formed and fleet in his motions, our credulity is taxed to the utmost when we are told that all sprang from a common stock. If we turn and look at the various breeds of cattle we see just as great diversity; some large and some small; some bred for their meat and some for their milk; and some for butter. It would have required more than a half dozen average dairy cows thirty years ago to make as much butter as a single one will make now-a-days; to say nothing of the improved quality. I will pass over dogs and swine, as I am not fond of either, and leave the reader to make his own observations; and proceed to speak of sheep; for I was a shepherd in early life. Doubt-

less sheep have been longer under domestication than has any other animal, and man has molded them, and fitted the different breeds to meet his various wants, quite as much as he has other races. Mountain breeds are always different from lowland breeds. Some have been bred for their meat and wool; while others almost wholly for their wool. We find different breeds furnishing different kinds of wool; some so fine as to fit it for the finest fabrics; some long and coarse for combing or worsteds.

The town in which I live has long been the headquarters of the industry of breeding American Merinos. Commencing about sixty years ago, with the Spanish Merinos as a basis, with rams that would shear from twelve to fourteen pounds of wool, and ewes that would give a fleece of six pounds, these sheep have been improved until now the ewes (the best of them) will give a fleece of twenty-five pounds and the rams from thirty to nearly forty pounds; while the weight of the carcass has *remained nearly the same*. While the nose has been left clean, the rest of their head, neck, body and legs have been covered with wool to their very *hoofs*; and not content with this, they have folded the skin over their necks, shoulders and sides, that more wool might be added. As Lord Somerville has said of English breeders, "*It would seem as if they had chalked out upon a wall, a form, perfect in itself, and then given it existence.*"

The pedigrees of these sheep have been kept with the greatest care. They have been sent to South Africa, South America and Australia, to say nothing of our Western States. They have been sold for almost fabulous prices; thousands of dollars having been paid for a single sheep. This is the result of less than sixty years of thoughtful and skillful breeding.

Who will furnish us with pedigree queens of the highest type, whose queen and worker offspring will come true, and all like their queen mother for a few generations? Would ten, or twenty, or fifty,

or one hundred dollars, be too much? I think not.

The same general laws of heredity run alike through all animal and plant life; although changes appear to be more abrupt in vegetable than in animal life. It would seem as if the florists were veritable wizards, from the bewondering profusion of flowers which they bring out each year.

Let us look at the sugar beet; a very prosaic root, yet one of national importance; and one that may mean more to us bee-keepers than we think. Early in this century, when beet sugar began to be a source of wealth in France, the average amount of crystallizable sugar to be obtained from beets was six per cent. In 1896 a plant was started in this country, and the average amount of best grade of sugar obtained from beets was fourteen per cent., two and one-third times that obtained eighty years ago. Already, single beets have been produced that have given twenty-five per cent of pure sugar. Unless our bees keep pace, what is likely to be the effect upon bee-keeping when the sugar industry shall have been developed in this country and the average amount of sugar from beets raised, during the next century, to twenty-five or thirty per cent., and sugar and flour sell at the same price? Or will sugar be the cheaper? Quite likely. How comes this great change in the richness of the beet? I answer that it comes by the most careful and painstaking care in breeding the seed; which is a business by itself.

Enough, perhaps, has already been said, but I would like to give an illustration, coming under my own hand. Some years ago, while visiting at the house of a friend, we had upon the table the tenderest and sweetest corn I had ever eaten. He gave me an ear of this variety, but I found the kernels quite too small to be satisfactory; and, from year to year, I selected the largest ones for seed; and, slowly, it has changed until now it would not be recognized as the same corn. Should I be able to carry the improve-

ment still farther, and make the improvement *permanent*, it may prove a valuable variety.

Yonatt, who was, doubtless, the best informed man of his time as to what had been accomplished by careful selection, says: "It is the magician's wand by means of which he may summon into life whatever form or mould he pleases."

This discussion will be concluded in another paper.

MIDDLEBURY, Vt. Dec. 10, 1897.



FACING CASES OF COMB HONEY.

The Subject turned this way and that and
Viewed in Various Lights.

DR. C. C. MILLER.

Who shall decide when doctors disagree?—POPE.



whether a man could hold such views and be entirely honest. I recalled, however, having more than once slept in the same room with you and yet having found my Waterbury all right in the morning. But I don't suppose a thief is always born a thief. So I questioned whether it might not be that you had been entirely honest as to any overt act up to the time of my sleeping with you. Then the painful question arose, "Could it have been the silently unconscious influence of sleeping companionship that first started you on the wrong track?"

FRIEND H., I read over what you said on page 60, 61, about putting the best sections of a case at the outside. Then I read it all over again, carefully. Then I discussed the question in my own mind

I referred the matter to a friend in whose utter integrity I had the most implicit confidence, one that I *knew* wouldn't steal. Not to misrepresent you in the least, I simply presented the case by reading your own words. Looking up for an answer at the close of the reading, it came promptly with decision, "Hutchinson's right." I'm glad the effect on me was only temporary. It must be very unpleasant to have the hay fever, when you have long spells of gasping for breath. But on recovery I knew that the holding of such views was not entirely incompatible with strict integrity of character. Must be something in the point of view.

Now I'm going to show you my point of view; you come and stand there with me, and then if you find there's any ocular deception,

* And things are not what they seem,"—

you take me to your stand-point and show me just how it ought to look.

Perhaps we can start on nearly common ground with that proposition of yours, that "The whole world has been putting the best side out so long that it is no longer deception." That is, every body's been fooled so many times you can't fool him any more, so its no harm to try to fool him when you're sure you can't succeed. Maybe it oughtn't to be put just that way. The best side has been put out for so long, that every one understands that the outside is the best, so no one is deceived, and it isn't for the sake of deceiving that the best side is put out. But if we accept that as of universal application, then it's all right to put culls in the middle of the barrel and face with fancy, for that's been done so much and so often that no one is deceived. And yet you yourself draw the line at culls in the heart of a barrel of fancy apples. Evidently we must modify the rule, and say the middle may be poorer than the outside, but not too much poorer.

Perhaps we can fix it up better by taking honey instead of apples. And we'll take that case of honey you were talking

about. As you say the honey ought to be graded honestly, and "there ought to be three grades; fancy, No. 1, and culls. Now let us suppose that the honey is graded, and we are crating the fancy. We take enough sections to fill a case. Now I, at least you, "believe it is perfectly right, legitimate and honest, to select from *that case* of sections, those that are the best, and put them next the glass—yes, and turn the best side out at that. But to face No. 1 or culls, with fancy is wrong." How can there be any deception about the twelve sections in that case? They've all been inspected and come within the requirements of the grade. They're all fancy, the purchaser of the case expects fancy and he gets fancy; what can be wrong about it? Let's follow that case till it reaches the consumer, the editor of a country weekly who has got hold of a honey leaflet and thinks it would be nice to have a whole case of such fine honey for his five growing hopefuls. The grocer told him he could rely on that case as straight goods, being put up by a thoroughly honest beekeeper. When he takes it home and opens it, he finds that the nine sections he didn't see are not as good as the three he saw, and he feels he has been cheated.

Now I'll leave you to settle with him, and explain matters so he'll know that's exactly the right thing for an honest beekeeper to do, and if you please I'll crate the rest of that fancy honey. There are fifty cases of it, half of which you have bought, and the other half goes to another man. As I sit crating it, memories of the past come before me; and as I think that I still have the watch I had when I slept with you, a kindly feeling comes over me and I want to make sure that you are not wronged in the crating. So I keep two cases always before me, putting into one the best and into the other the poorest. You get all the best and he gets all the poorest. Do you suppose he'll make any complaint when he sees his honey and sees what you got? I'll leave you to explain to him that he was to get fancy

honey and he's got fancy honey, so has no cause for complaint.

You believe in three grades. Some have more than you, some less. Here's a man who has only two grades, No. 1 and culls, his No. 1 containing your No. 1 and fancy. In each case he puts the best next the glass. That must be all right, for the whole case is No. 1. But it wouldn't be right for *you* to sell a case of honey like that, for part of it would be No. 1, and the facing fancy, according to your grading. Now I'll leave you to settle with the consumer just how it's right for the other man to sell that honey and wrong for you.

I'm with you in putting the best side of the section next the glass. That's like putting a coat right side out, the consumer will put only one side up on the table, and that's the side he cares for. But just as it looks to me now, putting the *best section* next the glass promises too many chances for dissatisfaction. If the public has reached that point where it always expects to be deceived, I believe in deceiving it by giving it a case of honey in which it shall see next the glass a fair average of the contents of the case. Now how does it look to you?

MARENGO, Ill. Feb. 25, 1898.

[My dear doctor, I suppose that, according to the rules of logic and debate, you have beaten yourself. When you admit that it is permissible to turn the best side of a section out, you practically admit that it is admissible to put the less perfect sections in the center. The same line of reasoning that would allow a man to turn uppermost the handsomer side of a section when placing it upon the table, would allow him to keep the handsomer sections for company and eat the others when there was no one present except "his own folks." Then, again, in the lower grades of honey, it is often the case that many sections will be found in which one side of each section will be nicely sealed, while the opposite side is not more than half capped over. With such sections as these it would be an easy matter to put

the worst looking *section* next the glass, and yet, by turning the handsomer *side* out, give the impression that the honey is nicely capped over.

I still believe exactly as I did when I wrote before. I would grade the honey; putting into each grade, as nearly as possible, exactly what belonged there; putting in nothing to which a purchaser would object; nothing but what I should be perfectly willing he should see; nothing that would cause him to reject the honey if he *should* see it. Having done this, I feel justified in putting the best looking faces next the glass, for the sake of adding beauty to the appearance of the package. I believe in making goods as attractive as possible—in turning the rosy side of the apple uppermost. I have no quarrel, however, with those who think differently. I have a sincere respect for those who have other convictions and have the courage of these convictions.—ED.]

[The last line of the foregoing was being put in type as the postman brought in the following article—ED.]



CRATING AND SELLING COMB HONEY.

How Different Kinds and Grades may be Mixed,
Yet the Mixer be Honest.

G. M. DOOLITTLE.

If circumstances lead me, I will find
Where truth is hid, though it were hid in lead
Within the center. SHAKESPEARE.

I HAVE read and re-read two or three times, Bro. Hasty's criticisms on page 117 and 118 of the Review for April; and, for the life of me, I can see there only "a man of straw." After once putting up an untruth as a target, it is very easy to fire a whole lot of truth at it with no fatal effect. I am reminded of the "sugar-honey" matter; which, if my memory serves me right, was espoused by Bro. Hasty; or at least he leaned toward the side the Review took in the matter. The

opposition took precisely the position Bro. Hasty is now taking; firing round after round at the thing; and wondering why Hasty, Cook, Hutchinson and the Review did not come tumbling down. But they did not tumble. Why? Because the guns were loaded with something besides real proof of the claim they had set up. In other words, they were so incensed with "righteous indignation" that they "shot wide of the mark." Not even a single arrow found a lodging place; because the target they were shooting at was only a "man of straw."

Now let us go back a little. The date was 1856, 42 years ago, which was a good honey year, according to my father's account. He obtained several boxes of honey; each box weighing from 15 to 22 pounds. He took it to market and sold it for so much a pound, never breaking a box, and the "XXX, XX, X" and buck-wheat honey was all mixed up in those boxes. Anything dishonest there, Bro. Hasty? Next date, 1870. Doolittle, with several hundred pounds of all sorts of honey in six-lb. boxes, glassed on two sides, turned "rosy cheeks" out, *a la* Hutchinson, and sold it as comb honey. "Gently stroking the Devil down the back" did you say? Prove it if you please! Next, 1877. Had five tons in two-pound sections. Buyer came; looked over the whole pile and bought it. Doolittle said:

"How do you want it crated, and what size of crates?"

Buyer said:

"Put 48 sections in a crate. Take an average of the honey for each crate and put the nicest side of the nicest honey facing out, filling the center with what remains. That is the way the New York market calls for it."

"Doing something discreditable to a good man," eh? "Almost hear his [saturnic] majesty purr?"

Next, a call by the North American Bee Keepers' Association, which assembled at Albany, N. Y. in the early 90's, for a committee of six, eight, or ten, (have

forgotten which, and have not time to look up the matter) to formulate rule for grading honey. I wonder if the apiarists of to day realize that it is only about a decade of years since the grading of honey was seriously thought of, and that the scheme originated with bee-keepers themselves. Doolittle was one of that committee; and there were also one or two commission men on the committee. Doolittle said to the commission man:

"Do you open crates of honey consigned you on commission?"

"Yes, always; just as we try butter shipped to us, to see if it runs alike all the way through, unless the shipper guarantees that packages are alike all the way through, according to outside appearances. Where they do this, if it is not so, the fraud falls on them, and we are not responsible; but where no guarantee is made by the shipper we would be responsible if the contents of case or tub were not alike all the way through. Besides, all those who buy insist on seeing the quality of goods by sampling one or more packages of any lot before purchasing."

"Would you consider it dishonest for a producer to average his year's crop of honey, then put it accordingly in each crate, facing it up with the whitest and nicest sections?"

"No; not unless said producer wrote us it was all alike all the way through. It is my business to *know* what I am selling where anything can be looked into as easily as can a crate of honey; and with its consignment the responsibility of the producer is changed from him to me; I acting as proxy. To fill a crate of honey with white outsides and dark centers, shows a lack of financial make-up; as honey put up that way rarely sells much in advance of the regular price for dark honey; but I can see nothing *dishonest* in so doing."

And I have since talked with other commission men on this same subject, and all very nearly agree with the above. If I put up honey as above, and upon consigning it to be sold, I write; "I ship

you 20 cases of *fancy white* honey to be sold on commission," or sell those cases *my own self* to any consumer as fancy white, then I am *dishonest*; but if I simply write: "I ship 20 cases of honey to be sold on commission, according to your best judgment," then there can be no claim of dishonesty made that will touch me; and all "smelling the strongest of brimstone," and "talking around the outside of the tent" that Bro. Hasty can do, will not prove "faithful are the wounds of a friend," because such things fail to wound the truth. Claims of dishonesty should be proven, not asserted. Give us your proof gentlemen, or be content to hold your peace.

I considered well what I was writing on page 165 of *Gleanings*; and should not have written as I did, only I had become so sick and tired of those old chestnuts in various forms, being brought up to prove that the low prices for honey came about because bee-keepers "put up their honey dishonestly," that they "massed too much honey on the large city markets." Then follow "adulteration," "over production," "farmer bee-keepers under-selling," "slovenly and unattractive shape," "lack of forming exchanges," etc., while the great mass of the bee-keepers of the land have been, and *are*, pushing on with might and main a system which has brought the price of honey to where it stands, and which will, if continued in, down the price to where it will mean starvation for *us*, even though we may bring to our use all the "short cuts and lightning methods that his [W. L. Cogshall] bright brain can devise." In trying to solve the question of, "Why has the price of coal gone from \$3.50 a ton in 1874 to \$5.20 a ton in 1897, while butter has gone from 50 cents a pound in 1874 to 15 cents per pound in 1897?" light may dawn on our mental vision which may teach us something regarding an unjust system.

BORODINO, N.Y. April 18, 1898.

[I felt sure that our good friend Hasty did not fully understand brother Doo-

little's position. Others, probably, viewed the matter in the same light as did friend Hasty; and it is well that friend Doolittle has explained more fully. By the way, our Borodino friend uses one illustration that seems scarcely to the point. It is true, as he says, that with the large, old fashioned boxes the outside combs might be more inviting and of a better grade than the inside; but this is something over which the bee-keeper has no control. He is not to blame if such proves to be the case. With our modern sections and system of grading, the character of the contents of the case is under the control of the bee-keeper; and he is responsible for that character. That is, if the outside is one grade, and the inside another, it is the bee-keeper who made it so.—ED.]



CLOSED-END FRAMES.

Some of Their Advantages as Compared
With Other Frames.

L. A. ASPINWALL.



THE inherent objections to all open end frames are more or less prejudicial to those having closed ends. With many bee-keepers, movable frames are *movable*, only to a certain extent. Frequently, upon opening hives which have been occupied by bees two or three seasons, we find the frames firmly secured by burr combs and propolis. The present low price of honey has necessitated its production with the least possible manipulation; resulting in an increased accumulation of propolis and burr-combs. Under such circumstances most bee-keep-

ers can scarcely afford to scrape and clean sections by hand-work, much less attend to keeping open end frames in working order; while many are inclined to neglect that which adds no immediate profit.

If through disuse, or otherwise, open end frames are in any degree immovable, the logical conclusion will be that closed ends are altogether impracticable. Therefore, all advantages possessed by closed end frames must be based upon the facilities offered in manipulation. Closed ends being subject to propolis, necessitates other features of construction which shall compensate for that which is seemingly objectionable; so, in considering the advantages of closed end frames, a distinction should be made between them as a class, and those possessing additional points of excellence.

Frames of any and all construction are much more difficult to remove from hives without a removable side. This being a recognized fact, most closed end frame hives are so constructed.

While the projecting top bar of the Langstroth frame is an essential feature, which has given it more prominence than most of us realize, still, it has been discarded by most users of closed end frames.

Although a small feature in construction, let me emphasize its importance. Projecting ends are the handles for manipulation, without which the inconvenience of propolis and bees is much increased. Another advantage is the facility offered for rapid handling by placing them in a comb rack or empty hive. Like the combs attached above, projecting top bars afford the most natural support, without the slightest danger of falling over. Furthermore, the projections as used by myself are entirely outside and beyond the reach of bees and consequent gluing. It is a comfort to handle frames without the necessity of bringing our fingers in contact with bees or propolis.

The seemingly objectional feature already alluded to in closed ends (that of propolis) to me is one (like the pro-

jecting top bars) possessing many advantages. But, before proceeding to enumerate them, let me mention the importance of preparation for the manipulation of them, without which they are more or less immovable. To illustrate I might say that a bottle of ink without a pen is useless; so closed end frames necessitate an aid to manipulation. I herewith give measurement of what I consider requisite



to perfect success in handling closed end frames. With it I can manipulate them two-fold faster than the ordinary L. frame. It can be made by an ordinary blacksmith from an old ten inch file. One end should be drawn thin and turned to a right angle; making a blade $1\frac{1}{2}$ inches long by $1\frac{1}{4}$ inches wide, with a handle 8 inches long. It should be tempered rather hard and dully sharpened. This shaped lever when placed between the projecting ends of top bars, and pressed to one side, separates the frame ends with perfect ease. It also serves equally well for a scraper, being the best I ever saw.

Having considered closed end frames relative to manipulation, let us briefly note a few additional features essential to an all-purpose hive. Having had experience with open end frames for years, I am forced to the conclusion that bees not only winter better in closed ends, but maintain their strength, and breed up much faster during the spring months; while the colonies are uniformly stronger. This one feature transcends all others, and is the essential element of success to be sought for in the selection of a hive. It results in bees for the harvest; without which the largest yields of honey cannot be obtained.

Closed ends, preclude the building of burr combs *at the ends most surely*, and with wide top bars, very little labor is required to keep the frames clean and movable. Closed ends are favorable to transportation. True, staples and spaces may

be used on open ends to offset this advantage, with a little additional cost. Closed ends are self spacing, but staples and spacers are used by many to secure this advantage also.

Properly constructed closed end frames can be manipulated with less liability to kill bees than those having open ends.

That open end frames have been bolstered up, by making them self-spacing, and consequently, more portable, needs no comment. But there are two reasons for it. Had there been an all-purpose closed end frame, and no great investment of open end frames to supplant, the situation would have been widely different. Nevertheless, there are a goodly number of bee-keepers throughout our broad land using closed end frames. They seem to be making a still hunt, something like the advocates of plain sections.

In view of the many advantages possessed by closed ends I am inclined to believe the time will come when the majority of our bee-keepers will adopt them.

JACKSON, Mich. April 13, 1898.

A Condensed View of Current Bee Writings.

E. E. HASTY.

"I'll trace the garden o'er and o'er,
And meditate on each sweet flower." *UNKNOWN.*

"ND so friend Daggitt, in Review 113, ⁴⁴ sends in another request for my "half-tone." Since I've been giving him my *wholic* tone so long and faithfully 'pears like he might be "asy." I quit off from having my picture taken some twenty or thirty years ago. My pictures always used to look *sleepy*, and I got mad about it. Not for me to say the camera lies; but leastwise that is one of the very few truths which I am not willing to aid in circulating. But, say, there is a time to be born and a time to die; and when the time comes to close these papers—either by reason of advancing infirmity, or intense preoccupation with things still dearer to me than apiculture, or any other reason—

you may have my picture then, even if it is sleepy. Shall it be a bargain?

Thanks for brother D's good opinion of my hymn. If he will look at the book in which it originally appeared ("Good Will," by Revell of Chicago) he will see that it bears no name but mine. Both words and music are mine; and the initials which have crept in over the left hand side in some books are a fraud.

The simplicity of Mr. Crane's experiment, showing that bees will accept wax offered them when capping surplus honey, is almost sublime. Sure enough the yellow of rendered wax is very different from the ashy white of virgin comb; and a mixture of the two of course looks speckled. Review, 114.

In A. B. J., 146, H. Lampman gives us a new section-leveler. It is a plane, of which the cutter is home-made from pieces of tin, and which works in a bottom-upward position attached to a properly sized box. Apparently the section is to be slid along directing slides; while the plane remains stationary. The box has hot water in the bottom, and a lamp underneath to melt the shavings. Comb must be clean, dry and brittle. Looks practical, and is said to work at the rate of 1,000 a day.

An editorial, A. B. J., 152, reports from a foreign bee paper some interesting details of special kinds of honey. Locust, delightful flavor and good body, sometimes white, sometimes a decided green. Apple, yellow and pleasantly aromatic. Cherry, yellow and pleasant (I doubt this a trifle. What I have supposed cherry has a cinnamon color and flavor.) Chestnut, dark and almost offensive. Mustard, onion and fennel, pretty strong of the flavors we would expect. Rape, sometimes so, but sometimes of fair color and nearly free from turnip taste. Heather, reddish, powerfully flavored, and jelly-like in consistency. I believe natives of heather regions often pronounce heather honey the best of all honeys. I would remark that the quantity of essential or flavoring oil secreted by a plant seems to

be about the same whether the honey secretion be much or little. As the honey secretion varies enormously we of course get varied characteristics from the same kind of honey—slightly flavored when the flow is profuse, and strongly flavored when the flow is very scanty. The amount of coloring matter in the honey is also affected in the same way; abundant harvests always lightest in color. Thus basswood honey is sometimes yellow by scant secretion; apple honey, from the same cause, over flavored and bitter; and rape often good by profuse secretion diluting the flavor beyond notice.

If we don't mind, the Spanish will have some support for their decision that we are "pigs." A. F. Seward of California wants to know, in A. B. J., 158, how much more honey he must eat to be the champion. Editor thinks he is already champion at six pounds a week. He may have my claim.

By the way I've got a bone to pick with editor Ernest Root—two bones in fact, for it is his second offense. Fine and imprisonment both are usual, I believe, for second offenses of the same kind. When the Court incidentally mentioned her pleasure to eat two meals a day, and partake of six ounces of honey each meal, he got somebody to add up the total, and then feloniously, and to the general discredit of the Bench, multiplied it by three. Gleanings, 126.

"Shame on the man who will rob the bees of their stores and honesty too." Shot from Dan White for the fellows who extract thin honey. Gleanings, 126.

Aikin in Gleanings, 136, takes up the interesting subject of the relation of weather to honey flow. He notes an important difference between local showers and general rains. The latter usually close the honey flow for the time being, while the former generally do not.

Doolittle says his goldens excel in the white capping of honey. Gleanings, 138.

Tarred paper used around sections gives the honey a taste that can not be gotten rid of; according to Gleanings, 141.

Some people grumble when they are going to be hung—leastwise on all available occasions previous to being hung. Gleanings on page 144 shows up the letter of a man who grumbled because a prominent commission house discouraged him from shipping honey (just the thing which rogues never do) and soon after he heard of their buying a carload. We are not to "boss" a commission man's business. He is supposed to know his own. All that we have a right to ask is that he shall not cheat us—nor tell us the market is 14 cents when it is 11, nor in any way inveigle us into rushing in honey to be slaughtered off on a demoralized market. That he might see no clear sight to give satisfaction on a small shipment of extra honey near by, and at the same time see cheerful dollars in a carload of tobacco-ist's honey off in California, is as natural as anything in the world. Every man to his business—but the grumbling business to pay a \$50.00 license first.

It seems that our prevalent assumption that worker cells are five to the inch is a little off. Natural ones never *quite* so small as that it seems. Gleanings, 144.

The Coggshall extractor (Gleanings, 209) seems to be altogether too good an idea to be allowed to escape. Big can that allows regular frame to go in as in the hive—two frames side and side with a tin between, and two more just so on the other side of the reel. *No turning* combs to extract the second surface, but instead *shift* them from side to side. If you're smart, and the combs are not too heavy, all four can be taken centrally in the two hands at one grab. This takes so little time that self-reversing mechanism in the extractor itself seems like an absurdity of complication.

But, excellent as our ingenious brother's extractor seems to be, it is not enough of "anti-goat" to balance the "bane" of his bee grinding and honey polluting way of operating—letting robbers run at will right to the extractor while in motion. I do not wish to eat honey that has been filtered through an inch of dead bees.

The general public don't want to eat it either. Sooner or later the general press would get on to such outrageous proceedings, and show us up. Then the whole fraternity would suffer for the fault of a few. If Mr. C. and his men can stand the stings, that is their own affair, we cheerfully admit. The destruction of bee life can perhaps be justified, although some would say no pretty loudly. But when it comes to polluting a choice article put on the market for human food we have some rights in the premises; all of us. 'Spects that like the Spaniards in Cuba he'll have to be held up in the interests of humanity and civilization.

In Gleanings, 167, Aikin thinks the voluntary and the involuntary both come in a little when bees are secreting wax. As to the relative amount of comb honey and extracted, he has done such a thing as to get somewhat more of extracted—at the expense of starvation the next winter. Another year the yields would be very nearly the same. (I produce both comb and extracted; and my best figures last year were scored by a comb honey colony.) Mr. Aikin notes that a scale-colony, when it scores a five pound run, will shrink a pound or a pound and a half of it before the next morning. Just so here.

Prof. Cook says, "I still believe that melilot, while it is excellent for honey, has little value as a forage plant." A. B. J., 97. All right; let's have honest experiences and views, not blowing hot for lies that profit us, and cold blowing for truths that cost us something.

Several at the Northwestern convention had lost queens by swapping positions, a weak colony with a strong one. A. B. J., 101. Lazy man's way to strengthen a weak colony.

W. H. Egertv, A. B. J., 116, says a bee in flight moves in a gentle zig-zag, somewhat as a skater does. I think this observation is new, and if correct is quite interesting.

Two colonies with clipped queens swarm at once, and fail to follow program in coming back—cluster temporarily, and

all together. A questioner wants to know what to expect next. Dr. Miller shows familiarity with disagreeable facts by the following.

"They may cluster together and then each one go back to its own hive. They may cluster together and the united cluster go to one of the hives. They may go together or separately to some other hive from which a swarm had lately issued, and were a lot of returning bees are making a loud call. They may break all up and go all sorts of ways. You see I put in that 'all sorts of ways' to cover some new way that your bees will invent. A. B. J., 122."

A correspondent in A. B. J., 122, contributes a very interesting experiment. Five colonies of bees *not fed* lost in weight during fall and the first part of winter an average of 6 and 3.5 pounds. Ten colonies fed lost in the same time an average of 13 pounds. Variation was great in this latter lot, the loss being nearly proportionate to the amount fed. One fed 20 pounds lost 24½. Very possibly 4 pounds would have covered their loss had they been let alone. In my opposition to fall feeding, except when absolutely necessary, I've been pretty lonesome in this generation; but a hundred years hence there'll be more of me.

Chance for a fight. Is the heat inside a hive moist heat or dry heat? A. B. J., 123. So much water is brought in with the nectar and evaporated that things must be as moist as it is under the cover of a steaming kettle—there now! If the air inside were saturated, or even nearly saturated, the water aforesaid wouldn't evaporate—there now!

In Progressive, 82, Doolittle comes out flat footed in favor of unpainted hives—the painting bill saved more than renews the hive when an unpainted one plays out, and painting is a positive damage to the well being of the inmates. Wouldn't have his single-wall hives painted if you'd paint 'em for nothing and pay a dollar a hive for the privilege. I rather suspect friend D's head is level in this—and also in the following.

"I can understand how anyone never having used properly made wide frames, can use the T-supers, but I cannot understand how any person after having used wide frames, could lay them one side, and adopt the section holders or T-supers."

The Progressive has been freshening up very decidedly of late.

Stachelhausen says the queen is not of herself able to eat pollen. Honey absolutely alone will not support life. It follows that the queen would starve to death if the workers did not feed her with digested pollen products. Southland Queen, 271.

And editor Bennett (Pacific Bee Journal, 44.) thinks he is ahead of me on the health movement. Has adopted the two meals a day method. Well I was there 15 or 20 years ago—when a person had to incur the odium of being an awful crank by taking such a step. Now the very best authorities in the country advise it for nearly all except the most vigorous stomachs. After he has had 20 years of benefit out of it, and old age gets to coming on, he may find, as I do, that it is not sufficient any more, and that something else, he knows not what, needs to be done. I am aware that a few make a success of a one-meal-a-day method. Going to find out whether it will work in my case. Get my obituary straw written Dr. Miller. Good by, unless—

C. C. Greiner thinks buckwheat's habit is to yield more honey when nearly mature than when it first begins to bloom. Gleanings, 86. Isn't it the advancing coolness of the nights that really makes the change? Buckwheat begins to bloom very soon after it comes up, in the hot weather of August, and it seems never to yield honey worth mentioning when it is oppressively hot night and day. He mentions also its habit of stopping secretion in the afternoon, a trick often in print before. Further on he protests against making such a fuss about bees hanging out—doubts whether there is any harm in it; and thinks the conditions that cause it are conditions that we can not help. Perhaps he is more than half right. Sometimes it's heat, or crowding, or lack of ventilation—if so mend things. Sometimes it signifies no more than the sitting of a family of folks in their shady front porch—let them alone.

Mendleson says when he moves his apiary to the great bean fields the hives get filled with honey in six days. Gleanings, 87.

Dr. Miller made a failure of corn husks as fuel. Gleanings, 123. Glad he saved me the bother of trying them. What a great variety of fuels we are getting that won't work worth a cent except with the inventor! Not sure that the Dr's small chips, or friend Golden's sunflower leaves would smile on me.

That is a very wise and timely saying of Ernest Roots in Gleanings, 124, that a little bulging at top or bottom, which is endurable in the old style of sections, will be altogether intolerable in the new style. True as a die. One may safely assume that things won't be right until a year or two of unpleasant experiences has compelled them to get right.

RICHARDS, O. April 26, 1898.



EDITORIAL offerings.

CANDIED HONEY can be thrown out of the combs with an extractor, if the combs are first uncapped and soaked several hours in water; so writes a Wisconsin bee-keeper—I have mislaid his letter and forgotten his name. He says that the water in which the combs are soaked may be used in making vinegar.

THAT LIME is the one thing needed for the growth of sweet clover is indicated by a fact pointed out in a letter just at hand from Mr. J. E. Crane of Vermont. He says that a friend living near the extensive marble quarries at Rutland, Vermont, once told him that upon the heaps of waste, where there was *nothing but marble* to the depth of twenty or thirty feet, sweet clover grew in great luxuriance. As is known, marble is a very pure variety of lime stone.

THE ADVERTISING pages of a journal ought to be just as bright, newsy, interesting and really valuable, as the reading pages. They may also be made things of beauty. Of late I have been giving some of the Review advertisements a shaking up; putting them through a sort of rejuvenating process—re-writing and re-clothing them. Just take a look at them; and if you patronize any of the advertisers, just tell that you saw their advertisement in the Review.

MY FATHER-IN-LAW, Clark Simpson of Flushing, Michigan, passed away Sunday, May 1st. He was 74 years of age; and had been an enthusiastic bee-keeper more than half of his life; being greatly given to the adoption of new things. I remember with pleasure the visits that I made him when scarcely out of my "teens," to "talk bees." It was during these visits that I made the acquaintance of the girl who has since been my good wife. Her mother will now make her home with us.

MY BEES wintered exceptionally well last winter. Not one colony lost out of 35, and not a weak one among them. The two or three brought in from the country and put into the cellar without a flight wintered equally as well as the others. As the years go by I am more and more convinced that *food* is the pivotal point in wintering bees here in the North. Although it was bright and warm when the bees were carried out, they seemed in no hurry to fly. Some colonies were not in full flight until they had been half an hour on their summer stands. They were quiet and closely clustered, and probably would have endured six weeks more of confinement with no discomfort.

"FACING" COMB HONEY when crating it for market is a subject upon which considerable has been written. Quite a little space is given up to it in this issue of

the Review; and Mr. Snyder, the man who started the discussion, writes that he would like to reply to some of those who have opposed him. Owing to my love of fairness, I presume I shall print his reply if he sends one, but it is evident that this is one of those abstruse subjects upon which a great amount of fruitless argument has been brought forward. I doubt the advisability of continuing it much longer. The best rule that I can give in the matter, is called the *golden rule*. So crate your honey that, if by chance you should unknowingly buy one of *your own cases* of honey, you would not be disappointed when you opened it.

SELLING HONEY requires a careful consideration of circumstances. Until the last year or two, nearly all of my honey has been sold by commission men in the large cities. Sold in this way, I realized more for the honey than our neighboring grocers sold it for at retail. Under such circumstances, what encouragement is there to "develop the home-market?" Of late the wholesale price of honey in the large cities has been so low, while that of our home-market has kept so nearly up to its old mark, that I have found it more profitable to sell my honey near home. I believe my friend Koeppen has, during the past year, obtained *nearly* as much per pound, *net*, for his second grade honey sold in our own home-market as for the first grade sold in a distant city. A home-market is very desirable; and, when circumstances will admit, should be cultivated with great care.

RAMBLER ON A HILL.

As mentioned in a previous issue of the Review, Mr. Hill, editor of the Am. Bee-Keeper, passed one season in California. That was before Rambler went there; but Rambler has been hearing about him; and tells some of the stories in Gleanings. Here is one item: "That Harry Hill, who worked for us, could beat anybody I ever saw in uncapping honey.

Why, he could uncap with an upward and downward stroke of the knife; and, before you knew it, it was ready for the extractor. Yes, sir; that Hill was the best all-round-bee-man I ever saw." Rambler winds up with the following: "Now if Mr. Hill can sling ink and scissors, and uncap editorials with an upward and downward stroke, the rest of the editorial family had better look out."

He can do those very things Mr. Rambler. There is no one of us bee-keeping editors who drives a smoother quill than does our eastern brother with the lofty name; besides this, he has a thorough knowledge of bee-keeping, is loaded to the muzzle with enthusiasm, and is rapidly pushing the American Bee-Keeper into the front rank.

J. A. GOLDEN, of Reinersville, Ohio, is not only a photographer but an artist. I'll tell you how I know. Last summer there came to me, by freight, a large flat box. Supposing it to be some "bee-trap" that some one had sent me, I took it out to the shop and knocked it open with a hammer. When I saw glass and a picture-frame, I worked a little more carefully. Over the face of the glass was pasted a sheet of paper, and upon the paper a nice letter signed by friend Golden, and so worded that the character of the picture must be guessed at. I tore off the paper, and was never more surprised in my life than to see a splendid life-size crayon picture of myself. Mrs. Hutchinson says that some two or three years ago friend Golden asked me for a photograph of myself, saying that he would not tell me then what he wished it for, but I had forgotten it entirely. The picture is an exact counterpart of the photograph; and if any of the friends are in need of work of this kind they can not do better than to patronize friend Golden.

THE QUEEN BREEDERS' UNION.

This is an era of organizations, and unions, and fraternities. The latest in

this line, in an apicultural way, is the Queen Breeders' Union. The idea originated with Mr. J. O. Grimsley, of Byrdstown, Tennessee.



The object is to protect and benefit both queen breeders and queen buyers. No breeder will be admitted who has not a *clean* record; and any case of crookedness on the part

of a member will cause him to be expelled. Only honest, straight-forward, reliable breeders will be admitted, and if it is found that a mistake has been made in admitting a man, that mistake will be rectified. Expulsion from the Union would practically ruin any breeder's business, and no man will be expelled unless his business proves to be such that it *ought* to be ruined. Of course, not to join the Union need not necessarily be construed as a reflection upon a man's honor or integrity, but *to* join it shows that he is willing and ready to stand with those who intend to do right; and to place himself in such a position that he *must* do right or be publicly branded as a rogue. If a man buys queens of a member of the Union he can rest assured that he will be treated fairly. If he isn't, he will have in his hands a pretty big club to hold over the head of the man who has dealt unfairly.

Another object of the Union will be to protect its members against dishonest queen-buyers. Occasionally there is a man who starts out with the deliberate purpose of defrauding queen breeders. He orders queens and promises to pay at a certain time; gets all the queens that he can on credit of one breeder, and then proceeds to "work" some one else. Of course, a man may not always be able to pay when he has promised to pay, but the man who deliberately goes to work to "beat" queen breeders will soon find out

that they are "on to him" as the saying goes.

The business of organizing this Union has, I believe, been all conducted by mail, and I am not certain that it is yet complete. It is likely that more particulars can be given in a later issue of the Review. In the meantime, all who are interested can probably gain more information by addressing Mr. Grimsley.

LATER—The election of officers has now been completed, and is as follows: President, G. W. Huffstodler, Beeville, Texas; Vice President, J. B. Case, Port Orange, Florida; General Manager, W. H. Pridgen, Creek, N. C.; Secretary and Treasurer, J. O. Grimsley, Byrdstown, Tenn.

BUCKWHEAT.

By the time that the June Review is out it will be time to begin thinking about the sowing of buckwheat. I would be glad of a few articles on that subject for publication in the June Review. In this part of the country the raising of buckwheat is somewhat of a side-issue. If there is some rough piece of ground, hard to work or cultivate, it is sown to buckwheat. In the newer parts of the country, after the spring crops are in, a piece of land is sometimes cleared and sown to buckwheat. Sometimes there is a piece of land that is too wet to work early in the spring, but it dries out in time to sow it to buckwheat. Occasionally an early sown crop of some other kind is destroyed or injured in some way, and it is too late to replace it, then the land is sown to buckwheat. Sometimes buckwheat is sown early and plowed under to enrich the soil. Circumstances like these lead to the cultivation of buckwheat in this part of the country; although it is true that good land is often designedly kept and used for the growing of buckwheat. There are, I believe, parts of the country, some parts of New York, for instance, where buckwheat is one of the main crops. I wish that some of the

owners of the great buckwheat fields of New York, or some one living in that region, would tell the Review *why* they grow buckwheat so extensively. Is it because the soil and climate are peculiarly adapted to its growth, or *what* is it?

The rule here is to sow your buckwheat "the Fourth of July, wet or dry." But this rule is not lived up to. It is often sown the middle of June; or as late as the first of August. Buckwheat needs cool, moist weather. If sown too early, the hot sun of August is likely to blast the kernels as they are forming. If sown too late, the frost may catch it before it ripens.

I wish that those who have had experience with this crop would write on the following points: The soil and its preparation. What kind of soil is best adapted to its growth? How shall it be prepared? What about the use of fertilizers? When shall it be sowed? How shall it be sowed? How much per acre shall be sowed? Then comes the harvesting and threshing. I may say that I have raised buckwheat in a small way. I cut it with a cradle, raked it up in small bunches and set it up with a small band of stalks around the top to keep it together. When dry enough to thresh, a machine was set in the field and the grain drawn right to it by two teams—one loading up while the other was unloading. I had the grain ground and sold the flour. The bran and middlings I fed to the pigs.

To me there is considerable fascination about buckwheat. It comes up so quickly; and the broad, green leaves scattered so thickly over the brown earth give a picture of thrift and life that has few equals. Then the clear amber of its stalks contrasts so sharply with the bright green of its leaves; and when the crowning glory of the blossoms transforms all into a field of waving white the picture is one of dazzling beauty. Then to see the white go through the various shades of color until it ends in the reddish brown of ripeness is really more enjoyable to me than going to a circus.



Department of Criticism

R. L. TAYLOR.

Blame where you must, be candid where you can,
And be each critic the Good-natured Man.

GOLDSMITH.

I WANT to protest that I am no pessimist; for I am charged with the thankless task of finding fault. I scarcely know, either, why I should so protest; for why should not the optimist, content with what is well, turn his attention to what seems to him ill; confidently hoping to bring about a more desirable state of things. But I'll let it stand.

NO DANGER OF ADULTERING WAX WITH
PROPOLIS.

I begin near home: I can but think that Mr. Aspinwall is entirely wrong in assuming that there is any special danger of unwittingly adulterating beeswax with propolis. (A. B. J., 148.) I do not know at what temperature propolis melts; but it requires a considerable higher one than wax; and their specific gravities are also very different. Propolis is heavier than water; and I doubt if it melts at the temperature of boiling water. For proof, take the fact that it answers very well instead of solder to stop holes in vessels in which water is to be boiled. I recently had occasion to extract the wax from a lot of section scrapings. I did it by putting them in boiling water. After considerable boiling the propolis was found in lumps at the bottom of the vessel; showing that while it had softened it had not melted sufficiently to spread out.

UNSKILLFUL USE OF LANGUAGE—NO
HARSHNESS TO BE USED EXCEPT IN
THE CASE OF EDITORS.

E. R. Poppleton writes of the cause of foul brood, quoted in A. B. J., 168. Though evidently unskilled in the exact use of words, his meaning is plain and

sound. The editor, to my surprise, indulges in some very captious criticism of the writer; taking him literally when it suits his (the editor's) purpose. For instance, Mr. Poppleton, speaking incidentally of moths destroying colonies of *bees*, uses the word "hives" instead of colonies of bees. The editor snaps him up in this style: "Then the idea of moths trying to kill 'hives' made of wood! Of course they couldn't." I'll try not to be so harsh—unless it is with the editors.

A HANDY REAR-ENTRANCE.

The Editor (Gleanings, 42) wants specifications for a handy rear entrance to the hive. This suits me: Make the front entrance by fastening strips of any size desired on the bottom board under the sides and rear of the hive, then when a rear entrance is desired move the hive forward on the bottom-board an inch or more and you have it.

LATE BREEDING CAN BE INDUCED BY FEEDING.

As Dr. Miller says, (same reference) it is quite generally supposed that late feeding induces late breeding, but both the doctor and the editor are thrown into a state of doubt because G. de Layens says "this is a mistake according to some cases he has noted, the intensity of the laying fading out toward the close of the season not to be rekindled again even by a late natural flow." It hurts me terribly to see such old heads in apiculture put all at sea by so slight a puff. May we not have some stable ground to stand on? Layens is right, except when he says, if he is correctly quoted, that the general supposition is a mistake. "The intensity of the laying" *does* fade out toward the close of the season and may not be "rekindled by a late natural flow" *because* such a flow is apt to be very *short*, but that it will invariably be "rekindled," though not with the intensity of early summer, by continued feeding so long as the bees can comfortably take the food, I abundantly proved to my satisfaction in the early years of my bee-keeping.

SURPLUS INCREASED TEN-FOLD BY ALLOWING ONLY ONE SWARM INSTEAD OF TWO FROM EACH COLONY.

But I am not disposed to be hard on the doctor for see what a revelation he makes to bee-keepers (Gleanings, 125) viz., one "might increase his surplus ten-fold by allowing only one swarm instead of two from each colony." I only hope that he has given the subject such mature consideration before reaching this conclusion that nothing can occur to make him think that "possibly this point needs fresh investigation," since, as yet, I am on the ragged edge of doubt. I would ever so much like the handsome income that that revelation, if it is well founded, will bring me. I can safely count on fifty pounds of comb honey in a good year from each good colony and allow two swarms from it. With only one hundred good colonies that would amount to 5,000 pounds; and, by allowing only one swarm from each, which I could easily manage, that would be increased ten-fold or to the amount of 50,000 pounds; which, at ten cents a pound, would amount to \$5,000. This is, I hope, a point in which location is not going to make any serious difference. But what a poor season the doctor must have had last year; getting only 17,150 pounds from, I infer, about 250 colonies.

THE PROFITS OF BEE-KEEPING.

This reminds me that, on page 43 of Gleanings, the same writer discusses the question, "Do Bees Pay?" and with the help of the editor it is made out that \$5.00 net was received for each day devoted to the bees during the year 1897. This is indeed a very satisfactory showing. Bees certainly pay. But, let's see, didn't I read somewhere something about his considering this a somewhat better year than some of the previous ones? Maybe that would make a difference. Couldn't the doctor be induced to write an article on the question, considering the outgo and income of the year 1896, or of the year 1895, or of the year 1894? If the doctor leaves us to draw wrong con-

clusions it may bring us sore disappointment.

THE INELEGANCE OF SLANG.

I notice on page 41 of Gleanings that Dr. Miller has been taking the editor to task for allowing the wordy phrase, "new beginner," to slip into his pages; and very properly, too, but what about such inelegant editorial phrases (not to put too fine a point on it) as the following: "It is more fun to 'sass' you," page 203. "You must have flopped over since the advent of that naughty canard," page 205. "They had to 'schrooch' down," page 205. "You are exasperating for sure," page 205. "I 'smoled' another big smile," page 208. And this jewel, on page 223, "A snide *house* may have an honest appearance; but a bee-journal can often uncover the swindling schemes *they* are about to launch forth; *i. e.*, how the *wolf* has put on sheep's clothing. Whenever that honest old *ram* comes, etc., bee-keepers will * * * recognize at once the true 'inwardness' of the *'baste*," etc. "If you do not look a 'leedle out,'" Page 43. And on page 123, Dr. Miller himself says: "I smole a smile of considerable extent." Page 203, "That 'sassy' Niver." Page 204, "Nary a hit." Page 248, "What for do you let" etc. Page 166, "Prof. Cook has riz up."

PHONETIC SPELLING.

The reformed spelling is evidently going to make trouble. For proof see page 38 of the Pacific Bee Journal. The editor is evidently wrestling with the problem, and, as a sample of the result I quote "Cyperian," "Cyprian," "Syperian," "Carnolan," "Carnolian," "Carolan" "Cornolon," "Syrian," "Serian," and "Zerman Brown." Perhaps the article is intended for burlesque. Witness this sentence. Speaking of "Syperians and Carnolians" the writer says: "This race or type of honey bee has given me better results, equal and excel in importance to any other class, race or type of honey bee I have had anything to do with. They truly are the giants of industry." Possi-

bly the Southland Queen, from which it purports to be taken, is responsible.

FASTENING FOUNDATION TO THE TOP

BAR.

Dr. Miller, (A. B. J., 182) prefers to fasten foundation in brood frames by slipping the edge of it into a saw-kerf cut into the under side of the top-bar and fastening it by drops of melted wax. That is good but too slow. I think this is preferable: Upon a board slightly larger than the frame fasten another board, just large enough to slip into the frame and scant half as thick as the top bar is wide. Put the frame over this "form," lay in the foundation with a straight edge close against the top, then, holding the whole firmly in the left hand, pour with a teaspoon into the angle between the top-bar and the foundation about half a teaspoon of melted wax and rosin half and half, holding the form in such a way that the melted material will run quickly from one end of the foundation to the other. Keep a cup of the wax warm over a lamp or in some other convenient way. I use this method even when the frames are well wired.

CURLING OF FOUNDATION IN SECTIONS.

Mr. Aspinwall finds the no-wall foundation liable to warp (A. B. J., 149), and Mr. C. P. Dadant gives a novel reason for warping (A. B. J., 177); one which I have as yet found no reason to consider correct. The reason he gives is that it is warped in milling by sticking alternately to the two rollers. This, at least, is not the warping that troubles *comb honey* producers. In their troubles the lower edge of the foundation turns *invariable out*, away from the centre of the super, which could not well be the case were Dadant's reason the correct one. The true reason is evident: there are not bees enough to fully occupy the super, and both the force they exert in following their habit of crowding together at the center of the super, and their drawing out under such circumstances the *inside* of the foundation first, cause the foundation to curl outward. No-wall foundation may curl

more easily than the other kind but the remedy is evident.

WHY BEES DO NOT LOSE THEIR STINGS
IN STINGING ONE ANOTHER.

Dr. Miller (page 123 A. B. J.) gives as the reason why bees do not lose their stings when they sting one another that they slide their stings into the spiracles and so can withdraw them. I wonder if that is one of the things he *knows*. At all events, I suspect he is wrong. It is not infrequently said that unless a bee stings a person when she strikes him she will not sting at all. This is nearly true. She needs the impetus motion gives her, or something to hold her to the work, as hair or clothing. Sometimes she stings without any of these helps, but it is then generally a slight prick, and she retains her sting. But a slight prick given a bee is sufficient. Neither clothing, hair nor motion is needed to assist in piercing the tender integuments that unite the horn-like rings. When one bee is trying to sting another, notice how carefully, almost tenderly, she feels, not for the spiracles, but for the opening between the rings; and that she does not seem to try to sting hard. Notice, too, that not infrequently the bee receives the sting in the neck where there are no spiracles. All have noticed how quickly a colony into whose hive a runaway swarm has come, will despatch that swarm. It is incredible that the bees, in such a case, spend any time in looking for spiracles. Then, I suspect that the spiracles are not so large but the barbs of stings would cling in them as fast as in any other part.

THE TIME OF PUTTING BEES INTO THE
CELLAR AND TAKING THEM OUT HAS
LITTLE INFLUENCE UPON SUCCESS-
FUL WINTERING.

Dr. Miller (A. B. J., 149) is still struggling with the wintering question; particularly with reference to the best time for putting the bees into the cellar and for putting them out. He rests the entire solution of the problem apparently upon "cold" and length of confinement.

The one thing he is bold enough to say he knows is that if bees have a good flight Nov. 15 they can stand the confinement from that time. If I *know* that I should feel that I had no further cause for anxiety about the wintering problem; for I can easily control the temperature. But if experience has taught me *anything* about the matter, it is that the time of putting in and out, within reasonable bounds, has very little to do with success. I think I can tell with much certainty before the end of January how my bees are going to come out in the spring; a time when I am without any knowledge as to what the length of the time of confinement is to be. Occasionally I know that, if spring were to come full fledged the first of February and the bees were put out *then*, there would be spring dwindling, and sometimes I know well at that time that they could bear confinement in the cellar till May 1, and come out bright and strong. More than this, if I could be informed Nov. 15 as to the character of the stores the bees have, I could tell at that time how they would come out in the spring. So far as I know, I was the first one to advocate setting bees out early, but the purpose I had in view was not to save the colonies but to enable them to settle down and be ready in good season for spring work. The doctor's idea leads him into what I esteem a serious error in the answer to a question in the American Bee Journal, page 183. He says: "If there comes a warm day and they don't seem inclined to wake up at all it will certainly be better to take them out for a flight than to let them stay where they are and not fly at all. If you can get at the hives inside to pound on them so as to stir up the bees on a warm day it might be a good thing to do so," etc. Locality must make a difference. Here, when the bees sleep very quietly they don't need a flight at all; when they need a flight they are so restless that they would fly out pell-mell if given an opportunity with scarcely any reference to the temperature.

LAFER, Mich., April 8, 1898.

EXTRACTED.

PEDDLING HONEY.

How it may be so Managed as to be both
Agreeable and Profitable.

For many years the demand for honey was in excess of the supply; and it sold readily at high prices. Movable combs, the honey extractor, comb foundation and bee journals gave the industry such a boom that large quantities of honey were produced; and prices took a tumble. How to dispose of the honey became a more serious problem than did its production. Then came a few years of poor seasons that most effectually settled the marketing question—temporarily. The indications are that there is to be a return of good seasons; when the question of marketing will again become paramount. Of course, it is early in the season to be talking about marketing; but it is also well to lay our plans ahead. For instance, a man may be so situated that it would be more profitable for him to produce extracted than comb honey if he could sell it to advantage. To such a man the following article may be worth many dollars. I think it one of the most sensible and helpful articles on the subject of selling extracted honey direct to consumers that I have ever seen. Just let this article linger in your memory until next fall when you have a crop of honey to sell. It was written by Mr. H. D. Burrell, of Covert, Michigan, and gives his experience in selling thousands of pounds of extracted honey direct to consumers at a good price. It was published in *Gleanings* and reads as follows:—

How to dispose of the honey crop profitably is becoming a serious problem with most bee keepers. Not many years ago it was easy to raise comb honey, ship it to some commission house in a near-by city, and realize 16 to 20 cents a pound for it. Now in many places most of the honey-producing timber is gone, and waste lands reclaimed and cultivated. These causes, with frequent poor seasons,

render the honey crop uncertain; and, worst of all, comb honey in the cities is quoted 7 to 12 cents.

Formerly I raised comb honey almost exclusively, and shipped nearly all of it to commission houses. But some years ago I unexpectedly had about a ton of autumn extracted honey to dispose of. Shipped to a commission house it would probably have netted 4 to 5 cents a pound, *some time*. I had never tried peddling honey, and was very much prejudiced against peddlers and peddling; but I wanted more for that honey. I loaded some of it into the wagon, put up in convenient packages for retailing, and started, though with much trepidation. I knew a few bluffs would send that honey to the city for what it would bring. But I sold honey at nearly every house, over 300 lbs. the first day, and decided that peddling (honey at least) was not such bad business after all. Many neighbors and acquaintances who had passed by frequently for years and seen the sign, "Honey for Sale," but never bought a pound of my honey, bought freely when it was carried to them. And they didn't buy afterward, either, unless I carried it to them and asked them to buy.

The ton of honey was soon sold at 8 to 11 cents per pound, according to quantity wanted, and several thousand pounds more were bought and sold at a fair profit. Since that time I have raised mostly extracted honey, always retail it myself, and am getting the same prices now in these times of very low prices that I did ten years ago. Honey, if a good article, will sell itself almost anywhere, if given a fair chance. I have never found a place, in country or town, where it would not sell fairly well, any time of year, though in the fall is the best time to sell, in my experience, after the bulk of fruit is gone, and the many needs of the winter season have not yet taxed the pocket-book.

But I think I hear some one say, "I can't peddle;" or, "I won't stoop to peddling!" Now, neighbor, stop a minute, and listen. When I was young and green I tried "canvassing" for a book. For years after, I had a horror of peddling. When I came to keep bees, and have honey to sell, I would not even ask a merchant with whom I traded regularly to buy my honey. If any one but a commission man wanted any of it, he had to ask for it. I am not a natural salesman, a poor talker—timid, diffident, and easily rebuffed. I can, however, sell an average of 100 pounds of honey a day in any fairly good farming country, and in villages and towns often much more. You

will find selling your own honey different from selling books or notions. People will be glad to see you come. You need not lose one atom of your dignity, if it is of the self-respecting kind. If any one thinks any less of you for selling honey, provided you are polite and respectful, it will be some one whose opinion is not worth minding. Any one with a little tact and energy can dispose of 3000 to 5000 lbs. of good extracted honey at fair prices, at odd times in fall and winter, when time is not worth much, and much more can be sold by devoting more time to it.

Comb honey is not satisfactorily retailed in my experience. It too easily gets to leaking, and is then mussy, and not attractive. Sell comb honey only by the case if at all. Perhaps I may be pardoned for saying, in such an article as this, that I have for many years kept from 50 to 195 colonies of bees, and have raised and sold over 60,000 pounds of honey, and bought and sold much besides. I write facts learned in the dear but thorough school of experience, and not plausible theories.

First, secure a good article of well-ripened extracted honey, and so care for it that it will remain good. My ways of doing this differ from the usual ones; but I will not take time now to explain. Perhaps in some future article I may do so if the editor wishes it.

When we are ready to sell, if the weather is mild, attach a sliding faucet to a five-gallon screw-cap tin can of honey; place the can on the wagon-seat, the dish to be filled on platform scales underneath, and weigh out any quantity wanted. It is usually most satisfactory at this time of year to let the purchaser furnish the dish, then there is no package to pay for or return.

Some writers have advocated selling not less than one dollar's worth when selling honey direct to consumers. I can't agree with them. A small sale often paves the way to a large one later, and it always pays to be accommodating and obliging; but I charge 1 cent per pound more for less than a dollar's worth.

In cold weather, when honey will not run readily, I put up honey in 1, 2, and 4 quart tin pails, and charge extra for the pails. Always, to every package sold, attach a neatly printed label, giving your name and address, and plain, simple directions for so caring for the honey that it may retain its good qualities until used. Dress neatly but plainly, like a farmer, not like a city man. Have everything clean, neat, and attractive.

Now we are ready, how shall we find buyers? Fill a small tin pail with honey, and label it. Call at every house—skip none. You will often make sales where you least expect it. When the door is opened, say, "I have some choice honey, please get a spoon and sample it." Right here is the main point. Get everyone, if possible, to taste your honey. Most people have sweet teeth, and a taste of good honey puts them in good humor. Be very sure that the children, if present, have a taste too. If you don't know already that parents' hearts are very easily reached through their children, you will soon learn it. If a servant or child goes to consult the housekeeper about buying honey, see that the honey-pail and a spoon go too. Twenty-four in twenty-five would say "no!" if asked if they wanted to buy extracted honey. If they taste first, many will buy. Many are prejudiced against extracted honey. Perhaps some time they have had a poor article of extracted or strained honey, or, may be, they think the honey is bogus. I have many times had such people taste my honey and say, in a surprised way, "Why, that is good. That is genuine honey. What is the price?"

One lady said to me last fall, "I never buy extracted honey. I buy comb, then I know what I am getting." After she had been induced to sample the honey she found it good, knew it was genuine, bought some, and asked me to call again.

Don't annoy people by urging them to buy when they don't want to, and be invariably polite and pleasant whether they buy or not. You can easily make friends who will be glad to see you come again. Follow the same route every year, and your sales will increase each trip. You can go over the same ground as often as once in six weeks to advantage. I have many customers who at first bought lightly, or not at all, who now buy 20 to 50 pounds of my honey every season. One near-by town of about 2000 population has used over 1500 lbs. of my honey this season up to Feb. 1, and all autumn honey too. I seldom have any other kind in my present location. There is but little buckwheat, and the honey is mostly from goldenrod, fireweed, and Spanish needle. One pleased customer will often find others for you. In this way I have this season sent three 5-gallon cans of honey to customers in Chicago at 9 cts. per pound net. "Can't buy genuine honey in Chicago!" they say. A little ridiculous, isn't it?

Some one will ask if I have no competition in selling honey. Yes, but that

doesn't matter much. There is plenty of room, and customers for all. Make a reputation for square dealing and selling a good article, and customers will wait for you. If someone undersells you, and gets some of your customers, never mind—there is a very large market almost entirely undeveloped.

Think of this matter, brother bee-keepers. Plan to raise a crop of good extracted honey next season, then get all there is in it. Don't divide with transportation companies or middlemen. A crop of extracted honey is much surer than a crop of comb, and, in most localities, two or three times as great. Ask a fair price for your honey (all you can get is a fair price), and adhere to it. It is much easier to lower prices in a good year than to raise them in a poor one. If there is a large or small crop of grain or fruit, every one knows it. Not so with honey.

There are two or three points in Mr. Burrell's article that ought to receive especial emphasis. One of the strongest points that he makes is that of getting people to *taste* of the honey; and especially to get the *children* to taste. Don't *urge* people to buy the honey, but let them and the children taste, and the taste and the children will do the urging. Many people will buy what their children want, even though they might be willing to deny it to themselves. Another point is that of being courteous and polite and not urge people *too* hard to buy. I believe that our most successful "drummers" never *urge* their customers to buy. I don't know as I ever mentioned it in the Review, but a good share of my time, after I was eighteen years old until I was twenty-eight, was passed in selling things—in canvassing from house to house selling picture frames. I carried samples of moldings and took orders for frames for pictures that people might have on hand unframed; made the frames, and then delivered them. I not only never urged a sale, but even went so far as not to *ask* anyone to buy. I asked for the privilege of showing my samples, suggested that if there were any pictures that were in need of frames that I should be glad to give prices, etc. The pictures were al-

most always forthcoming, and then I showed the different combinations of moldings, gave prices, etc., but I never *asked* the ladies to *buy*. If they chose to favor me with an order I took it; if not, I cheerfully gathered up my samples and trudged on. It is quite a point not to allow your prospective customer to say "No" in the beginning of the interview. Having once *said* "no," many persons are inclined to *stick to it*, even though they may change their minds; while, if they had not *said* "no" they might eventually say "yes."

Honey Quotations.

The following rules for grading honey were adopted by the North American Bee Keepers' Association, at its Washington meeting, and, so far as possible, quotations are made according to these rules.

FANCY.—All sections to be well filled; combs straight, of even thickness, and firmly attached to all four sides; both wood and comb unsoiled by travel-stain, or otherwise; all the cells sealed except the row of cells next the wood.

No. 1.—All sections well filled, but combs uneven or crooked, detached at the bottom, or with but few cells unsealed; both wood and comb unsoiled by travel stain or otherwise.

In addition to this the honey is to be classified according to color, using the terms white, amber and dark. That is, there will be "fancy white," No. 1, dark," etc.

CHICAGO, Ill.—There is a good demand for fancy white comb honey. This grade would sell for 11 cts—possibly higher. Considerable Amber and dark on the market—selling anywhere from 5 to 8. Extracted White sells at 5½ to 6; Amber 4½ to 5; dark, 4. Beeswax, 27.

S. T. FISH & CO.,

Mar. 24. 189 So. Water St., Chicago, Ill.

BUFFALO, N. Y.—Really fancy honey moves well but other grades require pushing and cutting to move. We quote as follows: Fancy White, 10 to 11; No. 1, white 9 to 10; Fancy Amber, 8 to 9; No. 1, Amber, 7 to 8; Fancy dark, 6 to 7; White, Extracted 5 to 6; Amber, 4½ to 5; Dark, 1 to 4½; Beeswax, 24 to 28.

BATTERSON & CO.,

Mar. 24. 167 & 169 Scott St., Buffalo, N. Y.

CHICAGO, Ill.—The season for the sale of comb honey will close with this month. A little is sold in April, but so small as to fall in changing prices. We quote as follows: Fancy White, 10; No. 1, white, 8 to 9; Fancy Amber, 7 to 8; No. 1, Amber, 7; Fancy dark, 7 to 8; No. 1, dark, 7; White, Extracted, 5 to 6; Dark, 4; Beeswax, 27.

R. A. BURNETT & CO.,

Mar. 24. 163 So. Water St., Chicago, Ill.

CLEVELAND, OHIO. We quote as follows: Fancy white 12 to 13. No. 1 white, 11 to 12; fancy amber 9 to 10; No. 1 amber 8 to 9; Fancy dark, 7 to 8; white, extracted. 6½; amber 5½; beeswax, 28.

A. B. WILLIAMS & CO.,
Nov 22, 80 & 82 Broadway, Cleveland, O.

KANSAS CITY.—The supply of both comb and extracted honey is large, and the demand light. We quote as follows: Fancy white 10; No. 1 white, 9; Fancy amber, 8; No. 1 amber 7; white, extracted, 5 to 5½; amber, 4 to 5; dark, 4; beeswax, 20 to 22.

C. C. CLEMONS CO.,

Feb. 10 521 Walnut St., Kansas City, Mo.

NEW YORK. —We have had a good trade in comb honey the past week. Fancy white is in demand. Our stock of fair and mixed honey is working down very well. Extracted honey is selling well. Fancy white clover and basswood find ready sale. We quote as follows: fancy comb honey, 11½ to 12½; fair grades, 9 to 10; buckwheat and mixed, 6½ to 7; Extracted, California, white, 5 to 5½; amber, 4¾ to 5; white clover and basswood, 5¼ to 5½; buckwheat, 4 to 4½; southern, 50 to 55 per gal.; beeswax finds ready sale at 27 to 28.

FRANCIS H. LEGGETT & CO.,

Jan. 24 W. Broadway, Franklin & Varick Sts.

NEW YORK, N. Y.—Demand for comb honey is rather slow, especially for off grades, white and dark, and, as we have a large stock of these would not advise shipping for the near future. Our stock of fancy white is light and such would find ready sale at quotations. Our market for extracted buckwheat will open up shortly and we would advise bee-keepers to ship this along now. Beeswax steady. We quote as follows: Fancy white, 11 to 12; No. 1. White, 10; Fancy Amber, 9; No. 1. Amber, 8; Fancy Dark, 7; No. 1. Dark, 6; White, extracted, 5 to 5½; Amber, 4½ to 4¾; Dark, 4 to 4¼; Bee wax, 26 to 28.

HILDRETH BROS. & SEGELKEN,

Jan. 7, 120 & 122 West Broadway New York

WM. A. SELSER,

10 VINE ST., PHILA., PENN.

White Clover Honey Specialist.

—If you are going to—

BUY A BUZZ-SAW,

write to the editor of the REVIEW. He has a new Barnes saw to sell and would be glad to make you happy by telling you the price at which he would sell it.



See That Wink?

Bee Supplies. Root's go ds at Root's prices. POWDER'S HONEY JARS Prompt service. Low freight rates Catalog free. WALTER S. POWDER, 162 Mass. Ave., Indianapolis, Ind., the only exclusive bee supply house in Indiana.

THE MONITOR PAPER FILE

Binds securely and neatly all periodicals. Preserve your papers, magazines, pamphlets, bulletins, music, &c., by binding them together as you get them. Each new number filed quickly and easily. Will bind 52 numbers of any periodical aggregating 1000 or fewer pages. All lengths from 6 to 28 inches. Light and handsome. PRICE.—All sizes 12 inches and under 12 cents; over 12 inches one cent per inch. When wanted by mail add one cent for each 5 inches or fraction thereof.

For sale by the Publisher of this paper

Dovetailed Hives,

Sections, Smokers, Queen Cages, and everything needed in the apiary. Warranted Italian queens 75 cts. each. Two-frame nucleus, with a queen, \$2.60. Send for catalog.

DEANES & MINER, Ronda, N. C.

QUEENS 75 cts each by return mail; either golden, or three-banded, young and warranted. Two separate yards with competent assistants. Circular free.

J. B. CASE, Port Orange, Fla.

Please mention the Review.

Holy Land: YOUR CHOICE: Golden Italian QUEENS.

The best that knowledge and ten years' of experience can produce.

Untested Queens,	One	Six	Twelve,
In June, July, Aug., Sep.,	.75	\$1.25	\$3.00
At other months,	1.00	1.50	3.00
Tested Queens,	1.50	3.00	15.00

Nuclei, in Mar., Apr. and May,	One	Two	Three	Six	Twelve,
One L. frame,	.90	\$1.60	\$2.25	\$4.25	\$8.00
Two " frames,	1.50	2.75	4.00	7.50	14.00
Three " "	1.80	3.25	4.50	8.50	16.00

These prices are for nuclei without queens, and a discount of ten per cent. will be given on the nuclei if queens at the above prices are ordered sent with them. Bees by the pound at the same price as nuclei. File your order for six or more queens 30 days before you want them shipped, and get ten per cent discount from above prices.

E. R. JONES.

Milano, Texas

3-98-121

Please mention the Review

THE LOSS

Of one Queen in introducing, means a loss greater than the cost of a copy of "ADVANCED BEE CULTURE," which has one entire chapter devoted to "The Introduction of Queens." It shows when the cause of failure lies with the colony, when with the queen, and points out the *conditions* necessary to success. Although one infallible method is given, but little attention is given to the setting forth of exact rules and methods; the subject being treated with a view to teaching *principles* that may be followed to success.

Price of the book, 50 cts. ; the Review one year and the book for only \$1.25.

W. Z. HUTCHINSON,

Flint, Michigan.

18



98

This is the original one-piece section-man who furnishes one-piece sections as follows:—

500 sections, \$1.50; 1,000 for \$2.50; 3,000 for \$6.75; 5,000 for \$10.00; 10,000 for \$17.50.

No. 2 sections are not made to order, but when in stock are sold at \$1.50 per M.

J. FORNCROOK,

Watertown, Wisconsin.

Listen! Take my advice and buy your bee supplies of August Weiss; he has



tons and tons of the very finest

FOUNDATION

ever made; and he sells it at prices that *defy competition!* Working wax into foundation a specialty. Wax wanted at 26 cents cash, or 28 cents in trade, delivered here. Millions of *Sections*—polished on both sides. Satisfaction guaranteed on a full line of *Supplies*. Send for catalogue and be your own judge. **AUG. WEISS,** Hortonville, Wisconsin.

When you buy

QUEENS,

You want, first, *good* queens; then you want them *promptly*; and, lastly, you want them at a reasonably *low price*. You can secure all of these advantages by sending your orders to Mr. **W. H. PRIDGEN,** Creek, Warren Co., N. C. He is *now* ready to mail either golden, or from imported stock, mated to golden drones, at 75 cts, each for untested queens. Mr. Pridgen is a member of the National Queen Breeders' Union; and he sends out (free) a catalogue containing valuable information for queen breeders and buyers. Money order office, Warrenton.

Bee-keepers in the



Northwest

Can save money and freight by getting their supplies from the Minn. Bee-keepers' Supply Mfg Co., Nicolllet Island Power Building, Minneapolis, Minn. They have all the latest and most improved machinery and manufacture and handle a full line of supplies. Send for catalogue before ordering.

Please mention the Review.

Root's Bee-Supplies,

Shipped from Jackson at Root's prices. Honey bought and sold. White, Plymouth Rock chicks and eggs for sale. Send for prices.

W. D. SOPER, Box 565
2-98-1f Jackson, Mich.

I have several hundred

QUEEN CAGES

of different styles and sizes, made by C. W. Costellow, and I should be pleased to send samples and prices to any intending to buy cages.

W. Z. HUTCHINSON, Flint, Mich.

ITALIAN QUEENS,

They are large, yellow, healthy and prolific, and their bees the best of workers. Untested, 75 cts each; or \$6.00 a dozen. Tested, \$1.00 each. Satisfaction guaranteed. Send for circular. 5-98-1f

J. W. K. SHAW & CO., Loreauville, La.

Farm Bee - Keeping.

The only bee paper in the United States edited in the interests of the farmer-bee-keeper and the beginner is the **Busy Bee**, published by EMERSON T. ABBOTT, St. Joseph, Mo.

Send for free sample copy NOW.

Now is the time to order your supplies, bee-hives, sections, foundation, smokers, and everything that is needed in the Apiary at prices that are right. Send for circular. W. H. BRIGHT, M-2-ppa, Wabasha county, Minn.

To stick things, use **MAJOR'S CEMENT**. Beware!!! Take no substitute. 2-98-12t

JOHN F. STRATTON'S CELEBRATED



MANDOLINS,

Importers of and Wholesale Dealers in all kinds of **MUSICAL MERCHANDISE**,
811, 813, 815, 817 East 9th St., New York

Bee keepers should send for our

'97 CATALOG.

We furnish a full line of supplies at regular prices. Our specialty is Cook's Complete hive.
J. H. M. COOK, 62 Cortland St., N. Y. City

Franklin House DETROIT MICH.

Gas Rates and Lard etc. Very central. Elevator. Steam heat, electric lights, tile floors, etc. Rates \$1.50 to \$2 per day. H. H. JAMES & SOSS, Props

The Land of Honey. The Italy of America!

Send for a copy of the **PACIFIC BEE JOURNAL**: 365 E. 2nd St., Los Angeles, California.

Please mention the Review

Michigan Headquarters for the G. B. Lewis Company's

SUPPLIES,

Dadant's foundation, and everything needed in the apiary. Send for price-list to **L. C. WOODMAN**, 3-98-6t Grand Rapids, Mich.



ITALIAN QUEENS.

untested, either golden or three-banded, unexcelled for gentleness, purity and industry, sent **now** at \$1.00; tested, \$1.50; select tested, \$2.00; imported, \$5.00.

Huffine & Davis,

Ooltewah, Tenn.

Please mention the Review

Beeswax Extractor.

The only Bees Wax Extractor in the world that will extract all the wax from old combs rapidly by steam. Send for descriptive illustrated catalogue.

C. G. FERRIS,
South Columbia, N. Y.

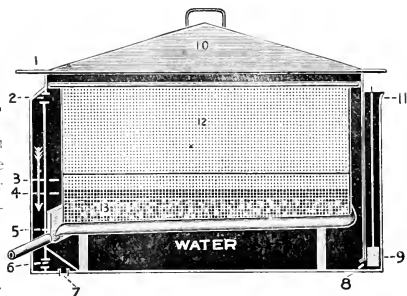

Are you Going

To the fairs this fall?

My bees and queens take first premium.

Fifteen, Barred Plymouth Rock eggs for 50 cts. Ask for catalogue. 4-98-1f

J. F. MICHAEL, Greenville, Ohio.

The place to get your best
QUEENS

is of H. G. Quirin, of Bellevue, Ohio. Ten years of experience, and the best of methods and breeders enable him to furnish the best of queens. Golden Italian, warranted purely mated, at 75 c.; after June, 50 c.; or 6 for \$2.75. Leather-colored, same price.

— If you wish the best, low-priced —

TYPE - WRITER.

Write to the editor of the REVIEW. He has an O.E.-11, taken in payment for advertising, and he would be pleased to send descriptive circulars or to correspond with any one thinking of buying such a machine.

1898 Queens 1898

For Business—Queens for Strong Colonies. Queens for large surplus. Competition in Quality, but not in price.

If you want queens, nuclei or supplies at bottom prices, send for my illustrated price list. 12-97-tt

J. P. H. BROWN, Augusta, Ga.

Please mention the Review.

We are headquarters for the

Albino Bees,

the best in the world. If you are looking for the bees that gather the most honey, and are the gentlest of all bees to handle, buy the Albino. I can furnish the Italian, but orders stand 50 to 1 in favor of the Albino. I manufacture and furnish supplies generally. Send for circular.

S. VALENTINE,

4-98-21

Hagerstown, Md.

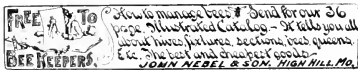

Best on Earth. 19 Years Without a Complaint.



	Dozen	Each
Smoke Engine (largest smoker made) 4 inch stove...	\$13.00—mail,	\$1.50
Doctor	9.00—	1.10
Conqueror	6.50—	1.00
Large	5.00—	.90
Plain	4.75—	.70
Little Wonder (wt. 10 oz.)	4.50—	.60
Honey Knife	6.00—	.80

For further description, send for circular.

T. F. BINGHAM, Farwell, Michigan.

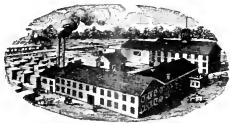

Bee-Supplies

We have the best equipped factory in the West. Capacity, one carload a day. We carry the

largest stock and greatest variety of everything needed in the apiary, assuring **Best Goods** at the **Lowest Prices**, and prompt shipment. Illustrated catalogue, 72 pages, free.

We also manufacture tanks of either wood or galvanized steel, all sizes, any form, and for all purposes. Price list free. Address

E. Kretschmer, Red Oak, Ioa.

Page & Lyon,

Mfg. Co.

New London, Wis.

Nearness to pine and bass-wood forests, the possession of a saw-mill and factory fully equipped with the best of machinery, and years of experience, all combine to enable this firm to furnish the best goods at lowest prices. Send for circular, and see the prices on a full line of supplies.

TESTED QUEENS,

At \$1.00 each. As usual, I am requeening my apiary this spring with young queens from the South, and, that the tested queens that are removed may move off quickly, I offer them at \$1.00; or six for \$5.00. These queens are fine Italians of last year's rearing, and right in their prime. The Review one year and one of these queens for only \$1.75.

W. Z. Hutchinson,
FLINT, MICHIGAN.

No Fish-Bone

Is apparent in comb honey when the Van Deusen, flat-bottom foundation is used. This style of foundation allows the making of a more uniform article, having a *very thin* base, with the surplus wax in the side-walls, where it can be utilized by the bees. Then the bees, in changing the base of the cells to the natural shape, work over the wax to a certain extent; and the result is a comb that can scarcely be distinguished from that built wholly by the bees. Being so thin, one pound will fill a large number of sections.

All the Trouble of wiring brood frames can be avoided by using the Van Deusen *wired*.

Send for circular; price list, and samples of foundation.

J. VAN DEUSEN,
SPROUT BROOK, N. Y.

Violin for Sale.

I am advertising for the well known manufacturers of musical instruments, Jno. F. Stratton & Son, of New York, and taking my pay in musical merchandise. I have now on hand a fine violin outfit consisting of violin, bow and case. The violin is a "Stradivarius," Red, French finish, high polish, and real ebony trimmings, price \$14.90. The bow is of the finest snakewood, ebony frog, lined, inlaid (pearl lined dot) pearl lined slide, German silver shield, ebony screw-head, German silver ferules, and pearl dot in the end, price \$2.50. The case is wood with curved top, varnished, full-lined, with pockets, and furnished with brass hooks, and handles and lock, price \$3.50. This makes the entire outfit worth an even \$20.00. It is exactly the same kind of an outfit that my daughter has been using the past year with the best of satisfaction to herself and teachers. Her violin has a more powerful, rich tone than some instruments here that cost several times as much. I wish to sell this outfit, and would accept one-half nice, white extracted honey in payment, the balance cash. It will be sent on a five days' trial, and if not entirely satisfactory can be returned and the purchase money will be refunded.

W. Z. HUTCHINSON, Flint, Mich.

G. M. LONG, Cedar Mines, Iowa, manufacturer of and dealer in Apitarian Supplies. Send for circular. 1-96-6

Please mention the Review.

Holy Land QUEENS. Golden Italian

The best that knowledge and ten years' of experience can produce.

Untested Queens.	One	Six	Twelve.
In June, July Aug., Sep.,	.75	\$4.25	\$8.00
All other months.....	1.00	5.00	9.00
Tested Queens.....	1.50	8.00	15.00

Nuclei, in Mar., Apr. and May.	One	Two	Three	Six	Twelve.
One L. frame,	.90	\$1.60	\$2.25	\$4.25	\$8.00
Two " frames,	1.50	2.75	4.00	7.50	14.00
Three "	1.80	3.25	4.50	8.50	16.00

These prices are for nuclei without queens, and a discount of ten per cent. will be given on the NUCLEI if queens at the above prices are ordered sent with them. Bees by the pound at the same price as nuclei. File your order for six or more queens 30 days before you want them shipped, and get ten per cent discount from above prices.

E. R. JONES,

3-98-12t

Milano, Texas

QUEENS

Reared from imported mothers, warranted purely mated, 75 cents each. Breeders,

\$1.25 each. No better stock to be had at any price. Send for catalogue of queens and bees. DEANES & MINER: Ronda, N. C.

Make Your Own Hives.

Bee-Keepers
Will save money by using our Foot Power Saw in making their hives, sections and boxes.

Machines on trial.
Send for Catalogue.

W. F. & JNO. BARNES CO.,

384 Ruby St.,

Rockford, Ills.

2-96-12

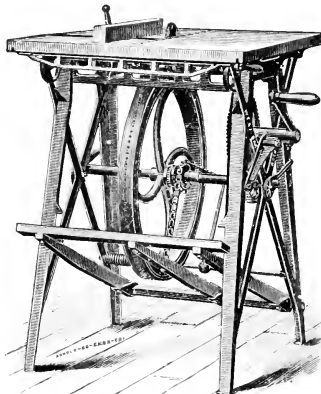

ROOT'S GOODS,

At wholesale and retail. Honey is cheap, and, to be successful, goods must be bought at the lowest possible price. I can help you in this. Try it by sending a list of what you want—you will get prices by return mail. Large Illustrated Catalogue, full of information, free. Beeswax wanted in exchange for goods, or cash, at best prices.

M. H. HUNT,

BELL BRANCH, MICH.

If the REVIEW

Is mentioned when answering an advertisement in its columns a favor is conferred upon both the publisher and the advertiser. It helps the former by raising his journal in the estimation of the advertiser, and it enables the latter to decide as to which advertising mediums are most profitable. If you would help the Review, be sure and say "I saw your advertisement in the Review," when writing to advertisers.

SUGGEST

Is one of the most pleasant experiences with which a man can meet. If this is what you would like to meet, but are a little doubtful as to which road to follow, take the advice of one who has met success, and can tell you all about it. Few men have met with greater success in bee-keeping than has Mr. Jas. Heddon, of Dowagiac, Mich.; and the paths that he has trod are clearly mapped out in a book which he has published, and which is very appropriately called "SUCCESS IN BEE-CULTURE." The price is 50 cents. The foregoing is given as the honest opinion of the editor of the Review.

COMB Foundation.

We can now furnish the very best that can be made from pure wax. Our new process of milling enables us to surpass our previous efforts in the manufacture of foundation. It is always pure and sweet. It does not sag. It is the kind that you want. If you once try it you will have no other. Samples furnished free. Large, illustrated catalogue of bee-keepers' supplies, and a copy of the *American Bee-keeper* sent upon application.

W. T. Falconer Mfg. Co.,
JAMESTOWN, N. Y.

Dovetailed Hives.
 Cowan Extractors.
 Danzenbaker Hives.
 Porter Bee - Escapes.
 No-Drip Shipping Cases.
 Gleanings in Bee-Culture.

Root's Goods.



OUR SPECIALTIES.

The Fence and Plain Sections.
 Weed New Process Foundation.

Catalog of goods and sample of Gleanings sent for your name on a postal.

The A. I. ROOT CO., Medina, Ohio.

Branch Offices :

118 Michigan St., Chicago, Ills. 1024 Mississippi St., St. Paul, Minn.
 1635 W. Genesee St, Syracuse. 10 Vine St., Philadelphia. Mechanic Falls, Me.



Our Prices are worth looking at. We are making the new

Champion Chaff Hive

with dovetailed body and supers and a full line other Supplies, and we are selling them **CHEAP**. A postal sent for a price list may save you \$ \$ \$ \$ \$.
 R. H. SCHMIDT & CO.,
 Box 187 Sheboygan, Wis

4-98-tf

Please mention the Review.

ALBINO QUEENS

For sale. Best bees in existence. Untested, in May, \$1 00; after June 1st, 75 c.

5-98-3t J. D. GIVENS, Lisbon, Texas.

Please mention the Review.



\$100

Given as **Bounties** to purchasers of the improved Danz. Hives and Sections See schedule in my bee-book "Facts About Bees." Tells

how to produce honey that sells for the most money. Free for 2c in stamps. Address

THE A. I. ROOT CO., Medina, Ohio,
 of F. DANZENBAKER, Box 466, Washington, D. C.

Please mention the Review.

QUEENS, Untested, 75 c; 6 for \$4.00; tested, \$1.00; 6 for \$5.00; breeders, \$2.00. The best stock, imported or golden. W. H. LAWS, Lavaca, Ark.

Sweet Clover Seed.

We have about 3,000 lbs. of sweet clover seed, (of the white variety) that we offer for sale at the following prices :

25 lbs., \$2 25; 50 lbs., \$4.00; 100 lbs., \$7.50.

BERTSCH & FLIEMAN, Holland, Mich.

COMB

FOUNDATION

WHOLESALE AND RETAIL.

Working wax into foundation, for cash, a specialty. Hives, Sections, and a full line of Supplies. The best of everything. Write for Catalog, with price s, and samples of Foundation and Sections. Beeswax always wanted for cash or trade.

GUS. DITTMER,

10-97 12t

Augusta, Wis.

The A. I. Root Co.'s Goods, **WHOLESALE AND RETAIL.**



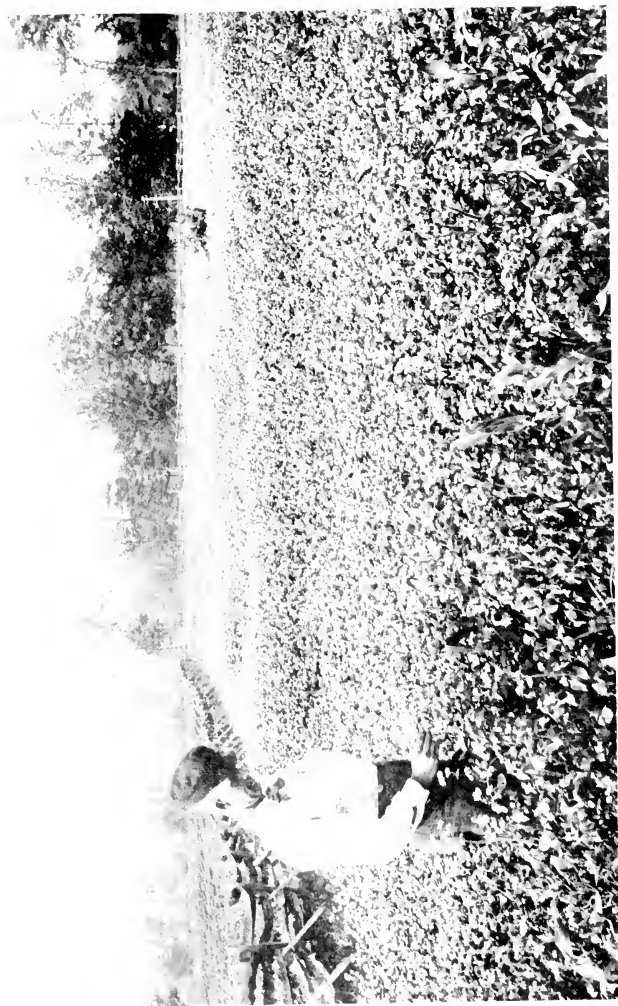

Corner of a Buckwheat Field in August.

The Bee-Keepers' Review

A MONTHLY JOURNAL

Devoted to the Interests of Honey Producers.

\$1.00 A YEAR.

W. Z. HUTCHINSON, Editor and Proprietor.

VOL. XI. FLINT, MICHIGAN, JUNE 10, 1898. NO 6.

VARIETIES OF BUCKWHEAT.

Also a few Words about the Discussion on Facing Comb Honey.

AARON SNYDER.

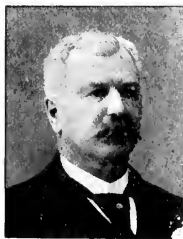

HAVING lived many years in an extensive buckwheat district, I may be able to interest the fraternity somewhat on that subject. There are two or three varieties of

American buckwheat; the black, the grey, and the silverhull; all having nearly the same habit of growth; viz., that of branching considerably. For this reason we should sow only from two to three pecks per acre. Of late, the Japanese variety has been introduced into this country; and is pretty well liked as a main crop, but not as good for honey. The grains are black, and little larger than the American. It does not weigh quite so much per bushel, and the straw grows larger and does not branch out so much

as the American. For the latter reason, farmers generally sow more seed; about a bushel to the acre.

Here in Eastern New York, buckwheat is usually sown from the 20th of June to the 6th of July. It is generally thought the later it is sown, and yet have time to ripen before frost comes, the better the yields. There is a wide range in yield; all the way from 10 to 35 bushels per acre; all depending upon the soil and amount of fertilizer used. I know of no grain that will respond so readily to the use of fertilizer as will buckwheat. The crop is generally cut by hand, with grain cradles, raked up in small bundles, set up on end, left to dry, and just as soon as dry enough to thresh is hustled into the barn on the principle of "hurrah boys, make hay while the sun shines." The straw is almost worthless, except for bedding. Stock will eat very little of it; in fact, they might about as well eat so much wind.

As a honey plant it is one of the best; so much so that a bee-keeper located in a buckwheat district has a *sure thing*. Failures are so scarce they are not worth mentioning; at least, that has been my experience. The weather should be a little damp to have it secrete honey to best advantage; for that reason the bulk

of the crop is gathered in the first half of the day, unless it should be a little damp all day; in that case the bees buckle right in as long as they can see.

I desire to say just a few words in regard to my article. "Facing Comb Honey," published in *Gleanings* for Feb. 1st, 1898. It seems to be the rule that after a discussion has run along to a certain degree it is wise to "drop it for the present;" then, after a while, if there were some points that were not fully understood, bring up the matter again; so I am willing to drop the subject where it is, thinking that it has been fully and fairly discussed. The case of Snyder vs the people went to the jury, and the verdict rendered is almost unanimously in my favor; only one (Doolittle) standing out; and he I think through stubbornness. I believe this has been a very healthy discussion; causing the bee-keepers to open their eyes and bringing them to their senses more than any subject published in a long while.

KINGSTON, N. Y. May 25, 1898.



THE LAWS OF HEREDITY.

How Honey Producers and Queen Breeders Working Together may Profit by Them.

J. E. CRANE.



IN previous issues of the Review I have given a number of illustrations showing the great changes in plant and animal life brought about by the agency of man. It may be briefly noted

that such changes have been made as are most *useful* to man, or have most pleased his fancy. Thus we see that the blossoms

of different varieties of cabbages or potatoes remain quite unchanged, as man has taken no special interest in them; while in plants cultivated for the beauty of their flowers we find the greatest changes made in these parts.

There is really very little that is new in knowledge regarding the laws of heredity; as in an ancient Chinese encyclopedia the principles of selection are fully given. Explicit rules are laid down by some of the Roman classical writers; and we find Jacob, nearly 4,000 years ago, breeding for color. In early English history, laws were made prohibiting the exportation of choice animals and also for the destruction of horses that were undesirable.

The most eminent breeders do not favor the *crossing* of different breeds, but rather that of taking that breed that most nearly approaches their ideal, and then, by the most careful selection, breed out defects and up to their standard. To do this the greatest skill is required; as the law of reversion comes in by which all improved varieties tend to revert back to to their former type. Charles Darwin says; "What English breeders have actually effected is proved by the enormous prices given for animals with a good pedigree; and these have been exported to almost every quarter of the world. The improvement is by no means generally due to crossing different breeds; all the best breeders are strongly opposed to this practice except sometimes among closely allied sub-breeds. And when a cross has been made, the closest selection is far more indispensable even than in ordinary cases. If selection consisted merely in separating some very distinct variety, and breeding from it, the principle would be so obvious as hardly to be worth notice; but its importance consists in the great effect produced by the accumulation in one direction, during successive generations, of differences absolutely inappreciable by an uneducated eye—differences which I for one have vainly attempted to appreciate. Not one man in a thousand has accuracy of eye and judgement sufficient

to become an eminent breeder. If gifted with these qualities, and he studies his subject for years, and devotes his lifetime to it with indomitable perseverance, he will succeed; if he lacks any of these qualities he will assuredly fail. Few would readily believe in the natural capacity and years of practice requisite to become even a skillful pigeon-fancier."

It may be objected that the breeder of bees can not control his male bees, consequently his work is largely one of chance; and there is some ground for this objection, but, on the other hand, the queen breeder can raise several generations in a single season, or raise and thoroughly test two or three generations, while the breeder of domestic animals can rear only one; which will largely compensate for his inability to control the mating of his queens.

Before the advent of movable combs the breeding of bees or the improvement of bees was attended with far greater difficulties than at present; and we are not surprised that they have changed less than other animal life under domestication; but now with the improvements of the last fifty years, and the light these improvements have given us, may we not expect that future improvement will be rapid?

The separation of bees into several well known breeds, and the tendency of these breeds to vary, aided by the skill of some of our queen breeders, leads me to believe that we may some day have a distinctively American breed adapted to our hot summers and cold winters, and great variety of flowers. Already I believe we have much lighter colored bees than may be found in Europe. As there has been a demand for light colored bees, the change in this direction has been more marked than in any other, but we must not forget that the amount of honey gathered by a hive of bees does not depend upon their color, but rather upon other and more valuable points of excellence. I do not object to color, for bright colored bees give pleasure to our love of the

beautiful, and our climate and flora seem well adapted to such a race of bees, but I believe this matter of color has been carried far enough for the present. Let us rather select for queen breeding those varieties the workers of which show the greatest ability to gather honey; white honey if it is to be had, and if not, can gather that which is darker; and those in which the swarming impulse is but feebly developed. Strength of constitution, gentleness, comb-building, prolificness and other qualities should not be neglected in making up the scale of points. A stream can not rise above its fountain. Let our ideal bees be far in advance of our present breeds, and let us do what we can to bring our bees up to our ideal standard. "Bring the flag back to the ranks" was the command of the Captain to his color bearer who had planted his flag in advance of his company. "Bring your ranks up to the flag" was his heroic reply. How shall we reach our ideal? Says a popular writer: "The key is man's power of cumulative selection; nature gives successive variations; man adds them up in certain directions useful to himself. In this sense he may be said to have made for himself useful breeds."

Doubtless honey producers must depend to a considerable extent upon the queen breeder for these improvements. His experience, the time at his command, and the skill he has acquired, gives him greatly the advantage of those who are working for honey alone. The efforts of the queen breeder may also be greatly aided by the honey producer. Both must work together for a common object. The honey producer from his larger number of colonies has a better chance to test the value of queens than has the queen breeder; while the latter can do more to multiply and make valuable qualities permanent. Sometimes a single colony will be very marked in almost every good quality, in a yard of one hundred hives. Such a colony came under my observation some years ago in one of my yards. Quiet, gentle, business-like in brooding and

comb-building, without any disposition to swarm, it worked on year after year for three years; when I moved it home to obtain brood from it to improve my home yard. Here it remained two years more with the same queen; always maintaining the same character. If I could have every queen as good as the one in this colony the profits of my bees would be largely increased—I believe twice what they now are. But a long series of years and many generations with the most careful selection will be required to make such traits permanent, so they will "come true." Already the outlook is hopeful. Already there is reason to believe that some of our queen breeders are working along these lines, and if these papers shall stimulate others in the same work I shall feel that they have not been written in vain.

MIDDLEBURY, Vt. Dec. 10, 1897.



CURING FOUL BROOD IN WISCONSIN.

Enforcing the Law. Common Sense and Sociability Versus Official Dignity.

N. E. FRANCE.

There is naught in this bad world like sympathy.—BYRON.



FRIEND H.—Your letter asking several questions upon the working of Wisconsin's foul-brood law is at hand. At present I am quite busy, and will simply answer questions and a little later will write an article or

two for the Review.

(1.) I am 40 years old; never used tobacco or any kind of liquors. After 12 years of age I went to school winters; and in summer worked with 300 to 500 colonies of bees and also with a small

fruit farm. Then I changed winter-work by teaching school to winters; all but one term in the same room.

(2.) How I enforce the law. If I hear any remark that some bee-keeper I am to visit may make me trouble, I learn all possible about him; then I decide what is best to do, and, like Sherman in his march to the sea, cut loose all behind me, and with all kindness visit the man to do all the good possible for him. As to the *enforcing* of the law where I should be refused, I believe in *nearly all* cases, if the owner is kindly treated there will be no need of enforcing law; while if I should go with a stiff official air to such a man and *demand* to see his bees, I should expect trouble—and ought to. Here is an illustration; last summer I was to call on a bee-keeper who was a desperate fellow. Was told by several not to dare to eat with him for fear of poison; and if I did not take an officer along I could expect a clinch fight. After some inquiry I hired a livery and driver to take me to said man's house. In the woods I found a small log house, partly furnished. A woman came to the door. I inquired if Mr. — lived there.

"Yes, sir;"

"Is he at home?"

"Yes sir; he is in yonder field burning brush."

I took my grip from the buggy and told the livery man he could go; I was going to stop here. He replied,

"Rather it be you than me."

I called on the man; helped to burn brush, at the same time talking bees, and in a few moments he said;

"Are you our State inspector?"

"Yes sir."

"Well, let the brush take care of itself; let's go and look at the bees."

I stayed all night; and the man left his farm-work for two days, using his team to take me, free of charge, to every bee-keeper within ten miles of him. I prefer in every case to stay with the bee-keeper instead of at a hotel, be one of the family while there, and I *never* have had a

chance to enforce a privilege to inspect bees. If it ever *does* come to that, which I never expect, if the owner of bees orders me away, I will read to him section 4 of the law, which says "If the owner of bees, honey, or appliances shall sell, barter or give away any bees, honey or appliances or *refuse to allow said inspector to inspect such apiary*, honey, or appliances, he shall, on conviction before a justice of peace, be liable to \$50.00 fine."

When I suspect that an apiary is diseased, what do I do? Write to the owner and learn the condition of the bees, etc., and how much disease is likely to exist. Then if satisfied there *is* foul brood, I call on the owner and make an inspection; and, if other bee-keepers are very plentiful, at once set a date, soon, where *all* bee-keepers for several miles around, are notified, date and hour, when to meet. There, in a room together with the men, I give directions how to know the disease, and how to cure it.

In general, I follow Wm. McEvoy's treatment, and, so far, have cured *every* case I have handled; burning only two hives. Such property as can be saved, I never destroy. The old diseased comb and frames contain the danger, and in most cases are burned. Right there is where several have spread the disease. If left to themselves they will not be careful; will leave pieces of comb, or let the honey run on the grass from the fire; and, of course, such methods will spread the disease. I *build a fire in a hole on level ground*, and all diseased material is burned on these coals; then the hole filled. I have seen a large pile of refuse from a solar extractor where diseased combs were melted; and bees working freely on this pile; and seen cases of disease that came from the same.

This season I take with me a camera and take views of diseased bee-yards, and every thing interesting to bee culture. If there are any new ideas in use, or tools, or location of hives etc., for convenience, I snap them also; and a little later will send you some views.

PLATTEVILLE, Wis. April 8, 1898.

SECTIONS AND FOUNDATION.

Some Points to be Considered in Using Plain Sections, Foundation, Separators, etc.

ADRIAN GETAZ.



THIS is my first contribution to the readers of the Review; and I wish to begin by stating my high appreciation of the Review and the "reviewer" who owns and edits it.

The January number contains a half tone of sections of honey, which seems to show the superiority of the plain section represented by the lower row.

I am afraid some of the conclusions regarding this picture have been too hasty. There is an element which has, evidently, been overlooked; and that is the size of the sheets of foundation used. I can reproduce at will, at any time, all the sections shown in that illustration. If the foundation sheet comes within about $\frac{1}{8}$ of an inch of the section walls, the bees will attach the comb to the walls of the section, and the section will be filled full; just as represented in the lower row shown in the engraving. If there is from $\frac{1}{4}$ to $\frac{1}{2}$ of an inch between the edges of the foundation and the section walls, the bees will build up just the size of the foundation, except here and there some attachment pieces extending to the wall, reproducing fairly well the sections represented in the upper row; the one at the right corner corresponding to a sheet $\frac{1}{2}$ inch smaller all round than the section. Of course, if the bees were cramped for space (which is not supposed to occur in a well regulated apiary) a better filling of the sections could be expected. With a still smaller sheet, or a starter, the sheet or starter is extended, and there

is generally a better filling of the sides and bottom, except two big pop-holes at the bottom corners, and two at the upper corners; depending on the width of the starter. If the starter comes clear to the upper corners, no holes, or only very little ones, will be found there.

Concerning the filling up of the section in regard to thickness, it is unquestionable that the closer the honey comes to the edge of the section the fuller the section looks; and the more valuable it will be. When the surface of the honey lacks $\frac{1}{4}$ of an inch or more of reaching the edge, the section looks as if it were only half full. That is the point; the artistic question raised by friend Bingham is not "in it" at all. That is one of the reasons why I do not use separators; but with the "fence" now offered for sale at a low price, I may change my system. However, there is against the use of separators another reason besides the lack of plumpness in the sections. The bees will work in the sections sooner and better without than with separators. Anyone who wishes to try, can very easily set apart a portion of his apiary to each process; taking care that the colonies average alike as nearly as possible in each lot, repeat the experiment, three or four years in succession, and he will find out that the separators are a hindrance to the bees. The temperature inside the hive and the strength of the colonies have something to do with it; if the temperature is high enough so that comb building can go on without making it necessary for the bees to gather in heavy clusters, then it matters but little whether there are separators or not; but if the temperature in the supers is low and the bees have to cluster in large bunches to produce the necessary wax, then the colonies not having separators will be found far ahead of the others.

The irregularity of the sections is the objection to the non-use of separators. This irregularity can be considerably diminished by using sections open all around; in fact, that is the only kind I use now. With them, in a good continuous honey

flow, and a temperature not too low, I can obtain a whole crop of sections as regular as can be wished, notwithstanding the absence of separators, but, if these conditions are not all present a certain percentage of the sections will be irregular. So far, I have not been seriously inconvenienced; as I sell altogether in the home market. But if I had a much larger crop, and had to ship, I would probably have to return to the use of separators.

As to using full sheets of foundation, or only starters, in the sections, I have had by far the best results in using full sheets. There may be, however, some cases in which starters are sufficient. If the temperature is rather high and the honey flow continuous, the secretion of wax will, after a few days, be perhaps sufficient to build up full combs; and the full foundation given them would be a waste of wax; but it must be remembered that it is only after a few days of flow that the wax secretion is well established; so, at the beginning, full sheets should be used anyhow. Another point to be considered is that the comb building takes place chiefly in the night, when all the bees are home, and the night temperature is to be considered rather than the day temperature. In countries high above the sea level, such as east Tennessee, the nights are always comparatively cool.

It takes the bees but a little time to draw the foundation, and if a large amount of foundation is given, quite an amount of honey can be stored in it, as soon as it is drawn, and then the foundation given answers the same purpose as would a less amount of full comb. It must be remembered, however, that the larger the surplus room the more difficult it is for the bees to keep up the temperature; and if entirely too much is given, the bees might even be compelled to cluster very closely in the brood nest, and neglect the supers entirely, in order to keep the brood sufficiently warm. This would be certainly disastrous so far as the honey crop is concerned.

In my own market, I can sell the honey in drone combs as well as worker combs. When giving full sheet, either will do. In using starters, I decidedly prefer drone comb. If worker comb foundation is used in a small starter, the bees will almost invariably turn it into drone comb before half of the section is built and a section thus built does not look well at all.

KNOXVILLE, Tenn. Feb. 25, 1898.



THE CRITIC CRICISED.

Dr. Miller thinks that our new Critic is not
Exactly Fair.

DR. C. C. MILLER.



A NOVICE in a ten-pin alley was making wild work throwing the balls, and the boy who was setting up the pins was having a lively time jumping first one side then the other, when the novice called out to him,

"Stand in among the pins, boy, you'll be safe there." Somewhat in the same way, I think I'll be safe from the shafts of the man in the Department of Criticism if I get into the columns of the Review, for I note that he finds fault only with what appears in other bee-journals.

It is somewhat unfortunate that the readers of the Review may not have before them the items and articles in other journals to which Mr. Taylor refers, and it will be somewhat strange if the critic is always able to give an entirely impartial view of the case without taking up too much room. For example, taking me to task on the wintering question, he says, "The one thing he [Miller] is bold

enough to say is that if bees have a good flight Nov. 15 they can stand the confinement from that time." The reference is to page 149 of the American Bee Journal. I can find nothing of the kind on that page; and after looking through the numbers of that journal from the beginning of the year I cannot find to what he refers. Of course some mistake has been made as to the page, and I am left in the position of one who has the Review and not the American Bee Journal. Taking the sentence quoted and having no chance to know what else may have been connected with it, the plain teaching would seem to be, "If your bees have a good flight Nov. 15 they will winter perfectly, no matter what the character of their food, no matter how long the confinement, no matter about anything else." Now without being able to see the page to which the critic refers, I hardly dare say there's anything incorrect in his statement, but I'm sure I must have made very bad use of the English language to allow such teaching to be inferred. But if I may be allowed to have a guess in the case, I'll guess that Bro. Taylor has entirely mis-represented me; not from any wish to misrepresent—for although at times given to scold, down at the bottom he has a good heart and means to be entirely fair—but because he has not taken the time fully to understand what I said, or else fully to notice how he was representing me.

If I knew nothing about Mr. Taylor's belief than just what appears on page 153, it seems to me I would be pretty well justified in saying, "Mr. Taylor teaches that if bees have the right kind of stores it makes no difference how long they are confined nor how cold they are." I don't believe he thinks so; and I have very little doubt that we are very little apart in our views. He says I rest the entire solution of the problem apparently upon "cold" and length of confinement. With equal justification I might say that he rests the entire solution of the problem apparently upon the character of the food,

Now I don't believe either statement is correct; but if I had to stand by either theory I'd take my chance with the one he attributes to me. For with anything short of poison for stores—anything they could safely use in summer—bees will winter perfectly if not too cold and not too long confined. For, if hard pressed, you see I could give them a daily flight and never allow a freezing temperature. But with the best stores in the world I hardly think Bro. Taylor would say bees would winter well confined six months at a zero temperature.

Referring to page 183, American Bee Journal, the critic thinks I am led into serious error when I advise steps to induce a colony to fly. A case, no doubt, of unintentional, but none the less clear, misrepresentation. Never mind for the present the misrepresentation. Taking into account what Mr. Taylor esteems "a serious error," and what he says afterward, the impression is left that he thinks he would never be justified in disturbing a colony so as to induce flight thereby. I am not going to say Mr. Taylor is wrong, but it may not be out of place to say that some very good authorities do not agree with him. On page 341 of Revised Langstroth mention is made of a rather pleasant day, Jan. 16, 1873, in one of the coldest winters, after six weeks confinement, and Mr. Dadant says, "We took occasion of this to examine our weak colonies, being anxious in regard to their condition. To our astonishment, they were found alive; and our disturbing them caused them to fly and discharge their excrements. Being convinced that all our bees were safe, we did not disturb the strong colonies; and a few of the latter remained quiet. The next day cold weather returned, and lasted three weeks longer. Then we discovered that the weak colonies, that had had a cleansing flight, were alive and well, while the strong ones which had remained confined, were either dead or in bad condition." Clearly, it looks as though too much leaning toward Mr. Taylor's belief had led Mr. Dadant into a

"serious error" in practice. But whichever view is right, Mr. Taylor has either failed to notice, or else has not thought it worth while to mention, the special circumstance connected with the case, that the bees under consideration were in a building "double-boarded and tar-papered outside, and lined and papered inside," with a foot of chaff between the hive and the inside wall, a spout 3x3 inches leading out through the chaff. Under such circumstances, suppose that during a severe winter (this was in North Dakota) the bees had been confined a number of weeks, and a day came when bees on summer stands would fly freely, but these bees would not fly, and suppose that every time throughout the winter when a flight-day came the warmth was not quite enough to wake up these buried bees for a flight, please tell us, Bro. Taylor, whether you think it would be a serious error to take them out for a flight or to stir them up by pounding.

Mr. Taylor says it hurts him terribly because Editor Root and myself are not thoroughly established that late feeding induces late laying. I quoted De Layens as raising the question, a man who is considered worth heeding, and hint that fresh investigation might not be entirely out of place. Mr. Taylor says he has abundantly proven that continued feeding will invariably start laying so long as the bees can comfortably take the food. But say, Bro. Taylor, it isn't like you to be so utterly unfair as to take no notice of the testimony given by Editor Root, who said feeding did not induce laying, and it seems fair to suppose that his feeding was continued in comfortable weather; you apparently thinking no testimony but your own must be taken. After all, perhaps there's no real difference of opinion; for you think there's a difference between fall and early summer, and I think we all believe that feeding may make a difference in laying. If I understand you correctly, you think De Layens is wrong when he says it is a mistake to suppose "that late feeding induces late laying."

Pardon me if I say that taken in that unqualified sense he is right and you are wrong. Late feeding may and it may not induce laying, depending upon weather, age of queen and other circumstances; but it may be pretty safely said that the same amount of feeding in spring is more sure of results than in the fall, generally speaking, and the unqualified statement that "late feeding induces late laying" is, as De Layens thinks, a mistake.

On page 151 Mr. Taylor makes a quotation from me that he thinks warrants him in making the conclusion that a man can increase his income from 100 colonies in a good year \$5,000 by allowing only one swarm instead of two from each colony. In this, as in a previous case, there is the exasperating circumstance that one cannot know to what he refers; for he quotes Gleanings, 125, and on that page I can find nothing of the kind, and I don't know where to find what he's talking about. He quotes me as saying that one "might increase his surplus tenfold by allowing only one swarm instead of two from each colony." Will Bro. Taylor be kind enough to tell us where he finds that? I'll venture the guess that taken in its connection it is entirely correct, and that he has subjected it to unwarranted distortion. Mind you, that's only a guess.

Under the head of "Inelegance of Slang," Bro. Taylor takes me to task. I supposed I was something of a purist in such matters, but if I offend the good tastes of such a man it may at least be worth while to be somewhat on my guard, I must say, however, that I don't like the idea of being too prim in speech. But I'll consider the matter, Bro. Taylor.

On page 152 our critic says my plan of fastening foundation in brood frames (in saw-kerf) "is good but too slow," and advises the old way of running on wax and rosin with a teaspoon. I wish he would tell us how many frames he ever filled according to my directions. I can hardly think "locality" should make any difference, and I may say that after filling hundreds of frames in the way he di-

rects I *know* that I can do it *faster* by the kerf method, and I think better. I can not but think it is "a serious error" to advise using rosin for fastening foundation, for some day that rosin may be melted up in beeswax after the combs have served their day.

Mr. Taylor thinks I am wrong in believing bees when stinging each other thrust the sting into a spiracle. Possibly I am. What makes me think as I do is the fact that the sting rarely remains in the bee, that it does sometimes, and I do not think the cases of remaining would be so rare if the stings were always in the integument instead of occasionally. I can hardly believe that the integument is so much more delicate than the human skin that it should so rarely remain. Mr. Taylor says that not infrequently the bee is stung in the neck, but in such cases is not the sting usually left? I think the sting usually enters the spiracle and occasionally the integument. But I don't pretend to know, and perhaps ought to have said so more distinctly.

Mr. Taylor refers to Gleanings, 43, and rather more than hints that I mislead by giving the good and not the bad. Bro. Taylor, if you have any memory at all, you ought to know that you are unfair, and I'm hardly ready to excuse you—no, if you want me to take you back into my confidence—and you know you do—you'll explain, or apologize—or something. If there's any one thing I've tried to be fair about it has been in not trying to paint with too vivid colors the profits of bee-keeping. Over and over I have said I could make more money out side of bee-keeping, and have very plainly told of my failures. You ask about the years 1894 and 1895. I'm glad of one more occasion to say that those two years cost me my labor and a ton of granulated sugar with no return whatever. Haven't I told you that before just as plainly? Please send me a very large apology and prepay the postage in full.

MARENGO, Ill., May 28, 1898.

NOTES FROM FOREIGN BEE JOURNALS.

 F. L. THOMPSON.

As cold waters to a thirsty soul, so is good news from a far country.—*BIBLE*

German beginners in bee-culture in this country, who read English with difficulty or not at all, may learn the elements of contemporary honey production in America in their own language, in a book written by J. F. Eggers, of Grand Island, Nebraska. It is entitled "Bienenzucht und Honiggervvung nach der neuesten Methode" (Bee-Culture and Honey Production by the Latest Method). Like Mr. Benton's book, this work is not easy to review, for the same reasons, adhering as it does closely to standard methods and implements, and giving the most essential points in simple language. The following recommendations and statements, while practiced and confirmed by many, savor more of an individuality in the author, so as to be either not approved by all, or suited rather to particular localities: feeding of substitutes for pollen; watering; production of extracted honey by putting the brood in the upper story and leaving the queen below the excluder, repeating the process in three weeks; fall feeding to promote brood-rearing when the bees stop breeding early; assigning as one reason for recommending full sheets of foundation in the brood chamber (except when swarms are contracted), that the bees consume 10 to 15 pounds of honey to produce one of wax; stating that only half as much comb as extracted honey can be produced; recommending a self-hiver (Kretschmer's); and stating that other bee-diseases than foul brood are of little significance. The latter statement may stand, if applied to the comparative frequency of severe outbreaks of paralysis or "evaporation;" but certainly the latter are far worse than foul brood when they do occur. On the whole, the book is evidently the work of

an experienced and practical bee-keeper, and will serve its purpose admirably. The treatments of comb-honey production, increase and queen-rearing are particularly likely to be stimulating to the beginner, while at the same time safe.

L'APICULTEUR.—In a discussion on moving bees, M. Beuve called attention to the fact that as long as the vehicle is in motion, all is probably well, but at the least stop the bees are greatly disturbed and become heated. M. Minoret said that in his experience colonies transported in the state of a swarm gathered more than those moved with combs and all. Frere Jules moves bees and brood separately, leaving only a few workers on the brood. He has noticed that the workers carry in pollen only 20 minutes after the entrance is opened.

In a subsequent article, M. Minoret states his practice of migratory bee-keeping, on the plan practiced by an old bee-keeper with a hundred colonies for the last fifty years, modified by extensive experiences of his own. He does not move established colonies, but swarms only, procured artificially. None but large swarms are transported. Two swarms weighing five kilos (about 11 pounds) will yield much more surplus with much less trouble than five swarms weighing two kilos. Plain light boxes are used, containing frames with starters, and covered with wire cloth. The same boxes serve for hives after the arrival. When the destination is inaccessible by wagons, narrow boxes with wire cloth sides are temporarily substituted. To procure the swarms, the transportation-box is set on the stand of a strong colony, two combs containing a little honey and brood of all stages removed and set in it, then the bees brushed into it from the rest of the combs. The old hive with its combs is then set on the stand of another colony, and the latter moved to a new location, after brushing the bees from three or four frames, so that the brood of the hive set in its place will not become chilled. When evening comes, the transportation-boxes

are closed, and the trip made in the night. The home-hives, containing from 16 to 20 frames, are large enough to winter two colonies apiece. When the colonies from the out-apiary are brought home in the fall, each is domiciled in one half of a home-hive, with a division board between. The next spring, when the flow opens at the home-yard, the colonies may either be run on the Wells system, or united to make strong colonies. This management, of course, presupposes an early flow at home and a later one elsewhere.

A correspondent notes that the part of the bottom-board opposite the entrance of a hive which has just cast a swarm is always tinted a smoky black.

De Layens believed that stimulative feeding in the fall, for the purpose of exciting the queen to lay so as to produce more young bees for wintering, is perfectly useless. In taking off the surplus of 20 colonies at the end of September, after they had been getting some honey every day for several weeks from plants stimulated by August rains, he found sealed brood in two or three colonies only, and no young brood in any of them. On another occasion, out of fifteen colonies which had been favored with a late flow, for a fortnight, but one contained sealed brood, and young brood was entirely absent, though new unsealed honey was still present in all the hives.

Young queens lay later in the fall than old ones, says M. Devauchelle. A queen beginning to lay even in the middle of September will produce enough young bees for safe wintering. But young queens begin later in the spring.

Abbe Pincot, after six year's experience with an apiary (now 47 colonies) in cubical hives with frames 13 by 13 inches, inside measure, has found it to be an invariable rule, without an exception, that worker brood will be found in the extracting supers when their frames run in the same direction as the frames below but no worker brood will be found in them when their frames are at right angles to those below. The rule does

not apply to drone brood. On comparing this experience with those of others which have resulted differently, he infers that it is necessary, in order to succeed, to put the supers on early enough to catch any early flow, thus relieving the brood nest of honey; and to use as deep brood-frames as he himself has, since in Dadant hives the queen will lay worker eggs above, when the supers are placed crossways.

A. Bassaler reports an "evaporation" that at first thought seems traceable to a local cause. One hundred colonies in straw hives were in good condition in March. Finding many bottom boards moist, he replaced these with others which had been painted with "carbonyle" (a preparation for preserving the wood) five or six months before. On the 20th of April only twenty-nine colonies were left, and they were on the old bottom-boards, and in good condition. In the rest of the hives not a bee was left, dead or living. As he was constantly in the apiary, but saw no swarms decamping, he supposes the bees left one by one, never to return. In a later issue, three correspondents state that they have freely employed carbonyle on the insides of hives and supers without repugnance being manifested by the bees.

The same writer, on another occasion, observed a queen of a small colony entering her hive evidently returning from a promenade. The colony was flying freely at the time.

Once a day is not often enough to get exact information of the influence of different seasons and different hours of the same day, says Leon Dufour. Often two days furnish the same total increase in weight, while the variations during such days have been entirely dissimilar. By weighing three hives eight times a day, on an average, for five months, he reached the conclusion that during a slight flow the variations are almost entirely due to the exit and return of flight bees. In the morning the weight steadily diminishes, owing to the departure of bees. When the tempera-

ture is high enough to affect the secretion of nectar, the weight increases a little, owing to the excess of returning over departing bees. When the heat of the day is over, it again diminishes for awhile, then increases steadily until evening, showing, finally, a slight increase over the weight of the morning. Weighings of one colony on the 12th of May, the 18th of July, and 21st of August all showed the characteristic fluctuations of a weak flow, and the increase in weight on each of three days was very nearly the same, but the hourly variations were very different in intensity. Judging by these differences, M. Dufour estimates that the number of field bees on the 11th of May was 8,000, on the 18th of July 13,000, and on the 21th of August only 3,000. All have noticed how the bees sometimes fly freely, apparently having all they can do to carry the nectar, yet the super shows little perceptible increase. Hourly weighings show that sometimes when the flow is scanty, the bees return to unload themselves long before they have all they can carry, thus making a great bustle with little to show for it. During a fall flow, the first fluctuation of the day occurs at a much later hour, and the last one sooner than in an early flow. This indicates that a fall flow may be much stronger than an early one, yet yield no more, not only on account of decrease in population but also because the days are shorter. During an abundant flow, the only fluctuation consists of bees, after which there is a steady increase during any fixed space of time while the flow is abundant, a quarter of an hour, for example, is practically the same at any time of the day.

Sugar in France is only 10 to 13 per cent dearer at retail than at wholesale, and is sold in large quantities, while honey is 170 to 190 dearer, and is sold in small quantities, because, says G. Levant, of the competition in sugar based on advertising, its extensive consumption on account of its low price, and because all grocers keep it, while only wholesale

dealers control the honey market, too few retailers keep it, it is sold too dear to consumers, and is subject to no advertising or competition. He thinks the only remedy is extensive advertising and organization. In this country, however, there are many retailers, of comb honey at least, but the profits of the producer are steadily diminishing, while there is far from being as much sold as might be. His other reasons are suggestive, nevertheless, and his remedy is really the only thing left. It is certainly worth while to recollect the fact that the consumer of groceries and other wares here guides himself mainly, in large cities at least, by announcements in the newspapers. Lately in Denver a number of the largest clothing houses and groceries got together and struck for lower advertising rates. But the newspapers stood firm, and the strikers had to give it up. They found they could not get along without advertising. Bargain stores, and owners of proprietary articles such as Pearline and Ivory Soap, also owe much of their success to persistent advertising just where people are accustomed to look for information. Honey leaflets are a praiseworthy attempt at advertising, but my own experience shows they have been over-estimated; leaflets of all sorts being as thick already in large cities as autumn leaves, and as little regarded. I very seldom heard remarks, on subsequent visits, indicating that leaflets distributed had been read, nor was it likely they would be, when lurid tracts heralding the virtues of Dr. Williams' Pink Pills for Pale People, Paine's Celery Compound, or Hood's Sarsaparilla, littered the steps, and hung suspended on the door-knobs; and even the giving away of samples proved to be a stale trick, when samples of some brand of tapioca or coffee cereal could sometimes be picked up in every yard. Probably nearly all know what Scott's Emulsion claims to be by having read newspaper advertisements, but seldom do more than glance at the printed matter that accompanies a bottle. In

brief, honey has never been effectively advertised, and never will be until organizations take hold of the matter.

MONTROSE, Col. May 6, 1898.



EDITORIAL Offerings.

HASTY'S COMMENTS were a little late this month; and in order to use them I would have to throw out something already in type. I thought best to leave them over until next month.

LOADING A BEE with honey adds to its weight a trifle more than one-half, according to some experiments made by Prof. C. P. Gillette of the Colorado college. A pound of empty workers contains, on the average, about 5,500 bees.

EIGHT DOLLARS a dozen instead of six dollars a dozen, is the way it ought to read in the advertisement of queens by J. W. K. Shaw & Co. of Loreauville, La. The error was not discovered until the advertising pages were printed.

WHITE CLOVER has made a good growth in this locality; and is now in bloom. The weather is quite dry, though, and but little honey is being gathered. Bees have swarmed a little; but at this writing, June 7, none of them have yet commenced to work in the supers to amount to anything.

THE PACIFIC BEE JOURNAL, has suspended publication. Its editor is connected with the National Guards, and expects any day to receive orders to take the field; besides this, the drouth of this year is very discouraging to all apicultu-

ral ventures in California. For these reasons the publication of the Journal will be dropped until some more fitting time.

THE ATCHLEYS of Beeville, Texas, write me that they have had excellent rains and prospects are very bright. They have 900 colonies and are now busy harvesting a crop that they expect will reach 100,000 pounds; 80,000 pounds of which are already sold. This sounds a good deal like counting chickens before they are hatched; but, as some one has said, "It is only the man who counts his chickens before they are hatched that sets any eggs."

SOLAR WAX EXTRACTORS are of no value in purifying wax; so says Mr. Dandant in the American Bee Journal. The dirt will run out with the wax. Neither is the solar extractor suitable for use in rendering old combs. They absorb too much wax. Water should be used in rendering them, as it should in purifying wax. When wax is melted and allowed to stand on water, and cool very slowly, much of the dirt settles to the bottom and may be scraped off. Don't use iron vessels in rendering wax. It makes the wax dark. Use tin or copper. The copper must be kept clean.

FOUL BROOD may possibly be disseminated by the queen bee traffic. Not through the queen, but through the workers or the food that accompanies them. So long as this is possible, there ought to be caution. I suppose there are few if any breeders who would knowingly send out bees or food so affected, but for fear that it might be done unwittingly, it is well to be cautious. I remember reading somewhere, not long ago, of some one who always removed the queen to a new cage and burned the old cage and its contents—bees and all. Such caution may seldom be necessary, but it can do no harm.

CARNIOLAN BEES are often inquired about in the correspondence that comes to this office. A report that appears in the last issue of the Canadian Bee Journal, from an experience with two dozen queens purchased in the fall of 1896, shows that the bees were found to be gentle, and not more inclined to swarm except when lived upon starters only. Their building of combs, when not furnished with foundation, was very irregular, and the proportion of drone-comb was too large. Illustrations were given showing the combs that were thus built.



PAINTING HIVES is objected to by Mr. Doolittle, on the grounds that it costs something and makes them no better. He thinks the hive will last just about as long and that the bees will winter better in an unpainted hive. Mr. Leahy thinks that Doolittle's views may be all right in New York, but would not answer in every climate. J. H. Martin of California agrees with Mr. Leahy. He also calls attention to the fact that a dark hive, like one that is old with age, absorbs more heat and is more likely to cause the combs to melt down. This latter point is really an advantage in the spring and winter, and I would shade my hives in hot weather—at the same time I prefer them painted.



ALLEY'S QUEEN REARING,

Mr. Henry Alley, of Wenham, Mass., ex-editor of the American Apiculturist, has gotten out a new book on queen rearing. It is not a large book, contains only twenty pages, but it gives the main points of his former book, and in addition it tells how to rear queens in the brood nest of a colony having a laying queen. This is done by fencing off with perforated metal the lower part of a frame from which the comb has been removed, and putting in a strip of wood to which are attached the cell-cups. It is not clear from the way Mr. Alley tells it whether the cells are built in this place by the colony in which it is placed, or that the

cells are built elsewhere, then transferred to this place for hatching; but I think that he means the former. The price of the book is twenty-five cents.



THAT QUEEN EXCLUDERS have a tendency to cause swarming is the belief of Mr. Fred S. Thorrington of Missouri. He thinks that he gets more extracted honey when he uses no queen excluders. He says that he has a colony in which no excluder is used; and that it has stored about 100 pounds of honey each year for two or three years; seldom swarming. Other colonies with queen excluders swarmed "like mad" even if not so strong as this colony. Of course, this idea is worth thinking about, but there so many factors that may cause swarming, or that may result in the storing of surplus, that our friend's experience ought not to be looked upon as conclusive.



THE SAD DEATH OF CHAS. F. MUTH.

Mr. Chas. F. Muth, of Cincinnati, one of the grandest, whole-souled men in our ranks, has passed away; probably by his own hand. He was found dead, (shot) May 16th, at his farm near Morristown; Ind. Mr. Muth suffered from sunstroke several years ago, and since then his head has troubled him more or less. Although he was possessed of considerable property, it was scattered and he was in debt, and these things probably worried him.

I remember so well my meeting with him at the World's Fair in Chicago, and noting how well and ruddy he looked, and asking him how it was. He said "Well, Brother Hutchinson, I'll tell you. I have a farm out a few miles, and I spend a good deal time there out in the open air. That explains it." The last time I met him was at the State fair, last fall, in Indianapolis. He came and talked with me as much as two hours, and told me, among other things, how he had suffered when his son died. The world had never seem-

ed the same since. He also tried to speak cheering words to me, and did all that his big sympathetic heart could to lift the burden from mine. It is too bad that we do not know how to take better care than we do of these frail minds and bodies of ours, and, knowing it, do it.

WORK WITH BEES KEEPS US "NEAR TO NATURE'S HEART."

In a private letter received some time ago from Mr. James Heddon, there are a few sentences that it seems as though his friends would read with pleasure. He says: "This is my 31st year as a specialist, and I am beginning it all alone with 200 colonies; enjoying it as I never have before. The shop that once stood in our yard up town has been moved down here in the apiary among the big apple trees. The high board fence keeps out the boys with their guns; and the wrens and other song birds come here and sit and swing and sing through all the balmy days. Down town, three-fourths of a mile away, I have a daily and a weekly newspaper. They are the first and the best in this rich county; and pay, yes, pay *well*; especially so since my youngest son has developed into such a good editor, publisher and manager; but that commercial strife which he so enjoys, I dislike; preferring to deal with honest nature. This work here, pays well, too; and, besides, feeds the soul; while that down in the city is distasteful to my nature. In my opinion no rural pursuit is the equal of honey production for pleasure and independence, and I may say for profit, if it is rightly managed. In no year have I ever failed to realize a good profit on the labor and capital invested. I am sure that I shall always follow it as my life-work."

CONTRACTION OF THE BROOD NEST.

In a late issue of *Gleanings* the editor referred to the contraction of the brood nest as a "fad;" classing it with self-hivers, etc. From the tone of Bro. Root's

remarks it is evident that he has misunderstood the time and manner in which contraction of the brood nest has been practiced. For instance, he says: "But, oh how the bees did swarm, and no wonder! The whole trouble was that queen did not have brooding space enough; and the bees were quick to catch on to the fact; and the result was the queen and bees connived together for larger quarters."

Bro. Root, so far as I know, no one has practiced contraction of old established colonies, those that had their brood nests filled with bees, brood and honey—it was only in hiving swarms that contraction was practiced. It is *possible* that some practiced contraction with established colonies; it seems that you have understood it that way, but you are the first man that I have ever met who so understood it or practiced it. I have corresponded with many of the prominent bee-keepers who practice contraction of the brood nest, have met many of them, and visited the apiaries of many of them, especially here in Michigan, where, as you say, contraction is practiced most extensively, and I have yet to know of a bee-keeper who contracts his brood nests except in hiving swarms. If there are those who contract the brood nest of established colonies, do it in the spring, or just before putting on the sections, or if there are those who have practiced it and abandoned it, I hope they will speak out, for it will be news to me. According to my views and experience, it would be a most unwise course to pursue. In the first place, we need to raise all the bees possible before the opening of the main honey harvest. We must have the workers, or the harvest will be in vain. To rear them there must be cells in which to cradle them while babies. We need all of the cells that an ordinary queen will keep full of brood; and enough other cells for the storing of the honey and pollen to be used in caring for the brood. When the coming of the harvest finds these combs all filled with brood, honey and

pollen, there is nothing to be gained in taking out some of these combs and putting in dummies. If the brood nest is full when the honey comes, the surplus must go into the supers. I am at a loss to conceive where, when, how or why there could have been conjured up the idea of contracting the brood nest of an established colony in the spring or before the opening of the harvest. There is only one instance in which I could think it advisable. If a colony were weak in numbers, and the harvest already present, and it was thought advisable to secure some comb honey from that colony at all hazards, then a taking out of the occupied, or partly occupied combs and putting dummies in their places would force the bees into the sections; but with colonies in which the brood nest is full of bees, honey and brood, contraction of the brood nest is wholly unnecessary.

Contraction of the brood nest in living swarms when working for comb honey is an entirely different thing; and when practiced intelligently in the right locality is a most important factor in securing a crop of honey. Here in Michigan, and similar localities, the surplus white honey is gathered in a short period—never extending over six weeks; usually lasting only a month; and sometimes the main harvest is all gathered inside of two weeks. Then comes a period of a month or six weeks in which no honey is gathered; this being followed by buckwheat or fall flowers in some localities. In some localities, like the one in which I am now situated, white clover furnishes the only surplus. Years ago, in localities similar to mine, when contraction of the brood nest in living swarms, and several other "wrinkles" were unknown, how often we heard even the veterans lamenting the issuing of swarms, because, they said, with the swarm went all hopes of surplus. As the business was then conducted there were good grounds for lamentations. The management was about as follows: The swarm would be put into a ten-frame

hive, and no supers put on until the hive was filled. If they were put on they would not be occupied until the lower hive was filled, and by the time this was accomplished it usually happened that the white honey harvest was passed. If the old colony did not swarm (usually it did) some return might be expected from that, unless the season was nearly over. If a colony is in condition to begin work in the supers at the opening of the white honey harvest, and continues faithfully at work without swarming, as I have already said, no contraction is needed; but, suppose the harvest is half over, the bees working nicely in the supers, there may be one case of sections nearly ready to come off, another two-thirds finished, and a third in which the work has only nicely commenced; now the colony swarms. What shall be done? By hiving the swarm in a contracted brood chamber, upon the old stand, transferring the supers to the newly hived swarm, and practicing the Heddon method of preventing after-swarming, work will be resumed and continued in the supers without interruption, and the surplus will be nearly as great as though no swarming had taken place. In brief, contraction of the brood nest, coupled with the plan of putting the swarm on the old stand and practicing the Heddon method of preventing after-swarming, enables us to throw the whole working force into the super just at the critical time, and secure a crop of white honey that would otherwise have been stored in the brood nest or used in the rearing of bees that would have come upon the stage of action when about the only thing that they could do would be to hang on the shady side of the hive.

We all know that white honey brings a higher price than does the dark honey gathered in the fall; while the latter, unless it may be in some few special instances, is equally as good for winter stores. The contraction of the brood nest in living swarms puts this white honey in the market and the cheaper grades in the hive for winter.

It has been urged against contraction that it results in small colonies at the end of the season. If it is carried to too great an extent, or too long continued, it certainly does. If a man wishes to turn bees into honey, contraction will enable him to accomplish his object. If colonies are too weak in the fall as the result of severe contraction, they must be united; but the course pursued by nearly all who practice contraction is to enlarge the brood nest again in time for the colony to build up for winter.

If the locality is such there is a continuous flow through the whole season, or if the main flow comes in the fall, as is the case in many localities, it will be readily seen that little or nothing would be gained by contracting the brood chamber of swarms. There would be time in which to fill the brood chamber and be all ready for the fall flow when it came.

Bro. Root speaks about the small crops of honey that have been secured, that perhaps 25 or 30 pounds were the average, and that some Michigan bee-keepers thought that they were doing well if they got 10 pounds to the colony, and he rather intimates that these are the results of contraction. He well knows that we have been having some very poor seasons of late, with the exception of the last year or two, and it seems scarcely fair to attribute them to contraction of the brood nest. I have been practicing it now for at least fifteen years. One year I got no surplus, and neither did those who did not practice contraction. By the way, I did not practice it *that* year, as there were no swarms to practice it on. Other years my surplus has varied from ten pounds a colony to over one hundred pounds. Perhaps the average would be about sixty pounds. Both Mr. Heddon and Mr. Taylor have practiced contraction for years; and it does not seem as though bright men like these would continue a practice that they did not find advantageous. But let us not forget in this discussion that there is a difference in locali-

ties, as I have mentioned. This is really very important. It is so difficult for us, sometimes, to comprehend conditions with which we are not personally familiar. Mr. C. P. Dadant and myself used to have arguments over the size of hives; and I can see now that we were both right, according to our localities and methods.

Since the foregoing was written Gleanings for June 1st has put in an appearance, and I notice that Bro. E. R. Root in his advocacy of large brood nests says, that some one else says "Oh, yes, everyone believes in two or more stories when running for extracted." Then Mr. Root says "Well, try it for *comb* honey; it will cost you nothing." Suppose, brother Ernest, that you try a few colonies with two or more stories for a brood nest in working for comb honey and *see* what it will cost you. As I have said so many times in reference to these "fads," if you must try them, do it on a small scale first. If you find it is profitable to double or triple the size of your brood nests do it by all means, but first find out that it *does*.

Just one more word: If many, or any, of the experts who formerly practiced contraction, as I have explained it, have "gone back on it," as Bro. Root says he believes they have, let us hear from them, with the reason *why*. It matters little which of us, Bro. Root or myself, is right, if we only get at the truth.



Department of criticism

R. L. TAYLOR.

Blame where you must, be candid where you can,
And be each critic the Good-natured Man.

GOLDSMITH.

NOT TALKING TO THE POINT.

The American Bee-Keeper, page 81, publishes an article of considerable length

entitled "The Italian Bee." I can scarcely be charged with "setting down aught in malice" when I say that it contains absolutely nothing about Italian bees except a hint that one gets fewer stings from them and that the majority of bee-keepers prefer them. The article comes dangerously close to what is sometimes called "padding."

BEE-KEEPERS OUGHT TO MAKE THEIR
OWN HIVES.

Dr. Miller, *Gleanings*, 240, although he confesses that he is a good workman, is unwilling to accept Doolittle's advice that a good workman with the necessary tools should make all his needed wares, after starting, except sections, preferring rather to sprout potatoes at 10 cents an hour. I think the doctor is decidedly wrong. One cannot afford to keep many bees unless he is a skillful enough workman to make his own hives, etc., and does it.

STIMULATIVE FEEDING UNPROFITABLE.

Though Ed. Jolley, *American Bee Keeper*, 66, admits that stimulative feeding is a tedious, troublesome job, he takes the trouble to describe and recommend a most troublesome, dangerous and ineffectual way of doing it; viz: on plain boards in the open air. By that method those colonies that need it least will get most of the feed; and those that need it get little benefit. But I am satisfied that stimulative feeding does not pay. I do not say that it is of no benefit, but that it does not pay. Each colony ought to have plenty of stores; and, if it has, feeding will add but little to the amount of brood reared, and may serve to encumber the brood chamber.

WHY BEES TEAR DOWN AND REBUILD
COMB.

R. C. Aikin, *Gleanings*, 250, having noticed that bees sometimes tear down the cell walls of old combs, arrives at the conclusion that they do it to remove the cocoons that the cells may not be too much diminished in size. I am not ready

to accept the conclusion. I have frequently seen comb torn down in the manner mentioned, but it was always, I think, where the comb had been injured by mold or spoiled pollen, or to remove hardened pollen. I am somewhat surprised at his statement that in one case "the cells were gnawed down and being rebuilt," "when little or no honey was coming it." Bees do not often do so.

"FADS" OF CONTRACTION AND EXPAN-
SION. LARGE HIVES DO NOT AL-
WAYS CAUSE POPULOUS
COLONIES.

The editor of *Gleanings*, 358, dilates upon fads—the contraction fad and the self-hiver fad. He admits having been carried away by the former; and my recollection is that he found it like pulling teeth to give up the latter. In view of all that, he nevertheless makes an unreserved surrender to the *expansion* fad. (*Gleanings*, 141, 298, 358). Michigan bee-keepers are given more than any others to contraction, and they are glad to get even to pounds a colony, he says. (He prints it "per" colony instead of "a" colony—I wonder why.) The big double deckers, he goes on, at the out-yard are the ones that went right on minding their own business piling in the honey and not swarming, while the single-story colonies scarcely made a showing. He believes that the best solution of the swarming problem is big colonies in two-story, Langstroth hives. In some cases three stories may be advisable. Sometimes I take it he prefers *four* stories, for that must be what he means when he speaks (page 41) of the "two-story double-deckers" getting honey when those in a single story do little or nothing. So, successful bee-keeping is all reduced to the adding of two or three stories! But I find an interrogation point asserting itself as to the quality of the colonies at the time some were given extra stories and others left with only one. In other words, was the division between the two fairly made in respect to the strength in the spring?

One would take it as a matter of course, from the exuberant language of the editor, that the remarkable success of the "double-deckers" was owing mainly to the extra number of stories, but were the extra stories the cause or the effect? In another paragraph the editor remarks, as if almost alone in the opinion, "Our own readers know what a leaning I have toward large colonies, and how I have more than once said, that in our experience at least they would get more honey both [either?] comb and [or?] extracted, than smaller ones." Well, the editor has all Michigan with him, however it may be in non-contracting Ohio. He continues: "But I cannot see that these results are necessarily attributable to a large frame or to a large hive rather than to an equally large hive made up of one or more stories. According to my notion it is not the size of the brood-frame or the size of the hive so much as it is the *numerical strength of the bees themselves.*" *Exactly!* It is evident that the editor would have us believe that in some occult way those extra stories add to the numerical strength of the colonies. Let us see. To keep eight L. frames full of brood there must be 2,500 eggs deposited daily, continuously. That means a heavy swarm every two weeks. Not one queen in a hundred will do that previous to the height of the clover and basswood season. To keep ten L. frames full of brood the queen must lay more than 3,000 eggs daily, continuously. A heavy swarm every eleven days. Not one queen in a thousand will do that previous to the time when such great numbers would become worse than useless. It is no answer to say a good queen will put brood in 15 or 20 frames. A frame filled one-third full of brood, as it is usually put in, looks pretty large. So the extra stories cannot be needed to obtain numerical strength. Then the editor makes the almost unpardonable mistake of confounding large colonies and large hives. He says some of our most successful bee-keepers "use large colonies;" and then

goes on to name some who use "double-deckers," or large Quinby's. Is it possible he thinks Michigan bee-keepers object to "large colonies" and that they wouldn't use a larger hive if they thought it would materially increase the "numerical strength?" But he says the colonies in the two and three story hives don't swarm. Well, how does he know? How long has he tried them? Doolittle in the Progressive, page 19, gives answer to some one who had found out how to prevent swarming: The main cause lay in the season. In '77 I had little swarming with colonies all strong in the spring; while, another year 49 colonies in the spring gave 348 swarms! That is a good answer; and here is another: The plan of tiering up brood chambers is practically the management for extracting; and it is a common place fact that swarming is easily controlled with *that* management. The editor no doubt will protest that the plan works equally well for comb honey. He says, Gleanings 140, "after the bees have pretty well filled up the upper story * * * I may remove the upper story crowd all the brood as far as possible into the lower story and put two supers of comb honey (sic) on in its stead." So, after all, though the editor tries to cut loose from the contraction fad he finds it necessary to practice it in order to produce comb honey, only he practices a laborious and inconvenient method. How much better it would be to have the brood in so compact a shape that it could all be put into the lower story; or, better still, to have had it *produced* in the lower story, and not require any handling at all. How much better, too, would it have been to have had on one or two comb honey supers to prevent swarming and to catch the incoming honey instead of using brood comb, for this purpose. This contraction practiced by the editor is equal in extent to that practiced previous to swarming by any Michigan bee-keeper, so far as I know, and I am not inclined to be captious about methods with one who is right at heart.

ROBBING WHEN HIVES ARE RAISED ON
BLOCKS.

The editor (Gleanings 298) advises care, in speaking of the danger of robbing at the close of the honey season when the hive is raised on blocks, "that is providing he uses one-story colonies. A good strong colony, a double or triple-decker, such as I would use and do use—I think would be fully capable of holding its own. No little colonies for me." Does the editor really think a colony could defend three sets of combs more easily than one set? Or does he only mean that a very strong one could defend three better than a despicably weak one could one? If so, why should the weak one be set upon blocks at all? It would be a proper subject for contraction.

SOME POINTS IN USING DRAWN COMB.

In discussing the subject of using sections containing drawn-out comb (Gleanings, 343) Dr. Miller quotes me as saying that the bees are slower to fill and cap them. I cannot believe he quotes me correctly. Bees *fill* them more quickly but *cap* them more slowly. Further on he says, "in years of failure I have had hundreds of cases in which one unfinished section in the super was filled and sealed and the remaining sections with foundation were left untouched." Certainly; I trust however, that the doctor's logical faculty will not allow him to claim there is any argument in that. Again, to the claim that honey stored in deep cells is not so good in quality and that it is better to reduce the depth of the cells he says "if that be true, a cell $\frac{1}{2}$ inch deep will not give as nice honey as one $\frac{3}{8}$ inch deep; a cell $\frac{3}{8}$ inch deep will be excelled by one $\frac{1}{4}$ inch deep; this in turn is not so good as one $\frac{1}{8}$ inch deep." "The less the depth the better the honey; the best honey of all being produced on the Michigan no-wall foundation." The doctor is up in the healing art equally well as in bee-keeping; and if I should say to a convalescent who was trying to take four hours of exercise a day: "You are exerting

yourself too much; two hours of exercise would be much better;" he (Dr. Miller), if he overheard me, and were feeling pugnacious, would say to the invalid: "That's all bosh; if two hours are better than four, then one is better than two; and a half better than one; and none at all best of all. Any one could see that is bad advice; don't listen to it; take all the time there is for it—24 hours a day."

TYPOGRAPHY AND GRAMMAR.

E. A. Daggitt talks of typographical beauty (Review 111). I think I prefer the print in which the "extracted" articles appear to that in the body of the Review, and I would be inclined to put the likenesses on a page by themselves.

Mr Daggitt also says "I have noticed that if a person once keeps bees that he or she is apt," etc., "Although they are going" etc. I have a particular antipathy to the use of the words "or she" in such connection; they add nothing and mean nothing. "He" in such a place being generic may mean one of either sex, and "they" is of course out of place.

TO MUCH ITALICIZING.

The writer of the article on page 150 of the Review is made to squirm at the amount of Italicizing the editor has seen fit to introduce; and in one case (first example, second column, page 153) he would put the emphasis on the wrong word. I sympathize with the writer.

ONE BY ONE THE IDOLS FALL—TO BE
PICKED UP BY OTHERS.

How are the idols falling! Dr. Miller has parted with the under-ground ventilation to his bee cellar (A. B. J., 231). It had become stopped up so that it didn't work at all; but, strange to say, the bees wintered well notwithstanding. It was built to satisfy the doctor's fresh-air theory; and, now that it is stopped, the same theory is gratified because when open it probably brought in underground gases. I am looking for his artificial heat fan to follow speedily. How comfortable it is to have some little simple matter of routine management to rest up-

on for safe wintering. The painful thing is that one after another they will keep slipping from under one. But it is reassuring that the prop will not be lonely if you are—someone else will lean on it. Chrysostom (A. B. J., 211) promptly takes up artificial heat and pure air; and adds sunshine; all very good in their place, but sure to prove broken reeds to any trusting one whose bees get a stock of unsound winter stores.

LAPEER, Mich. May 26, 1898.

EXTRACTED.

BUCKWHEAT.

The Preparation of the Soil and the Seed.

Buckwheat is called the lazy man's crop, because, no matter how poor the cultivation, he is pretty sure to get something. But I find there is no crop that responds quicker to good treatment. The cultivation of buckwheat for grain or honey is the same; but in selection of soil, and time of sowing, there is a material difference. To yield honey freely, the soil must be strong enough to produce a good crop of corn or potatoes. A field that, with good cultivation, would produce a good crop of grain, nine times out of ten would not furnish a crop of honey.

If I were sowing expressly for honey, I should proceed as follows: If the field to be sown were greensward, I would plow it as soon as the frost left the ground in the spring, and let it lie until about the first of June. At that time I would select some very warm day, and go over it several times with a two-horse cultivator. My reason for taking a warm day is, that I would be sure to kill all weeds and grass. If the field had been cropped the previous season, I would cross-plow in place of cultivating.

Buckwheat is such a quick-growing crop, the point is to get the soil loose and light as deep as the roots go, and also have the surface pulverized very fine for a seed-bed. The time for sowing with us is the tenth of June, but would vary according to locality. In average seasons the bees commence storing honey 45 days after sowing; and as there should not be a break between bass wood and buckwheat, it would be impossible to fix a

date. The seed should be soaked 24 hours, and then rolled in plaster or quicklime; this insures an even catch, and also gives the young plants a start. The quantity of seed for smooth ground would be half a bushel per acre; for rough and uneven ground, double the amount will be required. Most grain, where a small quantity of seed is sown, will send up several stalks from each grain. Buckwheat sends up but one from this main stalk. Side branches are thrown out, on which the bulk of the crop is matured; and unless the surface of the ground is very smooth, the stalk can not be cut below the side branches. When more seed is used per acre, the branches are thrown out nearer the top of the stalk, and there is less trouble in harvesting.

In regard to soil: If I could have just what I wanted, it would be a sandy loam. When grain is the only object, I would sow the fifteenth of July. I have had a good yield of grain when sown early; but on an average, my late sowing does much the better. —*H. T. Bishop in Gleanings for 1882.*

THE CULTIVATION OF BUCKWHEAT.

It is the "Lazy man's Crop," but it well Repays all care and Thoroughness in Cultivation.

Buckwheat is a crop which costs but little, either for manure, labor, or seed; and it is a very convenient crop wherewith to occupy land that could not be planted with any spring crop in proper season, on account of the hurry of spring work, unfavorable weather, or want of help. Besides, the grain can always be readily marketed, and at prices much more remunerative than those of the corn crop, when the extra labor of cultivating the latter is taken into consideration. It has been remarked, that buckwheat "favors slack husbandry, being proverbially the lazy man's crop." This may be true to some extent, as fair crops are sometimes grown on quite inferior or worn soils, and with but very little preparation. In fact, the opinion appears to prevail among many farmers, that this crop will do well on land hastily and imperfectly plowed, at any time when most convenient, and put in in a slovenly, slipshod manner, without the ordinary care and labor bestowed on other and perhaps less important crops. It deserves good cultivation, however, and I think my

bee-keeping friends will find that the increased yield will amply repay for all extra labor performed.

My own practice is to plow as soon as possible after corn-planting—usually about June first—and then harrow occasionally to get the land clean and fine by sowing time. This is very important in dry seasons, the mellow surface retaining the moisture, as was clearly proven during the extreme drought of last summer, where fields treated in this way came up finely and produced fair crops, while neighboring fields, turned over just before sowing, scarcely sprouted at all, and the crop was an entire failure. Buckwheat thrives well on a wide range of soils, and will give a tolerable crop, in some cases, on fields which would scarcely produce any thing else of much value. If manure is to be applied, it is best put on the previous year; yet fair crops may be grown on very light and quite inferior soils without manure. Bringing the soil into fine tilth, and rolling the land after sowing the seed, especially on light, dry soils, will improve the growth of the crop, and increase the average product. It is a cleansing crop, of the nature of a fallow, subduing or choking out troublesome weeds. Instances have come under our observation where dock, sorrel, charlock, and even quack-grass and Canada thistle, have been pretty well subdued by crops of buckwheat. One reason why this crop kills out or subdues weeds and grass is, that the land for growing it is plowed and harrowed in midsummer, by which process the roots of the weeds and grass are exposed to the scorching rays of the sun; and then, after the seed is sown, it grows so rapidly that it gets the start of all other vegetation, overshadowing and smothering everything that springs up.

Besides furnishing food for man, buckwheat is an excellent food for almost all domestic animals, and has been highly recommended by experienced farmers for feeding purposes. It is also valuable for bee pasturage, being in blossom at a season when honey producing plants are scarce—not so much on account of the quality of its honey, but for the fact that it keeps the bees breeding late in the season, putting them in better condition for successful wintering. I have sometimes thought, that being near to a considerable area of this crop, has had much to do with my success in wintering, when others, in less fortunate localities, have lost heavily.

Buckwheat may be sown from the middle of June to the middle of July in latitudes north of forty degrees. It runs the

risk of being injured by early frost, if sown much after the 4th of July. It is usually cut with the cradle, and to avoid loss of grain by shelling when very ripe, it may be cut when damp, as in the morning or evening. Being slow to dry out, it should never be stacked or mowed away in large quantities together. A better way is to thrash it as it is drawn in, on a dry warm day. The average yield is from fifteen to thirty bushels per acre. Under favorable circumstances, and in favorable seasons, from thirty to forty-five, and even fifty bushels, have been obtained.—*L. M. Rogers in Gleanings for 1882.*

THE BUCKWHEAT FIELDS OF NEW YORK.

The Large Yields Result in Honey of Superior Quality.

Through my vicinity here in the eastern part of Schoharie County, and through a large part of Albany County, buckwheat is raised very extensively; and one not accustomed to seeing very many buckwheat fields, can not but enjoy the beautiful sight and fragrant smell of the thousands of acres of buckwheat, while in full bloom. It is a very common thing for farmers through this vicinity to raise 200 to 500 bushels of buckwheat; and while passing through a portion of Albany County last fall I was shown a farm, and saw the ground, where 1000 bushels of buckwheat were harvested. Through this country it is one of the most paying crops that the farmer raises; and to give you some idea of the amount of buckwheat raised, I will give the amount of bushels ground at our mills the past season in our village: 15,000 bushels at West Berne, three miles east; the same number at Berneville, six miles east; 14,000 bushels at East Berne, ten miles east; upward of 40,000 bushels at Schoharie, 3½ miles west; 10,000 bushels at Central Bridge, 5 miles northwest; besides thousands of bushels were shipped away upon our railroads that were not ground the past year. The buckwheat crop has been a paying one; in fact, it is a paying one every year; but more so the past year, as it has commanded a higher price in market. The flour at one time brought as much as \$4.00 per 100 lbs.; and as three bushels, upon an average, will make 100 lbs. of flour, and the bran is worth from \$16 to \$20 per ton, you see that it is a good crop for the farmers to raise, as they often get from 30 to 50

bushels from one acre of ground through some parts of this and a greater portion of Albany County. Where bees are kept in box hives, and have not much care, the whole surplus is nothing but pure buckwheat honey. I know of bee-keepers who keep from 100 to 200 colonies, and seldom get a pound of white honey; in fact, a good share of these box-hive men do not think of putting on surplus boxes until the first of August, or when the buckwheat commences to bloom; which is about that time. In some localities, buckwheat will not do as well as in others; on light sandy soils it does not do as well as where the soil is more fertile and heavy; and in locations where it is lime-rock soil it will thrive and give more and a better quality of honey than upon any other soil that I am acquainted with. This latter fact I have fully satisfied myself of.

Here in this vicinity we have a lime-rock soil. I have noticed that the honey produced here is much superior in flavor and color to that produced upon sandy or slate-rock soil. In some parts of Vermont, the honey from buckwheat is inferior in taste and color to ours here. The combs are dark, and the honey has a rank and disagreeable smell, while that gathered from buckwheat here is of a pleasant taste, and the combs produced from it are whiter than the combs that are produced from any other I ever saw. A bee-keeper from Vermont stopped with me several weeks last fall. He was much surprised when he came to see the buckwheat honey that was produced in this vicinity, and we actually put it by the side of some choice white honey made from bass wood, and the buckwheat actually showed a whiter comb than the other, the latter having a pale yellow appearance, while the former showed a comb of almost snowy whiteness.

I have found that soil and climate have much to do in changing the quality of honey made from the same kind of bloom. The basswood honey produced in Vermont is much superior, and of better flavor, than the basswood honey gathered here. The reason for it is, that it is more natural for basswood to grow and flourish there in that State than in our vicinity, and *vice versa*. In regard to buckwheat, the farmers here generally choose a field of sod. Sometimes it is turned over in the fall, and left through the winter. In the spring it is cross-plowed, and covered with a sprinkling of manure, and well harrowed in; then about the 20th of June they commence to sow the seed, and continue along from that

time up until the 5th of July. A good many put the seed in with a drill. When sown with a drill, they use, upon an average, from 2 to 3 pecks per acre; if sown broadcast, a little more seed is required. The bees commence to work upon the bloom about August 1; and if the weather is fair it produces honey up until the second week in September. Sometimes the west winds will blast the blossoms, where the buckwheat is sown upon high ground, or in unsheltered positions; then it does not load, or fill, so well, and does not produce as much honey.

I have seen it stated, that bees in some locations do not gather honey from buckwheat except in the morning or fore part of the day; but in this vicinity they will work the whole day long, if the weather is favorable and not cold and rainy. If I were going to sow buckwheat expressly for honey, I would choose a field of stiff sod. I would turn it over as early as I could in the spring; let it lie in this condition till about the first of July; then cross-plow and harrow until the soil is in a good mellow condition; then roll the seed in plaster, or equal parts of plaster and leached ashes, and apply about 3 pecks of seed per acre. I would sow the ground about the 10th or 12th of July, so as to have it come in bloom as soon as the earliest blossoms fall. A great many locations, where there is not fall forage, could be greatly benefited by sowing a few acres of buckwheat.—*F. Boomhower in Gleanings for 1882.*

Honey Quotations.

The following rules for grading honey were adopted by the North American Bee-Keepers' Association, at its Washington meeting, and, so far as possible, quotations are made according to these rules.

FANCY.—All sections to be well filled; combs straight, of even thickness, and firmly attached to all four sides; both wood and comb unsoiled by travel-stain, or otherwise; all the cells sealed except the row of cells next the wood.

No. 1.—All sections well filled, but combs uneven or crooked, detached at the bottom, or with but few cells unsealed; both wood and comb unsoiled by travel-stain or otherwise.

In addition to this the honey is to be classified according to color, using the terms white, amber and dark. That is, there will be "fancy white," No. 1, dark," etc.

CLEVELAND, OHIO.—We quote as follows: Fancy white, 12; No. 1 white, 11; No. 1 amber, 9 to 10; buckwheat, 8; white, extracted, 6; amber, 4 to 5.

A. B. WILLIAMS & CO.,
May 26, 80 & 82 Broadway, Cleveland, O.

KANSAS CITY.—The supply of 1897 comb honey is about all cleaned up, and we think shipments of new comb would sell for about 12 cents. C. C. CLEMONS, CO.,
May 19. 521 Walnut St., Kansas City, Mo.

CHICAGO, Ill.—There is a good demand for fancy white comb honey. This grade would sell for 11 cts.—possibly higher. Considerable Amber and dark on the market—selling anywhere from 5 to 8. Extracted White sells at 5½ to 6; Amber 4½ to 5; dark, 4. Beeswax, 27.
S. T. FISH & CO.,
Mar. 24. 189 So. Water St., Chicago, Ill.

CHICAGO, Ill.—There is but little honey on the market, and we are looking for a good demand for the coming crop. We quote as follows: Fancy white, 11 to 12; No. 1, white, 9 to 10; fancy amber, 9; No. 1, amber, 7 to 8; fancy dark, 8; No. 1, dark, 7; white extracted, 5 to 6; amber, 4 to 5; dark, 4; beeswax, 27 to 30.

R. A. BURNETT & CO.,
May 25. 163 So. Water St., Chicago, Ills.

BUFFALO, N. Y.—There is no demand for honey at this time of the year; except for a limited quality of strictly fancy, at 10 to 11 cents; commoner grades are dull at 8 to five cents according to color, condition, etc. Of course, any and every grade can be sold for what it will bring. Extracted ranges from 4 to 6 cents, as to quality. Beeswax from 20 to 26 cents. We would like some beeswax.

BATTERSON & CO.,
May 25. 167 & 169 Scott St., Buffalo, N. Y.

NEW YORK.—Trade in honey is fairly active. Fancy white and buckwheat comb find quite ready sale with us. Trade in Southern and California extracted has been very good the past few weeks. We quote as follows: Fancy white, 11 to 12; No. 1, white, 9 to 10; buckwheat, 6½ to 7; extracted, California, water white, 6½; California, white, 6; California, light amber, 5½; Southern extracted, 5¼ to 5½ a gallon. New York extracted not in demand at present. Beeswax, 27½ to 28¼. Write for shipping instructions. FRANCIS H. LEGGETT & CO.,
May 6. W. Broadway, Franklin & Varick Sts.

NEW YORK, N. Y.—Demand for comb honey is rather slow especially for off grades, white and dark, and, as we have a large stock of these would not advise shipping for the near future. Our stock of fancy white is light and such would find ready sale at quotations. Our market for extracted buckwheat will open up shortly and we would advise bee-keepers to ship this along now. Beeswax steady. We quote as follows: Fancy white, 11 to 12; No. 1, white, 10; Fancy Amber, 9; No. 1, Amber, 8; Fancy Dark, 7; No. 1, Dark, 6; White, extracted, 5 to 5½; Amber, 4½ to 4¾; Dark, 4 to 4¼; Beeswax, 26 to 28.

HILDRETH BROS. & SEGELKEN,
Jan. 7, 120 & 122 West Broadway New York

WM. A. SELSER,
10 VINE ST., PHILA., PENN.

White Clover Honey Specialist.

Lamp Nursery

FOR SALE CHEAP.

A few years ago, my father-in-law, the late Clark Simpson, had made, for his own use, a very fine lamp nursery, or incubator, for hatching queens. It is not made of tin, but of galvanized iron, throughout. First, there is the outer casing, about two feet square and three feet high; the lower part having a door through which to introduce a lamp. (There is a metal lamp holding a gallon that goes with the nursery.) In the upper part is the nursery proper, the sides of which are thoroughly tied together with braces so that the walls will not bulge when the five or six pails of water required to fill it are put in. Inside the nursery are four drawers; each drawer being composed of sixteen little apartments about three inches square, the sides of which are glass, and can be easily opened. These little apartments are for isolating cells that are nearly ready to hatch; the glass sides allowing one to see which queens have hatched, without opening the doors. I used a nursery for years; and know that it is a great convenience for keeping cells that will soon hatch. I rear so few queens now, however, that it would not pay me to keep a nursery running, hence this nursery is offered for sale at \$8.00—not quite one-third what it cost. I would exchange it for a dozen good Italian queens to be sent me this month—June.

W. Z. HUTCHINSON, Flint, Mich.



The American Bee Journal...

Sent to New Subscribers from now until the end of the year, and the 160-page book, "Bees and Honey," for only FIFTY CENTS. Sample Bee Journal free.

GEO. W. YORK & CO., 118 Mich. St., Chicago, Ill.

Please mention the Review

—If you are going to—

BUY A BUZZ-SAW,

write to the editor of the REVIEW. He has a new Barnes saw to sell and would be glad to make you happy by telling you the price at which he would sell it.



WALTER POWDER'S AD

See That Wink!

Bee Supplies. Root's goods at Root's prices. POWDER'S HONEY JARS. Prompt service. Low freight rates. Catalog free. WALTER S. POWDER, 162 Mass Ave., Indianapolis, Ind., the only exclusive bee supply house in Indiana.

Please mention the Review.

Some Odds and Ends That Will be Sold Cheap.

For a dozen or more years Mr. M. S. West of this place dealt in bee-keeper's supplies. Since his death, two years ago, his daughter has endeavored to close out his stock of goods, and has succeeded to large extent. There are still a few odds and ends, and she has brought them to me and left them for me to sell. Here is a list of the articles with prices at which they will be sold.

- One ten inch foundation mill, (second-hand) Root's make, complete with dipping tank, etc. in excellent condition... \$10.00
 - One ten inch foundation mill, (second-hand) Root's, (one of recent make) dipping tank, etc. in good order... 15.00
 - 500 Hoffman frames in the flat for Langstroth hive, per 100... 1.50
 - Seven, 8-frame (Langstroth) hives, (new but not painted) complete with bottom boards, covers, brood frames, super, section-holders and sections in them, for the lot... 6.00
 - Three, ten-frame Simplicity hives, complete, with frames, covers, supers and wide frames with sections in them, but no bottom boards, each... 1.35
 - Ten supers for Simplicity hives, furnished with wide frames with sections in them, each... .45
 - Thirty supers for simplicity hives, second hand and no frames in them, for the lot... 1.80
 - Three Woodcock foundation fasteners, each... .75
 - Eighty seven entrance guards, each... .05
 - Thirteen Porter Bee Escapes... 2.25
 - Twenty five Hastings Bee Escapes... 2.00
 - One Cowan Automatic Honey extractor for Langstroth frames, new, except that it has been exhibited at fairs... 9.00
 - Thirty-three Simplicity hives, in the flat, six frames, ends, covers and tin rabbits, but no frames nor bottom boards, each... .40
- Send all orders to W. Z. HURCHINSON,
Flint, Mich.

Queens

6-98-1f

untasted Italians 70 cents each; 3 for \$2.01. After July 1st, 50 cents each. Safe arrival and satisfactory return. Catalogue free.

THEO. BENDER, Canton, Ohio.

Please mention the Review

START IN BUSINESS!
HATCH THOUSANDS
 WITH THE PRAIRIE STATE
INCUBATOR
 200 FIRST PREMIUMS.
PRAIRIE STATE INC. CO.
 HOMER CITY, PA.



SEND FOR CATALOG.

THE MONITOR PAPER FILE

Binds securely and neatly all periodicals. Preserve your papers, magazines, pamphlets, bulletins, music &c., by binding them together as you get them. Each new number filed quickly and easily. Will bind 52 numbers of any periodical aggregating 1000 or fewer pages. All lengths from 6 to 28 inches. Light and handsome. PRICE.—All sizes 12 inches and under 12 cents; over 12 inches one cent per inch. When wanted by mail add one cent for each 5 inches or fraction thereof.

For sale by the Publisher of this paper.

Queens

75 cts each by return mail; either golden, or three-banded, young and warranted. Two separate yards with competent assistants. Circular free.

J. B. CASE, Port Orange, Fla.

Without Stopping

the machine to reverse the combs is the way you can work with the Williams Automatic

Honey Extractor.

Such an extractor will save you time and annoyance and it does not cost much more than an ordinary machine. Send for descriptive price list.

Read what the famous bee-keeper, N. E. France, says:

PLATTEVILLE, Wis., July 5, 1897.
 Dear Sirs: To day I extracted 2,780 lbs. of honey with your Automatic Honey Extractor in 5 1/2 hours and could have done the same this afternoon but let the boys go to the city to play a game of base ball. Have extracted 27,135 lbs. so far with good prospects for as much more. My bees and State work keep me very busy. Hope to see you before very long—will write you later.
 Yours truly, N. E. FRANCE,
 State Inspector of Apiaries,
 Platteville, Wisconsin.

We can also furnish choice queens, either golden or leather colored Italian, at 75 cents each, or two for \$1.40.

Van Allen & Williams,
 6-98-1f. BARNUM, WIS.

THE LOSS

Of one Queen in introducing, means a loss greater than the cost of a copy of "ADVANCED BEE CULTURE," which has one entire chapter devoted to "The Introduction of Queens." It shows when the cause of failure lies with the colony, when with the queen, and points out the *conditions* necessary to success. Although one infallible method is given, but little attention is given to the setting forth of exact rules and methods; the subject being treated with a view to teaching *principles* that may be followed to success.

Price of the book, 50 cts. ; the Review one year and the book for only \$1.25.

W. Z. HUTCHINSON,
Flint, Michigan.

Listen! Take my advice and buy your bee supplies of August Weiss; he has



tons and tons of the very finest

FOUNDATION

ever made; and he sells it at prices that *defy competition!* Working wax into foundation a specialty. Wax wanted at 26 cents cash, or 28 cents in trade, delivered here. Millions of **Sections**—polished on both sides. Satisfaction guaranteed on a full line of **Supplies**. Send for catalogue and be your own judge. **AUG. WEISS,** Hortonville, Wisconsin.

18



98

This is the original one-piece section-man who furnishes one-piece sections as follows:—

500 sections, \$1.50; 1,000 for \$2.50; 3,000 for \$6.75; 5,000 for \$10.00; 10,000 for \$17.50.

No. 2 sections are not made to order, but when in stock are sold at \$1.50 per M.

J. FORNCROOK,

Watertown, Wisconsin.

When you buy

QUEENS,

You want, first, *good* queens; then you want them *promptly*; and, lastly, you want them at a reasonably *low price*. You can secure all of these advantages by sending your orders to Mr. **W. H. PRIDGEN**, Creek, Warren Co., N. C. He is *now* ready to mail either golden, or from imported stock, mated to golden drones, at 75 cts, each for untested queens. Mr. Pridgen is a member of the National Queen Breeders' Union; and he sends out (free) a catalogue containing valuable information for queen breeders and buyers. Money order office, Warrenton.

Bee-keepers in the



Northwest

Can save money and freight by getting their supplies from the Minn. Bee-keepers' Supply Mfg Co., Niccollet Island Power Building, Minneapolis, Minn. They have all the latest and most improved machinery and manufacture and handle a full line of supplies. Send for catalogue before ordering.

Please mention the Review.

Root's Bee-Supplies,

Shipped from Jackson at Root's prices. Honey bought and sold. White, Plymouth Rock chicks and eggs for sale. Send for prices

W. D. SOPER, Box 565
2-98-tf Jackson, Mich.

I have several hundred

QUEEN CAGES

of different styles and sizes, made by C. W. Costellow, and I should be pleased to send samples and prices to any intending to buy cages.

W. Z. HUTCHINSON, Flint, Mich.

ITALIAN QUEENS,

They are large, yellow, healthy and prolific, and their bees the best of workers. Untested, 75 cts each; or \$6.00 a dozen. Tested, \$1.00 each. Satisfaction guaranteed. Send for circular, 5-98-tf
J. W. K. SHAW & CO., Loreauville, La.

Farm Bee - Keeping.

The only bee paper in the United States edited in the interests of the farmer-bee-keeper and the beginner is the **Busy Bee**, published by EMERSON T. ABBOTT, St. Joseph, Mo. Send for free sample copy NOW.

Queens bred in the North are hardy and fertile. Every bee-keeper should try one of these Northern grown queens. Pure bred Italian queens at 75 cents each; or 12 for \$6.00.

WM. H. BRIGHT, Mazeppa, Minn.

To stick things, use **MAJOR'S CEMENT**. Beware!!! Take no substitute.
2-98-12t

JOHN F. STRATTON'S CELEBRATED



MANDOLINS,

Importers of and Wholesale Dealers in all kinds of
MUSICAL MERCHANDISE,
811, 813, 815, 817 East 9th St., New York

Bee keepers should send for our

'97 CATALOG.

We furnish a full line of supplies at regular prices. Our specialty is Cook's Complete hive.
J. H. M. COOK, 62 Cortland St., N. Y. City

Please mention the Review.

Franklin House DETROIT, MICH.

Cor. Bates and Larned sts. Very central. Elevator service. steam heat, electric lights, tile floors, etc. Rates \$1.50 to \$2 per day. H. H. JAMES & SONS, Props.

Please mention the Review.

The Land of Honey, The Italy of America!

Send for a copy of the **PACIFIC BEE JOURNAL**: 365 E. 2nd St., Los Angeles, California.

Please mention the Review

Michigan Headquarters for the G. B. Lewis Company's

SUPPLIES,

Dadant's foundation, and everything needed in the apiary. Send for price-list to **L. C. WOODMAN**,
3-98-6t Grand Rapids, Mich.

Please mention the Review



ITALIAN QUEENS,

untested, either golden or three-banded, unexcelled for gentleness, purity and industry, sent **now** at \$1.00; tested, \$1.50; select tested, \$2.00; imported, \$5.00.

Huffine & Davis,

Ooltewah, Tenn.

Please mention the Review.

Beeswax Extractor.

The only Bees Wax Extractor in the world that will extract all the wax from old combs rapidly by steam. Send for descriptive illustrated catalogue.

C. G. FERRIS,
South Columbia, N. Y.

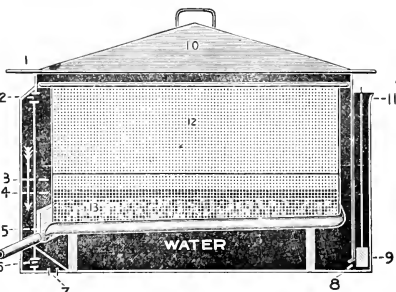

Are you Going

To the fairs this fall?

My bees and queens take first premium.

Fifteen, Barred Plymouth Rock eggs for 50 cts. Ask for catalogue. 4-98-1f

J. F. MICHAEL, Greenville, Ohio.

The place to get your best QUEENS

is of H. G. Quirin, of Bellevue, Ohio. Ten years of experience, and the best of methods and breeders enable him to furnish the best of queens. Golden Italian, warranted purely mated, at 75 c.;

after June, 50 c.; or 6 for \$2.75. Leather-colored, same price.

— If you wish the best, low-priced —

TYPE - WRITER.

Write to the editor of the REVIEW. He has an Odell, taken in payment for advertising, and he would be pleased to send descriptive circulars or to correspond with any one thinking of buying such a machine.

1898 Queens 1898

For Business—Queens for Strong Colonies - Queens for large surplus. Competition in Quality, but not in price.

If you want queens, nuclei or supplies at bottom prices, send for my illustrated price list. 12-97-tr

J. P. H. BROWN, Augusta, Ga.

Please mention the Review.

We are headquarters for the

Albino Bees,

the best in the world. If you are looking for the bees that gather the most honey, and are the gentlest of all bees to handle, buy the Albino. I can furnish the Italian, but orders stand 50 to 1 in favor of the Albino. I manufacture and furnish supplies generally. Send for circular.

S. VALENTINE,

4-98 2f

Hagerstown, Md.

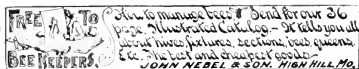

Best on Earth. 19 Years Without a Complaint.



		Dozen	Each
Smoke Engine	(largest smoker made)	4 inch stove	\$13.00— mail, \$1.50
Doctor		3 1/2	9.00— " 1.10
Conqueror		3	6.50— " 1.00
Large		3 1/2	5.00— " .90
Plain		2	4.75— " .70
Little Wonder (wt. 10 oz.)		2	4.50— " .60
Honey Knife			6.00— " .80

For further description, send for circular.

T. F. BINGHAM, Farwell, Michigan.

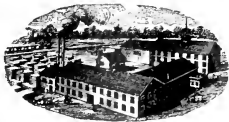

Bee-Supplies

We have the best equipped factory in the West. Capacity, one carload a day. We carry the largest stock and greatest variety of everything needed in the apiary, assuring *Best Goods* at the *Lowest Prices*, and prompt shipment. Illustrated catalogue, 72 pages, free.

We also manufacture tanks of either wood or galvanized steel, all sizes, any form, and for all purposes. Price list free. Address

E. Kretschmer, Red Oak, Ia.

Page & Lyon,

Mfg. Co.

New London, Wis.

Nearness to pine and bass-wood forests, the possession of a saw-mill and factory fully equipped with the best of machinery, and years of experience, all combine to enable this firm to furnish the best goods at lowest prices. Send for circular, and see the prices on a full line of supplies.

TESTED QUEENS,

At \$1.00 each. As usual, I am requeening my apiary this spring with young queens from the South, and, that the tested queens that are removed may move off quickly, I offer them at \$1.00; or six for \$5.00. These queens are fine Italians of last year's rearing, and right in their prime. The Review one year and one of these queens for only \$1.75.

W. Z. Hutchinson,

FLINT, MICHIGAN.

No Fish-Bone

Is apparent in comb honey when the Van Deusen, flat-bottom foundation is used. This style of foundation allows the making of a more uniform article, having a *very thin* base, with the surplus wax in the side-walls, where it can be utilized by the bees. Then the bees, in changing the base of the cells to the natural shape, work over the wax to a certain extent; and the result is a comb that can scarcely be distinguished from that built wholly by the bees. Being so thin, one pound will fill a large number of sections.

All the Trouble of wiring brood frames can be avoided by using the Van Deusen *wired*.

Send for circular; price list, and samples of foundation.

J. VAN DEUSEN,

SPROUT BROOK, N. Y.

Violin for Sale.

I am advertising for the well-known manufacturers of musical instruments, Jno. F. Stratton & Son, of New York, and taking my pay in musical merchandise. I have now on hand a fine violin outfit consisting of violin, bow and case. The violin is a "Stradivarius," Red, French finish, high polish, and real ebony trimmings, price \$14.00. The bow is of the finest snakewood, ebony frog, lined, inlaid (pearl lined dot) pearl lined slide, German silver shield, ebony screw-head, German silver ferules, and pearl dot in the end, price \$2.50. The case is wood with curved top, varnished, full-lined, with pockets, and furnished with brass hooks, and handles and lock, price \$3.50. This makes the entire outfit worth an even \$20.00. It is exactly the same kind of an outfit that my daughter has been using the past year with the best of satisfaction to herself and teachers. Her violin has a more powerful, rich tone than some instruments here that cost several times as much. I wish to sell this outfit, and would accept one-half nice, white extracted honey in payment, the balance cash. It will be sent on a five days' trial, and if not entirely satisfactory can be returned and the purchase money will be refunded.

W. Z. HUTCHINSON, Flint, Mich.

G. M. LONG, Cedar Mines, Iowa, manufacturer of and dealer in Apiarian Supplies. Send for circular. 1-96-5

Please mention the Review

Holy Land QUEENS. Golden Italian

The best that knowledge and ten years' of experience can produce.

Untested Queens.	One	Six	Twelve.
In June, July Aug., Sep.,	.75	\$4.25	\$8.00
All other months.....	1.00	5.00	9.00
Tested Queens.....	1.50	8.00	15.00

Nuclei, in Mar., Apr. and May.	One	Two	Three	Six	Twelve.
One L. frame,	.90	\$1.60	\$2.25	\$4.25	\$8.00
Two " frames,	1.50	2.75	4.00	7.50	14.00
Three "	1.80	3.25	4.50	8.50	16.00

These prices are for nuclei without queens, and a discount of ten per cent. will be given on the NUCLEI if queens at the above prices are ordered sent with them. Bees by the pound at the same price as nuclei. File your order for six or more queens 30 days before you want them shipped, and get ten per cent discount from above prices.

E. R. JONES.

3-98-12t Milano, Texas.

QUEENS Reared from imported mothers, warranted purely mated, 75 cents each. Breeders, \$1 25 each. No better stock to be had at any price. Send for catalogue of queens and bees. DEANES & MIXER; Ronda, N. C.

Make Your Own Mives.

Bee-Keepers
Will save money by using our Foot Power Saw in making their hives, sections and boxes.

Machines on trial. Send for Catalogue.

W. F. & JNO. BARNES CO.,

384 Ruby St.,

Rockford, Ills.

2-96-12

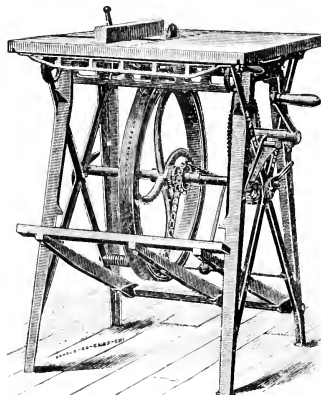

ROOT'S GOODS,

At wholesale and retail. Honey is cheap, and, to be successful, goods must be bought at the lowest possible price. I can help you in this. Try it by sending a list of what you want—you will get prices by return mail. Large Illustrated Catalogue, full of information, free. Beeswax wanted in exchange for goods, or cash, at best prices.

M. H. HUNT,

BELL BRANCH, MICH.

If the REVIEW

Is mentioned when answering an advertisement in its columns a favor is conferred upon both the publisher and the advertiser. It helps the former by raising his journal in the estimation of the advertiser, and it enables the latter to decide as to which advertising mediums are most profitable. If you would help the Review, be sure and say "I saw your advertisement in the Review," when writing to advertisers.

SUCCESS

Is one of the most pleasant experiences with which a man can meet. If this is what you would like to meet, but are a little doubtful as to which road to follow, take the advice of one who has met success, and can tell you all about it. Few men have met with greater success in bee-keeping than has Mr. Jas. Heddon, of Dowagiac, Mich.; and the paths that he has trod are clearly mapped out in a book which he has published, and which is very appropriately called "SUCCESS IN BEE-CULTURE." The price is 50 cents. The foregoing is given as the honest opinion of the editor of the Review.

COMB Foundation.

We can now furnish the very best that can be made from pure wax. Our new process of milling enables us to surpass our previous efforts in the manufacture of foundation. It is always pure and sweet. It does not sag. It is the kind that you want. If you once try it you will have no other. Samples furnished free. Large, illustrated catalogue of bee-keepers' supplies, and a copy of the *American Bee-Keeper* sent upon application.

W. T. Falconer Mfg. Co.,
JAMESTOWN, N. Y.

Dovetailed Hives.
Cowan Extractors.

Danzenbaker Hives.
Porter Bee-Escapes.

No-Drip Shipping Cases.

Gleanings in Bee-Culture.

The Fence and Plain Sections.

OUR SPECIALTIES. Weed New Process Foundation.

Root's



Goods.

Catalog of goods and sample of Gleanings sent for your name on a postal.

The A. I. ROOT CO., Medina, Ohio.

Branch Offices :

118 Michigan St., Chicago, Ills.

1024 Mississippi St., St. Paul, Minn.

1635 W. Genesee St, Syracuse.

10 Vine St., Philadelphia.

Mechanic Falls, Me.



Bee-keepers in the

Northwest

Can save money and freight by getting their supplies from the Minn. Bee-Keepers' Supply Mfg. Co., Nicollet Island Power Building, Minneapolis, Minn. They have all the latest and most improved machinery and manufacture and handle a full line of supplies. Send for catalogue before ordering.

Michigan Headquarters for the G. B. Lewis Company's

SUPPLIES,

Dadant's foundation, and everything needed in the apiary. Send for price-list to **L. C. WOODMAN,**

3-98-6t

Grand Rapids, Mich.

Please mention the Review

Profitable Bee-Keeping,

With Hints to Beginners.

BY C. N. WHITE, OF ENGLAND.

To new subscribers the *American Bee Journal* will be sent the last six months of 1898 (which will contain all of Mr. White's articles) for only 40 cents (stamps or silver) ; and for 10 cents more we will send in addition the 160-page book " Bees and Honey." Sample copy of the *Bee Journal* free.

GEO. W. YORK & CO., 118 Michigan St., Chicago, Ills.

A series of nine illustrated articles to begin in the weekly *American Bee Journal* this month (July). Subjects as follows:

1. General and Introductory.
2. Bees. 3. Handling Bees.
4. Swarming. 5. Hives. 6. Foundation. 7. Supering. 8. Diseases. 9. Wintering.



The Great Willow Herb in Full Bloom.

The Bee-Keepers' Review

A MONTHLY JOURNAL

Devoted to the Interests of Honey Producers.

\$1.00 A YEAR.

W. Z. HUTCHINSON, Editor and Proprietor.

VOL. XI. FLINT, MICHIGAN, JULY 10, 1898. NO 7.

THE GREAT WILLOW HERB.

Its Home, Habits and Honey.

W. Z. HUTCHINSON.

Full many a flower is born to blush unseen,
And waste its sweetness on the desert air.

GRAY



YEARS ago, when I lived at Rogersville, I for several years made annual trips to the home of two ladies living in Northern Michigan, near Farwell, and bought and brought home a portion of their bees. I well remember that among other dainty viands appearing upon their tea table was a comb of the whitest, sweetest honey I had ever tasted. The flavor was not very pronounced, but contained a suggestion of spiciness. Upon inquiry I was told that this honey was from the great willow herb. It is known under various names such as fire-weed, Indian pink, rose bay, etc. Its scientific name is *angustifolium epilobium*. Later, when collecting samples of different kinds of

honey to exhibit at fairs, I sent for a bottle of this honey. When it came and I held it up to the light I could compare it with nothing else that a bottle of spring water, it was so clear. It certainly has no more color than so much water.

This plant grows from two to six feet in height, and as a rule, inclines to a single stalk. The blossoms are a dark pink and arranged in a cluster around the central stalk. In fact they remind me of the phlox of the flower garden. One peculiarity of the bloom is that it continues from July until frost. So long as it is in bloom there seems to be a cluster of buds pushing themselves up from the center of the bloom. As these buds unfold, others take their place, and so the stalk pushes up and up, always tipped with a sprig of buds, below which is a cluster of bloom that in time gives way to seed-pods. Thus we have, on the same stalk, buds, blossoms and seed pods, and, in many instances, the oldest pods have burst and winds are scattering the downy seeds far and near. I think such seeds might be carried in great numbers—well, possibly, hundreds of miles. Perhaps this explains why it springs up, apparently in a spontaneous manner, after the ground has been burned over by fires; whereas the fire simply burns the turf

and furnishes a seed-bed for the wandering seed. It grows most profusely among the stumps, and burned forest districts of Wisconsin, Northern Michigan, and Canada.

Two or three years ago, in the month of June, while on my way to visit my father and brother in an adjoining county (Tuscola) I noticed a few stalks of what I took to be this plant growing by the roadside. I had never seen any of it before, but had read descriptions of it. In August my brother wrote me that the highways and byways, hedges and swamps, old clearings and "slashings" were fairly purple with the bloom of the willow herb, and the hives were filling up with honey to beat all. I packed up my camera and took another trip expressly to get a characteristic view of this plant on its native heath. The result is the frontispiece for this month, which shows the willow herb right in its glory. The splashes of white are seed-pods that have burst and are scattering their contents to the four winds.

As a rule, willow herb yields honey every year. In my knowledge of the matter it has failed once in a dozen years. For two years in succession our Michigan bee-keepers have met at Mt. Pleasant, which is the region of country where the willow herb flourishes at its best; and it really makes us outsiders feel just a bit envious to hear those folks talk about their 100 and 125 pounds of surplus, per colony, each year. There are thousands and thousands and thousands of acres of this plant in Northern Michigan that actually waste their sweetness on the desert air. If I were going into the business of honey production as a specialty, I should go to Northern Michigan where I could have the benefit of wild raspberries, clover, basswood and willow herb. There are locations in that part of the State that are veritable bee-keepers' paradises; and they can be found by patient search.

FLINT, Mich. June 28, 1898.

HOW TO PREVENT SWARMING;

And at the Same Time get the largest Yield of Honey.

J. E. CRANE.



WELL, now! That heading looks like a good one. The only difficulty, so far as I am concerned, is that I do not know just how to do it; *i. e.* with every colony. To be sure, I can re-

move the queen from every colony that I find preparing to swarm, remove queen cells, etc., to the end, but I may not in this way get the largest yield of honey; besides, how about such colonies as swarm without so much as an egg in a queen cell, and evidently without thinking about it more than fifteen minutes. Again, we may shake a colony from its combs and give it an empty hive; but this does not always work as I have had them swarm under exactly these conditions; besides, our vision of finished surplus grows less very rapidly with this treatment. Another way is to produce a non-swarming strain, or breed, that we can depend upon, that will keep right on storing honey to the close of the season without a thought of swarming; but, as it might take from fifty to one hundred years, or perhaps much longer, to produce such a breed, it does not seem altogether practical; especially to us whose locks are turning grey. But this does not prevent us from doing what we can to develop such a strain of bees. If but partially developed, it would help in a degree. That some method is necessary is evident from the short time in which bees can gather surplus honey. In this section of country

about four weeks is a full average. Now, if the brood chamber is filled with honey at the end of the first week, and during the second week a swarm issues, it will be well on to the fourth week before this colony will be strong enough to go into boxes again to much purpose, and this leaves only a few days for filling our clean white sections. Our new swarm will require from one to two weeks to fill its hive; and will be ready to go into the surplus department just in time to start its combs, and then, as the flow is over, coat its sections with propolis.

There are some non-swarming devices; but, as they have not seemed to me practical, I shall not speak of them. But what *is* to be done? Something must be done, or, in most seasons, we shall get little surplus honey, and much increase. We have all observed, or most of us have, that what will break up one "broody" hen will not another. You can frighten one from her nest and she will scarcely return to it again; while with others you can take them off and they *will* "set," on a board or on the floor or even on their roost. You may imprison them for several days and when you liberate them they will go back to "sitting" on sticks or stones with the most provoking stupidity. It is thus with our bees; what will cure the swarming fever in one colony will have but little effect upon others. With one you can cut out the queen cells nearly ready to seal and they will give it up; with another colony it is of no use whatever.

The presence of a large amount of brood in the hive appears to be the most exciting cause of swarming. This leads me to the first method of preventing swarming. I remove every brood comb and replace them with empty combs; or at least those having no brood. While a little honey seems to do no harm, a little brood given them or left in their hive may upset our best intentions; for the colony is apt to start queen cells upon it and then swarm. The brood combs that are removed can be given early in the

season to any weak colonies, and thus quickly bring them into a profitable condition, while the colony that would have swarmed, finding its brood gone, usually gives up swarming at once and goes to work with a will, quickly filling the brood chamber with honey, and a moderate amount of brood, and is again at work in the boxes. This plan works well about nine times in ten; when perhaps the tenth time they will start brood and queen cells at once and out they swarm. This tenth time is apt to be where a swarm or part of one has gone into our colony before we operated on them. Strong colonies only should be treated in this way, as having no hatching brood in their hive they soon become weakened.

Another class of colonies, such as have a very moderate amount of brood, or an old queen, or one we wish to supersede, we open their hive and remove the queen, if we can find her, and cut out the queen cells. Eight days later we again cut out queen cells; and in from four to eight days more give them a young virgin queen. If she is young enough, she is usually accepted and soon laying, and as the brood from the old queen keeps hatching until near the close of the season, it remains strong and does quite fair business. If we fail to find the queen we cut out all queen cells every eight days to the end of the season, and the queen usually disappears before that time, so we can give them a virgin queen.

But there are many colonies that have young vigorous queens of the previous season that we do not wish to destroy, and we have not a sufficient number of dry combs to give them. These we treat in another way. Finding the queen, we remove her with a brood comb, one from which the young bees are just hatching, if possible, and place the comb with another having considerable honey and one having a little honey and no brood, in a new hive, and after shaking off bees enough from the combs of the hive from which the queen was removed to make a good nucleus, when the old

bees have returned to the parent hive, we close it up, after making sure the comb of brood we gave it has no queen cells. We remove all queen cells from the hive from which we removed the queen, that are likely to hatch within eight days. Of course we return the partly filled sections, and in eight or nine days we again cut out all queen cells, and later give a virgin queen, the same as we did to the colonies whose queens we destroyed. This plan keeps us very well supplied with young queens.

In eight days we again go over our hives, giving the strongest ones, preparing to swarm, a full set of dry combs in place of their brood combs, and give these brood combs to the nuclei formed the previous week, thus quickly building them up into profitable stocks that will sometimes give as much surplus as the colony from which they were started. Italian bees are at their best when placed in small nuclei; they give up all thoughts of swarming, and seem to store two or three times as fast in proportion to their numbers as when in full colonies.

I am apt to find some queenless colonies near the close of the season. My young queens are frequently several days old before I get around to introduce them, as I have several yards to look after. Then there are some that get mixed and a part of the bees appear to want an old queen and a part a young virgin and so like some families that pull in different directions, neither get what they want. These I give two or three brood combs and they usually come out all right. Some apiarists return old queens to hives that have been unqueened, but I have never succeeded in returning them satisfactorily.

In removing queen cells I select the best and place in nurseries to hatch and thus keep myself well supplied with virgin queens of good quality.

While the plan above outlined does not wholly prevent swarming, it does prevent very much increase; enough to use all my old combs and keep my stock

good; and while I do not get nearly as much honey as I believe I should if the bees would give up the foolish habit of swarming, I have reason to believe that I get more than I should by any other system with the same expense. Of course, it will be understood that I am working wholly for comb honey. Where a yard of bees is run for extracted honey a modification of this view should be used.

MIDDLEBURY, Vt. June, 20, 1898.



REPLIES TO MR. TAYLOR'S CRITICISMS.

Some Fine Points Regarding the Depth of Cells in Partly Drawn Combs.

DR. C. C. MILLER.



IN Gleanings, 343, I say, "Mr. Taylor mentions an objection that has also been given by others: The bees are slower to fill and cap unfinished sections." He is correct, Review, 184, in saying that Miller

misquotes him, as he only mentioned the capping. I had in mind the whole job of filling and capping, in which form the objection has been frequently made. I am sorry I did not discriminate more closely.

On the same topic he quotes my saying that I've had hundreds of cases in which the one unfinished section in the super was filled and sealed, and the remaining sections with foundation were left untouched, and he then says he trusts my logical faculty will not allow me to claim there is any argument in that. As I do not desire immediate annihilation, I hasten to say that I do not disagree in the least with that view; certainly not, my logical faculty allows nothing of the kind. But I'll merely suggest, in a ten-

tative manner, that my *lack* of logical faculty allows me still to think there's something of argument in it. But why didn't he continue his quotation just a sentence further? In that I say, "Again, in years of plenty I have always found the bait sections filled and sealed first." Will Bro. Taylor's logical faculty allow him to see any argument in that?

I do not see that Mr. Taylor's story about exercising 24 hours parallels the deep cell business. I might just as well say that the folly of advising 24 hour's exercise proves that \$2. in Bro. Taylor's pocket is better than \$22. Let me give the point under discussion. Editor Ernest held persistently that unfinished combs must be cut down to a certain depth (he has had the good sense finally to give up the notion) no matter what the character of the comb. In other words that a depth of $\frac{1}{4}$ or $\frac{3}{8}$ was better than more, as well as better than less. Now if Mr. Taylor holds that view, will he tell us why he thinks $\frac{3}{8}$ better than $\frac{1}{4}$ and at the same time better than $\frac{1}{8}$?

MARENGO, Ills., June 14, 1898.



NOTES FROM FOREIGN BEE JOURNALS.

F. L. THOMPSON.

As cold waters to a thirsty soul, so is good news from a far country. *BIBLE*

LE REVUE INTERNATIONALE.—The best method of causing the bees to go up quickly into the extracting supers, says Ulrich Gubler, is to not have them clean out the combs after extracting, but preserve these as they are, in a dry place secure from robbers and moths.

L. Matter-Perrin stops robbing by feeding the colony which is doing the robbing.

To preserve pollen combs from mold, says an Austrian paper, dust them with powdered sugar before setting them away. When returned to the bees they are to be sprinkled with water.

Chas. Dadant thinks most colonies that are lost in winter die because of poor food. His remedy is to have as much of the winter stores as possible consist of early honey.

"At one time I stopped up all cracks, including the least; cushions, paper, paste-board, old clothes, etc., were all laid under contribution; the entrances were contracted as much as the authors of the period advised. Result: very irregular wintering, damp combs, damaged stores, dysentery, queenless colonies, and I don't know what all. This was repeated every year. Gradually I made experiments, more and more conclusive, and for more than ten years I have no more winter losses, after deducting some losses due to causes having no connection with my method. I have hives with big frames and with little frames, some parallel and some at right angles to the entrance; it makes little difference. I promise you I shall see them all in good health in March. Some years I winter on sugar syrup, others on dark honey; I have no more dysentery or losses." — E. Ruffy. The foregoing is from a discussion on wintering, and Mr. Ruffy refers to his plan of leaving the entrances wide open in winter. He also says it is necessary to begin wintering preparations early, the best time being the end of July or the first of August. Colonies deficient in stores at this time are fed, so that by the 15th of August all are ready. By thus doing, the bees that have no value for winter do the work of ripening and storing, and the extra brood called into being by the stimulation emerges at the end of August. These young bees will not become aged before that time arrives, as is the case with bees in colonies fed in September or October. Speaking of sealed covers, he is of the opinion that the primary use of propolis is to defend against enemies, not to keep out ventilation. Another correspondent calls attention to the fact that bees in hot countries, such as the Tunisian or Punic bees, are lavish of propolis.

Chas. Dadant having warned against the dangers of setting bees out of the cellar without taking the precautions of doing the work a little at a time, and setting each colony on its old stand, Dr. Miller mixes in (in French), to the effect that impure air in the cellar is the only reason for the swarming out and confusion and loss sometimes experienced when bees are set out. He has wintered his bees in a cellar 37 years, not taking the precautions mentioned in returning them to the yard, without any such disasters. But on the evening before the day on which the bees are set out, the doors and windows of his cellar are opened wide remaining so all night. Mr. Dadant had also said that when the temperature of the cellar goes beyond 46°, the bees are in continual motion, quitting the hives in great numbers and perishing in going to the least ray of light admitted by the ventilator. Dr. Miller has not had that experience with higher temperatures, and accounts for the fact by the purity of the air in his cellar.

Some put a sheet of paper on the bottom-board in the fall, in order to facilitate cleaning in spring. Ulrich Gubler says the number of dead bees on this paper is always less in hives wintered in the open air than in hives arranged pigeon-hole style in a closed pavilion.

The same writer reports that most of his hives which were turned to the south had brood in all stages at the beginning of January, and in February he found as many as 60 eggs per hive on the sheets of paper he put on his bottom-boards. He considers this precocity prejudicial to the proper development of the colony in May and June. Several other writers in this paper favor a northern position for the entrance.

M. Gubler also advises all who can put their hives under shelter not to paint them. His experience for a number of years has been that colonies in hives not painted winter much better.

Another cure of a bad case of foul brood with powdered camphor is reported; also one with formic acid.

It has been found that the sunflower (*Helianthus annuus*) is injurious to bees, says Adam Sonsiedsky, but he does not say why.

Pastor Michael, who regularly practices migratory bee-keeping with his 200 colonies in the mountains of Switzerland, has found that in most localities more than 25 or 30 colonies will not do well; although in our locality, a buckwheat region, 150 to 200 colonies at once get enough for their living. An average yield in an average season he puts at 18 lbs. per colony.

It was a pet theory of mine, based on some facts, that swarms took a year or two to develop to their ultimate strength. For some conclusions based on this, Mr. C. Davenport, of Southern Minnesota, took me rather sharply to task. I was gratified, therefore, to see the statement made by Abbe' Boyer: "M. de Layens has written that the movable-comb hive does not enter upon its full strength until the third year." It is a little provoking to have to add that Chas. Dadant says "We have never noticed the slightest difference, in the following spring, between swarms of the preceding year and old colonies, if the queens are equally prolific," and Editor Bertrand says "In spring the population of swarms hived the preceding year is equal to other colonies, and the yield of these swarms depends only on the prolificness of their queens during the first part of the season. We have observed this a hundred times." Possibly the reason for the discrepancy of opinions lies in the new combs which some swarms build, and the old combs in whole or in part given to others, since good authorities notice a difference in the wintering and springing qualities of new and old combs.

Editor Bertrand says the excessive swarming propensity of the Carniolans disappears in a few generations if they are put in hives larger than the little flat boxes in use in their native country.

"In adopting the Dadant-Blatt hive [a large hive] I hoped to be no longer com-

pelled to feed; but my queens become more and more prolific. The amount of pollen gathered (which, I do not complain of) is considerable; enough room for honey is not left, and I am often embarrassed to complete the stores. A little more attention is required, but the result is worth the labor. I thus gain large yields."—E. Pinard.

It is often said that bees need salt. Od. de Pratire says in the *Rucher Belge* that his apiary is but to minutes' walk from the sea, and has salt, brackish and sweet water all accessible, but his bees generally go for the sweet water. One year his bees had access to two trenches of manure and one of chaff and waste straw. They assiduously frequented the trench of straw, but few or none were seen in the manure trench. This, he thinks, indicates that they are not seeking salty matters when seen on manure heaps, but water containing compositions of azote resulting from the decomposition of vegetables.

Propolis taken from a barricade erected by the bees at the entrance was found by Dr. Planto to contain only 22 per cent. of pure propolis, the rest being nearly all wax.

MONTROSE, COLO., June 5, 1898.



CONTRACTION OF THE BROOD-NEST.

It is Done at the Time of Putting on the Sections, and When Hiving Swarms, and in Michigan, too.

WM. CRAIG.

BEING in the last Review that you would like to hear whether bee-keepers practiced contraction of the brood-nest here in Michigan, I will tell you how I manage my bees.

I use two kinds of hives, the Heddon, and a hive I make myself out of dry goods boxes from my store. These hives

are of the Langstroth size, except that they are only seven inches deep.

Here is my plan that I have practiced for the last three years; and I find that it works well. Early in the spring, as soon as a colony begins to show signs of getting strong, I raise up the hive and set one of these shallow hives under it; and as soon as I see that the bees are getting this last hive pretty well filled, I raise the hive up as before and put another one of these shallow hives under; and so on until the honey flow comes; then I take away all of the hives except two. These two hives will contain sixteen frames of *solid brood*. I put the sections on at once and the bees are all ready for business.

If one of these colonies should swarm, I hive the swarm in two of these shallow hives filled with foundation, setting it on the old stand. The second day after they swarm, as a rule, I go to the hive and raise the top hive and set it on a bench. Then I pick up the bottom hive and set it to one side. Then I set the top hive back on the stand, and pick up the other hive which is full of bees and shake them out in front of the hive, and they all go into the one hive. I always make this change just at night. I neglected to say that I always transfer the sections to the new swarm when hiving it; and I also shake out quite a lot of the bees from the old hive at the time of swarming. This saves the time of going through with the Heddon method of preventing after-swarms; and I have never had a second swarm issue when the old colony was treated in this way.

Now, friend Hutchinson, I have written this in an awful hurry, as I am quite busy just now building a cellar, working an acre of land in garden truck, taking care of 125 swarms of bees, and running a store that does a business of five or six thousand dollars a year; so you will excuse all mistakes and poor writing.

LIFE, Mich., July 9, 1898.

[My editorial on contraction of the brood-nest was all in type, and I was

nearly ready to make up the last form, when the foregoing article came to hand. The plan used by Mr. Craig is somewhat similar to the one now being advocated by the editor of *Gleanings* and Dr. Miller; that of using two sets of Langstroth combs before the beginning of the harvest, and then removing the upper set and putting sections in their place. None of these men tell us what is to be done with the upper set of combs that are removed. At least, I do not remember seeing any such instructions. Of course, this plan brings the sections right close down to the sealed brood, which is an advantage, but this same condition can be secured with the Heddon Hive by simply transposing the two sections of the hive; and the honey that may be stored along under the top-bars of the upper section will be removed and brood put in its place when thus transferred to the center of the hive.—Ed.]



ENTHUSIASM.

A Graphic Letter From a Beginner.

[Among the many interesting letters that I received last winter was one from a lady living in Johnstown, Pa. I asked her permission to publish it and she declined; but, knowing that a woman's no sometimes means yes, I repeated my solicitations with greater earnestness, and she finally consented. Since then it has seemed as so there were so many things that must go in, that, until now, there has been no room for it. Of course, it does not pretend to give any great information regarding bee-keeping, but, as a picture of that first stage through which we have all passed, it is seldom excelled.—Ed.]

JOHNSTOWN, Pa., Dec. 31, 1897.

Mr. W. Z. Hutchinson,

Flint, Mich.

Dear Sir:—The Review in its new dress was welcomed to-day, and had so much of interest that, when my husband brought it, at dinner time, my dinner was cold when at last I sat down to the table. I know it is not meant especially for beginners, but, nevertheless, I can understand all of it and will be able to look

back next year to those numbers that had articles that may prove practical in my environment.

I suppose many will take advantage of your offer to put them in print. I confess to a weakness for it myself, or rather for my bees, when I accomplish something to be proud of.

This time last year I had never seen a hive; thought they were all like those pictures of straw "skeps;" but became interested while studying up a little in entomology, as my little ones, girls three and two years old, ask so many questions about bugs, beetles, ants, etc., and I always try to answer, if I know what they are enquiring of me. If not, then I look it up, and we all learn something new.

The bees seemed so interesting that I looked for an advertisement I had seen somewhere, and found it at last in an old Ladies' Home Journal. It was of Root's catalogue and *Gleanings*. I sent for them, and in *Gleanings* found your "ad." I believe, or else it was in some paper that I sent for that I found advertised in *Gleanings*, for I sent for copies of all. I decided on taking the American Bee Journal, because it came every week, and thus my enthusiasm would have a weekly stimulus, in case, as often happens, interest in my hobby would show signs of abating.

I got Cook's, Langstroth's, Root's and Heddon's works on bee culture, your *Advanced Bee Culture*, Doolittle's *Scientific Queen Rearing*, and many little pamphlets—anything and everything I could afford. I presume that was stage "one" of the bee fever.

Then I sent for some of Mr. Bell's hives from you, an eight dollar order, including your periodical. One of Doolittle's queens and a colony of bees cost another eight dollars, and the express to Johnstown was \$1.90. Some foundation from Van Deusen, a can of honey from Heddon and some supplies from Root, besides a colony of common bees, the first hive I ever saw, ran my expense column up to over fifty dollars.

I sold some of the honey, however, took a twenty-dollar and four-dollar prize at our State Fair, and raised a dozen queens, five of which I sold. I could have sold more, but August 17th little No. 3 arrived, our first boy, and put an end to my experiments with bees until next season.

I fear now that they are not strong enough to winter over, for, of course, I divided them to have more, and will probably in the spring have less bees, but more experience. I put a nucleus in one section of the Heddon hive in one of the green houses, so that I could look at it once in a while. Of course, I feed it, and having no neighbors to attempt robbing they are very docile.

My husband raises lettuce, etc., in winter, and thought he would try some tomatoes if the bees would fertilize the blossoms, but it was not successful. The queen started laying and they had very little pollen, but they paid no attention to the tomatoes, getting moisture from the leaves of the lettuce plants. I believe I will get no more Heddon hives, although I think they are the best for one who is not a beginner. *You* could tell at a glance, while *I* must examine carefully for any information concerning the interior of the hive.

I got two sections of honey but I was not disappointed, as I handled them so much—"wanted to know, know." Will send my renewal when it is due.

Yours as ever, MRS. ANDREW AKERS.

A Condensed View of Current Bee Writings.

E. E. HASTY.

Sometimes when we get hot in a scrimmage it is a good plan to give ourselves and the cause a respite to cool off, before trying to close it up. Of course I notice with heed Mr. Doolittle's articles on the honey-facing question. Presumably I shall want to say something in rejoinder,

but not now—and whether in a private letter or a public article I have not decided yet. (This is a month old now, but still undecided.)

And Rambler back again at ramble 147—just as if there had been no intermission of rambling! Three cheers! Rambling was friend Martin's strongest hold, and we are willing to see 'him "wrestle" that way indefinitely. Gleanings, 473.

T. R. Woodward of Quebec, and the editor of the American Bee Journal (Page 415) are exploiting the plan of retailing extracting honey *in paper bags*. Bags can be had, it seems, that will hold liquid honey nicely in the store room of the apiary; and when the honey is candied solid, it can be sent to market thus. Quite likely there's something in it (granting that the honey continues in it, that is) but the demand for candied honey will have to improve some before much will go that way. The most advanced bag honey enthusiast will hardly claim that the ordinary customer can liquefy the honey in the bags.

Comrade Taylor (Review, 150) doubts at what temperature propolis melts. Propolis does not melt at all, strictly speaking, will take fire and burn up first; but under continued high temperature in the sun extractor it will, some of it, spin out in threads and work its way through the meshes of cheese cloth. Never gets fluid enough to stir into melted wax. Yet probably wax and propolis at 90° could be rubbed together mechanically. That is the way the bees themselves are continually doing. They seldom use propolis pure. When it looks to be pure you just apply heat and be astonished to see how much nice wax will melt out of it.

THE SOUTHLAND QUEEN.

The Queen continues a well-appearing magazine although the queen herself has been retired for a season by protracted illness. It is much to be hoped that Mrs. Atchley may be fully restored to her health and to her place in the editorial

labors. One old fashioned but not unpleasant wrinkle about the Queen is its way of interleaving pages of engraving paper with portraits on them. The May number thus presents E. J. Atchley, the queen's "other half," and W. H. Pridgen.

As to the correspondents of the last Queen, H. H. Hyde thinks that two inches slope to the front is altogether too much for a hive.

L. B. Smith says they had a blizzard this year when bees should be swarming, and the result will be the death of a great many colonies in Texas—especially among box hive keepers. It seems the Texas variety of that species of Solomon holds that what honey a colony has left on the arrival of spring should be taken away, *else the bees will carry it out of the hive and throw it away.* (5, May.)

E. R. Jones thinks he has a cure for paralysis, sulpho-calcine—half an ounce in a quart of well salted honey and water—hive, bees and combs well sprayed with an atomizer. He thinks that the real point of advantage in the plain section is that there is more entrance way at the bottom—and entrance extending practically clear across the hive. Obviously the same thing could easily be had with very little change of the old style arrangements, if it is true that better filling of the section results. He also contributes a valuable observation. When a sheet of foundation is drawn *only on one side* he finds that the cell bottoms are hemispherical, and when looked at from the reverse or unworked side they look like the cappings of drone brood. So it would seem that the usual cell bottom (so greatly celebrated by mathematical folks) is simply the compromise or resultant of two opposite sets of punchings and scrapings, not the deliberate work of the bee either intentional or unintentional. This, if correct, will lead to quite a breaking of the old crockery (4, May.) Now my attention is called to it, it half seems to me as if I had seen just such round-bottomed work myself.

L. L. Skaggs (5, May) contributes a new bee tent. Two wagon bows are

lengthened with strips of wood till you can stand up under them; and each extremity is shod with a sharp iron to punch into the ground. Bind the completed bows with cloth, to make sure that the tent proper will slip on and off without catching on a splinter. Now set the two bows so they will cross and form an X over your head. Fasten them thus by about three loops of strong wire—all on the upper half of the concern. Make a fourth hoop, of six inches larger diameter than the frame, and hang it in place with long strings. This keeps the shape of the fabric at the bottom; and by its lifting up properly lets you out and in. The cover, or tent, proper, is mosquito-bar. Cheap calico part way up would be an improvement I think. But say, both my tents went to ruin years ago, and I get along nicely without any.

C. B. Bankston and A. W. Cotton robbed one of those newspaper bee caves which contain honey by the wagon load, and "pizen death" sufficient to kill an army. Got a very slender show of honey—scarce what a colony might use between spring and harvest. Of old dry comb there was indeed a big lot. Nobody got even a single sting. (7, May)

W. H. Pridgen says when he finds out the bees of a certain colony are following him about he screens them in (12, May.)

J. H. Siple says he gets ten cents a gallon for extracting. (13, May) I believe we do not often see the value of that sort of work stated in that way. Made \$14.00 one day, besides walking twelve miles.

On page 14 and onward the Texas state association is reported. Perhaps the best thing I glean is to fish for honey customers in different ways according to your chap. If he's well-to-do, only never got in the habit of buying honey, just politely make him the present of a section. If he's one of the scratch around folks, offer to trade him some honey for some vegetables. (W. H. White.)

The Editorial Notes of the Queen are very like those of other journals. Also, in line with editorial practice elsewhere

there is a series of clippings from business letters.

The portrait of Mr. Atchley is accompanied by a biography written by a clergyman relative, and also a short sketch by a lady friend. Mr. A. is evidently a person of considerable individuality. His biographer lumps off in batches the names of the countries in which he has resided. Exceedingly fond of and skillful with the rifle, as people of roving turn usually are. Doubly drawn to bee-keeping by the pleasure of capturing wild ones. Five years a school teacher in his early days. Thought himself old enough to be married at 19. Long subject to sudden attacks of illness, insomuch that his intimate friend got the name of his "traveling drug store." Much better now—both of his attacks and his rolling-stone proclivities, and putting in from ten to sixteen hours a day of office work. Best of all a gentle, tender hearted man, and a Christian—not a Christian drone, but a Christian worker. (Strange that in Christian lives there should be twenty drones to one worker, when in nature's hives it's the other way.)

One of the characteristic features of the Queen is the "School" in which those who choose ask questions, and Mrs. Atchley answers—thus rather reversing the usage of the ordinary school.

Willie Atchley ventures to set the fertile workers term of life at two months. (259, March.) Presumably there is little or no positive evidence on this point, and therefore the best judgement of intelligent manipulators is of value.

As an example of a good strong divergent view of things esteemed settled, G. F. Davidson says he don't want all his bees to start even in the spring—would get too many swarms in one day. (262, March)

A very non-professional newspaper account of bee-hunting in Australia is quoted to make fun of (235, Feb.) but, would you believe it? it sets me to wondering whether a new method is not referred to. Is it possible to encumber a

bee with a lock of cotton, not big enough to prevent flight entirely, and yet big enough to compel stops to rest every few rods? The object of this would be to enable the hunter to keep up, and follow one single bee right on continuously to his home.

THE GENERAL ROUND-UP.

I'm so fond of theorizing in fresh territory that I think I must try on the somewhat striking experience of Ernest Root given in *Gleanings*, 378. Cane sugar, maple sugar and candy directly bring on something comparable to a sneezing catarrh. Honey does not do this, unless an excessive amount is taken; but in that case the result is the same. I have often noticed something similar with myself, only usually without the sneezing—nose suddenly beginning to run when I was quite unaware of its being in a weeping mood. I *think* this sometimes occurs with me when no sweet of any kind is involved; the only essential being to eat something good with unusual gusto. In such a case the energetic movements of muscles and cheeks continue quite a spell. Vigorous activity is catching between one organ and a related or adjoining one. When we eat something good the salivary glands spring into activity. The glands of the stomach follow suit—and telegraph back again to keep up the salivary business. Some of the organs involved put into their movements an amount of "bounce" and "play ball" not absolutely necessary. A wave of healthy life and activity is thus generated which soon rolls on to the next organs, which happen to be the nasal passages. Now the nasal passages of invalids are often in a torpid condition—yet not bad enough to give pain, or attract any attention. Their first response to a wave of health and life is to *clear themselves*—the results being as given above. Now why should maple sugar do this, and honey not? For two reasons. First, he likes maple sugar better; therefore there is more of the *superfluous* action of nerve and muscle

while eating it, and a *communicable* wave of activity gets started. But when the honey is unusually good, or his relish for it unusually keen—the only time when he eats too much—then the manifestations are identical. Second, honey needs very little digestion, almost none, and therefore the stomach does not telegraph back its activity. And the moral? Well that seems to be, eat the maple sugar and let her sneeze.

Doolittle gives a pretty case of the queen's ability to adapt herself to circumstances, in that she often when beginning an additional comb in spring, begins on the further side of it. The near side is too much encumbered with pollen, which same the bees will clear out when she goes over beyond. *Gleanings*, 174.

W. B. Ranson (*Gleanings*, 180) thinks it's more than worth the trouble to have hives level both ways, and get the bottom sloped $\frac{3}{4}$ inch by means of wedge shaped strips. Correct comb building in both frames and sections is what he is after.

It is suggested, *Gleanings*, 216, and I think I have noticed it elsewhere, that corn yields so much pollen that it *may* prove worth while to gather it artificially and keep a supply for use in time of need. In case some one can invent a cheap machine that will go over an acre in a moderate number of hours, I shouldn't wonder if it would pay in some cases. At present the most rapid device seems to be an umbrella, held bottom side up, and a stick two or three feet long whereby the tassels are gently bent over the umbrella, and then deftly jarred a little. And I just can't tell at this writing who is the inventor of this pollen machine. Ah! it was one of the sweet clover folks, and clover seed not pollen was the original idea.

Mr. Leyvraz finds the bee-killing dragon-fly so plenty in Florida that he has killed as many as 440 in a day. *Gleanings*, 221.

Gleanings, 224, shows a cleated bottom board with dissected cleats. Five pieces (comprising all the wall except mere studs to support the hive) pull out at

pleasure to give ventilation. Looks like a good thing—but not unless every piece be made exactly alike so as to be interchangeable.

"As a man thinketh so is he." C. P. Dadant says the worst feeder is the outside feeder to feed your neighbor's bees—the next worst the entrance feeder. He also remarks that he has lost more bees by starvation in June, just before a big harvest, than in winter, or any other time of year. A. A. J., 162. Such an immense lot of young brood as some colonies will have in June quickly brings famine if the outside supply of food stops.

Again on page 194 he makes the important statement that beeswax can be so changed in its *condition* (a sort-of inter-cellular change instead of a chemical one) that it will hold some 25 percent of water, and yet appear to be simply beeswax of poor quality. I have often had good beeswax "bewitched" so that it persisted in remaining in a powdered or granular form, and refused to cool in a solid cake. This occurs usually (if not always) when you try to render wax with a good deal of honey in it, and lazily omit to soak the honey out first.

Mrs. Effie Brown, A. B. J., 210, seems to have solved a problem which has "stumped" me hitherto. In apiary work one often gets badly stuck up—how to remedy this without too much loss of time? I have set a dish of water where I hoped it might be useful—but when the crisis came it was too far off or I had forgotten where I put it. Also bought some canteens to facilitate carrying water about. Nothing came of it—from half-heartedness in the trial perhaps. Well, she wears an oil cloth apron, in the big pocket of which there is always a nice clean wet cloth. This gives the means of putting sticky fingers in order at once—all except that villainous stuff, propolis. Might we have another pocket, and another cloth, wet with the best available solvent of propolis? Or is that solvent awaiting discovery?

RICHARDS, Ohio, July 1, 1898.



EDITORIAL Offerings.

THE AMERICAN BEE JOURNAL has commenced a series of articles by an English bee-keeper, Mr. C. N. White. See particulars in the advertising columns.

A FOUL-BROOD LEAFLET, on the same lines as the honey leaflet, is being gotten out by the Roots. It will be sent out free of charge, or, at least, at only a nominal price.

MY BROTHER ELMER consented to "dress up," shoulder an axe, put on the proper expression, and pose as a "settler," in a new country, when I took the photograph of the willow herb that appears as a frontispiece this month.

HEDDON'S few lines in the last Review express my feelings and position. My business in the city has lost its charms. The little army out in the shade of the orchard produces greater harmony than all else—so writes J. F. Miller of Ontario, Canada.

THE HONEY-FLOW has been good in this locality—the best that it has been in years—but I see by a report in Gleanings, written by the editor, and by private reports that come to this office, that, generally, throughout the country, the yield from clover has been light.

COMB FOUNDATION, made by Aug. Weiss, of Wisconsin, for use in the sections, is, I think, the finest I have ever seen. My neighbors who have used it think the same. The wax is purified

most completely, the foundation very thin, and it has about it a soft, tender look that is difficult to describe. Mr. Weiss says that he has a peculiar method of sheeting which is his "trade secret," and I can well believe him.

THE AMERICAN BEE-KEEPER has a frontispiece this month; but it isn't of honey posies such as the Review has been giving; it is a collection of portraits of the officers of the United States Bee-Keepers' Union; each portrait having a hexagonal frame around it and the whole embellished with a tasty background and border. Send for a copy and see it for yourself—it will be so much more satisfactory than anything I can say about it. This issue also has an article from manager Secor upon "The Power of Association."

OMAHA TO BE THE PLACE OF MEETING.

Omaha is to be the place for holding the next meeting of the United States Bee-Keepers' Union. Here is the notice that I have received from the Secretary, Dr. A. B. Mason.

EDITOR OF REVIEW:—Please say in the next issue of your journal that after thoroughly considering the matter of the place for holding the next convention of the United States Bee-Keepers' Union, the executive committee has decided in favor of Omaha, Nebr., as the place, and probably early in October as the time, but the exact date will doubtless be fixed by Bro. Whitcomb, who has in charge the securing of reduced railroad and hotel rates, etc.

A short time since he sent me some particulars regarding rates from which I take the following: "Every day during the Expositon, tickets will be on sale from all Western Passenger Association territory to Omaha at one and one-third fare for the round trip, except their rates from the following points, which will be as follows: Chicago, \$20; Peoria, \$17; St. Louis, \$17; Denver, \$25. Tickets will be limited to return 30 days from date of sale, not to exceed November 15. From June 1 to October 15 the passenger rates

to Omaha from all the principal cities and towns in the United States beyond the the Western Passenger Association territory will be 80 per cent of double the first class fare. Tickets good to return until November 15. I am, however, expecting (?) lower rates, for Bro. Whitcomb told the convention at Buffalo last summer that if the Union would hold its next convention at Omaha during the time of the holding of the Trans-Mississippi Exposition we should have "as low rates as any place on earth."

We know that Bro. Whitcomb will do his level best for those who attend the convention, and show us "the sights" on the Exposition grounds.

Further notice of rates, time of meeting, etc., will be given when known.

A. B. MASON, Sec'y.

Sta. B., Toledo, O., June 30, 1898.

It is not likely that we will receive quite so low rates to Omaha as we would have received to Cincinnati, but there is the added attraction of the big Exposition that will probably stand next to the World's Fair in grandeur. The apiarian exhibit will probably be ahead of anything the world has yet seen in that line. Then there will be a meeting of the pure food congress at which it is very desirable that our delegates and other bee-keepers be present. It is likely that the dates can be so arranged that we will meet at nearly the same time as the pure food congress, and thus be able to attend its sessions. And last, but by no means to be overlooked, is the fact that those western people will take care of us in "great shape."

ABBREVIATING THE NAMES OF JOURNALS.

In a recent issue of his journal, editor York objects to the use of A. B. J. as an abbreviation for American Bee Journal. I believe he has before now made the same objection. Out of deference to his feelings I always write it American Bee Journal in my editorials, but I always do it with a feeling that I wish that he didn't feel that way about it. He says that he is the highest authority as to what his journal shall be called; and I

suppose that is true, but the next thing is to get people to call it by its whole name. I might request all my friends to call me William Zenas Hutchinson, but I doubt if they would do it. I am almost universally called "W. Z."; not only by my bee-keeping friends, but by my neighbors, and all those with whom I come in contact in a social way. And, say, "Geo.," I don't feel bad about it. I look upon it as a mark of goodfellowship, or comradeship, or friendship. It's only to the fellow to whom you feel "chummy" that you ever give a nickname, or cut his name down to an abbreviation. American Bee Journal is a long name, Its almost as bad as William Zenas Hutchinson. Its editor may request us to spell it all out every time we write it, and we may do it because we like him and wish to please him, but when we get to talking one with another, it will slip out "A. B. J." in spite of all we can do. Whenever I go I always hear it referred to as "A. B. J." All orders and correspondence that come to me in reference to the American Bee Journal, call it the "A. B. J." Bro. York, himself, in his letters to me, always uses this abbreviation. If we could simply contract it to the one word "Journal," as we can "Bee-Keepers' Review" to simply "Review," or "Gleanings in Bee Culture," to "Gleanings," it wouldn't be so bad; but to have to write it all out each time—well it shows that we have some regard for the feelings of its editor, and that is all it does show—in the Review. Of course, if I were writing an article for some paper outside of our special class organs, I should most assuredly refer to it as the American Bee Journal, and do it with pride, too, but right in our own family, where every one will know exactly which journal is meant, it seems as though we might be indulged that much. Bro. York, won't you reconsider, and allow us, right here at home, when there isn't company, to use that short, chummy abbreviation that has slipped off our tongues and the points of our pens so many times—A. B. J.?

SIDE-ISSUES IN CLASS-JOURNALS.

One of my little girls (they seem like little girls to me, although they will soon be twenty years old) could not bear to see her father, her ideal man, held up to the world as sedate and dignified (see Extracted Department), when she well knows that the reverse is true; but, bless her innocent heart, she does not know that, concealed beneath the surface of that "take off," is a sly clip at me for having condemned funny things in bee journals. (The twins are away to-day, having an outing at Long Lake, so I can put into type whatever I like, and Nora will not be likely to know it.) It is true that I have condemned side-issues in bee journals. I have thought, and still think, that the closer the bee journals stick to bees, the better it is. These matters of religion, gardening, health, home-interests, humor, wit, etc., are all legitimate subjects for discussion; but there are journals devoted to these subjects, just as we have journals devoted to bees, and they are far superior to the little items upon these subjects that can be put in the bee journals, as the bee journals are superior to the apiarian departments of agricultural journals. At the same time the great mass of bee-keepers are not able to, or, at least, do not, take papers devoted to all of these special subjects; and the occasional introduction of some outside topic is a pleasing break in the monotony of page after page of beeism. As the years go by I am coming to have more charity, or consideration, or respect for the views of others. The editor of the Ladies' Home Journal says that "The most uncomfortable people in the world are those who assert their judgments in a hard, decisive and final manner, as if they were the courts of last resort." As an illustration of taking a broad view of things, he says that one of a party made the assertion that "Corn isn't fit for human beings to eat;" and then turned to another for corroboration of the statement. "Well," said the woman appealed

to, "I should hardly say that. Corn may be good, but I do not relish it."

Here is another point. I believe that all successful editors soon learn that to simply make a paper that *suits them* will not answer. They must, to a large extent, lay aside their own tastes, and study those of their subscribers. By this I do not mean that they must sink their own individuality; far from it, the successful editor leaves the indelible stamp of his individuality upon his journal; but, at the same time, he gives due regard to the tastes and wishes of others. I know it is quite natural to think that the majority believes as you do. This isn't always true. For instance, I like to have all my periodicals stopped promptly at the expiration of the time paid for. I supposed that this course pleased everybody; and for several years conducted the Review on that plan. Finally I learned that the reverse was true; that a very large majority prefers to have a paper continued and be allowed to renew when it is most convenient. I suppose that my being so cock sure that I was right in the matter cost me at least several hundreds of dollars. But I fear I am wandering a little from my text, so I will conclude with a statement of my present views of side-issues in class-journals. A little touch of them occasionally, like pepper in our food, may be all right, but the less the better.



CONTRACTION OF THE BROOD NEST.

"Open confession is good for the soul." There is a saying something like this. Perhaps I have not given it exactly as it is, but the meaning is that when you see that you are wrong, the best thing that you can do is to "own up." So, I am going to admit that bee-keepers *have* practiced contraction of the brood nest at the beginning of the harvest. The editor of Gleanings shows most conclusively, by references to articles right in the Review, that such things have been done. In writing on this subject last

month in the Review I was depending entirely upon my memory, and this instance is only another illustration of many that have come to me in the past two or three years, showing that that once almost infallible memory of mine is not what it was once. It is true, as Bro. Root says, that this kind of contraction has been abandoned; and it has been abandoned so long, or so thoroughly, that I had really forgotten it; but the kind of contraction that I advocated, that of contracting the brood nest of a newly hived swarm, has not been abandoned by those who live where it can be used to advantage and who use it rightly. Bro. Root quotes from the American Bee Journal the experience of two bee-keepers who have tried contraction of the brood nest when hiving swarms, and who have given it up. One of them, a Mr. S. H. Hovis, says that he secured not a pound of surplus honey from swarms hived on six frames, while those hived in box hives gave him some surplus. It is very evident that there is something wrong here. On the face of it, it seems almost senseless. The idea! that a swarm given six brood frames and presumably a super or supers above, will not store any honey in the supers, while a swarm hived in a box hive gives some surplus. There is no explanation as to whether supers were given the swarm in the box hive or not. If not, then the surplus may have come from the body of the hive. As it appears in the quotation, no practical bee-keeper can believe the statement unless some explanation is given. The case of Mr. C. A. Bunch is entirely different. I can well believe him. I have been through the same mill. His trouble is that the bees swarm out when hived on only five Langstroth frames in the brood nest. He does not say that he put on supers at the time of hiving, but I presume he did. If contraction is too severe when a swarm is first hived, at least half of the swarms will swarm out the next day and abscond; at least, that has been my experience. This trouble is worse some years, and some

parts of the season than in others. The remedy is not to contract the brood nest until about the third day. By this time the swarming fever has abated and the bees have settled down to business and will not swarm out, no matter how severe the contraction. When using eight-frame hives I give the bees the whole brood nest at first, and then on the morning of the third day I contract to five or six frames; the number depending upon the size of the swarm. In using the Heddon hive I put the swarm in the two sections of the brood nest, and then the third day I take away the lower section of the brood nest. With this management I have never had any swarming out.

Bro. Root says that he has tried using two or more eight-frame hives as a brood-nest when working for comb honey, and he has secured more honey than he has from a single-story, eight-frame hive. I do not doubt that; but to make the matter right he ought to get *twice as much*. Here is an eight-frame hive sitting this side of the apple tree. On the other side is another eight-frame hive. Let them alone as they are, put on the supers, and we get fifty pounds of surplus comb honey from each colony. Set one of these on top of the other, and if we don't get 100 pounds we have lost. Bro. Root is a bright man, and I like him and respect him, and I hope that I may be spared the shock that will come to me if I find him advocating the idea that the more we get *per colony* the better filled will be our pocket books. I cannot believe that of him. I prefer to think that I have misunderstood him. Don't you see, Ernest, that our capital is in the hives and combs. It isn't in the queens. Queens don't cost us anything. We could have a queen to each comb if it were going to be any advantage. As I have just said, the capital is in the hives and combs, and the more completely they are occupied the greater will be our profit. I would have a brood-nest of such a size that an ordinary queen will fill it with brood at the proper season of the year;

and because some queens might do twice this, I see no advantage in allowing them the privilege. We need colonies large enough to protect themselves and their combs and stores, to generate sufficient heat to keep themselves warm and to rear brood and work wax, and to furnish bees in sufficient numbers to go up into the sections when the main harvest comes and work wax and build comb. When this can be done I can see no advantage whatever in having a colony still more populous. It might be an advantage to have more bees in the field, but, if so, I would be in favor of giving them another hive and another queen. When working for extracted honey, where there is little need of comb building in the supers, I agree most fully with the idea expressed by Mr. J. E. Crane in this issue of the Review, that Italian bees often store more honey, in proportion to their numbers, when in colonies that are not so very populous.

There is one point in all this matter that ought not to be overlooked; and that is this: If a man has tried both large and small brood chambers, or, perhaps, I better say, brood chambers of different sizes, and found that some particular size brings him in greater profits, then that is the size for him to use, regardless of the theorizing of editors.



Department of Criticism

R. L. TAYLOR.

Blame where you must, be candid where you can,
And be each critic the Good-natured Man.
G. L. SMITH

THE SEARCH FOR DR. MILLER'S LOST CHILDREN—THEY ARE FOUND!

I little thought what I was contracting for when I undertook to write for this

department. Here it is in the beginning of the honey season, the bees swarming, the weeds growing, and all manner of other work pressing, and Dr. Miller apparently frantic to have me stop in the middle of it all and hunt for some of his own children whom he cannot find; though they are exactly where he left them, and whose whereabouts I think he ought to remember, as but a few weeks have supervened. He has failed to find them, yet he expects me, a stranger, to look them up. The printer and the proof-reader of the Review have also, apparently, entered into a conspiracy to make the burden as galling as possible by confounding the record I made of the hiding place of the doctor's offspring. Among them they have a heavy bill to settle for the great amount of time I have spent in the search.

The doctor no doubt might have found them—the lost ones—but he was full of doubt as to their existence; and, instead of putting confidence in my statement of their existence and character, and making a hopeful search, he falls upon me with a stream of polite charges of misrepresentation. Review 171-173. I, on the other hand, knowing that my statements were correct, made the search, expecting to find, and was successful.

THE WINTERING PROBLEM—THE PARTS PLAYED BY COLD, CONFINEMENT AND FOOD.

The first topic to which the doctor refers in which the reference is wrong in my article in the May Review is my criticism of his discussion of the wintering problem. The reference should be A. B. J., 194, instead of 149. Let the doctor produce proof of misrepresentation. I trust he will be able to control his feelings sufficiently so as not to be unfair. I say this because in his onslaught on me in this matter he falls into some bad errors. He says that the plain teaching of my quotation from him would seem to be "if your bees have a good flight Nov. 15, they will winter perfectly no matter

what the character of the food, no matter how long the confinement, no matter about anything else." I am at a loss to imagine how the doctor could have made that assertion; for I said expressly (Review, 153) right in connection, "he rests the entire solution of the problem apparently upon 'cold' and length of confinement." Nor did I suppose that anyone of sense would take the doctor's language to mean (for I quoted him correctly) that bees would winter well on molasses for stores; or if they were kept confined much beyond the proper time for setting them out. The doctor can have it the other way if he chooses, but I really do not believe his language should be taken to mean all he says it would. Referring again to page 153, he thinks he "would be pretty well justified in saying, Mr. Taylor teaches that if bees have the right kind of stores it makes no difference how long they are confined or how cold they are." May be he would in his own eyes, but I cannot see how, for I said expressly, right in connection, "for I can easily control the temperature;" and of the length of the time of confinement I used the expression "within reasonable bounds." And, after all, why should we fear length of confinement, if the doctor's feelings are right, for he says (A. B. J., 194) "I have a strong feeling that when cold weather sets in every day they are left out is as bad as five day's confinement in the cellar." Is not that equivalent to saying that if they winter well through three months of cold outside, as they often do, that they could stand fifteen months in the cellar?

THAT "TEN-FOLD INCREASE OF SURPLUS"
 THAT MAY BE EXPECTED (?) IF A COL-
 ONY IS PREVENTED FROM
 SWARMING MORE
 THAN ONCE.

The false reference to Gleanings when corrected stands 123 instead of 125. The reference is to the first "stray straw." The doctor guesses I have "subjected it to unwarranted distortion," and that

"taken in its connection it is entirely correct" To show that I have not distorted it I quote the whole "straw." "In addition to the advice given John Camm, p. 96, he might increase his surplus ten fold by allowing only one swarm instead of two from each colony." I can find nothing in the matter to which he refers that can at all help him to make out any distortion. I certainly wish that "taken in its connection it is evidently correct" for it would prove a great boon. Only let him explain what the further management must be to "increase the surplus tenfold." At all events, I hope he will explain to Mr. Camm how he may prevent more than one swarm, for I think the editor's advice (Gleanings, 96) entirely inadequate.

HAS THE CRITIC "SCOLDED?" IF SO, WHEN
 AND WHERE?

In connection with these matters, where the printer bungled the references, I wish to call the doctor's attention to the fact that in addition to continually charging me with misrepresentation he says that I am "at times given to scold," and does not even attempt to give book and page. I hope he will yet do so. If I have either misrepresented or scolded (for I *guess* that is what he means by "given to scold") I am anxious to make an apology and I'll not mail it either. I'll make it publicly.

FALL-FEEDING DOES CAUSE BREEDING.

Again the doctor affirms that I say "it hurts him (me) terribly because editor Root and myself (himself) are not thoroughly established that late feeding induces late laying." Not at all, but because they were "put all at sea by so slight a puff." Few things are better established than that by proper feeding in the fall, breeding may be induced. In many cases I have had it continued till into November. If one man's assertion, and that not definite, makes these two great file-leaders in apiculture more than doubt that, then I am compelled to think that the assertion of almost any man to whose name "distance lends enchant-

ment" would make them doubt almost any of the cardinal facts of apiculture, and nothing would be stable. "Hence these tears." I say DeLayens' assertion is indefinite, because F. L. Thompson (Review, 175) refers to what I take to be the same article, and from that it appears that his (DeLayens') assertion is a mere inference. He infers it from the fact that at the end of September he found no young brood, though "some honey had been coming in every day for several weeks from plants." His facts as interpreted by Thompson I do not question. Every bee-keeper of experience and observation knows them to be true, but the inference is unwarranted. I know it will not stand the test. The doctor complains because I do not take the editor's general statement in support of the doctor's doubts, instead of my own knowledge. I am willing to put the editor against the editor. Has he not many times recommended late feeding to produce late breeding and given definite direction how to proceed to make it successful?

THE DISCUSSION OF "DOES BEE-KEEPING PAY?"

The doctor thinks me unfair because I bantered him for giving the results of one year only, and that perhaps his best one, in his discussion of the topic, "Do Bees Pay?" I know the other side, and a good many others do, also, but there may be a good many other readers who do not, and are liable to be misled in some degree. It does not seem to me an altogether fair discussion of such a comprehensive topic. Perhaps, however, the editor gave the article its title. That would let the doctor out.

BEEES DON'T ALWAYS CHOOSE LARVÆ OF THE BEST AGE FOR REARING QUEENS.

The doctor is a large "pin," and he should not wonder if the "balls" of even a novice sometimes make him dodge into new corners.

He argues (A. B. J., 295) that in a colony made queenless, with eggs and larvæ

of all ages present, that it looks rather reasonable that the bees will select what will make the best queens if it is left entirely to them. It may look reasonable that they should, but they don't; at least they don't altogether; and the trouble is that when they err, as they generally do, I suppose, from their eagerness to get a queen as soon as possible, by selecting one or more larvæ for the purpose that are too old to produce the best queens, the queen from such hatch first, and so the later and better ones are destroyed. The remedy is to remove the larvæ, in four or five days from all but three or four of the most satisfactory cells.

ARE BAIT SECTIONS A BENEFIT?

The doctor is still using time and energy on "bait sections." (Gleanings, 422.) I have been looking to see that notion steal silently away with underground ventilation and the others. There must be something wrong with the doctor's strain of bees. Of Ranson's plan of "baiting" the doctor says: "It will probably work all right with enough baits, providing colonies are not equal in strength." Will he explain why it would not be better to have the colonies all equally strong if there are enough baits?

DECOY HIVES VS. QUEEN-TRAPS.

The doctor (A. B. J., 374) gives, to one who is forbidden to go on his neighbor's land, where his swarms generally go, and and who asks for some means to induce them to alight on his own lot, as the first remedy the putting up of a decoy hive. That might be effective one time in a thousand, but I doubt it. Queen traps! Queen traps! The doctor thinks of them later.

BEEES DON'T MOVE EGGS.

H. Rohrs (A. B. J., 381) thinks he has found the question: Do bees move eggs? answered in the affirmative. "A comb for seven days separated from the queen by a queen excluding honey-board shows a queen cell with an egg in it." Excuse me, but bees don't move eggs. Let him

watch the cell and he will find, if the bees go on with it, that the larva from the egg will grow into a drone—some enterprising worker produced the egg.

CANE SUGAR AND BEET SUGAR ARE IDENTICAL.

Doctor Miller (Gleanings, 377) quotes B. F. Onderdonk as saying West India sugar is mixed with beet sugar, refined, losing half its sweetness when it becomes granulated sugar. The doctor is "all stirred up to know more;" and asks "Is it the mixing with beet or is it the refining that loses the sweetness?" Neither. It don't lose its sweetness. The editor is in doubt, too. From samples he has tried he doubts whether anybody but a chemist could tell the difference by the taste "between cane sugar and beet sugar." I think even a chemist could not tell. The highest chemical authority at the Michigan State, Agricultural College says they are identical—beet sugar *is* cane sugar.

THE BEES' INSTINCT TO SWARM NOT EASILY OVERCOME.

In reply to doctor Miller's admission that "I've had a good many colonies swarm with two stories, sometimes with little but empty combs in the lower story." (Gleanings, 422) The editor says, in part, of a colony of his own bent on swarming: "But if this colony had in the first place been in quarters large enough to hold them so that the notion of swarming did not get possession of them they would, if I had gone down and given them more room, have never thought of swarming the whole season." Does the editor really think the instinct "to multiply" can be so easily overcome? Do the bees in the rocks not swarm until the cave is crowded? The doctor's facts are such as most of us are meeting with very frequently.

NOVEL REASON FOR THE SUPERIORITY OF HONEY STORED BY ITALIAN BEES.

Mr. Volkert (A. B. J., 331) makes a funny argument to show why Italians

"produce a finer quality of honey" than other bees. It is in brief because they are more active. As Leghorns, being more active, produce finer (?) eggs than other hens, so with bees. The admission used to be made that Italians, being more active, often produced inferior honey to that produced by the blacks because they would collect it from sources which the blacks shunned.

WHAT THE U. S. B. K. UNION OUGHT TO DO,

The American Bee-Keeper (page 105) is not entirely satisfied with an answer I made to a question in the A. B. J., and propounds a supplemental one: "How can the Union (The U. S. B. K. U.) be made of any possible good (not to say the 'greatest') to its members without an increased membership?" I answer, the membership of the Union is already large, and its resources abundant. Let its officers make a determined and effective campaign, offensive and defensive, against the evils and dangers that threaten bee-keepers and bee-keeping, and doubters will fall in rapidly enough.

LAPEER, Mich. June 24, 1898.

EXTRACTED.

A DIGNIFIED(?) EDITOR.

He Astonishes Mr. J. H. Martin.

The following, which was written by Mr. J. H. Martin, appears in the May 15 issue of Gleanings.

Well, wonders never cease. The Review has started a joke department. Just see the column of good white paper and black ink that Mr. Aspinwall wasted in the last Review. But really the most astonishing thing in the same number of the Review, under editorial offerings, is that the editor winds up one of the offerings with a "Whoop-e-e!" Well, just as sure as you live I should not be more astonished should I go into a graveyard and have a tombstone waltz up to me and shout "Whoop-e-e!" Just think of it! "whoop-e-e" from the dignified and se-

date editor of the Review! I did think for a minute that I would stop the paper; but I will hold on a little longer. This joking business in bee-literature has got to stop. I don't see what this world is coming to, any way.

Now, Mr. Martin, I see that you think the editor of the Review sedate and dignified, but I will inform you that he is not. When at his desk answering correspondence, or writing editorials, he is, to a certain degree, sedate and dignified, but he can stop almost any time to make or take a joke; and if that little "Whoop-e-e!" of his astonished you, I think I can relate an incident that will astonish you even more.

While cleaning house this spring the putting down of the new parlor carpet had just been completed when this "dignified and sedate editor" came in to look at it. He said "Now if we only had a nice big cat to roll on this new carpet." He didn't stand and wish very long but got down *himself* and rolled over and over like a cat. I made the remark at the time that "the readers of the Review ought to have his picture."

Now, Mr. Martin, do you think him sedate and dignified?

THE TWIN THAT SETS THE TYPE.

BEE-BREAD IN SECTIONS.

This is Largely a Question of Locality and Management; and, Possibly, of the Season. How it may be Avoided.

My method of working for comb honey is identical with that of Mr. C. Davenport, of Minnesota. I have never had any serious trouble with pollen being stored in the sections. I never had any put in the sections over a colony having an old established brood nest. If I ever did have any it was in sections having drawn combs in them that were placed over swarms that were hived in a contracted brood nest furnished with nothing except starters. It seems that Mr. Davenport has had considerable loss from

pollen in sections, and in an article in the American Bee Journal for June 9, he sets forth his trouble in this direction, and tells how he has overcome it. Here is the article:—

In my last I made mention of the fact that the previous season I lost a large amount—large at least for a bee-keeper—by not understanding the business of producing honey better than I do. This loss was caused partly by bee-bread. A number of thousand sections, when finished, contained so much of this that they were unsalable, and the honey in thousands more was so poorly fastened to the wood that it was almost impossible to haul them to the nearest towns without breakage, let alone shipping them. In fact, a great many were broken in handling before they left the apiary, as a large part of them were but slightly attached to the wood at the top.

With but few exceptions, bee-bread or pollen in sections has always caused me some loss each season, and to a less extent sections containing honey imperfectly fastened also, but never anything like this. The year before, under the same management, there was practically no loss from either cause. The season might, therefore, in some sense, be accounted to blame, but a bee-keeper in order to make a success of the business at present must be able, and understand how, to meet the conditions of different seasons, and I have no doubt this loss I have described might have been avoided if one had known how; and while I will admit that I might not be able to entirely avoid it if the same conditions were to occur again this season, yet I consider what I did learn in regard to the matter was of more benefit to me than what was lost; that is, that it will, or may be, in the years to come, for I am a young man yet, and expect to continue to follow bee-keeping as a business in the future.

As I have said, what I learned last year cost me hundreds of dollars, and now it is to be laid before the reader at a cost to them of but a fraction of a cent. I wonder if many of us appreciate what benefit a first-class journal like this is to its readers. By this I do not necessarily mean that anything from me may be of value, but there are hundreds of others who each year, through its columns, tell us their experiences, and what is constantly being learned that is of value to our pursuit. There have been in the past, and no doubt there will be in the future, single copies that are worth much more to

me than the entire numbers cost for a year. But to return to the matter in hand.

I will first say that pollen in this my immediate locality is very abundant through the entire season, but as this is used mainly in brood-rearing, the natural instinct of bees causes them, when conditions are so they can, to store it in the brood-chamber, where it will be easily accessible for this purpose. But the plan I follow with swarms, either natural or artificial, and one which I believe is largely practiced, is to hive them in a hive with frames containing only starters, when, if the supers from the parent hives, in which work has already commenced, is put on in a day or two, work will be resumed in them at once, and a good queen will usually lay in a large part of the comb below as fast as it is built, so that most of the honey brought in is necessarily for sometime stored in the sections.

I do not believe there is any other method by which as much honey can be secured in sections; and, in a good season, or during a good flow, a swarm when first hived will not bring in much pollen for a few days. Last year the flow, except during the first few days, was very scant and irregular; and as it was those swarms treated the way I have described that put pollen in the sections, it will be seen that this method should not be practiced during a poor flow in a locality where pollen is as abundant as it is here, for when they can not secure honey, if pollen is plentiful, they will carry in an excessive amount of it, and must of necessity store it in the sections.

Now, I have not much doubt that two, or possibly one, frame in each hive containing drawn comb, then waiting until considerable comb was built before putting on the sections, would overcome the difficulty, or if no frames containing combs were on hand, a like number filled with foundation would prove effective.

There is so much pollen here that colonies that did not swarm would oftentimes carry it into the sections; but years ago I accidentally learned how to almost entirely overcome this by changing the places of combs in the hive. This was done to discourage swarming.

My practice was, and is largely yet, at the approach of the swarming season to replace the two outside combs with those that contain the most sealed brood, the two from the outside which usually contain a large proportion of what pollen there is in the hive are then placed in the center. If done at the right time this has

a tendency to check swarming, and I soon noticed sections over colonies so treated hardly ever contained any pollen. Such an abundance of pollen right in the center of the brood-nest may possibly act as a check to their gathering much more for a time. However this may be, there would soon be plenty of room for them to store a large amount again in the two outside combs.

As to sections containing honey but slightly fastened to the wood, I believe there are means by which this can be largely avoided, no matter what the character of the flow is, and even if only small starters are used. But as this article is already so long I will have to wait to explain my experiments in regard to this matter until some other time.

Southern Minnesota.

RIPEXING HONEY.

It Proceeds more Rapidly when the Honey is

Unsealed. Sealed Honey not Always

Ripe. Weight of Ripe Honey.

Nothing has been more damaging to the sale of honey than the putting upon the market of an unripe article. Time and again have bee-keepers been scolded because they extracted honey before it was capped over; but here comes a man from California, Mr. Delos Wood, who tells us in Gleanings—well, here is what he says:—

On page 125, Feb. 15, 1898, Dan White complains of all bee-keepers who extract honey before the bees have sealed it, and gives hot shot, but fails to point his gun in the proper direction. His article is a good one, and will bear careful study even by himself. There have been so few writers who advocate extracting unsealed honey that I cannot call the names of any of them. I, for one of those hit by Mr. White's bombs, am willing to join hands with him in condemnation of putting thin, watery honey, or unripe honey on the market. "The everlasting footnote" to Mr. White's article says we should "agree not to put on the market extracted honey weighing less than 11 lbs. to the gallon." That is too thin and watery for me Mr. Editor. Honey that does not weigh 12 lbs. to the gallon is not well ripened. Weigh that "over at the house" and you will find it about 13 lbs.

On page 249, April 1, in "California Echoes," J. H. Martin gives a kick especially aimed at the California bee-keepers who extract before sealing. His paragraph saying "Thin honey is liable to sour, and more or less of it will be a dead loss, the flavor raw and unpalatable, etc.," is correct; and any one selling such an article will soon ruin his market. In another place he says, "It is pure shiftlessness to produce unripe honey." This, if taken just as it reads by itself, can not be objected to; but, taken in connection with what precedes it, I infer that it is a mere kick at extracting before the honey is sealed.

Now, in reply to both of these articles I would ask, "Who has ever advocated putting unripe honey on the market?" I never have, and am willing that every buyer and user of honey may know that I advocate and practice extracting honey before it has been sealed by the bees; but I have never sold a pound of *unripe* honey since I quit selling comb honey. I have never sold a can of extracted honey that did not weigh 12 lbs. or over to the gallon. In a lot of two tons, sent to a commission house in San Francisco a few years ago, in 5-gallon tin cans, the net-weight returns showed 63 pounds per can. This honey was taken as fast as the bees stored it, not waiting for any to be sealed, and ripened in the sun, and sold a fraction above market quotations. I always put my name and address on every case shipped, and have never received one complaint of sour or unripe honey.

Who sells unripe, watery, or sour honey? It is those who wait for the bees to seal their honey. Then they honestly think they can join Dan White's society. Bees are like some farmers. When work is pressing, everything is done in a hurry. Example: The farmer in the East, where summer rains abound, has a large lot of hay cut, and a rain is threatened. That hay is hustled into the barn as soon as he thinks it will do. If he fears it is not well cured he perhaps will dose it with salt, and in goes another load, and so on until the last is well sprinkled with rain. Result: That hay heats, sweats too much, molds, and is unfit for market.

Bees are rushed by the enormous honey-flow at times, and they go it pellmell, slap, kick'em off, get done quick, *a la* Coggshall, and seal their honey before it has had time to evaporate or ripen. The comb-honey man takes off the nice ripe honey (?) while it is white, and sells the watery stuff. The man who works for extracted has waited until all is sealed, and he honestly thinks it is well ripened.

He uncaps and extracts, and runs the honey direct from the extractor into the can, and sells it, and these are the ones who are selling unripe honey weighing 11 lbs. per gallon. When honey is sealed it ripens very slowly, and this is why E. R. Root once advocated leaving it on the hive until travel-stained.

I have cut open well-sealed honey, stored in May and June, and kept on the hive until winter, that would run from the combs almost as fast as water, and would smell strongly of vinegar. Was it well ripened?

It would take a long article to tell what constitutes well-ripened honey, and how to produce it, and I will not attempt it at present, as you may condemn this to the waste-basket; but if you do not, you may put a No. 10, double-soled footnote to it.

In conclusion I wish to say that, in my opinion any one who runs honey direct from the extractor into the cans, no matter if every cell is sealed, is liable at times to put unripe honey on the market.

The editor of *Gleanings* makes the following comments upon the foregoing.

There is a good deal of truth in what you say. May be it is all truth. If so, it only goes to show that your conditions, so far as ripening honey is concerned, are different from what they are in Ohio. I do not think I ever saw the time when sealed honey in Ohio was unripe; but I can imagine that the bees might pour the honey into combs pellmell, and seal it before it is really ripe. If that were the case, then of course the honey ought not to go from the extractor into the marketing-cans or barrels, but should, on the other hand, as you imply, go into evaporating-cans, there to remain until it has attained the proper consistency.

You ask me to weigh that honey "over at the house," that you think will run about 13 lbs. I did do that, friend Wood, and just as it comes from the can, and presumably as it came from your people on the Pacific slope; but I find it weighs 12 lbs. to the gallon. I thought it would go nearly 13; but even at the 12-pound mark it is very nice and thick. I could get it to the 13-pound mark by letting it stand in an open vessel for days at a time.

Why, friend Wood, we in Ohio consider 11 lbs. a fair specific gravity; and in our climate I doubt whether it is possible to ripen it in the hive so it will be thicker than this. We can run it up to 12 lbs., and perhaps 13, by letting it stand in a dry place in an open vessel. During the last three or four weeks we have been having a spell of weather during which

the honey would get *thinner* rather than thicker. Nearly everything has been reeking with dampness from frequent rains, fogs, etc. This condition does not usually prevail; but our atmosphere is by no means as dry as it is in California, and I doubt whether it is possible for us to raise the specific gravity of honey much above the 11-pound mark.

In speaking of California honey, I never saw anything yet that came from cans that was thicker than 12 lbs. to the gallon. I am not saying that you West Coasters can not or do not produce 13 lb. honey; but I am one of those chaps who are very fond of thick waxy honey; and if you have something that runs 13 and 14 lbs., I wish you would send me a sample. I will pay express, and give it the best write-up I know how.—ED.]

Most of us know that honey is often sealed over before it is fully ripe. At least, we know that it often improves by leaving it on the hive after it is sealed. To preserve the whiteness of the combs, we remove the sections as soon as possible after they are capped over. This proceeding does not improve the quality of the honey. To leave it on would, or might, improve it. That honey ripens more rapidly before being capped over is very apparent. Mr. Heddon has repeatedly urged us to take advantage of this fact when working for extracted honey. He would have us use shallow extracting supers, and then tier them up as rapidly as possible. Get the honey up away from the brood nest as quickly as possible. In this position the bees are more slow in capping it; so slow that it often ripens before they get it capped; and thus we are saved the labor of uncapping. Honey ought to be thoroughly ripened before taken from the comb; and it may then be put into cans very soon after extracting. Its flavor is much better preserved if sealed up in a can or keg than if left open to the air.

The average weight of well ripened honey in this locality is 12 pounds to the gallon. So many times have I proved this that when a customer comes with a quart can I usually fill it and call it three pounds without taking the trouble to weigh it.

Honey Quotations.

The following rules for grading honey were adopted by the North American Bee-Keepers' Association, at its Washington meeting, and, so far as possible, quotations are made according to these rules.

FANCY.—All sections to be well filled; combs straight, of even thickness, and firmly attached to all four sides; both wood and comb unsoiled by travel-stain, or otherwise; all the cells sealed except the row of cells next the wood.

No. 1.—All sections well filled, but combs uneven or crooked, detached at the bottom, or with but few cells unsealed; both wood and comb unsoiled by travel-stain or otherwise.

In addition to this the honey is to be classified according to color, using the terms white, amber and dark. That is, there will be "fancy white," No. 1, dark," etc.

CLEVELAND, OHIO.—We quote as follows: Fancy white, 12; No. 1 white, 11; No. 1 amber, 9 to 10; buckwheat, 8; white, extracted, 6; amber, 4 to 5.

A. B. WILLIAMS & CO.,

May 26 80 & 82 Broadway, Cleveland, O.

CHICAGO, Ill.—There is a good demand for fancy white comb honey. This grade would sell for 11 cts.—possibly higher. Considerable Amber and dark on the market—selling anywhere from 5 to 8. Extracted White sells at 5½ to 6; Amber 4½ to 5; dark, 4. Beeswax, 27.

S. T. FISH & CO.,

June 28. 159 So. Water St., Chicago, Ill.

CHICAGO, Ill.—Not enough new comb honey yet on sale to make a market. Extracted in good request. We quote as follows: Fancy white, 11 to 12; No. 1 white, 10; No. 1 Amber, 7 to 8; Fancy dark, 8; No. 1 Dark, 7; White, extracted, 5½ to 7; Amber, 5 to 5½; Dark, 4½ to 5; Beeswax, 27 to 30.

R. A. BURNETT & CO.,

June 28. 163 So. Water St., Chicago, Ills.

BUFFALO, N. Y.—There is no demand for honey at this time of the year; except for a limited quality of strictly fancy, at 10 to 11 cents; commoner grades are dull at 8 to five cents according to color, condition, etc. Of course, any and every grade can be sold for what it will bring. Extracted ranges from 4 to 6 cents, as to quality. Beeswax from 20 to 26 cents. We would like some beeswax.

BATTERSON & CO.,

May 25. 167 & 169 Scott St., Buffalo, N. Y.

NEW YORK.—Trade in honey is fairly active. Fancy white and buckwheat comb find quite ready sale with us. Trade in Southern and California extracted has been very good the past few weeks. We quote as follows: Fancy white, 11 to 12; No. 1, white, 9 to 10; buckwheat, 6½ to 7; extracted, California, water-white, 6½; California, white, 6; California, light amber, 5½; Southern extracted, 52½ to 55 a gallon. New York extracted not in demand at present. Beeswax, 27½ to 28½. Write for shipping instructions. FRANCIS H. LEGGETT & CO.,
May 6. W. Broadway, Franklin & Varick Sts.

KANSAS CITY.—The supply of 1897 comb honey is about all cleaned up, and we think shipments of new comb would sell for about 12 cents. C. C. CLEMONS CO.,
 May 19. 521 Walnut St., Kansas City, Mo.

NEW YORK, N. Y.—Demand for comb honey is rather slow, especially for off grades, white and dark, and, as we have a large stock of these would not advise shipping for the near future. Our stock of fancy white is light and such would find ready sale at quotations. Our market for extracted buckwheat will open up shortly and we would advise bee-keepers to ship this along now. Beeswax steady. We quote as follows: Fancy white, 11 to 12; No. 1, White, 10; Fancy Amber, 9; No. 1, Amber, 8; Fancy Dark, 7; No. 1, Dark, 6; White, extracted, 5 to 5½; Amber, 4½ to 4¾; Dark, 4 to 4¼; Beeswax, 26 to 28.

HILDRETH BROS. & SEGELKEN,
 Jan. 7, 120 & 122 West Broadway New York

WM. A. SELSER,
 10 VINE ST., PHILA., PENN.

White Clover Honey Specialist.

QUEENS, Untested, 75 c; 6 for \$4.00; tested, \$1.00; 6 for \$5.00; breeders, \$2.00. The best stock, imported or golden. W. H. LAWS, Lavaca, Ark.

Our Prices are worth looking at. We are making the new **Champion Chaff Hive** with dovetailed body and supers and a full line other Supplies, and we are selling them **CHEAP**. A postal sent for a price list may save you \$ \$ \$ \$.
 R. H. SCHMIDT & CO.,
 Box 187 Sheboygan, Wis.

Please mention the Review.

ITALIAN bees for sale. Queens \$1.00. Bees by the lb., \$1.00. One-frame nucleus with queen, \$1.50; two-frame, \$2.00. Queens, after Aug., 50 cents each.

Mrs. A. A. SIMPSON, Swarts, Pa.

7-9R-2t Please mention the Review.



I have had 30 years of experience in queen rearing, and make a specialty of the business. I have my cells built in full colonies, and send out no poor queens. I can furnish the best and purest of Italian queens, either 3 or 5-banded, at only 50 cts. each. My P. O. is a money order office.

Daniel Wurth, Falmouth, Ind.

7-5R 3t Please mention the Review

JOHN F. STRATTON'S
 CELEBRATED



MANDOLINS,

Importers of and Wholesale Dealers in all kinds of **MUSICAL MERCHANDISE,**
 611, 813, 815, 817 East 9th St., New York

Bee keepers should send for our

'97 CATALOG.

We furnish a full line of supplies at regular prices. Our specialty is Cook's Complete hive.
 J. H. M. COOK, 62 Cortland St., N. Y. City

Please mention the Review.

Franklin House DETROIT MICH.

Our Rates and Earned! Very central. Elevator service. Steam heat, electric lights, tile floors etc. Rates \$1.50 to \$2 per day. H. H. JAMES & SONS, Props

Please mention the Review.

ALBINO QUEENS

For sale. Best bees in existence. Untested, in May, \$1.00; after June 1st, 75 c.
 5-9S-3t J. D. GIVENS, Lisbon, Texas.

Please mention the Review.

—If you are going to—

BUY A BUZZ-SAW,

write to the editor of the REVIEW. He has a new Barnes saw to sell and would be glad to make you happy by telling you the price at which he would sell it.

COMB

FOUNDATION

WHOLESALE AND RETAIL.

Working wax into foundation, for cash, a specialty. Hives, Sections, and a full line of Supplies. The best of everything. Write for Catalog, with prices, and samples of Foundation and Sections. Beeswax always wanted for cash or trade.

GUS. DITTMER,

10-97-12t Augusta, Wis.

The A. I. Root Co.'s Goods, WHOLESALE AND RETAIL.

Please mention the Review

THE LOSS

Of one Queen in introducing, means a loss greater than the cost of a copy of "ADVANCED BEE CULTURE," which has one entire chapter devoted to "The Introduction of Queens." It shows when the cause of failure lies with the colony, when with the queen, and points out the *conditions* necessary to success. Although one infallible method is given, but little attention is given to the setting forth of exact rules and methods; the subject being treated with a view to teaching *principles* that may be followed to success.

Price of the book, 50 cts.; the Review one year and the book for only \$1.25.

W. Z. HUTCHINSON,
Flint, Michigan.

Listen! Take my advice and buy your bee supplies of August Weiss; he has tons and tons of the very finest



FOUNDATION

ever made; and he sells it at prices that *defy competition!* Working wax into foundation a specialty. Wax wanted at 26 cents cash, or 28 cents in trade, delivered here. Millions of **Sections**—polished on both sides. Satisfaction guaranteed on a full line of **Supplies.** Send for catalogue and be your own judge. **AUG. WEISS,** Hortonville, Wisconsin.

18



98

This is the original one-piece section-man who furnishes one-piece sections as follows:—

500 sections, \$1.50; 1,000 for \$2.50; 3,000 for \$6.75; 5,000 for \$10.00; 10,000 for \$17.50.

No. 2 sections are not made to order, but when in stock are sold at \$1.50 per M.

J. FORNCROOK,

Watertown, Wisconsin.

When you buy

QUEENS,

You want, first, *good* queens; then you want them *promptly*; and, lastly, you want them at a reasonably *low price*. You can secure all of these advantages by sending your orders to Mr. **W. H. PRIDGEN,** Creek, Warren Co., N. C. He is *now* ready to mail either golden, or from imported stock, mated to golden drones, at 75 cts, each for untested queens. Mr. Pridgen is a member of the National Queen Breeders' Union; and he sends out (free) a catalogue containing valuable information for queen breeders and buyers. Money order office, Warrenton.

Some Odds and Ends That Will be Sold Cheap.

For a dozen or more years Mr. M. S. West of this place dealt in bee-keeper's supplies. Since his death, two years ago, his daughter has endeavored to close out his stock of goods, and has succeeded to large extent. There are still a few odds and ends, and she has brought them to me and left them for me to sell. Here is a list of the articles with prices at which they will be sold.

- One ten inch foundation mill, (second-hand) Root's make, complete with dipping tank, etc. in excellent condition... \$10.00
 - One ten-inch foundation mill, (second-hand) Root's, (one of recent make) dipping tank, etc. in good order..... 15.00
 - Three Woodcock foundation fasteners, each,75
 - Eighty seven entrance guards, each,05
 - Thirteen Porter Bee Escapes 2.25
 - Thirty-three Simplicity hives, in the flat, sides, ends, covers and tin rabbits but no frames nor bottom boards, each.....40
- Send all orders to W. Z. HUTCHINSON,
Flint, Mich.

Queens

untested Italians, 70 cents each; 3 for \$2 00. After July 1st, 50 cents each. Safe arrival and satisfaction guaranteed. Catalogue free.

6 98-tf THEO. BENDER, Canton, Ohio.

I have several hundred

QUEEN CAGES

of different styles and sizes, made by C. W. Costellow, and I should be pleased to send samples and prices to any intending to buy cages.

W. Z. HUTCHINSON, Flint, Mich.

Farm Bee - Keeping.

The only bee paper in the United States edited in the interests of the farmer-bee-keeper and the beginner is the **Busy Bee**, published by EMERSON T. ABBOTT, St. Joseph, Mo. Send for free sample copy NOW.



See That Wink ?

Bee Supplies. Root's goods at Root's prices. PODDER'S HONEY JARS Prompt service. Low freight rates. Catalog free. WALTER S. POWDER, 162 Mass Ave., Indianapolis, Ind., the only exclusive bee supply house in Indiana.

WATER POWDERS AD

THE MONITOR PAPER FILE

Binds securely and neatly all periodicals. Preserve your papers, magazines, pamphlets, bulletins, music &c., by binding them together as you get them. Each new number filed quickly and easily. Will bind 52 numbers of any periodical aggregating 1000 or fewer pages. All lengths from 6 to 28 inches. Light and handsome. PRICE.—All sizes 12 inches and under 12 cents; over 12 inches one cent per inch. When wanted by mail add one cent for each 5 inches or fraction thereof.

For sale by the Publisher of this paper

Queens 75 cts each by return mail; either golden, or three-banded, young and warranted. Two separate yards with competent assistants. Circular free.

J. B. CASE, Port Orange, Fla.

Without Stopping

the machine to reverse the combs is the way you can work with the Williams Automatic

Honey Extractor.

Such an extractor will save you time and annoyance and it does not cost much more than an ordinary machine. Send for descriptive price list.

Read what the famous bee-keeper, N. E. France, says:

PLATTEVILLE, Wis., July 5, 1897.
Dear Sirs: To day I extracted 2,780 lbs. of honey with your Automatic Honey Extractor in 5½ hours and could have done the same this afternoon but let the boys go to the city to play a game of base ball. Have extracted 27,135 lbs. so far with good prospects for as much more. My bees and State work keep me very busy. Hope to see you before very long—will write you later.
Yours truly, N. E. FRANCE,
State Inspector of Apiaries,
Platteville, Wisconsin.

We can also furnish choice queens, either golden or leather colored Italian, at 75 cents each, or two for \$1.40.

Van Allen & Williams,

6-9S-tf. BARNUM, WIS.

Beeswax Extractor.

The only Bees Wax Extractor in the world that will extract all the wax from old combs rapidly by steam. Send for descriptive illustrated catalogue.

C. G. FERRIS,
South Columbia, N. Y.

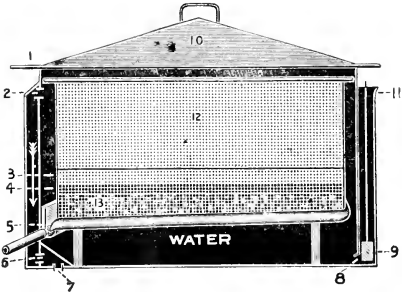

Are you Going

To the fairs this fall?

My bees and queens take first premium. Fifteen, Barred Plymouth Rock eggs for 50 cts. Ask for catalogue. 4-98-tf

J. F. MICHAEL, Greenville, Ohio.

The place to get your best
QUEENS
is of H. G. Quirin, of Bellevue, Ohio. Ten years of experience, and the best of methods and breeders enable him to furnish the best of queens. Golden Italian, warranted purely mated, at 75 c.; after June, 50 c.; or 6 for \$2.75. Leather-colored, same price.

— If you wish the best, low-priced —

TYPE - WRITER.

Write to the editor of the REVIEW. He has an Ode-ll, taken in payment for advertising, and he would be pleased to send descriptive circulars or to correspond with any one thinking of buying such a machine.

1898 Queens 1898

For Business—Queens for Strong Colonies - Queens for large surplus. Competition in Quality, but not in price.

If you want queens, nuclei or supplies at bottom prices, send for my illustrated price list. 12-97-tt

J. P. H. BROWN, Augusta, Ga.

Queens bred in the North are hardy and fertile. Every bee-keeper should try one of these Northern grown queens. Pure bred Italian queens at 75 cents each; or 12 for \$6.00.

WM. H. BRIGHT, Mazeppa, Minn.

Please mention the Review.

To stick things, use **MAJOR'S CEMENT.** Beware!!! Take no substitute. 2-98-12t

FREE TO BEE KEEPERS. How to manage bees? Send for our 26 page Illustrated Catalog - It tells you all about hive fixtures, sections, bees, queens, &c. The best and cheapest goods. **JOHN NEBEL & SON, HIGH HILL, MO.**

Best on Earth. 19 Years Without a Complaint.



		Dozen	Each
Smoke Engine (largest smoker made)	4 inch stove	\$13.00—mail,	\$1.50
Doctor	3½	9.00—	1.10
Conqueror	3	6.50—	1.00
Large	2½	5.00—	90
Plain	2	4.75—	70
Little Wonder (wt. 10 oz.)	2	4.50—	60
Honey Knife		6.00—	80

For further description, send for circular.

T. F. BINGHAM, Farwell, Michigan.



Bee-Supplies

We have the best equipped factory in the West. Capacity, one carload a day. We carry the largest stock and greatest variety of everything needed in the apiary, assuring *Best Goods* at the *Lowest Prices*, and prompt shipment. Illustrated catalogue, 72 pages, free.

We also manufacture tanks of either wood or galvanized steel, all sizes, any form, and for all purposes. Price list free. Address

E. Kretschmer, Red Oak, Iowa.

Page & Lyon,

Mfg. Co.

New London, Wis.

Nearness to pine and bass-wood forests, the possession of a saw-mill and factory fully equipped with the best of machinery, and years of experience, all combine to enable this firm to furnish the best goods at lowest prices. Send for circular, and see the prices on a full line of supplies.

TESTED QUEENS,

At \$1.00 each. As usual, I am requeening my apiary this spring with young queens from the South, and, that the tested queens that are removed may move off quickly, I offer them at \$1.00; or six for \$5.00. These queens are fine Italians of last year's rearing, and right in their prime. The Review one year and one of these queens for only \$1.75.

W. Z. Hutchinson,

FLINT, MICHIGAN.

No Fish-Bone

Is apparent in comb honey when the Van Dusen, flat-bottom foundation is used. This style of foundation allows the making of a more uniform article, having a *very thin* base, with the surplus wax in the side-walls, where it can be utilized by the bees. Then the bees, in changing the base of the cells to the natural shape, work over the wax to a certain extent; and the result is a comb that can scarcely be distinguished from that built wholly by the bees. Being so thin, one pound will fill a large number of sections.

All the Trouble of wiring brood frames can be avoided by using the Van Dusen *wired*. Send for circular; price list, and samples of foundation.

J. VAN DEUSEN,

SPROUT BROOK, N. Y.

Dovetailed Hives.
Cowan Extractors.

Danzenbaker Hives.

Porter Bee-Escapes.

No-Drip Shipping Cases.

Gleanings in Bee-Culture.

OUR
SPECIALTIES.

The Fence and Plain Sections.

Weed New Process Foundation.

Root's



Goods.

Catalog of goods and sample of Gleanings sent for your name on a postal.

The A. I. ROOT CO., Medina, Ohio.

Branch Offices :

118 Michigan St., Chicago, Ills.

1024 Mississippi St., St. Paul, Minn.

1635 W. Genesee St, Syracuse.

10 Vine St., Philadelphia.

Mechanic Falls, Me.



Bee-keepers in the

Northwest

Can save money and freight by getting their supplies from the Minn. Bee-Keepers' Supply Mfg. Co., Nicollet Island Power Building, Minneapolis, Minn. They have all the latest and most improved machinery and manufacture and handle a full line of supplies. Send for catalogue before ordering.

Please mention the Review.



I have had 30 years of experience in queen rearing, and make a specialty of the business. I have my cells built in full colonies, and send out no poor queens. I can furnish the best and purest of Italian queens, either 3 or 5-banded, at only 50 cts. each. My P. O. is a money order office.

Daniel Wurth, Falmouth, Ind.

7-98-3t

Please mention the Review.

Michigan Headquarters for the G. B. Lewis Company's

SUPPLIES,

Dadant's foundation, and everything needed in the apiary. Send for price-list to **L. C. WOODMAN,**

3-98-6t

Grand Rapids, Mich.

Please mention the Review

COMB

FOUNDATION

WHOLESALE AND RETAIL.

Working wax into foundation, for cash, a specialty. Hives, Sections, and a full line of Supplies. The best of everything. Write for Catalog, with prices, and samples of Foundation and Sections. Beeswax always wanted for cash or trade.

GUS. DITTMER,

10-97-12t

Augusta, Wis.

The A. I. Root Co.'s Goods, WHOLESALE AND RETAIL.

Please mention the Review.

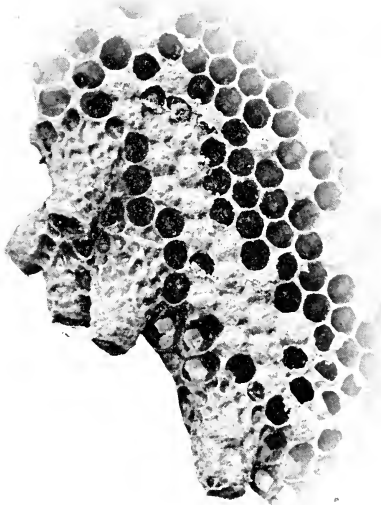

Cluster of Queen - Cells.

The Bee-Keepers' Review

A MONTHLY JOURNAL

Devoted to the Interests of Honey Producers.

\$1.00 A YEAR.

W. Z. HUTCHINSON, Editor and Proprietor.

VOL. XI. FLINT, MICHIGAN, AUGUST 10, 1898. NO. 8.

QUEEN REARING.

Some of the Ingenious Plans and Devices now
Employed in the Business.

W. H. PRIDGEN.



THIS article will not treat of all the ways by which queens can be reared; nor of such as work well under the most favorable circumstances, with the least labor, but, at other times, are attended with a partial or total failure. Instead, it will give a sure way of securing good ones and having cell-cups invariably accepted, whether the honey flow is continuous, or feeding has to be resorted to; and it is suited to the rearing of a few or to queen rearing on an extensive scale.

The preparation of the cell-builders is an important factor. To begin with, we will fill a hive with combs of brood, without bees, taken from the colonies that can best spare them, substituting empty combs or frames filled with foundation.

Place this brood over a populous colony with a queen-excluder between. Ten days later remove all queen-cells, if any; give the hive-body a top and bottom, set the lower hive containing the queen off a few feet, and the other in its place. If the bees are flying freely the queenless half will be ready to accept a batch of cells in four or five hours.

This plan has the advantage of having young bees added to the cell-builders, for a day or two, from the part containing the queen and brood, and adds much to the quality of the young queens.

When the batch of queen-cells are removed, select the next colony for cell building; find the queen and hang the comb she is on in an empty hive near by. Set her hive off its stand and the former cell builders on it with an empty body over the latter. Now shake the bees from nearly all the combs in among the queenless bees; return the comb and queen, and place her hive where the queenless one stood. In a few hours, or as soon as the bees become restless, or show the queenless sign, they will be ready for cell-building. As they have no brood, we must not forget to place a comb on each side of the cells as soon as they are sealed; as it has a good effect generally and prevents the bees from gnawing off the

points of the cells too soon. Besides, if this is not done, this operation cannot be repeated more than twice before laying workers will appear, and then we will have to start with a new set of combs. In fact, when the second batch is removed, the queen from the next colony to be prepared should be given to them, the bees to build the next cells shaken off on combs free from unsealed brood, and the brood placed over an excluder as in the first case, to be used ten days later for cell building. If one is in so much of a hurry that ten days is too long to wait, the first batch can be built by bees prepared as in the last case by forming a nucleus with the queen, or otherwise disposing of her.

Whenever the combs are to be used the second time, by exchanging places and shaking bees into the hive so as to get young ones, the brood given about the time the cells are sealed should be from over an excluder or from bees long enough queenless so that all the brood will be sealed by the time the first batch of cells mature, then it will not have to be removed.

The main idea is to have bees just deprived of their queen and of unsealed brood. The cups can be given in an hour or so when they have some sealed brood.

Those who do not desire increase, but wish to rear a few queens, can live the swarm on empty combs on the old stand, cage the queen and place her on the frames and return her to the parent colony at night.

The cells should be given as soon as they can be prepared after the swarm is lived; and, when they are mature, the parent colony returned to its former position, having been set back a few feet, at the time of swarming, and the swarm shaken from the combs.

No one can tell in one article of all of the little things connected with the manipulation of the bees, or anything else about queen rearing, but it is hoped that some ideas will be advanced that will aid

others in properly varying matters according to circumstances, for no one can make a success of it unless he can do some planning and thinking for himself.

The dipping stick should be made as shown in the illustration, and not larger than 5-16 of an inch in diameter. The

tapering part should be 5-16 of an inch long; reduced rapidly for the first $\frac{1}{8}$ of an inch and then gradually reduced to the end. It should slip into a worker cell $\frac{1}{8}$ of an inch before filling the mouth of the cell, form a sink in the wax cup that will bear sufficient pressure to make the cocoon fit snugly without touching the bottom.

The stick should be dipped rather less than $\frac{1}{2}$ of an inch deep into the wax, and four dips complete a cup and attach it to the bar. For the first three times hold the stick so that the drops will form and set on first one side and then the other, and thus form a foot to fit in the notches as shown in bar with cells attached. [See the cut on page 240.] Then loosen it up on the stick, dip again, place in the notch, and it will adhere, and not snap off when the transfer of cocoon is made. The notches are exactly $\frac{5}{8}$ of an inch apart from center to

center, and the tin divisions in the nursery the same, so that a whole batch can be placed into it without detaching the cells. Some may imagine that the notches in the bar interfere with the cutting off of the cells when it is desirable to do so, but such is not the case, as a table knife inserted at one side of a cell will easily pry it out. After a bar is notched it should be mopped with melted wax, especially in the notches, before the cups are attached. During a honey flow the cells are joined together by the bees



building wax between, but they can be easily separated with a hot knife. Any number of cups desired can be used. I usually have eighteen, and out of five batches built within the last few days there were only three cups rejected.

Cut out the lower half of a comb and notch the end bars of the brood frame even with the part left, and by having the slat or bar (I use bars $\frac{1}{2} \times \frac{5}{8}$ of an inch) just the right length they can be slipped in and out very handily.

Instead of alternating the cells I now have them built in one straight row, so as to be convenient to insert in the nursery. If it is not desirable to remove and introduce the young queens as fast as they hatch, which I prefer doing, so as to discard such as I do not like, it will be found that the cells will be more readily accepted if protected by the nursery until the first queen emerges.

I have not yet determined how many days in advance of hatching it will do to protect the cells with the nursery and thus reduce the number of days of queenlessness by the cell builders.

The comb should be quite old, such as has been used for many generations of brood; so that the cocoons that are to be transferred from will be thick and heavy, and then shaven down with a thin, sharp knife, slightly heated, so that the cells are barely $\frac{1}{8}$ of an inch deep. It should be cut very smoothly so that there will be no ragged edges; and when bent back and forth the cocoons will loosen up, and can easily be removed. Some allow them to fall out on a piece of flannel, and then take them up, but with a properly made transfer stick such as shown at the small end of the forming stick, made a little tapering, so as to stretch the cocoon a little just above the hollowed out point, I have no trouble in taking the cocoons right out of the comb. By having cups warm (at a temperature of 90°) they stretch when the cocoon is pressed in and then a little twist of the stick makes all smooth and nice.

This plan is objected to by some because the combs have to be cut, but practice will prove that the advantages in being able to use larvæ too small to transfer otherwise, surrounded by food supplied by the bees to suit its age, will more than counterbalance the damage to combs. Besides, old ones that have been in use until they need removing can be used repeatedly during a season.

In selecting the larvæ, that used in the different sets of cups should all be of the same age, if it is expected that all will be accepted, fed alike and hatch the same day. For the best results it should not be larger than can be just seen easily with the natural eye; and many times I use it when only a tiny wet spot can be seen in the bottom of the cell. It is best after a comb is filled with eggs to give it to queenless bees, as the larvæ is fed more abundantly; especially is this the case during a honey dearth. My experience is that there is not as much difference in the hatching of the queens as there is in the age of the larvæ used; and unless surrounded with an abundance of food, one larger than the head of an ordinary pin produces a black tipped runty queen.

If it be desirable to form nuclei, a hive can be filled with combs of brood (sealed and hatching preferred) and placed under the cell-builders when the cells are sealed. In any of the cases mentioned, when the cells mature slip them in the nursery described on page 240, or any nursery you have convenient, and as soon as enough young queens hatch, form nuclei by using a comb of honey and one of brood, giving each a queen. Place them in a dark room one day for them to become accustomed to their changed condition, when most of the bees will remain, when the nuclei are set out; especially so, if the weather or conditions have been such that they have not flown freely for several days.

If only one batch of cells is to be built, and the first arrangement be used, when the nuclei are formed as described

above, the hive over which the first brood was placed can be set in its former position, and it will be seen that a batch of cells has been built, and a number of nuclei formed without stopping a queen from laying or removing her from her hive.

CREEK, N. C. June 22, 1898.



ARRANGEMENT OF HIVES.

Objections to the Hexagonal Plan; Advantages of Proper Grouping.

J. E. CRANE.

Where order in variety we see,
And where, though all things differ, all agree.

POPE



JUDGING from the many illustrations of apiaries in our bee journals, there seems to be about as many ways of arranging the hives as there are persons to do it. Some are arranged in

two or three long rows, while others are very compact. Others are without order or system of any kind. Of course, the location and surroundings make some difference; as a steep side-hill, or a cramped enclosure or perhaps an immense boulder in the middle of the yard, are "circumstances that alter cases."

If possible, a yard should be out of the wind. One who has not had experience will find it hard to realize how much damage a strong draft of air through a yard of bees will do. I have, in one or two instances, had almost every colony die, during the winter and spring, on one side or end of the yard where there was a strong draft of air. In one such yard,

where once I lost heavily, I last winter wintered nearly 100 colonies without the loss of a single colony; and, with the exception of two or three, every colony was in good condition in the spring; and these exceptions came on and made good stocks a little later; but the wind is now headed off by an arbor vitae hedge across an end and part of one side; while the other side is enclosed by a high picket fence.

I know of no way to arrange an apiary that looks better on paper, than the hexagonal plan recommended by A. I. Root; especially when each hive is shaded by a neatly trimmed grape vine; but, unfortunately, grape vines will not grow in every place as they do in Medina; and, even if they did, we have little time to care for them in out-apiaries. Some twenty years ago I started a yard on the hexagonal plan, without the vines, only to find the next spring the central part of the yard greatly weakened from bees missing their own hives or mistaking another for their own. There was also a large loss of queens. My hives were all one color, which, doubtless, made matters worse.

After various trials I have found nothing so satisfactory as placing hives in groups of ten. If you can have a tree

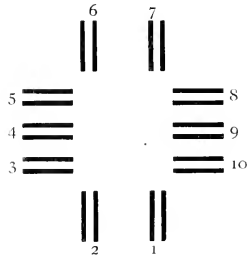

planted in the center of each group, and each group painted a different color, so much the better. A basswood tree grows quickly and looks well, and I have one planted in most of the groups of one yard. This is the way I would make a group:

Two hives facing the north, three facing the east, two the south and three the west. Now, if we have three groups in a row, and three rows, we shall have ninety hives in a very compact body and yet so arranged that we can have ample passage ways between the groups, and the bees can with little difficulty recognize their own group and then their own hive.

Reference has been made in some of our bee journals within the last year or two to the numbering of hives. While a few hives may be run successfully without numbers, I scarcely see how several large apiaries can be run without serious loss, unless one person is constantly on hand at each yard to watch them, or else they are so located that each number or hive can be quickly located and remembered. This system of grouping, if we let each group be numbered the same, greatly simplifies the matter; for, if we let the two hives facing the north represent 1 and 2, and those facing the east 3, 4, and 5, those south 6 and 7, while those facing the west 8, 9, and 10, we shall know just where to find these hives. Now, if the first group in the first row take the first ten, the second group the second ten, or up to twenty, the third group will take the twenties, and the first of the second row the thirties, and so on to the end, you will see we can go to any particular hive or number in the darkest night without the slightest difficulty. While I can readily remember the condition of many hives from their location, I like to go by numbers; for there are many things I want to note down; especially is this true when I have several hundred hives and take care of all of them myself with perhaps one man to assist me.

What I use for a record book and how I keep my records will be told in another paper.

MIDDLEBURY, Vt. June 20, 1898.

QUEEN REARING ON A LARGE SCALE.

Description of an Apiary Containing Five Hundred Nuclei.

H. G. QUIRIN.



FRIEND H.—
The photo of my apiary was mailed you on Friday, the 24th. As will be seen, the shot was taken from an elevated position; the camera being placed on a wind-mill tower which is about centrally located among the bees.

Right down in front of the tower was an apple tree; the top branches showing in the photo. The foot-path through the open gate leads directly to the honey house, or house where all general work is done. The house is not visible, except a small white spot showing above the tree tops, which is the chimney. The house is a one and a half story, with three rooms below. One of the rooms has a stove in it so that we are independent of the weather in handling cells. Just beyond the house, and in the farthest left hand corner, is the solar wax extractor. On the south side of each nucleus is a nice large stalk of catnip. This catnip was planted last spring for the purpose of furnishing the nuclei with shade during the middle of the day and yet allow them plenty of sun, as I find that nuclei will not do so well in either a dense shade or when right out in the open where the sun has full swipe at them during the hottest part of the day. Some of the catnip is two to three feet in height, and partly hides from view some of the nuclei. Just beyond the first picket fence can be seen part of the queen rearing hives. But few of the hives appear in the picture on account of the trees. I might also add that only a very

small percent of the nuclei can be seen, the trees hiding many of them, while the camera took in but one corner of the business; the boxes being scattered over such a large area that it would be impossible to show it all without taking from four to six shots; so we took the part which I thought would show the best. The nuclei are of regular L. size, but I do not use the regular sized frames in them.

business assumed such proportions, I was engaged in rearing broilers for the early markets. It is only a year ago last winter when that same building contained 1,800 little chicks at one time; and that, too, when the temperature was down to twenty-four degrees below zero. A little this way, and to the left, beef can be seen grazing in the pasture; yes, and even ham and eggs are visible in the photo., but I

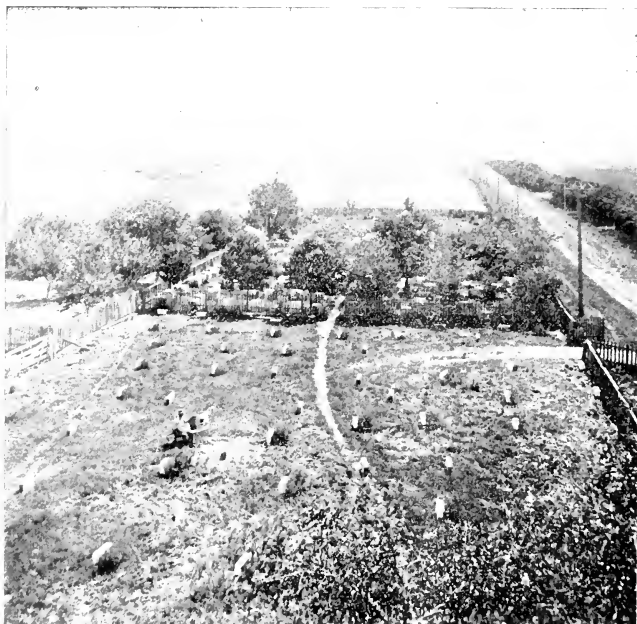

QUEEN REARING APIARY OF H. G. QUIRIN, BELLEVUE, OHIO.

The boxes have a division in the center so that a frame only half the size of the regular L. frame is used; and two nuclei occupy one box. Away in the distance can possibly be seen a low but rather long building with three windows. As some might naturally wonder, I will tell you what it is. Years ago, before the bee

shall not tell you where. You see I am located on a farm; the country roundabout is quite level; in fact, it is one of the most extensive prairies in northern Ohio. To the right can be seen a telegraph line which leads from Chicago to N. Y. Well, I guess I have told you all about the picture except that the writer is seated on

one of A. I. Root's daisy wheel-barrows, with a comb of bees and brood in hand. I appear there just as I was working with the bees, as the photographer came along while I was busy at work.

Probably, friend H., you would like to know something more about the writer, personally; well, for your private ear, will say that I am twenty-six years old, and live with my parents. My bee-keeping dates back some fourteen years; when I became greatly interested in the queen bee of the hive; and at once went to rearing queens for pleasure. After my nuclei were filled with laying queens I used to kill them off and begin over; but I finally found there was a market for queens; and, when about 18 or 19 years old, I began to offer them for sale through Gleanings; and have continued rearing them for market ever since. I often think I am too far north for queen rearing, as the seasons are so short, and I have for some time been thinking quite seriously of going farther south, where queen rearing could be engaged in much earlier in the season.

BELLEVUE, Ohio, June, 17, 1898.



NOTES FROM FOREIGN BEE JOURNALS.

F. L. THOMPSON.

As cold waters to a thirsty soul, so is good news from a far country. BIBLE.

EITHER the "kobold in the compositor's case," or the transcriber, has thoroughly mixed a sentence on page 176, first column. Read "During an abundant flow, the only fluctuation consists of a slight decrease in the early morning, caused by the departure of bees, after which there is a steady increase until evening. The increase during any fixed space of time," etc.

L'APICOLTORE.—Water from an external source as a means of softening gran-

ules of honey has a very subordinate influence, or none at all, asserts Editor Von Ranschenfels as a result of experiments. (Lately I fed several hundred pounds of granulated honey in crooked and drone combs, by simply setting them outside in receptacles. When the bees got through with them, they appeared about as light as empty combs: 150 lbs. of granulated honey in cans was also removed almost without residue. All this honey, however, had a very fine and uniform grain.)

The editor has tried giving water in the hive on the rare occasions in March when eggs are present but no unsealed brood; but without appreciable results.

He thinks Prof. Cook in error in asserting that bees frequent watering-places in summer in order to quench their thirst. As proof he refers to the numerous instances in which bees have been successfully sent from Italy in midsummer to all parts of the world, without a drop of water. Drones are never seen drinking water.

Homeopathic doses in stimulative feeding he thinks are worthless.

Colonies belonging to N. Jozelli which were in the shade all winter and most of the day in spring were nearly a month later in development than those which received the sun's rays.

The editor reports that 27 stations of observation in Switzerland take minute observations the year round by means of steelyards and thermometers. At each place a colony is weighed once every ten days in winter, once a day before and after the main flow, and twice a day during the gathering of the principal crop. Notes are made of the population, wind, flight, plants that bloom, rains, dews, etc. Many stations emphasize the fact that those colonies which have the brood surrounded by a compact circle of full honey-cells are the best. The hive that has brood and pollen promiscuously contains poor workers. At some stations it was observed that combs of sealed honey lost from 32 to 50 grammes in weight in two months.

"My watering-bottles are frequented even during a rain. I have observed that on days in which the flow is heavy, they are almost entirely abandoned. This has become one of my most certain signs that the bees are gathering honey."—G. Laufranchi. "If during a period of bloom the bees gather abundant pollen all day, it is a certain sign that nectar is lacking."—Editor.

The editor has never been able to convince himself of the exactness of the affirmation that when forage is deficient near by, the bees will go four miles for it. Twice at a distance of two miles, and once three miles away, pasturage was abundant, but his bees gathered nothing.

"Many still believe that the entrance of the surplus apartment serves to shorten the travel of the foragers. No, the bee that flies in the fields goes and returns through the brood-nest entrance; it does not frequent the super, having nothing to do there. When it enters the hive it delivers its load of nectar to the first home bee that extends its tongue to it. This one either employs it for the nutrition of the brood, or keeps it in its own body, where it is separated from the water it contains, part of which is absorbed by the organism, and part by respiration. That the nectar is stored in the cells by the honey-gatherers as it comes from the flowers, and is there condensed by direct evaporation, is a fable to which no one who wishes and knows how to observe will lend credence."—Editor.

The strongest colonies of Guiseppe Laufranchi in 1897 yielded less than half as much surplus apiece as many of the other colonies. He comments thus: "For years now I have observed that especially in poor seasons the strongest colonies here among us northerners eat their heads off; and for that reason, under ordinary circumstances, I prefer colonies not too populous, which in poor and good seasons alike, when the extractor is handy, give me a good quality of honey." The editor has this foot-note: "This is a truth of which the lamented Dr. Metelli

never wished to persuade himself, accustomed as he was to practice apiculture in Reggio Calabria, the promised land of bees, and at Berlingo, where, as he said himself, from the beginning of the season until late autumn, pasture for his bees was never lacking. In a region with a very rich nectar-bearing flora, especially in spring, capacious hives and gigantic populations will always have the advantage over those of more modest proportions; in less favored zones, as a rule, not."

The editor says an artificial swarm should always have the queen of the hive from which it was taken, not a strong one, because otherwise it becomes too excited, and might abscond.

On his plan of introducing queens by means of an artificial cell, or wax cage (Review, p. 14), he remarked "The acceptance of laying queens is so certain that I no longer take pains to verify it. I have not yet tried it with virgin queens. The operation is simple, easy, and speedy. In two to four hours the queen is liberated, while when she is in a wire cage from 24 to 48 hours elapse."

A writer named Jukos, quoted by Dr. Dubine, assigns as a reason for waiting five or six days before destroying the queen-cells after the issue of a first swarm, that the bees destroy the cells from which only small queens would emerge.

Rev. Caruana Dingli writes on bee-keeping in Malta as follows: "Neither size of my hives, nor abundant ventilation and the substitution of full sheets of foundation for brood combs, which are removed, check the swarming impulse of my bees in seasons like the present one. Our queens lay the whole year, and especially when January comes the hives are boiling over with bees. Queens are fecundated in every season of the year. . . . When a colony swarms here, it is not, as the books say, 6 or 7 days before the second swarm issues, but it does so on the next day, or, at most, two or three days later, and several times I have had two swarms in the same day from the same hive. The queen-cells are very

numerous; several times I have counted 50 or more on one comb, and many newly hatched queens accompany every swarm. Signor Giovanni Francia has always told me that the Maltese bee has characteristics and valuable points which distinguish it from all other races, among which are noteworthy its singular activity, the prolificness of its queens and its lack of inclination to rob. He wished to keep bees by Italian methods, but very soon had to change his plan. The colonies remain at the same degree of development all the year." The editor adds this foot-note: "The Maltese bee, of the black race, is doubtless more disposed to swarm than the Italian; for by never having a lack of empty cells to deposit eggs and store honey in, supplying continual work to the home bees by giving them full sheet. of foundation to draw out, keeping the hive well ventilated internally, shaded from the scorching rays of the sun, and above all, by preventing *precocious* drone-rearing, our colonies, as a rule, give no more than 15 per cent of swarms. There are rare seasons, however in which the swarming impulse becomes absolutely incoercible. At such times the only efficacious method is that employed by the Rev. Caruana Dingli."

MONTROSE, Colo., July 15, 1898.



EDITORIAL Offerings.

THE EDITORS of most of the bee journals are taking little outings this season, even if some of the trips are not very extended. Good thing to do.

THE APIARY BUILDING at the Omaha Exposition is 148 feet long by 75 feet wide and there is a skylight on each side of the ridge pole, extending the whole length of the building.

HASTY was not behind this month, but we were ahead, and had the Review so nearly up when his copy came, that I thought best to let it go over until next month—then it will surely get in.

A WEEK'S OUTING is what I have recently enjoyed with my camera among the bee-keepers of Northern Michigan. I shall probably begin next month to tell you "what I saw up North."

MY NEIGHBOR KOEPPEN, who has six apiaries, will have at least 20,000 pounds of white comb honey. From some of his apiaries he may get some fall honey. He had a young man help him about three months this season.

MR. WM. A. SELSER, the honey man of Philadelphia, bottled and sold thirty tons of honey last year. Mr. Selser recently visited Mr. Snyder of Kingston, N. Y., and bought his crop of extracted, and while there he told Mr. Snyder of the amount of honey he had sold, and Mr. Snyder in writing me mentioned the visit and this little bit of tale that has thus been told out of school.

THE WIDTH OF SECTIONS that I used this year is only one and one-half inches. Several years ago, when I lived at Rogersville, I used several thousands of sections of this width. This is the width that bees naturally build their comb, and they build this width of combs more even and straight, without separators, than they do the thicker combs. They complete and cap the combs quicker. Fourteen sections weigh about twelve pounds. I like sections of this width.

CONSOLIDATION among the bee journals is recommended in a private letter that comes to me from the Pacific coast. It is urged that if there were only one bee journal it would or could be made vastly superior to any we now have; and the expense to bee-keepers would be greatly re-

duced to what it is now in subscribing for several journals. Of course, there is truth in this view, but there is another view; competition is a great spur to improvement.



THE UNITED STATES BEE-KEEPERS' UNION will hold its annual convention in Omaha, September, 13, 14, and 15, at the Delone Hotel, corner 14th St. and Capital Avenue. Rates for rooms, on the European plan, will be \$1.00 a day, and board \$1.00 a day. Railroad rates will be one fare, plus \$2.00, except from points within 150 miles of Omaha, where the rate will be simply one fare. The round trip from Chicago will be \$14.75; Peoria, \$13.25; St. Louis, \$15.50.



SNOW-WHITE SECTIONS are in demand by bee-keepers, but I agree with Mr. Hubbard, as he expresses himself in the article that I copy this month, that they are the only ones that demand them. Neither the merchant nor the consumer asks for them. It is the *honey* they look at. Of course, the sections ought not to look rough, dirty or mildewed, they should be neat and smooth, but, in ordinary cases, I believe it is poor business management to pay extra for snow-whiteness.



FOLDING PAPER FOR THE BOTTOMS OF SHIPPING-CASES.

Gleanings for June 15th uses more than a page and several diagrams in describing the method and tools used by Mr. Muth-Rasmussen in folding the paper trays that go in the bottom of the no-drip shipping-cases. There is no doubt that the plan described will work all right, but there is a much simpler and quicker method. It was described in the Review of a year ago. I quote as follows:

"If any one experiences any trouble in folding up the paper tray that goes in the bottom, let him make a board about one-

eighth of an inch, or a trifle more, smaller than the inside of the case. Place the sheet of paper on top of the case, lay on the board, and then gently press down upon the board, forcing the paper to the bottom of the case. A nail driven in the upper end of the board will furnish a handle for removing the board. The lower corners of the board may need rounding off to prevent their puncturing the paper. It may require a little patience and practice to get the board just right and to learn how to use it, but the neatness and dispatch that follow will amply repay the trouble."



SLANG.

Mr. Taylor has given some of his criticisms to slang; and in the last issue of Gleanings its editor is inclined to defend the use of slang, on the ground of its expressiveness. He says their proof reader calls slang, "language in gestation—formed but not born." Beautiful, pure language, and clear, and well formed, logical sentences are very enjoyable, and are to be commended; at the same time, as editor Root says, slang is very expressive. The temptation to use it is sometimes very great; and perhaps a moderate use of *respectable* slang is not so very objectionable. Slang is born from some stress of circumstances, and so thoroughly is the spirit of the occasion impressed upon it, so pat are the words thus coined, that the meaning is at once recognized without any definition. Let us not be too hard on slang. Old words are dying and new words taking their places; and when these new words are babies they are called slang.



HONEY-DEW FOR WINTER-STORES.

Quite a number have written me that their bees have gathered honey-dew this season. In some localities the bees have filled their hives with it. Gleanings for August 1st has an editorial of about a column on this subject. In this article

it is advised that honey-dew be left for the bees to winter upon. The editor uses the following sentence: "Indeed, I am coming to believe that food has less to do with successful wintering than we formerly supposed it had." Oh, Ernest, how heretical! The reason given for this belief is that they (the Roots) have wintered their bees successfully on all sorts of stuff, including this honey dew. This article also explains that there is a difference in honey-dew; some is almost black, and sickening in flavor; while some is light in color and rather pleasant in taste. I remember that Prof. Cook used to tell us of these two kinds of honey-dew, and explain that one came from one source, and the other from some other source, but I have forgotten now what was the exact difference in the sources. He used also to tell us that he considered the light colored wholesome, and that with the right conditions it might be safe for winter-food for the bees; but he most emphatically condemned the dark ill-flavored variety. It is quite likely that in southern localities, where it is not so cold, and where bees may enjoy an occasional flight during the winter, honey-dew may be all right for winter-stores, but there have been too many heavy losses from this source, where the winter is long and cold, to trust it for winter-stores.



A FEW WORDS IN DEFENSE OF OUR CRITIC.

Ever since beginning the "Department of Criticism" I have been receiving letters of advice in regard to it. Do not think that this has displeased me; on the contrary I am always glad to have my readers say what they think of the Review and its management. Some of these letters have been commendatory, while others have condemned. The greatest fault has been found on account of the style that Mr. Taylor used. One correspondent wrote that Mr. Taylor and Dr. Miller both wrote as though they were personal enemies. Another thought Mr. Taylor hit pretty hard; he would not

like to have Mr. Taylor get after him; "but," he added, "I do like to see him kick the other boys." The most of these letters have been sent to Mr. Taylor, and he and I have corresponded over this matter of style. He says that he is glad of any suggestions, and is willing to do what he can to avoid giving offense, but he doubts his ability to make a success of the "school girl style." You know, Mr. Taylor was, for several years, a practicing lawyer; being, at one time, the Prosecuting Attorney of Lapeer county, and lawyers soon learn not to mince matters, but to say in plain United States exactly what they mean.

Perhaps you have not noticed it, but our apicultural journalism has somewhat degenerated in the line of criticism. It has fallen into what Mr. Heddon calls the "pussy cat style." Attempts at criticism are couched in language so apologetic and "mealy mouthed" as to nearly rob them of all force. The object of our bee journals is to teach; to tell their readers how to make of bee-keeping a more pleasant, safe and profitable business. Errors and fallacious ideas will creep in in spite of the best intentions; and if we have found a man who has the courage and ability to point them out, let us have patience with him, even if his vigorous style does startle us. Criticism is a thankless task at best; so let us have charity. I have faith in Mr. Taylor's good intentions, and believe that his department will prove to be the best that the Review has ever started. He is doing better work now than at first, and I think it will continue to improve. It seems to me that no one could take offense, even at his style, in his criticisms for this month.

Some fault has been found because Mr. Taylor is rather lenient in his criticism of what appears in the Review. I suppose it does come a little tough to criticize one's employer, but I hope that Mr. Taylor will yet be able to bring himself to the task. I certainly have no desire to see favoritism shown the Review.

MODERN QUEEN REARING

Queen rearing has kept pace with the other strides made in the apicultural line; and it is doubtful if any queen breeder uses any more advanced methods than those employed by Mr. W. H. Pridgen.

Illustration, they are supplied with just-hatched larvae, using the small, concaved end of the forming stick, whereby the larva can be picked up, cocoon and all, and deftly transferred to the bottom of the cell-cup. This is "taking up the baby without waking it up," as somebody

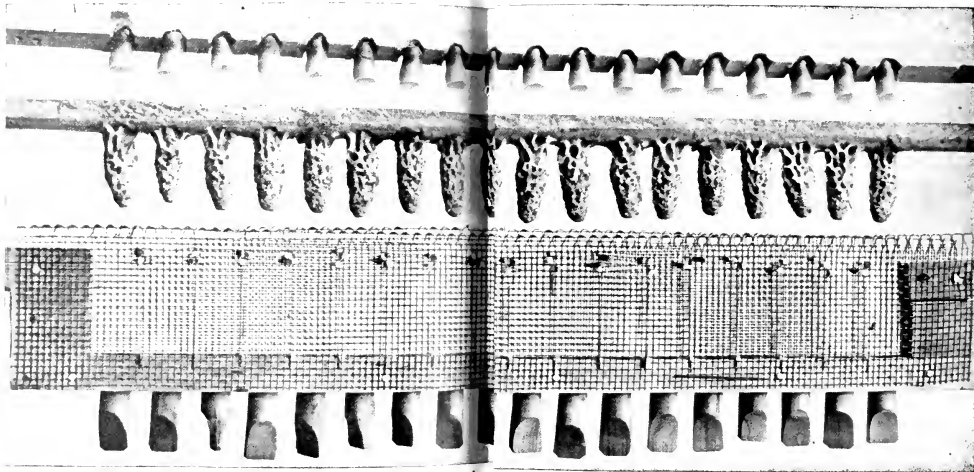

CELL-CUPS, COMPLETED CELLS AND QUEEN-NURSERIES, AS USED BY W. H. PRIDGEN, CREEK, N. C.

of Creek, N. C., who furnishes an article for this month's Review. He also furnished the originals from which the accompanying engraving was made. The process of dipping the cell-cups is described on page 230. After the cups are attached to a stick, as shown in the il-

lustration, they are supplied with just-hatched larvae, using the small, concaved end of the forming stick, whereby the larva can be picked up, cocoon and all, and deftly transferred to the bottom of the cell-cup. This is "taking up the baby without waking it up," as somebody

with them is well shown in the engraving. Isn't this away ahead of the old way where the bees went at it to suit themselves, as shown in this month's frontispiece, where it is almost impossible to save all of the cells? Before the cells are ready to hatch they are placed

in a little apartment all by itself. If a queen hatches it can do no damage, and it can find food in the shape of soft candy placed in a depression or cavity in the top of the wooden plug that closes the lower part of each little cage. The queens are safe and well cared for here

in the nursery. This is done without so much as detaching them from the stick. They are all an even distance apart, and this distance just equals the distance between the tin divisions in the nursery, so that the cells can be lowered all at once into the nursery, and each cell has a

until needed to put in nuclei. It would seem that so far as securing virgin queens is concerned, we had pretty nearly reached perfection. The great cost, however, of rearing queens, is in getting them fertilized and laying—the nuclei and bees cost much more than the queens. When

this part of the business is cheapened and simplified to the same extent as has been done with that of cell building and queen hatching, queens may be sold for a "quarter"—I guess. Some attempts have been made in this direction by having small frames, section honey boxes, for instance, for nuclei, and massing them on top of a colony of bees so that they may derive warmth from the colony; but such methods have never come into general use. It is clear to me that there would be some disadvantages.

WHAT THE DEALERS THINK OF FACING
COMB HONEY. MR. DOOLITTLE
MISUNDERSTOOD.

Several times I have thought of writing to the commission men and honey dealers asking for their views regarding the "facing" of comb honey when crating it for market. It seems that Bro. York not only thought of the same thing, but had the enterprise to carry it out. In his letter to the dealers, Bro. York quoted the paragraph in which Mr. Doolittle said that he could see nothing out of the way, that is, dishonest, in putting even buckwheat honey in the center of the case, and facing with white honey; provided it was to be sold on commission. All dealers are opposed to the putting up of honey in such a way as to deceive the buyers, or to the mixing of inferior grades with those of a higher grade. I suppose that pretty nearly every one takes this view of the matter.

By the way, I think that Mr. Doolittle has been entirely misunderstood in this matter by a great many. If anyone will take the pains to read carefully, they will see that Mr. Doolittle never *advised* the putting of buckwheat honey in the same crate with white honey. The real point of his argument seems to have been overlooked. Some one said that it was *wrong* to "face" cases of comb honey. Mr. Doolittle said that it was *not*, *if* the honey was sold on commission; that it would

not be wrong under such circumstances even to put buckwheat in the center of the case. In short, he believes that a man has a right to put up his honey in that manner if he wishes, and to say to his customer "There is a case of honey. Look it over; and if you want it you can have it for 12 cents a pound." That is his argument; and it is correct. But when it comes to the *advisability* of so putting up honey, that is a horse of an entirely different color; and if you will examine him carefully I think you will find that Doolittle has not on its back.

The foregoing was put in type for use in the July Review, but was finally crowded out. Since then Mr. Doolittle has had an article in the American Bee Journal in which he takes similar grounds. I feel positive that Mr. Doolittle has been grievously misunderstood.

In his comments upon Mr. Doolittle's article Bro. York says that Mr. Doolittle's weak point is in saying that there is no wrong even in putting buckwheat honey in the center of a case of white honey that is to be sold on commission. Like almost every one else, Bro. York fails to catch the true spirit of this position, viz., that goods sold on commission are supposed to be opened and examined and sold for what they will bring.



Department of criticism

R. L. TAYLOR.

Blame where you must, be candid where you can,
And be each critic the Good-natured Man.
GOLDSMITH,

CONTRACTION OR SUBSTITUTION, WHICH
IS IT? LET'S AVOID QUIBBLING.

In Gleanings, 519, the editor is not satisfied with my calling his removing

one of the two hives in which his colony has been, when he puts on the caps for comb honey, contraction. He is inclined to think it should be termed substitution. I wish he would be so good as to define exactly what he understands by contraction. Is Doolittle's method of taking out one, two, or more, combs from the brood chamber, when he puts on section supers, contraction or substitution? My practice till lately has been to hive swarms in one section of the Heddon hive for a brood chamber. If taking away one half the brood chamber is not contraction, why should *that* practice be called contraction? There will be little profit in discussing these points, if, in order to get out of a tight place, we wrest words from their usual significations.

SIZE OF BROOD-NEST IS NOT SIZE OF COLONY.

Again, the editor, on the same page, in reply to the editor of the Review on using two or more stories for brood nests in working for comb honey, says: "This is no theory of mine, for I have tried it at our out-yard and the results showed decidedly more honey than I could get from single eight-frame colonies. . . . If the colony is very strong I let them [it] have the two stories clear through the season. If they are of medium strength I take away one of the stories and give them the same room in supers with section honey-boxes." This is tantalizing. I presume it is my stupidity, but I cannot understand it. As he says, "perhaps we are not so far apart," but I cannot say as to that, till I understand his position. Is he comparing those "very strong" colonies that he allows two stories with those "of medium strength" that he contracts to one story? If so, we are very close together. But if he means that one of the very strong ones when allowed two stories would be more profitable for the production of comb honey than the same one would be if allowed but one story for a brood nest, then we are very far apart. But let me add, whether near

together or far apart, there is no danger of animosity at this end of the line. I wonder why the editor takes space to intimate, page 517, there might be danger of it somewhere? Again, he quotes my statement, page 519, that it is evident that the editor would have us believe that in some occult way those extra stories add to the numerical strength of the colonies, and replies: "Now Bro. Taylor how could you read so much between the lines? Such a proposition is ridiculous. I might just as well try to claim that big shoes make big feet." I did think I understood the editor this far, viz., that the extra stories added to the strength of the colonies but this denial mystifies me.

CONTRACTION, CONTRACTION, CONTRACTION—LET US KNOW WHAT IT REALLY MEANS.

To show the ill results of hiving swarms in contracted brood chambers, and that that plan is being abandoned, the editor quotes two instances from the "first volume of the American Bee Journal that he picked up." (Gleanings, 518). The first instance is that of C. A. Bunch. He hived swarms on five L. frames with starters. He says they "began to swarm and at one time four of these swarms came out at once." He was obliged to give them more room, when scarcely a swarm issued. I suppose Mr. Bunch refers to "swarming out," or the refusal of swarms to stay hived. The other instance is that of Mr. Hovis. He hived swarms on six frames and expected "nice honey in sections," but got none; while he got "some surplus" from those in box hives. He does not say whether those in box hives were old colonies or swarms; nor, if swarms, does he give the size of box hives, nor any of the particulars that would be necessary to know to enable one to form a judgment concerning the cause of the results. These cases are fair samples of most of those in which contraction is given up. The apiarists gave it up with almost no trial, not to say no reasonable trial. They

expected unreasonable or impossible results and were so easily discouraged that they made no effort to overcome difficulties. If all bee-keepers acted thus, improvement in methods would be impossible. And the worst of it is that prominent, not to say celebrated, apicultural editors are willing to use such reports, at least inferentially, to show that such contraction is to be condemned. Is it to be supposed that Mr. Hovis would have got honey in sections if he had given each swarm an entire one or two-story brood nest? The difficulty is evidently that either there was little or no nectar to be gathered, or the swarms were too small to occupy even six frames. The explanation of Mr. Bunch's case is that in some seasons the desertion of contracted brood chambers by swarms is a difficulty; but it is easily met. To remedy that—and it is a remedy—I hive each swarm in a brood chamber of two sections of the Heddon hive and when the swarm gets settled down, in three or four days, I remove the lower section.

Editor Root (*Gleanings* 519) reminds me that I report him as saying that "two and three-story colonies do not swarm;" a sentiment he now affirms he does not believe in. I am glad of this explicit statement. His exact former statement was that such colonies went right on "piling in the honey and not swarming" and that they were "the best solution of the swarming question." The sentiment he now disavows seemed to me to be fairly drawn from his exact words.

I discover, *Gleanings* 5 2, that Dr. Miller is also at loggerheads with the editor as to the meaning of the word contraction. He asks whether taking one of two stories away when the sections are put on isn't "about as near contraction as you can come to it?" The doctor being the lexicographer ought to know, but the editor disagrees. I would like to have the editor give a categorical answer to this question: Hasn't the word contraction always, till within the last few weeks, been used with reference to a

reduction of the size of the brood chamber, and never with reference to the size of the surplus apartment in any shape? If we use the same words with different significations we can never know whether we agree or not.

PREVENTION OF AFTER-SWARMING.

It is so seldom that I find anything to criticise in Doolittle's statements that I must not fail to take advantage of it when I do find something. In the *American Bee Journal*, 402, he details his plan of preventing second swarms, which is done by cutting out queen cells on the morning of the eighth day. Perhaps Doolittle is led to practice this method from the fact that he is largely engaged in the production of queens, since by this process, he gets plenty of good queen cells almost ready to hatch. In the absence of some such reason I would never follow the method he gives; because it is a laborious time-consuming operation, at a season of the year when it is especially wise to economize both in time and labor, without any corresponding advantage. It is no small task to go over five or six colonies every day or two in such a way as to find every queen cell. Then there is still an element of uncertainty, with the greatest care. It is possible to overlook a cell, or the first swarm may have been so delayed that the second swarm issues before the eighth day. I had one case in which a young queen emerged from her cell the very day the prime swarm issued. As the old queen was clipped there could have been no mistake about it. A greatly preferable plan, in my estimation, is that of reducing the bees in the old hive by hiving the prime swarm on the old stand, then gradually turning the old hive around beside it and carrying it (the old hive) away, while the bees are flying, on the sixth or seventh day, using a queen trap in connection. I get, also, all of the bees remaining in the supers by removing them at once to the new hive; and generally remove the honey board and shake off all bees adhering to it into the

swarm. With this method, in some years, there will be an occasional second swarm; but I doubt whether there will be any more than by Doolittle's plan; and there will be a very great saving of energy. Of course, the trap must be removed in due time; and it may be dispensed with altogether without serious risk if the principle of the method, viz., the draining of the old hive of all superfluous bees, be carefully applied.

A CONCISE STATEMENT OF SOME LABOR-SAVING METHODS.

Labor is much the greatest item in the cost of the production of honey; so I am cutting it down wherever I find it practicable. To explain briefly my management may help some, and perhaps give the editor of *Gleanings* a clearer idea of my methods with regard to contraction, etc. I use the Heddon hive; two sections of which equal to L. frames. I seldom remove a brood frame except from an occasional colony to discover the reason that it is not prospering. I go over my colonies in the spring—in April—when it is cool enough so that the bees are clustered, and raise the front end of each hive from the bottom board sufficiently to enable me to see the size of the cluster. Unless the bees already occupy both sections of the hive, or are likely to do so immediately, the lower section of the hive is removed, and the colony retains but one. The other stronger colonies are left with two. All the one-section colonies that during the last half of May are ready to rush into another section are given one more each, and those not found strong enough to do that, get no more before the end of the early honey season. Next, as the honey season approaches, I put supers on all hives as soon as they are found with bees lying plentifully on top of the honey board. It is of no use before that. Swarms are hived on the old stand, as already intimated, in two sections of the hive, to prevent attempts to abscond, and the lower section is removed in three or four days. Queen

traps are used to prevent the escape of swarms and no time is now spent in hunting and clipping queens. All comb honey is removed by the case when finished, or at the end of the honey flow. Then, so far as is necessary, a second section is given to those colonies having only one. The colonies in single sections generally are apt to furnish more comb honey than those given another section the last of May, and swarm much *less* than those retaining two sections throughout the season. But it will be asked, as intimated by editor Root, don't you reverse and otherwise manipulate frames to get large amounts of brood? Not at all. An abundance of stores is the best and all-sufficient receipt for producing great quantities of bees for the honey season. Some combs partly filled with honey placed above the honey-board not only provide a reinforcement of the stores but also furnish a receptacle for surplus honey that might chance sometimes to be in the way in the brood-chamber. The object is not the greatest surplus from a colony, but the greatest profit to a man. Against my position on these points it will not be pertinent to quote something I wrote or did years ago. I claim to have learned something from experience.

CARELESS READING OF A QUESTION.

Does something like the swarming fever attack apiarists sometimes? In the *American Bee Journal*, 427, question 2, query 75, is: 'How many days after hatching before she [the queen] commences laying?' No less than five of the most prominent bee keepers, Dadant, Cook, Mason, Secor, and Demaree answer from 2 to 4 days, or within those limits, less time than any of them gave her from hatching till her flight. Of course they failed to catch the meaning of the question, but it is a curious instance.

IMPROVEMENTS IN GRAMMAR AND SPELLING. THE USE OF INITIALS.

Brother York of the same *Journal*, page 425, seems to have a light opinion

of the literary ability of apicultural correspondents and editors as well as of their susceptibility to improvement. Referring to my having pointed out some literary infelicity he says I seem to have started in to reform their grammar, and goes on, to quote his exact language, to encourage me thus: "He [I] will have a large job, and likely his trouble for his pains." I by no means look upon the case as either so bad or hopeless as Brother York seems to think it. I think their grammar very good, and that they are so bright as to quickly correct points in which they fail. An editor who so lately "started out to reform" spelling should not so suddenly despair on the point of grammar.

Editor York also takes me to task for using the letters "A. B. J." for American Bee Journal. I beg his pardon. A man's name should be written and pronounced as he chooses to have it, and the name of a man's publication should also, I suppose, appear as he likes it. But I was innocent. I thought it was a great distinction to be conscious that one's journal enjoyed the eminence of being known everywhere by the initials of its name simply. But it is so unusual to have to write the full name in a reference, in parenthesis, that I hope he will have the grace to yield to that extent.

LAPEER, Mich. July 18, 1898.

EXTRACTED.

ABBREVIATING THE NAMES OF JOURNALS.

This Practice, When Copying Articles, Does
not Always Give a Sufficient Credit.

Bro. York of the American Bee Journal copies my editorial of last month in relation to the abbreviation of the names of journals, and comments upon it as follows:—

Had Mr. Hutchinson read our remarks on page 425 *more carefully*, he wouldn't have written one-quarter of the above extract, for we plainly said that we objected to the use of the letters "A. B. J.," when meaning the American Bee Journal, *in public print*. What do we care what people call it in their private correspondence or conversation? Why, they can call it "A. B. J.," "B. A. J.," "J. A. B.," or anything else they please, outside of public print, and we won't object at all.

Really, it is the editors of some of the bee-papers that need to learn that giving the initials of a paper from which they copy is no credit at all—neither to themselves nor to the papers they copy from.

"William Zenas Hutchinson" is not a parallel illustration at all, so need not be noticed further than to say that of course no editor would be guilty of copying an article that was written by Mr. Hutchinson, and then sign it "W. Z.," or "W. Z. H.," and call that a proper credit. But we are now talking about publications, and not about "chummy" names.

We said *we* were the highest authority as to how our journal should be referred to *in public print*. To this statement Mr. Hutchinson says: "I *suppose* that is true"—he isn't quite sure of it. If that isn't "cool" we don't know what is. If *we* are *not* the highest authority in this matter we think it is time we are finding out who *is*. Surely, not a man who hasn't a cent invested in the American Bee Journal.

Now, we don't want any editor to print in full the words "American Bee Journal" just because he regards our feelings, nor because he wishes to please us—those reasons are too weak to consider at all. We want him to do it because it is only simple *justice* so to do—because he has no *right* to copy original articles or ideas, and then not give full and intelligent credit for them.

On page 208 of the July Review, second column, after referring to something Mr. Dadant said in this paper about feeding, Mr. Hutchinson has "A. A. J.," 162." That might mean "American *Ant* Journal," if there were one by that name; but of course he meant the American Bee Journal. Then why not say so, if Mr. Dadant's remark was worth mentioning in the Review?

We stand ready—as we have always stood—to credit other bee-papers for what we take from their columns in just the way their editors wish us to credit them; and we have a right to expect that the editors of the other papers will reciprocate that readiness.

In reply to Mr. Hutchinson's final question, we must say firmly, but kindly, *no*—if he refers to public print. And we would say to any and all editors, whether of the aparian or agricultural press, if you are not willing to give the American Bee Journal proper credit for what you consider worth taking from its columns, then don't take it. We are not begging editors to copy from our columns, but we are perfectly willing they shall take all they want, provided they always give credit therefore as they should—to the American Bee Journal.

There are minor points in the foregoing to which I might take exceptions, but perhaps it isn't worth while to argue over them, as I most certainly agree with Bro. York that credit should be given in such a manner that no doubt of the identity of the journal referred to can exist. I am satisfied, however, that no abbreviations are used that are not fully understood by any bee-keeper who is at all conversant with apicultural literature; but new readers might not fully understand; besides this, there is another point that I did not consider before, viz., if a copied article with an abbreviated credit should be re-copied, say, into a farm journal, full credit would probably be lost; as most of the readers of an agricultural journal might not know the meaning of "A. B. J.," nor of "Review;" nor "Gleanings;" nor "Progressive."

SELLING COMB HONEY TO GROCERS.

Be Your Own Drummer; Work for and Expect
Large Sales; Be Businesslike, and Answer
Objections; Labels and Second-
Class Sections.

It is sometimes difficult to give the exact gist of an article in the title, but the above heading tells pretty nearly what might be expected in a long but excellent article that appears in *Gleanings*. It was written by Mr. G. K. Hubbard, a neat, tidy businesslike little gentleman whom I have often had the pleasure of meeting.

The time for selling honey is now here, and the man who has a crop to sell can read with pleasure and profit the article that I now lay before him.

Editor Gleanings:—Although you have published a number of articles on the subject of selling honey, I thought it possible that I could contribute something on this that would be helpful, and that might encourage some one to make an effort in this line who has dreaded to undertake it. The object of this article is to encourage those who have a crop of honey to dispose of to sell it at the groceries in neighboring towns, thus accomplishing the desired result of getting better prices and keeping the small shipments from going to the city commission men.

We Californians are doubly interested in keeping honey from going into the city markets, for the reason that we are compelled to sell our produce there. There is no escape from it except for those who have small amounts to sell. Our honey must of necessity go to market in carload lots of 1000 or more cases, and it is only the large cities that can handle it in such quantities. The smaller cities and flourishing towns offer a splendid market at fair prices, and ought, in nearly every case, to be supplied without the grocers having any shipped in from the wholesale cities. The cost of getting a pound of comb honey to the eastern market, counting the loss from having to pay freight on the cases, is about 2½ cents for freight, if shipped in car lot. Less than carload, if we care to take the risk of breakage, the cost per pound, with the extra crating necessary, is 4½ cents. This extra 2 cents, with the accompanying risk, shuts us out of any market except those that can handle honey in car lots, and this leads me to emphasize the point that the smaller cities should be supplied from the surrounding territory, and the city markets largely left to those who are of necessity compelled to use them.

Now, my reader, if you have a crop of comb honey of from 20 cases anywhere up to 200 or so, I suggest that you sell it to the grocers in your surrounding territory. You may answer that you are not a salesman; that it takes time and ability to push off your crop a few cases at a time; that you would prefer to take less for it and see it all go at once than to get more in smaller sales. Of course, you would if the difference were not too great; but the difference is too great for you to afford if you wish to make the best success from your pursuit. Suppose

it does take time to sell a crop; if it pays you well for your time, can you not afford to take it? I wish to urge you strenuously to make a brave trial and see if you do not get along better than you expected.

I am going to give some experiences and suggestions, and will say at first that you might make a score of calls and not use many of the ideas; but if I gave you the idea of how it can be done, your tact and good sense will suit your talk to the right person. I cannot map out a minute program for you, but I can give you some insight of a plan that has proved very profitable to me, and incidentally you will learn something about my ideas of having a crop in such readiness for market that it will command the highest price the grade will bring.

You probably know all that is to be known about your own home market. You often go to town to do your trading, and know as well as any man in the community about how much honey your grocers have on hand, and what the possibilities are for business. As an almost invariable rule you will never make a large sale in the town where you are best acquainted. Your merchant will say, "I might take one case of you. You are in town often, and I can get more of you almost any time." Therefore I urge you to make a longer drive, get out of your own immediate community, where you will have a fighting chance of selling several cases to one customer.

Start with a load of 10 to 20 cases, according to the size of the place you are going to visit. Put on the best suit you have; collar and necktie; if you ever wear cuffs, do not leave them off this time; give your shoes an extra good shine, and look just as neat as possible. You are not a farmer or bee-keeper now; you are a business man, and are going out to do business in a businesslike way. Take along your horse-feed if you wish; but go to a modest hotel where you can get a meal for 25 cents, and have the almost as desirable point of being able to wash, and to brush the dust thoroughly from you, from hat to shoe-sole. I do not think I overestimate the value of your personal appearance. While clothes do not make the man, they do, very largely, make the estimate that people place upon you, especially among strangers. You will walk with a firmer tread and feel more like business, if your appearance is not being criticised, but, instead, is helping you to appear as though you meant business. I trust my reader's good sense to understand me aright, and not think I advocate unreasonable extremes.

You know what your honey is worth, and the price you ought to get, which should be enough above the price at which you hold the entire crop to pay for the time you put in distributing it. Adopt your prices for your different grades, and stick to them, treating all alike. It is all right to miss a sale occasionally on this account, as it will save you so much time, and be such a help in making sales to these parties in the future.

Being all in readiness to be your own "drummer," go to the leading grocer, and be as pleasant and polite as possible. Make your business known at once, for busy men do not care to talk much with strangers about the weather, crops, condition of roads, etc.

"I have driven over from Blankville with comb honey, and this case is a fair sample of my best grade. I take a great deal of care in producing a good article, and casing it up fair, and I think if I could sell my load to you, would find it to give good satisfaction to yourself and to your customers."

Of course, he will look at the honey, and likely pass his opinion on it, comparing it with the honey he has handled. You will soon know whether he is at all interested or not, whether he is well stocked, whether or not he is supplied regularly, as his trade demands, by some home bee-keeper who is his regular customer, and who may put an article on the market that compares favorably with yours. If there is no chance at all for a sale, bid him a pleasant good-day and tell him you will probably see him again sometime when he is nearer ready to buy. Then if he wants to visit a little with you, and start an acquaintance, meet him half way, letting him make the advances; but make it short, and leave him with the impression that you are out for business, and that your business is just as important to you as any other man's business can possibly be to him.

The next grocery you call at, the man you take to be the proprietor is busy. After waiting a little, and you see he is not apt to be through with his customer very soon, you start out. Likely he or one of the clerks will inquire if you wish to get anything; but you reply that you have a little business with the proprietor, and that you will call again in a little while. Thus you save your own time, and impress the grocer that you are a man of business, and too much of a hustler to waste your time waiting for some independent chap to give you a little of the time he wants you to think is so extremely precious.

At another grocery you see at once that the proprietor is interested in what you have. He has but little honey, or none at all; and when you see there is probably a chance to sell him some you say, "I have just come to town, and have talked to but one man. I am very sure you could do well with the honey I have if I could sell it to you. I have only 15 cases with me—7 of the fancy grade and 8 of the dark; and if I could sell you my load, I am confident you would realize well on the purchase."

He looks at you with eyes wide open; he thinks to himself, "Fifteen cases of honey at one purchase? Gracious! wonder if he thinks I sell all the groceries used in this county." But all the same you have made a favorable impression. You have flattered him by assuming that he is one great big merchant, and you have impressed him with the idea that you are out to do business on a big scale.

"Fifteen cases? oh! I couldn't use that much. You see, the grocery business is terribly cut up here. There are many stores and of course every man has his friends. We never buy very heavily. We keep pretty close to shore, as the saying is; but then I don't mind buying a few cases of you if I can get it right."

If you had taken in a case and asked him to buy it he would hardly have thought of asking for more; but now that you have put the idea into his head of buying the load he feels safe in risking a few cases. Likely you sell him three of each grade. You set the cases in a conspicuous place and he remarks that it looks like enough to run his trade for three months; but you thank him for the money, and wish him better luck in moving it than he imagines. You certainly would not have sold him six cases if you had tried to sell him one, and it is almost as certain you would not have sold him six if you had not first talked up the sale of your load.

Now you go back to the man who was too busy at your first call. You tell him your business, and where you are from, and that, he will soon be out of honey. He is interested in what you say; but he is one of those men who always want to cut and slash prices; and to do this he begins to talk hard times and low prices.

"I have only nine cases of this left, and I should like to sell you the lot."

"But your price is too high."

"I do not think so, considering the quality I furnish."

"But I can get it shipped in from the wholesale houses and commission men in Blank City for at least a cent, and likely

a cent and a half, less than your prices, and get my business discounts besides."

"It is barely possible that you can do as well; but I very much doubt about your getting as good value for the money as I offer you. There is the risk of your not getting as good an article as you expect when you place an order, and also risk of breakage in transit. I am right here with the honey; every section of it is in first-class condition; you can see exactly what you are buying—no freight, drayage, or breakage; and if any case I sell you is not as represented I will take it off your hands next time I come over, without any hard feelings on the part of any one, or a lot of unpleasant correspondence over such a matter. I sell to every one alike; and while it is natural for every buyer to want to do a little better, and have a small advantage over his competitor (and I do not blame you for it), at the same time I know by experience that it is more satisfactory all around to treat all alike. You can make 25 per cent easily enough on my honey at the prices I offer; and the rebate on the cases when empty, if you will let me have them back in good condition, will more than equal the business discount you mention. If you had these nine cases standing up in front here I do not doubt it would attract as much attention, and make as fine a show, as any lot of honey you ever handled."

He tries to beat you down on the price; but you are firm, though very gentlemanly, and, as a result, he concludes to take two cases of fancy and two of dark, after you have reassured him that you will be over again in 60 days or so, and will pay 10 cents each for the empty cases if he keeps them in good condition.

At your next call you find a man who hardly ever keeps any honey unless he gets a little occasionally from a customer.

"The times are too hard. It won't sell."

"But sometimes people buy honey because the times are hard."

"How so?"

"I see you have some high-priced preserves and jams on your shelves here. The trade that has been getting such goods is apt to buy 15 cents' worth of honey just because it does not feel flush enough to buy something more expensive. Or, instead of going home without candy or something that the children expect, a man will take home a few sections of honey and tell the children that these hard times they will have to get their sweetmeats at the table with their meals. In such cases you would sell the honey, if you had it, when you would not sell

either the expensive preserves or confectionery. You are not paying store rent, and putting in your time, for amusement, but you are here to sell goods; and if the people do not find what they want here they will buy elsewhere."

"I do not think my trade would pay the price for the fancy honey, and I do not like the cheaper grade."

Removing the contrast by turning the fancy case so that the honey in it can not be seen, you reply, "This is a better grade of honey than you think. The only possible objection to it is that of color. It is just as pure and healthful, is well filled, and in every way as good an article as the bees can make from the flowers it was gathered from. You would be surprised at the ease with which you can sell this grade of honey by mentioning its purity and flavor if any one remarks about its color. I have only three cases of this dark grade left, and I can't see how you would regret it if you would let me bring in the lot."

"I could not use three cases of it, but I believe I will try one case and see how it goes."

At your next call where you find any prospect of a sale the proprietor says, "Yes, that is fine-looking honey; but I have had it here as nice, or nicer; and when I took it home to eat I found so much filler in it that it was tough inside."

"You mean the comb foundation used in the middle, I suppose. Yes, I know some bee-keepers are very careless about this. They use an inferior grade of home-made foundation which cannot be detected until the honey is cut, and it is bound to give anything but satisfaction. We all use some foundation in order to get the combs built straight in the sections; but I am very careful to use only the best article that can be made. The foundation I use runs 12 square feet to the pound, is the purest and best to be had, and is actually thinner than much naturally built comb. In all the little points in honey production I try to keep posted, and put out as fine an article for its grade as any bee-keeper I know. If I sell you the four cases I have left, and you do not find them to be strictly all right I will take them off your hands and refund the money the next time I am over; or if you write me a line I will come promptly and get them. I am not here to-day merely to sell what honey is now needed, but to build up a trade and make an outlet for my large crop this season, and probably for other seasons."

"We always sell our honey by the frame, and we sometimes get it that is every

weight and thickness, which results in a lot of culling-over, and then having to sell the last few frames at a discount, may be below cost. I see this case is pretty nearly all one thing, but you have irregular or partly filled frames sometimes, don't you."

"Yes, sir; but when you buy regular-grade honey of me, that is exactly what you get. I dispose of extra thick and thin combs at some boarding-houses near home. The honey I put on the general market is cased up with the wishes of the grocer in view. Well-capped sections that will not weigh 12 ounces are cased by themselves and sold together. There are some grocers who prefer these light weight sections because they cost less, and they prefer to sell something that goes at a small price. By having the honey in a case somewhat uniform in weight it saves the picking-over that is apt to happen when there is a great difference in either color or weight in the sections in a given case."

"But I wouldn't want to buy four cases. You would sell me one of your best grade, wouldn't you?"

"Yes; but surely one case of honey is a small matter for a man with the trade you appear to have. I should like to sell you enough to last until I come over again. Better take one case of each grade, at least."

"My trade does not go much on a poor article."

"But my dark honey is not a poor article; in fact, many bee-keepers who are not so careful with their honey would call this their best. It is a good idea to let a customer have his choice in such matters, and then you will not have people saying they can buy for a cent or two less elsewhere. It is easy for them to be deceived in quality while remembering the price. To illustrate, you probably have a great variety in price in the same kind of canned goods, and your customers make their selection. Why not give them the same chance on honey?"

He objects to the price, and wants a liberal discount if he takes two cases; but you emphasize the rebate on the cases if in good condition; tell him the last section in a case will sell as readily as the others, and that you warrant satisfaction.

You get your money, and go back to your wagon with two cases yet to dispose of. You have been to all the groceries, and are not sold out. Now you try the bakeries.

"I see you do not have any honey on sale here, yet some of the bakeries over

our way sell more than some of the groceries."

"We never have any call for it."

You smile, and say, "Yet that does not prove you could not sell it. You do not have call for strawberries at this time of the year, either; but they would surely sell if you had them in sight. Probably half the comb honey that is sold is carried home because the customers are in the store on other business, and, seeing the honey, take a fancy to it and buy it. If you had this case of honey on the shelf back of you, right in plain sight, it would not be long before some customer, taking home some fresh bread or rolls would want to take along a section or two of honey."

"But we buy some strained honey for use in our baking, and we have some Mason jars of it on the shelf up there you see, and it does not pay for the bother of fussing with it, for we hardly ever sell any."

"Well, I'm not much surprised, because it is not labeled, and people do not know what it is. When you strain your honey the 'poetry' is all taken out of it, as a lawyer friend of mine says. Comb honey is always attractive, will sell itself, and if other bakers do well with it I don't see how you would miss it. You can make 25 per cent on it, and whatever you make will be just that much extra to help pay rent and keep business on the move. You can rest assured that if you had these two cases here in sight, the people would buy it. Besides it is attractive, and helps give your place a neat and filled up appearance."

"If you want to leave one case here and let me try it I will pay you for it if it sells, and if not you can get it again some time."

"I thank you for the offer, but I can't accept it. If I should do business that way I should have to raise my prices to cover an occasional loss from failure or fire, or something else. My prices are as low as they can be for a good article, and I have to sell for cash."

"Another sale made; but the other bakeries do not care to take the remaining case, and so you go to the hustling young fellow who runs a fruit and confectionery store in a little 7 x 9 room under a stairway a few feet from the leading business corner of the place.

"You occasionally have quite a loss by your fruit spoiling on your hands. Here is an article that will make you a good percentage, and will last for years so far as its keeping qualities are concerned.

The investment is absolutely a safe one because it is sure to sell, even if it does not go off with a rush."

He likes the idea first rate, and your purse is heavier and your wagon empty.

Now, do you think I have made this appear too easy? Not a bit of it, unless the market is actually glutted with an enormous crop. In that case my advice would be that, if you can not make sales after trying various places within your reach, wait a few months and try it over. You had better borrow money and hold your crop than to sacrifice it. I am sure, however, that some earnest work along this line will give good results under almost any circumstances that you are apt to find, for conditions vary greatly in towns within a few miles of each other. I know of two cities 9 miles apart where the retail price of honey has been different by 25 to 40 per cent. You will find a good many things that are new to you if you will do some exploring in this line.

If you are fortunate enough to have a crop of honey that averages very high, you will be surprised to see how easy it is to interest people; but your lower grades should be pushed along in proportion to what you have. You do not want a lot of low-grade honey on hand, with the best all gone. The price-mark is the safety-valve. You can sell anything if the price is right; but have your price high enough so you will have to talk it up to sell it.

One party said to me, "Your honey gives good satisfaction, and I have made a good profit on it; and any time you are over, come in and see how I am stocked."

No wonder he was pleased, for he had sold lots of it, and at prices from 20 to 25 per cent higher than the other grocers in town were getting. He had a large and fancy trade, and was actually clearing 40 to 45 per cent on my honey.

Give your customer a square deal on grading, etc., and you will often be pleased to hear such expressions as: "Just set it right on the counter; here is your money. I am too busy to open it and look at it. The other was all right, and I will risk this being the same." "How many have you?" "Two cases of fancy and three of amber?" "All right; carry it to the back of the store; I'll take your word for it." "I don't know but your price is a little high; but I like the way you put it up, and it sells as well as any honey I ever bought."

You will soon get acquainted with your trade, and if you do your part you will get a top-notch price, will not hear anything about "trade it out," will not be

badgered about cutting prices, and will be treated in a friendly and businesslike way on every trip, with numerous invitations to "call again when you are over."

Once on my first call, as I set a beautiful case of honey with a three-inch glass front on a gentleman's counter, and removed the cover, he read aloud the fourteen-inch label on the front of the case, "Gathered from Orange Blossoms;" and then as he saw the 28 neat labels printed in red ink, pasted on the sections, with the snow white-honey smiling up at him from between, he slapped his hands together and exclaimed, "By jolly!" I need not tell you he has been my steady customer since, although he thought my price was high, and I knew it was high enough.

With the finest honey from clover, orange, willow-herb, sage, etc., you need not be doubtful about placing it to advantage in almost any market; and while I know that the majority of readers will not take the pains with their crops that I do, nevertheless, if you will take the honey you have, and make a businesslike effort, something like the one above, you will find that you can dispose of it, even if that supplied by more expert apiarists does surpass yours in quality. With a first-class article you will find yourself taking too small a load to market oftener than too large.

I do not label all my honey, but I think I shall do more of it in the future. I have observed that it gives the honey a finish, and pleases the customer well enough so that I am pretty safe in counting it to bring 25 cents extra per case.

The labels cost less than three cents, and a boy will stick them for one cent per case. The cost of this is offset by using second-grade sections. I get my finest honey that I expect to label in the cheapest sections. In fact, the only advantage worth mentioning that I know of, in using snow-white sections, is in the clean appearance when the cover is removed. The labels do the same; and while I have had scores of merchants take out the sections and examine my labeled honey I never heard one remark that the sections were not the whitest. They look at the honey and not the frame it is in. There is too much straining after "snow-white," "extra polished," etc., according to my way of thinking.

There are a good many ideas in the above that may be helpful to those who sell their crops by peddling from house to house; but in such cases the point I would emphasize is to first quote the price per case or so many sections for a dollar.

If there is to be any talk about your selling just a few sections let the other party start it, or you can make the offer after your first proposition has been refused. You will never sell a case to one party by trying hard to sell 25 cents' worth. Work for large sales, and expect to make them.

The foregoing is a pretty long article; the longest, I believe that has ever appeared in the Review; but the hints and suggestions that it contains are, I believe, of sufficient value to justify the space used. The most that can be done in these articles upon marketing is to give hints and suggestions. Of course, Mr. Hubbard tells exactly how he manages, but some other salesman in some other market, might find some other plan desirable. The most of my honey has been sold by commission men; for the reason that sold in this manner it would net me more than sold direct to grocers near home. Of late the prices of honey in the large cities has fallen, while in our local markets it has remained about the same, hence I now find it profitable to be my own salesman; and I really enjoy it; so much so, in fact, that I often feel as though I would like the business of being a "drummer."

Honey Quotations.

The following rules for grading honey were adopted by the North American Bee-Keepers' Association, at its Washington meeting, and, so far as possible, quotations are made according to these rules.

FANCY.—All sections to be well filled; combs straight, of even thickness, and firmly attached to all four sides; both wood and comb unsoiled by travel-stain, or otherwise; all the cells sealed except the row of cells next the wood.

No. 1.—All sections well filled, but combs uneven or crooked, detached at the bottom, or with but few cells unsealed; both wood and comb unsoiled by travel-stain or otherwise.

In addition to this the honey is to be classified according to color, using the terms white, amber and dark. That is, there will be "fancy white," No. 1, dark," etc.

KANSAS CITY.—We have several shipments of new comb honey from Florida—the first of the season. We quote as follows: Fancy white, 12; No. 1 white, 11½; fancy amber, 10½; No. 1 amber, 10; white, extracted, 5½; amber, 5; dark, 4. Beeswax, 25.

C. C. CLEMONS CO.
521 Walnut St., Kansas City, Mo.

CLEVELAND, OHIO.—We quote as follows: Fancy white, 12; No. 1 white, 11; No. 1 amber, 9 to 10; buckwheat, 8; white, extracted, 6; amber, 4 to 5.

A. B. WILLIAMS & CO.,

May 25 89 & 82 Broadway, Cleveland, O.

CHICAGO, ILL.—There is a good demand for fancy white comb honey. This grade would sell for 11 cts—possibly higher. Considerable Amber and dark on the market—selling anywhere from 5 to 8. Extracted White sells at 5½ to 6; Amber 4½ to 5; dark, 4. Beeswax, 27.

S. T. FISH & CO.,

June 28. 189 So. Water St., Chicago, Ill.

CHICAGO, ILL.—Very little comb honey on sale at present; but we look for higher prices than last season. We quote as follows: Fancy white, 12; No. 1 white, 10 to 11; fancy amber, 9 to 10; No. 1 amber, 8 to 9; fancy dark, 9; No. 1 dark, 7 to 8; white, extracted, 6 to 7; amber, 5 to 6; dark, 4 to 5; beeswax, 27.

R. A. BURNETT & CO.,

July 25. 163 So. Water St., Chicago, Ills.

BUFFALO, N. Y.—There is no demand for honey at this time of the year sufficient to warrant liberal shipments. A few cases now and then will fly. We have noticed no new arriving yet. Fancy 1-pound would probably bring about 12 to 14 cents, and poor grades proportionally lower. We could use a small amount of fancy one pound at this time.

BATTERSON & CO.,

July 28. 167 & 169 Scott St., Buffalo, N. Y.

NEW YORK.—Our market is in very good shape for the new crop of comb honey. We have had several shipments of white comb honey from Florida, which have sold at from 10 to 11½ cents per pound. Market on Southern Extracted honey is very steady, there being a good trade for the cheaper grades. We quote as follows: Ordinary at 50 to 52 cents per gallon. Good at 55 to 60 per gallon. Florida, white, 6c. New California is beginning to arrive. Beeswax market is quiet, prices ruling a little lower. We quote pure beeswax at 26½ to 27½. Write us for shipping instructions.

FRANCIS H. LEGGETT & CO.,

July 23. W. Broadway, Franklin & Varick Sts

NEW YORK, N. Y.—Demand for comb honey is rather slow, especially for off grades, white and dark, and, as we have a large stock of these would not advise shipping for the near future. Our stock of fancy white is light and such would find ready sale at quotations. Our market for extracted buckwheat will open up shortly and we would advise bee-keepers to ship this along now. Beeswax steady. We quote as follows: Fancy white, 11 to 12; No. 1 White, 10; Fancy Amber, 9; No. 1 Amber, 8; Fancy Dark, 7; No. 1 Dark, 6; White, extracted, 5 to 5½; Amber, 4½ to 4¾; Dark, 4 to 4¼; Beeswax, 26 to 28.

HILDRETH BROS. & SEGELKEN,

Jan. 7, 120 & 122 West Broadway New York

WM. A. SELSER,

10 VINE ST., PHILA., PENN.

White Clover Honey Specialist.

JOHN F. STRATTON'S CELEBRATED



MANDOLINS,

Importers of and Wholesale Dealers in all kinds of
MUSICAL MERCHANDISE,
811, 813, 815, 817 East 9th St., New York

Please mention the Review

Bee keepers should send for our

'97 CATALOG.

We furnish a full line of supplies at regular prices. Our specialty is Cook's Complete hive.

J. H. M. COOK, 62 Cortland St., N. Y. City

Please mention the Review

Franklin House DETROIT MICH.

Electric Heat and Lighted Stoves. Very central Elevator
Electric Heat, electric lights, tile floors, etc.
Rates \$1.50 to \$2 per day. H. H. JAMES & SONS, Props

Please mention the Review.

—If you are going to—

BUY A BUZZ-SAW,

write to the editor of the REVIEW. He has a new Barnes saw to sell and would be glad to make you happy by telling you the price at which he would sell it.

QUEENS,

Untested, 75 c; 6 for \$4.00; tested, \$1.00; 6 for \$5.00; breeders \$2.00. The best stock,

imported or golden. W. H. LAWS, Lavaca, Ark.

Please mention the Review.



Our Prices are worth looking at. We are making the new

Champion Chaff Hive

with dovetailed body and supers and a full line other Supplies, and we are selling them CHEAP. A postal sent for a price list may save you \$ \$ \$ \$.

R. H. SCHMIDT & CO.,
Box 187 Sheboygan, Wis.

1-98-1f

Please mention the Review.

ITALIAN bees for sale. Queens \$1.00. Bees by the lb., \$1.00. One-frame nucleus with queen, \$1.50; two-frame, \$2.00. Queens, after Aug., 50 cents each.

Mrs. A. A. SIMPSON, Swarts, Pa.

7-98-2t

Please mention the Review.

THE LOSS

Of one Queen in introducing, means a loss greater than the cost of a copy of "ADVANCED BEE CULTURE," which has one entire chapter devoted to "The Introduction of Queens." It shows when the cause of failure lies with the colony, when with the queen, and points out the *conditions* necessary to success. Although one infallible method is given, but little attention is given to the setting forth of exact rules and methods; the subject being treated with a view to teaching *principles* that may be followed to success.

Price of the book, 50 cts. ; the Review one year and the book for only \$1.25.

W. Z. HUTCHINSON,

Flint, Michigan.

18



98

This is the original one-piece section-man who furnishes one-piece sections as follows:—

500 sections, \$1.50; 1,000 for \$2.50; 3,000 for \$6.75; 5,000 for \$10.00; 10,000 for \$17.50.

No. 2 sections are not made to order, but when in stock are sold at \$1.50 per M.

J. FORNCROOK,

Watertown, Wisconsin.

Listen! Take my advice and buy your bee supplies of August Weiss; he has



tons and tons of the very finest

FOUNDATION

ever made; and he sells it at prices that *defy competition!* Working wax into foundation a specialty. Wax wanted at 26 cents cash, or 28 cents in trade, delivered here. Millions of **Sections**—polished on both sides. Satisfaction guaranteed on a full line of **Supplies**. Send for catalogue and be your own judge. **AUG. WEISS,** Hortonville, Wisconsin.

When you buy

QUEENS,

You want, first, *good* queens; then you want them *promptly*; and, lastly, you want them at a reasonably *low price*. You can secure all of these advantages by sending your orders to Mr. **W. H. PRIDGEN**, Creek, Warren Co., N. C. He is *now* ready to mail golden stock at 75 cents each for untested queens; three for \$2.00; or six for \$3.50. Mr. Pridgen is a member of the National Queen Breeders' Union; and he sends out (free) a catalogue containing valuable information for queen breeders and buyers. Money order office, Warrenton.

Some Odds and Ends That Will be Sold Cheap.

For a dozen or more years Mr. M. S. West of this place dealt in bee-keeper's supplies. Since his death, two years ago, his daughter has endeavored to close out his stock of goods, and has succeeded to large extent. There are still a few odds and ends, and she has brought them to me and left them for me to sell. Here is a list of the articles with prices at which they will be sold.

- One ten inch foundation mill, (second-hand) Root's make, complete with dipping tank, etc. in excellent condition... \$10 00
 - One ten-inch foundation mill, (second-hand) Root's, (one of recent make) dipping tank, etc. in good order15.00
 - Three Woodcock foundation fasteners, each,75
 - Eighty seven entrance guards, each,05
 - Thirteen Porter Bee Escapes 2.25
 - Thirty-three Simplicity hives, in the flat, sides, ends, covers and tin rabbits, but no frames nor bottom boards, each,40
- Send all orders to W. Z. HUTCHINSON, Flint, Mich.

Queens

untested Italians, 70 cents each; 3 for \$2 00. After July 1st, 50 cents each. Safe arrival and satisfaction guaranteed. Catalogue free.

6-9S-1f THEO. BENDER, Canton, Ohio.

I have several hundred

QUEEN CAGES

of different styles and sizes, made by C. W. Costellow, and I should be pleased to send samples and prices to any intending to buy cages.

W. Z. HUTCHINSON, Flint, Mich.

Farm Bee - Keeping.

The only bee paper in the United States edited in the interests of the farmer-bee-keeper and the beginner is the **Busy Bee**, published by EMERSON T. ABBOTT, St. Joseph, Mo. Send for free sample copy NOW.



See That Wink!

Bee Supplies. Root's goods at Root's prices. **POUDER'S HONEY JARS** Prompt service. Low freight rates. Catalog free. **WALTER S. POUDER**, 162 Mass. Ave., Indianapolis, Ind., the only exclusive bee supply house in Indiana.

THE MONITOR PAPER FILE

Binds securely and neatly all periodicals. Preserve your papers, magazines, pamphlets, bulletins, music, etc., by binding them together as you get them. Each new number filed quickly and easily. Will bind 52 numbers of any periodical aggregating 1000 or fewer pages. All lengths from 6 to 28 inches. Light and handsome.

PRICE.—All sizes 12 inches and under 12 cents; over 12 inches one cent per inch. When wanted by mail add one cent for each 5 inches or fraction thereof.

For sale by the Publisher of this paper.

Queens

75 cts each by return mail; either golden, or three-banded, young and warranted. Two separate yards with competent assistants. Circular free.

J. B. CASE, Port Orange, Fla.

Without Stopping

the machine to reverse the combs is the way you can work with the Williams Automatic

Honey Extractor.

Such an extractor will save you time and annoyance and it does not cost much more than an ordinary machine. Send for descriptive price list.

Read what the famous bee-keeper, N. E. France, says:

PLATTEVILLE, Wis., July 5, 1897.

Dear Sirs: To day I extracted 2,780 lbs. of honey with your Automatic Honey Extractor in 5 1/2 hours and could have done the same this afternoon but let the boys go to the city to play a game of base ball. Have extracted 27,135 lbs. so far with good prospects for as much more. My bees and State work keep me very busy. Hope to see you before very long - will write you later.

Yours truly, N. E. FRANCE,
State Inspector of Apiaries,
Platteville, Wisconsin.

We can also furnish choice queens, either golden or leather colored Italian, at 75 cents each, or two for \$1.40.

Van Allen & Williams,

6-9S-1f.

BARNUM, WIS.

Beeswax Extractor.

The only Bees Wax Extractor in the world that will extract all the wax from old combs rapidly by steam. Send for descriptive illustrated catalogue.

C. G. FERRIS,
South Columbia, N. Y.

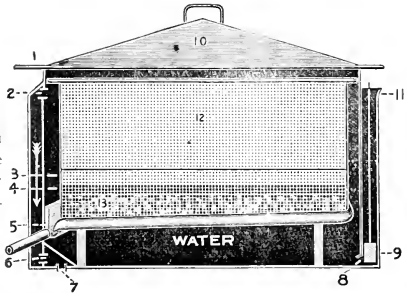

Bees and Queens

from Kansas. A really superior strain of golden Italians. Warranted or tested queens 75 cents each; six for \$4.00; twelve for \$7.50. Full colony of bees, \$5.00.

J. W. KUHN, Belleville, Kans.
Please mention the Review

1898 Queens 1898

For Business—Queens for Strong Colonies—Queens for large surplus. Competition in Quality, but not in price.

If you want queens, nuclei or supplies at bottom prices, send for my illustrated price list. 12-97-11

J. P. H. BROWN, Augusta, Ga.

The place to get your best QUEENS

is of H. G. Quirin, of Bellevue, Ohio. Ten years of experience, and the best of methods and breeders enable him to furnish the best of queens. Golden Italian, warranted purely mated, at 75 c.; after June, 50 c.; or 6 for \$2.75. Leather-colored, same price.

— If you wish the best, low-priced —

TYPE - WRITER.

Write to the editor of the REVIEW. He has an Odell taken in payment for advertising, and he would be pleased to send descriptive circulars or to correspond with any one thinking of buying such a machine.

Queens bred in the North are hardy and fertile. Every bee-keeper should try one of these Northern grown queens. Pure bred Italian queens at 75 cents each; or 12 for \$6.00.

WM. H. BRIGHT, Mazeppa, Minn.

Please mention the Review.

To stick things, use MAJOR'S CEMENT. Beware !!! Take no substitute. 2-98-12t

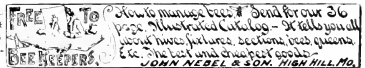

Best on Earth. 19 Years Without a Complaint.



	Dozen	Each
Smoke Engine (largest smoker made) 4 inch stove...	\$13.00—mail,	\$1.50
Doctor	3 1/2	9.00— " 1.10
Conqueror	3	6.50— " 1.00
Large	2 1/2	5.00— " .90
Plain	2	4.75— " .70
Little Wonder (wt. 10 oz).....	2	4.50— " .60
Honey Knife		6.00— " .80

For further description, send for circular.

T. F. BINGHAM, Farwell, Michigan.

(Keep this before you,)
We pay *cash* for

HONEY.

We want honey; and ask cor-
respondence from those having
it to sell. State quantity, quality
and style of package. We are
dealers in green fruit and dried
fruit and all kinds of produce.

S. T. FISH & CO.,

(Established 22 years.)
189 South Water St.,

CHICAGO.

Reference, First National
Bank, Chicago. Your banker
can show you our rating.

Page & Lyon,

Mfg. Co.

New London, Wis.

—♦♦♦—
Nearness to pine and bass-
wood forests, the possession of
a saw-mill and factory fully
equipped with the best of ma-
chinery, and years of expe-
rience, all combine to en-
able this firm to furnish the
best goods at lowest prices.
Send for circular, and see the
prices on a full line of supplies.

COMB Foundation,

We can now furnish the very
best that can be made from pure
wax. Our new process of mill-
ing enables us to surpass our
previous efforts in the manufac-
ture of foundation. It is always
pure and sweet. It does not sag.
It is the kind that you want. If
you once try it you will have no
other. Samples furnished free.
Large, illustrated catalogue of
bee-keepers' supplies, and a copy
of the *American Bee-Keep-
er* sent upon application.

W. T. Falconer Mfg. Co.,

JAMESTOWN, N. Y.

No Fish-Bone

Is apparent in comb honey when
the Van Deusen, flat-bottom
foundation is used. This style
of foundation allows the making
of a more uniform article, hav-
ing a *very thin* base, with the
surplus wax in the side-walls,
where it can be utilized by the
bees. Then the bees, in chang-
ing the base of the cells to the
natural shape, work over the
wax to a certain extent; and the
result is a comb that can scarcely
be distinguished from that built
wholly by the bees. Being so
thin, one pound will fill a large
number of sections.

All the Trouble of wiring
brood frames can be avoided by
using the Van Deusen *wired*.

Send for circular; price list,
and samples of foundation.

J. VAN DEUSEN,

SPROUT BROOK, N. Y.

Violin for Sale.

I am advertising for the well known manufacturers of musical instruments, Jno. F. Stratton & Son, of New York, and taking my pay in musical merchandise. I have now on hand a fine violin outfit consisting of violin, bow and case. The violin is a "Stradivarius," Red, French finish, high polish, and real ebony trimmings, price \$14.00. The bow is of the finest snakewood, ebony frog, lined, inlaid (pearl lined dot) pearl lined slide, German silver shield, ebony screw-head, German silver ferules, and pearl dot in the end, price \$2.50. The case is wood with curved top, varnished, full-lined, with pockets, and furnished with brass hooks, and handles and lock, price \$3.50. This makes the entire outfit worth an even \$20.00. It is exactly the same kind of an outfit that my daughter has been using the past year with the best of satisfaction to herself and teachers. Her violin has a more powerful, rich tone than some instruments here that cost several times as much. I wish to sell this on fit, and would accept one-half nice, white extracted honey in payment, the balance cash. It will be sent on a five days' trial, and if not entirely satisfactory can be returned and the purchase money will be refunded.

W. Z. HUTCHINSON, Flint, Mich.

G. M. LONG, Cedar Mines, Iowa, manufacturer of and dealer in Apiarian Supplies. Send for circular. 1-96-6

Please mention the Review.

THE STRATTON American GUITARS & MANDOLINES



THE HANDLED BY ALL THE LEADING MUSIC STORES
Oak Ash Birmingh Maple, Mahogany and Rosewood.

JOHN F. STRATTON & SON,

Manufacturers of and Wholesale Dealers to all kinds of.

Musical Merchandise.

37 & 40 Wall St. N.Y.

NEW YORK

Holy Land QUEENS. Golden Italian

The best that knowledge and ten years' of experience can produce.

Untested Queens.	One	Six	Twelve.
In June, July Aug., Sep.,	.75	\$4.25	\$8.00
All other months,	1.00	5.00	9.00
Tested Queens,	1.50	8.00	15.00

3-98-12t

E. R. JONES.

Atlanta, Texas.

QUEENS

Reared from imported mothers, warranted purely mated, 75 cents each. Breeders, \$1 25 each. No better stock to be had at any price. Send for catalogue of queens and bees. DEANES & MINER; Ronda, N. C.

Make Your Own Hives.

Bee-Keepers

Will save money by using our Foot Power Saw in making their hives, sections and boxes.

Machines on trial. Send for Catalogue.

W. F. & JNO. BARNES CO.,

384 Ruby St.,

Rockford, Ills.

2-96-12

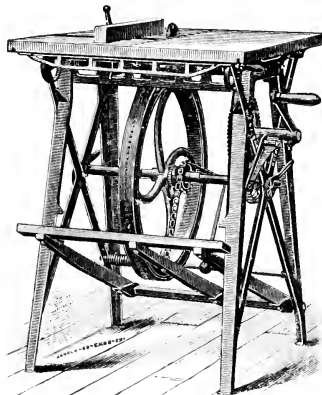

Some Odds and Ends That Will be Sold Cheap.

For a dozen or more years Mr. M. S. West of this place dealt in bee-keeper's supplies. Since his death, two years ago, his daughter has endeavored to close out his stock of goods, and has succeeded to large extent. There are still a few odds and ends, and she has brought them to me and left them for me to sell. Here is a list of the articles with prices at which they will be sold.

- One ten-inch foundation mill, (second-hand) Root's make, complete with dipping tank, etc. in excellent condition. \$10.00
 - One ten-inch foundation mill, (second-hand) Root's, (one of recent make) dipping tank, etc. in good order. 15.00
 - Three Woodcock foundation fasteners, each. 75
 - Eighty seven entrance guards, each. 05
 - Thirteen Porter Bee Escapes. 2.25
 - Thirty three Simplicity lives, in the flat, sides, ends, covers and tin rabbits but no frames nor bottom boards, each. .40
- Send all orders to W. Z. HUTCHINSON, Flint, Mich.

Queens

untested Italians 70 cents each; 3 for \$2.00. After July 1st, 50 cents each. Safe arrival and satisfaction guaranteed. Catalogue free.

698-tf

THEO. BENDER, Canton, Ohio.

I have several hundred

QUEEN CAGES

of different styles and sizes, made by C. W. Costellow and I should be pleased to send samples and prices to any intending to buy cages.

W. Z. HUTCHINSON, Flint, Mich.

Farm Bee - Keeping.

The only bee paper in the United States edited in the interests of the farmer-bee-keeper and the beginner is the **Busy Bee**, published by EMERSON T. ABBOTT, St. Joseph, Mo.

Send for free sample copy NOW.



See That Wink?

Bee Supplies. Root's goods at Root's prices. POWDER'S HONEY JARS Prompt service. Low freight rates. Catalog free. WALTER S. POWDER, 162 Mass Ave., Indianapolis, Ind., the only exclusive bee supply house in Indiana.

WALTER POWDER'S AD

THE MONITOR PAPER FILE

Binds securely and neatly all periodicals. Preserve your papers, magazines, pamphlets, bulletins, music &c., by binding them together as you get them. Each new number filed quickly and easily. Will bind 52 numbers of any periodical aggregating 1000 or fewer pages. All lengths from 6 to 28 inches. Light and handsome. PRICE.—All sizes 12 inches and under 12 cents; over 12 inches one cent per inch. When wanted by mail add one cent for each 5 inches or fraction thereof.

For sale by the Publisher of this paper.

Queens 75 cts each by return mail; either golden, or three-banded, young and warranted. Two separate yards with competent assistants. Circular free. J. B. CASE, Port Orange, Fla.

Without Stopping

the machine to reverse the combs is the way you can work with the Williams Automatic

Honey Extractor.

Such an extractor will save you time and annoyance and it does not cost much more than an ordinary machine. Send for descriptive price list.

Read what the famous bee-keeper, N. E. France, says:

PLATTEVILLE, Wis., July 5, 1897.
Dear Sirs: To day I extracted 2,780 lbs. of honey with your Automatic Honey Extractor in 5½ hours and could have done the same this afternoon but let the boys go to the city to play a game of base ball. Have extracted 27,135 lbs. so far with good prospects for as much more. My bees and State work keep me very busy. Hope to see you before very long—will write you later. Yours truly, N. E. FRANCE, State Inspector of Apiaries, Platteville, Wisconsin.

We can also furnish choice queens, either golden or leather colored Italian, at 75 cents each, or two for \$1.40.

Van Allen & Williams,

6-98-tf.

BARNUM, WIS.

Dovetailed Hives.

Cowan Extractors.

Danzenbaker Hives.

Porter Bee-Escapes.

No-Drip Shipping Cases.

Gleanings in Bee-Culture.

The Fence and Plain Sections.

OUR

SPECIALTIES.

Weed New Process Foundation.

Root's



Goods.

Catalog of goods and sample of Gleanings sent for your name on a postal.

The A. I. ROOT CO., Medina, Ohio.

Branch Offices :

118 Michigan St., Chicago, Ills.

1024 Mississippi St., St. Paul, Minn.

1635 W. Genesee St, Syracuse.

10 Vine St., Philadelphia.

Mechanic Falls, Me.



Bee-keepers in the

Northwest

Can save money and freight by getting their supplies from the Minn. Bee-Keepers' Supply Mfg. Co., Nicollet Island Power Building, Minneapolis, Minn. They have all the latest and most improved machinery and manufacture and handle a full line of supplies. Send for catalogue before ordering.

Please mention the Review.



I have had 30 years of experience in queen rearing, and make a specialty of the business. I have my cells built in full colonies, and send out no poor queens. I can furnish the best and purest of Italian queens, either 3 or 5-banded, at only 50 cts. each. My P. O. is a money order office.

Daniel Wurth, Falmouth, Ind.

7-18-31

Please mention the Review.

The No-Drip Shipping Cases

Are what you need in marketing your honey. They are clean, neat and convenient, and a great help in making sales.

Root's goods at Root's prices. Cash paid for wax. We want your trade.

M. H. HUNT, Bell Branch, Mich.

Please mention the Review

COMB



FOUNDATION

WHOLESALE AND RETAIL.

Working wax into foundation, for cash, a specialty. Hives, Sections, and a full line of Supplies. The best of everything. Write for Catalog, with prices, and samples of Foundation and Sections. Beeswax always wanted for cash or trade.

GUS. DITTMER,

10-97-121

Augusta, Wis.

The A. I. Root Co.'s Goods, WHOLESALE AND RETAIL.

Please mention the Review.



A Northern Michigan Apiary.

The Bee-Keepers' Review.

A MONTHLY JOURNAL

Devoted to the Interests of Honey Producers.

\$1.00 A YEAR.

W. Z. HUTCHINSON, Editor and Proprietor.

VOL. XI. FLINT, MICHIGAN, SEPTEMBER 10, 1898. NO. 9.

NORTHERN MICHIGAN.

Some of the Conditions that have made it an
Excellent Honey Producing Locality.

W. Z. HUTCHINSON.

"Bells' ding dong,
And choral song,
Deter the bee
From industry;
But hoot of owl,
And 'wolf's long howl,
Incite to toil
And steady toil."



NORTHERN Michigan, the home of the pine and the popple, bright with the beauty of the gold-rod, gorgeous with the purple of the great willow herb, most emphatically illustrate the

truth of the old German couplet that stands at the head of this article.

Nature, having had things pretty much her own way in this region until quite recently, and having plenty of time at her disposal, proceeded to raise a crop more valuable than Michigan will probably ever again produce—great forests of soft, white pine. But, now, alas! to the

stroke of the woodman's axe, and the song of the circular saw, nearly all of these grand old forests have been floated down the rivers and out upon the sea of commerce.

Desolation, is the one word that best describes that country from which the lumberman has stripped the pine timber. Stumps, logs, brush and fallen tree tops cover the ground in a confusion that is indescribable; while here and there, in their loneliness, with withered limbs outstretched, stand old dead, dry pines—ghosts of former grandure.

After the summer's sun has poured down for many days upon this mass of resinous material, only a spark from some settler's clearing starts a fire that sweeps across the country mile after mile—leaving the earth bare and blackened.

In the wake of these fires there spring up, as by magic, berry briars, goldenrod, fireweed and the incomparable willow herb. As all of these plants die in the fall, the earth and old logs and stumps are soon again covered with a mass of inflammable material; and the burning is almost sure to be repeated every two or three years. In fact, during a recent trip in northern Michigan, I learned that the willow herb is inclined to "run out" in two or three years; and is kept at its best only by these repeated burnings.

The frontispiece for this month shows a northern Michigan apiary near Thompsonville, Benzie county. It is the property of Mr. Geo. E. Hilton, who owns two other apiaries in that locality. The man



GEO. E. HILTON.

standing at the right is Mr. Hilton. Leaning against a raised hive-cover is Mr. John Calvert, Mr. Root's son-in-law. The little chap behind the veil is the son of the man who manages the apiary for Mr. Hilton; and is quite an enthusiast for a boy. The man in the foreground is the driver of the team that brought us in from Thompsonville. We took a drive a mile or more into the region shown in the background, winding here and there along the old woods-road, and admiring the acres and acres of willow herb in full bloom. By the way, we found one stalk of *pure white* willow herb—something none of us had ever seen.

While on the train Mr. Hilton occasionally pointed out of the window and said: "Right there is a splendid location for an apiary." He did not reach this conclusion simply from what could be seen from the car window, but because he had been there and investigated. There are many places in this region where bees have access to raspberries, basswood and willow herb; and, as the land is cleared, white clover comes in and completes the chain—making one continuous flow from spring until fall.

For years to come, northern Michigan will be an ideal location for honey production. That bee-keepers are becoming aware of the fact is shown by the way they are bringing in their bees. While we were at Mr. Hilton's apiary, his man told us that Mr. L. C. Woodman of Grand Rapids had just brought in 150 colonies; and so it goes. Regard for the rights of

others, combined with self interest and the number of unoccupied locations, have thus far kept bee-keepers from crowding one another.

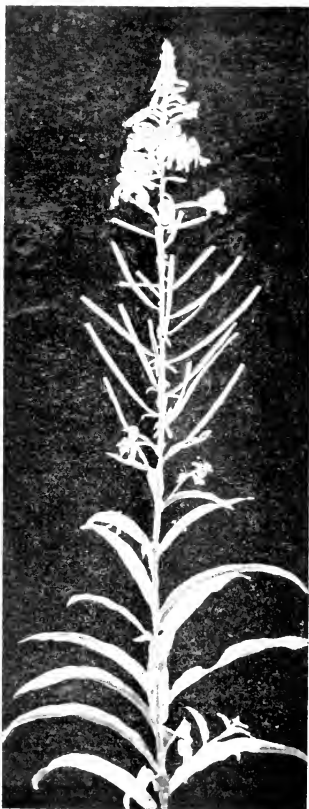

SPRIG OF WILLOW HERB.

If any are led to consider the advisability of moving to northern Michigan, let me say, if accustomed to the comforts and advantages of civilization, don't forget that this is a *new* country.

FLINT, Mich., Aug., 17, 1898.

FALL MANAGEMENT.

Look After the Queens and Winter-Stores.

E. D. OCHSNER.



NOW that the main honey-flow is over, and the days are growing shorter, the next question is the condition of the colonies that must pass the coming winter. I examine all of those

that have swarmed; as, in twelve to sixteen days after a queen has hatched she is laying. No eggs, show queenlessness. When there is a laying queen she must have plenty of room to lay in August and September or we need not expect to have her colony come through the winter in good condition; as the old bees will all die before spring, and there will not be enough young bees to pull through a late spring. If a queen does not lay good in September she should be encouraged by feeding the colony.

Now for an examination of the colonies that have not swarmed, and of the first swarms, to see if any queens are failing. If the lack of brood shows a failing queen, look her up and destroy her, and then go to the nuclei and take a laying '98 queen and proceed to introduce her. I have just put in six very fine Italian queens bought of W. Z. Hutchinson; and two days later they were all laying.

To introduce a queen to a colony that has been queenless 12 to 16 days, I proceed as follows:

Put the caged queen between two combs, leaving the face of the cage open to the bees, and allow it to remain for 24 hours. About sunset I open the hive, after smoking mildly, and taking out a comb of bees, let the queen (but no bees) out upon the comb. After watching her for fifteen

minutes, if the bees show no signs of fight, I daub her with honey, put back the comb, and close the hive, and put on a feeder. Four days later the results will be surprising.

Now for winter stores. If the apiary was run for extracted honey, there should have been saved out about three full frames of capped honey to each colony; as the best honey is none to good for wintering. Besides, we do not know whether there will be a fall flow; so you see it will be safer with plenty of nice capped honey on hand. This is better than feeding sugar so late that the bees cannot cap it.

If bees are to be moved to the home-yard for wintering, attend to it at once, or as soon as there is no more honey to be gathered. Do not make the sad mistake of waiting until it is so late that they will not have a few good flights before putting into the cellar. Do not move them when it goes down 40° above zero.

PRAIRIE DU SAC, Wis. Aug. 3, 1898.



THE BREEDING OF BEES.

Cross-Breeding to be Abandoned. The Importance of Beauty-

E. A. DAGGITT.

A thing of beauty is a joy forever.—KEATS.



His excellent article on the laws of heredity in the June issue of the Review. Mr. Crane brings out one important point in breeding that deserves particular notice by those interested

in the improvement of the honey bee. I refer to the mistake of crossing different

breeds or varieties of bees with each other. For years back, in fact, ever since I have given this matter proper thought, it has seemed to me wrong to cross the different kinds of bees with each other. By cross-breeding we are just as likely to get the bad qualities of both breeds in the cross as to get the good ones; in fact, the cross is more likely to inherit the bad qualities of the parents than to inherit the good ones. I believe that about all the general improvement in our bees that has so far been made has been attained by taking one variety and improving it by selection, without any cross-breeding whatever.

I am of the opinion that if the superb Italian bee had been taken and bred for all the desirable qualities in a honey bee, by careful and scientific selection, that we would now have closely approximated, if not secured, the ideal bee. I have often thought of the breeding of the Spanish merino sheep into the American merino breed. When our breeders secured stock of the former they commenced to improve the breed; and the improvement so advanced that, after a time, only a few years I think, the improved breed had become so much superior to the old, that importations of the latter ceased. In time the celebrated American merino was developed; being far in advance of the original breed from which it was bred. This was done by careful and proper selection in the right direction; and, I think, without the introduction into the new breed of a drop of blood from any other breed. In the same manner let us breed up to the highest desirable standard the beautiful Italian bee—the grandest of all varieties of honey bees.

When bees are cross-bred to improve the stock, there is no certain way of knowing if the crosses are pure or not; and new blood could be infused into them without it being known, and to their injury. This objection is insurmountable unless some way can be found to fertilize the queens other than the natural way. Different strains of honey bees

can be produced having one or more special features. Thus, one strain could be produced especially to secure extracted honey; mere honey gathering being its particular feature; the comb building feature being undeveloped. Another strain could be produced that, besides having honey gathering as its special feature, would also have comb building as a special feature. This would be the bee for the comb honey producer. Still another strain could be produced with the special feature of beauty—the bee for the bee fancier.

Although beauty is not one of the most important qualities of a honey bee, still, it is an important one and one that cannot be ignored or neglected in breeding the ideal bee. We all admire beauty. It is an important factor in human enjoyment. Life without it would be an existence hardly worth possessing. We fail to appreciate fully what a blessing it is, because we see so much of it. This world was created in beauty. Over the whole earth was spread the mantle of beauty; over the mountains, and the valleys, the hills and the plains, and over the mighty deep. We see the firmament arched with the rainbow of beauty. At night the moon sheds its mellow light of beauty; and the heaven is decked with "starry gems" of beauty. The "orb of day" rises in beauty, passes westward, bathing the earth in the sunshine of beauty, and sinks behind the western hills in beauty—often in the most resplendent beauty. There is, too, the beauty of the animal, vegetable and mineral worlds. Beauty of form, beauty of shape, and beauty of color. Beauty is not only external, but it is also internal. There is beauty of structure, beauty of function and beauty of action. Endless beauty. Indeed, "beauty lingers everywhere." Let us then give beauty the prominence it deserves. Let us have its brightening and refining influence. We need its companionship through life to cheer us, to brighten us and uplift us. We can perform our labors more easily when surrounded by

beauty. The farmer who appreciates beauty in his home, on his farm and in his animals and other things on the farm, even if he can not realize all his desires in this regard, is better to the extent of such appreciation. Putting a pursuit down to a mere dollar and cent basis is degrading it. We should carry on our work from a love of it. The bees are the most important thing about the apiary; and how much better it is to work about it when they are beautiful. Then why not have the advantages of beauty in our little friends and get all the enjoyment we can from our intercourse with them?

Several years ago I purchased a queen that was bred from a noted queen. The worker bees from her were the prettiest bees that I ever saw. The three yellow bands were so deep and bright in color! They did not have the pale dead color so common to the present yellow strains of bees. Often did I go to the hive and look at them—they were so beautiful. Queen breeders are making a mistake in breeding their bees so pale in color. They should select colonies to breed from the workers of which are the deepest and brightest in color; provided, of course, the bees have the other necessary good qualities. While breeding to develop the ideal bee, let not the two beauties—beauty of color and beauty of disposition—be neglected.

If we are to develop hardiness in our bees we must cease importing them, and even stop bringing them from warm sections of our country to the colder ones.

As the flora of our country is not the same everywhere, it seems to me that for each locality there should be strains of bees that are not only adapted to the climate but also adapted to the flora of the section.

If our critic is too severe upon mistakes in grammar, he may possibly discourage those from writing who would give us valuable facts.

WHITE HOUSE STA. July, 15, 1898.

KEEPING A RECORD.

How it may be done on a Board with the use of very Little Space.

J. E. CRANE.



FOR a book, I have found a board much the most satisfactory. Formerly, I used blank books to note down items and history, so to speak, of the various hives in an apiary; but

the wind would shut it so unceremoniously, or, in spite of my best endeavors, open it in a wrong place. Not only this, but the honey and propolis the paper absorbed from my hands while handling the frames of my hives would so stick the leaves together as to make the whole thing very disagreeable.

Since I began to use a board I have no desire to return to paper. A light colored board, say four inches wide by twenty inches long by one-fourth thick, gives ample room for the season's record of seventy hives. On such a board one can readily find the number of the hive and all one wants to know; the wind can not shut in up nor propolis stick it together in such a provoking way.

But how can a season's record of seventy hives be kept in so small a space? Briefly, by the use of short-hand, or signs. I know but little of scientific short-hand writing, but I know that a system of signs on paper or wood, each sign to represent some condition of the queen, or colony, is just as good, or a great deal better than if it were all written out. I can illustrate this better by giving a few examples from my records than in any other way. If we place the number of our hives on the left hand side of the record board we

shall still have left a line of 3½ inches for each hive. Let us see how it works.

Now, if the record of these five hives were all written out it would be about like this:

67. Queen's wing clipped. In fair condition. Eggs in queen cells. Brood in queen cells. Eight days later destroyed all queen cells and made colony hopelessly queenless. Later a young virgin queen given. Young queen laying. Need 15 pounds of honey or sugar syrup to be given for winter stores.

73. Queen's wing clipped; two years old. Strong. Eggs in queen cells. Re-

42. Queen one year old. Wing clipped. In fair condition. Removed brood combs and gave old dry combs to check swarming. Later found them queenless and gave frames of young brood. Found them with laying queen. Need 12 lbs. syrup to be fed for winter supply.

The reader will observe that these signs relate mostly to queens and swarming. As I run several yards of bees with only one man to assist me, it is of much importance to control swarming, so no stray swarms run away; and to have young and vigorous queens. I have found young

No. 67. C. F. - = \boxtimes , O, 15.
 " 73. S. V. - , \boxtimes , X, O, 5.
 " 86. S. F. \boxtimes , O 0.
 " 98. W. = , O. 10.
 " 42. C. F., S. D. C. X, O, 12.

moved queen and queen cells. Eight days later gave virgin queen. Three weeks later found it queenless and gave frames of young brood. Next, found a young laying queen, Needs five pounds of sugar syrup to make enough for winter stores.

86. Queen's wing clipped. Queen three years old and poor. Needs superseding. Took away queen and destroyed queen cells. Later again destroyed queen cells. After eight days introduced a young queen. Found young queen laying. Have honey enough for winter.

98. Weak. Have brood in queen cells. Later have given up swarming. Needs 10 lbs. sugar to make enough for winter.

queens, as a rule, much more satisfactory than old ones. So, in making new swarms, I use, by preference, last year's queens to those that are older; and I destroy my old queens unless they are very choice.

I will now explain my signs. C, after a number, stands for a year old queen with wing clipped. If I find her wing clipped in spring, I know she is two years old; and I mark this by crossing the C. If I find a queen that lacks vigor and looks old, I cross the C twice. I often wish to remember the condition of hives in spring, so I mark them or their number with a letter. F stands for fair. S for strong, and W for weak, or V W for very weak.

As the season advances, preparation for swarming commences; and when I find an egg in a queen cell I note it down by a simple dash. If I find brood in a queen cell I make two parallel dashes. Should I find sealed queen cells and I do not exchange the brood combs for dry ones or remove the queen I destroy the cells and mark the number with three parallel dashes. Sometimes I find it almost impossible to find a queen, and I look the hive over every eight or nine days and destroy all queen cells; continuing this to the close of the swarming season. It is interesting to note how many times bees prepare to swarm and then change their minds.

When I remove a queen from a colony having the swarming fever, I mark it with a square, and remove all sealed queen cells. Eight or nine days later I go over such hives again and cut out cells, when I mark the square with one diagonal mark. When I give them a queen I mark again thus, making a cross inside a square. Later, when I find my young queen laying all right, I mark with a circle. A circle, you know, denotes completeness. Should my queen be destroyed when on her wedding trip, or by the bees of her own hive, I give them two or three combs of young brood and mark with a cross. Often I use abbreviations; as G. D. C. for "gave dry combs;" D. Q. for "drone laying queen."

Numbers at the outer or right hand side of the board indicate the amount of sugar syrup to be fed to fit the colony for winter.

I have not given these signs or shorthand methods because I think they are the best that might be invented, for I have usually used what came into my mind on the spur of the moment, but simply to show how much time some such method will save the bee-keeper both in writing down and afterwards in reading. When I have been over a yard and marked them in this way, I can sit down and tell at a glance the exact condition of every hive

in the yard, just how many are queenless, just how many ought to be requeened, how many are preparing to swarm, etc. If we wish to remember just the condition of our surplus sections we can give their approximate condition of fullness by fractions, thus, $\frac{1}{4}$, $\frac{1}{2}$, $\frac{3}{4}$ and so on to the end; thus saving a large amount of time when time is to the largest degree valuable.

Another advantage in keeping such a record is that we learn many important facts that would otherwise escape our notice.

MIDDLEBURY, Vt. June 20, 1898.



THE CRITIC CRITICISED.

The Prevention of After-Swarming.—A Few Parting Words on the Facing of Comb Honey.

G. M. DOOLITTLE.

"Circumstances alter cases."



BRO. Taylor tells us in the Review, page 244, that "It is so seldom that he finds anything to criticise in Doolittle's statements that he must not fail to take advantage of it when he does find something." Well, Bro. Taylor, I am glad you took pains to criticise the thing you did, for now I have a chance to say a few words that I have long wanted to say; and had you criticised many other things I have "stated," which would not "hold water," I might

have held my head in shame and kept silent. Allow me to paraphrase Mr. Taylor's third and fourth sentences as found on the above quoted page, under "Prevention of After-Swarming:"

"Perhaps Taylor is led to practice his method from the fact that he is largely using the Heddon hive and wishes to engage others toward a favorable opinion of that hive. In the absence of some such reason I would never follow the method he gives; because it is a laborious, time-consuming operation, at a season of the year when it is especially wise to economize both in time and labor, without any corresponding advantage."

Wonder if Bro. Taylor ever tried the Doolittle plan of preventing after swarms. Then I wonder if he ever tried the Heddon-Taylor plan with any other hive save the Heddon. I tried the Heddon-Taylor plan for three years, and I found that the changing the old hive to one side of the new, "then gradually turning the old hive around beside it and carrying it (the old hive) away, while the bees were flying, on the sixth or seventh day," to a new stand, was a "laborious, time-consuming operation, without any corresponding advantage." The whole of this operation during the seven days consumed *double* the time of that of the plan of cutting queen-cells which Bro. Taylor criticises, while the queen-trap purchase was entirely avoided; and this trap-money saved for some glad surprise to the family, by way of some needful things they could have with the money. But the *laborious* part came in the carrying of the *hive*; yes, even with the *Heddon* hive. And, Brother, the especial part of this criticism comes in your failing to take into consideration, that not *one* Heddon hive is in use to where there are *fifty* to *one hundred* other kinds of hives. Imagine Mrs. Harrison, or Mrs. Axtell, following your plan with the regular Langstroth hive. See them stoop over, then straighten up, with the blood nearly ready to burst through the veins on their faces, then walk to a new stand

and lower the hive thereon, and then talk about the "laboriousness" of my plan. Then there are thousands upon thousands of chaff hives in use; and, sure as you live, swarms issue from those hives. Imagine Bro. York picking up one of these hives, setting it back, gradually turning it for seven days, then picking the thing up bodily and "trotting off" with it to some new location, five to ten rods away. Then, Brother, there are hundreds of tenament hives in use, the same holding from four to six or eight colonies. Imagine Bro. Taylor picking one of these up and carrying it off at arm's length and depositing it on a new stand. Then, my dear, good friend Taylor, there are scores, if not hundreds, of house-apiaries in use. Just imagine 260-pound Doolittle picking up—but, hold on, Doolittle don't have to do any such thing. Nor need anyone do any of this *laborious* work by the plan *you* "would never follow." It was because the plan I gave in the American Bee Journal, 402, was adapted to *any* frame hive or any climate, that I recommended it, and *not* because "I get plenty of good queen-cells ready to hatch;" for 99 out of every 100 queens reared in my apiary are reared by the plan I gave in my book. And now, Bro. Taylor, I am perfectly willing that each reader of the Review should use the Heddon-Taylor plan of prevention of after-swarming if they believe it is more to their ease and comfort so to do, for I give my plans and ways of working only with the hope that it may help, ease and lighten the burdens of my brethren and sisters.

I wish to thank the editor for the light he threw on the "facing" matter in last Review, page 242. I know that this subject has been long drawn out, and twice the room taken with it that would seem necessary; yet there are some who do not seem to see the *truth* yet. Therefore, allow me just a few words more to try and make my position plain. From more than twenty years' business with commission men I feel authorized in saying

that it is *always* the commission merchant's business to *show the goods* sent him unless their *quality is guaranteed*. If I consign a commission man comb honey saying, "I ship you twenty cases of 'fancy white honey,'" then I guarantee the honey, and he is not expected to open it, unless he chooses to do so. If it is not *all* fancy white honey, but faced with fancy white, and the "behind" sections are No. 1 dark, or buckwheat, then I make the commission merchant a "scapegoat;" an "dishonest," "a fraud," a "cheat," and a "doer of wicked practices," (all of which have been hurled at me); and there would be no call for Bro. York to defend my "good character," or for Bro. Hasty to speak of "Doolittle's honest practice and advice."

But if I consign the same number of cases of honey, writing thus, "I ship you twenty cases of honey to be sold on commission, accordidg to you best judgment," and fix up said honey in any way to suit myself, then it is *his business* to show that honey to any prospective buyer and say, "There you have it; look it over and see what you can give me for it;" and if he does not do this, he is not doing the part of a consignee, and is the party of dishonest practices; for, as one of the commission men truthfully says, in reply to the questions in the American Bee Journal, "The commission merchant's buyer is depending on *him*." Italics mine. And there is nothing that can be considered dishonest in the consignor, or as wishing to make the "commission man a scapegoat" by any righteous law, or by any right thinking person, who will lay aside his prejudices long enough to look all around the question. It is not "what will be thought of Doolittle" that I care about, but when I make a statement that is *right*, it is my business to stand by that right and prove it, even though the whole world says to the contrary.

BORODINO, N. Y., Aug. 19, 1898.

NOTES FROM FOREIGN BEE JOURNALS.

F. L. THOMPSON.

As cold waters to a thirsty soul, so is good news from a far country.—BIBLE.

(Continued from last month.)

Speaking of obtaining wax cakes by molds of paper alone, the editor says "The wax cools quickly without a trace of cracks, and is detached from the paper like a kernel from a ripe peach. I melted cappings in the solar extractor, and poured the wax obtained, 31 lbs., into forty such paper trays, of various sizes. The cakes were clear, without a trace of dregs, because the wax in the trough of the solar extractor remains liquid for hours in July and August, thus giving time for all impurities and leavings of honey to settle to the lowest part of the wax, which of course is not poured into the trays." From this it appears that the solar extractor may be made a perfect means of purifying wax. I should not have thought otherwise, had it not been for the editorial paragraph on page 177 of the Review, quoting C. P. Dadant. Evidently, however, Mr. Dadant refers to extractors of the ordinary type, in which wire cloth allows the melted wax to carry refuse with it, which is then nicely distributed through out the cake because it cools nearly as fast as it runs through. I use an extractor with a tin tray, perforated with holes near one end. These holes are stopped up with refuse which I never clean out, thus acting as a filter; and although the wax cools quickly below, it only shows dregs here and there, while the intervals are perfectly pure. By running the wax through the second time, I have secured reasonably clean chunks of bright yellow wax, with which I have made brood foundation good enough for home use. The solar extractor does not work too slowly for me, having this season furnished between fifty and sixty pounds up to date, mainly from old combs and scrapings. Only a modification is necessary to enable it to puri-

fy the whole as perfectly as it does the part. All that is necessary to procure salable wax is to keep it melted for awhile after it runs through, by letting the sun shine on the lower part as well as the upper. For some years Rauchfuss Bros. of this state have been using an extractor which does just that thing, with satisfactory results. In addition, the pan receiving the wax below is divided into compartments with flaring sides, so that when one compartment is full, the wax flows into the next. I believe each holds just a pound of wax. There are absolutely no impurities in the resulting cakes, except on the bottom of the first one. Then the sun's heat alone does the whole work of preparing merchantable and uniform cakes of wax, of the first quality. It is not necessary, by this plan, to handle the wax again by pouring it into paper trays, for wax melted by solar heat has very little tendency to crack, and never does in such small cakes.

"None of the Americans who make use of the solar extractor speak of the reflector, which so greatly increases the melting power of the sun's rays."—Dr. Dubini. The first solar extractor I ever saw had a reflector. It was a concave sheet of bright tin, fixed on the inside of the outer cover so that when the latter was lifted and set at a certain angle, the reflected rays were cast upon the glass.

From 20 to 25 percent of the wax of the combs is left in the slumgum by the extractor, according to certain writers reported by Dr. Dubini, and is to be obtained by boiling with water. If I am not mistaken, Messrs. Boardman and Aikin have very considerably reduced this percent in their extractors, by having them large, spreading the residue out thin, and letting it drain a long time. This, by the way, is a field which seems to have been neglected by the experiment stations.

The color of wax is darkened by repeated meltings and coolings, even in the sun-extractor, says G. Barrucco.

Dr. Dubini expresses surprise that so common and cheap a material as turf is never spoken of for smoker fuel in North America. So far as I know, that substance does not exist here.

Baldensperger cleans kerosene cans for honey by exposing them to the sun for a fortnight, washing with lye, drying, and then igniting a few drops of alcohol in each one. Every trace of odor disappears.

The editor stops robbing by covering the hive entirely with a piece of canvas, leaving the entrance wide open. The canvas is left on 2, 4, or 8 days, or until not a single strange bee is seen prowling around.

The fears generally felt of the consequences of disturbing bees in winter are exaggerated, says the editor, after an experience in moving bees very late and subsequently opening the hives.

Herr Reamer, as reported by the editor, introduced 23 slender thermometers into the cluster of a colony while the outside temperature was 30°F., and found the temperature of its center was 86°. In another case the outside temperature was 16°, and that of the center 83°.

Dr. Dzierzon thinks it beyond a doubt that during severe cold spells in winter the greater part of the colony enters into the cells, the rest remaining in the intervals between those combs which the cluster occupies. The editor thinks not. The bees found in cells in winter are dead. In times of severe cold, the bees produce heat by vibrations of the body and especially of the wings. They could not do this in the cells. If bees stayed habitually in the empty cells in winter, there could be no such thing as a winter repose, for they would have to make continual excursions for food. He has observed that in colonies which starved during the winter many bees are to be found in the cells, but in experiments with live colonies, found the bees in the comb spaces, with the main part of the cluster on the honey, above the empty cells. He thinks the bees Dr. Dzierzon

observed were either dead of hunger or frightened by the disturbance of inspection.

Dr. Latinne, of Belgium, in a monograph on wintering, which has attracted considerable attention, contends that if a cushion above the brood-nest attracts moisture, it does so simply because it lets warm air pass through it; and when once moist, its effect is injurious rather than beneficial. He advises hermetical sealing of the top and sides of the hive, to avoid all currents of air, with contraction of the entrance. As the bees can do the sealing best, he would have wintering preparations finished early before the leaves fall, so as to give plenty of time to gather propolis. Feeding to supply lack of stores in the fall should be accompanied by a contraction of the brood-chamber, in order that the feed may not be too much scattered; and then continued until the bees refuse to take more. To be able to carry strong colonies through the winter with a sufficient quantity of young bees, he thinks stimulative feeding in August necessary.

The editor lends his authority to the common belief that it is the abdomen of the queen, instead of the thorax, which prevents her from going through perforated zinc, by saying that probably when empty of eggs a queen passes through the excluder.

In 1894, G. Lanfranchi propounded his theory that a fertilized queen always lays fertilized eggs which in themselves are neutral; the difference in sex being due to the difference of nutriment on the part of the bees, which rear workers, males or queens according to their needs and instincts. He gave apparently convincing proofs, the result of experiments of several years. The editor of the Noerdliche Bienenzeitung, a physiologist and microscopist, has independently reached the same conclusion after similar experiments. In this country C. Theilman, on page 356 of the American Bee Journal, sets forth the same conclusion, which he also seems to have arrived at independently.

Flaminio Barbieri says the reason the queen does not sting one is that she has a curved and flexible sting, which cannot enter a resisting body, while that of a worker is hard like a needle. The same writer says foul brood is rare in Italy.

To get the capacity of a hive, says he, fill it with grain, and measure the grain. (Where the metric system is not used, it will be necessary to remember the number of cubic inches in a gallon.)

"I have chanced to observe apple-trees in full bloom visited by very few bees; fruit cannot be expected from such trees." —Comola Fedele.

MONTROSE, Colo. July 10, 1898.

A Condensed View of Current Bee Writings.

E. E. HASTY.

"I'll trace the garden o'er and o'er,
And meditate on each sweet flower."

AMONG the old fables there is one in which a wolf is eaves-dropper at a feast which some shepherds are celebrating (main item of the repast a shoulder of mutton) and he soliloquises thus: "Bless me, what a fuss there'd be if I should be caught at such a banquet!" As the sugar-honey wolf, I would make the same remark about Gleanings, Mr. Vernon Burt, et al, and all the folks who gave me "fits" about open sugar honey, sold under its own name, and now would fain feel syrup down stairs, and look the other way while the bees carry it up stairs—and all to redeem this very barren season.

No, no, gentlemen! It won't do. Every tub on its own bottom, and no subterfuges. If honey from syrup feeding is so nearly the same thing as floral honey that it is mere nonsense to discriminate, why, then say so openly; give mankind a chance to protest if they want to; and when the smoke clears up in victory and peace, feed your syrup with a clear conscience. As you are going on now

you will never feel quite right, as to the conscience, unless said consciences are impalpably small.

Of course the ostensible idea is to have the syrup fed to the young bees, and the fresh nectar stored in sections; but until somebody proves that this is actually done we are expecting something entirely in defiance of reason and probability. The syrup is thick and ripe and *cannot* be fed to brood till much work at bringing water is done first—but it is just right to put in sections. On the other hand the fresh nectar cannot be sealed in sections until much and long work has been put upon it first; but, in thinness at least, it is adapted to use in brood feeding. Let us not twist our thinkers and feelers all "out of whack" by expecting such wasteful tactics as boiling down the water of the nectar and bringing water for the syrup simultaneously. There now!

Away from the other side of the globe in Australia, another Miller, to wit, H. L. Miller grinds us a surprising grist of wisdom as to the piping of the queen. His young queens (virgins I infer) were greatly in the habit of piping when he was holding the frame in hand on which the queen was at the time located. He often observed the operation scientifically and dissectively. It seemed to be a work requiring considerable effort, and there were three parts to it. First, the queen (usually running about just previously) would stop. Never a pipe without stopping first. Second, she would crouch or squat down till thorax and abdomen were pressed snug against the comb. Third, the head was turned upward until facing straight upward instead of straight ahead. This third item was the most conspicuous one, and would occur just as the sound was emitted. So far I can sack the grist nicely, whether I can swallow it or not, but what follows rather stumps me. "Between the notes" the head would return to its normal position. If I am level on piping, it consists of long and short notes, separated by long and short intervals—and the whole

so diversely put together that seldom two queens pipe just alike, even as seldom as two striped grass blades look just alike. Many queens, however, close their pipe with a number of short notes divided by short intervals—as if a tiny saw were wrestling with a tiny splinter. Now does friend Miller wish us to understand that the queen's head is turned 90 degrees and back again during each one of those minute intervals? If so I fear that my credulity will "streak it" to the woods. Or does he mean no more than a return to normal position between one pipe and the next one? One would hardly think so from his language. Quite likely the fact is the head is turned during the long intervals but not during the short ones. Granting the correctness of the observation, one would suspect that there are serrations on the rear part of the head and the front part of the thorax, and that the sound is made by rasping the two together. Gleanings, 512.

Section cleaning by machinery is one of the topics which have the public ear just at present, and Gleanings for July 1 makes several noteworthy contributions. Arthur Howe shows a worn-out bike made over into a section cleaner, which the editor thinks rather locates the high water mark of machine excellence so far. Having tried both ways, Mr. H. prefers the rim of the cleaning wheel as a working surface, rather than its flat diameter. Finds it a great improvement to introduce elasticity by having several thicknesses of felt under the sandpaper. Two cleaning wheels, one on each side of the belt—one coarse to take off propolis, and one fine to polish the wood.

Harvey Perry gets the same division of the work on a flat disk machine by using a large disk, in which the center is surfaced with sandpaper and the outer part set with rasps. In manipulation the rasps are first in play, then the section is slipped the width of it forward for sandpapering.

Quite astonished were we to find that A. I. Root, the "guide, philosopher and friend" of beedom, has ceased to be the

market gardener and greenhouse man of Medina. And to think that instead of counseling with us about it six months in advance he kept it from us about six months afterward!

CANADIAN BEE JOURNAL

The Canadian, being a very staid and steady journal, hardly needs another characterization at this time, but only that ordinary attention to contents which would be better given each month, but which I find a little easier to give all in a heap. Perhaps the advent of "Notes and Pickings" by D. W. Heise should be mentioned as a new and interesting feature. The Canadian reports a fire March 3rd which specially damaged the supply and manufacturing department. But the look of the paper is not changed—no blisters on its face—nor flies.

One of the most noteworthy things in recent numbers is the Canadian experiment stations report on Carniolan bees. Get a black eye for their awful comb-building. Photo-pictures are given of the combs of a colony not very exceptionally bad. Or rather seven combs are pictured, and the other has merely an evil mention as being all drone comb. These bees evidently start about four centers of work on each frame (not unusual with other bees) and then scandalously neglect to join their work together, leaving deep, ugly sinuses, oak-leaf style. Inspecting the six worst combs pictured, we find twelve of these work centers drone comb, and only eleven worker. The one respectable comb has a large patch of drone in a lower corner, and is marred by what seem to be recently half-filled pop holes. The picture is not distinct enough to show unsealed brood. Of sealed brood there is but little, and that little nearly all drones. Although themselves a swarm of the current year, they swarmed again (or repeated) at the point where the pictures were taken. The swarms from 12 more were hived on starters merely. It was the latter lot of course that did the bad work. The others not only produced good combs but also re-

frained from starting a new series of swarms, which is an item that deserves being remembered and pondered over. If we *had to keep* repeating bees—as fortunately we do not—the relief would be valuable. Still this one test, although extended and official, should not be regarded final. The year 1897 was an exceptionally swarmy year. The queens were all tested queens bought the previous year, and maybe many of them have been too old for the best results. Perhaps Carniolans get aged sooner than Italians. D. W. Heise (Canadian, 292) tells of introducing eleven Carniolans bought in the U. S. Six of these were superseded the next year.

That poem on the Widow of Windsor [Victoria] which the July number carries on its cover front—well, if a British poet can father it, and a loyal British journal can put it at mast head, surely we Yanks needn't do anything but laugh.

Charles Mitchell got stumped trying to make naphthol mix with honey (for bee medicine) and wrote to his friend Corniel for help. He, up the same stump, wrote to Thomas Cowan, England. While waiting, Mr. Mitchell *learned* some honey, and, lo, the stubborn medicine mixed in as easily as milk mixes in water. Canadian, 295. Quite a sermon in the above. A new commandment I give unto you, that ye try again—with slight variations.

C. W. Post sows on his apiary in early spring two barrels of dry road dust (saved over from the previous fall) sometimes does it twice—and all to make the snow melt off quicker. Canadian, 301. Did you ever see the like of those hyperborean Canadians?

The Bee-Keeper's Association seems getting a trifle unrestful on the matter of foul-brood—whether with all the inspection and effort any satisfactory headway is being made against it from year to year. Inspector M'Evoy allows that a little more severe burning will have to be done.

Simple directions about comb honey—not to set it down with a bang, not to

grasp it with finger ends touching the comb itself, not to pick at it with pen-knife or splinter, and above all the never-enough-repeated warning, don't put it down cellar. G. A. Deadman thinks these should be printed in quantity on a slip, and one put in each case of honey. Canadian, 246. Good idea. One half of private customers, and grocers as well, to this day "don't know beans" on these needful and trite subjects.

Some valuable wax experiments appear on page 248. Two pailfuls of crushed old comb, soaked for two days, were steamed out. Result 11 $\frac{3}{4}$ pounds; and the residue *seemed* to contain no wax. Put in a suitable press however the experimenter (Mr. F. A. Gimmelario) was astonished to see 5 $\frac{1}{4}$ pounds more come out. A somewhat similar charge was boiled out in a sack, in the old fashioned way, and only 1 pound 6 ounces was recovered by the press. The first treatment got out 9 $\frac{1}{4}$ pounds. So unless the press is used also steaming is not an improvement—drives the water out of the cocoon silk so completely that melted wax is absorbed later on.

D. W. Heise the picker says that last winter, so mild in Yankeedou, was both mild and severe in Kamuckshire. It was mild as to zeros, but severe in that it wouldn't let up enough to allow of cleansing flights. Page 249.

In the same paper he says he likes leaves for winter packing, although he admits that they are bothersome to take out and replace. Seems to me that that is not their worst fault—will get wet and stay wet with the moisture of the cluster of bees. Doubtless in Canadian zero weather damp leaves and dry leaves seem much alike; but in a mild climate there is a heap of difference. He makes a very good point in saying that four flights in winter [if equi-spaced of course] are better than more. Yes, we should keep that in mind. Probably a shade board set to keep the bees from flying would often pay for the trouble of setting it. Too much winter flight often seems

to make wintering in the South about as destructive as it is in the North.

On page 257 Prof. Shutt of the Canadian experiment station reports that in some samples of foundation 50 percent of the wax is drawn or moved into the structure of the comb away from the base, while other samples show various lesser percentages, even down to a paltry 7 percent. But as these last were mostly samples so thin that there wasn't any wax to spare the enlargement of our practical knowledge seems not to be very great.

In an able article on spraying fruit trees in bloom, the editor, R. F. Holterman, expresses a doubt whether or not nectar thus poisoned will affect the bee carrying it if none is taken into the true stomach for food. Page 259. I think the facts we already have at hand enable us to say with almost certainty that it must do so. It is in evidence that bees carrying quantities of thin nectar are constantly ejecting water as urine. This water must come from the bees' blood; and the supply in the blood must be kept up by percolation directly through the walls of the honey sac. Now for water containing poison in solution to pass through a thin living membrane and not carry any of the poison along with it—well, pending positive proof, I think we should assume that a trace at least of the poison will go along. Perhaps a counter-minded person would say, easier to hold back all the poison and let the water pass than to hold back all the honey and let the water pass.

The two most important points of bee-keeping, according to friend Holterman (page 220) are, wintering bees with the least loss of vitality, and, keeping down the desire to swarm. It should serve to keep us humble when we think that both those points are unsolved, if not unsolvable. As to wintering, the change proposed is the forced introduction of a small but constant supply of pure air. As is well known, self-acting ventilators work too well in fiercely cold weather and almost not at all during a thaw. The new de-

vice I judge is one which he is *going to try*. When somebody has actual experience in this promising line we shall be all ears.

Mr. Hall at the Association gets rather acetic on honey vinegar. He says if one wants to make it for fun all right; but it will cost more than it is worth. Canadian, 229.

Not every editor could make the avowal which the editor of the Canadian makes on page 200—to wit, that he has never refused publication to any article criticising his own utterances. Good thing to be able to say. But *sometimes* such criticisms are so gross that they ought to be refused—and a pledge to always publish them would be quite apt to bring out a crop of intolerable ones.

RICHARDS, Ohio, August 1, 1898.



EDITORIAL offerings.

THE STATE FAIRS will claim my whole attention for the next few weeks. I shall probably attend the fairs of Indiana, Illinois and Missouri, and send an exhibit to the Michigan fair. The October Review will probably be a little late on account of my absence on this trip.

BLACK, in my experience, seems to rouse the ire of bees more than is the case with other colors. Dr. Miller says in *Gleanings* that is his experience. The editor has had no such experience. If I wear a black hat the bees will go "bump," "bump," against it. A straw hat with a black band around it causes the bees to "bump" against the black band. I once saw worn in the apiary a hat having a black binding around the rim, and it was really conical to see the way the bees would pitch for that black binding.

LANGUAGE that is pure and perfect is certainly to be admired. A journal the columns of which are plentifully sprinkled with slang cannot, of course, receive the respect of one that uses choice language. At the same time, let us not forget that criticisms on this subject may become hypercritical.

THE OMAHA CONVENTION.

The United States Bee-keepers' Union will hold its 29th annual convention, September 13, 14 and 15, at the Delone Hotel, corner 14th street and Capitol avenue, Omaha, Nebraska. Here is a list of the topics and of the papers that are to be read:

- General Advice to Bee-keepers—Rev. E. T. Abbott, St. Joseph, Mo.
- Bee-keeping in Cuba and Porto Rico—O. O. Pöppleton, Stuart, Fla.
- Co-operation among Bee-keepers—P. H. Elwood, Starkville, N. Y.
- Organization among Bee-keepers—W. F. Marks, Chapinville, N. Y.
- Bees in America—Prof. Lawrence Bruner, Lincoln, Neb.
- Recent Progress in Apiculture—E. R. Root, Medina, Ohio.
- Feeding Bees for Best Results—W. Z. Hutchinson, Flint, Mich.
- Bee-keepers and Supply Manufacturers—Dr. C. C. Miller, Marengo, Ill.
- Foul Brood in the Apiary—Wm. McEvoy, Woodburn, Ont., Can.
- Advanced Methods of Comb-honey Production—S. T. Pettit, Belmont, Ont., Can.
- Experiences and Suggestions in Marketing Honey—S. A. Niver, Groton, N. Y.
- Migratory Bee-keeping—H. E. Hill, Titusville, Pa.
- Best Methods for Developing and Maintaining a Market for Honey—Herman F. Moore, Chicago, Ill.
- Honey-producing Plants—Prof. Charles E. Bessey, Lincoln, Neb.
- The Scientific Side of Apiculture—C. P. Dant, Hamilton, Ill.
- A Half-century of Bee-keeping in America—Hon. Eugene Secor, Forest City, Iowa.
- Best Size of Hives to Use in the Apiary—J. F. McIntyre, Sespe, Cal.
- The Relation Existing Between the Apiary and the Successful Production of Fruit—G. M. Whitford, Arlington, Neb.
- The Apiary on the Farm and in the Orchard—E. Whitcomb, Friend, Neb.
- Needs of Bee Culture in the South—Dr. J. P. H. Brown, Augusta, Ga.

THE GRADING OF HONEY.

Mr. H. R. Boardman, of East Townsend, Ohio, made me a short, sweet visit a few days ago. We sat out in the hammock in the moonlight and talked bees until—well, it wasn't so *very* late. The next day we went over and made R. L. Taylor a short call. Mr. Boardman then started for the western part of Michigan. He got no surplus this year, and when he read what I said in the Review about northern Michigan it stirred him all up. After he is home again I may ask him to give the readers of the Review his impressions of that country. You may, in the future, often see me remark: "Mr. Boardman says," but, at present, there is not room for much of this. As this is an appropriate time of the year, I will say that he is opposed to the grading of honey into "fancy" and "No. 1." He says that we get no more for our fancy than we would for both "fancy" and "No. 1" crated together. After the "fancy" is sold, "No. 1" is hard to sell and we must sell it at a low figure. These are the very views taken by neighbor Koeppen. I must admit that I have never practiced these Washington rules for grading. I put the "fancy" and "No. 1" all together, and what is lower than these grades I sell to private customers at a reduced price.



THE DEPARTMENT OF CRITICISM.

A subscriber over in Merrie England objects to the Department of Criticism on the ground that it contains too much fault finding. He thinks that the good things ought to be pointed out as well as the faults. Perhaps the heading to that department is not exactly what it ought to be. According to the dictionary, criticism is the art of judging well, of judging and remarking with exactness. I suppose it means judging of the good as well as the bad qualities. Somehow I had fallen into the idea that criticism meant the pointing out of defects. I think a great many have that understanding of the word. We say "the course

that he took laid him open to criticism." That is, fault could be found with what he did. We say a painting, or a book, "is above criticism." It is so good that no fault can be found with it. You may call Mr. Taylor's work "fault finding," or "criticism," or whatever you like; what I have asked him to do is to point out errors and fallacious ideas, and when it is possible for him to give better plans in place of the ones that he condemns, to do so. I thought that this would be a good feature; that subscribers and even the other journals would welcome it. Some subscribers *have* praised, while others have condemned. One journal has praised. While none of the journals have condemned, there is to me, as I read between the lines, in some of them, or else I imagine it, a sort of antagonism. Now, if this department is going to stir up ill will and hard feelings, and break up friendships, and cause the Review to be looked upon with resentment, the sooner it is dropped the better. Than to have such a state of affairs we better allow each man to be his own discoverer of "errors and fallacious ideas." While I appreciate *deserved* praise, there is a still greater thankfulness when my errors are pointed out; and, if I am making a mistake in publishing this department, I wish to know it.

I am running the Review to make a living and for the good that I can do bee-keepers; and in this work I have always tried to keep close to my readers; to keep in touch with them; to take them into my confidence; and it is to this that the success of the Review is largely due. Now there has come a time when I wish to again ask for their advice. Let each one who has the success of the Review at heart, who wishes to see it and bee-keepers prosperous, write to me and say what he thinks of the Department of Criticism as it now conducted. Even if it is to be continued, there may be changes that would be desirable; and I know that Mr. Taylor and myself would give careful consideration to any suggestions. If

any of the other journals care to make suggestions, or express their views, I shall be thankful. Of course, I am running the Review; I am the one that must decide how it shall be conducted; but I have not yet reached that point where advice and suggestions are not welcome. If anyone wishes to write me confidentially on this subject, or any subject, that confidence will be respected.



LARGE HIVES, LARGE COLONIES, AND THEIR INFLUENCE UPON SWARMING.

There has been, and is yet, considerable talk about large hives and large colonies, and small hives and contraction of the brood nests, etc., and the relation of these things to swarming. The idea that large colonies swarm less is, of course, erroneous. Colonies in large hives may swarm less, and probably do, because they have more room. Large hives must not be confounded with large colonies. As E. R. Root remarked in *Gleanings*, "Large hives do not make large colonies any more than large shoes make big feet." Perhaps these are not his exact words, but they express the idea. The only way in which large hives could assist in the production of large colonies would be in allowing more room for breeding. A large colony, if crowded for room, is just as likely to swarm, perhaps more so, than a small colony. When all of the hives of an apiary are of the same capacity, the large colonies are the more likely to swarm. Lack of room is a great incentive to swarming. Mr. Aspinwall has prevented it entirely this season among 50 colonies; and the principal feature of his plan is that of separating the combs of the brood nest with dummies that give the bees room; but the room thus given is of such a shape that no honey can be stored in it, but must be put into the sections. In the production of extracted honey there is not much difficulty in controlling swarming, because of the abundance of room that can be given. Some time ago the editor of *Gleanings* referred

me to Mr. N. E. Doane of Breckenridge, Mich., as a man who used large hives, and urged me to visit him. I followed his advice, and, about a month ago, called on Mr. Doane rather late in the evening; and all of the members of the family, including the dog, left their beds to get up and welcome me. I am not sure but the dog ought to be placed first on the list. I stayed with Mr. Doane that night and a part of the next forenoon. He explained to me why he had preferred large hives. It was because by their use he had been able to largely prevent swarming. Of late he has adopted the plan of removing sections as soon as they are completed; not waiting until a whole case is completed; in fact, I believe he does not use a case, but manipulates them by the wide frame-full, or section holder, rather, and in this way is able to always have an abundance of room in the supers. Giving room by this method does away with swarming to a great extent, and now he does not care to have a brood-nest larger than ten frames.

While I believe that for the bee-keeper who has a single apiary under his care, and that at home where it is constantly under his eye, a brood-nest of at least moderate capacity is best, I will admit that possibly for out-apiaries, or under any condition where *neglect* is likely to play a prominent part in the management, large brood-nests may be better than small ones.



A VISIT TO THE HOME OF MR. ASPINWALL—HIS NON-SWARMERS, SECTION-CLEANER, ETC.

Mrs. Hutchinson and myself have just returned from a flying trip to the pleasant and hospitable home of Mr. and Mrs. L. A. Aspinwall of Jackson, Mich.

For some eight or ten years, Mr. Aspinwall has been struggling with the problem of preventing swarming. This year perfect success has crowned his efforts. Out of about 50 colonies, pre-

pared according to his latest plans, *not one has swarmed*. The *main* feature of his plan is that of separating the combs with dummies of peculiar construction. This relieves the crowded condition of the combs (which brings on swarming) yet leaves all of the bees in the hive. He has taken colonies that have swarmed under the old management, cut out the queen-cells, spread the combs with dummies, returned the bees, and there was no more swarming—the bees going promptly to work in the sections. Mr. Aspinwall will certainly have an average of 25 pounds of surplus comb honey per colony; and may

way of section cleaners, it is safe to say that he has now cut the ground from under all future inventors in that line. Although the frame and general construction of his machine is the same as described in the Review of December 1897, he has discarded sand-paper, emery-cloth, and even solid emery, and returned to "first principles," so to speak, but has applied them in a manner that challenges admiration. As Mr. Aspinwall expects to patent this invention, I am not at liberty to describe it; but when it is given to the public I am sure many will exclaim "Well, well, if that isn't ingen-



A LOOK OUT OF MR. ASPINWALL'S HONEY-HOUSE WINDOW.

have much more, as the bees are now working nicely on buckwheat and fall flowers. His neighbor's bees have swarmed; and, thus far, have stored no surplus.

Mr. Aspinwall is continually experimenting; in fact, his apiary is really a veritable experiment apiary. In the

ious!" Mr. Aspinwall has used the machine in cleaning nearly 1,000 sections; and it does the work quickly, easily and perfectly; while there is nothing that gums up or wears out.

Mr. Aspinwall has a fine microscope with which he has spent days and weeks

and months examining the different parts of the bee; and his original knowledge in this field is probably the equal of some who have made greater pretensions.

The space for an apiary in his backyard is very limited, but his peculiar arrangement of hives enables him to crowd them quite closely together without any danger of the bees mixing up or queens getting lost. The apiary is so surrounded by trees, vines and a high picket fence that the only way in which I could get a view of even a part of the hives was by poking the camera's nose out of the up stairs window of his honey house.

By the way, Mr. Aspinwall has also made some minor improvements in shipping-cases; but, as he expects soon to take up his pen again for the Review, I won't tell any more.



Department of Criticism

R. L. TAYLOR.

Blame where you must, be candid where you can,
And be each critic the Good-natured Man.

G. LODSMITH.

THANKFUL FOR CRITICISMS.

Dr. Miller (Gleanings, 609) points out a gross error of mine in using "it don't." Mr. Bevins (A. B. J., 457) also takes me to task for using an adjective for an adverb, but in a case palpably the fault of the printer. To both I want to express my hearty thanks. Helpful criticism is more than meat and drink to me.

A STRONG PLEA FOR PURE, PERFECT LANGUAGE.

I am considerably disappointed at the attitude of the editors of the journals above referred to, including Dr. Miller, in this matter of the improper use of

language. Both editors refer to the proverbial glass houses and stone throwing, and Dr. Miller says in effect: "I like to say this, but I wouldn't say that as you do." They appear to look upon criticism as a mere personal contest, and to think that my idea is simply to get what sport I can out of attempts to worry them. No, no! If it is necessary to say so expressly, I will admit that the house I live in is as defective as theirs; but I am very thankful to have the defects pointed out that I may mend them. I am reminded of an answer given to a question at a Sunday school convention by the person who presided at the question-box. The question was, should a hypocrite be allowed to teach a class in Sunday school. The answer began: That depends; we are *all* hypocrites. As no one is too good to teach a class in Sunday school, so no one can select language too pure and sweet for every day use; but no one is perfect in this respect. Even Homer nods, and Addison himself, a noted pattern in style, makes many slips. It has been said that choice language is an index of good character; but I feel a personal pride in the matter. I would like any journal in which I am interested to be up to the highest standard. I do not like to be put to shame on a comparison. I can't help comparing apicultural journalism with other journalism of the country. I would take delight in believing the journalism of our country to be equal or superior in point of choice language to that of any other in the English tongue. The newspaper press has been a reproach to our country though greatly improved it is not yet above reproach. I will not compare apicultural literature with that of the newspapers. I could wish it to be at least equal—it ought to be much superior. Much has been justly said in commendation of the typography of our journals, but good language is of as much greater concern than that as substance is of more importance than form. Beautiful typography is a treat; pure, choice language is a feast.

Dr. Miller justifies the use of the class of words to which I object because a "good many like it." And he admits he likes to use some of the words. He is right in saying "a good many like it." The multitude likes it. The more's the pity. What we like is easy. We are prone to it as the sparks to fly upward. *Facilis decessus Averni*. The ease of it is the evil of it.

The language of the masses is rotten with it. Its breeding place is in the dens of thieves and in the holes reeking with the fumes of alcohol and tobacco. Its appearance in print is an echo from such places. To our youth it is more familiar than their mother-tongue. Even our educated youth can hardly utter a sentence without introducing it. Can citizens, especially can parents, look upon this condition of things and encourage its continuance by using the same expressions in public print? Even the editor of the Review is inclined to make an apology for it, and the editor of *Gleanings* fears to check it would prevent the proper growth of the language, and quotes approvingly, "It is language in gestation." Wouldn't it be well to let it come to maturity, rather than to force it to an untimely birth? The truth is, it must have an untimely birth or a still-birth.

The editor of *Gleanings*, at page 590, makes this cautious admission: "I grant that I do *once in a great while* use some expressions that are not in the dictionary; but if I do so it is because they convey for me a certain shade of meaning that cannot be imparted by any of the dignified staid synonyms." Italics mine. He cites "scrooch," "sass", and "smoled." I cannot conceive how those words can be held to convey any other meaning than is conveyed by "cronch," "sauce" and "smiled." I make no objection to a word that is needed, such as "mugwump."

The editor also asks me why I single out *Gleanings*? Well, that's a delicate question. When I used to go black-berrying, I always found it the easiest

picking where the berries were most plentiful. He wants to know too why I neglect to criticise the Review. Well, Editors Root and York attend to that thoroughly and sooner than I am able to get into print.

At last he says: "If some of my English is not as good as it might be, it is because all that I 'write' for *Gleanings* is dictated to a stenographer, often amid frequent interruptions, and when I hardly know how to spare the time even to talk it off." This is indeed a sad state of affairs. It would be sadder still if it could not easily be remedied. What could be of greater concern than the editing of a journal that goes into thousands of families and is eagerly read by tens of thousands, old and young, inevitably influencing their speech and lives? I should say, nothing should interrupt—nothing should draw off attention from such a work.

I am afraid a blush covered my face, when, in the account of Mr. Cowan's visit, where that cultivated Englishman would be sure to see it, I found the word "canine" used for dog or puppy.

A MISLEADING DESCRIPTION OF FOUL BROOD.

In the *American Bee Journal*, page 502, is a description of foul brood in which I find the statement that it "is a disease that kills the young bee in the larva [larval] state *after it has been capped over*." Italics mine. This is a mistake that may lead some astray. To be sure, much of the brood lives till it is capped, but sometimes a large proportion dies before it is ready for that operation, and never is capped.

HOW THE UNION MAY EFFECTIVELY USE WHAT STRENGTH IT HAS.

In answer to certain questions put to me, as to how the membership of the U. S. B. K's. U. could be increased so it could do effective work, I replied, in substance, let it go ahead and use the strength it has effectively, and its membership will

be increased fast enough. In the American Bee Journal, page 505, the editor takes me to task, and says, in part, "we could name several large honey-adulterating firms here that would simply laugh at the presumption of an organization that numbers only a few hundred members with an equal number of dollars, attempting to fight their millions of dollars!" Let me say in reply that it isn't necessary nor desirable to attack the strongest organizations first. The United States army in Cuba first attacked Santiago, not Havana. Then the editor forgets that in such cases the action is criminal; and the people of the State prosecute and furnish the prosecutor and all the machinery necessary for a thorough trial. In this State, and I presume the same is the case in Illinois, the Union would not be permitted to secure the services of an additional attorney to assist at the trial. The work of the Union in such a case would be principally to discover evidence, and set the machinery in motion by making a complaint. If adulteration is carried on in Chicago in so public a manner as the language of the editor would imply, a very large sum of money ought not to be necessary to do the work required.

A CRITICISM THAT LOOKS LIKE A BOOMERANG.

In Beedom Boiled Down, same reference, is this item: "The Department of Criticism in the Bee Keeper's Review seems to be given up almost entirely to controversy between the critic and Dr. Miller. Both the men might be better employed." I wonder who is responsible for Beedom Boiled Down. The style seems strangely familiar. The writer ought to stand out squarely and meet the result of his statements. Anonymous publications are never looked upon with much favor.

BOILING FOUL BROODY HONEY.

Dr. Miller, to the question, could I safely feed it [honey from a colony having foul brood] by boiling? replies (A. B. J., 278) "Put water with it, bring it to a

boil (sic) then after it comes to a boil (sic) *keep it boiling for two hours and a half.*" The italics are his. Was the doctor in a playful mood? That would surely be hard on the bacilli unless plenty of water were added. I consider fifteen minutes boiling sufficient; having first added an equal amount of water.

THE LAYING OF FERTILE WORKERS.

In the American Bee-Keeper, page 142, is an item taken from the American Bee Journal in which Mr. Devauchelle is credited with saying that laying workers deposit eggs only in drone cells. Dr. Miller replies "In drone cells when they are present, otherwise in worker cells, one egg in a cell, regularly, so that the work cannot be distinguished from that of a fertile queen." The editor says "Of all the cases we have seen, a worker has rarely succeeded in depositing her egg upon the base of a worker cell as a queen invariably does." In my experience a worker generally lays in worker cells, often more than one egg in a cell, and while they are generally placed on the bottom of the cells, their positions there are irregular, so that I think I can always distinguish them from those of a fertile queen in good condition.

HOW MUCH SURPLUS ROOM TO GIVE AT FIRST.

The editor of Gleanings seems always to insist, as in a note on page 621, that when a "two-story colony" is contracted, preparatory to putting on supers for comb honey, to one story, that "not one but two" supers should be put on at once. In practice I am sure one would be enough in most cases.

LARGE COLONIES SWARM MORE THAN SMALL ONES.

Mr. Averill (Gleanings, 622) says: "Large colonies are much more inclined to swarm than small ones provided with a proportionate amount of room for storage of surplus." Consequently, to prevent swarming, he favors restricting brood rearing to five frames. The editor is

amazed, and exclaims, "When you say that *large* colonies are more inclined to swarm than small ones I wondered (sic) what kind of bees or locality you have. Your experience is almost diametrically opposed to that of the great majority of the whole bee-fraternity. Whv, I supposed it was almost an axiom that large colonies are *less* inclined to swarm than small ones. What does the Dadants' experience mean all these years on this point?" Well, well! I always supposed large colonies were more liable to swarm than small ones; and I have been in the habit of providing against swarming on that theory by putting queen-traps on the large ones some time before I do on the small ones. And strange to say, results have always justified that course. Not only have always the large ones always swarmed earliest but always a very much larger per cent. of them have swarmed. I can't guess how the Dadants' experience helps the editor's theory, for I have never understood that their small colonies swarmed more than their large ones.

BEES DO NOT CARRY THEIR QUEEN WHEN
THEY SWARM.

G. Gross (Gleanings, 626) relates how he found one of his swarms with a clipped queen 200 yards from his apiary; and concludes, "there is but one explanation of it—the bees carried her." The only prime swarm I remember having lost in many years went to the woods with a clipped queen; and the bees didn't carry her. Bees don't carry queens under such circumstances; but queens are very strong on the wing. The moral is, be sure in clipping queens to clip the wings sufficiently.

INSTRUCTION THAT MIGHT POSSIBLY BE
MISUNDERSTOOD BY A NOVICE.

"Illinois," who is evidently very much of a novice, writes that he put the division board in "the middle of the frames" and asks whether that is the right place. Dr. Miller replies in the American Bee Journal, page 438: "Put in all the frames, crowd them all close to one side, then put

the dummy close up against the last frame." With such frames as the doctor uses that advice would no doubt be sufficient, even for one as wanting in experience as "Illinois" is, but with the common hanging frame used by most of the beginners who read the doctor's replies, one can imagine what a deplorable mess would be made in carrying out these instructions.

Upon the same page there is apparently an unfortunate jumble, either of the questions or of the answers, but that is not entirely clear, as one of the questions is evaded. Will the doctor please straighten out these things?

WHAT KIND OF COLONIES OUGHT TO BE
COMPARED IN DISCUSSING CONTRAC-
TION OF THE BROOD-NEST?

In Gleanings, 630, the editor returns to the subject of contraction; but I do not see that he anywhere answers the question I ask in the Review, 243, as to what sort of colonies he is comparing those much lauded two-story colonies with.

IS IT FAIR TO THE WORKER?

A queen is said to be a perfect female, and a worker an undeveloped female, says Dr. Miller (Gleanings, 573), who then asks: "Is that fair to the worker, for parts fully developed in her are left undeveloped in the queen?" It strikes me as entirely fair. The fact that she is well developed in some characteristics having no relation to sex surely cannot help her out as a female.

'T WAS THE WORK OF A WORKER.

Upon the same page the doctor tells how, in an upper story, shut off from the brood chamber by an excluder, but having had brood and eggs in it eight days before, he found "three queen-cell cups containing eggs." I have confidence that I can give correct answers to the four questions he asks touching the matter. My answers are: 1. Bees do not keep eggs eight days, nor any other extra time, without hatching if they are able to keep the eggs warm. 2. Bees do not carry eggs from the lower story nor any other place

with any purpose of using them as eggs. 3. Queens do not go through excluders to lay an egg in each of several queen-cell cups and then return through the excluder. 4. Yes, workers or a worker laid the eggs. Close observation will reveal the fact that they do that very frequently under such circumstances.

LAPEER, Mich., Aug. 26, 1898.

EXTRACTED.

THE FEEDING OF SUGAR.

How it may aid in Securing a crop of Honey,
and yet not get into the Sections

In this issue of the Review Mr. Hasty takes Mr. Vernon Burt and Gleanings to task for the feeding of sugar, that he thinks may be stored in the sections. (See what he says in his comments this month.) In order that the readers of the Review may judge fairly of the matter I will quote from Gleanings the editorial paragraph to which our friend Hasty has reference. It reads as follows:—

Owing to a great crowd of general work I was not able to get down to friend Burt's until yesterday, the 13th. You will remember that I reported in our last issue that he was getting a crop of honey when the rest of us around here were getting no surplus; that the secret lay in the fact that he had fed his colonies *a la* Boardman until the brood-nest were crammed full or sealed sugar syrup and sealed brood at the opening of the harvest, the nectar, when it did come, and what there was of it, went right into the sections.

According to my way of thinking Hasty has not fully understood the matter. At least, I understand that the feeding is done only before the opening of the white clover honey harvest—not continued after the harvest has opened and sections are put on. In my opinion, but little, if any, stores are removed from the brood-nest to sections after the main harvest begins.

USING TWO-STORY BROOD-CHAMBERS.

Which is the More Important, Keeping the
Queen Occupied, or the Combs
Occupied?

In the American Bee Journal for August 4, page 486, some one asks Dr. Miller's advice in regard to the use of two-story - brood chambers. Here is the query:—

You advise for comb honey two-story 8-frame dovetailed hives, or 16 frames, until the time to put on supers, then one story is to be taken off, reducing them to one story or eight frames. My experience is that in this locality the honey harvest opens and supers are to be put on somewhere near May 15, and up to that time the queen never occupies or fills more than eight frames with brood. In that case I should think it would not be necessary or practicable to put on the second story. Am I correct or not?

To this the doctor replies as follows:—

I don't know. If a single story gives all the room the queen will occupy, and if no more room is needed then there can hardly be any advantage in giving a second story. But you can hardly be very sure about this if you've never tried it. Are you sure none of your queens will occupy more than eight frames if they have a chance? I think you'll find it true that, as a rule, bees don't like to use either of the two outside combs for brood, using them only for honey and pollen. If you find brood in either of the outside combs and you may find it in both; you may feel pretty sure that they are somewhat crowded for brood-room; and if you find eight combs occupied with brood in an 8-frame hive, the probability is that more than eight frames would be used if the bees had two stories. Keep a strong colony in one story of eight frames, and it will have brood in not more than eight frames, if, indeed, it has more than six, whereas the same colony in two stories may have 9 to 14 frames with brood. Some colonies do not need the second story; some do. If you practice using two stories you'll find a good many more of your colonies needing them than if you kept all of them constantly confined to one story. That is, by giving always all the room needed, you'll have stronger colonies.

It seems to me that some of us are not looking at this matter in the right

light. Dr. Miller's idea, if I understand him, is something like this: In order to get honey we must have bees. The more bees the more honey. If the queen has filled all the available cells in eight frames, give her more in an additional story; then you will get more bees, and, consequently, more honey. I think this is correct reasoning. I agree with it. But, doctor, let's go a little farther. A queen that has eight combs well filled with brood just at the approach of the honey harvest, will not fill eight more so full as another queen would have filled them if she had had them early in the spring. To put it in a different shape, if a man is going to put his capital into an extra hive and set of combs for each of his colonies, he will get more bees, and, consequently, more honey, if he has a queen for each of these new hives; in short, if he has then occupied by regular colonies. The profitable keeping of bees does not depend so much upon having each *queen* occupied to her full capacity, as it does in having the *combs* and *hives* occupied to *their* full capacity.

THE SOLAR WAX EXTRACTOR.

How it may Also be Used for Purifying the Wax.

In a recent issue of the American Bee Journal, Mr. C. P. Dadant had an article on the rendering of wax, and in that article he condemned the solar extractor as valueless for purifying wax. In the same journal for July 21st, Mr. O. O. Poppleton has an article in which he shows how the solar extractor may be so arranged as to furnish wax of the highest purity. Here is what he says.

On page 338 Mr. C. P. Dadant writes quite an article under the above caption, at the close of which he suggests that it might be well to give the subject a thorough examination.

My experience with purifying beeswax in the sun extractor has been exactly opposite to what Mr. Dadant's seems to have been. When I first read his article I was

almost lost in amazement to understand how it were possible for two such experienced men as we are, to have had such directly different experience. A careful re-reading of what he wrote explains it, I think, and if I have misunderstood him he can set me right.

The details of our extractors, as well as our methods of using them, must be quite different, he only getting from his the one result of melting the comb, while I get both melting and the best results in purifying the wax of any method I have ever tried. It seems that Mr. Dadant allows the wax, as it drips from the comb-pan in his extractor, to cool and harden as it drips. This works exactly as he explains in his second paragraph, and more or less dregs and dirt come off and are mixed all through the wax, and remelting in the extractor is only doing over again the same process with the same results.

Mr. Dadant has fully explained in the next paragraph the method and principle of purifying wax by allowing it to remain for several hours at a temperature between its melting and boiling points, giving a chance for all impurities to settle to the bottom. This is exactly what can be done in the sun extractor just as easy as not to do it, and I had no idea that any one was using an extractor any other way. All one has to do to secure this in an extractor is to have it made enough larger to allow the dish which receives the melted wax from the comb-pan to be in the sun under glass, which keeps it in a melted condition for hours.

The extractors I use are of a size to take glasses 30 x 40 inches in size. The comb-pans are made from 20 x 28 inch sheets of tin, thus allowing ample room inside of the extractor for both comb and melted wax pans to remain in the sun.

When the melted wax is in the right condition, that is, just before the sun sinks low enough so the wax commences to cool, I dip off the wax into molds, using oblong square-cornered bread-pans for molds, and a small flat-sided dipper. Empty square cans, such as those used for cocoa or corned beef, one-pound size, are good. With care, nearly all the wax can be dipped off in an absolutely pure condition, leaving all the dirt and a thin layer of wax. These last thin cakes of wax, with such dirt as adheres to them, are allowed to accumulate until there is enough to make a charge for the extractor, when they are re-melted and treated the same as were the original combs.

Of course, if one doesn't wish to take the trouble of dipping off the wax into

molds, he can, after it has hardened, scrape off the adhering dirt, as suggested by Mr. Dadant, but I greatly prefer the dipping process.

In either rendering wax otherwise than caps that contain more or less honey, or purifying any that has already been rendered, I use water in the wax dish, substantially as suggested by Alder Bros., except that it is unnecessary to heat either extractor or water before placing combs in it, as the same heat that melts the wax will heat the other things. I use about an inch of water in the wax dish for two purposes—to keep wax from sticking to the dish, and having it in the dish makes it much easier to dip off the melted wax.

In one of the numbers of *Gleanings* (Aug. 15, I think) in 1883 appears the original article describing solar wax extractors, which article was the starting-point of all the extractors now in use, east of the Rocky Mountains, at least. Attention was especially called to this point, of the advantages of these extractors for the purifying of wax. I was at first much puzzled to understand how such an able, practical man as Mr. Dadant could have overlooked this feature of the sun extractor, until I thought of the fact that his establishment is equipped with as good a steam-purifying apparatus as exists, and it is much easier for him to use this than to fuss any other way with small lots. To the ordinary bee-keepers, however, who are the real users of these extractors, my method of using them will, I think, be much the best.

[Accompanying the foregoing article by Mr. Poppleton, was the request that a proof of it to be forwarded to Mr. Dadant before publication, so that Mr. D.'s comments might appear in the same number with it. Here is what Mr. Dadant has to say further:—EDITOR.]

This article of Mr. Poppleton's is excellent, and I can add nothing to it except the instructions he gives.

I will say, however, that in rendering up residues, as we do here, where the beeswax rendered has been water-damaged, and has carried with it the very lightest of the impurities, it is necessary to still purify it with water, as the water becomes loaded with much of the coloring-matter which would otherwise remain in the wax, and we can obtain a better result than from the sun melting alone.

Allow me here, if I have not done it before, to criticise our manufacturers of sun extractors who use *iron pans*. The iron discolors a great deal of beeswax be-

fore it becomes sufficiently coated with it to cease damaging it. We have been several times enabled to test this to our entire satisfaction. The rust darkens the wax, and no amount of sun melting would remove this stain. Water alone can help it.

C. P. DADANT.

In Notes From Foreign Bee Journals for this month, this same point is brought out, viz., that by having the dish of rendered wax so placed that it will be kept liquid by the sun, there will be given the greatest opportunity possible for the impurities to settle. It is doubtless true that the solar extractor may be used to advantage in rendering cappings and new combs, and also that it can be so arranged as to produce a high grade of wax, but for getting the greatest amount of wax out of old combs, water and pressure are needed.

Honey Quotations.

The following rules for grading honey were adopted by the North American Bee-Keepers' Association, at its Washington meeting, and, so far as possible, quotations are made according to these rules.

FANCY.—All sections to be well filled; combs straight, of even thickness, and firmly attached to all four sides; both wood and comb unsoiled by travel-stain, or otherwise; all the cells sealed except the row of cells next the wood.

No. 1.—All sections well filled, but combs uneven or crooked, detached at the bottom, or with but few cells unsealed; both wood and comb unsoiled by travel-stain or otherwise.

In addition to this the honey is to be classified according to color, using the terms white, amber and dark. That is, there will be "fancy white," No. 1, dark," etc.

KANSAS CITY.—We have several shipments of new comb honey from Florida the first of the season. We quote as follows: Fancy white, 12; No. 1 white, 11½; fancy amber, 10½; No. 1 amber, 10; white, extracted, 5½; amber, 5; dark, 4. Beeswax, 25.

C. C. CLEMONS CO.

June 29. 521 Walnut St., Kansas City, Mo.

NEW YORK.—Our market is in very good shape for the new crop of comb honey. We have had several shipments of white comb honey from Florida, which have sold at from 10 to 11½ cents per pound. Market on Southern Extracted honey is very steady, there being a good trade for the cheaper grades. We quote as follows: Ordinary at 50 to 52 cents per gallon. Good at 55 to 60 per gallon. Florida, white, 6c. New California is beginning to arrive. Beeswax market is quiet, prices ruling a little lower. We quote pure beeswax at 26½ to 27½. Write us for shipping instructions.

FRANCIS H. LEGGETT & CO.,

July 23. W. Broadway, Franklin & Varick Sts

CLEVELAND, OHIO.—The supply of fancy white honey is light, and the demand good at the following prices: Fancy white, 13 to 14; No. 1 white, 12 to 13; fancy amber, 10 to 11; No. 1 amber, 9 to 10; fancy dark, 8 to 9. White extracted, 7; amber, 6.

A. B. WILLIAMS & CO.,
Aug. 26 80 & 82 Broadway, Cleveland, O.

CHICAGO, Ill.—As yet very little new honey has been received. We do not expect to have the demand until small fruits are out of the market. Indications are that prices will be higher than for last year. We are in good position to take care of both comb and extracted honey; and always follow shipper's instructions.

S. T. FISH & CO.,
Aug. 17. 189 So. Water St., Chicago, Ill.

CHICAGO, Ill.—Honey is arriving freely, and is of good quality; trade is of a satisfactory nature for this season of the year. We quote as follows: Fancy white, 12; No. 1 white, 10 to 11; fancy amber, 8 to 9; No. 1 amber, 7; fancy dark, 5; No. 1 dark, 7; white extracted, 5 to 7; amber, 5 to 6; dark, 4 to 5. Beeswax, 27.

R. A. BURNETT & CO.,
Aug. 25. 163 So. Water St., Chicago, Ills.

BUFFALO, N. Y.—Owing to the liberal supplies of fruit, there is, as yet, very little demand for any kind of honey. We would encourage the shipments of small lots only for the present. Strictly fancy white clover, 1-lb. combs, 11 to 12; other grades range from 6 to 10 cents. No demand yet for extracted honey. Fancy beeswax, 25 to 38.

BATTERSON & CO.,
Aug. 25. 167 & 169 Scott St., Buffalo, N. Y.

NEW YORK, N. Y.—Demand for comb honey is rather slow especially for off grades, white and dark, and, as we have a large stock of these would not advise shipping for the near future. Our stock of fancy white is light and such would find ready sale at quotations. Our market for extracted buckwheat will open up shortly and we would advise bee-keepers to ship this along now. Beeswax steady. We quote as follows: Fancy white, 11 to 12; No. 1 white, 10; Fancy Amber, 9; No. 1 Amber, 8; Fancy Dark, 7; No. 1 Dark, 6; White, extracted, 5 to 5½; Amber, 4½ to 4¾; Dark, 4 to 4¼; Beeswax, 26 to 28.

HILDRETH BROS. & SEGELKEN,
Jan. 7, 120 & 122 West Broadway New York

WM. A. SELSER,
10 VINE ST., PHILA., PENN.

White Clover Honey Specialist.

Bees for Sale.

Fifty colonies of bees, in 8-frame Simplicity or Langstroth hives, at \$2.50 each. Free on board cars. A. W. GARDNER,

Centerville, Mich.

Please mention the Review

JOHN F. STRATTON'S CELEBRATED



MANDOLINS,

Importers of and Wholesale Dealers in all kinds of
MUSICAL MERCHANDISE,
811, 813, 815, 817 East 9th St., New York

Please mention the Review

Bee keepers should send for our

'97 CATALOG.

We furnish a full line of supplies at regular prices. Our specialty is Cook's Complete hive.

J. H. M. COOK, 62 Cortland St., N. Y. City

Please mention the Review.

Franklin House DETROIT, MICH.

Hot and Lardless. Very central. Elevator. Steam heat, electric lights, tile floors, etc. \$1.50 to \$2. per day. H. H. JAMES & SONS, Props.

Please mention the Review.

—If you are going to—

BUY A BUZZ-SAW,

write to the editor of the REVIEW. He has a new Barnes saw to sell and would be glad to make you happy by telling you the price at which he would sell it.

QUEENS, Untested, 75 c; 6 for \$4.00; tested, \$4.00; 6 for \$5.00; breeders, \$2.00. The best stock, imported or golden. W. H. LAWS, Lavaca, Ark.

Please mention the Review.



Our Prices are worth looking at. We are making the new

Champion Chaff Hive

with dovetailed body and supers and a full line other Supplies, and we are selling them CHEAP. A postal sent for a price list may save you \$ \$ \$ \$ \$.

R. H. SCHMIDT & CO.,
Box 187 Sheboygan, Wis.

1-98-1f

Please mention the Review.

ITALIAN bees for sale. Queens \$1.00. Bees by the lb., \$1.00. One-frame nucleus with queen, \$1.50; two-frame, \$2.00. Queens, after Aug., 50 cents each.

Mrs. A. A. SIMPSON, Swarts, Pa.

7-98 2t

Please mention the Review.

THE LOSS

Of one Queen in introducing, means a loss greater than the cost of a copy of "ADVANCED BEE CULTURE," which has one entire chapter devoted to "The Introduction of Queens." It shows when the cause of failure lies with the colony, when with the queen, and points out the *conditions* necessary to success. Although one infallible method is given, but little attention is given to the setting forth of exact rules and methods; the subject being treated with a view to teaching *principles* that may be followed to success.

Price of the book, 50 cts.; the Review one year and the book for only \$1.25.

W. Z. HUTCHINSON,

Flint, Michigan.

18



98

This is the original one-piece section-man who furnishes one-piece sections as follows:—

500 sections, \$1.50; 1,000 for \$2.50; 3,000 for \$6.75; 5,000 for \$10.00; 10,000 for \$17.50.

No. 2 sections are not made to order, but when in stock are sold at \$1.50 per M.

J. FORNCROOK,

Watertown,

Wisconsin.

Listen! Take my advice and buy your bee supplies of August Weiss; he has



tons and tons of the very finest

FOUNDATION

ever made; and he sells it at prices that *defy competition!* Working wax into foundation a specialty. Wax wanted at 26 cents cash, or 28 cents in trade, delivered here. Millions of *Sections*—polished on both sides. Satisfaction guaranteed on a full line of *Supplies*. Send for catalogue and be your own judge. **AUG. WEISS,** Hortonville, Wisconsin.

WINTER

Losses are not always the result of the same cause. They may come from starvation; from poor food; from improper preparations; from imperfect protection; from a cold, wet, or possibly, a poorly ventilated cellar, etc., etc. Successful wintering comes from a proper combination of different conditions. For clear, concise, comprehensive conclusions upon these all-important points, consult "ADVANCED BEE CULTURE." Five of its thirty-two chapters treat as many different phases of the wintering problem.

Price of the book, 50 cts.; the REVIEW one year and the book for \$1.25. Stamps taken, either U. S. or Canadian.

W. Z. HUTCHINSON,

Flint, Mich.

Beeswax Extractor.

The only Bees Wax Extractor in the world that will extract all the wax from old combs rapidly by steam. Send for descriptive illustrated catalogue.

C. G. FERRIS,
South Columbia, N. Y.

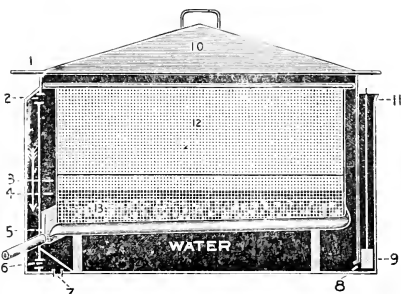

Bees and Queens

from Kansas. A really superior strain of golden Itallans. Warranted or tested queens 75 cents each; six for \$4.00; twelve for \$7.50. Full colony of bees, \$5.00.

J. W. KUN, Belleville, Kans.
Please mention the Review

The place to get your best
QUEENS
is of H. G. Quirin, of Bellevue, Ohio. Ten years of experience, and the best of methods and breeders enable him to furnish the best of queens. Golden Italian, warranted purely mated, at 75 c.; after June, 50 c.; or 6 for \$2.75.
Leather-colored, same price.

— If you wish the best, low-priced —

TYPE - WRITER.

Write to the editor of the REVIEW. He has an Odell, taken in payment for advertising, and he would be pleased to send descriptive circulars or to correspond with any one thinking of buying such a machine.

Best on Earth. 19 Years Without a Complaint.



	largest smoker made	4 inch stove	Dozen	Each
Smoke Engine	3 1/2	"	\$13.00—mail.	\$1.50
Doctor	3	"	9.00 "	1.10
Conqueror	3 1/4	"	6.50 "	1.00
Large	2 3/4	"	5.00 "	.90
Plain	2	"	4.75 "	.70
Little Wonder (wt. 10 oz)	2	"	4.50 "	.60
Honey Knife	2	"	6.00 "	.80

For further description, send for circular.

T. F. BINGHAM, Farwell, Michigan.

1898 Queens 1898

For Business—Queens for Strong Colonies
Queens for large surplus. Competition in Quality,
but not in price.

If you want queens, nuclei or supplies at bottom prices, send for my illustrated price list 12-97-tt

J. P. H. BROWN, Augusta, Ga.

Queens bred in the North are hardy and fertile. Every bee-keeper should try one of these Northern grown queens. Pure bred Italian queens at 75 cents each; or 12 for \$6.00.

WM. H. BRIGHT, Mazeppa, Minn.
Please mention the Review.

To stick things, use **MAJOR'S CEMENT.**
Beware !!! Take no substitute. 2-98-12t

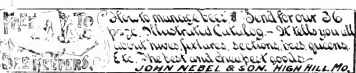

If the
REVIEW

Is mentioned when answering an advertisement in its columns a favor is conferred upon both the publisher and the advertiser. It helps the former by raising his journal in the estimation of the advertiser, and it enables the latter to decide as to which advertising mediums are most profitable. If you would help the Review, be sure and say "I saw your advertisement in the Review," when writing to advertisers.

Page & Lyon,

Mfg. Co.

New London, Wis.

Nearness to pine and bass-wood forests, the possession of a saw-mill and factory fully equipped with the best of machinery, and years of experience, all combine to enable this firm to furnish the best goods at lowest prices. Send for circular, and see the prices on a full line of supplies.

**The Usual
Fall
DISCOUNT**

Is now allowed on orders. If you want shipping cases, crates, extractors, or anything else, write to us. Catalogue free.

Sample copy of *American Bee - Keeper* (monthly) at 50 cents a year (free).

W. T. Falconer Mfg. Co.,
JAMESTOWN, N. Y.

No Fish-Bone

Is apparent in comb honey when the Van Deusen, flat-bottom foundation is used. This style of foundation allows the making of a more uniform article, having a *very thin* base, with the surplus wax in the side-walls, where it can be utilized by the bees. Then the bees, in changing the base of the cells to the natural shape, work over the wax to a certain extent; and the result is a comb that can scarcely be distinguished from that built wholly by the bees. Being so thin, one pound will fill a large number of sections.

All the Trouble of wiring brood frames can be avoided by using the Van Deusen *wired*.

Send for circular, price list, and samples of foundation.

J. VAN DEUSEN,
SPROUT BROOK, N. Y.

Violin for Sale.

I am advertising for the well known manufacturers of musical instruments, Jno. F. Stratton & Son, of New York, and taking my pay in musical merchandise. I have now on hand a fine violin outfit consisting of violin, bow and case. The violin is a "Stradivarius," Red, French finish, high polish, and real ebony trimmings, price \$14.00. The bow is of the finest snakewood, ebony frog, lined, inlaid (pearl lined dot) pearl lined slide, German silver shield, ebony screw-head, German silver ferules, and pearl dot in the end, price \$2.50. The case is wood with curved top, varnished, full-lined, with pockets, and furnished with brass hooks, and handles and lock, price \$3.50. This makes the entire outfit worth an even \$20.00. It is exactly the same kind of an outfit that my daughter has been using the past year with the best of satisfaction to herself and teachers. Her violin has a more powerful, rich tone than some instruments here that cost several times as much. I wish to sell this outfit, and would accept one-half price, white extracted honey in payment, the balance cash. It will be sent on a five days' trial, and if not entirely satisfactory can be returned and the purchase money will be refunded.

W. Z. HUTCHINSON, Flint, Mich.

G. M. LONG, Cedar Mines, Iowa, manufacturer of and dealer in Apiarian Supplies. Send for circular. 1-96-6

Please mention the Review



THE STRATTON American GUITARS & MANDOLINES

BE HANDED BY ALL THE LEADING MUSIC STORES

Oak, Ash, Birdseye Maple, Mahogany and Rosewood.

JOHN F. STRATTON & SON

Manufacturers of and Wholesale Dealers to all kinds of

Musical Merchandise.

63 & 45 Walker St.

NEW YORK

Holy Land QUEENS. Golden Italian

The best that knowledge and ten years' of experience can produce.

Untested Queens. One Six Twelve.

In June, July, Aug., Sep.,	75	\$4.25	\$8.00
All other months,	1.00	5.00	9.00
Tested Queens,	1.50	8.00	15.00

E. R. JONES.

3-98-12t

Mitono, Texas

QUEENS

Reared from imported mothers, warranted purely mated, 75 cents each. Breeders, \$1.25 each. No better stock to be had at any price. Send for catalogue of queens and bees. **DEANES & MINER**; Ronda, X. C.

Make Your Own Hives.

Bee-Keepers

Will save money by using our Foot Power Saw in making their hives, sections and boxes.

Machines on trial. Send for Catalogue.

W. F. & JNO. BARNES CO.,

384 Ruby St.,

Rockford, Ills.

2-96-12

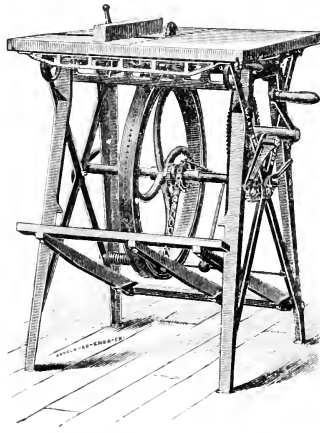

Some Odds and Ends That Will be Sold Cheap.

For a dozen or more years Mr. M. S. West of this place dealt in bee-keeper's supplies. Since his death, two years ago, his daughter has endeavored to close out his stock of goods, and has succeeded to large extent. There are still a few odds and ends, and she has brought them to me and left them for me to sell. Here is a list of the articles with prices at which they will be sold.

One ten inch foundation mill, (second-hand) Root's make, complete with dipping tank, etc. in excellent condition. \$10.00

One ten inch foundation mill, (second-hand) Root's, (one of recent make) dipping tank, etc. in good order. 15.00

Three Woodcock foundation fasteners, each. 75

Eighty seven entrance guards, each. 05

Thirteen Porter Bee Escapes. 2.25

Thirty-three Simplicity hives, in the flat, sides, ends, covers and tin rabbits but no frames nor bottom boards, each. 40

Send all orders to W. Z. HUTCHINSON, Flint, Mich.

QUEENS, Untested, 75 c; 6 for \$4.00; tested, \$1.00; 6 for \$5.00; breeders \$2.00. The best stock, imported or golden. W. H. LAWS, Lavaca, Ark.

Please mention the Review.

I have several hundred

QUEEN CAGES

of different styles and sizes, made by C. W. Costellow, and I should be pleased to send samples and prices to any intending to buy cages.

W. Z. HUTCHINSON, Flint, Mich.

Farm Bee - Keeping.

The only bee paper in the United States edited in the interests of the farmer-bee-keeper and the beginner is the **Busy Bee**, published by EMERSON T. ABBOTT, St. Joseph, Mo.

Send for free sample copy NOW.



Walter P. POUDETS, JR.

See That Wink?

Bee Supplies. Root's goods at Root's prices. POUDETS' HONEY JARS. Prompt service. Low freight rates. Catalog free. WALTER S. POUDETS, 162 Mass. Ave., Indianapolis, Ind., the only exclusive bee supply house in Indiana.

THE MONITOR PAPER FILE

Binds securely and neatly all periodicals. Preserve your papers, magazines, pamphlets, bulletins, music &c., by binding them together as you get them. Each new number filed quickly and easily. Will bind 52 numbers of any periodical aggregating 1000 or fewer pages. All lengths from 6 to 28 inches. Light and handsome.

PRICE.—All sizes 12 inches and under 12 cents; over 12 inches one cent per inch. When wanted by mail add one cent for each 5 inches or fraction thereof.

For sale by the Publisher of this paper

If you are going to—

BUY A BUZZ-SAW,

write to the editor of the REVIEW. He has a new Barnes saw to sell and would be glad to make you happy by telling you the price at which he would sell it.

Without Stopping

the machine to reverse the combs is the way you can work with the Williams Automatic

Honey Extractor.

Such an extractor will save you time and annoyance and it does not cost much more than an ordinary machine. Send for descriptive price list.

Read what the famous bee-keeper, N. E. France, says:

PLATTEVILLE, Wis., July 5, 1897.

Dear Sirs: To day I extracted 2,780 lbs. of honey with your Automatic Honey Extractor in 5½ hours and could have done the same this afternoon but let the boys go to the city to play a game of base ball. Have extracted 27,135 lbs. so far with good prospects for as much more. My bees and State work keep me very busy. Hope to see you before very long—will write you later.

Yours truly, N. E. FRANCE,
State Inspector of Apiaries,
Platteville, Wisconsin.

We can also furnish choice queens, either golden or leather colored Italian, at 75 cents each, or two for \$1.40.

Van Allen & Williams,

6-98-st.

BARNUM, WIS.

Dovetailed Hives.
 Cowan Extractors.
 Danzenbaker Hives.
 Porter Bee-Escapes.
 No-Drip Shipping Cases.
 Gleanings in Bee-Culture.
 The Fence and Plain Sections.
 Weed New Process Foundation.

OUR SPECIALTIES.

Root's Goods.



Catalog of goods and sample of Gleanings sent for your name on a postal.

The A. I. ROOT CO., Medina, Ohio.

Branch Offices :

118 Michigan St., Chicago, Ill. 1024 Mississippi St., St. Paul, Minn.
 1635 W. Genesee St, Syracuse. 10 Vine St., Philadelphia. Mechanic Falls, Me.

Bee-keepers in the

Northwest

Can save money and freight by getting their supplies from the Minn. Bee-Keepers' Supply Mfg Co., Nicollet Island Power Building, Minneapolis, Minn. They have all the latest and most improved machinery and manufacture and handle a full line of supplies. Send for catalogue before ordering.

Please mention the Review.

Our Prices are worth looking at. We are making the new

Champion Chaff Hive

with dovetailed body and supers and a full line other Supplies, and we are selling them CHEAP. A postal sent for a price list may save you \$ \$ \$ \$.

R. H. SCHMIDT & CO.,
 Box 187 Sheboygan, Wis

4-98-tf

Bee keepers should send for our

'97 CATALOG.

We furnish a full line of supplies at regular prices. Our specialty is Cook's Complete hive.

J. H. M. COOK, 62 Cortland St., N. Y. City

The No-Drip Shipping Cases

Are what you need in marketing your honey. They are clean, neat and convenient, and a great help in making sales.

Root's goods at Root's Prices. Cash paid for wax. We want your trade.

M. H. HUNT, Bell Branch, Mich.

Please mention the Review

COMB

FOUNDATION

WHOLESALE AND RETAIL.

Working wax into foundation, for cash, a specialty. Hives, Sections, and a full line of Supplies. The best of everything. Write for Catalog, with prices, and samples of Foundation and Sections. Beeswax always wanted for cash or trade.

GUS. DITTMER,

10-97-12t

Augusta, Wis.

The A. I. Root Co.'s Goods, WHOLESALE AND RETAIL.

Please mention the Review.

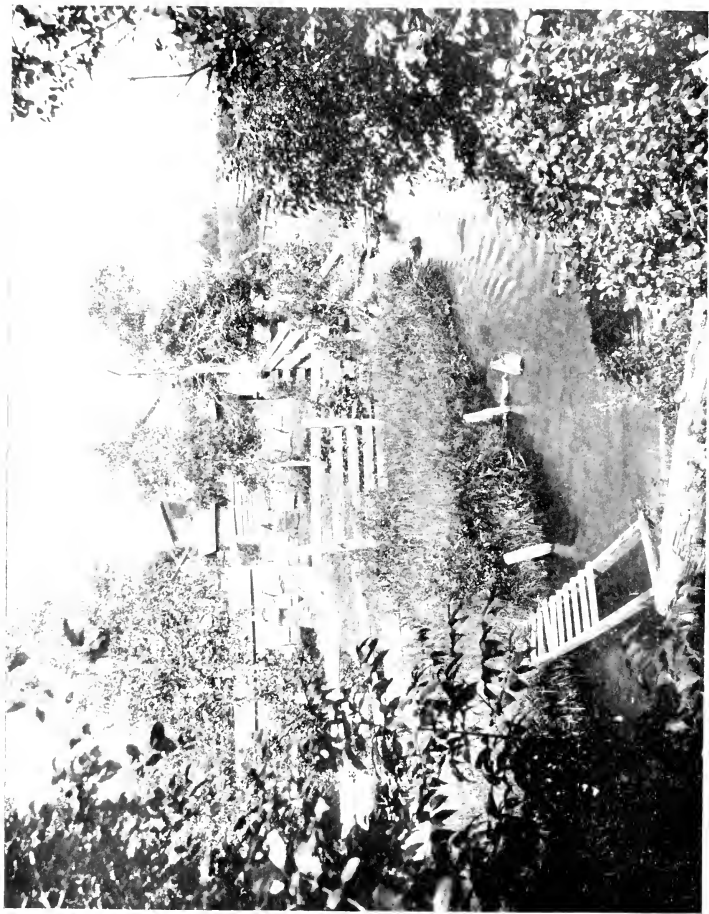

A Northern Michigan Apiary—Mr. Walker's.

The Bee-Keepers' Review.

A MONTHLY JOURNAL

Devoted to the Interests of Honey Producers.

\$1.00 A YEAR.

W. Z. HUTCHINSON, Editor and Proprietor.

VOL. XI. FLINT, MICHIGAN, OCTOBER 10, 1898. NO 10.

NORTHERN MICHIGAN.

Its Advantages and Disadvantages as a Honey Producing Country Viewed Through the eyes of Experience.

BYRON WALKER.

EDITOR Review:—Had I stopped to consider a moment when I promised you an article for the October Review, to appear in connection with the cut of my home-apiary, I think I should have felt compelled to decline the honor. I have been suffering greatly from ill health for several years, as you are aware; while all this time my work has been as great as several well men ought to undertake. The care of a half dozen apiaries located from six to sixteen miles distant from the home yard, including the management of a rather large supply business, and a still larger trade in comb and extracted honey, requiring about nine months of almost continual hard labor the present season, ten entire nights moving bees, with a large correspondence incident to the accumulation and disposal of the goods, ought to furnish reasons enough for declining to perform any literary work. In addition to this, when I consider how little I can offer that will be interesting to your readers I am the

more fully persuaded that I made a mistake in granting your request; but, as it is too late to back out, I will do the best I can, and trust to the charity of your readers to make proper allowances.

You have asked me to tell the readers of the Review something of the advantages and disadvantages of my present location, as compared with my former one in St. Clair Co., in the Southeast part of the State, where I kept bees for nearly twenty years; and I will try and do so, as I am having quite a few letters from bee-keeping friends in Southern Michigan who write me they will have to sell their bees or move further north. Besides, the advantages for locating apiaries in the Northern part of our State have been set forth from time to time by different writers in our bee journals in somewhat glowing colors.

My location in St. Clair Co. could scarcely be regarded as a typical one for that section of the State; as, aside from Alsike clover, which was sown to a considerable extent, I had little to depend upon except fall flowers—boneset, fireweed, asters etc., which commonly covered a large area of an immense swamp that lay within easy reach of my apiary, and which could commonly be relied upon to furnish a good yield of honey, which I was usually able to dispose of in

market (as the honey was by no means dark) for about as good a price as though it had been gathered from early flowers. At the same time, I had this ever-present, overshadowing drawback to contend with, that no matter what the protection and ventilation given for winter, in doors or out, dysentery and death were sure to be the result; so that for a period of fifteen years my average loss in wintering was at least 100 colonies; or say seventy-five per cent. of the number put up for winter. So, while I often had a good crop of honey to market when apiarists located beyond the reach of such fall pasturage would fail of securing a crop, on the other hand, when my bees would be dying with dysentery, even in comparatively mild winters, the other fellows, who had clover, basswood or even buckwheat honey to winter their bees on, would, even in severe winters, with comparatively slight protection, winter their bees with but little loss; while I would be obliged to buy of them each spring; or, on account of low prices, go South and buy a car lot to stock my yard. But the time came when this swamp became largely cleared up, and could no longer be relied upon as a source of nectar; and, being impressed with the apparent advantages offered for locating apiaries in this part of the State, I located, six years ago, at this place (Ewart), after looking over the ground somewhat carefully.

I have, perhaps, been here long enough to enable me to give a tolerably fair statement of the merits of this part of the country as a location for bee-keeping; and, as I have traveled not a little through many counties of this section of the State, as far north as the Straits, and from lake to lake, with my eyes and ears open wide to learn all that could be learned, both of the inducements and drawbacks to be met with by the apiarist seeking a location, I will venture to give the conclusions I have reached in this matter.

Perhaps the chief advantage to be gained here over the average location in the Southern part of the State, is the

chance to reach a flora comprising a greater diversity of plants yielding honey of fine quality for a comparatively long time; extending with the most favorable locations and seasons, from early in May, until late in September. The chief sources of surplus are wild red raspberries, Alsike clover, basswood, willow-herb, golden-rod and asters; while, in some locations, the maples, wild fruit bloom, whortle berries, white clover, boneset, sumach, buckwheat and Spanish needle, common fire-weed and various other fall flowers help to lengthen out the flow.

The wild raspberry, which, in the best locations, is to be found in profusion over large areas, is one of the most reliable sources of nectar; and the period of bloom commonly lasts for about three weeks, beginning with clover bloom. The quality of this honey is fine but the color is light amber.

The basswood flow, which follows with but slight intermission, is not nearly so reliable. It has not produced much in this locality except two out of the past six seasons; seldom lasting more than ten days; and, the present season, the real flow lasted only about four days. The bloom was very abundant, but unfavorable weather, including a heavy frost, cut the flow short.

Willow-herb comes next; and, where the basswood flow lasts ten days, the willow-herb commonly begins to yield before it is over with; and, with favorable conditions, continues the chief part of a month; so as to lap on to the flow from fall flowers. The mild flavor, and unsurpassed color of this honey, is too well known to require mention. By seeking favorable locations I have secured yields from this source three out of six seasons. Last season it failed to yield except in a few localities. While the bloom was abundant on plants of three years' growth, an insect stripped the stalks bare of leaves; so that, on the same ground, where, the two preceding seasons, vast amounts of honey went to waste for want of bees to gather it, the yield was a total

failure. The present season also, as no extensive forest fires have prevailed for two years past, the yield has been almost nothing in most sections. Three out of six seasons we have also had a fair yield from fall flowers.

Now, what are the drawbacks to be met with by the apiarist seeking a location here? The first I will mention is that the most desirable locations, at least, those in proximity to towns large enough to afford the advantages of good schools, churches, etc., are commonly occupied; and, not infrequently, overstocked; in fact, there are very few such locations occupied or unoccupied to be found in Northern Michigan. While it is not difficult to find these advantages in connection with good raspberry pasturage, and, occasionally, also, considerable areas of Alsike clover and fall flowers, (especially golden-rod and asters) within range, either bas wood or willow-herb pasturage, that would afford a desirable range for an apiary of considerable size, is, as a rule, out of the question in connection with the advantages referred to; so, if one will have these privileges, he must be content with inferior locations.

Another draw-back is that with the best of locations the country affords, it seldom happens that all or nearly all of these sources of nectar are available for a crop even with the most favorable weather during any one season. Extensive forest-fires, which are essential about once in two years in a region adapted to the growth of willow-herb, in order to insure at least a good chance for a flow from that source the following two seasons, are not to be depended on so often; and when they do occur, are quite likely to cut off the raspberry pasturage to a great extent for one or more seasons, and, of course, it sometimes happens that these fires destroy the prospect of a flow from willow-herb that same season also. But the loss from this source, however, is commonly made up in some measure, by a good flow from common fireweed when bees are apt to be in good condition to secure it.

From what I have said above, the necessity of establishing out-yards, where one is bound to have the benefit of school and other privileges offered by large villages, which, of course, means not a little additional labor, expense, and risk of loss without certainty of adequate returns to pay for the outlay; and, as the roads are usually quite sandy, stony, and hilly, the care of these out apiaries during hot weather is no small item; but where run for extracted honey I manage by keeping queens' wings clipped to avoid loss from swarms leaving, by spending one day each week at each yard; but as this keeps one on the go continually where one has a half dozen yards to see to, I have of late adopted the plan of renting the bees for a term of years, giving, besides a certain share of the honey, also a share of the increase at the conclusion of term of lease; and where competent, conscientious parties can be found (which is rarely the case) I regard this as the better plan; especially as it does away with the tedious and risky job of moving the bees back and forth over bad roads each season when time is especially valuable in other directions.

At the present time I am running about 500 colonies in nine different yards. They are chiefly managed on the plan last mentioned. The chief drawback to this plan is the scarcity of suitable locations, within reach, not already occupied; or which do not become speedily overstocked by those who take up the business and work for increase; drawn to it through what seems to them, at least, one's great success. Then there is, if possible, the still greater scarcity of competent, conscientious men upon whom you can rely to run these yards. The lack of these keeps one on the lookout for new locations; which, of necessity, must be further and further removed from the home yard; and for new men; the overseeing of whom becomes, of course, the more difficult as the distance increases.

Another drawback to the bee business in this section is the very large percentage of cool nights that prevail. This, together with the cold winds common, especially in the vicinity of the Great Lakes, of course, seriously interferes not only with the secretion of nectar, but also renders the production of comb honey in a large part of northern Michigan rather a hazardous undertaking.

I will conclude the mention of what may seem rather a formidable array of drawbacks, by predicting that many a location that at the present time would be regarded as quite desirable on account of the amount of basswood within range, will very soon no longer have this feature as a recommend; as probably no previous time has witnessed such a general onslaught on this one of our leading sources of honey supply. About the only resource left the apiarist, who can afford the outlay in this direction, is to purchase some desirable tract of timber before it passes into the hands of the destroyer.

In conclusion, I will say that after six years' trial of this section of our State as a location for bee-keeping, I have been well suited with the change, as the wintering problem has practically been eliminated (although nearly one hundred miles further North), on account of the superior stores; and the fine quality of honey produced has given my honey a reputation on the market which would otherwise hardly be possible.

Two successive seasons the output from my apiaries approximated about 30,000 lbs. extracted each season, from 350 colonies; but, for the last two seasons, with no willow-herb, the yield will scarcely reach two-thirds that amount. Though the increase is quite large, especially this season, and about 5,000 lbs., or one-fourth the amount, is comb honey.

I have tried to give such information to readers of the Review as I would appreciate if I were thinking of changing my location to this part of the State.

EVART, Mich. Sept. 7, 1898.

ACCURACY.

How Essential it is to the Bee-Keeper's
Success.

J. E. CRANE.



WHAT I shall say in this paper is largely for the benefit of beginners, or those of small experience in keeping bees, and something that they might not otherwise learn except in that

school which is proverbially expensive. There may be some who are older that can read it with benefit.

Few things, including bee stings, are more provoking or try the temper more than a set of hives which vary in size, or the different parts are ill-fitting, or poorly made.

The large number of manufacturers who make a speciality of making bee-keepers' supplies renders it very much easier to get well made hives and other fixtures than was the case twenty years ago. Still, there are many who do not care to pay large freight bills, and who have mills near at hand doing work of a similar character, and would prefer to have their work done near at home. To such let me say that before making a large number of hives, make a careful study of hives and find out accurately just what you want, or is best adapted to your work or business. If you propose to produce extracted honey, your hives may be quite different from what would be required for comb honey. Make out a bill of pieces for hives and fixtures. Make out an agreement that each and every piece shall be got out accurately from well seasoned lumber without the variation of an eighth of an inch; one-sixteenth of an inch would be better. Then put them

together so that every part will fit accurately with no loose joints or leaky roofs. Let the frames be made square, not even a *little* diamond shape, or the bees may stick one end to the end of the hive with propolis, and at the other end build a "bit" of comb between. See that the space between the top of the frames and the honey board is just right, and will stay so. If the top bars are too light they may sag, and thus while the space is one fourth inch at the ends, it may be one-half inch in the middle when the frames are filled with honey. See that just the right space is given at the ends of frames; for, if too much is given, combs may be built between the ends of the frames and the hive; and, if too little, the bees will fill up that little with propolis. The same rule applies to the space under the frames. I had one lot of hives made where the brood chamber shrank so as to let the frames to many of them rest on the bottom board. Not only must the frames be of the right size, but so arranged as to space at exactly the right distance apart. I have sometimes looked over bees for others and found the frames anywhere from one and one-fourth to two inches apart. The nearer the brood combs can come together and leave sufficient "bee-space" between them, the better can the bees economise their heat in spring time, and advance their brood.

When all is completed the foundation must be put into the center of the frames and the foundation drawn out so as to remain inside the frames. When the hives are placed upon the stand where they are to remain, see that they are leveled up accurately, and not leave them looking too much like the head stones in some cemeteries; pointing to every star in the heavens. The bees, with only their antennae for compass and square will build their cells with the greatest accuracy, and without plumb line or level will build their combs exactly downward. Shall we by a little carelessness allow the hives to stand tilted a little this way or

that so the combs will sag or be built partly in the frame and partly outside, and thus be unfitted to exchange with some other comb that is perhaps out of the frame in the other side?

If we turn to the surplus department we shall find that even greater accuracy is demanded than in the brood chamber of the hive. If our clamp or section holder is 17 inches inside and we order our sections cut $4\frac{1}{4}$ exactly and we find when put together they are a $1\text{-}32$ of an inch over we shall be in trouble. Or if they are cut exactly right and then set up the least bit diamond shape, the same trouble comes in when we place four of them end to end—they will not go into our clamp. Again, if not quite large enough, or $1\text{-}32$ of an inch too small, when four are put together there may be left a space of one-eighth of an inch to filled by propolis; very much to our discomfort, and the appearance of the sections when ready for market.

The sections should also be of exactly the right width and quite smooth. I have found them to vary so much as to make it very difficult to get in the full number; or, again, so they would not fill the space in the clamp. Where honey is sent to market in paper boxes, or cartons as they are called, it is very desirable that they, too, should fit accurately. One year a new firm begged my trade in paper boxes, offering to make them much cheaper than I had been paying. I gave them two or three orders of several thousand, and when received, notwithstanding they had the exact size of the section, not one lot was of the right size. One lot was so small as to make it quite impossible to get my sections into a large share of of them; while another lot was so large as to make it almost impossible to get them into my packing cases.

Thus it will be readily seen that where we purchase our sections of one firm, our paper boxes of another, and our packing cases of a third, accuracy is a prime factor in our success, in getting our honey to market in good shape.

Not only in the matter of making hives and surplus arrangements is it necessary to be accurate, but in the management of our bees will it be found equally so. How many times I have seen it stated in print that bees would not rear a queen from brood four days old, I do not know; but I do know that I have found them doing it many times; very much to my disadvantage and their's too. Again it has been said that they would not hatch out a young queen in less than ten days after being deprived of their queen, and with out brood in queen cells, but I have found out that they *will* sometimes do so to my sorrow.

And now, in conclusion, let me say that we should not only make our hives and sections, our management and queen rearing accurate, but let us learn to observe closely and think accurately and *clearly* if we can.

MIDDLEBURY, Vt. June 20, 1898.



NATURE'S WAYS.

The Use of Section Cleaners. What to Expect of Criticism.

L. A. ASPINWALL.

The man with understanding great
Sees Nature with a lavish hand
On all her precious gifts bestow;
But reflex thought on years gone by
Shows man with eye grasping hand.
Unless that knowledge brings him low.



THE above sentiment is paradoxical, taking the season, with its dearth of honey, into consideration.

Had Nature with her benign influences, showered such phenomenal honey yields as

that of 1897 upon us for a series of years, what would have been the result? Or

rather, what would have been the price? And where would we have found a market for the product?

Although our ledgers may show but a small profit, we have been impelled onward in the field of knowledge—we have a better comprehension of the situation; hence better able to cope with similar contingencies in the future. Let us consider Nature's workings contrasted with our innate, or uncultivated demands.

First of all, she furnishes changes which are inconceivably sublime. The days as they come and go are resplendent with color and hue, emanating from sunshine and clouds. The change of seasons furnish an untold volume of beauty and varied temperatures productive of food in endless variety to satisfy the wants of all her creatures. Imagine the monotony of weather continuing intensely hot, cold, wet, dry or windy for weeks without interruption. Also, no change in her products as to variety; which the seasons in their ever changing course furnish us. Although lavish in quantity, it would not satisfy the demands of her creatures.

Nature's workings transcend our highest conceptions of harmony and beauty; notwithstanding, at times, she seems somewhat erratic. She pours her downfall of rain hither and thither, and her currents of temperature seem to move in a hap-hazard manner.

But when our understanding is enlarged, when we begin to comprehend her workings, then comes the acknowledgement, that her builder and maker is God. Nature distributes her gifts in ever variable amounts, naturally increasing the activity, in the mingling and commingling of her creatures.

Perennial honey yields like that of '97 would stagnate and degrade the pursuit. The money end would absorb the intellectual side, leaving it absolutely barren in both respects. Friend Daggitt expressed the real truth on page 265 when he said: "Putting a pursuit down to a mere dollar and cent basis is degrading it."

Upon reflection, we find ourselves eagerly grasping, not only what Nature is constantly bestowing, but that which our fellowman produces. The struggle in one sense is for existence; but is intensified by lack of compensation which is everywhere found in Nature. But some one will enter an objection, that Nature's compensation is due to inexorable law, producing a continuous rotation of results. Still the fact remains; and the noblest men in all ages have been followers of her workings.

The struggle for existence under favorable circumstances has enabled many to receive much larger compensation than others who are equally deserving. The race then is unequal. The present century has been one of exceptional opportunities; and the last twenty-five years, during which opportunities have been growing less, men have combined to make them, so to speak, by obtaining control, and limiting the output, enabling them to fix a price on the products. What will the outcome be, and how shall we adjust human affairs, to render equal compensation to those equally deserving?

A reply to Mr. Golden on the subject of section cleaners, page 441. Gleanings, is necessary to avoid all misunderstanding. He says: "I don't believe Aspinwall ever tried a belt machine, and his talk is all theory." The failure of a disk, through whirling small particles of propolis into the honey was sufficient to convince me that a belt would be equally objectionable. Although having never tried the latter, I gave the matter through consideration long before Mr. Golden made public mention of his machine. If a section, upon being held against a disk surface be dusted with propolis, it will also be affected in like manner if held against a belt surface. "Things which are equal to the same thing are equal to each other." Mr. Golden makes an admission when he says: "Hold one edge at a time lengthwise. * * * Why not place the section broadly upon the belt

and insure more rapid work? To do so would sustain my objection to the belt. I admit, that by cleaning one side at a time, all dusting will be avoided; but, it is too slow.

Mr. Golden also asks: "how many combs were cracked out of a thousand." I will reply, possibly a half dozen or thereabouts, most of which were cleaned when the temperature was below zero in my honey room, a condition sufficient to crack them even if untouched by a machine. My experience has proved, that the liability to crack combs is lessened in proportion as we diminish the diameter of the cleaning cylinder. My present machine has a cylinder but two inches in diameter against two and a half last seasons make. Furthermore, with the improved cleaner all cracking is avoided, although the work is exceedingly rapid, being more than 150 sections per hour.

On page 268. Gleanings, the editor, Mr. E. R. Root inquires: "how much my honey in plain sections netted me first and second quality." I received 12 cents for the first and 11 cents for the second. This, of course, was for white clover honey. My dark honey brought 8, 9 and 10 cents, according to quality, the demand being slow for dark grades last season owing to an abundance of white clover.

Acknowledgement is due Editor E. R. Root for a package of extra thin foundation, (I think about 18 feet to the pound). Overwork in designing and making new hives and dummies for 52 colonies of bees, together with my other duties, have prevented all writing for the Review since May. Unfortunately, the storage of honey was too slow for a decisive test. However, I feel satisfied of its success, it being readily accepted by the bees.

On page 276 the editor asks those interested in the success of the Review, for opinions relative to the Department of Criticism. It is unquestionably true that criticism hurts most where it strikes; but, according to my judgment, will have a tendency to produce a higher standard

of literature for bee keepers. Already its effect is visible in the department of Stray Straws, Gleanings. As this includes both Dr. Miller and the editor, each of whom command my highest regard, a passing word is due in lieu of an apology. Most of us at times have indulged somewhat in slang. We are differently constituted. The jovial natures of the gentlemen referred to is manifest in their writings. But, with advanced years and knowledge we substitute the purer language, and reflex thought brings approbation to our minds for making the change.

My name was first to receive a blow from the department of criticism, page 150, and I was pleased with the gentlemanly stroke of its editor. However, like Dr. Miller and others I will try and defend myself in the future by being more explicit, as well as thorough in my investigations. My impression is that propolis is composed of two parts—that which is soluble in hot water, and a residuum, thick and plastic in its texture. It is certainly soluble with formic acid and saliva as the bee prepares it for varnish stain on new comb and cappings, also through the action of concentrated lye as given by Dr. Miller. Having a large quantity on hand, obtained by use of the section cleaner, I will experiment somewhat in the near future with a view of determining the true facts.

JACKSON, Mich. Sept. 30, 1898,



DISCUSSIONS.

The Need of them. Some of the Difficulties
in the way of their Proper Management.

F. L. THOMPSON.

THE immediate cause of this article is an editorial foot-note on page 180 of the American Bee Journal, shutting off a discussion. In so doing an implication is made that every reader of a foot-note

on page 628 of 1897 will apply to me. The editor tells me privately he did not dream of referring to me; but refuses to make a public statement to that effect. I do not object so much to the discussion itself being cut off (though of course I have my own opinion about that) as to the manner in which it was done. But I have no more than the ordinary stock of patience, and will not discuss this matter here. However, it has by emphasis received a train of thought which had previously often occurred to me, even before Mr. Hasty's remarks on page 186 of last year's Review, which I fully endorse.

An editor has a technical right to do anything he wants to, short of libel. Has he a moral right to cut off *any* discussion he pleases? We can easily imagine discussions that would have to be stopped. But let us do no imagining, but take actual illustrations. A few years ago Messrs. McEvoy and Clarke had a scrap in the American Bee Journal about some details of foul brood inspection. The editor printed a long article by each, then said that each had had his say, and no more would be accepted, or something to that effect. This is one of those assertions which impose on the unthinking by their very audacity—in other words, a "bluff." One, at least, had *not* had his say, for the other had made fresh statements, and thus the matter already printed was rendered worse than useless; and this state of things was taken to support the editor's standpoint—a curious example of reasoning in a circle.

A discussion on evolution between Chas. Dadant and Rev. I. Templin in the American Bee Journal was treated on the same plan; the latter being given the last word, which he employed with a great flourish of trumpets, but very shallow arguments.

Another on the same subject in that paper, between Allen Pringle and W. F. Clarke, was likewise squelched just as it became interesting, and the evolutionist's opponent would have again been given the last word, had not Mr. Pringle risen to a point of order; and, strange to say, was recognized by the editor. But that

has not happened again, though a similar opportunity offered.

A discussion on disturbance of bees in winter in the Review, and one on eight and ten-frame hives in Gleanings, were closed, because even new facts would add nothing to the principles brought out. This I think was fair, so far as that reason was concerned.

Another discussion in the American Bee Journal, on the first introduction of the Italian bee, was severely let alone through many dreary wastes of unprofitable wrangling. At last the editor ventured to summarize one of the articles, instead of giving it entire. I do not remember the outcome. Had both disputants first argued for the editor's eye alone, the final result—if there was any—might have been given in one-tenth the space either in the editor's words or their own. In this case the editor seemed to realize that some things needed to be said, but did not know how to manage the undue length of the discussion until too late. The experience seems to have discouraged him; for in subsequent cases he has gone back to the old autocratic method, regardless of a trifling matter like fairness—it saves so much fuss. (A layman can not see how the energy expended could be much more than that of printing the first two articles in a discussion.)

The Canadian discussion of two years ago in the Review was also tedious and mostly unprofitable. But in view of some of the statements made, one could not but feel that it would be a shame not to allow a reply. The editor did not make himself responsible for any injustice by meddling, and, so far, is to be commended. But here, also, condensation would have been welcomed. Dr. Miller, however, advised him to choke it off entirely—thus putting himself on record as a would-be autocratic editor.

In the evolutionary discussion in which I was engaged, a slight variation was adopted. A proof of the second article of Mr. Doolittle's principal opponent was printed, after a long delay, and sent to

Mr. Doolittle, who thus understood, without doubt, that he was to have the last word in the discussion. He accordingly improved the opportunity to the full, assuming an air of injured innocence, accusing his opponents of abuse, of setting up a straw man, and of giving him no liberty to think as he pleased, while he did them; pure assertions, every one of them; though in his warmth he seems to have been sincere in making them; while the editor was saying, in effect, "See how fair I am!"

In the discussion on facing comb honey, in Gleanings, in which I was also engaged, virtually the same plan was adopted. Mr. Doolittle was again invited to say the last word; and promptly resorted to misrepresentation, saying I recommended putting the worst outside. In this case a novel reason was given for closing the discussion, viz., that if not, Mr. Doolittle's logic might be attacked! Since when is a man's logic so sacred?

A discussion on a bounty on honey in Gleanings was also closed when it tended to become political. Now politics is a subject that nearly everyone thinks he knows all about, but really knows next to nothing; and "practical" men are as wild theorizers as any one on this subject; so that it, if anything, ought to be discouraged in bee journals. But even this line of discussion is favored lately by editor Hill, according to "Boiler." That is, reason and judgement, not cast-iron rules, must determine the subjects of discussion.

In each of the foregoing cases (all I remember) we may see that except possibly the last one, each subject, in itself, was worthy of more or less discussion; but that in eight of the ten the management of the discussions was crude and unsatisfactory, and, as a precedent, did harm as well as good—when it did do good. Either bad motives were imputed, which an editor has no more right than any other man to either do, or connive at, without allowing defense; or the undue length of the arguments took up space

that might have been more profitably employed; or fallacies were left unexposed. So far, then, the management of discussions has not been a success; and the plan of giving the last word to *one* disputant is simply a farce.

Having reviewed our data, let us go back to first principles. I take four newspapers. Not one of them but is opened and glanced over first, when other printed matter comes with it in the mail. I am entirely dependent on bees for not only a living, but also the realization of all my cherished plans; then, too, all knowledge is related, and in reading and thinking of matters into which we have gone somewhat more deeply than others, we constantly approach a better conception of the universe, and our place in it. Readers, then, have an interest in newspapers and their contents, not measured by the sum invested in them. They may legitimately criticise, and the autocratic editor is dependent upon us after all.

Now some one will say "You have a big job on hand. Newspapers are autocratic; the immensely popular Ladies' Home Journal is autocratic. Explain their success." Quite easily done. The majority of mankind have an idea that ultimate fixity of conception on all essential subjects is perfectly attainable—in fact, is already here, and we only have to listen to a few wise men to grasp it. With them the sign of truth is an untroubled brain. In accordance with this craving, uncertainty is feared and hated; didacticism eagerly welcomed. A smart man, like Edward W. Bok, or Charles A. Dana, with a gift of making narrowness appear breadth, and of concealing dogmatism by specious reasoning, is sure to be popular, even though he is regarded as a degrading influence in American literature by solid thinkers. What if the former does insist rather more on correct than right conduct? Few know the difference. To be a social prig is to be successful; therefore the paper that gives pointers in this line is a complete guide to the philosophy of life; and, when en-

livened by a fund of superficially acute sayings, quite irresistible. I don't know whether anybody ever tried it, but should imagine no one would ever think of differing with the editor of the Ladies' Home Journal with any expectation of seeing himself in print in its columns—it is so well understood to have authority to teach, but will not discuss. And whatever applies to that paper applies to those which look upon it as a model. Of course the autocratic editor who systematically caters to tastes intellectually low enough will address a wide public.

But is this right? Can this course commend itself to the broad-minded man, who wants to do his whole duty to mankind? We are not babes, but men. If the facts of existence can not be discussed without bickering, it is unfortunate, to be sure, but trebly so if we give the matter up and take refuge in intellectual sloth. The primary purpose of journalism is to spread truth. The wise teacher knows that if he takes up the whole hour in talking, many of his words will fall upon dull and inattentive ears; but if, Socrates-like, he so manages that his pupils seem themselves to arrive at the knowledge he desires them to have when the hour is up, they will not only know it thoroughly, but be inclined to strike out in investigations of their own. The suppression of discussion is the suppression of truth. It may make a journal uniform in policy, and this may attract large numbers of such subscribers as can not bear to have their pet notions opposed; but the greatest, though least remunerative, object of journalism is defeated. The autocratic editor is not dependent on the opinions of the thoughtful for his income, but he is for the esteem worth having.

But why, one asks, should not a legitimate sphere of activity consist in just making public one's own opinions? Has not a purely editorial publication, for example, just as much right as any other to the field? If so, why should not an editor go a little farther, and add the opin-

ions of others which coincide with his own, leaving out those which do not? Well, I would not undertake to maintain that this activity is not technically legitimate. But it is so immeasurably lower than the unselfish interchange of ideas; it is so limited in usefulness, and yet *popularly* made equal to the other, that the man who engages in it deceives—he employs that condition of affairs to make one man's version of the truth of as much force as a hundred men's, though each of them may be his equal. "O, but they have the right to do the same; and so the thing may be evened. Two attorneys in the court-room, two or more newspapers in a city—that is the rule." It may be the rule in the court-room, but is far from being true in technical journalism. To have the right to do a thing, and to have the means to do it, are two very different matters. To get your opponents cornered, then have your side of the discussion cut off while articles on the other side are printed, and then be told if you do not like that style of journalism you can start a journal of your own, is rather ironical justice.

I might argue at much length how one-sidedness in journalism is to be deprecated, pointing out how in practical life, supposed truth, in one mind, invariably needs to have little angles and corners rubbed off by contact with other minds before its universal fitness is established; how language is so deficient that, sometimes, only the criticism of an opponent indicates at last the proper presentment of the case; and if at this critical juncture falls the interdiction of a hasty editor, the cause of truth is injured; and many other points. But, really, in free America, the desirability of free discussion ought to be axiomatic.

Assuming that it is such, have editors any excuse for sometimes falling short of their duty? Doubtless. It is very easy to criticise in one's easy chair, but quite another matter to carry out one's own ideas when confronted with practical conditions. It may be there are pal-

liations of which I have no conception. What I do see is this: a discussion may run into a dispute, and a dispute into personalities. The farther it goes, the more delicate the task of the really conscientious editor to bring it to a close; hence he may naturally wish to do so as soon as possible. Three of the ten examples quoted did run into personalities. But was it not apparent from the very start that they would turn out as they did? Then what was the editor there for? By what process of reasoning will it offend a contributor less to reject all articles but one, than to suggest private argument first of all, and then condensed and *combined* last words? Speaking for myself, I would meet the editor half-way if the latter course were suggested to me.

Custom, no doubt, is at the bottom of the evil. Editors have got used to being arbitrary; but there are such things as bad customs. This is a grave question. Discussion is what makes conventions so profitable. Can we afford to keep it out of literature?—for, of course, the actual number of discussions stopped must be small, compared with those that are not entered into on account of the known attitude of some editors.

I earnestly hope this will not be the only article on the subject.

MONTROSE, Colo. Aug. 31, 1898.

A Condensed View of Current Bee Writings.

E. E. HASTY.

"I'll trace the garden o'er and o'er,
And meditate on each sweet flower."

Our editor, the editor of *Gleanings*, and Dr. Miller have it between them whether cross bees have a special spite against black or not. They stand two to one. Hereupon I run to the assistance of the minority, in the effort to make it count

two and two. My bees have never *impressed me* with the idea that black displeased them more than other colors. Perhaps if I had been looking out sharper I should have seen something of the kind; but it seems to me that if the alleged fact had been very prominent I should certainly have noticed it. Tell you what I think. Wherever bees are worried at night by sknuks they are liable by day to charge on whatever reminds their excited fancy of the vile "varmint's" nigritudinous appearance, as he comes round in the gloaming. But where no nocturnal prowlers prowl, bees are peaceable towards all colors alike.

Friend Doolittle thinks some of us, when we throw bricks at his honey-facing doctrines, do not take space enough in saying that he does not either advise or practice facing crates with sections of higher quality than the body of the crate. Thought I made that clear enough at the outset; but, as a comrade desires it, I will cheerfully say so some more. Mr. Doolittle is an honest man, and acts accordingly—only in this particular case he doesn't *talk* accordingly. And having tried our best to reconstruct him in that one particular, we have to give reconstruction up in despair. Mind you, nothing herein contained shall admit, in the least degree, that the man who faces honey with higher grades has done other than a wicked act, as well as an unwise act.

In reply to a rather sharp challenge from critic Taylor, editor York says the American Bee Journal is editorially responsible for "Beedom Boiled Down." Yet he says it in such language as leaves us still guessing whether the Boiler is Mr. York or some assistant. The editor of a journal has special temptation to write with a *nom-de-plume* when he wishes to stretch his wings in some unaccustomed direction. Can see himself as others see him better; because friends who would not criticise the editor will freely criticise the unknown writer.

And so the theory that a fertilized queen always lays fertilized eggs gains ground and is spreading. Should think that the microscopic finding of seminal particles in worker eggs, and the non-finding of them in drone eggs would negative that. But perhaps that observation (like things seen along the canals of Mars) lies too near the boundaries of invisibility to be of much value as an argument. We are queer creatures, and are most of us too anxious to get our facts into invariable rank and file. Difference of fool does seem to determine whether an egg shall develop as a queen or a worker (forms very different in many details) and if still another kind of food would make the same egg develop as a drone we should have "three in a row."

AMERICAN BEE-KEEPER.

This paper, as noted some time since, made a decided change when it put a responsible editor's name at mast head. Since then it has kept quietly on in the path marked out for itself—editorial matter showing a tendency to increase both in quantity and interest. The opening article is usually by Doolittle; and the funny little non-germane department of Literary Notes still fetches up the rear.

On page 149 Mr. Doolittle says he thinks much honey is lost in the attempt to stop prime swarming by destroying cells. And the attempt to stop after-swarming by the same practice often *increases* the number of after-swarms. This is the issue when the cells are cut before all the unsealed larvae are too old to be coaxed into something that will temporarily answer for a queen. Wait *eight days*; shake off the bees; vigilantly destroy every last cell; then give a good ripe cell or its equivalent, and the plan is a success. Yet he would show us a "more excellent way," by listening every night at the hives where an after-swarm is possible. Can't say that I admire so much listening; but may be its the best way. When the young queen is out, and tells you herself

that there'll be a hot time in the old town to—, well, to-morrow you can shake things at pleasure, and if you main the not yet emerged cell-occupants, why it is no loss. At an earlier date shaking the combs will hardly do.

The Queen Breeders' Union makes its bow on page 151. Honestly purposes not to be a "trust" and dictate about the price of queens. Just wishes to assure customers that they will not be fleeced by defective queens, and to assure each other that they will not be worked by dead beats, or overshadowed by breeders of the "cheap and nasty" article. 'Pears like the Union had a sensible reason for existing.

Fred Thorington, page 152, thinks that one with care and practice can test the amount of honey on hand in the hive with sufficient accuracy by resting the rear end of the hive on the fingers—this to be done about the first of March. If short give them a comb with honey in it.

Harry Howe, who is a champion lighting operator, gives an article on page 153 in which he reverses himself for once, and jots down the things in which it pays to take plenty of time. Article so good that I can hardly resist the temptation to chuck it in entire. Brilliant idea of Harry's. Would we might all take one good long look in the opposite direction from our controlling animus—what a galaxy of gems these articles, for example, would be; D—ttle on Scoundrelly Honey Packing, T—lor on Classic English Run Into the Ground, H—sty on Too Much Pop-Gun Expression, A. I. R—t on Bee Keeping, M—ler on One Week that Sampson Didn't Grind, Ram—r on Home, Sweet Home, and a dozen more that a live editor would think of and engage. Well, Mr. Howe says take time to let your dinner settle. Says he takes time to read four bee journals. He once found it worth a day's time to watch two decidedly non-electric brethren extract honey—expanded his mind (or at least his belt) to see them lay a comb flat on a board and hew off pieces of cap-

ping off it. They kept their knife hot; and their chips were as big as a silver dollar. And take time to the amount of several years in deciding to change your style of hive. Has six totally different kinds himself (not two in any one apiary however) and finds them all about equally good.

Dr. Miller says, on page 155, that he suspects that fertile workers prefer drone comb to lay in because it is more comfortable to back into.

On the same page O. O. Poppleton, now a migratory apiarist in Florida, says the honey flow has been continuous there, but very light.

On page 156 the editor doesn't think much of Rambler's rubber soles to keep one's feet unincumbered with wads of wax, honey and propolis. Says keep your floor clean instead—and a whole rubber suit, changed often, would be needed in some honey-houses of Rambler's adopted state.

Does milkweed yield dark honey or light? The editor and Mr. Eggleston find themselves on opposite sides of this question—editor softening down some, but not quite giving up yet. (Page 158.)

In regard to the safe introduction of queens, Doolittle says most of the sure plans fail sometimes. The prevalent method, letting caged bees slowly eat their way to each other through the candy of the cage, only fails about once in fifty times—but when it does fail it somehow happens to be with a costly queen that has come a long distance. As a method for high priced queens he has practiced for fifteen years without a failure caging a full comb of emerging brood in the heart of a full colony, and placing the queen and escort upon it. After six days, if enough young bees are out in the cage, it is established elsewhere and built up into a colony. A. B. K., 129.

On page 133 is something about native Japanese bees by a Japanese writer. A little smaller than our bees, gentle, diligent, gray, swarms never large, peculiar

trait of always leaving some honey in each flower. Guess we shall be slow to believe that they are any different from our bees in this last respect. Our bees, if you will just watch them once, try a great many florets that they hurriedly abandon before they reach one which they take a good long pull at; and the whim that they are principled to leave some behind might easily grow if it got started. I presume there is some thin nectar in these abandoned flowers, but Mr. Bee is hunting for one which no one has pumped for so long that the nectar has got rich and thick. Knows his own business best presumably.

As to preventing increase, Mr. C. Theilmann claims success in cutting off the cells, and laying a few of the best at the entrance. The prime swarm is allowed to come out naturally, but, queens being all clipped, the swarm is expected to return. The queen at this time is caged, and the cage laid at the entrance indefinitely—still there, if I get the idea, when the cells are laid there also. Eventually the old queen is to be killed, and the first queen emerging from the cells at the door reigns. He does not explain how he makes sure of all the cells without shaking off bees, or how he shakes off bees without damaging immature queens. And then the question whether doorstep, foundling queens are as good as lawful ones will bear some discussion. Even if a small bunch of bees stays there faithfully the temperature inside the bunch gets low on a cold rainy night. All the same, something may come out of the plan. A. B. K., 133.

A model hive cover is illustrated on page 139. It rests on the cleats of an inner cover or honey-board so that a space of unconfined air keeps the hot outer wall from unduly heating the comb within. A permanent feeder and a slide way for a slate also nestle within the narrow space. Good thing very likely.

On page 140 the editor muses on the not over-pleasant prospect of our being

swamped in a sea of Cuban cheap honey not long hence.

On page 114 W. Z. Hutchinson gives some points in producing comb honey. The first is sections of nice drawn comb, all you can get of them, at the very commencement of the harvest. They sometimes approximate in value to finished sections of honey—for the simple reason that they will be finished when almost nothing would be done in ordinary sections of foundation. The second point is, make everything of a prime swarm. Give it the old location and supers; and a week later give it the flying bees of the old hive, which has been set close by with a view to carrying it away just at this date. Only five frames for brood nest, so that the honey will all have to go above. To keep the queen from going above too, there will have to be an excluder. The next point is, don't put on more than three tiers of sections. An occasional colony will need more in a big harvest; but when you put the fresh tier on take one of the previous ones off, and give it, bees and all, to some colony which has not yet needed so many as three. Says he has done so often, and finds no objection to the plan. Point four is sort your unfinished sections into two lots. Those half done or more, feed back honey and finish them. Those less than half done use as feeders to stock up your light colonies for winter.

Doolittle remarks on page 119 that for some reason queens long caged, as well as those shipped long distances, are much more liable to be killed in introduction than queens in full laying carried from one hive to another in the same apiary. He suspects it is because they do not lay at first, and also because they run about more, causing their new subjects to get disgusted and vote them "no good." My suspicion would be that it is the lack of the *scint* of fertility that prevents acceptance. Doubt whether bee thinking is deep enough to make any logical connection between eggs in the cells and a queen.

Editor Hill says there is one universal rule for all cases of moving bees; and that is always carry a wad of cotton to stop unexpected leaks. He has a right to talk about moving bees, having moved a hundred indescribable hives in Cuba on carts and on mule back—more than half of said hives being so rotten as to require winding with rope to commence with. A. B. K., 121.

Ed. Jolley says our trouble is [as to prices and such matters] that honey has got to a lower plane in relation to other produce. The shoes we buy have come down 50 per-cent; but the honey we pay for them with has come down 60 per-cent. The shoe man has more than made good his loss by improved machinery. He can make shoes now for *less* than half what it used to cost him. We poor chaps, having failed to invent the cheap-honey-into-beeswax chemical machine, have been unable to reduce our cost of production by nearly so much as one half (let alone the 60 per-cent that is called for) therefore we are short just the discrepancy. A. B. K., 99.

In the same number Mr. Doolittle has an article on the other side of the low prices controversy. In the course of it he presents this little eye-opener, which any complete rationale of our fiscal situation must be able to account for as well as for other declines. In 1874 he paid \$100 an acre on his 30 acre place. Now it would be hard to sell it for \$50 an acre, although the buildings are good. Perhaps we had better admit that there are more things in earth [Horatio] than our philosophy gets around to include. And when two writers wade into economics it is rather the rule than the exception for both, in bland unconsciousness, to lay down as axioms of truth old, rotten exuviae of the world's twilight, which the world's better to-morrow will call self-evident lies.

RICHARDS, Ohio; Oct. 6, 1898.



EDITORIAL offerings.

THE FRONTISPIECE this month shows the home-apiary of Mr. Byron Walker, of Evart Michigan. Last month the back-ground of the frontispiece was characteristic or Northern Michigan—this month it is the fore-ground. Trout-brook is the very appropriate name of the little stream that goes rippling around the rear of friend Walker's little farm—and yet, he says he has never cast a hook into it. Friend Walker, I believe you ought to play and go fishing more than you do.

BRO. YORK gave me a warm welcome during the hour or two that I could stop while on my way home from the fairs. We went out and took dinner together at a restaurant, and he told me about the Omaha convention, and made me wish I had been there. In one thing he was disappointed, and that was in the number present. He thinks now that the best thing we can do is to meet when the G. A. R. folks have their annual encampment. We are then sure of low rates. Philadelphia will probably be the next place of meeting. The American Bee Journal is giving a very full report of the Omaha meeting.

BRO. ROOT of Gleanings has secured the services of Mr. Dadant to help him out in this discussion on large versus small hives. This is all right; as facts are facts regardless of who sets them forth. It should not be forgotten, however, that Mr. Dadant will write from the experience of an extracted honey producer; while the late discussion has been carried on almost wholly as regards the production of comb honey. In the production of extracted honey the size of the hive matters very little, provided it is large enough. In producing comb honey the

line between brood and surplus must be very sharply drawn, and to get the right proportion of the fine, white honey stored above this line requires skillful and peculiar management.

THE VALUE OF DISCUSSION.

Mr. F. L. Thompson has so thoroughly covered the ground in his article on the subject of discussions, that there is little room for editorial comment. In my opinion there is nothing like free discussion for bringing out the whole truth. As a rule, I think we bee-keeping editors are too much afraid of criticism and discussion. As soon as the "fur begins to fly," just when the interest in a discussion is thoroughly aroused, down comes the editorial gavel. As Mr. Thompson well says, one great difficulty is that a discussion is so likely to drift into some side-issue somewhat foreign to bee-culture. It may also degenerate into a dispute or into personalities. To the majority of readers these things become very tiresome. So long as the original subject is kept in view, and each "round" brings out *new* facts and ideas, and argument takes the place of dispute and personalities, I see no reason for closing a discussion. If others wish to express their views on the subject, the columns of the Review are open.

DOES A PEOPLE'S COLONY STORE MORE HONEY IN PROPORTION TO ITS NUMBERS THAN IS THE CASE WITH A WEAK COLONY?

Dr. Miller, in the American Bee Journal, admits the correctness of my reasoning regarding the securing of more bees, per comb, or per hive, by having a queen for each single story, instead of doubling them up, but defends his position by saying that he thinks it is agreed that a large colony produces more honey *in proportion to the number of bees* than a small one; also that it will consume less honey in a year in proportion to the number of bees than a small one.

Doctor, I am not so sure about the last assertion; it is possible that it is true, but I do not agree with the first one. So far as securing honey as surplus is concerned, I believe nothing is gained by having a colony above the normal size. Other things being equal, the colony that has the least brood to care for, in proportion to its numbers, while the harvest is on, will store the most surplus in proportion to its population. This question of the size of colonies and its relation to success is a real, live, practical subject, and the Review will be glad to publish articles on both sides of the question. Give your reasons, gentlemen.

HOW OUR CRITIC IS REGARDED.

I have received a large number of letters regarding the Department of Criticism. I am very thankful for them. I can not print all of them, but I will give a few characteristic ones. As permission to publish has been given in only a few instances, no names are given.

"Mr. Taylor is a severe critic."

"Mr. Taylor is taking the shine off some your other correspondents."

"You ask for expressions of opinion touching the Department of Criticism. It is not to be expected said department will be *liked* by those most open to criticism; but I think it is much needed. Apicultural literature is very sloppy and and needing a tonic. Mr. Taylor will need much discretion and tact in order to make a success of his delicate task. Let me suggest an avoidance of that style which will seem to indicate enjoyment of the fray. Mr. Hasty illustrates better than I can describe the light and kindly but firm touch which is needed for such work. If you can make it go, by all means continue it; for we need an antidote to the ——— slush."

"Friend H. It is 10:15 P. M. I have just read what you say about the new Department of Criticism; and, as I am a very poor correspondent, I will drop you this as I may not do so if I put it off.

As a practical apiarist I give it as my humble opinion, that the critic is doing *grand work* in straightening out the teaching of those who are doing most of their apiary work in the office, and not with the bees. These men can not spare the time to do practical work and note all the little things that must be done in a bee yard. For the benefit of the young and beginners, do continue the criticisms, and let the critic have his own way of doing it."

"As you ask your readers to commend or condemn, as they think best; the Department of Criticism in the Review I wish to say, as far as I am concerned, I commend it fully. I think it is a stride in the right direction. What are bee papers for if not to teach people truths in regard to bee keeping? What should a writer care, if he makes a mistake, to be corrected? How I wish at times to have a Taylor, a Miller, a Doolittle or some other good bee-keeper to criticise my methods. How helpful it would be.

We are too prone to want someone to praise us; not to point out our errors. How we flare up if this is done.

If Bro. Taylor makes a mistake, criticise *him*. Let it all be done in a good natured spirit. Let all be critics, when they see errors set forth as truths; but let it be in a kindly spirit. Of course I would regret to see the Review injured, and if you think this department likely to do so I would discontinue it; but I don't believe it will do so; I think the majority will see the usefulness of it; or, at least, I hope so; as I would regret to see it discontinued."

"Friend Hutchinson, but for lack of time I would have written you and Bro. Taylor long ago. Your words in last Review make me write a short note without waiting for time.

I was glad when I saw the announcement that Bro. Taylor would start the new department, and counted on something instructive and useful from one of his ability. The outcome has been a real disappointment. I had supposed that I

had learned to be glad to have my faults pointed out, whether it was done by friend or foe, and I count Bro. Taylor as a friend. I don't say there's anything wrong in his manner, but I do say that the reading of his matter makes the impression on the mind that he is anxious to find fault and to make it unpleasant for those he criticises. So much so is this that he hardly seems the same man whom I have known and admired for his integrity and ability. A number have spoken to me about him, and expressed themselves as impressed the same way. I think you and he have been pluming yourselves that he was not mincing matters but speaking with great frankness. The impression upon others is that of intense disagreeableness.

I'm not saying this because he made a special target of me. I take that as a compliment. I replied to his first article because I thought he was 'off' in his charges. His reply to me, instead of appearing simply reaching after the plain truth wherever it might be found, as a true critic should do, looked like the work of a pettifogging lawyer, so complicating matters that it would take a great deal of space to make any further reply, and although I think I could have met all his points, I don't believe any good would have come of it, and I've neither time nor taste for a mere war of words.

In giving his judgement upon any given point, it might be an improvement if he would have less of that style which says, 'No doubt I am the people, and wisdom will die with me.' There are some things in which there is a bare possibility that he may be mistaken.

If I seem to have fallen into the same fault in this letter that I criticise in Bro. Taylor, it is because I think both he and you have wanted the plain truth, and I care enough for him and the Review that I don't want him to injure both.

This letter is intended for both of you, and both have the esteem and good wishes of
C. C. MILLER."

"I have done so much talking already this morning that I do not feel inclined to quit without bothering you a little further with a word in regard to that greatest of modern agitators of current bee literature, the Department of Criticism. From my own personal point of view I would say, privately, that I cannot express the high estimate I place upon that department. To those less in need of such knowledge as is there imparted, than myself, it may appear differently. I realize fully my inefficiency in a literary way, and I am not blind to the superior, scientific knowledge of Mr. Taylor in apicultural matters. I feel that if by sacrificing five years of my life, I could be associated directly with him for one year, I would be the gainer to avail myself of the opportunity. It is a school that combines the two branches of learning in which I am most interested, and I therefore place no light value upon its lessons. You have not wielded a pen for all of these years, brother H., without realizing the total inadequacy of language in giving expression to certain sentiments of the heart; you will understand me then when I say sincerely that my regard for the Department of Criticism can not be expressed in words. Mr. Taylor's criticisms are, obviously, honest and rendered in an admirable style. They are simply expressions of individual views emanating from a thoughtful and experienced mind. Facts are facts, just the same after criticism as before. Existing facts remain the same and new ones are revealed by criticism; the successive revelation of facts is progression itself. I, for one, vote for progression. Our flight (?) to that era of perfect methods and knowledge will be none too swift if we all apply ourselves to the fullest extent of our talents, to the detection of error in every form."

"When I saw the first installment of Mr. Taylor's criticisms, I experienced a feeling of antagonism, although I had not yet read it, on account of his *previous* utterances. It may be that others have

felt the same. To an inquiry in the American Bee Journal, asked in good faith, he replied 'Poppycock.' When E. R. Root misunderstood one of his experiments he alluded to 'the gray matter of the brain.' When Mr. F. Rauchfuss criticised another, he remarked that 'he was writing for bee-keepers who think.' I consider these remarks uncalled for and ungentlemanly. However, in his critical articles of late, I do not see anything to which exception need be taken in that line. Criticism in the way of pointing out errors, is badly needed; and I say by all means continue the department. I think everything he has spoken of is a legitimate subject for discussion; only the *percentage* of some of the topics, in a bee-paper, needs to be kept low—and in this I think he has hardly succeeded; at least, if he intends to go on in the same way. Of course, it would be all right to deal fully with those subjects, if once for all, or once in a considerable interval. It seems to me a mere absurdity to put the praise as well as the blame in those articles. Mr. Hasty attends to that; so that the Review, as a whole, can not be criticised on that score; and there are enough errors to be corrected to take up a whole department.

I think E. R. Root is away off in defending the use of "canine" for dog. That is what it means, but *that* isn't the point. It is plainly as a sample of the common and vicious reportorial style that Mr. Taylor criticised it, and Mr. Root falls into precisely the same trick again in speaking of the "crimson fluid from his sympathetic heart," etc. This is merely childish dallying with language. And how any one can attribute a distinct and necessary shade of meaning to "smoled" is more than I can conceive. Such language is only fit for low dandies, who tip their hats habitually on one side. I presume most of us fall into it occasionally, but we need to be reminded of its looseness. In one sense, it has a shade of meaning, but that shade is vulgarity. On the other hand, it is possible to go too

far the other way. 'Sauce' is about obsolete, and its use in ordinary discourse would be the next thing to affectation. 'Sass' is merely countrified, not vulgar. It might pass as a colloquialism.

Here is a bit of criticism for the editor. Would it not be well, when printing letters originally not written for publication, to state the circumstances in the *same issue?*"

I think that perhaps enough has been said upon this subject. What has been published will enable Mr. Taylor to get his finger on the public pulse, so to speak, and to govern himself accordingly.



Department of Criticism

R. L. TAYLOR.

Blame where you must, be candid where you can.
And be each critic the Good-natured Man.

GILDSMITH.

WHEN POLLEN IS GATHERED.

Dr. Miller (Gleanings 645) has found two reasons given for bees bringing in pollen more plentifully in the early part of the day than later. One is that the flowers secrete nectar more freely in the latter part of the day and the bees give up pollen gathering for the nectar; the other is that the pollen gets too dry, as the day advances, to gather easily and so that work is given up. I suspect that in many varieties of flowers, as in corn, the pollen is either gathered by the bees or falls away to do its proper work early in the day, so the bees have none to gather later. One may easily see that this is true by observing soft maples and willows at the proper season. One of the sources of information says when honey is abundant carriers of pollen are scarce but is it not true that when white clover yields nectar plentifully that, though it is not readily seen, as are most other kinds,

abundance of clover pollen is gathered and that throughout the day?

THOSE POINTED QUEEN-CELLS.

The doctor (Gleanings 681) seems to think that the queen cells shown in Gleanings 647 would look better if they were not quite so pointed. The editor says "I do not know. I am inclined to think however that the fact whether they are pointed or rounding is due to the peculiarity of the bees building the cells." If our friends will have patience those cells will all be nicely rounded off within a few days. I have never noticed any difference in the shape of the points of cells internally but often after cells are capped the bees decorate the free end with a point of wax and pollen; but this is all carefully removed before the cells are ready to be opened by the enclosed queens.

THE INVARIABILITY OF ACTION IN BEES.

The editor of Gleanings page 645 inquires "do bees ever perform any work always in the same way?" To this the doctor (page 682) replies "perhaps not; but I never knew any exception to the rule that, left to nature, a queen enlarges her brood-nest in the spring by laying eggs outside the cells already occupied. Did you?" The editor replies: "Yes, I think I do." And adds "there are some freaky things that will do almost the very opposite." I am extremely interested to have the editor tell us what it is he knows of a queen doing differently from what the doctor intimates is her necessary course; and while he is doing so will he kindly explain what it is "almost the very opposite" that the "freaky things" will do? The editor adds "I still think you cannot attach the word 'always' to anything that either the bees or the queens do in the domestic economy of the hive." On the preceding page and also on page 645 he expresses the same sentiment. Notwithstanding, I think there are several things that bees can be relied on to do under appropriate conditions.

WHY HYBRIDS ARE PREFERRED.

The writer of *Beedom Boiled Down* (A. B. J., 586) quotes Gleanings as thinking "that the majority of progressive bee-keepers use hybrids because they secure as much honey as the Italians and more than blacks" and says the American Bee-Keeper thinks that is not the true reason, without giving any other. The Boiler then asks "Don't they have hybrids just because it is too much trouble to keep pure Italians?" That is not the true reason I opine. They keep them because they are better bees. They are as good honey gatherers, they go readily into the comb-honey supers—no fussing with bait sections—combs and comb-honey supers are freed from them very much more readily; and as to the color, handsome is that handsome does. I discovered recently that I especially admired the appearance of the sorts of grapes of which I am the fondest.

PREVENTION OF ABSCONDING.

Reference is made on the same page to D. W. Heise's complaint of trouble from the desertion of swarms and his request for a remedy. In one of these articles I gave a remedy that has worked well with me so far, viz.: plenty of room in the brood chamber for three or four days, till the swarm becomes reconciled to their new home.

HIVE MAKING AND STIMULATIVE FEEDING.

H. F. Moore of Cook Co. Ill. writes in the *American Bee Journal*, 596, that I am "promulgating some rank heresies and must be 'called down.'" The first heresy he points out is my advice to those who keep many bees to make their own hives. He thinks a show of hands would prove me wrong by a large majority. He goes astray however when he imagines that my advice implies that one should make his hives with a hand-saw and chisel. If one has no saw-table of his own he can easily get the use of one by going not far from home.

The opinion I hold that stimulative feeding of bees does not pay, he esteems

another heresy. He started with one colony last spring and "fed small amounts of honey and water every evening for weeks" and as a result has now eight colonies. He concludes by saying "I can rear bees for less than \$2.00 a colony by this means; not including the hives of course." I think it would be a safer course to pursue to arrive at the exact amount of profit in this operation for Mr. Moore to offer his increase (seven colonies) for sale without the hives at \$2.00 each and when he has succeeded in selling them then sit down and count his profits. Whether he will admit it or not I think he will conclude that he could make more money making hives with a hand-saw.

MICHIGAN RHETORIC AND GEOGRAPHY.

Though I have no remembrance of criticising any one's rhetoric he says that all will agree that my criticism of grammar and rhetoric are entirely out of place in a bee-paper; but he seems to be in a measure reconciled to it, for he says "it is nice to understand Michigan rhetoric and know wherein it differs from that of the settled portions of the country." I have a copy of an old *Gazetteer* which describes Michigan as lying largely under water the greater part of the year. Mr. Moore no doubt has drawn his geographical knowledge from some equally ancient source. I'll write some railroad office to have some modern literature sent him.

SOME CLAIMS FOR FENCE SEPARATORS
THAT DO NOT SEEM WELL
SUSTAINED.

Mr. Golden in *Gleanings*, page 689, discusses the result of using three different kinds of separators with plain sections, and illustrates the matter with a photograph of three samples of comb honey produced with the use of those separators, severally. The separators are his own, the A. I. Root Co's. and the plain. He would make out, and the illustration *seems* to sustain him, that the whiteness of the honey de-

pends upon the kind of separator used. In this case the whitest honey is the product with the use of the Root fence, and the darkest with the plain separator. Each sample of honey was produced by a different colony of bees from the others. I am not now going to call in question the claim that the kind of separator makes a difference in the color of the cappings of comb honey. That may, or may not, be a fact. What I wish to protest against is the sort of evidence used in the effort to establish that fact. I know that the cappings of honey from different colonies vary greatly in color when each one has the same kind of separator as the others, and I don't know why they shouldn't vary just as much when the separators vary, without furnishing grounds for ascribing credit or discredit to the separators. In other words, the facts presented furnish no evidence to support the claim.

The editor is apparently somewhat staggered and suggests that "there might have been some difference in the bees," but goes on to say that "it stands to reason that the fence gives better ventilation, and, consequently, better and thicker ripening of the honey." How can it give better ventilation? Would an empty wicker chair standing in a room give better ventilation to the room? And then, is there any evidence that honey with raised cappings, as the black bees make them, is any "thicker ripened" than that with cappings that lie on the honey?

The most remarkable thing in the photograph is that the sections all appear to be rather scantily filled. From the claims heretofore made for plain sections and fences I have been looking to find the sections filled nearly solid.

I want to say further, touching Mr. Golden's statement, that he had found no "ribbed comb honey as the result from slatted separators" though the slats were from $\frac{1}{4}$ inch to $\frac{3}{8}$ inch, that this has not been a proper year for testing the fences in this particular. Only a year of profuse honey flow can properly try them.

DO BEES MOVE EGGS OR LARVÆ?

In the American Bee Journal, page 578, Doolittle places himself "on the side of those who claim that bees never remove eggs;" but he holds to the opinion that they transfer larvæ from one comb to another and to queen cells; of which transference he believes he has observed many instances, and of which he gives one strong case, but the particulars of which he confessedly quotes from memory after a considerable lapse of time. The case was this: A swarm issued and returned, and the queen cells were cut out the same day. The next day the swarm issued again and returned, and almost immediately three other swarms issued and entered the hive of the one in question, without their queens. The day following all the swarms issued as one; after which the hive was examined and a great number of queen cells were found containing larvæ; many of the cells being in places where "it would have been impossible for larvæ to have gotten in them (or the cells built over larvæ) other than by bees carrying them there," as he says. His statement, backed by the strength of his name, furnishes what the editor of Gleanings would call "heavy testimony." I have not observed the ways of bees for so long a time as has Doolittle, but for a good many years I kept a sharp lookout for just such cases as the above, in many instances where such transference would seem highly desirable to the bees, but, though in a considerable number of cases I thought I saw what might be evidence of the transferring of eggs or larvæ, continued observation showed that it was not. Of course, this does not show that Doolittle is wrong; but I may be excused for registering my doubts.

MOVING THE HIVE VS. CUTTING OUT QUEEN CELLS TO PREVENT AFTER- SWARMING.

In the last number of the Review, 267, Doolittle vigorously takes issue with me

touching my criticism of his method of preventing after-swarms. In the heat of his onset he falls into several errors. The first error I notice is the idea he harbors that the method I pursue for preventing after swarms is bound up with the Heddon hive. He says "the especial part of this criticism comes in your failure to take into consideration that not *one* Heddon hive is in use to where there are *fifty* to *one hundred* other kinds of hives." But, my brother, I did not fail to take that into consideration. I have followed the plan probably as much with other hives as I have with the Heddon; and it is just as convenient with them as with the Heddon; always excepting chaff hives, tenement hives and house apiaries. These latter are stationary; and no one using either of them would suppose I advised my plan for either of them.

The second error Doolittle falls into is where, after referring to my largely using the Heddon hive, he says, "and wishes to engage others toward a favorable opinion of that hive." This is gratuitous, if not unkind.

Further along he seems to imply that I have some other sinister motive in giving my plan; as he paraphrased me, I may be allowed to paraphrase him: "And now Bro. Doolittle I am perfectly willing that each reader of the Review should use the Doolittle plan of preventing after-swarms if he believes it more to his ease and comfort so to do, for I give my plans and ways of working only with the hope that it may help, ease and lighten the burdens of my brethren and sisters."

A fourth error he falls into is his supposition that I made queen traps a necessary part of my plan. I do not. They are very convenient, however, and would be as convenient in Doolittle's plan as in mine; in fact, if I practiced his plan I should consider them a necessity. As to the cost of them, of which Doolittle makes so much, they surely save me that in one way and another many times over; indeed, their first cost is not heavy if one makes them himself as he should.

Doolittle's counter claim that his plan is less laborious and time consuming than mine seems ridiculous to me; but I suppose this is only a good illustration of how much better one's own way of doing things seems than some other person's way. Of course, my plan would not do very well for invalids, or weakly women; neither would Doolittle's unless there be some one who delights in a broiling sun. This, with what I had already said in speaking of hives, illustrates Bro. Doolittle's fifth error, viz., that a plan to be of value must be the best for every sort of hive and for every individual bee-keeper. Another one is his supposition that it is literally necessary to raise up a hive and carry it away. I generally do that because I can do it without difficulty, and quickly, but giving it two or three hitches at one end and the other is just as good. As to the consumption of time, I certainly can do all the work necessary in a case inside of two minutes; and I would put down any one who can cut all the queen cells from the hive of a strong colony with certainty within that time as a marvel. Doolittle writes the editor of the American Bee Journal, page 585, "I am driven to work from 5 A. M. to 9:30 P. M., out in the hot sun the larger part of the time." I suppose I oughtn't, but I can't help putting this and that together.

THE QUEEN LAYING ACCORDING TO NATURE.

Dr. Miller when in a controversy sometimes seems to have a happy faculty of overlooking the part of a matter that might interfere with his making the point desired. Thus, in Gleanings 645, he says: "According to Bro. Doolittle, page 624, Nature's plan is to have eggs in the brood nest placed 'in the center, always.' Then when a queen varies from Nature's plan, when left to herself, by putting eggs all around the outside of the brood, Bro. Doolittle will you please tell us whose plan *that* is?" If the doctor had seen the whole matter he would have found it according to Doolittle to have

the *first* eggs placed in the center, always, and his question would have been pointless. The editor in a foot note adds two or three questions the pertinency of which, in any view, I am unable to discover.

LAPER, Mich. Sept., 20, 1898.

EXTRACTED.

FOUNDATION NOT ALWAYS PROFITABLE.

Its Use a Convenience rather than a Profit:
Deep-Cell-Foundation Experience.

The use of comb foundation is one of the live, practical topics connected with bee-keeping; and R. C. Aikin of Colorado is a live practical bee-keeper, and when he writes as clearly and sensibly upon the subject of comb foundation as he has recently in *Gleanings*, I shall esteem it a privilege to copy his writings into the *Review*. Here is the article to which I refer:—

The question of the use of foundation is one that is vitally connected with that of wax secretion. In the second and third *Musings* preceeding this one, wax secretion was touched upon to some extent. Just now, since the new product, deep-cell or "drawn foundation," is on trial, much interest is manifested in the foundation question, and possibly no better time could be taken to offer results of experiments and some opinions on the matter.

Ever since the general introduction of foundation I have had more or less to do with it. At first there was a decided opposition to its use, both on the ground of the suspicion it would create, even though used in brood chambers only, and because of the "fishbones," or tough bases, where used in section honey. I entertained grave doubts about the advisability of using it in sections, and it was a good many years before I could make up my mind that I wanted to so use it, preferring to stick to the old method of using natural-comb starters.

During the past eight years I have used many hundred pounds, principally of the *Dadant* make, and have made nearly a ton myself. I have used it in

very narrow starters and in full sheets; have had many brood-combs built on it. I have used the *Van Deusen* flat-bottomed to some extent, and have, the past season, tried the new product known as "drawn foundation," using ten pieces in which the cells were about $\frac{1}{4}$ inch deep. I am now going to give as fair and candid an opinion as possible upon this subject. I would say, right here, that the chapter on "Use and Abuse of Foundation," in *Mr. Hutchinson's* book, "Advanced Bee Culture," is about as near the truth as anything I have ever seen written on the subject.

Many years ago I made an observation hive which would take from one to three L. frames. The first real study of foundation I ever made was when I put a sheet of it into that hive and watched it develop into comb. Foundation accomplishes two things in a very satisfactory manner when carefully used; viz., all worker and straight combs. It is a very convenient article for use in sections, so handy to put in for starters. I suspect that its convenience as a starter material will go further toward maintaining its free use in the years to come than will its value as a money saver or maker. I feel constrained to take a middle ground on this question.

From my own experience and study of the matter, together with all I have read on the subject, which has been much, leads me to believe that, in the great majority of cases where foundation is used, it is thinned more or less by the bees. The amount of thinning depends very much upon conditions. The temperature, needs of comb at the time, whether urgent or not, the amount of wax being secreted, and perhaps other minor points, all have to do with the matter. I hold to the opinion that wax is secreted more or less freely at all times during a honey-flow, the quantity varying as influenced by the prospect of its need, the presence of bees of proper age, and the state of the flow of nectar.

While there seems to be but little doubt that foundation is, in the great majority of cases, thinned more or less, it remains, I think, almost an undisputed fact that comb built upon it is not by any means equal to natural comb for tenderness and fine edible qualities. I refer strictly to the quality of the comb. It is self-evident that the very quality that makes it less edible is an improvement on its shipping quality. The product is less edible only in the matter of a somewhat increased toughness and amount of wax, the taste in no way being impaired.

If it is true that wax is usually secreted in sufficient quantities to hold the honey gathered—a belief I hold to—the use of full sheets in sections can not pay, viewed from the point of the saving of honey-consumption in wax secretion. Neither can great stress be laid upon the thought of retaining bees to build comb that otherwise would field, unless we give up the generally accepted teaching that those under field age are the wax-workers. It seems that the economy of nature is such that provision has been made for all these things. The influences that bring on the honey-yielding plants also bring on the colony of bees; so that, when the flow arrives, there are in the colonies those suited to the various duties to be performed; and I sometimes wonder if we do not cease to be economical in too far departing from the natural.

As hereinbefore intimated, foundation is a very handy article; and if starters can be produced and used in this way cheaper than by natural comb, that will cause it to be used. Bees can start their own comb as well as we; but to induce the building in the place and manner that serve our purpose to the best advantage is another matter. A starter—a very narrow strip of foundation, or bit of natural comb—serves the purpose of guiding the bee; and if the use of such gives as perfect a comb as do full sheets of foundation, we come right back to the question of wax-secretion.

It is claimed that the full sheet brings a better finish; but if so, it is only a minor point among many. I shall send to the Root Co. sections built out from brood foundation, from extra thin, from half-sheets, from very narrow starters, "drawn foundation," and natural comb, all in one super, and I doubt if expert judges can tell which is which by the finish. I have believed for years, and practiced accordingly, that the strongest point in favor of full sheets in sections was the extent to which they act as bait-combs. They do have some inducement in this way. We know that a colony can build a lot of comb in a very little time when it is needed; but to determine just whether foundation is a help in any great degree is a problem very difficult to determine. There has been a great deal of haphazard guessing done; but thorough practical tests are as "scarce as hens' teeth."

To take into consideration all fields and conditions, I do not think a wholesale use of foundation in sections is profitable. Starters or guides we must have from some source; and a bit at the top, and a like one at the bottom, serve the purpose.

Some place much stress on the use of full sheets to avoid the building of drone comb, because worker is thought to be prettier. Years ago I admired a finished section of drone comb above that of worker-cells, and 'tis a fact that I did not know the worker comb was more beautiful until somebody told me so—don't even yet know it.

Now, when it comes to eating honey I will take natural comb before that on foundation, and the clear honey without *any* wax before either of the others. More than this, I find a whole lot of customers whose likes in the matter are just like mine, as to taking it with or without the wax; they are not versed on the foundation question.

As to the "drawn foundation," my own experience with last summer's limited test shows it to be no more objectionable than the old-style foundation. It "tasted" no more waxy. It looked just as nice. The bees took kindly to it, putting honey in it within 24 hours after putting on the hive. I did not watch to see if it was sealed first, but know it was not the last to be sealed. Evidently my bees used it just as they would a piece of natural comb equally developed. The flow was quite moderate, comb-building a little tedious, weather rather hot, and general conditions favorable to excellent super work had the flow been more free.

I have seen one sample of the "drawn foundation" from another part of the State where the yield was better than mine. I do not know the conditions at the time it was put on; but there was a lot of extra wax plastered on for some reason. The honey was removed from the comb, and cells broken off to the foundation. The party who tried it was disgusted with it.

Super 3 was on a strong colony that was doing good work. The finish was good considering the very moderate flow in which it was worked. This super I have sent to The A. I. Root Company just as it left the hive, together with samples of the sections from the other two supers. Notice that there were three supers on three colonies of different strength, but all worked at the same time.

Here are the numbers of the sections, and what they contained when put on the hives; and by referring to the maps you can see the position occupied. All starters less than full sheets were put in so that the short way was up and down, the most of them running clear across the top of the section. No. 1, starter of Weed extra thin, $1\frac{1}{2}$ x 2; 2, Weed thin, $1\frac{1}{2}$ x 2;

3, Weed light brood, 2 x 2; 4, Weed medium, 2 x 2; 5, 6, 7, 8, full sheets of "drawn foundation" (the new deep cell product); 9 to 32, my own make of extra-thin foundation, $3\frac{1}{2}$ long by 2 inches deep.

Super 2. Numbers 37, 43, and 49, full sheets of "drawn foundation;" 46 and 52, full sheets of heavy brood. All other numbers in this super, half-sheets of extra thin.

Super 3. Numbers 54, 55, 56, 58, 59, 60, 61, 70, 74, 75, 76, 77, 80, and 81, half-depth sheets, extra thin, with bottom starters; 57, 64, and 78, "drawn foundation;" 63, 66, 67, 73, very narrow top and bottom starters; 72 and 79, full sheets of heavy brood foundation; 69, drone comb starters, top and bottom. This is the super I have sent to Root just as it left the hive; and if he thoroughly examines it he can tell you how the different grades compare as worked in it.

The editor of *Gleanings* expresses his views as follows:—

[I will explain to our readers that this is the last of a number of articles written by R. C. Aikin last winter; but on account of its being at the tail end of the series it is a little belated.

I have spent half a day in looking over the honey; but, unfortunately, the maps and figures do not seem to tally in case of the drawn foundation, and I was therefore able to prove nothing; but as we know that the flat-base drawn foundation of last season, which friend Aikin is writing about, had thickened bases in some instances, at least, we will assume that at least a part of what he refers to came under the same objection. Drawn foundation with deep walls and flat bases is a thing of the past. Mr. Weed can now make in its stead drawn foundation with walls $\frac{1}{8}$ inch deep, and natural bases, which, as I have said before, seems to eliminate the objection of "gob" or thick midrib.

Super No. 3 contained, according to the last paragraph of friend Aikin's article, a series of sections containing half-depth sheets with bottom starters; also another series with narrow starters top and bottom. In the earlier part of the article Mr. A. thinks no one could tell the difference. As he sent the crate on to us just as it came from the hive, and as the sections stuck considerably in pulling them out, I concluded he had not previously examined it. I found that all of the sections where the greatest amount of foundation was used looked more even than the rest. There were two or three

sections of the other lot (mere starters top and bottom) that looked about as well; but there were also some among them that had almost entirely *drone* comb; and speaking of such I cannot see how any one can think it looks as neat and pretty as sections of all worker. To me it has a coarse, rough appearance. I have asked several in our office, without first giving them my preference, and they seem to be of the same opinion. I do not mean to say that nice combs can not be secured with starters only at top and bottom; but drone comb is quite liable to be built. Some little time ago, by means of plaster casts I showed that *natural-hull drone comb* is more gobby by considerable than worker comb off from ordinary thin foundation. I do not, therefore, see that friend Aikin would eliminate the trouble of thick midrib by using a scant amount of foundation. If the bees would always build *worker* comb, as they will do a great many times, then I grant that the difference will be in favor of the scant use of foundation.

There is one point that has, perhaps, never been thought of sufficiently. Mr. Danzenbaker is very particular, Mr. Weed says, to have full sheets of foundation, and those sheets *must reach clear out to sides*—that is, come actually in contact with the wood. If it reaches to within only $\frac{1}{8}$ inch, the bees will be pretty sure to make bee-spaces, or pop-holes. This is one secret of his getting such beautiful honey, Mr. Weed believes.

A good many other bee-keepers use full sheets, but there is almost a bee-space around the sides and edges; and this, according to Mr. Weed, does not give the perfect slab of honey, which we so much admire.—[Ed.]

I agree entirely with Mr. Aikin, but I *think* more stress ought to be placed upon the fact that in a heavy flow the use of foundation enables the bees to furnish storage for honey that could not be stored if comb were built naturally. To my mind this is the only, or the greatest, reason for using full sheets of foundation in sections. To my mind, drone-comb-honey is at least the equal of worker comb so far as beauty is concerned; and when it comes to a choice between naturally built drone-comb-honey, and that built from comb foundation, as regards eating qualities, the foundation stands no show whatever. I know that drone-comb

is thicker than worker-comb, thicker than the base of some foundation, but it is not wholly a question of thickness, it is one of *quality*. The gobbiness does not come from the amount of wax in comb-foundation-honey, but from its *character*. When Mr. Boardman was here we talked over this point, and he agreed most emphatically with me in the view that once comb is melted, its flaky, brittle character is lost *forever*.

Honey Quotations.

The following rules for grading honey were adopted by the North American Bee-Keepers' Association, at its Washington meeting, and, so far as possible, quotations are made according to these rules.

FANCY.—All sections to be well filled; combs straight, of even thickness, and firmly attached to all four sides; both wood and comb unsoiled by travel-stain, or otherwise; all the cells sealed except the row of cells next the wood.

No. 1.—All sections well filled, but combs uneven or crooked, detached at the bottom, or with but few cells unsealed; both wood and comb unsoiled by travel-stain or otherwise.

In addition to this the honey is to be classified according to color, using the terms white, amber and dark. That is, there will be "fancy white," No. 1, dark," etc.

KANSAS CITY.—We have several shipments of new comb honey from Florida the first of the season. We quote as follows: Fancy white, 12; No. 1 white, 11½; fancy amber, 1¾; No. 1 amber, 10; white, extracted, 5½; amber, 5; dark, 4. Beeswax, 25.

C. C. CLEMONS CO.
June 29. 521 Walnut St., Kansas City, Mo.

CLEVELAND, OHIO. The supply of fancy white honey is light, and the demand good at the following prices: Fancy white, 13 to 14; No. 1 white, 12 to 13; fancy amber, 10 to 11; No. 1 amber, 9 to 10; fancy dark, 8 to 9. White extracted, 7; amber, 6.

A. B. WILLIAMS & CO.
Aug 26 80 & 82 Broadway, Cleveland, O.

CHICAGO, Ill.—As yet very little new honey has been received. We do not expect to have the demand until small fruits are out of the market. Indications are that prices will be higher than for last year. We are in good position to take care of both comb and extracted honey; and always follow shipper's instructions.

S. T. FISH & CO.,
Aug. 17. 189 So. Water St., Chicago, Ill.

CHICAGO, Ill.—Honey is arriving freely, and is of good quality; trade is of a satisfactory nature for this season of the year. We quote as follows: Fancy white, 12; No. 1 white, 10 to 11; fancy amber, 8 to 9; No. 1 amber, 7; fancy dark, 8; No. 1 dark, 7; white extracted, 5 to 7; amber, 5 to 6; dark, 4 to 5. Beeswax, 27.

R. A. BURNETT & CO.,
Aug. 25. 163 So. Water St., Chicago, Ills.

BUFFALO, N. Y.—Owing to the liberal supplies of fruit, there is, as yet, very little demand for any kind of honey. We would encourage the shipments of small lots only, for the present. Strictly fancy white clover, 1-lb. combs, 11 to 12; other grades range from 6 to 10 cents. No demand yet for extracted honey. Fancy beeswax, 25 to 38.

BATTERSON & CO.,
Aug. 25. 167 & 169 Scott St., Buffalo, N. Y.

NEW YORK.—Our market is in very good shape for the new crop of comb honey. We have had several shipments of white comb honey from Florida, which have sold at from 10 to 11½ cents per pound. Market on Southern Extracted honey is very steady, there being a good trade for the cheaper grades. We quote as follows: Ordinary at 50 to 52 cents per gallon. Good at 55 to 60 per gallon. Florida, white, 6c. New California is beginning to arrive. Beeswax market is quiet, prices ruling a little lower. We quote pure beeswax at 26½ to 27½. Write us for shipping instructions.

FRANCIS H. LEGGETT & CO.,
July 23. W. Broadway, Franklin & Varick Sts

NEW YORK, N. Y.—Demand for comb honey is rather slow, especially for off grades, white and dark, and, as we have a large stock of these would not advise shipping for the near future. Our stock of fancy white is light and such would find ready sale at quotations. Our market for extracted buckwheat will open up shortly and we would advise bee-keepers to ship this along now. Beeswax steady. We quote as follows: Fancy white, 11 to 12; No. 1. White, 10; Fancy Amber, 9; No. 1. Amber, 8; Fancy Dark, 7; No. 1. Dark, 6; White, extracted, 5 to 5½; Amber, 4½ to 4¾; Dark, 4 to 4¼; Beeswax, 26 to 28.

HILDRETH BROS. & SEGELKEN,
Jan. 7, 120 & 122 West Broadway New York

WM. A. SELSER,

10 VINE ST., PHILA., PENN.

White Clover Honey Specialist.

JOHN F. STRATTON'S

CELEBRATED



MANDOLINS,

Importers of and Wholesale Dealers in all kinds of
MUSICAL MERCHANDISE,
811, 813, 815, 817 East 9th St., New York

THE LOSS

Of one Queen in introducing, means a loss greater than the cost of a copy of "ADVANCED BEE CULTURE," which has one entire chapter devoted to "The Introduction of Queens." It shows when the cause of failure lies with the colony, when with the queen, and points out the *conditions* necessary to success. Although one infallible method is given, but little attention is given to the setting forth of exact rules and methods; the subject being treated with a view to teaching *principles* that may be followed to success.

Price of the book, 50 cts.; the Review one year and the book for only \$1.25.

W. Z. HUTCHINSON.

Flint, Michigan.

Listen! Take my advice and buy your bee supplies of August Weiss; he has



tons and tons of the very finest

FOUNDATION

ever made; and he sells it at prices that *defy competition!* Working wax into foundation a specialty. Wax wanted at 26 cents cash, or 28 cents in trade, delivered here. Millions of *Sections* polished on both sides. Satisfaction guaranteed on a full line of *Supplies*. Send for catalogue and be your own judge. **AUG. WEISS,** Hortonville, Wisconsin.

18



98

This is the original one-piece section-man who furnishes one-piece sections as follows:—

500 sections, \$1.50; 1,000 for \$2.50; 3,000 for \$6.75; 5,000 for \$10.00; 10,000 for \$17.50.

No. 2 sections are not made to order, but when in stock are sold at \$1.50 per M.

J. FORNCROOK.

Watertown, Wisconsin.

WINTER

Losses are not always the result of the same cause. They may come from starvation; from poor food; from improper preparations; from imperfect protection; from a cold, wet, or possibly, a poorly ventilated cellar, etc., etc. Successful wintering comes from a proper combination of different conditions. For clear, concise, comprehensive conclusions upon these all-important points, consult "ADVANCED BEE CULTURE." Five of its thirty-two chapters treat as many different phases of the wintering problem.

Price of the book, 50 cts.; the REVIEW one year and the book for \$1.25. Stamps taken, either U. S. or Canadian.

W. Z. HUTCHINSON.

Flint, Mich.

Beeswax Extractor.

The only Bees Wax Extractor in the world that will extract all the wax from old combs rapidly by steam. Send for descriptive illustrated catalogue.

C. G. FERRIS,
South Columbia, N. Y.

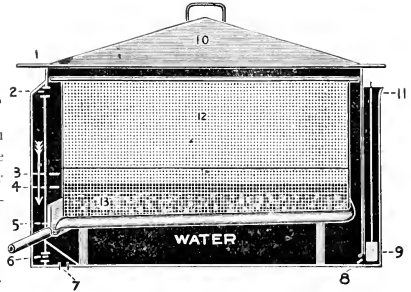

Bees and Queens

from Kansas. A really superior strain of golden Itallans. Warranted or tested queens 75 cents each; six for \$4.00; twelve for \$7.50. Full colony of bees, \$5.00.

J. W. KUHN, Belleville, Kans.
Please mention the Review.

The place to get your best **QUEENS**

is of H. G. Quirin, of Bellevue, Ohio. Ten years of experience, and the best of methods and breeders enable him to furnish the best of queens. Golden Italian, warranted purely mated, at 75 c.; after June, 50 c.; or 6 for \$2.75. Leather-colored, same price.

— If you wish the best, low-priced —

TYPE - WRITER.

Write to the editor of the REVIEW. He has an Odell, taken in payment for advertising, and he would be pleased to send descriptive circulars or to correspond with any one thinking of buying such a machine.

1898 Queens 1898

For Business—Queens for Strong Colonies—Queens for large surplus. Competition in Quality, but not in price.

If you want queens, nuclei or supplies at bottom prices, send for my illustrated price list. 12-97-11

J. P. H. BROWN, Augusta, Ga.

Please mention the Review.

Queens bred in the North are hardy and fertile. Every bee-keeper should try one of these Northern grown queens. Pure bred Italian queens at 75 cents each; or 12 for \$6.00.

WM. H. BRIGHT, Mazepa, Minn.

Please mention the Review.

To stick things, use **MAJOR'S CEMENT.** Beware!!! Take no substitute. 2-98-121

Please mention the Review.

Best on Earth. 19 Years Without a Complaint.



	Dozen	Each
Smoke Engine (largest smoker made)	4 inch stove	\$13.00—mail, \$1.50
Doctor	3 1/2	9.00— " 1.10
Conqueror	3	6.50— " 1.00
Large	2 1/2	5.00— " .90
Plain	2	4.75— " .70
Little Wonder (wt. 10 oz.)	2	4.50— " .60
Honey Knife		6.00— " .80

For further description, send for circular.

T. F. BINGHAM, Farwell, Michigan

THE AMERICAN BEE JOURNAL

10 WEEKS FOR 10 CENTS!

For *Ten Cents* THE AMERICAN BEE JOURNAL will be sent *for ten weeks on trial* to any bee-keeper not now a subscriber. (OR for \$1.00 we will send the weekly AMERICAN BEE JOURNAL to a new subscriber from Oct. 1, 1908, to Jan. 1, 1909—15 months—less than 7 cts. a month.) This is a splendid chance to become acquainted with the weekly BEE JOURNAL. Getting it ten weeks *regularly* will show pretty well what may be expected when it comes to a bee-keeper's home week after week for years.

These Special Articles Will Appear, with Others

During the ten weeks Following October 1.

General Advice to Bee-keepers.

By REV. E. T. ABBOTT, of Missouri.

Bee-Keeping in Cuba and Porto Rico.

By O. O. POPPLETON, of Florida.

Recent Progress in Apiculture.

By E. R. ROOT, Editor Gleanings.

Bee-keepers and Supply-Manufacturers.

By DR. C. C. MILLER.

Foul Brood in the Apiary.

By WM. McEVROY, Foul-brood Inspector of Canada.

Migratory Bee-keeping.

By H. E. HULL, Ed. Am. Bee-keeper.

The Scientific Side of Apiculture.

By C. P. DADANT.

Experiences and Suggestions in Marketing Honey.

By S. A. NIVER, of New York.

Needs of Bee Culture in the South.

By DR. J. P. H. BROWN, of Georgia.

Best Method for creating and Maintaining a Market for Honey

By HERMAN F. MOORE.

First Half-Century of Bee-keeping in America.

By HON. EUGENE STOR, Gen'l Manager U. S. Bee-keepers' Union.

The Apiary on the Farm and in the Orchard.

By HON. E. WILLIAMS, Supt. Apiary Dept. Trans. Mississippi Exposition.

Advanced Methods of Comb-Honey Production.

By S. T. PELLER, of Canada.

The Relation Existing Between the Apiary and the Successful Production of Fruit.

By G. M. WHITFORD, of Nebraska.

The foregoing list of special articles represents a part of the program at the Omaha convention. Many of the subjects will be followed by much helpful discussion. Of course, many other interesting and valuable contributions will be found in the AMERICAN BEE JOURNAL during the ten weeks' "trial trip," besides the other regular departments. But, in order to secure all of the above articles, the trial subscriptions should be sent in promptly, as we may soon run out of back numbers from Oct. 1.

Every bee-keeper in America ought to have the old AMERICAN BEE JOURNAL for 10 weeks from Oct. 1, 1908, and right along thereafter. It will be worth to any one of them many times its full subscription price. Send ten cents now, anyway, and get it for the 10 weeks. Address

G. W. York & Co., 118 Mich. St., Chicago, Ill.

If the

REVIEW

Is mentioned when answering an advertisement in its columns a favor is conferred upon both the publisher and the advertiser. It helps the former by raising his journal in the estimation of the advertiser, and it enables the latter to decide as to which advertising mediums are most profitable. If you would help the Review, be sure and say "I saw your advertisement in the Review," when writing to advertisers.

Page & Lyon,

Mfg. Co.

New London, Wis.

Nearness to pine and bass-wood forests, the possession of a saw-mill and factory fully equipped with the best of machinery, and years of experience, all combine to enable this firm to furnish the best goods at lowest prices. Send for circular, and see the prices on a full line of supplies.

The Usual Fall DISCOUNT

Is now allowed on orders. If you want shipping cases, crates, extractors, or anything else, write to us. Catalogue free.

Sample copy of *American Bee-Keeper* (monthly at 50 cents a year) free.

W. T. Falconer Mfg. Co.,
JAMESTOWN, N. Y.

No Fish-Bone

Is apparent in comb honey when the Van Deusen, flat-bottom foundation is used. This style of foundation allows the making of a more uniform article, having a *very thin* base, with the surplus wax in the side-walls, where it can be utilized by the bees. Then the bees, in changing the base of the cells to the natural shape, work over the wax to a certain extent; and the result is a comb that can scarcely be distinguished from that built wholly by the bees. Being so thin, one pound will fill a large number of sections.

All the Trouble of wiring brood frames can be avoided by using the Van Deusen *wired*.

Send for circular; price list, and samples of foundation.

J. VAN DEUSEN,
SPROUT BROOK, N. Y.

Violin for Sale.

I am advertising for the well known manufacturers of musical instruments, Jno. F. Stratton & Son, of New York, and taking my pay in musical merchandise. I have now on hand a fine violin outfit consisting of violin, bow and case. The violin is a "Stradivarius," Red, French finish, high polish, and real ebony trimmings, price \$14.99. The bow is of the finest - hickwood, ebony frog, lined, inlaid (pearl lined dot) pearl lined slide, German silver sheath, ebony screw head, German silver ferules, and pearl dot in the end, price \$2.50. The case is wood with curved top, varnished, full-lined, with pockets, and furnished with brass hooks, and latches and lock, price \$3.50. This makes the entire outfit worth an even \$20.00. It is exactly the same kind of an outfit that my daughter has been using the past year with the best of satisfaction to herself and teachers. Her violin has a more powerful, rich tone than some instruments here that cost several times as much. I wish to sell this on fit, and would accept one-half nice, white-extracted honey in payment, the balance cash. It will be sent on a five days trial, and if not entirely satisfactory can be returned and the purchase money will be refunded.

W. Z. HUTCHINSON, Flint, Mich.

G. M. LONG, Cedar Mines, Iowa, manufacturer of and dealer in Apiarian Supplies. Send for circular. 1-96-6

Please mention the Review



THE STRATTON
American
GUITARS & MANDOLINES

THE HANDED BY ALL THE LEADING MUSIC STORES
Oak Ash Brocade Maple Mangony and Rosewood.

JOHN F. STRATTON & SON,

Manufacturers and Retail Dealers to all Cities

Musical Merchandise.

63 & 40 Walker St.

NEW YORK

Holy Land QUEENS. Golden Italian

The best that knowledge and ten years' of experience can produce.

Untested Queens.	One	Six	Twelve.
In June, July, Aug., Sep.,	75	\$1.25	\$3.00
All other months,	1.00	5.00	9.00
Tested Queens,	1.50	8.00	15.00

E. R. JONES.

3-98-121

Milano, Texas.

QUEENS

Rared from imported mothers, bred from pure mated, 75 cents each. Breeders, No better stock to be had at any price. Send for catalogue of queens and bees. DEANES & MINER, Ronda, N. C.

Make Your Own Hives.

Bee-Keepers
Will save money by
using our Foot Power
Saw in making
their hives, sections
and boxes.

Machines on trial.
Send for Catalogue.

W. F. & J. O. BARNES CO.,

384 Ruby St.,

Rockford, Ills.

6-97 121

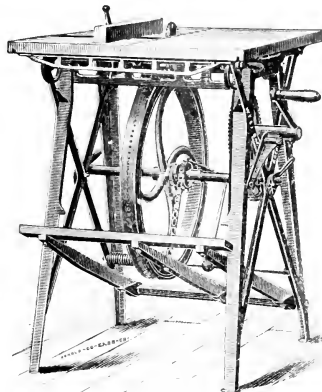

Dovetailed Hives.

Cowan Extractors.

Danzenbaker Hives.

Porter Bee-Escapes.

No-Drip Shipping Cases.

Gleanings in Bee-Culture.

The Fence and Plain Sections.

OUR

SPECIALTIES.

Weed New Process Foundation.

Root's



Goods.

Catalog of goods and sample of Gleanings sent for your name on a postal.

The A. I. ROOT CO., Medina, Ohio.

Branch Offices :

118 Michigan St., Chicago, Ills.

1024 Mississippi St., St. Paul, Minn.

1635 W. Genesee St. Syracuse.

10 Vine St., Philadelphia.

Mechanic Falls, Me.

Without Stopping

the machine to reverse the combs is the way you can work with the Williams Automatic

Honey Extractor.

Such an extractor will save you time and annoyance and it does not cost much more than an ordinary machine. Send for descriptive price list.

Read what the famous bee-keeper, N. E. France, says:

PLATTEVILLE, WIS., July 5, 1897.
Dear Sirs: To day I extracted 2,780 lbs. of honey with your Automatic Honey Extractor in 5½ hours and could have done the same this afternoon but let the boys go to the city to play a game of base ball. I've extracted 27,435 lbs. so far with good prospects for as much more. My bees and State work keep me very busy. Hope to see you before very long will write you later.
Yours truly, N. E. FRANCE,
State Inspector of Apiaries,
Platteville, Wisconsin.

We can also furnish choice queens, either golden or leather colored Italian, at 75 cents each, or two for \$1.40.

Van Allen & Williams,

6-9S-1f.

BARNUM, WIS.

The No-Drip Shipping Cases

Are what you need in marketing your honey. They are clean, neat and convenient, and a great help in making sales.

Root's goods at Root's prices. Cash paid for wax. We want your trade.

M. H. HUNT, Bell Branch, Mich.

*Please mention the Review***COMB****FOUNDATION****WHOLESALE AND RETAIL.**

Working wax into foundation, for cash, & sp. candy, Hives, Sections, and a full line of Supplies. The best of everything. Write for Catalog, with prices, and samples of Foundation and Sections. Beeswax always wanted for cash or trade.

GUS. DITTMER,

10-97 121

Augusta, Wis.

The A. I. Root Co.'s Goods, **WHOLESALE AND RETAIL.***Please mention the Review*



The old Home of two Lady, Pioneer Bee-Keepers.

The Bee-Keepers' Review.

A MONTHLY JOURNAL

Devoted to the Interests of Honey Producers.

\$1.00 A YEAR.

W. Z. HUTCHINSON, Editor and Proprietor.

VOL. XI. FLINT, MICHIGAN, NOVEMBER 10, 1898. NO. 11.

THE SUCCESS OF TWO WOMEN WITH BEES.

Also a Charming Picture of Pioneer Life in
Northern Michigan.

W. Z. HUTCHINSON.

This is the forest primeval. The murmuring pines and the hemlocks.—LONGFELLOW



SOMETHING more than a dozen years ago, when I first began the production of comb honey, and my brother Elmer was working with me in the apiary, the late Dr. Whiting of Saginaw wrote

me that two ladies in the northern part of the State had some bees that they would sell upon very reasonable terms. It was then nearly the middle of June, and I went at once to their home. It stood in a good sized clearing; but, as I gazed at the forest that rose upon every side, there came to me over and over the opening line of Longfellow's *Evangeline*, that I

have placed at the head of this article. We went out to the old, vine clad log house, with its surrounding shade trees, grape vines, and grassy hillsides, the spot that had once been, in reality, a pioneer home; and, as I walked down to the foot of the farther hill, then turned and looked back at the seventy or more colonies of bees nestling on this sunny, grassy slope, and took in the back ground and surroundings, I said to myself "How picturesque!" How I wish I had a picture of it." Little did I dream then that sometime I should visit this spot with a camera (as I did last summer) and that I should have a cut made and put it in a bee journal published by *myself*. Things turn out so strangely, so wonderfully, sometimes, in this world of ours.

Of course, our frontispiece this month is a view of this relic of pioneer days. It should be explained that the owners are now practically out of the business—the five colonies shown being all that they possessed at the time of my visit last summer. Naturally, my readers will have a curiosity to see a picture of the house that is now the home of these ladies, and, as I see no objection to gratifying that curiosity, the accompanying picture is given. It would sound more story-like if I could say that the new house was built from

the proceeds of the apiary; but I happen to know that such isn't the case. This does not alter the fact, however, that these ladies have been very successful in keeping bees. I, myself, from first to last, have paid them several hundreds of dollars for bees. The honey that they produce is certainly as fine as any I have seen. They use the Doolittle hive and white popular, nailed, two-pound sections. Separators are used and the sec-

could be easily turned back, or else the ordinary broad shade-board was used instead.

At my most earnest and repeated solicitation, one of these ladies has consented to write a few lines descriptive of those pioneer days; and you little know with what pleasure they are appended.

OUR log house—christened "Forest Home" by our dear father, at the "rais-



PRESENT HOME OF CYCLA LINSWIK AND HER SISTER.

tions are scraped scrupulously clean with pieces of glass before the honey is crated. They have also had most excellent success in wintering their bees packed in chaff. One special feature should be mentioned. The cover to the hive is removed and a cap filled with chaff substituted. In the top of this cap is cut a hole nearly a foot square. This allows all moisture to escape. To prevent mice from entering, these holes are covered with wire cloth. To keep out the storms there is a rough roof over each hive. This roof is also used in summer as a shade. I believe that when there were more bees kept the roof was hinged and supported so that it

ing" to which had been summoned all the neighbors within nine miles—is thirty years old this fall. On the 6th of next February, at high noon, it will be thirty years since my sister and I caught our first glimpse of it through tall trees as we neared the end of our journey into the woods; a journey by rail from Central New York to Ingham Co. Mich., and thence, under the care of a relative, a drive of over one hundred miles north to the unorganized township of ———, in the unorganized county of ———.

The first year was strictly pioneer life. A visit to the Post Office meant a twenty mile trip over a road that for eight or nine

miles wound in and out among the trees, and for the whole distance was unspeakably bad. During the first winter the footprints of wolves were seen in our vicinity; and once, at midnight, we heard a howling pack sweep by the corner of the clearing. Bears were often seen; but it so chanced that we never had the pleasure of meeting one in the botanizing rambles which were almost the only recreation of our first summer. Once, sister walked a mile and a half to our nearest neighbors, spent the night there, and then in company with her hostess walked seven and a half miles—passing on the way but two small clearings—to the home of a neighbor who had invited them to spend the Sabbath with her, and listen to preaching at the log school-house near by. And, to their sore disappointment, the preacher did not come!

The second year was made memorable by the building of the F. & P. M. R. R. through our section of country; an event which materially changed the situation for the better. Our mail now came in care of Messrs. B. & P., contractors, to their store on the line, where also provisions could be purchased, and all the surplus produce of the clearing disposed of at fair prices.

Early in the third year—the railroad then being completed to some point west of us—a village was located within a mile of our place; a village of great expectations and many unfulfilled prophecies. The enterprising people who then began to come in by rail, called themselves pioneers—but for us, the *true* pioneer stage had passed. Pioneers?—with a railroad station almost at one's door! Nevertheless, apart from the narrow line of railroad, the country was then an almost unbroken wilderness, and remained a new country—a *very* new country—for many years. Indeed, certain Eastern friends who visited us in 1893, seemed to think it sufficiently new and unkempt at that late date. It is even possible that the editor of the Review may consider it a new country to day!

But during the summer of 1871, and for two or three seasons later, deer were sometimes seen, in the early morning, feeding in our clearing; and bears were often met in the vicinity; and the forest itself—the great primeval forest—still stood close about us and stretched away to the north untouched and unwasted. But its hour had struck! The advancing railroad was followed close by the lumberman; and ravaging fires came soon in his wake.

In December 1871, there appeared in the New York Tribune an interesting report of the meeting of the American Bee-Keepers' Association at Cleveland.

Glancing it over, my attention was arrested by the fact that two ladies took a prominent part in the proceedings; and that they recommended bee-keeping as pleasant and profitable employment for women. Correspondence with these ladies ensued, advice was asked, received and acted upon, with this result: early in May, 1872, I became the happy possessor of a colony of Italian bees, which had cost me only \$25.00, plus nearly \$5.00 express charges. When, in June, my sister came home from a six month's visit with a brother in the South, she became my efficient helper and full partner in the enterprise.

We began with no knowledge whatever of bee-keeping; nor had we a bee-keeping friend or acquaintance. The Italian Bee Co.—Mrs. E. S. Tupper and Mrs. Annie Savery—of whom our bees were purchased, had recommended to us a small text book and a monthly bee-journal partly devoted to Agriculture. As the publishers of this journal did not advertise rival publications nor give the address of correspondents, we were shut out from access to the bee-keeping fraternity. Still, much of our text-book's teaching was good, and often the paper contained interesting and valuable articles from the pens of writers of repute. Perhaps it was as well that, for our first year, we were not too much distracted by opposing counsels, even at the price of some mistakes,

Early in the year 1873, at his office in Saginaw, I met the late Dr. L. C. Whiting, and learned, from some chance word, that to the duties of his profession he added the pleasures of bee-keeping. During the remainder of that sitting every opportunity for articulate speech on my part was filled by a question. I think Dr. Whiting recognized it, compassionately, as a case of bee-fever in the acute stage; for, in addition to the kindly patience with which he answered all my queries, he quite overwhelmed me with gratitude by offering to loan me a bound volume of the American Bee Journal. It was, I think, the first volume after the interruption in publication made during the war. As I turned its pages at home, I could scarcely believe in my good fortune: That a stranger from the remote backwoods should have been trusted with such a treasure! It was our *open sesame* into the bee-keeping world.

We soon had in our possession the works of Langstroth and Quinby, while the American Bee Journal, the Bee-keeper's Magazine and Gleanings—we began with the first tiny copy of the latter—were regular visitants.

And thenceforth how we studied, and experimented, and rejoiced over our bees. Ah me! That such enjoyment cannot last: That the enthusiasm must die out, leaving only a faint thrill at the memory thereof—the memory of those early days when the bee-yard was a charmed spot—a refuge from loneliness, despondency, even one's own bad temper! And later, when we had more work than play in the apiary, it was still enchanted ground; a place where one could forget the dinner hour (if there chanced to be a maid in the kitchen), forget the temperature (with the mercury in the nineties), and be totally unmindful and unconscious of extreme weariness—until nightfall and a summons to the supper-table made it only too apparent.

It would have been *pleasant* employment to the last, had health and strength remained equal to its demands; but there

came a time when we thought best to recognize the need of almost total abstinence from the bee-yard. For several years we have aimed to begin the season with no more than two or three colonies, and to give these the least attention possible; without a murmur to let swarms escape and go to the woods; and to cheerfully put off till to-morrow, or next week, or next month, even, the removal of sections which should come off to-day.

Did we find our bee-keeping profitable employment?

That depends; if you mean something more than modest wages for time and labor spent—no!

But if we may count as gains returns which cannot be measured in dollars and cents—yes!

Nov. 3, 1898. CYULA LINSWIK.



FENCE-SEPARATORS.

An Explanation in Regard to a Misunderstood Article.

J. A. GOLDEN.



If the October Review is a fair sample of what is to follow, it behooves the correspondents of our bee-journals to use greater care in preparing articles for publication. For my part, I hail criticism with delight so long as it is kind and reaches from the highest to the lowest—the rich and the poor alike.

I am glad that Mr. Taylor criticised my article describing the experiments with separators; as I presume that others took

the same view that he did; and I can now explain. That photograph was taken at the request of Mr. Root with a view to show the difference in the filling of the sections with the different kinds of separators in use. I could see scarcely any difference in this respect, but I did notice that there was a difference in the color, and called attention to it, but did not intend to convey the idea that the style of separator used had anything to do with the color of the honey.

REINERSVILLE, Ohio, Nov. 1, 1898.



THE BUILDING OF DRONE COMB.

Do Bees Without a Fertile Queen Invariably
Build Only Drone Comb?

I. W. BECKWITH.

THIRTY years ago I was taught that this question should be answered in the affirmative; and as nearly as I now remember, in years past, they did; although I never experimented for the purpose of proving it, but always tried to avoid allowing queenless colonies to build comb, and am not sure that I ever noticed any comb that they had built.

Langstroth Revised, page 103, says "If the queen of a swarm is removed, or dies while the bees are building, all the combs made during her absence will consist of drone cells." On page 239 it says "It is one of the laws of the hive that bees that have no mature queen seldom build any cells except such as are designed merely for storing honey, and are too large for rearing workers."

Now, I would like to know if my experience during the past season has been entirely exceptional, or have other writers on the subject all been mistaken? Last summer I noticed that some queenless colonies were building straight worker

comb; and so universal was this that when I divided the colonies I allowed each queenless part to raise a queen from the brood I gave it, and to build comb to fill the hive while she was maturing. Very few built any drone comb, and those but little, unless they were *hopelessly* queenless. My bees are three banded, with a little mixture of five-banded.

Dadant says the builders prefer making the large sized cells, and almost invariably build that kind except when the queen is depositing eggs in the cells close to the builders, and so superintending their work, and then there will be no drone comb built. He also says the queen dislikes to lay in the large cells, and only does so when there are no others at her disposal.

Here, again, my experience is at variance with that of that writer. Wherever I put an empty comb in the brood nest at the height of the breeding season, I find that any patch of drone cells that it may contain are first utilized by the queen. I fill the sections with drawn comb before putting them on the hive, and when one contains drone comb, and there is but little below, I have known the queen to go above and fill that comb and then return without disturbing the other sections. So, from these observations, I conclude that the queen does not lay either kind of eggs simply because it pleases her best to lay that kind, but because instinct prompts her to lay the kind that best suits the interests of the colony.

Dadant also says "If all, or part of the store combs of a hive are removed, the bees will rebuild large cells, at least three times out of four." This last statement is the reverse of all my experience with bees. Whenever I want some comb built, I usually remove most of the combs from a populous colony, and it is always replaced with the small sized cells.

I think the experience of bee-keepers generally is about the same as mine in these last two cases; but, if my experience is exceptional, or if I have been mistaken in any of these points, I should be glad

to know it; and it would be to the interest of the bee-keeping fraternity to be set right.

LANDER, Wyoming, Oct. 4, 1898.



SEPARATORS.

They may be Dispensed with if the Conditions are Right.

H. R. BOARDMAN.



FRIEND Hutchinson, you may remember that, as we sat in the hammock at your place and talked bees that beautiful evening, we discussed, among other things, the use of separators. I may have appeared a little intolerant then about the advisability of dispensing with them. If so, I am sure that it was partly, at least, the result of prejudice, as my knowledge came more from the reports of others than from actual experience or observation. I was greatly surprised in my visits among the bee-keepers of your State to find that so many progressive, practical men had dispensed with separators. I had supposed that that practice was about obsolete. Many of the lots of honey that I saw compared favorably with that produced with separators. That the most perfect honey possible can be produced without separators I have had the most positive proof. Some of the claims in favor of laying aside separators are, I must admit, worthy of consideration. There is a freer communication; just as the fence separator gives a freer communication, so no separators at all gives still better communication. That there is an economy in fixtures calls for no argument. Whether honey built without

separators is more attractive than that built with them is a point for the doctors to decide; but sections filled with no separators between them certainly have a more plump appearance. Seven-to-the-foot seems to be the best width to use when no separators are used. Slipshod or careless bee-keepers better cling to the use of separators, but thoughtful and careful apiarists may dispense with them.

EAST TOWNSEND, Ohio, Oct. 10, 1898.

[Friend Boardman, this is one of the questions in which locality plays a most important part. I have used separators just enough to find out that we do not need them here. It is not so much a question of skill. The first 1,000 pounds of comb honey that I ever produced was sent to Cleveland, to Mr. A. C. Kendall. It was raised without separators, and when I wrote to Mr. Kendall and told him how it was produced, he was greatly surprised—if I had not told him he would have thought that separators were used. Separators are needed where the flow is slow, or comes on slowly. Then the bees begin work in the center of the super and gradually work towards the outside. They are loth to commence on a new comb, so the one they are working on is bulged and drawn out as far as possible. At last they must begin on the next; and then that must be bulged to correspond with the preceding one; and so it goes on until the last section is reached. Here in Michigan the flow from clover or basswood usually comes on suddenly, and the bees are soon at work in every section; and the result is that all of the combs grow at the same time, and are alike as so many bricks. I do occasionally get a bulged section, but there are so few of them that can not be crated satisfactorily, that they are all used in our own family or sold to neighbors. If I found it necessary to use separators I should most assuredly use them, as I do not approve of the putting of bulged combs upon the market.—ED.]

THE SIZE OF HIVES.

Also Something About Sections, the Selling
of Honey and the Wintering of Bees.

T. M. STEVENS.

HERE is no such thing as the making of a standard size of hive or brood nest for all parts of the country. The conditions are too varied. Here in the East we use an eight-frame Langstroth hive. The season is so short that if we used a larger hive the main part of the surplus would be stored in the brood chamber. Where the season is longer, or the flow comes in the fall, a larger hive may be all right.

Just as we had all settled down to the use of sections with bee-ways, out come the plain sections with fence separators. After a bee-keeper has got all of his fixtures, and become accustomed to their use, he does not like to throw them away and be to the expense of getting something new every few years. I am well enough satisfied with the sections as I have them now. I fill them full of thin foundation, and the combs are built out full and smooth with very few holes at the sides.

I sell all of my honey direct to the grocery stores, or to the White Mountain hotels. I carry it to them in July and leave it with the understanding that I will take back what is not used. I very seldom have to take any back—oftener they want more. After a man gets a trade established, and gives good honey, there is no trouble. I have sold all of my No. 1 honey this year for 15 cents and my fancy at 18cents. There was a good crop this year, and honey is lower than usual. Other years I have gotten from 20 to 25 cents for a pound section, and that without weighing.

I winter my bees on the summer stands, packed in buckwheat hulls. As I have said, I use the eight-frame, Langstroth hive, and I set the brood nests on end for winter; and the arrangements are such

that there is ventilation at both top and bottom of the brood nest. The packing is from two to four inches in thickness. It is very cold here winters, the mercury sometimes going down to 20 30 or degrees below zero, yet my bees come out in good condition.

LITTLETON, N. H. Nov. 7, 1898.

Bee-News From
Over the sea.

Translated From Foreign Bee Journals.

BY E. L. THOMPSON.

As cold waters to a thirsty soul, so is good news from a far country. BIBLE.

QUERY 78.—What makes one colony, if left to itself, build more drone-comb than another? Or, what induces a colony to build drone-comb, and what to build worker-comb?

2. Is a swarm of bees one organism, or is it a crowd of organs—self-sufficient beings?

3. What do you think of the organic conception of the honey-bee?

4. As the larvae need different food during the time of their growth, how do the nurse-bees make the change, and how do they know how to make it at the proper time?—German. American Bee Journal, page 476.

For a taking medley of helplessness and assurance, with a little pertness to help out, see some of the answers to the above. The question was a strange one to ask, to be sure, in view of the very little that has been said of the "organic conception" in America, so that it is practically unknown here; but several of those who replied seemed to think their time had come to show an admiring public that *they* weren't any of your impractical theorists—o-ho no—and so proceeded to show their paces, unconscious that

their neighbors were going through the same motions. Display this prancing crowd but once a year, respected American Bee Journal, and we will not ask for a joke department. Thus, Dr. Brown, who certainly should have the prize as the champion high kicker, says, "These questions more particularly concern the ethereal [sic] biological, metaphysical [sic] and theosophical [sic] minded bee-keeper than the real honey producer." And doctor Miller throws this sop to the Philistines: "2. and 3. I don't believe we better [sic the purist] fool with such things this side of the water. Wait till they settle it in Germany." Beg pardon, doctor, but that remark is just talkee, talkee. Have we not recently been edified by an instructive discussion on stings and spiracles? And are Americans less scientifically built than Germans? Shades of Gray and Cope! And this brings to light a startling omission. No Straw has yet appeared, showing the utter folly of printing such articles as those of Mr. Crane on heredity. And why was not Mr. Heddon used as a floor-mop when he went back to evolution to support his non-swarming plans? Hasty, too, and Aikin, and several others, have dared to go back to first principles in discussing the swarming question. Decidedly, bee-literature needs renovating. Mr. J. A. Stone remarks "4. By the instinct that God has given them—and in no other way;" and a number of others refer to "instinct," apparently under the impression that they are explaining something. "Instinct" has long been recognized as a mere name, or device, by which to refer to certain phenomena for the sake of convenience. This class of authorities has scant sympathy with Lear's attitude—"First let me talk with this philosopher. What is the cause of thunder?"—but let them beware lest some Franklin arise to discomfit them and preserve his reputation for piety at the same time. As to the importance of discussion, a reference to the swarming problem alone ought to suffice, let alone that of breeding. There

are two methods of discovery—one empirical, one rational. Edison's work shows the equal importance of both. To ignore either one means the expenditure of much fruitless labor.

Most of those who replied to the first question were satisfied with empiricism; but Mr. R. L. Taylor, in addition, has favored us with a theory, as follows: "When a colony realizes that it may soon be necessary to rear a new queen, it is anxious first to provide drones and so builds drone-comb." If this means anything, it means anthropomorphism—human standards and motives. A drone, then, is the very incarnation of knightly valor. If the workers foresee, why may not the drone foresee too? Yet out he goes to find a queen, though his success means his death. A cow in heat merely indicates thereby that she is anxious to do her part in preserving the species; etc. Delightful simplicity of the universe!

DIE DEUTSCHE BIENZUCHT IN THEORIE UND PRAXIS.—"German Bee-Culture in Theory and Practice"—so runs the full title of the paper published and edited by the author and promoter of the theory of the "organic conception of the colony," Pastor J. Gerstung, of Ossmanstedt, Thuringen, Germany. From a reading of this paper I infer that Gerstung would probably answer the first and fourth questions by saying that one colony builds more drone-comb than another, or part drone and part worker comb, or secretes different kinds of brood food, for reasons precisely analogous to those implied in the words "First the blade, then the ear, then the full corn in the ear"—an orderly succession of physiological conditions as those of simple growth, the existence of which entitles the colony as a whole to the designation "organism." The reaction of these conditions he calls "impulses," such as the building impulse, the drone-rearing impulse, the swarming (reproductive) impulse, etc., each occurring when the need for it exists. That which we blindly call "instinct" is thus physiological, just as a

bird would seek to mate, or a stalk of wheat to form a head. By thus removing the ultimate mystery one step farther back, he parts neither with modern science nor with common sense.

It would astonish those who replied to the foregoing questions to learn that claims of great immediate practical value are made for this theory and system; another illustration of the darkening of counsel by words without knowledge. Certainly the contributors and the editor of "Die Deutsche Bienenzucht" are sane and sound enough when speaking of practical matters, from the German point of view; thus making it possible that their practical applications of their theory may not be entirely unworthy of regard. But from any authoritative judgment on this point I must retire, as gracefully as may be, not having read Gerstung's books. I incline to the opinion, however, that a long practical experience, such as that of Gravenhorst, would enable one to build up colonies just as quickly, and get just as much honey, as the most painful regard to the principles of the development of the colony; only, it should not be forgotten that the study of those principles may shorten the road to skill, rendering more easily available the necessary training of experience. But even if this were not so, it is so easy to waste energy in wrestling with swarming and breeding, which absolutely demand some kind of a theory to work on, that anything which promises to lead us to the right theory is worthy of the most respectful attention.

"CAN WE ASCRIBE PSYCHICAL QUALITIES TO BEES AND ANTS?" is the title of a small book by Albert Bethe, published at Bonn by Emil Strauss. Extracts from the editor's review will incidentally illustrate his opinions: "An interesting book for every one who adopts not only the pocket-book or honey-pot point of view of nature in general and bees in particular, but seeks *in minimis maxima, i. e.*, in the vital phenomena of the smallest creatures, eternal formative laws for the whole organic world. Our readers know

that this standpoint has always been ours. It is also very gratifying that, in this book, a man of exact science wholly adopts the collective conception of social insects, which we were the first to apply to the bee-colony, in opposition to all bee-keepers of the old school, and against the anthropomorphic presentations of Buechner, Romanes, and others." Romanes, as is well known, made a list of all human passions which in their entirety constitute what we call the soul, and found clear and decided manifestations of each one among animals, some of the higher animals possessing many of them. It is not clear, though, why there should be any inconsistency in accepting both factors—the reflex and other physiological influences, and the ability to learn and remember through feeling and passion; man himself, especially in infancy, being subject to the former. Rather does it seem reasonable that through all animal nature runs a varying proportion of the two. For, to go still farther back, it is now eleven years since Prof. Ladd, our chief American authority in physiological psychology, admitted that the immediate causes of the operations of the soul, through the brain, were physiological and mechanical. Yet he was, and is, as orthodox as could be desired. —Gerstung continues "The aim of the book is then, to scientifically prove that the apparently so complicated vital phenomena of ants and bees are to be ascribed to and satisfactorily explained by very simple causes, mostly of a physiological nature (reflexes). We accompany the author with pleasure in his investigations up to the point where he declares that the explanation of biological facts by means of mechanical laws shuts out every other explanation; for example, that of creative activity. Not because we are a theologian, but because we can not also explain the harmonious combination of all mechanical laws and their purposeful adaptation to service, do we firmly believe that the mechanical explanation does not shut out the teleological-deistical one,

but furthers and includes it." I commend the foregoing to the attention of Mr. Doolittle and the American Bee Journal. Mr. Doolittle's reading ought to have taught him that evolution is accepted by the more intelligent members of the clergy, both Catholic and Protestant, and that that stronghold of orthodoxy, the Chautauqua Circle, expressly teaches it in its text-book of Geology. I would like to ask Mr. Doolittle, or any one else, how mechanical laws, either singly or in combination, (for Gerstung is too fearful here) are any less mysterious than vital ones, and how their contemplation in that light, shutting out as it does *anything* which we can account for short of infinite power, does not unspeakably widen our conceptions of the Creator. Evolution, by the way, is the necessary basis for the "organic conception of the colony." Thus the American Bee Journal, as was to be expected, after issuing a solemn pronouncement against such subjects, turns right around and prints them again.

The reason for the rearing of drones, as stated by Dr. Dzierzon, and accepted by every one in Germany until the birth of the "new school," is that while colonies can not foresee the opportunity for swarming or queen-rearing, they do foresee its possibility—thus crediting bees with foresight and calculation. In like manner, drones are said to be destroyed because the colony foresees winter, when the drones if kept would eat up all the colony has stored. The editor states the position of the "new school" to be, that drones are the result of a surplus of albuminous matter in the brood food. Worker brood needs on the average 40.62 per cent. of albuminous matter, drone brood 43.79 per cent., and queen brood 45.14 per cent. The percentage of this in the brood food is influenced by the flow and the age of bees. The lack of this surplus causes the destruction of drones. A number of other items from this paper I must reserve until next time.

MONTROSE, Colo. Aug. 10, 1898.



EDITORIAL offerings.

THE REVIEW has twenty-seven subscribers in the little island of Jamaica.

"R. L. TAYLOR'S articles are all right; although they would please me better if he would criticise ideas rather than the language in which they are expressed." This is the way one of my correspondents puts it in a private letter.

TROUBLE comes to us all. Mr. and Mrs. Thos. W. Cowan of England are called upon to mourn the loss of a son and daughter who lost their lives last month in the wrecking of the Atlantic Liner, Mohegan.

THE BUSY BEE has changed its name and character to The Model Farmer and the Busy Bee; raised its price to \$1.00 a year; and will hereafter come weekly instead of monthly. It starts out well, and I hope that Bro. Abbott will make a success of it.

THE AMERICAN BEE JOURNAL is giving a most excellently reported account of the Omaha convention. I think it is as good a report of a convention as I have ever read. If you are not a subscriber to the Journal, better take advantage of the offer on the first page of the Review and get this report.

EXPERIMENTING ON TOO SMALL A SCALE.

I have several times advised my readers to try new things first upon a small scale. If they proved satisfactory, then they could be adopted on a larger scale. My friend C. P. Dadant criticises that position on the ground that small experiments are not always conclusive. Mr. Heddon takes the same position. I have heard him argue against small experiments. "You don't catch me that way;"

I have heard him say, "when I make an experiment I make it upon a large enough scale to give it some value." There are two sides to this question, as there are to most questions. Some facts can be determined by small experiments; others need large experiments upon a large scale; and several times repeated, at that. The point I would make is this: It is not advisable to adopt a new plan or invention, about which there is any doubt, upon a larger scale than that upon which you can afford to meet with failure.

THE ONTARIO BEE-KEEPER'S ASSOCIATION will hold its annual meeting in Guelph, Dec. 6, 7 and 8. The Guelph Fat Stock Show and the Guelph Pet Stock Show and the Experimental Union will all meet at the same time in Guelph. Owing to these attractions, a large meeting is expected, and a cordial invitation is extended to all bee-keepers to attend. The editor of the Review accepts the invitation and will try and be there.

CONTACT with our fellow mortals has a wonderfully brightening effect upon our minds. To visit those in a business like our own helps us more than we would have dreamed possible. Mr. H. R. Boardman of Ohio had no honey crop last season, the first time he has failed in years, and he took a trip up here in Michigan to see if he could learn something to his advantage. At the end of an account of this trip, given in *Gleanings*, the editor says:

"There is nothing, I think, that so broadens the mind of a bee-keeper as to go out among his fellows. I have learned more by coming in contact with bee-keepers, and seeing and comparing their ways and methods for a few hours, than I have learned in months of time among our own bees."

One thing that has helped greatly in making *Gleanings* the success that it is, is that its editors have made frequent and extensive trips among bee-keepers. Even attending a bee convention is a

great help. I have often noticed how some journal has brightened up for an issue or two after its editor has attended a good convention.

USING THE BLUE PENCIL.

From two or three sources there has been urged upon me the freer use of the blue pencil—that is, the marking out in correspondence of matter that I think ought not to appear. Some, if in the editorial chair, would even go so far as to mark out matter with which they did not agree. If a man is to do this he might as well dispense with correspondents, and let his paper be all editorial. If there is one thing in which I take a pride it is the fact that the columns of the Review are always open for every one to express their views freely, so long as respectable language is used. Except in correcting grammatical errors, the blue pencil is seldom used. I always like to let a man's article go in exactly as he has written it. To mark out this, and mark out that, seems, to me, a sort of reflection upon the writer. It seems like saying "You don't know what you ought to say." Before taking such a liberty I almost always write to my correspondent and suggest certain changes, giving my reasons. If he then sees the matter as I do, well and good.

TO WHAT EXTENT SHALL THEORIZING BE ALLOWED?

When I began publishing the Review I had some very definite ideas as to how it should be conducted; in fact, I believe I printed a sort of platform upon which the Review was to be built. I am still inclined to follow the rules that I then laid down; or, to be more exact, I still think they are pretty good rules; but eleven years of experience as an editor have taught me the folly of being too closely bound by rules. One of those rules was "not to waste space in the discussion of fine-spun theories that may be interesting but have no practical bearing upon the

bread and butter side of bee-keeping." I think this rule a good one, and the only difficulty is in always deciding whether the matter under discussion has a practical bearing or not. That which at first appears simply a theory, with no practical application whatever, sometimes leads to very important results. For instance, this matter of *why* bees build drone comb and of the "organic conception of the colony," of which Mr. Thompson writes so readily in this issue, may be of more importance than now appears. If we could learn exactly why bees build drone comb, we might possibly be able to in some manner so change the condition as to prevent it, and thus bees could be allowed to build their own combs in the brood nest without the use of foundation, which could often be done at a profit. Theorizing is all right, but let us try and keep practical ends in view as much as possible.

POSITIVENESS—CRITICISM—COURTESY.

As I read some of the reflections cast upon Mr. Taylor because of the positiveness of some of his assertions, there came to my mind a little verse that I remember to have read some time ago. I do not remember where I saw it, nor who is its author, but I will give it as nearly as I can recall it.

He who knows not, and knows not he knows not, is a fool; shun him.

He who knows not, and knows he knows not, is ignorant; teach him.

He who knows, and knows not he knows, is asleep; wake him.

He who knows, and knows he knows, is wise; follow him.

Men of the latter class are most earnestly desired as correspondents for the Review; those who "know and know they know." At the same time it must not be forgotten that there are different ways of telling what one knows. Knowledge, of the accuracy of which one is absolutely positive, if imparted with an air of superiority, often arouses resentment instead of gratitude. To be able to point out the ignorance or fallacious ideas, of a friend, with such tact that he seems to have discovered them himself, to start in his

mind a train of reasoning that will lead him to a correct conclusion, to thus bring out the best that is in him, is an accomplishment worthy of great effort. One can be positive and outspoken, and yet courteous.

DO FENCE-SEPARATORS AFFORD BETTER VENTILATION?

Mr. O. O. Poppleton of Florida sends in what he calls "One wee, small criticism of Critic." It reads as follows:

On page 313, Critic, in criticising the idea that fence separators give better ventilation than do other kinds of separators, asks: "How can it give better ventilation? Would an empty wicker chair standing in a room give better ventilation to the room?" Now I have had but little experience in producing comb honey, but all the separators I have ever seen could much more truthfully be compared to the partitions in a house instead of to any small piece of furniture therein; and it does make very much difference in the ventilation of a room whether the partitions surrounding it are made of open wicker work or of some tight, close material.

I must admit that the illustration of Mr. Taylor does not *appear* to be a very good one, while that of Mr. Poppleton seems a fair one. Mr. Root, of Gleanings, uses a similar illustration when combating the views of Mr. Taylor. Mr. Root also uses another illustration, that of the open manner in which lumber is piled in dry-kilns, that the hot air may circulate more readily. All this sounds reasonable, but I fear it does not go far enough. We are forgetting that the sections filled with combs extend from the very top to the very bottom of the super; thus shutting off all ventilation or circulation that does not pass either above or below the sections. In other words, the sections themselves, when full of comb, are more complete dividing walls than solid separators that do not usually quite reach to the tops or bottoms of the sections. Perhaps the "room" Mr. Taylor had in his mind was the space between two sections of honey, and not simply the whole super. In that case his illustration is not so bad. My

own opinion is that the style of the separator has precious little to do with the ventilation of the super. I think that the difference is in the freer communication allowed the bees.

POOR QUEENS ARE THE RESULT OF SIMPLY REMOVING A QUEEN FROM A COLONY.

Dr. Miller, in a recent issue of *Gleanings*, uses a page or more to prove that when a queen is removed from a colony of bees, the latter, if left to themselves, do not choose too old larvæ for the rearing of queens. Mr. Taylor in this issue of the *Review* uses about the same amount of space in showing that the doctor is wrong. I shall leave my readers to say which is more correct in his theorizing, but my own experience in the matter has showed very clearly that poor queens usually result from simply removing a queen and allowing the bees to make their own selection of larvæ for queen rearing. As most of you know, I was, for several years, engaged in the rearing of queens for the market. When I first began queen rearing I followed the plan of simply removing the queen and allowing the bees to go on and construct queen cells, exercising their own choice of larvæ.

I was not long in noticing the inferiority of the queens that resulted from such practice. Mr. Taylor has well described their peculiarities. Such queens were also short lived; usually being superseded the second season. After a colony had been deprived of its queen, and allowed to build one batch of cells in this manner, it was given a comb of just hatched larvæ, holes being cut in the comb just at the line where the larvæ were beginning to hatch. The cells were almost invariably built where these holes were cut, and it was a surprise to me, at first, to see what fine queens were thus obtained, as compared with the first batch.

I think there are no experienced queen breeders who now rear queens by simply removing the queen and allowing the

bees to make their own selection of larvæ for queen rearing. Experience has taught them that such a course results in inferior queens.

Of all the things that Dr. Miller has written, I think none have surprised me more than the following that I take from his recent article in *Gleanings*.

"I know it is a quite commonly accepted belief that bees left to themselves select larvæ too old for the best queens; but it is high time to lay such beliefs aside. The truth is, they don't make such mis- choice."

I am a little at a loss to know what could have led the doctor to make such an assertion. If bees are left entirely to themselves in this matter of queen rearing, left to swarm and to supersede their queens as they see fit, no mistakes of this kind occur, but when man puts in his clumsy finger and takes a laying queen in her full prime from a flourishing colony, the bees are placed in a position in which Nature never has placed them; and that they, in their inexperience with this particular condition, should make a mistake is not surprising.

NO OCCASION FOR JEALOUSY AMONG THE BEE JOURNALISTS.

Perhaps some of us have never thought of it, but there is no occasion for jealousy among us bee-keeping journalists. In a certain city or territory, only about so many groceries or dry goods can be sold; there is a somewhat sharply defined limit to the demand. If new stores come in, the amount of goods sold by each store will be lessened. With literature it is somewhat different; especially is this true in regard to journals devoted to some special subject or industry. If a man reads one good bee-journal, the benefit he derives from it is so apparent that he is inclined to subscribe for another. It is one of those cases in which the appetite grows upon what it feeds upon. I have never hesitated to say a good word for another journal when I thought it deserved it; and I feel certain that I never lost

a subscriber by so doing. Some of the other journals have been kind to the Review in the way of mentioning its good qualities; and while these kind words have undoubtedly helped the Review, it is not at all likely that those who gave utterance to them have thereby lost any subscribers. Withholding deserved praise of a contemporary has never helped any journal in the race for fame and fortune. Letting a journal "run down" editorially, or typographically, or any other way, allowing it to become dull, prosy and common-place, these are the things that kill a journal. Keep your journal bright, fresh, clean, newsy, helpful and up-to-date, put some *life* into it, and it will live and prosper, though there are complimentary notices of other journals in every issue.



SHALL BEE-KEEPERS MAKE THEIR OWN HIVES AND FIXTURES?

A subscriber wishes the above question discussed in the Review. He says that it costs him a good share of the crop of one season to buy supplies for the next season, and he wishes to know if it would not be more profitable to make his own supplies, with possibly the exception of sections.

The answer to this question all depends upon the circumstances. Mr. Doolittle used to make all of his supplies, even to the sections; and I believe he does yet with the exception of sections. I have always made all of my hives, supers, shipping cases, etc., and did once make sections to advantage with the aid of my brother and a foot power saw upon which we could put our combined strength. When I made sections they were worth \$8.00 a thousand. I could not afford to make them now. Even the manufacturer with power and some special machinery finds that he can not successfully compete with the more extensive manufacturer. For the last two years I have also been buying my shipping cases more cheaply than I could make them. My hives I still make. I am in a lumber region, or

what was once a lumber region, and lumber is not so expensive as it is some localities. I am also near planing mills that have good machinery and competent workmen. The hives that I use are of very simple construction—simply a plain box without top or bottom. The bottom board is cleated at each end and has a little strip of wood on each side and one end to raise the hive from the bottom board. The cover is simply a plain board with cleats at the ends. I can get the material for such hives cut out and delivered at my door for *much* less than I can buy it at any factory of which I have any knowledge. It is a short, easy job to nail the hives together and paint them. The frames I buy away from home, as the planing mills here can not cut them out so cheaply as the bee hive factories do.

Mr. Taylor contends that bee-keepers should make their own hives, supers, and other fixtures. Perhaps in a majority of instances they should. Some men are bunglers with tools, but it is hard for me to understand how such men can be successful bee-keepers. If a man is a good workman with tools, can buy lumber cheaply and can get it cut up near home, or, can get a foot power saw and do it himself, and has the leisure for the work, it will pay him to make his own hives. If he must send away for the lumber, does not need a large number of hives, and must go some distance to get lumber cut up, or else buy him a foot power saw, or if he is a bee-keeper but not a mechanic it may be more profitable to buy his hives of some manufacturer. This is one of those questions that each man must solve for himself. He alone knows all of the circumstances. Let him figure it all out carefully, taking into consideration all of the points that will have a bearing on the subject, and then do what seems best. If any one else can offer any additional thoughts on this topic that will be helpful in enabling bee-keepers to decide whether to make or to buy their hives, I shall be very glad to hear from them.

NEEDED IMPROVEMENTS IN EXTRACTORS.

Mr. Heddon was somewhat surprised when I walked in one evening while on my way home from the fairs. We had not met before in five years. I went on the next morning, but we managed to get in considerable bee-talk while I was there. He has a four-basket, Cowan, reversible extractor, and likes it the best of any extractor he has ever had. He is, however, going to make some changes in it. He will extend the shaft below the can and attach a brake by means of which he can stop it almost instantly. The crank shaft will be so arranged that it can be slipped back and thus thrown out of gear. The machine will be run up to a high speed, the gearing slipped back, and the comb baskets left to revolve like a top while more combs are being uncapped. When half enough combs for another batch are uncapped, the extractor will be stopped by means of the brake, the combs reversed and again set in motion. By the time the rest of the combs are uncapped, those in the extractor will be empty and ready for removal. Mr. Heddon says he would give very little for an automatic, reversible feature; as so little time is used in reversing the baskets when they are all connected. It must not be forgotten, however, that some time is consumed in stopping the machine, even with an effective brake, and some time also used in getting the machine started again. Mr. Heddon says that if he could only get the honey ripened without its being capped, he could extract it without even taking the combs from the hives. He would slip pieces of tin down between the combs, the same as separators are used between sections, set the hives on a large extractor arranged *a la* merry-go-round, and hitch on a windmill. This year, however, he says that the bees filled one cell and then sealed it over. He has sold his house and lot at Glenwood and will bring home the bees, making about 400 colonies in one yard.



Department of criticism

R. L. TAYLOR.

Blame where you must, be candid where you can,
And be each critic the Good-natured Man.
GOLDSMITH.

WHEN DEPRIVED OF THEIR QUEEN, BEES SELECT TOO OLD LARVÆ IN REPLAC- ING THEIR LOSS.

Dr. Miller, in *Gleanings*, 725, returns to the question of whether bees when deprived of their queen, always select larvæ of the proper age for producing queens of the best quality, and makes a very specious, and, on first blush, apparently conclusive, argument to show that they do. As the editor doubts, and says his experience rather leads him to lean towards my opinion, the doctor again replies; and, pointing with pride to his argument, says "I think I never knew a *strong* colony made queenless to have a young queen emerge sooner than 10 days or later than 12 days. If you will read with care page 725, column 2, paragraph 3, I think you will see that in such case the bees *must* have chosen a larva of proper age." The editor replies, "perhaps your reasoning is correct." The matter is of the highest importance; and the doctor's opinion ought not to stand, unless his reasoning is sound. To make the matter clear, I quote his argument.

"Now suppose a queen emerges ten days after the colony is unqueened. How old was that queen, or, rather, larva, when the bees began to treat it as a thing of royalty? Ten days taken from its entire inter-cell life of 15 days leaves 5 days as its age from the laying of the egg, or two days of age as a larva. Allowing that the bees did not discover their queenlessness immediately, there is still leeway enough to secure the selection of the larva before it was older than three days. When the young queen emerges 11 to 12 days after

unqueenings, then a still younger larva must have been chosen."

I make no question now that this reasoning would be conclusive were all the elements that enter into the matter considered and given their proper and due weight; but are they? In answer to this, I have to acknowledge that in the argument there is an inclination, no doubt unintentional on the part of the doctor, to pare down the length of the time between the hatching of the egg and the emerging of the queen. He makes that time twelve days. I should put it at thirteen. The egg hatches in somewhat less than three days, and I never could make out in my investigations that a queen emerges in much if any less than sixteen days.

Secondly, although he properly allows about twenty-four hours for the bees to become satisfied that they are queenless, he takes no account of their want of preparation to furnish at once proper food to a larva designed for a queen. This is a most important point. No one who has watched the larvæ fed for queens under the circumstances under consideration can have failed to note the scantiness and watery appearance of the food. Of course, the length of time lost by the bees on account of want of preparation is, with our present knowledge, rather indefinite; but I judge from the appearances of the queens produced under such circumstances, if the bees are allowed to have their own way entirely, that it should be fixed at at least a day. These considerations, if I have not given them too much weight, would allow the selection of a larva at least four and a half to five days old, and still give no more time than needed for it to emerge in ten days from the time of queenlessness.

Thirdly, another element that enters into this calculation of time, and which seems not to have been considered by the doctor, is the difference in the rapidity with which the worker and the queen develop. The queen matures in three-fourths the time required by a worker; and, counting from the time when the

cells are capped, only about half as long. The worker develops more slowly. What is the significance of this? Just this: That a queen's emerging at a time not less than ten days from the time of unqueening is no proof that the larva from which the queen was produced was taken by the bees at the normal parting of the ways between the worker and the queen, and devoted from that point by ample and proper supplies and attention to the office of queen. This proposition is in exact contradiction to the doctor's position as set forth in his argument. Which is correct? We may agree that a larva fully devoted to royalty when three days old will emerge as a queen ten days later; but if taken at five days of age would she emerge in eight days? We must consider that where three days old, at most, she was set apart for the production of a worker, and adopted the comparatively slow pace that required fifteen days' time to complete her full development. When her destiny is changed at five days of age she has not only lost time already but her pace for the future can be only partially mended. Her nourishment and care will necessarily be very defective, the time before her cell is capped is so short, so that it could be manifestly unreasonable to expect her to reach her goal in less than ten days.

Besides this, my experience, obtained by actual inspection of brood when the bees are beginning efforts to replace a lost queen, and of the queens thus produced, fully confirms me in the opinion that the argument referred to is unsound. Many a time have I seen the bees beginning attempts to make queens out of larvæ almost old enough to be capped over; and many a queen produced from such larvæ, having one or more of the characteristics of the worker, have I examined. One I remember had the head of a worker—many had ill-shaped bodies; and all were of small size.

I recall that a year or two since the doctor was much exercised as to whether queen excluders would exclude, and whether queen traps would entrap, and I

thought at the time that he had some queens which had been reared according to the theory which he now entertains.

SIZE OF ENTRANCES—TEMPERATURE "IN THE SHADE."

Doolittle and the doctor have been having a long contest in Gleanings, for and against large entrances. The former insists that an entrance one half inch deep clear across the hive is sufficient and better in every way; while the latter wants the hive put up on blocks so as to leave a large opening under the hive all around; claiming that with this arrangement the bees are enabled to keep down the temperature of their hive the better and that there is much less swarming. The contest is closed, apparently, on page 758, but, unfortunately, without results. It seems Doolittle had made the assertion that the bees do not cluster outside because it is cooler there, but to get out of the way, for it is in reality cooler inside. This suggests to the doctor the idea of settling the whole matter by the use of the thermometer. By the aid of that instrument he compares the temperature of the brood-nest, both with a large entrance and a small one, with the temperature outside *in the shade*. If we are to take literally his statement of the method he pursued, then that method was manifestly not a fair one; and not calculated to give any valuable results. The temperature in the shade is one thing, the temperature in the apiary in August, outside the hives, is quite another. Temperature in the shade is found where there is heat neither from the direct nor the reflected rays of the sun, while in any apiary in the open air there must always be a good deal of heat from both these sources from sun to sun in summer time. The former has nothing to do with the truth of Doolittle's statement; while the latter is the very essence of the matter; but, so far as appears definitely, this was not considered. A definite expression is used but once—"91° in the shade"—and it is only fair to suppose that the other figures are to be taken in the same sense.

I am sorry that Doolittle did not take enough interest in the matter to insist on the truth of his statement and use the thermometer himself to establish its truth; which I think he could triumphantly do.

In the same article Dr. Miller, addressing Doolittle, says: "You say the sections immediately above the large entrance were slower in being finished, and cite my objection to upper back entrances as explaining why. I suppose because cooler; and if it's cooler for the sections isn't it cooler for the bees?" The bees never willingly put honey near an opening to the outside; not because it is too cool, for they build comb freely entirely outside the hive when compelled, but because it is so much more liable to the depredations of robber bees.

AN INCOMPLETE EXPERIMENT.

On page 657 of the American Bee Journal Mr. Hartzell gives glowing praise to Mr. Golden's method of comb-honey production. Forty colonies on that method gave an average of 46 13-20 sections, while twenty-one on the ordinary plan averaged 23 2-7 sections, which shows about 100 per cent. in favor of the new plan. Mr. Hartzell seems to be impressed with the idea that this naked statement should be sufficient to convince any one of the great superiority of the new plan; but I doubt if any one will be convinced. In the first place, it is entirely too good to be true. I am not questioning the truth of Mr. Hartzell's statement; but before one can arrive at a just judgment there are many other things to be considered; things which he does not touch upon at all. There is almost always a great difference in the condition of colonies in the spring as to amount of stores, strength and health, and the quality and age of the queen. This being so, it would be an easy matter by selecting colonies to make almost any plan appear twice as good as any other. To be at all satisfactory, such statement must show *all* the conditions and *all* the results with all the exactness that the closest scrutiny with the aid of scales can give. How were Mr. Hartzell's

colonies divided? What was the weight of each in the spring? Was any feeding done and to which ones and how much? What was the strength of each colony, and the quality of each queen, and how much care was taken to determine these points? What was done with the swarms from each class, and what was the weight and condition of each brood-nest at the close of the honey season? There are too many high claims made for new discoveries, which after a little time are given up as valueless, to warrant one in accepting with confidence any new plan whose results are proclaimed only in general and indefinite terms, unless there are inherent reasons to indubitably recommend it. This fact furnishes one reason why I insist so much on serious and exact language.

A CONTINUED PLEA FOR GOOD ENGLISH.

In the commerce of speech use only coin of gold and silver.—JOBERT.

In *Gleanings*, 736, and in the *American Bee Journal*, 665, the editors severally deprecate the public criticism of language used in the apicultural journals; but the latter devotes a half column and the former more than a column to that work. Their practice is better than their creed. Public criticism, if good at all, will accomplish many times as much benefit as it would if purely private.

Mr. Root properly points out that I used could be pleased for should be pleased and earliest for earlier; but he defends his use of "canine," and cites the *Standard Dictionary* in his support. If he will examine that dictionary more closely he will find that the word is designated as "humorous." I at least did not get the idea that when he used the word he was writing a humorous article. The *International Dictionary* does not recognize the word at all in that sense. Mr. Root says then "the joke is on Mr. Taylor and Mr. Cowan has the laugh." Mr. Cowan has the laugh, no doubt, but not at me. Further on he says "some of the very

words that the critic classed as slang the *Standard Dictionary* recognizes as colloquialisms." Will he please state where? Inexact statements are in some respects worse than slang. Colloquialisms have seldom any place in reasonably good serious writing.

If Mr. Root wishes to be strictly just he will recall his assertion "that he [I] has been hypercritical and hardly up to the latest authorities," until he makes further investigation.

I don't know that Dr. Miller feels about this sort of criticism as the other editors do; at least, he seems to want me to go even further and supply the place of the dictionary; for he asks me (*American Bee Journal*, 612) what I mean by the word "sic," but I shall have to draw the line there. There are plenty of good dictionaries, and, as he must see, there is plenty of work already laid out for me.

The doctor gives unwittingly, in *Gleanings*, 754, a good illustration of the evil of bad English. He says "A late French journal quoting a 'straw' from *Gleanings*, page 379, translates the sentence 'Then smoke like sixty till bees rush out of hive' after this fashion: 'Then smoke till about sixty bees rush out of the hive.'" He tells the story in great glee, evidently thinking it a good joke on the Frenchman. But without doubt the Frenchman would have had no difficulty with good English. Curiously enough, the doctor, speaking of the difficult languages of other lands, asks: "Why couldn't they [foreigners] write every thing in plain English?" That's asking a good deal when *we* don't seem to be able to do so.

A GENUINE COMPLIMENT UNWITTINGLY GIVEN.

I do not usually value compliments very highly; but when they come unintentionally, and from an opponent, too, I cannot help receiving comfort from them. Dr. Miller (*Review*, 309) criticises me very sharply and at considerable length on account of the style of my criticisms, and then says: "If I seem to have

fallen into the same fault in this letter, that I criticise in Bro. Taylor, it is because I think both he and you [the editor of the Review] have wanted the plain truth." So, after all, the doctor agrees with me that the style I employ is well calculated to convey the plain truth. The purpose for which I write is to convey the plain truth; and as my style is the most effectual the doctor can discover for that purpose, why should I be asked to change my style? I have no itching for the drudgery of writing unless there is some hope that it may benefit some one. I am quite willing others should have a monopoly of writing simply to amuse. Of course, criticism, if well founded, is not usually pleasing to the person criticised; especially if some of the seeds of original depravity are still in his heart; but it may nevertheless be profitable. For scripture says: "All chastening seemeth for the present to be not joyous but grievous: yet afterward it yieldeth peaceable fruit unto them that have been exercised thereby."

CARELESSNESS OR MALICIOUSNESS.

I sometimes get discouraged in the work of a critic, and wish some one who could do it more effectually would step into my place. There is so much of careless statement, and careless editing, that ought to be reformed! A good example of both sorts of carelessness (I call it carelessness, though it is hard to see how it can be other than maliciousness) is found in the American Bee Journal, 618, in the anonymous department called Beedom Boiled Down. The item containing it is in part as follows: "Critic Taylor, speaking of Doolittle's plan of preventing after-swarms, said: 'Perhaps Doolittle is led to practice his method from the fact that he is largely using the Gallup hive and wishes to engage others toward a favorable opinion of that hive.' " I don't know certainly that Doolittle uses the Gallup hive, and I am sure he doesn't wish to engage others toward a favorable opinion of it, and of course I could never have written such absurd nonsense. I cannot yet believe

it was ascribed to me through impotent malice. Still, it is difficult otherwise to account for it. I am inclined to believe that the writer, becoming all exhausted by too steady and too long continued writing, merely jotted down the fitting imaginings of his worn out brain when he was no longer morally responsible.

The editor, on the second page preceding the item containing the above fiction, proclaims himself responsible for the B. B. D. department. Will he please to make due apology and correction and also have the writer of it explain how it happened?

LAPEER, Mich. Oct. 25, 1898.

EXTRACTED.

COMB FOUNDATION IN SECTIONS.

**Comb Honey Better Flavored than Extracted,
and Why. Worker Cappings More Beau-
tiful than Drone.**

My son, eat thou honey because it is good;
and the honey comb, which is sweet to thy taste.

Last month I copied from Gleanings the views of Mr. R. C. Aikin on this subject. It seems that the publication of those views stirred up another practical man to send his views to Gleanings. This man is Mr. F. Greiner of Naples, N. Y. Of course, the use of foundation in the sections versus its non-use, is a practical subject; at the same time I very much doubt if its use in this place will ever be abandoned. Here is what Mr. Greiner has to say on the subject.

It was with a great deal of satisfaction that I read friend Aikin's article on the use of comb foundation—in particular the part that touches upon foundation in sections. It is just exactly for the reason that honey built upon foundation is not equal to the natural product for "tenderness and fine edible qualities" that I have always been opposed to the use of foundation in sections, except for starters.

It does me good to find occasionally a bee-keeping brother who thinks as I do on this subject, and has the courage to say so in public. I am pretty well satisfied that it pays to use full sheets in sections in order to get the combs well attached to the wood, and sealed all around, and also to get a larger yield generally; but it seems to me that the one thing of greatest importance in the production of section honey is not so much to have the combs solidly attached and sealed all around as to produce an article possessing the finest edible qualities possible.

The ardent writer who, some time ago, told his brother bee-keepers who produce such honey as was pictured on page 128, Feb. 15, top tier of plate, "they had better soak their heads and brimstone their bees," has shot far over the mark, and I very much doubt that his honey is anywhere near the fine quality that I like so well in the comb honey for my table. I consider it immaterial whether the comb is attached to the wood or not, if the kind and the quality are right, the comb delicate and of a melting character. Once in a while I have had whole supers filled with fancy honey, sections all well filled, combs built out separately into the corners, and still not attached to the wood except along the top, and perhaps a brace or two at each corner. A cake of such honey is indeed a beauty when it appears on the table, for it need not be mutilated by the knife in cutting it out. I do not imply that it would be prudent to aim to produce such honey, because it would not carry well; but I believe it would attract just as many buyers if we could get it into the market.

It has not occurred to Bro. Aikin that worker comb in the finished product looks any better than drone comb till he was told by some one, and now, he confesses, he does not know it yet. That, of course, is a matter of taste; but to the great majority of bee-keepers and honey consumers, worker-comb honey looks much the prettier. I can detect but little difference in the edible qualities of the two. No, I have not measured the thickness of drone comb and compared it with that of the worker-comb; but I have eaten both kinds often; and when they were built out under the same conditions the difference has appeared to me infinitely small. However this may be, I should be glad if I could induce my bees to build more worker comb in the sections. So many bee-keepers use full sheets of foundation, and their product is so very uniform and well built out, that I have been tempted many a time to do likewise. This year I

filled all my sections about half full of extra-light section foundation, but with a result that I am anything but pleased with. I am sorry enough to have used so much foundation. I have gained the point of more uniformity, but the gobbiness of the upper half of each comb is beyond endurance. Wife says, "Don't bring any more such fishbone honey up to the house." No more foundation for me! However, this does not include the new drawn foundation, which I have not yet fully tested. From its fragility and delicateness, I think it has a promising future providing the price is not prohibitory.

Aside from having our sections filled with all worker comb, they may be made more attractive by glassing and trimming with colored paper. Before we adopted the one-piece section, which is not well suited for glassing, we did a great deal of such work; and when we wanted to do a very fancy job we used paper lace in connection with the colored paper, as shown in the accompanying drawing. We al-

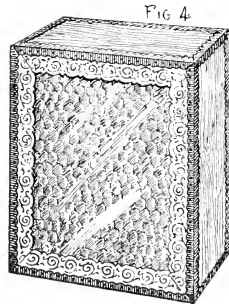

most always obtained a higher price for such "fixed-up" honey; and the glass, being sold as honey, paid for the work. The glassing itself was a very simple operation. I would say the sections we used were four-piece nailed, the glass fitting in between top and bottom pieces, which projected over the sides $\frac{1}{8}$ inch on each side, or about the thickness of the glass. We used common glue to fasten on the glass. After being cleaned from propolis the section was placed on the table flat, dropping just a little glue on the edge near each corner of the narrow sides; the glass was adjusted, and the section turned over. However, it had to be laid on two little sticks a trifle shorter than the glass was wide, and about $\frac{1}{4}$ inch thick. The object of this was to have the

weight of the box press the glass tight against the wood. The other side of the section was now treated in the same way, placing a drop of glue near each corner, and laying on the glass. Two more short sticks were placed on top of the section, ready to receive the next section. So they were piled up eight or ten high with these sticks between, and left so till the glue had hardened. As glass varies in thickness sometimes, we found it necessary to trim off any superfluous wood projecting over the glass with the knife. The boxes were then ready to be given the finish. Gum arabic being colorless, we found this to be the best for sticking the paper to the glass and wood.

With a suitable pinking-iron we prepared the necessary strips and cut them the proper lengths to just go around the boxes. We then bound the edges as shown in the illustration, making a very neat package. Of course, it was a great deal of work to do all this with several tons of honey each year, but we did much of it evenings. Children and all helping, we could turn out quite a lot in one night. The crating had to be done by day-light the next morning. One cannot well grade by lamplight.

The people hereabout must be different from what they are with Bro. Aikin, for I find but few who like their honey without some wax. Indeed I do not know one person who prefers extracted honey to that in the comb. It is my opinion that honey out of the comb soon loses that fine aroma peculiar to it when in the comb, or when first extracted; and after it has granulated and is liquefied again, all the fine qualities it had once are then gone, even when the liquefying has been done with the greatest of care. My faithful better half, for instance, dislikes liquefied honey, while she rather enjoys the new article. Thus our experience is contrary to Bro. Doolittle's, who recently made the claim that extracted honey improves by liquefying.

My plain sections are not filled perceptibly better than the others, but we have had a very scant honey flow all around, and of short duration at that. The cappings of the sections used in connection with the fence are perfectly level, except in a few instances where a space in the fence had by accident become wider than the two-twelfths inch. Here I can notice a slightly wavy appearance. I am more favorably impressed with the plain section than I am with the fence, although the fence works all right. I intend to use whole cleated separators by the side of the fence, and in the same

cases, too, in order to be better able to determine more correctly how far the fence may be relied upon as giving us better-filled-out sections. I find there is not any more danger of injuring the plain section in handling than the scalloped. If there is any difference it is in favor of the plain. They have no projections to catch into the next section. It may be necessary to use followers with them in the shipping-cases, for it is difficult to get the first sections out of a crate without this convenience.

The editor of *Gleanings* "foot-notes" as follows:—

[We down here in Ohio do not know of any method whereby worker comb can be generally secured from a mere starter in the section box. Over half of the combs will be finished drone, and these will be more "gobby" eating than comb honey from full sheets of worker foundation. Or, to put it another way, if we use only starters we shall have more drone than worker; and natural-built drone-comb is less friable than worker comb from full sheets of foundation.

It is possible that honey, when extracted, loses some of the delicate aroma that it has while in the comb. Wax of itself has a beautiful aroma, even when there is no honey in it. Over and over again, persons when visiting our wax-room call attention to the beautiful honey flavor that they smell, notwithstanding there may not be an ounce of honey in the room. Now, then, if wax has a flavor or aroma peculiarly its own, this, when added to honey, would give a combined effect that is pleasanter to the eater than the same honey free of wax.]

It is true that a comb but slightly attached to the section can be cut out with less trouble, and presents a neater appearance on the table, than one built solidly to the wood; but such combs are almost certain to be broken loose in shipment. This is undesirable. It causes broken combs and leakage and trouble to the retailer. Such honey is in an unsalable condition; and, if sold, must go at a reduced price. As I have remarked before in these columns, there are some fruits and vegetables very desirable for home use that will not bear shipment. It is the same with this class of honey. As shippers of honey, our efforts should be in the direction of securing combs that

are well attached to the wood, rather than the reverse. Mr. Greiner is right in saying that the use of full sheets of foundation is a great aid in securing the attachment of combs to the wood. This is one advantage in the use of foundation. Right here let me say that a section in which comb is built naturally, with no help from foundation, unless it may be a small starter, is more likely to be well filled than one partly filled with foundation.

I presume that the majority of people would admire the appearance of worker comb above that of drone comb. To me there is a peculiar, rugged beauty about a well filled section of drone-comb. If the section is not well filled the comb has a more ragged appearance if of the drone variety than one partly filled with worker comb. I doubt if consumers would object to the appearance of drone comb—if many of them would even notice its appearance. Some objection of which I know not would have to arise to induce me to use foundation in the sections simply because the bees would build drone comb in them if allowed to build combs naturally. The editor says that naturally built drone-comb-honey will be more "gobby" than worker comb built from foundation. My experience will not allow me to agree with this. As I said last month, the walls of naturally built drone-comb may be thicker than those of worker comb, but their *character* is far different. For my own eating, give me naturally built drone-comb-honey to that of worker built from comb foundation.

In regard to the building of drone comb in the sections when starters only are used, an established colony would be almost certain to build drone comb before it has swarmed; unless it had a great abundance in the brood nest; which is something that we bee-keepers do not find to our advantage. A newly hived swarm, or a colony that has swarmed and possesses a young laying queen, would be less likely to build drone comb. Mr. H. R. Boardman could probably

give us as much information as any man upon this subject of producing honey with naturally built combs. Will he please write an article for the Review on this subject?

The majority of people prefer comb to extracted honey; and in this case I am with the majority. There are reasons why comb honey is more palatable. One is that it is almost always well ripened. But, even when extracted honey is well ripened there is a difference. As Mr. Root says, it seems to lose some of its delicate aroma; although I doubt if there is so very much in this when it is immediately sealed up. I must agree with Mr. Greiner that liquefied honey loses, in a degree, its fine taste. To me it has a sort of cooked taste. Next comes this point of eating the wax with the honey. Wax *does* have an aroma or a taste which, mingled with that of the honey, gives a combined taste that is different from that of honey alone. In the eating of extracted honey such a large quantity of sweetness is brought in contact with the organs of taste all at once as to overtax them, so to speak. In eating comb honey there is a gradual breaking down of the cells, the honey is released in small quantities, and the "sweetness long drawn out" is not only poetical but really real.

I notice that at the Omaha convention this matter of the digestibility of the wax received quite a little attention. It is true that the wax is indigestible, but those are in error who imagine that because wax is indigestible its consumption in comb honey is attended with injurious results, or that it is in the least unwholesome. Some fifteen years ago Prof. Hasbrouck, in the Bee-Keepers' Magazine, explained most fully the philosophy of this subject; and, although it has been copied before in the Review, it was several years ago, and I believe it will bear repeating. The Professor said:—

So much is said now-a-days by such influential men as King, Dadant, Jones, and many others, to "boom" extracted honey, that it seems necessary that some-

thing should be said to recall the claims of comb honey, that its virtues may not be forgotten and its production neglected. It may be that, for the present, more money can be made in running bees for extracted honey—five dollars to one, as Jones says; but I think I can see reasons why, with increased production, we may expect extracted honey to depreciate in price much faster than comb honey. Extracted honey must always compete with similar sweets; such as sugar, molasses, syrups, and glucose, and its principal recommendation will be its novelty or cheapness; while it is weighted in the race for popularity by its inconvenient tendency to candy, and if it does not candy, it is immediately exposed to the suspicion of being adulterated. On the other hand, comb honey stands without a rival—a thing *sui generis*—captivating to the eye—the symbol of sweetness—a royal luxury. But so industriously have they who ought to know better, talked about the enormity of eating "indigestible wax," that the proper use of comb honey is almost a "lost art." People struggle to reject every flake of wax, or else eat their hot biscuit and honey as forbidden indulgence, dared with full expectation of gripes and nightmare as a penalty. The fact is, that honey comb is one of the most wholesome foods ever eaten. It will make hot biscuit and fresh bread easily digestible. These alone are rightly considered much harder of digestion than stale bread, from the fact that they pack, in chewing, into masses impermeable to the solvent juices of the digestive organs. But when they are eaten with honey comb, the delicate flakes of wax prevent the packing, while the honey pervading the whole mass, is readily dissolved out, leaving free access for the gastric juice to all parts of the food. The scales of wax, though indigestible, are soft and smooth, and will not irritate the most delicate membrane.

But besides being a delicious and wholesome article of food, I regard comb honey as a specific cure for many difficulties of digestion and irregularity of the bowels. In our day, drugs are at a discount for the treatment of chronic diseases, and people are generally seeking health from a proper selection of foods instead of medicines. For a long time Graham bread and bran crackers have been prescribed by the medical faculty for dyspeptic affections and obstinate constipation; but the doctors are about finding out that these things will ruin the digestion of anything but a horse, as the rough, silicious scales of bran irritate and lacer-

ate the delicate membranes of the digestive organs, to their speedy ruin. I can assure all persons whose digestion needs a little assistance, that they will find in comb honey, eaten wax and all, just the thing to help them—and a very agreeable medicine to take, it is, too.

The flakes of wax furnish a gentle stimulus to the digestive membranes, without in any way injuring them. To bee-keepers I would say, produce extracted honey by all means, if you can make more by it; but for your own bread and butter, and hot biscuit and hot cakes, use comb honey, without being anxious to save all the wax to make up into foundation, and see if it isn't the best way to eat honey.

The septum of comb built from foundation, or comb built from deep cell foundation, if the cells were very deep, could never be broken up into the flakes of which the Prof. writes so delightfully.

— — —

WHEN COLONIES STORE THE MOST HONEY.

It is not Solely a Question of Numbers—There are other Conditions.

— — —

Last month in commenting upon Dr. Miller's idea that a populous colony stores more honey in proportion to the number of bees than does a small colony, I fear that I did not make myself perfectly clear upon one point. I said I believed nothing was gained by having a colony above the normal size. By this I did not mean that a populous colony might not, and probably would, store more surplus than a weak colony or even a colony of ordinary strength. What I mean is this: that I believe that a colony of normal strength will store as much honey per *bee*, other things being equal, as will a very populous colony. Those words, "other things being equal," are very important. What bee-keeper has not noticed that when everything seemed to be apparently equal, some colonies stored a much larger surplus than others? It often happens that a colony weak in numbers stores more surplus than the most populous colony in the yard. Even in a poor season it sometimes happens that

some colonies store a fair surplus. In 1892 one of my colonies stored more than 75 pounds of surplus comb honey, while the average was less than 40 pounds. Some colonies did not go much over 20 pounds each; yet there was no remarkable difference in the strength of the colonies. Last month I mentioned one condition that has a most important bearing upon the amount of honey stored as surplus, viz., the amount of unsealed brood compared with the number of hatched bees. One great point of superiority with the Italians is that when the big harvests of clover and basswood come on, the main energies of the bees seem to be bent in the direction of securing the harvest—brood rearing is a secondary consideration and treated accordingly.

If we could discover the why and wherefore of these greatly varying amounts of surplus, and apply the remedy, so that all colonies would come up to the high water mark what, a stride it would be. The late Mr. Gravenhorst of Germany tried to solve the problem, and a few years ago, in an extract from the journal that he published, I gave his views on this subject. Under the circumstances I think that I may be pardoned for reproducing them. Mr. Gravenhorst said:—

There are not many attentive bee-keepers of long experience who have not noticed that in so-called poor seasons one or more of their colonies not only stored enough honey for its own use but perhaps even a surplus; while the majority of colonies may not have secured even sufficient for their winter stores. Likewise, in a good season, it must have been noticed that some colonies give an astonishing surplus in comparison with others.

These results are the more striking if all the colonies had access to the same pasture, and if the work was carried on under seemingly exactly the same domestic conditions as regards combs, hives, strength of colonies, etc.

Even in the beginning of my business as a practical bee-keeper, it often happened in a poor season that three or four of my colonies in the round straw hives with no frames had more than enough for winter, while the majority, often stronger in bees, had not sufficient for

winter. Then in a good honey flow I often observed that some of the small colonies went far ahead of the stronger ones. I have had four-frame nuclei give me from ten to twenty pounds of extracted honey in a season, while others of the same strength, and stronger ones, gave me scarcely as much. Still more remarkable seemed the fact that small queen-rearing colonies that had in the aggregate not more comb than one full sized frame, little by little at a time, would finally yield five or six pounds, or more, of honey, while others in apparently the same condition gathered only their daily supply. In the face of all this, the assertion is frequently heard that only strong colonies yield a surplus!

When such results come about with the colonies, comb, hives and pasturage apparently the same, there must be other factors not so easily discovered. By repeated examination and observation I have learned that there exists a certain condition under which a colony will gather the most honey whether it be strong or weak. If this condition has not yet been reached, or if it has been passed, the storing of surplus will be neglected or at least carried on only moderately.

That being the case, the question naturally arises, what is this condition? By an exact examination there will be found five central points. Three of these are well-known to first-class bee-keepers, and they are mentioned only that I may be able to give a complete statement, and in my second part be able to refer to them if desirable.

1.—The ideal colony must have a faultless queen; hardy, sound of body and, above all things, fertile, and her progeny distinguished by diligence.

2.—Nevertheless, such a queen alone does not make an ideal colony. At the right time, that is, when honey is coming in freely, there must be plenty of empty comb that no time nor honey be lost in building comb.

3.—Our ideal colony must swarm at the right time or not at all. It swarms at the right time when it swarms so early that the queens of the after-swarms, if such are allowed, become fertile, and the first or prime swarm has its combs completed, before the opening of the main harvest.

4.—The ideal colony must not be over-populous. A hive is over-populous when its working force is too great in comparison to the dimension of the hive and to the number of wax-building bees.

Such a condition is intolerable to the bees and they try to help themselves by

loafing. Their instinct teaches them to begin this loafing even before the hive is over-populous. The bees seem to see that the combs are filled and capped, that bees are daily hatching and that they will soon be crowded. A colony in such a condition will never perform the wonders in gathering honey that we may expect from one less populous. Such a colony feels instinctively that its abode will soon be too small, and the swarming fever sets in, and we know that when that is awakened the bees will continue to loaf. At the most, only as much honey will be gathered as is needed for making the swarming preparations. A colony with the swarming fever is of little value as a honey gatherer.

5.—The best honey gathering colonies are not kept at home during the best honey flow by the nursing of too much brood. If there is too much brood in proportion to the working force, most of the honey gathered will be consumed by the brood. The bee-keeper whose bees rear a large amount of brood during the main honey harvest, or near its close, will find, as he stands before his colonies at the close of the harvest, that although they are strong in bees and the combs faultless, the latter will be *empty* and will *stay* so.

I am not ready to assert that large hives or populous colonies are not desirable in some localities or under some conditions, but I am opposed to the putting on of an upper story in the forepart of the season, just before the beginning of the main harvest, if the colony is managed for comb honey. The energy and work that fill this upper story with honey and brood would fill the same space with section honey.

The Companion for the Rest of 1898.

The principal attractions offered by THE YOUTH'S COMPANION for the remaining weeks of 1898 provide a foretaste of the good things to follow in the new volume for 1899. To the first issue in November Frank R. Stockton will contribute a humorous sketch, entitled "Some of my Dogs," and in the issue for the week of November 10th will appear Rudyard Kipling's thrilling story of the heroism of soldiers in the ranks, "The Burning of the SARAH SANDS." In the seven issues to follow there will be contributions by Lord Dufferin, William D. Howells, J. E. Chamberlin, the American war correspondent, Mary E. Wilkins, Hon. Thomas B. Reed, the Marquis of Lorne, Mme. Lillian Nordica and I. Zangwill. Those who subscribe now for the 1899 volume will receive every November and December issue of THE COMPANION from the time of subscription to the end of the year free, the Companion Calendar for 1899 free, and then the entire 52 issues of THE COMPANION to Jan. 1,

1900. An illustrated announcement of the 1899 volume and sample copies will be sent free to any one addressing

THE YOUTH'S COMPANION,
211 Columbus Ave. BOSTON, MASS

Honey Quotations.

The following rules for grading honey were adopted by the North American Bee Keepers' Association, at its Washington meeting, and, so far as possible, quotations are made according to these rules.

FANCY.—All sections to be well filled; combs straight, of even thickness, and firmly attached to all four sides; both wood and comb unsoiled by travel-stain, or otherwise; all the cells sealed except the row of cells next the wood.

No. 1.—All sections well filled, but combs uneven or crooked, detached at the bottom, or with but few cells unsealed; both wood and comb unsoiled by travel stain or otherwise.

In addition to this the honey is to be classified according to color, using the terms white, amber and dark. That is, there will be "fancy white," No. 1, dark," etc.

KANSAS CITY.—We quote as follows: Fancy white, 12 to 12½; No. 1 white, 11 to 12; No. 1 amber, 10 to 11; fancy dark, 9 to 10; No. 1 dark, 9; white extracted, 5½ to 6; amber, 5 to 5½; dark, 4 to 4½; beeswax, 25.

C. C. CLEMONS CO.,
Nov. 1. 521 Walnut St., Kansas City, Mo.

NEW YORK.—We quote as follows: Fancy white, 13 to 14; No. 1 white, 12; fancy amber, 11, No. 1 amber, 9, fancy dark, 9; No. 1 dark, 8; white extracted, 6½; amber, 5½ to 6; dark, 5; beeswax, 27.

HILDRETH BROS. & SEGELKEN,
Nov. 1. 120 West Broadway, New York.

CHICAGO, Ill.—Receipts of honey light, demand good. Can send prompt sales. We quote as follows: Fancy white, 14; No. 1 white, 12 to 13; Amber, 11 to 12, Buckwheat, 10 to 11; Extracted, white, 6 to 7, depending on quality. Dark, 5 to 5½.

S. T. FISH & CO.,
Oct. 29. 189 So. Water St., Chicago, Ills.

CLEVELAND, O.—Demand for white Honey is very good, and market firm. We quote as follows: Fancy white, 13 to 14; No. 1 white, 12 to 13; Fancy amber, 10 to 11; No. 1 amber, 9 to 10; Fancy dark, 8 to 9; White, extracted, 7; Amber, 6; Dark, 5.

A. B. WILLIAMS & CO.,
Nov. 1. 80 & 82 Broadway, Cleveland, Ohio

BUFFALO, N. Y.—We submit the following quotations: Strictly fancy, 1 lb comb honey is scarce and firm at 13 to 14, in fact, we have not had one lot of strictly fancy honey out of all we have received this season, and would like some. So-called No. 1, 1-lb. combs, 11 to 12; dark, etc., 7 and 8; Fancy extracted, 5 to 6; dark, 4½ to 5; Fancy beeswax, 27 and 28.

BATTERSON & CO.,
Oct. 28. 167 & 169 Scott St., Buffalo, N. Y.

CHICAGO, ILL.—Honey of all kinds sells well, and now is the most favorable time for shipment. We quote as follows: Fancy white, 13; No. 1 white, 11 to 12; Fancy amber, 9 to 10; No. 1 amber, 7 to 8; Fancy dark, 8; No. 1. dark, 7; White, extracted, 5 to 7; Amber, 5 to 6; Dark, 5; Beeswax, 26 to 27.

Nov. 1.

R. A. BURNETT & Co.,
163 So. Water St., Chicago, Ill.

NEW YORK, N. Y.—Demand for honey very good at steady prices. Receipts during the past few weeks have been fully up to the average years. Fancy white honey is in demand; other grades of white and buckwheat are plenty. We quote as follows: Fancy white, 13½ to 14½; Fair, 12 to 13; Buckwheat, 8½ to 10; Amber, 9 to 11; Mixed, 9 to 11. Our market is in good shape for all grades of extracted honey. We quote as follows: White clover, 6 to 7; Amber, 5½ to 6½; Buckwheat, 5 to 6; Florida white, 6 to 7; Florida light amber, 5½ to 6½. Other grades of Southern honey from 55 to 65 per gal. according to the quality. Beeswax, during the past week, has shown a slight improvement, though we do not anticipate much more advance for some time to come. We are selling at 25½ to 26½ per lb.

When shipping, we would ask that all packages be marked plainly, the gross tare and net weight.

FRANCIS H. LEGGETT & CO.
Oct. 25. W. Broadway, Franklin & Varick Sts.

WM. A. SELSER,
10 VINE ST., PHILA., PENN.

White Clover Honey Specialist.

Some Odds and Ends That Will be Sold Cheap.

For a dozen or more years Mr. M. S. West of this place dealt in bee-keeper's supplies. Since his death, two years ago, his daughter has endeavored to close out his stock of goods, and has succeeded to large extent. There are still a few odds and ends, and she has brought them to me and left them for me to sell. Here is a list of the articles with prices at which they will be sold.

One ten inch foundation mill, (second-hand) Root's make, complete with dipping tank, etc., in excellent condition... \$10.00

One ten inch foundation mill, (second-hand) Root's, (one of recent make) dipping tank, etc. in good order 15.00

Three Woodcock foundation fasteners, each,75

Eighty seven entrance guards, each,05

Thirteen Porter Bee Escapes 2.25

Thirty-three Simplicity hives, in the flat, sides, ends, covers and tin rabbits but no frames nor bottom boards, each,40

Send all orders to W. Z. HUTCHINSON,
Flint, Mich.

THE MONITOR PAPER FILE

Binds securely and neatly all periodicals. Preserve your papers, magazines, pamphlets, bulletins, music &c., by binding them together as you get them. Each new number filed quickly and easily. Will bind 52 numbers of any periodical aggregating 1000 or fewer pages. All lengths from 6 to 28 inches. Light and handsome.

PRICE.—All sizes 12 inches and under 12 cents; over 12 inches one cent per inch. When wanted by mail add one cent for each 5 inches or fraction thereof.

For sale by the Publisher
of this paper.

Bee keepers should send for our

'97 CATALOG.

We furnish a full line of supplies at regular prices. Our specialty is Cook's Complete hive.
J. H. M. COOK, 62 Cortland St., N. Y. City

Please mention the Review

QUEENS,

Untested, 75 c; 6 for \$4.00; tested, \$1.00; 6 for \$5.00; breeders \$2.00. The best stock, imported or golden. W. H. LAWS, Lavaca, Ark.

Please mention the Review.

I have several hundred

QUEEN CAGES

of different styles and sizes, made by C. W. Costellow, and I should be pleased to send samples and prices to any intending to buy cages.

W. Z. HUTCHINSON, Flint, Mich.

Farm Bee-Keeping.

The only bee paper in the United States edited in the interests of the farmer-bee-keeper and the beginner is the **Busy Bee**, published by EMERSON T. ABBOTT, St. Joseph, Mo.

Send for free sample copy NOW.



See That Wink?

Bee Supplies. Root's goods at Root's prices. POWDER'S HONEY JARS Prompt service. Low freight rates. Catalog free. WALTER S. POWDER, 162 Mass. Ave., Indianapolis, Ind., the only exclusive bee supply house

WALTER POWDER'S AD in Indiana.

THE LOSS

Of one Queen in introducing, means a loss greater than the cost of a copy of "ADVANCED BEE CULTURE," which has one entire chapter devoted to "The Introduction of Queens." It shows when the cause of failure lies with the colony, when with the bee, and points out the *conditions* necessary to success. Although one infallible method is given, but little attention is given to the setting forth of exact rules and methods; the subject being treated with a view to teaching *principles* that may be followed to success.

Price of the book, 50 cts.; the Review one year and the book for only \$1.25.

W. Z. HUTCHINSON,

Flint, Michigan.

Listen! Take my advice and buy your bee supplies of August Weiss; he has



tons and tons of the very finest

FOUNDATION

ever made; and he sells it at prices that *defy competition!* Working wax into foundation a specialty. Wax wanted at 26 cents cash, or 28 cents in trade, delivered here. Millions of *Sections* - polished on both sides. Satisfaction guaranteed on a full line of *Supplies*. Send for catalogue and be your own judge. **AUG. WEISS,** Hortonville, Wisconsin.

18



98

This is the original one-piece section-man who furnishes one-piece sections as follows:—

500 sections, \$1.50; 1,000 for \$2.50; 3,000 for \$6.75; 5,000 for \$10.00; 10,000 for \$17.50.

No. 2 sections are not made to order, but when in stock are sold at \$1.50 per M.

J. FORNCROOK,

Watertown,

Wisconsin.

WINTER

Losses are not always the result of the same cause. They may come from starvation; from poor food; from improper preparations; from imperfect protection; from a cold wet, or possibly, a poorly ventilated cellar, etc., etc. Successful wintering comes from a proper combination of different conditions. For clear, concise, comprehensive conclusions upon these all-important points, consult "ADVANCED BEE CULTURE." Five of its thirty-two chapters treat as many different phases of the wintering problem.

Price of the book, 50 cts.; the REVIEW one year and the book or \$1.25. Stamps taken, either U. S. or Canadian.

W. Z. HUTCHINSON,

Flint, Mich.

A decorative border of stylized floral motifs surrounds the text. The motifs are arranged in a repeating pattern along the top, bottom, and sides of the page.

Gleanings at Half Price,

Or two papers for the price of one. We have made arrangements whereby, for a limited time, we can send either the *Farm Journal*, published at Philadelphia, or the *Poultry-Keeper*, published at Parkesburg, Pa., both fifty-cent monthlies, and the very best in their line, with *Gleanings in Bee Culture*, to a new or old subscriber, both for one year. But the conditions of this offer are that the money (one dollar) shall be sent in advance, and that all arrearages to *Gleanings*, if any, shall be squared up.

The Ohio Farmer and *Gleanings* both one year for \$1.10, to a new or old subscriber, if paid in advance, and all arrearages to *Gleanings*, if any, squared up. The *Farmer* is a dollar weekly, and is one out of a few really good farm papers.

The Farm Journal is now in its twenty-first year, and takes the lead among all low-priced agricultural papers. It is packed full of practical hints and suggestions; puffs no swindles, and inserts no humbug advertisements.

The Poultry-Keeper is monthly, edited by P. B. Jacobs, and published at Parkesburg, Pa. It has a tinted cover in two colors, and is beautifully gotten up.

Remember that, in order to secure any one of these three papers, in combination with *Gleanings*, the money must be paid in advance, and arrearages to *Gleanings*, if any, squared up. These offers are very low, and will be withdrawn soon.

The A. I. Root Co., Medina, O.

YOUR PROFITS

Next season will depend largely upon how your bees come through the winter. Many beekeepers believe that after bees are put into winter quarters nothing more can be done for their welfare until spring has come. All who believe thus, and all who believe that care is needed, but are a little uncertain as to what that care should be, ought to buy the book **ADVANCED - BEE CULTURE**, and read the chapter entitled "Care of Bees in Winter." Remember, too, that the book contains 31 other chapters.

Price of the book, 50 cts.; the Review one year and the book for only \$1.25.

W. Z. HUTCHINSON,

Flint, Michigan.

Listen! Take my advice and buy your bee supplies of August Weiss; he has



tons and tons of the very finest

FOUNDATION

ever made; and he sells it at prices that *defy competition!* Working wax into foundation a specialty. Wax wanted at 26 cents cash, or 28 cents in trade, delivered here. Millions of **Sections**—polished on both sides. Satisfaction guaranteed on a full line of **Supplies**. Send for catalogue and be your own judge. **AUG. WEISS,** Hortonville, Wisconsin.

18



98

This is the original one-piece section-man who furnishes one-piece sections as follows:—

500 sections, \$1.50; 1,000 for \$2.50; 3,000 for \$6.75; 5,000 for \$10.00; 10,000 for \$17.50.

No. 2 sections are not made to order, but when in stock are sold at \$1.50 per M.

J. FORNCROOK,

Watertown, Wisconsin.

WINTER

Losses are not always the result of the same cause. They may come from starvation; from poor food; from improper preparations; from imperfect protection; from a cold, wet, or possibly, a poorly ventilated cellar, etc., etc. Successful wintering comes from a proper combination of different conditions. For clear, concise, comprehensive conclusions upon these all-important points, consult "ADVANCED BEE CULTURE." Five of its thirty-two chapters treat as many different phases of the wintering problem.

Price of the book, 50 cts.; the REVIEW one year and the book for \$1.25. Stamps taken, either U. S. or Canadian.

W. Z. HUTCHINSON.

Flint, Mich.

Violin for Sale.

I am advertising for the well-known manufacturers of musical instruments, Jno. F. Stratton & Son, of New York, and taking my pay in musical merchandise. I have now on hand a fine violin outfit consisting of violin, bow and case. The violin is a "Stradivarius," Red, French finish, high polish, and real ebony trimmings, price \$14.90. The bow is of the finest snakewood, ebony frog, lined, inlaid (pearl lined dot) pearl lined slide, German silver shield, ebony screw-head, German silver ferules, and pearl dot in the end, price \$2.50. The case is wood with curved top, varnished, full-lined, with pockets, and furnished with brass hooks, and handles and lock, price \$3.50. This makes the entire outfit worth an even \$20.00. It is exactly the same kind of an outfit that my daughter has been using the past year with the best of satisfaction to herself and teachers. Her violin has a more powerful, rich tone than some instruments here that cost several times as much. I wish to sell this on fit, and would accept one-half nice, white extracted honey in payment, the balance cash. It will be sent on a five days' trial, and if not entirely satisfactory can be returned and the purchase money will be refunded.

W. Z. HUTCHINSON, Flint, Mich.

G. M. LONG, Cedar Mines, Iowa, manufacturer of and dealer in Apiarian Supplies. Send for circular. 1-96-6

Please mention the Review.

I am advertising for B. F. Stratton & Son, music dealers of New York, and taking my pay in

MUSICAL INSTRUMENTS.

I have already bought and paid for in this way a guitar and violin for my girls, a flute for myself, and one or two guitars for some of my subscribers. If you are thinking of buying an instrument of any kind, I should be glad to send you one on trial. If interested, write me for descriptive circular and price list, saying what kind of an instrument you are thinking of getting.

W. Z. HUTCHINSON, Flint, Mich.

QUEENS Reared from imported mothers, warranted purely mated, 75 cents each. Breeders, \$1.25 each. No better stock to be had at any price. Send for catalogue of queens and bees. DEANES & MIXER, Ronda, N. C.

Make Your Own Hives.

Bee-Keepers

Will save money by using our Foot Power Saw in making their hives, sections and boxes.

Machines on trial.

Send for Catalogue.

W. F. & JNO. BARNES CO.,

384 Ruby St.,

Rockford, Ills.

6-97 12t

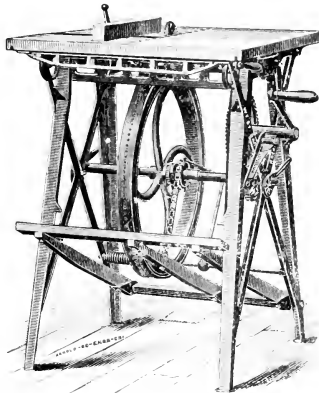

COMB

FOUNDATION

WHOLESALE AND RETAIL.

Working wax into foundation, for cash, a specialty. Hives, Sections, and a full line of Supplies. The best of everything. Write for Catalog, with prices, and samples of Foundation and Sections. Beeswax always wanted for cash or trade.

GUS. DITTMER,

10-97-12t

Augusta, Wis.

The A. I. Root Co.'s Goods, WHOLESALE AND RETAIL.

Holy Land YOUR CHOICE Golden Italian
QUEENS.

The best that knowledge and ten years' of experience can produce.

Untested Queens.	One	Six	Twelve.
In June, July Aug., Sep.,	.75	\$4.25	\$8.00
All other months,	1.00	5.00	9.00
Tested Queens.	1.50	8.00	15.00

E. R. JONES,

3-98-12t

Milano, Texas.

Without Stopping

the machine to reverse the combs is the way you can work with the Williams Automatic

Honey Extractor.

Such an extractor will save you time and annoyance and it does not cost much more than an ordinary machine. Send for descriptive price list.

Read what the famous bee-keeper, N. E. France, says:

PLATEVILLE, Wis., July 5, 1897.
Dear Sirs: To day I extracted 2,780 lbs. of honey with your Automatic Honey Extractor in 5½ hours and could have done the same this afternoon but let the boys go to the city to play a game of base ball. Have extracted 27,135 lbs. so far with good prospects for as much more. My bees and State work keep me very busy. Hope to see you before very long - will write you later.
Yours truly, N. E. FRANCE,
State Inspector of Apiaries,
Platteville, Wisconsin.

We can also furnish choice queens, either golden or leather colored Italian, at 75 cents each, or two for \$1.40.

Van Allen & Williams,

6-98-tf.

BARNUM, Wis.

THE INDEPENDENT.

NEW YORK.

CHANGE OF FORM.

REDUCTION IN PRICE.

Semi - Centennial Year.

THE INDEPENDENT emphasizes its Fiftieth Year by changing its form to that of a magazine, and by reducing its annual subscription price from \$3.00 to \$2.00; single copies from ten to five cents.

It will maintain its reputation as the Leading Weekly Newspaper of the World.

THE INDEPENDENT in its new form will print 3,640 pages of reading matter per year at a cost to subscribers of \$2.00, while the prominent magazines, which sell for \$1.00 a year, print only about 2,000 pages. The subscriber to THE INDEPENDENT gets 82 per cent. more of equally good reading matter at one-half the cost!

ONLY \$2.00 PER YEAR,

or at that rate for any part of a year.

Send a Postal for Free Sample Copy.

THE INDEPENDENT,

130 Fulton St., N. Y.;

Please mention the Review

The No-Drip Shipping Cases

Are what you need in marketing your honey. They are clean, neat and convenient, and a great help in making sales.

Root's goods at Root's prices. Cash paid for wax. We want your trade.

M. H. HUNT, Bell Branch, Mich.

Please mention the Review

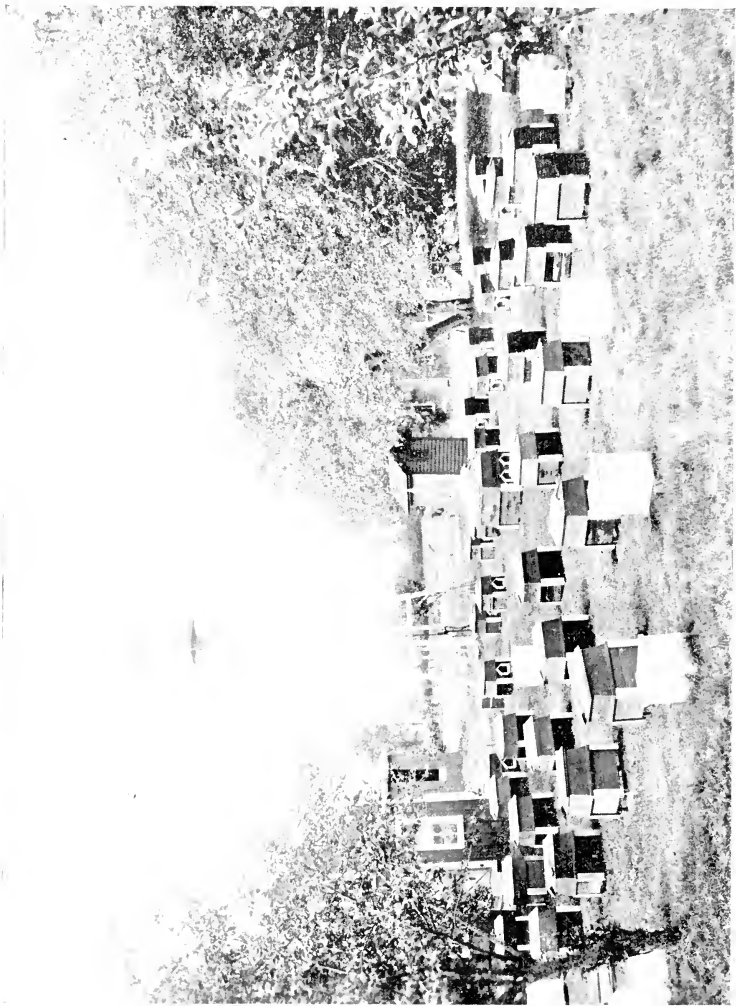

The Neatest Apiary in Michigan—M. H. Hunt's.

The Bee-Keepers' Review.

A MONTHLY JOURNAL

Devoted to the Interests of Honey Producers

\$1.00 A YEAR.

W. Z. HUTCHINSON, Editor and Proprietor.

VOL. XI. FLINT, MICHIGAN, DECEMBER 10, 1898. NO 12

BEAUTY AND NEATNESS.

They are of Considerable Importance in the
Aptary.

ELMER H. HUNT.

If eyes were made for seeing,
Then beauty is its own excuse for being.
EMERSON.



MANY people have the idea that a man who is not fitted for any other vocation, has talent enough to be a farmer. The time was once, too, when any one who had sufficient moral courage, could be a bee-keeper. Happily, thanks to science, that time is past. Farmer or bee keeper, he must read, study, and experiment in order to be successful. The man who is contented to keep bees in the old-fashioned way, because that is the way he learned, can not compete with his wide-awake neighbor, who makes use of the experience of others. New methods and new inventions are constantly being

brought before his attention, which he must either accept or reject. This is where his judgement and past experience will be of use to him. But there are other points to be remembered that play a prominent part in his business. I will refer particularly to beauty and neatness in the aptary.

Neatness is tact dressed in its working clothes, and is a fairly accurate barometer of a man's usefulness. Work done carelessly is never done right; but if a man takes pains to do his work neatly, he is quite sure to do it well. If the arrangement of his hives is slipshod without any idea of symmetry, you are led to suspect that he is careless in his care of the bees through the honey-season. Beauty and neatness may not seem, at first thought, a source of profit, financially at least. But have you tried it? The bee-keeper that lets the grass grow up in front of his hives is leaving hindrance sufficient to strip him of several pounds of honey every year. His honey-house, unless constant care is exercised, will be made unsightly by leaky sections, broken combs and propolis. Neatness will pay here in the wax it will save. Every bee-keeper should, as far as he is able, create a market in his own vicinity for his honey. Neatness and cleanliness are the two

essential points here. People are unwilling to eat the produce of an untidy man. They don't like to buy extracted honey from a dirty looking can, with perhaps a fly or bee to be fished out occasionally. Neatness here will be his trade winner. His honey-house and his honey-can can be his best advertisement, or the ruination of his trade, if honey can be secured from some other place. How long would your store-keeper hold your trade if his untidiness were so apparent as to become offensive to you? You would probably look elsewhere for your groceries if such were the case.

There are many clever ways by which one can not only make their apiary beautiful, but often time more convenient. I have in my mind a bee-keeper whose daughter is something of an artist. She added to the beauty of her father's apiary by painting over the entrance of each hive a bit of scenery or landscape. The effect was pleasing; but this, of course, is not practicable for us all; but will serve as an example of one of the many things a person can do to make an apiary attractive.

In our own yard the hives are arranged in two squares; or rather a square within a square. All the hives face the centre of the yard, at which spot stands a large hive so arranged as to accommodate four swarms of bees. This we have found a very convenient hive to use. The flag of our country floats from a staff on its roof; and as our hives are painted red and white, it adds to the beauty of the yard. It is not only patriotic, but, as it floats on the breeze, it has a tendency to accustom bees to motion. It seems very reasonable to me that it would have this effect; and, although our bees are within a few yards of the house, it is a very rare occurrence for them to trouble us. The ground is dug out where each hive is placed, eight inches larger all around than the hive. Four cedar stakes are driven into the ground for the hives to rest on. The part dug out is then filled with coal cinders and packed hard. This leaves a

space all around the hives free from grass, and allows room for the lawn-mower to be run. We have found cedar stakes more satisfactory than hive stands, because the moles cannot work around them to such an advantage, and change the hives from their level. In driving these stakes a square frame is used for a guide, and a spirit-level to get them true on top. Our yard has been laid out in this way for twenty years, and during this time the grass has always been kept short, and we know that it pays.

There is another fact that has a bearing on the care of the apiary. Most bee-keepers follow up this vocation in connection with something else. The farmer with his forty or eighty acres finds that his bees add a good sum to his income, besides furnishing his family with the choicest of sweets. The market-gardener also finds that it pays. The fruit-man has his bees do a double duty by having them fertilize his flowers. Professional men find them a pleasant pastime for leisure moments. Nearly all bee-keepers, in fact, divide their time between the bees and some other occupation, and because of this the bees often suffer for want of better care. His other business is liable to take the bee-keeper's attention away from his bees, except to do what is absolutely necessary to insure a fair crop of honey; and sometimes results in their getting less attention than this. However, the bees cannot furnish him with employment at all seasons of the year (not in this State, at least) as other work is necessary if he is to be a busy man. His bees at certain seasons of the year will suffer worse from neglect than anything else he has; but he will find it to his advantage to give them their share of his time.

In treating this subject, it would hardly be doing justice to the bee not to give her her due as to neatness and beauty. Who has seen a better piece of workmanship than that of the honey-comb? Neat, because of its cleanliness, and its greatest possible economy of space. It is tact

dressed in its working clothes again. It is beautiful in the eyes of every lover of nature. Surely the example of the bee is a worthy one for its keeper to follow in the care of the apiary. But, dropping all other arguments, it is well worth a man's time to give his apiary this care merely for the satisfaction he will derive from it. It carries with it the spirit of "Whatever is worth doing at all is worth doing well."

BELL BRANCH, Mich. Nov. 16, 1898.



SECTIONS AND SECTION CLEANERS.

Also a few Hints in Regard to the Construction of Shipping Cases.

L. A. ASPINWALL.



IN ANOTHER season's experience with plain sections fully sustains their reputation. I find them well filled to the corners, notwithstanding the slow flow of honey. Although an occasional section

was found that bulged opposite the separator passage ways last season, not a single occurrence of the kind has been noticeable this or other previous years. The honey yield of 1897 being exceptionally good, necessitated a removal of all sections from the hives as soon as finished, to prevent any excess of filling.

In all probability I shall make no effort toward farther improvement in sections. I may eventually adopt a tall section in preference to the square; still, no argument or reason has thus far been presented to influence me in that direction in the slightest degree. I saw tall sections in the Albany market upwards of twenty years ago; and conclude that such were

originally made to accommodate supers and frames shorter than the standard Langstroth. I think the Hetherington-Quinby hive, as made by Hetherington Bros., is somewhat shortened. If so, these large producers would certainly popularize any shape they might adopt. Furthermore, a change of shape or fashion usually attracts attention, and is in keeping with much, not only in the fashionable, but in the business world. However, the best is as good as any, and men of good judgement usually adhere to it.

In the distant future a scarcity of basswood or other suitable timber may necessitate a new construction or new material; still, such a change is not an immediate necessity. The construction of a strong and cheap separator that will obviate the necessity of a holder or frame, slats, super, or anything cumbersome, is the only thing needful in the line of appliances for comb honey. A deep cover is preferable to a super that cannot be taken apart upon removing the sections; and stored in a small space. Deep covers occupy no valuable room when on the hives, and are advantageous in protecting the supers from the direct rays of the sun in extremely warm weather, which will often cause the bees to suspend all work.

Referring to section cleaners, and section cleaning, the plain sections offer obvious advantages in favor of their adoption. However, the wonderful success of my present machine is certainly greater than I first anticipated, it being adapted not only to plain, but to old style sections. The speed attainable in cleaning plain sections is far greater than I first supposed could possibly be. The highest speed I have thus far attained was at the rate of 192 sections per hour, being upwards of 2000 per day. The test of speed, however, was upon a few; and possibly with a larger number I would have failed to maintain that record. Still, I am by no means an expert as yet; but I believe that, in the hands of such, 100 sections could be cleaned per hour.

My present machine does not remove all stain of propolis from the wood; which I believe will serve as a trade mark of pure honey. Several articles that have already appeared in the American Bee Journal and Gleanings, expressive of the artificial taint which might be entertained, have convinced me that the machine as now constructed will be the most desirable.

A valuable feature in my present machine is that of durability; compared with emery cloth or sand-paper, which will gum in cleaning 25 or 30 sections, in this locality. More than 2,500 sections have been most thoroughly cleaned without any breakage, and withal, the machine is not perceptibly worn. The transcendent point of excellence is, the machine requires no sharpening.

Plain sections, as I have previously shown, occupy less space; consequently lessen the size and cost of shipping cases about 20 per cent. All bee-keepers are especially interested in lessening the expense of those supplies which, in the nature of things, are transient and must be purchased annually. Having made a few changes, I give herewith what will answer equally well in the construction of one, two or three-row cases. Although I prefer the two-row, the single one is very cheap and convenient, being made of narrow or cull lumber, with a proportionally small piece of glass. The sections pack beautifully with no side-play; an important feature in transportation. Preferring as I do a size for 12 sections in the one and two-row cases, I will give the dimensions of the pieces; the construction being alike for any size which may be required. For a single-row case $\frac{1}{4} \times 4\frac{5}{8} \times 19$ sides are used. The rear end piece is $\frac{3}{8} \times 4\frac{5}{8} \times 4\frac{1}{4}$, plump, in order to give width to receive the sections easily. Front end pieces for glass $\frac{3}{8} \times 1\frac{1}{2} \times 4\frac{1}{4}$, plump, rabbeted instead of a saw-kerf. These front pieces nailed within the sides retain the glass, which is held in place by the first section. The saw kerf in ost cases is objectionable, being too

small for many pieces of glass, as well as too frail. The bottom piece is $\frac{1}{4} \times 4\frac{1}{4} \times 18\frac{1}{4}$, nailed inside. The top is $\frac{1}{8}$ thick, otherwise the same as the bottom; and fits within, resting upon the sections, and, for home or local markets requires no fastening save a string. The two-row case sides are the same in width and thickness, 13 inches in length, with rear end, and front pieces 8 9-16 inches long; otherwise the same as the single-row case. The top and bottom are respectively $\frac{1}{8}$ and $\frac{1}{4}$ thick, $12\frac{1}{4}$ long and 8 9-16 wide.

Aside from the advantages of the simplicity of construction and beauty of finish, the laying aside of the no-drip feature further lessens the cost.

JACKSON, MICH. Nov. 16, 1898.



READING THE BEE JOURNALS.

What is Wanted in Them, and how to get
The Most out of Them.

HARRY S. HOWE.



WHEN I first began working for Mr. W. L. Coggshall, in 1885, the introduction that he gave me to the theory of bee-keeping, came in the shape of a big bundle of Gleanings and American Bee Journals.

These, he said, would answer my questions, as well as furnish me with some idea of what the bee business was like.

As soon as one lot was read, another was forthcoming, until I had read the files of those papers, from their beginning, as well as several bee books.

The method which I followed at that time in reading the papers, and still follow

with a slight modification, is to note, first, any idea that might be of practical value to me. Second, new theories that seemed worth studying further. Third, methods that did not seem to be as good as the ones in use in the apiaries under my care.

In addition to the above, there was a great collection of articles which, although carefully read, were of no value to me, or at least not of immediate value. These were, first, articles on queen-rearing, or other special branches which I did not work at. Second, articles giving methods which were of value only under some special conditions which we do not have in this locality. Third, and largest class, rehash of things fully proven, reports of beginners, controversies over unimportant points, descriptions of new hives, etc.

Of course, many things which seemed of slight interest to me were of value to some one else, or probably they would not have been printed; but this article is written entirely as the result of *my own way* of looking at it.

Having noted the articles, the next thing was the discussion. As Mr. Coggshall's apiaries average about ten miles from home, and there was plenty of time for discussion while on the road. As we drove along, I would either read, or repeat the substance of, one of those marked articles; and Mr. Coggshall would discuss the merits and demerits of the plans advanced; and often of the writer's views as well; telling personal experiences to prove his points and giving reminiscences of some conventions where he had met the writer of the article under discussion. In this way I soon came to have an idea of the relative value of the work of the different writers. One of the first questions asked in the case of a new author was "Is he a success, personally? Are the ideas advanced as the result of successful personal experiments, or are they mere theories evolved out of the reading of some other man's work?" If the man was not making his plans *pay*, they

received scant consideration. The final test was, "Will it pay?" By this touchstone, all of the new theories and plans were tried, and usually found wanting.

Whenever there was a plan which stood the test of these discussions and of the careful figuring of cost compared with probable profits, it was tried on a small scale; and, if found to be adapted to our local conditions, it was made part of the regular system upon which Mr. Coggshall runs his bees.

As the years went by, and, with the growth of the business, other young men were employed to assist in the work, I saw that Mr. Coggshall tried them by that same old bundle of papers.

Often have I heard him say of a new man or of a neighbor who was starting in the bee business, "He will never make a bee-keeper;" or, "That man will be all right. He wants to read all he can about bees." The end usually showed that he was correct in his estimate of the man.

As fast as new bee papers came out we would try them by much the same standard that the articles in the papers were tried. If they had enough bee knowledge to make it worth while to read them, they were kept on the list; if not, we stopped reading them. I may say in passing that the larger share of new papers did not seem to fill any long felt want.

As years went by, and I came to have charge of an extracting crew, I have tried to live up to the traditions of the past by using a part at least of the hours spent on the road in discussing the current problem of bee keeping with the other boys; and I may say right here that these discussions have been of more value to me than all the reading. The men Mr. Coggshall has hired from other localities have brought with them more practical ideas than the papers have. They have been mostly men who had had experience with some successful bee-keeper before coming here; and so have been able to see and to show us where our

system was inferior to the one they had studied.

For the last few years I have not had so much chance to enjoy those long bee talks with Mr. Coggshall, as we do not now very often go to an apiary together. The apiaries have become so numerous that it is usually necessary to visit two upon the same day, and the result is that Mr. Coggshall takes one of the boys and goes one way and sends me another way.

This season we read the Review, Gleanings, American Bee Journal, and American Bee Keeper in about the order named; although when any two chance to come together, I am like the boy who sat down between two pies; it doesn't make much difference where I begin.

In reading a special trade paper one wants information on that special topic. That is, when one wants to be amused, or to read wordy discussions as to the exact shade of meaning to be given to the word "canine" he will read the papers devoted to that sort of literature; while if bees, or sheep, or any other special branch is what he wants, he will read that kind of a paper.

Of course, if a man reads only one paper, and I suppose there are such men, he would want it all in, but at Coggshall's house there are papers devoted to each of the special subjects of interest to the members of the family; so, in the bee paper, what we most want is *bee-literature*.

In conclusion I will give the plan I now follow in reading the bee papers:

1. Re-read the articles that seem of especial value.
2. Discuss them with any bee-keeper who gets in range.
3. Test a few of the best ideas on a small scale at first.

Lastly, read all of the advertising matter in each paper.

ITHACA, N. Y. Nov. 11, 1898.

TAKING OUR OWN MEDICINE.

How Monopolies and Trusts rob Bee-Keepers and Others.

C. M. DOOLITTLE.



DID the readers of the Review see what a wry face Bro. Taylor made in taking his own medicine? (See page 314 of October Review.) In criticising Bro. Taylor I paraphrased a

sentence of his, using "Heddon hive" in place of "production of queens," and he exclaims at once "an error"*** is gratuitous, if not unkind." Well, that was just what I thought, when he attributed queen rearing to be my motive in practicing the plan I did for the prevention of after-swarms; but instead of saying so, I allowed Bro. Taylor to take his own medicine, and the readers of the Review have seen that he takes medicine with no better "grace" than the rest of us. Certainly, if Bro. Taylor thinks the Heddon hive is a good thing, it can be no more sin to "wish to engage others toward a favorable opinion of that hive," than for Doolittle to do the same regarding "queens." Then his last sentence on page 314 gives the reader the understanding that he knew when he said the same, that he was advancing "gratuitous, if not unkind thoughts" regarding Doolittle's plan of preventing after-swarms; so I may be allowed to say to the reader that Doolittle did not spend to exceed 15 minutes "in the hot sun" with his plan during the past season, and not more than three hours during 1897. The production of honey and thousands of queens requires some labor aside from prevention of after-swarms. But I freely forgive Bro.

T. for all his sharp little hits at me, in as much as he says he is perfectly willing that the readers of the Review shall use any plan that will give them "ease" and "comfort," and because I believe him to be writing *solely* for the good of the world, and not from any "sinister motive." And now, Bro. Hutchinson, I wish to say, without your withholding my name, that I *thank* you for introducing the "Department of Criticism," for it is of great worth, and I read it with rather more avidity than I do anything else published in any of the bee papers. This department gives the Review the *lead of the other bee papers* in a new direction, and one of profit to us, as it is well for us sometimes to "see ourselves as others see us." So keep Bro. Taylor "firing away," at Doolittle and others, as he sees the need of doing, only let him do it in the spirit of *love* toward the one criticised, and bee-keepers in general.

I see by page 304 of October Review that Bro. Hasty is still firing away at that "wicked act" of facing comb honey. If I have read him aright during the months which have passed since this facing matter came up, the "crime" of facing consists in robbing the buyer and "lowering" the price of honey to the producers. This is in accord with Bro. Snyder's first article, found in February Gleanings, page 83, which was the leader in the matter. Snyder there asserts that the facing of comb honey "has caused more mischief and done more to lower prices than all other evils combined." Thus we have the matter presented like this: It is a "wicked act, mischievous and dishonest" to rob bee-keepers and others, through the facing of honey, and such facing has done more to *lower price* (rob) than all other evils combined. This can be the only meaning presented, when carried to a logical end. In past articles I have proven that the "dishonest" part set up was a myth, and now I wish to prove the fallacy of Bro. Snyder's assertion.

How does the lowering of the price of honey rob bee-keepers? Let us take a

look at the matter and see if we can find out. Lower prices for honey could not possibly rob bee-keepers, if the price of *ALL other things was lowered in proportion*. But it has not. Why? Because many of the necessities to bee-keepers are held by monopolies. Let us see how monopoly robs the bee-keeper. Two miners struck a rich vein of gold. The heat was intense, and there was no water. The gold they could not drink. Without drinking they could not live, and without life the gold was of no value. Their vein was worthless until they discovered near by a freak of nature. A brook sprang from the ground, cool and sparkling, and after running a few feet suddenly disappeared. The miners were rejoiced. Now they could toil on. In the course of time a stranger came into the valley. They were glad of company; they showed him how fortunate they had been in discovering the brook, and urged him to stake out a claim, for there was gold enough for all. The stranger did not like digging for his own gold. Instead, he staked his claim around the brook. He put a barbed wire fence about it. He erected a stockade and supplied it with men armed with rifles. Then he told the miners that if they wanted water they must bring him half the gold they dug. They were at his mercy, for he had a monopoly on one of the necessities of life. No man can get \$1,000,000 without a similar monopoly; and there are 156 trusts and monopolies on the wants and the necessities of bee-keepers to-day; robbing them all the while; taking from them through that monopoly "fence" of something for which they give no *equivalent*. The taking from bee-keepers in this way, was what I meant by "unearned incomes" and "unearned charges," as spoken of in the June American Bee Keeper, and which seemed to be a "riddle" to Bro. York's "Bee Boiler," friend Hasty, and others. Every bit of gold taken from the miners through that fence and rifles was by way of unearned charges or unearned incomes. Now, if the read-

er of this, takes Gleanings, I want him or her to turn to page 816 of the November first (1898) number and read the fourth notice in the first column, regarding the price of glass advancing. Three years ago I purchased my glass at \$1.25 a box. Two years ago, I paid \$1.79 a box; and last year when I wrote for prices, \$2.35 was the best I could do. I wrote for an explanation. "All glass factories have gone into the trust," was the reply I got. It costs no more to produce glass to-day than it ever did, if as much, and the *extra price* (unearned charges) is taken from the bee-keeper through that "barbed wire fence," or robbery. Wonder if the "Bee Boiler" and Hasty can see it now. When a bee-keeper builds a hive, the nails to hold it together are from the Nail Trust, capitalized at \$100,000,000; and, should he paint it, the oil to mix the paint is from the Linseed Oil Trust, capitalized at \$18,000,000; and if he uses any glass about it or his honey, it is from the American Window Glass Trust, capitalized at \$20,000,000. To light his smoker, a match is struck from the Diamond Match Trust, capitalized at \$11,000,000; and the oil he uses for the light necessary to go into his bee cellar is from the Standard Oil Trust, capitalized at \$97,500,000. Should he get sick and want medicine he must patronize the Wholesale Druggists' Trust, capitalized at \$25,000,000; and should he die, the chances are that he would be put away in a coffin from the National Casket Trust, capitalized at \$10,000,000, and the lid screwed down with screws from the American Screw Trust, capitalized at \$3,300,000. Let the bee-keeper turn which way he will, the monopolies and trusts gouge and rob him all along the road from the cradle to the grave; and yet with all this before him, Bro. Snyder had the audacity to tell us that the "facing" of honey had more to do with the robbing of bee-keepers than all other evils combined.

In 1874 I drew away my honey at 28½ cents a pound, taking the whole crop,

buckwheat honey and all, at the same price; and on my return home I purchased coal at \$3.50 a ton. The Coal Trust has now forced the price of coal up to \$5.00, and honey has gone down to less than 10 cents, taking the whole crop together, and yet it costs less to produce a ton of coal than it ever did; the miners being in a starving condition from the low wages the Trust allows them. And the bee-keepers are wondering how it comes about that prices of honey are so low, and that the miners and others do not use honey regularly on their tables. A year ago last June sugar was put up one cent a pound through this unjust system; and every bee-keeper and his family has been compelled to pay that much to the Sugar Trust on every pound of sugar they have used ever since. And it now comes out (through our colonial expansion ideas) that the *full* cost of the best refined granulated sugar is only 2½ cents a pound, the rest going to the Trust, because it could build a fence around the thing. And how came this wicked unjust system to prevail in our land? Because bee-keepers have abetted and sanctioned the same. And after doing this, they have dared to lift up in holy horror, their black, foul hands, hands covered with the blasted hopes of bee-keepers, the groans of the oppressed, the cries of the orphans, and the tears of the widow, because Doolittle had something to say about the facing of honey *not* being a dishonest act, when said honey was shipped *on commission*, and the opposition has taken up column after column in our bee-pipers, spent the larger part of one session of the Bee-Keepers' Union convention, and "shouted at the top of their voice" about the wickedness of "facing," but not one single word about this unjust system which is doing more toward injuring those engaged in apiculture, than all the columns written on practical bee-keeping can do good. I charge that the opposition has established a system of private ownership of natural resources, which ownership licenses a few

to exact toll from every bee-keeper in the United States for the privilege of living on the earth; and I stand ready to defend that charge in a gentlemanly and loving way. As Christ said to the accusers of the sinful woman which was brought to him, "Let him that is without sin among you cast the first stone."

BORODINO, N. Y. Nov. 29, 1898.

A Condensed View of Current Bee Writings.

E. E. HASTY.

"I'll trace the garden o'er and o'er,
And meditate on each sweet flower."

NO, comrade Miller, that apology to Mrs. Bee will not be forthcoming. Hasty wouldn't be Hasty unless he could face the nearly unanimous company of his fellow bee-keepers, and smoothly tell them that they are wrong. The habit of calling the worker bee "she" is a mere fad, not well founded in the facts, not in accord with the best usage of our language; and the rest of the human race not bee keepers neither follow nor like the usage. Unless I mistake badly, Bible usage, and literary usage, and household usage are all three in accord in allowing masculine forms to be used for real females, whenever the matter of sex is immaterial or inconspicuous (especially when the writer desires his reader to ignore it) and still more is this the case with bees, which are not practically females but neuters. At our house they are raising a nice calf. Its name is Dinah. The two little boys of the house and their mother are specially interested in the calf. Now when Dinah's name is put in a sentence the pronouns must of course be feminine; but otherwise masculine pronouns are heard sometimes. "*He* capers." "*He* has very small and quite sharp horns." "*He* thinks it a solemn duty to drink up

all that's offered him, no matter how much there may be of it." If I am right, this style of speaking is nearly or quite universal; and popular usage, when founded in reason, always defeats in the end even the great grammarians of the language—and Hasty figures that you will be defeated, ought to be if you are not.

What are the absolute facts of the case? The worker bee (barring a few exceptional ones) is *anatomically* a female but *functionally* a neuter. If we say "he" we contradict the anatomical truth. If we say "she" we contradict the functional truth. Can't help doing one or t'other. Which then, is the most important aspect of the two, that we may contradict that? I think that we must say that the anatomical aspect is usually less important. The strictly logical result would be the use of neuter pronouns; but neuter pronouns, used of living things, give a stiffness to our discourse which is not agreeable. Both speaker and hearer feel better when the pronouns are thrown into the masculine, which is perfectly admissible. Though you paint an inch thick you can't get rid of the ugly fact that readers will feel that sex must be important in some way if feminine pronouns, in non-figurative discourse, are used of an insect; and that is really the most important consideration we have to meet in the case. Tell you what ails you brethren. You are proud of knowing more about the bee's gender than the laity do; and therefore you must needs be airing your wisdom before them, just as callow preachers air their Hebrew.

THE PROGRESSIVE.

In November '97 R. C. Aikin began a series of papers on his experience and its lessons which have continued to the present date. Directly, Doolittle, who is the big assistant editor of the *Progressive*, responded with extended criticisms; and this collocation of the views of two very able apiarists has for some time been the characteristic and leading feature of the magazine.

Aikin tells us that a Colorado *June*, as well as previous months, draws heavily on the old stores of a colony to get through it. Progressive, 307. How's that for "locality"?

Here's a strong sentence on the too big brood chamber. "After all, the honey is stored somewhere; far better than to have a *dwarfed colony* not capable of storing. Progressive, 309.

Aikin's last efforts are in outlining a new hive, with trisected brood chamber, which appears to have not been sufficiently tried yet by anybody. And Doolittle gives it to him hotly about his theoretical bee-keeping. Quinby was an apostle of big hives, and favored a brood chamber of 2,000 to 2,500 cubic inches. Aikin's first outline is 6,144. But presumably he doesn't intend that supers shall *always* be put on over the whole space. It seems that Mr. D. once used, for two seasons, some twenty hives which held bisected frames. Didn't like them.

I am a trifle surprised to see that Doolittle is getting weak in the knees as to his advocacy of the Gallup frame and hive. If beginning over again, and intending to winter in the cellar, he rather thinks he would adopt the Langstroth frame. Progressive, 312. About the same here, and I *don't* winter in the cellar.

On page 283 Aikin says that it seems to be an undisputed fact that bees will not rear brood freely unless they have on hand plenty of stores to back them. I guess that's about so; although hard on the doctrine and practice of stimulative feeding. Yet the undisputed maxim is not quite *always* true. An occasional colony does starve to death in midsummer because it has an immense lot of young brood and nothing sufficient to back it through a few days of cold rain.

On page 238 a rather absurd non-sequitur is indulged in in reference to the clipping of queens. Mr. A. clips with scissors without catching the queen; and he says you will not clip her feet because she is walking on them. Rather strange for-

getfulness of the fact that a queen has six feet, of which four are plenty to stand on. If I am right the queen is very free to use her extra feet as hands if she is touched. And the cutting off of her feet is one of the very common and very deplorable incidents of clipping. Doolittle's method is evidently greatly superior—pressing a sharp knife blade directly on the spot to be cut, and then cutting by a slight draw, when you are sure there can be nothing but the wing under the blade.

On page 241 Doolittle mentions a valuable manipulation in preparing for winter that is not familiar to some of us. It is for the common case where there is barely enough honey for winter and most of it in the outside combs. The danger is that they will first eat all the honey in the center combs, then move to one side and eat that clean; and when they need to make the long move across to the other side a cold spell may be on and such a move impossible—else they don't remember that there is any more honey to be struggled for. Mr. D. says put the four lightest combs at one side, and the heaviest ones right next to them. Then the cluster will start on the light combs and move steadily across the hive, securing all the honey without necessitating any break up and long move.

Aikin says he has retailed nearly a ton of candied honey in three months, mostly in 4-pound pails. Progressive, 217. Rest of us must make a note of it. Most of us think that selling honey in the candied state is a desirable but unattainable trade.

To halt swarming Mr. A. makes nuclei with the good queens, kills the poor ones, and cuts off every queen cell. Cell cutting is repeated the eighth (or preferably the ninth) day after. He emphasizes the fact that the seventh day will not do—worst kind of a worker-queen will result, and a swarm. He has proved his method by eight years' practice. Progressive, 151.

Putting all brood, except a little for a rallying point, above an excluder, and the queen below on another set of frames, he thinks is going to work as well, and

be but half the work. When all brood above is sealed, the entire lower story is made a nucleus by carrying it away. But in this case a cell, or some sort of royal daylight, will have to be given at the old stand to keep them from stopping work.

Doolittle uses the fact that a colony of bees greatly swells in volume when a honey flow comes on, as proof that field bees do *not* put the nectar in the cells themselves. Probably it's true that they don't, but the proof offered is hardly logic. Nothing to hinder the hive bees from immediately stocking up on the proceeds for wax secretion purposes. He also thinks that sufficient brood chamber space, *if filled with clean empty comb*, will always prevent swarming. Thinks it isn't true that all worker larvae will be sealed the eighth day. Has found in a number of cases several hundred in each hive after over eight days had passed. *Progressive*, 155.

That escaped swarms *sometimes* just wander from place to place until they find a hollow to go into can hardly be doubted; but both Aikin and Doolittle, on pages 114 and 118, give strong evidence that sometimes they select a home before starting. During the summers of '90 and '91 Mr. Aikin saw thousands of bees exploring all sorts of places, houses, boxes, cracks, holes and empty lives. This hunting was only when they had queen cells; and with the passing of swarm conditions the exploring ceased. Mr. Doolittle adds that the first Italian bees in his vicinity selected an empty hive in a neighboring apiary, were detected at it by their unusual color, their owner heard of it before the swarm actually left home, and with the help of a lively horse he stood by that hive to see his run-aways come down and go in. Presumably in locations where hollows are scarce the policy of setting decoy hives for run-away swarms is more profitable than elsewhere.

Doolittle reminds us that when moving bees if the load stops long near other col-

onies that are at liberty, the smell of the imprisoned ones will attract many from the outside; and severe stinging may follow from a cause not usually thought of.

Aikin says that loads of supers of honey containing more or less bees may be hauled without any fear or fussing *unless there is a queen or a patch of brood somewhere*. In this latter case the bees will rally at that point and very quickly put on their fighting clothes.

When he first located in Colorado he hit a place where the honey resources were nothing at all or almost that; and the last of his twenty colonies perished of starvation inside of a year. He says that far the greater part of the State is in the same predicament.

Mr. Aikin tried reversing sections to prevent the obnoxious and frequent bee space under the bottom. Failed—and decided in his own mind that it must always be a failure. Reversing one section at a time is of course too fussy; and when you reverse a whole case at once the combs in some sections are pretty sure to be so thin and weak as to topple over—unless you wait so long that many sections are done and beyond any beneficent change.

He also threw up the sponge about close spacing with hanging frames on which no spacers are used.

It's rather late to compliment editor Leahy's travel notes, which ran through the early part of the year; but I think that late in this case may be a little better than never. I did not read them till reading up for this View. In fact, I have pretty thoroughly *failed* in doing the reading necessary for such articles as these. Well, I want to say, even now, that Mr. Leahy is one of the very rare few who know how to write articles of travel—can actually give us the little touches of live nature we are delighted to get—and spare us the ponderous information and immaterial details which usually render travel articles dreadful. It is one of the puzzles hardly solved, why sensible people (people who write well on some

topics) should be foredoomed to stuff their narratives of travel with dull rubbish, when they actually ran against things with which a traveler of Mr. Leahy's class would delight us. It isn't faultlessness that is required, for fault could easily be found with this series of papers if one desired to do so. But it would be a strange being that could read the series without being a better person for it. And what does a flaw or two count against winsomeness, when coupled with resolute zeal to make one's own corner of this bad world a little better? Surely you must travel again, friend Leahy.

The Progressive is a good hand to keep its old departments rather than to be fitfully changing them. Some of them are nongermine, too, notably the department of instruction in law, by lawyer Sprague. *Sommambulist* and the poet Will Ward Mitchell still hold their places. In the November number comrade F. L. Thompson appears both as a bee writer and as a poet. I hadn't caught on to F. L. T.'s being a poet before, and therefore I prick up my ears.

It seems that sweet alyssum, one of the plants of the old fashioned flower garden, has got loose in Colorado, and has become so plentiful that this year it began to yield surplus honey. Its honey is well flavored and light amber in color. Friend Thompson finds the difference microscopic between the new "fence" and the old separator, as to getting the sections well filled. *Progressive*, 313.

Fred Thorington has a department now called "Straws from the Apiary." On page 317 he reminds us that sometimes one case of sections is better as a super than several tiered up—if we will take pains to remove sections individually when they get full. Much less danger of a lot of half built ones to close with. August 29th his bees were still in swarming mood, which is pretty late for swarms.

J. E. Crane well says that the inexperienced find it hard to realize how much harm exposure to wind will do in an apiary. In the same apiary the windy side

or corner often loses bees much worse in winter than the rest of the yard. *Progressive*, 290. Same with me.

Sommambulist says that every time he sees sweet clover he is reminded how excellent is its continuation quality. *Progressive*, 258.

I was going to go on and give several selections from *Sommambulist*; but *Sommambulist*, though a very pleasant writer is also a very unquotable one—as he dispenses his gas and dreams—won't it do just as well to refer all you'uns to the original pages? In fact, I don't know but the dreamers, whose stock in trade can't be stolen and retailed around at second hand, are to be congratulated on that incidental.

RICHARDS, Ohio; Nov. 26, 1898.



EDITORIAL Offerings.

A. MERRY CHRISTMAS and a happy New Year is what I most sincerely wish all who read these words.

.....

THE PROGRESSIVE BEE-KEEPER will pay \$50. for the best bee-story. For further particulars write to the Leahy Mfg. Co., of Higginville, Mo.

.....

MR. C. DAVENPORT, of Southern Minnesota, whose intensely practical and interesting articles have appeared occasionally, during the past year or two, in *Gleanings* and the *American Bee Journal*, will begin for the *Review*, in January, a series of articles that will run through the year.

.....

MR. HUNT'S APIARY, the picture of which appears this month as a frontispiece, is the neatest I have seen in Michigan—yes, or anywhere. If anyone else has a neater apiary, I wish that he would send me a picture of it and let it appear in the *Review*. Until this is done, Mr. Hunt will wear the belt.

MICHIGAN STATE BEE-KEEPERS will hold their annual convention Dec. 30 and 31, at the King Hotel in Reed City. Let all come who can.

THE ONTARIO Bee-Keepers' convention, from which I have recently returned, was marked by peace and pleasantness; and many are the little items of interest and information that I picked up while there; but there is not room to give them in this issue. Next month they will begin to appear, and will continue to do so, on fitting occasions, until all have been held up to view. The next meeting will be held at Toronto.

WHEN RENEWING your subscription tell me about yourself, your family, your bees, your crop of honey, your market, or anything else about your surroundings that you think may be of interest to me. Tell me what you think of the Review and its different departments. Tell me what there is about it that you like and what you dislike—be free with your suggestions. These chatty letters, in which I can catch glimpses of my subscribers, are really of more help to me in making the Review bright and fresh than many of you may think.

THE KIND OF CRITICISM THAT IS WANTED.

Publishing a department of criticism in a bee journal is something new, and it is evident that time and a little patience will be required before it can be so conducted as to suit the greatest possible number of readers.

The criticising in regard to undesirable language may have been needed, I am inclined to think it was, and that good will result from the shaking up that some of us have received, but I doubt if good will come from continuing it much longer. I am not writing this because Gleanings has an editorial taking the same views, as I had arrived at that decision before I saw the editorial in Gleanings. Bee-keepers

subscribe for the bee journals for the information that they are supposed to contain regarding the profitable management of bees; and they are not particularly interested in long-drawn-out discussions regarding the language in which this information is given.

Neither do they care for hypercriticism; especially upon unimportant points. For instance, they don't care so very much if Bro. York did make a mistake in applying the rules for the new phonetic spelling that he is trying to popularize.

What they care for is the substance, the *idea*, rather than the form or style in which it comes clothed. I grant that the latter is of some importance, but not of so much as the former.

The kind of criticism that is most needed, is similar to that that pointed out the fallacy of removing a queen from a colony and allowing the bees to choose the larvæ from which to rear queens, thinking that larvæ of the best age would be chosen; or of using a two-story, eight-frame, Langstroth brood chamber in attempting to produce comb honey. Such errors as these need pointing out; but there is no necessity of being severe—one can be outspoken and frank and yet be kind. Bro. Taylor, pick out the errors that, if believed in and put in practice, will lead to undesirable results—let the others go. If this should shorten up your department, never mind; it will improve it and place it above criticism.

SUCCESS—IT COMES ONLY WITH HARD
STUDY, COURAGE, THOROUGHNESS
AND GENUINE ENTHUSIASM.

—

Attempt the end, and never stand to doubt;
Nothing's so hard, but search will find it out.
HERRICK.

—

The most important point is to think, *think*, THINK. Not in the ordinary, desultory manner, but in a strong, clear, steady, persistent manner, with some

definite object in view. Take up some question that you wish decided, and give it earnest, continued thought. Think all around it. Look at it from every side. Gather information upon the subject from every possible source; then think about it; go over the ground over and over and over again. Think about it so much that, if you wake up in the night the subject will come to you. There is such a thing as acquiring skill in thinking out and deciding difficult problems. As the thinking is continued day after day, new thoughts will come. They will pop into the mind at a time and in such a way, almost unconsciously, as it were, as to surprise one. One thought is sure to lead to or suggest another; and soon there is a foundation upon which to build a new plan. When sufficient thought is given to a matter it is astonishing to notice how seldom a wrong decision is made. It is wise to use all possible sources for hints or suggestions, and for means of stimulating the mind. To get the "seed thought," so to speak, is the most difficult; the others follow on quite easily; and it is to get this first thought that all available means should be employed. It is for this purpose largely, that I now, as a bee-keeper, read the bee-journals—not simply to be told exactly how to do this or that, but for the stimulative effect that it has upon my mind. I get ideas, hints and suggestions that *set me to thinking*. It is the same in regard to the typographical work upon the Review. Some of you may remember that soon after I started the Review, I saw that some radical change must be made if it were to prove a success. Careful thought and investigation showed me that the profits were all going to the printer—that to succeed I must print it myself. The best front room in my home was given up for an office, materials were purchased, and I set out to master a new branch of industry—that of printing. No one will ever know how I studied and worked, how I haunted the printing offices and read the journals devoted to printing. I went into it with all of the

enthusiasm that I did when I began bee-keeping. That enthusiasm is still with me. I still read the typographical journals, and look over the leading magazines of the day, but now it is more for the stimulative effect upon the mind—for suggestions. But few of the ideas are carried out literally, but they have their influence upon my mind, and that, in turn, has its effect upon the Review.

Another important factor in the problem of success is that of thoroughness. "Oh that is good enough," has kept many a man from success. Nothing is good enough so long as it can be made better. When I was making the photographs, three years ago, for use in the bee-keeping articles that I wrote for the *Cosmopolitan*, I took infinite pains with the work. My wife would often say "Why, Will, that is good enough." So long as I could see a fault I was not satisfied. As soon as a negative was developed I would begin finding fault with it—if I could. I never gave up until each negative was as good as I could make it.

I beg pardon for referring in this egotistical manner to my own work; but I have succeeded in some things, and I know it, and I know how and why I have succeeded, and if I can help others by the telling of it, I think that I may be excused.

One more illustration: When I decided to put a new cover on the Review, and to use colored ink, the questions arose, what kind of paper shall I use? What color shall it be? What colored ink shall it be? Samples of all kinds and colors and styles of cover paper were ordered. Specimen sheets printed with ink of different colors were also secured. After numerous combinations were considered, samples of inks were ordered and used in printing the front cover picture of the Review upon specimens of the paper under consideration, in order that I might see the *exact* effect. In going about the city I was always noticing the colors in which houses were painted and trimmed; in fact, I reached that point where I could put col-

ors together, when I awoke in the night, and note the effect almost as well as by actually laying them side by side. Soon after getting out the first issue of the Review having the new cover, I visited my mother-in-law; and among the first things that she said to me was: "I admire the Review's new cover. I think that it is a handsome combination of colors." I felt then that my thoroughness had not been in vain—that I had succeeded. I have been trying other colors again this fall, but I have not found anything that suits me any better.

I once heard Prof. Beal, of our agricultural college, tell of his first experience as a pupil of Agassiz. Agassiz gave him a shell, an oyster shell or something like that, and asked him to examine it thoroughly and then write a description of it. It seemed a simple thing to do; and the report was soon forthcoming. Agassiz asked: "Is that all you can find? Try again." He went at it again, and soon found something more. He kept on for several hours, and found quite a number of things not seen at first. A second report was then written and submitted. It was commended, but he was urged to still further search. This was kept for one *whole week* before Agassiz was satisfied with the report. In telling of this, Prof. Beal said that after he had been examining the shell for three or four days he could see it just as clearly whether he was looking at it or not. This is thoroughness.

Enthusiasm must not be overlooked. If the feelings in your breast, as you go to your work, are akin to those of the galley slave, driven to his task, success will never be yours. If there is not that about your work that fills and thrills you, that leads you to forget fatigue, hunger and even yourself, then you have missed your calling. Enthusiasm over one's work is an absolute necessity. If you can not arouse yourself and take some interest in your work for the *work's sake*, then find some work in which you can. Enthusiasm in one begets confidence in

others. As I heard Mr. Heddon say, the last time I met him, "I have no faith in the man who has no enthusiasm."

I can not mention all of the points that have a bearing on success, but I must say a few words about courage—I had almost said *daring*. I think that many men fail because they are afraid—they don't dare to go ahead and take chances. They are afraid that they may make mistakes. Figuratively speaking, they stand on the bank shivering, not daring to brave the dangers of the dark waters, while the more courageous plunge in, strike out boldly, and finally reach the promised land. No, I don't advise hastiness nor rashness; go over the ground carefully, thoroughly, and "be sure you are right," or as near right as you can be, then, having fully decided what is best, go to work earnestly, enthusiastically, boldly. There is even a sort of momentum, or rush, gained by this method that actually carries one over rough places and overturns obstacles that would otherwise bar the progress.

Once more let me refer to myself. A year or more ago I saw that if the Review was to become the success that I wished it to be, "something must be done." Weeks passed ere I fully decided exactly what to do. After I had decided what to do, then came the courage to spend money for new type, better paper, more pages, a new cover, more and better engravings, better correspondence, and extensive and "pushing" advertising. Every dollar thus spent has come back, bringing another dollar with it. Suppose I had been lacking in courage—some call it "nerve?"

Just a word about taking advantage of modern methods, inventions and improvements. When I bought a type writer several years ago, it seemed as though I could not possibly afford it. Experience soon showed me that I could not possibly afford *not* to have it. Then came the bicycle that enabled any member of the family to make the trip down town and back in one-third the time

needed for walking. A few months ago I put in a telephone. That certainly did seem like an extravagance at the time, but I know now that it is an economy.

My bee-keeping friend, are you sure that you are doing the best that you can under the circumstances? Are you using the best hives and fixtures? Wouldn't it pay you to have a better honey extractor? A reversible—possibly an automatic reversible? Is your wax extractor the best there is? Is your smoker, your honey-knife, and all of these little tools and conveniences the best that can be secured? Are your buildings and hives so arranged that you can work to the best advantage? Have you the best kind of bees? Are you producing the kind of honey that is the most profitable for you to produce? Are your methods of marketing the best? Would it pay you to start an out-apiary? Would it pay you to *discontinue* some of your out-apiaries? Would some other locality be better for your business? If it would, would it be advisable to go there? Are all of your methods of management the best? Are you reading all of the literature there is that may furnish you thoughts, and suggestions, and ideas? But why multiply subjects, they are almost endless; the question is, have you given them all careful thought, and brought to bear all of the information possible? Or do you "just think so," in an easy, careless, indifferent sort of way, with no very definite idea as to *why* you think so? Rouse yourself! Take yourself by the shoulder and shake yourself until you are wide awake. Think, read, work, be courageous, energetic and enthusiastic, get the best there is, and *compel* success.

One more illustration: Some one, in talking with a successful German regarding his good fortune, quoted the saying that "Fortune knocks once at every man's door," and the German replied as follows: "Mine friendt, I did not wait for her to knock, I vas holding der door open for her ven she came."



Department of criticism

R. L. TAYLOR.

Blame where you must, be candid where you can,
And be each critic the Good-natured Man.
GOLDSMITH.

THE DANGERS OF A HIGH TEMPERATURE IN THE BEE-CELLAR.

In the American Bee Journal, 741, in response to a question concerning the cellar temperature for wintering bees, it is stated that "with good pure air 65° could be borne for a considerable time and it might do good to have that temperature for a day or so when the bees become uneasy in winter. It is possible that 65° continued for a week or two might start bees to breeding—an undesirable thing in winter—but with pure air, darkness and quiet I should hardly expect it." I think the greatest evil resulting from a too high temperature is the loss of bees from their leaving their hives. We are accustomed to the teaching that such bees as leave the hive would die under any circumstances, and that they are better away from the hives. This no doubt is largely true when the temperature is kept below the point at which bees are accustomed to seek the open air, but when that point is exceeded I am more and more inclined to the belief that they begin to seek a way to the light and the open air; and the longer their confinement the greater is that inclination; and it is natural it should be so. It is what they do when they are wintered outside, and we may reasonably expect them to do the same thing when inside. I have become satisfied that 50° is too high a temperature, even for the dampest cellar, though it might do no harm if continued only for two or three days at a time. Cellars differ, but the

right temperature, as determined by the quietness of the bees, will generally be between 40° and 45° . The strength of the colonies will also be found to have something to do with it. The weaker the colonies the higher the temperature they will bear with impunity, and at the same time the harder will it be to get and keep the higher temperature.

CARRYING BEES INTO THE CELLAR.

In the same journal, 711, in reply to a question as to the best way to get the bees into the cellar for the winter, the answer is in substance: Don't smoke or disturb them. Get them in at a time when they are not easily stirred. This is sound and unobjectionable, but the answer goes on "if they are very troublesome about flying out, take a big cloth make it pretty wet, then lay it against the entrance so no bees can get out." This would be intolerable if many colonies were to be so treated, and it is not necessary. I should say take them in on a cloudy, dark day, when there is little or no wind, with the temperature between 30° and 45° . See to it before hand, that the part to be taken in, whether the hive without the bottom board or the hive with it, is loose and will be found loose at the proper time, so there will be no noise or jarring when it comes to be taken in; then, when the time comes, pick it up firmly but gently and put it in its winter's resting place as quickly as possible. I carried in 160, or more, five days ago, without the bottom boards, and hardly a bee took wing. When they are to be taken in without the bottom board, in case the cluster reaches down so as to rest on the bottom board, it is advisable to raise one end of the hive from the bottom board with a block a day or two beforehand, so as to compel the cluster to draw up into the combs.

THE PERPLEXING SUBJECT OF TEMPERATURE IN BEE-CELLARS.

On the same page is the question, how should I ventilate a cellar 18 x 29 feet and

8½ feet deep to winter 23 colonies in it? After explaining different methods by which ventilation could be secured, the answer goes on "if the number of colonies is not more than 23 it is possible that your cellar may winter all right without any special attention." As I look at it, the chief difficulty to be encountered in such a case is not the matter of ventilation but of the temperature. The normal winter temperature of most cellars is much too low for the successful wintering of bees. If the cellar mentioned is an average one the successful wintering of so small a number as 23 colonies in it may require strict attention. The reason of this is that 23 colonies would, without aid, be found insufficient to raise the temperature to the proper point. If the temperature goes no lower than 40° in the severest weather, when not occupied by bees, the cellar would do excellently probably for 23 colonies; but if it goes to 30° then more bees, or some other device, would be required to bring the temperature up sufficiently to make successful wintering certain. To another question the answer is that 100 or more colonies ought to be comfortable in such a cellar. As to that, one cannot say with any degree of certainty without knowing the cellar. My cellar, which is a little smaller, takes 150 to 250; something depending on the strength of the colonies. Then a cellar that is warm in severe weather is cool in warm weather and a cellar that is very cold in severe winter weather is apt to go to the other extreme, in warm weather; and with such a cellar a fight is almost inevitable at one extreme or the other, and very likely at both.

DISTURBING BEES IN WINTER IS NOT NECESSARILY INJURIOUS.

An answer in the same journal, 678, contains this: "The only trouble is that they may not have a flight again for a few weeks after being moved, and the disturbance of moving will be bad for them." This is a time-honored opinion,

but I have never found any good reason for accepting it. At one time I disturbed some of my bees a good deal during the winter, but I always failed to detect any evil effect. And if we look into the reason of the thing, why should it be expected to have any bad effect? Grant that the bees may consume a little more honey, say twice as much as they would have consumed that day if they had not been disturbed, that at the worst would only be equivalent to adding one day to the length of their confinement, which would not usually be considered a very serious matter. To be sure, they are liable to load up with honey, but that no doubt will be unloaded without injury to the bees when the disturbance ceases.

A SAFE METHOD OF INTRODUCING QUEENS.

On page 727 instructions are given to enable a novice to "make a sure thing" of introducing a queen. Two or more frames of brood, all capped, and some hatching, and "every last" bee brushed off, are shut up bee-tight with a comb or two of honey in a hive for five days and kept sufficiently warm. That is substantially all. I don't know when would be the best time to let the queen in but I suppose not until a handful of bees appear.

DISCUSSION ON "NATURE'S WAY" TOO LONG DRAWN OUT.

On page 698 we find there is room in Beedom Boiled Down, too, for ringing the changes on Nature's plan in the queen laying the first eggs. Wouldn't it be wise to put Nature's plan in this matter in its little bed?

A DOUBTFUL FOUL BROOD CURE.

In the same department, page 713, appears another easy way of curing foul brood. It comes from over the water. It is done by "vigorously smoking (sic) every two or three days in the evening for two weeks." Whatever that may mean, I hardly think I would trust it.

BOILING FOUL BLOODY HONEY FIFTEEN MINUTES IS SUFFICIENT TO KILL

THE GERMS.

Dr. Miller (Gleanings, 790) has found a statement that confirms him in the opinion that foul-broody honey should be boiled 2½ hours to make it a safe food for bees, so he returns to the subject and expresses the opinion that possibly I am giving dangerous advice in saying that 15 minutes are enough. I have had considerable experience in this matter; sometimes boiling combs honey and brood altogether to get them out of the way quickly; always aiming to have the boiling continue 15 minutes; and such honey I have fed in considerable quantities to a good many colonies; and it never carried the disease. Every one who has anything to do with foul brood should be careful and continually on his guard, but it is worse that useless to boil honey 2½ hours to kill the germs of foul brood which it contains.

HONEY IN THE COMB DOES NOT LOSE ITS FLAVOR AND AROMA.

The editor of Gleanings and Dr. Miller are having a discussion of the question whether comb imparts a flavor to the honey it contains. The editor thinks it does, and as proof cites the fact that so many prefer comb honey, and suspects that those who prefer extracted honey do so for convenience in eating. He says further, "only yesterday I was eating a nice sample of comb honey and one of extracted, both clove", but it seemed to me the comb had the better flavor." (Gleanings, 790, 826) The doctor thinks comb has practically no flavor to impart, but confesses "I always prefer the honey that has run out on the bottom of the plate." I like to see brethren agree. Can they not make common ground of the fact that the comb preserves the aroma and the fine flavor of the honey? Honey exposed to the air readily takes up moisture and its aroma is as readily dissipated; hence it is that so many prefer comb honey, notwithstanding the undesirable presence of the wax. There

are very few, I think, who are not like the doctor in that they would prefer what has run out presently on the bottom of the plate.

THE DELIBERATE AND PERSISTENT
ERRORS OF THE EDUCATED ARE

THE ONES TO POINT OUT.

Dr. Miller has an article in *Gleanings*, 831, on apicultural literature. He seems to complain that I single out *Gleanings* for criticism and says that I stated in substance as a reason for so doing that errors were more plentiful there. I think I said in substance more plentiful picking, and the doctor has perhaps naturally misconstrued it. I made no effort to "pick" everything even in *Gleanings*. It would do no good to spend time on errors in opinion, language, grammar or otherwise that are mere slips, nor errors made by the unskillful; the pointing out of which would be superfluous. When what seem to me errors are committed deliberately, and persistently, by the educated, then I see some chance of doing good by a gentle hint, and it is there I find the most "plentiful picking."

A LITTLE MORE ABOUT SLANG.

In the article referred to, the doctor, to my surprise, defends the use of the word "sass," and insists that it is not slang. But I have no time to follow him in that matter. What seems incongruous to me is that he immediately speaks of "scrooch" for "crouch," and says "I do not justify Mr. Root in using it as a correct word in *Gleanings*." He should use the correct word so that his readers would learn, if they have not already learned, to attach to the word "crouch" all the meaning they now give to "scrooch." Before leaving this matter, since the doctor thinks "sass" such a good word, I should like to ask him what he thinks of the following expressions: "Will 'bamboozle' you for using slang." *Gleanings*, 789. "I know for sure." *Gleanings*, 790. "It is one of the biggest things that the Union has to do." *American Bee Journal*, 707. "It

makes me feel badly." Ditto, 723. "It is a big thing to get the right kind of nails." Same page.

'TWAS SAID IN SOBER EARNEST.

We are all, no doubt, liable to inattention in construing the language of others; and sometimes it does not seem altogether excusable. As an instance of this Mr. Root has—I was about to say continually—proceeded on the assumption that I have been charging him with using slang. (*Gleanings*, 789, 826, 590, 737.) I do not say that slang has not been used, and that I have pointed it out as undesirable language, but I have no recollection of charging him with using slang. Another instance of this is found in *Gleanings*, 807, under the title of journalistic courtesy. The part I refer to reads as follows: "I am sorry to see that Mr. Taylor mars some of his criticisms by what I may call the lack of journalistic courtesy. For instance, in speaking of Doolittle this is what he says: 'His statement backed by the strength of his name furnishes what the editor of *Gleanings* would call heavy testimony.' I care not for myself; but the sarcastic reference to Doolittle's name is uncalled for. It adds absolutely nothing to Taylor's argument, etc." This is all very perplexing to me, though it helps to an explanation of some of the editor's previous strictures. My statement is a plain one, of a widely received fact, which is unquestionably complimentary to Doolittle; and as to the intimation that he (the editor) is also aggrieved I simply quoted a phrase which he is accustomed to apply to what he esteems important testimony. I am more amazed than ever when, (*Gleanings*, 826) after Dr. Miller intercedes for me, and asks him to apologize, he replies to the doctor: "Perhaps you are right; but when I first read it over and even now as I read it the impression is the same & & &. I gladly give him the benefit of the doubt." Forsooth! I suppose an "impression" allowed to have weight in determining the

meaning of language, but which the language itself does not warrant, is what we sometimes call prejudice.

Dr. Miller in pursuance of his charge, spurred on by my challenge, cites the paragraph beginning "The language of the masses" (Review, 280) as a sample of scolding. (Gleanings, 832) I hardly think I owe an apology yet.

VENTILATION OF SUPERS.

On the suggestion of an entrance directly to the super, instead of one below, as is usual, as a remedy for swarming, the editor (Gleanings, 789) asks: "Is it not possible that the honey in the supers would ripen more slowly because of the proximity of the opening?" Ventilation surely is a great aid to the ripening of honey, and would not an entrance to the supers give them ventilation? I should suppose that such an entrance would give better ventilation to the whole hive and I am sure the editor is not going to question the advantage of thorough ventilation.

NOT RESPONSIBLE FOR WHAT APPEARS OUTSIDE OF THIS DEPARTMENT.

One or two writers seem to have an impression that I am in some way responsible for what appears in the Review outside of my own contributions. (Gleanings, 807, and elsewhere) Let this be taken as a notice that the impression is groundless.

THE "TOM-CAT" STYLE OF CRITICISM.

The editor of the Canadian Bee Journal quotes from the Review, and, commenting, criticizes the "pussy-cat style." A writer in the American Bee Journal, 744, quotes, and changing the meaning to what he calls "tom-cat style" devotes his attention to that, furnishing, in so doing, an apt illustration of the sort of criticism he condemns.

AN ERROR IN THE REFORMED SPELLING.

Upon the same page I find the word "mealy-mouthit." I am not a competent judge of the reformed spelling, and so would inquire whether its rules permit the changing of final "ed" into "t" when

the sound to be indicated is that of "d," as in the word quoted.

IS BLACK REALLY OBJECTIONABLE TO BEES.

Much is being said in the journals in agreement with the notion that bees have an antipathy to black, but I fear without sufficient evidence. A writer in Gleanings, 845, says if you want to prove it, tie a strip of dark woolen cloth around the wrists one day while working among the bees. I venture to say that a strip of white woolen cloth around the wrists would draw as many stings as the black, if the latter is free from the odor of filth and dye. Bees dislike hairy garments. If you want to prove that bees dislike a light color undertake to handle them with uncolored buckskin gloves. I know of no other way in which one could deprive a colony of bees of their stings so quickly. Sometime since a friend went with me into the apiary when the bees at once attacked his black hat; very fiercely pelting it with their bodies, like hail, but to my black hat they paid no attention; which shows that the illustration which Dr. Miller uses against Mr. Hasty is not an apt one. (Gleanings, 826) We easily solved the matter in that case by the criterion of odor. To determine how little dependence bees put on the perception of color at stinging distance, move a colony, having a white hive, a little to one side of its accustomed stand, and put a dark hive of the same dimensions as much to the other side when the bees are coming in in large numbers and notice how many are deceived. No doubt that dark clothing, other things being equal, would receive more stings than light, but it would be, no doubt, on account of the odor, owing to the dye, or to the liability to let dark clothing go longer without washing. The case of black and white chickens cited can be explained by the greater natural odor of black animals over white ones; or by the fact that the greater effect of the sun on black ones makes their odor more perceptible.

LAFEEK, Mich, Dec. 1, 1898.

EXTRACTED.

THE SIZE OF HIVES.

Producing Comb Honey with either Large or Small Brood-Chambers; Some of the Conditions to be Observed.

We have been having quite a little discussion in regard to the size of hives or brood nests, particularly when one is producing comb honey, and I think that one of the fairest and most logical articles that have appeared lately upon the subject is from the pen of Mr. Doolittle, and was published in *Gleanings* of Nov. 1. It reads as follows:—

Question.—Is it true, as I see it advanced by some, that, if we use large hives, we shall have large colonies when working for comb honey, with no swarming? I see that quite a few are talking that way; and if this is a fact, would it not be well for us to drop all of our former notions regarding the contraction of the brood-nest, when working for comb honey, and give all colonies a great big hive, and so let the bees take care of themselves, very largely? for it is conceded by nearly every one that *labor* is the chief factor in the production of a crop of comb honey.

Answer.—All of the older readers of the bee-papers know that I have been an advocate of a brood-chamber as small as or smaller than nearly any one else, when working for comb honey, the same holding only nine Gallup frames. These nine Gallup frames give a capacity about the same as 6½ Langstroth frames would; and from a brood-nest of that capacity I secured an average yield of nearly 100 pounds of comb honey for each of the years between 1872 and 1883, from each colony I had during that time, spring count—a record which has rarely been excelled, and never equaled, if I am right, by any of the large-hive advocates. But I am free to confess that, without doubt, more labor is required in rightly managing such small hives than is needed in the larger hives. But with me it always seemed that, from the extra amount of honey obtained, I always secured enough to more than pay for the extra labor expended; and if so, could the cry of "labor saving" enter into the problem? The question is, "Which will give the best

returns for the amount of labor expended?" not, "With how little labor is it possible to run an apiary and secure any returns at all?"

But I wish to look a little at the statement often made, that "large hives will give large colonies, with little or no desire to swarm; and if any swarms do issue, they will be large swarms, not the little cramped-up things which always come from small hives," or words of that import, which are going the rounds of the papers, and which are doubtless what is hinted at by the questioner. I can look upon such talk only as a fallacy which has been passed from one mouth to another till those telling it really believe they are giving expression to words of truth; for with those nine-frame Gallup hives, I had fully as little swarming as I have had with ten-frame Langstroth hives, and the average of the swarms was not materially different as to size in either case. I am free to admit that, if each were placed side by side, with *no sections* on, the ten-frame L. hives would probably be later in swarming, and send out larger swarms; but, if I am right, no one working on the contraction plan treats his colonies in that way. With the small hive or brood-chamber, the sections are put on as soon as any honey comes in from the field, and the brood-combs are manipulated till the whole nine are *solid* full of brood and pollen; and when in this shape, if any honey is stored at all it must go into the sections, for there is no other place for it to go. Thus started *early* in the sections, the bees become accustomed to their surroundings, and thus these fully occupied combs of brood entertain the best queen to her capacity as to egg-laying; and, if so, how could a larger hive give any larger colonies, even though 100 L. frames were used? Large hives do not make large colonies any more than a large hat, worn all through our boyhood days, gives the world larger-headed men. If the queen has all the vacant cell room her prolificness requires, more room is only a damage to our crop of comb honey; for in the finding of many vacant cells in the brood chamber, at the beginning of the honey-harvest, comes an "accustomment" to the brood chamber" for storing honey, instead of the sections, and thus the queen is crowded upon with honey, instead of said honey going into the sections; and, with restricted room for her eggs, comes discontent, and from this comes the desire, and from the desire comes swarming, the very thing that we have been working to avoid.

Remember, we are talking about working for *comb* honey, or honey in *sections*, not extracted honey.

Some eight or ten years ago I was persuaded, through the urgency of a farmer bee-keeper living five miles from me, to purchase his bees, as he did not wish to bother with them any longer, so offered them to me for almost a song, and gave me the privilege of keeping them where they were as long as I wished, for 25 sections of honey a year. These bees were in ten-frame L. hives, and I have kept them in those hives, and at the same place, ever since I bought them, and thus I have had a chance to know about the workings of these hives as compared to the nine-frame Gallup hives of my own yard. The result has been that I can, by giving plenty of section room, hold these colonies at the out-yard back from swarming about a week later, on an average, than where the nine Gallup frames are used; but this out-apiary is no nearer being a non-swarming apiary than my home yard; and, in fact, I often consider them more determined to swarm than those here; but the swarming comes a little later in the season. And this *little later* in the season has quite a bearing upon the problem of comb-honey production, from my present standpoint, for, when colonies are managed by the caging-of-queen plan, as I gave last winter (I think in the January 1st issue of *Gleanings*, but I have no time to hunt it up), this holding back a week puts them in just the right condition to take advantage of the honey harvest when it comes, with the largest kind of working force all kept together, with no desire to swarm after the manipulation. In this is way I secured nearly 117 pounds of comb honey on the average from each of the 30 colonies there, this poor season, while those all about me, and that apiary, got little or nothing. But one thing I find, no matter what hive is used, or how many frames that hive contains, within the bounds of reason, either way, toward large or small brood-chambers, a given amount of labor *must* be performed, so that the "letting the bees take care of themselves" part of our questioner's query is nearly or quite a myth, if we expect to reap any great success from our bees. This labor part has been harped on so much that it has become a sort of bugbear, and a desire seems to have sprung up for a "holding of the pot to catch the porridge" sort of apiculture. Let us away with such a thought, for "in the sweat of thy face shalt thou eat bread" brings the highest joy that is attained unto in this life. To whom come the greatest joy

and contentment in life? Is it not to the one who has labored and toiled patiently, day after day, till at last the problem worked upon has been fully conquered and solved? And are not the discontented ones of our day those who are eating their bread from the sweat of the faces of others? No, no! there comes no real joy in rolling around in luxury while others toil to supply that *unearned* luxury which we are trying in vain to make ourselves believe is true happiness. 'Tis far more to our usefulness and happiness to "wear out instead of rusting out."

The editor of *Gleanings* replies as follows:—

[It appears to me, friene D., that you have overlooked in the discussion above a very important factor in the problem, and that is the one of locality, else perhaps you would not be so ready to pronounce the opinions and practices of others "fallacious." Last week I called upon Mr. S. A. Niver, who is at present managing the estate of the late Miles Morton. Said he, "Doolittle's methods may be all right for his locality, but they would not answer at all in this vicinity. Miles Morton used to say that many a bee-keeper, if he were to remove to Tompkins Co., would have to unlearn many of his old methods and acquire new ones." In a bee-line there is a distance of only about 17 miles from Borodino to Groton. What must be the difference between other localities separated by hundreds or even thousands of miles? You have no buckwheat worth mentioning, in and about Borodino. Your main dependence is upon clover and basswood. In Tompkins Co., later in the season, buckwheat is one of the main crops.

Even at our-yard only two miles north of us, I can see a difference in the conditions. Our north yard is near a river, with an abundance of fall flora. Our home yard has nothing of this sort to fall back on.

Now, if there is indeed so much being said in favor of large colonies, and a consequent reduction of swarms, there must be some localities favoring such colonies. There could hardly be so *much* smoke without some fire.

And there is still another factor I think you have not fully considered. If you were running a hundred or a thousand colonies you would have to operate quite a little differently from what you now do. W. L. Cogshall, whom I also saw last week, and who runs 1300 colonies, reiterated a former statment, that he could not afford to spend much time with individ-

ual colonies. He had to work on the wholesale plan. It was results he was after, in the shape of dollars and cents.

You say large hives do not make large colonies any more than large hats make large heads, as if you felt that some one had been holding to the affirmative. But even if large hats do not make large heads, may it not be true that bandaged feet may, as in the case of Chinese girls, make a nation of limping women? and,

similarly, may not small hives make scrimpy colonies? I think it is quite easy for us to combate opinions that are not entertained by anybody. Critic Taylor, of the Review, tried to make it appear that I believed that large hives would make large colonies, and you remember I said (page 519) that could be no more true than that big shoes would make big feet; but it is true that big shoes allow feet to grow to their proper size.—ED.]

General Index to Volume XI.

INDEX TO SUBJECTS.

Abbreviating the Names of Journals, 210, 245, 246
 Absconding, Prevention of 312
 Accuracy 269
 After-swarming, Prevention of 244, 267, 313
 Alley's Queen Rearing 178
 American Bee-Keeper's new Editor, the 81, 148
 American Bee Journal 15, 334
 Apple Blossoms, bees and 133
 Arrangement of hives 232
 Aspinwall, A visit to the Home of Mr. 277
 Bait Sections a benefit, Are 215
 Beauty and Neatness..... 357
 Bees, the Best 120
 Beauty, Importance of 203
 Bee-bread in Sections 217
 Bee-News from Over the Sea 334
 Blocks, Robbing when Hives are Raised on..... 181
 Black Arouses the ire of Bees 275
 Blue Pencil, Using the 335
 Book-Learning is Good but it is not Every-
 thing 16
 Boyden, Arthur L. 51
 Brood nest, Contraction of the 179
 Breeding can be induced by feeding, Late 151, 214
 Breeding of Bees 263
 Brood-Chambers, using Two-Story 283
 Buckwheat 149, 165, 185, 186
 Carelessness or Maliciousness..... 343
 Cane Sugar and Beet Sugar are Identical 216
 Carniolan bees 178
 Canded Honey, How to extract 147
 Cellar Wintering 153
 Changes in Plants and Animals. 135
 Cleaner, the Golden Section Honey 16
 Comb Honey, Managing Swarms for 46, 57
 Comb Honey up to a High Standard, Keep 116
 Comb Honey, Ridged Appearance of 51
 Comb Honey of its Deliciousness, are Modern
 Improvements Robbing 110
 Combs, Where to Keep Empty 7
 Color upon a bee's Vision, the Influence of a
 dazzling White 80
 Condensed View of Current Bee Writings 23,
 53, 82, 117, 143, 205, 271, 303
 Compliment Unwittingly Given, A Genuine 342
 Contraction of the Brood nest 179, 181, 203, 211, 242
 Critic Criticised, the 171, 267
 Critic, A few Words in Defense of our. 239
 Critic is Regarded, How our 308
 Crooked or Shaky Firms, How to Report. 115
 Criticisms, Replies to Mr. Taylor's 200
 Criticism 336
 Criticism, Department of 267
 Curing Foul Brood in Wisconsin 152
 Curling of Foundation in Sections. 152
 Disturbing Bees in Winter 86
 Dignified Editor, A 216

Discussions, 300, 308
 Drones and Their Influence 17, 27
 Drone Comb, the building of, 329
 Drawn Comb, Some Points in Using 184
 Eggs or Larvæ, Do Bees Move 313
 Eggs, Bees Don't Move 215
 Enthusiasm 204
 English, A Continued Plea for Good 342
 Entrances, Size of 341
 Entrance, A Handy rear 151
 Excluders, Queen 178
 Experiment, an Incomplete 341
 Experimenting on too Small a Scale 334
 Full Management 293
 Facing Comb Honey 58, 138, 140, 147, 242, 267
 Fairs, Making Exhibitions at 177
 Feeding wax to bees 113
 Fertile Workers, the Laying of 281
 Feeding of Sugar, the 283
 Fence Separators Afford better Ventilation, do
 328, 330.
 Fiddle, a Cornstalk 15
 Firms, How to Report Crooked or Shaky 115
 Foul Brood Laws, Needed Changes in 81
 Foul Brood, A Misleading Description of 280
 Foul Broody Honey, Boiling 281
 Foul Brood law that is perfect, a 74
 Foul Brood may be Disseminated by the Queen
 Traffic 177
 Foul Brood 39, 74, 81, 168, 177
 Foundation to the top bars, Fastening. 152
 Foundation, Some of the Advantages and Dis-
 advantages of the no-wall 8
 Foundation in Sections 343
 Foundation not Always Profitable. 315
 Foundation in Sections, Curling of 152
 Foundation the Thinnest of all, No-Wall. 103
 Foundation, the no-Wall 21
 Foundation and Sections..... 169
 Foundation, Some Views Concerning the No-
 Wall 46
 Foundation, Tests of Comb 103
 Fence-Separators 328
 Frames, Closed-end 142
 Golden an Artist, J. A. 148
 Golden Method of Securing Comb Honey 57
 Golden Section Honey Cleaner 16
 Grammar and Typography 184
 Grammar and Spelling 245
 Grading of Honey 276
 Heredity, the Laws of 166
 Hive Making 182, 312
 Hives, Bee-Keepers Ought to Make Their own 182
 Hives and Fixtures, Shall Bee-Keepers Make
 Their own..... 338
 Hives, the Size of 331
 Honey, Well Ripened 11

Honey Dew for Winter Stores.....	238
Hybrids are Preferred, Why	312
Invariability of Action in Bees.	311
Italian Versus Black Bees	43
Jealousy Among the Bee Journals, no Occasion for	337
Language, Unskillful use of	150
Larvae in Replacing their Loss, Bees select too old	339
Large Colonies Swarm More than Small ones	281
Large Hives and Large Colonies and their Influence upon Swarming.....	277
Language, A Strong Plea for pure Perfect	379
Larvae for Queen Rearing, Bees do not Always Choose the Best	215
Lime Influencing the Growth of Sweet Clover	147
Make their own Hives and Fixtures, Shall Bee-Keepers	338
Make their own Hives, Bee-Keepers Ought to	182
Maple, the Sugar	69
Migratory Bee-Keeping	80
Michigan, Northern.	261, 293
Money Producing Honey, How to make.	115
Muth, Sad Death of Chas. F.....	178
Nature's ways	298
Nature's Heart, Work with bees Keeps us near to	179
Northern Michigan.....	261, 293
Notes From Foreign Bee Journals 13, 47, 174, 201, 235, 260.	
Out-Apiaries	37
Painting Hives	178
Peddling Honey	154
Plain Sections Versus Strain of Bees	71, 107
Plain Sections, 5, 10, 12, 20, 41, 71, 169	
Populous Colony more Profitable in Proportion to its members, Is a..	308
Pollen is Gathered, When.	311
Profits of Bee Keeping	151
Praise a man to his Face, Shall we	51
Promptness and Exactness	41
Pure Food Congress	50
Queens are the Result of Simply Removing a Queen, Poor	337
Queen Rearing on a Large Scale	233
Queen Rearing	229, 233, 240
Queen Rearing, Alley's	178
Queen Excluders	178
Queen Breeders' Union	148
Queen, the Southland	15
Review that brings a Flush to the Cheek of its editor, Some Praises of the	111
Review, Some Comments on the	79
Review is Regarded by its Readers, how the	18
Record, Keeping a	265
Reading the Bee Journals.	360
Ripening Honey	218
Robbing when Hives are raised on Blocks	184
Scolded, Has the Critic.....	214
Sections, Combs are Easily Damaged in Plain	10
Sections, the Simple or Plain	5
Section after being Filled, a novel Method of Changing the old style to the Plain.	5
Sections the Result of free Communication, Well Filled	52
Sections, Plain	5, 10, 12, 20
Sections Severely Condemned, Plain	12
Sections are a Failure from an Artistic Standpoint, Plain	10
Sections, Some Points to be observed in Using Plain	41
Sections, Different Styles of	7
Sections Really Desirable, are Well Filled	71
Sections, Snow White	238
Sections and Foundation.....	169
Sections, the Width of	237
Section Cleaners	50, 107
Separators	169, 312, 330
Separators may be Dispensed with	330
Separators that do not seem well Sustained, Some Claims for	312
Selling Comb Honey to Grocers	247
Selling Honey	148
Side-Issues in Class-Journals.....	211

Simpson, Death of Clark.....	147
Shipping Cases	15, 238
Shipping Cases, Folding Paper for the Bottom of	238
Shipping Bees, Hints in Regard to	89
Slang	152, 238
Solar Wax Extractors	177
Southern Bee-Keeping.....	79
Spelling, Phonetic	152
Stings in Stinging one Another, Why Bees do not Lose their	153
Stimulative Feeding Unprofitable	182
Stimulative Feeding	312
Store the Most Honey, When Colonies	347
Sugar Maple, the	60
Sugar, the Feeding of	283
Success of two Women with Bees, the.	325
Success in Life, A Journal Devoted to.	119
Surplus Increased by Allowing only one Swarm	151
Swarming-Troubles	15
Sweet Clover, When to Sow	106
Sweet Clover Makes good Pasture	106
Sweet Clover a success on Lime Soils	101
Sweet Clover	101, 106, 120
Swarming, How to Prevent	198
Swarming, prevention of After-	244
Tear Down and Rebuild Comb, Why bees	182
Temperature and how it may be Modified, Something About	27
Temperature in the Shade.....	341
Theorizing be Allowed, to What Extent shall	335
Tongue in Bees, Length of	15
Typographical Beauty, Influence of.	111
Typography and Grammar	184
Unions, Consolidating the two Bee-Keepers'..	50
Union Ought to do, What the U. S. B. K.	216
Union may use What Strength it has, how the	280
Variation of Bees	75
Wax Extractors, Solar	284
Wax with Propolis, no Danger of Adulterating	150
Wax to bees, Feeding	113
Wax Rendering, a Pointer in	11
Winter Stores, Honey Dew for.	238
Wintering Problem, the.....	213
Winter, Disturbing Bees in.....	86
Wintering of Bees, Cellar	27
Willow Herb, the Great	197
Women with bees, the Success of two	325

INDEX TO CORRESPONDENTS.

Aikin R. C.	315
Akers Mrs. A.	204
Alverson A. A.	106
Aspinwall J. A.	8, 41, 107, 142, 298
Baldridge M. M.	7, 101
Beckwith I. W.	329
Bertsch D.	106
Bishop H. T.	185
Bingham T. F.	10, 46
Boardman H. R.	121, 330
Brown A. F.	89
Burrell H. D.	154
Crane J. E. 5, 43, 52, 75, 113, 135, 166, 198, 232, 265	
Craig Wm.	203
Danzenbaker F.	51
Daggitt E. A.	111, 263
Dadant C. P.	27, 86
Davenport C.	217
Doolittle G. M.	71, 120, 133, 149, 267
Ferris C. G.	110
France N. E.	168
Gemmill F. A.	39
Getaz Adriaux	169
Golden J. A.	16, 46, 328
Greiner F. C.	343
Harrison J. T.	15
Hasty E. E.	23, 53, 82, 117, 143, 295, 271, 303
Hasbrouck Prof.	346

Office of
THE **B**ee-KEEPER'S REVIEW,
Flint, Michigan.

My Bee-Keeping Friend,

If I am correct, your subscription to the REVIEW has expired. Having learned that the publishers of the REVIEW have their periodicals printed and distributed by special shill, unless I receive orders to the contrary, I shall send the REVIEW right upon receipt of your order. I will need your approval that you wish to continue. First, I enclose an order sheet and if you think it would be convenient for you to send a penny order, please say you desire the REVIEW until you receive another sheet for the time that you wish the REVIEW to continue. Say when you *can* pay, and I will send it.

But if you wish the REVIEW stopped, please return the order sheet, with a statement to that effect *immediately*, and you wish the REVIEW to stop, please bear in mind that, *if I do not hear* from you immediately, I shall enter that you wish the REVIEW stopped, and that you will shortly return the order sheet with a remittance.

Whether your decision favor or against the REVIEW, I most sincerely thank you for past patronage.

As ever yours,

W. J. HILLMAN, JR.

P. S. If you prefer to have the REVIEW stopped at the expiration of the time paid for, please say so when renewing, and your wish shall be complied with.

Heddon Jas.	12
Howe Harry S.	360
Hutchinson W. Z.	69, 197, 262, 325
Hubbard G. K.	247
Hunt Elmer H.	357
Matthews S. D.	227
Martin J. H.	77, 216
McEvoy Wm.	74
McNeal W. W.	57
Miller C. C.	138, 171, 209, 283, 309, 337
Miller A. C.	11
Ochsner E. D.	37, 263

Peete A. T.	79
Poppleton O. O.	284, 336
Pridgen W. H.	15, 50, 229
Quirin H. G.	233
Rogers L. M.	188
Snyder Aaron	58, 165
Stevens T. M.	331
Taylor R. L.	87, 103, 150, 181, 213, 242, 279, 311, 339
Thompson F. L.	13, 15, 47, 174, 201, 235, 269, 300, 331
Walker Byron	294
Wood Delos	215
York G. W.	246

Honey Quotations.

The following rules for grading honey were adopted by the North American Bee Keepers' Association, at its Washington meeting, and, so far as possible, quotations are made according to these rules.

FANCY.—All sections to be well filled; combs straight, of even thickness, and firmly attached to all four sides; both wood and comb unsoiled by travel-stain, or otherwise; all the cells sealed except the row of cells next the wood.

No. 1.—All sections well filled, but combs uneven or crooked, detached at the bottom, or with but few cells unsealed; both wood and comb unsoiled by travel-stain or otherwise.

In addition to this the honey is to be classified according to color, using the terms white, amber and dark. That is, there will be "fancy white," "No. 1, dark," etc.

KANSAS CITY.—We quote as follows: Fancy white, 12 to 12½; No. 1 white, 11 to 12; No. 1 amber, 10 to 11; fancy dark, 9 to 10; No. 1 dark, 9; white extracted 5½ to 6; amber, 5 to 5½; dark, 4 to 4½; beeswax, 25.

C. C. CLEMONS CO.,
Nov. 1, 521 Walnut St., Kansas City, Mo.

NEW YORK.—We quote as follows: Fancy white, 13 to 14; No. 1 white, 12; fancy amber, 11; No. 1 amber, 10; fancy dark, 9; No. 1 dark, 8; white extracted, 6½; amber, 5½ to 6; dark, 5; beeswax, 27.

HILDRETH BROS. & SEGELKEN,
Nov. 1 126 West Broadway, New York

CHICAGO, Ill.—We are having good trade and our stocks are light. Shipments can be encouraged and we quote as follows: fancy white, 14; No. 1 white, 13; fancy amber, 12; No. 1 amber 11; fancy dark, 10; white, extracted, 7; amber, 6; dark, 5 to 5½; beeswax, 27.

S. T. FISH & CO.,
Nov. 29, 189 So. Water St., Chicago, Ills.

CLEVELAND, O.—Demand for white honey is very good, and market firm. We quote as follows: Fancy white, 13 to 14; No. 1, white, 12 to 13;

Fancy amber, 10 to 11; No. 1, amber, 9 to 10; Fancy dark, 8 to 9; White, extracted, 7; Amber, 6; Dark, 5.

A. B. WILLIAMS & CO.
Nov. 29, 80 & 82 Broadway, Cleveland, Ohio.

BUFFALO, N. Y.—Our market is quite active on all grades of honey. Absolutely fancy, 1-lb., 12 and 13 cents; choice 1-lb., 11 to 12 cents, fair to good, 1-lb., 9 to 10 cents; all dark grades, 7 to 8 cents; extracted 5 to 6 cents. Beeswax 24 to 25 cents, and wanted. We believe in selling honey now.

BATTERSON & CO.
Nov. 29, 197 & 199 Scott St., Buffalo, N. Y.

CHICAGO, Ill.—Our market is in a healthy state; arrivals and sales compare about equally, but that there is no surplus—prices being well maintained. We quote as follows, fancy white, 13; No. 1 white, 11 to 12, fancy amber, 9 to 10; No. 1 amber, 7 to 8; fancy dark, 8; No. 1 dark, 7; white extracted, 6 to 7; amber, 5 to 6; dark, 5; beeswax, 27.

R. A. BURNETT & CO.,
Nov. 29, 194 So. Water St., Chicago, Ill.

NEW YORK, N. Y.—Demand for honey very good at steady prices. Receipts during the past few weeks have been fully up to the average years. Fancy white honey is in demand; other grades of white and buckwheat are plenty. We quote as follows: Fancy white, 13½ to 14½; Fair, 12 to 13; Buckwheat, 8½ to 10; Amber, 9 to 11; Mixed, 9 to 11. Our market is in good shape for all grades of extracted honey. We quote as follows: White clover, 6 to 7; Amber, 5½ to 6½; Buckwheat, 5 to 6; Florida white, 6 to 7; Florida light amber, 5½ to 6. Other grades of Southern honey from 55 to 65 per gal. according to the quality. Beeswax, during the past week, has shown a slight improvement, though we do not anticipate much more advance for some time to come. We are selling at 25½ to 26½ per lb.

When shipping, we would ask that all packages be marked plainly, the gross tare and net weight.

FRANCIS H. LEGGETT & CO.
Oct. 25, W. Broadway, Franklin & Varick Sts.

WM. A. SELSER,
10 VINE ST., PHILA., PENN.
White Clover Honey Specialist.

Farm Bee - Keeping

Is one of the leading departments in the *Modern Farmer and Busy Bee*, the best Farm and Bee paper in existence. Write for sample copy and for clubbing rates with any paper you want.

E. TAYLOR ABBOTT,
St. Joe., Mo.

SPECIAL OFFER—The price of the *Modern Farmer* and the *Busy Bee* is \$1.00, but I will club it with the *Review* for only \$1.60.

W. Z. HUTCHINSON, Flint, Mich.

Some Odds and Ends That Will be Sold Cheap.

For a dozen or more years Mr. M. S. West of this place dealt in bee-keeper's supplies. Since his death, two years ago, his daughter has endeavored to close out his stock of goods, and has succeeded to large extent. There are still a few odds and ends, and she has brought them to me and left them for me to sell. Here is a list of the articles with prices at which they will be sold.

One ten-inch foundation mill, (second-hand) Root's make, complete with dipping tank, etc. in excellent condition....\$10 00

One ten-inch foundation mill, (second-hand) Root's, (one of recent make) dipping tank, etc. in good order15.00

Three Woodcock foundation fasteners, each,75

Eighty seven entrance guards, each,05

Thirteen Porter Bee Escapes 2.25

Thirty-three Simplicity hives, in the flat, sides, ends, covers and tin rabbits but no frames nor bottom boards, each,40

Send all orders to W. Z. HUTCHINSON,
Flint, Mich.

THE MONITOR PAPER FILE

Binds securely and neatly all periodicals. Preserve your papers, magazines, pamphlets, bulletins, music &c., by binding them together as you get them. Each new number filed quickly and easily. Will bind 52 numbers of any periodical aggregating 1000 or fewer pages. All lengths from 6 to 28 inches. Light and handsome.

PRICE.—All sizes 12 inches and under 12 cents; over 12 inches one cent per inch. When wanted by mail add one cent for each 5 inches or fraction thereof.

For sale by the Publisher of this paper

Bee keepers should send for our

'97 CATALOG.

We furnish a full line of supplies at regular prices. Our specialty is Cook's Complete hive.

J. H. M. COOK, 62 Cortland St., N. Y. City

Please mention the *Review*

QUEENS, Untested, 75 c; 6 for \$4.00; tested, \$1.00; 6 for \$5.00; breeders \$2.00. The best stock, imported or golden. W. H. LAWS, Lavaca, Ark.

JOHN F. STRATTON'S

Celebrated



Band Instruments

ALSO

DRUMS, FIFES,

Piccolos and Band Supplies.

Send for **JOHN F. STRATTON,**
Catalogue. 811, 813, 815, 817 E. 9th St., N. Y.

I have several hundred

QUEEN CAGES

of different styles and sizes, made by C. W. Costellow, and I should be pleased to send samples and prices to any intending to buy cages.

W. Z. HUTCHINSON, Flint, Mich.

See That Wink?



WATER **POUDERS' AD**

Bee Supplies. Root's goods at Root's prices. **POUDERS' HONEY JARS** Prompt service. Low freight rates. Catalog free. **WALTER S. POUDER**, 162 Mass. Ave., Indianapolis, Ind., the only exclusive bee supply house in Indiana.

Beeswax Extractor.

The only Bees Wax Extractor in the world that will extract all the wax from old combs rapidly by steam. Send for descriptive illustrated catalogue.

C. G. FERRIS,
South Columbia, N. Y.

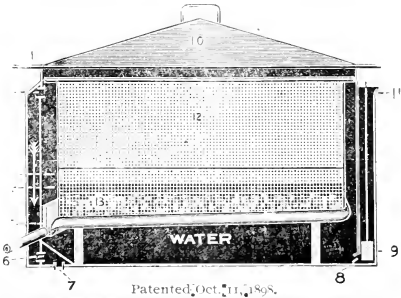

Wanted, for the Salvation Army Colony, Amity, Colorado about twenty colonies of bees. Address, stating price, etc., THOS. HOLLAND, Amity, Colo.

—If you are going to—

BUY A BUZZ-SAW,

write to the editor of the REVIEW. He has a new Barnes saw to sell and would be glad to make you happy by telling you the price at which he would sell it.



Our Prices are worth looking at. We are making the new

Champion Chaff Hive

with dovetailed body and supers and a full line other Supplies, and we are selling them CHEAP. A postal sent for a price list may save you \$ \$ \$ \$.

R. H. SCHMIDT & CO.,
Box 157 Sheboygan, Wis

1-98-1f

—If you wish the best, low-priced—

TYPE - WRITER.

Write to the editor of the REVIEW. He has an Odell, taken in payment for advertising, and he would be pleased to send descriptive circulars or to correspond with any one thinking of buying such a machine.

1898 Queens 1898

For Business—Queens for Strong Colonies. Queens for large surplus. Competition in Quality, but not in price.

If you want queens, nuclei or supplies at bottom prices, send for my illustrated price list. 12-97-11

J. P. H. BROWN, Augusta, Ga.

Please mention the Review

Queens bred in the North are hardy and fertile. Every bee-keeper should try one of these Northern grown queens. Pure bred Italian queens at 75 cents each; or 12 for \$6.00.

WM. H. BRIGHT, Mazonia, Minn.

Please mention the Review.

To stick things, use **MAJOR'S CEMENT.** Beware!!! Take no substitute. 2-98-12t

Please mention the Review.

Best on Earth. 19 Years Without a Complaint.



		Dozen	Each
Smoke Engine (largest smoker made)	4 inch stove	\$13.00—mail,	\$1.50
Doctor	3 1/2 "	9.00— "	1.10
Conqueror	3 "	6.50— "	1.00
Large	2 1/2 "	5.00— "	.90
Plain	2 "	4.75— "	.70
Little Wonder (wt. 10 oz.)	2 "	4.50— "	.60
Honey Knife		6.00— "	.80

For further description, send for circular.

T. F. BINGHAM, Farwell, Michigan.

If the
REVIEW

Is mentioned when answering an advertisement in its columns a favor is conferred upon both the publisher and the advertiser. It helps the former by raising his journal in the estimation of the advertiser, and it enables the latter to decide as to which advertising mediums are most profitable. If you would help the Review, be sure and say "I saw your advertisement in the Review," when writing to advertisers.

Page & Lyon,

Mfg. Co.

New London, Wis.

—♦♦♦—
Nearness to pine and basswood forests, the possession of a saw-mill and factory fully equipped with the best of machinery, and years of experience, all combine to enable this firm to furnish the best goods at lowest prices. Send for circular, and see the prices on a full line of supplies.

**The Usual
Fall
DISCOUNT**

Is now allowed on orders. If you want shipping cases, crates, extractors, or anything else, write to us. Catalogue free.

Sample copy of *American Bee-Keeper* (monthly at 50 cents a year) free.

W. T. Falconer Mfg. Co.,

JAMESTOWN, N. Y.

No Fish-Bone

Is apparent in comb honey when the Van Deusen, flat-bottom foundation is used. This style of foundation allows the making of a more uniform article, having a *very thin* base, with the surplus wax in the side-walls, where it can be utilized by the bees. Then the bees, in changing the base of the cells to the natural shape, work over the wax to a certain extent; and the result is a comb that can scarcely be distinguished from that built wholly by the bees. Being so thin, one pound will fill a large number of sections.

All the Trouble of wiring brood frames can be avoided by using the Van Deusen *wired*.

Send for circular; price list, and samples of foundation.

J. VAN DEUSEN,

SPROUT BROOK, N. Y.

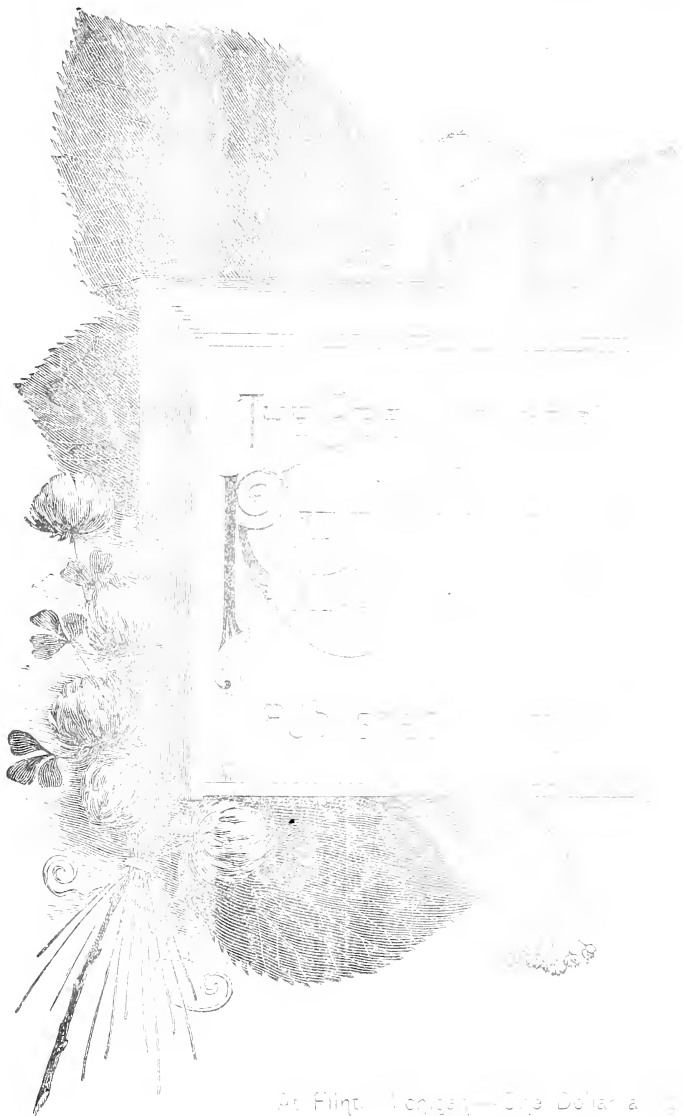

At Flint, Michigan—One Dollar a Copy

ADVERTISING RATES.

All advertisements will be inserted at the rate of 15 cents per line, Nonpareil space, each insertion: 12 lines of Nonpareil space make 1500. Discounts will be given as follows:

On 10 lines and upwards, 5 times, 5 per cent; 6 times, 15 per cent; 4 times, 25 per cent; 12 times, 35 per cent.

On 20 lines and upwards, 3 times, 10 per cent; 6 times, 20 per cent; 9 times, 30 per cent; 15 times, 40 per cent.

On 30 lines and upwards, 3 times, 20 per cent; 6 times, 30 per cent; 9 times, 40 per cent; 12 times, 50 per cent.

Clubbing List.

I will send the REVIEW with—

Gleanings, (new).....	\$1.00	\$1.75
American Bee Journal, (new).....	1.00	1.75
Canadian Bee Journal.....	1.00	1.75
Progressive Bee Keeper.....	.50	1.25
American Bee Keeper.....	.50	1.25
The Southland Queen.....	1.00	1.75
Ohio Farmer.....	1.00	1.75
Farm Journal (Phila.).....	.50	1.10
Farm Poultry.....	1.00	1.75
Rural New York.....	1.00	1.85
Frank Leslie's Popular Monthly.....	3.00	7.50
The Century.....	4.00	4.50
Michigan Farmer.....	1.00	1.65
Prairie Farmer.....	1.00	1.75
American Agriculturist.....	1.00	1.75
Ladies' Home Journal.....	1.00	1.75
The Independent (New York).....	3.00	7.50
Ladies' World.....	.40	1.25
Country Gentleman.....	2.50	7.15
Harper's Magazine.....	4.00	4.10
Harper's Weekly.....	4.00	4.20
Youth's Companion (new).....	.75	2.35
Scrivener's Magazine.....	3.00	7.50
Cosmopolitan.....	1.00	1.90

It will be noted that in order to secure these rates on Gleanings, American Bee Journal and the Youth's Companion, the subscribers to these Journals, must be NEW. If it is any convenience, when sending in your renewal to the REVIEW, to include your renewal to any of these Journals, you can do so, but the full price must be sent.

If You Wish Neat, Artistic

PRINTING,

Have it Done at the Review.

A SURE WINNER.



OUR SUCCESSFUL INCUBATOR will prove it if you use it. Send for new 128 page catalog and study the merits of our machines. Invaluable points on artificial incubation and poultry culture generally. We manufacture a greater variety of incubators and Brooders than any other firm. Sizes 50 to 800. Prices from \$8.00 to \$70.00.

Testimonials by the yard

DES MOINES INCUB. CO.
Box 145 DES MOINES, IOWA

100 cent

Please mention the Review

Names of Bee-Keepers.

TYPE WRITTEN.

The names of my customers, and of those asking for samples, plus, have been saved and written in a book. There are several thousand all arranged alphabetically (in the largest States), and, although, this list has been secured at an expense of hundreds of dollars, I would furnish it to advertisers or others at \$2.00 per thousand names. The former price was \$1.50 per 1000, but I now have a type writer, and, by using the manifold process, I can furnish them at \$2.00. A manufacturer who wishes for a list of the names of bee-keepers in his own state only, or, possibly, in an adjoining state, can be accommodated. Here is a list of the States and the number of names in each State.

Arizona.....	77	Ky.....	144	New Mex.....	29
Ark.....	10	Kans.....	226	Oregon.....	60
Calif.....	284	La.....	38	Ohio.....	1,000
Canada.....	30	Mo.....	500	Penn.....	645
Conn.....	120	Minn.....	270	R. I.....	37
Del.....	18	Mich.....	1,320	S. C.....	40
Fla.....	74	Mass.....	194	Tenn.....	112
Ga.....	56	Md.....	66	Tex.....	225
Ind.....	38	Miss.....	70	Utah.....	40
Ills.....	90	N. Y.....	1,122	Vt.....	160
Iowa.....	68	Neb.....	272	Va.....	110
		N. J.....	130	W. Va.....	118
		Ills.....	95	Wash.....	30
		Low.....	60	Wis.....	432

W. Z. HUTCHINSON, Flint, Mich.

2nd-

Supplies Cheap.

Mr. L. B. Bell, formerly of Brecksville, Ohio, has accepted a permanent position in Arizona, and wishes to dispose of his apianian fixtures. He wrote to me about it, and I told him if he would have them shipped to me I would sell them for him on commission. Here is a list of the articles and the price at which they are offered.

1 Cord Wire.....	60
61 Section Cases, Wide Frame and tin separators at.....	25
62 Covers at.....	15
24 Bottom Boards at.....	10
24 Honey Boxes, Queen excluder at.....	15
24 Escapes at.....	15
24 Feeders, Holston Excelsior's at.....	25

All of the above are in my possession and can be shipped promptly. The hives and cases are well made and nicely painted, and having been in use only two or three seasons are practically as good as new. The combs are in wired frames and are all straight and nice. Any one wishing to buy anything out of this lot can learn fuller particulars upon inquiry.

W. Z. HUTCHINSON, Flint, Mich.

BEE-KEEPERS

We Make the Finest Line of SUPPLIES in the Market, and sell Them

At Low Prices

Free Illustrated Catalogue and Price List

G. B. LEWIS CO., Milwaukee, Wis.

E. T. BABBOTT, St. Joseph, Mo., Sells our Goods and Services at Factory Prices

★ **THE** ★

The Commission *The*

E. ROSENBERG & CO.

\$5.00

Express Charges



Extra Postage

JUST MADE TO ORDER

\$14.00

THIS STYLE



What you can get from the...

Woolen Fancy Blue Tweed lined with blue trimmed with Custom Tailor Applique Pockets sizes 34 to 44

The same for Youth and Youth and Youth How to measure Measure around the waist and to heel for pants

When ordering send Office Express money order or Registered Letters. Money should be satisfactory. Send stamp or samples, tape measure, measuring blanks, etc.

Advanced Bee Culture

IS a book of nearly 100 pages (the size of the Review) that I wrote and published in 1891; and I will tell you how I gathered the information that it contains. For 15 years I was a practical bee-keeper, producing tons of both comb and extracted honey; rearing and selling thousands of queens, reading all of the bee books and journals, attending conventions and fairs, visiting bee-keepers, etc., etc. Then I began publishing the Review, and, for several years, each issue was devoted to the discussion of some special topic: the best bee-keepers of the country giving their views and experience. **ADVANCED BEE CULTURE** is really the summing up of these first few years of special topic numbers of the Review; that is, from a most careful examination of the views of the most progressive men, and a thorough consideration of the same in the light of my experience as a bee-keeper, I have described in plain and simple language what I believe to be the most advanced methods of managing an apiary, for *profit*, from the beginning of the season through the entire year. The book is illustrated, nicely printed, and neatly bound in thick, heavy paper of such a color and so printed that it resembles a sheet of queen-excluding zinc. Price of the book, 50 cts.; the Review one year and the book for only \$1.25.

W. Z. Hutchinson, Flint, Mich.



THE BEE-KEEPERS'

REVIEW

Published Monthly

At Fargo, Michigan.—One Dollar a No.

ADVERTISING RATES.

All advertisements will be inserted at the rate of 15 cents per line, Nonpareil space, each insertion: 12 lines of Nonpareil space make 1 inch. Discounts will be given as follows:

On 10 lines and upwards, 3 times, 5 per cent; 6 times, 15 per cent; 3 times, 25 per cent; 12 times, 35 per cent.

On 20 lines and upwards, 3 times, 10 per cent; 12 times, 20 per cent; 3 times, 30 per cent; 15 times, 40 per cent.

On 30 lines and upwards, 3 times, 25 per cent; 6 times, 30 per cent; 9 times, 40 per cent; 12 times, 50 per cent.

Clubbing List.

I will send the REV. FW with—

Gleanings, new \$1.00 \$1.75
American Bee Journal, new 1.00 1.75
Canadian Bee Journal 1.00 1.75
Progressive Bee Keeper 1.50 1.75
American Beekeeper 1.50 1.75
The Southern Beekeeper 1.00 1.75
Ohio Farmer 1.00 1.75
Farm Journal, Indiana75 1.17
Farm Power 1.00 1.75
Rural New Yorker 1.00 1.75
Frank Leslie's Popular Monthly 3.00 4.50
The Century 3.00 4.50
Michigan Farmer 1.00 1.75
Prairie Farmer 1.00 1.75
American Agriculturist 1.00 1.75
Ladies' Home Journal 1.00 1.75
The Independent, New York 3.00 4.50
Ladies' World5075
Country Gentleman 2.50 3.75
Harper's Magazine 1.17 1.75
Harper's Weekly 1.00 1.75
Yontus' Companion, new75 1.25
Scribner's Magazine 2.00 3.00
Cosmopolitan 1.00 1.75

It will be a good deal in order to secure these rates of clubbing, American Bee Journal and the Yontus' Companion, the subscribers to these journals must be NEW. If it is your convenience in sending in your renewal of the Review, a helpful renewal to any of these Journals, you can do so, but the full price must be sent.

If You Wish Neat, Artistic

PRINTING

Have it Done at the Review.

A SURE WINNER.



OUR SUCCESSFUL INCUBATOR will prove it if you use it. Send for new 128 page catalog and study the merits of our machines. Has valuable points on artificial incubation and poultry culture generally. We manufacture a greater variety of Incubators and Brooders than any other firm. Sizes \$5 to \$60. Prices from \$5.00 to \$70.00. **DES MOINES INC'G. CO.** Box 145, DES MOINES, IOWA.

Testimonials by the yard

Names of Bee-Keepers.

TYPE WRITTEN.

The names of my customers, and of those asking for supplies, have been saved and written down. There are several thousand all over the country (in the largest States), and the following list has been secured at an expense of many dollars. I would furnish it to any one who offers at \$2.00 per thousand names. The average price was \$1.50 per 1000, but I may be able to write, and by using the machine I used, I can furnish them at \$2.00. A customer who wishes for a list of the names of bee-keepers in his own state only, or, possibly, of adjoining states, can be accommodated. Here is a list of the States and the number of names in each State.

Alabama 144	New Mex. 22
Arkansas 226	Oregon 60
Arizona 28	Ohio 1,600
California 209	Penn. 645
Colorado 250	R.I. 37
Connecticut 1,320	S. Carolina 40
Delaware 113	Tenn. 112
District of Columbia 63	Texas 225
Florida 70	Utah 40
Georgia 1,122	Vt. 160
Idaho 272	Va. 110
Illinois 130	W. Va. 118
Indiana 95	Wash. 30
Iowa 20	Wis. 432

W. Z. HUTCHINSON, Flint, Mich.



Supplies Cheap.

My business is formerly of Brockville, Ohio, and I am in a permanent position in Arizona. I have a large stock of his apianary fixtures. He would like to sell them, and I told him if he would let me have them shipped to me I would sell them for him on commission. Here is a list of the articles and the price at which they are sold now.

1000 lbs. of bees 60
1000 lbs. of wax 25
1000 lbs. of honey 15
1000 lbs. of sugar 19
1000 lbs. of molasses 15
1000 lbs. of corn 15
1000 lbs. of wheat 25

As you are in my possession and can be shipped to you. The hives and cases are well made, neatly painted, and having been in use only for three seasons are practically as good as new. The combs are in wired frames and are all straight and nice. Anyone wishing to buy any of this lot can learn fuller particulars by inquiry.

W. Z. HUTCHINSON, Flint, Mich.

Advanced Bee Culture

IS a book of nearly 100 pages (the size of the Review) that I wrote and published in 1891; and I will tell you how I gathered the information that it contains. For 15 years I was a practical bee-keeper, producing tons of both comb and extracted honey; rearing and selling thousands of queens, reading all of the bee books and journals, attending conventions and fairs, visiting bee-keepers, etc., etc. Then I began publishing the Review, and, for several years, each issue was devoted to the discussion of some special topic; the best bee-keepers of the country giving their views and experience. **ADVANCED BEE CULTURE** is really the summing up of these first few years of special topic numbers of the Review; that is, from a most careful examination of the views of the most progressive men, and a thorough consideration of the same in the light of my experience as a bee-keeper, I have described in plain and simple language what I believe to be the most advanced methods of managing an apiary, for *profit*, from the beginning of the season through the entire year. The book is illustrated, nicely printed, and neatly bound in thick, heavy paper of such a color and so printed that it resembles a sheet of queen-excluding zinc. Price of the book, 50 cts.; the Review one year and the book for only \$1.25.

W. Z. Hutchinson, Flint, Mich.



ADVERTISING RATES.

All advertisements will be inserted at the rate of 15 cents per line, Nonpareil space, each insertion; 12 lines of Nonpareil space make 1 line. Discounts will be given as follows:

- On 10 lines and upwards, 3 times, 5 per cent; 6 times, 15 per cent; 12 lines, 25 per cent; 12 times, 25 per cent.
- On 25 lines and upwards, 3 times, 10 per cent; 6 times, 20 per cent; 12 lines, 30 per cent; 15 times, 40 per cent.
- On 30 lines and upwards, 3 times, 20 per cent; 6 times, 30 per cent; 12 times, 40 per cent; 12 times, 50 per cent.

Clubbing List.

I will send the Review with:

Greenings, New York	\$1.00	\$1.75
American Bee Journal, New York	1.00	1.75
Canadian Bee Journal, Toronto	1.50	2.75
Progressive Bee Keeper, New York	.50	1.00
American Bee Journal, New York	.50	1.00
The South Bee Journal, New York	.50	1.00
Ozark Bee Journal, New York	.50	1.00
Farm & Garden, New York	.50	1.00
Farm & Garden, New York	.50	1.00
Rural New Yorker, New York	.50	1.00
Frank Leslie's Popular Monthly, New York	.50	1.00
The Country Gentleman, New York	.50	1.00
Michigan Farmer, New York	.50	1.00
Prairie Farmer, New York	.50	1.00
American Agriculturist, New York	.50	1.00
Ladies' Home Journal, New York	.50	1.00
The Independent, New York	.50	1.00
Ladies' World, New York	.50	1.00
Country Gentleman, New York	.50	1.00
Harpers Magazine, New York	.50	1.00
Harpers Weekly, New York	.50	1.00
Yontas, New York	.50	1.00
Scribner's Magazine, New York	.50	1.00
Cosmopolitan, New York	.50	1.00

It will be understood that in order to secure these and other publications, American Bee Journal and the Year Book of Beekeeping, the subscribers to the Year Book must be NEW. If it is inconvenient to send in your order to the Review, you should give your removal to any of these dealers, and send them the full price must be paid.

KEYSTONE NEW ARTISTIC

PRINTING

HAND SET AND COMPOSITION

A SURE WINNER.



OUR SUCCESSFUL INCUBATOR will prove it if you use it. See our new 12 page catalog and study the merits of our machines. Has valuable hints on artificial incubation and poultry culture generally. We manufacture a greater variety of incubators and Brooders than any other firm. Sizes \$5 to \$25. Prices from \$5.00 to \$100.00.

DES MOINES HATCH CO. Box 143, DES MOINES, IOWA.

100-101 First National Bank Bldg.

Name of Bee-Keepers.

BE WRITTEN.

My dear customers, and of those asking for names of bee-keepers, have been saved and written out in full. There are several thousand all over the country (in the largest States). A complete list has been secured at an expense of \$1000 dollars, I would furnish it to you for \$2.00 per thousand names. The original price was \$2.75 per 1000, but I have reduced the price, and by using the name of the bee-keeper furnish them at \$2.00. If you wish for a list of the names of bee-keepers in his own state only, or, possibly, of bee-keeping states, can be accomplished. A list of the states and the names of bee-keepers in each State.

Alabama	141	New Mex.	22
Arizona	225	Oregon	69
Arkansas	98	Ohio	1,000
California	700	Penn.	37
Colorado	270	R. I.	65
Connecticut	100	S. C.	40
Delaware	101	Tenn.	112
District of Columbia	65	Texas	225
Florida	70	Utah	40
Georgia	112	Vt.	160
Idaho	252	Va.	110
Illinois	180	W. Va.	118
Indiana	95	Wash.	30
Iowa	60	Wis.	432

W. Z. HUTCHINSON, Flint, Mich.



2nd - Supplies Cheap.

My dear customers, I am sorry of Brecksville, Ohio, has secured a prominent position in Arizona, and has secured a large quantity of his apicultural fixtures. He was very kind and I told him if he would send me a shipment to me I would sell them at a very low price. Here is a list of the articles and the price at which they are sold.

1 Good Wire	.60
2 Good Wire	.60
3 Good Wire	.60
4 Good Wire	.60
5 Good Wire	.60
6 Good Wire	.60
7 Good Wire	.60
8 Good Wire	.60
9 Good Wire	.60
10 Good Wire	.60

All of these are in my possession and can be shipped to you. The lives and cases are well made and are painted, and I having been in use for several seasons are practically as good as new. Combs are in wired frames and are made of wax. Any one wishing to buy a good lot of this lot can learn fuller particulars upon inquiry.

W. Z. HUTCHINSON, Flint, Mich.

BEE-KEEPERS

We Make the Finest Line of **SUPPLIES**
 in the Market, and sell Them
At Low Prices.

Free Illustrated Catalogue and Price List.

G. B. LEWIS CO., Wauwatosa, Wis.

E. T. BBEOTT, St. Joseph, Mo., Sells our Hives and Supplies at Factory Prices.



Direct from the
 * **Woolen** *
 The Commission
E. ROSENBERG & CO.



\$5.00 **\$2.00**

Woolen
 Express
 Charge



Woolen
Express
Charge

* **JUST** *
A CUSTOMER MADE TO ORDER

\$14.00 **\$8.00**

Woolen
 Express
 Charge

Woolen
Express
Charge

What we
 feel
 for
 you
 We
 Five
 Two
 Four
 Five
 Six
 Seven
 Eight
 Nine
 Ten
 Eleven
 Twelve
 Thirteen
 Fourteen
 Fifteen
 Sixteen
 Seventeen
 Eighteen
 Nineteen
 Twenty

The
 You
 How
 Measure
 When

THIS
STYLE



STYLISH

When
 Express
 Letters
 not
 samples,
 tape
 measuring
 blank



STYLISH



Advanced Bee Culture

IS a book of nearly 100 pages, the size of the Review, that I wrote and published in 1891; and I will tell you how I gathered the information that it contains. For 15 years I was a practical bee-keeper, producing tons of both comb and extracted honey; rearing and selling thousands of queens, reading all of the bee books and journals, attending conventions and fairs, visiting bee-keepers, etc., etc. Then I began publishing the Review, and, for several years, each issue was devoted to the discussion of some special topic: the best bee-keepers of the country giving their views and experience. **ADVANCED BEE CULTURE** is really the summing up of these first few years of special topic numbers of the Review; that is, from a most careful examination of the views of the most progressive men, and a thorough consideration of the same in the light of my experience as a bee-keeper, I have described in plain and simple language what I believe to be the most advanced methods of managing an apiary, for *profit*, from the beginning of the season through the entire year. The book is illustrated, nicely printed, and neatly bound in thick, heavy paper of such a color and so printed that it resembles a sheet of queen-excluding zinc. Price of the book, 50 cts.; the Review one year and the book for only \$1.25.

W. Z. Hutchinson, Flint, Mich.



At Flint, Michigan—One Dollar a Year.

ADVERTISING RATES.

All advertisements will be inserted at the rate of 15 cents per line, Nonpareil space, each insertion: 12 lines of Nonpareil space make 1 inch. Discounts will be given as follows:

On 10 lines and upwards, 3 times, 5 per cent; 6 times, 15 per cent; 9 times, 25 per cent; 12 times, 35 per cent.

On 20 lines and upwards, 3 times, 10 per cent; 6 times, 20 per cent; 9 times, 30 per cent; 15 times, 40 per cent.

On 30 lines and upwards, 3 times, 20 per cent; 6 times, 30 per cent; 9 times, 40 per cent; 12 times, 50 per cent.

Clubbing List.

I will send the REVIEW with -

Gleanings, (new).....	\$1,000	\$1.75
American Bee Journal.... (new)	1,000	1.75
Canadian Bee Journal.....	1,000	1.75
Progressive Bee Keeper.....	1,500	1.35
American Bee Keeper.....	1,500	1.40
The Southland Queen.....	1,000	1.75
Ohio Farmer.....	1,000	1.75
Farm Journal Phila.....	1,500	1.40
Farm Poultry.....	1,000	1.75
Rural New Yorker.....	1,000	1.85
Frank Leslie's Popular Monthly.....	3,000	3.50
The Century.....	4,000	4.50
Michigan Farmer.....	1,000	1.65
Prairie Farmer.....	1,000	1.75
American Agriculturist.....	1,000	1.75
Ladies' Home Journal.....	1,000	1.75
The Independent (New York).....	3,000	3.50
Ladies' World.....	40	1.25
Country Gentleman.....	2,500	3.15
Harper's Magazine.....	4,000	4.40
Harper's Weekly.....	4,000	4.20
Youth's Companion (new).....	1,750	2.95
Scribner's Magazine.....	3,000	3.50
Cosmopolitan.....	1,000	1.80
Success.....	1,000	1.75

It will be noticed that in order to secure these rates on Gleanings, American Bee Journal and the Youth's Companion, the subscribers to these Journals must be NEW. If it is any convenience, when sending in your renewal to the Review, to include your renewal to any of these Journals, you can do so, but the full price must be sent.

If You Wish Neat, Artistic

PRINTING,

Have it Done at the Review.

Muth's HONEY EXTRACTOR PERFECTION Cold-Blast Smokers

Square Glass Honey Jars, Etc.

For Circulars, apply to CHAS. F. MUTH & SON
Cor. Freeman & Central Aves., Cincinnati, O.
Send 10c. for Practical Hints to Bee-Keepers.

Names of Bee-Keepers.

TYPE WRITTEN.

The names of my customers, and of those asking for sample copies, have been saved and written in a book. There are several thousand all arranged alphabetically (in the largest States), and, although this list has been secured at an expense of hundreds of dollars, I would furnish it to advertisers or others at \$2.00 per thousand names. The former price was \$2.50 per 1000, but I now have a type writer, and, by using the manifold process, I can furnish them at \$2.00. A manufacturer who wishes for a list of the names of bee-keepers in his own state only, or, possibly, in the adjoining states, can be accommodated. Here is a list of the States and the number of names in each State.

Arizona 17	Ky. 144	New Mex. 22
Ark. 28	Kans. 226	Oregon 60
Ala. 29	La. 85	Ohio 1,000
Calif. 284	Mo. 500	Penn. 645
Colo. 27	Minn. 270	R. I. 37
Canada 27	Mich. 1,320	S. C. 40
Conn. 12	Mass. 196	Tenn. 112
Del. 25	Mt. 66	Tex. 225
Iowa 28	Miss. 70	Utah 40
Fla. 28	N. Y. 1,122	Vt. 160
Ga. 28	Neb. 272	Va. 110
Ind. 28	N. J. 180	W. Va. 118
Ill. 28	N. H. 95	Wash. 30
Iowa 28	N. C. 60	Wis. 432

W. Z. HUTCHINSON, Flint, Mich.

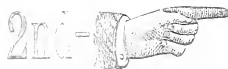

Supplies Cheap.

Mr. J. Z. Bell, formerly of Brecksville, Ohio, has secured a permanent position in Arizona, and wishes to dispose of his apianian fixtures. He wrote me about it, and I told him if he would have them shipped to me I would sell them for him on commission. Here is a list of the articles and the price at which they are offered.

1 Good Wagon.....	60
61 Section Cases (Wide Frame and tin sep- arated).....	25
62 Section Cases.....	15
53 Boarding Boards at.....	10
54 Honey Boards, Queen excluding at.....	15
39 Honey Boards.....	15
55 Frames (Haddon Excelsior) at.....	25
30 Alar, Queen and Drone traps, at.....	35

All of the above are in my possession and can be shipped promptly. The hives and cases are well made and nicely painted, and having been in use only two or three seasons are practically as good as new. Any one wishing to buy anything out of this lot can learn fuller particulars upon inquiry.

W. Z. HUTCHINSON, Flint, Mich.

DADANT'S

Foundation

By the new *Weed Process* is made in the best manner, upon the best machines, and from the best wax—that free from dirt, pollen, propolis, burnt wax, etc., that decrease its tenacity, and make it offensive to the bees. Every inch of foundation is guaranteed to be equal to the sample that will be sent upon application.

Langstroth on the Honey Bee, nests, Smokers, Tin Pails, Sections and other supplies. Send for circular.

Dadant & Son,

Hamilton, Ills.

We make the finest line of

Bee-Keepers' Supplies

in the market, and sell them at *Low Prices*. Free Illustrated Catalogue and Price List.

G. B. Lewis Co.,

Watertown, Wis.

E. T. Abbott, St. Joseph, Mo., sells our hives and sections at factory prices.

Sections

We make millions of them yearly, with uniformity, smoothness and finish that be better. The basswood grows right here. If you want the good *Shipping Cases*, you can get them. Also a full line of *Bee Supplies* on hand.

Write for our special catalogue and price list.

Marshfield
Mfg. Co., Marshfield,
Wis.

Our sections are made of the finest material, and are uniform in size and finish. Write for our catalogue and price list.

One-Piece Sections

in the market. Price list and sample sent free. Special prices on large quantities.

One-Piece SECTION
COMPANY
Prairie du Chien, Wis.

THE

Progressive Bee-Keeper



Is a 28-page monthly bee journal published at Higginsville, Mo.; price, 50¢ per year. With the year of 1898, we begin the eighth volume; hence it is past the experimental stage. *R. B. Leahy* and *G. M. Doolittle*, editors. Some of the features of 1898 will be a continuation of *Wayside Fragments*, by *Somnambulist*. *Experience and its Lessons*, by *R. C. Aikin*. This series of articles will be reviewed by Mr. Doolittle which is practically giving *his* experience with its lessons. "Experience" and its lessons, as reviewed, will be a gold mine for beginners and advantageous to those more advanced in bee culture. The Somnambulist articles are written in a pleasing style, as none but *Somny* could write them. They are highly entertaining and instructive. *Dr. C. C. Miller*, and other popular writers also contribute to its columns. The PROGRESSIVE is a popular journal at a popular price. Printed in the highest art, on beautiful paper. Fearless in its character, newsy in its contents, and artistic in its make-up. Remember the PROGRESSIVE BEE-KEEPER is but 50¢ per year. The PROGRESSIVE and that "one only" book for beginners, the *Amateur Bee-Keeper*, by *Prof. J. W. Rouse*, both for 65¢. A sample copy of the PROGRESSIVE for your name and a beautiful illustrated catalogue of aparian supplies for the asking.

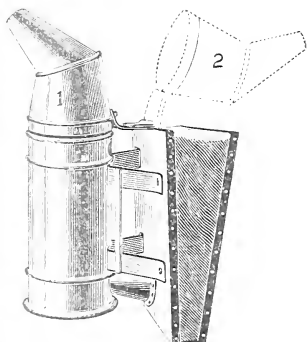

The accompanying cut shows the Higginsville Smoker with the nozzle thrown back for filling. This Smoker is strong and well made of the best material, has a strong draft, and will burn any kind of fuel. One smoker, 75 cts.; three for \$1.80. When sent by mail add 25 cts each for postage. Send for catalogue of other supplies.

THE AMATEUR BEE-KEEPER, a book for beginners, 25 cts., by mail, 28 cts.

For all the above, address the

Leahy Mfg. Co., Higginsville, Mo.



At Flint, Michigan.—One Dollar a Year.

ADVERTISING RATES.

All advertisements will be inserted at the rate of 15 cents per line, Nonpareil space, each insertion: 12 lines of Nonpareil space make 1 inch. Discounts will be given as follows:

On 10 lines and upwards, 3 times, 5 per cent; 6 times, 15 per cent; 9 times, 25 per cent; 12 times, 35 per cent.

On 20 lines and upwards, 3 times, 10 per cent; 6 times, 20 per cent; 9 times, 30 per cent; 15 times, 40 per cent.

On 30 lines and upwards, 3 times, 20 per cent; 6 times, 30 per cent; 9 times, 40 per cent; 12 times, 50 per cent.

Clubbing List.

I will send the REVIEW with—

Cleanings—new.....	\$1.00	\$1.75
American Bee Journal... (new)	1.00	1.75
Canadian Bee Journal.....	1.00	1.75
Progressive Bee Keeper.....	.50	1.35
American Bee Keeper.....	.50	1.40
The Southern Queen.....	1.00	1.75
Ohio Farmer.....	1.00	1.75
Farm Journal, Ill.50	1.10
Farm. Postery.....	1.00	1.75
Rural New Yorker.....	1.00	1.85
Frank Leslie's Popular Monthly.....	3.00	5.50
The Century.....	4.00	4.50
Mid. Ga. Farmer.....	1.00	1.65
Pearl River Farmer.....	1.00	1.75
American Agriculturist.....	1.00	1.75
Ladies' Home Journal.....	1.00	1.75
The Land Magazine (New York).....	3.00	3.50
Ladies' World.....	.40	1.25
Country Gentleman.....	2.50	3.15
Harpers Magazine.....	1.40	4.10
Harpers Weekly.....	4.00	4.20
Youth's Companion (new).....	.75	2.35
Saturday Magazine.....	3.00	3.50
Cosmopolitan.....	1.00	1.90
Success.....	1.00	1.75

It will be noticed that in order to secure these rates on Cleanings, American Bee Journal and the Youth's Companion, the subscribers to these Journals must be NEW. If it is any convenience, when sending in your renewal to the Review, to include your renewal to any of these Journals, you can do so, but the full price must be sent.

If You Wish Neat, Artistic

PRINTING,

Have it Done at the Review.

Muth's HONEY EXTRACTOR PERFECTION Cold-Blast Smokers

Square Glass Honey Jars, Etc.

For Circulars, apply to CHAS. F. MUTH & SON Cor. Freeman & Central Aves., Cincinnati, O. Send 10c. for Practical Hints to Bee-Keepers.

1-97-11. Please mention the Review.

Names of Bee-Keepers.

TYPE WRITTEN.

The names of my customers, and of those asking for sample copies, have been saved and written in a book. There are several thousand all arranged alphabetically (in the largest States) and, although this list has been secured at an expense of hundreds of dollars, I would furnish it to advertisers or others at \$2.00 per thousand names. The former price was \$2.50 per 1000, but I now have a type writer, and, by using the manifold process, I can furnish them at \$2.00. A manufacturer who wishes for a list of the names of bee-keepers in his own state only, or, possibly, in the adjoining states, can be accommodated. Here is a list of the States and the number of names in each State.

Arizona.....	17	Ky.....	144	New Mex.....	22
Ark.....	109	Kans.....	226	Oregon.....	60
Ala.....	80	La.....	88	Ohio.....	1,000
Calif.....	281	Mo.....	500	Penn.....	645
Colo.....	37	Minn.....	370	R. I.....	37
Canada.....	56	Mich.....	1,329	S. C.....	40
Conn.....	126	Mass.....	196	Tenn.....	112
Del.....	70	M. I.....	66	Tex.....	225
Fla.....	70	Miss.....	70	Utah.....	40
Ga.....	75	N. Y.....	1,122	Vt.....	160
Ill.....	275	Neb.....	272	Va.....	110
Ind.....	270	N. J.....	180	W. Va.....	118
Iowa.....	88	N. H.....	95	Wash.....	30
		N. C.....	60	Wis.....	432

W. Z. HUTCHINSON, Flint, Mich.



Supplies Cheap.

Mr. L. B. Bell, formerly of Brecksville, Ohio, has accepted a permanent position in Arizona, and wishes to dispose of his apiarian fixtures. He wrote to me about it, and I told him if he would have them shipped to me I would sell them for him on commission. Here is a list of the articles and the price at which they are offered.

1 Coil Wire.....	60
61 Section Cases, Wide Frame and tin separators.....	25
68 Covers.....	15
53 Bottom Boards at.....	10
53 Honey Boards, Queen excluding at.....	15
30 Escapes.....	15
50 Feeders (Heddon Excelsior) at.....	25
30 Alby, Green and Drone traps, at.....	35

All of the above are in my possession and can be shipped promptly. The hives and cases will be made and nicely painted, and having been in use one or two or three seasons are practically as good as new. Any one wishing to buy anything out of this lot can learn fuller particulars upon inquiry.

W. Z. HUTCHINSON, Flint, Mich.

DADANT'S

Foundation

By the new *Weed Process* is made in the best manner, upon the best machines, and from the best wax—that free from dirt, pollen, propolis, burnt wax, etc., that decrease its tenacity and make it offensive to the bees. Every inch of foundation is guaranteed to be equal to the sample that will be sent upon application.

Langstroth on the Honey Bee, revised, Smokers, Tin Pails, Sections and other supplies. Send for circular.

Dadant & Son,
Hamilton, Ills.

We make the finest line of

Bee - Keepers' Supplies

in the market, and sell them at *Low Prices*. Free Illustrated Catalogue and Price List.

G. B. Lewis Co.,
Watertown, Wis.

E. T. Abbott, St. Joseph, Mo., sells our hives and sections at factory prices.

Sections

We make millions of them yearly; workmanship, smoothness and finish can't be better. The basswood grows right here. If you want some good *Shipping Cases*, you can get them of us. Our full line of *Bee Supplies* is good.

Write for illustrated catalogue and price list free.

Marshfield
Mfg. Co., Marshfield,
Wis.

Our basswood lumber is as *white as snow*, our machinery *up to date*, and we can furnish the *finest*

One - Piece Sections

in the market. Price list and sample section free. Special prices on large quantities.

One-Piece SECTION
COMPANY
Prairie du Chien, Wis.

THE Progressive Bee-Keeper

Is a 28-page monthly bee journal published at Higginsville, Mo.; price, 50c per year. With the year of 1898, we begin the eighth volume; hence it is past the experimental stage. *R. B. Leahy* and *G. M. Doolittle*, editors. Some of the features of 1898 will be a continuation of *Wayside Fragments*, by *Somnambulist*. *Experience and its Lessons*, by *R. C. Aikin*. This series of articles will be reviewed by Mr. Doolittle, which is practically giving *his* experience with its lessons. "Experience" and its lessons, as reviewed, will be a gold mine for beginners and a gem to those more advanced in bee culture. The *Somnambulist* articles are written in a pleasing style, as none but *Sommy* could write them. They are highly entertaining and instructive. *Dr. C. C. Miller*, and other popular writers also contribute to its columns. The *PROGRESSIVE* is a popular journal at a popular price. Printed in the highest art, on beautiful paper. Fearless in its character, newsy in its contents, and artistic in its make-up. Remember the *PROGRESSIVE BEE-KEEPER* is but 50c per year. The *PROGRESSIVE* and that "one only" book for beginners, the *Amateur Bee-Keeper*, by *Prof. J. W. Rouse*, both for 65c. A sample copy of the *PROGRESSIVE* for your name, and a beautiful illustrated catalogue of apian supplies for the asking.

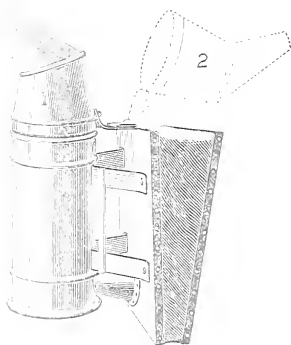

The accompanying cut shows the Higginsville Smoker with the nozzle thrown back for filling. This Smoker is strong and well made of the best material, has a strong draft, and will burn any kind of fuel. One smoker, 75 cts.; three for \$1.80. When sent by mail add 25 cts each for postage. Send for catalogue of other supplies.

THE AMATEUR BEE-KEEPER, a book for beginners, 25 cts., by mail, 35 cts.

For all the above, address the

Leahy Mfg. Co., Higginsville, Mo.



THE BEE-KEEPERS'

REVIEW

Published Monthly.

At Flint, Michigan.—One Dollar a Year.

ADVERTISING RATES.

All advertisements will be inserted at the rate of 15 cents per line, Nonpareil space, each insertion: 12 lines of Nonpareil space make 1 inch. Discounts will be given as follows:

On 10 lines and upwards, 3 times, 5 per cent; 6 times, 15 per cent; 8 times, 25 per cent; 12 times, 35 per cent.

On 20 lines and upwards, 3 times, 10 per cent; 6 times, 20 per cent; 9 times, 30 per cent; 15 times, 40 per cent.

On 30 lines and upwards, 3 times, 20 per cent; 6 times, 30 per cent; 9 times, 40 per cent; 12 times, 50 per cent.

Clubbing List.

I will send the Review with—

Gleanings, new year	\$1.00	\$1.75
American Bee Journal, (new)	1.00	1.75
Canadian Bee Journal	1.00	1.75
Progressive Bee Keeper	.50	1.00
American Bee Keeper	.50	1.00
The Southern Queen	1.00	1.75
Ohio Farmer	1.00	1.75
Farmer Journal, Ill.	.50	1.00
Farmer, Pa.	1.00	1.75
Rural New Yorker	1.00	1.75
Frank Leslie's Popular Monthly	3.00	5.25
The Century	4.00	6.50
Michigan Farmer	1.00	1.75
Prairie Farmer	1.00	1.75
American Agriculturist	1.00	1.75
Ladies' Home Journal	1.00	1.75
The Independent (New York)	1.00	1.75
Ladies' World	.40	1.25
Country Gentleman	2.50	4.25
Harper's Magazine	4.00	6.75
Harper's Weekly	4.00	6.75
Youth's Companion (new)	.75	2.25
Scientific Magazine	3.00	5.25
Cosmopolitan	1.00	1.75
Success	1.00	1.75

It will be noted that in order to secure these rates of Gleanings, American Bee Journal and the Youth's Companion, the subscribers to these Journals must be NEW. If it is, of course, convenient, when sending in your renewal to the Review, to include your renewal to any of these Journals, you can do so, but the full price must be sent.

If You Wish Neat, Artistic

PRINTING,

Have it Done at the Review.

Muth's HONEY EXTRACTOR PERFECTION Cold-Blast Smokers

Square Glass Honey Jars, Etc.

For Circulars, apply to CHAS. F. MUTH & SON, Cor. Freeman & Central Aves., Cincinnati, O. Send 10c. for Practical Hints to Bee Keepers.

Notes of Bee-Keepers.

TYPE WRITTEN.

My customers, and of those asking for copies, have been saved and written for. There are several thousand all together, (in the largest States) and this list has been secured at an expenditure of hundreds of dollars, I would furnish it to you, or others at \$2.00 per thousand and the former price was \$2.50 per 1000, but I have a new type writer, and, by using the double process, I can furnish them at \$2.00. Anyone who wishes for a list of the bee-keepers in his own state only, or, possibly, the adjoining states, can be accommodated. This is a list of the States and the number of names in each State.

Ala.	114	New Mex.	22
Ark.	235	Oregon	60
Cal.	38	Ohio	1,000
Conn.	500	Penn.	645
Del.	270	R. I.	37
Fla.	1,320	S. C.	40
Ill.	195	Tenn.	112
Ind.	66	Tex.	225
Iowa	70	Utah	40
Ky.	1,122	Va.	190
La.	272	Vt.	110
Maine	180	W. Va.	118
Mass.	95	Wash.	30
Mich.	90	Wis.	432

C. F. HUTCHINSON, Flint, Mich.



Applies Cheap.

Mr. H. C. Bell, formerly of Brockville, Ohio, has secured a permanent position in Arizona, and has to dispose of his apiarian fixtures. He has read about it, and I told him if he would have them shipped to me I would sell them on a commission. Here is a list of the fixtures and the price at which they are offered.

1000	Wide Frame and tin sep.	25
500	Queen excluder	15
250	Queen excluder at	10
250	Queen excluder at	15
250	Queen excluder at	15
250	Queen excluder at	25
250	Queen and Drone traps, at	35

These fixtures are in my possession and can be had on empty. The hives and cases are nicely painted, and having been in use for three seasons are practically as good as new. Any one wishing to buy any of these fixtures can learn fuller particulars by inquiry.

C. F. HUTCHINSON, Flint, Mich.

DADANT'S

Foundation

By the new *Feed Process* is made in the best manner, upon the best materials, and from the best wax—that free from dirt, pollen, propolis, burnt wax, etc., that does not irritate and make it repulsive to the bees. Every piece of foundation is guaranteed to be equal to the sample that you will see in our application.

Langstroth on the Honey Bee, revised and enlarged. Paris. Sewing and binding supplies. Send for sample.

Dadant & Son,

Riverton, Ills.

We are the largest dealer

Bee-keepers'

Supplies

in the market, and sell them at *Low Prices*. Free Price List and Catalogue. Price List.

G. B. Lewis Co.,

Watertown, Wis.

E. T. Adler, St. Joseph, Mo., sells our hives and sections at factory prices.

Sections

We make sections of them nearly perfect in shape, smoothness and finish can't be better. The best sections right here. They are made in good *Shipping Cases* so you can get them in any quantity. Write to *Bee Supplies*, 107 E. 1st St., St. Joseph, Mo.

Send for sample and price list.

Marshfield

Mfg. Co., Marshfield, Wis.

We are the largest dealer in the market, and sell them at *Low Prices*. Free Price List and Catalogue. Price List.

One-Piece

Sections

made in the same size and shape as the *Standard*. Special prices on large quantities.

One-Piece SECTION COMPANY

Prairie du Chien, Wis.

THE **Progressive** Bee-Keeper

Is a 28-page monthly bee journal published at Higginsville, Mo.; price, 50c per year. With the year of 1898, we begin the eighth volume; hence it is past the experimental stage. **R. B. Leahy** and **G. M. Doolittle**, editors. Some of the features of 1898 will be a continuation of *Wayside Fragments*, by **Somnambulist**. *Experience and its Lessons*, by **R. C. Aikin**. This series of articles will be reviewed by Mr. Doolittle which is practically giving *his* experience with its lessons. "Experience" and its lessons, as reviewed, will be a gold mine for beginners and a banquet to those more advanced in bee culture. The *Somnambulist* articles are written in a pleasing style, as none but *Sommy* could write them. They are highly entertaining and instructive. **Dr. C. C. Miller** and other popular writers also contribute to its columns. The *PROGRESSIVE* is a popular journal at a popular price. Printed in the highest art, on beautiful paper. Fearless in its character, newsy in its contents, and artistic in its make-up. Remember the *PROGRESSIVE BEE-KEEPER* it is but 50c per year. The *PROGRESSIVE* and that "one only" book for beginners, the *Amateur Bee-Keeper*, by **Prof. J. W. Rouse**, both for 65c. A sample copy of the *PROGRESSIVE* for your name, and a beautiful illustrated catalogue of apian supplies for the asking.

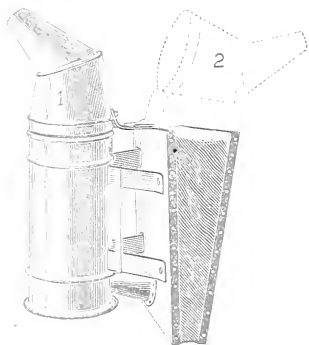

The accompanying cut shows the Higginsville Smoker with the nozzle thrown back for filling. This Smoker is strong and well made of the best material, has a strong draft, and will burn any kind of fuel. One smoker, 75 cts.; three for \$1.80. When sent by mail add 25 cts each for postage. Send for catalogue of other supplies.

THE *AMATEUR BEE-KEEPER*, a book for beginners, 25 cts., by mail, 28 cts.

For all the above, address the

Leahy Mfg. Co., Higginsville, Mo.



DADANT'S

Foundation

By the new *Weed Process* is made in the best manner, upon the best machines, and from the best wax—entirely free from dirt, pollen, propolis, burnt wax, etc., that does not injure its tenacity and make it offensive to the bees. Every inch of foundation is guaranteed to be equal to the sample that will be sent upon application.

Langstroth on the Honey Bee, revised. Smokers, Tin Pails, Sections and other supplies. Send for circular.

Dadant & Sons

Hamilton, Ills.

We make the finest line of

Bee-keepers'

Supplies

in the market, and sell them at *Low Prices*. Free Illustrated Catalogue and Price List.

G. B. Lewis Co.

Wauertown, Wis.

E. T. Abbott, St. Joseph, Mo., sells our hives and sections at factory prices.

Sections

We make millions of them, perfectly uniform in shape, smoothness and finish, can't be better. The best in the market right here. They are made by the *Strip-Piling Process*, and are guaranteed to be equal to the sample that will be sent upon application.

They are made of the best material, and are guaranteed to be equal to the sample that will be sent upon application.

They are made of the best material, and are guaranteed to be equal to the sample that will be sent upon application.

They are made of the best material, and are guaranteed to be equal to the sample that will be sent upon application.

They are made of the best material, and are guaranteed to be equal to the sample that will be sent upon application.

They are made of the best material, and are guaranteed to be equal to the sample that will be sent upon application.

They are made of the best material, and are guaranteed to be equal to the sample that will be sent upon application.

They are made of the best material, and are guaranteed to be equal to the sample that will be sent upon application.

They are made of the best material, and are guaranteed to be equal to the sample that will be sent upon application.

They are made of the best material, and are guaranteed to be equal to the sample that will be sent upon application.

They are made of the best material, and are guaranteed to be equal to the sample that will be sent upon application.

They are made of the best material, and are guaranteed to be equal to the sample that will be sent upon application.



At Flint, Michigan — One Dollar a Year

DADANT'S

Foundation

By the new *Weed Process* is made in the best manner, upon the best machines, and from the best wax—that free from dirt, pollen, propolis, burnt wax, etc., that decrease its tenacity and make it offensive to the bees. Every inch of foundation is guaranteed to be equal to the sample that will be sent upon application.

Langstroth on the Honey Bee, revised. Smokers, The Pails, Sections and other supplies. Send for Circular.

Dadant & Son,
Hamilton, Ill.

We make the best line of

Bee-Keepers' Supplies

in the market, and sell them at *Low Prices*. Free Illustrated Catalogue and Price List.

G. B. Lewis Co.,

Watertown, Wis.

E. T. Abbott, St. Joseph, Mo., sells our hives and sections at factory prices.

Sections

We make sections of them ready for shipment, smoothness and finish guaranteed. The best you can get right here. If you want to see our *Shipping Catalogue*, send for them. We will send you the *One-Third* and *One-Five* sections.

Send for our *Illustrated Catalogue* and *Price List*.

One-Third
One-Five
Mfg. Co., Watertown, Wis.

We make sections of them ready for shipment, smoothness and finish guaranteed. The best you can get right here. If you want to see our *Shipping Catalogue*, send for them. We will send you the *One-Third* and *One-Five* sections.

One-Third One-Five Sections

in the market, and sell them at *Low Prices*. Free Illustrated Catalogue and Price List.

One-Third SECTION COMPANY,

Franklin, Wis.

Progressive Bee-Keeper

This is our monthly bee journal, published at Higginsville, Mo.; price, 50c per copy. With the year of 1878, we begin the eighth volume; hence we are in the experimental stage. R. B. Leahy and G. M. Doolittle, Editors. Some of the features of 1898 will be a continuation of Wayside Excursions, by Somnambulist, Experience and its Lessons, by R. C. Anderson. This series of articles will be reviewed by Mr. Doolittle, which is not only giving his experience with its lessons, "Experience" and its lessons reviewed, will be a gold mine for beginners and advantageous to those more advanced in bee culture. The Somnambulist articles are written in a pleasing style, as none but Somnambulist could write them. They are both entertaining and instructive. Dr. C. C. Miller, and other popular writers also contribute to his columns. The Progressive is a popular journal, of a popular price, printed in the highest art on beautiful paper. It is plain in its design, concise in its contents, and artistic in its appearance. Remember the Progressive Bee-Keeper is but 50c per year. The Progressive and the "only one" book for beginners, the Amateur Bee-Keeper, by Dr. F. J. W. Rouse, both for 50c. A sample copy of the Progressive for your name, and a beautiful illustrated catalogue of apian supplies for the asking.



The accompanying cut shows the Higginsville Smoker with the lid thrown back for filling. This smoker is strong and well made of the best material, has a strong draft, and will burn any kind of fuel. One smoker, 75 cts.; three for \$1.80. When sent by mail add 25 cts. each for postage. Send for catalogue of other supplies.

For all the above, address the

Leahy Mfg. Co., Higginsville, Mo.

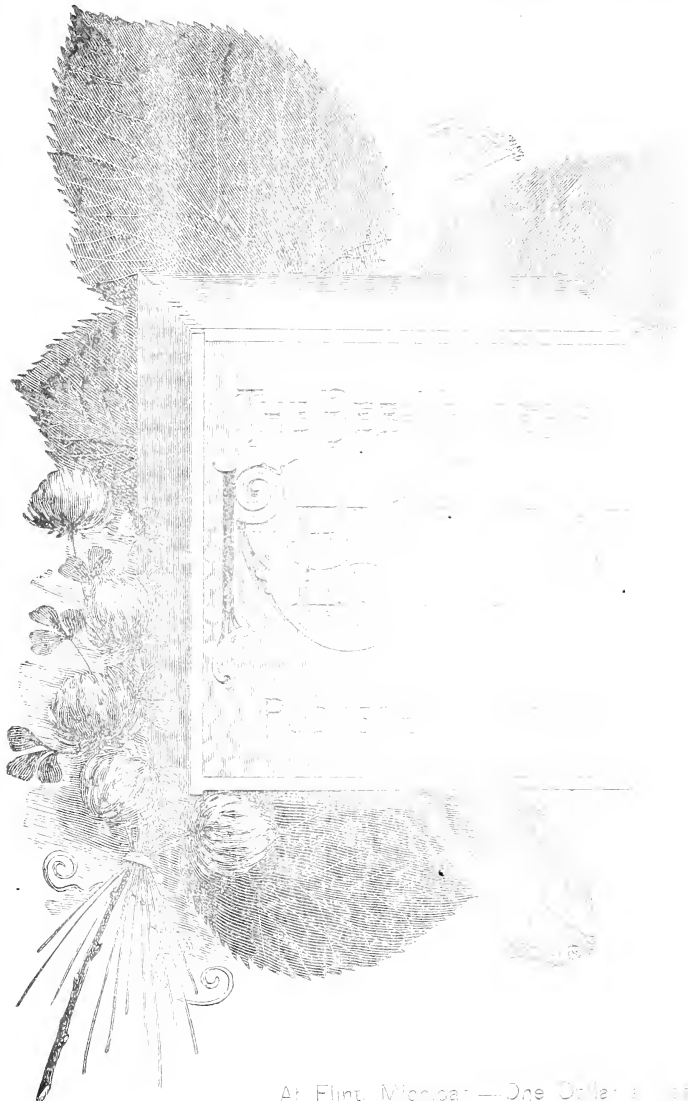

At Flint Mill, One Dollar

Savers.

...those ask-
...paid writ-
...usand all
...States).
...at an ex-
...ish it
...thousand
...but
...using the
...\$2.00.
...of the
...only, or,
...a com-
...and the

...	32
...	69
...	1000
...	17
...	57
...	41
...	112
...	25
...	9
...	50
...	28
...	50
...	67

Cheap.

...Ohio,
...Arizona,
...detures,
...if he
...sell
...list of
...they are

...	89
...	25
...	15
...	10
...	15
...	15
...	25
...	35
...and can	
...are	
...been	
...tionally	
...any-	
...partien-	

DADANT'S

Foundation

By the new *Wood Process* is made in the best manner, upon the best machines, and from the best wax—that free from dirt, pollen, propolis, burnt wax, etc., that decrease its tenacity and make it offensive to the bees. Every inch of foundation is guaranteed to be up to the sample that will be sent upon application.

Langstroth on the Honey Bee, revised. Success, The Pills, Sections and other supplies. Send for circular.

Dadant & Sons

Hamilton, Wis.

We make the best line of

Bee-Keepers' Supplies

in the market, and sell them at *Low Prices*. Free Illustrated Catalogue and Price List.

G. B. Lewis Co.,

Watertown, Wis.

E. T. Abbott, St. Joseph Mo., sells our hives and sections at factory prices.

Sections

Sections are made in the best manner, upon the best machines, and from the best wax—that free from dirt, pollen, propolis, burnt wax, etc., that decrease its tenacity and make it offensive to the bees. Every inch of foundation is guaranteed to be up to the sample that will be sent upon application.

Sections are made in the best manner, upon the best machines, and from the best wax—that free from dirt, pollen, propolis, burnt wax, etc., that decrease its tenacity and make it offensive to the bees. Every inch of foundation is guaranteed to be up to the sample that will be sent upon application.

Sections are made in the best manner, upon the best machines, and from the best wax—that free from dirt, pollen, propolis, burnt wax, etc., that decrease its tenacity and make it offensive to the bees. Every inch of foundation is guaranteed to be up to the sample that will be sent upon application.

Progressive Bee-Keeper

A monthly bee journal published at Higginsville, Mo.; price, \$1.00 per year. With the year of 1898, we begin the eighth volume; hence the experimental stage. R. B. Leahy and G. M. Doolittle, 1898. Some of the features of 1898 will be a continuation of Wayside Thoughts, by Somnambulist. Experience and its Lessons, by R. C. Ainsworth's series of fables will be reviewed by Mr. Doolittle, which is highly giving of experience with its lessons. "Experience" and its lessons reviewed, will be a gold mine for beginners and advantageous to the already used in bee culture. The Somnambulist articles are in a pleasing style, as none but Sammy could write them. They are entertaining and instructive. Dr. C. C. Miller, and other popular writers also contribute to its columns. The Progressive is a popular journal, popular price. Printed in the highest art on beautiful paper, harmless in its character, newsy in its contents, and artistic in its appearance. Remember the Progressive Bee-Keeper is but 50c per year. The Progressive and that "only one" book for beginners, the Amateur Bee-Keeper, by Prof. J. W. Rouse, both for 65c. A sample copy of the Progressive will be sent for your name, and a beautiful illustrated catalogue of apian supplies for the asking.



The accompanying cut shows the Higginsville Smoker with the nozzle thrown back for filling. This smoker is strong and well made of the best material, has a strong draft, and will burn any kind of fuel. One smoker, 75 cts.; three for \$1.50. When sent by mail add 25 cts. each for postage. Send for catalogue of other supplies.

For all the above, address the

W. W. Root & Co., Higginsville, Mo.



DADANT'S

Foundation

By the new *Weed Process* is made in the best manner, upon the best machines, and from the best wax—that free from dirt, pollen, propolis, burnt wax, etc., that decrease its tenacity and make it offensive to the bees. Every inch of foundation is guaranteed to be equal to the sample that will be sent upon application.

Langstroth on the Honey Bee, revised, Smokers, Tin Pails, Sections and other supplies. Send for circular.

Dadant & Son,

Hamilton, Ills.

We make the finest line of

Bee-Keepers' Supplies

in the market, and sell them at *Low Prices*. Free Illustrated Catalogue and Price List.

G. B. Lewis Co.,

Watertown, Wis.

E. T. Abbott, St. Joseph, Mo., sells our hives and sections at factory prices.

Sections

We make millions of them yearly: workmanship, smoothness and finish can't be better. The loss of wax grows right here. If you want the good *Shipping Cases*, you can get them of us. A full line of *Bee Supplies* on hand.

Write for illustrated catalogue and price list.

Marshfield

Mfg. Co., Marshfield, Wis.

We make sections as white as snow, and as strong as iron. Get our complete list of *the finest*

One-Piece

Sections

in the market. Price list and sample section free. Special prices on large quantities.

One-Piece SECTION COMPANY.

Prairie du Chien, Wis.

THE Progressive Bee-Keeper

Is a 28-page monthly bee journal published at Higginsville, Mo.; price, 50c per year. With the year of 1898, we begin the eighth volume; hence it is past the experimental stage. R. B. Leahy and G. M. Doolittle, editors. Some of the features of 1898 will be a continuation of Wayside Fragments, by Somnambulist, Experience and its Lessons, by R. C. Aikin. This series of articles will be reviewed by Mr. Doolittle, which is practically giving *his* experience with its lessons. "Experience" and its lessons, as reviewed, will be a gold mine for beginners and advantageous to those more advanced in bee culture. The Somnambulist articles are written in a pleasing style, as none but Sommy could write them. They are highly entertaining and instructive. Dr. C. C. Miller, and other popular writers also contribute to its columns. The Progressive is a popular journal at a popular price. Printed in the highest art on beautiful paper. Fearless in its character, newsy in its contents and artistic in its make-up. Remember the Progressive Bee-Keeper is but 50c per year. The Progressive and that "only one" book for beginners, the Amateur Bee-Keeper, by Prof. J. W. Rouse, both for 65c. A sample copy of the Progressive for your name, and a beautiful illustrated catalogue of apian supplies for the asking.

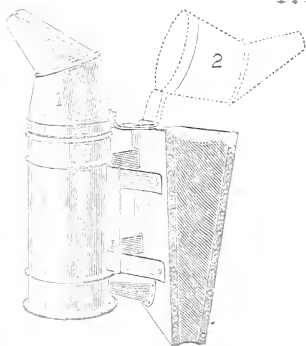

The accompanying cut shows the Higginsville Smoker with the nozzle thrown back for filling. This smoker is strong and well made of the best material, has a strong draft, and will burn any kind of fuel. One smoker, 75 cts.; three for \$1.80. When sent by mail add 25 cts. each for postage. Send for catalogue of other supplies.

For all the above, address the

Leahy Mfg. Co., Higginsville, Mo.

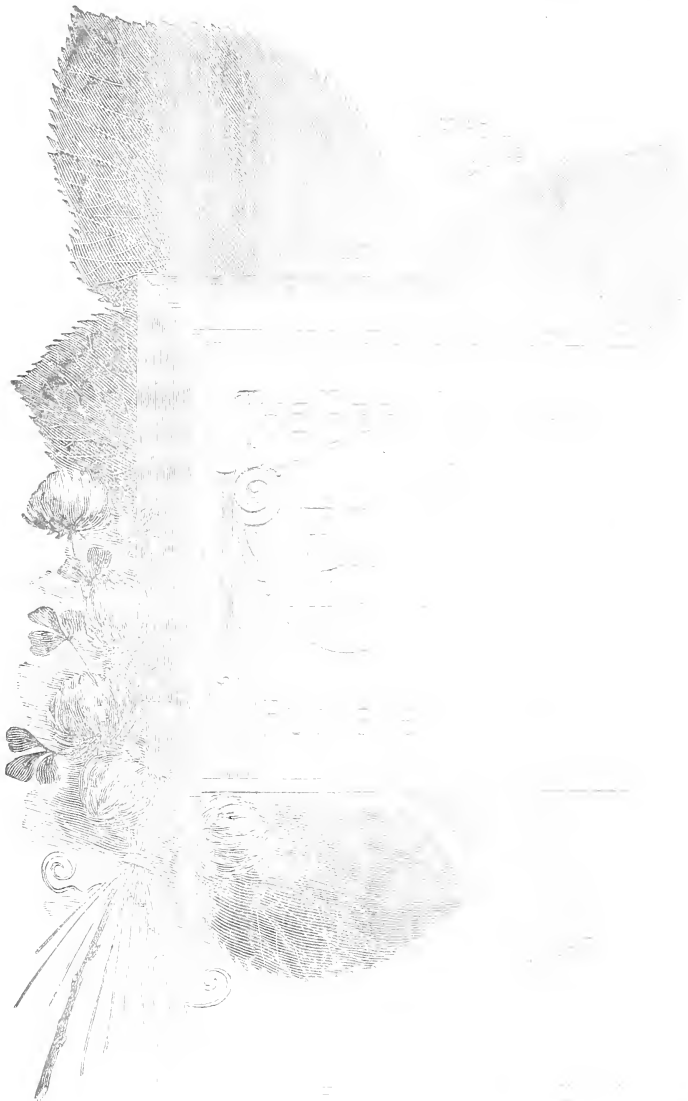

DADANT'S

Foundation

By the new *Weed Process* is made in the best manner, on the best machines, and from the best material—free from dirt, pollen, propolis, brimstone, etc., that does not sting, and makes the bees keep clean and healthy. It is guaranteed to be a perfect sample that will bear every application.

Langstroth on the Honey Bee, revised, Second Edition, Pills, Seeds, and other supplies. See our advertisement.

Dadant & Son,

Hamilton, Ill.

We will send you a free

Bee-keeper's

Supplies

in the world, and sell them at *Lowest* prices. Free illustrated Circular and Price List.

G. B. Lewis Co.,

Wauertown, Wis.

E. T. Cress, St. Joseph, Mo., sells our hives and sections at factory prices.

Sections

There are millions of them made in the best manner and they will be better than any you can get right here. They are made on our *Ship-*ping cases, so you can get them in any quantity. Write for our circular and price list.

See our advertisement for the *Langstroth* and *Warren* hives.

Marshfield

W. C. Miller, Marshfield, Wis.

We will send you a free circular and price list. Write for it. We will send you a free circular and price list. Write for it.

One-Piece

SECTIONS

in the world. Price list and circular sent free. Special prices on large quantities.

One-Piece SECTION COMPANY.

Prairie du Chien, Wis.

Progressive Bee-Keeper

A quarterly bee journal published at Higginsville, Mo.; price, 50c per year. With the year of 1898, we begin the eighth volume; hence we are past the experimental stage. R. B. Leahy and G. M. Doolittle, editors. Some of the features of 1898 will be a continuation of Wayside Emigrants, by Somnambulist, Experience and its Lessons, by R. C. Aldrich. His series of articles will be reviewed by Mr. Doolittle, which is practically giving *his* experience with its lessons. "Experience" and its lessons reviewed, will be a gold mine for beginners and advantageous to those more advanced in bee culture. The Somnambulist articles are written in a pleasing style, as none but Tommy could write them. They are most entertaining and instructive. Dr. C. C. Miller, and other popular beekeepers, contribute to its columns. The Progressive is a popular journal, and of popular price. Printed in the highest art on beautiful paper, and less in its character, newsy in its contents, and artistic in its illustrations. Remember the Progressive Bee-Keeper is but 50c per year. It is the Progressive and that "only one" book for beginners, the Amateur Beekeeper, by Prof. J. W. Rouse, both for 65c. A sample copy of the Progressive for your name, and a beautiful illustrated catalogue of apian supplies for the asking.

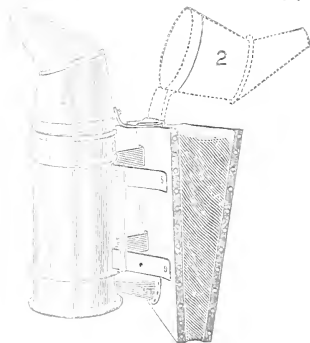

The accompanying cut shows the Higginsville Smoker with the nozzle thrown back for filling. This smoker is strong and well made of the best material, has a strong draft, and will burn any kind of fuel. One smoker, 75 cts.; three for \$1.50. When sent by mail add 25 cts. each for postage. Send for catalogue of other supplies.

For all the above, address the

Leahy Mfg. Co., Higginsville, Mo.



ADVERTISING RATES

All advertisements will be inserted at a rate of 15 cents per line. Non-pamphlet advertisements will be inserted at 12 lines of Non-pamphlet space makes 100 lines. Discounts will be given as follows:

On 10 lines and upwards, 3 times, 50 per cent. on 10 lines, 15 per cent. on 15 lines, 25 per cent. on 20 lines, 35 per cent.

On 20 lines and upwards, 3 times, 15 per cent. on 20 lines, 20 per cent. on 25 lines, 30 per cent. on 30 lines, 40 per cent.

On 30 lines and upwards, 3 times, 20 per cent. on 30 lines, 30 per cent. on 35 lines, 40 per cent. on 40 lines, 50 per cent.

Clipping List.

I will send the names with—

American Boy	new	50
American Boy	old	50
Progressive Boy	new	50
American Boy	new	50
The Saturday Evening Post	new	50
Ohio Farmer	new	50
Farm Journal	new	50
Farm Journal	old	50
Rural New Yorker	new	50
Frank Leslie's Farm Journal Monthly	new	50
The Century	new	50
Michigan Farmer	new	50
Practical Farmer	new	50
American Agriculturist	new	50
Ladies Home Journal	new	50
The Independent	new	50
Ladies Home Journal	new	50
Country Gentleman	new	50
Harpers Weekly	new	50
Harpers Weekly	old	50
Yonkers Herald	new	50
Scrubber Magazine	new	50
Cosmos	new	50
Success	new	50

It will be a pleasure to send these rates on application. A national list of these publications is available to these publications. For a convenient way of ordering, see the Review, which also carries these Journals. A list of subscribers must be sent.

If You Wish to Wear America's

PRINTING

—has a Dog in the Face—

MULLER'S HONEY EXTRACTOR

Square Glass Honey Jar, Etc.
For Order, Write to: MULLER'S PATENT
Co., Freeport, N. Y. and Agents Everywhere.
Send 16c. for Catalogue and Name of Agent.

Keepers.

BE KEPT.

... of these ask-
... saved and writ-
... and thousand all
... (largest States).
... at an ex-
... furnish it
... per thousand
... per 1000, but
... by using the
... at \$2.00.
... a list of the
... state only, or
... can be accom-
... States and the

New Mex.	22
Arizona	61
Idaho	1,000
Ill.	65
W. Va.	37
S. C.	40
Tenn.	112
Texas	225
Utah	30
Vt.	150
W. Va.	130
W. Va.	118
Wis.	30
Wis.	432

... S. W. Flint, Mich.



Cheap.

... Desksville, Ohio,
... in Arizona,
... fixtures.
... him if he
... would sell
... a list of
... they are

...	1.00
...	.25
...	.15
...	.10
...	.15
...	.15
...	.25
...	.35

... and can
... cases are
... having been
... practically
... buy any-
... offer particu-



THE Progressive Bee-Keeper

Is a 28-page monthly bee journal published at Higginsville, Mo.; price, 50¢ per year. With the year of 1898, we begin the eighth volume; hence it is just the experimental stage. R. B. Leahy and G. M. Doolittle, editors. Some of the features of 1898 will be a continuation of Wayside Fragments, by Somnambulist. Experience and its Lessons, by R. C. Aikin. This series of articles will be reviewed by Mr. Doolittle, which is practically giving *his* experience with its lessons. "Experience" and its lessons, as reviewed, will be a gold mine for beginners and advantageous to those more advanced in bee culture. The Somnambulist articles are written in a pleasing style, as none but Somny could write them. They are highly entertaining and instructive. Dr. C. C. Miller, and other popular writers also contribute to its columns. The Progressive is a popular journal, at a popular price. Printed in the highest art on beautiful paper. To dress in its character, newsy in its contents, and artistic in its make-up. Remember the Progressive Bee-Keeper is but 50¢ per year. The Progressive and that "only one" cook for beginners, the Amateur Bee-Keeper by Prof. J. W. Rouse, both for 65¢. A sample copy of the Progressive for your name, and a beautiful illustrated catalogue of apian supplies for the asking.

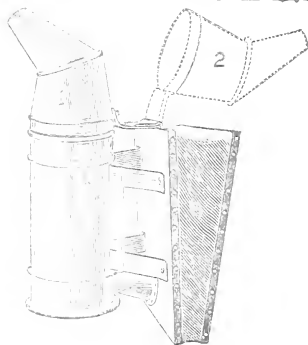

The accompanying cut shows the Higginsville Smoker with the nozzle thrown back for filling. This smoker is strong and well made of the best material, has a strong draft, and will burn any kind of fuel. One smoker, 75 cts.; three for \$1.80. When sent by mail add 25 cts. each for postage. Send for catalogue of other supplies.

For all the above, address the

Leahy Mfg. Co., Higginsville, Mo.

