











# THE BIOLOGICAL BULLETIN

PUBLISHED BY  
THE MARINE BIOLOGICAL LABORATORY

## Editorial Board

W. C. ALLEE, University of Florida  
L. R. BLINKS, Stanford University  
K. W. COOPER, University of Rochester  
L. V. HEILBRUNN, University of Pennsylvania  
M. E. KRAHL, University of Chicago  
E. T. MOUL, Rutgers University

A. K. PARPART, Princeton University  
BERTA SCHARRER, University of Colorado  
ALBERT TYLER, California Institute of Technology  
JOHN H. WELSH, Harvard University  
DOUGLAS WHITAKER, Stanford University  
RALPH WICHTERMAN, Temple University

DONALD P. COSTELLO, University of North Carolina  
*Managing Editor*

VOLUME 106  
FEBRUARY TO JUNE, 1954

Printed and Issued by  
LANCASTER PRESS, Inc.  
PRINCE & LEMON STS.  
LANCASTER, PA.

THE BIOLOGICAL BULLETIN is issued six times a year at the Lancaster Press, Inc., Prince and Lemon Streets, Lancaster, Pennsylvania.

Subscriptions and similar matter should be addressed to The Biological Bulletin, Marine Biological Laboratory, Woods Hole, Massachusetts. Agent for Great Britain: Wheldon and Wesley, Limited, 2, 3 and 4 Arthur Street, New Oxford Street, London, W. C. 2. Single numbers \$2.50. Subscription per volume (three issues), \$6.00.

Communications relative to manuscripts should be sent to the Managing Editor, Marine Biological Laboratory, Woods Hole, Massachusetts, between June 15 and September 1, and to Dr. Donald P. Costello, Department of Zoology, University of North Carolina, Chapel Hill, North Carolina, during the remainder of the year.

Entered as second-class matter May 17, 1930, at the post office at Lancaster, Pa., under the Act of August 24, 1912.

---

LANCASTER PRESS, INC., LANCASTER, PA.



# CONTENTS

NO. 1. FEBRUARY, 1954

ARVY, L., AND M. GABE	
The intercerebralis-cardiacum-allatum system of some Plecoptera. . . . .	1
CABLE, R. M.	
A new marine cercaria from the Woods Hole region and its bearing on the interpretation of larval types in the Fellodistomatidae (Trematoda: Digenea). . . . .	15
CHILD, C. M.	
Redox indicator patterns in relation to echinoderm exogastrulation. II. Reduction patterns. . . . .	21
FRASER, RONALD C.	
The utilization of some carbohydrates by in vitro cultured chick blastoderms in wound healing. . . . .	39
HARRISON, JOHN R., AND IRVING KLEIN	
Effects of lowered incubation temperature on the growth and differentiation of the chick embryo. . . . .	48
MATSUMOTO, KUNIO	
Neurosecretion in the thoracic ganglion of the crab, <i>Eriocheir japonicus</i>	60
NICOLL, PAUL A.	
The anatomy and behavior of the vascular systems in <i>Nereis virens</i> and <i>Nereis limbata</i> . . . . .	69
OKAZAKI, KAYO, AND KATSUMA DAN	
The metamorphosis of partial larvae of <i>Peronella japonica</i> Mortensen, a sand dollar. . . . .	83
RAY, DAVID T., AND P. W. WHITING	
An x-ray dose-action curve for eye-color mutations in <i>Mormoniella</i> . . . . .	100
SCHILLER, EVERETT L.	
Studies on the helminth fauna of Alaska. XVII. Notes on the intermediate stages of some helminth parasites of the sea otter. . . . .	107
SLIFER, ELEANOR H.	
The permeability of the sensory pegs on the antenna of the grasshopper ( <i>Orthoptera: Acrididae</i> ). . . . .	122
THOMAS, LYELL J., JR.	
The localization of heparin-like blood anticoagulant substances in the tissues of <i>Spisula solidissima</i> . . . . .	129

NO. 2. APRIL, 1954

CHADWICK, L. E., J. B. LOVELL AND V. E. EGNER	
The relationship between pH and the activity of cholinesterase from flies. . . . .	139

FRAENKEL, G., AND GLENN E. PRINTY	
The amino acid requirements of the confused flour beetle, <i>Tribolium confusum</i> , Duval.....	149
HEILBRUNN, L. V., ALFRED B. CHAET, ARNOLD DUNN AND WALTER L. WILSON	
Antimitotic substances from ovaries.....	158
MONROY, A., L. TOSI, G. GIARDINA AND R. MAGGIO	
Further investigations on the interaction between sperm and jelly-coat in the fertilization of the sea urchin egg.....	169
MOOREFIELD, HERBERT H., AND G. FRAENKEL	
The character and ultimate fate of the larval salivary secretion of <i>Phormia regina</i> Meig. (Diptera, Calliphoridae).....	178
NORTH, WHEELER J.	
Size distribution, erosive activities, and gross metabolic efficiency of the marine intertidal snails, <i>Littorina planaxis</i> and <i>L. scutulata</i> .....	185
RYTHER, JOHN H.	
The ecology of phytoplankton blooms in Moriches Bay and Great South Bay, Long Island, New York.....	198
SCHNEIDERMAN, HOWARD A., AND CARROLL M. WILLIAMS	
The physiology of insect diapause. VIII. Qualitative changes in the metabolism of the <i>Cecropia</i> silkworm during diapause and development	210
SCHNEIDERMAN, HOWARD A., AND NED FEDER	
A respirometer for metabolic studies at high gaseous pressures.....	230
SCHNEIDERMAN, HOWARD A., AND CARROLL M. WILLIAMS	
The physiology of insect diapause. IX. The cytochrome oxidase system in relation to the diapause and development of the <i>Cecropia</i> silkworm.	238
WICHTERMAN, RALPH, AND FRANK H. J. FIGGE	
Lethality and the biological effects of x-rays in <i>Paramecium</i> : Radiation resistance and its variability.....	253

No. 3. JUNE, 1954

BODINE, JOSEPH HALL, AND WILLIAM LIONEL WEST	
Effect of adenosinetriphosphate (ATP) on the endogenous oxygen uptake of developing grasshopper embryos.....	265
BRENT, MORGAN M.	
Nutritional studies on the amoeba-flagellate, <i>Tetramitus rostratus</i> .....	269
BROOKS, SUMNER C., AND EDWARD L. CHAMBERS	
The penetration of radioactive phosphate into marine eggs.....	279
CHAMBERS, EDWARD L., AND WILLIAM E. WHITE	
The accumulation of phosphate by fertilized sea urchin eggs.....	297
BROWN, FRANK A., JR., MILTON FINGERMAN AND MARGARET N. HINES	
A study of the mechanism involved in shifting of the phases of the endogenous daily rhythm by light stimuli.....	308
GRANT, PHILIP	
The distribution of phosphorus ( $P^{31}$ and $P^{32}$ ) in dorsal and ventral halves of the <i>Rana pipiens</i> gastrula.....	318

LANE, CHARLES E., J. Q. TIERNEY AND R. E. HENNACY	
The respiration of normal larvae of <i>Teredo bartschi</i> Clapp. ....	323
LASKER, REUBEN, AND ARTHUR C. GIESE	
Nutrition of the sea urchin, <i>Strongylocentrotus purpuratus</i> . ....	328
MC SHAN, W. H., SOL KRAMER AND VERA SCHLEGEL	
Oxidative enzymes in the thoracic muscles of the woodroach, <i>Leucophaea maderae</i> . ....	341
RAO, K. P.	
Tidal rhythmicity of rate of water propulsion in <i>Mytilus</i> and its modifi- ability by transplantation. ....	353
VERNBERG, F. JOHN	
The respiratory metabolism of tissues of marine teleosts in relation to activity and body size. ....	360
WEBB, H. MARGUERITE, MIRIAM F. BENNETT AND FRANK A. BROWN, JR.	
A persistent diurnal rhythm of chromatophoric response in eyestalkless <i>Uca pugilator</i> . ....	371





# THE BIOLOGICAL BULLETIN

PUBLISHED BY THE MARINE BIOLOGICAL LABORATORY

## THE INTERCEREBRALIS-CARDIACUM-ALLATUM SYSTEM OF SOME PLECOPTERA<sup>1</sup>

L. ARVY AND M. GABE

*Laboratoire d'Anatomie et Histologie comparées, Sorbonne, Paris, France*

In spite of the interesting taxonomic position of the Plecoptera and the biological peculiarities of these insects their endocrine glands have been studied only by a small number of investigators. The existence of corpora allata in *Perla maxima* Scop. was first reported by Nabert (1913). In *Nemura vallicularia*, Wu (1923) described "lateral ganglia" which perhaps correspond to the corpora cardiaca. Hanström (1940) gave the first exact description of the endocrine glands in four species of Plecoptera (*Nemura variegata* Oliv., *Chloroperla virrens* Zett., *Isopteryx burmeisteri* Pictet, and *Perla cephalotes* Curt.). He showed that the anatomy of the endocrine glands of *Nemura* differs greatly from that of the three other species. In *Nemura* the medially located corpora cardiaca are fused with an unpaired lateral corpus allatum, while the three other species possess symmetrical paired corpora allata which are connected with the corpora cardiaca by anatomically defined nervi corporis allati. Histologically, according to Hanström, the corpora cardiaca of the Plecoptera contain cells whose general appearance is that of neurons but whose glandular function seems probable on account of the presence of fuclisinophilic secretory granules. Likewise, the glandular function of the corpora allata is indicated by the occurrence of acidophilic secretory granules. Regarding the innervation of these endocrine glands, Hanström found, in the four species of Plecoptera studied, the two pairs of protocerebral nerves whose existence he had demonstrated in other Pterygota, and indicated that their cells of origin have the same location as in other insects. No new data have been added to this description in the general survey on the subject by Cazal (1948).

This brief summary indicates that the endocrine glands in the head region of the Plecoptera are only incompletely known. The study of a larger number of species seems desirable because of the pronounced anatomical differences in the representatives of this order studied by Hanström (1940). Furthermore, none of the papers quoted above contain any information on two important histophysiological problems recently brought to light, *i.e.*, the relationships of the endocrine glands with the

<sup>1</sup> Translated from the French by Dr. Berta Scharrer, University of Colorado School of Medicine, Denver.

neurosecretory cells, and the changes which these glands undergo in the course of post-embryonic development.

We have, therefore, undertaken a study of the endocrine glands of the head region in representatives of seven families of the Plecoptera of the European fauna.<sup>2</sup> In the present paper we shall report new data regarding the "organ system" formed by the neurosecretory cells of the pars intercerebralis, the corpora cardiaca and the corpora allata (Scharrer and Scharrer, 1944; B. Scharrer, 1952).

#### MATERIAL AND METHODS

We were able to examine numerous specimens, in different stages of post-embryonic development, belonging to the following species (classification and nomenclature according to Aubert, 1946):

Perlodidae	<i>Perlodes intricata</i> Pict. <i>Perlodes mortoni</i> Klap. <i>Isogenus alpinus</i> Pict. <i>Isogenus fontium</i> Ris.
Perlidae	<i>Perla maxima</i> Scop. <i>Perla marginata</i> Panz. <i>Perla cephalotes</i> Curt. <i>Perla carlukiana</i> Klap.
Chloroperlidae	<i>Isoperla grammatica</i> Scop. <i>Isoperla rivulorum</i> Pict.
Taeniopterygidae	<i>Brachyptera risi</i> Morton <i>Rhabdiopteryx alpina</i> Küht.
Capniidae	<i>Capnioneura nemuroides</i> Ris.
Leuctridae	<i>Leuctra hippopus</i> Kemp. <i>Leuctra inermis</i> Kemp.
Nemuridae	<i>Nemura mortoni</i> Ris. <i>Nemura marginata</i> Ris. <i>Nemura intricata</i> Ris. <i>Nemura praecox</i> Morton <i>Nemura nimborum</i> Ris. <i>Nemura lateralis</i> Ris.

The tissues were fixed in Bouin, Duboscq-Brazil, or Carnoy. The material was embedded in celloidin-paraffin and cut serially at 5 and 7  $\mu$ . Among stains for general survey we have used especially hemalum-picroindigocarmin, the triple stain of Prenant (as modified by Gabe and Prenant, 1949), and azan. The neurosecretory cells can be well demonstrated with the latter method, but the study of the migration of the neurosecretory product along the axons is greatly facilitated by the use of the chrome hematoxylin-phloxine method of Gomori (1941). Furthermore, we have employed the method of Brachet for the histochemical determination of ribonucleic acid, the method of Hotchkiss-McManus for the demonstration of polysaccharides, and Best's carmine stain with the saliva test for glycogen.

<sup>2</sup>We are obliged to Dr. J. Aubert, Musée zoologique, Lausanne, Switzerland, and to Dr. T. T. Macan, Ambleside, Westmorland, England, for supplying us with well preserved material.

## RESULTS

The information regarding the intercerebralis-cardiacum-allatum system of the Plecoptera obtained in the present study concerns (a) the anatomy of the endocrine glands, (b) the relationships of these glands with the neurosecretory cells, and (c) the development of these glands of internal secretion in the course of post-embryonic life.

*I. Anatomy of the endocrine glands of the head region*

It is known since the work of Hanström (1940) that certain Plecoptera have paired symmetrical corpora allata, while others have an unpaired lateral corpus allatum. To these two we can add a third type, characterized by a median unpaired corpus allatum (Arvy and Gabe, 1953b).

(a) *Type: Chloroperla.* Under this category Hanström classifies animals which are characterized by the existence of paired corpora allata, *i.e.* *Chloroperla vivens*, *Isopteryx burmeisteri* and *Perla cephalotes*. The examination of a more extensive material permits us to state that the classification of Hanström is valid for all Perlodidae, Perlidae, and Chloroperlidae which we were able to examine.

In all representatives of this type the corpora cardiaca are fused in the midline and surround the dorsal vessel; they receive two pairs of nerves from the protocerebrum, the nervi corporis cardiaci I and II, whose cells of origin lie in the pars intercerebralis and next to the corpora pedunculata. The corpora cardiaca give rise to two nervi corporis allati which are rather short, but thick. The ventral portion of the corpora cardiaca is fused with the hypocerebral ganglion which re-

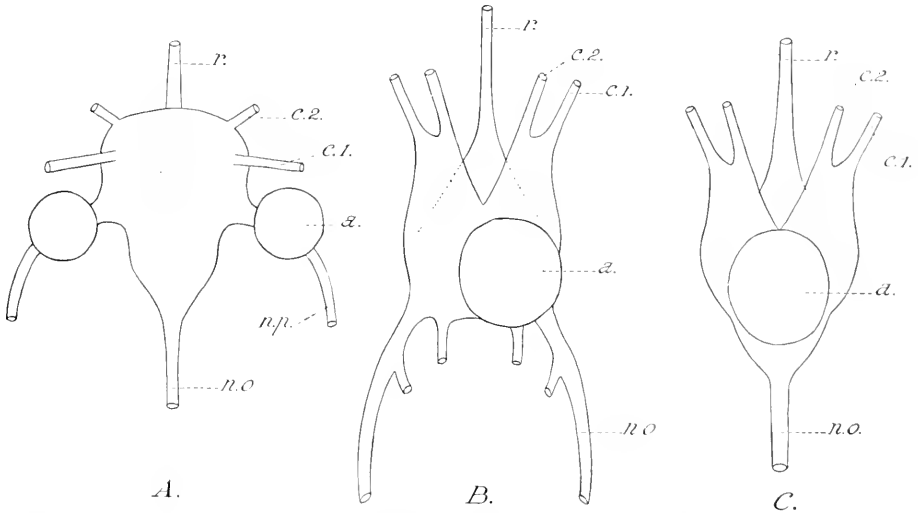
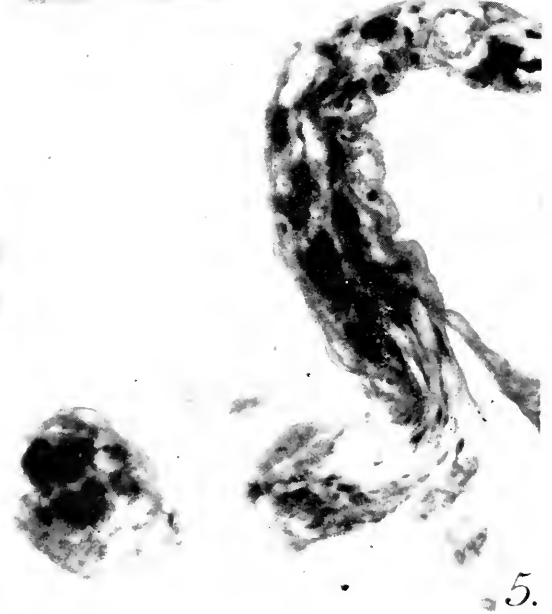
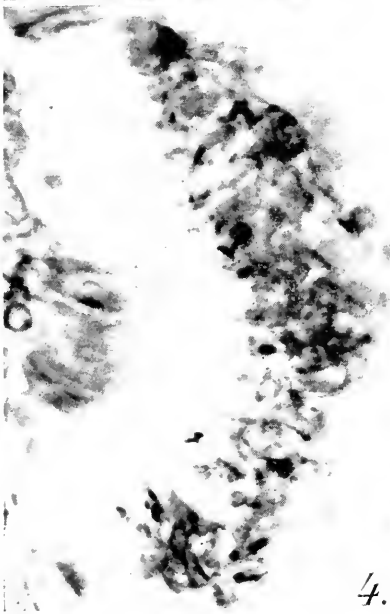
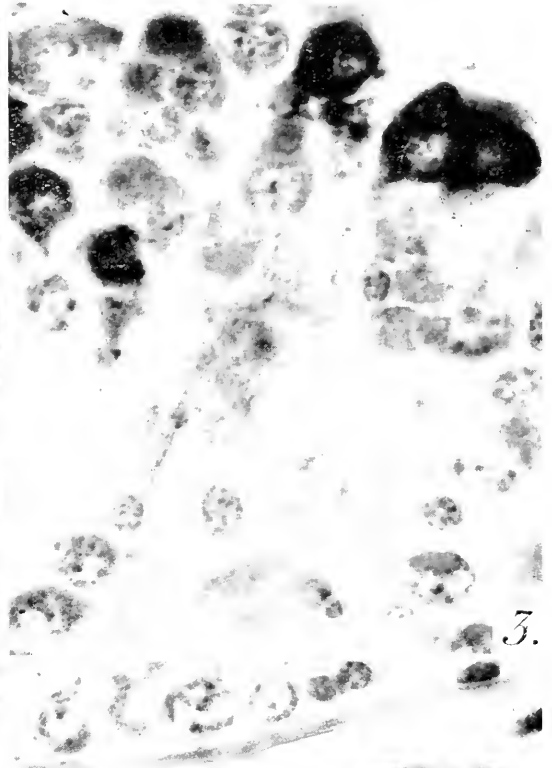
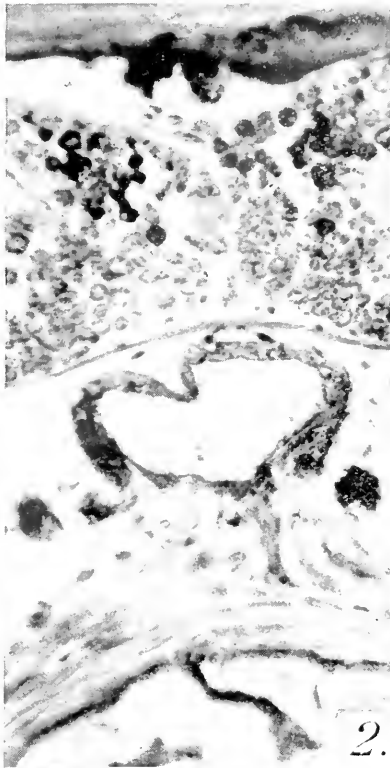

FIGURE 1. Diagrams of the three anatomical types of the retrocerebral glandular complex in the Plecoptera. A. Type of *Chloroperla* (according to Hanström, 1940), found in Perlodidae, Perlidae, and Chloroperlidae; B. Type of *Nemura* (according to Hanström, 1940), found in Capniidae, Leuctridae, and Nemuridae; C. Type of Brachyptera (according to Arvy and Gabe, 1953b), found in Taeniopterygidae. a., corpus allatum; c.1., nervus corporis cardiaci I; c.2., nervus corporis cardiaci II; n.o., esophageal nerve; n.p., prothoracic nerve; r., recurrent nerve.



FIGURES 2-5.



ceives the recurrent nerve and sends off the median unpaired esophageal nerve. From each corpus allatum a good-sized nerve originates which traverses the posterior part of the head, receives a branch from the connective which links the subesophageal and the prothoracic ganglia and branches in the prothorax (Figs. 1A, 10).

(b) *Type: Nemura*. The anatomy of the endocrine glands of the head of *Nemura variegata* is quite different (Hanström, 1940). According to our studies this type of organization also applies to the Capniidae, the Leuctridae and the Nemuridae. The corpora cardiaca, fused in the midline, also in this group receive the same nerves from the protocerebrum as those of the insects of the Chloroperla type. The unpaired corpus allatum lies asymmetrically at the right side and is intimately connected with the fused part of the corpora cardiaca and the hypocerebral ganglion. There are no anatomically defined nervi corporis allati. From the posterior end of this organ complex arise two esophageal nerves which supply the stomodaeum (Fig. 1B).

(c) *Type: Brachyptera*. This type was found only in representatives of the Taeniopterygidae and resembles that of *Nemura* with which it has in common the anatomy of the corpora cardiaca which are fused in the midline and receive the same innervation from the protocerebrum. The corpus allatum is unpaired but lies exactly medially (Fig. 2). As in *Nemura*, it is fused with the corpora cardiaca and the hypocerebral ganglion. The esophageal nerve arising from the caudal extremity of this organ complex is unpaired and median (Fig. 1C).

## II. Relationships between the endocrine glands and the neurosecretory cells

The morphological peculiarities of the cells of origin of the nervi corporis cardiaci I of the Plecoptera are known from the work of Hanström (1940). This author emphasizes the acidophilia of the cytoplasm of these cells, compares them with the elements of the same type which give rise to the nervi corporis cardiaci I in the Palaeoptera, and homologizes them with the paired frontal organs of the Apterygota. These cells possess all the morphological attributes of the neurosecretory cell as defined by Scharrer (for the bibliography see Scharrer and Scharrer, 1954). They elaborate an acidophilic product which stains with iron hematoxylin, with azocarmin and with chrome hematoxylin (method of Gomori). The secretory product passes along the axons arising from these cells. The course of the fibers can be followed with particular ease in preparations stained with chrome hematoxylin-phloxine. Comparable in their major outlines to the course

---

FIGURE 2. Section through caudal portion of cerebral ganglion, showing also corpora cardiaca (in center) and nervi corporis cardiaci I, in a larva of *Perla carlukiana*. Bouin, chrome hematoxylin-phloxine,  $\times 250$ . Note neurosecretory cells and accumulation of neurosecretory product in the corpora cardiaca and their nerves.

FIGURE 3. Neurosecretory cells in the pars intercerebralis of a larva of *Perlodes mortoni*. Bouin, chrome hematoxylin-phloxine,  $\times 1000$ . Note abundance of neurosecretory product in the cells and granules of the same material along the axons.

FIGURE 4. Frontal section through fused portion of corpora cardiaca in a larva of medium age of *Brachyptera risi*. Bouin, chrome hematoxylin-phloxine,  $\times 1000$ . Accumulation of neurosecretory product between the cells.

FIGURE 5. Detail from Figure 2,  $\times 1000$ . Accumulation of neurosecretory product in nervus corporis cardiaci I (bottom, left) and in corpus cardiacum.



6.

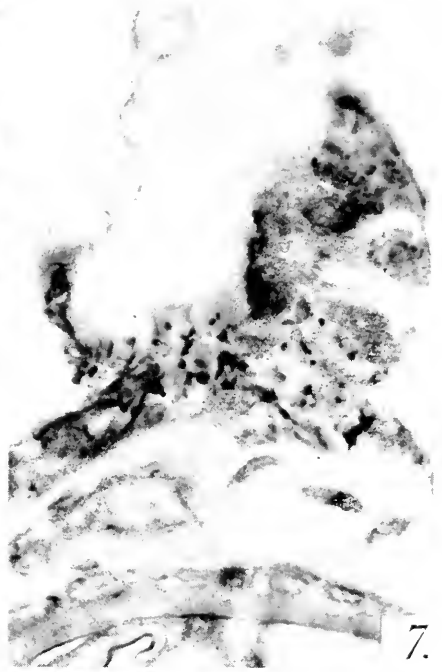

7.

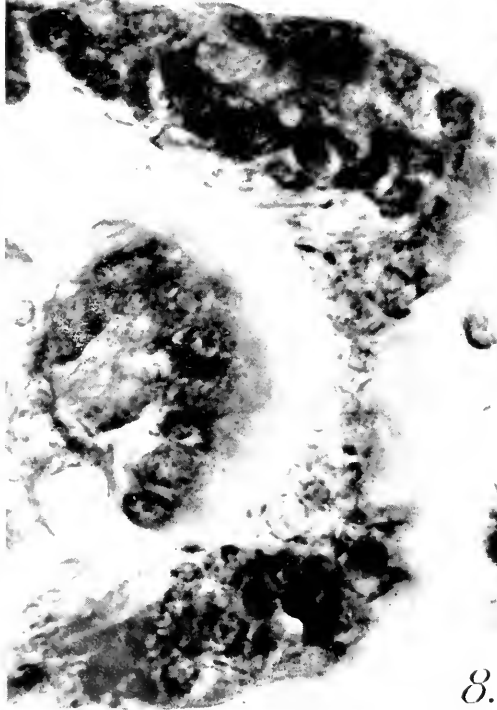

8.



9.

FIGURES 6-9.

of the nervi corporis cardiaci I of the Palaeoptera, the corresponding nerves in the Plecoptera show certain peculiarities in their anatomy. The cells of origin occupy a caudal position (Fig. 2), and the nervi corporis cardiaci I which cross the midline in the anterior portion of the protocerebrum leave the cerebral ganglia shortly after the decussation so that they accomplish a relatively long extraganglionic course on the ventral surface of the cerebral ganglion before entering the corpora cardiaca. The techniques used show in the intraganglionic portion of the nervi corporis cardiaci I very fine granules along the axons (Fig. 3). The extraganglionic portion of the nerves is much richer in secretory products, which accumulate markedly at the point where the nervi corporis cardiaci I change their course (Figs. 2, 5 and 6). In representatives of the type of *Chloroperla* the neurosecretory material appears in form of elongated and knotty masses, of big granules and droplets. This accumulation of the neurosecretory product where the fiber bundles arising from neurosecretory cells change their direction represents a rather frequent occurrence according to E. Scharrer (personal communication).

The neurosecretory product can be demonstrated between the cells of the corpora cardiaca. The study of preparations stained with Gomori's chrome hematoxylin method suggests also here an arrangement along the nerve fibers. We have never found a trace of the substance stainable with chrome hematoxylin *within* the cells of the corpora cardiaca. The small secretory granules occurring in these elements stain intensely with phloxine (Figs. 4-8).

In the species of which *Chloroperla* represents the type and which possess anatomically well defined nervi corporis allati, the neurosecretory substance is very abundant in these nerves. One can trace it without the slightest difficulty to the corpora allata, and in preparations stained with the Gomori technique its destination can be observed (Figs. 7, 9, 13, 14, 15). The majority of the fibers of the nervus corporis allati, which are neatly outlined by the secretory product, ramify under the connective tissue capsule of each corpus allatum. From these subcapsular plexus, clearly defined by the accumulation of the neurosecretory material, issue fibers also charged with neurosecretory material which ramify between the allatum cells. As in the case of the corpora cardiaca, this product remains extracellular. The transport of the neurosecretory material does not terminate in the corpora allata. The nerves which originate from them and run to the prothorax also contain a greater or less amount of the material stainable with chrome hematoxylin.

In the species whose cephalic endocrine glands belong to the types of *Nemura* and *Brachyptera*, the passage of the neurosecretory product into the corpus allatum appears less pronounced. As a matter of fact, there exists no anatomically defined

---

FIGURE 6. Corpus cardiacum of an old larva of *Perla marginata*. Bouin, chrome hematoxylin-phloxine,  $\times 1000$ . Neurosecretory product between the cells.

FIGURE 7. Frontal section through retrocerebral glandular complex of an old larva of *Nemura mortoni*. Bouin, chrome hematoxylin-phloxine,  $\times 1000$ . Esophageal wall (bottom), corpora cardiaca (above it), and corpus allatum (to the right). Presence of neurosecretory product between the cells of the corpora cardiaca and of the corpus allatum.

FIGURE 8. Frontal section through hypocerebral ganglion and corpora cardiaca of a larva of *Leuctra inermis*. Bouin, chrome hematoxylin-phloxine,  $\times 1000$ . Neurosecretory product between the cells of the corpora cardiaca.

FIGURE 9. Nervus corporis allati and corpus allatum of a young larva of *Perla carlukiana*. Bouin, chrome hematoxylin-phloxine,  $\times 1000$ . Accumulation of neurosecretory product in the nervus corporis allati (top, left) and under capsule of corpus allatum.

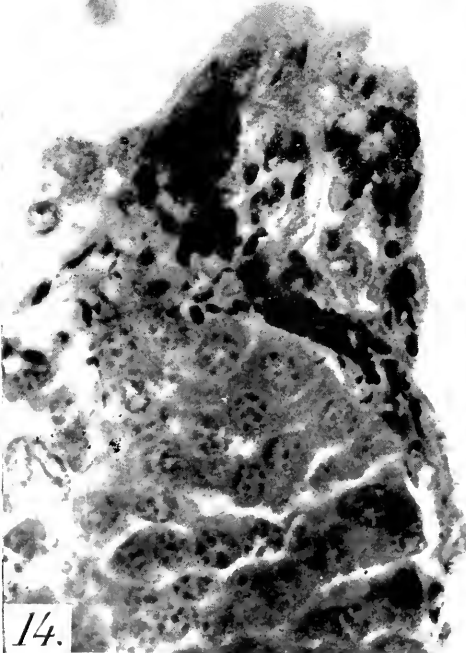
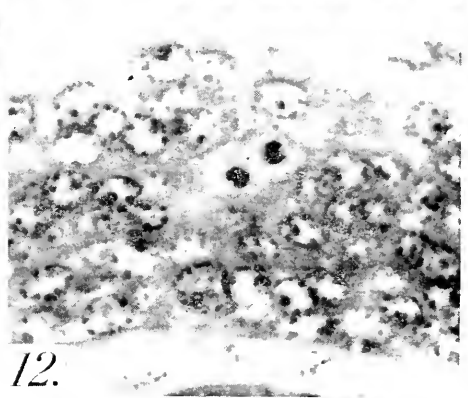
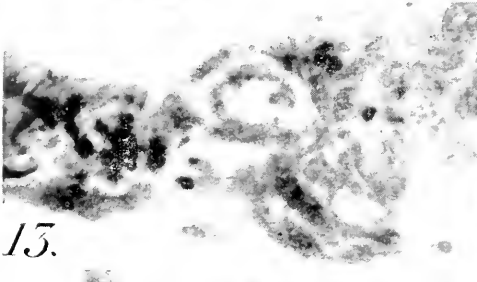
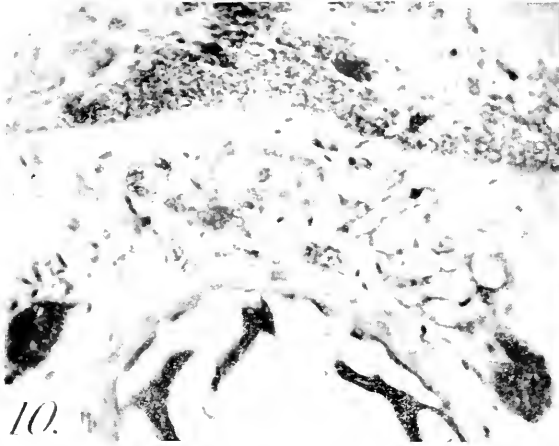

FIGURES 10-15.

nervus corporis allati. The corpus allatum is innervated by a certain number of very thin fibers which are accompanied by a substance staining with Gomori's hematoxylin, but which ramify directly among the cells of the corpus allatum without forming a subcapsular plexus, so that there exists no real accumulation of the neurosecretory material. Only the study of sections with very powerful magnifications shows the existence of a phenomenon which, although being less spectacular than in representatives of the type of *Chloroperla*, probably possesses the same physiological significance.

### III. Development of the endocrine glands in the course of post-embryonic life

A comparison of the endocrine glands in various stages of post-embryonic development shows the following facts:

(a) The neurosecretory cells of the pars intercerebralis reach their maximum activity at a stage considerably ahead of the imaginal molt. In the larva whose wing buds are still far from having reached their maximal development one finds the most pronounced transport of neurosecretory substance along the nervi corporis cardiaci and the greatest accumulation of this substance in the corpora cardiaca and allata. The secretory activity of the pars intercerebralis is less noticeable in older larvae and in the imago.

(b) The corpora cardiaca reach their maximal size at a larval stage which corresponds to the maximal secretory activity of the pars intercerebralis. Their volume remains stationary in the older larva and starts to diminish after the adult stage is reached.

(c) The corpora allata develop in the same fashion. Their maximal size falls into the middle of the larval life. During the second half of the post-embryonic period these organs undergo a pronounced atrophy, which is the more clearly visible since it coincides in time with the increase in size of all organs in the head region other than the corpora cardiaca. The size of the corpora allata of the imago is substantially smaller than that of larvae which are about halfway through their post-embryonic development.

FIGURE 10. Cross section through caudal portion of cerebral ganglion of larva of medium age of *Isoptera grammatica*. Dubosq, azan,  $\times 250$ . Fused corpora cardiaca (center) and corpora allata (on either side of upper third of esophagus).

FIGURE 11. Cross section through head of a larva of medium age of *Brachyptera risi*. Carnoy, Prenant's triple stain,  $\times 100$ . Esophagus in center, above it the unpaired medial corpus allatum, above the corpus allatum the common, fused portion of corpora cardiaca.

FIGURE 12. Detail of Figure 11,  $\times 1000$ . Note mitosis in corpus allatum.

FIGURE 13. Nervus corporis allati (at left) and beginning of corpus allatum in an old larva of *Perla marginata*. Bouin, chrome hematoxylin-phloxine,  $\times 1000$ . Note accumulation of neurosecretory product in nervus corporis allati and non-neurosecretory ganglion cell at entrance of nerve into the corpus allatum.

FIGURE 14. Nervus corporis allati and corpus allatum in a larva of medium age of *Perla carlukiana*. Bouin, chrome hematoxylin-phloxine,  $\times 1000$ . Accumulation of neurosecretory product in nerve and subcapsular plexus, as well as in thin fibers penetrating corpus allatum.

FIGURE 15. Nervus corporis allati and corpus allatum of a larva of medium age of *Perla cephalotes*. Technique and magnification as in Figure 14. Note abundance of neurosecretory product in the nerve and between the cells of corpus allatum.

## DISCUSSION

From the anatomical point of view, the differences between the various Plecoptera studied are even more marked than was expected from the work of Hanström (1940). One should perhaps mention here that the anatomy of the endocrine glands is always the same in all representatives of the same family, and that the grouping of the different families according to the morphology of their retrocerebral glandular complex results in an arrangement which is in agreement with present concepts regarding the taxonomy and phylogeny of the Plecoptera.

Concerning the structure of the corpora cardiaca and allata, certain data reported in this paper correspond to facts well established in other insects. Thus, the significance of the connection between the cells of the pars intercerebralis and the corpora cardiaca has been known since Hanström (1940). B. and E. Scharrer (1944) compared this neurosecretory system with the hypothalamic-hypophyseal system of the vertebrates. The newer techniques for the demonstration of the neurosecretory product, in particular the chrome hematoxylin-phloxine method, greatly facilitate the study of this neurosecretory pathway, and the accumulation of the neurosecretory product in the corpora cardiaca described by B. Scharrer (1951) in *Leucophaca maderae*, was confirmed in all insects studied with sufficiently selective methods. We should like to point out in this connection that the use of the chrome hematoxylin-phloxine method permits one to correct an error of interpretation due to the use of unsuitable techniques, *i.e.*, the description of "pseudopodial processes" of the "chromophile cells" of the corpora cardiaca by Casal (1948). These "processes" are apparently nothing but accumulations of neurosecretory products along nerve fibers.

The existence, in the corpus cardiacum cells themselves, of a second secretory product which differs from that of the neurosecretory cells of the protocerebrum has been debated for a longer time than the accumulation of the glandular product of the protocerebrum. This secretory activity on the part of the corpora cardiaca themselves exists, however, in a variety of insects. It was reported in the Thysanura (Gabe, 1953a), the Ephemeroptera (Arvy and Gabe, 1952a), the Odonata (Arvy and Gabe, 1952b), in *Leucophaca maderae* (B. Scharrer, personal communication), *Carausius morosus* (Stutinsky, 1952), and *Bombyx mori* (Arvy, Bounhiol and Gabe 1953a); the case of the Plecoptera constitutes another example. The particular timing of this secretory process, whose physiological significance was recently discussed by Wigglesworth (1954), explains why its product cannot be as easily demonstrated as the accumulation of the neurosecretory material. In fact, the corpora cardiaca are actively secreting only at well defined periods in the post-embryonic development. Studies, as yet unpublished, showed that the secretory activity of the endocrine glands of the Myrmeleconidae is sharply restricted to certain periods.

Attention should be called to the fact that the existence of two separate secretory products in the corpora cardiaca corresponds to that in other endocrine glands of arthropods. The sinus gland of the crustaceans (Malacostraca) in which the neurosecretory product furnished by the x-organ of Hanström and by other neurosecretory cells of the central nervous system is stored, contains in decapods (Gabe, 1952a) and isopods (Gabe 1952b, 1952c) a second product of secretion. This substance is formed *in loco* and differs from the neurosecretory product in its

chemical constitution. Similarly, the brain gland of the Chilopoda which receives the product of the neurosecretory cells of the protocerebrum contains a second secretory product formed in the cells of the organ themselves and different from the first in its histological and histochemical characteristics (Gabe, 1952d, 1953b). This structural analogy of the three principal neurosecretory systems in arthropods, recently emphasized by one of us (Gabe, 1953c), suggests a comparison with the hypothalamic-hypophyseal system of the selachians (E. Scharrer, 1952); in these the product of the neurosecretory cells of the preoptic nucleus accumulates in the terminals of the hypothalamo-hypophyseal tract between the cells of the intermediate lobe which possesses its own secretory activity.

The transport of neurosecretory material to the corpora allata and its accumulation between the cells of this organ deserves special emphasis because it represents the first example among Heterometabola of a phenomenon recently described in *Bombyx mori* (Arvy, Bounhiol and Gabe, 1953a). The extension of the neurosecretory pathway, which begins in the pars intercerebralis, to the corpora allata speaks in favor of the existence of relationships between the neurosecretory cells of the protocerebrum and the corpora allata (B. Scharrer, 1952; Thomsen, 1952).

The transport of the neurosecretory product in the nerves leaving the corpora allata in the Plecoptera of the Chloroperla type seems to show that the product of the cells of the pars intercerebralis can, in certain cases, reach thoracic organs. This observation is related to the presence of neurosecretory material in the aortic nerves arising from the corpora cardiaca of the Thysanura (Gabe, 1953a), and to the existence of this substance in the esophageal nerve of *Calliphora erythrocephala* (Thomsen, 1954).

The study of the post-embryonic development shows that the relations of the corpora cardiaca and allata to the neurosecretory cells do not merely represent an anatomical peculiarity. The maximal size of the corpora cardiaca and the onset of their own secretory activity coincide with the maximal abundance of the neurosecretory product between the cells and the appearance of numerous vacuoles in the cells of origin of the nervi corporis cardiaci I. The largest size of the corpora allata is reached at the same time and seems to be correlated with the arrival of the neurosecretory product.

The development of the corpora cardiaca throughout the post-embryonic life of the Plecoptera is very different from that reported for other insects. The corpora cardiaca reach their maximal size at the time of the imaginal molt in Ephemeroptera (Arvy and Gabe, 1950, 1952a), in Odonata (Arvy and Gabe, 1952b), and in *Panorpa communis* L. (Schwinck, 1951), during pupation in *Ephestia kühniella* Zell. (Rehm, 1951) and in *Bombyx mori* (Arvy, Bounhiol and Gabe, 1953a, 1953b). This difference in development whose physiological significance cannot be determined except by experimentation seems to correspond to a difference in timing regarding the neurosecretion in the protocerebrum. We could show a time relationship between the maximal transport of the neurosecretory product and the maximal size of the corpora cardiaca in the Ephemeroptera and Odonata (Arvy and Gabe, 1952a, 1952b, 1953a). The same agreement exists in *Ephestia kühniella* as shown by the measurements and descriptions of Rehm (1951). Finally, in *Bombyx mori* the increase in the volume of the corpora cardiaca takes place at the same time as a "discharge" of the neurosecretory product of the cells of the pars intercerebralis (Arvy, Bounhiol and Gabe, 1953a, 1953b).

The development of the corpora allata shows the same feature. The maximal size of these organs corresponds, in the Plecoptera, to a larval stage still far from the imaginal molt; these organs undergo atrophy in the second half of post-embryonic development. In other insects whose corpora allata are innervated by the protocerebrum the maximal size is reached in the imago. It coincides with an intense secretory activity in the cells of the pars intercerebralis. In the Ephemeroptera, the corpora allata develop as in the Plecoptera. Their maximal size is also reached towards the middle of the post-embryonic period, and the atrophy which follows corresponds to a reduction of secretion in the cells of origin of the nervi corporis allati lying in the subesophageal ganglion in the Ephemeroptera, and in the pars intercerebralis in the Plecoptera.

In general, the study of the modifications which the endocrine glands of the head region of the Plecoptera undergo during post-embryonic life illustrates the parallelism between the state of the endocrine glands and the secretory activity in the cells of origin of the nerves which innervate these organs. This fact underlines the important role of the neurosecretory phenomena in the physiology of these insects.

#### SUMMARY

The histophysiological study of the intercerebralis-cardiacum-allatum system in 21 species of Plecoptera resulted in the following observations:

1. From the anatomical point of view, the type of *Chloroperla* (Hanström, 1940) characterized by paired symmetric corpora allata, exists in the Perlodidae, Perlidae, and Chloroperlidae. The type of *Nemura*, characterized by an unpaired, laterally located corpus allatum, corresponds to the Nemuridae, Leuctridae, and Capniidae. A third anatomical type of which an unpaired but definitely medial corpus allatum is typical (type of *Brachyptera*) exists among the Taeniopterygidae.

2. The cells of origin of the nervi corporis cardiaci I of the Plecoptera possess all the morphological characteristics of neurosecretory cells. Their secretory product is stainable with acid dyes, azocarmin, iron hematoxylin, and chrome hematoxylin. This secretory product migrates along the axons and accumulates between the cells of the corpora cardiaca. These elaborate a secretory product of their own which stains with the phloxine of the method of Gomori.

3. The neurosecretory product migrates along the nervi corporis allati and occurs between the cells of the corpora allata; one also encounters it in the nerves which run from the corpora allata to the prothorax in the Plecoptera of the *Chloroperla* type.

4. The secretory activity in the cells of the pars intercerebralis is at its peak towards the middle of the larval period; the phenomena of neurosecretion are less pronounced in the later stages of larval life and in the imago.

5. The corpora cardiaca and allata reach their maximal volume in larvae which are still a considerable period away from the imaginal molt. In the latter stages of post-embryonic development atrophy of the endocrine glands of the head region is observed. This mode of development is different from that described in other insects belonging to the Neoptera; it must be understood in relationship with the peculiar chronology of the neurosecretory activity of the Plecoptera.



## LITERATURE CITED

- ARVY, L., J. J. BOUNHOL AND M. GABE, 1953a. Déroulement de la neuro-sécrétion protocérébrale chez *Bombyx mori* L. au cours du développement post-embryonnaire. *C. R. Acad. Sci., Paris*, **236**: 627-629.
- ARVY, L., J. J. BOUNHOL AND M. GABE, 1953b. Données histophysiologiques sur la neuro-sécrétion chez *Bombyx mori* L. et sur ses rapports avec les glandes endocrines. *Bull. biol. France Belgique* (in press).
- ARVY, L., AND M. GABE, 1950. Données histophysiologiques sur les formations endocrines rétro-cérébrales chez les *Ecdyonuridae* (Ephéméroptères). *Bull. Soc. zool. France*, **75**: 267-285.
- ARVY, L., AND M. GABE, 1952a. Données histophysiologiques sur la neuro-sécrétion chez quelques Ephéméroptères. *La Cellule*, **55**: 203-222.
- ARVY, L., AND M. GABE, 1952b. Données histophysiologiques sur les formations endocrines rétro-cérébrales de quelques Odonates. *Ann. Sci. Nat. Zool.*, (II), **14**: 345-374.
- ARVY, L., AND M. GABE, 1953a. Données histologiques sur la neuro-sécrétion chez les Insectes Paléoptères. *Zeitschr. Zellf. mikr. Anat.*, **38**: 591-610.
- ARVY, L., AND M. GABE, 1953b. Données histophysiologiques sur les glandes endocrines céphaliques de *Brachyptera risi* Morton (Plécoptère). *Arch. Zool. exp. gén.* (in press).
- AUBERT, J., 1946. Les Plécoptères de la Suisse romande. Doctoral Thesis, Faculty of Science, Lausanne, 128 pages.
- CAZAL, P., 1948. Les glandes endocrines rétro-cérébrales des Insectes (Étude morphologique). *Bull. biol. France Belgique, suppl.*, **32**: 1-227.
- GABE, M., 1952a. Particularités histochimiques de l'organe de Hanström (organe X) et de la glande du sinus chez quelques Crustacés décapodes. *C. R. Acad. Sci., Paris*, **235**: 90-92.
- GABE, M., 1952b. Sur l'existence d'un cycle sécrétoire dans la glande du sinus (organe pseudofrontal) chez *Oniscus asellus* L. *C. R. Acad. Sci. Paris*, **235**: 900-902.
- GABE, M., 1952c. Particularités histologiques de la glande du sinus et de l'organe X (organe de Bellonci) chez *Sphacroma serratum* Fabr. *C. R. Acad. Sci., Paris*, **235**: 973-975.
- GABE, M., 1952d. Sur l'emplacement et les connexions des cellules neuro-sécrétrices dans les ganglions cérébroïdes de quelques Chilopodes. *C. R. Acad. Sci., Paris*, **325**: 1430-1432.
- GABE, M., 1953a. Données histologiques sur les glandes endocrines céphaliques de quelques Thysanoures. *Bull. Soc. zool. France* (in press).
- GABE, M., 1953b. Particularités histologiques de la glande cérébrale de *Scutigera coleoptrata* Lmk. *Bull. Soc. zool. France* (in press).
- GABE, M., 1953c. Quelques acquisitions récentes sur les glandes endocrines des Arthropodes. *Experientia*, **IX** 19: 352-356.
- GABE, M., AND M. PRENANT, 1949. Contribution à l'étude cytologique et histochimique du tube digestif des Polyplacophores. *Arch. Biologie*, **60**: 39-77.
- GOMORI, G., 1941. Observations with differential stains on human islets of Langerhans. *Amer. J. Path.*, **17**: 395-406.
- HANSTRÖM, B., 1940. Inkretorische Organe, Sinnesorgane und Nervensystem des Kopfes einiger niederer Insektenordnungen. *Kungl. Svenska Vetenskapsakad. Hdl.*, (3) **18**: 1-265.
- NABERT, A., 1913. Die Corpora allata der Insekten. *Zeitschr. wiss. Zool.*, **104**: 181-358.
- REHM, M., 1951. Die zeitliche Folge der inkrretorischen Organe von *Ephestia külniella* während der Metamorphose und des Imaginallebens. *Arch. f. Entw.*, **145**: 205-248.
- SCHARRER, B., 1951. The storage of neurosecretory material in the corpus cardiacum. *Anat. Rec.*, **111**: 554-555.
- SCHARRER, B., 1951. Über neuroendokrine Vorgänge bei Insekten. *Pflügers Arch.*, **255**: 154-163.
- SCHARRER, B., AND E. SCHARRER, 1944. Neurosecretion VI. A comparison between the intercerebralis-cardiacum-allatum system of the insects and the hypothalamo-hypophysial system of the vertebrates. *Biol. Bull.*, **87**: 242-251.
- SCHARRER, E., 1952. Das Hypophysen-Zwischenhirnsystem von *Scyllium stellare*. *Zeitschr. Zellforsch. mikr. Anat.*, **37**: 196-204.

- SCHARRER, E., AND B. SCHARRER, 1954. Neurosekretion. v. Möllendorffs *Hdbch. mikr. Anat.*, VI/5 (in press).
- SCHWINCK, I., 1951. Veränderungen der Epidermis, der Perikardialzellen und der Corpora allata in der Larvenentwicklung von *Panorpa communis* unter normalen und experimentellen Bedingungen. *Arch. f. Entz.*, **145**: 62-108.
- STUTINSKY, F., 1952. Étude du complexe rétro-cérébral de quelques Insectes avec l'hématoxyline chromique. *Bull. Soc. zool. France*, **77**: 61-67.
- THOMSEN, E., 1952. Functional significance of the neurosecretory brain cells and the corpus cardiacum in the female blow-fly, *Calliphora erythrocephala* Meig. *J. Exp. Biol.*, **29**: 137-172.
- THOMSEN, E., 1954. Experimental evidence for the transport of secretory material in the axons of the neurosecretory cells of *Calliphora erythrocephala* Meig. *Pubbl. Staz. zool. Napoli*, **25** (3): (in press).
- WIGGLESWORTH, V. B., 1954. Neurosecretion and the corpus cardiacum in insects. *Pubbl. Staz. zool. Napoli*, **25** (3): (in press).
- WILC, C. F., 1923. Morphology, anatomy and ethology of *Nemoura*. *Bull. Lloyd Libr., entomol. ser.*, n°3: 1-51.

A NEW MARINE CERCARIA FROM THE WOODS HOLE REGION  
AND ITS BEARING ON THE INTERPRETATION OF LARVAL  
TYPES IN THE FELLODISTOMATIDAE  
(TREMATODA: DIGENEA)

R. M. CABLE

*Department of Biological Sciences, Purdue University, Lafayette, Indiana, and  
The Marine Biological Laboratory, Woods Hole, Mass.*

The concept of two great groups of digenetic trematodes as proposed by La Rue (1926) is based in part on the type of cercaria which is furcocercous in the order Strigeatoidea and non-furcocercous in the order Prosostomata. However, the tails of cercariae are subject to such varied and extreme modifications in many instances as to give little indication of the basic type. Unfortunately, the pioneering life history studies in some families concerned species having just such extremely modified larvae and hence did not reveal fundamental relationships, a knowledge of which has had to await investigations dealing with more "typical" representatives. Excellent examples of groups in which this situation has proved to be the case are the families Brachylaemidae and Fellodistomatidae.

In the Fellodistomatidae, the first life history to be reported was that of *Bacciger bacciger* which according to Palombi (1934) has a trichocercous cercaria with a non-bifid tail. Subsequent studies have shown that at least some fellodistomatids have furcocercous larvae as discussed in a recent paper (Cable, 1953) which should have taken into account also the life cycle of *Fellodistomum fellis* as described by Chubrick (1952). In reporting for that species a furcocercous larva developing in marine lamellibranchs, her observations lend further confirmation of the view that the Fellodistomatidae properly belong in the order Strigeatoidea. This view poses no difficulty in the interpretation of caudal structure of many fellodistomatid cercariae in which the tail is reduced or even absent. Such instances obviously are examples of caudal reduction associated with the abbreviation of free-living activity now recognized to occur in various distantly related families. It is this modification that has led to classifying larval trematodes into such unnatural categories as *Microcercous Cercariae* and *Cercariaca*.

The interpretation of the cercaria of *Bacciger bacciger* and similar larvae in respect to the furcocercous type is quite another matter. In such larvae, the tail is well developed without possessing furcae and has paired lateral setaceous tufts, the elements of which may be joined by delicate webbing to form finlets. Such a larva was among the fellodistomatid cercariae found by the writer in Puerto Rico and figured in a recent paper (Cable, 1953). That cercaria was found in but one clam, before the other larvae included in that paper were seen and hence before the significance of determining the precise relationship of the excretory system to the tail was appreciated. Fortunately, the writer was aware that a very similar cercaria occurs in the Woods Hole region and a brief visit to that area was made during the summer of 1953 to study the species. It was quickly found, thanks to Prof. P. S. Crowell, Jr. and students of the Invertebrate Zoology class

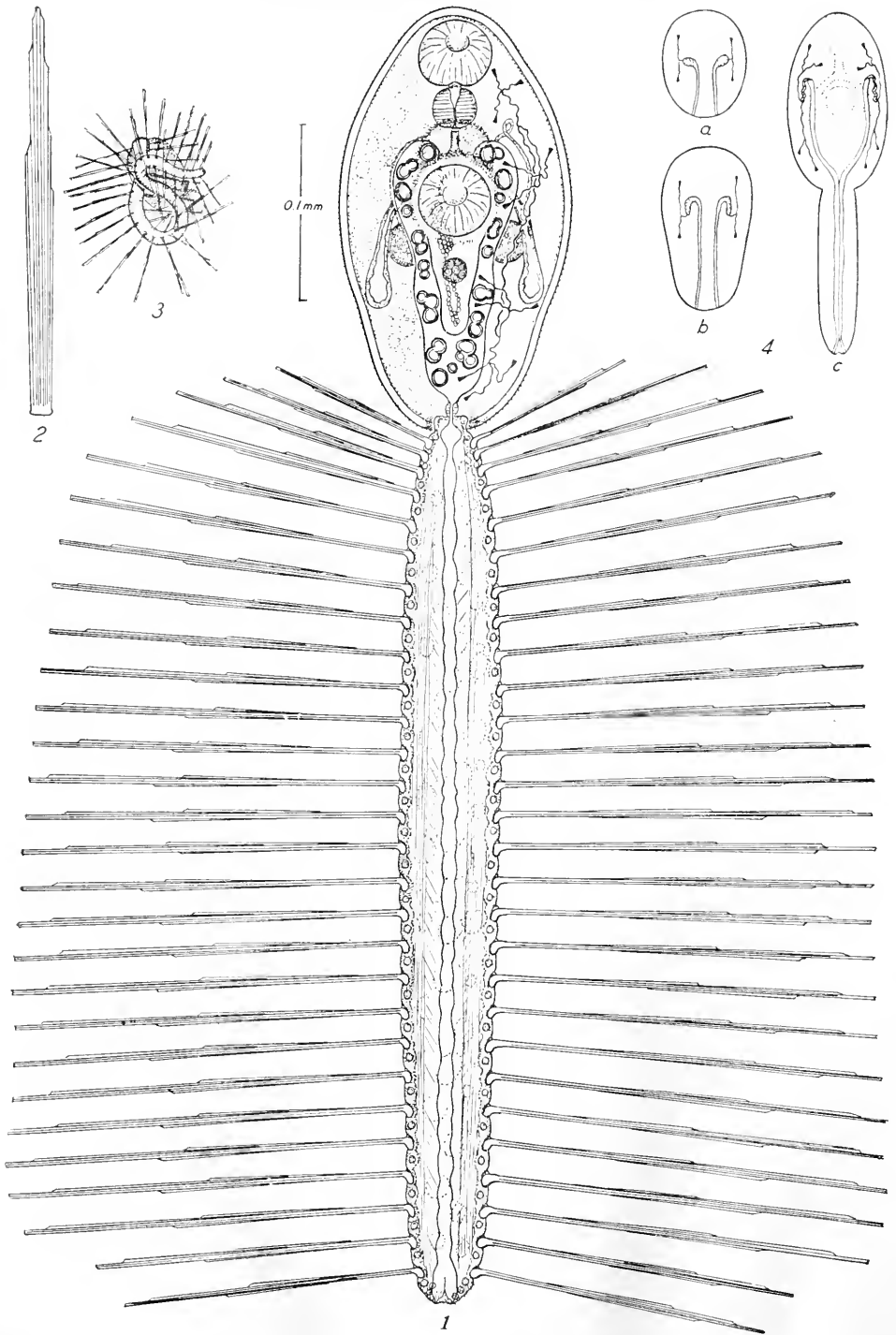

EXPLANATION OF PLATE I

(All figures concern *Cercaria laevicardii*)

through whose assistance over 200 specimens of the clam serving as the host were made available. As the larva has not yet been reported, it is here described and named after the host.

*Specific diagnosis:* distome, non-ocellate, trichocercous cercaria developing in simple sporocysts in the visceral mass of a marine lamellibranch. Body of cercaria yellowish in life, tail with 28 pairs of slender, lateral finlets, each composed of setae, usually 10 in number, united by a delicate web; finlets shorter at each end of tail and closer together at its proximal end. Associated with bases of finlets on each side is a uniform row of similar nuclei which are prominent in stained specimens. Dorsal and ventral caudal fins are absent; tail widest at about mid-length and rather blunt posteriorly. Entire body and tail finely spinose, cuticle of body thick and with fine striae. Suckers about equal with the ventral sucker embedded in a prominent protrusion somewhat anterior to mid-level of body and overhanging a ventral depression of the fore body. Oral sucker not at extreme anterior end of body, with the mouth opening ventrally. Prepharynx extremely short, pharynx well developed, esophagus about as long as pharynx and receiving just anterior to ventral sucker the ceca which reach about halfway between ventral sucker and posterior end of body; ceca thick-walled and with somewhat inflated blind ends. Cephalic and cystogenous glands not evident. Primordia of reproductive system well developed; testes dorsal, symmetrical, and just posterolateral to ventral sucker; ovary more ventral, median, and just posterior to level of testes; other primordia are represented by strands of nuclei and a prominent mass posterodorsal to ventral sucker. Excretory vesicle U- or almost V-shaped, with wide arms extending anterior to ventral sucker and with large, refractile concretions. From each arm of the excretory vesicle, a ciliated recurrent tubule extends posteriorly to about mid-level of body and receives an anterior and a posterior collecting tubule, each of which is joined by two groups of flame cells, three cells per group. The excretory formula is accordingly  $2 [(3 + 3) + (3 + 3)] = 24$  flame cells. A distinct bladder sphincter is present and from it the prominent caudal excretory tubule extends the length of the tail, bifurcating just before reaching the pair of embryonic excretory pores at the posterior tip of the tail. Measurements in millimeters of cercariae killed in hot sea water, mounted without pressure, and selected for specimens showing a minimum of body flexure are as follows: body length 0.185–0.243, maximum body width 0.10–0.13; tail 0.426–0.517 long and 0.050–0.054 in maximum width exclusive of appendages. Caudal finlets range in length from 0.095 near base of tail to a maximum of about 0.30 elsewhere. Oral sucker 0.035–0.040 in diameter, usually a little wider than long; ventral sucker 0.038–0.040 and pharynx 0.022–0.025 in diameter. Sporocysts elongate, young ones with pointed ends which are very motile; older sporocysts up to 3.0 in length, rounded or truncate posteriorly and with a pointed anterior end bearing a terminal birth pore.

---

FIGURE 1. Entire cercaria in ventral view, drawn to scale from a heat-killed specimen with internal structures added from observations on living and stained larvae.

FIGURE 2. Detail of caudal finlet.

FIGURE 3. Sketch of cercaria to show resting attitude near surface of water.

FIGURE 4. Embryology of the excretory system.

Host: *Laevicardium murtoni* Conrad.

Locality: Lagoon Pond, Martha's Vineyard, Massachusetts.

Incidence of infection: 25-33% of clams collected in August, selected for large size, and opened for examination.

Although over 200 clams were isolated in bowls of sea water for 48 hours, no cercariae emerged spontaneously. In some of the clams then opened, the infection was immature but from the visceral mass of others, large numbers of evidently fully developed cercariae escaped and remained alive over 24 hours. They swam energetically, tail-first with the body bent ventrally on the base of the tail. The larvae made rapid progress, often swimming somewhat erratically in one direction and then spinning around before coming to rest near the surface of the water with the body downward and the tail contracted into a coiled mass (Fig. 3). During rest periods, which were frequent, the body would contract and expand and on several occasions cercariae were observed creeping upside down in an inch-worm fashion with the suckers attached to the surface film. No photactic behavior was observed.

Several species of cercariae resembling *C. laevicardii* have been described, mostly by earlier workers whose accounts are so inadequate that a critical evaluation of them is impossible. Dollfus (1925) gave a summary of trichocercous larvae known at that time, dividing marine species into two groups, one in which eye-spots are present, and one in which they are absent. Subsequent studies have revealed that such a distinction may be an artificial one, for instances are known in which one cercaria may be ocellate whereas another larva in the same family lacks eye-spots. On the basis of known life histories, it is certain that the trichocercous cercariae listed by Dollfus have adults belonging to at least three distinct families, the Lepocreadiidae, the Monorchiiidae, and the Fellodistomatidae. Furthermore, the last two groups and perhaps all three have some larvae that are not trichocercous. Thus in distinguishing the larvae of these families, the morphology of the body and type of molluscan host are more dependable than is the structure of the tail which can be positively misleading. Of the non-ocellate cercariae listed by Dollfus, *C. setifera* Müller *nec* Monticelli (the larva of *Bacciger bacciger* according to Palombi, 1934), *C. villoti*, *C. pelsenceri*, *C. chiltoni*, and *C. pectinata* Huet *nec* Chilton may be assigned to the Fellodistomatidae. *C. laevicardii* evidently differs from all of these in at least one of the following respects: size of body, tail and suckers; proportionate length of body and tail; and number of setaceous tufts. Among the ocellate cercariae listed by Dollfus, it seems highly probable that *C. elegans* Müller also is a larva of the Fellodistomatidae although the molluscan host is unknown. In a personal communication, Prof. G. R. La Rue has informed the writer of what evidently is an ocellate fellodistome larva taken in plankton from Lake Pontchartrain, Louisiana.

The development of the excretory system provides an interpretation of *Cercaria laevicardii* and similar larvae in respect to the furcocercous type with which they obviously are closely related. In young embryos (Fig. 4), each definitive excretory tubule terminates with a ciliated largement which is joined by capillaries from two flame cells. With further development, four flame cells are seen on each side and this pattern persists until the embryo is well advanced. As the tail develops, the definitive tubules extend its full length to open posteriorly and at about the time

the caudal finlets first appear as small knobs, the tip of the tail shows a tiny but distinct notch separating two short, terminal papillae with the excretory pores at their tips. A faint suggestion of this condition is evident in the fully developed cercaria. After the caudal tubules fuse, the resulting excretory canal is large and conspicuous, just as in furcocercous larvae of the Fellodistomatidae.

From these observations and other studies, it seems evident that larvae of the Fellodistomatidae are basically furcocercous and show at least three types of modification: (1) symmetrical reduction of the entire tail until in some forms it has become a mere knob of cells or lost altogether; (2) disappearance of the furcae without a corresponding reduction of the tail stem; and (3) reduction of the stem only, with the furcae becoming greatly elongate. The first type of modification has a counterpart in other trematode families such as the Brachylaemidae which is closely related to the Fellodistomatidae and the Microphallidae and Monorchidae which are not. In all such cases, caudal modification is associated with reduction or suppression of free-swimming activity of the cercarial stage. However, such an adaptation cannot explain the second type of modification in which the development of finlets from paired lateral setaceous tufts makes the tail an exceedingly effective natatory organ but no more so than in trichofurcocercous species. The third type of modification is exemplified by the unnamed cercaria described by Jones and Rothschild (1932). That larva develops in a marine bivalve, *Nucula nucleus*, and has a tail with an extremely short stem and long, slender furcae which are very extensile. From the structure and host relationship of that cercaria as interpreted in the light of recent studies, there seems no doubt that its adult is a member of the Fellodistomatidae.

Caudal modifications shown by cercariae of the Fellodistomatidae may have considerable phylogenetic significance. Jones and Rothschild (1932) observed that the cercaria from *N. nucleus* superficially resembled bucephalid larvae. That this resemblance may be significant is indicated by the papers of Allison (1943) and Cable (1953) who presented evidence that the Brachylaemidae, Fellodistomatidae and Bucephalidae may form a related group within the Strigeatoidea.

Life history studies of the last two decades have supported and greatly extended La Rue's (1926) concept of two orders of digenetic trematodes, the Strigeatoidea and the Prosostomata. Without exception, it has been found that the definitive excretory pores of cercariae in the Strigeatoidea are posterior in location, at or near the tips of the furcae when present, although secondary openings nearer the body may develop later as in the Bucephalidae. This position of the excretory pores is characteristic also of the rediae and sporocysts in at least some families of the Strigeatoidea. The most striking example of this situation is provided by the family Bivesiculidae in which Le Zotte (1954) has found that the cercariae are furcocystocercous and produced in rediae in which not only is the posterior end cleft but also the excretory pores are at the tips of the resulting lobes just as they are at the tips of the furcae in the cercarial stage. Furthermore, the excretory patterns of the redia and cercaria differ only in respect to the number of flame cells in certain groups, the number of flame cell groups being the same in both stages.

On the other hand, the location of the definitive excretory pores in the cercariae of the Prosostomata is variable. In some families, the pores are at the junction of the body and tail and in others on the sides of the tail at varying distances from

the body. In a few groups, the pores are well toward the posterior end of the tail and thus approach the situation described above for *C. laevicardii*. In the Strigeatoidea, the excretory vesicle of the cercaria is always thin-walled, whereas in the Prosostomata it may be either thin- or thick-walled, the latter condition being evidently a secondary one. These facts and many others beyond the scope of a brief discussion suggest that as a group, the Strigeatoidea is more primitive than the Prosostomata. Yet the two orders have so much in common that their having arisen independently from turbellarian stock is inconceivable; their point of divergence must have been considerably removed from that source. It may be doubtful whether the Fellodistomatidae is the extant group closest to such a point of divergence but at least present knowledge of that family affords a plausible explanation of how the larvae of one order could have arisen from those of the other. In this connection, it is of interest to note that in the Fellodistomatidae the genital pore of the adult is anterior to the ventral sucker whereas in other families of the Strigeatoidea it is either at the extreme posterior end of the body or closer to that end than to the anterior extremity except in some blood flukes. Thus in respect to the location of this opening, the fellodistomatids are more like the Prosostomata than strigeatoids.

#### SUMMARY

*Cercaria laevicardii* sp. nov. is described from the marine lamellibranch, *Laevicardium mortoni*. The cercaria develops in simple sporocysts and is similar to the larva of *Bacciger bacciger*. The excretory formula is  $2 [(3 + 3) + (3 + 3)]$  and the structure and development of the excretory system is such that the larva is interpreted as having been derived from the furcocercous type. Various caudal modifications in fellodistomatid cercariae are discussed and the possible phylogenetic significance of some types is mentioned.

#### LITERATURE CITED

- ALLISON, L. N., 1943. *Leucochloridiomorpha constantiae* (Mueller) (Brachylaemidae), its life history and taxonomic relationships among digenetic trematodes. *Trans. Amer. Micros. Soc.*, **62**: 127-168.
- CABLE, R. M., 1953. The life cycle of *Parvatrema borinqueña* gen. et sp. nov. (Trematoda: Digenea) and the systematic position of the subfamily Gymnophallinae. *J. Parasitol.*, **39**: 408-421.
- CHUBRICK, G. K., 1952. (The immature stages of the trematode *Fellodistomum fellis* Nicoll, 1909, from invertebrates of the Barents Sea.) (In Russian.) *Zool. Zhur.*, **31**: 653-658.
- DOLLFUS, R. P., 1925. Liste critique des cercaires marines à queue sétigère signalées jusqu'à présent. *Trav. Stat. Zool. Wimereux*, **9**: 43-65.
- JONES, E. I., AND M. ROTHSCHILD, 1932. On the sporocyst and cercaria of a marine distomid trematode from *Nucula*. *Parasitol.*, **24**: 260-264.
- LA RUE, G. R., 1926. Studies on the trematode family Strigeidae (Holostomidae) No. III. Relationships. *Trans. Amer. Micros. Soc.*, **45**: 265-281.
- LE ZOTTE, L. A., JR., 1954. Studies on marine digenetic trematodes of Puerto Rico: the family Bivesiculidae, its biology and affinities. *J. Parasitol.*, **40** (in press).
- PALOMBI, A., 1934. *Bacciger bacciger* (Rud.), trematode digenetic: fam. Steringophoridae Odhner. Anatomia, sistematica e biologia. *Pub. Staz. Zool. Napoli*, **13**: 438-478.



# REDOX INDICATOR PATTERNS IN RELATION TO ECHINODERM EXOGASTRULATION. II. REDUCTION PATTERNS

C. M. CHILD

*Hopkins Marine Station and School of Biological Sciences,  
Stanford University, Stanford, Calif.*

Continued use of redox indicators on echinoderm material during the last six years has brought to light certain characteristics of the patterns of intracellular oxidation and reduction of the indicators, particularly in their relation to exogastrulation, and has made it desirable to call attention again to certain features of these patterns. Some of these were not known to be present, and the physiological significance of certain others was still uncertain at the time of early studies of indicator patterns. Intracellular oxidation patterns have already been considered in a preceding paper (Child, 1953c), with suggestions concerning their significance in exogastrulation. The present paper is concerned with reduction patterns.

The first studies of redox indicator patterns in echinoderms also described only reduction patterns; these became visible after staining by certain redox dyes only when external oxygen was decreased to a certain critical level. The dyes became hydrogen acceptors and in the case of methylene blue and various other dyes merely became colorless, or with diazine green (Janus green) reduction to the red diethyl safranine occurred first and might be followed by further reduction to colorless, with return to red after oxygen increase (Child, 1936a, 1936b). In these papers presence of distinct regional differentials in rapidity of reduction was demonstrated. These constituted gradient patterns of reduction obviously correlated in some way with the physiological axes and with the course of morphogenesis. At that time nothing was known concerning intracellular oxidation patterns of the indicators; consequently the physiological significance of certain features of the reduction patterns was not clearly recognized.

As a background for the recent studies of reduction pattern, it seems necessary to call attention briefly to some of the more important results of the earlier papers. The material consisted of *Strongylocentrotus purpuratus*, *S. franciscanus*, *Dendraster excentricus*, all echinoids, and the asteroid starfish, *Patiria miniata*. In normal development (*i.e.*, the course or courses of development under as nearly as possible natural conditions and without experimental modification) the egg, cleavage stages, and the earlier blastulae showed a reduction gradient decreasing basipetally from the apical region without any visible change in this pattern at the time of formation of the micromeres in the echinoids. In *Patiria* there are no micromeres; also the basipetal differential in rate of reduction seemed to be somewhat greater in the starfish than in the echinoids. It was further noted that when the cells of the cell wall of blastulae and early gastrulae were stained throughout, reduction progressed from the blastocoelar surface outward, and during and after immigration of primary mesenchyme cells in echinoids they reduced more rapidly than any other cells. The decrease in rate of reduction from the blastocoel outward was regarded as resulting from lower oxygen content in the blastocoel than in the external fluid and was believed to be rather an incident of development than of any

real significance. The arrows used to indicate directions of decrease in rate of reduction were intended to indicate primarily differentials in the polar reduction gradients and other regional gradients of later development. In most figures the arrows indicate reduction beginning on the blastocoelar surface of the cell-wall, but in their further course they were often drawn entirely outside the body. With approach of gastrulation a second reduction gradient appeared in the basal region with decrease acropetally, and variation in extent toward the apical region with different experimental conditions.<sup>1</sup> In somewhat later studies a similar reduction pattern of intracellular indophenol was observed in *Dendraster* and *Patiria* (Child, 1941b, 1944).

In all these earlier papers attention was repeatedly called to the possible significance of this change in the intracellular reduction pattern with approach of gastrulation, as suggesting a change of some sort in the oxidation-reduction mechanism, apparently associated with activation of primary mesenchyme and prospective entoderm in echinoids and of prospective entoderm in the starfish, perhaps a step in differentiation of the basal region. It is accompanied or almost immediately followed by immigration of the mesenchyme in echinoids and by entodermal invagination in both echinoids and starfish.<sup>2</sup> In the early papers on reduction patterns it was further noted that in the entogastrula the reduction differential in the entodermal cell wall underwent a reversal in direction, at least in the apical entoderm, with reduction no longer progressing from the blastocoelar surface but from the archenteric cavity.<sup>3</sup> This change was regarded as probably resulting from lower oxygen content in the cavity than elsewhere. The apical archenteric region attains high developmental activity and high susceptibility to inhibiting agents during these stages. Adequate supply of oxygen through the blastopore (anus) appears improbable and fluid in the cavity apparently moves toward, rather than from the anus. Oxygen diffusing inward from the exterior must now pass, not only through the ectoderm, but through the entodermal cell-wall to reach the archenteric cavity. With external oxygen decrease by a reducing agent, and with the oxygen uptake of the ectodermal and entodermal cell-walls, it appears highly probable that oxygen content in the blastocoel will become lower than elsewhere, as the course of reduction indicates.

In the evaginated entoderm of the exogastrula no such reversal in direction in the entodermal cell-wall was found (Child, 1936b, p. 484). If the preceding interpretation of the reversal is correct, no reversal is to be expected. The internal entodermal cavity in the exogastrula is still a part of the blastocoel and diffusion of oxygen is merely through the entodermal cell-wall. With external oxygen decrease, the oxygen uptakes of the entoderm cells and of mesenchyme in the echinoids and dissociated entoderm cells in the starfish, which are evidently not dead in most cases, all contribute to decrease oxygen content in the blastocoel below that elsewhere and so to determine entodermal reduction in the exogastrula decreasing from the blastocoel outward. If the exogastrular ectoderm is thick enough to show

<sup>1</sup> The basipetal reduction gradient is indicated in Child, 1936a, Figs. 8-21, the later appearance of the acropetal reduction pattern in Figs. 22-26 and 29-31.

<sup>2</sup> Child, 1936a, p. 450; 1941a, p. 129; 1941b, p. 525, bottom; 1944, pp. 450-51. The reduction pattern in *Dendraster* was described only briefly without figures, 1941b. The new acropetal reduction of *Patiria* was indicated in Child, 1944, Figs. 11 and 13-20.

<sup>3</sup> Child, 1936a, Figs. 33 and 36-38.

a cell-wall gradient, reduction progresses from the blastocoel outward there, as in the entoderm.

The frequently repeated studies of redox indicator patterns of echinoderms in recent years confirm in general the earlier observations on the reduction patterns of normal development, and perhaps contribute something to the physiological analysis of these patterns. As regards exogastrulae, however, the earlier observations are less complete, and conditions determining the entodermal reduction pattern observed in almost all exogastrulae were not analyzed. In almost every one of thousands of exogastrulae reduction was found to begin at the ect-entodermal junction or in the entoderm near it. A very few elongated exogastrulae of *Dendraster* were found with entodermal reduction decreasing from the tip (Child, 1936b, Figs. 21 and 22) and later (Child, 1941b, p. 527) it was noted that in some elongated *Dendraster* exogastrulae entodermal reduction progressed from the tip, but little attempt to account either for the usual course of entodermal reduction from the ect-entodermal junction or the few cases of reduction from the entodermal tip was made. The rapid development, and often the great elongation of the entoderm in exogastrulae, suggest that the evaginating, like the invaginating, entoderm develops with activity decreasing from the tip. It was suggested in the early paper that this gradient might have been reversed in direction by the much greater susceptibility of the tip to the exogastrulating agent, but this suggestion was not fully discussed. It appears from recent studies that a reversal of this sort may occur in some of the more extreme degrees of exogastrulation, though by no means in all exogastrulae.

When the early studies were made it was not clearly recognized that the conditions under which the reduction pattern becomes visible represented, or might represent, differentially inhibiting factors in addition to the agent used for exogastrulation. If the tip of the evaginated entoderm is the most active and most susceptible region, the external oxygen decrease necessary for intracellular reduction may also be a highly important factor in decreasing or obliterating, or perhaps even reversing, the direction of the oxidation gradient. Lack of oxygen has been found to be a differential inhibitor with the same relation to oxidation gradient pattern as other differentially inhibiting agents.

Staining by oxidized dye, particularly by the relatively toxic diazine green, used very largely in the earlier study, is also a differential inhibitor with the same relation to gradient pattern as others. If staining is too long continued, reduction in the more susceptible region or regions is retarded. If the entodermal tip is the most susceptible region of the evaginated entoderm it will be most retarded in reduction. In the earlier study of reduction the oxygen decrease necessary for reduction was brought about gradually by the oxygen uptake of a number of animals sealed in a small volume of water or sometimes in dilute dye solution. Consequently oxygen decrease occurred gradually and the critical level for reduction was attained after a variable length of time. During this time the animals remained stained by oxidized dye.

And finally, it is possible that the physiological age of the exogastrula may sometimes be a factor concerned to some degree in determining the reduction pattern. In normal plutei and starfish larvae the oxidase gradient patterns gradually decrease with the progress of starvation of the larvae and may almost completely disappear while the larvae are still motile. The exogastrula is not a

stage in the progress of development. It represents the end of that form of development when it has attained its final stages. Exogastrulae may live for days after growth and elongation of the evaginated entoderm have ceased, but it seems probable that they usually, if not always, die from other conditions than starvation. The entodermal oxidase gradient evidently persists in exogastrulae for a considerable time (Child, 1953c); it sometimes seems to become less evident in older exogastrulae, but comparison of the degree of differential in this gradient or in the reduction gradient in different individuals is of no real value.

With continued exposure to moderate degrees of differential inhibition by the exogastrulating agent, there is the possibility of development of differential tolerance to the agent. With return of material to water, even after relatively extreme degrees of inhibition there is often a very considerable degree of differential recovery in definite relation to the gradient pattern, and a continuation of exogastrular

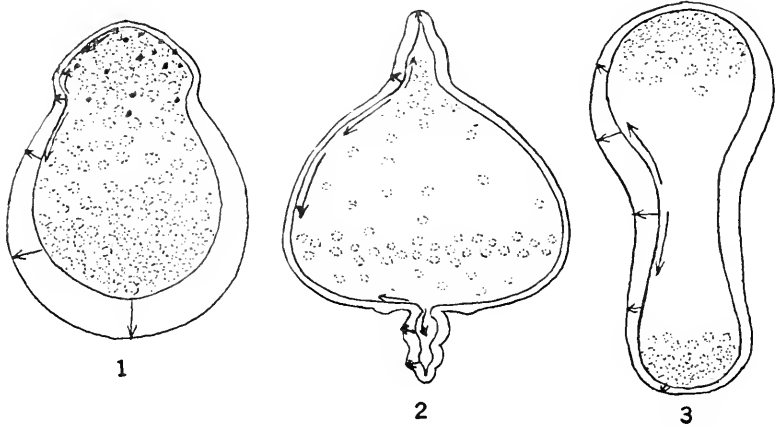

FIGURES 1-3. Slightly modified from figures of the early study of reduction pattern for greater clarity as regards gradient pattern: Figure 1, *Dendraster*, six days in LiCl  $M/50$ ; Figure 2, *Strongylocentrotus*, extreme crowding in water; Figure 3, *Patiria*, 60 hours in LiCl  $M/30$ . Further data in text.

modification. Differences in susceptibility in eggs of the same or of different lots and the difficulty of exposing different individuals, even in the same container, to conditions that are really similar, emphasize the desirability of covering similar experimental ground repeatedly with different lots of material.

At the time of the first study of reduction pattern nothing was known concerning the indicator oxidation or oxidase pattern. The reduction pattern must now be considered in relation to what has been learned concerning the oxidase pattern. The oxidase gradient of the cell-wall decreasing from the blastocoelar surface in blastulae and early gastrulae of normal development (Child, 1953c) suggests that under natural conditions oxygen content in the blastocoel may not differ greatly from that outside but may become much less than outside after external oxygen decrease, in consequence of oxygen uptake by cells of the wall and mesenchyme and dissociated cells in the blastocoel. The purpose of this discussion is merely to call attention to various factors which are or may be con-

cerned in determining reduction patterns; few suggestions concerning the roles of particular factors in individuals are possible.

Figures 1-3 are exogastrulae of *Dendraster*, *S. purpuratus* and *Patiria* from the early paper, but with positions of the arrows indicating directions of decrease in rates of reduction altered in order to show more exactly the patterns described in the text of that paper. In Figure 1 (6 days in LiCl *M*/50 from 2-cell stage) the ectoderm still shows a very slight polar gradient. In Figure 2 (extreme crowding in water) there is evidently entodermization of the apical ectoderm with elongation of the entodermized region outward, as in basal exogastrulation (Child, 1948). In both the basal and the apical exogastrulation reduction progresses from the ect-entodermal junction and in the ectoderm the polar gradient is still present, except basally. In Figure 3 (60 hours in LiCl *M*/30 from 2-cell stage) reduction progresses from a region of the entoderm, perhaps entodermized ectoderm, nearer the ect-entodermal junction than the entodermal tip. In all cases reduction in the cell-wall progresses from the blastocoel outward. These were the reduction patterns observed in thousands of exogastrulae of all four echinoderms.

#### MATERIAL AND METHODS

The three echinoderms chiefly used in the early study of reduction and in the preceding paper on oxidation pattern, *Dendraster excentricus*, *S. purpuratus* and *Patiria miniata*, were again used in this further study of reduction patterns.<sup>4</sup> The dyes used were chiefly diazine green and in some cases methylene blue. Diazine green, with the two steps in reduction and with color change, first from the blue-green of the oxidized dye to the red diethyl safranine, and second, the further reduction to colorless, has been more useful than other dyes which merely lose color on reduction. Intracellular reoxidation of colorless reduced diazine green to the red diethyl safranine is possible, but further reoxidation to the blue green, fully oxidized dye does not usually occur in echinoderm material, though it has been observed in some other organisms. Diazine green is more toxic than many other "vital" dyes and has been used in concentrations of 1/100,000 and 1/50,000, and usually only with staining periods from 5-15 minutes.

Patterns of intracellular indophenol reduction with loss of color are similar to the dye reduction patterns. As repeatedly described in earlier papers, intracellular indophenol reaction (the Nadi reaction) results from oxidation of the reagents, para-aminodimethyl aniline (dimethylparaphenylene diamine) and  $\alpha$ -naphthol, catalyzed by an oxidase, often regarded as cytochrome oxidase. Both of the indophenol reagents are toxic but with use in very low concentrations both the intracellular reaction with deep blue color and reduction to colorless are possible in apparently uninjured embryos and larvae and in motile stages still moving. Also alkali is not required to dissolve the naphthol. Use of this indicator is more fully described in earlier papers (*e.g.*, Child, 1944, 1953c and various other papers).

<sup>4</sup> The kindness of the Director and staff of the Hopkins Marine Station in providing material, facilities for work, and in some cases for transportation of material to Palo Alto, and of Dr. Olin Rulon for sharing *Dendraster* material and transporting it to Palo Alto is again gratefully acknowledged.

Although certain organisms or certain regions or organs can reduce intracellular methylene blue and low intracellular concentrations of diazine green and indophenol without external oxygen decrease, intracellular reduction of these and various other redox indicators is not generally characteristic of development or life under natural conditions, but occurs only after oxygen in the external environment and in the tissues has undergone decrease to a critical concentration. The indicator then becomes a hydrogen acceptor and is reduced. This reduction is considered to be catalyzed by one or more dehydrogenases. Obviously this reduction of the indicator represents oxidation of some intracellular substrate by loss of hydrogen to the indicator and becomes the characteristic reaction with sufficient oxygen decrease.

Decrease of available oxygen can be brought about in various ways. In some of the earliest studies of intracellular reduction of indicators highly toxic reducing agents were used, *e.g.*, sodium hyposulphite and hydrochloric acid, also another, rongalite, containing formalin. These required extreme caution in use and in certain cases their use led to errors as regards regional differentials in rates of reduction. Regions most susceptible to the toxic effects were injured, so that reduction in them was delayed or did not occur, though when they were not greatly injured reduction was more rapid in them than in any other parts (Child, 1941a, pp. 90-92 and footnote). In the earliest studies of indicator reduction in echinoderms these toxic reducing agents were not used. After staining by oxidized dyes a number of embryos or larvae were sealed in a small volume of water or, in some cases, dilute dye solution and oxygen decrease resulted from oxygen uptake of the living material. With this procedure the length of time before reduction varied with number of individuals and volume of fluid. Intracellular reoxidation occurred rapidly on opening the sealed preparation and reduction and reoxidation could often be repeated several times before the intracellular concentration of oxidized indicator became toxic. Some years later this method was used for intracellular indophenol reduction in *Dendroaster* (Child, 1941b).

In recent indicator studies, however, a much more satisfactory reducing agent, sodium hydrosulphite ( $\text{NaHSO}_2$  or  $\text{Na}_2\text{H}_2\text{S}_2\text{O}_4$ ), has been used. A fraction of a milligram is sufficient to bring about reduction in echinoderm developmental stages in one ml. of water. The chief difficulty is to keep the quantity used small enough so that reduction will not be too rapid for observation of regional differentials. This agent is not appreciably toxic in concentrations much higher than those required for reduction, though in sealed preparations animals finally die from lack of oxygen. Hydrosulphite has been used for reduction in all cases considered in this paper and in thousands of other individuals.

Figures are essentially optical sections along the polar axes. They do not indicate actual differences in size in the different species. Arrows, drawn only for the left side, though the two sides are similar, point in the direction of decrease in rate of reduction. Mesenchyme and dissociated entoderm cells in the blastocoels are indicated in dotted outlines or areas.

#### REDUCTION PATTERNS OF DENDROASTER AND STRONGYLOCENTROTUS EXOGASTRULAE

Exogastrular reduction patterns and their variations are similar in these two echinoids. A highly effective method for producing exogastrulation in these forms is exposure to low temperature during early development with later de-

velopment at a much higher temperature. Figures 4-8 are from a lot kept at 10° C. for 29 hours from the 2-4 cell stage and later at 22°-24° C. Neither change of temperature was sudden. At the low temperature development did not usually

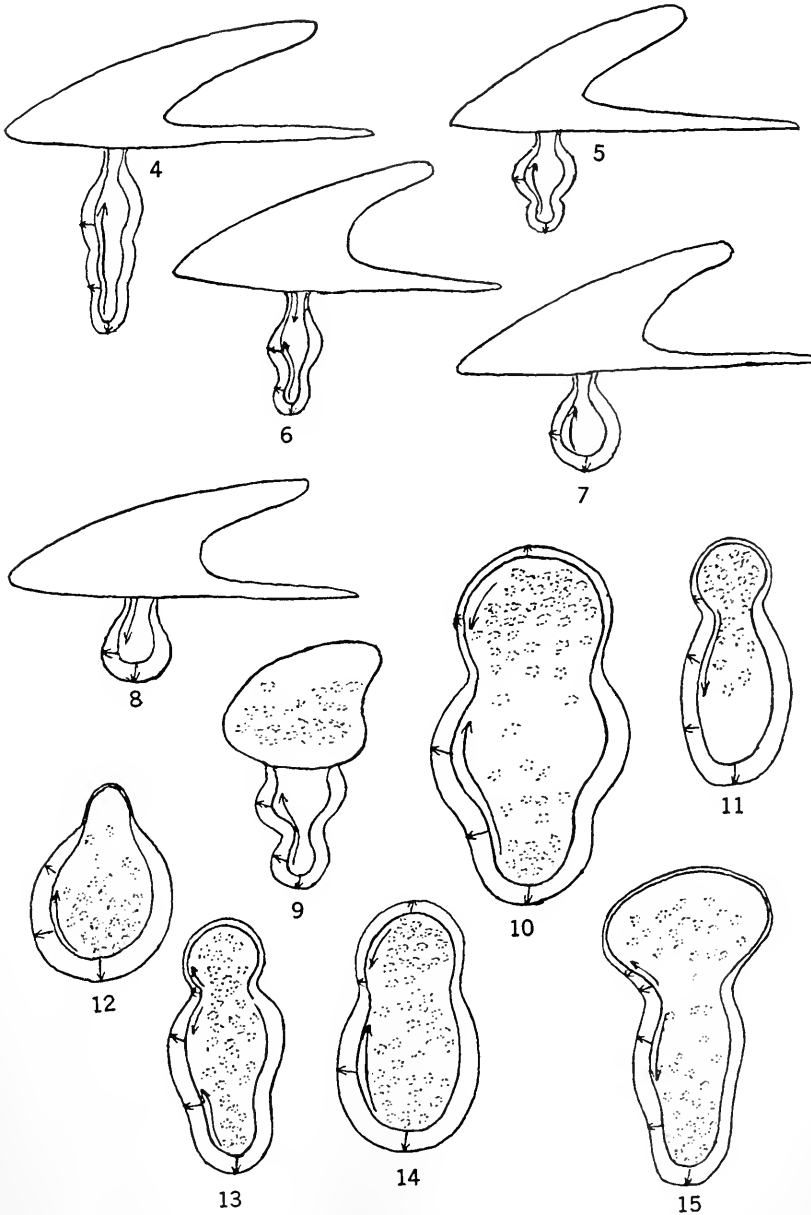

FIGURES 4-15. Reduction patterns in *Dendraster exogastrulae*: Figures 4-8, exogastrulae resulting from temperature change; Figure 9, 2 days in sodium azide *M*/600; Figures 10-15, 2 days in water after 28 hours in LiCl *M*/50. Further data in text.

progress beyond blastula stages and if these were left too long at the low temperature death occurred. Figures 4-8 represent exogastrulae with high degrees of differential recovery at the higher temperature. Ectoderm and mesenchyme attain complete pluteus development and in Figures 4-6 there is more or less development of three entodermal segments. More extreme degrees of exogastrulation occur with slightly longer exposure to low temperature. In Figures 4-6 entodermal reduction progresses from the tip, though in Figure 6 the thin-walled region adjoining the ectoderm reduces from the ectoderm. In Figure 7, with less entodermal development, reduction progresses from the tip, but in Figure 8, with very similar degree of entodermal development, entodermal reduction progresses from the ectoderm. Reduction in the entodermal cell-wall progresses from the blastocoel outward. Ectodermal reduction pattern is like that of the normal pluteus; tips of the oral lobe and of the arms are the high ends of reduction gradients. Figure 9 with ectodermal development stopped in a prepluteus stage, and entodermal reduction progressing from the tip was exposed to sodium azide only after it attained the blastula stage (azide  $M/600$ , 2 days). With this relatively later exposure to azide only a small number of exogastrulae appeared; inhibited entogastrulae developed in an estimated 95 per cent of the lot, and the few exogastrulae were not extremely inhibited by azide. Figures 10-15 represent exogastrulae two days in water after 28 hours from the 2-4 cell stage in  $\text{LiCl } M/50$ . All are from a single container and serve as examples of the variations in form and development under more or less similar conditions. In Figures 10-12 entodermal polar reduction progresses from the tip and in Figures 10 and 11 a slight ectodermal polar gradient, decreasing basipetally, still persists. Figure 12 is particularly interesting; evidently it was greatly inhibited by  $\text{LiCl}$ , apparently with entodermization of much of the ectoderm, but reduction progressing from the entodermal tip suggests that after return to water the entoderm underwent a high degree of differential recovery, with the tip becoming the region of most rapid reduction. Figure 13 is also of interest, as suggesting some degree of recovery of the entoderm at and near the tip, though not sufficient to prevent occurrence of reduction in both directions at the ect-entodermal junction. In Figures 14 and 15 reduction progresses in both or only in one direction from the ect-entodermal junction, the usual course of reduction in the early study of exogastrulation. Similar varieties of form and course of reduction occur very generally in a single container, except with extreme degrees of inhibition by the exogastrulating agent or other conditions. In all cases in which the entodermal cell-wall is thick enough to show the cell-wall gradient clearly, reduction progresses from the blastocoelar surface outward.

Exogastrulae of *Strongylocentrotus* differ so little from those of *Dendraster* that they require only brief attention. Figures 16 and 17 are forms two days in water after two days in azide  $M/800$  from 2-4 cell stages. There was evidently considerable differential recovery after return to water, with further development of entoderm. Reduction progresses from the entodermal tip and in Figure 16 a slight polar gradient is present in the ectoderm. Figure 18, from a lot two days in  $\text{LiCl } M/50$  from the 2-cell stage with dilution of the solution to approximately half water after that period, is much like Figure 12 of *Dendraster*. Here also there is probably entodermization of ectoderm and differential recovery of entoderm



with reduction progressing from the entodermal tip. Many other exogastrulae in this lot were very similar. In Figure 19, after three days in LiCl  $M/40$  without return to water, reduction is from the ect-entodermal junction. Figure 20, three days in LiCl  $M/60$  without return to water, also showed reduction from the ect-entodermal junction. Figure 21, from a lot one day in LiCl  $M/30$ , followed by two days in water, shows reduction progressing from the ect-entodermal junction, like most others in the lot, but in a few individuals reduction progressed from the entodermal tip. Perhaps the *Strongylocentrotus* exogastrulae, not merely

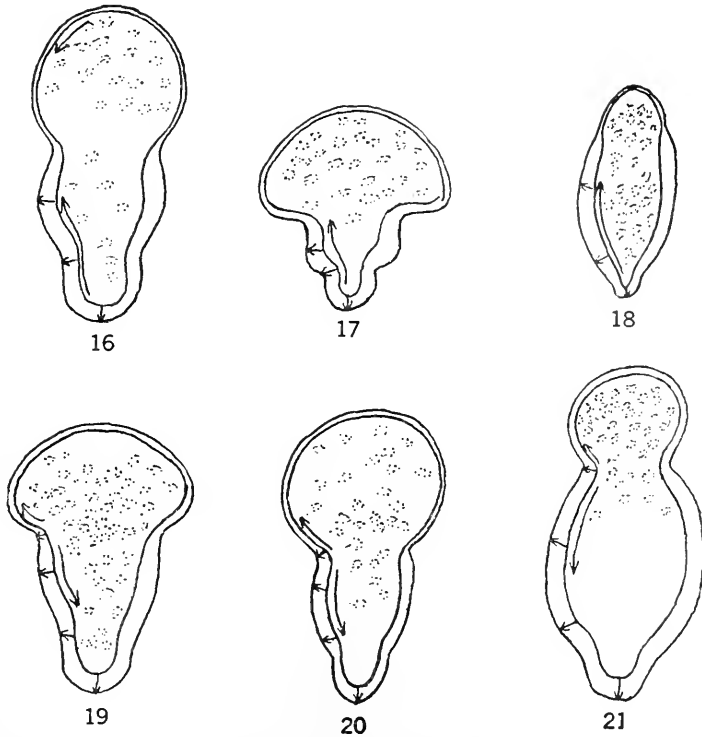

FIGURES 16-21. Reduction patterns in *Strongylocentrotus* exogastrulae: Figures 16 and 17, 2 days in water after 2 days in sodium azide  $M/800$ ; Figure 18, 2 days in LiCl  $M/50$  followed by dilution to approximately  $M/100$ ; Figure 19, 2 days in LiCl  $M/40$ ; Figure 20, 3 days in LiCl  $M/60$ ; Figure 21, 2 days in water after one day in LiCl  $M/30$ . Further data in text.

those of the figures, but many hundreds of exogastrulae in many lots, suggest that recovery of the evaginated entoderm, so that reduction progresses from its tip occurs less frequently in this echinoid than in *Dendraster*. This difference is perhaps to be expected, as *Strongylocentrotus* is in general somewhat more susceptible to inhibiting conditions than *Dendraster*. In both forms reduction in the cell-wall progressed from the blastocoelar surface outward in all cases in which the cell-wall was not so thin that the gradient was uncertain.

It is a point of incidental interest that in these echinoid exogastrulae there are usually free cells in the blastocoel; immigration of mesenchyme or of some part of

it often occurs before actual evagination of entoderm. Not infrequently most of the mesenchyme cells reach the ectodermal region, but, except in the lesser degrees of exogastrulation such as Figures 4-8 of *Dendraster*, the ectodermal factors localizing mesenchyme are obliterated, and, in Figure 9, almost obliterated. In those exogastrulae skeleton does not develop, or at most a few irregularly localized spicules or rods appear. In addition to mesenchyme cells in the blastocoel, cells may dissociate internally from the entoderm; these are usually still capable of reduction and oxidation of indicators. These dissociated cells in the blastocoel reduce earlier than other parts of the exogastrulae, and, as pointed out above, doubtless play some part in decreasing oxygen content in the blastocoel by their own oxygen uptake, *i.e.*, as external oxygen decrease occurs these cells probably determine their own rapid reduction and may also be factors in determining the cell-wall gradient decreasing from the blastocoel outward. All figures of echinoid exogastrulae were drawn from individuals in which direction of the cell-wall gradient was clearly distinguishable. In some exogastrulae the entoderms may become so thin that direction of the cell-wall gradient becomes difficult or impossible to determine. Occasionally it was noted at the time of observation that reduction seemed to progress from the external entodermal surface inward. With rapid and extreme oxygen decrease, this is of course possible, but it seems quite beyond question that the characteristic cell-wall reduction gradient decreases from the blastocoel outward in the evaginated entoderm and also in the ectoderm, if that is not too thin to show a distinct cell-wall gradient.

#### REDUCTION PATTERNS IN EXOGASTRULAE OF PATIRIA

With exposure to exogastrulating agents, beginning in the earlier blastula stages, development of differentially inhibited entogastrulae may precede exogastrulation. For example, Figures 22 and 23 are from a lot in which every individual of several samples, including large numbers, was an inhibited entogastrula after 15 hours in LiCl  $M/30$  from early blastula stages. In many of these, entodermal dissociation was already occurring. After 48 hours in LiCl every individual of numerous samples was an exogastrula and in most of them the invaginated part of the entoderm was dissociating or dissociated. Figure 24 is an exogastrula with its development stopped in early stages during three days in a high concentration of LiCl ( $M/7.5$ ). Only the cell-wall gradient, decreasing from the blastocoel outward, is distinguishable. Figure 25 is also stopped in an early stage of exogastrulation by three days in azide  $M/250$ . Entodermal dissociation is beginning internally and here also only the cell-wall gradients are distinguishable.

Figures 26 and 27, two days in LiCl  $M/30$  from early blastula stages, are cases of polar entodermal reduction progressing from the tip and without entodermal dissociation. This pattern of reduction has not been observed as frequently in *Patiria* as in the echinoids; in those cases in which it has been observed, no evidence of entodermal dissociation has appeared. In Figures 28-32 polar entodermal reduction progresses in both directions from an entodermal region near the ecto-entodermal junction and all show more or less entodermal dissociation. Figure 28, 2 days in LiCl  $M/30$  from the early blastula, may have been originally an entexogastrula; if it was, the invaginated part of the entoderm has dissociated internally and the remaining entoderm cells have come together and are intact.

Figure 29, with similar LiCl exposure, is an entexogastrula with the invaginated part of the entoderm in process of dissociation. In Figures 30 and 31, also with the same LiCl exposure, entodermal dissociation occurred earlier, perhaps during an entogastrula stage, and the remaining entoderm has healed. Figure 32, three days in LiCl *M/30*, is an example of the great length sometimes attained by the

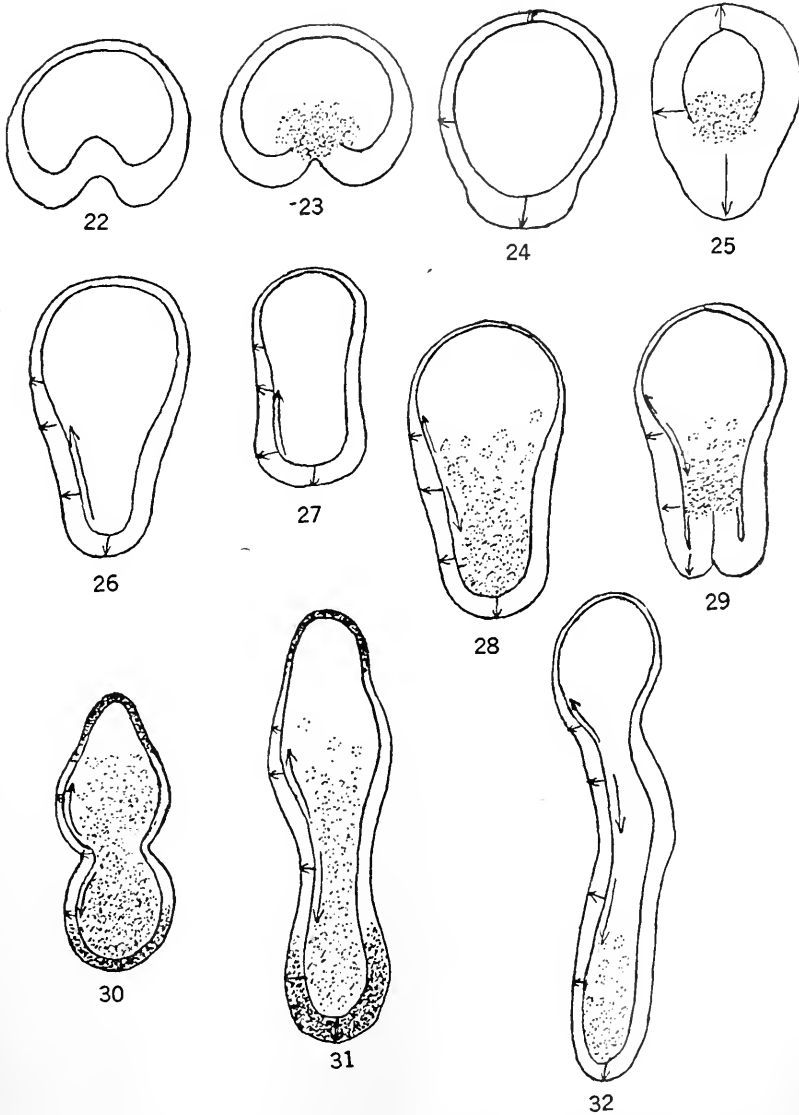

FIGURES 22-32. Reduction patterns in *Patiria* exogastrulae: Figures 22 and 23, inhibited entogastrulae after 15 hours in LiCl *M/30*, after 48 hours in LiCl were exogastrulae; Figure 24, exogastrula stopped in early stage after 3 days in LiCl *M/7.5*; Figure 25, stopped in early exogastrulation after 3 days in sodium azide *M/250*; Figures 26-31, 2 days in LiCl *M/30* from early blastula stages; Figure 32, 3 days in LiCl *M/30*. Further data in text.

evaginated entoderm when little or no dissociation occurs. These figures suggest that the most active and therefore the most susceptible entodermal region often undergoes dissociation; other less susceptible regions remain intact and may apparently develop some degree of tolerance to this concentration of LiCl and undergo further elongation (Figs. 31 and 32).

Figures 30 and 31 are intended to indicate another interesting characteristic of starfish exogastrulae. In the course of observations of reduction of oxidized diazine green it was found, first by accident and later confirmed by many cases, that when staining by this dye was continued somewhat longer than the usual 5–15 minutes with 1/100,000 or 1/50,000, reduction occurred as the arrows in these figures and in Figures 28 and 29 indicate. Reduction to the red diethyl safranine occurred first; reduction to colorless followed in the dissociated cells but a variable region of the ectoderm and of the entodermal tip remained red and did not reduce to colorless at any time. In Figures 30 and 31 this is indicated by the deep shading of the apical region of the ectoderm and of the entodermal tip. In some cases in which lots were left in oxidized diazine green for half an hour or somewhat more, these two regions remained blue-green, *i.e.*, did not reduce at all. These cases are regarded as indicating differential injury of these regions, the most susceptible of the individual, while the less susceptible are still able to reduce the dye, even to colorless. In use of diazine green on other organisms and even with other less toxic dyes it has been found that with over-staining by oxidized dyes reduction is retarded or may not occur at all. Indophenol reduction is retarded similarly if the intracellular concentration of indophenol becomes sufficiently high.

Although the length of the evaginated entoderm in the starfish exogastrulae varies greatly, further differentiation of the entoderm with development of two or three segments has been observed only in nine individuals among the thousands of exogastrulae observed. In the starfish, as in other echinoderms, degrees of exogastrulation and indicator patterns are dependent on experimental procedures, temperatures and susceptibilities of individuals and different lots of eggs. It is of course possible that with different exposure periods to exogastrulating agents or other differences in experimental conditions frequencies of the different reduction patterns may differ. However, the present paper is primarily concerned with occurrence, rather than with frequencies of the different patterns.

There is no primary mesenchyme in the starfish. The dissociated cells in the blastocoels of most starfish exogastrulae are cells dissociated from the entoderm, but usually still capable of reducing and reoxidizing the indicators. They unquestionably contribute to the low oxygen content in the blastocoel and, like the mesenchyme of the echinoids, usually reduce before other parts. Apparently the entoderm cells which dissociate into the blastocoel represent the most susceptible entodermal region; when there is no dissociation, reduction progressing from the entodermal tip appears to be more frequent than in cases of dissociation of this region. The progress of reduction in the entodermal cell-wall from the blastocoel outward is even more distinct in the starfish than in the echinoids; the larger size of starfish stages and the greater thickness of the evaginated entoderm in most of the exogastrulae account for this difference.

ENTODERMAL REDUCTION IN NORMAL DEVELOPMENT WITHOUT  
EXTERNAL OXYGEN DECREASE

Although this section concerns certain observations on normal development, rather than on exogastrulae, it is included here as an example of determination by metabolic activity of decrease in oxygen content in internal cavities below that in external environment, and therefore as bearing on certain questions of reduction pattern.

It was recently observed that in normal plutei and somewhat earlier stages of *Dendraster* after 10–15 minutes in oxidized diazine green the mesenchyme cells and the archenteron became distinctly red in well-aerated water, though the ectoderm remained completely oxidized. Indophenol reduction of the archenteron also occurs without external oxygen decrease, though this reduction consists merely in loss of color and is less striking, and must also be observed through the more or less deep blue ectoderm. In the midgut with thicker cell-wall than other parts of the entoderm reduction appears to progress from the internal cavity toward the blastocoelar surface. As noted above, oxygen diffusing inward must now pass through two cell-walls to reach this cavity and muscular contraction of the gut begins to occur at about this time. To what extent oxygen reaches the archenteric cavity from the mouth is not known at present; evidently it is not sufficient in amount to prevent low oxygen content and early reduction in the cavity. Apparently the hindgut also undergoes early reduction from the inside outward.

In the later stages of normal larval development of *Patiria* entodermal reduction of diazine green to the red diethyl safranine occurs more rapidly and to a greater degree than in *Dendraster* after a few minutes in the oxidized dye and in well-aerated water, while ectoderm remains completely oxidized. Indophenol reduction also occurs under the same conditions, though if the ectodermal reaction becomes deep in color it may be difficult to observe. Here, even more distinctly than in *Dendraster*, reduction progresses from the entodermal cavity toward the blastocoel, at least in the midgut and apparently in the hindgut. The foregut becomes thin-walled as it enlarges, and direction of reduction is less clearly distinguishable there. Oxygen entering through the mouth is evidently not sufficient in amount to prevent this early entodermal reduction. Probably the sea urchin will also show early entodermal reduction in later stages of normal larval development without external oxygen decrease, but this question must await another breeding season.

## DISCUSSION AND CONCLUSIONS

As regards the pattern of indicator reduction, it must again be emphasized that intracellular reduction of the indicators represents an intracellular oxidation in the living tissues. With oxygen decrease to a critical point the indicator becomes a hydrogen acceptor with catalysis of the reaction by dehydrogenase. Some substrate in the cells loses a hydrogen to the indicator. The substrate concerned in this dehydrogenase oxidation is undoubtedly different from that involved in the oxidase or oxidation patterns. In other words, the pattern of indicator reduction is actually the pattern of certain intracellular oxidations, a component of the metabolism of the living cells.

In the echinoderms thus far investigated by means of redox indicators the patterns of intracellular oxidation, catalyzed by an oxidase or by oxidases, and the patterns of indicator reduction, catalyzed by one or more dehydrogenases, are the same, as regards regional differentials, in early development under natural conditions to stages just preceding gastrulation and in early stages of entodermal invagination. As those stages are attained, the primary mesenchyme cells of the echinoids and the prospective entoderm, previously the least active region, evidently undergo a considerable activation, apparently involving rapid growth of the entoderm. With this activation a new reduction gradient decreasing from the basal region, *i.e.*, opposed in direction to the reduction gradient of earlier stages and also to the oxidase or oxidation gradient, appears. The oxidase gradient remains unaltered and still decreases from the apical region basipetally over the entire individual. The new acropetal reduction gradient varies in length according to degree and duration of oxygen decrease. It may extend into the ectoderm. Attention was repeatedly called to the appearance of this new reduction pattern, and it was suggested that it indicated a change in physiological condition, decreasing from the basal region acropetally, and perhaps representing a step in differentiation.<sup>5</sup> In later gastrula and larval stages oxidation and reduction patterns again become similar as regards regional differentials and show the same relation to morphogenesis in normal development. In exogastrulae differences in relations of oxidase and reduction patterns appear. The polar patterns of both indicator oxidation and reduction may be decreased or entirely obliterated. The polar oxidation pattern in the evaginated entoderm is still present with decrease from the entodermal tip, though its differential may become slight when entodermal elongation is inhibited at an early stage (Child, 1953c). The reduction pattern of the evaginated entoderm may decrease from the tip or from the ect-entodermal junction or an entodermal region near it. In general, reduction from the entodermal tip, like that in entogastrulae, seems to occur more frequently, as might be expected, in the less extreme degrees of exogastrulation, though differences in susceptibility to inhibiting conditions differ so greatly in individuals and in different lots of eggs that it may also appear in more extreme forms. These variations in the entodermal reduction pattern indicate that the inhibiting conditions, noted above as necessary for exogastrulation, may obliterate, or perhaps reverse, the polar entodermal gradient. Under these conditions, the region at or near the ect-entodermal junction becomes the most active and most rapidly reducing region, not through increase in its own activity, but in consequence of inhibition of other regions.

In the starfish exogastrulae, and to a lesser degree in the echinoids, the dissociation into the blastocoel of cells from the entodermal tip apparently constitutes loss of the most active and most susceptible cells from the entodermal cell-wall. Even after dissociation, these cells, free in the blastocoel, may, and almost always do, reduce more rapidly than other cells, but they are no longer a part of the entodermal gradient pattern. After such dissociation, together with other condi-

<sup>5</sup> Child, 1936a; 1941a, pp. 133-143 and figures on these pages; 1941b; 1944. The writer is indebted to Dr. E. L. Tatum for the suggestion that the new reduction pattern might be associated with an increase in synthetic activity chiefly in the prospective entoderm, and that the two opposed gradient patterns may perhaps be regarded as indicating a competition of different intracellular substrates as regards oxidation, one catalyzed by oxidase with relatively high oxygen tension, the other catalyzed by dehydrogenase and favored by low oxygen tension.

tions tending to obliterate the entodermal polar gradient, reduction from the ect-entodermal region becomes increasingly probable. In the starfish reduction from the tip of the evaginated entoderm has usually been observed only when dissociation of entodermal cells did not occur. In the exogastrulae of *Dendraster* determined by change from low to high temperature reduction progressed from the entodermal tip with few exceptions in large numbers observed. Differential recovery after return to water following exposure to the inhibiting agent may also permit reactivation of the entodermal gradient and reduction from the tip.

The general polar and ventrodorsal gradients of the echinoderm embryo and larva are obviously different in character from the gradients between the surfaces of the cells which constitute the cell-walls of the embryo and larval stages. Polar and ventrodorsal gradients are differentials from cell to cell, involving the entire individual or extensive regions of it, though slight differentials may be present within the limits of single cells, *e.g.*, in cleavage stages (Child, 1953c). These general body-gradients are apparently determined in the ovary; at least this appears clearly to be the case as regards the polar gradient. However, this gradient can be decreased or even obliterated by differentially inhibiting conditions, and with differential recovery or with certain degrees of differential tolerance, the differential may become greater than in normal development, not only in echinoderms, but also in various other organisms. In a coelenterate early developmental stage it has been possible to determine experimentally a new polarity, and in reconstitution new polarities have been determined experimentally in many forms (Child, 1941a, Chapters X and XI). When and how the ventrodorsal gradient is determined still remains uncertain, though it may perhaps also be in the ovary in association with the growth of the gonad. It can be modified experimentally by the same conditions as the polar gradient and it can be experimentally reversed in direction, apparently by a differential inhibition (Pease, 1941, 1942a, 1942b). The cell-wall gradients are usually differentials between the two exposed surfaces of single cells, though in the thick entodermal masses of some exogastrulae and certain other modified forms the cell-wall is not a single cell-layer, and the cell-wall gradient becomes a multicellular differential. In the preceding paper it was pointed out that the presence in early normal development of the cell-wall gradient, decreasing from the blastocoel outward, did not support the earlier conclusion, based on reduction alone, that oxygen content in the blastocoel was normally less than externally (Child, 1936a). If this were the case, it seemed improbable that the oxidation gradient of the cell-wall could decrease from a region of lower, to one of higher, oxygen content. Moreover, the cell-wall oxidation gradient is not present from the beginning of development. Its appearance as a visible gradient, decreasing from the blastocoel outward, is associated with the appearance of the blastocoel. No visible indication of presence of this gradient has been observed in the 16-cell stage, but at 32 cells a slight cell-wall oxidation differential has been observed and later it becomes increasingly visible. It still remains a question as regards the conditions which determine the origin of this gradient with its high end toward the blastocoel in normal development. Further investigation is necessary to determine whether it is in any way correlated with position of the nucleus in the cell. Most figures of echinoderm larval development do not show the nuclei. There are, however, a few figures with nuclei in the

earliest studies of exogastrulae by Herbst,<sup>6</sup> but even these are not satisfactory. In some of them, at least some of the nuclei seem to be slightly nearer the blastocoelar, than the outer surface of the wall; in others no distinguishable difference with respect to the two surfaces of the wall appears. As regards the presence of this oxidation gradient there is no question. It has been observed in many hundreds of blastulae and early gastrulae, and its presence has been confirmed by others. It is possible to advance various hypotheses as regards conditions determining this gradient but at present they are little more than guesses.

The presence of this gradient in normal development by no means excludes the possibility that with external oxygen decrease oxygen content in the blastocoel may become much lower than outside in consequence of oxygen uptake by cells of the wall and cells which happen to be in the blastocoel, that the indicator reduction gradient may also decrease in the cell-wall from the blastocoel, and that immigrated mesenchyme and dissociated entoderm cells in the blastocoel may reduce most rapidly of all. Reduction from the internal cavity of the gut in later larval stages, entirely without external oxygen decrease, is further evidence along this line.

The cell-wall oxidation gradient of the entoderm undergoes reversal in direction with entodermal evagination; it was suggested in the preceding paper that this reversal is an essential factor in exogastrulation (Child, 1953c). In the exogastrular ectoderm there is no reversal of the oxidation gradient.

The indicator reduction gradient in the cell-wall of the evaginating or evaginated entoderm of exogastrulae undergoes no reversal and no definite changes. It becomes visible only after marked external oxygen decrease, and evidently in exogastrulae, as in normal development, results from more rapid oxygen decrease in the blastocoel than externally. The only difference from normal development is that in the evaginated entoderm the inner surface, in normal development, the outer surface, is the blastocoelar surface of the cells.

Whether an escape or partial escape from physiological dominance of a metabolically more active region of the developing echinoderm larva or an integrating factor or factors of some sort which may be concerned in what we call normal development, is concerned in exogastrulation, as suggested by J. W. MacArthur (1924), remains a question. Obviously the normal larva does not develop as an aggregation of independent parts. It is also obvious that the controlling or integrating factor or factors concerned in normal development are altered or, at least in part, absent in exogastrulae and other experimental developmental modifications. In the exogastrula the relation of ectoderm and entoderm has become different from that in the normal larva. In the elongated exogastrulae with great over-development of entoderm, and often more or less entodermization of ectoderm and dissociation of cells, the entoderm seems, to a greater or less extent, to have gained the upper hand. To that extent, apparently extreme in some exogastrulae, there appears to be a partial, or in some cases almost complete, entodermal independence. It develops as far as available material permits. Regional differential susceptibility to experimental differentially inhibiting factors is involved in this more or less extreme alteration or breakdown of physiological dominance or integrating and ordering factors concerned in determining a normal individual.

<sup>6</sup> Herbst, 1895, various figures, Plate IX; Figures 42 and 43, Plate X. 1896, Plate XXVI.



## SUMMARY

1. The paper consists primarily of a new investigation of intracellular reduction patterns of certain redox indicators in relation to exogastrulation, with the echinoids, *Strongylocentrotus purpuratus*, and *Dendraster excentricus*, and the asteroid, *Patiria miniata*, as material. Its purpose is: first, to record results of recent studies of these patterns, made with more adequate conditions for reduction than in earlier work; and second, to attempt somewhat further physiological analysis of the patterns and of their relation to oxidation patterns, than was undertaken in the earlier study.

2. Conditions which make the reduction patterns visible involve, not only the differentially inhibiting action of the exogastrulating agent, but also differentially inhibiting effects of oxygen decrease externally, and in some cases, of intracellular concentrations of oxidized dye or indophenol, and perhaps also the physiological age of the exogastrula. Usually the significance of these different factors for individual exogastrulae is not certainly distinguishable, but the differentially inhibiting effect of the exogastrulating agent is probably in general the most important.

3. In the less inhibited and less extreme forms of echinoid exogastrulae, in which ectoderm attains or approaches fully developed pluteus differentiation, the evaginated entoderm almost always reduces progressively from the tip toward the ectoderm, though occasional alterations of this pattern appear. In *Patiria* exogastrulae, dissociation of entoderm cells from the most susceptible and most inhibited entodermal tip and adjoining regions into the blastocoel occurs very frequently. Entodermal reduction progressing from the tip has been observed less frequently in *Patiria* than in the echinoids and thus far only when little or no dissociation from the entodermal tip occurs. In the echinoids entodermal dissociation may also increase the cells in the blastocoel far beyond the usual number of mesenchyme cells. In general, it appears evident that the larger the number of dissociated cells in the blastocoel, the less frequently does reduction progress from the entodermal tip.

4. When entodermal reduction does not progress from the tip, it begins at or near the ect-entodermal junction, or in *Patiria* in the entoderm near this junction, and progresses toward the entodermal tip and often acropetally for a short distance in the adjoining ectoderm. Under natural conditions, these regions are the least rapidly reducing regions of the entoderm after its activation preceding gastrulation, and of the adjoining ectoderm. In these exogastrulae they have become the regions of most rapid reduction, probably not by change in their own conditions, but by more extreme inhibition of other parts and obliteration or perhaps reversal in direction of their polar gradients.

5. In completely radial exogastrulae with rounded ectoderm lacking differentiation a slight polar reduction gradient may still be visible in the apical region, usually in cases of some degree of differential recovery after return to water, perhaps sometimes with development of differential tolerance to the exogastrulating agent, or a polar ectodermal reduction gradient may be completely absent. The ventrodorsal ectodermal gradient is completely obliterated by less extreme inhibition than the polar gradient.

6. Even if oxygen content in the blastocoel differs little or not at all from that in the external water, as the oxidase gradient of normal development seems to

indicate, it may become much lower in the blastocoel than outside, in consequence of oxygen uptake of cells of the cell-wall and of dissociated cells in the blastocoel with sufficient decrease of external oxygen tension. Under these conditions reduction must occur most rapidly in dissociated cells in the blastocoel, which are evidently not dead in most cases, and in the cell-wall reduction will progress from the blastocoelar surface outward in exogastrulae, as well as in normal development, and not only in entoderm, but also in ectoderm unless this has become so thin that a cell-wall gradient is not distinguishable. As might be expected, the cell-wall reduction gradient does not undergo reversal in exogastrulation, as does the oxidase gradient. The reduction gradient in the cell-wall is not directly related to exogastrulation.

7. In intracellular indicator reduction the indicator becomes a hydrogen acceptor and an intracellular substrate undergoes oxidation catalyzed by one or more dehydrogenases. Both intracellular oxidation of reduced redox indicators, catalyzed by oxidase, and intracellular reduction, catalyzed by dehydrogenase, are directly visible evidences of certain characteristics of oxidative metabolism, though different enzyme systems and undoubtedly different intracellular substrates are concerned in the two oxidative reaction systems.

#### LITERATURE CITED

- CHILD, C. M., 1936a. Differential reduction of vital dyes in the early development of echinoderms. *Arch. f. Entw.*, **135**: 426-456.
- CHILD, C. M., 1936b. A contribution to the physiology of exogastrulation in echinoderms. *Arch. f. Entw.*, **135**: 457-493.
- CHILD, C. M., 1941a. Patterns and problems of development. University of Chicago Press, Chicago, Illinois.
- CHILD, C. M., 1941b. Formation and reduction of indophenol blue in development of an echinoderm. *Proc. Nat. Acad. Sci.*, **27**: 523-528.
- CHILD, C. M., 1944. Developmental pattern in the starfish *Patiria miniata*, as indicated by indophenol. *Physiol. Zool.*, **17**: 129-151.
- CHILD, C. M., 1948. Exogastrulation by sodium azide and other inhibiting conditions in *Strongylocentrotus purpuratus*. *J. Exp. Zool.*, **107**: 1-38.
- CHILD, C. M., 1953a. Exogastrulation and differential cell dissociation by sodium azide in *Dendraster excentricus* and *Patiria miniata*. *Physiol. Zool.*, **26**: 28-58.
- CHILD, C. M., 1953b. Indicator gradient pattern in oöcytes and early developmental stages of echinoderms: a reexamination. *Biol. Bull.*, **104**: 12-27.
- CHILD, C. M., 1953c. Redox indicator patterns in relation to echinoderm exogastrulation. I. Oxidation patterns. *Biol. Bull.*, **105**: 62-79.
- HERBST, C., 1895. Experimentelle Untersuchungen über den Einfluss der veränderten chemischen Zusammensetzung des umgebenden Mediums auf die Entwicklung der Tiere. II. *Mittcil. Zool. Stat. Neapel.*, **11**: 136-220.
- HERBST, C., 1896. Experimentelle Untersuchungen etc. III-VI. *Arch. f. Entw.*, **2**: 455-516.
- MACARTHUR, J. W., 1924. An experimental study and a physiological interpretation of exogastrulation and related modifications in echinoderm embryos. *Biol. Bull.*, **46**: 60-87.
- PEASE, D. C., 1941. Echinoderm bilateral determination in chemical concentration gradients. I. The effects of cyanide, ferricyanide, iodoacetate, picrate, dinitrophenol, urethane, iodine, malonate etc. *J. Exp. Zool.*, **86**: 381-404.
- PEASE, D. C., 1942a. Echinoderm bilateral determination in chemical concentration gradients. II. The effects of azide, pilocarpine, pyocyanine, diamine, cysteine, glutathione and lithium. *J. Exp. Zool.*, **89**: 329-345.
- PEASE, D. C., 1942b. Echinoderm bilateral determination in chemical concentration gradients. III. The effects of carbon monoxide and other gases. *J. Exp. Zool.*, **89**: 347-386.

# THE UTILIZATION OF SOME CARBOHYDRATES BY IN VITRO CULTURED CHICK BLASTODERMS IN WOUND HEALING<sup>1, 2</sup>

RONALD C. FRASER<sup>3</sup>

*Department of Zoology, University of Minnesota, Minneapolis, Minnesota*

Studies by Spratt (1949a, 1949b, 1950a, 1950b) have shown us that there are rather specific requirements for differentiation and form building in the early chick embryo. By the use of chemically defined media he has been able to show the ability of the blastoderms to utilize different carbohydrate energy sources in development. One of the general conclusions drawn from this work is that there are specific nutritional requirements for many of the normal processes of development.

Former work, to be published elsewhere, devoted to the mechanical aspect of wound healing in the chick, has shown that this process is essentially of a morphological nature. When blood carbon is applied around holes of variable sizes produced in the extra-embryonic tissues of 24-hour blastoderms, it is observed that those particles placed immediately at the periphery of the wounds converge during closure of the holes, and come to lie within a very small area upon completion of healing. The distance that the carbon-marked cells move toward the center of the wound is inversely proportional to their initial distance from the margin, until a point is reached, beyond which the cells move outward instead of inward. The implication from such behavior is that the closure process is effected by a mass movement of cells, rather than by an unusually high cell proliferation at the borders of the wounds. This conclusion has been verified by observing in prepared slides that there is no difference in mitotic counts at any region around the sites of the injuries.

The present study represents an extension of the general problem of wound healing in the early chick blastoderm to include certain nutritional considerations. It is the purpose here to determine the ability of these organisms to utilize various media of known chemical composition for (1) the closure of wounds (for gross tissue movements in the extra-embryonic region) and (2) the closure of wounds in comparison to development in the embryo proper. It might be assumed that there would be greater requirements by the rapidly developing embryonic region.

## MATERIALS AND METHODS

All of the blastoderms used in the present study were of twenty-two hours incubation (head process to head fold stages). They were removed from the yolk, freed from the vitelline membrane and trimmed in a manner described in detail by Spratt (1947). By the use of sharp steel needles small, approximately

<sup>1</sup> A portion of a thesis submitted to the Graduate School of the University of Minnesota in partial fulfillment of the requirements for the degree of Doctor of Philosophy.

<sup>2</sup> I am deeply indebted to Dr. Nelson T. Spratt, Jr. for his guidance during this study, and to the University of Minnesota for the excellent facilities provided.

<sup>3</sup> Present address: Department of Biology, Reed College, Portland, Oregon.

square holes measuring  $300\ \mu$  to  $400\ \mu$  on a side were cut through all tissues in the pellucid area (Fig. 2). Following injury the embryos were transferred to the medium (see below) contained in watch glasses placed on moist cotton rings within petri dishes. Camera lucida diagrams were made at the time of injury and after intervals during subsequent incubation as indicated in the experiments, to note the degree of wound closure and the development of the embryo. Two hundred and thirty-four blastoderms were used in the study.

The preparation of the various sugar media has been described by Spratt (1949a). By volume the constituents were: chick Ringer solution (77.5%), penicillin-streptomycin solution (10%), phenol red (5%), phosphate buffer (5%), bicarbonate buffer (2.5%), sugar (quantity in mg% varying in the experiments); 425 mg. agar per 100 ml. total volume of medium were used.

The solutions utilized were prepared as follows:

*Chick Ringer solution.* 0.9 per cent NaCl, 0.042 per cent KCl, 0.024 per cent  $\text{CaCl}_2$  in distilled water.

*Penicillin-streptomycin solution.* To 100,000 units penicillin-G-potassium and 20 mg. dihydro streptomycin sulfate (Squibb) add 20 ml. sterile Ringer saline. Refrigerated (frozen) this is claimed to be bacteriologically effective for one week.

*Phenol red.* 0.001 per cent solution in Ringer.

*Phosphate buffer.* Add 100 ml. distilled water to 0.290 gm.  $\text{Na}_2\text{HPO}_4 \cdot 12\text{H}_2\text{O}$  + 0.052 gm.  $\text{KH}_2\text{PO}_4$ . Autoclave to sterilize.

*Bicarbonate buffer.* Saturate a solution of 1.100 gm.  $\text{NaHCO}_3$  in 100 ml. distilled water with  $\text{CO}_2$ . This is accomplished by blowing expired air into the solution through a tube for an extended period of time (ca. one hr.). Sterilize by filtration.

*Sugar.* Stock solution consists of 400 mg. monosaccharide per 100 ml. Ringer solution (400 mg% = 0.022 M). This was diluted to the desired concentration in the total volume of other medium ingredients. As an example, in preparing 40 ml. of 100 mg% glucose medium the following would be incorporated: Ringer (21 ml.), glucose stock solution (10 ml.), penicillin-streptomycin (4 ml.), phenol red (2 ml.), phosphate buffer (2 ml.), bicarbonate buffer (1 ml.), agar (170 mg.).

In making the media the agar, Ringer solution, phenol red and sugar preparation were combined and autoclaved. On cooling to approximately  $45^\circ\ \text{C}$ . the penicillin-streptomycin and sterile phosphate and bicarbonate buffers were added. After mixing by swirling this was poured into the watch glasses, where gelation occurred.

Aseptic technique was used throughout the experiments. The antibiotics were used as a precautionary measure. It was essential to guard against bacterial contamination, a factor not prominent when using an albumen medium. All of the equipment was dry-sterilized at  $350^\circ\ \text{C}$ . for 1.5 hours.

For the purpose of determining the nutritional requirements for wound healing in the blastoderms the following sugar concentrations were used: glucose, 100 mg%, 50 mg%, 10 mg% and 5 mg%; fructose, 100 mg% and 50 mg%; galactose, 50 mg%. Embryos explanted on a non-nutrient medium (all constituents except the carbohydrate) served as controls.

## RESULTS

The results of the experiments may be seen in Table I.

It will be observed that there was no healing except in one case in the controls on a medium lacking a carbohydrate substrate. This would imply that there was insufficient endogenous utilizable material for the necessary cell movements in wound healing. It was apparent that the embryos could succeed very well in

TABLE I  
*Nutritional requirements for wound healing*

Medium	No. explants	Number healed		
		8 ± Hrs	20 ± Hrs	Total
Saline	27	0	1	1
Glucose 100 mg%	15	12	3	15
Glucose 50 mg%	12	12	—	12
Glucose 10 mg%	15	7	7	14
Glucose 5 mg%	20	5	7	12
Fructose 100 mg%	6	0	2	2
Fructose 50 mg%	17	1	8	9
Galactose 50 mg%	12	0	6	6

this process on media containing 100 mg% and 50 mg% glucose. These media have been found by Spratt (1949a) to be adequate for the development of normal-appearing embryos. The value of the additional carbohydrate source was obvious in these explants; wounds healed completely on those media containing glucose and essentially never on those without a sugar.

On the medium containing 10 mg% ( $5.5 \times 10^{-4} M$ ) glucose the blastoderms began to show the effects of substrate dilution. While essentially all (14 out of 15) explants healed by 20 hours, only one half had done so at 8 hours. Compare this with those on 100 mg% and 50 mg% glucose, where practically all healing had

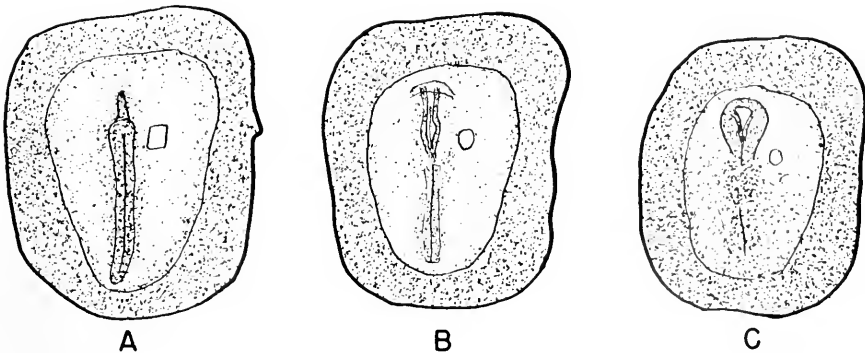

FIGURE 1. Camera lucida diagrams of an explant on agar-saline (control) medium to illustrate progress in wound closing and embryonic development. A = initial; B = after 8 hours; C = after 20 hours.



FIGURE 2. A young chick blastoderm showing the location of a wound in the pellucid area.  $\times 20$ .

FIGURE 3. The appearance of a wounded chick blastoderm which had been incubated on a non-nutrient (agar-saline) medium for twenty hours. The arrow indicates an unhealed wound.  $\times 15$ .

FIGURE 4. Photograph of a chick blastoderm which had been wounded and explanted on a medium containing glucose in concentration of 5 mg% for twenty hours. Note that in this

occurred by 8 hours. Of the twenty blastoderms explanted on the 5 mg% medium only twelve had healed by 20 hours, and of these only five had done so at the end of 8 hours.

The volume of the medium on which the embryos lay was very large (ca. 2 ml.) compared to the size of the blastoderms. It is safe to assume that at the end of twenty hours there was, for all practical purposes, approximately the same amount of sugar in the medium as there was initially. It is thus inconceivable that there was a significant depletion of the exogenous substrate. The argument that there may have been a localized depletion at the site of the embryo also cannot be valid, because there was a film of solution around them through which nutritional material could pass. There was thus a constant supply of substrate available to the explants. It is only logical to assume that the reason for the delay in closure or the failure to heal was that, while the total amount of sugar was ample, the concentration of it was insufficient to meet the requirements of the embryo for this purpose.

Both fructose and galactose were not as adequate as glucose as carbohydrate sources. Similarly it was found by Spratt (1949a) that they were inferior to glucose in terms of their utility in general developmental processes. This presumably reflected an inadequacy on the part of the embryos of this stage to bring these monosaccharides into the general glycolytic scheme.

Turning to the development of the embryos it was found that the controls continued to develop on the sub-minimal medium. By 8 hours the head was well undercut, neurulation was evident and somites were present. At this time the holes had closed somewhat in most cases. At 20 hours, however, there was evidence of degenerative changes. The anterior region had developed somewhat more than at 8 hours, but the node had become quite opaque, and had failed to regress (Fig. 3). When a drop of saline was placed gently on the embryos at this time, there was marked cell dispersal at the node region. This area has been generally recognized as one of high metabolic activity (Moog, 1943; Hyman, 1927), showing great sensitivity to metabolic inhibitors (Spratt, 1950b). The effects of starvation were therefore in accordance with these previous observations. While there was limited development in the embryos between 8 and 20 hours, there were no significant changes in wound sizes during this period. This point will be considered in more detail shortly. Figure 1, showing camera lucida illustrations made of an explant at time 0, 8 and 20 hours, reveals these points.

Development on glucose media in concentrations of 100 mg% and 50 mg% was fairly normal over the twenty-hour period with brain, heart and somites forming. Such media, however, were not as adequate as an albumen medium for typical embryonic development. On 10 mg% glucose the explants still continued to develop over the twenty-hour period, there being no indication of nutritional deficiency except as indicated; there was a longer period of time required for wound healing. If there was any damage to the node region, it was not readily apparent in the explants.

---

embryo the wound has healed, that development is limited to the anterior end, and that the node shows signs of marked deterioration.  $\times 15$ .

FIGURE 5. A chick blastoderm after twenty hours of incubation on a fructose medium (50 mg%) following injury. The same features as indicated in Figure 4 may be seen.  $\times 15$ .

On the 5 mg% glucose medium there was no perceivable influence of nutritional deficiency at 8 hours, but by 20 hours these blastoderms resembled the controls (Fig. 4). While there was slight development between these time intervals, again this was limited to the head region, with lower (axial) levels showing degeneration. The somites which had formed became indistinct, the node region failed to regress and took on an opaque appearance. Illustrating details by the camera lucida became very difficult, due to the lack of translucency and the dispersal of cells. In these embryos the wounds were in all stages of closure at 8 hours. After this time about one half of the unhealed ones completed this process, as shown in Table I.

Blastoderms on fructose and galactose media showed the effects of nutritional deficiency in terms of development as well as in wound healing. These embryos behaved very similarly to those on 5 mg% glucose, again showing marked node deterioration (Fig. 5).

### *Pretreatment study*

There was one further factor to consider in attempting to determine the minimum concentration of exogenous substrate required for wound healing. This was

TABLE II  
*Wound healing on minimal media after pretreatment*

Medium	No. explanted	No. hrs. pretreated	No. healed after 12 ± hrs.
Glucose 10 mg%	12	5	12
Glucose 10 mg%	12	10	12
Glucose 5 mg%	18	10	12
Glucose 5 mg%	18	20	18*

\* Hole filled in by loose cells during embryo degeneration.

the endogenous material present in the embryo itself. It will be noticed that even on a medium lacking any carbohydrate there was a certain amount of development. Wounds in explants on this medium also started to heal, and in one case closed completely. If, then, the effect of the carbohydrate alone was to be determined, it was necessary to minimize the endogenous substrate factor.

This was done by "pretreating" the embryos on a non-nutrient (agar-saline) medium prior to explanting them on another containing the sugar. The blastoderms were placed on the non-nutrient medium for a specified period of time, removed and wounded, and then transferred to the sugar-bearing medium. It was desirable to have the blastoderms use up most of their own available energy sources without damaging them beyond recovery.

After 8 hours of incubation there had been no apparent closure in the controls. The pretreatment period was therefore set around this interval of time. Some embryos were starved for five hours, some for ten, and some for twenty hours. Glucose concentrations of 10 mg% and 5 mg% were used, because it was around these values that the effect of deficiency became apparent.



Table II indicates the results obtained. From the data it seems that glucose in a concentration of 10 mg% was sufficient for the embryos to use in healing. This is evident even after 10 hours of pretreatment. Blastoderms explanted on a medium containing 5 mg% glucose were found, after 12 hours incubation, to have healed in approximately the same proportion as those not treated. Not included in the table were twelve embryos that were pretreated, wounded, and then transferred again to a saline-agar medium. These served as controls. None of these had healed within the twelve-hour period. From these data it may be concluded that 5 mg% glucose is near the minimal concentration that meets the requirements of the blastoderms in wound closing. Differences in ability to heal on this medium may be interpreted as an indication of variability in the embryos themselves, when explanted on synthetic media.

After twenty hours of pretreatment the node region of the explants was undergoing degeneration. When these embryos were wounded and explanted on the 5 mg% medium, it was noticed after 12 hours that the wound had apparently healed. This is indicated in Table II. When a drop of saline was gently placed over the blastoderms by means of a wide-bored pipette, however, the cells in the wound area and those at the node dispersed leaving holes in the explants. This healing was therefore not taken as normal in the sense that it was brought about by the general movements of normal tissues, but was the result of the association of cells dispersed from other areas during deterioration of the embryos.

Elsewhere (Fraser, 1953) it was mentioned that attempts to incubate the blastoderms under the medium against a cover glass failed. It was not known whether the inability of the embryos to develop was the result of insufficient oxygen or of some other agent, such as pressure of the medium on the embryo. In the course of this study the effect of anaerobiosis on wound closure was explored. Twenty embryos of 20 hours incubation were used for this purpose.

Following wounding these embryos were explanted on an agar-albumen medium in the usual manner (see Spratt, 1947). The lids of the petri dishes in which the embryos were incubated were kept elevated slightly with pieces of aluminum foil to permit the removal of oxygen. Moist cotton rings were again used in the petri dishes to maintain a moist atmosphere. The petri dishes were placed in a large desiccator into which was poured 50 ml. of 40 per cent pyrogallol acid and 100 ml. of 20 per cent KOH for the removal of oxygen. The lid was sealed immediately and the desiccator placed in the incubator.

After 12 hours the explants were removed for observation. At this time it was found that there was no embryonic development, the wounds were as large as initially made, and the blastoderms showed extensive deterioration. They had an opaque appearance masking all internal structure. When a drop of Ringer solution was gently placed on them, they tore apart with much cell dispersal, quite unlike blastoderms of a comparable age cultured on this medium under normal conditions. This indicated that normal cell-cell adhesiveness was lacking. It was apparent from this that oxygen is required for wound healing, and, in general, for all normal development. Since carbon dioxide was also removed by the alkaline pyrogallol, the effects may be in part due to its deficiency as well (Spratt, 1949b). The problem of oxygen requirement for early chick development has been considered elsewhere (Philips, 1941, 1942; Spratt, 1950a).

## DISCUSSION

There exists, as would be expected, a good correlation between the ability of the embryos to undergo development (including all of its component processes) and extra-embryonic tissue movements on various media. This correlation is not perfect, however, as evidenced by the fact that on a non-nutrient medium the blastoderms continued to develop (even though limited to the anterior region) after 8 hours of incubation, while the wounds failed to undergo any appreciable change in size beyond this time. This is a strange situation in view of the fact that one might assume that more carbohydrate (= potential energy or carbon skeleton source) would be utilized in morphogenesis, histogenesis of tissues, maintenance etc. occurring in the embryo proper than in more peripheral areas of the pellucid area, where presumably little such activity is taking place. If this assumption is correct, and we have no basis for not believing it to be so, then an answer must be sought for the observations.

It is not likely that more carbohydrate is required in tissue movements involved in wound healing, because there is more of such activity taking place in the development of the embryo itself. In this regard, however, it is interesting to note that the trunk level of the embryos failed to develop, but this is associated with, and probably a consequence of, the degeneration of the whole node region.

Since embryonic development ensues on a non-nutrient medium after general cell movements cease in the extra-embryonic region, and since it is assumed that more exogenous nutrient is required in the axial area, the suggestion is made that there may be a greater concentration of endogenous substrate localized in the embryo proper than in the outlying pellucid tissues. Although we have no direct evidence for this, such a localization is not hard to conceive in view of the general consideration that substrate and corresponding enzyme are found together. The presence of indophenol oxidase and dehydrogenase activities restricted mainly to axial tissues has been demonstrated by Moog (1943) and Spratt (1952), respectively. It is stressed, however, that the demonstration of localized enzyme activity cannot be offered as proof that there is an accumulation of its corresponding substrate.

## SUMMARY

1. Wounds produced in the pellucid area of chick embryos cultured on a non-nutrient medium failed to heal within 20 hours. Although there was little or no change in the dimensions of the holes after 8 hours, differentiation of the head region continued beyond this time.

2. On media of 100 mg%, 50 mg% and 10 mg% glucose the blastoderms healed, for the most part, within 8 hours, while development continued in the embryo proper. On a medium containing glucose in concentration of 5 mg%, however, about one half of the wounds did not heal, correlated with degenerative changes in the embryos, principally at the node, occurring between 8 and 20 hours after injury.

3. Fructose and galactose were found to be quite ineffective as carbohydrate sources for the closure of wounds and for development in general. Results using these media were comparable to those when 5 mg% glucose was utilized.

4. By pretreating the blastoderms for 5 and 10 hours on saline-agar prior to wounding, with subsequent transfer to media containing glucose, it was determined that 5 mg% glucose was approximately the minimal concentration required by the embryo for wound closure.

5. In view of the observation that embryonic development continued beyond the time when healing stopped, and because it was assumed that more carbohydrate must be required for the former to take place, it was postulated that there is a greater concentration of endogenous substrate localized in the axial tissues than in the outlying pellucid region.

## LITERATURE CITED

- FRASER, R. C., 1953. Studies on morphogenesis in the young chick embryo cultured *in vitro*. Unpublished thesis.
- HYMAN, L. H., 1927. The metabolic gradient of vertebrate embryos. III. The chick. *Biol. Bull.*, **22**: 1-39.
- MOOG, F., 1943. Cytochrome oxidase in early chick embryos. *J. Cell. Comp. Physiol.*, **22**: 223-231.
- PHILIPS, F., 1941. The oxygen consumption of the early chick embryo at various stages of development. *J. Exp. Zool.*, **86**: 257-287.
- PHILIPS, F., 1942. Comparison of the respiratory rates of different regions of the chick blastoderm during early stages of development. *J. Exp. Zool.*, **90**: 83-100.
- SPRATT, N. T., JR., 1947. A simple method for explanting and cultivating early chick embryos *in vitro*. *Science*, **106**: 452.
- SPRATT, N. T., JR., 1949a. Nutrition requirements of the early chick embryo. I. The utilization of carbohydrate substrates. *J. Exp. Zool.*, **110**: 273-298.
- SPRATT, N. T., JR., 1949b. Carbon dioxide requirements of the early chick embryo. *Anat. Rec.*, **105**: 118.
- SPRATT, N. T., JR., 1950a. Nutritional requirements of the early chick embryo. II. Differential nutrient requirements for morphogenesis and differentiation of the heart and brain. *J. Exp. Zool.*, **114**: 375-402.
- SPRATT, N. T., JR., 1950b. Nutritional requirements of the early chick embryo. III. The metabolic basis of morphogenesis and differentiation as revealed by the use of inhibitors. *Biol. Bull.*, **99**: 120-135.
- SPRATT, N. T., JR., 1952. Differentiation in reducing enzyme systems in the early chick blastoderm. *Anat. Rec.*, **113**: 602.



# EFFECT OF LOWERED INCUBATION TEMPERATURE ON THE GROWTH AND DIFFERENTIATION OF THE CHICK EMBRYO<sup>1</sup>

JOHN R. HARRISON<sup>2</sup> AND IRVING KLEIN<sup>3</sup>

*Department of Zoology, Miami University, Oxford, Ohio*

Development of an animal embryo under normal conditions consists of three fundamental processes: 1) growth, meaning an increase in mass; 2) differentiation, which includes visible changes in form (morphogenesis) and invisible changes on the molecular level; and 3) maintenance, which permits the embryo to maintain its structure intact. Many investigators have studied the effect of temperature upon development with respect to the commercial implications and to gaining knowledge concerning the developmental processes. Broca (1862) held chicken eggs at room temperature (20°–30° C.) for 27 days before incubating them and obtained blastoderms without primitive streaks. This anomaly had been described by Panum (1860) and was later given the name of "anidian" by Dareste (1877). The anidian chick blastoderm is often cited as an example of growth without differentiation. It is a blastoderm in which growth, due to cell proliferation, has occurred without evidence of embryonic axiation.

Dareste (1877) divided the anidians into two principal types: those blastoderms which possess normal ectoderm and endoderm but which lack mesoderm and a primitive streak; and those blastoderms which possess embryonic areas more or less degenerated. Other types have been subsequently described: 1) blastoderms without morphological traces of the embryo and which show no development of the area vasculosa; 2) blastoderms without embryonic axiation but which show development of the area vasculosa; and 3) blastoderms with a hole in the center of the area pellucida and without trace of an embryonic structure (Grodzinski, 1933; Tur, 1907).

The present investigation was undertaken to determine if the definition of an anidian as given by Needham, a blastoderm in which "an active proliferation of cells goes on but no trace of axiation appears" (Needham, 1950, p. 223), is valid. A more general definition, as given above, is accepted by many and does not exclude the formation and later disintegration of a streak in these blastoderms. Both viewpoints include the final morphological structure of a blastoderm which has increased in size but which does not possess a primitive streak. In this respect both agree with Dareste's (1877) original conception when he called these anomalies anidians, meaning "without form." In addition to the re-evaluation of the anidian, this investigation was carried out in the hope that the results obtained would provide a basis for further investigation of growth and differentiation.

<sup>1</sup> The authors wish to express their appreciation to Dr. C. G. Grosscup for aid in the statistical analysis, to Mr. Daniel Reynolds for help with the photography, and to Dr. H. Burr Steinbach for critical suggestions in the preparation of the manuscript.

<sup>2</sup> A portion of this investigation was made possible by a grant from the National Science Foundation.

<sup>3</sup> Material in this paper was used in partial fulfillment of the requirements for the M.S. degree from Miami University, Oxford, Ohio.

The present experimental procedure was followed because it is felt that no one has followed the development of blastoderms at one experimental temperature for prolonged periods. The principal paper on the anidian is usually stated as being that of Edwards (1902) in which he analyzed the index of development for incubation temperatures from 21° to 31° C. for five to eight days. Within this temperature range he obtained an overall yield of about 63% anidian blastoderms. A temperature of 25° C. was chosen as being above Edwards's (1902) physiological zero (20°–21° C.) but sufficiently below normal temperature to produce an effect.

The blastoderms incubated in this investigation at 25° C. for two to fifteen days show a slowed development, followed by a disintegration with continued incubation. The two processes, growth and differentiation, are affected differentially.

### MATERIALS AND METHODS

Fertile eggs were obtained locally from a flock of two year old New Hampshire Reds during the winter of 1951–52. A total of 806 eggs was used. All eggs were less than three days old and had been stored at temperatures of 5°–18° C. previous to incubation. Two identical forced-draft, thermostatically controlled incubators were employed with a constant humidity of  $65 \pm 5.0\%$ . The experimental incubator was held at  $25 \pm 0.5^\circ$  C., while the control was kept at  $37.5 \pm 0.5^\circ$  C. All eggs were placed on their sides in the incubators. Incubation at the normal temperature produced normal embryos for all the incubation periods used.

After incubation the eggs were candled to determine the position of the blastoderm. Windows, about one centimeter square, were cut in the egg shells over the blastoderm region. Blastoderms were stained by placing small squares of neutral-red-impregnated-Bacto Agar on top of the vitelline membrane immediately over the blastoderm (Hamburger, 1942). Each blastoderm was then measured *in vivo* with respect to the total blastoderm width, the area pellucida width, and the area opaca width on one side, using a Spencer binocular microscope equipped with an ocular micrometer. After blastoderm measurement, the egg was broken into a dish containing Ringer solution.<sup>4</sup> The blastoderm was cut from the yolk, floated free, and transferred to a Syracuse dish containing Ringer solution. In this dish the vitelline membrane and excess yolk were removed by means of fine steel needles. After noting the gross morphology, the blastoderm was fixed, stained with Delafield's haematoxylin and mounted *in toto* for further gross examination. Representative mounts were embedded, serially sectioned at  $10 \mu$  and remounted for an analysis of their cellular morphology.

### RESULTS

#### *The blastoderm measurements*

The experimental blastoderm measurements, with their standard deviations and coefficients of variability, are presented in Table I. The diameter increases from 4.07 mm. in the uninucleated eggs to 8.29 mm. in eggs incubated for twelve days. These data show clearly that the growth of the total blastoderm is dependent mainly on the increase of the area opaca, as the area pellucida remains relatively constant in size throughout this incubation period.

<sup>4</sup> 0.9% NaCl, 0.042% KCl, and 0.024% CaCl<sub>2</sub>.

TABLE I

*Average measurements of experimental blastoderms resulting from incubation at 25° C. for 0-15 days*

No. days at 25° C.	No. anidians	Width of blastoderm			Width of area pellucida			One side of area opaca		
		Size in mm.	$\sigma^*$ in mm.	V** as %	Size in mm.	$\sigma$ in mm.	V as %	Size in mm.	$\sigma$ in mm.	V as %
0***	68	4.07	0.54	13.31	2.23	0.38	17.20	0.94	0.27	29.49
2	15	4.68	0.68	14.48	2.30	0.26	11.45	1.28	0.31	24.12
3	13	4.61	0.35	7.64	2.22	0.41	18.45	1.20	0.27	22.43
4	16	4.64	0.64	13.77	2.38	0.40	16.93	1.29	0.34	25.99
5	6	5.08	0.76	14.88	2.51	0.46	18.18	1.31	0.29	22.00
6	7	5.62	0.46	8.09	2.62	0.23	9.05	1.53	0.20	12.78
7	6	5.05	0.66	13.12	2.57	0.30	11.82	1.24	0.32	25.54
8	2	5.00	0.14	2.80	2.57	0.29	11.13	1.29	0.14	11.13
9	2	5.80	0.37	6.40	2.91	0.06	2.06	1.43	0.28	20.03
10	3	8.19	0.48	5.81	3.77	0.54	14.01	1.54	0.12	7.84
12	9	8.29	0.72	8.70	3.11	0.95	34.89	2.60	0.43	16.68
14	5	8.22	1.79	21.74	2.91	0.28	9.62	2.76	0.81	29.23
15	7	7.97	1.56	18.32	2.19	0.33	14.86	2.57	0.55	21.44

\*  $\sigma$  designates the standard deviation.

\*\* V designates the coefficient of variability.

\*\*\* These measurements were made to obtain a pre-incubation blastoderm size to be used in growth comparisons.

A series of eggs was incubated at normal temperature (37.5° C.) for two to eighteen hours to determine the normal blastoderm size changes over a comparable period of growth. In each of these runs a two hour warm-up period was used, but this was not included as part of the incubation time. These blastoderm measurements, with their standard deviations and coefficients of variability, are presented in

TABLE II

*Average measurements of normal blastoderms of eggs incubated at 37.5° C.*

Hours incubated	No. of eggs	Width of blastoderm			Width of area pellucida			One side of area opaca		
		Size in mm.	$\sigma^*$ in mm.	V** as %	Size in mm.	$\sigma$ in mm.	V as %	Size in mm.	$\sigma$ in mm.	V as %
0	68	4.07	0.54	13.31	2.23	0.38	17.20	0.94	0.27	29.49
2	12	4.55	0.20	4.45	2.21	0.25	11.22	1.17	0.27	23.27
4	12	5.15	0.93	18.12	2.51	0.32	12.61	1.39	0.44	31.33
6	12	5.61	1.80	32.02	1.99	0.43	21.63	1.68	0.64	38.14
8	12	6.11	0.89	14.51	2.36	0.28	11.68	1.89	0.40	20.98
10	12	6.35	0.69	10.91	2.45	0.30	12.26	1.93	0.44	22.88
12	11	8.37	1.56	18.68	2.57	0.80	31.22	3.01	0.56	18.67
14	12	9.81	0.63	6.45	2.55	0.33	12.02	3.58	1.08	30.19
16	12	9.83	0.84	8.57	2.62	0.27	10.36	3.74	0.94	25.27
18	11	10.28	3.73	36.29	2.36	0.41	17.16	4.46	0.80	17.04

\*  $\sigma$  designates the standard deviation.

\*\* V designates the coefficient of variability.

Table II. Normal blastoderms increase throughout the incubation period to 10.28 mm. for eggs incubated eighteen hours. As with the experimental blastoderms, growth of the area opaca is responsible for normal growth of the blastoderm, since the width of the area pellucida remains relatively constant.

In Figure 1 the growth curve for blastoderms incubated at 37.5° C. has been superimposed on the growth curve for blastoderms incubated at 25° C. The scale

COMPARISON OF BLASTODERM MEASUREMENTS  
OF EGGS INCUBATED AT 25° C. & 37.5° C.,  
USING SIGHT FITTED CURVES

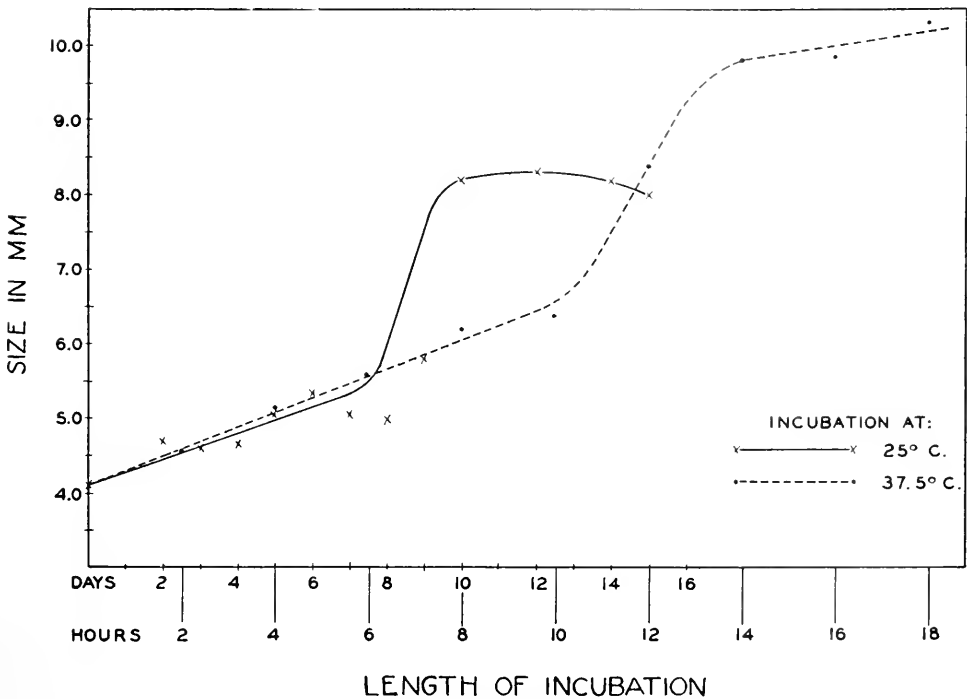

FIGURE 1

for the hours incubation at the higher temperature has been adjusted for comparison of the growth to about 5.75 mm. The graph shows that blastoderms must be incubated at the low temperature for about thirty hours to attain the size of normal blastoderms incubated at the higher temperature for one hour. Analysis of the average growth rates of blastoderms incubated at the two temperatures shows that the high temperature blastoderms grow about thirty-four times faster than those at the low temperature. Sixty-seven blastoderms incubated for 2 to 9 days at the low temperature had an average hourly increase of 0.0088 mm., while one hundred

and six blastoderms incubated for 2 to 18 hours at the high temperature had an average hourly increase of 0.3016 mm. In this comparison only growth of the low temperature blastoderms during the first nine days was considered, since it is felt that the increase from the ninth to tenth day is not true growth, rather an increase in diameter resulting from degenerative spreading.

### ANIDIAN AND DEGENERATE STREAK PRODUCTION AT 25° C.

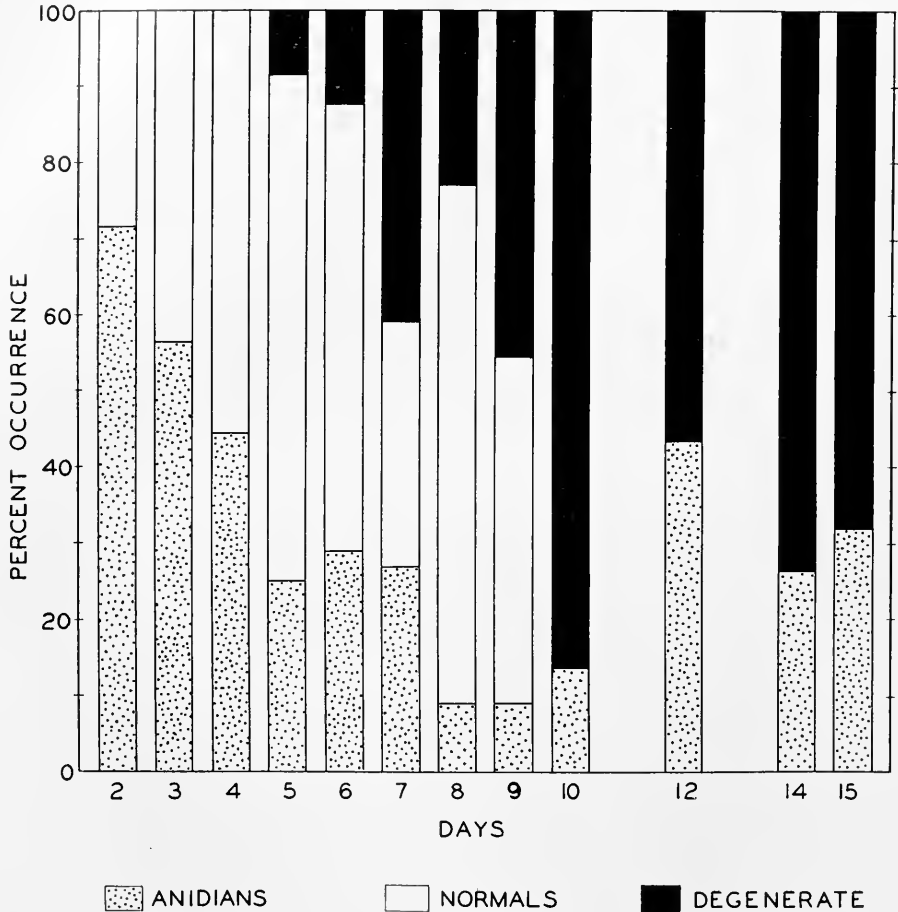

FIGURE 2

There is a corresponding slowed differentiation of primitive streaks in blastoderms incubated at the low temperature. Primitive streaks, as distinguished from the more diffuse primitive shields, first appear in blastoderms incubated at the low temperature after forty-eight hours of incubation. At the high temperature, primitive streaks first appear after four hours of incubation. The ratio of development, as measured by streak appearance, between blastoderms incubated at the high tem-



perature and those incubated at the low temperature is 1:12. If this ratio were to hold true during continued development, one would expect 50% of the low temperature blastoderms to show axiation after about seventy-two hours of incubation, since at the high temperature 50% of the blastoderms possess streaks after six hours of incubation. The data show that it required twenty times as long (120 hours) for 50% of the low temperature blastoderms to develop streaks. The extrapolation cannot be made for 100% streak formation, since at the low temperature this percentage is never attained. The streaks which are formed degenerate, producing blastoderms without axiation. The closest approach to this developmental state is on the ninth day when 91% of the blastoderms show axiation, either normal or degenerate. Since 100% streak formation occurs after ten hours of incubation at the high temperature, it takes the low temperature blastoderms about twenty-two times as long (216 hours) to reach the same stage of development. An analysis of variance was made to determine whether this apparent increased effect of low temperature with continued incubation is significant or merely a chance phenomenon. Comparison of percentages of blastoderms exhibiting streaks for incubation periods of from two to nine days with the percentages occurring for individual experiments of the same day showed that this effect of low temperature incubation is very significant ( $F_{3,51}$ ). Disregarding the individual variations in blastoderms, *i.e.*, their inherent capabilities to respond to the lowered temperature in differing ways, the developmental picture of the average blastoderm is an enhanced effect of the low temperature with continued incubation. The slowing effect of temperature is less during the early period of incubation, increasing with continued exposure to the low temperature.

#### *The gross morphology*

The general morphological changes occurring during prolonged incubation at the low temperature are presented in Figure 2.<sup>5</sup> The chart shows that anidians are present early in incubation, comprising 71.5% of the cases. The remainder is made up of blastoderms showing axiation. With continued incubation the percentage of axiate embryos increases at the expense of the number of anidians. On the fifth day of incubation a third form appears, the degenerating streak. It can be seen that with continued incubation the percentage of anidians decreases, due presumably to development of axiation in blastoderms which were anidian. However, at the same time the streaks are commencing to degenerate, thus increasing the number of degenerate forms. By the tenth day of incubation all of the streaks have disappeared, leaving only anidians or degenerate streaks. The percentage of anidians at this day is increased over that of the ninth day. This increase in the number of anidians results from complete degeneration of streaks.

Examination of the various blastoderms resulting from prolonged incubation at low temperature indicates that there are two types of anidians: 1) early anidians, present from the onset of incubation to about the eighth day; and 2) later anidians, resulting from degeneration of primitive streaks. Figure 3 is an early anidian, corresponding to the first type described by Dareste. There is no embryonic axiation present. The mid-streak blastoderm derived from the early anidian is shown

<sup>5</sup> The data present in this chart were tested for analysis of variance with the following  $F$  ratios: Anidian  $F_{3,60}$ ; Normal  $F_{4,60}$ ; and Degenerate  $F_{7,20}$ . All of these trends are significant at the 2% level or less.

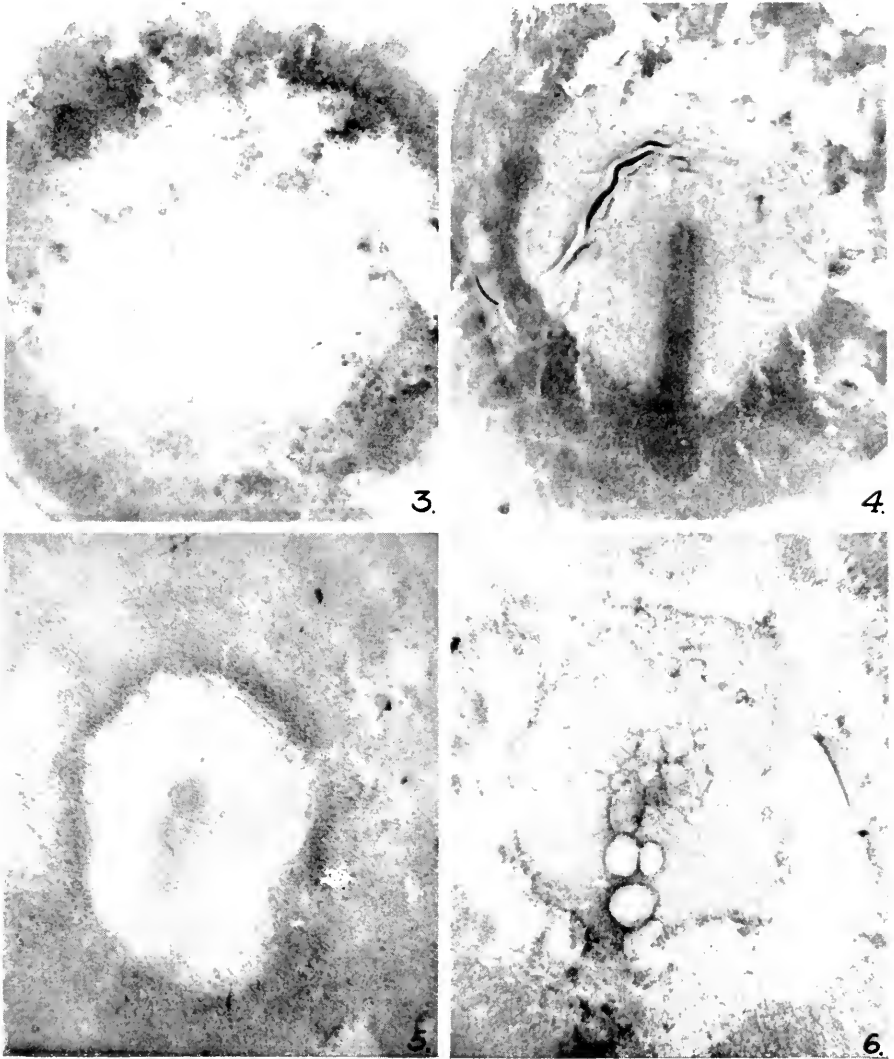

FIGURE 3. Early anidian; 3 days incubation. 20  $\times$ .

FIGURE 4. Mid-streak blastoderm; 5 days incubation. 23  $\times$ .

FIGURE 5. Degenerating streak, showing tendency of node cells to disperse more slowly; 5 days incubation. 13  $\times$ .

FIGURE 6. Later anidian, resulting from vacuolation of the streak; 9 days incubation. 13  $\times$ .

in Figure 4. These experimentally produced streaks never attain the maximum streak length exhibited by blastoderms incubated at normal temperature. The maximum streak length of a low temperature blastoderm was 1.999 mm. as compared with 3.141 mm. maximum length of a normal temperature blastoderm. Furthermore, as Edwards (1902) has pointed out, incubation at this low temperature never results in the formation of a notochord, neural plate or groove, or meso-

dermal somites. Rather the primitive streak, after appearing on the experimental blastoderm, goes on to degenerate in one of the following ways: 1) by dispersal of the streak cells peripherally to the margin of the area pellucida; 2) by the vacuolation of the streak region; or 3) by a combination of these forms of degeneration. In Figure 5 degeneration has begun with the peripheral dispersion of the posterior cells. A central clump of cells marks the node region which tends to disperse more slowly. Degeneration of the second type is illustrated in Figure 6 in which the former streak is vacuolated. Figure 7 illustrates the third type. Here the streak is degenerating with a general cell dispersal and vacuolation of the posterior streak region. Figure 8 shows a secondary anidian formed by cell dispersal and some vacuolation.

The onset and particular forms of degeneration, resulting in blastoderms of the later anidian type, appear to depend on the inherent qualities of the individual eggs, as the same experimental conditions were used throughout the investigation. How-

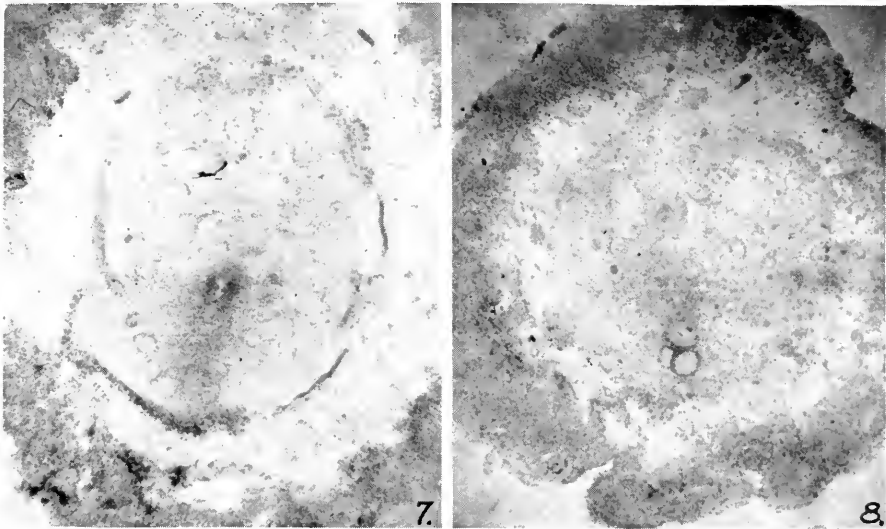

FIGURE 7. Degenerating streak with general cell dispersal and vacuolation of the posterior streak region; 9 days incubation. 14 $\times$ .

FIGURE 8. Later anidian, resulting from cell dispersal and some vacuolation of the streak; 7 days incubation. 15 $\times$ .

ever, all the experimentally incubated blastoderms appear to go through the same stages, i.e., early anidian with subsequent streak formation followed by degeneration of the streak to produce later anidians. It is difficult to explain the morphological changes in any other way. Final proof for this explanation, of course, would be to follow single blastoderms throughout the prolonged period of incubation. This was attempted but found impractical, since a very high mortality rate of blastoderms occurs when windows are placed in unincubated eggs. However, it is felt that the explanation for the morphological changes is supported by: 1) the significance of the morphological trends shown in Figure 2 which is great enough to eliminate chance; and 2) the strikingly different morphological appearance of early and later anidians.

*The cellular morphology*

Examination of serial sections of various blastoderms incubated at low temperature showed that the cellular picture was essentially normal. In those blastoderms which had developed a streak the epiblast layer was three or four cells thick, forming a more or less regular layer when compared with the hypoblast layer. In the latter the cells were larger and frequently contained yolk granules. In the region of the streak proper the cells were compact next to the epiblast layer, but loosely arranged ventrally next to the hypoblast. In no section was mesoderm observed.

In older blastoderms in which the streak had degenerated, the picture was much the same. In these the streak was gone, leaving the epiblast and hypoblast completely separated in the region of the area pellucida. The cells showed no evidence of being under any stretching influence or of having changed shape. There was no indication of basophilic granules, resulting from cytolysis. The only deviation from normality was the presence of vacuoles. These occurred for the most part between the epiblast and hypoblast layers, causing the later to bulge prominently. In many of the vacuoles there was a neutral staining material, contracted in appearance as if resulting from dehydration during staining. In the area opaca the epiblast was a definite layer of one or two cells in close contact with the underlying yolk-laden cells.

TABLE III

*Morphology of eggs incubated at 25° C. followed by two days incubation at 37.5° C.*

No. days at 25° C.	No. of eggs	Development in somites				Distinctly abnormal by			C <sub>1</sub> Development	C <sub>2</sub> Abnorma
		7-12	12-17	18-22	22	Mor- phology	Degen- eration	Hole anidians*		
2	12	0	6	6	0	0	0	0	100.0	0.0
4	11	0	0	6	5	0	0	0	100.0	0.0
6	12	0	3	6	3	0	0	0	100.0	0.0
8	11	1	3	7	0	0	0	0	100.0	0.0
10	10	2	6	1	0	1	0	0	90.0	10.0
12	12	1	0	0	0	6	5	0	8.3	91.7
14	12	0	1	0	0	5	5	1	8.3	91.7
20	12	0	0	0	0	0	6	6	0.0	100.0

\* Tur (1907) and Grodzinski (1933) described blastoderms with holes in the center of the area pellucidas and without traces of embryonic structure. They considered these to be non-teratogenic formations. Such anomalies were encountered in eggs incubated at low temperature for long periods and seemed to be the result of stress sufficient to cause a rupture in the blastoderm.

*The effect of low temperature incubation on potency*

The ability of eggs incubated at the experimental temperature to resume development when shifted to normal incubation temperature was tested. The results of this phase of the investigation are shown in Table III. In this work eggs were kept for two to twenty-one days at 25° C. and then transferred to 37.5° C. for two days. It was found that all the eggs kept for less than ten days at the low temperature exhibited various degrees of normal, although slowed, development when incubated at the normal temperature. But in eggs held for ten days or longer at the low temperature there occurred a marked increase in the percentage of distinct

abnormalities. This is particularly evident in the drop in development from 90.0% to 8.3% for the eggs held for ten and twelve days, respectively, at 25° C.

#### GENERAL DISCUSSION

Edwards (1902) noted that blastoderms incubated at low temperatures failed to form notochords, neural plates and grooves, and mesodermal somites. Blastoderms formed, at best, short primitive streaks. The failure in the present experiments to obtain development beyond the primitive streak agrees with Edwards' work. Obviously the low temperature incubation affects one of the developmental factors concerned with formation of the head process. Grodzinski (1933) believes that changes in the primary germ wall cause peripheral dispersion of cells, resulting in failure of head process formation. Needham (1950, p. 223) considers the anidial to be a case in which there has been a "failure either of the formation, or more probably the liberation, of the primary evocator." In either event a differential susceptibility to temperature exists between the stages of development. The formation of a streak is less sensitive than the formation of a head process, although both are dependent upon cell movements. However, the streaks formed at the low temperature never reach the length of streaks formed at the normal temperature.

The increased degeneration of low temperature axiate blastoderms between the ninth and tenth days of incubation can be correlated with the nearly two-fold increase in blastoderm size shown in Figure 1. Table I shows that this increase is primarily due to an increase in the area pellucida. Prior to and following this period, the area pellucida contributes very little to the blastoderm growth. The degeneration of the streak region by vacuolation and cell dispersal could account for this size increase. The tendency for the blastoderm size to decrease in Figure 1 after the twelfth day is not valid, since the fourteenth and sixteenth day mean measurements have a large standard deviation.

Another consequence of degeneration is the effect on the potency of the experimentally incubated eggs. Where the degenerate streaks become the predominate form of blastoderm, *i.e.*, after the tenth day of incubation, the potency of eggs to resume development when shifted to normal incubation temperature falls off strikingly. If the eggs are kept at the low temperature for less than ten days, only slowed development results. This fact was also brought out by Romanoff *et al.* (1938), who showed that exposure of 0-1 day old embryos to 29° C. for twenty-four hours resulted in extremely retarded development, but had no significant effect on embryo mortality.

The results obtained, showing a susceptibility of growth and differentiation to low temperature, do not support the concept of a separation of the two processes with low temperature incubation. Both growth and differentiation are affected during the same period of incubation, *i.e.*, at about the tenth day. It was pointed out that the effect of low temperature upon streak formation is enhanced with continued incubation. The same effect is seen in analyzing the rate of growth of the primitive streaks. In such an analysis it is necessary to consider both normal and degenerate streak lengths which introduces a question of inaccuracy due to either shrinkage or expansion in the degenerate streaks. The growth rates of streaks in the blastoderms incubated at the low temperature show a consistent decline from 0.0202 mm./hr. with two days of incubation to 0.0054 mm./hr. after nine days of in-

cubation. The only exception to this consistent decline is during the eighth day when the growth rate is higher than that of the seventh day. In comparison, the rate of growth of streaks in the normal temperature blastoderms shows an initial high rate in the streaks first appearing after four hours of incubation. This rate of 0.3033 mm./hr. declines to 0.01185 mm./hr. in blastoderms incubated for ten hours and remains more or less constant through fourteen hours of incubation. The sixteen and eighteen hour streaks show a slight decline in rate to 0.09 mm./hr. The initially high growth rate in the normal temperature blastoderms could be explained on the variations in individual blastoderms, *i.e.*, that these first streaks appear in blastoderms which show a faster initial development and represent a small percentage, rather than the average.

The same phenomenon is not true for growth rates of the blastoderms incubated at the two temperatures. The blastoderms incubated at the low temperature show a consistent rate of growth through the tenth day of incubation at which time they cease growing. The normal blastoderms, however, show a fairly consistent growth rate which is broken only during the tenth to fourteenth hours of incubation when there is an abrupt increase in rate. Although low temperature incubation does not result in growth without differentiation, it does affect the two processes differentially. Differentiation, as seen in axiation and head process formation, is more susceptible than growth.

Interest in the anidian has centered on its being an example of growth without differentiation. A better understanding of development would be possible if the component processes could be separated and studied individually. The present investigation has shown that chick blastoderms incubated at low temperature develop slowly. The anidians present early during incubation correspond to blastoderms which show no axiation during the early hours of incubation at normal temperature. However, the anidians which appear later in development are not comparable. These correspond to the second type of anidian described by Dareste (1877): those which possess embryonic areas more or less degenerated. This type, however, would not fall under Needham's definition of anidian which states that the anidian is a blastoderm which has grown but which has failed to form a streak. Blastoderms which once possessed a primitive streak would not exemplify the instance of growth without differentiation unless they continued to grow after the streaks disintegrated. The results obtained show that growth and differentiation are stopped at about the same time. The data obtained in the present investigation lead to the conclusion that Needham's interpretation of the anidian anomaly is not valid. However, the term anidian, meaning "without form," is aptly applied to either the early blastoderms or the later blastoderms which show no axiation.

#### SUMMARY AND CONCLUSIONS

1. The present investigation was concerned with the effects of a prolonged incubation on the size and morphology of chick blastoderms incubated at 25° C. for two to fifteen days.
2. Comparison of the measurements of blastoderms incubated at the low temperature with those incubated at the normal temperature showed that growth for about thirty hours at the low temperature is equal to growth for one hour at the normal temperature.

3. Comparison of the appearance and growth of primitive streaks in blastoderms incubated at the low temperature with those incubated at the normal temperature also showed a slowed development at the low temperature. This effect of temperature is enhanced with continued incubation.

4. The morphology of the blastoderms incubated for two to fifteen days at 25° C. changes during the course of incubation. At the onset anidians predominate, but give rise to axiate blastoderms after further incubation. Degeneration of the streak by dispersal of the streak cells peripherally, by a vacuolation of the streak region, or by a combination of both patterns, follows. Further degeneration of the axiate blastoderms results in the formation of anidians once more.

5. A possible relationship between differentiation and growth is seen in the cessation of growth concurrent with degeneration of the primitive streak.

6. Cytologically the blastoderms show normal epiblast and hypoblast formation, with the exception of numerous vacuoles appearing between the epiblast and hypoblast in those blastoderms incubated for long periods.

7. Degeneration at the lowered temperature is correlated with a two-fold increase in the blastoderm size between the ninth and tenth days of incubation. It also causes a marked decline in the potency of blastoderms to resume development when shifted to normal incubation temperature.

8. Neither the early anidian, on which a primitive streak will differentiate, nor the later anidian, resulting from degeneration of the axiate blastoderm, is a valid example of growth without differentiation.

#### LITERATURE CITED

- BROCA, P., 1862. Expériences sur les oeufs à deux jaunes. *Annales des Sciences Naturelles*, 4<sup>e</sup> Série. Zool., t. XVII, p. 81.
- DARESTE, C. R., 1877. Recherches sur la production artificielle des monstruosités ou essais de teratogénie expérimentale. Reinwald, Paris.
- EDWARDS, C. L., 1902. The physiological zero and the index of development of the eggs of the domestic fowl, *Gallus domesticus*. *Amer. J. Physiol.*, 6: 351-397.
- GRODZINSKI, Z., 1933. Über die Entwicklung von unterkühlten Hühnereiern. *Arch. f. Entw.*, 129: 502-521.
- HAMBURGER, V., 1942. A manual of experimental embryology. Univ. of Chicago Press, Chicago.
- NEEDHAM, J., 1950. Biochemistry and morphogenesis. Cambridge Univ. Press, Cambridge. 785 pp. Reprinted.
- PANUM, P. L., 1860. Untersuchung über die Entstehung der Missbildungen, zunächst in den Eiern der Vogel. Kiel.
- ROMANOFF, A., LAURA L. SMITH AND R. SULLIVAN, 1938. Biochemistry and biophysics of the developing hen's egg. III. Influence of temperature. *Cornell Univ. Agr. Expt. Sta. Memoir*, 216: 1-42.
- TUR, J., 1907. Une forme nouvelle de l'évolution anidienne. *C. R. Acad. Sci., Paris.*, 144: 515-518.

# NEUROSECRETION IN THE THORACIC GANGLION OF THE CRAB, *ERIOCHEIR JAPONICUS*

KUNIO MATSUMOTO

*Department of Biology, Faculty of Science,  
Okayama University, Okayama, Japan*

In a study of sacculinization in *Charybdis japonica* (Matsumoto, 1952) the author reported that the thoracic ganglia of the host crabs are damaged by the root system of the parasites, *Heterosaccus papillosus*. The same kind of damage is also observed in other species of sacculinized crabs. More recently, in a study of epicaridization in the fresh water crab, *Eriocheir japonicus* (Matsumoto, 1953), it was observed that the thoracic ganglia of male hosts become greatly deformed by the pressure of the parasites, *Entionella fluviatilis*. In order to elucidate the nature of the abnormalities found in the ganglia of crabs subjected to so-called parasitic castration, a detailed histological study of the thoracic ganglion of normal animals became necessary. In the course of this work the presence of neurosecretory cells was observed in the thoracic ganglion of *Eriocheir japonicus*. While Enami (1951b) found only one type of neurosecretory cells (*a* cells) in the thoracic ganglion of the crab *Sesarma*, that of *Eriocheir* seems to contain three cytologically different types of these cells. Their description, in the present paper, appears of interest, since differences in cytological appearance may indicate different functions of the cellular products. Furthermore, these cells exhibit signs of a mode of discharge of the neurosecretory material which has so far been observed only in vertebrates.

## MATERIALS AND METHODS

*Eriocheir japonicus* is a grapsoid crab, commonly found in the fresh waters of Japan; animals collected at the Asahi River in Okayama City were used for this study. The observations are based on sectioned tissue of thoracic ganglia. The crabs used (80 males and 72 females) were in various stages of development. They ranged from 5 to 45 mm. carapace length. The thoracic ganglia were fixed in Bouin's solution or Zenker-formol and cut into serial sections of  $8\ \mu$  thickness by the usual paraffin method. They were stained with Gomori's chrome-alum hematoxylin and phloxine or Delafield's hematoxylin and eosin. Besides these methods some materials were fixed in Susa or trichloroacetic acid and were stained with Mallory's triple stain or Masson's trichrome stain in order to compare them with those described in Enami's (1951b) study.

## OBSERVATIONS

### 1. *Types of nerve cells and their location in the thoracic ganglion*

There are four kinds of nerve cells in the thoracic ganglion of *Eriocheir* each of which shows a definite localization. For the time being these cells are designated as types A, B, C, and D. Their distribution is shown diagrammatically in Figure 1. A-type nerve cells are giant elements with diameters of 80–100  $\mu$  in the adult and



are mainly found in the medial and posterior parts of the ganglion. B-type nerve cells are small with diameters of  $15\text{--}20\ \mu$  and are distributed all over the ganglion. They are mingled with the A-cells in the medial and posterior parts. In the anterior part, many B-cells are found on the ventral side. C-type nerve cells are also small with diameters of  $10\text{--}20\ \mu$ ; they are located in paired groups at the anterior end of

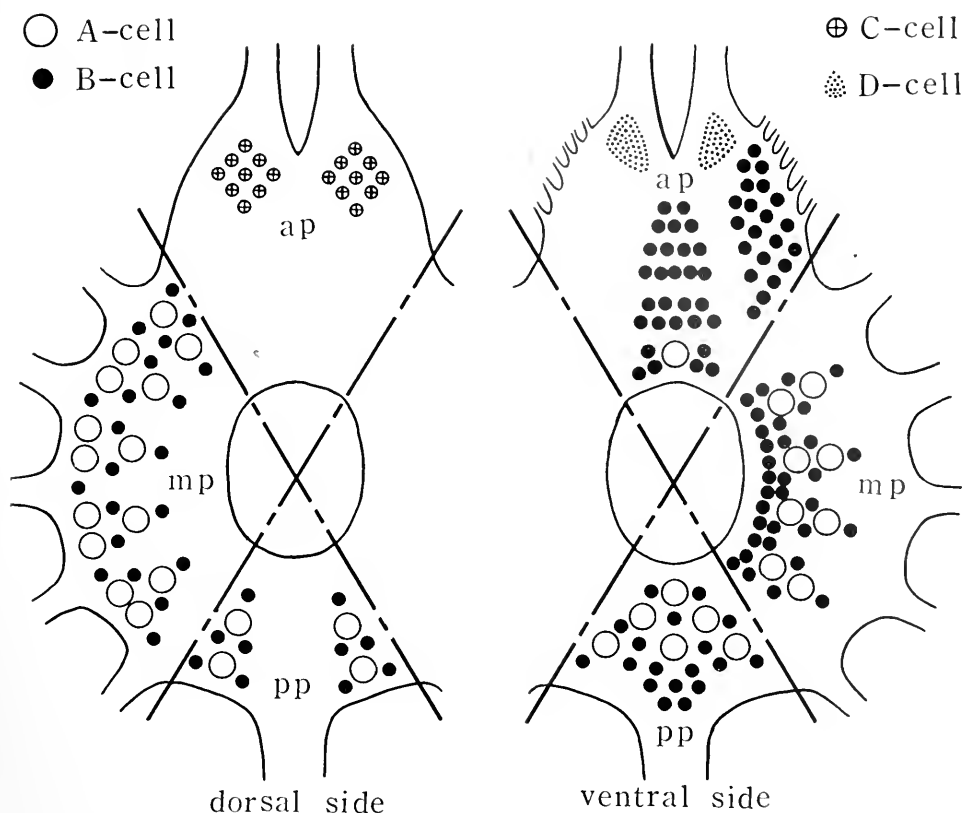
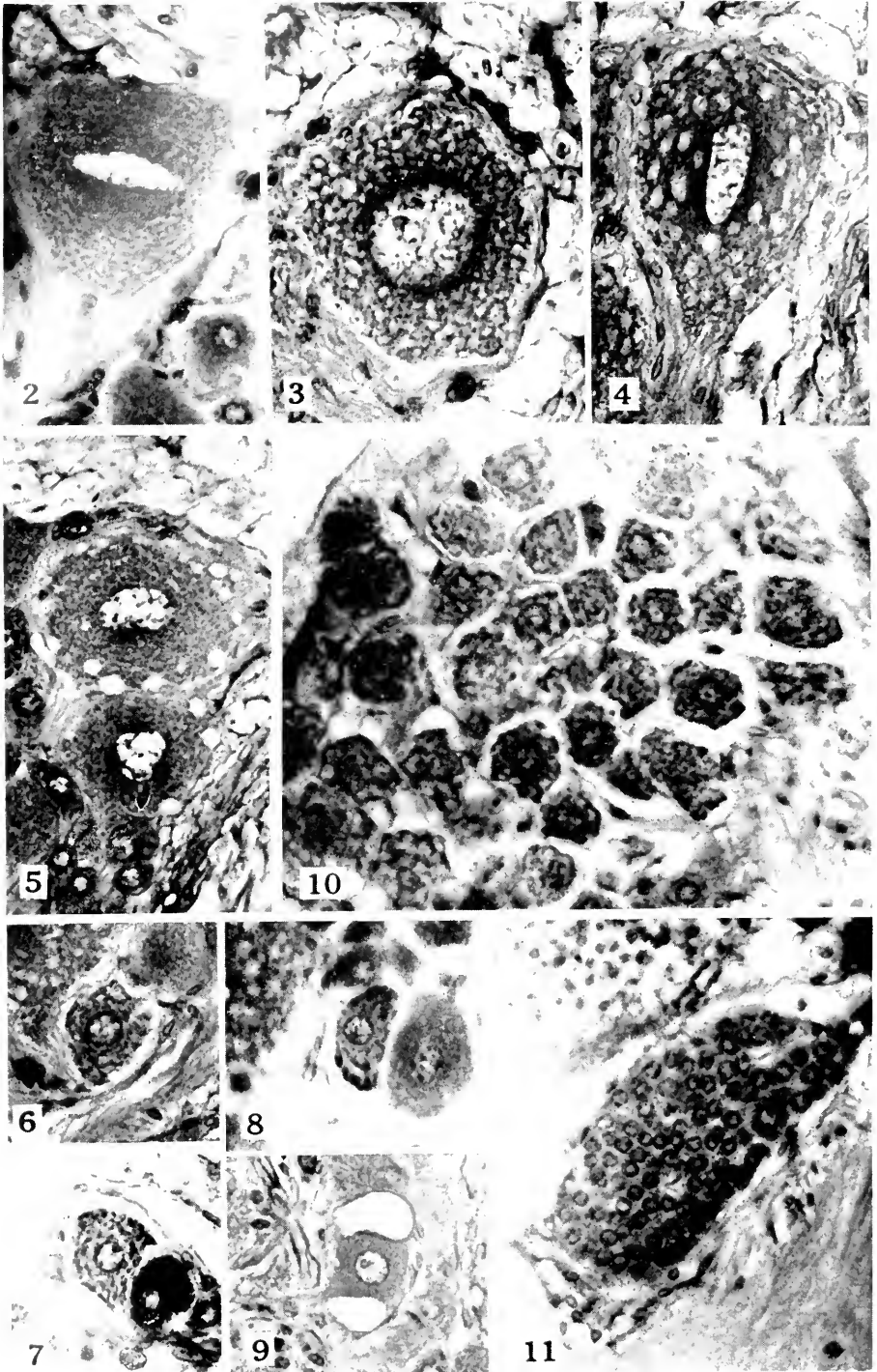

FIGURE 1. Diagrammatic illustration of the distribution of four types of nerve cells in the thoracic ganglion of *Eriocheir japonicus*. The dorsal and ventral sides of the ganglion are shown separately. Each diagram is subdivided into three parts, anterior (ap), median (mp), and posterior (pp), for convenience in description.

the dorsal side of the ganglion. D-type nerve cells are minute and are arranged in densely packed, paired masses ventral of the C-cells.

## 2. Neurosecretory activity of different cell types

*A-cell*: The giant A-cells are considered to be neurosecretory on account of cytological features such as modifications of their nuclei, the appearance of minute granules, and the occurrence of small vacuoles. Some giant cells in the thoracic ganglion contain nuclei which differ considerably from the round nuclei of ordinary cells. These modified nuclei may be flat or crescent-shaped; as a rule, their contents



FIGURES 2-11.

show no affinity for nuclear stains. Many minute dark blue granules are seen to gather closely around the crescent-shaped or flat nuclei in preparations stained with Gomori's method (Fig. 2). In the cytoplasm, the occurrence of small vacuoles is noticeable. Some giant cells have a coarse cytoplasm as shown in Figure 3. This appearance is considered as typical of a stage preceding that marked by vacuolated cytoplasm illustrated in Figure 4. The latter seems to be the most vigorous stage of secretion. Many small vacuoles appear over the whole cytoplasm; some vacuoles stain pale violet, others seem quite empty. This figure resembles one depicting certain neurosecretory cells in the suboesophageal ganglion of the cockroach, *Leucophaea*, studied by B. Scharrer (1941a, Fig. 2C). Certain other A-cells have only small vacuoles in the periphery of the cell body but never in the central portions (Fig. 5).

Judging from all these figures, it may be assumed that the minute granules which appear in the vicinity of the modified nuclei spread over the entire cytoplasm, while simultaneously many small vacuoles containing neurosecretory substance appear in the cytoplasm; then the vacuoles gradually migrate toward the periphery of the cell and disappear. This seems to be the mode of discharge of the neurosecretory material in these cells; it will be discussed in later sections of this paper.

During these secretory cycles apparent in the cytoplasm, the nucleus shows concomitant changes of its shape, *i.e.*, the round nucleus gradually becomes flat or crescent-shaped during phases of cytoplasmic activity and then expands and rapidly regains its round shape during the resting stage of the cytoplasm. The nucleus may, therefore, be considered as playing an important part in the neurosecretory activity of the A-cells. These various pictures are commonly found in the thoracic ganglion of the normal adult crab.

*B-cell:* B-cells are not only much smaller than A-cells but they also show a different kind of neurosecretory behavior. The secretory activity of B-cells is illustrated in Figures 6-9. Since all photomicrographs shown in this paper have the same magnification, differences in cellular size can be readily appreciated.

---

FIGURE 2. Giant neurosecretory cell (A-cell) showing many minute dark granules surrounding a flat nucleus. Male, 30 mm. carapace length. Bouin, paraffin, 8  $\mu$ , Gomori's chrome alum hematoxylin phloxine. Photomicrograph,  $\times 410$ . Figures 3-9 are from the same specimen, shown at the same magnification.

FIGURE 3. A-cell with coarse cytoplasm. The minute granules are scattered throughout the cytoplasm and the nucleus has regained its round shape.

FIGURE 4. A-cell with many small vacuoles in the cytoplasm. The ellipsoid nucleus is typical of this stage of secretory activity which is interpreted as the most vigorous in the cycle.

FIGURE 5. A-cell showing vacuoles only in the periphery of the cell. This figure may represent the last stage in the secretory cycle.

FIGURE 6. Small neurosecretory B-cell with granulated cytoplasm containing many irregular masses.

FIGURE 7. B-cell containing dark staining larger masses in the cytoplasm.

FIGURE 8. B-cell in which two dark staining large masses are concentrated in the cell periphery.

FIGURE 9. B-cell in which the dark cell inclusions have been replaced by two large vacuoles.

FIGURE 10. A group of secreting C-cells. These seem to correspond to Enami's  $\beta$  cells. Male, 31 mm. carapace length. Zenker-formol, paraffin, 8  $\mu$ , Gomori's chrome alum hematoxylin phloxine. Photomicrograph,  $\times 410$ .

FIGURE 11. A mass of minute D-cells which never show any secretory activity. Note round nuclei of uniform size. The cytoplasm is scarce and the cell boundaries are difficult to discern. Same specimen as shown in Figure 10. Photomicrograph,  $\times 410$ .

The first stage in the secretory cycle of B-cells may be that in which the cytoplasm as a whole becomes granulated and many small irregular masses appear in it, as shown in Figure 6. No changes in the nucleus are observed. In the next stage, these irregular masses show a tendency to aggregate into larger, darker staining masses (Fig. 7). Presumably the third stage is depicted in Figure 8; the granular material is concentrated into one or two large dark masses at the edges of the small cell. Figure 9 illustrates the last stage of secretion. The dark masses have disappeared, and large vacuoles remain in their place. The nucleus does not show any signs of activity during the secretory process. The structure of the cell shown in Figure 9 closely resembles the photomicrograph of a neurosecretory cell in the suboesophageal ganglion of *Blaberus craniifer* published by B. Scharer (1941a, Fig. 6).

These signs of neurosecretory activity are not observed in all B-cells present in the thoracic ganglion, but there are regional differences. The secretory activity of B-cells seems most pronounced in the posterior part; it is less frequently observed in the anterior part, and rather rare in the median part.

*C-cell:* C-cells have small granules and droplets in the cytoplasm which stain with aniline blue. The number and size of the granules and droplets vary, but in their general appearance the C-cells resemble Enami's  $\beta$  cells. When fixed in Zenker-formol and stained according to Gomori, the C-cells show a characteristic lumpy cytoplasm with black minute granules and small droplets (Fig. 10). The C-cells are much less frequent than the A- or B-cells, but they all show signs of secretory activity as described above.

*D-cell:* D-cells are the smallest nerve cells in the thoracic ganglion. The nuclei are round and, for the most part, approximately uniform in size and appearance. The cytoplasm is not abundant but stains deeply with basic dyes; the cell boundaries are difficult to discern. These cells form two small, densely packed masses as illustrated in Figure 11. They show no secretory activity.

### 3. *Capillary networks in the thoracic ganglion*

It is a matter of common knowledge that the crustaceans possess an open circulatory system. There are several main arteries originating from the heart; these open into the haemocoel, and no capillaries are found in the majority of the organs. Within the thoracic ganglion, however, there are exceedingly well developed capillary networks. They surround individual giant nerve cells, and enclose groups of two or three smaller cells. Figures 12 and 13 show examples of these capillary networks in the thoracic ganglion of *Eriocheir*. In Figure 12 capillaries are seen to enclose giant nerve cells, in Figure 13 groups of smaller cells. This capillary network branches out from five or six small arteries which enter the thoracic ganglion in the mid-ventral region and pass through it to the dorsal side. The rich capillary bed forms plexus around ventrally and dorsally located neurosecretory cells; it also penetrates the entire medulla of the ganglion. On the dorsal side certain capillaries join small vessels which, on leaving the ganglion, open into the haemocoel; others empty directly into the haemocoel at the periphery of the ganglion.

Such a special arrangement of the circulatory system of the thoracic ganglion suggests special functions. Neurosecretory cells must be expected to have a high

metabolism and, therefore, require a rich blood supply. This is also the case in vertebrates where nuclei composed of secreting nerve cells are among the most richly vascularized of the central nervous system (see Scharrer and Scharrer, 1954). Furthermore, it seems that in the crab studied here, neurosecretory substances are given off at the periphery of the cell into these capillaries and thus reach the general circulation of the body.

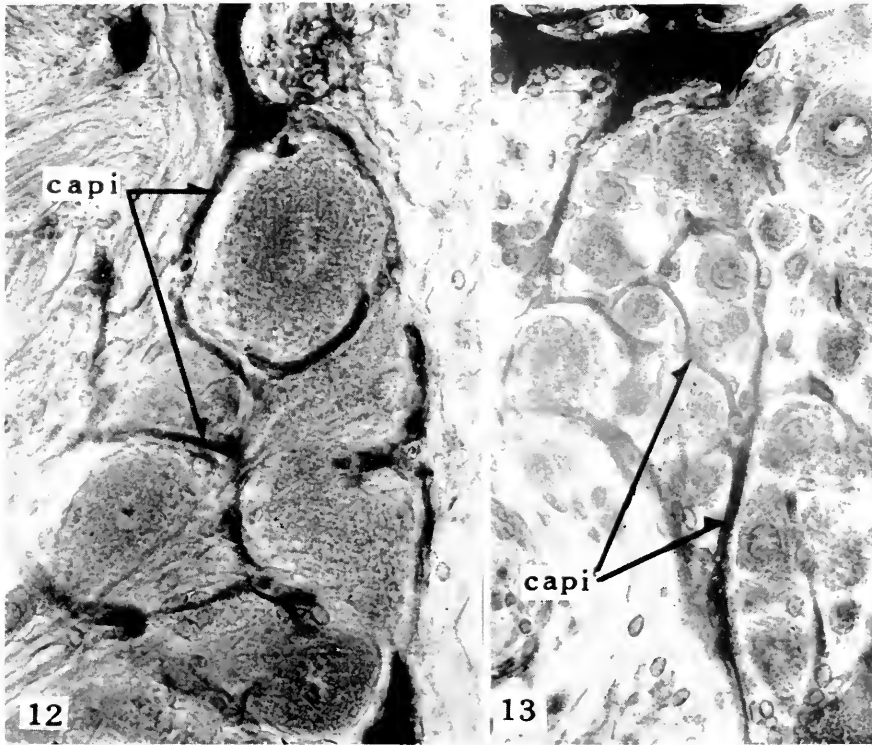

FIGURE 12. Capillaries closely surrounding individual giant neurosecretory cells within the thoracic ganglion of *Eriocheir*. Female, 25 mm. carapace length. Capi, capillary. Zenker-formol, paraffin,  $8\mu$ , Masson's trichrome stain. Photomicrograph,  $\times 410$ .

FIGURE 13. Capillaries enclosing groups of two or three small cells in the thoracic ganglion of the same specimen as shown in Figure 12. Capi, capillary. Photomicrograph,  $\times 410$ .

#### DISCUSSION

The histological examination of the thoracic ganglion of *Eriocheir japonicus* showed the presence of three types of neurosecretory cells. In a recent publication, Enami (1951b) studied neurosecretion in the central nervous system of *Sesarma* and reported that only one type of neurosecretory cells ( $\alpha$  cells) is found in the thoracic ganglion of this crab. On account of their size, the giant  $\alpha$ -cells in the thoracic ganglion of *Eriocheir* would seem to correspond to the  $\alpha$  cells of *Sesarma*. But the morphological characteristics of these two cell types are quite different:

in particular, the central body of the  $\alpha$  cell is never found in A-cells of *Eriocheir*, even when the same fixation and the same staining methods are used.

The C-cells in the anterior region of the thoracic ganglion of *Eriocheir* have the same histological structure as Enami's  $\beta$  cells. But in *Sesarma*, these cells according to Enami (1951b) occur in the optic ganglia, the brain, and the commissural ganglia, but never in the thoracic ganglion. These differences in cellular distribution may be considered as genus differences.

Some cellular details in the A-cells and B-cells of *Eriocheir* are quite similar to those in the suboesophageal ganglion of cockroaches studied by B. Scharrer (1941a). Thus neurosecretory processes in insects and crustaceans seem to have certain features in common.

Concerning the discharge of neurosecretory substances, two possible ways were considered in earlier studies on neurosecretion. Scharrer and Scharrer (1945) in their review on neurosecretion described as one way the discharge of the secretory substances into the capillaries, and as the other a transport of neurosecretory material along nerve fibers. The latter way, *i.e.*, the movement of neurosecretory substances along axons, was confirmed by many recent investigators.

These observations resulted in the concept of neurosecretory systems, *i.e.*, the hypothalamic-hypophyseal system of vertebrates (Bargmann and Scharrer, 1951), the intercerebralis-cardiacum-allatum system of insects (Scharrer and Scharrer, 1944; B. Scharrer, 1952), and the neurosecretory system of crustaceans (Bliss, 1951; Bliss and Welsh, 1952; Passano, 1951). Because of its physiological implications this concept received considerable attention in recent work on neurosecretion. By comparison, less emphasis was placed on studies demonstrating the direct discharge of neurosecretory substances from the cell surface into surrounding capillaries or tissue spaces. There are many reported cases of neurosecretory activity in which the mode of discharge of the secretory product either was not studied in particular or could not be determined; for example in the neurosecretory cells of the stellate ganglion in vertebrates (Eichner, 1952) or of the central nervous system of *Limulus* (B. Scharrer, 1941b).

With regard to crustaceans, Enami (1951b) suggested an axonal transport of neurosecretory material, and Bliss and Welsh (1952) came to the conclusion that in decapod crustaceans neurosecretory substances produced in various parts of the central nervous system migrate along nerve fibers to the sinus gland where they are stored and released.

The present study furnishes evidence of a different mode of discharge of neurosecretory products in crustaceans. It is of considerable interest that, although the circulation in crustaceans represents an open system, capillaries were found to surround neurosecretory cells in the thoracic ganglion of *Eriocheir*. Moreover, the neurosecretory substances produced in the perikaryon gradually seem to move to the periphery of the cell and there to disappear. From these observations it may be concluded that in the thoracic ganglion of *Eriocheir*, neurosecretory material is given off directly into the surrounding capillaries and does not migrate along nerve fibers. Thus both ways of discharge of neurosecretory products, as first described by Scharrer and Scharrer (1945, 1954) for vertebrates, have now been established also for invertebrates with an open circulatory system.

The physiological significance of the three types of neurosecretory cells in the thoracic ganglion of *Eriocheir* is as yet unknown. Smith (1948), Enami (1951a),

and Brown and his collaborators (Brown, 1949, 1950; Brown, Sandeen and Webb, 1949; Sandeen, 1950) demonstrated the existence of chromatophorotropins in the thoracic ganglia of crustaceans. Furthermore, Brown and Cunningham (1941) reported that neurosecretory cells in the central nervous system of *Limulus* furnish chromatophorotropic principles. Hence, it seems reasonable to assume that some of the neurosecretory cells in the thoracic ganglion of *Eriocheir* may be the source of chromatophorotropic principles.

In recent studies of sacculinization and epicaridization of crabs (Matsumoto, 1952, 1953), the thoracic ganglia of the hosts, which had changed to an intersexual condition, were found to be damaged by the presence of the parasites. The deformed ganglia contained fewer nerve cells than normal ones, and their distribution was disarranged. It seems possible, therefore, that a relationship exists, either direct or indirect, between the neurosecretory activity in the thoracic ganglion and the development of secondary sex characters, but this possibility needs further exploration.

The author wishes to express his gratitude to Dr. Berta Scharrer, University of Colorado School of Medicine, Denver, for her criticisms of the manuscript and to Dr. Frank A. Brown, Jr., Northwestern University, Evanston, Ill., for his continuous encouragement.

#### SUMMARY

1. The different types of nerve cells occurring in the thoracic ganglion of the fresh water crab, *Eriocheir japonicus*, their distribution, neurosecretory activity, and the mode of discharge of the neurosecretory substances were studied.

2. There are four types of nerve cells which show a definite localization in the thoracic ganglion; three of them are considered to be neurosecretory cells. Giant A-cells are interpreted as neurosecretory cells on account of the cyclic changes of their nuclei and the gradual movement of many small vacuoles toward the cell periphery. B-cells are small cells showing secretory cycles: numerous granules appear in the cytoplasm, then concentrate into one or two masses at the edge of the cells, and finally disappear leaving large vacuoles in their place. Their nuclei show no changes. C-cells are also small neurosecretory cells; they are thought to correspond to Enami's  $\beta$  cells. The minute D-cells do not possess characteristics to suggest a secretory activity.

3. Several small arteries enter into the thoracic ganglion at the mid-ventral region and pass through to the dorsal side, branching out into many capillaries. These capillaries form networks and closely surround the neurosecretory cells.

4. From these observations it is concluded that the neurosecretory substances in these cells are given off into the capillaries and thus reach the general circulation of the body. This mode of discharge of the cellular product is of interest in view of comparable mechanisms in vertebrates.

5. The physiological activities of these neurosecretory substances in the thoracic ganglion of *Eriocheir* are as yet unknown.

#### LITERATURE CITED

- BARGMANN, W., AND E. SCHARRER, 1951. The site of origin of the hormones of the posterior pituitary. *Amer. Sci.*, **39**: 255-259.

- BLISS, DOROTHY E., 1951. Metabolic effects of sinus gland or eyestalk removal in the land crab, *Gecarcinus lateralis*. *Anat. Rec.*, **111**: 502-503.
- BLISS, DOROTHY E., AND J. H. WELSH, 1952. The neurosecretory system of brachyuran Crustacea. *Biol. Bull.*, **103**: 157-169.
- BROWN, F. A., JR., 1949. The mechanism of color changes in Crustacea. *Collecting Nct*, **19**: 8-12.
- BROWN, F. A., JR., 1950. Studies on the physiology of *Uca* red chromatophores. *Biol. Bull.*, **98**: 218-220.
- BROWN, F. A., JR., M. J. SANDEEN AND H. M. WEBB, 1949. Responses of the red chromatophores of the fiddler crab. *Anat. Rec.*, **105**: 615.
- BROWN, F. A., JR., AND O. CUNNINGHAM, 1941. Upon the presence and distribution of a chromatophorotropic principle in the central nervous system of *Limulus*. *Biol. Bull.*, **81**: 80-95.
- EICHNER, D., 1952. Zur Frage der Neurosekretion in den Ganglienzellen des Grenzstranges. *Zeitschr. Zellforsch.*, **37**: 274-280.
- ENAMI, M., 1951a. The sources and activities of two chromatophorotropic hormones in crabs of the genus *Sesarma*. I. Experimental analyses. *Biol. Bull.*, **100**: 28-43.
- ENAMI, M., 1951b. The sources and activities of two chromatophorotropic hormones in crabs of the genus *Sesarma*. II. Histology of incretory elements. *Biol. Bull.*, **101**: 241-258.
- MATSUMOTO, K., 1952. On the sacculinization of *Charybdis japonica* (A. Milne-Edwards). *Biol. J. Okayama Univ.*, **1**: 84-89.
- MATSUMOTO, K., 1953. On the epicaridization of fresh water crab, *Eriocheir japonicus* (in Japanese with English summary). *Dobutsugaku Zasshi* (Zoological Magazine), **62**: (in press).
- PASSANO, L. M., 1951. The X organ-sinus gland neurosecretory system in crabs. *Anat. Rec.*, **111**: 502.
- SANDEEN, M. I., 1950. Chromatophorotropins in the central nervous system of *Uca pugilator*, with special reference to their organs and actions. *Physiol. Zool.*, **23**: 337-352.
- SCHARRER, BERTA, 1941a. Neurosecretion. II. Neurosecretory cells in the central nervous system of cockroaches. *J. Comp. Neur.*, **74**: 93-108.
- SCHARRER, BERTA, 1941b. Neurosecretion. IV. Localization of neurosecretory cells in the central nervous system of *Limulus*. *Biol. Bull.*, **81**: 96-104.
- SCHARRER, BERTA, 1952. Neurosecretion. XI. The effects of nerve section on the inter-cerebralis-cardiacum-allatum system of the insect, *Leucophaea maderae*. *Biol. Bull.*, **102**: 261-272.
- SCHARRER, BERTA, AND E. SCHARRER, 1944. Neurosecretion. VI. A comparison between the inter-cerebralis-cardiacum-allatum system of the insects and the hypothalamo-hypophyscal system of the vertebrates. *Biol. Bull.*, **87**: 242-251.
- SCHARRER, E., AND B. SCHARRER, 1945. Neurosecretion. *Physiol. Reviews*, **25**: 171-181.
- SCHARRER, E., AND B. SCHARRER, 1954. Neurosekretion. In: v. Moellendorffs Handb. d. mikr. Anat. d. Menschen, VI/5 (in press).
- SMITH, R. I., 1948. The role of the sinus glands in retinal pigment migration in grapsoid crabs. *Biol. Bull.*, **95**: 169-185.



# THE ANATOMY AND BEHAVIOR OF THE VASCULAR SYSTEMS IN NEREIS VIRENS AND NEREIS LIMBATA<sup>1</sup>

PAUL A. NICOLL

*Department of Physiology, Indiana University, Bloomington, Indiana<sup>2</sup>*

No finer examples of contractile blood vessels may be found than those observed in many species of annelids. Functionally considered this is rather surprising since the annelids have few rigid structures; as a group are highly motile; and rarely possess any tissue masses that are not bathed directly by their coelomic fluid. The significance of these contractile vessels is further clouded by the fact that within the class Chaetopoda one finds a very wide range of blood and vascular development. This extends from species with a complete absence of any vascular system through forms that exhibit various degrees of vascular development, coupled with different levels of blood specialization, to specimens with completely closed vascular systems some of which contain plasma or even cells with functional amounts of hemoglobin (Romieu, 1923; Redfield, 1933).

Observations made on a variety of animals have indicated that the minute vessels of most vascular systems retain this power of contractility (Lutz, Fulton and Akers, 1950). The long disputed site of this minute vascular behavior has to a large extent been settled through the application of more refined techniques and rigid terminology (Zweifach and Kossman, 1937; Clark and Clark, 1940; Nicoll and Webb, 1946). It is now generally agreed that contractility depends on the activity of smooth muscle-like cells that surround the endothelial tubes. Clark and Clark (1947) have recently demonstrated that periendothelial muscle cells develop along endothelial tubes following specific flow and pressure patterns within the tubes and that these vascular structures then show typical contractility.

Webb and Nicoll (1944) have shown that lymphatics in the subcutaneous beds of the bat show marked contractility which extends even to the large bulbous capillaries (Webb, 1952). The activity of these bulbous lymphatic capillaries is of special interest since they do not possess true muscle cells in their wall structure but have syncytial cell mats that are the contractile elements. Their activity may reflect a primitive mechanism and be functionally related to certain vessels observed in the annelids.

Despite this recent revival and clarification of minute vascular contractility of both the blood and lymphatic systems, no satisfactory explanation of its functional significance has been advanced. It is more than likely that no single purpose is subserved by this behavior and in the final analysis several mechanisms will be shown to be dependent upon its existence. It was in the hope that a study of contractility in the more primitive vascular systems of the Annelida might throw added light on this basic activity that this investigation was undertaken.

<sup>1</sup> This study was supported in part by grant H-676 Federal Security Agency, Public Health Service.

<sup>2</sup> This study was carried out at the Marine Biological Laboratory, Woods Hole, under a temporary appointment as Research Associate, Department of Physiology, Harvard University, Boston.

The work was carried out at the Marine Biological Laboratory, Woods Hole, during the summer of 1950. Except for preliminary observations on all species of polychaetes collected, this study was restricted to the two species commonly classified as *Nereis virens* and *Nereis limbata*. The vascular anatomy and behavior of the entire specimen were established only for *N. virens*. However, at the typical segmental level these aspects of *N. limbata* were compared in detail with the findings on *N. virens*.

Several deficiencies in the published descriptions of the vascular anatomy of *N. virens* became evident early in attempts to analyze its vascular behavior. This, coupled with failure to find any published descriptions of the vascular anatomy of *N. limbata*, necessitated as a primary step a study of the vascular anatomy of both forms.

Turnbull (1876) published the first detailed descriptions of *N. virens*, which contains a brief discussion of its vascular system. Unfortunately he made several mistakes that are quite significant from a functional standpoint. Because of his excellent plates these have been handed on by most subsequent investigators. Linville (1907) in a very brief note on the vascular system of *Nereis*, presumably *N. virens*, actually corrected Turnbull's errors in so far as he went. His description of the lateral segmental vessels is essentially correct, but he failed to follow through with sufficient detail for complete functional analysis. Federighi (1928) followed Linville's description but made no significant extension or addition in his published paper.

Carlson (1908) in a brief note describes the contractility of the vessels in *N. virens* and concludes that extrinsic nerves appeared to play no part in initiating or regulating their activity. Parker (1923) describes the muscle cells that are so prominently seen after staining with methylene blue. They coil around most of the vessels in *N. virens*, and he suggests that they are analogous with the Rouget vascular cells in higher forms. Krogh (1922) also speaks of these cells as Rouget cells. Federighi (1928) undertook an extensive analysis of the contractile elements in the vessels of *N. virens*. His review of the earlier literature is quite extensive. Following observations on living dissected specimens and detailed histological study, he concludes that the vessels show two distinct types of motor response: the regular rhythmical peristaltic contraction waves that pass along the vessels, which he believes represent contraction of the endothelial cells; and a localized response limited to the region directly excited that is the result of the contraction of the circular, slightly branched, smooth muscle cells on the outside of the endothelial tubes.

#### MATERIALS AND METHODS

Specimens of *N. virens* were either obtained from the Supply Department of the Laboratory or for the most part personally collected during low tide from the shallow water of the cove on Nonamesset Island that lies directly across the Hole from the Laboratory. Collections were made at least once a week since it proved difficult to keep the worms in aquaria. Specimens of *N. limbata* were collected during low tide from under the rocks along the shore between the Yacht Club beach and the public dock adjacent to the Fisheries grounds. Fresh collections were made every two or three days as required.

In order to evaluate the activity of a vessel in the vascular behavior of the individual, it was necessary to work out the contribution of each vessel in the intact living animal under conditions as near normal as possible. This required that all information obtained by dissection studies be checked later on intact specimens.

The manipulation of the living specimens in order that their vascular behavior could be studied while observing them under the microscope, often at high magnification, is a difficult task. The individuals are capable of considerable movement of various kinds and maintain their activity for prolonged periods. Their natural tendencies towards these various types of movement were further aggravated by their extreme sensitivity to light stimulation. All parts of the worms seem to possess light-sensitive receptors so that even the use of surviving segments could not avoid this problem. Forcible restraint without anesthesia was generally unsuccessful or impractical for microscopical studies. Of necessity, therefore, the major portion of the analysis of vascular behavior was carried out on specimens where some form of anesthesia was employed. The procedure of choice was to work with fully anesthetized specimens during their recovery in sea water.

Sodium amytal, usually applied by adding a few crystals to a petri dish of sea water containing the worm, was the most commonly used anesthetic agent. There is no doubt that vascular activity was reduced or even abolished during deep anesthesia by this agent. However the worms always showed complete recovery following their return to fresh sea water.

Narcotization was also achieved by placing the worms in dilute solutions of ethyl alcohol and sea water. The alcohol concentrations ranged from 3.0 to 7.0% by volume. In still other cases a type of narcotization was brought about by placing the worms in various dilutions of sea water with distilled water. This proved in many ways a very valuable procedure since the specimens would become quite swollen, and thus not only sluggish or quiescent but also more transparent. Thus internal vessels were more visible than in normal worms. Also vascular behavior of the larger vessels was as little modified under these conditions as under any employed.

In procedures where dissection was employed in order to expose internal vessels or for other purposes, specimens lightly anesthetized by one of the foregoing agents were used. The region or site of dissection was then painted with 1.0% procaine. This permitted rather extensive surgery on lightly anesthetized worms without excessive muscular stimulation. The exposed vessels continued to react for a limited time in what was probably a normal manner. Exposure to sea water for long periods produced marked changes in the reactions of the vessels. This was surprising but invariably true. Numerous attempts to use artificial sea water with modified salt values were not successful. For these reasons observations following exposure were limited to an hour in most cases.

Vital staining was done with methylene blue added to sea water. The effect was transient and the color faded, somewhat irregularly, within a few hours. Fixing with ammonium molybdate was successful histologically but very toxic to the tissues.

Attempts to cannulate individual vessels were not too successful. This was surprising since no difficulty has been encountered in cannulating much smaller

vessels in higher forms. In the few times when cannulation was successful attempts to inject formed material in order to visualize blood flow were disappointing. India ink is quickly salted out and precipitated in the walls in the immediate vicinity of its injection. Occasionally a few specks would remain in solution and their progress along the vessels was very helpful in determining flow patterns.

## RESULTS

### A. Vascular anatomy

Unlike some of the Annelida neither *N. virens* nor *N. limbata* has developed a specialized heart or hearts within their vascular system. Although Linville (1907)

*N. VIRENS*, ANTERIOR END DORSAL VIEW

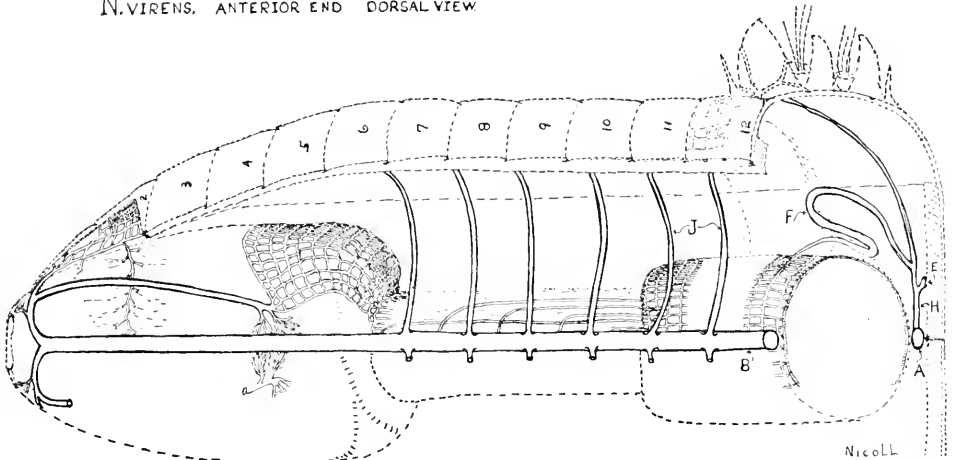

FIGURE 1. Principal vascular elements in anterior segments of *Nereis virens*. Dorsal view. A, ventral longitudinal vessel; B, dorsal longitudinal vessel; E, recurrent branch—ventral lateral vessel; F, G-I plexus-lateral connective; G, medial branch—ventral lateral vessel; H, stem-ventral-lateral vessel; J, dorsal-lateral vessel.

calls the gastro-intestinal branch (vessel F) in each segment a heart, this is hardly justified in the sense that it functions as a force pump. As explained below these vessels appear rather as pace-makers of the segmental system, most vessels of which are also contractile in their own right. Before considering the flow patterns and vascular behavior it is necessary to understand the anatomical relationships that actually exist in these forms.

In *N. virens* the typical reduplicated, segmental vascular pattern is extensively modified in the anterior segments. The vascular organization in this region is an adaptive development to fit the needs of the pharyngeal structures internally and the reduced parapodia externally. No special function within the vascular system itself can be ascribed to these anterior vessels. In a similar sense the segmental pattern is modified in the posterior portion of *N. virens*. Strictly speaking this is limited to the terminal segment where the only definitive, simple and direct connection between the dorsal and ventral vessels is to be found in the entire

animal. The zone immediately anterior to this terminal segment is the site of formation of new segments and one can follow, more or less completely, the evolution of the definitive segmental pattern by careful comparison of the vascular structures in adjacent segments from this site forward.

Although a similar detailed study of anterior and posterior portions of *N. limbata* has not yet been carried out, preliminary observations indicate this species also has no specialized development within the vascular system at either extremity. Thus vascular function in these species is basically concerned with segmental flow, which, however, is modified by the contiguous union of adjacent segments.

Figures 1 and 2 represent semi-diagrammatic sketches of the principal vascular structures in the anterior twelve segments of a typical specimen of *N. virens*.

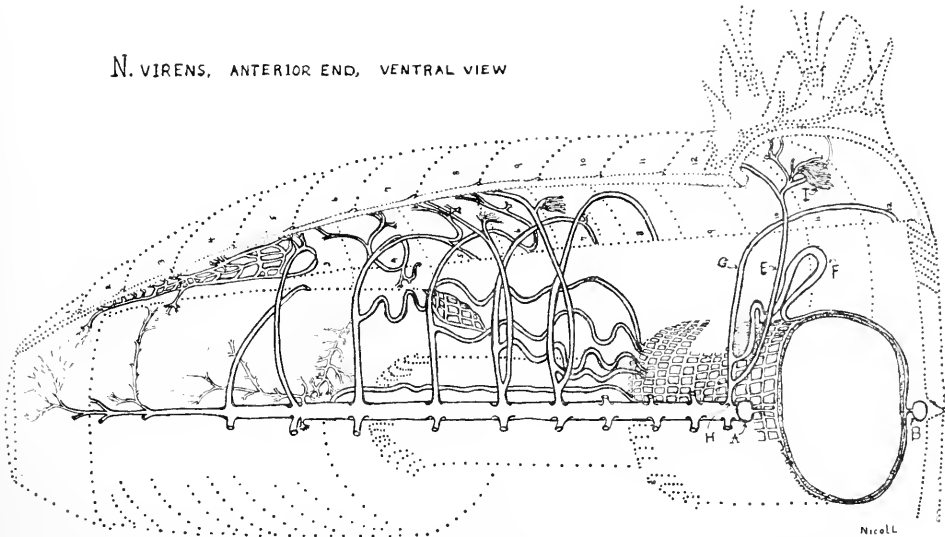

FIGURE 2. Principal vascular elements in anterior segments of *Nereis virens*—ventral view. Vessels marked as in Figure 1.

Figure 1 represents the structures as seen from a dorsal view with the dorsal muscle mass cut away. Figure 2 is a similar view as observed from the ventral surface.

As shown in Figure 1 the homologues of vessel J in the six anterior segments are either lost or must be accounted for in the terminal arborization of vessel B. Only two branches of this arborization are prominent. One appears as a recurrent vessel of large size that terminates in a prominent capillary net covering the posterior and lateral surface of the pharyngeal muscle mass. This striking capillary plexus also anastomoses with the third segmental homologue of vessel H and finally forms numerous connections with the upper border of the esophageal capillary plexus. The other prominent branch of the terminal arborization forms the principal anterior connection with another extensive capillary net that hangs free between the anterior-lateral pharyngeal mass and the body wall. This second capillary net makes numerous small connections with body vessels and terminates

posteriorly in the arborization of the fourth segmental homologue of vessel H. Another branch of the arborization, while not very large, is of special interest in that it supplies a rich capillary net that closely surrounds the dorsal ganglia and circumpharyngeal connectives of the nervous system. All vessels are present bilaterally except for A, B, C and D.

As shown in Figure 2, the branches of the ventral vessel in the anterior segments of *N. virens* are all retained and the homologous branches of the typical segmental vessel H may all be identified except for vessel F in the first four segments.

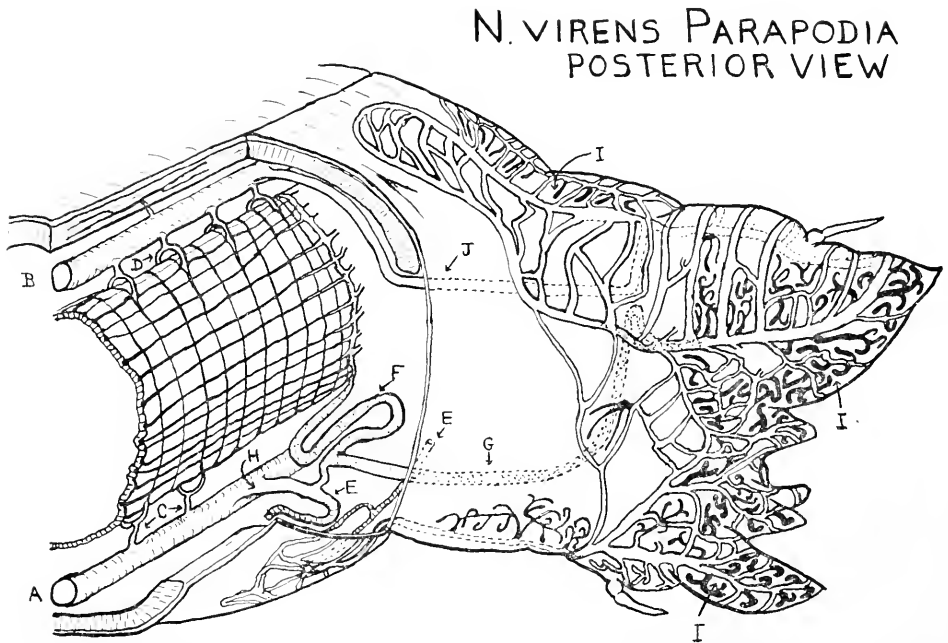

FIGURE 3. Vascular patterns in a typical adult segment of *Nereis virens*. Right parapodium viewed from posterior surface. Semi-diagrammatic. A, ventral longitudinal vessel; B, dorsal longitudinal vessel; C, G-I plexus to ventral vessel connectives; D, G-I plexus to dorsal vessel connectives; E, recurrent branch—ventral lateral vessel; F, G-I plexus-lateral connective; G, medial branch—ventral lateral vessel; H, stem ventral-lateral vessel; I, blind ending "capillaries"; J, dorsal-lateral vessel.

The homologues of vessel F appear as extended recurrent structures that pass backward to make a characteristic anastomotic contact with the anterior margin of the gastro-intestinal capillary plexus. The connections of vessel H in segments 3 and 4 with the pharyngeal capillary plexuses have been mentioned above. The remaining branches and terminal arborization of vessel A in the pharyngeal and adjacent tissue are easily observed. It is important to note that no direct anterior connections between vessels A and B occur.

Since the vascular organization throughout the entire worm is basically a series of joined segmental patterns, a typical segment from each species has been diagrammatically sketched in considerable detail. Despite the variations in seg-

mental pattern that are present in segments at certain locations along the animal, the important relationships from a functional standpoint remain identical in all mature segments. Figures 3 and 4 show the segmental vascular distribution in *N. virens* and *N. limbata*, respectively. Each sketch represents the vessels in the right half of a segment as viewed from the posterior surface of the parapodium. The body wall is cut away to expose the internal vessels and their connections with the various lateral branches.

A previously unrecognized phenomenon in the type and distribution of capillary vessels found in these species and their relationship with the rest of the segmental vessels underlies the principal differences between the segmental patterns of *N. virens* and *N. limbata*. The terminal arborizations or "capillary" vessels of

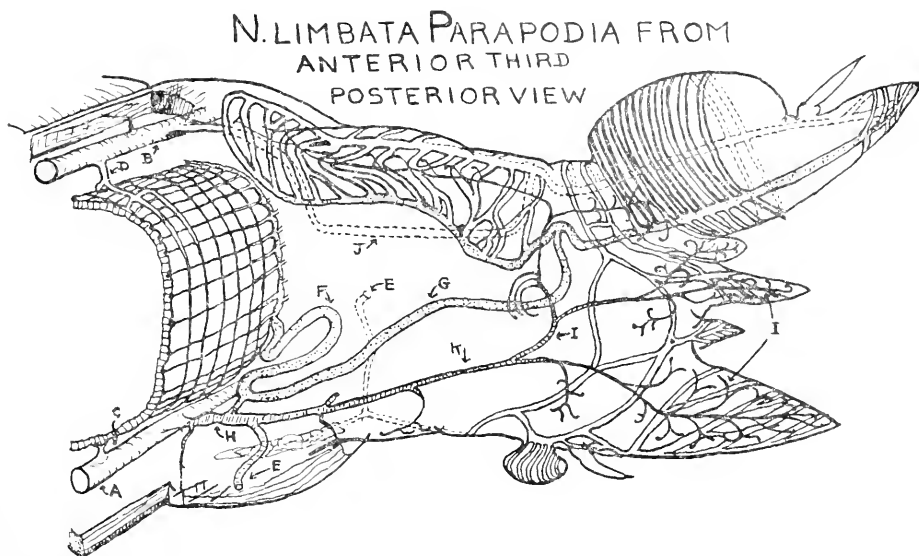

FIGURE 4. Vascular pattern in a typical adult segment of *Nereis limbata*. Right parapodium viewed from the posterior surface. Semi-diagrammatic. Vessels marked as in Figure 3, except for K = direct deep lateral branch of ventral lateral vessel.

the vascular system in both forms are divided into two distinct types. The first type clearly satisfies the classical concept of capillaries as being simple endothelial tubes that are the terminal anastomotic arborizations of larger vessels. Blood passes through them, on the average, in a given direction and some sort of exchange occurs here between the blood and surrounding environment. In both species the vascular plexus of the stomach-intestine and most of the superficial sub-epidermal plexus of the body wall and parapodia are examples that satisfy this concept of capillaries. The former, no doubt, serves as the site of absorption of the digestive products while the latter is the site for gaseous exchange between blood and environment. These capillaries are non-contractile and except for differences in their extent and distribution are essentially the same in both forms.

The second type terminal vessel found in both species is a highly contractile blind-ending structure which supplies the internal structures and tissues of the

body. They are apparently quite similar to the blind-ending vessels described for *Sabella* and *Spirographis* by Ewer (1941), who also cites several reports of such vessels in other species. Their origin, ramification and distribution in each species show marked differences. They have been termed vessel I in both Figures 3 and 4 where their distribution in the body wall and coelomic space is diagrammatically indicated by solid lines. The outstanding difference between *N. virens* and *N. limbata* in regard to these type II capillaries concerns their origin and interrelationships with the other vessels. In *N. virens* they arise at numerous sites throughout the segmental vascular system and display considerable differences in their internal ramification and complexity of branching between individual vessels. In *N. limbata*, on the other hand, all type II capillaries apparently are the arborizations of branch K of vessel H which is not present in *N. virens*. Thus in *N. virens* both types of capillaries must be served by the same major vascular supply, vessels G and E, while in *N. limbata* almost complete separation between the supplying trunks of the two capillary types has been achieved. The functional significance of this fact will be discussed below.

With the exception of branch K, the segmental vessels of the two species are essentially the same. In both forms blood is supplied to all peripheral structures through either the ventral-lateral vessel H and its branches and/or through the gastro-intestinal vessel F and its lateral extension, vessel G. Drainage essentially occurs through the dorsal-lateral vessel J into the dorsal-longitudinal vessel B. In both species direct connections also occur between the dorsal vessel B; the ventral vessel A and the gastro-intestinal capillary plexus through the short, variable numbered, vessels D and C, respectively. In addition some small connections between B and A with the immediate musculature are present. Occasionally, as is shown in Figure 4, such a vessel may arise from vessel H. No doubt other connections between these major vessels and the various tissues and organs will be found with further study but the major, and functionally important, branches and their various connections are adequately diagrammed in these Figures 3 and 4.

### B. Flow patterns and vascular behavior

Although the final details of flow through the vascular systems of these species may be lacking, the fundamental character and pattern can now be described. The total circulation of a normal intact adult specimen represents a partial interdigitation of two flow patterns. One is the primitive segmental system upon which is superimposed a dorsal-anterior to ventral-posterior sluggish flow involving the entire worm. This anterior-posterior circulation no doubt represents an adaptation to supply the modified cephalad segments of the individual where the primitive segmental systems have been essentially lost.

The actual volume displacement, or even the direction of flow, through any particular portion of the vascular system is dependent on the nature of the worms' activities and may change considerably from time to time. Furthermore, flow evaluation is made rather difficult by the lack of any reference point such as the heart serves for most other forms. In these species the motivating force for blood flow is supplied by the local contractions of muscle cells that surround the vessels. This activity spreads along each vessel in a peristaltic wave form, and volume displacement from one portion to another of the vascular system depends in part



on the relative timing of the contractile waves. They frequently conflict with each other and flow may stop or be reversed within a given vessel when this occurs.

The anterior-posterior flow in both forms is essentially the same. The peristaltic waves in the dorsal longitudinal vessel originate in the immature segments just anterior to the terminal anal segmental ring and sweep cephalad. Usually three distinct waves may be observed at one time in a large intact adult *N. virens*. Not infrequently the pace-maker originates two distinct waves which fuse in the posterior segments of the specimen and continue on cephalad as a single peristaltic contraction. Injury or marked irritation at any point along the vessel may set up a new pace-maker at this point. The contractile waves then originate at the new site and sweep in both directions over the dorsal vessel. If the injury is neither too severe nor too far forward this disturbance seems to produce little effect on the worms' behavior. The volume of blood displaced by these peristaltic waves is much less than would appear to be the case from simple observation. Frequently the vascular constriction is far from complete and much of the blood within the vessel is not affected by the peristaltic contraction wave.

Blood flows caudad through either the ventral vessel or the gastro-intestinal capillary plexus. From approximately the tenth anterior segment, where a definite segmental flow exists, a posteriorly directed flow in the ventral vessel is readily demonstrated despite the absence of contractile waves. In front of this region, however, the ventral vessel is probably not an important pathway for caudal flow of blood reaching the region via the dorsal vessel. The anterior connections of the dorsal vessel and the medial to lateral flow through vessels H suggest rather that blood from this area returns caudad through the gastro-intestinal plexus.

The segmental circulation would logically appear to be the more primitive circulation but may in its present form represent a more or less degenerate flow pattern. The general direction of blood movement is ventral-lateral to dorsal and medial in both halves of each segment, the return occurring from the dorsal vessel through its connectives D into the gastro-intestinal plexus. Some blood must eventually reach the ventral vessel through vessels C but the greater portion leaves the G-I capillaries by way of the lateral vessel F in a typical body segment. That such a flow is possible can be readily demonstrated by placing two tight ligatures around the entire worm and so isolating a few segments. Flow in the various vessels can be observed to continue in the normal manner for a reasonable length of time. Ultimately the various peristaltic waves lose their necessary time relationships and flow ceases. The fewer the number of segments included between the ligatures the sooner will the circulation become disorganized.

This failure of the circulation in isolated segments indicates the interdependence that now exists between the segmental and longitudinal flow patterns. Interruption of flow in either the dorsal or ventral vessel alone produces little disturbance in segmental flow. However, if both vessels of the longitudinal system are ligated a few segments apart, the intervening segments are soon drained of their blood despite the patency of the gastro-intestinal pathways and the continued normal activity of the segmental vessels.

This was borne out in experiment on an adult *N. virens* where the dorsal vessel alone was ligated about one-third of the way forward. Little disturbance in the specimen's circulation resulted except for some over-distension of the dorsal vessel posterior to the ligature which, however, was soon taken care of by the

development of antidromic waves in the posterior third of the worm. Two hours later the ventral vessel was also ligated about 12 segments more anteriorly than the site of ligation of the dorsal vessel. No immediate change resulted from this second ligation but after several hours the segments lying between the two ligatures were essentially bloodless and the peristaltic waves in the dorsal vessel, anterior to the ligation of that vessel, were quite irregular showing both normal and antidromic peristaltic waves.

Peristaltic contraction waves passing medial-laterally in vessel H and its branches and vessel F-G, coupled with similar waves that pass lateral-medially in vessel J, seem to provide the basic means for segmental flow. However an additional factor is also present which would seem to insure this ventral-lateral-dorsal-medial flow pattern. It concerns the relative frequency of the peristaltic waves in the various vessels. In both forms vessel F-G always shows a higher frequency of the peristaltic contractile wave than occurs in vessel J or B, which is usually the same. Table I gives some typical values for the frequency ratios of the activity in vessels F-G and J of *N. virens*. With the exception of the last value, which was determined from a specimen in deep anesthesia, the average ratio is 1.64. One

TABLE I  
*Frequencies of peristaltic contractile waves in cycles/minute in vessels of N. virens*

Vessel used	Specimen number							
	1	2	3	4	5	6	7	8
F-G	35	27	21	24	31	26	23	11.7
J	17	14	12	18	19	19	17	1.6
Ratio F-G/J	2.08	1.93	1.75	1.33	1.63	1.37	1.35	7.3

Average 1-7 = 1.64.

would expect, therefore, a higher mean pressure in vessel F-G than in vessel J. This would tend, of course, to keep blood flowing in a ventral-dorsal direction through the parapodial capillaries. Similar data are not yet available for *N. limbata* but a few counts indicate the F-G/J frequency ratio in this species to be about the same even though the absolute frequencies are much higher.

The activity in vessel H and its branches seems to contribute little towards determination of flow by this means. The waves all pass medial-lateral-dorsal as expected but their frequency shows considerable variation. In *N. virens* they are usually about as frequent as the waves in F-G, while in *N. limbata* they are much slower. It should be noted here that in both species the contractile waves do not pass along the short connection between vessels F-G and H. Therefore these systems do not interfere with each other's activity, and little blood is ever seen to flow from either vessel into the other.

The much greater frequency of the peristaltic contractile waves seen in comparable vessels of *N. limbata* but not exhibited by vessel K, apparently is dependent on the anatomical relationship of the two types of terminal arborizations (capillaries) exhibited by these species. The simplest explanation for the difference is that *N.*

*limbata* has, in the evolution of its vascular system, advanced to the point of nearly complete separation of its mechanism for gaseous exchange between the blood and environment and its mechanism for supplying the needs of the tissues and organs of the body. Functionally this is certainly true despite the few open connections between vessels F-G and H or their branches. Blood is forced through the expansive capillary field of the superior ligula at rapid flow rates with a resultant far greater potential supply of oxygen being available to *N. limbata* than to *N. virens*. This may, in part at least, account for the marked differences in the capacities of the two forms to develop and sustain rapid swimming movements.

In *N. virens*, on the other hand, no anatomical separation of the two types of terminal arborization exists. Flow through the limited sub-epidermal capillary plexus is continually being disrupted by the in-and-out wash of blood of the numerous, highly contractile, blind-ending type II capillaries. Even the superficial sub-epidermal capillaries themselves are frequently contractile in *N. virens* while their homologues in *N. limbata* do not exhibit contraction. Flow from vessel F-G through these terminal vessels is therefore slow and often scanty, with minimal forward volume displacement. Thus the potentially available blood-borne oxygen supply to the tissues of *N. virens* must be much less than is the case with *N. limbata*; certainly *N. virens* is quite incapable of rapid or extended swimming movements and frequently resorts to a slow undulatory type behavior that has been ascribed to respiratory activity.

The activity of the type II, blind-ending terminal vessels that supply the internal tissues and organs of the body, while unique in vascular systems as well organized as these species exhibit, probably represents a vestigial mechanism for movement of blood in primitive systems where true circulation has not developed. The underlying stimulus of their contraction is, without doubt, the stretch or distension produced by the blood forced into each branch by the peristaltic wave in the supplying vessel. If it were not for this reaction flow would soon cease in such systems.

In *N. virens* the numerous branches of these type II capillaries show considerable differences in the extent of their ramification after they branch off from the thoroughfare channels. However each subdivision of the branch finally ends in a finger-like tube that at rest is bent more or less back upon itself. When the incoming peristaltic wave reaches that structure it is extended both outward and in diameter. The recoil is sudden and precise, resulting in greater shortening and reduction of lumen size, than the resting state exhibits.

Several attempts were made to stain with methylene blue the more superficial of the type II capillaries in isolated parapodia of *N. virens*. If a ligature was tightened around the parapodium just at the time a parapodial flush was developing and the parapodium then cut away from its segment, the vessels were isolated while more or less filled with blood. The parapodia could be mounted on a slide and examined at high powers with a compound microscope and transmitted light. In most cases such a preparation continued to exhibit marked activity in the type II capillaries for several hours. After study of the characteristic behavior of the type II capillaries the entire parapodium was covered with methylene blue-sea water solutions for varying lengths of time. After the dye solution was washed away, the type II capillaries were observed for possible staining of cells or other contractile elements.

In no case were any contractile elements stained that appeared similar to the smooth muscle cells along the larger vessels. Small signet-shaped structures partially surrounding the vessel along the basic branches were observed. These may have been the nuclei of small but typical smooth muscle cells which were wrapped around the vessels, similar to those seen in arterioles of mammalian forms. Frequently there appeared to be a thickened granular region, not clearly marked off from the wall of the blind fingers, that lay parallel with the finger sacks and seemed to be on their outer surface. These may be contractile elements since frequently protoplasmic filaments of smooth muscle cells will stain in this manner with methylene blue.

### DISCUSSION

Although this paper is concerned mainly with the anatomy and behavior of the blood vessels, together with the resultant flow patterns, some comments on contractility *per se* will not be out of place. This quality of a vessel can be considered from three points of view. First, the structural elements whose activity is responsible for contractility; second, the immediate stimulus and control mechanisms that determine the quantitative aspects of contractility; and third, the value or purpose of contractility for the organism.

Federighi (1928) comes to the rather astonishing conclusion that the typical peristaltic contractile waves represent the activity of the endothelial tubes and not the muscle cells in the walls of the vessel. This is certainly not in agreement with the majority of work on the minute vessels of higher forms and is based on very sketchy evidence where the vessels were observed at low magnification.

Several incidental observations made during this study fail to confirm Federighi's conclusions but point instead to the circular, slightly branched muscle cells as the structural elements responsible for contractility. Thus contractility was never observed along any vessel where staining with methylene blue failed to show either typical muscle cells or granular thickenings outside the endothelial tubes. Also, direct study under high magnification always showed actual contraction of these muscle cells to be directly correlated with the peristaltic contractile waves. Finally the failure of the contractile waves to spread over certain branches or short connectives free of muscle cells, such as the connection between vessels F-G and H, but rather to spread only along the vessels with the muscular elements in their walls argues for these muscle cells, rather than the endothelial tubes, as the structures involved.

The stimulus for contractility, here as in other similar cases, may be divided into two categories. One is the initial origin of the activity while the second is its propagation. No attempt is made here to deal with the first condition. It is sufficient to say that there are pace-maker foci at various locations along the vascular system, and that these show the same type of behavior, and are affected by the same type of conditions, as act on muscular pace-makers in other contractile systems.

The spread of the contractile wave probably could be separated into an excitatory wave and a contractile wave but this has not yet been attempted. There is ample overlap of adjacent circular fibers to account for direct muscular transmission. In those instances where such transmission would be impossible for anatomical or other reasons, the contractile wave could, by forcing fluid ahead of

itself, produce distension in the vessel beyond, and so lead to excitation at the new site. Here the action would be similar to the type III deglutition waves described for the posterior portion of the mammalian esophagus. Three examples of this type of behavior in *N. virens* can be cited. One is the antidromic wave observed to pass over vessel D from the gastro-intestinal margin to the dorsal vessel immediately following the sudden distension of vessel D by the passage of a peristaltic contraction wave along the dorsal vessel. Another example is the occasional anti-dromic wave that may be observed to pass over vessel F-G when the higher frequency of the peristaltic waves in this vessel leads to the condition that a normal wave reaches the parapodia over vessel F-G and finds all of the small vessels contracted. The most outstanding case, however, is the sudden and forceful contraction of the type II capillaries immediately after each incoming peristaltic rush causes their sudden distension. These are, no doubt, all examples of the behavior for simple tubular hearts discussed by Haywood and Moon (1950).

As to the ultimate value or purpose of such contractility in blood vessels no conclusions can be made at this time. Two possibilities, not mutually exclusive, suggest themselves. One is the simple development of a propulsive force that produces movement of the fluid along the vascular systems. There is no doubt that such a purpose is in fact fulfilled by the activity in these primitive vascular systems.

A second possible function of such contractile behavior would be the production of pressure waves within the fluid contained in these vessels. This might play a significant role in the exchange between the blood and tissue fluid across the capillary beds. Nicoll and Webb (1947) have suggested such a role for the active vasomotion of the spiral smooth muscle cells found along the arterioles of mammals.

#### SUMMARY AND CONCLUSIONS

1. The anatomical organization of the vascular system of *N. virens* has been studied in considerable detail. Certain insufficiencies and errors in past studies have been supplied or corrected. The detailed anatomy of *N. limbata* for a typical segment has been worked out and compared to that of *N. virens*.

2. The most striking observation was the discovery of many minute blind-ending capillary-like vessels. These differ in the two species in their mode of origin from the vascular system which permits, in the case of *N. limbata*, a partial separation of a lesser or respiratory circulation from the general or systemic circulation.

3. The flow patterns in both forms are shown to consist of an interdigitation of two circulatory systems, one a primitive segmental type and the second a posterior-anterior flow involving the entire worm. Neither system is independent of the other, with the result that actual flow is rather sluggish and inefficient throughout the entire worm. In *N. limbata* the separation of the type II capillaries from the superficial respiratory (lesser) circulation has partially overcome this deficiency.

4. No true hearts are present in the systems of either species, but rather the majority of the vessels show contractility. Certain foci appear to function as pace-makers for the contractile waves, and flow is determined in part by the relative frequencies of the peristaltic waves in the different vessels.

5. Some discussion is given as to the nature of contractility *per se*. It is concluded that the structural elements involved in all vascular contractility are the slightly branched smooth muscle cells, or a primitive type granular area, of the vessel wall.

6. The primary stimulus for the contractile waves is assigned to the inherent activity of pace-maker foci, while their propagation along the vessels is thought to spread by way of the circular muscle fibers. Sudden distension of a vessel, with the resultant stretch of these muscle cells, is shown to be capable of exciting the vessel at that site.

7. Two possible functions are suggested for the contractile waves in these vessels: one, the propagation of blood within the system, and second, a pressure wave that aids in exchange between the blood and interstitial fluid.

#### LITERATURE CITED

- CARLSON, A. J., 1908. Comparative physiology of the invertebrate heart. X. A note on the physiology of the pulsating blood vessels in the worms. *Amer. J. Physiol.*, **22**: 353-356.
- CLARK, ELIOT R., AND ELEANOR L. CLARK, 1940. Microscopic observations on the extra endothelial cells of living mammalian blood vessels. *Amer. J. Anat.*, **66**: 1-49.
- CLARK, ELIOT R., AND ELEANOR L. CLARK, 1947. Arterial anastomoses, some factors concerned in their formation. *Anat. Rec.*, **97**: Abstr. Am. Assoc. Anat. 10.
- EWER, D. W., 1941. The blood systems of *Sabella* and *Spirographis*. *Quart. J. Mic. Sci.*, **82**: 587-620.
- FEDERIGHI, HENRY, 1928. The blood vessels of annelids. *J. Exp. Zool.*, **50**: 257-294.
- HAYWOOD, C. A., AND H. P. MOON, 1950. The mechanics of the blood vascular system of *Ascidella aspersa*. *J. Exp. Biol.*, **27**: 14-28.
- KROGH, A., 1922. The anatomy and physiology of capillaries. Yale University Press. New Haven, Conn.
- LINVILLE, H. R., 1907. The circulatory system in *Nereis*. *Science*, **25**: 727-728.
- LUTZ, BRENTON R., GEORGE P. FULTON AND ROBERT P. AKERS, 1950. The neuromotor mechanism of the small blood vessels in membranes of the frog (*Rana pipiens*) and the hamster (*Mesocricetus auratus*) with reference to the normal and pathological conditions of blood flow. *Exp. Med. Surgery*, **8**: 258-287.
- NICOLL, PAUL A., AND RICHARD L. WEBB, 1946. Blood circulation in the subcutaneous tissue of the living bat's wing. *Ann. N. Y. Acad. Sci.*, **46**, Art. 8: 697-711.
- NICOLL, PAUL A., AND R. L. WEBB, 1947. Studies on the behavior of the vascular network in an intact mammal. Memorandum Report No. TSEAA-696-112. Army Air Forces HDQS Air Material Command Engineering Division.
- PARKER, G. H., 1923. Are there Rouget cells on the blood vessels of invertebrates? *Anat. Rec.*, **26**: 303-305.
- REDFIELD, ALFRED C., 1933. The evolution of the respiratory function of the blood. *Quart. Rev. Biol.*, **8**: 31-57.
- ROMIEU, M., 1923. Recherches histophysiologiques sur le sang et sur le corps cardioque des annelides polychetis. *Arch. Morph. Gen. Exper.*, **17**: 339.
- TURNBULL, FREDERICK M., 1876. On the anatomy and habits of *Nereis virens*. *Trans. Conn. Acad. Arts Sci.*, **3**: 265-280.
- WEBB, RICHARD L., AND PAUL A. NICOLL, 1944. Behavior of lymphatic vessels in the living bat. *Anat. Rec.*, **88**: 351-367.
- WEBB, RICHARD L., 1952. The lymphatic system. *Ann. Rev. Physiol.*, **14**: 351-367.
- ZWEIFACH, B. W., AND C. E. KOSSMAN, 1937. Micromanipulation of small blood vessels in the mouse. *Amer. J. Physiol.*, **120**: 23-35.

# THE METAMORPHOSIS OF PARTIAL LARVAE OF PERONELLA JAPONICA MORTENSEN,<sup>1</sup> A SAND DOLLAR<sup>2</sup>

KAYO OKAZAKI AND KATSUMA DAN

*Department of Biology, Tokyo Metropolitan University, Meguro-ku, Tokyo and  
Misaki Marine Biological Station, Misaki, Kanagawa-ken, Japan*

Following the discovery by Hans Driesch (1891), that in sea urchins an isolated blastomere of the two-cell stage can develop into an harmonic larva, much work has been done on this subject. However, since the majority of experiments in the past have been concerned with the developmental capacity only as far as the pluteus stage, emphasis in the present investigation was placed on the aspect of metamorphosing capacity. The inadequacy of past experiments is due to the difficulty of rearing plutei to metamorphosis in the majority of sea urchin species, which, fortunately, can be obviated in the sand dollar *Peronella japonica* Mortensen. In this species metamorphosis is completed in the course of three or four days.

*Peronella* is found in great numbers on the sandy bottom of a shallow lagoon in the neighborhood of the Misaki Marine Biological Station, and the breeding season extends from the latter part of June to September.

The main developmental features of this animal have been worked out by Mortensen (1921), but some new points were noticed by the authors. In the present paper, the results obtained by operative experiments, and points regarding normal development which have a direct concern with the description of the experiments will be reported.

## I. DEVELOPMENT OF THE WHOLE LARVA

*Egg.* The egg, about 300  $\mu$  in diameter, is heavily laden with yolk and opaquely pink. The color is imparted by a rosy pigment which is associated with doubly refractive crystals.

Elevation and hardening of the fertilization membrane are very slow, so that the membrane can be removed until 10 minutes after insemination. Since the hyaline layer is extremely delicate and remains sticky, the denuded eggs adhere to the bottom of the container, and after cleavage, the blastomeres arrange themselves in a plane, suggesting sea urchin blastomeres in calcium-low sea water. Later, however, the larva rounds up and gives rise to a typically spherical blastula.

*Micromeres.* Frequently, in this species, at the fourth cleavage all sixteen cells are of equal size. In such cases, the micromeres are formed in the succeeding cleavage. The micromeres, are, as a rule, relatively large in comparison with those of other echinoderms. Toward the end of the breeding season, however, there is an increasing tendency to produce smaller micromeres. In eggs which are considered to be more or less overripe, as early as the eight-cell stage, the vegetal four

<sup>1</sup>Dr. F. Uchinomi called the authors' attention to the fact that *Peronella lesucuri* has recently been changed to *Peronella japonica* Mortensen by Mortensen (1948), for which the authors' thanks are due.

<sup>2</sup>This research was supported in part by the Ministry of Education Research Expenditure.

blastomeres are smaller than the animal blastomeres; and in the sixteen-cell stage, still smaller micromeres are formed.

*Blastula.* At about five hours after fertilization, one or two grooves are noticeable in the blastula, coinciding with the cleavage-furrows of the two- or four-cell stages. However, these grooves gradually flatten out as the blastocoel expands, and the embryo again becomes spherical. This is somewhat similar to the condition which is found in the development of *Astropecten aranciacus* (Hörstadius, 1939a).

At about seven hours after fertilization, the blastula acquires cilia and begins to rotate within the fertilization membrane. From this time on, primary mesenchyme cells migrate inward and disperse in the blastocoel, so that the embryo takes on an opaque appearance. At nine hours, the embryo breaks through the membrane; it is now elongated, with a truncated posterior end having an accumulation of primary mesenchyme cells along the vegetal wall, so that the larva looks somewhat like the

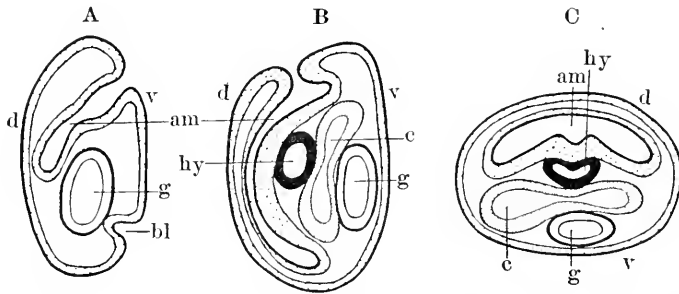

FIGURE 1. Diagram of section of successive stages showing the position of amniotic cavity and hydrocoel. A, B, longitudinal sagittal section. A, late gastrula (18 hours); B, early pluteus (26 hours), amniotic opening has shifted toward the dorsal side and blastopore has closed. C, transverse section, early pluteus (26 hours). am, amniotic cavity. hy, hydrocoel. c, coelom. g, gut. bl, blastopore. d, dorsal side. v, ventral side.

gastrula of regular sea urchins. The apical tuft does not usually differentiate, and even when it can be recognized, the cilia are fewer and less conspicuous than in other forms.

*Gastrula with the amniotic invagination.* Gastrular invagination begins at about the twelfth hour. Within a few hours, another ingrowth of the ectoderm appears in the center of the flattened oral field (Fig. 7 D, W) and develops into a stomodaeum-like invagination, but that it is not a true stomodaeum is shown by its subsequent failure to unite with the archenteron. Instead, its sac-shaped prolongation extends along the dorsal side of the entoderm and forms a cavity (Fig. 1, A). Mortensen correctly identified this as an amniotic cavity. No mouth opens, and the blastopore closes sooner or later, so that the archenteron remains as a free blind sac within the body, without forming any functional digestive tract. This obviates the necessity for feeding the larvae and greatly facilitates their culture.

*Pluteus.* At about twenty hours after fertilization, the fully formed pluteus typically has only two post-oral arms, equal in length to the rest of the body. The number of arms may vary, however, from none to four, without apparently causing any essential difference in the later development, since all such larvae are able to



complete metamorphosis. At this stage, the hydrocoel begins to differentiate from the coelomic sacs, which lie close to the ventral side of the body. The hydrocoel is usually derived from the left, but occasionally from the right, coelom; in either case, it is formed in a nearly median position (Fig. 1, B, C). This location of the hydrocoel, together with the unusual median position of the amniotic invagination, forms a

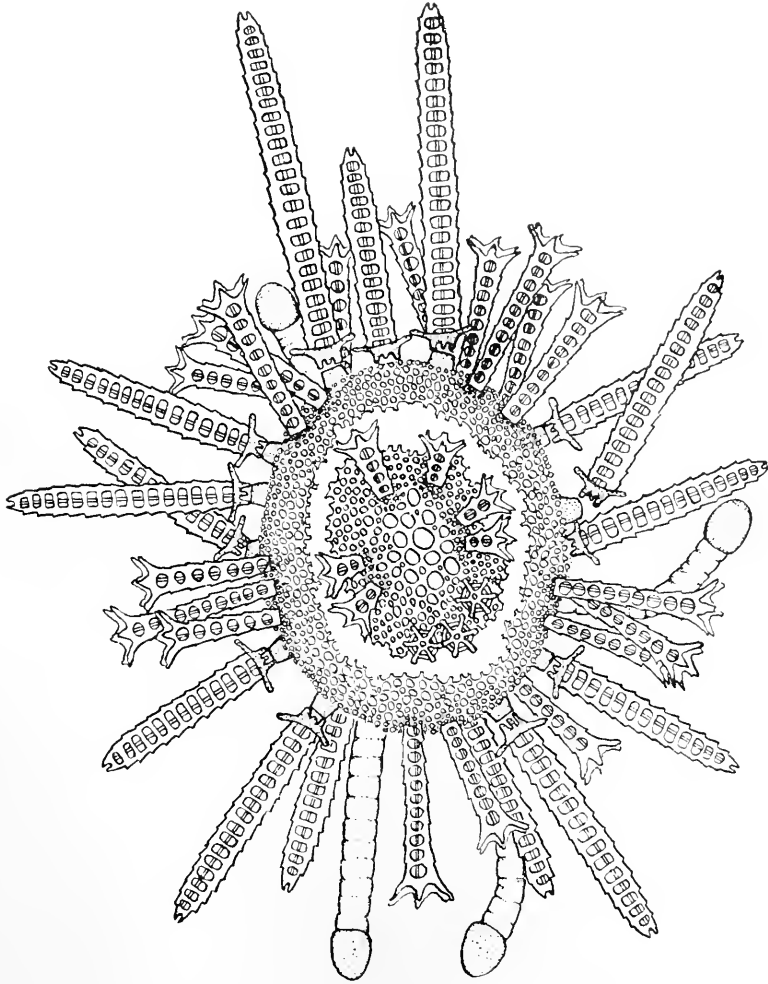

FIGURE 2. Control whole imago of *Peronella japonica* Mortensen, 4 days after metamorphosis. Aboral view.  $\times 160$ .

striking contrast to the location of the corresponding structures in other echinoderms. After the enlargement of the hydrocoel, five lobes are pushed out, arranged in a bilaterally symmetrical fashion with regard to the median plane of the pluteus. At about fifty hours after fertilization, the amniotic cavity constitutes a large part of the pluteus and its inner wall is covered with well-developed adult spines. The pluteus sinks to the bottom at this stage.

*Pigment.* Simultaneously with the formation of adult spines and plates, clypeastroid pigment (green) is deposited in the echinus rudiment and is gradually concentrated as development advances. The pluteus, as a whole, is greenish at this stage, but if it dies, a splendid green color pervades the entire body. Although this pigment is green in an alkaline fluid, it gradually loses its color completely as the medium is acidified. The green pigment is also found in the mesenchyme cells of the late pluteus of *Astriclypeus manni* and *Clypeaster japonicus*, especially clearly in the echinus rudiment. If the test of an adult *Peronella*, *Astriclypeus* or *Clypeaster* is injured, the same green color appears on the test integument.

*Metamorphosis.* Among relatively fast-growing larvae of *Peronella*, metamorphosis sets in at about sixty hours after fertilization with the protrusion from the amniotic cavity of rudimentary spines and tube-feet. Since the dorsal wall of the body and the amnion are very thin at this time, they are occasionally broken through by the protruding spines. On the contrary, slowly growing larvae, in spite of the fact that they have the typical pluteus form, may fail to metamorphose, or finally succeed after a delay of a week or more. When metamorphosis fails completely in such retarded larvae, they eventually become edematous. In such a case, the already differentiated spines degenerate and disperse within the body as fine spicules. It is interesting that in such degenerating larvae, the above-mentioned clypeastroid pigment cannot be recognized at all.

Usually, metamorphosis is completed within seventy or eighty hours. Concerning the external features of the adult, Onoda's report is available (1937). The mouth opening, masticatory apparatus, typical spines and six-rayed spines and tube-feet can be recognized a few days after metamorphosis (Fig. 2). The young sand dollars survive for about ten days without being fed, and can even increase the number of spines and tube-feet.

The most unusual feature in the development of this animal is certainly the rapid rate of development as compared with other related forms. It can be said that the pluteus stage is only a phantom, so to speak, and the larva is preparing for metamorphosis from the start.

## II. DEVELOPMENT OF PARTIAL LARVAE

The fertilization membranes were removed immediately after fertilization by squirting the eggs through a slender pipette, and the blastomeres were separated in sea water by a fine glass needle. In this form the hyaline layer is so delicate that it can easily be cut, even in a calcium-containing medium. Pairs of half-larvae or quartettes of quarter-larvae were kept in separate glass containers in 5 cc. of sea water. The plane of section at each stage is shown diagrammatically in Figure 3, and the results of the experiments are summarized in Table I and indicated in Figure 4.

- (1) Isolated blastomeres of the two-cell stage; *equi-* and *toti-potent* regarding metamorphosing capacity.

Blastomeres isolated in this stage show partial cleavage as regards the number of meso-, macro- and micromeres, and form more or less open half-blastulae, which, however, soon round up and close, and gastrular invagination occurs at the vegetal

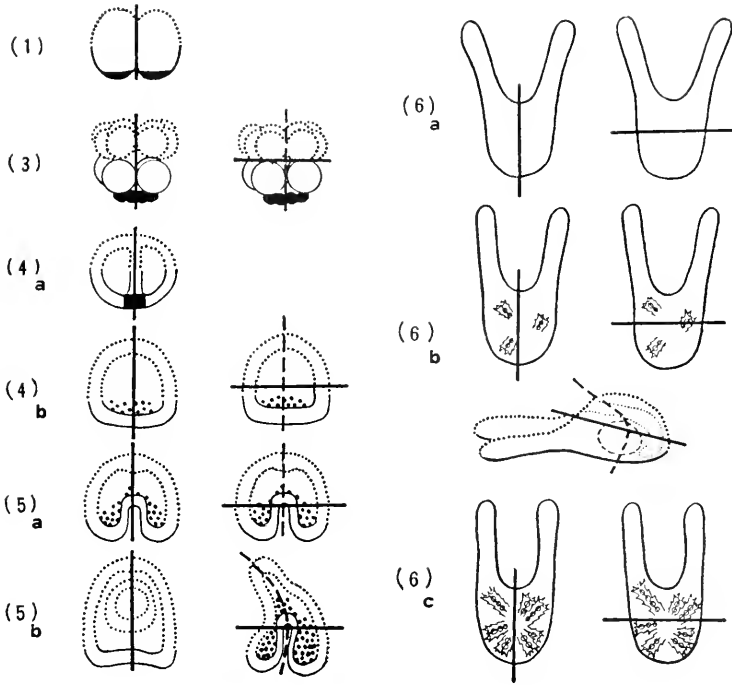

FIGURE 3. Diagram indicating plane of section at each stage. Dotted line, animal elements; fine continuous line, vegetal elements. Thick straight line, plane of sections; broken line, original egg-axis. Stages of operation numbered as follows: (1), 2-cell. (3), 16-cell. (4)a, grooved blastula. (4)b, blastula with primary mesenchyme cells. (5)a, gastrula with archenteron and two small triradiate spicules. (5)b, late gastrula with amniotic invagination. (6)a, early pluteus with two fully developed arms but without adult skeleton. (6)b, pluteus with some adult skeleton. (6)c, late pluteus with well developed adult skeleton.

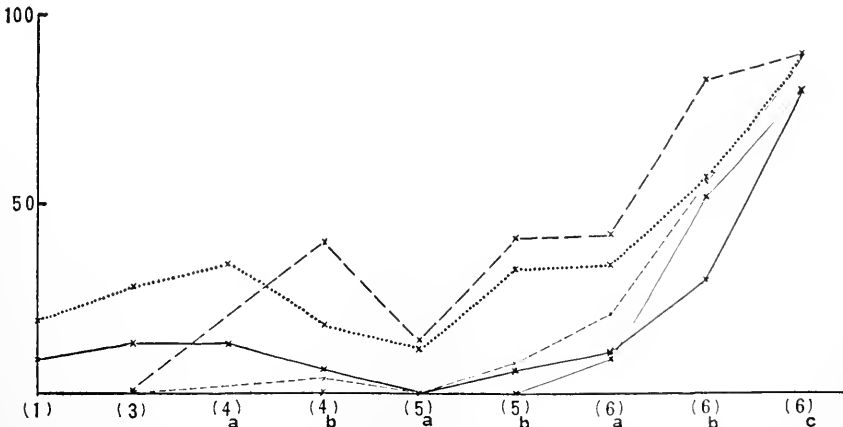

FIGURE 4. Percentage of metamorphosis of separated halves of *Peronella japonica* Mortensen. Dotted line, meridional halves. Thick continuous line, meridional pairs. Thick broken line, vegetal (posterior) halves. Fine broken line, animal (anterior) halves. Fine continuous line, equatorial pairs.

TABLE I  
*Number and percentage of metamorphosed half larvae*  
 Meridional halves

Stage of operation	(1) Two-cell stage	(2) Sixteen-cell stage	(3) Grooved blastula stage	(4)a Blastula stage with mesenchyme cells	(4)b Gastrula stage	(5)a Late gastrula stage with amniotic invagination	(5)b Early pluteus stage with no adult skeleton	(6)a Pluteus stage with some adult skeleton	(6)b Late pluteus stage with well-developed adult skeleton
Hours after fertilization	1	2½ - 3	5 - 7	7 - 9	11 - 15	15 - 17	19 - 25	45 - 55	70 - 90
Number of operated larvae	236	45	32	53	22	15	28	27	20
Number and percentage of metamorphosed pairs	22 9%	6 13%	4 13%	3 6%	0 0%	1 6%	3 11%	8 30%	16 80%
Number of metamorphosed single halves	46	13	14	13	5	8	13	15	4
Number and percentage of metamorphosed meridional halves*	90 19%	25 28%	22 34%	19 18%	5 11%	10 33%	19 34%	31 57%	36 90%

TABLE I—Continued  
Equatorial halves (anterior and posterior halves)

Stage of operation	(1) Two-cell stage	(3) Sixteen-cell stage	(4)a Grooved blastula stage	(4)b Blastula stage with mesenchyme cells	(5)a Gastrula stage	(5)b Late gastrula stage with amniotic invagination	(6)a Early pluteus stage with no adult skeleton	(6)b Pluteus stage with some adult skeleton	(6)c Late pluteus stage with well-developed adult skeleton
Number of operated larvae		431		25	37	12	33	29	20
Number and percentage of metamorphosed pairs		0 0%		0 0%	0 0%	0 0%	3 9%	15 52%	16 80%
Number of metamorphosed animal (anterior) single halves		0		1	0	1	4	1	2
Number and percentage of metamorphosed animal (anterior) halves†		0 0%		1 4%	0 0%	1 8%	7 21%	16 56%	18 90%
Number of metamorphosed vegetal (posterior) single halves		4		10	5	5	11	9	2
Number and percentage of metamorphosed vegetal (posterior) halves‡		4 1%		10 40%	5 14%	5 41%	14 42%	24 83%	18 90%

\* Single halves + 2 members of each pair.

† Single animal halves + animal half of pairs.

‡ Single vegetal halves + vegetal half of pairs.

side. Such operation at the two-cell stage does not destroy the basic arm-forming capacity of the larvae, since the resultant plutei usually have two arms, and very rarely three- or four-armed half-plutei are encountered. However, the general tendency is toward a reduction in the number of arms as the result of the operation :

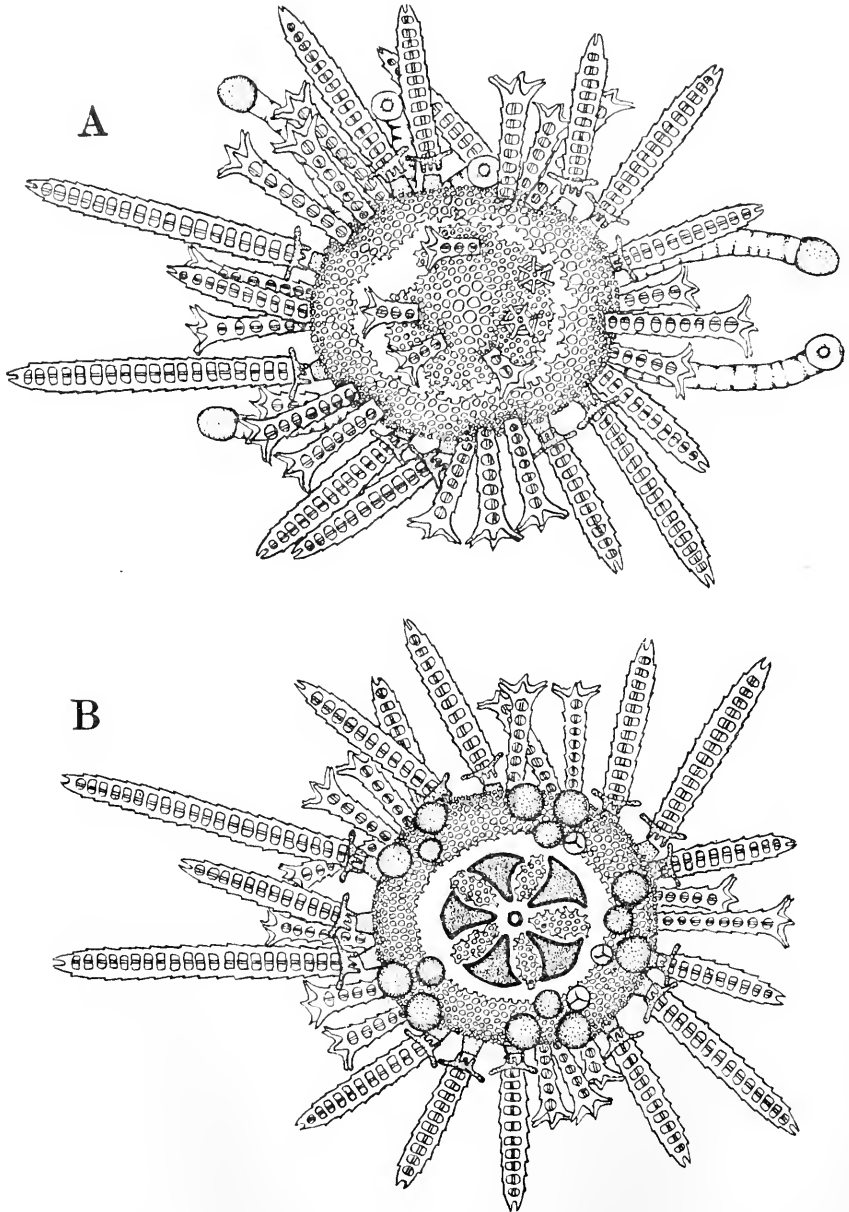

FIGURE 5. Pair of half-imagos derived from single blastomeres of the two-cell stage, 4 days after metamorphosis. A, aboral view. B, oral view. They do not show any difference from whole imagos except for their small size.  $\times 160$ .

*i.e.*, the percentage of one-armed plutei is greater among the half-larvae than among the unoperated controls. Even in this case, however, it does not mean that each of the pairs has a right and left arm, respectively. At any rate, development of the arms, as in the case of the whole larva, shows no connection with the capacity of the half-larva for metamorphosis.

The young half sand dollar does not show any difference from the whole sand dollar except that it is dwarf, the two members of the pair being completely equal in all points (Figs. 2, 5). There is not even much delay in development as a result of the operation.

(2) Isolated blastomeres of the four-cell stage: *equi- and toti-potent regarding metamorphosing capacity.*

The results of the operation are as follows:

Operated 4-cell stages .....	207
All members of the quartettes metamorphosed .....	2 sets
Three members of the quartettes metamorphosed .....	6 sets
Two members of the quartettes metamorphosed .....	24 sets
One member of the quartettes metamorphosed .....	65 singles

In contrast to the relative frequency with which both members of a pair of half-larvae completed metamorphosis, all four quarter-larvae derived from isolation in the four-cell stage were rarely able to metamorphose. The probable reasons for this are presented below.

The development of quarter-larvae is much like that of the half-larvae described above, except for their smaller size. However, quarter-plutei usually have only one arm or none at all. The number of arms has, again, no essential meaning for metamorphosis.

The physiological condition of the quarter-imagos seems to be inferior to that of the half-imagos, since the metamorphosis of the former is delayed as compared with that of the latter, and many of the former die soon after metamorphosis. Even when they survive for a while, they do not usually show any sign of growth and eventually become edematous. But a point to be stressed is that even in such quarter-imagos, no part of the body is missing.

There were, altogether, 8 instances in which three or four members of a quartette metamorphosed. In these cases, not only was the general developmental condition very poor, but the respective rates of growth and degrees of differentiation were extremely variable (Fig. 6). On the contrary, there were 89 cases in which one or two members of a quartette succeeded in metamorphosing. These imagos appeared to be much better developed than those of the 8 cases in which three or four survived, occasionally even reaching a state comparable to that of half-imagos. This may probably mean that  $\frac{1}{4}$  of the protoplasm of a single egg is about the minimum of material sufficient to permit metamorphosis; and further, that when blastomeres of the 4-cell stage do not share the egg protoplasm strictly equally, the smaller ones fall below the viable level. Harvey (1940) reported the similar fact that although isolated quartettes from a single egg of *Arbacia punctulata* may all develop into perfect dwarf plutei, there is considerable variation in size among them.

(3) Half-larvae of the 16-cell stage: *Meridional halves: equi- and toti-potent with respect to metamorphosis.*

Of 45 pairs of half-larvae obtained by meridional section of the 16-cell stage, 6 pairs and 13 singles completed metamorphosis. Early half-imagos resulting from this operation are indistinguishable from those derived from the 2-cell stage.

*Equatorial halves: animal half fails to metamorphose; vegetal half shows weak capacity for metamorphosis, always followed by immediate death.*

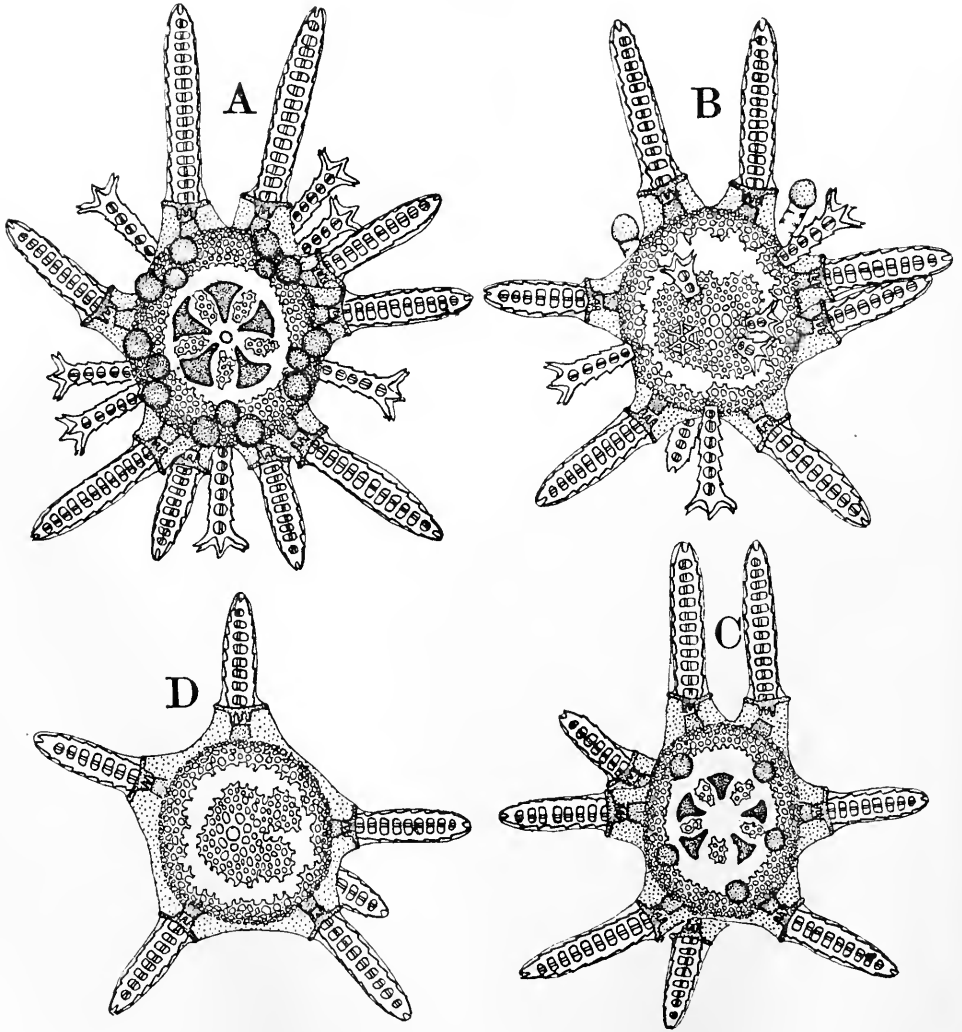

FIGURE 6. Quartettes derived from single blastomeres of the four-cell stage, 4 days after metamorphosis. A, C, oral view. B, D, aboral view. Their developmental condition is very poor as compared with half-imagos, and further, there is a lack of uniformity in their respective rates of growth.  $\times 160$ .



It is rather difficult to find differences in the mode of development of the animal and vegetal halves before the appearance of the primary mesenchyme cells, although the vegetal half tends to round up somewhat earlier than the animal half. Simultaneously with the migration of the primary mesenchyme cells, however, a distinction between the two halves suddenly appears. The vegetal half becomes opaque because of the presence of the mesenchyme cells in the blastocoel, while the animal half remains transparent (Fig. 7, A). Another striking difference between the two regions is that on dying, the animal half becomes a brilliant pink, while the vegetal half is turned green by the clypeastroid pigment. A detailed account of their respective courses of development follows.

*Animal half.* The blastula of the animal half gradually becomes flattened—usually in the dorso-ventral direction.<sup>3</sup> At about 12 hours after fertilization—in the control whole-larvae gastrular invagination begins at this time—a depression appears in the ventral field (Fig. 7, C, An). This is exactly the position at which amniotic invagination occurs in control whole-larvae a few hours later.<sup>4</sup> At this time, the animal half-larva has remarkably long cilia on almost the whole or a part of the surface, the wall of which is more or less thickened. A few hours later, larvae are frequently found with two, and occasionally with three depressions at once (Fig. 7, D, An II). Some larvae have separate cells in the blastocoel, but probably these are not mesenchyme cells, since they neither form spicules nor contain clypeastroid pigment. In other words, they do not show any differentiation. The situation is the same for amphibians (Ruud, 1925; Vintemberger, 1934, 1935).

Several hours later, the wall of the animal region rapidly increases in area and begins to wrinkle (Fig. 7, E, An). The wrinkled area spreads from the animal toward the vegetal side, so that these blastulae finally have the appearance of a mass of many small ciliated vesicles (Fig. 7, E, An), closely resembling the isolated and cultured *Triton* epidermis as described by Holtfreter (1933). Occasionally, separate small vesicles fall off from the main mass, and some of these swim around as small blastulae without showing any further development even after several days. As a rule, animal half-larvae have a tinge of pink, in contradistinction to the greenness of the mesenchyme cells, but upon death the pink color increases its brilliance and often pervades the entire body. Although a pink pigment exists originally in the unfertilized egg of *Peronella*, and, moreover, the epidermis of normal larvae has a slight tinge of the same color, their tones are not so deep as that of the dead animal half. Occasionally, such a pink color is also recognized in a part of a whole embryo which has died at the morula or the early blastula stage.

<sup>3</sup> The animal pole region of the gastrulae is indicated by a tuft of long cilia. On animal half-larvae after flattening, these long cilia are usually found at one pole of the long axis. Occasionally, however, cases are found in which one of the flattened sides bears somewhat longer cilia than the other surfaces (Fig. 7 B, An I).

<sup>4</sup> At the stage of formation of the amniotic invagination, not only the animal half- but also the control whole-larva becomes flat in the dorso-ventral direction (Fig. 7 D). It may be possible that the animal half which is released from the effect of vegetal elements flattens, and amniotic invagination occurs earlier than normally. Moreover, Hörstadius showed (1935, 1939b) that animal halves of *Paracentrotus* often develop into blastulae with stomodaea, and, as before mentioned, the amniotic invagination of *Peronella* bears a striking resemblance, morphologically, to the stomodaeum of the sea urchin larva. However, it is very difficult to judge whether the depression of the animal half-larva of *Peronella* corresponds to the amniotic invagination.

*Vegetal half.* The swimming vegetal blastula takes on a very dark appearance earlier than does the whole larva, since the blastular wall is extremely thick and the small blastocoel is filled with mesenchyme cells (Fig. 7, A, Ve). In a short time, the cells in the vegetal region begin to dissociate and fall out of the blastular wall (Fig. 7, B, Ve). The dissociated cells adhere to each other, forming a green mass on the outside of the vegetal wall (Fig. 7, C, Ve).

Some larvae soon cast off this mass of dissociated cells and develop into small gastrulae or plutei (Fig. 7, E, Ve), although a few exogastrulae with long, pro-

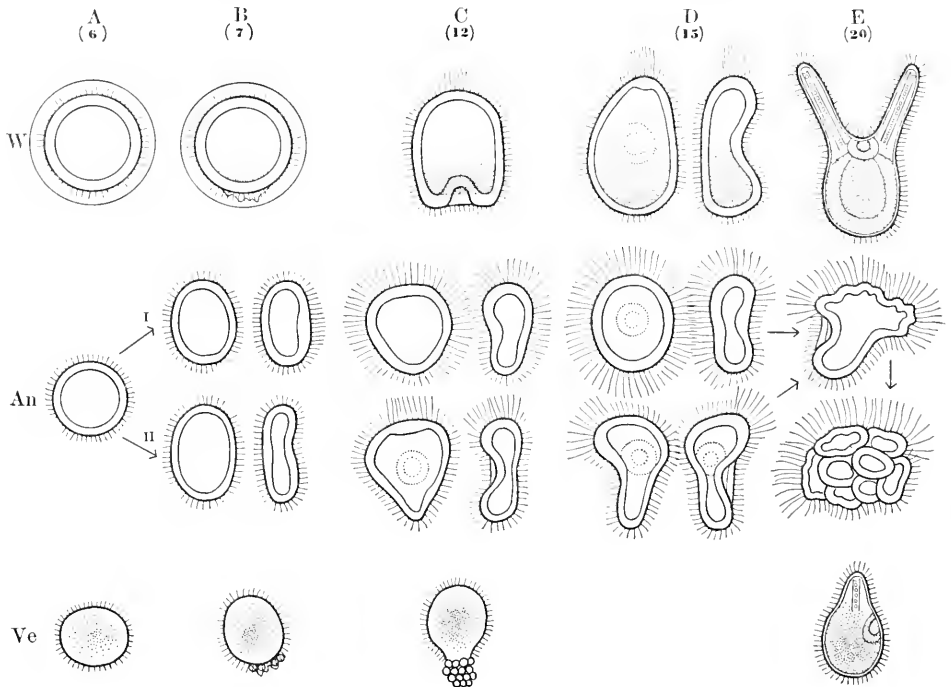

FIGURE 7. Comparison of development of equatorial half-larvae of 16-cell stage and control whole larvae of *Peronella japonica* Mortensen. Numbers of the upper row indicate hours after fertilization. W, control whole larvae. An, animal halves. Ve, vegetal halves. I and II, two types of animal half-larvae at each stage.

truding archenterons are also formed. Of 431 vegetal halves, 71 developed into plutei with or without arms. Four of these plutei succeeded in metamorphosing. However, such young imagos had only two or three spines on an extremely edematous body, and died immediately after metamorphosis.

On the other hand, when the mass of dissociated cells becomes larger than the larval body, which is rather frequently the case, the larvae adhere to the substratum with a part of the sticky cell mass and consequently are unable to swim in spite of their ciliary activity. Even if they succeed in freeing themselves from the cell mass, they can develop only into small blastulae filled with mesenchyme cells. This is no doubt because such larvae have lost too many cells to continue further development.

In either case, dead vegetal larvae exhibit a green color, although whole larvae of such a young stage never do so. It is quite an impressive contrast that the animal half turns a brilliant pink on death, while the vegetal half assumes a green color as it dies.

#### (4) Half-blastulae.

Larvae were bisected meridionally at the following two stages and equatorially at the second stage (see Fig. 3 (4) a, b):

- a. Grooved blastula (5 hours after fertilization).
- b. Late blastula with primary mesenchyme cells (7-9 hours after fertilization).

*Meridional halves: equi- and toti-potent with respect to metamorphosis.*

Grooved blastulae were bisected along the groove. The development proceeds in much the same way as in isolated blastomeres of the 2-cell stage. Since the grooves of the blastula coincide with the cleavage furrows of the two- or four-cell stage, the distribution of material in half-larvae of this kind is identical with that in half-larvae of the two-cell stage. Consequently, such operative results as were obtained are quite according to expectation. This experiment furthermore indicates that the regulative capacity in the meridional half has not at all decreased by the grooved blastula stage.

Halves separated at the late blastula stage go through metamorphosis only half as frequently as the previous stage and the physiological condition of the half-imagos is much poorer.

*Equatorial halves: metamorphosing capacity of the animal halves negligible, of vegetal halves strong.*

Among the equatorial halves, there was no instance in which both members of a pair succeeded in metamorphosing. Commonly, the animal half became a blastula with mesenchyme cells, and soon died without further development, except in one instance. However, this animal became extremely edematous and did not show typical differentiation and, moreover, its sister half (vegetal) developed only as far as the pluteus stage. It is likely that the plane of cutting might have been further toward the vegetal pole than usual.

In general the vegetal halves developed into plutei, usually having two arms, and many of them metamorphosed. The young imagos mostly showed typical differentiation and survived for several days after their metamorphosis.

#### (5) Half-gastrulae.

Larvae were operated on in the following two stages:

- a. Gastrula with archenteron and two small triradiate spicules (11-15 hours after fertilization).
- b. Late gastrula with amniotic invagination (15-17 hours after fertilization).

*Meridional halves: percentage of metamorphosis is minimal at the stage a, physiological condition poor, progressive decrease in regulative capacity.*

Results of operation through these stages show a general downward trend of regulative power. As for the degree of bodily differentiation, by the time the late gastrula stage is reached, many half-imagos show a reduced number of plates or tooth-rudiments or spines on the side of the operation.

The same is true with the number of arms: the later the stage of operation, the more larvae with one arm are produced until finally all of them become one-armed if operated on at the late gastrula stage.

However, from the standpoint of metamorphosing capacity, a rather unexpected result was obtained. It was found that the frequency of successful metamorphosis improves toward the end of the gastrula stage in spite of a continual loss of regulating power for bodily organization. Although it is recognized that operation during the invagination process seems to act more deleteriously than in later stages, the situation does not seem to be so simple, since in still later stages, such as the pluteus or imago stages, the percentage of metamorphosis keeps on improving despite more defective organization of the larvae.

*Equatorial halves: metamorphosing capacity of animal halves negligible, of vegetal halves rather strong.*

The development of the equatorial halves of the gastrulae is very much the same as that of operated blastulae. Animal halves can only reach the stage of blastulae with mesenchyme cells except one instance of metamorphosis in an extremely edematous larva. On the contrary, vegetal halves do metamorphose in much better condition and even survive several days after metamorphosis.

#### (6) Half-plutei.

Larvae were bisected at the following stages:

- a. Early pluteus with two fully developed arms, but without adult skeleton (19–25 hours after fertilization).
- b. Pluteus with some adult skeleton (45–55 hours after fertilization).
- c. Late pluteus with well-developed adult spines and plates (70–90 hours after fertilization).

The results are included in Table I and Figure 4.

*Meridional halves: equi- and toti-potent; capacity for metamorphosis stronger than that of half-blastulae and -gastrulae.*

Meridional half-larvae operated on at these stages had one arm and were not able to form another, but many of them metamorphosed, although many half-imagos became more or less edematous.

*Anterior and posterior halves: equi- and toti-potent with respect to metamorphosis.*

Anterior half-larvae apparently were not able to regenerate the posterior portion, and posterior half-larvae re-formed no arms, yet both halves metamorphosed. It is particularly worth mentioning that both anterior and posterior halves of a single larva are able to metamorphose.

In young imagos derived from anterior halves, the physiological condition seems to be inferior to that of those derived from meridional or posterior halves, since all the former became edematous and died without developing, while the latter survived longer and grew to some extent, although eventually they also became more or less edematous.

Usually, in any of these half-imagos, some lack of plates, spines or teeth is found on the side of the operation. This absence of parts in the half-imagos becomes more and more conspicuous as the stage of operation advances. However, the total number of the plates, spines and teeth found in the two halves from a bisected larva is always greater than that of the control whole imagos.

*Animal and vegetal halves: equi- and toti-potent in metamorphosing capacity.*

As indicated in Figure 3, (5)b and (6)b, the original egg-axis is bent at the pluteus stage, so that the anterior and posterior halves of the pluteus do not coincide with the animal and vegetal halves, respectively, of the blastula or gastrula, regarding the egg-axis. Therefore, in order to obtain half-larvae corresponding as nearly as possible in this respect to the animal and vegetal halves of the earlier stages, plutei were cut by a frontal section into front (animal) and rear (vegetal) parts (see Fig. 3, (6)b).

Of 15 plutei operated on, 7 pairs and 5 vegetal halves metamorphosed. These young sand dollars are much like those derived from meridional halves of plutei of the same age.

(7) Bisected imagos: both halves survive for several days and continue growth.

Young imagos were bisected immediately after metamorphosis. Of 10 imagos so treated, 7 pairs and 3 singles survived for several days after the operation and were able to increase the number of spines and tube-feet to some extent, although they could not regulate them to the typical numbers. It appears that physiological recovery in the bisected animal is relatively easy even after metamorphosis.

#### DISCUSSION

As is indicated in Figure 4, the metamorphosing capacities of both meridional and equatorial halves of *Peronella* larvae show a similar tendency to drop to a minimum at stage (5)a (gastrula stage). The regulative capacity, on the other hand, steadily decreases as the stage of operation advances. Such a relation is precisely that which would be expected from the experiments of previous workers (Jenkinson, 1911; Hörstadius, 1936, 1939b), so far as they go within the limit of the pluteus stage. However, the fact that all the curves of half-larval metamorphosing capacity rise steadily from the late gastrula stage on, seems to be of considerable significance. Especially animal halves, which were found to be almost lacking in metamorphosing capacity before the gastrula stage, acquire the capacity in the pluteus stage.

The interpretation of these curves is very difficult. However, several suppositions with regard to each point will be presented, although no final conclusion can be reached at this time.

The percentage of half-larvae operated on at the two-cell stage which are able to metamorphose is unexpectedly low. This is probably due to the fact that there is no way for the investigator to reject individuals with low viability at such an early stage, although this elimination is automatically realized when older larvae are used. If the selection of larvae with high viability were possible, a higher metamorphosing capacity than that which appears in the present results would undoubtedly be demonstrated.

When the four blastomeres of the four-cell stage are separated, all four quarter-larvae metamorphosed. This is a further amplification of Hörstadius' well known work. Corresponding experiments on *Amphibia* by Ruud (1925) indicate that the situation differs slightly in these forms, and only blastomeres carrying the future site of the organizer are totipotent. For mammals the data are lacking, except that Seidel (1952) succeeded in obtaining a perfect rabbit from one blastomere of a two-cell stage which was implanted in another female in the right physiological condition.

Of equatorial halves separated at the sixteen-cell stage, the animal halves developed only to the blastula stage, while the vegetal halves, generally speaking, were able to metamorphose. However, for some reason not yet understood, only a few of such vegetal halves were able to metamorphose. On the other hand, relatively many vegetal halves of blastulae or gastrulae were able to metamorphose, as compared with vegetal halves of the sixteen-cell stage. A possible explanation might be that since the ectoderm overgrows toward the vegetal pole as the larvae develop (see Fig. 3), the vegetal halves of the swimming stages contain a larger amount of ectoderm than similar halves of early stages, so that the balance between animal and vegetal elements in later stages will approach more closely to the normal than in earlier stages.

Although the direction of the egg-axis shows a clear correlation with the presence and absence of metamorphosing capacity through the gastrula stage, this is lacking in the pluteus stage, as evidenced by the fact that animal and vegetal half-larvae are equally able to metamorphose, and produce imagos resembling those developing from meridional halves of the same stage. This result indicates that some other factor has superseded in importance the original animal-vegetal relation by the time the pluteus stage is reached.

When larvae were operated on after the formation of the amniotic invagination, both meridional and transverse halves metamorphosed, and the percentage of metamorphosis increased as the stage of operation advanced. This result is probably due to the specific developmental mode of *Peronella*. Since the echinus rudiment of this form is found in the center of the body and develops to a large size, bisection in any direction will give each half approximately half of the rudiment, and the size of the half-echinus rudiment which goes to each half-larva becomes larger and larger with advance of the stage of operation. Consequently, regulation for metamorphosis of half-larvae will become increasingly easier as the operational stage advances. It seems quite possible that this central position and marked development of the echinus rudiment in the pluteus stage constitute the factor which takes primary importance, over that of the animal-vegetal axis, in determining the metamorphosing capacity of larval regions.

The writers wish to express their sincere thanks to Dr. J. C. Dan for her assistance in the preparation of the manuscript.

#### SUMMARY

1. In the larva of the sand dollar *Peronella*, the mouth does not open, and no functional digestive tract is formed so that no feeding is necessary before metamorphosis.
2. Both the amniotic cavity and the hydrocoel take a median position in the larval body.
3. Cutting experiments show that single blastomeres of the two- or four-cell stage are totipotent regarding metamorphosing capacity.
4. Any meridional half of the larval stages has the capacity for metamorphosis.
5. The vegetal half of the sixteen-cell stage metamorphoses, but the animal half develops only to the blastula stage.

6. The vegetal halves, but not the animal halves, of the blastula and gastrula stages are able to metamorphose.

7. Both anterior and posterior halves of the pluteus stage are able to metamorphose.

8. The percentages of metamorphosis of partial larvae fall to a minimum at the gastrula-stages after which they rise while the regulative capacity falls as a course of a steady decrease.

## LITERATURE CITED

- DRIESCH, H., 1891. Entwicklungsmechanische Studien. I-II. *Zeitschr. Wiss. Zool.*, **53**: 160-184.
- HARVEY, E. B., 1940. A new method of producing twins, triplets and quadruplets in *Arbacia punctulata*, and their development. *Biol. Bull.*, **78**: 202-216.
- HOLTGRETER, J., 1933. Nachweis der Induktionsfähigkeit abgetöteter Keimteile. *Arch. f. Entw.*, **128**: 584-633.
- HÖRSTADIUS, SVEN, 1935. Über die Determination im Verlaufe der Eiachse bei Seeigeln. *Pub. Staz. Zool. Napoli*, **14**: 251-429.
- HÖRSTADIUS, SVEN, 1936. Über die zeitliche Determination im Keim von *Paracentrotus lividus* Lk. *Arch. f. Entw.*, **135**: 1-39.
- HÖRSTADIUS, SVEN, 1939a. Über die Entwicklung von *Astropecten aranciacus*. *Pub. Staz. Zool. Napoli*, **17**: 221-312.
- HÖRSTADIUS, SVEN, 1939b. The mechanism of sea urchin development, studied by operative methods. *Biol. Rev.*, **14**: 132-179.
- JENKINSON, J. W., 1911. On the development of isolated pieces of gastrulae of the sea urchin, *Strongylocentrotus lividus*. *Arch. f. Entw.*, **32**: 269-297.
- MORTENSEN, TH., 1921. Studies of the development and larval form of echinoderms. Published at the Expense of the Carlsberg Fund. Copenhagen.
- MORTENSEN, TH., 1948. A monograph of the Echinodea. Copenhagen IV, 2.
- ONADA, K., 1937. Note on development of some Japanese echinoids with special reference to the structure of the larval body. II. *Japanese J. Zool.*, **8**: 1-13.
- RUUD, G., 1925. Die Entwicklung isolierter Keimfragmente frühesten Stadien von *Triton taeniatus*. *Arch. f. Entw.*, **105**: 209-293.
- SEIDEL, F., 1952. Die Entwicklungspotenzen einer isolierten Blastomere des Zweizellenstadiums im Säugetierei. *Naturwiss.*, 39 Ja. Ht. **15**: 355-356.
- VINTEMBERGER, P., 1934. Résultats de l'auto-différenciation des quatre macromeres isolés au stade de huit blastomeres dans l'oeuf d'un amphibien anoure. *C. R. Soc. Biol.*, **117**: 693-696.
- VINTEMBERGER, P., 1935. Sur les résultats du développement des quatre micromeres isolés au stade de huit blastomeres, dans l'oeuf d'un amphibien anoure. *C. R. Soc. Biol.*, **118**: 52-53.

# AN X-RAY DOSE-ACTION CURVE FOR EYE-COLOR MUTATIONS IN MORMONIELLA

DAVID T. RAY AND P. W. WHITING<sup>1</sup>

*Howard University, Washington, D. C., University of Pennsylvania, Philadelphia, Pa.,  
and the Marine Biological Laboratory, Woods Hole, Mass.*

Visible mutations have been induced in many widely diverse species of organisms by the use of x-rays and other ionizing radiations. The literature has been reviewed by Lea (1947) and by Catcheside (1948). Rate of such mutations is low, only one-tenth to one-fifteenth that of lethals, and hence conclusions in regard to effect of intensity differences, fractionation of dose, wave-length and combination with other factors such as oxygen pressure, infra-red rays and temperature have been drawn largely from work with lethals. Because, insofar as data have been accumulated, the proportion of visibles to lethals appears to be the same under different conditions of irradiation, these conclusions have seemed justified.

## DOSE-ACTION CURVES

Dose-action curves for visibles have been shown in several organisms and have, within the limits of error of the experiments, proved similar to those for lethals. The curves formed are of the straight-line type of direct proportionality, meaning that, for a given increment of dose at any interval within the range, a similar proportion of mutations is added.

*Drosophila.* The most satisfactory information regarding dose-action curves for visibles is available from work with the fruit-fly *Drosophila melanogaster* (Timoféeff-Ressovsky and Delbrück, 1936). Two methods were used for identifying sex-linked visibles—the attached-X and the C1B. The former is the more convenient. Wild-type males are x-rayed and mated to females with their X-chromosomes attached so that the offspring are one hundred per cent non-disjunctional. Since the sons receive only paternal and therefore treated X-chromosomes, any visibles induced may be observed without further breeding. The C1B method is much more laborious. The treated wild-type males are mated to C1B females (females having in one X-chromosome an inversion preventing crossing-over, a recessive lethal factor and the factor for bar eyes) and the bar (C1B) daughters from this cross are set in individual cultures. If a visible is induced in a given X-chromosome, all the males in a culture from a bar female receiving that chromosome will show the mutant trait.

Table I shows data re-arranged from Timoféeff-Ressovsky and Delbrück (1936). Linearity is indicated by both methods, but percentages for total visibles recognized by the C1B are considerably higher for each of the three doses given. As pointed out by the authors this is not caused by any errors in dose, because the males from

<sup>1</sup>The research herewith reported was conducted under a contract with the U. S. Atomic Energy Commission to the Marine Biological Laboratory and was aided by grants to P. W. Whiting from the Johnson Fund of the American Philosophical Society and from the Board of Graduate Education and Research of the University of Pennsylvania. The author is indebted to Dr. John R. Preer and Dr. Sewall Wright for suggestions regarding the statistical aspects.



TABLE I

*X-ray dose-action data re-arranged from Timoféeff-Ressovsky and Delbrück (1936) on sex-linked mutations in Drosophila melanogaster as identified by C1B and attached-X methods. The data are presented as—mutations/total cultures (or total males) = percentage (lower—upper 0.95 confidence limits)*

Dose r units	C1B method. Total visibles	Attached-X method. Total visibles	Attached-X method. Seven selected
0	0/2378 = 0 (.00- .15)	0/7936 = 0 (.00-.05)	
1500	10/4583 = 0.22 (.10- .40)	13/9317 = 0.14 (.07-.24)	9/18,000 = .05 (.02-.10)
3000	16/3396 = 0.47 (.27- .77)	21/8442 = 0.25 (.15-.38)	28/22,500 = .12 (.08-.18)
6000	15/1809 = 0.83 (.46-1.37)	26/5183 = 0.50 (.33-.73)	32/14,500 = .22 (.15-.31)
	Cultures—12,166	Males—30,878	Males—55,000

the same lot were rayed at the same time for both methods. The disparity is due rather to the fact that the mutant type appears as a single individual in the attached-X method but as all the males of a culture produced by a C1B female. A single mutant may be missed by the observer, especially if the trait is not very distinct, or it may fail to develop if the mutant type is of lowered viability. It is obvious that the labor of dealing with the 12,166 C1B cultures in search of total visibles must have been far greater than that of rearing and observing the 30,878 sons from the attached-X mothers.

A method of avoiding both the viability disadvantage and the subjective factor causing failure to observe some of the less distinct visibles is to select a limited number of easily recognized traits of high viability which may then be used in an attached-X experiment. This was utilized by the authors who selected seven sex-linked mutant traits (*w<sup>e</sup>*, *w*, *y*, *v*, *m*, *g*, *f*) in a test in which 55,000 sons of treated wild-type males were counted. Percentage of mutations noted is here less than half that for total visibles but undoubtedly a high degree of accuracy was attained. Dose-action linearity is again indicated.

In Table I lower and upper 0.95 confidence limits are presented as calculated from Ricker's (1937) table for Poisson frequency distributions. The authors give

TABLE II

*X-ray dose-action data on eye-color mutations from Woods Hole wild-type stock of Mormionella vitripennis (Walker)*

Dose r units	Mothers	Total sons	Sons per mother	Mutants						Dark red
				Bright-eyed					Dark red	
				Scarlet	Orange	Oyster	Total	% (0.95 confidence limits)		
0	632	18,039	28.54	0	0	1	1	.0055 (.00055-.03104)	0	
1340	729	16,011	21.96	17	2	3	22	.14 (.08-.21)	8	
2680	874	10,058	11.51	17	3	5	25	.25 (.16-.37)	5	
4020	853	5,268	6.18	20	2	4	26	.49 (.32-.72)	1	
5360	855	2,708	3.17	17	3	3	23	.85 (.54-1.27)	0	
Totals	3942	52,084		71	10	16	97		14	

standard errors following percentages of mutations. Standard errors are not applicable to very low percentages because of asymmetry in the distributions. Ricker's method has likewise been followed in Table II and in Figure 1 for our *Mormoniella* data.

A dose-action curve for production of visibles in the X-chromosomes of the egg might be obtained by x-raying the females of *Drosophila* and examining their sons. Their daughters also might be set individually and the  $F_2$  males examined. The former procedure would be less laborious but would, like the attached-X method, be less satisfactory because of the subjective factor in failure to recognize less dis-

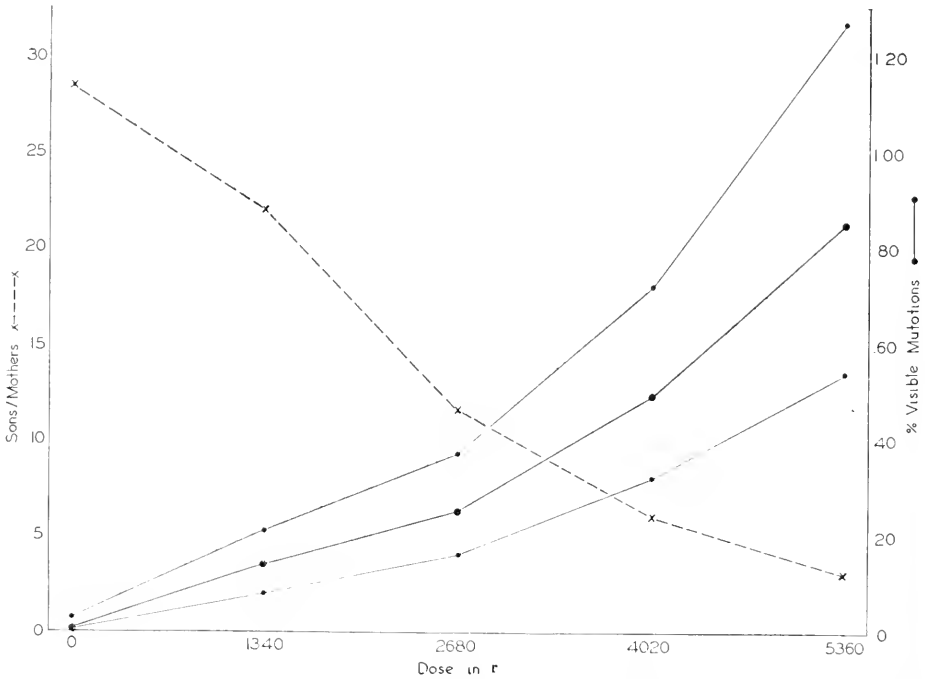

FIGURE 1. Average numbers of sons per mother and percentages of eye-color mutations produced by *Mormoniella* females, control and x-rayed with different doses. Lower and upper 0.95 confidence limits calculated from Ricker's (1937) table are given for the mutation percentages.

tinct types and because of reduced viability of some of the mutants. Testing of daughters, although laborious, would have the advantage, as in the C1B method, of many mutants resulting from the same mutation, but only half, instead of all, of the males in the fraternity would be expected to show the mutant trait. This last point might be advantageous in the case of less distinct mutant types because wild-type sibs with the same residual heredity as their mutant brothers would be present for comparison. Relatively little has been published with regard to radiation of females in *Drosophila*, aside from a few abstracts which have recently appeared. Now, however, these investigations are actively under way. Differences in dose-action relationships are to be expected, not only between sperm and egg, but between different meiotic stages of the latter.

*Habrobracon*. Many x-ray visibles have been produced in the parasitic wasp *Habrobracon juglandis* (Ashmead) by radiation of both males and females (Whiting, 1932, 1934, 1935). Treatment of unmated females results in mutant sons. Treatment of males gives rise to  $F_2$  fraternities in some of which half the males are mutant. The same occurs following the mating of treated females to untreated males. When mated females are treated both eggs and sperm are exposed and mutants may appear singly as  $F_1$  males and as many males in some  $F_2$  fraternities. A few dominants have been produced as in *Drosophila* which may show directly in the heterozygous females and some recessive mutations have been recognized because of their dominance over a third allele in a compound female. While *Habrobracon* has the theoretical advantage of male haploidy, there are practical disadvantages (web- and cocoon-spinning of both parasite and host) making isolation of virgin females and collection of food more laborious. For these reasons dose-action curves have not as yet been obtained.

*Mormoniella*. In the chalcidoid wasp *Mormoniella vitripennis* (Walker) numerous x-ray-induced eye-color mutations from wild type (dark brown) have already been reported (Whiting, 1951). These range from dark red through tomato, vermilion, scarlet and peach to "oyster," the last named being devoid of pigment and transparent so that the black color of the underlying integument shows through. Thus the appearance of the eye suggests an oyster. When oyster wasps are placed in alcohol, the eyes become opaque white. The eye colors ranging from tomato to oyster may be classed as "bright." All of these that have been tested have proved to be hereditary, dependent upon recessive gene differences from wild type. The dark reds are for the most part also hereditary but occasionally one is found which has bred as a somatic overlap from wild type. Some very dark reddish-brown types occurring in wild stock have proved to be hereditary. These are readily separated as "red-eyed pupae" from their sibs which have dull reddish-brown eyes in the late pupal stage.

Spontaneous eye-color mutations are rare or at most very infrequent in pure stocks, either wild-type or mutant-type. Spontaneous "mutants" are relatively frequent among the offspring of heterozygous females. However, some at least of these "mutants" are recombinants. The problem of spontaneous mutation is being further investigated.

All of the induced eye-color mutations have been obtained by radiation of females. The majority have appeared as single sons of unmated females but in a few cases, when treated females were crossed to untreated males, the mutants from any one mutation constitute about one-half of the sons of a single daughter from the cross. Because testing daughters individually is time-consuming, rates for visible viable mutations are determined from inspection of haploid sons of treated females. By exclusion of dark reds and reddish-browns from the final calculations, the subjective factor is reduced to a minimum.

Genetic evidence indicates that all males are haploid (Whiting, 1951). Biparental diploid males such as occur as sex homozygotes in the ichneumonoid wasp *Habrobracon* have not been found in *Mormoniella*. Females carry genes derived from both parents, but sons of mated females as of unmated are gynogenetic except for rare instances interpreted as possible androgenesis. Sex determination must then be different from that in *Habrobracon* as it has been shown to be in the

related chalcidoid *Melittobia* (Schmieder and Whiting, 1947). The mechanism of sex determination has yet to be discovered for this group.

During the summer of 1952 tests were made at the Marine Biological Laboratory by David T. Ray of wild-type and of various mutant stocks of *Mormoniella* to determine which might be more suitable for a dose-action curve. Wild-type (WH+) was selected, a stock inbred from wasps that were infesting fly pupae at the Supply Department dock on the Eel Pond. Female pupae were isolated and freshly eclosed virgins or very dark female pupae were placed in gelatine capsules for raying. Treatments were given with the x-ray apparatus having two tubes in alternate parallel, cross-firing through the specimens which were placed 13 centimeters from the targets. KVP was 182, MA 25, equivalent filtration .152 mm. Cu, intensity approximately 2680 r/min. Rayings were made on 26 different days. Females from each host puparium were divided among the capsules given the different doses as a precaution to equalize distribution in case a mutant trait were running in the stock. Among the 52,084 sons of 3,942 mothers there were 97 mutants classed as having "bright" eyes and 14 with eyes dark red (Table II). While none of the latter occurred among the 18,039 controls, their distribution was irregular among the treated. Rate is higher but not significantly so among those from females given 1340-2680 r (13/26069), .050% (.026-.086), than among those from females given 4020-5360 r (1/7976), .013% (.001-.070). Rate for total treated (14/34045), .041% (.023-.069), is significantly higher than the zero rate for the controls (0/18039), 0.0% (0.000-0.021). Test of one dark red from the 2680 r treatment showed that he bred as wild type. The others were not tested.

The 97 bright-eyed mutants were classed as scarlet, orange and oyster. One oyster appeared among the controls. Scarlet, represented by 71 mutants among the total 97, is by far the most frequent. Only in one instance were two eye mutants found in a single vial and these were different, a scarlet and an oyster from the 5360 r treatment. Each bright-eyed mutant may then be considered to result from a separate mutation.

Stage of meiosis at time of treatment is of interest. With the controls and lower treatments mutations might appear from first meiotic metaphase as well as from prophases. With higher treatments, 2000 r and above, few if any metaphase-treated eggs would be expected to produce offspring, if inferences may be drawn from lethal rates in *Habrobracon*. It is very unlikely that any progeny have been included from treated gonial cells because transfers were not made to new vials. Death of offspring developing from eggs treated as young oocytes, if indeed the parents survived to lay such eggs, would be expected to result from exhaustion of food supply. Replication could occur from mutations in early gonial divisions only, since a single egg and its accompanying nurse cells comprise the products of the last four gonial divisions. Failure of similar mutant types to appear in the same vial is in agreement with this expected lack of replication. However, the presence of similar mutant types in one vial would not prove replication. They should occur rarely by chance from two separate mutations, especially in the case of scarlet, the most frequent mutant type.

Figure 1 shows percentage of bright-eyed mutants increasing with increasing dose. The curve dips at 2680 r but this dip is not a significant departure from the straight line expected on the basis of single hits producing the mutations.

A method of calculating goodness of fit of these data to a straight line has been suggested by Dr. Sewall Wright (Table III). Since doses given were simple multiples of the minimum dose, 1340 r, this may be taken as the unit dose. "Wasp-doses" are then the number of surviving wasps multiplied by the number of 1340 r units to which the eggs were subjected. Ninety-six bright-eyed mutants resulted from 62,763 "wasp-doses." Distribution of mutants calculated (c) on the basis of 1340 r having the same chance ( $96/62,763 = .00153$ ) of producing a mutation, regardless of amount of dose, would then be in proportion to the distribution of "wasp-doses" among the survivors. From the differences between the observed number of mutants (o) and the calculated (c), chi square, 3.97, was obtained. This deviation is insignificant.

Average numbers of sons per mother (Table II and Figure 1) show decrease with increasing dose. Females subjected to x-radiation become sterile or die

TABLE III

*Calculation of goodness of fit to linearity of bright-eyed Mormoniella mutants from x-rayed mothers. Data from Table II. (Method suggested by Dr. Sewall Wright)*

Dose in 1340 r units	Total sons	"Wasp-doses"	Mutants		$\frac{(o-c)^2}{c}$
			(o)	(c)	
1	16,011	16,011	22	24.49	.25
2	10,058	20,116	25	30.77	1.08
3	5,268	15,804	26	24.17	.14
4	2,708	10,832	23	16.57	2.49
Totals	34,045	62,763	96	96.00	3.97
$\chi^2 = 3.97$		n = 3	P = .26		

after four or five days. Many of the untreated also die at this time but a minority may be transferred to fresh host pupae and will produce further offspring. In the present experiment transfers were not made so that average potential fecundity of controls is higher than that indicated.

#### DISCUSSION

Dose-action curves for visibles in *Drosophila* are essentially linear, indicating single hits producing the mutations. There is no dip at the mid-point (3000 r), and in two of the three experiments a slight rise occurs. The dose-action curve for bright-eye-color mutations in *Mormoniella* is likewise consistent with linearity but there is a dip at the mid-point (2680 r). However, the confidence limits are wide enough both in *Drosophila* and in *Mormoniella* to permit an hypothesis either of uninterrupted linearity or of a dip (at 2680-3000 r). Neutron experiments (unpublished) indicate a dip in the dose-action curve for eye colors in *Mormoniella*. More extensive x-ray experiments are in progress with *Mormoniella* which should narrow the confidence limits sufficiently to establish definitely whether or not a dip is present. Comparison may then be made with the neutron tests and the significance of the dip may be considered.

## SUMMARY

1. X-ray dose-action curves for visible mutations in *Drosophila* are discussed. An x-ray dose-action curve for eye-color mutations in *Mormoniella* is presented. Within the limits of error of the experiments the curves may be of the straight-line type indicating that single hits produce the mutations. However, in the *Mormoniella* curve an insignificant dip occurs at the mid-point, 2680 r, suggesting the possibility of a second factor.

2. A shortened chi square method of testing goodness of fit to a straight line is presented. With reference to the present *Mormoniella* data, the deviation is shown to be insignificant.

## LITERATURE CITED

- CATCHESIDE, D. G., 1948. Genetic effects of radiations. *Advances in Genetics*, 2: 271-358. Academic Press, New York.
- LEA, D. E., 1947. Actions of radiations on living cells. The Macmillan Co., New York.
- RICKER, WM. E., 1937. The concept of confidence or fiducial limits applied to the Poisson frequency distribution. *J. Amer. Stat. Assoc.*, 32: 349-356.
- SCHMIEDER, R. G., AND P. W. WHITING, 1947. Reproductive economy in the chalcidoid wasp *Melittobia*. *Genetics*, 32: 29-37.
- TIMOFÉEFF-RESSOVSKY, N. W., AND M. DELBRÜCK, 1936. Strahlengenetiche Versuche über sichtbare Mutationen und die Mutabilität einzelner Gene bei *Drosophila melanogaster*. *Zeitschr. indukt. Abstramm.-u. Vererb.*, 71: 322-334.
- WHITING, P. W., 1932. Mutants in *Habrobracon*. *Genetics*, 17: 1-30.
- WHITING, P. W., 1934. Mutants in *Habrobracon*, II. *Genetics*, 19: 268-291.
- WHITING, P. W., 1935. Recent x-ray mutations in *Habrobracon*. *Proc. Pa. Acad. Sci.*, 9: 60-63.
- WHITING, P. W., 1951. Multiple complementary alleles in *Habrobracon* and *Mormoniella*. *J. Genetics*, 50: 206-214.

STUDIES ON THE HELMINTH FAUNA OF ALASKA. XVII.  
NOTES ON THE INTERMEDIATE STAGES OF SOME  
HELMINTH PARASITES OF THE SEA OTTER

EVERETT L. SCHILLER<sup>1</sup>

*Arctic Health Research Center, Anchorage, Alaska*

According to the work of Rausch (1953), two species of helminth parasites, *Porrocaecum decipiens* (Krabbe, 1878) and *Microphallus pirum* (Afanas'ev, 1941), are pathogenic for the sea otter, *Enhydra lutris* (L.), on the Aleutian Island of Amchitka. In continuation of investigations of sea otter mortality on Amchitka during the latter part of May and early June, 1952, the writer made an attempt to obtain information on the life cycles and developmental characteristics of these parasites. It is the purpose of this paper to report the results of these observations.

MATERIALS AND METHODS

Collections of marine invertebrates were made with special effort to obtain those which are known, from previous studies (Murie, 1940), to be included in the diet of the sea otter. For the most part, these collections were restricted to the intertidal area. Attempts to procure samples of bottom forms in the deeper waters of Constantine Harbor by means of dragging a triangular dredge from the stern of a small collapsible canvas boat were relatively unsuccessful.

Fishes, *Lepidion superciliosus* (Pallas) and *Hemilepidotus hemilepidotus* (Tilesius), were obtained from the waters of Constantine Harbor by means of funnel-type fish traps baited with carcasses of birds previously autopsied in connection with related parasite studies. Efforts to obtain the larger species of crabs by the use of crab traps at a depth of about 15 fathoms were unsuccessful. Amphipods, *Ampithoe rubricata* (Montagu) and *Anonyx nugar* (Phipps), were usually abundant on the baits when the traps were pulled for inspection.

With the exception of representative specimens preserved for purposes of identification, most of the marine animals were autopsied in the field.

Trematode metacercariae were placed on a glass slide and excysted by gentle pressure of a cover glass. The excysted larvae were stained *in vivo* with orcein dissolved in acetic acid, by allowing the staining fluid to flow slowly under the cover glass until the desired differentiation was attained. Additional metacercariae which had been removed from the host tissue in the field were counted and preserved in alcohol-formalin-acetic acid (AFA) solution. Supplementary specimens were preserved in AFA, with the metacercariae intact in the host tissue.

Nematode larvae were fixed in AFA and cleared for study in liquefied phenol.

RESULTS

Two species of fishes, a greenling, *L. superciliosus*, and a sculpin, *H. hemilepidotus*, abundant in the waters around Amchitka, were commonly found to contain the larvae of a nematode, *Porrocaecum decipiens*. Observations indicate that

<sup>1</sup> Parasitologist, Animal-borne Disease Branch, Arctic Health Research Center, Public Health Service, Department of Health, Education and Welfare, Anchorage, Alaska.

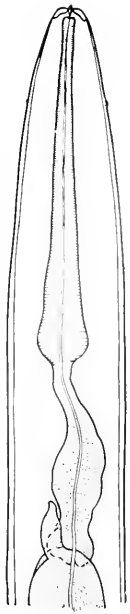

500 μ 1

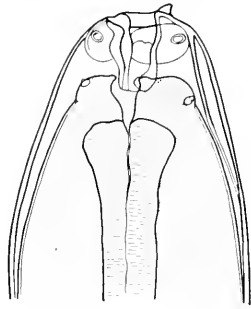

600 μ 3

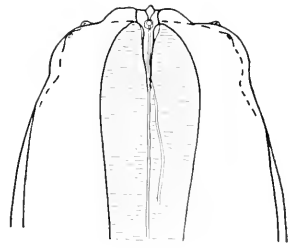

56 μ 6

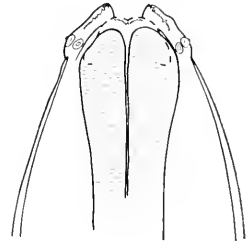

175 μ 7

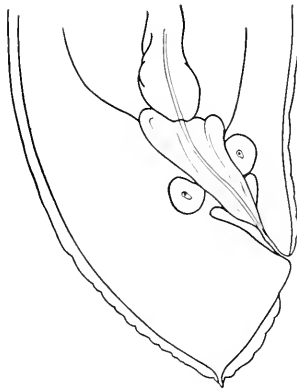

150 μ 4

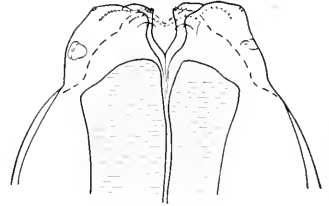

100 μ 8

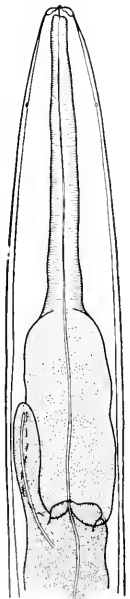

500 μ 2

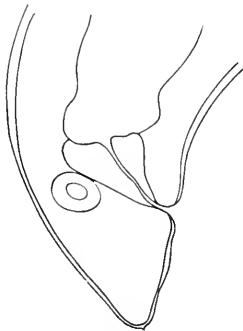

100 μ 5

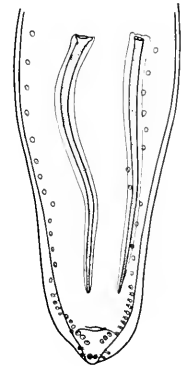

375 μ 9

FIGURES 1-9.  
108



the greenling occurs frequently in the diet of the sea otter and probably constitutes the most important source of severe nematode infections acquired by these mammals.

The greenling and sculpin also harbored larval acanthocephalans (*Corynosoma* sp.) which may represent the second intermediate stage of a species parasitic in the sea otter. A brief discussion of this form is included.

The metacercarial stage of the trematode *Microphallus pirum* was found in a hermit crab, *Pagurus hirsutiusculus* (Dana). The finding of the intermediate host for the last larval stage of *M. pirum* permits an understanding of the probable source of the heavy infections with this trematode in the Amchitka sea otter, and will make it possible to obtain additional information on the life cycle and pathogenicity of this species through experimental infections.

The larval stages of *Porrocaecum decipiens* and the metacercaria of *M. pirum* are considered separately in some detail from the standpoint of host occurrence, prevalence of infection, and morphology.

Stiles and Hassall (1899) published a description of *Ascaris decipiens*, to which Baylis (1916) contributed further details. The species was later referred by Baylis (1920) to the genus *Porrocaecum* Railliet and Henry, 1912. Although there appears to be some disagreement concerning the validity of the name *Porrocaecum decipiens*, as indicated by the discussion of the taxonomic status of this nematode given by Johnston and Mawson (1945), the writer has preferred to retain this name for the purposes of this paper.

Several species of marine mammals harbor the adult stage of *P. decipiens*. Around Amchitka, the harbor seal, *Phoca vitulina* L., Steller's sea lion, *Eumetopias jubata* (Schreber), and the sea otter, serve as definitive hosts for this nematode. A list of species from which *P. decipiens* has been recorded in the northern hemisphere was given by Baylis (1937). Several investigators have reported the occurrence of the larval stages in various species of fishes, and it is apparent from these published records that this nematode has an extremely wide geographical distribution.

Although the complete life cycle of *P. decipiens* has never been demonstrated experimentally, Stiles and Hassall (1899) recognized no difference between encysted larvae found in fishes and the youngest worms occurring in the fur seal, *Callorhinus ursinus* (L.). The seal harbored all intermediate stages between the youngest forms and the adults of *P. decipiens*. These authors concluded that such close relationships between the definitive host and the probable intermediate hosts suggested the source of infection nearly to the point of certainty—a view commonly accepted by helminthologists.

---

FIGURE 1. *Porrocaecum decipiens*; head and esophageal portion of second stage larva from stomach of sea otter. (Earliest larval stage found in this animal.)

FIGURE 2. *P. decipiens*; head and esophageal portion of third stage larva from musculature of *Lebius superciliosus*.

FIGURE 3. *P. decipiens*; head of third stage larva from stomach of sea otter. (In process of shedding cuticular sheath.)

FIGURE 4. *P. decipiens*; tail of third stage larva from musculature of *L. superciliosus*.

FIGURE 5. *P. decipiens*; tail of second stage larva from stomach of sea otter.

FIGURE 6. *P. decipiens*; head of third stage larva from musculature of *L. superciliosus*.

FIGURE 7. *P. decipiens*; head of fourth stage larva from small intestine of sea otter.

FIGURE 8. *P. decipiens*; head of adult male from small intestine of sea otter.

FIGURE 9. *P. decipiens*; tail of adult male from small intestine of sea otter.

According to Stiles and Hassall, both the Alaskan pollock, *Theragra chalcogramma* (Pallas), and the Pacific cod, *Gadus macrocephalus* Tilesius, collected in the Bering Sea, harbored encysted larvae of *P. decipiens*. They considered the former species to be probably the chief source of infection of the fur seal. Scheffer and Slipp (1944) reported *P. decipiens* abundant in the harbor seal from the Pacific coast of the United States. They found the larval stage encysted in the mesentery of *Gadus macrocephalus* in the Aleutian Islands, where the same species of seal was found to be parasitized by the adult worm.



FIGURE 10. Section of dorsal musculature of *L. superciliosus* showing larva of *P. decipiens* in wound cavity.

Rausch (1953) reviewed previous reports of *P. decipiens* in the Aleutian Island sea otter and recorded his observations on the prevalence of the species in the sea otter of Amchitka. His report included an account of the pathological changes in this animal associated with certain developmental stages of *P. decipiens*.

*Data:* A total of 106 fishes was examined during the present study on Amchitka. These consisted of 75 greenlings, *L. superciliosus*, 15 sculpins, *H. hemilepidotus*, 11 blennies, (Stichacidae) *Anoplarchus purpurescens* Gill, and 5 tide pool sculpins, *Myoxocephalus niger niger* (Bean). Of these, both *L. superciliosus* and *H. hemilepidotus* were found to contain the larvae of *P. decipiens*. Data concerning these infections are summarized in Table I. Prevalence of infection does not appear to be correlated with either sex or size of the fishes examined.

*Morphology:* The larval stages of *P. decipiens* from the musculature of *L. superciliosus* ranged in length from 30 to 50 mm. All of these immature worms possessed a boring tooth in the position of the left ventral lip (Fig. 3) and a small conical projection at the tip of the tail (Fig. 4). The exposed part of the boring tooth measured about 15  $\mu$  in length by 30  $\mu$  in maximum diameter. The terminal projection attained a length of about 17  $\mu$ . The dorsal and ventral lips, although visible beneath the cuticular sheath characteristic of this larval stage, were compressed together in such a manner as to obscure the morphological details. Examination of identical specimens from the sea otter revealed that several were in the process of shedding the cuticular sheath (Fig. 3). The boring tooth and terminal projection are lost during this molt. The three characteristic ascarid lips are incompletely developed but appear to be functional as

TABLE I

*Prevalence of larval Porrocaecum decipiens according to sex and size of fishes collected at Amchitka*

Fish species:	<i>L. superciliosus</i>		<i>H. hemilepidotus</i>	
	Total number examined:	75	Total number examined:	15
Total number infected:	30 (40%)		3 (20%)	
Sex	Male	Female	Male	Female
Number of specimens	27	48	10	5
Range in length	210-375 mm.	210-395 mm.	154-345 mm.	170-285 mm.
Average length	292 mm.	319 mm.	251 mm.	248 mm.
Range in weight	101-609 g.	105-960 g.	114-520 g.	57-342 g.
Average weight	336 g.	444 g.	252 g.	230 g.
Numbers infected	10 (37%)	20 (41.5%)	1 (10%)	2 (40%)
Range in numbers of larvae per infected fish	1-9	1-14	1-	1-3
Average number of larvae per infected fish	2.7	2.9	1.0	2.0

soon as the cuticle is shed. The dorsal lip bears two large papillae and each of the ventral lips is provided with one. The excretory organ consists of a single, flattened, band-like cell which extends ventrally, with several lateral branches, through the anterior region of the worm. The excretory pore is located ventrally between the two ventro-lateral lips. The esophagus is divided transversely into an anterior muscular portion and a posterior glandular organ or ventriculus. The digestive tract is well developed and an intestinal diverticulum, directed anteriorly, is present in all specimens from the musculature of the greenling. The esophageal region of a typical larva from the musculature of this fish is illustrated in Figure 2. Measurements of pertinent structures are included in Table II.

In comparing larvae from the fish musculature, no differences, except for those of size, were noted. A grouping of these larvae according to length, and their location within the fish musculature, indicates that these differences in size are correlated with growth and development.

There was no evidence of the beginning development of reproductive organs in larvae from the fish musculature.

A study of the immature stages of *P. decipiens* harbored by the sea otter revealed that they are morphologically identical with those found in the musculature of *L. superciliosus*. Some of these still retained their cuticular sheaths, a few were in the process of shedding the cuticle, and others had completed this molt.

Smaller specimens (18 to 30 mm. in length), representing a stage of development earlier than any found in the fish, were also present in the sea otter (Fig. 1). These larvae were usually seen in dense clusters with their anterior ends deeply

TABLE II

*Data on morphological details of larval Porrocaecum decipiens grouped according to location of larvae, showing relationship between stages of development and migration through the fish musculature. (Measurements of youngest larvae from stomach of sea otter included for purposes of comparison)*

Source of larvae		Youngest larvae from stomach of sea otter.	In musculature next to abdominal wall of fish.	In thick dorsal musculature of fish.	In tail musculature of fish.
Total length		18-30 mm.	30-37 mm.	38-44 mm.	45-50 mm.
Boring tooth and tail spike		Present	Present	Present	Present
Total length of esophagus	Range	2.66-4.16 mm.	3.29-3.64 mm.	3.38-3.85 mm.	3.45-4.35 mm.
	Average	3.29 mm.	3.41 mm.	3.61 mm.	3.84 mm.
Length of muscular part	Range	1.82-3.15 mm.	1.89-2.10 mm.	1.93-2.38 mm.	2.01-2.80 mm.
	Average	.235 mm.	1.99 mm.	2.15 mm.	2.30 mm.
Length of ventriculus	Range	770-1260 $\mu$	1.28-1.54 mm.	1.43-1.47 mm.	1.33-1.86 mm.
	Average	946 $\mu$	1.39 mm.	1.45 mm.	1.56 mm.
Length of diverticulum		Absent in larvae 18-28 mm. Beginning in larvae 30 mm.			
	Range	112-490 $\mu$	700-980 $\mu$	756-1048 $\mu$	700-1050 $\mu$
	Average	340 $\mu$	864 $\mu$	870 $\mu$	885 $\mu$
Distance to cervical papillae	Range	392-700 $\mu$	588-728 $\mu$	700-770 $\mu$	700-770 $\mu$
	Average	523 $\mu$	679 $\mu$	737 $\mu$	750 $\mu$

imbedded in the mucosa of the stomach, or associated with intestinal perforations (see Rausch, 1953). These larvae closely resembled those from the greenling, although the ventriculus had a shrunken appearance and the diverticulum was absent in all specimens up to 28 mm. in length. An anteriorly-directed structure about 112  $\mu$  in length was present in the position of the ventriculus in most larvae 29 mm. long (Fig. 1), however, and its length had increased more than four times (490  $\mu$ ) by the time the larvae had reached 30 mm. (Fig. 2). This seems to indicate that development of the diverticulum was very rapid during this stage.

Although larvae of a comparable size were not seen in the greenling, it is

possible that these smallest forms represent an earlier developmental stage— one occurring in the intestine or abdominal cavity of the fish, prior to invasion of the musculature. Measurements of the pertinent morphological characters in the youngest larvae from the sea otter are included in Table II.

The nematode infections in the sea otter usually comprised all of the immature stages. The pattern of development of these worms, as interpreted from the study of morphological characteristics and location in the intermediate host (fish) and/or in the definitive host (sea otter), is presented below:

*First stage larvae:* Motile larva in the egg.

*Second stage larvae:* Larvae up to 28 mm. in length; boring tooth and tail projection present; ventriculus smaller in diameter than posterior third of muscular part of the esophagus; lips incompletely developed; diverticulum absent or only slightly developed; beginning development of reproductive organs not evident (Figs. 1, 5).

*Location in intermediate host:* Probably in gastrointestinal tract and/or abdominal cavity of fish.

*Location in definitive host:* Attached in dense clusters to mucosa of stomach in pinnipeds and sea otter; associated with intestinal perforations in the case of the sea otter.

*Third stage larvae:* Larvae 30 to 50 mm. in length; boring tooth and tail projection may or may not be present; lips incompletely developed but functional when cuticular sheath is shed; ventriculus well developed; diverticulum present, attaining a length of about  $\frac{4}{7}$  the length of the ventriculus; beginning development of reproductive organs not evident (Figs. 2, 3, 4, 6).

*Location in intermediate host:* In the musculature of fish (greenling). Larvae possessing cuticular sheath with boring tooth and tail projection.

*Location in definitive host:* Attached in clusters to mucosa of stomach in pinnipeds and sea otter. Larvae possessing cuticular sheath with boring tooth and tail projection, cuticle being shed, or molt completed.

*Fourth stage larvae:* Larvae over 50 mm. in length; boring tooth and tail projection absent; lips completely developed, with dentigerous ridges conspicuous; diverticulum well developed and equal or nearly equal to length of ventriculus; beginning development of reproductive organs evident, but worms sexually immature (Fig. 7).

*Located in definitive host only:* In stomach and intestine of pinnipeds and sea otter.

*Adult stage:* Males about 78 mm. in length; females about 110 mm. in length. Characteristics of male: total length of esophagus, 4.5 mm., muscular portion, 3.2 mm., ventriculus, 1.2 mm.; diverticulum extends to anterior extremity of ventriculus; spicules equal, 2.2 mm. in length; post-anal tail length, 271  $\mu$ ; six lateral pairs of post-anal papillae, three pairs near anus and three pairs terminal (Figs. 8, 9). All morphological characters of the adult *P. decipiens* examined in this study conform to descriptions given by Stiles and Hassall (1899) and Baylis (1916).

*Located in definitive host only:* In small intestine of pinnipeds and sea otter.

*Larval migration, development and encapsulation:* In considering the life cycle of *P. decipiens*, it is assumed here that the eggs released by the adult worms in the definitive host are passed into the sea and are ingested by the intermediate host (fishes). The larvae apparently are released from the egg, either in the stomach or intestine of the fish, then penetrate the walls of these organs and migrate through the abdominal cavity into the musculature. Kahl (1938) discussed the occurrence of *P. decipiens* larvae in different parts of the body of the fish (stomach, body cavity, and musculature) and presented a detailed account of the process of encapsulation of these larvae within the muscle tissue.

The pattern of migration, development, and encapsulation of the larvae of *P. decipiens* as observed in *L. superciliosus* appears to be essentially the same as that in smelt, *Osmerus epurlanus*, and red perch, *Sebastes norvegicus*, as described by Kahl. Living larvae were recovered from various places throughout the fish musculature, and it was possible to correlate the stage of larval development with the amount of host-tissue reaction and extent to which migration had progressed. The smallest larvae (30 to 37 mm. long) were found lying in an extended position in the muscle tissue adjacent to the abdominal wall. Macroscopically there was no visible evidence of tissue reaction at this location. Slightly larger forms (38 to 44 mm. long) were found deeper in the muscle tissue dorso-lateral to the abdominal cavity. Here, also, the larvae were lying in a more or less extended position and there was little, if any, change in the tissue in which they were imbedded. The largest larvae (45 to 50 mm.) were usually found in the dorso-caudal region of the fish. These larvae were usually more or less coiled, and apparently had ceased migrating. The worms imbedded in the form of a loose coil appeared to have evoked moderate cellular changes, visible as cellular infiltration contrasting in color with the adjacent tissue. More tightly coiled individuals were seen within cavities apparently produced by them (Fig. 10). The reaction of the surrounding tissue was more pronounced here and the cavity contained a reddish-brown amorphous substance along with the worm. The degree of tissue reaction probably is correlated with the duration of larval localization. Other larvae occurred in compact coils within thin-walled capsules. Sections through these capsules demonstrated that the capsule membrane is composed of connective tissue; however, the connective tissue formation is not nearly as extensive as that described by Kahl (1938). This last condition represents the most advanced stage in the process of host tissue reaction observed in the greenling, although on two occasions during examination of the sculpins, the characteristic opaque, lenticular capsule containing a dead worm, similar to those described by Martin (cited by Kahl, 1938), was found. The late "wound-cavity stage" or early "encapsulation stage" in the greenling occurred most frequently in the muscle tissue on either side of the pterygiophores of the ventral fin.

It is of interest to note that exposure of any part of the worm during dissection of the fish usually resulted in its becoming very active, freeing itself completely from the surrounding tissue within a few minutes. When a living larva, soon after removal, was placed free upon the musculature and covered with another sizeable piece of the same tissue, it re-entered and completely imbedded itself in the muscle in less than ten minutes. These observations suggest that the

method of penetration is mechanical. The connective tissue of the flesh apparently offers little resistance to penetration by these worms, since they are not restricted by the connective tissue septa as observed by Kahl (1938) to be the case in other large species of fishes.

There is disagreement among investigators concerning the role of the fish in the infection of marine mammals by these nematodes. Joyeux and Baer (1934) expressed the opinion that the life cycle could be accomplished perfectly well without this intermediate host, but that it served to accumulate and distribute the larvae. Other authors (Pinter, 1922; Giovannola, 1936; and Fülleborn, 1923; cited by Punt, 1941) regarded the passage of the larvae through the fish as a physiological requisite for completion of larval growth and development. Kahl (1939) was of the opinion that encapsulation of the larva is a method of defense on the part of the intermediate host but is by no means indispensable for the development of the larva. He concluded that larvae of *P. decipiens* in the digestive tract of the intermediate host had already completed the development necessary to permit establishment within the definitive host, following ingestion. This seems to be the case in the sea otter-greenling cycle as well, although establishment of larvae of this developmental stage is not without adverse effect upon the sea otter. Rausch (1953; p. 594) stated that "The earliest stage found in the sea otter (*i.e.*, worms having a cephalic spike) appears to be the most pathogenic. This larval stage was always associated with intestinal perforation and seemed directly responsible for all sea otter deaths known to have resulted from nematode infection." Inasmuch as the development ordinarily attained during migration and localization in the fish has not been completed, these larvae may have a tendency to continue their vigorous migration following ingestion by the definitive host. This might explain, in part, the pathogenicity of such early stage larvae of *P. decipiens* in the sea otter.

Twice during this study, several immature specimens of *P. decipiens*, identical with those found in the flesh of the greenling, were taken from the stomach of the bald eagle, *Haliaeetus leucocephalus* (L.), and on one occasion from the stomach of Baird's cormorant, *Phalacrocorax pelagicus* (Pallas). These worms were intermixed with the stomach contents and were probably ingested with infected fishes. This species is not considered to be parasitic in these birds. Murie *et al.* (unpublished data) reported finding *L. superciliosus* in the nests of the bald eagle on several occasions. Krog (1953) has discussed the occurrence of greenling and other species of fishes in the nests of the bald eagle on Amchitka.

#### *Corynosoma* sp.

Most of the greenling and sculpin examined in this work harbored late-stage acanthocephalan larvae of the genus *Corynosoma*. These were found attached to the mesenteries. Rausch (1953) recorded *C. strumosum* (Rudolphi, 1802) in addition to an undescribed species of this genus<sup>2</sup> from both the sea otter and Steller's sea lion at Amchitka. Afanas'ev (1941) described *C. enhydriis* from the sea otter of the Komandorskii Islands. It is quite probable that the immature form in the fish is an intermediate stage of one of these species. Immature specimens of

<sup>2</sup> This species has been recently described by Dr. H. J. Van Cleave as *Corynosoma villosum* (J. Parasit., 39: 1-13. 1953).

this genus, similar to those taken from the fishes, were also found in the small intestine of the bald eagle. It is doubtful that these worms reach maturity in this avian host. A discussion of the status of these worms in the bald eagle has been presented in a previous publication (Schiller, 1952). All acanthocephalan material was studied by the late Dr. H. J. Van Cleave, Department of Zoology, University of Illinois.

Rausch (1953) reviewed the taxonomic status of this species and presented a discussion of the pathological changes in the intestine of the sea otter associated with the presence of this parasite.

*Microphallus pirum* (Afanas'ev, 1941)

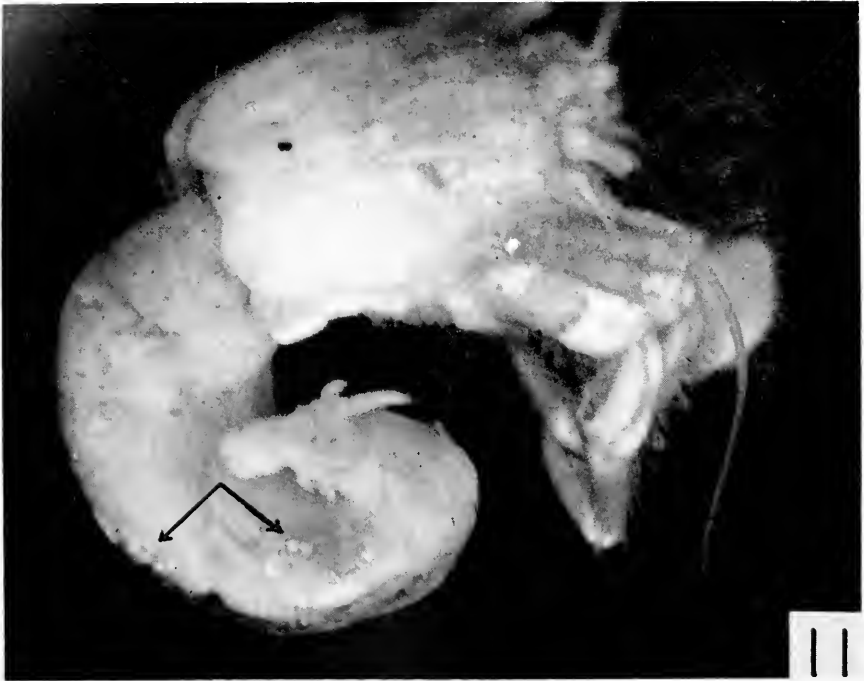

FIGURE 11. *Pagurus hirsutiussculus* (about  $3\frac{1}{2}\times$ ). Arrows indicate metacercariae of *Microphallus pirum*.

Studies of the life cycle of trematodes of the genus *Microphallus* have been mainly concerned with fresh-water species. A notable exception is the work of Stunkard (1951) with *M. limuli*, whose metacercariae were found in the horseshoe crab, *Limulus polyphemus*. His work included a critical consideration of the systematic position of the genus *Microphallus*.

During the present study the metacercarial stage of *M. pirum* was found attached rather insecurely to the inner lining of the abdominal wall and to the tissue supporting the viscera of a hermit crab, *P. hirsutiussculus* (Fig. 11). They were usually most numerous at the juncture of the cephalothorax and abdomen, but in heavy infections these cysts occurred throughout the abdomen and occasionally



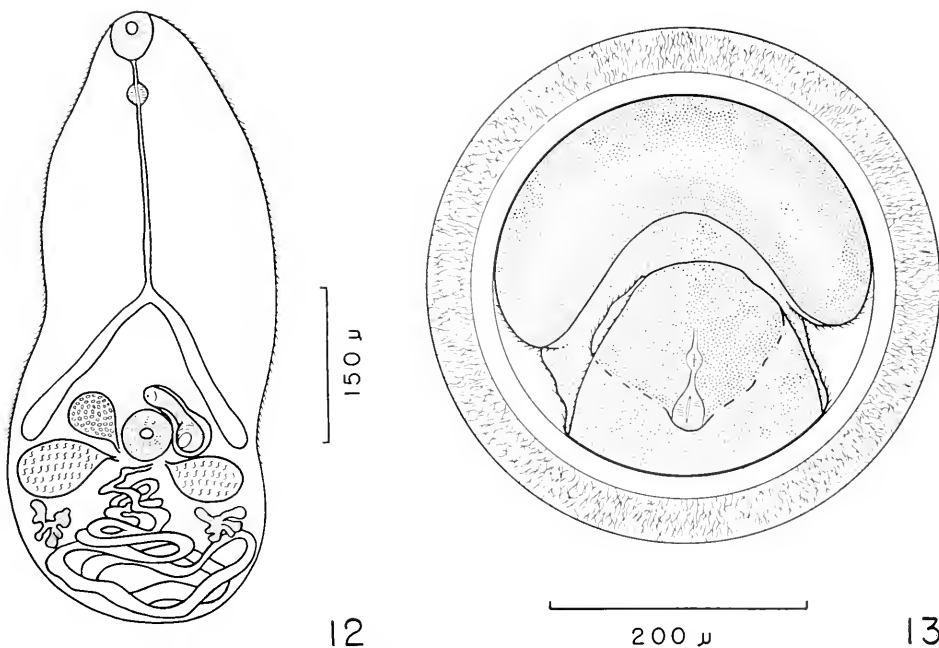

FIGURE 12. Metacercariae of *M. pirum* from *P. hirsutiusculus* following mechanical excystment.

FIGURE 13. Metacercaria of *M. pirum* from *P. hirsutiusculus* prior to excystment.



FIGURE 14. Metacercaria of *M. pirum* encysted in the hypodermis lining the carapace of *Telmessus* sp. (Average diameter about 300 μ.)

in the thoracic region, where they were attached to the hypodermis lining the carapace.

According to Dr. Femer A. Chace, Jr., Curator, Division of Marine Invertebrates, U. S. National Museum (personal communication), *P. hirsutiunculus* is one of the most common hermit crabs on the west coast of North America, ranging from the Pribilofs and Aleutians to San Diego, California, and vertically from low tide to a depth of 17 fathoms. It also occurs in Kamchatka and Japan.

The hermit crabs collected at Amchitka were housed in shells of the gastropods *Buccinum baeri* Middendorff and *Thais emarginata* (Deshayes).

*Data:* Forty-six (90%) of 51 hermit crabs examined in this study were found to contain encysted metacercariae of *M. pirum*. The numbers of cysts in the infected crabs ranged from 11 to 382, with an average of 87. There appeared to be no correlation in the prevalence of infection with either sex or size of these hermit crabs.

*Description of the metacercariae:* Cyst spherical; varying from 392 to 490  $\mu$  in diameter. Cyst wall double: external wall striated and opaque, about 33  $\mu$  in thickness. Metacercaria occupies almost all of the space within the cyst. Body of larva curled ventrad upon itself with anterior end innermost and lateral margins of posterior extremity bent over ventral surface as shown in Figure 13. Excysted larvae variable in length, but average about 580  $\mu$ . Cuticular spination conspicuous. Digestive tract well developed. Subterminal oral sucker measures 48  $\times$  42  $\mu$ . Prepharynx 6 to 14  $\mu$  in length; pharynx about 42  $\times$  19  $\mu$ . Length of esophagus about 240  $\mu$ . Ceca 160  $\mu$  in diameter. Genital pore located to left and adjacent to posterior margin of acetabulum. Male copulatory papilla about 20  $\mu$  in diameter. Seminal vesicle about 77  $\mu$  in length. Testes ovoid, about 80  $\mu$  long, located near lateral margins just posterior to ends of ceca. Subspherical ovary about 46  $\mu$  in diameter, situated between but somewhat anterior to right testis and acetabulum. Deeply lobed vitelline glands, incompletely developed, occur just posterior to testes. Vitelline ducts were not observed. Uterine loops fill body area posterior to acetabulum. The uterus is devoid of eggs.

The reproductive organs are well developed in the metacercaria of *M. pirum* (Fig. 12). Except for the extent of the vitelline glands and the absence of eggs in the uterus, the metacercaria appears to be identical with the adult worm.

The work of several authors (Strandine, 1943; Rausch, 1947; Stunkard, 1951) suggests a considerable degree of morphological variation and a remarkable lack of host specificity in members of the genus *Microphallus*. This may well be the case with *M. pirum*, since a rather wide range in cyst dimensions is seen in this species and since the adult is known to occur in the arctic fox as well as in the sea otter—two hosts phylogenetically not closely related.

The complete life cycle of *M. pirum* is unknown, but because this species is a digenetic trematode, it can be assumed that the first intermediate host is a snail. In view of this, together with the present knowledge of the second intermediate host, the life cycle of this species, in general, is thought to be as follows: The eggs are released by the adult worms in the small intestine of the sea otter and/or arctic fox and are eliminated in the feces. The miracidia gain entrance to the body of a suitable snail in which the subsequent generations of sporocysts, rediae, and cercariae are produced. The cercariae leave the snail and penetrate the body of the second intermediate host, the hermit crab, in which they encyst and develop

to the metacercarial stage. Upon ingestion of the infected hermit crab by the sea otter and/or arctic fox, the metacercariae are liberated and attain sexual maturity in the small intestine of the final host.

Stunkard (1953) found the herring gull, *Larus argentatus*, to be the final host of *M. limuli* and considered it very probable, in view of the lack of host specificity among microphallid trematodes, that shore-birds may also serve as natural definitive hosts for this species. Rausch (1953) suggested that *M. pírum* might infect birds. It therefore seems appropriate to note that no infections of *M. pírum* were found in any birds collected at Amchitka by the writer during the present study. These included the following species with the number examined: red-throated loon, *Gavia stellata* (Pontoppidan) (2); Baird's cormorant, *Phalacrocorax pelagicus resplendens* Audubon (1); lesser Canada goose, *Branta canadensis leucopareia* (Brandt) (1); Aleutian teal, *Anas crecca* (L.)<sup>3</sup> (20); lesser scaup, *Aythya affinis* (Eyton) (3); Pacific eider, *Somateria mollissima r-nigra* Gray (4); bald eagle, *Haliaeetus leucocephalus* (L.) (3); black oyster-catcher, *Haematopus bachmani* Audubon (5); lesser yellow-legs, *Totanus flavipes* (Gmelin) (2); Aleutian sandpiper, *Erolia ptilocnemis* (Ridgway) (5); Pacific godwit, *Limosa lapponica baueri* Naumann (1); northern phalarope, *Lobipes lobatus* (L.) (1); parasitic jaeger, *Stercorarius parasiticus* (L.) (3); glaucous-winged gull, *Larus glaucescens* Naumann (2); arctic tern, *Sterna paradisaca* Pontoppidan (1); pigeon guillemot, *Cephus columba columba* Pallas (1); Aleutian rosy finch, *Leucosticte tephrocotis griseonucha* (Brandt) (2); Pribilof snow bunting, *Plectrophenax nivalis tozcnseudi* Ridgway (2).

The following marine invertebrates were examined, in addition to the hermit crabs, and were found to be negative for larval stages of parasites infecting the Amchitka sea otter: limpet, *Acmaca digitalis* Eschscholtz (15); mussel, *Mytilus edulis* L. (18); anemone, *Actinea* sp. (16); sea urchin, *Strongylocentrotus dröbachiensis* (Müller) (22); snails, *Buccinum picturatum* Dall (19), *B. baeri* Middendorff and *Thais emarginata* (Deshayes) (37); amphipods, *Amphithoe rubricata* (Montagu) (13) and *Anonyx nugax* (Phipps) (33); isopods, *Idothea (Pentidotca) wosnesenskii* (Brandt) and *Ligia pallasii* Brandt (29); barnacles, *Balanus* spp. (24); octopus, *Octopus ?apollyon* Berry (2).

#### DISCUSSION

Though the percentage of greenlings infected with the larvae of *P. decipiens* at Amchitka is quite high, the number of larvae per infected fish is relatively low—consequently a large number of fishes would have to be consumed by the sea otter to produce the massive infections frequently found in them. This indicates that fishes may be much more important food species for this animal than formerly supposed. Practically all available information concerning feeding habits of the sea otter has been derived from a study of their feces. A young otter, kept in captivity for a short time during this investigation, was fed living greenlings. The flesh and viscera of the fish were consumed, but the more substantial parts of the skeleton were usually discarded. Such feeding habits, if characteristic of sea otter under natural conditions, would explain the scarcity of recognizable fish remains

<sup>3</sup> The cestode parasites of this bird have been reported separately by Schiller (Proc. Helm. Soc. Wash., 20: 7-12. 1953).

in their feces. According to Murie *et al.* (unpublished data, referring to the report on fishes collected on the 1937 Biological Survey Expedition to the Aleutian Islands) 42 species of fishes were taken in the Aleutian Islands proper. Probably a number of these may also serve as intermediate hosts for *P. decipiens*.

The relatively large number of metacercariae of *M. pirum* occurring in an individual hermit crab, combined with a high prevalence of infection, would seem to assure parasitism in any suitable final host feeding on these crabs. In consideration of the tremendous numbers of worms occurring in some of the infected sea otter at Amchitka (see Rausch, 1953), it is apparent that a great quantity of hermit crabs must be consumed by these animals. This leads to the conclusion that under present conditions at Amchitka, the hermit crab may also be an important species in the diet of the sea otter.

Other species of crabs, remains of which frequently occur in the feces of the sea otter at Amchitka, may afford additional sources of infection with *M. pirum*. Recent examinations of marine crabs collected on Kodiak<sup>4</sup> disclosed that, in addition to *Pagurus hirsutiunculus*, a crab of the genus *Telmessus*, also harbored the metacercariae of *M. pirum*. The metacercariae in the latter were found attached to the hypodermis lining the carapace (Fig. 14).

In addition to ecological relationships favoring a high degree of parasite survival at Amchitka, crowding of the sea otter and their continual occupation of a rather restricted home-range have resulted in a heavy concentration of parasites here. As a consequence, any mortality due to this parasitism in the sea otter may be expected to increase in proportion to the population density and it is conceivable that disease may continue in epizootic proportions until the sea otter population here is greatly reduced. In view of these circumstances, artificial reduction of the population through redistribution and/or harvest of the sea otter as recommended by Rausch (1953) may be the only practical solution.

The writer wishes to take this opportunity to express his appreciation to the individuals whose assistance and cooperation contributed much to this work. Identification of material was made by the following: Dr. H. Friedmann, Curator, Division of Birds, U. S. National Museum (birds); Mr. Vladimir Walters, Department of Biology, New York University (fishes); Dr. S. S. Berry, U. S. National Museum (octopus); Dr. Fenner A. Chace, Jr., Curator, Division of Marine Invertebrates, U. S. National Museum (hermit crab); Dr. Harald A. Rehder, Curator, Division of Mollusks, U. S. National Museum (mollusks); Dr. Robert Menzies, Scripps Institution of Oceanography, La Jolla, California (isopods); and Mr. C. R. Shoemaker, U. S. National Museum (amphipods).

The U. S. Fish and Wildlife Service supported the cost of the field work on Amchitka and the Military Air Transport Service provided transportation to and from Amchitka.

#### SUMMARY

1. Two species of fishes, *Lebius superciliosus* and *Hemilepidotus hemilepidotus*, serve as the intermediate host for *Porrocaecum decipiens*. Observations indicate that *L. superciliosus* is the most important source of the nematode infections acquired by the sea otter on the Aleutian Island of Amchitka.

<sup>4</sup>The field work on Kodiak was undertaken by Dr. R. Rausch and Miss R. V. Saachsen of this laboratory.

2. The morphological characteristics of the developmental stages of *P. decipiens* from fish and the sea otter are described.

3. A hermit crab, *Pagurus hirsutiussculus*, has been found to harbor the metacercariae of *Microphallus pirus*, an important parasite of the sea otter at Amchitka, and this larval stage is described.

4. Some ecological relationships which favor a high degree of parasite survival at Amchitka are discussed.

## LITERATURE CITED

- AFANAS'EV, V. P., 1941. Parazitofauna promyslovykh mlekopitainushchikh Komandorskikh Ostrovov. *Uchenie Zapiski, Seriya biologicheskikh Nauk.*, **18**: 93-117.
- BAYLIS, H. A., 1916. Some ascarids in the British Museum. *Parasit.*, **8**: 360-378.
- BAYLIS, H. A., 1920. On the classification of the Ascaridae. I. The systematic value of certain characters of the alimentary canal. *Parasit.*, **12**: 253-264.
- BAYLIS, H. A., 1937. On the ascarids parasitic in seals, with special reference to the genus *Contracaecum*. *Parasit.*, **29**: 121-130.
- JOHNSTON, T. H., AND PATRICIA M. MAWSON, 1945. Parasitic nematodes. In B.A.N.Z. Antarctic Research Expedition 1929-1931. Reports—Ser. B, Pt. 2, **5**: 77-159.
- JOYEUX, C. H., AND J. G. BAER, 1934. Les hôtes d'attente dans le cycle évolutif des Helminthes. *Biol. Méd. Paris*, **24**: 482-506.
- KAHL, W., 1938. Nematoden im Seefischen. I. Erhebungen über die durch Larven von *Porrocaecum decipiens* Krabbe in Fischwirten hervorgerufenen geweblichen Veränderungen und Kapselbildungen. *Zeitschr. f. Parasitenk.*, **10**: 415-431.
- KAHL, W., 1939. Nematoden im Seefischen. III. Statistische Erhebungen über den Nematodenbefall von Seefischen. *Zeitschr. f. Parasitenk.*, **11**: 16-41.
- KROG, J., 1953. Notes and observations of birds on Amchitka Island, Alaska. *Condor* **55**: 299-304.
- MURIE, O. J., 1940. Notes on the sea otter. *J. Mammal.*, **21**: 119-131.
- PUNT, A., 1941. Recherches sur quelques nématodes parasites de poissons de la mer du Nord. *Ném. du Mus. D'Hist. Nat. de Belgique*, No. 98, p. 1-110.
- RAUSCH, R., 1947. Some observations on the host relationships of *Microphallus opacus* (Ward, 1894) (Trematoda: Microphallidae). *Trans. Amer. Micr. Soc.*, **66**: 59-63.
- RAUSCH, R., 1953. Studies on the helminth fauna of Alaska. XIII. Disease in the sea otter, with special reference to helminth parasites. *Ecology*, **34**: 584-604.
- RAUSCH, R., AND BETTY LOCKER, 1951. Studies on the helminth fauna of Alaska. II. On some helminths parasitic in the sea otter, *Enhydra lutris* (L.). *Proc. Helm. Soc. Wash.*, **18**: 77-81.
- SCHEFFER, V. B., AND J. W. SLIPP, 1944. The harbour seal in Washington State. *Amer. Mid. Nat.*, **34**: 373-416.
- SCHILLER, E. L., 1952. Studies on the helminth fauna of Alaska. V. Notes on Adak rats (*Rattus norvegicus* Berkenhout) with special reference to helminth parasites. *J. Mammal.*, **33**: 38-49.
- SCHILLER, E. L., 1953. Studies on the helminth fauna of Alaska. XIV. Some cestode parasites of the Aleutian seal (*Anas crecca* L.) with the description of *Diorchis longiorum* n. sp. *Proc. Helm. Soc. Wash.*, **20**: 7-12.
- STILES, CH. W., AND A. HASSALL, 1899. Internal parasites of the fur seal. In D. S. Jordan. The fur seals and fur-seal islands of the North Pacific Ocean. *Rept. of Fur-Seal Invest. 1896-1897, Pt. 3, 1899*. U. S. Govt. Ptg. Off., Washington, D. C., p. 99-177.
- STRANDINE, E. J., 1943. Variation in *Microphallus*, a genus of trematodes, from fishes of Lake Lelanau, Michigan. *Trans. Amer. Micr. Soc.*, **62**: 293-300.
- STUNKARD, H. W., 1951. Observations on the morphology and life-history of *Microphallus limuli* n. sp. (Trematoda: Microphallidae). *Biol. Bull.*, **101**: 307-318.
- STUNKARD, H. W., 1953. Natural hosts of *Microphallus limuli* Stunkard, 1951. *J. Parasit.*, **39**: 225.

# THE PERMEABILITY OF THE SENSORY PEGS ON THE ANTENNAE OF THE GRASSHOPPER (ORTHOPTERA, ACRIDIDAE)

ELEANOR H. SLIFER

*Department of Zoology, State University of Iowa, Iowa City, Iowa,  
and the Marine Biological Laboratory, Woods Hole, Mass.*

In 1906 Röhler described three types of sense organs—pegs (*Kegel*, sensilla basiconica), pit pegs (*Grubenkegel*, sensilla coeloconica) and bristles (*Sinnesborsten*, sensilla chaetica)—which are present on the antennae of a grasshopper, *Acrida turrita* (Linnaeus).<sup>1</sup> Jannone (1940) states that the antenna of another species, *Dociostaurus maroccanus* (Thunberg), is provided with the same kinds of sense organs. He counted 125 pit pegs on the antenna of a first instar female and found between 470 and 490 on the antenna of an adult female. Eiben (1949) showed that similar structures occur on the antennae of *Melanoplus differentialis* (Thomas). He recorded the number of each type present on the antennae of each of the six nymphal instars and of the adults of this species and found that there is a five-fold increase in the total number of these sense organs during post-embryonic development. In addition to the sensory structures found by Röhler others have been described on the surface and inside the antennae of grasshoppers (McIndoo, 1920; Eggers, 1924; Slifer, 1936; Jannone, 1940; McFarlane, 1953) but these need not be considered here.

Of the three types of sense organs which were found by Röhler on the antenna of the grasshopper the basiconic pegs are most numerous. Sensilla of this kind are known to be present in many species of insects and are generally considered to be chemoreceptors (Snodgrass, 1926, 1935; Frings and Frings, 1949; Roth and Willis, 1951; Hodgson, 1953 and others) but, as Dethier (1953) says of these and related structures (p. 546): "Nothing is known concerning the chemical or physical properties of the cuticle surmounting these receptors." Richards' (1952) studies on the antennae of the honeybee have recently supplied some information on the properties of the cuticle of fixed and sectioned sense organs. It is the purpose of the present paper to show that in the living grasshopper the tip of certain of the sensory pegs is permeable to aqueous solutions of a dye.

## MATERIALS AND METHODS

The species of grasshoppers which were examined in the living condition represent the three major North American subfamilies (Acridinae, Oedipodinae and Cyrtacanthacridinae) and included male and female *Orphulella pelidna* (Burmeister), *Dissosteira carolina* (Linnaeus), *Psinidia fenestralis fenestralis* (Serville), *Melanoplus differentialis differentialis* (Thomas), *Melanoplus femur-rubrum* (DeGeer) and *Melanoplus mexicanus mexicanus* (Saussure). Some of these were raised in the laboratory and others were caught in the field. Newly-hatched nymphs of *Melanoplus mexicanus mexicanus* were used in certain experiments and newly-molted adults of several species in others. Preserved specimens of adult *Acrida bicolor* (Thunberg),<sup>2</sup> *Dissosteira carolina*, *Locusta migratoria migratorioides*

<sup>1</sup> Known to Röhler as *Tryxalis nasuta* L.

<sup>2</sup> The preserved specimens of *Acrida bicolor* and *Locusta migratoria migratorioides* were kindly sent to the writer by Dr. B. P. Uvarov of the Anti-Locust Research Centre in London.

(Reiche and Fairmaire), *Melanoplus femur-rubrum femur-rubrum* and *Melanoplus mexicanus mexicanus* were also studied.

Of several dyes tried a 0.5% aqueous solution of acid fuchsin was found to be especially useful. It is a vivid stain and can be detected when present in minute quantities. When used as described below it has no toxic effects and nymphs immersed in it for an hour recovered completely after removal from it. The method used to demonstrate the penetration of the dye was simple. If the individual to be tested was small its head was removed, wrapped in a bit of absorbent cotton and the whole placed in the dye. For larger insects the antennae were severed at the base, wrapped in cotton and immersed in the stain. The cotton prevents the specimen from rising to the surface of the solution where it would, otherwise, float. Care must be taken that no air bubbles are trapped in the cotton for they may prevent the stain from reaching all parts of the antennae. After a suitable interval—a few minutes to several hours—the head or antenna was removed and dipped very rapidly, and in turn, into distilled water, 70% alcohol and absolute alcohol to wash off stain which was clinging to the surface. The specimen was then placed in n-butyl alcohol or dioxan where it was left for five minutes or longer depending upon its size. Here the antennae were removed from the head if this had not been done earlier. Toluol was used as a final clearing agent and the antennae were mounted in a synthetic resin (Harleco H. S. R.) which was dissolved in toluol. In using this method it is of the first importance that passage from the stain to n-butyl alcohol or dioxan be very rapid for the fuchsin is lost quickly if there is any delay. Dehydrating agents in which acid fuchsin is soluble must be avoided and the same applies to clearing and mounting media. Before any other reagent is substituted for one of those used here a sample should first be tested by adding a small amount of the dry, powdered dye to it. Finally, it should be noted that special difficulties will be encountered when this method is used for studying large structures which have much soft tissue or body fluid associated with them. The water in this tissue or fluid may dilute and carry the stain away with it while the specimen is being dehydrated.

#### RESULTS AND DISCUSSION

The basiconic or peg-like sensilla on the antennae of the grasshoppers studied may be subdivided into at least three kinds: <sup>3</sup> (1) long, slender pegs with a narrowly-rounded tip (Figs. 1 to 7, a), (2) short, stout pegs with a broadly-rounded tip (Figs. 1 to 7, b), and (3) short, slender pegs with a pointed tip (Figs. 1 to 7, c). Of these only the first are permeable to acid fuchsin. The other two are unaffected by the stain. No clue as to their function has been obtained, and they will not be considered further here.

<sup>3</sup> Snodgrass (1935, p. 519) discusses variations in basiconic sensory structures as follows: "Sensory pegs and cones are innervated hairs reduced in size, and there is no sharply dividing line between sensilla trichodea and sensilla basiconica, either in the character of the external parts or in the structure of the internal parts. In a typical sensillum basiconicum the external process is a small peglike or conical structure (Fig. 269 A, *Pg*). The walls of the process are thick or strongly sclerotic in some cases, while in others they are thin and transparent, or the process may terminate in a delicate membranous cap."

The extent to which the stain penetrates the long, slender pegs which were described in the preceding paragraph, depends largely, although not entirely, upon the time of exposure. If the antenna is left for a short time in the dye only the extreme tip of each peg is colored and examination with an oil immersion lens may be necessary to detect the minute red spots. This indicates that the whole outer

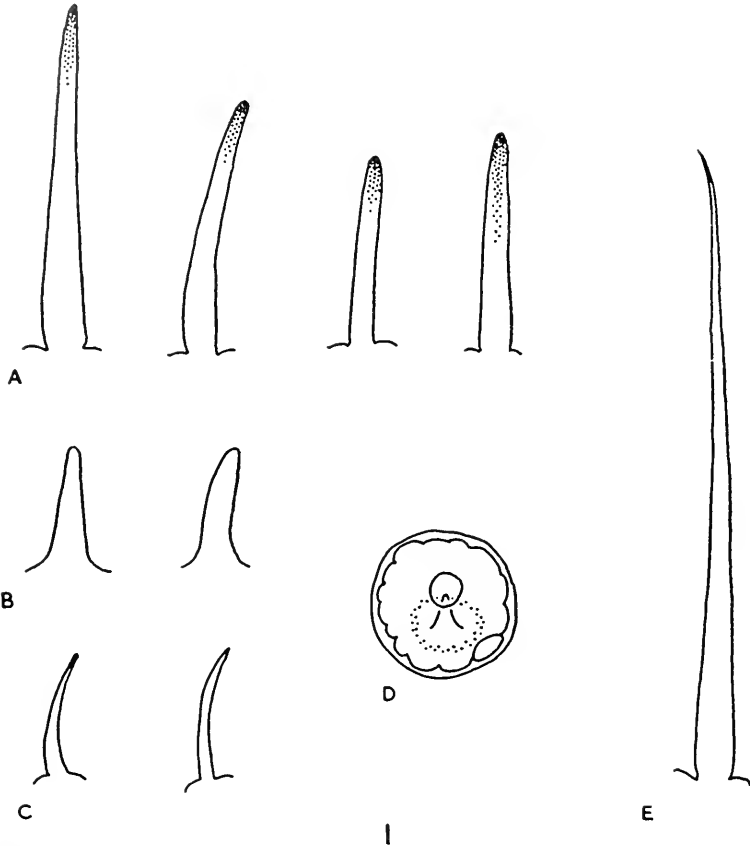
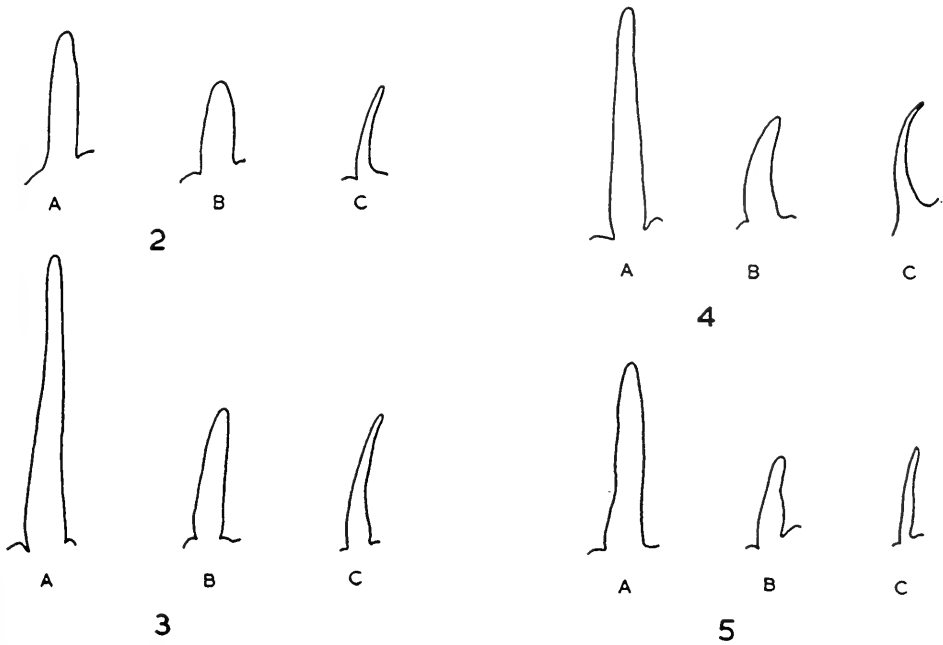

FIGURE 1. Sensory structures from surface of the antenna of an adult female *Melanoplus differentialis differentialis* which, nineteen hours after the final molt, was treated for 30 minutes with an aqueous solution of acid fuchsin. A, long, slender basiconic pegs which are permeable to the dye at their tips; stippled area shows extent of penetration of the stain during 30 minutes; B, short, stout basiconic pegs which are unaffected by the dye; C, short, slender basiconic pegs which are unaffected by the dye; D, surface view of coeloconic peg; small, brownish, oval mass of unknown origin and identity which is commonly present in such pits shown at lower right; E, sensory bristle which is unaffected by stain.  $\times 1100$ .

surface of the peg is waterproof except at the tip. Here the usual waxy or lipid layers of the cuticle must be missing. The inner, permeable layers of the cuticle extend across the tip and there is no actual opening or pore. In antennae which have been left longer in the stain the dye will be found to have traversed the permeable cuticle at the tip and to have entered the central cavity or core of the peg. The extent of this cavity can be seen in antennae which have been allowed to dry before



being mounted in resin, for the air-filled core of the peg then appears black under the microscope. Since the cavity of the peg in the living insect contains either fluid or cytoplasm, which extends up into it from the cellular layer below, the passage of the dye is more rapid down the central core. At the same time, but a little more slowly, diffusion occurs laterally from the core through the inner, cuticular layers of the peg. After very long exposures the entire peg is colored and the dye may reach the interior of the antenna itself.



FIGURES 2 TO 5. Basiconic pegs from the surface of the flagellum of the antennae of adults of four species of grasshoppers. Figure 2, male *Acrida bicolor*; Figure 3, male *Orphulella pelidna*; Figure 4, female *Dissosteira carolina*; Figure 5, male *Locusta migratoria migratorioides*. A, long, slender peg which is permeable at the tip; B, short, stout peg which is unaffected by dye; C, short, slender peg which is unaffected by dye.  $\times 1100$ .

The tips of the long pegs stain with great regularity and the rest of the surface of the antenna shows no trace of the dye except in those regions where an obvious injury has occurred. To eliminate all possibility that the tips of the pegs stained because they had been worn or abraded tests were made with the antennae of adults which had just molted. The results with these were the same as had been obtained with older animals. On the antennae of a freshly-molted individual, where the cuticular surface is still perfect, only the tips of the long, basiconic pegs are colored by the dye.

These pegs are permeable to acid fuchsin in the newly-hatched grasshopper. To establish this point nymphs of *Melanoplus mexicanus mexicanus* which had left the egg a few moments before and had just shed the cuticle with which they hatch were treated with fuchsin. The tips of their long basiconic pegs stained brilliantly but

the entrance of the dye into the cavity of the peg was slower than it is in the adult. It was interesting to find that these sensilla in the newly-hatched nymph are of approximately the same size as are those of the adult (Figs. 6 and 7) although, as Jannone (1940) and Eiben (1949) have shown, antennal sense organs are much fewer in number in the former. Why penetration of the dye should be slower in the young insect is not known but the size of the colored area at the tip suggests that the permeable surface is even smaller than it is in the older animals.

The bristles or sensilla chaetica described by Röhler for *Acrida turrita* are also present on the antennae of the species studied here (Fig. 1,e) but they are few in number and are located only on the proximal segments. Such bristles are usually believed to have a tactile function. They are entirely unaffected by the dye in newly-molted individuals, but these long bristles are often found to be damaged in older animals and the stain then enters rapidly through the broken end.

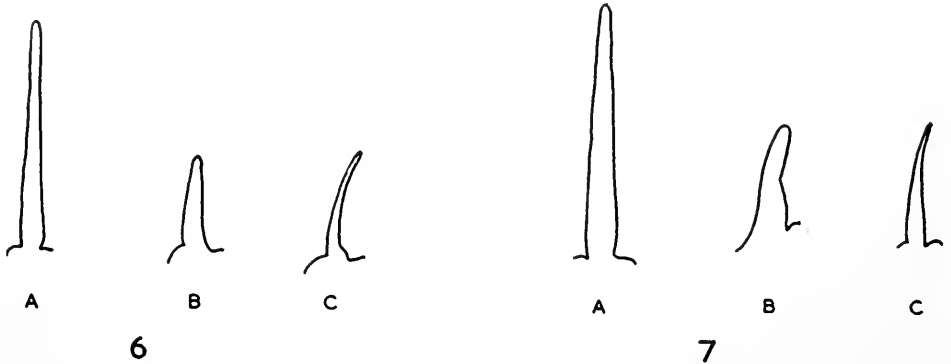

FIGURES 6 AND 7. Basiconic pegs from surface of flagellum of antenna of newly-hatched and of adult *Melanoplus mexicanus mexicanus*. Figure 6, newly-hatched; Figure 7, adult male. A, long, slender peg which is permeable to dye; B, short, stout peg which is unaffected by dye; C, short, slender peg which is unaffected by dye.  $\times 1100$ .

As Röhler reported in 1906 another type of sense organ present on the grasshopper antenna is the pit peg or sensillum coeloconicum. There is considerable evidence that coeloconic sensilla in other insects are chemoreceptors. In these sense organs, in the grasshopper, the peg is located at the bottom of a small, globular pit which opens to the surface through a still smaller hole (Fig. 1, d). The cavity, in life, is filled with air and because of this it has not been possible to demonstrate, with the method outlined above, that the tip of the peg is permeable. When the antenna is immersed in water or in an aqueous solution of acid fuchsin the pits remain filled with air and this prevents the fluid from coming into contact with the tip of the peg. The air bubbles in the pits are easily seen under the microscope. No method for removing these bubbles, which may not be suspected of damaging or altering the tip, has yet been devised. Attempts to remove the bubbles with a vacuum pump and with a detergent solution were made but the results were not satisfactory. It is possible that dye might be placed in the pit with the aid of a microdissection syringe but this was not tried. Antennae from animals which have been fixed in Bouin's solution and preserved in 70% alcohol provided some information concerning the permeability of the pegs. In these the pits have filled with

alcohol and when such antennae are placed in fuchsin, as were the living antennae, the dye replaces the alcohol in the pits and the tips of the pegs then take up the stain just as do the tips of the long, basiconic pegs of the same specimen. It will be noticed in such preparations that the stain penetrates the latter more rapidly than it does in fresh material but the manner of entry is the same. From these observations we may conclude that the tips of the coeloconic pegs also differ from the general cuticular surface in respect to permeability and that it is probable, although, of course, not yet proved, that they, too, would be permeable to an aqueous solution of fuchsin in the living condition were it possible to bring the dye into contact with them.

Since the relatively large molecule of acid fuchsin penetrates the tip of the living basiconic peg so readily there can be no doubt that this region is also permeable to water and it is highly probable that a great variety of other substances could also be shown to pass through it if methods suitable for their detection were applied. The results reported here, then, strongly support the conclusions of many previous investigators who, on other grounds, and with other species of insects, have believed certain basiconic pegs to be chemoreceptors, hygroreceptors or both. The results obtained with fixed material suggest that the coeloconic pegs may have a similar function or functions although the evidence is less reliable than it is for the long, basiconic pegs.

Preliminary examinations of other parts of the body of the grasshopper have shown that long, slender pegs of the type present on the antenna occur also in other regions, although more sparsely, and that they, too, have a permeable tip.

Whether insects other than grasshoppers also possess basiconic pegs which are permeable to water and dyes is not known with certainty at present. A few adults belonging to other orders (Collembola, Thysanura, Dermaptera, Isoptera, Neuroptera, Coleoptera, Hymenoptera and Diptera) were tested with interesting but inconclusive results. In some specimens definite and regular staining occurred but since only a few tests were made and since the individuals used were of unknown age and past history it is possible that the tips of the sensilla which stained may have previously been damaged. For critical work the animals should be freshly-molted or, at least, known never to have been in contact with a surface or object which might injure the tips of the pegs. These cursory tests, however, brought out several of the difficulties which may be encountered when insects other than grasshoppers are studied. In some the covering of long, close-set hairs retains a film of air which prevents the stain from reaching the pegs even though the specimen is wrapped in cotton which is covered by the dye solution. In others the cuticle is heavily pigmented and it is impossible to decide whether or not any staining has occurred. In still other individuals faint staining was apparent only after many hours exposure to the dye which suggests that the rate of penetration must be extremely slow in these forms. In certain species large, thin-walled pegs were found barely tinged with pink. Here, seemingly, small amounts of the dye had penetrated and then diffused through the fluid contents of the peg. Finally, it should be emphasized that failure to stain with acid fuchsin does not mean that the structure tested is impermeable to all materials. It may still be permeable to water and to substances other than the dye used here. Clear-cut, positive results, such as are given by the long, slender pegs of the grasshopper antenna, lend very strong support to the idea that these structures, in this insect, serve as chemoreceptors, as

hygroreceptors, or, perhaps, as both. Negative results, on the other hand, prove only that, under the conditions of a particular experiment, the structure tested is either impermeable to acid fuchsin in detectable amounts or that any dye which did penetrate was later lost.

#### SUMMARY

1. When an aqueous solution of acid fuchsin is applied to the surface of the living antenna of a grasshopper the dye enters the tips of the largest of three types of basiconic sense organs while the other two types are unaffected.

2. The permeability to water and to dye of these long basiconic pegs on the antenna of the living grasshopper strongly supports the conclusions of earlier workers with other insects that such structures may serve as chemoreceptors, as hygroreceptors, or as both.

3. The permeability to water and to dye of the pegs of the coeloconic sense organs on the surface of the antennae of preserved grasshoppers suggests that these, too, may function as chemoreceptors, as hygroreceptors, or as both but the evidence is less satisfactory than it is for the long basiconic pegs.

4. *Positive results* with the staining method described in the present paper indicate that the structure tested is permeable to acid fuchsin and to water and, probably, to many other substances as well. *Negative results* mean either (1) that the structure is completely or nearly impermeable to acid fuchsin or (2) that any of the stain which did enter was lost in later handling.

#### LITERATURE CITED

- DETHIER, V. G., 1953. Chapter on Chemoreception. Insect physiology, edited by K. D. Roeder, John Wiley & Sons, New York.
- EGGERS, F., 1924. Zur Kenntnis der antennalen stiftführenden Sinnesorgane der Insekten. *Zeitschr. Morph. und Ökol. Tiere*, 2: 259-349.
- EIBEN, C. H., 1949. A study of the sense organs on the surface of the antennae of the grasshopper, *Melanoplus differentialis*, during post-embryonic development. Unpublished Master's Thesis, State University of Iowa.
- FRINGS, H., AND M. FRINGS, 1949. The loci of contact chemoreceptors in insects—A review with new evidence. *Amer. Mid. Nat.*, 41: 602-658.
- HODGSON, E. S., 1953. A study of chemoreception in aqueous and gas phases. *Biol. Bull.*, 105: 115-127.
- JANNONE, G., 1940. Studio morfologico, anatomico e istologico del *Dociostaurus maroccanus* (Thumb.) nelle sue fasi transiens congregans, gregaria e solitaria. *Boll. R. Lab. Entom. Agraria di Portici*, 4: 1-443.
- McFARLANE, J. E., 1953. The morphology of the chordotonal organs of the antennae, mouthparts and legs of the lesser migratory grasshopper, *Melanoplus mexicanus mexicanus* (Saussure). *Can. Ent.*, 85: 81-102.
- McINDOO, N. E., 1920. The olfactory sense of Orthoptera. *J. Comp. Neuro.*, 31: 405-427.
- RICHARDS, A. G., 1952. Studies on arthropod cuticle. VIII. The antennal cuticle of honeybees, with particular reference to the sense plates. *Biol. Bull.*, 103: 201-225.
- RÖHLER, E., 1906. Beiträge zur Kenntnis der Sinnesorgane der Insekten. *Zool. Jahrb., Abt. Anat. u. Onto.*, 22: 225-288.
- ROTH, L. M., AND E. R. WILLIS, 1951. Hygroreceptors in Coleoptera. *J. Exp. Zool.*, 117: 451-487.
- SLIFER, E. H., 1936. The scoloparia of *Melanoplus differentialis* (Orthoptera, Acrididae). *Ent. News*, 47: 174-180.
- SNODGRASS, R. E., 1926. The morphology of insect sense organs and the sensory nervous system. *Smithsonian Misc. Coll.*, 77 (8): 1-80.
- SNODGRASS, R. E., 1935. Principles of insect morphology. McGraw-Hill Book Co., Inc., New York.

# THE LOCALIZATION OF HEPARIN-LIKE BLOOD ANTICOAGULANT SUBSTANCES IN THE TISSUES OF SPISULA SOLIDISSIMA

LYELL J. THOMAS, JR.<sup>1</sup>

*Marine Biological Laboratory, Woods Hole, Mass., and Department of Zoology,  
University of Pennsylvania, Philadelphia, Pa.*

As previously reported (Thomas, 1951) a potent blood anticoagulant resembling heparin can be extracted from the common surf clam *Spisula (Macra) solidissima*. This has recently been confirmed by Frommlhagen *et al.* (1953). They attempted to develop the *Spisula* anticoagulant for clinical use.

The discovery of the *Spisula* anticoagulant stemmed from previous studies by Heilbrunn and his students concerning the biological significance of heparin and related substances. There is an increasing amount of evidence that such substances may be of rather general importance. Thus in the monograph by Jorpes (1946) there are numerous references indicating that in addition to acting as a blood anticoagulant heparin may serve other functions. It is known, for example, that heparin will inhibit growth in tissue culture and that it can inhibit the action of various enzymes. Heparin is chemically related to the sulfated polysaccharides found intercellularly in the connective tissues and in mucus secretions so that functions served by these latter substances are also of interest when considering the significance of heparin-like substances. As will be discussed later there is evidence that chondroitin sulfate may be of importance in calcification.

As compared with the number of investigations concerning heparin and related substances in mammals the number of similar investigations on adult invertebrate animals have been relatively few. However there is evidence that these substances may be of major importance to the eggs of invertebrate animals. Thus it is known that the jelly coat of sea urchin eggs contains a highly sulfated polysaccharide capable of preventing the clotting of blood. The significance of this fact and the general importance of the jelly coat to fertilization have been discussed by Runnström (1952). Polysaccharide sulfate esters seem to be of significance for reactions in the protoplasm of egg cells as well as for reactions at the surface. Thus Heilbrunn and Wilson (1949) found that heparin seems to inhibit the protoplasmic gelations which normally occur during division of the *Chaetopterus* egg. Also, as shown by Kelly (1953), not only the jelly coat but also certain elements in the protoplasm of some marine eggs show the metachromatic staining reaction for polysaccharide sulfate esters. The metachromatic reaction is a shift in color caused by the polymerization of certain basic dyes such as toluidine blue (Michaelis, 1947) and is often produced when the dye combines with large negatively charged molecules. Heparin and other highly sulfated polysaccharides produce a very intense red metachromatic color with toluidine blue.

From the histological investigations of Kelly it was known that the eggs and ovaries of *Spisula* exhibit strong metachromatic staining and, as will be shown in this paper, a metachromatic blood anticoagulant substance can be isolated from

<sup>1</sup> Present address: Department of Pharmacology, Woman's Medical College, Philadelphia 29, Pa.

Spisula eggs. However it was observed that other tissues of this clam also had a very high affinity for toluidine blue and that breis of the tissues showed an impressive metachromasia *in vitro*. Thus it seemed desirable to isolate the metachromatic substance in order to determine some of its properties. Also an attempt has been made to discover the origin of the substance within the tissues. From the work of Soda and Egami (1938) it was known that a heparin-like anticoagulant can be obtained from the mucous secretions of *Charonia lampas*, a marine gastropod. Thus it was suspected that the anticoagulant from Spisula might also be of mucous origin. In part this seems to be true. However, blood clotting assays made on extracts of various portions of the clam have revealed that in addition to an anticoagulant of mucous origin another anticoagulant substance is present in the tissues of Spisula. From histological examination it appears that this latter substance is an intercellular material possibly analogous to the chondroitin sulfate of mammalian connective tissues. As pointed out in the discussion there is a possibility that such substances may be of importance in calcification processes.

#### ISOLATION OF THE SPISULA ANTICOAGULANT BY MEANS OF A HEPARIN EXTRACTION PROCEDURE

The clams (Spisula) were obtained from commercial fishermen along the New Jersey coast and at Woods Hole. At first, anticoagulant preparations were made from thoroughly washed clam meat containing all the organs except the viscera and shell. The visceral mass was removed because of complications caused by the gonadal material. The presence of sperm rendered it difficult to extract the anticoagulant. This was probably due to the basic proteins of the sperm which are known to precipitate heparin-like substances. On the other hand the viscera from female clams did not seem to contain any anticoagulant other than that which could be ascribed to the ovaries and eggs.

After grinding the clam meat several times in a food chopper, extraction and purification of the anticoagulant were carried out according to the procedure for preparing beef lung heparin described by Homan and Lens (1948). Thus the chopped tissue was allowed to autolyze for 24 hours and then was extracted for an hour with a warm alkaline buffer containing half normal sodium hydroxide and enough ammonium sulfate to maintain a pH of 9 or 10. The supernate was then heated to 70° C.–80° C. to denature protein, filtered, and the crude anticoagulant was precipitated together with protein by acidification to pH 2–3. The precipitate after extraction with alcohol was digested with trypsin. Some impurities could be removed from the digest by adding ammonium carbonate, centrifuging, and then boiling at pH 7 followed by another centrifugation. The active material was then precipitated by two volumes of alcohol and subjected to a partition between water and neutralized phenol. This left the active material in the aqueous phase whereas most of the remaining proteinaceous impurities entered the phenol phase. The product was obtained from the aqueous phase by adding NaCl and two volumes of alcohol. Further impurities could be removed with lead acetate at pH 5 and the lead removed with an excess of sodium carbonate. The anticoagulant was then obtained as the sodium salt by precipitation with a large excess of acetic acid followed by neutralization in an alcohol-ether mixture.

Anticoagulant tests were performed by the thrombin method of Jaques and Charles (1941), with the modification that instead of beef blood citrated sheep plasma was used. The anticoagulant activities of all clam preparations were compared to commercial samples of sodium heparin (generously supplied by the Upjohn Co., Kalamazoo, Mich.) rated in U.S.P. units by the manufacturer. These values ranged from 120 to 156 U.S.P. units/mg.

In all, three anticoagulant preparations were made from eviscerated clams as described above. Following the stage of phenol partition, the average anticoagulant activity of these preparations was 40 heparin units per milligram. By further purifying one of these preparations with lead acetate and then forming the sodium salt, a product with an activity of 50 heparin units per milligram was obtained. The yield obtained from these initial preparations was about 11,000 units per kilogram of starting material. The preparations that were carried only through the stage of phenol partition gave weak positive biuret and ninhydrin reactions indicating traces of protein material, but the lead-purified product seemed to be protein-free. All samples gave a positive color reaction for hexosamine (Palmer *et al.*, 1937) and a barium precipitate after hydrolysis with HCl indicated the presence of ester sulfate. In view of later findings it would appear that both the yield and activity from these initial preparations were rather low. Some of the probable reasons for this are discussed below.

The most active product obtained thus far was a lead acetate-purified sodium salt of the anticoagulant from *Spisula* mantle tissue. It had an activity of 130 heparin units per milligram which is equivalent to the activity of mammalian sodium heparinate. The yield of this final product from one kilogram of mantle was about 19,000 units which is equal to the best yields reported for beef lung heparin (Kuizenga and Spaulding, 1943). However, as will be discussed below, even this yield apparently represents only a fraction of the total anticoagulant substance in the *Spisula* mantle tissue. The final product was a white powder readily soluble in water, which seemed to be free of lead and proteins. After acid hydrolysis it gave positive tests for reducing sugar, hexosamine and ester sulfate. But it was interesting to note that the hexosamine color and barium sulfate precipitate appeared from qualitative examination to be only one half to two thirds as great as the same reactions given by beef lung heparin of the same anticoagulant strength.

The mantle tissue anticoagulant discussed above was purified from an alkaline extract in the same manner as the previous preparations. But in an effort to extract as much anticoagulant as possible, the mantle tissue was homogenized in a Waring Blendor and allowed to autolyze for a relatively long period (48 hours). It was then subjected to prolonged extraction (6 hours) with the alkaline sodium hydroxide-ammonium sulfate mixture. However, even after this more thorough extraction it was found that a large amount of the anticoagulant substance remained in the tissue. After extraction, the residue was washed with several changes of water and then with alcohol and ether. When stained with toluidine blue the residue still showed a strong metachromatic color and, after digestion of the residue with trypsin, the metachromatic material appeared in solution. The digest was boiled and centrifuged, then tested for anticoagulant activity, whereupon it was discovered that the digested residue yielded as much anticoagulant activity as the crude product from the alkaline extract. The alkaline extract and the digested residue each yielded about 30,000 units per kilogram of original tissue, thus in-

dicating a total potential yield of 60,000 units or more per kilogram of mantle tissue. It would seem, then, that alkaline extraction is not a very efficient method of removing the anticoagulant from *Spisula* tissues, and in subsequent work tryptic digestion was used as the method of extraction.

Since alkaline extraction did not remove all of the anticoagulant from the tissue it seemed wise to investigate other aspects of the procedure. By assaying tryptic digests of fresh and autolyzed mantle tissue it was found that no change in the total yield of anticoagulant was produced by autolysis. However more anticoagulant could be extracted with alkali after autolysis and the crude product obtained in this way was more active than when autolysis was omitted. This increased activity was probably due to the preferential destruction of contaminating substances during autolysis. Another factor of importance in obtaining a high final yield is that the active material precipitates rather slowly out of alcoholic solution after the removal of proteins. Even after the addition of salt to the alcoholic solution it was usually necessary to let the mixture stand for 24 hours or more. Centrifugation prior to this time often left some of the active material dispersed in the supernate. Partition of the crude product between neutralized phenol and water was a very effective step in purification if repeated two or three times. Provided that there was a clean separation of the two phases, none of the active material was found in the phenol phase. Most of the protein impurities following tryptic digestion could be removed in this manner.

#### LOCALIZATION OF ANTICOAGULANT SUBSTANCES WITHIN THE TISSUES OF SPISULA

Extracts obtained from various organs and tissues were assayed for anticoagulant activity and these data were compared with results obtained from metachromatic staining of tissue sections and from *in vitro* observations on metachromasia.

For the histological localization of acid polysaccharides in the tissues, paraffin sections of formalin-fixed material were stained according to the method of Sylvén as described by Glick (1949). Staining was done with toluidine blue in 30 per cent alcohol followed by destaining in 95 per cent alcohol. For the assay of total anticoagulant content of various organs and tissues the following method was adopted. A small quantity of tissue was extracted with alcohol and ether to remove lipids, and the extracted tissue was then digested with trypsin (Difco 1:250). Usually an amount of trypsin equivalent to one tenth the extracted dry weight of the tissue was used. After 24 hours digestion (35° C., pH 8) the digest was boiled and insoluble material centrifuged down. The supernate, made to a known volume and representing a known weight of tissue, was then assayed for anticoagulant activity. Table I represents the average anticoagulant activities per wet weight of tissue for two series of digests made in the above manner. It seems reasonably certain that these values represent activity due only to the heparin-like substances in the tissue. Preliminary trials indicated that the anticoagulant action of digests of this type could be abolished entirely by adding toluidine blue. Furthermore, no loss of activity resulted from dialysis, phenol partition, or from precipitation with two volumes of alcohol if these steps were carried out carefully. It was also found that such digests had no effect on the clotting time of a purified fibrinogen-thrombin clotting system. This indicates that a co-factor is probably necessary for the action of the anticoagulant from *Spisula* as is known to be the case for heparin (Chargaff, Ziff and Moore, 1941).



As can be seen from Table I the eggs of *Spisula* appear to contain a relatively large amount of anticoagulant substance. A partially purified sample of this material was obtained from a tryptic digest of eggs previously extracted with alcohol and ether to remove lipids. After removal of some of the impurities by phenol partition, the active material was precipitated from the aqueous phase with alcohol. The material so obtained had an anticoagulant activity of about 20 heparin units per milligram. A large part of this anticoagulant from the egg no doubt was derived from the jelly coat, but some may also have been derived from elements in the protoplasm. As discussed below, not only does the jelly coat stain metachromatically but also there are regions in the interior of the egg that give a metachromatic color with toluidine blue. At the time the assays listed in Table I were performed, attempts to obtain anticoagulant jelly coat solutions by the acid sea water treatment of Vasseur (1947) proved unsuccessful. However this problem is being re-investigated and it now seems probable that the eggs used at that time, although fertilizable, were immature. Recent preliminary results indicate that although a thin jelly coat is present on immature *Spisula* eggs it is not easily removed by acid sea water,

TABLE I  
*Anticoagulant activity of various Spisula tissues*

	Heparin units per gram tissue wet weight
Mantle edge inner fold	180
Mantle edge outer fold	130
Gills	140
Palps	160
Eggs	100
"Skin" of foot	45
Foot devoid of "skin"	30
Adductor muscle	20

but can be removed by treating the eggs with 3% NaCl containing 0.1 *M* Versene (generously supplied by the Bersworth Chemical Co., Framingham, Mass.) at pH 8. On the other hand, some of the jelly coat from ripe eggs seems to be rather easily removed by acidified (pH 3.5-4) sea water.

Recently, *Spisula* eggs<sup>2</sup> fixed in Zenker-formal fluid and sectioned at three microns have been stained with toluidine blue (0.1% toluidine blue in 30% alcohol with destaining in 95% alcohol) after extraction with hot 4 per cent trichloroacetic acid (TCA) according to the method of Monné and Hårde (1951). Presumably this extraction removes the nucleic acids. The jelly coat of both the extracted and unextracted sectioned eggs exhibited brilliant red metachromatic staining. Unextracted eggs showed an intense blue to purple color in the cytoplasm and a purple metachromasia in the nucleolus. The main bulk of the germinal vesicle was practically unstained. After TCA extraction the cytoplasmic staining was reduced to a pale blue except for a diffuse red metachromasia in the outermost region of the cortex. The cortical granules which had previously been obscured by the strong cytoplasmic staining were very prominent after TCA extraction. These were seen to stain with an intense blue color. The staining of the nucleolus was not changed

<sup>2</sup>I wish to thank Dr. W. S. Vincent, Department of Anatomy, Syracuse Medical Center, Syracuse, New York, for the sectioned eggs.

appreciably by TCA extraction except that the metachromatic red color was more prominent. A more thorough study of the *Spisula* egg is planned and will be reported at a later date. It would be particularly interesting to determine more precisely whether the metachromatic staining of the nucleolus and cortical region is due to the presence of sulfated polysaccharides. In a preliminary report Allen (1951) mentions that mucopolysaccharide (as determined by the method of Monné and Slautterbach, 1950) appears to be transferred from the nucleolus to the spindle during cleavage of the *Spisula* egg.

Returning now to a discussion of the adult clam, it will be observed (Table I) that digests of the mantle, gills and palps had five or six times more anticoagulant activity than digests of the foot and muscles. Histological sections of the mantle edge revealed several regions of metachromasia. The mucous cells of the inner and outer folds (adjacent to the shell) of the mantle edge are both metachromatic. However it was observed that the mucous cells of these two folds are distinctly different with respect to intensity of staining reaction and with respect to size and shape. Thus the mucous cells of the inner mantle surface are smaller and take the metachromatic color much more intensely than the mucous cells adjacent to the shell. No mucous cells were observed on the middle fold of the mantle edge. The mucosal basement membranes were stained a brilliant red as were certain areas of connective tissue in the interior of the mantle. Distally in the mantle folds this connective tissue is a dense compact material resembling cartilage. The histological picture for the gills and palps resembles that of the mantle. Thus the basement membranes and interior connective tissue of these structures also are metachromatic. The mucous cells lining the palps and gill filaments resemble the mucous cells lining the inner surface of the mantle. Probably these mucous cells, peculiar to the mantle cavity, provide the sticky secretion which aids in the collection of food particles. The secretion of the large mucous cells of the outer mantle fold possibly enters into the composition of the shell matrix.

Very little metachromasia was observed in cross sections of the foot and none could be detected in the muscle tissues. The foot was seen to contain large mucous cells in the perimeter. These were stained a pronounced blue color with toluidine blue but little, if any, of the metachromatic red color was evident. The mucosal basement membrane in the foot, however, stained metachromatically.

The known presence of a heparin-like substance in gastropod mucus suggested that the anticoagulant from *Spisula* might be of mucous origin. Also the intense metachromasia exhibited by the mucous cells lining the gills, palps and inner mantle surface suggested that the mucus from these cells might contain a highly sulfated heparin-like polysaccharide. However the intensity of the metachromatic staining observed in the connective tissues of the mantle and elsewhere suggested that there might be another heparin-like substance in the connective tissues. In order to determine this, mucosal scrapings were taken from both sides of the mantle edge and the three folds of the mantle edge were separated from one another. During these operations special precautions were taken to insure that no mucous contamination was transferred from one part of the mantle edge to another. After extraction of the tissue and mucus fractions with alcohol and ether, tryptic digests were made of these fractions, as described previously, and the digests were assayed for anticoagulant activity. In Table II are given the results of these assays together with the dry weights of the starting material after extraction of lipids. The numbers at the far

left of the table identify the different types of data obtained from a given series of digests. To obtain the metachromatic ratios given in Table II a series of tubes, each containing the same amount of toluidine blue with phosphate buffer (pH 6.6) plus increasing concentrations of digest, was matched in a comparator block with an identical series of tubes containing buffered toluidine blue and heparin. The ratios are the number of anticoagulant units of heparin required to produce a given color, divided by the number of anticoagulant units of digest required to produce the same color. Thus, for example, if a digest had a metachromatic ratio of three, only one-third of an anticoagulant unit of digest would be required to produce the same mixture of red and blue color with a given amount of toluidine blue as was produced by one anticoagulant unit of heparin.

TABLE II

*Anticoagulant activities and metachromatic ratios for various portions of the mantle edge*

A. Heparin units per mg. dry weight					
Inside mantle edge mucosa	Outside mantle edge mucosa	Remainder of mantle edge after scraping			
		Whole mantle edge	Inside mantle fold	Outside mantle fold	Middle mantle fold
1) 1.44	0.28	0.80			
2) 1.30	0.07	0.68			
3) 0.98	0.08		0.84	0.64	
4)			0.80	0.72	0.93

B. Total weight of mantle edge and mucosal scrapings in milligrams					
1) 44	60	2,480			
2) 32	48	1,700			

C. Metachromatic ratio of extracts (see text)					
1) 5.6	not meta-chromatic	0.8			
2) 5.2		1.0			
3) 4.4			1.6	1.0	1.2

It will be noted that the tryptic digests of mucus from the outside mantle fold had little if any anticoagulant activity. Although this mucus was metachromatic in tissue sections, tryptic digests of this mucus were not metachromatic. On the other hand, the digested mucus from the inner mantle fold had anticoagulant activity and was highly metachromatic. In fact, it was about five times as metachromatic per anticoagulant unit as the heparin standard. Apparently this mucous substance has the ability to bind toluidine blue very strongly in comparison with its ability to prevent blood clotting. In digests of mantle edge tissue after scraping off the mucosae the metachromasia was about equal to that of heparin.

The data in Table II clearly indicate that another anticoagulant factor is present in the mantle edge tissue besides that originating from the mucous secretions. In the first place, digests of the outer mantle fold had nearly as much anticoagulant activity as those of the inner mantle fold, in spite of the fact that the mucus of the outer fold

was nearly inactive. Quite possibly the slight activity that was associated with this mucus can be ascribed to the small amount of tissue scraped off with the mucus. It will be observed that the middle fold had a high anticoagulant activity but, as stated previously, the middle fold of the *Spisula* mantle edge is apparently devoid of mucous cells. It is true that the highest anticoagulant activity per weight of starting material was given by the mucosal scrapings from the inside mantle fold. However, these scrapings had less than twice the potency of the scraped mantle edge and weighed only about one fiftieth as much. Furthermore, histological examination of scraped mantle edges showed that more than half of the mucosa had been removed. This means then that only about one twenty-fifth of the total anticoagulant activity of the mantle edge can be accounted for by the inner mucosa. Thus the only other obvious source of heparin-like anticoagulant in the *Spisula* mantle edge is the strongly metachromatic substance in the connective tissue.

Since the middle fold of the mantle is very rich in metachromatic connective tissue substance but has few if any mucous cells, it seemed desirable to isolate a sample of anticoagulant exclusively from this portion of the mantle. The middle fold was cut from mantle edge of several clams and thoroughly cleaned of debris.

TABLE III  
*Anticoagulant from middle fold of Spisula mantle edge*

Tissue wgt., milligrams		Product wgt., milligrams	Heparin units per milligram	
Wet	Dry		Product	Dry tissue
4,950	830	14	45	0.75

After alcohol-ether extraction and tryptic digestion of the tissue, the digest was boiled and centrifuged to remove impurities. Following this the active material was precipitated from solution with two volumes of alcohol and redissolved in water. This solution was then shaken out with two changes of phenol neutralized with ammonium hydroxide. After acidifying the aqueous supernate to pH 4 or 5, NaCl was added to a concentration of 1% and two volumes of alcohol were added. The solution was heated to 50° C. and allowed to stand for 24 hours, after which time the active precipitate adhered firmly to the vessel. This material was washed with an alcohol-ether mixture, then taken up in a small amount of water and allowed to dry in a weighing bottle over CaCl<sub>2</sub>. After weighing, this material was made to a known concentration and assayed for anticoagulant activity. The results are given in Table III. Wet weight of the starting material refers to the fresh tissue and dry weight refers to this tissue after extraction with alcohol and ether. The heparin units per milligram dry tissue refer to the amount of anticoagulant recovered in the product. The final product (Table III) was quite metachromatic and as can be seen its anticoagulant activity was almost half that of genuine heparin. Undoubtedly further purification would increase the activity. The amount of anticoagulant recovered per milligram of dry starting material is nearly as much as was indicated from the assay of crude digests in Table II.

## DISCUSSION

Probably the anticoagulant substance from the middle fold of *Spisula* mantle is identical with the metachromatic substance detected histologically in the connective tissues. This substance, although most abundant in the mantle and associated structures, is apparently present in other parts of the clam. Thus the basement membrane in the foot mucosa was quite metachromatic. No metachromasia was detected histologically in certain other tissues such as the adductor muscle, but digests of adductor muscle were slightly metachromatic corresponding to the low anticoagulant activity of these digests.

It seems possible that this connective tissue substance serves much the same function in the clam as does chondroitin sulfate in the tissues of mammals. Thus it is interesting that chondroitin sulfate has been implicated in calcification processes. Neuman and co-workers (1952) have shown that the chondroitin sulfate in cartilage acts as a cation exchange resin. Also Miller, Waldman and McLean (1952) found that toluidine blue and other basic dyes which have a high affinity for polysaccharide sulfate esters can prevent the *in vitro* calcification of hypertrophic cartilage. Apparently this inhibition is reversible. As they point out, there are various interesting correlations between metachromatic staining coincident with calcification. Thus Rubin and Howard (1950), for example, found that the metachromatic staining of growing bones is most intense in those regions about to calcify.

In view of the apparent relationship between calcification and acid polysaccharides in mammalian tissues, the recent paper by Bevelander (1952) was read with considerable interest. From his radioautograph showing distribution of  $\text{Ca}^{45}$  in the mantle edge of *Anodonta* it would appear that calcium is taken up in certain regions of the mantle edge connective tissues. Similar regions in the *Spisula* mantle edge appear to contain an abundance of acid polysaccharide. A further investigation is planned to determine in what way mucopolysaccharides could be involved in the calcification of molluscs.

I wish to express my sincere gratitude to Dr. L. V. Heilbrunn for his encouragement and advice during this investigation.

## SUMMARY

1. A heparin-like blood anticoagulant has been isolated from the surf clam *Spisula solidissima*.
2. The most potent preparation obtained had an anticoagulant activity of 130 U.S.P. heparin units per milligram and was derived from mantle tissue.
3. Anticoagulant assays made on tryptic digests from various portions of the clam revealed that the mantle, gills and palps had about five times more anticoagulant activity per gram of tissue than the foot and adductor muscles. It was also found that the eggs of *Spisula* yield a high anticoagulant activity. ✓
4. Toluidine blue staining of sectioned eggs revealed metachromasia in the jelly coat, cortical region and nucleolus.
5. In order to determine the origin of the anticoagulant from the adult clam, the results from anticoagulant assays made on digests of isolated portions of the mantle edge were compared with histologic observations concerning metachromasia. It was concluded that at least two substances with heparin activity are present in the mantle tissue. One of these substances is present in the mucus secretion of

the inner mantle fold and apparently also in the mucus secretions of the palps and gills. The mucus secretion of the outer mantle fold was nearly devoid of anticoagulant activity. The other anticoagulant substance seems to be an intercellular material in the connective tissues, possibly analogous to chondroitin sulfate. This substance also seems to be most abundant in the mantle, palps and gills.

6. The possibility that polysaccharide sulfate esters may be important in calcification processes is discussed.

#### LITERATURE CITED

- ALLEN, R. D., 1951. The role of the nucleolus in spindle formation. *Biol. Bull.*, **101**: 214.
- BEVELANDER, G., 1952. Calcification in molluscs. III. Intake and deposition of  $\text{Ca}^{45}$  and  $\text{P}^{32}$  in relation to shell formation. *Biol. Bull.*, **102**: 9-15.
- CHARGAFF, E., M. ZIFF AND D. H. MOORE, 1941. Studies on the chemistry of blood coagulation. XII. An electrophoretic study of the effect of anticoagulants on human plasma proteins with remarks on the separation of heparin complement. *J. Biol. Chem.*, **139**: 383-405.
- FROMMHAGEN, L. H., M. J. FAHRENBAACH, J. A. BROCKMAN, JR. AND E. L. R. STOKESTAD, 1953. Heparin-like anticoagulants from Mollusca. *Proc. Soc. Exp. Biol. Med.*, **82**: 280-283.
- GLICK, D., 1949. Techniques of histo- and cytochemistry. Interscience Publishers Inc., New York.
- HEILBRUNN, L. V., AND W. L. WILSON, 1949. The effect of heparin on cell division. *Proc. Soc. Exp. Biol. Med.*, **70**: 179-182.
- HOMAN, J. D. H., AND J. LENS, 1948. A simple method for the purification of heparin. *Biochim. et Biophys. Acta*, **2**: 333-336.
- JAQUES, L. B., AND A. F. CHARLES, 1941. The assay of heparin. *Quart. J. Pharm. Pharmacol.*, **14**: 1-15.
- JORPES, E., 1946. Heparin in the treatment of thrombosis. Oxford Univ. Press, London.
- KELLY, J. W., 1953. Metachromasy in the eggs of fifteen lower animals. *Protoptasma* (in press).
- KUIZENGA, M. H., AND L. B. SPAULDING, 1943. The preparation of the highly active barium salt of heparin and its fractionation into two chemically and biologically different constituents. *J. Biol. Chem.*, **148**: 641-647.
- MICHAELIS, L., 1947. The nature of interaction of nucleic acids and nuclei with basic dyestuffs. *Cold Spring Harbor Symp. Quant. Biol.*, **12**: 131-142.
- MILLER, Z., B. J. WALDMAN AND F. C. MCLEAN, 1952. The effect of dyes on the calcification of hypertrophic rachitic cartilage *in vitro*. *J. Exp. Med.*, **95**: 497-508.
- MONNÉ, L., AND S. HÄRDE, 1951. On the cortical granules of the sea urchin egg. *Ark. Zool.* [2] **1**: 487-497.
- MONNÉ, L., AND D. B. SLAUTTERBACK, 1950. Differential staining of various polysaccharides in sea urchin eggs. *Exp. Cell. Res.*, **1**: 477-491.
- NEUMAN, W. F., E. S. BOYD AND I. FELDMAN, 1952. The ion binding properties of cartilage. Metabolic Interrelations, Fourth Conference, pp. 100-112. Jos. Macy, Jr. Foundation, New York.
- PALMER, J. W., E. M. SMYTH AND K. MEYER, 1937. On glycoproteins IV. The estimation of hexosamine. *J. Biol. Chem.*, **119**: 491-500.
- RUBIN, P. S., AND J. E. HOWARD, 1950. Histochemical studies on the role of acid mucopolysaccharides in calcifiability and calcification. Metabolic Interrelations, Second Conference, p. 155. Jos. Macy, Jr. Foundation, New York.
- RUNNSTRÖM, J., 1952. The cell surface in relation to fertilization. Symposia of the Society for Experimental Biology VI. Structural Aspects of Cell Physiology, pp. 39-88. Academic Press, New York.
- SODA, T., AND F. EGAMI, 1938. A new sulfuric acid ester in the mucus of *Charonia lampas*. *Bull. Chem. Soc. Japan*, **13**: 652.
- THOMAS, L. J., JR., 1951. A blood anti-coagulant from surf clams. *Biol. Bull.*, **101**: 230.
- VASSEUR, E., 1947. The sulfuric acid content of the egg coat of the sea urchin, *Strongylocentrotus droebachiensis* Müll. *Ark. Kemi, Mineral. Geol. Bd. 25B*, no. 6: 1-2.

# THE BIOLOGICAL BULLETIN

PUBLISHED BY THE MARINE BIOLOGICAL LABORATORY

---

## THE RELATIONSHIP BETWEEN pH AND THE ACTIVITY OF CHOLINESTERASE FROM FLIES

L. E. CHADWICK, J. B. LOVELL AND V. E. EGNER

*Medical Laboratories, Army Chemical Center, Maryland*

In order to make useful comparisons of similar enzyme systems from different organisms, or of the response of a given system to different chemical agents, some understanding of the possible effect of changes in the conditions of assay is essential. This requirement becomes especially conspicuous in attempts to correlate results from laboratories whose techniques are not identical, as illustrated, for example, by certain discrepancies that will be discussed below. In commencing a series of studies intended to bring to light the distinctive properties of insect cholinesterases (ChE's), we have therefore found it expedient to examine in detail the effects of altering our experimental conditions, and have already reported the results of tests in which the activity of fly head ChE was measured in relation to the composition of the suspending medium (Chadwick, Lovell and Egner, 1953).

Another factor with significant influence *in vitro* on the rate of hydrolysis of acetylcholine (ACh) by ChE is the hydrogen ion concentration. For most ChE's that have been studied in this connection, enzymic activity was maximal somewhat on the alkaline side of neutrality, fell rather sharply at still higher pH values, and declined more gradually as hydrogen ion concentration was increased. The pertinent references are discussed by Augustinsson (1948); see also Table IV below.

Three studies of the problem with insect material have been reported. Tahmisian (1943) found a relationship of typical form and a pH optimum of 8.5 with the enzyme from developing grasshopper eggs. Stegwee (1951), working with central nervous tissue of the beetle, *Hydrophilus*, and the roach, *Periplancta*, recorded rather sharp optima at pH 7.4. Data of Babers and Pratt (1950) with fly head suspensions are in contrast with these and all other reports in that they indicate a peak in activity at about pH 5.75. In their preparations, ChE activity was maintained near half peak level between pH 6.25 and 9.00, and decreased abruptly at higher pH values, as at values below 5.50. They comment (p. 61) that "this activity over such a wide pH range not only was unexpected but is also unexplained"; however, the most unusual feature of their results is the position of the optimum.

At the time their work was published, our investigations of the same problem were already in progress, and it was apparent immediately that our observations did not agree fully with theirs. We therefore extended the scope of the experiments, first in order to establish more firmly the nature of the relationship between

pH and the activity of fly head ChE, and secondly with the hope of reconciling the differences between our data and those of Babers and Pratt. In addition, since the reduction in activity at low and high pH was found to involve some irreversible inactivation of the enzyme, we made measurements of this aspect of the process.

#### EXPERIMENTAL

Culture of flies (*Musca domestica* L.) preparation of head suspensions, and our application of Glick's (1937) titrimetric method of measuring ChE activity have been described in an earlier report (Chadwick, Lovell and Egner, 1953). In the present experiments, data were obtained at 25.0 degrees C. on 20-ml. aliquots, containing the equivalent of 20 heads each, with three suspension media. Of these, the first was buffer: NaCl, 26.30 gm.;  $\text{KH}_2\text{PO}_4$ , 3.85 gm.; NaOH, 1.00 gm.;  $\text{H}_2\text{O}$ , to one liter. This solution was designed to promote maximal enzymic activity, which had been found to require the presence of a salt at about 0.5 N concentration; and was buffered lightly, so as to minimize fluctuation of pH during assay and yet retain sufficient sensitivity for accurate determination of the rate of production of acid. Since our results with this medium differed considerably from those reported by Babers and Pratt (1950), whose suspensions contained glycerol, a second series of observations was made with head tissue ground and assayed in 30 per cent glycerol. In a third set of experiments, the brei was suspended in de-ionized water. With all the suspensions, pH was adjusted to the desired level by addition of NaOH or HCl.

The total acid production during test periods of approximately 15 minutes was corrected by subtraction of the acid produced under conditions that were identical except that the enzyme had been inactivated by exposing the stock brei overnight or for a longer time to  $1 \times 10^{-5}$  M diisopropyl fluorophosphate (DFP). The net, or enzymic, activity was then converted into micromoles of ACh.Br hydrolyzed per ml. (*i.e.*, per head) per hour.

The rate of permanent inactivation of fly head ChE at low and high pH was determined on aliquots that were incubated at the desired pH value for definite periods of time, and then readjusted rapidly to pH 8.0 before addition of ACh.Br for assay.

In all these experiments, the concentration of substrate at the beginning of measurement was 0.015 M. Other concentrations were used in a few experiments for special purposes, as cited in the discussion.

#### RESULTS

Average rates of enzymic hydrolysis of 0.015 M ACh.Br at various pH values in the three media tested are given in Table I. The data have been plotted in Figure 1 as percentages of the average value determined for these tissue samples in buffer at pH 8.0.

Also shown in Table I are the corresponding corrections for non-enzymic hydrolysis. These were evidently not identical in the several media. As pointed out in our previous paper, such variation results in part from the fact that pH



is not truly constant in our method of measurement. Each addition of NaOH during titration pushes pH to the alkaline side of the chosen value, and, for a given amount of alkali, such excursions are greater the more weakly buffered the solution. Error from this cause is not overly significant at pH 8.0 and below, but increases rapidly in more alkaline solutions, where the rate of non-enzymic hydrolysis of ACh is rising steeply with increase in pH. Since ChE activity, as measured in well buffered solutions, increases but slightly above pH 8.0, the error resulting from fluctuation of pH in the experimental samples is largely in the nonenzymic fraction and should theoretically be compensated by the nearly equal error in the controls. In practice, however, we found it difficult to obtain satisfactorily consistent results at pH 9.5 and 10.0.

In order to supply some indication of the range of variation encountered, we have computed standard errors for the means in each series except for those

TABLE I  
*Enzymic activity of fly head ChE as a function of pH*

pH	4.0	5.0	5.5	6.0	7.0	7.5	8.0	8.5	9.0	9.5	10.0
In buffer											
Net rate*	nil	0.34	1.97**	2.05	4.05	4.39	4.88	5.08	5.27	4.64	1.17
±s.e.	—	0.03	—	0.13	0.18	0.11	0.10	0.24	0.22	0.36	0.83
n***	4	10	5	9	10	11	31	10	13	10	10
Correction	—	—	-0.03	-0.03	-0.07	-0.09	-0.24	-0.56	-1.52	-4.78	-13.60
In de-ionized water											
Net rate*	nil	0.54	1.42	1.66	2.24	2.54	2.15	1.66	2.88	1.46	0.88
±s.e.	—	0.07	0.18	0.24	0.21	0.24	0.12	0.16	0.51	—	—
n***	6	10	10	10	10	10	17	10	10	5	5
Correction	—	—	-0.01	-0.02	-0.04	-0.28	-0.56	-1.21	-3.10	-7.63	-22.17
In glycerol, 30 per cent											
Net rate*	nil	0.44	0.88	1.27	1.42	0.98	1.37	0.88	1.51	0.63	0.15
n***	5	5	5	6	5	5	13	5	5	5	5
Correction	—	—	—	-0.01	-0.02	-0.25	-0.54	-1.14	-2.63	-4.24	-7.25

\* Average net rates, standard errors, and corrections in micromoles ACh.Br hydrolyzed per ml. (= per head) per hour.

\*\* pH, 5.75.

\*\*\* n, number of tests.

All runs at 25.0 degrees C.; ACh.Br, 0.015 M.

where only 5 determinations were made at each pH level. We report these calculations with some hesitation, first because of the relatively small "n," and secondly because the measurements at different pH values in a single series were not wholly independent. For example, aliquots of a stock brei which showed more than average activity at one pH value tended to give higher than average measurements at all pH levels. Thus, the sampling was not truly random, and on this account the standard errors listed in the table should not be relied on for estimates by the t-test of the significance of differences between means.

The second table shows the average activity remaining in samples that had been incubated at the indicated pH values for 30 minutes and then readjusted to pH 8.0 for assay. In Table III are recorded the results of exposing samples to pH 4.0 for different periods of time, up to two hours. Some few additional data pertinent to these experiments are cited in the discussion.

Table VI shows ChE activity as a function of pS at two pH levels, *viz.*, 6.0 and 8.0.

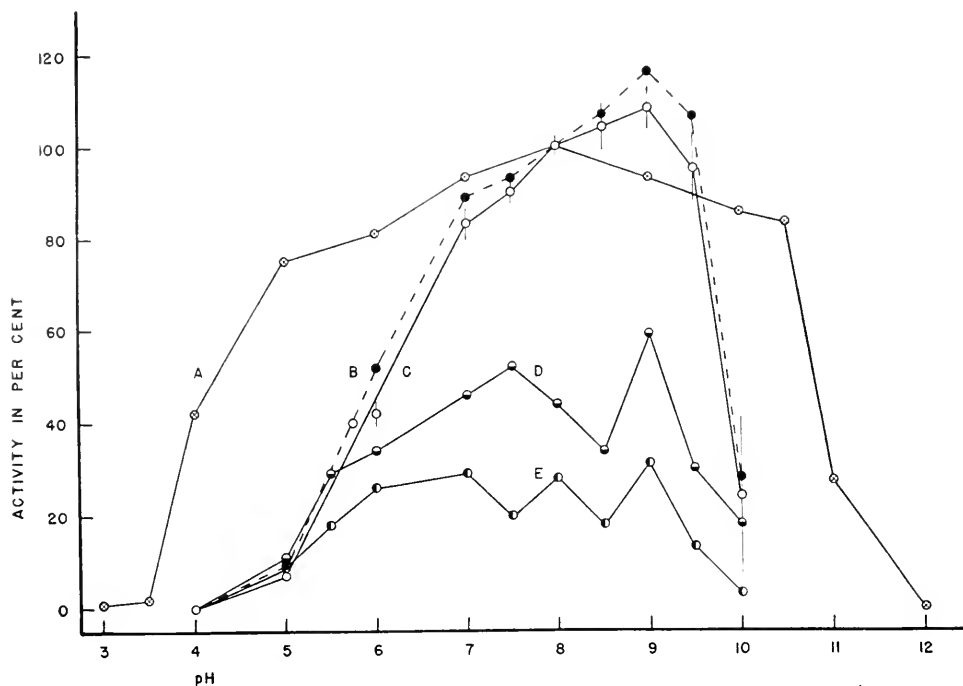

FIGURE 1. Variation in ChE activity of fly heads as a function of pH. Curve A. Residual activity after 30-minute exposures at indicated pH values; all measurements at pH 8.0 in buffer. Curve B. Specific activity at indicated pH values, computed by correcting Curve C for degree of inactivation shown in Curve A. For fuller explanation, see text. Curve C. Activity measured during 15-minute exposures at indicated pH values in buffer. The open circles give the mean values, and the vertical bars indicate the limits for  $\pm 3$  s.e. Curve D. Activity measured during 15-minute exposures at indicated pH values in water. Curve E. Activity measured during 15-minute exposures at indicated pH values in 30 per cent glycerol. All data shown have been corrected for non-enzymic hydrolysis.

TABLE II

*ChE activity of fly head suspensions after 30 minutes exposure at various pH values*

pH	Average enzymic activity (per cent)	Number of observations	pH	Average enzymic activity (per cent)	Number of observations
3.0	1.0	1	8.0	100.0	10
3.5	1.9	5	9.0	93.2	5
4.0	41.9	4	10.0	85.6	5
5.0	75.0	4	10.5	83.2	5
6.0	81.1	5	11.0	27.2	5
7.0	93.4	5	12.0	nil	2

All runs at 25.0 degrees C.; ACh.Br, 0.015 M; samples readjusted to pH 8.0 for measurement.

TABLE III

*Rate of inactivation of fly head ChE at pH 4.0 as a function of duration of exposure*

Time exposed minutes, . . . . .	0	15	30	60	90	120
Activity in per cent	100	65.9	41.9	30.1	24.9	20.5
Number of observations	20	5	4	4	4	4

All runs at 25.0 degrees C.; ACh.Br, 0.015 M; samples readjusted to pH 8.0 for measurement

## DISCUSSION

1. *ChE activity as a function of pH*

Examination of the measurements in buffer convinces us that the ChE of our fly heads differs little, in respect to the effect of pH on activity, from most other ChE's hitherto studied (*cf.* Table IV). The optimum is clearly on the alkaline side, being at least as high as 8.0 and probably as high as 9.0.

In aqueous suspensions or in 30 per cent glycerol, activity was generally low in comparison with observations at corresponding pH values in buffer, with the rates in glycerol somewhat less than those in water. These data provide a further demonstration of the activating effect of 0.5 N salt and the depressant effect of glycerol, to which we called attention earlier (1953). In water or glycerol there appeared to be little significant change in ChE activity over the pH range from

TABLE IV

*pH optima of ChE's from various sources*

Source of enzyme	pH optimum	Authority
Eggs, developing, <i>Melanoplus</i>	8.5	Tahmisian, 1943
Erythrocytes, human	7.6 or above	Plattner <i>et al.</i> , 1928
Erythrocytes, human	7.5 to 8.0	Alles and Hawes, 1940
Serum, human	8.2 or above	Plattner <i>et al.</i> , 1928
Serum, human	8.0 or above	Easson and Stedman, 1936
Serum, human	8.4 to 8.5	Glick, 1937
Serum, human	8.0 to 8.5	Werle and Uebelmann, 1938
Serum, horse	ca. 8.5	Glick, 1938
Serum, horse	7.2 or above	Kahane and Levy, 1936
Serum, horse	8.0 to 8.5	Werle and Uebelmann, 1938
Heart extract, frog	7.5 or above	Loewi and Navratil, 1926
Electric organ, <i>Electrophorus</i>	ca. 8.5	Wilson and Bergmann, 1950
Gastric mucosa, pig	ca. 8.5	Glick, 1938
Brain, rat (also rabbit, guinea pig, cat, dog)	ca. 8.4	Bernheim and Bernheim, 1936
Brain, cat	ca. 8.5	Glick, 1938
c.n.s., <i>Periplaneta</i> , <i>Hydrophilus</i>	7.4	Stegwee, 1951
Heads, <i>Musca</i>	5.75	Babers and Pratt, 1950
Heads, <i>Musca</i>	8.0 or above	This paper

6.0 to 9.0, in agreement with the findings of Babers and Pratt (1950); however, variation in our measurements was considerable and the curves are quite irregular.

Neither in these media nor in buffer could we find any evidence for an activity peak in the neighborhood of pH 5.75, as reported by Babers and Pratt. This led us to attempt one final comparison, in which activity at pH 5.75 and 7.0 was measured under conditions as nearly like theirs as we could make them. For this purpose, tissue was prepared in 30 per cent glycerol and diluted 1:6 for assay, which was carried out on 9.0-ml. aliquots that contained 150 mg. of tissue and 0.045 *M* ACh.Br. Babers and Pratt had used 3.0-ml. samples containing 50 mg.

TABLE V

*Comparison of ChE activity of fly head suspensions in 5 per cent glycerol at pH 7.0 and 5.75*

	pH 7.0	pH 5.75
	ml. 0.02 N NaOH per 3 ml. per 20 minutes	
	1.00	1.05
	1.05	1.03
	0.98	1.09
	1.03	1.02
	1.01	1.01
	1.01	1.04
Average	1.01	1.04
*Correction	-0.04	-0.01
Net	0.97	1.03

\* Correction values from Babers and Pratt (1950). All runs at 25.0 degrees C.; ACh.Br, 0.045 *M*; tissue, 150 mg.; total volume, 9.0 ml. Data computed to 3.0 ml. volume for sake of comparison with results of Babers and Pratt.

of tissue, but this volume was too small for our electrodes. As in their tests, acid produced was titrated with 0.02 N NaOH over a 20-minute test period. Five replications were made. The results, corrected for non-enzymic hydrolysis with values taken from Babers and Pratt (1950), are shown in Table V.

These data suggest the following comments. First, activity was nearly equal at both pH values; *i.e.*, evidence for a pronounced peak at pH 5.75 was not forthcoming. Secondly, as was to have been expected, activity per unit weight of tissue, or per head, was intermediate at pH 7.0 between the values previously found with suspensions in water and in 30 per cent glycerol, respectively. Finally we may

TABLE VI

*Activity of fly head ChE as a function of substrate concentration at two pH levels*

Molar concentration of ACh.Br	0.001	0.003	0.01	0.03	0.10
	Average enzymic activity in micromoles per head per hour				
pH 8.0	4.83	5.11	5.29	4.51	2.83
pH 6.0	1.22	1.77	2.37	2.44	1.71

Each datum is the mean of 5 determinations. All runs on aliquots of the same stock brei in buffer at 25.0 degrees C.

note that the activity of our preparation, at both pH levels, was more than twice the peak value reported by Babers and Pratt (1950). Unless some undetected difference in our methods of preparing the tissue can be held responsible, this observation indicates a possible strain difference between their flies and ours; and should strain differences of this magnitude exist, they could conceivably extend to a shift in the pH optimum from above 8.0 to 5.75. This, however, seems very unlikely in view of the bulk of evidence (Table IV) in favor of an alkaline pH optimum for ChE's in general. The remaining alternative is to ascribe the observation of Babers and Pratt to fortuitous variation in the activity of different breis; *i.e.*, to a somewhat unlikely coincidence of sampling errors, that led them repeatedly to exceptionally high values at pH 5.75. This solution does not appeal to us, since it is obviously indemonstrable and because the same sort of inference could, with equal justification, be applied to our own data; but all our efforts to find a more satisfactory explanation have failed.

Theoretical reasons for anticipating an increase in optimal concentration of substrate as conditions of measurement depart from the pH optimum have been put forward by Wilson and Bergmann (1950). The data in Table VI bear on this question, and do in fact indicate a slight shift of  $pS_{opt}$  in the predicted direction at pH 6.0 as compared with pH 8.0. Although it is of interest that this shift should appear in our results, the presence of the effect will hardly demand correction of the pH-activity data in Table I and Figure 1, for the following reasons. The magnitude of the shift is small, the optima are relatively flat, and the standard concentration of 0.015 *M* ACh.Br used routinely in our experiments is already somewhat above the optimum for pH 8.0.

## 2. Inactivation of fly head ChE

The reduction in activity of fly head ChE at hydrogen ion concentrations that depart appreciably from pH 8.0 is not wholly reversible. This fact raises a question as to what portion of the activity change observed at different pH levels is due to an effect of pH on reaction rate, and what portion to permanent destruction of a fraction of the enzyme. Obviously, data such as those in Table I must reflect a summation of both these processes.

We have attempted in a preliminary manner to separate the two effects by measuring the irreversible inactivation of ChE that results when the suspensions are exposed in buffer to different pH values for a constant period of time. The interval chosen was 30 minutes, this being somewhat longer than the average total exposure during our routine 15-minute determinations. As indicated in Table II, the percentage inactivation observed under these conditions remained within moderate limits until one passed below pH 5.0 or above pH 10.5. Other observations not given in the table showed that, within this pH range, there was little if any additional loss of activity during exposures of as much as two hours; and further that subsequent incubation of the samples at pH 8.0 for as long as 18 hours caused no reversal of the loss that had already occurred.

That inactivation did not take place instantaneously was demonstrated by a series of tests at pH 4.0, where suspensions were held for periods varying from 15 minutes to two hours, before return to pH 8.0 for assay (Table III). Here

the process of inactivation was rapid for the first 30 minutes, and followed a slower course thereafter. Both segments of the relationship have the characteristics of a first order reaction, as indicated in Figure 2.

Below pH 4.0 and above pH 11.0, inactivation was rapid and extensive. As a matter of fact, the enzyme, together with large amounts of eye pigment, was precipitated from aqueous suspensions of head tissue at about pH 5.0 to 5.1. Some 75 per cent of the original activity could be recovered if this precipitate

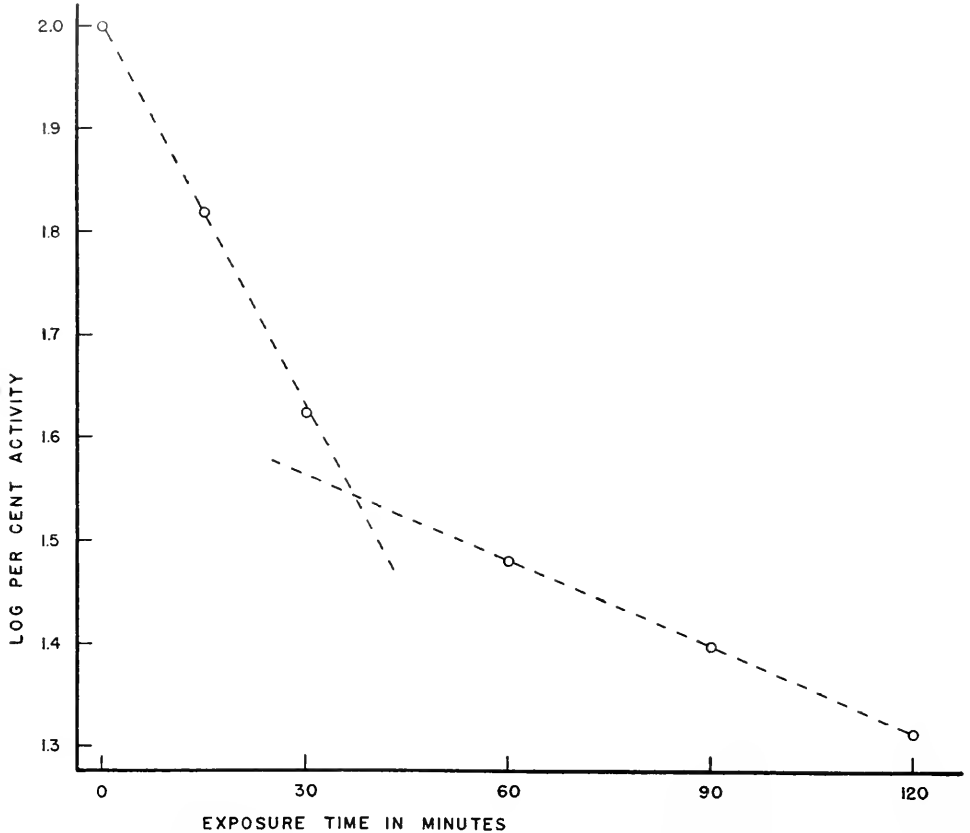

FIGURE 2. Rate of inactivation of fly head ChE in buffer as a function of duration of exposure at pH 4.0. All measurements made at pH 8.0. For further details, see text and Table III.

was quickly re-suspended in buffer at pH 8.0; but it was evident that the enzyme had been altered, since it was no longer as soluble as before precipitation. It was now easily re-separated by light centrifugation. According to Augustinsson (1948), the isoelectric point of several other ChE's has been reported as about pH 4.5. He also notes that precipitation at this level results in more or less permanent solubility changes.

By combining the data of Table II, which show the fraction of enzyme still active after half-hour exposures at the various pH values, with those of Table I,

which give the rates at which similar aliquots were able to hydrolyze substrate while at the same pH levels, it is possible to construct a corrected curve that compensates for changes in the relative amount of active enzyme. Such a curve is shown as B in Figure 1. The divergence from Curve C, which embodies the uncompensated activity data, is slight. This is because 30-minute exposures at pH values between 5.0 and 10.5 inactivated only small fractions of the enzyme, while the effect of pH on reaction rate was already considerable, well within these limits. The compensated curve (B) emphasizes the activity peak at pH 9.0, since the proportion of active enzyme has already begun to fall in this region, whereas the measured activity per unit of tissue has increased slightly above the value determined at pH 8.0. The results also show incidentally that the drop in activity at still higher pH levels is not due wholly to denaturation of the enzyme, since the measured activity decreased more rapidly than the enzyme was destroyed.

These data suggest a pH of about 8.0 as a suitable compromise for experiments where an approach to maximal activity of fly head ChE is desired. Although the true optimum probably lies as much as a full pH unit to the right of pH 8.0, the increase in enzymic activity over this range is slight, whereas the correction for non-enzymic hydrolysis is rapidly becoming larger. At pH 8.0, this correction is less than 5 per cent of the average total activity measured under our conditions; *i.e.*, with tissue concentration at one head per ml.; temperature, 25.0 degrees C.; substrate, 0.015M; and salt present in the buffered suspension at about 0.5 N concentration. The correction could be still further reduced by shifting to even lower pH levels, but only with increasing sacrifice of enzymic activity.

#### SUMMARY

1. Variation in activity of fly head cholinesterase (ChE) was measured titrimetrically at 25.0 degrees C. with ACh.Br 0.015 M as substrate, as a function of the pH of the assay medium over the range from pH 4.0 to 10.0. Ground tissue obtained from *Musca domestica* L. was suspended at a concentration of one head per ml. in three media: (1) buffer of composition NaCl, 26.30 gm.;  $\text{KH}_2\text{PO}_4$ , 3.85 gm.; NaOH, 1.00 gm.;  $\text{H}_2\text{O}$ , to one liter; (2) 30 per cent glycerol; (3) de-ionized water.

2. Enzymic activity was greater in buffer than in the other media. The pH optimum was definitely on the alkaline side, being at least as high as pH 8.0 and probably as high as 9.0. In glycerol or water suspensions, enzymic activity changed little between pH 6.0 and 9.0.

3. Some permanent inactivation of the enzyme was observed in half-hour exposures at high and low pH values. This effect was measured over the pH range from 3.0 to 12.0. Between pH 5.0 and 10.5, the degree of inactivation was moderate and essentially complete within 30 minutes. The time course of the process was followed at pH 4.0 for intervals from 15 minutes to two hours, and appeared to involve a rapid phase during the initial 30 minutes and a slower phase thereafter. Both phases had the characteristics of a first order reaction. Inactivation of ChE resulting from exposure to low or high pH was not reversed during subsequent incubation of the sample at pH 8.0 for as long as 18 hours.

4. Correction of the pH-activity curve to allow for changes in the relative amounts of enzyme that result from permanent inactivation requires only minor

alterations, since the effect of pH on reaction rate makes itself felt within pH limits where the degree of permanent inactivation is slight.

## LITERATURE CITED

- ALLES, G. A., AND R. C. HAWKES, 1940. Cholinesterases in the blood of man. *J. Biol. Chem.*, **133**: 375-390.
- AUGUSTINSSON, K.-B., 1948. Cholinesterases. A study in comparative enzymology. *Acta physiol. Scand.*, **15** (Suppl. 52): x + 1-182.
- BABERS, F. H., AND J. J. PRATT, JR., 1950. Studies on the resistance of insects to insecticides. I. Cholinesterase in house flies (*Musca domestica* L.) resistant to DDT. *Physiol. Zool.*, **23**: 58-63.
- BERNHEIM, F., AND M. L. C. BERNHEIM, 1936. Action of drugs on the choline esterase of the brain. *J. Pharmacol. Exp. Therap.*, **57**: 427-436.
- CHADWICK, L. E., J. B. LOVELL AND V. E. EGNER, 1953. The effect of various suspension media on the activity of cholinesterase from flies. *Biol. Bull.*, **104**: 323-333.
- EASSON, L. H., AND E. STEDMAN, 1936. The absolute activity of choline-esterase. *Proc. Roy. Soc. London, Ser. B*, **121**: 142-164.
- GLICK, D., 1937. LXXII. Properties of choline esterase in human serum. *Biochem. J.*, **31**: 521-525.
- GLICK, D., 1938. Studies on enzymatic histochemistry. XXV. A micro method for the determination of choline esterase and the activity-pH relationship of the enzyme. *J. Gen. Physiol.*, **21**: 289-295.
- KAHANE, E., AND J. LEVY, 1936. Sur l'hydrolyse diastatique de l'acétylcholine par le sérum. *C. R. Acad. Sci. Paris*, **202**: 781-783.
- LOEWI, O., AND E. NAVRATIL, 1926. Über humorale Übertragbarkeit der Herznervenwirkung. X. Mitteilung. Über das Schicksal des Vagusstoffes. *Pflügers Arch.*, **214**: 678-688.
- PLATTNER, F., O. GALEHR AND Y. KODERA, 1928. Über das Schicksal des Acetylcholins im Blute. IV. Mitteilung. Die Abhängigkeit der Acetylcholinzerstörung von der Wasserstoffionenkonzentration. *Pflügers Arch.*, **219**: 678-685.
- STEGWEE, D., 1951. Studies on cholinesterase in insects. *Physiol. Comp. et Oecol.*, **2**: 241-247.
- TAHMISIAN, T. N., 1943. Enzymes in ontogenesis: choline-esterase in developing *Melanoplus differentialis* eggs. *J. Exp. Zool.*, **92**: 199-213.
- WERLE, E., AND H. UEBELMANN, 1938. Zur Kenntnis des Blutegeltestes. *Arch. f. exp. Pathol. u. Pharmacol.*, **189**: 421-432.
- WILSON, I. B., AND F. BERGMANN, 1950. Acetylcholinesterase. VIII. Dissociation constants of the active groups. *J. Biol. Chem.*, **186**: 683-692.



# THE AMINO ACID REQUIREMENTS OF THE CONFUSED FLOUR BEETLE, *TRIBOLIUM CONFUSUM*, DUVAL.

G. FRAENKEL AND GLENN E. PRINTY<sup>1</sup>

*Department of Entomology, University of Illinois, Urbana, Illinois*

The rapidly accumulating literature on the nutrition of insects contains comparatively few data on amino acid requirements. However, all present evidence seems to indicate that insects require the ten amino acids which are essential for the rat.

Work on the nutrition of *Tribolium confusum* in a chemically well-defined medium, consisting of casein, glucose or starch, cholesterol, a salt mixture and eight to 10 vitamins of the B-complex, has been previously published by several authors (Fraenkel and Blewett, 1943, 1947; Fraenkel and Stern, 1951; Offhaus, 1952). An entirely successful "synthetic" diet for *Tribolium*, on which growth is as good as on the best natural diets, has not yet been reported. It has only very recently been found that carnitine is required for adult development (French and Fraenkel, 1954). The addition of 1% brewers yeast to a synthetic diet invariably leads to an improvement of growth. However, even in the absence of yeast, *Tribolium* grows sufficiently well to determine the effect of amino acid deficiencies. The results of the present study largely confirm and extend work on similar lines by Lemonde and Bernard (1951).

## METHODS

The basic diets used in this investigation were derived from diets which had been previously used in work with *Tribolium*. However, the fact that amino acid mixtures were used in the place of casein necessitated certain modifications in the diet. It was desirable to reduce the proportion of amino acids to a relatively low level which would still allow for adequate growth. *Tribolium* grows well on a wide range of carbohydrates ranging in concentration from 5 to 80% of the diet. In most of our previous work the protein level used was 50%. In the present study this was reduced to a total of 15% casein or mixtures of amino acids. In almost all our previous work the carbohydrate in the diets had been glucose. However, in the present study corn starch was used as the carbohydrate in all tests. Glucose could not be used because of the Maillard reaction between sugars and amino acids described by Friedman and Kline (1950a, 1950b). All the starch used in the experiments to be described was from the same batch.

The diets consisted of 15 parts casein or amino acid mixture, 85 parts corn starch, one part cholesterol, 2 parts McCollum's salt mixture no. 185 and the following vitamins of the B-complex (expressed as  $\mu\text{g}$ . per gram of the dry diet): thiamin 25, riboflavin 12.5, nicotinic acid 50, pyridoxin 12.5, pantothenic acid 25, choline chloride 500, inositol 250, pteroylglutamic acid 2.5 and biotin 0.25. All the ingredients, except the vitamins, were mixed in the dry state. To ensure a good distribution of those ingredients which were present in very small amounts,

<sup>1</sup> Present address: Department of Entomology, Citrus Research Station, Riverside, California.

the mixture of amino acids was first ground with an equal amount of starch, the cholesterol and salts were then added and ground together, and the balance of starch finally added and mixed in. The diets also contained  $\text{NaHCO}_3$  in amounts of approximately ten per cent of the amino acid mixture (to neutralize free acids). The vitamins were then added in solution in the amounts stated above to add 10% water to the dry diet. After mixing the vitamin solution into the diet with a spatula, the diets were left standing for two days in a constant temperature chamber at about 30° C. and 60–70% relative humidity, and then ground by hand in a mortar.

The tests were performed in shell vials, 1 × 2 inches, with one gm. of dry diet per vial, two vials to each diet. Ten first stage larvae were placed in each vial. All the tests were performed in a constant temperature chamber at 29–30° C. and 60–70 per cent relative humidity.

To assess the efficiency of a diet, two criteria were used. The number of surviving larvae and their average weight were determined after a period long enough to allow larvae on the optimal diet in a particular experiment to reach their maximum weight before pupation had started. This period varied somewhat, according to the composition of the diets, but was usually 20 days. On optimal diets, with glucose as the carbohydrate and the addition of yeast, pupation may occur after 15 days; however, since all the diets contained starch and few contained yeast, the period required for full growth was longer. The date of pupation was then recorded for each individual larva. From these results the average time to pupation was calculated for each test. In some cases the pupae were kept until the adult beetles emerged and the newly-formed beetles were examined. In following this procedure it was considered possible that certain amino acid deficiencies might affect larval mortality, growth rate, pupation or emergence in a different way than others. The most significant data were usually derived from the weights of the larvae. Since slow growth always leads to a delay in the onset of pupation, a positive correlation should exist between weights, growth rate and days to pupation. However, in some experiments, the number of pupae was unexpectedly small. The data concerning adult emergence finally proved to be without significance, since after most of the work was completed, it was discovered that the adults of *Tribolium*, which were grown on artificial diets, were not viable or failed to emerge, unless carnitine was added to the larval diets. There was, however, no indication that carnitine was necessary for larval growth and successful pupation (French and Fraenkel, 1954).

Growth and survival of *Tribolium* vary somewhat in diets run at different times. This may be due to slight changes in temperature and humidity, a difference in the viability of different batches of larvae and possibly other factors which are not too well understood. It makes it necessary to include in each experiment the appropriate positive and negative controls, and to make strict comparisons only between diets run at the same time.

## EXPERIMENTS

### *A. The amino acids mixtures used, and their effect on three species of insects*

In the absence of data about the amino acid requirements of *Tribolium* when this study was initiated, it was considered advisable to start the work with mixtures

which had proved successful with higher animals. Three were used altogether, two of which were amino acid mixtures used by Rose, Oesterling and Womack (1948) with the white rat. The third was one devised by Almquist and Grau (1944) for chicks. Table I gives the percentage composition of these amino acid mixtures. They were at first tested for their effect on the larvae of three beetles, *Tribolium confusum*, *Tenebrio molitor* and *Dermestes vulpinus*. The diets for *Tribolium* and *Tenebrio* were identical, except for the addition of 1.5  $\mu$ g. carnitine per gram of the diet for *Tenebrio*. *Tenebrio* and *Tribolium* received 15% amino acids whereas *Dermestes*, which is a typical protein feeder, received 30% amino

TABLE I

Composition of the amino acid mixtures used in studies of the amino acid requirements of *Tribolium confusum*, *Tenebrio molitor*, and *Dermestes vulpinus*

Amino acid	Per cent of the total amino acid mixture		
	Rose <i>et al.</i> , 1948 19 amino acids	Rose <i>et al.</i> , 1948 10 amino acids	Almquist and Grau, 1944 20 amino acids
DL-alanine	2.54		3.33
L-arginine hydrochloride	3.18	4.20	4.67
DL-aspartic acid	2.54		6.67
L-cystine	1.27		1.33
L-glutamic acid	12.69		16.65
Glycine	.64		6.00
L-histidine hydrochloride	6.03	8.15	2.67
L-hydroxyproline	.63		.67
DL-isoleucine	10.16	13.95	6.67
L-leucine	7.62	10.40	6.67
L-lysine	9.53	13.01	4.67
DL-methionine	5.07	6.97	3.33
DL-norleucine			.67
DL-phenylalanine	7.62	11.40	3.33
L-proline	1.27		6.67
DL-serine	1.27		1.33
DL-threonine	8.89	12.10	10.00
L-tryptophane	2.54	3.49	1.33
L-tyrosine	3.81		6.67
DL-valine	12.70	17.35	6.67
NaHCO <sub>3</sub>	8.07	11.00	5.00
Total	108.07	111.02	105.00

acids, and no carnitine. The results of these tests are given in Table II. *Dermestes* failed to grow on these diets, and *Tenebrio* grew very poorly. *Tribolium*, however, grew on Rose's 19 amino acid mixture as well as it did on casein. With only the 10 essential amino acids in the diet, growth was somewhat delayed. The Almquist mixture proved very much inferior. The experiments with *Tenebrio* and *Dermestes* were first started with first stage larvae. When these larvae failed to develop on the diets, the tests were repeated with larvae of larger size (*Tenebrio* larvae of about 20 mg. and *Dermestes* larvae of about 10 mg.). It was expected that larger larvae which had originally been grown on an optimal diet might be more robust and more able to survive and overcome any adverse effect of amino acid

TABLE II  
*Response of three insects to amino acid diets*

Amino acid mixture and reference	<i>Dermestes vulpinus</i>	<i>Tenebrio molitor</i>	<i>Tribolium confusum</i>
19 amino acids Rose <i>et al.</i> , 1948	—	—	++++
10 amino acids Rose <i>et al.</i> , 1948	—	±	+++
20 amino acids Almquist <i>et al.</i> , 1944	—	±	++
Casein control diet	++++	++++	++++

++++ is growth equal to that on casein.  
 — is no growth.

diets. However, the larger larvae also failed to develop. All attempts to grow *Dermestes* and *Tenebrio* on amino acid mixtures have so far failed. The good results obtained with *Tribolium* on Rose's mixtures, however, were a starting point for further experiments.

#### B. The requirements of *Tribolium* for individual amino acids

Two of Rose's amino acid mixtures were used, one which contained 19 amino acids and another which contained only the 10 "essential" acids, in the proportion shown in Table I. A series of diets was then devised in which each of the amino acids was left out, one at a time. The results were clear cut. In every single case in which one of the 10 essential acids was omitted, the larvae failed to grow (Tables III and IV). Each of the remaining "non-essential" acids could be omitted from the diet, without noticeable effects (Table IV). However, larvae

TABLE III  
*Effect on Tribolium larvae of omitting each amino acid from a diet containing the 10 "essential" amino acids\**

Exp. 12—weighed at 15 days			Exp. 14—weighed at 20 days		
Diet	No.	Avg. wt. (mg.)	Diet	No.	Avg. wt. (mg.)
Casein control	18	0.55	Casein control	16	1.80
All 10 amino acids	18	0.40	All 10 amino acids	11	0.80
Without L-arginine	10	0.10	Without L-lysine	1	0.10
Without L-histidine	6	0.10	Without DL-methionine	0	
Without L-isoleucine	9	0.08	Without DL-phenylalanine	1	0.10
Without L-leucine	0	—	Without DL-threonine	0	
Without L-tryptophane	13	0.09	Without DL-valine	0	

\* None of the larvae on deficient diets survived to pupate.

always grew faster in the presence of 19 amino acids than of ten, in spite of the fact that the total level of amino acids was the same in both instances (Table IV). Superior growth of rats on a mixture of 19 amino acids, as compared with the 10 essential acids, has previously been reported by Rose *et al.* (1948).

TABLE IV

*Tribolium confusum.* Effect of omitting each amino acid from a diet containing 19 amino acids (Rose diet XXIII)  
Experiment 17

Omission or other variation	20 day larvae		Pupae		Adults	
	No.	Avg. wt. (mg.)	No.	Avg. time (days)	No.	No. normal
Casein	15	0.73	14	33.0	14	1
19 amino acids	20	1.11	20	30.1	16	3
No alanine	19	1.14	16	31.4	12	1
No aspartic acid	17	1.18	17	32.2	16	3
No cystine	19	1.17	18	30.9	18	2
No glutamic acid	19	1.11	15	31.4	11	1
No glycine	18	1.31	17	30.3	10	2
No hydroxyproline	12	1.09	10	30.7	9	0
No proline	18	1.00	16	32.7	13	0
No serine	18	0.84	15	32.0	14	3
No tyrosine	19	1.17	19	33.2	16	1
The 10 essential amino acids	18	0.53	12	41.5	11	1

(Rose diet XXIV)  
Experiment 16

Casein	19	.96	18	30.7	15	0
19 amino acids						
Ground by hand, mortar	12	.93	9	34.2	8	0
Ground in ball mill—22 hrs.	17	.8	13	35.5	8	3
No arginine	5	.01	0	*	0	0
No histidine	4	.01	0		0	0
No isoleucine	4	.01	0		0	0
No leucine	3	.03	0	*	0	0
No lysine	3	.01	0	*	0	0
No methionine	9	.01	0	**	0	0
No phenylalanine	4	.01	0	**	0	0
No threonine	3	.01	0		0	0
No tryptophane	2	.01	0		0	0
No valine	7	.01	0	*	0	0

\* One small larva at 90 days.

\*\* Two small larvae at 90 days.

At the end of 8 weeks, when it was apparent that growth was not possible in the absence of any of the 10 essential amino acids and when most of the larvae had died, 1% yeast was added to each of the deficient diets and the experiment run again with a fresh lot of first stage *Tribolium* larvae. Growth was very much faster after the addition of yeast, and the effect of amino acid deficiencies was largely

obscured. This phenomenon is difficult to understand in view of the fact that the addition of 1% yeast only insignificantly adds to the total amount of certain of the essential amino acids in the diet.

Since a diet which contained 19 amino acids always proved superior to one with only 10 essential amino acids, an attempt was made to evaluate the effects of the non-essential amino acids in the diet. Omitting any single non-essential acid had no effect on the diet (Table IV).

It was then considered possible that the amino acids in the mixtures used in the tests might not have been present in optimal proportions. In fact there was no *a priori* reason for such an assumption to be true. Thus those differences in growth rate, which existed between a 10 and a 19 amino acid mixture, might possibly be due to changes in the total amount of some of the acids present. Accordingly, further

TABLE V  
*Response of Tribolium to D-amino acids in a medium of 19 amino acids*

Substitution in diet	D-form substituted				L-form added*			
	20-day larvae		No. of pupae	Av. time to pupation (days)	20-day larvae		No. of pupae	Av. time to pupation (days)
	No.	Av. wt. (mg.)			No.	Av. wt. (mg.)		
Casein control diet	16	0.90	4	27.0				
Amino acid control diet	19	0.60	12	38.0				
D-arginine	6	0.04	0		11	0.66	10	35.0
D-histidine	9	0.05	0		13	0.40	2	38.0
D-isoleucine	0				16	0.30	2	43.0
D-leucine	0				18	0.3	3	41.0
D-lysine	18	0.67	7	34.5				
D-methionine	18	0.80	2	31.0				
D-phenylalanine	17	0.50	0					
D-threonine	0				14	0.30	6	46.3
D-tryptophane	1	0.05	0		15	0.40	4	38.5
D-valine	0				17	0.30	1	39.0

\* The L-forms of the respective amino acids were added and the diets re-infested with larvae.

tests with 19 amino acids were devised in which the amount of each amino acid was doubled in individual tests. The hypothesis was that this procedure might produce two kinds of effects. If the diets had been improved, there would have been an indication that the original mixtures did not contain enough of certain acids for optimal growth. If the diets became worse, there would have been an indication that the basic mixtures already might have contained excessive quantities of certain acids. This experiment did not show any clear-cut changes in the efficiency of the diets. Poorer growth resulted with double amounts of aspartic acid and valine. Somewhat poorer growth also resulted when these amino acids were added to a casein diet. However, these effects were only slight.

In further series of tests the D-forms of the ten essential amino acids were individually substituted for the L- or DL-forms, in a diet consisting of 19 amino acids. The D-forms of arginine, histidine, isoleucine, leucine, threonine, trypto-

phane and valine were entirely inactive (Table V). It was considered possible that some of them might have been not merely inactive, but actually inhibitory. Consequently the diets with D-acids, on which the larvae had failed to grow, were later supplemented with the respective L-form and new larvae added. The larvae grew somewhat slowly on most of the diets, which might have been due to the age of the diets. The results, however, did not suggest that the D-forms were inhibitory.

In one experiment (Table V) the D-forms of lysine and methionine gave as good larval growth as the L-forms, but pupation was fairly good with D-lysine and very poor with D-methionine. D-phenylalanine also showed good growth, but no pupation occurred. In a repeat of this experiment (Table VI), in which carnitine had been added to the diets, D-lysine proved entirely inactive. D-methionine was as active, and D-phenylalanine almost as active as the respective L-forms. All through this test the larvae pupated well and the adults were normal in the presence

TABLE VI

*Response of Tribolium to the D-forms of lysine, methionine and phenylalanine in a medium of 19 amino acids*

Substitution in diet	20-day old larvae		Pupation		No. of adults	
	No.	Av. weight (mg.)	No.	Av. time (days)	Abnormal	Normal
Casein control diet:						
Carnitine absent	20	.83	20	29.4	17	3
Carnitine present	20	.76	20	29.6	—	20
Amino acid control diet:						
Carnitine absent	16	1.12	12	28.6	12	—
Carnitine present	19	1.68	19	26.1	—	19
D-lysine*	dead	—	—	—	—	—
D-methionine*	17	1.68	17	25.9	—	17
D-phenylalanine*	20	.89	16	29.2	—	16

\* Carnitine present.

of carnitine. The result shows that the small number of pupae in the first test might have been, in part, attributable to the absence of carnitine. This, however, would not explain why D-lysine was fairly active in one, and entirely inactive in another test.

## DISCUSSION

The results on the amino acid requirements of *Tribolium*, as reported in this paper, closely follow those previously reported for other insects. Lemonde and Bernard (1951), in their work with the same insect, *Tribolium confusum*, reached similar conclusions. They obtained some growth, and even pupation in the absence of either lysine, threonine, phenylalanine, methionine, isoleucine, arginine, leucine and tryptophane, although growth in all these cases was very slow. This may have been due to the presence, in the diets, of one half per cent of yeast. Moore (1946) demonstrated the necessity of the 10 essential amino acids in the nutrition of

a carpet beetle, *Attagenus* sp.; the effect of the non-essential acids was, however, not studied. The larva of the yellow fever mosquito, *Aedes aegypti* L. was shown to require glycine for normal growth in addition to the essential amino acids, plus tyrosine for normal pigmentation, and in addition, cystine for normal emergence (Golberg and DeMeillon, 1948). *Drosophila* seems to require, in addition to the 10 essential acids (Schultz *et al.*, 1946; Rudkin and Schultz, 1947) glycine and cystine (Hinton, Noyes and Ellis, 1951). Contrary to some of the aforementioned authors, we have never had any indication that *Tribolium* benefitted by the presence in the diet of cystine or glycine, nor did we find evidence of a toxic effect of D- or L-serine as had been reported for *Drosophila* (Hinton *et al.*, 1951).

Information about the nutritional value of the D-form of an essential amino acid has been so far lacking for insects. In the amino acid requirements of man for maintenance of nitrogen equilibrium, D-methionine was as effective as the L-form and D-phenylalanine showed partial activity. The D-forms of valine, leucine, isoleucine, threonine, lysine and tryptophane were inactive (Rose, 1949). In the nutrition of the rat it is generally agreed that the D-forms of tryptophane, phenylalanine and methionine show full or partial activity, while those of the remaining essential acids are inactive (Rose, 1938; Rose *et al.*, 1948; Nasset and Anderson, 1951). For *Tetrahymena* which, in addition to the 10 essential amino acids, also requires serine, the D-forms of methionine, lysine and arginine are active, that of leucine is inhibitory, and those of the remaining six acids are inactive (Elliott *et al.*, 1952). *Tribolium* utilizes fully or partly the D-forms of lysine, methionine and phenylalanine. It therefore appears that the D-methionine is utilized by *Tetrahymena*, *Tribolium*, the rat and man, D-phenylalanine by *Tribolium*, the rat and man, D-arginine alone by *Tetrahymena*, D-lysine possibly by *Tribolium*, and D-tryptophane alone by the rat.

The authors wish to express their sincere thanks to Swift and Co., Chicago, for the grant of a scholarship to one of us (G. E. P.). This investigation was also supported in part by a research grant from the National Institutes of Health, Public Health Service. The authors are greatly indebted to Dr. C. B. Berg, State University of Iowa and Dr. A. A. Albanese, St. Luke's Convalescent Hospital, Greenwich, Conn., for valuable gifts of D-arginine and D-lysine, respectively, and to Merck & Co., for gifts of some of the amino acids.

#### SUMMARY

1. The larvae of the flour beetle *Tribolium confusum* have been successfully grown on diets which contain 19 amino acids or the 10 amino acids which are essential in the nutrition of the rat. The larvae of two other beetles, *Tenebrio molitor* and *Dermestes vulpinus*, failed to grow on similar diets.

2. *Tribolium* requires the following amino acids for growth: arginine, histidine, lysine, tryptophane, phenylalanine, methionine, threonine, leucine, isoleucine and valine.

3. On a mixture of 19 amino acids, which in addition to the above-named acids also contains glycine, alanine, proline, hydroxyproline, glutamic acid, aspartic acid, serine, cystine and tyrosine, growth is somewhat faster than in the presence of 10 amino acids.



4. Addition of any one of the non-essential acids to the mixture of the 10 essential ones has no marked effect. None of the amino acids exerted toxic effects when added to the diet in double amounts.

5. *Tribolium* utilizes fully or partly the D-form of methionine, phenylalanine and, possibly, lysine. The D-forms of the 7 remaining essential acids were entirely inactive, but did not show marked toxic effects.

## LITERATURE CITED

- ALMQUIST, H. J., AND C. R. GRAU, 1944. The amino acid requirements of the chick. *J. Nutrition*, **28**: 325-331.
- ELLIOTT, ALFRED M., JAMES F. HOGG AND CHUNG WU, 1952. Utilization of D-amino acids by *Tetrahymena geleii*. *Fed. Proc.*, **11**: 207.
- FRAENKEL, G., AND M. BLEWETT, 1943. The vitamin B-complex requirements of several insects. *Biochem. J.*, **37**: 686-692.
- FRAENKEL, G., AND M. BLEWETT, 1947. The importance of folic acid and unidentified members of the vitamin B-complex in the nutrition of certain insects. *Biochem. J.*, **41**: 469-475.
- FRAENKEL, G., AND H. R. STERN, 1951. The nicotinic acid requirements of two insect species in relation to the protein contents of their diets. *Arch. Biochem.*, **30**: 438-444.
- FRENCH, E. W., AND G. FRAENKEL, 1954. Carnitine (vitamin B<sub>12</sub>) as a nutritional requirement for *Tribolium confusum* Duval. *Nature*, **173**: 173.
- FRIEDMAN, L., AND O. L. KLINE, 1950a. The amino acid-sugar reaction. *J. Biol. Chem.*, **18**: 599-606.
- FRIEDMAN, L., AND O. L. KLINE, 1950b. The relation of the amino acid-sugar reaction to the nutritive value of protein hydrolysates. *J. Nutrition*, **40**: 295-307.
- GOLBERG, D., AND B. DEMELLON, 1948. The nutrition of the larva of *Aedes aegypti* L. 4. Protein and amino acid requirements. *Biochem. J.*, **43**: 379-387.
- HINTON, T., D. T. NOYES AND J. ELLIS, 1951. Amino acids and growth factors in a chemically defined medium for *Drosophila*. *Physiol. Zool.*, **24**: 335-353.
- LEMONDE, A., AND R. BERNARD, 1951. Nutrition des larves de *Tribolium confusum* Duval. II. Importance des acides amines. *Canad. J. Zool.*, **29**: 80-83.
- MOORE, W., 1946. Nutrition of *Attageus* (?) Sp. II. Coleoptera: Dermestidae. *Ann. Ent. Soc. Amer.*, **39**: 513-521.
- NASSET, E. S., AND J. T. ANDERSON, 1951. Nitrogen balance index in the adult rat as affected by diets low in L- and DL-methionine. *J. Nutrition*, **44**: 237-247.
- OFFHAUS, K., 1952. Der Vitaminbedarf des Reismehlkäfers *Tribolium confusum*. *Zeitschr. Vitamin. Horm. Fern. Forsch.*, **4**: 555-563.
- ROSE, W. C., 1938. The nutritive significance of the amino acids. *Physiol. Rev.*, **18**: 109-136.
- ROSE, W. C., 1949. Amino acid requirements of man. *Fed. Proc.*, **8**: 546-552.
- ROSE, W. C., M. J. OESTERLING AND M. WOMACK, 1948. Comparative growth on diets containing ten and nineteen amino acids with further observations upon the role of glutamic and aspartic acids. *J. Biol. Chem.*, **176**: 753-762.
- RUDKIN, G. T., AND J. SCHULTZ, 1947. Evolution of nutritional requirements in animals: amino-acids essential for *Drosophila melanogaster*. *Anat. Rec.*, **99**: 613.
- SCHULTZ, J., P. ST. LAWRENCE AND D. NEWMAYER, 1946. A chemically defined medium for the growth of *Drosophila melanogaster*. *Anat. Rec.*, **96**: 540.

## ANTIMITOTIC SUBSTANCES FROM OVARIES<sup>1</sup>

L. V. HEILBRUNN, ALFRED B. CHAET, ARNOLD DUNN AND  
WALTER L. WILSON<sup>2</sup>

*Department of Zoology, University of Pennsylvania, and the Marine Biological Laboratory,  
Woods Hole, Massachusetts*

In a paper published two years ago (Heilbrunn, Wilson and Harding, 1951), it was shown that a powerful antimittotic substance could be extracted from the ovaries of the common starfish (*Asterias forbesii*). This substance tends to exert a liquefying influence both on the cortex and on the interior protoplasm of marine eggs, and because it prevents the mitotic gelation in somewhat the same way that heparin does, we were led to believe that it might possibly be a heparin or heparin-like substance. However, we had very little direct evidence to support this belief.

Accordingly, we have been eager to find out what we could as to the nature of the antimittotic substance. The work is part of a broad general program in which we seek to establish that all living material contains substances which favor protoplasmic clotting and those which tend to prevent such clotting. It is now clear that the colloidal behavior of protoplasm is quite similar to the behavior of vertebrate blood; and if this is true, it would be logical to suppose that the anticlotting substances of living cells include heparins and heparin-like substances. For a detailed discussion of protoplasmic clotting and how it influences not only cell division but other vital processes as well, see Heilbrunn (1951, 1952a, 1952b).

The fact that we can obtain a potent antimittotic substance from the starfish ovary is perhaps not surprising, for the eggs in the ovary do not divide until they leave it. In our earlier paper (Heilbrunn, Wilson and Harding, 1951), it was suggested that "perhaps the ovaries of many organisms are rich in heparin-like substances." As will be seen later, this idea is apparently a fruitful one.

### MATERIALS AND METHODS

In general, extracts were prepared in much the same manner as in our previous work, except for the fact that instead of merely cutting up the ovaries, we homogenized them before extraction with acidified sea water. Specific details concerning the preparation of various individual extracts are given in relation to individual experiments. When the extracts were dialyzed, cellulose dialysis tubing was used. This was purchased from the Arthur H. Thomas Co. of Philadelphia, and they state that according to the manufacturer, the Visking Corporation of Detroit, the average pore diameter of the cellulose material is 24 Ångströms. The purity of the cellulose is said to be very high, but it contains some glycerine and approximately 0.1 per cent sulfur. During the process of dialysis, the tubes were agitated on a shaking apparatus.

<sup>1</sup>This investigation was supported by a research grant from the National Cancer Institute, National Institutes of Health, Public Health Service.

<sup>2</sup>Department of Physiology and Biophysics, Colleges of Medicine, University of Vermont, Burlington, Vt.

In testing for antimittotic action, in most cases we used the eggs of a marine worm, *Chaetopterus pergamentaceus*. As in earlier works, the eggs were kept in a constant temperature bath maintained at a temperature of 21° C.

Protoplasmic viscosity tests were made with an Emerson-type centrifuge. For information about the use of the centrifuge in viscosity determinations, see Heilbrunn (1950), Wilson and Heilbrunn (1952).

### RESULTS

The substance we extract from starfish ovaries is presumably responsible for the inhibition of mitosis in the ovary. As is well known, as soon as the starfish eggs leave the ovary and enter sea water, the large nucleus of the immature egg, that is to say, the germinal vesicle, breaks down and the maturation divisions begin. In order to prevent the breakdown of the germinal vesicle and the subsequent maturation divisions, it is only necessary to leave the eggs in contact with the ovary. Thus in one experiment, the ovaries of a starfish were cut up in 25 ml. of sea water. Left in this sea water in the presence of the minced ovaries, only 2 per cent of the eggs showed germinal vesicle breakdown. However, with pro-

TABLE I  
*Effect of starfish ovary extract on division of Chaetopterus eggs. Eggs exposed two minutes after fertilization*

Dilution	Per cent cleavage
1/100	0
1/200	0
1/400	93
1/800	97
Control	97

gressive dilution of the sea water which had been in contact with the ovary, there was a progressive increase in the percentage of germinal vesicle breakdown, so that when the original fluid was diluted 64 times, the percentage of germinal vesicle breakdown rose to 69 per cent. The inhibitor effect of the ovarian substance is largely reversible. As a matter of fact, this effect of ovarian substance both on maturation and cleavage divisions has long been known to students of marine eggs, and they commonly wash eggs two or three times before experimenting with them; that is to say, they pour off the sea water over the eggs and replace it with fresh sea water, and then repeat this operation several times.

In the work reported previously (Heilbrunn, Wilson and Harding, 1951), the extracts from starfish ovaries that we studied, when diluted to more than 1 part in 10, did not have much effect on *Chaetopterus* eggs. But in the extracts that were prepared from homogenized ovaries, a dilution of 1 to 200 was still effective. This is shown in Table I, which illustrates the effect on cleavage of one of our extracts. To prepare this extract, 100 ml. of acid sea water at pH 5.8 were added to 50 g. of starfish ovaries, and the ovaries were then homogenized in a Waring blender. (The acid sea water was prepared as in our previous work.) The homogenate was centrifuged in a Sorvall centrifuge at about 15,000 g. and the resultant supernate was neutralized with 0.1 N NaOH so that its final pH was 7.0.

*Nature of the antimetabolic substance in starfish ovary extract.* What is the nature of the antimetabolic substance in the extract from starfish ovaries? If we knew that, then we might go ahead to discover various other antimetabolic substances in the hope that one or another of them would be useful in the treatment of cancer. From the beginning, our suspicion has been that the potent substance in our extracts was a heparin-like compound. Let us summarize the old and new evidence in support of this opinion. Some of this evidence will later be presented in more detail by individual members of our group.

1. The extract from starfish ovaries is strongly metachromatic, just as heparin is. That is to say, the extract gives a reddish color with dilute solutions of toluidine blue. Tests for metachromasy are best made in calcium-free sea water or distilled water, for the calcium ions tend to prevent the metachromatic reaction.

2. The metachromatic reaction with toluidine blue disappears in the presence of protein, just as the metachromatic reaction of heparin disappears in the presence of protein (Kelly, 1951). If the crude extract from starfish ovaries is salted out with varying concentrations of ammonium sulfate, the activity appears in the globulin fraction and not in the albumin fraction. If now the globulin fraction is re-suspended in 0.3 molar sodium chloride solution and digested with trypsin, the resultant solution is metachromatic. This solution, after boiling to destroy trypsin, exerts a strong anticoagulant action on sheep plasma and it also prevents cell division in *Chaetopterus* eggs. Also if the re-suspended globulin fraction is dialyzed for 48 hours against 0.3 molar sodium chloride, a metachromatic reaction is obtained in the dialysate, and the dialysate is likewise effective in preventing cell division in *Chaetopterus* eggs. These facts will be discussed more fully by one of us (Dunn). The fact that the potent substance is able to pass through the dialysis sac indicates that it is not a substance of high molecular weight. Perhaps a correlation is to be found with the fact that, as Chaet (1952) has shown, ordinary heparin in solution can break down and yield substances capable of passing through a dialysis membrane and nevertheless capable of powerful physiological activity. Chaet's experiments, so far presented only as a preliminary note, will be published *in extenso* before long.

3. The active substance is heat-stable. Solutions containing it can be heated to 99.5° C. for 30 minutes and still retain their activity. On the other hand, when the substance is combined with globulin as a result of the salting out procedure described above, its activity is lost after exposure to a temperature of 80° C. for 20 minutes. (Following such inactivation, the active substance can no longer be separated off by dialysis.)

4. The activity of the starfish ovary extracts is destroyed by dilute solutions of periodate. Potassium periodate was added to potent extracts. Then the excess periodate was removed by dialysis. The control, containing extract without periodate, was dialyzed in similar fashion. The precipitates that formed were all removed by centrifugation and the potency of the extracts was tested on *Chaetopterus* eggs. The periodate was completely successful in destroying the antimetabolic activity of the extracts. This is shown in Table II. These experiments are consistent with the idea that a polysaccharide is responsible for the activity of the extracts, but they do not constitute absolute proof of such an idea, for substances other than polysaccharides may also be destroyed by periodate.

TABLE II

*Effect of potassium periodate on potency of starfish ovary extract*

% periodate	% cleavage			
	Exp. 1	Exp. 2	Exp. 3	Exp. 4
0 (control-extract alone)	0	0	0	0
0.25	96	84		100
0.5	93	92	94	
0.75	98	95	96	
1	96	96		
Control (no extract)	99	96	98	100

5. The dialysis behavior of the extracts is similar to that of heparin. As already noted, Chaet (1952) has found that when preparations of commercial heparin are dialyzed, a potent substance keeps coming through the dialysis membrane. He believes that heparin is continually breaking down to produce more of this substance. Similarly, when starfish ovary extract is dialyzed, a substance passes through the membrane and this substance is strong in antimittotic properties. However, the material that remains in the dialysis sac also prevents cell division. Table III shows the results of an experiment on Chaetopterus eggs. Both the substance or substances remaining in the sac after prolonged dialysis and the substance that diffused through the sac into sea water completely inhibited cell division. The active substance is not completely removed by a single dialysis

TABLE III

*The effect of dialysis on the potency of starfish ovary extract in preventing cell division. (The extract was first dialyzed against double its volume of sea water for 7 hours, then against running sea water for 9 hours)*

	Exp. 1	% cleavage	Exp. 2
Contents of sac after dialysis	0		0
Dialysate	0		0
Control (dialyzed sea water)	99		99

TABLE IV

*The effect of repeated dialysis on the potency of starfish ovary extract in preventing cell division. (The extract was dialyzed against an equal volume of sea water for 12 hours and the antimittotic effect of the dialysate tested. Then the contents of the sac were dialyzed against running sea water for 12 hours, following which the contents were dialyzed against an equal volume of sea water for 12 hours and the antimittotic effect of the second dialysate tested)*

	% cleavage
Contents of sac (after 2 dialyses)	0
First dialysate	0
Second dialysate	0
Sea water dialysate	95
Second sea water dialysate	90
Control (sea water)	96

operation. This is shown in Table IV, which gives the data on an experiment in which a second dialysate was still strongly antimittotic and completely prevented the division of Chaetopterus eggs. In this experiment, control tests were made with dialyzed sea water, for it is sometimes found that dialysis tubes give off substances that have some slight antimittotic action. (This might well be expected from the fact that, as previously noted, the cellulose dialysis tubes consist of polysaccharide containing a little sulfur.) In another experiment, an active antimittotic substance continued to pass through the dialysis membrane after seven successive dialyses. It is quite possible that when a living cell is exposed to a heparin-like substance or to a combination of such a substance with protein, breakdown products of the heparin-like substance diffuse into the cell, whereas the components of larger molecular size remain outside.

6. When an active extract of starfish ovary is placed in a dialysis sac, carbohydrate diffuses through the sac into the surrounding fluid. This is shown clearly by chromatographic tests. The carbohydrate is a polysaccharide. Chromatographic tests of the dialysate also indicate the absence of nucleic acids and amino acids. Details of these tests will be published later (by Dunn).

7. The ultraviolet absorption spectrum of starfish ovary extract is similar to that of heparin. This is shown in Figure 1. In this figure, the open circles show the absorption spectrum of a 0.17 per cent solution of sodium heparinate, kindly supplied by the Upjohn Co. of Kalamazoo, Michigan. The closed (completely black) circles show the absorption spectrum of a 2 per cent solution of the globulin fraction of starfish ovary extract in 0.5 *M* NaCl. In the preparation of this fraction, 100 g. of starfish ovary were washed in 0.5 *M* NaCl for one hour to remove excess mucus; the washed ovaries were then suspended in 200 ml. 0.3 *M* NaCl and homogenized in a Waring blender. Following centrifugation, the globulin fraction of the supernatant solution was salted out with half-saturated ammonium sulfate solution, and the precipitate was made salt-free by dialysis against distilled water. The triangles show the spectrum of a highly dilute solution of starfish ovary extract. This was prepared from an extract made by extracting 20 gm. of homogenized starfish ovary in 40 ml. of acid sea water (pH 5.8) and then neutralizing the resultant solution. This extract was then diluted with ordinary sea water until it was only 0.26 per cent of its original strength. The dilution was made in order to obtain a curve at about the same position on the graph at the heparin curve. The readings on the (Beckman) spectrophotometer were made by Dr. Lester Goldstein.

The general similarity of the three curves in Figure 1 is obvious, and although this similarity does not provide proof that the starfish ovary extract does actually contain a heparin-like substance, it is certainly consistent with such a view.

Indeed, no one of the seven arguments that we have presented is in itself very cogent, but taken as a whole they do indicate rather strongly that the starfish ovary extract contains a heparin-like substance and that this substance is responsible for its anticlotting and antimittotic activity.

*Antimittotic substances in fish ovaries.* In our thinking about the starfish ovary extract, we were bothered by two facts. In the first place, we knew of no evidence in the biochemical literature of heparin or heparin-like compounds splitting to form compounds of lower molecular weight capable of passing through dialysis membranes. Secondly, and this from a practical clinical standpoint is more important,

we were soon led to believe that the starfish ovary extract which had so drastic a liquefying action and so strong an antimitotic effect on invertebrate marine eggs, was rather powerless on vertebrate cells and tissues. The starfish ovary extract acts on starfish eggs, Chaetopterus eggs, eggs of the sea urchin *Arbacia* and eggs of the clam *Spisula*; but we found no very great antimitotic activity on frog eggs, and the antimitotic action of the extract on embryo mouse cells in tissue culture was much less than that of ordinary commercial heparin. [The studies on tissue culture cells were made by Carol Bocher and were presented by her as a Master's thesis (Bocher, 1952).] Moreover, although ordinary heparin, or a breakdown

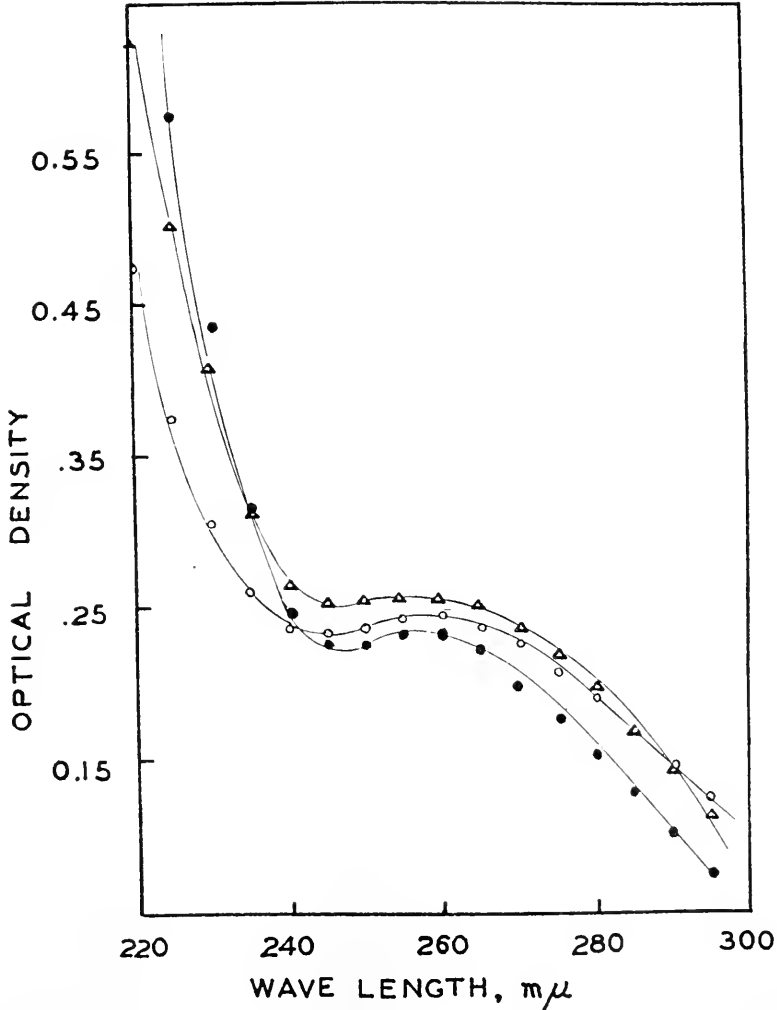

FIGURE 1. Comparison of the absorption spectra of heparin and two samples of starfish ovary extract. The open circles show the absorption spectrum of sodium heparinate. For further details, see text.

product of it, stops the frog heart in diastole (Kraus, Fuchs and Merländer, 1931; Chaet, 1952), starfish ovary extract has no effect on frog heart, although it does stop the clam heart in diastole. Also, in a few preliminary experiments, we found that starfish ovary extract had no obvious toxic action when injected subcutaneously into mice.

Fortunately, our attention was called to the fact that some fish of the family Tetraodontidae have in their ovaries a substance which has a very potent pharmacological and toxic action. This substance stops the heart of a toad or frog in diastole, and it thus acts like heparin, or rather like the breakdown product of heparin studied by Chaet (1952). Partly because of the toxic nature of this substance—it kills a few people in Japan each year—the literature concerning it is quite voluminous and goes back several hundred years. Useful papers include those of Tawara (1910), Ishiwara (1924), and Yudkin (1944, 1945). The substance has been called tetrodotoxin, and it is manufactured under that name in Japan. There it is used in the treatment of neuralgia and arthritis. Chemical study of tetrodotoxin has indicated that it is a carbohydrate of no very great molecular weight, containing both amino nitrogen and sulfur; also it is precipitated by alcohol. In all these properties, except for its low molecular weight, it resembles heparin. Like heparin also, it has an inhibitory effect on the clotting of bird and mammalian blood.

Here, then, is the kind of substance we have been looking for. Also, it is an ovarian substance and therefore of particular interest to us. Accordingly, we began experiments on the antimutic properties of substances in the ovaries of the common puffer of the Atlantic coast, *Spheroides maculatus*. This fish belongs to the Tetraodontidae, and extracts of its ovaries stop the frog heart in diastole (Yudkin, 1945). The work on the puffer ovary is being done by Pierre Couillard, who first called our attention to the paper by Yudkin. Suffice to say at this point that extracts of the puffer ovary actually are antimutic; they act in much the same manner as extracts of starfish ovary.

If it is true, as we have suggested, that ovaries in general may be rich in antimutic substances, then it ought to be possible to extract such substances from the ovaries of many fishes, rather than just those of the family Tetraodontidae. Accordingly, we made extracts of the ovaries of some common fishes and tested their effect on the eggs of *Chaetopterus*. The extracts were made in much the same manner as the extracts of starfish ovaries. The following experiment will serve as an example.

Ovarian material was gathered from females of the small fish, *Fundulus heteroclitus*. To 10 gm. of this material, 10 ml. of acid sea water at a pH of 5.3 were added. (The acid sea water had had its bicarbonates removed.) The ovaries were then homogenized in a small glass homogenizer, and the homogenate diluted to a volume of 25 ml. and centrifuged in a high-speed Sorvall centrifuge. The pH of the supernatant solution was 6.15; it was brought to a pH of 8.00 with 0.1 N NaOH, and the resultant solution was used in the experiment. *Chaetopterus* eggs were fertilized, and then two minutes after fertilization, some of the eggs were placed in each of 4 dishes, *A, B, C, D*. The first dish, *A*, contained full strength extract; in *B* the extract was diluted with an equal volume of sea water, so that the resultant mixture was half strength. *C* had three parts of sea water for each



part of extract, and *D* had seven parts of sea water for each part of extract. Of the control eggs in sea water, 100 per cent gave off polar-bodies, but in *A*, polar-body formation was completely inhibited. In *B*, there was 12 per cent polar-body formation; in *C*, 27 per cent, and in *D*, 42 per cent. Thirty minutes after fertilization, at a time when it is known that the gelation has developed (Heilbrunn and Wilson, 1948), centrifuge tests were made rapidly with a hand centrifuge, as in previous studies from this laboratory. These tests showed that whereas the protoplasm of normal eggs had a viscosity well above the arbitrary value of 8 (and presumably, in accordance with earlier studies, about 14), the eggs in *A* exposed to the full strength *Fundulus* ovary extract had a protoplasmic viscosity of about 4. The eggs in *B* had a protoplasmic viscosity value of about 6. At 55½ minutes after fertilization, 50 per cent of the control eggs had cleaved, and a few minutes later, 97 per cent had cleaved. No one of the eggs in *A* ever cleaved, and only 25 per cent of those in *B*. The *C* eggs showed 27 per cent cleavage, and the *D* eggs 31 per cent. Some of the eggs from *A* and *B* were transferred to ordinary sea water. The eggs in *A* were badly injured, and following transfer to sea water they did not divide. When the eggs in *B* were transferred to sea water (after a 63-minute exposure to the extract), 53 per cent showed cleavage. Thus the effect of the extract is to some extent reversible.

Results similar to these were obtained with extracts from the ovaries of various other fishes. In all our studies with fish ovary extracts, we noticed that the active antimittotic substances tended to lose their potency in a relatively short time. Thus when the experiment with the *Fundulus* ovary extract was repeated a day later with the same extract, which had been kept overnight in a refrigerator, the effect both on the cleavage and on the protoplasmic viscosity was decidedly less. It should be noted that the extracts we use are very crude; no doubt in addition to anticlotting substances, they contain thromboplastic substances which promote clotting. When the extracts age, the effect of these thromboplastic substances may tend to override the effect of the anticlotting substances.

Because of the fact that powerful anticlotting and antimittotic substances are found not only in the ovaries of fishes of the family Tetraodontidae but also in ovaries of other fishes as well, we began to wonder if there might not be some evidence to indicate a pharmacological action or a toxicity of ovaries of fish not belonging to the Tetraodontidae. Literature in support of this idea does indeed exist, but it is very hard to assemble. For over four hundred years, scientific writers have commented on poisoning due to the eating of fish, but many of the articles that were written are in obscure journals, difficult of access. Gudger gathered together numerous references for Dean's bibliography of fishes, published in 1916-1923, and in the fifteen years following the collection of these references, he was able to find 180 others (Gudger, 1930). In the West Indies, there is a special word—*ciguatera*—that means fish poisoning; and in the East Indies and the South Seas, there is frequent reference to fish poisoning. Useful sources of information include papers by Taft (1945), Cohen, Emmert and Goss (1946), Vonfraenkel and Krick (1945), Gilman (1942), and Gudger (1918, 1930). Books by Phisalix (1922) and Pawlowsky (1927) may also be consulted. When men are poisoned by eating fish in the tropics, there is often uncertainty as to the

cause. Always there is a possibility that the fish may have spoiled; also there is an old superstition that fish become poisonous because they have eaten poisonous fruit. In the case of the barracuda, often found to be poisonous, it seems clear that only larger fish contain poison and then only at certain seasons of the year (Chisholm, 1808). This seems to indicate that the gonads may be involved. According to Coker (1930), the roe of garpikes (genus *Lepisosteus*) is said to be toxic, and in Germany it is well known that the ovaries of the barbel, a large cyprinid fish (*Barbus vulgaris*) are poisonous. According to McCrudden (1921), the ovaries of the pike are even more toxic than those of the barbel. Köhler, in 1933, writing in a magazine for practicing physicians, states: (p. 292) "Manche an sich ungiftige Fische geben zur Laichzeit unter nicht näher bekannten Verhältnissen Ursache zur Vergiftungen." There is thus clear indication that fish ovaries may contain potent substances, substances which under certain conditions have a serious effect when ingested.

In fishes, the ovaries are not alone in containing substances that prevent the clotting of protoplasm. This is only to be expected if, as we believe, all types of living material contain anticlotting as well as clotting factors (see Heilbrunn, 1952b). We were not surprised, therefore, that when we extracted the testis of the toadfish (*Opsanus tau*) in the same manner that we extracted the ovary, we were able to obtain a substance that kept the protoplasm fluid and prevented cell division. As a matter of fact, in the Tetraodontidae, the testis is toxic as well as the ovary (Remy, 1883), and apparently contains the same type of substance that the ovary does. Also it will be remembered that the starfish testis contains much antimittotic substance (Heilbrunn, Wilson and Harding, 1951). In animals that breed only once a year, at times when little or no mitosis is occurring in the testis, this organ may presumably be rather rich in substances which prevent cell division. We found too that fish liver might also contain easily recognizable amounts of anticlotting and antimittotic substances—we used the liver of the angler or goosefish (*Lophius piscatorius*). This is to be correlated with the fact that the liver is a ready source of heparin and also with the fact that in Tetraodon the liver may be poisonous as well as the ovary (Tani, 1940). It is possible that the tetrodotoxin of the ovary is secreted in the liver.

The results reported in this paper provide additional evidence to show that many diverse types of living tissue, and indeed possibly all types of living cells, contain substances that prevent the clotting of protoplasm and exert a powerful antimittotic action. The ovaries of many animals are especially rich in such substances. Many of the anticlotting substances are either heparins or heparin-like substances. There is good reason to believe that the various substances vary widely both in molecular size and molecular composition.

At the present time the search for antimittotic substances in various organs and tissues of various organisms is being continued. There is undoubtedly a large and diverse group of naturally occurring heparin-like compounds which can act as anticlotting and antimittotic agents. Out of this large group of compounds, it should be possible to discover some which may be of real value in the treatment of tumors. More work is urgently needed. We need to know more about the chemistry of these heparin-like compounds, and their effect should be tested not only on simple isolated cells, but also on tumors.

## SUMMARY

1. Starfish ovaries contain a substance which prevents maturation divisions in the eggs contained in these ovaries.

2. By homogenizing starfish ovaries before extracting them with acid sea water, we have been able to prepare antimittotic extracts much more powerful in their action on Chaetopterus eggs than the extracts reported on previously.

3. There is additional many-sided evidence to indicate that the potent substance in these extracts is a heparin-like compound. Some of this evidence comes from chromatographic studies; also from studies of the absorption spectrum of the extract. Moreover, the potency of the extract disappears after treatment with periodate.

4. Ovaries of various species of fishes contain antimittotic substances which resemble in their action the substance or substances in starfish ovary extracts. In at least one family of fishes, the ovaries are known to contain a potent substance of heparin-like chemical composition and heparin-like properties.

## LITERATURE CITED

- BOCHER, C., 1952. The effect of an extract of starfish gonads and heparin upon cells grown in tissue culture. Master's thesis, University of Pennsylvania, Philadelphia.
- CHAET, A. B., 1952. The action of heparin preparations on cells and tissues. *Biol. Bull.*, **103**: 281.
- CHISHOLM, C., 1808. On the poison of fish. *Edinburgh Med. and Surg. Jour.*, **4**: 393.
- COHEN, S. C., J. T. EMERT AND C. C. GOSS, 1946. Poisoning by barracuda-like fish in the Marianas. *U. S. Naval Bull.*, **46**: 311-317.
- COKER, R. E., 1930. Studies on common fishes of the Mississippi River at Keokuk. *Bull. U. S. Bureau Fisheries*, **45**: 141-225.
- DEAN, B., 1916-1923. A bibliography of fishes. 3 vols. Amer. Museum Nat. History, N. Y.
- GILMAN, R. L., 1942. A review of fish poisoning in the Puerto Rico-Virgin Islands area. *U. S. Naval Bull.*, **40**: 19-27.
- GUDGER, E. W., 1918. *Sphyræna barracuda*, its morphology, habits, and history. *Carnegie Inst. Wash.*, **12** (Publ. no. 252): 53-108.
- GUDGER, E. W., 1930. Poisonous fishes and fish poisonings, with special reference to ciguatera in the West Indies. *Amer. J. Trop. Med.*, **10**: 43-55.
- HEILBRUNN, L. V., 1950. Viscosity measurements. Chap. 4 of F. M. Uber's Biophysical research methods. Interscience Press, N. Y.
- HEILBRUNN, L. V., 1951. The colloid chemistry of narcosis. In: *Mécanisme de la Narcose* (Colloques Internat. du Centre. Nat. de la Recherche Sci.), pp. 163-178.
- HEILBRUNN, L. V., 1952a. The physiology of cell division. In: *Modern trends in physiology and biochemistry*. Academic Press, N. Y., pp. 123-134.
- HEILBRUNN, L. V., 1952b. An outline of general physiology. W. B. Saunders Co., Philadelphia. Third Ed.
- HEILBRUNN, L. V., AND W. L. WILSON, 1948. Protoplasmic viscosity changes during mitosis in the egg of Chaetopterus. *Biol. Bull.*, **95**: 57-68.
- HEILBRUNN, L. V., W. L. WILSON AND D. HARDING, 1951. The action of tissue extracts on cell division. *J. Nat. Cancer Inst.*, **11**: 1287-1298.
- ISHIWARA, F., 1924. Studien über das Fugutoxin. *Arch. f. exp. Path. u. Pharm.*, **103**: 209-218.
- KELLY, J. W., 1951. Effects of x-ray and trypsin on the metachromasy of heparin-basic protein combinations. *Biol. Bull.*, **101**: 223.
- KOHLER, F., 1933. Muschel- und Fischvergiftung. *Fortschritte d. Med.*, **51**: 291-292.
- KRAUS, F., H. J. FUCHS AND R. MERLÄNDER, 1931. Über das Koagulin des Muskels III. *Zeitschr. f. d. ges. exp. Med.*, **79**: 59-75.
- MCCRUDEN, F. H., 1921. Pharmakologische und chemische Studien über Barben- und Hechtrogen. *Arch. f. exp. Path. u. Pharm.*, **91**: 46-80.
- PAWLOWSKY, E. N., 1927. Gifttiere und ihre Giftigkeit. Fischer, Jena.

- PHISALIX, M., 1922. Animaux venimeux et venins. 2 vols, Masson, Paris.
- REMY, C., 1883. Sur les poissons toxiques du Japon. *C. R. Soc. de Biol.*, **35** (Mem.) : 1-28.
- TAFT, C. H., 1945. Poisonous marine animals. *Texas Reports on Biol. and Med.*, **10**: 43-55.
- TANI, I., 1940. Changes and individual variations of the toxicity of "hugu" (globe fishes). *Jap. J. Med. Sci., II. Pharm.*, **13**: 174-177.
- TAWARA, Y., 1910. Über das Tetrodongift. *Biochem. Zeitschr.*, **30**: 255-275.
- VONFRAENKEL, P. H., AND E. S. KRICK, 1945. Fish poisoning by barracudas in the Marianas. *U. S. Naval Bull.*, **40**: 19-27, 1942.
- WILSON, W. L., AND L. V. HEILBRUNN, 1952. The protoplasmic cortex in relation to stimulation. *Biol. Bull.*, **103**: 139-144.
- YUDKIN, W. H., 1944. Tetradon poisoning. *Bull. Bingham Oceanographic Collection*, **9** (1) : 1-18.
- YUDKIN, W. H., 1945. The occurrence of a cardio-inhibitor in the ovaries of the puffer, *Spheroides maculatus*. *J. Cell. Comp. Physiol.*, **25**: 85-95.

FURTHER INVESTIGATIONS ON THE INTERACTION BETWEEN  
SPERM AND JELLY-COAT IN THE FERTILIZATION OF  
THE SEA URCHIN EGG<sup>1</sup>

A. MONROY, L. TOSI,<sup>2</sup> G. GIARDINA AND R. MAGGIO

*Laboratory of Comparative Anatomy, The University of Palermo, Palermo, Italy*

The role played in fertilization by fertilizin, the sperm-agglutinating substance of egg water, was first emphasized by F. R. Lillie (1914). This substance has been shown (Tyler and Fox, 1939, 1940; Tyler, 1940) to be derived from the gelatinous coat of the egg and the evidence shows no other macromolecular constituents to be present in the latter. The gelatinous coat slowly dissolves as the eggs stand in sea water, providing thus the egg water of Lillie (1914), who had erroneously supposed its agglutinating property to be due to some substance actively secreted by the egg. Eggs deprived of their gelatinous coat are still fertilizable but require insemination with larger amounts of sperm (Tyler, 1941). In such eggs there is evidence (Tyler, 1941 *et seq.*) that a layer of fertilizin remains as a part of the vitelline membrane of the surface of the egg proper. It appears likely that reaction of the sperm with fertilizin on the surface of the egg is essential for successful fertilization to occur (see Tyler, 1948a, 1948b, 1949a, 1949b).

The well known fact that a jelly-coat solution causes sperm agglutination suggests already either a binding of jelly-coat molecules to the surface of the sperm or at least a modification of the sperm surface induced by the jelly-coat. The observation that the organic material of a purified solution of sea urchin jelly-coat can be practically completely adsorbed by sperm (Tyler, 1948b), speaks strongly in favor of the former interpretation to which the results presented in this paper give further support.

Our investigations started from the study of the mechanism by which the sperm are able to go through the jelly-coat in fertilization. An enzymatic mechanism was suggested by the finding of a jelly-coat splitting enzyme in extracts of sea urchin sperm (Monroy and Ruffo, 1947; Lundblad and Monroy, 1950; Vasseur, 1951). The activity of this enzyme was, however, weak. Furthermore its existence in some species of sea urchin was questioned (Krauss, 1950). Monroy and Tosi (1952), re-investigating the matter, interpreted their new results as being contrary to the early assumption of an enzymatic splitting and discussed the possibility of a quite different mechanism by which the sperm may be able to find its way to the egg through the jelly-coat.

<sup>1</sup> This investigation has been supported by grants of the Istituto Superiore di Sanità, Rome and Consiglio Nazionale delle Ricerche. A generous gift of chemicals by the Farmitalia, S. A. is also acknowledged.

<sup>2</sup> Present address: Stazione Zoologica, Napoli.

*Summary of the experiments suggesting a non-enzymatic splitting of the jelly-coat by the sperm* (Monroy and Tosi, 1952)

The previously mentioned conclusion on the non-enzymatic splitting of the jelly-coat by the sperm rested upon the following experimental evidence:

1. Living sperm added to a jelly-coat solution agglutinate and cause a sudden decrease of viscosity of the jelly. Irrespective of the quantity of sperm added, the viscosity drops in the course of about one minute and then remains constant. Washing of the agglutinated sperm with sea water does not restore their ability either to be re-agglutinated (see Lillie, 1914; Tyler, 1948b) or to "depolymerize" a fresh viscous solution of jelly-coat. That suggests that the reactive groups at the surface of the sperm have been blocked by the first reaction with the jelly-coat.

2. The interesting observation was recently made (Metz and Donovan, 1951) that fixed sperm can be agglutinated by jelly-coat solutions. We have also found that fixed sperm added to a solution of jelly-coat are able to "depolymerize" it just as well as living sperm do (for further details see Monroy and Tosi, 1952).

From these experiments it was suggested as a working hypothesis that in the reaction between sperm and jelly-coat, surface groups of the former react with groups in the jelly. As a result of this reaction fragments of the jelly-coat substance would become attached to the sperm surface. That would account for the apparent depolymerization of the jelly-coat.

#### THE NEW EXPERIMENTS

In order to develop further the analysis of the reaction between jelly-coat and sperm, two kinds of experiments were undertaken:

1. Attempts to recover the agglutinating factor from the agglutinated sperm
2. Quantitative estimation of some typical component of the jelly-coat substance before and after reaction with sperm

#### *Material*

Jelly-coat and sperm of *Arbacia lixula* were used throughout these experiments. Jelly-coat solution was prepared according to Tyler (1949b). Sperm were obtained by spontaneous shedding following cutting of the shells and were centrifuged once at  $500 \times g$  for 10 minutes in order to remove impurities and excess of seminal fluid. In our experience, washing with sea water prior to agglutination proved to be detrimental to the sperm.

#### *1. Recovery of the agglutinating factor from agglutinated sperm*

To a jelly-coat solution in sea water, sperm were added to saturation, *i.e.*, to the point when the solution had lost its agglutinating ability. The sperm were then centrifuged in the cold, washed twice with cold sea water and finally suspended in 4% formaldehyde at room temperature for one hour, being gently stirred from time to time. The suspension was centrifuged at high speed in the cold and the supernatant dialyzed against several changes of sea water and then tested for

agglutinating ability. Non-agglutinated sperm were treated similarly and the solution used as a control.

The extract from agglutinated sperm proved to have agglutinating power, whereas no effect whatsoever was obtained with the extract from non-agglutinated sperm.

Attempts to elute the agglutinating factor from agglutinated sperm by possibly a less drastic procedure (changes of pH, incubation at 37° C., salt solutions) were unsuccessful. In most cases, indeed, nucleic acid passed into the solution in rather large amounts and the solution was devoid of any agglutinating activity. A very small contamination with nucleic acid was actually found also in the formalin extract (small absorption peak in the U. V. at 260  $m\mu$ ); we do not know whether this fact may be of any importance.

In the discussion following the presentation of these data by one of us (A. M.) at the Symposium on "The biochemical basis of morphogenesis" (Utrecht, August, 1952), Prof. Runnström objected that on account of the great ability of jelly-coat molecules to polymerize, especially under the influence of Ca-ions, it is possible that after a certain number of jelly-coat molecules have reacted with the sperm surface, other molecules may simply form a cloud around them. The recovered agglutinating ability may thus be due to the secondarily linked jelly molecules rather than to those which have become linked directly to the sperm surface.

The possibility of the formation of a cloud of jelly-coat molecules around the sperm, after the first ones have reacted with it, although difficult to imagine on the basis of our immunological knowledge, cannot be ruled out with certainty. This, however, does not invalidate the main fact that in the reaction between jelly-coat and sperm, jelly-coat molecules become attached to the sperm surface.

## 2. Importance of salts for the molecular architecture of the jelly-coat

The view that Ca-ions play an important rôle in the molecular architecture of the jelly-coat has been entertained especially by Vasseur (1949) who conceives the polysaccharide chains of the jelly-coat substance as being held together by Ca-bridges. Our experiments, however, in which the effect of addition of  $\text{CaCl}_2$  on the viscosity of jelly-coat solutions was tested, have demonstrated that Ca causes a decrease of viscosity of the latter (Fig. 1). Much more dramatic is the effect of a 3.6% NaCl solution and of sea water, the former causing a drop of viscosity of 60% and the latter a drop of 70%. Urea, on the contrary, has no effect, thus suggesting that H-bonds play no part in holding together the molecules of the jelly-coat.

Furthermore there is another observation to which we would like to draw attention. The jelly-coat stains metachromatically with toluidine blue both *in vivo* and *in vitro*: as it is known this is a reaction given by all sulfonated polysaccharides. Now, *in vitro* this reaction is positive only if the jelly-coat is dissolved in distilled water whereas it is negative, *i.e.*, there is no metachromatic colour change, if the jelly-coat is dissolved in sea water, probably because under these conditions the  $-\text{SO}_3$  groups of the jelly are present in a salt form. All this would suggest that the native jelly-coat must have a very low salt content, if any, and the  $-\text{SO}_3$  groups are either free or linked to some anionic group by very weak bonds. Evidently

when the jelly-coat is brought into solution by the ordinary acid treatment the  $-\text{SO}_3$  groups become free to react and they do in fact react with the ions of the sea water.

To the influence of salts is also probably due the swelling and dissolution of the jelly-coat of unfertilized eggs when standing in sea water.

### 3. Quantitative estimation of a component of the jelly-coat substance before and after reaction with sperm

In order to obtain further evidence for the attachment of the jelly-coat material to the surface of the sperm, experiments were performed to determine quantitative changes in some typical component of the jelly-coat as a result of its reaction with sperm. Analyses of sea urchin jelly-coat have proved it to be a hexosamine-free sulfonated glycoprotein (Vasseur, 1949, 1950; Tyler, 1948a, 1949a, 1949b). The

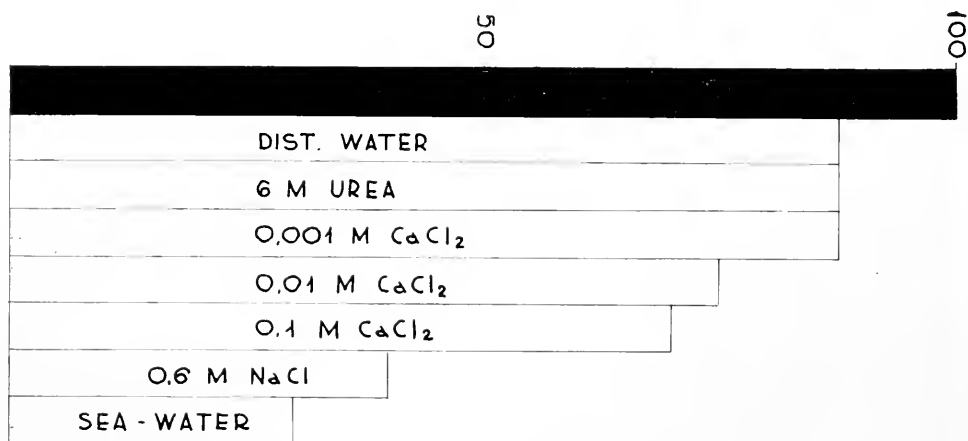

FIGURE 1. Effect of different salt solutions and urea on the viscosity of a jelly-coat solution in distilled water. The viscosity of the undiluted sample is taken as 100. To 3.0 cc. of this, 0.5 cc. of the solutions to be tested were added.

carbohydrate components are different in the different genera thus far studied (reviewed by Runnström, 1951). As to the jelly-coat of *Arbacia lixula*, fucose is by far its largest component, only small amounts of galactose being also present (Minganti, personal communication). Fucose estimation in the jelly-coat solution before and after reaction with sperm was therefore thought to be a good indication for the attachment of jelly-coat substance to the sperm. Such analyses are complicated by the fact that *Arbacia* sperm in sea water and in jelly-coat solution release a fucose-containing phosphate ester. The study of the latter phenomenon is being carried out by one of us (L. T.). The results of the analyses therefore had to be corrected for a blank in which sperm were suspended in sea water.

#### Experimental

In a typical experiment, to 1.0 cc. of jelly-coat solution in sea water, 2.0 cc. of sperm suspension were added and after 30 seconds the agglutinated sperm were



centrifuged off. The supernatant was collected quantitatively, brought to 4.0 cc. with sea water and 1.0 cc. of chilled 10% perchloric acid was added. The solution was kept in the cold for one hour and then centrifuged. The addition of perchloric acid was found to be necessary as otherwise sperm may remain in suspension and interfere with the colorimetric estimation of fucose. Sea water was substituted for jelly-coat in the blank for the fucose released by the sperm. The zero point, *i.e.*, the estimation of fucose content of the jelly-coat before reacting with the sperm, was done diluting 1.0 cc. of the jelly-coat solution to 4.0 cc. with sea water and then adding 1.0 cc. of perchloric acid. Aliquots of these solutions were used for fucose determination according to Dische and Shettles (1948). Three fucose standards were run with each analysis.

The results of these analyses are summarized in Table I.

Quite independently, similar results have been recently communicated in a short paper by Hultin *et al.* (1952).

These experiments conclusively indicate that the interaction between jelly-coat and sperm consists of a reaction in which surface groups of the sperm react with

TABLE I

*Effect of the treatment with sperm on the fucose content of Arbacia jelly-coat solution*

Jelly-coat control	$\mu\text{g}$ fucose/cc. in	Sperm treated jelly-coat*
234.0		44.0
9.8		4.2
120.0		49.0
19.8		2.2
42.0		25.6

\* Corrected for the fucose released by the sperm in sea water.

and bind to some groups in the jelly. Now, Metz and Donovan (1951) have shown that alkylation of the  $-\text{NH}_2$  groups in the sperm results in prevention of the agglutination by jelly-coat solution. That makes it highly probable that the reaction occurs between  $-\text{NH}_2$  groups at the surface of the sperm and  $-\text{SO}_3$  groups in the jelly-coat.

#### *Model experiments*

If the conclusion as to the groups entering in the reaction between jelly-coat and sperm is correct, it must be possible to duplicate the experiment using ion-exchangers having reactive groups similar to those of the sperm. Anionic exchange resins in fact have proved to be a satisfactory model. Most of our experiments were carried out with Amberlite IR 4B which is a weakly basic phenol-formaldehyde type resin with  $\equiv\text{N}$  as an active group. Before use, the resin was blotted on filter paper to avoid dilution of the sample. Jelly-coat solution in distilled water was shaken with the resin and the viscosity was measured before and in the course of the experiment. As seen in Table II, treatment of the jelly-coat with the resin causes a drop of viscosity of the jelly. When the viscosity had reached that of water, a very low agglutinating titer was found and chromatography showed that the fucose spot had entirely disappeared, while the one of galactose was apparently

unchanged (Fig. 2). This different behavior of fucose and galactose is very peculiar and deserves further attention.

The resin used in the treatment of the jelly-coat solution was thoroughly washed with distilled water and eluted with 0.5–2% Na-bicarbonate or 5% ammonium sulphate. The eluate, after dialysis against distilled water and sea water, proved to be endowed with agglutinating ability.

That by this procedure the jelly-coat fraction adsorbed on the resin can be recovered almost quantitatively is demonstrated by the following experiment.

Two samples of 3.0 cc. of jelly-coat solution in distilled water were shaken with about 3.0 g. of resin. The supernatant was collected quantitatively, the resin washed three times with distilled water and the washings added to the first supernatant. Finally the material adsorbed on the resin was eluted as previously described and fucose estimated in the supernatant and in the eluate (Table III).

TABLE II  
*Effect of treatment with Amberlite IR-4B on viscosity, fucose content and agglutinating titer of Arbacia jelly-coat solution*

% control	% treated	Fucose $\mu\text{g. 'cc. in}$		Agglutinating titer	
		Control	Treated	Control	Treated
1.52	1.0	present*	absent*	not tested	1/50
12.10	2.0	350.0	125.5	not tested	
2.48	1.01	present*	absent*	not tested	
4.23	1.04	136.0	1.0	>1/10,000	1/50
14.5	1.92	460.0	185.0	1/100,000	1/5000

\* Qualitative estimate from paper chromatography.

## CONCLUSIONS

The results of the present experiments suggest that in the reaction between sperm and jelly-coat substance, "molecules" of the latter adhere to the sperm surface. As previously mentioned, a similar point of view has been defended also by Tyler (1948b). Coating of bacteria by mucin is a well known phenomenon (reviewed by Olitzki, 1948). We think, however, that in this case not a simple coating but an actual chemical reaction occurs. Very likely the reaction is between the  $-\text{NH}_2$  groups at the surface of the sperm and  $-\text{SO}_3$  groups in the jelly-coat. This reaction may also account for the so-called depolymerization of the jelly-coat caused by the sperm. In a previous communication (Monroy and Tosi, 1952) it was suggested that as a consequence of this reaction the molecules of the jelly-coat would undergo fragmentation. As, however, nothing is known as to the length of the molecules of the jelly-coat before and after reaction with the sperm, it is difficult at present to decide whether a fragmentation actually occurs or the decrease of viscosity is due to the fact that *whole* jelly-coat molecules bind to the sperm surface.

Following the multivalence theory of antigens and antibody of Heidelberger (1939), Tyler thinks (1948b) that fertilizin molecules (*i.e.*, jelly-coat molecules) may each bind with two or more spermatozoa and each spermatozoon may in turn

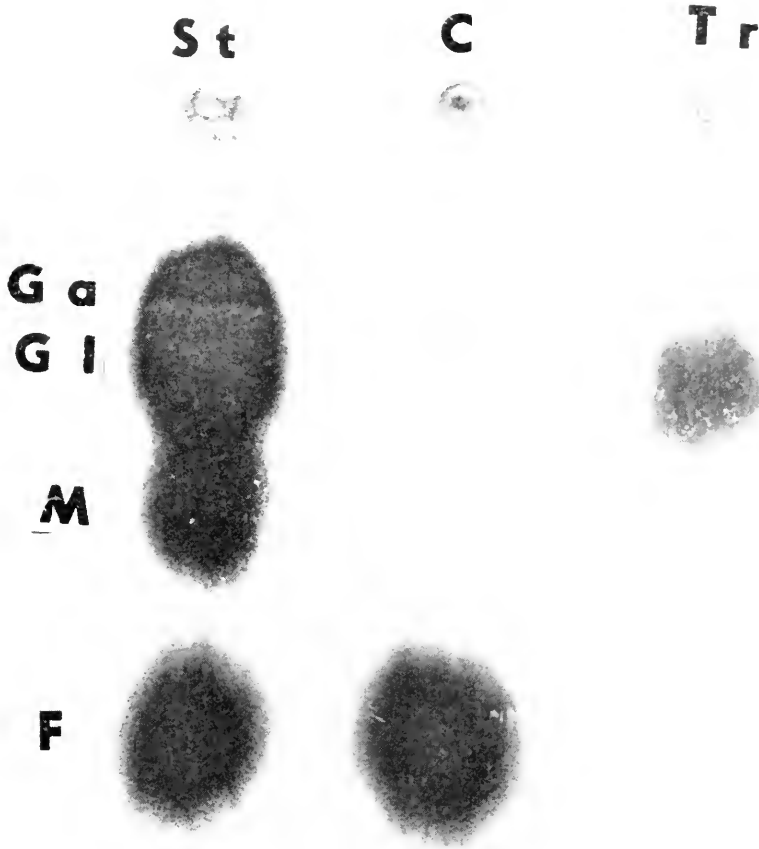

FIGURE 2. A chromatogram showing the disappearance of the fucose spot after treatment of a jelly-coat solution with Amberlite IR 4B(Tr). C=untreated jelly-coat. The greater intensity of the galactose spot in the treated sample is due to the higher concentration of the hydrolysate. St = standards of: Ga = Galactose; Gl = glucose; M = Maltose; F = Fucose.

bind to several fertilizin molecules. According to our findings, the jelly-coat in the living state should have a very low salt content, if any, whereas when dissolved in sea water its  $-\text{SO}_3$  groups probably react and bind with the ions of the sea water. However, the jelly-coat in sea water not only agglutinates sperm but Vasseur has maintained (1949) that Ca reinforces the agglutinating power of the jelly-coat solution. That may be an indication that the type of bond that is estab-

TABLE III

*Recovery of fucose after treatment of jelly-coat solution with Amberlite IR-4B*

Control (untreated)	µg Fucose in		Supernatant
	Eluate	Treated	
1002.0	119.0	850.0	
91.0	20.4	65.6	

lished between sperm surface and jelly-coat is different when the sperm cross the jelly-coat at fertilization and when they are agglutinated by a solution of jelly-coat.

When a spermatozoon crosses the jelly-coat surrounding the egg, it is coated by a halo of jelly-coat molecules which will not react with any other sperm and therefore a number of reactive groups of these molecules will remain free. Now the question arises whether the spermatozoon carries inside the egg its jelly-coat halo or the whole sperm surface is left outside. Should the former prove to be the case, then one could assume that the free groups of the jelly-coat molecules enter into reaction with the egg cytoplasm and this reaction may be of great importance either for the activation of the egg or for the reaction that establishes the block against polyspermy. In fact it is known that parthenogenetically activated eggs can be entered by a number of spermatozoa (reviewed by Monroy, 1953). Evidence on this point may be, however, hard to obtain.

We are indebted to Prof. A. Tyler, California Institute of Technology, for interesting discussions and for reading the manuscript, and to Prof. T. Ajello, Dept. of Pharmaceutical Chemistry, University of Palermo, for his suggestions. The technical assistance of Mr. A. O. Oliva is also acknowledged.

#### LITERATURE CITED

- DISCHE, Z., AND L. B. SHETTLES, 1948. A specific color reaction of methylpentoses and a spectrophotometric micromethod for their determination. *J. Biol. Chem.*, **175**: 595-603.
- HEIDELBERGER, M., 1939. Quoted by Tyler, 1948b.
- HULTIN, E., G. KRISZAT, S. LINDVALL, G. LUNDBLAD, H. LÖW, J. RUNNSTRÖM, E. VASSEUR AND E. WICKLUND, 1952. On the interaction between the gametes of the sea-urchin at fertilization. *Ark. f. Kemi*, **5**: 83-87.
- LILLIE, F. R., 1914. Studies of fertilization. 6. The mechanism of fertilization in Arbacia. *J. Exp. Zool.*, **16**: 523-590.
- LUNDBLAD, G., AND A. MONROY, 1950. Mucopolysaccharase activity of sea-urchin sperms. *Ark. f. Kemi*, **2**: 343-347.
- KRAUSS, M., 1950. On the question of hyaluronidase in sea-urchin spermatozoa. *Science*, **112**: 759.
- METZ, C. B., AND J. DONOVAN, 1951. Specific fertilizin agglutination of dead sperm. *Biol. Bull.*, **101**: 202.
- MONROY, A., AND A. RUFFO, 1947. Hyaluronidase in sea-urchin sperm. *Nature*, **159**: 603.
- MONROY, A., AND L. TOSI, 1952. A note on the jelly-coat sperm interaction in sea-urchin. *Experientia*, **8**: 393.
- MONROY, A., 1953. Biochemical and structural changes at fertilization. Proc. Symposium on "The biochemical and structural basis of Morphogenesis" in *Arch. Néerl. Zool.*, **10**: 19-25.
- OLITZKI, L., 1948. Quoted by H. P. Lambert and J. Richley, 1952. The action of mucin in promoting infections. *Brit. J. Exper. Pathol.*, **33**: 327-339.
- RUNNSTRÖM, J., 1950/51. The problems of fertilization as elucidated by work on sea-urchins. The Harvey Lectures, Ser. XLVI, 116-152.
- TYLER, A., AND S. W. FOX, 1939. Sperm agglutination in the keyhole limpet and the sea-urchin. *Science*, **90**: 516-517.
- TYLER, A., AND S. W. FOX, 1940. Evidence for the protein nature of the sperm agglutinins of the keyhole limpet and the sea-urchin. *Biol. Bull.*, **79**: 153-165.
- TYLER, A., 1940. Sperm agglutination in the keyhole limpet, *Megathura crenulata*. *Biol. Bull.*, **78**: 159-178.
- TYLER, A., 1941. The role of fertilizin in fertilization of eggs of the sea-urchin and other animals. *Biol. Bull.*, **81**: 190-204.

- TYLER, A., 1948a. On the chemistry of the fertilizin of the sea-urchin *Strongylocentrotus purpuratus*. *Anat. Rec.*, **101**: 8-9.
- TYLER, A., 1948b. Fertilization and immunity. *Physiol. Rev.*, **28**: 180-219.
- TYLER, A., 1949a. Serological aspects of fertilization. *The Collecting Net*, **19**: 6-8.
- TYLER, A., 1949b. Properties of fertilizin and related substances of eggs and sperm of marine animals. *Amer. Nat.*, **83**: 195-215.
- VASSEUR, E., 1949. Effect of calcium ions on the agglutination in *Strongylocentrotus droebachiensis* Müll. *Ark. f. Kemi*, **1**: 105-116.
- VASSEUR, E., 1948. Chemical studies on the jelly-coat of the sea-urchin egg. *Acta Chem. Scand.*, **2**: 900-913.
- VASSEUR, E., 1950. L-Galactose in the jelly-coat of *Echinus esculentus* eggs. *Acta Chem. Scand.*, **4**: 1144-1145.
- VASSEUR, E., 1951. Demonstration of a jelly-splitting enzyme at the surface of the sea-urchin spermatozoon. *Exp. Cell Res.*, **2**: 144-146.

THE CHARACTER AND ULTIMATE FATE OF THE LARVAL  
SALIVARY SECRETION OF PHORMIA REGINA MEIG.  
(DIPTERA, CALLIPHORIDAE)

HERBERT H. MOOREFIELD AND G. FRAENKEL

*Department of Entomology, University of Illinois, Urbana, Illinois*

The study of insect salivary glands has now attained a near classic interest, and diverse fundamental researches involving them have been stimulated in many fields. Fraenkel and Brookes (1953) have recently reviewed the literature concerning these glands in Diptera; especially the cytoplasmic changes occurring during the late larval period of *Phormia regina* and several species of *Drosophila*, together with the subsequent passage of cellular components into the lumen of the glands. Various functions have been assigned to this accumulated salivary material and a few postulations have been made regarding its disposition, but it is a noticeable fact that none of the previous workers has offered any experimental evidence as to the fate of the final larval gland contents. Fraenkel and Brookes (1953) have also described the manner in which *Phormia* and certain *Drosophila* orally release a fluid that flows along the underside of the insect, solidifies and securely attaches the newly formed puparium to the surface upon which it rests. By observing the comparative sizes of the salivary glands and investigating the volumes of glandular contents in the larvae before and after this secretion was released, they concluded from this indirect evidence that the secretion produced in the salivary glands was the same material which glued the puparium to its substrate.

The purpose of the present investigation was to collect the secretion from the late larval salivary glands and the material on the exterior of the puparium; to analyze them chromatographically in order to establish the identity of these products and to characterize it as well as the limited quantities would permit.

METHODS

Laboratory cultures of adult *Phormia* were maintained on sugar and water. Eggs were collected on pork liver; the larvae were reared in battery jars with moist wood shavings and were furnished fresh liver daily. Prior to pupation, this species leaves its food supply, migrates through the shavings and evacuates its crop. This is referred to as the "empty-crop" stage in this work, and dissections revealed that during this period, the salivary gland lumen contains the greatest quantity of fluid attained throughout the larval life.

The salivary secretion was collected from empty-crop larvae by dissection in a modified Ringer solution (Ephrussi and Beadle, 1936). This was accomplished by cutting off the terminal third of the maggot with scissors, and then manipulating the insect with two pairs of fine forceps to turn it inside out over one of the points of the forceps. With the aid of a dissecting microscope, the glands which previously extended well into the abdomen were then readily discernible, floating free

in the saline, and could be easily teased free of the fat body. They were removed to a fresh solution of Ringer's to be freed of haemolymph, then quickly dipped into a dish of distilled water to remove the salts, and finally transferred to a clean, oversize slide ( $2 \times 3''$ ). Here the glands were punctured with a teasing needle and the secretion permitted to flow out onto the glass. The material from many insects was accumulated on a single slide and pooled by washing it off with distilled water. The volume was reduced in a vacuum desiccator over solid NaOH.

Full grown, empty-crop larvae were placed in petri dishes (about ten insects per dish) to pupate on a layer of clean sand. When the maggots pupated, the material which ordinarily flowed along the underside of their bodies and later anchored them now poured into the sand and merely aggregated a few sand grains at the anterior end of the puparia. By collecting the tanned puparia, carefully chipping off these small clumps of sand grains, pooling them and treating with warm water, the external secretion was extracted.

Hydrolysates were prepared by placing the secretions in small Pyrex tubes, evaporating to dryness in the desiccator, adding 2 ml. of 6 N HCl and sealing off the tubes. These were then steam-autoclaved for 18 hours at 15 lbs. pressure. After hydrolysis, the acid was removed by vacuum desiccation, distilled water added and completely evaporated four times to free the samples of HCl.

The hydrolyzed and raw secretions were analyzed by paper partition chromatography (Consden, Gordon and Martin, 1944), using the ascending modification of Williams and Kirby (1948). Two-dimensional chromatograms were prepared on Whatman No. 1 paper ( $9 \times 11''$ ), using phenol and water (80 gms. and 20 ml.) as the first phase solvent and a water-saturated mixture of equal parts of collidine and lutidine in the second phase. A 0.2% ninhydrin (in water-saturated butanol) spray was used to develop the colors. The final chromatograms were air dried and examined in transmitted light with the aid of a light-box viewer. Resultant spots were identified by, first, Rf values; second, cochromatography (an authentic sample of a known substance is added to the original application on the paper, intensifying the provisionally identified chromatographic spot which then acts as a single entity—behavior as such in different solvents presents strong evidence that the known and unknown are identical materials); and third, specific reactions for some of the components (to be described in a later section).

## RESULTS AND DISCUSSION

Four separate hydrolysates of the secretion collected from the salivary glands were prepared, and four from the material gathered from larvae which had pupated in the sand. The majority of these preparations were made from insects of different generations. In no cases was there any discrepancy in the number of spots on well prepared chromatograms, and the similar composition of these materials was repeatedly demonstrated by identical patterns consisting of the same components, present in constant relative intensities. The typical pattern, distribution and identification of spots are portrayed in Figure 1.

To test for free amino acids, unhydrolyzed preparations were chromatographed, and a single spot moved off the original site of application. This spot was present in both the glandular secretion and material collected from the puparia; but, when portions of these preparations were first dialyzed and then chromatographed, the

spot was absent. Cochromatography proved the free amino acid to be lysine. Chromatograms of dialyzed and nondialyzed materials, after hydrolysis, yielded lysine spots in each, but the nondialyzed preparations gave a more intense lysine spot. This indicated that, although lysine was present as a free amino acid, there was also lysine conjugated in the protein molecule.

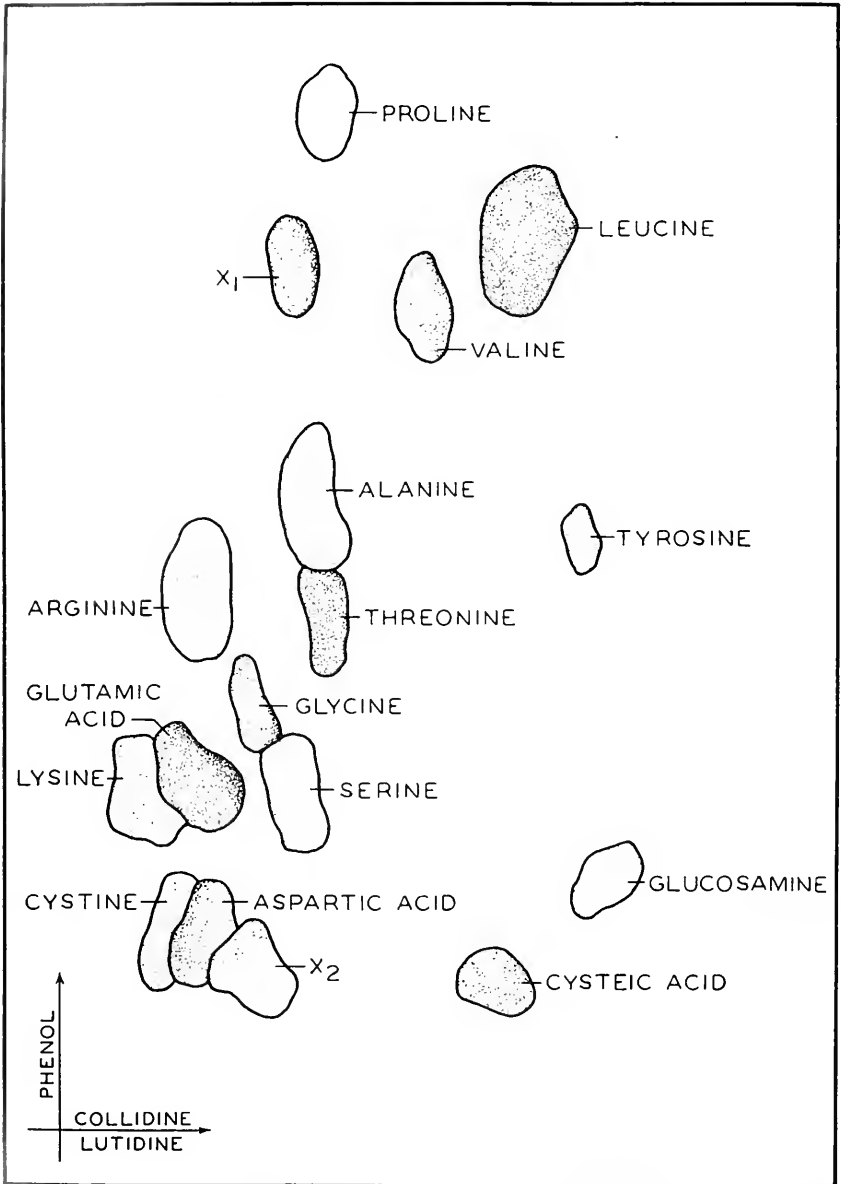

FIGURE 1. Chromatogram of hydrolyzed salivary secretion of larval *Phormia regina*.



Table I presents a complete list of the identified components found in this study together with a compilation of reported analyses made on dipterous salivary glands and associated products.

Cystine and its oxidation product, cysteic acid, appear brown when sprayed with ninhydrin, and both were present in the salivary material. Dent (1947) suggested that cysteic acid may be produced by secondary decomposition during chromatography; however, a sample of cystine hydrolyzed alone and treated as were the salivary products showed but a single cystine spot when chromatographed.

TABLE I

*Comparison of chromatographic analyses of dipterous salivary glands and associated products*

Component	Salivary gland chromosome <i>D. melano.</i>	Salivary gland chromosome <i>D. virilis</i>	Salivary gland ( <i>in toto</i> ) <i>D. virilis</i>	Salivary gland protein <i>D. melano.</i>	Salivary gland* secretion <i>Phormia</i>
	Vasuzumi and Miyao, 1950	Blumel and Kirby, 1948	Blumel and Kirby, 1948	Kodani, 1948	
Glycine	+	+	+	+	+
Alanine	+	+	+	+	+
Serine			+	+	+
Threonine			+	+	+
Valine	+	+	+	+	+
Leucine	+	+	+	+	+ <sup>1</sup>
Tyrosine			+	+	+
Phenylalanine			+	+	-
Proline	+	+	+	+	+
Aspartic acid	+	+	+	+	+
Glutamic acid	+	+	+	+	+
Arginine	+		+	+	+
Lysine			+	+	+
Cystine					+
Cysteic acid				+	+
Methionine sulfoxide				+ <sup>2</sup>	
Glucosamine				+	+
Unidentified			four		two
Free amino acids	none		none <sup>3</sup>		lysine

\* Analysis of material from salivary gland and exterior of puparium.

<sup>1</sup> Leucine and/or isoleucine.

<sup>2</sup> Probably in error (Dent, 1948).

<sup>3</sup> LaCour and Drew (1947).

Cystine oxidized with 30% H<sub>2</sub>O<sub>2</sub> was used for identification of the cysteic acid spots. Dent (1948) pointed out that by superimposing the peroxide directly on the hydrolyzed material on the paper, cystine would be quantitatively converted to cysteic acid. In chromatograms so treated, the cystine spot did not appear, and the cysteic acid spot was intensified. Further confirmation of cystine was accomplished by spraying the chromatograms with an iodine-azide spray reagent. As demonstrated by Chargaff, Levine and Greene (1948), the sulfur-containing amino acids were revealed as white spots against a brown background. After the location of the spot was marked, and the iodine faded, the paper could be resprayed with ninhydrin.

The spot labeled  $X_1$  occupies the position ascribed by Dent (1947) to methionine sulfoxide and was later reported as such in the salivary secretion of *Drosophila* by Kodani (1948). When methionine was treated with 30%  $H_2O_2$ , mixed oxidation products of methionine sulfoxide and methionine sulfone resulted, and when this mixture was cochromatographed with the salivary secretion,  $X_1$  was reinforced by methionine sulfoxide. However, neither adding the peroxide to the original material on the paper before chromatography, nor treating the final chromatogram with the iodine-azide reagent gave the anticipated reactions of a sulfur-containing amino acid in this position. Beta-aminoisobutyric acid has also been reported to have the same Rf values as methionine sulfoxide (Crumpler, Dent, Harris and Westall, 1951), but as this compound has never been identified as a protein hydrolysate product, it is unlikely that this amino acid is  $X_1$ .

A second unknown substance, labeled  $X_2$ , was characterized by a yellow ninhydrin reaction. Although this reaction is typical of the imino acids,  $X_2$  does not migrate to the site occupied by any of the known substances of this nature.

TABLE II  
*Nitrogen composition of salivary products of Phormia regina*

Product	Dry weight of material analyzed	Total nitrogen	Per cent nitrogen	Mean nitrogen per cent
Secretion collected from salivary glands	1.4 mg.	0.111 mg.	7.9	8.0
	3.6	0.289	8.0	
Secretion collected from puparia (in sand)	2.9	0.231	8.0	7.9
	3.4	0.261	7.7	
	4.8	0.382	8.0	
	4.9	0.388	7.9	
Secretion collected from puparia and dialyzed	7.3	0.732	10.0	10.0
	5.9	0.597	10.0	

A compound with a similar ninhydrin color and Rf values has been reported on chromatograms of free amino acids in potatoes (Dent, Stepka and Steward, 1947), and has also been found free in other dipterous tissues (unpublished data). In the salivary material, this unknown substance is undoubtedly conjugated in the protein molecule, as it appears only after hydrolysis.

In Table II, micro-Kjeldahl nitrogen determinations are compiled. These materials were collected in small aluminum-foil boats, and dried to constant weight before analysis. The nitrogen content of the fluid collected from the glands is in good agreement with that of the material emitted into the sand. The nitrogen values are higher in dialyzed samples, but are still unusually low for a typical protein. Kodani (1948), working with the glandular secretion of *D. melanogaster*, reported 10.8% nitrogen in samples exhaustively extracted with ether, and further demonstrated that a considerable quantity of crystalline, inorganic salt was present after hydrolysis and evaporation of HCl from the residue. He proposed that the low nitrogen figures could be accounted for by the presence of the salt together with a large amount of glutamic acid and glucosamine, both of which are low in

nitrogen. The *Phormia* products, when permitted to dry on glass slides, frequently crystallized in dendritic patterns which could be a result of the presence of inorganic salts. However, if this were the principle contributing factor to the low nitrogen figures, it would be expected that dialyzed samples would contain more nitrogen than the determined values of 10%. Leshner (1952) presented data suggesting that the substance synthesized by the larval salivary gland of *Drosophila robusta* is a conjugated protein composed of a protein bonded to a polysaccharide, *i.e.*, a mucopolysaccharide. This could possibly explain the low nitrogen figures obtained by Kodani and in this study.

Biuret and ninhydrin (triketohydrindene hydrate) tests were both strongly positive and indicative of the proteinaceous nature of the salivary gland secretion. The protein was water soluble and could be precipitated with hot or cold 10% trichloroacetic acid. Millon's reaction was positive, confirming the presence of tyrosine, and the xanthoproteic test also gave a strong reaction. The Hopkins-Cole test for tryptophane was slightly positive, but as only acid hydrolysates were prepared, the presence of this amino acid was undetected. Although glucosamine was demonstrated as a constituent of the protein, results of the Molisch test were doubtful. Specific carbohydrate tests, Benedict's, Barfoed's and Selivanoff's, were all negative.

#### SUMMARY

1. In a comparative chromatographic study of the fluid in late larval salivary glands, and the substance which is responsible for adhering puparia of *Phormia regina* to their substrate, evidence is presented indicating that these materials are identical in nature and composition; this constitutes convincing proof that the "puparial cement" is the ultimate fate of the larval salivary secretion.

2. The identity of these secretions, collected from two different sites (the salivary glands and the exterior of the puparia), has been demonstrated by like nitrogen composition; the presence of a single free amino acid, lysine, in each fluid; the same components in the protein constituent (amino acids—glycine, alanine, serine, threonine, valine, leucine, tyrosine, proline, aspartic acid, glutamic acid, arginine, lysine and cystine; two unknown substances, and the carbohydrate, glucosamine); as well as by the reactions to several biochemical characterization tests.

#### LITERATURE CITED

- BLUMEL, J., AND H. KIRBY, 1948. Amino acid constituents of tissues and isolated chromosomes of *Drosophila*. *Proc. Nat. Acad. Sci.*, **34**: 561-566.
- CHARGAFF, E., C. LEVINE AND C. GREEN, 1948. Techniques for the demonstration by chromatography of nitrogenous lipid constituents, sulfur-containing amino acids, and reducing sugars. *J. Biol. Chem.*, **175**: 67-71.
- CONSDEN, R., A. H. GORDON AND A. J. P. MARTIN, 1944. Qualitative analysis of proteins; a partition chromatographic method using paper. *Biochem. J.*, **38**: 224-232.
- CRUMPLER, H. R., C. E. DENT, H. HARRIS AND R. G. WESTALL, 1951.  $\beta$ -aminoisobutyric acid ( $\alpha$ -methyl- $\beta$ -alanine): A new amino acid obtained from human urine. *Nature*, **167**: 307-308.
- DENT, C. E., 1947. The amino-aciduria in Falconi syndrome. A study making extensive use of techniques based on paper partition chromatography. *Biochem. J.*, **41**: 240-253.

- DENT, C. E., 1948. A study of the behavior of some sixty amino acids and other ninhydrin-reacting substances on phenol-collidine filter-paper chromatograms, with notes as to the occurrence of some of them in biological fluids. *Biochem. J.*, **43**: 169-180.
- DENT, C. E., W. STEPKA AND F. C. STEWARD, 1947. Detection of the free amino acids of plant cells by partition chromatography. *Nature*, **160**: 682-683.
- EPHRUSSI, B., AND G. W. BEADLE, 1936. A technique of transplantation for *Drosophila*. *Amer. Nat.*, **70**: 218-225.
- FRAENKEL, G., AND V. J. BROOKES, 1953. The process by which the puparia of many species of flies become fixed to a substrate. *Biol. Bull.*, **105**: 442-449.
- KODANI, M., 1948. The protein of the salivary gland secretion in *Drosophila*. *Proc. Nat. Acad. Sci.*, **34**: 131-135.
- LACOUR, L. F., AND R. DREW, 1947. Partition-chromatography and living cells. *Nature*, **159**: 307-308.
- LESHER, S. W., 1952. Studies on the larval salivary gland of *Drosophila*. III. The histochemical localization and possible significance of ribonucleic acid, alkaline phosphatase and polysaccharide. *Anat. Rec.*, **114**: 633-652.
- WILLIAMS, R. J., AND H. KIRBY, 1948. Paper chromatography using capillary ascent. *Science*, **107**: 481-483.
- YASUZUMI, G., AND G. MIYAO, 1950. A qualitative analysis of the amino acids in isolated chromosomes. *Exp. Cell. Res.*, **2**: 153-157.

SIZE DISTRIBUTION, EROSIIVE ACTIVITIES, AND GROSS METABOLIC EFFICIENCY OF THE MARINE INTERTIDAL SNAILS, *LITTORINA PLANAXIS* AND *L. SCUTULATA*<sup>1,2</sup>

WHEELER J. NORTH

*Division of Marine Biochemistry, Scripps Institute of Oceanography, University of California, La Jolla, California*

The two common representatives in Southern California of the nearly world-wide genus, *Littorina*, are *L. planaxis* and *L. scutulata*. The former generally occurs at higher levels in the intertidal, but the zones of distribution of the two species overlap. *L. planaxis* may often be found 5 to 10 feet above spring high tide level, but *L. scutulata* prefers a zone two or three feet on either side of the high tide mark. Published information concerning these two species of snail is scanty in spite of their great abundance and their availability. Their importance to the high intertidal community, however, warrants an extensive study of their ecology, and the present paper describes some of the basic biology of these interesting animals.

SIZE DISTRIBUTION

Inspection of colonies of *Littorina* at different places along the La Jolla shore has revealed that the majority of snails at any given locality fall within certain rather well defined size limits. Lysaght (1941) noted a similar condition in *L. neritoides* on the Plymouth Breakwater. In order to gain a more exact picture of size distributions in the present study, three typical *Littorina* environments were chosen, and height measurements were made of all the periwinkles found within a selected area, representative of the environment.

*Environmental description*

The three environments are shown in Figure 1. The first (Fig. 1a) is a group of pools at Whale View Point in La Jolla. The area is subjected to vigorous wave action at even moderate tides. The second environment (Fig. 1b) is the seaward edge of the top of a broad shelf of rock that extends out from a cliff about 1/4 mile north of the Scripps Institution of Oceanography. The top of Shelf Rock is 1 to 1½ meters above spring tides, but the area under discussion is well splashed at high tide and a large wave may occasionally wash over it. The

<sup>1</sup> This work was supported by a research grant from the Rockefeller Foundation and represents a portion of a thesis submitted in partial fulfillment of the requirements of the Ph.D. degree, University of California. The author would like to express his gratitude to Professor Denis L. Fox for his continued interest and friendly supervision, and to Dr. Arthur L. Kelly and Messrs. James S. Kittredge and John R. Maher for helpful assistance.

<sup>2</sup> Contribution from the Scripps Institution of Oceanography, New Series No. 685.

third environment (Fig. 1c) is a protected portion of Shelf Rock some three meters removed from the second environment and splashed only occasionally by large waves.

All three localities are sedimentary sandstone, but the grain size is much finer at Shelf Rock. By exerting pressure the point of a knife may be forced into



FIGURE 1. Photographs of the three environments studied. *a*. Whale View Point; arrow points to typical tidepool from which snails were gathered. *b*. Pools of Shelf Rock; arrow points to region studied. *c*. Dry area of Shelf Rock; Region studied enclosed by white line and marked with arrow labeled 3; arrow labeled 2 points to second environment, about 3 meters away.

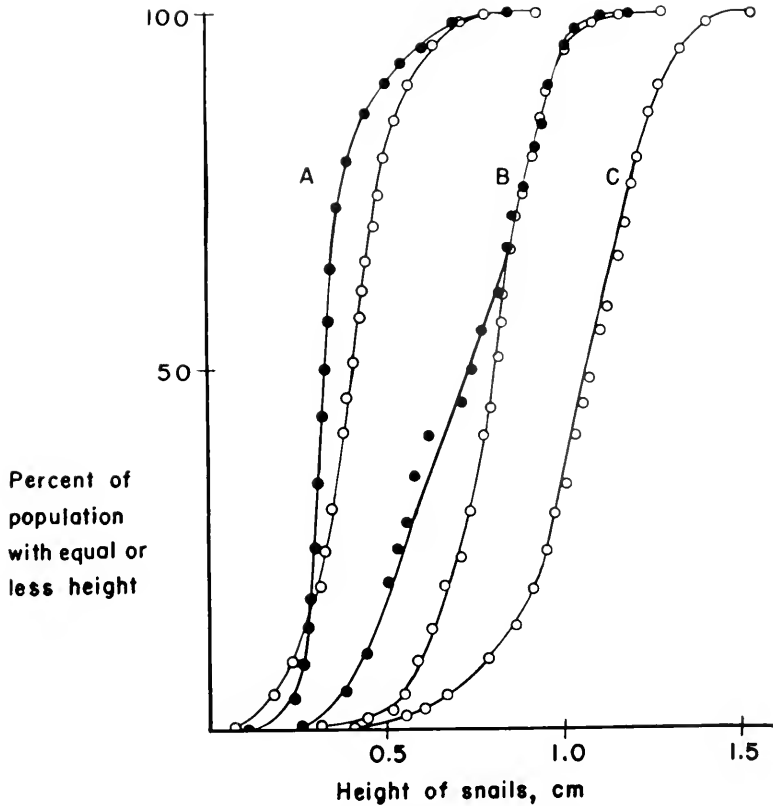

FIGURE 2. Cumulative curves for the *Littorina planaxis* populations of three environments. A. Whale View Point; B. Shelf Rock pools; C. Dry area, Shelf Rock. Measurements made in August, 1951, shown as circles; measurements made in July, 1953 shown as dots.

the sandstones to a depth of about half an inch. The top layers of sand particles may easily be removed by scraping. The topography is characteristically very irregular, great numbers of pools, depressions, basins, and small holes being present.

#### *Results of measurements*

The size distribution of *L. planaxis* and *L. scutulata* in each of these environments is shown by means of cumulative curves in Figures 2 and 3. The greatest dimension, "height," was measured, being the distance from the tip of the spire to the lower lip of the aperture. It can be seen that the populations at Whale View Point are rather small, averaging about 0.4 cm. The snails in the pools of Shelf Rock are generally intermediate in size, approximately 0.8 cm., while those on the sheltered dry area of Shelf Rock, although more heterogeneous than the other groups, are generally the largest, averaging almost 1.1 cm. in height. In the latter environment there were insufficient numbers of *L. scutulata* to enable the construction of a reliable curve.

In attempting to explain the variation in size distribution with locality, two possibilities suggest themselves. A favorable set of spawn in different areas at different times, for example, would produce curves of the type that have been obtained. Equally plausible is the contingency that some factor or factors operate in the environment to produce selection for a particular size of periwinkle. If the first hypothesis is correct, curves obtained from measurements made at a later

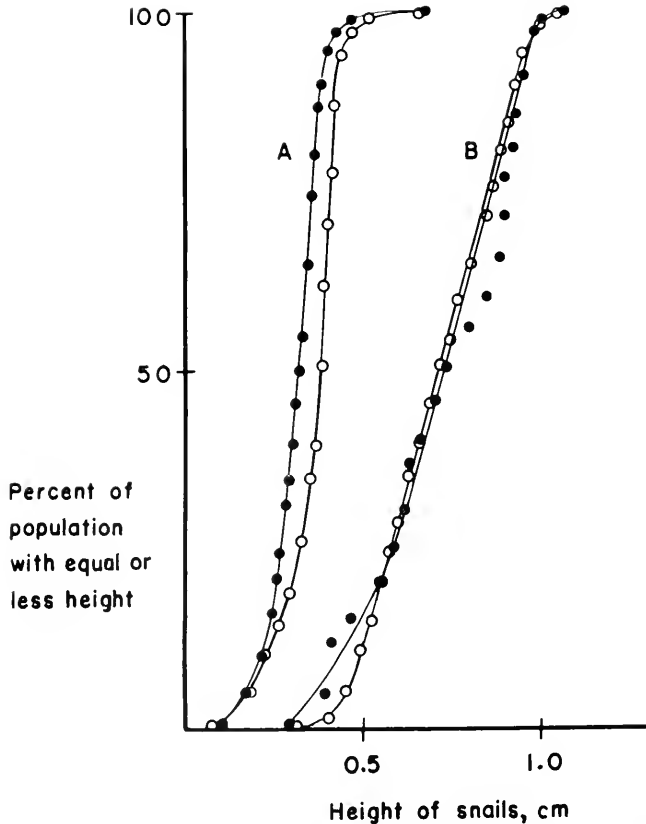

FIGURE 3. Cumulative curves for the *Littorina scutulata* populations of two environments. A. Whale View Point; B. Shelf Rock pools. Measurements made in August, 1951, shown as circles; measurements made in July, 1953, shown as dots.

date should be shifted towards the right along the abscissa; that is, effects of growth should be evident. If the latter hypothesis is the proper explanation for the phenomenon, the position on the abscissa of a curve should remain constant with time. Figures 2 and 3 show cumulative curves for populations in the first and second environments, constructed from measurements made about two years after the data discussed above were obtained. Measurements were not attempted for the third environment as appreciable numbers of large periwinkles had been permanently removed from this locality for other experiments. The expected



height increase of *L. planaxis* during this time can be calculated from data given below, and would be of the order of 0.5 cm., but the two sets of curves occupy approximately the same position. Environmental factors, therefore, appear to determine the size distribution of snail populations at any particular locale.

It should be mentioned that the three environments were under constant observation over the period that intervened between the measurements of Figures 2 and 3. The populations were never noticeably different in their size distribution during this time.

#### *Factors affecting size*

Wave action and salinity may be among environmental mechanisms capable of causing selection for a given snail size. In many places these two factors are inversely correlated. The higher levels of the spray zone are not wetted by the ocean so frequently as are the lower levels, and have therefore more opportunity for undergoing evaporation and achieving correspondingly greater salinities. The water of the pools and the surface moisture films of the lower levels, on the other hand, are renewed often by waves, and salinities at these localities are therefore not elevated.

As already noted, the three environments studied are subjected to different degrees of wave action. The snail populations composed of larger individuals appear to occupy the drier areas of the spray zone. In order to determine whether water currents might be more effective in removing large than small snails the following experiments were performed.

Four small (approx. 0.6 cm.), four intermediate (0.9–1.2 cm.), and four large (1.4–1.6 cm.) specimens of *L. planaxis* were placed on a small flat rock in a tidepool. When all the snails had emerged from their shells and were observed creeping, the rock was moved rapidly through the pool, creating a water current across the shells. After several vigorous swings through the water, only three small snails were left. A repetition of the experiment using six small, four intermediate, and four large snails ended with only four small snails remaining attached to the rock. When twelve medium-size *L. scutulata* (approx. 0.9 cm.) were placed on the stone with three small and two large *L. planaxis* for comparison purposes, the large specimens of the latter species were washed off with relative ease. After much effort three of the *L. scutulata* were eventually swept away, leaving nine of this species and the three small *L. planaxis* when the experiment was discontinued.

When a stream of sea water from a hose was allowed to play against the shells of *L. planaxis* creeping on a flat rock, large individuals were washed off more readily than small ones, and a snail of a given size was removed with greater ease when the stream was directed against the posterior part of the shell.

In order to gain an idea of the current velocities necessary to dislodge a snail, specimens of *L. planaxis* were placed in a Plexiglass tube of 3.5 cm., inside diameter, and after the animals had emerged from their shells and were crawling on the surface of the Plexiglass, the tube was gently filled with sea water. A current of known velocity was then allowed to flow through the tube and notations were made of the ability of the snails to remain attached for 10 seconds. The results

are given in Table I. A total of 10 large and 8 small snails was used in the experiment, and 6 trials were conducted.

Several hypotheses offer plausible explanations for the ability of small *L. planaxis* to withstand currents that remove large individuals. Physical factors might include greater water friction acting as drag on larger shells, or frictional forces slowing the current in the vicinity of the rock-water interface<sup>3</sup> thus favoring smaller snails. Biological factors might include loss of vigor and of tenacity with increasing age, or a disproportionate growth of the various parts such that the sole of the foot does not increase as rapidly as the surface area of the shell. Figure 4 shows that the last hypothesis is not supportable, hence one or more of the other factors may contribute to the distribution phenomenon.

TABLE I  
*Effect of current velocity on two size groups of Littorina planaxis*

Size group	Velocity of current flowing over snails meters/second	Fraction of snails removed by current per cent
Large snails (1.3 to 1.6 cm.)	3.4	90
	2.3	90
	2.0	80
Small snails (approx. 0.7 cm.)	3.4	50
	2.0	50

The absence of large snails from areas exposed to vigorous wave action may thus be explained, but account has not yet been taken of the absence of small snails in the high, dry areas of the spray zone. The solution to this problem may lie in physiological age changes rendering the animal more capable of coping with exposure to air or to more variable salinity conditions. Salinity has been shown to influence shell size and shape in *Littorina* (Thorson, 1946; Agersborg, 1927) and further study along these lines will be necessary before a complete explanation of the observed size distribution can be proposed.

#### EROSIVE ACTIVITIES

Many intertidal animals bring about erosion of rock. *Littorina* species often occur in small basins above high water mark (Fischer-Piette, 1932; Clench, 1938; Lysaght, 1941) and have been credited by some investigators (Brunelli, 1928; Welch, 1929) with the production of depressions in rock. The snails feed by applying a file-like ribbon, the radula, to the substratum and transfer bits of it to the mouth by a scraping action. On the cliffs around La Jolla the animals scrape algae and fine detritus from the rocks and at the same time remove particles of the rock itself. Because of their great abundance, erosion resulting from their feeding is believed to be appreciable, and a quantitative estimation of the magnitude of the erosion will be useful in determining its importance with respect to other erosive processes.

Since the animals may not behave as they do in nature when kept in the laboratory over long periods of time, it seemed wisest to obtain as much data

<sup>3</sup>An idea for which I am indebted to Professor Roger R. Revelle.

as possible from snails in their normal environment. The simplest means for accomplishing this appeared to be to determine the number of times daily the gut contents are completely renewed, and also the proportion of the gut contents that is inorganic matter. The product of the two quantities would yield the daily rate of erosion.

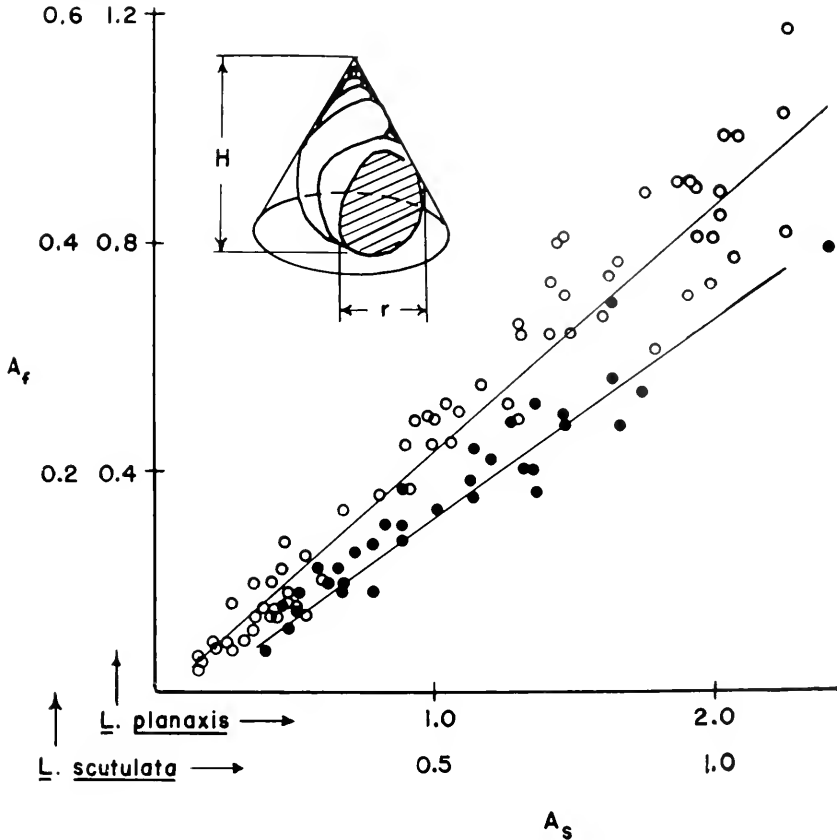

FIGURE 4. Relationship of shell surface to surface of the sole of the foot for *Littorina planaxis* and *L. scutulata*, indicating that the increase in area of each with age is proportionately the same. The sole area ( $A_f$ ) was measured while the animals were crawling up the sides of a glass vessel. Shell surface ( $A_s$ ) was arbitrarily taken as  $1/\pi$  of  $\pi \sqrt{r^2 + H^2}$ , the formula for the curved surface of a right cone.

#### *Time required to renew material in the gut*

The number of times daily the gut contents are renewed will depend on the rate at which material is passed along the gut, which in turn may vary with the amount of time the snail is able to feed. Dissection of specimens of *L. planaxis* taken both from pools (46 specimens) and from areas that become dry at low tides (30 specimens) revealed that throughout the day the intestines of the former group were always full of unconsolidated material, whereas the intestines of the latter

TABLE II

Summary of an experiment to determine the time required for *Littorina* to cycle food completely through the gut; May 18, 1953; water temperature range 17° to 30° C.; 20 snails per size group

Species	Height cm.	Time elapsed until		
		First blue fecal pellet observed, hr.	Half of group defecated blue feces, hr.	Entire group defecated blue feces, hr.
<i>L. planaxis</i>	0.4-0.5	1 <sup>2</sup> / <sub>3</sub>	2	3
<i>L. planaxis</i>	0.7-0.95	2	3 <sup>3</sup> / <sub>4</sub>	5
<i>L. planaxis</i>	1.3-1.6	2 <sup>1</sup> / <sub>2</sub>	4 <sup>2</sup> / <sub>3</sub>	—*
<i>L. scutulata</i>	0.3-0.45	1 <sup>2</sup> / <sub>3</sub>	2	3
<i>L. scutulata</i>	0.8-0.95	2 <sup>1</sup> / <sub>3</sub>	4	5

\* Thirteen had defecated blue feces after 7 1/2 hours.

group were generally at least partially full but sometimes almost empty. It was concluded that animals in the pools graze sufficiently to keep the gut full at all times. Snails feeding on areas that become dry at low tide appear to graze only when the surface is moist, and the amount of material in the gut consequently is variable.

In order to determine the rate at which material is passed through the gut, groups of snails were allowed to graze on a section of Shelf Rock stained with the

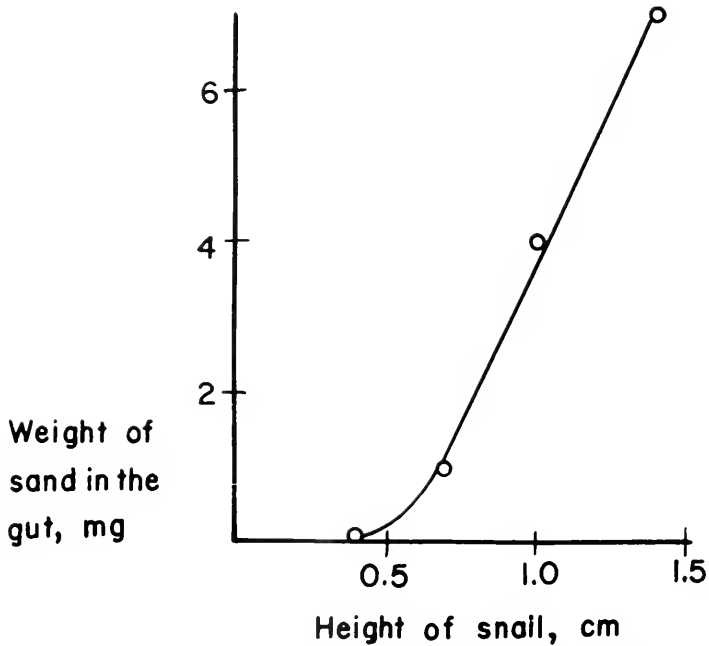

FIGURE 5. Relationship of sand contained in the gut to height of *Littorina planaxis*.

harmless dye methylene blue. After a period of an hour and a half had elapsed, the animals were removed to an unstained area and carefully observed for the first appearance of blue fecal pellets. While they were on the stained and unstained rock, the periwinkles were washed with fresh sea water every 10 minutes, and their behavior during the experiment seemed normal. Five such experiments were conducted on two spring and on three summer days. For snails of height 0.8 cm., cycling times of  $2\frac{1}{2}$  to 6 hours were obtained. The results were always similar and are described in Table II for one of the experiments.

A typical 0.8-cm. snail in a Shelf Rock pool, therefore, feeds sufficiently to keep the gut full at all times and probably renews the material completely four to eight times daily.

#### *Inorganic matter in the gut*

Sand in the gut was determined by extracting snails from their shells, incinerating the bodies in a tared crucible, cooling, adding a little concentrated hydrochloric acid to dissolve body ash, carefully decanting, rinsing, re-incinerating and weighing. Four size groups of 50 *L. planaxis* each were thus analyzed and the results are presented in the curve of Figure 5. An 0.8-cm. snail therefore contains on the average about 1.6 mg. of sand in the gut.

#### *Calculated rate of erosion*

Taking the Shelf Rock region, and considering the simplest case of a snail feeding in a pool, an estimation of erosion may now be made. It has been shown (Fig. 2) that the population in this environment averages 0.8 cm. in height. The average amount of inorganic material contained in the gut of an 0.8-cm. snail was found to be 1.6 mg., and, if we take the most conservative cycling period of 4 times daily, we obtain the value of  $1.6 \times 4 = 6.4$  mg. of inorganic material passing through the gut of the snail per day. This presumably is equivalent to the amount of rock eroded daily. The density of Shelf Rock is approximately 2.5 g./cc. and calculations show that 100 snails, 0.8 cm. in height, would be capable of excavating a basin of 86 cc. yearly, almost a liter in a decade.

The concentration of *L. planaxis* in the environment under discussion is of the order of one snail per 30 cm.<sup>2</sup> Erosion by this species alone, therefore, may be calculated to deepen the pools one cm. every 40 years. If *L. scutulata* is considered, the snail concentration increases to one snail per 12 cm.<sup>2</sup> and assuming that 0.8-cm. individuals of both species have similar feeding rates and weight of gut contents, erosion by both *Littorina* species combined will deepen the pools one cm. every 16 years. The snail concentration has remained fairly constant over the two-year period that is covered by these observations.

#### *Comparison with erosion from other sources*

Other erosive processes acting on the sandstone rocks of this area have been studied by Emery (1941, 1946). For exposed surfaces a general erosion rate of one cm. every 20 years was estimated, while for pools at Whale View Point nocturnal p<sub>H</sub> changes at low tides were calculated to cause a deepening of the

pools by one cm. every 33 years. The different processes causing rock erosion are probably additive in some cases and in other instances facilitate each other and are not additive.

#### GROSS EFFICIENCY

The average, gross metabolic efficiency, or the ratio of ingested food to organic matter incorporated as living tissue, may now be estimated for *L. planaxis* with the aid of additional data that have been obtained.

#### Growth

Growth rates were determined by measuring the increases in height of marked specimens of *L. planaxis* on Shelf Rock at various intervals for a period of a

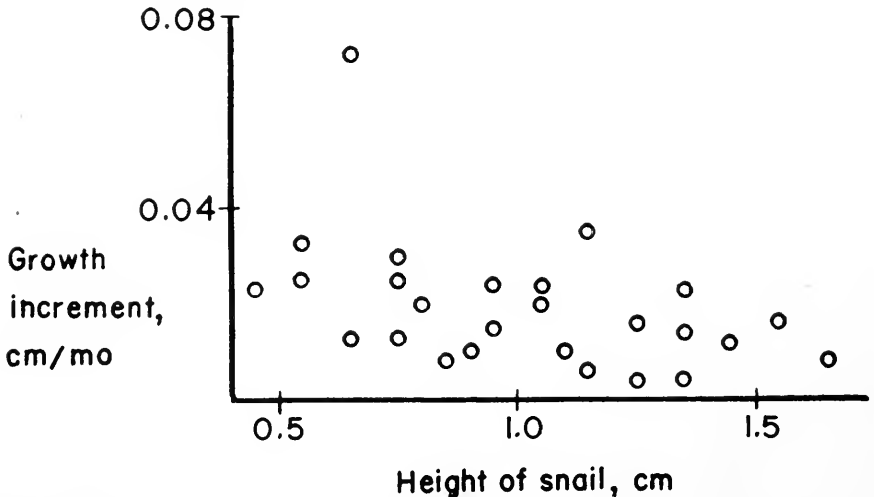

FIGURE 6. Twenty-six monthly growth increments observed in specimens of *Littorina planaxis* at Shelf Rock.

year and a quarter. The methods of converting an increase in spiral length to a height increase, used by Moore (1937) and Lenderking (1951) with other littorines, seemed to be complicated in the present case, since the apex angle of *L. planaxis* varies considerably, and it therefore appeared simplest to measure height increments over a long period of time. Figure 6 illustrates the results of the experiment, showing the growths of positively identified individuals from the snails that were recovered, out of a total of 300 originally marked. It may be noted that an 0.8-cm. snail has an average height increment of about 0.02 cm. per month.

To convert this value to an increase in tissue weight the relationship between snail height and dry tissue weight was obtained and is shown in Figure 7. Specimens of *L. planaxis* were dried in a vacuum oven for 24 hours at 80° C. and 460 mm. pressure. After cooling in a desiccator, the shell and dry tissue were weighed and the shell weight was obtained after removing the dry tissue by a half hour's immersion in boiling 20% KOH. Dry tissue weight was then readily calculated

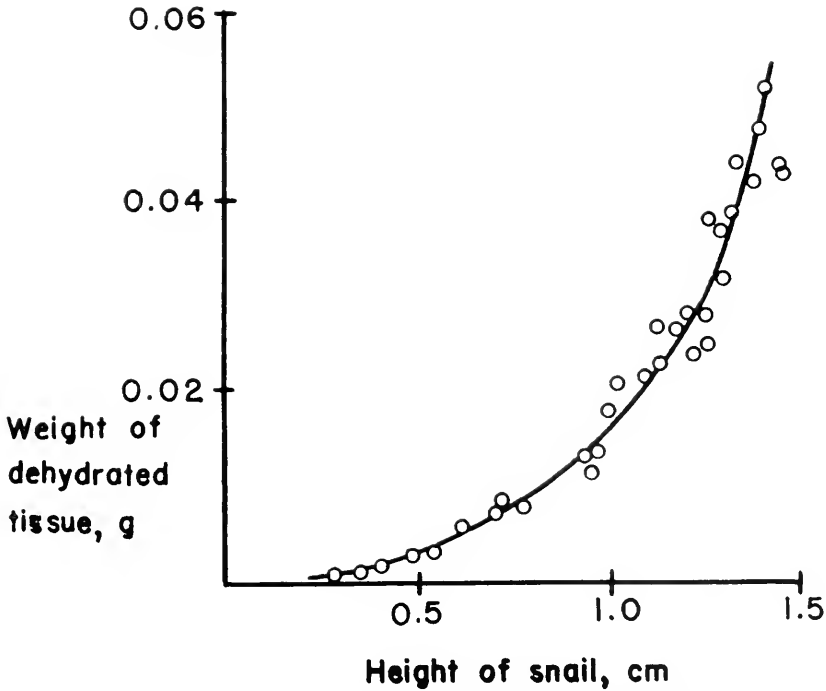

FIGURE 7. Relationship between dry tissue weight of *Littorina planaxis* and height.

by subtraction. Computations using Figure 7 indicate that an 0.8-cm. snail growing 0.02 cm. per month would have an increase in dry weight of 0.6 mg. for a like period.

#### *Ingestion of organic matter*

Determination of the amount of food ingested monthly could be readily accomplished if the organic matter per cent of the material swallowed by the snail were known. In scraping the surface of rocks, however, the snail has an excellent

TABLE III  
*Organic content of various materials*

Material analyzed	Organic matter per cent	Average
Snail feces	2.4	2.7
	2.0	
	3.0	
	3.2	
Light manual knife scrapings of rock surface	2.4	2.5
	2.6	
Loose sand from tidepool bottom	0.8	0.9
	1.0	

mechanism for removing only a thin, organic-rich layer of material. Even the lightest of scrapings made by a knife might remove much underlying rock along with the surface "skin" of organic matter. To estimate the organic matter per cent of the material swallowed by the snail, therefore, it seemed best to assume that only a small fraction of the organic molecules will be assimilated through the gut wall, and that the feces would therefore have approximately (and conservatively) the same organic content as the ingested material. Corrections for this assumption can then be made and the efficiency recalculated.

Fresh snail feces may easily be obtained in abundance, and the results of organic analyses on these and other materials by Walkley and Black's rapid titration method (chromic acid digestion) are given in Table III.

It was found in calculating erosion that an 0.8-cm. snail voids 6.4 mg. of inorganic material daily and this amounts to 192 mg. per 30-day month. If the feces are 2.7% organic matter the amount of organic material voided per month is 5.3 mg. Making use of the assumption explained above, this is approximately equal to the monthly ingested organic matter.

#### *Calculation of gross efficiency*

For an 0.8-cm. snail in the pools of Shelf Rock the gross efficiency may now be estimated as  $\frac{\text{Organic matter added as tissue}}{\text{Organic matter ingested}} \times 100$  which equals  $\frac{0.6}{5.3} \times 100 = 11\%$ .

In order to refine the calculation let us consider how much of the ingested organic matter might reasonably be assimilated across the gut wall from the food, of which some is built into new tissue. There must also have been assimilated a sufficient quantity of material to account for organic matter lost in respiration, and since the animals are poikilothermic and slow in movement, it would seem that this loss should be less than 4 times the amount added as new tissue. Taking the latter, then, as 20% of the total assimilated, and all other losses combined as 80%, and knowing that the animal adds 0.6 mg. per month as new tissue, we have 3 mg. per month as an estimate of the amount of organic matter assimilated across the gut wall. Recalculating the efficiency gives a value of  $\frac{0.6}{5.3 + 3.0} \times 100 = 7\%$ .

It will be recalled that in calculating erosion the time for cycling food through the gut was taken conservatively as 6 hours. The average value might be less, which would increase the erosion rate and depress the efficiency.

#### SUMMARY

1. Size distribution curves for populations of the marine intertidal snails *Littorina planaxis* and *L. scutulata* in three environments are presented.
2. It is concluded that environmental factors cause the observed size distributions, and the amount of wave action at a given locale appears to be one of the influencing factors. *L. planaxis* was observed to cling to a smooth surface in current velocities of two to three meters per second for 10 seconds.
3. The time for littorines to cycle food completely through the gut varied with size. Snails 0.8 cm. in height required from  $2\frac{1}{2}$  to 6 hours.



4. Erosion resulting from the snails' feeding activities was estimated for certain tidepools and found to deepen tidepools one cm. every 16 years. This is of the same order of magnitude as other erosive processes which have been studied in the same region.

5. Growth of *L. planaxis* was found to average 0.02 cm. per month in height increment, and 0.6 mg. per month in dry weight of organic matter.

6. The gross metabolic efficiency was computed and is estimated to be in the neighborhood of 7%.

## LITERATURE CITED

- AGERSBORG, H. P. K., 1927. The distribution, variation, and evolution of certain prosobranchiate mollusca from the littoral zone of the coasts of New England and Norway. *Anat. Rec.*, **37**: 149.
- BRUNELLI, G., 1928. Sulla natura biofisica della erosione foveolare della arenaria nella costa Tirrena. *Atti. R. Acad. Naz. Lincei Rend. Cl. Sci. Fis. Mat. e Nat.*, **8**: 423-424; *Biol. Abstr.*, **3**, 1929.
- CLENCH, W. J., 1938. A new species of *Olivia* from Santo Domingo with notes on other marine forms. *Nautilus*, **51**: 109-114.
- EMERY, K. O., 1941. Rate of surface retreat of sea cliffs based on dated inscriptions. *Science*, **93**: 617-618.
- EMERY, K. O., 1946. Marine solution basins. *J. Geol.*, **54**: 209-228.
- FISCHER-PIETTE, E., 1932. À propos du caractère euryhaline des littorines. *Bull. Lab. Mar. Saint-Servan*, **9**: 16-17.
- LENDERKING, R. E., 1951. Observations on *Littorina anguilifera*, Lam., from Biscayne Key, Florida. *Quart. J. Fla. Acad. Sci.*, **14**: 247-250.
- LYSAGHT, A. M., 1941. The biology and trematode parasites of the gastropod *Littorina neritoides*, L., on the Plymouth breakwater. *J. Mar. Biol. Assoc.*, **25**: 41-67.
- MOORE, H. B., 1937. The biology of *Littorina littorca*. Part I. Growth of the shell and tissues, spawning, length of life, and mortality. *J. Mar. Biol. Assoc.*, **21**: 721-742.
- THORSON, G., 1946. Reproduction and larval development of Danish marine bottom invertebrates, with special reference to the planktonic larvae in the sound (Øresund). Meddelelser Fra Kommissionen For Danmarks Fiskeri-Og Havundersøgeleser Serie: Plankton. Bind 4. Nr. 1.
- WELCH, R. J., 1929. *Littorina* perforations in indurated chalk. *Irish Nat. J. Belfast*, **2**: 131.

THE ECOLOGY OF PHYTOPLANKTON BLOOMS IN  
MORICHES BAY AND GREAT SOUTH BAY,  
LONG ISLAND, NEW YORK<sup>1</sup>

JOHN H. RYTHER

*Woods Hole Oceanographic Institution, Woods Hole, Massachusetts*

In recent years Great South Bay and Moriches Bay have supported an extremely heavy growth of phytoplankton which characteristically appears early in the spring and persists throughout the summer and fall. At the peak of their growth, the contributing organisms have been found to exceed concentrations of ten million cells per ml., and the resulting turbidity may reduce Secchi disc transparency to less than one foot in places.

Records maintained since 1922 by Mr. J. B. Glancy show that the recurrent annual populations of algae in Great South Bay have consisted almost without exception of small, unicellular, green organisms 2-4  $\mu$  in diameter, which have been referred to locally as "small forms." This type of population differs greatly from the mixed communities of diatoms, green flagellates, and dinoflagellates which are typical of the plankton flora in other bays and estuaries of the same general region. Another striking feature is the persistence of the "small form" populations throughout the spring, summer, and fall, in marked contrast to the seasonal succession of dominant species which is commonly observed elsewhere. It is the purpose of this report to analyze the physiological factors which may account for the dominance of "small forms" in the recurrent plankton blooms.

These dense growths of algae have greatly reduced the value of the surrounding region as a recreational area, and are also considered to be the principle cause of the failure of what was formerly a prosperous oyster industry in Great South Bay. Correlated with and suspected as a cause of the algal blooms is the existence of a large duck industry which now consists of over 40 individual farms centered along the tributary streams and coves of Moriches Bay. These farms are so situated that their waste products eventually enter the bays, greatly enriching the water and presumably creating conditions conducive to the development of the plankton blooms.

The results of a study of various aspects of the hydrography, chemistry, and biology of Great South Bay and Moriches Bay, will appear elsewhere (Ryther, unpublished data). This investigation has revealed that the embayments under consideration represent a unique ecological environment which results partly from pollution contributed by the surrounding duck farms, and partly from the topographic and hydrographic features of the area. The pollution not only provides an extensive fertilization of the bay waters with nutrients essential to phytoplankton growth, but, in addition, the presence of organic nitrogen compounds and the low ratio of nitrogen to phosphorus in the pollutants create conditions which differ

<sup>1</sup> Contribution No. 685 from the Woods Hole Oceanographic Institution.

considerably from the chemical composition of natural sea water. The shallow nature of the embayments contributes to the development of abnormally high water temperatures which may reach 30° C. during the summer months. Their extremely low flushing rate results in the retention for long periods of time of both the pollutants and their entraining fresh water, which further builds up the concentrations of nutrients and the resulting phytoplankton crop and also reduces salinities to approximately 50% of normal sea water in the open embayments and less than 10% in the estuaries.

This report includes the results of experiments performed with the two dominant species of "small forms," and, for contrast, with the common neritic diatom, *Nitzschia closterium*. Growth rates of these algae were studied in relation to the temperature, salinity, and nutrient conditions peculiar to Great South Bay and Moriches Bay as described above. The results of these experiments were then related to the distribution of the "small form" population and associated physical and chemical conditions existing in the embayments.

The author expresses his sincere thanks to Mr. J. B. Glancy, the Messrs. G. H. Vanderborgh, Sr., and Jr., and the New York State Department of Conservation for their generous assistance in providing laboratory and boat facilities in the field. Appreciation is also tendered to Dr. Wm. Butcher and Dr. R. A. Lewin for their help in the identification of the phytoplankton. The investigation was carried out, in part, with the assistance of a grant from the National Science Foundation.

#### CULTURE METHODS

The "small form" population of 1952 and 1953 consisted principally of two species of algae. That which was the more numerous was identified by Dr. Wm. Butcher as his recently described *Nannochloris atomus* (Butcher, 1952). The other species was tentatively placed by Dr. Ralph Lewin in the genus *Stichococcus*, possibly *S. cylindricus* Butcher.

Because of their similarity of appearance, it was impossible to distinguish between the two species in routine examinations of the natural population. Consequently they will be considered together as a single community and referred to collectively as the "small form" population.

The *Nannochloris*, *Stichococcus*, and *Nitzschia* used in the experiments were isolated from water samples collected from Great South Bay. Pure cultures were obtained by the agar streak method incorporating the use of penicillin (200 units/ml.) and streptomycin (10–20 units/ml.) in the enriched agar. Colonies isolated from streaks were transferred several times on the antibiotic agar and then inoculated into liquid media.

Pure cultures were used in all experiments involving nutrient studies, while cultures of *Nannochloris* and *Stichococcus* used in the temperature and salinity experiments were unialgal but not bacteria-free.

Growth studies were made with algal cultures grown in 300 ml. of media in 500-ml. Erlenmeyer flasks. Lighting was provided by a bank of mixed daylight and white fluorescent lamps which produced 500 foot candles of illumination.

Temperature was controlled by keeping cultures immersed in running tap water, which provided a range of 20–30° C. over a six-months period by varying the rate of flow of the water. This method permitted control to  $\pm 2^\circ$  C. for periods of one to two weeks, the normal duration of the experiments. Cultures grown at temperatures of 5–15° C. were maintained to a variability of  $\pm 1^\circ$  C. in an illuminated, constant temperature box. Except where the effect of temperature upon growth was being studied, cultures were routinely grown at 18–22° C.

The same basic medium was employed for the culture of all three species of algae, and consisted of a modification of the artificial sea water of McClendon *et al.* described in Sverdrup, Johnson and Fleming (1942), enriched with N, P, Si, and Fe. At full strength (34.62<sup>0</sup>/<sub>00</sub>) it consists of the following, in parts per thousand:

NaCl	26.726	H <sub>3</sub> BO <sub>3</sub>	0.058
MgCl <sub>2</sub> ·6H <sub>2</sub> O	2.260	Na <sub>2</sub> SiO <sub>3</sub> ·9H <sub>2</sub> O	0.020
MgSO <sub>4</sub> ·7H <sub>2</sub> O	3.248	NH <sub>4</sub> Cl	0.053
CaCl <sub>2</sub>	1.153	Na <sub>2</sub> HPO <sub>4</sub> ·12H <sub>2</sub> O	0.020
KCl	0.731	Fe Citrate	0.001
NaHCO <sub>3</sub>	0.198		
KBr	0.058		

Since the growth of *Nitzschia* is relatively poor in ammonia-nitrogen, as will be demonstrated, NH<sub>4</sub>Cl was replaced with 0.10<sup>0</sup>/<sub>00</sub> KNO<sub>3</sub> in media used for growing the diatom. Several of the other constituents have been altered in concentration or replaced with other ingredients in the various experiments, as will be discussed below.

Growth in all experimental cultures was determined by cell counts with a Levy hemacytometer. Cultures were grown for periods of 10 days to two weeks, and cell counts were made at intervals of two to three days.

The growth rate, expressed as divisions per day ( $d$ ), was calculated for the entire period of growth from the expression:

$$d = l_n \frac{C_t}{C_o} \times \frac{1}{t l_n 2},$$

where  $C_t$  and  $C_o$  are cell concentrations at times  $t$  and  $o$ , respectively.

## EXPERIMENTS AND THEIR APPLICATION TO FIELD OBSERVATIONS

### 1. Nutrients

#### A. Experiments

A series of laboratory experiments was conducted to determine the relative growth rates of *Nannochloris*, *Stichococcus*, and *Nitzschia* in each of several different forms of nitrogen. Pure cultures of the three species were used, and each was grown at its optimum salinity, as will be discussed in a later section. All three algae were grown in media containing one mg. atom per liter of nitrogen in each of the following forms: nitrate, nitrite, ammonia, urea, uric acid, l-cystine, asparagin, and glyocoll. The resulting growth rates, in divisions per day, are given in Table I.

TABLE I

The effect of the nitrogen source upon the growth rates of *Nannochloris*, *Stichococcus*, and *Nitzschia*

Nitrogen source (1 mg. A N/L)	Growth rate: Divisions per day		
	<i>Nannochloris</i>	<i>Stichococcus</i>	<i>Nitzschia</i>
NO <sub>3</sub>	0.54	0.57	0.37
NO <sub>2</sub>	0.65	0.57	0.40
NH <sub>3</sub>	0.72	0.61	0.04
Urea	0.62	0.56	0.21
Uric acid	0.68	0.59	0.23
l-cystine	0.77	0.62	0.00
Asparagin	0.68	0.62	0.15
Glycocoll	0.66	0.61	0.07

It may be seen that the diatom grew about equally well in nitrate and nitrite, poorly in ammonia, and slowly or not at all in the organic N compounds. Both *Nannochloris* and *Stichococcus* showed good growth in all of the forms of nitrogen tested. However, the growth rate of both species in nitrite and nitrate was slightly lower than that in ammonia, and, in general, was less than growth rates in the organic compounds. The best growth of *Nannochloris* was observed in cultures containing l-cystine.

TABLE II

The effect of the N:P ratio upon the growth rates of *Nannochloris*, *Stichococcus*, and *Nitzschia*

N:P ratio (by atoms)	Growth rate: Divisions per day		
	<i>Nannochloris</i>	<i>Stichococcus</i>	<i>Nitzschia</i>
15:1	0.68	0.53	0.39
5:1	1.32	0.88	0.40

In another series of experiments, growth rates of the three species of algae were determined in media containing the same concentrations of nitrate-nitrogen (one mg. atom per liter) but two different concentrations of phosphate-phosphorus (0.066 and 0.200 mg. atoms per liter). By varying the concentrations of phosphorus in this manner, the resulting N:P ratios by atoms in the two media were 15:1 and 5:1, respectively.

In this experiment, increasing the P concentration, or lowering the N:P ratio, had no effect upon the growth of the diatom, *Nitzschia*, but approximately doubled the growth rates of *Nannochloris* and *Stichococcus* (Table II).

B. Application to field observations

Richards (unpublished data) measured the nitrogen present as uric acid, ammonia, nitrite, and nitrate in the duck farm effluents, the tributaries to Moriches

Bay receiving these effluents, and in Moriches and Great South Bays on August 21, 1952. His analyses showed that uric acid could be detected only in the duck farm effluents, ammonia was present in both the effluents and the tributary streams, while nitrite and nitrate were found nowhere except as traces. No appreciable concentrations of inorganic N in any of the forms tested for was found in either Moriches Bay or Great South Bay.

Phosphorus, on the other hand, appears to have been present in excess of the requirement of the phytoplankton during most of the year, not only in the polluted estuaries, but also throughout the bay waters. Filtered water samples collected from several locations in Great South Bay and Moriches Bay failed to support the growth of *Stichococcus*, if untreated or enriched with phosphate. However, dense growth of the alga occurred in all samples if enriched with ammonia-N indicating that the latter was the principal limiting factor to the growth of the algae population.

The population maxima normally occurred in Moriches Bay and its polluted tributaries. The distribution pattern of the organisms in Great South Bay and Shinnecock Bay is strongly suggestive that their presence in these waters was largely the result of the seaward flushing of Moriches Bay water, and that growth was principally confined to an area close to the source of the nutrient rich duck farm pollutants.

In its original state in the duck wastes, nitrogen occurs as excreted uric acid and amino compounds contained in the undigested food residues. Investigations in this laboratory by Vaccaro, Norton and Plunkett (unpublished) have disclosed that bacteria present in the duck farm effluents are capable of decomposing uric acid with great rapidity. In water samples collected from these effluents, the contained uric acid was found to decrease to 10% of its original concentration in an average of 15 hours at 2° C. The nitrogenous end products of this decomposition were not investigated, but Copeman and Dillman (1937) observed that the decomposition of the uric acid of guano in water was accompanied by an increase in ammonia from 32.2% to 85.0% of the total nitrogen in four days.

According to the classical concept of the nitrogen cycle of the sea, the decomposition of organic nitrogen to ammonia is followed by the nitrification of the ammonia to nitrite and nitrate. This phase of the cycle appears never to occur to any appreciable extent in the Moriches Bay area. Since nitrogen is the limiting factor to the growth of the phytoplankton, it is utilized as quickly as it becomes available and before decomposition to nitrite and nitrate can occur.

It follows that those organisms will have a distinct advantage which are able to utilize the nitrogen in the earliest stages of its decomposition. The laboratory experiments have demonstrated that *Nannochloris* and *Stichococcus* are particularly well adapted to growth in organic nitrogen and its early decomposition products. In contrast, the diatom, *Nitzschia closterium*, grew poorly or indifferently in these N forms. The advantage of the "small forms" over the latter in the Moriches Bay environment is therefore obvious.

Nitrogen and phosphorus are contained in duck faeces at a ratio of approximately 3.3 atoms of nitrogen to one atom of phosphorus. Total N and total P data from the tributaries of Moriches Bay and from the bay itself show N:P ratios ranging from 2.3:1 to 4.4:1 (Richards, unpublished data). Approximately

one-half of the total phosphorus consisted of inorganic phosphate in these analyses. On the other hand, no appreciable concentrations of available nitrogen were found anywhere in the bay waters, as previously discussed. If it is assumed that half of the total phosphorus and all of the total nitrogen were incorporated in particulate matter, which consisted principally of algal cells, then the N:P ratio of the phytoplankton would range from 4.6:1 to 8.8:1 by atoms.

Various authors have pointed out that the ratio of nitrogen to phosphorus in open ocean water is rather constant at approximately 15:1 by atoms, which is closely reflected in the ratio of these elements in marine phytoplankton (Redfield, 1934; Cooper, 1937, 1938; Fleming, 1940). Harvey (1940) found that natural populations of diatoms utilized about 20 atoms of nitrogen to one atom of phosphorus.

Ketchum and Redfield (1949) showed that laboratory cultures of *Nitzschia closterium* contained N and P at a ratio of 11.6:1, but cultures of six species of Chlorophyta, including *Stichococcus bacillaris*, had N:P ratios ranging from 3.5:1 to 6.6:1, or two to three times as much phosphorus per atom of nitrogen as the diatoms. This compares favorably with the estimated N:P ratio of the phytoplankton of Moriches Bay which consisted predominantly of the Chlorophyta, *Stichococcus* and *Nannochloris*.

These data indicate that there is a basic difference between the chemical composition of the green algae, typical of fresh and brackish water, and oceanic diatoms, at least with respect to the N:P ratio in the cells. The growth studies bear out this contention by demonstrating the fact that the Chlorophyta grow much more rapidly in water containing three times as much phosphorus per atom of nitrogen as normal sea water, while this increase in phosphorus has no effect upon the growth of the diatom, *Nitzschia closterium*.

The N:P ratio of the polluted water of Moriches Bay and its environs thus appears to be another factor favoring the growth of the "small forms" and their competition with organisms similar to *Nitzschia* in their nutritional requirements.

## 2. Salinity

### A. Experiments

To determine the effect of salinity upon the growth rates of *Nannochloris*, *Stichococcus*, and *Nitzschia*, each species was grown in a series of dilutions of the artificial medium described above. This series consisted of 100, 75, 50, 25, and 1 per cent solutions of the indicated concentrations of NaCl, MgCl<sub>2</sub>, MgSO<sub>4</sub>, CaCl<sub>2</sub>, and KCl. The concentrations of the other ingredients, which together account for less than 0.50/100, were not altered to avoid possible deficiencies of those nutrients.

The salinities of the resulting solutions, in ‰, totaled, respectively, 34.51, 25.91, 17.44, 8.91, and 3.80, with an additional 0.048‰ in each of the *Nitzschia* media as a result of replacing NH<sub>4</sub>Cl with KNO<sub>3</sub>.

These experiments indicate a salinity optimum at or near that of full sea water for *Nitzschia*, a typical marine species, while the "small forms" grow well within a wide range of salinities, with optima at about 50% sea water, and may be considered as brackish water species (Table III).

TABLE III

The effect of salinity upon the growth rates of *Nannochloris*,  
*Stichococcus*, and *Nitzschia*

Salinity: ‰	Growth rate: Divisions per day		
	<i>Nannochloris</i>	<i>Stichococcus</i>	<i>Nitzschia</i>
34.51	0.45	0.44	0.40
25.91	0.61	0.55	0.34
17.44	0.69	0.61	0.28
8.91	0.56	0.58	0.09
3.80	0.37	0.52	0.00

### B. Application to field observations

The highest concentrations of "small forms" normally occurred in Moriches Bay in water of approximately 15‰ salinity, or close to the physiological optima of the organisms. While this does not imply that salinity was the factor controlling the distribution of the phytoplankton, particularly in view of the preceding discussion concerning the distribution of nutrients, it nevertheless represents another environmental condition favoring the growth of the "small forms" over that of the more typical marine forms.

Of still greater importance, however, is the fact that *Nannochloris* and *Stichococcus* were able to grow remarkably well within the entire range of salinities tested in the experimental cultures, in contrast to the diatom, which was unable to grow at all in the low salinity cultures. This is particularly significant in view of the wide range of salinities which were observed in Great South Bay and Moriches Bay and their tributaries. Over a million "small forms" per ml. were present throughout the late spring and summer in the upper Forge River, directly opposite a group of duck farms, in water of less than 1‰ salinity. In addition, evidence was obtained in the experiment described in Section 1B that nitrogen-enriched water from Fire Island Inlet (26‰ salinity) was able to support a prolific growth of *Stichococcus*.

The population which thus becomes established in the highly enriched rivers and estuaries is able to continue growth as it is borne out to sea until its source of nutrients becomes depleted. At no time does salinity limit its growth and thereby permit the succession of other forms.

## 3. Temperature

### A. Experiments

Growth rates of the three algae were determined for cultures grown at temperatures ranging from 5° to 30° C. at intervals of 5° (Table IV). *Nitzschia* was grown in the full strength artificial medium (34.51‰) while the "small forms" were grown in the half-strength media (17.44‰) found to give optimum growth in the preceding section.



The diatom multiplied within a temperature range of 5–25° with optimum growth at 15°. Its division rate was relatively high at the lower limit of 5°, but decreased rapidly above 20°.

No appreciable growth of *Nannochloris* or *Stichococcus* occurred at temperatures of 10° or lower, but both species grew rapidly at temperatures of 15–30°. No clear-cut optimum could be detected between 15° and 25°, but growth rates of both “small forms” decreased considerably at 30°.

B. Application to field observations

When field studies were begun on April 1, a mixed diatom bloom occurred in the bays, which consisted of 890,000 *Leptocylindrus minimus*, 35,000 *Thalassiosira nana*, and 12,000 *Skeletonema costatum* per ml. at a station in central Moriches Bay. There were also present at that time 211,000 “small forms” per ml. On May 13 the situation was reversed, with “small forms” dominating the plankton and diatoms reduced to a total of 40,000 cells per ml. The latter subsequently disappeared from the plankton and did not reappear until the following February.

The principle cause of this succession of dominants appears to be temperature. Experimental evidence has shown that *Nannochloris* and *Stichococcus* are unable to grow appreciably at the 10° temperature which prevailed throughout the embayments on April 1, while the diatom, *Nitzschia*, maintained a relatively high growth rate at temperatures as low as 5°.

During the period of May–September, temperatures in Moriches Bay ranged from 13° to 30°. The growth experiments demonstrated that both *Nannochloris* and *Stichococcus* divide rapidly within that temperature range. The seasonal distribution of inorganic phosphorus in the Forge River at a station close to the source of pollution indicates that the heaviest enrichment of the bay waters also occurred during the same period of May–September. The situation therefore exists that during that part of the year when the bay is most heavily enriched with nutrients, temperatures may be expected which will fall approximately within the range for optimum growth of the “small forms.”

The month of July, 1952, was characterized by abnormally high temperatures throughout the Long Island area. Water temperatures of the three embayments under consideration ranged from 28–30° during the July 22–23 survey. A

TABLE IV

The effect of temperature upon the growth rates of *Nannochloris*, *Stichococcus*, and *Nitzschia*

Temperature: ° C.	Growth rate: Divisions per day		
	<i>Nannochloris</i>	<i>Stichococcus</i>	<i>Nitzschia</i>
5	0.00	0.00	0.29
10	0.14	0.12	0.42
15	0.65	0.48	0.48
20	0.80	0.48	0.40
25	0.71	0.43	0.19
30	0.32	0.26	0.00

decrease in the "small form" population at that time was generally observed throughout the area. This may be explained by the fact that the July temperatures exceeded the optima of the "small forms." The division rates of both *Nannochloris* and *Stichococcus* at 30° were observed to be approximately one half of that at 25° (Table IV). This population drop was obviously not associated with a nutrient depletion, as indicated by unusually high inorganic phosphorus concentrations on that date.

The presence of relatively large numbers of "small forms" between October and April, when temperatures were presumably too low to permit their growth, may be explained on the basis of the slow flushing time of Moriches Bay and the low death rate of the organisms. This subject will be discussed at length elsewhere.

It is significant, however, that the slow rate of disappearance of the static population during the winter months not only accounts for the presence of the organisms during that part of the year when they are unable to grow, but it also provides for a substantial seed population by the following spring, when conditions again become favorable for growth. The latter may be one of the chief reasons for the annual recurrence of the "small form" populations.

#### DISCUSSION

The "small forms," *Nannochloris* and *Stichococcus*, have been found to be particularly well adapted for growth under the peculiar physical and chemical conditions which occur in Great South Bay and Moriches Bay. In addition, it has been brought out that the slow flushing time of the bay waters allows for the retention of a considerable fraction of the summer bloom during the unproductive winter months, thereby providing for a substantial seed population on the following spring. This combination of circumstances alone is perhaps sufficient to account for the presence of "small form" blooms in these waters every year.

It is significant, however, that ecological conditions not only approach an optimum for the growth of the "small forms" but are also quite unsatisfactory for the development of the diatom, *Nitzschia closterium*. It is perhaps suggestive that the physiological characteristics of *Nitzschia* considered here are representative of diatoms, dinoflagellates, and other plankton flora normally found in unpolluted estuaries. While this provides a convenient hypothesis, such an assumption is unwarranted on the basis of the existing evidence.

The utilization of ammonia and amino acids by the green algae has been described by many workers (Schreiber, 1927; Braarud and Føyne, 1930; Algéus, 1946, 1949, 1950, and other papers). If diatoms in general are similar to *Nitzschia* in the matter of their nitrogen utilization, their absence from the summer blooms of Moriches Bay could be explained on that basis alone. This, however, does not appear to be the case.

Harvey (1940) found that natural populations of mixed diatoms could utilize nitrogen as nitrate, ammonia, urea, uric acid, and several amino acids, and that the growth of some species appeared to be better in ammonia than in nitrate. Chu (1943) observed that several diatoms (*Nitzschia palea*, *Fragilaria crotonensis*, *Asterionella gracillima*) grew equally well in ammonia or nitrate.

A recent paper by Harvey (1953) describes the exponential growth of *Nitzschia closterium* cultures in media containing ammonia as a source of nitrogen. Since

this is contradictory to the results of the experiments described in this paper, in which *Nitzschia* was found to grow very poorly in ammonia, these experiments were repeated, using both the artificial medium and natural sea water containing one mg. atom per liter of ammonia as a nitrogen source. The growth of *Nitzschia* in both of these media was equally as poor as that reported in the earlier experiments. Since the concentration of ammonia used here was probably higher than that employed by Harvey, there is the possibility that this was the factor which was toxic to the diatom (see Algéus, 1946) although it obviously was not so for either *Nannochloris* or *Stichococcus*. It is equally plausible that the *Nitzschia* used by Harvey and the present author represented different physiological varieties.

From the existing evidence of both the laboratory and the field observations, it appears that the only time of the year when organisms other than the "small forms" are able to dominate the phytoplankton is that period during which temperatures are too low to permit the growth of the Chlorophyta. In this respect, however, the natural situation in the bay waters differs somewhat from that which might be expected from the culture work. The experiments have shown that the "small forms" are able to grow very slowly if at all at the temperatures observed in the bays after October, while diatoms did not begin to flourish there until February. Although the bays were heavily enriched only during the duck growing season, relatively high concentrations of nutrients appear to be present throughout the year, presumably from the decomposition of the rich sediments in the tributaries receiving the duck farm effluents.

A remaining possibility exists that the absence of diatoms and other forms from the water between October and February may have been due, in part, to the production of inhibitory substances by the "small forms" and the accumulation of these products in the bay waters. This is suggested by the work of Pratt and his group (1944, and earlier papers) who found that *Chlorella* produces an antibiotic which inhibits its own growth, and by experiments of Rice (1949) who demonstrated that *Chlorella* and *Nitzschia frustrulum* produce substances which are mutually inhibitory.

Lefèvre and his co-workers (1951) have further shown that filtrates of both laboratory cultures and of pond water containing blooms of different species of algae produce inhibitory effects upon a wide variety of phytoplankton organisms.

It is perhaps significant that Pratt's group (Pratt, Oneto and Pratt, 1945) found that the maximum inhibitory effect of *Chlorella* was produced by senescent, non-dividing cultures, typical of the late fall and winter population of "small forms" in Great South Bay and Moriches Bay.

#### SUMMARY

1. The phytoplankton bloom in Great South Bay and Moriches Bay during the spring, summer, and early fall of 1952 consisted of the Chlorophyta, *Nannochloris atomus* and *Stichococcus* sp., to the virtual exclusion of other species. These organisms persisted throughout the year, but were accompanied by minor diatom blooms during the winter and early spring.

2. Growth rates of *Nannochloris*, *Stichococcus*, and the diatom, *Nitzschia closterium* were determined from laboratory cultures grown under various conditions

of temperature, salinity, and nutrients which are peculiar to the Great South Bay-Moriches Bay area.

3. *Nannochloris* and *Stichococcus* grew well in nitrogen present as nitrate, nitrite, ammonia, urea, uric acid, cystine, asparagin, and glycocholl. *Nitzschia* grew equally well in nitrate and nitrite, but showed poor growth in ammonia and the organic N compounds.

4. *Nannochloris* and *Stichococcus* grew approximately twice as fast in media containing an N : P ratio of 5 : 1 as they did in media with a 15 : 1 ratio of these elements. The growth rate of *Nitzschia* was the same in both media.

5. *Nannochloris* and *Stichococcus* appear to be brackish water forms with salinity optima of about 17‰, but both species grew well within a salinity range of 3–34‰. *Nitzschia*, a typical marine form, was unable to grow in low salinity water.

6. *Nannochloris* and *Stichococcus* grew at temperatures of 10–30° C., with very slight growth at 10° and an optimum range of 15–25°. *Nitzschia* grew within a temperature range of 5–25° with its best growth at 15°.

7. Pollution from duck farms bordering Moriches Bay heavily enriches the bay waters with plant nutrients. The presence of organic nitrogen compounds and the low ratio of nitrogen to phosphorus in the pollutants favor the growth of *Nannochloris* and *Stichococcus* over that of the more typical estuarine phytoplankton.

8. The peculiar nature of the pollutants together with low salinities and high water temperatures occurring at the time and place of maximum enrichment of the bay waters are factors which may explain the persistent dominance of the *Nannochloris-Stichococcus* community in the annually recurring plankton blooms in Great South Bay and Moriches Bay.

#### LITERATURE CITED

- ALGÉUS, S., 1946. Untersuchungen über die Ernährungsphysiologie der Chlorophyceen. *Bot. Notiser*, 1946: 129–278.
- ALGÉUS, S., 1949. Alanine as a source of nitrogen for green algae. *Physiol. Plant.*, 2: 266–271.
- ALGÉUS, S., 1950. Further studies on the utilization of aspartic acid, succinamide, and asparagin by green algae. *Physiol. Plant.*, 3: 370–375.
- BRAARUD, T., AND B. FØYNE, 1930. Beiträge zur Kenntnis des Stoffwechsels im Meere. Aushand, Norske Videnskaps-Akademi Mat. Nat. Klasse, 1930, no. 14: 1–24. Oslo.
- BUTCHER, R. W., 1952. Contributions to our knowledge of the smaller marine algae. *J. Mar. Biol. Assoc.*, 31: 175–191.
- CHU, S. P., 1943. The influence of the mineral composition of the medium on the growth of planktonic algae. Part II. The influence of the concentration of inorganic nitrogen and phosphate phosphorus. *J. Ecol.*, 31: 109–148.
- COOPER, L. H. N., 1937. On the ratio of nitrogen to phosphorus in sea water. *J. Mar. Biol. Assoc.*, 22: 177–182.
- COOPER, L. H. N., 1938. Redefinition of the anomaly of the nitrate-phosphate ratio. *J. Mar. Biol. Assoc.*, 23: 179.
- COPEMAN, P. R. R., AND F. J. DILLMAN, 1937. Changes in the composition of guano during storage. *J. Agr. Sci.*, 27: 178–187.
- FLEMING, R. H., 1940. The composition of plankton and units for reporting populations and production. *Proc. Sixth Pac. Sci. Cong., Calif.*, 1939, 3: 535–540.
- HARVEY, H. W., 1940. Nitrogen and phosphorus required for the growth of phytoplankton. *J. Mar. Biol. Assoc.*, 24: 115–123.
- HARVEY, H. W., 1953. Synthesis of organic nitrogen and chlorophyll by *Nitzschia closterium*. *J. Mar. Biol. Assoc.*, 31: 477–487.

- KETCHUM, B. H., AND A. C. REDFIELD, 1949. Some physical and chemical characteristics of algae grown in mass culture. *J. Cell. Comp. Physiol.*, **33**: 281-299.
- LEFÈVRE, M., H. JAKOB AND M. NISBET, 1951. Compatibilités et antagonismes entre Algues d'eau douce dans les collections d'eau naturelles. *Trav. Assoc. Internat. Limn. Theor. et Appl.*, **11**: 224-229.
- PRATT, R., 1944. Studies on *Chlorella vulgaris*. IX. Influence on growth of *Chlorella* of continuous removal of chlorellin from the culture solution. *Amer. J. Bot.*, **31**: 418-421.
- PRATT, R., J. F. ONETO AND J. PRATT, 1945. Studies on *Chlorella vulgaris*. X. Influence of the age of the culture on the accumulation of chlorellin. *Amer. J. Bot.*, **32**: 405-408.
- REDFIELD, A. C., 1934. On the proportions of organic derivatives in sea water and their relation to the composition of plankton. James Johnstone Memorial Volume. The University Press. Liverpool.
- RICE, T. R., 1949. The effects of nutrients and metabolites on population of planktonic algae. Ph.D. Thesis, Harvard University, Department of Biology.
- SCHREIBER, E., 1927. Die Reinkultur von marinen Phytoplankton und deren Bedeutung für die Erforschung der Produktionsfähigkeit des Meerwassers. *Wiss. Meeresuntersuch. Abt. Helgoland N.F.*, Bd. 16, No. 10:1-34.
- SVERDRUP, H. U., M. W. JOHNSON AND R. H. FLEMING, 1942. The oceans, their physics, chemistry, and general biology. New York, Prentice-Hall, Inc.

THE PHYSIOLOGY OF INSECT DIAPAUSE. VIII.  
QUALITATIVE CHANGES IN THE METABOLISM  
OF THE CECROPIA SILKWORM DURING  
DIAPAUSE AND DEVELOPMENT<sup>1</sup>

HOWARD A. SCHNEIDERMAN<sup>2</sup> AND CARROLL M. WILLIAMS

*The Biological Laboratories, Harvard University, Cambridge 38, Massachusetts*

In the *Cecropia* silkworm the termination of pupal diapause and the progress of adult development are accompanied by large and predictable changes in respiratory metabolism. Thus, as described in the preceding paper of this series, the respiration of *Cecropia* midway its adult development is approximately seven times that of the diapausing pupa. In the present study efforts were made to ascertain the enzymatic basis of the quantitative changes in respiration. Considerable evidence was already at hand pointing to pronounced alterations in the cytochrome system in synchrony with the termination of diapause in the eggs of the grasshopper *Melanoplus* (Bodine and Boell, 1934a, 1934b), the eggs of the commercial silkworm *Bombyx* (Wolsky, 1943), and the pupa of the *Cecropia* silkworm (Sanborn and Williams, 1950; Pappenheimer and Williams, 1952; Schneiderman and Williams, 1952). For this reason attention focussed on the role of the terminal oxidases in relation to diapause and development.

The principal terminal oxidases which have been demonstrated in animals and higher plants are cytochrome oxidase, flavoproteins, and copper-containing proteins such as ascorbic acid oxidase and tyrosinase (Lardy, 1949; Goddard and Meeuse, 1950). Among these, all save ascorbic acid oxidase are thought to function as terminal oxidases in certain animal cells, though the precise role which tyrosinase may play has never been satisfactorily defined (Sussman, 1949).

In animals such as insects, when hemoglobin and other erythrocrucorins are absent, carbon monoxide inhibits cytochrome oxidase and tyrosinase (Warburg, 1949), but apparently fails to inhibit flavoproteins or any other enzymes or substrates. It is true that carbon monoxide forms spectroscopically identifiable complexes with certain peroxidases, but peroxidase activity remains uninhibited (Theorell, 1953). Carbon monoxide's inhibition of cytochrome oxidase and tyrosinase can be distinguished in that the former is reversed by light while the latter is not (Warburg and Negelein, 1928; Kubowitz, 1937, 1938). Carbon monoxide therefore affords a remarkably specific tool for tracking the participation of the cytochrome oxidase system in biological reactions. In the present study we have exploited this specificity in an effort to characterize the terminal oxidases of the *Cecropia* silkworm during diapause and development.

<sup>1</sup> This study was aided by the Lalor Foundation, by a grant from the U. S. Public Health Service, and by an Institutional Grant to Harvard University from the American Cancer Society.

<sup>2</sup> Former Atomic Energy Commission Fellow. Present address: Department of Zoology, Cornell University, Ithaca, New York.

For reasons considered elsewhere (Schneiderman and Feder, 1954), the effects of high concentrations of carbon monoxide were studied by positive pressure techniques. Animals were placed in transparent, air-filled, polymethyl methacrylate (Lucite) chambers, compressed with carbon monoxide, and measurements of respiration performed by means of respirometers developed for use at high pressures. Under these conditions the oxygen tension remained unchanged at its normal value of one-fifth of an atmosphere, while the carbon monoxide pressure could be increased to as high as seven atmospheres. The positive pressure techniques were supplemented by experiments performed at atmospheric pressure and testing the effects of carbon monoxide, oxygen tension, and cyanide.

#### MATERIALS AND METHODS

Diapausing pupae and developing adults of the giant silkworm, *Platysamia cecropia*, were used as experimental animals. In the case of the pupal material the brains were commonly removed to stabilize the animals in permanent diapause (Williams, 1946). In order to avoid the complication of "post-injury metabolism" (Schneiderman and Williams, 1953a), one month or longer was allowed for the recovery of animals subjected to surgical manipulation. All experiments were performed at 25° C.

##### 1. *Metabolic studies*

In studies performed at atmospheric pressure the insects were placed in individual 45-cc. vessels of the type described previously (Schneiderman and Williams, 1953a), and the oxygen consumption determined by the Warburg method. Experiments at positive pressures were carried out in high pressure respirometers (Schneiderman and Feder, 1954). Measurements were begun approximately 1½ hours after compression and continued for 20 to 30 hours in order to compensate for the discontinuous release of carbon dioxide by diapausing pupae (Punt, 1950; Schneiderman and Williams, 1953a, 1953b). The gas volume of the individual respirometers was sufficiently large to preclude any important decrease in oxygen tension during the experimental period.

At the end of positive pressure experiments, acid was added to the alkali and the displaced carbon dioxide measured volumetrically (Schneiderman and Williams, 1953a). The total output of carbon dioxide was measured from the moment the respirometers were sealed to the moment the animals were removed, and the average carbon dioxide production estimated during this period. The over-all respiratory quotient for the duration of the experimental period was calculated from the average carbon dioxide production divided by the average oxygen consumption.

##### 2. *Experimental gases*

The gases were obtained in commercial cylinders and assayed as follows:

Nitrogen (Airco), 99.5% N<sub>2</sub> plus less than 0.5% oxygen. Oxygen (Airco), 99.5% oxygen plus less than 0.5% nitrogen. Carbon monoxide (Matheson Co.), 96.8% carbon monoxide, 0.36% carbon dioxide, 0.97% hydrogen, 1% nitrogen, 0.8% saturated hydrocarbons, 1.19 mg. iron per liter, 0.32 mg. sulfur per liter.

Prior to its use, the carbon monoxide was bubbled through a solution of 10% sodium hydroxide to remove carbon dioxide and iron carbonyl compounds.

In one series of experiments, 200 liters of extremely pure carbon monoxide were prepared by the action of hot concentrated sulfuric acid (C. P. reagent) on formic acid (analytical reagent). The carbon monoxide was passed, in turn, through an aqueous solution containing 5% pyrogallol and 25% KOH, a dry ice-acetone trap,  $\text{CaCl}_2$ ,  $\text{Mg}(\text{ClO}_4)_2$  ("Anhydron"), a liquid nitrogen trap, and then compressed to 100 psi in small steel cylinders. Since the effect of this pure carbon monoxide on respiration could not be distinguished from that of the alkali-treated commercial carbon monoxide, the less expensive commercial gas was used in subsequent experiments.

Mixtures of carbon monoxide, oxygen, and nitrogen were prepared under pressure in steel or Lucite tanks and their compositions checked by gas analysis (Scho-lander and Roughton, 1953).

### 3. Cyanide experiments

To appraise the metabolic effects of cyanide, the insects were first weighed and their water content assumed to equal 75 per cent of the live weight. Then, by means of an extremely small (30) gauge hypodermic needle, each pupa was injected just lateral to the midline of the thoracic tergum with 0.05 to 0.09 ml. of freshly prepared neutralized KCN. The latter's concentration was regulated to establish a specific final concentration after dilution with the fluid volume of the insect. At the pH of the insect, KCN exists almost wholly as HCN; the molar concentration of HCN within the insect was calculated on this basis.

Immediately after injection each pupa was enclosed in a Warburg vessel. As recommended by Robbie (1946), mixtures of KCN and KOH were placed in the vessel for the absorption of carbon dioxide; in this manner the HCN concentration of the chamber was balanced against the internal concentration established within the insect by the injection. At internal HCN concentrations of  $10^{-3}$  M or greater, a constant external HCN tension of  $5 \times 10^{-4}$  was employed—the highest concentration that one can establish by means of KCN-KOH mixtures. In one series of experiments the experimental animals were equilibrated *via* the tracheal system with a specific tension of HCN for 60 hours and then studied without the actual injection of cyanide.

## EXPERIMENTAL RESULTS

### 1. *Effects of carbon monoxide at atmospheric pressure on the respiration of diapausing pupae*

In experiments performed on two diapausing pupae and five brainless diapausing pupae the rate of oxygen consumption was first measured in air, then in 6 per cent oxygen plus 94 per cent nitrogen, and, finally, in 6 per cent oxygen plus 94 per cent carbon monoxide (carbon monoxide/oxygen = 16:1). During the course of the experiment the respirometers were flushed periodically with the experimental gases to prevent the uptake of oxygen from appreciably diminishing the oxygen tension in the vessels. As recorded in Table I, it is evident that between the first and eighth hours of exposure to carbon monoxide only one pupa showed any appreciable inhi-



TABLE I

*The effects of carbon monoxide on the oxygen consumption of two diapausing and five brainless diapausing pupae\**

Type of pupa	Rate of oxygen consumption (mm. <sup>3</sup> /gm. live wt./hr.)		Relative rate of oxygen consumption in 16:1 CO/O <sub>2</sub> (%)		
	Air	16:1 N <sub>2</sub> /O <sub>2</sub>	After 1 hour	Between 1st and 8th hour	Between 8th and 28th hour
Diapausing	9.0 (76%)	11.8 (100%)	126	87	—
Diapausing	11.5 (91%)	12.6 (100%)	132	132	—
Brainless diapausing	8.8 (106%)	8.3 (100%)	116	94	144
Brainless diapausing	9.7 (99%)	9.8 (100%)	85	94	85
Brainless diapausing	9.9 (89%)	11.1 (100%)	95	93	84
Brainless diapausing	11.8 (91%)	13.0 (100%)	106	98	89
Brainless diapausing	13.4 (106%)	12.7 (100%)	73	65	79

\* All measurements performed at a total pressure of one atmosphere.

bition of respiration. Between the eighth and twenty-eighth hours four of the brainless diapausing pupae showed about 15 per cent inhibition.

These results demonstrate that only a small fraction of the metabolism of *Cecropia* pupae is carbon monoxide-sensitive when the carbon monoxide/oxygen ratio is 16:1. To test the effects of still higher ratios, a considerable number of experiments were performed making use of the positive pressure respirometers.

### 2. *Effects of high pressures of nitrogen on the respiration of brainless diapausing pupae*

Figure 1 illustrates results typical of a number of control experiments in which the respiration of five brainless diapausing pupae was determined in one atmosphere of air and then in air compressed with five atmospheres of nitrogen. It is evident that positive pressures of five atmospheres of an inert gas such as nitrogen were without notable effects on either the rate of oxygen consumption or carbon dioxide output. The slight increase in carbon dioxide output is most probably an artifact attributable to the flushing of stored carbon dioxide from the animal during the period of decompression (Schneiderman and Williams, 1953b).

### 3. *Effects of high pressures of carbon monoxide on the respiration of brainless diapausing pupae*

Brainless diapausing pupae were placed in air-filled respirometers and their respiration measured after compression with five atmospheres of nitrogen; they were then decompressed to air and the measurements repeated after recompression with five atmospheres of carbon monoxide (carbon monoxide/oxygen ratio of 25:1). Figure 2 records the results obtained in an experiment utilizing five brainless diapausing pupae. A comparison of the respiration in nitrogen and in carbon monoxide reveals that about one-third of the oxygen consumption was inhibited by the high pressure of carbon monoxide. Carbon dioxide production was affected to a lesser degree to yield an apparent increase in the respiratory quotient.

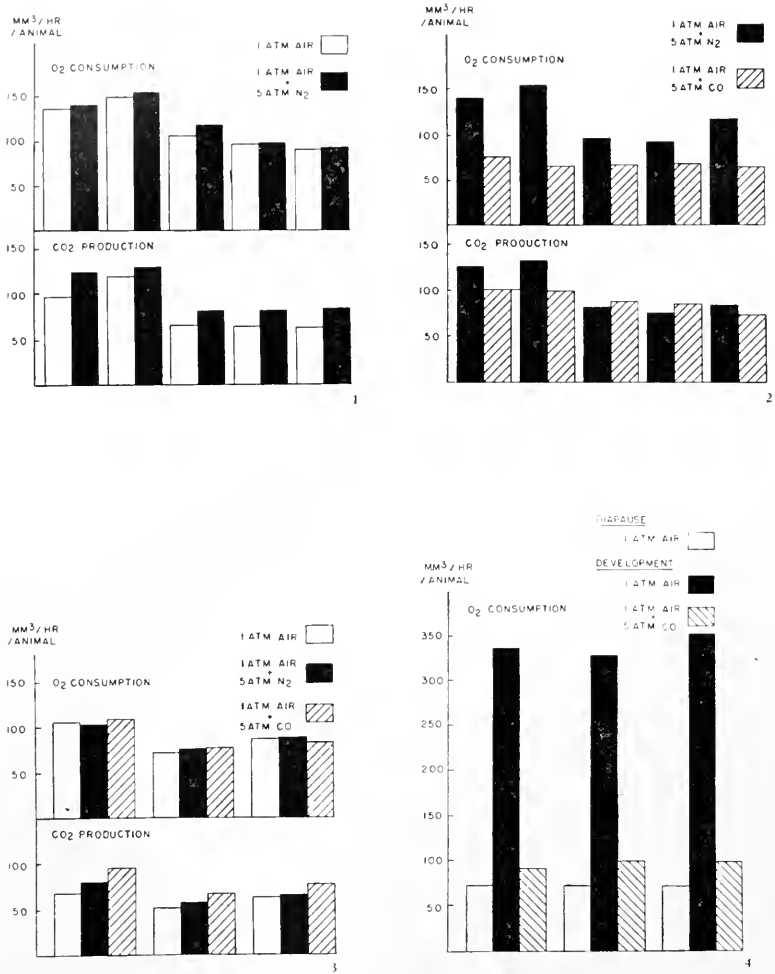

FIGURE 1. The average respiration of five brainless diapausing pupae in air at one atmosphere compared with the average respiration of the same animals in air compressed with 5 atmospheres of nitrogen.

FIGURE 2. The average respiration of five brainless diapausing pupae in air compressed with 5 atmospheres of nitrogen compared with the average respiration of the same animals in air compressed with 5 atmospheres of carbon monoxide.

FIGURE 3. The average respiration of three brainless diapausing pupae, lacking abdominal ganglia, in air at one atmosphere pressure, in air compressed with 5 atmospheres of nitrogen, and in air compressed with 5 atmospheres of carbon monoxide.

FIGURE 4. The average oxygen consumption of three developing animals on the sixth day of adult development, in air at one atmosphere pressure, and in air compressed with 5 atmospheres of carbon monoxide. The normal average oxygen consumption of diapausing pupae in air at one atmosphere pressure is also recorded.

4. *Effects of high pressures of carbon monoxide on the respiration of brainless diapausing pupae lacking abdominal ganglia*

Taken at face value, experiments of the type just considered suggest that about one-third of the metabolism of diapausing pupae is mediated *via* the cytochrome oxidase system. However, it was noted that diapausing pupae showed a conspicuous depression in the frequency and amplitude of spontaneous muscular movements of the abdominal segments in the presence of high pressures of carbon monoxide. It seemed possible that the observed inhibition by carbon monoxide might arise from a suppression of these movements rather than from inhibition of the pupa as a whole.

This possibility was tested by a repetition of the preceding experiment on a series of brainless diapausing pupae in which the intersegmental muscles of the abdomen had previously been denervated by removal of the chain of eight abdominal ganglia. A total of four such animals were studied in detail. Figure 3 records the respiratory exchange of three of these individuals in air, in air compressed with five atmospheres of nitrogen, and in air compressed with five atmospheres of carbon monoxide. The rates of oxygen consumption under all three conditions were indistinguishable—a result which indicates that in the absence of muscular movements of the abdomen the metabolism of diapausing pupae is insensitive to carbon monoxide.

5. *Effects of carbon monoxide on pilocarpine-stimulated muscular activity and respiration*

It was known from studies to be considered elsewhere that the injection of suitable concentrations of pilocarpine causes diapausing pupae to move their abdomens continuously for up to a year thereafter. Consequently, animals stimulated in this manner afforded ideal material for testing the sensitivity of the abdominal motion and the accompanying respiration to inhibition by carbon monoxide. To this end, each of a series of nine diapausing pupae was injected with 0.1 ml. of 0.1 *M* pilocarpine hydrochloride that had previously been neutralized to pH 6.6 with sodium hydroxide. Two days later, the pupae were enclosed in an air-filled Lucite chamber, compressed with specific pressures of carbon monoxide or oxygen, and the effects on abdominal motion noted.

Carbon monoxide inhibited the abdominal motion to a degree dictated by the carbon monoxide/oxygen ratio. Thus, when a ratio of 10:1 was established by the addition of 30 psi carbon monoxide to the initial atmosphere of air, abdominal motion was markedly inhibited. When the ratio was then decreased to 3:1 by the addition of 7 psi of oxygen, vigorous movements reappeared. Further compression with carbon monoxide once again restored the inhibition. In virtually all cases abdominal motion ceased when the ratio was as high as 15:1, but was resumed within 10 minutes after the decompression and return to air.

Ten days after the experiment just considered the oxygen consumption of five of the continuously wriggling pupae was measured at atmospheric pressure in air, and in specific mixtures of oxygen, nitrogen, and carbon monoxide. The results summarized in Table II reveal that 16:1 carbon monoxide/oxygen caused a prompt cessation of the abdominal motion and inhibited the oxygen consumption by approximately 30 per cent.

TABLE II

*The effects of carbon monoxide on the oxygen consumption and abdominal motion of five diapausing pupae injected with 0.1 ml. of 0.1 M pilocarpine hydrochloride\**

Rate of oxygen consumption (mm. <sup>3</sup> /animal/hour)		Relative rate of oxygen consumption in 16:1 CO/O <sub>2</sub> (%)	
Air	16:1 N <sub>2</sub> /O <sub>2</sub>	During 1st hour	During 3rd hour
81 (89%) (+)	91 (100%) (+)	52 (-)	52 (-)
86 (77%) (+)	112 (100%) (+)	90 (-)	87 (-)
113 (94%) (+)	120 (100%) (+)	58 (-)	58 (-)
133 (116%) (+)	115 (100%) (+)	81 (-)	81 (-)
179 (80%) (+)	223 (100%) (+)	75 (-)	75 (-)
Average: 118 (89%)	132 (100%) (+)	72 (-)	71 (-)

\* All measurements performed at a total pressure of one atmosphere.

(+) Records the presence of abdominal motion; (-) the absence of same.

Taken along with the previously mentioned experiments, these findings provide a consistent body of evidence that the contraction of the intersegmental muscles of the diapausing pupa is inhibited by carbon monoxide, whereas the other tissues of the dormant insect are not inhibited by carbon monoxide.

#### 6. *Effects of carbon monoxide on the increased respiration accompanying adult development*

After the termination of pupal diapause the onset and progress of adult development are accompanied by a rapid increase in respiration. Thus on the sixth day of adult development the average respiration is approximately five times that during diapause. In order to ascertain the carbon monoxide-sensitivity of this additional metabolism accompanying development, the respiration of four animals on the sixth day of adult development was first measured in air and then in air compressed with five atmospheres of carbon monoxide. The results, illustrated in the case of the three individuals in Figure 4, demonstrate a striking effect of this 25:1 carbon monoxide/oxygen ratio on the respiration of developing animals. About two thirds

TABLE III

*The effects of carbon monoxide on the oxygen consumption of developing adults\**

Days after initiation of adult development	Rate of oxygen consumption (mm. <sup>3</sup> /gm. live wt./hr.)		Relative rate of oxygen consumption in 16:1 CO/O <sub>2</sub> (%)		
	Air	16:1 N <sub>2</sub> /O <sub>2</sub>	During 1st hour	During 4th hour	During 8th hour
2	54 (102%)	53 (100%)	68	56	55
5½	84 (129%)	65 (100%)	64	52	39
6½	99 (121%)	82 (100%)	68	56	54

\* All experiments performed at a total pressure of one atmosphere.

of the oxygen consumption was inhibited and the metabolism dropped to a level almost as low as that of diapausing pupae. Consequently, it appears that the increased oxygen consumption accompanying adult development is completely or almost completely inhibited by carbon monoxide.

Table III records analogous findings in an experiment in which three developing adults were exposed to a mixture of carbon monoxide and oxygen at a total pressure of one atmosphere. To compensate for the utilization of oxygen, the Warburg vessels were refushed with the experimental gas every 2½ hours. It will be noted that the 16:1 carbon monoxide/oxygen inhibited the oxygen consumption of the developing insects by approximately 50 per cent.

#### 7. *The effects of carbon monoxide on the post-injury metabolism of diapausing pupae*

In addition to the increased metabolism which accompanies the onset of adult development, the pupa during diapause can undergo a substantial increase in its metabolism under certain experimental conditions. Thus, after small localized injury to the pupal integument, the oxygen consumption and carbon dioxide production are considerably enhanced for one to several weeks thereafter (Sussman, 1952; Schneiderman and Williams, 1953a). This result has been regularly observed in both normal pupae and in pupae immobilized by prior removal of the abdominal ganglia.

Experiments were performed to test the sensitivity of the injury metabolism to carbon monoxide. To this end, the brains and abdominal ganglia were removed from six diapausing pupae. Two months later the rate of oxygen consumption was determined for each animal. A V-shaped 4-mm. incision was then made in the thoracic tergum of each animal, and the rate of oxygen consumption measured one day later. Three of the pupae were then placed in air-filled respirometers, compressed with five atmospheres of carbon monoxide, and the measurements repeated.

TABLE IV

*The effects of carbon monoxide on the injury-stimulated respiration of brainless diapausing pupae lacking abdominal ganglia and connectives*

		Rate of oxygen consumption* (%)					
		No. 1	No. 2	No. 3	No. 4	No. 5	No. 6
Prior to injury	In air	100	100	100	100	100	100
24 hours after injury	In air	158	208	108	198	146	146
30 hours after injury	In air	153	183	118	—	—	—
	In CO	—	—	—	183	152	128
Percentage difference between 1st and 2nd post-injury measurements		-3	-12	+9	-8	+4	-12

\* Initial pre-injury oxygen consumption varied from 91 to 143 mm.<sup>3</sup>/animal/hour.

The respiration of the other three pupae was again measured in air at one atmosphere. The results recorded in Table IV show that the extra respiration stimulated by injury is *uninhibited* by carbon monoxide.

### 8. Effects of cyanide on the respiration of diapausing pupae

Diapausing pupae were injected with specific concentrations of cyanide and their oxygen uptake then ascertained. A typical set of measurements is plotted in Figure 5. In control experiments in which distilled water was injected, the oxygen uptake began to increase about five hours after the injection, and the typical pattern of injury metabolism became apparent. When cyanide was injected

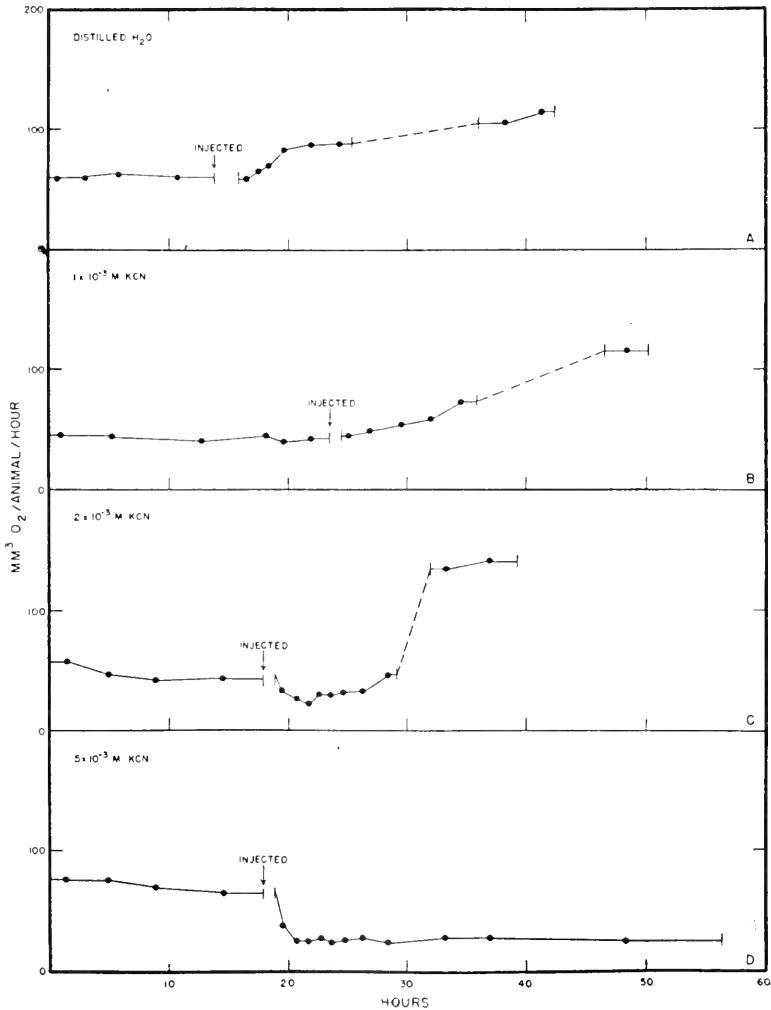

FIGURE 5. The effects of cyanide injection on the oxygen consumption of diapausing pupae. Concentrations of cyanide refer to calculated final internal concentrations.

to attain a final internal concentration of  $10^{-3}$  *M*, a slight inhibition was usually observed, though in some cases the effect did not differ from that of distilled water. With further increase in cyanide to a final concentration of  $2 \times 10^{-3}$  *M*, an immediate inhibition of 50 per cent always occurred which persisted at a steady level for about ten hours and then gradually returned to normal. Still higher concentrations of cyanide ( $5 \times 10^{-3}$  *M* and above) caused a prompt inhibition of 70 to 90 per cent, followed by the death of the animal several days later.

In the interpretation of experiments of this type it is necessary to separate the effects of injury from those of cyanide. This can most easily be accomplished by

TABLE V  
*The effects of cyanide on the respiration of diapausing pupae*

Calculated internal concentration of HCN	Prior to injection		After injection	
	Average rate of oxygen consumption (mm. <sup>3</sup> /gm. live wt./hr.)	Lowest hourly rate of oxygen consumption as per cent of average initial rate*	Lowest hourly rate of oxygen consumption in 48-hour period as per cent of average initial rate	Behavior
0	10.7	97	98	Normal
	11.4	87	96	
	15.8	79	104	
	17.4	92	108	
	Average	89	102	
$5 \times 10^{-4}$ <i>M</i>	9.9	92	80	Normal
	10.3	96	102	
	10.5	88	97	
	12.1	91	89	
	12.5	94	98	
Average	92	93		
$5 \times 10^{-4}$ <i>M</i> (Exposed to HCN gas for 60 hours but not injected)	8.1	95	93	Normal
	9.1	95	91	
	11.0	91	98	
	13.0	97	87	
	13.5	90	96	
	14.7	93	76	
Average	93	90		
$1 \times 10^{-3}$ <i>M</i>	8.5	87	110	Normal, or slight decrease in abdominal motility
	9.7	95	107	
	11.4	88	94	Conspicuous decrease in abdominal motility for 12 to 24 hours
	11.4	94	51	
	10.5	83	85	
	12.2	100	72	
	28	93	67	
	Average	91	84	

\* Measured during a four- to eight-hour period prior to cyanide injection.

TABLE V (Continued)

Calculated internal concentration of HCN	Prior to injection		After injection	
	Average rate of oxygen consumption (mm. <sup>3</sup> /gm. live wt./hr.)	Lowest hourly rate of oxygen consumption as per cent of average initial rate*	Lowest hourly rate of oxygen consumption in 48 hour period as per cent of average initial rate	Behavior
$2 \times 10^{-3} M$	8.1	95	53	Electrically inexcitable for one day. Spontaneous abdominal movements reappeared after 2 days
	11.0	91	50	
	13.0	97	52	
	Average	94	52	
$5 \times 10^{-3} M$	9.1	96	39	Died
	13.5	90	13	
	14.7	93	36	
	Average	93	29	
$1 \times 10^{-2} M$	11.9	90	21	Died
	13.7	97	19	
	20.2	93	26	
	Average	93	22	

focusing attention on the oxygen uptake in the first few hours after injection and prior to the onset of the injury metabolism. As a measure of cyanide inhibition we chose the *lowest oxygen uptake* measured over a one hour interval during this period. To prevent any normal hour-to-hour variations in oxygen uptake from being interpreted as cyanide inhibition, we also recorded the *lowest hourly rate* of oxygen consumption during a four- to eight-hour period prior to cyanide injection. Table V summarizes such calculations on a series of 31 diapausing pupae. Detectable inhibition of abdominal motion and of respiration appeared only when the internal cyanide concentration, as calculated, was increased to or above  $10^{-3} M$ .

In the evaluation of these findings it is worth recalling a technical difficulty mentioned in the section on Methods; namely, that it was impossible by the use of KCN-KOH mixtures to establish HCN concentrations higher than  $5 \times 10^{-4} M$  in the air surrounding the insect. Consequently, at internal concentrations higher than  $5 \times 10^{-4} M$ , detoxification and unspecific combinations of the injected HCN, along with the loss of HCN by diffusion from the tracheal system, necessarily reduced the internal concentrations below the calculated values. This fact complicated a decision as to the cyanide-sensitivity of the abdominal muscles. However, in experiments of short duration performed on a total of 18 diapausing pupae, we found that  $10^{-3} M$  cyanide uniformly impaired the contractility of the abdominal muscles of normal pupae and totally eliminated the contractility of pilocarpine-stimulated muscles. In the latter case the muscles no longer responded to electrical stimulation. Consequently, we conclude that the carbon monoxide-sensitive abdominal muscles of diapausing pupae are likewise cyanide-sensitive.



Warburg (1949) emphasizes the fact that cyanide is a specific inhibitor of heavy metal enzymes only at concentrations up to about  $10^{-3} M$ ; above this level cyanide undergoes significant combinations with a large number of substrates and metabolic intermediates. In the case of *Cecropia* we attribute the lethal effects of cyanide concentration of  $5 \times 10^{-3} M$  and above to these unspecific side-reactions of cyanide.

### 9. Effects of cyanide on the respiration of developing adults

After the termination of diapause and the initiation of adult development, the effect of cyanide was easier to ascertain by virtue of the absence of injury metabolism, the latter being peculiar to diapausing pupae (Schneiderman and Williams, 1953c). Table VI summarizes the inhibition by cyanide of the respiration of 19

TABLE VI  
*The effects of cyanide on the respiration of developing adults*

Calculated internal concentration of HCN	Days after initiation of adult development	Average rate of oxygen consumption prior to injection (mm. <sup>3</sup> /gm. live wt./hr.)	Oxygen consumption as per cent of average initial oxygen consumption at intervals after injection					Behavior after injection	
			1.5 hrs.	8.5 hrs.	20 hrs.	26 hrs.	40 hrs.		
$10^{-4} M$	3	69	(124)	(66)			(110)	Emerged Emerged Emerged Died Died	
	9	119	79	52			122		
	12	136	83	41			124		
	15	166	70	39			54		
	17	279	(92)	(20)			(30)		
		Average		77	44				100
$2 \times 10^{-4} M$	10	112	90		5	5		Died Died Died Died Died	
	12	114	68		7	7			
	12	140	67		6	6			
	13	186	63		5	5			
	14	206	69		12	12			
		Average		71		7	7		
$5 \times 10^{-4} M$	9	95	57		4		6	Died Died Died Died Died	
	10	100	52		6		7		
	10	118	43		25		6		
	11	128	41		10		7		
	13	160	42		12		7		
		Average		47		11			7
$10^{-3} M$	8	110	27		6		7	Died Died Died Died	
	11	150	21		7		6		
	12	131	30		9		7		
	13	162	23		9		7		
		Average		25		8			7

Figures in parenthesis ( ) were not included in the average since these animals were not at comparable stages of adult development.

developing adults. The results have been averaged for animals between the 8th to 15th day of adult development. In contrast to the findings on diapausing pupae, cyanide at final concentrations of  $2 \times 10^{-4} M$  or higher was lethal; moreover  $10^{-4} M$  cyanide now inhibited the oxygen uptake 35 to 80 per cent. In Table VI it also appears that the proportion of total metabolism which was cyanide-sensitive undergoes definite increase during the course of the twenty-two day period of adult development.

10. *Effects of oxygen tension on the respiration of brainless diapausing pupae lacking abdominal ganglia*

The experimental results, up to this point, demonstrate that systematic changes occur in the insect's dependency on metabolism sensitive to carbon monoxide and to cyanide. Aside from the intersegmental muscles of the abdomen, the metabolism of the diapausing pupa and the extra metabolism which it exhibits in response to injury are substantially insensitive to carbon monoxide and cyanide; by contrast, the metabolism of the developing insect is markedly inhibited by these agents.

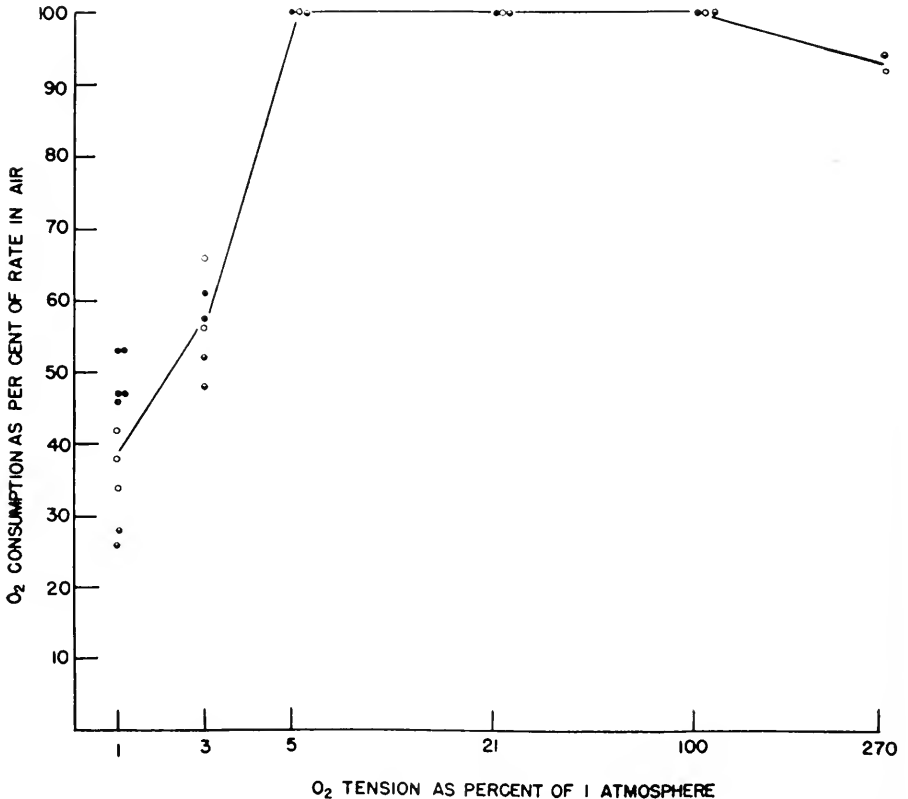

FIGURE 6. The effects of oxygen tension on the oxygen consumption of three brainless diapausing pupae lacking abdominal ganglia and connectives. The abscissa is marked off in arbitrary units.

Carbon monoxide-stable respiration has generally been found to require oxygen tensions far higher than does carbon monoxide-sensitive respiration (see Discussion). For this reason the effect of oxygen tension was studied in relation to the metabolism of diapause and development.

The oxygen consumption of three brainless diapausing pupae, previously immobilized by the removal of their abdominal ganglia, was determined at a series of oxygen tensions ranging from 1 to 270 per cent of an atmosphere of oxygen. The results of measurements at six different oxygen tensions are recorded in Figure 6. Each individual determination represents a steady-state value obtained after exposure to the gas mixtures for several hours. After each determination the pupae were returned to air for three days. The respiration in air was then re-determined before the pupae were exposed to a new oxygen tension.

As Figure 6 indicates, the oxygen consumption was independent of oxygen pressure at tensions from 5 per cent to 100 per cent of an atmosphere. In 3 per cent oxygen a conspicuous decrease was evident. But even in one per cent oxygen the average oxygen consumption was still 40 per cent of that in air. At the extremely high oxygen tension of 2.7 atmospheres, there appeared to be a slight depression, presumably attributable to the toxic effect of oxygen (Williams and Beecher, 1944).

Four pupae were stored in one per cent oxygen for ten hours. When returned to air, the oxygen consumption increased approximately 25 per cent above the normal rate in air and persisted at this level for several hours. This observation suggests the accumulation of a small but definite oxygen debt at the low oxygen tension. It is clear, however, that diapausing pupae possess limited ability to accumulate an oxygen debt for, as demonstrated in numerous experiments, several days of exposure to 0.5 per cent oxygen is lethal (L. D. 50% = 3 days at 25° C.).

## DISCUSSION

### 1. *Insensitivity of insects to compression*

Interpretation of the experimental results obviously requires a decision as to whether the experiments at high gaseous pressures were complicated by unspecific or narcotic effects of pressure *per se* (Behnke, 1940; Lawrence *et al.*, 1946).

As far as nitrogen is concerned, narcotic effects have not been demonstrated in any experiments on insects. Chadwick and Williams (1949) found that *Drosophila* could fly in 4.5 atmospheres of nitrogen plus one atmosphere of air, although the wingbeat frequency was decreased because of the increased gas density. Case and Haldane (1941) observed that *Drosophila* was active at 10 atmospheres of nitrogen plus one atmosphere of air, and Williams (unpublished) found that seven hours of exposure to 24 atmospheres of nitrogen plus one atmosphere of air failed to affect the vitality of *Drosophila* upon subsequent return to air. Moreover, experiments on the Cecropia silkworm at all stages of development, from egg to adult, have demonstrated that prolonged exposure to 6.7 atmospheres of nitrogen plus one atmosphere of air fails to retard embryonic or adult development, heart beat, movement, or the spinning of the cocoon (unpublished observations). And as demonstrated in the present study, the oxygen consumption was the same in air and in air compressed with five atmospheres of nitrogen. These results give assurance that nitrogen, at the pressures utilized, was not a narcotic.

We feel that the same conclusion is valid in the case of carbon monoxide. Thus, the oxygen consumption of immobilized diapausing pupae was the same in air and in air compressed with five atmospheres of carbon monoxide. Moreover, we shall subsequently show that many of the effects of high pressures of carbon monoxide on the post-diapausing insect are reversed by light (Schneiderman and Williams, 1954). Consequently, high pressure techniques appear to be useful and uncomplicated tools for experiments on insects.

## 2. Significance of carbon monoxide-sensitive respiration

As mentioned in the Introduction, suitable pressures of carbon monoxide are known specifically to inhibit the function of two enzymes, cytochrome oxidase and tyrosinase. Inhibition of cytochrome oxidase is reversed by light; inhibition of tyrosinase is not. Though the light-reversibility of carbon monoxide's action on post-diapausing *Cecropia* has already been described in the case of the male sex cells of *Cecropia* (Schneiderman, Ketchel and Williams, 1953) and will be considered in further detail at a later occasion, for our present purposes the phenomenon is doubly significant since it excludes tyrosinase as the critical target of carbon monoxide. This conclusion is further substantiated by the failure of phenylthiourea or any of a number of other potent anti-tyrosinases to duplicate the effects of carbon monoxide or of cyanide (Schneiderman and Williams, 1953a). We are therefore persuaded that the actions of carbon monoxide on *Cecropia* are due to its combination with cytochrome oxidase.

The factors which condition the quantitative effects of carbon monoxide on respiration mediated by the cytochrome oxidase system are four in number: (1) the relative affinity of the insect's cytochrome oxidase for carbon monoxide and for oxygen; (2) the carbon monoxide/oxygen ratio established at the site of enzyme action; (3) the degree to which cytochrome oxidase limits the transfer of electrons from substrate to oxygen; and (4) the oxidation of carbon monoxide to carbon dioxide. We shall briefly consider each of these points as it pertains to the present study.

Detailed measurements of the relative affinity of cytochrome oxidase for carbon monoxide and oxygen are available only in the case of yeast (Warburg, 1949) and mammalian heart muscle (Ball *et al.*, 1951). A 17:1 carbon monoxide/oxygen ratio inhibits the cytochrome-catalyzed respiration of yeast 75 per cent and the cytochrome oxidase activity of heart muscle 64 per cent. Since the relative affinities are so similar for such dissimilar cell types, it is a reasonable presumption that the insect cytochrome oxidase does not differ greatly. This probability has been confirmed by the finding that a carbon monoxide/oxygen ratio of 16:1 causes a light-reversible inhibition of the cytochrome oxidase activity of homogenates of the thoracic muscles of *Cecropia* moths by approximately 50 per cent (Pappenheimer and Schneiderman, unpublished observations).

In the positive pressure experiments on *Cecropia* a ratio of 25:1 was routinely established in the air surrounding the insect. The utilization of oxygen in the respirometer gradually lowered the oxygen tension over a period of 30 hours from 21 per cent to as low as 14 per cent, and thus increased the carbon monoxide/oxygen ratio. And, in each instance, the utilization of oxygen in the tissues decreased the internal oxygen tension still further. Consequently, the recorded ratio of 25:1 is

a minimal estimate of the effective carbon monoxide/oxygen ratio that was actually established in the insect's tissues at the site of enzyme action. For these several reasons we conclude that carbon monoxide in the positive pressure experiments effectively inhibited a large proportion of the insect's cytochrome oxidase—probably not far short of 100 per cent.

As mentioned above, one might anticipate that an excess of cytochrome oxidase relative to cytochrome *c* and other electron donors would tend to camouflage the participation of cytochrome oxidase in the metabolism of diapause. However, it is worth recalling that carbon monoxide combines exclusively with reduced cytochrome oxidase; that is, with functional oxidase receiving electrons from cytochrome *c*. An excess of the oxidase would necessarily be present in the oxidized form and therefore incapable of combining with carbon monoxide.

Finally, there is circumstantial evidence that the oxidation of carbon monoxide to carbon dioxide was not a complicating factor in the present study. If such an oxidation occurred, as described in the case of frog muscle by Fenn and Cobb (1932) and Stannard (1940), the oxidation of each molecule of carbon monoxide would be recorded manometrically as  $1\frac{1}{2}$  molecules of oxygen consumed and one molecule of carbon dioxide produced. The theoretical R.Q. of this process is 0.66, and in the case of the *Cecropia* pupa would thus tend to *decrease* the normal R.Q. of 0.78. However, since as recorded in Figures 2 and 3, a slight *increase* in R.Q. was actually observed in the presence of carbon monoxide, the oxidation of carbon monoxide was not a serious complication in the present experiments.

Thus, in summary, the conclusion seems acceptable that metabolism insensitive to high ratios of carbon monoxide/oxygen signals the utilization of terminal oxidases other than cytochrome oxidase.

### 3. Significance of cyanide-insensitive respiration

Cyanide is a far less specific inhibitor of cytochrome oxidase than is carbon monoxide. It inhibits not only cytochrome oxidase, but also catalase, peroxidase, and tyrosinase, and, as previously mentioned, at concentrations higher than about  $10^{-3}$  M, cyanide also combines with various substrates, metabolic intermediates, and enzymes possessing carbonyl groups. For this reason cyanide-sensitivity is far less significant than cyanide-insensitivity. Cyanide-insensitivity strongly suggests that neither cytochrome oxidase nor any of a number of other enzymes are prerequisite for the reaction in question.

### 4. Respiration during diapause and development

As judged by its insensitivity to cyanide and carbon monoxide, virtually all of the metabolism of the diapausing pupa appears to proceed *via* pathways independent of cytochrome oxidase, save for the metabolic events responsible for the contraction of the abdominal muscles. It is therefore of particular interest and importance that the intersegmental muscle of the abdomen is the only major tissue within the diapausing pupa containing a high concentration of the classical cytochrome system (Williams, 1951; Pappenheimer and Williams, 1952).

The termination of diapause and the onset of adult development, however, usher in a new situation in which a progressively larger fraction of metabolism becomes dependent on the presence of a functional cytochrome oxidase system. Evidently,

at this time, a carbon monoxide- and cyanide-sensitive respiration mediated by cytochrome oxidase is superimposed on the carbon monoxide- and cyanide-stable metabolism of diapause.

Analogous changes in the relative activities of carbon monoxide-sensitive and carbon monoxide-stable respiratory systems have been demonstrated in a variety of plants, animals, and micro-organisms (Bodine and Boell, 1934a, 1934b; Wolsky, 1943, 1949; Paul, 1951). In the case of *Cecropia* the shift to cytochrome oxidase-mediated respiration is synchronized with the action of the insect's "growth and differentiation hormone" in terminating the pupal diapause—a correlation which suggests that the change in metabolism, in itself, is a part of the biochemical action of the hormone.

### 5. *Effects of oxygen tension on the respiration of brainless diapausing pupae*

The experimental results demonstrate that the metabolism of diapausing *Cecropia* pupae becomes independent of oxygen tension when the latter is five per cent of an atmosphere or higher. The tension of oxygen is usually considered to limit respiration at the cellular level only when it approximates zero (Krogh, 1916; Oppenheimer, 1925); this consideration is valid in most organisms since cytochrome oxidase, the usual terminal oxidase, is saturated by oxygen at tensions ranging from 0.25 to 2.5 mm. Hg (Winzler, 1941). However, flavoproteins when functioning as terminal oxidases are ordinarily thought to be unsaturated at low oxygen tensions. Thus, the "old yellow enzyme" which Warburg and Christian (1932) isolated from yeast was markedly influenced by variations in oxygen tension: in 100 per cent of an atmosphere of oxygen the respiration which it mediated was nearly five times that in 5 per cent oxygen. A corresponding dependency on oxygen tension has also been observed for flavoprotein-mediated respiration *in vivo*. Thus, in thin sections of the *Arum* spadix (James and Beevers, 1950), flavin-catalyzed oxygen uptake increased progressively as the oxygen tension was raised to one atmosphere.

The fact that the respiration of diapausing pupae is independent of oxygen at tensions greater than 5 per cent of an atmosphere, and the further fact that one per cent oxygen sustains 40 per cent of the normal respiration suggest that the carbon monoxide- and cyanide-stable oxidase of *Cecropia* differs from the flavoproteins reported in plants and bacteria and studied *in vitro*. However, we cannot exclude the possibility that such an oxidase may be present in relative excess in *Cecropia* and that it may fail to limit electron transmission even when driven slowly at low oxygen tensions.

### 6. *Identification of the terminal oxidases mediating respiration in diapausing pupae*

The results of the present study permit the following characterization of the terminal oxidases in diapausing *Cecropia* pupae. The principal terminal oxidase in the intersegmental muscles of the abdomen is cytochrome oxidase; in other major tissues of the diapausing insect it is not cytochrome oxidase. The latter unknown oxidase is uninhibited by high concentrations of carbon monoxide (carbon monoxide/oxygen ratios of 25:1), or by cyanide concentrations up to  $10^{-3}$  M, or by phenylthiourea. Moreover, the oxidase in question is saturated by oxygen tensions of 5 per cent of an atmosphere or less.

On the basis of these several lines of evidence, the most probable candidates appear to be either an autoxidizable flavoprotein transferring electrons from reduced pyridine nucleotides to molecular oxygen, or an autoxidizable heme-containing enzyme which fails to combine with either cyanide or carbon monoxide.

#### SUMMARY

1. The respiration of the *Cecropia* silkworm was studied after the injection of cyanide or in the presence of specific mixtures of oxygen, nitrogen, and carbon monoxide. Positive pressure techniques were utilized to test the effects of carbon monoxide/oxygen ratios as high as 25:1.

2. It was found that the respiration of the diapausing pupa is only slightly affected by high concentrations of carbon monoxide or cyanide. This minor effect was accounted for in terms of the cyanide- and carbon monoxide-sensitivity of the contraction of the intersegmental muscles of the pupal abdomen. The other tissues in the dormant insect showed no detectable inhibition by high concentrations of cyanide or carbon monoxide.

3. The termination of the pupal diapause and the progress of adult development are accompanied by a marked increase in the insect's sensitivity to cyanide and carbon monoxide. The effects of these agents are then no longer limited to muscular tissue but extend to the insect as a whole. Cyanide or carbon monoxide appear to act exclusively on the extra metabolism accompanying development and, thereby, to reduce the overall metabolism to the old diapausing level.

4. The modes of action of cyanide and carbon monoxide within the diapausing and non-diapausing insects are considered in detail. Insensitivity to these agents, as in most tissues of the diapausing pupa, argues in favor of the presence and utilization of a terminal oxidase other than cytochrome oxidase.

5. It is concluded that cytochrome oxidase is the principal terminal oxidase of only the somatic musculature of the diapausing pupa. Months later, with the termination of the pupal diapause, cytochrome oxidase becomes the principal terminal oxidase of the growing, post-diapausing insect as a whole.

6. These qualitative changes in the insect's metabolism are synchronized with the secretion of the hormone responsible for the termination of diapause and the development which follows, and appear to be a more or less immediate result of the hormonal action.

#### LITERATURE CITED

- BALL, E., C. F. STRITTMATTER AND O. COOPER, 1951. The reaction of cytochrome oxidase with carbon monoxide. *J. Biol. Chem.*, **193**: 635-647.
- BEHNKE, A. B., 1940. High atmospheric pressures; physiological effects of increased and decreased pressure; application of these findings to clinical medicine. *Ann. Int. Med.*, **13**: 2217-2228.
- BODINE, J. H., AND E. J. BOELL, 1934a. Carbon monoxide and respiration: action of carbon monoxide on the respiration of normal and blocked embryonic cells (Orthoptera). *J. Cell. Comp. Physiol.*, **4**: 475-482.
- BODINE, J. H., AND E. J. BOELL, 1934b. Respiratory mechanisms of normally developing and blocked embryonic cells (Orthoptera). *J. Cell. Comp. Physiol.*, **5**: 97-113.
- CASE, E. M., AND J. B. S. HALDANE, 1941. Human physiology under high pressure. I. Effects of nitrogen, carbon dioxide and cold. *J. Hygiene*, **41**: 225-249.
- CHADWICK, L., AND C. M. WILLIAMS, 1949. The effects of atmospheric pressure and composition on the flight of *Drosophila*. *Biol. Bull.*, **97**: 115-137.

- FENN, W. O., AND D. M. COBB, 1932. The burning of carbon monoxide by heart and skeletal muscle. *Amer. J. Physiol.*, **102**: 393-401.
- GODDARD, D. R., AND J. D. MEEUSE, 1950. Respiration of higher plants. *Ann. Rev. Plant Physiol.*, **1**: 207-232.
- JAMES, W. O., AND H. BEEVERS, 1950. The respiration of *Arum* spadix. A rapid respiration resistant to cyanide. *New Phytologist*, **49**: 353-374.
- KROGH, A., 1916. The respiratory exchange of animals and man. Monogr. Biochem., Longmans, Green and Co., London.
- KUBOWITZ, F., 1937. Über die chemische Zusammensetzung der Kartoffeloxydase. *Biochem. Zeitschr.*, **292**: 221-229.
- KUBOWITZ, F., 1938. Spaltung und Resynthese der Polyphenoloxydase und des Hämocyanins. *Biochem. Zeitschr.*, **299**: 32-57.
- LARDY, H. A., 1949. Respiratory enzymes. Burgess Publ. Co., Minneapolis.
- LAWRENCE, J. H., W. F. LOOMIS, C. A. TOBIAS AND E. H. TURPIN, 1946. Preliminary observations on the narcotic effect of xenon with a review of values for solubilities of gases in water and oils. *J. Physiol.*, **105**: 197-204.
- OPPENHEIMER, C., 1925. *Die Fermente*, **2**: 1402. Georg Thieme, Leipzig.
- PAPPENHEIMER, A. M., AND C. M. WILLIAMS, 1952. The effects of diphtheria toxin on the Cecropia silkworm. *J. Gen. Physiol.*, **35**: 727-740.
- PAUL, K. G., 1951. Iron-containing enzymes—A. Cytochromes. The enzymes. Vol. II, part 1. Academic Press, New York.
- PUNT, A., 1950. The respiration of insects. *Physiol. Comp. et Occol.*, **2**: 59-74.
- ROBBIE, W. O., 1946. The quantitative control of cyanide in manometric experimentation. *J. Cell. Comp. Physiol.*, **27**: 181-209.
- SANBORN, R. C., AND C. M. WILLIAMS, 1950. The cytochrome system in the Cecropia silkworm with special reference to the properties of a new component. *J. Gen. Physiol.*, **33**: 579-588.
- SCHNEIDERMAN, H. A., AND N. FEDER, 1954. A respirometer for metabolic studies at high gaseous pressures. *Biol. Bull.*, **106**: 230-237.
- SCHNEIDERMAN, H. A., M. KETCHEL AND C. M. WILLIAMS, 1953. Physiology of insect diapause. VI. Effects of temperature, oxygen tension, and metabolic inhibitors on *in vitro* spermatogenesis in the Cecropia silkworm. *Biol. Bull.*, **105**: 188-199.
- SCHNEIDERMAN, H. A., AND C. M. WILLIAMS, 1952. The terminal oxidases in diapausing and non-diapausing insects. *Anat. Rec.*, **113**: 55-56.
- SCHNEIDERMAN, H. A., AND C. M. WILLIAMS, 1953a. The physiology of insect diapause. VII. The respiratory metabolism of the Cecropia silkworm during diapause and development. *Biol. Bull.*, **105**: 320-334.
- SCHNEIDERMAN, H. A., AND C. M. WILLIAMS, 1953b. Discontinuous carbon dioxide output by diapausing pupae of the giant silkworm, *Platysamia cecropia*. *Biol. Bull.*, **105**: 382.
- SCHNEIDERMAN, H. A., AND C. M. WILLIAMS, 1953c. Metabolic effects of localized injury to the integument of the Cecropia silkworm. *Anat. Rec.*, **117**: 640-641.
- SCHNEIDERMAN, H. A., AND C. M. WILLIAMS, 1954. The physiology of insect diapause. IX. The cytochrome oxidase system in relation to the diapause and development of the Cecropia silkworm. *Biol. Bull.*, **106**: 238-252.
- SCHOLANDER, P. F., AND F. J. W. ROUGHTON, 1943. Microgasometric estimation of the blood gases. I. Oxygen. *J. Biol. Chem.*, **148**: 541-550.
- STANNARD, J. N., 1940. An analysis of the effect of carbon monoxide on frog skeletal muscle. *Amer. J. Physiol.*, **129**: 195-213.
- SUSSMAN, A. S., 1949. The functions of tyrosinase in insects. *Quart. Rev. Biol.*, **24**: 328-341.
- SUSSMAN, A. S., 1952. Tyrosinase and the respiration of pupae of *Platysamia cecropia* L. *Biol. Bull.*, **102**: 39-47.
- THEORELL, H., 1951. The iron containing enzymes. B. Catalases and peroxidases. "Hydroperoxidases." The enzymes. Vol. II, part 1. Academic Press, New York.
- WARBURG, O., 1949. Heavy metal prosthetic groups and enzyme action. Oxford at the Clarendon Press.
- WARBURG, O., AND W. CHRISTIAN, 1932. Über ein neues Oxydationsferment und sein Absorptionsspektrum. *Biochem. Zeitschr.*, **254**: 438-458.
- WARBURG, O., AND E. NEGELEIN, 1928. Über den Einfluss der Wellenlänge auf die Verteilung des Atmungsferments. *Biochem. Zeitschr.*, **193**: 339-346.



- WILLIAMS, C. M., 1946. Physiology of insect diapause: the role of the brain in the production and termination of pupal dormancy in the giant silkworm, *Platysamia cecropia*. *Biol. Bull.*, **90**: 234-243.
- WILLIAMS, C. M., 1948. Extrinsic control of morphogenesis as illustrated in the metamorphosis of insects. *Growth*, **12**: 61-74.
- WILLIAMS, C. M., 1951. Biochemical mechanisms in insect growth and metamorphosis. *Fed. Proc.*, **10**: 546-552.
- WILLIAMS, C. M., AND H. K. BEECHER, 1944. Sensitivity of *Drosophila* to poisoning by oxygen. *Amer. J. Physiol.*, **140**: 566-573.
- WINZLER, R. J., 1941. The respiration of bakers yeast at low oxygen tension. *J. Cell. Comp. Physiol.*, **17**: 263-276.
- WOLSKY, A., 1943. Respiratory mechanism of eggs of the silkworm moth. III. Effect of treatment with HCl on respiration. *Magyar Biol. Kutato intezet Munkai*, **14**: 445-464. (*Chem. Abstracts*, 1947.)
- WOLSKY, A., 1949. The effect of carbon monoxide on the respiration of artificially bivoltinized silkworm eggs. *Current Science (India)*, **18**: 323-325.

## A RESPIROMETER FOR METABOLIC STUDIES AT HIGH GASEOUS PRESSURES<sup>1</sup>

HOWARD A. SCHNEIDERMAN<sup>2</sup> AND NED FEDER<sup>3</sup>

*The Biological Laboratories, Harvard University, Cambridge 38, Massachusetts*

The use of carbon monoxide as a specific inhibitor of cytochrome oxidase is accompanied by one serious complication—the inhibition is reversed by oxygen (Warburg, 1949). The degree to which one can inhibit the enzyme is therefore dependent, not alone on the carbon monoxide pressure, but also on the pressure of oxygen that is simultaneously present. In short, the inhibition of cytochrome oxidase is a function of the carbon monoxide/oxygen ratio. To achieve an effective inhibition of the enzyme, this ratio must be high. Fifty per cent inhibition requires approximately a 10 to 1 ratio; 75 per cent inhibition, a 20 to 1 ratio. For greater degrees of inhibition, still higher ratios are necessary (Warburg, 1949; Ball *et al.*, 1951).

To achieve this goal it has been customary to use an atmosphere containing 95 per cent carbon monoxide and 5 per cent oxygen; indeed, an atmosphere of 98 per cent carbon monoxide and 2 per cent oxygen has occasionally been employed. However, oxygen at these low pressures fails to satisfy the normal respiratory requirements of most plants and animals *in vivo* or *in vitro* (Tang, 1933). Experimental results are thereby complicated by anoxia, and there is uncertainty as to whether an observed effect is due to the presence of carbon monoxide or a deficiency in oxygen. The earth's atmospheric pressure (760 mm. Hg) is too low to permit one to inhibit cytochrome oxidase effectively by substituting carbon monoxide for the nitrogen in air. If the oxygen tension is to be maintained at its normal value ( $\frac{1}{5}$ th atmosphere), then several atmospheres of carbon monoxide must be superimposed.

For this reason there has long been a need for a simple and practical method for measuring oxygen consumption and carbon dioxide production at high gaseous pressures. This objective seems doubly attractive in view of the insensitivity of most biological preparations to pressure *per se*, as long as the latter is not extremely high.

Two methods have been described for this purpose; namely, that of Libbrecht and Massart (1937) and that of Stadie and Riggs (1944). Both of these methods utilized a pressure chamber containing a manometric apparatus of the Warburg type. The chamber designed by Stadie and Riggs had a capacity of 60 liters and enclosed 6 Warburg manometers and vessels. The apparatus was con-

<sup>1</sup> This study was aided by grants to Professor C. M. Williams from the Lalor Foundation and the U. S. Public Health Service, and by an Institutional Grant to Harvard University from the American Cancer Society.

<sup>2</sup> Former Atomic Energy Commission Fellow. Present Address: Department of Zoology, Cornell University, Ithaca, N. Y.

<sup>3</sup> Present address: Philadelphia General Hospital, Philadelphia, Pa.

structed so that the necessary manipulations and readings were made from the outside, while high pressure and constant temperature were maintained inside. As might be anticipated, such an apparatus was extremely costly, presented an explosive hazard, and required careful checks to police a dozen separate gaskets and fittings.

The present paper describes a simple and practical technique for measuring gas exchange at positive pressures up to seven atmospheres. The respirometer itself is inexpensive, safe, leak-proof, and yields results of the same degree of accuracy as conventional manometric and volumetric techniques. In its present form it is suitable for studies of intact animals, plants, and tissues where agitation is not required. However, the principle of the technique is readily adaptable to studies of solutions, slices, and homogenates, and also to studies at pressures below atmospheric.

#### PRINCIPLE OF METHOD

A small glass respiration chamber, containing the experimental animal plus a carbon dioxide absorbant, is joined to a graduated capillary tube. Provisions are made so that the capillary can subsequently be sealed with a fluid index drop. After assembly, the respiration chamber is enclosed in a large polymethyl methacrylate (Lucite) chamber capable of withstanding high internal gas pressure. At the start of the experiment the capillary tube is patent; the lumen of the capillary therefore affords a direct connection between the gas space of the respiration chamber and the Lucite compensation chamber. Consequently, when the latter is filled with gas to a desired pressure, gas passes through the capillary and fills the respiration chamber at the same pressure. When a desired pressure is attained, an index drop is tipped into the graduated capillary, thus sealing the respiration chamber. The measurements are then performed in the same manner as in an ordinary volumeter of the Fenn type (Fenn, 1935). Since the plastic compensation chamber is closed off from the outside air, excursions of the index drop are independent of changes in atmospheric pressure (*cf.* Gerard and Hartline, 1934).

#### APPARATUS (see Fig. 1)

*a. Compensation chamber.* The plastic compensation chamber is a transparent Lucite cylinder fitted with brass endplates, gaskets, and needle valves. Figure 2 shows the chamber and its component parts. The Lucite cylinder is 4" I. D.  $\times$  4.50" O. D.  $\times$  18" long. The endplates are 5"  $\times$  5"  $\times$  0.5" brass plates with a 0.25" deep circular channel milled on the inner surface to receive the Lucite cylinder. A rubber gasket is inserted into this channel. Half-inch Hoke needle valves are threaded and silver brazed in the center of each endplate. The two endplates are held together by four brass rods, 0.5" in diameter. Endplate A is bolted to the rods, while endplate B is removable. On endplate A the rods extend 0.5" beyond the reducing valve so that the tank may be placed on end. The internal volume of the assembled compensation chamber was 3460 cc.

*b. Capillary volumeter.* The size of the respiration chambers and capillaries is dictated by the dimensions of the experimental animal, the rate of oxygen consumption, and the desired sensitivity. The size most frequently used in this laboratory

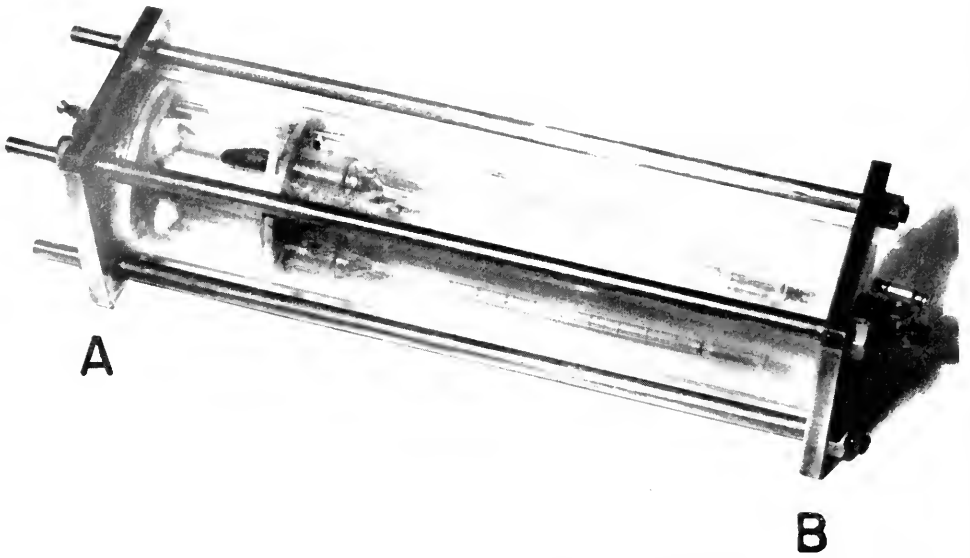

FIGURE 1. High pressure respirometer: an animal-containing *capillary volumeter*, a *reference volumeter*, and a *capillary barometer* are mounted on the *capillary volumeter frame*.

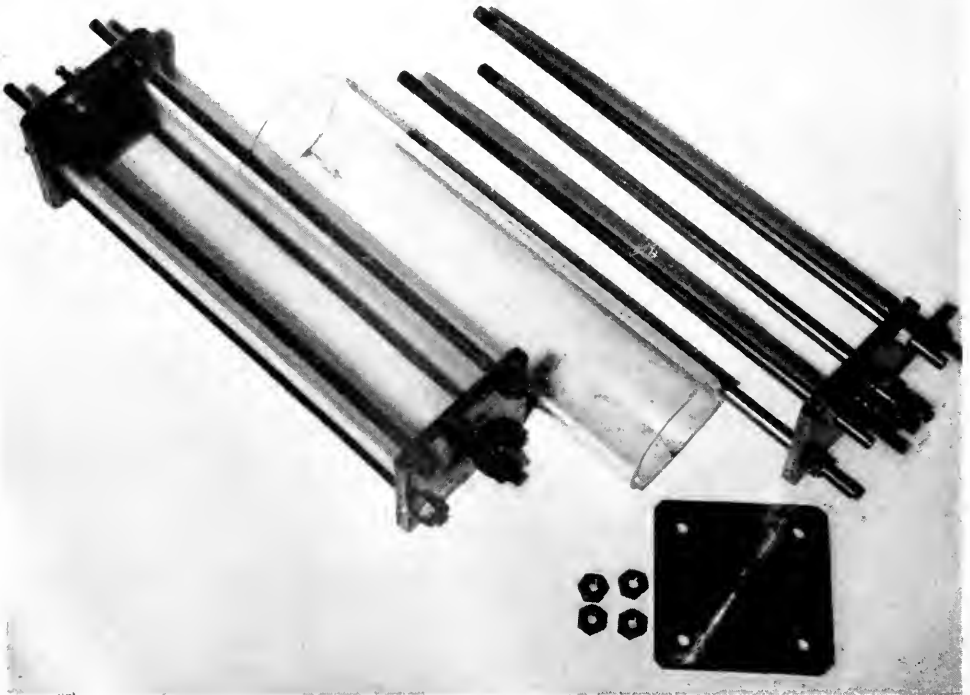

FIGURE 2. A 3460-cc. Lucite compensation chamber and its component parts.

is shown in Figure 3.<sup>4</sup> It consists of a 20-cm. length of 2 mm. bore capillary tubing, calibrated in 0.005 cc. units, and fitted by a 20/40 standard taper joint to a 30-cc. Pyrex shell vial, 85 mm. long. To the tip of the capillary is fused a 3.5 cm. length of 7-mm. bore Pyrex tubing. The latter is slightly constricted at its distal open end and serves as a reservoir for the index drop solution. The calibrated volume of each capillary is 550 mm.<sup>3</sup> The total volume of each volumeter to the tip of the capillary is 45 cc.



FIGURE 3. A 45-cc. capillary volumeter.

The respiration chamber can be attached to a standard Warburg manometer by means of an adapter previously described (Schneiderman and Williams, 1953). Thus the respiration of the animal in air before and after exposure to high pressure may be conveniently measured by conventional methods without removal of the animal from the respiration chamber.

*c. Capillary barometer.* Measurements of absolute pressure, accurate to within one per cent, are required for the proper determination of gas exchange in the present apparatus (see discussion of calculations below). Since the standard Bourdon type pressure gauges are subject to errors in excess of 5 per cent, a capillary barometer is utilized. Each such barometer consists of a one-cc. pipette of approximately 2 mm. internal diameter, graduated in 0.01 cc., and sealed at one end. By means of a long hypodermic needle a drop of colored detergent solution is placed in the closed end of the capillary and another drop at the beginning of the graduations. In each experiment three capillary barometers of this type are enclosed in the Lucite compensation chamber. The pressure in the closed system is calculated by application of the gas law from readings of the capillary barometer taken before and after compression and from a reading of the local barometric pressure.

*d. Water bath.* Glass aquaria make the most satisfactory water baths since the glass sides facilitate reading the capillaries.

*e. Reagents.* (1) The *index drop solution* has the following formula: 1 part "Aquet" (detergent of Emil Greiner Co.), 500 parts distilled water, a few drops of dilute  $H_2SO_4$  to prevent carbon dioxide absorption by the index drop, and a few crystals of acid fuchsin to give the solution a red color. This fluid flows easily, keeps almost indefinitely at room temperature, and forms an index drop which responds regularly to slight pressure changes. (2) The *carbon dioxide absorbant* is carbonate-free 1 N KOH. (3) The grease used on the ground-glass joints connecting the respiration chambers to the capillaries and on the gaskets of the brass endplates is Dow-Corning silicone stopcock grease. Conventional organic greases

<sup>4</sup>The assistance of Dr. Conrad Yocum in the design of the final capillary volumeter is gratefully acknowledged.

have a tendency to oxidize or react in other ways with oxygen and carbon monoxide under pressure.

#### PROCEDURE

A roll of filter paper is deposited in the bottom of each respiration chamber and moistened with 0.5 cc. of 1 N KOH. A small paraffin-coated tube is placed in the chamber to support the experimental animal. The latter is inserted and the ground-glass joint in the respiration chamber plugged with the capillary tube.

Four animal-containing respiration chambers, two reference volumeters not containing animals, and three capillary barometers are mounted in a plywood frame (Fig. 1) and held in place with rubber bands. The assembly is then placed in a horizontal position in the compensation chamber with the base of the frame flush against the brass endplate A. By means of a hypodermic syringe 0.05 cc. of the index drop solution is introduced into each of the index drop reservoirs, care being taken not to occlude the capillaries themselves. With valves A and B open, brass endplate B is now bolted on. One then records the temperature of the room, the position of the index drop in the capillary barometers, and the atmospheric barometric pressure.

The experimental gas is supplied from standard cylinders through a manually controlled reduction valve connected by a flexible 0.25" bore copper tubing to valve A. About 10 liters of experimental gas are flushed slowly through the compensation chamber.<sup>5</sup> Valve B is closed and the experimental gas introduced under pressure through valve A to approximately the desired pressure, as indicated by the capillary barometers. Valve A is then closed.

The compensation chamber is now tilted to a vertical position so that the index drops flow into the lumina of the calibrated capillaries. Valve A is opened slightly and sufficient gas introduced under pressure to force a drop of index fluid a few centimeters into each of the six capillary tubes. Valve A is then closed and the compensation chamber returned to a horizontal position. Valve A is reopened and gas under pressure is slowly admitted until the drops have traversed the lengths of the capillary tubes to the proximal end of the calibrations. Valve A is then closed, the flexible coupling disconnected, and the compensation chamber immersed in a water bath controlled to  $\pm 0.01^\circ$  C.

Valve A is now opened carefully until a barely detectable outward movement of the index drops is observed. The rate of gas escape is adjusted so that 10 to 20 minutes are required for the drops to migrate to the distal end of the capillaries. Valve A is finally closed when the distal ends of the index drops are about 2 centimeters from the distal ends of the calibrations. By running the drops up and down in this manner, one wets the walls of the measuring capillaries and thereby assures both a sensitive response and a constant size in the index drops.

Temperature equilibration requires 80 to 100 minutes. After equilibration, the

<sup>5</sup> If this flushing procedure is not carried out, then, upon compression of the compensation chamber with the experimental gas mixture, some of the air in the compensation chamber will be forced into the respiration chambers along with the experimental gas. This introduces considerable error; for example, if the air-filled compensation chamber is compressed with 5 atmospheres of carbon monoxide without prior flushing, the carbon monoxide/oxygen ratio in the compensation chamber will be approximately 25:1 while the carbon monoxide/oxygen ratio in the volumeters will be less than 6:1.

bath's temperature and the position of the drops in the capillary barometers are recorded to determine the absolute pressure in the compensation chamber. The two barometric pressures that agree most closely are averaged. Readings of the position of the index drop in each calibrated capillary also begin at this time. The positions of the drops are recorded at intervals ranging from 30 minutes to 6 hours, as dictated by the rate of oxygen consumption and the duration of the experiment. Thermobarometric corrections are applied to each reading, taking into account the fact that the actual volume of gas in the reference volumeters is slightly larger than that in the animal-containing chambers. Calculation of thermobarometric corrections may be simplified by enclosing in each thermobarometer a glass rod of approximately the same volume as the animal in the experimental chamber.

To calculate the oxygen consumption in mm.<sup>3</sup> at S. T. P. from the excursion of the index drop, the following calculations are employed:

- Let:  $v$  = volume in mm.<sup>3</sup> of capillary that the index drop traversed.  
 $P$  = absolute pressure in atmospheres after compression.  
 $V_r$  = gas volume of respiration chamber in cc. (*i.e.*, 45 cc. minus volume of organism and reagents).  
 $V_c$  = gas volume of compensation chamber in cc. (*i.e.*, 3460 cc. minus volume of 6 respiration chambers and frame = ca. 3000 cc.).  
 $T$  = Temperature of bath.

A calibration factor  $F$  is calculated at each pressure and temperature to convert the measurements of  $v$  to mm.<sup>3</sup> oxygen. Thus:

$$Fv = \text{mm.}^3 \text{ oxygen consumed at S. T. P.}$$

Fenn (1935) has shown that the value of  $F$  is provided by the formula

$$F = \left[ \frac{V_c + V_r}{V_c} \right] \times P \times \frac{273}{T}.$$

Under ordinary experimental conditions the quantity in brackets is very nearly 1.01. Thus

$$F = P \times \frac{273}{T} \times 1.01$$

$$\text{mm.}^3 \text{ oxygen consumed} = Fv = P \times \frac{276}{T} \times v.$$

Corrections for the vapor pressure of water and for the solubility of oxygen in the insect and the reagents were not applied since the combined errors thereby introduced were less than one per cent.

At the conclusion of the experiment, the compensation chamber is slowly decompressed and unbolted and the animals removed from the respiration chambers. By the addition of acid the total carbon dioxide produced in each respiration chamber during the experiment is displaced from the alkali and measured volumetrically in the gas analyzer described by Bliss (1953) or manometrically by coupling the respiration chamber to a standard Warburg manometer. The average carbon dioxide output may then be calculated.

## ACCURACY OF METHOD AND RANGE OF APPLICATION

The calibrated capillaries can be read to  $\pm 0.1$  division. This and the total capillary excursion (110 divisions) establish the theoretical limits of accuracy. The actual limits are, of course, determined in large measure by the degree of agreement between the thermobarometers. Table I records the results of a series of readings on two sets of thermobarometers in two typical sets of experimental conditions. The maximum standard deviation of  $\pm 0.16$  corresponds to an error of about 0.1 division in reading the positions of the index drops, in close agreement with the theoretical limits. Therefore any individual reading corrected for thermobarometric change is accurate to within  $\pm 0.2$  division. A capillary excursion of 30 divisions would thus be accurate to  $\pm$  one per cent.

TABLE I  
*Typical series of thermobarometric readings*

Time reading taken (hours)	Difference between initial and subsequent thermobarometric readings					
	T <sub>1</sub>	T <sub>2</sub>	T <sub>3</sub>	T <sub>4</sub>	T <sub>5</sub>	Standard deviation
Series 1						
Five thermobarometers each containing 1 ml. 1 N KOH compressed with 5 atmospheres of nitrogen						
2.00	.8	.8	.8	.9	.7	.07
4.00	1.4	1.4	1.4	1.6	1.4	.08
4.70	1.7	1.8	1.6	1.7	1.6	.07
16.90	2.6	2.8	2.6	2.7	2.4	.16
18.65	2.9	3.0	2.9	3.0	2.8	.07
Series 2						
Two thermobarometers each containing 1 ml. 1 N KOH compressed with 5 atmospheres of carbon monoxide						
1.02	.7	.7				0
2.12	1.1	1.3				.15
7.50	2.2	2.3				.1
20.75	1.7	1.5				.15

The experimental method has been applied without difficulty to studies of organisms and tissues having oxygen uptakes between 20 and 1000 mm.<sup>3</sup>/hour, and by the use of high pressures of carbon monoxide the role of cytochrome oxidase has been studied in both animals (Schneiderman and Williams, 1954), and plants (Hackett, Yocum and Thimann, personal communication).

We wish to express our sincere appreciation to Professor Carroll M. Williams in whose laboratory these experiments were performed.



## SUMMARY

A simple and practical apparatus is described for the measurement of oxygen consumption and carbon dioxide production at positive pressures up to seven atmospheres. It consists, essentially, of a series of capillary respirometers enclosed in a large Lucite compensation chamber capable of withstanding a positive pressure. The details of the construction and operation of the apparatus and the accuracy and range of application are considered.

## LITERATURE CITED

- BALL, E. F., C. F. STRITTMATTER AND O. COOPER, 1951. The reaction of cytochrome oxidase with carbon monoxide. *J. Biol. Chem.*, **193**: 635-647.
- BLISS, D. E., 1953. Endocrine control of metabolism in the land crab, *Gecarcinus lateralis*. I. Differences in the respiratory metabolism of sinusglandless and eyestalkless crabs. *Biol. Bull.*, **104**: 275-296.
- FENN, W. O., 1935. The differential volumeter for the measurement of cell respiration and other processes. American Instrument Company, Inc. publication.
- GERARD, R. W., AND H. M. HARTLINE, 1934. Respiration due to natural nerve impulses. A method for measuring respiration. *J. Cell. Comp. Physiol.*, **4**: 141-160.
- LIBBRECHT, W., AND L. MASSART, 1937. *Compt. rend. Soc. Biol.*, **194**: 299. (Cited in Stadie and Riggs, 1944.)
- SCHNEIDERMAN, H. A., AND C. M. WILLIAMS, 1953. The physiology of insect diapause. VII. The respiratory metabolism of the *Cecropia* silkworm during diapause and development. *Biol. Bull.*, **105**: 320-334.
- SCHNEIDERMAN, H. A., AND C. M. WILLIAMS, 1954. The physiology of insect diapause. VIII. Qualitative changes in the metabolism of the *Cecropia* silkworm during diapause and development. *Biol. Bull.*, **106**: 210-229.
- STADIE, W. C., AND B. C. RIGGS, 1944. An apparatus for the determination of the gaseous metabolism of surviving tissues *in vitro* at high pressures of oxygen. *J. Biol. Chem.*, **154**: 669-686.
- TANG, P. S., 1933. On the rate of oxygen consumption by tissues and lower organisms as a function of oxygen tension. *Quart. Rev. Biol.*, **8**: 260-274.
- WARBURG, O., 1949. Heavy metal prosthetic groups and enzyme action. Oxford at the Clarendon Press.

THE PHYSIOLOGY OF INSECT DIAPAUSE. IX. THE CYTO-  
CHROME OXIDASE SYSTEM IN RELATION TO THE  
DIAPAUSE AND DEVELOPMENT OF THE  
CECROPIA SILKWORM<sup>1</sup>

HOWARD A. SCHNEIDERMAN<sup>2</sup> AND CARROLL M. WILLIAMS

*The Biological Laboratories, Harvard University, Cambridge, Massachusetts*

During the pupal diapause the respiratory metabolism of the *Cecropia* silkworm proceeds at a low and relatively constant rate which, except in the case of the inter-segmental muscles of the abdomen, is insensitive to carbon monoxide and cyanide. However, with the termination of diapause and the initiation of adult development, a carbon monoxide- and cyanide-sensitive respiration appears and increases progressively, being superimposed on the carbon monoxide-stable respiration of diapause. It was concluded from these and other observations that the metabolism of the developing insect is largely mediated by the cytochrome oxidase system while that of the diapausing pupa is not (Schneiderman and Williams, 1954).

But respiratory measurements in themselves can provide only circumstantial evidence that the coupling of metabolism to cytochrome function is causally related to the termination of diapause and the development which follows. The problem is basically morphogenetic in character and therefore demands solution in morphological terms. Is the change in terminal oxidase coincidental, or is there an obligatory coupling between the function of the cytochrome oxidase system and the actual development of the insect? The present study was designed to answer this question by direct observations of the effects of carbon monoxide on the growth of the *Cecropia* silkworm during successive stages of metamorphosis.

MATERIALS AND METHODS

1. *Experimental animals*

Experiments were performed on embryos, mature larvae, pupae, developing adults, and adults of the giant silkworm *Platysamia cecropia*. The pupae were of three types: (a) Normal diapausing pupae removed from their cocoons and stored continuously at 25° C. ("unchilled diapausing pupae"). (b) Diapausing pupae such as the preceding, except that the brains had been removed and plastic windows established in the facial region and at the tip of the abdomen ("brainless diapausing pupae"). (c) "Previously chilled diapausing pupae"—animals that had been stored at 5° C. for approximately six months and provided with plastic terminal abdominal windows. As previously reported (Williams, 1946), prolonged exposure to low

<sup>1</sup> This study was aided by the Lalor Foundation, by a grant from the U. S. Public Health Service, and by an Institutional Grant to Harvard University from the American Cancer Society.

<sup>2</sup> Former Atomic Energy Commission Fellow. Present address: Department of Zoology, Cornell University, Ithaca, New York.

temperature renders the brain competent to secrete its hormone and results in the initiation of adult development approximately two weeks after such pupae are returned to 25° C.

In previously chilled pupae provided with plastic windows, the heart-beat and the initiation and day-to-day progress of adult development could be observed directly under the dissecting microscope. As has been emphasized in the previous papers of this series, the visible initiation of adult development is an event of special significance since it signals the end of the months of pupal diapause. Table I records the time sequence of adult development as observed beneath facial and terminal abdominal windows at 25° C., from the first visible signs of hypodermal retraction to the emergence of the adult moth approximately 22 days later. The table records the average tempo of development of a large series and permits one to estimate the stage of development to within  $\pm 12$  hours in the vast majority of individuals.

TABLE I

*Time-table for the development of male chilled Cecropia at 25° C. as witnessed in pupae equipped with facial and abdominal windows\**

Day	Characters
0	Initiation of hypodermal retraction just ventral to imaginal disc of genitalia; no retraction elsewhere.
1	Hypodermal retraction under terminal window extends half way up each side; the aedeagus and harpal lobes have tripled in size and migrated slightly toward center of window; hypodermal retraction under facial window has occurred only along posterior margin and is restricted to the midline and the lateral angles; <i>no retraction of leg hypodermis.</i>
2	<i>Initiation of retraction of leg hypodermis</i> , harpes show considerable enlargement and sharply defined outer edges; beginning of midventral fold between harpes; the aedeagus has migrated about half way to center of window.
3	Facial retraction nearly complete; eye lobes partially visible; terminal retraction complete except dorsally; mid-ventral fold of genitalia extends dorsally to aedeagus; harpes show considerable molding and beginning of subdivision into upper and lower lobes; tips of dorsal harpal lobe slightly forked.
4	Facial and terminal retraction complete; eye lobes well developed but unpigmented; further subdivision of harpes into dorsal and ventral lobes; aedeagus has a cone-shaped, transparent, undivided, membranous tip.
5	Palps and "stalks" of antennae visible for first time. Harpes considerably enlarged and show well developed upper and lower fleshy, semi-transparent lobes; no pubescence; no eye pigment.
6	Membranous tip of aedeagus subdivided into two or three semi-transparent processes; harpal lobes with sharp edges; extremely delicate transparent pubescence along outer edge of upper harpal lobes; no pubescence of lower lobes; no eye pigment.
7	Initiation of pink eye pigment; transparent pubescence now extends along outer edge of lower harpal lobes; genitalia deeply telescoped into preceding segment.
8	Generalized reddish brown eye pigment; genitalia fully formed but fleshy and unpigmented; pubescence generally distributed over outer side of all harpal lobes, but longer and "silky" along edge of upper lobes.
9	Dark reddish brown eye pigment; long silky hairs on upper harpal lobes and shorter silky hairs on lower lobes.
10	Dark brown eye pigment; long silky hairs on all harpal lobes; membranous tip of aedeagus with fleshy spine.
11	No further change.

(Continued on next page)

\* The same time-table may also be used for the female insect, save for the characteristics pertaining to the male genitalia. Characters printed in italics are visible without windows and can be seen by moistening the overlying cuticle with 70 per cent alcohol. The adult genitalia of *Cecropia* have been described and figured by Michener (1952).

TABLE I—Continued

Day	Characters
12	Tan streak of pigment present on each side of mouth opening; white hairs on upper harpal lobes and on face; earliest tan pigment on genitalia along surface of gnathos and on ridge connecting upper and lower harpal lobes on each side.
13	<i>Tarsal claws black</i> ; facial cuticle with pale diffuse tan pigmentation; coarse white hairs on harpes; tannish pigmentation of triangular plate (annulus) below base of aedeagus, the pigment extending bilaterally to lower tip of lower harpal lobes; the latter, in turn, show minute black punctate spots; tip of aedeagus dark brown; tan pigmentation of upper harpal lobes; spine on membranous tip of aedeagus still transparent.
14	Spine on tip of aedeagus black; <i>black, fully-formed antennal barbs</i> .
15	
16	Persistence of coarse white hairs.
17	<i>Three black spots along posterior edge of each forewing</i> ; the coarse white hairs on genitalia show initiation of pale pink pigmentation.
18	<i>Generalized but incomplete wing pigmentation</i> ; red, pink, and white hairs on genitalia; cuticle "soft" only in region of forewings.
19	<i>Complete wing pigmentation</i> ; <i>softening of cuticle extends to dorsum of abdomen</i> .
20	<i>Cuticle "soft" throughout but not crisp</i> ; moulting fluid partially absorbed under facial and abdominal windows.
21	<i>Cuticle crisp throughout</i> ; <i>moulting fluid fully resorbed except under abdominal window</i> ; <i>cuticle semi-transparent</i> .
22	<i>Animal distended</i> ; <i>adult emergence</i> .

## 2. Experimental methods

All experiments were performed at 25° C. Three techniques were utilized in the management of the various gas mixtures:

a. In the *flow method* one or more insects were enclosed in a glass tube through which an approximately streamlined and steady flow of a specific gas mixture was maintained. The mixtures were prepared in pressure cylinders and analyzed prior to use.

b. In the *static pressure method* each animal was placed in a shell vial and the latter loosely plugged with cotton. The vial was then sealed in an individual 2.5-liter air-filled steel chamber and compressed with a specific gas, the pressure being read on a gauge calibrated in pounds per square inch. Alternatively, one or more animals were enclosed in a 3.5-liter air-filled polymethyl methacrylate (Lucite) chamber and compressed with a specific gas. The oxygen tension in the chambers was that of air (20.9 per cent of an atmosphere), while the pressure of the added gas was the gauge pressure. After storage at 25° C. for specific periods the chambers were slowly decompressed, the animals returned to air, and observations continued over a period of several weeks.

c. In the *constant composition pressure method*, a series of insects was placed in a Lucite holder so that their terminal abdominal windows faced uppermost; the holder was then enclosed in a 3.5-liter air-filled Lucite chamber (Fig. 1). The animals were therefore visible through the transparent wall of the chamber and could be studied under the dissecting microscope. A glass trough containing 10 per cent NaOH was placed in the chamber for the purpose of absorbing carbon dioxide. Control experiments revealed that the reaction of carbon monoxide with the concentrated alkali to produce formate occurred so slowly that it did not detectably dimin-

ish the total carbon monoxide pressure. The chamber also contained a calibrated capillary barometer for the measurement of absolute pressure (Schneiderman and Feder, 1954). The air-filled tank was compressed with carbon monoxide, the final pressure being recorded on the tank gauge and the capillary barometer. The latter was read at three-day intervals and the oxygen consumed by the animals replaced by the addition of a corresponding amount of oxygen. On each such occasion a sample of gas was removed and analyzed (Scholander and Roughton, 1943), thus

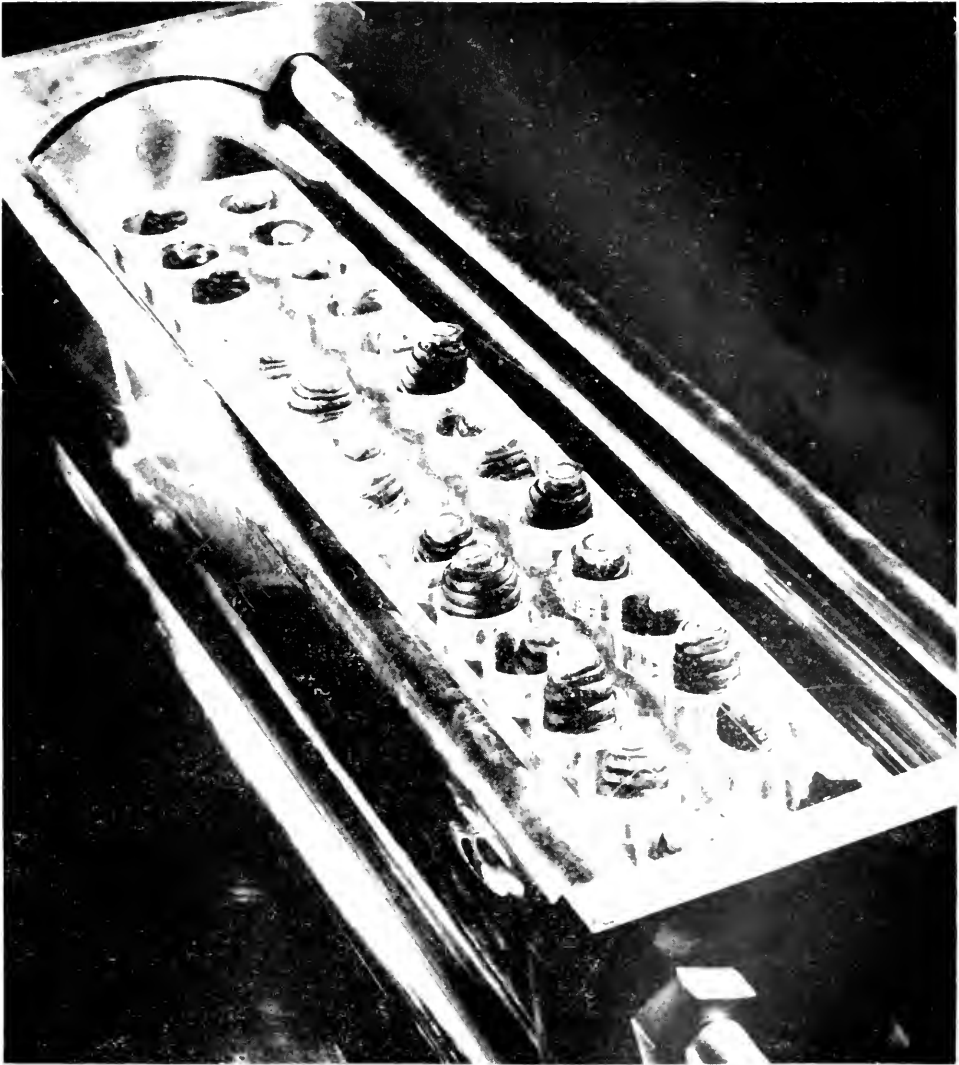

FIGURE 1. Transparent pressure chamber for studying the effects of high pressures of carbon monoxide on the day-to-day progress of development. Thirty animals have been equipped with plastic windows and sealed within the chamber in the presence of five atmospheres of carbon monoxide.

giving double assurance that the oxygen tension in the chamber remained within the desired limits. At the termination of the exposure period the chamber was slowly decompressed, the animals returned to air, and observations continued.

### 3. *Experimental gases*

The compressed gases (oxygen, nitrogen, and carbon monoxide) were handled as previously described (Schneiderman and Williams, 1954). In one series of experiments extremely pure carbon monoxide was prepared (*ibid.*). Since the latter was indistinguishable from alkali-washed carbon monoxide in its effects on growth, the less expensive commercially available carbon monoxide was utilized in subsequent experiments.

## RESULTS

### 1. *Effects of high pressures of nitrogen*

Chilled and unchilled diapausing *Cecropia* pupae and post-diapausing animals at several stages in adult development were placed in individual air-filled 2.5-liter steel or Lucite chambers and compressed with from 4 to 7 atmospheres of nitrogen. The static pressure technique was utilized and each experiment continued for 21 days. Under this treatment the animals behaved as in air at atmospheric pressure. Spontaneous movements of the abdomen and the beating of the heart continued without interruption. Moreover, the rate of adult development was the same as in air at one atmosphere, and the resulting adults were normal in all respects.

From these control experiments we learn that pressures up to seven atmospheres of an inert gas such as nitrogen are without detectable effects on the adult development of *Cecropia*. It is also clear that the 525 cc. of oxygen initially present in each air-filled chamber was sufficient to permit a pupa to undergo normal adult development without interference from oxygen lack or from the accumulation of metabolic carbon dioxide during the 21-day period of confinement.

### 2. *Effects of carbon monoxide on diapausing pupae*

Diapausing pupae and brainless diapausing pupae were exposed to carbon monoxide by all three of the above-mentioned experimental methods. When the carbon monoxide/oxygen ratio was increased above 10:1, spontaneous movements of the abdomen showed considerable reduction in both amplitude and frequency. Residual extremely feeble movements, occasionally detectable even at 15:1 carbon monoxide/oxygen, completely disappeared after further increase in the ratio. When decompressed and returned to air, normal abdominal motion reappeared within a few hours. In contrast to the paralysis of the intersegmental muscles, the heart continued to beat normally throughout the 21 days of exposure to carbon monoxide even when the carbon monoxide/oxygen ratio was 25:1.

It will be recalled that diapausing pupae initiate adult development after continuous storage at 25° C. for five months or longer (Williams, 1946). This behavior was unimpaired by three weeks of prior exposure to high pressures of carbon monoxide. Evidently, within the diapausing insect the viability of neither the pupal tissues, nor the anlagen of the adult tissues, nor the endocrine organs themselves is dependent on enzymes inhibited by carbon monoxide.

### 3. *Inhibition of wound healing in diapausing pupae by carbon monoxide*

Although brainless diapausing pupae are incapable of initiating adult development (Williams, 1946), they retain the ability to repair integumentary wounds. One can study this process to good advantage by removing a disc of hypodermis plus overlying cuticle and covering the wound with a plastic window, the latter being sealed in place with melted paraffin. Spindle-shaped blood cells promptly adhere to the window and begin to string out tenuous cytoplasmic processes. The latter interlace and form a fenestrated tissue which, after 4 or 5 days, is transformed into a transparent, shiny membrane. Meanwhile, the hypodermis begins to close in around the margins of the wound, accompanied by minute tracheae and tracheoles. A continuation of this centripetal growth leads to a central closure of the wound after about 10 to 14 days.

In order to ascertain the effects of carbon monoxide on wound healing, the following experiment was performed. From a series of six previously chilled diapausing pupae the brains were removed and facial and abdominal windows established in each individual. Two days after the operation, three animals were placed in a transparent 3.5-liter air-filled Lucite tank and compressed *via* the static pressure method with five atmospheres of carbon monoxide (carbon monoxide/oxygen ratio of 25:1). The other three animals served as controls and were maintained in air. Each individual was examined daily under the dissecting microscope for signs of regeneration. After a total of 13 days the control group in air had completely repaired the wounds under both facial and abdominal windows. By contrast, the experimental group in carbon monoxide showed no evidence of repair. But when decompressed and returned to air, repair began at once and was completed within 13 days.

Thus, it is clear that even in the diapausing pupa the localized morphogenesis inherent in the repair of a wound is completely inhibited by carbon monoxide.

### 4. *Inhibition of adult development by carbon monoxide*

All three of the techniques for the administration of carbon monoxide were utilized in a study of the adult development of previously chilled pupae and of animals that had already initiated adult development. The progress of development in each individual was judged by observations of its genitalia, the day-to-day changes being compared with the normal tempo already defined (Table I). Each experiment was continued for 21 days.

As recorded in Table II it is of special interest that during exposure to carbon monoxide the termination of pupal diapause, as signalled by the onset of adult development, was blocked or greatly delayed. Moreover, individuals which already showed early adult development at the outset of the experiment remained alive in most cases, but further development was either prevented or greatly inhibited.

It is also clear from Table II that the degree of inhibition was a function, not of the carbon monoxide concentration alone, but of the carbon monoxide/oxygen ratio. When the latter was higher than 20:1, development was completely or almost completely blocked. Such animals, when returned to air, promptly resumed normal development where they had left off and produced normal adult moths. However, when development was incompletely blocked in carbon monoxide/oxygen ratios less than 20:1, the insects, upon return to air, continued in a pattern of ab-

TABLE II

*Effects of twenty-one days exposure to various carbon monoxide/oxygen ratios on previously chilled Cecropia pupae and on animals at specific stages of adult development*

CO:O <sub>2</sub> ratio	Gas content of chamber (atmospheres)	Stage of development at outset	Number of animals	Number of survivors	Average rate of development in CO as % of rate in air	Development after return to air
33:1	6.7 CO +1 air	Previously chilled pupae <5-25% development	6 9	6 8	(0.5) 1	6 normal adults 5 normal adults; 3 died
25:1	5 CO +1 air	Previously chilled pupae <5-25% development	8 6	5 5	(2) 2	2 normal adults; 3 died 3 normal adults; 2 died
20:1	4 CO +1 air	Previously chilled pupae	8	5	2	No data
19:1	0.95 CO +0.05 O <sub>2</sub>	<5-25% development	6	6	11	3 abnormal adults; 1 normal adult; 2 died
		26-50% development	3	3	12	3 slightly abnormal adults
		70% development	1	1	18	1 slightly abnormal adult
15:1	3 CO +1 air	Previously chilled pupae	2	2	(3)	1 abnormal adult; 1 normal adult
		<5-25% development	2	2	15	1 abnormal adult; 1 normal adult
10:1	4 CO +0.2 O <sub>2</sub> +1 air	Previously chilled pupae	8	8	(7)	3 abnormal adults; 3 normal adults; 2 died
		<5-25% development	10	10	14	6 abnormal adults; 4 died
		25-50% development	4	2	25	2 died at 70% stage of development
5:1	1 CO +1 air	Previously chilled pupae	2	2	(15)	No data
1:1	1 CO +0.8 O <sub>2</sub> +1 air	<5-25% development	3	0	70	3 died at 70% stage of development
		Total	78			

Parentheses () indicate that one or more individuals initiated development in the presence of carbon monoxide.

normal development and produced adult moths with various abnormalities. The latter included defective scales, hairs, and pigmentation, along with incomplete or malformed eyes, legs, antennae, and genitalia.

The endocrine competency of the brain itself was found to be unaffected by exposure to carbon monoxide. Thus, brains removed from previously chilled pupae after 21 days of exposure to 25:1 carbon monoxide/oxygen retained their activity and evoked adult development when implanted into brainless diapausing pupae.

### 5. *Effects of carbon monoxide on mature larvae*

Mature larvae at the outset of spinning were exposed to carbon monoxide by the static pressure method for one to six days. In control experiments four atmospheres of nitrogen was substituted for the carbon monoxide.

The results recorded in Table III show that neither the behavior nor the viability of the caterpillars was affected by four atmospheres of nitrogen. By contrast, no individual was able to survive exposure to 33:1 carbon monoxide/oxygen for as long as five days. Moreover, in the presence of carbon monoxide/oxygen ratios as low as 1:1, the spinning of a normal cocoon was inhibited, the insect either failing to spin or spinning only a flat sheet of silk.



TABLE III

*Effects of various carbon monoxide/oxygen ratios on mature fifth instar Cecropia larvae*

CO:O <sub>2</sub> ratio	Gas content of chamber (atmospheres)	Duration of exposure (days)	Type of spinning behavior in chamber	Type of spinning behavior after removal from chamber	Pupated
—	1 air	2	Normal cocoon	Normal cocoon	+
—	4 N <sub>2</sub> +1 air	2	Normal cocoon	Normal cocoon	+
33:1	6.7 CO+1 air	5	None	Dead on removal	0
		2	None	Normal cocoon	+
25:1	5 CO+1 air	6	None	Dead on removal	0
20:1	4 CO+1 air	1	None	Normal cocoon	+
15:1	3 CO+1 air	5	Flat sheet	None	+
		4	Flat sheet	Normal cocoon	+
		2	Flat sheet	None	+
		1	Flat sheet	None	+
5:1	1 CO+1 air	3	Flat sheet	Normal cocoon	+
3:1	0.67 CO+1 air	5	Flat sheet	None	+
2:1	0.4 CO+1 air	3	None	Normal cocoon	+
1:1	0.2 CO+1 air	3	None	Normal cocoon	+
		3	Flat sheet	Normal cocoon	+
		3	Flat sheet at first, then continued with a normal cocoon	None	+

#### 6. *Effects of carbon monoxide on fertile eggs and embryos*

Embryonic development of *Cecropia*, from oviposition to hatching, requires about ten days at 25° C. From the sixth to the tenth day, one can easily track the progress of embryonic development under the dissecting microscope and thereby estimate the stage of embryonic development.

By means of the static pressure method, freshly oviposited fertile eggs were exposed to a carbon monoxide/oxygen ratio of 20:1 for 1, 3, and 5 days, respectively. Similar experiments were performed on developing embryos which had already completed 10, 30, 70, and 90 per cent of embryological development.

In control experiments compression with four atmospheres of nitrogen was without major effects on viability, and approximately 90 per cent of eggs and embryos hatched. However, even one day of exposure to 20:1 carbon monoxide/oxygen considerably decreased the viability of the embryos. When returned to air, only 10 per cent of the eggs eventually hatched and only 50 per cent showed any detectable progress in embryonic development. Three days of exposure to the 20:1 mixture was lethal in nearly all cases; when returned to air, no eggs hatched and almost all of the embryos were already dead. It is clear that both the development and the viability of eggs and embryos are extremely sensitive to brief exposure to carbon monoxide.

#### 7. *Effects of carbon monoxide on the adult moth*

By the use of the static pressure method, adult *Cecropia* moths, 12 to 36 hours after emergence, were exposed to various carbon monoxide/oxygen ratios for periods up to five days. The results summarized in Table IV demonstrate that the

TABLE IV

*Effects of various carbon monoxide/oxygen ratios on the viability of adult Cecropia moths*

CO:O <sub>2</sub>	Gas content of chamber (atmospheres)	Number of animals	Duration of exposure (days)	Behavior in chamber	Behavior after removal from chamber
	1 air	2	2	Fluttering	Flying
	4 N <sub>2</sub> +1 air	2	2	Fluttering	Flying
33:1	6.7 CO+1 air	2	2	Slight tremors which ceased after 2 hours	Flaccid upon removal. Recovery after 1 and 10 minutes. Feeble coordinated motion within 3 hours, but no flight. Died within 4 days
20:1	4 CO+1 air	2	5	Slight tremors which ceased after 2 hours	Flaccid and dead upon removal
		4	3	Slight tremors which ceased after 2 hours	Flaccid upon removal. Recovery after 10, 10, 20, and 60 minutes. Extremely feeble uncoordinated activity within 3 hours. Died within 3 days without regaining coordination
		2	2	Slight tremors which ceased after 2 hours	Flaccid upon removal. Recovery after 1 and 10 minutes. Considerable coordinated activity within 3 hours, but no flight. Both lived for 6 days after removal, one female laid eggs
		8	1	Slight tremors which ceased after 2 hours	Flaccid upon removal. Recovery after 30 seconds. Flying within 3 hours

moth is definitely sensitive to carbon monoxide. After three days of exposure to a carbon monoxide/oxygen ratio of 20:1, the insects showed considerable decrease in vitality when returned to air; exposure for five days was lethal. Equivalent compression with nitrogen had no effect.

#### *8. Photoreversibility of the carbon monoxide inhibition*

Six pupae showing early adult development were placed head-down in an air-filled Lucite tank such as illustrated in Figure 1, and compressed with carbon monoxide to a final carbon monoxide/oxygen ratio of 20:1. Three individuals were illuminated continuously with a 250-watt mercury vapor lamp (General Electric AH-5) *via* their terminal abdominal windows. The light was collected with a reflector and passed through a solution of sodium nitrite to cut off the ultraviolet and through 5 cms. of water to eliminate the infra-red (Bowen, 1949). Three control animals were loosely wrapped in aluminum foil to maintain them in darkness, and

placed in the same chamber. The latter was immersed in a water bath at 25° C., the distance from the light source to the animals being approximately 25 cms.

Exposure to carbon monoxide and simultaneous illumination were continued for 5 days. The chamber was then decompressed and the experimental animals compared with the controls. The genitalia of the illuminated animals had progressed an average of 3.5 days; that is, at 70 per cent of the rate in air. By contrast, the genitalia of the unilluminated individuals showed no detectable progress. This difference was particularly striking at the anterior and posterior ends of the illuminated animals in that the illuminated genitalia showed considerable progress in development whereas the unilluminated facial region showed no morphological advance. Since light-reversibility is a distinguishing property of carbon monoxide's inhibition of cytochrome oxidase, the demonstration of light-reversibility is especially critical, confirming for the insect as a whole the phenomenon as previously encountered in cultures of isolated *Cecropia* spermatocytes (Schneiderman, Ketchel and Williams, 1953).

#### 9. Effects of oxygen tension on animals at the initiation of adult development

Pupae showing the first day of adult development were exposed to continuously flowing mixtures of oxygen and nitrogen for specific periods, usually 21 days. The results recorded in Table V show that development was retarded by 13 per cent in

TABLE V

*Effects of oxygen tension on the adult development of Cecropia  
(animals on first day of development at outset)*

Oxygen tension (per cent of an atmosphere)	Number of animals	Days in gas mixture	Average rate of develop- ment as per cent of rate in air	Average rate of development after return to air	Final state
100	3	21	90	2 at 100% normal rate; 1 at 60% normal rate	1 normal adult; 2 slightly abnormal
21 (air)	3	21	100	100%	Normal adults
5	3	21	87	100%	Normal adults
3	3	21	52	100%	Abnormal adults
1	3	15	0	After 10 days in air, de- velopment began again and continued at 100% normal rate	1 adult with minimal de- fects in antennal struc- ture; 2 dead after 45% and 70% development
Less than 0.5	3	7	0	0	Dead when removed from gas

5 per cent of an atmosphere of oxygen, and by 10 per cent in an atmosphere of pure oxygen. Between these limits the rate of development was independent of oxygen tension. Evidently, a gradient in oxygen pressure slightly in excess of 5 per cent of an atmosphere is sufficient to meet the oxygen requirements of the developing tissues. Those individuals which underwent development in the presence of oxygen pressures less than 5 per cent showed abnormalities similar to those encountered after exposure to carbon monoxide (*cf.* section 4).

### 10. *Effects of oxygen tension on mature larvae*

Eleven mature larvae were subjected for one to four days to specific low oxygen tensions established by the flow method. The effects were judged in terms of the insect's spinning behavior and subsequent pupation.

Essentially normal cocoons were spun until the oxygen tension was reduced below 3 per cent of an atmosphere. At 2.5 per cent oxygen the animal usually spun silk in a flat sheet (*cf.* section 5). At tensions lower than 2 per cent, spinning ceased; however, animals that had been exposed to this low tension for three days spun normal cocoons when returned to air.

### 11. *Effects of anoxia on larvae, diapausing pupae, and adults*

Mature larvae and adult moths were killed by one day of exposure to tank nitrogen containing less than 0.5 per cent oxygen. When diapausing pupae were treated in like manner, the heart ceased to beat after 4 to 7 hours. Half the animals were dead after 72 hours; the survivors, when returned to air, showed resumption of heart beat and abdominal motion after one to two days.

## DISCUSSION

### 1. *Systematic changes in sensitivity to carbon monoxide*

In the preceding paper of this series, evidence derived from respiratory studies on the *Cecropia* silkworm demonstrated that marked changes occur in the sensitivity of respiration to carbon monoxide during embryonic and post-embryonic development. The results of the present study reaffirm these changes by demonstrating that diverse physiological activities of the insect show parallel variations in sensitivity to carbon monoxide. In the analysis of these findings it is convenient to subdivide the physiological activities of the insect into processes concerned with "maintenance" and with "growth and activity." The first of these include the minimal metabolic events which sustain the viability and *status quo* of the organism. The second category includes physiological processes responsible for morphogenesis and similar highly involved and specialized activities.

Prolonged survival in the presence of high pressures of carbon monoxide signifies that the gas fails to block the function of any tissue or organ required for the maintenance of life. Death signifies that the function of at least one such tissue or organ is blocked by carbon monoxide. In these terms it is clear that both the maintenance and the growth-and-activity processes are blocked by carbon monoxide in the egg, embryo, and larva. After pupation, however, the maintenance and survival of the diapausing pupa in the dormant state are insensitive to carbon monoxide.

The carbon monoxide-stable mechanism apparently remains intact during the early stages of adult development. But, here also, carbon monoxide continues to block development and to inhibit the contraction of all muscles except the heart. Finally, in the late stages of adult development and in the adult moth, carbon monoxide once again interferes with maintenance as well as with growth and activity.

Evidence has heretofore been presented that the target of carbon monoxide in the insect is cytochrome oxidase (Schneiderman and Williams, 1954). The light-reversibility of carbon monoxide's inhibition of growth is strong confirmation of this

view. Moreover, as was inferred in the previous study, the ability of the diapausing pupa to survive in the presence of high concentrations of carbon monoxide signifies that the loss or inactivation of the carbon monoxide-sensitive cytochrome oxidase system at the time of pupation is compensated by the development of activation of a carbon monoxide-stable respiratory system capable of underwriting the maintenance requirements and the heart-beat of the diapausing insect. This finding affords a remarkably clear illustration in biochemical terms of the dissociability of "maintenance" and "growth" (Needham, 1942, p. 505 ff.).

## 2. The cytochrome-cytochrome oxidase system and the energetics of development

The dependency of the growth and activity processes of *Cecropia* at all stages of development upon respiration mediated by cytochrome oxidase finds many parallels. From a study of the literature we have assembled in Table VI a number of processes

TABLE VI  
*Vital processes in which the inhibitory action of carbon monoxide  
has been found to be reversed by light*

Material		Reference
1. <i>Arbacia</i> eggs	Cell division (mitosis)	Clowes and Krahl (1940)
2. <i>Cecropia</i> spermatocytes	<i>In vitro</i> spermatogenesis (meiosis and spermiogenesis)	Schneiderman, <i>et al.</i> (1951, 1953)
3. <i>Drosophila</i>	Adult development	Wolsky (1937)
4. <i>Avena</i> (oat)	Growth of isolated coleoptile sections (cell elongation)	Hackett and Schneiderman (1953)
5. <i>Pisum</i> (pea)	Growth or isolated stem sections (cell elongation)	Hackett and Schneiderman (1953)
6. <i>Solanum</i> (white potato)	Water uptake by tissue slices	Hackett <i>et al.</i> (1953)
7. <i>Daucus</i> (carrot)	Salt accumulation by tissue slices	Weeks and Robertson (1950)
8. Rat	Incorporation of radioiodine in surviving thyroid tissue	Schachner <i>et al.</i> (1943)
9. <i>Pteridium</i> (bracken sperm)	Movement of bracken spermatozooids	Rothschild (1951)
10. <i>Fundulus</i> (fish) heart	Heart-beat	Fisher and Cameron (1936, 1938)
11. Frog nerve	Action potential	Schmitt (1930)

where a light-reversible carbon monoxide inhibition has been reported. These include meiosis, mitosis, differentiation, cell elongation, water uptake, salt accumulation, flagellar movement, and nerve conduction. As Lemberg and Legge (1949) have reasoned (p. 383): "Whether the respiration of the resting cell is always catalyzed by the cytochrome system or not, it has become increasingly clear that the functional activity of the cell depends on this system." See also Drabkin (1948).

For our present purposes it is of special interest that the inhibition of cytochrome oxidase within the post-diapausing *Cecropia* establishes and enforces an artificial diapause during the period of exposure of carbon monoxide. It is also noteworthy that even in the diapausing pupa the inhibition of this enzyme prevents wound-healing. From these several lines of evidence we learn that carbon monoxide-sensitive metabolism plays an obligatory role in the energetics of development.

The absence of all but a trace of a complete cytochrome oxidase system in the diapausing pupa therefore assumes special significance (Williams, 1951). Since the presence and function of this system appear to be prerequisite for adult development, its virtual absence in the dormant pupa can, in itself, account for the developmental stand-still of diapause.

In diapausing embryos of the grasshopper, *Melanoplus*, and of the commercial silkworm, *Bombyx*, the absence of a cytochrome-mediated respiration has been attributed to an inactivation of the cytochrome oxidase that is already present; the oxidase is thought to be re-coupled to metabolism in synchrony with the termination of diapause (Bodine and Boell, 1938; Wolsky, 1949). But, in the case of the *Cecropia* silkworm, the termination of diapause and the onset of development are accompanied by an actual synthesis of a new cytochrome system—not a mere re-coupling of enzymes already present (Sanborn and Williams, 1950). The results of the present investigation therefore link the respiratory and enzymatic studies and demonstrate that cytochrome oxidase is the terminal oxidase in processes energizing the insect's development.

The present study confirms the fact that qualitative as well as quantitative changes occur in the energy metabolism of the *Cecropia* silkworm during the course of metamorphosis. It also contributes to a coherent body of evidence that the cytochrome oxidase system plays an obligatory role in the energetics of morphogenesis. We are therefore persuaded that the recruitment and resynthesis of the cytochrome oxidase system are among the biochemical changes set in motion by the growth and differentiation hormone—changes which couple the endocrine action to the termination of the pupal diapause.

The experiments reported in Sections 5 and 10 were performed in collaboration with Dr. William Van der Kloot and those in Section 9 in collaboration with Mr. Roger Milkman. The photograph in Figure 1 was made by Dr. Roman Vishniac and is used with the permission of *Time*, Inc.

#### SUMMARY

1. The effects of mixtures of carbon monoxide and oxygen on the growth and metamorphosis of the *Cecropia* silkworm were examined at successive stages of embryonic and post-embryonic development.

2. Embryos, mature larvae, and adults are killed by five days of exposure to carbon monoxide/oxygen ratios of 20:1 or 25:1. Diapausing pupae, by contrast, survive at least 21 days of exposure to carbon monoxide/oxygen ratios as high as 33:1.

3. While failing to interfere with the viability of diapausing pupae, carbon monoxide blocks or greatly retards the termination of the pupal diapause; it also inhibits the healing of experimental wounds in the pupal integument.

4. The ability to survive in the presence of high pressures of carbon monoxide persists throughout the early stages of adult development. Exposure of the developing, post-diapausing insect to suitable pressures of carbon monoxide establishes and enforces an artificial diapause which is reversed upon return to air.

5. The inhibition of adult development by carbon monoxide is light-reversible; the degree of inhibition is a function of the carbon monoxide/oxygen ratio. These

findings indicate that the effects of carbon monoxide are due to the poisoning of cytochrome oxidase.

6. Resistance to carbon monoxide, as in the diapausing pupa, signals the presence and utilization of an oxidase other than cytochrome oxidase.

7. On the basis of these several lines of evidence, it is concluded that growth and metamorphosis, at all stages in the life history, are dependent on metabolism catalyzed by cytochrome oxidase. The function of cytochrome oxidase is likewise prerequisite for the maintenance of life of the embryo, larva, and adult.

8. Only the diapausing pupa survives without regard to the presence or function of cytochrome oxidase, the maintenance metabolism of the pupae being served by an unidentified oxidase which is insensitive to carbon monoxide.

9. With the termination of pupal diapause the growth and differentiation of the adult moth again requires the function of the cytochrome oxidase system. This fact is considered in relation to the endocrine control of the pupal diapause.

#### LITERATURE CITED

- BODINE, J. H., AND E. J. BOELL, 1938. The influence of some dinitrophenols on respiratory metabolism during certain phases of embryonic development. *J. Cell. Comp. Physiol.*, **11**: 41-63.
- BOWEN, E. J., 1949. The chemical aspects of light. 2nd edition. Oxford at the Clarendon Press.
- CLOWES, G. H. A., AND M. E. KRAHL, 1940. Oxygen consumption and cell division of fertilized sea urchin eggs in the presence of respiratory inhibitors. *J. Gen. Physiol.*, **23**: 401-411.
- DRABKIN, D. C., 1948. Distribution and metabolic aspects of derivatives of iron protoporphyrin (hemin). *Fed. Proc.*, **7**: 483-492.
- FISHER, D. C., AND J. A. CAMERON, 1936. Effect of light on the CO-poisoned embryonic *Fundulus* heart. *Biol. Bull.*, **71**: 404.
- FISHER, D. C., AND J. A. CAMERON, 1938. The frequency of the CO-poisoned heart at different mean light intensities. *J. Cell. Comp. Physiol.*, **11**: 433-454.
- HACKETT, D. P., AND H. A. SCHNEIDERMAN, 1953. Terminal oxidases and growth in plant tissues. I. The terminal oxidase mediating growth of *Avena* coleoptile and *Pisum* stem sections. *Arch. Biochem. Biophysics*, **47**: 190-204.
- HACKETT, D. P., H. A. SCHNEIDERMAN AND K. V. THIMANN, 1953. Terminal oxidases and growth in plant tissues. II. The terminal oxidase mediating water uptake by potato tissue. *Arch. Biochem. Biophysics*, **47**: 205-214.
- LEMBERG, R., AND J. W. LEGGE, 1949. Hematin compounds and bile pigments. Interscience Publ. Inc., New York.
- MICHENER, C. D., 1952. The Saturniidae (Lepidoptera) of the western hemisphere. *Bull. Am. Mus. Nat. Hist.*, **98**: 341-501.
- NEEDHAM, J., 1942. Biochemistry and morphogenesis. Cambridge University Press.
- ROTHSCHILD, LORD, 1951. Cytochrome-catalysis of the movement of bracken spermatozoids (*Pteridium aquilinum*). *Proc. Roy. Soc., London, Ser. B*, **138**: 272-277.
- SANBORN, R. C., AND C. M. WILLIAMS, 1950. Oxidative enzymes in relation to pupal diapause and adult development in the *Cecropia* silkworm. *Anat. Rec.*, **108**: 70.
- SCHACHNER, H., A. L. FRANKLIN AND I. L. CHAIKOFF, 1943. The effect of cytochrome oxidase inhibitors on the formation *in vitro* of thyroxine and diiodotyrosine by thyroid tissue with radioactive iodine indicator. *J. Biol. Chem.*, **151**: 191-199.
- SCHMITT, F. O., 1930. On the nature of the nerve impulse. I. The effect of carbon monoxide on medullated nerve. *Amer. J. Physiol.*, **95**: 650-661.
- SCHNEIDERMAN, H. A., AND N. FEDER, 1954. A respirometer for metabolic studies at high gaseous pressures. *Biol. Bull.*, **106**: 230-237.
- SCHNEIDERMAN, H. A., M. KETCHEL AND N. FEDER, 1951. The cytochrome system in relation to *in vitro* spermatogenesis in the *Cecropia* silkworm. *Anat. Rec.*, **111**: 102.

- SCHNEIDERMAN, H. A., M. KETCHEL AND C. M. WILLIAMS, 1953. The physiology of insect diapause. VI. Effects of temperature, oxygen tension, and metabolic inhibitors on *in vitro* spermatogenesis in the *Cecropia* silkworm. *Biol. Bull.*, **105**: 188-199.
- SCHNEIDERMAN, H. A., AND C. M. WILLIAMS, 1953. The physiology of insect diapause. VII. The respiratory metabolism of the *Cecropia* silkworm during diapause and development. *Biol. Bull.*, **105**: 320-334.
- SCHNEIDERMAN, H. A., AND C. M. WILLIAMS, 1954. The physiology of insect diapause. VIII. Qualitative changes in the metabolism of the *Cecropia* silkworm during diapause and development. *Biol. Bull.*, **106**: 210-229.
- SCHOLANDER, P. F., AND F. J. W. ROUGHTON, 1943. Microgasometric estimation of the blood gases. I. Oxygen. *J. Biol. Chem.*, **148**: 541-550.
- WEEKS, D. C., AND R. N. ROBERTSON, 1950. Studies in the metabolism of plant cells, VIII. Dependence of salt accumulation and salt respiration upon the cytochrome system. *Australian J. of Sci. Res., B.*, **3**: 487-500.
- WILLIAMS, C. M., 1946. Physiology of insect diapause: the role of the brain in the production and termination of pupal dormancy in the giant silkworm, *Platysamia cecropia*. *Biol. Bull.*, **90**: 234-243.
- WILLIAMS, C. M., 1951. Biochemical mechanisms in insect growth and metamorphosis. *Fed. Proc.*, **10**: 546-552.
- WOLSKY, A., 1937. Production of local depressions in the development of *Drosophila* pupae. *Nature*, **139**: 1069-1070.
- WOLSKY, A., 1949. The effect of carbon monoxide on the respiration of artificially bivoltinized silkworm eggs. *Current Science (India)*, **18**: 323-325.



LETHALITY AND THE BIOLOGICAL EFFECTS OF X-RAYS  
IN *PARAMECIUM*: RADIATION RESISTANCE  
AND ITS VARIABILITY

RALPH WICHTERMAN<sup>1</sup> AND FRANK H. J. FIGGE<sup>2</sup>

*Department of Biology, Temple University; Department of Anatomy, University of Maryland  
Medical School; Marine Biological Laboratory, Woods Hole, Massachusetts*

It has been known for a long time that *Paramecium* and certain other Protozoa are able to survive exceedingly high dosages of x-rays (see review, Wichterman, 1953). With low, sub-lethal dosages, paramecia become perceptibly accelerated. In normal bacterized culture media, dosages of 200,000 roentgen (r) and above usually retard motility in *Paramecium*, and there are generally no survivors above 510,000 r. Occasionally, survivors of this high dosage produce clones which, after overcoming irradiation effects, reproduce and flourish in a manner comparable to controls (Wichterman, 1948). X-ray survival curves for microorganisms as reported in the literature vary considerably, apparently depending upon the conditions employed for irradiation. We find, for instance, that with certain methods and under certain conditions in the irradiation of *Paramecium caudatum*, the LD 50—that dosage which results in the death of 50 per cent of irradiated organisms—may vary from 75,000 r to 350,000 r.

The purpose of the present investigation was to establish a standard, repeatable method of irradiation and to analyze the causes of radiation resistance and variability in *Paramecium*.

To fully appreciate the insensitivity of paramecia to x-radiation, we need only examine the LD 50 dosages of other organisms. According to Lea (1947), the 50 per cent survival dosage for yeast is 30,000 r; for the bacterium *B. coli*, 5600 r, and for spores of *B. mesentericus*, 150,000 r. For the algae *Chlorella*, *Ankistrodesmus*, and *Chroococcus*, the LD 50 is 22,000 r, 11,000 r, and 9,000 r, respectively (Bonham and Palumbo, 1951). In this connection, it is to be noted that bacteria in culture fluid, as well as those in the body of *Paramecium* and the symbiotic *Chlorella* in *Paramecium bursaria*, can be destroyed by x-rays without killing the paramecia (Wichterman, 1948). It is thus possible to sterilize such cultures to yield species-pure clones of *Paramecium* as well as colorless races of the normally green species, *Paramecium bursaria*. The recent accounts given by Curtis (1951) and Nickson (1952) for some vertebrate animals commonly used in the laboratory are seen to vary, but relatively low dosages of x-rays are required to produce 50 per cent lethality. For instance the LD 50 for "baby" rats is given as 510 r but 590–1280 r for adults. The LD 50 for other animals follows: mice, 400–840 r; guinea

<sup>1</sup> Supported by the Committee on Research, Temple University and aided by a contract between the Office of Naval Research, Department of the Navy and Temple University (NR 135-233).

<sup>2</sup> Supported by grants from the Anna Fuller Fund and the American Cancer Society, Maryland Division, Inc.

pigs, 200–310 r; rabbits, 790–1500 r; dogs, 300–335 r; monkeys, 500 r. According to Sparrow and Rubin (1952), it has been estimated that the LD 50 for man would be approximately 400 r when the x-radiation is received over the whole body in a fairly short period of time. It is therefore worthy of note that *Paramecium caudatum*, with an LD 50 of approximately 340,000 r when irradiated in Nylon syringes, has a radiation resistance 850 times as great as that of man and some common vertebrate laboratory animals.

As a test animal for the evaluation of irradiation effects and associated phenomena, *Paramecium* has many useful features. Beginning with a single specimen, it is possible to obtain for experimentation a genetically uniform, pedigreed strain of enormous numbers of paramecia. This allows for speed and precision of observation generally impossible with other test animals. In addition to being a completely isolated cell, *Paramecium* is a structurally complex organism; hence morphologic changes as a result of irradiation can be determined readily. Irradiation effects are manifested in loss of motility, which may include a change in ciliary action or its complete cessation, dysfunction of contractile vacuoles, change in rate of cyclo-sis, vacuolization, blistering of the pellicle, changes in body shape, and finally disintegration of the body. Also the division rate, which is an index of vitality, can be compared with the control specimens and expressed in quantitative terms. Additional advantages in x-radiation experiments with paramecia may lie in the field of biochemistry, especially in regard to the effects on respiratory mechanisms which appear to be greatly involved.

#### MATERIALS AND METHODS

In the present study, all irradiation work was done at the Marine Biological Laboratory, Woods Hole, Massachusetts. The x-ray generator operates simultaneously two water-cooled Coolidge tubes in alternate parallel. One tube was mounted rigidly on a platform on the floor, and the other tube was supported on a counter-balanced arm which allowed it to be moved vertically and in line directly over the fixed tube. Paramecia in irradiation chambers were thus cross-fired from above and below. The x-ray tubes operated at 182 kv. pk., and 25 ma., with an equivalent filtration of 0.2 mm. of copper. When the tubes were brought very close together (position A), which was the position used for all experiments, intensity was 6300 r per minute. Not only were the tubes water-cooled, but an electric fan was directed upon them, and the irradiated material was surrounded by an ice chamber. Temperature determinations were made by the use of a thermo-junction and galvanometer. The junction was placed directly into the control irradiation chamber; thus it was possible to determine the small temperature changes—which proved to be insignificant—during the entire time specimens were irradiated. Most of the irradiation work was done at a temperature of 15° C.

Although different species of *Paramecium* were irradiated and results indicated species differences in regard to x-ray susceptibility, the results reported here are based upon the use of *P. caudatum*.<sup>3</sup> Cultures were begun with a single specimen and cultivated in covered flasks containing either lettuce or hay infusions which were inoculated with the bacterium *Aerobacter aerogenes* as the food source.

<sup>3</sup> The original strain of *Paramecium caudatum* (57-14) was kindly supplied by Dr. Lauren C. Gilman, University of Miami.

A

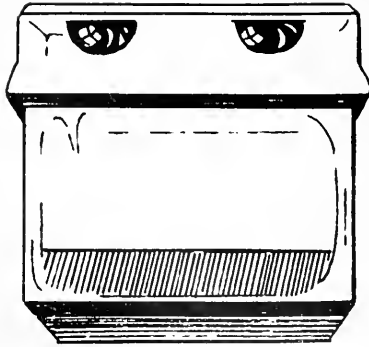

B

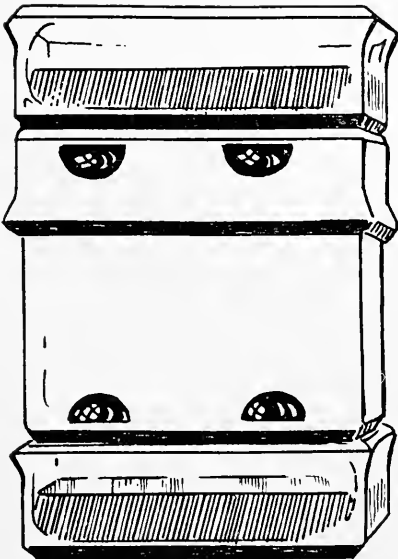

STEVENS

C

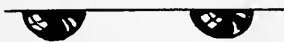
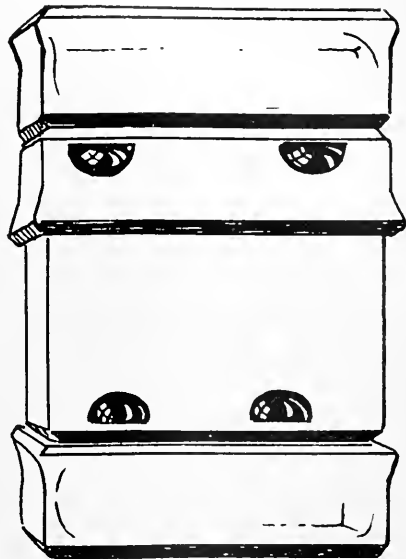

DROPS OF CULTURE FLUID  
+ 5 - 20 PARAMECIA



1 CC OF CULTURE FLUID  
+ 100 PARAMECIA

FIGURE 1. Drawings illustrating how conventional plastic boxes were used to irradiate *Paramecium caudatum* in drops and larger volumes of fluid.

Usually vegetative specimens to be irradiated were removed with a micropipette from rich clonal cultures of pH 7.1 following the logarithmic growth phase. Such active and vigorous animals were commonly uniform in size and shape. The environmental culture fluid to be irradiated with the paramecia contained fewer bacteria than during the active growth phase.

For most of the investigations, two types of irradiation chambers were employed. At first, the chambers used consisted of rigid, transparent, plastic boxes with tightly fitting lids and of a type commonly used in such experiments with microorganisms. The boxes measured approximately  $24 \times 24 \times 18$  mm. with a volume of about 6 cc. (Fig. 1, A). It was possible to irradiate four boxes containing paramecia at one time. To study the influence of the ratio of the numbers of animals to volume of fluid, drops of uniform size were suspended as hanging drops from the lids of the boxes. The drops, each containing 10, 25, 50 and 100 paramecia, were then irradiated. Additional variations were made utilizing the plastic boxes as shown in Figure 1 and described later. Subsequent experiments indicated that the number of paramecia per unit of volume was not as important in determining the lethal effects of x-radiation as the depth of the exposed culture medium, volume of the moist air-space, and the amount of surface of the culture medium exposed to the air in the radiation chamber.

A new type of radiation chamber was therefore employed to avoid the complicating factor of the air-space which appeared to diffuse from the moist air and which appeared to be extremely lethal to paramecia (Fig. 2). This new chamber consists of a Nylon hypodermic syringe of 2 cc. capacity and graduated in units of one-tenth of a cc. (0.1 cc.). A tightly fitting Lucite cap is applied over the tapering tip of each syringe. The syringe absorbs very little irradiation, eliminates air from the irradiation chamber, and permits the introduction of various substances to be tested during irradiation. The syringes may be sterilized in an autoclave. Accurate sampling of specimens after intervals of irradiation without changing the depth of the medium is also a desirable feature. A Plexiglas holder<sup>4</sup> measuring  $11.5 \times 8.5 \times 2.5$  cm. was designed to hold four syringes, all of which could be irradiated at the same time. The syringe-chamber method is thus ideal for the study of lethality of x-rays in *Paramecium* and should prove to be useful for similar studies with other microorganisms. Before sampling and immediately after irradiation, the syringe was quickly rotated between the fingers of both hands in order to distribute the paramecia uniformly. Usually 100 specimens in two cc. of fluid were placed in each syringe and irradiated in steps of 20,000–50,000 r. By expressing 0.2 cc. of irradiated fluid after a given dosage, it was possible to deliver into sterile Pyrex spot plates a precisely countable number of specimens—commonly ten—for the establishment of survival curves. Animals were examined immediately after irradiation, then placed in moist chambers for subsequent observation.

## RESULTS AND DISCUSSION

Irradiation with x-rays markedly increases the viscosity of the protoplasm of *Paramecium caudatum*; greater dosages lead to irreversible coagulation. Prior to

<sup>4</sup>The Plexiglas syringe holder with self-contained ice chambers was constructed by Mr. Michael Troisi, Instrument Maker, Temple University.

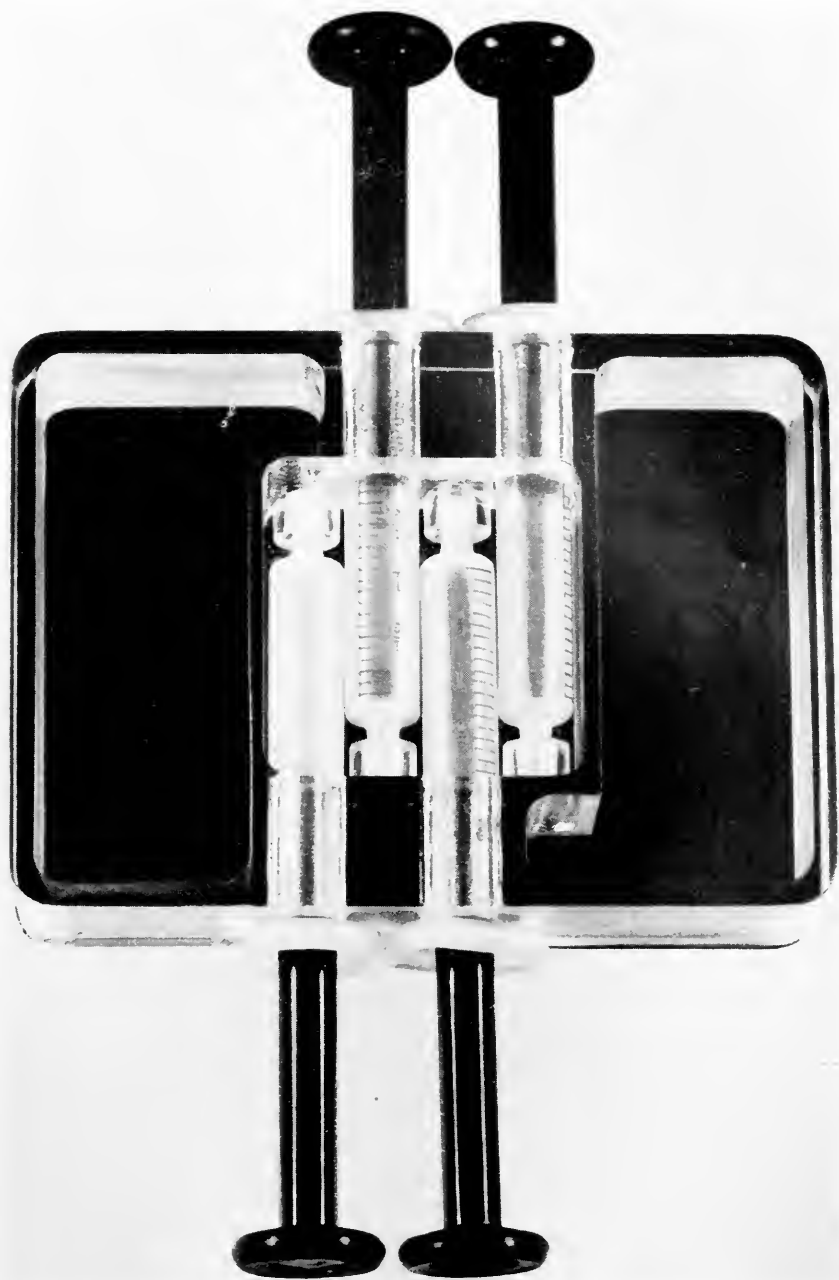

FIGURE 2. Photograph showing four 2-cc. Nylon syringes (with Lucite caps in place) being used as irradiation chambers. An ice well is present on each side of the syringe holder. (Slightly less than actual size.)

death, paramecia become immobilized, change shape to become broadly ellipsoidal and settle on the bottom of the irradiation chamber. Contractile vacuoles function more slowly and sometimes become abnormally large. Active cyclosis ceases as the protoplasm becomes conspicuously darker and vacuolated. Clear, transparent, structureless, blister-like swellings appear on the pellicle prior to death. Near death, waves of trichocysts are extruded, suggesting that these structures—commonly thought of as organelles of defense—represent a response to an injury reaction. Specimens frequently become sub-spherical before their disintegration (Fig. 3).

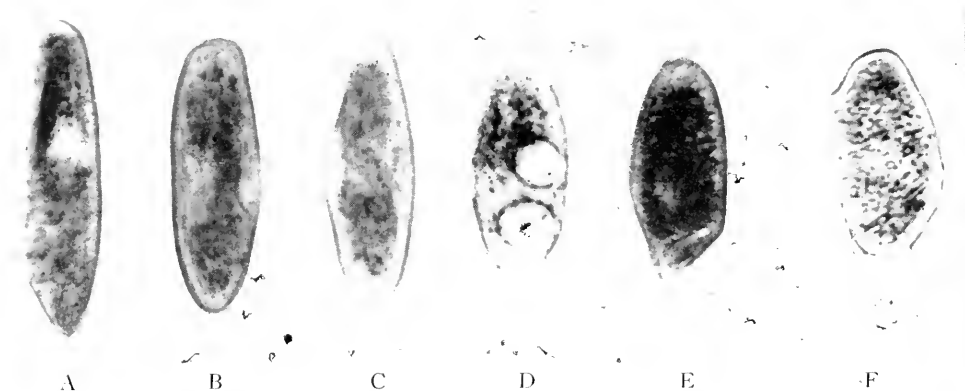

FIGURE 3. Effects of high dosage x-radiation on *Paramecium caudatum* ( $\times 190$ ). A: Unirradiated control specimen. B: Irradiated with 255,000 r resulting in slight change of body shape; animals generally recover from this dosage. C: Irradiated with 340,000 r (approximately the LD 50 dosage) in which locomotion and cyclosis are retarded. D: Irradiated with 425,000 r in which body shape becomes broadly ellipsoidal; greatly decreased locomotion; vacuolization. E and F: Irradiated with 510,000 r resulting in cessation of locomotion and cyclosis, increased vacuolization, blistering of pellicle, darkening (coagulation) of protoplasm followed by disintegration and death. (Photographs taken of specimens irradiated in Nylon syringes immediately after removal from x-ray generator.)

Our data are based on specimens observed for at least 24 hours after irradiation, commonly longer. The survival curves based upon this method are sigmoid as is the case with most irradiated biological material. Occasionally the slope of the curve is so steep approaching lethality as to be almost vertical. For a 24-hour period, the LD 50 for *Paramecium caudatum* is approximately 340,000 r (Fig. 4). It was soon found that the I. L. D. (immediate lethal dose), as defined by Back and Halberstaedter (1945)—that dosage which produced a complete cessation of motility within 10–15 minutes after irradiation—was not reliable as a useful endpoint. We have found that such immobilized paramecia may appear to be dead, but if examined hours later may be seen to be not only as active as control specimens but may eventually divide and produce successful clones. However, it is of interest to note that Back and Halberstaedter report the I. L. D. to be approximately 350,000 r, a dosage close to our results when using the syringe method.

The results showing percentage survival after irradiating paramecia in drops and larger volumes of fluid in plastic boxes (Fig. 1) and in Nylon syringes are

TABLE I

*Survival of Paramecium caudatum after roentgen irradiation  
in plastic boxes and nylon syringes  
Influence of the degree of exposure of animals and culture medium  
to air during irradiation*

Type of chamber	No. of dosage groups	No. of animals observed	Per cent survival dosage in kr.									
			85	128	170	212	255	300	340	383	425	510
Paramecia in hanging drops in 6-cc. plastic boxes containing 1 cc. of culture fluid	4	55			0	0	0	0	0	0		
	12	260			0	0	0	0	0	0		
	12	140			5		0		0			
Paramecia in 1 cc. of culture fluid in bottom of plastic boxes with cover (volume 6 cc.)	10	1000	100									
	4	400			100			0				
	12	335	100		100		0		0		0	0
Paramecia in 1-2 cc. of culture fluid in Nylon syringe (no air bubbles)	36	1335	100	100	95	94	81	57	44	19	2	0

given in Table I. From this tabulation, it may be seen that the paramecia in hanging drops in plastic boxes were much more sensitive to roentgen radiation than the paramecia in the one cc. of culture fluid placed in the bottoms of the plastic boxes (Fig. 1, A). Dosages of 170 kr. killed nearly all of the paramecia in the drops whereas such dosages failed to kill any of the paramecia in the one cc. of fluid in the bottom of the plastic boxes. In most instances, the paramecia placed in hanging drops in the covers of the plastic boxes and the paramecia in the culture fluid in the bottom of the boxes were irradiated simultaneously. Variations in the concentration of paramecia in the drops and in the culture fluid in the bottom of the box did not alter this great difference in radiation sensitivity between drop and culture fluid in the bottom of the box. The only essential difference between these two conditions was the difference in the relative amount of surface exposed to air in the chambers.

It was also quite apparent that even the paramecia in the culture fluid in the bottom of the boxes succumb to the radiation in an almost "all or none" manner. When a dose of 170-200 kr. was exceeded, all paramecia died; in lower dosages, all lived. Some experiments were performed in which the influence of the depth (volume) of the culture medium was tested, since it was thought that variations in culture medium might have been responsible for an x-ray filtration effect. This did not appear to be the reason, however, for the differential sensitivity in drops, as compared with sensitivity in larger volumes of culture fluid. In some experiments, drops with 5-20 paramecia were placed in plastic boxes and one cc. of culture fluid containing 100 paramecia was placed in inverted lids above and below the plastic box chamber containing the drops (Fig. 1, B). The two cc. of culture fluid in the lids thus partially shielded the paramecia in the drops in the boxes. In other similar boxes containing drops with 5 and 20 paramecia per drop, the one

cc. of culture medium above and below was omitted (Fig. 1, C). Both sets of boxes were irradiated with 170 kr. This dose killed all of the paramecia in the drops in both boxes. All of the paramecia in the one cc. of culture fluid in the inverted lids survived. In the case of the paramecia in the inverted lid on top of the box (uncovered and exposed to the atmospheric oxygen at the surface of the culture medium), survival was 100 per cent. Thus it was apparent that all the paramecia in the drops in the plastic container were killed even though they were partially shielded by two cc. of culture fluid (one cc. above and one cc. below).

Because of this differential sensitivity resulting from differences in the degree of exposure of the culture medium to air, the plastic boxes and hanging drops were abandoned and the Nylon syringes were utilized as x-radiation chambers for the reasons given earlier. The irradiation of paramecia in the syringes (which contained no air bubbles) yielded results that were much more uniform. Using the syringe method, the results of seven experiments involving nine different dosage groups and 36 determinations are shown in Table I and the survival curve of Figure 4. In the Nylon syringes, most of the paramecia survived a dose of 170–212 kr. (lethality = 5–6 per cent). As this dosage is exceeded, however, the per cent of animals that survive 24 hours after irradiation takes a sharp drop. Generally no animals survived a 510 kr. dose.

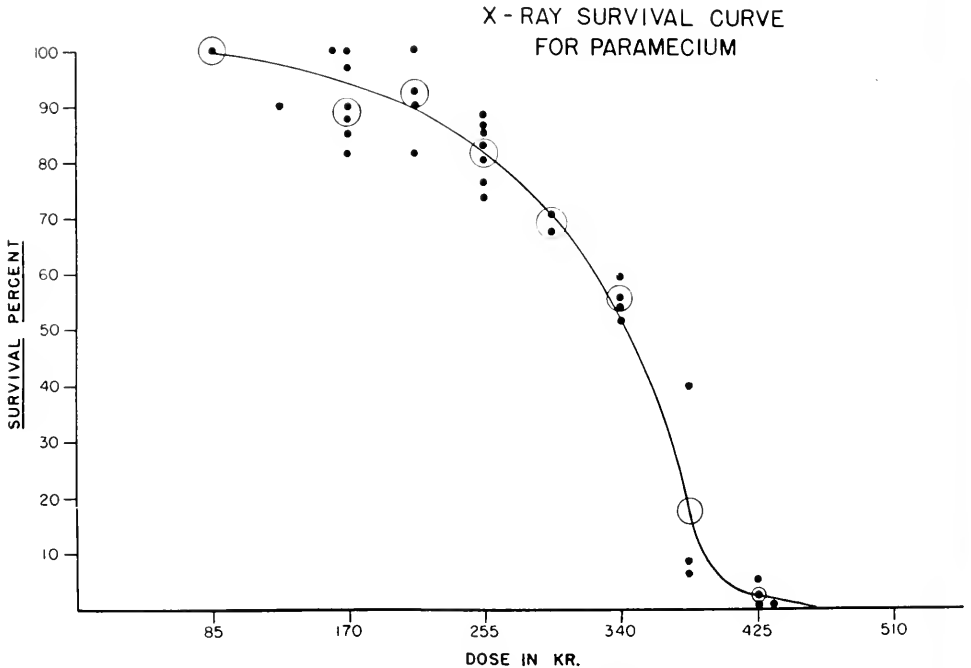

FIGURE 4. X-ray survival curve for *Paramecium caudatum* irradiated in Nylon syringes. This curve is based on seven experiments and after irradiated paramecia were observed for 24-hour period after expulsion from Nylon syringes. Coincident points are not indicated. Each point represents observations on 10–25 counted paramecia.



## LETHALITY OF ROENTGEN RADIATION IN PARAMECIA

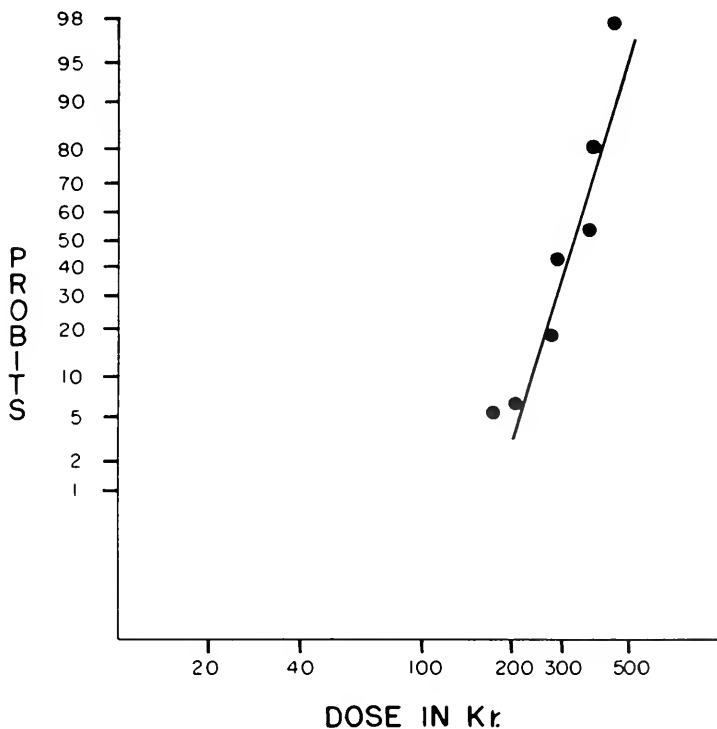

FIGURE 5. Dosage-effect curve for lethality of roentgen radiation in *Paramecium caudatum*. Results were recorded on probability paper for plotting percentages directly on a probit scale.

The data for the per cent survival after irradiation in Nylon syringes were also plotted on log-probit paper (Fig. 5). The significance of such a curve to assist in the analysis of data concerned with all-or-none responses is described by Bliss (1952). From this curve, it may be seen that while there was not a straight line relationship at the higher and lower percentages, one was present in the important range between 10 and 90 per cent. From an examination of this curve, it may be concluded that the LD 50, 24 hours, for *Paramecium caudatum* irradiated in Nylon syringes is approximately 340 kr.

From the experiments with plastic boxes, it was concluded that the number of paramecia per unit of volume was not as important in determining the lethal effects of x-radiation as the depth of the exposed culture medium, volume of the moist air-space, and the amount of surface of the culture medium exposed to the air in the irradiation chamber. This gave rise to the hypothesis that some toxic gaseous substance, possibly ozone (Taylor, 1935) was diffusing into the fluid from the irradiated moist air-space of the chamber. However, we were unable to detect ozone formation in the irradiated air of the chamber, even with the most sensitive tests. The toxic factor derived in whole or in part from the moist air in the closed boxes

during irradiation is probably oxygen or a derivative of oxygen, hydrogen peroxide or some other oxidation product.

When sealed Nylon chambers of air are irradiated with 400 kr. and unirradiated paramecia then drawn into such chambers without outside air being permitted to enter, the paramecia live for as long a period of time as the controls. This shows conclusively that the irradiated air by itself is not toxic to the animals. Also when unirradiated paramecia are placed in irradiated fluid (400 kr.) exposed and not exposed to air, and in irradiated mixtures of air and culture fluid, paramecia are not killed.

It has been known for a long time that water exposed to ionizing radiations forms hydrogen peroxide which may be lethal to ciliates (Taylor, Thomas and Brown, 1933). This does not hold for oxygen-free pure water in which no hydrogen peroxide can be demonstrated even photocolometrically (sensitivity 0.1  $\mu$  per ml.) (Bonét-Maury, 1951). In irradiation chambers containing clear culture fluid with bacterized paramecia, minute amounts of the enzyme catalase originate from the microorganisms and tend to offset the toxic effect of hydrogen peroxide. According to Dale (1951), one molecule of catalase can decompose 5,000,000 molecules of hydrogen peroxide per minute at 0° C. Kimball and Gaither (1952, 1953), using *Paramecium aurelia*, report that hydrogen peroxide is of major importance in the production of certain kinds of nongenetic effects but only under certain circumstances.

A study of the biological effects of ionizing radiations upon *Paramecium* must take into account the effect of these radiations on the environment in which these organisms live. The culture fluid in which the specimens are irradiated consists mainly of water with organic matter from the hay or lettuce infusions. A great body of literature demonstrates that as a result of irradiation of water, hydrogen peroxide, hydrogen and oxygen are formed in which the amounts and relative proportions depend upon such factors as dissolved oxygen concentration, radiation ionic density, dose, temperature and pH. Water that is irradiated oxidizes reducing agents and reduces oxidizing agents (Bonét-Maury, 1951).

In the irradiation of paramecia, another factor that plays a part besides the effect of ionizing radiations of water on the cell is the effect of the accompanying x-rayed bacteria present in the culture as the food source. Experiments in which the irradiated bacteria of paramecia cultures were plated out at intervals up to 350 kr. show the bacteria to have a far lower LD 50 than the paramecia. Another factor to take into account is the indirect or direct effect of radiations of the dead bacteria and their fragmented cells upon paramecia. The experiments with bacteria also showed the necessity of bacterizing spot plates containing irradiated paramecia and fluid if one is to make observations over long periods of time. Failure to do this will result in slower division rates; perhaps ultimate starvation of the paramecia in irradiated paramecia samples.

#### SUMMARY

1. Irradiation with x-rays markedly increases the viscosity of the protoplasm of *Paramecium caudatum*; greater dosages lead to irreversible coagulation. With increased irradiation, paramecia become immobilized, become broadly ellipsoidal and settle on the bottom of the irradiation chambers. Contractile vacuoles function

more slowly and occasionally become abnormally large. Prior to death, cyclosis ceases and the protoplasm becomes darker and vacuolated. Clear, blister-like swellings appear at the pellicle. Before death, waves of trichocysts are extruded suggesting that their function may represent an injury-reaction. Finally, paramecia frequently become sub-spherical before their disintegration.

2. It was found that one of the most important factors influencing the lethal effects of x-radiation was the degree and extent of exposure of the fluid containing paramecia to air. Paramecia in hanging drops were killed by dosages (170 kr.) that exhibited no lethality for paramecia in larger volumes of culture fluid. This difference in lethality occurred even though the numbers of paramecia per unit volume were kept uniform in both drops and larger volumes.

3. A new method using Nylon syringes was devised to minimize the variability of x-radiation effects.

4. Survival curves were established for *Paramecium caudatum* using this new method. It was found that the LD 50, 24 hours was approximately 340 kr.

#### LITERATURE CITED

- BACK, A., AND L. HALBERSTAEDTER, 1945. Influence of biological factors on the form of Roentgen-ray survival curves. *Amer. J. Roentgenol.*, **54**: 290-295.
- BLISS, C. I., 1952. The statistics of bioassay. Academic Press Inc., New York. Pp. 445-628.
- BONÉT-MAURY, P., 1951. Hydrogen peroxide formation in water exposed to ionizing radiations. *Brit. J. Radiol.*, **24**: 422-428.
- BONHAM, K., AND R. F. PALUMBO, 1951. Effects of x-rays on snails, crustacea and algae. *Growth*, **15**: 155-188.
- CURTIS, H. J., 1951. Advances in biological and medical physics. Academic Press Inc., New York. Volume 2, pp. 1-50.
- DALE, W. M., 1951. Some aspects of the biochemical effects of ionizing radiations. *Brit. J. Radiol.*, **24**: 433-435.
- KIMBALL, R. F., AND N. GAITHER, 1952. Role of externally produced hydrogen peroxide in damage to *Paramecium aurelia* by x-rays. *Proc. Soc. Exp. Biol. Med.*, **80**: 525-529.
- KIMBALL, R. F., AND N. GAITHER, 1953. Influence of oxygen upon genetic and nongenetic effects of ionizing radiation on *Paramecium aurelia*. *Proc. Soc. Exp. Biol. Med.*, **82**: 471-477.
- LEA, D. E., 1947. Actions of radiations on living cells. The Macmillan Co., New York. Pp. 1-402.
- NICKSON, J. J., 1952. Symposium on radiobiology. John Wiley and Sons, Inc., New York. Pp. 1-465.
- SPARROW, A. H., AND B. A. RUBIN, 1952. Survey of biological progress: Effects of radiation on biological systems. Academic Press Inc., New York. Volume 2, pp. 1-43.
- TAYLOR, C. V., 1935. The effects of x-rayed medium on living cells. Estratto dagli Atti del I Congresso Internazionale di Elettro-radio-biologia. Vol. II.
- TAYLOR, C. V., J. O. THOMAS AND M. G. BROWN, 1933. Studies on Protozoa, IV: Lethal effects of the x-radiation of a sterile culture medium for *Colpidium campyllum*. *Physiol. Zool.*, **6**: 467-492.
- WICHTERMAN, R., 1948. The biological effects of x-rays on mating types and conjugation of *Paramecium bursaria*. *Biol. Bull.*, **94**: 113-127.
- WICHTERMAN, R., 1953. The biology of *Paramecium*. The Blakiston Company, Inc., New York. Pp. 1-527.

### ERRATUM

In the paper by John R. Gregg and Norma Ornstein on "Explant systems and the reactions of gastrulating amphibians to metabolic poisons," which appeared in the December, 1953 issue of THE BIOLOGICAL BULLETIN (Volume 105, No. 3), paragraph (3) on page 476 should read as follows:

"(3) Among the inhibitors that we have studied, sodium barbital is unique in suppressing all three of Em (en, en), St (m, en) and Sp (ec, en), but in allowing Fu (m, ec, en) to occur to some extent. The precise embryological interest of this result is not clear."

# THE BIOLOGICAL BULLETIN

PUBLISHED BY THE MARINE BIOLOGICAL LABORATORY

---

## EFFECT OF ADENOSINETRIPHOSPHATE (ATP) ON THE ENDOGENOUS OXYGEN UPTAKE OF DEVELOPING GRASSHOPPER EMBRYOS<sup>1</sup>

JOSEPH HALL BODINE AND WILLIAM LIONEL WEST

*Zoological Laboratory, State University of Iowa, Iowa City, Iowa*

A phosphate transfer system has been found in practically every tissue thus far investigated (Lardy, 1949). It functions directly or indirectly in almost every phase of metabolism and has become so well established that its presence and functions are very often inferred without further demonstration. Previous studies in this laboratory have revealed that homogenates of the embryos of the grasshopper, *Melanoplus differentialis*, in 0.25 M sucrose can oxidize hexose phosphates to a greater extent than glucose (Bodine and West, 1953). Bodine and Thompson (1938) reported that labile phosphate is found in both the embryo and yolk while Lu and Bodine (1953) found a gross transformation of phosphorus from yolk to embryo. However, very few direct observations seem to have been made on the chemical or functional nature of the phosphate transfer system in developing organisms. Recently Albaum and Kletzkina (1948) and Calaby (1951) confirmed the presence of ATP in insects. Humphrey and Siggins (1949) presented indirect evidence that glycolysis in insect muscle involves the phosphate transfer system while Sacktor (1953) describes a specific ATPase in flight muscle mitochondria.

The present paper is concerned with results of a study on the effects of ATP on the endogenous O<sub>2</sub> uptake of grasshopper embryos at different developmental stages. These results are discussed in the light of a functional phosphate transfer system as exhibited by other organisms.

### MATERIALS AND METHODS

Embryos of the grasshopper, *Melanoplus differentialis*, were dissected from eggs in Ringer solution (buffered at pH 6.8 with M/15 phosphate) and washed free of adhering yolk (Bodine and Boell, 1934, 1936). The washed embryos, suspended in a suitable volume of the selected medium, were homogenized using a Pyrex glass tube with a tight fitting selenite rod as a pestle. The pestle rotated at 1150 r.p.m. and the time of homogenation was two and one-half minutes at 0° C.

Two suspension media were used, Ringer solution containing 0.0035 M mag-

<sup>1</sup> Aided by a grant from the National Institutes of Health.

nesium chloride (pH 6.8) and 0.25 *M* sucrose containing 0.0035 *M* magnesium and 0.0035 *M* calcium chlorides and 0.03 *M* phosphate (pH 6.8) (Bodine and West, 1953). One hundred intact embryos or homogenates containing the equivalent of one hundred embryos per cubic centimeter were used throughout this investigation.

Oxygen uptake determinations (air as gas phase) were carried out by standard Warburg techniques at 25° C.; 0.5 cc. of substrate were tipped from the sidearm to make the final volume of the reactants 1.5 cc.

Adenosinetriphosphate (ATP) (sodium salt) was obtained from the Sigma Chemical Company, St. Louis, Missouri.

## RESULTS

The effect of ATP on the endogenous O<sub>2</sub> uptake of intact embryos (mitotically active or blocked) was investigated over a range of concentrations from 2.5 to 10.0  $\mu$ moles per 1.5 cc. Data for a typical experiment are summarized in Table I. From an examination of this table it is apparent that ATP has little, if any, sig-

TABLE I

	Prediapause (17 days)		Diapause (40 days)		Postdiapause (3 days)	
	E	H	E	H	E	H
Control (sucrose)	17.0	5.7	10.0	4.6	17.4	5.9
ATP	16.0	9.4	9.3	6.5	16.5	13.3
ATP+glu	15.0	10.2	9.1	8.0	16.7	14.3
ATP+glu-1-PO <sub>4</sub>	19.6	13.2	14.2	9.7	18.2	13.6
Glucose-1-PO <sub>4</sub>	18.8	8.5	15.2	6.5	18.5	9.0

Shows O<sub>2</sub> uptake (cc.) for 100 minutes for prediapause, diapause and postdiapause embryos (E) and their homogenates (H) in 0.25 *M* sucrose plus Mg<sup>++</sup> and Ca<sup>++</sup> after addition of ATP, 5  $\mu$ moles per flask; glucose 1.0%; glucose-1-phosphate 0.5%. Stimulation due to hexosephosphate has previously been pointed out (Bodine and West, 1953). Data in table are taken from one series of experiments and represent averages from a minimum of 8 determinations. All data from different experiments have been statistically analyzed and differences, indicated in text, found to be significant.

nificant stimulating effect on the respiration of intact embryos either in 0.25 *M* sucrose or Ringer solution. This lack of effect may be related to or conditioned by the permeability of the intact embryo to these reagents.

The effect of ATP on the endogenous O<sub>2</sub> uptake of homogenates of embryos in 0.25 *M* sucrose is strikingly different from that of the intact embryo. ATP augmented the endogenous respiration of homogenates in sucrose (Table I). The concentration effect was found to be quite variable at high concentrations and this is attributed to the formation of clumps which entangled the mitochondrial elements, thus preventing or interfering with electron transfers. This clumping effect was more apparent in diapause and postdiapause stages at the 10  $\mu$ mole level of ATP. Clumping is believed to be caused by an involvement of embryonic actin, myosin, and ATP and is given support by the observation that clumping seldom occurred in the prediapause stages before 17 days at which time the percentage

stimulations were more consistent. Maximal augmentation of respiration was obtained at the 5  $\mu$ mole level where the clumping effects were absent. This concentration has been selected as optimal in these experiments. ATP, when tipped from the sidearm, produces a lag before maximum augmentation of oxygen uptake. Homogenates made in 0.25 *M* sucrose plus ATP (employed only for diapause) showed a greater oxygen uptake than when ATP was added to the sucrose homogenate. The magnesium ion was necessary for maximal stimulation by ATP.

Homogenates made in Ringer and  $Mg^{++}$  showed no stimulation of endogenous oxygen uptake when ATP was added.

Combinations of ATP and glucose produced no marked hexokinase activity in either the intact embryo or its homogenate. Similarly, no marked phosphoglucokinase activity was apparent.

Washed nuclei in sucrose or Ringer showed no response in their endogenous oxygen uptake to these concentrations of ATP.

#### DISCUSSION

The exact nature of the labile phosphorus compounds of the phosphate transfer system in this material has not yet been satisfactorily demonstrated, due largely to various inherent technical difficulties. However, it is known that the labile phosphorus component of the embryo is adsorbed on activated charcoal (method of Crane and Lipmann, 1953), which is a characteristic of the adenosine-containing nucleotides (unpublished data). The ability of hexosephosphates to stimulate endogenous respiration of intact embryos is quite unusual and no active mechanism has been revealed (Bodine and West, 1953). ATP, unlike the hexosephosphates, seems to have no stimulating effect on the endogenous respiration of the intact embryo (mitotically active or blocked). Similarly, glucose plus ATP gave no increased endogenous  $O_2$  uptake, indicating no marked hexokinase activity at or near the cell membrane.

ATP markedly stimulates endogenous respiration of the homogenates in 0.25 *M* sucrose ( $Mg^{++}$ ,  $Ca^{++}$ ) and thus one can infer a functional phosphate transfer mechanism. This effect may take place through "active" phosphorylation of endogenous substrates, making them more available for oxidation, or "active" dephosphorylation by a specific ATPase, increasing the concentration of high energy phosphate acceptors (ADP + AMP) and permitting the oxidation of available endogenous substrates or a combination of both. (This discussion presupposes that oxidation and phosphorylation are linked.) Studies are in progress to clarify this point.

ATP does not stimulate the endogenous respiration of Ringer homogenates. The mitochondria lose their morphological integrity in this medium and show a marked functional difference to added succinate and hexosephosphates. Thus structural integrity of the mitochondria in this material seems related to their functions.

Combinations of glucose or hexosephosphates with ATP in sucrose homogenates yield variable results. No effort was made to remove the endogenous substrate, and at present it can be said that there appears to be no marked hexokinase or phosphohexokinase activity in this material.

## SUMMARY

1. A study has been made on the effects of ATP on the endogenous O<sub>2</sub> uptake of grasshopper embryos and homogenates at different developmental stages.
2. ATP has little, if any, effect upon the O<sub>2</sub> uptake of the intact embryo.
3. ATP augments the O<sub>2</sub> uptake of homogenates in sucrose.
4. The magnesium ion is necessary for maximal stimulation of ATP.

## LITERATURE CITED

- ALBAUM, H., AND M. KLETZKIN, 1948. Adenosinetriphosphate from *Drosophila melanogaster*. *Arch. Biochem.*, **16**: 333-337.
- BODINE, J. H., AND E. J. BOELL, 1934. Respiratory mechanisms of normally developing and blocked embryonic cells. *J. Cell. Comp. Physiol.*, **8**: 357-366.
- BODINE, J. H., AND E. J. BOELL, 1936. Respiration of embryo versus egg. *J. Cell. Comp. Physiol.*, **8**: 357-366.
- BODINE, J. H., AND V. THOMPSON, 1938. Phosphorus distribution in the grasshopper egg. *J. Cell. Comp. Physiol.*, **12**: 247-254.
- BODINE, J. H., AND W. L. WEST, 1953. Carbohydrate metabolism of the developing egg and embryo. *Biol. Bull.*, **104**: 1-11.
- CALABY, J. H., 1951. Adenosinetriphosphate from insect muscle. *Arch. Biochem. Biophysics*, **31**: 294-299.
- CRANE, ROBERT K., AND FRITZ LIPMANN, 1953. The effect of arsenate on aerobic phosphorylation. *J. Biol. Chem.*, **201**: 235-243.
- HUMPHREY, G. F., AND LORRAINE SIGGINS, 1949. Glycolysis in the wing muscle of the grasshopper, *Locusta migratoria*. *Australian J. Exper. Biol. Med. Sci.*, **27**: 353-359.
- LARDY, H. A., Ed., 1949. Respiratory enzymes. Burgess Publishing Company, Minneapolis.
- LU, KIAO-HUNG, AND J. H. BODINE, 1953. Changes in the distribution of phosphorus in the developing grasshopper (*Melanoplus differentialis*) embryo. *Physiol. Zool.*, **26**: 242-254.
- SACKTOR, BERTRAM, 1953. Investigation on the mitochondria of the house fly, *Musca domestica* L. *J. Gen. Physiol.*, **36**: 371-387.



# NUTRITIONAL STUDIES ON THE AMOEBO-FLAGELLATE, TETRAMITUS ROSTRATUS<sup>1</sup>

MORGAN M. BRENT<sup>2</sup>

*Department of Zoology, University of California, Berkeley 4, California*

Nutritional studies on amoebae have lagged far behind those on ciliates and flagellates. The earliest controlled work on the nutrition of members of the Sarcodina concerned the cultivation of single species of amoebae in the presence of bacterial mixtures. Here, most emphasis was placed upon the culture medium itself, the living bacteria being considered as obligate factors for growth of the phagotrophic forms. Scattered reports of axenic (Dougherty, 1953) cultures of amoebae have been recorded in the literature, but the earliest accounts have not been corroborated by other investigators. Included in these is the reported cultivation of some amoebae *in vitro* on sterile mammalian tissues by Williams (1911). She believed that these amoebae were parasites, but this is doubtful in the light of present research upon known parasitic forms. Oehler (1924) claims to have grown several unknown species of free-living amoebae under axenic conditions upon water-agar containing coagulated serum. As far as is known this work has not been re-investigated.

One of the first species to be grown free of living bacteria and which can be obtained today is the free-living amoeba, *Acanthamoeba castellanii*. Castellani (1930) found that this amoeba was capable of growing upon a killed bacterium and dead yeast. Cailleau (1933b) succeeded in obtaining an entirely liquid medium for *A. castellanii* consisting of peptone and added salts. This has been modified somewhat by Storm, Hunter and Cowperthwaite (1951) who grew the amoeba upon a medium containing acid-hydrolysate of gelatin and a low concentration of skim milk. The same authors (1951) have also reported growth of *Hartmannella rhysodes* upon an autoclavable liquid medium containing hydrolysates of gelatin and free oleate esters.

Reich (1935) reported axenic cultivation of the soil amoeba, *Mayorella palestinensis*, upon a clear medium consisting of peptone, a balanced salt solution, and added dextrose. The latter component appeared indispensable for good growth.

On the other hand, many investigators have failed to grow amoebae axenically. Among these is Wherry (1913) who, in preliminary experiments, could not succeed in growing an amoeboid-flagellate (probably *Naegleria gruberi*) free of the bacterial flora. Rice (1935) succeeded in growing the marine amoeba, *Flabellula mira*, in monobacterial cultures, but failed to cultivate this form axenically by adding either killed bacteria or various amino acids to the basal medium.

<sup>1</sup> A portion of a dissertation presented to the graduate school of Northwestern University in partial fulfillment of the requirements for the Ph.D. degree in biology. The author wishes to express his appreciation to Dr. William Balamuth for his helpful suggestions and interest during the course of this investigation.

<sup>2</sup> Present address: Department of Zoology, University of California, Berkeley, California.

Although a few of the parasitic flagellates have been cultured axenically *in vitro*, the nutrition of the parasitic amoebae has provided a more difficult problem. In the case of *Entamoeba histolytica*, the amoebae apparently require not only certain metabolites provided by the basal medium but also an anaerobic environment mediated by the associated bacteria (Snyder and Meleney, 1943), as well as the bacterial bodies themselves (Shaffer, 1952). As far as is known at present, *E. histolytica* has not been grown *in vitro* free of the influence of living protoplasm (other Protozoa, bacteria, embryonic tissue cultures).

As one approach to the nutrition of the parasitic amoebae it seemed desirable to investigate a free-living coprophilic form, since these Protozoa pass sporadically through the lower digestive tract of various animals. Although sharing the same environment as intestinal parasites in this respect, they seem to be incidental guests of their hosts and might conceivably stand at the threshold of parasitism. Little work has been done on the amoeba-flagellate, *Tetramitus rostratus*, apart from morphological and cytological studies. According to most investigators this organism is a coprophile which actively feeds and multiplies in its trophic stages upon substrates rich in organic material. It has also been found in fecal cultures of various animals by Bunting (1922) and Rafalko (1951). In view of these facts this organism provided an excellent opportunity for a nutritional investigation which might link free-living and parasitic forms.

#### MATERIALS AND METHODS

The strain of *Tetramitus* used in this investigation was obtained in December, 1950 by Dr. William Balamuth from Miss Lois Norman at the Communicable Disease Center in Chamblee, Georgia. It had been found in a "sterile" urine specimen in Austin, Texas in the same year. Routine cultures of the wild stock were maintained at room temperature upon a medium consisting of 0.5% Difco yeast extract plus 0.5% Difco peptone (YP) made up in distilled water. The diphasic nature of this organism was first demonstrated by Bunting (1922, 1926), who pointed out a reversible amoeba-to-flagellate transformation in its life cycle. Although both stages of the present strain appeared in the bacterized maintenance broth only the amoeboid form was present on solid agar-containing media or under axenic conditions.

#### *Handling of cultures*

In order to obtain large numbers of bacteria-free amoebae for use in nutritional studies it was thought advisable to establish the trophozoites in a two-membered culture with a penicillin-sensitive bacterium. Washed cysts from the wild stock of *Tetramitus* were first sterilized by a series of chemical procedures. These included successive treatment at 23° C. with 1:50,000 HgCl<sub>2</sub> for one hour and with 1:5000 KMnO<sub>4</sub> for 30 minutes. The cysts were then implanted into a tube of YP broth containing *Micrococcus pyogenes* var. *aureus*. Bacteria-free amoebae could be obtained from this culture by inoculating 6- to 14-day-old trophozoites onto plates of YP medium containing 1.5% agar plus 500 units/ml. of penicillin and incubating them for 3 days at room temperature. Their sterility was routinely tested by

inoculating them into Difco fluid thioglycollate medium and Difco stock culture agar (SCA).

In assaying prepared media the general plan was as follows: Penicillin-treated amoebae were gently flushed off the agar surface with sterile tap water and pooled in a test tube. The organisms were inoculated in 0.1-ml. amounts into  $150 \times 18$  mm. cotton-stoppered tubes containing 5 ml. of sterile test broth. The viability of the treated amoebae used in each experiment was tested by inoculating them into broth containing living bacteria. All cultures were incubated in a moist chamber at 30° C. in a slanting position and observed at regular 2- to 4-day intervals for as long as 10 to 14 days. Transplants were made in approximately 0.2-ml. amounts. In order to eliminate carry-overs consideration was given only to the fourth sub-culture when evaluating positive results. Positive cultures were always re-checked for bacterial sterility in fluid thioglycollate medium and SCA.

As required in population runs, amoebae from broth cultures were counted upon four hemocytometer fields and the results averaged.

#### *Preparation of media*

In axenic assays, initial experiments were designed to modify the concentration of components of the original YP medium. In some cases substitution for the yeast extract was made with Anheuser-Busch autolyzed or pepsin-digested yeast. Protein digests including BBL trypticase, BBL phytone, Difco proteose-peptone and Difco tryptone in concentrations from 0.1% to 3.0% were substituted for the peptone fraction. More complex media involved the addition of Cerophyl (dehydrated cereal grass leaves), liver extract, cream, whole egg, blood and selected vitamins to the basic YP medium in varying concentrations.

A review of the literature suggested types of media which have been used to grow Protozoa axenically. Pressed-yeast juice was prepared according to the method of Johnson and Baker (1942), in which they cultivated *Paramecium multimicronucleatum*. Variations of their medium, sterilized by Sela filtration, consisted of adding the concentrated juice to distilled water in amounts ranging from 3.0% to 50.0% in approximately two-fold concentrations. Cailleau (1933a, 1933b) reported growth of *A. castellanii* upon two kinds of media. Her first medium (1933a) and variations of her later medium (1933b) were tried. Trypticase, phytone and peptone in concentrations from 1.0% to 3.0% were substituted for the peptone fraction in her newer medium. Reich's medium (1935) for *M. palestinensis* was also utilized in the screening procedures.

All media except Johnson's and Baker's pressed-yeast juice were sterilized by autoclaving for 20 minutes at 15 pounds pressure. The hydrogen-ion concentrations were not critically controlled but were adjusted when possible to approximate neutrality.

Various species of dead bacteria were utilized as a food source in many of the experiments. The organisms were grown upon YP agar in large petri dishes for 24 to 48 hours. After maximum growth was obtained the cells were scraped off the plates, suspended in tubes of distilled water and autoclaved for 30 minutes at 15 pounds pressure.

*Preparation of bacterial hydrolysates and extracts*

It later became evident that certain substances present in the dead bacterial cells (particularly in *Bacillus cereus* and *B. subtilis*) were required for growth of the amoebae. The *B. cereus* cells were fractionated in the following manner: Thirty grams of freshly harvested bacteria were added to an equal weight of alumina and the aggregate ground by hand with dry ice. One hundred and sixty milliliters of distilled water were added to the crushed cells and the alumina centrifuged out. The suspended cells were divided among three beakers in equal amounts and enough 1 N HCl and 1 N NaOH added separately to two of the containers to make 0.1 N solutions of acid and base, respectively. The contents of the third beaker were adjusted to pH 7.00. All three of the vessels were autoclaved for 30 minutes at 15 pounds pressure yielding acid-, alkaline-, and neutral-hydrolyzed fractions. The contents from each beaker were then divided into two parts:

(a) One-half of the cell suspension from each beaker was subjected to dialysis through a Visking casing for 28 hours at 4° C. in liter beakers with four changes of cold distilled water. The dialysates were discarded for the purposes of these experiments. After dialysis the pH of the three non-dialyzable<sup>3</sup> fractions containing the cell-residues was adjusted to neutrality. The cell-residues were collected and washed and the non-dialyzable supernatants concentrated to 5 ml. by boiling.

(b) The pH of the remaining non-dialyzed acid, alkaline and neutral fractions was also adjusted to neutrality; the cell-residues were collected and the non-dialyzed supernatants concentrated in a similar manner.

All fractions were then re-autoclaved and stored at 4° C.

In later investigations it became necessary to extract the fat-soluble fractions of the neutral-hydrolyzed non-dialyzed supernatants with various fat solvents. This was accomplished by shaking each supernatant with an equal volume of solvent, collecting the latter and repeating the procedure several times. The solvent was evaporated to dryness and the sediment brought up to the original volume with distilled water. Before extracting with alcohol or acetone it was first necessary to evaporate the supernatants to dryness; the insoluble materials were then centrifuged out.

*Vitamins, purines, pyrimidines and amino acids*

In experiments requiring special nutrients, mixtures of vitamins, purines, pyrimidines and amino acids were added in place of certain bacterial fractions. A stock solution of vitamins was prepared consisting of 50 mg. each of choline·HCl, folic acid, inositol, nicotinic acid, paramino-benzoic acid, calcium pantothenate, pyridoxine·HCl, riboflavine, thiamine·HCl and 25  $\mu$ g of biotin. The purine-pyrimidine mixture consisted of 50 mg. each of adenine sulfate, cytidylic acid, guanine, thymine, uracil and xanthine. Both of the above mixtures were separately suspended in 500 ml. of distilled water, filtered through No. 03 Selas filters and stored at 4° C. The amino acid stock mixture contained 50 mg. each of L-asparagine, DL-alanine, L-cystine, L-glutamic acid, DL-methionine and DL-tryptophane. The above acids were added to 50 ml. of distilled water and autoclaved for 10 minutes at 15 pounds pressure.

<sup>3</sup> *Non-dialyzable* refers to a retained fraction after being subjected to dialysis, as opposed to *non-dialyzed* fractions which were not subjected to dialysis.

## EXPERIMENTS AND RESULTS

*Selection of a medium*

Experiments with most empirical formulae and those media already known to support axenic growth of the free-living Protozoa described above, proved unsuccessful for *Tetramitus*. Axenic growth of *Tetramitus* could be obtained, however, when washed autoclaved *Bacillus cereus* was added to a medium consisting of 0.5% yeast extract, 0.5% peptone and 1.0% Wilson liver concentrate (N.F.). In the yeast-peptone-liver medium (designated as YPL) sterile young amoebae were 2-3 times larger than normal ( $60\ \mu$  in diameter) and usually appeared opaque and immobile, but they became progressively more active as the cultures became older. Through varying the pH from 5.5 to 7.9 it was found that better growth could be ob-

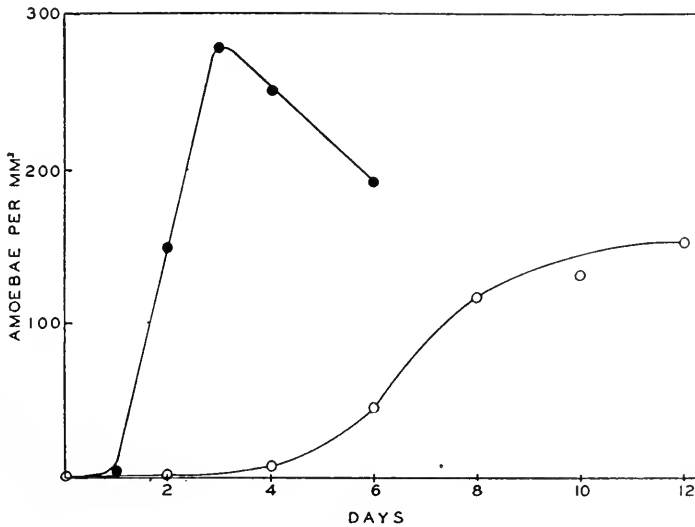

FIGURE 1. Comparison of growth of populations of *T. rostratus* with living vs. autoclaved *B. cereus* in 5 ml. of YPL medium at 30° C. Inoculum = 870/ml. ●: Growth with living bacteria; ○: Growth with dead bacteria. Note: Each point represents a separate tube.

tained near neutrality (6.8-7.3). Altering the temperature from 20° C. to 35° C. demonstrated that optimum growth (150 per mm.<sup>3</sup>) could be reached in approximately 12 days at 30° C.

A distinct lag phase was observed when the amoebae were grown with dead *B. cereus* (Fig. 1), which was considerably longer than that obtained with living bacteria. This would seem to indicate that although this medium is capable of supporting growth and reproduction of the amoebae, it is far from perfect and is incapable of supplying all the factors derived from cultures containing living bacteria. Preliminary experiments to shorten this lag with Selas-filtered, pre-conditioned bacterial cultures have not proved promising.

Attempts were made to substitute other autoclaved bacteria for *B. cereus* in YPL broth. Considerable growth of the amoebae could be obtained with killed *Escherichia coli*, *Neisseria catarrhalis*, *Sarcina lutea* and *Bacillus subtilis* by culturing

at 8-day intervals. No growth could be obtained with autoclaved *Pseudomonas fluorescens*. Substitution of autoclaved yeast Harris, Anheuser-Busch and Difco whole yeast failed to replace this bacterial factor.

Although the liver portion of the medium could be reduced to 0.25% without appreciably affecting growth, its complete elimination resulted in poor numbers of amoebae. However, amoebae have been cultured in this medium (YPL) for two months with the addition of large amounts of autoclaved *B. cereus* or *B. subtilis* at each sub-culture. The liver-deficient medium would not support growth of the

TABLE I  
Growth-supporting capacity of fractions of *Bacillus cereus* for *Tetramitus rostratus*  
in sterile yeast-peptone-liver medium

			Neutral hydrolysis		Acid hydrolysis		Alkaline hydrolysis	
			Non-dialyzed supernatant	Non-dialyzable supernatant	Non-dialyzed supernatant	Non-dialyzable supernatant	Non-dialyzed supernatant	Non-dialyzable supernatant
			-	-	-	-	-	-
Neutral hydrolysis	Non-dialyzed cell-residue	* -						
	Non-dialyzable cell-residue	-	+	-	-		-	
Acid hydrolysis	Non-dialyzed cell-residue	+						
	Non-dialyzable cell-residue	+			+			
Alkaline hydrolysis	Non-dialyzed cell-residue	-	* -				-	
	Non-dialyzable cell-residue	-						-

\* Present only in initial culture.

+ Growth of amoebae.

- No growth of amoebae.

Note: All supernatants were added as 1 pt. to 4 pts. of YPL medium. Cells were added in excess (approx. 0.1 ml. wet mass).

amoebae with added autoclaved *E. coli* or *N. catarrhalis*. Apparently *B. cereus* and *B. subtilis* contain at least one or more factors found in liver extract which seem to be lacking in the two non-spore-forming bacteria. These factors remain to be elucidated.

#### *Bacterial hydrolysates*

Since something in the bacterial cell appeared necessary for sustained growth of *Tetramitus* in YPL medium, partial hydrolysis of *B. cereus* was carried out as

described, in order to separate possible essential fractions. It was found at the outset that the substance(s) survived autoclaving for as long as 50 minutes, and a thorough washing of the intact cells failed to remove any activity.

It can be seen from Table I that amoebic growth resulted in YPL medium with the addition of the neutral-hydrolyzed non-dialyzable cell-residue to the neutral-hydrolyzed non-dialyzed supernatant. Although the non-dialyzed supernatant was routinely added as one part to four parts of YPL medium (by choice), it was found that it would maintain trophic growth in one-half this amount as long as the cell-residue was added. No growth could be obtained using the supernatant alone even when raised to 50% of the total medium. It can also be seen that the non-dialyzable supernatant is completely inactive whether used alone or with the non-dialyzable cell-residue. This residue still retained a small quantity of fat which was demonstrated with the Sudan Black B stain of Burdon (1946). The results obtained with the neutral-hydrolyzed fractions, therefore, would seem to indicate that at least two factors from the bacterial cell are required for growth of the amoebae: one dialyzable found in the bacterial supernatant and the other non-dialyzable found in the cell-residue.

Macerated cells treated with 0.1 N HCl and then subjected to dialysis retained their activity. Microscopical examination of the cells revealed mostly disintegrated cell husks with some fat retained in the debris. The non-dialyzed supernatant from these cells (Table I) was inactive when utilized with the neutral-hydrolyzed non-dialyzable cell-residue.

Alkaline hydrolysis of *B. cereus* seemed to destroy more than one factor required for growth of *Tetramitus*. Combinations of alkaline-hydrolyzed fractions together or with neutral-hydrolyzed fractions were inactive. Examination of the cell fragments revealed the absence of fat. When alkaline-treated fractions were added with normal autoclaved whole cells growth ensued, demonstrating that there is no toxicity factor involved here.

### 1. Preliminary attempts to replace the dialyzable fraction

Utilizing the lead obtained from neutral hydrolysis, experiments were performed to discover the nature of the factor(s) which were removed by dialysis. In these experiments the non-dialyzable fraction was provided by the non-dialyzable cell-residue. The possible dialyzable factors were sought separately in a mixture of vitamins, a mixture of purines and pyrimidines and amino acids. The vitamin mixture described above added in 0.002-ml., 0.02-ml. and 0.2-ml. amounts per 5 ml. of YPL medium gave no indication of supporting growth. The mixture of purines and pyrimidines added in 0.02-ml., 0.2-ml. and 2.0-ml. amounts to the vitamin-containing medium also failed to maintain growth. Mixed amino acids added in 0.25-ml., 0.5-ml. and 1.0-ml. amounts in combination with the vitamins and the purine-pyrimidine mixture gave no promising results.

In view of the fact that the substituted mixtures showed no activity, it was postulated that non-dialyzable fractions in the bacterial supernatant were also required for growth. This immediately suggested lipoidal material. To test this possibility, the non-dialyzable supernatant was utilized with the non-dialyzable cell residue as non-dialyzable fractions. No growth of the amoebae resulted with the addition of the vitamin mixture to these fractions in YPL medium. This was

re-investigated with the lipoid-extracted portions of the supernatant added as one part to four parts of YPL medium. In no case was growth of *Tetramitus* observed when either benzene-, alcohol-, ether-, or acetone-extracted supernatant was added to the vitaminized medium containing the non-dialyzable cell-residue.

## 2. Preliminary attempts to replace the non-dialyzable fraction

In routine investigation of the non-dialyzable fraction, neutral-hydrolyzed non-dialyzed supernatant was added to every tube of YPL broth as one part to four parts of medium; and in addition the vitamin mixture was added in a concentration of 0.1 ml. per 5 ml. of broth.

In order to eliminate the possibility that an essential metal might be tied up in the bacterial residue, the cells were completely ashed by flaming them in a Pyrex tube and then added to the culture medium. No growth of *Tetramitus* could be obtained. The separate addition in 1.0% and 5.0% proportions of peptone, tryptone, tryptose, proteose-peptone, yeast extract, trypticase and phytone failed to replace this factor. Skim milk in concentrations of 0.01% to 0.5% has also failed. Experiments are planned to replace this factor with known proteins and polysaccharides.

## DISCUSSION

Although only preliminary experiments have been carried out on the nutritional requirements of *Tetramitus*, it has been shown that the dead bacterial cell provides some essential constituent(s) for axenic growth of the amoebae in the yeast-peptone-liver medium. The types of killed bacteria it can use in this medium are non-specific since it has utilized gram-negative and gram-positive representatives of the cocci group, gram-positive spore-formers and a gram-negative coliform. It appears, however, that although *Tetramitus* will grow in YPL medium with most of the species of autoclaved bacteria investigated, only the spore-formers were utilized by the amoebae in the liver-deficient medium. Since *Bacillus cereus* and *B. subtilis* contained large quantities of fat, it is interesting to speculate whether they provide certain lipoidal substances present in the liver extract. This hypothesis should be tested by adding to the YP medium the fat-extracted portions of these cells together with the autoclaved non-spore-forming bacteria.

The finding that *Tetramitus* can utilize certain heat-stable metabolites found in microorganisms is not a new one when considering Protozoa in general. Johnson (1936) was able to obtain growth of the holotrichous ciliate, *Glaucoma ficaria*, in suspensions of 11 species of dead bacteria as well as 6 species of dead flagellates, using a balanced salt solution as a basal medium. Glaser and Coria (1935) established *Paramecium caudatum* and *P. multimicronucleatum* as well as other Protozoa upon a medium containing dead yeast cells as an indispensable nutrient. Van Wagtenonk and Hackett (1949) secured axenic growth of *Paramecium aurelia* but had to provide a 24-hour-preconditioned, autoclaved lettuce infusion culture of *A. aerogenes* with autolyzed yeast. When either component was omitted growth of the ciliates stopped, indicating essential substances other than the bacterial fraction.

It is evident from the preliminary work on *Tetramitus* that this organism is not



as fastidious in its growth requirements as the parasitic amoebae. The fact that it can grow and multiply aerobically in the absence of other living protoplasm tends to make the nutritional approach an easier one. With *Entamoeba histolytica*, on the other hand, nutritional studies have been hampered by its dependency upon associated living organisms and upon its extreme sensitivity to oxygen. Recently a certain substance(s) in dead bacteria has also proved essential for this latter species. Karlsson, James and Anderson (1952) have shown that when an autoclaved culture of a streptobacillus in liver-proteose-peptone medium was used as a substrate for *E. histolytica* under antibiotic treatment to suppress bacterial growth, fair growth of the amoebae resulted. Use of filtered media resulted in the loss of activity, suggesting the active material was present in the cells. Later Karlsson (1952) showed that 90% of the cells' activity was destroyed during the first 20 minutes of autoclaving. In the present work on *Tetramitus* the bacterial fractions are clearly heat-stable, since prolonged autoclaving for 50 minutes does not seem to destroy their activity. The streptobacillus factor for *Entamoeba* was completely destroyed by 0.1 N NaOH in 5 minutes at room temperature but could withstand treatment with 0.1 N HCl for one hour, suggesting similarity to those factors found in the *B. cereus* cell. It is also interesting to note that Karlsson's streptobacillus fraction could not be extracted with fat solvents.

Although no definite decision can as yet be made, the dialyzable factor in the cell-extracted supernatant of *B. cereus* suggests some protein fragment, for example, a polypeptide or some other dialyzable substance of relatively low molecular weight. There exists the possibility that several essential substances, both dialyzable and non-dialyzable, may be present in the supernatant. Collection and analysis of the dialysates would be of value in elucidating these fractions. The supernatant fraction appears to remain with the cell-residue when subjected to acid hydrolysis (Table I). Further evidence for this was shown by complete inactivity of the acid-hydrolyzed non-dialyzed supernatant. Preliminary experiments have shown that this acid fraction contained no inhibiting substance when added to acid-hydrolyzed cells.

The non-dialyzable fraction in the cell residue would suggest substances either proteinaceous or polysaccharide in nature. More complete analysis of this fraction is required before arriving at any conclusions.

#### SUMMARY

1. *Tetramitus* was cultivated indefinitely under axenic conditions upon a medium consisting of 0.5% Difco yeast extract, 0.5% Difco peptone and 1.0% Wilson liver concentrate (N.F.) with selected types of autoclaved bacteria.

2. The liver concentrate could be eliminated with subsequent reduction in trophic growth, only if killed *B. cereus* or *B. subtilis* was utilized as the bacterial fraction. Other bacteria (*Neisseria catarrhalis*, *Escherichia coli*) could not be substituted for these spore-formers in this medium.

3. It was found that the *B. cereus* cell contained at least two heat-stable fractions necessary for growth; neutral hydrolysis yielded a non-dialyzable fraction found in the cell-residue and a dialyzable fraction found in the bacterial cell supernatant.

4. Both factors were stable to autoclaving with 0.1 N HCl for 30 minutes at

15 pounds pressure and were retained in the acid-treated cell-residue. Alkaline hydrolysis destroyed activity of all the fractions.

5. Preliminary attempts have failed to substitute for the factors found in the neutral-hydrolyzed bacterial supernatant by employing selected vitamins, amino acids, purines and pyrimidines.

#### LITERATURE CITED

- BUNTING, M., 1922. A preliminary note on *Tetramitus*, a stage in the life cycle of a coprozoic amoeba. *Proc. Nat. Acad. Sci.*, **8**: 294-300.
- BUNTING, M., 1926. Studies of the life-cycle of *Tetramitus rostratus* Perty. *J. Morph.*, **42**: 23-81.
- BURDON, K. L., 1946. Fatty material in bacteria and fungi revealed by staining dried, fixed slide preparations. *J. Bact.*, **52**: 665-680.
- CAILLEAU, R., 1933a. Culture d'*Acanthamoeba castellanii* en milieu liquide. *C. R. Soc. Biol., Paris*, **113**: 990-992.
- CAILLEAU, R., 1933b. Culture d'*Acanthamoeba castellanii* sur milieu peptoné. Action sur les glucides. *C. R. Soc. Biol., Paris*, **114**: 474-476.
- CASTELLANI, A., 1930. An amoeba found in cultures of a yeast: Third note. *J. Trop. Med. Hyg.*, **33**: 221-222.
- DOUGHERTY, E., 1953. Problems of nomenclature for the growth of organisms of one species with and without associated organisms of other species. *Parasit.*, **42**: 259-261.
- GLASER, R. W., AND N. A. CORIA, 1935. The culture and reactions of purified Protozoa. *Amer. J. Hyg.*, **21**: 111-120.
- JOHNSON, D. F., 1936. Growth of *Glaucoma ficiaria* Kahl in cultures with single species of other microorganisms. *Arch. f. Protistenk.*, **86**: 359-378.
- JOHNSON, W. H., AND E. G. S. BAKER, 1942. The sterile culture of *Paramecium multimicro-nucleata*. *Science*, **95**: 333-334.
- KARLSSON, J. L., 1952. Studies on the physical properties of a growth factor for *Endamoeba histolytica*. *Amer. J. Trop. Med. Hyg.*, **1**: 548-551.
- KARLSSON, J. L., M. B. JAMES AND H. H. ANDERSON, 1952. Studies on nutritional principles for *Endamoeba histolytica* in autoclaved bacterial cells. *Exp. Parasit.*, **1**: 347-352.
- OEHLER, R., 1924. Weitere Mitteilungen über gereinigte Amöben- und Ciliaten-zucht. *Arch. f. Protistenk.*, **49**: 112-134.
- RAFALKO, J. S., 1951. Mitotic division in the amoeba-flagellate, *Tetramitus rostratus*. *J. Morph.*, **89**: 71-90.
- REICH, K., 1935. The cultivation of a sterile amoeba on media without solid food. *J. Exp. Zool.*, **69**: 497-500.
- RICE, N. E., 1935. The nutrition of *Flabellula mira* Schaeffer. *Arch. f. Protistenk.*, **85**: 350-368.
- SHAFFER, J. G., 1952. Studies on the growth requirements of *Endamoeba histolytica*. V. Studies on the nature of some of the factors in the Shaffer-Frye medium that affect the propagation of *E. histolytica*. *Amer. J. Hyg.*, **56**: 119-138.
- SNYDER, T. L., AND H. E. MELENEY, 1943. Anaerobiosis and cholesterol as growth requirements of *Endamoeba histolytica*. *J. Parasit.*, **29**: 278-284.
- STORM, J., S. H. HUTNER AND J. COWPERTHWAITTE, 1951. Preliminary notes on the nutrition of two small amoebae in pure culture. *Proc. Amer. Soc. Protozool.*, **2**: 3.
- VAN WAGTENDONK, W. J., AND P. L. HACKETT, 1949. The culture of *Paramecium aurelia* in the absence of other living organisms. *Proc. Nat. Acad. Sci.*, **35**: 155-159.
- WHERRY, W. B., 1913. Studies on the biology of an amoeba of the limax group. *Vahlkampfia* sp. no. I. *Arch. f. Protistenk.*, **31**: 77-94.
- WILLIAMS, A., 1911. Pure cultures of amebae parasitic in mammals. *J. Med. Res.*, **25**: 263-283.



## THE PENETRATION OF RADIOACTIVE PHOSPHATE INTO MARINE EGGS<sup>1, 2</sup>

SUMNER C. BROOKS AND EDWARD L. CHAMBERS<sup>3</sup>

*Department of Zoology, University of California, Berkeley, California*

Needham and Needham (1930) showed that the gastrulae and plutei of the echinoderm *Dendraster excentricus* have a higher total phosphate content than that of the unfertilized eggs. These authors suggested that the increased phosphate content of the larvae was related to the formation of the skeletal spicules.

Brooks (1943a) obtained results, using radioactive phosphate, which indicated that soon after first cleavage in the fertilized eggs of *Arbacia punctulata*, the intake of radiophosphate was accelerated. During the winter of '46 to '47 these experiments were repeated using more refined methods and the eggs of several different species of sea urchins, as well as the eggs of the gephyrean worm, *Urechis caupo*. The results are presented in this paper. Radiophosphate was found to enter the fertilized eggs of sea urchins more than one hundred times faster than it entered the unfertilized eggs (Brooks and Chambers, 1948). There was no evidence for alternating phases of intake and loss of phosphate ions, such as have been reported to occur during the early period of ion uptake by single *Nitella* cells and by uniform populations of egg cells (Brooks, 1939a, 1939b, 1940, 1943a, 1943b). The previously obtained results are to be ascribed to the considerable variability inherent in the methods which had been used (Brooks, 1951).

Independently Abelson (1947), using the eggs of *Arbacia punctulata*, and Lindberg (1948), using the eggs of *Psammechinus miliaris*, demonstrated the relatively more rapid penetration of radioactive phosphate into the fertilized, as compared to the unfertilized, sea urchin egg.

### METHODS

*Materials.* Eggs shed from the ovaries of the freshly collected Pacific coast sea urchins *Strongylocentrotus purpuratus*, *S. franciscanus* and *Lytechinus pictus*, and eggs obtained from the "egg collectors" (MacGinitie, 1935) of the worm *Urechis caupo* were used. The eggs were strained through cheese cloth and washed four times by centrifugation. In each experiment eggs from only a single animal were used, unless otherwise stated.

*Conduct of the experiment.* Egg suspensions containing 1 ml. eggs/liter sea water were used. Impaired development occurs if the concentration exceeds 5-6

<sup>1</sup> Presented at the 28th Annual Meeting of the AAAS, June, 1947, at San Diego, California.

<sup>2</sup> This investigation was aided by a research grant (C-559) to the University of California at Berkeley, from the National Cancer Institute of the National Institutes of Health, U. S. Public Health Service.

<sup>3</sup> Work done while Porter Fellow of the American Physiological Society, 1946-1947; now at the University of Oregon Medical School, Portland 1, Oregon.

ml. eggs/liter sea water. The pH of the sea water surrounding the eggs varied from 8.0 to 8.2 throughout the duration of each experiment, and the temperature of the egg suspensions was maintained at  $15 \pm 0.1^\circ \text{C}$ ., except that suspensions of *Lytechinus pictus* eggs were maintained at  $20^\circ$  to  $21^\circ \text{C}$ .

The eggs were kept suspended by using a stirrer rotated at 50 r.p.m.  $\text{P}^{32}$  of high specific activity was added directly to the egg suspensions. The initial concentration of orthophosphate in the suspension fluid, after addition of  $\text{P}^{32}$ , varied from 50 to  $434 \mu\text{g P/liter}$  (see Protocols). When thoroughly mixed, the homogeneous egg suspension was divided into two lots, one of which was inseminated by adding one drop (0.05 ml.) of solid sperm, directly removed from the testis, to 1000 ml. of suspension. Examination of the eggs shortly after insemination showed approximately two to three spermatozoa at the periphery of each egg. The remainder of the experiment consisted of removing samples of both unfertilized and fertilized eggs at frequent intervals. At the completion of the experiment, the

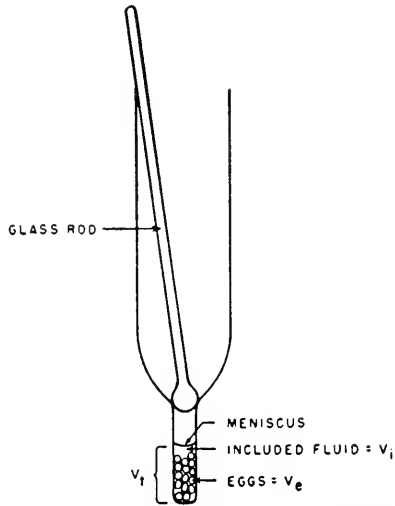

FIGURE 1. Diagram of Hopkin's tube containing sample of eggs.

eggs previously left unfertilized were inseminated. Development of these eggs, as well as those inseminated earlier, was followed, without diluting the egg suspension, through the pluteus stage for the sea urchin eggs and the trochophore stage for *Urechis* eggs. Development in every case was normal as compared to controls in sea water. This indicated that the  $\text{P}^{32}$  had been used in concentrations, of the order of 1 to  $30 \mu\text{c/liter}$ , which were below the toxic level.

All experiments were rejected in which (1) the time from insemination to 50 per cent cleavage deviated appreciably from normal, (2) there was undue prolongation of the period between the time when the eggs first started to cleave to the time when cleavage was completed, and (3) less than 95 per cent of the eggs developed to normal swimming embryos.

*Removal of egg samples for radioactivity measurements.* Each sample of eggs was taken by drawing up one- to two-ml. quantities of the well stirred homogeneous

suspension into a large bore pipette with a wide mouth, and depositing the aliquots in a Hopkin's vaccine tube (Fig. 1) up to the 10.0-ml. mark. The tube was then centrifuged at  $86 \times g$  for 60 seconds in a hand centrifuge. This force was just sufficient to drive the eggs into the narrow end of the tube. Within 30 seconds the supernatant was decanted and the fluid remaining within the narrow prolongation of the Hopkin's tube drawn off to a level just above the eggs, using a capillary pipette. The tube was then immediately inverted, and the walls dried with filter paper. The "end point" of penetration of isotope into the eggs was taken as being at the end of the 60 seconds' centrifugation.

The total volume ( $V_t$ ) of the eggs together with the suspension fluid contained within the narrow prolongation was then determined (Fig. 1). This volume ( $V_t$ ) amounted to 0.03 to 0.05 ml. in the different experiments. The Hopkin's tube was fixed in a holder fastened to the mechanical stage of a horizontally placed low power microscope provided with an ocular hair line. By operating the stage, the level of the meniscus could be read on the stage scale. Since each tube had been previously accurately calibrated with mercury, the stage scale readings could be converted directly into volume.

After completion of the reading, a thin glass rod with rounded ends was inserted into the tube in order to seal off the mouth of the narrow prolongation (Fig. 1). By holding the rod in place with the index finger, any radioactive solution adhering to the upper walls of the tube was washed out with distilled water without disturbing the eggs at the bottom. After removing the rod, the eggs, together with washings from the bottom of the tube, were transferred to a flat nickel dish 3 cm. in diameter and 3 mm. deep, and dried. The dried material formed a thin even layer on the bottom of the dish, amounting to no more than 1 mg. solids/cm.<sup>2</sup> of surface. The radioactivity was measured using a Geiger-Müller tube, having a thin mica window 8 cm. in diameter. Samples of the decanted supernatant fluid were dried in the identical dishes and the radioactivity measured.

The question arose as to how accurately the 10.0-ml. aliquots represent the suspension as a whole. This was determined by taking a batch of unfertilized eggs and removing the jelly by several washings. A dozen 10.0-ml. samples were taken as above described in the Hopkin's tubes and centrifuged for ten minutes at  $2000 \times g$ . The top of the eggs packed in the narrow prolongation of the Hopkin's tubes formed a perfectly straight line, and its level was measured as previously described. The volumes thus obtained were within a maximum range of 0.2 per cent of each other, indicating the validity of the sampling procedure used.

The advantage of the above described method for determining the quantity of radioactive isotope in the eggs is that, by eliminating the necessity for washing the cells, errors which might arise from injury to the eggs and from outward leaching of ions or compounds are avoided.

*Egg volume measurements.* The mean diameter of fertilized eggs in the early one-cell stage was determined by averaging 25 individual measurements made with a filar micrometer. The unfertilized eggs of the sea urchin are never spherical when freshly removed from the ovaries, and *Urechis* eggs in the unfertilized state are indented on one side. Soon after fertilization the eggs of both species become spherical with only slight changes in volume (Tyler, 1932). The average diameter of *S. purpuratus* eggs is 81.3  $\mu$ , *S. franciscanus* eggs 119  $\mu$ , and *Urechis caupo* eggs

110  $\mu$ . The number of eggs per ml. of suspension was determined as follows. Using a wide-mouthed pipette a sample, approximately 0.2 ml. in volume, was withdrawn from the homogeneous suspension, deposited on a ruled slide, covered with a coverslip, and weighed in order that the volume of the sample could be accurately determined. The total number of eggs on the slide was then counted. This procedure was repeated twice and the results averaged. Knowing the number of eggs in a given mass of sea water and the average diameter of one egg, the total volume of egg protoplasm ( $V_e$ ) in a 10.0-ml. volume of suspension could be readily calculated.

Egg volume determinations were also carried out by centrifuging the jelly-free unfertilized eggs for 10 minutes at  $2000 \times g$ . Results obtained by this method were not significantly different from volume determinations carried out by counting the number of eggs in aliquots and measuring diameters.

*Calculations.* The concentration of  $P^{32}$  within the eggs was calculated as follows. Knowing the total volume of eggs with included fluid ( $V_t$ ) contained within the narrow prolongation of the Hopkin's tube (Fig. 1), and the volume of eggs in 10.0 ml. of suspension ( $V_e$ ), the volume of the included fluid alone is: ( $V_i$ ) = ( $V_t$ ) - ( $V_e$ ). The included fluid volume ( $V_i$ ) represents the quantity of fluid exterior to the protoplasmic surface of the eggs. This volume, therefore, includes the space occupied by the egg jelly and the space enclosed within the fertilization membrane, structures which allow free diffusion of phosphate ions. The radioactivity of the included fluid is obtained by multiplying ( $V_i$ )  $\times$  C.P.M. (counts per minute) of one ml. suspension fluid. Since the radioactivity of the total sample is known, the radioactivity of one ml. of eggs is:

$$\text{C.P.M./ml. eggs} = \frac{(\text{C.P.M. of sample}) - (\text{C.P.M. of included fluid})}{V_e} \quad (1)$$

Under the conditions of the counting method used, 1 C.P.M. =  $3.6 \times 10^{-6}$   $\mu\text{C } P^{32}$ . Using this conversion factor, the results have been expressed in terms of  $\mu\text{C } P^{32}/\text{ml. eggs}$ .

*Accuracy of method.* The following sources of error were taken into consideration in calculating the standard deviation for each determination of the  $\mu\text{C } P^{32}/\text{ml. eggs}$  (see Tables I and II): the sampling error, error in determining the egg volume ( $V_e$ ) and the included fluid volume ( $V_i$ ), error in determining the C.P.M. of the sample, of the background, and of the supernatant fluid. When the radioactivity contributed by the included fluid in each sample is more than half that of the entire sample, the error of the method is considerable. Accurate results are obtained when the concentration of isotope in the eggs exceeds the concentration of isotope in the suspension fluid.

#### PROTOCOLS

*Experiment 1.*  $P^{32}$  was added to a suspension containing 1.00 ml. *S. purpuratus* eggs/liter 120 minutes after the eggs had been removed from the ovaries, and the eggs were inseminated five minutes later. The initial concentration of  $P^{32}$  in the sea water was 1.22  $\mu\text{C}/\text{liter}$ , and the orthophosphate concentration approximately 71  $\mu\text{g P}/\text{liter}$ . First cleavage started 97 minutes after insemination, was 50 per cent complete at 104 minutes and finished at 110 minutes.

Experiment 2. P<sup>32</sup> was added to a suspension containing 1.09 ml. *S. purpuratus* eggs/liter 135 minutes after removal of the eggs from the ovaries, the eggs being inseminated 12 minutes later. The initial concentration of P<sup>32</sup> in the sea water

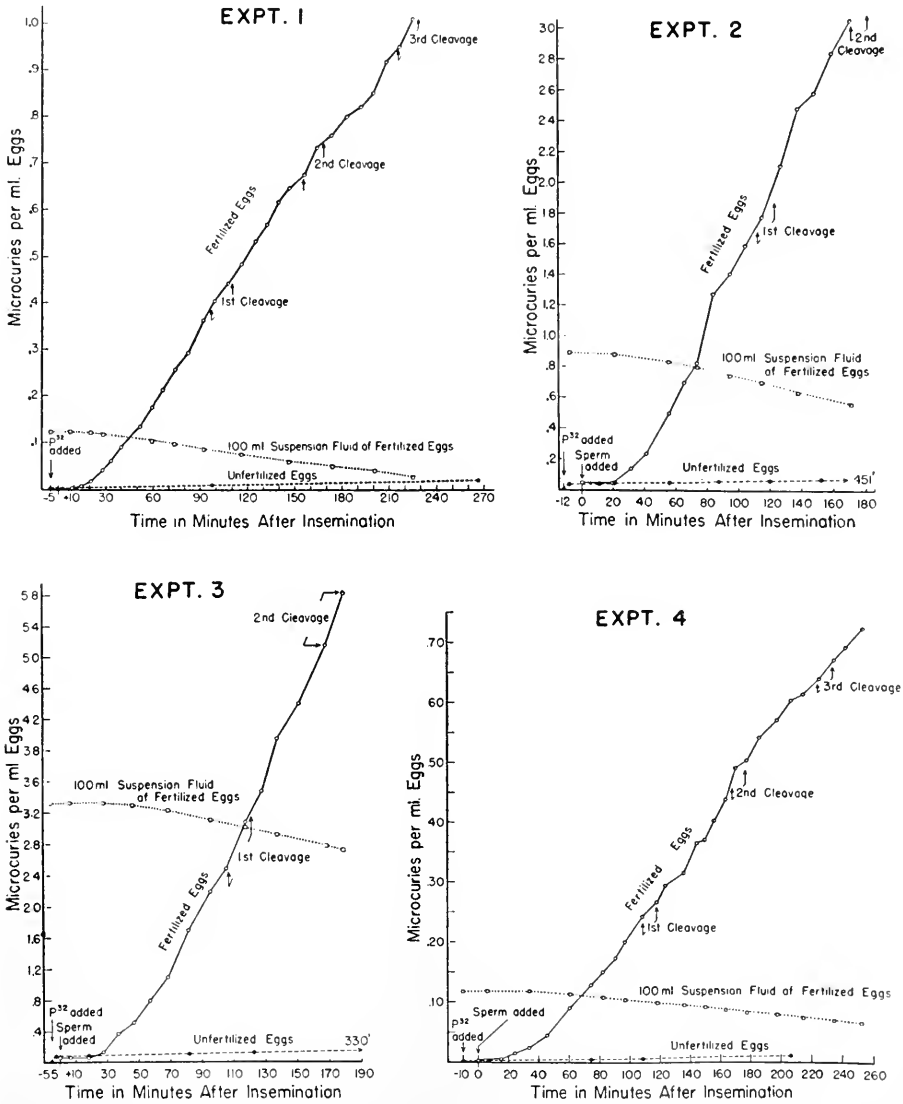

FIGURE 2. Uptake of P<sup>32</sup> by unfertilized and fertilized sea urchin eggs. Expts. 1, 2 and 3: *S. purpuratus* eggs. Expt. 4: *S. franciscanus* eggs. At beginning of each experiment P<sup>32</sup> added to suspension and then divided into two lots. Sperm added to one lot at 0 minutes in all experiments—fertilized eggs. The second lot was not inseminated—unfertilized eggs. Ordinates:  $\mu\text{c P}^{32}/\text{ml. eggs}$ . Abscissae: Time in minutes before and after insemination, 0 = time of insemination. (○—○) fertilized eggs, (●----●) unfertilized eggs, (□····□)  $\mu\text{c P}^{32}/100 \text{ ml. suspension fluid of fertilized eggs}$ .

TABLE I

Uptake of  $P^{32}$  by the unfertilized and fertilized eggs of *S. purpuratus*. Expts. 1, 2, and 3

Time after insemination in minutes	Unfertilized, $\mu\text{c } P^{32}/\text{ml. eggs}$	Fertilized, $\mu\text{c } P^{32}/\text{ml. eggs}$	Suspension fluid of fertilized eggs, $\mu\text{c } P^{32}/\text{ml.}$
Expt. 1, <i>S. purpuratus</i>			
-5.0	$P^{32}$ added to suspension		
0.0	One-half of suspension inseminated		0.00122
8.3	0.00184 $\pm$ .0009	0.00111 $\pm$ .0009	0.00122
59.6	—	0.175 $\pm$ .003	0.00103
92.4	0.00810 $\pm$ .0009	0.359 $\pm$ .004	0.00085
173.8	—	0.756 $\pm$ .006	0.00048
225.1	—	1.01 $\pm$ .01	0.00024
266.5	0.0188 $\pm$ .0010	—	—
Expt. 2, <i>S. purpuratus</i>			
-12.0	$P^{32}$ added to suspension		
-8.2	0.034 $\pm$ .002		
0.0	One-half of suspension inseminated		0.00885
21.0	0.046 $\pm$ .002	0.047 $\pm$ .003	0.00872
56.0	0.050 $\pm$ .002	0.494 $\pm$ .009	0.00826
84.4	—	1.27 $\pm$ .09	0.00770
87.1	0.063 $\pm$ .002	—	—
127.2	—	2.09 $\pm$ .14	0.00665
152.0	0.069 $\pm$ .003	—	—
171.1	—	3.02 $\pm$ .16	0.00560
Expt. 3, <i>S. purpuratus</i>			
-5.5	$P^{32}$ added to suspension		
-2.5	0.0809 $\pm$ .0064		
0.0	One-half of suspension inseminated		0.0335
18.0	0.0924 $\pm$ .0061	0.0444 $\pm$ .0044	0.0333
46.6	—	0.496 $\pm$ .071	0.0328
81.5	0.102 $\pm$ .007	1.68 $\pm$ .09	0.0316
122.5	0.119 $\pm$ .006	—	—
128.0	—	3.46 $\pm$ .10	0.0294
179.2	—	5.79 $\pm$ .12	0.0270

was 8.9  $\mu\text{c}/\text{liter}$ , and the orthophosphate concentration approximately 133  $\mu\text{g } P/\text{liter}$ . First cleavage started at 113 minutes after insemination, 50 per cent had cleaved at 118 minutes and completed at 123 minutes.

*Experiment 3.*  $P^{32}$  was added to a suspension containing 1.10 ml. *S. purpuratus* eggs/liter 127 minutes after the eggs had been removed from the ovaries, and the eggs were inseminated 5.5 minutes later. The initial concentration of  $P^{32}$  in the sea water was 33.5  $\mu\text{c}/\text{liter}$  and the orthophosphate concentration approximately 434  $\mu\text{g } P/\text{liter}$ . First cleavage started 107 minutes after insemination, was 50 per cent complete at 114.5 minutes and was finished at 121 minutes.

*Experiment 4.*  $P^{32}$  was added to a suspension containing 0.72 ml. *S. franciscanus*



eggs/liter 120 minutes after the eggs had been removed from the ovaries, and the eggs inseminated 10 minutes later. The initial concentration of P<sup>32</sup> in the sea water was 1.2  $\mu\text{C}$ /liter, and the orthophosphate concentration approximately 59  $\mu\text{g}$  P/liter. First cleavage started 108 minutes after insemination, was 50 per cent complete at 113 minutes and reached completion at 117 minutes.

*Experiment 5.* P<sup>32</sup> was added to a suspension containing 1.29 ml. *U. caupo* eggs/liter 180 minutes after removal of the eggs from the animal, and the eggs were

TABLE II

*Uptake of P<sup>32</sup> by the unfertilized and fertilized eggs of S. franciscanus and Urechis caupo. Expts. 4 and 5*

Time after insemination in minutes	Unfertilized, $\mu\text{C}$ P <sup>32</sup> /ml. eggs	Fertilized, $\mu\text{C}$ P <sup>32</sup> /ml. eggs	Suspension fluid of fertilized eggs, $\mu\text{C}$ P <sup>32</sup> /ml.
<i>Expt. 4, S. franciscanus</i>			
-10.0	P <sup>32</sup> added to suspension		
0.0	One-half of suspension inseminated		0.00118
6.3	0.0031 $\pm$ .0013	0.0012 $\pm$ .0012	0.00118
74.8	0.0038 $\pm$ .0014	0.127 $\pm$ .005	0.00109
108.2	0.0075 $\pm$ .0015	0.240 $\pm$ .005	0.00100
163.2	—	0.435 $\pm$ .007	0.00086
206.7	0.0094 $\pm$ .0015	0.600 $\pm$ .009	0.00076
252.0	—	0.718 $\pm$ .011	0.00066
<i>Expt. 5, Urechis caupo</i>			
-10.0	P <sup>32</sup> added to suspension		
-5.0	0.0007 $\pm$ .0004		
0.0	One-half of suspension inseminated		0.00089
33.3	—	0.0028 $\pm$ .0005	0.00089
43.0	0.0039 $\pm$ .0006	—	—
91.5	—	0.0066 $\pm$ .0005	0.00088
100.8	0.0056 $\pm$ .0006	—	—
176.9	—	0.0145 $\pm$ .0006	0.00087
184.1	0.0103 $\pm$ .0007	—	—
223.2	—	0.0220 $\pm$ .0007	0.00085
266.0	—	0.0369 $\pm$ .0010	0.00083
275.0	0.0174 $\pm$ .0007	—	—
517.0	—	0.285 $\pm$ .005	0.00052

inseminated 10 minutes later. The initial concentration of P<sup>32</sup> in the sea water was 0.89  $\mu\text{C}$ /liter, and the orthophosphate concentration about 50  $\mu\text{g}$  P/liter. First cleavage was 50 per cent complete at 119 minutes after insemination, second cleavage at 160 minutes and third cleavage at 209 minutes.

## RESULTS

### *Uptake of P<sup>32</sup> by unfertilized and fertilized eggs*

The results of five experiments are presented in Figures 2 and 3. The data are abbreviated in Tables I and II, in which only a few of the determinations are

presented for each experiment. The first column in each table indicates the time when samples of unfertilized and fertilized eggs were removed for radioactivity measurements.  $P^{32}$  was added to the suspension of the unfertilized eggs at the beginning of the experiment. Shortly thereafter the first sample was removed, the suspension divided into two lots, and one lot inseminated. In every case the time of insemination is set as zero time. In the second column the quantity of  $P^{32}$  which has penetrated the unfertilized eggs after various time intervals is shown. The third column presents the same data for the fertilized eggs. In the fourth column the decrease in concentration of  $P^{32}$  in the suspension medium is shown.

*Eggs of Strongylocentrotus purpuratus and S. franciscanus.* The uptake of  $P^{32}$  by the unfertilized eggs is shown in Figure 2, interrupted line with solid circles.

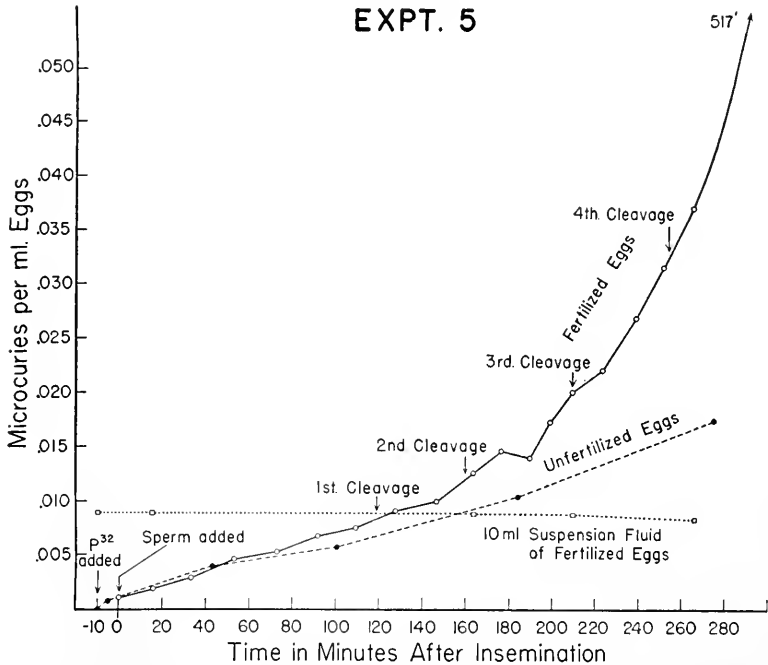

FIGURE 3. Uptake of  $P^{32}$  by the unfertilized and fertilized eggs of *Urcchis caupo*, Expt. 5. Legend as for Figure 2.

In Experiments 2 and 3 the initial uptake of  $P^{32}$ , during the first three to four minutes after adding the isotope, appears to be greater than the uptake in the subsequent 200 minutes. This initial increase, however, undoubtedly does not represent penetration of  $P^{32}$  into the eggs, but is an artifact arising from a small error in determining the absolute volume of the eggs, or from the initial absorption of a small quantity of the isotope to the extraneous coats or the surface of the eggs. In Experiments 1 and 4, in which the concentrations of P (as orthophosphate) and  $P^{32}$  in the suspension fluid were much less than in Experiments 2 and 3 (see Protocols), the absence of an initial phase of rapid  $P^{32}$  uptake is evident. In all

experiments, with the exception of the initial phase in Experiments 2 and 3, the uptake of P<sup>32</sup> by the unfertilized eggs occurred at a constant rate.

The uptake of P<sup>32</sup> by fertilized eggs (Fig. 2, solid line with open circles) during the first 10 to 15 minutes following fertilization is identical to the uptake shown by unfertilized eggs. By 15 to 20 minutes following fertilization the rate of uptake increases until by 50 to 60 minutes in *S. purpuratus*, and 80 to 90 minutes in *S. franciscanus* the uptake has reached a maximum rate. Thereafter, except for minor variations, the uptake occurs at a constant rate through the third cleavage. The minor variations in the rate of uptake which occurred were within the range of experimental error. No change in rate of uptake during the cleavage cycles was evident.

Results obtained using the eggs of *Lyttechinus pictus* are essentially identical to those obtained using the eggs of the two species of *Strongylocentrotus* (Chambers and Whiteley in Whiteley, 1949).

*Eggs of Urechis caupo.* The uptake of P<sup>32</sup> by the unfertilized eggs (Fig. 3, interrupted line with solid circles) was observed to occur at a slow constant rate. The uptake of P<sup>32</sup> by the fertilized eggs (Fig. 3, solid line with open circles) was essentially identical to that of the unfertilized eggs throughout the period of maturation and the first two cleavages (the eggs, laid in the germinal vesicle stage, do not mature until after insemination occurs). Shortly after the second cleavage the rate at which the fertilized eggs removed P<sup>32</sup> from the medium increased. Even after the fourth cleavage the rate continued to increase.

#### *Loss of P<sup>32</sup> from the eggs*

Experiments were carried out to determine whether or not P<sup>32</sup> contained within the eggs is lost to the medium when the P<sup>32</sup> in the sea water surrounding the eggs is removed. The experiments were carried out using the eggs of *Lyttechinus pictus* as follows: Unfertilized and fertilized eggs were exposed to sea water containing P<sup>32</sup> and approximately 60  $\mu$ g P as orthophosphate/liter for one hour. Samples of the suspension were then taken to determine the quantity of P<sup>32</sup> which had entered the eggs, and immediately thereafter the remainder of the suspension was gently centrifuged, the supernatant decanted, and replaced by fresh non-radioactive sea water containing about 60  $\mu$ g P as orthophosphate/liter. After washing three times by centrifugation, a suspension of the washed eggs was prepared containing 3.0 ml. eggs/liter sea water. Ten-ml. samples of this suspension were removed at various intervals of time for radioactivity determinations. The washing of the eggs was repeated at frequent intervals, in order to remove any P<sup>32</sup> which may have entered the medium from the eggs. The results are shown in Figure 4. The quantity of P<sup>32</sup> remaining within the eggs is expressed in terms of the per cent of the quantity of P<sup>32</sup> within the eggs immediately preceding the first washing. The times when the eggs were washed are indicated by the small arrows in the figures. During careful washing of the eggs, in spite of the greatest precautions it is impossible to avoid destroying or losing some of the eggs. This is particularly true of the fragile unfertilized eggs. Accordingly, the volume of unfertilized eggs in each 10-ml. sample taken was determined by the centrifugal method, and correction made for any loss of eggs which may have occurred during the repeated washings.

The results obtained on the unfertilized eggs (Fig. 4, curves in upper half) reveal that in two experiments 15 per cent, and in one experiment 4 per cent of the  $P^{32}$  initially contained within the eggs was lost to the medium during the first 100 minutes after washing was started. The  $P^{32}$  continues to be lost at a slow rate over a long period of time. However, the results obtained after 300 minutes from the time the eggs were first washed are open to question, because fertilization and development of these eggs were impaired.

The fertilized eggs are far more resistant to the washing procedure, since they are protected by their fertilization membranes. It was not possible, however, to correct for such losses of eggs as may have occurred, during washing, as egg volumes

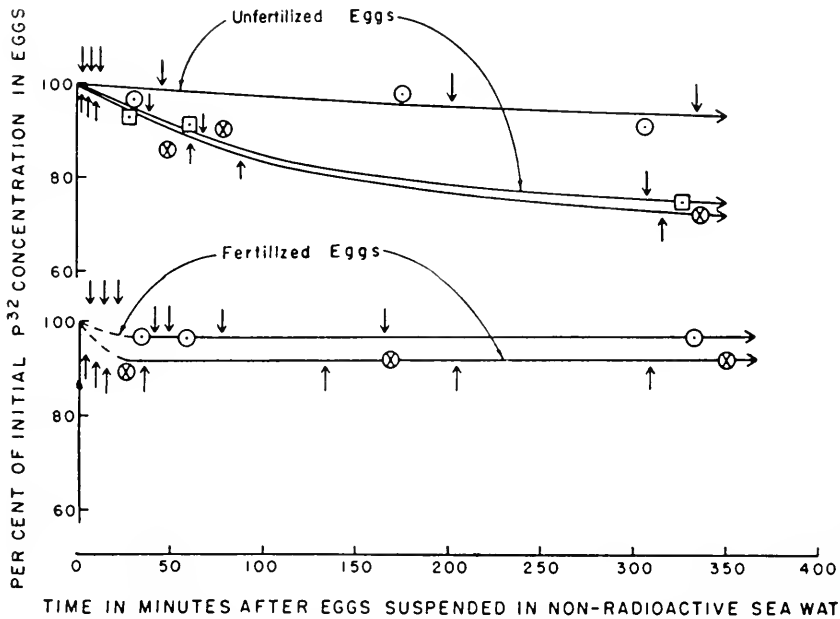

FIGURE 4. Effect of washing unfertilized and fertilized *Lytechinus pictus* eggs containing  $P^{32}$  in non-radioactive sea water.

in the samples cannot be determined when the eggs are fertilized. The results of two experiments on fertilized eggs are shown in Figure 4 (curves in lower half). A loss of  $P^{32}$  from the samples taken after the first series of washings occurred, but subsequently, no appreciable loss of  $P^{32}$  from the eggs was observed. The initial loss of  $P^{32}$  is undoubtedly due to the loss of some eggs, for which no correction could be made.

In six experiments carried out using unfertilized and fertilized *S. purpuratus* eggs, similar results were obtained.

#### *The influence of extraneous coats on the uptake of $P^{32}$*

The uptake of  $P^{32}$  by the fertilized eggs of *Lytechinus pictus* from which the extraneous coats had been removed was compared to that of normal eggs possessing

all their coats intact. The experiment was performed as follows: A suspension of unfertilized eggs was divided in two beakers. The eggs in one beaker were inseminated. One-half of this suspension was centrifuged, the supernatant discarded and two minutes after insemination, at the time when observation revealed that the fertilization membranes were rising, the eggs were suspended in a mixture of 95 parts 1 M urea, pH 8.0, and five parts sea water. The eggs were allowed to settle, and five minutes after insemination the urea solution was decanted and replaced by sea water. The decantations were repeated several times until the eggs had been washed free of the urea solution. Observation of the eggs revealed that the jelly coats and the fertilization membranes had been completely removed and that the hyaline plasma layer did not form (Moore, 1930). When the urea-treated eggs cleaved, they separated into two spherical blastomeres, fastened together only by delicate stalks. The fertilized untreated eggs and the urea-treated eggs cleaved 100 per cent and at the same time. At 50 minutes after insemination, P<sup>32</sup> was added to all three suspensions, the control unfertilized eggs, the control fertilized eggs, and the urea-treated fertilized eggs. Samples were removed at intervals for radioactivity determinations. The results are shown in Table III. They reveal that in the 25-minute interval during which the uptake of P<sup>32</sup> was measured, 75 times as much P<sup>32</sup> entered the fertilized eggs as the unfertilized eggs,

TABLE III

*Uptake of P<sup>32</sup> by unfertilized, normal fertilized and urea-treated fertilized Lytechinus pictus eggs*

Condition of eggs	Uptake of P <sup>32</sup> in C.P.M./ml. eggs
Unfertilized	2,000
Fertilized, controls	150,000
Fertilized, urea treated	145,000

and that as much P<sup>32</sup> entered the denuded urea-treated eggs as the control fertilized eggs. Since the urea-treated eggs in sea water may still have possessed a thin but invisible coating of proteinaceous material, at the end of the 25-minute interval these eggs were washed for 10 minutes in three changes of an isotonic mixture of 10 parts 0.53 M KCl and 90 parts 0.52 M NaCl at pH 6.0 and then suspended in this mixture. Such a treatment should have dissolved away any remaining extraneous material surrounding the eggs (Chambers, 1940). The washing of the urea-treated eggs in the Na/K mixture did not remove an appreciable quantity of P<sup>32</sup> from the eggs, revealing that no significant quantity of P<sup>32</sup> is absorbed to the coats, which surround the eggs external to the protoplasmic surface.

#### *Rate of penetration into the eggs*

The quantity of P<sup>32</sup> in  $\mu\text{c}$  entering one ml. eggs in a given interval of time,  $t_2 - t_1$ , may be obtained directly from the graphs. Rates of penetration were determined only for the constant phases of uptake, *i.e.*, from five minutes ( $t_1$ ) to 200 minutes ( $t_2$ ) after addition of P<sup>32</sup> for the unfertilized eggs, from 70 minutes ( $t_1$ ) to 170 minutes ( $t_2$ ) after insemination for the fertilized sea urchin eggs, and from 250 minutes ( $t_1$ ) to 275 minutes ( $t_2$ ) after insemination for the fertilized *Urechis* eggs.

In spite of a very considerable decrease in the concentration of P<sup>32</sup> in the medium

surrounding the fertilized sea urchin eggs, the uptake of  $P^{32}$  by the eggs remained constant throughout the duration of Experiments 1-4. In experiments on the unfertilized eggs, and the fertilized eggs of *Urechis caupo*, no appreciable change in concentration of  $P^{32}$  in the suspension fluid occurred, since only a small quantity of  $P^{32}$  penetrated the eggs.

*Fertilized eggs of S. purpuratus and S. franciscanus.* The decrease in concentration of  $P^{32}$  in the medium surrounding the fertilized eggs could be due either to an exchange of  $P^{32}$  from the external medium for P inside the eggs, or to an accumulation of P within the eggs, depleting the P in the suspension fluid. Experiments described in this paper reveal that when fertilized eggs, which had been exposed to sea water containing  $P^{32}$ , are immersed in radioactive-free sea water containing about 60  $\mu\text{g P/liter}$  no appreciable quantity of  $P^{32}$  leaves the eggs. Chambers and White (1949, 1954) have shown that fertilized eggs remove orthophosphate from a medium containing between 10 to 100  $\mu\text{g P/liter}$  at the same rate as the  $P^{32}$ .

The specific activity ( $\mu\text{C } P^{32}/\mu\text{g P}$ ) of the P (as orthophosphate) in the medium, therefore, remains constant throughout the duration of the experiment. Accordingly, the rate of penetration of orthophosphate into the eggs can be accurately calculated as follows:

$$\mu\text{g P/ml. eggs/min.} = \left( \frac{\mu\text{g } P_s}{\mu\text{C } P_s^{32}} \right) \left( \frac{\mu\text{C } P_e^{32} \text{ at } t_2 - \mu\text{C } P_e^{32} \text{ at } t_1}{(t_2 - t_1)} \right), \quad (2)$$

where  $\mu\text{g } P_s$  = initial concentration of orthophosphate in the suspension fluid in  $\mu\text{g P/ml.}$ ,  $\mu\text{C } P_s^{32}$  = initial concentration of  $P^{32}$  in  $\mu\text{C/ml.}$  in the suspension fluid,  $\mu\text{C } P_e^{32}$  at  $t_2$  and  $t_1$  = concentration of  $P^{32}$  in  $\mu\text{C/ml.}$  eggs at the time in minutes  $t_2$  and  $t_1$ .

The rates of penetration of orthophosphate, calculated according to equation (2) are shown in Table IV, including three experiments from Chambers and White (1954.)

For the fertilized eggs of *S. purpuratus*, the rate of P uptake, from 70 to 170 minutes after insemination, at 15° C., in four experiments, varied from 0.54  $\mu\text{g P/ml.}$  fertilized eggs/minute at an external orthophosphate concentration of 416  $\mu\text{g P/liter}$  to 0.28  $\mu\text{g P/ml.}$  fertilized eggs/minute at an external orthophosphate concentration of 20  $\mu\text{g P/liter}$  (Table IV, columns 3 and 5). With a twenty-fold change in concentration of P, only a 1.9-fold change in the rate of penetration of P occurred. As long as the orthophosphate concentration exceeds about 20  $\mu\text{g P/liter}$ , the more dilute the orthophosphate concentration, the greater is the fraction of P in the medium which is absorbed by the fertilized eggs in a given period of time.

The rate of penetration of orthophosphate into fertilized *Strongylocentrotus franciscanus* eggs from 70 to 170 minutes after insemination, at 15° C., in three experiments, ranged from 0.11 to 0.17  $\mu\text{g P/ml.}$  fertilized eggs/minute, with the concentration of orthophosphate in the external medium varying from 63 to 20  $\mu\text{g P/liter}$  (Table IV, columns 3 and 5). The rate of uptake by the fertilized *S. franciscanus* eggs is about half that of *S. purpuratus* eggs.

*Unfertilized eggs of S. purpuratus and S. franciscanus.* In the experiments carried out with unfertilized eggs, no change could be detected in the concentration

of P<sup>32</sup> in the suspension fluid. Although the concentration of orthophosphate in the sea water surrounding unfertilized sea urchin eggs remains constant or slowly increases (Chambers and White, 1954), the amount of increase is not sufficient to appreciably alter the specific activity of the orthophosphate in the medium as long as the egg suspension is dilute (1.0 ml. eggs/liter suspension) and the concentration of orthophosphate in the medium exceeds 50  $\mu\text{g P/liter}$ .

Unlike fertilized eggs, unfertilized eggs containing P<sup>32</sup>, when immersed in non-radioactive sea water, slowly lose P<sup>32</sup> to the surrounding medium. The rate, however, at which P<sup>32</sup> is lost from eggs which had been exposed to P<sup>32</sup> sea water is over a hundred times slower than the rate at which the P<sup>32</sup> originally entered the eggs. In view of these considerations and the linear P<sup>32</sup> uptake curves, equation

TABLE IV

Rate of penetration of phosphate into unfertilized and fertilized *S. purpuratus*, *S. franciscanus* and *Urechis caupo* eggs at 15° C.

Experiment	Condition of eggs	Initial and final P conc. $\mu\text{g P/liter}$ susp. fluid	$\mu\text{g P/ml. eggs/min.}$		Fertilized, $\mu\text{g P/ml. eggs/min.}$ Unfertilized, $\mu\text{g P/ml. eggs/min.}$
			Unfertilized	Fertilized	
<i>S. purpuratus</i> , Expt. 1	Unfert.	71	0.0035		86
	Fert.	56 to 29		0.30	
<i>S. purpuratus</i> , Expt. 2	Unfert.	133	0.0035		106
	Fert.	122 to 84		0.37	
<i>S. purpuratus</i> , Expt. 3	Unfert.	434	0.0041		132
	Fert.	416 to 359		0.54	
<i>S. purpuratus</i> *	Unfert.	78	0.0026		106
	Fert.	78 to 20		0.28	
<i>S. franciscanus</i> , Expt. 4	Unfert.	59	0.0015		113
	Fert.	55 to 42		0.17	
<i>S. franciscanus</i> †	Fert.	53 to 20		0.11	—
<i>S. franciscanus</i> ‡	Fert.	63 to 20		0.14 to 0.17	—
<i>U. caupo</i> , Expt. 5	Unfert.	50	0.0033		7
	Fert.§	47 to 46		0.024	

\* From Chambers and White (1954), Expts. 5 and 6.

† From Chambers and White (1954), Expt. 7.

‡ From Chambers and White (1954), Expt. 8.

§ After third cleavage.

(2) may be used to calculate the rate of entry of orthophosphate into unfertilized sea urchin eggs.

In the case of the unfertilized eggs of *S. purpuratus* the rate of penetration of orthophosphate at 15° C. in three experiments varied between 0.0041 to 0.0026  $\mu\text{g P/ml. unfertilized eggs/minute}$  with concentration of P (as orthophosphate) in the medium ranging from 434 to 71  $\mu\text{g P/liter}$  (Table IV, columns 3 and 4). For the unfertilized eggs of *S. franciscanus* the rate of P uptake, in one experiment, was 0.0015  $\mu\text{g P/ml. unfertilized eggs/minute}$ , at an external orthophosphate concentration of 59  $\mu\text{g P/liter}$ .

*Fertilized and unfertilized Strongylocentrotus eggs compared.* As shown in Table IV, column 6, phosphate penetrates fertilized *S. purpuratus* eggs 86 to 132 times more rapidly than unfertilized eggs.

In *S. franciscanus* eggs, approximately a 113-fold increase in rate occurs after fertilization.

*Eggs of Urechis caupo.* The rates of penetration of orthophosphate into the unfertilized and fertilized eggs were arbitrarily calculated according to equation (2). In view of the slow rate of  $P^{32}$  uptake, the inappreciable change in concentration of  $P^{32}$  in the suspension fluid, and the dilute egg suspension, it is probable that the use of equation (2) is justified.

Phosphate penetrates the unfertilized eggs of *Urechis caupo* and *S. purpuratus* at about the same rate (Table IV, columns 3 and 4). The important difference between the *Urechis* and the sea urchin egg is that in the former species, after fertilization, no increase in the rate of P uptake occurs. After the *Urechis* eggs have undergone second cleavage, however, the rate starts to increase, attaining a rate 7 times that of the unfertilized eggs by the time of fourth cleavage (Table IV, column 6). Even by this time the rate has not reached its maximal level (Fig. 3).

#### DISCUSSION

When fertilized sea urchin eggs which had been exposed to sea water containing  $P^{32}$  are immersed in radioactive free sea water, no appreciable quantity of  $P^{32}$  leaves the eggs. Furthermore, fertilized sea urchin eggs remove orthophosphate from sea water at the same rate as  $P^{32}$  (Chambers and White, 1949, 1954). These data reveal that the entry of  $P^{32}$  into the fertilized sea urchin eggs measures the rate at which phosphate accumulates within the cells.

On the other hand, when  $P^{32}$  is added to a suspension of unfertilized eggs, no appreciable change in concentration of  $P^{32}$  occurs in the suspension fluid. The concentration of orthophosphate in the suspension fluid surrounding unfertilized eggs remains constant or slowly increases (Chambers and White, 1954). When unfertilized eggs, containing  $P^{32}$ , are immersed in non-radioactive sea water,  $P^{32}$  slowly washes out into the external medium. On the basis of these data, the conclusion may be made that the uptake of  $P^{32}$  by unfertilized eggs measures the rate at which phosphate enters the eggs, presumably by exchange, at the same time that the internal concentration remains constant, or even decreases. The change from the unfertilized to the fertilized state, therefore, involves not only a change in magnitude but also a reversal of "driving forces." Although the two-fold increase following fertilization in permeability to water (Lillie, 1916) and non-electrolytes (Stewart and Jacobs, 1932) may contribute to the striking increase in uptake of orthophosphate which follows fertilization, it is probable that changes in "driving forces" play the dominant role.

Of interest is the relatively constant rate at which phosphate accumulates within fertilized sea urchin eggs, irrespective of large changes in concentration in the external medium. This resembles the constancy in the rate of oxygen consumption of cells, over a wide range of different oxygen tensions, as long as the tension exceeds a certain minimal value. Apparently the primary factor which determines the rate of phosphate entry into fertilized eggs is the rate at which phosphate is bound or combined within the cells.

The question arises as to the importance of phosphate in sea water for the development of the eggs. Both Loeb (1907) and Herbst (1898) reached the conclusion that phosphate in the medium is not necessary for normal development.



However, these investigators used artificial sea water prepared from the individual salts, which had not been specially purified, and the only criterion for the absence of phosphate was the lack of a positive test with a molybdate method which was far too insensitive. Herbst used highly dilute sea urchin egg suspensions in the order of several drops of eggs to a beaker of sea water. In view of the data presented in this paper, under such conditions even a trace of phosphate would have been sufficient to adequately supply the eggs. Eggs with a very low intracellular inorganic phosphate content, such as the eggs of *S. purpuratus* (Chambers and White, 1949) and *S. dröbachiensis* (Chambers and Mende, 1953a, 1953b), may have more need for an external source of phosphate than eggs with a high content of inorganic phosphate, such as *Arbacia punctulata* (Chambers and Mende, 1953b), and *Paracentrotus lividus* (Zielinski, 1939).

On the basis of experiments in which the rate of P<sup>32</sup> uptake by *S. purpuratus* spermatozoa was measured in a suspension containing 1.0 ml. solid sperm/liter sea water, it was found that one ml. of solid sperm takes up P<sup>32</sup> more slowly than a corresponding volume of unfertilized eggs (Chambers and White, unpublished data). Accordingly, the amount of P<sup>32</sup> which would enter the few excess spermatozoa attached to the outer surface of fertilized eggs is infinitesimal, compared to the amount actually found to enter the eggs.

*Relation to oxygen consumption.* The slow rate of P<sup>32</sup> uptake by unfertilized sea urchin eggs (two to six hours after removal from the ovaries) is observed during the period when the eggs would show a fairly constant and low rate of oxygen consumption (Borei, 1948, 1949). The prominent increase in the rate of uptake of P<sup>32</sup>, which occurs after sea urchin eggs are inseminated and represents the accumulation of phosphate within the fertilized eggs, takes place during a period when the rate of oxygen consumption increases markedly (Borei, 1948; Tyler and Humason, 1937).

Laser and Rothschild (1939) describe a marked increase in the rate of oxygen consumption of *Psammechinus miliaris* (sea urchin) eggs at 20° C. within the first five minutes after insemination, followed by a fall to the original unfertilized level within ten minutes. During the corresponding period in the eggs of sea urchins, no increase in the rate of penetration of orthophosphate was observed. However, within the first 6 to 7 minutes after insemination at 16° C., a prominent decrease in the concentration of intracellular inorganic phosphate has been noted in the eggs of *S. purpuratus* (Chambers and White, 1949) and *S. dröbachiensis* (Chambers and Mende, 1953b).

The rate of oxygen consumption of sea urchin eggs reaches a maximum some time before first cleavage (Runnström, 1933) and remains fairly constant during the next several cleavages. The rate of P<sup>32</sup> uptake (at 15° C., for both species of *Strongylocentrotus* eggs) reaches a maximum between 30 to 40 minutes before first cleavage and remains constant thereafter through the first two or three cleavage cycles.

Zeuthen (1949, 1950a, 1950b, 1951) has demonstrated that superimposed on the basic oxygen consumption curves of sea urchin eggs are definite waves of relatively small magnitude, the minima corresponding to the periods of cytoplasmic division, the maxima to the prophases. Although no alterations could be detected

in the rate of  $P^{32}$  uptake during the first few cleavages, it should be emphasized that the accuracy of the  $P^{32}$  uptake method described in this paper is such that waves of considerably greater magnitude than those described by Zeuthen would not have been detected. However, using a method of much greater accuracy, cyclic variations in the rate of  $P^{32}$  uptake have been observed during the later segmentation stages of sand dollar eggs (Chambers, White and Zeuthen in Zeuthen, 1951).

In the experiment carried out using the eggs of *Urechis caupo*, obtained from freshly collected animals, the rate of  $P^{32}$  uptake did not increase following fertilization until after the second cleavage. This may be related to the fact that an increase in the rate of oxygen consumption does not occur in these eggs, obtained from freshly collected animals, until during the later cleavage stages (Tyler and Humason, 1937; Horowitz, 1940).

Changes in the rate of oxygen consumption appear to parallel changes in the rate of accumulation of phosphate in the marine eggs studied, at least before and after fertilization and during the early cleavage stages. Following fertilization, the sea urchin eggs accumulate phosphate, since energy from oxidative processes is utilized in the synthesis of organic phosphorous-containing compounds (Chambers and Mende, 1953b).

#### SUMMARY

1. A method is described for measuring the concentration of radioactive isotope in cells without washing the cells free of the surrounding radioactive medium.

2.  $P^{32}$  as orthophosphate penetrates the unfertilized eggs of all species at a slow and constant rate.

3. During the first 10 to 15 minutes following the insemination of *Strongylocentrotus purpuratus* and *S. franciscanus* eggs, the rate of  $P^{32}$  uptake is essentially identical to that of the unfertilized eggs. The rate of uptake increases by 15 to 20 minutes, and reaches a maximum by 50 to 90 minutes after insemination. Thereafter, through the first three cleavages the rate remains constant, within the limits of error of the method, as long as the concentration of P in the medium is in excess of 20  $\mu\text{g}$  P/liter.

4. Following insemination of *Urechis caupo* eggs, the rate of  $P^{32}$  uptake does not increase. After the second cleavage, however, the rate of  $P^{32}$  uptake increases, and a maximum rate has not been attained even after the fourth cleavage.

5. When fertilized eggs containing  $P^{32}$  are suspended in non-radioactive sea water, they slowly lose  $P^{32}$  to the external medium. On the other hand, no  $P^{32}$  is lost from fertilized eggs containing radioactive phosphate when they are washed in non-radioactive sea water.

6.  $P^{32}$  is not absorbed to the extraneous coats of fertilized eggs.

7. The rate of penetration of phosphate into the unfertilized and fertilized eggs has been calculated in terms of the  $\mu\text{g}$  P entering one ml. eggs/minute. The rate at which phosphate enters fertilized *Strongylocentrotus* eggs is relatively independent of the external concentration, as long as this exceeds 20  $\mu\text{g}$  P/liter. Phosphate enters fertilized *Strongylocentrotus* eggs 86 to 132 times faster than it penetrates the unfertilized eggs.

## LITERATURE CITED

- ABELSON, P. H., 1947. Permeability of eggs of *Arbacia punctulata* to radioactive phosphorus. *Biol. Bull.*, **93**: 203.
- BOREI, H., 1948. Respiration of oocytes, unfertilized eggs, and fertilized eggs from *Psammechinus* and *Asterias*. *Biol. Bull.*, **95**: 124-150.
- BOREI, H., 1949. Independence of post-fertilization respiration in the sea-urchin egg from the level of respiration before fertilization. *Biol. Bull.*, **96**: 117-122.
- BROOKS, S. C., 1939a. Ion exchanges in accumulation and loss of certain ions by the living protoplasm of *Nitella*. *J. Cell. Comp. Physiol.*, **14**: 383-401.
- BROOKS, S. C., 1939b. Intake and loss of radioactive cations by certain marine eggs. *Proc. Soc. Exp. Biol. Med.*, **42**: 557-558.
- BROOKS, S. C., 1940. The intake of radioactive isotopes by living cells. *Cold Spring Harbor Symposia Quant. Biol.*, **8**: 171-177.
- BROOKS, S. C., 1943a. Intake and loss of ions by living cells. I. Eggs and larvae of *Arbacia punctulata* and *Asterias forbesi* exposed to phosphate and sodium ions. *Biol. Bull.*, **84**: 213-225.
- BROOKS, S. C., 1943b. Intake and loss of ions by living cells. II. Early changes of phosphate content of *Fundulus* eggs. *Biol. Bull.*, **84**: 226-239.
- BROOKS, S. C., 1951. Penetration of radioactive isotopes, P<sup>32</sup>, Na<sup>24</sup> and K<sup>42</sup> into *Nitella*. *J. Cell. Comp. Physiol.*, **38**: 83-93.
- BROOKS, S. C., AND E. L. CHAMBERS, 1948. Penetration of radioactive phosphate into the eggs of *Strongylocentrotus purpuratus*, *S. franciscanus*, and *Urechis caupo*. *Biol. Bull.*, **95**: 262-263.
- CHAMBERS, E. L., AND T. J. MENDE, 1953a. The adenosine triphosphate content of the unfertilized and fertilized eggs of *Asterias forbesii* and *Strongylocentrotus dröbachiensis*. *Arch. Biochem. Biophys.*, **44**: 46-56.
- CHAMBERS, E. L., AND T. J. MENDE, 1953b. Alterations of the inorganic phosphate and arginine phosphate content in the eggs of *Strongylocentrotus dröbachiensis* following fertilization. *Exp. Cell Research*, **5**: 508-519.
- CHAMBERS, E. L., AND W. E. WHITE, 1949. The accumulation of phosphate and evidence for synthesis of adenosine triphosphate in the fertilized sea-urchin egg. *Biol. Bull.*, **97**: 225-226.
- CHAMBERS, E. L., AND W. E. WHITE, 1954. The accumulation of phosphate by fertilized sea urchin eggs. *Biol. Bull.*, **106**: 297-307.
- CHAMBERS, ROBERT, 1940. The relation of extraneous coats to the organization and permeability of cellular membranes. *Cold Spring Harbor Symposia Quant. Biol.*, **8**: 144-153.
- HERBST, C., 1898. Über zwei Fehlerquellen beim Nachweis der Unentehrlichkeit von Phosphor und Eisen für die Entwicklung des Seeigellarven. *Arch. f. Entw.*, **7**: 486-510.
- HOROWITZ, N. H., 1940. The respiratory metabolism of the developing eggs of *Urechis caupo*. *J. Cell. Comp. Physiol.*, **15**: 299-308.
- LASER, H., AND LORD ROTHSCHILD, 1939. The metabolism of the eggs of *Psammechinus miliaris* during the fertilization reaction. *Proc. Roy. Soc. (London), Series B*, **126**: 539-557.
- LILLIE, R. S., 1916. Increase of permeability to water following normal and artificial activation in sea-urchin eggs. *Amer. J. Physiol.*, **40**: 249-266.
- LINDBERG, O., 1948. On the turnover of adenosine triphosphate in the sea-urchin egg. *Arkiv. Kemi, Mineral. Geol.*, **26B**: No. 13: 1-4.
- LOEB, J., 1907. The chemical character of the process of fertilization and its bearing upon the theory of life phenomena. *Univ. Cal. (Berkeley) Pub. Physiol.*, **3**: 61-81.
- MACGINITIE, G. E., 1935. Normal functioning and experimental behavior of the egg and sperm collectors of the echiuroid, *Urechis caupo*. *J. Exp. Zool.*, **70**: 341-355.
- MOORE, A. R., 1930. Fertilization and development without membrane formation in the egg of the sea-urchin, *Strongylocentrotus purpuratus*. *Protoplasma*, **9**: 9-17.
- NEEDHAM, J., AND D. M. NEEDHAM, 1930. On phosphorus metabolism in embryonic life. I. Invertebrate eggs. *Brit. J. Exp. Biol.*, **7**: 317-348.
- RUNNSTRÖM, J., 1933. Zur Kenntnis der Stoffwechselfvorgänge bei der Entwicklungserregung des Seeigels. *Biochem. Zeitschr.*, **258**: 257-279.

- STEWART, D. R., AND M. H. JACOBS, 1932. The effect of fertilization on the permeability of the eggs of *Arbacia* and *Asterias* to ethylene glycol. *J. Cell. Comp. Physiol.*, **2**: 275-283.
- TYLER, A., 1932. Change in volume and surface of *Urechis* eggs upon fertilization. *J. Exp. Zool.*, **63**: 155-173.
- TYLER, A., AND W. D. HUMASON, 1937. On the energetics of differentiation, VI. Comparison of the temperature coefficients of the respiratory rates of unfertilized and fertilized eggs. *Biol. Bull.*, **73**: 261-279.
- WHITELEY, A. H., 1949. The phosphorous compounds of sea-urchin eggs and the uptake of radio-phosphate upon fertilization. *Amer. Naturalist*, **83**: 249-282.
- ZEUTHEN, E., 1949. Oxygen consumption during mitosis; experiments on fertilized eggs of marine animals. *Amer. Naturalist*, **83**: 303-322.
- ZEUTHEN, E., 1950a. Respiration during cell division in the egg of the sea-urchin *Psammechinus miliaris*. *Biol. Bull.*, **98**: 144-151.
- ZEUTHEN, E., 1950b. Respiration and cell division in the egg of *Urechis caupo*. *Biol. Bull.*, **98**: 152-160.
- ZEUTHEN, E., 1951. Segmentation, nuclear growth and cytoplasmic storage in eggs of echinoderms and amphibia. *Pubbl. staz. zool. Napoli*, **23** (Suppl.): 47-69.
- ZIELINSKI, M. A., 1939. Carbohydrate metabolism and phosphorus compounds in the fertilized eggs of the sea-urchin (*Paracentrotus lividus*). *Acta Biol. Exptl. (Lodz)*, **13**, No. 4: 35-48.

# THE ACCUMULATION OF PHOSPHATE BY FERTILIZED SEA URCHIN EGGS<sup>1</sup>

EDWARD L. CHAMBERS<sup>2</sup> AND WILLIAM E. WHITE<sup>3</sup>

*Department of Zoology, University of California, Berkeley, California*

Radioactive phosphate enters fertilized sea urchin eggs far more rapidly than it enters the unfertilized eggs (Brooks and Chambers, 1948, 1954; Abelson, 1947; Lindberg, 1948; Whiteley, 1949). Investigations described in this paper demonstrate that the entry of  $P^{32}$  into the eggs represents an accumulation of phosphate within the eggs. In addition, the concentrations of P and  $P^{32}$  in the inorganic and organically bound phosphate fractions of the eggs have been measured, with the purpose of determining in which fractions the phosphate, accumulated by the fertilized eggs, is incorporated, and whether the process of accumulation is associated with alterations in the distribution of P within the eggs.

## MATERIALS AND METHODS

Eggs of the Pacific coast sea urchins *Strongylocentrotus purpuratus*, *S. franciscanus*, and *Lytechinus pictus* were prepared for use, and measurements of egg volume, and of  $P^{32}$  concentration in the eggs and suspension fluid carried out as described previously (Brooks and Chambers, 1954). The jelly was removed from the eggs by repeated washings in sea water. The sea water used in the experiments was filtered through fine mesh filter paper. The experiments were performed at  $15 \pm 0.1^\circ$  C. unless otherwise stated. The pH of the sea water in which the eggs were suspended was measured at intervals throughout the duration of the experiments, and varied between pH 8.0 to 8.2. Carrier-free  $P^{32}$ , as orthophosphate, was added to the egg suspensions in amounts which varied from 0.2 to 2  $\mu$ c  $P^{32}$ /liter of suspension. The concentration of orthophosphate in the sea water was measured using the Deniges-Atkins method (Atkins, 1923) with corrections for reagent blank and salt error (Cooper, 1938).

Trichloroacetic acid extracts of unfertilized and fertilized eggs were prepared as described by Chambers and Mende (1953a). Measurements of the P and  $P^{32}$  content of the inorganic and easily hydrolyzable phosphate fractions of the trichloroacetic acid-soluble extracts were carried out using the isobutyl alcohol extraction method of Borbiri and Szent-Györgyi (1949). After measurement of the phosphomolybdate concentration in the isobutyl alcohol extracts, aliquots were pipetted into flat dishes, evaporated, and the  $P^{32}$  concentration measured using a Geiger-Müller counter. In all experiments described in this paper samples of the egg

<sup>1</sup> This investigation was supported by a research grant (C-559) to the University of California, at Berkeley, from the National Cancer Institute of the National Institutes of Health, U. S. Public Health Service. Preliminary reports of the research described in this paper have been published (Chambers, Whiteley, Chambers and Brooks, 1948; Chambers and White, 1949).

<sup>2</sup> Now at the University of Oregon Medical School, Portland 1, Oregon.

<sup>3</sup> Now at the University of Kansas Medical School, Kansas City, Kansas.

suspensions, as originally prepared, were kept for observation. If the suspension was of unfertilized eggs, these were inseminated at the completion of the experiment. Over 95 per cent of the eggs in these samples developed to normal swimming gastrulae.

### RESULTS

#### *Removal of P and P<sup>32</sup> from the suspension fluid, and uptake of P<sup>32</sup> by the eggs in suspensions of sea urchin eggs*

Suspensions of unfertilized and fertilized eggs were prepared in filtered sea water containing 2.5 to 5.6 ml. eggs/liter. Small quantities of orthophosphate and P<sup>32</sup> were added to the suspensions. The initial concentration of orthophosphate in the suspension fluid varied between less than 4 µg to 78 µg P/liter, and the initial concentration of P<sup>32</sup> from 0.23 to 0.28 µc/liter.

*Unfertilized eggs.* The results obtained using suspensions of unfertilized *S. purpuratus* eggs are shown in Table I. Measurements of P and P<sup>32</sup> concentrations were begun two hours after the eggs had been removed from the ovaries. In Experiments 1, 2 and 3 the concentration of P in the external medium increased,

TABLE I

*Concentration of P in the suspension fluid of a suspension of unfertilized S. purpuratus eggs. Experiments 1 to 5*

Expt. No.	Ml. eggs/l. suspension	Time between P analyses in minutes	Initial P conc., µg/l. susp. fluid	Final P conc., µg/l. susp. fluid	µg P lost/ml. eggs min.	µg P entering/ml. eggs/min.
1	5.6	97	38	55	0.032	0.0011
2	4.1	120	8	20	0.024	—
3	4.7	312	30	56	0.019	—
4	5.5	115	4	5	0.0	—
5	2.5	159	78	78	0.0	0.0026

while in Experiments 4 and 5 no appreciable change in the P concentration could be detected (Table I, columns 4, 5 and 6). There was no measurable change in concentration of P<sup>32</sup> in the suspension fluid in any of the experiments. In Experiments 1 and 5 the uptake of P<sup>32</sup> by the eggs was measured and the quantity of P entering one ml. eggs/minute calculated (Table I, column 7), as previously described by Brooks and Chambers (1954). The results reveal that P enters unfertilized eggs whether or not the eggs simultaneously lose P to the external medium. At the completion of the experiments the unfertilized eggs were inseminated, and they developed normally through the gastrula stage.

*Fertilized eggs.* The results obtained using suspensions of fertilized *S. purpuratus* and *S. franciscanus* eggs are shown in Tables II and III, and Figure 1. The eggs were inseminated two hours after removal from the ovaries, washed free of spermatozoa by gentle centrifugation, and suspended in sea water containing known concentrations of orthophosphate and P<sup>32</sup>.

In Experiment 6 (Table II, Fig. 1) at 20.5 minutes after insemination 2.5 ml. of *S. purpuratus* eggs were suspended in a liter of sea water containing 78 µg P/liter. A prominent decrease in concentration of P and P<sup>32</sup> in the medium occurred (Expt.

6, Table II, columns 2 and 4, and Fig. 1). The rate of uptake of  $P^{32}$  by the eggs (Table II, column 6) was identical to the rate of disappearance of P and of  $P^{32}$  from the medium (Table II, compare columns 3, 5 and 7). The initial lag in the disappearance of orthophosphate and of  $P^{32}$  from the medium (Fig. 1, Expt. 6, from 0 to 30 minutes) is due to the fact that the uptake of P by fertilized eggs does not reach a maximum until about one hour after insemination (Brooks and Chambers, 1954). Subsequently, orthophosphate is removed from the medium at a constant rate until the concentration falls to 15 to 20  $\mu\text{g}$  P/liter (Fig. 1, Expt. 6). The rate of uptake then falls off sharply.

TABLE II  
Concentration of P and  $P^{32}$  in the suspension fluid, and of  $P^{32}$  in the eggs in suspensions of fertilized eggs.

Experiments 6 and 7

Time after initial measurement in minutes	$\mu\text{g}$ P/l. susp. fluid	Per cent initial P conc. in susp. fluid	CPM $P^{32}$ /l. susp. fluid	Per cent initial $P^{32}$ conc. in susp. fluid	CPM $P^{32}$ in eggs/l. suspension	Per cent initial $P^{32}$ conc. in eggs
Experiment 6. <i>S. purpuratus</i> eggs						
0.0*	78	100.0	61,000	100.0	0	0.0
17.5	75	96.0	56,600	92.6	4,780	7.8
60.5	48	61.5	36,780	60.2	24,900	40.8
91.5	22	28.2	16,960	27.8	42,920	70.5
129.5	6	7.7	6,600	10.8	54,480	90.0
213.0	<2	<3.0	3,200	5.2	58,140	95.5
387.5	<2	<3.0	2,360	3.8	—	—
Experiment 7. <i>S. franciscanus</i> eggs						
0.0†	53.5	100.0	76,000	100.0	0	0.0
31.0	40.0	74.8	62,000	81.6	15,200	20.0
68.0	27.5	51.4	—	—	—	—
139.0	10.0	18.7	17,160	22.6	57,380	75.4
192.0	5.0	9.3	9,200	12.1	67,020	88.0

\* Eggs inseminated 20.5 minutes before initial measurement.

† Eggs inseminated 63 minutes before initial measurement.

In Experiment 7 (Table II, Fig. 1) at 63 minutes after insemination 3.5 ml. of *S. franciscanus* eggs were suspended in a liter of sea water containing 53.5  $\mu\text{g}$  P/liter. The results are similar to those obtained in Experiment 6. The eggs remove orthophosphate from the external medium at a constant rate until the concentration falls below 20  $\mu\text{g}$  P/liter, when the rate of uptake by the eggs falls off sharply (Fig. 1).

In Experiment 8 (Table III) at 43 minutes after insemination 4.9 ml. of *S. franciscanus* eggs were suspended in a liter of sea water. The P and  $P^{32}$  concentrations in the suspension fluid were measured at the beginning and at the end of successive 30-minute periods. Additional amounts of P and  $P^{32}$  were added to replenish the external medium prior to each 30-minute period. As in the two

previous experiments, the decrease in concentration of  $P^{32}$  parallels the decrease in concentration of P in the suspension fluid (Table III, columns 6 and 7). The results show that as long as the concentration of orthophosphate is over 18 to 20  $\mu\text{g}$  P/liter, the rate of uptake of P and  $P^{32}$  remains fairly constant during the first 430 minutes after insemination (Table III, column 8).

*Distribution of  $P^{32}$  between the trichloroacetic acid-soluble and -insoluble fractions of the eggs*

Suspensions of *Lytechinus pictus* eggs were prepared containing one ml. eggs/liter of sea water maintained at a temperature of 20 to 21° C. Two hours after

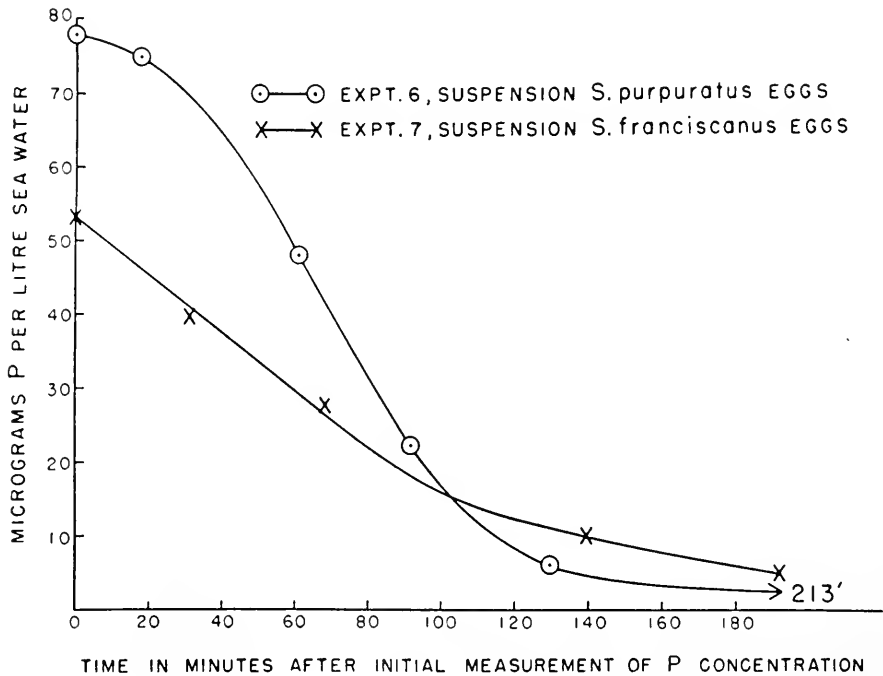

FIGURE 1.

the eggs had been removed from the ovaries, carrier-free  $P^{32}$  was added. At various intervals of time duplicate 20-ml. samples of the suspension were removed, the eggs washed three times by centrifugation at  $86 \times g$  for three minutes in non-radioactive sea water, the supernatant sea water decanted, an equal volume of ice cold 10 per cent trichloroacetic acid added to each of the duplicate samples, the trichloroacetic acid-soluble and -insoluble fractions separated, and the  $P^{32}$  content of the fractions measured.

In unfertilized eggs, between 95.7 to 95.9 per cent of the  $P^{32}$  was recovered in the trichloroacetic acid-soluble extracts, with 4.1 to 4.3 per cent in the acid-insoluble fractions, after the eggs had been exposed to  $P^{32}$  for two hours.

In the process of washing the unfertilized eggs in non-radioactive sea water



prior to homogenization, from 4 to 8 per cent of the  $P^{32}$  initially present in the eggs was removed. The effect of this loss of  $P^{32}$  is to decrease the relative proportion of  $P^{32}$  contained in the trichloroacetic acid-soluble extracts of the washed eggs by 0.2 to 0.3 per cent.

In experiments carried out using fertilized eggs, the eggs were inseminated two hours after removal from the ovaries and  $P^{32}$  was added at the time of insemination. In eggs exposed to  $P^{32}$  for a period of 45 to 120 minutes after insemination, and washed for a period of 20 to 30 minutes in non-radioactive sea water, 96.3 to 96.4 per cent of the  $P^{32}$  was found in the trichloroacetic acid-soluble extracts, and 3.6 to 3.7 per cent in the acid-insoluble residue. No appreciable quantity of  $P^{32}$  is lost from fertilized eggs when washed in non-radioactive sea water (Brooks and Chambers, 1954). The slightly lower proportion of  $P^{32}$  in the acid-insoluble fraction of fertilized eggs, as compared to the unfertilized, may be entirely due to the loss of  $P^{32}$  from the unfertilized eggs when they are washed prior to homogenization.

TABLE III

*Suspension of fertilized S. franciscanus eggs. Disappearance of P and  $P^{32}$  from the suspension fluid during thirty-minute periods, following successive additions of P and  $P^{32}$ . Experiment 8*

Time after insemin., in 30 minute intervals	Initial concentration:		Final concentration:		Per cent decrease P conc.	Per cent decrease $P^{32}$ conc.	$\mu\text{g P/ml. eggs/min.}$
	$\mu\text{g P/l.}$	CPM $P^{32}/l.$	$\mu\text{g P/l.}$	CPM $P^{32}/l.$			
50 to 80	63.5	598,000	41.0	356,000	35	37	0.15
110 to 140	50.5	473,000	25.7	248,000	49	48	0.17
160 to 190	47.0	—	23.5	—	50	—	0.16
210 to 240	57.0	578,000	35.8	350,000	37	39	0.14
290 to 320	38.5	385,000	18.0	214,000	53	45	0.14
325 to 355	(16.0)	(220,000)	(10.0)	(140,200)	(37)	(35)	(0.04)
400 to 430	57.5	550,000	30.7	286,000	47	48	0.18

In a series of experiments, after exposing the inseminated eggs to  $P^{32}$  for 50 minutes and washing, the eggs were allowed to develop 400 minutes in non-radioactive sea water to the early blastula stage prior to homogenization. No  $P^{32}$  was lost from the fertilized eggs during the long period of development in the sea water free of  $P^{32}$ , even though the medium surrounding the eggs was repeatedly replaced by fresh sea water. The quantity of  $P^{32}$  found in the acid-soluble extract amounted to 93.0 per cent of the total, with 7.0 per cent in the acid-insoluble fraction, as compared to 96.4 and 3.6 per cent, respectively, in the corresponding experiment on fertilized eggs homogenized immediately after washing. The experiment reveals that a substantial portion of the phosphate, initially accumulated in the eggs, becomes incorporated in the acid-insoluble fraction. This conclusion is based on the consistency with which a lower percentage of  $P^{32}$  was found in the acid-insoluble residue of fertilized eggs continuously exposed to  $P^{32}$ .

In the control experiment  $P^{32}$  was added only after the eggs had been suspended in trichloroacetic acid. Even after repeated washing of the acid-insoluble residue with trichloroacetic acid, 1.0 per cent of the  $P^{32}$  was retained in this fraction. This experiment indicates that the quantity of  $P^{32}$  organically combined in the acid-

insoluble residue is probably less by at least one per cent than the quantities actually found.

The distribution of  $P^{32}$  between the trichloroacetic acid-soluble and -insoluble fractions of *S. purpuratus* eggs, both unfertilized (four experiments) and fertilized (six experiments) is essentially identical to that found in the eggs of *Lytechinus pictus*.

Lipids and phospholipids were extracted from the acid-insoluble residue of the fertilized *L. pictus* eggs. The acid-insoluble residue, after complete extraction with a mixture of three volumes ethanol and one volume ether, retained 92.1 per cent of the original  $P^{32}$  content. The ethanol-ether extract was dried, and the residue extracted with petroleum ether. The petroleum ether fraction containing the phospholipids accounted for 7.5 per cent of the total  $P^{32}$  content of the trichloroacetic acid-insoluble fraction. The remaining 0.5 per cent was in the petroleum ether-insoluble fraction.

TABLE IV

*Distribution of P and P<sup>32</sup> in the acid-soluble extracts of Strongylocentrotus purpuratus eggs. Experiments 9, 10 and 11*

Expt. No.	Condition of eggs	$\mu\text{g P/ml. eggs} \pm \text{std. dev.}$			Per cent total $P^{32}$ :		
		Inorg. P	Labile P	Inorg. +labile P	Inorg. $P^{32}$	Labile $P^{32}$	Acid stable $P^{32}$
9	Unfertilized	58 $\pm$ .6	408 $\pm$ 4	466 $\pm$ 4	24	66	10
	Fertilized	16 $\pm$ .2	456 $\pm$ 5	472 $\pm$ 5	6	88	6
10	Unfertilized	69 $\pm$ .7	415 $\pm$ 4	484 $\pm$ 5	—	—	—
	Fertilized	34 $\pm$ .4	451 $\pm$ 5	485 $\pm$ 5	8	84	8
11	Unfertilized	77 $\pm$ .8	460 $\pm$ 5	537 $\pm$ 5	—	—	—
	Fertilized	39 $\pm$ .4	496 $\pm$ 5	535 $\pm$ 5	9	84	7

*Distribution of P and P<sup>32</sup> in the trichloroacetic acid-soluble extracts of S. purpuratus eggs*

The quantities of inorganic P and P liberated after 10 minutes' hydrolysis in 1 N HCl at 100° C. in the trichloroacetic acid-soluble extracts of unfertilized and fertilized eggs were determined. The results of three representative experiments are shown in Table IV, Experiments 9, 10 and 11. Five ml. of *S. purpuratus* eggs were suspended in a liter of sea water containing 20 to 50  $\mu\text{g P}$  as orthophosphate/liter. The suspension was divided into two equal lots. Carrier-free  $P^{32}$ , 1  $\mu\text{c}/100$  ml. suspension, was added to one lot of unfertilized eggs one hour after removal from the ovaries. The other lot was inseminated two hours after the eggs had been removed from the ovaries, and at the same time duplicate 100-ml. samples were removed from the suspension of unfertilized eggs, centrifuged, and the trichloroacetic acid extracts prepared. Thirty minutes after insemination 0.1  $\mu\text{c P}^{32}/100$  ml. suspension was added to the fertilized eggs, and at 60 minutes after insemination, duplicate 100-ml. samples were removed, the fertilized eggs washed twice in non-radioactive sea water by centrifugation, and the trichloroacetic acid extracts pre-

pared. The results show that following insemination, a prominent decrease in the concentration of inorganic P occurs within the eggs (Table IV, column 3), and at the same time a corresponding increase in the concentration of P liberated after hydrolysis (Table IV, column 4). Within the errors of the measurements, the sum of the inorganic P and P liberated after hydrolysis is the same both before and after insemination (Table IV, column 5).

The distribution of  $P^{32}$  between the various P fractions in the trichloroacetic acid extracts is shown in Table IV, columns 6, 7 and 8. The results reveal that the major portion of the  $P^{32}$  is associated with easily hydrolyzable organic P compounds. Following insemination, with the accompanying decrease in quantity of inorganic P and the increase in amount of P liberated after hydrolysis, the proportion of  $P^{32}$  in the easily hydrolyzable P fraction increases markedly. The proportion of  $P^{32}$  in the acid-stable P compounds is small, in spite of the fact that Whiteley (1949) reports the presence, in trichloroacetic acid extracts, of 511  $\mu\text{g}$  acid-stable P/ml. *S. purpuratus* eggs, which amounts to approximately one-half of the total P content in the acid-soluble extract.

#### DISCUSSION

The experiments presented in this paper establish conclusively that the entry of  $P^{32}$  into the fertilized eggs quantitatively measures the accumulation of orthophosphate within the eggs. However,  $P^{32}$  probably enters unfertilized eggs by an exchange process, since the quantity of orthophosphate in the medium surrounding the eggs either remains constant, or slowly increases. Measurements of the distribution of  $P^{32}$  in the trichloroacetic acid-soluble extracts of the eggs reveal that in both unfertilized and fertilized eggs the  $P^{32}$  is confined primarily to the intracellular inorganic phosphate fraction and the easily hydrolyzable organic P compounds. In fertilized eggs, between 84 to 88 per cent of the  $P^{32}$  entering the eggs is found in the easily hydrolyzable fraction, indicating that the accumulation of phosphate by fertilized eggs involves primarily its incorporation in the easily hydrolyzable P compounds.

In cells actively metabolizing substrate the intracellular inorganic phosphate concentration may be markedly lower than in slowly metabolizing cells, devoid of or with a limited supply of substrate (yeast: MacFarlane, 1936, 1939; bacteria: Wiggert and Werkman, 1938, O'Kane and Umbreit, 1942; brain tissue: Schachner *et al.*, 1942; retinal tissue: Bumm and Fehrenbach, 1931; liver: Lundsgaard, 1938). Furthermore, many investigators have shown that orthophosphate rapidly enters and accumulates in actively metabolizing cells (diatoms: Ketchum, 1939a, 1939b; yeast: Hevesy *et al.*, 1937, Mullins, 1942; bacteria: Vogler and Umbreit, 1942, Wiggert and Werkman, 1938, O'Kane and Umbreit, 1942, Hotchkiss, 1946; brain tissues: Schachner *et al.*, 1942). When the same cells are devoid of substrate, phosphate ions enter slowly and the cells may even lose phosphate to the external medium.

Unfertilized sea urchin eggs, at least after a period of sojourn in sea water, present the picture of cells with limited available or utilizable substrate. They possess a characteristically low metabolic rate (Borei, 1948), have a high inorganic phosphate content, a relatively low content of easily hydrolyzable P (see also

Chambers and Mende, 1953b), may slowly lose phosphate to the external medium, and P penetrates the eggs at an extremely slow rate (Brooks and Chambers, 1954). However, after the eggs are fertilized, the eggs behave as if an abundant supply of substrate had been made available, or had become utilizable. The oxygen consumption increases, the inorganic phosphate content of the eggs is strikingly lowered, the quantity of easily hydrolyzable P increases (see also Chambers and Mende, 1953b), and the eggs now accumulate phosphate, absorbing it from the external medium.

The fertilized eggs would appear to accumulate orthophosphate against a concentration gradient of a thousand-fold or more (compare column 2, Tables II and III with column 3, Table IV). This, however, is unlikely since the analytically determined inorganic P content of cells probably represents, in addition to the true intracellular ionic orthophosphate, hydrolysis products of highly labile phosphate esters and orthophosphate which, in the living cell, had been present in undissociated salt-like complexes. The binding of orthophosphate by electrostatic forces has been shown to occur, for example, in the protein aldolase (Velick, 1949). Denaturation of proteins may abolish their ability to bind anions (Klotz and Urquhart, 1949). Furthermore, the anions of an extracting agent, such as trichloroacetic acid, would tend to displace phosphate ions which, in the living cells, had been present in undissociated salt-like complexes and in equilibrium with free orthophosphate ions. It is proposed that in the living sea urchin eggs the actual concentration of free ionic orthophosphate is only a fraction of the analytically determined inorganic P. Following fertilization of the eggs, along with the demonstrated decrease in concentration of the analytically determined inorganic P, the concentration of free orthophosphate ions in the egg protoplasm may be reduced to such a low order of magnitude as to favor the entry of orthophosphate from the external medium.

The hypothesis has been advanced that the penetration of orthophosphate into cells requires esterification at the cell surface. The marked effects of changes in temperature and of certain metabolic inhibitors (Kamen and Spiegelman, 1948, Villet *et al.*, 1949) on the rate of penetration of orthophosphate have been cited in support of this hypothesis. However, Jacobs and co-workers (1935) have emphasized that changes in temperature may cause marked shifts in "equilibrium" states, and such alterations would have to be taken into account before the effects of temperature changes on the rate of penetration of orthophosphate could be properly evaluated. Similarly, metabolic inhibitors must induce profound changes in "equilibrium" states within cells. For example, Spiegelman, Kamen and Sussman (1948) have shown that azide prevents the decrease in concentration of intracellular inorganic P which normally occurs when yeast ferments glucose.

The claim has also been made that orthophosphate must enter cells by a process of esterification at the cell surface, since the specific activity of the P in certain organic compounds may be higher than that of the intracellular inorganic P (*e.g.*, Lindberg, 1950). Such an interpretation from specific activity measurements is open to serious question, since the analytically determined inorganic P of cells is undoubtedly derived from several different components, and does not represent the true ionic orthophosphate content of the living cell.

The observed great differences in the rates of penetration of orthophosphate into cells at different levels of metabolic activity may just as well be explained by

changes in "driving forces" such as the rate at which orthophosphate is esterified within the cells, and changes in the concentration gradient of free orthophosphate ions.

The authors desire to thank Miss Nylan Jeung for technical assistance during the course of this investigation.

#### SUMMARY

1. The concentration of phosphate in the external medium of a suspension of unfertilized *Strongylocentrotus* eggs remains constant, or increases, while in a suspension of fertilized eggs, the concentration of phosphate in the external medium decreases.

2. Fertilized *Strongylocentrotus* eggs absorb  $P^{32}$  and phosphate from sea water at identical rates, revealing that the exchange of phosphate between the cell interior and the external medium is inappreciable.

3. The rate at which phosphate is removed from sea water by fertilized *Strongylocentrotus* eggs is relatively independent of the external concentration as long as this exceeds 15 to 20 micrograms P per liter.

4. When unfertilized and fertilized sea urchin eggs are continuously exposed to sea water containing  $P^{32}$  and more than 20 micrograms P per liter, 95.9 to 96.4 per cent of the  $P^{32}$  which enters the eggs is found in the trichloroacetic acid-soluble fraction, with 3.6 to 4.1 per cent of the  $P^{32}$  being recovered in the acid-insoluble fraction. The distribution of  $P^{32}$  between these two fractions is not significantly different in the unfertilized, as compared to the fertilized eggs. Although a slightly lower proportion of  $P^{32}$  was found in the acid-insoluble residue of unfertilized eggs, outward leaching of  $P^{32}$  during the washing of the unfertilized eggs may well account for the difference noted.

5. If fertilized *Lytechinus pictus* eggs containing  $P^{32}$  are suspended in a non-radioactive medium shortly after insemination, the proportion of  $P^{32}$  in the acid-insoluble fraction increases from 3.6 per cent at the two-celled stage to 7.0 per cent at the blastula stage.

6. The concentration of inorganic P in the trichloroacetic acid-soluble extracts of the eggs decreases prominently following insemination. A corresponding increase occurs in the quantity of P liberated after 10 minutes' hydrolysis of the extracts in 1 N HCl at 100° C.

7. The major portion of the  $P^{32}$  which enters the eggs is found in the easily hydrolyzable P fraction of the trichloroacetic acid-soluble extracts. After fertilization, the proportion of  $P^{32}$  in the easily hydrolyzable P fraction increases.

#### LITERATURE CITED

- ABELSON, P. H., 1947. Permeability of eggs of *Arbacia punctulata* to radioactive phosphorus. *Biol. Bull.*, **93**: 203.
- ATKINS, W. R. G., 1923. The phosphate content of fresh and salt waters in its relationship to the growth of the algal plankton. *J. Marine Biol. Assoc. U. K.*, **13**: 119-150.
- BORBIRO, M., AND A. SZENT-GYÖRGYI, 1949. On the relation between tension and ATP in cross striated muscle. *Biol. Bull.*, **96**: 162-165.
- BOREI, H., 1948. Respiration of oocytes, unfertilized eggs, and fertilized eggs from *Psammechinus* and *Asterias*. *Biol. Bull.*, **95**: 124-150.

- BROOKS, S. C., AND E. L. CHAMBERS, 1948. Penetration of radioactive phosphate into the eggs of *Strongylocentrotus purpuratus*, *S. franciscanus*, and *Urechis caupo*. *Biol. Bull.*, **95**: 262-263.
- BROOKS, S. C., AND E. L. CHAMBERS, 1954. The penetration of radioactive phosphate into marine eggs. *Biol. Bull.*, **106**: 279-296.
- BUMM, E., AND K. FEHRENBACH, 1931. Über verschiedene Wege des Zuckerabbaues im tierischen Organismus II. *Hoppe-Seyler's Zeitschr. physiol. Chem.*, **195**: 101-112.
- CHAMBERS, E. L., AND T. J. MENDE, 1953a. The adenosine triphosphate content of the unfertilized and fertilized eggs of *Asterias forbesii* and *Strongylocentrotus dröbachiensis*. *Arch. Biochem. and Biophys.*, **44**: 46-56.
- CHAMBERS, E. L., AND T. J. MENDE, 1953b. Alterations of the inorganic phosphate and arginine phosphate content in the eggs of *Strongylocentrotus dröbachiensis* following fertilization. *Exp. Cell Research*, **5**: 508-519.
- CHAMBERS, E. L., AND W. E. WHITE, 1949. The accumulation of phosphate and evidence for the synthesis of adenosine triphosphate in fertilized sea urchin eggs. *Biol. Bull.*, **97**: 225-226.
- CHAMBERS, E. L., A. WHITELEY, R. CHAMBERS AND S. C. BROOKS, 1948. Distribution of radioactive phosphate in the eggs of the sea urchin *Lytechinus pictus*. *Biol. Bull.*, **95**: 263.
- COOPER, L. H. N., 1938. Salt error in determinations of phosphate in sea water. *J. Marine Biol. Assoc. U. K.*, **23**: 171-178.
- HEVESY, G., K. LINDERSTRÖM-LANG AND N. NIELSEN, 1937. Phosphorous exchange in yeast. *Nature*, **140**: 725.
- HOTCHKISS, R. D., 1946. Gramicidin, tyrocidine and tyrothricin. *Advances in Enzymol.*, **4**: 153-199.
- JACOBS, M. H., H. N. GLASSMAN AND A. K. PARPART, 1935. Osmotic properties of the erythrocyte. VII. The temperature coefficients of certain hemolytic processes. *J. Cell. Comp. Physiol.*, **7**: 197-225.
- KAMEN, M. D., AND S. SPIEGELMAN, 1948. Studies on the phosphate metabolism of some unicellular organisms. *Cold Spring Harbor Symposia Quant. Biol.*, **13**: 151-163.
- KETCHUM, B. H., 1939a. The absorption of phosphate and nitrate by illuminated cultures of *Nitzschia closterium*. *Amer. J. Bot.*, **26**: 399-407.
- KETCHUM, B. H., 1939b. The development and restoration of deficiencies in the phosphorus and nitrogen composition of unicellular plants. *J. Cell. Comp. Physiol.*, **13**: 373-381.
- KLOTZ, I. M., AND J. M. URQUHART, 1949. The binding of organic ions by proteins. Comparison of native and of modified proteins. *J. Amer. Chem. Soc.*, **71**: 1597-1603.
- LINDBERG, O., 1948. On the turnover of adenosine triphosphate in the sea-urchin egg. *Arkiv Kemi. Mineral. Geol.*, **26B**: No. 13, 1-4.
- LINDBERG, O., 1950. On surface reactions in the sea urchin egg. *Exp. Cell Research*, **1**: 105-114.
- LUNDGAARD, E., 1938. The phosphate exchange between blood and tissue in experiments with artificially perfused livers and hind limb preparations. *Skand. Arch. Physiol.*, **80**: 291-302.
- MACFARLANE, M. G., 1936. CXCv. Phosphorylation in living yeast. *Biochem. J. (London)*, **30**: 1369-1379.
- MACFARLANE, M. G., 1939. LXX. The phosphorylation of carbohydrate in living cells. *Biochem. J. (London)*, **33**: 565-578.
- MULLINS, L. J., 1942. Permeability of yeast cells to radiophosphate. *Biol. Bull.*, **83**: 326-333.
- O'KANE, D. J., AND W. W. UMBREIT, 1942. Transformations of phosphorous during glucose fermentation by living cells of *Streptococcus faecalis*. *J. Biol. Chem.*, **142**: 25-30.
- SCHACHNER, H., B. A. FRIES AND I. L. CHAIKOFF, 1942. The effect of hexoses and pentoses on the formation in vitro of phospholipids by brain tissue as measured with radioactive phosphorus. *J. Biol. Chem.*, **146**: 95-103.
- SPIEGELMAN, S., M. D. KAMEN AND M. SUSSMAN, 1948. Phosphate metabolism and dissociation of anaerobic glycolysis from synthesis in the presence of sodium azide. *Arch. Biochem.*, **18**: 409-436.
- VELICK, S. F., 1949. The interaction of enzymes with small ions. *J. Phys. Colloid Chem.*, **53**: 135-149.

- VILLEE, C. A., M. LOWENS, M. GORDON, E. LEONARD AND A. RICH, 1949. The incorporation of  $P^{32}$  into nucleoproteins and phosphoproteins of the developing sea-urchin embryo. *J. Cell. Comp. Physiol.*, **33**: 93-112.
- VOGLER, K. G., AND W. W. UMBREIT, 1942. Studies on the metabolism of autotrophic bacteria. III. The nature of the energy storage material active in the chemosynthetic process. *J. Gen. Physiol.*, **26**: 157-167.
- WHITELEY, A. H., 1949. The phosphorus compounds of sea-urchin eggs and the uptake of radio-phosphate upon fertilization. *Amer. Naturalist*, **83**: 249-267.
- WIGGERT, W. P., AND C. H. WERKMAN, 1938. XVIII. Phosphorylation by the living bacterial cell. *Biochem. J. (London)*, **32**: 101-107.

A STUDY OF THE MECHANISM INVOLVED IN SHIFTING OF  
THE PHASES OF THE ENDOGENOUS DAILY RHYTHM  
BY LIGHT STIMULI

FRANK A. BROWN, JR.,<sup>1</sup> MILTON FINGERMAN AND MARGARET N. HINES

*Department of Biological Sciences, Northwestern University, and  
The Marine Biological Laboratory, Woods Hole, Mass.*

A persistent diurnal rhythm of color change in the fiddler crab, *Uca*, was first reported by Abramowitz in 1937, and has been abundantly confirmed by numerous investigators since that time. The character of the chromatophore rhythm is such that the crabs darken by day and blanch by night owing to dispersion and concentration, respectively, of the melanin within their melanophores. This rhythm has been discussed most recently and described in considerable detail by Brown, Fingerman, Sandeen and Webb (1953). These investigators demonstrated that the rhythm not only persists for long periods in constant darkness, but actually increases in amplitude to reach a maximum value only after ten days to two weeks. This high value was then observed to persist without diminution for the longest period of observation which was about a month. Furthermore, there appeared to be no measurable drift of the rhythm away from its normal phase relations with solar day-night, indicating the mechanism to have a remarkable precision of frequency determination. This frequency was shown by Brown and Webb (1948) to be independent of temperature over the twenty degree range from 6 to 26° C.

Although the mechanism appears to be a moderately stable one in the fiddler crab, it was shown by Brown and Webb (1949), Webb (1950), and Brown, Fingerman, Sandeen and Webb (1953) to be capable of having its phases readily shifted by light-to-dark and dark-to-light changes under certain circumstances. Examples of these shifts are (1) a backward shift of 4 to 5 hours in the phases of the rhythm by three consecutive midnight-to-6 A.M. periods of illumination of animals otherwise in continuous darkness, (2) a forward shift of about 6 hours in animals whose rhythm had been inhibited by several days sojourn in continuous bright illumination and then were placed in constant darkness at 7 A.M., and (3) a shift of about twelve hours, or in other words a reversal, of phases by a few cycles of illumination from 7 P.M. to 7 A.M. and darkness from 7 A.M. to 7 P.M. Brown and Webb (1949) using illuminations of 150, 80, and 50 ft. c. found that the brighter the light the sooner the reversal. With the highest illumination, reversal occurred on the first day and with 40 ft. c. it occurred on the fourth. Once shifted, the rhythms are as stable in their new phase relations as they were in their original normal ones.

The experiments to be described were performed in order to gain further insight into the mechanism involved in inducing persistent shifts and certain other modifications in the endogenous diurnal rhythm.

<sup>1</sup> This investigation was supported by a research grant from the graduate school of Northwestern University.



## MATERIALS AND METHODS

For the experiments to be described, 400 fiddler crabs were collected at Chapoquoit, near Woods Hole, Massachusetts at about three o'clock on the afternoon of June 24, 1952. They were kept in the natural daylight of the laboratory until 7:00 P.M. when they were divided into sixteen groups of 25 crabs each and placed in white enamelled pans in sea water to a depth of about a centimeter. One group, the control one, whose normal rhythm was to be determined was placed in darkness and left for the duration of the experiment. The remaining fifteen groups, the experimental ones, were placed in the conditions of illumination to which they were to be exposed during the night (7 P.M. to 7 A.M.) and the next morning placed in the lower illumination or darkness to which they were to be exposed by day (7 A.M. to 7 P.M.).

The illuminations for the experiments were obtained by frosted incandescent lamps of various wattages held at different distances above the white pans containing the animals. The illuminations were measured with a Weston photometer. The nighttime-daytime illuminations for the fifteen groups of animals subjected to the alternating illuminations were, in ft. candles, respectively: (1) 100-80, (2) 100-50, (3) 100-10, (4) 100-2, (5) 100-0, (6) 50-10, (7) 50-5, (8) 50-2, (9) 25-10, (10) 25-5, (11) 25-2, (12) 10-5, (13) 10-2, (14) 5-2, (15) 2-0.

The temperatures in the inside rooms of the Marine Biological Laboratory in which the experiments were carried on did not show any significant diurnal variation, and there was an irregular variation of only three or four degrees at most during the course of the eleven days in which the experiment was carried out. All the animals, furthermore, both experimentals and controls, were subjected to essentially the same temperature conditions other than the rhythmic differences in heat radiation during the periods of illumination.

The experimental groups were subjected to the twelve-hour alternating conditions of illumination for six days; at 7 P.M. on June 30, they were placed in constant darkness. Beginning at 11 P.M. and continuing at six-hour intervals (11 P.M., 5 A.M., 11 A.M., 5 P.M., . . .) for four daily cycles the average chromatophore stage of ten crabs randomly sampled from the fifteen experimental groups and the controls were staged by the method of Hogben and Slome (1931). Through the next or fifth daily cycle the chromatophores were staged at hourly intervals.

## EXPERIMENTS AND RESULTS

A summary of the results is found in Table I.

1. *Controls*: The control group possessed a high-amplitude rhythm at the time the staging of chromatophores commenced and showed no significant increase during the five-day period of study. The highest value was found at 11 A.M., and the lowest at 11 P.M. in every daily cycle.

2. *100-80 ft. c.*: In these, it is evident that there was a strong initial depression of rhythm-amplitude, which rapidly diminished during the five days. In every cycle the maximum stage was now at 5 A.M. and the minimum at 5 P.M.

3. *100-50 ft. c.*: This group, unlike the preceding, exhibited little or no initial amplitude depression nor increase during the period of observation. It resembled the preceding in having the maximum average stage always at 5 A.M. and the minimum at 5 P.M.

TABLE I

The average stage of melanin dispersion at each of four times of day, under constant conditions, for *Uca* which were earlier subjected to five days of higher illumination by night and lower illumination by day

Illum. (ft. c.)	11 P.M.	5 A.M.	11 A.M.	5 P.M.	Illum. (ft. c.)	11 P.M.	5 A.M.	11 A.M.	5 P.M.
Control	1.0†	2.3	5.0*	3.8	50-2	2.7*	1.0†	1.6	1.8
	1.0†	1.9	4.7*	4.1		2.8*	1.4	1.0†	1.6
	1.2†	1.9	4.5*	3.5		3.4*	1.3†	1.9	2.8
	1.1†	2.4	4.7*	4.4		3.0*	1.1†	1.9	2.4
	1.3†	3.1	4.5*	3.5		4.0*	1.4†	1.9	3.9
100-80	1.3	1.8*	1.3	1.0†	25-10	1.1†	1.9*	1.8	1.6
	1.2	1.2*	1.0	1.0†		1.0†	2.0*	1.7	1.3
	1.3	3.6*	2.9	1.1†		1.2†	3.2*	3.2	2.3
	1.9	4.3*	3.0	1.1†		1.6†	3.2	4.2*	1.7
	2.3	4.0*	2.3	1.0†		1.3†	3.7*	2.7	1.7
100-50	3.4	4.7*	2.2	1.2†	25-5	1.2†	1.3	2.2	2.4*
	2.4	4.2*	1.7	1.2†		2.3	2.1†	2.1	2.5*
	3.4	4.2*	3.5	1.1†		2.2†	2.9	3.9*	3.2
	3.0	4.5*	2.7	1.2†		2.4†	3.1	4.0*	4.0*
	3.4	3.8*	3.1	1.4†		1.8†	2.9	2.8	3.5*
100-10	3.5*	3.0	1.6	1.0†	25-2	1.3	1.0†	1.2	1.3*
	1.8	3.0*	1.4	1.0†		1.3	1.0†	1.3	1.3*
	2.8	3.6*	2.7	1.2†		1.4	1.0†	2.0	2.6*
	2.5	3.1*	1.6	1.0†		2.6	1.0†	2.6	3.7*
	2.5	3.2*	1.7	1.1†		2.6	1.0†	1.3	2.9*
100-2	1.8*	1.3	1.0†	1.4	10-5	1.2	1.1†	1.5	2.0*
	1.7*	1.0	1.0†	1.0		1.3†	1.3	2.2*	1.8
	1.9	1.6†	2.0	2.7*		1.2†	2.0	3.4	3.6*
	2.7	2.3	2.1†	3.0*		1.7†	1.7	3.0	3.3*
	3.0	2.1	2.0†	3.2*		1.0†	2.4	3.0*	2.7
100-0	4.4*	3.8	1.0†	3.2	10-2	1.6	1.3†	1.9	2.1*
	3.9*	3.0	1.0†	1.9		1.0†	1.4	1.6*	1.4
	4.4*	1.7	1.0†	2.4		1.7†	2.1	2.3	2.9*
	3.8*	2.1	1.0†	2.5		2.4	1.9†	3.1*	2.7
	4.0*	2.7	1.0†	3.0		2.5	1.7†	1.7	3.0*
50-10	2.1	3.9*	2.4	1.2†	5-2	1.0†	1.2	2.1	2.3*
	2.1	4.4*	3.2	1.2†		1.1†	1.8	2.7*	2.1
	1.9	4.9*	4.7	1.5†		1.1†	1.5	3.0*	2.6
	1.5	4.3*	3.6	1.2†		1.0†	1.0	4.0*	2.2
	2.4	4.6*	3.6	1.5†		1.2†	1.6	2.6*	2.5
50-5	1.9*	1.8†	1.7	1.6	2-0	2.4	1.2†	2.8	2.9*
	1.6	1.4†	1.4	1.8*		2.0	1.3†	2.9	3.4*
	1.3†	1.8	2.6*	2.2		3.1	1.7†	3.7	4.0*
	2.3	1.8†	2.7*	2.6		3.2	1.4†	3.7	4.5*
	2.6	1.9†	3.0*	2.4		2.6	1.5†	2.5	3.4*

\* Signifies maximum values for a cycle.

† Signifies minimum values for a cycle.

4. *100-10 ft. c.*: The group subjected to these illuminations appeared to show an intermediate degree of depression in amplitude from the beginning and no systematic increase thereafter; but still again, the maximum was nearly always at 5 A.M. and the minimum always at 5 P.M.

5. *100-2 ft. c.*: This group showed initial amplitude depression with a rapid increase during the five days in darkness. Now, the maximum evidently was between 5 and 11 P.M. and the minimum between 5 and 11 A.M.

6. *100-0 ft. c.*: This was the only one of the experimental groups which had undergone a complete reversal of phases. The amplitude was very great from the start and showed no increase. The maximum pigment dispersion was seen at 11 P.M. and the minimum at 11 A.M. in every cycle.

7. *50-10 ft. c.*: This group showed little or no initial depression of amplitude. The maximum occurred at 5 A.M. and the minimum at 5 P.M. in every instance.

8. *50-5 ft. c.*: This group initially showed not only great depression in rhythm amplitude, but initially almost an absence of a recognizable daily cycle. A clear daily cycle did reappear in two or three days and gain in amplitude. But now, strangely, the maximum was close to or at 11 A.M. and the minimum at 5 A.M.

9. *50-2 ft. c.*: This group also showed an initial low amplitude of rhythm, but one which increased rapidly. The maximum value was at 11 P.M. in every cycle and the minimum at 5 A.M. in all but one.

10. *25-10 ft. c.*: An initial amplitude depression was observed in this group but it rapidly disappeared. The time of maximum dispersion appeared to lie between 5 and 11 A.M. and the minimum was always at 11 P.M.

11. *25-5 ft. c.*: The rhythm of this group exhibited an initial depression, and the maximum was between 11 A.M. and 5 P.M. with the minimum at 11 P.M. in four out of the five cycles.

12. *25-2 ft. c.*: In this group, there was an initial depression in amplitude which rapidly vanished; the daily cycle was reasonably symmetrical with an unequivocal maximum at 5 P.M. and minimum at 5 A.M.

13. *10-5 ft. c.*: A great reduction in rhythm amplitude was initially seen in this group. The time of maximum pigment dispersion appeared clearly to lie between 11 A.M. and 5 P.M., and the minimum close to 11 P.M.

14. *10-2 ft. c.*: Again, the amplitude gradually increased during the five days in darkness. The time of the maximum was sometimes seen at 11 A.M. and sometimes at 5 P.M. The minimum, on the other hand was distributed between 11 P.M. and 5 A.M. during the five daily cycles.

15. *5-2 ft. c.*: The amplitude for this group was rather low throughout the five days. The minimum was invariably at 11 P.M. and the maximum nearly always at 11 A.M.

16. *2-0 ft. c.*: There was only slight, rapidly transitory amplitude depression in this group. The maximum value was clearly at 5 P.M. and the minimum at 5 A.M.

#### DISCUSSION AND CONCLUSIONS

Viewing the data of Table I as a whole, it is clearly evident that even though the animals have all received in common a higher illumination during 12 hours from 7 P.M. to 7 A.M. and a lower one from 7 A.M. to 7 P.M., there is to be found among the results a whole spectrum of apparent kinds and degrees of shifts of the phases

of the daily rhythm. Furthermore, for any given illumination combination, although the amplitude of the rhythm might undergo considerable change during the five-day period of observation after the animals were left in darkness, the phases of the rhythm in no case showed any evidence of a drift in one direction or the other. The forms of the daily variations of Table I were essentially confirmed on the last day of the five-day series when staging of chromatophores was performed hourly.

In order to obtain a better estimate of the direction and amount of shift in the times of the phases of the rhythms in the experimental crabs away from the con-

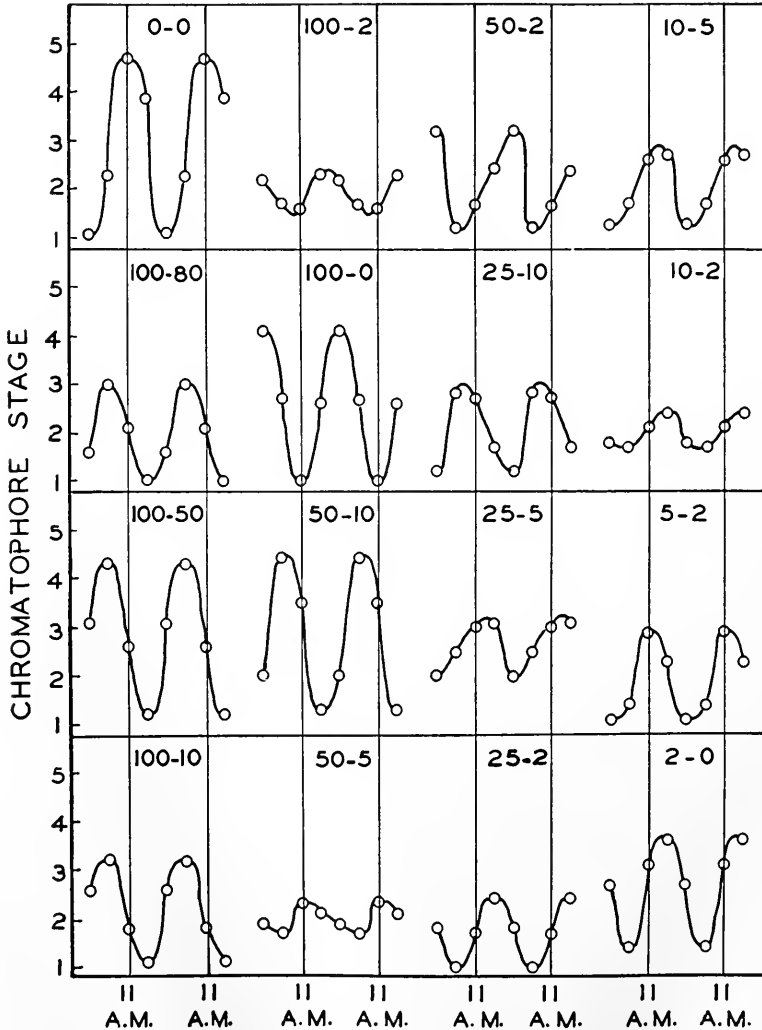

FIGURE 1. The average form and phase relations of the daily melanophore rhythm of *Uca pugnax* in constant darkness after five days of subjection to various higher illuminations by night and lower ones by day. The night-day illumination combinations are indicated for each rhythm.

dition in the controls, it was considered a reasonable procedure to average the values for each time of day for the five days for each group, plot these averages against time of day, and draw smooth curves. This has been done, and two average daily cycles are illustrated in Figure 1. Obviously, the amplitudes illustrated are only the mean ones for the five-day periods, but the forms of the curves and the relationship of the times of their various phases to the actual hour of the day are the factors of chief concern in this consideration. These two factors showed no significant alteration during the five days as is quite evident from Table I.

An examination of Figure 1 clearly shows that the control curve obtained in continued darkness can be illustrated as a more or less sinusoidal one with a

TABLE II

*The number of hours by which the phases of the persistent daily rhythm are shifted forward (+) or backward (-) by alternating periods of brighter illumination by night and dimmer illumination by day*

Shift of maximum (hrs.)	Illumination night-day (ft. c.)	Shift of minimum (hrs.)	Illumination night-day (ft. c.)
+12	100-0 50-2	+12	100-0
+9	100-2	+9	100-2 50-2
+6	25-2 10-2 2-0	+6	25-2 10-2 2-0
+3	25-5 10-5	+3	50-5
0	50-5 5-2	0	25-5 10-5 5-2
-3	25-10	-3	25-10
-6	100-80 100-50 100-10 50-10	-6	100-80 100-50 100-10 50-10

maximum at 11 A.M. and a minimum at 11 P.M. In sharp contrast with this control, those crabs which had been subjected to 100 ft. c. by night and darkness by day, though similarly capable of depiction as a relatively simple sinusoidal rhythm, were in almost exactly opposite phase.

Although the great majority of the experimental groups appear capable of description in terms of simply a change in amplitude of the cycles, together with more or less displacement forwards or backwards in time relative to the control, there are a few that appear quite definitely to have undergone a modification of form capable of approximate description in terms of the times of maximum and minimum having

been displaced to different extents away from the controls. This is evident in the 50-2 ft. c. group in which the minimum appears to have been displaced to the right by only about 9 hours while the maximum was being shifted by 12 hours.

Comparable differential shifts are also apparent in the 25-5 ft. c. group, where the minimum appears unshifted while the maximum is moved about three hours to the right, in the 10-5 ft. c. group where almost exactly the same situation obtains, and in the 50-5 ft. c. group where the maximum is probably unshifted and the minimum moved to the right, by about three hours.

The differential shifts just described give rise to persistently skewed daily cycles as is evident from all of these curves.

If one considers the 100-0 ft. c. group with a completely reversed rhythm as having both maximum and minimum displaced to the greatest extent, and this to be 12 hours to the right, or forward, in each case, all the other experimental groups tend to fall naturally into a series of lesser amounts of shift to the right, through no shift, and finally to a maximum amount of shift to the left, or backward, of 6 hours. This graded series is described in Table II.

Study of Table II reveals that with 100 ft. c. by night and darkness by day, both maximum and minimum points in the daily cycle are considered as shifted 12 hours forward. For the same illumination by night, an increase in the illumination by day progressively decreases the amount of the shift. With 2 ft. c. by day, the shift is only about 9 hours; with 10 ft. c. by day, the shift is 6 hours backwards, and this value is not exceeded for 50 and 80 ft. c. by day. Similarly for 50 ft. c. by night the greatest amount of shift, 9 to 12 hours forward, occurs when the day value is 2 ft. c. At 5 ft. c. by day the amount of shift has dropped to 0 to 3 hours; and elevating the day to 10 ft. c. produces again the maximum shift backwards of 6 hours.

A comparable series is seen for 25 ft. c. by night. Two ft. c. by day yields a 6-hour shift forwards, 5 ft. c. a 0- to 3-hour shift forwards, and 10 ft. c. a 3-hour shift in the opposite direction. Similarly for 10 ft. c. at night, 2 ft. c. by day gives a 6-hour forward shift, while 5 ft. c. by day yields only a 0-3-hour one.

Five ft. c. by night and two by day produces no change in either direction. Two ft. c. by night and darkness by day gives a 6-hour shift forward.

It is evident that 25 ft. c. at night is not sufficiently great to produce the maximum shift of 6 hours backwards, only 3 being possible. And 10 ft. c. by night appears to be capable of producing no backward shift whatsoever.

These results suggest that for darkness by day, there is a direct relationship between the number of hours of shift and the illumination by night. One-hundred ft. c. gave the maximum shift of 12 hours forwards; two ft. c. gave only about 6 hours forwards. It seems reasonable to postulate that for other values between 100 ft. c. and darkness, other degrees of shift ranging down to no shift at all might be found.

In summary, the amount and direction of shift of the phases of the persistent diurnal rhythm appear to be determined in these experiments by at least two factors. One is the strength of the stimulus in the form of a light increase at 7 P.M., and the other is the intensity of the illumination during the period from 7 P.M. to 7 A.M. A minimum intensity of 50 to 100 ft. c. during the 7 P.M. to 7 A.M. period is necessary to produce the maximum 6-hour shift backwards, and the minimum strength of the stimulus of illumination change at 7 P.M. necessary to produce the

total 12-hour forward shift is produced by some light change between 0–100 or 0–50 ft. c. on the one hand and 2–100 or 2–50 ft. c. on the other.

All of these results, and others that have been obtained in previous work with respect to shift in phases of the diurnal rhythm by illumination changes, are capable of being explained in terms of one hypothesis which will now be presented.

Let it be assumed that the endogenous rhythm in those crabs is one in which the general form of some key aspect of the rhythm can be described as illustrated in Figure 2. Instead of being composed of symmetrical cycles, it is skewed so that one limb is of about 6 hours in duration and the other one about 18 hours. Let the normal relationship of the phases of this endogenous rhythm to the solar day be

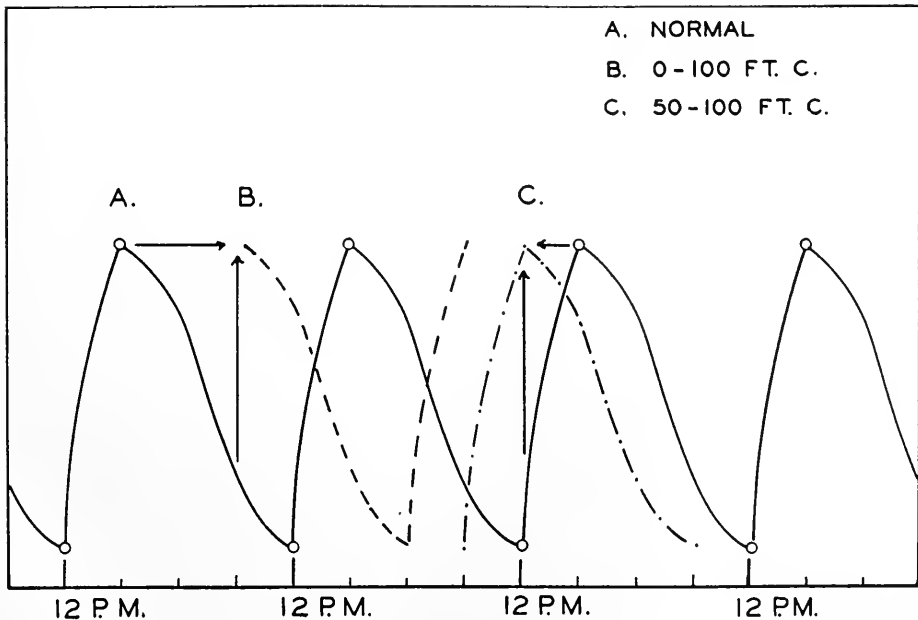

FIGURE 2. Diagram describing an hypothesis for the mechanism of inducing persistent shifts in rhythm phase by light stimuli. Solid curve—normal phase relations. Broken curve—rhythm reversed by a strong illumination change stimulus at 7 P.M. Dot-dash curve—6-hour backward shift by bright illumination from 6 P.M. to 6 A.M. (See text for discussion.)

as indicated in the figure, with the minimum occurring at about midnight and the maximum at about 6 A.M. Since in nature this maximum is normally correlated with the rapid morning increase in illumination and the succeeding 12 hours of the rhythm is normally correlated with the period of daytime, let it be assumed that both of these are normally involved in the bringing of the phases of the endogenous rhythm into their usual and characteristic relationship to the daily light cycle.

In this hypothesis, a strong stimulus in the form of a large increase in illumination at 7 P.M. (*e.g.*, 0 to 100 ft. c. . . .) induces the endogenous state normally correlated with the maximum in the endogenous cycle, or what would amount to a displacement of the phases of the rhythm 12 hours to the right or forward. Smaller

increases in illumination at 7 P.M. (*e.g.*, 2 to 100, 2 to 25, and 5 to 10 ft. c.) would have progressively less effect and the cycle of the endogenous rhythm would be displaced progressively less to the right and only to a degree that the displaced cycle at 7 P.M. was brought into an equilibrium for the light-increase stimulus. To an intensity change represented by the 5 to 50 or 2 to 5 ft. c. shifts at 7 P.M., the endogenous rhythmic mechanism appears normally to be in equilibrium. At still lower strengths of the "shift stimulus," *e.g.*, 10-25 and 10-50, and 10-100 ft. c., the strength can be considered less than the equilibrium one, but now the phases of the rhythm will not automatically shift backwards. The backward shift, if permitted by the intensity-change stimulus strength, is induced by the continuing illumination. A value higher than 25 ft. c. during the 7 P.M. to 7 A.M. period is necessary to move the phases of the rhythm backwards to the maximum extent of 6 hours, the limit being determined possibly by the correlation of the time of minimum strength of the light-shift stimulus at 7 P.M. with the minimum in the endogenous daily rhythm. It seems reasonable to assume that the continuing illumination exerts its backward shifting action at the time of the ascending limbs of the cycle, namely between about midnight and 6 A.M., but that this cannot occur except in the absence of a threshold light change at 7 P.M. Illuminations of 25 ft. c. or below produce less shift, backward, as a direct function of intensity.

An endogenous daily rhythm curve of the kind illustrated in the hypothesis is not entirely without experimental support. This postulated one has almost exactly the same form and phase relations with respect to the day-night cycle as has the rhythm of retinal-pigment movement in the shrimp, *Palaemonetes* (Webb and Brown, 1953). *Uca pugilator* melanophores in autotomized legs also exhibit a 6-18-hour daily cycle.

In addition to accounting readily for all the results in the current complex series of experiments, it also explains readily the well-known shift of 6 hours backwards obtained by Webb (1950) by three consecutive daily periods of bright illumination from 12 midnight to 6 A.M., and then a few days later still another backward shift of 6 hours to a total of 12 hours, by three consecutive daily periods of illumination from 6 P.M. to 12 midnight. It also provides an explanation for the value, 6 hours, which in much of the initial work on the mechanism of shift of the endogenous rhythm, appeared to come forth with an inexplicably high frequency.

Speculating further upon the actual nature of the physiological processes involved in these light-induced shifts probably would not be very productive at this time. One of numerous possibilities could be that the hypothetical curve describing the diurnal rhythm is a curve describing the intensity of a physiological state which may be altered by light stimuli. A change from darkness to light at any time during the endogenous reduction of this state could elevate it in proportion to the strength of the stimulus. Once abruptly altered in this manner, the endogenous, temperature-independent mechanism could take over with the cycle exhibiting a renewed start at a point in the cycle normally characterized by this higher level. Increase in level of this rhythmic state would be the equivalent, during the descending portion of the curve, to moving the phases of the cycle to the right. On the other hand, the ascending limb of the curve describing an increase in the intensity of the state of the rhythm could be capable of being accelerated by light up to the degree that is nearly instantaneous, provided the phases of the rhythm had not been rigidly de-



terminated at an earlier stage in the same cycle by threshold change from light to darkness for that particular phase of the cycle. This would amount to a shift of the phases of the cycle to a maximum of 6 hours to the left. This would not shift further to the left, because the presence of a sub-threshold dark-to-light stimulus for 7 P.M. would earlier in each cycle have freed the cycle to move to the point with the minimum at 7 P.M.

#### SUMMARY

1. A study was made of the mechanism of reversal of phases of the persistent daily rhythm in the fiddler crab, *Uca pugnax*, by illumination by night and darkness by day.

2. Fiddler crabs were subjected to a series of combinations of brighter illumination by night and dimmer illumination by day.

3. A graded series of amount of shift was obtained which was capable of being interpreted in terms of two operating factors: (a) the strength of the stimulus in the form of the dark to light change, and (b) the absolute brightness of the higher illumination.

4. An hypothesis is advanced which appears to account adequately for all currently known characteristics of the mechanism of persistent shift in phases of the daily rhythm by light stimuli.

#### LITERATURE CITED

- ABRAMOWITZ, A. A., 1937. The chromatophorotropic hormone of the crustacea: standardization, properties and physiology of the eyestalk glands. *Biol. Bull.*, **72**: 344-365.
- BROWN, F. A., JR., M. FINGERMAN, M. I. SANDEEN AND H. M. WEBB, 1953. Persistent diurnal and tidal rhythms of color change in the fiddler crab, *Uca pugnax*. *J. Exp. Zool.*, **123**: 29-60.
- BROWN, F. A., JR., AND H. M. WEBB, 1948. Temperature relations of an endogenous daily rhythmicity in the fiddler crab, *Uca*. *Physiol. Zool.*, **21**: 371-381.
- BROWN, F. A., JR., AND H. M. WEBB, 1949. Studies of the daily rhythmicity of the fiddler crab, *Uca*. Modifications by light. *Physiol. Zool.*, **22**: 136-148.
- HOGBEN, L. T., AND D. SLOME, 1931. The pigmentary effector system. VI. The dual character of endocrine coordination in amphibian colour change. *Proc. Roy. Soc., London, Ser. B.*, **108**: 10-53.
- WEBB, H. M., 1950. Diurnal variations of response to light in the fiddler crab, *Uca*. *Physiol. Zool.*, **23**: 316-337.
- WEBB, H. M., AND F. A. BROWN, JR., 1953. Diurnal rhythm in the regulation of distal retinal pigment in *Palaemonetes*. *J. Cell. Comp. Physiol.*, **41**: 103-122.

THE DISTRIBUTION OF PHOSPHORUS ( $P^{31}$  AND  $P^{32}$ ) IN  
DORSAL AND VENTRAL HALVES OF THE  
RANA PIPIENS GASTRULA<sup>1</sup>

PHILIP GRANT<sup>2, 3</sup>

*Department of Zoology, Columbia University, New York 27, N. Y.*

Studies of the distribution of enzymatic activity and oxygen consumption in the amphibian gastrula have led to hypotheses concerning the role of metabolic gradients in development (Child, 1941). Although considerable confusion exists as to whether such gradients have been established, the appearance of the dorsal lip does delineate a region of distinct morphogenetic activity from one presumably less active (the ventral half), and does suggest that a comparison of their respective metabolic activities would reflect these morphogenetic differences.

Considering the important biological and metabolic role of phosphate compounds, it was felt that a study of their distribution between these two morphogenetically distinct regions would reveal specific metabolic differences of a more convincing nature. Furthermore, radioactive phosphorus was used to make possible an analysis of shifts of phosphorus, either from one region to another, or from one component to another.

METHODS

*Rana pipiens* females were weighed and injected with pituitary glands to induce ovulation. They were then injected intraperitoneally with approximately 0.1 mc. of  $P^{32}$  in the form of  $H_3PO_4$ . Forty-eight hours later, the eggs were harvested and fertilized. They were allowed to develop in large finger bowls at 15° C. until Shumway stage 10.

The jelly and vitelline membrane were removed and the gastrulae were then dissected into two halves as shown in Figure 1. Dorsal and ventral halves were collected in separate stender dishes standing in an ice water bath. From twenty to forty halves were transferred to 12-ml. graduated centrifuge tubes and washed twice with full strength Holtfreter's solution. All operations were carried out in full strength Holtfreter's solution in vessels kept in ice water and the homogenization and extraction were completed in a 4° C. cold room.

The fractionation procedure was a modified Schmidt- Thannhauser extraction (1945). The fractions isolated were the following: (1) total acid-soluble phosphorus, (2) "desoxyribonucleic acid phosphorus," (3) "ribonucleic acid phosphorus," (4) "phosphoprotein phosphorus," (5) "phospholipid phosphorus," and (6) residue phosphorus.

<sup>1</sup> This research was supported in part by a grant from Public Health Service, National Institutes of Health, administered by Dr. L. G. Barth.

<sup>2</sup> Postdoctoral Public Health Research Fellow, National Cancer Institute.

<sup>3</sup> Present address: Institute for Cancer Research, Philadelphia 11, Pa.

After alkali digestion of the defatted material, the supernatant was poured off, DNA was precipitated by the addition of an HCl-TCA mixture and DNA phosphorus determined according to the procedure outlined by Sze (1953). The residue remaining in the alkali digest was analyzed as "residue phosphorus."

After precipitation of DNA, the remaining supernatant was precipitated with magnesia mixture overnight to obtain the inorganic phosphorus liberated from phosphoprotein. The resulting filtrate was hydrolyzed in 60% perchloric acid and analyzed as "ribonucleic acid phosphorus."

All fractions isolated were hydrolyzed in 60% perchloric acid in a sand bath until clear, and inorganic phosphorus was precipitated as the magnesium ammonium complex with magnesia mixture. The precipitates were collected on filter paper and mounted on brass discs for counting, which was done with a Geiger-Muller end window tube (3.3 mg./cm.<sup>2</sup>) using a Nucleonic RC 2 scaler. All samples were corrected for decay and the instrument was checked daily against a standard beta source.

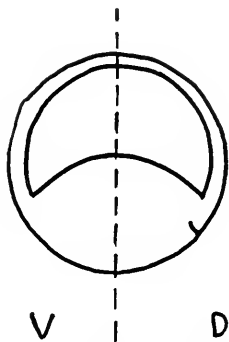

FIGURE 1. Dissection of gastrula. V = ventral half; D = dorsal half.

The precipitates were eluted in 1 N sulphuric acid and the phosphorus determined by the method of Berenblum and Chain (1938) using the vessel described by Wiame (1947).

Six separate experiments were completed, each run in duplicate, with appropriate reagent blanks.

The fractions isolated represent heterogeneous groups of phosphate compounds with a wide range of different origins (Grant, 1953). Furthermore, there is considerable doubt as to the extent of purity of these isolated fractions, particularly those fractions that may be contaminated with inorganic phosphorus (Davidson *et al.*, 1951). Because of the relative nature of the data, however, it was assumed that any significant differences between dorsal and ventral halves should be evident using this technique.

#### RESULTS AND DISCUSSION

In Table I, the distribution of phosphorus ( $P^{31}$  and  $P^{32}$ ) in dorsal and ventral halves of the gastrula is shown, in absolute values and in percentages of total phosphorus and total radioactivity. No significant differences are evident in any of the fractions. In two experiments, whole gastrulae were extracted along with

the halves to determine the efficiency of recovery, which was fairly good. The low recoveries of acid-soluble phosphorus and phospholipid phosphorus may be attributed to loss of blastocoel fluid in the case of the former and loss of yolk granules during the dissection procedure in the case of the latter. The data do illustrate that dorsal and ventral halves have a similar distribution of phosphorus and that cleavage produces a uniform apportionment of the egg constituents.

In a recent study of the regional chemical differences in the frog gastrula (Barth and Sze, 1953), gradients of lipid and of total nitrogen (animal-vegetal) were demonstrated; however, no dorso-ventral gradient was evident, which agrees with the absence of a phosphorus gradient shown in Table I. Although the analyses of Barth and Sze were performed on several small regions of the gastrula, their data, calculated on the basis of dorsal and ventral regions (to make them approximately equivalent to half-gastrulae analyzed here), exhibit no dorso-ventral differences.

TABLE I

*Distribution of phosphorus ( $P^{31}$  and  $P^{32}$ ) in whole gastrulae and in dorsal and ventral halves*

Fraction	Whole			Dorsal half			Ventral half		
	$\mu\text{gms. } P^{31}$	% total $P^{31}$	% total $P^{32}$	$\mu\text{gms. } P^{31}$	% total $P^{31}$	% total $P^{32}$	$\mu\text{gms. } P^{31}$	% total $P^{31}$	% total $P^{32}$
Acid-soluble P	77.0	5.35	90.00	32.5	5.10	86.74	30.5	4.34	87.58
Ribonucleic acid P	45.0	3.18	1.03	20.0	2.82	2.82	25.5	3.65	2.33
DNA P	5.0	0.39	1.34	2.5	0.40	1.23	2.0	0.33	1.14
Phospholipid P	283.5	19.65	4.78	112.8	17.47	5.79	127.7	18.12	6.09
Phosphoprotein P	974.5	67.55	2.41	489.5	73.68	4.02	517.3	72.81	3.20
Residue P	58.0	3.95	0.18	15.0	3.46	0.75	23.5	4.38	0.97

Values for  $\mu\text{gms. } P^{31}$  expressed as micrograms of phosphorus per 100 embryos or per 100 half-embryos. Values for % total  $P^{32}$  obtained from values expressed as counts per minute per whole or half-embryo.

The values for all fractions, except DNA phosphorus and RNA phosphorus, compare closely with Kutsky's (1950) results. The low values for these latter two fractions may have been due to a failure to obtain complete precipitation with magnesia mixture, since the amounts involved are relatively small. In addition, loss of RNA phosphorus may have been due to adsorption onto the magnesium ammonium precipitate of phosphoprotein phosphorus. However, the relative values are significant and these indicate that no differences exist.

The per cent distribution of  $P^{32}$  also illustrates that no significant differences are apparent when the halves are compared to each other, or to the whole embryo.

When the number of cells in the two regions is considered (Sze, unpublished data), Table II is the result. Since the ventral half contains fewer, larger cells (approximately 15,800 cells with an average volume of  $67,500 \mu^3$  compared to the dorsal half with 18,100 cells with an average volume of  $52,600 \mu^3$ ) the results are to be expected. The larger ventral cells contain a greater proportion of cellular constituents, particularly yolk granules, which represent about 70% of total egg phosphorus (Grant, 1953). Thus, phosphoprotein phosphorus and phospholipid

TABLE II  
*Distribution of phosphorus ( $P^{31}$ ) per cell of half gastrulae*

Fraction	Dorsal	Ventral
Acid-soluble P	0.178	0.193
Ribonucleic acid P	0.109	0.161
Desoxyribonucleic acid P	0.014	0.013
Phospholipid P	6.155	8.075
Phosphoprotein P	26.750	32.750
Residue P	0.082	0.149

Values expressed as micrograms  $P^{31}$  per cell  $\times 10^6$ .

phosphorus, the major constituents of yolk phosphorus (Panijel, 1950), exhibit the greatest differences.

The specific activity data (Table III) suggest that differences between dorsal and ventral halves may exist. However, these differences are insignificant when tested by the comparison of individuals method. The high specific activity of the acid-soluble fraction in the whole embryo may be attributable to the retention of blastocoel fluid, possibly rich in highly active inorganic phosphorus.

It is possible that differences could be made more evident (that is, if they exist) if smaller regions of the gastrula were compared; regions similar to those analyzed by Barth and Sze (1953). The dissection into half gastrulae includes large areas of tissue of similar metabolic activity such that small differences between halves are masked. Possibly, in later stages of gastrulation, where metabolic differences are more pronounced (Brachet, 1950), dorsal and ventral halves would exhibit divergencies in their phosphorus distribution and specific activity.

The residue phosphorus exhibited activities of the same order of magnitude as the ribonucleic acid fraction, suggesting that it might be undigested nucleic acid. It is also possible that the residue might be metaphosphate as described by Wiame (1947) in yeast. The possible existence of metaphosphate is interesting in the light of recent findings by Berg (unpublished data) that there is a strong metaphosphatase present in the developing embryo.

No specific activity values are reported for DNA phosphorus since those experiments which yielded activities for this fraction failed to yield detectable amounts of phosphorus.

TABLE III  
*Relative specific activity  $\times 10^6$ .  
 Whole and half gastrulae*

Fraction	Whole	Dorsal	Ventral
Acid-soluble P	202.25	142.48	141.72
Ribonucleic acid P	4.15	7.16	4.39
Desoxyribonucleic acid P			
Phospholipid P	2.98	2.78	2.38
Phosphoprotein P	0.38	0.43	0.31
Residue P	0.58	3.43	5.09

Values expressed as  $\frac{\text{cts./min./}\mu\text{gms. P}}{\text{act. injected/wt. gms.}}$

Kutsky (1950) reports significant shifts in activity from gastrulation to neurulation. These have also been found by the author (unpublished data). This points to the need for continued study of more advanced stages of gastrulation to demonstrate and localize these changes. This report represents the completed portion of such experiments now in progress.

#### SUMMARY

1. A preliminary investigation of the distribution of phosphorus in dorsal and ventral halves of the *Rana pipiens* gastrula was undertaken to demonstrate the possible existence of a metabolic gradient of phosphate compounds correlated with the apparent morphological gradient. Radioactive phosphorus was employed to permit an analysis of shifts of phosphorus.

2. A modified Schmidt-Thannhauser extraction procedure was applied to dorsal and ventral halves of stage 10 (Shumway) embryos obtained from a frog injected with approximately 0.1 mc. of  $P^{32}$  before inducing ovulation. Total acid-soluble phosphorus, RNA phosphorus, DNA phosphorus, phosphoprotein phosphorus, phospholipid phosphorus and a residue phosphorus were extracted and analyzed for specific activity.

3. The distribution of phosphorus ( $P^{31}$  and  $P^{32}$ ), expressed either as micrograms  $P^{31}$  per half embryo or as per cent of total  $P^{31}$  or  $P^{32}$ , exhibited no significant difference between dorsal and ventral halves. However, expressed as micrograms  $P^{31}$  per cell, a ventral-dorsal gradient was apparent. Data expressed as specific activity (counts per minute per microgram  $P^{31}$ ) exhibit no significant differences.

#### LITERATURE CITED

- BARTH, L. G., AND L. C. SZE, 1953. Regional chemical differences in the frog gastrula. *Physiol. Zool.*, **26**: 205-211.
- BERENBLUM, I., AND E. CHAIN, 1938. An improved method for the colorimetric determination of phosphate. *Biochem. J.*, **32**: 286-298.
- BRACHET, J., 1950. Chemical embryology. Interscience Publishers Inc., New York, N. Y.
- CHILD, C. M., 1941. Problems and patterns of development. University of Chicago Press, Chicago, Illinois.
- DAVIDSON, J. N., S. C. FRAZER AND W. C. HUTCHINSON, 1951. Phosphorus compounds in the cell. I. Protein bound phosphorus fractions studied with the aid of radioactive phosphorus. *Biochem. J.*, **49**: 311-321.
- GRANT, P., 1953. Phosphate metabolism during oogenesis in *Rana temporaria*. *J. Exp. Zool.*, **124**: 513-544.
- KUTSKY, P. B., 1950. Phosphate metabolism in the early development of *Rana pipiens*. *J. Exp. Zool.*, **115**: 429-460.
- PANIJEL, J., 1950. L'organisation du vitellus dans les oeufs d'amphibiens. *Biochim. et Biophys. Acta*, **5**: 343-357.
- SCHMIDT, G., AND S. J. THANNHAUSER, 1945. A method for the determination of deoxyribonucleic acid, ribonucleic acid and phosphoprotein in animal tissues. *J. Biol. Chem.*, **161**: 83-90.
- SZE, L. C., 1953. Changes in the amount of deoxyribonucleic acid in the development of *Rana pipiens*. *J. Exp. Zool.*, **122**: 577-602.
- WIAME, J., 1947. Étude d'une substance polyphosphorée basophile et metachromatique chez les levures. *Biochim. et Biophys. Acta*, **1**: 234-255.

## THE RESPIRATION OF NORMAL LARVAE OF *TEREDO BARTSCHI* CLAPP<sup>1</sup>

CHARLES E. LANE, J. Q. TIERNEY<sup>2</sup> AND R. E. HENNACY

*The Marine Laboratory, University of Miami, Coral Gables, Florida*

The free-swimming, infective larval stage of *Teredo* in local waters does not significantly exceed seventy-two hours in duration (Isham and Tierney, 1953). During this time the animals have not been observed to feed (Lane, Posner and Greenfield, 1952). The pre-attachment activities of the animal must be presumed to be powered chiefly by glycogen. This is deposited in the ovum in granular form during oogenesis. Additional glycogen may be contributed to the larva during the time that it is actually embedded in the maternal gill. At the termination of this transient, free-swimming stage, the larvae attach themselves permanently to a wooden substratum within which they spend the rest of their adult life span. A cellulase enzyme system exists in both larval and adult *Teredo* (Greenfield and Lane, 1953). This enzyme complex may significantly facilitate the invasion of wood by the larvae.

The act of penetration of wood renders the larva virtually immune to environmental hazard except for substances in solution either in the wood itself or in the water which constitutes the respiratory stream. Thus it is that preventive measures, to be effective, must be directed against the larva during the vulnerable first seventy-two hours of its free-living life.

A sensitive index of physiological condition, or of the effectiveness of sub-lethal concentrations of toxic substances, is provided by the rate of oxygen consumption of living systems. Some of the parameters of normal respiration in free-living, pre-attachment stages of *Teredo* were delimited preliminary to a study of the effectiveness of some toxic agents. Details of this latter phase of the investigation will be presented elsewhere. It is the purpose of the present communication briefly to describe the methods and some of the results observed in the study of normal animals.

### MATERIALS AND METHODS

All larvae employed in this study were reared in the laboratory by methods described by Lasker and Lane (1953).

Oxygen consumption was measured in a capillary microrespirometer (Fig. 1). It consists of a pear-shaped chamber blown in one end of capillary tubing. The volume of the chamber varied in different respirometers over the range of six to 125 microliters. The volume should be kept as small as possible to increase the stability of the system (Tobias, 1943). The opposite end of the capillary tubing

<sup>1</sup> Contribution No. 120 from the Marine Laboratory, University of Miami. These studies were aided by a contract between the Office of Naval Research and the University of Miami in cooperation with the U. S. Navy Bureau of Yards and Docks.

<sup>2</sup> Present address: Hydrographic Office, U. S. Navy, Washington, D. C.

bears an inside syringe-taper ground joint. This seats in the outer matching ground joint of the thermobarometer or compensation chamber. This latter portion of the apparatus should be as large as is consistent with ease of manipulation. We have generally sought to have its volume at least 1000 times that of the respirometer chamber. This insures maximum sensitivity of the system. The upper end of the compensation chamber is closed by a stopcock. In use the entire assembly is immersed in a constant temperature water bath maintained at 25.0° C.

The chamber is first loaded with a single animal confined in a droplet of medium whose volume varied for different respirometers between one and ten microliters. This volume provides a mass of medium from 100 to 1000 times the volume of the organism. The isolation of the larva and the determination of the volume of the medium can be effected most easily by making use of specially drawn and calibrated micropipettes. These may be actuated either by a syringe device or by a mouth-piece similar to that of a hemocytometer pipette. Calibration of pipettes and other micro-glassware is readily accomplished with the micrometer burette described by

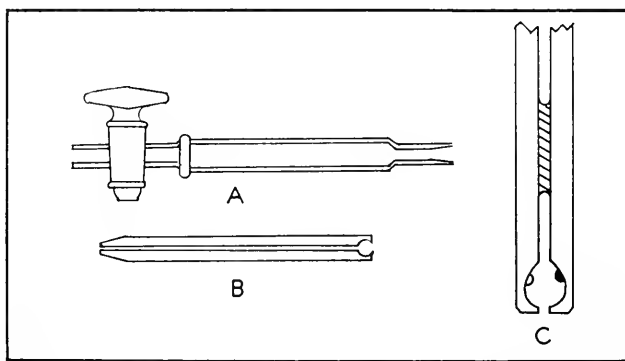

FIGURE 1. Sketch of components of the capillary microrespirometer. A. Thermobarometer with outer syringe-taper ground joint in end opposite stopcock. B. Microrespirometer with matching inner syringe-taper ground joint in end opposite respirometer bulb. C. Enlarged view of respirometer bulb to show the disposition of droplets and the kerosene indicator fluid.

Scholander (1942). Various loading pipettes may be calibrated to deliver precisely known total volumes. The delivered volume, of course, will include the volume of the organism. Separate pipettes are constructed for each respirometer, and are then used only with that particular apparatus.

The droplet of medium and larva is delivered onto one wall of the respirometer chamber. The chamber wall is previously rendered hydrophobic by the application of a suitable silicone coating. Under these conditions the integrity of the droplet of medium is retained for long periods of time. It has, for example, frequently been possible to make continuous observations of the oxygen consumption of a single larva during periods as long as twenty-four hours without opening the sealed system.

After the respirometer has been charged with the animal and medium, a droplet containing one to five microliters of alkali, either 10% NaOH or 5% Ba(OH)<sub>2</sub>, is placed on the contralateral wall. The indicator fluid in the capillary is kerosene which has been distilled at 250° C. after exhaustive oxidation with concentrated sulfuric acid for several days. The open end of the respirometer is sealed with a



non-oxidizing wax. For best adhesion and complete sealing it is preferable to employ a wax of comparatively low melting point. With the upper stopcock of the compensation chamber open, the two portions of the apparatus are united, seated and the joint is sealed with the same wax which was used to close the lower end of the respirometer. The assembly is then placed in the water bath and permitted to come to temperature equilibrium. Under our conditions a steady state is generally reached by respirometers without respiring tissue within thirty minutes.

With the system sealed and equilibrated the mode of operation is as follows. The larva extracts dissolved oxygen from the sea water medium. This creates a diffusion gradient across the air-water interface, as a consequence of which additional oxygen diffuses into the water from the air phase. The loss of oxygen from the air phase causes a decrease in pressure in the air phase which is reflected in displacement of the kerosene meniscus. The position of the meniscus is observed with a compound microscope equipped with a long-focus objective. It is clear that

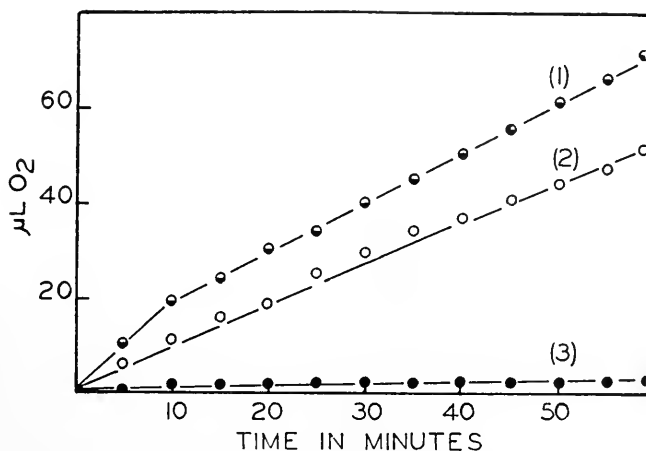

FIGURE 2. Average rate of oxygen uptake by 24-hour larvae of *Teredo*. Each point is the average of from three to 17 determinations on different animals. (1) in the presence of  $M/1000$  glucose in sea water, (2) normal sea water and (3) blank.

the sensitivity of the apparatus is limited by the resolving power of the optical system. In our studies we have found it convenient to detect a displacement of ten microns. This represents a change in volume of  $0.002 \text{ mm}^3$ . In the terminology proposed by Scholander and Evans (1947) this is  $2.0 \gamma$ l. Naturally the sensitivity of the entire system could be increased either by increasing the magnification of the optical system or by decreasing the diameter of the capillary out of which the respirometer is constructed. For the present study sufficient sensitivity was provided by the dimensions described.

## RESULTS

In Figure 2 are shown average oxygen consumption values for over one hundred individual determinations. The lowest curve is the sea water blank. Inasmuch as this generally consisted simply of the water in which the Tereidids were living at the time of their capture, it usually contained microorganisms which showed a small

but significant oxygen consumption. Blank figures were always subtracted from the oxygen consumption of experimental animals. The middle curve shows the average rate and magnitude of oxygen consumption by normal 24-hour larvae. The upper curve shows the oxygen consumption by normal 24-hour larvae when the sea water medium had been rendered 0.001 *M* by the addition of appropriate amounts of glucose.

Figure 3 shows the change in rate of oxygen consumption with increasing age of the larvae. The increase during the first twenty-four hours is real and significant. From seventy-two hours to three hundred hours the decrease in oxygen consumption is progressive. This decline is associated with general involutinal changes in the larva which will lead to its death by three hundred hours if it is denied access to wood.

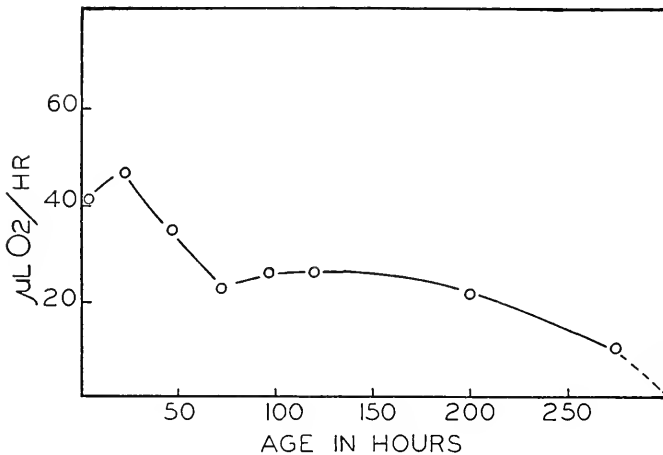

FIGURE 3. Oxygen consumption by normal larvae of *Teredo* at various times after release from the maternal gill. Each point is the average of all determinations made for that age. Data on 38 different larvae are presented in the curve.

#### DISCUSSION

These data serve to emphasize both similarities and differences between the larval behavior of *Teredo bartschi* Clapp and *T. navalis*. Imai, Hatanaka and Sato (1950) have described the large-scale culture of larvae of *T. navalis*. They emphasize the importance of suitable supplies of food organisms in the maintenance of normal growth of the cultures. They also figure the larvae at various stages of its free-living life. In *T. navalis* this pre-attachment period may occupy as much as 34 days. During this time the larva continues to grow. The maximum pre-attachment size is approximately 245 microns in diameter.

*T. bartschi*, on the other hand, has been shown to be 250 microns in diameter when it is released from the maternal gill. The length of its normal free-swimming life does not exceed four days.

In a previous publication from this laboratory (Lane, Posner and Greenfield, 1952) the statement was made that larvae of *T. bartschi* "do not appear to feed." It was thought that the large supplies of glycogen which are characteristic of the

mature oocyte were sufficient to power the pre-attachment activities of the larvae during a short free-living life. There can now be little doubt that this conception is erroneous in view of the observed oxygen consumption of the larva during this portion of its life. Elementary calorimetric considerations show that larvae of *T. bartschi*, which weigh approximately 10 micrograms alive, and contain close to 60% moisture, fall far short of containing sufficient metabolic fuel materials to justify the measured oxygen consumption during their free-living existence. The deficit must be made up by the ingestion of microorganisms from their environment.

The large glycogen stores probably represent emergency reserves which are used after 72 hours. At this stage the larvae cease to swim and assume a pedestrian mode of progression. Clearly they do not come into contact with the same number of suspended food organisms when crawling in two dimensions as when swimming relatively rapidly through three dimensions.

The increased oxygen consumption at twenty-four hours is correlated with behavioral changes in the free-swimming larvae which have been described by Isham and Tierney (1953). These investigators have shown that crawling with the aid of the muscular foot replaces swimming with the velar cilia as the chief method of locomotion at this stage of development. The enhanced oxygen consumption during this portion of the life cycle may also be related to the post-natal development of enzymatic mechanisms for complete glycolysis.

The increased oxygen consumption in the presence of *M*/1000 glucose can be most reasonably attributed to the increased metabolism of microorganisms present in the medium along with the larva. The possibility of direct absorption of dissolved organic materials by *Teredo* larvae should not be overlooked, but it is certainly not proved by this work.

#### SUMMARY AND CONCLUSIONS

1. A capillary microrespirometer is described, with the aid of which the normal respiration of free-living larvae of *Teredo bartschi* Clapp has been studied.

2. Oxygen consumption during the total three hundred-hour pre-attachment life averages approximately 25 microliters per hour, when measured at 25° C. At twenty-four hours there is a significant augmentation. After seventy-two hours the rate of oxygen consumption decreases regularly until the death of the larva. The significance of these alterations in rate is discussed. Differences between larval behavior of *T. bartschi* and *T. navalis* are described.

#### LITERATURE CITED

- GREENFIELD, LEONARD J., AND CHARLES E. LANE, 1953. Cellulose digestion in *Teredo*. *J. Biol. Chem.*, **204**: 669-672.
- IMAI, TAKEO, M. HATANAKA AND R. SATO, 1950. Breeding of the marine timber-borer *Teredo navalis* in tanks and its use for antiboring test. *Tohoku J. Agricul. Res.*, **1**: 199-209.
- ISHAM, L. B., AND J. Q. TIERNEY, 1953. Some aspects of the larval development and metamorphosis of *Teredo (Lyrodus) pedicellata* De Quatrefages. *Bull. Mar. Sci.*, **2**: 574-590.
- LANE, CHARLES E., G. S. POSNER AND L. J. GREENFIELD, 1952. Distribution of glycogen in the shipworm. *Bull. Mar. Sci.*, **2**: 385-392.
- LASKER, REUBEN, AND CHARLES E. LANE, 1953. Origin and distribution of glycogen in *Teredo bartschi* Clapp. *Biol. Bull.*, **105**: 316-319.
- SCHOLANDER, P. F., 1942. Microburette. *Science*, **95**: 177-178.
- SCHOLANDER, P. F., AND H. J. EVANS, 1947. Microanalysis of fractions of a cubic millimeter of gas. *J. Biol. Chem.*, **169**: 551-560.
- TOBIAS, JULIAN M., 1943. Microrespiration techniques. *Physiol. Rev.*, **23**: 51-76.

# NUTRITION OF THE SEA URCHIN, *STRONGYLOCENTROTUS PURPURATUS*<sup>1</sup>

REUBEN LASKER AND ARTHUR C. GIESE

*Hopkins Marine Station of Stanford University, Pacific Grove, California*

The gut of the purple sea urchin, *Strongylocentrotus purpuratus*, reveals a mass of algae in various stages of decomposition. Algae contain relatively small amounts of nutrients which are readily handled by enzymes ordinarily present in animals, but they possess galactans, alginic acid, agar and possibly some cellulose, none of which are digested by man or most animals. The urchins in the course of evolution may have developed enzymes which have enabled them to use these materials, or, like many of the ungnulate herbivores, they might harbor bacteria, or, like the termites, they might shelter protozoans which perform this role for them.

The first study was therefore concerned with the role of the digestive enzymes present in the gut of the urchin. The second consisted of studies of the digestive action of the flora of the urchin gut. The third was concerned with the over-all nutritional economy of the sea urchin.

## MATERIALS AND METHODS

Sea urchins were collected on the Monterey Peninsula at Yankee Point below Carmel Highlands and at Pescadero Point. A large number of urchins were planted just outside the Hopkins Marine Station to make them available for experiments requiring an occasional fresh specimen. While some of those transplanted died or disappeared, a fairly large number took hold and fed upon the prevalent coralline algae. Monthly studies were made on the urchins from Pescadero Point, because they could always be obtained even in rough weather, whereas those at Yankee Point sometimes became inaccessible in stormy weather. All the locations from which the urchins were taken were free of industrial waste and relatively free of sewage. The sea urchins brought in fresh monthly were kept in the laboratory in aerated rapidly running sea water. Even so, most of them aggregated near the top of the water in a tank, except when they wandered in search of food. Unless only a relatively small number of urchins were kept in an aquarium, they became unhealthy in time.

For determination of the sugar and nitrogen content in the body fluid, ten urchins were sacrificed the first day and ten the second after collection. The pH of body fluid was determined with a Beckman pH meter directly in the field, and

<sup>1</sup> The study was supported by a grant from the National Science Foundation. The authors are indebted to Dr. L. R. Blinks, Director of the Hopkins Marine Station and to Dr. C. B. van Niel for suggestions, advice and help as well as friendly interest in the work, to Mr. F. Falconer, Head Librarian of the Biological Libraries, for help in bibliographic research, to Dr. Bachman-Beam for suggestions in handling the bacteria, to Mr. W. K. Bowen for preparing the sections of the intestine, to Dr. W. Z. Hassid for a sample of iridophycin and to Mr. R. Aughry and Dr. R. Bolin for unpublished data on water temperatures.

the pH of gut contents as soon as possible after opening a normal, healthy urchin in the laboratory.

The body fluid was withdrawn from an urchin by excising Aristotle's lantern and pouring out the contents of the coelom. The fluid was allowed to stand and the clot, containing wandering blood cells, was removed by filtration. Reducing sugars were determined in the filtrate by the method of Somogyi (1945, 1952). The non-protein nitrogen (NPN) in the coagulum-free filtrate of body fluid was determined by the standard Kjeldahl procedure, the proteins being first precipitated with trichloroacetic acid (TCA).

#### EXPERIMENTAL

##### 1. Structure of the digestive tract of the sea urchin

The mouth opening between the teeth of Aristotle's lantern leads through an oesophagus to the stomach-intestine which is suspended in the coelom by a mesentery. The oesophagus possesses well developed villus-like papillae which contain glands, perhaps producing mucus. The intestine has two turns; looking in at the mouth of the urchin the first turn is clockwise and the second, doubling back upon this, is counter-clockwise. The intestine is also lined by a glandular epithelium in which secretory cells are found, some forming glands possessing a body and a neck which opens into the digestive cavity. The connective tissue of this portion of the gut is inconspicuous and the epithelium appears to be bounded by the visceral peritoneum. Since the wall of the gut is so thin it is probable that absorption can occur readily through any part of it.

##### 2. Feeding habits of the sea urchin

Over the last ten years, sea urchins kept in aquaria have been fed a great variety of foods. If starved, they were found to ingest almost anything offered them such as boiled eggs, boiled potatoes and vegetables, as well as fresh vegetables, but not leaves of geranium or *Pelargonium*. However, meat and fruits were taken in preference to vegetables. In nature the sea urchin feeds upon various algae (green, red and brown) as well as upon the "surf-grass," *Phyllospadix*. In local areas the diet may be largely restricted to the most abundant alga. In the laboratory, the sea urchins were usually fed the red alga, *Iridophycus flaccidum*, because of its availability and its acceptability to the urchin.

The ingested food apparently remains in the gut for a long period of time since during starvation in an aquarium, feces were ejected for two weeks, suggesting a very slow rate of digestion. When urchins brought in from the field were roughly handled, they eliminated considerable amounts of material for a short period. When slowly eliminated, the algae in the feces were found to be fairly completely decomposed and were heavily laden with bacteria. If feeding was continuous, so was defecation, and the algal pellets appeared to be less completely digested.

When an urchin which had been starved for some time in the laboratory was given food, it quickly fed to capacity with any material, algal or otherwise, upon which tests were desired. Starvation for two weeks was used as standard practice since in this time the gut will have become considerably, if not completely, cleared of contents.

Considering the low temperature of the water in which the sea urchins live, the

rate of digestion is not surprising. The water temperature for Moss Beach varied from 9.2 to 15.5 and at Stillwater Cove from 8.7 to 16.1° C. during the year. On the rare occasions when the urchins were exposed to sunlight at low tide the temperature may have risen considerably over this.

### 3. Digestive enzymes of the intestine

Since the normal food of the purple sea urchin consists of algae, the digestive enzymes most likely to be found in the gut are those which can handle the nutrients found in the algae. The protoplasm of algal cells, of course, contains protein, and floridean starch is stored in red algae. However, much organic material is present in red algae in the form of galactans or galactans mixed with other materials, *e.g.*, agar and various gums. Enzymes which can handle proteins (proteases), starch (amylase) and the various substances peculiar to algae are therefore of special interest. Tests were made for each of these.

For extraction of enzymes, the gut contents were flushed out with sterile 3% NaCl, and the gut rinsed three times in the salt solution. The entire digestive tracts of several animals were then ground with crushed Pyrex glass in a mortar with a small amount of water, extracted with buffer solution and centrifuged. The buffer used in extraction was a 0.5 M McIlvaine buffer of pH 6.8–7.0. This pH was used because the first measurements of the pH of a sea urchin gut gave readings of 6.8–7.0. Subsequent measurements indicate that a pH of 7.2 to 7.3 is probably more nearly correct for a freshly opened gut. When the urchin is kept in the laboratory for a brief time the pH falls.

That a protease is present was easily demonstrated by mixing the gut extracts with casein, adding toluol to inhibit bacterial growth and determining the increase in NPN with lapse of time. Since some NPN appears in the control without casein, the data given in Figure 1 are for the differences between the two. The data demonstrate that the NPN rises rapidly after action of the enzymes on the protein.

That an amylase is present was shown by the appearance of reducing sugar in a sample of boiled starch mixed with gut extract (toluol as antiseptic). As seen in Figure 1 considerable reducing sugar appears after action of the enzymes in the extract on the boiled starch. As a control the gut extract was incubated without starch and tested for appearance of reducing sugar.

Agar and other gums contained in the algae are made up principally of polymerized galactose often combined with other substances. The ability of the sea urchin to digest agar was tested by adding the enzymes extracted from the gut to warm agar (about 37–40° C.) and mixing. The results, shown in Figure 1, may be considered negative since the very small change in reducing sugar concentration following exposure to the extracts is probably within the limits of error of the experimental method. The results for iridophycin, a galactan isolated from *Iridophycus flaccidum* by Hassid (1933), indicate that an iridophycase is present (Fig. 1). In all cases a control was incubated without the substrate and tested for reducing sugar. It would be desirable to test other substances peculiar to algae but they were not available in pure form for the tests.

### 4. Fauna and flora of the sea urchin gut

Ciliate protozoans occur in small numbers in the sea urchin gut, about ten to a hundred being counted per ml. of gut contents of several sea urchins. Several

species of *Entorhpidium* and *Lechriopyla mystax* have been identified (Lynch, 1929a, 1929b). Few were ever seen in division by Lynch; therefore they seem to represent a static population. The protozoans appear to ingest bacteria and small particles of well-disintegrated algae. While the activities of the protozoans, some of which live for several days outside the intestine, should be studied, it is unlikely that the protozoans contribute to the digestion of the algae because of their small numbers and their feeding habits.

Bacteria are present in the gut of the sea urchin in sufficient numbers to be of consequence. Almost every pellet of algal material in the second section of the intestine was found to be surrounded by a translucent membrane which, upon

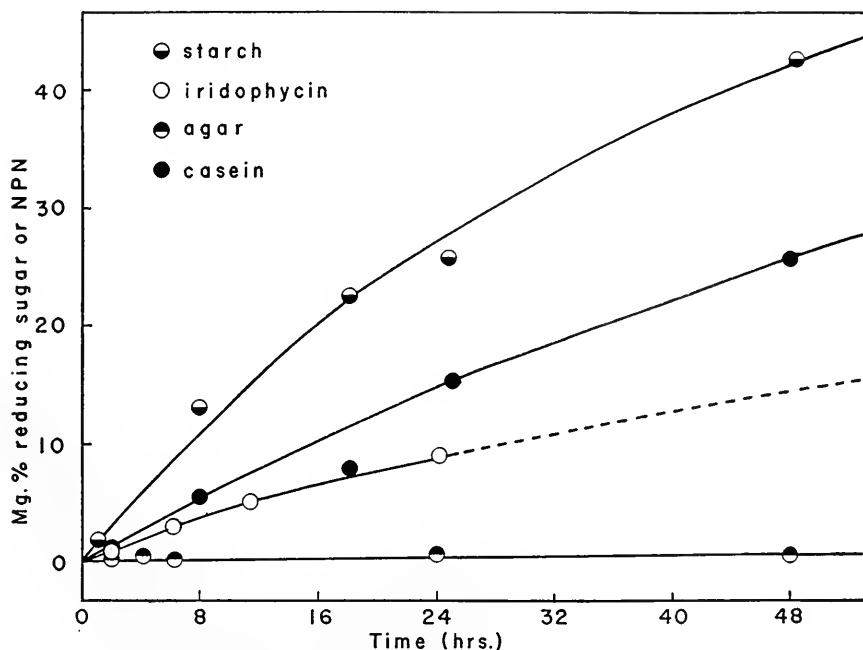

FIGURE 1. Rate of digestion of 1% casein by the extract of the intestine of the purple sea urchin at pH 6.8 and 30° C., and of 1% boiled starch, 0.1% agar and 0.02% iridophycin by the extract of the intestine of the purple sea urchin at pH 6.8 and 30° C.

microscopical examination, proved to be a film lined with coccus and rod-shaped bacteria. The films develop soon after the algal pellets enter the gut. When defecated the enveloped pieces were largely digested and no longer recognizable as algal pellets. An unenveloped piece of alga may become colorless but the cell walls remain intact and while no bacteria are seen within the walls, they occur around the cells damaged by the teeth. The envelope of mucilaginous material develops in the gut of the sea urchin, but not in cultures of the bacteria from the sea urchin gut growing on algae *in vitro*.

Since the enzymes from the sea urchin gut do not digest intact algal tissue, yet the latter disintegrates in the gut, it would appear that either the algae autolyze or

the bacteria digest them. Experiments eliminated the first possibility: algae in sea water under toluene did not autolyze. Attempts were therefore made to determine whether the bacteria from a sea urchin were capable of digesting the algae. An autoclaved sample of the red alga *Iridophycus* was inoculated with a loopfull of bacteria removed aseptically from the hind gut of a sea urchin. In one week at room temperature the algae had completely decomposed. The experiment was repeated several times.

Next, to test whether the bacteria in the lumen of the gut digest agar, a constituent of the cell walls of many algae, a sample of gut fluid was aseptically removed and transferred onto a 2% agar-sea water plate. The sample was poured over the plate or spread over it with a sterile glass spreader. Many colonies appeared within a few days. These were identified by the pits which they produced in the agar. Other colonies which did not form deep pits were detected by staining the agar surface with iodine. A clear area was noted around agar-decomposing colonies. The number of agar-digesting bacteria found in various tests was of the order of  $10^6$  per ml. of gut contents. For an urchin fed the red alga, *Iridophycus flaccidum*, the counts indicate 1.8, 2.1 and  $1.4 \times 10^6$  bacteria and for one fed the brown alga, *Alaria marginata*, 1.7, 1.8 and  $0.7 \times 10^6$ . In a similar sea urchin, the total number of bacteria determined with a Petroff Hausser counting chamber was  $2.6 \times 10^{11}$ . In an urchin starved for a week after being fed *Iridophycus*,  $1.0 \times 10^6$  agar decomposers appeared out of a population of  $3.3 \times 10^6$ .

Several individual colonies transferred to fresh agar-sea water plates were found to grow quite well on agar after a number of transfers, but some required additional nutrients or growth factors which could be supplied in the extract of algae or yeast extract. For culture purposes, the former was more convenient.

A loopfull of a pure culture of agar-decomposing bacteria was inoculated into a sample of autoclaved *Iridophycus flaccidum*. Within a week, at room temperature, the alga had completely disintegrated, therefore some of the agar-decomposing bacteria are capable of digesting this alga.

##### 5. Possible role of the intestinal flora in nutrition

While some of the bacteria of the sea urchin intestine are capable of digesting the algae ingested, a symbiotic relationship between the bacteria and the sea urchin is not thereby proven. It is possible that the sea urchin maintains itself on the more readily available nutrients in the algae which it is capable of digesting—*i.e.*, the floridean starch and the proteins of the algae. The presence of enzymes capable of digestion of starch and protein supports this possibility.

On the other hand, the intestinal flora may render the nutrients in the cells of the algae more readily available to the sea urchin, by digesting the cell walls. However, it seems unlikely that the bacteria would spare the more generally utilizable nutrients such as starch and protein while selectively digesting the generally less available cell wall materials. It seems more likely that the enzymes present in the foregut of the sea urchin digest the more readily available materials in the algal cells before the bacteria have multiplied sufficiently to offer competition, and that the residue is then attacked by the bacteria which gradually decompose the algal cell walls.

The bacteria nevertheless may contribute to the host by digesting the structural



components of the algae and releasing some of the nutrients which can then be absorbed by the host into the body fluid. This would constitute a type of symbiosis. Sugar is mobilized (Table 1) in the body fluid of a sea urchin soon after a meal of algae but this could be explained adequately as a result of digestion of starch in the algae by the amylases of the gut. Reducing sugars did not accumulate in cultures of the agar-digesting bacteria tested. It is possible that they are present only transiently in the intestine and might be absorbed to a small extent. Cultures of bacteria tend to become acidified and fatty acids may be demonstrated in the culture fluid and in the body fluid of the sea urchin. Identification tests indicate lactic acid, judging from the position of the spot in chromatographic analysis (Reid and Lederer, 1952) and the Friedemann-Graeser determination (1933).

TABLE I  
*Reducing sugar in the body fluid of the sea urchin after starvation for two weeks and refeeding or injection of glucose*

Fed	Days fed	Weight of food ingested in grams	Wet weight of urchin	mg. % reducing sugar
<i>Iridophycus</i> (red alga)	0	0	37.5	0
	1	1.33	42.4	12.0
	2	2.07	57.1	4.5
	4	3.43	40.5	1.3
	8	6.86	41.9	1.0
Boiled potato	0	0	36.9	0
	1	2.89	47.8	47.0
	2	4.69	48.4	62.0
	4	4.55	38.5	1.7
	8	10.09	43.9	24.3
Glucose injected	Hours time lapse	Mg. glucose injected		% glucose withdrawn
	0	0.0	34.5	0
	1	1.0	54.2	64.5
	2	1.0	41.4	78.0
	4	1.0	39.0	95.8
	8	1.0	37.9	88.5

The nature of the relationship between the sea urchin and the bacteria could be ascertained if the bacterial flora of the intestine could be removed and replaced at will. Killing the flora by a meal of  $\text{CuSO}_4$ , as has been done with some vertebrates, kills the sea urchin as well. Defloration by high oxygen tensions is not practical since the bacteria present in the gut are only facultative anaerobes, not obligate like the termite protozoa. Raising sea urchin larvae aseptically to the adult stage is not likely to be successful with present techniques. A mixture of streptomycin and penicillin, 50 ppm in gelatin, was unsuccessful in killing the bacteria in the gut of the urchins tested. Therefore a crucial direct test for digestion in the absence of bacteria cannot be performed. Only circumstantial evidence can therefore be adduced at present, to support the possibility of symbiosis between the sea urchin and the bacteria, but it is not so overwhelming as to exclude other possibilities.

6. Reducing sugar in the body fluid and glycogen stores in tissues

Reducing sugar is usually present in the body fluid of the sea urchin as shown in Figure 2. The amount of sugar in individual cases varies from 0 to 13 mg. per cent. The sugar practically disappears after starvation (Table I). However, it is mobilized quickly in such an animal after a meal of algae or boiled potato (Table I). In the latter case the sugar rose from 0 to 62 mg. per cent in two days, the highest value ever obtained with this species of sea urchin over the course of a year of analyses. The intestinal amylases may be responsible for digestion but since bacteria are present in the gut their possible share in the digestion of the starch cannot be ignored.

Glucose injected into a starved sea urchin rapidly disappears from circulation (Table I). This suggests that the tissues take up glucose and other reducing

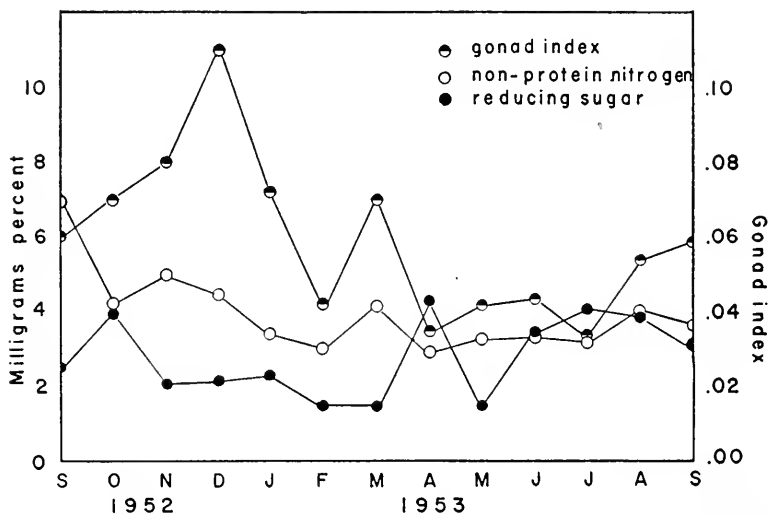

FIGURE 2. The gonad index (volume of gonad divided by the wet weight of the sea urchin) correlated with the average content of non-protein nitrogen (NPN) and reducing sugar in the body fluid of the purple sea urchin obtained monthly by analyses of twenty urchins.

sugars and store them in some insoluble form. Preliminary experiments have demonstrated glycogen in various tissues, but most appears in the intestine (Hilts and Giese, 1949). To determine the storage of glycogen a male sea urchin was drained of body fluid and the gut tissues were rinsed free of contents in distilled water and dried in an oven. The pulverized material, including the test, was extracted with alkali and the glycogen precipitated in alcohol. The glycogen present in a sample of the sea urchin was found by the method of Meyer (1943) to be 472 mg.% on the basis of dry weight, while 123 mg.% nitrogen was present. The amount of glycogen per unit weight of protoplasm was estimated as follows. Assuming that the protein of protoplasm contains all the nitrogen of the animal and that protein constitutes about 15% of the protoplasm, 3.84 units of glycogen are present per unit nitrogen or 0.62 unit of glycogen per unit protein, or almost 0.1 per cent glycogen in the protoplasm (muscle contains 1 per cent). The data

show that a considerable store of glycogen exists in the tissues and apparently the tissues draw upon this store for their respiratory activities. Stott (1931) found that in *Echinus esculentus* glycogen accumulated during growth of the gonads but declined just before the annual spawning in spring.

The avidity with which glucose is taken up following injection after starvation (Table I) suggests the possibility that the tissues of an urchin are starved for sugar. If this were true one might expect that addition of sugar would increase the respiration of excised tissues. Respiration of sea urchin intestine determined with the standard Warburg technique shows that this is not so. Regardless of whether glucose or yeast extract or both were added, the respiration of tissues freshly removed from a well-fed or a starved sea urchin and suspended either in sea water

TABLE II  
*Non-protein nitrogen (NPN) of the body fluid of the sea urchin  
after two weeks starvation and refeeding*

Fed	Days fed	Weight of food ingested in grams	Wet weight of sea urchin	mg. % NPN
<i>Iridophycus</i>	0	0	48.0	1.20
	1	2.73	56.6	4.30
	2	2.87	51.2	0.80
	4	3.28	45.9	3.75
Boiled egg albumin	0	0	28.9	3.19
	0	0	31.0	3.20
	1	3.03	35.3	6.67
	2	4.72	45.0	8.20
	3	2.54	44.3	3.75

or in the body fluid of the sea urchin did not increase significantly over the endogenous value. The average  $Q_{O_2}$  of digestive tissue was found to be about 0.7 ml./mg./hr.

#### 7. Non-protein nitrogen in the body fluid

Non-protein nitrogen (NPN) is generally present in the body fluid of a sea urchin to the extent of about 5 mg. per cent. Data (averages) for monthly samples of groups of 20 urchins tested for a year are given in Figure 2. The NPN does not decrease markedly after starvation (Table II), but increases markedly after feeding with a high protein diet (Table II) rising in a day to twice the value for a control, and to an even higher concentration the second day. It falls off again on the third day.

The NPN seems to be regulated to some degree, since unlike the reducing sugar, it never falls to zero even after prolonged starvation. Nitrogen compounds stored in tissues must be liberated upon starvation to maintain the supply of soluble NPN. Storage of the nitrogenous compounds in the gonad is suggested, since the gonad of a sea urchin starved for a month is almost completely resorbed.

An attempt was made to determine the nature of the NPN by paper chromatography. The filtered body fluid from which proteins were removed with TCA

was treated with Duolite C3 resin in the acid cycle. The anions were washed out with distilled water and the amino acids were then separated from the cations by removal with  $\text{NH}_4\text{OH}$  and chromatographed in butyl alcohol (Redfield, 1953; Slotta and Primosigh, 1951). Only spots for alanine and glutamic acid were located. If other amino acids are present they occur in amounts too small to be detectable by even the very sensitive method used.

#### 8. Nutrition and the reproductive cycle

Collections of this species of sea urchins over many years clearly suggest cyclic gonadal activity. Sperm are available practically all year but eggs are available only during a limited portion of the year. However, the gonads of both males and females undergo cyclic variation in volume. The cycle is probably different for each ecological habitat since differences in maturity were observed between the development of gonads of urchins at Yankee Point and at Pescadero Point. To ascertain the nature of the cycles, the gonads were removed monthly from twenty animals and their volume was determined by immersion in a graduate partially filled with sea water. The volume of gonadal tissues, divided by the weight of the urchin, designated the *gonad index*, was used for comparison of data which are given in Figures 2 and 3.

The growth of the gonads and the development of large numbers of gametes mean a synthesis involving the conversion of a considerable amount of nutrient to protein and nucleic acid. The amount of nitrogen in a gonad is large—a ripe testis containing 2.32% and a ripe ovary, 3.95% nitrogen per unit dry weight; therefore the nitrogen present in an animal probably increase several-fold during the breeding season. However the monthly determinations of the reducing sugar and the NPN in the body fluid given in Figure 2 provide no evidence of excessive mobilization or withdrawal of NPN or glucose during the breeding season.

#### DISCUSSION

Van der Heyde (1922) states that whereas the European sea urchin, *Echinus esculentus* is herbivorous and feeds largely on *Laminaria* and other algae, Neapolitan sea urchins such as *Sphaerechinus* and *Toxopneustes* may be carnivorous and may even capture various crustaceans. *Arbacia punctulata* appears to be omnivorous in nature since algae, brittle stars, hydroids and spicules of sponges are found in its gut (van der Heyde, 1922). *Strongylocentrotus droebachiensis* has similar feeding habits (Scott, 1901; Weese, 1926). The western purple sea urchin, *Strongylocentrotus purpuratus*, studied here was found to be quite omnivorous under laboratory conditions, but specimens found in the field invariably were feeding on any algae available or on the "surf-grass," *Phyllospadix*. The gut contents of hundreds of individuals examined appeared to consist entirely of algal pellets, although small amounts of animal food might have been missed since critical examination for this purpose was not attempted. *Lytechinus anamesus* also appears to be an algal feeder, judging from its depredations on algal beds used for commercial extracts (A. P. Steiner, personal communication).

Algae contain proteins and other constituents of protoplasm and may possess small amounts of sugar and starch. In place of the latter may be found sugar alcohols such as mannitol, dulcitol and sorbitol. However, the greater part of

the bulk of dry algae consists of the constituents of the cell walls and supporting materials. These are made up mainly of polysaccharides other than cellulose although the latter is sometimes found, *e.g.*, in some of the brown algae. Algin, found in the brown algae, is a condensation product of mannuronic acid,  $(C_6H_7O_6)_n$ . Hassid (1936) has demonstrated sulfuric acid esters of galactans which make up to 40% of the dry weight of the red alga, *Iridophycus flaccidum*. When the sulfuric acid is split off, hydrolysis gives rise to pure galactose. Red algae also store floridean starch. Other compounds have also been demonstrated in algae but the knowledge of many is incomplete and the characterizations quite vague (see Blinks, 1951 for a review). Such lack of knowledge seriously hampers experiments on digestion of the algae by the sea urchin since it is generally necessary to use the entire algae rather than individual compounds.

Starch, glycogen, sucrose and maltose were found to be digested by ground-up intestine and contents of the sea urchin, *Echinus esculentus* (Roaf, 1908) and sucrose and protein by a similar preparation of *Strongylocentrotus droebachiensis* (Weese, 1926) and starch but not fats by *Sphaerechinus granularis* (Cohnheim, 1901; Scott, 1901). Weese (1926) failed to demonstrate lypolytic activity in *Echinus* but van der Heyde (1922) found evidence for it in *Arbacia*, the gut extracts of which developed acid when incubated with olive oil.

In the studies on *S. purpuratus* performed here, strong protease and amylase activity were demonstrated in ground, washed intestinal tissue, but no evidence was obtained for an invertase nor unequivocal evidence for an agar-decomposing enzyme, even though agar is ingested by hungry urchins. The sugar content of the body fluid of the starved sea urchin is not increased by a meal of agar. No increases in reducing sugar were observed nor were the algae decomposed in two weeks when they were mixed with the gut extract of the sea urchin and kept under pentachlorophenol. However, in one series of experiments in which the galactan iridophycin was mixed with the extract of the intestinal wall, an increase of reducing sugar was obtained, demonstrating the presence of an iridophycase in the gut. This experiment probably has more validity than those with algae, since in the latter case side reactions may occur by which the reducing sugar is bound. Other algal polysaccharides should be tested in a like manner, but none were available in pure form.

The possibility that bacteria might play a role in digestion has not been previously seriously considered although Weese (1926) observed bacteria present in a film about the algal particles in the gut of *S. droebachiensis*. The present study on *S. purpuratus* indicates that large numbers of bacteria are present, of which a considerable number are capable of digesting algae. The population of bacteria is even greater per unit volume than the figures given because for these determinations a 0.1-ml. quantity of gut contents was ground up with sand and an aliquot was counted or plated. The bacteria actually develop in films about the algal particles; therefore they occupy only a fraction of the volume sampled. The bacteria decomposing agar and other algal cell-wall materials might well be present in sufficient numbers to digest the algae in the gut of the urchin. Furthermore the food is retained in the intestine for a week to two weeks, a period of time adequate for even slow digestion.

It was not possible to determine whether the sea urchins could survive loss of their bacterial flora; therefore the role of the bacteria could not be defined. They

may be commensals which use what is left by the digestive enzymes of the sea urchin or they may be symbionts. The tentative conclusion is drawn that the sea urchin possesses enzymes which hydrolyze protein and starches of algae and perhaps slowly decompose some of the more resistant algal polysaccharides. In the latter action they may be greatly aided by the bacteria present in the gut.

Under normal nutritive conditions reducing sugar was almost always found in the body fluid of sea urchins taken in the field or feeding in the laboratory, the amount being greatest just after active feeding and least after starvation. Lang and MacLeod (1920) also report that little reducing sugar is present in the body fluid of the echinoderms which they tested, although Myers (1920) reported an unusually large content in *S. franciscanus*. The possibility exists that additional sugar is present in a combination with proteins or other nutrients as in some other invertebrates (Morel and Bellion, 1910).

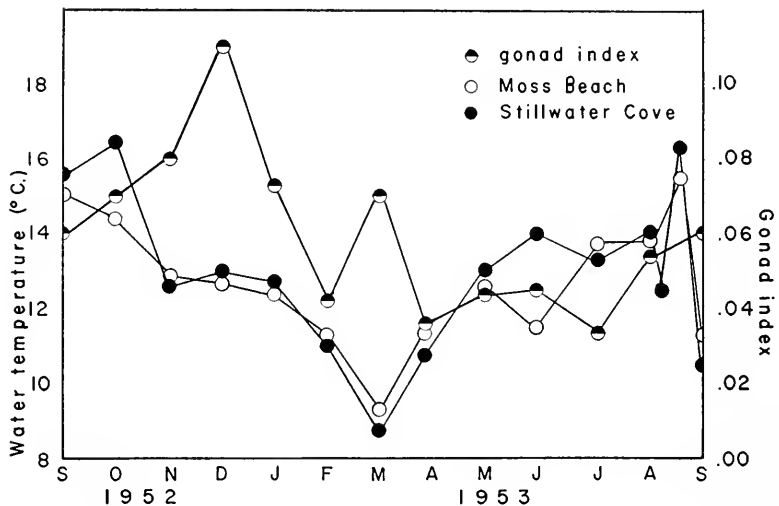

FIGURE 3. The gonad index (volume of gonad divided by the wet weight of the sea urchin) correlated with the water temperature during the year at Moss Beach, a habitat chosen because it lies on the open ocean, and at Stillwater Cove, a habitat chosen because it is sheltered.

The non-protein nitrogen (NPN) showed about the same variations throughout the entire year as the sugar but it was more closely regulated than reducing sugar during starvation. On starvation the NPN in the body fluid remained almost constant but the gonads shrank to a fraction of their former size. It would seem that the gonadal nitrogen was mobilized to maintain the NPN in the body fluid during starvation.

The gonads vary in size during the year and instead of a single growth period several were found in the monthly examinations made over a period of a year. The most striking was in December, but peaks occurred in March and June, presumably followed by spawning although all the spawning periods were not revealed by the monthly examinations. The gonadal cycle does not vary with temperature (Fig. 3) but may be related to cyclic changes in the algae providing

more food or more nutritious food at one time than at another. For lack of pertinent data in the literature it is impossible to test such a possible correlation, but on completion of a current study of algal populations in this region during the year, the necessary data may be available.

#### SUMMARY

1. The intestinal tract of the sea urchin, *Strongylocentrotus purpuratus*, consists of two loops, the first clockwise, the second counter-clockwise (as seen looking in at the mouth). Both loops are well supplied with glands.

2. Experiments present evidence for an amylase and a proteinase in the sea urchin intestine but none for enzymes capable of digesting entire algae or agar. However, the extract of ground gut was capable of digesting iridophycin, a galactan from the red alga, *Iridophycus*.

3. Agar-digesting bacteria are present in the second loop of the intestine in large numbers from  $10^6$  to  $10^7$  per ml. of gut contents. Total bacteria as determined by a count with a Petroff-Hauser counting chamber reach the value of  $2 \times 10^{11}$  per ml. They are largely confined to the pellicle which surrounds each particle of alga.

4. The bacteria inoculated from the gut of the sea urchin are capable of completely digesting the alga, *Iridophycus flaccidum*, in the course of a week. Many of the intestinal bacteria are capable of digesting agar. Pure cultures of agar-decomposing bacteria were isolated from the intestine.

5. The isolated bacteria grown on algae or agar do not liberate reducing sugars into the culture medium.

6. While it seems likely that the sea urchin obtains some nutrient from the activities of its intestinal flora, proof for this is lacking.

7. Some glycogen is stored in the tissue of the sea urchin and the body fluid normally contains a small amount of reducing sugar. No striking changes occur in the latter during the breeding season, but the sugar falls to zero or nearly zero on starvation. Glucose injected into the body fluid is removed by the tissues.

8. The body fluid of the sea urchin always contains a small amount of non-protein nitrogen (NPN), even after two weeks of starvation, and no striking change occurs during the breeding season.

9. The stimulus that sets off the increased effectiveness of the economy of the sea urchin resulting in the growth of the gonads and accumulation of nitrogenous compounds in them is unknown. After gonads reach their maximal size spawning occurs.

10. Several cycles of gonadal growth and spawning are suggested but the data were not collected at sufficiently frequent intervals to make this certain.

#### LITERATURE CITED

- BLINKS, L. R., 1951. Physiology and biochemistry of the algae. Chapter 14 in "Manual of Phycology" ed. by G. M. Smith. Chronica Botanica, Waltham, Mass.
- COHNHEIM, O., 1901. Versuche über Resorption, Verdauung und Stoffwechsel von Echinodermen. *Zeitschr. f. Physiol. Chem.*, **33**: 9-54.
- FRIEDEMANN, T. E., AND J. B. GRAESER, 1933. The determination of lactic acid. *J. Biol. Chem.*, **100**: 291-308.

- HASSID, W. Z., 1933. The isolation of a sodium sulfuric acid ester from *Iridaca laminarioides* (Rhodophyceae). *J. Amer. Chem. Soc.*, **55**: 4163-4167.
- HASSID, W. Z., 1936. Carbohydrates in *Iridaca laminarioides* (Rhodophyceae). *Plant Physiol.*, **11**: 461-463.
- VAN DER HEYDE, H. C., 1922. On the physiology of digestion, respiration, and excretion in echinoderms. Academic Thesis de Boer Jr., den Helder (Pays Bas). 111 pp. 6 fig.
- HILTS, S., AND A. C. GIESE, 1949. Sugar in the body fluid of a sea urchin. *Anat. Rec.*, **105**: 140.
- LANG, R. S., AND J. J. R. MACLEOD, 1920. Observations on the reducing substance in the circulating fluids of certain invertebrates and fishes. *Quart. J. Exp. Physiol.*, **12**: 331-337.
- LYNCH, J. E., 1929a. Studies on the ciliates from the intestine of *Strongylocentrotus*. I. *Entorhipidium* gen. nov. *Univ. Calif. Publ. Zool.*, **33**: 27-56.
- LYNCH, J. E., 1929b. Studies on the ciliates from the intestine of *Strongylocentrotus*. II. *Lechriopyla mystax*, Gen. nov., sp. nov. *Univ. Calif. Publ. Zool.*, **33**: 307-350.
- MEYER, K. H., 1943. The chemistry of glycogen. *Advances in Enzymol.*, **3**: 109-135.
- MOREL, A., AND M. BELLION, 1910. Contribution a l'étude du sucre du sang chez les invertébrés. Sucre libre et sucre combiné du sang de l'escargot. *C. R. Soc. Biol.*, **69**: 27-28.
- MYERS, R. G., 1920. A critical study of the blood of several invertebrates. *J. Biol. Chem.*, **41**: 119-135.
- REDFIELD, R. R., 1953. Two dimensional chromatographic systems with high resolving power for amino acids. *Biochem. Biophys. Acta*, **10**: 344-345.
- REID, R. L., AND M. LEDERER, 1952. Separation and estimation of saturated C<sub>2</sub>-C<sub>7</sub> fatty acids by paper partition chromatography. *Biochem. J.*, **50**: 60-67.
- ROAF, H. E., 1908. The hydrolytic enzymes of invertebrates. *Biochem. J.*, **3**: 462-472.
- SCOTT, F. J., 1901. Food of the sea urchin (*Strongylocentrotus droebachiensis*). *Contrib. Canad. Biol.*, 1901: 49-54.
- SLOTTA, K. H., AND J. PRIMOSIGH, 1951. The amino-acid composition of crotoxin. *Nature*, **168**: 696-697.
- SOMOGYI, M., 1945. Determination of blood sugar. *J. Biol. Chem.*, **160**: 69-73.
- SOMOGYI, M., 1952. Notes on sugar determination. *J. Biol. Chem.*, **195**: 19-23.
- STOTT, F. C., 1931. The spawning of *Echinus esculentus* and some changes in gonad composition. *J. Exp. Biol.*, **8**: 133-150.
- WEESE, A. O., 1926. The food and digestive processes of *Strongylocentrotus droebachiensis*. *Publ. Puget Sound Biol. Stat.*, **5**: 165-179.



## OXIDATIVE ENZYMES IN THE THORACIC MUSCLES OF THE WOODROACH LEUCOPHAEA MADERAE<sup>1</sup>

W. H. McSHAN, SOL KRAMER AND VERA SCHLEGEL<sup>2</sup>

*Department of Zoology, University of Wisconsin, Madison, Wisconsin*

Our present knowledge of cellular metabolism is based largely on results obtained from studies using mammalian tissues. The mechanisms of many of the enzyme-catalyzed reactions of respiration and glycolysis have been elucidated during the past twenty years. During recent years the methods developed for the study of mammalian tissues have been used to study some of the oxidative enzymes in insect tissues, with the result that considerable information has accumulated concerning certain of the oxidative enzymes in various insect tissues.

In this connection Barron and Tahmisian (1948) found that the oxygen consumption of muscle from male cockroaches, *Periplaneta americana*, is double that from female roaches. Sacktor and Bodenstein (1952) reported on the cytochrome oxidase activity of various tissues of the American cockroach, and Harvey and Beck (1953) studied in considerable detail the succinoxidase and cytochrome oxidase systems in the leg muscle of this form. They found that the succinoxidase activity of muscle from the male cockroach is three times that of muscle from the female. Spirtes (1951) demonstrated the presence of Krebs cycle enzymes such as aconitase, isocitric, malic and succinic dehydrogenases, fumarase and condensing enzyme, and also cytochrome oxidase and lactic dehydrogenase in the tissues of *Drosophila melanogaster*; and Bodenstein and Sacktor (1952) studied the cytochrome oxidase during metamorphosis of *Drosophila virilis*; Sacktor (1951a, 1951b, 1952) reported on the cytochrome oxidase activity of normal and DDT resistant house flies, *Musca domestica*; Sanborn and Williams (1950) studied the cytochrome system in the tissues of the *Cecropia* silkworm; Watanabe and Williams (1951) showed that succinic,  $\alpha$ -glycerophosphate, malic and pyruvic dehydrogenases and cytochrome oxidase are present in the sarcosomes of insect muscles; and Collias, McShan and Lilly (1952) reported results of studies on the succinoxidase and cytochrome oxidase systems in the tissues of the large milkweed bug, *Oncopeltus fasciatus*. Bodine, Lu and West (1952) found marked differences in the succinoxidase activity in mitotically active and blocked cells of the developing embryo of the grasshopper, *Melanoplus differentialis*.

Investigations of this kind serve to clarify further our knowledge of the relationship of the cellular metabolic reactions of insect tissues to those already known for mammalian tissues. Furthermore, information obtained for insects and other lower forms is of value from the comparative standpoint and may provide the basis for an insight into the mechanism by which energy is provided for certain specialized behavior patterns in insects such as the cockroach.

<sup>1</sup> This investigation was supported in part by a grant from funds supplied by the Wisconsin Alumni Research Foundation.

<sup>2</sup> Present address: Department of Biochemistry, University of Minnesota, St. Paul.

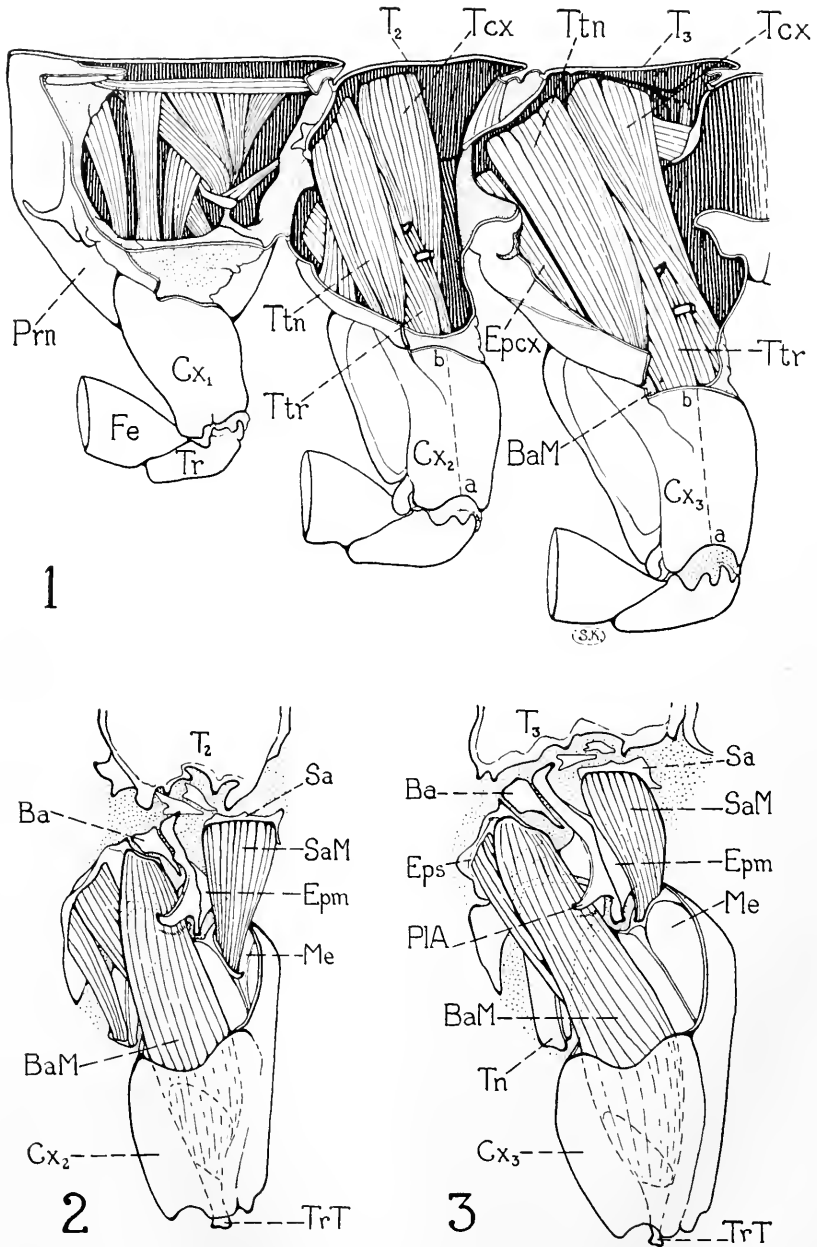

FIGURE 1. Mesal view of the right half of the thorax of the woodroach, *Leucophaea maderae*, showing some of the pigmented mesothoracic and metathoracic muscles (*BaM*, basalar muscle; *Tcx*, tergo-coxal muscle; *Ttn*, tergo-trochantinal muscle; *Ttr*, tergo-trochanteral apodeme muscle) used in the preparation of "leg muscle" homogenate. *a-b*, line of incision along coxae made to expose the entire muscles prior to removal; *Cx*, coxa; *Epcx*, episternalcoxal

The present paper reports results of a study of the succinoxidase, cytochrome oxidase and fatty acid oxidase of thoracic pigmented muscle from the woodroach, *Leucophaea maderae*. The mechanism of action and optimum conditions for these systems have been studied extensively in some mammalian tissues by Keilin and Hartree (1949), Slater (1949a, 1949b), Chance (1952), Lehninger (1946), and Lehninger and Kennedy (1948).

#### MATERIALS AND METHODS

The woodroaches used in this study were isolated soon after metamorphosis and kept in dated containers so that muscle tissue could be obtained from roaches of known age. In certain of the earlier experiments, however, adult roaches of unknown age were used. Males and females were kept separately. All roaches were fed on the same constant dog pellet diet and ample food and water were always available to them.

The muscle tissue used was dissected from the meso- and metathoracic segments immediately after the roaches were killed by severing the head and abdomen. A mid-ventral incision through the thorax divided it into two halves. Remnants of the gut, large tracheal tubes and fat body were quickly cleaned away, and the large bundles of thoracic muscles were exposed as shown in Figure 1. Incisions along the meso- and metathoracic coxae along dotted lines *a-b* made it possible to separate these muscles in bulk with a few ventral and dorsal incisions. The tissue was weighed and placed in ground glass homogenizing tubes contained in an ice bath, and homogenized within 8 minutes after the roaches were killed. Sufficient water was added to give a 2.5 per cent homogenate which was used for the succinoxidase determinations. It was necessary to prepare a 0.5 per cent homogenate for the cytochrome oxidase and a 10 per cent homogenate for the determinations of fatty acid oxidase.

These muscles are sometimes referred to as the "leg muscles," and most of these muscles are in fact concerned with leg function. Roaches, such as the cockroach, *Periplaneta americana* as well as the woodroach, *Leucophaea maderae* and others, although comparatively weak flyers, can and do fly. Woodroaches in particular were observed on rare occasions to fly distances of 10-12 feet in slow, labored flight in the insectary. Further, Roth and Willis (1952) have shown that the wings of male *Periplaneta americana* and male *Blatta orientalis* are vibrated actively prior to copulation.

It is clear, then, that some muscles in roaches must function in flight and wing vibration. Carbonell (1947) in a detailed study of the thoracic musculature of the cockroach *Periplaneta americana* noted that these muscles bore little resemblance to

---

muscle; *Fe*, femur; *Prn*, pronotum; *T<sub>2</sub>*, mesothoracic tergum; *T<sub>3</sub>*, metathoracic tergum; *Tr*, trochanter.

FIGURE 2. Mesal view of the mesothoracic flight muscles (*BaM*, basalar muscle; *SaM*, subalar muscle) which lie among the leg muscles and also included in the homogenate preparations. *Ba*, basalar; *Epm*, epimeron; *Me*, meron; *Sa*, subalar; *TrT*, trochanteral tendon. Other abbreviations as above.

FIGURE 3. Similar view of metathoracic flight muscles included in the homogenate preparations. *Eps*, episternum; *PLA*, pleural apodeme; *Tn*, trochatin. Other abbreviations as above.

those of other insects, and that in the musculature of the wings the cockroach thorax differs widely from the normal scheme of wing-bearing segments as given by Snodgrass (1935). The size of the basalar muscles (pronator-extensor of the wings) and the subalar muscles (depressor-extensor of the wings), which lie in the midst of the large leg muscles, led Carbonell to conclude that they must play an important role in flight.

Dissection of the woodroach revealed that prominent basalar muscles (BaM) and subalar muscles (SaM) are present in both the mesothoracic (Fig. 2) and metathoracic segments (Fig. 3). In fact, the basalar muscles<sup>3</sup> in both segments are the largest and longest of all the individual muscles present. These large flight muscles, together with the large leg muscles, are pigmented pink, in contrast to the smaller ventral longitudinal and certain smaller oblique muscles which are a translucent white color—and it was these pink pigmented muscles as a group which were used for the preparation of homogenates. Further, each homogenate represents not a mixture of muscles from several insects, but a preparation from the muscles of one roach of known age.

The enzyme determinations were made by use of the conventional Warburg apparatus. The homogenates were prepared by use of sharp-pointed, ground-glass homogenizers. The homogenates used for the study of succinoxidase and cytochrome oxidase were made with water and those for fatty acid oxidase with 0.154 *M* KCl. The proper amount of homogenate was placed in the flasks with the required cofactors for each of the enzyme systems studied. The flasks were placed in the bath at 38° C., and ten minutes were allowed for equilibration in the case of succinoxidase and cytochrome oxidase, and 6 minutes for fatty acid oxidase. Readings of oxygen consumption were taken at 10-minute intervals for at least 40 minutes. The average value for the number of 10-minute periods during which the oxygen consumption was constant, which was usually four periods, was used as a basis for calculating the  $Q_{O_2}$  values.

The methods used for the determination of succinoxidase and cytochrome oxidase were those reported by Schneider and Potter (1943). The optimum concentrations of required factors, and other conditions for maximum succinoxidase activity of thoracic muscle of the woodroach were determined. The concentrations of factors used for the cytochrome oxidase determinations were the same as those that have been reported for mammalian tissues. The fatty acid oxidase determinations were done by the method reported by Lehninger and Kennedy (1948). Final flask concentrations for the different enzyme systems are given in the footnotes to the tables.

The inhibitors were prepared in stock solutions which were in most cases 0.001 *M*. The solution of diethylstilbestrol was prepared by the procedure reported by McShan and Meyer (1946). The dry weight determinations of flight muscle were done by weighing the fresh tissue, placing it in a weighed tube and drying at 75° C. for 24 hours, after which the dry tissue was weighed and the weight used for calculating the percentage dry weight in terms of fresh weight.

Cytochrome *c* used for the determinations of succinoxidase and cytochrome oxidase was prepared by a modification of the method of Keilin and Hartree (1937).

<sup>3</sup> The basalar muscle actually arises from a tendon at the margin of the episternum adjacent to the basalare in each segment, but Crampton (1927) regards this margin of the episternum as an anterior portion of the basalare in the cockroach, *Periplaneta americana*.

or was obtained from the Sigma Chemical Company. Analytical reagent grade chemicals were used.

RESULTS AND DISCUSSION

The succinoxidase activity of homogenates of thoracic muscle from female roaches of different ages was determined with different concentrations of succinate, phosphate buffer, calcium chloride, aluminum chloride and cytochrome *c*. The

TABLE I

*Determination of the optimum concentrations of constituents required for maximum activity of succinoxidase in homogenates of woodroach thoracic muscle*

Constituents			Concentrations of variable constituents and Q <sub>O<sub>2</sub></sub> values**									
Absent	Present	Final M in flask										
AlCl <sub>3</sub>	Phosphate pH 7.3	variable	M*	0.0	0.0083	0.017	0.033	<i>0.050</i>	0.066	0.100	0.133	
CaCl <sub>2</sub>	Sod. succ. Cyto. <i>c</i>	0.1 2 × 10 <sup>-5</sup>	Q <sub>O<sub>2</sub></sub>	37.0	40.0	69.0	83.0	<i>132.0</i>	115.0	115.0	98.0	
AlCl <sub>3</sub>	CaCl <sub>2</sub>	variable	M	0.0	0.0004	0.0008	0.0012	<i>0.0016</i>	0.0020			
	Sod. succ. Cyto. <i>c</i> Phosphate	0.1 2 × 10 <sup>-5</sup> 0.05	Q <sub>O<sub>2</sub></sub>	107.0	135.0	158.0	193.0	<i>208.0</i>	199.0			
CaCl <sub>2</sub>	AlCl <sub>3</sub>	variable	M	0.0	0.0004	0.0008	0.0012	<i>0.0016</i>	0.0020			
	Sod. succ. Cyto. <i>c</i> Phosphate	0.1 2 × 10 <sup>-5</sup> 0.05	Q <sub>O<sub>2</sub></sub>	126.0	175.0	177.0	166.0	<i>186.0</i>	177.0			
None	Sod. succ. Cyto. <i>c</i> Phosphate CaCl <sub>2</sub> + AlCl <sub>3</sub> each	variable 2 × 10 <sup>-5</sup> 0.05 1.6 × 10 <sup>-3</sup>	M	0.025	0.050	0.075	0.100	0.125	0.150	0.175	0.200	
			Q <sub>O<sub>2</sub></sub>	99.0	125.0	142.0	160.0	174.0	189.0	199.0	199.0	
None	Cyto. <i>c</i> (× 10 <sup>-5</sup> M)	variable	M	0.5	1.0	1.5	2.0	2.5	3.0			
	Sod. succ. Phosphate CaCl <sub>2</sub> + AlCl <sub>3</sub> each	0.1 0.05 4 × 10 <sup>-4</sup>	Q <sub>O<sub>2</sub></sub>	94.0	113.0	128.0	<i>131.0</i>	115.0	103.0			
None	pH	variable	pH	6.38	6.76	7.17	7.3	7.59	7.91			
	Sod. succ. Phosphate CaCl <sub>2</sub> + AlCl <sub>3</sub> each Cyto. <i>c</i>	0.1 0.05 4 × 10 <sup>-4</sup> 2 × 10 <sup>-5</sup>	Q <sub>O<sub>2</sub></sub>	94.0	112.0	128.0	<i>131.0</i>	115.0	103.0			

\* Final molarity in flask.

\*\* Q<sub>O<sub>2</sub></sub> values are based on a dry weight content of 18.2 per cent and are averages of 2 to 5 runs using 0.1 ml. of 2.5 per cent homogenate except 0.2 ml. was used when cytochrome *c* and the pH were varied.

results italicized in Table I indicate the concentrations which gave maximum activity are 0.2 M succinate, 0.05 M phosphate buffer of pH 7.3, 1.6 × 10<sup>-3</sup> M of each calcium and aluminum chlorides, and 2 × 10<sup>-5</sup> M cytochrome *c*. Results of runs made at different pH values show that maximum activity was obtained at pH 7.3.

The data of Table II (Experiments 1 to 3) show that under the above conditions the oxygen consumption was directly proportional to the amount of tissue reacting

for 0.05, 0.10 and 0.15 ml. of 2.5 per cent homogenate but not for 0.20 and 0.25 ml. The results from Experiments 1, 2 and 3 are shown graphically in Figure 4. When 0.175 *M* succinate was used (Experiment 4, Table II) there was not quite a direct proportionality between the oxygen consumption and the amount of tissue reacting. These results indicate that a much higher concentration of succinate is required for optimum activity of the succinoxidase system of woodroach muscle than for this system of other tissues such as rat liver which requires only 0.05 *M* (Schneider and Potter, 1943). Harvey and Beck (1953) found 0.11 *M* succinate optimum for American cockroach muscle.

Essentially no oxygen was consumed when the succinoxidase system was run without substrate, and without tissue. When the cytochrome *c* was left out of the

TABLE II  
*Relation of oxygen consumption to amount of woodroach thoracic muscle used in the succinoxidase system*

Amount of tissue* ml. 2.5% homogenate	Experiment No.							
	1(3)**		2(3)**		3(1)**		4(1)**	
	Oxygen consumption							
	Cmm. per 10 min.	Q <sub>O<sub>2</sub></sub>	Cmm. per 10 min.	Q <sub>O<sub>2</sub></sub>	Cmm. per 10 min.	Q <sub>O<sub>2</sub></sub>	Cmm. per 10 min.	Q <sub>O<sub>2</sub></sub>
0.05	7.6	201.2	6.1	160.8			8.0	210.9
0.10	15.0	197.3	12.1	160.0	19.5	257.2	15.5	204.0
0.15	22.4	196.9	18.4	161.3	28.6	252.0	21.9	192.0
0.20			23.4	154.1	34.6	228.0		
0.25					39.0	205.7		

\* Flask concentrations of the constituents used in the system were sodium succinate 0.2 *M* except it was 0.175 *M* for experiment 4, phosphate buffer of pH 7.3 0.05 *M*, aluminum and calcium chlorides each  $1.6 \times 10^{-3}$  *M*, cytochrome *c*  $2 \times 10^{-5}$  *M*. The muscle used in these experiments was taken from adult females of unknown age.

\*\* Number of runs with two flasks per each amount of tissue. The Q<sub>O<sub>2</sub></sub> values are based on the average oxygen consumption for the first four 10-minute periods and a dry weight content of 18.2 per cent.

system the average oxygen consumption per 10 minutes was 2.9, 5.3 and 7.5 mm.<sup>3</sup>, respectively, for 0.05, 0.10 and 0.15 ml. of 2.5 per cent homogenate. This was presumably due to the presence of cytochrome *c* in the flight muscle since this cytochrome has been shown to be present in cockroach muscle (Barron and Tahmisian, 1948; Harvey and Beck, 1953). Homogenates of woodroach muscle were therefore treated with sodium hydrosulfite to reduce the cytochromes and examined by use of a Hartridge Reversion Spectroscope. Absorption bands at the proper wave-lengths for cytochromes *a*, *b* and *c* were found, indicating the presence of these cytochromes in the woodroach muscle. On the basis of this evidence it appears that the activity of the system without added cytochrome *c* was caused by the presence of this component in the muscle homogenate.

The Q<sub>O<sub>2</sub></sub> values of the different amounts of muscle homogenate used in Ex-

periments 1, 2 and 3 (Table II) were essentially constant and the average values were, respectively, 198.5, 161.0 and 254.6. The over-all average  $Q_{O_2}$  was 205. Adult female woodroaches of various ages were used for these experiments. These  $Q_{O_2}$  values are based on a dry weight of 18.2 per cent. The dry weights given in Table III, which range from 21.5 to 29.8 per cent, were done at different times than were those on which the above 18.2 per cent is based. The reason for this difference in the dry weights of these two series of experiments is not apparent.

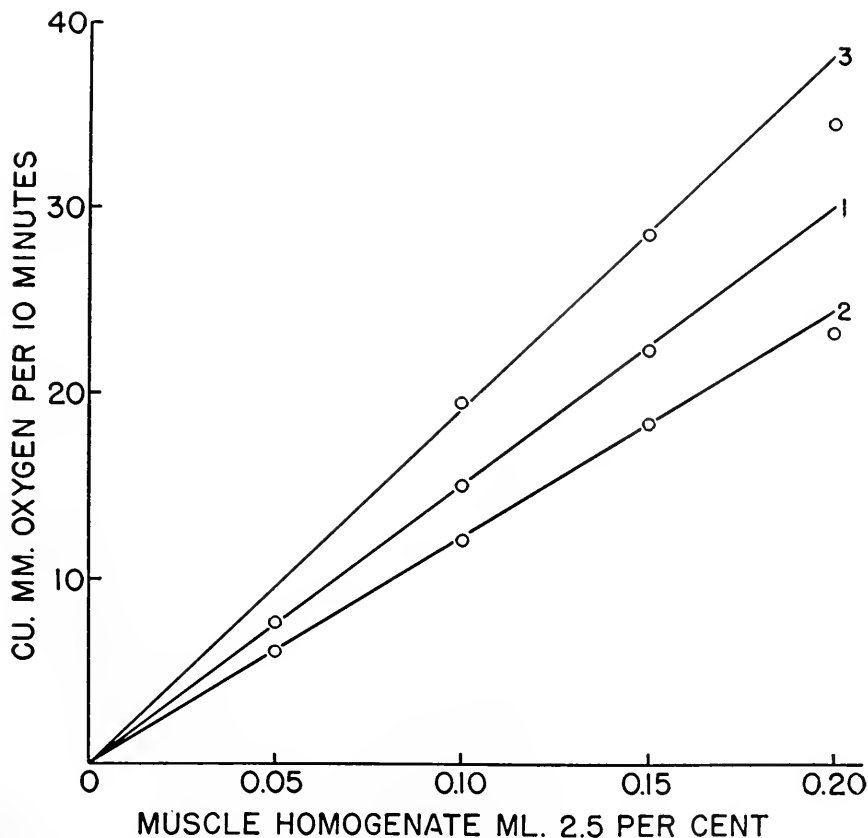

FIGURE 4. Results showing relation of different amounts of enzyme or tissue to oxygen consumption. Tissue concentrations which resulted in directly proportional oxygen uptakes are shown.

The roaches were kept under essentially constant conditions as to water, food and temperature, but factors other than these and the possible relation of dry weight to age may be involved.

The results given in Table III show the relation of age and sex to the dry weight and succinoxidase activity of woodroach muscle. There seems to be some tendency for the dry weight of muscle of both sexes to increase with increase in age after 5 days of adulthood. These results also show that there was an increase in

the succinoxidase activity of the muscle with increase in age of the roaches. Although most of these experiments were done during the spring of 1952, they were repeated for certain ages in the spring of 1953 with similar results, Table III). Further work, however, is necessary to clarify the variation in dry weight content of roach muscle.

The inhibition of the succinoxidase system of woodroach thoracic muscle was studied by use of diethylstilbestrol, cyanide, azide and malonate. Forty to 60 per cent inhibition was obtained with  $0.27 \times 10^{-4}$  M diethylstilbestrol,  $0.5 \times 10^{-4}$  M potassium cyanide,  $0.5 \times 10^{-3}$  M sodium azide and  $0.5 \times 10^{-2}$  M sodium malonate (Table IV). The malonate is known to inhibit the succinic dehydrogenase of the succinoxidase system. The diethylstilbestrol (McShan and Meyer, 1946), cyanide

TABLE III  
*Dry weight content and succinoxidase activity of thoracic muscle  
from woodroaches of different ages*

Sex	Age days	1952		1953	
		Dry wt. %	Q <sub>o</sub> <sup>*</sup>	Dry wt. %	Q <sub>o</sub> <sup>*</sup>
Female	0.5	25.0	120	23.4	106
	5	23.9	143		
	10	24.2	148		
	20	26.4	145		
	30	29.8	140		
	40	27.1	188		
	82			27.3	155
Male	0.5	24.3	129	23.9	128
	5	21.5	149		
	10	23.7	154		
	20	27.3	143		
	40	25.3	178		
	77			26.2	156

\* Values based on 1 to 4 runs with 2 to 3 flasks per run, and on the oxygen uptake during the first 3 or 4 ten-minute periods.

and azide inhibit the cytochrome oxidase of this system and this prevents the oxidation of the cytochrome *c* when it is reduced by the action of the dehydrogenase. These inhibitors appear to affect the succinoxidase system of woodroach muscle in the same way as they affect this system in mammalian tissues.

Experiments were done to determine directly the succinic dehydrogenase activity of woodroach muscle by using brilliant cresyl blue (BCB) in the system as the mediator of hydrogen transport in place of the cytochrome system. When BCB was used in the system a Q<sub>o</sub> of 76.5 was obtained as compared with 194 and 173, respectively, when cytochrome *c*, and BCB plus cytochrome *c* were present in the system. Similar results were obtained with rat liver which was run as a control. When cyanide was used in the system with BCB there was an increase of 83 per cent in the Q<sub>o</sub> of woodroach muscle (Q<sub>o</sub> of 76.5 for BCB alone) but under the same conditions cyanide did not cause an increase in the activity of rat liver. This in-



creased oxygen consumption when cyanide is added to the BCB system has been reported previously for leg muscle of the American cockroach (Harvey and Beck, 1953).

A  $\dot{Q}O_2$  of 1770 was obtained for the cytochrome oxidase of muscle from female roaches 30 days of age when 0.05 ml. and 0.1 ml. of 0.5 per cent homogenate were used per flask. Each flask also contained final concentrations of 0.033 *M* phosphate buffer of pH 7.3, 0.0114 *M* ascorbic acid,  $4 \times 10^{-5}$  *M* aluminum chloride, and  $8.7 \times 10^{-5}$  *M* cytochrome *c* which are essentially the amounts of these factors used for rat liver cytochrome oxidase by Schneider and Potter (1943). The  $\dot{Q}O_2$  of 1770 obtained for woodroach muscle is close to that of 1520 reported by Harvey and Beck (1953) for cockroach muscle but is much greater than the  $\dot{Q}O_2$  of 377 and 387 found, respectively, for cytochrome oxidase of rat liver and corpora lutea from

TABLE IV

*Effect of inhibitors on the succinoxidase system of thoracic muscle of the woodroach*

Inhibitor	Concentration in flask <i>M</i>	Inhibition %
Diethylstilbestrol	0.27 ( $10^{-4}$ )	59*
	0.50	92
	1.0	96
Potassium cyanide	0.5 ( $10^{-3}$ )	40
	1.0	93
	10.0	97
Sodium azide	0.27 ( $10^{-3}$ )	44
	0.50	56
	1.0	61
	1.3	79
	2.7	80
	5.8	78
Sodium malonate	0.5 ( $10^{-2}$ )	41
	1.0	60

\* Values are based on 4 to 7 runs with two flasks per run.

pregnant rats by McShan, Meyer and Erway (1947) and McShan, Erway and Meyer (1948).

The fatty acid oxidase activity is low as compared to the succinoxidase activity of woodroach muscle, and there does not appear to be a significant change in activity with increase in age of the roach (Table V).

The results of this study show that succinoxidase and cytochrome oxidase systems are present in the thoracic pigmented muscle of the woodroach, *Leucophaea maderae*. In this muscle, however, the succinoxidase is more than twice as active and the cytochrome oxidase more than four times as active as in rat liver. On the other hand the fatty acid oxidase of rat liver is about ten times that of the woodroach muscle. Perhaps this is to be expected since the liver is known to be the locus for fatty acid metabolism.

Optimum conditions were determined for eliciting the maximum succinoxidase activity of woodroach muscle and it was found that this muscle requires four times

the concentration of succinate as does rat liver. In this connection Harvey and Beck (1953) found that the succinoxidase of leg muscle from the American cockroach requires 0.11 *M* succinate which is more than double that required by rat liver (Schneider and Potter, 1943). These results suggest that tissues high in succinoxidase, such as roach muscle, require higher concentrations of succinate for maximum activity than do tissues which contain a lower concentration of this system.

The results obtained with the BCB system, inhibitors and the required cofactors indicate that the mechanism of action of woodroach muscle succinoxidase is similar to that of mammalian tissues.

The increase in the succinoxidase activity of woodroach muscle with increase in age and the possible trend toward an increase in dry weight with increase in age may have physiological significance which is not apparent at present. In this connection Sacktor (1951b) showed that the cytochrome oxidase activity of normal and DDT-resistant house flies changes during pupal development, and Watanabe and Williams (1951) have reported differences in the cytochrome oxidase activity

TABLE V

*Fatty acid oxidase activity of thoracic muscle from female woodroaches*

Age in days	Q <sub>02</sub> **
10*	3.1
20	5.8
40	3.0
60	4.5
Adult	3.7
Ave. for all ages	4.0

\* When water was used for homogenizing muscle from a roach 10 days old a Q<sub>02</sub> of 2.3 was obtained as compared to 3.1 for 0.154 *M* KCl.

\*\* The amount of muscle tissue used per flask was 0.25 ml. of 10 per cent homogenate made with 0.154 *M* KCl. The final flask concentrations of reagents were 0.033 *M* KH<sub>2</sub>PO<sub>4</sub>-K<sub>2</sub>HPO<sub>4</sub> of pH 7.4, 0.002 *M* potassium octanoate, 0.07 *M* KCl, 0.013 *M* MgSO<sub>4</sub>, and 6.6 × 10<sup>-4</sup> *M* KATP. The Q<sub>02</sub> values are based on a dry weight content of 18.2 per cent.

of sarcosomes of *Phormia* isolated from insects of different ages. Further, Harvey and Beck (1953) found that succinoxidase is three times as active in the thoracic muscle of the male as in the female American cockroach, *Periplaneta americana*. These results for *Periplaneta* have been confirmed in our laboratory. It is therefore of interest that the succinoxidase activity in the thoracic muscle of the woodroach, *Leucophaea maderae*, is essentially the same in both sexes.

#### SUMMARY

1. The thoracic muscle of the woodroach, *Leucophaea maderae*, was shown to contain high concentrations of succinoxidase and cytochrome oxidase and a low concentration of fatty acid oxidase as compared to rat liver.

2. The conditions required for optimum activity of the succinoxidase system were determined and it was found that this system requires four times the concentration of succinate as does succinoxidase of rat liver.

3. Succinoxidase activity of thoracic pigmented muscle in the woodroach is essentially the same in both sexes, whereas in the American cockroach, *Periplaneta*

*americana*, the activity is three times as great in the muscle of the male as in that of the female. These latter results with *P. americana* (Harvey and Beck, 1953) have been confirmed in our laboratory.

4. Results were obtained which indicate that the succinoxidase activity of woodroach thoracic muscle increases with increase in the age of the roach.

5. The results of studies with cofactors, inhibitors and the brilliant cresyl blue system indicate that the mechanism of action of the succinoxidase of woodroach muscle is similar to that of mammalian tissues.

## LITERATURE CITED

- BARRON, E. S. G., AND T. N. TAHMISIAN, 1948. The metabolism of cockroach muscle, *Periplaneta americana*. *J. Cell. Comp. Physiol.*, **32**: 57-76.
- BODENSTEIN, D., AND B. SACKTOR, 1952. Cytochrome *c* oxidase activity during the metamorphosis of *Drosophila virilis*. *Science*, **116**: 299-300.
- BODINE, J. H., KIAO-HUNG LU AND W. L. WEST, 1952. Succinic dehydrogenase in mitotically active and blocked embryonic cells. *Physiol. Zool.*, **25**: 109-123.
- CARBONELL, C. S., 1947. The thoracic muscles of the cockroach *Periplaneta americana* (L.). *Smith. Misc. Coll.*, **107**: 1-23.
- CHANCE, B., 1952. The kinetics and inhibition of cytochrome components of the succinic oxidase system. *J. Biol. Chem.*, **197**: 567-576.
- COLLIAS, E. C., W. H. MCSHAN AND J. H. LILLY, 1952. Oxidative enzyme systems of the large milkweed bug, *Oncopeltus fasciatus* (D), and the effect of sabadilla on them. *J. Cell. Comp. Physiol.*, **40**: 507-528.
- CRAMPTON, G. C., 1927. The thoracic sclerites and wing bases of the roach *Periplaneta americana* and the basal structure of the wings of insects. *Psyche*, **34**: 59-72.
- HARVEY, G. T., AND S. D. BECK, 1953. Muscle succinoxidase in the American cockroach. *J. Biol. Chem.*, **201**: 965-973.
- KEILIN, D., AND E. F. HARTREE, 1937. Preparation of pure cytochrome *c* from heart muscle and some of its properties. *Proc. Roy. Soc. (London)*, **122B**: 290-308.
- KEILIN, D., AND E. F. HARTREE, 1949. Activity of the succinic dehydrogenase-cytochrome system in different tissue preparations. *Biochem. J.*, **44**: 205-218.
- LEHNINGER, A. L., 1946. Quantitative study of the products of fatty acid oxidation in liver suspensions. *J. Biol. Chem.*, **164**: 291-306.
- LEHNINGER, A. L., AND E. P. KENNEDY, 1948. The requirements of the fatty acid oxidase complex of rat liver. *J. Biol. Chem.*, **173**: 753-771.
- MCSHAN, W. H., AND R. K. MEYER, 1946. The effect of estrogens on the succinoxidase system of liver and pituitary tissues. *Arch. Biochem.*, **9**: 165-173.
- MCSHAN, W. H., R. K. MEYER AND W. F. ERWAY, 1947. Effects of estrogens on the succinoxidase system of rat tissues. *Arch. Biochem.*, **15**: 99-110.
- MCSHAN, W. H., W. F. ERWAY AND R. K. MEYER, 1948. Malic dehydrogenase and cytochrome oxidase of lutein and other ovarian tissues during pregnancy and lactation. *Arch. Biochem.*, **16**: 379-387.
- ROTH, L. M., AND E. R. WILLIS, 1952. A study of cockroach behavior. *Amer. Mid. Nat.*, **47**: 66-129.
- SACKTOR, B., 1951a. A comparison of the cytochrome oxidase activity of two strains of house flies. *J. Econ. Entomol.*, **43**: 832-838.
- SACKTOR, B., 1951b. Some aspects of respiratory metabolism during metamorphosis of normal and DDT-resistant house flies, *Musca domestica* L. *Biol. Bull.*, **100**: 229-243.
- SACKTOR, B., 1952. The cytochrome *c* oxidase of the house fly, *Musca domestica* L. *J. Gen. Physiol.*, **35**: 397-407.
- SACKTOR, B., AND D. BODENSTEIN, 1952. Cytochrome *c* oxidase activity of various tissues of the American cockroach, *Periplaneta americana*. *J. Cell. Comp. Physiol.*, **40**: 157-161.
- SANBORN, R. C., AND C. M. WILLIAMS, 1950. The cytochrome system in the *Cecropia* silkworm, with special reference to the properties of a new component. *J. Gen. Physiol.*, **33**: 579-588.

- SCHNEIDER, W. C., AND V. R. POTTER, 1943. The assay of animal tissues for respiratory enzymes. *J. Biol. Chem.*, **149**: 217-227.
- SLATER, E. C., 1949a. The measurement of the cytochrome oxidase activity of enzyme preparations. *Biochem. J.*, **44**: 305-318.
- SLATER, E. C., 1949b. A respiratory catalyst required for the reduction of cytochrome *c* by cytochrome *b*. *Biochem. J.*, **45**: 14-30.
- SNOODGRASS, R. E., 1935. Principles of insect morphology. McGraw-Hill Book Co., New York and London.
- SPIRITES, M. A., 1951. Demonstration of the presence of Krebs cycle enzymes in *Drosophila melanogaster*. *Fed. Proc.*, **10**: 251.
- WATANABE, M. I., AND C. M. WILLIAMS, 1951. Mitochondria in the flight muscles of insects. *J. Gen. Physiol.*, **34**: 675-689.

TIDAL RHYTHMICITY OF RATE OF WATER PROPULSION IN  
MYTILUS, AND ITS MODIFIABILITY  
BY TRANSPLANTATION<sup>1, 2</sup>

KANDULA PAMPAPATHI RAO<sup>3</sup>

*Department of Zoology, University of California, Los Angeles, California*

While studying the rate of water propulsion in *Mytilus californianus* (Rao, 1953) it was observed that the behavior of the mussels was not the same at different periods of the day. A detailed study revealed that these differences were of the nature of a tidal rhythm, with periods of greater activity, corresponding to the times of high tide, alternating with those of lesser activity, corresponding to the times of low tide in the area from which the animals were collected.

Since the discovery of a persistent tidal rhythm in *Convolvata roscoffensis* (Bohn, 1903; Gamble and Keeble, 1903), similar rhythms have been described for a number of marine organisms from nearly all groups, and these have been reviewed by Calhoun (1944) and Brown, Fingerman, Sandeen and Webb (1953). Several molluscs have been described as exhibiting tidal rhythmicity in their activity. *Littorina rudis*, which is covered by water only during the semilunar high, high tides, becomes active at 15-day intervals when kept in the laboratory (Bohn, 1904). Brown, Bennett and Graves (1953) report a long-term tidal rhythm in *Venus*. Gompel (1937, 1938) reported the occurrence of a persisting tidal rhythm of oxygen consumption in *Patella*, *Mytilus*, *Pecten* and *Cytherea* while in *Haliotis tuberculata* it was not so marked. Brown, Bennett and Webb (1953) found the same in the crab *Uca*.

In the following studies an attempt was made to learn something of the nature of this rhythm in *Mytilus*, using as an index of activity the rate of water propulsion.

It is a pleasure to acknowledge my indebtedness to Professor Theodore H. Bullock for helping me in the procurement of the material; offering me all the laboratory facilities; for his enthusiastic encouragement during the course of this investigation and for critically reading through this paper. To the Chairman and Secretary of the Department of Zoology, and the other members of the staff, I am most grateful for several courtesies extended to me during my stay in the Department. My especial thanks are due to Professor G. E. MacGinitie, Director of the Kerckhoff Marine Laboratory, Corona del Mar, California, and to his staff for allowing me to make use of their laboratory pier for the experiment in transplantation of mussels. Finally I should like to place on record the promptness with

<sup>1</sup> Aided by a grant to Dr. Theodore H. Bullock, from the National Institutes of Health, U. S. Public Health Service.

<sup>2</sup> Work done while the author was a holder of a Fulbright Travel Grant, awarded through the Institute of International Education, New York, N. Y., and the U. S. Educational Foundation in India.

<sup>3</sup> Present address: Department of Zoology, Andhra University, Waltair, India.

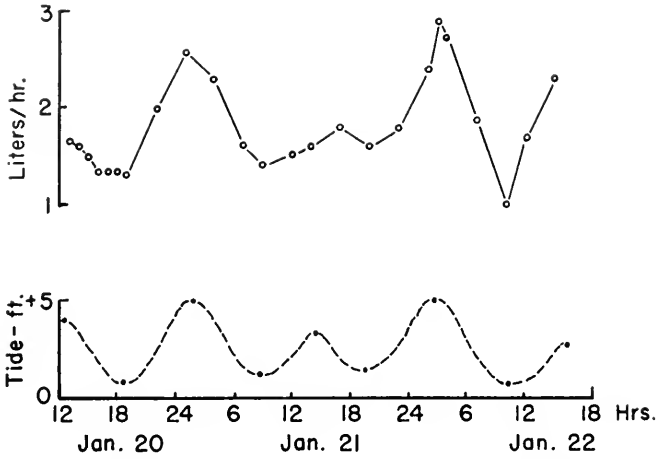

FIGURE 1. Variations in the rate of water propulsion in a single specimen of *M. californianus* collected inter-tidally from +1.0 ft. and kept in darkness at  $14 \pm 1^\circ$  C. Dotted line indicates the tidal cycle in the locality of collection, in this and the following figures.

which the Supply Department of the Marine Biological Laboratory, Woods Hole, Massachusetts, sent us the required supply of *Mytilus edulis*.

MATERIALS AND METHODS

*Mytilus californianus* collected from about +1.0 ft. (tidal datum zero is mean lower low water, tidal range here about 8 feet) on pilings at Santa Monica, California, were transferred to aquaria containing sea water at  $14 \pm 1^\circ$  C. One large mussel was placed in each of three enamel-coated pans containing sea water at  $9 \pm 1^\circ$ ,  $14 \pm 1^\circ$ , and  $20 \pm 1^\circ$  C., respectively, while a duplicate series of three pans contained ten to twelve mussels each, at the same three temperatures. All

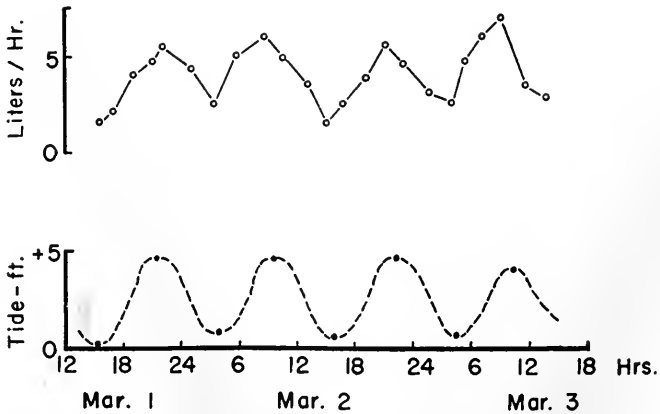

FIGURE 2. Rhythmicity in the rate of water propulsion in *M. californianus* collected from a depth of about 30 ft. off Los Angeles, and kept in darkness at  $14^\circ$  C.

the containers were covered with lids, making them virtually dark chambers. The method used for measuring the rate of water propulsion has been detailed elsewhere (Rao, 1953). Measurements were made at hourly intervals round the clock for 72 hours in continuity and this was repeated at three-day intervals, over a period of four to six weeks.

The same procedure as above was followed for *M. californianus* from about + 4.0 ft., on pilings and for *M. edulis* from pilings and from the underside of floats a few feet away. A collection of *M. californianus* obtained from a depth of about 30 ft. off the shore near Los Angeles, and a consignment of *M. edulis* collected at

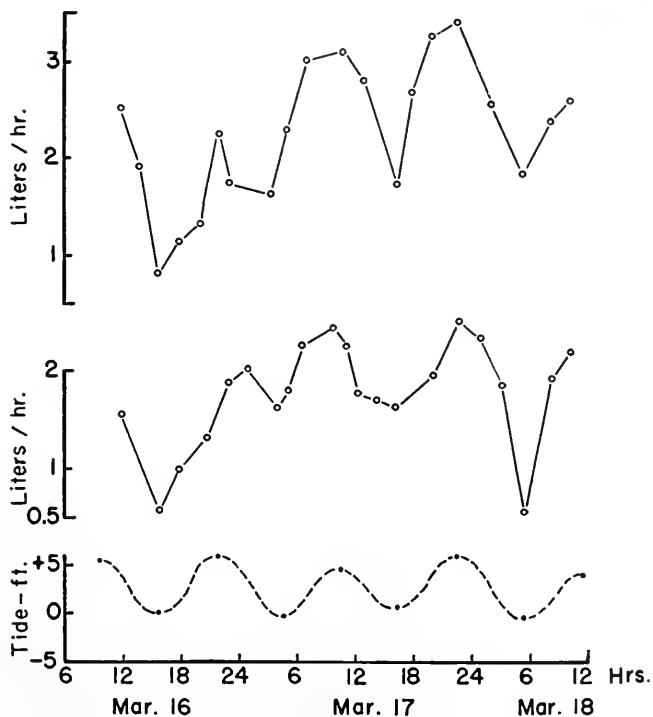

FIGURE 3. Variations in the rate of water propulsion over a period of 48 hours in *M. edulis* collected from floats and pilings at Santa Monica, California, and kept in darkness at  $14^{\circ}$  C. Upper graph for animals from floats and the lower one for those from pilings.

Barnstable Harbor on Cape Cod and flown to Los Angeles, California, were studied at  $9 \pm 1^{\circ}$  C. and  $14 \pm 1^{\circ}$  C.

Besides measurements on animals kept in continuous darkness, all the above samples were subjected to continuous light and the natural day and night environment and measurements made.

## RESULTS

### *Mytilus californianus*

Individuals of *M. californianus*, when observed in the laboratory, exhibit a pattern of activity (measured by the rate of water propulsion) which corresponds in

time and degree to the tidal levels in the locality from where they have been collected (Fig. 1). The pattern holds good even when several individuals are grouped together and their activity as a whole is measured. The rhythm is independent of temperature over the whole range measured, from 9 to 20° C. (as has been found by Brown, Bennett and Sandeen, 1953, in the fiddler crab) and persists for over four weeks in the laboratory in continuous darkness or continuous light, or the normal day and night environment. No indications of a diurnal rhythm in the rate of water propulsion were noticed.

Similar results were obtained regardless of the height inter-tidally from which animals were collected and even with mussels obtained from a sub-tidal population at a depth of about 30 ft. off the shore (Fig. 2).

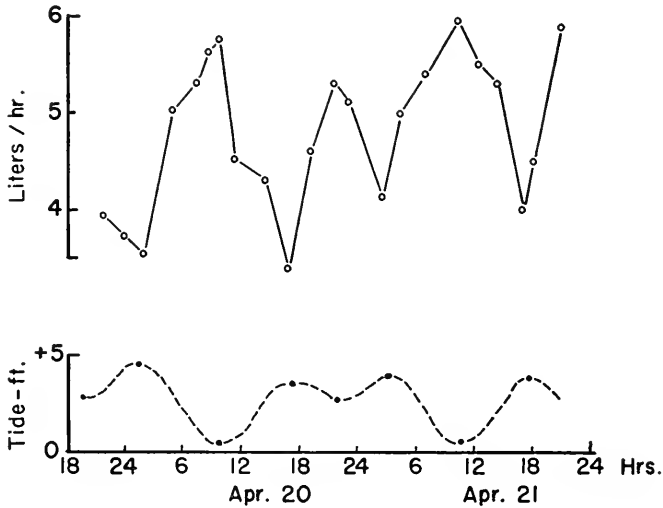

FIGURE 4. Record of rate of water propulsion in *M. edulis* from Barnstable Harbor on Cape Cod, kept in darkness at 9° C. at Los Angeles, California. Dotted line indicates the tidal cycle at Los Angeles.

### *Mytilus edulis*

Samples of *M. edulis* collected from the same locality and treated similarly showed a tidal rhythmicity in their rate of water propulsion. What is more remarkable, mussels collected from the underside of floats showed a pattern of activity which was quite parallel to that exhibited by mussels collected from the pilings nearby (Fig. 3).

*M. edulis* collected at Barnstable Harbor on Cape Cod and studied at Los Angeles, California—nearly 3000 miles west—showed a rhythm in their rate of water propulsion which was out of phase with the local tidal cycle by about 6½ hrs. (Fig. 4), and this difference persisted for over four weeks in the laboratory.

Of the mussels obtained from Cape Cod, one dozen were kept in a small wire cage and, during low tide, were secured at +1.0 ft. to a piling of the pier at the Kerckhoff Marine Laboratory, Corona del Mar, California, to study the effect of the local tidal schedule on these mussels. After a week's sojourn at this place,



they were brought back to the laboratory along with a sample of local *M. edulis* attached to the same piling at the same inter-tidal height, which served as controls for the experimental animals. Study of the activity pattern (at 9 and 14° C.) revealed a prompt shift in the rhythm to synchronize with the local tidal cycle and

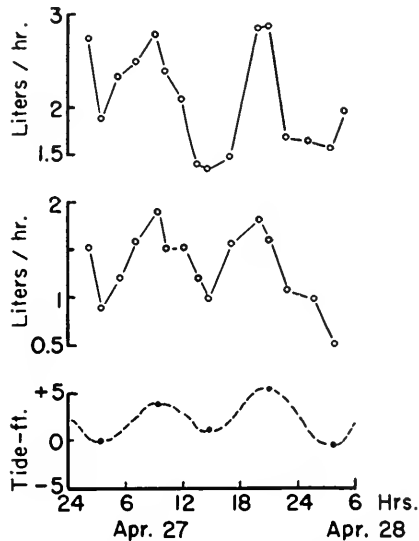

FIGURE 5. Record of rate of water propulsion in *M. edulis* from Barnstable Harbor on Cape Cod, after having been kept for one week at +1.0 ft. in the inter-tidal at Corona del Mar, California, and of the control. Upper graph for *M. edulis* transplanted from Barnstable Harbor, and lower graph for mussels from pilings at Corona del Mar, California, serving as control. Dotted line indicates the local tidal cycle.

there is found to be good agreement between the transplanted east-coast mussels and the local controls (Fig. 5). They continued to keep in phase with the local tidal cycle for a period of over three weeks in the laboratory.

#### DISCUSSION

A marked tidal rhythmicity of rate of water propulsion is exhibited by populations of *Mytilus* occurring under a great variety of environmental conditions and persists in the laboratory for long periods (over four weeks) in phase with the tidal cycle of their natural environment, independent of a wide range of temperature (9 to 20° C.) and varying conditions of light and darkness. That it exhibits the same frequency in populations from high and low inter-tidal levels and even in sub-tidal populations (30 ft. deep) and that it persists in the laboratory, in phase with the tidal cycle outside, for long periods under constant conditions, demonstrate the intrinsic (or endogenous) nature of the rhythm.

It is most interesting that such a rhythm is evident in populations from the underside of floats (and hence not subject to the direct physical effects of the tides), with the same frequency and in phase with the local tidal cycle. It is equally of interest that a persistent rhythm with the same frequency, but out of phase with

the local tidal cycle, is exhibited by mussels removed nearly 3000 miles west from their natural environment. Such instances as these indicate that the rhythm, once set, is independent of external factors, such as cosmic influences, and can persist over long periods in the laboratory.

Instances like the foregoing demonstration of a tidal rhythm in a single species under a great variety of natural conditions lead one to suppose that organisms in general have rhythmic properties and that the frequency of the rhythm is intrinsic and perhaps inherited. But how such intrinsic rhythms at a given frequency come to be in synchrony with rhythmic events in nature is difficult to answer. But the ease with which they can be reset to suit a new environment, without a change in the frequency, though not abundantly demonstrated, is of sufficient significance inasmuch as it helps us to understand the existence of so many instances of tidal or other kinds of rhythmic behavior patterns. An intrinsic, inherited rhythmic pattern of activity is set in phase with external events of a rhythmic nature, which perhaps are of the same frequency as the organismic ones. Transplantation, as has been done for the first time in the above case, offers an ideal tool for studying this phenomenon in greater detail. Likewise, studying laboratory-grown individuals of species which show a rhythmic behavior in their natural environment, might yield fruitful results.

But the degree to which the rhythm is marked, perhaps, is dependent on the amplitude of the environmental rhythm. Thus the different findings (Bohn and Piéron, 1906; Bohn, 1906, 1907; Piéron, 1906, 1908; Gee, 1913; Parker, 1916; Crozier, 1921, and Hoffman, 1926) on the rhythmic behavior in sea anemones may be due to the fact that the intrinsic rhythm becomes marked and measurable only when the fluctuations of the environmental factors reach a certain, but unknown, threshold value.

#### SUMMARY

1. The occurrence of a tidal rhythm in the rate of water propulsion in *Mytilus californianus*, collected from high and low inter-tidal levels and from a depth of 30 ft. off the shore, and also in *M. edulis* collected from pilings and the underside of floats, has been demonstrated.

2. Such a rhythm is independent of temperature (9 to 20° C.) and persists in the laboratory, in phase with the external tidal cycle, for over four weeks, in continuous darkness, or continuous light or the natural day and night environment.

3. No indications of a diurnal rhythm in the rate of water propulsion have been observed.

4. A rhythm of similar frequency, but out of phase with local tidal cycle by about 6½ hrs., was observed in *M. edulis* collected from Barnstable Harbor on Cape Cod and studied at Los Angeles, California, after transporting them by air.

5. Some of the east coast mussels were secured in the inter-tidal at Corona del Mar, California, for a week. Examination of their activity pattern after this period, revealed a prompt shift in their tidal rhythm to synchronize with the local tidal schedule.

6. The intrinsic nature of the rhythm is discussed and the probable inheritable nature of the rhythmic properties of organisms, coupled with the ease with which they could be set in synchrony with natural environmental rhythms, are suggested as likely causes for the widespread occurrence of rhythmic patterns in organisms.

7. It is suggested that the degree to which the intrinsic rhythm of the organism becomes marked and measurable depends upon the amplitude of the environmental rhythm.

## LITERATURE CITED

- BOHN, G., 1903. Sur les mouvements oscillatoires des *Convoluta roscoffensis*. *C. R. Acad. Sci., Paris*, **137**: 576-578.
- BOHN, G., 1904. Periodicité vitale des animaux soumis aux oscillations du niveau des hautes mers. *C. R. Acad. Sci., Paris*, **139**: 610-611.
- BOHN, G., 1906. La persistance du rythme des marées chez l'*Actinia equina*. *C. R. Soc. Biol., Paris*, **61**: 661-663.
- BOHN, G., 1907. Le rythme nyctéméral chez les Actinines. *C. R. Soc. Biol., Paris*, **62**: 473-476.
- BOHN, G., AND H. PIÉRON, 1906. Le rythme des marées et la phénomène de l'anticipation réflexe. *C. R. Soc. Biol., Paris*, **61**: 660-661.
- BROWN, F. A., JR., M. F. BENNETT AND R. C. GRAVES, 1953. Rhythmic activity of the quahog, *Venus mercenaria*. *Anat. Rec.*, **117**: 634-635.
- BROWN, F. A., JR., M. F. BENNETT AND M. I. SANDEEN, 1953. Temperature independence of the frequency of the endogenous tidal rhythmicity of the fiddler crab, *Uca pugnax*. *Biol. Bull.*, **105**: 371.
- BROWN, F. A., JR., M. F. BENNETT AND H. M. WEBB, 1953. Endogenously regulated diurnal and tidal rhythms in metabolic rate in *Uca pugnax*. *Biol. Bull.*, **105**: 371.
- BROWN, F. A., JR., M. FINGERMAN, M. I. SANDEEN AND H. M. WEBB, 1953. Persistent diurnal and tidal rhythms of color change in the fiddler crab, *Uca pugnax*. *J. Exp. Zool.*, **123**: 29-60.
- CALHOUN, J. B., 1944. Twenty-four hour periodicities in the animal kingdom. Part I. The invertebrates. *J. Tenn. Acad. Sci.*, **19**: 179-200 and 252-262.
- CROZIER, W. J., 1921. Notes on some problems of adaptation. 8. Concerning "Memory" in actinians. *Biol. Bull.*, **41**: 117-120.
- GAMBLE, F. W., AND F. KEEBLE, 1903. The bionomics of *Convoluta roscoffensis* with special reference to its green cells. *Proc. Roy. Soc., London*, **72**: 93-98.
- GEE, W., 1913. Modifiability in the behavior of the California shore-anemone *Cribrina xanthogrammica* Brandt. *J. Anim. Behav.*, **3**: 305-328.
- GOMPEL, M., 1937. Recherches sur la consommation d'oxygène de quelques animaux aquatiques littoraux. *C. R. Acad. Sci., Paris*, **205**: 816-818.
- GOMPEL, M., 1938. Recherches sur la consommation d'oxygène de quelques animaux aquatiques littoraux. *Ann. de Physiol.*, **14**: 914-931.
- HOFFMAN, R. W., 1926. Periodische Tageswechsel und andere biologische Rhythmen bei den poikilothermen Tieren (Reptilien, Amphibien, Fische, Wirbellose). *Handbuch der Normalen und Pathologischen Physiologie*, **17**: 644-658.
- PARKER, G. H., 1916. The behavior of sea-anemones. *Proc. Nat. Acad. Sci.*, **2**: 450-451.
- PIÉRON, H., 1906. La réaction aux marés par anticipation réflexes chez *Actinia equina*. *C. R. Soc. Biol., Paris*, **61**: 658-660.
- PIÉRON, H., 1908. La rythmicité chez *Actinia equina* L. *C. R. Soc. Biol., Paris*, **65**: 726-728.
- RAO, K. PAMPAPATHI, 1953. Rate of water propulsion in *Mytilus californianus* as a function of latitude. *Biol. Bull.*, **104**: 171-181.

# THE RESPIRATORY METABOLISM OF TISSUES OF MARINE TELEOSTS IN RELATION TO ACTIVITY AND BODY SIZE<sup>1</sup>

F. JOHN VERNBERG

*Department of Zoology, Duke University, Durham, North Carolina, and  
Marine Biological Laboratory, Woods Hole, Massachusetts*

Rates of oxygen uptake of tissues of fishes at different temperatures have been investigated by various workers (Fuhrman *et al.*, 1944, brain of large-mouthed bass; Peiss and Field, 1950, brain and liver of polar cod and golden orfe; and Freeman, 1950, brain and muscle of goldfish). In 1953 Vernberg and Gray reported a direct correlation between general body activity and oxygen metabolic rate of excised brain. They also noted that within the size range of animals used, no relationship between body size and rate of oxygen uptake was evident in the toadfish and the pinfish.

Although some workers reported a decrease in  $Q_{O_2}$  of tissues with increasing body size (Kayser, Le Breton and Schaeffer, 1925; Hawkins, 1928; Kleiber, 1941; Weymouth, Field and Kleiber, 1942; and Weymouth *et al.*, 1944), other investigators do not find this relationship to exist (Terroine and Roche, 1925; Grafe, 1925; Crandall and Smith, 1952; Bertalanffy and Pirozynski, 1953). Recently Krebs (1950), following a determination of the  $Q_{O_2}$  of five tissues of nine mammals, reported that there is not a simple correlation between body size and  $Q_{O_2}$  within the same species, and that, in general tissues of larger species have lower values than homologous values of tissues from smaller species.

The present investigation was undertaken for two specific reasons. First, to continue the study of the relationship of activity and metabolism of various tissues in marine fishes. Secondly, to examine the relationship of tissue metabolism and body size in a group of poikilothermic vertebrates.

## MATERIALS AND METHODS

The oxygen uptake of tissues was determined by the direct method of Warburg. Liver, muscle, and brain tissue from three species of marine teleost fishes, toadfish (*Opsanus tau*), scup (*Stenotomus chrysops*), and menhaden (*Brevoortia tyrannus*), were studied. These three species of fishes were used because of their diverse habits and differences in general activity levels. Menhaden is an extremely active swimming form which normally lives and feeds at the surface of the ocean. On the other hand, the toadfish is a relatively inactive pugnacious bottom-dweller, and the scup is intermediate to these two in respect to activity.

All animals were killed by severing the spinal cord in the region immediately posterior to the skull. Brain tissue was obtained by cutting off the roof of the skull and removing all tissue anterior to the vagal lobes. The brain was blotted

<sup>1</sup> Aided by a grant from the Duke University Research Council.

TABLE I  
*Respiration of tissues of three species of marine fishes*

Species	N	Mean $Q_{O_2}$	Standard deviation
Brain			
Toadfish	28	6.78 ± .290	1.54
Scup	20	10.51 ± .578	2.59
Menhaden	21	13.04 ± .721	3.30
Liver			
Toadfish	27	4.42 ± .323	1.68
Menhaden	11	11.08 ± 1.173	3.89
Scup	16	14.87 ± 1.219	4.88
Muscle			
Scup	10	.410 ± .064	.202
Toadfish	18	.727 ± .084	.356
Menhaden	12	1.024 ± .140	.485

quickly on filter paper to remove all blood and foreign matter, then weighed and ground in a dry mortar. Sufficient amount of a phosphate buffer of pH 7.5 (glass electrode) was added to bring the volume to 3.0 ml. and the brei transferred to a Warburg flask. Muscles from the dorsal trunk region were treated in the same manner, using samples weighing about 450 mg. The liver tissue was sliced with a Stadie-Riggs tissue microtome; each sample weighed about 125 mg. The center well of the respirometer flask contained both 0.2 ml. of 10% KOH and filter paper wicks.

Time between the death of the animal and the beginning of the 10-minute period of thermal equilibration was kept constant at 10 minutes. Readings, taken at 10-minute intervals, carried for a minimum time of 60 minutes. Manometric determinations were made in a bath maintained at 30° C. Results are expressed in terms of wet weight  $Q_{O_2}$ . Thus  $Q_{O_2}$  denotes microliters of oxygen consumed per gram of wet weight per minute. The water content of the various tissues studied was determined by drying to a constant weight at 105° C.

This study was conducted at the Marine Biological Laboratory, Woods Hole, Mass., during the summer of 1953. All specimens were obtained from the Supply Department and maintained in the laboratory in aerated tanks supplied with running

TABLE II  
*Significance of differences of means of  $Q_{O_2}$  of tissue from marine teleost fishes*

Tissue	Species compared	Probability	
Brain	Toadfish-scup	<.01	Highly significant
Brain	Menhaden-scup	<.01	Highly significant
Liver	Toadfish-menhaden	<.01	Highly significant
Liver	Menhaden-scup	.03	Significant
Muscle	Scup-toadfish	<.01	Highly significant
Muscle	Toadfish-menhaden	.07	Not significant

TABLE III  
*Water content of tissues of three species of marine fishes*

Species	Tissue	No. of determinations	Average %	Range
Toadfish	Brain	7	83.19	81.1-84.7
	Liver	10	73.75	66.9-80.6
	Muscle	8	82.18	79.6-86.1
Scup	Brain	6	80.40	78.8-82.4
	Liver	8	76.40	71.4-78.8
	Muscle	8	78.58	75.4-80.6
Menhaden	Brain	10	78.94	75.3-81.4
	Liver	5	60.69	58.4-63.0
	Muscle	5	72.88	70.1-73.9

sea water. Scup and toadfish could be kept very well in these tanks but the menhaden would soon die of apparent oxygen lack. Thus it was necessary to use these animals as soon as they were brought into the laboratory. Menhaden, partially asphyxiated when brought from the traps, were not normal (Hall, Gray and Lepkovsky, 1926).

In the statistical analysis of the data pertaining to the relationship of  $Q_{O_2}$  to body size, the following formulae were used:

$$M = aW^b \quad (1)$$

or

$$\log M = \log a + b \log W, \quad (2)$$

where  $M$  is the  $Q_{O_2}$ ,  $W$  the body weight, and  $a$  and  $b$  are constants, indicating the intercept and the slope of the regression line in the log-log plot. Additional statistics calculated were the standard error ( $S_{(\log y \cdot \log x)}$ ) and  $\rho$  (coefficient of correlation).

Weights of animals used are as follows: toadfish, average 349 gms., range 78-

TABLE IV  
*Statistical analysis of relation of  $Q_{O_2}$  to body size in tissues of two marine fishes*

	N	a	b	$S(\log y \cdot \log x)$	$\rho$
Toadfish					
Brain	28	2.055	.202	.1115	.780
Liver	27	9.998	-.1448	.0972	.742
Muscle	18	.327	-.1182	.2800	.409
Scup					
Brain	20	4.795	.1504	.111	.568

586 gms.; scup, average 166 gms., range 83–462 gms.; and menhaden, average 345 gms., range 193–495 gms.

### RESULTS

The  $\dot{Q}_{O_2}$  values of brain, liver and muscles are indicated in Table I. Significance of differences of means is shown in Table II.

In respect to brain tissue a definite correlation between animal activity and oxygen consumption is noted. This is in accord with previous reported results of Vernberg and Gray (1953). As shown in Table II, there is a significant difference between the mean  $\dot{Q}_{O_2}$  of all three species.

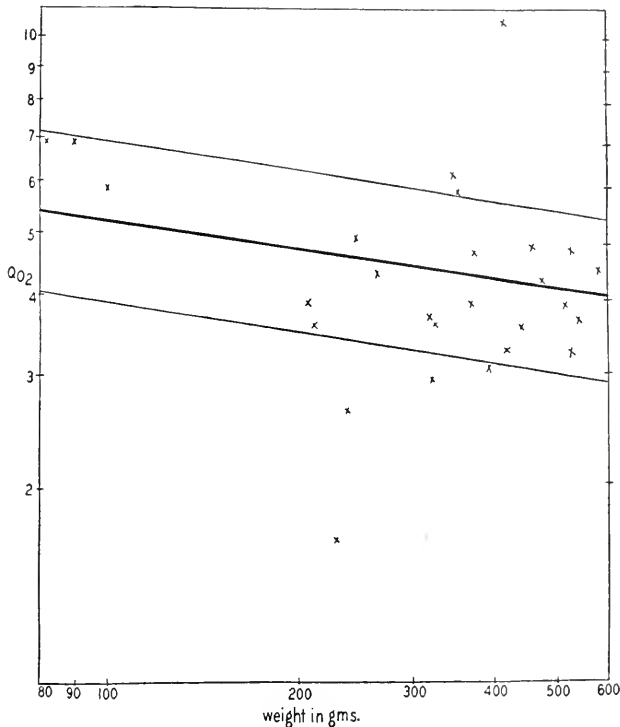

Fig 1.  $\dot{Q}_{O_2}$  of toadfish liver in relation to body size. \*

When comparing interspecifically the  $\dot{Q}_{O_2}$  values of liver, no correlation between total animal activity and rate of oxygen uptake was noted. The liver of scup, the intermediate form in regard to activity, had a higher metabolic rate than liver of menhaden, the most active species. The degree of significance of difference of means is not as great when comparing menhaden and scup as when comparing menhaden and toadfish.

Scup muscle had the lowest  $\dot{Q}_{O_2}$  values, menhaden the highest. However, there is no significant difference between means of toadfish and menhaden. As in

the case of liver, no correlation between animal activity and metabolic rate of muscle was noted.

Results of water content determination of the tissues studied are shown in Table III. In general intraspecific values were fairly constant; liver tissue showed the greatest variation. Interspecific comparison showed that similar values were obtained for brain and muscle tissues, but that the liver of menhaden had a much lower water content than either scup or toadfish livers. It is well-known that the liver of menhaden contains enormous quantities of oil and this probably accounts

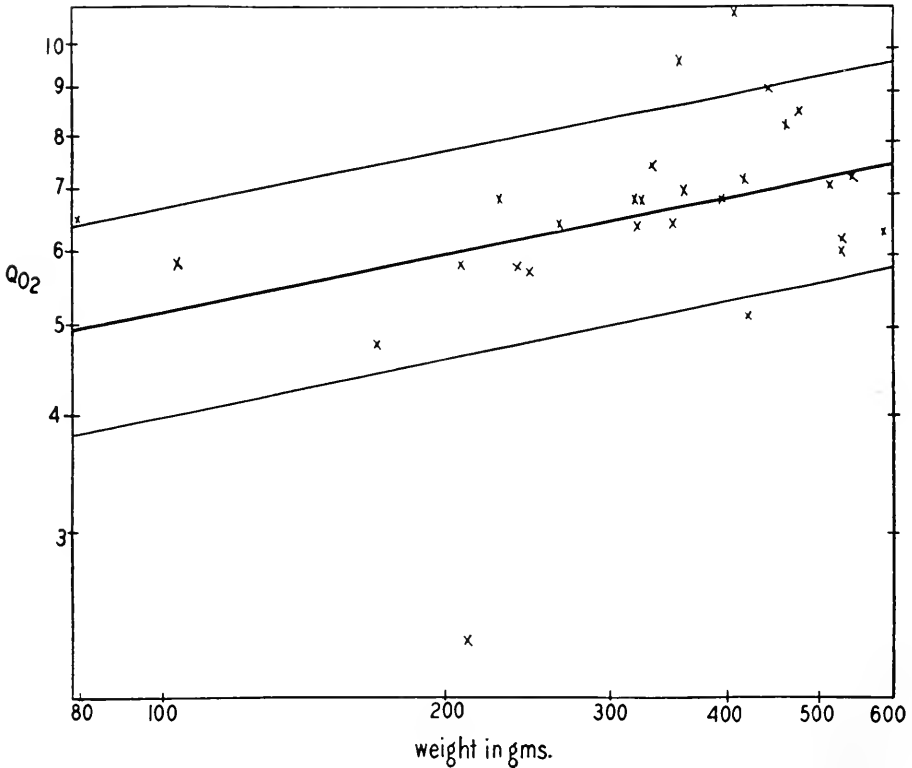

Fig. 2.  $Q_{O_2}$  of toadfish brain in relation to body size.

for the lower water content. Only when comparing  $Q_{O_2}$  values of these three species would the significance between means be appreciably altered when results were based on dry weights. In this case the average  $Q_{O_2}$  values would be: toadfish 16.84 microliters/minute/gm. of dry weight, menhaden, 28.2, and scup 63.0. Thus, on this basis, the difference between scup and menhaden liver would be highly significant rather than significant.

Comparison of  $Q_{O_2}$  values for liver, brain and muscle from different individuals of the same species did not show any consistent tendency for one animal to have



a higher metabolic rate for all three tissues than another animal. The  $Q_{O_2}$  of brain of one animal may be higher and the liver  $Q_{O_2}$  lower than that of another.

The statistical analysis of the relation of  $Q_{O_2}$  to body size in toadfish and scup is presented in Table IV.  $Q_{O_2}$  values of menhaden were not evaluated because of the small size range of animals used (193–495 gms.). Figures 1–4 represent the log-log plot of  $Q_{O_2}$  values of various tissues against body weight. The middle line is the regression of  $Q_{O_2}$ , and the two outer parallel lines give the standard error in per cent, including  $\frac{2}{3}$  of the determinations.

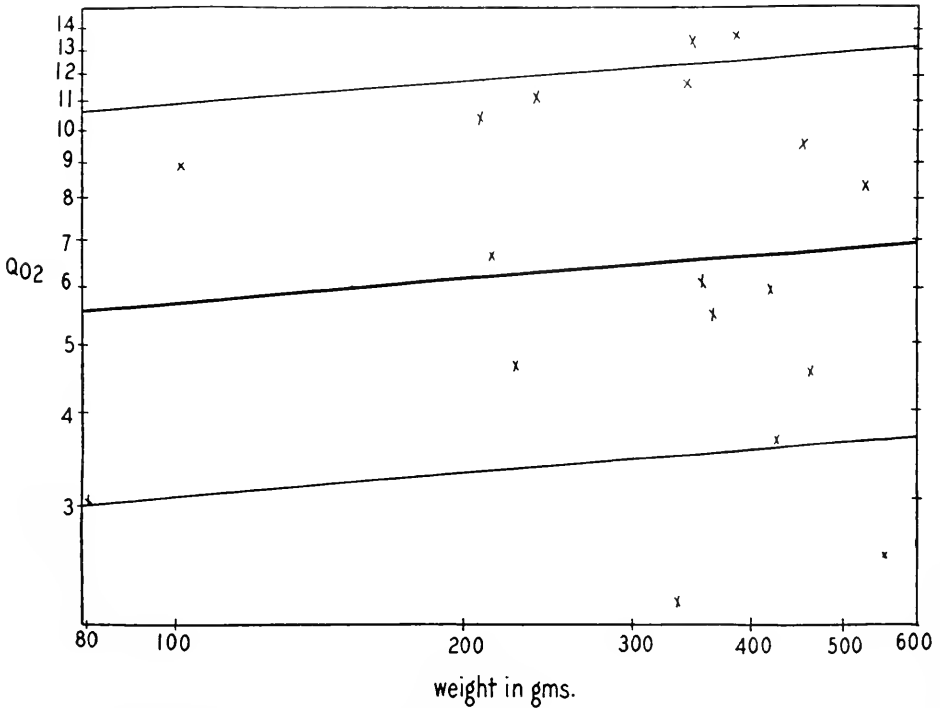

Fig. 3.  $Q_{O_2}$  of toadfish muscle in relation to body size.

*Toadfish liver* (Fig. 1). There is a slight decrease with increasing body weight but the correlation coefficient is low.

*Toadfish brain* (Fig. 2). A slight increase in  $Q_{O_2}$  values with increasing body weight is noted. In general these results correspond with the tendency observed by Bertalanffy and Pirozynski (1953) and Elliott (1948) for oxygen consumption of mammal brains.

*Toadfish muscle* (Fig. 3). Similar results to those of brain tissue.

*Scup brain* (Fig. 4). The same general tendency is noted for brain of scup as that of toadfish brain.

A significant difference in mean  $Q_{O_2}$  is noted between toadfish brain from Woods Hole and toadfish brain from Beaufort, N. C. (Vernberg and Gray, 1953).

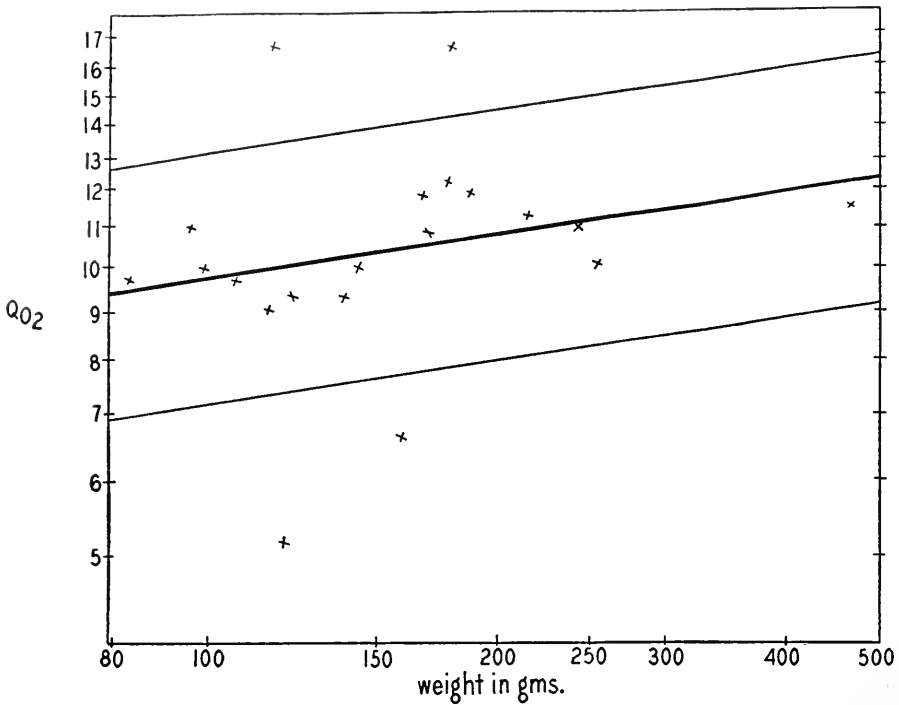

Fig. 4.  $Q_{O_2}$  of scup brain in relation to body size.

Determinations were made at the same temperature and the same method was employed in both studies.

#### DISCUSSION

##### *Tissue metabolism and activity*

Many phases of the activity of marine fishes have been studied and certain physiological indexes have been correlated with their activity. A direct relationship between blood sugar concentration and activity was noted by Gray and Hall (1930); menhaden 75.2 mg.%, scup 52.6 mg.%, and toadfish 15.4 mg.%. Hall and Gray (1929) demonstrated a positive correlation between hemoglobin and activity: menhaden 41 mg. % iron, scup 25.3% iron, and toadfish 13.5% iron. A correlation between number of immature circulating erythrocytes and activity was shown by Dawson (1933): menhaden 16.5%, scup 4.7%, and toadfish less than 1%. Root (1931) studied the respiratory function of blood of marine fishes and found a definite adjustment on the part of the blood to the habits or characteristics of the fishes. His results, as they pertain to activity, are in agreement with those cited above.

Oxygen consumption determinations by Hall (1929) showed toadfish to have a low resting metabolic rate with a higher rate for scup. Menhaden have been found to have a high rate of oxygen consumption. In comparing gill area of

menhaden and toadfish, Gray (1947) found that the former has about 10 times more gill surface than the toadfish per gram of body weight and 15 times more gill area per square cm. of body surface. Gray (1946) found the scup to be intermediate to toadfish and menhaden in total number of gill lamellae. Thus, the physiological indexes of activity would substantiate field observations and indicate that menhaden is the most active form, toadfish the least active and scup intermediate. Vernberg and Gray (1953) found the brain of menhaden to have a higher  $Q_{O_2}$  than that of toadfish. The findings of the present paper demonstrate again the relationship of brain  $Q_{O_2}$  and activity for menhaden and toadfish and include results of another species, the scup.

In view of the fact that the comparative oxygen consumption rate of the entire organism for menhaden is high and toadfish is low, one might surmise that the tissues of the menhaden had a higher "basal" metabolic rate than tissues of the toadfish.

Because so much of an animal's body consists of muscle tissue, one might expect to find significant differences between  $Q_{O_2}$  of muscle of menhaden and toadfish. However, no correlation between metabolic rates of liver and muscle with either activity or total animal  $O_2$  consumption was observed. Thus, it would seem that in the physiological organization of the entire organism, the coordinating mechanisms of the more active species, the menhaden, are operating in such a manner as to stimulate the tissues to an activity level higher than indicated by *in vitro* determinations. Many factors are operative in organismic make-up and would include such factors as hormonal and neural regulators. From the results reported in this paper it might seem possible to suggest that an integral part of the coordinating system of the body, the brain, is extremely important in maintaining the "basal" metabolic rate of the entire organism. Thus an animal having brain tissue with a high "basal" metabolic rate would have a high total organism "basal" metabolic rate.

Other workers have reported results which would indicate the importance of the brain to the general physiological functioning of the organism. In work with mammals by Himwich *et al.* (1939) and Hoagland (1949), rhythmic potential changes in brain tissue are dependent upon the metabolic rate of the tissue. A correlation of brain metabolism, respiratory movements and total oxygen consumption to temperature acclimatization was noted by Freeman (1950). He stated that the metabolic activity of the brain is a major factor in determining the level of the total oxygen consumption of a fish. The brain exerts this governing action through its influence on the other tissues of the body.

An interesting question remains to be investigated further. If the brain tissue  $Q_{O_2}$  is correlated with total oxygen consumption, why then should the  $Q_{O_2}$  of brain tissue be slightly increased in older animals, whereas, the  $Q_{O_2}$  of the whole animal is decreased. Undoubtedly the role of the other factors, such as endocrine relationships, must not be overlooked. Hoagland (1936) emphasized the modification of respiratory rhythms by reflexes and humoral agents.

#### *Tissue metabolism and body size*

The results of this study indicate that in a poikilothermic animal such as the toadfish, brain and muscle tissue  $Q_{O_2}$  values do not decrease with size as does liver,

but actually show a slight increase in "basal" metabolic rate with size. In general it would seem that any decrease in basal metabolic rate of the entire organism with increased size could not be accounted for on the basis of decline in muscle  $Q_{O_2}$ . Bertanlanffy and Estwick (1953) reported that in the rat, although  $Q_{O_2}$  of muscle decreased slightly with body size, it was not of sufficient magnitude to account for decreased whole-animal oxygen consumption. Recently Bertanlanffy and Perozynski (1953) concluded, after investigating 7 different tissues of rats of various sizes, that any decline in basal metabolic rate depends not upon factors lying in the tissues themselves but rather on regulative factors in the organism as a whole. The present investigation would substantiate this view.

### *Geographical differences*

Although the present study was not undertaken specifically to study geographic physiological adaptation, a significant difference in brain tissue metabolism of two populations of toadfishes was noted. The question arises as to whether this difference is due to genetic differences or to an acclimatization phenomenon.

Numerous workers have reported on the relationship of temperature acclimatization to whole animal oxygen consumption (Wells, 1935a, 1935b; Fry and Hart, 1948; Sumner and Doudoroff, 1938; Fox, 1936; and Fox and Wingfield, 1937). In general, animals from a northern habitat or acclimatized at lowered temperatures consume more oxygen when determined at intermediate or elevated temperatures than those that are from a southern area or acclimatized at a higher temperature. At the tissue level, Peiss and Field (1950) found that brain tissue from an arctic-adapted fish, the polar cod, had a higher metabolic rate than a warm-adapted southern species, the golden orfe, when determined at a temperature which corresponded to the acclimatization temperature of the warm-adapted animal. Freeman (1950), working with brain of goldfish, noted a similar relationship. The temperature of the water in which animals were kept averaged approximately 10° C. lower at Woods Hole than in the region of Beaufort. Thus, one would expect the brain  $Q_{O_2}$  of the northern population to be higher than the southern one. However, no attempt was made to study this phenomenon at different temperature levels or to investigate the possible genetic differences.

### SUMMARY

1. Determinations were made of the  $Q_{O_2}$  of brain, muscle and liver of three species of marine fishes representing different ecological habitats; a very active constantly swimming species, menhaden; a sluggish bottom-dweller, toadfish; and an intermediate form, scup.

2. Although a direct correlation between  $Q_{O_2}$  of brain and activity of the whole organism was noted, liver and muscle did not show any correlation with activity. The possible significance of this relationship was discussed.

3. A slight increase in  $Q_{O_2}$  of brain and muscle of toadfish and brain of scup with increasing body size was noted. The  $Q_{O_2}$  of toadfish liver decreased with body size.

## LITERATURE CITED

- BERTALANFFY, L. VON, AND R. R. ESTWICK, 1953. Tissue respiration of musculature in relation to body size. *Amer. J. Physiol.*, **173**: 58-60.
- BERTALANFFY, L. VON, AND W. J. PIROZYNSKI, 1953. Tissue respiration, growth, and basal metabolism. *Biol. Bull.*, **105**: 240-256.
- CRANDALL, R. R., AND A. H. SMITH, 1952. Tissue metabolism in growing birds. *Proc. Soc. Exp. Biol. Med.*, **79**: 345-346.
- DAWSON, A. B., 1933. The relative numbers of immature erythrocytes in the circulating blood of several species of marine fishes. *Biol. Bull.*, **64**: 33-43.
- ELLIOT, K. A. C., 1948. Metabolism of brain tissue slices and suspensions from various mammals. *J. Neurophysiology*, **11**: 473-484.
- FOX, H. M., 1936. The activity and metabolism of poikilothermal animals in different latitudes—1. *Proc. Zool. Soc. London*, Part IV: 945-955.
- FOX, H. M., AND C. A. WINGFIELD, 1937. The activity and metabolism of poikilothermal animals in different latitudes. *Proc. Zool. Soc. London*, Part III: 275-282.
- FREEMAN, J. A., 1950. Oxygen consumption, brain metabolism and respiratory movements of goldfish during temperature acclimatization, with special reference to lowered temperatures. *Biol. Bull.*, **99**: 416-424.
- FRY, F. E. J., AND J. S. HART, 1948. The relation of temperature to oxygen consumption in the goldfish. *Biol. Bull.*, **94**: 66-77.
- FUHRMAN, F. A., NELL HOLLINGER, J. M. CRISMON, J. FIELD II AND F. W. WEYMOUTH, 1944. The metabolism of the excised brain of the largemouthed bass (*Huro salmoides*) at graded temperature levels. *Physiol. Zool.*, **17**: 42-50.
- GRAFE, E., 1925. Problems der Gewebsatmung. *Deutsche Med. Wchnschr.*, **51**: 640-642.
- GRAY, I. E., 1946. The relation between gill surface and activity in marine fishes. *Anat. Record*, **96**: 518.
- GRAY, I. E., 1946. The relation between gill surface and activity in marine fishes. *J. Elisha Mitchell Sci. Soc.*, **63**: 106.
- GRAY, I. E., AND F. G. HALL, 1930. Blood sugar and activity in fishes with notes on the action of insulin. *Biol. Bull.*, **58**: 217-223.
- HALL, F. G., 1929. The influence of varying oxygen tensions upon the rate of oxygen consumption in marine fishes. *Amer. J. Physiol.*, **88**: 212-218.
- HALL, F. G., AND I. E. GRAY, 1929. The hemoglobin concentration of the blood of marine fishes. *J. Biol. Chem.*, **81**: 589-594.
- HALL, F. G., I. E. GRAY AND S. LEPKOVSKY, 1926. The influence of asphyxiation on the blood constituents of marine fishes. *J. Biol. Chem.*, **67**: 549-554.
- HAWKINS, J. A., 1928. The metabolism of tissue from rats of different ages. *J. Gen. Physiol.*, **11**: 645-647.
- HIMWICH, H. E., Z. HADIDIAN, J. F. FAZEKAS AND H. HOAGLAND, 1939. Cerebral metabolism and electrical activity during insulin hypoglycemia in man. *Amer. J. Physiol.*, **125**: 578-585.
- HOAGLAND, H., 1936. Some pacemaker aspects of rhythmic activity in the nervous system. *Cold Spring Harbor Symposia Quant. Biol.*, **4**: 267-276.
- HOAGLAND, H., 1949. Rhythmic behavior of the nervous system. *Science*, **109**: 157-164.
- KAYSER, CHARLES, ELAINE LE BRETON AND G. SCHAEFFER, 1925. Grandeur de la respiration des tissues et masse active au cours du développement des organismes. *C. R. Acad. Sci. (Paris)*, **181**: 255-257.
- KLEIBER, M., 1941. Body size and metabolism of liver slices *in vitro*. *Proc. Soc. Exp. Biol. Med.*, **48**: 419-422.
- KREBS, A. H., 1950. Body size and tissue respiration. *Biochem. et Biophys. Acta*, **4**: 249-269.
- PEISS, C. N., AND J. FIELD, 1950. The respiratory metabolism of excised tissues of warm- and cold-adapted fishes. *Biol. Bull.*, **99**: 213-224.
- ROOT, R. W., 1931. The respiratory function of the blood of marine fishes. *Biol. Bull.*, **61**: 427-456.
- SUMNER, F. B., AND P. DOUBOROFF, 1938. Some experiments on temperature acclimatization and respiratory metabolism in fishes. *Biol. Bull.*, **74**: 403-429.

- TERROINE, E., AND J. ROCHE, 1925. Production calorique et respiration des tissus *in vitro* chez les homeothermes. *C. R. Acad. Sci.*, **180**: 225-227.
- VERNBERG, F. J., AND I. E. GRAY, 1953. A comparative study of the respiratory metabolism of excised brain tissue of marine teleosts. *Biol. Bull.*, **104**: 445-449.
- WELLS, N. A., 1935a. Variations in the respiratory metabolism of the Pacific killifish *Fundulus parvipinnia*, due to size, season and continued constant temperature. *Physiol. Zool.*, **8**: 318-336.
- WELLS, N. A., 1935b. Change in rate of respiratory metabolism in a teleost fish induced by acclimatization to high and low temperature. *Biol. Bull.*, **69**: 361-367.
- WEYMOUTH, F. W., J. M. CRISMON, V. E. HALL, H. S. BELDING AND J. FIELD II, 1944. Total and tissue respiration in relation to body weight: A comparison of the kelp crab with other crustaceans and with mammals. *Physiol. Zool.*, **17**: 50-71.
- WEYMOUTH, F. W., J. FIELD II AND M. KLEIBER, 1942. Relationship between body size and metabolism. *Proc. Soc. Exp. Biol. Med.*, **49**: 367-370.

## A PERSISTENT DIURNAL RHYTHM OF CHROMATOPHORIC RESPONSE IN EYESTALKLESS *UCA PUGILATOR*

H. MARGUERITE WEBB, MIRIAM F. BENNETT AND FRANK A. BROWN, JR.<sup>1</sup>

*Department of Physiology and Bacteriology, Goucher College, Towson 4, Md.; Department of Biological Sciences, Northwestern University, Evanston, Ill.; and the Marine Biological Laboratory, Woods Hole, Mass.*

1954

On the basis of their response to eyestalk removal crustaceans have been classified into three types (Brown, 1948). The members of Group I, represented by *Palaemonetes*, respond to eyestalk removal by dispersion of the dark pigment and to injection of eyestalk extract by concentration of the pigment. *Crago*, the single member of Group II, responds to eyestalk removal by assuming an intermediate condition with the dark pigment partially dispersed. Group III contains all of the brachyurans except *Sesarma* (Enami, 1951) and is characterized by the complete concentration of the dark pigment on removal of eyestalks. Further investigations have led to the development of a concept of dual hormonal control in members of two of these groups. The evidence supporting such a concept for *Crago* has been reviewed by Brown (1948). In 1952, Brown, Webb and Sandeen demonstrated the presence in the central nervous system of *Palaemonetes* of a red-pigment-dispersing substance and adduced arguments in favor of its normal functioning.

The study of the mechanism of control of the melanophores of *Uca*, a representative of Group III, has been complicated by the presence in these animals of a persistent diurnal rhythm. Under the influence of the rhythmical mechanism the black pigment is dispersed by day and concentrated by night. The extent of dispersion is susceptible to modification by such factors as light, background, and temperature and in at least one species, *Uca pugnax*, an endogenous tidal rhythm has been shown to influence the condition of the chromatophores (Brown, Fingerman, Sandeen and Webb, 1953). All of these factors are thought to act on the chromatophores, at least in part, by virtue of alterations in the blood level of one or more hormones. The eyestalks are known to produce a hormone which causes dispersion of the black pigment. The central nervous system has been shown to contain a substance which disperses the black pigment of eyestalkless animals (Brown, 1948; Sandeen, 1950) but the participation of this substance in physiological color change has not been conclusively demonstrated.

Although all efforts at direct demonstration of a substance acting to concentrate the black pigment of *Uca* have ended in failure, there are cases in which investigators have been led to postulate the existence of such a substance (Brown and Stephens, 1951; Brown and Hines, 1952). Furthermore, Brown and Scudamore (1940) reported observations which suggested that eyestalkless *Uca* do not have their rhythm completely abolished.

<sup>1</sup> This investigation was supported in part by contracts NONR-09703 and NONR-122803 with the Office of Naval Research, and in part by a grant from the Graduate School of Northwestern University.

The data to be reported here contribute to our understanding of two problems: the mechanism of control of the black chromatophores of *Uca pugilator*, and the mechanisms involved in diurnal rhythmicity.

#### EXPERIMENTAL PROCEDURE

All of these animals used in these experiments were specimens of *Uca pugilator* collected at Chapoquoit beach, near Woods Hole, Mass. during August, 1953. In the laboratory the animals were kept in white enamelled pans with a small amount of water and at a constant illumination of about 2 ft. c.

Two types of experiments were performed. One type involved a study of the changes occurring in chromatophores of legs which had been autotomized and were then maintained in sea water for a period of one hour. The other type of experiment consisted of injection of various concentrations of eyestalk extracts into eyestalkless animals.

*Study of changes in chromatophores of isolated legs.* Animals were forced to autotomize two or three legs each by applying pressure or by slightly injuring a distal segment of a walking leg. The legs so obtained were placed in sea water and observed at the time of isolation and again after thirty and sixty minutes. The total number of legs removed at any one time varied from six to ten and the legs were taken from two, three or five animals, depending upon the particular experiment. On each occasion a minimum of six legs from normal animals and the same number from eyestalkless animals were observed. Legs were isolated from two such groups at 66 different times; the total number of animals used was 226. The experiments were performed on four different days. In one series legs were removed every hour from 8 P.M. of one day until 8 P.M. of the succeeding day; in the other three series legs were isolated from both normal and eyestalkless animals as follows: 1) hourly from 8 A.M. till the next 1 A.M.; 2) hourly from 7 A.M. until the next 1 A.M.; 3) at 1, 2, 3, and 4 P.M. and at 8 and 9 P.M. of the same day. The eyestalkless donors had been operated on not more than 48 hours and not less than 8 hours before being used in an experiment.

*Injection of eyestalk extract.* A stock solution was made by grinding 10 dried eyestalks and extracting in one cc. of sea water. This solution was boiled for one minute and then cooled to room temperature. Five-hundredths cc. of this extract (the amount used for a single injection) contained  $\frac{1}{2}$  of an eyestalk or  $\frac{1}{4}$  of the normal complement of eyestalk tissue of one animal. Such an extract is said to have a concentration of one quarter. This stock extract was then used to make up a series of concentrations as follows: 1/16, 1/64, 1/128, 1/512, 1/1024, and 1/2048. Seven groups of five eyestalkless animals were injected for each experiment. Each of the five animals in a group received 0.05 cc. of one dilution injected at the base of a walking leg. A control group of five animals received 0.05 cc. of sea water. The state of the chromatophores of each animal was determined at 15 minutes after injection, again at 30 minutes and at 30-minute intervals until they had returned to stage 1.

This experiment was performed four times, using two stock extracts. On one occasion a stock extract was made up in the afternoon, part of it was used immediately and the remainder refrigerated and used in the evening. Again an extract



was made up and part of it used in the evening while a second portion was refrigerated and used the next morning.

Since the chromatophores are initially in stage 1, the observed chromatophore stage minus 1 gives a measure of the dispersion present at any given time of observation. Summing the corrected values obtained during one experiment for any one concentration of extract then gives a measure of the activity of that extract. The activity of each extract tested was calculated in this manner.

#### RESULTS AND DISCUSSION

Figure 1 shows the average stage of the chromatophores of legs isolated from eyestalkless animals, as determined 60 minutes after removal, plotted against time of day at which autotomy occurred. The data used for this curve are those obtained

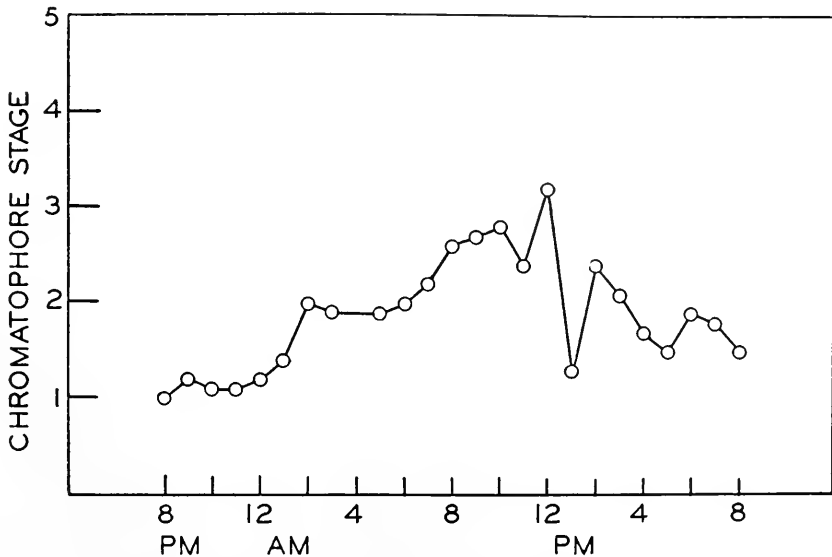

FIGURE 1. Average index of the melanophores in legs isolated from eyestalkless crabs sixty minutes after isolation at various times during a twenty-four hour period.

in the complete 24-hour series of observations. The other experiments of this type yielded entirely similar results. Since the initial average condition for all chromatophores in legs from eyestalkless animals was stage 1.0 the distance of any point from the abscissa gives a measure of the amount of dispersion occurring at that time of day. It can be seen that during the hours from 8 P.M. to 1 A.M. only very slight dispersion of the pigment occurs in 60 minutes. From 1 A.M. until 12 M. there is a gradual increase in the amount of dispersion observed, while from noon until 8 P.M. a gradually decreasing amount is found.

Curve A of Figure 2 represents the average initial stages of the chromatophores of legs isolated from intact animals plotted against the time of day of removal. Curve B of Figure 2 is obtained by similarly plotting the average stages, at 60

minutes after removal, of the chromatophores of legs from intact animals. These data were obtained on the same day and at the same times as those shown in Figure 1. Results obtained in other experiments of this series were similar to those represented in Figure 2. It can be seen that Curves A and B of Figure 2 are similar in general shape to that describing the conditions for eyestalkless animals. The values are low from 8 P.M. to 2 A.M., increase rather rapidly until about 5 A.M., remain fairly constant until 1 P.M., and then decrease gradually until 8 P.M. The distance between a point of Curve A and the point for the same hour on Curve B gives a measure of the change, concentration or dispersion, occurring in legs removed at that particular hour of the day. It is immediately obvious that the chromatophores in legs isolated from intact animals undergo more or less concentration throughout

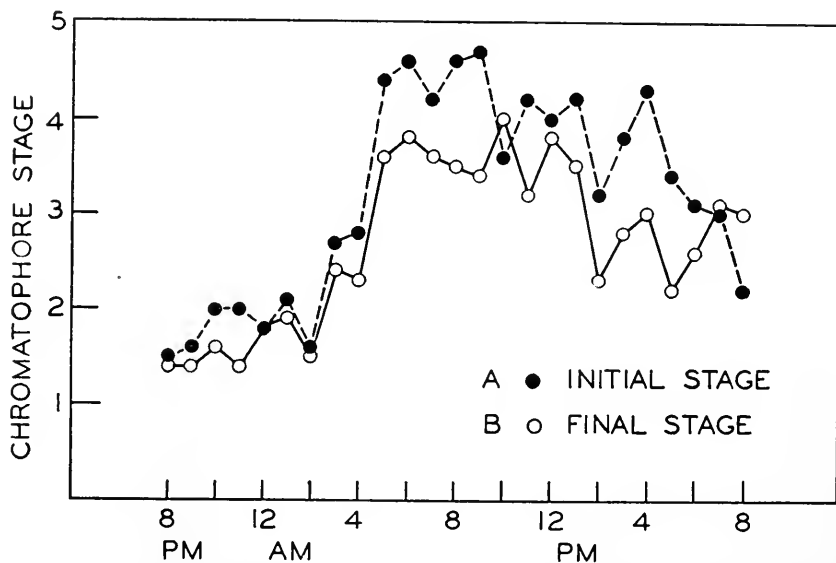

FIGURE 2. Average index of the melanophores in legs isolated from normal crabs at the time of isolation (A) and sixty minutes afterwards (B) as a function of the time of day.

most of the day. In only one case (10 A.M.) is there any noticeable degree of dispersion.

Since all of the isolated legs were kept in sea water and at a constant light intensity, any differences found among experimental groups must be accounted for in terms of differences in the body fluids at the time of isolation. The fact that the chromatophores of legs isolated from eyestalkless animals show different degrees of dispersion at the end of 60 minutes, depending upon time of day of isolation, clearly indicates a diurnal rhythm in eyestalkless animals marked by alterations in the body fluids of the animals.

The results of the injection experiments are presented in Table I. The activity values (calculated by the method previously described) are given for each of the four times the experiment was performed. It is seen that for each of the four lowest

concentrations the activity is lower at night than in the daytime. Although it is possible that some decrease in activity of the extracts occurred between the time of first preparing an extract and the time of injection any such decrease should tend to obscure the differences rather than accentuate them. Thus a decrease with time could result in relatively low daytime values when the extract was made up at night. When the extract was made up in the daytime and used at night the time elapsed was only six hours as compared with 12 hours when the reverse order was followed. The reduction in activity observed is such as would be expected by a two- to four-fold reduction in concentration.

The results obtained in both types of experiments clearly demonstrate that a diurnal rhythm exists in eyestalkless *Uca pugnator*. The changes observed in

TABLE I

*Difference between day and night activity for a series of concentrations of eyestalk extract injected into eyestalkless animals*

Concentration	Activity of extracts		Difference
	Day	Night	
1/16	18.8	20.0	1.2
	16.0	18.4	2.4
1/64	12.4	13.7	1.3
	12.0	9.0	-3.0
1/128	10.4	8.4	-2.0
	8.0	7.8	-0.2
1/512	6.0	2.2	-3.8
	4.8	3.6	-1.2
1/1024	1.8	0.2	-1.6
	2.6	0.8	-1.8
1/2048	1.6	0.0	-1.6
	1.0	0.0	-1.0

isolated legs show that the rhythm may be characterized as consisting of two distinct phases whose time relationships correspond quite closely with those of the rhythm found under the same conditions for normal animals. From the results obtained following injection of eyestalk extract it is not possible to describe the duration of the phases. The "night injections" were made in both cases shortly after 8 P.M. and it is clear that the response of the eyestalkless assay animals was different from that observed when injections were made in either morning or afternoon.

When an attempt is made to define the nature of the rhythm in terms of substances in the body fluid it is immediately obvious that two substances must be involved. A dispersing substance produced in the eyestalks has long been recognized and it is reasonable to assume that the disappearance of this substance

permits the concentration of pigment that occurs in legs isolated from normal animals. The absence, or presence in smaller concentrations, of dispersing hormone at night might be assumed but whether this is sufficient to account for the observations is questionable. If one postulates a single substance which causes dispersion of the pigment and which is present during the day and absent or reduced in amount at night then one is implicitly assuming that in the absence of any hormone the pigment will be concentrated. Following eyestalk removal the black pigment is maintained in the concentrated condition but disperses in isolated legs. If this concentrated condition is maintained by virtue of the absence of chromatophorotropic hormone then there is no logical explanation for the dispersion that follows isolation. The conclusion is therefore inescapable that the pigment is maintained in the concentrated condition by some factor which is present in the body fluid and which disappears gradually from the isolated legs. The central nervous system is a known source of dispersing hormone but at the present time no source of a black-pigment-concentrating substance has been demonstrated.

Assuming that there are two antagonistic substances which function in the control of the black chromatophores of *Uca pugilator* the rhythm of eyestalkless animals appears to consist of an increased amount of concentrating factor at night. The rhythm of normal animals appears to consist of the production primarily of dispersing hormone in the day phase and primarily of concentrating substance at night. Regardless of the site of production of the concentrating factor it seems likely that control of secretion is nervous and it is clear that the structures of the eyestalk are not essential for continued rhythmicity.

The results obtained on injection of eyestalk extract are consistent with the interpretation that eyestalkless animals possess in their body fluid at night a substance antagonistic to the dispersing hormone of the eyestalk. The fact that no difference was observed with the highest concentrations used may indicate that a maximum response was obtained even at night and that therefore no further response could be expected.

#### SUMMARY

1. The responses of the black chromatophores of *Uca pugilator* as observed in legs autotomized and maintained in sea water are described.

2. The pigment in legs from normal animals in the day (dispersed) phase becomes concentrated after isolation; that from normal animals in the night (concentrated) phase remains concentrated.

3. The pigment in legs isolated from eyestalkless animals disperses in the daytime and fails to disperse when the legs are removed from 8 P.M. to 2 A.M.

4. The activity on eyestalkless animals of a series of concentrations of eyestalk extract was determined in the daytime and at night. Four of the six concentrations tested were found to be more effective in the daytime than at night.

5. The results clearly demonstrate the existence of a diurnal rhythm in eyestalkless animals and that the structures of the eyestalk are not necessary for this rhythm.

6. The data provide strong evidence that a black-pigment-concentrating substance participates in the regulation of the chromatophore system of these animals.

## LITERATURE CITED

- BROWN, F. A., JR., 1948. Hormones in crustaceans. Chapter V, The Hormones. Academic Press, Inc. New York.
- BROWN, F. A., JR., M. FINGERMAN, M. I. SANDEEN AND H. M. WEBB, 1953. Persistent diurnal and tidal rhythms of color change in the fiddler crab, *Uca pugnax*. *J. Exp. Zool.*, **123**: 29-60.
- BROWN, F. A., JR., AND M. N. HINES, 1952. Modifications in the diurnal pigmentary rhythm of *Uca* effected by continuous illumination. *Physiol. Zool.*, **25**: 56-70.
- BROWN, F. A., JR., AND H. H. SCUDAMORE, 1940. Differentiation of two principles from the crustacean sinus gland. *J. Cell. Comp. Physiol.*, **15**: 103-119.
- BROWN, F. A., JR., AND G. C. STEPHENS, 1951. Studies of the daily rhythmicity of the fiddler crab, *Uca*. Modifications by photoperiod. *Biol. Bull.*, **101**: 71-83.
- BROWN, F. A., JR., H. M. WEBB AND M. I. SANDEEN, 1952. The action of two hormones regulating the red chromatophores of Palaemonetes. *J. Exp. Zool.*, **120**: 391-421.
- ENAMI, M., 1951. The sources and activities of two chromatophorotropic hormones in crabs of the genus *Scarma*. I. Experimental analyses. *Biol. Bull.*, **100**: 28-43.
- SANDEEN, M. I., 1950. Chromatophorotropins in the central nervous system of *Uca pugilator* with special reference to their origins and actions. *Physiol. Zool.*, **23**: 337-352.

## INDEX

- A**CCUMULATION of phosphate by fertilized sea urchin eggs, 297.
- Acid fuchsin permeability of grasshopper sensory pegs, 122.
- Activity of fly cholinesterase, relation between pH and, 139.
- Activity, relation of to metabolism of marine teleost tissues, 360.
- Air, role of in radiation resistance of *Paramecium*, 253.
- Alaska, helminth fauna of, 107.
- Algae as food for sea urchin, 328.
- Algae, blooms of, in Long Island waters, 198.
- Amino acid requirements of *Tribolium*, 149.
- Amino acids in *Phormia* larval salivary secretion, 178.
- Amoeboid-flagellates, nutritional studies on, 269.
- Anatomy and behavior of vascular system in *Nereis*, 69.
- Anidian chick embryos, 48.
- Antennae of grasshopper, permeability of sensory pegs on, 122.
- Anticoagulant substances from *Spisula* tissues, 129.
- Antimitotic substances from ovaries, 158.
- Arbacia lixula*, interaction of sperm and jelly coat in fertilization of, 169.
- ARVY, L., AND M. GABE. The intercerebralis-cardiacum-allatum system of some Plecoptera, 1.
- Asterias* ovaries, extraction of antimitotic substance from, 158.
- Asteroids, redox indicator patterns in exogastrulae of, 21.
- ATP, effect of on endogenous oxygen uptake of developing grasshopper embryos, 265.
- Axenic culture conditions for *Tetramitus*, 269.
- B**ARNACLE, respiration of normal larvae of, 323.
- Basic sense organs on grasshopper antennae, permeability of, 122.
- Beetle (*Tribolium*), amino acid requirements of, 149.
- BENNETT, MIRIAM F. See H. M. WEBB, 371.
- Biological effects of x-rays in *Paramecium*, 253.
- Blastoderm, chick, effect of lowered incubation temperature on, 48.
- Blastoderms, chick, wound healing in, 39.
- Blastomeres, isolated, of *Peronella*, development of, 83.
- Blood anticoagulant substances from *Spisula*, 129.
- Blood vessels of *Nereis*, 69.
- "Blooms," phytoplankton, ecology of in Long Island waters, 198.
- BODINE, J. H., AND W. L. WEST. Effect of adenosinetriphosphate (ATP) on the endogenous oxygen uptake of developing grasshopper embryos, 265.
- Body size, relation of to metabolism of marine teleost tissues, 360.
- BRENT, MORGAN M. Nutritional studies on the amoeboid-flagellate, *Tetramitus rostratus*, 269.
- BROOKS, SUMNER C., AND EDWARD L. CHAMBERS. The penetration of radioactive phosphate into marine eggs, 279.
- BROWN, FRANK A., JR., M. FINGERMAN AND M. N. HINES. A study of the mechanism involved in shifting of the phases of the endogenous daily rhythm by light stimuli, 308.
- BROWN, F. A., JR. See H. M. WEBB, 371.
- C**ABLE, R. M. A new marine cercaria from the Woods Hole region and its bearing on the interpretation of larval types in the Fellodistomatidae, 15.
- Carbohydrates, utilization of in chick wound healing, 39.
- Carbon monoxide, effect of on diapausing silkworm larva, 210, 238.
- Cecropia silkworm, metabolism of during diapause and development, 210, 238.
- Cell division, effects of ovary extracts on, 158.
- Cercaria laevis*, description of, 15.
- Cercaria*, marine, from Woods Hole region, 15.
- CHADWICK, L. E., J. B. LOVELL AND V. E. EGNER. The relationship between pH and the activity of cholinesterase from flies, 139.
- CHAET, ALFRED B. See L. V. HEILBRUNN, 158.
- Chaetopterus, extraction of antimitotic substance from eggs of, 158.
- CHAMBERS, EDWARD L., AND W. E. WHITE. The accumulation of phosphate by fertilized sea urchin eggs, 297.
- CHAMBERS, EDWARD, L. See S. C. BROOKS, 279.
- Character of *Phormia* salivary secretion, 178.
- Chick blastoderms, wound healing in, 39.

- Chick embryo, effect of lowered incubation temperature on growth and differentiation of, 48.
- CHILD, C. M. Redox indicator patterns in relation to echinoderm exogastrulation. II. Reduction patterns, 21.
- Cholinesterase from fly heads, relationship between activity of and pH, 139.
- Chromatography of antimetabolic substances from ovaries, 158.
- Chromatography of *Phormia* larval salivary secretion, 178.
- Chromatography of sea urchin gut NPN, 328.
- Chromatography of sea urchin jelly-coat solutions, 169.
- Chromatophoric response in eyestalkless *Uca*, 371.
- Corpus allatum* in Plecoptera, 1.
- Crab, neurosecretion in thoracic ganglion of, 60.
- Culture method for amoeba-flagellate, 269.
- Culture of chick blastoderms in vitro, 39.
- Cyanide, effect of on metabolism of *Cecropia* silkworm, 210, 238.
- Cytochrome oxidase in thoracic muscle of woodroach, 341.
- Cytochrome oxidase system in diapause and development of *Cecropia* silkworm, 238.
- DAN, KATSUMA. See KAYO OKAZAKI, 83.
- Dendroaster excentricus*, redox indicator patterns in exogastrulae of, 21.
- Developing grasshopper embryos, effects of ATP on endogenous oxygen uptake of, 265.
- Development of *Cecropia* silkworm, physiology of, 210, 238.
- Development of *Peronella*, 83.
- Diapause, insect, physiology of, 210, 238.
- Dietary requirements of *Tribolium*, 149.
- Differentiation of chick embryo, effect of lowered incubation temperature on, 48.
- Digenetic trematode larval types, 15.
- Distribution of P-31 and P-32 in dorsal and ventral halves of frog gastrula, 318.
- Diurnal rhythm of chromatophoric response in *Uca*, 371.
- Dorsal gastrula half of frog embryo, distribution of phosphorus in, 318.
- Dose-action curve for x-ray-treated *Mormoniella*, 100.
- DUNN, ARNOLD. See L. V. HEILBRUNN, 158.
- ECHINODERM exogastrulation, redox indicator patterns in relation to, 21.
- Echinoderm (sea urchin), nutrition of, 328.
- Echinoderm eggs, accumulation of phosphates by, 297.
- Echinoderm partial larvae, metamorphosis of, 83.
- Echinoids, redox indicator patterns in exogastrulae of, 21.
- Ecology of California *Littorina*, 185.
- Ecology of phytoplankton blooms in Long Island waters, 198.
- Effect of ATP on endogenous oxygen uptake of developing grasshopper embryos, 265.
- Effect of lowered incubation temperature on growth and differentiation of chick embryo, 48.
- Effects of x-rays on *Paramecium*, 253.
- Egg, sea urchin, interaction of jelly-coat and sperm in fertilization of, 169.
- Eggs, marine, penetration of P-32 into, 279.
- Eggs, sea urchin, accumulation of phosphates by, 297.
- EGNER, V. E. See L. E. CHADWICK, 139.
- Embryo, chick, effect of lowered incubation temperature on growth and development of, 48.
- Embryo, chick, wound healing in, 39.
- Embryo, frog, distribution of phosphorus in dorsal and ventral gastrula halves of, 318.
- Embryo, grasshopper, effect of ATP on endogenous oxygen uptake of, 265.
- Embryo, sand dollar, metamorphosis of, 83.
- Endocrine glands of Plecoptera, 1.
- Endogenous daily rhythm shifted by light stimuli, 308.
- Endogenous oxygen uptake of developing grasshopper embryo, effect of ATP on, 265.
- Enzyme kinetics of cholinesterase from fly heads, effect of pH on, 139.
- Enzymes, oxidative, in thoracic muscles of woodroach, 341.
- Eriocheir japonicus*, neurosecretion in thoracic ganglion of, 60.
- Erosive activities of California *Littorina*, 185.
- Exogastrulation in echinoderms, 21.
- Eye-color mutation in *Mormoniella*, 100.
- Eyestalkless *Uca*, persistent diurnal rhythm of chromatophoric response in, 371.
- FAUNA, helminth, of Alaska, 107.
- FEDER, NED. See HOWARD A. SCHNEIDERMAN, 230.
- Fellodistomatidae, interpretation of larval types in, 15.
- Fertilization of marine eggs, effect of on rate of P-32 uptake, 279.
- Fertilization of sea urchin egg, interaction of sperm and jelly-coat in, 169.
- Fertilized sea urchin eggs, accumulation of phosphate by, 297.
- FIGGE, FRANK H. J. See RALPH WICHTERMAN, 253.
- FINGERMAN, M. See F. A. BROWN, JR., 308.
- Fishes, antimetabolic extracts from ovaries of, 158.

- Fly head cholinesterase, relation between activity of and pH, 139.
- Food and feeding of *Strongylocentrotus*, 328.
- FRAENKEL, G., AND GLENN E. PRINTY. The amino acid requirements of the confused flour beetle, *Tribolium confusum*, 149.
- FRAENKEL, G. See H. H. MOOREFIELD, 178.
- FRASER, RONALD C. The utilization of some carbohydrates by *in vitro* cultured chick blastoderms in wound healing, 39.
- Function of vascular system in *Nereis*, 69.
- GABE, M. See L. ARVY, 1.
- Ganglion, thoracic, of crab, neurosecretion in, 60.
- Gaseous pressures, high, respirometer for metabolic studies at, 230.
- Gases, effects of on physiology of diapausing silkworm, 210, 238.
- Gastrula of frog, distribution of phosphorus in, 318.
- GIARDINA, G. See A. MONROY, 169.
- GIESE, A. C. See REUBEN LASKER, 328.
- Glucose, role of in chick wound healing, 39.
- Glycogen reserves in *Teredo* larvae, 323.
- Gradient of phosphorus distribution in frog gastrula, 318.
- GRANT, PHILIP. The distribution of phosphorus (P-31 and P-32) in dorsal and ventral halves of the *Rana pipiens* gastrula, 318.
- Grasshopper antennae, permeability of sensory pegs on, 122.
- Grasshopper embryos, effect of ATP on endogenous oxygen uptake of, 265.
- Great South Bay, ecology of phytoplankton blooms in, 198.
- Gross metabolic efficiency of California *Littorina*, 185.
- Growth and differentiation of chick embryo, effect of lowered incubation temperature on, 48.
- HARRISON, JOHN R., AND IRVING KLEIN. Effect of lowered incubation temperature on the growth and differentiation of the chick embryo, 48.
- Healing, wound, in chick blastoderms, 39.
- HEILBRUNN, L. V., ALFRED B. CHAET, ARNOLD DUNN AND WALTER L. WILSON. Antimitotic substances from ovaries, 158.
- Helminth fauna of Alaska, 107.
- HENNACY, R. E. See CHARLES E. LANE, 323.
- Heparin-like anticoagulant substances in *Spisula*, 129.
- High gaseous pressures, respirometer for metabolic studies at, 230.
- HINES, MARGARET N. See FRANK A. BROWN, JR., 308.
- Histology of crab neurosecretory cells, 60.
- Histophysiological study of Plecoptera endocrine glands, 1.
- Hydrogen ion concentration, relationship between activity of fly head cholinesterase and, 139.
- I**N vitro culture of chick blastoderms, 39.
- Incubation temperature, lowered, effect of on growth and differentiation of chick embryo, 48.
- Indicators, redox, in relation to echinoderm exogastrulation, 21.
- Insect diapause, physiology of, 210, 238.
- Interaction between sperm and jelly-coat in sea urchin egg fertilization, 169.
- Intercerebralis-cardiacum-allatum system of some Plecoptera, 1.
- Intermediate stages of sea otter helminth parasites, 107.
- Interpretation of larval types in Fellodistomatidae, 15.
- Intertidal snails, ecology of, 185.
- Investigations on interaction between sperm and jelly-coat in fertilization of sea urchin egg, 169.
- Irradiation of *Mormoniella* with x-rays, 100.
- Irradiation of *Paramecium* with x-rays, 253.
- Isolated blastomeres of *Peronella*, development of, 83.
- J**ELLY-coat, interaction of with sperm in sea urchin egg fertilization, 169.
- K**LEIN, IRVING. See JOHN R. HARRISON, 48.
- KRAMER, SOL. See W. H. McSHAN, 341.
- L**AMELLIBRANCH, cercaria from, 15.
- LANE, CHARLES E., J. Q. TIERNEY AND R. E. HENNACY. The respiration of normal larvae of *Teredo bartschi* Clapp, 323.
- Larvae of helminth parasites in Alaska, 107.
- Larvae of *Peronella*, metamorphosis of, 83.
- Larvae of *Teredo*, respiration of, 323.
- Larvae of *Tribolium*, amino acid requirements of, 149.
- Larval salivary secretion of *Phormia*, character and ultimate fate of, 178.
- Larval types of Fellodistomatidae, interpretation of, 15.
- LASKER, REUBEN, AND A. C. GIESE. Nutrition of the sea urchin, *Strongylocentrotus purpuratus*, 328.



- Lethality and biological effects of x-rays in *Paramecium*, 253.
- Leucophaea maderae*, oxidative enzymes in thoracic muscles of, 341.
- Light, role of in shifting endogenous daily rhythm, 308.
- Littorina, size distribution, erosive activities and gross metabolic efficiency of, 185.
- Localization of heparin-like substances in *Spisula*, 129.
- Long Island waters, ecology of phytoplankton blooms in, 198.
- LOVELL, J. B. See L. E. CHADWICK, 139.
- Lowered incubation temperature, effect of on growth and differentiation of chick embryo, 48.
- Lytechinus eggs, accumulation of phosphates in, 297.
- Lytechinus, penetration of P-32 into eggs of, 279.
- MAGGIO, R. See A. MONROY, 169.
- Magnesium ion, role of in maximal stimulation of ATP, 265.
- Marine cercaria from Woods Hole region, 15.
- Marine eggs, penetration of P-32 into, 279.
- Marine intertidal snails, ecology of, 185.
- Marine teleosts, respiratory metabolism of tissues of, 360.
- MATSUMOTO, KUNIO. Neurosecretion in the thoracic ganglion of the crab, *Eriocheir japonicus*, 60.
- McSHAN, W. H., SOL KRAMER AND VERA SCHLEGEL. Oxidative enzymes in the thoracic muscles of the woodroach *Leucophaea maderae*, 341.
- Measurement of metabolism, method for, 230.
- Melanoplus differentialis, effect of ATP on endogenous oxygen uptake of embryos of, 265.
- Metabolic efficiency of California *Littorina*, 185.
- Metabolic studies at high gaseous pressures, respirometer for, 230.
- Metabolism of ATP-treated grasshopper embryos, 265.
- Metabolism of *Cecropia* silkworm, 210, 238.
- Metabolism of teleost tissues, 360.
- Metabolism of *Teredo* larvae, 323.
- Metacercariae in Alaskan fauna, 107.
- Metachromasia in *Spisula* tissues, 129.
- Metamorphosis of *Cecropia* silkworm, 210, 238.
- Metamorphosis of partial larvae of *Peronella*, a sand dollar, 83.
- Method for studying metabolism at high gaseous pressures, 230.
- Mitosis, effects of ovary extracts on, 158.
- Modifiability of tidal rhythmicity of rate of water propulsion in *Mytilus* by transplantation, 353.
- MONROY, A., L. TOSI, G. GIARDINA AND R. MAGGIO. Further investigations on the interaction between sperm and jelly-coat in the fertilization of the sea urchin egg, 169.
- MOOREFIELD, HERBERT H., AND G. FRAENKEL. The character and ultimate fate of the larval salivary secretion of *Phormia regina* Meig., 178.
- Moriches Bay, ecology of phytoplankton blooms in, 198.
- Mormoniella, x-ray dose-action curve for eye-color mutations in, 100.
- Musca domestica, relation between cholinesterase activity of and pH, 139.
- Muscles of woodroach, oxidative enzymes in, 341.
- Mutation, eye-color, in *Mormoniella*, 100.
- Mytilus*, tidal rhythmicity of rate of water propulsion of, 353.
- NANNOCHLORIS, ecology of blooms of, 198.
- Nereis, anatomy and behavior of vascular system in, 69.
- Neurosecretion in the thoracic ganglion of the crab, *Eriocheir japonicus*, 60.
- Neurosecretory cells of Plecoptera, 1.
- NICOLL, PAUL A. The anatomy and behavior of the vascular systems in *Nereis virens* and *Nereis limbata*, 69.
- Nitrogen requirements of phytoplankton in Long Island waters, 198.
- NORTH, WHEELER J. Size distribution, erosive activities, and gross metabolic efficiency of the marine intertidal snails, *Littorina planaxis* and *L. scutulata*, 185.
- Nutrition of sea urchin, 328.
- Nutrition of *Tribolium*, 149.
- Nutritional studies on amoeboid flagellate, 269.
- OKAZAKI, KAYO, AND KATSUMA DAN. The metamorphosis of partial larvae of *Peronella japonica* Mortensen, a sand dollar, 83.
- Otter, sea, parasites of, 107.
- Ova, marine, penetration of P-32 into, 279.
- Ovaries, antimitotic substances from, 158.
- Oxidases in diapausing *Cecropia* larva, 210, 238.
- Oxidative enzymes in thoracic muscles of woodroach, 341.
- Oxygen consumption of *Teredo* larvae, 323.
- Oxygen uptake by echinoderm exogastrulae, 21.
- Oxygen uptake of developing grasshopper embryos, effect of ATP on, 265.

- P**H, relationship between activity of fly head cholinesterase and, 139.
- Paramecium, effect of x-rays on, 253.
- Parasites of sea otter in Alaska, 107.
- Partial larvae of *Peronella*, metamorphosis of, 83.
- Patiria miniata*, redox indicator patterns in exogastrulae of, 21.
- Patterns of reduction in echinoderm exogastrulation, 21.
- Pegs, sensory, on grasshopper antennae, permeability of, 122.
- Penetration of radioactive phosphate into marine eggs, 279.
- Permeability of sensory pegs on grasshopper antennae, 122.
- Peronella japonica*, metamorphosis of partial larvae of, 83.
- Persistent diurnal rhythm of chromatophoric response in eystalkless *Uca*, 371.
- Phases of endogenous daily rhythm shifted by light stimuli, 308.
- Phormia regina* larva, character and ultimate fate of salivary secretion of, 178.
- Phosphate, accumulation of by fertilized sea urchin eggs, 297.
- Phosphate transfer system in grasshopper embryos, 265.
- Phosphorus, distribution of in dorsal and ventral halves of frog gastrula, 318.
- Phosphorus-32, distribution of in dorsal and ventral halves of frog gastrula, 318.
- Phosphorus-32, penetration of into marine eggs, 279.
- Photoreversibility of carbon monoxide inhibition of metabolism in *Cecropia*, 238.
- Phylogeny of digenetic Trematode larval types, 15.
- Physiology of insect diapause, 210, 238.
- Phytoplankton blooms in Long Island waters, ecology of, 198.
- Pigment responses in *Uca*, 371.
- Platysamia cecropia*, physiology of diapause of, 210, 238.
- Plecoptera, intercerebralis-cardiacum-allatum system of, 1.
- Pollution as a factor in phytoplankton blooms, 198.
- Pressure, respirometer for metabolic studies under, 230.
- PRINTY, GLENN E. See G. FRAENKEL, 149.
- Propulsion, water, tidal rhythmicity of rate of, in *Mytilus*, 353.
- Protoplasmic viscosity, effect of x-rays on in *Paramecium*, 253.
- Protozoa, nutritional studies on, 269.
- Puparia, role of *Phormia* larval salivary secretion in cementing of, 178.
- R**ADIATION resistance and its variability, 253.
- Radiophosphorus, accumulation of by fertilized sea urchin eggs, 297.
- Radiophosphorus, distribution of in dorsal and ventral halves of frog gastrula, 318.
- Radiophosphorus, penetration of into marine eggs, 279.
- Rana pipiens*, distribution of phosphorus in gastrula of, 318.
- RAO, K. P. Tidal rhythmicity of rate of water propulsion in *Mytilus*, and its modifiability by transplantation, 353.
- RAY, DAVID T., AND P. W. WHITING. An x-ray dose-action curve for eye-color mutations in *Mormoniella*, 100.
- Redox indicator patterns in relation to echinoderm exogastrulation. II, 21.
- Relation of metabolism of marine teleost tissues to activity, 360.
- Relationship between pH and activity of fly head cholinesterase, 139.
- Respiratory metabolism of teleost tissues in relation to activity and size, 360.
- Respiration of normal larvae of *Teredo bartschii*, 323.
- Respiration of sea urchin intestine, 328.
- Respirometer for metabolic studies at high gaseous pressures, 230.
- Rhythm of chromatophoric response in *Uca*, 371.
- Rhythm of color change shifted by light stimuli, 308.
- Rhythmicity, tidal, and rate of water propulsion in *Mytilus*, 353.
- RYTHER, JOHN H. The ecology of phytoplankton blooms in Moriches Bay and Great South Bay, Long Island, New York, 198.
- S**ALIVARY secretion of *Phormia* larva, character and ultimate fate of, 178.
- Salinity requirements of phytoplankton in Long Island waters, 198.
- Sand dollar, metamorphosis of partial larvae of, 83.
- SCHILLER, EVERETT L. Studies on the helminth fauna of Alaska. XVII. Notes on the intermediate stages of some helminth parasites of the sea otter, 107.
- SCHLEGEL, VERA. See W. H. McSHAN, 341.
- SCHNEIDERMAN, HOWARD A., AND NED FEDER. A respirometer for metabolic studies at high gaseous pressures, 230.
- SCHNEIDERMAN, HOWARD A., AND CARROLL M. WILLIAMS. The physiology of insect diapause. VIII. Qualitative changes in the metabolism of the *Cecropia* silkworm during diapause and development, 210.

- SCHNEIDERMAN, HOWARD A., AND CARROLL M. WILLIAMS. The physiology of insect diapause. IX. The cytochrome oxidase system in relation to the diapause and development of the *Cecropia* silkworm, 238.
- Sea otter, parasites of, 107.
- Sea urchin, nutrition of, 328.
- Sea urchin egg, interaction of sperm and jelly-coat in fertilization of, 169.
- Sea urchin eggs, accumulation of phosphate by, 297.
- Sensory pegs on grasshopper antennae, permeability of, 122.
- Silkworm, physiology of diapause in, 210, 238.
- Size, relation of to metabolism of marine teleost tissues, 360.
- Size distribution of California *Littorina*, 185.
- SLIFER, ELEANOR H. The permeability of the sensory pegs on the antennae of the grasshopper, 122.
- Snails, marine intertidal, ecology of, 185.
- Sperm and egg jelly-coat interaction during fertilization of sea urchin, 169.
- Spisula solidissima*, localization of anticoagulant substances in tissues of, 129.
- Stichococcus*, ecology of blooms of, 198.
- Strongylocentrotus* eggs, accumulation of phosphates in, 297.
- Strongylocentrotus*, nutrition of, 328.
- Strongylocentrotus*, penetration of P-32 into eggs of, 279.
- Strongylocentrotus purpuratus*, redox indicator patterns in exogastrulae of, 21.
- Studies on helminth fauna of Alaska, 107.
- Study of mechanism involved in shifting of phases of endogenous daily rhythm by light stimuli, 308.
- Succinoxidase in woodroach thoracic muscle, 341.
- Survival curves for x-irradiated *Paramecium*, 253.
- T**ELEOSTS, marine, respiratory metabolism of tissues of, 360.
- Temperature of incubation, effect of on growth and development of chick embryo, 48.
- Temperature requirements of phytoplankton in Long Island waters, 198.
- Teredo bartschi*, respiration of normal larvae of, 323.
- Tetramitus rostratus*, nutritional studies on, 269.
- THOMAS, LYELL J., JR. The localization of heparin-like blood anticoagulant substances in the tissues of *Spisula solidissima*, 129.
- Thoracic ganglion of crab, neurosecretion in, 60.
- Thoracic muscles of woodroach, oxidative enzymes in, 341.
- Tidal rhythmicity of water propulsion in *Mytilus*, 353.
- Tidepools, role of erosive activities of snails in deepening of, 185.
- TIERNEY, J. Q. See CHARLES E. LANE, 323.
- Tissue respiration of marine teleosts, 360.
- Tissues of *Spisula*, blood anticoagulant substances in, 129.
- Tosi, L. See A. MONROY, 169.
- Totipotency of sand dollar blastomeres, 83.
- Transplantation, modifiability by, of *Mytilus* water propulsion rate, 353.
- Trematode larval types, interpretation of, 15.
- Trematodes in Alaskan fauna, 107.
- Tribolium confusum*, amino acid requirements of, 149.
- U**CA, shifting of phases of endogenous daily rhythm of, by light stimuli, 308.
- Uca pugnator*, persistent diurnal rhythm of chromatophoric response in, 371.
- Urechis, penetration of P-32 into eggs of, 279.
- Utilization of carbohydrates in chick embryo wound healing, 39.
- V**ARIABILITY in radiation resistance, 253.
- Vascular system in *Nereis*, anatomy and behavior of, 69.
- Ventral gastrula half of frog embryo, distribution of phosphorus in, 318.
- VERNBURG, F. JOHN. The respiratory metabolism of tissues of marine teleosts in relation to activity and body size, 360.
- Viscosity of protoplasm as affected by x-rays, 253.
- W**ATER propulsion in *Mytilus*, tidal rhythmicity of rate of, 353.
- Wave action as a factor in ecology of *Littorina*, 185.
- WEBB, H. M., M. F. BENNETT AND F. A. BROWN, JR. A persistent diurnal rhythm of chromatophoric response in eyestalkless *Uca pugnator*, 371.
- WEST, W. L. See J. H. BODINE, 265.
- WHITE, WILLIAM E. See EDWARD L. CHAMBERS, 297.
- WHITING, P. W. See DAVID T. RAY, 100.
- WICHTERMAN, RALPH, AND FRANK H. J. FIGGE. Lethality and the biological effects of x-rays in *Paramecium*: Radiation resistance and its variability, 253.
- WILLIAMS, CARROLL M. See HOWARD A. SCHNEIDERMAN, 210, 238.
- WILSON, WALTER L. See L. V. HEILBRUNN, 158.
- Woodroach, oxidative enzymes in thoracic muscles of, 341.
- Wound healing in chick blastoderms, 39.
- X**-RAY dose-action curve for eye-color mutations in *Mormoniella*, 100.
- X-rays, effects of on *Paramecium*, 253.



# THE BIOLOGICAL BULLETIN

PUBLISHED BY  
THE MARINE BIOLOGICAL LABORATORY

## Editorial Board

W. C. ALLEE, University of Florida  
L. R. BLINKS, Stanford University  
K. W. COOPER, University of Rochester  
L. V. HELBRUNN, University of Pennsylvania  
M. E. KRAHL, University of Chicago  
E. T. MOUL, Rutgers University

A. K. PARPART, Princeton University  
BERTA SCHARRER, University of Colorado  
ALBERT TYLER, California Institute of Technology  
JOHN H. WELSH, Harvard University  
DOUGLAS WHITAKER, Stanford University  
RALPH WICHTERMAN, Temple University

DONALD P. COSTELLO, University of North Carolina  
*Managing Editor*

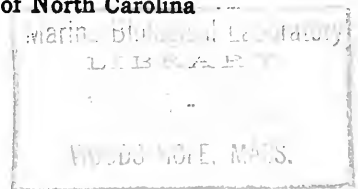

## FEBRUARY, 1954

Printed and Issued by  
LANCASTER PRESS, Inc.  
PRINCE & LEMON STS.  
LANCASTER, PA.

# ELECTROPHORESIS APPARATUS

## PAPER STRIP MODEL

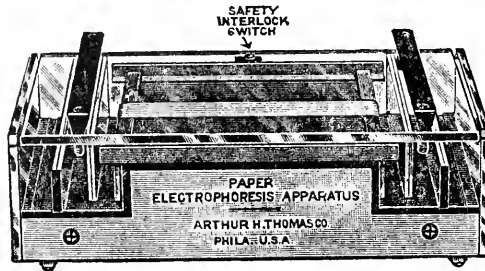

4937-W5.

**ELECTROPHORESIS APPARATUS, Paper Strip Model, A.H.T. Co. Specification.** With recessed,  $9 \times \frac{1}{4}$ -inch platinum foil electrodes,  $10\frac{1}{4}$  inch migration chamber, and separate variable power supply. For preparing a series of horizontal paper electrophorograms of micro quantities (8 to 15 lambda for testing human serum) of mixtures the components of which are separable by migration upon application of an electric potential. Offering the following features:

**Compact, lightweight cabinet.** The transparent plastic cabinet is readily portable, and easily inserted and operated in refrigerators or incubators.

**Safety interlock switch.** Raising of the cover automatically shuts off current to avoid accidents.

**Polarity reversing switch.** Changing direction of current between tests prolongs life of buffer solution.

Designed specifically for clinical estimation of protein constituents of human blood serum, but useful also for the study of other organic or inorganic systems with similar electromigratory characteristics.

Sharp separation by migrating components of normal serum can be completed in approximately 6 hours, using a 250-volt potential, and the entire procedure—including fixing, staining, drying and evaluating—can be accomplished in from 7 to 10 hours.

Overall dimensions of cabinet: 16 inches long  $\times$   $9\frac{1}{2}$  inches wide  $\times$  6 inches high. Cabinet includes removable plate glass cover, and phenolic plastic paper strip carrier which permits use of a single paper sheet or multiple strips up to a maximum width of  $7\frac{3}{8}$  inches.

Direct Current Power Supply is a rectifier-transformer type unit with voltmeter, milliammeter, precise fine and coarse voltage controls and polarity reversing switch. Maximum output without load, 300 volts. With two polarized receptacles for simultaneous connection, if desired, to two Cabinets.

*More detailed information sent upon request.*

**4937-W5. Electrophoresis Apparatus, Paper Strip Model, A.H.T. Co. Specification,** as above described, consisting of Cabinet with recessed platinum foil electrodes, removable plate glass cover, plastic carrier for paper strips, and Direct Current Power Supply, 300 volts, 50 milliamperes, with two receptacles. With directions for use. For 115 volts, a.c. only .....

**NOTE**—An improved Recording Densitometer for use with above is now under development. Upon request, information will be sent as soon as available.



## ARTHUR H. THOMAS COMPANY

*Laboratory Apparatus and Reagents*

WEST WASHINGTON SQUARE

PHILADELPHIA 5, PA.

Teletype Services: Western Union WUX and Bell System PH-72

# BIOLOGICAL ABSTRACTS

COVERS THE WORLD'S BIOLOGICAL LITERATURE

How do you keep abreast of the literature in your field? No individual possibly could accumulate and read all of the biological contributions in the original—yet some relatively obscure journal might publish a revealing paper on the very subject in which you are most interested.

*Biological Abstracts* now publishes concise, informative abridgments of all the significant contributions from more than 2,500 journals. As well as the complete edition, it also is published in nine low-priced sectional editions which are specially designed for individuals who are interested only in one or more closely related fields.

Production costs have increased to such an extent that the active support of all biologists is needed to maintain this important service. Write for full details and a sample copy of the sectional edition covering your field.

BIOLOGICAL ABSTRACTS  
UNIVERSITY OF PENNSYLVANIA  
PHILADELPHIA 4, PA.

# INSTRUCTIONS TO AUTHORS

The Biological Bulletin accepts papers on a variety of subjects of biological interest. In general, however, review papers (except those written at the specific invitation of the Editorial Board), short preliminary notes and papers which describe only a new technique or method without presenting substantial quantities of data resulting from the use of the new method cannot be accepted for publication. A paper will usually appear within three months of the date of its acceptance.

The Editorial Board requests that manuscripts conform to the requirements set below; those manuscripts which do not conform will be returned to authors for correction before they are refereed by the Board.

1. *Manuscripts.* Manuscripts must be typed in double spacing (including figure legends, foot-notes, bibliography, etc.) on one side of 16- or 20-lb. bond paper, 8½ by 11 inches. They should be carefully proof-read before being submitted and all typographical errors corrected legibly in black ink. Pages should be numbered. A left-hand margin of at least 1½ inches should be allowed.

2. *Tables, Foot-Notes, Figure Legends, etc.* Tables should be typed on separate sheets and placed in correct sequence in the text. Because of the high cost of setting such material in type, authors are earnestly requested to limit tabular material as much as possible. Similarly, foot-notes to tables should be avoided wherever possible. If they are essential, they should be indicated by asterisks, daggers, etc., rather than by numbers. Foot-notes in the body of the text should also be avoided unless they are absolutely necessary, and the material incorporated into the text. Text foot-notes should be *numbered* consecutively and typed *double-spaced* on a separate sheet. Explanations of figures should be typed double-spaced and placed on separate sheets at the end of the paper.

3. A *condensed title* or running head of no more than 35 letters and spaces should be included.

4. *Literature Cited.* The list of papers cited should conform *exactly* to the style set in a recent issue of The Biological Bulletin; this list should be headed LITERATURE CITED, and typed *double-spaced* on separate pages.

5. *Figures.* The dimensions of the printed page, 5 by 7¾ inches, should be kept in mind in preparing figures for publication. Illustrations should be large enough so that all details will be clear after appropriate reduction. Explanatory matter should be included in legends as far as possible, not lettered on the illustrations. Figures should be prepared for reproduction as line cuts or halftones; other methods will be used only at the author's expense. Figures to be reproduced as line cuts should be drawn in black ink on white paper, good quality tracing cloth or blue-lined coordinate paper; those to be reproduced as halftones should be mounted on Bristol Board, and any designating numbers or letters should be made directly on the figures. *All* figures should be numbered in consecutive order, with no distinction between text- and plate-figures. The author's name should appear on the reverse side of all figures, as well as the desired reduction.

6. *Mailing.* Manuscripts should be packed flat; large illustrations may be rolled in a mailing tube. **All illustrations larger than 8½ by 11 inches must be accompanied by photographic reproductions or tracings that may be folded to page size.**

*Reprints.* Authors will be furnished, free of charge, one hundred reprints without covers. Additional copies may be obtained at cost; approximate prices will be furnished by the Managing Editor upon request.

---

## THE BIOLOGICAL BULLETIN

THE BIOLOGICAL BULLETIN is issued six times a year at the Lancaster Press, Inc., Prince and Lemon Streets, Lancaster, Pennsylvania.

Subscriptions and similar matter should be addressed to The Biological Bulletin, Marine Biological Laboratory, Woods Hole, Massachusetts. Agent for Great Britain: Wheldon and Wesley, Limited, 2, 3 and 4 Arthur Street, New Oxford Street, London, W. C. 2. Single numbers, \$2.50. Subscription per volume (three issues), \$6.00.

Communications relative to manuscripts should be sent to the Managing Editor, Marine Biological Laboratory, Woods Hole, Massachusetts, between June 15 and September 1, and to Dr. Donald P. Costello, Department of Zoology, University of North Carolina, Chapel Hill, North Carolina, during the remainder of the year.



# ***BIOLOGY MATERIALS***

The Supply Department of the Marine Biological Laboratory has a complete stock of excellent plain preserved and injected materials, and would be pleased to quote prices on school needs.

## **PRESERVED SPECIMENS**

*for*

**Zoology, Botany, Embryology,  
and Comparative Anatomy**

## **LIVING SPECIMENS**

*for*

**Zoology and Botany**

**including Protozoan and  
Drosophila Cultures, and  
Animals for Experimental and  
Laboratory Use.**

## **MICROSCOPE SLIDES**

*for*

**Zoology, Botany, Embryology,  
Histology, Bacteriology, and  
Parasitology.**

**CATALOGUES SENT ON REQUEST**

Supply Department

**MARINE  
BIOLOGICAL LABORATORY**

Woods Hole, Massachusetts

# CONTENTS

---

	Page
ARVY, L., AND M. GABE The intercerebralis-cardiacum-allatum system of some Plecoptera . . . . .	1
CABLE, R. M. A new marine cercaria from the Woods Hole region and its bearing on the interpretation of larval types in the Fellodistomatidae (Trematoda: Digenea) . . . . .	15
CHILD, C. M. Redox indicator patterns in relation to echinoderm exogastulation. II. Reduction patterns . . . . .	21
FRASER, RONALD C. The utilization of some carbohydrates by in vitro cultured chick blastoderms in wound healing . . . . .	39
HARRISON, JOHN R., AND IRVING KLEIN Effect of lowered incubation temperature on the growth and differentiation of the chick embryo . . . . .	48
MATSUMOTO, KUNIO Neurosecretion in the thoracic ganglion of the crab, <i>Eriocheir japonicus</i> . . . . .	60
NICOLL, PAUL A. The anatomy and behavior of the vascular systems in <i>Nereis virens</i> and <i>Nereis limbata</i> . . . . .	69
OKAZAKI, KAYO, AND KATSUMA DAN The metamorphosis of partial larvae of <i>Peronella japonica</i> Mortensen, a sand dollar . . . . .	83
RAY, DAVID T., AND P. W. WHITING An x-ray dose-action curve for eye-color mutations in <i>Moroniella</i> . . . . .	100
SCHILLER, EVERETT L. Studies on the helminth fauna of Alaska. XVII. Notes on the intermediate stages of some helminth parasites on the sea otter . . . . .	107
SLIFER, ELEANOR H. The permeability of the sensory pegs on the antenna of the grasshopper (Orthoptera, Acrididae) . . . . .	122
THOMAS, LYELL J., JR. The localization of heparin-like blood anticoagulant substances in the tissues of <i>Spisula solidissima</i> . . . . .	129

# THE BIOLOGICAL BULLETIN

PUBLISHED BY  
THE MARINE BIOLOGICAL LABORATORY

Editorial Board

W. C. ALLEE, University of Florida  
L. R. BLINKS, Stanford University  
K. W. COOPER, University of Rochester  
L. V. HELBRUNN, University of Pennsylvania  
M. E. KRAHL, University of Chicago  
E. T. MOUL, Rutgers University

A. K. PARPART, Princeton University  
BERTA SCHARRER, University of Colorado  
ALBERT TYLER, California Institute of Technology  
JOHN H. WELSH, Harvard University  
DOUGLAS WHITAKER, Stanford University  
RALPH WICHTERMAN, Temple University

DONALD P. COSTELLO, University of North Carolina  
*Managing Editor*

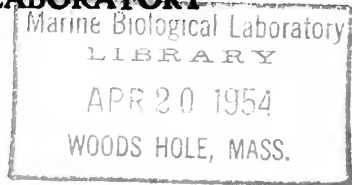

APRIL, 1954

Printed and Issued by  
LANCASTER PRESS, Inc.  
PRINCE & LEMON STS.  
LANCASTER, PA.

# DENSIGRAPH

(RECORDING DENSITOMETER)

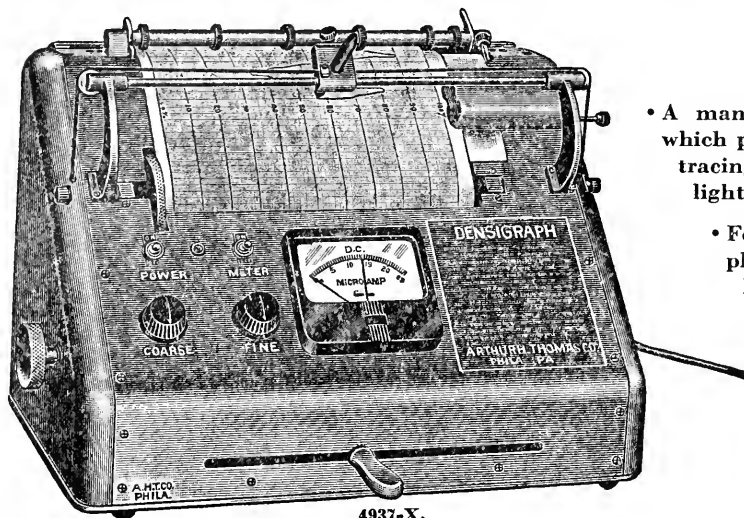

- A manually operated Recorder which provides a continuous ink tracing indicating percentage light transmission
- For convenient and rapid photometric analysis of light absorbing materials on dry paper strips obtained in electrophoresis and chromatography

**DENSIGRAPH (Recording Densitometer), A. H. T. Co. Specification, (Patent Applied For),** manually operated. For convenient and rapid photometric analysis of light-absorbing materials by determining light transmission and lineal separation of stained areas on dry strips of paper as obtained in electrophoresis and chromatography.

Simultaneously combines the usual operations of scanning, indicating and recording to produce a continuous inked tracing of the output of a photo-voltaic cell on graph paper marked in millimeter squares to indicate percentage light transmission. Takes paper strips up to 40 mm wide and treatment of the paper to make it translucent is not required.

Consisting of a modified microammeter with extra manually controlled pointer, photocell, 6-volt lamp, adjustable slit, constant voltage transformer to operate the lamp, and a pen which traces a curve when the pointer on the microammeter is followed closely by the manually controlled pointer which is operated from the front of the cabinet by means of a mechanically linked lever.

In use, stained paper strips are attached by adhesive tape to the right edge of the graph paper, below the adjustable slit, and advanced beneath the photocell housing by the hand wheel at the left of the cabinet. Lateral movement of the lever with the right hand makes it possible to align the manually controlled pointer continuously with the indicating pointer of the meter and, as the rate of travel of the graph paper is under the control of the operator's left hand, *the fidelity of the resulting curve depends upon the manipulative skill of the operator.* A continuous record of an electrophogram 6 inches long can be completed in approximately 5 minutes and portions of the curve can be rechecked by simple roll-back of the graph paper.

4937-X. Densigraph (Recording Densitometer), A. H. T. Co. Specification, (Patent Applied For), as above described, complete with constant voltage transformer, 50 ft. roll of graph paper, ink writing pen, 4 oz. bottle of ink, roll of adhesive tape with dispenser, carrier for 2 x 2-inch glass filters, 6 ft. three-wire cord with two-prong plug with grounding lug, and directions for use. Power consumption 460 watts. For use on 115 volts, 60 cycles, a.c. only.....\$475.00

Copy of Bulletin 117 sent upon request.

**ARTHUR H. THOMAS COMPANY**

*Laboratory Apparatus and Reagents*

WEST WASHINGTON SQUARE

PHILADELPHIA 5, PA.

Teletype Services: Western Union WUX and Bell System PH-72



# BIOLOGICAL ABSTRACTS

COVERS THE WORLD'S BIOLOGICAL LITERATURE

How do you keep abreast of the literature in your field? No individual possibly could accumulate and read all of the biological contributions in the original—yet some relatively obscure journal might publish a revealing paper on the very subject in which you are most interested.

*Biological Abstracts* now publishes concise, informative abridgments of all the significant contributions from more than 2,500 journals. As well as the complete edition, it also is published in nine low-priced sectional editions which are specially designed for individuals who are interested only in one or more closely related fields.

Production costs have increased to such an extent that the active support of all biologists is needed to maintain this important service. Write for full details and a sample copy of the sectional edition covering your field.

BIOLOGICAL ABSTRACTS  
UNIVERSITY OF PENNSYLVANIA  
PHILADELPHIA 4, PA.

# INSTRUCTIONS TO AUTHORS

The Biological Bulletin accepts papers on a variety of subjects of biological interest. In general, however, review papers (except those written at the specific invitation of the Editorial Board), short preliminary notes and papers which describe only a new technique or method without presenting substantial quantities of data resulting from the use of the new method cannot be accepted for publication. A paper will usually appear within three months of the date of its acceptance.

The Editorial Board requests that manuscripts conform to the requirements set below; those manuscripts which do not conform will be returned to authors for correction before they are refereed by the Board.

1. *Manuscripts.* Manuscripts must be typed in double spacing (including figure legends, foot-notes, bibliography, etc.) on one side of 16- or 20-lb. bond paper, 8½ by 11 inches. They should be carefully proof-read before being submitted and all typographical errors corrected legibly in black ink. Pages should be numbered. A left-hand margin of at least 1½ inches should be allowed.

2. *Tables, Foot-Notes, Figure Legends, etc.* Tables should be typed on separate sheets and placed in correct sequence in the text. Because of the high cost of setting such material in type, authors are earnestly requested to limit tabular material as much as possible. Similarly, foot-notes to tables should be avoided wherever possible. If they are essential, they should be indicated by asterisks, daggers, etc., rather than by numbers. Foot-notes in the body of the text should also be avoided unless they are absolutely necessary, and the material incorporated into the text. Text foot-notes should be *numbered* consecutively and typed *double*-spaced on a separate sheet. Explanations of figures should be typed double-spaced and placed on separate sheets at the end of the paper.

3. A *condensed title* or running head of no more than 35 letters and spaces should be included.

4. *Literature Cited.* The list of papers cited should conform *exactly* to the style set in a recent issue of The Biological Bulletin; this list should be headed LITERATURE CITED, and typed *double*-spaced on separate pages.

5. *Figures.* The dimensions of the printed page, 5 by 7¾ inches, should be kept in mind in preparing figures for publication. Illustrations should be large enough so that all details will be clear after appropriate reduction. Explanatory matter should be included in legends as far as possible, not lettered on the illustrations. Figures should be prepared for reproduction as line cuts or halftones; other methods will be used only at the author's expense. Figures to be reproduced as line cuts should be drawn in black ink on white paper, good quality tracing cloth or blue-lined coordinate paper; those to be reproduced as halftones should be mounted on Bristol Board, and any designating numbers or letters should be made directly on the figures. *All* figures should be numbered in consecutive order, with no distinction between text- and plate-figures. The author's name should appear on the reverse side of all figures, as well as the desired reduction.

6. *Mailing.* Manuscripts should be packed flat; large illustrations may be rolled in a mailing tube. **All illustrations larger than 8½ by 11 inches must be accompanied by photographic reproductions or tracings that may be folded to page size.**

*Reprints.* Authors will be furnished, free of charge, one hundred reprints without covers. Additional copies may be obtained at cost; approximate prices will be furnished by the Managing Editor upon request.

---

## THE BIOLOGICAL BULLETIN

THE BIOLOGICAL BULLETIN is issued six times a year at the Lancaster Press, Inc., Prince and Lemon Streets, Lancaster, Pennsylvania.

Subscriptions and similar matter should be addressed to The Biological Bulletin, Marine Biological Laboratory, Woods Hole, Massachusetts. Agent for Great Britain: Wheldon and Wesley, Limited, 2, 3 and 4 Arthur Street, New Oxford Street, London, W. C. 2. Single numbers, \$2.50. Subscription per volume (three issues), \$6.00.

Communications relative to manuscripts should be sent to the Managing Editor, Marine Biological Laboratory, Woods Hole, Massachusetts, between June 15 and September 1, and to Dr. Donald P. Costello, Department of Zoology, University of North Carolina, Chapel Hill, North Carolina, during the remainder of the year.

# ***BIOLOGY MATERIALS***

The Supply Department of the Marine Biological Laboratory has a complete stock of excellent plain preserved and injected materials, and would be pleased to quote prices on school needs.



## **PRESERVED SPECIMENS**

*for*

**Zoology, Botany, Embryology,  
and Comparative Anatomy**

## **LIVING SPECIMENS**

*for*

**Zoology and Botany  
including Protozoan and  
Drosophila Cultures, and  
Animals for Experimental and  
Laboratory Use.**

## **MICROSCOPE SLIDES**

*for*

**Zoology, Botany, Embryology,  
Histology, Bacteriology, and  
Parasitology.**

***CATALOGUES SENT ON REQUEST***



**Supply Department**  
**MARINE**  
**BIOLOGICAL LABORATORY**  
Woods Hole, Massachusetts

# CONTENTS

	Page
CHADWICK, L. E., J. B. LOVELL AND V. E. EGNER The relationship between pH and the activity of cholinesterase from flies . . . . .	139
FRAENKEL, G., AND GLENN E. PRINTY The amino acid requirements of the confused flour beetle, <i>Tribolium confusum</i> , Duval . . . . .	149
HEILBRUNN, L. V., ALFRED B. CHAET, ARNOLD DUNN AND WALTER L. WILSON Antimitotic substances from ovaries . . . . .	158
MONROY, A., L. TOSI, G. GIARDINA AND R. MAGGIO Further investigations on the interaction between sperm and jelly-coat in the fertilization of the sea urchin egg . . . . .	169
MOOREFIELD, HERBERT H., AND G. FRAENKEL The character and ultimate fate of the larval salivary secretion of <i>Phormia regina</i> Meig. (Diptera, Calliphoridae) . . . . .	178
NORTH, WHEELER J. Size distribution, erosive activities, and gross metabolic efficiency of the marine intertidal snails, <i>Littorina planaxis</i> and <i>L. scutulata</i> . . . . .	185
RYTHER, JOHN H. The ecology of phytoplankton blooms in Moriches Bay and Great South Bay, Long Island, New York . . . . .	198
SCHNEIDERMAN, HOWARD A., and CARROLL M. WILLIAMS The physiology of insect diapause. VIII. Qualitative changes in the metabolism of the <i>Cecropia</i> silkworm during diapause and development . . . . .	210
SCHNEIDERMAN, HOWARD A., AND NED FEDER A respirometer for metabolic studies at high gaseous pressures . . . . .	230
SCHNEIDERMAN, HOWARD A., AND CARROLL M. WILLIAMS The physiology of insect diapause. IX. The cytochrome oxidase system in relation to the diapause and development of the <i>Cecropia</i> silkworm . . . . .	238
WICHTERMAN, RALPH, AND FRANK H. J. FIGGE Lethality and the biological effects of x-rays in <i>Paramecium</i> : Radiation resistance and its variability . . . . .	253



# THE BIOLOGICAL BULLETIN

PUBLISHED BY  
THE MARINE BIOLOGICAL LABORATORY

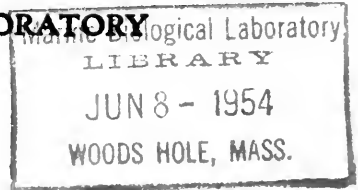

## Editorial Board

- W. C. ALLEE, University of Florida
  - L. R. BLINKS, Stanford University
  - K. W. COOPER, University of Rochester
  - L. V. HELBRUNN, University of Pennsylvania
  - M. E. KRAHL, University of Chicago
  - E. T. MOUL, Rutgers University
  - A. K. PARPART, Princeton University
  - BERTA SCHARRER, University of Colorado
  - ALBERT TYLER, California Institute of Technology
  - JOHN H. WELSH, Harvard University
  - DOUGLAS WHITAKER, Stanford University
  - RALPH WICHTERMAN, Temple University
- DONALD P. COSTELLO, University of North Carolina  
*Managing Editor*

## JUNE, 1954

Printed and Issued by  
LANCASTER PRESS, Inc.  
PRINCE & LEMON STS.  
LANCASTER, PA.

# MILLER, SMALL MODEL K Y M O G R A P H SPRING MOTOR DRIVEN

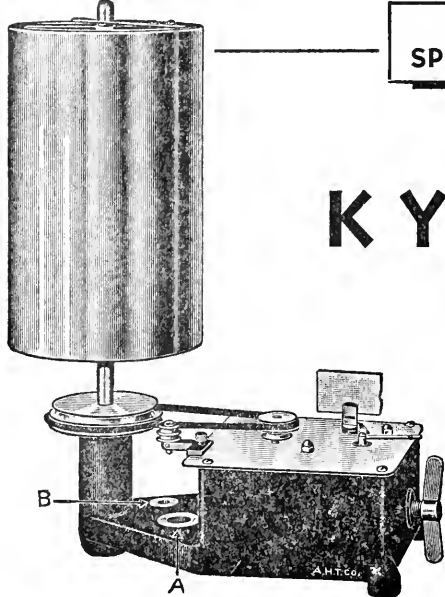

8014-A.

- Drums are 10 inches high × 6 inches diameter
- Speed is adjustable from 0.32 mm per second to 40 mm per second
- Will operate at slow speed for 10 hours and at fast speed for six minutes without rewinding

**KYMOGRAPH, MILLER, Small Model.** Drums are 10 inches high, made of brass tubing with cast aluminum ends, supported on polished steel shafts, ½-inch diameter, which revolve in ball bearing races fitted into heavy cast bases, and can be fastened in position on the shaft instantly by means of a simple friction clamp located on top.

Opening A in the base is intended for insertion of 8015-A Apparatus Support, Simple Form, on which to mount writing levers, etc. Opening B in the base is threaded to take one of the 2¼-inch posts which support the spacer rod of the Long Paper Attachment.

With belt attachment between the drum and spring mechanism. Will operate at a slow speed for 10 hours and at fast speed for 6 minutes without rewinding. The speed rotation at the drum surface is adjustable from approximately 0.32 mm per second to approximately 40 mm per second by means of two grooved aluminum pulleys and a series of five sizes of interchangeable aluminum governing vanes. Starting and stopping are accomplished by means of a simple friction clutch operated by a lever on the top face of the housing.

**8014-A. Kymograph, Miller, Small Model, Spring Motor Drive, as above described.** With brass drum, set of five aluminum governing vanes from ½ to 6 inches long, and belt for attaching drum to spring mechanism ..... **124.75**

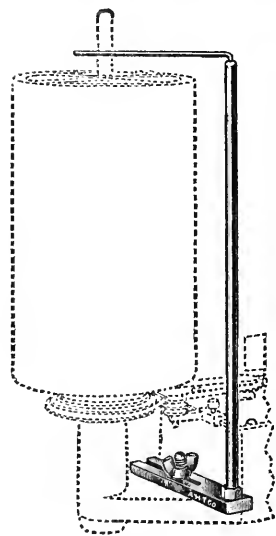

8015-A.

**8015-A. Apparatus Support, Simple Form, for mounting writing levers, with fixed vertical rod and holder for attachment to kymograph base, and with horizontal arm for suspending a plummet.** For attachment to 8014-A in opening A ..... **9.25**

**8015-L. Long Paper Attachment, with brass idler drum, 10 inches high × 2½ inches diameter, on heavy triangular base with leveling screw, two attachment posts, Stainless steel spacer rod, 36 inches long × ½-inch diameter, and two Connectors for attaching spacer rod to the support and to the spring-wound Kymograph** ..... **47.00**



## ARTHUR H. THOMAS COMPANY

*Laboratory Apparatus and Reagents*

WEST WASHINGTON SQUARE

PHILADELPHIA 5, PA.

Teletype Services: Western Union WUX and Bell System PH-72

with **AO**  
**Converging Eyetubes**  
 your **EYES**  
 do **LESS WORK**

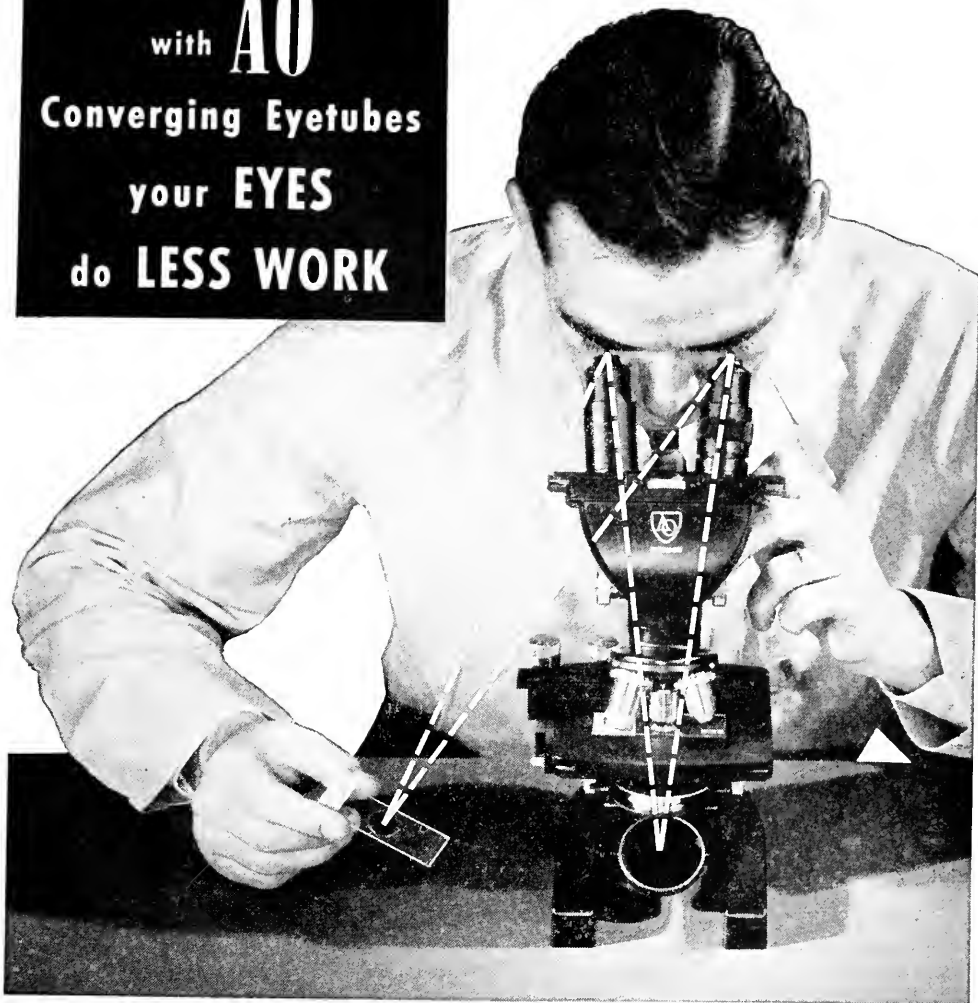

AO also makes a binocular body with parallel eyetubes for those who prefer them.

When using a binocular microscope your eyes are constantly shifting from eyepieces to worktable and back again. If the microscope has parallel eyetubes your eyes must work to readjust themselves each time — now converging on the table at an angle of approximately  $8^\circ$ , now pointing parallel into the eyetubes in order to fuse the two images.

To many people this is uncomfortable, tiring, and slows down the work — so AO optical scientists originated the familiar binocular body with converging eyetubes which is standard on AO Microscopes.

This example of AO *Design Perfection* is also apparent in the renowned AO Spencer Optics, dust-proof, dual-cone nosepiece, "pinch-grip" mechanical stage, "autofocus", custom tension adjustment, and

many other features. Test the many AO advantages *yourself*. Ask your AO distributor for a demonstration, or write Dept. F185.

**American Optical**



INSTRUMENT DIVISION  
 BUFFALO 15, NEW YORK

# INSTRUCTIONS TO AUTHORS

The Biological Bulletin accepts papers on a variety of subjects of biological interest. In general, however, review papers (except those written at the specific invitation of the Editorial Board), short preliminary notes and papers which describe only a new technique or method without presenting substantial quantities of data resulting from the use of the new method cannot be accepted for publication. A paper will usually appear within three months of the date of its acceptance.

The Editorial Board requests that manuscripts conform to the requirements set below; those manuscripts which do not conform will be returned to authors for correction before they are refereed by the Board.

1. **Manuscripts.** Manuscripts must be typed in double spacing (*including* figure legends, foot-notes, bibliography, etc.) on one side of 16- or 20-lb. bond paper, 8½ by 11 inches. They should be carefully proof-read before being submitted and all typographical errors corrected legibly in black ink. Pages should be numbered. A left-hand margin of at least 1½ inches should be allowed.

2. **Tables, Foot-Notes, Figure Legends, etc.** Tables should be typed on separate sheets and placed in correct sequence in the text. Because of the high cost of setting such material in type, authors are earnestly requested to limit tabular material as much as possible. Similarly, foot-notes to tables should be avoided wherever possible. If they are essential, they should be indicated by asterisks, daggers, etc., rather than by numbers. Foot-notes in the body of the text should also be avoided unless they are absolutely necessary, and the material incorporated into the text. Text foot-notes should be *numbered* consecutively and typed *double*-spaced on a separate sheet. Explanations of figures should be typed double-spaced and placed on separate sheets at the end of the paper.

3. A *condensed title* or running head of no more than 35 letters and spaces should be included.

4. **Literature Cited.** The list of papers cited should conform *exactly* to the style set in a recent issue of The Biological Bulletin; this list should be headed LITERATURE CITED, and typed *double*-spaced on separate pages.

5. **Figures.** The dimensions of the printed page, 5 by 7¾ inches, should be kept in mind in preparing figures for publication. Illustrations should be large enough so that all details will be clear after appropriate reduction. Explanatory matter should be included in legends as far as possible, not lettered on the illustrations. Figures should be prepared for reproduction as line cuts or halftones; other methods will be used only at the author's expense. Figures to be reproduced as line cuts should be drawn in black ink on white paper, good quality tracing cloth or blue-lined coordinate paper; those to be reproduced as halftones should be mounted on Bristol Board, and any designating numbers or letters should be made directly on the figures. *All* figures should be numbered in consecutive order, with no distinction between text- and plate-figures. The author's name should appear on the reverse side of all figures, as well as the desired reduction.

6. **Mailing.** Manuscripts should be packed flat; large illustrations may be rolled in a mailing tube. **All illustrations larger than 8½ by 11 inches must be accompanied by photographic reproductions or tracings that may be folded to page size.**

**Reprints.** Authors will be furnished, free of charge, one hundred reprints without covers. Additional copies may be obtained at cost; approximate prices will be furnished by the Managing Editor upon request.

---

## THE BIOLOGICAL BULLETIN

THE BIOLOGICAL BULLETIN is issued six times a year at the Lancaster Press, Inc., Prince and Lemon Streets, Lancaster, Pennsylvania.

Subscriptions and similar matter should be addressed to The Biological Bulletin, Marine Biological Laboratory, Woods Hole, Massachusetts. Agent for Great Britain: Wheldon and Wesley, Limited, 2, 3 and 4 Arthur Street, New Oxford Street, London, W. C. 2. Single numbers, \$2.50. Subscription per volume (three issues), \$6.00.

Communications relative to manuscripts should be sent to the Managing Editor, Marine Biological Laboratory, Woods Hole, Massachusetts, between June 15 and September 1, and to Dr. Donald P. Costello, Department of Zoology, University of North Carolina, Chapel Hill, North Carolina, during the remainder of the year.

# **BIOLOGY MATERIALS**

The Supply Department of the Marine Biological Laboratory has a complete stock of excellent plain preserved and injected materials, and would be pleased to quote prices on school needs.



## **PRESERVED SPECIMENS**

*for*

**Zoology, Botany, Embryology,  
and Comparative Anatomy**

## **LIVING SPECIMENS**

*for*

**Zoology and Botany  
including Protozoan and  
Drosophila Cultures, and  
Animals for Experimental and  
Laboratory Use.**

## **MICROSCOPE SLIDES**

*for*

**Zoology, Botany, Embryology,  
Histology, Bacteriology, and  
Parasitology.**

**CATALOGUES SENT ON REQUEST**



**Supply Department**

**MARINE  
BIOLOGICAL LABORATORY**

**Woods Hole, Massachusetts**

# CONTENTS

---

	Page
BODINE, JOSEPH HALL, AND WILLIAM LIONEL WEST Effect of adenosinetriphosphate (ATP) on the endogenous oxygen uptake of developing grasshopper embryos . . . . .	265
BRENT, MORGAN M. Nutritional studies on the amoeba-flagellate, <i>Tetramitus rostratus</i> . . . . .	269
BROOKS, SUMNER C., AND EDWARD L. CHAMBERS The penetration of radioactive phosphate into marine eggs . .	279
CHAMBERS, EDWARD L., AND WILLIAM E. WHITE The accumulation of phosphate by fertilized sea urchin eggs.	297
BROWN, FRANK A., JR., MILTON FINGERMAN AND MARGARET N. HINES A study of the mechanism involved in shifting of the phases of the endogenous daily rhythm by light stimuli . . . . .	308
GRANT, PHILIP The distribution of phosphorus ( $P^{31}$ and $P^{32}$ ) in dorsal and ventral halves of the <i>Rana pipiens</i> gastrula . . . . .	318
LANE, CHARLES E., J. Q. TIERNEY AND R. E. HENNACY The respiration of normal larvae of <i>Teredo bartschi</i> Clapp . .	323
LASKER, REUBEN, AND ARTHUR C. GIESE Nutrition of the sea urchin, <i>Strongylocentrotus purpuratus</i> . .	328
MCSHAN, W. H., SOL KRAMER AND VERA SCHLEGEL Oxidative enzymes in the thoracic muscles of the woodroach, <i>Leucophaea maderae</i> . . . . .	341
RAO, K. P. Tidal rhythmicity of rate of water propulsion in <i>Mytilus</i> and its modifiability by transplantation . . . . .	353
VERNBERG, F. JOHN The respiratory metabolism of tissues of marine teleosts in relation to activity and body size . . . . .	360
WEBB, H. MARGUERITE, MIRIAM F. BENNETT AND FRANK A. BROWN, JR. A persistent diurnal rhythm of chromatophoric response in eyestalkless <i>Uca pugilator</i> . . . . .	371











MBL WHOI LIBRARY



WH 1AZB K

