

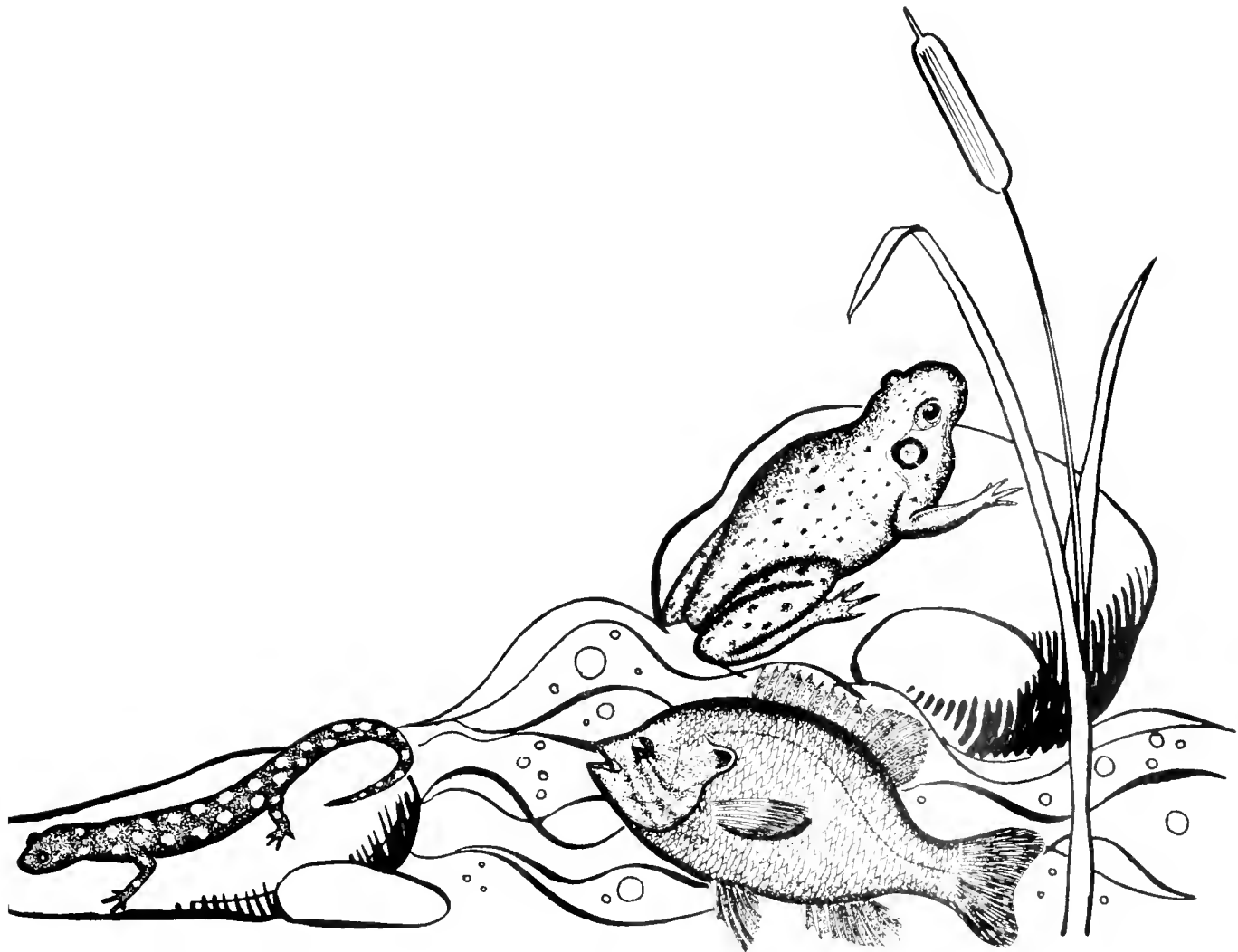

BIOLOGICAL IMPACT OF A LARGE-SCALE DESALINATION PLANT AT KEY WEST



QH
545
.06
C4
1971

WATER POLLUTION CONTROL RESEARCH SERIES

The Water Pollution Control Research Series describes the results and progress in the control and abatement of pollution in our Nation's waters. They provide a central source of information on the research, development, and demonstration activities in the water research program of the Environmental Protection Agency, through inhouse research and grants and contracts with Federal, State, and local agencies, research institutions, and industrial organizations.

Inquiries pertaining to Water Pollution Control Research Reports should be directed to the Chief, Publications Branch (Water), Research Information Division, R&M, Environmental Protection Agency, Washington, DC 20460.

BIOLOGICAL IMPACT OF A LARGE-SCALE
DESALINATION PLANT AT KEY WEST

by

Richard H. Chesher
Westinghouse Ocean Research Laboratory
Annapolis, Maryland

for the

OFFICE OF RESEARCH AND MONITORING
ENVIRONMENTAL PROTECTION AGENCY

Project No. 18080 GBX
Contract # 14.12.888

December, 1971



EPA REVIEW NOTICE

This report has been reviewed by the Environmental Protection Agency, EPA, and approved for publication. Approval does not signify that the contents necessarily reflect the views and policies of the Environmental Protection Agency, nor does mention of trade names or commercial products constitute endorsement or recommendation for use.

ABSTRACT

An eighteen month biological study showed the heated brine effluent from a desalination plant in Key West, Florida caused a marked reduction in biotic diversity. Some organisms were more abundant in the receiving waters than in control areas but these were generally capable of isolating themselves from the effluent by closing up or by moving to other areas during periods of high contamination. Ionic copper, discharged from the plant, was the most toxic feature of the effluent. Temperature and salinity of the effluent and the receiving water were such that the effluent stratified at the bottom of the receiving basin. This stratification reduced water circulation and the man-made harbor acted as a settling basin which lessened the impact of the discharge on surrounding natural environments.

Periodically, the plant shut down for maintenance or cleaning. When it resumed operations, low temperature water of ambient salinity was discharged which was highly contaminated with ionic copper. These sudden effusions caused more biological damage than steady-state conditions. At the end of the study, extensive engineering changes were made to correct corrosion problems and lower copper discharge.

This report was submitted in fulfillment of Contract No. 14.12.888 under the sponsorship of the Environmental Protection Agency.

CONTENTS

<u>Section</u>		<u>Page</u>
I	CONCLUSIONS	1
	The Effluent and its Distribution	1
	Effusions and their Distribution	2
	General Biological Impact of the Effluent and Effusions	2
	Assessment of Experimental Design	4
	Effluent Dispersion	5
	Biological Investigation	6
	Summary of Conclusions	7
II	RECOMMENDATIONS	11
III	INTRODUCTION	13
IV	MATERIALS AND PROCEDURES	17
	Desalination Plant Operation	17
	Characterization of the Effluent	17
	Station Locations	20
	Effluent Dispersion	20
	Biological Investigations	30
	Quadrat and Biomass Samples	30
	Transects	32
	Plankton Tows	33
	Settlement Panels and Diatometers	33
	Transplants	34
	Laboratory Bioassays	36
	Graphic Techniques	38

<u>Section</u>	<u>Page</u>	
V	SAFE HARBOR	41
	Bathymetry	41
	Water Circulation	41
	Tidal Flushing	43
	Sediments	43
VI	PHYSICAL PARAMETERS	45
	Desalination Plant Operation	45
	Ambient Conditions	45
	Effluent Distribution	45
	Distribution at Point of Discharge	48
	Distribution of Effluent Stratum	48
	Copper and Nickel	58
VII	HISTORICAL ANALYSIS OF SAFE HARBOR SEDIMENTS	65
	Heavy Metals in the Sediments	65
	Foraminifera	70
VIII	BIOLOGICAL PARAMETERS	77
	Concentrations of Effluent at Biological Stations	77
	Quadrat Analysis	77
	Foraminifera	92
	Transects	92
	Plankton Tows	100
	Settlement Panels	102
	Diatometers	112
	<i>In situ</i> Bioassays	119
	Laboratory Bioassays	126
	Copper Toxicity	136

<u>Section</u>		<u>Page</u>
IX	ACKNOWLEDGEMENTS	143
X	REFERENCES	145
XI	APPENDIX A	149

FIGURES

		<u>Page</u>
1	Projection of future world-wide desalting use.	14
2	Schematic diagram of the operation of the Key West desalination plant.	18
3	Phase II station locations in Safe Harbor, Stock Island, Florida Keys.	21
4	Schematic of biological station installation near the top of a vertical canal wall.	23
5	Location of thermister strands in Safe Harbor Canal.	27
6	Dates of dredging and filling in Safe Harbor.	29
7	Bioassay experiments.	37
8	Monthly mean percent effluent and the 90 percent confidence limits of the mean at Station 3C, 73m (240 feet) from the discharge of the desalination plant.	39
9	Bathymetry of Safe Harbor.	42
10	Monthly operating parameters of the Key West desalination plant from August, 1970 to August, 1971.	46
11	Average monthly physical parameters from all stations in Safe Harbor from August, 1970 to August, 1971.	47
12	Twelve month average of the rise in temperature and salinity caused by the desalination plant effluent at all stations in Safe Harbor.	49
13	Average monthly depth of the effluent stratum at all stations in Safe Harbor.	51
14	Average monthly rise in temperature caused by the desalination plant effluent at all stations in Safe Harbor.	53
15	Isotherms in Safe Harbor Channel March 12, 1970 from 1200 to 1205 hours.	54

	<u>Page</u>	
16	Isotherms in Safe Harbor Channel May 14, 1971 from 1005 to 1010 hours.	55
17	Movement of 25°C isotherm in Safe Harbor Channel March 12, 1970 from 1220 to 1730 hours.	56
18	Movement of 29°C isotherm in Safe Harbor Channel May 14, 1971 from 0900 to 1900 hours.	57
19	Monthly average copper concentrations at all stations.	63
20	Distribution of copper (ppm dry sediment) in upper centimeter of sediment in Safe Harbor.	66
21	Age of sediment layers in core samples	67
22	Copper and nickel concentrations in the sediment at Bay 2 from 1952 to present.	68
23	Copper and nickel concentrations in the sediment at Station 3 from 1950 to present.	69
24	Species diversity in foraminifera population from core sample at Station 3 and at Bay 2.	73
25	Numbers of foraminifera per cc of dry sediment from core samples at Station 3 and at Bay 2.	74
26	Monthly percent effluent at each station in Safe Harbor from August, 1970 to August, 1971.	78
27	Mean percent effluent with 90 percent confidence limits of the mean for all deeper stations in Safe Harbor from August, 1970 to October, 1971.	79
28	Dominance diversity indices for all Safe Harbor stations based on collections accumulated from July, 1970 to October, 1971.	85
29	Two largest similarity indices for each station in Safe Harbor, indicating affinities in population structures from July, 1970 to October, 1971.	87
30	Similarities in population structure between shallow stations in Safe Harbor from July, 1970 to October, 1971.	88
31	Similarities in population structure between deep stations in Safe Harbor from July, 1970 to October, 1971.	89

	<u>Page</u>
32	Live foraminifera per cc of wet sediment found at all shallow water stations from October, 1970 to October, 1971. 93
33	Live foraminifera per cc of wet sediment found at all deep water stations from October, 1970 to October, 1971. 94
34	Number of individuals per 100 feet of canal wall in Safe Harbor, Stock Island, Florida Keys July, 1970 to October, 1971. 96
35	Numbers of <i>Lytechinus variegatus</i> and <i>Tripneustes ventricosus</i> per square meter in <i>Thalassia</i> flats east and west of the Safe Harbor turning basin. 99
36	Aerial surveys of turtle grass beds adjoining the Safe Harbor turning basin (1968-1971). 101
37	Numbers of serpulids on thirty-day settlement panels at shallow water Safe Harbor stations November, 1970 to April, 1971. 103
38	Numbers of serpulids on thirty-day settlement panels at shallow water Safe Harbor stations May, 1971 to October, 1971. 104
39	Numbers of serpulids on thirty-day settlement panels at deep water Safe Harbor stations October, 1970 to April, 1971. 105
40	Numbers of serpulids on thirty-day settlement panels at deep water Safe Harbor stations May, 1971 to October, 1971. 106
41	Mean number of serpulids settling per 50 cm ² per month at biological stations in Safe Harbor. 107
42	Monthly indices of serpulids settling on 50 cm ² wooden panels at biological stations in Safe Harbor compared to effluent exposure November, 1970 to April, 1971. 109
43	Monthly indices of serpulids settling on 50 cm ² wooden panels at biological stations in Safe Harbor compared to effluent exposure May, 1971 to October, 1971. 110
44	Mean number of barnacles settling per 50 cm ² per month at biological stations in Safe Harbor. 111

	<u>Page</u>
45	Mean number of sabellids settling per 50 cm ² per month at biological stations in Safe Harbor. 113
46	Monthly average of diatom and protozoan species per 2 mm ² at Safe Harbor and control stations. 114
47	Monthly averages of diatoms and protozoans per mm ² at Safe Harbor and control stations. 115
48	Monthly averages of <i>Vorticella</i> settling at Safe Harbor and control stations. 117
49	Monthly averages of <i>Nitzschia longissima</i> settling at Safe Harbor and control stations. 118
50	Echinoid survival versus maximum percent effluent during exposure. 121
51	Average number of days survived by gorgonians (<i>Pterogorgia anceps</i>) at "A" series stations from August, 1970 to March, 1971 and average percent effluent at "B" series stations during this period. 125
52	48 and 96-hour TIm acute bioassay of desalination plant effluent on <i>Lytechinus variegatus</i> . 127
53	48 and 96-hour TIm acute bioassay of desalination plant effluent on <i>Ascidia nigra</i> . 128
54	48 and 96-hour TIm acute bioassay of desalination plant effluent on <i>Menippe mercenaria</i> . 129
55	24-hour, 50 percent reduction of photosynthetic rate of <i>Thalassia testudinum</i> exposed to various dilutions of desalination plant effluent. 130
56	Comparison of toxic effects of copper in effluent and in seawater on <i>Lytechinus variegatus</i> . 132
57	Comparison of toxic effects of copper in effluent and in seawater on <i>Ascidia nigra</i> . 133
58	Comparison of toxic effects of copper in effluent and in seawater on <i>Menippe mercenaria</i> . 134
59	Comparison of toxic effects of copper in effluent and in seawater on photosynthetic rates of <i>Thalassia testudinum</i> . 135
60	Maximum monthly barnacle growth compared to total average dissolved copper exposure April, 1971 to October, 1971. 140

TABLES

		<u>Page</u>
I	Biological station summary.	22
II	Analysis of effluent from Key West desalination plant.	59
III	Ionic analysis of effluent.	61
IV	Temporal distribution of foraminifera in sediment cores from Station 3 and Bay 2 Safe Harbor.	71
V	List of invertebrates and algae found at all stations between July, 1970 and October, 1971.	81
VI	Faunal similarity indices between Safe Harbor stations.	86
VII	Transect comparisons 1969, 1970, 1971.	97
VIII	Mean abundance of a ciliate protozoan (<i>Vorticella</i>) and a diatom (<i>Nitzschia</i>) settling per mm ² on diatometers at Safe Harbor and control stations.	116
IX	Survival of echinoids at biological stations September, 1970 to June, 1971.	120
X	Number of echinoid deaths related to start-ups, shut-downs, unstable plant operation or normal operation of the desalination plant from October, 1970 to October, 1971.	123

SECTION I

CONCLUSIONS

THE EFFLUENT AND ITS DISTRIBUTION

The desalination plant produced two types of discharge; one emitted when the plant was operating normally (effluent), the other produced during cleaning and maintenance cycles (effusions).

The effluent was turbulently mixed with the ambient water at the point of discharge and, because the combined density was greater than ambient water, it sank to the bottom of the man-made Safe Harbor. Since the harbor was deeper than surrounding flats, the submerged effluent filled the basin to the depth of the surrounding flats. Surplus effluent then flowed onto the flats and mixed with the shallower water.

The biota occupying portions of the harbor below 16 feet (4.9m) was constantly exposed to the major contaminants: heat, salinity, and copper. Temperature and salinity controlled the depth and density of the effluent stratum but they were not biologically damaging by themselves. The effluent stratum averaged only 0.3 to 0.5°C above ambient temperatures and only 0.2 to 0.5 o/oo above ambient salinities. Together they caused the effluent to stratify and reduced the mixing rate of the other major contaminant - copper. Consequently, copper concentrations were often five to ten times above ambient levels; amounts found toxic to experimental animals in acute toxicity bioassays.

Although this situation proved deleterious for the biota in deeper portions of Safe Harbor, the configuration of the system protected shallower areas in the harbor and the surrounding *Thalassia* flats.

Poor water circulation in the deeper Safe Harbor water created an enormous settling tank. Effluent remained in the effluent stratum from 24 to 48 hours and copper, the major deleterious feature of the effluent, was actively absorbed onto sediments during this time. Some copper also precipitated out of the water when the effluent became super-saturated with copper.

Thus, distribution of the effluent was fortuitous during normal plant operation. It was unfortunate that copper was produced in toxic quantities but the biological impact would have been more widely distributed had the effluent been discharged into a shallower embayment or directly onto the flats.

EFFUSIONS AND THEIR DISTRIBUTION

Periodically, the desalination plant produced a second type of discharge; low in temperature and salinity but high in copper, nickel, and iron. During most of the study copper discharge was high; amounting to between 50 to 100 pounds (22.7 to 45.4 kg) lost per day. When the plant shut down for maintenance the corroded copper-nickel surfaces dried and oxidized. When resumption of activities began, the loosened copper powder and scale was washed into the sump with the first water circulated through the system.

For the first few hours of operation, when the plant was building up vacuum and heating brine, there was little concentration of the well water and the discharge was, consequently, close to normal seawater in salinity and temperature. Copper contamination, however, was two to three times higher than 'normal' and the discharge was turbid and black. Because the salinity and temperature were close to ambient levels, the turbid, copper-laden effusions mixed well with ambient water and did not sink. Consequently, the shallower areas of the harbor and surrounding flats were inundated by copper effusions each time the plant started up.

The dispersion of effusions varied with wind currents and tidal movements. They maintained their turbid characteristics for some distance from the plant and could be visually identified by the black water extended from the inner harbor to the *Thalassia* flats west of the turning basin.

GENERAL BIOLOGICAL IMPACT OF THE EFFLUENT AND EFFUSIONS

The fauna and flora of Safe Harbor were adversely affected by the effluent from the desalination plant. Some species of animals were prolific in the harbor, however, including foraminifera, serpulid and sabellid annelid worms, and barnacles. Other organisms, such as fish, were abundant in the canal but were continuously recruited from adjacent areas and could also avoid the periodic, turbid effusions.

All of the biological experiments showed the effluent had a pronounced impact on the biological system within Safe Harbor. Even the organisms which were more abundant at Safe Harbor stations than at control stations were adversely affected in the immediate vicinity of the discharge.

A variety of organisms vanished from the harbor during the course of the fifteen months of field work. Sea squirts (*Ascidia nigra*), various species of algae, bryozoans, and sabellid worms were excluded during at least a portion of the study. Dead shells of various clams and oysters were abundant in the harbor, many of them still attached to the coral rock canal walls. Live specimens were relatively common when the preliminary survey was conducted in 1968 and 1969 (Clarke *et al* 1970) but

by 1970 they were rare. By 1971, no live lamellibranchs were found in the harbor.

Effects of the effluent were less at the stations in the turning basin and not detectable at the stations in the approach canal seaward of the turning basin. On the grass flats to the west of the Safe Harbor turning basin, echinoids were killed by the effluent but the rest of the fauna and flora remained relatively stable from 1968 to 1971.

Effusions following the start-up of the desalination plant after maintenance operations caused more biological damage than effluent from the normally operating desalination plant, especially at shallow water stations normally not subjected to effluent. Maintenance work increased as the study progressed with the result that effusions were more common in the fall of 1970 and the winter and spring of 1971 than earlier in the study.

When the harbor fauna was assessed in June, 1970 there was a significant difference in the deep versus the shallow fauna at all stations. As the study progressed, and effusions became more common, the differences between the shallow and deep stations became less pronounced.

By the spring of 1971, effusions had depleted the shallow water Safe Harbor fauna and the shallow stations were not greatly different from the deep stations. In the turning basin, however, and at the station in the innermost portion of the harbor, the shallow stations remained different from the deep stations throughout the study, indicating the impact of the deeper effluent stratum was more extensive, geographically, than the impact of the periodic effusions.

Effusions, however, caused more deaths of experimental animals than the effluent, even at stations in the turning basin. Between October, 1970 and October, 1971 no experimental animals died at the biological stations when the plant was operating normally. Prior to October, 1970 numerous experimental animals died during normal operating conditions and it was evident that 'normal' effluent was deleterious. Later in the study, however, effusions became so frequent that the test organisms were eliminated by transient peaks of contaminants before the long-term effects could cause mortalities. The success of at least two and possibly three of the more abundant organisms in Safe Harbor can be attributed to their ability to avoid the transient peaks of contaminants associated with effusions from the desalination plant and their ability to tolerate the steady-state conditions. Fish were able to swim out of the turbid effusions and were observed doing so. Smaller species of fishes which fled into holes and crevices in the canal wall did not escape and some of these were found to have hepatic lesions similar to those found in fish experimentally poisoned with copper.

Barnacles, by sealing their shells with an operculum, also avoided the toxic effusions and were able to inhabit rocks immediately in the path

of the discharge pipe. Serpulids (by far the most common macroinvertebrate in Safe Harbor) also inhabited rocks in the immediate vicinity of the discharge and they also had opercula to seal the ends of their calcium carbonate tubes.

Comparison of average copper concentrations (without the effusion copper) and barnacle growth rates proved the barnacles were not exposed to the transient high levels of copper associated with effusions. Divers also confirmed that opercula of barnacles exposed to effusions were closed and that barnacles did not feed during exposure. Serpulids were also withdrawn and not feeding during exposure to the effusions.

Sabellids are also tube-worms but these do not have opercula to seal the entrance to their parchment-like tubes. Although they were common in Safe Harbor in the summer of 1970 and again in the summer of 1971 (after copper discharges had been reduced), they had a mass mortality in October, 1970 and were relatively rare at the biological stations in the harbor throughout the fall, winter, and spring of 1970-71.

Laboratory bioassays confirmed the hypothesis that copper was the most toxic element of the effluent. Except for ascidians, copper explained the observed mortalities in acute bioassay studies. Although the ascidians were also susceptible to copper toxicity, the effluent was more toxic than could be explained by the copper contained in it. It was suggested, but not proven or explained, that synergism of copper and temperature may be more pronounced for ascidians than for the other organisms investigated.

ASSESSMENT OF EXPERIMENTAL DESIGN

In setting up the experimental design for this investigation, the researchers included experiments which would adequately delimit the biological impact of the effluent. Most of the techniques had shown success in other ecologically-oriented pollution research but some of the techniques had not been tried before. The final experimental design, therefore, included experiments which final analysis showed to be redundant or unproductive or more laborious than the information gained was worth. It is worthwhile to discuss the relative value of the various experiments for the benefit of other workers involved in similar studies.

The experiments are outlined below with the most productive experiments listed first under the two headings Effluent Dispersion and Biological Investigations.

EFFLUENT DISPERSION

1. Copper in the Sediment: Concentration of metals by marine sediments proved the most useful, least expensive, method of characterizing the dispersion of the effluent. It was also more sensitive than hydrographic measurements and had the added benefit of permitting analysis of the effluent conditions recorded in the sediments dating back to ambient conditions prior to the construction of the desalination plant.
2. Dye Observations and *in situ* Diver Observations: Ascertaining the overall distribution of the effluent and its dynamics was facilitated by simply following the top of the submerged effluent stratum which was visually and tactilly detectable by divers. Adding Rhodamine B dye to the sump and visually following the dye with divers permitted more accurate analysis of the flow of effluent through the harbor.
3. Temperature Inversion Analysis: The hot effluent stratum was easily detectable as a temperature inversion. An electric thermometer proved invaluable in following the dispersion of the effluent and analyses of the position of the effluent stratum could be made rapidly from a small boat. Installation of the Westinghouse thermometer array permitted instant analysis of the movement of the effluent in the field and the long-term movements of particular isotherms.
4. Hydrographic Surveys: The twice-weekly analyses of the water conditions were exceedingly time consuming and probably did not add significantly to the understanding of the biological impact. An initial hydrographic survey of one or two months would have provided an adequate knowledge of the relationship of the effluent in the water column to the amount of copper in the sediment or to temperature inversions and these could have supplanted the less productive and time consuming hydrographic surveys. Of the variety of parameters measured, temperature, salinity, and copper provided the most useful data as they controlled movement of the effluent stratum and its relative toxicity. Alkalinity, pH, and oxygen measurements were not greatly influenced by the effluent and occasional (perhaps monthly) measurements would have sufficed.

The worst feature of the regular hydrographic surveys was their failure to record rapid changes induced by sudden effusions from the desalination plant. These high, transient peaks were more important in damaging the environment than the normal effluent and deserved closer attention. Future surveys should plan to incorporate the analysis of these effusions in hydrographic surveys.

BIOLOGICAL INVESTIGATIONS

1. Analyses of Foraminifera: The foraminifera, because they are small, shelled protozoans, had several attributes which made them one of the most profitable animal groups studied. They left easily identifiable shells in the sediment when they died. These shells provided a biological history of the benthos which could be compared to the copper and nickel history of the sediments and yielded information on conditions in Safe Harbor dating back to before the plant was built.

In the collection of any biological field data, it is important to obtain enough specimens to be statistically valid and to be confident of obtaining the most representative species at any particular station. Foraminifera were easy to collect in large numbers and were readily identified. Foraminifera experts are not uncommon and foraminifera identification catalogues have received considerable attention from geologists of oil companies.

2. Settlement Panels: The second most useful biological data came from the wooden settlement panels. These collected organisms over known exposure times and on substrates which were uniform in size and material. Monthly collections showed availability of larvae (reproduction and recruitment), diversity, relative abundance, growth, and mortality of a variety of common fouling organisms. Because of the uniform exposure and substrate, quantification of the data were simplified.
3. Transects: Transects proved valuable in assessing general trends in macroinvertebrates. The transects were more useful than the quadrats as larger sections of the benthos were examined. They were oriented toward determining changes in particular organisms rather than attempting to quantify the entire population structure.
4. Laboratory Bioassays: Acute static bioassays determined the relative toxicity of the effluent and identified the most toxic element. The bioassays were not designed to be overly sophisticated yet they yielded the desired information without elaborate procedures.
5. Quadrat Analyses: Although difficult and time consuming, the quadrats provided useful information on diversity and population structure. Similar conclusions were available from the foraminifera and settlement panel experiments but quadrats included data on a wider variety of organisms.
6. Transplants: Transplant experiments were relatively inexpensive in terms of time and materials needed for assessment of the *in situ* effects on the test animals. Critical examination of the results, however, showed the only fact of major significance

provided by the experiments was the extraordinary correlation of mortalities with the cleaning and maintenance cycles. While this helped document the importance of effusions, the same conclusions could be drawn from the bioassays, settlement panels and transect studies.

7. Biomass Studies: These were difficult and yielded little additional information not gained from other studies. Since the fauna of the Safe Harbor canal walls was impoverished and many of the species living there were rock borers or encrusting organisms the biomass studies required elaborate and not very successful sampling which compromised the analysis.
8. Diatometers: Glass microscope slides in special racks (diatometers) collected benthic diatoms and protozoans for analyses. They were, however, unsuccessful. While collection and analysis of the data were neither time consuming nor costly, variables introduced by filter feeding predators settling on the glass slides reduced the information content of the slides. Two slides could not be satisfactorily compared for differences in benthic diatom or protozoan populations if one was heavily encrusted with filter-feeding serpulids (which competed for space and ate the settling organisms) and the other populated only by diatoms and protozoans.
9. Plankton Tows: The rapidity with which plankton populations change in nearshore areas limited the information possible from the periodic plankton tows. Daily plankton tows would have required considerable expense in return for conclusions on the impact of the effluent available from other experiments. By comparing plankton populations at the various stations with one another, some information was gained which indicated effluent was deleterious to the plankton populations near the discharge.
10. C¹⁴ Measurements of Photosynthesis: C¹⁴ studies yielded unusual results. Frequently more carbon was fixed in the dark bottle than in the light. This, in itself, was significant but a review of the literature suggested the phenomenon may be a function of the effect of illumination on copper toxicity. The variables that entered into the experiment required additional research into the techniques and theory of C¹⁴ measurements which were beyond the scope of the program.

SUMMARY OF CONCLUSIONS

In addition to the general conclusions outlined above, the following are pertinent facts obtained during the field work between July,

1970 and October, 1971.

1. Safe Harbor has an average depth of 22.6 feet. Deep water circulation is restricted by a 17-foot sill in the approach channel. Tidal flushing results in a 10.76 million cubic feet per day exchange. The volume of Safe Harbor is 101.8 million cubic feet.
2. The desalination plant effluent averaged 35°C, 7.0 pH, 50.00 o/oo salinity, and 1,766 ppb copper. Its volume averaged 1.33×10^8 gal/month or about 0.77 million cubic feet per operational day.
3. The effluent was diluted about twenty times at the point of discharge and sank to form a warm, dense stratum which was found throughout the Safe Harbor basin. The top of the stratum had an average depth of 18 feet. Although it occasionally floated in mid-water, it was normally in contact with the bottom. The volume of the effluent stratum was about 20.6 million cubic feet.
4. The effluent heated the receiving water at deeper stations in Safe Harbor by an average of 0.2 to 0.5°C and raised its salinity by an average of 0.2 to 0.45 o/oo over ambient conditions.
5. Diluted effluent escaped from the system along the floor of the approach canal and along the western edge of the turning basin.
6. Ambient salinity, the volume of effluent, and the 17-foot sill in the approach channel controlled the depth of the effluent stratum. Intensity of the stratum was closely correlated with total hours of sunshine.
7. Copper was discharged from the desalination plant at concentrations up to 6,700 ppb. It was found to be 78.4 percent ionic, 3.4 percent particulate, and 18.2 percent organically complexed.
8. Copper discharge was highest following plant maintenance periods and during periods of unstable pH. Raising pH in the plant significantly reduced copper discharge.
9. Copper in sediments of Safe Harbor and Lindbergh Bay (St. Thomas, U.S. Virgin Islands) showed the average, long-term distribution of effluent and provided a permanent record of copper build-up from pre-plant conditions to the present. Analysis of copper in sediments is a rapid technique for determining the average distribution and intensity of effluent.

10. Foraminifera shells left a permanent record of changes in sediment fauna from pre-plant conditions to the present. This record indicated that the foraminifera populations had increased substantially over pre-plant densities. Numbers of species did not change significantly.
11. Densities of live foraminifera decreased in the immediate vicinity of the discharge but, in general, were higher in Safe Harbor than at control stations. Conditions improved for foraminifera during the cooler months.
12. Shallow stations near the desalination plant were exposed to high concentrations of effluent following shut-down periods. Sudden, large doses of ionic copper, produced as the plant began operation or changed operational modes were more deleterious than steady-state conditions.
13. Copper and temperature were the two major deleterious aspects of the effluent. High discharges of copper resulted in mortality of test organisms at *in situ* bioassay stations.
14. *In situ* bioassays showed echinoids and ascidians were more sensitive to the effluent than stone crabs or gorgonians. A concentration of only 1.5 percent effluent was lethal to echinoids in long-term studies. Gorgonians survived brief exposures to five percent effluent and stone crabs survived exposures to six to seven percent effluent.
15. *Ascidia nigra* was the most sensitive organism to effluent in laboratory acute toxicity experiments; fifty percent dying in 96 hours in 5.8 percent effluent. Echinoids had a 96-hour TLM of 8.5 percent effluent; stone crabs a 96-hour TLM of twelve percent effluent. Photosynthesis of *Thalassia testudinum* was reduced by fifty percent in twenty-four hours in concentrations of twelve percent effluent.
16. Fewer specimens of diatoms and protozoans settled on diatometers in effluent-laden water but diversity was not significantly decreased. *Vorticella* sp. and *Nitzschia longissima* had higher population levels on Safe Harbor shallow water diatometers and lower populations in deep water diatometers when compared to control stations.
17. Plankton populations were reduced in deep, effluent-laden Safe Harbor water when compared to shallow water and control stations.
18. Serpulids were more abundant in Safe Harbor than at control stations but their numbers were reduced by effluent-laden water in the immediate vicinity of the discharge.

19. Effluent reduced numbers of barnacles, bryozoans, and sabellids settling on settlement panels in Safe Harbor.
20. *Ascidia nigra* and most oysters were excluded from the Safe Harbor canal during most of the study period. *A. nigra* returned when copper concentrations decreased.
21. Quadrats showed a gradual biotic depletion. Annelid worms, blue-green algae, and bryozoans comprised the benthic flora and fauna in Safe Harbor during most of the study period.
22. Stone crabs and lobsters decreased in transect areas. Lobsters were attracted to the desalination plant sea wall during cooler winter months. Fish were more abundant near the discharge than elsewhere in the study area. Some of these were injured by copper toxicity.
23. Transects showed a decrease in echinoid populations on *Thalassia* flats to the west of the Safe Harbor turning basin. High copper levels in sediments from this area implicated the effluent in the echinoid mortality.
24. *Thalassia* grass beds surrounding the entrance to Safe Harbor did not change their distribution appreciably between 1968 and 1971.
25. Copper uptake and toxicity increased with increasing illumination in phytoplankton samples and in the ascidian, *Ascidia nigra*.

SECTION II

RECOMMENDATIONS

The primary recommendation would have been to reduce the copper discharge from the Key West desalination plant but this is in progress thanks to the environmental concern of the Florida Keys Aqueduct Commission and the Westinghouse Electric Corporation.

It follows that the second recommendation would be to improve future desalination plant designs to keep copper discharge at the lowest possible level. Since copper loss reflects internal damage to the facility and eventual increased maintenance costs, it is beneficial to the owners of desalination plants to keep copper discharge to a minimum. The use of titanium as the primary heat transfer surface may provide the best solution. Westinghouse Electric Corporation has already constructed a titanium desalination plant in St. Croix and it would be beneficial to examine the ecological impact of that plant to ascertain if titanium is as environmentally compatible as suspected.

It would also be useful to:

1. Examine the modified discharge from the Key West installation to determine if the engineering changes do, in fact, reduce the copper discharge.
2. Monitor the biological health of Safe Harbor to determine how rapidly (and if) it recovers from the copper polluted environment.
3. Examine the impact of the improved Key West facility to determine the effects of a desalination plant with low copper discharge.
4. Design an experimental program to determine the ecological impact and dispersion of sudden effusions containing high levels of toxicants.
5. Conduct further investigations into the dynamics and mechanisms of copper toxicity in the marine environment.

SECTION III

INTRODUCTION

DESALINATION PLANTS

Large-scale desalination plants are commonplace in many tropical and subtropical areas where freshwater is limited. A 1970 world-wide survey by the U.S. Department of the Interior, Office of Saline Water, showed a total of 686 desalting plants of 25,000 gallons-per-day capacity or greater. They had a total capacity of 247,166,000 gallons of freshwater per day. The largest plants were at Rosarita, Mexico (7.5 mgd); Terneuzen, Netherlands (7.6 mgd) and Schevchenko, Russia (31.7 mgd). The largest plant in the U.S. was the facility in Key West, Florida (2.6 mgd).

About 98 percent of the desalination plants used the flash distillation process employed by the Key West facility and most were constructed of similar materials. The major difference between the Key West facility and other desalination plants was the source of seawater. The Key West plant obtained its seawater from deep wells rather than from the sea. They benefited from this by eliminating biological fouling problems and obtaining water of uniform, low temperature but were penalized by the corrosive action of hydrogen sulfide present in the well water.

Within the next five years the Office of Saline Water predicts world capacity for desalination will quadruple (Fig. 1). Desalination plants of one billion gallons of freshwater per day capacity have been designed. The ecological impact of the effluent from these plants requires immediate consideration as engineering plans (including effluent discharge designs and materials for construction) are already nearing completion. Small modifications in outfall design and forethought about the location of these outfalls may make significant differences in the ecological impact of the wastes. Since heavy metals produced by internal corrosion endangers marine biota, careful selection of materials for various portions of the plants can have vital importance on the biological impact.

In 1968, Westinghouse Ocean Research Laboratory began preliminary surveys on the biological impact of the desalination plant at Key West, Florida (Clarke *et al* 1970), with support of the Federal Water Pollution Control Administration (now the Environmental Protection Agency). Their findings prompted a more extensive biological investigation to quantify the biological impact and determine which constituents of the effluent were deleterious. Therefore, in July, 1970, Westinghouse Ocean Research Laboratory

PROJECTION OF FUTURE WORLD-WIDE, CUMULATIVE DESALTING PLANT CAPACITY IN OPERATION OR UNDER CONSTRUCTION

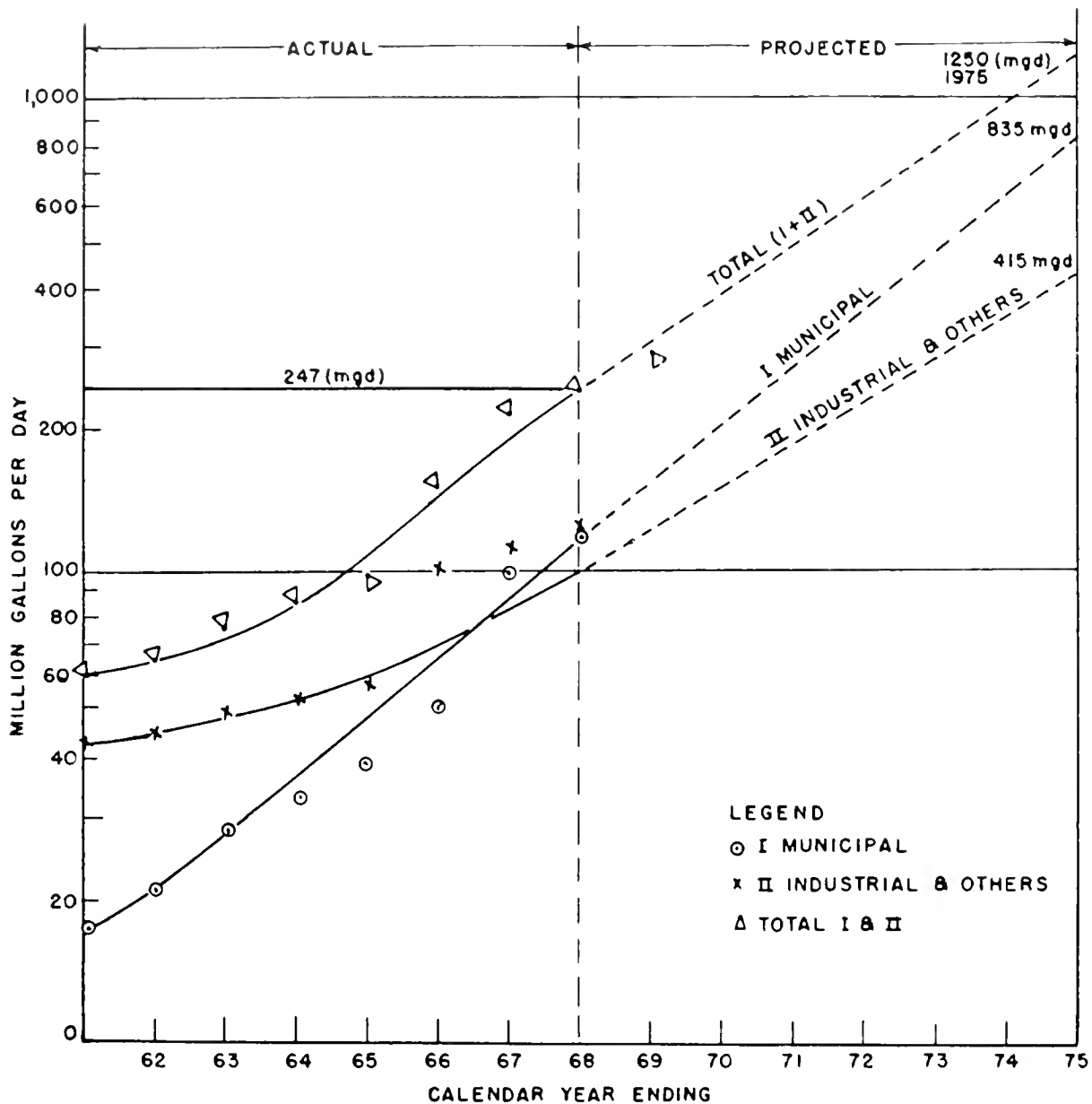

FIG. 1 PROJECTION OF FUTURE WORLD-WIDE DESALTING USE.
 (FROM SACHS 1969)

began the first large-scale biological investigation of the impact of desalination plants on the marine environment.

Previous researches (Le Gros *et al* 1968, Zeitoun *et al* 1969a) had surveyed the literature for theoretical effects of heated brine effluents and high levels of trace metals. Some experimental laboratory studies and analyses of effluents had been conducted on the effects of copper on the marine environment (Zeitoun *et al* 1969b). These works contain excellent summaries of previous studies relating to biological tolerances for excessive heat, salinity, and copper.

The desalination plant at Key West is owned by the State of Florida and managed by the Florida Keys Aqueduct Commission. It supplies the City of Key West with about 2.4 million gallons of freshwater per day. Additional water is pumped from the mainland of Florida to this island community. Since the facility is located in subtropical areas, the effects of added heat and salinity were expected to be more pronounced here than in cooler waters. Since the plant was constructed by the Westinghouse Electric Corporation, it was also felt that cooperation between the plant operators and the researchers would be good, thus facilitating the research.

The objectives of the research program were to determine the biological impact of the desalination plant effluent, to define the most toxic elements of the discharge, to develop predictive capabilities on effects of additional thermal, heavy metal, and organic loading of Safe Harbor, and to establish possible methods for management of such stresses.

In addition to reaching the planned objectives, Westinghouse Ocean Research Laboratory assisted the Florida Keys Aqueduct Commission and Westinghouse Electric Corporation in planning actual corrective measures to improve the water quality of the effluent.

The study showed copper discharge to be in excess of safe biological levels. Reasons for the excessive corrosion were sought and engineering methods were designed to overcome the corrosion problems. Westinghouse Electric Corporation donated the engineering time involved in the corrective measures, but the cost of the actual changes were still great. The following steps were taken beginning in 1971:

1. Large copper-nickel separatory trays were removed from the deaerator and temporarily replaced with wood screens (June, 1971). Stainless steel trays have been ordered and will replace the remaining copper-nickel trays by the spring of 1972.
2. An entire tube-bundle (1,200 tubes, 110 feet long) was removed and replaced with titanium tubes (November, 1971).
3. A new boiler was installed to prevent frequent shut-down

periods for boiler maintenance. A building was constructed around the new and the old boiler to reduce corrosion problems, (December, 1971).

4. The capacity and efficiency of the decarbonizer will be improved to increase aeration of the feed water and reduce H_2S to negligible levels.

To further reduce environmental effects of the facility, washings from the boiler will be dumped into a large excavated holding pond and not into the marine environment.

SECTION IV

MATERIALS AND PROCEDURES

DESALINATION PLANT OPERATION

The desalination plant is a 50 stage flash-evaporator type (Fig. 2). Its general operation has been described by Clarke *et al* (1970) and Popkin (1969). The plant draws saline water from three 120 feet deep wells, acidifies it with H_2SO_4 to remove carbonates, adjusts the pH with NaOH, heats and degasses⁴ the water, and passes it through a series of 50 chambers with ever diminishing pressures. As the hot water enters each chamber it boils violently, cools slightly, then flows to the next chamber where an increase in vacuum causes it to boil again.

The steam created by the boiling brine is condensed on cooling tubes, drips onto product trays and is then pumped through a filter and into the city water system. Brine flowing through the system is recycled many times with only a portion drawn off each cycle as brine blowdown. The blowdown and a smaller volume of cooling water (called reject water) empty into an open sump and flow through a three-foot pipe into Safe Harbor canal. The discharge is located on the upper portion of the canal wall about three feet under the surface of the water.

CHARACTERIZATION OF THE EFFLUENT

The effluent was monitored in three ways; by continuous recording instrumentation, by measurements and calculations based on the operating characteristics of the plant, and by periodic manual sampling and laboratory analysis of the effluent.

Sample water for continuous monitoring was drawn from the effluent pipe by a nonmetallic pump and passed through a bubble remover reservoir to continuous recording instrumentation. Temperature was recorded from a thermister probe located in the effluent pipe and conductivity from a probe in the bubble removing reservoir. The pH was measured in a flow-through cup in a small laboratory facility adjacent to the desalination plant.

Copper was measured by a flow-through Hach Chemical Company, Inc., Model 2006 copper analyzer. Temperature, conductivity, and pH data were processed by a Hydrolab, Inc., battery-operated Hydrolab IV system.

Throughout the study continuous monitoring instruments were a problem. The copper analyzer suffered from clogged capillaries and electronic

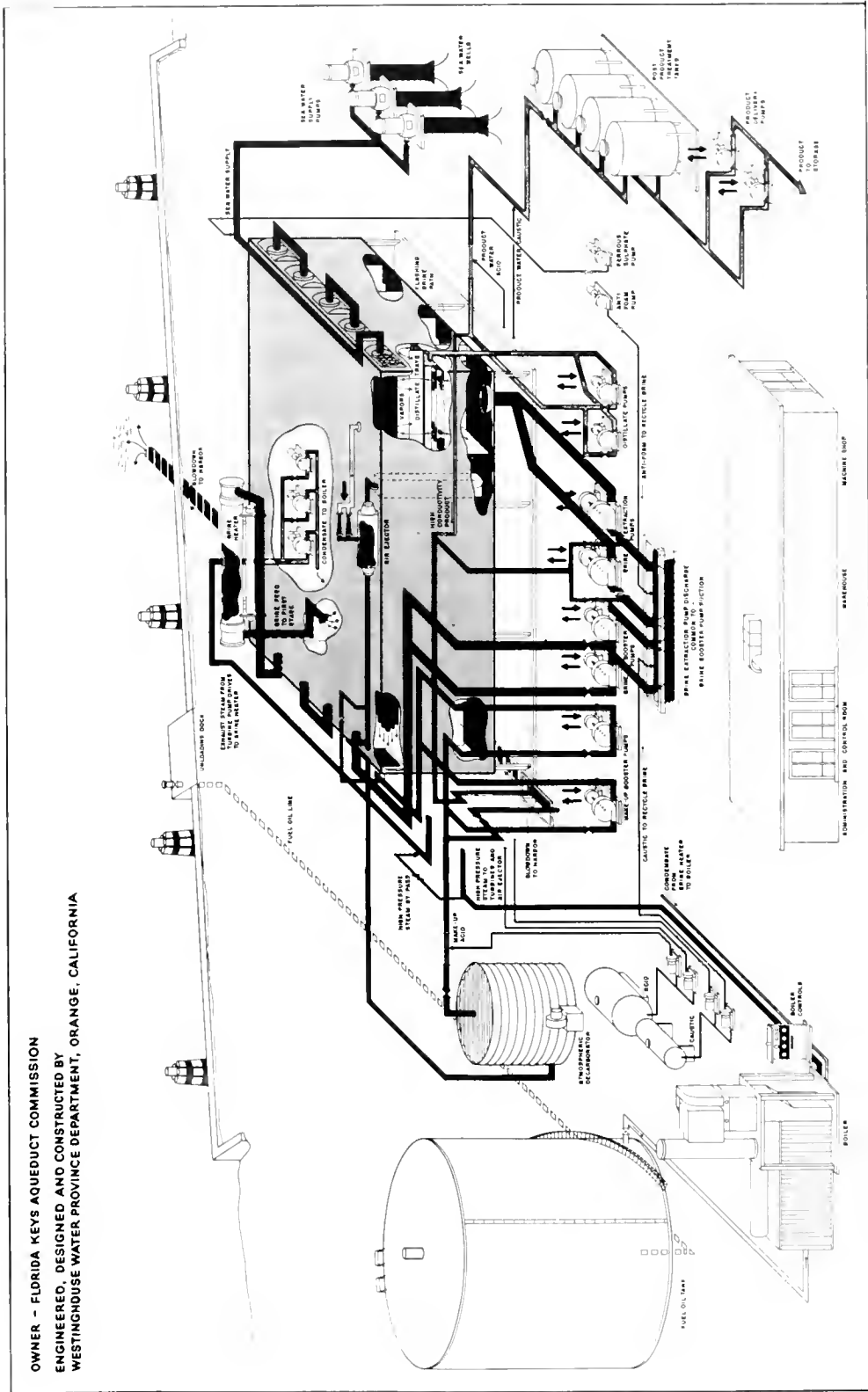

FIGURE 2 SCHEMATIC DIAGRAM OF THE OPERATION OF THE KEY WEST DESALINATION PLANT

failures. Almost a year went by before it was properly corrected and began consistently producing reliable results. The Hydrolab IV temperature and conductivity modules worked well but the pH probe suffered from large electrostatic charges generated by the seawater flowing through the desalination system. The pH measurements were, therefore, made twelve times daily by testing a sample of the effluent on a Beckman laboratory pH meter.

Independent samples of well water and effluent were taken twice a week during normal field collections. These samples were analyzed along with the samples from the harbor (see below) for temperature, salinity, alkalinity, and total copper. The effluent was also sampled quarterly for emission spectrographic and atomic absorption analyses of the major elements. Additional samples were taken periodically to examine heavy metal discharge following periods when the plant had been closed for maintenance and descaling.

Every two hours, the plant operators recorded maintenance data for the desalination plant including temperatures, water flows and pH readings. These measurements provided the most reliable data on the long-term operation of the facility and were the source of the averages presented in the report showing long-term trends in parameters of the effluent.

Samples taken and analyzed concurrently with the field station collections were used for estimation of the percent effluent at the stations and as a cross-check for the data calculated from maintenance records.

Salinity, temperature, and pH were calculated from the maintenance books. Since salinity measurements of the blowdown were not taken by the plant operators, they were calculated by comparing the total water flowing through the system, the amount of freshwater being produced, and the salinity of the well water. Well water salinity averaged 38.266 o/oo with a standard deviation of only 0.01 o/oo.

Using the observed salinity of the well water (S_w), the total amount of seawater pumped (T), and the amount of water produced (P), the salinity of the effluent (S_e) was calculated as:

$$S_e = S_w \frac{T}{T - P}$$

Temperature of the effluent was recorded by laboratory-grade glass thermometers at the point of discharge into the open sump. Two separate readings were taken; one for the stage 50 brine (brine blowdown temperature) and one for the reject water. Since the volume of the reject water was known to be one third the volume of the brine blowdown (under normal operating conditions) the temperature of the combined effluent (T_e) was calculated from the temperatures of the brine blowdown (T_b) and the reject water (T_r) using the formula:

$$T_e = \frac{T_b + T_r}{4}$$

Data from these calculations were compared with direct measurements of the combined effluent and found to be accurate to 0.1°C and 0.05 o/oo salinity.

STATION LOCATIONS

Figure 3 shows the location of stations in Safe Harbor. Stations 10A and 10B were used as controls and were located in another basin about two kilometers east of Safe Harbor (Fig. 3). They were located on a vertical rock wall adjoining undeveloped military property. Hydrologic conditions were similar to those in Safe Harbor but there were no effluents discharged into the control area.

Before selecting locations for the stations a survey was made of Safe Harbor and basic characteristics of the effluent discharge. This survey showed that the effluent did not mix uniformly in the harbor and that a dense, hot layer of effluent-laden water formed a well defined stratum throughout the harbor (see Section V). Stations were installed in and above this stratum on the vertical rock walls. The shallower stations, 8 to 10 feet (2.4 to 3.0 meters), were designated "A" stations and were relatively free from effluent from the desalination plant. The deeper "B" stations, 24 to 26 feet (7.3 to 7.9 meters), were exposed to the effluent and were placed directly below each "A" station. Biological activities at the stations are listed in Table I and depicted in Figure 4.

EFFLUENT DISPERSION

To interpret the biological data, it was essential to determine the distribution and concentration of effluent in the receiving water. Hydrographic measurements, sediment analyses, and observations of dye dispersion by divers provided the required effluent dispersion data.

Hydrographic measurements included temperature, salinity, copper, dissolved oxygen, alkalinity, and currents. Since the purpose of these measurements was to determine the amount of effluent present at the biological field stations, the technique of collection and analysis of the data was designed to eliminate ambient fluctuations and to calculate the percent effluent at the stations. This was accomplished by comparing characteristics of the water at the station with similar data from the discharge and the mixing water and calculating, by a simple dilution formula, the percent of effluent. Both conservative (salinity and copper), and semi-conservative (temperature) measurements were used for determinations.

If (l) represents the percent effluent at the station, (P_{st}) the parameter measured at the station, (P_m) the same parameter of the mixing water, and (P_e) the same parameter of the effluent then:

FIG. 3 PHASE II STATION LOCATIONS IN SAFE HARBOR, STOCK ISLAND, FLORIDA KEYS

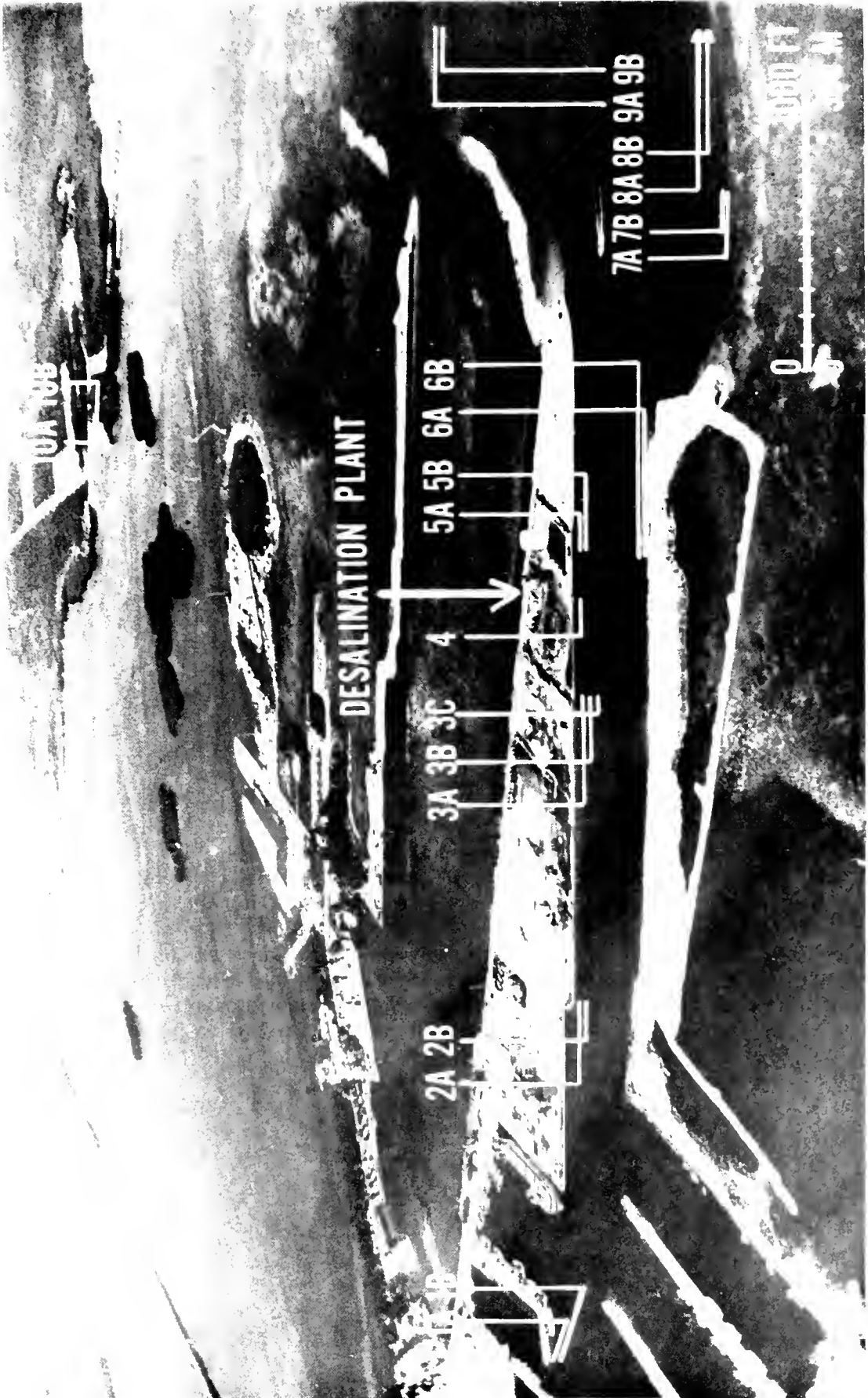

TABLE I

BIOLOGICAL STATION SUMMARY

Activities in and above effluent stratum. Shallow stations are "A" series, deeper stations "B" series.

	STATIONS (Both A and B)									
	1	2	3	4	5	6	7	8	9	10
Meter Square Quadrats (Monthly)	x	x	x	x	x	x	x	x	x	x
Foraminifera Collections (Quarterly)	x	x	x	x	x	x	x	x	x	x
Biomass Collections (Quarterly)			x				x			x
<i>In situ</i> Bioassays (Crabs, Echinoids, <i>Thalassia</i>)			x				x			x
<i>In situ</i> Bioassays (Ascidians, Gorgonians)		x	x		x	x	x			x
Settlement Panels (Monthly)		x	x		x	x	x			x
Diatometers (Bi-weekly)			x				x			x
Transects: (Monthly)	T1: Along desalination plant sea wall. T2: Along City Electric plant dock (about 300 feet [91.5m] north of the desalination plant sea wall).									
Plankton Tows: (Monthly 100 meters long)	P1: Along desalination plant wall at 28 feet (8.5m). P2: Along desalination plant wall at 6 feet (1.8m). P3: Along eastern edge of turning basin at 6 feet (1.8m). P4: Along eastern edge of turning basin at 28 feet (8.5m).									

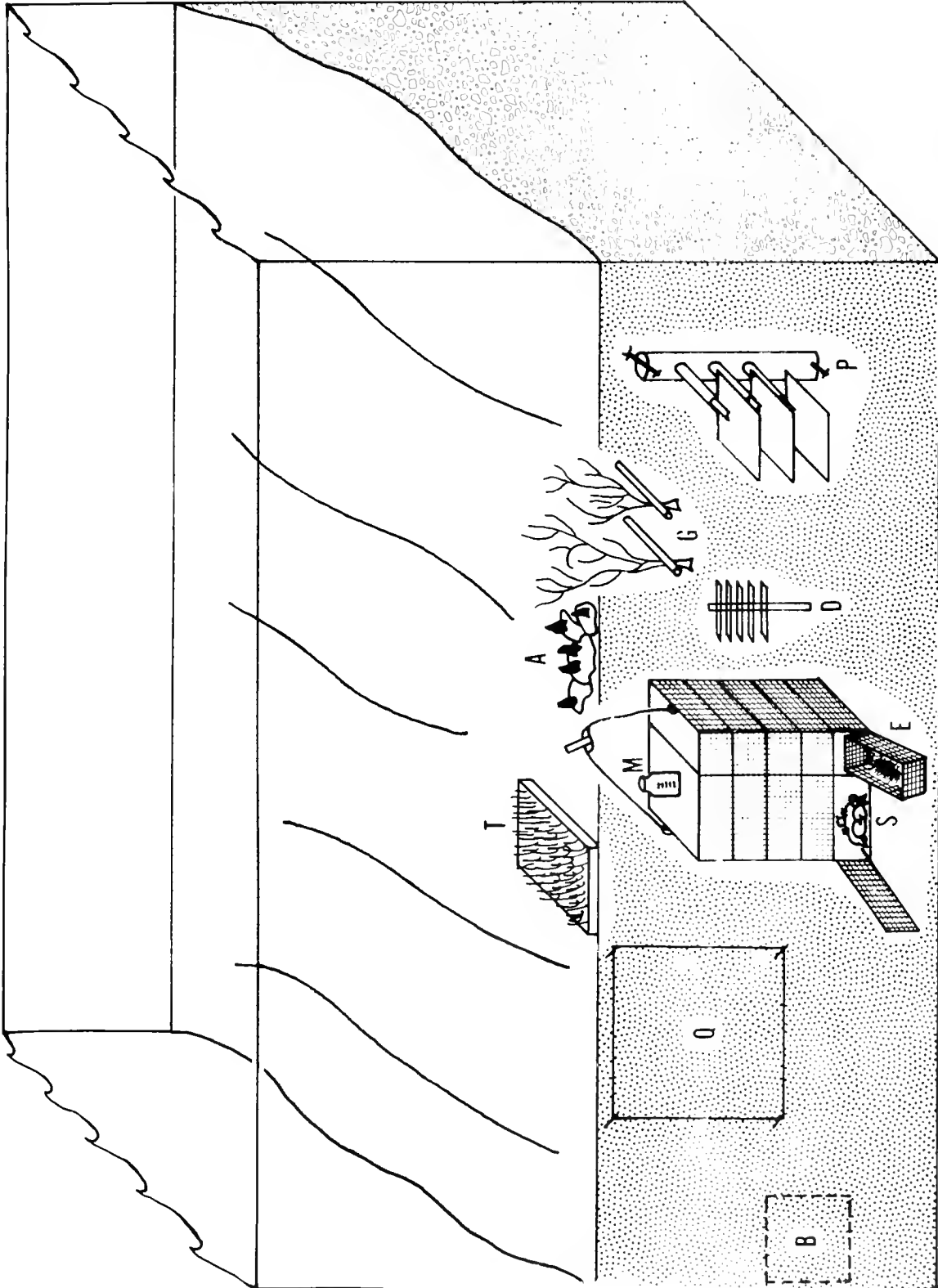

FIG. 4 SCHEMATIC OF BIOLOGICAL STATION INSTALLATION NEAR THE TOP OF A VERTICAL CANAL WALL. (B) BIOMASS SAMPLE AREA, (Q) 1m² QUADRAT, (T) TRANSPLANTED *LYTECHINUS* (SEA URCHINS), (A) TRANSPLANTED *THALASSIA* (SEA GRASS), (G) TRANSPLANTED *PTEROGORGIA* (SEA WHIPS), (M) SEDIMENTATION JARS, (S) *MENIPPE* CAGES (STONE CRABS), (E) *LYTECHINUS* CAGES (SEA URCHINS), (D) DIATOMETERS, (P) SETTLEMENT PANELS IN PVC HOLDER.

$$E = \frac{P_{st} - P_m}{P_e - P_m} \times 100$$

Thus, if the salinity of the effluent was 50.00 o/oo, and the receiving water had a salinity of 35.00 o/oo and Station 3C had a salinity of 36.00 o/oo, the percent effluent at 3C was:

$$\frac{36.00 - 35.00}{50.00 - 35.00} \times 100 = 6.67\%$$

This technique eliminated seasonal fluctuations and made measurements of the influence of the desalination plant comparable all year. It had some disadvantages, however. Percent effluent could only be determined when the plant was operating while the data were being collected. During the months when the plant was operating sporadically, it was difficult to obtain many estimates of the concentration of effluent at the stations.

Studies showed it took between 24 and 48 hours for the effluent to reach all stations in the harbor and a similar time for the effluent to disperse. During these times, the percentage of effluent was either increasing or decreasing at the stations and a sample at any one station would not necessarily be representative of effluent levels during these sampling periods. Therefore, data taken within 48 hours following a start-up period gave relatively unreliable results, especially for more distant stations.

Since discharging effluent was required for calculation of the percent effluent, data taken immediately after the plant shut down could not be incorporated in the monthly averages even though some effluent was still in the harbor. If the plant shifted its mode of operation, the shift was not reflected in the more distant stations for 24 to 48 hours and the calculated percent effluent was correspondingly wrong. When the plant operated continuously (as it did in the first portion of the study) the method worked exceedingly well. During months when the operations were sporadic and unstable the averages were less reliable.

A final problem was related to short-term differences that occurred between measurements made in the harbor and on the surrounding grass flats. During periods of rapid temperature or salinity changes, the characteristics of the water in the shallows changed more rapidly than in the deep water of Safe Harbor (due to the ratio of surface area relative to volume). Thus, water at the shallower stations occasionally had different characteristics from that which mixed with the effluent at depth. Because of this shallow-water effect, it was possible to obtain negative values for percent effluent present, at the shallower stations after heavy rains or when there was a rapid change in temperature.

Despite these difficulties, the method worked within acceptable limits. Figure 8 shows the mean monthly percent effluent at a station near the discharge with 90 percent confidence limits of the mean, and Figure 27

shows the fifteen month mean percent effluent at all Safe Harbor stations with 90 percent confidence limits. While the percentage of effluent was not within the accuracy expected for laboratory bioassays, it was generally within ± 1 percent and was adequate for *in situ* bioassay work.

The duration of the average percentage of effluent had to be included in correlations of biological and physical data. An effluent exposure index was devised by multiplying the average percent effluent times the number of days that average was present (i.e., the number of days the plant was operating during the period of exposure).

To increase the validity of the hydrographic data, all stations were sampled within two hours of taking the effluent and mixing water samples. Generally, Stations 1 through 3 were sampled first followed by the effluent samples, then the remaining Safe Harbor stations. Station 10, the control station, was sampled last. Physical and chemical measurements were taken on Mondays and Thursdays.

Water samples were collected adjacent to each of the twenty biological quadrats in a two-liter Plexiglas Van Dorn bottle manufactured by Hydro Products (Model No. 120). Sub-samples, used for salinity and alkalinity determinations, were decanted into polyethylene bottles having poly-seal stoppers and analyzed the same day they were taken. Sub-samples for dissolved oxygen measurements were placed in standard 300 milliliter BOD bottles with ground glass stoppers and immediately fixed with manganous sulfate, alkaline iodide, and sulphamic acid. Sub-samples for copper analyses were placed in aged polyethylene bottles and fixed for later analyses with two milliliters of Baker analyzed hydrochloric acid.

Temperature profiles were taken at each station by lowering a Yellow Springs Instrument Company Model 437A telethermometer from the surface to the bottom and recording temperatures to 0.1°C at two feet (0.6m) intervals. The telethermometer was calibrated with two Kahl Scientific Instrument Corporation thermometers and found accurate to within $\pm 0.1^{\circ}\text{C}$.

Salinity was determined with a Bisset-Berman Hytech Model 6220 salinometer. Oxygen determinations were made using a Hach Chemical Company oxygen kit. The powdered reagents for this kit were eminently practical, especially when adverse weather conditions made handling the samples difficult. Phenylarsene oxide supplied by Hach Chemical Company was used in the laboratory titrations.

Alkalinity was measured by a Hach Chemical Company alkalinity kit. Alkalinity was obtained directly as equivalent CaCO_3 in grains per gallon from burette readings at the end of titration (1.0 grain/gallon - 17.118 mg/liter or 0.34205 milli-equivalents of hydrogen ion per liter).

Copper analyses were made using the neocuperoine technique of Alexander and Corcoran (1967) summarized in Appendix A.

In situ, rapid determinations of effluent dispersion were made utilizing the unusual temperature inversion associated with the effluent stratum. Normally, temperature gradients decrease with depth (Sverdrup *et al* 1942) and thermoclines generally have colder water underlying warmer water. The hot, saline effluent, however, formed the reverse situation with warmer water under cooler water. This peculiarity enabled rapid identification of the effluent even at some distance from the plant. It could be detected easily in temperature casts with the electric thermometer and could also be felt by SCUBA divers. The surface of the temperature inversion was sufficiently well defined that a diver could swim above it and feel the hot water with his hand. The rapid density change also caused a visible, shimmering layer because of changes in the refractive index of the water.

On several occasions, effluent distribution throughout the harbor was plotted by divers swimming along the top of the submerged effluent stratum. In the first portion of this study, Rhodamine B dye was added to the effluent and its distribution traced by divers in the receiving water. This enabled analysis of the flow of effluent into the system and showed a self-insulating mechanism which is described below.

Thermal differences also enabled instantaneous analysis of the distribution of the effluent by use of a Westinghouse thermister net. The instrument consisted of fourteen cables deployed in the canal and connected to a single control unit with a three-dimensional light display. At the points indicated in Figure 5, the cables were connected to five thermisters buoyed at five-foot intervals from the bottom up to a depth of ten feet (3m). One strand (#5) continued to the surface to give data above the ten-foot level. All the cables were connected to a tie-down system so the array could be lowered to the bottom when not in use. Although normal boat traffic carried less than ten feet (3m) draft, occasional vessels drawing eighteen feet (5.5m) entered the canal. In addition, tugs and fuel barges on occasion tied up to the dock at the desalination plant which could have damaged the array.

Each of the 72 thermisters was represented by a small light bulb in a scale model of the canal. When the single control dial was set at a particular temperature all of the lights representing thermisters above that temperature lit up. By sequentially changing the dial setting, all of the isotherms in the canal could be viewed three-dimensionally. With the dial set at a particular temperature, an isotherm could be followed over several hours or days. In this way, one could watch the hottest portion of the effluent move through the canal as the plant began operation or as tides or winds shifted.

Initially, the cables were set in a rectangular grid pattern. This pattern was changed to provide greater coverage of the canal, particularly along the eastern portion, as this arrangement was more representative of the general movement of the stratum under normal conditions. The final arrangement, shown in Figure 5, provided readings along a

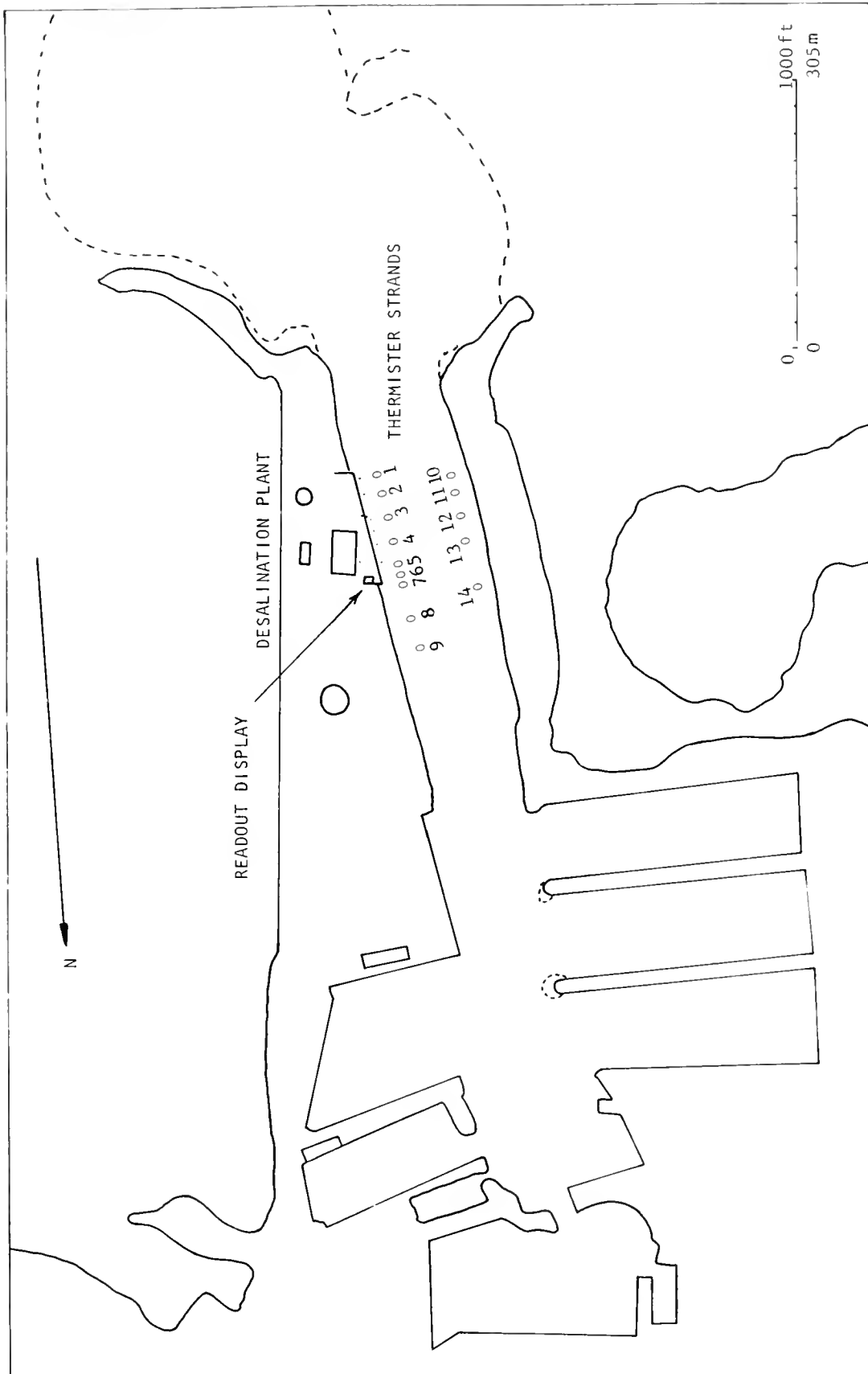

FIG. 5 LOCATION OF THERMISTER STRANDS IN SAFE HARBOR CANAL. FIVE THERMISTERS EXTENDED FROM THE BOTTOM TO A DEPTH OF TEN FEET IN FIVE FOOT INTERVALS. STRAND 5 CONTINUED TO THE SURFACE.

700-foot (213.4m) portion of the eastern half of the canal and a 450-foot (137.2m) portion of the western half.

The dispersion of effluent was also examined by analyzing copper concentrated in the sediments. Duke *et al* (1966) and others have shown that sediments concentrate trace elements from seawater. Since the effluent had more copper than ambient water, it followed that sediments exposed to the effluent would be correspondingly higher in copper than sediments not so exposed. Further, sediments are continually depositing and would bury older sediments and leave a continuous record of copper loading in the muddy bottom which could be traced back to conditions before the desalination facility was built.

Sediments were collected from 150 different locations in and around Safe Harbor. The samples were collected by SCUBA divers using Whirl-Pak polyethylene bags. These containers are inexpensive, compact, and have a wire rim at the opening which serves as a scoop and as a method of sealing the bag. Each sample was taken by opening the bag at the point of collection and carefully scooping up the surface layer of sediment (less than 1 cm in depth). Four separate sub-samples were taken per bag from each area to provide a composite sample of a larger bottom area. These samples were frozen for later analysis of total copper and foraminifera.

Core samples were taken at four locations to examine the history of copper levels back to before the plant was constructed. PVC pipe, three inches (6.4 cm) in diameter and three feet (1m) long, was used as the coring device. It was driven into the sediment, capped, and removed. The mud core was extruded with a piston and split in half longitudinally using a thin stainless steel knife. The different strata were noted for age determination later and sub-samples of the core were placed in Whirl-Paks for copper, nickel, and foraminifera analysis. The strata were aged using known data from the history of the construction of Safe Harbor, sedimentation rates from jars placed at all the stations, and by measuring the percentage water content in the upper layers of the sediments.

Safe Harbor is entirely man-made. Construction of the harbor was carried out over approximately ten years as shown in Figure 6. Whenever a bulkhead was installed or a portion of the harbor dredged for fill, coarse sediments were produced which formed strata clearly different from the normal fine sediments deposited in the basin. Coarse sand strata, therefore, offered useful datum planes in core samples for checking calculated ages.

The level where the coarse sediment left by the original construction of the harbor canal and the sediment which settled later is clearly delineated by the microscopic appearance of sediment particles and by the onset of seasonal cycles which have left numerous strata of varying tones of grey. The depth of this level in core samples demarcates the total amount of sediment which has accumulated since that portion of the canal was built.

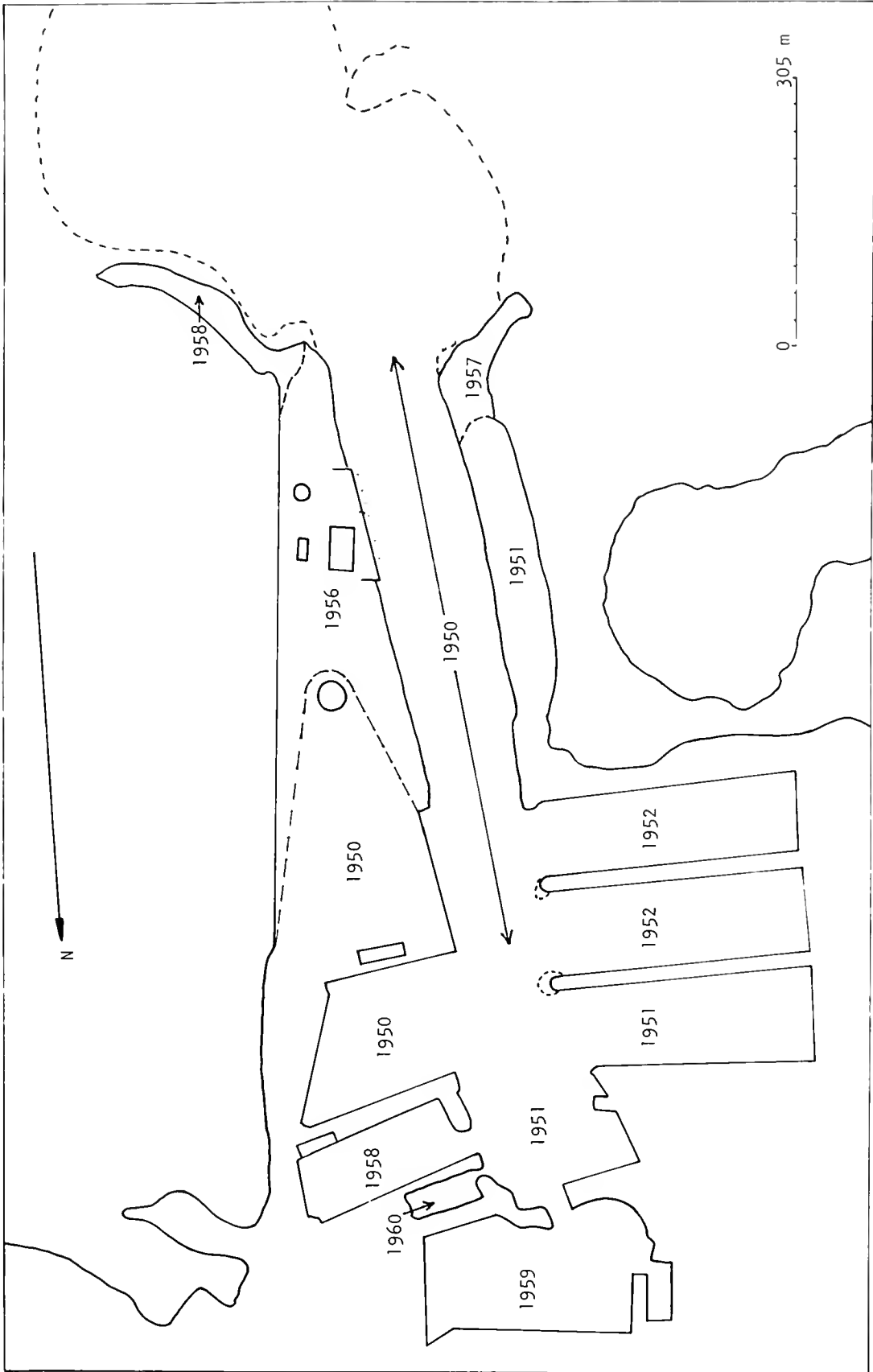

FIG. 6 DATES OF DREDGING AND FILLING IN SAFE HARBOR.

Compaction of the sediment in the core, however, was not uniform; the sediment near the core's surface contained much more water than the older, deeper sediments. By measuring the volume of water in successive layers of cores frozen immediately after collection, a correction was made for the changes in sediment density and a theoretical sedimentation rate calculated. This deposition rate was compared to sediment accumulated monthly in glass jars at the harbor stations and to coarse sand deposits in the sediment caused by dated dredging and filling activities.

A layer of coarse sand 5.25 inches (13.33cm) below the existing surface of the sediment near the desalination plant corresponded well to the calculated depth of sediment that should have deposited since the desalination plant sea wall was constructed in 1967.

BIOLOGICAL INVESTIGATIONS

Two approaches were used in the design of the biological work. The major emphasis of the biological program was *in situ* investigations of the effects of the desalination plant effluent. Laboratory bioassays were conducted to isolate the more toxic features of the effluent, but were strictly an aid to interpreting the *in situ* data.

The harbor itself formed the basis for a large scale toxicological study. Three lines of investigation were used to take advantage of this opportunity; data were collected from selected quadrats and transects, new surfaces for the settlement of diatoms and larger organisms were examined, and selected organisms were transplanted to sites where effects of the discharge on individual specimens could be followed.

QUADRAT AND BIOMASS SAMPLES

One-meter square quadrats were roped off at each of the twenty stations. To achieve comparable data, the stations were set on the vertical calcarenite walls of the canal area; one quadrat near the top of the wall and one near the bottom. Divers recorded the organisms present in each quadrat once a month. Near these quadrats divers took monthly $0.1m^2$ samples of the substrate for biomass analysis. Species found at each of the stations were tabulated both from quadrat and biomass collections.

Diversity was calculated using Margalef's proposed index (Margalef 1957). This index was selected since the mathematical weighting of the sample is related to the concept of entropy in the third law of thermodynamics. It satisfactorily accounts for species present and

their relative abundance without being heavily biased by the large numbers of serpulids which inhabited many of the stations. The Margalef diversity index can be designated as an index of dominance diversity (Whittaker, 1965) since it indicates the numerical percentage composition of the species present in the sample (Sanders 1968). The more species are represented by equal numbers of individuals the more diverse the fauna. When the numbers of individuals in the various species differ greatly (i.e., when some species greatly dominate the sample) the sample is less diverse.

Dominance diversity, therefore, is a measure of how equally or unequally the species divide the sample. The formula for Margalef's diversity index (Margalef 1957) is:

$$I = \sum P_i \cdot \ln P_i$$

Where I is the dominance diversity index, P_i is the number of organisms in species i divided by the total number of organisms in the sample, and $\ln P_i$ is the natural logarithm of P_i .

The structure of the animal populations in the quadrats were compared with each other and ranked by similarity using the Bray and Curtis (1957) similarity coefficient modified of Pearson *et al* (1967).

The prominence value (PV) of Pearson *et al* (1967) was changed slightly using the formula $PV = AF$ rather than $PV = A(F)^{1/2}$ where A is the average number of individuals of a particular species and F is the frequency of occurrence. Thus, if an organism had an average abundance of 500 specimens per square meter but was present only twenty percent of the time, its prominence value would be 100. Since this figure represents the average abundance of the organism with its absence during any given month included in the average as 0, it was felt more realistic and meaningful than the arbitrary use of $(F)^{1/2}$.

Once prominence values were calculated for each species present at the station, these were summed. The stations were compared to each other by determining the minimum percentage of individuals of each species shared in common using the formula given by Pearson *et al* (1967):

$$S = 2W/(a + b)$$

Where S is the similarity index, a and b are the sums of the prominence values of the two stations being compared, and W is the sum of the smallest prominence values for each species shared in common. This index varies from 0 when no two species are shared in common to 1 where both stations have identical population structures.

Quarterly samples of sediments were collected from all stations for analysis of foraminifera (shelled, microscopic protozoans). Divers

scooped about 100 cc of the upper 1 cm of sediment into Whirl-Pak bags and these were preserved in alcohol.

Each sediment sample was placed in a 100 ml graduated cylinder and allowed to settle two hours before its volume was recorded. The sample was then wet sifted through a U.S. Standard 63 micron mesh sieve, replaced in the 100 ml graduated cylinder and the new volume recorded. After transfer to a petri dish, an aliquot was spread evenly on a microscope slide until there was only a single layer of sediment. This was examined wet under a 40X compound microscope with transmitted light. A mechanically operated stage permitted the entire slide to be examined systematically.

The four major species of foraminifera were sorted and a fifth category, "others", recorded. Live specimens, characterized by proto-plasm inside the chambers, were recorded separately from dead specimens. Aliquots were examined until over 100 live specimens were recorded. The volume of each aliquot was measured in a water-filled 1 cc graduated cylinder calibrated to 0.01 cc.

The number of live specimens in 1 cc of the original sample was calculated from the formula:

$$L_o = \frac{L_c V_s}{V_c V_o}$$

Where L_o = live foraminifera per cc of original sample, L_c = number of live specimens counted, V_c = volume examined, V_s = volume of sifted sample, V_o = original volume.

TRANSECTS

Each month, divers swam two transects; one along the desalination plant sea wall, and the other along the pilings of the City Electric property 393.6 feet (120m) farther into the harbor. Distributions of lobsters (*Panulirus argus*), stone crabs (*Menippe mercenaria*), sea squirts (*Ascidia nigra*), bryozoans, serpulids, barnacles, and macroscopic algae were recorded on plastic slates. Observations included the entire wall of the canal from the inter-tidal zone to the soft sediment about twenty feet from the surface. To equate the data collected on these transects, they were reduced to numbers of organisms per one hundred feet (30m) of sea wall.

In addition to the transects in Safe Harbor Canal, a series of transects were made both east and west of the turning basin. Ten 100 m² transects were made 100 meters apart beginning on the edges of the turning basin as shown in Figure 35. The transects were made using

a 50-meter nylon line stretched and anchored at both ends along the transect path. Two one-meter long wooden dowels were attached at one end with eye bolts to the line. Divers swam the length of the nylon line with the dowels held at right angles to the line and at the level of the base of the turtle grass. Echinoids were counted as the dowels turned them over along the 50m transect. *Lytechinus* and *Tripneustes*, with similar ecological and morphological characteristics, were counted together and *Diadema* was counted separately.

PLANKTON TOWS

Four plankton tows were taken monthly; two at Station 9 in the turning basin and two along the desalination plant sea wall. At both locations one tow was taken at 6 feet (1.8m) depth and another at 28 feet (8.5m). A 0.1m² plankton net with 50 meshes per cm (125 per inch) was towed 100 meters by a SCUBA diver, thus filtering 10m³ of water. At the end of each tow the net was sealed off at depth and the sample transferred to a Whirl-Pak and preserved with alcohol. The entire sample was later reduced to 10 ml by allowing it to settle in a graduated cylinder for four hours and siphoning off the supernatant fluid. The remaining sample was then mixed thoroughly, sampled, and the plankters counted on a Palmer counting cell. Data were recorded as numbers of cells or zooplankters per m³ of original sample.

To determine effects of effluent on plankton populations, the tows at Station 9 were used as controls for the tows made in front of the desalination plant. The two shallow tows and the two deep tows were compared with each other and the number of plankters found at the desalination plant expressed as percentages of the Station 9 tows. Station 9 (600 meters south of the desalination plant) was similar, topographically, to the canal in front of the plant discharge. Since water from Station 9 generally moved into the harbor the plankton population should have been similar at both locations. Differences between Station 9 plankton populations and the canal were attributed to effluent effects. Tows were made in front of the desalination plant with effluent present and after the plant had been shut down for several days for confirmation of the similarity of plankton populations.

SETTLEMENT PANELS AND DIATOMETERS

Wooden settlement panels and glass diatometers were placed at selected stations in Safe Harbor and in the control area and recovered at periods ranging from two weeks to two months. The panels were settled by organisms which survived the effluent during larval,

metamorphosing, juvenile, and young adult stages. Settlement panels were valuable biological integrators which provided an easily quantified sample. Since the surface area and time exposed were constant, various parameters, including species diversity, density, and growth, could be determined and compared directly between stations.

Settlement panels were 0.05m² squares (about 9 inches x 9 inches) of 1/4 inch untreated plywood. They were attached to PVC racks at Stations 2A, 2B, 3A, 3B, 3C, 5A, 5B, 6A, 6B, 7A, 7B, 10A, and 10B. Each rack held three squares and each month two were collected and two replaced. By rotating one panel, each monthly collection had one panel exposed for thirty days and one exposed for sixty days. Panels were collected in individual labeled polyethylene sacks and analyzed the same day.

Settlement panels were examined for larger invertebrates and these counted and recorded as to their position on the top or bottom of the panel. A 0.005m² plastic grid was then randomly placed on the panel and the smaller organisms counted. During some months, serpulid settlements were so thick that it was not practical to count the whole 0.005m². During these periods, five 1cm² sub-samples were marked off and the serpulids counted under a dissecting microscope.

Diatometers consisted of five glass microscope slides held in a PVC rack at Stations 3A, 3C, 7A, 7B, 10A, and 10B. Benthic diatoms, protozoans, and a variety of invertebrates settled on the slides. Every two weeks the slides were collected and replaced with new ones. The organisms on the exposed slides were counted under a compound microscope using a grid divided into 0.01mm units. Diatom and protozoan species and numbers of individual cells were recorded. Other organisms (i.e., barnacles, serpulids, etc.) were noted as present or absent.

TRANSPLANTS

To assess the impact of the effluent on individuals of selected species, specimens were transplanted into particular effluent regimes and their survival and growth noted. Sea squirts (*Ascidia nigra*), sea whips (*Pterogorgia anceps*), turtle grass (*Thalassia testudinum*), stone crabs (*Menippe mercenaria*), and sea urchins (*Lytechinus variegatus*) were moved from neighboring flats to harbor and control stations. The first two are filter feeding, attached organisms, the last two are motile benthic organisms (*L. variegatus* is herbivorous and *M. mercenaria* is carnivorous).

Previous work (Clarke *et al* 1970, Chesher, unpublished data) showed stone crabs were relatively resistant to the effluent and sea urchins, sea squirts, and sea whips were highly sensitive to the effluent.

Since the filter feeders required little maintenance, they were placed at more stations (2A, 2B, 3A, 3C, 5A, 5B, 6A, 6B, 7A, 7B, 10A, and 10B). Stone crabs and sea urchins had to be confined in specially built cages and required feeding three times per week, consequently, they were limited to Stations 3A, 3C, 7A, 7B, 10A, and 10B.

The sea whip, *Pterogorgia anceps*, is a common, nearshore, Caribbean horny coral, which was known to be sensitive to the effluent. Large numbers of *P. anceps* were located east of the turning basin in two to three meters of water. They were pried loose from the substrate and mounted in PVC holders. Two-foot (60cm) lengths of half inch diameter (1cm) PVC pipe were split longitudinally for about three inches (8cm) and the bases of the sea whips forced into the splits. The elasticity of the PVC clamped the stalks firmly enough to hold the colonies in place. At the designated stations, the free end of a holder was forced into the sediment or into the coral wall. Two specimens were placed at each station and divers checked their condition twice a week. Dead colonies were replaced monthly.

Sea squirts (*Acidia nigra*) are filter feeding tunicates and were extremely common in the Key West area. Specimens were collected attached to loose rocks and moved, along with their rocks, to the biological stations. Five specimens were placed at each station. Unfortunately, whenever a specimen was bruised or otherwise damaged, it was almost immediately attacked and eaten by fish at the station. Because of their susceptibility to predation, they yielded poor data as transplant organisms.

Turtle grass (*Thalassia testudinum*) was also vulnerable to predator pressure. Because of the dearth of algae and turtle grass near the Safe Harbor biological stations, herbivorous fish rapidly cropped transplants to the roots. While the roots survived for a time, the intensity of fish feeding prevented regrowth and the transplants died. At the control station, turtle grass survived the transplantation for the entire study period.

Stone crabs (*Menippe mercenaria*) were easily maintained in experimental cages but specimens were periodically released by sport divers. On several occasions the cages were found opened and empty. A sign reading, "Danger, Poison, U.S. Government Survey, \$1,000 fine for tampering", was placed on the cages and the releases stopped for several months. There were five stone crabs located at each station. Three times per week the stone crabs were fed either fish or squid by SCUBA divers. Missing or dead animals were replaced every month.

Sea urchins (*Lytechinus variegatus*) were maintained in individual cages and fed turtle grass three times per week. Escapes were rare and sport divers did not molest the cages. Dead urchins were replaced as they died for the first few months and then every month for the remainder of the study.

Stone crab and sea urchin cages were constructed from plywood and steel hardware cloth. They survived eighteen months in the field and provided additional data on wood boring organisms when dismantled.

Experimental animals were collected from outside the harbor area by SCUBA divers. To minimize damage to the organisms, they were handled as little as possible and transplanted to the cages and holding sites within a few hours of collection. Effects of the transplantation techniques were evaluated from survival at the control station (Station 10).

LABORATORY BIOASSAY

Laboratory 96-hr TLm acute bioassays were conducted on the same species used for the *in situ* bioassays to determine the relative toxicity of the fresh effluent from the desalination plant and to isolate the most toxic features of the effluent. The experimental design used is shown in Figure 7. The experiments began by conducting static 96-hr TLm acute bioassays (Doudoroff *et al* 1951) of fresh effluent in 50 liter, all glass aquaria. A wide range of effluent dilutions, plus a control, assured sufficient data points to make the interpretation valid.

Each dilution contained ten experimental animals and the 96-hr TLm experiments were run at least twice to obtain replicate data. Samples of the effluent dilutions were taken daily to ascertain levels of oxygen, pH, copper, salinity, and temperature in the aquaria.

The experiments were complicated by the variability in copper content of the effluent and by the unpredictable operation of the desalination plant. Obviously, if the plant shut down on a day when effluent was needed for the bioassays, the experiment had to wait until the plant resumed operation and became stabilized.

Following the determination of the 96-hr TLm dosage, a second experiment was set up to isolate the major parameters of the effluent to determine which parameter was most toxic (Fig. 7). Copper, salinity, and temperature were independently elevated in normal, filtered seawater to a level comparable to that found in the 96-hr TLm effluent dilution. 96-hr TLms were then conducted for these individual parameters. Salinity was raised by the addition of artificial dried seawater salts, copper was raised by the addition of copper sulphate salts and temperature was raised by thermostatically controlled, glass protected heating units.

Bioassays on the turtle grass, *Thalassia testudinum*, were conducted using

STEP 1

A series of aquaria containing various dilutions of the effluent in seawater were set up to determine the 96-hr TLM. Numbers indicate percentage dilution factors.

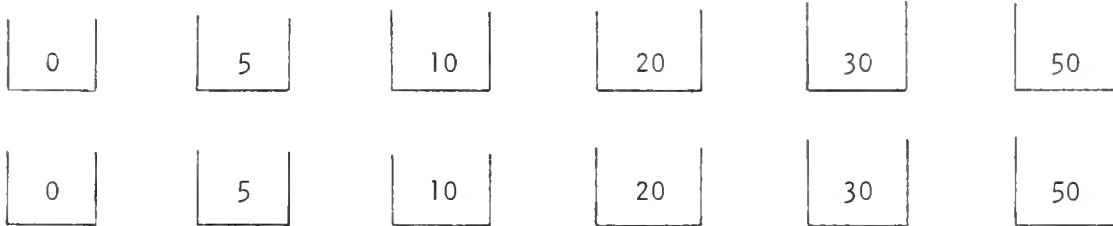

STEP 2

A second series was set up to find the most toxic element of the discharge using the 96-hr TLM dilution determined in Step 1 as a base. Temperature, salinity, and copper were the three factors examined.

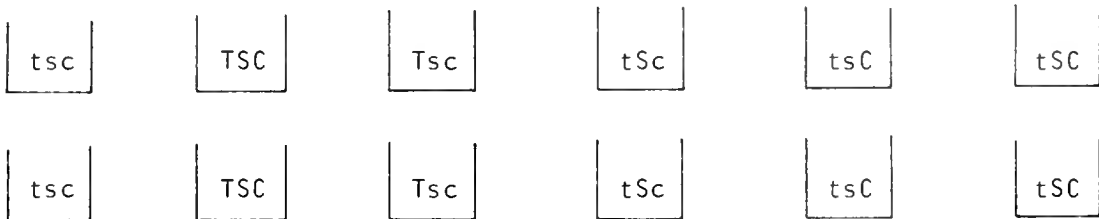

Seawater	Effluent at 96-hr TLM dilution	Seawater w/temp. elevated	Seawater w/salinity elevated	Seawater w/copper elevated	Effluent w/reduced temperature
----------	--------------------------------------	---------------------------------	------------------------------------	----------------------------------	--------------------------------------

96-hr TLM Parameters

T = Temperature
S = Salinity
C = Copper

Ambient Seawater Parameters

t = temperature
s = salinity
c = copper

FIG. 7 BIOASSAY EXPERIMENTS

s similar analytical approach but a different experimental setup. Freshly cut, clean, turtle grass was suspended in 500ml Erlenmeyer flasks. Photosynthetic rates were measured by oxygen production monitored continuously by an IBC Model 170 oxygen analyzer. The samples were stirred by magnetic stirring bars. Illumination was kept at a constant 1,000 lux using fluorescent lights.

To prevent oversaturation of the sample water with oxygen, the filtered seawater used during the experiment was scrubbed with nitrogen for one hour, lowering the oxygen content to less than 1 mg per liter (five percent saturated). Oxygen was normally low in the effluent and this did not require treatment.

After a two hour photosynthesis history was obtained for each lot in filtered seawater, toxicants were added and photosynthesis monitored for twenty-four hours. Toxicity was measured as the amount of contaminant required to lower the photosynthetic rate by 50 percent after twenty-four hours of exposure (Goldman, 1966, A.S.T.M. 1964, Wetzel, 1966, Clendenning and North, 1960).

GRAPHIC TECHNIQUES

Most of the graphic techniques used in the report are conventional and need no explanation. To compare numerous data points for the several stations involved for a complete year's cycle required use of circular graphs (Fig. 8). While circular graphs are in widespread use for data recording, they have not frequently been used for data reporting.

By dividing the graphs into twelve radii, each representing a calendar month and arranged as the hours on a watch, average monthly data can be compactly presented. Circular graphs are also useful in presenting data for comparison of one factor versus another. The shapes of the polygons formed by the graphs are representative of general trends and can be visually compared with one another when presented together. Thus, having data from all stations represented on one page (see Fig. 26, page 78) enables the reader to compare trends from one station to the next at a single glance. A critical look at Figure 26 yields the following observations:

1. The percent effluent at the shallow stations (the unshaded, center portions of the graphs) is negligible compared to the amount at the deeper stations (outer portions of the shaded area).
2. The amount of effluent is relatively constant at Stations 2 through 6 and erratic at the more distant stations.

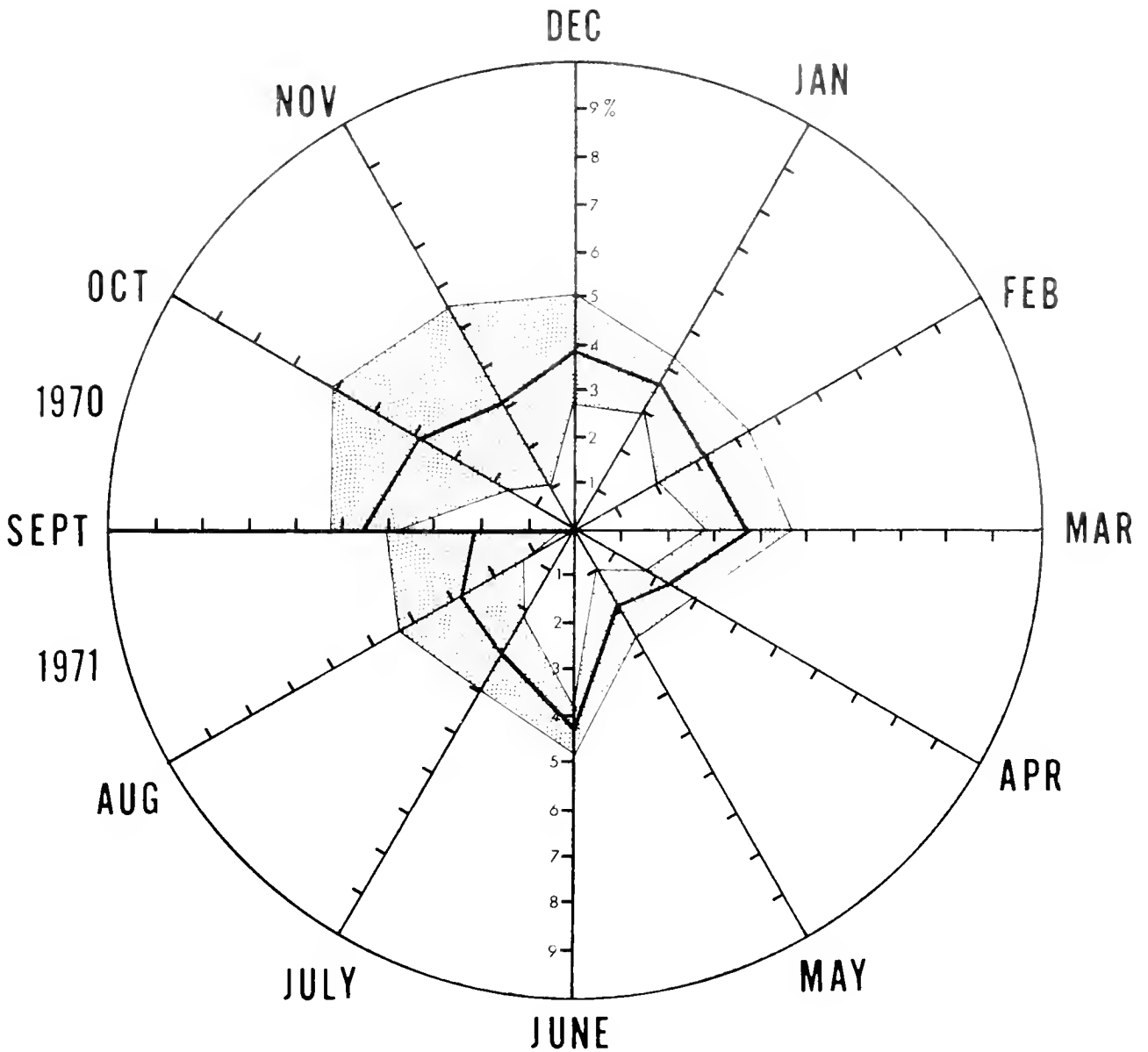

FIG. 8 MONTHLY MEAN PERCENT EFFLUENT AND THE 90 PERCENT CONFIDENCE LIMITS OF THE MEAN AT STATION 3C, 73m (240 FEET) FROM THE DISCHARGE OF THE DESALINATION PLANT.

3. The percent effluent has decreased slightly at the stations during the year's cycle.
4. There was more effluent at Stations 2 through 6 than elsewhere in the harbor.

Use of circular graphs also permits presentation of all the monthly operating data of the desalination plant on a single page (see Fig. 10, page 46), and monthly averages of pertinent ambient conditions on a single page (see Fig. 11, page 47). The cyclic nature of the average temperature and salinity and the noncyclic nature of the depth of the effluent stratum and of copper concentration in the harbor are clearly shown in Figure 11. Comparison of the shape of the shaded curves of salinity and the depth of the effluent stratum shows these two factors follow a similar pattern during the year, whereas changes in temperature are not reflected in changes of the depth of the effluent stratum.

SECTION V

SAFE HARBOR

BATHYMETRY

Safe Harbor is a man-made harbor built primarily for the shrimp boat fleet. It is divisible into four parts; an approach channel, turning basin, entrance canal, and series of embayments for docking boats. It was built in several stages between 1950 and 1960 (Fig. 6). Except for some of the inner basins the harbor was dredged to a depth of about 30 feet (9m) by shore-operated draglines.

The gently undulating floor of the harbor is covered with fine calcium carbonate silt and the vertical walls are coral rock encrusted with various organisms. Figure 9 shows the bottom topography as determined from fathometer tracings. The average depth of the harbor and turning basin is 22.6 feet (6.89m). Depths of 35 feet (10.67m) are found in two of the marina basins and in the turning basin. Thirty-foot (9m) depths occur in all marinas and along the edges of the entrance canal from the southern side of the City Electric dock to the turning basin. All of the 30-foot (9m) deep basins are surrounded by shallower bottom. They communicate with each other above the 25-foot (7.62m) level but are cutoff from the open sea by an 18-foot (5.49m) sill in the channel dredged across the shallow flats to the south of Stock Island. Thus, the water within the turning basin and harbor at depths greater than 18 feet (5.49m) circulated poorly.

WATER CIRCULATION

During the study, winds from the southeast moved surface water into the harbor. Most of this water, and water brought in by the flood tide, came from flats to the east of Safe Harbor. Current flow in deep water in the entrance canal was predominantly out of the harbor. On some spring flood tides, the current reversed on the bottom or stopped completely. Currents were imperceptible in harbor embayments at depths greater than 30 feet (9m) and anoxic conditions occasionally occurred. Surface currents inside the harbor and on adjacent shallow water flats were wind-driven with little or no tidal influence. Clarke *et al* (1970) provide additional wind and current data for Safe Harbor.

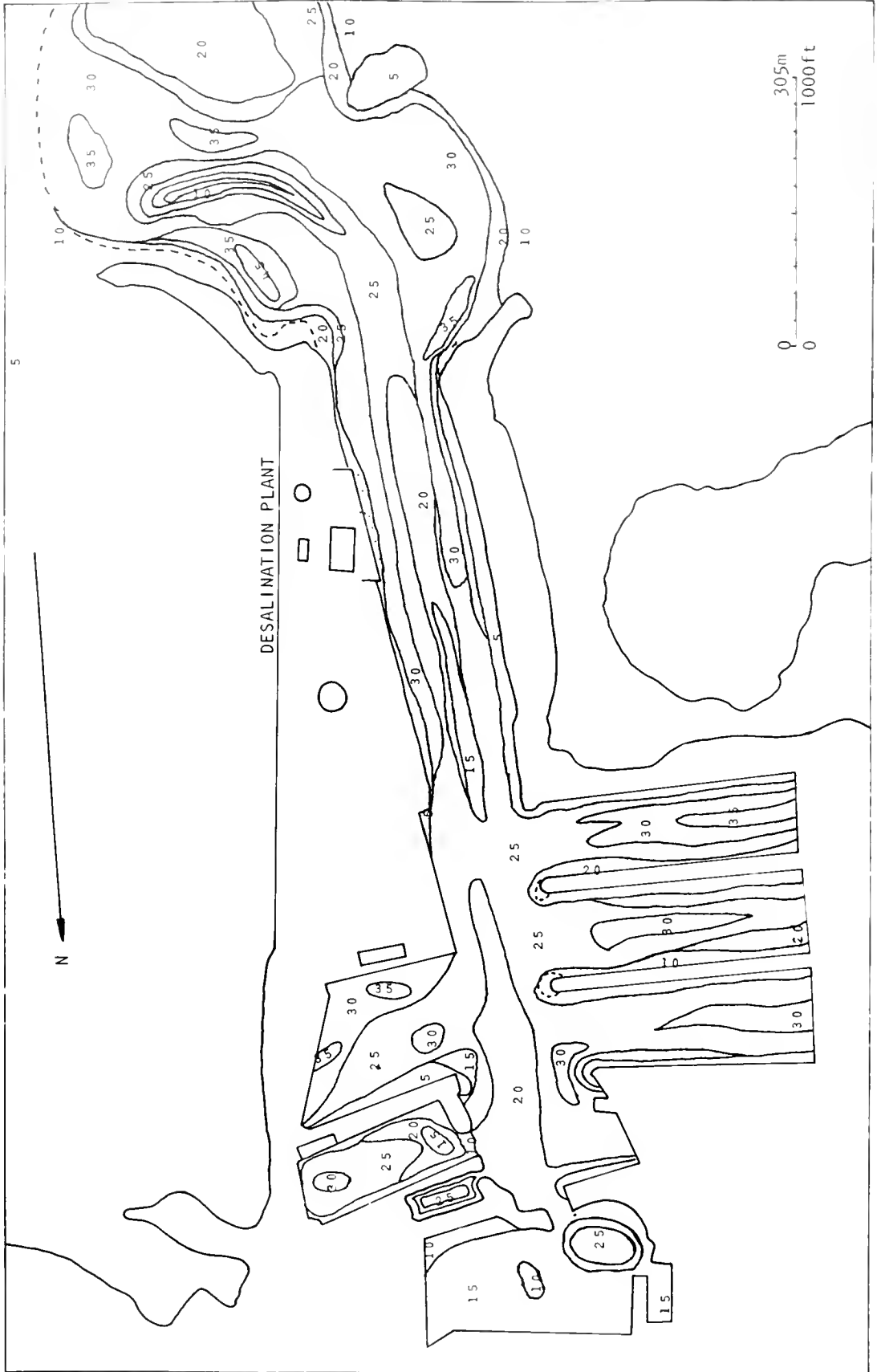

FIG. 9 BATHYMETRY OF SAFE HARBOR. DEPTHS IN FEET AT MEAN SEA LEVEL.

TIDAL FLUSHING

The total surface area of Safe Harbor was 4.48 million square feet (0.416 million m²) and its volume was 101.78 million cubic feet (2.88 million cubic meters). The mean tidal exchange was 1.2 feet (0.366m) (ESSA Tide Tables, 1970) and thus the mean tidal flushing was 5.38 million cubic feet (0.15 million cubic meters) of water per mean tidal cycle or 10.76 million cubic feet (0.3 million cubic meters) per day. During spring tides, tidal flushing increased to about 13.45 million cubic feet (0.38 million cubic meters) per day.

SEDIMENTS

Calcuim carbonate silt was 8.6 feet (2.6m) thick in the entrance canal in front of the desalination plant and only 4.5 to 3.5 feet (1.4 to 1.1m) thick in the inner harbor. Sediments in depths shallower than 25 feet (7.6m) generally had a covering of white or brown mud while those at greater depths often had a covering of black silt; the black color derived mainly from H₂S, copper and iron sulphide. These compounds formed because of poor water circulation in depths greater than 25 feet (7.6m), particularly during summer when there was strong thermal stratification of the water column. During the summer months, the water in these deep pockets was characterized by low oxygen, low temperature, high H₂S content, and high water clarity. Core samples of sediment taken to bedrock showed horizons of hydrogen sulfide present in the sediments in the past. This anoxic layer was not present from November, 1970 to May, 1971 and during that time the sediment was light grey.

SECTION VI

PHYSICAL PARAMETERS

DESALINATION PLANT OPERATION

Figure 10 shows monthly averages as well as high and low values for various operating parameters of the Key West desalination plant. The total volume of effluent discharged decreased during the study period as did the number of operating days per month. Effluent temperature averaged 35°C during the entire period. The pH averaged 7 with a range of 3.2 to 8.5. Salinity varied more than other parameters, averaging between 48.00 and 53.00 o/oo with a range of 40.00 to 55.00 o/oo. Copper discharge varied between 148 ppb to 6,515 ppb. It increased from a mean of about 1,000 ppb in June, 1970 to a mean of 2,656 ppb in January, 1971. In June, 1971 engineering changes drastically lowered the copper output and in August, copper concentration reached a minimum mean value of 425 ppb. Discharge of heavy metals is discussed further in the section below on copper and nickel.

AMBIENT CONDITIONS

Temperature, salinity, and copper data from all stations were pooled to present overall monthly averages (Fig. 11). Temperature steadily decreased from August, 1970 to February, 1971 then increased again through August, 1971. Salinity declined in October and November, 1970 reaching a low of 34.60 o/oo in November. From then until May, 1971 salinity increased to high ambient levels with a peak of 38.00 o/oo in April. During that time South Florida experienced a prolonged drought with little cloud cover. Lack of precipitation and long hours of sunshine (also plotted in Figure 11) explain the high ambient salinities.

EFFLUENT DISTRIBUTION

Distribution of the effluent was studied using Rhodamine B dye, direct observation while diving, thermal mapping, salinity data, and heavy metals distributions in the sediments (see Section IV Methods and Procedures).

FIG. 10 MONTHLY OPERATING PARAMETERS OF THE KEY WEST DESALINATION PLANT FROM AUGUST, 1970 TO AUGUST, 1971. (MEAN, HIGH, AND LOW VALUES PLOTTED EXCEPT VOLUME AND OPERATIONAL DAYS.)

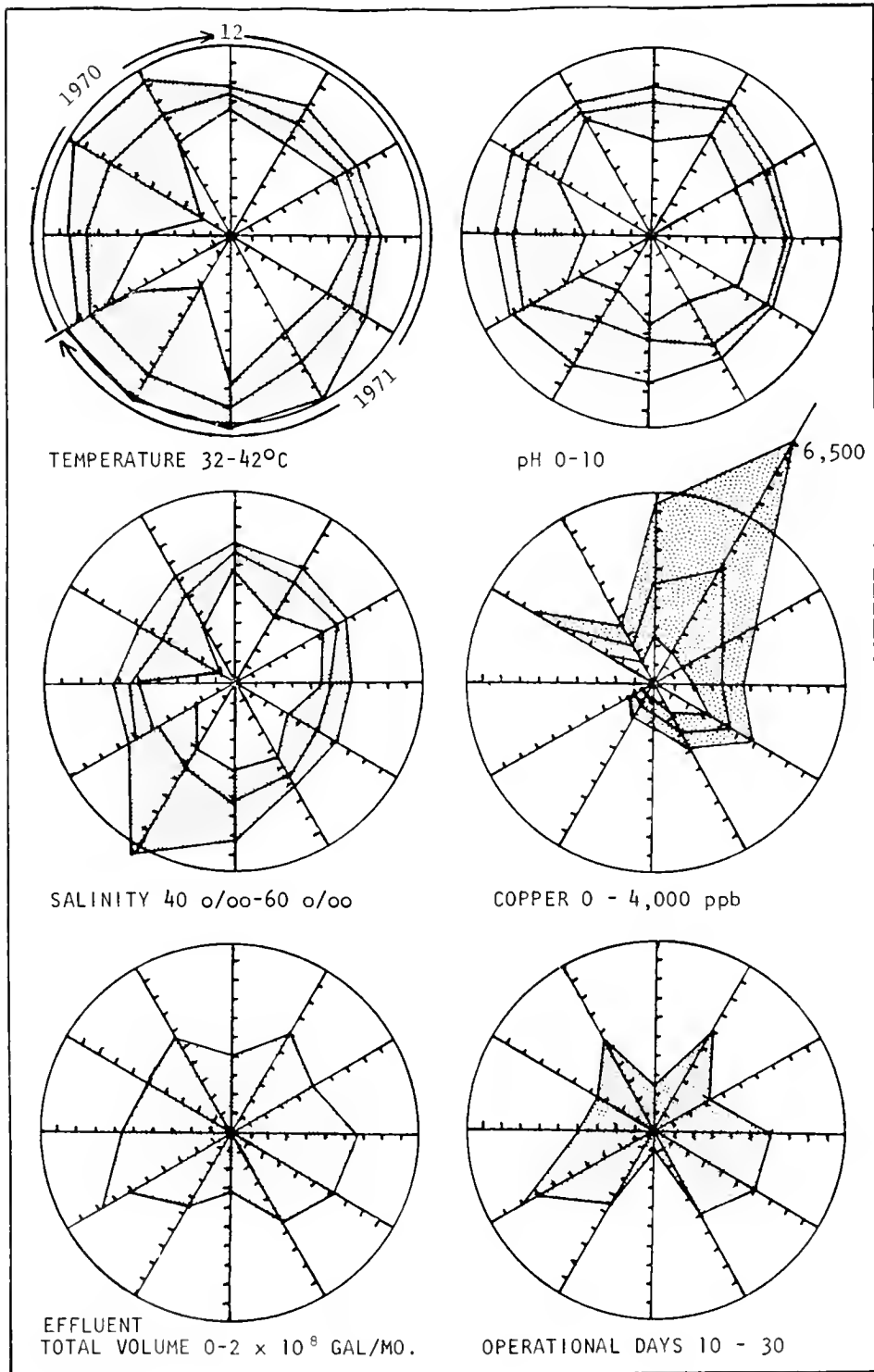

Each radius is numbered as the hours on a watch and represents that month. Values are read from the center to the circumference.

FIG. 11 AVERAGE MONTHLY PHYSICAL PARAMETERS FROM ALL STATIONS IN SAFE HARBOR FROM AUGUST, 1970 TO AUGUST, 1971.

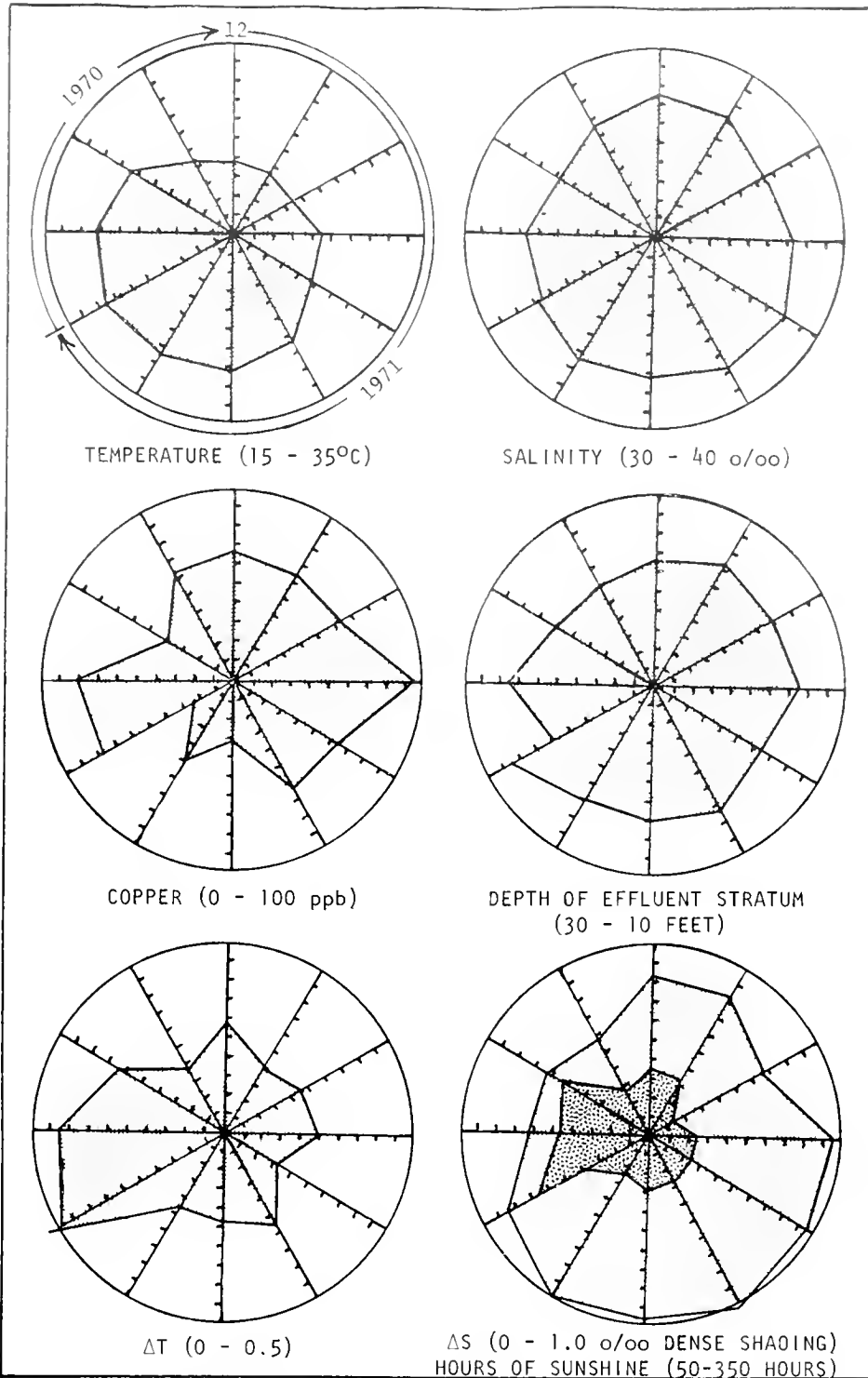

Each radius is numbered as the hours on a watch and represents that month. Values are read from the center to the circumference.

DISTRIBUTION AT POINT OF DISCHARGE

Dye studies showed two distinct plumes. The majority of the discharge mixed with ambient water and sank to the bottom of the canal scouring the silt from the canal wall. It fanned out to form a hot, high-saline layer which spread west and northwest along the bottom. At the point of discharge, a smaller portion of the effluent was carried to the surface by entrained air bubbles. Within 60 feet (18m) the bubbles escaped and the upper plume sank to lie on top of the layer formed by the lower plume. A large portion of the upper plume circulated around a group of pilings adjacent to the discharge pipe and was entrained into the effluent jet and carried to the bottom.

The effluent was diluted by surface water entrained at the point of discharge. Since surface water to the north of the discharge pipe consisted of effluent circulating around dolphin #4, the majority of ambient water that mixed with the effluent came from south of the discharge, along the eastern edge of the canal. By the time the effluent reached equilibrium depth it was diluted approximately twenty times with ambient seawater.

DISTRIBUTION OF THE EFFLUENT STRATUM

The effluent, after the initial turbulent flow to the deeper water of the canal, spread throughout the harbor and turning basin. There was little vertical mixing and the effluent retained its heat and salinity characteristics throughout the harbor to a point about 600 meters beyond the outer rim of the turning basin. Figure 12 shows the average increment in temperature (ΔT) and salinity (ΔS) associated with the effluent layer. The similar distribution of the two values demonstrates the conservation of temperature in the system. Greater temperature differences were found between points separated six inches vertically than between points over one kilometer apart horizontally. One rapid survey of the effluent stratum at a depth of 20 feet (6m) showed a temperature of 31.6°C at the inner end of the canal, 31.6°C directly in front of the discharge, and 31.6°C at the outer rim of the turning basin. The temperature increased from 30.6°C to 31.6°C in only six inches at the stratum-ambient water interface.

The effluent layer required constant discharge from the plant to remain stable. When the plant was operating, the effluent stratum was insulated in two ways. Because of the sill surrounding the harbor, the upper layer of water moved out of the harbor faster during ebbing tides than the lower layer containing the effluent. The most recent discharge from the desalination plant was less dense than older effluent

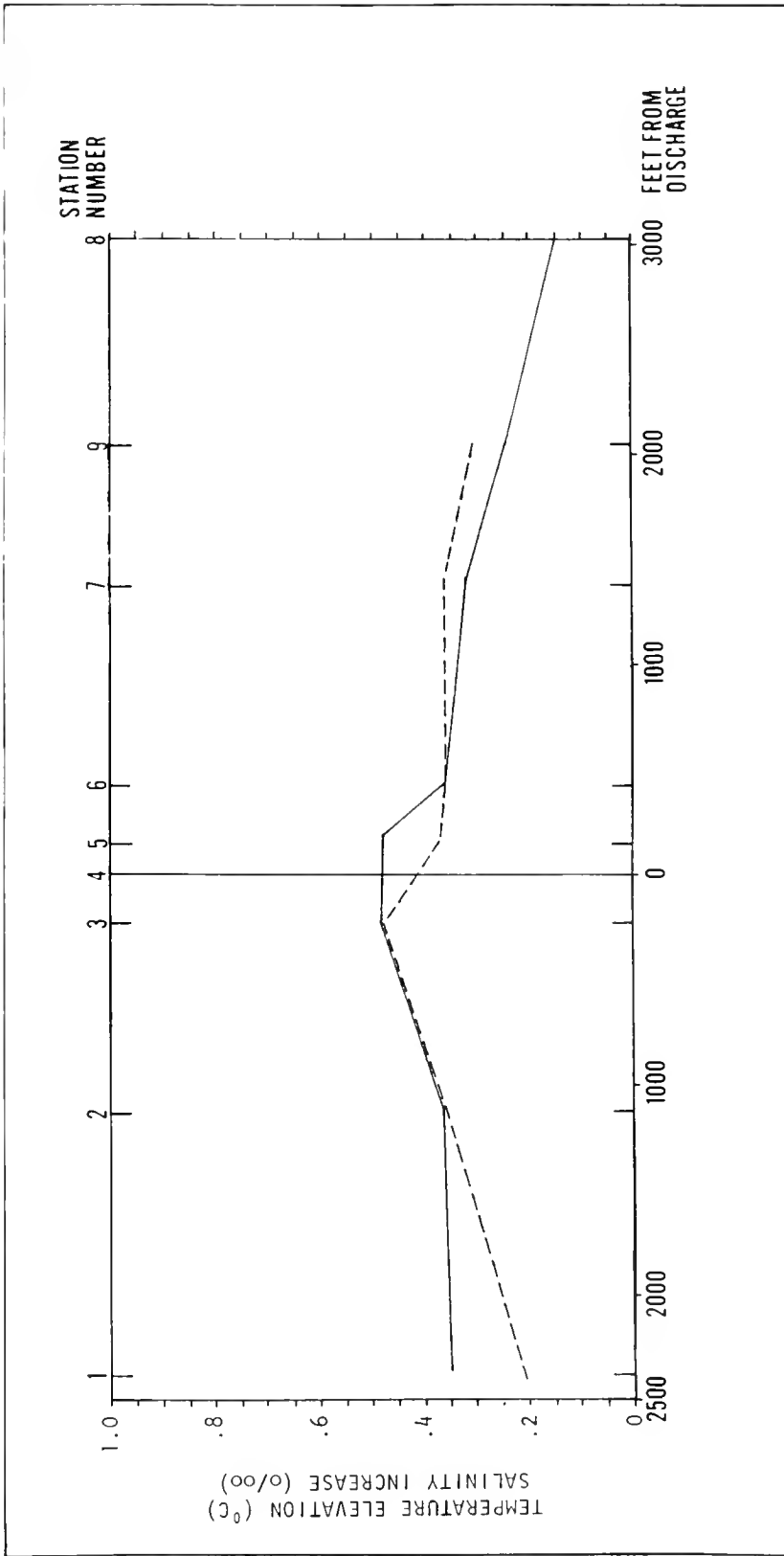

FIG. 12 TWELVE MONTH AVERAGE OF THE RISE IN TEMPERATURE (SOLID LINE) AND SALINITY (BROKEN LINE) CAUSED BY THE DESALINATION PLANT EFFLUENT AT ALL STATIONS IN SAFE HARBOR.

due to its higher temperature. Thus, it would lie on top of, and move over, the older effluent water. Dye studies clearly showed the formation of this midwater layer of lighter effluent and its moving out of the harbor on ebbing tides. This layer acted as a buffer zone and impeded vertical mixing of the deeper effluent. Internal convection cells within the effluent were also prevented from mixing with the overlying water. As the hot, high-saline water came in contact with ambient water the least conservative parameter, temperature, was the first to change. As heat was lost the high-saline effluent became denser and sank away from the interface thus slowing further cooling.

When the desalination plant shut down, the effluent stratum disappeared from the harbor within 24 hours. Some of the effluent water must have persisted longer than 24 hours, however, based on known flushing rates and the known volume of effluent.

The mean depth of the top of the effluent stratum was 18 feet (5.49m), the average thickness of the effluent layer was 4.6 feet (1.4m) and its volume was 20,615 cubic feet (0.58 million cubic meters). Tidal flushing was only 10,756,080 cubic feet (0.30 million cubic meters) per day and it is questionable if wind-driven currents could account for the dissipation of the remaining 10 million cubic feet. Probably, once the thermal barrier was eliminated, vertical mixing was accelerated. Some effluent cooled and remained stagnant in the deeper pockets but the remainder probably mixed with the surface water. The effluent stratum, however, lost its identity and was not detectable hydrographically after 24 hours.

The effluent production, including the entrained ambient water, was about 20 million cubic feet (0.57 million cubic meters) per day which was ample to reestablish the effluent layer within one day. Once the layer of 20 million cubic feet (0.57 million cubic meters) was established in Safe Harbor, there must have been some 20 million cubic feet of effluent per day mixing with the ambient water and possibly passing through the approach channel to deeper water.

Failure to find the effluent beyond 2,000 feet (600 meters) past the edge of the turning basin indicated it was probably mixing with the surface water to a point where it was not detectable by the hydrographic methods employed. That some effluent mixed with the surface water was shown by copper analysis of the sediments of the flats to the west of the turning basin (where the surface harbor water moves over the flats under prevailing wind conditions). These sediments showed much more copper than the upcurrent flats to the east. High copper levels in shallow water areas inside the harbor (see below) also indicated presence of the effluent in shallower water.

The effluent stratum was plotted in real time using the Westinghouse thermister array and was calculated from water measurements taken twice weekly at all stations. Figure 13 shows the monthly average

FIG. 13 AVERAGE MONTHLY DEPTH OF THE EFFLUENT STRATUM AT ALL STATIONS IN SAFE HARBOR.

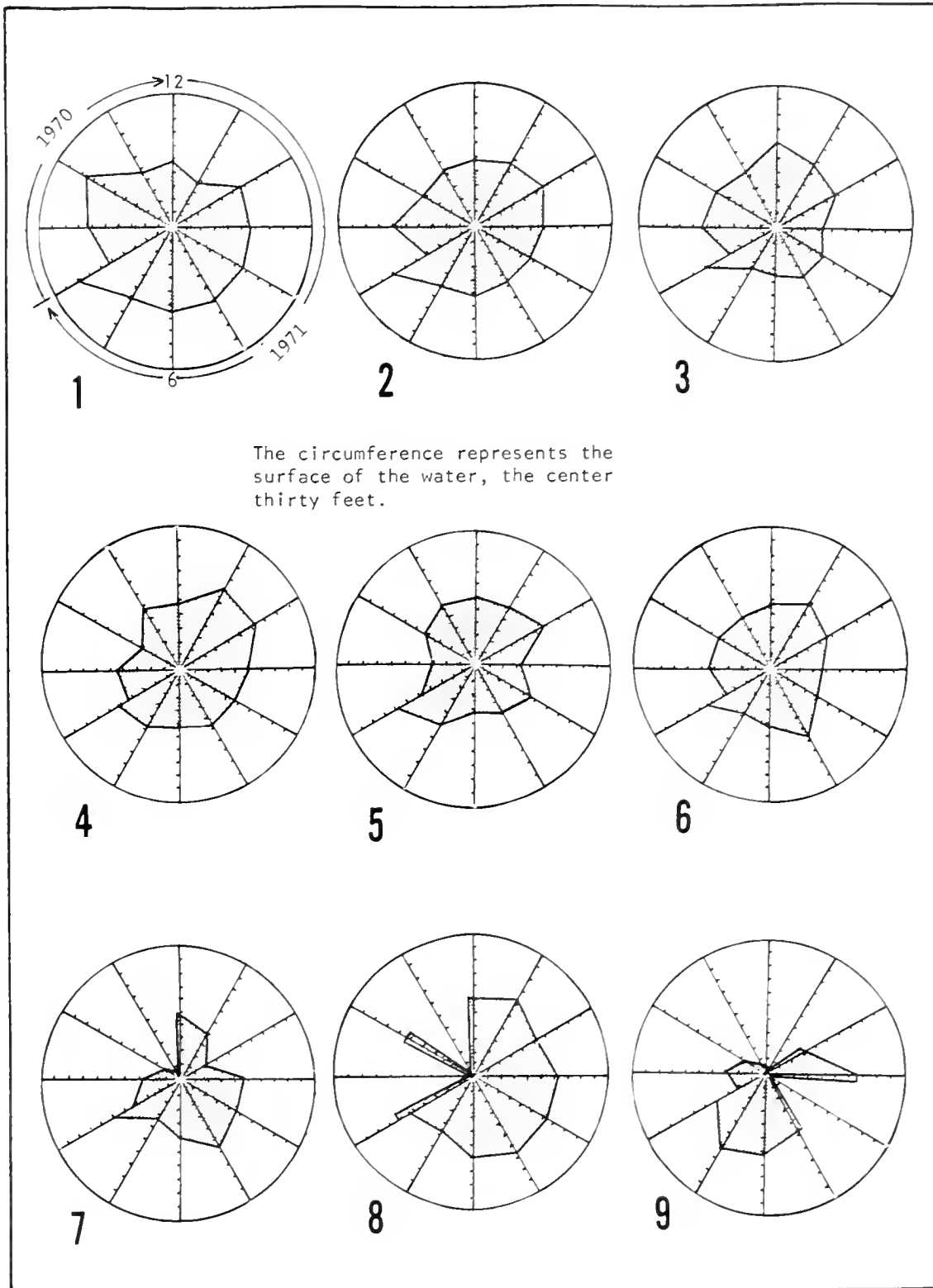

depth of the effluent stratum at all stations separately. These data are combined for a graph of the total average effluent depth in Figure 11. The effluent layer became shallower during the study as its strength, measured by the difference between the effluent's temperature and salinity and the surface water temperature and salinity, decreased. Figure 13 shows the average monthly location of the top of the effluent stratum at various stations. The top of the layer was shallowest at Station 1 and became continually deeper out to the stations in the turning basin (Stations 7 and 9). At Station 8, located seaward of the turning basin in the approach channel, the effluent was occasionally detected flowing out along the bottom at a depth of 17 feet (5.2m).

Ambient salinity and volume of effluent discharge apparently controlled the depth and intensity of the effluent stratum. Of all parameters measured, ambient harbor salinity showed the closest similarity to effluent depth when the two plots were compared (Fig. 11).

Total hours of sunshine per month are also plotted in Figure 11, along with the mean difference in salinity (ΔS) between the surface water and the effluent stratum. The two plots are more similar than those of solar radiation and ambient salinity, particularly in September, 1970. Hours of sunshine are, of course, related to the amount of evaporation on the shallow flats adjacent to Safe Harbor and the consequent changes in salinity. Water from these tidal flats mixed with the effluent discharged near the surface to form the submerged effluent stratum.

The effluent stratum received little contribution from freshwater run-off along the Safe Harbor shoreline. Consequently, increases and decreases of ΔS closely approximated the shallow flat salinity and solar radiation, as well as salinity changes during periods of high rainfall. During heavy rainfall the effluent layer was rapidly diluted by low salinity water entrained at the surface and within about two hours, the upper surface of the effluent stratum began moving shallower; first, near the point of discharge then gradually farther along the canal.

Differences between temperatures (ΔT) at 2 to 4 feet (0.61 to 1.2m) and of the effluent stratum closely followed ambient temperature. As the ambient water temperature decreased, so did the difference between the effluent layer and the water above it (Fig. 11). Figure 14 shows the monthly variation of ΔT at each station for one year. The lower ΔT values and shallower position of the effluent layer at Stations 1 and 8 indicate these were areas of mixing.

The Westinghouse Thermister array provided instantaneous measurement of the isotherm distribution in Safe Harbor canal (Figs. 15 and 16)

FIG. 14 AVERAGE MONTHLY RISE IN TEMPERATURE CAUSED BY THE DESALINATION PLANT EFFLUENT AT ALL STATIONS IN SAFE HARBOR.

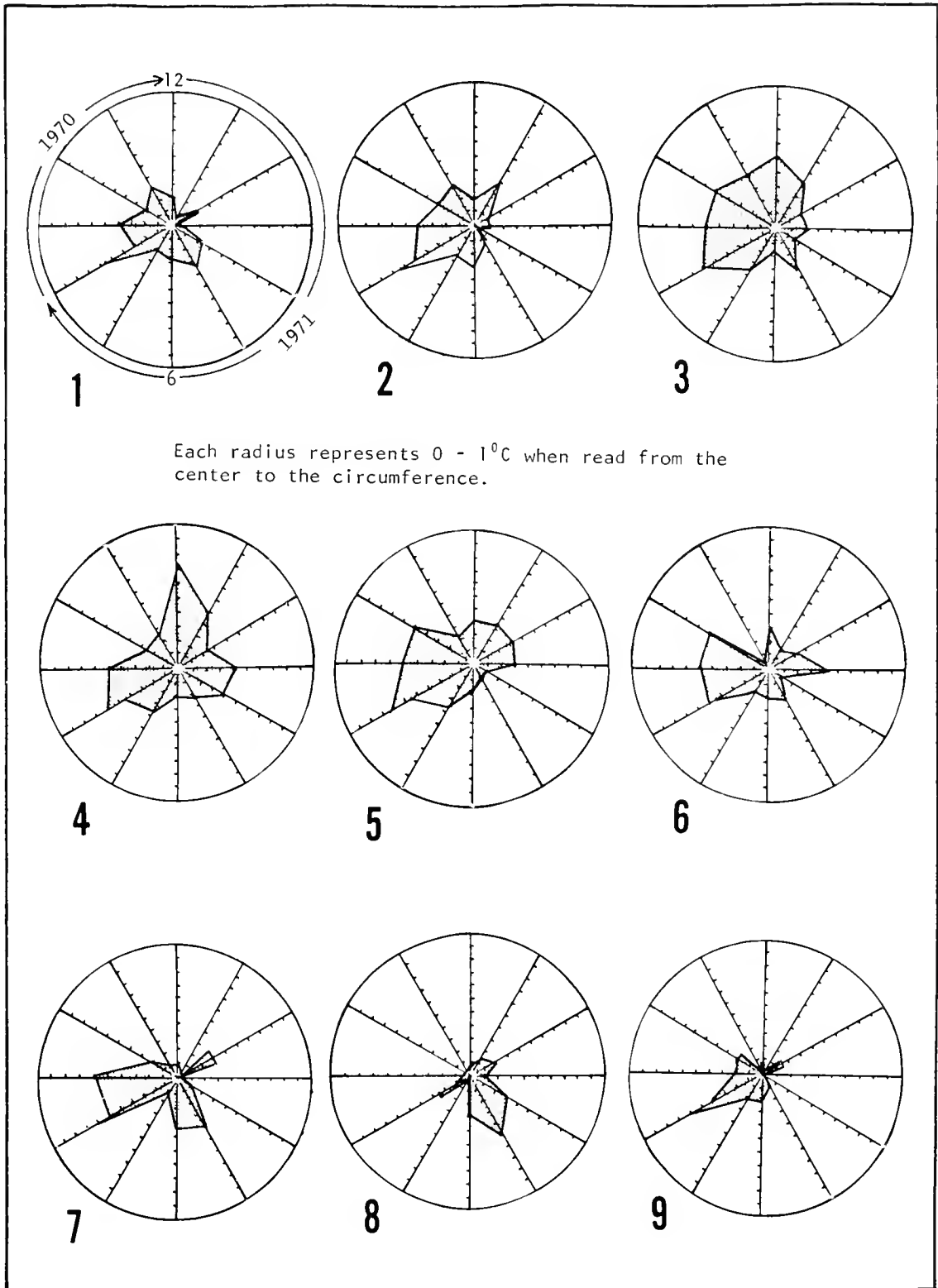

Each radius is numbered as the hours on a watch and represents that month.

FIG. 15 ISOTHERMS IN SAFE HARBOR CHANNEL MARCH 12, 1970 FROM 1200 TO 1205 HRS.

SAFE HARBOR CHANNEL - EASTERN PORTION

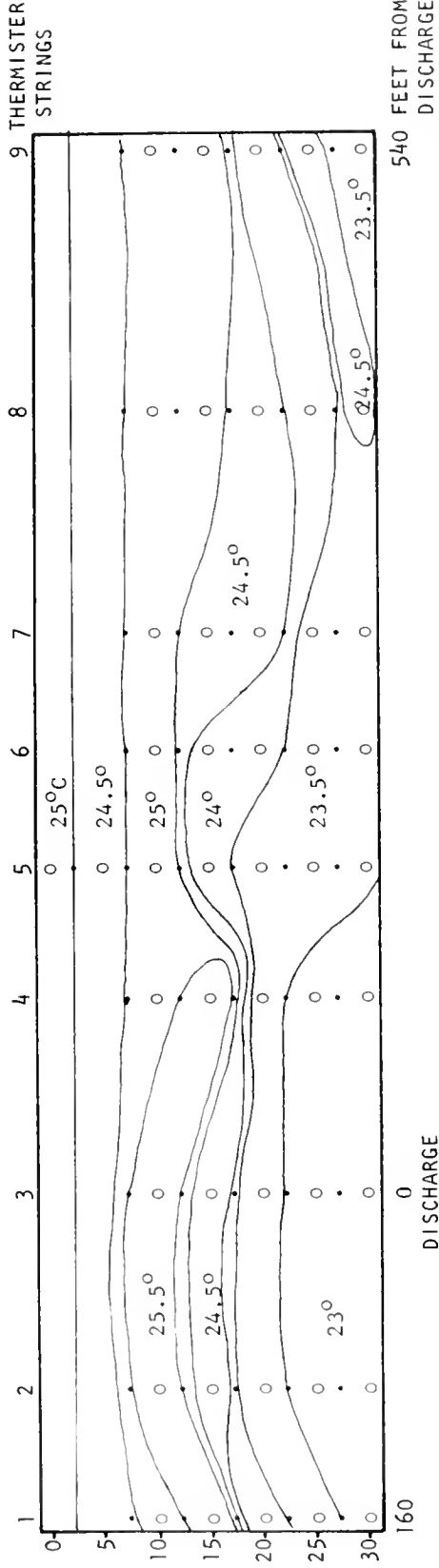

54

540 FEET FROM DISCHARGE

SAFE HARBOR CHANNEL - WESTERN PORTION

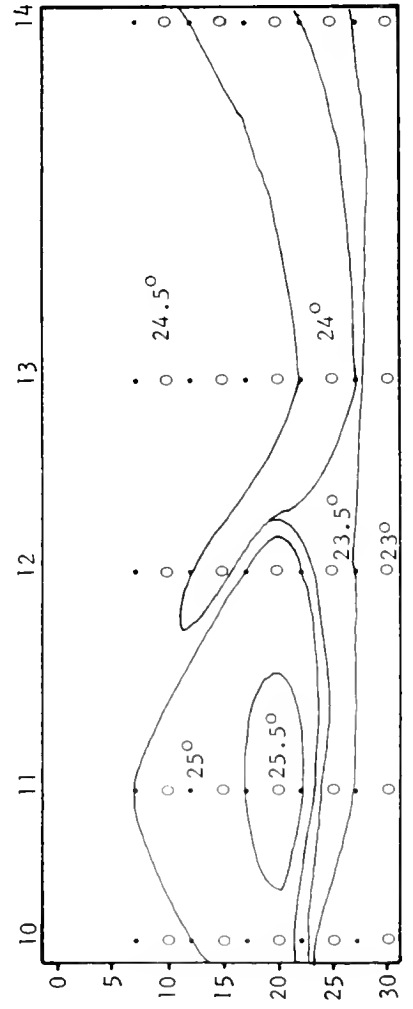

DATE	TIME	TEMP EFF.	VOL. EFF.	TIDE	COMMENTS
3/12	1200	39.2	4160	3	Plant operation normal. Wind S.E. 5-10 knots 5% Cloud No rain Tide high at 1020 +0.9'

FIG. 16 ISOTHERMS IN SAFE HARBOR CHANNEL MAY 14, 1971 FROM 1005 TO 1010 HOURS.

SAFE HARBOR CHANNEL - EASTERN PORTION

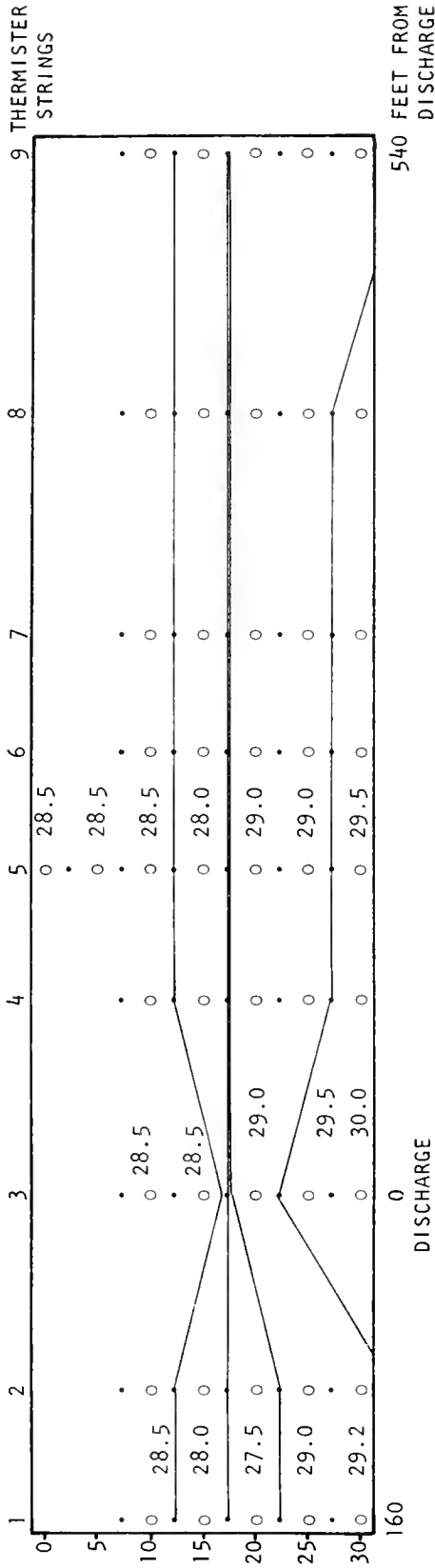

SAFE HARBOR CHANNEL - WESTERN PORTION

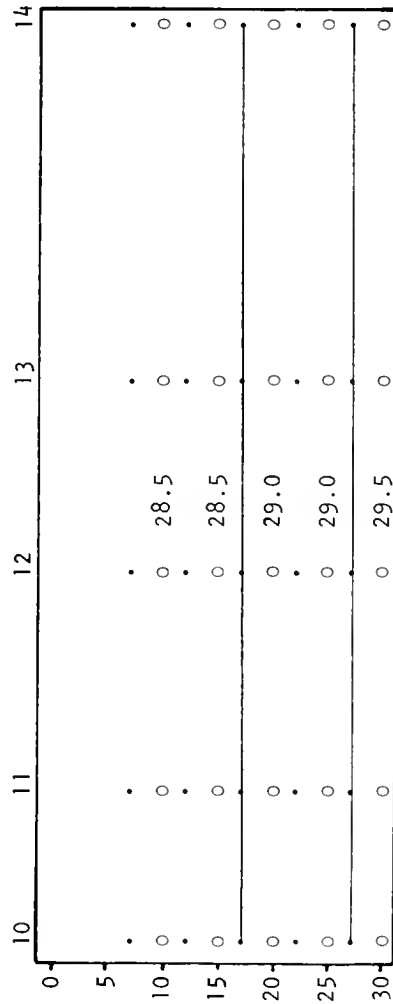

DATE	TIME	TEMP EFF.	VOL. EFF.	TIDE	COMMENTS
5/14	1005	39.3	4150	5	Plant operating normally. Wind SE 10-15 kts, cloud cover 10%, tide high at 1136 and 1.7 feet.

FIG. 17 MOVEMENT OF 25°C ISOTHERM IN SAFE HARBOR CHANNEL MARCH 12, 1970 FROM 1220 TO 1730 HRS.

SAFE HARBOR CHANNEL - EASTERN POSITION

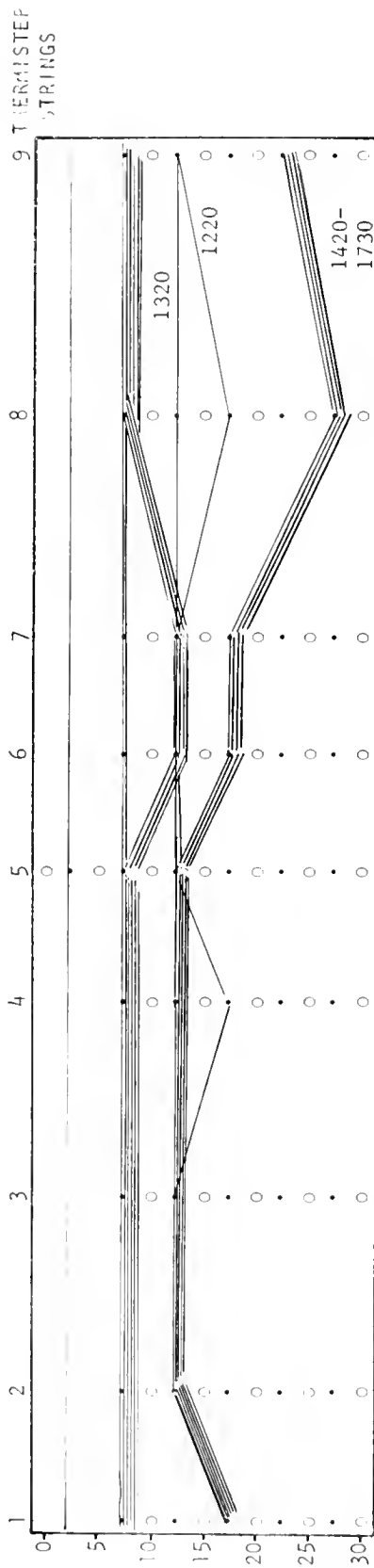

DISCHARGE

540 FEET FROM DISCHARGE

SAFE HARBOR CHANNEL - WESTERN PORTION

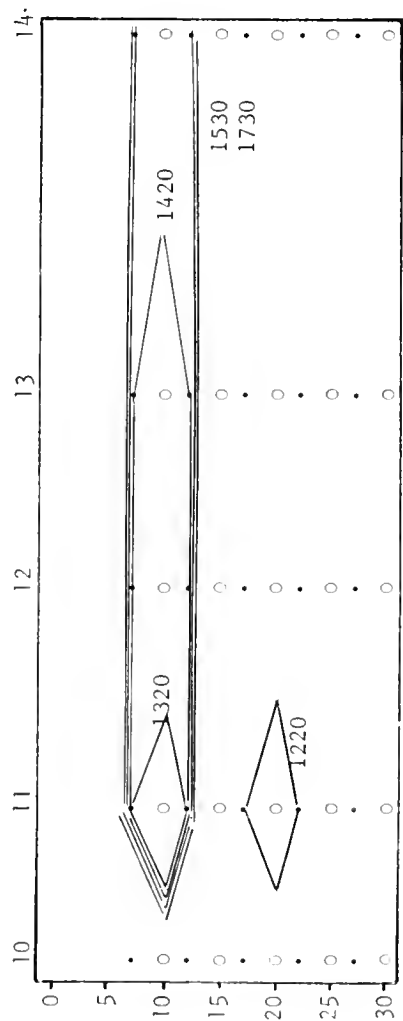

DATE	TIME	TEMP. EFF.	VOL. EFF.	TIDE	COMMENTS
3/12	1220	39.1	4160	3	Plant operation normal. Wind SE 5-10 kts. 5% cloud cover. No rain. (Tide stages = 3=falling 4=low 5=rising) Tide range +0.9 at 1020 -0.3 at 1620
	1320	39.3	4160	3	
	1423	39.2	4160	3	
	1530	39.1	4160	3	
	1630	39.1	4160	4	
	1730	39.1	4160	5	

FIG. 18 MOVEMENT OF 29°C ISOTHERM IN SAFE HARBOR CHANNEL MAY 14, 1971 FROM 0900 TO 1900 HOURS (ONE TIDAL CYCLE).

SAFE HARBOR CHANNEL - EASTERN PORTION

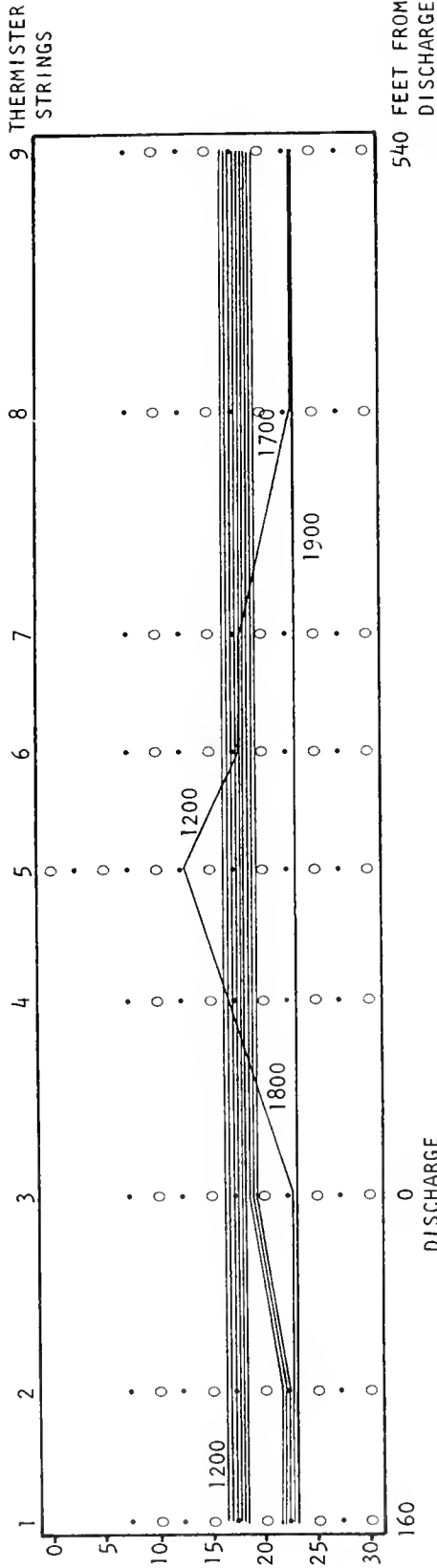

SAFE HARBOR CHANNEL - WESTERN PORTION

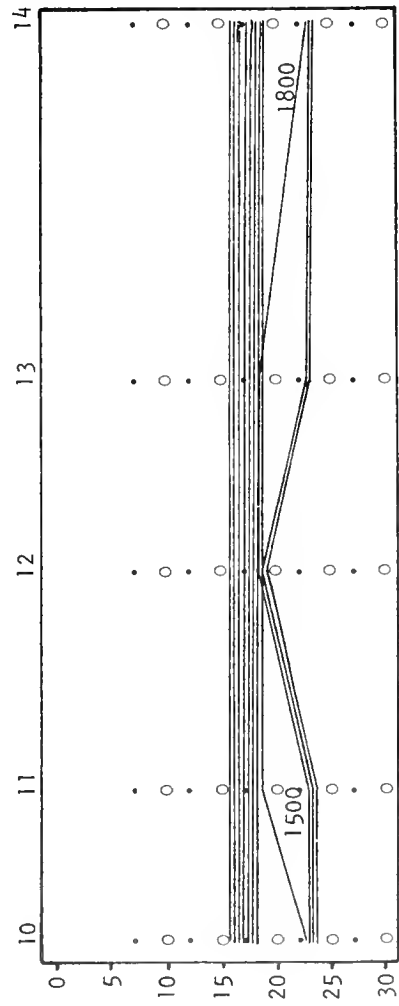

DATE	TIME	TEMP EFF.	VOL. EFF.	TIDE	COMMENTS
5/14	0900	39.3	4150	5	Plant operating normally. Wind SE 10-15 kts, cloud cover 10%, tide high at 1136 and 1.7 feet, low at 1912 - 0.4 feet
	1000	39.3	4150	5	
	1100	39.5	4150	2 hi	
	1200	39.5	4150	3	
	1300	39.2	4150	3	
	1400	39.2	4150	3	
	1500	39.3	4150	3	
	1600	39.3	4150	3	
	1700	39.4	4150	3	
	1800	39.5	4150	3	
	1900	39.5	4150	4 lo	

and permitted following the distribution of the hottest portion of the effluent stratum for several consecutive hours (Figs. 17 and 18). Figures 15 and 17 are typical of the isotherm distribution observed during March, 1971. At that time the effluent stratum was suspended in mid-water and moved regularly with the tide. Figures 16 and 18 show the typical effluent stratum in May, 1971 extending from fifteen feet to the bottom of the canal. Tidal influence was small during the periods of observation.

COPPER AND NICKEL

Copper and nickel discharged from the desalination plant increased to a maximum in January, 1971 and subsequently decreased until August, 1971. The copper and nickel came from corrosion in two areas of the plant: 1) from the first set of monel tube-bundles receiving the well water directly and 2) from copper-nickel (monel) separatory screens in the deaerator. Although monel normally is highly resistant to saltwater corrosion, the combination of heat, high water velocity, low pH, and excessive H_2S caused rapid removal of copper and then nickel from the metal alloy.

There are five tube-bundles in the desalination plant. Most of the corrosion, however, occurred in the tube-bundle which received the raw saltwater supply from the pumps (see Figure 2, page 18). This water contained 4 to 13 ppm H_2S (as normal for the large saltwater aquifer which underlies the Florida Keys). After treatment in the atmospheric decarbonator (aeration and acidification) the brine passed through the air ejector (to remove excess dissolved gas) and spilled down into the brine chambers through large separatory screens. The water, at this stage, had its lowest pH and the highest concentration of hydrogen sulfide. Most of the internal corrosion occurred at this point. From June, 1970 to June, 1971 the discharge averaged 1,766 ppb copper. Copper in the well water averaged only 56.32 ppb. Analysis showed the copper in the effluent to be 78.4% ionic, 3.4% particulate, and 18.2% organically complexed (Table II).

Copper discharge was greatest during periods when plant operation was not stable and particularly after the plant resumed operation following maintenance periods. The ionic analysis of the effluent shown in Table III was taken on February 3rd and 4th, 1971 following resumption of plant operation after maintenance. Samples were taken for twenty-four hours after start-up on February 3rd, 1971. Copper, nickel, and iron were all present in high concentrations following the onset of desalination operations. At that time, the salinity was lower than normal (39.14 o/oo as indicated by sodium levels) and the effluent did not sink. By midnight, six hours later, the effluent reached a salinity of 47.59 o/oo and peaked at 54.21 o/oo at 0300 on February 4th, 1971. Thereafter, the effluent continued discharging at its average value of 52 o/oo.

TABLE II

ANALYSIS OF EFFLUENT FROM KEY WEST DESALINATION PLANTCOPPER $\mu\text{g/lit.}$

<u>Sample #</u>	<u>Inorganic</u>	<u>Total</u>	<u>Particulate</u>	<u>Organically Complexed</u>
10/20/70 6 pm	1,562.5	1,925.0	23.5	
10/20/70 9 pm	1,175.0	1,587.5	173.3	
10/20/70 12 pm	1,431.25	1,937.5	108.0	
10/21/70 3 am	1,497.5	1,812.5	29.8	
10/21/70 6 am	1,486.25	1,837.5	25.8	
10/21/70 9 am	1,477.5	1,900.0	36.0	
10/21/70 12 am	1,675.0	2,062.5	94.0	
10/21/70 3 pm	1,754.0	2,312.5	28.3	
AVERAGE	1,507.38	1,921.9	64.84	349.68
PERCENT OF TOTAL	78.4%		3.4%	18.2%

During periods of irregular operation when pH adjustments were being made continuously to the desalination plant to control scale build-up, copper levels became extremely high. Since the continuously recording copper analyzer did not read above 2,000 ppb, these changes were not recorded in their entirety and, therefore, the duration of extremely high copper discharges is not known. Effluent samples taken during the bi-weekly water surveys demonstrated that copper values exceed 6,500 ppb during unstable operating conditions. When pH was lowered, the amount of copper discharge increased.

In June, 1971, most of the large copper-nickel alloy separatory trays were removed from the deaerator section and replaced with wood trays. After the plant resumed operation, copper levels decreased to a low of 205 ppb. Table III shows the analysis of the major ions in the effluent during July. The plant had operated only twelve hours prior to the sampling and should have been producing excessive amounts of copper.

Copper concentrations from July to October varied considerably. July and August had the lowest copper levels observed during the fifteen month study period (310 and 426 ppb respectively). In September, the average rose to 1,024 ppb but levels as low as 250 ppb were common. In October, copper levels reached an average concentration of 1,119 ppb but were extremely variable with the lowest concentration being 148 ppb and the highest 5,325 ppb.

In November, the plant closed down for extensive engineering modifications which would bring about the permanent reduction of copper discharge. Titanium tubing was used to replace the monel tube-bundles in the first tube-bundle and a new boiler plant was installed to minimize shut-down periods because of thermal energy requirements.

In 1972, the remaining copper-nickel separatory trays were replaced with stainless steel. Unfortunately, the field work for the study was terminated in October, 1971 and the results of the retubing have not been assessed.

Monthly copper concentrations at all stations in Safe Harbor are plotted in Figure 19. Concentrations of copper were generally higher at deeper stations (Series B, the denser shaded areas on the graph) reflecting a higher percentage of effluent present. In contrast, at Control Station 10, copper concentrations were generally greater in shallower water than deep. When the copper discharge was reduced in July and August, 1971, differences in copper concentrations between shallow and deep stations became less prominent.

TABLE III

IONIC ANALYSIS OF EFFLUENT

Hour of Sample	Na x 10 ³	Mg	Ca	K	Sr	Cu	Ti	Ni	Fe
<u>6/18/71</u>									
1200	14.85	1740	572	540	11	0.95	<0.1	<0.01	<0.1
1500	15.20	1820	605	550	12	1.1	<0.1	<0.1	<0.2
1800	15.60	1850	610	560	12	1.1	<0.1	<0.1	<0.2
1100	15.60	1840	625	560	12	1.3	<0.1	<0.1	<0.2
0300	15.50	1850	605	555	12	1.3	<0.1	<0.1	<0.2
0600	15.80	1880	620	565	12	1.2	<0.1	<0.1	<0.2
0900	15.20	1810	620	550	11	1.0	<0.1	<0.1	<0.2
Well	11.90	1430	480	430	9	0.05	<0.1	<0.1	<0.2
Blowdown	16.70	1980	605	600	12	1.2	<0.1	<0.1	<0.2
<u>10/20/71</u>									
1800	14.50	1780	585	542	11	1.50	<0.05	0.40	<0.05
2100	14.33	1740	590	538	11	1.50	<0.05	0.40	<0.05
2400	14.35	1740	577	530	11	1.55	<0.05	0.65	<0.05
0300	14.85	1810	590	545	11	1.55	<0.05	0.40	<0.05
0600	14.22	1700	572	533	11	1.40	<0.05	0.50	<0.05
0900	14.35	1730	577	540	11	1.30	<0.05	0.35	<0.05
1200	14.50	1740	592	540	11	1.55	<0.05	0.45	<0.05
1500	14.55	1770	585	540	11	1.50	<0.05	0.50	<0.05
B (5-8 ppm), Cr (<0.1 ppm), Al (<0.1 ppm), Zn (<0.05 ppm)									
<u>1/14/71</u>									
0400	15.60	1960	652	600	12	1.8	<0.1	0.8	<0.1
1000	15.80	1950	655	610	12	1.3	<0.1	0.6	<0.1
1600	15.70	1930	652	600	12	2.2	<0.1	0.8	<0.1
2200	15.70	1940	650	610	12	2.3	<0.1	0.8	<0.1
Zn (<0.05)									
<u>2/3/71 & 2/4/71</u>									
1800	12.42	1460	520	450	9.0	4.8	<0.1	2.8	29.0
2100	12.30	1410	495	442	8.7	3.8	<0.1	1.8	4.0
2400	15.10	1790	615	454	11.5	3.1	<0.1	1.8	2.0
0300	1720	2070	645	620	13.7	2.1	<0.1	1.9	0.2
0600	17.10	2050	660	611	13.0	2.7	<0.1	2.0	1.2
0900	16.85	1990	652	612	13.2	2.0	<0.1	1.2	0.3
1200	16.40	1940	645	598	13.0	2.0	<0.1	1.0	0.4
1500	16.10	1920	630	582	13.0	4.9	<0.1	3.4	6.0

Note: All the results are parts per million in original water as determined by spectrograph and atomic absorption.

IONIC ANALYSIS OF EFFLUENT

Hour of Sample	Na x 10 ³	Mg	Ca	K	Sr	Cu	Ti	Ni	Fe
0100	17.40	2100	660	640	12.0	2.1	0.1	1.2	0.4
0500	17.20	2100	640	630	12.0	2.3	0.1	2.3	0.1
0900	17.80	2100	660	640	12.2	2.2	0.1	2.2	0.8
1300	17.00	2000	660	630	12.0	2.0	0.1	2.0	0.15
1700	17.40	2000	660	630	12.0	2.4	0.1	2.4	0.3
2100	16.50	2000	650	610	11.8	2.9	0.1	2.9	1.2

7/20/71

0900	15.00	1810	690	565		0.40		0.60	5.7
1200	15.30	1850	720	565		0.31		0.55	4.4
1500	15.30	1850	720	560		0.26		0.45	3.0
1800	15.00	1800	720	550		0.20		0.30	2.3
2100	11.60	1420	590	430		0.62		0.70	2.2
2400	11.40	1400	535	410		0.22		0.60	1.7
0300	12.35	1450	485	440		0.20		0.35	2.7
0600	14.60	1800	585	530		0.23		0.40	4.2

Cr (<0.30), Zn (<0.02)

10/21/71

1800	16.40	1980	740	580		0.64		0.10	0.52
2100	16.50	1980	720	588		0.40		0.10	0.10
2400	16.70	1980	790	590		0.74		0.16	0.70
0300	15.30	1780	780	545		0.70		<0.05	0.65
0600	16.70	1980	780	590		0.50		0.05	0.35
0900	16.70	1990	780	583		0.65		0.13	1.1
1200	16.40	1950	720	585		0.24		<0.05	0.10

Cr (<0.05), Zn (<0.05), Al (<0.1)

Note: All the results are parts per million in original water as determined by spectrograph and atomic absorption.

FIG.19 MONTHLY AVERAGE COPPER CONCENTRATIONS AT ALL STATIONS.
 THE DENSER SHADING REPRESENTS THE LOWER, SERIES B STATIONS.
 DURING SOME MONTHS THE VALUES CLOSELY OVERLAP.

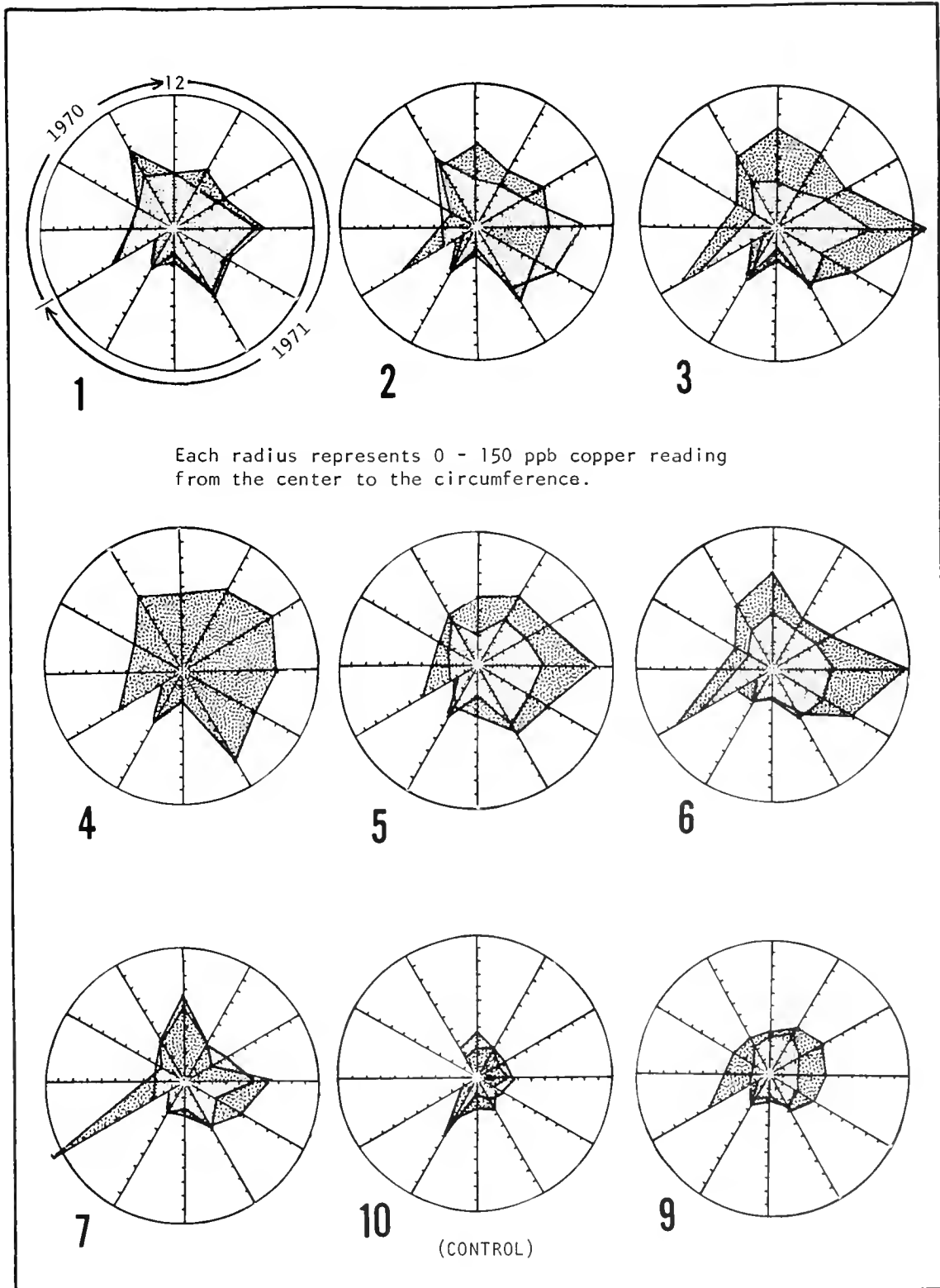

Each radius is numbered as the hours on a watch and represents that month.

Normally, copper concentrations at the "A" stations were similar to control station concentrations. However, when the plant resumed operations following maintenance, low salinities and high copper levels were discharged and high levels of copper contaminated these shallower stations. For example, at 1600 on January 17th, 1971 the plant resumed operation after a one week shut-down. On the 18th, at 0900, water samples were taken at the shallower stations in the harbor which showed far more copper contamination than during normal plant operation.

The discharge, at 0900 on the 18th, had a copper concentration of 2,061 ppb. Normally, the "A" stations had close to zero percent effluent reaching them, but following start-up, 3A had 2.3 percent effluent calculated from the copper concentration. Station 6A had 2.3 percent and 1A had 1.2 percent effluent. Stations 7A, 9A, and 8B remained close to their normal, low copper values until January 20th when all three stations showed abnormally high copper concentrations and effluent levels (3.3 percent at 7A, 2.0 percent at 9A, and 1.6 percent at 8B).

Average monthly copper concentrations for combined Safe Harbor stations are shown in Figure 19. Although copper concentration in the effluent was high for October, 1970 (Fig. 10) the average copper levels in the harbor were low. This was caused by two long shut-down periods (October 4th to October 12th and October 25th to October 31st), and a single start-up period. In December, when the plant shut down twice for extended time periods (December 1st to December 9th and December 19th to December 26th), there were two start-up periods and copper concentrations in Safe Harbor increased over the preceding month. Thus, resumption of operation after maintenance not only brought about better mixing of the effluent with the ambient water, but it significantly increased copper levels in the harbor.

SECTION VII

ANALYSIS OF SAFE HARBOR SEDIMENTS

HEAVY METALS IN THE SEDIMENTS

Initial analyses of the effluent showed a significant output of copper (Table III) from the desalination plant and analyses of sediments of Safe Harbor showed that copper levels were higher than normal in the upper layers of sediment (Fig. 20). Since copper antifouling paints are used on boats moored in the harbor, it was impossible to determine precisely how much copper was derived from antifouling paint, how much from the desalination plant, and how much was originally in the harbor.

Sediment cores were taken by divers to obtain a record of sediments laid down in the harbor since its construction. Changes in particle size and hydrogen sulfided deposits left clearly delineated strata in the sediments. Age determinations of these strata were made by two independent techniques and cross-checked with measurements of present day sedimentation rates. A graph was prepared based on these data, showing age in years versus the depth of different strata from the sediment-water interface (Fig. 21). This graph provided dating information for analyzed samples of various strata in the cores. Strata were analyzed for copper and nickel content, species diversity of foraminifera and their population levels.

Copper and nickel levels increased markedly in the strata layed down after construction of the desalination plant. In a core taken from one of the shrimp boat basins (near the center of the middle shrimp boat basin on the western side of the harbor) at a depth of 32 feet (9.7m), copper levels increased first in 1960 and then again in 1968, about a year after completion of the desalination plant (Fig. 22). Nickel levels, closely followed copper levels in the shrimp boat basin during the 1968 increase. Since the amount of nickel did not increase in 1960 along with a copper increase of about 470 percent, it can be assumed that the source of copper was from shrimp boat antifouling paints which leach copper but not nickel ions. After the desalination plant began operating copper levels increased another 360 percent (Fig. 22), accompanied by a 270 percent increase in nickel.

Near the desalination plant, in a core taken 100 feet (32.8m) off the north end of the cement sea wall in 32 feet (10m) of water, there was no increase in copper until about one year after the plant began operation and nickel did not begin increasing until two years after operation began (Fig. 23).

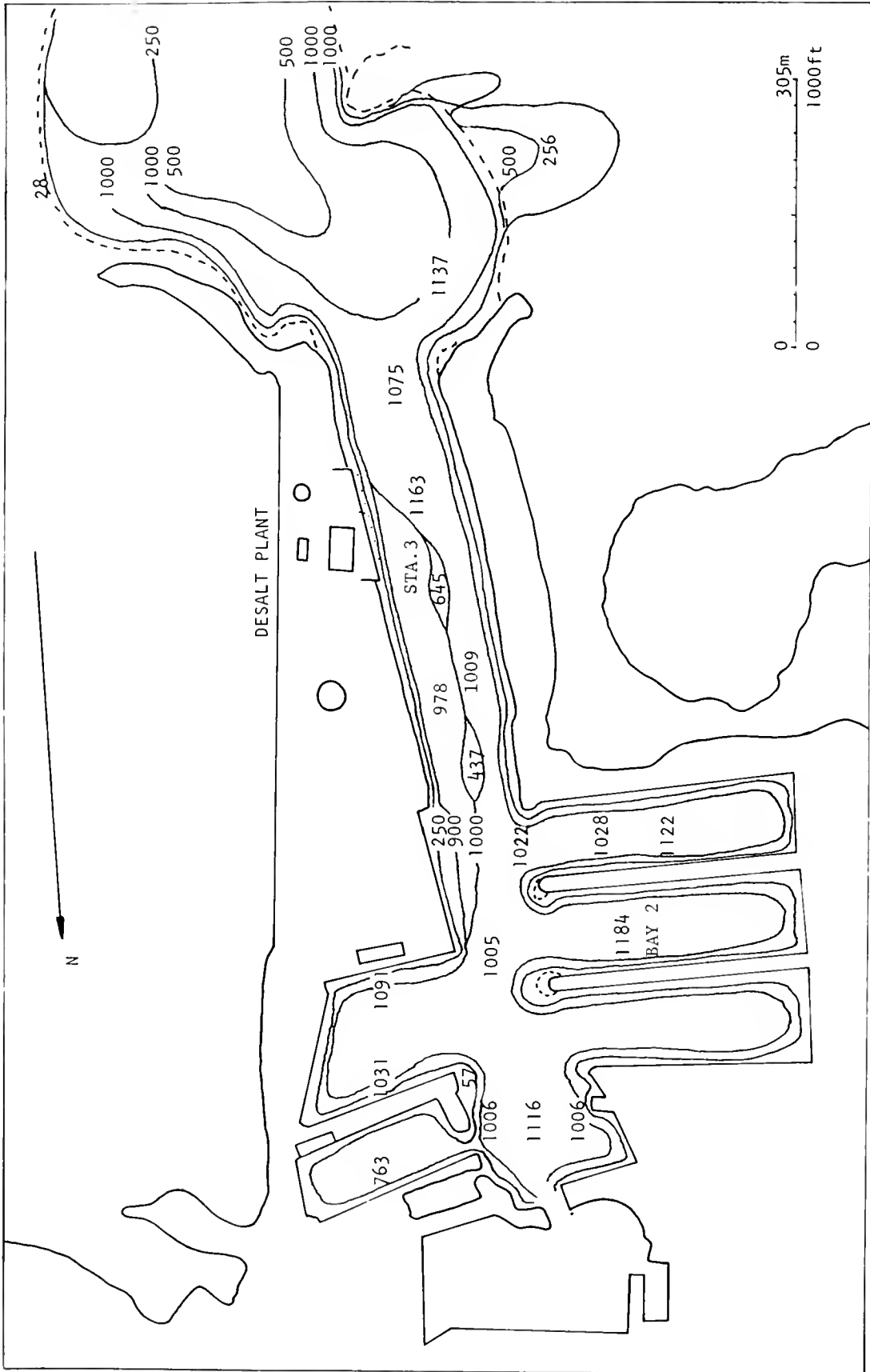

FIG. 20 DISTRIBUTION OF COPPER (PPM DRY SEDIMENT) IN UPPER CENTIMETER OF SEDIMENT IN SAFE HARBOR

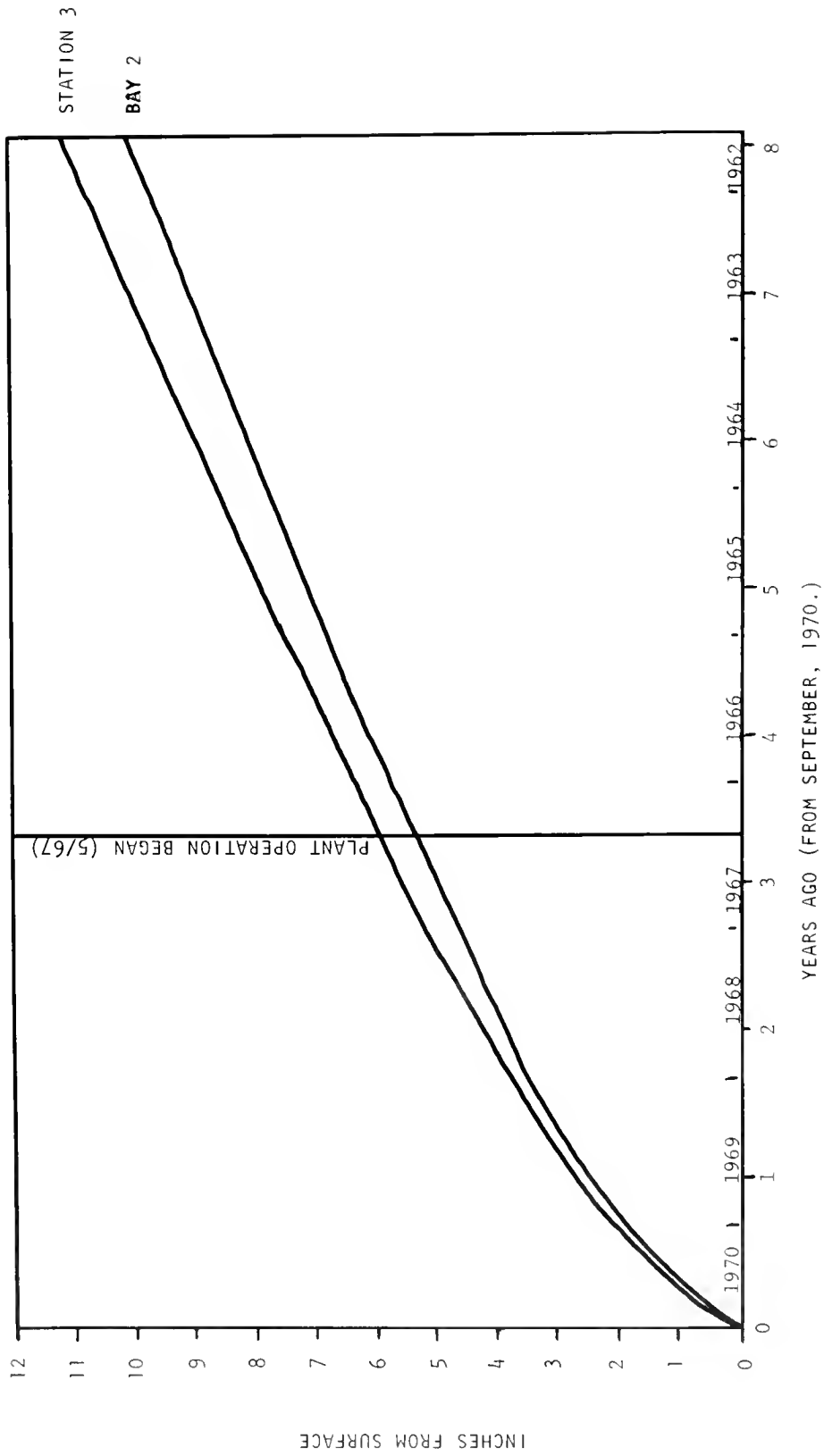

FIG.21 AGE OF SEDIMENT LAYERS IN CORE SAMPLES

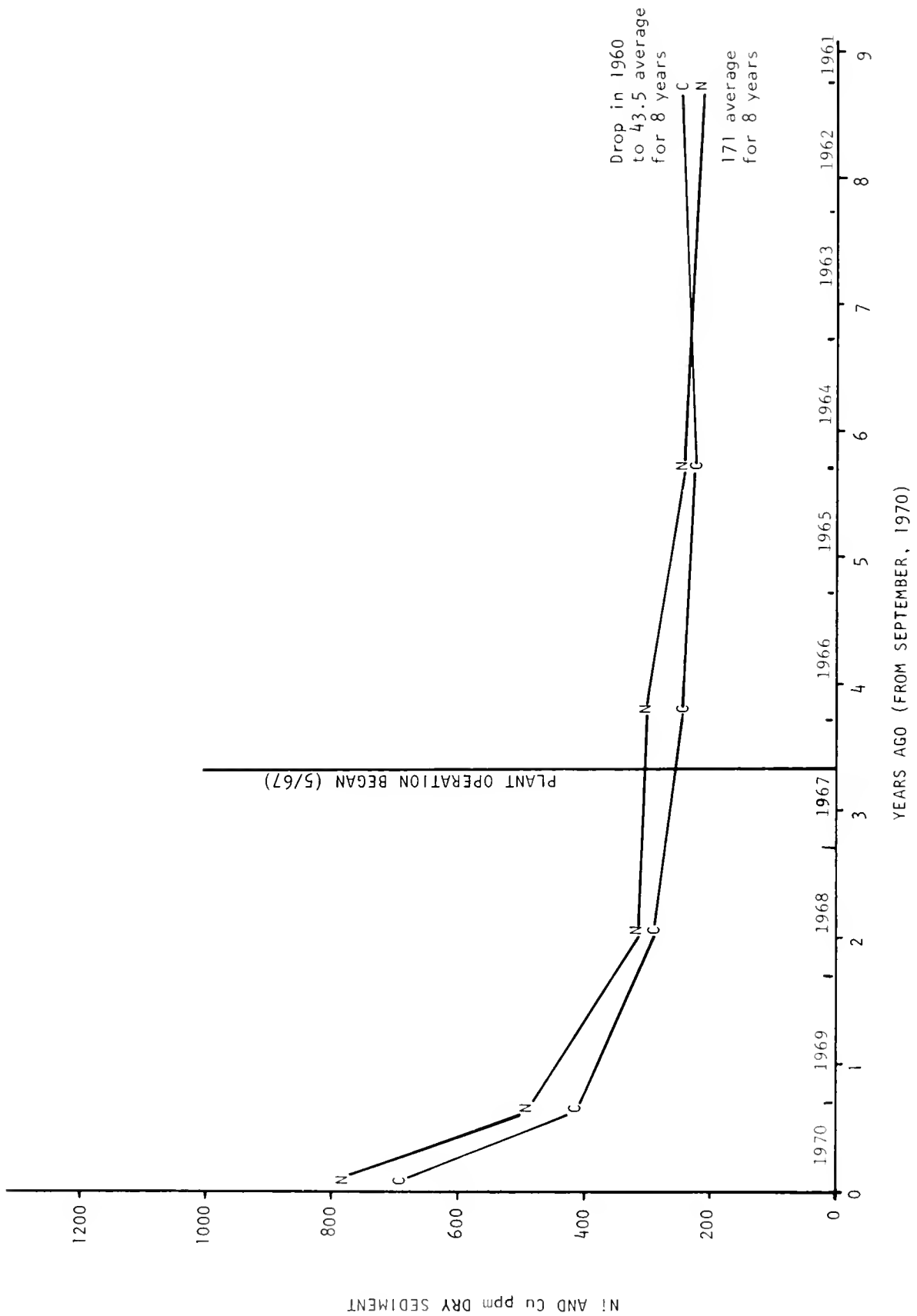

FIG. 22 COPPER (C) AND NICKEL (N) CONCENTRATIONS IN THE SEDIMENT AT BAY 2 FROM 1952 TO PRESENT

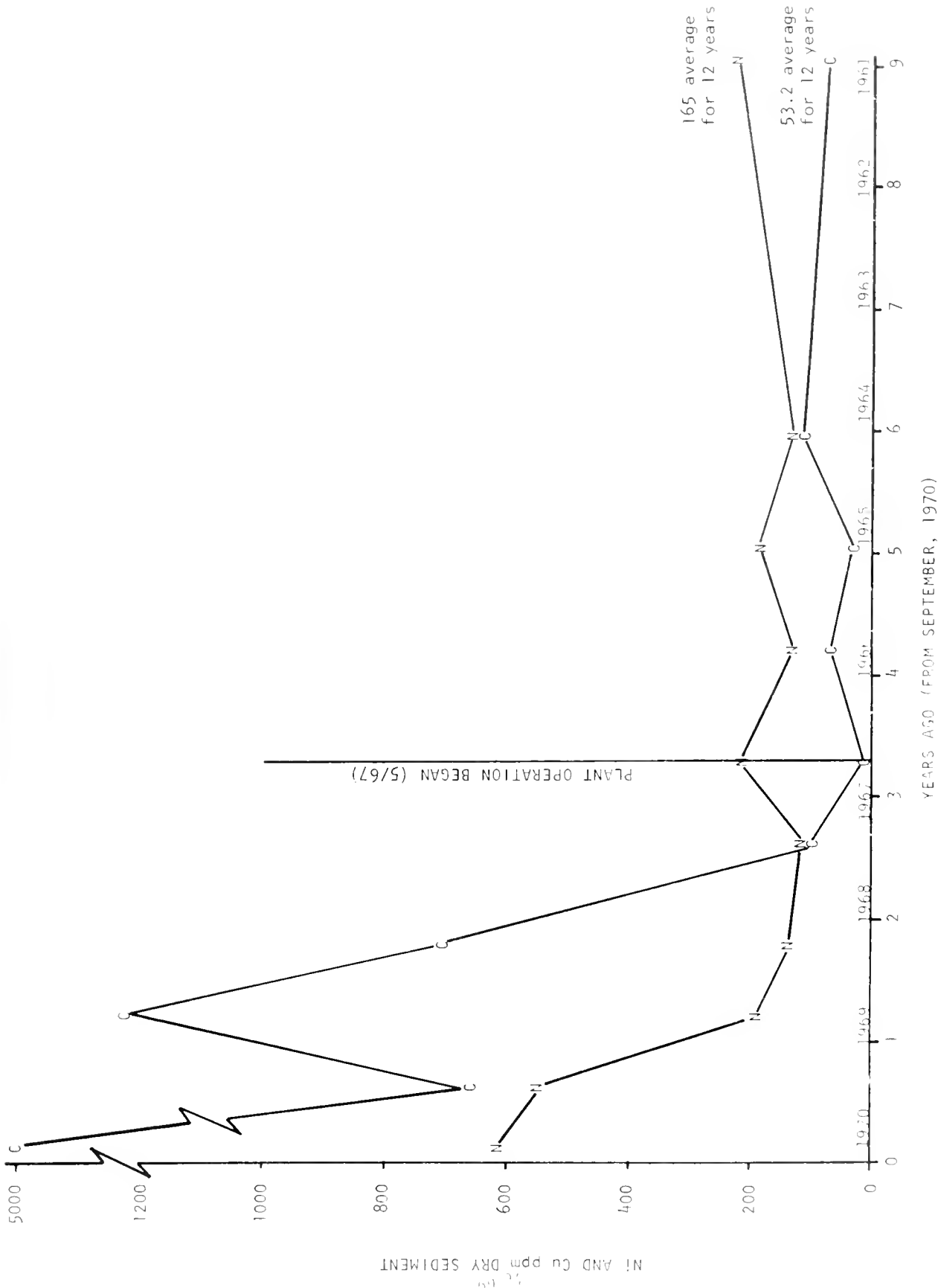

FIG. 4. COPPER (C) AND NICKEL (N) CONCENTRATIONS IN THE SEDIMENT AT STATION 3 FROM 1950 TO PRESENT.

Shrimp boat antifouling paint, therefore, did contribute to the level of copper in the boat basins but this source did not affect the level of copper in the canal. The desalination plant after starting operation contributed about half of the copper excess in the boat basin and essentially all of the excess nickel. The desalination plant was the source for the excess copper and nickel in the canal.

Sediment samples taken in and around the Safe Harbor area showed that excessively high copper levels were confined for the most part to the harbor and turning basin. Copper concentrations about 300 percent above the historical average, extend 400 feet (122m) west of the turning basin where the well-mixed effluent water flows out of the Safe Harbor (Fig. 20).

A similar copper level analysis was performed on sediments surrounding a desalination plant discharge in the Virgin Islands. The results of these data showed that the effluent path could be traced using copper in the sediments even though copper discharge was low and the effluent floated rather than sank (Chesher, manuscript in preparation).

FORAMINIFERA

The foraminiferan fauna from the various sediment strata was examined for species diversity and numbers of individuals per cc of dry sediment. A species list of all Foraminifera found in the cores is presented in Table IV. Presence or absence of a particular species in the core strata is indicated as well as the time when the desalination plant began operating. Several species appeared and disappeared in the course of time, but there was no marked reduction in the number of species. In fact, 75 percent of the species present in 1955 were still present in September, 1970 and the number of species had increased from 48 in 1955 to 51 in 1970. Some species may have been excluded due to high copper levels. Note, for example, the distribution of *Elphidium advenum*, *Pyro subsphaerica*, *Rosalina rosea*, *Quinqueloculina agglutinans*, *Triloculina rotunda*, and *Triloculina planiana* (Table IV). *Fursenkoina mexicana*, on the other hand, was found only in high copper sediment samples. The figure on species diversity (Fig. 24) shows little similarity to the graphs of copper and nickel distribution (Figs. 22 and 23). It is possible that the initial drop in species diversity during the second year of the operation of the desalination plant reflected a period of faunistic adjustment. The decline in species diversity in the core from Bay 2, however, began well prior to the construction of the desalination plant and continued unchanged through the initial period. Probably the fluctuations in species diversity were natural and unrelated to the plant.

Numbers of Foraminifera per cc of dry sediment are plotted in Figure 25. The core from Station 3, off the desalination plant sea wall,

TABLE IV TEMPORAL DISTRIBUTION OF FORAMINIFERA IN SEDIMENT CORES FROM STATION 3 AND BAY 2 SAFE HARBOR (A and I = SEPTEMBER, 1970, K and 8 = SEPTEMBER, 1955)

SPECIES NAME	CORE 3											CORE 2							
	A	B	C	D	E	*F	G	H	I	K	1	2	3	*4	5	6	7	8	
<i>Ammonia beccarrii parkinsoniana</i>				—						-			—		—				
<i>Ammonia beccarrii tepida</i>																			
<i>Amphistegina lessonii</i>															-				
<i>Archaias angulatus</i>										—	—				-		-		
<i>Articulina lineata</i>			-																
<i>Articulina mexicana</i>										-									
<i>Articulina mayori</i>					-														
<i>Articulina mucronata</i>			—																
<i>Articulina sagra</i>										—								-	
<i>Asterigerina carinata</i>										-					-				
<i>Bolivina inflata</i>						-				-	—						-		
<i>Bolivina lanceolata</i>			—								—				—				
<i>Bolivina lowmani</i>			-		-					-									
<i>Bolivina paula</i>										—									
<i>Bolivina pulchella primitiva</i>															-				
<i>Bolivina spathulata</i>										—									
<i>Bolivina striatula</i>										—	—				—				
<i>Bolivina subspinescens</i>										-									
<i>Bolivinita rhomboidalis</i>			-		-					—									
<i>Broeckina orbitolitoides</i>										-	-				-				
<i>Buccella</i> sp.										—									
<i>Bulimina marginata</i>															—			-	
<i>Buliminella elegantissima</i>										—	—				—				
<i>Cassidulina</i> sp.																	-	-	
<i>Cassidulina subglobosa</i>																			
<i>Cibicides</i> sp.															—			-	
<i>Clavulina tricarinata</i>											-								
<i>Cornuspiroides foliaceus</i>																	—		
<i>Criboelphidium poeyanum</i>																			
<i>Cyclogyra involvens</i>																		-	
<i>Cyclogyra planorbis</i>															—				
<i>Discorbis mira</i>																			
<i>Elphidium advenum</i>															—			-	
<i>Elphidium excavatum</i>															—				
<i>Elphidium fimbriatum</i>																			
<i>Elphidium gunteri</i>																	—		
<i>Elphidium incertum mexicanum</i>																			
<i>Elphidium sagrum</i>																			
<i>Fissurina</i> sp.																			
<i>Fissurina pellucida</i>																		-	
<i>Florilus grateloupi</i>																	—		
<i>Fursenkoina complanata</i>																		-	
<i>Fursenkoina compressa</i>																			
<i>Fursenkoina mexicana</i>																			
<i>Fursenkoina pontori</i>																			
<i>Globorotalia menardii</i>																			
<i>Hauerina</i> sp.																			
<i>Hemidiscella palabunda</i>																		-	
<i>Miliolinella circularis</i>																			
<i>Miliolinella fichteliana</i>																			
<i>Miliolinella labiosa</i>																	—		
<i>Miliolinella suborbiculari</i>																		-	

* TIME OF CONSTRUCTION OF DESALINATION PLANT

SPECIES NAME	CORE 3											CORE 2							
	A	B	C	D	E	*F	G	H	I	K	1	2	3	*	4	5	6	7	8
<i>Neoconorbina orbicularis</i>	-			-			-			-					-				-
<i>Nonion sp.</i>						-													
<i>Nonion depressulum matagordanum</i>																			
<i>Nubecularia lucifuga</i>																			
<i>Osangularia cultur</i>																			
<i>Patellina corrugata</i>		-																	
<i>Peneroplis carinatus</i>																			
<i>Peneroplis pertusus</i>																			
<i>Peneroplis proteus</i>																			
<i>Planorbulina acervalis</i>																			
<i>Planorbulina mediterraneensis</i>																			
<i>Planulina sp.</i>																			
<i>Pyrgo subsphaerica</i>																			
<i>Quinqueloculina agglutinans</i>																			
<i>Quinqueloculina bicarinata</i>																			
<i>Quinqueloculina bicostata</i>																			
<i>Quinqueloculina bidentata</i>		-																	
<i>Quinqueloculina boschiana</i>																			
<i>Quinqueloculina finafuttiensis</i>																			
<i>Quinqueloculina laevigata</i>																			
<i>Quinqueloculina lamareckiana</i>																			
<i>Quinqueloculina poeyana</i>																			
<i>Quinqueloculina polygona</i>																			
<i>Quinqueloculina sabulosa</i>																			
<i>Quinqueloculina seminula</i>																			
<i>Quinqueloculina subpoeyana</i>																			
<i>Quinqueloculina tenagos</i>																			
<i>Quinqueloculina venusta</i>																			
<i>Quinqueloculina wiesneri</i>																			
<i>Reophax nana</i>																			
<i>Reussella atlantica</i>																			
<i>Rosalina floridana</i>																			
<i>Rosalina floridensis</i>																			
<i>Rosalina rosea</i>																			
<i>Sigmavirgulina tortuosa</i>																			
<i>Sorites marginalis</i>																			
<i>Spirillina vivipara</i>																			
<i>Spiroloculina antillarum</i>																			
<i>Spiroloculina arenata</i>																			
<i>Testularia agglutinans</i>																			
<i>Testularia earlandi</i>																			
<i>Tretomphalus atlanticus</i>																			
<i>Trifarina bella</i>																			
<i>Triloculina bassensis</i>																			
<i>Triloculina bermudezi</i>																			
<i>Triloculina carinata</i>																			
<i>Triloculina fitteroi meningi</i>																			
<i>Triloculina limicola</i>																			
<i>Triloculina pliniana</i>																			
<i>Triloculina rotunda</i>																			
<i>Triloculina trigonula</i>																			
<i>Trochammina inflata</i>																			
<i>Uvulina oviedoana</i>																			

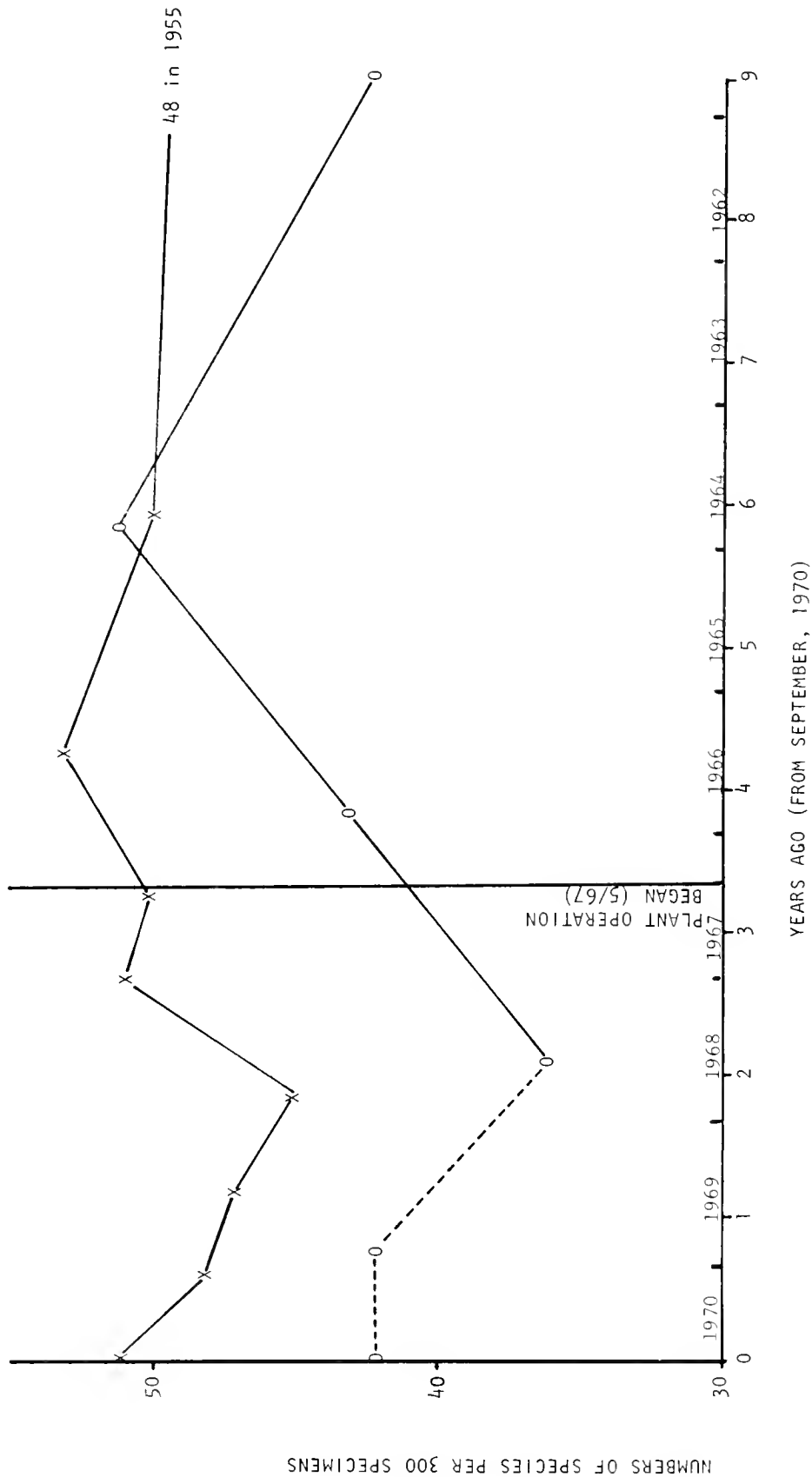

FIG. 24 SPECIES DIVERSITY IN FORAMINIFERA POPULATION FROM CORE SAMPLE AT STATION 3 (X) AND AT BAY 2 (O)

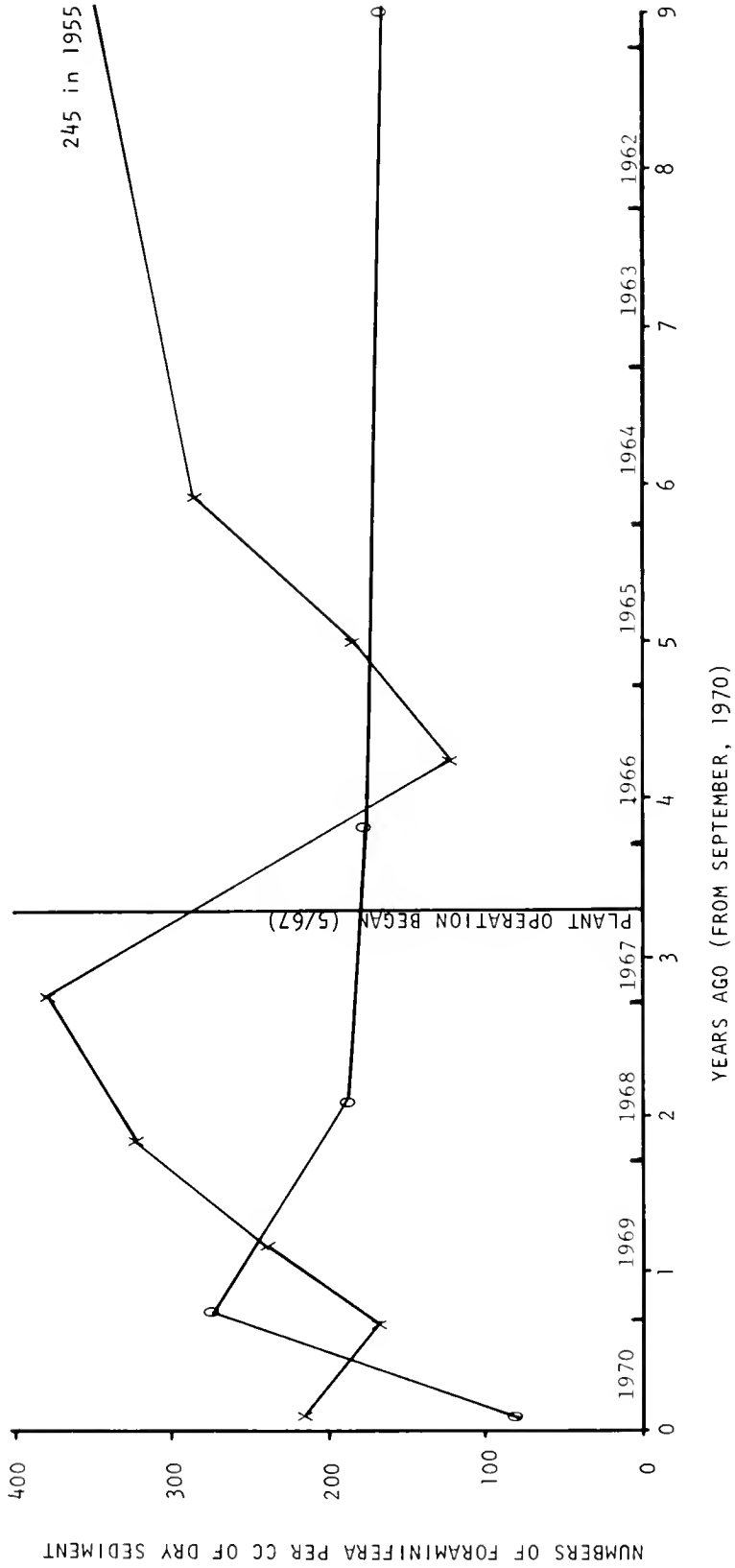

FIG. 25 NUMBERS OF FORAMINIFERA PER CC OF DRY SEDIMENT FROM CORE SAMPLES AT STATION 3 (X) AND AT BAY 2 (O)

showed two periods of declining populations; from October, 1964 to June, 1966 and from November, 1967 until January, 1970. From January, 1970 to October, 1971 conditions steadily improved. Numbers of Foraminifera increased from 218 per cc of dry sediment in September, 1970 to 621 in February, 1971; higher than present in all other strata at Station 3. It is evident, therefore, that the high levels of copper and nickel had little effect on the foraminiferan populations except in the immediate vicinity of the discharge (see Section VIII BIOLOGICAL PARAMETERS - Foraminifera below).

SECTION VIII

BIOLOGICAL PARAMETERS

CONCENTRATIONS OF EFFLUENT AT BIOLOGICAL STATIONS

Figure 26* shows the amount of effluent found at each station from August, 1970 to August, 1971. These averages exclude periods when the desalination plant was shut down. The outer edge of the shaded area represents percentage of effluent present at deeper stations (within the effluent stratum) and the inner edge of the shaded area represents percentage of effluent at the shallower stations. There were no shallow collections at Stations 4 or 8. Station 4 was at the point of effluent discharge and mixing was so active that measurements were unreliable. Station 8 was the farthest station from the effluent and the ledge was too shallow to permit two separate stations.

As pointed out in the section on copper levels, high concentrations of effluent were present at shallow stations for brief periods following resumption of desalination operations after maintenance periods. Although some such instances were measured, the low frequency of sampling coupled with the irregular times at which the plant resumed operations prevented documenting the movement of the effluent through the shallow stations. Therefore, although the average concentration of effluent at the "A" series stations remained low, transient highs were experienced which compared closely to the average conditions in deeper water.

Figure 27 shows the mean percent of effluent and the 90 percent confidence limits of the mean for all the deeper, series "B", stations from August, 1970 to October, 1971. The series "B" stations showed high effluent concentrations within the entrance canal of Safe Harbor and a marked reduction in concentrations both in the inner harbor (Station 1) and in the turning basin (Stations 7 and 9). The average concentration of effluent was negligible at Station 8.

QUADRAT ANALYSES

On July 16th, 1970 one-meter square quadrats were set up adjacent to the nineteen stations (Fig. 3). Organisms which were found in the

*Note that on Figure 26, 0 percent effluent is located two units from the center of the circle on all radii. This is a result of the technique used for isolating the present effluent from ambient variations.

FIG. 26 MONTHLY PERCENT EFFLUENT AT EACH STATION IN SAFE HARBOR FROM AUGUST, 1970 TO AUGUST, 1971. INNER EDGE REPRESENTS CONCENTRATIONS AT STATION A, OUTER EDGE, STATION B.

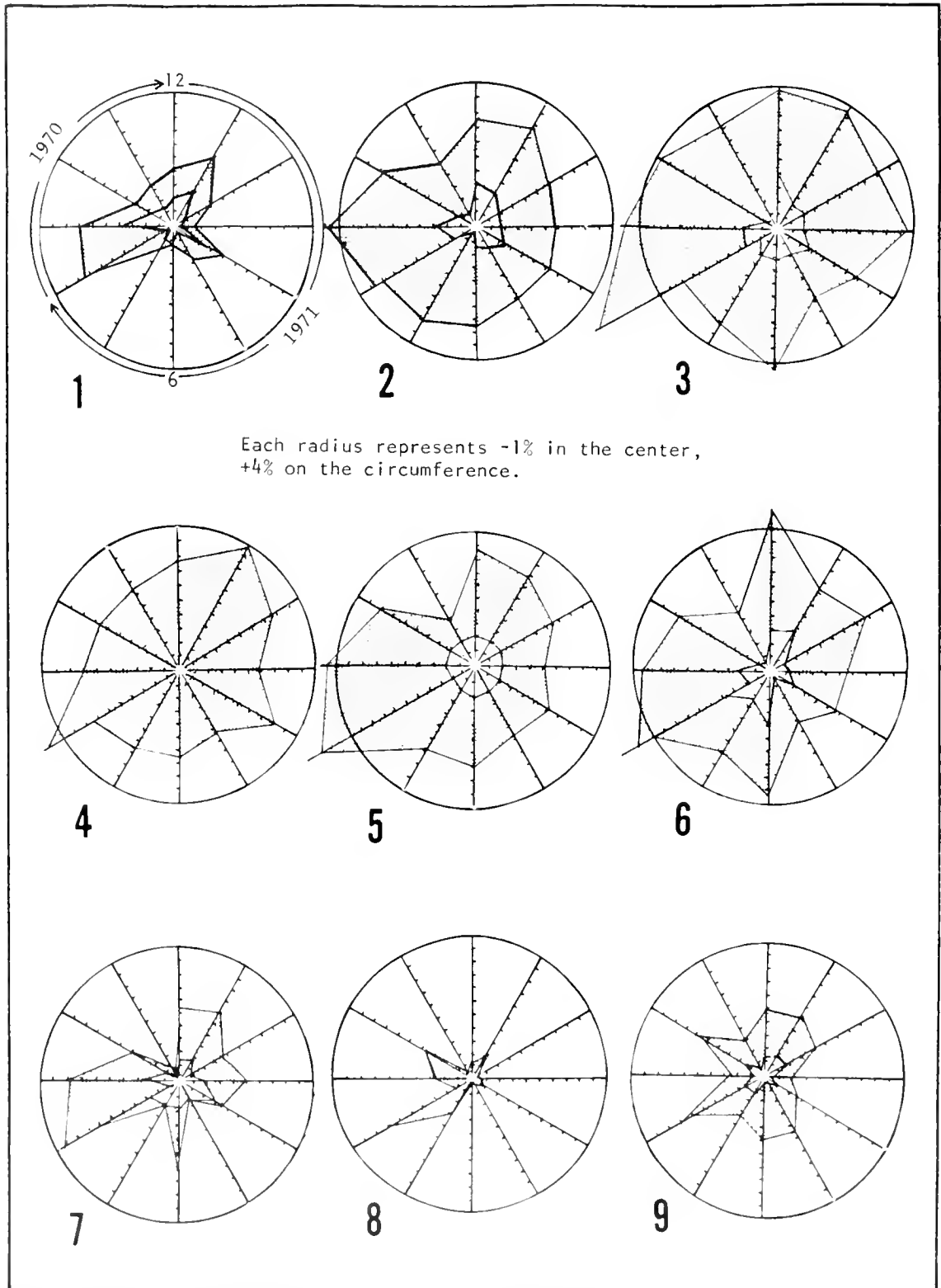

Each radius is numbered as the hours on a watch and represents that month. Values are read from the center to the circumference.

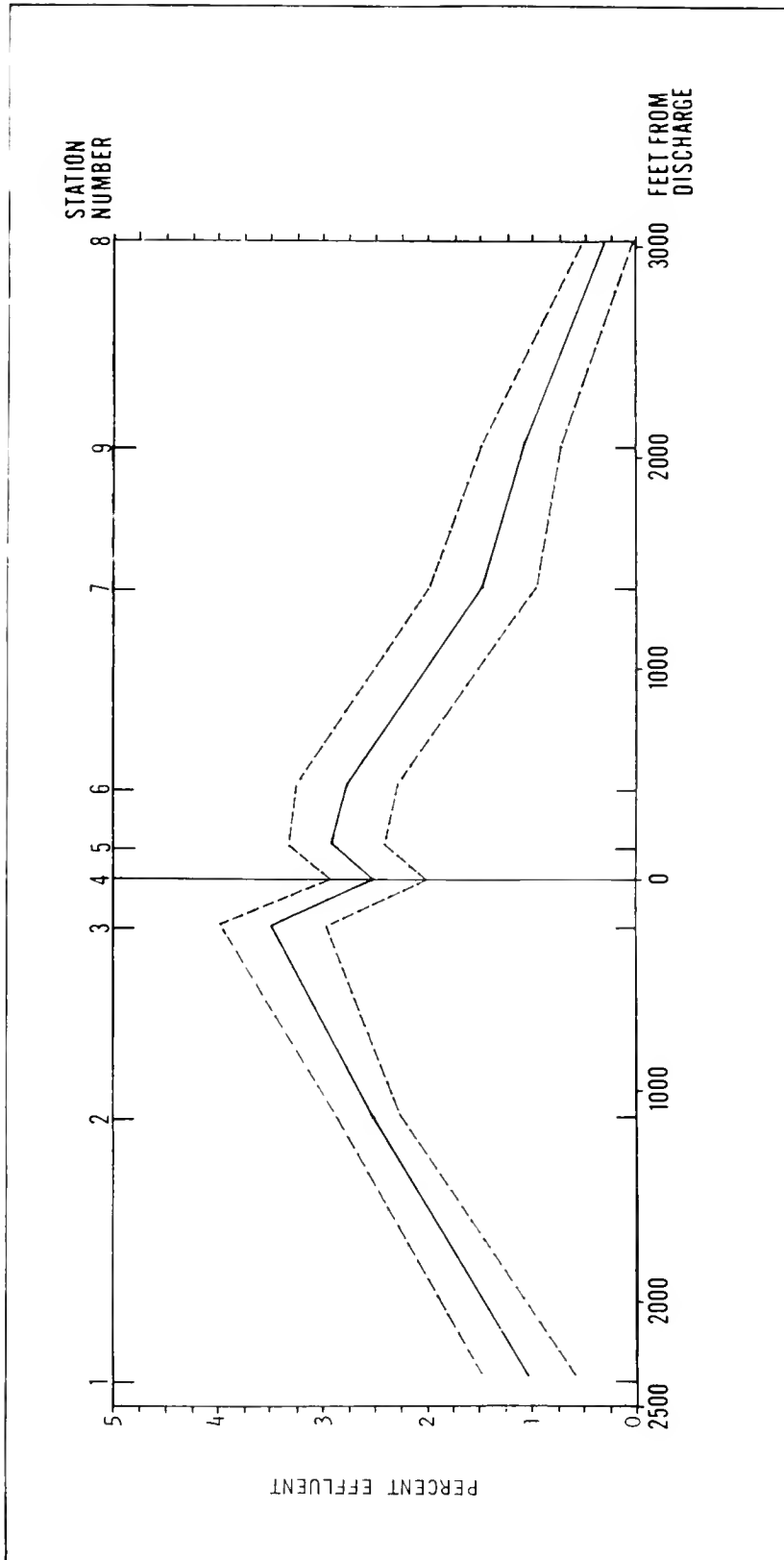

FIG. 27 MEAN PERCENT EFFLUENT (SOLID LINE) WITH 90 PERCENT CONFIDENCE LIMITS OF THE MEAN (BROKEN LINE) FOR ALL DEEPER STATIONS IN SAFE HARBOR FROM AUGUST, 1970 TO OCTOBER, 1971

monthly quadrat and biomass samples are listed in Table V along with their abundance values (average number of individuals per square meter based on twelve monthly samples in a year's period). Algae and hydroids and some of the small, burrowing, annelid worms could not be satisfactorily counted and are listed as Common (C), Present (P), or Absent (O). These organisms were not used in calculating similarity or diversity indices for the stations.

Dominance diversity indices (Margalef 1957) were calculated for each station (Fig. 28). They showed deeper stations were less diverse than shallow stations and that diversity in Safe Harbor was lower than in the turning basin or at the control station. At Station 5, the deeper station was more diverse than the upper station, possibly as a result of settlement by larval organisms entrained in the effluent. The unusually high diversity of Stations 7A and 7B was due to a mixing of faunas from Safe Harbor and the shallow water turtle grass flats. The low diversity at Station 9B was caused by high siltation rates at that station.

Similarity indices (Pearson *et al* 1967) were calculated between all stations in Safe Harbor to determine affinities in population structure (Table VI). Figure 29 shows the two largest similarity indices for each station. (The figured squares represent the actual relative geographic position of the quadrat stations in Safe Harbor). Station 1B, for example, was most closely related to Stations 2A and 2B. Station 2B was most closely related to Stations 1B and 3C. Stations 2A and 3A were closely related and apparently shared a fauna similar to that associated with the effluent at Stations 1B and 3C.

Based on similarity indices, the stations clustered into three main groups with two intermediate stations. Stations 1B, 2A, 2B, 3A, and 3C formed one group separated sharply at the point of effluent discharge from a second group, Stations 4B, 5A, 5B, 6A, and 6B. The third group of stations consisted of Stations 7A, 9A, 8A, 10A, and 10B. Station 1A showed its greatest affinities with Stations 5A and 6A. The fauna at Station 7B was most similar to the fauna at Stations 3C and 5B. Station 9B was loosely associated with Stations 5B and 4B.

Figure 30 shows the similarities between all of the shallow water (A) stations in Safe Harbor. There were two abrupt changes in the fauna; at the discharge to the desalination plant and between Stations 6A and 7A. Stations 7 to 9 were in the turning basin and approach channel while Stations 1 to 6 were in Safe Harbor proper (Fig. 3). At deep stations (Fig. 31), the fauna remained similar from Station 1B to 3C. There was a marked drop in similarity between 3C and 5B at the point of effluent discharge. The sharp decline in similarity shown for the shallow stations between the harbor and turning basin was not as pronounced in the deeper stations. The similarity in faunal populations between Stations 7B and 9B and the harbor stations may be attributed to the movement of effluent into deeper portions of the turning basin.

TABLE V

List of invertebrates and algae found at all stations between July, 1970 and October, 1971. Number represents abundance values of organisms (see test). Where these could not be calculated, C represents Common, P Present, 0 Absent.

Organism	Station																				
	1		2		3		4		5		6		7		8		9		10		
	A	B	A	B	A	C	B	A	B	A	B	A	B	A	B	A	B	A	B	A	B
ASCIDIACEA																					
<i>Ascidia nigra</i>	2.8	0	0	0	1.5	0	0	2.3	0	1.5	0	3.0	0.5	0	5.6	0.6	19.8	0.8	0	0	
<i>Botrylloides nigrum</i>	2.1	0	0.6	0	0	0	0	0	0	0	0	0	0	0	0	0	0	0	0	0	0
<i>Spp. A</i>	0	0	0	0	0	0	0	0.6	0	0	0	0.1	0	2.0	4.0	0	2.2	0	0	0	0
MOLLUSCA																					
<i>Cantharus tinctus</i>	1.0	0	0	0	0.1	0	0	0.2	0	0	0	1.1	0.7	0.1	1.0	0	0	0	0	0	0
<i>Area imbricata</i>	0	0	0	0	0	0	0	0	0	0	0	3.8	0	3.0	12.0	0	1.0	0	0	0	0
<i>Chama floridana</i>	0	0	0	0	0	0	0	0	0	0	0	0.8	0	4.0	0.4	0	0	0	0	0	0
<i>Littorina sticzae</i>	0	0	0	0	0	0	0	0	0	0	0	0	0	0	0	0	4.0	0.2	0	0	0
<i>Lima scabra</i>	0	0	0	0	0	0	0	0	0	0	0	0.4	0	0.2	0	0	0.5	0	0	0	0
<i>Ostrea frons</i>	0.2	0	0	0	0.1	0	0	0.4	0	0	0	0.4	0	0	0	0	0	0	0	0	0
<i>Ostrea equestris</i>	0	0	0	0	0	0	0	0.1	0	0	0	0	0	0	0	0	0	0	0	0	0
<i>Thais haemastroma</i>	0	0	0	0	0	0	0	0	0	0	0	0	0	0	0	0.1	0	0	0	0	0
<i>Strombus alatus</i>	0	0	0	0	0	0	0	0	0	0	0	0.1	0	0	0	0	0	0	0	0	0
COELENERATA																					
<i>Hydrozoa</i>	P	C	P	C	C	C	C	P	P	P	P	P	P	P	P	P	P	P	P	P	P
<i>Plumitaria sp.</i>	0	0	0	0	0	0	0	0	0	0	0	0	0	0	0	0	0	0	0	0	0
<i>Millepora alaicornis</i>	0	0	0	0	0	0	0	0	0	0	0	0	0	2.0	0	0	0	0	0	0	0
<i>Anthozoa</i>	0	0	0	0	0	0	0	0	0	0	0	1.0	0	2.0	0	0	0.4	0	0	0	0
<i>Bartholomea annulata</i>	0	0	1.0	0	0	0	0	0	0	0	0	4.0	0	13.0	1.0	0	0	0	0	0	0
<i>Siderastrea radians</i>	0	0	0	0	0	0	0	0	0	0	0	0	0	0	0	0	0	0	0	0	0
<i>Solenastrea bourmoni</i>	0	0	0	0	0	0	0	0	0	0	0	0	0	0	0	3.0	0	0	0	0	0
<i>Cladocora arbuscula</i>	0	0	0	0	0	0	0	0	0	0	0	0	0	0	0	0	3.0	0	0.8	0	0
<i>Oculina diffusa</i>	0	0	0	0	0	0	0	0	0	0	0	0	0	4.0	0	2.0	0	0	0	0	0
<i>Porites banneri</i>	0	0	0	0	0	0	0	0	0	0	0	0	0	1.0	0	0	0	0	0	0	0

Organism	Station																			
	1		2		3		4		5		6		7		8		9		10	
	A	B	A	B	A	C	B	A	B	A	A	B	A	B	A	B	A	B	A	B
COELENTERATA cont.																				
<i>Dicoecenia stokesii</i>	0	0	0	0	0	0	0	0	0	0	0	0	0	0	0	0	0	0	0	0
<i>Colpophyllia amaranthus</i>	0	0	0	0	0	0	0	0	0	0	0	0	0	0	0	0	0	0	0	0
<i>Muricea elongata</i>	0	0	0	0	0	0	0	0	0	0	0	0	0	0	0	0	0	0	0	0
<i>Plexaurella nitans</i>	0	0	0	0	0	0	0	0	0	0	0	0	0	0	0	0	0	0	0	0
<i>Pseudoplexaura wagnaari</i>	0	0	0	0	0	0	0	0	0	0	0	0	0	0	0	0	0	0	0	0
<i>Pseudoplexaura flagellosa</i>	0	0	0	0	0	0	0	0	0	0	0	0	0	0	0	0	0	0	0	0
<i>Pseudopterogorgia americana</i>	0	0	0	0	0	0	0	0	0	0	0	0	0	0	0	0	0	0	0	0
<i>Pseudopterogorgia rigida</i>	0	0	0	0	0	0	0	0	0	0	0	0	0	0	0	0	0	0	0	0
<i>Pseudopterogorgia acerosa</i>	0	0	0	0	0	0	0	0	0	0	0	0	0	0	0	0	0	0	0	0
<i>Pterogorgia ariceps</i>	0	0	0	0	0	0	0	0	0	0	0	0	0	0	0	0	0	0	0	0
<i>Pterogorgia citrina</i>	0	0	0	0	0	0	0	0	0	0	0	0	0	0	0	0	0	0	0	0
ECHINODERMATA																				
<i>Actinopyga agassizii</i>	0	0	0	0	0	0	0	0	0	0	0	0	0	0	0	0	0.1	0	0	0
<i>Astropecten duplicatus</i>	0	0	0	0	0	0	0	0	0	0	0	0	0	0	0	0	0.2	0	0	0
<i>Astrophyton muricatum</i>	0	0	0	0	0	0	0	0	0	0	0	0	0	0	0	0	0.1	0	0	0
ECTOPROCTA (BRYOZOANS)																				
<i>Bugula sp.</i>	92	84	66	15	85	21	0	37	8	25	11	0	0.6	0	0	0	0	0	0	0
CRUSTACEA																				
<i>Menippe mercenaria</i>	0.3	0	0.5	0	0.2	0	0	0.1	0.1	0.1	0	0	0	0	0	0	0	0	0	0
<i>Panulirus argus</i>	0	0	0	0	0	0	0	0	0	0	0	0.2	0	0	0	0	0	0	0	0
<i>Periclimenes americanus</i>	0	0	0	0.2	8.0	9.0	0	0.1	0	4.0	6.0	0	0	0	0	0	0	0	0	
<i>Alpheus floridanus</i>	0	0	0	0	0.2	0	0	0	0	0	0	0.4	0	0	0	0	0	0	0	0
<i>Pagurus sp.</i>	0	0	0	0	0	0	0	2.0	0	0	0	0.4	0	0	0	0	0	0	0	0
<i>Balanus amphitrite niveus</i>	210	0.4	85	6.0	190	10	65	17	49	0.5	0	0	0	0	0	0	0	0	0	0
<i>Stenopus hispidus</i>	0	0	0	0	0	0	0	0	0	0	0	0.2	0	0	0	0.2	0	0	0	0
<i>Squilla sp.</i>	0	0	0	0	0	0	0	0	0	0	0	0.2	0	0	0.1	0	0	0	0	0

Organism

Station

	1		2		3		4		5		6		7		8		9		10	
	A	B	A	B	A	C	B	A	B	A	B	A	B	A	B	A	B	A	B	

ALGAE

<i>Cyanophyceae</i>	C	C	C	C	C	C	P	P	P	P	P	P	P	P	P	P	P	P	P	P
<i>Schizothrix</i> sp.	C	C	C	C	C	C	P	P	P	P	P	P	P	P	P	P	P	P	P	P
<i>Oscillatoria</i> sp.																				
<i>Chlorophyceae</i>																				
<i>Halimeda discoidea</i>	O	O	O	O	O	O	O	O	O	O	O	O	C	O	C	C	P	P	P	P
<i>Cladophora gracilis</i>	P	O	P	O	P	O	P	O	P	O	P	O	P	P	P	P	P	P	P	P
<i>Caulerpa prolifera</i>	O	O	O	O	O	O	O	O	O	O	O	O	O	O	O	O	P	O	C	P
<i>Phaeophyceae</i>																				
<i>Dictyota dichotoma</i>	O	O	O	O	O	O	O	O	O	O	O	O	P	O	P	P	O	O	O	O
<i>Rhodophyceae</i>																				
<i>Gracilaria blodgettii</i>	P	O	P	O	P	O	P	O	P	O	P	O	P	O	P	O	O	O	O	O
<i>Ceramium tenuissimum</i>	C	P	P	P	C	P	O	P	P	P	P	P	P	P	O	O	O	O	P	P

SERPULIDAE

<i>Hydroides norvegica (elegans)</i>	36	46	294	60	350	150	0	49	20	8	0	0	0	20	0	0	0	0	2	4
<i>Hydroides parva</i>	0	0	0	0	0	0	0	0	0	0	0	0	7	0	0	0	0	0	10	53
<i>Hydroides dirampha (lumulifera)</i>	445	2467	2393	3263	1950	2062	205	440	170	220	426	0	185	0	0	0	129	2	6	6
<i>Fomatostegus stellatus (?)</i>	0	0	0	0	0	0	0	0	0	0	0	10	0	0	0	0	0	0	0	0
<i>Hydroides</i> sp.	0	0	0	0	0	0	0	0	0	0	0	1	24	0	0	0	0	0	0	0
<i>Serpula</i> sp. (undescribed)	0	0	0	0	0	0	0	0	0	0	0	10	73	0	12	0	0	0	0	0
<i>Spirorbis</i> sp.	0	0	0	0	0	0	0	0	0	0	0	0	0	0	0.2	0	0	0	0	10

CIRRATULIDAE

<i>Cirriformia filigera</i>	P	O	68	P	211	81	0	P	0	P	0	0	2	0	0	0	0	25	0	0
<i>Tharyx marioni</i>	C	P	C	P	740	50	0	P	0	P	P	63	560	0	0	0	0	13	0	0

EUNICIIDAE

<i>Eunice floridana</i>	0	0	22	0	11	11	0	20	0	P	0	39	12	0	0	0	0	0	0	0
<i>Eunice cariboea</i>	0	0	0	0	0	0	0	0	0	0	0	10	0	0	10	0	0	0	0	0
<i>Eunice antennata (?)</i>	0	0	0	0	0	0	0	0	0	0	0	10	0	0	0	0	0	0	0	0
<i>Eunice</i> sp. A	0	0	0	0	9	0	0	0	0	0	0	0	0	0	0	0	0	0	0	0
<i>Eunice</i> sp. B	0	0	0	0	0	0	0	0	0	0	0	30	0	0	0	0	0	0	0	0
<i>Lysidice collaris</i>	0	0	0	0	0	0	0	0	0	0	0	40	10	0	0	0	0	0	0	0
<i>Nematoneis</i> sp.	0	0	0	0	0	0	0	0	0	0	0	1	0	0	0	0	0	0	0	0

Organism	Station																				
	1		2		3		4		5		6		7		8		9		10		
	A	B	A	B	A	B	A	B	A	B	A	B	A	B	A	B	A	B	A	B	
SYLLIDAE																					
<i>Syllinae sp. A</i>	0	0	0	0	1.2	13	0	0	0	0	0	0	20	30	0	0	0	0	0	0	0
<i>Syllinae sp. B</i>	0	0	0	0	1.2	0	0	0	0	0	0	0	0	0	0	0	0	0	0	0	0
LUMBRINERIEDAE	0	0	0	0	5	0	0	0	0	0	0	0	60	11	0	0	0	0	0	0	0
SABELLIDAE																					
<i>Sp. A</i>	0	0	0	0	0	0	0	0	0	0	0	0	11	0	0	0	0	0	0	0	0
<i>Sp. B</i>	0	0	0	0	0	0	0	0	0	0	0	0	15	0	0	0	0	0	0	0	0
<i>Branchioma nigromaculata</i>	850	640	445	185	453	20	0	250	113	360	70	10	21	0.1	0	0	0	0	0	0	4
<i>Potamilla reniformis</i>	0	0	0	0	0	0	0	0	0	0	0	0	20	0	0	0	0	0	0	0	0
<i>Hypsicoelus elegans (?)</i>	0	0	0	0	0	0	0	0	0	0	0	15	0	0.5	11	0	0	0	2	0.2	0
<i>Jasmineira sp.</i>	0	0	0	0	0	0	0	0	0	0	0	0	10	0	0	0	0	0	0	0	0
DORVILLEIDAE																					
<i>Dorvilia sp.</i>	0	0	0	0	0	0	0	0	0	0	0	10	10	0	0	0	0	0	0	0	0
TEREBELLIDAE																					
<i>Terebellobranchia ricki</i>	0	0	0	0	0	0	0	0	0	0	0	12	0	0	0	0	0	0	5	1	0
<i>Pista cristata</i>	0	0	0	0	0	0	0	0	0	0	0	0	0	0	0	0	0	0	3	17	0
HESIONIDAE	0	0	0	0	0	0	0	0	0	0	0	4	0	0	0	0	0	0	0	0	0
NEREIDAE	0	0	0	0	0	0	0	0	0	0	0	1	0	0	0	0	0	0	0	0	0
SPIONIDAE	0	0	0	0	1	0	0	0	0	0	0	1	0	0	0	0	0	0	0	0	0
PHYLLODOCIDAE	0	0	0	0	0	0	0	0	0	0	0	2	0	0	0	0	0	0	0	0	0
LYSARETIDAE																					
<i>Oenone fulgida</i>	0	0	0	0	0	0	0	0	0	0	0	1	1	0	0	0	0	0	0	0	0
CAPITELLIDAE	0	0	0	0	2	0	0	0	0	0	0	0	0	0	0	0	0	0	0	0	0

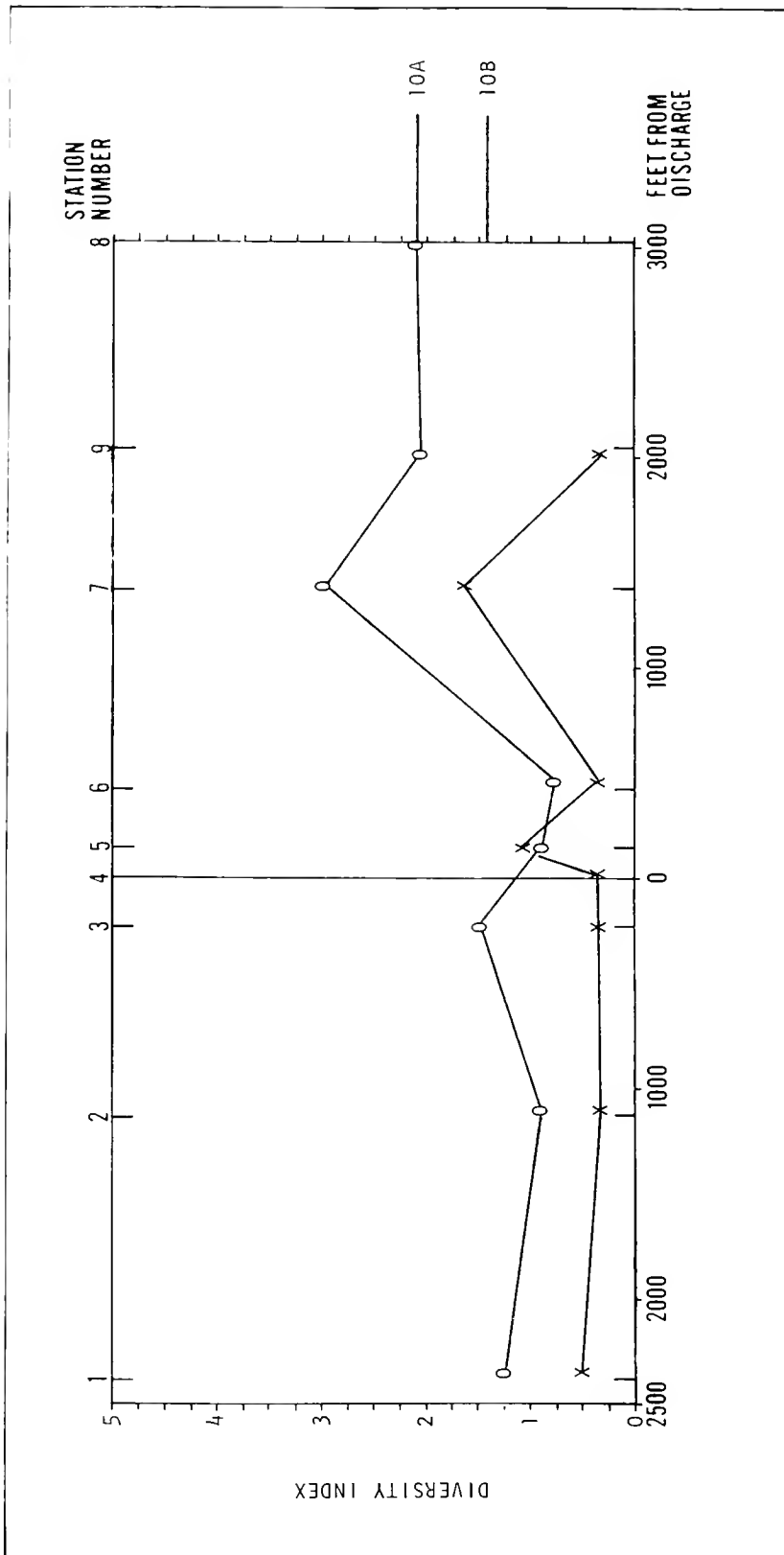

FIG.28 DOMINANCE DIVERSITY INDICES FOR ALL SAFE HARBOR STATIONS BASED ON COLLECTIONS ACCUMULATED FROM JULY, 1970 TO OCTOBER, 1971. X = B STATIONS, O = A STATIONS.

TABLE VI

FAUNAL SIMILARITY INDICES BETWEEN SAFE HARBOR STATIONS

STATIONS	1A	1B	2A	2B	3A	3C	4	5A	5B	6A	6B	7A	7B	8	9A	9B	10A
1A	-																
1B	0.494	-															
2A	0.430	0.892	-														
2B	0.266	0.802	0.766	-													
3A	0.428	0.575	0.790	0.587	-												
3C	0.262	0.759	0.790	0.796	0.714	-											
4	0.140	0.127	0.148	0.140	0.126	0.159	-										
5A	0.637	0.381	0.388	0.320	0.333	0.340	0.408	-									
5B	0.360	0.173	0.193	0.163	0.164	0.164	0.695	0.557	-								
6A	0.596	0.335	0.323	0.217	0.279	0.192	0.592	0.813	0.764	-							
6B	0.471	0.270	0.261	0.251	0.226	0.315	0.524	0.762	0.568	0.651	-						
7A	0.014	0.006	0.017	0.005	0.037	0.059	0	0.055	0.026	0.028	0.022	-					
7B	0.173	0.107	0.110	0.100	0.322	0.176	0.293	0.264	0.313	0.304	0.275	0.215	-				
8	0.0001	0	0.0005	0	0.0001	0.0001	0	0.001	0.0001	0.0001	0.0001	0.013	0.0003	-			
9A	0.004	0	0.001	0	0.001	0	0	0.007	0	0.006	0	0.177	0.025	0.028	-		
9B	0.146	0.076	0.037	0.070	0.062	0.101	0.633	0.271	0.518	0.461	0.397	0.002	0.229	0.003	0.006	-	
10A	0.008	0.002	0.017	0.002	0.021	0.033	0.011	0.015	0.018	0.021	0.007	0.102	0.036	0.006	0.147	0.023	-
10B	0.017	0.008	0.008	0.008	0.008	0.011	0.033	0.032	0.061	0.057	0.033	0.053	0.027	0.003	0.013	0.051	0.205

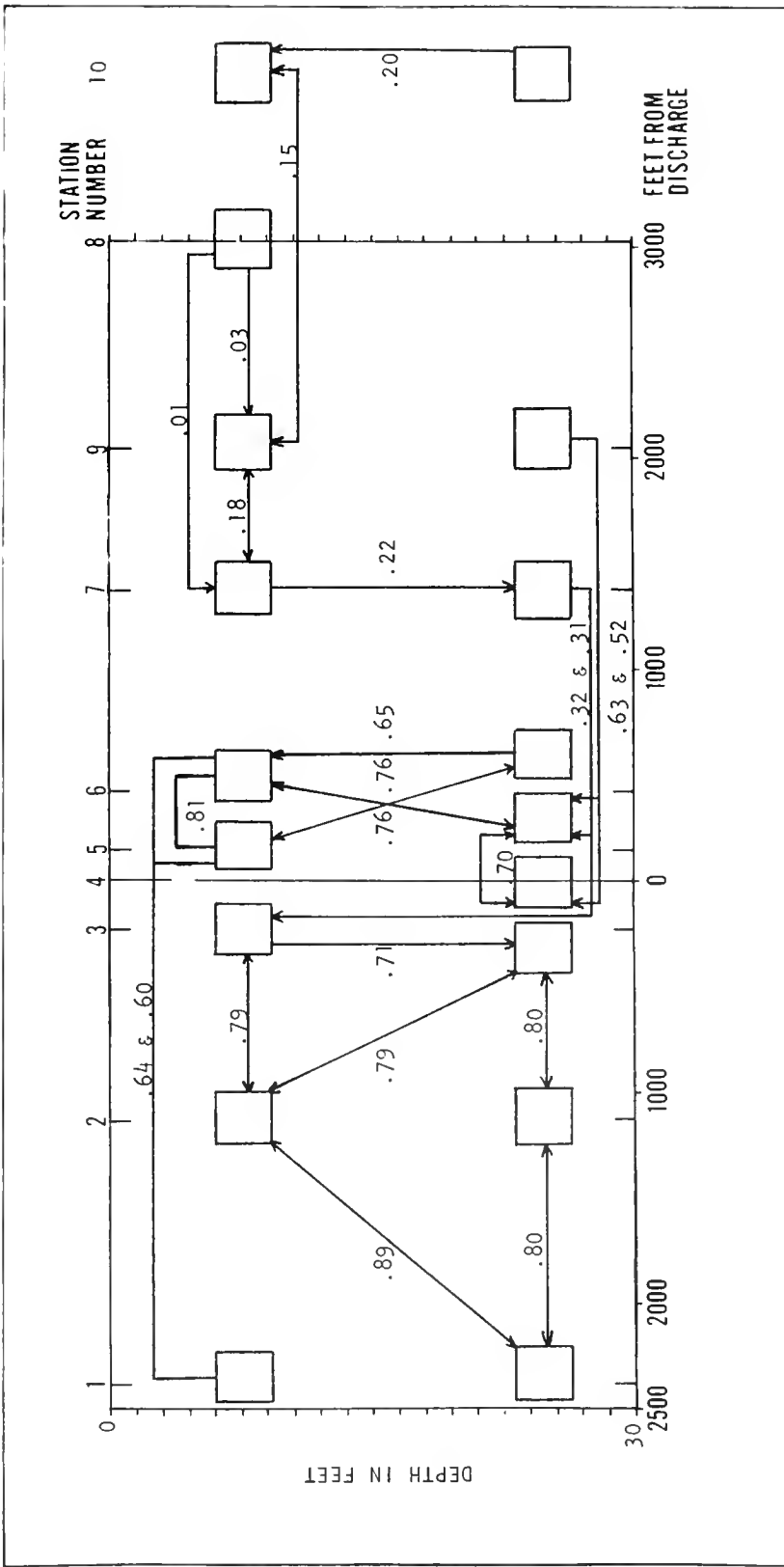

FIG. 29 TWO LARGEST SIMILARITY INDICES FOR EACH STATION IN SAFE HARBOR, INDICATING AFFINITIES IN POPULATION STRUCTURES, FROM JULY, 1970 TO OCTOBER, 1971.

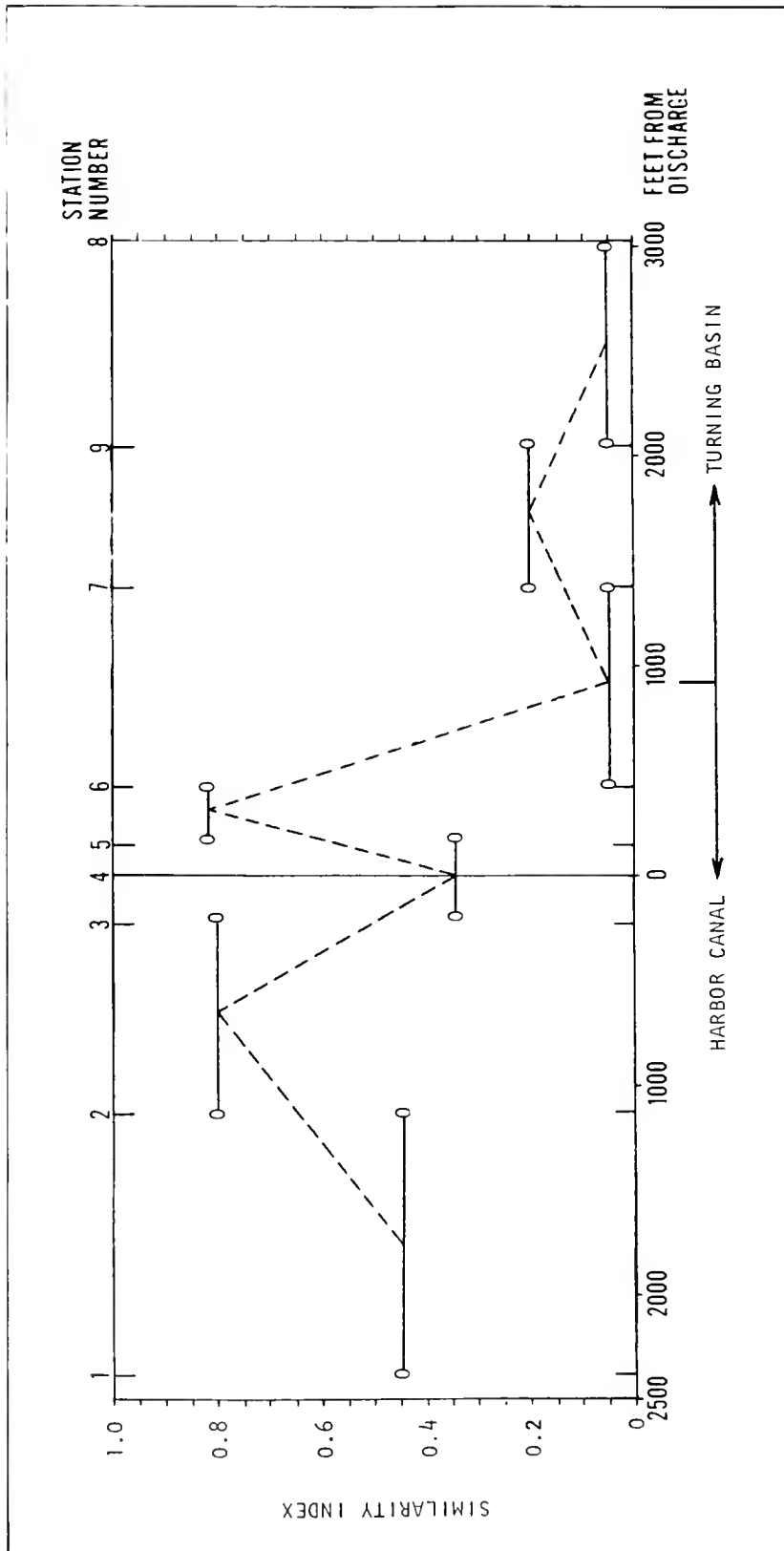

FIG. 30 SIMILARITIES IN POPULATION STRUCTURE BETWEEN SHALLOW STATIONS IN SAFE HARBOR FROM JULY, 1970 TO OCTOBER, 1971.

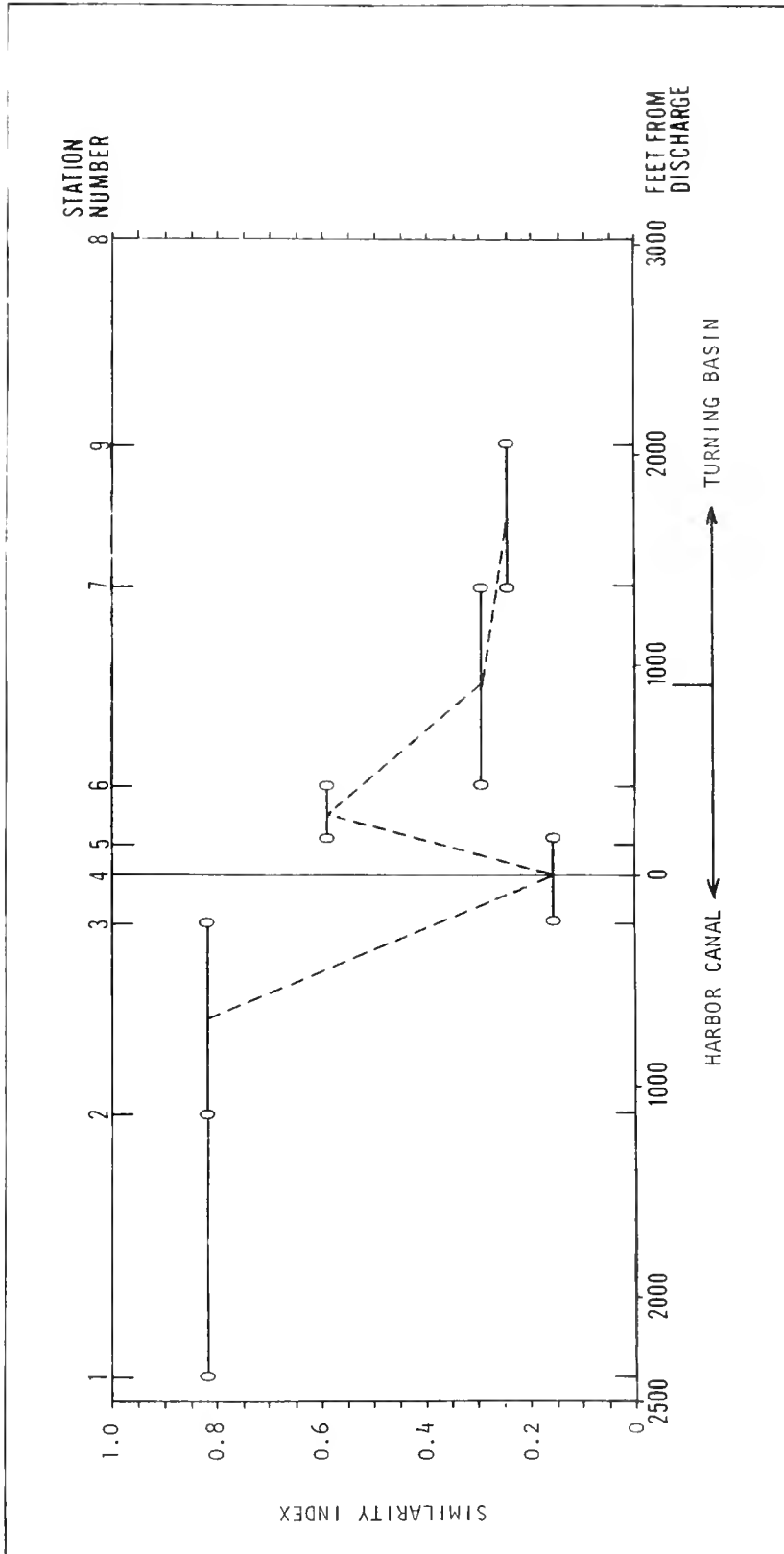

FIG. 31 SIMILARITIES IN POPULATION STRUCTURE BETWEEN DEEP STATIONS IN SAFE HARBOR FROM JULY, 1970 TO OCTOBER, 1971.

The quadrats provided a means of recording chronological changes in the macroinvertebrate fauna. Two of the quadrats were at locations set up in December, 1968. Clarke's (1970) Station 3, directly in the path of the effluent plume, became Station 4. From 1968 to 1971 only a sparse cover of serpulids and barnacles were common in this quadrat.

Clarke's (1970) Station 2A became Station 3A. There were marked changes in this quadrat from 1968 to 1971 in the number of specimens of *Ascidia nigra*. In December, 1968, there were three per square meter. This value rose to fifteen per square meter by February, 1969 and was ten per square meter in May, 1969. In July, 1970, there were six per square meter and by September, 1970, *A. nigra* had vanished from the quadrat as well as from the adjacent rock wall. By the end of October, 1970, *A. nigra* was gone from all of the entrance canal and inner harbor stations except 1A where they persisted until April, 1971. In September, 1971, ten specimens of *A. nigra* were present at Station 3A and in October there were seven specimens. The increase in numbers of *A. nigra* followed the pronounced drop in ambient dissolved copper and in copper content in the effluent (figs. 10 and 11).

The green algae, *Cladophoropsis membranacea*, and the red-green algal turf which was abundant in 1968 and during the summer months of 1970, was missing from 3A from October, 1970 to July, 1971. Cheilostomatid bryozoans (*Bugula* sp.) which were common in 1968 and the early summer months of 1970 were absent from March, 1971 until September, 1971. In August, 1970 *Branchiomma nigromaculata*, a sabellid worm, became very abundant at Station 3A. In November and December, 1970 these worms died out in a mass mortality from unknown causes. Populations of *B. nigromaculata* did not die in embayments adjacent to Safe Harbor, nor is the animal known to be seasonal in other Florida areas (Taylor, personal communication). In July, 1971 *B. nigromaculata* populations became established again at 3A. In October, 1971, however, relatively few remained.

From December, 1970 until July, 1971 the fauna at Station 3A consisted primarily of serpulid worms (mostly *Hydrooides dirampha*), a few barnacles (*Balanus amphitrite*), and two polychaete worms (*Cirriiformia filigera* and *Tharyx marioni*). These organisms maintained good populations at 3A from July, 1970 until October, 1971.

Station 1A was near Clarke's (1970) Station 1 in the inner harbor. *A. nigra* remained at about the same level of abundance at the inner harbor station from December, 1968 until February, 1971. There were three individuals per square meter in December, 1968; six in January, 1969; five in June, 1969; three in July, 1970; five in September, 1970; and seven in December, 1970. By April, however, the number decreased to zero, where it remained until one specimen appeared in October, 1971. Bryozoan colonies remained in good condition at 1A through the study period.

All stations in the effluent (i.e. the "B" series of stations) with the exception of 9B and the control station 10B, were similar. The quadrats were on rock outcroppings covered with a thick layer of serpulids (*H. dirampha* and *H. norvegica*). A few bryozoans (*Bugula* sp.) occurred at most stations in the summer of 1970 (4B had none), and occasionally sabellids settled on the rocks. Siltation was heavy in these quadrats and Station 6B, directly across from the discharge, completely silted over in December, 1970 killing everything in the quadrat.

There was a marked difference between the faunas in the "A" and "B" series quadrats throughout the Safe Harbor area during 1970. In 1971, however, deteriorating conditions at Stations 2A, 3A, 5A, and 6A caused these to resemble the lower stations (Fig. 29, Table VI). Station 7B (in the turning basin) showed many faunistic similarities with B stations inside the harbor, including a good serpulid fauna, a few bryozoans and ascidians, and little algae. The abundance of dead *Chama* and *Acra* shells attached to the wall also resembled the lower portions of the wall in the harbor. Station 7A, only about ten feet above 7B, was markedly different from 7B and the other stations in the harbor (Fig. 20). There were few serpulids or sabellids, good algal growth (predominantly *Halimeda* sp.), an occasional lobster (*Panulirus argus*), colonial tunicates, three genera of lamellibranches (*Lima scabra*, *Chama floridana*, and *Acra imbricata*), coral colonies (*Siderastrea radians*), shrimp (*Stenopus hispidus*), an anemone (*Bartholomea annulata*), and from two to five specimens of *A. nigra* (Table V). In December, 1970 the *Acra imbricata* died and the *Chama floridana* were not present in February, 1971. The *Halimeda* was in poor condition in February, 1971 and dead by April, 1971.

Station 8, in the approach channel to the turning basin, bore almost no similarity with Safe Harbor stations (Fig. 29, Table VI). The Station 8 quadrat had numerous gorgonian colonies, many specimens of *Acra imbricata* and *Chama floridana* and coral colonies (Table V). Absence of *A. nigra*, serpulids, and other 'harbor' organisms indicated this area was not frequently exposed to effluent water.

The control station, about one mile from Safe Harbor stations (Fig. 3) had a prolific fauna and flora similar to that recorded from Safe Harbor in the Phase I investigation. The two stations (10A and 10B) were placed on a vertical rock face, thirty feet (9m) high. Like the Safe Harbor counterpart, siltation was rapid and water circulation slight. The thirty foot (9m) deep basin which adjoined undeveloped U.S. Naval property (and received no effluents) was separated from Boca Chica Channel by a sixteen foot (5m) deep ridge. It was, therefore, physically quite similar to the Safe Harbor area. Station 10A had an average of 19.8 *Ascidia nigra* per square meter from November, 1970 until October, 1971. Three species of green algae made up the majority of the algal population which covered about twenty percent of the quadrat. There were relatively few serpulids or sabellids,

several large terebellids, *Lima scabra*, *Arca imbricata*, two anemones, and several specimens of *Cirriformia* sp. (Table V).

Station 10B, in thirty feet (9m), had an average of 0.8 *Ascidia nigra* per square meter. Four species of green algae including *Udotea* sp. and some five species of sabellids and serpulids were also present in the study quadrat.

FORAMINIFERA

Foraminifera were examined quarterly from sand or mud near each quadrat. The number of live Foraminifera per cc of wet sediment are plotted in Figures 32 and 33. Analysis of these figures leads to the following conclusions:

1. Effluent from the desalination plant reduced numbers of Foraminifera in the immediate vicinity of the outfall but increased the number of Foraminifera elsewhere in the harbor when compared to Control Station 10.
2. Shallow water stations were more densely populated with Foraminifera than deep water stations in Safe Harbor, except in April, 1971 when deep and shallow foraminiferan population densities were almost the same and in October, 1971 when there were more Foraminifera at deep water stations which was normally the case at Control Station 10.
3. Numbers of living Foraminifera increased from the inner harbor seaward. Generally, they were highest at stations in the turning basin.
4. Shallow water Safe Harbor stations averaged higher foraminiferan population densities than the Control Station. Deep water Safe Harbor stations averaged lower foraminiferan population densities than the Control Station in October, 1970 were almost the same in January and July, 1971, and considerably higher than the control area in April and October, 1971.

TRANSECTS

Two transects were monitored every month along the eastern edge of the entrance canal. One transect extended along the desalination plant sea wall 434.7 feet (132.5 meters) and covered a swath from the intertidal zone down to the soft sediment at the bottom of the channel

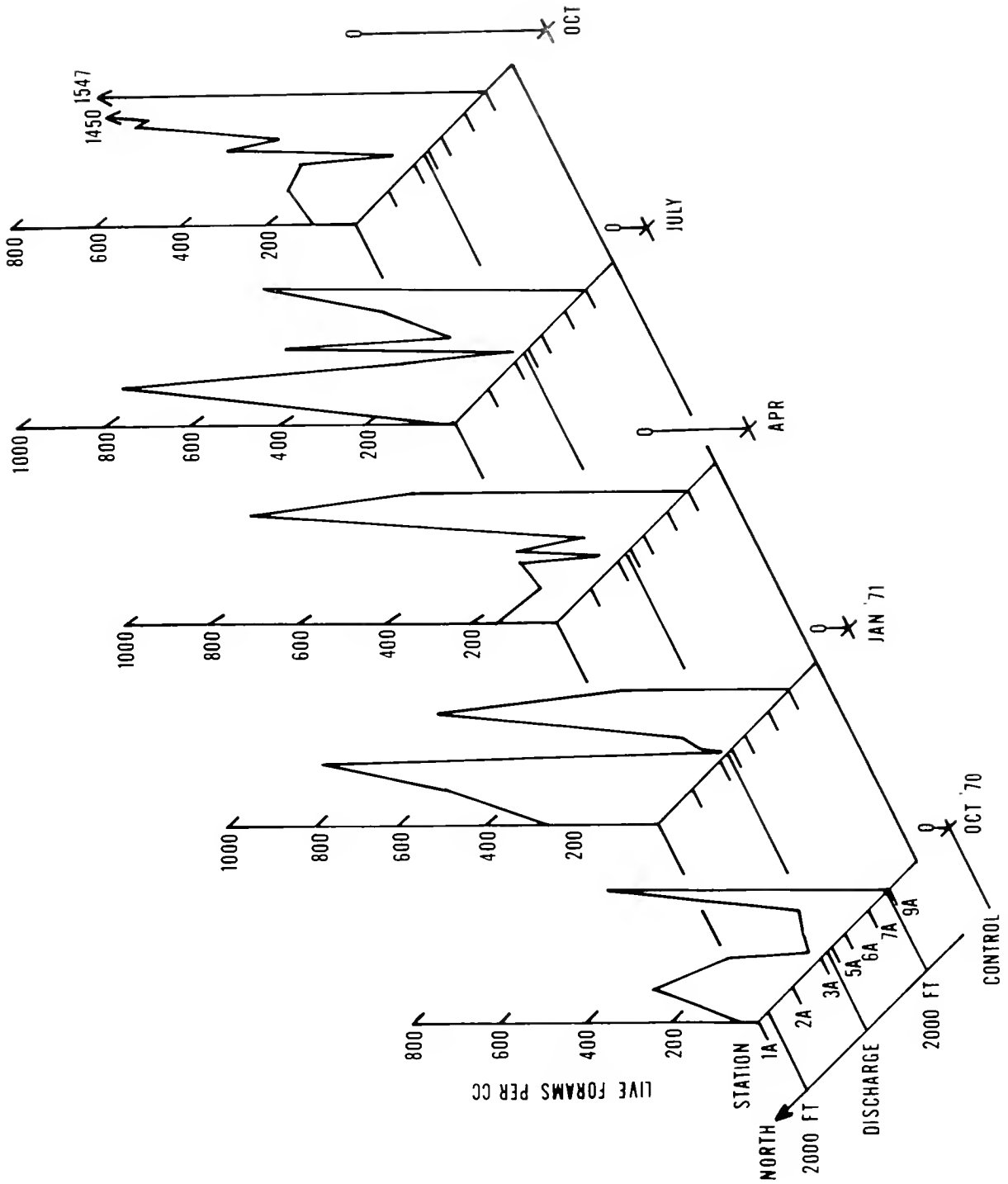

FIG. 32 LIVE FORAMINIFERA PER CC OF WET SEDIMENT FOUND AT ALL SHALLOW WATER STATIONS FROM OCTOBER, 1970 TO OCTOBER, 1971.

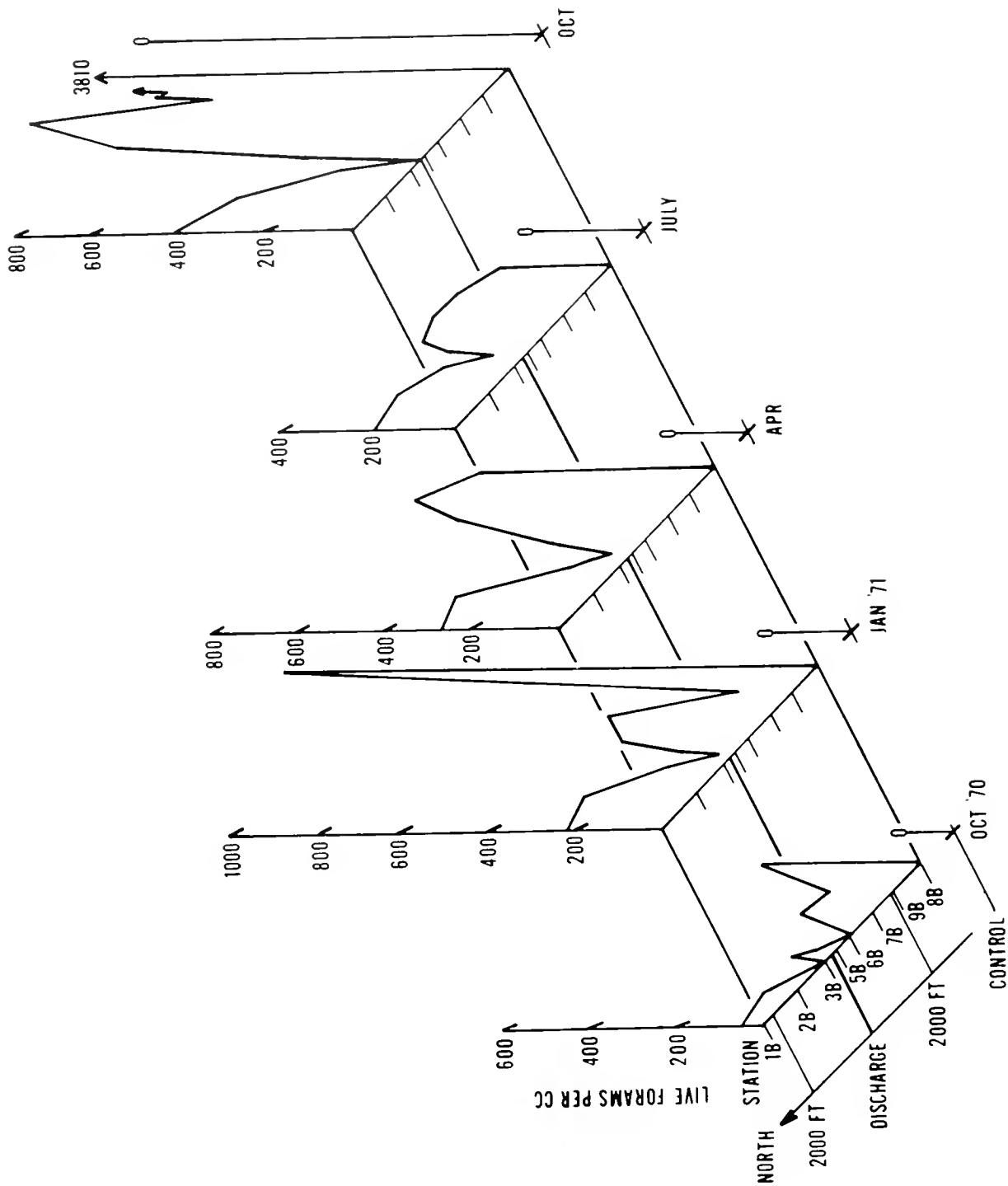

FIG. 33 LIVE FORAMINIFERA PER CC OF WET SEDIMENT FOUND AT ALL DEEP WATER STATIONS FROM OCTOBER, 1970 TO OCTOBER, 1971.

in about twenty feet (6.1m) of water. The second transect extended along the 250 foot (76.2 meter) sea wall where the new City Electric plant is being constructed. These two areas correspond closely to transect locations for the earlier 1968-69 study (Clarke *et al* 1970). Distributions of black tunicates (*Ascidia nigra*), stone crabs (*Menippe mercenaria*), lobsters (*Panulirus argus*), algae, bryozoans, serpulids, sabellids, and barnacles were plotted underwater on plastic sheets imprinted with scale drawings of the transect areas.

Figure 34 shows the monthly abundance (in numbers of individuals per 100 linear feet of sea wall) of *A. nigra*, *M. mercenaria*, and *P. argus* along the two transects. The abundance indices in Table VII, show that the numbers of all three organisms declined in both areas through June, 1971. In September, 1971, *A. nigra* achieved population levels comparable to those obtained for the 1968 study and the numbers of *P. argus* increased to 1970 levels along the City Electric plant sea wall. Numbers of *M. mercenaria* decreased well below 1968 and 1970 levels.

Comparisons between the two transect areas in Figure 34 show *A. nigra* was in lower numbers near the desalination plant (until August, 1971); *M. mercenaria* had similar numbers of individuals in both areas and *P. argus* tended to congregate in the desalination plant area during cooler months. Fluctuations in the numbers of *P. argus* were probably due to seasonal migrations in and out of shallow water areas.

The most notable changes during the monthly transects were a mass mortality of *Branchiomma nigromaculata* from October to November, 1970, and overall decline of algal turf and bryozoan colonies from October, 1970 to April, 1971, and the settlement and subsequent disappearance of *Ascidia nigra* in July, 1970 and a successful resettlement of *A. nigra*, algae, and bryozoans in August, 1971.

Observations were made of the fish populations inhabiting the transect and control areas. Since fish moved freely in and out of the Safe Harbor area and water visibility often limited observations under water, there was no satisfactory way of quantitatively assessing changes in the total fish population. Observations of fish occurrences made during the preliminary survey (Clarke *et al* 1970) remained essentially unchanged for the study period from 1970 to 1971, and few additions were made to the species list presented in the earlier study.

Observations during the past year confirmed the earlier observations that fish were attracted to the vicinity of the effluent and, in fact, numerous species were observed repeatedly swimming into the core of the effluent discharge. The tarpon (*Megalops atlantica*), mahogany snapper (*Lutjanus mahogoni*), grey snapper (*Lutjanus griseus*), and others were consistently seen in the hottest portion of the effluent. Indeed, the desalination plant sea wall had the largest number of fish and the greatest number of species seen anywhere in the harbor, turning basin, or control stations. Fish counts were occasionally made when water clarity permitted but these were of questionable accuracy

FIG. 34 NUMBER OF INDIVIDUALS PER 100 FEET OF CANAL WALL IN SAFE HARBOR, STOCK ISLAND, FLORIDA KEYS, JULY, 1970 TO OCTOBER 1971. UNSHADED AREA REPRESENTS 1970, SHADED AREA REPRESENTS 1971

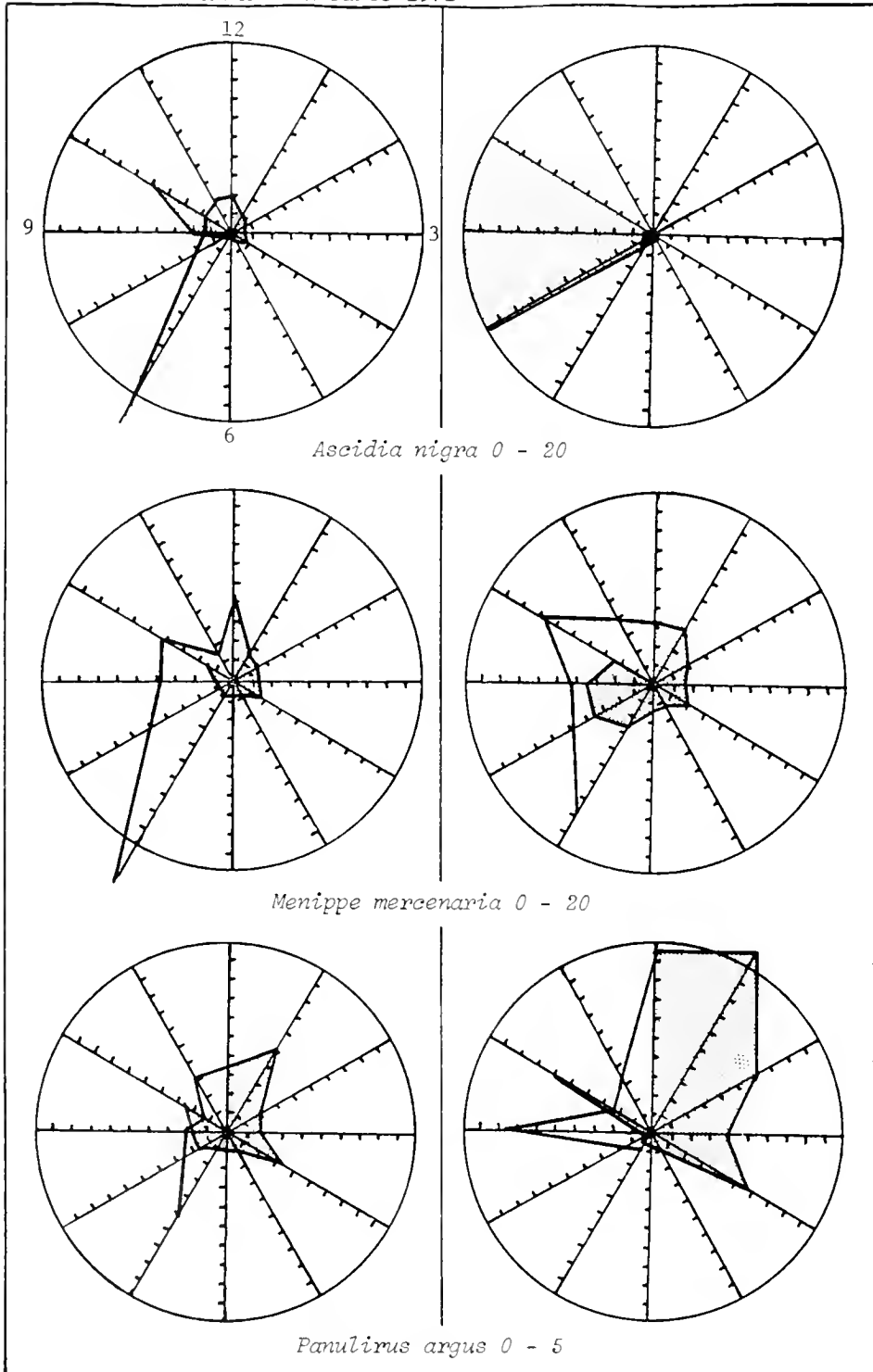

CITY ELECTRIC

DESALINATION PLANT

TABLE VII

TRANSECT COMPARISONS 1969, 1970, 1971

Abundance of organisms (number per linear 100 feet of sea wall)

		<i>Ascidia</i>	<i>Panulirus</i>	<i>Menippe</i>
June, 1969	Desalination plant sea wall	100	3.0	25.0
	City Electric sea wall	?	16.7	5.6
July, 1970	Desalination plant sea wall	2.1	0.5	14.3
	City Electric sea wall	25.0	0.8	25.0
June, 1971	Desalination plant sea wall	0	0.23	2.53
	City Electric sea wall	0	0.40	0.80
Sept. 1971	Desalination plant sea wall	118.4	0	6.7
	City Electric sea wall	4.4	0.8	1.6

since the larger fish could easily move ahead of the divers and avoid being counted or, in some cases, be counted more than once. Relative numbers of fish per unit distance, however, were obtained. In January, 1971, for example, 120 fish were counted per 100 feet (33m) of sea wall at the City Electric sea wall.

Fish showed definite avoidance reactions to turbid effusions from the desalination plant which followed the onset of operations after the plant had been shut down for maintenance. Large schools of snapper, mullet, and anchovies, as well as other species of fish, were observed swimming away from the turbid effusions or hovering in the adjacent clearer waters. Schools of mullet and anchovies, trapped by the turbid effusions in the inner canal entrance, were observed swimming in a distressed manner rapidly towards the harbor mouth. It could not be ascertained if fish were avoiding water turbidity or if they were responding to some other chemical contaminant. Sprague (1964) has made some observations along those lines, discussing the reactions of salmonid fishes to copper and zinc solutions at levels of 20 ppb in freshwater.

Many species of fish become inactive at night (Starck and Davis 1967). Night dives in the Safe Harbor canal revealed specimens of snook (*Centropomus undecimalis*) inactive on the floor of the canal and a variety of other fishes quietly resting along the rocky walls of the canal. These fish, presumably, would not flee high levels of contaminants should they be released at night. Many smaller species retreated into holes and crevices in the canal wall when alarmed during the day and were also unlikely to escape the contaminants in the effusions when they engulfed the area.

While it was true that fish congregated in the vicinity of the effluent when the desalination plant was operating normally, it does not necessarily follow that this was beneficial to them. Attractive parameters of the effluent such as heat and entrained plankton may have lured fish into the area while toxic parameters may have physiologically damaged them. Several fish were observed with epidermal lesions and histological examination of livers from Safe Harbor fish, discussed below, indicate that, in fact, copper toxicity was deleterious to some of the smaller fishes inhabiting the harbor.

In addition to the transects in Safe Harbor Canal, a series of transects were made both east and west of the turning basin, to determine effects of effluent moving over the western edge of the turning basin and onto the turtle grass flats. Observations by divers indicated that the echinoid population in the path of the effluent decreased markedly during 1970. The numbers per square meter of *Lytechinus variegatus* and *Tripneustes ventricosus* found in transects east and west of the turning basin are shown in Figure 35.

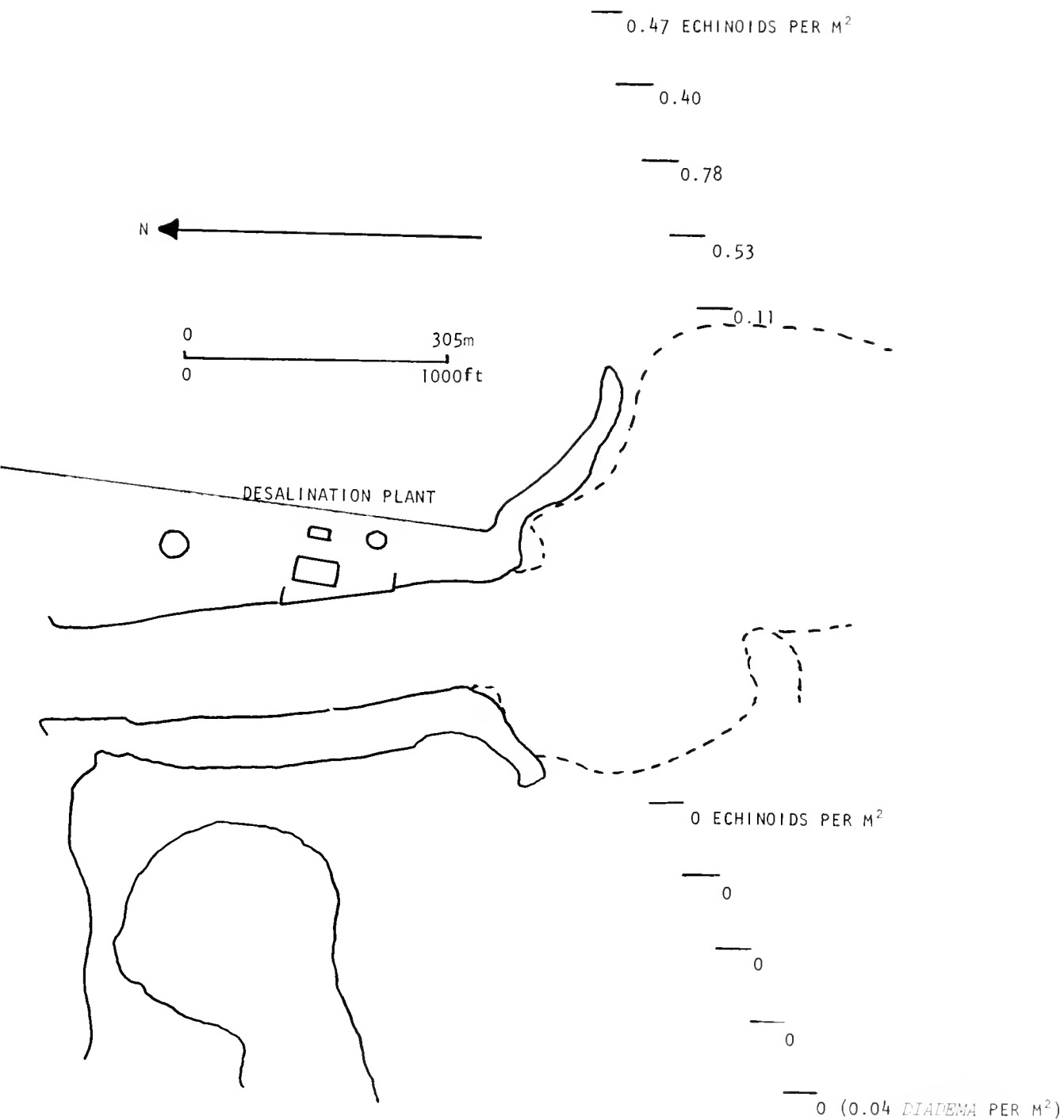

FIG. 35 NUMBERS OF *LYTECHINUS VARIEGATUS* AND *TRIPNEUSTES VENTRICOSUS* PER SQUARE METER IN TURTLE GRASS FLATS EAST AND WEST OF THE SAFE HARBOR TURNING BASIN

With the exception of five *Diadema antillarum* at the most distant points of the western transects, no live echinoids were seen in the flats west of the turning basin. Dead *Lytechinus variegatus* and *Tripneustes ventricosus* tests and fragments were found in the area indicating the recent presence of living specimens there.

During the 1968 and 1969 surveys, both *Lytechinus variegatus* and *Tripneustes ventricosus* occurred in the same area with densities closely approximating the recent population to the east of the turning basin (Clarke, unpublished data). Laboratory and *in situ* bioassays showed a high sensitivity of echinoids to the copper contained in the effluent. The high copper levels in sediments west of the turning basin implicate the flow of effluent over the flats as the cause of the echinoid mortality.

In November, 1971, an aerial photo transect was made over the turning basin to determine if there had been any changes in the pattern of turtle grass, *Thalassia testudinum*, along its borders since a similar photo transect was made in 1968 (Fig. 36). There were no detectable changes. In fact, the stability of the turtle grass was remarkable. Note, for example, the persistent shape and size of sand patches just off the two prominences which form the entrance to the canal (Fig. 36). The width of the barren area between the edge of the turning basin and the *Thalassia* beds did not change appreciably although in the 1971 survey it was covered with more algal growth and was thus darker in color.

PLANKTON TOWS

Plankton tows were taken along the desalination plant sea wall and along the eastern edge of the turning basin wall at Station 9. To determine effects of effluent on plankton populations, tows at Station 9 were used as references to compare with tows in front of the desalination plant. Shallow tows and deep tows were compared with each other and the number of plankters at the desalination plant expressed as percentages of comparable tows at Station 9. In October, 1970, the deep tow at the desalination plant had 33.8 percent the number of diatom cells found in the deep tow at Station 9. The comparable percentage for the shallow tows was 45.5 percent. Theoretically, the two tows at the desalination plant should have the same percentage differences from the control station tows. Effluent caused a greater reduction of the expected percentage in deep water (i.e. 33.8 percent rather than 45.5 percent). In October, therefore, the deep tow had only 74.3 percent the number of phytoplankters expected.

When the desalination plant was shut down, deep water was more productive than shallow water, averaging 132 percent more than the theoretical population. When the plant was operating the deep, effluent-laden, water averaged only 50.57 percent of the expected phytoplankton population.



1968



1971

Fig. 36 AERIAL SURVEYS OF TURTLE GRASS BEDS ADJOINING THE SAFE HARBOR TURNING BASIN (1968-1971).

Zooplankton data were limited. Some samples had to be acidified to remove excessive amounts of silt. Acid treatment, of course, made zooplankton counts unreliable. The data obtained showed a decrease in zooplankton populations in effluent-laden water. In October, the deep tow at the desalination plant yielded only 39.87 percent of its potential population compared to the shallow tow. In December, the zooplankton population in the deep tow was only 14.28 percent of its theoretical level. In April, the desalination plant was not operating and the zooplankton in the deep tow reached 167 percent of its theoretical population.

SETTLEMENT PANELS

Settlement panels provided data on the distribution and abundance of a variety of sessile filter feeders in Safe Harbor. For the first four months different materials were used for the panels to determine which surface provided the most suitable substrate for both settlement and analysis. By November, plywood panels were selected as the best material and analytical procedures were stabilized (see Section IV Methods and Procedures).

Monthly collections were carried out for twelve months, from November, 1970 to October, 1971. During the yearly cycle, three organisms dominated the panels; serpulid worms (*Hydroides norvegica*), sabellid worms (*Branchiomma nigromaculata*), and barnacles (*Balanus amphitrite niveus*). Other organisms which settled on the panels included hydroids, filamentous red and green algae, tunicates and bryozoans. These latter organisms occurred so infrequently at the stations that they were of little quantitative value. They became more abundant beginning in July, 1971 and reached a peak for the year in August and October. This peak was not present during the previous year and it is probable that the drop in copper discharge levels which began in June contributed to the improvement of living conditions for these organisms.

From November, 1970 to May, 1971, the settlement panels yielded an almost unispecific settlement of serpulid worms; a condition reflected in transect and quadrat analyses of the benthic fauna. Figures 37 through 40 show the distribution and abundance of the serpulid worms during the twelve month study period. They were most abundant in November, 1970. Their numbers gradually decreased until June, 1971 when there was a sudden change in the pattern of distribution of the worms and a marked decrease in their total abundance throughout the harbor. While the serpulid worms were clearly more tolerant of the effluent than other sessile organisms, the marked reduction in their numbers at Station 3C (Figs. 39 and 40) compared with adjacent stations clearly shows the deleterious impact of the effluent. This adverse effect is also brought out in Figure 41 which shows the mean number of serpulid worms at each station during the entire year. More serpulids

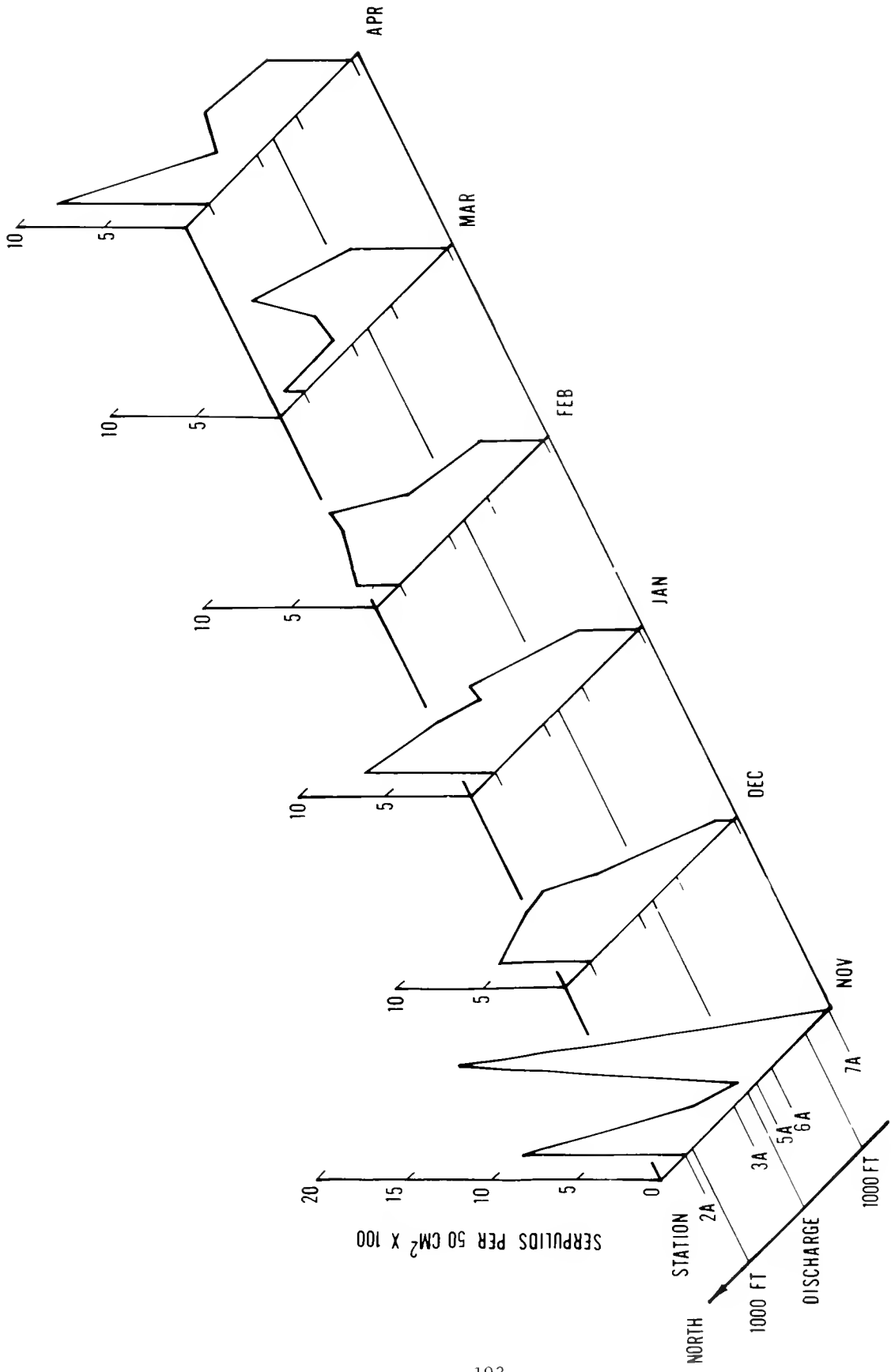

FIG. 37 NUMBERS OF SERPULID WORMS ON 30-DAY SETTLEMENT PANELS AT SHALLOW WATER SAFE HARBOR STATIONS NOVEMBER, 1970 TO APRIL, 1971.

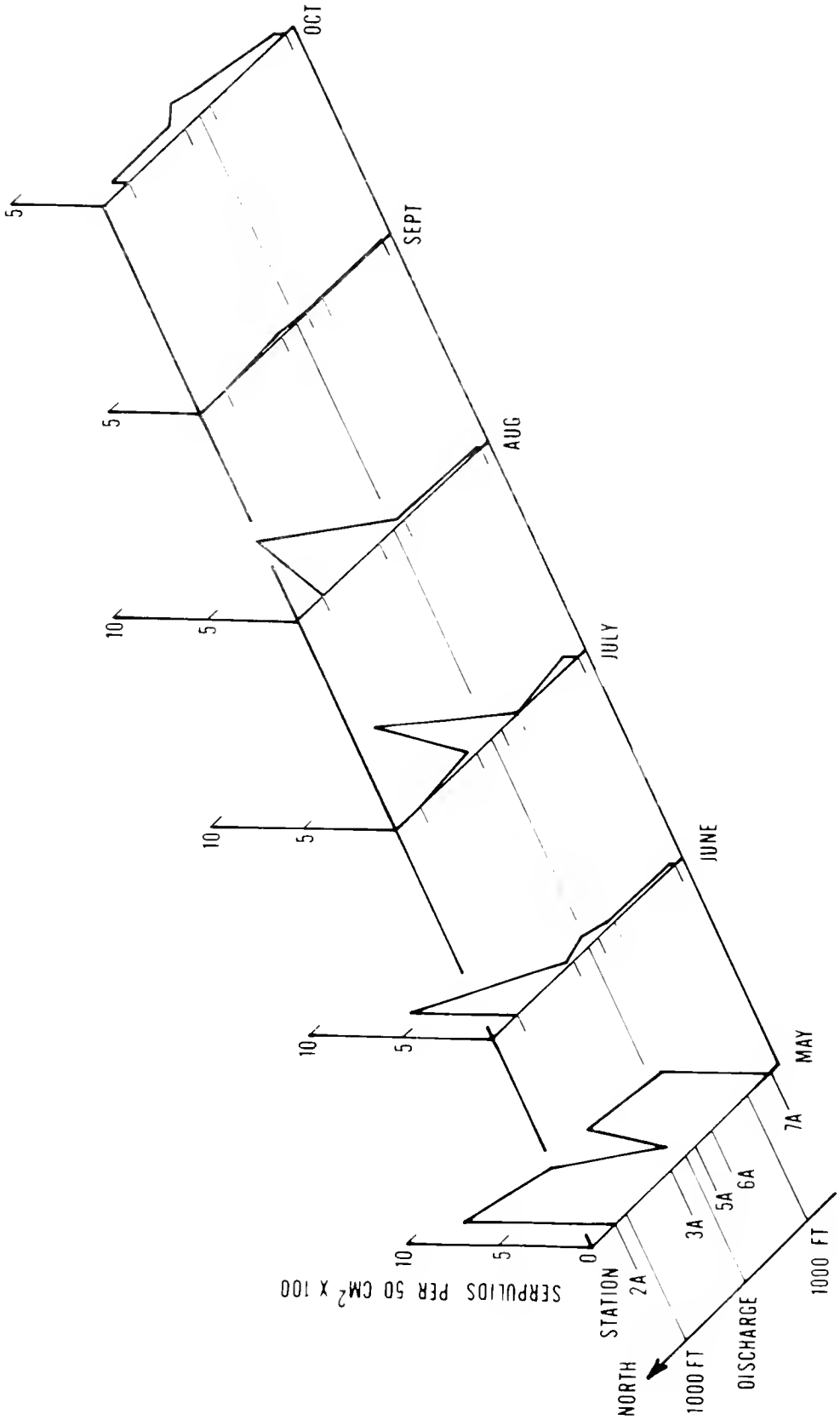

FIG. 38 NUMBERS OF SERPULID WORMS ON 30-DAY SETTLEMENT PANELS AT SHALLOW WATER SAFE HARBOR STATIONS MAY TO OCTOBER, 1971.

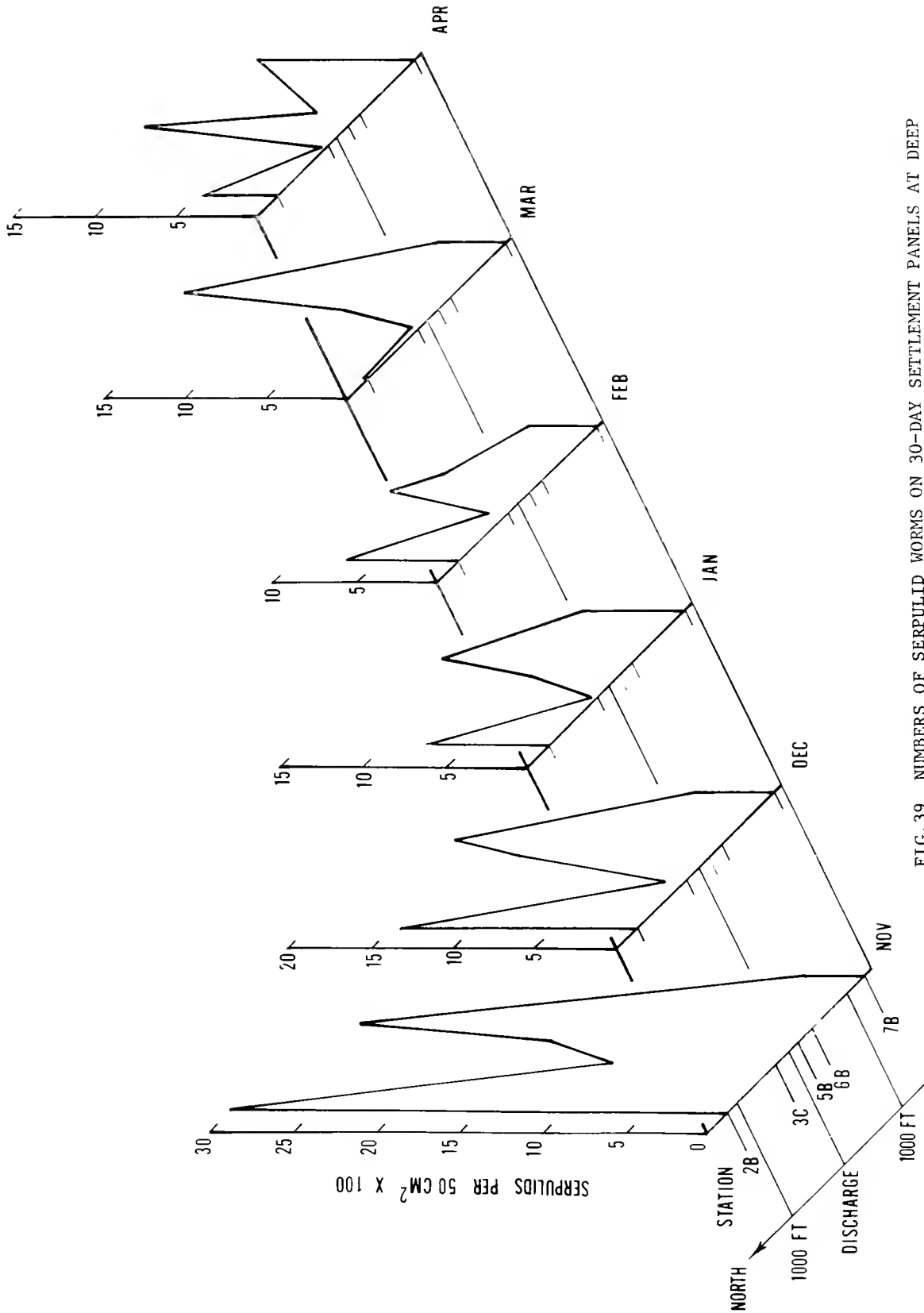

FIG. 39 NUMBERS OF SERPULID WORMS ON 30-DAY SETTLEMENT PANELS AT DEEP WATER SAFE HARBOR STATIONS NOVEMBER, 1970 TO APRIL, 1971

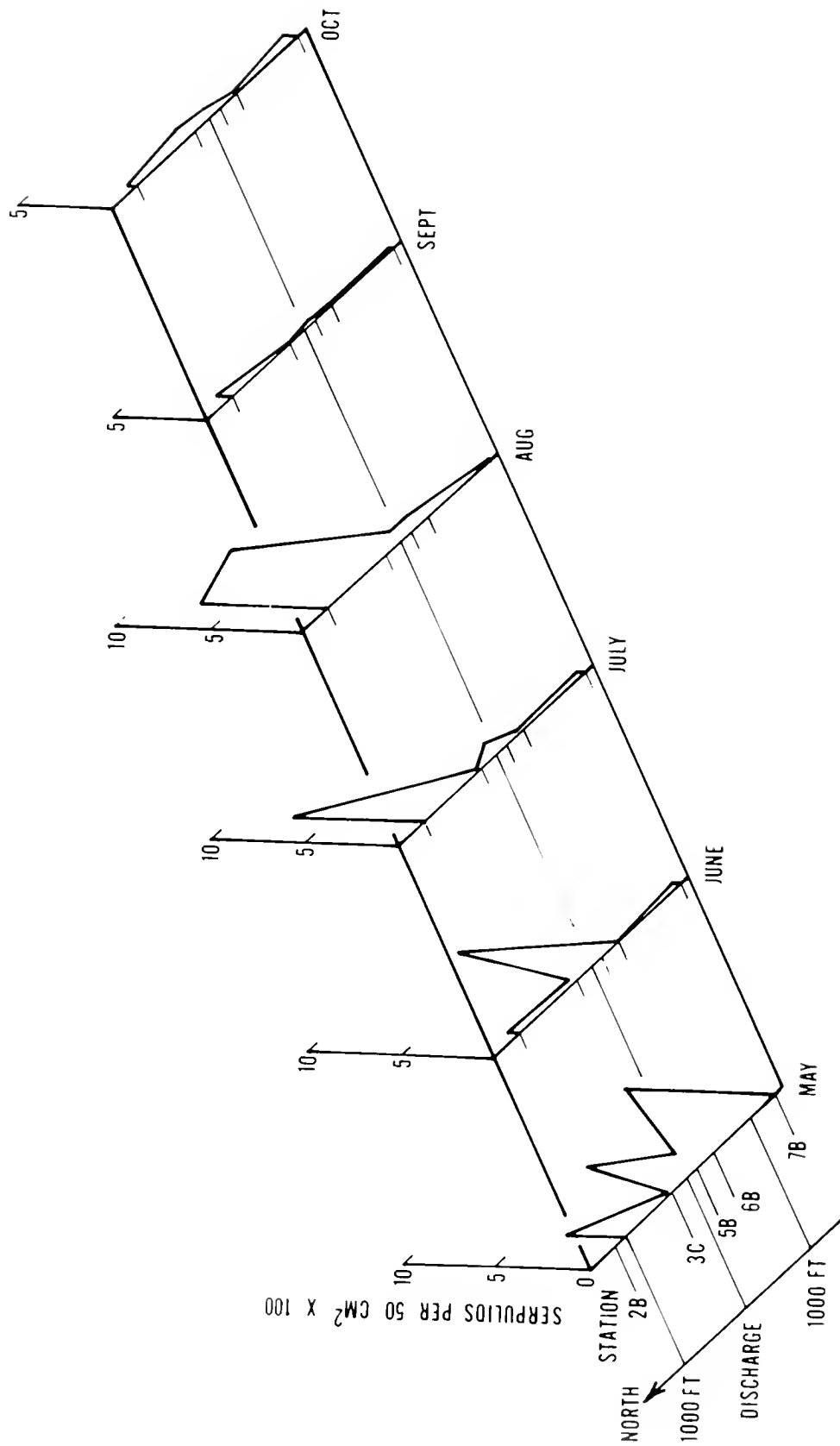

FIG. 40 NUMBERS OF SERPULID WORMS ON 30-DAY SETTLEMENT PANELS AT DEEP WATER SAFE HARBOR STATIONS MAY TO OCTOBER, 1971.

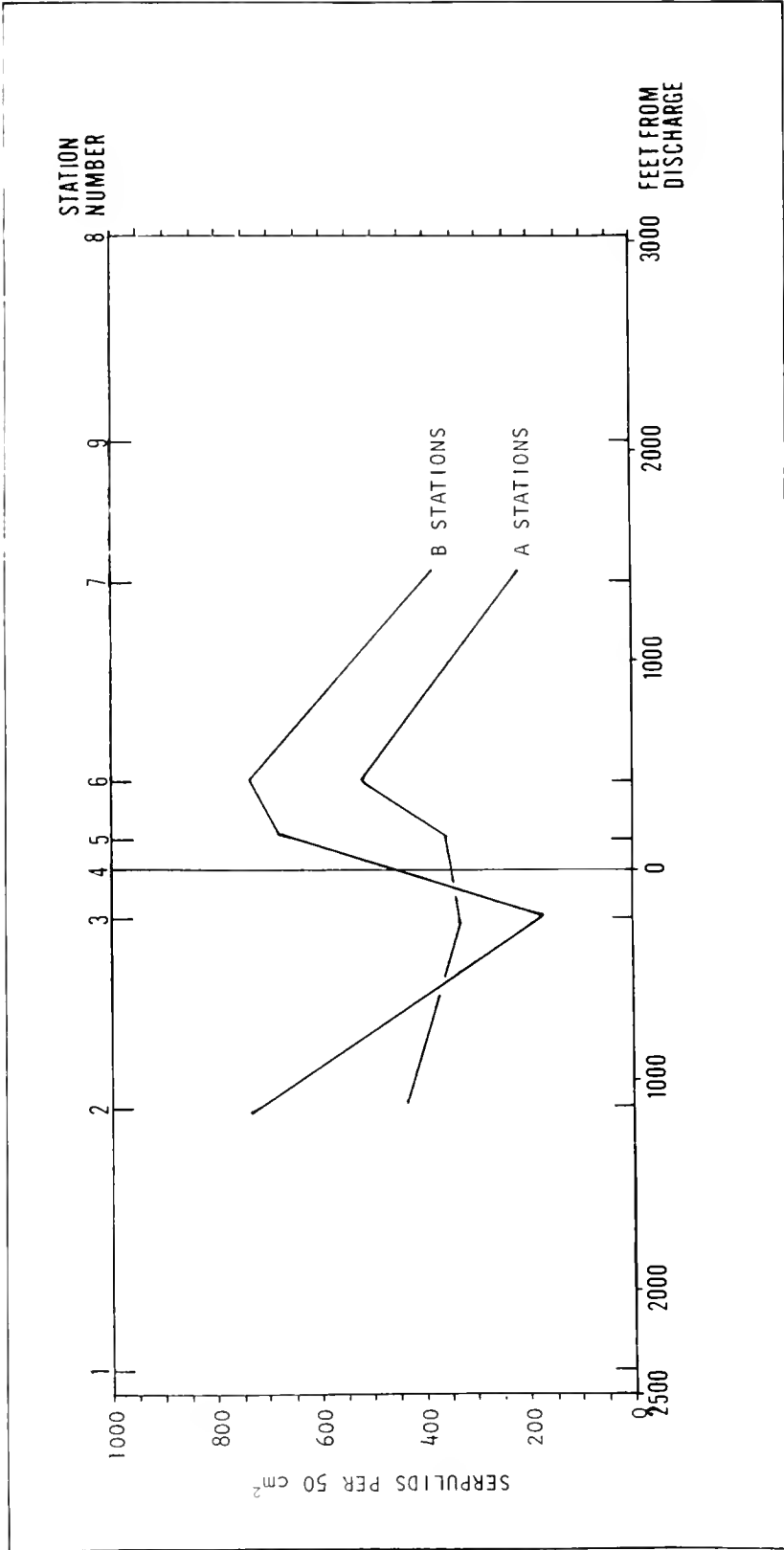

FIG. 41 MEAN NUMBER OF SERPULID WORMS SETTLING PER 50cm² PER MONTH AT BIOLOGICAL STATIONS IN SAFE HARBOR (NOVEMBER, 1970 TO OCTOBER, 1971).

settled at deep stations than shallow stations except for Station 3C. Figure 26 shows that the amount of effluent reaches a peak at Station 3C, averaging about three percent by volume throughout the year. Figures 42 and 43 show the number of serpulid worms settling per thirty day period compared with exposure to effluent. Since the seasonal availability of larvae, water currents, and larval behavior all interacted with water quality to determine numbers of individuals settling at any particular station, a 'serpulid index' was derived by comparing settlement at the "B" stations with the "A" stations directly above them. At any given time, both the "A" station and "B" station, separated by about 16 feet (4.8 meters), should have had similar exposure to larvae. By comparing the two stations for each month, differences due to availability of larvae were eliminated and the resulting differences in the abundance of larvae at the two stations reflected the influence of the effluent at the deeper station.

Use of the formula $I = \frac{A-B}{A+B}$ (where I is the serpulid index, A the number of serpulid worms settling during a thirty day period on 50cm^2 at the "A" station, and "B" the number of serpulid worms settling in the same time period on 50cm^2 at the "B" station) permitted direct comparison of the relative effect of the effluent throughout the year. If all of the serpulids settled at the deeper stations, the index would be -1 and if they all settled at the shallow station the index would be +1.

For the first six months of observation more serpulid worms settled on the shallower panels as the amount of exposure to effluent increased at the deeper panels (Fig. 42). In May, exposure to effluent was relatively constant throughout the harbor and the relative amount of settlement was also constant (Fig. 43). July and August were notable exceptions to the pattern shown in previous months. Relative numbers of serpulid worms settling in the different stations varied greatly, but were not related to the amount of effluent present (Fig. 43). During these two months the amount of copper discharged by the desalination plant was at a minimum (see section on copper and nickel above).

Settlement of the barnacle (*Balanus amphitrite niveus*) was seasonal with almost no settlement during the colder months of December through March. The adult barnacles on boats entering and mooring in the harbor contributed numerically to the local stock of adults in the inner harbor and so, the inner harbor was probably the major source of barnacle larvae. Tide and wind currents dispersed the larvae seaward, past the desalination plant. Most larval settlement was at shallow stations with Stations 2A and 3A receiving the highest number (Fig. 44). Few barnacles were able to settle on the seaward side of the effluent with the notable exception of Station 5B. At Stations 7A and 7B in the turning basin, only six specimens settled on the test panels from November, 1970 until July, 1971. This indicated that the desalination plant discharge formed a barrier to the movement of barnacle larvae out of the harbor.

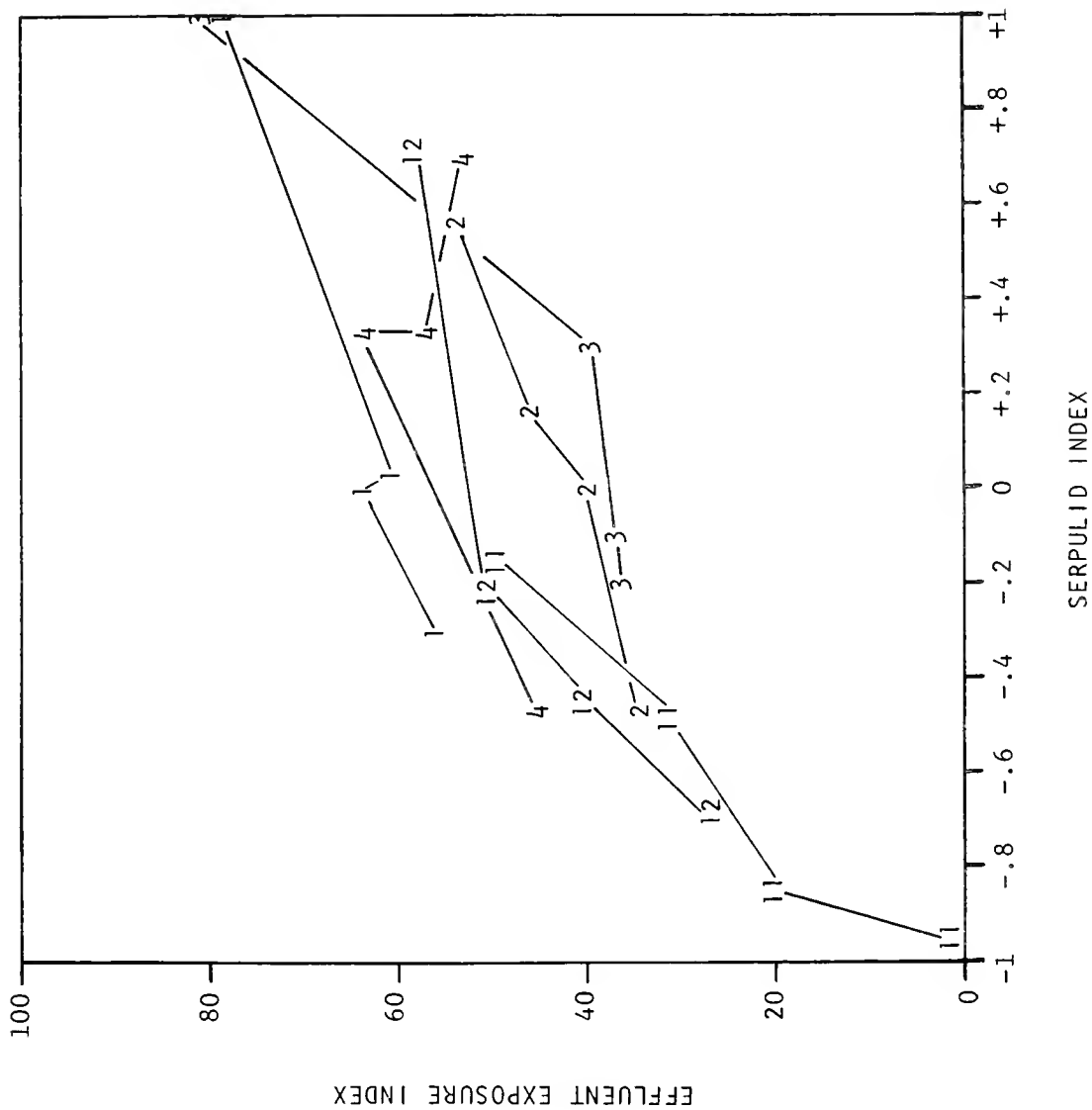

FIG. 42 MONTHLY INDICES (NOVEMBER, 1970 THROUGH APRIL, 1971) OF SERPULID WORMS SETTLING ON 50cm² WOODEN PANELS AT BIOLOGICAL STATIONS IN SAFE HARBOR COMPARED TO EFFLUENT EXPOSURE. SEE TEXT FOR EXPLANATION.

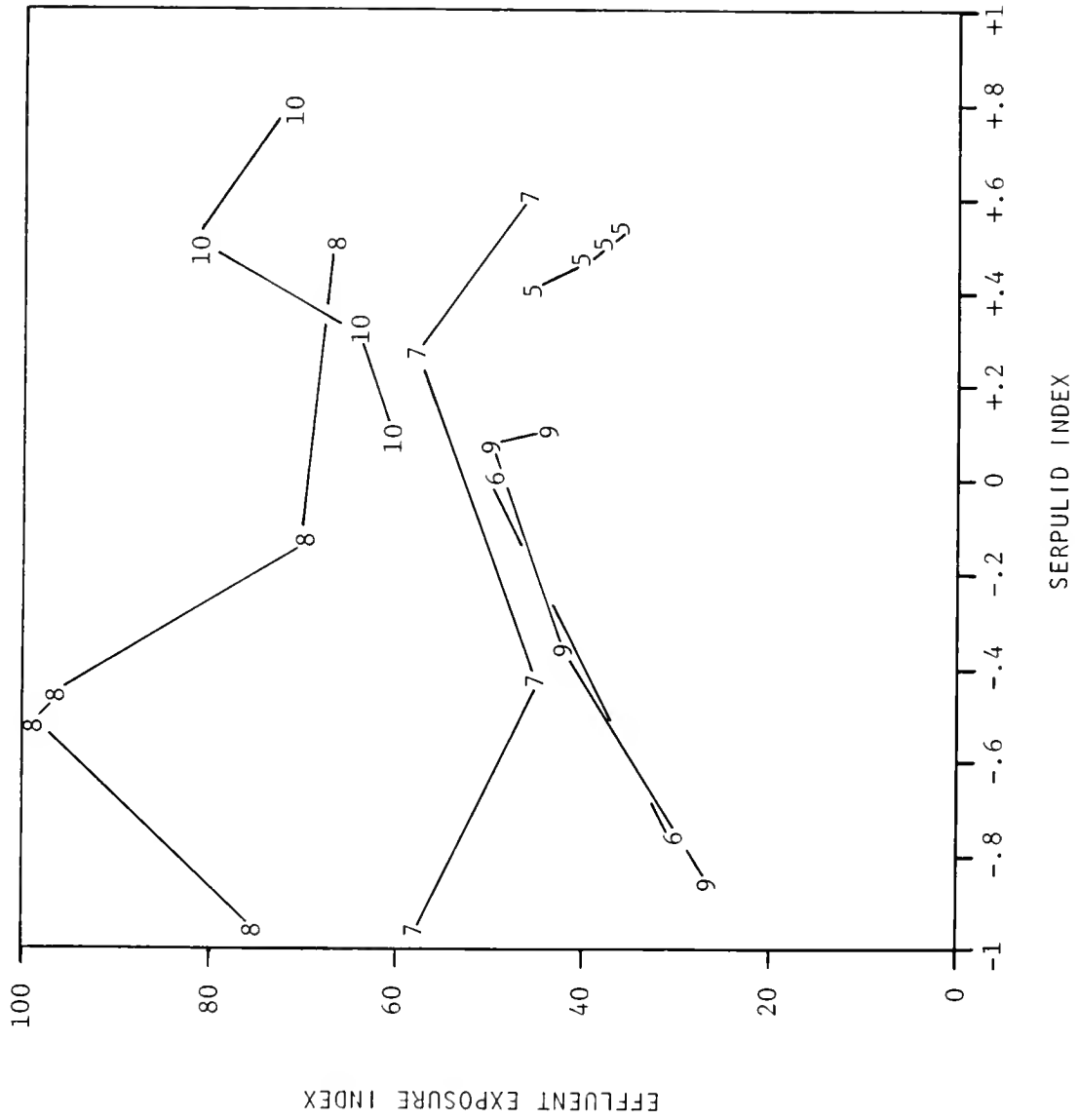

FIG. 43 MONTHLY INDICES (MAY, 1971 THROUGH OCTOBER, 1971) OF SERPULID WORMS SETTLING ON 50cm² WOODEN PANELS AT BIOLOGICAL STATIONS IN SAFE HARBOR COMPARED TO EFFLUENT EXPOSURE. SEE TEXT FOR EXPLANATION.

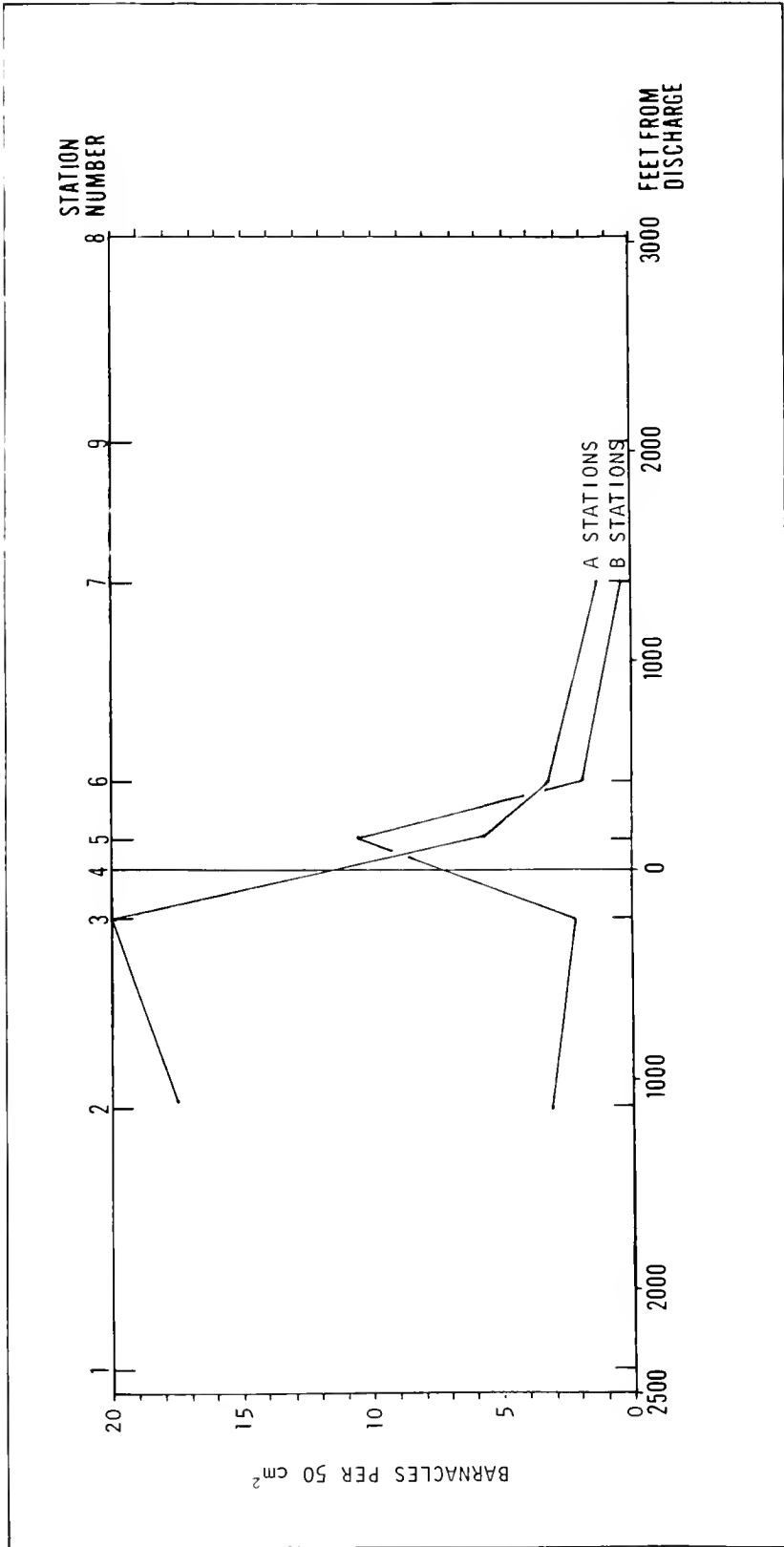

FIG. 44 MEAN NUMBER OF BARNACLES SETTLING PER 50 cm² PER MONTH AT BIOLOGICAL STATIONS IN SAFE HARBOR (NOVEMBER, 1970 TO OCTOBER, 1971).

Doochin and Smith (1951) showed that *B. amphitrite* settlement and growth were influenced by the velocity of water currents and Weiss (1948), Bertholf (1945), and Glaser and Anslow (1949) showed that shock from increased temperature, salinity and copper or reduced pH induced metamorphosis in barnacles and other invertebrates. All of these factors were characteristic of the discharge. Probably, barnacle larvae entrained in the effluent were induced to settle and metamorphose because of the combination of sudden increase in water velocity, temperature, salinity and copper along with the decrease in pH. The high rate of siltation at most of the deeper stations near the discharge prevented successful settlement of barnacle larvae. Many of the test panels were heavily covered with silt at Station 6B during the course of the study and the quadrat at that station was completely buried with silt. Station 5B, therefore, was the station at which most of the successful settlement of the entrained barnacle larvae occurred, explaining the peak in numbers shown in Figure 44.

Sabellid worms, *Branchiomma nigromaculata*, were the third most common invertebrate settling on the test panels. They were abundant during August through October, 1970. In October and November, 1970 there was a mass mortality of sabellid worms in Safe Harbor. The worms, which live in parchment-like tubes and feed on plankton, dropped out of their protective tubes and died, beginning at the desalination plant sea wall in October, and by December, reaching harbor stations. This mortality was not repeated in October, 1971 although the total number of sabellid worms settling on the test panels declined. Figure 45 shows the mean number of sabellid worms settling at the biological stations in Safe Harbor from November, 1970 to October, 1971. A decline associated with proximity to the desalination plant is evident.

All three of the common organisms on the test panels were adversely affected by high concentrations of effluent, but were much more abundant in Safe Harbor than at the control stations or in adjoining harbors. At the control stations, for example, a total of two *B. amphitrite*, twenty-two *B. nigromaculata*, and thirty *H. norvegica* settled on test panels during the twelve month period.

DIATOMETERS

Glass microscope slides were placed in PVC pipe racks at selected stations. Every two weeks, these were exchanged for a new set of slides and the exposed set was examined for protozoans and diatoms. Numbers of species and numbers of individuals per month were plotted (Figs. 46 and 47) and the values compared. Stations 3A, 7A, and 10A were shallow stations at 8 feet (24 meters), whereas Stations 3C, 7B, and 10B were deep stations at 28 feet (8.5 meters). Stations 10A and

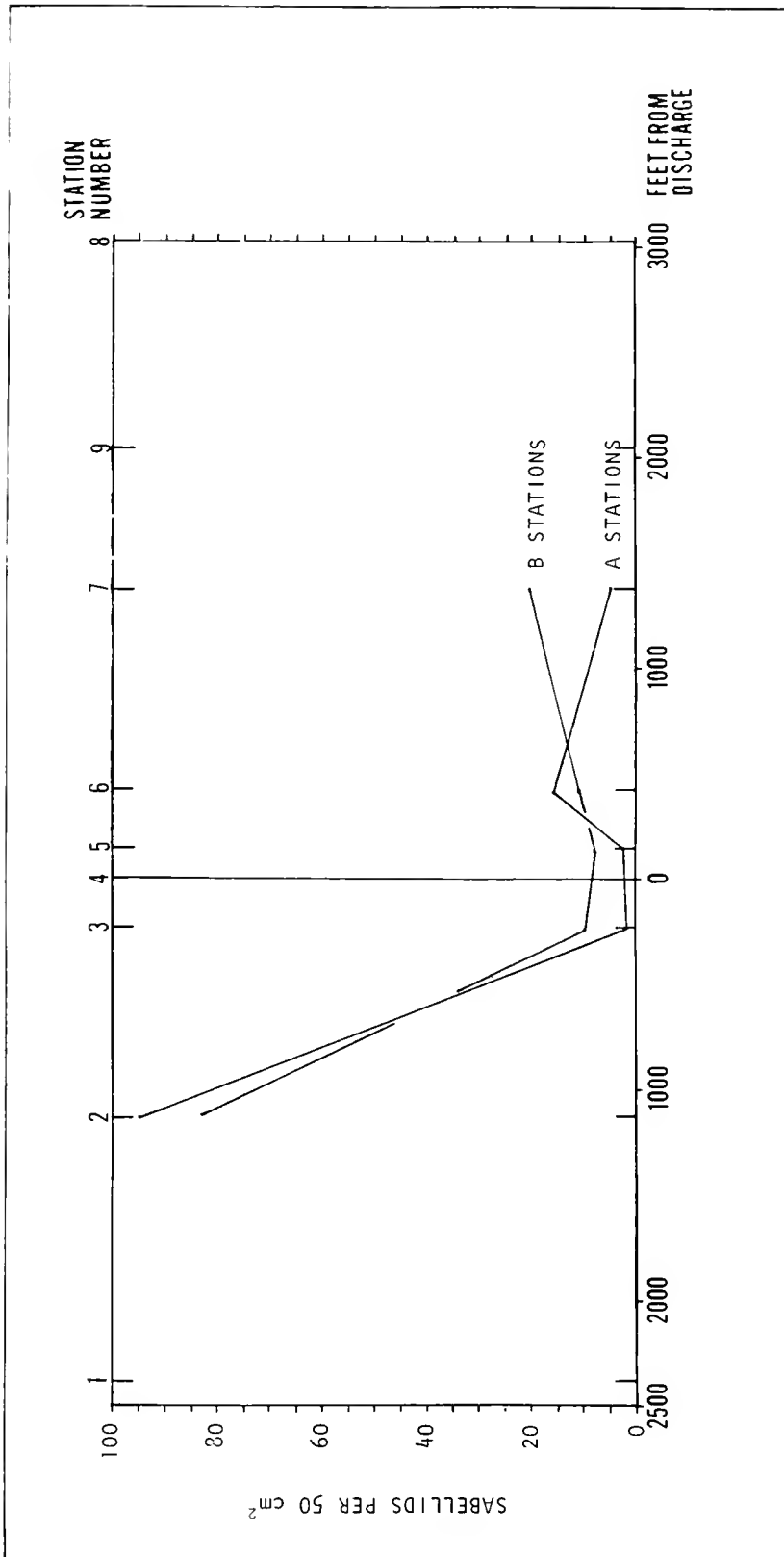
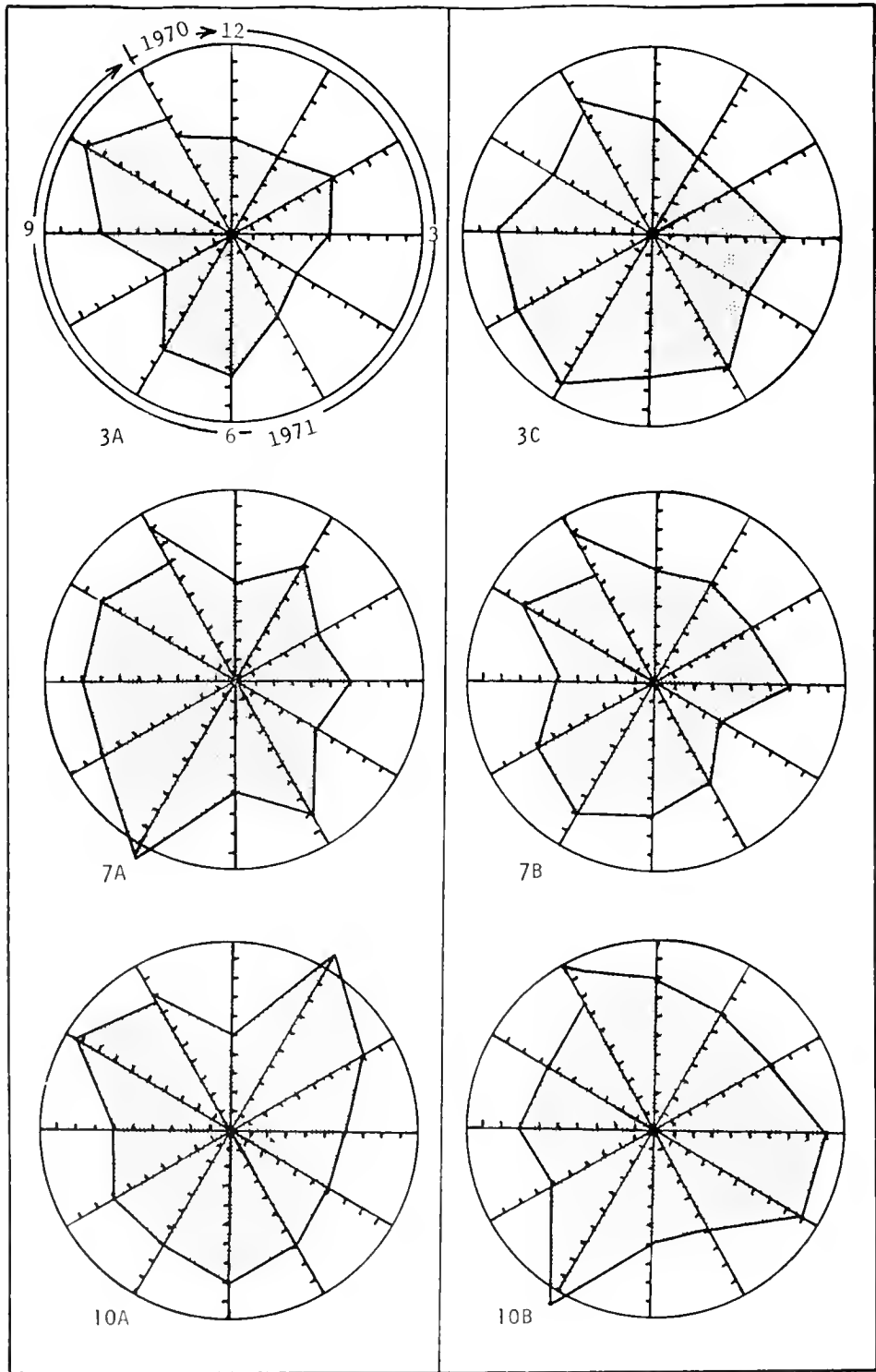

FIG. 45 MEAN NUMBER OF SABELLID WORMS SETTLING PER 50cm² PER MONTH AT BIOLOGICAL STATIONS IN SAFE HARBOR (NOVEMBER, 1970 TO OCTOBER, 1971).

FIG. 46 MONTHLY AVERAGES OF DIATOM AND PROTOZOAN SPECIES PER 2mm² AT SAFE HARBOR AND CONTROL STATIONS. EACH MONTHLY RADIUS REPRESENTS 0 - 100 spp READING FROM THE CENTER.



Each radius is numbered as the hours on a watch and represents that month.

FIG. 47 MONTHLY AVERAGES OF NUMBERS OF DIATOMS AND PROTOZOANS PER mm^2 AT SAFE HARBOR AND CONTROL STATIONS.

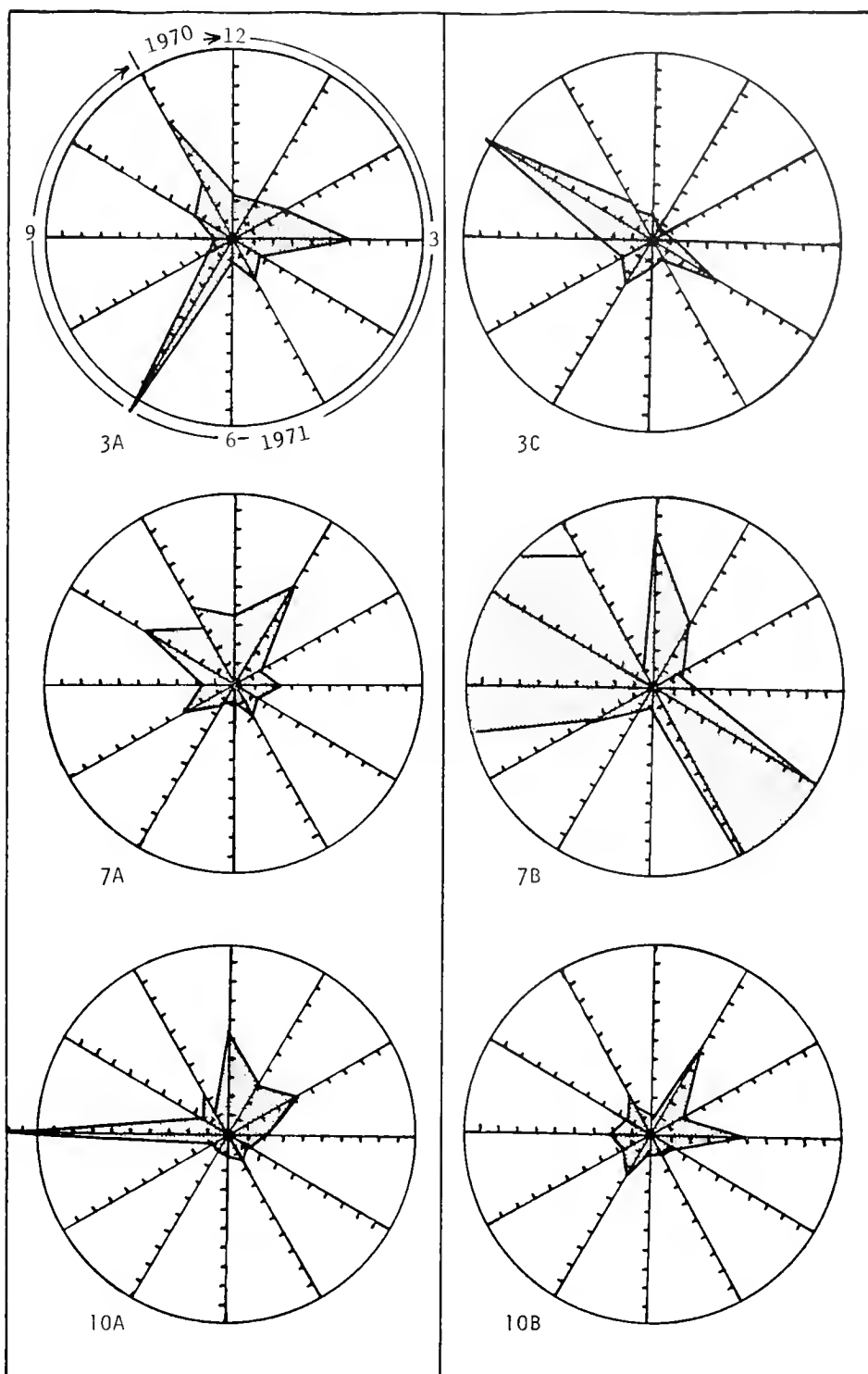

Each radius is numbered as the hours on a watch and represents that month. Values are read from the center to the circumference. A stations represent 0 - 500 individuals/ mm^2 , B stations 0 - 200 individuals/ mm^2 .

10B were in an uncontaminated environment, 7A and 7B were on the western edge of the turning basin and 3A and 3C were on the channel wall of the desalination plant.

Species diversity was often greater at the lower stations and the numbers of individuals per unit area of slide surface were generally greater at the shallower stations. The number of species shared in common between any two stations varied considerably. At the highest, it was 46 percent, Stations 10A and 7A on November 13th, 1970. More commonly, species shared in common were few and at the lowest 0 percent, Stations 10A and 7A on December 2nd and December 16th, 1970, between the same two stations. Stations 3C and 10B have had as much as 17 percent species similarity on December 2nd, 1970 and as little as 9 percent on December 16th, 1970.

Comparison of plots of percent effluent at the stations and the diversity and abundance of organisms on the diatometers showed no clear relation. Figures 48 and 49 show numbers of *Vorticella* sp. and *Nitzschia longissima* per mm² of slide surface settling each month at Safe Harbor and control stations. Compared to the control station, both organisms showed an increase in the numbers of individuals at Safe Harbor shallow stations and a decrease in numbers at the deep station (3C) in Safe Harbor near the effluent discharge (Table VIII).

TABLE VIII

Mean abundance of a ciliate protozoan (*Vorticella* sp.) and a diatom (*Nitzschia longissima*) settling per mm² on diatometers at Safe Harbor and control stations.

Station	Depth	Distance from Discharge Point	<i>Vorticella</i> /mm ²	<i>Nitzschia</i> /mm ²
3A	2.4m	73m	14	73
7A	2.4m	415m	2.7	47
10A	2.4m	Control	1.7	15
3C	7.0m	73m	2.5	1.2
7B	7.0m	415m	3.9	9.5
10B	7.0m	Control	3.5	6.0

Settlements of serpulids, barnacles, and hydroids occurred continuously on diatometers at Station 3C but did not occur on diatometers at Station 10B. The presence of these filter feeding organisms on the glass slides adversely affected the diatom and protozoan populations and made interpretation of the results difficult. These filter feeders not only

FIG. 48 MONTHLY AVERAGES OF *VORTICELLA SP.* SETTLING AT SAFE HARBOR AND CONTROL STATIONS. EACH RADIUS REPRESENTS 0 - 20 SPECIMENS READING FROM THE CENTER.

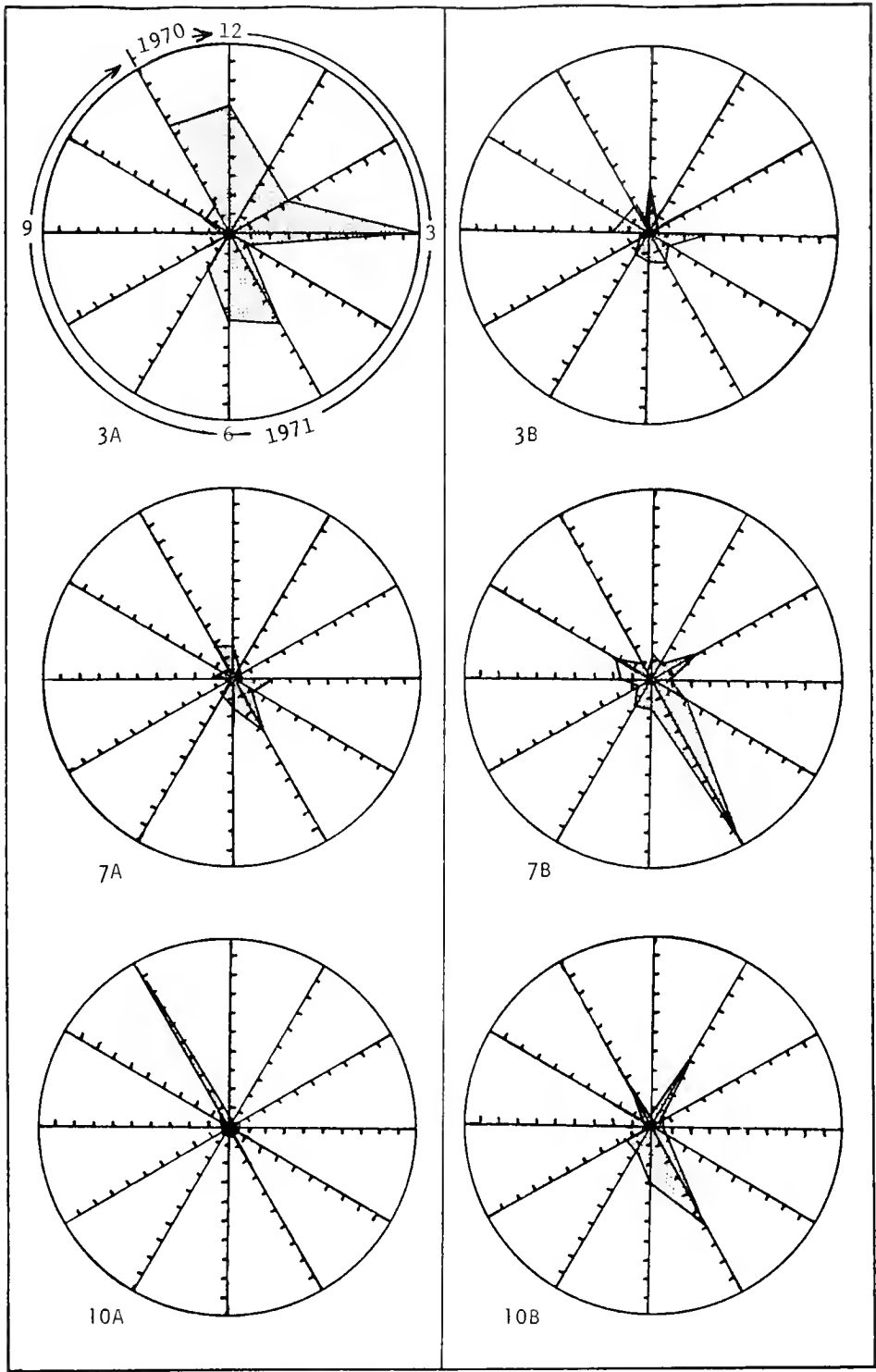

Each radius is numbered as the hours on a watch and represents that month.

FIG. 49 MONTHLY AVERAGES OF *NITZSCHIA LONGISSIMA* SETTLING AT SAFE HARBOR AND CONTROL STATIONS. EACH RADIUS REPRESENTS 0 - 100 SPECIMENS (A STATIONS) AND 0 - 50 (B STATIONS) READING FROM THE CENTER.

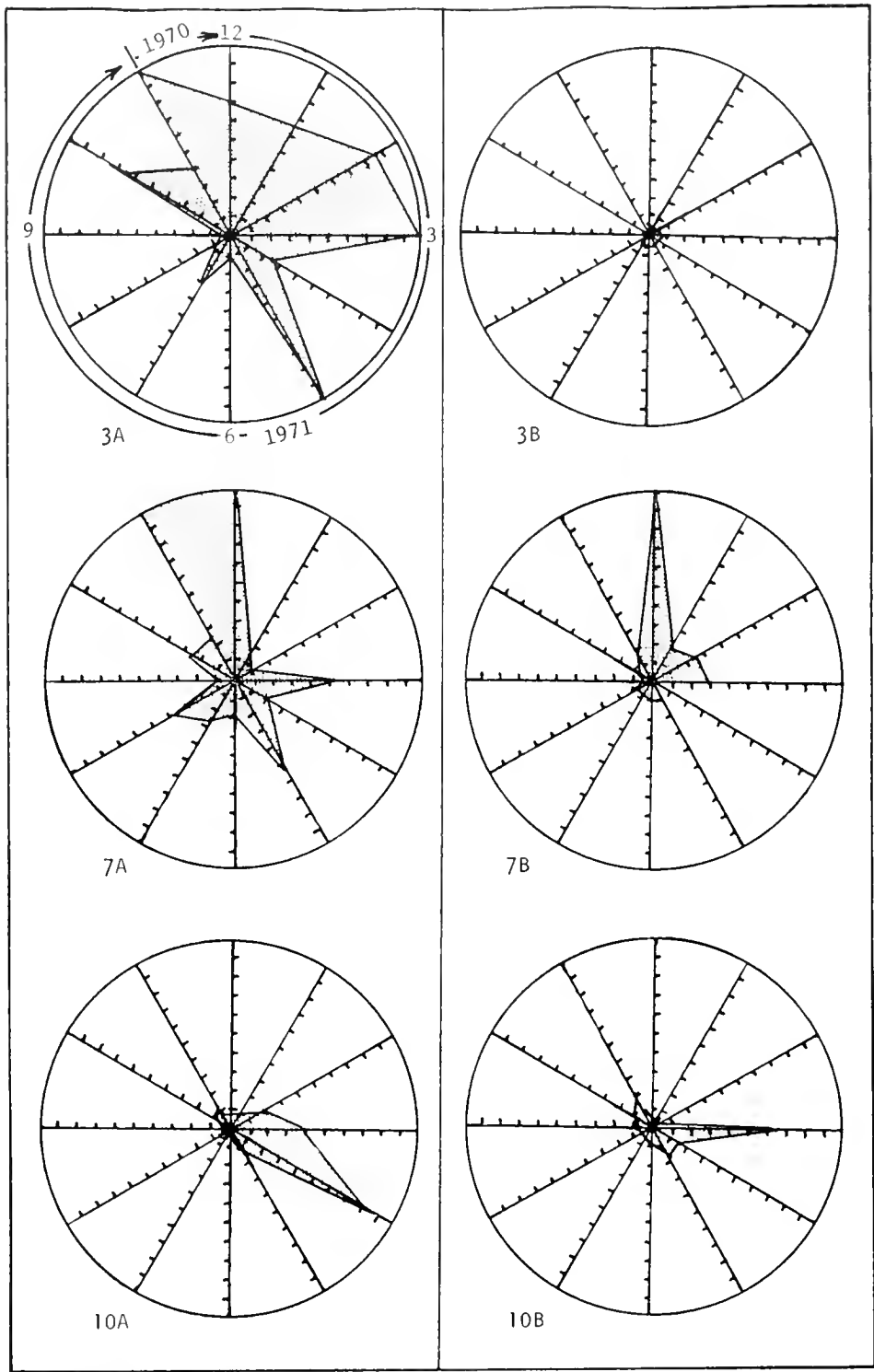

Each radius is numbered as the hours on a watch and represents that month.

competed for space on the slides but also preyed upon the diatoms and protozoans, accounting for some of the lower species diversity values and numbers of individuals at Station 3C compared to the control station.

IN SITU BIOASSAYS

Echinoids showed greatest sensitivity to the effluent and died rapidly at Station 3 (the closest biological station to the discharge). Table IX shows the average number of days echinoids survived at the three test stations from September, 1970 to June, 1971. The concentration of effluent decreased from an average of 3.8 percent in December, 1970 to 2.1 percent in February, 1971. Even so, echinoids placed at Station 3 in February died in only three days. In June, 1971, removal of the badly corroded copper-nickel trays from the desalination plant reduced the copper discharge. Following the lowering of copper content in the effluent, echinoid survival increased markedly (Table IX).

In Figure 50, the number of days survival of echinoids are plotted against maximum concentration of effluent during the total period of exposure. Levels of only 1.5 percent effluent were apparently toxic to the echinoids. Gorgonians survived brief exposure to four or five percent effluent and stone crabs tolerated six to seven percent peaks of effluent concentration. Numerous mortalities are indicated on Figure 50 during periods of supposedly low effluent concentrations. As the study progressed, more and more 'unexplained' deaths occurred. It became evident that the transient peaks of contaminants were critical and that the sampling technique used for the effluent was not adequate to register these peaks. Average percentage of effluent or effluent exposure indices showed little significant correlation ($P > .20$).

Continuous monitoring of the effluent during cleaning operations showed copper and nickel levels increased markedly in the effluent for about twenty-four hours after the plant resumed operation (see discussion in Section VI Copper and Nickel). Because of the low salinity of the effluent when the plant first began operation, the discharge readily mixed with the ambient water and did not stratify. As a result, shallow water stations, as well as deep water stations, received high concentrations of copper every time the plant began operating again after a maintenance period.

High copper levels were frequently associated with mortalities of the echinoids. On January 11th, 1971, for example, the copper concentration at Stations 7A and 7B increased 100 percent over the December, 1970 average. The following day one echinoid at 7A and two at 7B were dead. All of the echinoids at Stations 3A and 3C died the same day.

TABLE IX

SURVIVAL OF ECHINOIDS AT BIOLOGICAL STATIONS
SEPTEMBER, 1970 TO JUNE, 1971

<u>STATION</u>	<u>AVERAGE DAYS SURVIVED</u>	<u>NUMBERS OF INDIVIDUALS</u>
3A	15	41
3C	9	52
7A	49	19
7B	21	30
10A	130	1 (All others still living since
10B	38	1 10/23/70)

SURVIVAL OF ECHINOIDS AT BIOLOGICAL STATIONS
JUNE, 1971 TO OCTOBER, 1971

<u>STATION</u>	<u>AVERAGE DAYS SURVIVED</u>	<u>NUMBERS OF INDIVIDUALS</u>
3A	63	6
3C	17	17
7A	81	7
7B	118	5

- 1 = 3C
- 2 = 3A
- 3 = 7A
- 4 = 7B
- 5 = 8

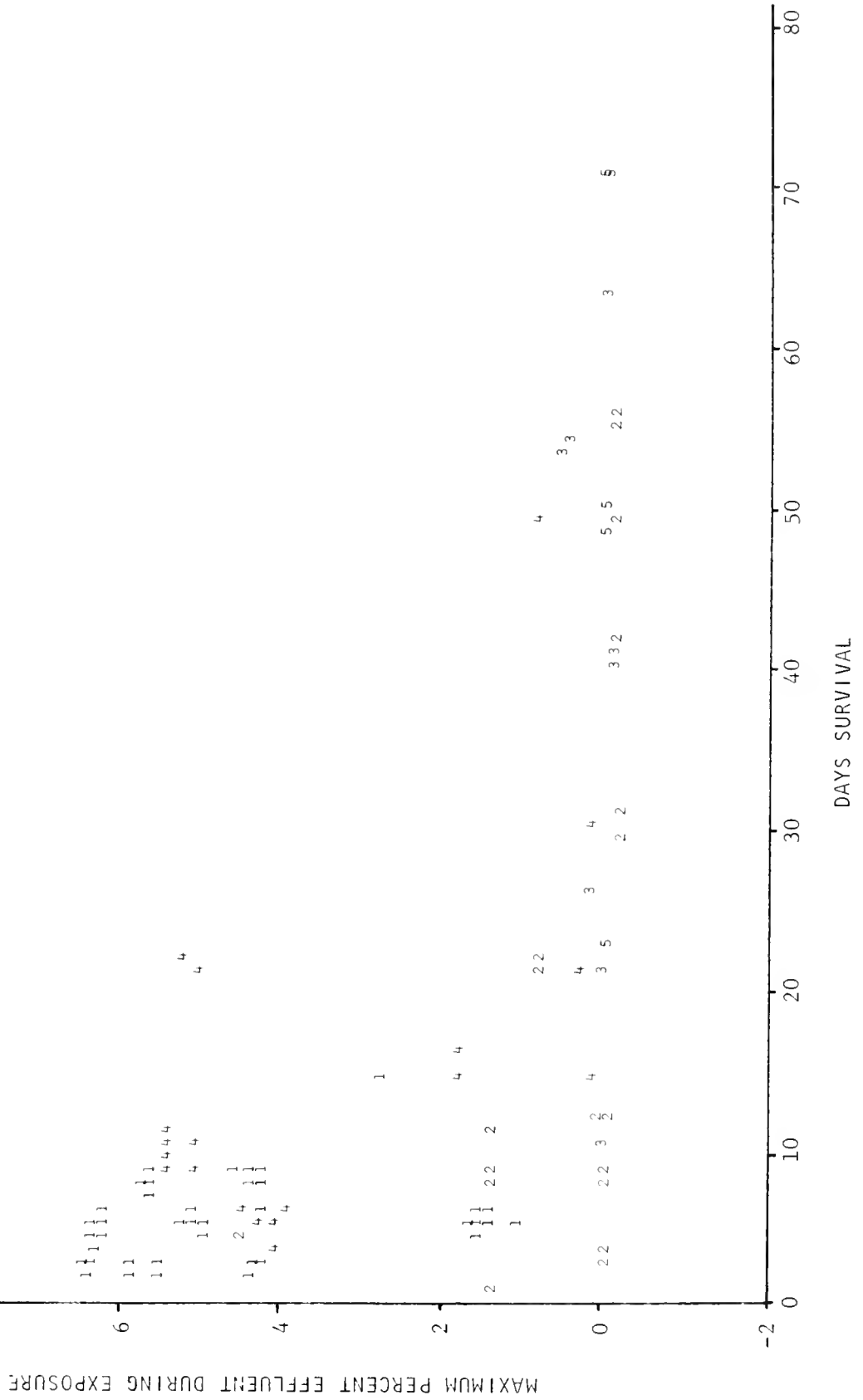

FIG. 50 ECHINOID SURVIVAL VERSUS MAXIMUM PERCENT EFFLUENT DURING EXPOSURE

On January 25th, the desalination plant was unstable and discharged 6,512 ppb copper. On the following day the remaining echinoids at Station 7 died. One of these animals had been at that station 170 days, one 80 days, and two 39 days. The copper concentration more than doubled at Station 7 on that day and there was no assurance that the sample was taken when the highest level of copper reached the station.

Correlations between copper levels at the stations and echinoid mortalities, however, were not significant ($P > .20$) suggesting that sampling frequency was not suitable, especially from November, 1970 to October, 1971 when the plant was frequently shut down for maintenance.

It became evident that the transient high peaks of copper released when the plant started operations were causing more mortalities of experimental animals than extended exposures to effluent during normal operation of the desalination plant. To test this hypothesis, the dates on which echinoids died were compared with the operation of the desalination plant. The four operating conditions chosen for comparison with mortalities were; 0 to 2 days following start-up, 0 to 2 days following shut-down, unstable operation, and normal plant operation (+2 days). The results are presented in Table X. Not one echinoid died while the plant was operating normally from October, 1970 to October, 1971. At Stations 3A, 3C, and 7A about 60 percent of the test animals died within two days following start-up of the desalination plant.

Surprisingly, a large percentage of deaths occurred following shut-downs. The causes of these mortalities are not clear. On one occasion (April 27th, 1971), two echinoids died at Station 3A following low pH discharges from cleaning of the evaporator just prior to shut-down. Plant operators insisted that this was not a common procedure and pH recordings taken during the study supported this. Low pH conditions within the plant were shown to increase copper discharge and this might account for some of the mortalities prior to shut-down periods. In many instances, however, mortalities could not be explained.

It should be noted that the arrangement of the discharge pipe and the sampling pipe prevented sampling of the effluent when the plant was being shut-down. At these times, the discharge pipe would empty. To avoid damage to the sampling system pump, which was not designed to operate dry for extended periods, the continuous sampling system was shut down when the plant was secured and turned on when operations had started again.

Many shut-down periods were caused by a blown tube in the boiler and, after the facility was secured the boiler was allowed to cool and then the water in the boiler was released. The boiler water amounted to about 5,000 gallons and had a pH of about 10. It was high in phosphates

TABLE X

Percentage of echinoid deaths related to start-ups, shut-downs, unstable plant operation or normal operation of the desalination plant from October, 1970 to October, 1971.

STATION	0-2 DAYS AFTER START-UP	0-2 DAYS AFTER SHUT-DOWN	0-2 DAYS UNSTABLE OPERATION	PLANT OPERATION NORMAL
3A	60%	40%	0	0
3C	66.7%	31.4%	1.9%	0
7A	66.7%	18.5%	14.8%	0
7B	45.7%	37.1%	17.2%	0

and sulfates to prevent scale build-up. The low density of the water, however, made the 5,000 gallon discharge float and it should not have caused mortalities at the deeper stations. Table X, however, shows mortalities in the deeper water were related to events surrounding the shut-down periods, and that Stations 7A and 7B were also influenced. The discharge from the boiler was probably too limited a volume to influence Station 7.

It was abundantly clear, however, that start-ups and shut-downs were intimately associated with the mortalities at the biological stations and that transient, high-level peaks of contaminants were more deleterious to the biota than steady-state operating conditions. The sampling program focused on steady-state, long-term conditions and was not designed to follow, and detect, sudden transients in levels of contaminants.

Although the plant operators were extremely cooperative during the course of the study, the investigators were not frequently able to obtain advance notice of when the plant would actually begin, or cease operation so that they could be on site for complete following of events. Most of the shut-downs were completely unpredictable, especially when caused by unexpected blown boiler tubes or other emergencies. Similarly, start-ups began as soon as repairs were completed and it was often impossible to know in advance when a blown tube would be found and repaired or when a pump would be made operational again. Consequently, only a few times during the study period could the research team plan an adequate investigation of the transient peaks.

In spite of this problem, plots of maximum effluent exposure against mortalities did produce a reasonable pattern and the numerous deaths shown in Figure 50 which appear unrelated to percentage of effluent exposure are a reflection of unmeasured transient peaks of contaminants. Since survival increased markedly when copper levels were reduced in June, and since copper was the major contaminant during start-up periods, it can be assumed the most deleterious constituent of the transient peaks was copper.

Figure 51 shows a plot of the average number of days of gorgonian survival at Stations 2 through 7, compared with the average concentration of effluent at the "B" stations from August, 1970 to March, 1971. The solid line, representing days of survival at "B" stations, is clearly inversely related to the amount of effluent present. As the effluent concentration increased, survival decreased. Survival at the "A" series stations is also plotted and shows a similar dependence on the effluent concentration. Survival was greater at the "A" series stations since the effluent concentration was also less at these upper stations.

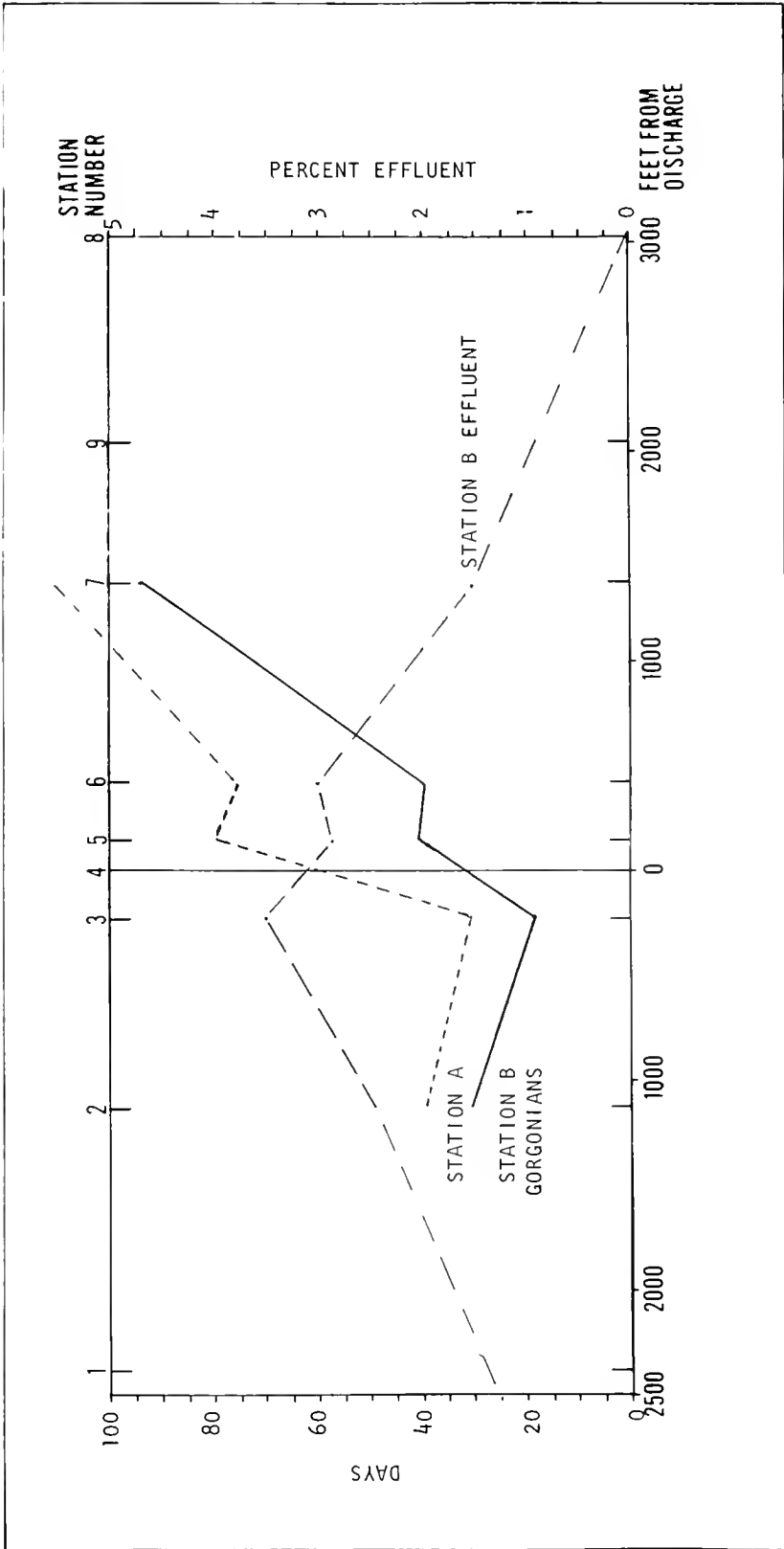

FIG. 51 AVERAGE NUMBER OF DAYS SURVIVED BY GORGONIANS (*PTEROGORGIA ANCEPS*) AT "A" SERIES STATIONS FROM AUGUST, 1970 TO MARCH, 1971 AND AVERAGE PERCENT EFFLUENT AT "B" SERIES STATIONS DURING THIS PERIOD

LABORATORY BIOASSAYS

Static 96-hr TLM acute bioassays (Standard Methods 1965) were conducted as shown in Figure 7. The *in situ* transplanting of organisms described above was designed to test the toxicity of the effluent on organisms under natural conditions. Laboratory experiments were performed only as a method of identifying the most toxic constituent in the effluent.

Initially, acute toxicity was determined for dilutions of the unaltered effluent. Samples of effluent were diluted with ambient water taken upcurrent from Safe Harbor. Ten, 50-liter glass aquaria were set up with various dilutions of the effluent and a natural seawater control. For experiments with echinoids (*Lytechinus variegatus*), crabs (*Menippe mercenaria*), ascidians (*Ascidia nigra*), and gorgonians (*Pterogorgia anceps*), ten experimental animals were used per tank (this being the largest number which survived well in the 50-liter aquaria). Turtle grass (*Thalassia testudinum*) was analyzed in a different set-up (see Section IV Methods and Procedures).

Analysis was complicated by the varying characteristics of the effluent, particularly in regard to copper concentration. The data plotted in Figures 52 through 55 represent resistance to effluent taken after the plant was operating at 80 to 90 percent load for more than 48 consecutive hours.

These data were plotted as recommended by Standard Methods 12th Edition, 1965 to interpolate 48 and 96-hr TLM's. It is recognized this method has been validly criticized, i.e. (Wilber, 1965) as not representative of effluent toxicity in the natural environment and that it is not statistically sophisticated. The method was used in this study for the express purpose of determining approximate, relative toxicological values to aid in identifying the more deleterious constituents of the effluent. The 48 and 96-hr TLM values given here are not intended to be representative of the toxicity of desalination plant effluents, especially since the toxicity varied greatly during the course of the study due to fluctuations in copper content.

Ascidia nigra had the least tolerance to the effluent with 50 percent of the test animals dying after a 96-hour exposure to 5.8 percent effluent (Fig. 52). *Lytechinus variegatus* showed a similar sensitivity with a 96-hr TLM value for 8.8 percent effluent (Fig. 53). *Menippe mercenaria* had a 96-hr TLM value for twelve percent effluent (Fig. 54). Photosynthetic activity of specimens of *Thalassia testudinum* was depressed by 50 percent in 24 hour exposure to 12 percent effluent (Fig. 55).

To determine if temperature, salinity, or copper (the three major detrimental factors identified in the effluent analyses) were responsible for

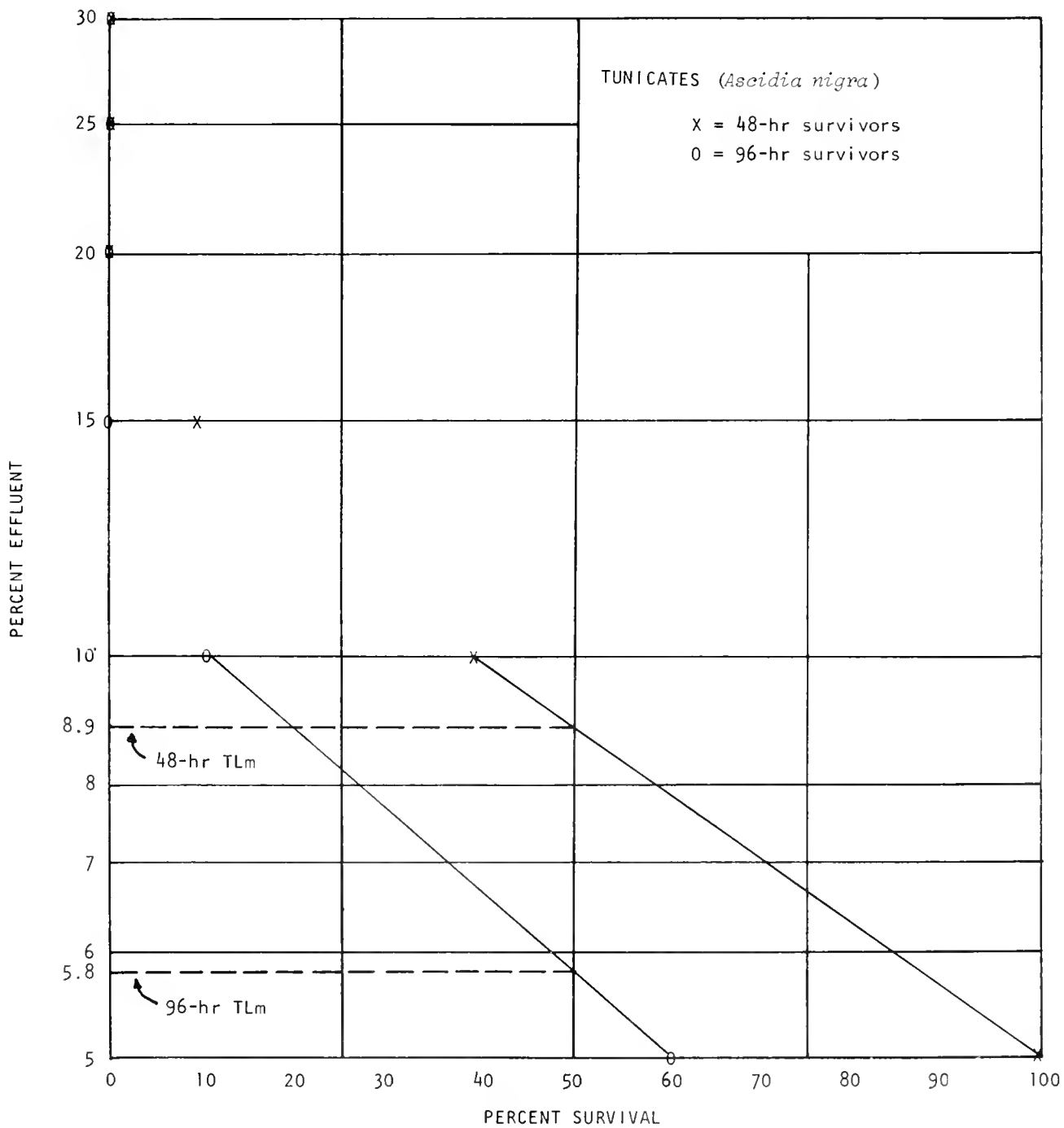

FIG. 52 48 and 96-HOUR TL_m ACUTE BIOASSAY OF DESALINATION PLANT EFFLUENT ON *ASCIDIA NIGRA*.

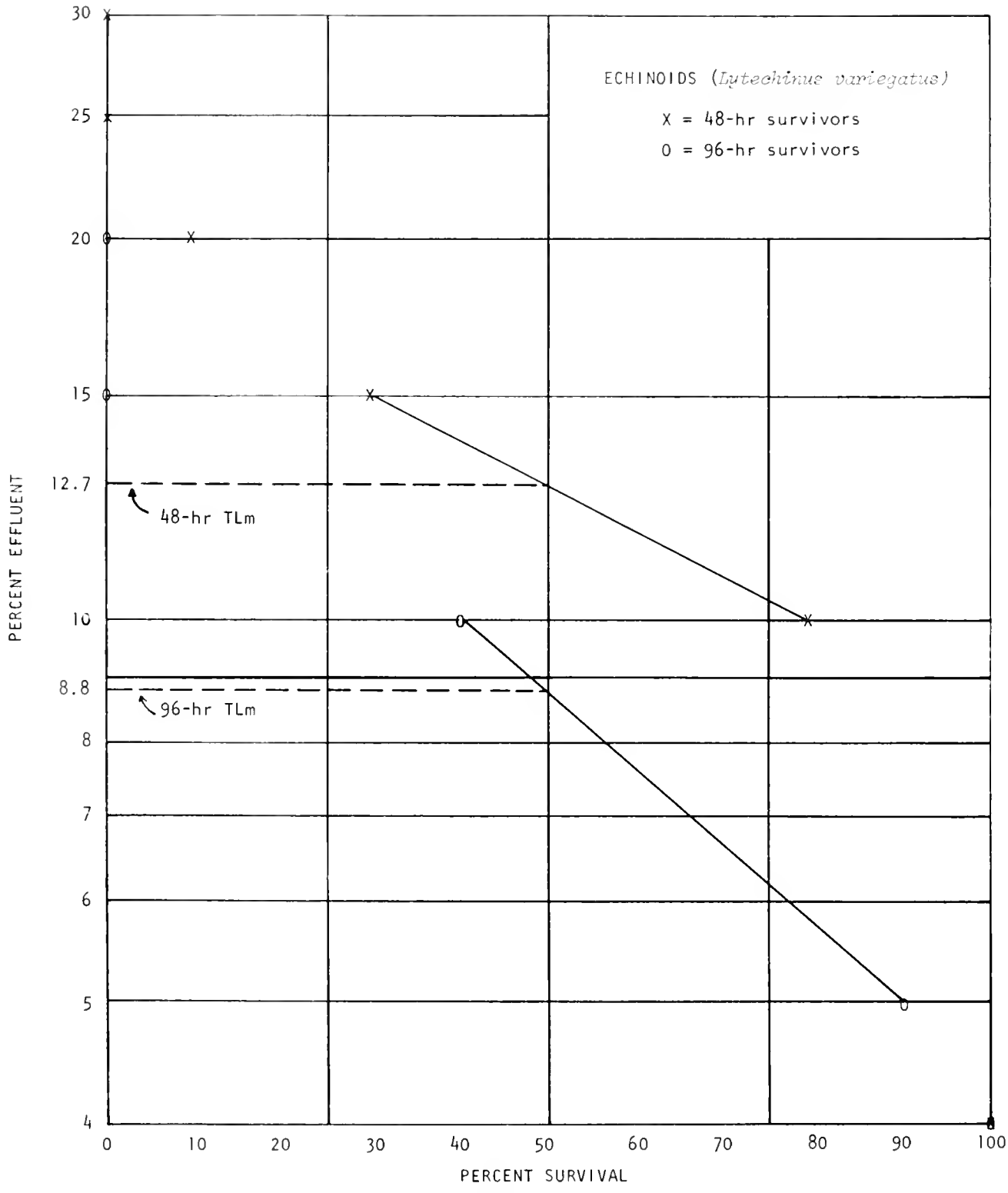

FIG. 53. 48 AND 96-HOUR TL_m ACUTE BIOASSAY OF DESALINATION PLANT EFFLUENT ON *LYTECHINUS VARIEGATUS*.

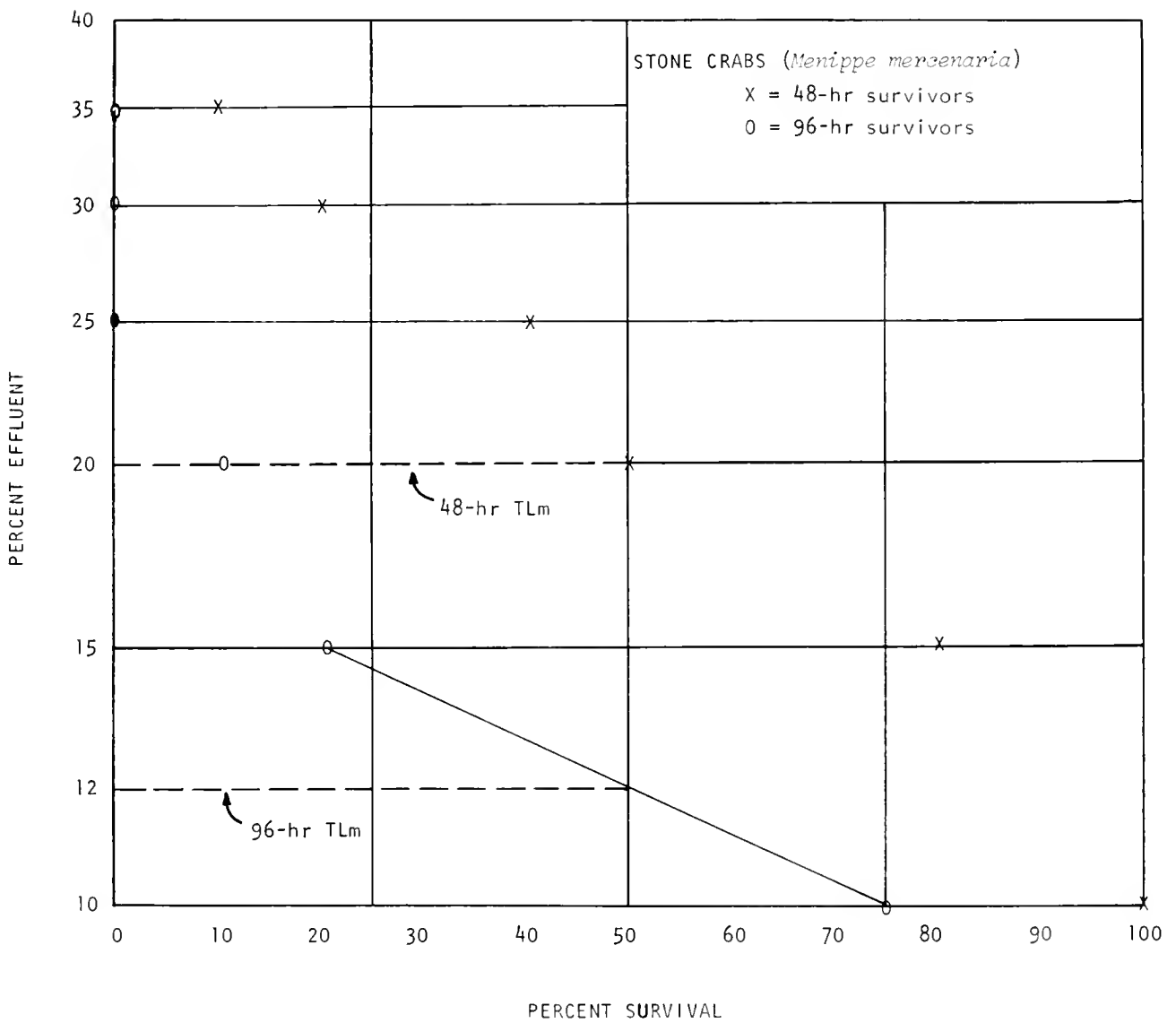

FIG. 54. 48 AND 96-HOUR TL_m ACUTE BIOASSAY OF DESALINATION PLANT EFFLUENT ON *MENIPPE MERCENARIA*.

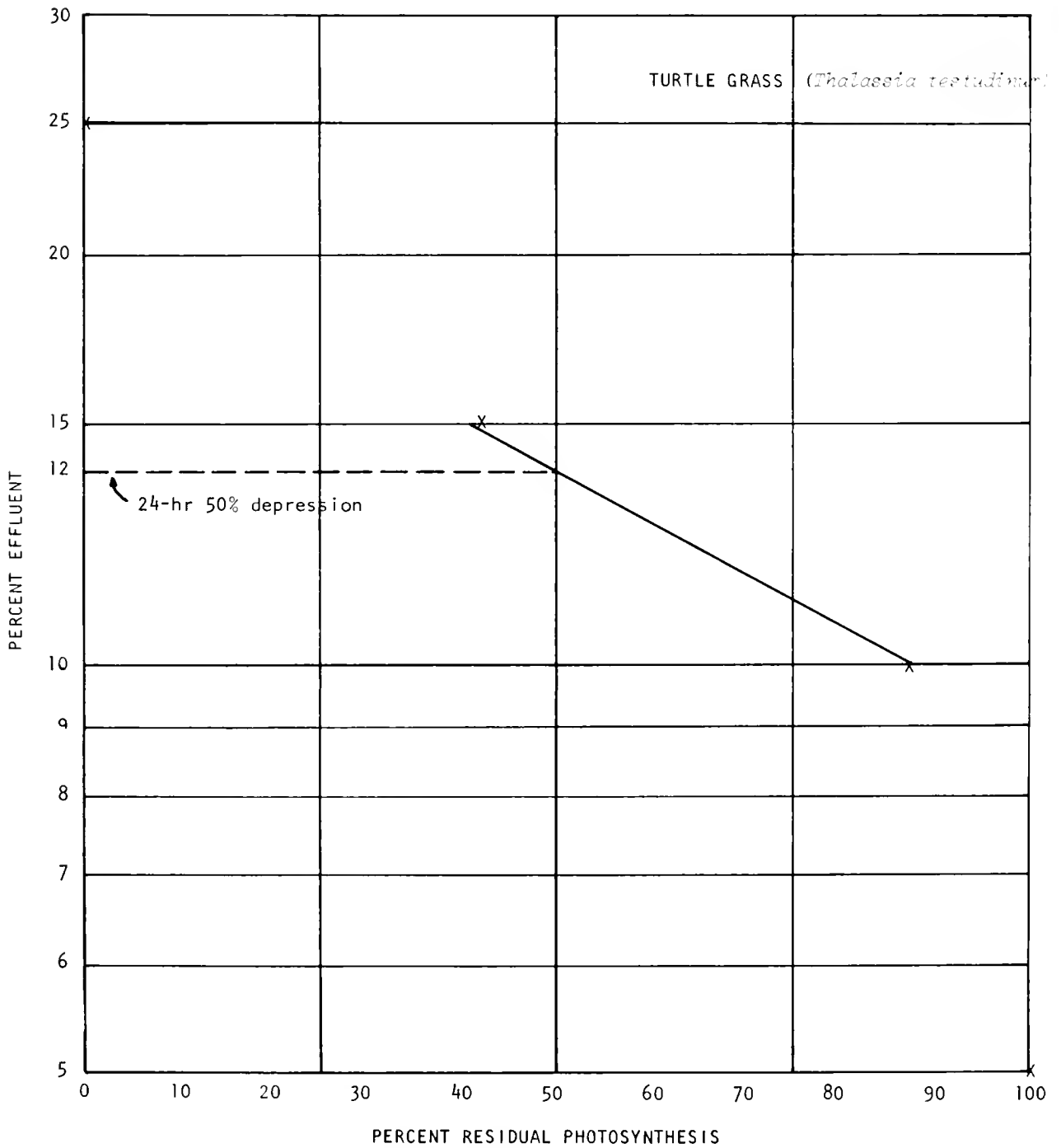

FIG.55 24 HOUR, 50 PERCENT REDUCTION OF PHOTOSYNTHETIC RATE OF *THALASSIA TESTUDINUM* EXPOSED TO VARIOUS DILUTIONS OF DESALINATION PLANT EFFLUENT.

observed mortalities, each of these parameters was raised independently in separate analyses (Fig. 7). Salinity, even when raised to the equivalent of 30 percent effluent (40.2 o/oo) produced no mortalities.

Copper was added to seawater as the cupric sulfate salt ($\text{CuSO}_4 \cdot 5\text{H}_2\text{O}$) and its toxicity tested using the same 96-hr static acute bioassay methods. Results of these bioassays were compared with bioassays of equivalent amounts of copper found in the dilutions of effluent (Figs. 56 through 59). Figure 56 shows that 100 ppb copper was present in the effluent dilution which caused 50 percent of the echinoid mortalities in 96 hours and that the toxicity of 105 ppb cupric copper in normal seawater was sufficient to cause the same mortality. Copper, therefore, was the sole toxic constituent in the effluent required to explain the observed echinoid mortalities. Similar results were found in the copper toxicity experiments with stone crabs (Fig. 57) and turtle grass (Fig. 58), although these organisms were on the whole less sensitive to copper than either echinoids or ascidians.

Copper toxicity did not explain all of the observed toxic effects of the effluent for specimens of *Ascidia nigra* (Fig. 59). One hundred and fifty ppb ionic copper were required to kill 50 percent of the experimental specimens of *A. nigra* when the copper was dissolved in seawater but the same mortality occurred with effluent which contained only 80 ppb copper. *Ascidia nigra*, therefore, was also sensitive to some other contaminant of the effluent, or to the interaction of the various contaminants. Zeitoun *et al* (1969), Lloyd (1965) and others have shown synergistic effects of copper with temperature and perhaps these are more pronounced for the filter feeding ascidians than for the other organisms tested. Alternatively, other contaminants in the effluent (i.e., nickel) may have had a greater affect on *A. nigra* than on the other organisms.

Although temperature tolerance tests showed the experimental organisms were within a few degrees of their lethal limits, the temperature elevations caused by the 96-hr TLM dilutions were within normal seasonal ambient ranges. Temperature, by itself, was not lethal to the test animals at the 96-hr TLM effluent dilutions. *Ascidia nigra* and *Lytechinus variegatus* showed an abrupt increase in mortality at about 32°C. At temperatures at or below 31°C all specimens of both species survived more than 96 hours. When temperatures were at or above 32°C more than 50 percent of the experimental specimens of both species died within 96 hours.

A temperature of 32°C represents the heat of an effluent dilution of 20 percent in the acute bioassay experiments. Since the 96-hr TLM dilution of the effluent for *L. variegatus* was about 9 percent (about 31°C) and that for *A. nigra* about 6 percent (about 30.5°C), temperature alone could not account for the observed mortalities.

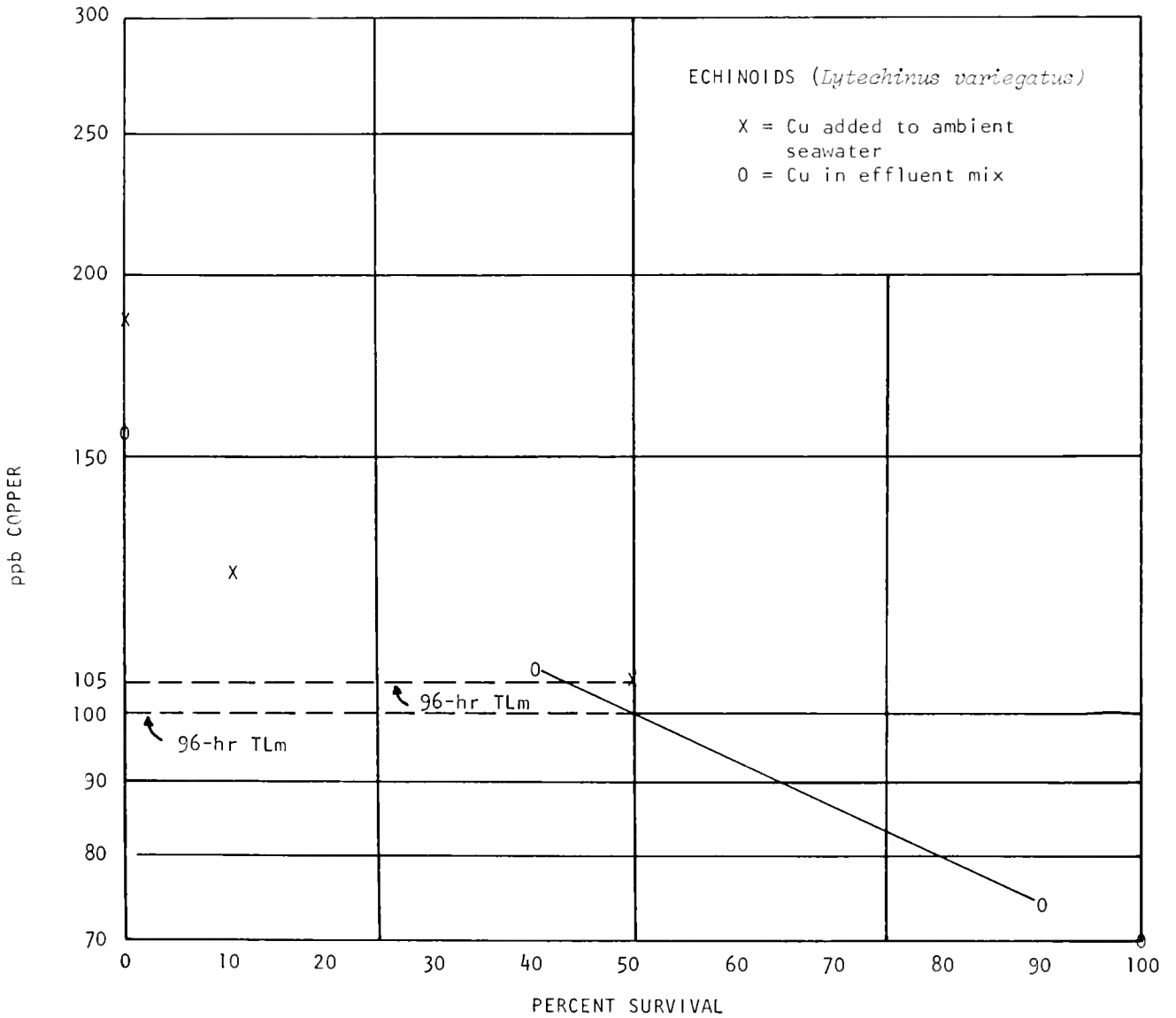

FIG. 56 COMPARISON OF TOXIC EFFECTS OF COPPER IN EFFLUENT (O) AND IN SEAWATER (X) ON *LYTECHINUS VARIEGATUS*.

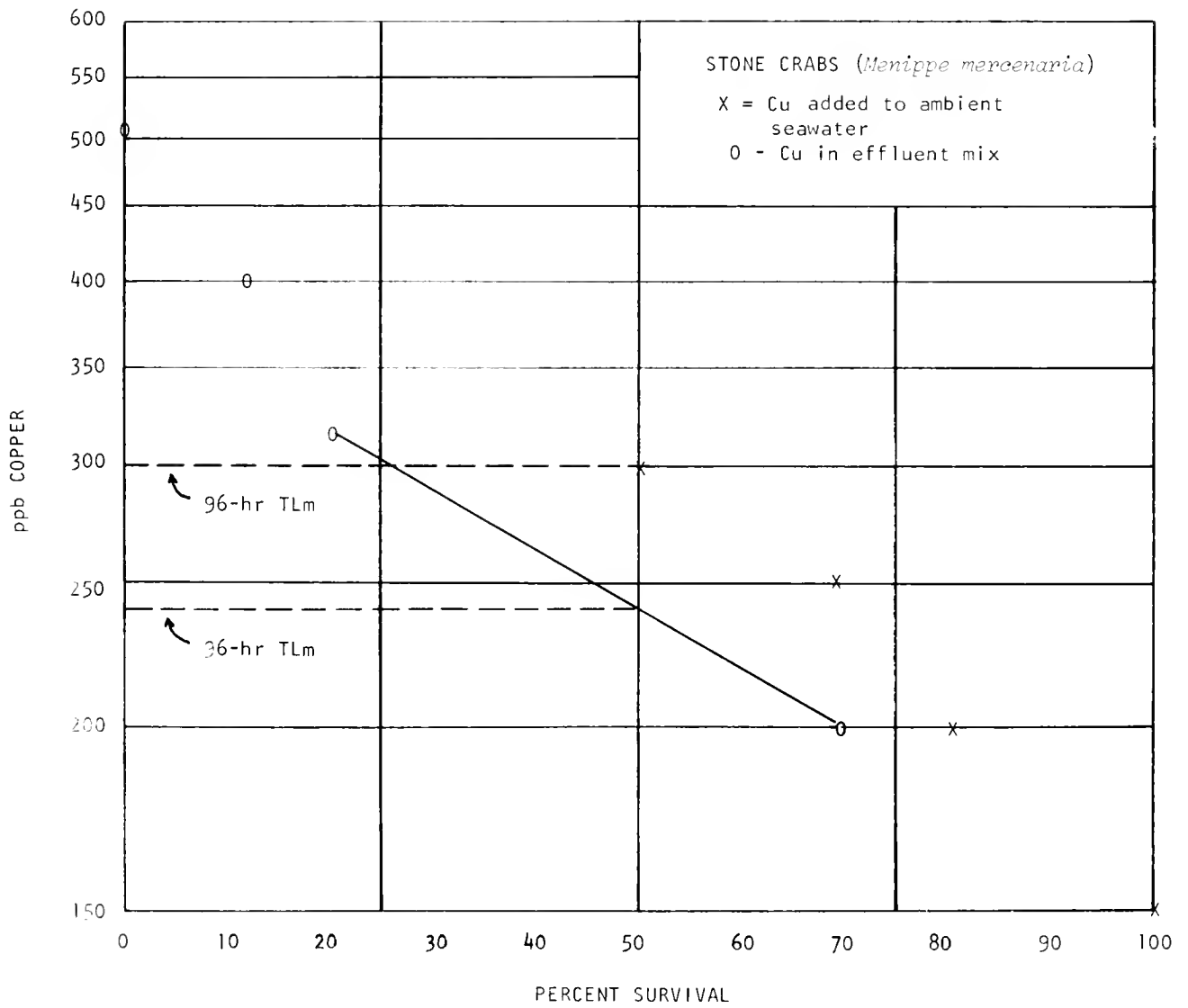

FIG.57 COMPARISON OF TOXIC EFFECTS OF COPPER IN EFFLUENT (O) AND IN SEAWATER (X) ON *MENIPPE MERCENARIA*.

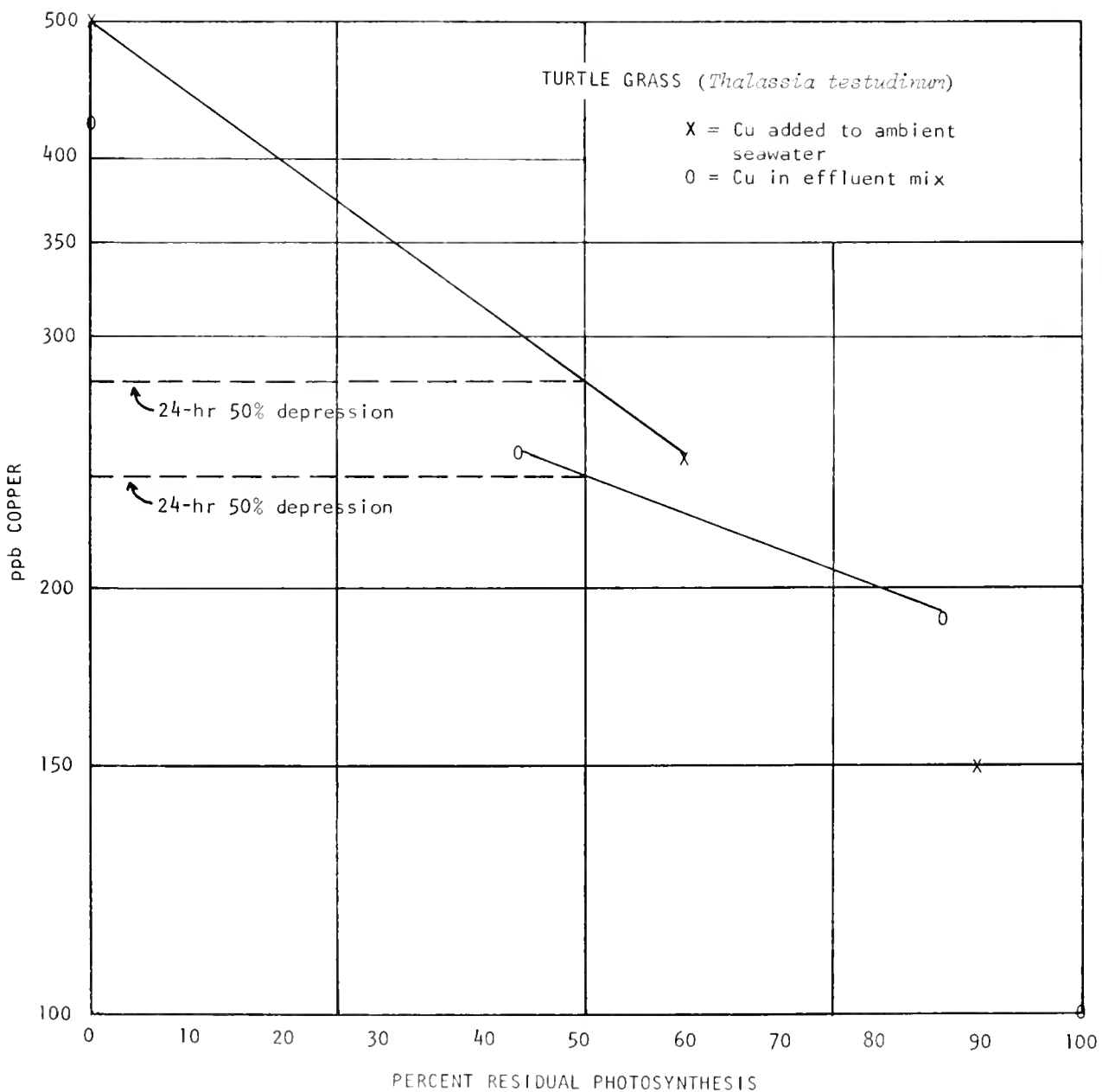

FIG.58 COMPARISON OF TOXIC EFFECTS OF COPPER IN EFFLUENT (O) AND IN SEAWATER (X) ON PHOTOSYNTHETIC RATES OF *THALASSIA TESTUDINUM*.

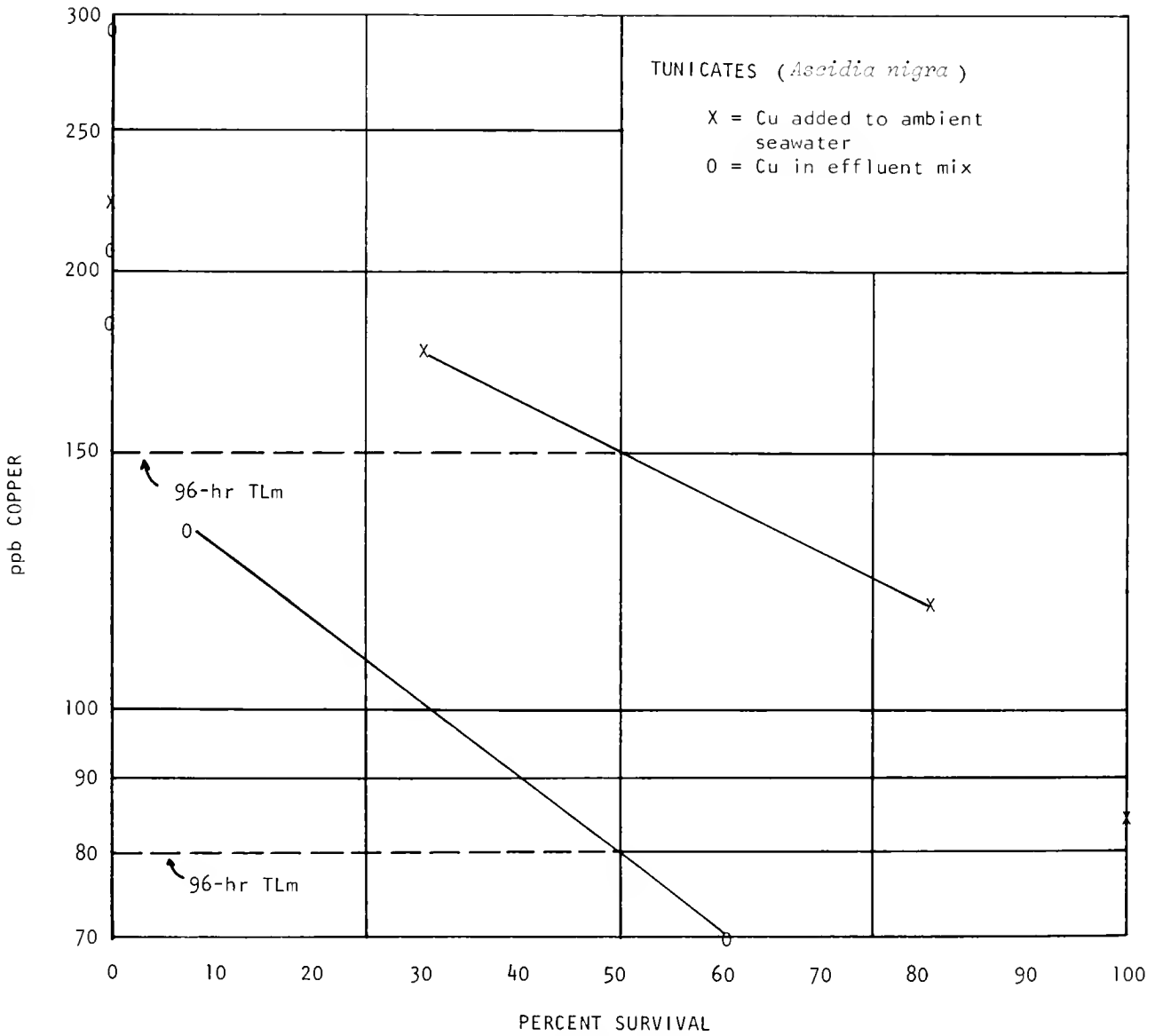

FIG.59 COMPARISON OF TOXIC EFFECTS OF COPPER IN EFFLUENT (O) AND IN SEAWATER (X) ON *ASCIDIA NIGRA*.

Similarly, *M. mercenaria* showed a 96-hr TLM between 32 and 33°C, while the 96-hr TLM effluent dilution temperature was about 31.5°C.

Experiments conducted with the gorgonian, *Pterogorgia anceps*, were unsatisfactory. The investigators were unable to establish satisfactory criteria for colony death. Frequently gorgonian specimens in higher effluent concentrations would withdraw their polyps and remain in this retracted position. There was no way to determine when the animals actually died until decomposition of the colony was well advanced. The rate of decomposition was also influenced by the concentration of the effluent. Dead gorgonian specimens placed in dilutions of 5 to 10 percent effluent decomposed more rapidly than those in 20 to 50 percent effluent dilutions. Some dead specimens placed in 50 percent effluent did not show signs of decomposition after 96 hours.

Copper was the most deleterious constituent of the desalination plant discharge as revealed by the laboratory bioassays. Copper probably was responsible for most of the observed changes in the Safe Harbor biota reported above. The small changes in temperature and salinity (Fig. 12) produced by the effluent were well within normal seasonal variations and within the tolerance limits of experimental animals in the static bioassay tests.

The amounts of copper discharged by the desalination plant frequently increased copper concentrations at the stations to levels shown to be toxic by acute bioassays. This was especially true during periods when the plant was beginning operations following a shut-down. During the acute bioassays, copper concentrations of only 250 ppb ionic copper caused 50 percent echinoid mortality in 17 hours. Copper concentrations up to 359 ppb were recorded at the *in situ* bioassay stations on days when the experimentally held animals died at those stations. Copper concentrations as high as 538 ppb copper were found at biological stations 3A and 3C associated with the turbid effusions following start-ups of the desalination plant.

COPPER TOXICITY

Copper toxicity in the marine environment has been studied by numerous workers. The literature has been recently reviewed by Raymont and Shields (1964), Le Gros *et al* (1968), Zeitoun *et al* (1969B), Lloyd (1965). Additional studies include those of Portman (1968) and Hueck *et al* (1968).

Galtsoff (1943) reported nearshore copper values of 0.01 and 0.02 ppm and emphasized that levels of this magnitude were required for physiological requirements of many marine invertebrates. Brooks and Rumsby (1965) and Galtsoff (1964) and others have demonstrated copper

is actively accumulated in the tissues of marine invertebrates and copper levels of 8 to 80 ppm have been reported in oysters from unpolluted areas. Copper concentrations from 120 to almost 400 ppm have been reported in oysters from polluted waters.

While copper in organic form does not appear to be excessively toxic, inorganic ions of copper are toxic to a wide variety of vertebrates and invertebrates. Toxicity of copper varies significantly between various species of organisms and with different physical and chemical properties of the water. Portman (1968), Lloyd (1965), and Zeitoun *et al* (1969) have discussed the synergistic relationship between copper toxicity and zinc, cadmium, mercury, and temperature and the antagonistic effects between copper toxicity and calcium as well as salinity.

Zeitoun *et al* (1969) found cultures of dinoflagellates died when exposed to copper concentrations of 0.05 ppm ionic copper as did two species of blue-green algae. Diatoms and green algae showed varying susceptibilities to copper ions ranging from 0.05 to 0.5 ppm. Miller (1946) found the bryozoan *Eugula neritina* could live, but not grow, in copper concentrations of 0.2 to 0.3 ppm and that their larval stages died at copper concentrations in excess of 0.3 ppm. Galtsoff (1932) found oysters were killed by 0.1 to 0.5 ppm copper ions. Bernard *et al* (1961) found that cyprids of the barnacle *Balanus amphitrite niveus* could survive but not settle in copper solutions of 0.5 to 10 ppm copper. North (1964), and Clendenning and North (1960) found only 0.1 ppm copper was sufficient to cause reduction in photosynthetic rate of the kelp (*Macrocystis pyrifera*).

Several species of fish and invertebrates were collected in Safe Harbor and at the control stations off Boca Chica Island for analyses of copper content. Collections of fish made simultaneously, in particular the goby (*Lophogobius cyprinoides*), were specially prepared for histological and histochemical analyses. The laboratory work was performed by G.R. Gardner at the National Marine Water Quality Laboratory in Rhode Island. Preliminary results showed that the gobies had an abnormal liver condition with highly vacuolated hepatic cells and unusual hepatic lesions. The rubeanic acid histochemical process showed copper deposition in the livers of fish from Safe Harbor; all but two of which had hepatic lesions. Two sets of collections were made. In the first, lesions were restricted to fish from Safe Harbor and all control fish were normal. In the second collections, however, three animals from the control station had lesions. During the period between the two sets of collections, the U.S. Navy had dumped a considerable amount of solid waste in the immediate vicinity of the control station. Some of the gobies may have been adversely affected by living in the submerged waste. Additional experiments are in progress to confirm the lesions are copper induced (Gardner, personal communication).

During the gathering of growth and survival data on *Ascidia nigra*, divers noted animals in protected environments survived better and grew faster than those in exposed locations. A survey of other copper sensitive organisms in Safe Harbor confirmed that those in sheltered, dark locations (under ledges, in caves, and behind submerged structures) also were larger and settled more densely than those in illuminated habitats. The same relationship did not appear in sites beyond the extent of the effluent.

According to Steemann Nielsen and Wium-Andersen (1970), copper toxicity occurs in *Chlorella* only in the light. When *Chlorella* were treated with copper but left in light-proof containers, they experienced no toxic effects until exposed to light. Perhaps a similar mechanism influences copper toxicity in invertebrates.

Normally, *Ascidia nigra*, which is a filter feeder, grows faster in unsheltered environments, where currents can circulate more freely. In the copper-rich Safe Harbor environment, however, animals protected from strong light outgrew those in more exposed positions. The effect of light on copper toxicity may explain this phenomenon and may also explain the settlement and success of organisms on only the lower surfaces of settlement panels. During the preliminary survey, Clarke (unpublished data), organisms settled equally successfully on the top and bottom of panels. From August, 1970 to August, 1971 the upper surfaces of the settlement panels were almost entirely barren of organisms after the normal exposure period, while serpulids, sabellids, and barnacles grew rapidly on the lower surfaces.

To determine if copper uptake and toxicity were influenced by illumination, specimens of *A. nigra* were collected from the desalination plant sea wall and from the control station in September, 1971. Specimens from the sea wall were collected from exposed, highly illuminated areas as well as from the dark situations in crevices in the sea wall. These were analyzed for total copper content by the method described in Appendix A.

Copper concentration in *A. nigra* specimens from the control station averaged 39 ppm; a concentration 2,300 times the ambient copper levels found in seawater at that station during the preceding four months. Copper concentrations in specimens from the illuminated portions of the sea wall at the desalination plant averaged 202 ppm; a concentration of 5,000 times the levels recorded in the water at that station during the months that *A. nigra* commenced resettling on the wall. The copper levels recorded from water at the sea wall station were, however, lower than actually occurred there during the periodic, transients of high copper concentrations associated with effusions following maintenance periods. The specimens collected from darkened crevices had copper concentrations of 132 ppm. The following findings emerge from these analyses:

1. *A. nigra* collected from illuminated areas along the desalination plant sea wall had more than five times the copper concentration found in specimens collected at the control stations.
2. *A. nigra* collected from illuminated areas had 1.5 times the amount of copper found in the specimens collected from crevices along the sea wall.

The ten largest specimens collected from illuminated areas had an average volume of 2.5cc. The ten largest specimens collected from dark crevices had an average volume of 6.2cc. Since settlement of these animals occurred in the first part of August (about 30 days prior to collection), it can be assumed that the *A. nigra* in the darker areas grew about 2.5 times more rapidly than those in the illuminated areas.

It can be concluded from the results of the *A. nigra* studies that copper was concentrated at a higher rate and was probably more toxic in illuminated versus dark habitats. The mechanism for this metabolic difference is not known, but illumination should certainly be considered a key parameter when conducting copper toxicity studies either in the laboratory or in the field.

Correlations between the biological data and copper concentrations recorded from the regular hydrographic samples were poor. As stated above, this was due to periodic effusions with high levels of copper which were (because of their brevity) impossible to measure *in situ* at the biological stations. Only organisms which could avoid the effusions would be expected to show a good correlation with the average copper levels recorded at the biological stations. Barnacles showed this conclusion to be true. Barnacles are able to completely seal their shells with their operculum. When shut, the operculum protects the barnacle from dessication at low tide or osmotic stress during exposure to freshwater. Divers, during the study, noticed that the barnacles closed their opercula and ceased feeding when exposed to turbid effusions containing high copper concentrations. Barnacles and serpulids are the only surviving sessile organisms at Station 4, immediately in the path of the discharge and their success at that station may be due to their ability to isolate themselves from the effluent when necessary.

When 30-day settlement discs were analyzed, the largest barnacles were measured to obtain an estimate of maximum barnacle growth during that month. These growth rates were plotted against average copper concentrations found at biological stations by regular sampling (Fig. 60). Two groups of stations were selected; Stations 3, 5, and 6 near the effluent and Stations 2 and 7 farther away (see Fig. 3). The regression lines shown in Figure 60 do not differ significantly in slope or elevation ($P > .20$ in a two-tailed F test), but do differ

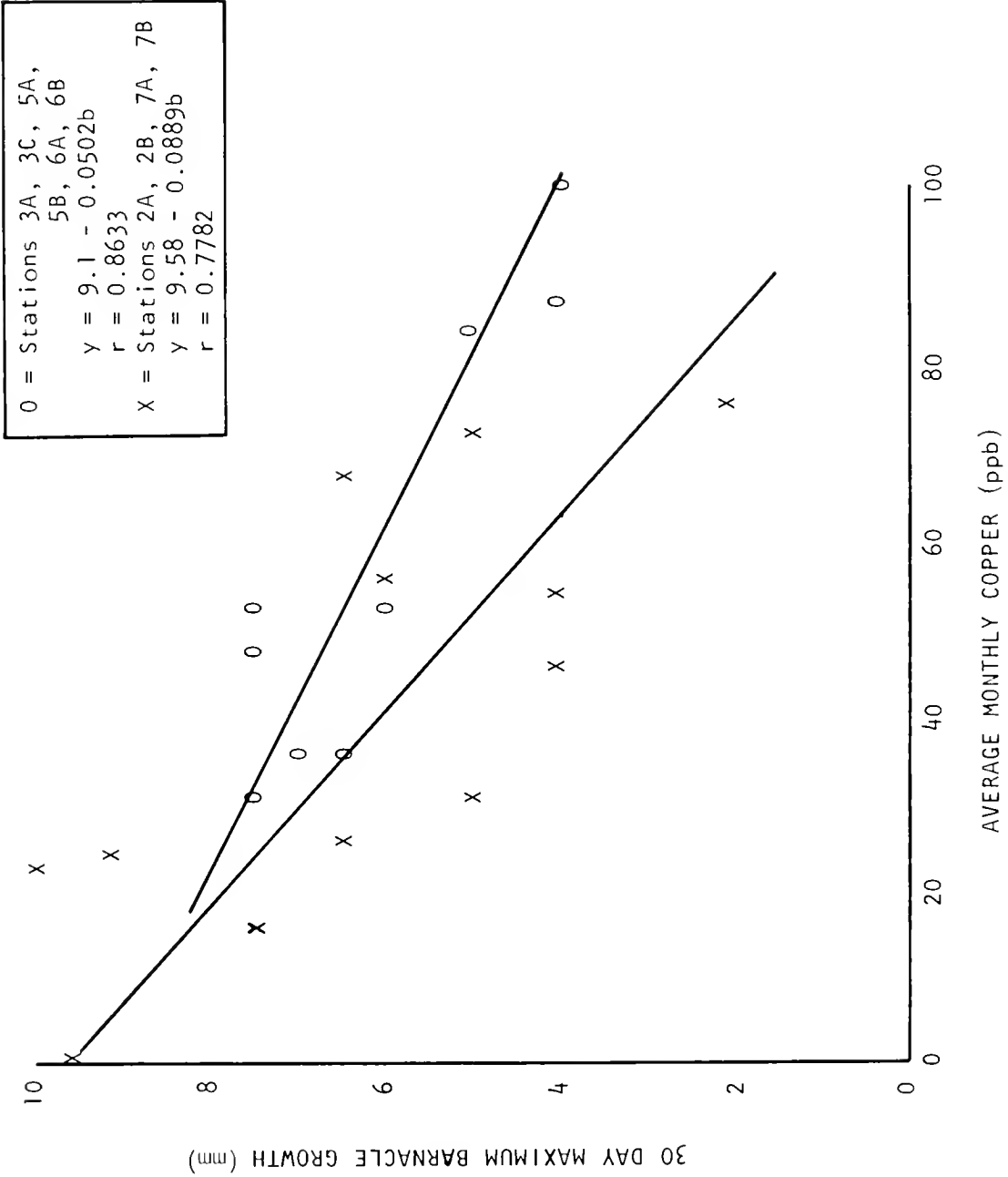

FIG. 60 MAXIMUM MONTHLY BARNACLE GROWTH COMPARED TO TOTAL AVERAGE DISSOLVED COPPER EXPOSURE, APRIL, 1971 TO OCTOBER, 1971.

The regression lines shown in Figure 60 do not differ significantly in slope or elevation ($P > .20$ in a two-tailed F test), but do differ significantly ($P > 0.01$) in residual variances. Correlation coefficients for the two groups of data are 0.863 (significant at $P > 0.01$ level) for Stations 2 and 7.

Since it was already established that the regular hydrographic sampling did not detect transient peaks, the copper concentrations shown in Figure 19 were primarily representative of steady-state conditions. Their significant correlation with the growth of the barnacle, *Balanus amphitrite*, substantiated the hypothesis that these barnacles were able to detect and isolate themselves from high copper concentrations associated with the periodic effusions. It also demonstrated the toxicity effects of copper on this species. Bernard *et al* (1961) demonstrated that larvae of *B. amphitrite* can not attach in copper concentrations in excess of 0.024 ppm using laboratory cultures. Since copper levels were never recorded that low at the point of effluent discharge, it must be assumed that larvae were more successful in settling in the natural environment than in laboratory cultures. Probably, settlement and metamorphosis occurred during periods when the plant was not operating.

A comparison of copper concentrations in a variety of fish was made to determine if levels were elevated in Safe Harbor fish compared to control station fish and if predatory fish contained more copper than herbivorous fish. Unfortunately, there was no method to determine the length of time a particular specimen had been feeding in the harbor. Spade fish (*Chaetodipterus faber*) tended to be a transient species along the desalination plant sea wall which fed on polychaetes, barnacles, and algae. Specimens speared adjacent to the effluent contained 8 ppm dry weight copper in the flesh and 34 ppm dry weight copper in the liver. Sheepshead (*Archosargus probatocephalus*) were almost always seen during dives and probably resided in the canal. Sheepshead fed on the same organisms as spade fish and specimens speared near the desalination plant had 7.2 ppm dry weight copper in the muscle tissue and 369 ppm dry weight copper in the liver tissue. Specimens of the same species from the control station had 6.9 ppm dry weight copper in the muscle and 30 ppm dry weight copper in the liver.

Other fish examined showed similar low copper levels in the flesh but high copper levels in the stomach and liver tissues. Since copper is an essential element for numerous physiological processes in organisms it was not surprising to find the low levels in muscle tissues. High levels of copper can be accepted by animals when in the organic form, and excess organically chelated copper can be eliminated by normal metabolic processes.

Spector (1956) lists some of the physiological functions of copper as: erythropoiesis, myelinization of the central nervous system, maintenance of several enzyme systems (polyphenol oxidase, tyrosinase,

laccase, catechol oxidase, and ascorbic acid oxidase), a component of hemocyanin, hepatocuprein and the hemocuprein-protein complexes found in liver tissue, to name a few. Relatively high levels of copper are regularly assimilated by animals and the Department of Health, Education and Welfare, Food and Drug Administration have not found it necessary to set a maximum limit for copper in foods (A.A. Russell, Bureau of Foods, personal communication). When ingested or absorbed in the ionic form, however, copper becomes toxic and its reaction with biological systems is generally attributed to damage to cellular membranes due to complexing of the copper with lipid fractions of the cell wall and subsequent interference with ion transport (Zeitoun *et al* 1969).

Because of the physiological ability to metabolize ingested, organically complexed copper it can be expected that copper will not show appreciable biological magnification in the predator-prey relationships. The work of Hueck and Adema (1968) on the role of copper toxicity in the predator-prey relationship of *Daphnia* and algae, although preliminary in nature, tends to confirm this hypothesis.

SECTION IX

ACKNOWLEDGEMENTS

Westinghouse Ocean Research Laboratory (WORL) is grateful to the Environmental Protection Agency for the financial support and technical guidance of this study. Funds were supplied under E.P.A. Contract Number 14.12.888. Dr. J. Frances Allen, Dr. Richard Wade, and Dr. Roy Irwin were project officers and their guidance and interest in the program were greatly appreciated.

WORL also thanks the Florida Keys Aqueduct Commission, particularly its chairman, John M. Koenig, for permission to work closely with the operators of the Key West Desalination Plant and for the generous use of their property for the installation of laboratory equipment and to conduct of biological experiments. Their cooperation reflects the genuine concern of the Commission for the environmental well-being of the nearshore Florida waters.

Lester Chillcott, the Westinghouse Plant Manager of the desalination facility, was especially helpful during the course of the study. His expert knowledge of the engineering aspects and operation of the desalination plant was of inestimable value in assessing the operational modes of the desalination plant which might affect the environment. Like the members of the Florida Keys Aqueduct Commission, Mr. Chillcott was vitally concerned about the environmental impact of the effluent and was as interested as the researchers in correcting deleterious effects.

George Smith, Plant Foreman for the Florida Keys Aqueduct Commission and the other members of the operational staff were also concerned about the results of the survey and their cooperation was greatly appreciated.

Dr. C.P. Tarzwell and George Gardner of the E.P.A. National Marine Water Quality Laboratory, cooperated extensively in the analysis of histological effects of copper toxicity on fish from Safe Harbor.

Dr. E.F. Corcoran of the Rosenstiel School of Marine and Atmospheric Sciences (RSMAAS) performed analyses of copper and nickel content in samples from the survey and provided insight into some of the toxic and chemical characteristics of these elements. Dr. O. Joensuu (RSMAAS) analyzed the effluent samples by emission spectroscopy and atomic absorption for a variety of elements. Dr. Wayne Bock (RSMAAS) analyzed the foraminiferan fauna from sediment samples and from core samples. Charlene D. Long from the Museum of Comparative Zoology at Harvard University identified the annelid worms collected in Safe Harbor and

Dr. F.M. Bayer (RSMAAS) identified the gorgonian fauna from the flats adjacent to Safe Harbor.

Several members of the staff of the Florida Keys Junior College (where WORL had an analytical laboratory) were helpful during the study and WORL thanks them for their cooperation.

The author thanks Dr. J.C.R. Kelly, Jr., Director of WORL for his advice and especially thanks the staff of the Florida Office of WORL for their dedicated efforts toward the completion of this project. All of the final drawings and manuscript preparations were done by Fay Brett. She and Charles Hamlin, Field Engineer for WORL at Key West, put in many long hours of difficult work beyond normal work hours and their efforts were deeply appreciated.

SECTION X

REFERENCES

- Alexander, J.E. and E.F. Corcoran. 1967. The distribution of copper in tropical seawater. Limnology and Oceanography 12(2):236-242.
- American Society for Testing and Materials. 1964. Tentative test method for evaluating inhibitory toxicity of industrial waste waters. ASTM Standards, 23:517-525.
- Bernard, F.J. and C.E. Lane. 1971. Absorption and excretion of copper ion during settlement and metamorphosis of the barnacle, *Balanus amphitrite niveus*. Biol. Bull. 121(3):438-448.
- Bertholf, L.M. 1945. Accelerating metamorphosis in the tunicate *Styela partita*. Biol. Bull. Woods Hole 89(2):184-185.
- Bray, J.R. and J.T. Curtis. 1957. Ordination of the upland forest communities of southern Wisconsin. Ecol. Monogr. 27:325.
- Brooks, R.R. and M.G. Rumsby. 1965. The biogeochemistry of trace element uptake by some New Zealand bivalves. Limnology and Oceanography 10:521-527.
- Butler, P.A. 1954. Selective setting of oyster larvae on artificial cult. Proc. Natl. Shellfish Assoc. 45:95-105.
- Bulter, P.A. 1965. Reactions of estuarine molluscs to some environmental factors, in Biological Problems in Water Pollution, Third Seminar: 92-104. U.S. Public Health Service, Division of Water Supply and Pollution, Cincinnati.
- Chesher, R.H. (in press). Rapid analysis of long-term effluent distribution, submitted to Nature.
- Clarke, W.D., J.W. Joy, and R.J. Rosenthal. 1970. Biological effects of effluent from a desalination plant at Key West, Florida. Water Pollution Control Research Series 18050 DAI 02/70.
- Clendenning, K.A. and W.J. North. 1960. Effects of wastes on the giant kelp *Macrocystis pyrifera*, in E.A. Pearson (ed) Proceedings of the First International Conference on Waste Disposal in the Marine Environment, Permagon Press, N.Y. 82-91.

- Doochin, H. and F.G.W. Smith. 1951. Marine boring and fouling in relation to velocity of water currents. Bull. Mar. Sci. Gulf and Caribbean 1(3):196-208.
- Doudorff, P. 1951. Bio-assay methods for the evaluation of acute toxicity of industrial wastes to fish. Sewage and Industrial Wastes 23(11):1380-1397.
- Duke, T.W., J.N. Willis, and T.J. Price. 1966. Cycling of trace elements in the estuarine environment. I. Movement and distribution of Zinc 65 and stable zinc in experimental ponds. Chesapeake Science 7(1):1-10.
- ESSA. 1971. Tide Tables east coast of North and South America including Greenland. U.S. Department of Commerce Publication:122-125.
- Galtsoff, P.S. 1932. The life in the ocean from a biochemical point of view. J. Wash. Acad. Sci. 22:246-257.
- Galtsoff, P.S. 1964. The American oyster, *Crassostrea virginica*. Fishery Bull. of the Fish and Wildlife Service, 64:480.
- Goldman, C.R. 1966. Micronutrient limiting factors and their detection in natural phytoplankton populations, in Goldman (ed) Primary Productivity in Aquatic Environments. University of California Press:120-135.
- Hueck, H.J. and D.M.M. Adema. 1968. Toxicological investigations in an artificial ecosystem. A progress report on copper toxicity towards algae and daphniae. Helgolaender wiss. Meeresunters. 17:188-199.
- Krumbein, W.C. and F.J. Pettijohn. 1938. Manual of sedimentary petrology. Appleton-Century Crafts Inc., New York. 549 pp.
- Le Gros, P.F., E.F. Mandelli, W.F. McIlhenny, D.E. Winthrode, and M.A. Zeitoun. 1968. A study of the disposal of the effluent from a large desalination plant. Office of Saline Water Research and Development Progress Report 316:491 pp.
- Lloyd, R. 1965. Factors that affect the tolerance of fish to heavy metal poisoning, in Biological Problems in Water Pollution, Third Seminar. U.S. Public Health Service, Division of Water Supply and Pollution Control, Cincinnati 181-187.
- Margalef, R. 1957. La teoria de la informacion en ecologia. Memorias de al real academia de ciencias y artes, Barcelona.

- McNulty, J.K. 1970. Effects of abatement of domestic sewage pollution on the benthos, volumes of zooplankton, and the fouling organisms of Biscayne Bay, Florida. Stud. Trop. Oceanogr. Miami 9:107 pp.
- Miller, M.A. 1946. Toxic effects of copper on attachment and growth of *Bugula neritina*. Biol. Bull. 90:122-140.
- North, W.J. 1964. Ecology of the rocky nearshore environment in Southern California and possible influences in discharged wastes, in E.A. Pearson (ed) Advances in Water Pollution Research 3 MacMillan, N.Y.:247-262.
- Pearson, E.A., P.N. Storrs, and R.E. Selleck. 1967. Some physical parameters and their significance in marine waste disposal, in Olson and Burgess (eds) Pollution and Marine Ecology. Interscience, New York:297-315.
- Popkin, R. 1969. Desalination: water for the world's future. F.A.Praeger Inc., N.Y. xv 235 pp.
- Portmann, J.E. 1968. Progress report on a programme of insecticide analysis and toxicity-testing in relation to the marine environment. Helgolaender wiss. Meeresunters. 17:247-256.
- Raymont, J.E.G. and J. Shields. 1964. Toxicity of copper and chromium in the marine environment, in E.A. Pearson (ed) Advances in Water Pollution Research 3 Macmillan, N.Y.: 275-290.
- Sachs, M.S. 1969. Desalting plants inventory report No.2, Office of Saline Water. U.S. Department of the Interior.
- Sanders, H.L. 1968. Benthic marine diversity and the stability-time hypothesis. American Naturalist 102:243-258.
- Smith, F.G.W., R.H. Williams, and C.C. Davis. 1950. An ecological survey of the subtropical inshore waters adjacent to Miami. Ecology 31(1):119-146.
- Spector, W.S. 1956. Handbook of Biological data. W.B. Saunders Co. Phil. 584 pp.
- Sprague, J.B. 1964. Avoidance of copper-zinc solutions by young salmon in the laboratory. Journ. Water Pollution Control Federation 36(8):990-1002.
- Standard Methods. 1965. Standard methods for the examination of water and wastewater. 12th edition. American Public Health Assoc. New York. 1965.

- Starck, W.A. and W.P. Davis. 1967. Night habits of fishes of Alligator Reef, Florida. Ichthyologica 38(4):313-357.
- Stemann Nielsen, E. and S. Wium-Andersen. 1970. Copper ions as poison in the sea and in freshwater. Marine Biology 6:93-97.
- Sverdrup, H.U., M.W. Johnson and R.H. Gleming. 1942. The Oceans: their physics, chemistry and general biology. Prentice-Hall Inc., Englewood Cliffs, N.J. xi:782 pp.
- Weiss, C.M. 1948. The seasonal occurrence of sedentary marine organisms in Biscayne Bay, Florida. Ecology 29(2):153-172.
- Wetzel, R.G. 1966. Techniques and problems of primary productivity measurements in higher aquatic plants and periphyton, in C.R. Goldman (ed) Primary productivity in Aquatic Environments. University of California Press: 249-267.
- Whittaker, J.R. 1964. Copper as a factor in the onset of ascidian metamorphosis. Nature 202(4936):1024-1025.
- Wilber, C.G. 1965. The biology of water toxicants in sub-lethal concentrations, in Biological Problems in Water Pollution, Third Seminar. U.S. Public Health Service, Division of Water Supply and Pollution Control, Cincinnati:326-331.
- Zeitoun, M.A. and E.F. Mandelli. 1969a. Disposal of the effluents from desalination plants into estuarine waters. Report to Office of Saline Water. U.S. Department of the Interior. Contract 14-01-0001-1161 (2):140 pp.
- Zeitoun, M.A., E.F. Mandelli, W.F. McIlhenny, R.O. Reid. 1969b. Disposal of the effluents from desalination plants: the effects of copper content, heat and salinity. Report to Office of Saline Water. U.S. Department of the Interior. Contract 14-01-0001-1161:192 pp.

SECTION XI

APPENDIX A

Procedures of copper analysis (by E.F. Corcoran, Resenstiel School of Marine and Atmospheric Sciences, University of Miami).

The basic neocuproine techniques used by Alexander and Corcoran (1967) were modified as follows for analyses of water, sediment and organic tissues for copper content:

1. Glassware Cleanliness: Clean glassware was considered of prime importance and each piece of chemical glassware was washed in a hot solution of Liquinox then rinsed with tap water. To remove remaining detergent, the glassware was rinsed with ethanol and again with tap water. Acid soluble metal ions were removed with acid wash then rinsed with distilled water. A 1 percent solution of disodium salt of EDTA was placed in the flasks and they were autoclaved at 248°F at 15 p.s.i. for fifteen minutes. The EDTA solution was removed and the glassware rinsed three times with distilled, deionized water.
2. Reagents: Sample blanks were kept as low as possible and reagents were selected carefully.

Distilled water - all reagents were prepared with glass-distilled water further purified by passage through a Barnstead cation exchange resin.

Neocuproine 0.1% - 1g of neocuproine was dissolved in 1 liter of redistilled ethyl alcohol.

Hydroxylamine hydrochloride 10% - 100 g of hydroxylamine hydrochloride was dissolved in 600 ml of distilled water and filtered through a Whatman GF/C filter pad. Five ml of 0.1% neocuproine were added to the solution and extracted with chloroform. Extractions were continued until the chloroform layer remained colorless. A final extraction was made with carbon tetrachloride and the hydroxylamine hydrochloride solution was diluted to 1 liter.

Sodium acetate, Crystal reagent grade 27.5% - 453 g of sodium acetate was dissolved in 800 ml distilled water and filtered through a Whatman GF/C filter pad. Two ml of hydroxylamine hydrochloride and 5 ml of 0.1% neocuproine were added. The solution was purified as

above, and after all traces of copper were removed, the solution was diluted to 1 liter.

Perchloric Acid 70-72% - Reagent grade Baker analyzed #9652.

Standard Solution - 113.36 mg of fine granular copper metal (Mallinkrodt Analytical Reagent) was dissolved in 6 ml of a nitric-sulfuric acid mixture (1 + 1). The solution was heated to dense fumes of sulfuric acid, cooled and diluted to 1 liter. This solution contained 113.36 µg/ml. A substandard solution was prepared by diluting 1 ml of the stock solution to 1 liter. This solution contained 0.113 µg Cu/ml. The standard curve was prepared by taking suitable subsamples of the dilute solution to cover the working range (zero to 50 µg/liter was sufficient for most seawater samples).

3. Procedures:

Water Samples: Digestion - add 3 ml perchloric acid to 25 ml of sample and cover with watch glass. Place on hot plate and boil slowly until almost dry. Add 25 ml distilled deionized water and dissolve precipitate completely.

Add reagents in the following order:

- a. 2 ml hydroxylamine hydrochloride
- b. 5 ml neocuproine solution
- c. 10 ml sodium acetate solution

Swirl sample between each addition. Allow fifteen minutes for color development.

Optical density was measured at 454 mµ in a Beckman DU spectrophotometer with 10 cm cells.

Sediment Samples: 200 mg of dried sediment was pulverized with mortar and pestle and digested as above with 3 ml of perchloric acid. Analysis then proceeded as with water samples.

Tissue Samples: The tissue was macerated and an aliquot selected and dried to obtain the dry versus wet weight. 3 ml of perchloric acid was added to a wet aliquot and the samples were treated as described for water samples.

1 Accession Number W	2 Subject Field & Group 053	SELECTED WATER RESOURCES ABSTRACTS INPUT TRANSACTION FORM
--------------------------------	--------------------------------	--

5 Organization	WESTINGHOUSE OCEAN RESEARCH LABORATORY, P.O. BOX 1771 ANNAPOLIS, MARYLAND. 21404
----------------	---

6 Title	BIOLOGICAL IMPACT OF A LARGE-SCALE DESALINATION PLANT AT KEY WEST
---------	---

10 Author(s) RICHARD H. CHESHER	16 Project Designation 18080 GBX
	21 Note

22 Citation

23 Descriptors (Starred First) Water pollution effects*, desalination plants*, biological communities*, copper toxicity*, thermal stratification, subtropic.

25 Identifiers (Starred First) Key West*, multi-stage-flash evaporation process.

27 Abstract An eighteen month biological study showed the heated brine effluent from a desalination plant in Key West, Florida caused a marked reduction in biotic diversity. Some organisms were more abundant in the receiving waters than in control areas but these were generally capable of isolating themselves from the effluent by closing up or by moving to other areas during periods of high contamination. Ionic copper, discharged from the plant, was the most toxic feature of the effluent. Temperature and salinity of the effluent and the receiving water were such that the effluent stratified at the bottom of the receiving basin. This stratification reduced water circulation and the man-made harbor acted as a settling basin which lessened the impact of the discharge on surrounding natural environments. Periodically, the plant shut down for maintenance or cleaning. When it resumed operations, low temperature water of ambient salinity was discharged which was highly contaminated with ionic copper. These sudden effusions caused more biological damage than steady-state conditions. At the end of the study, extensive engineering changes were made to correct corrosion problems and lower copper discharge. This report was submitted in fulfillment of Contract No. 14.12.888 under the sponsorship of the Environmental Protection Agency.
--

Abstractor	Institution
------------	-------------

ENVIRONMENTAL PROTECTION AGENCY

Publications Distribution Section
Route 8, Box 116, Hwy. 70, West
Raleigh, North Carolina 27607

Official Business



POSTAGE AND FEES PAID

ENVIRONMENTAL PROTECTION AGENCY

EPA - 335

CP P KETCHUM
WCODS HOLE CCE INST
WCODS HOLE VA

EPW-2
2542

If your address is incorrect, please change on the above label;
tear off; and return to the above address.
If you do not desire to continue receiving this technical report
series, CHECK HERE ; tear off label, and return it to the
above address.