

3
2
of insects

10

96447
Smiths
66

U. S. DEPARTMENT OF AGRICULTURE,

BUREAU OF ENTOMOLOGY—BULLETIN No. 109.-112, 1911-12

L. O. HOWARD, Entomologist and Chief of Bureau.

PAPERS ON INSECTS AFFECTING
VEGETABLES.

CONTENTS AND INDEX.



ISSUED SEPTEMBER 9, 1916.



WASHINGTON:
GOVERNMENT PRINTING OFFICE.
1916.

ADDITIONAL COPIES

OF THIS PUBLICATION MAY BE PROCURED FROM
THE SUPERINTENDENT OF DOCUMENTS
GOVERNMENT PRINTING OFFICE
WASHINGTON, D. C.
AT
5 CENTS PER COPY



U. S. DEPARTMENT OF AGRICULTURE,
BUREAU OF ENTOMOLOGY—BULLETIN No. 109.

L. O. HOWARD, Entomologist and Chief of Bureau.

PAPERS ON INSECTS AFFECTING VEGETABLES.

I. THE HAWAIIAN BEET WEBWORM.

By H. O. MARSH, *Agent, Engaged in Sugar-Beet and Truck-Crop Insect Investigations.*

II. THE SOUTHERN BEET WEBWORM.

By F. H. CHITTENDEN, *In Charge of Truck-Crop and Stored Product Insect Investigations.*

III. THE IMPORTED CABBAGE WEBWORM.

By F. H. CHITTENDEN, *In Charge of Truck-Crop and Stored Product Insect Investigations,* and H. O. MARSH, *Agent.*

IV. A LITTLE-KNOWN CUTWORM.

By F. H. CHITTENDEN, *In Charge of Truck-Crop and Stored Product Insect Investigations.*

V. ARSENITE OF ZINC AND LEAD CHROMATE AS REMEDIES
AGAINST THE COLORADO POTATO BEETLE.

By FRED A. JOHNSTON, *Entomological Assistant.*

VI. THE SUGAR-BEET WEBWORM.

By H. O. MARSH, *Entomological Assistant.*

VII. THE HORSE-RADISH WEBWORM.

By H. O. MARSH, *Entomological Assistant.*



WASHINGTON:
GOVERNMENT PRINTING OFFICE.

1916.

BUREAU OF ENTOMOLOGY.

L. O. HOWARD, *Entomologist and Chief of Bureau.*
C. L. MARLATT, *Entomologist and Assistant Chief of Bureau.*
E. B. O'LEARY, *Chief Clerk and Executive Assistant.*

F. H. CHITTENDEN, *in charge of truck crop and stored product insect investigations.*
A. D. HOPKINS, *Forest Entomologist.*
W. D. HUNTER, *in charge of southern field crop insect investigations.*
—————, *in charge of cereal and forage insect investigations.*
A. L. QUAINANCE, *in charge of deciduous fruit insect investigations.*
E. F. PHILLIPS, *in charge of bee culture.*
A. F. BURGESS, *in charge of gipsy moth and brown-tail moth investigations.*
ROLLA P. CURRIE, *in charge of editorial work.*
MABEL COLCORD, *in charge of library.*

TRUCK CROP AND STORED PRODUCT INSECT INVESTIGATIONS.

F. H. CHITTENDEN, *Entomologist in charge.*
C. H. POPENOE, T. H. JONES, M. M. HIGH, F. A. JOHNSTON, AND D. E. FINK,
entomological assistants.
H. O. MARSH, F. B. MILLIKEN, C. F. STAHL, FRANK R. COLE, A. B. DUCKETT, B. L.
BOYDEN, R. E. CAMPBELL, W. H. WHITE, and PAULINE M. JOHNSON, *Scientific*
assistants.
NEALE F. HOWARD, *Specialist.*
W. N. DOVENER, *Expert.*

CONTENTS.

	Page.
The Hawaiian beet webworm (<i>Hymenia fascialis</i> Cram.)..... <i>H. O. Marsh</i> ..	1
Introductory.....	1
Food plants and injury.....	2
Life history and habits.....	3
Natural enemies.....	7
Experiments with insecticides.....	7
Description of the earlier stages..... <i>H. G. Dyar</i> ..	11
Appendix..... <i>F. H. Chittenden</i> ..	12
Description and synonymy.....	12
Distribution.....	14
History.....	14
Bibliography.....	15
The southern beet webworm (<i>Pachyzancla bipunctalis</i> Fab.)... <i>F. H. Chittenden</i> ..	17
Injurious occurrences and notes on habits.....	17
Descriptive.....	19
The moth.....	19
The egg.....	20
The larva.....	20
The pupa.....	20
Distribution.....	21
Historical and biological notes.....	21
Natural enemies.....	21
Associated insects.....	21
Remedies.....	22
Paris green.....	22
"Dragging the log".....	22
The imported cabbage webworm (<i>Hellula undalis</i> Fab.)... <i>F. H. Chittenden</i> and <i>H. O. Marsh</i>	23
Introduction, spread, and ravages.....	23
Description and life-history notes.....	27
The moth.....	27
The egg and oviposition.....	28
The newly hatched larva.....	29
The full-grown larva.....	29
The pupa.....	29
Distribution.....	30
Food plants.....	30
Natural enemies.....	31
The imported cabbage webworm in Hawaii.....	32
Life history and habits.....	34
Natural enemies in Hawaii.....	37
Experiments with insecticides.....	38
Experiment in screening a seed bed.....	41
Conclusion.....	41
Recommendations for control.....	42
Bibliography.....	44

	Page
A little-known cutworm (<i>Porosagrotis vetusta</i> Walk.) <i>F. H. Chittenden</i> . .	47
Injurious occurrence	47
Results from applications of arsenate of lead	49
Description	50
The moth	50
The larva	50
Distribution	50
Natural enemies	51
Arsenite of zinc and lead chromate as remedies against the Colorado potato beetle <i>Fred A. Johnston</i> . .	53
Spraying experiments with arsenite of zinc and lead chromate in comparison with other arsenicals	53
Spraying experiments with arsenite of zinc of different strengths	55
A report of progress regarding the sugar-beet webworm (<i>Loxostege sticticalis</i> L.), <i>H. O. Marsh</i> . .	57
Introduction	57
General appearance of the sugar-beet webworm and nature of attack	58
Life history and habits	59
Character of injury	61
Natural enemies	62
Other checks	63
Experiments with remedies	63
Spraying machinery	66
Cost of spraying	69
Conclusion	70
The horse-radish webworm (<i>Plutella armoracia</i> Busck) <i>H. O. Marsh</i> . .	71
Introduction	71
Occurrence in Colorado	71
General appearance and habits	72
Life history	73
Rearing records	73
Egg-laying record	75
Natural enemies	75
Experiments with insecticides	76
Recommendations for control	76
Conclusion	76
Index	77

ILLUSTRATIONS.

PLATE.

	Page.
PLATE I. Fig. 1.—Geared traction sprayer, suitable for the treatment of sugar beets against the Hawaiian beet webworm.....	8
Fig. 2.—Geared traction sprayer in operation in sugar-beet field.....	8

TEXT FIGURES.

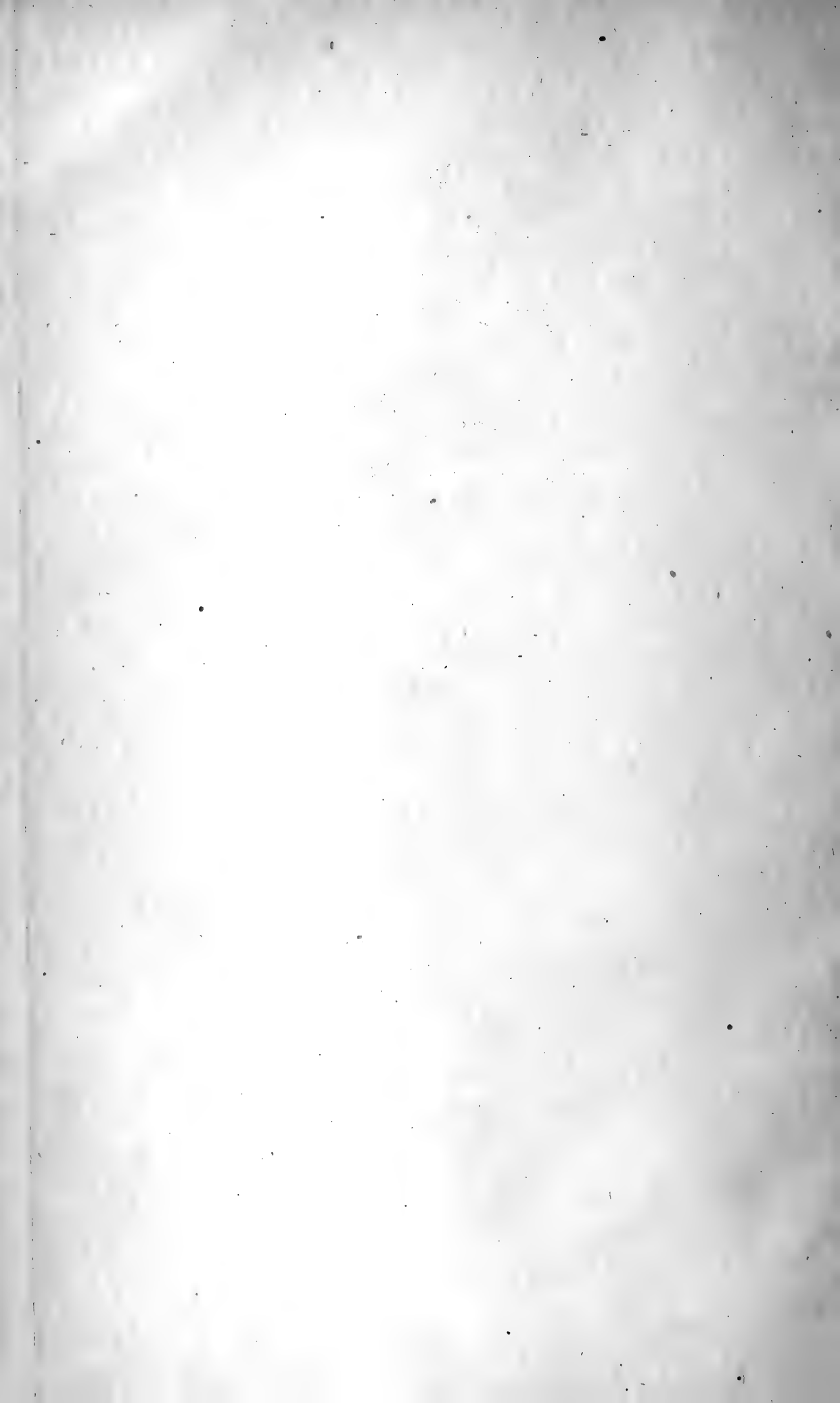
FIG. 1. The Hawaiian beet webworm (<i>Hymenia fascialis</i>): Female moth.....	3
2. The Hawaiian beet webworm: Egg, larva, pupa, details.....	4
3. The southern beet webworm (<i>Pachyzancla bipunctalis</i>): Moth, larva, pupa, details.....	19
4. The imported cabbage webworm (<i>Hellula undalis</i>): Adult, larva, pupa.....	28
5. The imported cabbage webworm: Wing venation; head and antenna..	28
6. <i>Exorista pyste</i> , a parasite of the imported cabbage webworm.....	31
7. Small compressed-air sprayer.....	38
8. <i>Porosagrotis vetusta</i> : Moth, larva.....	50
9. The sugar-beet webworm (<i>Loxostege sticticalis</i>): Moth.....	58
10. The garden webworm (<i>Loxostege similalis</i>): Moth, larva, pupa, details..	58
11. A medium-sized sugar-beet plant defoliated by the sugar-beet webworm in July.....	60
12. Sugar beets defoliated by the sugar-beet webworm in July.....	61
13. Large sugar-beet plants, showing defoliation and weakened roots due to attack by the sugar-beet webworm in August.....	62
14. Field of young sugar beets destroyed by the sugar-beet webworm in June.....	63
15. Barrel sprayer suitable for use against the sugar-beet webworm.....	64
16. Barrel sprayer in action against the sugar-beet webworm.....	65
17. Four-row attachment for beet sprayer.....	67
18. Four-row attachment for beet sprayer.....	67
19. Four-row attachment for beet sprayer.....	67
20. Geared traction sprayer suitable for use against the sugar-beet webworm.....	68
21. Geared traction sprayer in action against the sugar-beet webworm.....	68
22. Filling a traction sprayer for spraying against the sugar-beet webworm..	69
23. Type of Vermorel nozzles suitable for spraying sugar beets against the sugar-beet webworm.....	69
24. The horse-radish webworm (<i>Plutella armoracia</i>): Adult or moth, side view and with wings spread.....	72
25. The horse-radish webworm: Larva, lateral and dorsal views.....	72
26. The horse-radish webworm: Pupa.....	73
27. The horse-radish webworm: Cocoon.....	73

ERRATA.

Page 33, line 7, for *Agrostis* read *Agrotis*.

Page 72, line 14, for *scale like* read *scale-like*.

Page 76, last sentence, read, *In this garden the larvæ have evidently been prevented by a hymenopterous parasite from causing much damage, and at present no artificial control measures are necessary.*



U. S. DEPARTMENT OF AGRICULTURE,
BUREAU OF ENTOMOLOGY—BULLETIN NO. 109, Part I.

L. O. HOWARD, Entomologist and Chief of Bureau.

PAPERS ON INSECTS AFFECTING VEGETABLES.

THE HAWAIIAN BEET WEBWORM.

BY

H. O. MARSH,

Agent,

*Engaged in Sugar-Beet and Truck-Crop
Insect Investigations.*

[WITH APPENDIX BY H. G. DYAR AND F. H. CHITTENDEN.]

ISSUED NOVEMBER 6, 1911.



WASHINGTON:
GOVERNMENT PRINTING OFFICE.
1911.

BUREAU OF ENTOMOLOGY.

L. O. HOWARD, *Entomologist and Chief of Bureau.*
C. L. MARLATT, *Entomologist and Acting Chief in Absence of Chief.*
R. S. CLIFTON, *Executive Assistant.*
W. F. TASTET, *Chief Clerk.*

F. H. CHITTENDEN, *in charge of truck crop and stored product insect investigations.*
A. D. HOPKINS, *in charge of forest insect investigations.*
W. D. HUNTER, *in charge of southern field crop insect investigations.*
F. M. WEBSTER, *in charge of cereal and forage insect investigations.*
A. L. QUAINANCE, *in charge of deciduous fruit insect investigations.*
E. F. PHILLIPS, *in charge of bee culture.*
D. M. ROGERS, *in charge of preventing spread of moths, field work.*
ROLLA P. CURRIE, *in charge of editorial work.*
MABEL COLCORD, *in charge of library.*

TRUCK CROP AND STORED PRODUCT INSECT INVESTIGATIONS.

F. H. CHITTENDEN, *in charge.*

H. M. RUSSELL, C. H. POPENOE, WILLIAM B. PARKER, H. O. MARSH, THOMAS
H. JONES, M. M. HIGH, FRED A. JOHNSTON, *entomological assistants.*
I. J. CONDIT, *collaborator in California.*
P. T. COLE, *collaborator in tidewater Virginia.*
W. N. ORD, *collaborator in Oregon.*
MARION T. VAN HORN, *preparator.*

CONTENTS.

	Page.
The Hawaiian beet webworm (<i>Hymenia fascialis</i> Cram.)..... <i>H. O. Marsh.</i> ..	1
Introductory.....	1
Food plants and injury.....	2
Life history and habits.....	3
Natural enemies.....	7
Experiments with insecticides.....	7
Description of the earlier stages..... <i>H. G. Dyar.</i> ..	11
Appendix..... <i>F. H. Chittenden.</i> ..	12
Description and synonymy.....	12
Distribution.....	14
History.....	14
Bibliography.....	15

ILLUSTRATIONS.

PLATE.

	Page.
PLATE I. Fig. 1.—Geared traction sprayer, suitable for the treatment of sugar beets against the Hawaiian beet webworm	8
Fig. 2.—Geared traction sprayer in operation in sugar-beet field.....	8

TEXT FIGURES.

Fig. 1. The Hawaiian beet webworm (<i>Hymenia fascialis</i>): Female moth.....	3
2. The Hawaiian beet webworm: Egg, larva, pupa, details	4



PAPERS ON INSECTS AFFECTING VEGETABLES.

THE HAWAIIAN BEET WEBWORM.

(*Hymenia fascialis* Cram.)

By H. O. MARSH,

Agent, engaged in Sugar-Beet and Truck-Crop Insect Investigations.

INTRODUCTORY.

During the latter half of 1910 the author was engaged in a study of insects affecting truck crops in the Hawaiian Islands. The enemies of beets and of the so-called spinach (*Amaranthus* sp.) were among the insects which were studied. The species injurious to these two crops had previously received very little study from an economic standpoint, and the necessity of such study was further enhanced by the fact that a land company was experimenting with sugar beets on the island of Lanai¹ with the intention of growing this crop on a large scale, if it should offer promise of becoming profitable.

In the vicinity of Honolulu, on the island of Oahu, vegetables are grown in commercial gardens, managed by Chinese or Japanese. In a general sense, these growers may be considered "good farmers" although they have little regard for the necessity of clean culture and seldom make any intelligent effort to combat insect pests or plant diseases. In the rare cases where an effort is made to cope with such troubles, the methods employed are extremely crude. Practically all cultivation is done by hand, except that occasionally the water buffalo is used for plowing the land before the crops are planted. From the Oriental point of view this plowing is considered sufficient if the surface of the ground is scratched to the depth of a few inches. The fertilizing material used is in liquid form. It is prepared by soaking stable manure or other refuse material in water and is applied directly about the plants.

Table beets and "spinach" are produced exclusively for the local market. These vegetables are grown in beds, in a peculiar manner, which Mr. E. M. Ehrhorn has aptly designated "the graveyard style." The beds, which are very often about 10 yards long by 1

¹The sixth largest island of the group.

yard wide, are mounded up about 6 to 8 inches above the surrounding surface, the top is leveled, and the seeds are planted on these elevated plats, which have an appearance very suggestive of graves.

Although the climate is rather humid the normal rainfall, at Honolulu, is so light that irrigation is necessary to produce a crop. Practically all the gardens have an abundant supply of artesian water, but, owing to the manner in which the beds are elevated, it is impossible to run the water between the rows of plants, and as a result they have to be watered by hand. This is accomplished by dipping up the water in large watering cans and sprinkling it over the beds. It would seem that this slow and laborious method of irrigation could be eliminated if the beds were prepared in a more up-to-date manner.

The so-called spinach is not the plant which is recognized by that name in mainland markets, but is a species of *Amaranthus*. The leaves and stems of the young and tender plants, when properly cooked, make fairly palatable "greens."

FOOD PLANTS AND INJURY.

The most conspicuous enemy of this class of vegetables is the Hawaiian beet webworm (*Hymenia fascialis* Cram.). In the Hawaiian Islands the larvæ of this species include among their food plants table beets, sugar beets, stock beets (mangel-wurzels), several species of *Amaranthus*, *Euxolus*, purslane (*Portulaca oleracea*), cucumbers, and chenopodiaceous weeds. Among the wild food plants, *Amaranthus* is the favorite. These weeds grow in abundance along fences and in neglected spots, and it frequently happens that the plants are so completely stripped of foliage that large patches of them die. Cultivated *Amaranthus* is likewise severely damaged. Beets are a close second in attractiveness, and it is not unusual to see beds of this vegetable with nothing remaining of the foliage but the petioles. When infestation is very severe the plants are occasionally killed outright, and even when the larvæ are less abundant the infested beets are stunted in growth and injured in quality. Sugar beets are attacked as readily as the table variety. During the latter part of August, 1910, the author received some sugar beets from the experimental plats on Lanai, from which practically all the foliage had been stripped, and it was reported that all the beets in the plats were in a similar condition. This webworm is the most serious insect pest which menaces the production of sugar beets in Hawaii, and unless it is controlled it is unlikely that this crop can be profitably grown. Cucumbers are apparently only rarely attacked and the occasional larvæ which were found infesting this cucurbit were doubtless feeding on it because more attractive food was not available. *Portulaca* is commonly attacked but apparently is not so favored a food as *Amaranthus* or beets.

LIFE HISTORY AND HABITS.

All stages of this pest can be found throughout the year. The moths (fig. 1) are usually to be found in abundance among the foliage of *Amaranthus*, beets, or other low-growing plants. During the day they remain concealed, usually on the underside of the leaves, but when disturbed they fly readily. They are but rarely attracted by lights. The scale-like iridescent eggs (fig. 2, *a*) are almost invariably deposited on the underside of the leaves. They are placed singly, in pairs, or in rows of five or more. On beet leaves, the favorite place for depositing eggs is along the midrib and larger veins. As many as 40 eggs, which had been deposited in the field under normal conditions, were counted on a single beet leaf. The eggs have been ob-

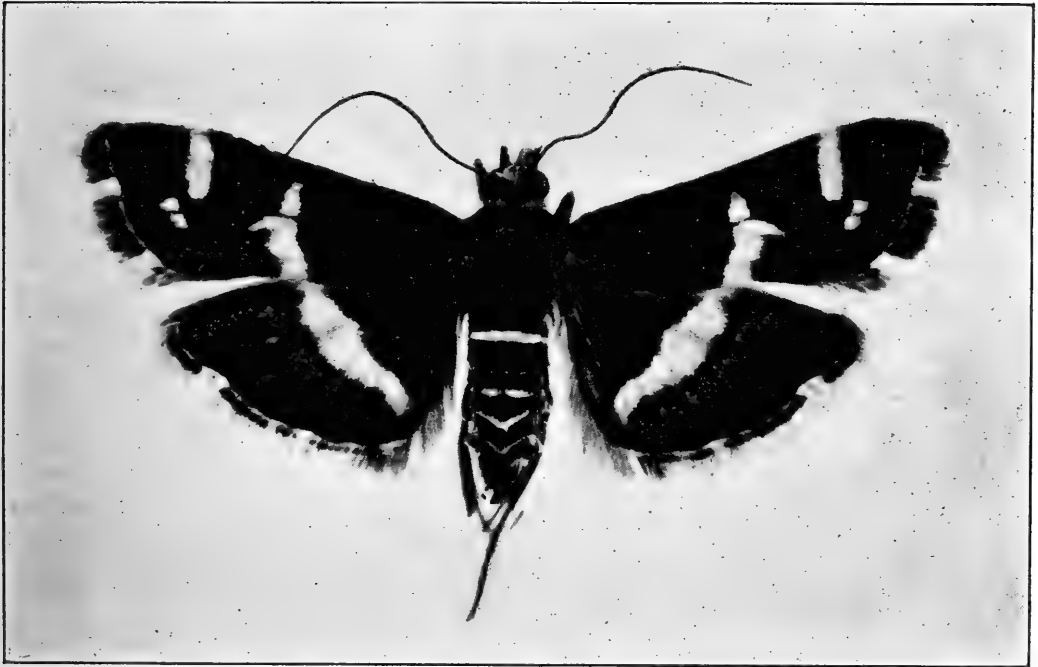


FIG. 1.—The Hawaiian beet webworm (*Hymenia fascialis*): Female moth. Enlarged. (Original.)

served to hatch in 4 days. The young larvæ feed on the lower surface of the leaves. On beets, and probably on other plants, the larvæ, except when nearly mature, consume only this surface. This habit of remaining on the underside of the leaves, without eating through the upper epidermis, adds to the difficulty of successfully treating this pest with insecticides. (See larva and details, fig. 2, *b-e*.)

In some cases the larvæ spin light webs, under which they rest. This web-forming habit is not very pronounced, and it is not unusual to find hundreds of larvæ without any webs whatever.

Under normal conditions the larvæ reach maturity in from 9 to 13 days. They then leave the plants, burrow slightly beneath the surface, and form firm, compact, oblong cocoons of webbed-together

grains of earth. From the time of hatching until fully mature, the larvæ are pale green, but while engaged in constructing their cocoons (fig. 2, *h*), they change to a reddish pink. They usually pupate about 2 days after entering the soil, and the adults issue from 7 to 13 days later, thus completing a generation in from 22 to 31 days. (See pupa and details, fig. 2, *f*, *g*.)

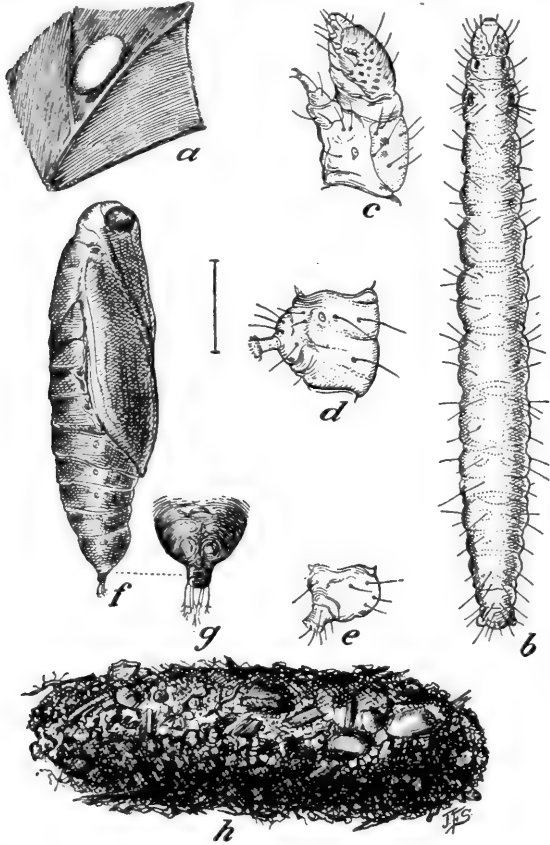


FIG. 2.—Hawaiian beet webworm: *a*, Egg on leaf; *b*, larva, dorsal view; *c*, larva, head and first thoracic segment; *d*, abdominal segment, lateral view; *e*, anal segment; *f*, pupa, lateral view; *g*, cremaster; *h*, cocoon. All enlarged. (Original.)

and is not included in this paper. For the sake of convenience the August-September generation is mentioned as the first, although, in reality, it was the second. The five following generations are in direct line of descent.

FIRST GENERATION.

August 20.—At this date four moths were collected in the field and confined in a cage.

August 25.....First eggs deposited.

August 29.....The eggs hatched.

September 7.....First larvæ reached maturity.

September 9.....First larvæ pupated.

September 16.....First adults issued.

¹ It is not probable, however, that more than six generations can be produced successively, beginning with one pair of moths, since insects in general, in the writer's experience, always undergo a resting stage—sometimes two.—F. H. CHITTENDEN.

The climate of Hawaii is so equable that this pest is enabled to breed continuously, and it is possible that ten or twelve generations might be produced annually. Owing to the overlapping of broods and to the fact that eggs, larvæ, pupæ, and adults are to be found at almost any time, it is practically impossible to work out the number of generations for a given year from field observations alone.¹

Beginning in July, 1910, and continuing past the middle of January, 1911, the author reared this species through six generations in the insectary. The records of five of these generations are given below. The actual first (July-August) generation was reared from larvæ which were collected in the field, and as the egg stage was not obtained the record is incomplete

From the above record the stages are as follows:

	Days.
Egg stage -----	4
Larval stage -----	11
Pupal stage -----	7
Total -----	22

SECOND GENERATION.

September 16 -----	Adults issued.
September 18 -----	First eggs deposited.
September 22 -----	The eggs hatched.
October 3 -----	First larvæ reached maturity.
October 5 -----	First larvæ pupated.
October 15 -----	First adults issued.

From the above record the stages are as follows:

	Days.
Egg stage -----	4
Larval stage -----	13
Pupal stage -----	10
Total -----	27

THIRD GENERATION.

October 15 -----	Adults issued.
October 17 -----	First eggs deposited.
October 21 -----	The eggs hatched.
November 1 -----	First larvæ reached maturity.
November 3 -----	First larvæ pupated.
November 12 -----	First adults issued.
November 13 -----	More adults issued.

From the above record the stages are as follows:

	Days.
Egg stage -----	4
Larval stage -----	13
Pupal stage -----	9
Total -----	26

Curiously enough the first moths, 10 in number, which issued November 12, failed to deposit any eggs, so the first eggs deposited by moths which issued the following day (Nov. 13) were retained to commence the succeeding generation.

FOURTH GENERATION.

November 13 -----	Adults issued.
November 16 -----	First eggs deposited.
November 20 -----	The eggs hatched.
December 2 -----	First larvæ reached maturity.
December 5 -----	First larvæ pupated.
December 17 -----	First adults issued.

From the above record the stages are as follows:

	Days.
Egg stage.....	4
Larval stage.....	15
Pupal stage.....	12
Total.....	31

FIFTH GENERATION.

December 17.....	Adults issued.
December 19.....	First eggs deposited.
December 23.....	The eggs hatched.
January 4.....	First larvæ reached maturity.
January 6.....	First larvæ pupated.
January 19.....	First adults issued.

From the above records the stages are as follows:

	Days.
Egg stage.....	4
Larval stage.....	14
Pupal stage.....	13
Total.....	31

These records were obtained in an open-air insectary at Honolulu. The moths were confined in open-wire cages, which contained an inch or more of moistened, sterilized soil. Beet or *Amaranthus* leaves, upon which the eggs were to be deposited, were placed in the cages and food was supplied the moths by putting in wads of absorbent cotton, which had been saturated in molasses and water. This food was evidently greatly relished. The moths were very "wild" and flew about very actively whenever the cages were approached. Copulation evidently took place at night, as during the several months that the species was kept under daily observation, in the insectary and field, no mating pairs were observed. Owing to the failure to obtain mating pairs and to the fact that it is difficult to distinguish the sexes when the moths are fluttering wildly about in the cages, no individual egg-laying records were obtained. In one case three newly emerged and unfertilized female moths were placed in a cage and supplied with molasses as food. They lived 10 days, and during this time deposited 300 eggs. Such a record is not conclusive, but it indicates that each female is capable of depositing at least 100 eggs. This is doubtless far short of the actual number of eggs that one female could deposit under normal conditions.

Temperatures at Honolulu during the time the species was reared.

Month.	Minimum temperature.	Maximum temperature.	Average mean temperature for entire month.
1910.	°F.	°F.	°F.
July.....	69	84	76.5
August.....	66	85	76.8
September.....	69	85	77.0
October.....	65	84	75.3
November.....	66	84	74.6
December.....	62	80	71.2
1911.			
January.....	58	79	70.0

NATURAL ENEMIES.

At various dates larvæ were collected in the field and confined in cages in the insectary. In this way three species of hymenopterous parasites were obtained. These were *Limnerium hawaiiense* Cram., *Chelonus blackburni* Cram., and *Cremastus hymeniae* Vier.

L. hawaiiense was obtained in greatest numbers during August and September, while *C. blackburni* apparently became more abundant during December. *C. hymeniae* was reared only in small numbers and at all times appeared to be more rare than the other species. No predaceous enemies were actually observed feeding on the *Hymenia* larvæ or pupæ, but on several occasions a species of wasp (*Polistes hebraeus* Fab.) was seen buzzing about infested plants. During the warmer months this wasp and allied species are efficient enemies of the common cabbage worm (*Pontia rapæ* L.), and it is not improbable that they also occasionally kill *Hymenia* larvæ. On the whole, the natural enemies apparently do not reduce the number of *Hymenia* larvæ sufficiently to be of much practical value.

EXPERIMENTS WITH INSECTICIDES.

During the fall of 1910, an opportunity was taken to make some experiments against the *Hymenia* larvæ with insecticides. The experiments were as follows:

Experiment No. 1.—Paris green, 4 pounds, and lime, 4 pounds, in 100 gallons of water. September 1, three beds of table beets, each 10 yards in length and 1 yard wide, were sprayed with about 2 gallons of this mixture. The application was made with a portable, compressed-air sprayer, which was fitted with a short extension-rod elbow and a Vermorel type nozzle. The mixture was applied chiefly to the upper surface of the leaves and it adhered very well. The weather at the time of the application was hot and clear and without a breeze.

The following day all the larvæ were alive, except those on occasional leaves which were poisoned on the underside. Thirty-three

live larvæ were counted on the underside of one leaf. These beds were examined daily, and on September 7 it was concluded that the experiment was a failure, as the larvæ, except on the leaves which had been thoroughly sprayed on the underside, were unharmed. It was noted that on leaves which had been but partially sprayed on the underside the larvæ avoided the poisoned portion but continued to feed on the part which had been missed by the spray. The failure of this experiment was due to the habit the larvæ have of feeding on the underside of the leaves, without eating through the upper epidermis. The mixture used in this experiment burned the partly consumed leaves slightly but caused no extensive injury.

Experiment No. 2.—Paris green, 2 pounds, and whale-oil soap, 8 pounds, in 100 gallons of water. September 7, three beds of table beets, each 10 yards in length and 1 yard wide, were sprayed with about 3 gallons of this mixture. The same apparatus was used as in experiment No. 1. A particular effort was made to wet the under surface of the leaves thoroughly. The mixture adhered perfectly and an extremely even distribution of the poison was obtained. The weather was hot and clear.

The following day nearly all the larvæ were dead and the few individuals which remained alive appeared very sick. September 10, the beets were free of larvæ and the foliage showed no burning by the spray mixture. Two weeks later the sprayed plants were still free of larvæ, while beets in adjoining (check) beds were badly infested. This experiment plainly demonstrates that if the spray is applied properly, i. e., to the underside of the leaves, it can be depended on to control this pest.

In addition to the experiments with Paris green, a few preliminary and somewhat inconclusive tests were made with arsenate of lead, lead chromate, and lime-sulphur solution. For the sake of convenience these will be classed as experiments.

Experiment No. 3.—Arsenate of lead, 1½ ounces, and molasses, 1 quart, in 1½ gallons of water. This mixture was experimented with as a poisoned bait for the melon fly (*Dacus cucurbitæ* Coq.), and was not originally intended for use against the Hawaiian beet webworm. September 7, a patch of *Amaranthus*, badly infested by larvæ varying in size from those recently hatched to others nearly mature, was sprayed with some of this mixture. The spray was applied very thoroughly to the upper and lower surfaces of the leaves with the same apparatus as used in experiment No. 1. The following day the larvæ were unharmed. The leaves showed a good even coat of the arsenate. The sprayed plants were kept under daily observation until September 13, at which date they were destroyed. On the 9th and 10th of September it was noted that the larvæ were growing nicely and appeared to relish the poison-coated leaves.

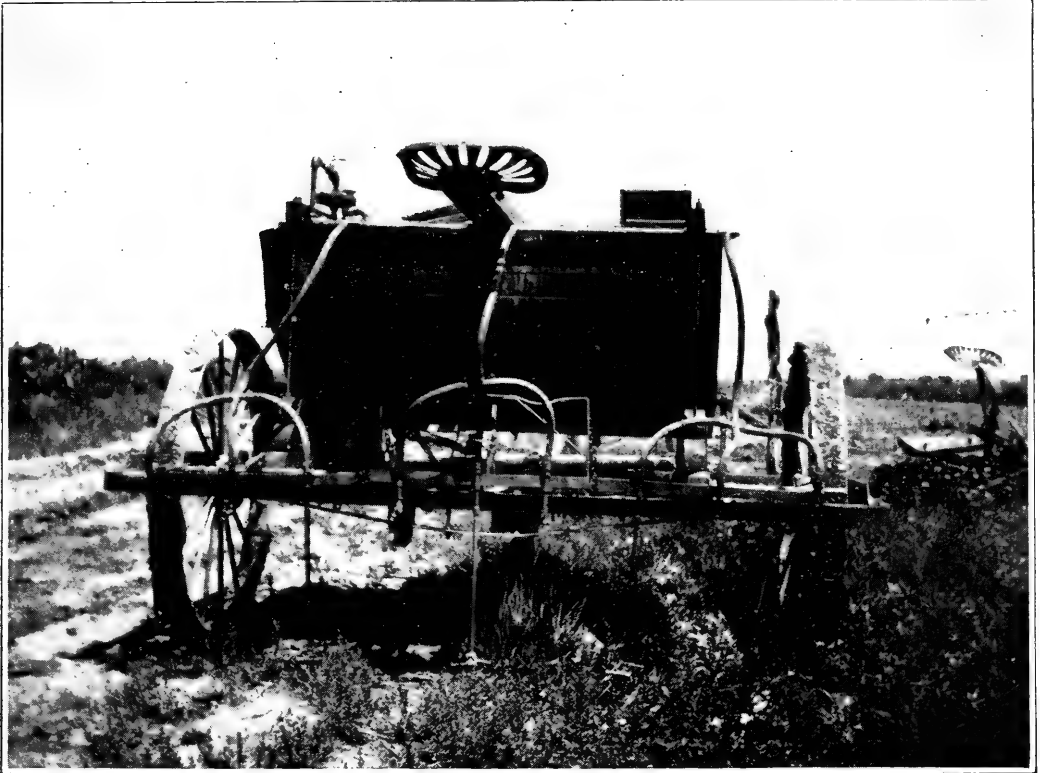
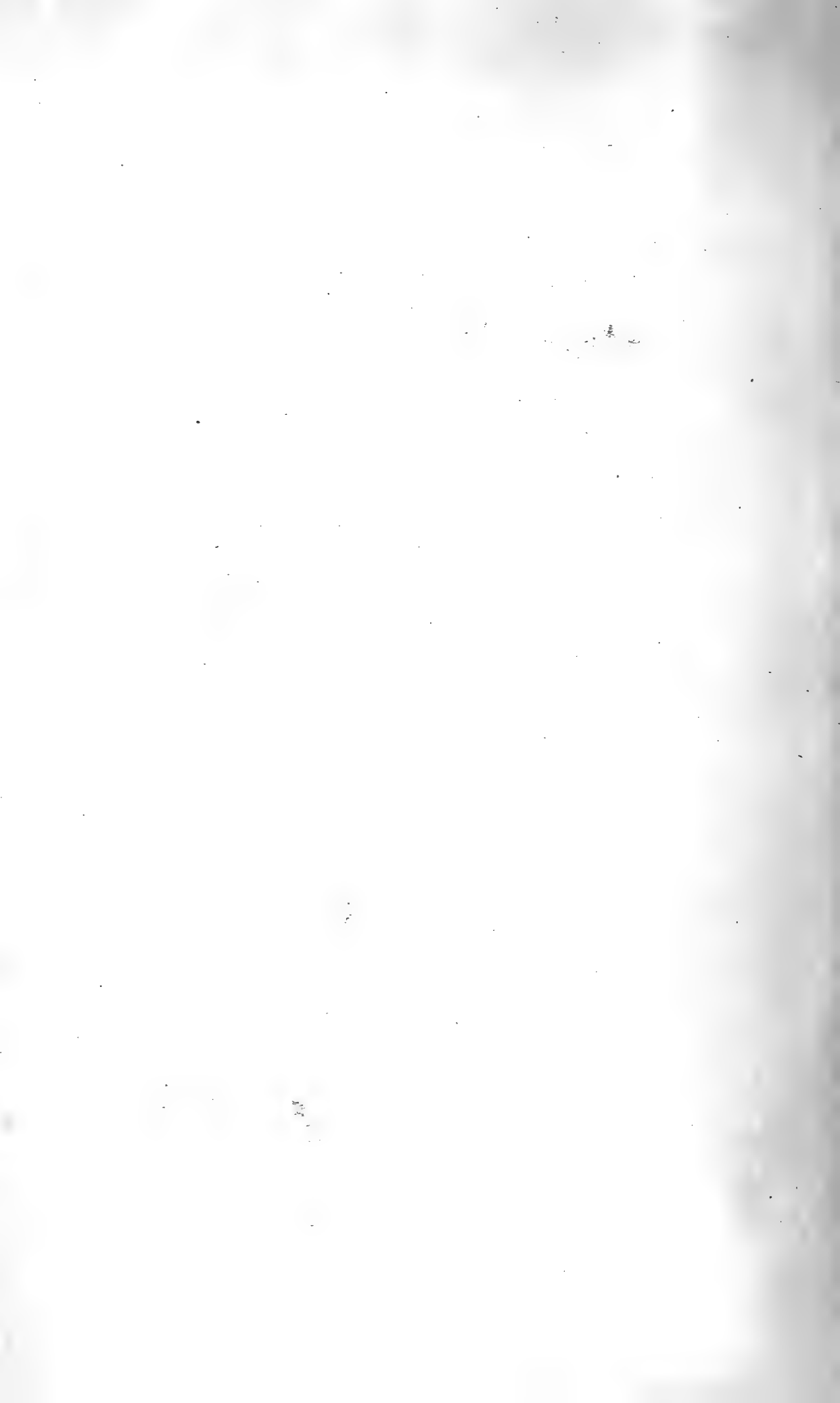


FIG. 1.—GEARED TRACTION SPRAYER SUITABLE FOR THE TREATMENT OF SUGAR BEETS AGAINST THE HAWAIIAN BEET WEBWORM. (ORIGINAL.)



FIG. 2.—GEARED TRACTION SPRAYER IN OPERATION IN SUGAR-BEET FIELD AGAINST THE HAWAIIAN BEET WEBWORM. (ORIGINAL.)



September 12, all the larvæ which had not matured were still feeding and showed no ill effects from their diet of arsenate of lead and *Amaranthus* leaves. The spray mixture caused no injury to the foliage.

In this test a standard grade of arsenate of lead was used at the rate of $6\frac{1}{4}$ pounds in 100 gallons of water, and it is difficult to understand why it failed to kill the tender *Hymenia* larvæ. Of course, such a test as this can not be considered conclusive, but it would indicate that less effective results would be obtained with arsenate of lead than with Paris green.

Experiment No. 4.—Lime-sulphur solution, 1 gallon, in 15 gallons of water. November 1, a few infested beets were sprayed with a small quantity of this solution. A thorough application was made to the upper surface and underside of the leaves with an atomizer. Larvæ which were drenched with the solution appeared to die promptly. The weather was hot and clear at the time of the application. Two days later the larvæ had been reduced somewhat in numbers but there were still plenty of living specimens present. Some of the leaves were severely burned. November 5, the coat of lime was still very good. The larvæ were feeding on the coated leaves and were apparently unharmed. This solution apparently killed only the larvæ which were thoroughly drenched at the time of the application. The beet foliage was severely burned, and on the whole the results were not promising.

Experiment No. 5.—Lead chromate, 2 ounces, in 8 gallons of water. December 16, a few infested beets were sprayed with a small quantity of this mixture. The application was made to the upper and lower surfaces of the leaves with an atomizer. The mixture appeared as a yellow coating on the leaves and adhered very well. The weather was hot and clear. Three days later the larvæ were still alive, but had ceased feeding, and were clinging to the leaves in a listless manner. During the following two or three days they dropped to the ground and died. The sprayed foliage showed no burning. It is not possible to form a definite conclusion from this meager test, but it indicates that lead chromate at this strength is very slow in its killing effects.

In another similar test lead chromate was used on beets at the rate of 2 ounces in 4 gallons of water. Unfortunately an illness of the author prevented the making of observations as to the effect of this strength on the larvæ. Ten days after the application it was noted that two heavy rains had failed to wash the coat of poison from the leaves and that no burning had resulted. It is evident that this new insecticide has some good points, and it should be given a thorough trial.

The results of the experiments may be summarized as follows:

Experiments with insecticides.

Experiment No.	Date.	Insecticide used.	Effect on larvæ.	Injury to foliage.	Remarks.
1	1910 Sept. 1	Paris green, 4 pounds, and lime, 4 pounds, in 100 gallons of water.	Ineffective....	Slight...	The poor results were due to the poison being applied to the upper surface of beet leaves where the larvæ failed to reach it.
2	Sept. 7	Paris green, 2 pounds, and whale-oil soap, 8 pounds, in 100 gallons of water.	Absolutely effective.	None....	Spray applied properly to the under surface of beet leaves.
3	...do.....	Arsenate of lead, 1½ ounces, and molasses, 1 quart, in 1½ gallons of water.	Ineffective....	...do.....	Applied to the upper and lower surface of Amaranthus leaves. There is no apparent reason for its failure to kill the larvæ.
4	Nov. 1	Lime-sulphur solution, 1 gallon, in 15 gallons of water.do.....	Severe..	Applied to beet leaves. A few larvæ were killed by contact with the solution.
5	Dec. 16	Lead chromate, 2 ounces, in 8 gallons of water.	Possibly effective.	None....	Applied to beet leaves. The poison was very slow in its killing effect.

It will be seen from the record of experiment No. 2 that this web-worm can be effectively controlled on beets with Paris green. When this poison is applied at the rate of 2 pounds in 100 gallons of water it will not burn beet foliage and in this formula it is better to omit lime and use whale-oil soap. The soap serves as an effective adhesive agent and when it is used the poison is very evenly distributed over the leaf surface.

As "spinach" is used as food by human beings while the plants are still young and tender, it is obvious that it would be unsafe to spray this crop with an arsenical. Instead of an arsenical it is recommended that the following nicotine-soap combination be used on spinach:

Nicotine sulphate.....	1 fluid ounce.
Whale-oil soap	4 ounces.
Water	4 gallons.

This formula was successfully used by the author at Honolulu, against the common cabbage worm (*Pontia rapæ* Linn.), the larva of the diamond-back moth (*Plutella maculipennis* Curtis), a looper (*Autographa precatationis* Guen.), and the beet army worm (*Caradrina exigua* Hbn.). It has also been used effectively against several species of aphides or plant-lice and thrips. Although this formula has not been actually tested on Hymenia larvæ, there is no reason to believe that it would not prove entirely effective.

For treating moderate-sized plats in gardens a portable compressed-air sprayer or a bucket pump will give good results. The sprayer should be fitted with a short extension rod, an elbow, and a nozzle of the Vermorel type, which will deliver a fine, mist-like

spray. The elbow makes it possible to coat the underside of the leaves thoroughly. It is essential to bear in mind that, unless this surface of the foliage is thoroughly covered with the poison, the spraying will be ineffective. In the gardens about Honolulu, the difficulty of spraying the lower surface of the leaves is greatly increased by the closeness with which beets are planted in the mounded-up beds. If the method of planting were modified so that the plants were grown in slightly separated rows, it would simplify the matter of spraying.

It is evident that if sugar beets are to become a profitable crop in the Hawaiian Islands it will be necessary to spray them to prevent the ravages of this pest. For spraying large areas, such as fields of sugar beets, it is better to use a large geared or power sprayer. In some experiments which the author conducted on sugar beets in Colorado, against a somewhat similar species, the sugar-beet webworm (*Loxostege sticticalis* L.), ordinary barrel sprayers and geared sprayers, of 125 gallons capacity, were successfully used. With the nozzles arranged as in the accompanying illustration (Plate I, figs. 1, 2), it is an easy matter to spray thoroughly the underside of the leaves, if a pressure of 80 to 120 pounds is maintained.

DESCRIPTIONS OF THE EARLIER STAGES.

By H. G. DYAR, PH. D.

The egg.—Uniformly elliptical, strongly flattened on the upper and lower sides, smooth, minutely granular; white (in alcohol). Size 0.6 by 0.4 by 0.25 mm.

Laid singly on the underside of the leaf near a vein.

Larva, stage 1.—Head rounded, not much higher than wide, slightly notched at vertex; smooth, shining testaceous whitish, with four large, black, pigmented ocelli close together in a semicircle, setæ rather coarse, pale, those next the ocelli darker. Width, about 0.25 mm. Body cylindrical, slender, uniform, whitish or colorless (in alcohol). Setæ coarse, from small concolorous tubercles, i and ii nearly in line with some coarse skin spinules near them; iv and v superposed, approximate; vi wanting; vii of three setæ at the leg base. Legs long, slender, normal.

The intermediate stages are not complete in the material. In all the larva is whitish throughout, marked only with a subdorsal black speck on joints 2 and 3.

Larva, last stage.—Head rounded, higher than wide, notched on vertex, clypeus high, reaching vertical notch; whitish, with brown freckles on the vertices of the lobes, cut by a central space devoid of these spots; five pigmented ocelli in a semicircle and one colorless one behind. Width, 1.2 mm. Body cylindrical, slender, uniform, the segments irregularly annulate; abdominal feet slender, cylindrical, the plantæ circularly expanded, the crochets in two-thirds of a circle, the open space on the outside; setæ fine, from concolorous invisible

tubercles, i and ii in line. iv and v approximate, superposed, iii and vi normal, vii of three separated setæ; joint 2 with six setæ on the shield in two rows, the shield concolorous; two setæ each for the prespiracular and subventral tubercles; joint 3 with iia and iib in line, iii separate. iv and v approximate, vi free. Color whitish, a long brown patch at the edge of the shield on joint 2 and over tubercles iia and iib on joint 3. Spiracles elliptical, those of joint 12 larger than the others.

The cocoon.—The cocoon is composed of silk with fragments of extraneous substances attached to the outside. Elliptical in shape, simple.

The pupa.—Of the obtected type; pale brown, the eyes dark. Cremaster square and flat, with a row of long, slender, terminal pale spines with hooked tips. Surface smooth, without sculpture. Size 10 by 2.5 mm.

APPENDIX.

By F. H. CHITTENDEN, Sc. D.

Owing to the fact that Mr. Marsh's report on the Hawaiian beet webworm (*Hymenia fascialis* Cram.) was completed at Rocky Ford, Colo., he had no facilities for looking up the literature on the species. Moreover, it was thought advisable, owing to the difficulty of describing the earlier stages in alcohol, that a technical description be made by a specialist, hence this latter work was kindly furnished by Dr. Dyar, while the writer has compiled the description and synonymy of the species and outlined its distribution, history, and bibliography. In the preparation of the bibliography, Mr. Thomas H. Jones assisted, while the photograph of the moth was prepared by Mr. C. H. Popenoe, and the drawing of the immature stages by Mr. J. F. Strauss.

Much has been written of this species in a technical way, but practically nothing has been published of importance, to the writer's knowledge, in regard to the biology of the insect, or description of its earlier stages. Hence the notes which Mr. Marsh has furnished are of great value, especially as he treats the insect in detail from the standpoint of its occurrence and injuries in Hawaii, and has also performed valuable experiments in the line of remedial measures. It should be added that this species, since it occurs throughout the Gulf region west to California, is apt to be troublesome at any time.

DESCRIPTION AND SYNONYMY.

Hymenia fascialis was first described in the year 1782 by Cramer. The following is the synonymy accorded by Dr. Dyar in his list of North American Lepidoptera, published in 1902.

fascialis Cramer, Pap. Exot., iv, 236, 1782, syn.

angustalis Fabricius, Mant. Ins., ii, 222, 1787.

recurvalis Fabricius, Ent. Syst., iii, 2.237, 1794.

diffascialis Hübner, Verz. bek. Schmett., 361, 1826.

albifascialis Boisduval, Faun. Ent. Mad., 119, 1834.

The species has also been placed in the genera *Zinckenia* and *Spoladea*.

The following is a somewhat free translation from Cramer's original description in French :

FIG. O.—*Fascialis*.—The white band and the spots on the black ground of this little moth, of which the two surfaces of the wings carry the same colors, are of a mother-of-pearl luster. The antennæ are filiform, the feet very long and slender, similar to all those which belong properly to the so-called family *Phal. [æna] Pyralis*. Monsieur M. Houttium has received it from Japan.

On the same page, as throughout the work, a similar description is furnished in Holland Dutch.

The reference to the illustration is Volume IV, of the same work, page 398, figure O.

The synonymy which follows is in accordance with Moore :

- Phalæna recurvalis* Fabricius, Syst. Ent., p. 407 (1775) ; Ent. Syst., iii, 2, p. 237 (1794).
Zinckenia recurvalis Zeller, Lep. Micro. Caffr. Kongl. Vet. Akad. Handl., p. 55 (1853) ; Lederer, Pyral. Wien. Ent. Mon., vii, p. 437 (1863) ; Snellen, Tijds. voor Ent., 1872, p. 95 ; Meyrick, Tr. Ent. Soc. Lond., 1884, p. 308.
Spoladea recurvalis Guenée, Delt. et Pyral., p. 225, pl. 8, fig. 5 (1854).
Hymenia recurvalis Walker, Cat. Lep. Het. B. M., xvii, p. 396 (1859).
Phalena fascialis Cramer, Pap. Exot., iv, pl. 398, fig. o (1782). Stoll, id., v, pl. 36, fig. 13 (1791).
Phalæna angustalis Fabricius, Mant. Ins., p. 309 (1787).
Hymenia diffascialis Hübner, Verz. bek. Schmett., 361 (1825-7).
Hydrocampa albifascialis Boisduval, Faun. Ent. Madag. Lep., p. 119, pl. 16, fig. 1 (1834).
 ?*Phalæna nigrella* Linnæus, Syst. Nat., Ed. 13, iii, App., p. 225.

DESCRIPTION OF THE GENUS.

The genus *Hymenia* is defined as follows :

Forewing rather narrow, triangular ; cell more than half the length ; first subcostal at one-fifth before end of the cell, third bifid, fifth straight from end of cell ; discocellular slightly concave, radials from the ends ; middle median very close to end of cell, lower at nearly one-third ; hindwing short, rather broad, apex convex, exterior margin convex in the middle ; cell two-fifths the length ; subcostals from end ; discocellular obliquely concave, radial from lower end ; two upper medians from end of cell, lower at one-third. Body moderately slender ; labial palpi ascending, slightly curved, reaching level of the eyes, second joint laxly squamous, broadest at the base, third joint small, slender, pointed ; maxillary palpi slender ; antennæ setaceous, basal joint nodular ; legs slender, smooth, spurs long, hind spurs equal. (Moore).

DESCRIPTION OF THE SPECIES.

The species is described as follows :

Dark vinaceous-brown ; in some lights olivescient greyish-brown ; forewing with a short blackish-bordered white band from the costa before the apex, below and exterior to which are three small inwardly curved superposed spots.

which approach a dentate transverse white band extending from upper end of the cell to the posterior margin, this band being continued across the hindwing to near anal angle. Cilia with an interrupted brown inner line, alternated with white on forewing, entirely white on hindwing, bands on abdomen white, collar, front of head, base of palpi, and legs yellowish; tip of palpi and bands on forelegs blackish.

Expanse seven-tenths to nine-tenths inch. (Moore.)

DISTRIBUTION.

In Dr. Dyar's list the distribution accorded this species includes the United States, South America, southern Europe, South Africa, and Australia. There is also a record of this species occurring in India.

Cramer's type was from Japan. Hampton states that its habitat comprises "Neotropical and Ethiopian regions"; Palæarctic Asia from Syria to Japan; the whole oriental and Australian regions.

In the United States National Museum this species is represented by specimens from Key West, Fla. (Evermann); Miami, Fla. (Barnes); Jamaica, Dallas County, Ala. (Trelease); and Port au Prince, Haiti. To make this list more complete we should add California and Hawaii, the islands of Madagascar, Bourbon (Reunion Id.), and Mauritius.

From the above it will be noted that this species is evidently of tropical origin, that it has been well disseminated nearly around the world, but that it is still confined to tropical, semitropical, and temperate climates. In the United States it probably has a larger range than above indicated. It at least ranges through the entire Gulf region to California.

HISTORY.

As has previously been stated, the species was first described by Pierre Cramer (1), who figured and described the moth, the description being in both French and Dutch, appearing in 1782. The type specimen was from Japan. In 1884-1887 Moore (2) furnished a technical description, with complete bibliography, which has been transcribed in previous pages. Following this, in 1900, Mr. Edward Barlow made mention of injuries by the larvæ to *Amaranthus mangostanus*, a pot herb in India, quoting Moore's synonymy and description. In 1907 Mr. W. W. Froggatt (6) stated that this little moth was common about Sydney, Australia, and that the larvæ were sometimes destructive to salt-brush hedges. Two years later (1909) Mr. O. H. Swezey (7) stated that the larva was fed on *Euxolus*, portulaca, garden beet, coxcomb, other amarantaceous plants, and on chenopodiaceous weeds. The same year Messrs. Lefroy and Howlett (8) published a short note on this species, stating that the larva attacked cultivated amaranthus, beet root, maize, and "other garden plants."

BIBLIOGRAPHY.

1. CRAMER, PIERRE.—Papillons Exotiques, pt. IV, p. 236, pl. 398, fig. 0, 1782.
Original description in French and Dutch. Colored figure of adult. Type from Japan.
2. MOORE, F.—The Lepidoptera of Ceylon, vol. III, pp. 293, 294, 1884–1887.
Technical description with complete bibliography.
3. BARLOW, EDWARD.—Ind. Mus. Notes, vol. 4, no. 1, pp. 16 and 17, pl. 11, fig. 5, 1900.
Mentioned as *recurvalis*. Injurious to *Amaranthus mangostanus* L., a "pot herb" of India. Synonyms and description after Moore. Localities of specimens in Indian Museum.
4. DYAR, H. G.—Bul. 52, U. S. Nat. Mus., p. 373, 1902.
Listed with synonymy and distribution.
5. HOLLAND, W. J.—The Moth Book, p. 392, pl. 47, fig. 28, 1909.
Mentioned as *Zinckenia fascialis*; synonymy; said to be found all over the temperate and subtropical regions of both hemispheres and to be common in southern portions of United States.
6. FROGGATT, W. W.—Austr. Ins., p. 270, Sydney, 1907.
"Common little moth about Sydney." Larvæ sometimes destructive to salt-bush hedges. Mentioned as *Zinckenia recurvalis*.
7. SWEZEY, O. H.—Proc. Haw. Ent. Soc., vol. 2, no. 3, p. 136, 1909.
Mentioned as *recurvalis*. Said to feed on *Euxolus portulaca*, garden beet, coxcomb, other amarantaceous plants, and on chenopodiaceous weeds.
8. LEFROY, H. M., and HOWLETT, F. M.—Ind. Ins. Life, p. 516, 1909.
Short note. Cultivated *Amaranthus*, beet-root, maize, and "other garden plants" mentioned as hosts.
9. VIERECK, H. L.—Proc. U. S. Nat. Mus., vol. 40, p. 189, 1911.
Description of a parasite, *Cremastus hymeniae* n. sp., reared from this species at Oahu, Hawaii.
10. MARSH, H. O.—Bien. Rept. Bd. Agr. and Forestry. Hawaii (1910), p. 157, 1911.
Short note. Paris green mentioned as an effective remedy.





U. S. DEPARTMENT OF AGRICULTURE,
BUREAU OF ENTOMOLOGY—BULLETIN No. 109, Part II.

L. O. HOWARD, Entomologist and Chief of Bureau.

PAPERS ON INSECTS AFFECTING VEGETABLES.

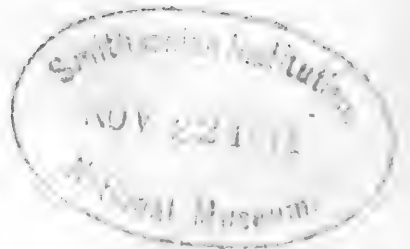
THE SOUTHERN BEET WEBWORM.

BY

F. H. CHITTENDEN, Sc. D.,

In Charge of Truck Crop and Stored Product Insect Investigations.

ISSUED NOVEMBER 11, 1911.



WASHINGTON:
GOVERNMENT PRINTING OFFICE.
1911.

BUREAU OF ENTOMOLOGY.

L. O. HOWARD, *Entomologist and Chief of Bureau.*
C. L. MARLATT, *Entomologist and Acting Chief in Absence of Chief.*
R. S. CLIFTON, *Executive Assistant.*
W. F. TASTET, *Chief Clerk.*

F. H. CHITTENDEN, *in charge of truck crop and stored product insect investigations.*
A. D. HOPKINS, *in charge of forest insect investigations.*
W. D. HUNTER, *in charge of southern field crop insect investigations.*
F. M. WEBSTER, *in charge of cereal and forage insect investigations.*
A. L. QUAINANCE, *in charge of deciduous fruit insect investigations.*
E. F. PHILLIPS, *in charge of bee culture.*
D. M. ROGERS, *in charge of preventing spread of moths, field work.*
ROLLA P. CURRIE, *in charge of editorial work.*
MABEL COLCORD, *in charge of library.*

TRUCK CROP AND STORED PRODUCT INSECT INVESTIGATIONS.

F. H. CHITTENDEN, *in charge.*

H. M. RUSSELL, C. H. POPENOE, WM. B. PARKER, H. O. MARSH, THOS. H. JONES,
M. M. HIGH, FRED A. JOHNSTON, *entomological assistants.*
I. J. CONDIT, *collaborator in California.*
P. T. COLE, *collaborator in tidewater Virginia.*
W. N. ORD, *collaborator in Oregon.*
MARION T. VAN HORN, *preparator.*

CONTENTS.

	Page.
Injurious occurrences and notes on habits.....	17
Descriptive.....	19
The moth.....	19
The egg.....	20
The larva.....	20
The pupa.....	20
Distribution.....	21
Historical and biological notes.....	21
Natural enemies.....	21
Associated insects.....	21
Remedies.....	22
Paris green.....	22
"Dragging the log".....	22

ILLUSTRATION.

FIG. 3. The southern beet webworm (<i>Pachyzancla bipunctalis</i>): Moth, larva, pupa, details.....	19
--	----



PAPERS ON INSECTS AFFECTING VEGETABLES.

THE SOUTHERN BEET WEBWORM.

(*Pachyzancla bipunctalis* Fab.)

By F. H. CHITTENDEN, Sc. D.,

In Charge of Truck Crop and Stored Product Insect Investigations.

INJURIOUS OCCURRENCES AND NOTES ON HABITS.

On September 24, 1906, the Bureau of Entomology obtained from Mr. F. W. Roeding, Wichita Falls, Tex., the larvæ, pupæ, and adults of the pyralid moth *Pachyzancla bipunctalis* Fab., which had been found operating on foliage of table beets in that vicinity. One larva transformed to pupa on September 25, and the adult issued October 3, the pupal period thus having occupied eight days in an average temperature of about 70° F. From this lot imagos continued to issue until October 2, and a larva matured October 10 which would have produced an imago about October 30.

During October, 1907, Mr. H. M. Russell observed larvæ at Dade City, Fla., on beet tops from 6 to 8 inches high, "webbing up" the leaves with the edges of the leaves folded together or joining two or more leaves to make a nest in which to hide. From this concealment they emerge and eat the leaf cells composing it, usually leaving the leaf skeletonized or very thin. In these nest-forming and leaf-eating habits the insect resembles the related Pyraustidæ. Mr. E. B. Embry, located at Dade City, Fla., stated that the larvæ of this species had injured the foliage of small beets so badly as to reduce his crop about 50 per cent. As late in the season as November 29, the webworm larvæ were found in another locality at Dade City, some of which showed parasitism. In January, 1909, larvæ were observed attacking beets at Boynton, Fla., and in March, beets at Miami, Fla.

From webworm material obtained October 18, one pupated October 23, and the moth issued November 8. Another larva pupated November 6 and the adult issued on November 21, thus indicating a pupal period covering from 15 to 16 days, in the latitude of Washington, D. C. In another case the pupal stage lasted from December 31 to January 22, or a total period of 23 days. The temperature at Washington was moderately cold.

This species was observed in 1908, by Mr. D. K. McMillan, at Brownsville, Tex., working in colonies on the foliage of pigweed (*Amaranthus retroflexus*), and on spiny amaranth (*A. spinosus*), the larvæ webbing and folding the foliage in the previously described manner. The colonies in question came under observation on April 30, May 14, June 15, and November 5, 1908. Mr. McMillan also observed the larvæ in large numbers during the spring of that year, working on "spinach" in the Rio Grande Valley and on beet foliage at Brownsville.

On May 28, 1909, Messrs. McMillan and H. O. Marsh observed these larvæ at Brownsville, Tex., embedded in the leaves of *Amaranthus retroflexus*. The larvæ were not in abundance at that time, doubtless owing to the extensive parasitism in May and June of the preceding year (1908). This was the first observed appearance of the insect that year.

During the same year this species twice came under the observation of Mr. H. M. Russell, in the first instance at Boynton, Fla., on January 27, 1909, when the larvæ were found in great abundance on the foliage of table beets. They had nearly stripped an early planting and were also abundant on a later planting. In many cases the larvæ were present on the underside of the leaves and had drawn the leaf into a fold, inside of which they were concealed. In other cases the larvæ were concealed by the folding up of the leaf from the edge, while in further instances two beet leaves were fastened together in such a manner that the larvæ were concealed between them. In feeding, the leaf substance is usually entirely eaten through to the surface, the leaf skeleton alone being left. The larvæ void a very soft excrement which produces a filthy condition of the leaves. Later on, March 3, the larvæ were found by Mr. Russell in fair abundance on beet tops at Cutler, Fla., and still later at Miami, Fla., on *Amaranthus retroflexus*.

Beginning with March, 1909, parasitic cocoons were seen on the leaves of beets, and early parasitism was indicated by the presence of parasitic cocoons on other food plants. Amaranth is abundant along the edges of many fields in southern Florida, and it is impossible to destroy it to a very great extent, as it grows luxuriantly on hundreds of acres of unclaimed lands. It costs from \$15 to \$75 an acre to clear hammock for planting. Perhaps, therefore, it is just as well to allow the amaranth to remain and to spray the weeds as a means of keeping this pest in check. There is little doubt that unless the parasites continue their good work the species is likely to cause a serious outbreak at almost any time in the future.

Of one lot of material received at Washington, D. C., the larvæ of which were nearly mature, it was noticed that they began to "spin up" preparatory to pupation on May 7; the following day some of

the larvæ had pupated and by May 20 the adults had commenced to issue, thus giving a total period for the pupal stage of about 12 days. The moths were placed in a large cage with a growing beet and at the end of the week all had died.

In other sendings of material the moths were observed to issue on May 25, June 3, and July 9.

The length of the egg stage was not ascertained, but it may be safely stated to be approximately 6 or 7 days, in moderate or warm weather. From eggs laid on June 5 and 6 the adults developed July 3, giving a total life cycle of 28 days, or 4 weeks, in hot weather, which will be about the minimum for the species. Assuming that

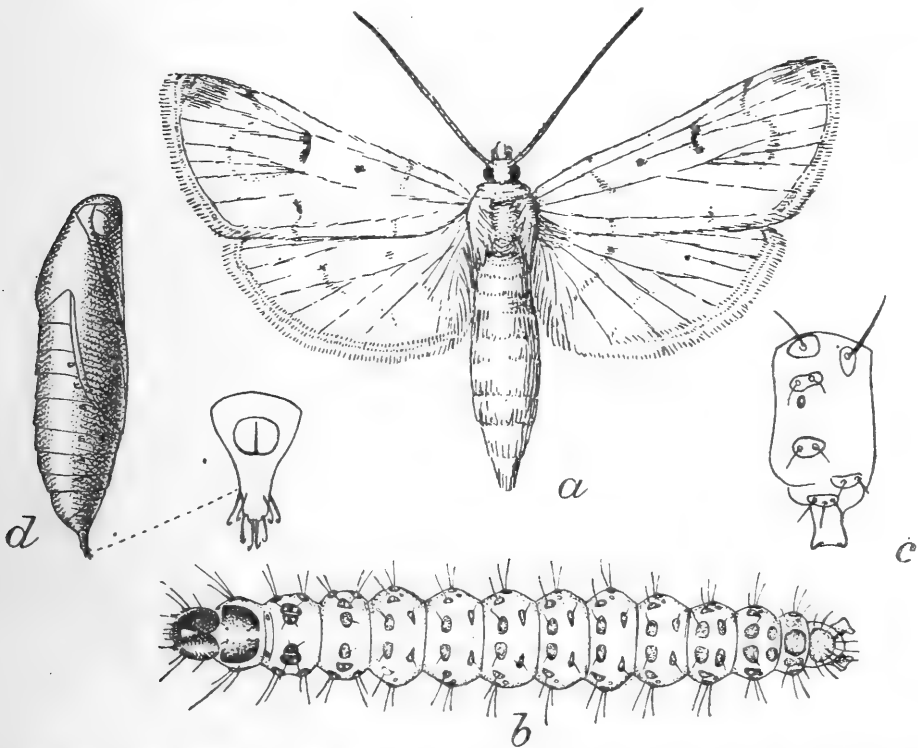


FIG. 3.—Southern beet webworm (*Pachyzancla bipunctalis*): a, Moth; b, larva; c, lateral view of first proleg and abdominal segment of larva; d, pupa, with cremaster showing location of hooks at right. c, b, d, About three times natural size. (Original.)

from 5 to 7 days is occupied by the egg stage, and approximately the same number of days for the pupal period in hot weather, the larval period would be approximately from 14 to 18 days. At least four generations are indicated for this species, and it is possible that there are more, but there are no positive data on record on this point.

DESCRIPTIVE.

The moth.—The moth in color varies from buff to very pale yellowish gray. The wings are slender and the antennæ long. In the pale forms the wings are nearly transparent, and the surface is rather iridescent purplish. The wing pattern of the pale individuals is faint, much more so than the illustration (fig. 3, a) would appear to indicate,

but is a little more definite in the dark forms. Near the anterior margin of the forewings there are three rather conspicuous black dots, one near the middle and one each side. The underside of the wings is paler and somewhat similar to the upper. The eyes are dark brown, nearly black. The abdomen is darker than the wings, and there are two black spots on the anterior margin of the third abdominal segment. The legs are long and slender. The total length of the body is less than one-half inch (12 mm.) and the wing expanse is about 1 inch (22 to 26 mm.).

The egg.—The egg is of irregular, short, oval outline, and considerably flattened upon the surface on which it is deposited. The color is pale yellowish, which looks green, owing to its semitransparency, permitting the color of the leaf to show through. The surface is finely reticulated, and under a high-power microscope is seen to be composed of minute, very irregular, moderately depressed areas, chiefly hexagonal and pentagonal in outline. The surface is rather strongly iridescent and glistens, presenting the appearance of a fish scale in miniature. Length, 0.6 mm.; width, 0.45 mm.

Eggs obtained in confinement, May 26, were deposited singly on the underside of beet leaves. Mr. Marsh also observed the eggs on the underside of amaranth leaves at Brownsville, Tex., June 22, 1909.

The larva.—The larva (fig. 3, *b, c*) is slender, cylindrical, and in the arrangement of the piliferous tubercles resembles *Loxostege similalis* Guen. and *L. oblitalis* Walk. The tubercles are not conspicuous in living specimens, but become prominent in preserved material. The color of the larva is dark, dirty green, with dark, mottled brown-and-black, or nearly black, head and thoracic plate, the latter widely separated at the middle. The dorsal piliferous tubercles are large and black, the two pairs being closely jointed. The remaining tubercles are large and infuscated, the dorsal ones transverse and arranged in two pairs, one pair on each segment. The tubercles of the last segment form a central plate, with a lateral one each side, in front of the larger anal plate. When boiled for preservation the larva becomes perfectly white, bringing into prominence the rings of tubercles which completely encircle each segment. The length of the larva when full grown is about three-fourths of an inch (19–20 mm.), and the width $\frac{3}{8}$ to $\frac{1}{2}$ of an inch (2.5–3 mm.).

The pupa.—The pupa (fig. 3, *d*) is mahogany-brown, moderately slender, with the anterior extremity rounded, and the posterior prolonged into a bill-shaped cremaster, armed at the end with four very fine hooks, one lateral and two apical pairs, their tips strongly recurved. The abdominal segments are without spines. The length is about two-fifths of an inch (10 mm.).

The species is a pyralid and is placed in our lists next to *Loxostege*. It bears some resemblance to *Loxostege similalis*, but is considerably larger.

DISTRIBUTION.

This is without doubt a species of tropical origin and inclined to be cosmopolitan in any country suited to it climatologically. We have in the National Museum collections material from Pernambuco, Bonito Province, Brazil, as well as from Georgia, Texas, Florida, and the District of Columbia. It is recorded also from the West Indies and South Africa.

HISTORICAL AND BIOLOGICAL NOTES.

This beet webworm was first described as "*Phalæna 2-punctalis*," in 1794.¹ In the year 1880 the larva was observed feeding upon cauliflower at Savannah, Ga., where it was stated to be very destructive. In consequence it was given the name of "Cauliflower botis."² It was also noticed that it fed on ragweed (*Ambrosia*), which is probably the original food plant, cauliflower being an acquired one, and perhaps not a food plant under normal conditions. The following year it was again noticed at Savannah, Ga., on pigweed, the larvæ webbing the leaves together and destroying many plants. Nothing further seems to have been recorded of its habits.

NATURAL ENEMIES.

Phorocera erecta Coq., a tachina fly, was reared from this species in September, 1906. This parasite has been reared from the related *Loxostege similalis*, at Victoria, Tex.

Amorphota sp. near *orgyia*, an ichneumonid parasite, was reared January 15-29, 1908, from *Pachyzancla bipunctalis*, obtained from Dade City, Fla., in October and December of the preceding year. A single female³ before the writer measures 8 mm. in length and is opaque black, with castaneous abdomen and middle and posterior legs. The fore legs, and the tibiæ and tarsi on the middle pair of legs are light yellow, as is also the first joint of the antenna, the remainder of the antenna being black.

Bracon sp., a small blackish species of this genus,⁴ was reared from this host at Brownsville, Tex., November 21, 1908.

ASSOCIATED INSECTS.

In addition to the parasitic natural enemies of this species which have been mentioned, some interesting species have been reared. Prominent among these is a moth of the same family and with somewhat similar habits, known as the Hawaiian beet webworm⁵ (*Hymenia* [*Zinckenia*] *fascialis* Cram.). It was reared by Mr. H. M. Rus-

¹ Fabricius, *Entomologia Systematica*, vol. 3, pt. 2, p. 232, 1794.

² *Botis repetitalis* Grote, n. sp., Comstock, J. H.—*Rept. U. S. Dept. Agr. for 1880*, p. 270, 1881.

³ Chttn. No. 303⁰¹.

⁴ Chttn. No. 1064⁰¹.

⁵ *Bul. 109, Part I, Bur. Ent., U. S. Dept. Agr., 1911.*

sell, at Cutler, Fla., March 23-29, 1909. It is interesting to remark that Mr. H. O. Marsh has found this species very destructive to sugar beets in Hawaii, and has made a special study of it for the Bureau of Entomology.

An agromyzid fly was reared February 17, 1909, with this beet webworm from material received from Mr. H. M. Russell on beets and *Amaranthus* collected at Boynton, Fla.

Pegomya ruficeps Stein, an anthomyiid fly, was reared under practically the same conditions as the moth *Hymenia fascialis* Cram., above mentioned.

REMEDIES.

The remedies that have been advised for use against the garden webworm (*Loxostege similalis* Guen.) should be found about equally effective against the present species. In any case their use is advised until more is learned of the habits of the southern beet webworm. These remedies are given below.

Paris green.—Paris green is applied at the rate of 1 pound to from 75 to 100 gallons of water, or dry, distributed with a powder gun, as practiced in the South. The latter method, however, is inferior to spraying. Since the two species share common natural food plants (*Amaranthus*), the usual care should be exercised to avoid planting beets in fields which have grown up in this weed until after thorough fall or spring plowing.

The experience which Mr. H. O. Marsh has had with the related Hawaiian webworm conclusively shows the value of Paris green. He states, in brief, that a spray of Paris green at the rate of 2 pounds of the arsenical and whale-oil soap, 8 pounds in 100 gallons of water, proved absolutely effective and did no injury to the plants on which it was applied. The spray was applied to the underside of beet leaves.¹ More complete information in regard to this is given in Part I of the present bulletin.

It should be added that a mixture composed of nicotine sulphate, 1 fluid ounce, with whale-oil soap, 4 ounces, in 4 gallons of water, was used by Mr. Marsh against a number of noxious lepidopterous larvæ, and although this formula was not tested on the Hawaiian beet webworm, he believes that it would prove entirely effective.

Dragging the log.—In the case of a bad attack of the garden webworm in Oklahoma in 1903, a satisfactory barrier to migration was employed, consisting of a dust furrow in which a log was dragged. This might be used in case the webworm under discussion should occur in great numbers before its presence is discovered—something that is likely to happen, as in the case of species of related habits.

¹ For some reason arsenate of lead applied to both sides of *Amaranthus* leaves was found ineffective and no explanation could be made of this, but the chemical was probably not pure.



U. S. DEPARTMENT OF AGRICULTURE,
BUREAU OF ENTOMOLOGY—BULLETIN No. 109, Part III.

L. O. HOWARD, Entomologist and Chief of Bureau.

PAPERS ON INSECTS AFFECTING VEGETABLES.

THE IMPORTED CABBAGE WEBWORM.

BY

F. H. CHITTENDEN, Sc. D.,

In Charge of Truck Crop and Stored Product Insect Investigations.

AND

H. O. MARSH,

Agent.

ISSUED APRIL 5, 1912.



WASHINGTON:
GOVERNMENT PRINTING OFFICE,
1912.

c
CANCELLED
221348

BUREAU OF ENTOMOLOGY.

L. O. HOWARD, *Entomologist and Chief of Bureau.*

C. L. MARLATT, *Entomologist and Acting Chief in Absence of Chief.*

R. S. CLIFTON, *Executive Assistant.*

W. F. TASTET, *Chief Clerk.*

F. H. CHITTENDEN, *in charge of truck crop and stored product insect investigations.*

A. D. HOPKINS, *in charge of forest insect investigations.*

W. D. HUNTER, *in charge of southern field crop insect investigations.*

F. M. WEBSTER, *in charge of cereal and forage insect investigations.*

A. L. QUAINANCE, *in charge of deciduous fruit insect investigations.*

E. F. PHILLIPS, *in charge of bee culture.*

D. M. ROGERS, *in charge of preventing spread of moths, field work.*

ROLLA P. CURRIE, *in charge of editorial work.*

MABEL COLCORD, *in charge of library.*

TRUCK CROP AND STORED PRODUCT INSECT INVESTIGATIONS.

F. H. CHITTENDEN, *in charge.*

H. M. RUSSELL, C. H. POPENOE, WM B. PARKER, H. O. MARSH, M. H. HIGH,

FRED A. JOHNSTON, JOHN E. GRAF, *entomological assistants.*

I. J. CONDIT, *collaborator in California.*

P. T. COLE, *collaborator in Tidewater Virginia.*

W. N. ORD, *collaborator in Oregon.*

THOMAS H. JONES, *collaborator in Porto Rico.*

MARION T. VAN HORN, PAULINE M. JOHNSON, *preparators.*

CONTENTS.

	Page.
Introduction, spread, and ravages	23
Description and life-history notes.....	27
The moth.....	27
The egg and oviposition.....	28
The newly hatched larva.....	29
The full-grown larva.....	29
The pupa.....	29
Distribution.....	30
Food plants.....	30
Natural enemies.....	31
The imported cabbage webworm in Hawaii.....	32
Life history and habits.....	34
Natural enemies in Hawaii.....	37
Experiments with insecticides.....	38
Experiment in screening a seed bed	41
Conclusion.....	41
Recommendations for control.....	42
Bibliography.....	44

ILLUSTRATIONS.

	Page.
FIG. 4. The imported cabbage webworm (<i>Hellula undalis</i>): Adult, larva, pupa..	28
5. The imported cabbage webworm: Wing venation; head and antenna ..	28
6. <i>Exorista pyste</i> , a parasite of the imported cabbage webworm.....	31
7. Small compressed-air sprayer	38



PAPERS ON INSECTS AFFECTING VEGETABLES.

THE IMPORTED CABBAGE WEBWORM.

(*Hellula undalis* Fab.)

By F. H. CHITTENDEN, 'Sc. D.,

In Charge of Truck Crop and Stored Product Insect Investigations,
and

H. O. MARSH, Agent.

INTRODUCTION, SPREAD, AND RAVAGES.

Beginning with the year 1897 the imported cabbage webworm (*Hellula undalis* Fab.) has repeatedly come under observation as a pest in new States and Territories, namely, in Florida, Mississippi, North Carolina, Texas, California, and Hawaii.

In 1907, Mr. H. M. Russell observed attack to collards at Lakeland, Fla., in June and July, to collards at Orlando, Fla., in July, and at Dade City, Fla., to cabbage in December. The species has undoubtedly been in that State for many years, since it has been known for more than a decade from South Carolina to Georgia, but this is the first record of injurious occurrence there.

In November, 1907, Prof. R. I. Smith reported injury to cabbage at West Raleigh, N. C. Whether this insect will be able to establish itself much farther north than the Carolinas is problematical. Our records show complete establishment throughout the Gulf States; in fact, the insect occupies a considerable portion of the same territory as that permanently inhabited by the harlequin cabbage bug (*Murgantia histrionica* Hahn), save that the latter, having been introduced many years earlier, is better known and occurs farther northward.

A review of the distribution of this species shows that it first came under notice as a pest in 1897, when it was destructive to crucifers about Augusta, Ga. Here it did great injury during that and the succeeding year. In after years it was observed in various other localities in Georgia, at Auburn, Ala., and at Charleston and Beech Island, S. C. Later it was noticed as a pest in Texas.

The list, which will be furnished under the heading of distribution, simply includes the localities reported to this bureau and is doubtless

far from being complete. The mere occurrence of this insect at Los Angeles, Cal., was observed as early as 1891 or 1892, but nothing further was heard of the insect in the Pacific States until 1907, when it was reported by Messrs. Ball and Titus, working on sugar beets in that same region.

In 1908 the species came under the observation of the junior author on several occasions in Orange County, Cal. In October it was found attacking horse-radish and cabbage at Santa Ana in the customary manner, namely, feeding in the heart, webbing the leaves, and eating out the tissues. At Garden Grove, Cal., it was attacking cabbage and mustard.

During June, 1908, Mr. D. K. McMillan observed this species on radish, cabbage, and kale at Brownsville, Tex., the plants being considerably damaged. The larvæ in most cases had destroyed the "buds" or had bored down into the center of the plants. They seemed to attack only the midrib of kale and most cabbage plants, feeding in a groove on the upper surface, which they cover with a web, varying this by eating a small cavity extending along the interior from one-fourth of an inch to an inch in some cases. Larvæ were observed on rape at Mission, Hidalgo County, and at Santa Maria, Cameron County, Tex. At Brownsville they were found in November on mustard cultivated for table use. At this time many were found with tachina eggs placed in the usual location near the head. Turnip tops were also affected, the work on turnip and mustard being similar to that observed on rape and radish. The larvæ concealed themselves along the midrib, boring down into it as well as along the groove, with a covering of silk under which they are fairly well protected.

From finding the insect in many localities, in several cases not in destructive numbers, Mr. McMillan expressed the opinion that the species in southern Texas is evidently largely controlled by parasites and other natural enemies, as most individuals observed, even in June, were parasitized. It is probable that the species is well distributed throughout nearly the entire State of Texas, and, although held in check during most seasons by natural enemies, there is always the likelihood that at any time it may crop out as a serious pest.

October 17, Mr. Charles M. Jones, Stallo, Miss., reported injury to turnip and collard. The larvæ were not so active when the weather was cool and appeared to work at all times of the day. An entire crop of collards was destroyed.

In Mississippi, also, Mr. M. M. High found larvæ September 9, 1909, in large numbers on cabbage and turnip near Columbia. He described them as beginning work by first spinning a web in which to retreat. They then eat out the ends of young plants and check their growth, besides causing the death of some of them. They did much damage, cutting out the "buds" of young cabbage, in addi-

tion to devouring the remaining leaflets and spinning their small but conspicuous webs over the plant. A grower here stated that the damage seemed greater that season than heretofore, and that he should have been marketing cabbage, but had none that had small heads, all having been destroyed by this larva.

He had tried to poison the larvæ with Paris green applied dry, but with little success. The webs prevent the poison in powdered form from reaching the caterpillar in its protected feeding quarters.

The insect infests the turnips to about the same extent as cabbage, while it seems to be not quite so serious with turnips.

September 16, 1909, the larvæ did considerable damage to cabbage and turnips at Kosciusko, Miss. When first hatched they are difficult to find, because of their habit of concealing themselves in the crotch of a stalk and turning the edges of the leaflet back, forming a domicile into which they retreat when not feeding.

September 24, this pest was seen in large numbers on turnips at Crystal Springs, Miss. Many had already transformed to adult, as many cocoons were found containing empty pupal cases. This pest had destroyed about 16 per cent of the turnips upon the plat and many dead leaflets were found among the remaining green ones, due to its ravages. Hundreds of moths were flying over the patch, alighting upon turnips and upon the ground. It was thought that the insect was destined to do greater damage before the season was over, as many larvæ were still spinning their webs and devouring the leaves.

The part of the plat most seriously affected by the pest was not nearly so well fertilized as the remaining portion. The portion where most damage was done was upon high dry land, while the remaining portion was upon damp rich soil. This same species was observed cutting buds from late cabbage at Columbus, Ridgeland, Starkville, and Gulfport, Miss. Mr. High wrote:

The moth undoubtedly deposits her eggs near the "bud," where they hatch, the young larvæ devouring the bud, spinning webs, tying the larger leaves together, one to three larvæ going to each leaflet, curling the edge of the leaf and forming an individual web, and, later, spinning a cocoon to transform into the pupal stage. The larvæ come out of these webs to feed and then retreat when their hunger has been satisfied. This is one of the most serious pests of the truck grower about Crystal Springs, Miss.

It is evident that this remark may apply to practically the entire State of Mississippi, and that similar conditions obtain in Georgia and South Carolina.

February 3, 1909, Dr. W. E. Hinds, entomologist to the Alabama Experiment Station, Auburn, Ala., wrote that he had received this species from Phoenix City and Montgomery, besides Auburn.

October 2, Mr. High reported that he had again found this pest at Gulfport, Miss., both upon late cabbage and turnips. Injury was

more serious on young cabbage, because the "buds" were being devoured and small webs filled with excrement were left in their stead. There was only a small plat of cabbage where, on the other hand, there were acres of turnips. The webs were distributed also over the turnips, some of them being empty, the larva having transformed to the moth. This pest was doing great damage to the two truck crops. Some other pests were associated with it and were doing some injury, such as the flea-beetle (*Phyllotreta bipustulata* Fab.) and the cabbage looper (*Autographa brassicæ* Riley).

During the fall of 1909 the late F. C. Pratt reported this webworm as a pest to cruciferous crops at Sabinal, Tex. About the middle of January, 1910, the junior author visited Sabinal and in company with Mr. Pratt examined the gardens where injury had occurred. The characteristic work of the larva was observed on radish and cabbage, which remained as crop remnants, but none of the insects was found. Mr. Pratt said he had taken an adult, out of doors, late in November and expressed the opinion that the insect might winter in the adult condition in that locality.

October 22 the larva was observed in large numbers at Columbus, Miss., upon cabbage, turnips, and collards grown by Mr. J. E. Slaughter. The larvæ bore into the stems of the cabbage and turnips for some little distance or eat out small crevices in the edges of the stems, enough to bury their bodies, and then, spinning a cocoon, they transform into pupæ.

November 2, 1909, the larva was found by Mr. M. M. High in large numbers at Starkville, Miss., upon turnips. The larva was observed in the crotch of every other plant, boring and hiding from the light. From one to three were found in the "buds." Fully 50 per cent of the turnip crop under consideration had the buds destroyed by this imported webworm. The plants attacked had small roots and looked stunted or checked in their growth.

This insect seems to do the greater damage to cabbage and turnips, although injury to collards is by no means slight, especially while the latter are young. The larva seems to prefer turnips in the row to those sown broadcast. There was not a plant, either cabbage or turnip, but that contained from two to many of these larvæ.

December 3, 1909, Mr. High found webworms of this species in large numbers in the crotch and stems of turnips at Hattiesburg, Miss., where they concealed themselves beneath their webs, destroying the most vital portion of the plant. One grower stated that this insect was a perfect nuisance to older plants and a menace to young ones. He said:

The little striped worm enters the bud of both cabbage and turnip when the plants are quite young and devours them, thus forcing the plant to grow a new bud and start or begin new growth—my first crop of cabbage in the spring being almost totally destroyed from the work of this striped worm.

The cabbage plat now appears to be unmolested by this larva, while nearly every turnip in the plat adjoining cabbage has one or more of the larvæ somewhere near the base of the stems or leaves.

A few mature larvæ were found at Brownsville, Tex., November 5, 1910, boring in stems of mustard and crowns of young cabbage plants. Evidence of past injury was common and indicated that the larvæ were more numerous in early October. Several cabbage growers stated that worms, which from their description were evidently this species, caused considerable damage in seed beds. One grower lost fully 50 per cent of his plants, which had the bud destroyed and were worthless for planting.

Turnip, radish, and mustard plants in the earlier stages were generally attacked and stunted or caused to grow misshapen, and in some cases were entirely destroyed, the larvæ boring down into the base of the crown and upward into the leaf stems after eating out the crown. Several larvæ attacked a plant simultaneously.

At a meeting of the truck growers on the Indiana Canal, 5 miles east of Brownsville, Tex., held November 28, 1910, nearly everyone reported more or less damage to seed beds of cabbage in October. Several had tried dusting with Paris green and lime, but evidently after the injury began to be noticed the larvæ could not be reached in their burrows under the protection of the web. Very few sprayers were in use among the farmers, who were mostly newcomers in this section. At Henry Keller's at least 25 per cent of his seed beds were ruined, and in small areas about 75 per cent had the bud eaten while the plants were small. More than 25 per cent of his young cauliflowers set in the field were injured, and in many cases would not make perfect heads. There were a few small larvæ found at this place and several adults were observed.

Particulars in regard to earlier occurrences are given by the senior writer in the following bulletins of the Bureau of Entomology: No. 19 (pp. 51-57), No. 23 (pp. 53-61), and No. 33 (pp. 48, 49).

DESCRIPTION AND LIFE-HISTORY NOTES.

THE MOTH.

The moth is illustrated at *a* of figure 4. It is gray in color, with the forewings marked and mottled, as shown. The wing expanse is about five-eighths of an inch (18 to 21 mm.). The following technical description is copied from Dr. Hulst's paper (4):

Palpi, head, thorax, and abdomen fuscous; forewings broken fuscous and fuscous cinereous; the basal space with a black spot medially, two white lines across the wings, the first extra basal edged with dark fuscous, the outer after the typical *Botis* pattern; a dark-brown spot annulate with white at reniform; a dark-brown subtriangular apical patch, and a subterminal white line; marginal line black, broken; hind wings, even fuscous; beneath, lighter, lines obsolete, reniform indistinct.

The following synonymy is recognized:

Hellula undalis Fab., Ent. Syst., vol. 3, 2, p. 226; Herrich-Schäffer, Eur. Schmett., vol. 4, pl. 8, f. 54.

Scopariaalconalis Walker, Catalogue, vol. 19, p. 827.

Leucinodes exemptalis Walker, Catalogue, vol. 34, p. 1313.

Botys rogatalis Hulst, Trans. Amer. Ent. Soc., vol. 13, p. 149.

The wing venation, head, and antenna are shown in figure 5.

THE EGG AND OVIPOSITION.

A pair of moths newly reared was placed in a vial July 24, and next morning the female was found to have deposited singly, doubly, and in masses of from 3 or 4 to 20, a total of 235 eggs. The following day 24 were laid; on the 27th, 37 were found, or 296 in all. Afterwards the moth died, having laid no more. A few eggs were found upon dissection, making the probable number usually deposited between 300 and 350.

Most of the moths die in confinement within a week.

The egg.—The egg is of sufficiently large size, about four one-hundredths of an inch in length, as to be readily discernible to the naked eye. It is of

oval form and rather variable in contour, being usually more or less flattened upon the surface of deposit, and there is often a distinct nipple at one extremity. Its greatest width is about three-fifths its length. The color when first laid is light gray, and under a strong hand lens the surface appears to be rugose and strongly iridescent. Under a higher power the surface is found to be made up of depressed irregular areas, mostly hexagonal and pentagonal in outline.

Length, about 0.5 mm.; greatest width, 0.3 to 0.35 mm.

A day after deposition the eggs begin to take on a pinkish hue, due to light reddish spots below the surface. On the second day the embryo can be detected, the head showing as a blackish dot near one end and on the lower surface of the egg or the side of attachment.

Experiments conducted in the latter days of July, in a temperature officially rated by the Weather Bureau of this department as mod-

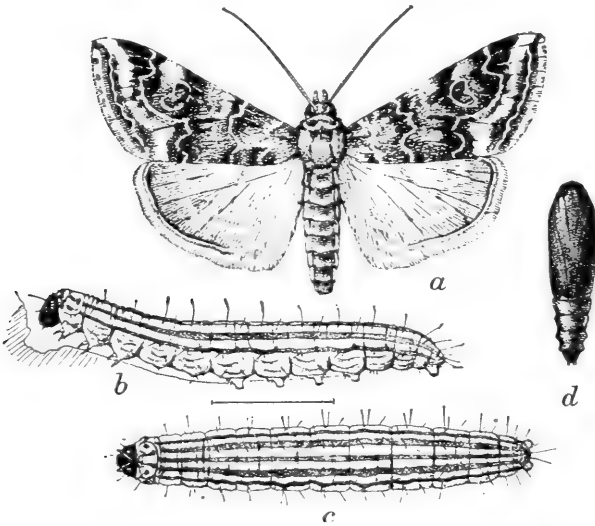


FIG. 4.—The imported cabbage webworm (*Hellula undalis*): a, Moth; b, larva, lateral view; c, larva, dorsal view; d, pupa. All three times natural size. (From Chittenden.)



FIG. 5.—The imported cabbage webworm: Wing venation, head, and antenna. All enlarged. (After Hampson.)

erate (indoor 80° to 84° F.), showed that the eggs hatched three days after deposition, a rather remarkably short period for the eggs of a moth with a wing expanse of nearly three-fourths of an inch.

THE NEWLY HATCHED LARVA.

The larva when just hatched measures about a millimeter in length and about a twelfth that in diameter across the abdomen. The head, as is usual with young larvæ, is prominent, wider than the body, and dusky in color. The thoracic plate is also dusky and of somewhat similar subcrescentic form to the more mature stage. The body is very pale yellowish gray, nearly white, and the surface is moderately clothed with long, fine hairs.

Very soon after hatching the larva shows the characteristic striæ of the more mature form. Thus larvæ 2 mm. in length are so little different in general appearance from the full-grown ones as to be readily recognized as of the same species.

THE FULL-GROWN LARVA.

The full-grown larva, shown at *b* and *c* of figure 4, measures a little upward of half an inch in length, being about six times as long as wide.

The form is subcylindrical, tapering toward each extremity, widest near the middle—the third, fourth, and fifth abdominal segments being nearly equal. The general color is dull opaque grayish-yellow or yellowish-gray, striped with broad, somewhat irregular, brownish-purple, longitudinal bands, which extend from the second thoracic to the terminal or anal segment. These are bright and conspicuous on the dorsal and more feebly indicated on the ventral surface. The dorsal stripes are five—a moderately wide medial one, a broader medio-lateral on each side, and a dorso-lateral one, of about equal width with the median one, also on each side. On each side below are two lateral lines, faint, and interrupted toward the ends of each segment; a similar ventro-lateral line; and a much fainter interrupted median line.

The head is black and shining, the V-mark well indicated, the cervical or thoracic shield is shining, light, somewhat purplish-gray, and is rather variably marked with brown, which forms, each side of the median stripe of the second thoracic segment, two irregular longitudinal dark brown patches, darkest and widest toward the posterior margin. On each side above the spiracle of that joint is a shorter dark patch. Near this there are sometimes two or three small dark rounded spots. The spiracle of this segment is dark brown, the remainder being concolorous with the body. The thoracic legs are more or less infuscated, and the prolegs are nearly concolorous with the venter. The entire surface of the body is sparsely covered with moderately long yellow and light brown hairs, proceeding from small and shining piliferous tubercles.

The anal shield bears from 10 to 12 round purplish spots, the most posterior one the largest and standing alone, the remainder forming a subcrescentic pattern.

The length when in natural position at rest is about 13 mm. and when extended 15 mm., the width being a trifle more than 2 mm. at the widest part.

THE PUPA.

The pupa is moderately shining, light yellowish brown in color and the surface is covered with a light pruinose bloom. The eyes are dark brown, varying

to black, and the dorsum is marked by a median stripe. The contracted antepenultimate segment is noticeable. The anal segment terminates in two pairs of straight brown hairs. It is of rather robust cylindrical form, measuring about three-tenths of an inch (7.5 mm.) in length and one-twelfth (2 mm.) in width.

The somewhat peculiar outline of the abdominal segments is shown at *d* of figure 4.

Transformation to pupa and thence to imago takes place in a rather compact cocoon composed of webbed-up grains of earth, which the larvæ form after burrowing into the soil. Those before the writer measure about three-eighths of an inch (9 mm.) long and a little less than half that in width.

The notes which appear above, on the life history of the species, were made by the senior writer at Washington, D. C., where the temperature and other conditions are not materially different from those of the Eastern Gulf States.

DISTRIBUTION.

In previous articles it was stated that this species would probably not spread beyond certain natural boundaries, i. e., not much above the Lower Austral life zone. Thus far this prediction has been verified.

The following is the known distribution as recorded in this branch of the bureau: West Raleigh, N. C.; Charleston and Beech Island, S. C.; Auburn, Phoenix City, and Montgomery, Ala.; Augusta, Waycross, Tifton, Athens, Griffin, Montreal, Albany, Marshallville, Macon, Fort Valley, Meansville, and Leesburg, Ga.; Lakeland, Dade City, and Orlando, Fla.; Stallo, Columbia, Kosciusko, Crystal Springs, Columbus, Ridgeland, Starkville, Gulfport, and Hattiesburg, Miss.; Corpus Christi, Brownsville, Beeville, Mission, Santa Maria, and Sabinal, Tex.; Los Angeles, Orange County, Santa Ana, and Garden Grove, Cal.; and Honolulu and Wahiawa, Hawaiian Islands.

The foreign localities need not be repeated.

FOOD PLANTS.

The first record of injury by this species was to cabbage, turnips, and beets. October 14, 1897, Mr. N. L. Willett, a reliable correspondent of this department, estimated that the cost to the grower of these plants and collards in the county of Richmond, Ga., alone would amount to \$15,000 to \$20,000 during that year, while Mr. W. M. Scott, at that time State entomologist of Georgia, estimated, November 26, 1897, a loss to that county of \$50,000.

Besides cabbage, turnips and beets, collards, cauliflower, kale, rutabaga, radish, kohlrabi, mustard, rape, horse-radish, and some other

cultivated plants, such as "Japanese radish," are subject to attack and injury. Among weeds and wild food plants are the common shepherd's purse (*Bursa* [*Capsella*] *bursa-pastoris*) and "pussley" or "cutter's grass," otherwise purslane (*Portulaca oleracea*).

NATURAL ENEMIES.

Natural enemies of cruciferous insect pests are of great value in keeping their hosts in check, and some dependence must be placed upon these agencies in restraining the undue multiplication of this webworm. Indeed, there is evidence that they do hold it in check in many regions, although they have not prevented its natural spread.

In spite of the short time that we have known of its occurrence in this country as a pest—since about 1899—we are already certain that at least five natural enemies, and probably more, are at work in decimating its numbers.

Exorista pyste Walk. (fig. 6), a tachina fly, has been repeatedly reared from the caterpillar of *Hellula undalis* from July 27 to as late as October 27.

Limnerium tibiator Cress., a very abundant parasite reared with this species, is an ichneumonid. It was reared from the latter part of October until the last week of December. It has not been positively ascertained to prey upon this larva, as it is a well-known enemy of the diamond-backed moth (*Plutella cruciferarum* Curt.), which was also present in smaller numbers, but as it is also known to attack the cabbage looper (*Autographa brassicæ* Riley) and *Mineola indiginella*, it seems probable that it is in reality an enemy of this webworm.

Plagiprospherysa sp., a tachinid fly parasite, was reared June 12 and 17, 1908, from its host from Brownsville, Tex. The identification was made by Mr. C. H. T. Townsend.

Two other hymenopterous parasites of this webworm, reared in 1899, were identified by the late Dr. William H. Ashmead as *Meteorus vulgaris* Cress. and *Temelucha* (*Porizon*) *macer* Cress., female. The

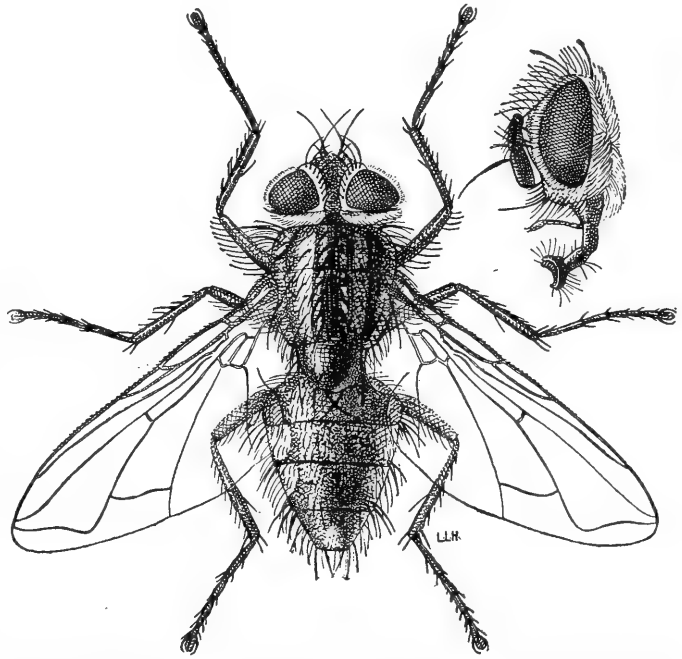


FIG. 6.—*Exorista pyste*, a parasite of the imported cabbage webworm (after Titus).

former, an ichneumonid, was reared in September from material received from Auburn, Ala.; the latter, a braconid, issued during the latter days of July from larvæ received from Charleston, S. C.

November 12, 1908, Prof. R. I. Smith, West Raleigh, N. C., stated that in attempting to rear larvæ of this species several were killed by mites, which bred in great numbers in a single night. Samples of the mites were forwarded to this office, for identification by Mr. Nathan Banks, who reported as follows:

The mite is *Tyroglyphus americanus* Bks., a species common in the Eastern States and feeding on a great variety of substances. These mites have a migratory stage which is attached to many insects, and so they gain access to places where one would not suspect them.

THE IMPORTED CABBAGE WEBWORM IN HAWAII.

In Hawaii the larvæ of the imported cabbage webworm (*Hellula undalis* Fab.) were observed by the junior author¹ attacking cabbage, radish, kohlrabi, and "Japanese turnips," at Honolulu and Wahiawa, on the island of Oahu. The investigation was confined to this island, and it was not determined if the species occurs as a pest on the other islands of the Hawaiian group.

On Oahu cabbage and a few other cruciferous crops are produced to a limited extent throughout the year, for consumption in the local market. Of these crops cabbage is probably the most valuable, although "Japanese turnips" are grown and used quite extensively by the Orientals. These turnips resemble what we in the States call "winter radish," but, unlike radishes, they are cooked before being eaten.

Most of the cabbage is grown during the cooler months, from November until April. According to the oriental gardeners, the other months of the year are "too hot," and the plants seemingly do not thrive. Ordinarily only a few acres are grown annually, and the production is so limited that it becomes necessary to import considerable quantities of this vegetable from the mainland to supply the demand at Honolulu and other towns. Cabbage grown during the cooler months is usually of good quality and is said to be a profitable crop. Under the circumstances it doubtless seems odd to one unacquainted with the conditions that this crop is not produced in sufficient quantities to supply the local demand. The failure to grow cabbage more extensively is due in part to the fact that this crop is preyed upon by a horde of insects. Although most of these pests can be easily controlled, the Chinese and Japanese gardeners are,

¹The notes on the occurrence of the imported cabbage webworm in Hawaii were made by the junior author while engaged as assistant Territorial entomologist and as a collaborator of the Bureau of Entomology. Thanks are due Mr. E. M. Ehrhorn for the courtesy of allowing Mr. Marsh to retain these notes. The junior author is not responsible for any statements made in other portions of this paper.—F. H. C.

almost without exception, ignorant of methods of control, and as a result much of the crop is injured and the growers become discouraged and plant other crops which are less damaged by insects.

Among these insects are the common cabbage worm (*Pontia rapæ* L.), the imported cabbage webworm (*Hellula undalis* Fab.), cutworms (*Agrostis crinigera* Butl.), a looper (*Autographa precatationis* Guen.), the diamond-back moth (*Plutella maculipennis* Curtis), the beet army worm (*Caradrina exigua* Hübn.), the cabbage aphid (*Aphis brassicæ* L.), the spinach aphid (*Rhopalosiphum dianthi* Schrank), and a number of minor pests. Among the latter is a leaf-miner (*Agromyza diminuta* Walk.), an unidentified species of thrips, and the melon fly (*Dacus cucurbitæ* Coq.). The larvæ of the melon fly work in cabbage which has previously been injured by the larvæ of *Hellula undalis*. This fruit fly is an exceedingly destructive enemy of cucurbits, and its occurrence in cabbage is rather uncommon.

The operations in Hawaii occupied a period of about seven months (July, 1910, until February, 1911), and during this time the insects affecting cabbage were kept under fairly constant observation. During this period the imported cabbage webworm apparently caused more damage to cabbage than any other insect. The growers claim, however, that from January to April the common cabbage worm (*Pontia rapæ* L.) is the most troublesome pest. During the period of actual observation, however, the webworm appeared to outrank the other species in destructiveness; in fact, at least a few of the webworms could be found whenever a search was made for them, although cabbage and turnips were the only crops which were noticeably damaged. The most serious infestation observed in 1910 occurred at Wahiawa, Oahu. On October 10, in company with Mr. E. M. Ehrhorn, a visit was made to a grower at Wahiawa, who planned to grow about 7 acres of cabbage that season. At this time he had three seed beds containing thousands of small cabbage plants. In one bed many plants had been killed, and of those which remained fully 75 per cent were infested by webworms and were worthless. In the other two beds in another field, at a distance of about 200 yards from the first, about 10 per cent of the plants were infested. The larvæ in the seed beds were all small. On large cabbage plants in a garden, a mile or more from the seed beds, full-grown larvæ were found in moderate numbers. One moth was observed, but no eggs were seen. In small garden patches at this place the Japanese killed occasional larvæ which lived in folded leaves or between two leaves, by crushing them with the fingers. Apparently only larvæ of conspicuous size were found, and as the majority of the webworms mined into the plants, beyond the reach of hand-picking, this method of control seemed of doubtful value.

The seed beds were again visited October 17. The conditions had not materially changed, except that some larvæ had reached maturity and left the plants. On November 2, 3,000 plants were taken from the three beds and transplanted to a field fully $2\frac{1}{2}$ miles from the seed beds. The plants were carefully examined and only those free from larvæ were transplanted. Unfortunately, small patches of old cabbage and Japanese turnips occurred but a short distance from the transplanted plants. The old cabbage was not badly infested, but the webworms were abundant in the turnips, and a portion, about one-fifth of an acre, of one patch was nearly destroyed. It will thus be seen that, although the young plants were free from larvæ when transplanted, they were placed in a badly infested and dangerous neighborhood. When these plants were examined November 18 nearly every one in the entire patch was found infested with from 1 to 10 webworms. These were mostly small—very few more than a week old—and many were not more than 4 days old. They had burrowed into or between the tender, curled leaves at the "bud" and were so well protected that they were apparently beyond the reach of a spray. Even at this early stage the plants showed plainly the results of infestation. It was obviously a hopeless case, and the man in charge, a Japanese, was advised to pull up the plants and burn them, but this he refused to do. At the next visit, December 8, little remained of these plants but stunted, worthless stumps. Larvæ were still abundant in them, although many had reached maturity and burrowed into the soil. About 700 plants which had been set out shortly after the middle of November in an adjoining patch were also generally infested and were rapidly becoming worthless.

In summing up these observations it will be seen that nearly 4,000 transplanted plants were destroyed by webworms, while at the same time the plants in seed beds were so generally infested that it was almost impossible to procure stock for replanting.

One of the most obvious factors making possible this loss was the almost utter indifference with which the necessity of clean culture was regarded. Old cabbage stumps and abandoned seed beds were not promptly destroyed, but were allowed to serve for months as breeding centers. An essential lesson that these growers have to learn is the absolute necessity of promptly destroying remnants of the crop by burning or some other equally effective method.

LIFE HISTORY AND HABITS.

Under normal conditions the eggs, when deposited on cabbage, are placed about the "bud" at the axils of the terminal leaves or on the leaves. From 1 to 12 eggs may be deposited on a single small plant.

At Honolulu eggs have been observed to hatch in from two to three days. Within a very short time after hatching the larvæ endeavor to conceal themselves. When very small cabbage plants in seed beds are infested the larvæ conceal themselves by folding a tender leaf and fastening the edges together with a web. Rarely is more than one larva found on a single leaf. With somewhat larger plants the larvæ mine into or crawl between the curled, terminal leaves at the "bud," and, as they increase in size, burrow deeper into the main stalk. When a plant is thus infested it is rendered worthless. With large plants which are beginning to head the larvæ mine into the mid-ribs or live in burrows between two leaves. The chief damage is caused by the larvæ destroying the "buds" of the small to medium-sized plants. When the "buds" of small plants in the seed bed are attacked the plants may be killed outright. With larger plants the destruction of the "bud" effectually prevents further normal development. Rain falling into the burrows hastens decay, thus completing the injury begun by the larvæ. On Oahu the larvæ are called "center worms," from their habit of mining into the center or "bud" of cabbage plants.

The larvæ usually reach maturity in from 13 to 15 days. They then leave the plants, burrow slightly beneath the surface of the soil, and form rather frail cocoons of webbed-together grains of earth, within which they pupate within 2 days. During the progress of these studies thousands of larvæ were under close observation, and they invariably burrowed into the soil and made cocoons of webbed-together grains of earth. The adults usually issue in from 6 to 12 days after pupation. They fly easily, but are shy and are rarely noticed by the casual observer.

It is probable that this species breeds throughout the year in Hawaii. Judging, however, from the reports of gardeners, it is evident that reproduction is at a low ebb during the cooler months. This idea is borne out by the fact that the larvæ were noticeably less abundant at Wahiawa in late December and at Honolulu in January than earlier in the season.

Four generations of this webworm were reared in an insectary at Honolulu. The record for the first generation is incomplete.

FIRST GENERATION.

September 2, 1910, several mature larvæ were collected from cabbage in a garden at Honolulu and confined in a cage. They burrowed into the soil September 3 and pupated September 5. The first moths, 4 in number, issued September 12, and the following day 8 more issued. The 12 moths were then put in another cage, containing a

living cabbage plant, and were supplied with diluted molasses as food. The following is a summary of the three succeeding generations:

SECOND GENERATION.

September 12-13	Twelve adults issued.
September 14	First eggs deposited.
September 16	The eggs hatched.
September 29	First larvæ reached maturity.
October 1	First larvæ pupated.
October 7	First adults issued.
October 8	More adults issued.

From the above record the stages are as follows:

	Days.
Egg stage	2
Larva stage	15
Pupa stage	6
Total	23

THIRD GENERATION.

October 7-8	Adults issued.
October 9	First eggs deposited.
October 12	The eggs hatched.
October 26	First larvæ reached maturity.
October 28	First larvæ pupated.
November 6	First adults issued.
November 7	More adults issued.

From the above record the stages are as follows:

	Days.
Egg stage	3
Larva stage	16
Pupa stage	9
Total	28

FOURTH GENERATION.

November 6-7	Adults issued.
November 9	First eggs deposited.
November 12	The eggs hatched.
November 27	First larvæ reached maturity.
November 29	First larvæ pupated.
December 11	First adults issued.

From the above record the stages are as follows:

	Days.
Egg stage	3
Larva stage	17
Pupa stage	12
Total	32

The moths which issued December 11 deposited eggs for a succeeding generation. Unfortunately, it was necessary to abandon the work at this point and records of further development were not obtained.

EGG-LAYING RECORDS.

On October 11 a pair of moths, which had issued that day, were observed mating. These moths, while still together, were put into a separate cage and the following record obtained:

	Eggs deposited.
October 13.....	79
October 14.....	49
October 15.....	31
October 16.....	32
October 17.....	13
October 18.....	15
October 19.....	5
October 20.....	11
Total	235

The female died October 21 and the male died the following day. The female lived 10 days and deposited 235 eggs. The male lived 11 days.

With another mating pair, which were likewise confined during October, the female lived 14 days and deposited 237 eggs. The male lived 17 days.

The life-history records were obtained in an open-air insectary in which open wire cages were used. Food was supplied the moths by putting in wads of absorbent cotton which had been saturated with molasses and water. They fed on the diluted molasses eagerly. The moths were docile and easily handled, and mating pairs were readily obtained during the daytime. In all cases, cabbage was used as food for the larvæ. Usually young, tender plants from seed beds were supplied.

Following is the temperature record at Honolulu during the time the species was reared:

Month.	Minimum tempera- ture.	Maximum tempera- ture.	Average mean tem- perature for entire month.
1910.	° F.	° F.	° F.
September.....	69	85	77.0
October.....	65	84	75.3
November.....	66	84	74.6
December.....	62	80	71.2

NATURAL ENEMIES IN HAWAII.

Many larvæ were collected at various dates from cabbage and other cruciferous plants in the gardens in Honolulu and Wahiawa

and confined in cages. No parasites were obtained, nor were predaceous enemies observed in the field. In one or two so-called stock cages in the insectary, which were crowded with surplus webworms and neglected, a disease or "wilt" developed which killed many larvæ. This "wilt" did not occur in the regular cages and was not observed in the field. Apparently, as far as Hawaii is concerned, this webworm seems to be remarkably free from natural enemies.

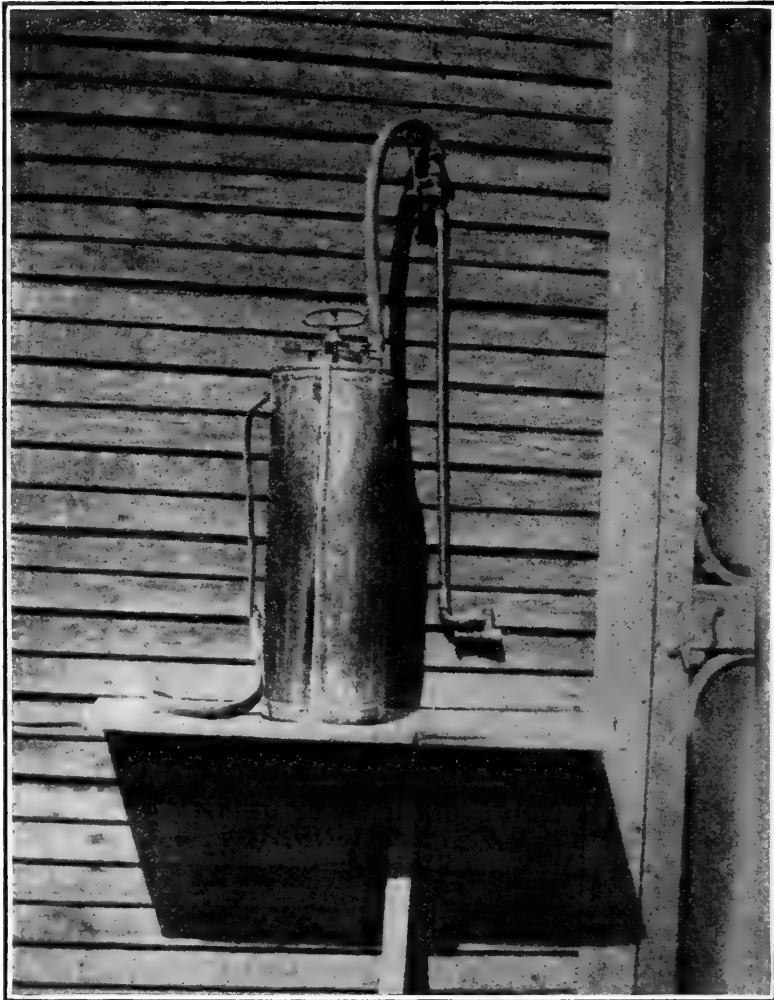


FIG. 7.—Small compressed-air sprayer, fitted with extension rod, elbow, and Vermorel type nozzle. (Original.)

EXPERIMENTS WITH INSECTICIDES.

During the fall of 1910 some experiments were made against this webworm. All experiments with insecticides were conducted on infested cabbage in a garden at Honolulu. In all cases the insecticides were applied with a small compressed-air sprayer (fig. 7), which was fitted with a short extension rod, elbow, and a small nozzle of the Vermorel type. The experiments were as follows:

Experiment No. 1.—Paris green, 2 pounds, and whale-oil soap, 8 pounds, in 100 gallons of water.

September 7 the plants in two seed beds and 495 older plants were sprayed. One seed bed contained plants from 1 to 3 inches in height, many of which were infested by small webworms. They had not entered the bud, but were working in folded leaves.

The second bed contained larger plants ready to transplant and only slightly infested. The few larvæ present were mostly in small folded leaves or occasionally in a bud. The 495 plants had been transplanted for some time and varied from small plants, which had made little growth, to a few which had just begun to head. In fully one-fifth of these plants the bud had been destroyed by webworms, making the plants worthless.

In this experiment the plants were simply wet from above. In the seed beds the entire upper surface of the plants was wet, but with the larger plants only the leaves at the center were reached. The mixture adhered very well. At the time of the application all the larvæ were concealed in the folded leaves or buds. The weather was hot and clear.

In the seed bed containing the small plants a few larvæ were dead the following day (September 8). They were found clinging and exposed on the surface of the leaves.

The plants sprayed in the second seed bed had been removed and transplanted. The infested ones were discarded, and as a result the effects of the treatment could not be determined.

In the large plants the larvæ were buried beyond the reach of the poison and none were killed.

September 9 it was noted that a few additional larvæ had died in the first seed bed. Some of the leaves were slightly burned by the arsenical. On the old plants no effect was apparent, either upon the larvæ or upon the foliage.

A heavy rain occurred September 10 which washed the poison from the plants, and the experiment was closed on that date.

As a result of this treatment only a moderate number of larvæ, in the folded leaves on the young plants, were killed. With the large plants no larvæ were killed. All things considered this experiment must be rated as a failure.

Experiment No. 2.—Paris green, 5 pounds; lime, 5 pounds; and whale-oil soap, 10 pounds, in 100 gallons of water.

September 12 a seed bed of small, well-infested plants was sprayed. The larvæ were practically all in folded leaves and only one was found entering the bud. The spray mixture adhered perfectly and the surface of the leaves was thoroughly coated with the poison. The weather was cloudy and sultry.

A shower occurred the following day, but the poison was not washed from the leaves. No dead larvæ could be found at this time. Some of the leaves were slightly burned.

September 15 the application was repeated. The older leaves were still well coated with the poison from the first dose, but many new leaves had been put out and these were unprotected. All were completely coated by the second spraying. At this date there were occasional dead larvæ, but they were not common.

September 16 it was noted that some of the larvæ were actually entering the bud and that very few of them had been killed.

Heavy showers occurred September 18, 19, and 20, but the coat of poison remained fairly good. At this latter date, most of the larvæ were in flourishing condition, and the experiment was considered a failure. The plants were slightly burned, but no serious damage resulted. One interesting point brought out by this experiment is that the mixture was remarkably adhesive and not readily washed from the foliage by rains.

Experiment No. 3.—Arsenate of lead, 5 pounds, and whale-oil soap, 10 pounds, in 100 gallons of water.

October 12, 418 good-sized cabbage plants were sprayed. The larvæ were moderately common. All were deeply buried and obviously beyond the reach of the poison. The mixture adhered well and the plants were completely coated. These plants were examined daily until October 19, but not a dead larva was found, and at that date the experiment was abandoned as a complete failure. The mixture did not burn the foliage.

Experiment No. 4.—Paris green, 2 pounds, whale-oil soap, 8 pounds, and nicotine sulphate, 25 ounces, in 100 gallons of water.

November 10, 410 good-sized moderately infested plants were sprayed. These plants were kept under almost daily observation until November 23, but not a dead larva was found. This mixture did not burn the plants, and it completely wiped out plant-lice (aphides) and several species of lepidopterous larvæ which were exposed on the leaves. It was, however, ineffective against the well-protected *Hellula* larvæ.

The experiments with insecticides may be summarized as follows:

Experiment No.	Date.	Insecticide used.	Effect on larvæ.	Injury to foliage.	Remarks.
1.....	1910. Sept. 7	Paris green, 2 pounds, and whale-oil soap, 8 pounds, in 100 gallons of water.	Ineffective..	Not worth mentioning.	A few larvæ, in folded leaves, on small cabbage plants were killed. None were killed on large plants.
2.....	Sept. 12	Paris green, 5 pounds, lime, 5 pounds, and whale-oil soap, 10 pounds, in 100 gallons of water.do.....do.....	A few larvæ, in folded leaves, on small cabbage plants were killed.
3.....	Oct. 12	Arsenate of lead, 5 pounds, and whale-oil soap, 10 pounds, in 100 gallons of water.do.....	None.....	Applied to large cabbage plants. No larvæ were killed.
4.....	Nov. 10	Paris green, 2 pounds, whale-oil soap, 8 pounds, and nicotine sulphate, 25 ounces, in 100 gallons of water.do.....do.....	Do.

EXPERIMENT IN SCREENING A SEED BED.

On October 18 two cabbage seed beds were planted at Wahiawa. The beds were about 11 yards in length and nearly 1 yard wide. They were separated by a path about 12 inches in width. One bed was screened and the other was left uncovered in the usual manner.

The screen was made by placing 12-inch boards on edge around the sides and ends of the bed, and over this a strip of cotton cheesecloth was tacked. This strip of cloth was a yard wide and a little more than 11 yards in length. It cost 5 cents per yard. It was originally intended to make the cover of the fine-meshed, cotton mosquito netting, but as this netting was not obtainable at the time cheesecloth was used instead.

These beds were examined November 8. At that date the plants in the exposed bed were well infested by *Hellula* larvæ. The plants in the screened bed were free from insect pests and were larger and in better condition than those in the exposed bed. Their condition was accounted for by the fact that the screen prevented rapid evaporation, as well as insect attack, and the abundant moisture and freedom from insects favored a thrifty growth.

November 18 fully 75 per cent of the plants in the exposed bed were ruined or injured by webworms. The plants in the screened bed were free from webworms and other insect pests and were of sufficient size to transplant. Owing to the protection they had received and their rapid growth, these plants were quite tender, and it was necessary to remove the cover and expose them to the sun to harden them. After being exposed a little more than a week the plants were well hardened, and several thousand were successfully transplanted.

A final examination of the transplanted cabbages was made December 23. At that date most of them were growing vigorously and only a few were infested by webworms.

On the whole this experiment was a success, although it is very evident that a mistake was made in using cheesecloth for the cover. This material shaded the plants from the sun and their growth was too rapid. Undoubtedly mosquito netting would have been an ideal cover.

CONCLUSION.

The observations on this webworm have been made under normal field conditions in several localities in Texas, California, and the Hawaiian Islands. Basing an opinion on the studies and experiments made in these places, arsenicals can not be depended on to control this species on cabbage. This belief is strengthened by the experience of Mr. M. M. High, who reports, as mentioned on another page of this article, that dry Paris green was unsuccessfully used against this pest on cabbage in Mississippi during 1909.

After the larvæ have crawled between the terminal leaves or mined into any portion of the plant they are beyond the reach of a stomach poison. The period between the hatching of the eggs and the concealment of the larvæ is so brief that it appears to be a practical impossibility to reach them under field conditions.

In the light of our present knowledge, the best methods of controlling this webworm consist of clean culture, the screening of seed beds, and thorough cultivation.

The necessity of prompt destruction of crop remnants and the employment of other clean cultural methods can not be too strongly emphasized. It is a disgraceful condition to allow worthless plants to serve as breeding centers for pests which will infest later planting.

By screening the seed beds it is possible to prevent infestation until the time of transplanting. When this method is followed it is advisable to leave a few plants exposed near the screened beds. These exposed plants will attract the moths, and eggs will be deposited on them. As soon as the eggs have hatched and the work of the larvæ becomes apparent these plants should be promptly burned.

Inasmuch as the larvæ of this species pupate in frail cocoons near the surface of the soil, it is possible that thorough cultivation would crush some of the pupæ and at the same time induce a more vigorous growth of the plants.

RECOMMENDATIONS FOR CONTROL.

While the limited stay on the part of the junior writer in Hawaii did not permit of experiments with other remedies than those which have been considered on previous pages, nevertheless it is believed by the senior writer that in the occurrence of this insect in the southern United States and in California it may be possible to successfully treat it on cabbage and other cruciferous plants by means of some form of spray, particularly if applied at the outset of attack. This point can never be too strongly emphasized, that if we expect to meet with success in combating this as well as so many other insects, work must be begun upon the first appearance of the insects each season, since if the pests can be destroyed then, it should materially decrease the injury for the entire year. If the first generation is missed, the second and third should be treated.

It should be stated that Mr. H. M. Simons, Charleston, S. C., one of the first to report this species as a pest in America, found that a mixture of kerosene oil and soap sprayed upon infested plants served as a deterrent against the larvæ of this moth, but that the larvæ returned as soon as the odor of the kerosene had become exhausted. Kerosene-soap emulsion and nicotine solutions and whale-oil soap should be given thorough tests as deterrents and insecticides, both alone and mixed with arsenicals.

Another method was tested by Mr. Simons. He captured many of the moths with the aid of a barrel having all but four of the staves sawed out, leaving 4 inches from the bottom to form a tub in which to hold water. From the top of this a light was suspended which attracted the moths. In this way he caught a great many insects in two seasons. The light barrels, as he terms them, were placed on seed beds of cabbage.

A thin scum of kerosene was used in this experiment, but it is suggested that this be eliminated in order not to destroy the predaceous insects, such as ground beetles and parasites, which are practically certain to be attracted. This suggestion is made in view of the fact that the destruction of one beneficial ground beetle or parasite is equivalent to the destruction of, perhaps, from 20 to 100 injurious insects. The predaceous and larger parasitic insects can be easily picked from the water, and though they may be apparently dead, it will soon be seen that they recover and crawl away. The moths are not apt to recover.

There can be little doubt that Bordeaux mixture sprayed on the plants when they are first set out, or when they first appear above ground, and continued at intervals of a week or two, should act as a deterrent of attack. It is advisable, therefore, in using an arsenical, to employ Bordeaux mixture as a deterrent. Where cabbage and similar plants, liable to infestation by this insect, are set out from sash or cold frames, dipping the plants in a solution of arsenate of lead, prepared at the rate of about 4 pounds of the arsenical to 50 gallons of water, should be useful.

Among other remedies which may be suggested for employment, at least on a small scale, are the following:

Planting an excess of seed with the aim of afterwards destroying the plants which are injured by the webworm beyond redemption.

Fall plowing, a standard remedy for many insects.

Clean culture, or the maintenance of the cabbage or other fields throughout the season free from weeds, especially cruciferous weeds, and prompt destruction of dead or dying plants during the season and the removal of all cabbage heads, stalks, and other refuse. All cruciferous crops should be treated in a similar manner.

The refuse material, including hopelessly injured cabbage heads and other crucifers, should be gathered in piles and promptly burned. The addition of straw or similar dry material will aid in ignition.

BIBLIOGRAPHY.¹

1. FABRICIUS, JOH. C.—Systema Entomologiæ, vol. 3, 2, p. 226, 1794.
Original description as *Phalæna undalis* n. sp. from Italy.
2. WALKER, FRANCIS.—Catalogue Lepid. Brit. Mus., vol. 19, p. 827, 1859.
Listed as *Scopariaalconalis* Walk.
3. HERRICH-SCHÄFFER.—Europäische Schmetterlinge, vol. 4, pl. 8, fig. 54, 1859.
(Not seen.)
4. WALKER, FRANCIS.—Catalogue Lepid. Brit. Mus., vol. 34, p. 1313, 1864.
Listed as *Leucinodes exemptalis* Walk.
5. HULST, G. D.—Trans. Amer. Ent. Soc., vol. 13, p. 149, 1886.
Description from a single female from Texas as *Botis rogatalis* n. sp.
6. HAMPSON, G. F.—Fauna of British India, Moths, vol 4, p. 373, fig. 200, 1893.
Description of genus and species. Of "Mediterranean subregion, and throughout the tropical and subtropical zones, except the Neotropical and Australian regions." Figure of female and venation.
7. LEA, ARTHUR M.—Journal of Board of Agriculture (Perth, West Australia), vol. 4, p. 1420, December 1, 1897.
The worst of all cabbage pests in West Australia; causes "balloon head" and "stinking head" diseases; notes on habits.
8. HAMPSON, G. F.—Proc. Zool. Soc. London, p. 760, fig. 87, 1898.
Description of the genus *Hellula* after Guenée. Synonyms of *undalis*. Figure of female from Moths Ind., vol. 4. Distribution: United States of America, Mediterranean subregion, Ethiopian and Oriental regions.
9. WILLET, N. L.—The Augusta Chronicle (Augusta, Ga.), October 9, 1898.
Short popular article.
10. CHITTENDEN, F. H.—Bul. 19, n. s., Div. Ent., U. S. Dept. Agr., pp. 51–57, fig. 12 (original), 1899.
A 6-page general economic account, including a discussion of habits, description, injuries in Georgia, life history, enemies, and remedial measures.
11. SCOTT, W. M.—Bul. 1, Georgia State Board of Entomology, pp. 17–25, figs. 3–4 (original). April, 1899.
A popular economic account of 8 pages, dealing with life history, habits, injuries, and remedies.
12. CHITTENDEN, F. H.—Bul. No. 23, n. s., Div. Ent., U. S. Dept. Agr., pp. 53–61, fig. 13, April, 1900.
"Additional notes on the imported cabbage webworm." Records of the first report of injuries in the United States at Charleston, S. C., in 1896; adds other localities, food plants, and literature; considers distribution abroad; complete life history, including descriptions of the egg and newly hatched larva.
13. CHITTENDEN, F. H.—Bul. 22, n. s., Div. Ent., U. S. Dept. Agr., p. 56, January, 1900.
Cold weather probably decreased this insect during season of 1899 at Charleston S. C.
14. FORBES, S. A., and C. A. HART.—Bul. 60, Ill. Agr. Exp. Sta., pp. 459–460, fig. 38. October, 1900.
A compiled account; history, distribution, life history, parasites.

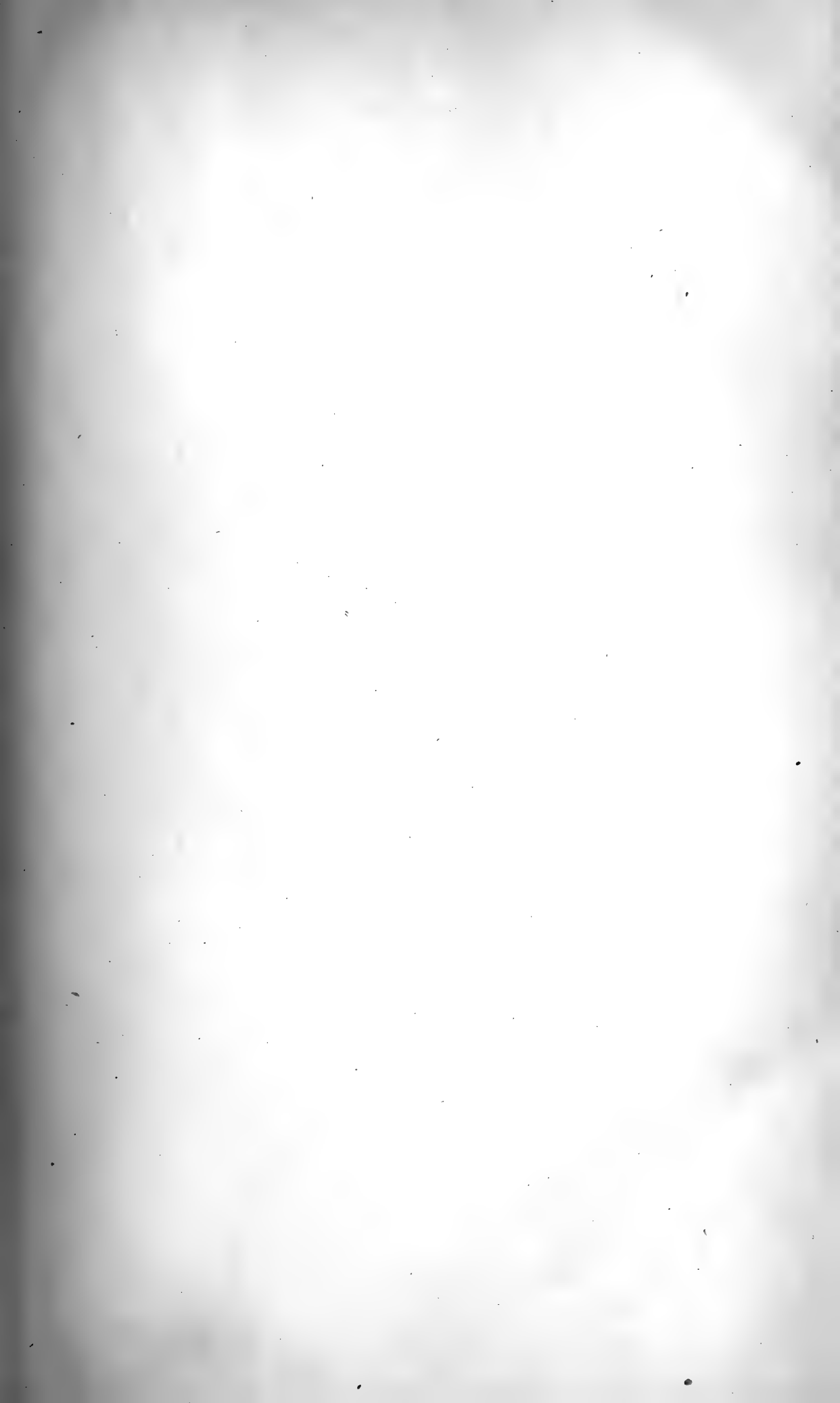
¹ Since the economic bibliography of this species has never been fully written out, to the writer's knowledge, the above list, which is somewhat complete, has been compiled with the assistance of Mr. Thomas H. Jones, of the Bureau of Entomology.

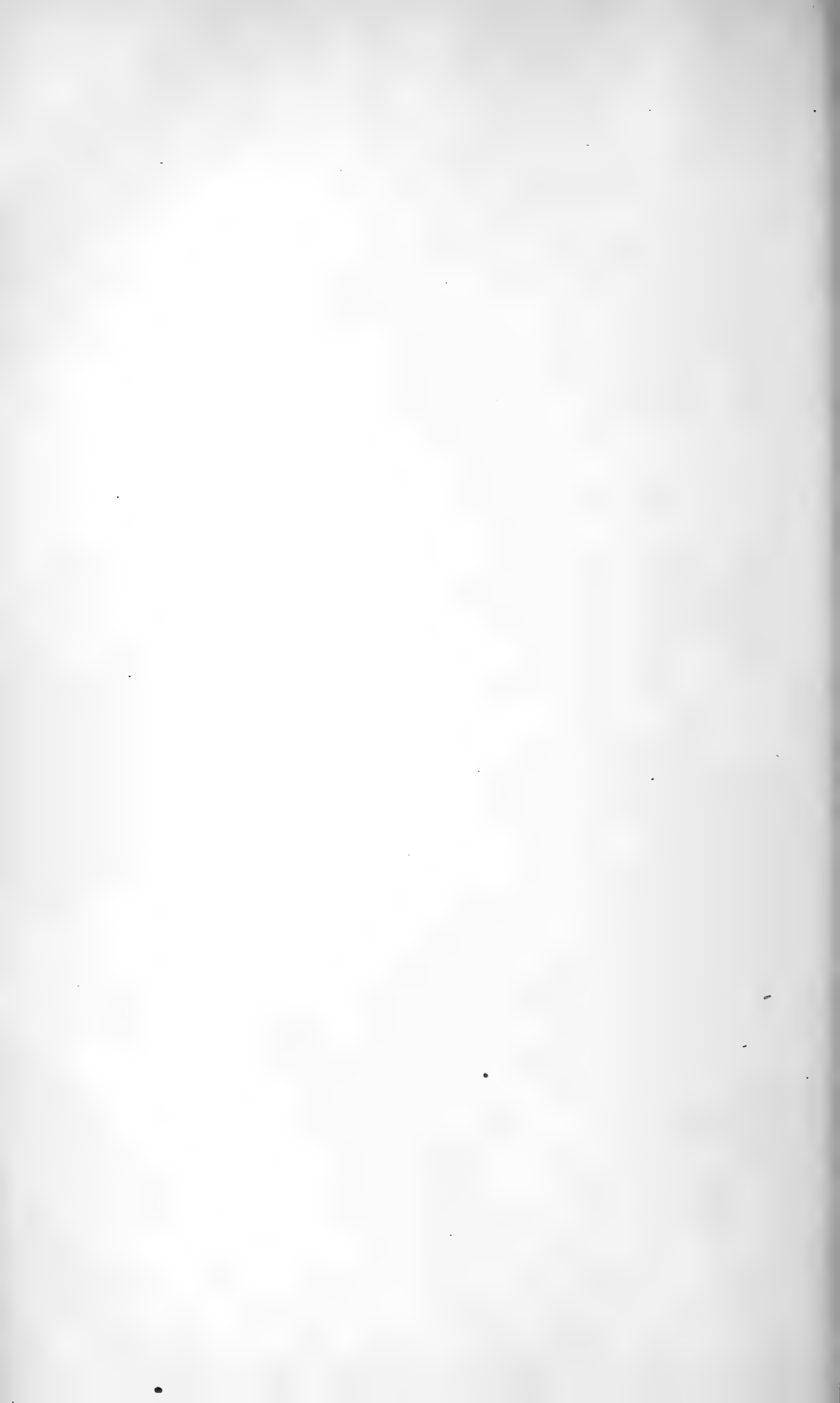
15. CHITTENDEN, F. H.—Bul. 33, n. s., Div. Ent., U. S. Dept. Agr., pp. 48-49, 1902.
Reports of injuries in new localities in Georgia and South Carolina.
16. DYAR, H. G.—Bul. 52, U. S. Nat. Mus., p. 379, 1902.
List of literature and synonymy. Southern States, Southern Europe, Africa, and India given as distribution.
17. CHITTENDEN, F. H.—Bul. 43, Div. Ent., U. S. Dept. Agr., p. 38, 1903.
States that "imported cabbage webworm" occasionally occurs on beets.
18. EDITORIAL.—Bul. 44, Div. Ent., U. S. Dept. Agr., p. 93, April, 1904.
Use of light trap against the imported cabbage webworm.
19. SNOW, F. H.—Trans. Kansas Acad. Sci., vol. 20, part 2, p. 155, 1907.
Taken at San Bernardino Ranch (Ariz.) in 1905.
20. SMITH, R. I.—Bul. 197, N. C. Agr. Exp. Sta., pp. 23-26, May, 1909.
Biologic account, with remedies. Illustrations from Chittenden.
21. MARSH, H. O.—Biennial Rept. Bd. Agric. and Forestry, Hawaii (1910), pp. 153, 157, 1911.
Brief notes. Recommends screening seed beds.
22. LEA, A. M.—Fourth Ann. Rept. Bur. Agr. Western Australia, pp. xxx, xxxii, 1897.
Mention as *Evergestis rimosalis* Gn. (,); account of injury to cabbage, etc. Description of larva and adult and mention of three unidentified natural enemies.

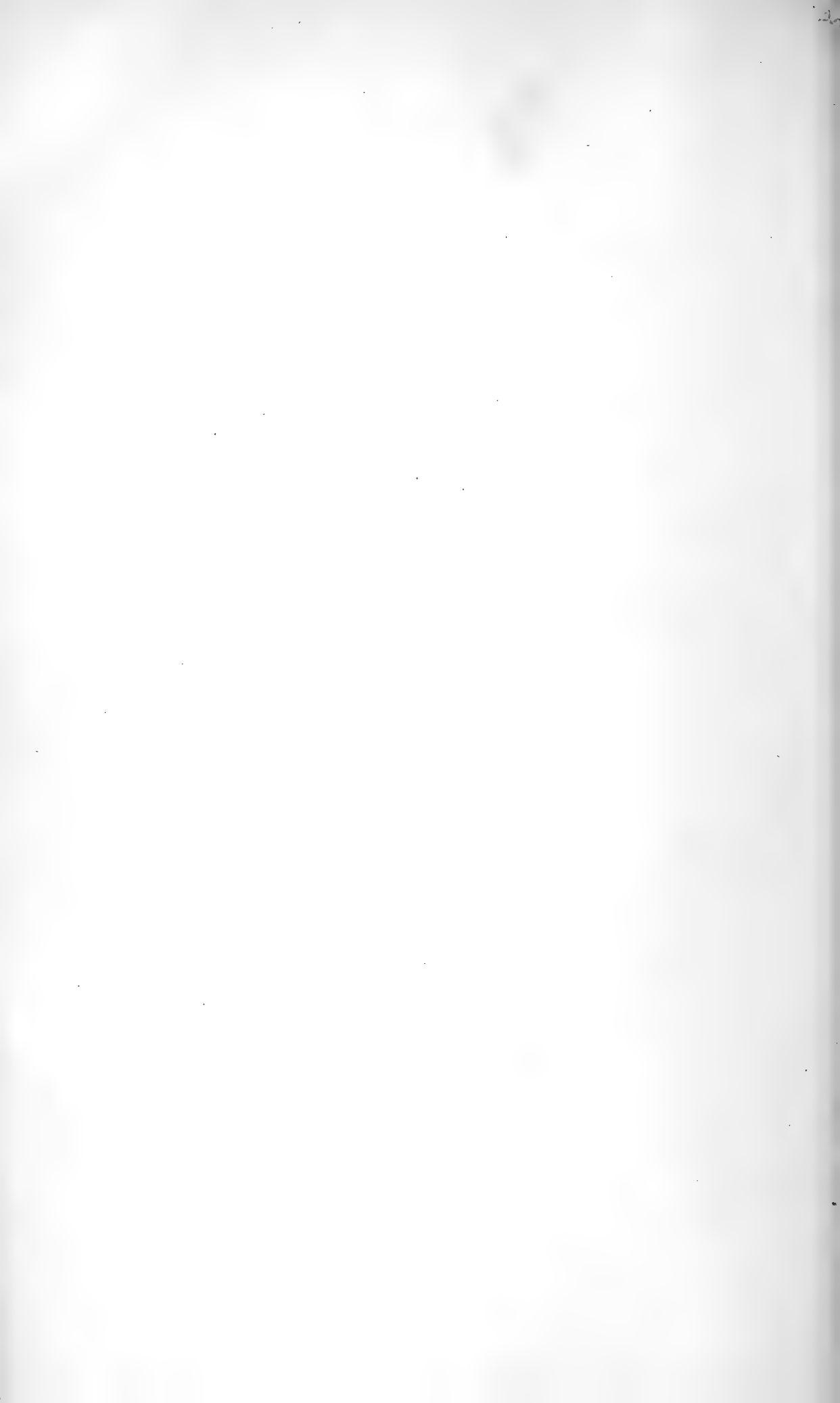
THIS PUBLICATION may be procured from the Superintendent of Documents, Government Printing Office Washington, D. C., at 5 cents per copy











U. S DEPARTMENT OF AGRICULTURE,
BUREAU OF ENTOMOLOGY—BULLETIN No. 109, Part IV.

L. O. HOWARD, Entomologist and Chief of Bureau.

PAPERS ON INSECTS AFFECTING VEGETABLES.

A LITTLE-KNOWN CUTWORM.

BY

F. H. CHITTENDEN, Sc. D.,

In Charge of Truck Crop and Stored Product Insect Investigations.

ISSUED APRIL 5, 1912.



CANCELLED
221226

WASHINGTON:
GOVERNMENT PRINTING OFFICE.
1912.

BUREAU OF ENTOMOLOGY.

L. O. HOWARD, *Entomologist and Chief of Bureau.*
C. L. MARLATT, *Entomologist and Acting Chief in Absence of Chief.*
R. S. CLIFTON, *Executive Assistant.*
W. F. TASTET, *Chief Clerk.*

F. H. CHITTENDEN, *in charge of truck crop and stored product insect investigations.*
A. D. HOPKINS, *in charge of forest insect investigations.*
W. D. HUNTER, *in charge of southern field crop insect investigations.*
F. M. WEBSTER, *in charge of cereal and forage insect investigations.*
A. L. QUAINANCE, *in charge of deciduous fruit insect investigations.*
E. F. PHILLIPS, *in charge of bee culture.*
D. M. ROGERS, *in charge of preventing spread of moths, field work.*
ROLLA P. CURRIE, *in charge of editorial work.*
MABEL COLCORD, *in charge of library.*

TRUCK CROP AND STORED PRODUCT INSECT INVESTIGATIONS.

F. H. CHITTENDEN, *in charge.*

H. M. RUSSELL, C. H. POPENOE, WILLIAM B. PARKER, H. O. MARSH, M. M. HIGH,
FRED A. JOHNSTON, JOHN E. GRAF, *entomological assistants.*
I. J. CONDIT, *collaborator in California.*
P. T. COLE, *collaborator in Tidewater Virginia.*
W. N. ORB, *collaborator in Oregon.*
THOMAS H. JONES, *collaborator in Porto Rico.*
MARION T. VAN HORN, PAULINE M. JOHNSON, *preparators.*

CONTENTS.

	Page.
Injurious occurrence.....	47
Results from applications of arsenate of lead.....	49
Description.....	50
The moth.....	50
The larva.....	50
Distribution.....	50
Natural enemies.....	51

ILLUSTRATIONS.

	Page.
FIG. 8. <i>Porosagrotis vetusta</i> : Moth, larva.....	50



PAPERS ON INSECTS AFFECTING VEGETABLES.

A LITTLE-KNOWN CUTWORM.

(*Porosagrotis vetusta* Walk.)

By F. H. CHITTENDEN, Sc. D.,

In Charge of Truck Crop and Stored Product Insect Investigations.

INJURIOUS OCCURRENCE.

During the past decade authentic evidence, based on specimens which have been reared to the adult, has been received of the injuriousness of the cutworm *Porosagrotis vetusta* Walk., and complaints have reached the bureau of other cases of injury doubtless wrought by the same insect.

* April 22, 1901, Mr. R. W. Caviness wrote from Southern Pines, N. C., sending numerous specimens of this cutworm, many nearly mature, with information concerning its ravages. His place at that time was described as literally alive with them, and there was an outbreak of the same species the previous year (1900), when it was impossible to get a stand of watermelons until the cutworms had matured. They seemed to eat "every green thing." Many cutworms were found on and about dewberry, sometimes a dozen or more to a vine. They crawled up the vines and ate the buds and leaves, and treated young peach and other trees in the same manner. It was impossible to get a stand of beans, cabbage, or any other garden "stuff." They were described as most abundant and doing their worst damage on cowpeas. In 1900 they cut fall-sown turnips until the weather became too cold for the larvæ to work.

May 18 Mr. Caviness made another sending of this cutworm taken from melon vines, 100 having been caught in an hour's time. They infested small vines that were just coming up, entirely destroyed one field of corn, and it was found necessary to replant both melons and corn. The land had previously been planted to cowpeas, but there was no apparent reason why this crop had any influence on the

development of the cutworm except for some evidence that it might be a preferred food plant.

The moths issued in our rearing jars during the first and second weeks of September, and conditions were such at that time that this is probably about the same period of issuance as that under natural conditions.

In May, 1902, this cutworm was again very abundant in the same locality, particularly around watermelon hills. Our correspondent wrote further of this species and of a related form (probably the granulated cutworm, *Feltia annexa* Treit.) with which it was associated, that it had been a terrible pest in his vicinity during the two years previous, and that in 1901 the insects were notably more numerous than before. He stated that it would have been impossible to have grown a crop like cotton or tobacco on his place that year. Some of the larvæ were remarkably late in transforming to pupæ, this being painfully evident in his melon field.

No positive information concerning damage by this species was reported for a few years thereafter, but there can be no doubt whatever that it was injurious, more or less, during many if not all of the remaining years.

In 1908 this species was observed by Mr. C. H. Popenoe and the writer injuring kale, spinach, and lettuce in June at Norfolk, Va., where it was also associated in every instance of observed injury with the granulated cutworm (*Feltia annexa*).

September 3, 1909, near Poplar Branch, N. C., these cutworms were found by Mr. W. L. McAtee, of the Biological Survey of this department, to be exceedingly numerous in a little truck garden kept by Capt. J. T. Westcott. Single rakes of the fingers over 6 inches of the sandy soil disclosed from 6 to 12 cutworms. He gathered a quart of these for fish bait in a few minutes. Cantaloupe and watermelon vines were entirely defoliated and corn and tomatoes were slightly attacked.

March 22, 1910, Mr. F. A. Johnston examined a field of about 3 acres of cultivated dandelions on the farm of Mr. Bruce Carney, at Churchland, Va., and found it badly infested with cutworms of this species. Hidden in the dead leaves around the base of some plants there were as many as 5 or 6 young larvæ. Some were quite small, and no appreciable damage had been done to the crop up to that date by this pest. The winter had been severe on the dandelions, most of them being killed back to the ground, but since the warmer weather set in the plants had made quite rapid growth and were in very fair condition. The crop was being cut for market and it seemed quite probable that a thorough spraying of the leaves that remained after the crop was harvested with either arsenate of lead or Paris green would control the pest.

Some of the larvæ obtained from this source were kept for rearing in this bureau. The first adult issued May 20, and others transformed to moths September 15 and 20.

During the first days of September, 1910, in an extremely heated spell, this species attracted attention on the farm of Mr. B. C. Haines, near Shelton, Va. Mr. Haines was advised to use arsenate of lead at the rate of 4 pounds in 50 gallons of water, and when the writer visited the infested locality a few days later he found that this remedy was producing excellent results. It should be mentioned that on Mr. Haines's farms truck plants are grown in alternate years, so as to produce four alternate crops. In this case parsley, growing between rows of lettuce, was badly affected. As soon as the lettuce was cut for market parsley began to appear and was cut off by the worms even with the ground, so that only a few plants could be seen here and there. The farm is being conducted by irrigation, both overhead and by means of hose, and it is probable that the prompt success in the use of arsenate of lead was doubtless due to the fact that the insects were watered, and thus cooled, at night and heated again by the extremely hot weather occurring during the day. It was found impossible to trace the occurrence of this species earlier in the season, and it was finally agreed between Mr. Haines and the writer that in all probability the cutworms had been introduced with stable manure grown up freely with grass and weeds which had been used when the lettuce and parsley were first planted. They could not have come from any outside source or from any earlier crop. The success of Mr. Haines in his treatment of this pest is shown in the accompanying abstract from his letter.

RESULTS FROM APPLICATIONS OF ARSENATE OF LEAD.

NORFOLK, VA., *November 18, 1910.*

I received your letter of the 16th instant, in regard to the cutworms on my parsley and the ravages of the army worm in this section this fall. As you remember, I had a hard fight with the cutworms on my parsley field, but I feel fully compensated for my work and expense in fighting them. I had several places in each bed where I had to reset plants where the cutworms cut them off, but aside from those few spots I have a perfect stand and am now marketing my crop, and I wish you could see that crop. The best outlook I have ever had.

I kept constantly spraying my parsley with arsenate of lead (4 pounds to 50 gallons of water), and in all I think I gave it five applications. * * *

B. C. HAINES.

It should be added to the above that a careful survey of the infested field by the author showed plainly that an arsenical was the only remedy that could be conveniently used after the outbreak was at its height. It should be added also that the arsenate of lead was not applied five successive times on the same plants.

DESCRIPTION.

The moth.—The moth of this species is quite unlike any common form which inhabits the North Atlantic region, being much paler in color. The forewings are gray, with a pinkish tinge in fresh specimens. There is a submedian dark spot and a row of spots in the form of a curve in the outer third of the wing. The markings are well illustrated in figure 8 (above). It will be noted that the hindwings, which are silvery whitish and are more or less tinged on the outer edges with gray, are considerably shorter. The thorax is of about the same color as the fore wings and nearly uniform throughout. The anterior portion of the abdomen is white and the posterior portion, sometimes a little more than half, is gray. The lower surface is pale, with the fore wings more or less suffused anteriorly with fuscous. The posterior legs are distinctly tessellated. The abdomen is rather more robust than in many related forms, being

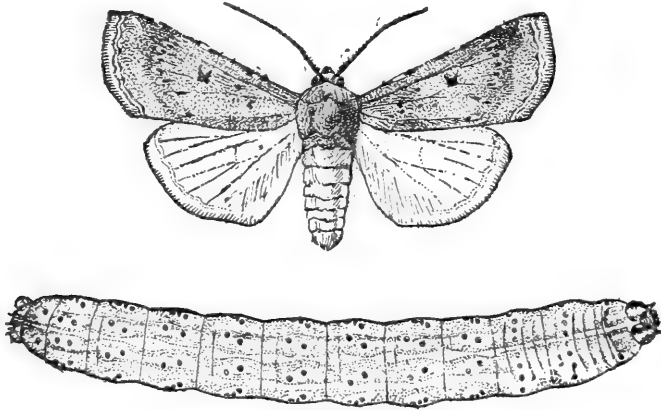


FIG. 8.—*Porosagrotis vetusta*: Moth and larva.

narrower in the male. The wing expanse is $1\frac{1}{2}$ inches and the length of the body is about five-eighths of an inch.

The eggs and earlier stages of the larva have not been studied to the writer's knowledge.

The larva.—The larva is subject to considerable variation, which may be dependent on the soil. Specimens received from North Carolina, in a very sandy soil, are pale, with a decidedly pinkish tinge. The arrangement of the tubercles is shown in figure 8, as is also the form of the thoracic plate. The larva, when alive and when fully matured, measures about $1\frac{1}{2}$ inches, but the inflated specimens run as high as 2 inches in length.

No specimens of the pupa have been preserved for description.

DISTRIBUTION.

All of the specimens of this species in the United States National Museum are from New York State, and are labeled as follows:

Albany, Long Island, Carver, Rochester, and Franklin County, N. Y.

There are also specimens of what appear to be races of this species, one of them being labeled *Porosagrotis satiens*, from Coleville, Wash., Glenwood Springs, Colo., and from Arizona, and a second

species labeled *P. catenula* Grote, from Los Angeles, Cal., Glenwood Springs, Colo., Phoenix, Ariz., and Kaslo, British Columbia.

We have reared *Porosagrotis vetusta*, which displays only slight variation as compared with many other forms of cutworm moths, from Shelton, Churchland, and Norfolk, Va., Rocky Ford, Colo., and Southern Pines, N. C. Another locality is Poplar Branch, N. C.

In 1895 Slingerland¹ mentioned this species in connection with other climbing cutworms under the name of the "spotted-legged cutworm," stating that it occurred in Erie, Lewis, and Monroe Counties, N. Y. Less than 2 per cent, however, of the climbing cutworms received from western New York in 1893 and in 1894 belonged to this species. Beyond the fact that it was found on peach buds, nothing was then known of its habits. The larvæ and moth were figured.

NATURAL ENEMIES.

This species no doubt has many natural enemies. The following, however, are the only ones at present known, both being parasitic:

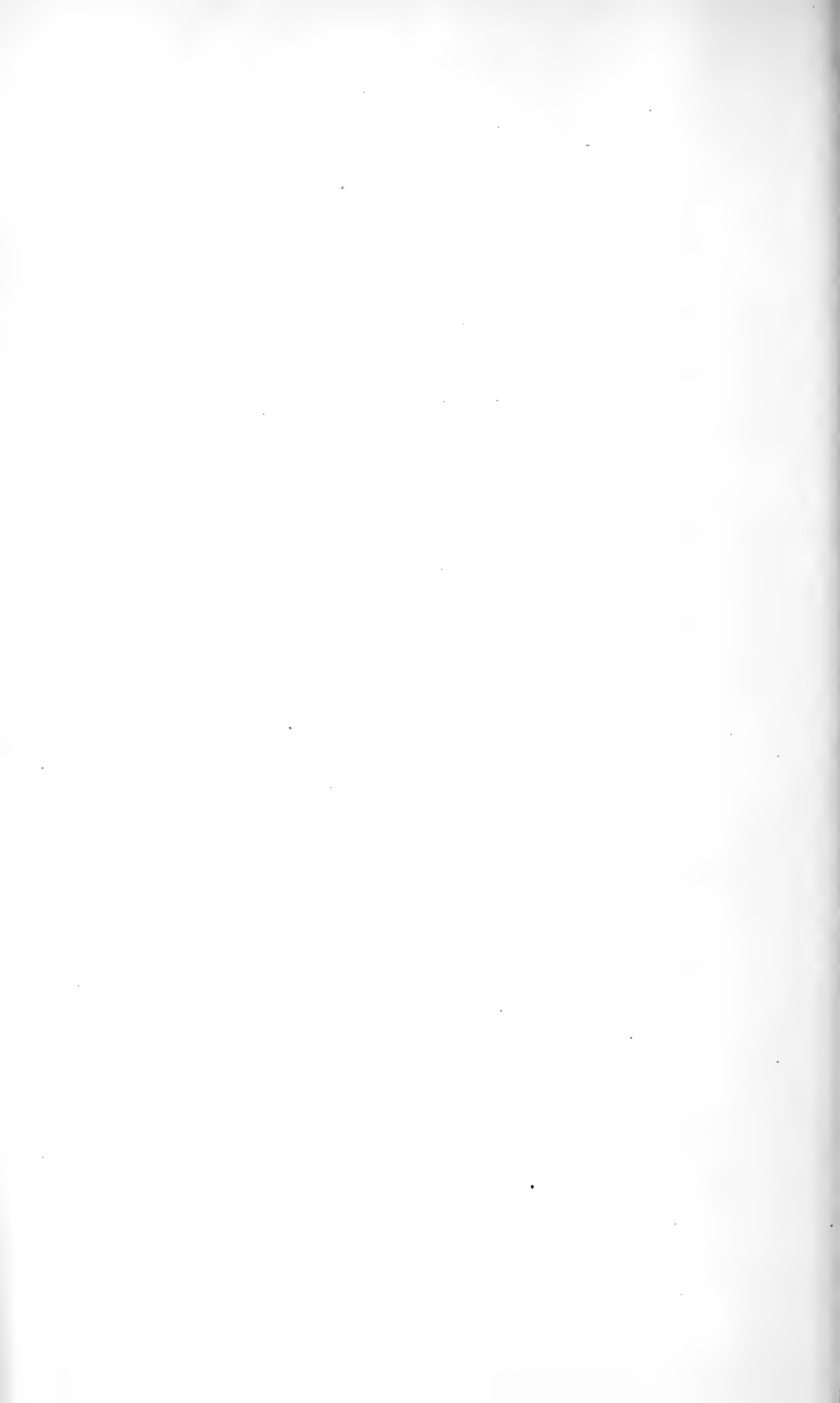
Apanteles n. sp., near *agrotidis*, issued from larvæ of this cutworm received from North Carolina, May 18, 1901. Determined by Ashmead.

Linnaemya picta Meig., a tachina fly, issued from the second lot, from North Carolina. It was identified by the late D. W. Coquillett. The same species of tachina fly was reared from this cutworm from material received from Norfolk, Va., the flies issuing October 8, 1910.

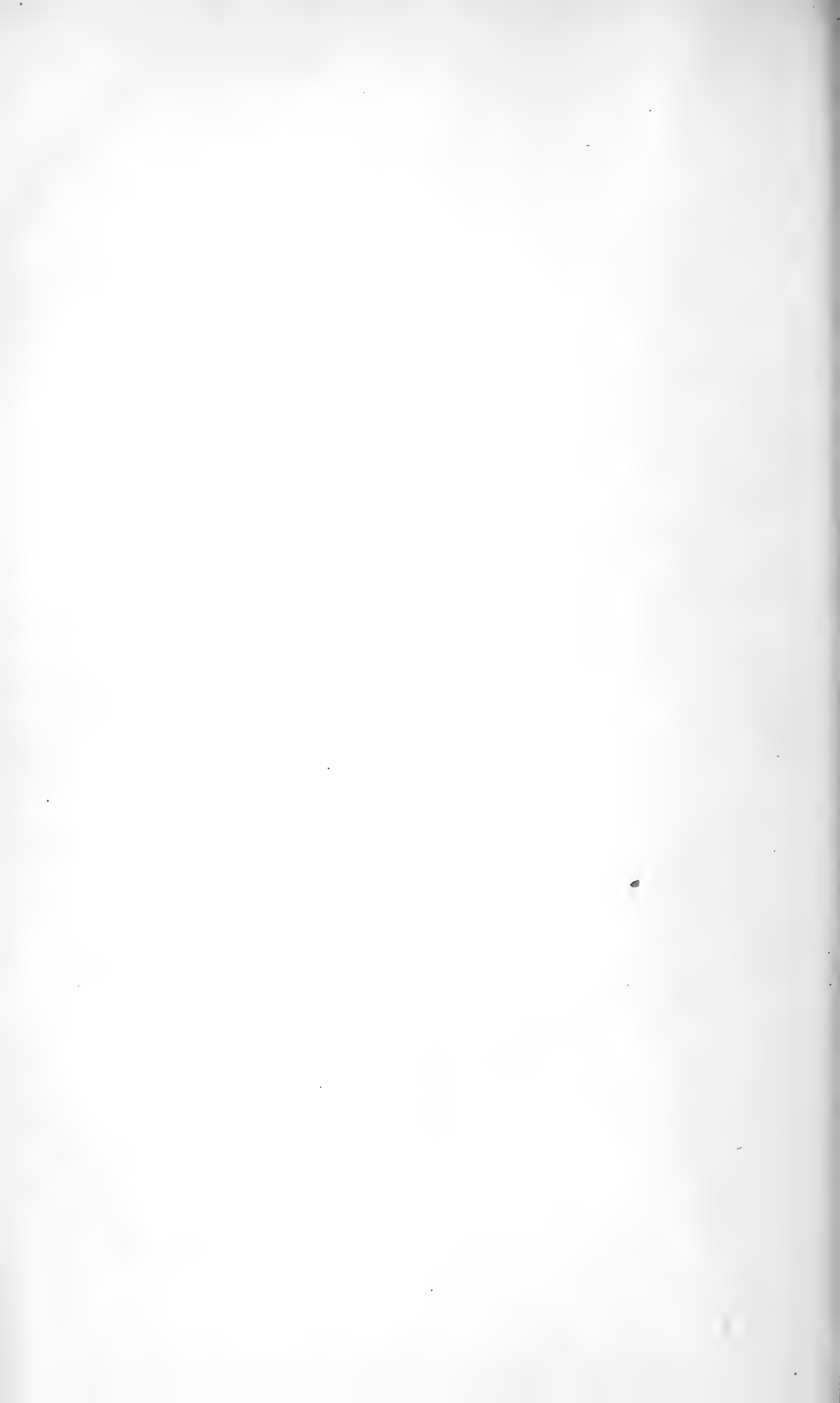
¹Bul. 104, Cornell University Experiment Station, pp. 570-571.

THIS PUBLICATION may be procured from the Superintendent of Documents, Government Printing Office Washington, D. C., at 5 cents per copy









U. S. DEPARTMENT OF AGRICULTURE,

BUREAU OF ENTOMOLOGY—BULLETIN No. 109, Part V.

L. O. HOWARD, Entomologist and Chief of Bureau.

PAPERS ON INSECTS AFFECTING VEGETABLES.

ARSENITE OF ZINC AND LEAD CHROMATE AS REMEDIES AGAINST THE
COLORADO POTATO BEETLE.

BY

FRED A. JOHNSTON,

Entomological Assistant.

[In cooperation with the Virginia Truck Experiment Station.]

ISSUED APRIL 5, 1912.



WASHINGTON:
GOVERNMENT PRINTING OFFICE.
1912.

c
221346

BUREAU OF ENTOMOLOGY.

L. O. HOWARD, *Entomologist and Chief of Bureau.*

C. L. MARLATT, *Entomologist and Acting Chief in Absence of Chief.*

R. S. CLIFTON, *Executive Assistant.*

W. F. TASTET, *Chief Clerk.*

F. H. CHITTENDEN, *in charge of truck crop and stored product insect investigations.*

A. D. HOPKINS, *in charge of forest insect investigations.*

W. D. HUNTER, *in charge of southern field crop insect investigations.*

F. M. WEBSTER, *in charge of cereal and forage insect investigations.*

A. L. QUAINANCE, *in charge of deciduous fruit insect investigations.*

E. F. PHILLIPS, *in charge of bee culture.*

D. M. ROGERS, *in charge of preventing spread of moths, field work.*

ROLLA P. CURRIE, *in charge of editorial work.*

MABEL COLCORD, *in charge of library.*

TRUCK CROP AND STORED PRODUCT INSECT INVESTIGATIONS.

F. H. CHITTENDEN, *in charge.*

H. M. RUSSELL, C. H. POPENOE, WM. B. PARKER, H. O. MARSH, M. M. HIGH,

FRED A. JOHNSTON, JOHN E. GRAF, *entomological assistants.*

I. J. CONDIT, *collaborator in California.*

P. T. COLE, *collaborator in tidewater Virginia.*

W. N. ORD, *collaborator in Oregon.*

THOS. H. JONES, *collaborator in Porto Rico.*

MARION T. VAN HORN, PAULINE M. JOHNSON, *preparators.*

CONTENTS

	Page.
Spraying experiments with arsenite of zinc and lead chromate in comparison with other arsenicals.	53
Spraying experiments with arsenite of zinc at different strengths.	55

PAPERS ON INSECTS AFFECTING VEGETABLES.

ARSENITE OF ZINC AND LEAD CHROMATE AS REMEDIES AGAINST THE COLORADO POTATO BEETLE.

By FRED A. JOHNSTON, *Entomological Assistant.*

[In cooperation with the Virginia Truck Experiment Station.]

SPRAYING EXPERIMENTS WITH ARSENITE OF ZINC AND LEAD CHROMATE IN COMPARISON WITH OTHER ARSENICALS.

In May, 1911, a series of experiments for comparing the insecticidal value of arsenite of zinc and of lead chromate with that of other arsenicals in controlling the Colorado potato beetle (*Leptinotarsa decemlineata* Say) was undertaken under the direction of Dr. F. H. Chittenden at the Virginia Truck Experiment Station, at Norfolk, Va.

The season was later than usual, making it unnecessary to spray for the potato beetle until about May 9. At this date no larvæ were present on the plants, though beetles and egg masses were abundant.

On May 9 six plats were sprayed. Table I gives the insecticides and strengths used.

TABLE I.—*Sprays used against the Colorado potato beetle, Norfolk, Va., May, 1911.*

Plat No.	Insecticide used.
I	Lime-sulphur, 2 pounds to 50 gallons of water and 3 pounds of arsenate of lead.
II	Arsenate of lead, 3 pounds to 50 gallons of water.
III	Lead chromate, 2 ounces to 4 gallons of water.
IV	Arsenite of zinc, 1½ pounds to 50 gallons of water.
V	Bordeaux mixture (4-6-50 formula) and 1½ pounds of Paris green.
VI	Bordeaux mixture (4-6-50 formula) and 1½ pounds of arsenite of zinc.

On May 22 all of the potatoes were resprayed, the same proportions of the different materials being used with the exception of the lead chromate in which case the strength was doubled. (One ounce to a gallon of water.)

At this date the larvæ were exceedingly numerous and doing much damage in unsprayed potato fields.

On the day following the second application of the sprays a count of the infested plants in each plat was made and the following figures obtained:

TABLE II.—*Results of spray applications against the Colorado potato beetle, Norfolk, Va., May, 1911.*

Plat No.	Insecticide used.	Number of infested plants.	Number of uninfested plants.	Infestation.
				<i>Per cent.</i>
I	Lime-sulphur (2-50 formula) and 3 pounds of arsenate of lead.....	37	347	9.6
II	Arsenate of lead, 3 pounds to 50 gallons of water.....	118	622	15.9
III	Lead chromate, 2 ounces to 4 gallons of water, and 1 ounce to 1 gallon of water.....	216	169	+56.0
IV	Arsenite of zinc, 1½ pounds to 50 gallons of water.....	206	1,048	16.4
V	Bordeaux mixture (4-6-50 formula) and 1½ pounds Paris green.....	152	741	+17.0
VI	Bordeaux mixture (4-6-50 formula) and 1½ pounds arsenite of zinc...	225	555	28.8

It will be seen that the results obtained from the use of lead chromate were very unsatisfactory as compared with those in the case of other insecticides used. The lead chromate employed was in the form of a powder, and great difficulty was experienced in making it mix well with water, it having a tendency to settle quite rapidly, requiring constant agitation to keep it in solution. It adhered well to the foliage, and its color stood out quite prominently in contrast to the other plats. However, the young larvæ seemed to be able to feed on plants that were thoroughly covered with the material without receiving much injury.

The arsenite of zinc employed was also in the powdered form. It is much lighter than lead chromate and remains in suspension in water much better. It adheres to the foliage very well and does not, so far as could be observed, burn or injure the plants in any way.

The percentage of infested plants in the plat that was treated with Bordeaux mixture and arsenite of zinc was somewhat greater than in the plat in which the arsenite of zinc alone had been used. This was no doubt due partly to the fact that the Bordeaux-arsenite of zinc plat was in a different field, one which had been in potatoes the previous year and was thus subject to the attack of a greater number of beetles. Also, many of the plants which were counted as infested were only slightly injured, and it is doubtful if the yield of potatoes would have been much lessened.

On June 29 the potatoes were dug, and following are the weights of one row of potatoes in each of the first four plats.

TABLE III.—*Yields of potatoes from one row from each of Plats I, II, III, and IV, sprayed as indicated in Table I.*

One row from plat No.	Insecticide used.	Number of plants in row.	Weight of No. 1 potatoes. ¹	Weight of No. 2 potatoes. ²
I	Lime-sulphur and arsenate of lead.....	384	<i>Pounds.</i> 188½	<i>Pounds.</i> 25½
II	Arsenate of lead.....	368	172¼	26
III	Lead chromate.....	385	128	19½
IV	Arsenite of zinc.....	374	143½	18

¹ Excellent to good.² Fair to indifferent.

By taking the yield of the same number of plants from each row the contrast between the different rows will be more marked. Table IV represents the yield of 374 plants from each row:

TABLE IV.—*Yields of potatoes from 374 plants from one row from each of Plats I, II, III, and IV, sprayed as indicated in Table I.*

One row from plat No.	Insecticide used.	Number of plants in row.	Weight of No. 1 potatoes. ¹	Weight of No. 2 potatoes. ²
I	Lime-sulphur and arsenate of lead.....	374	<i>Pounds.</i> 183.26	<i>Pounds.</i> 25.05
II	Arsenate of lead.....	374	175.401	26.18
III	Lead chromate.....	374	124.168	19.07
IV	Arsenite of zinc.....	374	143.5	18

¹ Excellent to good.² Fair to indifferent.

SPRAYING EXPERIMENTS WITH ARSENITE OF ZINC AT VARIOUS STRENGTHS.

An experiment with the three following strengths of arsenite of zinc in controlling the Colorado potato beetle was begun at the Virginia Truck Experiment Station, Norfolk, Va., on May 31, 1911.

No. I, arsenite of zinc, 1 pound to 50 gallons of water.

No. II, arsenite of zinc, 1½ pounds to 50 gallons of water.

No. III, arsenite of zinc, 2 pounds to 50 gallons of water.

On the day the spraying was done (May 31) the rows sprayed with No. I, No. II, and No. III had 47, 86, and 88 infested plants, respectively.

On June 2 the row treated with No. I had 33 infested plants, a decreased infestation of 14 plants, or 29.8 per cent. The row treated with No. II had 57 infested plants, a decreased infestation of 29 plants, or 33.7 per cent, while the row treated with No. III had 38 infested plants, a decreased infestation of 50 plants, or 56.8 per cent.

On June 3 the count was again taken, and the row treated with No. I had 15 infested plants, a decreased infestation of 32 plants, or 68+ per cent. The row treated with No. II had 23 infested plants, a decreased infestation of 63 plants, or 73.2 per cent, while the row treated with No. III had 13 infested plants, a decreased infestation of 75 plants, or 85.2 per cent.

The following table shows the number of infested plants in the plats before and after spraying:

TABLE V.—Results of applications of arsenite of zinc at different strengths against the Colorado potato beetle.

Date.	Solu- tion No.	Number of infested plants.	Decrease in number of infested plants.	Decrease of infesta- tion.
				<i>Per cent.</i>
1911.				
May 31.....	I	47		
Do.....	II	86		
Do.....	III	88		
June 2.....	I	33	14	29.8
Do.....	II	57	29	33.7
Do.....	III	38	50	56.8
June 3.....	I	15	32	68+
Do.....	II	23	63	73.2
Do.....	III	13	75	85.2

On June 3 the number of larvæ on the plants which were still infested was much smaller than the number present when the spray was first applied. The extent of infestation of some plants amounted to but one or two larvæ; these plants, however, were counted in as infested.

Results.—From the preceding table it will be seen that far better results were obtained where 2 pounds of arsenite of zinc to 50 gallons of water were used.

The results were obtained more quickly, and a larger percentage of larvæ was killed. At this strength arsenite of zinc did not burn or injure the foliage in any way, and without doubt an even greater amount of the arsenical might be used without injury to the plants and with correspondingly greater efficiency in killing the beetles.

ADDITIONAL COPIES of this publication
may be procured from the SUPERINTEND-
ENT OF DOCUMENTS, Government Printing
Office, Washington, D. C., at 5 cents per copy



U. S. DEPARTMENT OF AGRICULTURE,

BUREAU OF ENTOMOLOGY—BULLETIN No. 109, Part VI.

L. O. HOWARD, Entomologist and Chief of Bureau.

PAPERS ON INSECTS AFFECTING VEGETABLES.

THE SUGAR-BEET WEBWORM.

BY

H. O. MARSH,
Entomological Assistant.

ISSUED SEPTEMBER 16, 1912.



C
CANCELLED
323389

WASHINGTON:
GOVERNMENT PRINTING OFFICE.
1912.

BUREAU OF ENTOMOLOGY.

L. O. HOWARD, *Entomologist and Chief of Bureau.*
C. L. MARLATT, *Entomologist and Acting Chief in Absence of Chief.*
R. S. CLIFTON, *Executive Assistant.*
W. F. TASTET, *Chief Clerk.*

F. H. CHITTENDEN, *in charge of truck crop and stored product insect investigations.*
A. D. HOPKINS, *in charge of forest insect investigations.*
W. D. HUNTER, *in charge of southern field crop insect investigations.*
F. M. WEBSTER, *in charge of cereal and forage insect investigations.*
A. L. QUAINANCE, *in charge of deciduous fruit insect investigations.*
E. F. PHILLIPS, *in charge of bee culture.*
D. M. ROGERS, *in charge of preventing spread of moths, field work.*
ROLLA P. CURRIE, *in charge of editorial work.*
MABEL COLCORD, *in charge of library.*

TRUCK CROP AND STORED PRODUCT INSECT INVESTIGATIONS.

F. H. CHITTENDEN, *in charge.*

H. M. RUSSELL, C. H. POPENOE, WM. B. PARKER, H. O. MARSH, M. M. HIGH,
JOHN E. GRAF, FRED A. JOHNSTON, *entomological assistants.*
I. J. CONDIT, *collaborator in California.*
W. N. ORD, *collaborator in Oregon.*
THOS. H. JONES, *collaborator in Porto Rico.*
MARION T. VAN HORN, PAULINE M. JOHNSON, ANITA M. BALLINGER, *preparators.*

CONTENTS.

	Page.
Introduction.....	57
General appearance of the sugar-beet webworm and nature of attack.....	58
Life history and habits.....	59
Character of injury.....	61
Natural enemies.....	62
Other checks.....	63
Experiments with remedies.....	63
Spraying machinery.....	66
Cost of spraying.....	69
Conclusion.....	70

ILLUSTRATIONS.

	Page.
FIG. 9. The sugar-beet webworm (<i>Loxostege sticticalis</i>): Moth.....	58
10. The garden webworm (<i>Loxostege similalis</i>): Moth, larva, pupa, details.....	58
11. A medium-sized sugar-beet plant defoliated by the sugar-beet webworm in July.....	60
12. Sugar beets defoliated by the sugar-beet webworm in July.....	61
13. Large sugar-beet plants, showing defoliation and weakened roots due to attack by the sugar-beet webworm in August.....	62
14. Field of young sugar beets destroyed by the sugar-beet webworm in June.....	63
15. Barrel sprayer suitable for use against the sugar-beet webworm.....	64
16. Barrel sprayer in action against the sugar-beet webworm.....	65
17. Four-row attachment for beet sprayer.....	67
18. Four-row attachment for beet sprayer.....	67
19. Four-row attachment for beet sprayer.....	67
20. Geared traction sprayer suitable for use against the sugar-beet webworm.....	68
21. Geared traction sprayer in action against the sugar-beet webworm....	68
22. Filling a traction sprayer for spraying against the sugar-beet webworm..	69
23. Type of Vermorel nozzles suitable for spraying sugar beets against the sugar-beet webworm.....	59



PAPERS ON INSECTS AFFECTING VEGETABLES.

A REPORT OF PROGRESS REGARDING THE SUGAR-BEET WEBWORM.

(*Loxostege sticticalis* L.)

By H. O. MARSH,
Entomological Assistant.

INTRODUCTION.

During portions of the years 1909 and 1910 and nearly all of 1911 the writer, stationed in the Arkansas Valley of Colorado and Kansas, was engaged in a study of the insects affecting sugar beets and truck crops. Among the foremost of the species of insects studied was the sugar-beet webworm (*Loxostege sticticalis* L.). Although the investigation of this pest has not been completed, control measures have been fairly definitely worked out, and this preliminary article is presented with the hope that it will stimulate greater interest in the subject among the beet growers, and thus render the completion of the study more easily accomplished.

Sugar beets have been produced on a commercial scale in the Arkansas Valley since 1900, and almost from the beginning this crop has been infested by webworms. The injury produced by these infestations has varied greatly from year to year. During some seasons little noticeable damage has occurred, while on a few occasions the infested acreage has been extensive and the losses serious. As an example it may be mentioned that in 1910 practically 4,000 acres of beets grown for one of the sugar factories in the Arkansas Valley were attacked. The serious nature of this outbreak was not realized until too late, and although strenuous efforts were finally made to control the "worms," the loss resulting from this infestation was estimated at 20,000 tons of beets, which would have been worth approximately \$100,000 to the growers. Such severe losses are rather exceptional, although nearly every year the loss occasioned by webworms is far in excess of the amount imagined by the average beet grower.

To the progressive farmers in the Arkansas Valley the sugar-beet webworm is generally too well known to require a detailed description, although a few notes regarding the life history when infesting sugar beets may be of value.

GENERAL APPEARANCE OF THE SUGAR-BEET WEBWORM AND NATURE OF ATTACK.

The parent of this webworm (fig. 9) belongs to the lepidopterous family Pyralidæ, and is a tawny-brown, active moth, or "miller," with a wing expanse of about 1 inch.

It is larger and more conspicuously colored than the garden webworm which is shown in figure 10.

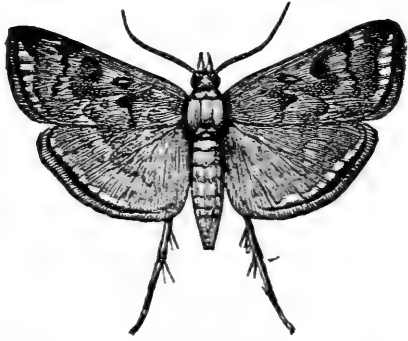


FIG. 9.—The sugar-beet webworm (*Loxostege sticticalis*): Moth. Twice natural size. (Reengraved after Insect Life.)

The moths deposit their pearly-white eggs singly or in rows of from two to five or more, usually on the under side of the leaf. When deposited in rows they overlap more or less. Each female moth is capable, under normal conditions, of depositing at least 200 eggs. From these eggs hatch the small larvæ, or "worms." When first hatched the "worms" are whitish, with black heads, but as they feed and increase in size they become green, with dark markings.

The very young larvæ eat small holes in the under side of the leaves without, however, cutting through the upper epidermis, but as they increase in size they consume almost the entire leaf, with the exception of the larger veins and the petioles. The "worms" prefer the older leaves, and unless the food supply is nearly exhausted do not eat the young leaves at the center of the plant. When full grown the "worms," which are slender and about an inch in length, leave the beets and burrow in the soil, usually close about the infested plants, and spin tubelike cases in which they later pupate. The pupæ are slender, yellow-brown, inactive objects, from which during the summer months the moths issue within a few days. The moths, after issuing, feed on the nectar in alfalfa or other blossoms and within a few days mate and are ready to commence depositing eggs for another generation or brood of "worms."

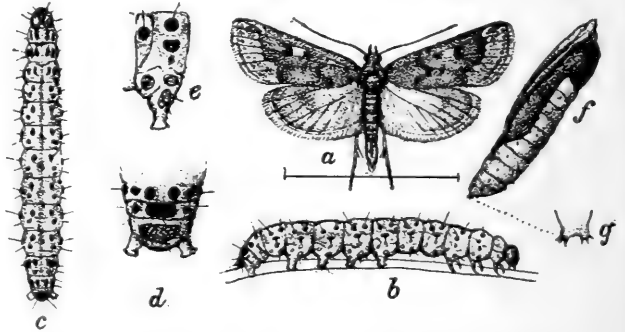


FIG. 10.—The garden webworm (*Loxostege similis*): a, Male moth; b, larva, lateral view; c, larva, dorsal view; d, anal segment; e, abdominal segment, lateral view; f, pupa; g, cremaster. a, b, c, f, somewhat enlarged; d, e, g, more enlarged. (After Riley, except c, from Chittenden.)

LIFE HISTORY AND HABITS.

In rearing experiments conducted at Rocky Ford, Colo., the average time required from the deposition of the eggs until the moths issued was a little more than a month. The egg stage was observed to vary from 3 to 5 days, the larva stage from 17 to 20 days, and the pupa stage was usually 11 days. These variations were from records of successive generations.

So far as the writer has been able to determine, there are three generations or "crops" of webworms in the Arkansas Valley each year. There may be a fourth generation, but if so it is not clearly marked and possibly occurs early in the season on weeds such as Russian thistle (*Salsola tragus*) and lamb's-quarters (*Chenopodium album*). For the sake of convenience we may assume that only three generations occur yearly. The periods during which the writer observed the webworms of these successive generations in evidence on sugar beets in the Arkansas Valley ranged from about the middle of June until early July for the first generation and from about the middle of July until well into August for the second generation, while the third brood occurred in September.

In reality the generations are not sharply marked and considerable overlapping may occur. In general the danger period extends from shortly before the middle of June until well into September. The first generation of webworms may be expected at its height of destructiveness during the latter half of June, at a time when the beets are comparatively small and least able to resist the attack. (See fig. 14.) At this season the infested beets may actually be killed by this webworm, which, after eating all the leaves, may destroy the crown of the plant. Whenever the crown is destroyed the beet dies. So far as the writer has observed, the acreage destroyed in this way is very small and ordinarily occurs only when the infested beets are young and the available leaf surface limited. By the time the "worms" of the later generation are present the beets have become of good size and, although they may be completely stripped of all but the youngest leaves, it is rarely that any are killed. (See figs. 11, 12.)

The larvæ of the first generation, after maturing and burrowing into the ground, pupate promptly and the moths issue within a few days and deposit eggs for the second generation. The "worms" of this next generation, on reaching maturity, likewise burrow into the ground and spin their tubelike cases. However, only about half of them pupate promptly, the others remaining unchanged in the tubes until the spring of the following year. From the pupæ which develop in August, moths issue which deposit eggs for the third or September generation, and these "worms" remain unchanged throughout the

winter. It will thus be seen that about half the webworms of the second generation and all of those of the third generation, which have not been destroyed by parasites or through artificial or natural agencies, live through the winter in their tubes in the soil. These "worms" pupate late in the spring and the moths which issue deposit eggs for the first generation.

The moths when depositing eggs are often to be found in the beet fields in enormous numbers, and when disturbed may be seen flying close above the beet leaves in "clouds." When such numbers of moths are observed in a beet field they should serve as a warning to the

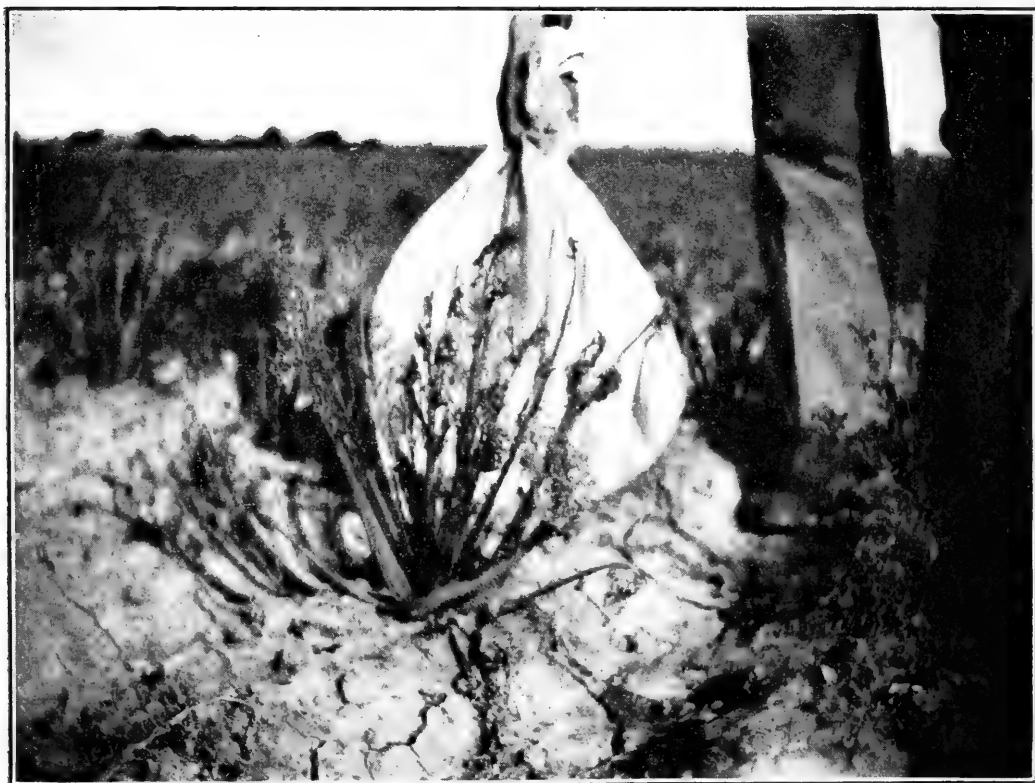


FIG. 11.—A medium sized sugar-beet plant defoliated by the sugar-beet webworm in July. (Original.)

grower that a "crop" of webworms may be expected within the next week or 10 days.

As a rule the first and second generations are the most destructive, the third generation, which is actually only a partial one, rarely causing serious damage. It seldom happens that the "worms" of successive generations infest the same patch of beets to a serious extent. Thus a certain field may be infested by the webworms of the first generation, while the moths which develop from them may drift to adjoining fields to deposit eggs for the next generation.

The webworms often appear very suddenly and apparently without warning in certain fields, and it is not uncommon for the growers to express the idea that they have migrated from adjoining fields.

This, however, is not the case, but their apparently sudden appearance is explained by the fact that the young webworms are easily overlooked and that during the last few days before they reach maturity their growth is very rapid. It frequently happens that from 50 to 300 eggs are deposited on single beet plants, and in extreme cases as many as 500 eggs may be so placed. The worms hatching from these eggs remain upon the beet on which they hatched until they reach maturity, unless all the leaves are destroyed and they are thus forced to crawl to another beet to obtain food.

CHARACTER OF INJURY.

It is impossible to state definitely the damage to sugar beets that an infestation of webworms may cause, as this may vary from almost no perceptible loss to the complete destruction of the infested plants, the extent of the injury depending on the number of webworms present, the size of the infested beets, and various other factors, such as climatic conditions, soil fertility, and water supply. As previously mentioned, small beets may be killed outright (see fig. 14), while larger beets may be completely stripped of foliage. With large

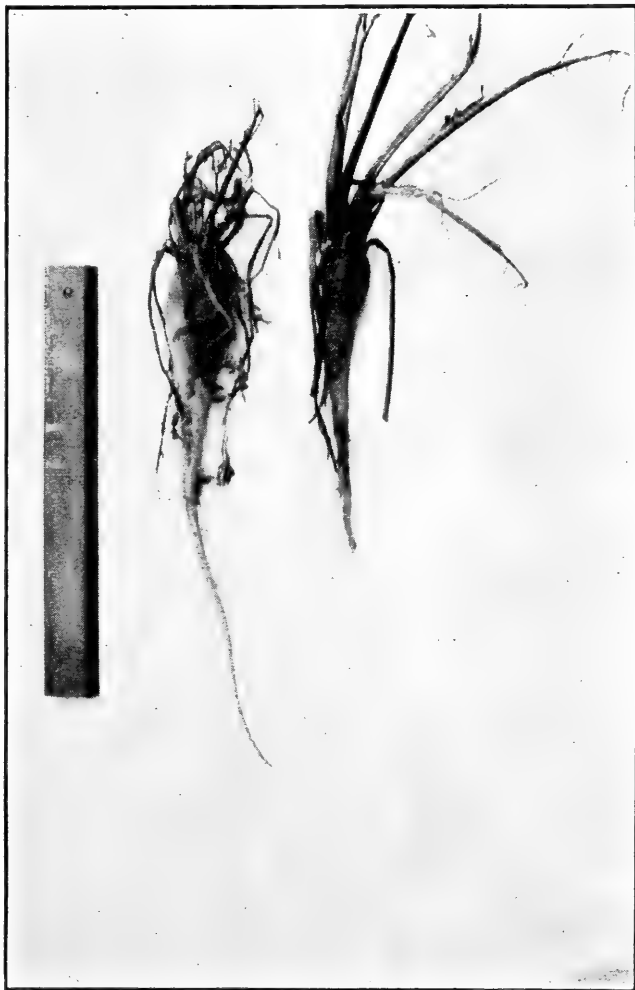


FIG. 12.—Sugar beets defoliated by the sugar-beet webworm in July. (Original.)

beets new leaves will usually be put out promptly and their apparent recovery will take place quickly, especially if they are irrigated as soon as possible after the defoliation. Although new leaves are soon put out, defoliation retards the growth of the beet roots. (See fig. 13.) The writer has seen beet roots which at the time the tops were defoliated, in early July, were more than an inch in greatest diameter that made absolutely no gain in weight or size for three weeks after the leaves were destroyed. It might be added that these beets were in good, fertile soil and were watered

even while the webworms were destroying the foliage. Judging from personal observations and from the statements of many growers, the writer may state that when sugar beets have been defoliated by webworms during the growing season a loss of from 1 to 5 tons of roots to the acre may be apparent at harvest time. The decrease in tonnage is not the only damage, as analyses of such beets have indicated losses of both sugar content and purity, which in some cases have reduced the price \$1 a ton. Another injurious feature which follows defoliation is that the soil about the beets is exposed to the direct rays of the sun, allowing the moisture to

evaporate rapidly, and if the supply of irrigation water is limited this may become a serious matter.

It will be seen that the sugar-beet webworm is a pest capable of causing extensive damage and that measures tending toward its control are worthy of careful consideration.

NATURAL ENEMIES.

Fortunately this species has natural enemies, among the most efficient of which are blackbirds. These birds often gather in enormous flocks in the infested beet fields and feed on the webworms.



FIG. 13.—Large sugar-beet plants, showing defoliation and weakened roots due to attack by the sugar-beet webworm in August. (Original.)

Unfortunately the webworms are not thus attacked until they have become nearly full grown and attain a size that renders them more conspicuous. As a result, it generally happens that the infested beets are partially or completely defoliated before the birds have completed their good work. The destruction of the "worms," however, lessens the possible number of the succeeding generation. The webworms are also reduced in number by true parasites, and in some cases the writer has found fully 50 per cent of the overwintered larvæ killed in this way. One of the most common parasites is a little wasplike insect known scientifically as *Diosphyrus vulgaris* Cress., a braconid.

OTHER CHECKS.

As previously noted, the webworms burrow into the soil about the infested plants, and when the beets are plowed out at harvest time many of the worms are crushed or are so deeply buried that the moths, if they succeed in developing, are unable to leave the tubes, and consequently perish. In spite of these checks there will be every year some areas of greater or less extent where the webworms will occur in injurious numbers and where spraying or other artificial control measures will be necessary.



FIG. 14.—Field of young sugar beets destroyed by the sugar-beet webworm in late June. (Original.)

EXPERIMENTS WITH REMEDIES.

During the time the writer has been stationed in the Arkansas Valley he has given special attention to means of controlling this webworm, and in his opinion spraying with Paris green has proven by far the most effective and satisfactory remedy. The writer has made many experimental tests with a variety of insecticides and has also supervised a considerable amount of practical work against this species, as a result of which study he considers the following formulas as most efficient:

Formula No. 1.

Paris green	pounds..	3
Whale-oil soap	do.....	6
Water	gallons..	100

Formula No. 2.

Paris green	pounds..	3
Lime	do.....	3
Water	gallons..	100

These mixtures have been applied to sugar beets with various types of sprayers (figs. 15-22) at the rate of from 80 to 125 gallons per acre, and the results have been uniformly successful in controlling the webworms. As a rule, 100 gallons per acre should be applied and the spraying commenced as soon as possible after the webworms have hatched. Where possible the spray should be applied at about 80 pounds pressure, although the writer has observed good results where only 40 to 50 pounds pressure was maintained. The leaves of sugar beets are quite smooth, and in order to apply an even coat of poison it is necessary to add some adhesive to the spray mixture. In the writer's experience nothing has proven more satisfactory for this

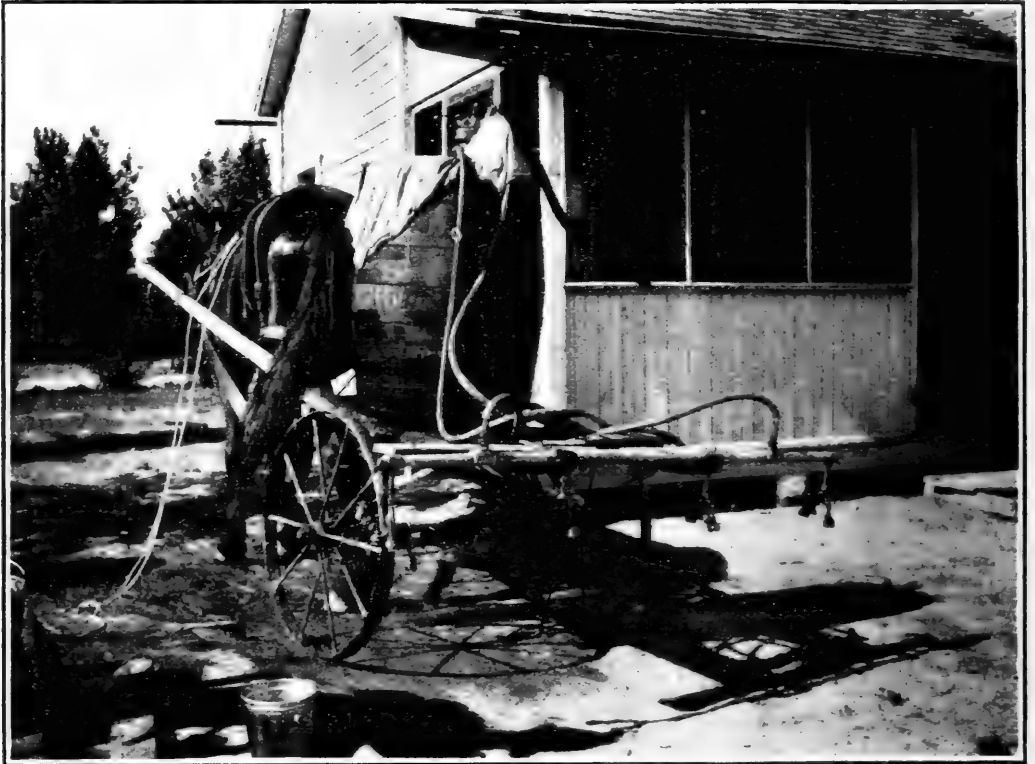


FIG. 15.—Barrel sprayer suitable for use against the sugar-beet webworm. (Original.)

purpose than whale-oil soap. If it is not obtainable, ordinary laundry soap may be used with about equally beneficial results, although it is more expensive. Lime, as recommended in formula No. 2, serves to an extent as an adhesive and has the additional effect of neutralizing any free arsenic which may be present in the Paris green. Lime, however, renders the mixture somewhat caustic, and this formula is less pleasant to use than is one in which soap is used as the adhesive agent.

Refuse molasses from the beet-sugar factories was given extensive tests as a substitute for soap, and when used at the rate of from 3 to 6 gallons in 100 gallons of mixture it served as an effective adhesive. The molasses, however, contains a considerable amount of

alkali and other impurities which tend to make soluble some of the arsenic and copper in the Paris green. The soluble arsenic burns the beet foliage, and on account of this injury refuse molasses is not recommended. It may be interesting to add that in experiments which the writer made with Paris green against other species of insects, using as an adhesive refuse molasses from cane mills, which was less highly charged with impurities, the results were satisfactory, and no burning of the sprayed foliage occurred.

Several standard brands of arsenate of lead have been tested against the sugar-beet webworm in the Arkansas Valley, and with-



FIG. 16.—Barrel sprayer in action against the sugar-beet webworm. (Original.)

out exception the results have proven unsatisfactory. The arsenate was used at the rate of 6, 8, and 10 pounds in 100 gallons of water, and 100 gallons per acre applied, but the webworm was not controlled. In these experiments a large traction sprayer and an ordinary barrel sprayer were used.

Zinc arsenite, when used at the rate of 4 pounds in 100 gallons of water and applied at the rate of 125 gallons per acre, was effective. It was, however, noticeably slower in its killing effects than Paris green as recommended in formulas Nos. 1 and 2, and when used at this strength was equally as expensive as an effective application of Paris green.

Paris green will kill the sugar-beet webworm when used at the rate of 2 pounds in 100 gallons of water, but its action is comparatively slow. It can also be safely used on sugar beets at the rate of 4 pounds in 100 gallons of water, although this amount is excessive and unnecessarily expensive. All things considered, either formula No. 1 or formula No. 2 can be depended on for the most satisfactory results.

Many beet growers demand that an insecticide to be used against webworms shall be immediately effective. It is of course unreasonable to expect immediately fatal results from a stomach poison. When Paris green is properly applied against this webworm at the rate of 3 pounds in 100 gallons of water, a fairly large number of dead webworms will be found about the sprayed beets at the end of 24 hours, and at the end of three days practically all webworms should be dead.

Dusting with Paris green and lime has also proven effective against this webworm when used at the rate of from 2 to 4 pounds of the poison in 100 pounds of air-slaked lime. The "dust" may be applied by shaking it from a coarse sack or with a "powder gun." This method is slow, would increase the cost of application more than 50 per cent, and is difficult to apply in an even coating.

Occasionally a field of beets may have been irrigated just before an infestation of webworms becomes apparent, and in such a case the soil is likely to be so wet that the prompt use of a sprayer will prove impracticable and dusting may then be employed to advantage.

SPRAYING MACHINERY.

For spraying large areas of sugar beets a geared traction sprayer of 125 gallons' capacity (figs. 20-22) will prove profitable; but for the average grower, whose planting does not exceed 20 acres, this type of machine is too expensive and unnecessarily large, and a smaller, much cheaper sprayer, which can be assembled at home, will give satisfactory results. Such a sprayer may be fitted up by mounting a spray pump in a 50-gallon barrel on an ordinary one-horse, two-row beet cultivator, from which the "handles" and "shoes" have been removed. This arrangement will be readily understood by referring to the accompanying illustrations (figs. 15, 16). The four-row attachment is connected with the pump by a rubber hose and is fastened to sections of plank which are bolted to the cultivator frame and extend out behind the wheels. The row attachment is made of $\frac{1}{2}$ -inch and $\frac{1}{4}$ -inch iron pipes and can be put together by a plumber. Three types of row attachments are illustrated. Number 1 (fig. 17) is the simplest and will give satisfaction under ordinary conditions. This may be built to cover eight rows of beets instead of four. The eight-row attachment, however, is rather cumbersome

and may cause some trouble by catching in fences, etc., when turning at the end of the field. Number 2 (fig. 18) is so arranged that two nozzles are above each row of beets. This is desirable, but not

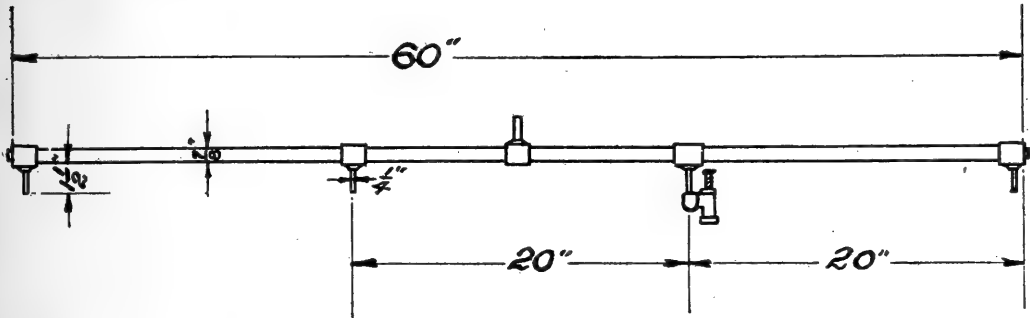


FIG. 17.—Four-row attachment for beet sprayer. (Original.)

absolutely necessary, when large beets are to be sprayed. Number 3 (fig. 19) is so made that both the surface and the underside of the beet leaves are reached by the spray. By using this attachment

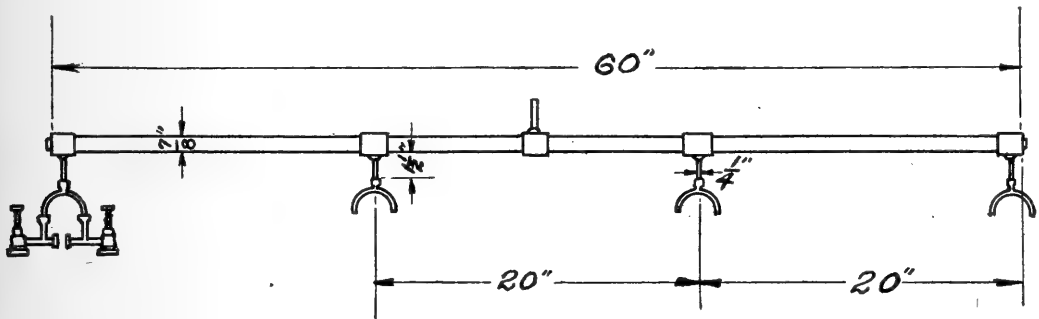


FIG. 18.—Four-row attachment for beet sprayer. (Original.)

beets can be very thoroughly sprayed and young webworms on the underside of the leaves will be more quickly killed than when only the surface of the foliage is wet by the spray. A nozzle arrange-

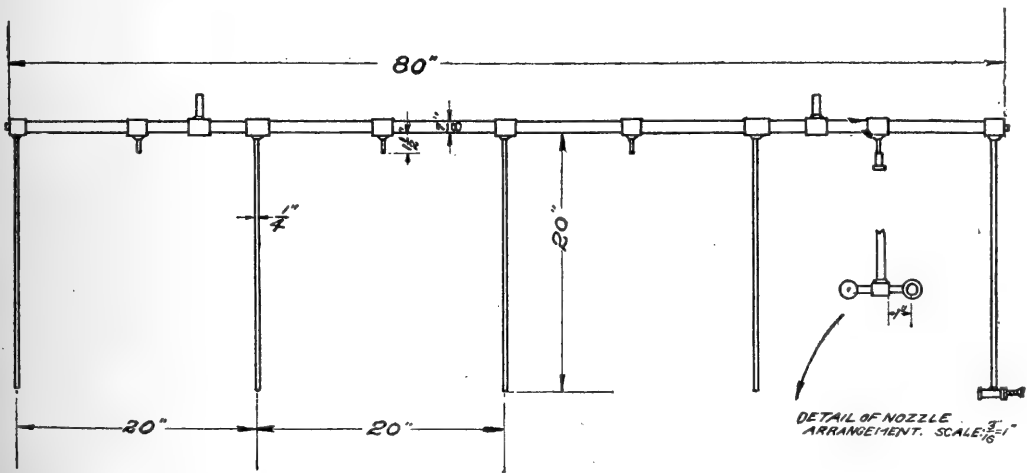


FIG. 19.—Four-row attachment for beet sprayer: Nozzles arranged so that both the upper and lower sides of the leaves may be wet by the spray. (Original.)

ment such as is obtained with this type is necessary when Bordeaux mixture is applied for the leaf-spot disease (*Cercospora beticola* Sacc.).



FIG. 20.—Geared traction sprayer suitable for use against the sugar-beet webworm. (Author's illustration.)



FIG. 21.—Geared traction sprayer in action against the sugar-beet webworm. (Author's illustration.)

In fitting up a sprayer a strong, heavily built pump provided with an agitator should be used, and the necessity of using first-class nozzles is imperative. The nozzles should be of the Vermorel type

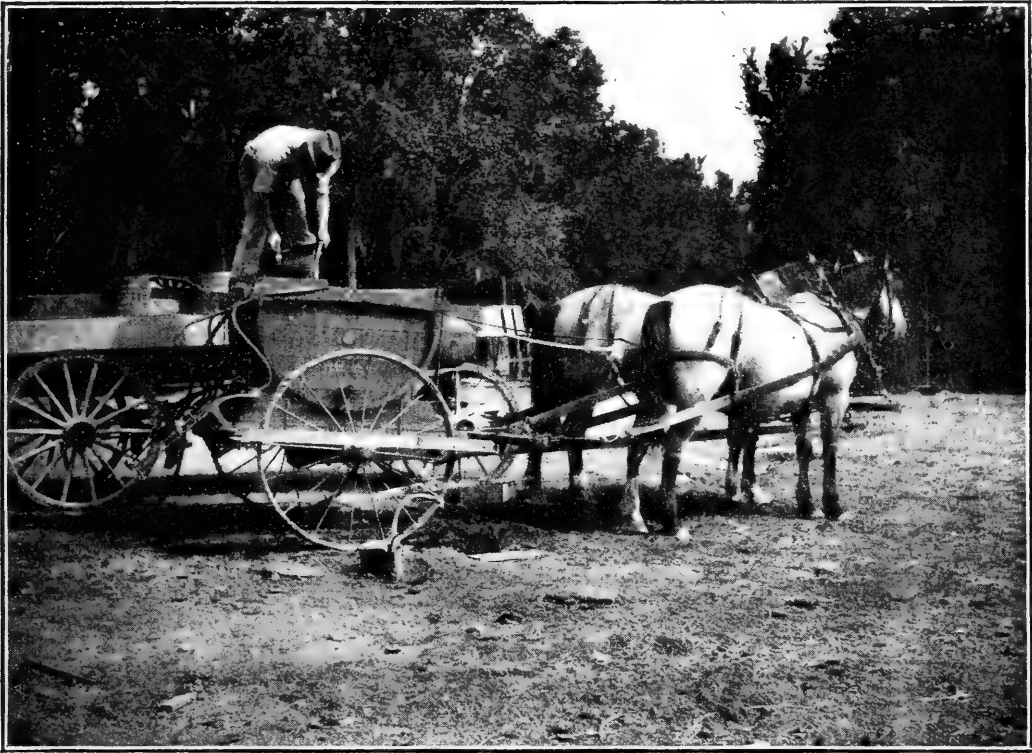


FIG. 22.—Filling a traction sprayer for spraying against the sugar-beet webworm. (Original.)

(fig. 23), which delivers a fine, mistlike spray. This type of nozzle, together with the pump, hose, and other fittings, can be purchased from any reliable dealer, and the entire sprayer can be fitted up at an expense not exceeding \$25.

With this sprayer and a horse it is easily possible for one man to spray 5 acres of sugar beets a day. With a large traction sprayer a much greater acreage may be treated in the same length of time.

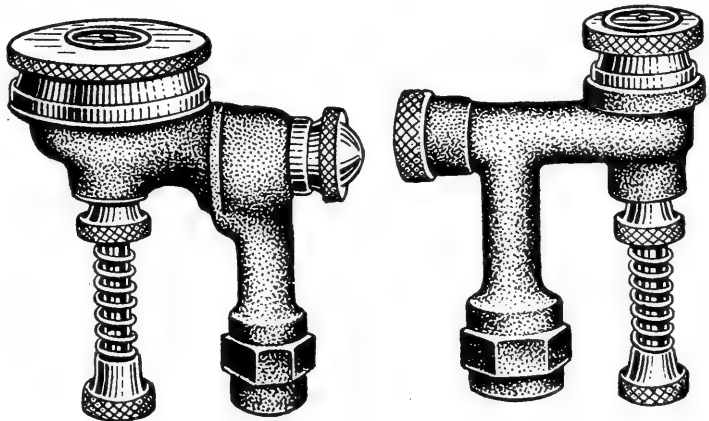


FIG. 23.—Type of Vermorel nozzles suitable for spraying sugar beets against the sugar-beet webworm.

COST OF SPRAYING.

The cost of labor, materials, etc., for spraying sugar beets will vary under ordinary circumstances from \$1 to \$2 an acre. The price received for sugar beets by the growers in the Arkansas Valley

usually exceeds \$5 a ton. As previously mentioned, a defoliation by the sugar-beet webworm may reduce the yield of sugar beets 1 to 5 tons to the acre and also cause a loss in sugar content and purity. As this damage can be absolutely prevented at a cost not exceeding \$2 an acre, the profits from spraying infested beets are apparent.

CONCLUSION.

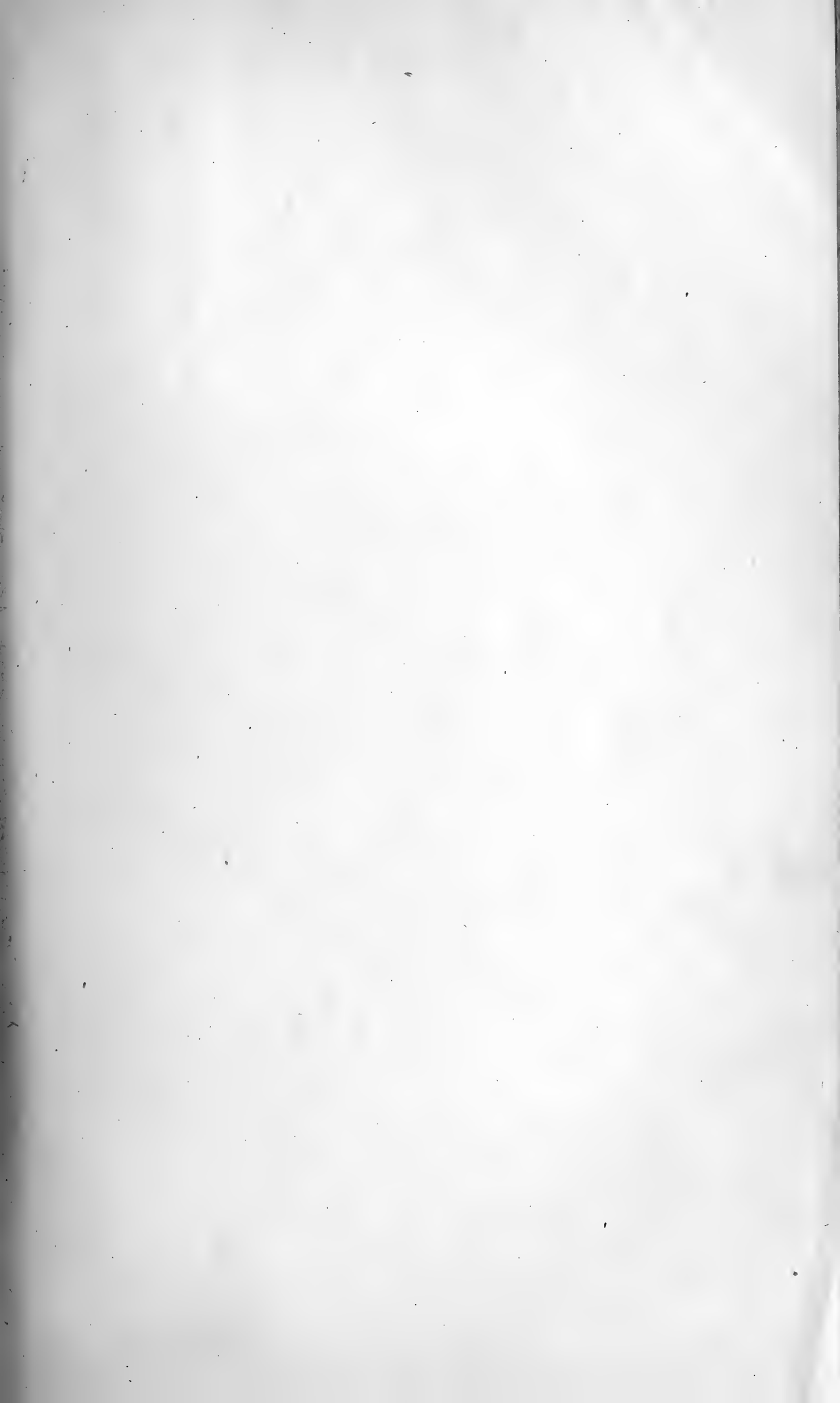
An easily accessible supply of water will aid materially in keeping down the cost of spraying. Water from the irrigation laterals may be used, but in all cases it should be carefully strained to prevent dirt and other material from getting into the pump and clogging the nozzles. Water that is highly charged with alkali should be avoided.

After a sprayer is used it should be carefully washed with clean water and all the working parts thoroughly oiled. It is a mistake to allow a sprayer to stand in the field exposed to sun and weather, and it will pay to keep it housed when not in actual use.

As a final word, it may be well to state that webworms, and with few exceptions most other insects which affect sugar beets in the Arkansas Valley, can be easily and cheaply controlled. When this fact is more generally accepted by the beet growers it is safe to say that sugar beets will produce still better profits.

ADDITIONAL COPIES of this publication
may be procured from the SUPERINTEND-
ENT OF DOCUMENTS, Government Printing
Office, Washington, D. C., at 5 cents per copy







U. S. DEPARTMENT OF AGRICULTURE,
BUREAU OF ENTOMOLOGY—BULLETIN No. 109, Part VII.

L. O. HOWARD, Entomologist and Chief of Bureau.

PAPERS ON INSECTS AFFECTING VEGETABLES.

THE HORSE-RADISH WEBWORM.

BY

H. O. MARSH,
Entomological Assistant.

ISSUED JANUARY 30, 1913.



WASHINGTON:
GOVERNMENT PRINTING OFFICE.
1913.

BUREAU OF ENTOMOLOGY.

L. O. HOWARD, *Entomologist and Chief of Bureau.*

C. L. MARLATT, *Entomologist and Acting Chief in Absence of Chief.*

R. S. CLIFTON, *Executive Assistant.*

W. F. TASTET, *Chief Clerk.*

F. H. CHITTENDEN, *in charge of truck crop and stored product insect investigations.*

A. D. HOPKINS, *in charge of forest insect investigations.*

W. D. HUNTER, *in charge of southern field crop insect investigations.*

F. M. WEBSTER, *in charge of cereal and forage insect investigations.*

A. L. QUAINANCE, *in charge of deciduous fruit insect investigations.*

E. F. PHILLIPS, *in charge of bee culture.*

D. M. ROGERS, *in charge of preventing spread of moths, field work.*

ROLLA P. CURRIE, *in charge of editorial work.*

MABEL COLCORD, *in charge of library.*

TRUCK CROP AND STORED PRODUCT INSECT INVESTIGATIONS.

F. H. CHITTENDEN, *in charge.*

C. H. POPENOE, WM. B. PARKER, H. O. MARSH, M. M. HIGH, JOHN E. GRAF,
FRED A. JOHNSTON, C. F. STAHL, D. E. FINK, A. B. DUCKETT, *entomological
assistants.*

I. J. CONDIT, *collaborator in California.*

W. N. ORD, *collaborator in Oregon.*

THOS. H. JONES, *collaborator in Porto Rico.*

MARION T. VAN HORN, PAULINE M. JOHNSON, ANITA M. BALLINGER, *preparators.*

CONTENTS.

	Page.
Introduction.....	71
Occurrence in Colorado.....	71
General appearance and habits.....	72
Life history.....	73
Rearing records.....	73
Egg-laying record.....	75
Natural enemies.....	75
Experiments with insecticides.....	76
Recommendations for control.....	76
Conclusion.....	76

ILLUSTRATIONS.

	Page.
FIG. 25. The horse-radish webworm (<i>Plutella armoracia</i>): Adult or moth, side view and with wings spread.....	72
26. The horse-radish webworm: Larva, lateral and dorsal views.....	72
27. The horse-radish webworm: Pupa.....	73
28. The horse-radish webworm: Cocoon.....	73



PAPERS ON INSECTS AFFECTING VEGETABLES.

THE HORSE-RADISH WEBWORM.

(*Plutella armoracia* Busck.)

By H. O. MARSH,
Entomological Assistant.

INTRODUCTION.

At Rocky Ford, in the Arkansas Valley of Colorado, horse-radish is grown on a very limited scale for home use. Among the insect enemies of this vegetable are a flea-beetle, *Phyllotreta pusilla* Horn, the spinach aphid (*Myzus persicæ* Sulz.), the common cabbage worm (*Pontia rapæ* L.), the southern cabbage worm (*Pontia protodice* Boisd.), the diamond-back moth (*Plutella maculipennis* Curtis) and the horse-radish webworm (*Plutella armoracia* Busck). This latter species is a new and hitherto unrecorded truck-crop pest. As nothing has been published regarding its life economy the author has drawn up this preliminary article touching its occurrence, life history, habits, and remedies.

OCCURRENCE IN COLORADO.

This species was first found at Rocky Ford by the author during the latter half of April, 1911. At this time larvæ, pupæ, and adults occurred in moderate numbers on horse-radish in one garden. The species was observed in this garden at various dates throughout the spring and summer. The larvæ checked the early growth of the plants somewhat, but no serious damage resulted. In 1912 the overwintered larvæ became active on these plants, which were then just showing above ground during the last days of March.

So far as the author has been able to determine, the infestation is limited to about 15 "clumps" of horse-radish plants in one garden at Rocky Ford. Careful search was made for this species on horse-radish in other gardens at Rocky Ford and on various species of wild and cultivated cruciferous plants in other portions of the Arkansas Valley, but without success. The infested horse-radish plants

have been in their present location for several years and it is impossible to determine their origin or whether they were infested when planted in the garden mentioned.

GENERAL APPEARANCE AND HABITS.

The horse-radish webworm (fig. 25) is a beautiful, slender moth belonging to the lepidopterous family Yponomeutidæ. The wings are cream colored with a brownish tinge and have an expanse of about five-eighths of an inch. The moths are shy and hide among the foliage of infested horse-radish plants. When disturbed they fly readily for a short distance and usually promptly hide. In captivity they feed eagerly on diluted honey.

The eggs (fig. 26, *c*) are scale like and are usually deposited singly on the upper or lower sides of the leaves.

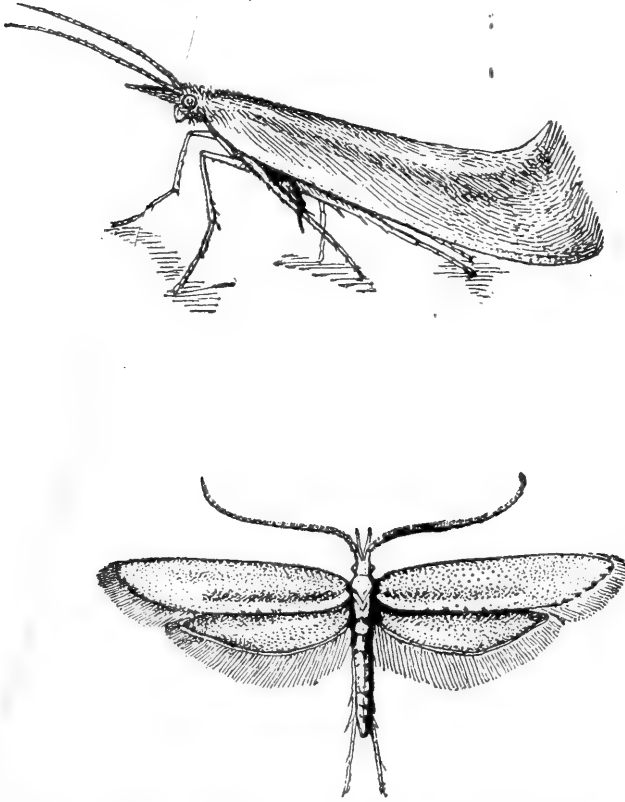


FIG. 25.—The horse-radish webworm (*Plutella armoracia*): Moth, side view, above; moth with wings spread below. Enlarged. (Original.)

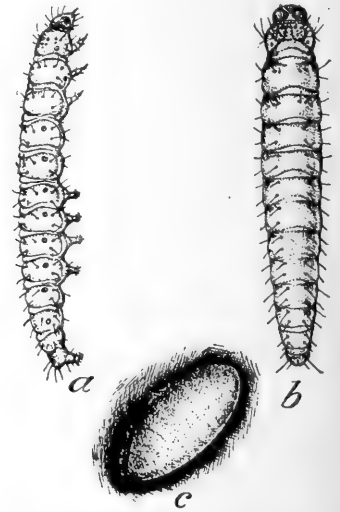


FIG. 26.—The horse-radish webworm: *a*, Larva, lateral view; *b*, larva, dorsal view; *c*, egg. All enlarged. (Original.)

The newly hatched larvæ are pale yellow. The mature larvæ (fig. 26, *a*, *b*) are yellowish green, with a more or less distinct yellow or orange band across the dorsal surface near the middle. Almost immediately after hatching the larvæ spin compact webs under which they rest and feed until mature. The webs are white or gray and are remarkably close-meshed. When the horse-radish plants are young the larvæ web together and feed on the first spikelike leaves and later a favorite location is among the blossom buds. With older plants the larvæ feed on the leaves generally, usually selecting the most tender ones.

Their most noticeable injury is caused by checking the first growth of the plants early in the spring and destroying the blossom buds.

The pupæ (fig. 27) are pale yellow marked with brown and are inclosed in cocoons. The cocoons (fig. 28) are placed on leaf petioles or among dead leaves and are exquisitely beautiful, silver-gray, lace-like, cigar-shaped objects.

LIFE HISTORY.

There are four generations each year and activity is continuous from the last days of March until well into October. A few of the larvæ of the fourth generation mature and produce moths in late September or October, but the majority live through the winter among dead leaves or in cracks in the soil and develop into moths the following April. The hibernating larvæ may vary from very small to nearly mature specimens. The moths are remarkably long lived and egg-laying extends over a considerable period. The genera-

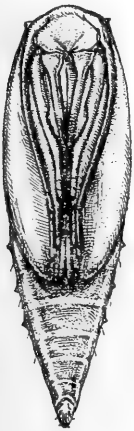


FIG. 27.—The horse-radish webworm: Pupa. Greatly enlarged. (Original.)

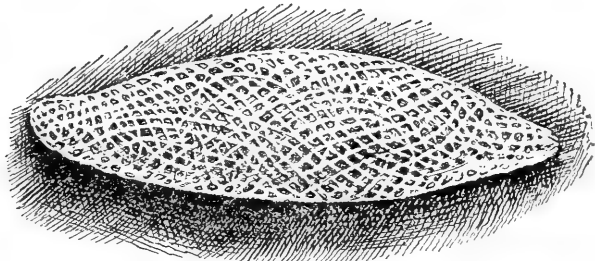


FIG. 28.—The horse-radish webworm: Cocoon. Greatly enlarged. (Original.)

tions overlap to such an extent that it is practically impossible to separate them in the field. The details of the generations and stages are given in the rearing records which follow.

REARING RECORDS.

On April 3 several overwintered larvæ were collected from horse-radish and placed in a cage. The record is as follows:

Apr. 3.....	Larvæ collected.
Apr. 4.....	First cocoons formed.
Apr. 6.....	First larvæ pupated.
Apr. 23.....	First adults issued.

On April 24 a pair of these moths mated and were placed in a separate cage containing horse-radish leaves and diluted honey. The record is as follows:

First generation.

Apr. 24.....	Moths mated.
Apr. 25.....	First eggs deposited.
May 3.....	First eggs hatched.
May 25.....	First cocoons formed.
May 26.....	First larvæ pupated.
June 3.....	First adults issued.

From the above record the stages are as follows:

	Days.
Egg stage.....	8
Larval stage.....	23
Pupal stage.....	8
Total.....	39

A pair of these moths mated June 9 and were placed in a separate cage.

Second generation.

June 9.....	Moths mated.
June 10.....	First eggs deposited.
June 20.....	Eggs hatched.
July 5.....	First cocoons formed.
July 6.....	First larvæ pupated.
July 17.....	First adults issued.

From the above record the stages are as follows:

	Days.
Egg stage.....	10
Larval stage.....	16
Pupal stage.....	10
Total.....	36

A pair of these moths mated July 24 and were placed in a separate cage.

Third generation.

July 24.....	Moths mated.
July 26.....	First eggs deposited.
July 31.....	Eggs hatched.
Aug. 12.....	First cocoons formed.
Aug. 13.....	First larvæ pupated.
Aug. 21.....	First adults issued.

From the above record the stages are as follows:

	Days.
Egg stage.....	5
Larval stage.....	13
Pupal stage.....	8
Total.....	26

A pair of these moths mated August 24 and were placed in a separate cage.

Fourth generation.

Aug. 24.....	Moths mated.
Aug. 25.....	First eggs deposited.
Sept. 1.....	Eggs hatched.
Sept. 26.....	First cocoons formed.
Sept. 28.....	First larvæ pupated.
Oct. 11.....	First adults issued.

From the above record the stages are as follows:

	Days.
Egg stage.....	7
Larval stage.....	27
Pupal stage.....	13
Total.....	47

Only a few adults of the fourth generation issued during October, and these deposited no eggs. The majority of the larvæ of this generation went into hibernation about the middle of October. These larvæ will hibernate among dead leaves and in cracks in the soil and develop moths during April of the following spring. It will thus be seen that the larval stage of the fourth generation may vary from 27 days to 6 months.

EGG-LAYING RECORD.

On May 3 a female issued and mated with a male which had emerged a day earlier. The pair, while still in copulation, was isolated in a cage containing a wad of absorbent cotton saturated with diluted honey and a horse-radish leaf. Eggs were deposited as follows:

No. of eggs deposited.		No. of eggs deposited.	
May 4.....	29	May 19 and 20.....	36
May 5 and 6.....	39	May 21.....	16
May 7.....	15	May 22.....	12
May 8.....	27	May 23.....	7
May 9.....	18	May 24.....	4
May 10.....	12	May 25.....	3
May 11.....	21	May 26.....	6
May 12 and 13.....	15	May 27.....	8
May 14.....	7	May 28.....	3
May 15.....	13	May 29.....	3
May 16.....	13	May 30.....	3
May 17.....	9		
May 18.....	12	Total.....	331

The moths were observed copulating May 3, 8, 13, and 20. The male died May 28 and the female June 4. The length of life of the male was 26 days and of the female 32 days.

The rearing records were obtained in the laboratory at Rocky Ford, Colo. The cages were placed in a window which was kept open night and day. Food was supplied the moths by putting in wads of absorbent cotton which were saturated with honey and water. This food was eaten eagerly. In the cages the moths were quiet and easily controlled. In all cases the larvæ were fed with horse-radish leaves.

NATURAL ENEMIES.

Only one natural enemy has been found preying on this species at Rocky Ford. This is a small, wasp-like hymenopterous insect which Mr. H. L. Viereck has described as *Angitia plutellæ* n. sp. This parasite is evidently largely responsible for checking the increase of the *Plutella* larvæ. The adults were found in the field from the latter part of April until the middle of November. In the cages the first adults developed from overwintered *Plutella* larvæ on April 23 and 27. It is probable that the parasites live through the winter as eggs or larvæ within the bodies of the hibernating *Plutella* larvæ.

EXPERIMENTS WITH INSECTICIDES.

During the spring of 1912 the following experiments were conducted at Rocky Ford, Colo.

On April 8 several infested horse-radish plants were sprayed with the following mixture:

Paris green.....	pounds..	2
Whale-oil soap.....	do....	8
Water.....	gallons..	100

These plants were kept under close observation for several days, but no dead larvæ were found.

On April 29 several infested horse-radish plants were sprayed with the following mixture:

Arsenate of lead.....	pounds..	10
Whale-oil soap.....	do....	10
Water.....	gallons..	100

This experiment was likewise a failure and no larvæ were killed.

In these experiments the poisons were carefully and thoroughly applied. The surface and underside of the leaves, and in fact all portions of the plants above ground, were coated. This treatment, however, failed to kill the larvæ. This was due to the habit the larvæ have of resting and feeding under compact webs, where they are completely protected from stomach poisons.

RECOMMENDATIONS FOR CONTROL.

The experiments indicate that this insect can not be controlled with arsenicals. If artificial control measures should become necessary, much could doubtless be accomplished by burning the dead horse-radish leaves and petioles during the winter. After the dead leaves are removed the surface of the soil about the roots of the plants should be thoroughly stirred with a rake. This cultivation would crush or bury the hibernating larvæ which were resting in cracks in the soil.

CONCLUSION.

The investigation of this insect indicates that infestation is limited to a few horse-radish plants in one garden at Rocky Ford, Colo. In this garden the larvæ have evidently been prevented from causing much damage by a hymenopterous parasite, and at present no artificial control measures are necessary.

ADDITIONAL COPIES of this publication may be procured from the SUPERINTENDENT OF DOCUMENTS, Government Printing Office, Washington, D. C., at 5 cents per copy



INDEX.

	Page.
<i>Agromyza diminuta</i> damaging cabbage in Hawaii.....	33
Agromyzid reared with <i>Pachyzancla bipunctalis</i> from beets and <i>Amaranthus</i> ..	22
<i>Agrotis crinigera</i> damaging cabbage in Hawaii.....	33
Amaranthus—	
cultivated, food plant of <i>Hymenia fascialis</i>	2
food plant of agromyzid.....	22
<i>Amaranthus mangostanus</i>—	
bibliographic reference.....	15
food plant of <i>Hymenia fascialis</i>	14, 15
<i>Amaranthus retroflexus</i> , food plant of <i>Pachyzancla bipunctalis</i>	18
<i>Amaranthus</i> sp., food plant of <i>Hymenia fascialis</i>	1
<i>Amaranthus</i> spp., food plants of <i>Hymenia fascialis</i>	2
<i>Amaranthus spinosus</i> , food plant of <i>Pachyzancla bipunctalis</i>	18
Amaranth, spiny. (See <i>Amaranthus spinosus</i> .)	
Ambrosia, food plant of <i>Pachyzancla bipunctalis</i>	21
<i>Amorphota</i> sp., near <i>orgyia</i> , parasite of <i>Pachyzancla bipunctalis</i>	21
<i>Angitia plutellæ</i> , parasite of <i>Plutella armoracea</i>	75
<i>Apanteles</i> n. sp., near <i>agrotidis</i> , parasite of <i>Porosagrotis vetusta</i>	51
Aphides, control by nicotine sulphate and whale-oil soap.....	10
<i>Aphis brassicæ</i> damaging cabbage in Hawaii.....	33
Arsenate of lead—	
against Colorado potato beetle.....	53, 55
against cutworm, <i>Porosagrotis vetusta</i>	49
and lime-sulphur against Colorado potato beetle.....	53, 55
and molasses against Hawaiian beet webworm.....	8, 10
and molasses against melon fly.....	8-9, 10
and whale-oil soap against horse-radish webworm.....	76
and whale-oil soap against imported cabbage webworm.....	40
unsatisfactory against sugar-beet webworm.....	65
Arsenical and Bordeaux mixture against imported cabbage webworm.....	43
Arsenite of zinc—	
against Colorado potato beetle.....	53, 56
against sugar-beet webworm.....	65
and Bordeaux mixture against Colorado potato beetle.....	53-54
<i>Autographa brassicæ</i> , association with <i>Hellula undalis</i> in damage to truck crops.....	26
<i>Autographa precatioris</i>—	
control by nicotine sulphate and whale-oil soap.....	10
damaging cabbage in Hawaii.....	33
Beans, food plants of <i>Porosagrotis vetusta</i>	47
Beet army worm. (See <i>Caradrina exigua</i> .)	
Beets—	
food plants of agromyzid.....	22
food plants of <i>Hellula undalis</i>	30
food plants of <i>Hymenia fascialis</i>	21-22

	Page.
Beets—Continued.	
food plants of <i>Pegomya ruficeps</i>	22
stock, food plants of <i>Hymenia fascialis</i>	2
sugar, food plants of <i>Hellula undalis</i>	24
sugar, food plants of <i>Hymenia fascialis</i>	2
sugar, food plants of <i>Loxostege sticticalis</i>	57-70
table, food plants of <i>Hymenia fascialis</i>	2
Beet webworm—	
Hawaiian. (See <i>Hymenia fascialis</i> .)	
southern. (See <i>Pachyzancla bipunctalis</i> .)	
Blackbirds, enemies of <i>Loxostege sticticalis</i>	62
Bordeaux mixture—	
against imported cabbage webworm.....	43
against leaf-spot disease of beet.....	67
and arsenical against imported cabbage webworm.....	43
and arsenite of zinc against Colorado potato beetle.....	53-54
and Paris green against Colorado potato beetle.....	53-54
<i>Botis repititalis</i> = <i>Pachyzancla bipunctalis</i>	21
<i>Botis rogatalis</i> —	
bibliographic reference.....	44
= <i>Hellula undalis</i>	28
<i>Bracon</i> sp., parasite of <i>Pachyzancla bipunctalis</i>	21
Burning against imported cabbage webworm.....	43
<i>Bursa</i> (<i>Capsella</i>) <i>bursa-pastoris</i> , food plant of <i>Hellula undalis</i>	31
Cabbage aphid. (See <i>Aphis brassicæ</i> .)	
Cabbage bug, harlequin. (See <i>Murgantia histrionica</i> .)	
Cabbage—	
food plant of <i>Hellula undalis</i>	23, 24, 25, 26, 27, 30, 32, 34
food plant of <i>Porosagrotis vetusta</i>	47
looper. (See <i>Autographa brassicæ</i> .)	
webworm, imported. (See <i>Hellula undalis</i> .)	
worm, common. (See <i>Pontia rapæ</i> .)	
worm, southern. (See <i>Pontia protodice</i> .)	
Cantaloupe, food plant of <i>Porosagrotis vetusta</i>	48
<i>Caradrina exigua</i> —	
damaging cabbage in Hawaii.....	33
nicotine sulphate and whale-oil soap as remedy.....	10
Cauliflower—	
food plant of <i>Hellula undalis</i>	30
food plant of <i>Pachyzancla bipunctalis</i>	21
<i>Cercospora beticola</i> , Bordeaux mixture as remedy.....	67
<i>Chelonus blackburni</i> , parasite of <i>Hymenia fascialis</i>	7
<i>Chenopodium album</i> , food plant of <i>Loxostege sticticalis</i>	59
CHITTENDEN, F. H.—	
and MARSH, H. O., paper, "The Imported Cabbage Webworm (<i>Hellula undalis</i> Fab.)".....	23-45
appendix, description and synonymy, distribution, history and bibliography [of <i>Hymenia fascialis</i>].....	12-15
paper, "A Little-known Cutworm (<i>Porosagrotis vetusta</i> Walk.)".....	47-51
paper, "The Southern Beet Webworm (<i>Pachyzancla bipunctalis</i> Fab.)".....	17-22
Collards, food plants of <i>Hellula undalis</i>	23, 24, 26, 30
Corn, food plant of <i>Porosagrotis vetusta</i>	48
Cotton, food plant of <i>Porosagrotis vetusta</i>	48
Cowpea, food plant of <i>Porosagrotis vetusta</i>	47

	Page.
<i>Cremastus hymenizæ</i> —	
bibliographic reference.....	15
parasite of <i>Hymenia fascialis</i>	7
Cucumbers, occasional food plants of <i>Hymenia fascialis</i>	2
Cultural methods against imported cabbage webworm.....	42
Culture, clean, against imported cabbage webworm.....	42, 43
“Cutler’s grass,” colloquial name for <i>Portulaca oleracea</i>	31
Cutworm—	
granulated. (See <i>Feltia annexa</i> .)	
“spotted-legged,” name applied to <i>Porosagrotis vetusta</i>	51
<i>Dacus cucurbitæ</i> —	
control by arsenate of lead and molasses.....	8
damaging cabbage in Hawaii.....	33
Dandelions, cultivated, food plant of <i>Porosagrotis vetusta</i>	48
Dewberry, food plant of <i>Porosagrotis vetusta</i>	47
Diamond-back moth. (See <i>Plutella maculipennis</i> .)	
<i>Diosphyrus vulgaris</i> , parasite of <i>Loxostege sticticalis</i>	62
Disease affecting <i>Hellula undalis</i> in Hawaii. (See “Wilt.”)	
“Dragging the log” against southern beet webworm.....	22
DYAR, H. G., appendix, “Description of the Earlier Stages” [of <i>Hymenia fascialis</i>].	11–12
<i>Evergestis rimosalis</i> , bibliographic reference.....	45
Euxolus, food plant of <i>Hymenia fascialis</i>	2
<i>Exorista pyste</i> , parasite of <i>Hellula undalis</i>	31
Fall plowing against imported cabbage webworm.....	43
<i>Feltia annexa</i> , association with <i>Porosagrotis vetusta</i> in injuries.....	48
Hand picking of no value against imported cabbage webworm.....	33
<i>Hellula undalis</i> —	
bibliography.....	44–45
conclusion as to remedies.....	41–42
damaging cabbage in Hawaii.....	33
description and life-history notes.....	27–29
distribution.....	30
egg, description.....	28
egg-laying records.....	37
enemies.....	31–32
enemies in Hawaii.....	37–38
experiment in screening a seed bed as remedy.....	41
experiments with insecticides in Hawaii.....	38–40
first generation.....	35–36
food plants.....	30–31
fourth generation.....	36–37
introduction, spread, and ravages.....	23–27
larva, full-grown, description.....	29
larva, newly hatched, description.....	29
life history and habits in Hawaii.....	34–37
moth, description.....	27–28
oviposition.....	28
pupa, description.....	29–30
recommendations for control.....	42–43
second generation.....	36
synonymy.....	28
third generation.....	36

	Page.
Horse-radish—	
food plant of <i>Hellula undalis</i>	24-30
insect enemies in Colorado.....	71-76
<i>Hydrocampa albifascialis</i> = <i>Hymenia fascialis</i>	13
Hymenia, description of genus.....	13
<i>Hymenia diffascialis</i> = <i>Hymenia fascialis</i>	13
<i>Hymenia fascialis</i> —	
adult, description.....	13-14
bibliography.....	15
cocoon, description.....	12
description of earlier stages.....	11-12
distribution.....	14
egg, description.....	11
enemies.....	7
food plants.....	2, 14, 15
habits.....	3-7
history.....	14
injury.....	2
insecticide experiments.....	7-11
larva, description.....	11-12
life history.....	3-7
pupa, description.....	12
reared with <i>Pachyzancla bipunctalis</i> from beets in Florida.....	21-22
synonymy.....	12, 13
<i>Hymenia recurvalis</i> —	
bibliographic reference.....	15
= <i>Hymenia fascialis</i>	13
JOHNSTON, FRED A., paper, "Arsenite of Zinc and Lead Chromate as Remedies Against the Colorado Potato Beetle".....	53-56
Kale, food plant of—	
<i>Feltia annexa</i>	48
<i>Hellula undalis</i>	24-30
<i>Porosagrotis vetusta</i>	48
Kerosene and soap against imported cabbage webworm.....	42
Kohl-rabi, food plant of <i>Hellula undalis</i>	30-32
Lambs'-quarters. (See <i>Chenopodium album</i> .)	
Lead chromate—	
against Colorado potato beetle.....	53-55
against Hawaiian beet webworm.....	9, 10
Leaf-spot disease of beet. (See <i>Cercospora beticola</i> .)	
Lettuce, food plant of—	
<i>Feltia annexa</i>	48
<i>Porosagrotis vetusta</i>	49
<i>Leucinodes exemptalis</i> —	
bibliographic reference.....	44
= <i>Hellula undalis</i>	28
Lights for trapping moths of imported cabbage webworm.....	43
Lime and Paris green against—	
Hawaiian beet webworm.....	7-8, 10
sugar-beet webworm.....	63-64
Lime and Paris green, dry, against sugar-beet webworm.....	66
Lime, Paris green, and whale-oil soap against imported cabbage webworm....	39-40

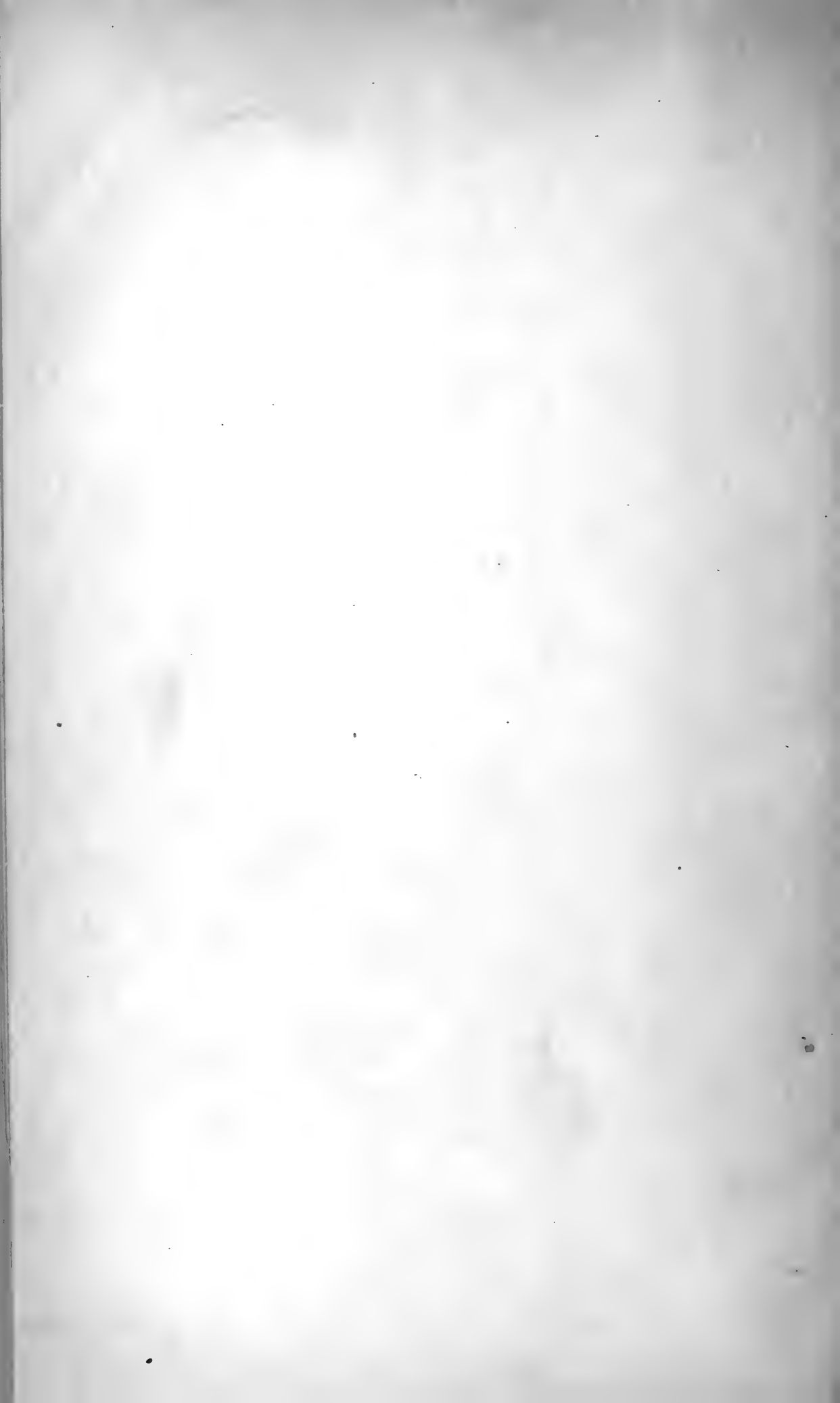
	Page.
Lime-sulphur—	
against Hawaiian beet webworm.....	9, 10
and arsenate of lead against Colorado potato beetle.....	53-55
<i>Limnerium hawaiiense</i> , parasite of <i>Hymenia fascialis</i>	7
<i>Limnerium tibiator</i> —	
parasite of <i>Autographa brassicæ</i>	31
parasite of <i>Mineola indiginella</i>	31
parasite of <i>Plutella cruciferarum</i>	31
probable parasite of <i>Hellula undalis</i>	31
<i>Linnæmya picta</i> , parasite of <i>Porosagrotis vetusta</i>	51
<i>Loxostege obliteralis</i> , resemblance of larva to that of <i>Pachyzancla bipunctalis</i>	20
<i>Loxostege similalis</i> —	
host of <i>Phorocera erecta</i>	21
resemblance of larva to that of <i>Pachyzancla bipunctalis</i>	20
<i>Loxostege sticticalis</i> —	
appearance, general.....	58
attack, nature.....	58
checks.....	63
conclusions regarding control experiments.....	70
control with barrel and geared sprayers.....	11
enemies.....	62
habits.....	59-61
injury, character.....	61-62
life history.....	59-61
losses through damage to beets.....	57
remedies, experiments.....	63-66
spraying, cost.....	69-70
spraying machinery.....	66-69
Mangel-wurzel. (See Beets, stock.)	
MARSH, H. O.—	
F. H. Chittenden and, paper, "The Imported Cabbage Webworm (<i>Hellula undalis</i> Fab.)".....	23-45
paper, "A Report of Progress Regarding the Sugar-beet Webworm (<i>Loxostege sticticalis</i> L.)".....	57-70
paper, "The Hawaiian Beet Webworm (<i>Hymenia fascialis</i> Cram.)".....	1-15
paper, "The Horse-radish Webworm (<i>Plutella armoracia</i> Busck)".....	71-76
Melon fly. (See <i>Dacus cucurbitæ</i> .)	
<i>Meteorus vulgaris</i> , parasite of <i>Hellula undalis</i>	31-32
Molasses—	
and arsenate of lead against Hawaiian beet webworm.....	8, 10
and arsenate of lead against melon fly.....	8-9, 10
refuse, substitute for soap in sprays against sugar-beet webworm.....	64-65
<i>Murgantia histrionica</i> , distribution.....	23
Mustard, food plant of <i>Hellula undalis</i>	24, 27, 30
<i>Myzus persicæ</i> on horse-radish.....	71
Nicotine sulphate and whale-oil soap against—	
aphides.....	10
beet army worm.....	10
common cabbage worm.....	10
diamond-back moth.....	10
Hawaiian beet webworm.....	10
looper, <i>Autographa precationis</i>	10
southern beet webworm.....	22
thrips.....	10

	Page.
Nicotine sulphate, Paris green, and whale-oil soap against imported cabbage webworm.....	40
<i>Pachyzancla bipunctalis</i> —	
associated insects.....	21
descriptive.....	19-20
distribution.....	21
egg, description.....	20
enemies.....	21
historical and biological notes.....	21
injurious occurrences and notes on habits.....	17-19
larva, description.....	20
moth, description.....	19-20
pupa, description.....	20
remedies.....	22
resemblance of larva to that of <i>Loxostege oblitalis</i>	20
resemblance of larva to that of <i>Loxostege similalis</i>	20
Paris green—	
against sugar-beet webworm.....	66
and Bordeaux mixture against Colorado potato beetle.....	53-54
and lime against Hawaiian beet webworm.....	7-8, 10
and lime against sugar-beet webworm.....	63-64
and lime, dry, against sugar-beet webworm.....	66
and water against southern beet webworm.....	22
and whale-oil soap against Hawaiian beet webworm.....	8, 10
and whale-oil soap against horse-radish webworm.....	76
and whale-oil soap against imported cabbage webworm.....	38
and whale-oil soap against southern beet webworm.....	22
and whale-oil soap against sugar-beet webworm.....	63-64
dry, against southern beet webworm.....	22
lime, and whale-oil soap against imported cabbage webworm.....	39-40
whale-oil soap, and nicotine sulphate against imported cabbage webworm.....	40
Parsley, food plant of <i>Porosagrotis vetusta</i>	49
Peach, food plant of <i>Porosagrotis vetusta</i>	47-51
<i>Pegomya ruficèps</i> , reared with <i>Pachyzancla bipunctalis</i> from beets.....	22
<i>Phalæna angustalis</i> = <i>Hymenia fascialis</i>	13
<i>Phalæna 2-punctalis</i> , first name for <i>Pachyzancla bipunctalis</i>	21
? <i>Phalæna nigrella</i> = <i>Hymenia fascialis</i>	13
<i>Phalæna recurvalis</i> = <i>Hymenia fascialis</i>	13
<i>Phalæna undalis</i> , bibliographic reference.....	44
<i>Phalena fascialis</i> = <i>Hymenia fascialis</i>	13
<i>Phorocera erecta</i> , parasite of—	
<i>Loxostege similalis</i>	21
<i>Pachyzancla bipunctalis</i>	21
<i>Phyllotreta bipustulata</i> , association with <i>Hellula undalis</i> in damage to truck crops.....	26
<i>Phyllotreta pusilla</i> on horse-radish.....	71
Pigweed (see also <i>Amaranthus retroflexus</i>)—	
food plant of <i>Pachyzancla bipunctalis</i>	21
<i>Plagiprospherysa</i> sp., parasite of <i>Hellula undalis</i>	31
<i>Plutella amoracea</i> —	
appearance, general.....	72-73
control recommendations.....	76
egg-laying record.....	75
enemies.....	75

	Page.
<i>Plutella amoracea</i> —Continued.	
habits.....	72-73
insecticide experiments.....	76
life history.....	73
occurrence in Colorado.....	71-72
rearing records.....	73-75
<i>Plutella maculipennis</i> —	
control by nicotine sulphate and whale-oil soap.....	10
damaging cabbage in Hawaii.....	33
on horse-radish.....	71
<i>Polistes hebræus</i> —	
enemy of <i>Pontia rapæ</i>	7
probable enemy of <i>Hymenia fascialis</i>	7
<i>Pontia protodice</i> on horse-radish.....	71
<i>Pontia rapæ</i> —	
control by nicotine sulphate and whale-oil soap.....	10
damaging cabbage in Hawaii.....	33
on horse-radish.....	71
prey of <i>Polistes hebræus</i>	7
<i>Porizon macer</i> . (See <i>Temelucha</i> [<i>Porizon</i>] <i>macer</i> .)	
<i>Porosagrotis catenula</i> , race of <i>P. vetusta</i> , distribution.....	51
<i>Porosagrotis satiens</i> , race of <i>P. vetusta</i> , distribution.....	50
<i>Porosagrotis vetusta</i> —	
description.....	50
distribution.....	50-51
enemies.....	51
injurious occurrence.....	47-49
larva, description.....	50
moth, description.....	50
<i>Portulaca oleracea</i> —	
food plant of <i>Hellula undalis</i>	31
food plant of <i>Hymenia fascialis</i>	2
“Powder gun,” use against sugar-beet webworm.....	66
Purslane. (See <i>Portulaca oleracea</i> .)	
“Pussley,” colloquial name for <i>Portulaca oleracea</i>	31
Radish, food plant of <i>Hellula undalis</i>	24, 27, 30, 32
“Radish, Japanese,” food plant of <i>Hellula undalis</i>	31
Ragweed. (See <i>Ambrosia</i> .)	
Rape, food plant of <i>Hellula undalis</i>	24, 30
<i>Rhopalosiphum dianthi</i> damaging cabbage in Hawaii.....	33
Rutabaga, food plant of <i>Hellula undalis</i>	30
<i>Salsola tragus</i> , food plant of <i>Loxostege sticticalis</i>	59
<i>Scopariaalconalis</i> , bibliographic reference.....	44
<i>Scopariaalconalis</i> = <i>Hellula undalis</i>	28
Screening a seed bed of cabbage in control of imported cabbage webworm.....	41, 42
Shepherd’s purse. (See <i>Bursa</i> [<i>Capsella</i>] <i>bursa-pastoris</i> .)	
Soap—	
and kerosene against imported cabbage webworm.....	42
whale-oil, and arsenate of lead against horse-radish webworm.....	76
whale-oil, and arsenate of lead against imported cabbage webworm.....	40
whale-oil, and nicotine sulphate against aphides.....	40
whale-oil, and nicotine sulphate against beet army worm.....	10
whale-oil, and nicotine sulphate against common cabbage worm.....	10
whale-oil, and nicotine sulphate against diamond-back moth.....	10

Soap—Continued.	Page.
whale-oil, and nicotine sulphate against Hawaiian beet webworm.....	10
whale-oil, and nicotine sulphate against looper, <i>Autographa precationis</i>	10
whale-oil, and nicotine sulphate against southern beet webworm.....	22
whale-oil, and nicotine sulphate against thrips.....	10
whale-oil, and Paris green against Hawaiian beet webworm.....	8, 10
whale-oil, and Paris green against horse-radish webworm.....	76
whale-oil, and Paris green against imported cabbage webworm.....	38
whale-oil, and Paris green against southern beet webworm.....	22
whale-oil, and Paris green against sugar-beet webworm.....	63-64
whale-oil, nicotine sulphate, and Paris green against imported cabbage webworm.....	40
whale-oil, Paris green, and lime against imported cabbage webworm.....	39-40
Spinach aphid. (See <i>Myzus persicæ</i> and <i>Rhopalosiphum dianthi</i> .)	
Spinach—	
food plant of <i>Feltia annexa</i>	48
food plant of <i>Porosagrotis vetusta</i>	48
“Spinach,” so-called, of Hawaii, not the cultivated spinach of America.....	2
“Spinach,” so-called. (See <i>Amaranthus</i> sp.)	
<i>Spoladea recurvalis</i> = <i>Hymenia fascialis</i>	13
Sprayers, barrel, use against sugar-beet webworm in Colorado.....	11
Spraying machinery against sugar-beet webworm.....	66-69
Sugar-beet webworm. (See <i>Loxostege sticticalis</i> .)	
<i>Temelucha</i> (<i>Porizon</i>) <i>macer</i> , parasite of <i>Hellula undalis</i>	31-32
Thistle, Russian. (See <i>Salsola tragus</i> .)	
Thrips, control by nicotine sulphate and whale-oil soap.....	10
Tobacco, food plant of <i>Porosagrotis vetusta</i>	48
Turnip, Japanese, food plant of <i>Hellula undalis</i>	32
Turnips—	
food plants of <i>Hellula undalis</i>	24, 25, 26, 27, 30
food plants of <i>Porosagrotis vetusta</i>	47
<i>Tyroglyphus americanus</i> , enemy of <i>Hellula undalis</i>	32
Watermelon, food plant of <i>Porosagrotis vetusta</i>	47-48
Webworm—	
Hawaiian beet. (See <i>Hymenia fascialis</i> .)	
horse-radish. (See <i>Plutella armoracea</i> .)	
imported cabbage. (See <i>Hellula undalis</i> .)	
southern beet. (See <i>Pachyzancla bipunctalis</i> .)	
sugar-beet. (See <i>Loxostege sticticalis</i> .)	
“Wilt” disease of <i>Hellula undalis</i> in Hawaii.....	38
<i>Zinckenia fascialis</i> —	
bibliographic reference.....	15
<i>Zinckenia recurvalis</i> —	
bibliographic reference.....	15
= <i>Hymenia fascialis</i>	13





630.67

U. S. DEPARTMENT OF AGRICULTURE,

BUREAU OF ENTOMOLOGY—BULLETIN No. 110.

L. O. HOWARD, Entomologist and Chief of Bureau.

THE SPRING GRAIN-APHIS OR
"GREEN BUG."

BY

F. M. WEBSTER,

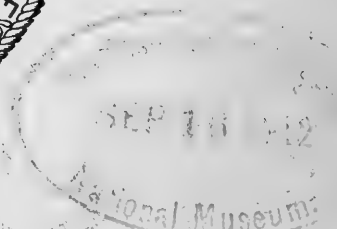
In Charge of Cereal and Forage Insect Investigations,

AND

W. J. PHILLIPS,

Entomological Assistant.

ISSUED SEPTEMBER 6, 1912.



WASHINGTON:
GOVERNMENT PRINTING OFFICE,
1912.

U. S. DEPARTMENT OF AGRICULTURE,
BUREAU OF ENTOMOLOGY—BULLETIN No. 110.
L. O. HOWARD, Entomologist and Chief of Bureau.

THE SPRING GRAIN-APHIS OR "GREEN BUG."

BY

F. M. WEBSTER,

In Charge of Cereal and Forage Insect Investigations,

AND

W. J. PHILLIPS,

Entomological Assistant.

ISSUED SEPTEMBER 6, 1912.



WASHINGTON:
GOVERNMENT PRINTING OFFICE.
1912.

BUREAU OF ENTOMOLOGY.

L. O. HOWARD, *Entomologist and Chief of Bureau.*
C. L. MARLATT, *Entomologist and Acting Chief in Absence of Chief.*
R. S. CLIFTON, *Executive Assistant.*
W. F. TASTET, *Chief Clerk.*

F. H. CHITTENDEN, *in charge of truck crop and stored product insect investigations.*
A. D. HOPKINS, *in charge of forest insect investigations.*
W. D. HUNTER, *in charge of southern field crop insect investigations.*
F. M. WEBSTER, *in charge of cereal and forage insect investigations.*
A. L. QUAINANCE, *in charge of deciduous fruit insect investigations.*
E. F. PHILLIPS, *in charge of bee culture.*
D. M. ROGERS, *in charge of preventing spread of moths, field work.*
ROLLA P. CURRIE, *in charge of editorial work.*
MABEL COLCORD, *in charge of library.*

CEREAL AND FORAGE INSECT INVESTIGATIONS.

F. M. WEBSTER, *in charge.*

GEO. I. REEVES, W. J. PHILLIPS, C. N. AINSLIE, E. O. G. KELLY, T. D. URBAHNS,
HARRY S. SMITH, GEO. G. AINSLIE, J. A. HYSLOP, W. R. WALTON, J. T. MONELL,
J. J. DAVIS, T. H. PARKS, R. A. VICKERY, V. L. WILDERMUTH, E. G. SMYTH,
HERBERT T. OSBORN, PHILIP LUGINBILL, C. W. CREEL, E. J. VOSLER, R. N. WIL-
SON, VERNON KING, *entomological assistants.*
NETTIE S. KLOPPER, ELLEN DASHIELL, *preparators.*
MIRIAM WELLES REEVES, *collaborator.*

LETTER OF TRANSMITTAL.

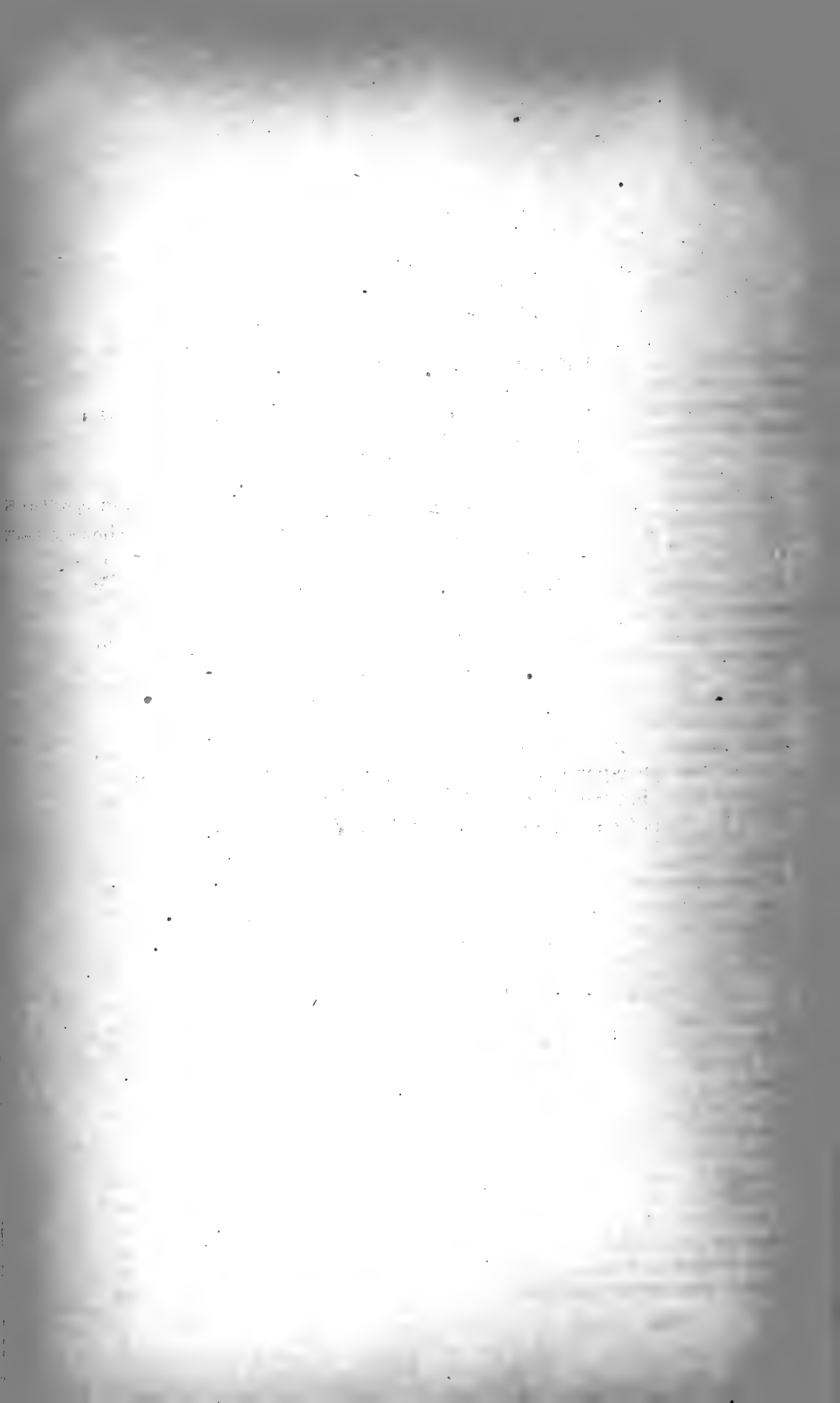
U. S. DEPARTMENT OF AGRICULTURE,
BUREAU OF ENTOMOLOGY,
Washington, D. C., December 28, 1911.

SIR: I have the honor to transmit herewith for publication the manuscript of a bulletin on the spring grain-aphis, popularly known as the "green bug," by F. M. Webster and W. J. Phillips, of this bureau. The investigations upon which this bulletin are chiefly based began under a special appropriation made by Congress in the spring of 1907. These investigations have been continued without interruption up to and including 1911. Preliminary reports upon the work were published in Circulars Nos. 85 and 93. The present report, however, is a complete record of the entire investigation, including many aspects of the problem not before touched upon in any publication relating to this group of insects. I recommend the publication of this manuscript as Bulletin No 110 of the Bureau of Entomology.

Respectfully,

L. O. HOWARD,
Entomologist and Chief of Bureau.

HON. JAMES WILSON,
Secretary of Agriculture.



CONTENTS.

	Page.
Introduction.....	11
Earliest observations on the insect in America.....	13
Early records in Europe.....	16
Known distribution in the Eastern Hemisphere.....	16
Known distribution in the Western Hemisphere.....	18
The outbreak of 1890.....	19
The outbreak of 1901.....	21
The outbreak of 1903.....	21
The outbreak of 1907.....	27
Losses from depredations in 1907.....	39
The situation in 1911.....	40
Food plants.....	41
Character of attack.....	44
Viviparous development.....	44
In the South.....	44
In the North.....	49
Rearing methods.....	51
Stem mothers.....	58
Description of the different instars.....	58
Description of the summer forms.....	59
Molting.....	61
Number of molts.....	61
Birth of young.....	63
Number of generations per year.....	63
Age at which females begin reproducing.....	70
Reproductive period.....	71
Longevity.....	72
Fecundity of viviparous female.....	73
Fecundity of wingless <i>vs.</i> winged females.....	75
Average number of young produced daily.....	76
Sexual forms.....	76
Descriptions.....	77
Molting.....	78
Oviparous development.....	78
Age at which females begin oviposition.....	78
Place of oviposition.....	79
Period of oviposition.....	79
Length of life of the sexes.....	80
Fecundity of oviparous forms.....	81
Aberrant individuals.....	81
Influence of winds on diffusion.....	81
Influence of temperature on diffusion.....	88

	Page.
Embryology.....	94
Methods and material.....	95
General description of the egg.....	95
Observations.....	97
Summary of embryological development.....	102
Natural enemies.....	103
Internal or true parasites.....	104
<i>Aphidius testaceipes</i> Cress.....	104
Description and identity.....	104
Life history.....	105
Oviposition.....	105
Length of period from egg to adult.....	106
Effect of parasitism by <i>Aphidius</i> upon development of host..	106
Effect of parasitism by <i>Aphidius</i> upon fecundity of host.....	107
Movement of larva within the host and manner of attaching it to the plant.....	109
Fecundity.....	113
Parthenogenesis.....	114
Hosts of <i>Aphidius testaceipes</i>	115
Hibernation.....	117
Influence of winds in the dispersion of <i>Aphidius testaceipes</i>	118
Temperature influences of <i>Aphidius</i>	119
Effects of wet weather on the diffusion of <i>Aphidius</i>	121
Other species of <i>Aphidius</i>	122
Aphelinus.....	122
Notes on life history and habits of Aphelinus.....	124
Secondary parasites.....	125
<i>Megorismus</i> sp.....	125
<i>Aphidencyrthus aphidiphagus</i> Ashm.....	126
<i>Pachyneuron</i> sp.....	127
<i>Allotria</i> sp.....	128
Predaceous enemies.....	128
Lady-beetles.....	128
Syrphid flies.....	129
Lacewing flies.....	132
Cecidomyiidæ.....	133
Birds.....	135
Miscellaneous enemies of Toxoptera.....	135
Ants and their relation to Toxoptera.....	136
Remedial and preventive measures.....	136
Field experiments.....	136
Cultural methods.....	139
Artificial introduction of parasites.....	142
Literature consulted.....	144
Index.....	145

ILLUSTRATIONS.

PLATES.

	Page.
PLATE I. Fig. 1.—Wheat field totally destroyed by the spring grain-aphis (<i>Toxoptera graminum</i>). Fig. 2.—Circular spot in wheat field where growing grain has been destroyed by the spring grain-aphis.....	32
II. Fig. 1.—Stand on which experiments were carried out in rearing the spring grain-aphis. Fig. 2.—Area on grounds of the United States Department of Agriculture, at Washington, D. C., where the spring grain-aphis usually occurs on bluegrass in excessive abundance during summer.....	36
III. Development of the embryo in the egg of <i>Toxoptera graminum</i> . Fig. 1.—Longitudinal section showing the blastoderm partly formed. Fig. 2.—Longitudinal section showing the thickening of the blastoderm about the ovarian yolk previous to invagination. Fig. 3.—Longitudinal section representing the germ band at the beginning of invagination folding inward about the ovarian yolk. Fig. 3a.—Section of the blastoderm. Fig. 4.—Longitudinal section of a more advanced stage of invagination, the germ band having almost closed over the ovarian yolk.....	100
IV. Development of the embryo in the egg of <i>Toxoptera graminum</i> . Fig. 1.—Longitudinal section representing the somewhat cone-shaped germ band ready to release itself from the surface of the egg. Fig. 2.—Sagittal section representing the tubular germ band completely submerged within the yolk. Fig. 3.—Transverse section of the germ band. Fig. 4.—Sagittal section showing the germ band folding and differentiating into amnion and germ band proper....	100
V. Development of the embryo in the egg of <i>Toxoptera graminum</i> . Fig. 1.—Sagittal section showing the germ band differentiated into three layers and folded almost upon itself. Fig. 2.—Surface view of Plate VI, figure 1. Fig. 3.—Surface view of Plate VI, figure 2..	100
VI. Development of the embryo in the egg of <i>Toxoptera graminum</i> . Fig. 1.—Sagittal section of the embryo, showing the segmentation. Fig. 2.—Sagittal section showing a much more advanced stage of growth than that of figure 1.....	100
VII. Development of the embryo in the egg of <i>Toxoptera graminum</i> . Fig. 1.—Sagittal section showing the embryo in position to escape from the center of the egg. Fig. 2.—Sagittal section showing the embryo at the surface of the egg. Fig. 3.—Sagittal section, later stage of development. Fig. 4.—Sagittal section; dorsal organ immersed within the body cavity where it has begun to disintegrate.	
VIII. A lady-beetle enemy of the spring grain-aphis. Pupæ of <i>Hippodamia convergens</i> attached to stem of cowpea and wheat straws in a field where the spring grain-aphis had been excessively abundant....	128
IX. Fig. 1.—Brush drag used by the junior author in experiments and also by farmers in destroying the spring grain-aphis in the fields at Hobart, Okla. Fig. 2.—Roller used in experiments by the junior author and by farmers in experiments in destroying the spring grain-aphis in Oklahoma.....	136

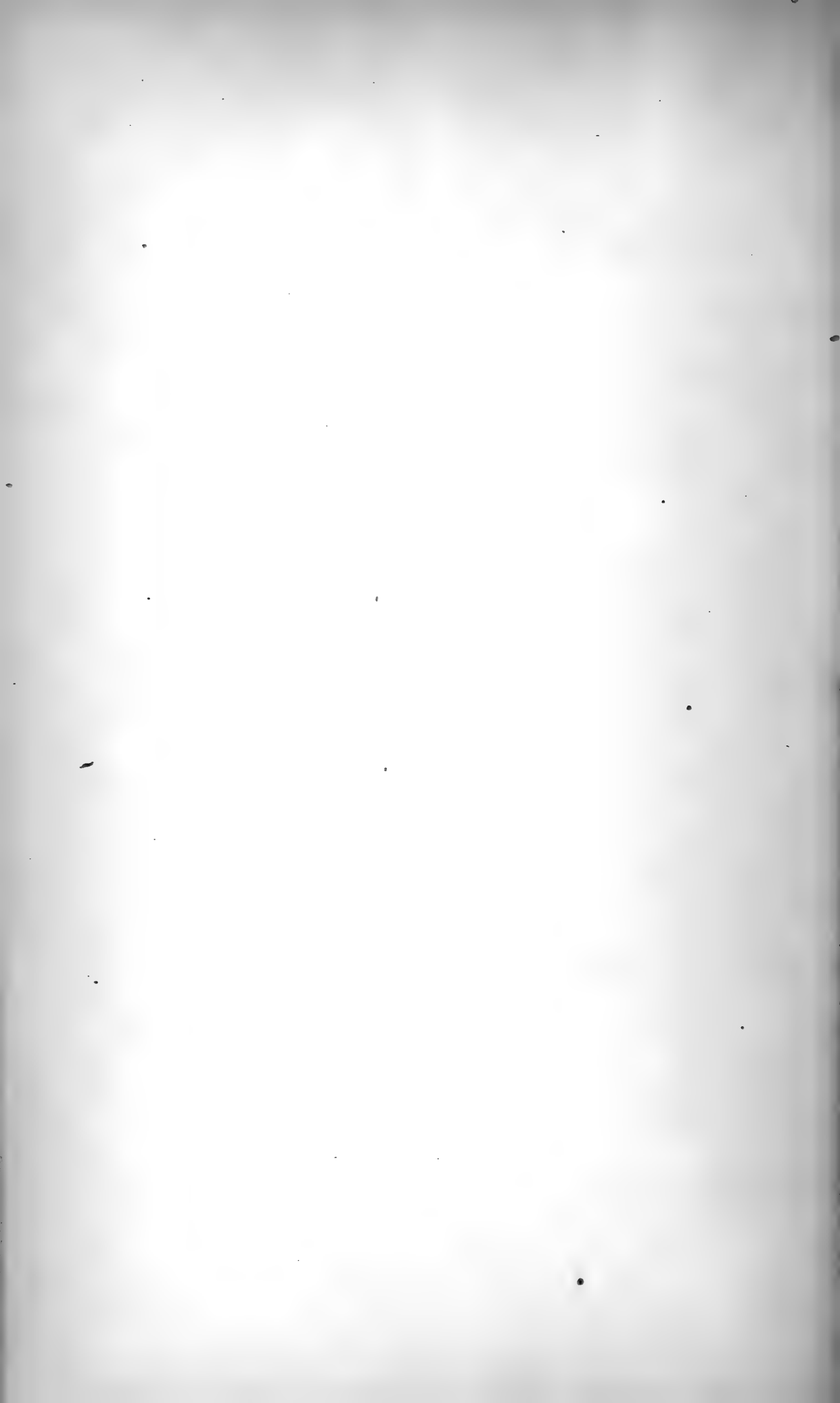
TEXT FIGURES.

	Page.
FIG. 1. The spring grain-aphis (<i>Toxoptera graminum</i>): Winged and wingless viviparous females and young on wheat plant.....	12
2. Map showing the locality from which the spring grain-aphis was received in 1882 and the two additional localities where it is probable that it also occurred in injurious numbers in that year; also the two localities where it was found in 1884.....	14
3. Map showing the distribution of the spring grain-aphis in both the eastern and the western hemispheres.....	17
4. Map showing the known distribution of the spring grain-aphis in the United States and Canada.....	19
5. Maps showing areas covered by outbreaks of the spring grain-aphis during the years 1890, 1901, 1903, and 1907.....	20
6. The spring grain-aphis: Male and antenna.....	45
7. The spring grain-aphis: Winged viviparous female and antenna.....	46
8. The spring grain-aphis: Wingless viviparous female.....	47
9. The spring grain-aphis: Oviparous female showing eggs within the abdomen.....	50
10. The spring grain-aphis: Hind tibia of oviparous female.....	50
11. The spring grain-aphis: Eggs.....	51
12. The spring grain-aphis: Young, first instar.....	59
13. The spring grain-aphis: Young, second instar.....	59
14. The spring grain-aphis: Pupa of winged viviparous female.....	60
15. The spring grain-aphis: Shrunken and nearly spent oviparous female..	79
16. The spring grain-aphis: Aberrant female with both eggs and embryos in abdomen showing through the body wall.....	80
17. The spring-grain-aphis: Aberrant female pupa which produced young.	81
18. The spring grain-aphis: Shell of egg after young stem-mother has emerged.....	103
19. <i>Aphidius testaceipes</i> , principal parasite of the spring grain-aphis: Adult female, antenna of male, egg.....	104
20. <i>Aphidius testaceipes</i> ovipositing in the body of the spring grain-aphis...	105
21. Position of larva of <i>Aphidius testaceipes</i> in the body of wingless adult female of the spring grain-aphis, from 11 a. m. to 12.32½ p. m.....	110
22. Position of larva of <i>Aphidius testaceipes</i> in the body of the spring grain-aphis at the beginning of the change to a yellowish color.....	111
23. Full-grown larva of <i>Aphidius testaceipes</i> taken from body of the spring grain-aphis as shown in figure 21.....	111
24. Larva of <i>Aphidius testaceipes</i> spinning its cocoon in the dead body of the spring grain-aphis.....	112
25. Larva of <i>Aphidius testaceipes</i> working its way prematurely from the body of the spring grain-aphis.....	112
26. Full-grown larva of <i>Aphidius testaceipes</i>	112
27. Pupa of <i>Aphidius testaceipes</i> immediately after pupation.....	113
28. Dead "green bugs" (<i>Toxoptera graminum</i>) showing exit holes of <i>Aphidius testaceipes</i>	113
29. The spring grain-aphis: Winged female parasitized by <i>Aphidius testaceipes</i>	118
30. <i>Aphelinus mali</i> : Adult and stigmal club.....	122
31. <i>Aphelinus nigrinus</i> : Adult and stigmal club.....	123
32. <i>Aphelinus semiflavus</i> : Adult and stigmal club.....	124
33. The spring grain-aphis: Dried remains from which adult <i>Aphelinus nigrinus</i> has emerged.....	124
34. <i>Megorismus</i> sp.: Male, female abdomen.....	126

	Page.
FIG. 35. <i>Aphidencyrthus aphidiphagus</i> : Adult.....	127
36. <i>Pachyneuron</i> sp.: Adult.....	127
37. <i>Allothria</i> sp.: Male, female antenna.....	128
38. The convergent lady-beetle (<i>Hippodamia convergens</i>): Adult, larva, pupa	129
39. The nine-spotted lady-beetle (<i>Coccinella 9-notata</i>): Adult.....	129
40. The nine-spotted lady-beetle (<i>Coccinella 9-notata</i>): Full-grown larva.	129
41. The spotted lady-beetle (<i>Megilla maculata</i>): Adult, larva, pupa.....	130
42. A South African lady-beetle, <i>Adalia flavomaculata</i>	130
43. <i>Syrphus americanus</i> : Adult female and details of male.....	131
44. <i>Eupeodes volucris</i> : Adult female and details of male.....	131
45. <i>Sphaerophoria cylindrica</i> : Adult female and details of male.....	132
46. The golden-eyed lacewing fly (<i>Chrysopa oculata</i>): Adult and details, eggs, larvæ, cocoon.....	133
47. <i>Aphidoletes</i> sp., a cecidomyiid fly enemy of the spring grain-aphis....	134
48. <i>Aphidoletes</i> sp., a cecidomyiid larva which attacks the spring grain- aphis.....	135

DIAGRAMS.

DIAGRAM I. Maps of the United States east of the Rocky Mountains, showing normal temperature and departure therefrom for the critical period December, 1881, to May, 1882.....	15
II. Maps of the United States east of the Rocky Mountains, showing normal temperature and departure therefrom for the critical period December, 1889, to May, 1890.....	21
III. Maps of the United States east of the Rocky Mountains, showing normal temperature and departure therefrom for the critical period December, 1900, to May, 1901.....	25
IV. Maps of the United States east of the Rocky Mountains, showing normal temperature and departure therefrom for the critical period December, 1902, to May, 1903.....	26
V. Maps of the United States east of the Rocky Mountains, showing normal temperature and departure therefrom for the critical period December, 1906, to May, 1907.....	28



THE SPRING GRAIN-APHIS OR "GREEN BUG."

INTRODUCTION.

Investigations of the spring grain-aphis, or "green bug" (*Toxoptera graminum* Rond.) (fig. 1), in America were first begun by the senior author in the year 1884, at Oxford, Ind., where the insect was accidentally introduced with, or had in some obscure way gained access to wheat plants which had been transplanted from the open to rearing cages standing out of doors on a blue-grass lawn (June 6) and used in carrying out investigations on the greater wheat straw-worm (*Isosoma grande* Riley). At that time the insect gave no indication of its present economic importance and for this reason was not then given special attention.

In 1890, when the pest really first gave evidence of its capabilities as a grain destroyer over a wide range of country, the senior author again took up its study, gaining considerable additional knowledge of its habits and of the influences of temperature and season upon its abundance. (See Diagrams I-V.)

The less serious outbreak of 1901 was not investigated and our information relative to it is derived chiefly from correspondence of the bureau for that year.

The incipient outbreak of 1903 was reported from Texas by Prof. E. D. Sanderson, at that time State entomologist, and from South Carolina by correspondents of the bureau.

The last and most disastrous outbreak of all, that of 1907, was investigated not only by both of the authors, but by Mr. C. N. Ainslie, who began his work on the species at Summers, Ark., on March 18, continuing the investigation almost uninterruptedly through the summer, working over the country from central Oklahoma northward to Canada, and returning to Washington in September. The junior author spent April, May, and a portion of June in Oklahoma and Kansas in field investigations, returning to Richmond, Ind., where he was at that time located and where he took up a systematic study of the insect, its habits, and development—a study which has been continued up to the time of preparation of this manuscript for publication. Messrs. E. O. G. Kelly and T. D. Urbahns spent much time in a study of the parasites; indeed, most of the assistants in cereal and forage insect investigations have

contributed more or less to our knowledge of the pest and its natural enemies, and throughout the following pages credit has been given



FIG. 1.—The spring grain aphid (*Toxoptera graminum*): Wheat plant showing winged and wingless viviparous females with their young clustered on the leaves, and a few parasitized individuals on lower leaves. About natural size. (Original.)

each individual where possible to do so. For a critical, technical study of the parasites of the species, credit should be given Mr. J. C. Crawford, assistant curator, Division of Insects, U. S. National

Museum, and Mr. H. L. Viereck, expert, Bureau of Entomology, who are specialists in the parasitic Hymenoptera.

During the winter of 1907-8 Congress provided the sum of \$10,000 for carrying on these investigations; otherwise this work would have been impossible.

EARLIEST OBSERVATIONS ON THE INSECT IN AMERICA.

The first examples of *Toxoptera graminum* to be found in America and identified as such were probably collected with the oats plants which they were destroying by Mr. H. S. Alexander, of Culpeper, Va., on June 15, 1882. A letter in the files of the Bureau of Entomology, written on the above date and addressed to Hon. George B. Loring, then Commissioner of Agriculture, stated that he, Mr. Alexander, was sending by that evening's mail specimens of an insect which had almost entirely destroyed the oats crop in his neighborhood. But he very evidently neglected to indicate on or within the package the name and address of the sender. Under date of June 17, 1882, the records of the old Division of Entomology show, however, that a package of oats or wheat plants—exactly which could not be determined by the person making the examination—were received on that date, badly infested by what was determined as *Toxoptera graminum*. As there was nothing on or within the package to indicate the source from which the material came, the locality has since remained in obscurity. Upon a recent examination of the old letter files, the communication of Mr. Alexander was found and a reply thereto by Dr. Riley, dated July 7, 1882, stating that the communication had been received from Mr. Alexander, but that the specimens referred to by him had not arrived. As the Division of Entomology did not have these specimens before them when Mr. Alexander's letter was received, or did not connect these specimens with his letter it was assumed that the species was the well known *Siphonophora avenæ* Fab., a name at that time applied to what is now called *Macrosiphum granaria* Buckt. Evidently the connection between the letter and package was never investigated, as the insects in the package proved to be Toxoptera. It is significant that of the eight communications received at the Department of Agriculture about that time, from various points in Virginia and including also one from Maryland, all relating to the wheat louse, this one from Mr. Alexander is the only one not shown to have been accompanied by specimens, and also it was the only communication in which reference was made to the destruction of oats, all of the other letters alluding to insects found infesting wheat or rye, which were probably *M. granaria* Buckt. Without a doubt, therefore, the letter of Mr. Alexander refers to the package received June 17, 1882, without

name or address of the sender. A correspondent of the "Country Gentleman," writing over the initials G. C., from Chrisman, Rockingham County, Va., about 50 miles west of Culpeper, under date of June 16, 1882, makes this statement:

Wheat looking well and promising, but there is a little green bug on it that may injure it. This same little green fellow is ruining the oats in this neighborhood, and has already destroyed them entirely in many localities.¹

It is not at all surprising that *Toxoptera* and *Macrosiphum* should have been confused at that time, as the former species was yet



FIG. 2.—Map showing the locality from which the spring grain-aphis was received in 1882 and the two additional localities where it is probable that it also occurred in injurious numbers in that year; also the two localities where it was found in 1884. (Original.)

unknown in the country and its presence could only be determined from winged individuals. In all of the succeeding outbreaks of *Toxoptera* it has been more or less difficult to separate the wingless individuals of these two species definitely from each other, even experts having been often at fault where there were only immature individuals upon which to base a separation. In this connection Mr. B. F. White, writing from Mebane, N. C., January 28, 1890, complaining of damage at that time to oats in his locality by *Toxoptera*, specimens of which accompanied

his communication, stated that the same insect appeared in 1882, in May. So, then, it seems quite likely that, while the discovery was first made at Culpeper, Va., the insect occurred over a considerable area of country in Virginia, extending southward into northern North Carolina (see fig. 2; Diagram I, p. 15).

From the foregoing it would appear that at this early date there was a more or less destructive outbreak of this pest in the southern Atlantic States. That the species was confined to this area, however, is hardly possible, and indeed it is not beyond possibility that damage to oats may have extended much farther westward, though we have been unable to find definite proof to that effect. The all-important temperature influences are also indicated.

¹ Cultivator and Country Gentleman, vol. 47, p. 498, June 22, 1882.

On June 7, 1884, Mr. Albert Koebele found this species infesting wheat plants at Cabin John Bridge, situated in Maryland a few miles above Washington, and about July 1 of the same year the senior

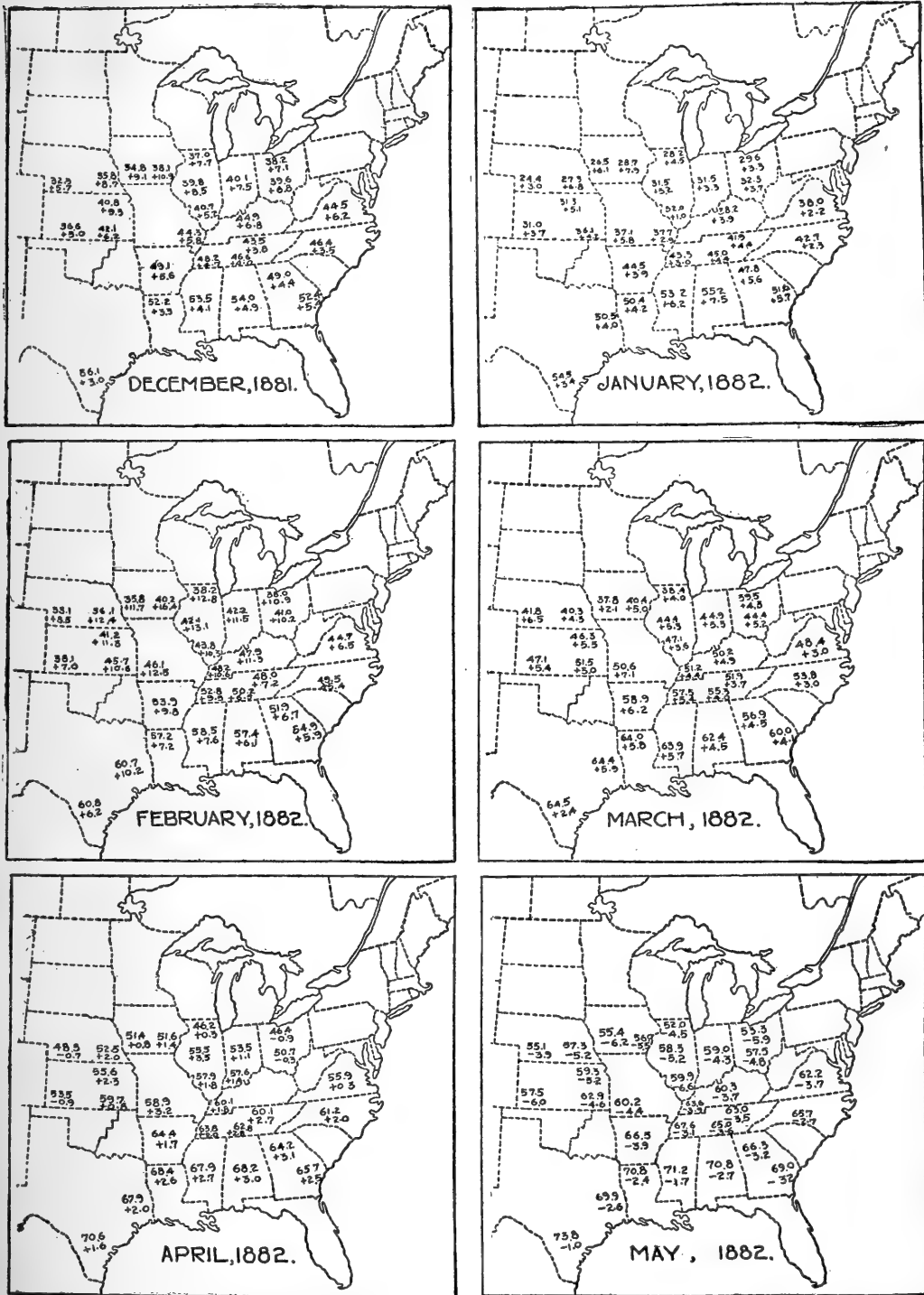


DIAGRAM I.—Maps of the United States east of the Rocky Mountains, showing normal temperature, upper line, and departure therefrom, lower line (+, above normal, and, —, below), for the critical period December, 1881, to May, 1882; above normal (+) in winter and below normal (—) in spring being favorable for outbreak of spring grain-aphis. (Original.)

author found it in one of his rearing cages, placed out of doors at Oxford, Ind. (see fig. 2). In the latter instance the species showed a preference for wheat plants over those of rye, and in September it

was common in the fields on volunteer wheat plants in the same locality and also about La Fayette, Ind. In some fields it was observed breeding on the young growing wheat throughout the autumn and early winter up to December 13. On the 30th of December it was still to be found alive in the fields, though not in great abundance.

EARLY RECORDS IN EUROPE.

The first exact knowledge we have of this insect is its occurrence in excessive abundance about Parma, Italy, in 1847. Five years later, in 1852, Rondani, who described the species during this year, wrote to Prof. Bertoloni under date of June 14, also from Parma, relative to the insect as follows:

We have in our city an innumerable number of insects of a species of the *Aphis* genus, of Linnæus, of the order of Hemiptera. Sometimes and in certain places the number of these insects flying in clouds in the air has been so great as to render them troublesome to people, entering the nose, eyes, and even the mouth, when one can not think how to protect oneself from them.

Elsewhere in this letter Rondani stated that he had never been able to find it on any but graminaceous plants, where it nestled on the leaves. In commenting on this letter of Rondani, Prof. Bertoloni took occasion to say that "innumerable specimens of the *Aphis graminum* Rondani are seen in the streets of the city of Bologna, and these have several times entered my nose and eyes when passing rapidly along the canal of Reno."

KNOWN DISTRIBUTION IN THE EASTERN HEMISPHERE.

Besides these occurrences in Italy and Hungary (see fig. 3), in 1884 Dr. G. Horvath records an attack on oats in central Hungary, which took place in June, 1883, and 10 years later, in 1894, Prof. Carl Sajo records a second outbreak among growing oats, also in Hungary.

Schouteden, in 1906, records the species from Belgium, but gives no further data except that it affects the Graminaceæ.

Under date of October 7, 1907, Mr. H. Neethling, chief of the horticultural and biological division, department of agriculture, Bloemfontein, Orange River Colony, South Africa, in a letter addressed to the United States Department of Agriculture, stated that the wheat aphid was one of the greatest scourges with which the farmers of his colony had to contend, nearly the whole crop having been destroyed by it for several consecutive seasons. Again, under date of September 28, 1908, the same gentleman stated that the pest had been particularly active that season, it being estimated that more than 50 per cent of the entire wheat crop of the colony had been destroyed by its ravages. This latter communication was accompanied by specimens of *Toxoptera graminum* as well as a small

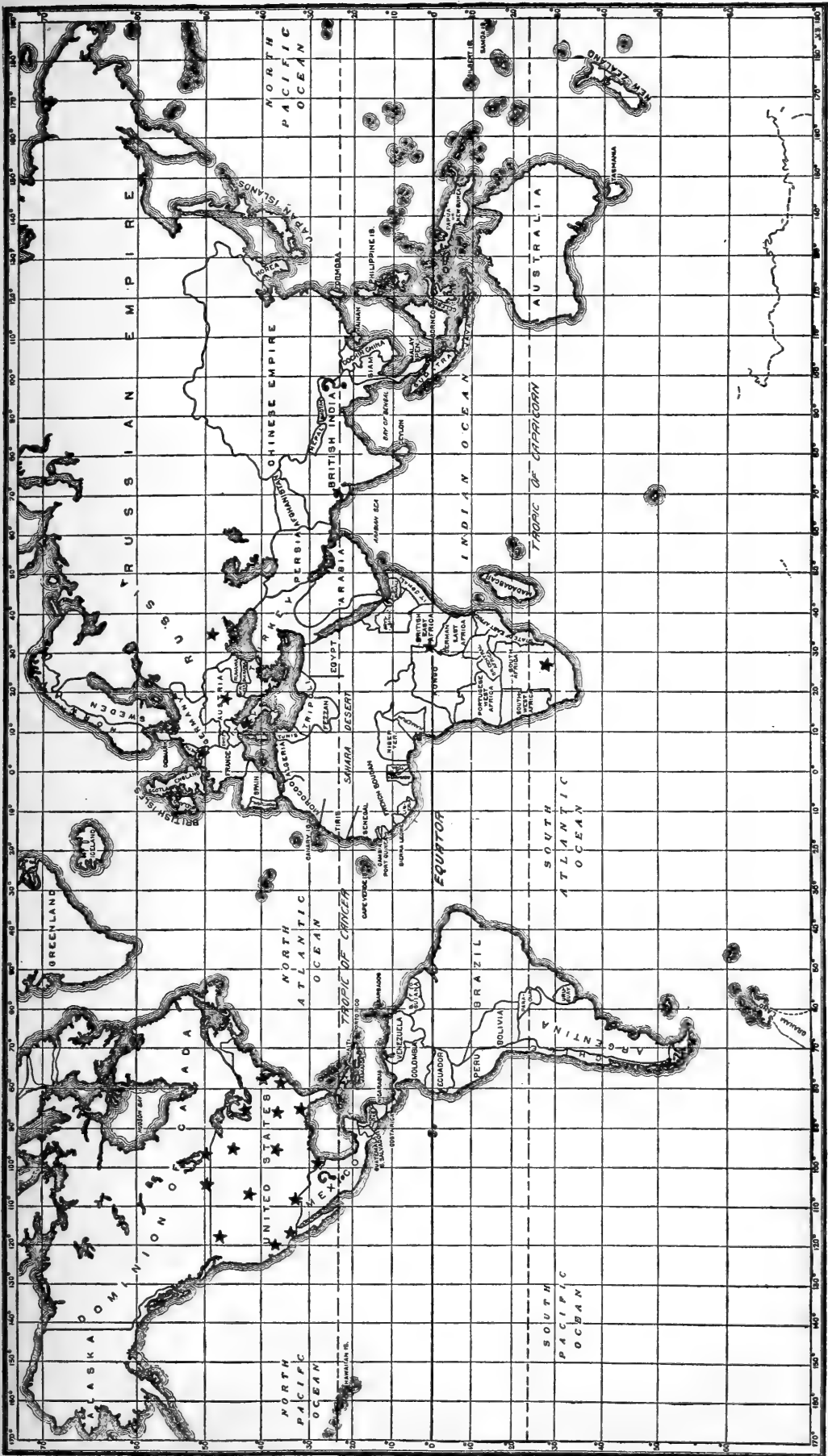


Fig. 3.—Map showing the distribution of the spring grain-aphis in both the eastern and the western hemispheres. Known localities are indicated by an *; suspected localities by ?.

(Original.)

hymenopterous parasite, *Aphidius* sp., and larvæ and adults of a coccinellid, *Adalia flavomaculata* De G., both of which were observed destroying the aphidids. Under date of October 1, 1910, Mr. C. P. v. d. Merwl, assistant biologist of the same department, stated that another outbreak of the pest had taken place that spring and considerable damage had been done. In this communication the statement was made that the writer had personal knowledge of the occurrence of the species during the past 20 years, and that farmers had stated that they had always known of its occurrence in that country. It had, however, become seriously destructive during recent years and at that time farmers were being forced to give up growing wheat extensively on account of its ravages.

In the *Agricultural Journal of India*¹ Mr. H. Maxwell-Lefroy, government entomologist of British India, stated that the wheat aphid (*Toxoptera graminum*) seeks shelter in the depths of the grass roots; in different ways insects adapt themselves, but these had probably done it gradually, moving in from cooler to hotter areas step by step. From the illustration of this insect accompanying this statement and from specimens later submitted by Mr. Maxwell-Lefroy, it has been found impossible to determine the species involved as *Toxoptera graminum*.

On November 25, 1910, Mr. William Sewall, of Njoro, British East Africa, called at the office of this bureau to complain of the ravages of a green louse or fly which attacked and destroyed wheat on his farm in the above-named locality, situated almost directly on the equator in a prairie-like country at an elevation of 7,000 feet above sea level. A communication was received from Mr. Sewall bearing date of August 22, 1911, accompanied by specimens, in which he stated that the ravages now extend over an area of 700 acres. He also stated that his neighbor, Lord Delamere, who had not been troubled previously, experienced severe losses over an area of about 4,000 acres. The specimens accompanying Mr. Sewall's letter have been determined as *Toxoptera graminum* by Mr. J. T. Monell.

With these records of the known and probable distribution of *Toxoptera graminum*, it does not seem improbable that if the minute insects of the family Aphididæ were carefully studied this species would be found generally diffused throughout the temperate and tropical regions of the world.

KNOWN DISTRIBUTION IN THE WESTERN HEMISPHERE.

With reference to the distribution of this insect in the Western Hemisphere (see fig. 4), it can be said that it has only been studied in the United States. Its occurrence in western Canada is well established. On the south it is known along the Mexican border from the Gulf of

¹ "Imported insect pests." *Agricultural Journal of India*, vol. 3, part 3, pp. 243-244, July, 1908.

Mexico almost to the Pacific Ocean. It has not actually been found in Mexico and no one has searched for it there. Wheat in Mexico is said to have been injured by a "green louse," and it is reasonable to suppose that the insect may occur far to the southward of its present known range of distribution. Its entire absence from eastern Canada and northeastern United States, except in eastern Massachusetts near Boston, where it seems to have been found by Mr. Paul Hayhurst in September, 1908, will be noted.

THE OUTBREAK OF 1890.

(Fig. 5, p. 20; Diagram II, p. 21.)

Up to the year 1890 in this country the very destructive nature of this insect had not yet become apparent; hence it had not received the close attention that, as we now understand, it justly deserves.

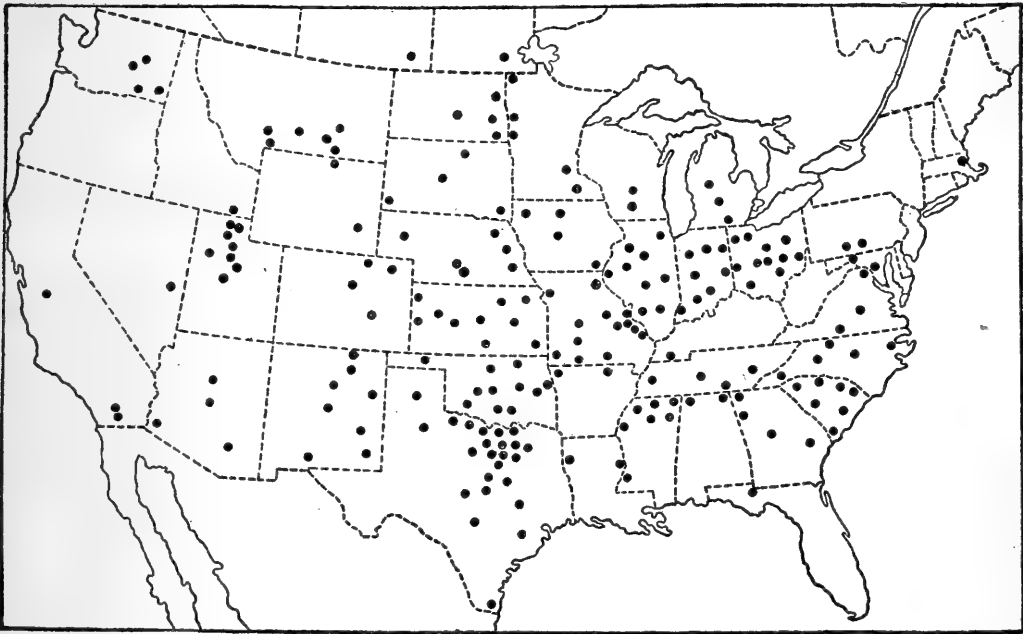


FIG. 4.—Map showing the known distribution of the spring grain-aphis in the United States and Canada. (Original.)

While the senior author was and had been engaged in grain-insect investigations in Indiana during the six years following its discovery by him at Oxford, the species was not looked upon as one of those deserving especial attention; therefore from 1884 to 1889 no notes were made upon it, and no references to it are to be found in the correspondence of the Division of Entomology. Mr. J. T. Monell, now of this bureau, however, has specimens in his collection from Illinois, taken in 1886.

During November and December, 1889, the insect was again observed in such abundance in fields of young wheat about Lafayette, Ind., as to attract the attention of the senior author, who found it repeatedly on young wheat in the fields during the entire winter. The influences of mild or high temperatures during winter, especially

in the South, and low temperatures during spring months were carefully observed and set forth in a report published later.¹

As early as the middle of January, 1890, it was reported by Mr. P. C. Newkirk as killing the young wheat about Jalapa, Tenn., and on the 26th of the same month Mr. B. F. White, of Mebane, N. C., reported it as ruining both wheat and oats in his neighborhood. Mr. J. L. Fooks, writing on the same date from Era, Tex., stated that the insect had played sad havoc with the wheat in his neighborhood, while April 7 Mr. D. J. Eddleman, Denton, Tex., complained of the pest destroying the wheat. Writing in 1901 Mr. H. K. Jones, Valley View, Tex., stated that the insect appeared there about 10 years pre-

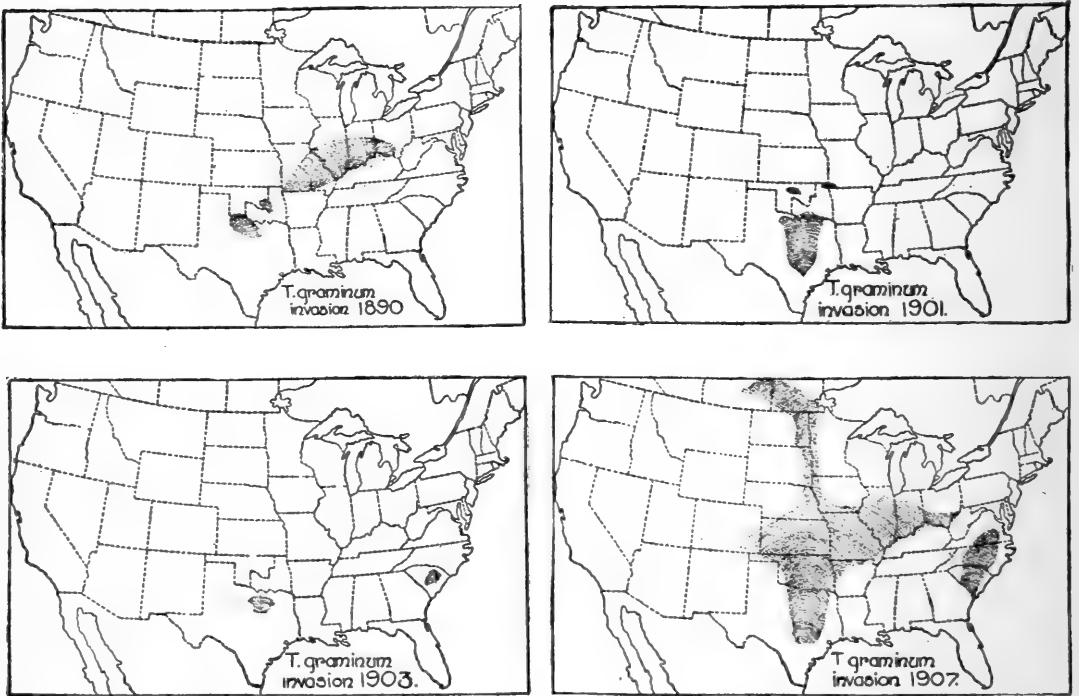


FIG. 5.—Maps showing areas covered by outbreaks of the spring grain-aphis during the years 1890, 1901, 1903, and 1907. (Original.)

vious and killed about all the wheat in the county. From this and other correspondence, accompanied by specimens, it seems that wheat in Cooke, Grayson, Collins, Denton, and Wilbarger counties, Tex., was more or less damaged by this pest.² No reports are at hand showing injuries to wheat or oats in what was at that time Oklahoma and Indian Territories, for the reason that little of either of these grains was at that time grown. But we now know that grains were not essential to its presence in that country.

In Missouri the situation was more acute and strongly indicates that the pest was present in southeastern Kansas and northern Arkansas. According to Mr. Monell's notes, the pest completely

¹ *Insect Life*, vol. 4, pp. 245-248, 1892; Bul. 22, Div. Ent., U. S. Dept. Agr., pp. 64-70, 1890; *Yearbook U. S. Dept. Agr. for 1907*, pp. 239-241.

² *Insect Life*, vol. 3, p. 75.

destroyed a field of 60 acres of oats belonging to Hon. Roland Hazard at Mine Le Motte, situated about 100 miles south of St. Louis, Mo.,

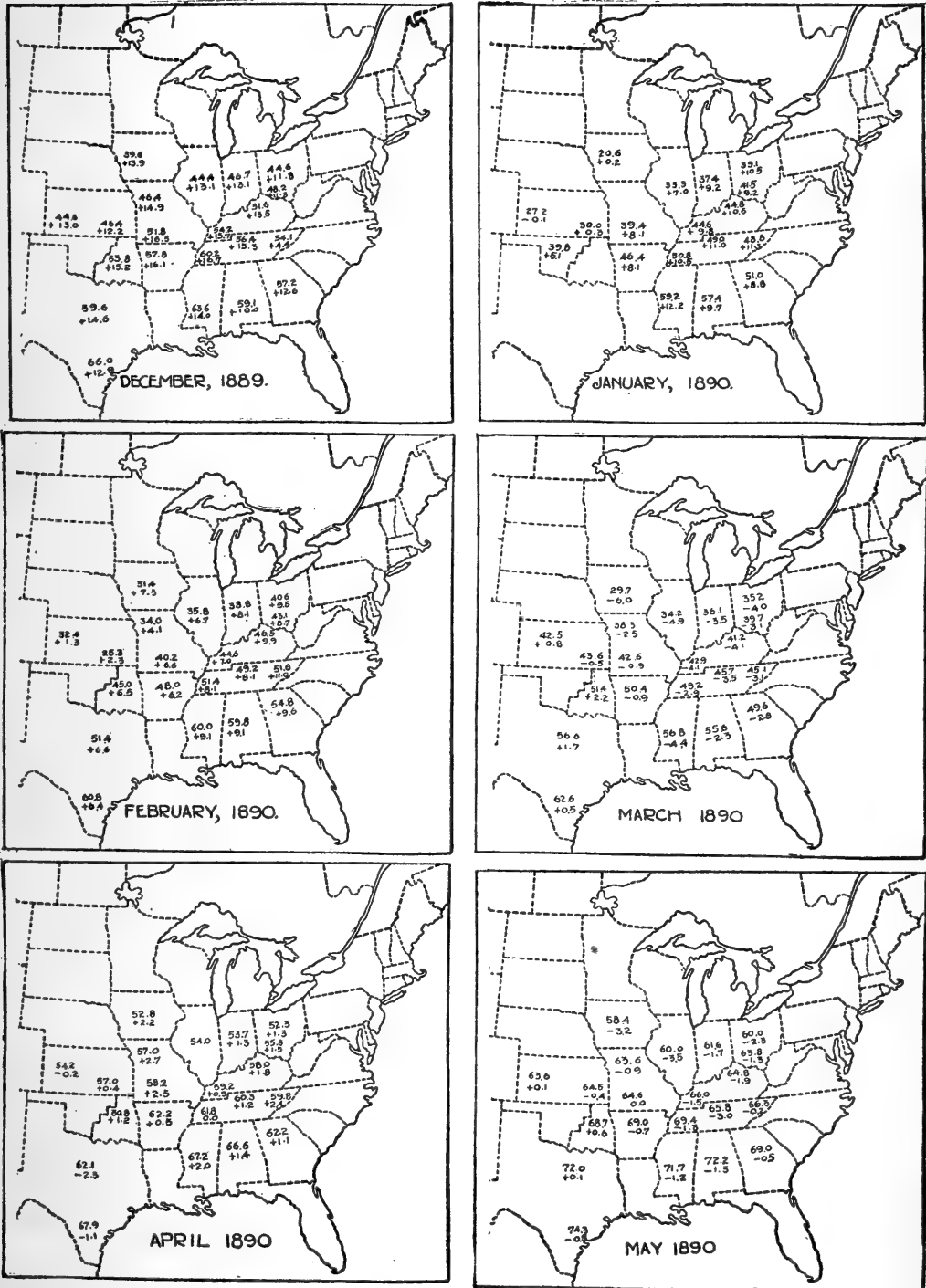


DIAGRAM II.—Maps of the United States east of the Rocky Mountains, showing normal temperature, upper line, and departure therefrom, lower line (+, above normal, and -, below normal), for the critical period December, 1889, to May, 1890; above normal (+) in winter and below normal (-) in spring being favorable for outbreak of spring grain-aphis. (Original.)

the observations being made June 10, 1890. In Missouri the situation appears to have been pretty clearly set forth by Colman's Rural World, then the leading agricultural paper of the Southwest. In the

issue of that publication for June 12, 1890, the following statement is made:

The oat crop in the vicinity of St. Louis and probably extending a hundred miles in every direction is being completely destroyed this season by an aphid, commonly called, we believe, the Texas louse. The oat fields look brown and bare, this little green insect sucking the juices and sapping the vitality of the plant. It increases with amazing rapidity, fully as rapidly, we judge, as the hop louse, swarming in every direction and carrying destruction in its path. The only thing they seem to feed upon is the oat.

In the issue of the same publication for June 19, a week later, the following statement is made:

The oat crop this season will be almost a total failure in St. Louis County. Hundreds of acres have been totally destroyed by the aphid, or plant louse, the depredations of which have been so widespread and effective that only a very small per cent of the crop will mature. Hundreds of farmers have despaired of the crop entirely, and have plowed up their oat fields and planted corn instead.

The Weather Crop Bulletin of the Missouri State Board of Agriculture for the week ending July 4, 1890, gives the following estimates of the oats crop throughout the State. Northeastern Missouri, 63 per cent; northwestern Missouri, 70 per cent; southeastern Missouri, 25 per cent; central Missouri, 30 per cent; southwestern Missouri, 54 per cent. As another writer describes it, the damage was most serious south of a line drawn diagonally across the State from the northeast to the southwest corner.

The statement made in Colman's Rural World to the effect that the oats crop within a radius of a hundred miles of St. Louis had been completely destroyed by the oats aphid or "Texas louse" would include within this radius territory nearly half way across southern Illinois. Mr. B. F. Johnson, of Champaign, Ill., an agricultural writer, who appears to have traveled over the country quite extensively and observed the situation closely, writing to the Country Gentleman under date of June 24, sized up the situation as follows:

For some weeks after it was seen above ground, the oat crop looked well and promised well, and this continued to the first or about that date in June. Since then oats have been going behind hand, with the threat now over them that all the crop has been more or less seriously reduced in yield and a considerable portion will be lost. In fact, the oat aphid, after ruining the oat crop south, has appeared on the black soil in force and nothing less than many and heavy rains will arrest his progress. As before reported, the dry weather in May favored a light growth of straw, as in 1887, and hopes were entertained that long heads of sound grain would result. Such would have been the case had not the aphid appeared and sucked a part of the life-blood of the plants. The present appearance of a majority of oat fields—the acreage on the black soil counties is an enormous one—is rather uneven as to growth, color, and measure of development, a part of which is owing to the greater or less fertility of the soil, but chiefly to the depredations of the aphid, that takes the weakest plants growing on the thinnest land.

In the issue of August 14 of the same publication, Mr. John M. Stahl, of Adams County, Ill., states that in western Illinois the only

cause of the failure of the oats crop recognized was the green louse. Directly upon this point his statements were as follows:

We never had a better prospect for oats until the green louse began its work. Some fields were not attacked by the louse, though it infested surrounding fields. From the fields not attacked by it there was a splendid yield of oats; while, of course, the other fields yield scarcely anything. In every township there were a few fields that were not attacked by the green louse and that made a good yield. The fact that those fields not attacked by the green louse invariably made a good yield, while those that were attacked made a poor yield, is proof that in this part of the State, at least, the green louse was the prime cause of the failure.

This feature of the apparent immunity of some fields from attack while others adjacent were destroyed has since been observed again and again, especially along the borders of a serious invasion, which was precisely the situation in western Illinois at the time indicated by Mr. Stahl. In Indiana the senior author investigated the outbreak personally, and while the pest was present as far north as Lafayette, there was little if any damage from its attacks north of Indianapolis. In the neighborhood of Franklin on June 25 many fields were badly damaged, but the injury was much more severe to the southward and at New Harmony, Ind., on June 11, the oats crop was ruined. The same was to be said of the country across the Wabash River in Illinois. While both Toxoptera and Siphonophora were present in most cases the former largely outnumbered the latter and there was no difficulty in properly crediting the destruction to Toxoptera.

The occurrence of this insect in southern Ohio was greatly obscured owing to the fact that it was, as elsewhere, confused with *Macrosiphum granaria* Buct. Clarence M. Weed, writing for the Ohio Farmer (see issue of July 12, 1890), states that in Ohio the grain plant louse had been reported from Pickaway, Clermont, Butler, and Franklin counties. It seems, however, that in Clermont County, according to Mr. Ed. C. Ely, the plant lice were at work as early as May 30.

In a later issue of the same paper, July 19, 1890, Hon. Abner L. Frazer, of Clermont County, Ohio, stated that the aphidids were very numerous in his fields on June 9. While it is impossible to say with absolute certainty that all damage was due to Toxoptera, nevertheless Waldo F. Brown, writing from Butler County¹ on June 19, says:

Oats are in a critical condition. The leaves have turned red. It has not the appearance of rust, looking more like the firing of a plant in dry weather, and I should not wonder if the crop proved a total failure.

In both Illinois and Missouri the aphidid causing the damage was termed the "Texas louse," and wherever a technical name for it was used at all it was called *Siphonophora avenæ* Fabr. Because Toxoptera was at that time but little known, and owing to the

¹ Country Gentleman, June 26, 1890, p. 506.

extreme difficulty in separating its young and its wingless adults from those of other species, it would seem that more or less damage to the oats crop might be with justice accredited to Toxoptera in Butler, Miami, and Clermont counties in extreme southern Ohio.

THE OUTBREAK OF 1901.

(Fig. 5, p. 20; Diagram III, p. 25.)

The outbreak of 1901 was less extensive than that of 1890. Little damage was reported south of Waco, Tex., but from this point northward wheat was more or less injured, and oats were destroyed to the northward into what was at that time Oklahoma and Indian Territories. The farthest point to northeast at which damage was reported, with specimens of the depredator, was Saratoga, in extreme southwestern Missouri. The specimens accompanying correspondence from Texas and Oklahoma gave ample proof of the identity of the destroyer, which in Texas alone ruined grain to the extent of several million dollars. In central Texas the ravages of the pest began to attract attention early in March, while the report from Missouri came under date of April 30. It will be noticed that the direction taken by this invasion followed very closely that of 1890 (see fig. 5), beginning, however, farther south in Texas, not extending so far to the northeast, and dying out, as it were, earlier in the season. These phenomena will be explained farther on under meteorological influences.

THE OUTBREAK OF 1903.

(Fig. 5, p. 20; Diagram IV, p. 26.)

As foreshadowing the impending outbreak of 1903, as early as November 26, 1902, Mr. J. F. Ordman, writing from Windthorst, Tex., complained to this bureau of the ravages of the green louse, stating that it had destroyed several small areas in his wheat field and that it was reported generally prevalent in his neighborhood. This outbreak was, however, an incipient one and resulted in little injury, the seriously infested areas being confined to northern Texas, exclusive of the "Panhandle," with possibly the country in the then Oklahoma and Indian Territories bordering the Red River, and in South Carolina. While the outbreak was thus limited in area, the natural enemies of the pest in the West evidently fell far short of completely subjugating it. In March, 1904, Prof. E. D. Sanderson and Mr. E. C. Sanborn found it in Grayson County, Tex., sufficiently abundant to work serious injury in the fields of young wheat and oats, in some cases the destruction of the growing grain

being complete. The same gentlemen reported the pest present in limited numbers during the spring of 1904 in Collin, Hunt, and

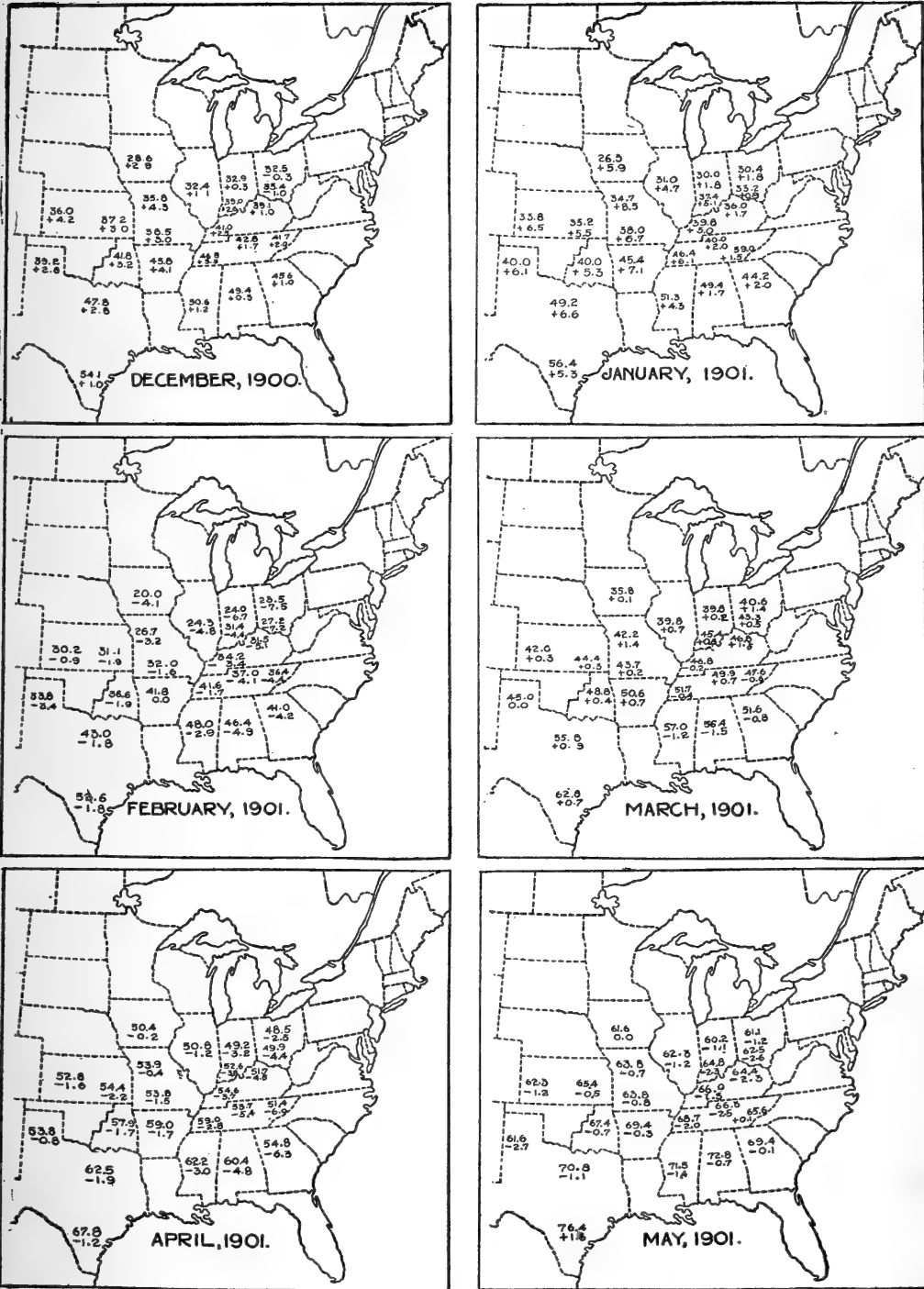


DIAGRAM III.—Map of the United States east of the Rocky Mountains, showing normal temperature, upper line, and departure therefrom, lower line (+, above normal, and -, below), for the critical period December, 1900, to May, 1901; above normal (+) in winter and below normal (-) in spring being favorable for outbreak of spring grain-aphis. (Original.)

Travis counties. This year, however, the parasites evidently did more effective service, as at Whitewright, Grayson County, Tex., on March 10, 1904, Mr. Sanborn found that 60 per cent of the Toxoptera

in some oats fields were parasitized. The junior author spent some time in northern Texas during November and December, 1904,

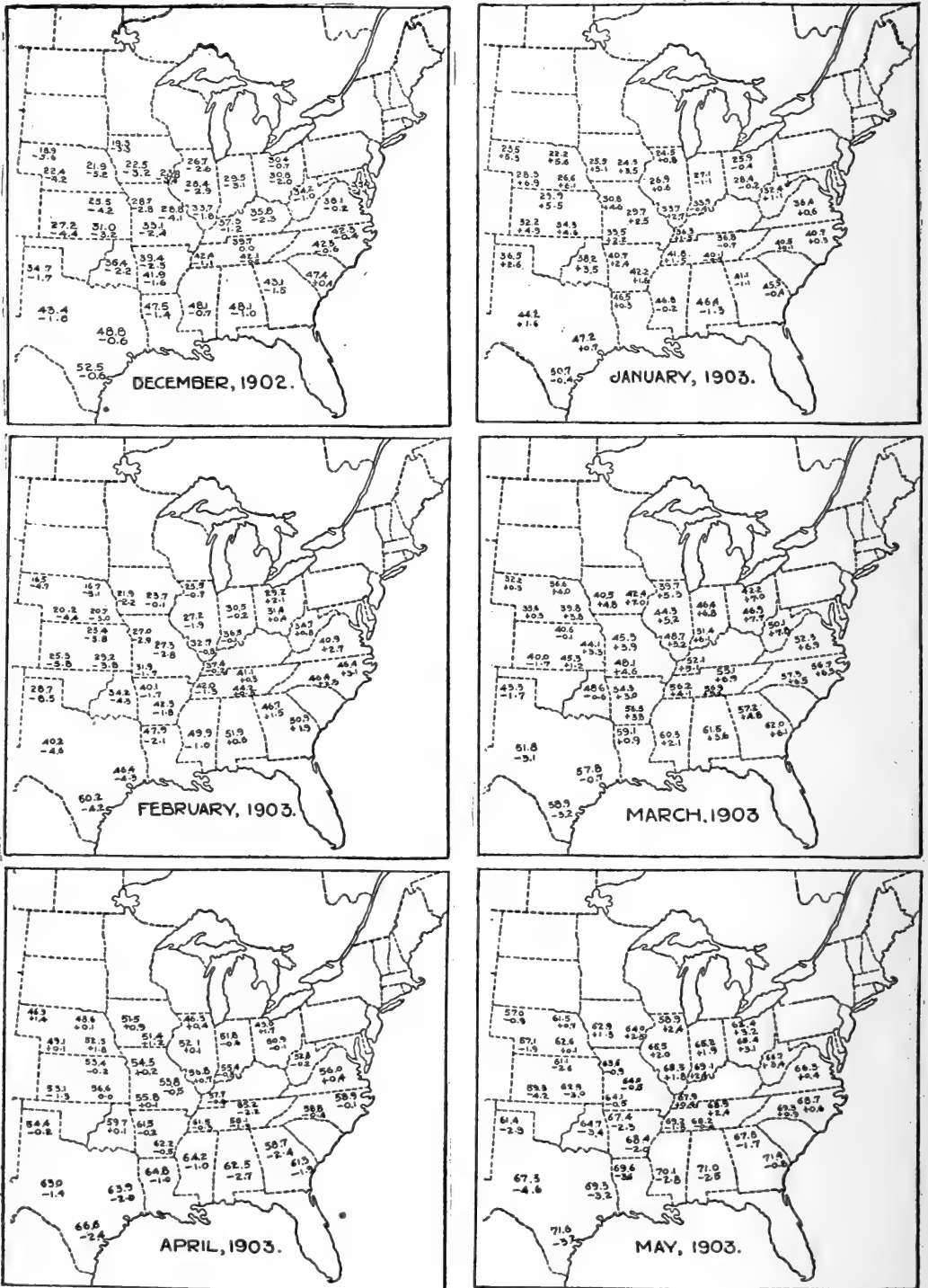


DIAGRAM IV.—Map of the United States east of the Rocky Mountains, showing normal temperature, upper line, and departure therefrom, lower line (+, above normal, and -, below), for the critical period December, 1902, to May, 1903; above normal (+) in winter and below normal (-) in spring being favorable for outbreak of spring grain-aphis. (Original.)

investigating insects in the fields of wheat and oats without finding the pest. He was not looking for this species particularly, and it was doubtless still present in very limited numbers.

THE OUTBREAK OF 1907.

(Fig. 5, p. 20; Diagram V, p. 28.)

The outbreak of 1907 was by far the most serious and widespread that has occurred in the United States up to the present time. Starting in east-central Texas, the invasion swept northward and eastward, covering a somewhat fan-shaped area, through Oklahoma, Kansas, northwestern Arkansas, Missouri, and across Illinois to within 60 miles of Chicago. Though possibly not doing so much damage in the Ohio Valley as in 1890, it extended westward through Oklahoma and Kansas into southeastern Colorado. While not especially injurious to oats and not at all to wheat in the States of Nebraska, Iowa, Minnesota or the Dakotas, the late Dr. James Fletcher states that in Canada it actually did some damage in Saskatchewan. Less damage was probably done in Indiana and Ohio than in 1890, though the ravaged area in general followed the ground covered by the previous outbreaks; in this latter case the northeastern terminus of the seriously ravaged area appeared to be confined more closely to the upper Mississippi River and Illinois River valleys than to that of the Ohio River, thus sweeping more broadly to the northward. On the Atlantic coast fall oats were destroyed or badly injured in South Carolina, and both wheat and oats in western North Carolina. In Virginia, Kentucky, and Tennessee neither grain was, as a rule, seriously damaged. The areas shown in figure 5 indicate all injury, even though slight, in occasional and widely separated fields. In the valleys of the upper Missouri River and the Red River of the North there was little or no injury, and it seems doubtful if the pest occurred in that section prior to this outbreak.

Forebodings of trouble from this pest came as early as November and December, 1906. According to copies of Mr. Sanborn's notes, as placed at our disposal by Prof. A. F. Conradi, the species was sent to the Texas experiment station from Howe, Grayson County, Tex., where it occurred on oats, as early as November 14, 1906, and one day earlier from Allen, Collin County, of the same State, where it was present in great numbers attacking volunteer oats plants. On December 22, 1906, it was sufficiently abundant about Plano, Collin County, Tex., to destroy oats in patches in the fields, its natural enemies at the time being in a dormant condition because the temperature had not reached and remained at a degree that would render them active. During January and February, 1907, these conditions continued, the Toxoptera breeding and spreading unrestrained by its enemies, so that the area over which it was becoming destructive continually increased.

Rumors of injuries by this pest came to us early in January, 1907, from east-central Texas, where the "green bugs" were reported to Mr. W. D. Hunter, in charge of cotton boll weevil investigations of

this bureau, as attacking fall oats. During this month in Texas east of a line drawn from near Gainesville through Abilene and San

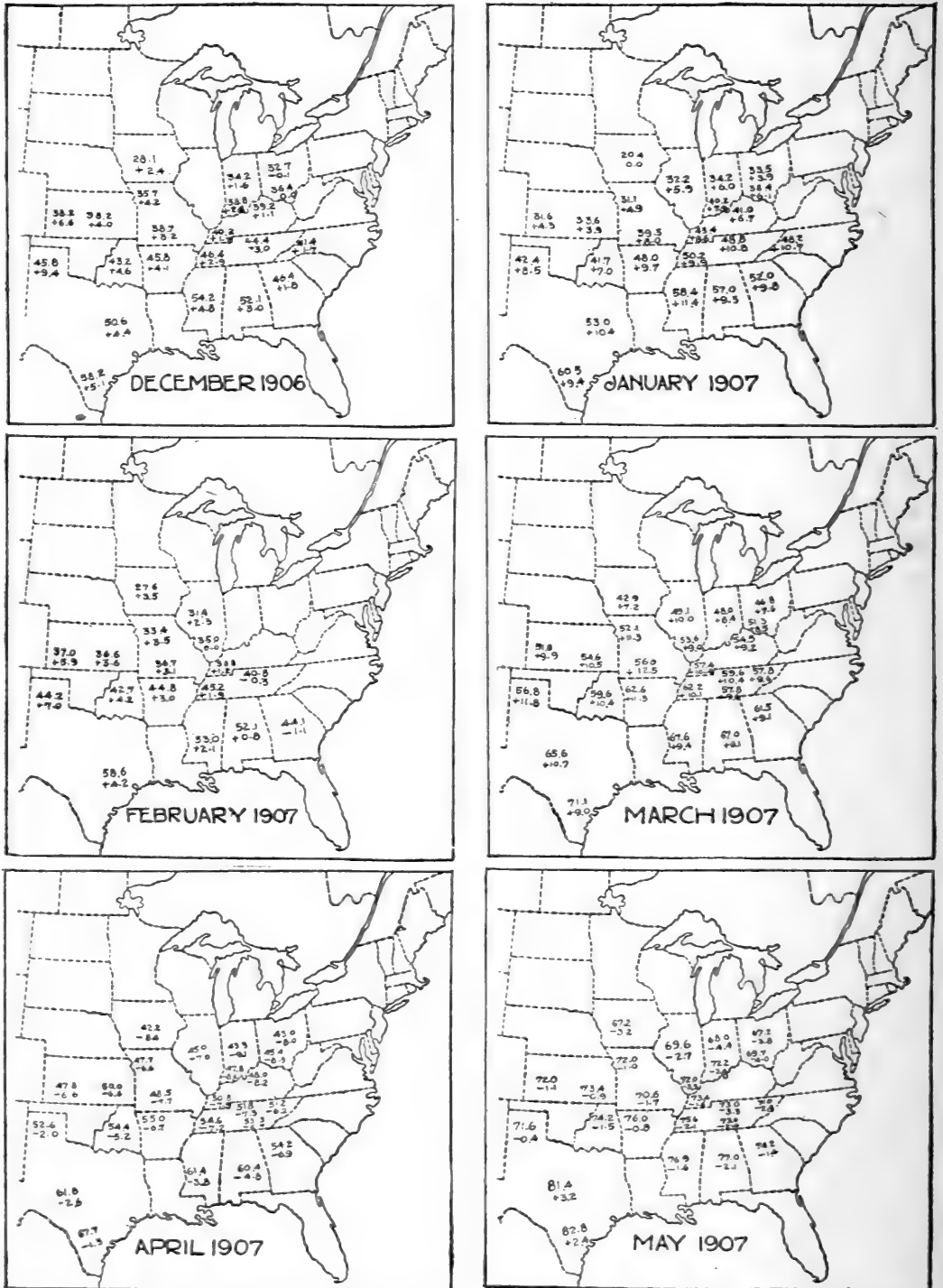


DIAGRAM V.—Map of the United States east of the Rocky Mountains, showing normal temperature, upper line, and departure therefrom, lower line (+, above normal, and -, below), for the critical period December, 1906, to May, 1907; above normal (+) in winter and below normal (-) in spring being favorable for outbreak of spring grain-aphis. (Original.)

Antonio to Galveston the temperature was 9° F., above the normal. Within this area was a smaller one, the boundaries of which may be indicated by a line drawn from Texarkana to Fort Worth, Waco, and

Joaquin. Over this latter area the temperature for the same month was 12° F. above the normal, and within this latter area the pest first began its work of destruction.

For reasons to be explained later in their proper place, the spread of the pest was much more rapid to the north and northeast from north-central Texas than it was in the opposite direction. In March the pest was found generally present about San Antonio, Kerrville, Menardville, and New Braunfels, of that State, but because of the small acreage of grain grown in that section the damage was not serious. Indeed, the same may be said of the country west of a line drawn from western Wilbarger County to the Brazos River at Round Timber, Baylor County, and west of the Brazos to and except about Waco. East and north of this the damage ranged from serious to total ruin.

As early as March 6 it was also reported to the bureau as destroying wheat in the vicinity of Summers, northwestern Arkansas. This was probably due to local causes, uninfluenced by invasions of swarms of winged viviparous females that were being continually swept from off the more disastrously affected country to the southwest and drifting toward the northeast. Mr. C. N. Ainslie was instructed to proceed from Washington, D. C., to this part of the country, where he arrived on March 16. On March 15 the Texas Grain Dealers' Association, through its secretary, Mr. H. B. Dorsey, made an appeal to the chief of this bureau for aid in devising means for destroying the pest and curtailing or preventing its ravages. In response to this appeal the junior author was dispatched to Fort Worth, Tex., arriving there on March 26. The situation here was found to be most serious. Hundreds of acres of both wheat and oats had been wiped out of existence; in many cases fields were observed where it was impossible to find a living plant, and as a rule numbers of such fields were being plowed and prepared for other crops. Plate I, figure 1, shows a field entirely destroyed. The weather at this time was hot and dry and *Toxoptera* appeared to have been entirely overcome by its natural enemies.

On March 25, 1907, a telegram was received from the Roosevelt Grain Elevator Co., of Hobart, Okla., reporting serious attacks from *Toxoptera* and appealing to the Secretary of Agriculture for assistance. The junior author was at once instructed to proceed to Hobart, where he arrived April 1, remaining until April 5. This point appeared to be on the western border of serious injuries by the pest, and the situation was therefore not so grave as in Texas. From the junior author's observations it appeared that much of the damage that was being done was caused by insects which had drifted into the fields and not from individuals originating therein. This was evidenced by the fact that in wheat fields where a part had been sown

early and the remainder later in the season the latest sown was very much more seriously damaged than that sown earlier. About the only portions of the early-sown part of the field to suffer serious injury were on the poorest soil. In short, the *Toxoptera* was found to be working its greatest damage in late sown or pastured wheat fields and among the young oats. Natural enemies were busily at work and apparently fast overcoming the pest.

In the meantime Mr. Ainslie had found the pest destroying wheat in spots in the wheat fields about Fayetteville and Summers, Ark., March 16 to 20, as well as at Chandler, Okla., March 24, and at Guthrie, Okla., on March 25. Near the latter place large circles were observed in the otherwise green fields of wheat. In the center of these circles the red soil was exposed by reason of the killing of the wheat plants, and these exposed circular areas were bordered by a band or girdle of yellow half-dead wheat plants, where the *Toxoptera* were most abundant. (See Pl. I, fig. 2.) In another field in this vicinity there was a stack of oats straw of the previous year, and from this stack a dead area extended at least 100 feet to the south. This area was nearly circular, with the stack almost in the center of the circumference. Near and surrounding the stack was an area of dead volunteer oats, and beyond this a stretch of bare ground indicated where wheat had once stood. From people occupying a house near by something was learned of the previous history of this straw stack from which Mr. Ainslie determined that volunteer oats had sprung up after thrashing in 1906; these oats turned brown soon after, causing some wonder among farmers, and during the winter the plants died. The trouble spread to the wheat adjoining and here the wheat plants died early in the spring. There was here seemingly a repetition of the conditions in the fields about Summers, Ark., where *Toxoptera* infesting volunteer oats extended its destruction from these to the wheat near by.

On March 26, between Guthrie and Kingfisher, Okla., Mr. Ainslie observed that the dead spots in the wheat fields were a striking feature of the landscape, for in the sunshine the bright green of the young grain made a striking contrast with the yellow-rimmed red circles where the *Toxoptera* had destroyed the wheat. Occasionally a field was free from these areas, but more of them were frightfully spotted in this manner. A field of wheat that was pastured more closely than most grain fields lay in the edge of Kingfisher and showed the attack of the *Toxoptera* worse than in adjoining grain. On March 27, at Kingfisher, *Toxoptera* was flying by the millions, the air being full of the migrants, and farmers who drove to town were covered on the windward side to their annoyance. The aphides seemed for the most part to fly low, but the wind hurried them at such a rapid rate that they might easily have been invisible when higher in the air. On the

following day large numbers of *Toxoptera* were on the wing, always moving north. In a field of oats, sown in February, the plants had hitherto been very thrifty, but at this time in a great many of the drill rows the plants were about dead for a space of 8 or 10 feet, and in case of later sown fields the plants were all fast dying under the attack. There was becoming gradually apparent a fact of considerable importance regarding the relative number of winged forms in the fields. In oats fields where the food was succulent and good it was difficult to find a single pupa, while in older and less succulent wheat, perhaps within a yard of the oats, pupæ would form 75 or 80 per cent of the population of the blades. This was afterwards verified repeatedly by observation and by actual counting; indeed, throughout the entire spring this fact seemed to be substantiated.

From March 31 to April 3 Mr. Ainslie carefully examined fields of wheat and oats in the vicinity of Wellington, Kans. He found wheat fields invariably evenly infested with *Toxoptera* though nowhere in any great numbers. Many of these were winged adults, indicating that they were migrants, and the young about them clearly evidenced a recent invasion. No dead areas were observed in the fields north of Pond Creek, Okla., but between Kingfisher and this point the circular dead spots were plainly in evidence. These dead areas, (Pl. I, fig. 2), from their regularity in the field, plainly indicated the rows of oats shocks of the fall previous and were clearly to be seen where the oats had been shocked and allowed to stand through a period of wet weather. This generally produced a vigorous growth of volunteer oats when the shocks were finally stacked or removed, and in this young grain the *Toxoptera* seem to have had an early start. In some cases it was easily possible to observe these spots all over a field, although the volunteer oats were rarely entirely killed—perhaps only changed to a reddish color. The infestation seemed to be more marked in the wheat in the vicinity of these spots, and later the *Toxoptera* swarmed about these places.

It may be noted that these observations of Mr. Ainslie in northwestern Arkansas, southern Kansas, and northern Oklahoma were made upon the same dates as those of the junior author about Fort Worth, Tex., and at Hobart in southern Oklahoma, thus covering a latitude of nearly 400 miles.

Mr. Ainslie returned to Kingfisher, Okla., April 3, and was joined there by the junior author on the 8th of the same month, where a number of experiments were carried out in the field, the results of which are given in the proper place. By the 8th of the month parasitized *Toxoptera* was found excessively abundant in the fields, in evidence of which a case was noted where a section of a leaf of wheat $1\frac{1}{2}$ inches in length carried 43 brown, parasitized individuals. Mr. Ainslie left Kingfisher, Okla., for Wellington, Kans., on the following

day, taking with him more than a bushel of these wheat plants with the parasitized Toxoptera thereon and on the 11th this material was put out in a field near Wellington where the Toxoptera was the most plentiful, in order to determine if it was possible to increase the limited numbers of parasites at the time observable in the field, so as to expedite the work of the latter in overcoming the pest. This was the first artificial introduction of *Aphidius* into Kansas, six days after which Prof. S. J. Hunter began distributing parasites. The following day a second lot of material sent from Kingfisher by the junior author, some of it carrying as many as 100 parasitized Toxoptera to a single blade of wheat, was distributed in a wheat field, also near Wellington, by Mr. Ainslie, some of it being placed in bunches to protect it from the weather and the remainder scattered over the ground among the growing wheat. The *Aphidius* already observed in the fields on the 11th appeared to be on the increase, as many as 11 parasitized individuals being observed on a single growing leaf, though but few of the adult parasites were observed abroad in the fields. On April 18 parasites were sent to McPherson and on May 18 to Manhattan, *Aphidius* being present in the fields at the time of introduction. These introductions will be taken up in detail farther on in this bulletin.

On April 12 a letter was received from Mr. J. A. Akers, at Hooker, Beaver County, Okla., stating that the "green bug" was destroying his wheat. The junior author, being notified of the outbreak, proceeded there, arriving on April 24, and found that Mr. Akers's field was the only one in that locality that had been injured, and, in fact, it was outside the zone of destructive infestation in this State. This field comprised 52 acres, over a portion of which oats had been sown the previous year, while cowpeas had been grown upon another and much smaller part. Volunteer oats were plentiful over the first mentioned area. One of the infested spots was located among the wheat and volunteer oats, while the second spot was in the area previously devoted to cowpeas. There were no other injured spots in the whole field, although an occasional Toxoptera could be found here and there over the field, which was also true of other fields in this vicinity. It is a significant fact that young plants of *Agropyron occidentale* Scrib. were found growing in both of these spots and they were as badly infested as the wheat plants. A few parasitized Toxoptera were found, but the parasites were apparently developing slowly on account of cold weather.

The junior author went to Indiana the latter part of the first week in May, but was recalled to Kansas and reached Manhattan on the 18th, where he was met by the senior author, and a final experiment for the artificial introduction of parasites was here planned and begun at this time, the results of which are given farther on in the proper place.



FIG. 1.—WHEAT FIELD TOTALLY DESTROYED BY THE SPRING GRAIN-APHIS (*TOXOPTERA GRAMINUM*).

Contrast with uninjured portion of field shown in figure 2. (Original.)

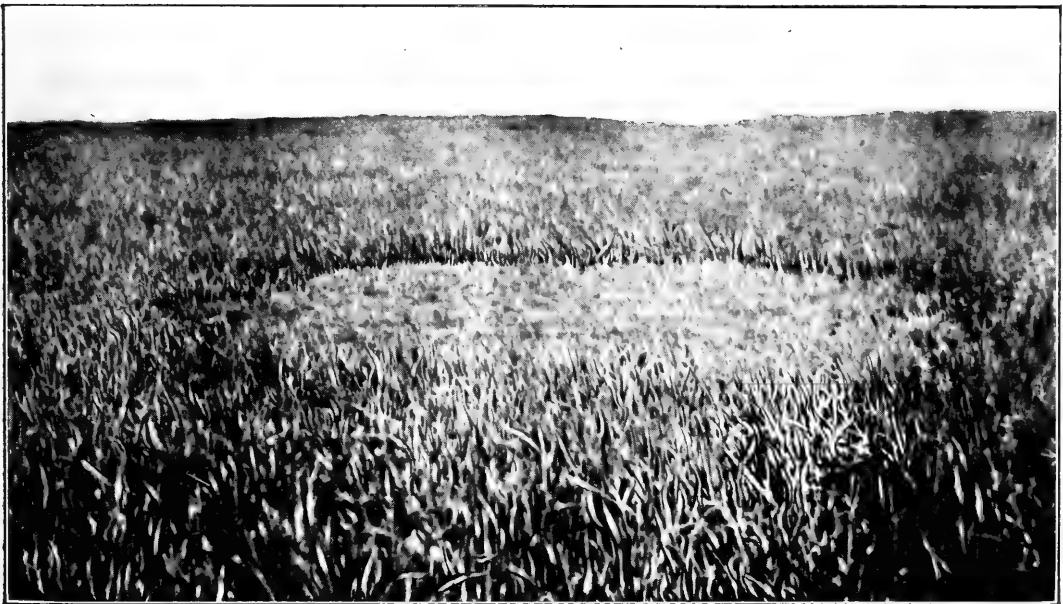
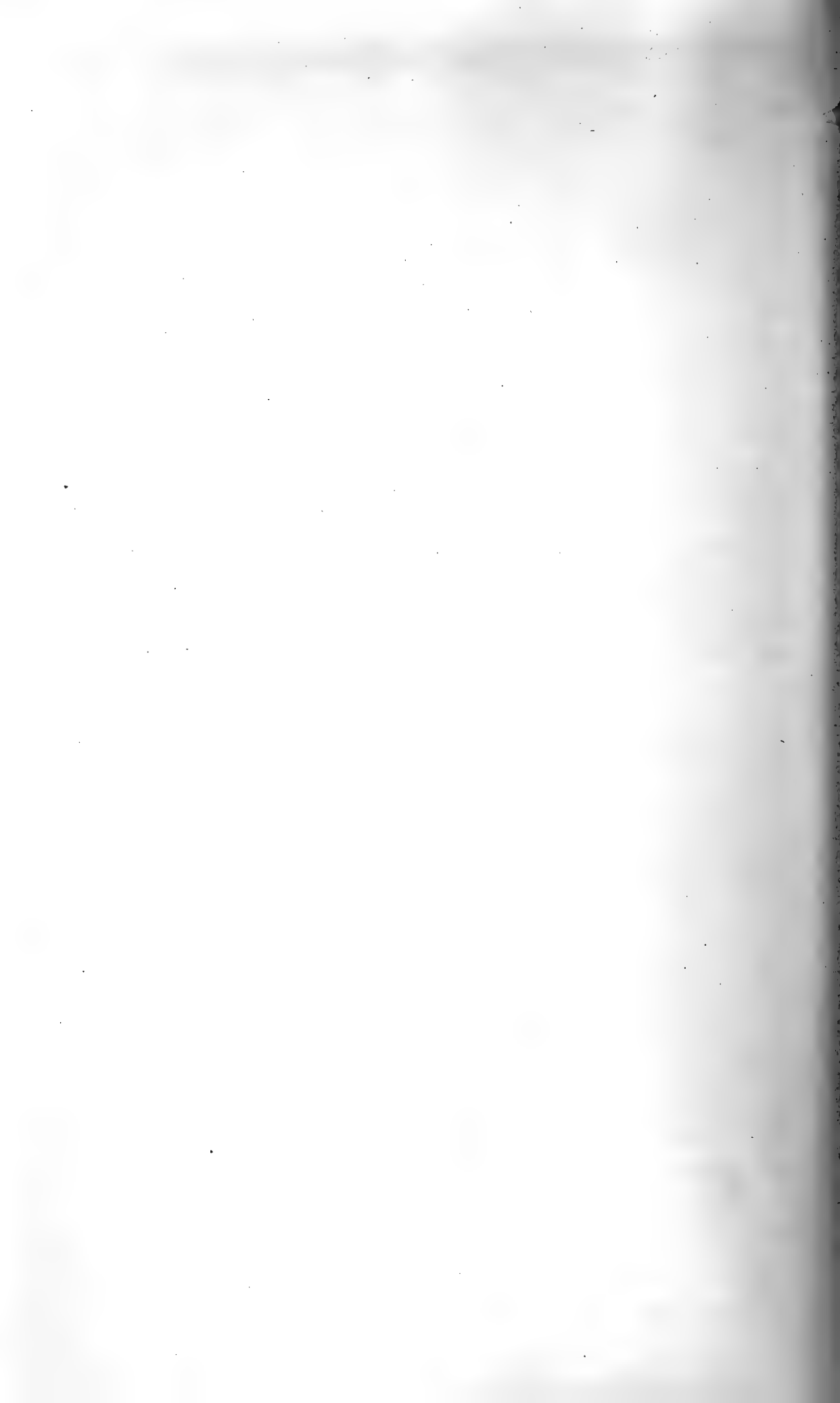


FIG. 2.—CIRCULAR SPOT IN WHEAT FIELD WHERE GROWING GRAIN HAS BEEN DESTROYED BY THE SPRING GRAIN-APHIS.

The growing grain on these circular areas is as completely destroyed as in the field shown in figure 1. Increasing in size and number, the spots come to include whole fields. (Original.)



From here the junior author made a trip into northwestern and northeastern Kansas and south-central Nebraska to determine the northern limit of destructive infestation. The following places were visited: Solomon, Dickinson County, Kans.; Beloit, Mitchell County, Kans.; Lenora, Norton County, Kans.; and Kearney, Buffalo County, Nebr. The infestation at all of these places was very slight and no damage was done. At two places only, Solomon and Beloit, were parasites found.

The senior author in the meantime proceeded to Great Bend, Barton County; Dodge City, Ford County; Garden City, Finney County; and Syracuse, Hamilton County—all in Kansas. The object of this trip was to see how far Toxoptera had spread to the westward. It was found at all of the above points, doing considerable injury; at Syracuse an unirrigated field of oats of 10 acres was found bordering an irrigation ditch. Along this ditch was a ragged border from 10 to 30 or 40 feet in width of vigorously growing oats where the "green bug" had apparently done no injury, while beyond this border, where the moisture from the ditch had not penetrated, the loss was total. In another case in the same locality, a part of the wheat in an unirrigated field came up in the fall and the rest not until the following spring; the former was uninjured by "green bugs," while the latter was killed. From Syracuse the senior author proceeded to Wellington, Kans., to join Mr. Ainslie.

In a letter dated June 5, 1907, Prof. C. P. Gillette states that he made a trip into the Arkansas valley early in the spring and found Toxoptera doing very serious injury to wheat fields; to such an extent was this the case that he advised some of the farmers to plow up some of their fields and plant other crops. Following this trip there was a heavy snowstorm and the "green bugs" were greatly diminished in numbers, though at the date of his writing (June 5) Toxoptera was abundant in the fields.

On July 9 Prof. Gillette sent us badly parasitized Toxoptera on blue grass from Fort Collins, Colo., with the statement that the "green bug" had largely disappeared from the grain fields in that locality.

Mr. Ainslie remained in the vicinity of Wellington, Kans., from the last week of April to the 21st of May, at which date he was joined by the senior author and went south to Kingfisher, Okla. The conditions found there were serious in the extreme, most of the grain fields being bare and many had been plowed and displaced by other crops. Between Wellington, Kans., and Kingfisher, Okla., a strip of country was encountered by them about 30 miles in width, beginning above Medford, Okla., with Pond Creek about midway between, and extending almost to Kremlin, Okla., over which the injury from Toxoptera was not nearly so great as in the country both to the

north and south. This area was investigated by Mr. Ainslie on the 23d of May. There was plenty of evidence of Toxoptera attack. Some fields were killed outright and others badly spotted, but a number of fields were little injured. No particular reason could be assigned for this condition of the fields, and this area, with a few interruptions, extended on to the west indefinitely. This belt extending across the wheat-growing section of Oklahoma was evidently observed by Mr. Sanborn, who stated in his notes, copies of which were furnished by Prof. Conradi, under date of March 29, 1907, "Northern boundary of parasitized infestation is between Kingfisher and Enid." Again, under date of March 30, "Pondcreek, Okla. Doing great damage, in large spots, here. There lies a peculiar feature between this and Kingfisher. At these two points the infestation was about equal. Enid has no damage yet."

Mr. Ainslie now started northward to trace Toxoptera to its most northerly point in the United States and to learn to what extent its parasite occurred with it, stopping at the following places: Kingman, Kingman County, Kans.; Hutchinson, Reno County, Kans.; Sterling, Rice County, Kans.; Scott, Scott County, Kans.; Great Bend, Barton County, Kans.; Oakley, Logan County, Kans.; Colby, Thomas County, Kans.; Goodland, Sherman County, Kans.; Manhattan, Riley County, Kans.; Lincoln, Lancaster County, Nebr.; Plainview, Pierce County, Nebr.; Dixon, Dixon County, Nebr.; Sheldon, O'Brien County, Iowa; Mason City, Cerro Gordo County, Iowa; Dodge Center, Dodge County, Minn.; Rochester, Olmsted County, Minn.; Brookings, Brookings County, S. Dak.; Aberdeen, Brown County, S. Dak.; Fargo, Cass County, N. Dak.; East Grand Forks, Polk County, Minn.; Hallock, Kitson County, Minn.; Grafton and Park River, Walsh County, N. Dak.; Larimore, Grand Forks County, N. Dak.; and Casselton, Cass County, N. Dak. He reached the last-mentioned place on August 5, after which he returned to Washington, D. C.

Except at Kingman, Hutchinson, Sterling, Great Bend, and Manhattan, Kans., Mr. Ainslie found but little damage resulting from Toxoptera, the most striking feature being the fact that parasites were found associated with Toxoptera at each point visited with the following exceptions: Goodland, Kans., very few Toxoptera in this immediate vicinity; Lincoln, Nebr., no Toxoptera found; Brookings, S. Dak., 2 to 3 Toxoptera only seen; Aberdeen, S. Dak., no Toxoptera found; Fergus Falls, Minn., only 1 Toxoptera observed here. The significant feature of this is that no parasites were introduced artificially at any of these points outside of Kansas.

From statements made by Prof. J. M. Stedman, who was professor of entomology at the University of Missouri at this time, it appears that Toxoptera was swept over the border from Oklahoma and Kansas into southwestern Missouri. Prof. Stedman states that there were from six to eight counties in the southwestern corner that were very

badly infested; outside of these counties the infestation was slight. He received very few if any reports of its occurrence north of the Missouri River. It probably occurred in the northern part of the State also, as the bureau received a report, with specimens, of injury to oats at Weaver, Lee County, Iowa, and Mr. C. N. Ainslie found it occurring in small numbers at several points in northwestern Iowa.

From reports received by this bureau it seems that *Toxoptera* was very abundant in northern Illinois, confining its injuries chiefly to oats. Mr. Edgar McGee, of Sciota, McDonough County, Ill., sent us specimens July 5 which proved to be *Toxoptera*, and in a letter dated July 29 he stated that it was very widespread, that his and adjoining counties were badly infested, and that some fields of oats were so seriously injured that the owners had plowed them under and planted other crops. The yield in that locality, from Mr. McGee's report, seems to have been greatly reduced.

At Sandwich, Dekalb County, Ill., there was apparently considerable damage to oats; no specimens were received; the injury in all probability was, however, due to *Toxoptera*. To quote from a letter from Mr. Clark Graves, bearing date of July 12:

I have today mailed to you, under separate cover, a fair sample of the oats of this vicinity, and I think from general appearances that the crop will be shortened half on account of the green bug. The bugs have now disappeared, and it would seem that the late oats have suffered considerably more than the early ones.

There were no specimens of plant-lice in this material from Mr. Graves.

A report, with specimens, was received from Manteno, Kankakee County, Ill., which stated that that section had suffered considerably from "green-bug" attack.

We have only one record of serious injury from Indiana in 1907 that can without doubt be attributed to *Toxoptera*. This was in a small field of oats just outside the limits of Indianapolis. The junior author examined this field and found that over an acre had been seriously affected, part of it being entirely destroyed. The "green bug" disappeared from the oats before the latter headed out, probably overcome by *Aphidius* and other enemies. This infestation apparently originated from rank bluegrass growing along one side of the field. Later in the season, when the oats had been harvested, *Toxoptera* could be found along this margin on the bluegrass, where the sexes appeared and eggs were produced. *Toxoptera* was found at other points in Indiana, but only in small numbers.

Mr. T. H. Parks, of this bureau, states that in the latter part of June, 1907, the oats on his father's farm in Pickaway County, Ohio, were badly damaged by aphides. He states that parts of some fields in the neighborhood were scarcely worth cutting. Aphides were very abundant on the plants and parasitized aphides were very plentiful also. The oats plants that were badly infested turned brown, and

before they were ready to head out the aphidids disappeared. This was probably due to the presence of the parasites. Wheat was not attacked or injured by these aphides. Mr. Parks did not have any of this material identified, and we can not say absolutely that this was *Toxoptera graminum* Rond., but the character of the attack, the sudden disappearance of the aphidids, and the fact that they did not disturb wheat coincide with our observations on this insect in this latitude and to us clearly point to *Toxoptera* as the originator of the trouble.

Part of the trouble referred to in letters cited in Bulletin 210 of the Ohio Agricultural Experiment Station was, in all probability, due to "green-bug" attack, since from our own observations on this species in northern latitudes a part of this injury appears to be characteristic of *Toxoptera*.

North and South Carolina also suffered somewhat from the deprivations of this insect in 1907. The senior author made a trip into this section, reaching Sumter, S. C., April 17, 1907. He found that all fields of oats, the only grain sown, were more or less affected; here and there brown areas occurred, showing the characteristic work of *Toxoptera*. This condition was noticeable from Sumter, S. C., to Charlotte, N. C., indicating that the infestation was general. Both *Macrosiphum granaria* Buckt. and *Toxoptera graminum* Rond. were present, but the latter was by far the more numerous. There were very few parasites or coccinellids in evidence. In a letter dated June 18 Mr. E. C. Haynsworth, of Sumter, stated that soon after the senior author's visit in April the weather became warmer and *Toxoptera* disappeared very rapidly.

In some parts of North Carolina the injury was quite serious. Mr. Franklin Sherman, jr., of the North Carolina Department of Agriculture, has kindly placed his notes on this outbreak at our disposal. He stated that the worst area of infestation centered about Winston-Salem, in Forsyth County, N. C., although some injury was also inflicted in Guilford, Davie, and Rowan counties in the same State, some fields being almost totally destroyed. Parasites were present, though not in sufficient numbers to hold *Toxoptera* in check.

The senior author went directly from Sumter, S. C., to Winston-Salem, N. C., reaching the latter place April 19, where he was met by Mr. Sherman, and they went over the ground together. A number of fields were examined, ranging from slightly infested to totally destroyed. In some fields of wheat, where there had been quantities of volunteer oats, the infestation was more severe. Parasites were present in great abundance in some fields, but they did not appear to have checked the pest in time to save all of the fields.

The senior author thus summarizes this outbreak:

From a study of the entire neighborhood it seems quite evident that the outbreak of *Toxoptera* in the vicinity of Winston-Salem was primarily due to the presence of



FIG. 1.—STAND ON WHICH REARING EXPERIMENTS WERE CARRIED OUT IN REARING THE SPRING GRAIN-APHIS. (ORIGINAL.)

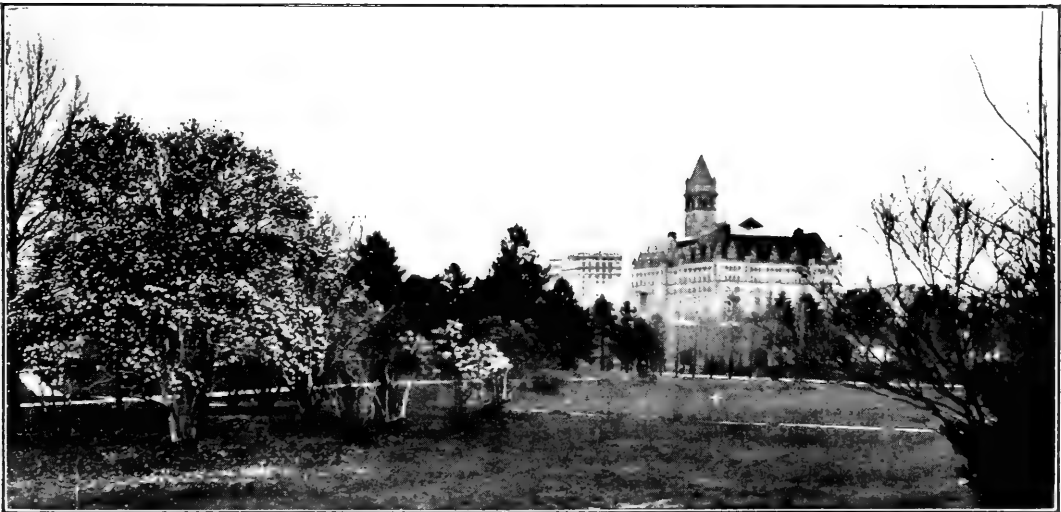
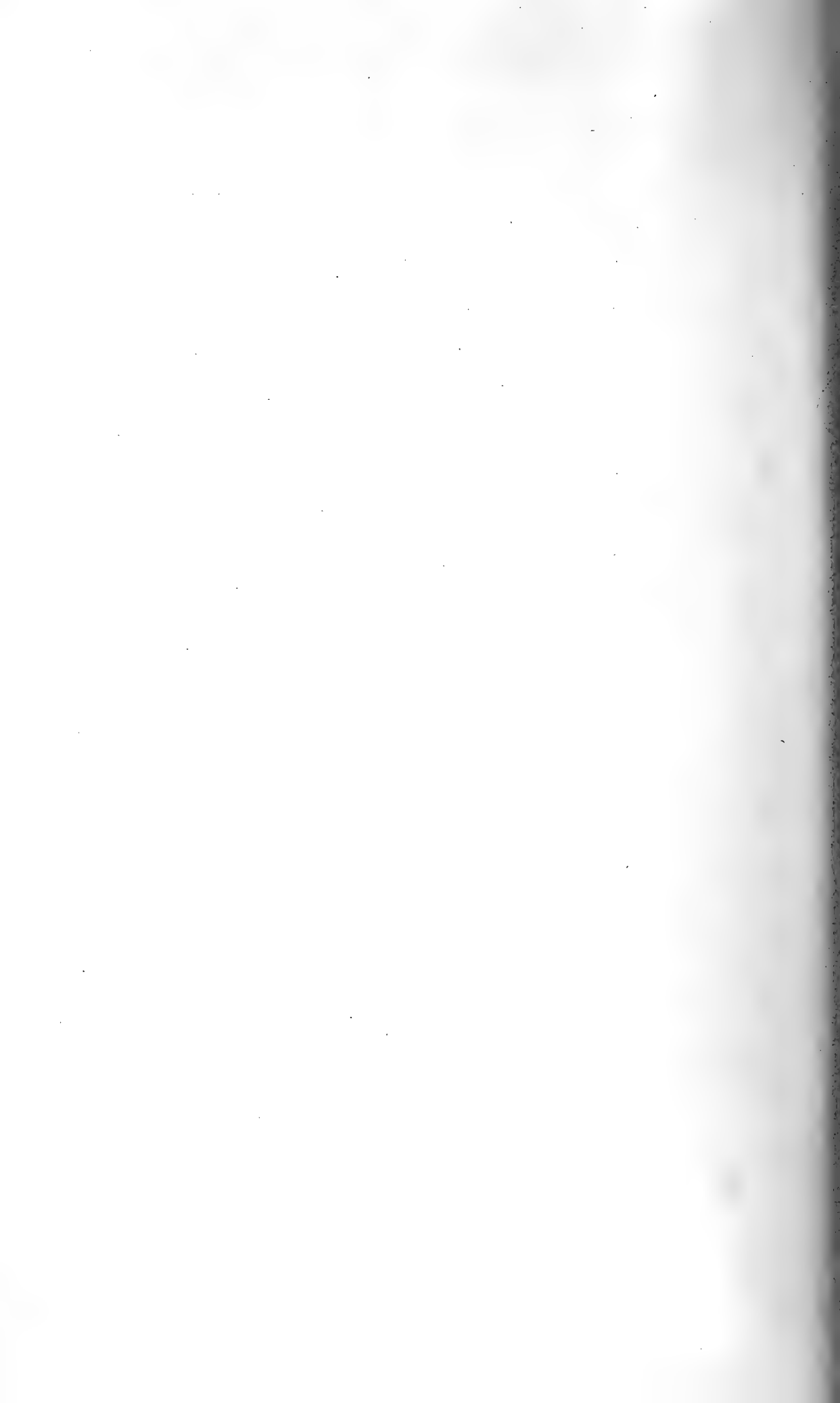


FIG. 2.—AREA ON GROUNDS OF THE UNITED STATES DEPARTMENT OF AGRICULTURE, AT WASHINGTON, D. C., WHERE THE SPRING GRAIN-APHIS USUALLY OCCURS ON BLUEGRASS IN EXCESSIVE ABUNDANCE DURING SUMMER.

The area infested is indicated by a +. (Original.)



fields of fall oats and more or less volunteer grain in other fields, all of which constituted breeding grounds for the pest during the preceding autumn, and from which winged individuals migrated and established new colonies in other fields; these, owing to influence of weather on the development of parasites, caused the most of the injury in wheat.

We received a letter with specimens from Mr. L. M. Smith, Mr. Sherman's assistant, at Newport, Carteret County, N. C., stating that he found a small field of oats in the outskirts of town that was considerably damaged by Toxoptera. This county is on the coast and Newport has an elevation of 19 feet. From this it seems that in all probability Toxoptera covered the entire State.

The senior author also found Toxoptera in destructive abundance at Midlothian, Chesterfield County, Va., in a small meadow of orchard grass. Mr. J. L. Phillips, the State entomologist, reported a slight outbreak at Cloverdale, Botetourt County, Va., in rye, and stated that considerable damage had been done in some parts of the field. One undetermined *Aphidius* was found at Midlothian, while none was reported from Cloverdale.

There was an outbreak of Toxoptera in the bluegrass lawns north of the buildings of the Department of Agriculture at Washington, D. C., in July, 1907. The infested area (see Pl. II, fig. 2) was apparently confined to the space of about an acre, where it was excessively abundant; outside of this area practically no Toxoptera could be found. This offered a good opportunity to test spray materials and a number of experiments of this kind were carried on.

Dr. Howard, personally, found *Aphidius* present in this infested area though in very limited numbers. In all probability this was *Aphidius avenaphis* Fitch, as we have since found this species in this exact locality but at no time have we found *A. testaceipes* Cress., which, until Mr. Viereck revised this group, had been considered to be *Lysiphlebus tritici* Ashm. We did not, in 1907, find any species of *Aphidius* present and did not know that Dr. Howard had done so, as he soon after sailed for Europe and at the time Circular 93 of this bureau was published the statement as to its nonoccurrence was not called to his attention in time to be corrected and he did not inform us of his find, supposing that we knew of it already. Mr. Kelly, however, found *Allotria* sp. present there in 1907, and we have since found this to be a parasite of *Aphidius*, which may account for the fact that the latter was present in such limited numbers. In 1908 *Aphidius avenaphis* was quite plentiful there, although specimens were not preserved, while *Allotria* sp. was found sparingly on the grounds elsewhere in the vicinity. As Toxoptera attracted no attention in this area on the grounds of the Department of Agriculture in 1909 we have no records for that year. In 1910 Toxoptera was again injuriously abundant on the same area and no *Aphidius* could be found, while *Allotria* sp. was still in evidence. It seems possible that condi-

tions were unfavorable for the rapid increase of *Allotria* in 1908, which conditions would prove favorable for *Aphidius* and also unfavorable for its host, the *Toxoptera*. This infested area on the department grounds in Washington has proved to be of considerable interest, as the fluctuations of *Toxoptera* there, as well as those of its parasite *Aphidius* and the secondary parasite *Allotria*, must coincide with what is going on in similar places over the country, thus forming small secluded breeding areas where *Toxoptera* survives throughout the summer, more especially in the South. The area in question is a depression covered chiefly by bluegrass, occupying perhaps half an acre, surrounded on all sides except the south by shade trees (See Pl. II, fig. 2.) It is rather more moist and therefore cooler in summer than other portions of the grounds and in common with the rest is kept closely mown. An underground steam pipe which affords heat for a large number of greenhouses extends along the southern and eastern margins; the ground above this pipe is always much warmer than the surrounding area during winter, the snow disappearing first and the grass in that location starting much earlier in spring. So far we have not found that these latter conditions have any influence in enabling the *Toxoptera* to breed viviparously during the winter. Even when the *Toxoptera* was excessively abundant here none could be found in the bluegrass-covered grounds only a few yards away, except in 1910, when it was quite numerous about the Washington Monument some four blocks away. Because of its isolation—there are no grain fields within miles on the Maryland side of the Potomac River and the department experiment farm at Arlington, Va., has the only grain for miles on the west side of the river—and because these last had never suffered from *Toxoptera* attack, this area became of too much importance as a convenient field of observation and experimentation to make an attempt at experimenting with the importation of great numbers of *Aphidius* desirable. There is every reason for believing that it is in similar favorable localities that *Toxoptera* passes the summer months in the southwestern portion of the country, where, as observations have shown, it is not able to withstand the high temperatures of the open fields.

Toxoptera has been studied throughout the summer in the Southwest with much difficulty, and not at all satisfactorily for the reason that we have been unable to keep it under continuous observation in the open fields.

Except in cases of local outbreaks here and there over the country there has been no serious injury to grain crops by the "green bug" since 1907. Many additional localities for the species have been added since then, however, and it now appears to cover almost the entire United States, excepting perhaps New York and the New England States. (See fig. 4, p. 19.)

LOSSES FROM DEPREDATIONS IN 1907.

It is impossible to arrive at the actual monetary loss occasioned by this fearful outbreak, as no data have been collected with this special end in view, either by the State or National governments. Several points must be considered in making such an estimate. Large areas planted to wheat and oats were abandoned, part being planted to other crops and the remainder left lying idle. Much money that was entirely lost was expended in seed, fertilizers, preparing the seed bed and planting; of course all of the fertilizer would not be lost where another crop followed. The greatest source of loss came through partial or actual destruction of the young wheat, thus greatly reducing the yield.

The Bureau of Statistics of the Department of Agriculture kindly compiled the following table for us, which will shed some light on the amount of loss probably attributable to the "green bug."

TABLE I.—Losses from depredations by the spring grain-aphis in 1907 in Kansas, Oklahoma, and Texas.

	Winter wheat.					Oats.		
	Acreage planted in fall of preceding year (preliminary).	Per cent abandoned.	Acreage harvested (revised).	Yield per acre.	Total production.	Acreage.	Yield per acre.	Total production.
				<i>Bush.</i>	<i>Bushels.</i>		<i>Bush.</i>	<i>Bushels.</i>
1905.....	5,645,000	6.3	5,290,000	13.9	73,527,000	858,000	27.1	23,248,000
1906.....	5,702,000	10.0	5,132,000	15.3	78,517,000	1,050,000	23.6	24,780,000
1907.....	5,930,000	4.8	5,645,000	11.3	63,788,000	1,092,000	15.0	16,380,000
1908.....	5,930,000	2.5	6,108,000	12.8	78,182,000	994,000	22.0	21,868,000
1909.....	6,173,000	4.5	5,895,000	14.5	85,478,000	964,000	28.2	27,185,000
1910.....	6,195,000	35.0	4,300,000	14.2	61,060,000	1,400,000	33.3	46,620,000
Average.....					73,425,000			26,680,000
OKLAHOMA.								
1905:								
Ind. T.....	286,000	5.5	270,000	10.0	2,703,000	202,000	36.0	7,258,000
Okla.....	1,493,000	3.9	1,435,000	8.2	11,764,000	294,000	33.0	9,717,000
1906:								
Ind. T.....	249,000	3.2	241,000	12.0	2,890,000	218,000	34.2	7,447,000
Okla.....	1,403,000	5.0	1,333,000	14.0	18,664,000	350,000	34.4	12,040,000
1907:								
Ind. T.....	216,000	28.0						
Okla.....	1,235,000	35.0	959,000	9.0	8,631,000	418,000	15.0	6,270,000
1908.....	1,379,000	2.3	1,347,000	11.6	15,625,000	450,000	25.0	11,250,000
1909.....	1,241,000	6.5	1,225,000	12.8	15,680,000	550,000	29.0	15,950,000
1910.....	1,604,000	3.0	1,556,000	16.3	25,363,000	632,000	36.5	23,068,000
Average.....					16,887,000			15,500,000
TEXAS.								
1905.....	1,319,000	5.3	1,249,000	8.9	11,118,000	914,000	31.4	28,713,000
1906.....	1,266,000	3.0	1,228,000	11.5	14,126,000	914,000	34.8	31,823,000
1907.....	1,266,000	70.0	380,000	7.4	2,812,000	500,000	19.0	9,500,000
1908.....	988,000	6.5	924,000	11.0	10,164,000	750,000	28.9	21,675,000
1909.....	929,000	27.5	555,000	9.1	5,050,000	615,000	18.7	11,500,000
1910.....	1,295,000	3.3	1,252,000	15.0	18,780,000	695,000	35.0	24,325,000
Average.....					10,342,000			21,256,000

If we average the 5-year period and calculate the loss on this basis for 1907, it will be seen that the total crop for Kansas, Oklahoma, and Texas fell about 50,000,000 bushels short of this average—both wheat and oats being considered. Seventy per cent of the Texas wheat acreage was abandoned.

This does not represent the loss as it actually occurred in various parts of the States, as some parts of each State were more badly affected than others and the good parts would bring up the yield for the poorer portions. Sumner County, Kans., is a good illustration of this. It is located in the extreme southern portion of the State and was in the badly infested districts. To quote from a letter from Mr. George H. Hunter, of Wellington, Kans., dated February 6, 1908:

I wish to explain that our crop of winter wheat in Sumner County for the year 1907 amounted to 1,909,574 bushels; this is our latest estimate, while the general average is about four and one-half million bushels for Sumner County, and that would be a safe basis for you to figure on. According to our acreage last year, if it had not been for the green bugs, I think we would have had at least four to four and one-half million bushels of wheat.

THE SITUATION IN 1911.

The winter and spring of 1910-11 west of the Mississippi River, but not east of it, was such as would tend to bring about another invasion from the pest. Some injury was reported, accompanied by specimens, from Pecos River valley in southeastern New Mexico. Mr. J. T. Monell of this bureau, however, visited the locality in April and reported the pest as having disappeared without doing serious injury. The material received was almost universally parasitized by *Aphidius testaceipes* Cress., which probably overcame the Toxoptera before its occurrence reached the magnitude of an invasion.

There was also a limited incipient outbreak in eastern Oklahoma, which was investigated by Mr. Kelly. Here, too, the parasites apparently gained supremacy before serious injury was done, except perhaps in a few isolated cases.

There is little doubt that the unusual and excessively high temperature for even a mild winter that prevailed throughout the Southwest during a portion of the winter months was sufficient to revive the parasites as well as to aid their host, and thus bring about conditions that enabled the parasites to prevent the aphidids from increasing in numbers to a point where they were beyond their control.

FOOD PLANTS.

This insect has a very wide range of host plants and can on that account find fresh food at any season of the year. In this way it is enabled to perpetuate itself over vast areas of country and under almost every variety of climate.

Rondani, who first described the species in 1852, gives the following list of host plants: Oats (*Avena sativa*); wheat (*Triticum vulgare*); spelt (*Triticum spelta*); *Arrhenatherum elatius* (*Avena elatior*); couch grass (*Triticum repens*); *Hordeum murinum*; *Lolium perenne*; *Capriola* (*Cynodon*) *dactylon*; soft chess (*Bromus hordeaceus*) (*mollis*); and corn (*Zea mays*). He states also that *Toxoptera* had been found quite abundant upon the foliage of rice (*Oryza sativa*) and common barley (*Hordeum vulgare*). We find no other references to its being found upon rice. In 1863 Passerini adds sorghum (*Andropogon* sp.) and he also observed it on barley.

Macchiati, in 1882, added the following hosts: *Dactylis glomerata*, *Bromus erectus*, and *B. villosus* (*maximus*); in 1883 he added *Triticum villosum*, *Avena fatua*, and *A. barbata*; in 1885, *Poa annua*.

Del Guercio, in 1906, mentions it as occurring upon buckwheat (*Fagopyrum esculentum*). This is the first and only reference we have found in which it has been accused of infesting plants other than those belonging to the Gramineæ.

Toxoptera was first observed upon wheat and oats in the United States. In 1889 the senior author observed it feeding upon rye and in 1890 he found it plentiful at Lafayette, Ind., upon *Dactylis glomerata*. In 1907 he found it destructively abundant upon the same grass at Midlothian, Va. This infested field was from 4 to 5 miles from wheat, oats, or rye fields. In *Insect Life*,¹ he states that *Toxoptera* will live upon the leaves of all kinds of grains, including corn, during summer. In 1902 he found *Toxoptera* feeding upon cheat (*Bromus secalinus*) and rye grass (*Elymus canadensis*) at Peotone, Ill.

The junior author found it quite abundant on volunteer corn plants among oats on April 2, 1907, at Hobart, Okla. A cornfield near a badly infested wheat field was found to be suffering also. Mr. C. N. Ainslie of this bureau, on April 4 of the same year, at Kingfisher, Okla., found a cornfield that was seriously injured by *Toxoptera*. Farmers in Oklahoma were very much disturbed over the prospect that the corn also would be swept away by the "green bug," but later developments proved that it was not a serious pest to corn. The junior author found *Hordeum pusillum* and *Alopecurus geniculatus* badly infested on April 12 at Kingfisher, Okla., and *Agropyron occidentale* was found harboring the pest in large numbers at Hooker, Okla., in May. The senior author, Mr. Ainslie, and Prof. E. A. Popenoe,

¹ *Insect life*, Div. Ent., U. S. Dept. Agr., vol. 4, p. 245.

of Kansas, also found the *Hordeum pusillum* much infested later in the season. In July there was an outbreak of Toxoptera on bluegrass (*Poa pratensis*) on the grounds of the United States Department of Agriculture, Washington, D. C. Later in the season the junior author found it on bluegrass in the fields about Richmond, Ind. In the fall of the same year (1907) this was the only plant on which the sexes and eggs could be found. In fact, for Indiana, Illinois, Ohio, and more northern localities bluegrass appears to be the normal host, and the "green bug" is readily found upon it at any time in the year even when it can be found only sparingly upon any other plant.

A number of new host plants were added to the list in 1908. Mr. Kelly, of this Bureau, found Toxoptera feeding freely in the fields upon *Hordeum jubatum* and *Distichlis spicata* in Montana and upon a species of *Andropogon* in Colorado. Mr. Ainslie found it breeding freely in the fields upon *Hordeum jubatum*, *H. cæspitosum*, *H. nodosum*, *Elymus striatus*, *Agropyron tenerum*, *Bromus unioloides*, *B. porteri*, *Stipa viridula*, and *Polypogon monspeliensis* about Artesia, N. Mex. In one instance Mr. Ainslie found several alfalfa plants (*Medicago sativa*) with colonies of Toxoptera upon them, as many as 21 specimens being observed on a single leaf. This seems very unusual and we have no other records of its occurrence on this plant. Prof. C. P. Gillette, of Fort Collins, Colo., found it infesting *Agropyron occidentale*, and in 1907 he found it feeding upon bluegrass. During the summer of 1908 Toxoptera was found by the junior author to breed freely upon *Dactylis glomerata*, *Eleusine indica*, *Eragrostis pilosa*, *E. megastachya*, *Sporobolus neglectus*, *Agropyron repens*, *Elymus virginicus*, *E. canadensis*, and *Bromus secalinus*, in his rearing cages at Richmond, Ind.

In 1909 and 1910 a few more plants were added to the list. Mr. Ainslie found it breeding freely upon *Hordeum murinum* in Arizona and upon *Agropyron occidentale* in New Mexico. Mr. Kelly found it breeding freely upon millet (*Chætochloa italica*) and upon Japanese millet (*Echinochloa crus-galli*) in Kansas. Mr. Harper Dean, jr., then of this bureau, found it feeding upon *Stipa leucotricha* in Texas. Mr. T. D. Urbahns, of this bureau, found that it bred readily in his cages at Dallas, Tex., upon Bermuda grass (*Capriola dactylon*), *Chætochloa viridis*, Johnson grass (*Sorghum halepense*), and upon rice (*Oryza sativa*).

During the summer of 1909 Mr. T. H. Parks, of this bureau, and the junior author observed that Toxoptera bred freely upon *Elymus striatus*, *Juncus tenuis*, *Poa compressa*, *Bromus commutatus*, *B. tectorum* (?), *B. inermis*, sheep's fescue (*Festuca ovina*), hard fescue (*F. duriuscula*), meadow fescue (*F. elatior*), various-leaved fescue

(*F. heterophylla*), *F. rubra*, *Agropyron occidentale*, and Italian rye grass (*Lolium multiflorum*), in their rearing cages at Lafayette, Ind.

The following is a complete tabulated list of host plants¹ to date, in so far as our records show.

IN EUROPE.

Barley.	<i>Bromus erectus.</i>
Corn.	<i>Bromus maximus</i> = <i>B. villosus.</i>
Oats.	<i>Bromus mollis</i> = <i>B. hordeaceus.</i>
Rice.	<i>Capriola (Cynodon) dactylon.</i>
Wheat.	<i>Dactylis glomerata.</i>
Spelt.	<i>Fagopyrum esculentum.</i>
Sorghum.	<i>Hordeum murinum.</i>
<i>Agropyron (Triticum) repens.</i>	<i>Lolium perenne.</i>
<i>Avena barbata.</i>	<i>Poa annua.</i>
<i>Avena elatior</i> = <i>Arrhenatherum elatius.</i>	<i>Triticum villosum.</i>
<i>Avena fatua.</i>	

IN AMERICA.

Barley.	<i>Eleusine indica.</i> ²
Corn.	<i>Elymus canadensis.</i> ²
Oats.	<i>Elymus striatus.</i> ²
Rice.	<i>Elymus virginicus.</i> ²
Rye.	<i>Eragrostis megastachya.</i> ²
Sorghum.	<i>Eragrostis pilosa.</i> ²
Spelt.	<i>Festuca duriuscula.</i> ²
Wheat.	<i>Festuca heterophylla.</i> ²
Alfalfa (<i>Medicago sativa</i>).	<i>Festuca ovina.</i> ²
<i>Agropyron occidentale.</i> ²	<i>Festuca elatior.</i>
<i>Agropyron repens.</i>	<i>Festuca rubra.</i> ²
<i>Agropyron tenerum.</i> ²	<i>Holcus halpensis.</i> ²
<i>Alopecurus geniculatus.</i> ²	<i>Hordeum cæspitosum.</i> ²
Cheat (<i>Bromus secalinus</i>). ²	<i>Hordeum jubatum.</i> ²
<i>Bromus commutatus.</i> ²	<i>Hordeum murinum.</i>
<i>Bromus inermis.</i> ²	<i>Hordeum nodosum.</i> ²
<i>Bromus porteri.</i> ²	<i>Hordeum pusillum.</i> ²
<i>Bromus tectorum</i> (?). ²	<i>Juncus tunuis.</i> ²
<i>Bromus unioloides.</i> ²	<i>Lolium multiflorum.</i> ²
<i>Capriola dactylon.</i>	<i>Poa compressa.</i> ²
<i>Chætochloa italica.</i>	<i>Poa pratensis.</i> ²
<i>Chætochloa viridis.</i> ²	<i>Polypogon monspeliensis.</i> ²
<i>Dactylis glomerata.</i>	<i>Sporobolus neglectus.</i> ²
<i>Distichlis spicata.</i> ²	<i>Stipa leucotricha.</i> ²
<i>Echinochloa crus-galli.</i> ²	<i>Stipa viridula.</i> ²

¹ During 1909 Mr. C. P. v. d. Merwl, Bloomfontein, Orange Free State, Africa, wrote us that he had found *Toxoptera graminum* attacking "Bermuda grass" and their native blue-grass (*Andropogon hirtus*).

² These are host plants not previously recorded.

CHARACTER OF ATTACK.

The actual effect upon the plant, whether chemical or physiological, is not clearly understood. If a few *Toxoptera* be placed upon a perfectly healthy plant, in a few days the tissue in the immediate vicinity of the aphidids will take on a yellowish tinge; if the aphidids remain in one place for a considerable time and increase in numbers, the whole plant gradually turns yellow and dies, the leaves changing to reddish brown.

When the original source of infestation arises from some one or more points within a field, as described elsewhere in this paper, the plants take on a yellowish color in small, almost circular areas, (Pl. I, fig. 2) and as the *Toxoptera* increase in numbers the plants in the center die, becoming reddish brown, and the aphidids work outward in every direction from the center, gradually enlarging the spot until it may cover many acres. When a field is infested from without by migrating forms, the aphidids appear to spread evenly over the entire field and the whole gradually turns yellow, and in cases of severe outbreaks a whole field may die simultaneously. (See Pl. I, fig. 1.) These aphidids are essentially leaf-feeders, rarely if ever being found injuring the heads or fruiting parts of the plant.

Toxoptera appears to have a more strikingly disastrous effect upon wheat or oats plants than any of the other common grain aphidids. Seemingly when in no greater numbers than other species the plants will succumb more quickly to the attack of *Toxoptera*.

VIVIPAROUS DEVELOPMENT.

Toxoptera graminum, as already shown, has been found to breed over a wide range of country, and its behavior, under the varying temperatures and climatic conditions prevailing over this vast territory, presents and opens up a broad field for investigation.

IN THE SOUTH.

In northern latitudes the normal manner of reproduction among the Aphididæ is both sexually and asexually. In southern latitudes these conditions, apparently, do not obtain, as here the normal means of reproduction seems to be asexually, each generation being composed entirely of viviparous females.

South of about the thirty-fifth parallel, except in high altitudes, it appears that *Toxoptera* breeds continuously throughout the year without the appearance of the true sexes. April 6, 1906, Mr. George I. Reeves, of this bureau, found the eggs of a plant-louse on wheat at Nashville, Tenn., and Mr. Kelly found males (fig. 6), females, and eggs of *Toxoptera* at Knoxville, Tenn., in December, 1908. The eggs found by Mr. Reeves may have been those of *Toxoptera*, but we

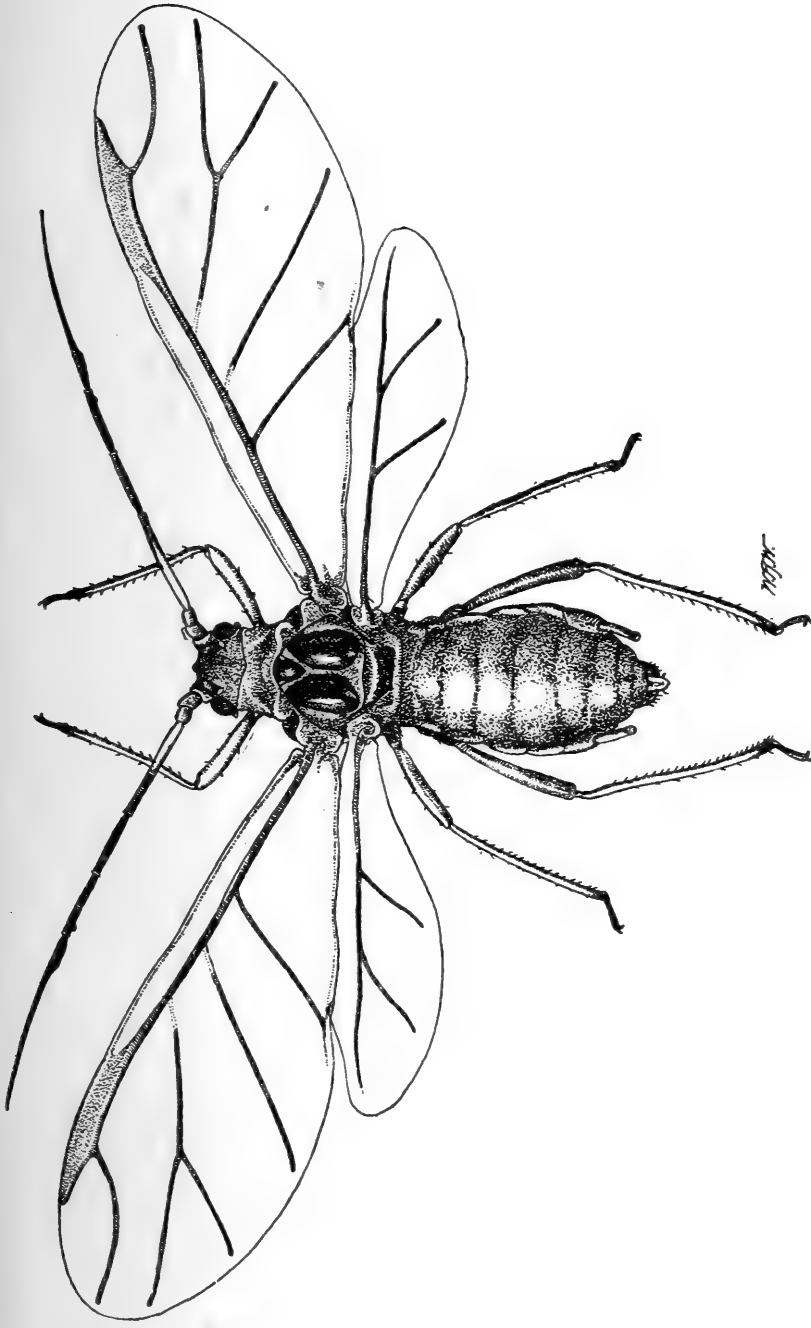


FIG. 6.—The spring grain-aphis (*Toxoptera graminum*); Male and antenna. Enlarged; actual size, 1.5 mm. (Original.)

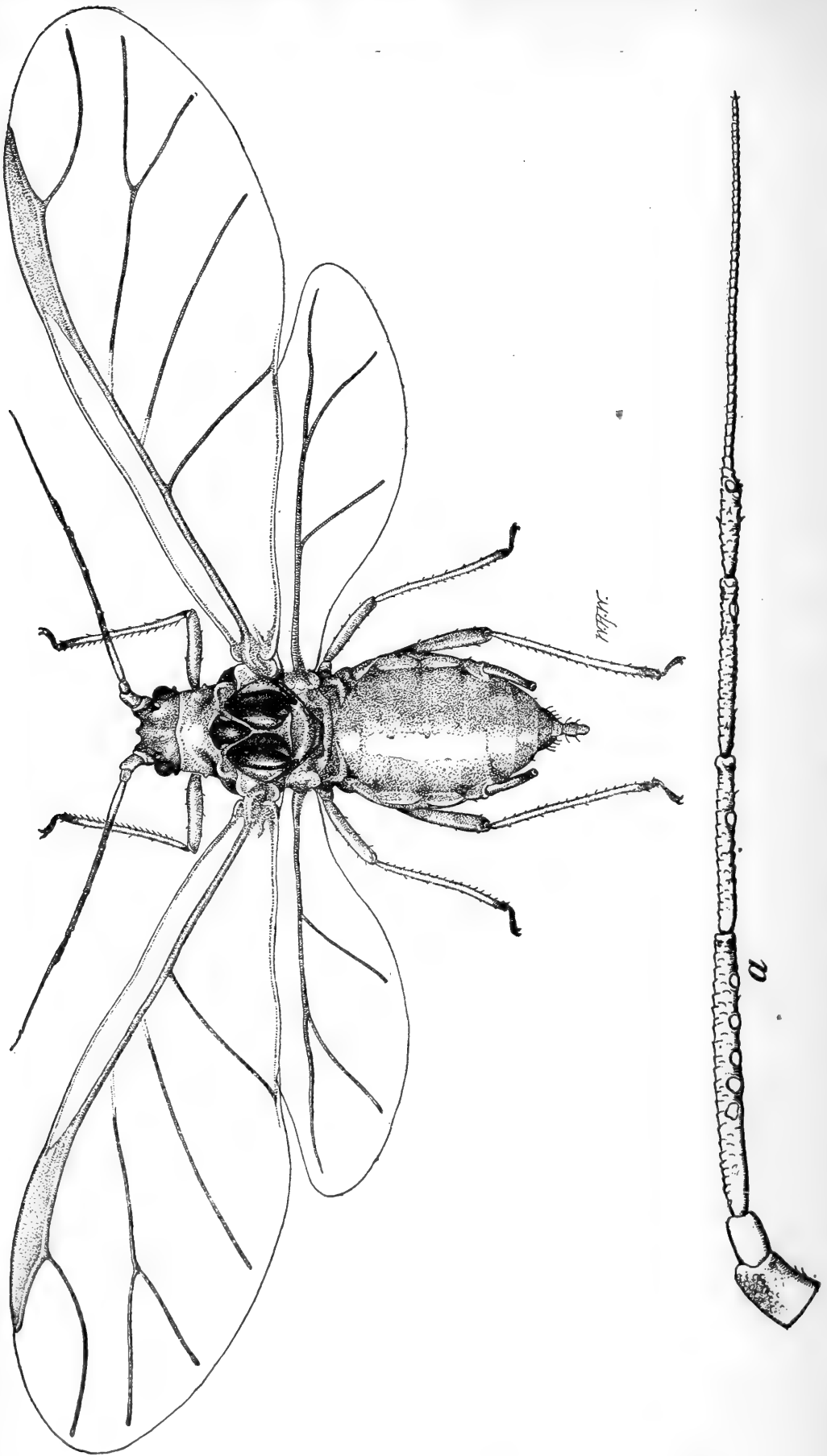


FIG. 7.—The spring grain-aphis: Winged viviparous female and antenna. Enlarged; actual size, 1.9 mm. (Original.)

can not be sure of the species as they were not reared. Winged and wingless viviparous females (figs. 7, 8) were, however, present at the time the eggs were found, as were also those of both *Aphis* (*Siphocoryne*¹) and *Macrosiphum*. Mr. E. Dwight Sanderson obtained the males and oviparous females of *Macrosiphum granaria* Buckt. in Texas but only artificially in his rearing cages. Mr. R. A. Vickery, of this bureau, found males, females, and eggs of *Aphis maidi-radicis* Forbes at Salisbury, N. C. These instances mentioned above are probably the most southerly points at which oviparous forms of plant-lice have so far been found in the United States.

In the Southern States, wherever there is sufficient food, *Toxoptera* apparently breeds viviparously throughout the year; for this reason the number of generations here, other things being equal, should far exceed that in the Northern States. As a matter of fact, however, the dry, hot, protracted summers of the Southwest are probably disas-

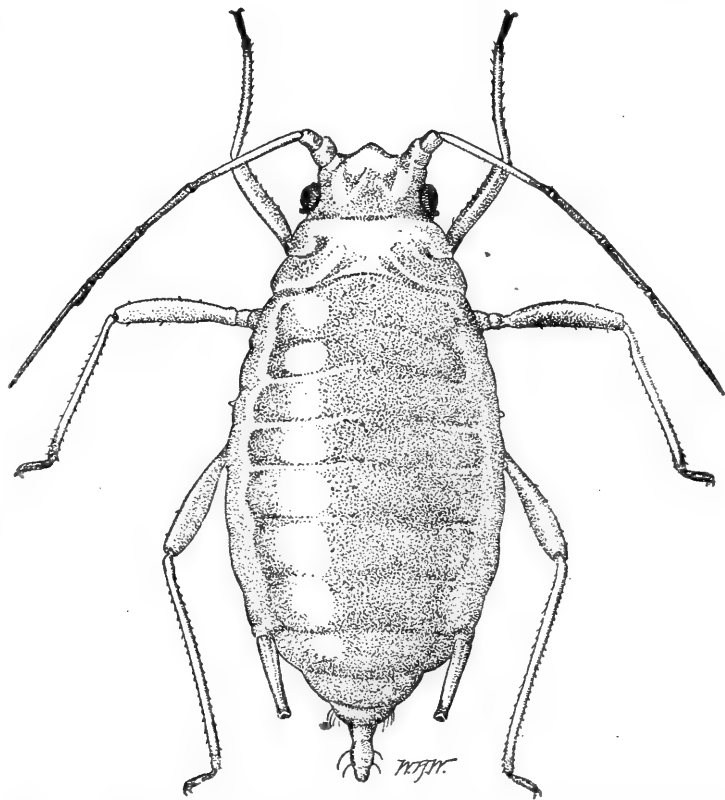


FIG. 8.—The spring grain-aphis: Wingless viviparous female. Enlarged; actual size, 2 mm. (Original.)

trous to the species during the hot months, except perhaps in secluded nooks, where there is a supply of succulent host plants.

In northern Texas, as observed by Mr. Urbahns, during June of 1909, *Toxoptera* rapidly disappeared with the ripening of the grain crops and the approach of hot weather. Winged forms migrated with the breeze early in this month, and wingless forms soon perished from extreme heat and a shortage of green food in the field. Observations clearly showed that it was almost impossible for the "green bug" to live and reproduce in grain fields during the summer. While

¹ Probably *Siphocoryne avenæ* Fab. The use of the generic name *Siphocoryne*, as applied to this species, is questionable, and is not at present followed by many, perhaps the major portion, of the students of the Aphididæ. According to Schouteden (*Ent. Soc. Belgique*, vol. 12, p. 217, 1906, *Catalogue Aphides de Belgique*) it should be *Aphis*. Some of our best students, however, admit that this particular species, *avenæ*, is on the borderland between *Siphocoryne* and *Aphis*.

the temperature was above and precipitation below normal, during this particular season, the effect was so evident that there is reason to believe that under normal conditions these aphidids do not live in fields directly exposed to the sun during the summer months.

The table on pages 64-69 on daily reproduction, length of reproductive period, and longevity show a decided decrease in all of these for the summer months over those of spring and fall. The facts upon which these figures were based could be secured only by protecting the aphidids from exposure to the hot summer sun. Aphidids exposed without such protection were unable to live through the season, though special care was taken to furnish them with a supply of green food plants.¹

Mr. Urbahns secured the following results by removing *Toxoptera*, together with its green food plants, from a shaded position and subjecting it to the temperature of loose, unshaded soil.

August 18, with the soil temperature at 145° F. in the sun, 12 *Toxoptera* on a wheat plant were exposed 30 seconds; 5 fell to the ground dead, 7 remained on the plant dead.

Three adults and 4 young on a wheat plant were similarly exposed for 30 seconds, after which time all were dead.

One winged and 4 wingless adults on a wheat leaf were exposed for 30 seconds, when they were found to be dead on the plant.

Thirteen adult aphidids on wheat plants were exposed for 15 seconds, 5 fell to the ground dead. After 30 seconds exposure the plant was removed to the shade; 6 more were then dead on the plant and 2 were alive between the leaves.

Soil temperature 118° F. (shaded by cloud). Nine aphidids on a wheat plant were exposed for 30 seconds, 2 died, and 7 remained alive.

A potted wheat plant bearing several hundred aphidids, the temperature being 114° F. in the shade, was removed from the shade for 5 minutes. A large percentage of the aphidids fell to the ground, some survived, but many died.

A potted wheat plant bearing several hundred aphidids was kept in the shade where the maximum temperature was 114° F. Next morning many of the aphidids were dead.

When the soil temperature was 116° F. shaded by a thin cloud, 3 aphidids on a plant were exposed for 60 seconds, 1 died, and 2 remained alive.

August 19, the soil temperature being 128° F. in the sun, 12 aphidids on a young plant were exposed for 30 seconds; 5 fell from the plant and died, while the other 7 were dead on the plant.

When the soil temperature was 130° F. in the sun 12 aphidids on a young plant were exposed for 20 seconds. All were then dead.

When the soil temperature was 128° F. in the sun 11 aphidids on a plant were exposed for 30 seconds; at the end of this time all were dead—4 fell to the ground, and 7 remained on plant.

At a soil temperature of 130° F. in the sun 8 aphidids on a plant were exposed for 15 seconds; all were then dead—3 fell to the ground, and 5 remained on the plant.

The results of these experiments prove that *Toxoptera* can not survive the summer in the open fields in sections of the country where the pest commits its most serious ravages with the greatest

¹ Mr. J. T. Monell suggests that this may be due as much or more to the hot, dry air as to the direct rays of the sun.

frequency. They also account for our inability to locate it in such territory during the summer months.

A careful search was made at different times for grasses that were actually serving as summer food plants. The only hope of finding such was in well shaded spots along streams, where, from all indications, *Toxoptera* would be sufficiently protected to live and reproduce throughout the summer.

At Plano, Tex., *Toxoptera* was rapidly disappearing from the fields in early June. By June 14 there was only a limited number of plants which still supported the remaining few of these aphidids and the latter were soon carried away by ants. When confined on green food plants and protected from their enemies by a large frame covered with thin cheesecloth *Toxoptera* lived until July 3. After this date it was apparently too hot for their existence. Out in the open, where young wheat and oats plants were sustained by frequent watering, they lived until July 15. After this date they apparently could not endure the summer temperature and no more were found. Since no reinfestation appeared up to November 30, it was quite evident that the aphidids had all perished.

On June 28 viviparous forms of this species were found rather abundantly in a small field of oats at McAlester, Okla. This field of a few acres in size was on the east slope of a rocky hill. A natural growth of timber surrounded the field and a few trees grew in its midst where rocks make cultivation impossible. Green vegetation was abundant in shaded places and along the creek one-half mile to the east. Conditions of this sort are certainly favorable for *Toxoptera* to live and reproduce throughout the summer as long as they find the food plants present. While these spots, favorable to *Toxoptera*, are characteristic of eastern Oklahoma, where, as has been stated, an incipient outbreak of the pest actually occurred in 1911, they are also found along streams in the central part of that State and in northern Texas. As there appears to be no resting or egg stage in the South, whenever there is a warm open winter these aphidids become very abundant and threaten the grain crops of this region.

IN THE NORTH.

Farther north, in the vicinity of Lafayette, Ind., viviparous reproduction is confined to the months of April, May, June, July, August, September, October, and November. During mild winters, however, the species may breed viviparously throughout the year, as the senior author found it breeding in the open throughout January, February, and March, 1890, notwithstanding the fact that on January 24 the temperature fell as low as + 3° F.; on February 9, to + 6° F., and on March 6 to + 4° F. It appears that a temperature of about

zero, with no protection, is fatal to Toxoptera, except to the egg, but the fact that it withstood the winter in 1890 can easily be accounted for. That winter was unusually mild throughout, with the exception of the dates mentioned, and if one consults the weather records it

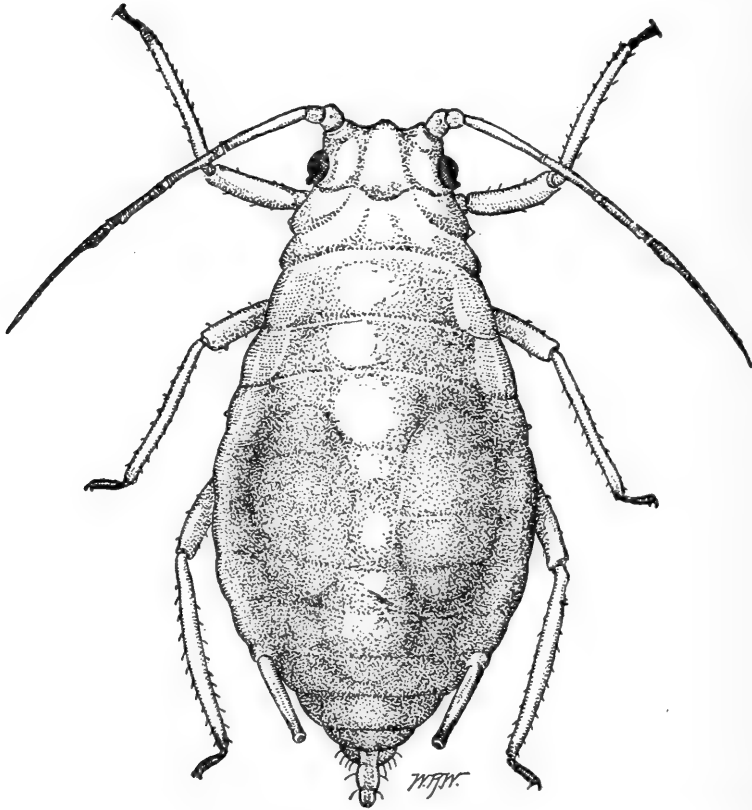


FIG. 9.—The spring grain-aphis: Oviparous female, showing eggs within the abdomen. Enlarged; actual size, 2.25 mm. (Original.)

will be found that on January 24 there were 3.5 inches of snow, February 9, 3.4 inches, and March 6, 4 inches. The covering of snow in each instance would appear to have been sufficient to protect the Toxoptera, as on December 8, 9, and 10, 1909, at Lafayette, Ind., the temperature fell as low as from -1° F. to -4° F. below zero, and



FIG. 10.—The spring grain-aphis: Hind tibia of oviparous female. Greatly enlarged. (Original.)

plant-lice of all kinds, in the rearing cages out of doors, were killed, while those in a near-by wheat field, covered with several inches of snow, were found to be in good condition on December 13, at which time the cold spell was broken and the ground began to thaw.

As a rule, Toxoptera breeds slowly in October and November, at which time the majority become oviparous females (figs. 9, 10) and males (fig. 6).

REARING METHODS.

All of the rearing work, unless otherwise stated in the text, was conducted out of doors under as nearly normal conditions as it was possible for us to secure. The wheat plants on which the *Toxoptera* were confined were grown in flowerpots and covered with lantern globes, over the top of which was drawn a very thin fabric commercially known as swiss. The pots were placed on a rearing stand having one side hinged in such a manner that it could be let down in fair weather and closed up in case of gales or severe beating storms. This stand with its contents is illustrated in Plate II, figure 1. A thermograph was placed in this stand, and thus continuous records of temperature were secured.

In the middle of the summer of 1907 two series of investigations were begun and were continued until December to determine the number of generations. In both 1908 and 1909 series of generation studies were begun in spring with the egg (fig. 11) and continued until the egg-laying forms appeared in the fall. In making these observations, the first individuals to hatch from the eggs in the spring were isolated; the first-born from these were in turn isolated, and this process was continued throughout the season until the egg-laying forms appeared. The last-born was also kept and the same mode of procedure con-

tinued until fall, as was the case in the line of the first-born. All young other than the first-born of the first series and the last-born of the second series were counted each day and destroyed. In this manner, each series being considered, we would arrive at the maximum and minimum number of generations. During these three years a vast amount of data, besides that on the number of generations, was thus accumulated. (See table, pp. 52-57.)

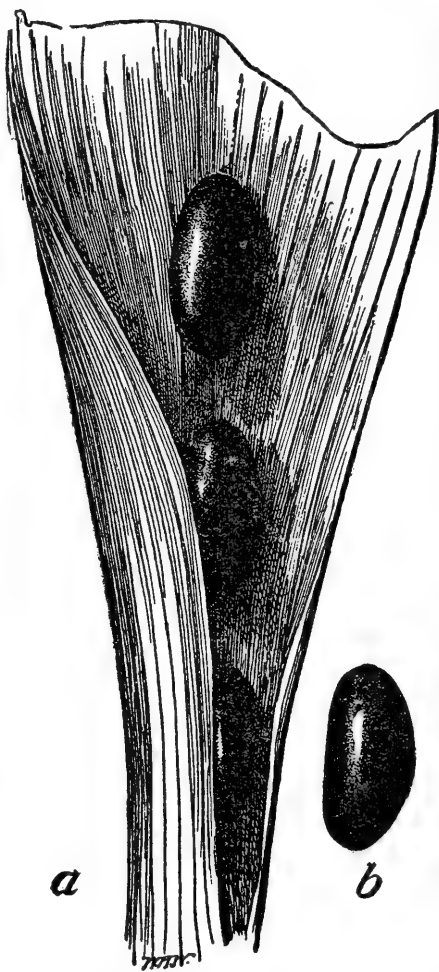


FIG. 11.—The spring grain-aphis: Eggs as deposited on leaf: *a*, Dorsal view; *b*, lateral view. Greatly enlarged. (Original.)

26	62	000000000000000000000000	000000000000000000000000
27	56
28	55
29	56
30	50
31	47
1	49
2	55
3	66
4	62
5	40
6	61
7	58
8	57
9	52
10	43
11	43
12	38
13	33
14	29
15	39
16	35
17	52
18	58
19	60
20	67
21	56
22	66
23	66
	47

Nov.

1 Adult oviparous. ♀

STEM MOTHERS.

At both Richmond and La Fayette, Ind., the eggs begin to hatch the latter part of March and continue until about April 10. The first generation, or stem mothers, differs from the next generation slightly in coloration, and there are besides some slight structural differences. The measurements of the body are not included in the following description, as the specimens are mounted in balsam.

DESCRIPTION OF THE DIFFERENT INSTARS.

First instar.—Before first molt: General color, very dark Nile green; head, beak, antennæ, legs, and cornicles very dark gray; tips of the antennæ, the tarsi, and the eyes black. Antennæ 4-segmented.

Measurements of antennal joints (average from 2 specimens): I, 0.034 mm.; II, 0.034 mm.; III, 0.093 mm.; IV, base, 0.046 mm.; IV, filament, 0.114 mm.; total length, 0.321 mm.

Second instar.—Before second molt: General coloration of head and body lighter than in the preceding stage, otherwise the coloration the same. Antennæ 5-segmented.

Measurements of antennal joints (average from 3 specimens): I, 0.045 mm.; II, 0.039 mm.; III, 0.127 mm.; IV, 0.082 mm.; V, base, 0.066 mm.; V, filament, 0.161 mm.; total length, 0.520 mm.

Third instar.—Before third molt: The color of the body now varies from pale green to deep apple green; head concolorous with body; legs slightly lighter; eyes, tip of beak, tip of cornicles, articulation of femora, and tibiæ black; distal two-thirds of antennæ black; basal portion greenish gray. Antennæ 5-jointed.

Measurements of antennal joints (average from 4 specimens): I, 0.050 mm.; II, 0.045 mm.; III, 0.152 mm.; IV, 0.093 mm.; V, base, 0.072 mm.; V, filament, 0.174 mm.; total length, 0.586 mm.

Fourth instar.—Before fourth molt: General coloration variable, though about the same as in third instar, with the exception that the eyes of the young begin to show through the body wall; eyes and tip of beak black; legs greenish gray, the articulation of femora and tibiæ and the distal portion of tibiæ very dark, and tarsi black; cauda lighter than the body, as is sometimes also the head; the two distal segments and distal portion of third segment of antennæ black, gradually shading off until at the base they are concolorous with the head; cornicles black at tips, shading off into pale grayish green at base. Antennæ 5-jointed; sometimes, however, there are 6 distinct joints.

Measurements of antennal joints (average from 4 specimens): I, 0.065 mm.; II, 0.051 mm.; III, 0.194 mm.; IV, 0.119 mm.; V, base, 0.088 mm.; V, filament, 0.196 mm.; total length, 0.713 mm.

Fifth instar.—In the adult stage the color varies from a clay yellow to greenish yellow and deep apple green; there is no central dorsal stripe; the eyes of the young show through the body walls. In some of the greener specimens the head is slightly lighter and in some of the lighter colored specimens the head is slightly darker than the body; eyes and tip of beak black; legs pale greenish gray, the articulation of femora and tibiæ and the distal third of tibiæ quite dark; tarsi black; cauda in yellow specimens with a yellowish tint and in the deep green specimens somewhat grayish, shape and length same as in summer form; cornicles concolorous with body except the distal third, which is black, shape and length same as in summer form; three distal segments of antennæ and distal half of fourth black, the basal joints concolorous with the head. Antennæ 6-segmented, though two specimens were found in which one antenna of each was only 5-segmented.

Measurements of antennal joints (average from 16 specimens): I, 0.066 mm.; II, 0.049 mm.; III, 0.226 mm.; IV, 0.140 mm.; V, 0.152 mm.; VI, base, 0.091 mm.; VI, filament, 0.225 mm.; total length, 0.951 mm. They are slightly pruinose in each stage.

The material from which these data were taken is mounted on slides and is in the collections of the Bureau of Entomology, bearing Webster number 5151.

The first generation, or stem mothers, is always wingless. All of the following generations differ in color, more especially in the first and second instars. The adult stem mothers; so far as we have been able to learn, never have the darker green dorsal stripe. The antennæ are shorter throughout the different instars, and in the adult also, than in the summer forms.

DESCRIPTION OF THE SUMMER FORMS.

First instar (fig. 12).—Before first molt: General color very pale green, the thorax probably the palest; head pale green with a dusky tinge; eyes brownish black; tip of cornicles black, bases dusky; articulation of femora and tibiæ and distal portion of tibiæ dusky; tarsi black; two apical segments of antennæ black, remaining segments concolorous with head. Antennæ 4-segmented.

Measurements of antennal joints (average from 3 specimens): I, 0.032 mm.; II, 0.033 mm.; III, 0.118 mm.; IV, base, 0.049 mm.; IV, filament, 0.154 mm.; total length, 0.386 mm.

Second instar (fig. 13).—Before second molt: General color slightly paler now; head not dusky; eyes same as in preceding stage; legs with a more greenish tinge now, otherwise same as in previous stage; the two basal joints and the proximal portion of the third joint of antennæ concolorous with head, other portion black. Antennæ 5-jointed.

Measurements of antennal joints (average from 2 specimens): I, 0.041 mm.; II, 0.035 mm.; III, 0.106 mm.; IV, 0.075 mm.; V, base, 0.062 mm.; V, filament, 0.204 mm.; total length, 0.523 mm.

Third instar.—Before third molt: Coloration practically same as in second instar; eyes almost black; bases of cornicles paler than abdomen. Antennæ 5-jointed.

Measurements of antennal joints (average from 2 specimens): I, 0.056 mm.; II, 0.045 mm.; III, 0.172 mm.; IV, 0.099 mm.; V, base, 0.076 mm.; V, filament, 0.259 mm.; total length, 0.707 mm.

Fourth instar.—Before fourth molt: General color deeper green now, very close to apple green; dorsal stripe apparent in this stage at times, eyes of young showing through body wall at this time, head a shade lighter than body and sometimes seeming to be tinged with yellow; eyes brownish black; beak black at tip; legs more of a yellowish green now, the articulation of femora and tibiæ and the distal portion of the tibiæ dusky; tarsi black; the two apical segments of antennæ black, next much lighter, third slightly dusky, and the two basal segments concolorous with head. Antennæ 5-segmented, although sometimes they appear to have 6 segments.

Measurements of antennal joints (average from 2 specimens): I, 0.060 mm.; II, 0.045 mm.; III, 0.272 mm. IV, 0.120 mm.; V, base, 0.086 mm.; V, filament, 0.282 mm.; total length, 0.865 mm.

All of the above stages slightly pruinose.

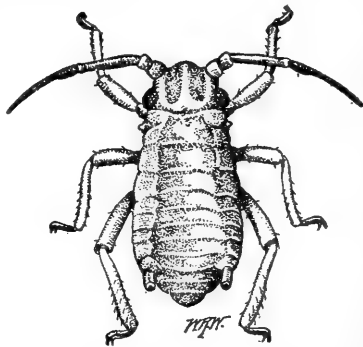


FIG. 12.—The spring grain-aphis: Young, first instar. Enlarged; actual size, 0.75 mm. (Original.)

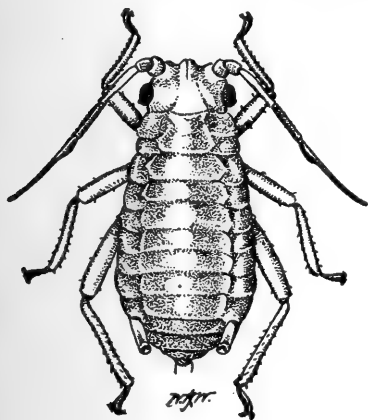


FIG. 13.—The spring grain-aphis: Young, second instar. Enlarged; actual size, 0.922 mm. (Original.)

The following is the description of the adult, summer forms, as given by Mr. Pergande:¹

Apterous female (fig. 6).—Length 1-1.8 mm.; color yellowish green and slightly pruinose, the median line darker green, the head and prothorax somewhat paler than the rest of the body. Eyes black. Antennæ black, the two basal joints and more or less of the third joint at base yellowish. Legs yellowish, the tibiae brownish toward the apex, tarsi black. Tail dusky. The general color of the larvæ and pupæ is like that of the apterous female. Wing pads of pupæ dusky to black. Antennæ slender and about one-half the length of the body. Nectaries slightly tapering, reaching to or slightly beyond the end of the body. Tail slender, somewhat constricted about the middle, and about two-thirds the length of the nectaries. There is a distinct fleshy tubercle each side of the prothorax and similar tubercles along both sides of the abdomen.

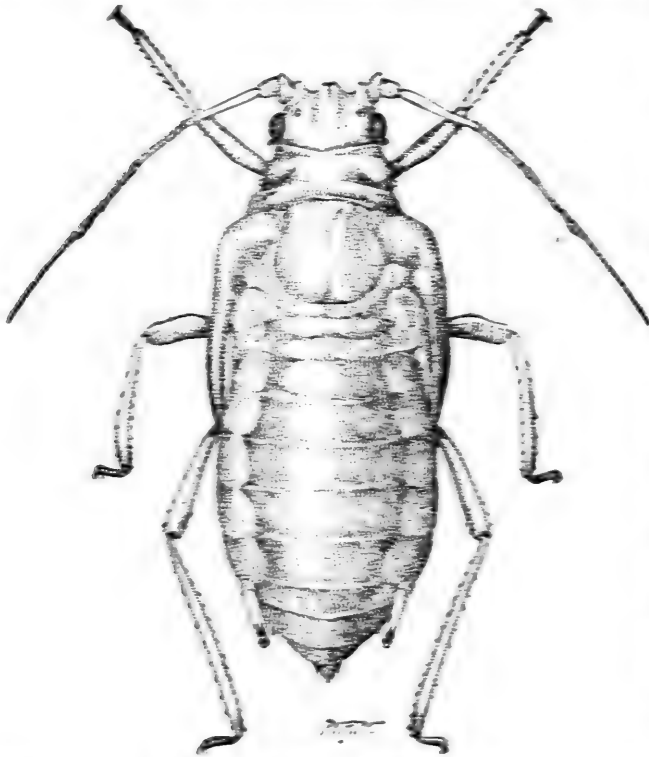


FIG. 14.—The spring grain-aphis: Pupa of winged virginopara female. Enlarged actual size, 1873 mm. (original.)

Migratory female (fig. 7).—Expanse of wings 5-7 mm.; length of body 1.5-2 mm. General coloration of the abdomen as in the apterous forms; head brownish yellow; the eyes brown; antennæ, thoracic lobes, the posterior margin of the scutellum, and the sternal plate black; the two basal joints of the antennæ yellowish green; legs yellow, the femora more or less dusky, the posterior pair darkest; apex of tibiae and the tarsi black; nectaries and tail yellowish, the latter changing gradually to dusky or black toward the end; wings transparent; costa and subcosta yellow; the stigma somewhat paler, its inner edge and the veins black. Third discoidal vein with but one fork. Antennæ long and slender, reaching nearly to the end of the

body, the third joint provided with 3 to 7 sensoria. Nectaries, tail, and lateral tubercles, as in the apterous females.

Besides the sensoria on the third segment of the antennæ mentioned in the above description, there are from 1 to 2 on the fourth, 1 near the apex of fifth, and several, more or less distinct, on the base of the sixth.

Measurements of antennal joints (average from 5 specimens): I, 0.082 mm.; II, 0.039 mm.; III, 0.300 mm.; IV, 0.223 mm.; V, 0.275 mm.; VI, base, 0.110 mm.; VI, filament, 0.395 mm.; total length, 1.384 mm.

To this description we add:

Winged female (fig. 8).—Coloration for this stage varying from a very pale green with a slight tinge of yellow to a deep apple-green. The dorsal stripe is not always

present. The size varies greatly in nearly all forms, wingless viviparous females varying from 1.5 mm. to over 2 mm.

Measurements of antennal joints (average for 8 specimens): I, 0.069 mm.; II, 0.045 mm.; III, 0.210 mm.; IV, 0.135 mm.; V, 0.140 mm.; VI, base, 0.089 mm. VI, filament, 0.305 mm.; total length, 0.993 mm.

Pupæ (fig. 14).—Measurements of antennal joints (average from 8 specimens): I, 0.064 mm.; II, 0.056 mm.; III, 0.186 mm.; IV, 0.127 mm.; V, 0.134 mm.; VI, base, 0.090 mm.; VI, filament, 0.270 mm.; total length, 0.927 mm.

Winged viviparous female (fig. 7).—Measurements of antennal joints (average from 8 specimens): I, 0.082 mm.; II, 0.059 mm.; III, 0.300 mm.; IV, 0.223 mm.; V, 0.215 mm.; VI, base, 0.110 mm.; VI, filament, 0.395 mm.; total length, 1.384 mm.

MOLTING.

The time required for molting, from beginning to completion, is 30 minutes. The first indication is restlessness; the antennæ are waved continuously and the legs move jerkily. This period of restlessness continues for 10 minutes, after which the antennæ are allowed to come to rest close down upon the dorsum. A few minutes later the tip of the abdomen will appear transparent and baggy, due to the old skin having slipped backward; the head and eyes are now being freed. It appears that the skin first ruptures in the cephalic region and only splits a part of the length of the dorsum, the insect gradually working its way out from this extremity. After the head, the antennæ are the first to be liberated, then each pair of legs in succession, and after all of the appendages have been freed the insect has still to struggle somewhat to free its abdomen. These observations were made on individuals casting the third or fourth molt.

NUMBER OF MOLTS.

Quite a number of observations were made on the number of molts and the period between the same, it being learned that stem mothers, the summer forms, and the sexes molt 4 times only.

To facilitate careful and accurate observations upon the number of molts, a young wheat plant was potted in a 5-inch flowerpot. A circle of black paper was cut small enough to fit down in the top of the pot. A small hole was then cut in the center and the paper disk was then fitted closely down about the base of the plant. After the paper was in place the space immediately around the plant was filled in with absorbent cotton made black with waterproof ink. Then a young *Toxoptera* that had just been born was placed on the plant inclosed by a clean lantern globe, with a piece of new cheesecloth firmly secured over the top to prevent the grayish cast skins from being overlooked. Each cast skin was removed as soon as the molt was completed, and a record made so that it could not possibly be counted a second time. All observations recorded in the notes on molting were made in this manner.

During the summer of 1907, at Richmond, Ind., careful observations were made on 7 individuals of the summer forms, and in the fall Mr. R. A. Vickery, of this bureau, made observations on 6 individuals, 3 of which proved to be males and 3 oviparous females. In each case there were 4 molts. In the spring of 1908, 4 stem mothers were found to molt 4 times only. In the spring of 1909 at Lafayette, Ind., 1 stem mother was found to molt 4 times. Later on in the summer, Mr. T. H. Parks, of this bureau, ran a series of experiments with the summer forms and, of the 30 individuals under observation, some of which were winged, he found that all without exception molted 4 times. In the fall of 1910 several additional oviparous females were found to molt 4 times only. This makes a total of over 50 specimens that came under our observation, under conditions that would absolutely preclude error, and there was not a single exception—all molting 4 times.

As it was found that the period between molts varied, experiments were begun in the summer of 1907 at Richmond, Ind., in order to learn how great the variation was when each individual was subjected to the same conditions.¹ This experiment was carried on indoors and all individuals were subjected to the same conditions. Table II will show the variations.

TABLE II.—*Variation in the duration of the different instars in Toxoptera graminum.*

Individual.	From time of birth to first molt.		From first molt to second molt.		From second molt to third molt.		From third molt to fourth molt.	
	H.	m.	H.	m.	H.	m.	H.	m.
A.....	38	35	28	29	31	37	39	40
B.....	40	15	29	15	34	36	34	37
C.....	50	20	26	40	35	48	40	22
D.....	45		54		40		64	
E.....	44	30	32	35	36	50	39	37

There is also considerable variation in the time from birth of individuals to the fourth molt and the appearance of the first young, as will be seen from Table III. Individuals in Table III are the same as in Table II, with the addition of "F" and "1b³."

TABLE III.—*Variation in the time from birth of individuals to fourth molt and appearance of first young in Toxoptera graminum.*

Individual.	From time of birth to fourth molt.		From time of birth until first young appear.		
	Hours.	Days.	H.	m.	Days.
A.....	143-144	5.9	144	35	6.02
B.....	143	5.9	143		6.1
C.....	153	6.3	164		6.8
D.....	153	6.3	165		6.8
E.....	204	8.5	246		10.02
F.....	195	8.1	205		8.5
1b ³	170-175	7.1	175		7.2

¹ Proc. Ent. Soc. Wash., vol. 10, Nos. 1-2, pp. 11-13, 1908.

² Approximate.

BIRTH OF YOUNG.

In the fall of the year 1907 adult individuals of *Toxoptera* were brought from out of doors into a warm room, placed under a microscope, and observations made on the manner of birth of the young. The embryonic young within the body of the parent are inclosed within a thin, transparent, structureless membrane that corresponds to the vitelline membrane in the true egg. Normally, in warm temperatures, the young *Toxoptera* frees itself from this enveloping sac during birth. At a temperature of about 60° F. or below, the young are oftentimes dropped before they free themselves from the sac. In this latter case, upon landing upon the surface of the leaf they expand and contract gently until the sac is ruptured at the cephalic extremity and they are freed from their prison.

NUMBER OF GENERATIONS PER YEAR.

During the summer of 1907, at Richmond, Ind., a study of the continuous generations of this species was begun and followed through until December 10, the sexual forms and eggs being secured from bluegrass in the fields in October. With some of the young that hatched from these eggs (stem mothers) March 27 five lines of continuous-generation studies were begun and continued until the appearance of the sexes and eggs in the fall. These eggs were carefully retained and taken to Lafayette, Ind., where, upon their hatching on the first day of the following April, two more lines of continuous-generation studies were begun and continued until ended by the appearance of the sexes and eggs in the fall of 1909, as was the case in 1908.

Mr. T. D. Urbahns, of this bureau, carried on a series of check experiments at Dallas, Tex., in 1909, starting in March and ending in the fall. (See table, pp. 64-69.) As will be observed, and for reasons explained farther on, he did not obtain the sexes. By these experiments the maximum number of generations was secured as described under rearing methods (p. 51). The maximum number of generations in 1908 among the five series of continuous generations was 21 and, as shown below, occurred in series I of first-born; the minimum being 6 in series FF of the series of last-born. The complete series are as follows: Series B, maximum (from first-born), 20 generations; series BB, minimum (from last-born), 9 generations; series C, maximum (from first-born), 18 generations; series CC minimum (from last-born), 8 generations; series F, maximum (from first-born), 16 generations; series FF, minimum (from last-born), 6 generations; series G, maximum (from first-born), 19 generations; series GG, minimum (from last-born), 9 generations; series I, maximum (from first-born), 21 generations; series II, minimum (from last-born), 10 generations. If all of these be added, we will find the average to be 13.6 generations. This will represent the approximate number of generations for the year. In 1909 there were two series reared, A and B, both resulting the same. Series A, maximum (from first-born), 18 generations; series AA, minimum (from last-born), 7 generations; series B, maximum (from first-born), 18 generations; series BB, minimum (from last-born), 7 generations. The average for these two lines would give 12.5 generations, a little lower average than at Richmond, Ind.

Mr. Urbahns carried out one series of first-born generation experiments at Dallas, Tex., in 1909, from which he obtained only the maximum number of generations. He began March 31 and finished November 3. In this time he reared through 25 generations but did not ascertain the sexes, neither was he successful in finding them in the fields.

It appears that the species will vary in the number of generations produced from individuals hatched the same day, and from the offspring kept under the same conditions throughout the year. This will readily be understood when the amount of individual variation in molting is considered.

AGE AT WHICH FEMALES BEGIN REPRODUCING.

The age at which females begin reproducing varies greatly between spring and summer and between fall and summer; as between spring and fall the age is very much the same. At Richmond and La Fayette, Ind., *Toxoptera* begins reproducing at from 5.9 to 16 days between the middle of May and latter part of September. From the time of hatching until the middle of May the period is from 20 to 27 days;

from the latter part of September to and including November the period varies from 12 to 53 days. A case occurred in the autumn of 1907 where it required 53 days for a single individual to reach maturity. This individual continued to live up to the 10th of December, when all experiments were closed. The average period from birth to reproduction for the summer months, early spring, and early fall is 9, 22, and 19 days respectively. The average for the entire year, or for the period in which the species breeds, parthenogenetically, for Richmond and La Fayette, Ind., is 16.6 days. In arriving at these averages, all individuals of the generation experiments for 1907, 1908, and 1909 were considered.

Mr. Urbahns found that at Dallas, Tex., the period varied from 7 to 12 days from birth to reproduction, from March to the middle of May; from 6 to 14 days from the middle of May until the last week in September, and from 9 to 11 days from the last week of September to November 3. The average number of days from birth to reproduction for each of these periods is 9.6, 7.4, and 9.7 days, respectively. Mr. Urbahns reared a number through December up to the middle of January. During this period the time between birth and reproduction was very much greater, varying from 18 to 25 days, with an average of 20.5 days. The average, beginning with April and continuing until November 3, is 8.9 days. From the foregoing data it will be seen that under favorable conditions *Toxoptera* breeds much more rapidly in the South than in the North. All of the reproduction experiments upon which these figures are based were carried on out of doors, but the insects were protected from the hot rays of the sun in the summer.

REPRODUCTIVE PERIOD.

The period of reproduction covers a greater average length of time in spring and fall than during summer, being greatest in the spring, even though the maximum period of reproduction for a single female is practically the same for the three periods.

In computing these averages each individual of all the lines of continuous generations was considered, even though they reproduced for a single day only and then died or disappeared from some unknown cause; hence the averages are lower than they would be had these latter individuals not been considered. From this data it will be seen that both the maximum and the average periods are the greatest in the North, where the insect is able to breed continuously in unprotected places throughout the summer.

At Richmond and La Fayette, Ind., the maximum period of reproduction for individuals born from March to the middle of June is 45 days, the minimum 1 day, and the average 18 days; the maximum for individuals born from the middle of June to the middle of August

is 43 days, the minimum 1 day, the average being 12.6 days; the maximum for those born after the middle of August is 45 days and the minimum 5 days, the average being 24 days, while the average for the entire season is 16 days.

In Texas the difference between summer, spring, and fall is still more marked, December and January being about the same as the summer months. Mr. Urbahns found that during December and January the maximum reproduction period was 19 days and the minimum 2 days, the average being 8 days; during April and May the maximum was 30 days and the minimum 4 days, the average being 16.8 days; during June, July, and August the maximum was 16 days and the minimum 4 days, the average being 8.4 days; during September, October, and November the maximum was 28 days and the minimum 3 days, the average being 17 days. The average for the entire season was 13.9 days.

LONGEVITY.

At Richmond and La Fayette, Ind., *Toxoptera* lives for a much longer period in the spring and fall than in the summer. In fact, in the summer it often survives a shorter time than is required for it to reach maturity in the spring and fall.

Those born from the latter part of March to the last week in May live from 15 to 78 days, the average being 43 days; those born from the first week in June to the middle of August live from 9 to 57 days, the average being 24 days; those born from the middle of August on through September live from 12 to 75 days, the average thus being 40 days. The average length of life for the whole viviparous breeding season is 35 days. These averages are not made up from the maximum and minimum alone but every individual in the line of first-born of the continuous generation experiments is considered.

Mr. Urbahns found that in Texas the spring grain-aphis lived much longer in spring and fall than in summer. In fact, in the summer it was difficult to keep it alive at all, it being necessary to keep the cages in the shade.¹ He also carried on some reproduction experiments in December and January, and in these two months found that it lived from 25 to 39 days, averaging 34 days. In April and May it lived from 13 to 47 days, averaging 35 days; in June, July, and August it lived from 10 to 30 days, averaging 17 days; in September, October, and part of November it lived from 11 to 56 days, averaging 28 days; the average for the season (from March to November) was thus 26 days.

In making up these averages only whole numbers are used, fractional parts of a day not being considered. Also, all individuals upon which we had complete observations were considered.

¹ Ante, p. 47.

FECUNDITY OF VIVIPAROUS FEMALE.

The average person, unfamiliar with the habits of the Aphididæ, would scarcely think it possible for such small creatures to become sufficiently numerous to devastate vast areas of grainfields, destroying millions of dollars' worth of property within the space of a few weeks. When one becomes familiar with their powers of reproduction, however, the problem seems very simple.

Prof. Huxley¹ states that the tenth generation alone of a single rose aphid, were all of its members to survive the perils to which they are exposed, would contain more substance than 500,000,000 stout men. Buckton,² commenting on Prof. Huxley's figures, states that he much underestimates the real quantity of animal matter capable of elaboration from a single aphid in a year, and goes on to say:

Basing the calculation, for simplicity, upon the supposition that every aphid lives twenty days, and that at the expiration of that period each aphid shall have produced twenty young and no more, then at the expiration of three hundred days *only*, the living individuals would be represented by the following figures:

Aphides.	Days.	Aphides.	
1 produces in	20.....	20.....	= a
a produces in	40=20 ²	400.....	= b
b produces in	100=20 ³	3, 200, 000.....	= c
c produces in	200=20 ⁴	10, 240, 000, 000, 000.....	= d
d produces in	300=20 ⁵ =32, 768, 000, 000, 000, 000.....		= e

Again, if 1,000 aphides weigh 1 grain, and
 1 man weighs 2,000,000 grains
 1 man weighs 2,000,000,000 aphides.

∴ $\frac{E}{2,000,000,000} = 1,638,400,000$ men; equal, perhaps, to the population of China sevenfold.

To quote further:

But a mathematical friend remarks that this calculation even does not express the real rate of increase, since it supposes the progeny of the first aphid to be produced *at once*, and not to commence producing until the expiration of the first twenty days. To this same friend I am indebted for the annexed calculation.

If we suppose the progeny of the first aphid to equal 20 in twenty days, and this progeny to begin producing when five days old 20 young, each of which again on attaining the age of five days begins the propagation of 20 young, and completes also that number in 20 days:

Then at the end of 20 days from the commencement of first aphid production there would be direct issue.....	= 20a
At the end of fifth day, progeny a begin to produce, which at the end of first 20 days will altogether equal 15+14+13+12, &c. +2+1.....	=120b
At the end of tenth day, progeny b begin to produce, which at the end of the first 20 days will altogether equal 10+9+8, &c. +2+1.....	= 55c
At the end of the fifteenth day, progeny c begin to produce, which at the end of the first 20 days will altogether equal 5+4+3+2+1.....	= 15d

Total at the end of 20 days equals $a+b+c+d$=210

The amount, therefore, at the end of 300 days (or 20×15) would not be less than the fifteenth power of 210, which is almost impossible to express in figures. There would be room in the world for nothing else but aphides.

¹ Trans. Linn. Soc., vol. 22, p. 215 (part 3, 1858).

² Monograph of British Aphides, vol. 1, p. 80.

Toxoptera, in all probability, would not fall far behind these figures and the number might even be greater. Be that as it may, the illustration will suffice to show us that Toxoptera, with such remarkable powers of reproduction, could easily overrun the whole country if not checked in some manner.

At Richmond and La Fayette, Ind., the maximum number of young produced in 24 hours was 8 in June, July, and August. The maximum number of young produced by any individual was 93, in the month of July. In Texas Mr. Urbahns found the maximum in 24 hours to be 10 young in May, and the total number of young for one individual reached as high as 84 during the same month.

At Richmond and La Fayette, Ind., considering the progeny from only the individuals of the line of first-born generations, the average number of young for the summer falls below either spring or fall, the spring being in the lead. When both the individuals from the line of first and last born generations are considered, those of the fall average less than those of the spring or summer. In 1908 the evidence was in favor of the line of first-born generations as being more prolific than the individuals of the line of last born. In 1909 the line of last-born generations held its own, especially in the spring and summer, falling behind slightly in the fall. In fact, in each line of generation experiments, the last born fall behind in average number of young in the autumn. Also, if an average be taken of the first and last born separately, the latter will fall behind. Considering each individual of both lines in all generations, both first and last together, the results are as follows: The maximum number of young produced by those born from March to the middle of June is 69, the average number for each individual for this period being 30.3; the maximum for those born from the middle of June until the middle of August is 93 young, the average number for each individual being 25.3; the maximum for those born after the middle of August is 66 young, the average for each individual being 24.

The average number of young, including every individual under observation, whether connected with the generation experiments or otherwise, for the entire viviparous breeding season, of the years 1907, 1908, and 1909, beginning the last week in March and continuing until November, both inclusive, is 28.2; there being 216 individuals used to obtain this average.

In the generation experiments were a number of individuals that produced from 1 to 10 young and then disappeared, apparently not dying from natural causes. All of these were included, however, in arriving at the final average, as any average obtained by excluding one or more individuals from any cause whatever would be more or less arbitrary, since in nature the mortality, in all probability, would be much greater. All of the rearings were carried on out of doors,

and as the individuals were isolated and protected as much as possible from natural enemies it is probably safe to say that this average is as high as would obtain in the open fields, where they are convenient prey for their enemies.

Mr. Urbahns found that in Texas the average number of young produced in the spring and fall was much greater than in the summer. The averages for December and January agree very well with those of the summer period.

The maximum number of young produced by a single individual, under observation by Mr. Urbahns, that began reproducing in December and January was 29, the average for this period being 17.1; the maximum for those that began reproducing in April and May was 84, the average being 58.5 young; the maximum for those that began reproducing in June, July, and August was 39, the average being 17.2 young; the maximum for those individuals that began reproducing after August was 73; the average for the period from March to November is 39.7; the average for the entire number of individuals upon which Mr. Urbahns made observations during 1909, including the rearings during December and January, is 34 young. As will be observed, this is considerably above the average for Indiana.

From the foregoing data it will be seen that the spring, in both the North and the South, is the most favorable period for reproduction; in the North the summer period ranks next, the fall coming last, while in the South the summer is so hot that the aphidids can scarcely live at all, the fall ranking next to spring for productiveness.

FECUNDITY OF WINGLESS VERSUS WINGED FEMALES.

In 1890 the senior author gathered from his observations that the wingless forms were more prolific than the winged. In 1907 the junior author came to the same conclusion. In 1909 Mr. Urbahns, in Texas, observed that the winged forms did not appear to be so prolific as the wingless forms. During the summer of 1909, at La Fayette, Ind., the junior author carried on some experiments with a view of learning, if possible, something definite in regard to this matter. For this purpose 8 nymphs with wing pads and 8 larvæ in the fourth stage were selected and each placed in a separate cage, each cage being placed under the same conditions. This experiment began on the 30th of August and all individuals became adult about the same time. The maximum number of young produced by a single winged individual was 44 and the minimum was 10; the maximum number of young produced by a single wingless individual was 61 and the minimum was 4. The total number of young produced by the 8 winged individuals was 224, or an average of 28 young for each individual; the total for the 8 wingless individuals was 274, or

an average of 34.25 young to each individual. While too small a number of individuals was taken to make the result conclusive, it plainly indicates that fecundity is greatest among the wingless individuals.

AVERAGE NUMBER OF YOUNG PRODUCED DAILY.

By "the average daily number of young produced" is meant the daily average for the reproductive period only of each individual. At Richmond and La Fayette, Ind., the average number of young produced daily for those born from March to the middle of June is 1.9; the daily average for those born from the middle of June to the middle of August is 1.7; the daily average for those born after the middle of August is 1.2. These figures, of course, include only those individuals in the generation experiments. The average number of young produced daily for the entire year is 1.6. The final average remains the same when all individuals are considered, irrespective of generation experiments.

From the above it will be seen that the daily average is greatest in the spring, the summer coming next, and the fall last. This corresponds also to the average total number of young for each individual for these periods.

Mr. Urbahns found that the average number of young produced daily at Dallas, Tex., for those individuals that began reproducing during December and January was 1.5; the daily average for those that began reproducing during April and May was 3.4; the average for those that began reproducing during June, July, and August was 2.1; the average for those born after August was 2.5. These averages will be seen to agree proportionately with the average number of young produced by a single individual during these periods, with the exception of the daily average for December and January, which is considerably lower. The average daily number of young for the entire breeding season for which Mr. Urbahns has any data is 2.

From the above data it will be seen that the average daily number of young for Texas is far above the average for Indiana. This can probably be accounted for from the fact that the reproductive period is much longer in the North and the young are distributed over a longer period. Also the average number of young for each individual is greater in the South.

SEXUAL FORMS.

The first young of the sexes in Indiana are apparently born the last week in September, the first adults oftentimes appearing as early as the first week of October. The adults can be found from this time on until December, or until they are killed off by extreme cold.

The males can easily be distinguished by their small size. The oviparous females (fig. 9) can be readily distinguished without a hand

lens by the yellowish areas over the abdomen, due to the fact that the eggs show through the body walls; also, if the males have not been with them, by the manner in which they rest upon the plant, the body being held at an angle of about 45° to the leaf upon which they rest. In assuming this position they hold to the plant only with the two first pairs of legs. Only unmated females rest upon the plant in this manner. The sexes may mate once or many times, although one mating is apparently sufficient to produce fertile eggs.

One agamic female may produce all agamic individuals, a combination of agamic males and oviparous females, or only true females and males. When only the latter, it seems that the females far outnumber the males.

Mr. C. N. Ainslie, in 1908, in Washington, D. C., records a very singular phenomenon. On April 4 of that year he observed males, oviparous females, and eggs of *Toxoptera* in his cages in the office. A number of eggs were obtained, but none of them would hatch. The source of this material, however, is somewhat obscure. Mr. Kelly had sent in material from Leavenworth, Kans., previous to these finds and this was kept breeding in the office, together with material collected locally. The junior author also found an adult male in his rearing cages in the insectary at Washington during April, 1911. This apparently developed from material that had been kept breeding all winter.

DESCRIPTIONS.

Since in the earlier stages the young can not be distinguished from those of the summer forms, it is unnecessary to go into detail with reference to them. The males may probably be identified in the third instar by their small size; they are much smaller and the abdomen more pointed, posteriorly, than the summer forms of this stage that later will become winged. Those young that will develop into oviparous females can not be determined with any degree of accuracy until the fourth instar. They are usually a little paler in color, and, instead of embryos, light yellowish ova can be seen, with a hand lens, developing within the body (see fig. 9). The description of the male and female first appeared in the *Canadian Entomologist*, in an article on "Sexual Forms of *Toxoptera graminum*, Rond.," by Prof. F. L. Washburn.¹ His description is as follows:

Oviparous female.—Length, 2-2.25 mm.; color, yellowish green, median line of abdomen darker green; head and prothorax somewhat paler than the rest of the body. Eyes black; antennæ black, except the two basal joints, and the basal half of the third, which are the same color as the head. Legs yellowish, tibia brownish toward the apex, tarsi black; cornicles greenish, their apex black; cauda greenish. Antennæ slender, hardly one-half the length of the body, no circular sensoria. Cornicles slightly tapering, not reaching to the end of the body. Cauda slender, somewhat

¹ *Can. Ent.*, vol. 40, No. 2, February, 1908.

constricted above the middle, about two-thirds the length of the cornicles. Tibia of hind leg (fig. 10) swollen and thickly covered with sensoria-like swellings. Lateral tubercles small and single.

Winged male.—Expanse of wings about 4.5 mm.; length of body about 1.3 mm. General coloration of the abdomen yellowish green; head brownish-yellow; eyes black; antennæ black, except the two basal joints and the proximal half of the third, which are yellowish green. Legs yellow, the femora more or less dusky, the posterior pair darkest; apex of the tibia and tarsi black; cornicles yellowish, with black apex; cauda yellowish. Wings, costa and subcosta yellow; stigma paler, the inner edge of the stigma and the veins black. Antennæ long and slender, reaching to or a little beyond the end of the body; third joint with about twenty circular sensoria; fourth with about eighteen; fifth with about nine. Cauda slender, somewhat constricted about the middle, as long as the cornicles. Lateral tubercles small and single.

To this description we add the following:

Oviparous female.—Measurements of antennal joints (average from eight individuals): I, 0.067 mm.; II, 0.050 mm.; III, 0.229 mm.; IV, 0.166 mm.; V, 0.172 mm.; VI, base 0.095 mm.; VI, filament, 0.369 mm.; total length, 1.148 mm.

Male (average from six individuals) (fig. 6): I, 0.064 mm.; II, 0.051 mm.; III, 0.361 mm.; IV, 0.243 mm.; V, 0.242 mm.; VI, base, 0.107 mm.; VI, filament, 0.407 mm.; total length, 1.475 mm.

We find also that the coloration of the oviparous female varies considerably from almost a clay-yellow with a faint tinge of green to a deep green. Individuals are somewhat pruinose also. As they become older the legs and bases of the antennæ get darker; each margin of the base of the cauda becomes quite dark.

The abdomen of the male varies somewhat in color from deep apple-green to pale green: the thoracic plates, dorsally and ventrally, are of an olive color.

MOLTING.

As stated on page 62 Mr. Vickery, of this bureau, conducted some experiments at Richmond, Ind., in 1908, to ascertain the number of molts for the sexes. He selected 6 individuals just as they were born and isolated each in cages as heretofore described. Three proved to be males and 3 oviparous females, all of which molted 4 times. Also, at La Fayette, Ind., in 1909, the junior author found that the oviparous forms molted 4 times.

OVIPAROUS DEVELOPMENT.

AGE AT WHICH FEMALES BEGIN OVIPOSITION.

The age at which females begin depositing eggs varies greatly according to weather conditions. From 11 to 41 days are required for them to become adult. If they happen to be born the last week in September or the first week in October the chances are that they will become adult within about 11 days. If they have the misfortune to be born the last week in October or during November it may take them over a month to reach maturity; perhaps they would

not reach maturity at all in case of an early winter. After reaching maturity they will, when accompanied by the male, begin ovipositing in from 3 to 9 days; if the weather is warm, in from 3 to 4 days. The period, then, from birth to oviposition varies from about 14 to 44 or 45 days. Females will, in rare instances only, oviposit without first having been with the male. They will live unfertilized from 31 to 71 days without ovipositing, the abdomen becoming very much distended, and, upon dissection, 6 or more fully developed eggs may be found. In one case a female deposited 2 eggs without having been with a male, but no development occurred within the egg and it shriveled and dried up within a few days. When nearly through ovipositing the female becomes shrunken and misshapen, as shown in figure 15. (Compare with fig. 9.)

PLACE OF OVIPOSITION.

Throughout the North it appears that bluegrass (*Poa pratensis*) is the most common host plant of Toxoptera, though it occasionally, on account of favorable weather conditions or the scarcity of natural enemies, becomes excessively abundant there and escapes to the grains in destructive numbers. Consequently it appears that the sexes normally occur on bluegrass. It is also true that they will be better protected from the extremes of temperature among tall, rank growing bluegrass than they would be on the grains in open, bleak fields.

In only a very few instances have we been able to find the sexes upon the growing grains in the fields. It is an easy matter, however, to locate them upon bluegrass in waste places. They apparently prefer dead or dying leaves and crawl out near the tip of the leaf, where it has begun to fold, and here deposit their eggs. (See fig. 11.) Several old females have been found at the same time within the curl of a leaf, and as many as 14 eggs have been found upon a single leaf.

PERIOD OF OVIPOSITION.

Here again, as in the case of viviparous development, varying temperatures are probably the main factor in determining the length of the productive period. Eggs continue to develop within the bodies of the females, apparently, as the embryos do within the

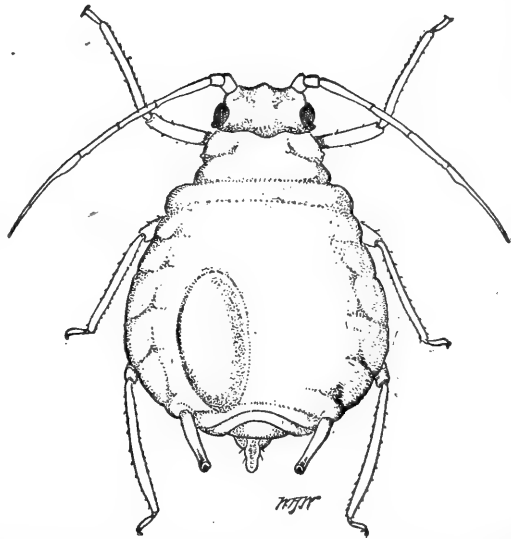


FIG. 15.—The spring grain-aphid: Shrunken and nearly spent oviparous female. Enlarged. (Original.)

bodies of the viviparous individuals, so long as warm weather continues or until the females become old and die a natural death. The viviparous forms appear to be as susceptible to extreme cold as are the oviparous individuals.

From the 14 experiments that were conducted to determine the period of oviposition it was found that it varied from 3 to about 25 days. If, after becoming adult, the female be kept for a week or more and then placed with the male it appears that the reproductive period is shortened.

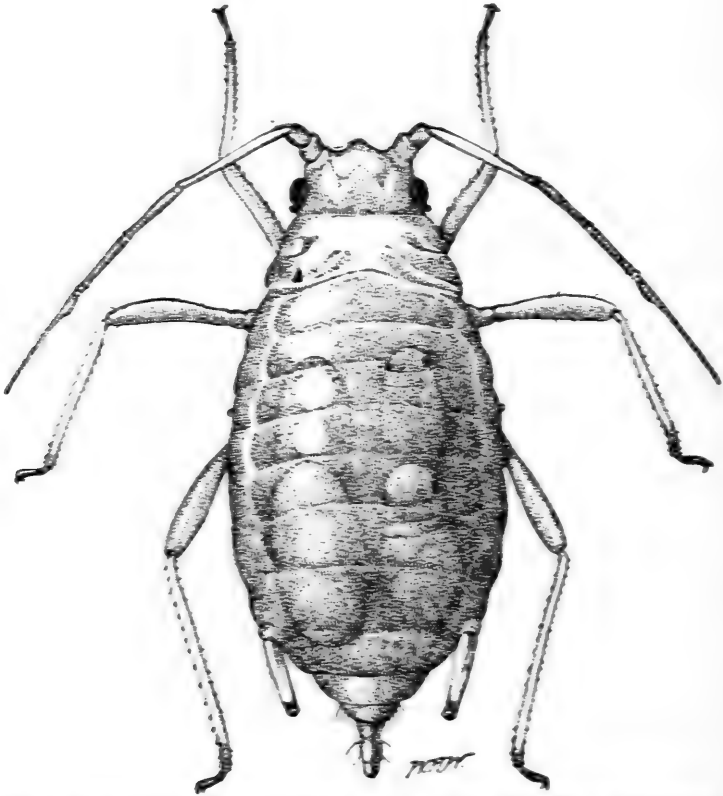


FIG. 16.—The spring grain-aphis: Aberrant female with eggs and embryos in abdomen, showing through the body wall. Enlarged. (Original.)

LENGTH OF LIFE OF THE SEXES.

The males reach maturity, it seems, as quickly as the oviparous females, but their lives are much shorter. The males live from 8 to 10 days after becoming adult.

The length of life of the oviparous females depends principally upon two factors, namely, weather conditions and the presence of the male. Under favorable weather conditions, and in the presence of the male, they will live from 31 to 68 days. If the male is not present they will sometimes live as long as 88 days. Under these circumstances they rarely deposit eggs, only one instance, as previously cited, having come under our observation where they did oviposit and then the eggs were not fertile. Their abdomens become greatly distended with eggs, and upon being dissected, as many as six or more full-sized eggs may be found.

FECUNDITY OF OVIPAROUS FORMS.

The oviparous forms are far less prolific than the viviparous. They produce, under favorable circumstances, from 1 to 10 eggs, or an average of 5.4 eggs per individual. This average was made up from observations on 27 individuals.

ABERRANT INDIVIDUALS.

During our studies of Toxoptera we have found some rather interesting abnormalities. In December, 1907,¹ while dissecting some individuals in the laboratory, two were found that contained both living embryos and true eggs. In April, 1908, Mr. C. N. Ainslie found the same phenomenon occurring in individuals here in Washington. These latter resembled the wingless viviparous forms externally (see fig. 16). Mr. S. J. Hunter, in "The Green Bug and Its Enemies," finds, besides this form, what he terms "winged intermediate females, resembling the winged agamic females in antennal characteristics." Other writers mention the same phenomenon as occurring among other species of plant-lice, and no doubt these abnormalities occur much oftener than any of us are aware. At present, however, there appears to be no satisfactory explanation of such occurrences.

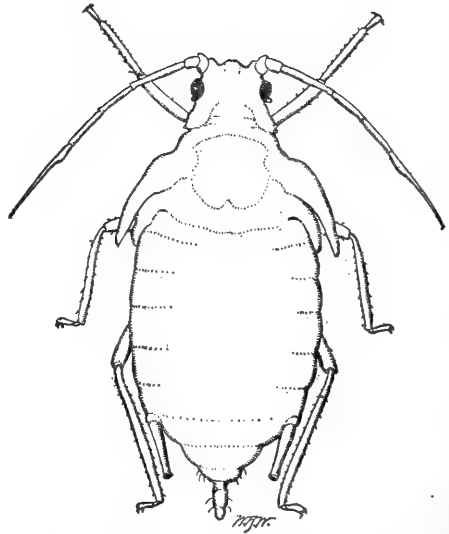


FIG. 17.—The spring grain-aphis: Aberrant female pupa which produced young. Enlarged. (Original.)

One single instance came under our observation where a puparium produced 6 young and then died. The cauda of this individual resembled that of an adult insect and the wing-pads were aborted, the abdomen being much broader than that of the normal pupa. (See fig. 17.)

INFLUENCE OF WINDS ON DIFFUSION.

By referring to the maps (fig. 5) showing the area covered by the different outbreaks of Toxoptera in the United States, west of the Mississippi River, it will be observed that they have all had their origin in central Texas, with a single exception, extending broadly to the north and northeast. This was especially true of two most destructive invasions of 1890 and 1907, and was also implied by that of 1901, the case of 1903 having been too incipient. This strongly indicates

¹ Proc. Ent. Soc. Wash., vol. 10, pp. 11-13, January, 1908.

the presence, during each extended invasion, of some important influence that shapes, to a marked degree, the course of these invasions across the country northward and northeastward from the point of their origin in the South. Probably this is due primarily to the direction of the winds during the months between January and June.

The degree of influence exerted by the winds in the diffusion of Toxoptera is, however, dependent upon several other factors. In the first place, with wingless individuals alone present, it is clear that no amount of wind of whatever velocity would distribute the species to any considerable degree. Therefore, it is necessary to understand the vital forces that regulate the abundance of winged individuals, which, at the critical period, would probably be almost without exception viviparous females. Field observations have shown, not only among this but among other species of aphidids, that a curtailing of the food supply is a most potent influence in producing the aerial form. Not only has it been observed with Toxoptera that as the food plants lose their vigor, affording less nutrition, the winged individuals become more and more abundant in the fields, but both Mr. Phillips and Mr. Urbahns have been able, by regulating the food supply, to produce these winged individuals, artificially at will, in their rearing cages. In the case of *Macrosiphum granaria* Buckt., it has always been noticed that though the heads of wheat be literally swarming with wingless females and young, these young do not perish as the food supply becomes exhausted on account of the ripening of the grain, but develop into winged adults which fly away, leaving only the cast larval and pupal skins on the ripening wheat heads. Therefore, so long as there is an abundant supply of vigorous young grain the percentage of winged adults appearing will be comparatively few. The condition of the food supply, then, is a prime factor in the diffusion of Toxoptera, except when greatly decimated in numbers from excessive parasitism.

If the temperature be below the point of activity for the species, it is very clear that the velocity of the wind would have no effect whatever upon the diffusion of the insect. The conditions necessary, then, for the wind to exert its greatest influence will be a decreasing food supply for the insect under a temperature considerably above that actually necessary for its activity, with numbers not seriously reduced by parasites; under these conditions, many species of aphidids are known to be carried about in immense numbers by the winds.

White, in his *Natural History of Selborne*¹ has this reference to a migration of small aphidids.

As we have remarked above that insects are often conveyed from one country to another in a very unaccountable manner, I shall here mention an emigration of small Aphides, which was observed in the village of Selborne no longer ago than August 1, 1785.

¹ *Natural History and Antiquities of Selborne*. By the Rev. Gilbert White, M. A., London, 1836, pp. 365-366.

At about three o'clock in the afternoon of that day, which was very hot, the people of this village were surprised by a shower of Aphides, or smother-flies, which fell in these parts. Those that were walking in the street at that juncture found themselves covered with these insects, which settled also on the hedges and gardens, blackening all the vegetables where they alighted. My annuals were discoloured with them, and the stalks of a bed of onions were quite coated over for six days after. These armies were then, no doubt, in a state of emigration, and shifting their quarters; and might have come, as far as we know, from the great hop plantations of Kent or Sussex, the wind being all that day in the easterly quarter. They were observed at the same time in great clouds about Farnham, and all along the vale from Farnham to Alton.

Prof. Karl Sajo calls attention to the fact that many aphidids creep to the crowns of the plant which they infest and then drop themselves at the proper moment into the boiling current of the storm.¹ In the studies made of Toxoptera many instances of this nature have been observed. It will be recalled that *Toxoptera graminum* appeared in swarms about Parma, Italy, in 1847 and again in 1852. The notes of Mr. C. N. Ainslie, made on Toxoptera in Oklahoma and Kansas, contain very many similar interesting records.

At Kingfisher, Okla., under date of March 27, 1907, Mr. Ainslie makes this record.

Toxoptera flying to-day by the million. The air was full of the migrants, and farmers who drove to town were covered on the windward side to their annoyance. The aphides seem for the most part to fly low, but the wind hurried them at such a rapid rate that they might easily have been invisible when higher in the air.

The following day his field notes contained these significant statements: "Large numbers of Toxoptera on the wing to-day, always moving north," and as those who have studied the species will understand, the most interesting statement was that "A heavy thunder shower passed by on the north last night, 30 miles away, and a few drops fell here." In the same locality, under date of April 3, he states that winged individuals of Toxoptera were taking to wing freely, for he had observed many leaving the blades in the fields and taking flight. Again, under date of April 6, "The air is full of flying Toxoptera to-day, going northeast with a light breeze. They do not fly high, from 2 to 15 feet." (The temperature at Wichita, 30 miles north, was from 42° to 57° F.) At Wellington, Kans., April 24 (with Wichita temperature 45° to 81° F.), he found Toxoptera flying by the million and farmers driving to town had to shelter their eyes from the swarm. On April 29, he records these observations:

Yesterday afternoon was warm for awhile (41° to 63° F. at Wichita), light north-west breeze. Toxoptera took wing in immense numbers for 15 or 20 minutes, drifting southwest, but soon saw their mistake and the air cleared. This is the only instance seen by me when these aphides failed to fly north. The wind did not carry them far this time. A Sunday ball game was in progress when they flew, and I was told that the myriads of aphides interfered with the game; it was like trying to play in a snowstorm.

¹ The Wanderings of Insects. Prometheus, vol. 1, by Prof. Karl Sajo.

Under date of May 17, 1907, also at Wellington, Kans., Mr. Ainslie made an interesting record as follows:

Yesterday, the 16th, the air was full of Toxoptera rising on wing, but the breeze was light and they had no chance to travel far. If the wind had favored their flight they must have carried parasites with them as guests, by the myriad, for many of them, probably the major part, were parasitized. [The temperature at Wichita ranged from 44° to 82° F.]

On the same day the senior author, in company with Prof. E. A. Popenoe, in driving about the country in the vicinity of Manhattan, Kans., during the afternoon found that they were in the midst of swarms of winged Toxoptera; frequently a number of individuals might be noted crawling about over their hats and coats and to an annoying degree traveling over their faces. Two days later, the senior author observed both winged Toxoptera and *Aphidius* crawling about on the inside of the windows of a Pullman car in which he was traveling over the Santa Fe, crossing central Kansas.

At Plano, Tex., June 4, 1909, Mr. Urbahns learned of a most interesting migration reported to him as having taken place two days before. A farmer, Mr. Foreman, reported to him that "green bugs" were observed flying east, probably coming from out of a very badly infested wheat field, moving with the evening breeze. In this case there was clearly a rapid disappearing of the food supply, precipitating a development to winged adults that were probably forsaking the fields for some other locality affording them a greater abundance of food. It would appear, then, that the influence of winds is more or less dependent upon several other phenomena.

With the natural advance of spring from the South, there would be a continually decreasing supply of fresh, tender, succulent food in the South, while to the North this condition would be reversed. Therefore, with winged viviparous females developing with increasing abundance along the area of a certain latitude, such winged females as were carried south or backward over an area already rendered barren of food would consequently perish. On the other hand, those females that drifted or made their way northward would encounter a continually increasing fresh supply of food; therefore they might be said to follow along with the advance of the spring from the South far into the North, until overtaken by their natural enemies. Then, too, south winds are associated with a warm temperature and north winds with the reverse, as will be seen from Tables IV-VIII, furnished by the United States Weather Bureau. Another factor that must not be lost sight of is that after about the latitude of southern Kansas and Missouri is reached wheat ceases to be the food plant for Toxoptera in spring, and spring oats takes its place in this respect.

Still another factor of greatest importance is in the fact that, with a wind from a southern quarter, blowing strongly under a temperature sufficient to render *Aphidius* active, both *Toxoptera* and parasite would thus be carried on the wing perhaps miles to the northward and scattered over fields not previously seriously infested. The following day, or some days after, there might come a north wind with greatly reduced temperature, which, though not sufficiently cold to prevent immediate reproduction on the part of migrant *Toxoptera*, would yet keep the parasite inactive. That precisely these weather conditions do often occur during years of excessive abundance of *Toxoptera* is shown by the following tables of the weather (Tables IV-VIII), while the dates thereof show conclusively that both *Toxoptera* and *Aphidius* were present and active. This last factor will be further discussed under natural enemies. These tables were compiled for us by the Weather Bureau.

TABLE IV.—Maximum and minimum temperatures, with direction and velocity of wind, and character of the day, San Antonio, Tex., 1907.

Date (1907).	Weather.	Maximum.	Minimum.	Direction of wind.	Velocity of wind.	Date (1907).	Weather.	Maximum.	Minimum.	Direction of wind.	Velocity of wind.
		° F.	° F.		Miles per hour.			° F.	° F.		Miles per hour.
Feb. 1	Clear.....	81	63	SE.	11	Mar. 3	Clear.....	80	49	SE.	13
2	Fair.....	83	48	N.	26	4	do.....	82	56	SE.	15
3	Cloudy.....	49	38	N.	22	5	Fair.....	84	64	S.	16
4	Fair.....	56	33	NE.	20	6	do.....	85	64	SE.	18
5	do.....	47	28	NE.	19	7	Clear.....	84	64	S.	15
6	Cloudy.....	43	34	NE.	15	8	Fair.....	82	66	SE.	18
7	Fair.....	60	39	N.	22	9	do.....	80	66	S.	16
8	Clear.....	68	33	N.	7	10	do.....	80	57	W.	23
9	do.....	73	38	S.	15	11	do.....	85	65	SE.	21
10	do.....	68	42	N.	22	12	do.....	87	65	S.	21
11	do.....	72	44	N.	10	13	do.....	80	70	NE.	17
12	do.....	74	36	S.	10	14	do.....	70	47	N.	36
13	do.....	78	46	S.	15	15	Clear.....	70	42	NE.	23
14	do.....	71	50	N.	24	16	do.....	76	46	SE.	14
15	do.....	70	40	N.	9	17	do.....	88	66	SE.	18
16	do.....	77	44	SW.	11	18	do.....	88	64	SE.	15
17	do.....	80	48	SE.	10	19	do.....	89	62	SE.	15
18	Fair.....	80	53	SW.	14	20	do.....	89	63	SE.	17
19	Clear.....	76	52	N.	18	21	do.....	88	63	SE.	24
20	do.....	79	44	SW.	10	22	do.....	87	64	SE.	20
21	do.....	80	47	S.	17	23	do.....	86	66	S.	15
22	Fair.....	80	52	SE.	19	24	do.....	88	67	SE.	16
23	Cloudy.....	79	62	SE.	15	25	Fair.....	87	68	SE.	18
24	do.....	67	56	NE.	22	26	do.....	86	68	SE.	20
25	do.....	66	48	N.	19	27	do.....	88	69	SE.	17
26	do.....	68	49	SE.	7	28	do.....	88	68	SE.	20
27	Fair.....	81	63	S.	15	29	Cloudy.....	73	55	N.	26
28	do.....	80	64	N.	30	30	Fair.....	72	55	N.	14
Mar. 1	Clear.....	73	52	NW.	27	31	Clear.....	70	52	N.	22
2	do.....	77	43	S.	14						

TABLE V.—Maximum and minimum temperatures, with direction and velocity of wind, and character of the day, Fort Worth, Tex., 1907.

Date (1907)	Weather	Maximum	Minimum	Direction of wind	Velocity of wind	Date (1907)	Weather	Maximum	Minimum	Direction of wind	Velocity of wind
		°F.	°F.		Miles per hour.			°F.	°F.		Miles per hour.
Feb. 1	Fair	71	42	SW.	16	Mar. 3	Clear	82	49	S.	20
2	Cloudy	61	30	NW.	30	4	do.	81	53	SW.	28
3	do.	32	26	N.	17	5	Fair	69	53	SW.	22
4	do.	30	23	NW.	16	6	do.	82	51	SW.	23
5	Fair	33	22	NE.	12	7	do.	86	63	SW.	22
6	do.	42	24	NE.	9	8	do.	70	53	NE.	17
7	do.	53	30	N.	23	9	do.	73	56	SW.	23
8	Clear	67	26	S.	20	10	Clear	62	39	N.	16
9	do.	80	44	S.	17	11	Fair	81	49	S.	35
10	Fair	65	43	NE.	21	12	do.	84	66	SW.	33
11	Clear	73	35	S.	16	13	Clear	73	44	S.	30
12	do.	79	46	SW.	22	14	do.	58	38	N.	20
13	do.	80	47	SW.	22	15	do.	64	39	SE.	11
14	do.	61	42	N.	20	16	do.	75	46	SW.	22
15	do.	66	33	SW.	17	17	Fair	83	63	SW.	24
16	do.	74	45	SW.	15	18	Clear	92	65	SW.	28
17	Fair	79	41	S.	20	19	do.	85	64	SW.	25
18	do.	81	55	NW.	32	20	do.	88	64	S.	24
19	Clear	69	41	N.	16	21	do.	89	63	SW.	25
20	do.	74	40	S.	15	22	do.	87	64	S.	29
21	Fair	74	44	SW.	25	23	Fair	87	65	S.	25
22	do.	58	39	E.	16	24	do.	86	64	S.	20
23	do.	81	52	S.	25	25	Clear	85	67	SW.	31
24	do.	68	44	NW.	23	26	Fair	83	67	SW.	31
25	Cloudy	58	42	NE.	12	27	do.	83	69	SW.	31
26	Fair	71	40	SE.	18	28	do.	84	70	S.	30
27	Cloudy	61	54	SE.	17	29	Cloudy	73	53	NW.	14
28	do.	74	41	NW.	28	30	Clear	70	47	NE.	14
Mar. 1	Clear	56	37	NW.	24	31	do.	59	49	NE.	21
2	do.	81	49	SW.	23						

TABLE VI.—Maximum and minimum temperatures, with direction and velocity of wind, and character of the day, Oklahoma City, Okla., 1907.

Date (1907)	Weather	Maximum	Minimum	Direction of wind	Velocity of wind	Date (1907)	Weather	Maximum	Minimum	Direction of wind	Velocity of wind
		°F.	°F.		Miles per hour.			°F.	°F.		Miles per hour.
Mar. 1	Clear	49	28	N.	30	Apr. 1	Fair	66	38	S.	34
2	do.	68	35	S.	35	2	do.	75	48	S.	52
3	do.	69	37	E.	23	3	do.	88	58	SW.	43
4	Cloudy	84	45	S.	36	4	Cloudy	68	54	N.	36
5	do.	55	34	N.	36	5	do.	58	42	N.	33
6	do.	68	48	S.	38	6	do.	72	48	SE.	34
7	Fair	60	44	N.	34	7	Clear	71	47	N.	24
8	Cloudy	54	35	E.	25	8	do.	63	44	N.	38
9	do.	71	38	NW.	47	9	Fair	79	41	W.	31
10	Fair	48	35	N.	35	10	Clear	74	43	S.	26
11	Cloudy	79	39	S.	36	11	do.	72	52	N.	42
12	Fair	68	43	S.	30	12	Fair	58	42	N.	36
13	Cloudy	44	32	N.	32	13	do.	57	33	NE.	22
14	Fair	54	27	N.	22	14	Cloudy	61	44	S.	32
15	do.	62	36	S.	25	15	do.	85	49	SE.	48
16	do.	71	42	S.	38	16	do.	64	34	NE.	33
17	do.	83	52	S.	37	17	do.	54	34	SE.	24
18	do.	89	60	S.	35	18	Fair	65	41	SE.	37
19	do.	97	63	S.	32	19	Cloudy	52	39	N.	26
20	Clear	92	61	S.	25	20	do.	48	36	NE.	26
21	do.	89	64	S.	32	21	do.	51	44	NE.	18
22	do.	86	62	S.	34	22	do.	46	40	N.	22
23	Fair	84	64	S.	31	23	Clear	69	36	S.	30
24	Cloudy	88	54	S.	35	24	Fair	79	52	S.	43
25	Fair	86	64	S.	38	25	Cloudy	64	40	N.	42
26	Cloudy	77	67	S.	47	26	Clear	66	35	NE.	20
27	do.	83	68	S.	38	27	Cloudy	80	55	S.	36
28	do.	82	61	S.	42	28	Fair	77	51	SE.	36
29	Fair	68	46	W.	22	29	Cloudy	64	34	N.	44
30	do.	70	42	N.	31	30	Fair	50	32	N.	30
31	Cloudy	55	44	N.	34						

TABLE VII.—Maximum and minimum temperatures, with direction and velocity of wind, and character of the day, Wichita, Kans., from Mar. 20 to May 31, 1907.

Date (1907).	Weather.	Maximum.	Minimum.	Direction of wind.	Velocity of wind.	Date (1907).	Weather.	Maximum.	Minimum.	Direction of wind.	Velocity of wind.
		°F.	°F.		Miles per hour.			°F.	°F.		Miles per hour.
Mar. 20	Clear	87	51	SW.	16	Apr. 26	Clear	63	31	SE.	13
21	do	91	63	SW.	24	27	Fair	77	48	SE.	19
22	Fair	92	63	SW.	24	28	Cloudy	63	41	N.	18
23	Clear	78	64	SW.	21	29	do	41	32	N.	27
24	do	85	54	S.	19	30	Fair	49	30	N.	16
25	do	89	62	SW.	24	May 1	Clear	61	31	SW.	9
26	Cloudy	78	69	SW.	28	2	Fair	67	45	E.	14
27	Fair	69	47	SW.	17	3	Cloudy	51	30	N.	27
28	Cloudy	79	52	W.	30	4	Fair	50	28	SE.	15
29	Clear	68	39	NW.	15	5	Cloudy	50	43	NE.	13
30	Fair	68	42	N.	21	6	do	51	45	NW.	15
31	do	57	39	NE.	17	7	do	57	46	N.	9
Apr. 1	Clear	65	37	S.	24	8	Fair	66	50	N.	12
2	Fair	71	49	S.	30	9	do	72	49	SE.	9
3	Clear	81	56	NW.	24	10	do	79	51	NE.	11
4	Fair	71	44	NE.	26	11	Clear	80	52	SE.	20
5	do	60	39	NE.	20	12	do	82	60	S.	35
6	Cloudy	57	42	W.	15	13	Cloudy	79	50	S.	24
7	do	62	44	W.	23	14	do	53	37	N.	27
8	Clear	60	41	N.	30	15	Fair	66	33	NW.	22
9	do	74	35	N.	23	16	Clear	82	44	S.	16
10	Fair	63	39	SE.	16	17	Fair	90	60	SW.	19
11	Clear	66	44	NW.	23	18	Cloudy	86	58	SW.	12
12	do	55	36	NW.	26	19	Fair	71	58	NE.	14
13	Fair	53	28	N.	13	20	Clear	79	50	SE.	16
14	Cloudy	52	36	SE.	22	21	Fair	85	61	SW.	24
15	Fair	74	46	N.	18	22	Clear	85	65	SW.	25
16	Cloudy	51	29	NE.	22	23	Fair	86	66	SE.	18
17	Fair	58	25	SE.	14	24	Cloudy	75	64	SW.	17
18	do	53	36	N.	25	25	Fair	82	55	NW.	14
19	do	53	32	N.	14	26	do	65	48	N.	26
20	Cloudy	52	37	NE.	14	27	Clear	66	37	N.	14
21	do	58	34	N.	9	28	Cloudy	54	54	SE.	16
22	do	56	43	S.	11	29	do	59	69	E.	10
23	Clear	73	36	SW.	17	30	do	61	61	N.	13
24	do	81	45	SW.	34	31	do	65	65	N.	21
25	Fair	53	36	NE.	24						

TABLE VIII.—Maximum and minimum temperatures with direction and velocity of wind, and character of the day, Dodge City, Kans., from Mar. 20 to May 31, 1907.

Date (1907).	Weather.	Maximum.	Minimum.	Direction of wind.	Velocity of wind.	Date (1907).	Weather.	Maximum.	Minimum.	Direction of wind.	Velocity of wind.
		°F.	°F.		Miles per hour.			°F.	°F.		Miles per hour.
Mar. 20	Fair	91	41	SE.	24	Apr. 8	Fair	63	41	NW.	23
21	do	94	54	SW.	28	9	Clear	73	40	NW.	16
22	do	89	43	S.	28	10	do	77	37	SE.	27
23	Clear	76	53	NW.	23	11	do	64	38	NW.	24
24	do	86	46	S.	26	12	Fair	59	35	NW.	15
25	Fair	89	46	SE.	30	13	Clear	55	28	E.	13
26	do	85	54	SE.	36	14	do	68	35	SE.	26
27	do	61	38	NW.	16	15	Fair	70	39	NW.	23
28	do	74	44	SE.	35	16	Cloudy	48	24	NE.	14
29	Clear	62	30	NW.	24	17	Clear	60	24	SE.	16
30	Cloudy	59	31	NW.	18	18	Fair	51	32	NW.	18
31	Fair	55	34	SE.	16	19	Cloudy	45	30	NE.	10
Apr. 1	Clear	72	36	SE.	28	20	do	46	33	NE.	9
2	Fair	85	51	E.	23	21	do	48	28	SE.	10
3	Clear	73	49	NW.	22	22	Fair	56	35	SE.	9
4	Cloudy	58	38	N.	15	23	Clear	78	30	SE.	18
5	Fair	61	26	SE.	10	24	do	76	36	W.	24
6	do	67	39	W.	25	25	Cloudy	44	31	NW.	17
7	Clear	66	33	SW.	12	26	Fair	64	28	SE.	18

TABLE VIII.—Maximum and minimum temperatures with direction and velocity of wind, and character of the day, Dodge City, Kans., from Mar. 29 to May 31, 1907.—Contd.

Date (1907).	Weather.	Maxi- mum	Mini- mum	Dirac- tion of wind.	Ve- locity of wind.	Date (1907).	Weather.	Maxi- mum	Mini- mum	Dirac- tion of wind.	Ve- locity of wind.
		°F.	°F.		Miles per hour.			°F.	°F.		Miles per hour.
Apr. 27	Clear.....	81	37	N.	16	May 15	Clear.....	67	30	W.	10
28	Fair.....	89	32	N.	16	16	do.....	86	42	SE.	7
29	Cloudy.....	42	35	N.	15	17	Fair.....	92	53	SE.	17
30	Fair.....	45	30	NW.	7	18	Cloudy.....	81	55	NE.	13
May 1	do.....	62	37	SE.	12	19	Clear.....	73	50	N.	10
2	Cloudy.....	57	32	NW.	15	20	Fair.....	81	50	SE.	24
3	Fair.....	58	27	NW.	20	21	do.....	86	60	SE.	35
4	do.....	67	27	SE.	22	22	Clear.....	83	65	SE.	33
5	Cloudy.....	48	41	SE.	8	23	Fair.....	87	64	SE.	32
6	do.....	50	42	NE.	7	24	do.....	78	55	SE.	29
7	do.....	66	40	E.	8	25	Clear.....	74	47	W.	41
8	Fair.....	68	43	N.	6	26	do.....	82	37	NW.	36
9	Clear.....	71	49	E.	10	27	do.....	64	30	SE.	16
10	do.....	73	45	NW.	5	28	Cloudy.....	52	42	SE.	28
11	do.....	84	48	SE.	24	29	do.....	53	46	SE.	22
12	do.....	92	60	SE.	31	30	do.....	59	49	N.	11
13	Fair.....	75	39	NW.	17	31	Fair.....	67	45	NW.	24
14	Clear.....	58	34	NW.	16						

INFLUENCE OF TEMPERATURE ON DIFFUSION.

Directly and indirectly, temperature is responsible for the destructive abundance of *Toxoptera graminum* in the United States. Directly, because the species will breed throughout the winter months at a temperature under which its natural enemies will remain inactive, and besides, it is probably due to this influence that the sexual forms and eggs occur, so far as known, only over the northern portion of its range. Our extended investigations have led to the suspicion that, but for the viviparous reproduction in such overwhelming numbers in the South, during winter end early spring, to drift northward with the season, there would be little if any damage caused by its occurrence in the Northern States, where in fairly severe winters it probably winters over in the egg stage only. For this reason the authors have thought investigations of the egg and its development of decided economic as well as scientific importance, and the junior author has therefore made a brief study of the embryology of the species.

The temperatures prevailing over the country where *Toxoptera* has worked its most serious ravages, and departures from the normal during the season of greatest activity are all given on the temperature diagrams, Nos. I to V (pp. 15, 21, 25, 26, 28). The upper numbers indicate the normal temperature, the lower the departure therefrom ("+" meaning above and "-" below). Each separate page relates to one of each of the five consecutive outbreaks. From these it will be seen that outbreaks of *Toxoptera* have succeeded only winters with

the temperature in the South above the normal, followed by springs during which the temperature was below the normal. The temperature during December, 1902, was below the normal in the Southwest. (See Diagram II.) In January, 1903, it was above, but below again in February, and about normal or above in March and April, the result being that only incipient outbreaks occurred in northern Texas and probably South Carolina. (See Diagram II; fig. 5, p. 20.) If the series of temperature maps (Diagrams I-V) be compared with those showing the area covered by each invasion the relation between abnormal temperatures and these invasions will be clearly apparent.

These records are those of the United States Weather Bureau and are therefore correct so far as general field temperatures are involved. When it comes to a consideration of the exact effects of temperature and humidity upon the individual Toxoptera, however, the figures will not apply with mathematical exactness, for the reason that to secure this information it is necessary to learn the exact conditions in the midst of the insects themselves at the exact time that such data are being secured. To illustrate, the instruments of the Weather Bureau kept in the shade may indicate a certain temperature, yet in a field perhaps a mile distant on a sunny day, and down among the plants in the midst of the developing insects, there may be several degrees difference in temperature. As will be noted farther on, Mr. Luginbill has found this difference to amount in some cases to several degrees. Besides, it is easy to conceive of other conditions which might have precisely the reverse effect. Furthermore, there will be a difference in temperature as between fields with a sandy and a clay soil or between a southern and a northern exposure, or with a soil dry on the surface as against a soil with a wet surface. It will be observed, therefore, that while the exact temperature at which Toxoptera will reproduce, viviparously, is of scientific interest, such information is of minor significance in the field, where it is the more generally prevailing weather conditions, such as are secured by the United States Weather Bureau, over wide areas that become of greatest importance, Mr. R. A. Vickery, on December 4, 1908, at Richmond, Ind., with 5 viviparous females under observation, found that young were produced sparingly at a temperature of 40° F. This was indoors, in a room slightly heated by an oil stove so that the temperature was under control, and frequent readings were made during the day. Under the same conditions numerous young were produced when the temperature reached 45° to 53° F.

Tabulated, the results of Mr. Vickery's rearings are as follows:

TABLE IX.—*Experiments with 5 viviparous females of Toxoptera graminum to determine minimum temperature at which reproduction will take place. Richmond, Ind., December, 1903.*

Date.	Temperature.		Number of young produced.
	Minimum.	Maximum.	
	°F.	°F.	
Dec. 3	40	45	0
4	40	41	1
5	40	53	6
6	40	45	0
7	26	49	1
8	35	50	7
9	39	50	0

After December 9 the outside temperature increased so that control indoors was not possible.

At Dallas, Tex., January 3 to 14, out of doors and under natural conditions, with thermometer within a few feet of the five female *Toxoptera* 1 to 3 days after maturity, Mr. Urbahns found that young were produced as follows:

TABLE X.—*Experiments with 5 viviparous females of Toxoptera graminum to determine minimum temperature at which reproduction will take place. Dallas, Tex., January, 1903.*

Date.	Temperature.		Number of young produced by each individual.					Total.
	Minimum.	Maximum.						
	°F.	°F.						
Jan. 3	47	56	1	1	1	1	1	5
4	55	75	2	3	1	3	4	15
5	37	69	3	3	1	2	2	11
6	25	42	0	0	0	0	0	0
7	21	32	0	0	0	0	0	0
8	29	45	0	0	0	0	0	0
9	44	74	4	2	0	3	4	13
10	37	74	4	4	(3)	3	5	18
11	34	55	0	0	0	0	0	0
12	39	55	0	0	0	0	0	0
13	26	31	0	0	0	0	0	0
14	32	51	0	0	0	0	0	0
Total			20	23	3	14	16	

* Died.

Of the five individuals involved in Table XI the two last hatched from the egg March 24, the other three on March 27. This table indicates the influence of high temperatures on reproduction, but also shows that these affect the individual female to varying degrees. The totals for the life of individual females show that all of these were in the vigor of life, not having reached the decline at the time the observations were made.

These tabulations are taken from records of regular rearing and reproduction investigations, and were selected wherever there occurred a number of consecutive days with temperatures varying both above and below freezing during each 24 hours.

By referring to the continuous rearing by the junior author it will be observed that with favorable conditions a female Toxoptera will produce young every day during the most vigorous portion of her life, the exceptions being toward the close thereof.

It would probably be well to mention in this connection some observations of the junior author in regard to the amount of cold that can be endured by Toxoptera.

On November 13, 1908, several viviparous females that had been producing young were frozen solidly in a block of ice. They were thawed out after 8 and 24 hours, respectively, and all died. These may have been somewhat weakened by age, however, so on the 14th 2 oviparous females, 1 winged viviparous female, 1 adult viviparous, and 2 individuals that had cast the third molt were frozen in a block of ice and allowed to remain so for 24 hours. About an hour after being thawed out, at a temperature of about 45° F., 1 oviparous female and the winged female turned dark and died, the others keeping color, but showing little signs of life. About 3 hours after there were signs of life among the remaining ones; 7 hours after thawing out they were still feeble; 24 hours after thawing out the temperature was raised to 60° F and 1 molted. On the third day after being thawed out there were 2 young in the cage. Six days later all were dead except the one that was giving birth to young, and her progeny. This will give some idea of the tenacious grip Toxoptera has on life.

Attention may properly be called to the fact that unless the utmost caution is employed in the examination of plants for newly-born young there is great likelihood that some of them may be overlooked. Thus they may be born one day under a high temperature but remain undiscovered until later, when the temperature is much lower, and of course be credited to the later date. In the light of all of the observations made by those engaged in these investigations, the minimum temperature under which reproduction begins is about 40° F. Possibly reproduction may occur under some obscure favorable circum-

stances at a slightly lower temperature, but these instances are probably too infrequent to become of economic importance.

With the eggs in the North the case may be more important, because these, deposited in dead leaves of bluegrass, and sometimes probably buried under several inches of this matted grass, with the living leaves covering this over, the temperature and moisture would both be greater than at several feet above ground without such protection. Mr. Philip Luginbill of this bureau in April, 1911, proved this to be true. He placed a thermometer in just such a position as mentioned above, in a protected nook where the sun could shine directly on it in the grass and no wind could reach it and found that the temperature was 10° to 12° F. higher than when the thermometer was several feet above the ground and in the shade. The junior author has found that eggs are deposited in just such places, and that hatching takes place in spring at a temperature ranging, as recorded by the thermograph, from 32° to 62° F. It would appear that eggs deposited in a position as mentioned above would hatch sooner than those deposited in places where the temperature would not be so high and the stem mothers from the former would reproduce, the pest becoming more abundant in the spring and making its way from grass to grain earlier and in greater numbers than they would from the cooler locations.

This leads us to a very interesting and important point in temperature effects on the species. In the South, seemingly south of about latitude 35° to 36° north, it has been impossible to find eggs of this and other species of aphidids in the fields. There is in the perpetuation of the species no apparent need of this stage, however, as it is able to continue throughout the entire year reproducing viviparously. In the North this is probably not possible except during very mild winters. The situation is therefore about like this: Gradually as we proceed southward from about latitude 38° the sexual forms and eggs disappear, while to the north of about latitude 36° hibernation is confined more and more to the egg stage, until this becomes exclusively the state in which the winter is passed.

The practical, economic importance of this is that there is considerable doubt relative to the amount of injury the pest would cause north of this belt of country if there were no Toxoptera drifting in from the south. In other words, but for the countless myriads developing south of this belt and sweeping over and beyond it, there would be few if any destructive ravages. If this is the true state of affairs, the oats crop north of this belt is to a certain degree dependent upon the success or failure in controlling the pest in Texas, Oklahoma, New Mexico, and South Carolina.

Summarizing, then, it would appear from the information we have been able to obtain, and which is given throughout this publication,

together with that contained in the various tables and diagrams relating to temperature effects upon this insect: (1) That mild winters are of much more vital importance in Texas than they are in the latitude of southern Kansas and northward, and (2) that the influences of abnormally warm weather, if the temperature rises high enough, have the effect of bringing about activity among the parasites, which has a restraining effect upon the increase of Toxoptera.

In the North, where the pest winters over wholly or largely in the egg stage, warm winters are of less importance, while abnormally cool weather during spring and early summer exerts a far greater influence. This fact renders a study of the embryology and temperature effects upon eggs and stem mothers necessary to a full understanding of the entire problem, extending as it does over both North and South.

The fact just stated is somewhat peculiar and was unexpectedly revealed by the combined studies of those engaged in the investigation of the insect, and called for a study of the development of the egg, which has been carried on by the junior author with the results given in the following pages. The most important influence of temperature is, of course, upon the development of its principal natural enemy, *Aphidius testaceipes*, further discussed in connection with the studies of that insect.

EMBRYOLOGY.

Although the development of the parthenogenetic egg in Aphididæ has received considerable attention from several authors, that of the true egg has received very little study. Hence the junior author has given a limited amount of time to the study of certain important phases in the development of the winter egg, as contrasted with the winter condition of the viviparous insect in the South.

Not wishing to duplicate the work of the other writers, who have confined their studies for the most part to the earlier stages of development, he has begun with the formation of the blastoderm, his main object being to follow the principal stages of development of the embryo through the fall until growth is checked by freezing temperatures, to note the time when growth is resumed in spring, and to observe the effect of varying temperatures on development, all of which has to do with the fluctuations of the insect in point of numbers in the North and relates to its economic importance, besides balancing our knowledge of the insect at a corresponding season in the South.

Most of these studies were carried out at the University of Illinois under the supervision of Dr. J. W. Folsom. We are deeply indebted both to him and to Dr. W. M. Wheeler of Harvard University for their kindly criticisms and helpful suggestions.

METHODS AND MATERIAL.

The material used in this investigation was collected in the autumn of 1908 at Richmond, Ind., and in 1909 and 1910 at La Fayette, Ind. The eggs were killed and fixed mainly in two solutions that are practically the same. The first was a saturated solution of bichlorid of mercury (corrosive sublimate) in 35 per cent alcohol, 95 volumes, and glacial acetic acid, 5 volumes. The second was a saturated solution of bichlorid of mercury in 50 per cent alcohol, 94 volumes, and glacial acetic acid, 6 volumes. The fixing fluid was raised to a temperature of 75° to 80° C., poured over the living specimens, and allowed to act from 5 to 10 minutes, after which it was replaced by the same solution, cold, for an equal length of time. The specimens were then washed in 70 per cent alcohol, in which they were kept until sectioned. Gibson's fluid was found to be a very good killing and fixing agent also.

For sectioning, the following method was employed: The eggs were punctured with a fine needle, dehydrated, and kept 20 to 30 minutes in paraffin of about 54° C. melting point. They were oriented in a watch glass (that had previously been smeared with glycerin) with a hot needle, under a binocular microscope, the bottom of the watch glass being first quickly cooled with a little cold water.

The eggs were cut with a Minot-Zimmermann microtome in sections from 8 to 13 μ in thickness, attached to the slide with Mayer's albumen fixative, and stained with Delafield's hæmatoxylin or by Heidenhain's iron-alum-hæmatoxylin method.

Surface views of the embryo were obtained by dissection. For dissections it was found that the best results were obtained by using material that had been freshly fixed and washed. Grenacher's alcoholic borax-carminé was used for staining in toto.

GENERAL DESCRIPTION OF THE EGG.

The eggs are broadly elliptical with a slight reniform tendency. They are 0.70 to 0.78 mm. in length and 0.33 to 0.45 mm. broad.

At oviposition the egg is a very pale yellow, changing in a few hours, at a temperature of 50° to 70° F., to a faint greenish color. At this stage there appears an almost circular area of darker green at one pole of the egg; we have termed this the "ovarian yolk," a brief description of which occurs in the following pages. At the end of 24 hours the walls of the egg about the ovarian yolk appear denser and of a deeper green. The germ band is now forming and invaginating. During the next 24 hours this process is completed, the egg becoming a darker green in the meantime. By the third day a rod-shaped body can be seen near the center of the egg. This object is the submerged germ band. By the end of the third day the egg becomes black.

All these changes can be readily observed with a hand lens by holding the egg up to the light. At low temperatures (below 40° F.) these changes take place slowly, 10 or more days being required for the egg to turn black, if the temperature is near the freezing point. The black coloration is apparently due to a pigment in the shell; the green color, to the developing embryo.

At deposition the egg is coated with a viscous substance which hardens in a few days, fixing the egg firmly to the object upon which it rests.

There are but two membranous coverings to the ripe egg, the chorion, or shell covering, and the vitelline membrane.

The chorion is a rather tough, leathery, homogenous membrane which under a hand lens appears smooth and shining. With a compound microscope very faint lines or cracks can be sometimes observed on the surface, although usually the surface appears perfectly smooth, with no markings whatever.

The vitelline membrane is structureless, colorless, and transparent. Under the vitelline membrane is the peripheral layer of protoplasm. This layer is very thin and very finely reticular. It is continuous over the surface of the egg, the cleavage cells lodging in it to form the blastoderm.

Internally the egg consists chiefly of a compact mass of yolk granules, supported within the meshes of almost clear protoplasm. The yolk granules are structureless and subspherical in shape and vary greatly in size, ranging from 0.0027 mm. to 0.013 mm. in diameter.

At the posterior pole of the egg is a large, dense, almost spherical, granular mass. These granules are 0.0019 mm. in diameter, are almost uniform in size, and the central area apparently takes the stain slightly as though it were a chromatinlike substance. As previously stated, we have termed this mass the ovarian yolk. It is evidently not homologous to the secondary yolk of the parthenogenetic embryos. The ovarian yolk is formed approximately at the same time as the formation of the main yolk mass of the egg, while in the case of the parthenogenetic forms of aphidids the secondary yolk enters the egg as the blastoderm is forming. It appears also, from our material, that this ovarian yolk is not exactly homologous to the "pole disk" described and observed by Hegner (1908), as we have not been able to observe that it affects the nuclei in any way, nor have we found any cells which we think correspond to his "pole cells." The function of this granular mass seems to be the nourishment of the developing ovaries, and we have therefore called it ovarian yolk. It is not entirely used up in the early stages of embryonic growth, and remains in close proximity to the developing ovaries throughout the later stages.

Tannreuther (1907, pp. 631, 632) states that in the species he studied some of the follicular nuclei of the wall of the oviduct which enter the posterior pole of the egg divide several times, the chromatin breaking up into smaller parts and becoming vesicular. These small vesicles then usually unite and form a common spherical mass, though in some cases they remain isolated.

In *Toxoptera graminum* we find no trace of true nuclei within the ovarian yolk (the homologue of Tannreuther's secondary yolk of the winter egg) until the blastoderm is formed, at which time cells may be found that are apparently migrants from the primary yolk.

OBSERVATIONS.

For convenience of reference 9 consecutive stages of development are here designated, as follows:

Stage 1 (Pl. III, fig. 1).—Blastoderm just forming, only part of the surface being covered by the cleavage cells.

Stage 2 (Pl. III, figs. 2-4).—This shows early and later stages of invagination of the germ band. The position of the ovarian yolk in relation to the invaginating germ band is shown here.

Stage 3 (Pl. IV, fig. 1).—The germ band is still adhering to the posterior pole of the egg.

Stage 4 (Pl. IV, figs. 2, 3).—The germ band is entirely submerged in the yolk, is tubular in form, and uniform in thickness.

Stage 5 (Pl. IV, fig. 4).—During the fifth stage the germ band has differentiated into the amnion and the germ band proper.

Stage 6 (Pl. V, fig. 1).—The germ band shows differentiation into layers, and the fundamentals of the segments are evident.

Stage 7 (Pl. V, fig. 2; Pl. VI, fig. 1).—The fundamentals of the appendages have appeared and the invaginations for the stomodæum and the salivary glands are evident.

Stage 8 (Pl. V, fig. 3; Pl. VI, fig. 2).—The appendages are much longer, and the invaginations for the stomodæum and proctodæum are well advanced. The latter is not indicated in Plate V, figure 3, as the last segment curves backward too far.

Stage 9 (Pl. VII, figs. 1, 2, 3, 4).—The illustration of this stage is intended mainly to show the manner in which the embryo reaches the surface and the position of the dorsal organ.

In *Stage 1* (Pl. III, fig. 1) the blastoderm is beginning to form. As the cleavage cells become more numerous within the yolk-mass some of them migrate to the surface and lodge within the peripheral layer of protoplasm, where, according to Tannreuther (1907), they divide again, the protoplasm of the nuclei merging with that of the peripheral layer. The formation of the blastoderm takes place more rapidly in the region of the anterior pole, the posterior being the last covered;

the entire layer is then one cell in thickness. The blastoderm, however, does not cover the surface of the ovarian yolk.

Not all of these cleavage cells reach the surface; many remain behind, increasing in number within the yolk. These latter cells are indistinguishable from those of the blastoderm. Figs. 1a and 1b represent two of these cells magnified 845 diameters, showing them to be star-shaped masses of protoplasm with a large oval coarsely granular nucleus, more often with a large clear area of nuclear substance around the mass of chromatin granules.

At the posterior pole, about the ovarian yolk, the blastoderm begins to thicken and to invaginate (Stage 2, Pl. III, figs. 2-4). This is the beginning of the germ band. At this stage (*Stage 2*) some of the yolk cells apparently pass into the ovarian yolk. Tannreuther (1907, p. 631) states that the thickening of the blastoderm is caused by the rapid division of the blastoderm cells of this particular part. We find, in addition, that some of the cells from the interior of the egg migrate to the posterior pole to assist in this process. Each of the cells of this thickened area is very elongate, and, from a surface view, now has a somewhat polygonal shape, with a large coarsely granular nucleus. The growth of the cells of the germ band carries the ovarian yolk toward the center of the egg (see Pl. III, fig. 4). The part of the blastoderm that invaginates first becomes the posterior part of the embryo, and that part that invaginates last becomes the anterior portion.

In *Stage 3* (Pl. IV, fig. 1) the germ band is ready to free itself from the blastoderm. The former is now cone-shaped, the base being closed by the ovarian yolk.

When the germ band releases itself from the blastoderm, it leaves behind what we have termed the "polar organ:" A cluster of cells embedded within a mass of protoplasm. These cells soon group themselves into a more or less spherical mass, with a less dense vacuolar area at the center (see Pl. IV, fig. 4). In later stages this central area appears denser and structureless, as though filled with a fluid, and is of a yellow color, not taking the stain, and opening directly upon the surface of the egg. For these reasons we suggest that it may be an organ of excretion. When development ceases in the fall, this body is still present.

What was formerly the blastoderm now becomes the serosa. The cells are much more widely spaced now and this wall is much thinner, except at the anterior pole, where the cells are apparently crowded more closely than before. Some of these cells often show large vacuoles on the side toward the yolk.

At *Stage 4* (Pl. IV, fig. 2) the germ band is completely submerged in the yolk, has assumed a tubular shape, and is near the center of the egg. The walls are of uniform thickness and composed of a com-

compact mass several cells thick, some of which are vacuolated, and having a coarsely granular nucleus. Figure 3 of Plate IV shows a cross section—slightly oblique, however—of the germ band.

The yolk granules of the primary yolk are now more numerous near the embryo.

In *Stage 5* (Pl. IV, fig. 4) the germ band has clearly differentiated into the amnion and the embryo proper; these gradually merge into each other. This differentiation apparently takes place by a gradual migration of cells to one side of the germ band. The cells of the amnion at this time resemble very closely those of the germ band proper. The germ band begins to fold in this stage and its anterior extremity begins to broaden and flatten. The ovarian yolk has decreased in volume and has assumed a more anterior position in relation to the embryo. The yolk cells in both the primary and ovarian yolk have lost somewhat their amœboid character, and now consist, each, of a large granular nucleus, with a much thinner area of protoplasm about it. The primary yolk granules are smaller and much less numerous than before and are collecting in masses about the yolk cells, with indications here and there of a partition, or wall, forming between them. This stage is reached by the end of the second day, under favorable weather conditions.

The "polar organ" and protoplasm at the posterior pole contain a large central vacuolar area now.

In *Stage 6* (Pl. V, fig. 1) the germ band has greatly increased in length, is folded upon itself, and almost forms a loop, the anterior and posterior extremities nearly touching, and both pointing to the posterior pole. A portion of the posterior extremity of the germ band is again folded upon itself. It is now differentiated into three layers, which we take to be, respectively, ectoderm, mesoderm, and entoderm. The ectoderm and mesoderm consist of a compact mass of columnar cells, two cells thick. The entoderm is much thinner and less compact and forms an almost continuous sheet over the inner surface of the germ band. Its cells resemble yolk cells very closely.

In this stage fundamentals of the body segments appear as slight elevations of the ectodermal surface. The ovarian yolk has assumed a more anterior position in relation to the embryo than in the preceding stage. Between the ovarian yolk mass and the germ band is a group of cells that have apparently separated off from the mesoderm. From this group of cells, in later stages, the generative organs arise. The amnion now covers the ventral surface of the embryo and the other surface of the embryo is in contact with the yolk. The amnion is a very thin, delicate membrane, its cells being widely spaced and quite small. The intervening protoplasm between the cells of the serosa has become more constricted and the cells have taken more of an elongated oval shape. The primary yolk has now become defi-

nately segmented into more or less spherical masses, separated by thin walls, each area or mass containing a number of yolk granules and from one to several cells. The polar organ is now almost spherical, with a central, pear-shaped area of dense, structureless, non-staining matter of a yellowish color, and an anterior opening. Although this evidence is insufficient it possibly indicates that the function of this organ is excretory. The embryo reaches this stage of development about the third day, under favorable conditions of temperature.

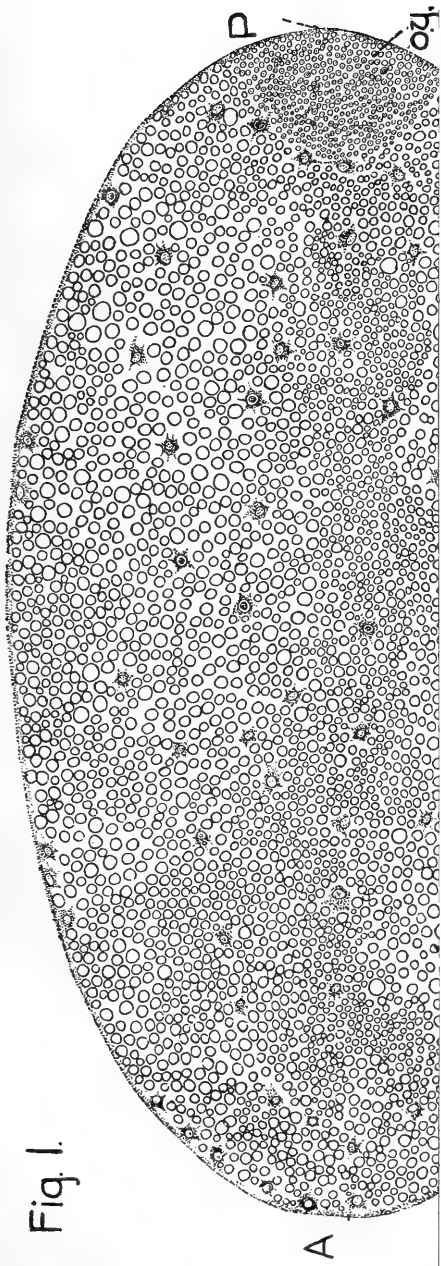
In *Stage 7* (Pl. VI, fig. 1) the embryo has changed its position so that from a side view it has the form of a reversed figure 6. The portion that in the preceding stage was folded upon itself ventrally has reversed its position and folded back dorsally. The ovarian yolk is now in the region of the first abdominal segments. It is in contact with the embryo, and the group of cells that separated it from the embryo in the preceding stage has assumed almost a spherical form, and a more posterior position, forming the genital organs later on.

The three primary regions, cephalic, thoracic, and abdominal, are now sharply marked. Each region is distinctly segmented. The cephalic region has 5 segments indicated, the thoracic 3, and the abdominal 9, the last abdominal being relatively quite large. There are now 15 conical appendages. The antennæ arise from the posterior margin of each cephalic lobe. The labrum is between and slightly anterior to the antennæ. The mandibles are nearer the median plane than the fundaments of the maxillæ and the labium. The next three pairs of appendages represent the first, second, and third pairs of legs. Plate V, figure 2, represents a surface view of stage 7, showing the embryo straightened out and the position of the appendages. All of these appendages are evaginations of the ectoderm, cross-sections showing an external layer of ectoderm cells and an inner layer of mesoderm cells.

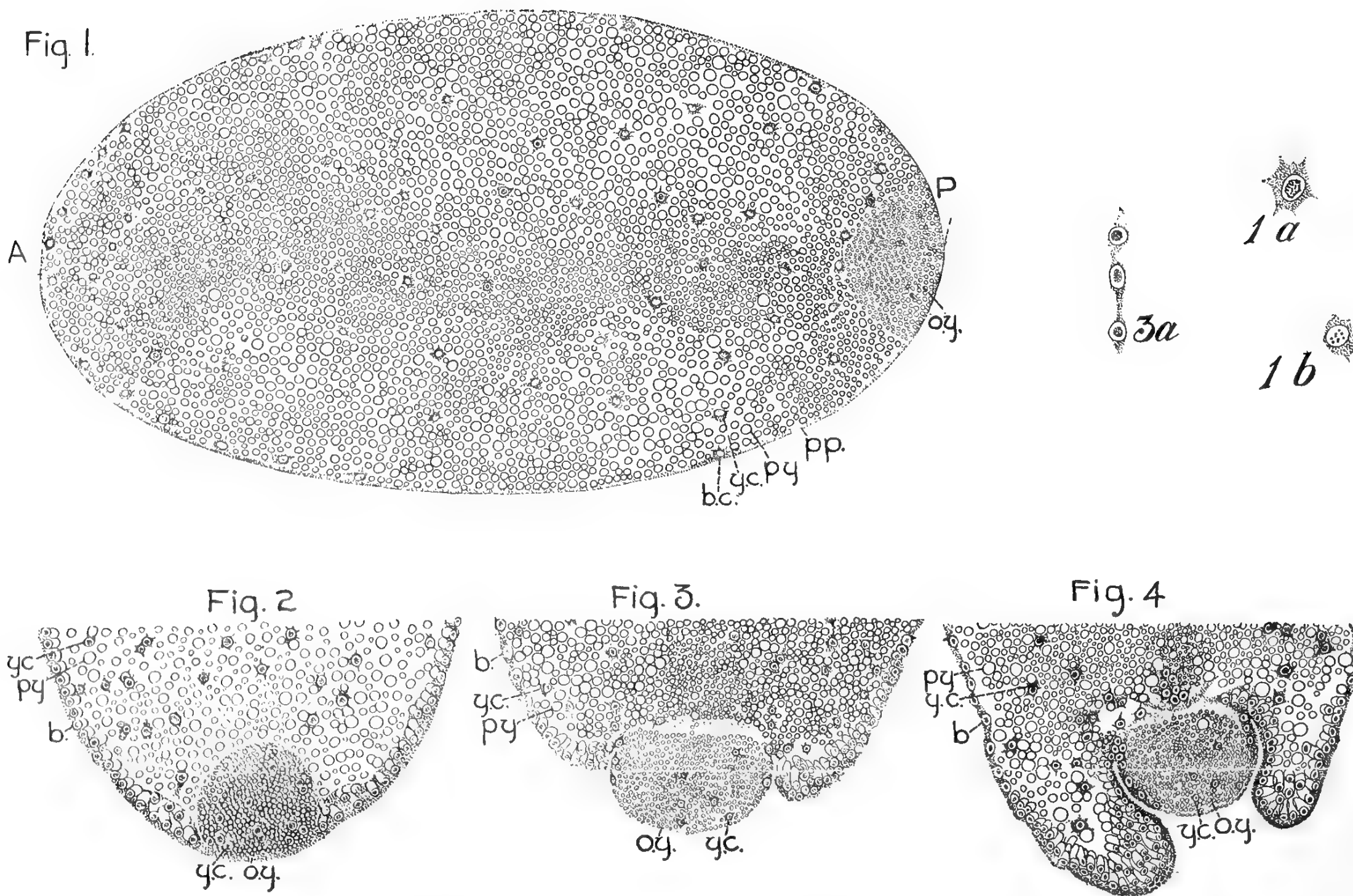
The stomodæum (Pl. VI, fig. 1) appears now as a simple invagination of the ectoderm, the posterior wall of the labrum forming its anterior wall. The proctodæum has not yet appeared. The salivary glands (Pl. VI, fig. 1) are represented by a deep, bilobed, ectodermal invagination between the cephalic and thoracic regions. There is now a star-shaped mass of protoplasm about the nucleus of the ovarian yolk cells and the yolk granules are grouped around these cells.

The primary yolk is grouped very much as in the preceding stage with the exception that the masses are smaller and do not contain as many nuclei.

The polar organ is smaller than formerly, with a smaller number of cells. It still contains a yellowish mass and communicates with the outer surface of the egg.

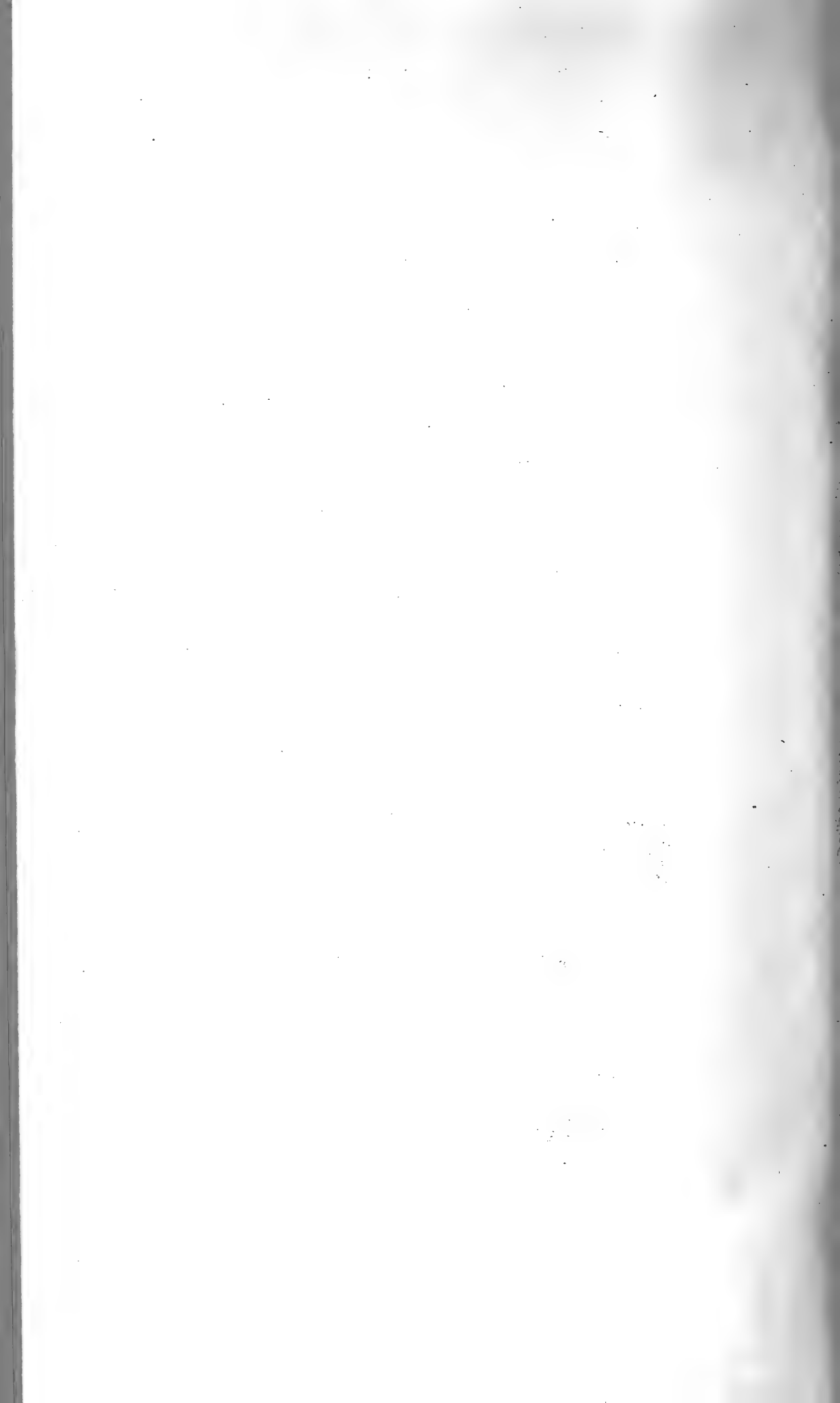


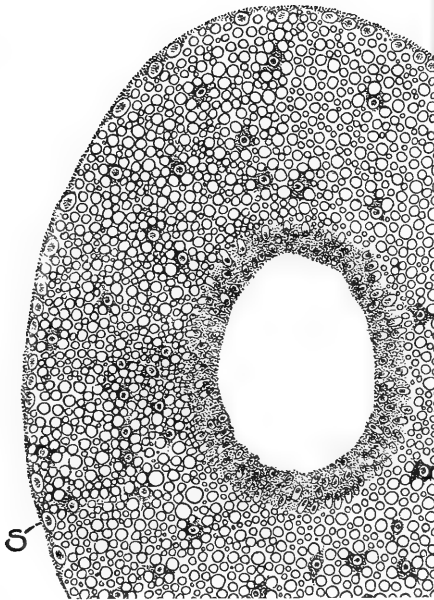
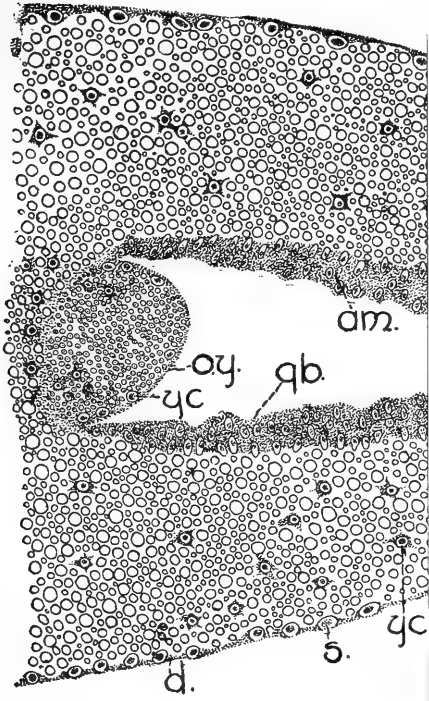




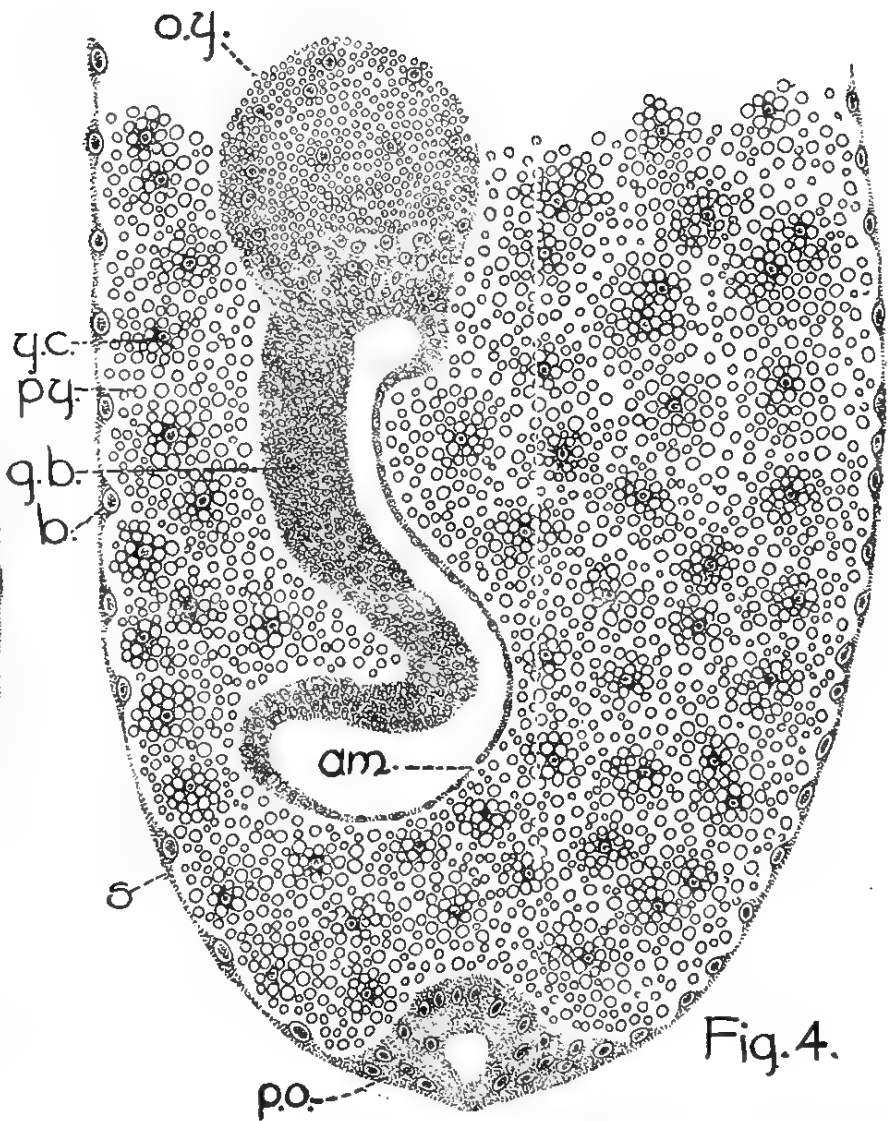
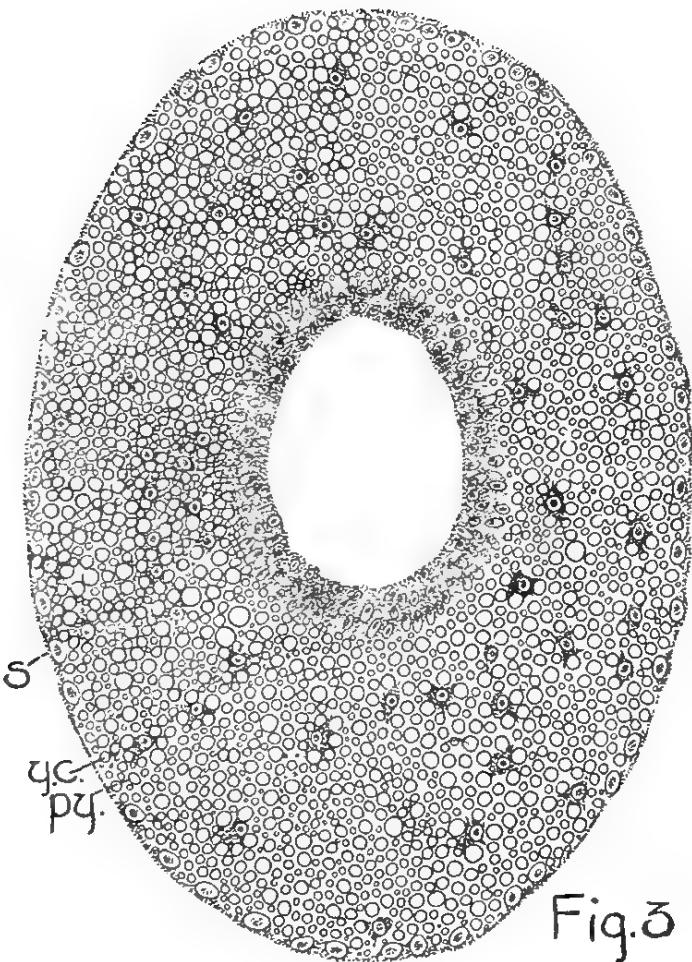
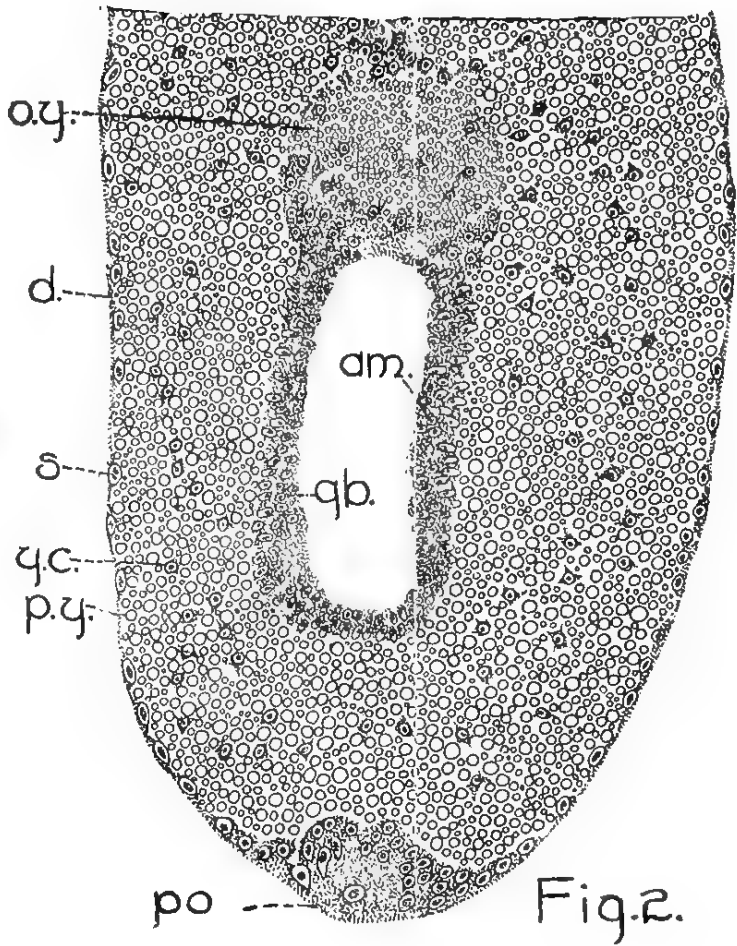
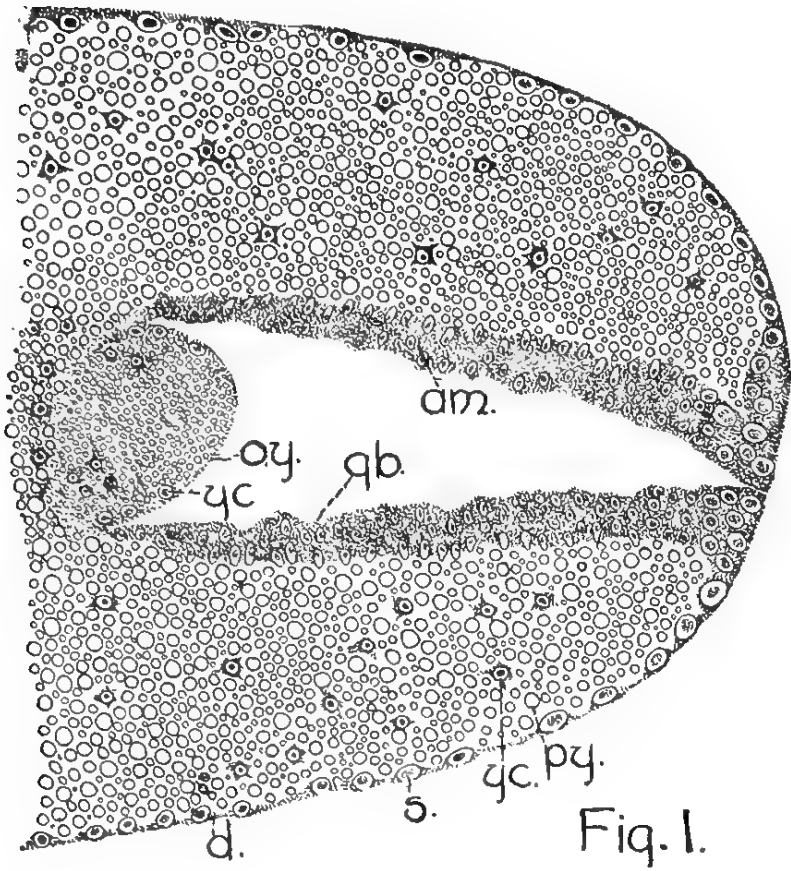
DEVELOPMENT OF THE EMBRYO IN THE EGG OF TOXOPTERA GRAMINUM.

Fig. 1.—Longitudinal section showing the blastoderm partly formed, being farthest advanced in the anterior region. The mass of ovarian yolk is lodged at the posterior pole. Figures 1a and 1b represent the yolk cells magnified 845 diameters. Fig. 2.—Longitudinal section showing the thickening of the blastoderm about the ovarian yolk previous to invagination. Magnified 156 diameters. Fig. 3.—Longitudinal section representing the germ band at the beginning of invagination, folding inward about the ovarian yolk. Magnified 156 diameters. Fig. 3a.—Section of the blastoderm. Magnified 430 diameters. Fig. 4.—Longitudinal section of a more advanced stage of invagination, the germ band having almost closed over the ovarian yolk. Magnified 156 diameters. (Original.)



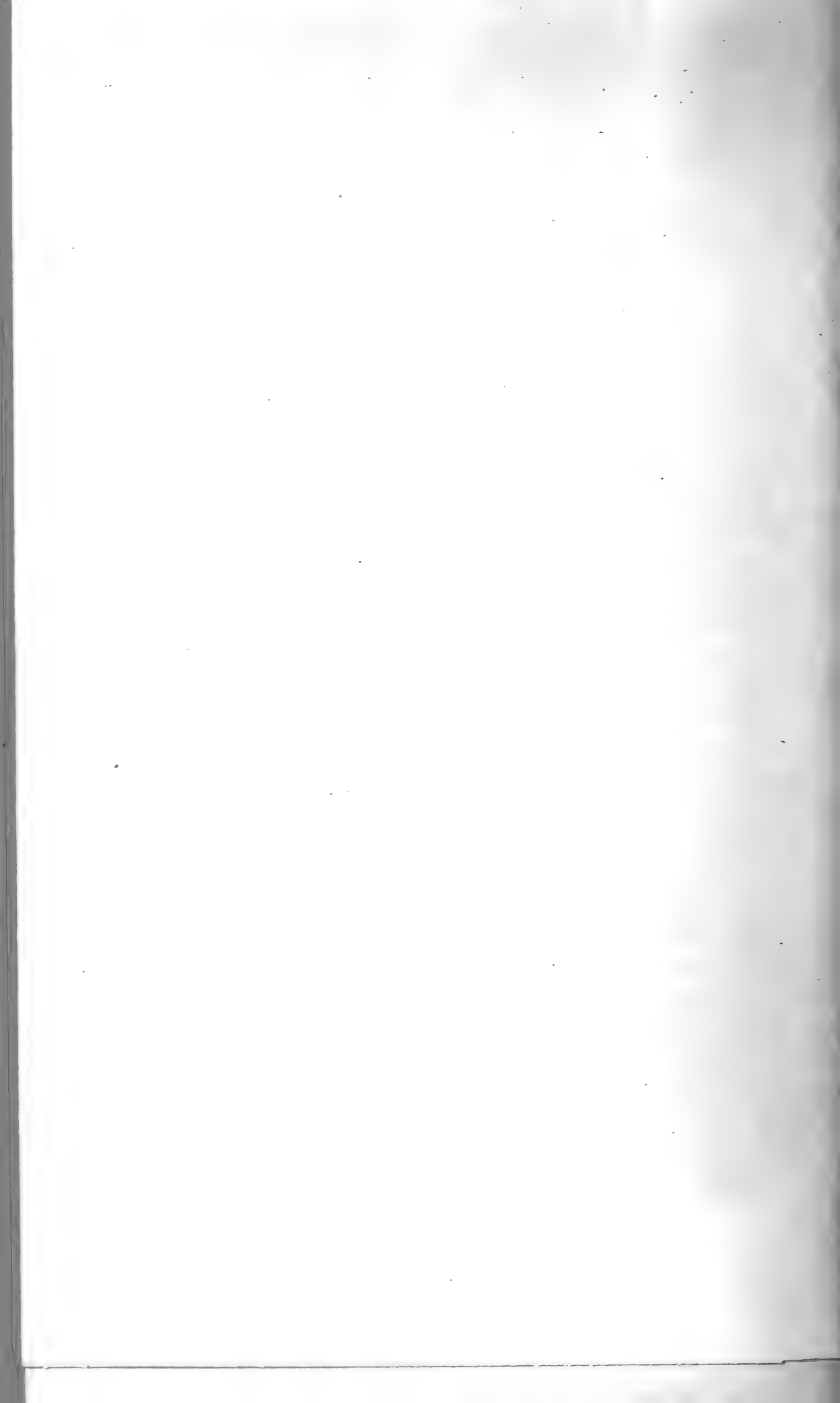






DEVELOPMENT OF THE EMBRYO IN THE EGG OF TOXOPTERA GRAMINUM.

Fig. 1.—Longitudinal section representing the somewhat cone-shaped germ band ready to release itself from the surface of the egg, the ovarian yolk closing the posterior extremity. Magnified 156 diameters. Fig. 2.—Sagittal section representing the tubular germ band completely submerged within the yolk, the anterior extremity being continuous with the sides and the posterior end closed by the ovarian yolk. The “polar organ” is represented by a mass of cells and protoplasm at the posterior pole. Magnified 119 diameters. Fig. 3.—Transverse (somewhat oblique) section of the germ band. Magnified 156 diameters. Fig. 4.—Sagittal section showing the germ band folding and differentiating into amnion and germ band proper. The ovarian yolk has taken a more anterior position. The “polar organ” is vacuolated now. Magnified 156 diameters. (Original.)



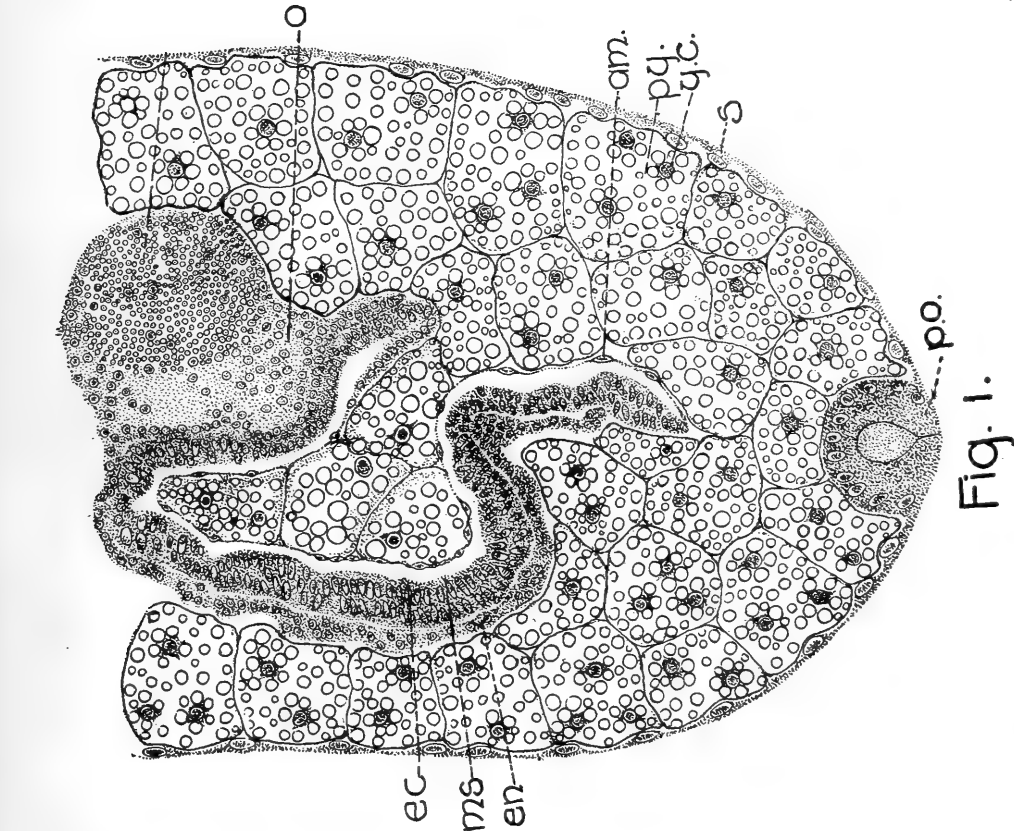


Fig. 1.

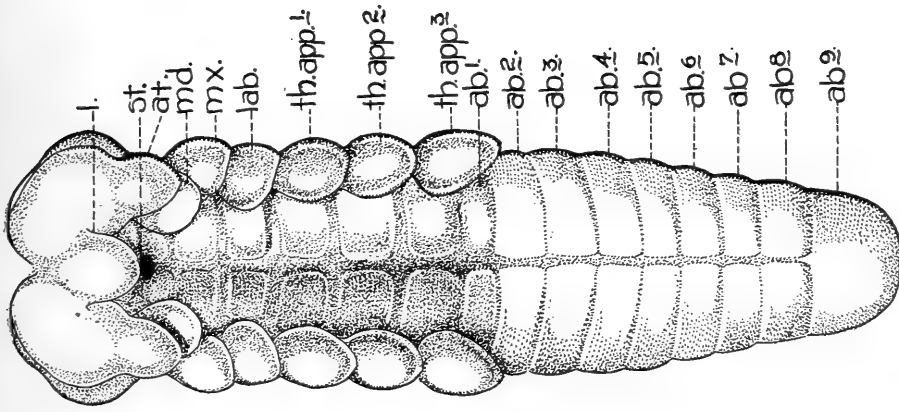


Fig. 2.

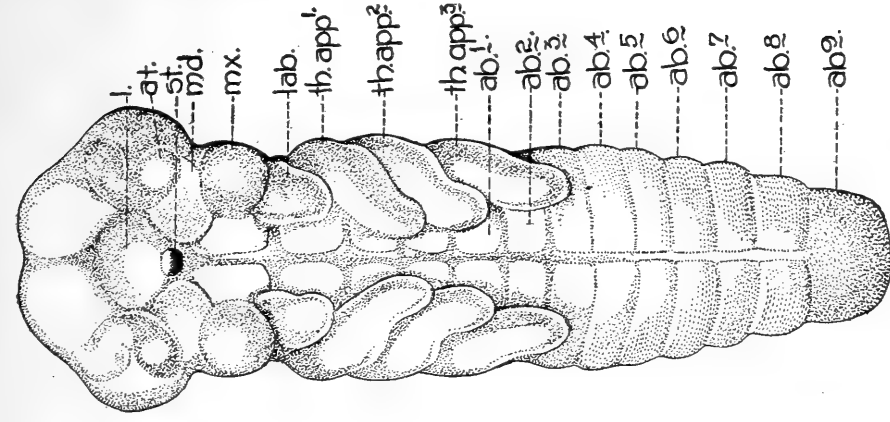
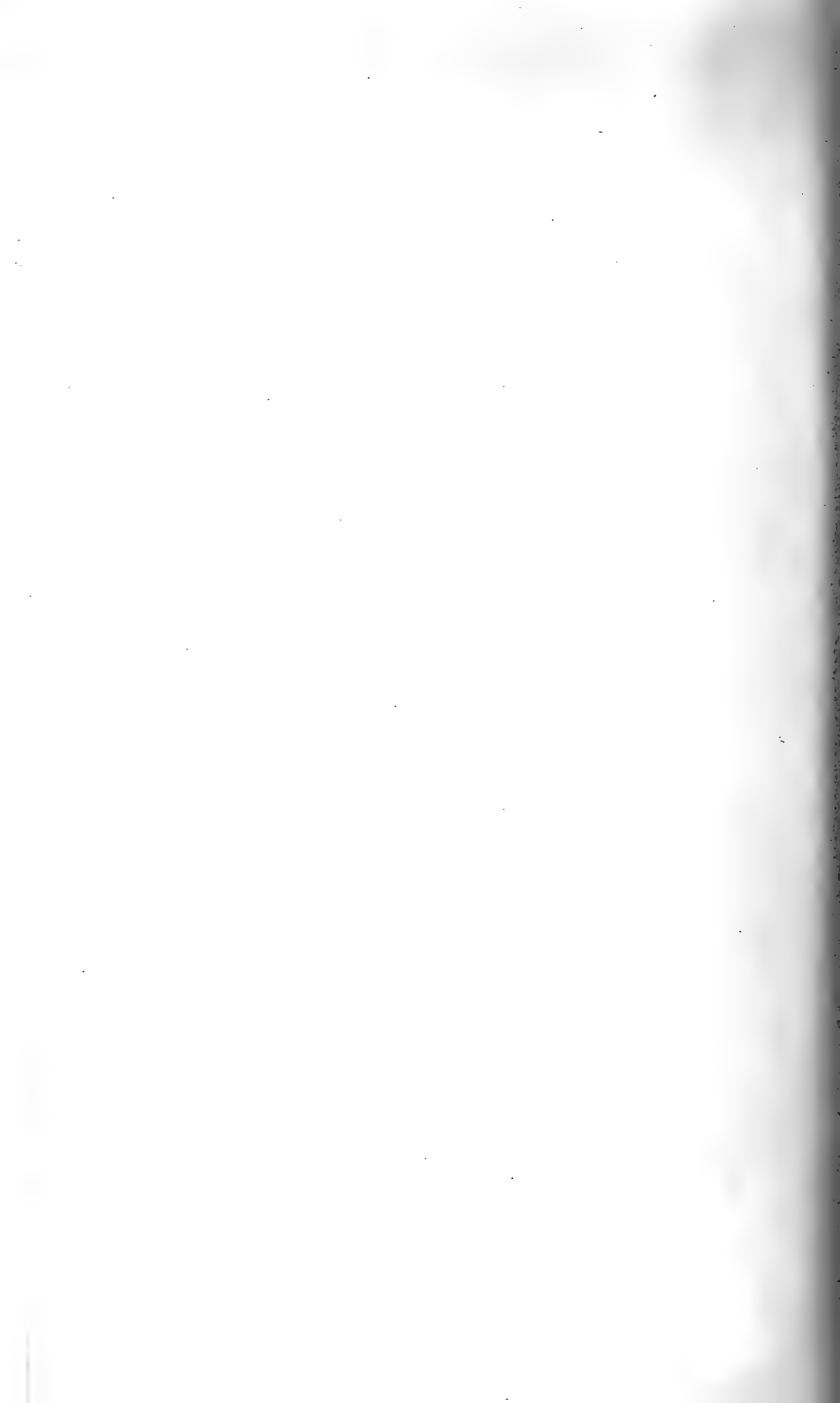
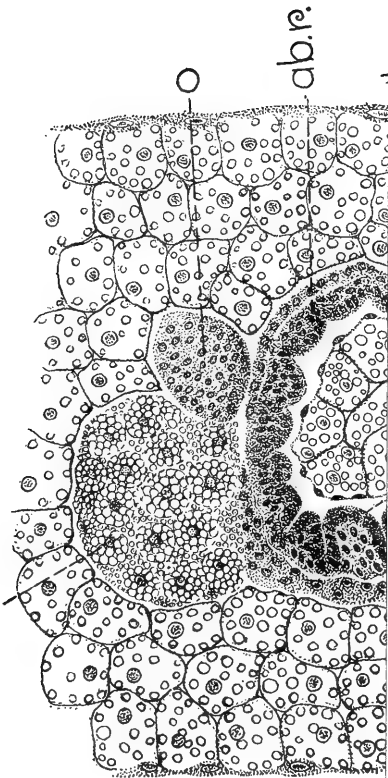
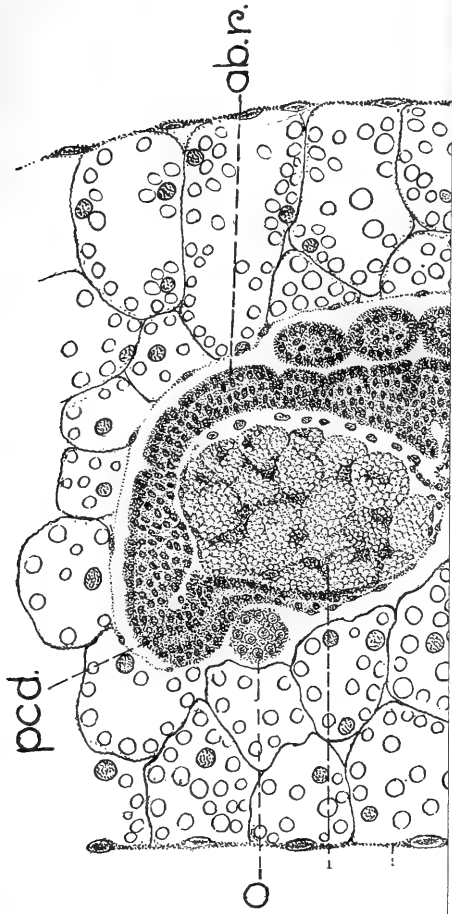


Fig. 3.

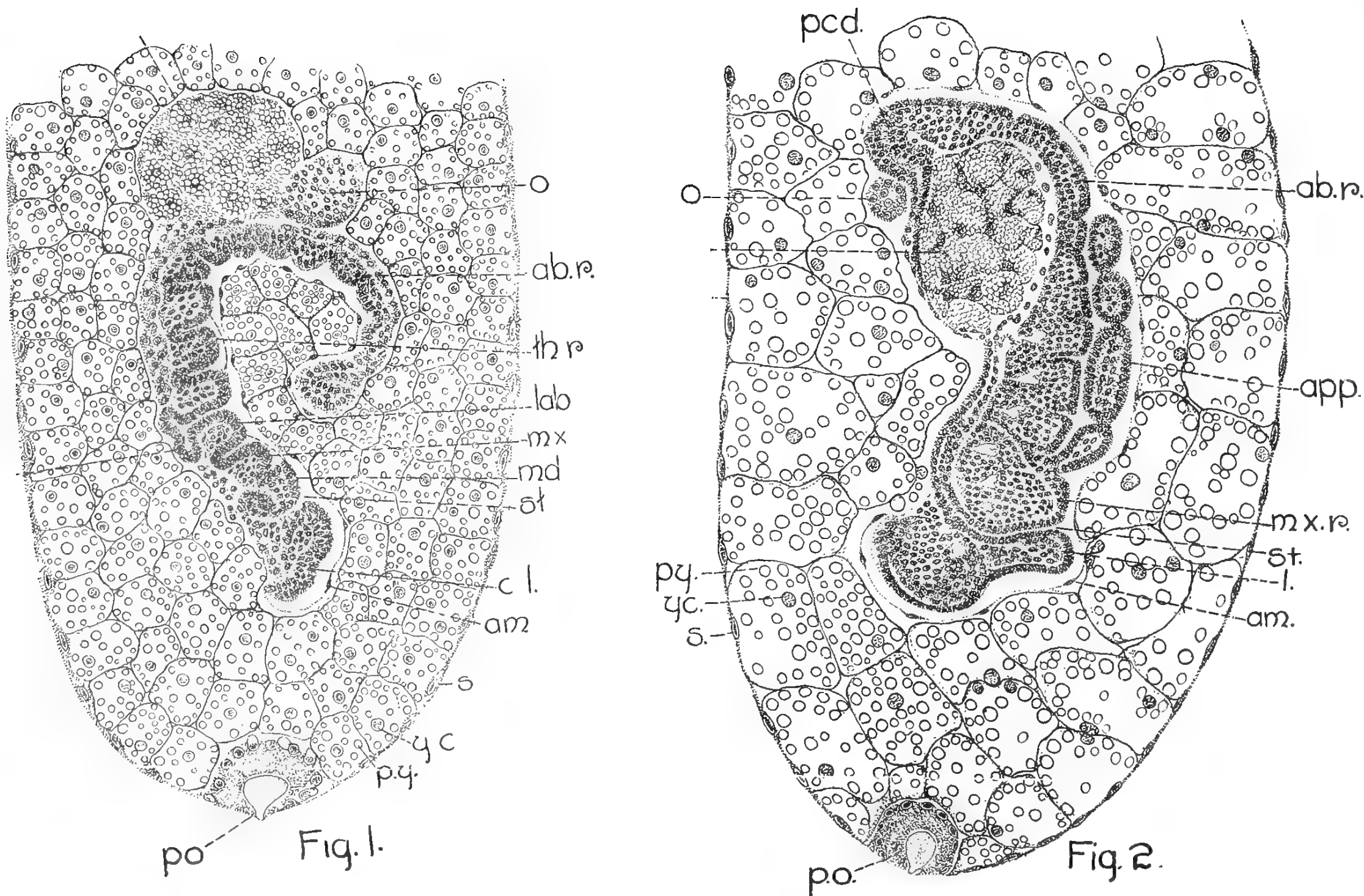
DEVELOPMENT OF THE EMBRYO IN THE EGG OF TOXOPTERA GRAMMINUM.

Fig. 1.—Sagittal section showing the germ band differentiated into three layers and folded almost upon itself, the ovarian yolk being separated from it by a group of cells that later becomes an ovary. The "polar organ" is now more nearly circular. Magnified 156 diameters. Fig. 2.—Surface view of Plate VI, figure 1. Magnified 156 diameters. Fig. 3.—Surface view of Plate VI, figure 2. Magnified 156 diameters. (Original.)









DEVELOPMENT OF THE EMBRYO IN THE EGG OF TOXOPTERA GRAMINUM.

Fig. 1.—Sagittal section of the embryo showing the segmentation. The invagination of the salivary glands is now evident. The fundaments of the ovaries have assumed more definite shape and have shifted in position. The ovarian yolk is greatly changed in appearance and has taken up a position at the anterior portion of the abdominal region. The "polar organ" now shows a large, somewhat pear-shaped central cavity which opens upon the surface of the egg and is filled with a yellowish substance. Magnified 156 diameters. Fig. 2.—Sagittal section (slightly oblique) showing a much more advanced stage of growth than that of figure 1, the abdominal region having reversed its position by bending around backward and inclosing the ovarian yolk. The mesenteron is in process of formation. The ovarian yolk is granular and its cells are breaking down. The "polar organ" is much the same as in the preceding stage. Magnified 156 diameters. (Original.)



In *Stage 8* (Pl. VI, fig. 2) the posterior or abdominal region of the embryo has now completely changed its position, having folded back dorsally about the ovarian yolk. Plate VI, figure 2, shows a sagittal (slightly oblique) section of an embryo at this stage. There are apparently only 9 abdominal segments. Both the stomodæum and the proctodæum are plainly in evidence now, and the mesenteron is in course of formation. The latter is formed above and rests upon the ovarian yolk. This yolk now has a granular appearance, and the yolk cells within it appear to be breaking down. It is still divided off into subspherical masses. The polar organ is smaller than in the preceding stage and the pear-shaped area in the center is filled with a yellowish substance as before. The ovaries are represented in this section by a circular mass of cells above the ovarian yolk. The primary yolk is grouped and divided off by protoplasmic threads, very much as in the preceding stage, but is not quite so abundant now. Plate V, figure 3, shows a surface view of the embryo, straightened out to its full length. It will be seen that the appendages are now much more elongate, the thoracic appendages showing traces of segmentation. All the appendages are now directed posteriorly and lie flat upon the body.

This is the stage in which the majority of the embryos pass the winter. It is very doubtful if any of the stages earlier than the seventh are able to survive the winter. Instances have come under our observation in which embryos in the sixth stage have been killed by very low temperatures. When heavy freezes do not occur until sometime in December, a very large percentage of the eggs hatches; on the other hand, however, when heavy freezes begin in November, large numbers of the eggs are killed in the early stages, since large numbers of the eggs are deposited in this month. An early autumn, therefore, followed by a severe winter, would limit to a great extent the number of stem mothers of the following spring.

Stage 9 (Pl. VII, figs. 1-4) represents the stages of growth occurring in the latter part of February and the first of March. When the embryo is ready to come to the surface of the egg (Pl. VII, fig. 1), it moves forward in the yolk until the cephalic lobes come into contact with the polar organ. It will be observed that there is quite a gap between figures 1 and 2, and at present we have no material from which this missing link can be supplied. Figure 2 shows the dorsal organ already formed. As we have no intermediate stages we can not state definitely whether this is the true dorsal organ or the dorsal and polar organ combined. It is probably the latter, as we do not find any traces of the polar organ at any other point in the embryo. It is very probable that the surplus cells of the serosa, at the time the embryo comes to the surface of the egg, collect at and group themselves about the polar organ, as there

appear to be a greater number of cells about this body at this time. There is no trace of the dense yellowish center of the polar organ, otherwise it resembles this body very closely. However, as we have lost track of this organ in the gap between figures 1 and 2, and on account of the close resemblance between it and the dorsal organ of other insects, we have designated it as the latter. At a later stage (Pl. VII, fig. 3) the dorsal organ has assumed a more nearly circular shape, the mouth having almost closed, inclosing a somewhat pear-shaped space. At a still later stage (fig. 4) the dorsal organ has released itself from the margin, migrated backward, and begun to disintegrate. At length it disappears by absorption in the body cavity.

At first we were not able to note a revolution of the embryo, but later studies show that such a revolution does occur between figures 1 and 2 of Plate VII.

After the ninth stage the development goes on very rapidly, and by the latter part of March the eggs are ready to hatch.

During the fall of 1909 a number of eggs were collected that had been deposited in October and November, and these were kept until the spring of 1910 to note the time of hatching. No heavy freezes occurred until the 3d of December. It was found that although there was nearly a month's difference in dates of deposition there was not more than four or five days' difference in the time of hatching. An average of 64 per cent of the eggs hatched. We have also learned that eggs will not hatch unless subjected to freezing temperatures.

SUMMARY OF EMBRYOLOGICAL DEVELOPMENT.

There is a large almost circular mass of ovarian yolk at the posterior pole of the egg.

Development begins almost immediately after oviposition, and proceeds more rapidly in the region of the anterior pole until after the blastoderm forms, after which growth almost ceases in this region.

The blastoderm originates through the migration of yolk cells from the interior to the surface of the egg. All of the yolk cells, however, do not take part in the formation of the blastoderm, part remaining behind to prepare the yolk for assimilation by the embryo.

After the blastoderm is formed it is one cell thick and covers the entire surface of the egg, with the exception of the ovarian yolk. The germ band originates in the region of the ovarian yolk, where it invaginates and grows downward into the egg. The germ band is of the completely submerged type, the uninvaginated blastoderm becoming the serosa.

Upon leaving the surface of the egg the germ band leaves behind it a group of cells embedded in a mass of protoplasm. This body the junior author has termed the "polar organ."

The development of the embryo can be observed in a general way, with a hand lens, up to and including the sixth stage. This stage is reached, under favorable weather conditions (50° to 75° F.), in about three days.

A large number of embryos are nearly or quite half grown by the time freezing weather begins, growth starting again with the first warm days of February. We have noted a revolution of the embryo within the egg, and this revolution takes place between figures 1 and 2 of Plate VII. Eggs begin to hatch by the last week in March, the typical appearance of the abandoned eggshell being shown in text figure 18. The number of stem mothers to appear in spring depends to a large extent upon the temperature of the preceding fall.



FIG. 18.—The spring grain-aphis: Shell of egg after young stem-mother has emerged. Greatly enlarged. (Original.)

ABBREVIATIONS USED IN PLATES III–VII.

<i>A.</i> , anterior pole.	<i>ms.</i> , mesoderm.
<i>ab</i> ¹ , <i>ab</i> ² , etc., abdominal segments.	<i>mx.</i> , maxilla.
<i>ab. r.</i> abdominal region.	<i>o.</i> , fundament of ovary.
<i>am.</i> , amnion.	<i>o. y.</i> , ovarian yolk,
<i>app.</i> , appendage.	<i>p.</i> , posterior pole.
<i>at.</i> , antenna.	<i>p. o.</i> , "polar organ."
<i>b. c.</i> , blastoderm cell.	<i>p. p.</i> , peripheral protoplasm.
<i>b.</i> , blastoderm.	<i>p. y.</i> , primary yolk.
<i>c. l.</i> , cephalic lobes.	<i>pcd.</i> , proctodæum.
<i>d. o.</i> , dorsal organ.	<i>s.</i> , serosa.
<i>ec.</i> , ectoderm.	<i>s. g.</i> , salivary gland.
<i>en.</i> , entoderm.	<i>st.</i> , stomodæum.
<i>g. b.</i> , germ band.	<i>th. app</i> ^{1, 2} , etc., thoracic appendages.
<i>l.</i> , labrum.	<i>th. r.</i> , thoracic region.
<i>lab.</i> , labium.	<i>y. c.</i> , yolk cells.
<i>md.</i> , mandible.	

NATURAL ENEMIES.

Toxoptera graminum is beset by a host of foes, without which we would be powerless to combat it. These enemies naturally group themselves into two classes: First, insects that develop within the body of the "green bug" and are termed true parasites; secondly, those foes that feed upon them externally or that take them directly into their bodies. These latter are termed predatory enemies. Under the true parasites we have *Aphidius testaceipes* Cress., *Aphidius avenaphis* Fitch, *Aphidius confusus* Ashm., *Aphelinus mali* Hald., *Aphelinus nigritus* How., and *Aphelinus semiflavus* How., all of which are minute four-winged flies; under predatory enemies there are lady-beetles, syrphids, and cecidomyiids (two-winged flies), lacewing flies, and birds. Besides these, there are *secondary* parasites, or those that prey upon the true parasites of *Toxoptera*. These latter are as truly our enemies as are *Toxoptera*.

INTERNAL OR TRUE PARASITES.

Aphidius testaceipes Cress.

(Fig. 19.)

Synonyms: *Lysiphlebus abutilaphidis* Ashm.; *Lysiphlebus baccharaphidis* Ashm.; *Lysiphlebus basilaris* Prov.; *Lysiphlebus citraphis* Ashm.; *Lysiphlebus coquilletti* Ashm.; *Lysiphlebus cucurbitaphidis* Ashm.; *Lysiphlebus crawfordi* Rohwer; *Lysiphlebus eragrostaphidis* Ashm.; *Lysiphlebus gossypii* Ashm.; *Lysiphlebus myzi* Ashm.; *Lysiphlebus minutus* Ashm.; *Lysiphlebus persicaphidis* Ashm. (= *L. persiaphidis* Ashm.); *Lysiphlebus piceiventris* Ashm.; *Lysiphlebus tritici* Ashm.

DESCRIPTION AND IDENTITY.

Female.—Piceous or shining black, smooth and polished, impunctured; mandibles and palpi pale; antennæ brownish-black, sometimes more or less pale beneath,

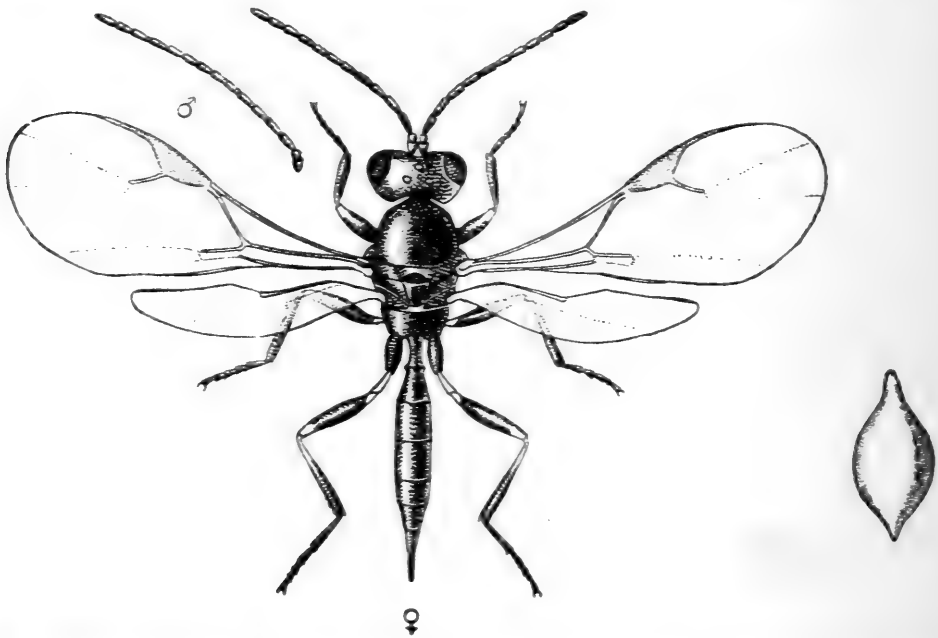


FIG. 19.—*Aphidius testaceipes*, principal parasite of the spring grain-aphis: Adult female and antenna of male, greatly enlarged. Egg at right, highly magnified. (From Webster.)

13-jointed, the joints faintly fluted or grooved, the last one longest and thickest; wings hyaline, iridescent, stigma pale; legs, including coxæ, yellowish-testaceous, the posterior pair generally more or less fuscous or blackish; abdomen often brown or pale piceous, with the first and sometimes part of the second segment more or less testaceous. Length, 0.07 inch.

Habitat.—Rockledge, Fla.; Selma, Ala.; and Pocomoke City, Md.

Parasitic upon an aphidid infesting twigs of orange, an aphidid on the cotton plant, and *Aphis avenæ* Fab.

This parasite, which is probably the most important of all the natural enemies of Toxoptera, has for this reason claimed more of our attention than all of the other foes combined. Hence a large amount of data has been collected, bearing upon nearly every phase of its development. Owing to the fact that large numbers of individuals have been reared by Messrs. Kelly and Urbahns from known par-

ents, both parent and offspring being preserved, Mr. H. L. Viereck, of this bureau, has been able to determine definitely for us the identity of this species and to clear up the obscurity heretofore surrounding it. He finds that it has been masquerading under 14 different names, and it seems that it may now be allowed to assume its rightful designation.

Mr. Viereck, after a careful study of all material at hand, has supplied us with the above list of synonyms. His work on the revision of the genera *Aphidius*, *Lysiphlebus*, and *Diæretus* will appear later in some other publication.

LIFE HISTORY.

OVIPOSITION.

Under favorable conditions the females begin ovipositing within a few hours after issuing, whether a male is present or not. When the female is placed in the presence of *Toxoptera* she will rush about

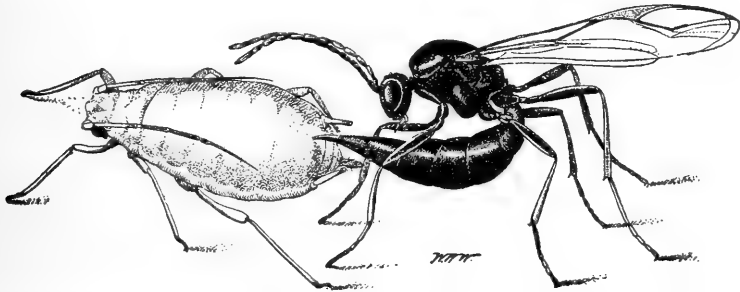


FIG. 20.—*Aphidius testaceipes* ovipositing in the body of the spring grain-aphis. Enlarged. (From Webster.)

in an excited manner and when her antennæ come in contact with an aphid she stops very quickly and thrusts her abdomen beneath her thorax and head (see fig. 20), giving the aphid a quick stab—sometimes several if the first attempts were unsuccessful; she oftentimes lifts the smaller plant-lice completely from the leaf, they are stabbed so fiercely. The act of oviposition shown in the illustration is not intended to convey the impression that the *Aphidius* always attacks the grain aphid at this point, as it will stab it from any position; it will oftentimes reach around the margin of a leaf and pierce an aphid on the opposite side. After being stung the aphids kick up the posterior part of the abdomen as though in pain, and sometimes a tiny drop of fluid will appear at the tip of the cornicles. At no stage do the aphids appear to be exempt from attack. The *Aphidius* readily attacks the winged, but apparently prefers the wingless forms.

If parasites are confined with plant-lice for quite a while they will stab them repeatedly, though we have never reared more than one individual from the body of an aphid. It is very probable that in cases of this kind it is the survival of the fittest, the strongest *Aphidius* larva devouring all of the others. The junior author and Mr. W. R.

Walton, of this bureau, observed a larva, taken from the body of a "green bug," to apparently feed upon another larva of the same species that was resting against it. This would seem to indicate a tendency toward cannibalism. The parasites have been observed apparently ovipositing in aphidids that were already dead from parasitic attacks, those killed by fungus, and sometimes even puncturing the leaves of the plants on which *Toxoptera* were located.

The period of oviposition varies from 3 days to a week or more, depending upon the temperature. In warm weather the females will easily live and oviposit for 5 or 6 days.

LENGTH OF PERIOD FROM EGG TO ADULT.

Messrs. Kelly and Urbahns found that at Wellington, Kans., from 7 to 15 days are consumed in passing from egg to adult during August and September, while for October and the first week in November it requires from 8 to 24 days. These figures are to a slight degree artificial, as the rearings upon which they are based were conducted indoors. The room was heated by a stove, during the day only, for a part of October and November, and all fire was extinguished at night, so that the temperature at night probably went almost as low as out of doors, the house being only a small two-room structure.

The average for August and September is 11.1 days; the average for October and November (first week) is 19 days, the average for the whole period being 15.9 days. These averages were made up from observations on 116 individuals and are therefore of more value than they would be if made from a few individuals only.

At Richmond, Ind., the period from egg to adult out of doors varies from 10 to 14 days during August and September, while *Toxoptera* that were parasitized during November of 1907 and kept out of doors did not give up adults until the 27th and 28th of March and the 4th of April, 1908, a period of over 4 months.

EFFECT OF PARASITISM BY APHIDIUS UPON DEVELOPMENT OF HOST.

It has been found, as previously stated, that at no time from birth to and including the adult stage is *Toxoptera* exempt from attack by *Aphidius*. It appears that a female *Aphidius* prefers to oviposit in *Toxoptera* of the second and third instars. The parasite apparently shows little or no fear of them at this stage, while if she is among a number of adult *Toxoptera* and they begin to kick up their abdomens, she often hurries away, apparently in alarm.

It appears from our observations that *Toxoptera* stung before the first or second molt will not reach maturity, nor will the developing parasite become adult, there being apparently insufficient nourishment contained in such small individuals. Aphidids parasitized after

the second molt will become adult, but may be either winged or wingless; the wings in such cases often being imperfect. Oftentimes parasitized aphidids reach the third molt, but do not become adult before death, though the parasite reaches maturity, and it is probable that such Toxoptera were parasitized just before casting the second molt. This may also account for some of the small individuals among the parasites.

EFFECT OF PARASITISM BY APHIDIUS UPON FECUNDITY OF HOST.

Experiments have been conducted with the view of learning the number of young that may be produced after parasitization. This can probably be best illustrated by Table XII.

TABLE XII.—Effect, on fecundity of *Toxoptera graminum*, of parasitization by *Aphidius testaceipes*.

Number of individuals.	Stage when parasitized.	Date parasitized.	Kind of adult.	Daily number young.										Total young.	Date aphid died.		
				Oct. 15.	Oct. 16.	Oct. 17.	Oct. 18.	Oct. 19.	Oct. 20.	Oct. 21.	Oct. 22.	Oct. 23.	Oct. 24.				
1	Fourth instar	Oct. 15	Winged		A.					6						6	Oct. 24
1	do.	Oct. 16	do.		A.					3						9	Do.
1	Wingless adult	do.	Wingless			2				3						6	Do.
1	do.	do.	do.			4				4						10	Oct. 27
1	do.	do.	do.			1				2						5	Oct. 20
				Daily number young.													
Number of individuals.	Stage when parasitized.	Date parasitized.	Kind of adult.	Daily number young.										Total young.	Date aphid died.		
				Mar. 15.	Mar. 16.	Mar. 17.	Mar. 18.	Mar. 19.	Mar. 20.	Mar. 21.	Mar. 22.	Mar. 23.	Mar. 24.				
1	Fourth instar	Mar. 17	Winged							A.	2					2	Mar. 25
1	do.	do.	do.							A.	4					4	Do.
1	do.	do.	do.				A.			6	2					8	Do.
2	do.	do.	do.				do.			A4	7					11	Do.
2	do.	do.	do.				do.			A1	10					14	Do.
6	do.	do.	do.				do.			A1	A16	3				26	Do.
9	Winged	do.	do.				do.			38	21	9				61	Do.
4	Fourth instar	do.	Wingless			1				A9	34					43	Do.
5	Third instar	do.	Winged							M1	A2					3	Do.

M. = Molt.

A. = Adult.

Two adult *Aphidius* issued from those individuals included in the first section of the table and 18 from those in the last section. In this latter section *Aphidius* began to issue March 30 and the last issued on April 3. Those that issued on the latter date were from those that were adult winged adults when parasitized.

All of these experiments were conducted indoors, and those of the last division of Table XII, under a daily temperature ranging from 50° to 80° F.

From Table XII it will be seen that *Toxoptera* that have molted only twice before being parasitized may become winged adults, and in some instances produce young. All of our observations show that individuals that have molted three times and then been parasitized will become adult and produce young, and in case they are wingless they may produce 10 or more. Eleven is the maximum number of young, according to our observations, produced by a single individual after parasitization.

MOVEMENT OF LARVA WITHIN THE HOST AND MANNER OF ATTACHING IT TO THE PLANT.

Observations were made upon the movements of the larva (fig. 21) within the host by the senior author at Manhattan, Kans., in 1907, and published in the Proceedings of the Entomological Society of Washington.¹

It appears that the larva of the parasite, at least until after it attains some growth, moves little if at all within the body of the host, and thus interferes with no vital functions of the *Toxoptera*.

When the larva nears maturity, as shown by the yellowish color of the abdomen of the "green bug," it becomes quite active, making a number of revolutions within the body of its host, at which time the latter seizes the leaf with a rigid death-grip and the last spark of life soon fades. The object of the revolutions is, apparently, to mold the body wall of the aphidid, while it is still plastic, into the most suitable shape for pupation. An idea of how this desired end is accomplished may be obtained by glancing at the accompanying illustrations. Figure 22 shows the normal position of the parasitic larva within the body of the host before the revolutions begin. It was found that a fully developed larva (fig. 23) made three revolutions within the body of the host, always going forward, in the space of 35 minutes. During the next 5 minutes it made another revolution; a fifth revolution was completed in the next 10 minutes; the sixth during the following 8 minutes; the seventh in the next 9 minutes; the eighth after a space of 4 minutes; the ninth in the following 4 minutes, after which, on account of the opaqueness of the walls of the host, no further count was kept of the revolutions, although several more were known to have been made. Some of these different positions of the larva and

¹ Proc. Ent. Soc. Wash., vol. 9, Nos. 1-4, pp. 110-114, 1907.

the shapes the body of the Toxoptera assumes are graphically represented in figure 21. At this time, or about one and one-half hours

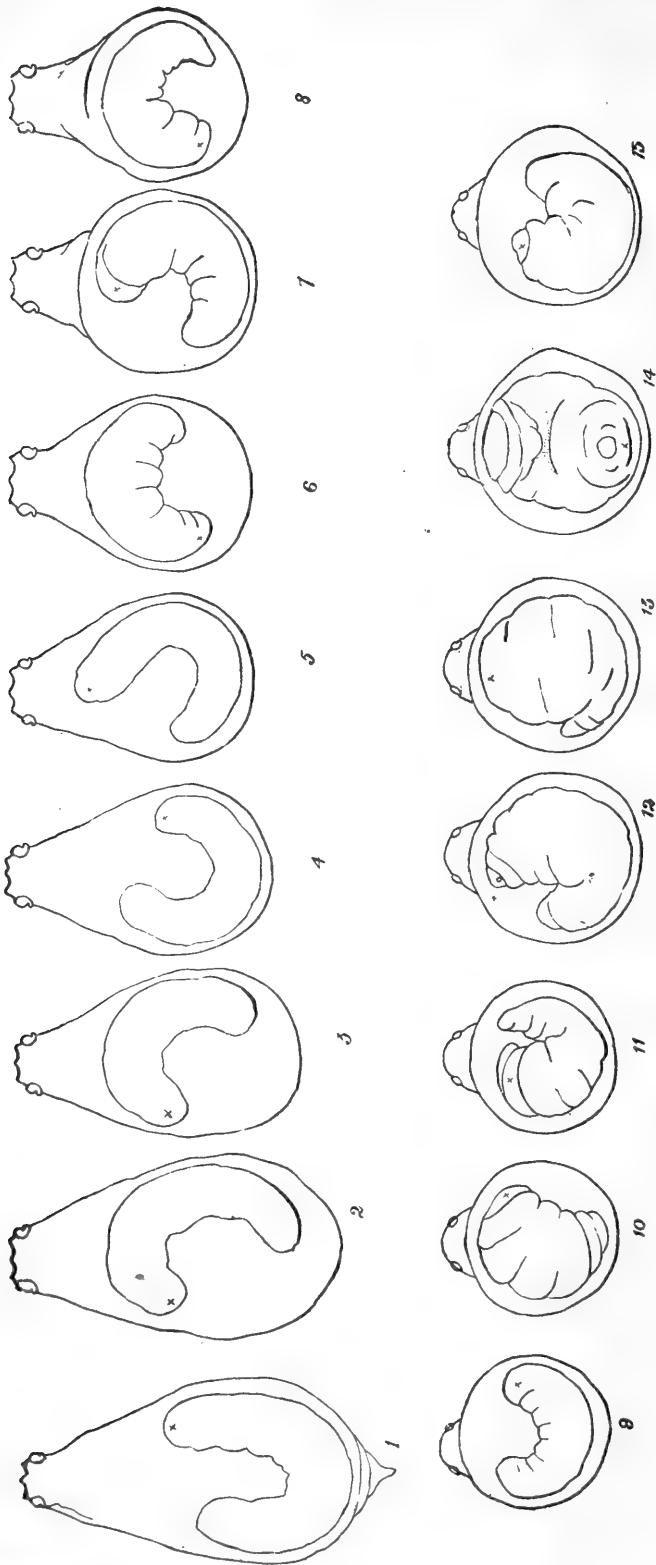


FIG. 21.—(1) Position of larva of *A. testaceipes* in body of wingless adult female of the spring grain-aphis, just before beginning its revolutions for fashioning the body of the aphid into a pupal envelope, 11 a. m. (2-7) Some of the positions assumed by the *A. testaceipes* larva between 11 a. m. and 11.35 a. m., during which time it made three complete revolutions. (8-9) Positions during and at completion of eighth revolution, 12.11 p. m. (10) Position at completion of ninth revolution, showing contraction of the larva, 12.15 p. m. (11) Position at 12.20 p. m. (12) Position at 12.22 p. m. (13) Position at 12.27 p. m. (14) Position at 12.32 p. m. (15) Position at 12.32½ p. m. (From Webster.)

after the observations were begun, the body wall of the "green bug" became quite dark and almost globular in form, and this shape it afterwards retained.

Mr. Kelly, of this bureau, later took up the observations at this point, during the fall of 1908, and published the results of his obser-

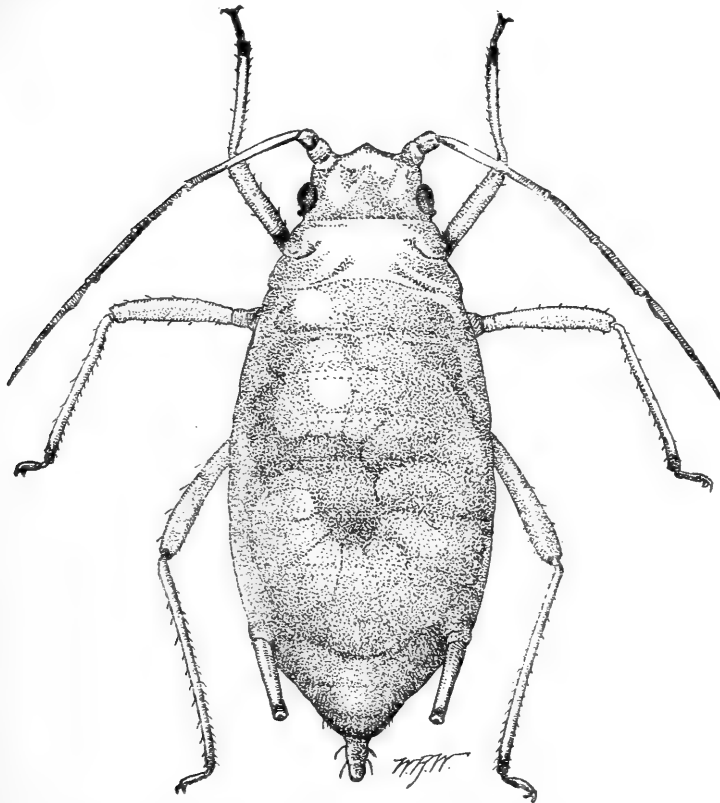


FIG. 22.—Position of larva of *Aphidius testaceipes* in the body of the spring grain-aphis at the beginning of the change to a yellowish color. Much enlarged. (Original.)

vations in the Proceedings of the Entomological Society of Washington.¹ Mr. Kelly confined some aphidids that were nearly dead

from parasite attack on a slide and observed them under the microscope. He found that as the body of the "green bug" takes on a brownish tint, the *Aphidius* larva within makes a longitudinal slit or opening in the ventrum and enlarges it until it is more or less oval in shape, as shown in figure 24.

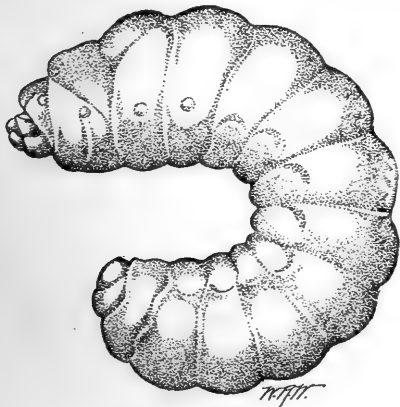


FIG. 23.—Full-grown larva of *Aphidius testaceipes* taken from body of the spring grain-aphis as shown in figure 22. Much enlarged. (Original.)

The rigid, firm manner in which *Toxoptera* grasps the object upon which it is resting at death apparently has the effect of holding it in place while the movements of the parasitic larva are going on within. When the opening is

complete the larva begins to spin its cocoon, at the same time ejecting a glutinous fluid that makes the strands adhere to any object

¹ Proc. Ent. Soc. Wash., vol. 11, No. 2, pp. 64-66, 1909.

with which they come in contact. The body of the aphidid is cemented firmly to the object upon which it finally comes to rest. The inner abdominal walls of the plant-louse are also lined with silk,

which firmly adheres to them, and it may be that the silk also acts as a tanning substance for the body of the aphidid, as the latter becomes leathery and is apparently impervious to water; the old leathery bodies of the plantlice may often be found firmly attached to plants after a heavy rain. After the cocoon is completed the larva becomes quiet and in most cases assumes, according to the junior author, a position directly opposite to that which it assumed while feeding and developing. Figure 22 shows a larva feeding, however, in the reversed position; this seems to be unusual, the normal position being as shown in Figure 21, *l*. The larva oftentimes, on becoming fully developed, is in some way dislodged from the body of the aphidid. This is probably due to some interference while attaching the host to the leaf. These

cases are quite numerous in badly infested fields and the larvæ apparently never become adult. Figure 25 is a graphic illustration of one of these accidents.

Mr. Kelly found that the pupal stage lasted from 3 to 4 days.

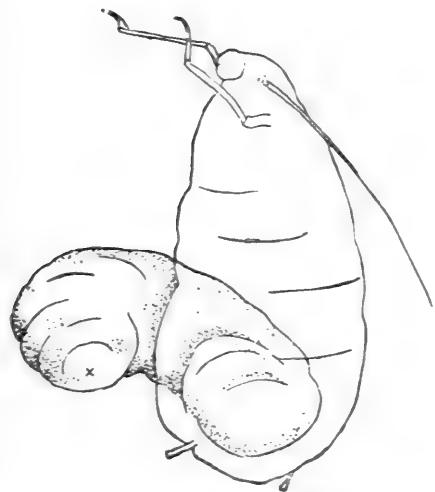


FIG. 25.—Larva of *Aphidius testaceipes* working its way prematurely from the body of the spring grain-aphis. (From Webster.)

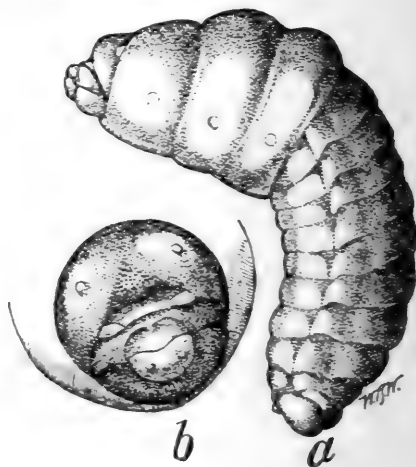


FIG. 26.—Full-grown larva of *Aphidius testaceipes*: *a*, Lateral view just prior to pupation; *b*, front view of head. Greatly enlarged. (Original.)

Figure 26 shows the larva just prior to pupation. These observations were made indoors, during the winter, at the ordinary room temperature. It requires from 3 to 5 hours for the *Aphidius* to

emerge as an adult after the first movements of the pupa begin, and when ready to issue the pupa expands and contracts the abdomen, moving the feet and antennæ until these are freed from their gum-like covering. Upon studying the pupæ (fig. 27) closely, we find that the prothorax bears two rows of distinct elevations or tubercles, but we have been unable thus far to ascribe any particular function to them and they disappear with the gum-like covering. The junior author finds that the adult gradually works itself about until it gets in a position with its back to the ventrum of the old aphidid shell, when it cuts a circular hole, as described by Mr. Kelly, and crawls out, always with its head pointing toward the head of the old aphidid. Figure 28 represents an old dead body of a "green bug" after the parasite has issued.

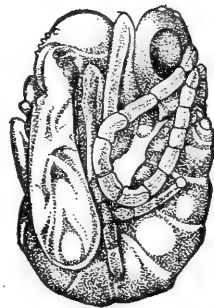


FIG. 27.—Pupa of *Aphidius testaceipes* immediately after pupation. Much enlarged. (Original.)

FECUNDITY.

From the prompt manner in which *Aphidius*, under favorable weather conditions, overcomes *Toxoptera* it will readily be seen that the former must be a very prolific breeder. The average adult female contains from 4 to 450 eggs. These eggs are lemon-shaped (see fig. 19), very pale, and translucent.

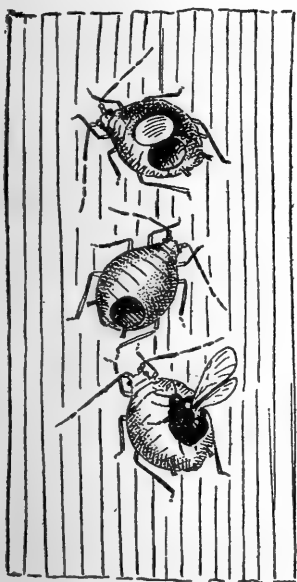


FIG. 28.—Dead "green bugs" (*Toxoptera graminum*), showing holes from which the matured parasites of *Aphidius testaceipes* emerge. The top figure shows the lid still attached, but pushed back; the bottom figure shows the parasite emerging. Enlarged. (From Webster.)

Messrs. Kelly and Urbahns conducted a number of experiments at Wellington, Kans., in 1908, to determine the number of offspring produced by one individual. They found that one *Aphidius* would parasitize as many as 206 *Toxoptera*. In their experiments, however, they used only a few more than 200 *Toxoptera* to each individual. Mr. Parks, at the same place in 1909, conducted 16 experiments, using from 300 to 500 *Toxoptera* and he had a maximum, in one case, of 301 aphidids parasitized from one individual *Aphidius*. His minimum was 3; his next highest number was 33, and his next was 44. Of the sixteen, 12 fell below 100; his average was 94.6.

Mr. Parks also conducted experiments at the same time as the above to ascertain what the effects of continuous mating of one male to different females would have on the offspring. In this experiment 1 male was mated to 12 unfertilized females within a period of two hours, after which each female was placed in a separate cage with about 100 *Toxoptera* that had not been exposed to *Aphidius*.

The male refused to mate with any more females after the twelfth. Table XIII shows the results of these observations:

TABLE XIII.—*Offspring produced as the result of mating one male Aphis with 12 females.*

Female, cage No.—	Female mated with male from cage No.—	Offspring.	
		Males.	Females.
180	180	29	55
181	180	14	33
182	180	21	30
183	180	35	41
184	180	2	8
185	180	0	0
186	180	13	30
187	180	39	25
188	180	1	0
189	180	50	0
190	180	8	9
191	180	26	16

From these data it appears that all of the eggs from the last few females were not fertilized, as Mr. Kelly finds that females predominate when the eggs are properly fertilized. Table XIV illustrates this latter point.

TABLE XIV.—*Offspring of Aphis produced from eggs properly fertilized.*

Cage No.—	Offspring.	
	Males.	Females.
197	39	67
297	15	20
299	13	33
300	24	40
302	20	34
304	16	50
306	47	12
333	115	15
403	26	41
404	38	93
405	26	44
Total ..	379	429

¹ These two females were apparently unfertilized, although they were supposed to have mated, as they give about the same results as some of the unmated females. If these two be eliminated it will be seen that the females are far in excess of the males.

PARTHENOGENESIS.

In all of the studies of parthenogenesis care was taken to preserve both parents and offspring, the individuals of each family or brood being preserved and kept entirely separate for future systematic studies, which were later carried out by Mr. Viereck.

The first record of parthenogenesis of this species was published in the Proceedings of the Entomological Society of Washington,¹ by the junior author, whose attention was first called to this phenomenon

¹ Proc. Ent. Soc. Wash., vol. 10, Nos. 1-2, September 15, 1908, pp. 11-13.



g
the

be
be
st

th
th

Ann. Ent. Soc. Amer. 2 (2): 67-71

Kelly and (Cabrera)

during the summer of 1907, while making observations on the life history of the species; hence, a series of experiments was begun in order to learn something definite in regard to it. Seven female *Aphidius* were selected, just as they issued from their cocoons (being therefore unfertilized), and placed in separate cages with 30 to 40 *Toxoptera* not previously exposed to parasite attack. All of the parasites began ovipositing at once. After one of the females had apparently parasitized all of the aphidids in her cage she was mated and placed in a second cage with a number of *Toxoptera* as before. All the offspring from unmated females were males, but the offspring from the single female, *after she had mated*, comprised 22 females and 4 males.

Messrs. Kelly and Urbahns elucidated this phenomenon more fully during the summer of 1908 at Wellington, Kans.¹ These experiments were conducted as follows:

Starting with a mated female, the females from among her offspring were isolated, even before emergence. On their appearance they were given *Toxoptera* not previously exposed to parasitic attack. The few females from among this second generation were again isolated in the same manner, the females in all cases being kept unmated. Nearly 100 experiments were conducted in this manner, but only 48 gave results. The offspring of 44 out of the 48 isolated were, all of them, males. Of the 4 remaining females, the offspring of 3 were as follows: 70 males and 3 females; 101 males and 6 females; 67 males and 1 female. In the case of the remaining female, some uncertainty exists as to whether she had been fertilized or not, and, for this reason, a census of her offspring is not here included.

Of the three exceptional cases the offspring from one female were not bred any further; from a second, the offspring became all males in the second generation; the offspring from the third female produced two females in the second generation, all finally becoming males in the third generation.

In this manner it will be seen that Messrs. Kelly and Urbahns were able to rear a limited number of females parthenogenetically to the third generation. Beyond this all of the offspring were males. While the conditions under which these experiments were conducted would not obtain under ordinary field conditions where the infestation was great, it could very easily occur where there are very few aphidids present. This apparently abnormal feature, then, would greatly assist the species in tiding over periods of scarcity of plant-lice.

HOSTS OF APHIDIUS TESTACEIPES.

Since we were able to find *Aphidius testaceipes* over almost the entire United States, it seemed clear to us that it must have hosts other than *Toxoptera graminum*. Accordingly Messrs. Kelly and Urbahns con-

¹ Ann. Ent. Soc. Amer., vol. 2, No. 2, 1909, pp. 67-87.

ducted about 200 experiments in order to gain some definite information on this point. Their mode of procedure was to search out different species of parasitized aphidids in the fields, rear the adult parasites, and breed them into *Toxoptera graminum*; then, if possible, breeding them again into the original host. One attempt, if unsuccessful, was not considered sufficient, several trials being made. While conducting these experiments, other species of parasites were found that would breed into *Toxoptera* also. These will be dealt with in their proper places. In all of these breedings, both parent and offspring were kept separate and preserved for future study.

It was found that *Aphidius testaceipes* would breed interchangeably from *Toxoptera* into *Aphis setariæ*, *Aphis maidis*, *Aphis middletoni* Thos.,¹ *Aphis gossypii*, and a species of *Chaitophorus*. This is the same as the list published by the senior author in the *Annals of the Entomological Society of America*,² with the exception that *Chaitophorus* is added and *Aphis brassicæ* has been expunged from the list, as it has been learned that the species of parasite that would interchange with *Toxoptera graminum* and *A. brassicæ* is another species of *Aphidius*.

Besides the above list of interchangeable breedings, *Aphidius testaceipes* has been reared from *Aphis anotheræ* at Salisbury, N. C., by Mr. R. A. Vickery; from *A. medicaginis* at Wellington, Kans., by Messrs. Kelly and Urbahns; from *A. rumicis* at Clemson, S. C., by Mr. G. G. Ainslie; from *Macrosiphum viticola* at Wellington, Kans., by Mr. Kelly; from *M. granaria* at Spartanburg, S. C., by Mr. G. G. Ainslie; from *Melanoxantherium* sp. at Leavenworth, Kans., by Mr. Kelly; from *Macrosiphum* sp. on black gum (*Nyssa sylvatica*) at Salisbury, S. C., by Mr. Vickery; from *Aphis avenæ*, at Salisbury, N. C., by Mr. Vickery; at Leavenworth, Kans., by Mr. Kelly, and at Washington, D. C., by Mr. C. N. Ainslie; and from *Aphis medicaginis* by Mr. J. T. Monell, at St. Louis, Mo. *Aphidius testaceipes* has also been reared from several unidentified species of aphidids, as follows: From an aphidid on *Ampelopsis* sp. by Mr. C. N. Ainslie; from an aphidid on *Capsella* sp. at Wellington, Kans., by Mr. C. N. Ainslie; from an aphidid on *Kochia scoparia* at Rochester, Minn., by Mr. C. N. Ainslie; from an aphidid on locust at Wellington, Kans., by Mr. Kelly; from an aphidid on plum at Salisbury, N. C., by Mr. Vickery; from an aphidid on pigweed (*Chenopodium album*) in Olmstead County, Minn., by Mr. C. N. Ainslie.

Further addition to this list of hosts may be made by citing the hosts of some of the synonyms of *Aphidius testaceipes*.³ We will deal

¹ *Aphis middletoni* can not be satisfactorily separated from *Aphis maidi-radicis* and when found on any other plant except *Erigeron* it has usually been identified as *Aphis maidi-radicis*. (See *Bul. 85, Bur. Ent., U. S. Dept. Agr.*, pp. 113-114. Contributions to a Knowledge of the Corn Root-Aphis, by R. A. Vickery.)

² *Ann. Ent. Soc. Amer.*, vol. 2, No. 2, pp. 67-87, June, 1909.

³ See *Proc. U. S. Nat. Mus.*, vol. 11, pp. 665-669, 1888.

with these synonyms collectively under *A. testaceipes*. The hosts then would be as follows: Reared from *Macrosiphum cucurbitæ* by the senior author at Lafayette, Ind.; reared from an aphidid on *Eragrostis* sp., by Mr. D. W. Coquillett; reared from *Macrosiphum* sp. on *Audibertia stochoides*, by Mr. Coquillett, at Los Angeles, Cal. Swept from *Eragrostis* sp. by the senior author at La Fayette, Ind., October 4, 1885; reared from *Myzus* sp. on *Hosackia glabra* by Mr. Coquillett at Los Angeles, Cal.; reared from *Myzus ribis* (currant aphis) by Prof. A. J. Cook, Lansing, Mich.; reared from *Aphis gossypii* by Prof. G. F. Atkinson, Columbia, S. C.; reared from *Macrosiphum* sp. on Abutilon by Mr. Coquillett at Los Angeles, Cal.; reared from *Aphis avenæ* by Mr. J. W. Barlow, June 20, 1882, at Cadet, Mo.; reared from Aphis on peach May, 1886, by Mr. Albert Koebele, Fresno County, Cal.; reared from an aphidid on *Baccharis viminalis* by Mr. Coquillett at Los Angeles, Cal.

There are probably many other hosts besides the ones we have mentioned of which as yet we have no knowledge; and when this situation is taken under consideration it is very easy to see that it would be only in rare instances and under peculiar conditions that a locality would be found where *Aphidius testaceipes* would not be lurking, waiting for favorable weather conditions and abundant supplies of its host aphidids to make its appearance in greater or less numbers.

HIBERNATION.

Aphidius is capable of withstanding extreme degrees of cold, as witnessed by the fact that Toxoptera parasitized during November, 1907, at Richmond, Ind., did not give up adults until the 27th and 28th of March and the 4th of April following. During February they were in the larval stage within an old dead body of a Toxoptera.

Mr. Kelly found that at Leavenworth, Kans., the parasites hibernated as larvæ and pupæ. This was shown by the fact that he found *Aphidius testaceipes* in the field in this condition on November 13, 1907. From a lot of 50 dead parasitized Toxoptera from the same field, that had been washed or rubbed off the leaves of the young grain and were taken out of the mud about the wheat plants on February 28, after the winter was practically over, Mr. Kelly found that 17 contained full-grown larvæ, 12 contained pupæ of a light color, and 21 contained pupæ of a dark color; the latter apparently were ready to develop promptly with the advent of warm weather. Mr. Kelly collected, on the same date and also from this same field, a number of Toxoptera in various stages of development that were hibernating in the fields and which showed no signs of parasitism; the weather had been such as to preclude the possibility of their having recently been parasitized. These were placed in a warm room and soon showed evidence of parasitism, *Aphidius testaceipes* being finally reared from them.

The junior author found that at Richmond, Ind., the adult *Aphidius* would live for at least two weeks when the temperature was below freezing. The parasites were taken into a warm room several times during these two weeks and they would become active, but when placed out of doors they would soon become numb. These adults were confined, however, so that excessive moisture was excluded, and they may not be able to live for so long a time in the fields unprotected.

The fact that *Aphidius* can during comparatively cold weather remain for a long period within the body of its host, and the latter give no external visible evidence of its presence, will readily account for the apparent absence of the parasite from any locality for an almost indefinite period; however, when the weather warms up sufficiently for development of the parasite to go on, its presence readily becomes apparent. For these reasons, as well as others that will be mentioned in their proper places, it is impossible to say, from a cursory examination, that *Aphidius* is not present.

INFLUENCE OF WINDS IN THE DISPERSION OF *APHIDIUS TESTACEIPES*.

As the natural suppression of an outbreak of *Toxoptera* is more dependent upon the activity of this parasite than of any other of its natural enemies, it is important to learn the extent to which the parasite is able to follow its host in its spread from the South over the country to the northward.

Dispersion of *Aphidius* may be accomplished in two ways—first,

as larvæ in the bodies of the winged host insect, where it is usually invisible, and, second, by being carried bodily with the winds along with the host.

By referring to Table XII on page 108, it will be observed that a number of cases are there recorded where individuals of *Toxoptera graminum* which were parasitized developed to winged adults, lived for a period of



FIG. 29.—Winged female of the spring grain-aphis, parasitized by *Aphidius testaceipes*. Enlarged. (From Webster.)

eight or nine days, and during this time gave birth to young, but from their dead bodies *Aphidius* afterwards issued. The presence of winged parasitized females on the leaves of grain and grasses inhabited by *Toxoptera* is of common occurrence (see fig. 29). Thus, while it has not been possible to observe the parasitism of individuals and follow out the final dispersion of the same, the evidence tending to show the probability of its general occurrence is so overwhelming that such direct proof does not seem necessary. With the obscurity

relative to this matter cleared away, it will be observed that it is entirely possible for great numbers of the adults, or those that are nearly mature, to become parasitized in a southern locality, the latter to develop to winged females under a more or less high temperature, and for both to be carried many miles to the northward, and then settle down and begin to reproduce, the *Aphidius* becoming adult and issuing later from the dead body of its host. In the meantime the offspring of the host *Toxoptera* would, of course, develop and themselves reproduce, some of them, without doubt, falling victims to the very parasite brought along by their parent. While this may not be the chief factor in the dispersion of this parasite, it probably enables it to follow along with the host insect and become diffused with it, although if low temperatures prevail after the time the migrating female settles in her new home there may be considerable delay in the issuing of the adult parasite without to any great extent delaying the development and preventing the increase of *Toxoptera*.

With the temperature at a point which enables *Aphidius* to become active there is no doubt that the parasite follows with the host insect, and, indeed, these parasites are usually found on the wing in the company of their hosts during warm sunny days. With high cold winds, which usually come from the northward and would tend to drive the parasites back over territory to which *Toxoptera* has already come and from which it has now largely disappeared, the adult *Aphidius* is observed to nestle down among the infested plants and not to venture abroad. Thus it is that this parasite is doubtless usually present in some form in the grain fields with the *Toxoptera*, though critical examinations of such fields may fail to reveal them until the temperature reaches a point that enables them to become active.

All of this is applicable to the insect in southern territory where no egg stage is yet known to occur. *Aphidius* occurs all over the country, and we have learned that in the North it winters as fully developed larvæ and pupæ within the "cocooned" bodies of its hosts, its emergence and activity in spring being controlled by the temperature and its dispersion influenced by the same forces and in much the same manner as in the South.

TEMPERATURE INFLUENCES ON APHIDIUS.

Probably the whole secret of these disastrous outbreaks of *Toxoptera* lies in the fact that this parasite is not active in a temperature much below 56° F., while, as has already been shown, the aphid begins to reproduce in a temperature at or slightly below 40° F.—a probable difference of at least 16° F. Therefore the situation in a field of wheat in the South in early spring may be described in this way: There are present many *Toxoptera* of all ages, with viviparous

reproduction continually going on during mild weather. *Aphidius* may also be present either as invisible undeveloped overwintering larvæ within the living bodies of its host, or it may be present as mature larvæ or pupæ in the dead and dried "cocooned" bodies of the same. Besides this, in the light of recent studies of *Aphidius* by Mr. Viereck, the same may be true with reference to its occurrence in a considerable number of other common species of aphidids, inhabiting a great variety of vegetation, in the same neighborhood, upon which this same species of *Aphidius* is parasitic. Thus, it is perfectly clear why, with *Toxoptera* swarming in the fields, and the parasite present, about 10 days, with the temperature ranging from 40° or 50° to 60° or 70° F., is sufficient to enable the latter summarily to suppress the invasion. The abruptness with which this change is brought about is easily explained by the fact that a parasitized female *Toxoptera* produces young during only a comparatively few days after being parasitized, although she may survive several days longer, especially if the weather be cool enough to retard the development of the parasite.

In the North the situation is usually quite different, as parasites can not begin their work here to any extent until after the eggs have hatched, and the stem mothers and their offspring have appeared in the fields, thereby furnishing host insects. The overwintering of immature *Aphidius* larvæ in the bodies of the host is in the North ordinarily precluded by the absence of living host individuals during severe winters, although mature larvæ may winter in the dead bodies of the host as in the South. Stem mothers are probably never present in great numbers and considerable time is therefore necessarily required for their offspring to become excessively abundant. For this reason parasitism, over the section where the host insects pass the winter in the egg, begins later, and, at the start, proceeds necessarily much slower than in the South, but on the other hand *Aphidius*, unless the winter be an exceptional one, must of necessity winter over in the "cocooned" bodies of its numerous hosts, as mature larvæ or pupæ, and would therefore promptly respond to the warm days of early spring, although delayed somewhat by low temperatures that might not retard the host insects.

There is one point in connection with parasitism by *Aphidius* that must be always kept in view, particularly to the southward, in order that mistakes and misstatements may be avoided regarding its actual occurrence in any particular locality. While the larva is contained within the still living body of its host its presence there is not easily detected. Indeed it is not until the larva becomes nearly full grown that it can be detected even by an expert. Therefore, in the light of what has previously been stated concerning the situation in milder latitudes, there may be millions of living larvæ

present for weeks in a field with no visible indication of their presence. Yet only a few warm days are required to bring about their final development, whereupon the presence of the more or less globular, leathery, brown bodies of the parasitized host first begin to attract attention and thus actually reveal the presence of the Aphidius, which has already been established there.

An excellent illustration of this is afforded by an occurrence of Toxoptera in eastern North Carolina, observed by Mr. L. M. Smith. In a small field of oats near Newport, wingless viviparous female Toxoptera and young were found in destructive abundance with no indication whatever of the presence of Aphidius. Yet when specimens of the pest submitted by Mr. Smith reached Washington, some of them were beginning to change color from the presence of Aphidius larvæ within their abdomens. Again, when Mr. C. N. Ainslie visited Wellington, Kans., April 1, 1907, he observed no trace of the presence of Aphidius, but upon returning to this same locality on April 10 he found them present. Only a few of the Toxoptera had yet become dark brown, but a large number showed the orange color that told the story of their parasitism. Therefore all statements made in previous publications relative to the lack of parasites, or to the extent to which they occurred in any field or locality, must be understood as applying only to either the adults or to the browned cocooned bodies of the host insects, and are not in any sense to be considered as indicating the extent to which these host insects were carrying obscured Aphidius larvæ about with them in their bodies to develop adults whenever there were a few sufficiently warm days.

EFFECTS OF WET WEATHER ON THE DIFFUSION OF APHIDIUS.

There is another element affecting the diffusion of this most efficient of natural enemies of Toxoptera, namely, protracted rains. When it is raining the parasite simply will not take wing at all or move about in a way to be affected by winds. This element will not admit of tabulation for the reason that a thunder shower followed by warm, bright sunshine tends to make these, as well as all winged insects, more active after the storm has passed. Thus, the amount of precipitation really means little, while a slow, drizzling, protracted rain (though the total precipitation may be much less) will keep the parasite in seclusion much more effectively. Hence it is that not only a comparatively high temperature accompanied by winds is essential, but the weather must also be fair and sunny.

In British East Africa Toxoptera is worse during seasons when there is much wet weather, and in the Orange Free State outbreaks of the pest seem to be also associated with similar meteorological conditions during spring.

Other Species of Aphidius.

Aphidius confusus Ashm. has been reared from *Toxoptera* from different parts of the country, including the Department of Agriculture grounds in Washington, but to what extent it assisted in overcoming *Toxoptera* in 1907 is not altogether clear. Its life history is apparently similar to that of *A. testaceipes* Cress., and its effect upon the aphides is apparently the same.

Aphidius avenaphis Fitch was reared from *Toxoptera graminum* in the insectary at the Department of Agriculture in Washington, the host insect having been parasitized, under observation, by adult virgin Aphidius reared from *Aphis* sp.

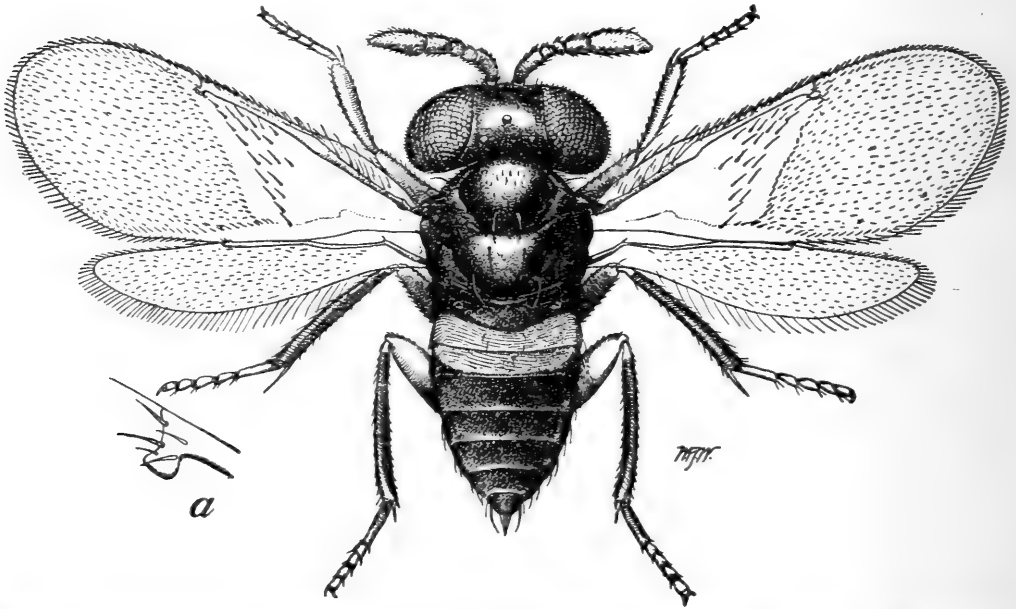


FIG. 30.—*Aphelinus mali*, a parasite of the spring grain-aphis. Greatly enlarged. a, Stigmatal club, much more enlarged. (Original.)

Species of *Aphidius*, apparently undescribed, were sent to the bureau from Njoro, British East Africa, and the Orange Free State, South Africa, as enemies of *Toxoptera graminum* in that country.

Aphelinus.

We have reared three species of *Aphelinus* from *Toxoptera graminum*; *Aphelinus mali* Hald., *A. nigritus* How., and *A. semiflavus* How.

Aphelinus mali Hald. (fig. 30) was reared from *Toxoptera* at Lafayette, Ind., in 1885 by the senior author, by Mr. R. A. Vickery at Richmond, Ind., and from the same species at Clemson, S. C., by Mr. G. G. Ainslie. Messrs. Kelly, Urbahns, and Parks reared it from *Aphis setariæ* Thos. at Wellington, Kans. Messrs. Kelly and Urbahns also reared it from *Schizoneura americana* Riley at Wellington. Mr. Vickery reared it from *Schizoneura lanigera* Hausm. at Richmond,

Ind., and from *Colopha eragrostidis* Middl. at Mt. Vernon, Ind. Mr. Kelly reared it from *Pemphigus fraxinifolii* Riley and from an aphidid taken on *Panicum* sp. Mr. C. N. Ainslie reared it from *Macrosiphum rosæ* Linn., at Mesilla Park, N. Mex.

This species has been previously reared, as stated by Dr. L. O. Howard¹ from *Schizoneura lanigera* Haussm., *Colopha eragrostidis* Middl., *Aphis brassicæ* Linn., *Pemphigus fraxinifolii* Riley, *Aphis monardæ* Oestl., *Macrosiphum rosæ* Linn., *Aphis sacchari* Zehntn., and *Tetraneura colophoidea*.

Aphelinus nigrinus How. (fig. 31) was first reared from Toxoptera at Spartanburg and Clemson, S. C., by Mr. G. G. Ainslie. It was

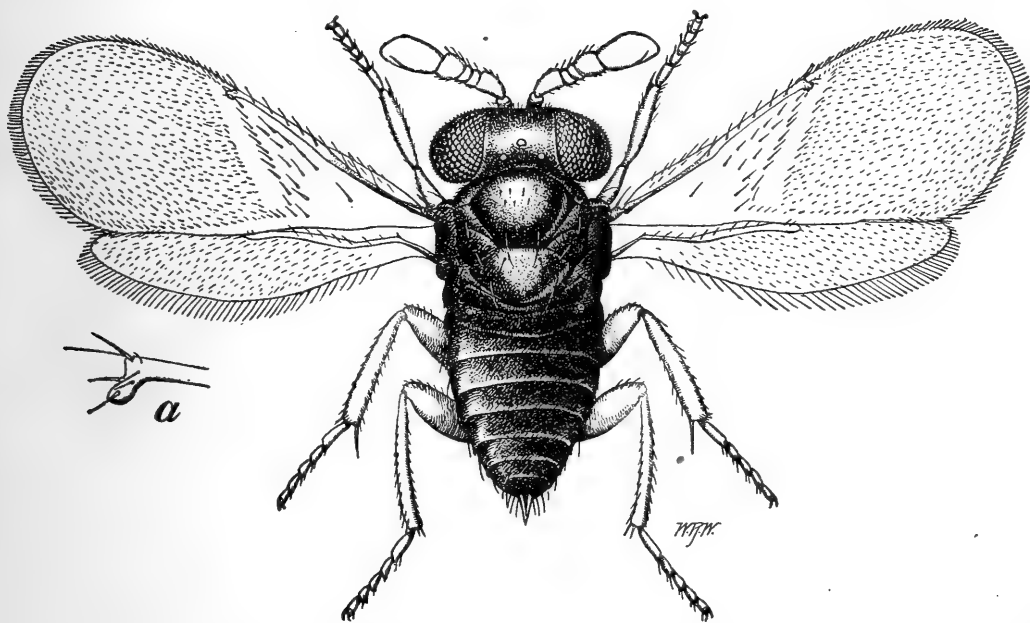


FIG. 31.—*Aphelinus nigrinus*, a parasite of the spring grain-aphis. Greatly enlarged. *a*, Stigmatal club, still more enlarged. (Original.)

reared from the same species of aphidid by Mr. C. N. Ainslie at Springer and Mesilla Park, N. Mex., and St. Anthony Park, Minn. Mr. T. H. Parks reared it from Toxoptera at Wellington, Kans., and Messrs. Kelly and Urbahns reared it from *Aphis setariæ* Thos. at Wellington.

Aphelinus semiflavus How. (fig. 32) was first reared from *Myzus persicæ* Sulz. and *Chaitophorus viminalis* Monell by Prof. C. P. Gillette at Fort Collins, Colo., in 1908. It was later reared by Mr. G. G. Ainslie from Toxoptera at St. Anthony Park, Minn., and from a black aphidid on bluegrass (probably *Rhopalosiphum poæ* Gill.) at Mesilla Park, N. Mex., by C. N. Ainslie.

¹ Ent. News., vol. 19, no. 8, pp. 365-366, 1908.

NOTES ON LIFE HISTORY AND HABITS OF APHELINUS.

Mr. C. N. Ainslie made some observations on *Aphelinus nigritus* at Mesilla Park, N. Mex., in 1908. He states that when the adult is ready to oviposit it approaches an aphidid very slowly and cautiously, moving or swaying its body slightly from side to side and waving its antennæ. When the antennæ finally touch the plant-louse it stops, turns suddenly about, moves backward slightly, and then gives the victim a thrust with its hairlike ovipositor. This operation apparently causes pain to the aphidid, as she begins to "kick up" her abdomen and there sometimes appears a tiny drop of fluid where the puncture was made.

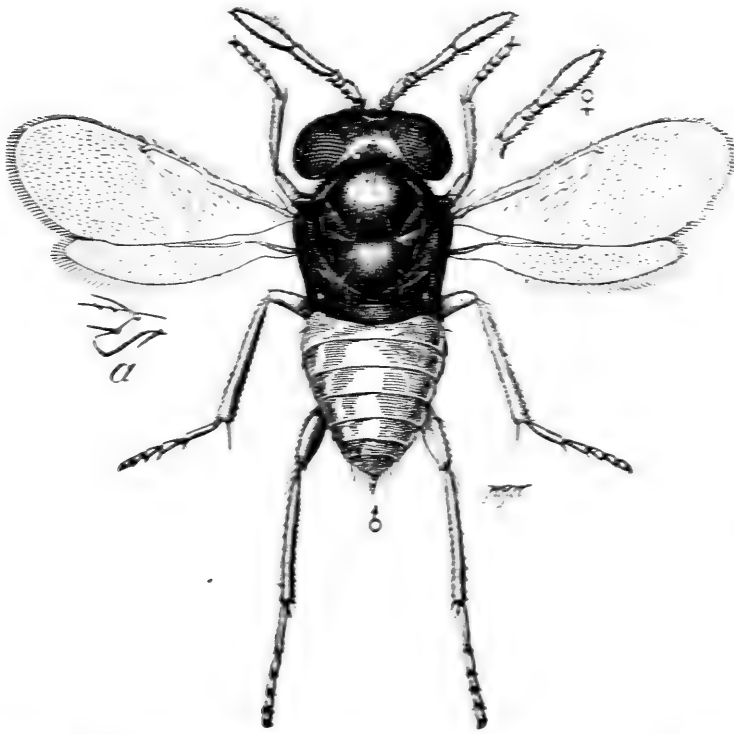


FIG. 32.—*Aphelinus semiflavus*, a parasite of the spring grain-aphis. Greatly enlarged. *s*, Stigmatal club, still more enlarged. (Original.)



FIG. 33.—Dried remains of body of the spring grain-aphis from which adult *Aphelinus nigritus* has emerged. Enlarged. (Original.)

When the larva of *Aphelinus nigritus* is fully grown the body of the plant-louse, according to Mr. G. G. Ainslie, turns black and the legs a conspicuous white (fig. 33), while in individuals parasitized by *A. mali* these appendages are black. The body, however, of so small an aphidid as *Toxoptera graminum* appears to be but little swollen. Mr. C. N. Ainslie found that under favorable weather conditions *A. nigritus* developed from egg to adult in from 12 to 13 days.

The following diagram will serve to illustrate the different hosts of *Aphidius testaceipes*, *A. avenaphis*, *A. confusus*, *Aphelinus mali*, *A. nigritus*, and *A. semiflavus*, which we have shown to attack *Toxoptera graminum*. This will give some idea of the numerous sources from which an army of parasites may be recruited to oppose any serious invasion of *Toxoptera*.

		<i>avenaphis</i> ..	<i>Macrosiphum granaria</i> Buck.
		<i>confusus</i> ...	<i>Macrosiphum erigeronensis</i> Thos.
		<i>testaceipes</i> ..	<i>Aphis avenæ</i> Fab.
			<i>Aphis gossypii</i> Glov. <i>Aphis</i> sp.
			<i>Aphis maidis</i> Fitch.
			<i>Aphis maidi-radici</i> Forbes.
			<i>Aphis medicaginis</i> Koch.
			<i>Aphis ænotheræ</i> Oestl.
			<i>Aphis rumicis</i> Linn.
			<i>Aphis setariæ</i> Thos.
			<i>Macrosiphum viticola</i> Thos.
			<i>Macrosiphum granaria</i> Buckt.
			<i>Melanoxantherium</i> sp.
	<i>Aphidius</i> ...		<i>Macrosiphum</i> sp. on black gum.
			<i>Myzus ribis</i> Linn. on currant.
			<i>Myzus</i> sp. on <i>Hosackia glabra</i> .
			<i>Macrosiphum</i> sp. on <i>Abutilon</i> .
			<i>Macrosiphum cucurbitæ</i> Thos.
			Aphidid on <i>Ampelopsis</i> sp.
			Aphidid on <i>Baccharis viminalis</i> .
			Aphidid on <i>Capsella bursa-pastoris</i> .
			Aphidid on <i>Eragrostis</i> sp.
			Aphidid on <i>Kochia</i> sp.
			Aphidid on locust.
			Aphidid on peach.
			Aphidid on pigweed (?).
			Aphidid on plum.
		<i>mali</i>	<i>Aphis brassicæ</i> Linn.
			<i>Aphis monardæ</i> Oestl.
			<i>Aphis sacchari</i> (?) Zehntn.
			<i>Aphis setariæ</i> Thos.
			<i>Colopha eragrostidis</i> Middl.
			<i>Myzus mahaleb</i> Boyer.
	<i>Aphelinus</i> ..		<i>Pemphigus fraxinifolii</i> Riley.
			<i>Macrosiphum rosæ</i> Linn.
			<i>Schizoneura americana</i> Riley.
			<i>Schizoneura lanigera</i> Haussm.
			<i>Tetraneura colophoidea</i> (?).
		<i>nigritus</i>	<i>Aphis setariæ</i> Thos.
		<i>semiflavus</i> ..	<i>Aphis maidis</i> Fitch.
			<i>Aphis gossypii</i> (?) Glover.
			<i>Chaitophorus viminalis</i> Mon.
			<i>Myzus persicæ</i> Sulz.

SECONDARY PARASITES.

Megorismus sp.

Species of the genus *Megorismus*, it appears, have been previously considered as primary parasites. Mr. Parks, however, has conducted some experiments with a species (fig. 34) at Wellington, Kans., and his results clearly indicate that in this case it is a secondary parasite. In no instance could he rear it from aphidids

that had not previously been parasitized; he experienced no difficulty, however, in rearing it when the adults were placed in cages with aphidids that were brown, having been killed by some species of *Aphidius*. It may be that under certain conditions *Megorismus* sp. is also a primary parasite. Mr. Parks finds that it takes about 30 days in developing from egg to adult in a temperature of about 70° F. indoors.

It has been reared in conjunction with *Aphidius* sp. from *Toxoptera graminum* and *Chaitophorus* sp. at Wellington, Kans., by Messrs. Kelly and Urbahns; from *T. graminum* and *Aphis brassicæ* in the same locality by Mr. Parks. Mr. Parks also reared it from *Macrosi-*

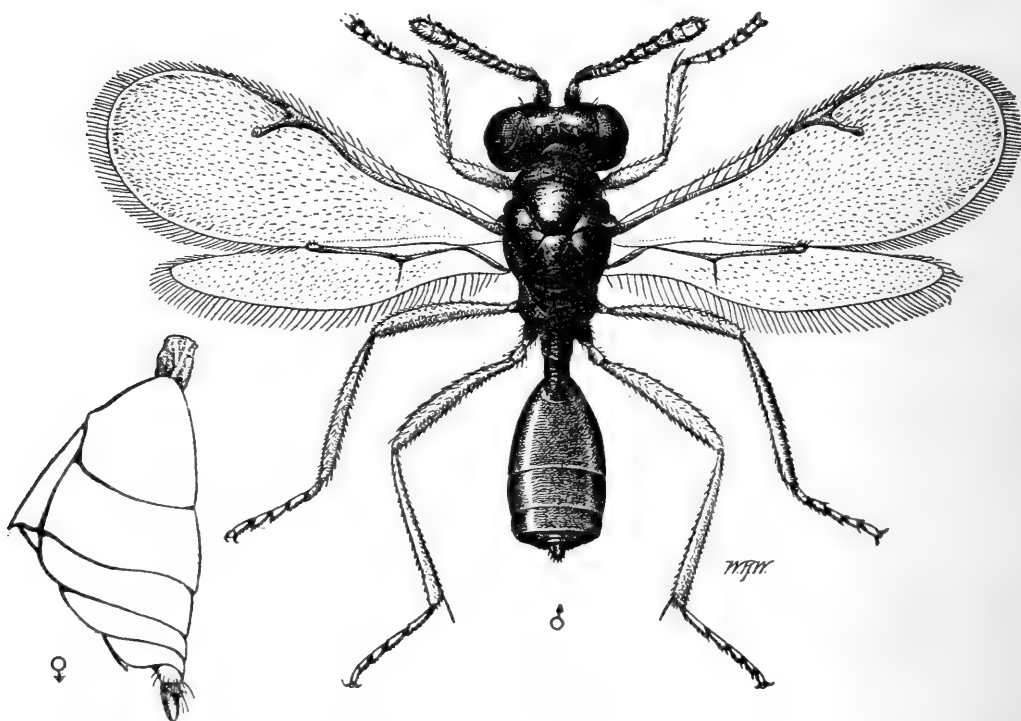


FIG. 34.—*Megorismus* sp., a secondary parasite of the spring grain-aphis: Male, greatly enlarged; female abdomen, more enlarged, at right. (Original.)

phum pisi at Washington, D. C. Mr. C. N. Ainslie reared it from *Hyalopterus dactylidis* in the same locality, and the junior author reared it from *Myzus persicæ* at Lafayette, Ind.

Aphidencyrthus aphidiphagus Ashm.

The species *Aphidencyrthus aphidiphagus* Ashm. (fig. 35) has also been considered a primary parasite, and while we have no direct evidence to disprove this we very strongly suspect that it is in this case a secondary parasite. Like *Megorismus*, which, we have shown, is sometimes, at least, a secondary parasite, we have reared it only in conjunction with known primary parasites. Mr. G. G. Ainslie could rear it only in connection with *Aphelinus* sp. from *T. graminum* at Clemson, S. C., and Mr. C. N. Ainslie reared it from *Aphis*

brassicæ at Mesilla Park, N. Mex., in conjunction with *Aphidius* sp. Nothing definite is known of its life history.

Pachyneuron sp.

A species of *Pachyneuron* (fig. 36) has been repeatedly reared from *Toxoptera graminum* and it appears to be generally accepted as a

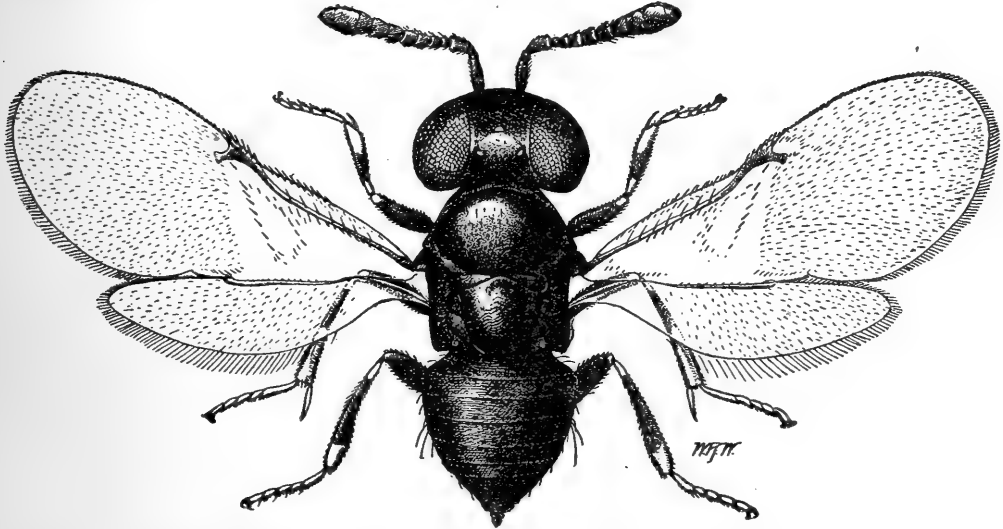


FIG. 35.—*Aphidencyrthus aphidiphagus*, a secondary parasite of the spring grain-aphis. Greatly enlarged. (Original.)

secondary parasite. Mr. Kelly has observed it ovipositing in brown parasitized *Macrosiphum viticola*. Mr. G. G. Ainslie reared it in conjunction with *Aphelinus* sp. from *Toxoptera* and with *Aphidius* sp. from

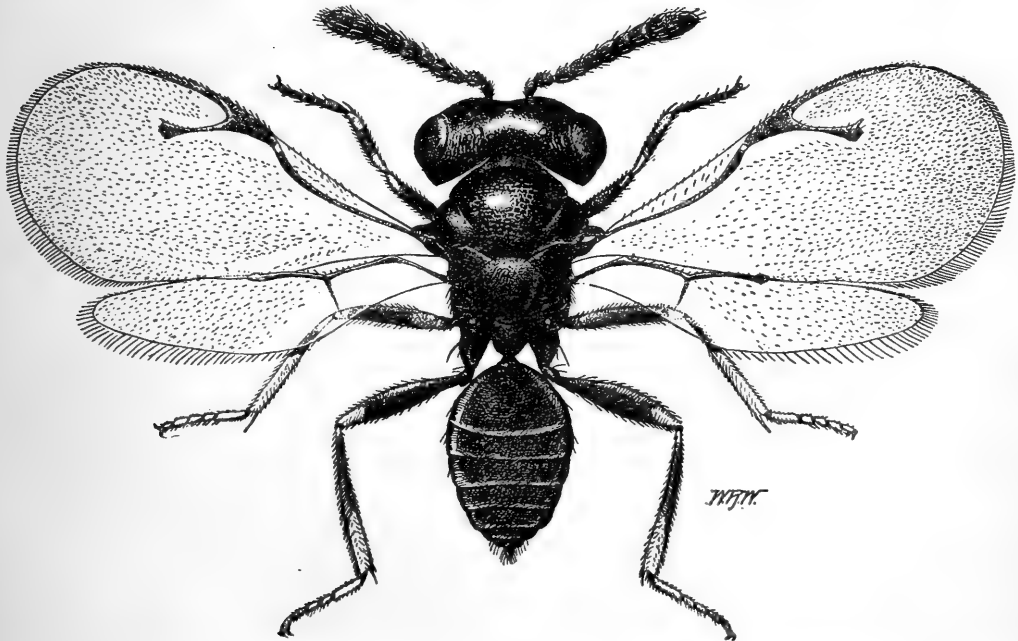


FIG. 36.—*Pachyneuron* sp., a secondary parasite of the spring grain-aphis. Greatly enlarged. (Original.)

Aphis maidis from Clemson, S. C., and from *Toxoptera* at St. Anthony Park, Minn. Mr. C. N. Ainslie reared it in connection with *Aphidius* sp. from *Aphis setariæ*, *A. gossypii*, *Macrosiphum granaria*, and *M. erigeronensis* and in connection with *Aphelinus* sp. from *Schizo-*

neura americana. He also reared it from *Macrosiphum viticola* and *Chaitophorus* sp. *Pachyneuron* sp. appears to be quite generally distributed but little or nothing is known of its life history.

Allotria sp.

Allotria sp. (fig. 37) is recorded as a secondary parasite. Mr. Parks verified this by careful rearings at Wellington, Kans., in 1909, for he was able to rear it only from parasitized aphidids. The junior author and Messrs. Kelly and Urbahns have observed it ovipositing in parasitized dead aphidids also. Mr. Parks found in his experiments that it developed from egg to adult in about 21 days, under favorable temperatures.

We have reared it only in conjunction with *Aphidius*. Messrs. Kelly and Urbahns reared it from *Aphis gossypii* and *A. brassicæ* at Wellington, Kans.; Mr. Parks reared it from *Toxoptera* from the same locality; Messrs. Parks and Kelly also reared it from *Toxoptera* at Washington, D. C. Mr. C.

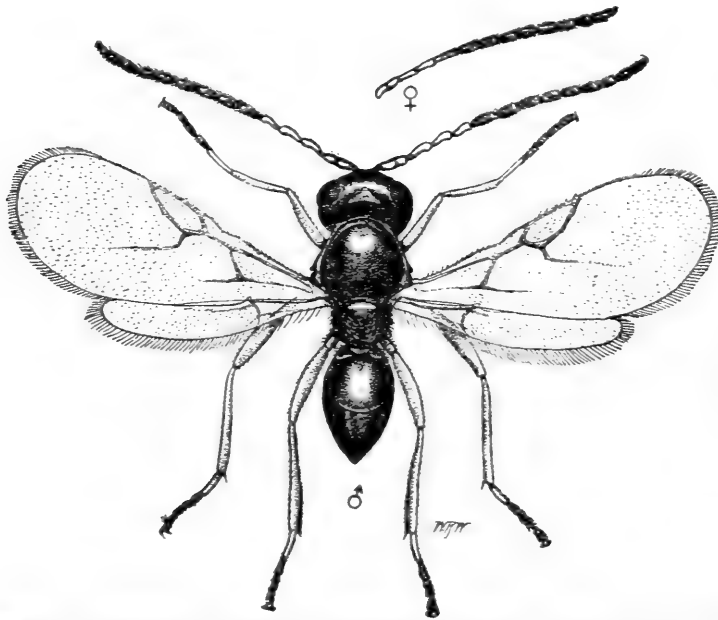


FIG. 37.—*Allotria* sp., a secondary parasite of the spring grain-aphis. Male, with female antenna at upper right. Greatly enlarged. (Original.)

N. Ainslie reared it from *Aphis avenæ* and *Hyalopterus dactylidis* from the same locality. Mr. Kelly reared it from *Macrosiphum viticola* from Wellington, Kans., and the junior author reared it from *Myzus persicæ* at Lafayette, Ind.

PREDACEOUS ENEMIES.

Lady-beetles.

Probably next in importance to the genus *Aphidius* come the ladybird beetles. These beetles, in both the adult and larval stages, feed upon plant-lice. In 1907 they became very abundant, destroying countless numbers of *Toxoptera* and greatly assisted *Aphidius* in subduing the pest. Plate VIII represents the manner in which the pupæ are found attached to plants in fields badly infested with *Toxoptera*; to the left is a 2-inch section of an old cowpea stem; to the right, two short sections of wheat stems. Oftentimes as many as 30 or more pupæ could be found within the space of a foot of a single drill row. Adults deposit eggs upon any convenient object,

Fig. 1.

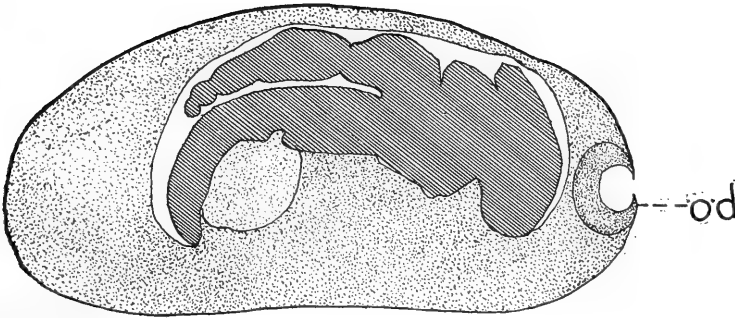


Fig. 2.

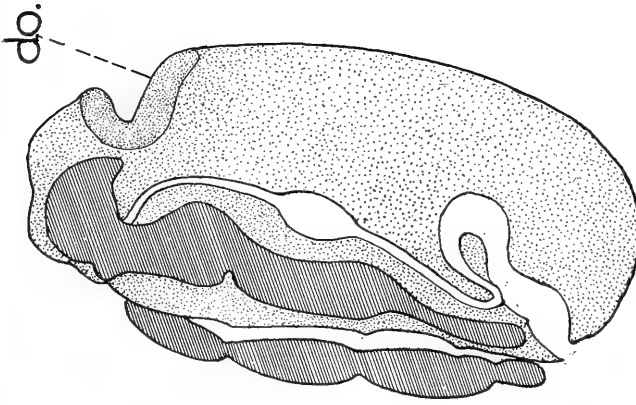


Fig. 3.

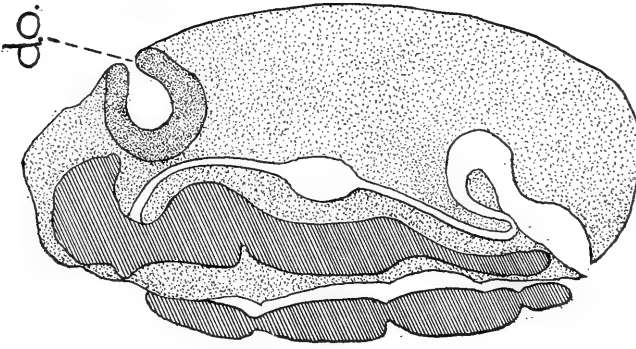
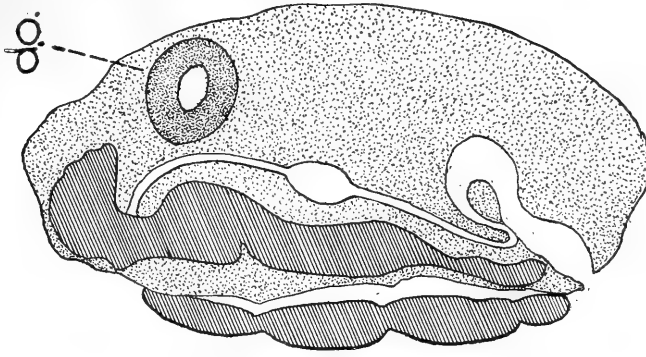
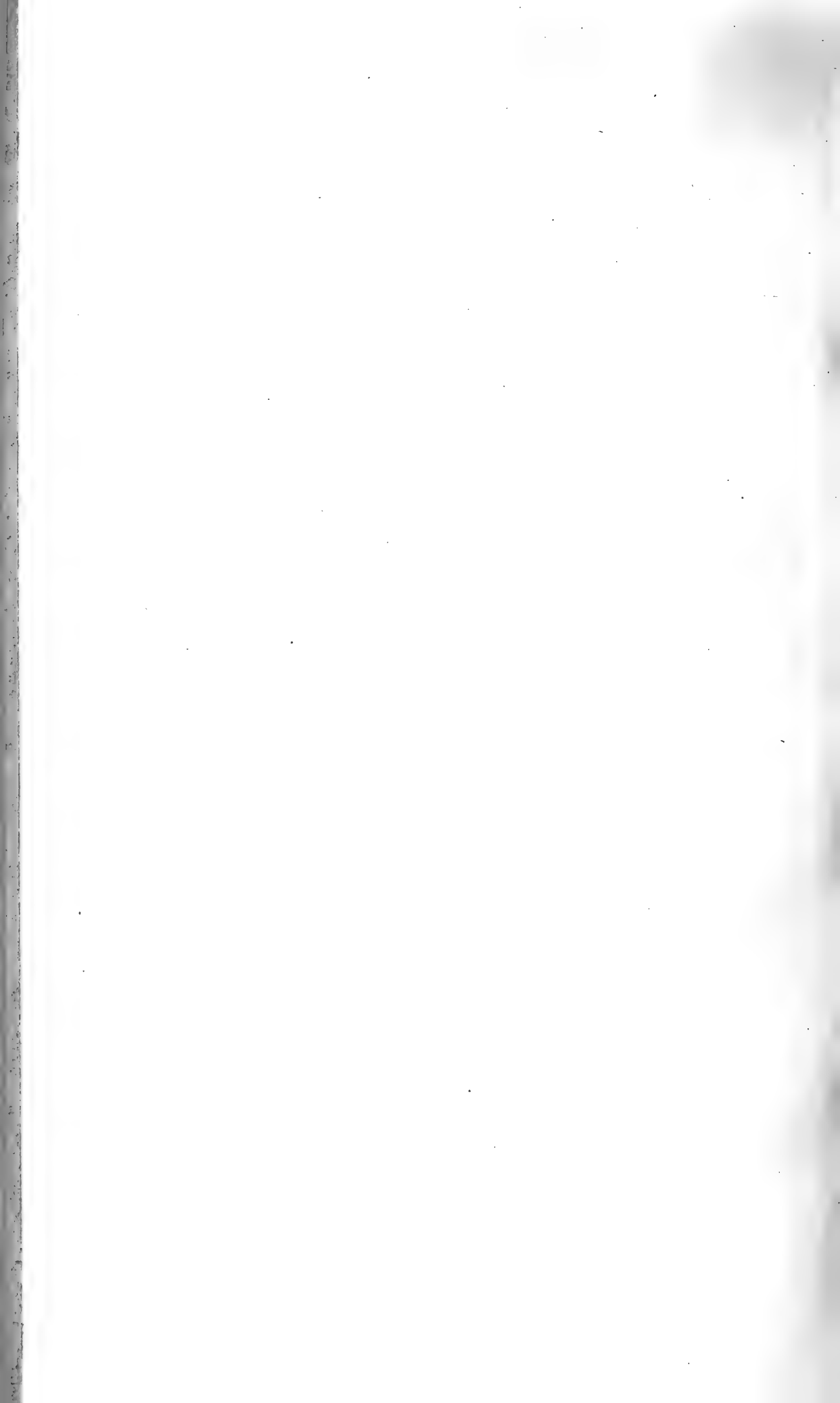


Fig. 4.



DEVELOPMENT OF THE EMBRYO IN THE EGG OF TOXOPTERA GRAMINUM.

Fig. 1.—Sagittal section (slightly oblique) showing the embryo in position to escape from the center of the egg. Magnified 83 diameters. Fig. 2.—Sagittal section (slightly oblique) showing the embryo at the surface of the egg. Dorsal organ now formed. Magnified 83 diameters. Fig. 3.—Sagittal section (slightly oblique), later stage of development. Magnified 83 diameters. Fig. 4.—Sagittal section (slightly oblique): The dorsal organ is immersed within the body cavity where it has begun to disintegrate. Magnified 83 diameters. (Original.)





A LADY-BEETLE ENEMY OF THE SPRING GRAIN-APHIS.

Pupæ of *Hippodamia convergens* attached to stem of cowpea and wheat straws in a field where the spring grain-aphis had been excessively abundant. Enlarged. (Original.)



and, as soon as hatched, the larvæ seem possessed of an insatiable appetite, devouring aphidids or even eggs and larvæ of their own species if no plant-lice are at hand. Mr. Kelly has found that an

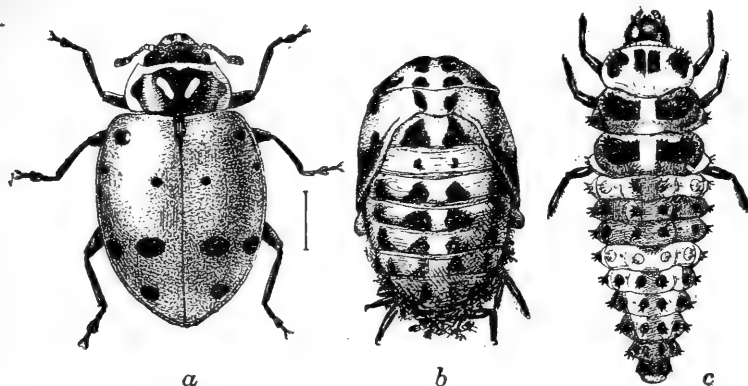


FIG. 38.—The convergent lady-beetle (*Hippodamia convergens*), an enemy of the spring grain-aphis: a, Adult; b, pupa; c, larva. Enlarged. (From Chittenden.)

adult ladybird (*Hippodamia convergens*) (fig. 38) will devour from 15 to 30 plant-lice in a day. Mr. S. J. Hunter, in "The Green Bug and its Enemies," page 6, states that instances have come under his observation where as many as 100 have been devoured in a single day by an adult lady-beetle. The larvæ when nearly grown are probably able even to exceed this record. In one of Mr. Kelly's experiments a single beetle deposited as many as 264 eggs, thus showing that this ladybird is very prolific. When all of these facts are considered it is easy to see that the lady-beetles are rather formidable enemies of Toxoptera.

Hippodamia convergens appeared to be by far the most abundant ladybird in the Southwest in 1907.

Coccinella 9-notata (figs. 39, 40) and *Megilla maculata* (fig. 41) were also quite abundant. *Coccinella abdominalis* was present in less abundance. *Adalia flavomaculata* DeG. (fig. 42), with its larvæ, has been sent to the bureau as an enemy of Toxoptera in the Orange Free State, South Africa.

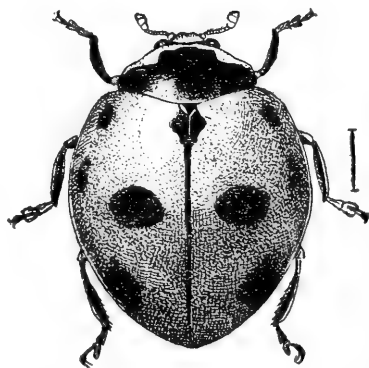


FIG. 39.—The nine-spotted lady-beetle (*Coccinella 9-notata*), an enemy of the spring grain-aphis: Adult. Enlarged. (From Chittenden.)

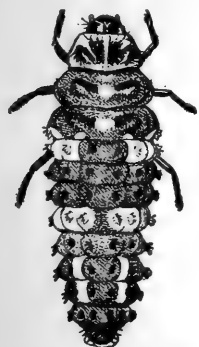


FIG. 40.—The nine-spotted lady-beetle (*Coccinella 9-notata*), an enemy of the spring grain-aphis: Larva. Enlarged. (From Chittenden.)

Syrphid Flies.

All through the Southwest in 1907 syrphids were very abundant and were an important factor in the control of Toxoptera.

These insects are beautiful two-winged flies with prominent golden bands across the abdomen. They are always present in mild weather

in grain fields badly infested with plant-lice, and when quite numerous attract attention by a buzzing noise made while in flight. The predaceous larvæ are sluglike and of a dirty grayish or yellowish green color; this is the only stage in which they are destructive to

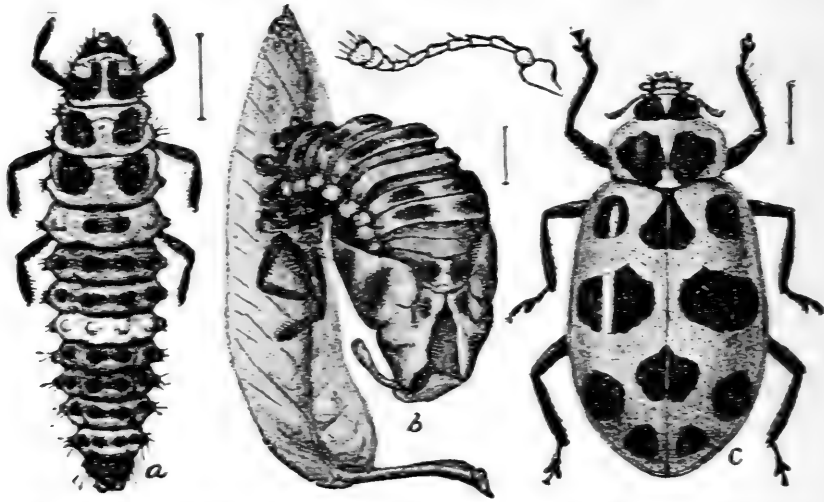


FIG. 41.—The spotted lady-beetle (*Megilla maculata*), an enemy of the spring grain-aphis: a, Larva; b, empty pupa skin; c, adult. Enlarged. (From Chittenden.)

plant-lice. Little is known of the life histories of these insects as very few careful rearings have been made.

Syrphus americanus Wied. (fig. 43) and *Eupeodes volucris* O. S. (fig. 44) were by far the most numerous syrphids in the grain fields in

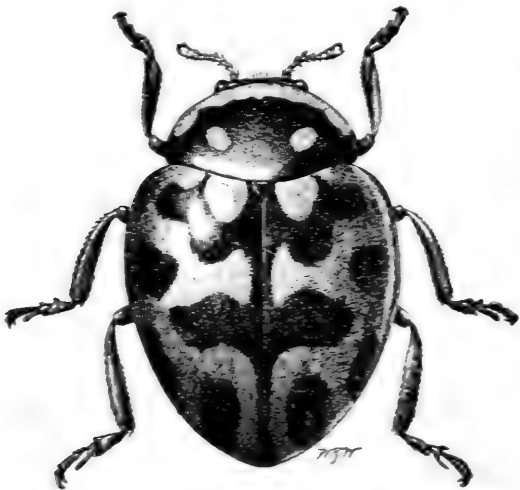


FIG. 42.—A South African lady-beetle. *Adalia flavo-maculata*, which with its larva attacks the spring grain-aphis in the Orange Free State, South Africa. Enlarged. (Original.)

the Southwest in 1907. A field at Kingfisher, Okla., in April, 1907, literally swarmed with them; 20 or more could be taken with each sweep of an insect net. A curious fact with reference to their occurrence in such abundance in this field, however, was that Toxoptera was not present there in destructive abundance, while the adjoining field was suffering greatly from their attack, though, curiously enough, the syrphid flies did not appear to be so plentiful there. These two species were present, apparently, over the entire south-

western area that suffered greatly from Toxoptera attack in 1907. *Syrphus americanus* was reared also from Toxoptera material sent in by Mr. E. C. Haynsworth from Sumter, S. C. Prof. J. M. Aldrich states in his catalogue of North American Diptera that he reared *Eupeodes volucris* from *Aphis avenæ* at Moscow, Idaho. Dr. C. V. Riley states,

in a report of the Department of Agriculture,¹ that he reared *Syrphus americanus* from *Macrosiphum granaria*.

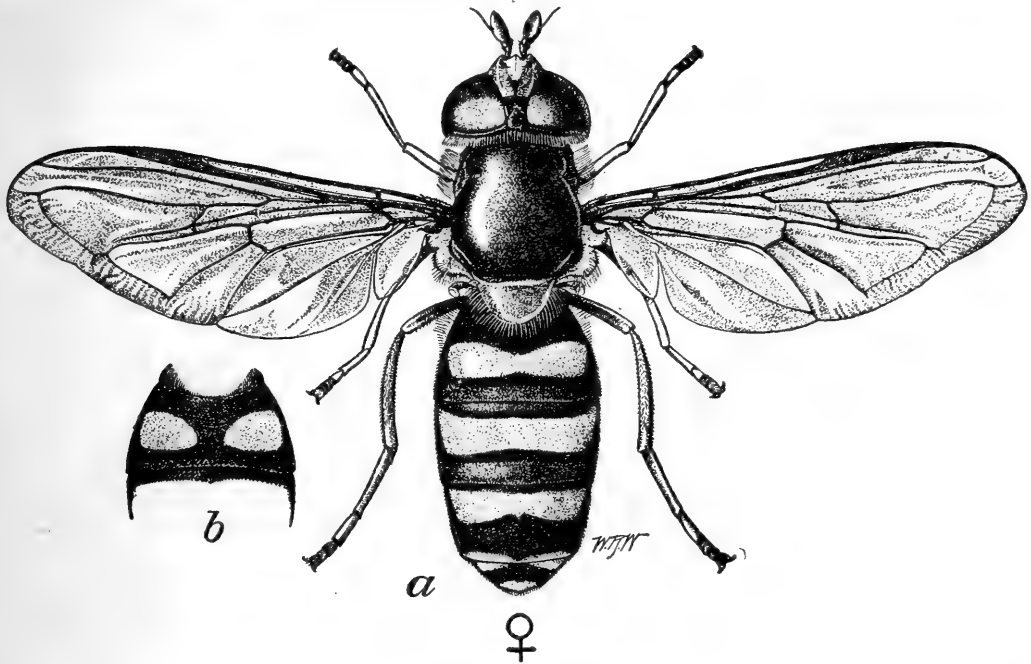


FIG. 43.—*Syrphus americanus*, whose larva destroys the spring grain-aphis: a, Female fly; b, second abdominal segment of male. Enlarged. (Original.)

Sphærophoria cylindrica Say (fig. 45) was collected from wheat fields at Hiawatha, Kans., in 1907, by the junior author and was also

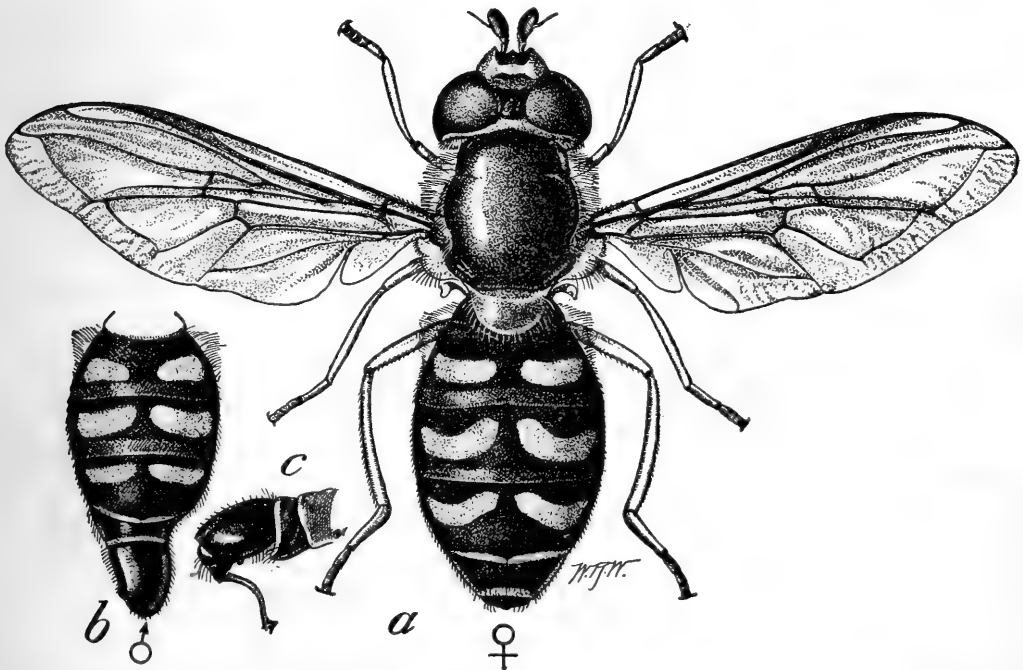


FIG. 44.—*Eupeodes volucris*, whose larvæ were the most abundant and useful in the fields where the spring grain-aphis was most abundant in the Southwest during the spring of 1907. a, Female fly; b, abdomen of male; c, hypopygium of male. Enlarged. (Original.)

reared from *Toxoptera* material sent in by Mr. Haynsworth from Sumter, S. C., the same year. Mr. G. G. Ainslie reared it from

¹ Report of the Entomologist, U. S. Dept. of Agr. for 1889, p. 351.

Toxoptera at Monetta, S. C., in 1908. Dr. Riley states that he found the larvæ feeding on *Macrosiphum granaria*.

Mr. Ainslie took quite a number of *Allograpta obliqua* Say in the Southwest in 1907, and, though we can not say definitely that it feeds upon Toxoptera, the chances are that it does, as Dr. Riley states that it feeds upon *Macrosiphum granaria*.

Mr. Kelly reared a number of *Baccha clavata* Fab. from *Aphis setariæ* at Wellington, Kans., in 1908; Mr. R. A. Vickery also reared *B. clavata* from *Aphis maidis* at Brownsville, Tex., in 1911; Mr. J. J.

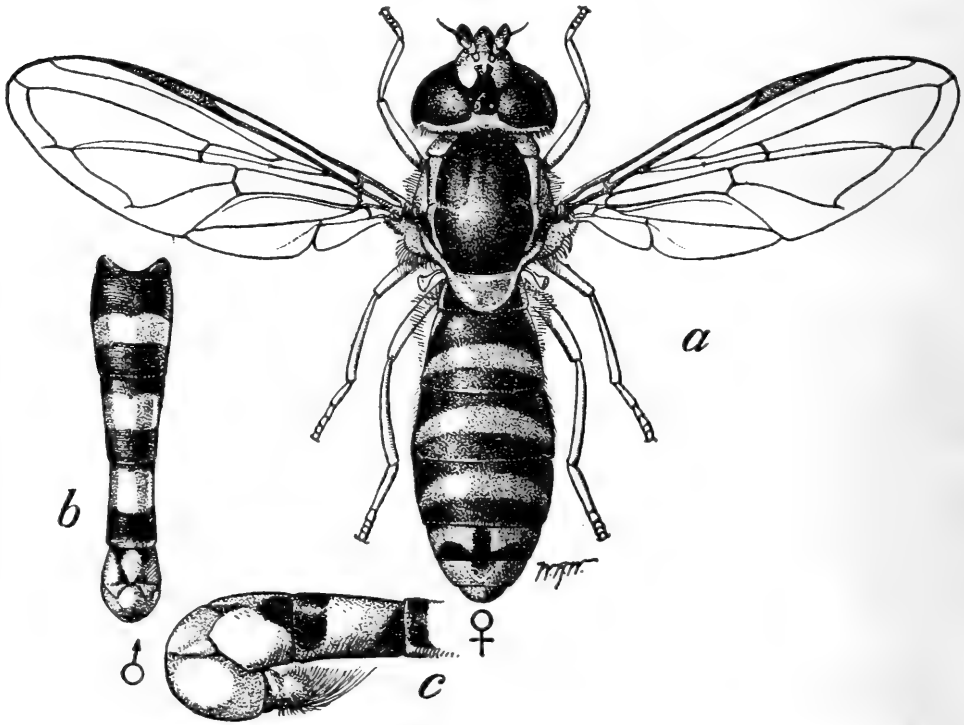


FIG. 45.—*Sphærophoria cylindrica*, a fly reared from larvæ attacking the spring grain-aphis in South Carolina in 1907: *a*, Female fly; *b*, dorsal view of abdomen of male; *c*, hypopygium of male, lateral view. Enlarged. (Original.)

Davis reared this species at Lafayette, Ind., from *Aphis medicaginis*, also in 1911. This species may in future be found to attack Toxoptera also.

Lace-Wing Flies.

The lacewing fly *Chrysopa plorabunda* Fitch was quite abundant in the grain fields in the Southwest in 1907 and without doubt assisted materially in the destruction of Toxoptera. This is the most common species in this section of the country, where it hibernates in the adult stage; thus, whenever the weather becomes suitable it is ready to at once begin oviposition. An allied species is shown in figure 46.

The larvæ of these insects can move about quite freely and are provided with two long, curved mandibles (see fig. 46) upon which

plant-lice or other insects are impaled and held prisoners until they are sucked dry. They are then released and the *Chrysopa* larvæ hunt other victims.

Cecidomyiidæ.

During September of 1909, at Lafayette, Ind., a new predaceous insect enemy to Toxoptera was discovered in the larvæ of a little cecidomyiid or two-winged fly, determined tentatively for us as *Aphidoletes* sp. by Dr. E. P. Felt. It was first observed in one of the stock cages and afterwards it was found to be reproducing in the fields on *Myzus persicæ*.

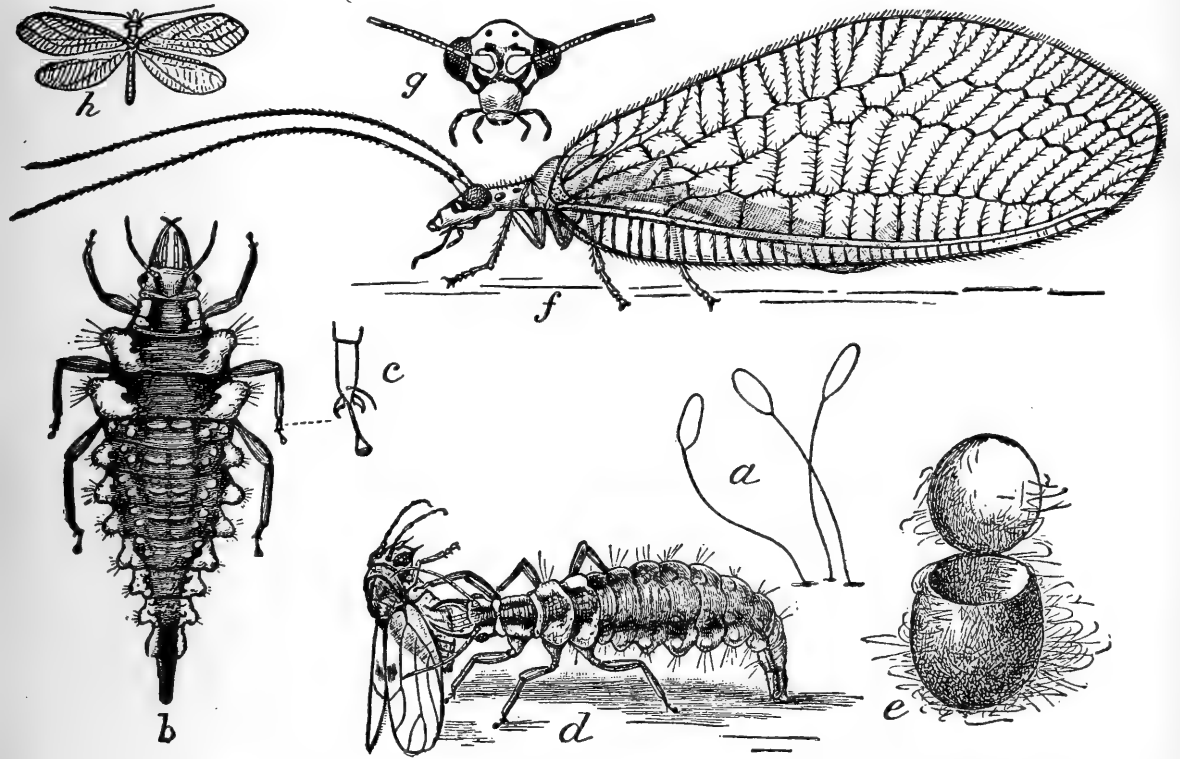


FIG. 46.—The golden-eyed lace-wing fly (*Chrysopa oculata*), an enemy of the spring grain-aphis. a, Eggs; b, full-grown larva; c, foot of same; d, larva devouring an insect; e, cocoon; f, adult insect; g, head of same; h, adult, natural size. All enlarged except h. (From Marlatt.)

We have not as yet carefully studied the life history of *Aphidoletes* sp. The adult fly (fig. 47) is a frail little creature, about the size of the clover-seed midge, pale cream in color, and the abdomen has a pinkish tinge, due to the pink eggs within. The eggs resemble those of the Hessian fly very closely except that they are much smaller. The larvæ (fig. 48), which are pinkish in color, descend to the ground when fully matured, and at or near the surface they spin a loose cocoon, to which particles of dirt and trash adhere. In a few days the adults issue. The time required for this little insect to complete the entire life cycle is apparently about 10 to 14 days. The species is not determinable further than the genus for the reason that only the female adults have been secured.

This little fellow goes about getting its meals in a very quiet, unobtrusive sort of way. It crawls quietly up among a number of Toxoptera and the first one it touches becomes its victim. It attaches its mouthparts to some joint of the legs, usually at the articulation of the femur and tibia, and sucks out the juices of the aphidid. With a compound microscope the blood can readily be seen flowing in a constant stream, through the limb of the aphidid attacked, into the larva of the cecidomyiid. Rarely is the aphid disturbed and upon close observation the skin of the aphidid will be seen to

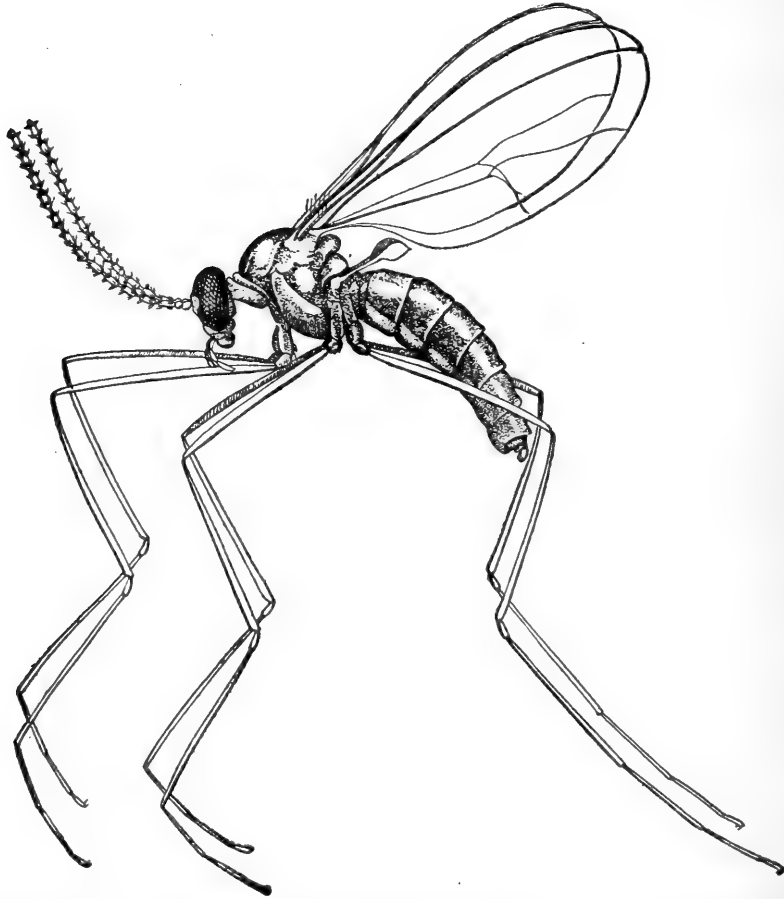


FIG. 47.—*Aphidoletes* sp., cecidomyiid fly whose larvæ feed upon the spring grain-aphis. Greatly enlarged. (Original.)

gradually shrivel up; finally nothing but the empty skin remains and the larva crawls away in search of more aphidids, frequently with the old empty aphidid skin adhering to it. The time required to consume the juices of an aphidid varies with the size of the larva and of the aphidid. A larva that is about full grown can dispatch a small aphidid in a few minutes, while from 15 to 30 minutes are required for it to empty a full-grown one. These cecidomyiid larvæ have enormous appetites and apparently keep up their work of destruction almost constantly until they become full grown.

It is not at all impossible for this insect to become a very important factor in the control of Toxoptera, as the adults are capable of flight and deposit large numbers of eggs.

Birds.

Birds devour immense numbers of the spring grain-aphis. Miss Margaret Morse, of Clark University, has been kind enough to conduct some experiments for us in feeding Toxoptera to quail. She has learned that they are very fond of the aphidids and estimates that about 5,000 individual Toxoptera were eaten by a single quail in one day, preference being shown for those that were unparasitized.

Mr. W. L. McAtee, of the Biological Survey of the United States Department of Agriculture, made some special studies of the aphis-eating habits of some of our birds in March-April, 1909, at Winston-Salem, N. C., at the time Toxoptera was so destructive in that vicinity. He states that in a wheat field of about

100 acres there were over 3,000 birds present daily; sometimes the number ran as high as 8,000 to 9,000. So large a number of birds would be found in the fields only during migration, and even at that time the presence of so many indicates that they were attracted to the fields by the abundant food. In so far as could be ascertained, about nine-tenths of the birds were feeding upon aphidids (including *Toxoptera graminum*, *Macrosiphum granaria*, and *Aphis avenæ*), some taking as many as 180 at a single meal. These aphidids are very small, soft-bodied insects and many meals would be required by a bird in a single day to satisfy its hunger. The average number per meal was at least 50, and we may assume that 6 times this number were taken per day. On this basis the number of aphidids destroyed by birds on the farm daily during the migration season is 90,000. Below is a partial list of the species Mr. McAtee found devouring Toxoptera at Winston-Salem. A complete list can not be given at this time, since his studies are not yet finished; many species will undoubtedly be added.

Goldfinch (*Astragalinus tristis*).

Vesper sparrow (*Poæcetes gramineus*).

Savanna sparrow (*Passerculus sandwichensis savanna*).

Chipping sparrow (*Spizella socialis*).

Song sparrow (*Melospiza melodia*).

All of these birds occur over the entire South.

MISCELLANEOUS ENEMIES OF TOXOPTERA.

Under the head of miscellaneous enemies may be considered enemies that are of very slight economic importance; those, in other words, that have been observed occasionally attacking Toxoptera.

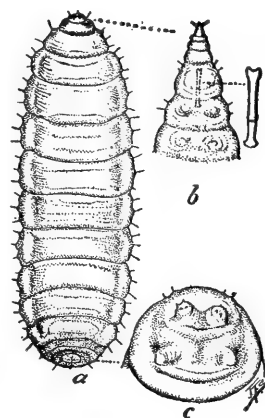


FIG. 48.—*Aphidoletes* sp., cecidomyiid larva which attacks the spring grain-aphis. *a*, Larva; *b*, anterior extremity protruded, showing breastbone; *c*, ventral view of posterior segment. *a*, Much enlarged; *b*, *c*, greatly enlarged. (Original.)

In 1890 the senior author, at Lafayette, Ind., found that the young of the snowy tree-cricket (*Æcanthus niveus* De G.) were very fond of Toxoptera and fed upon them freely.

Mr. A. N. Caudell, of this bureau, observed one of the soldier bugs, *Reduviolus fesus* L., attacking Toxoptera on the grounds of the Department of Agriculture at Washington in 1908. During the same year Mr. C. N. Ainslie found a larva of a species of the ladybird genus *Scymnus* at Mesilla Park, N. Mex., attacking Toxoptera, and he seems to think that numbers are devoured by this insect.

In 1909, at Washington, D. C., Mr. R. A. Vickery reared the braconid *Lipolexis piceus* Cress. in limited numbers from Toxoptera.

The junior author has at times found a fungous disease attacking the aphidids in his rearing cages, but we have never noted this in the fields.

ANTS AND THEIR RELATION TO TOXOPTERA.

So far as our observations go Toxoptera is not so attractive to ants as are many other species of plant-lice. We have often found various species of ants in attendance on Toxoptera, but the relations did not appear to be mutually beneficial, the ants nearly always gaining the most by such partnerships.

At Hooker, Okla., in 1907, the junior author found ant burrows beside plants in an area badly infested with Toxoptera. In this case some burrows were found where the aphidids were slightly below ground on plants in these burrows, the ants being busy about the aphidids, stroking them with their antennæ. Mr. C. N. Ainslie many times observed ants stroking Toxoptera with their antennæ. We have found no instances, however, in which ants care for the eggs of Toxoptera in winter, and Toxoptera does not appear to excrete so much honeydew as do some other aphidids. This probably accounts for the fact that they are not so popular with the ants as are certain other aphidids.

In Texas, during 1909, Mr. T. D. Urbahns found ants busily caring for Toxoptera in his rearing cages. He also noted that the ants always attacked the parasite of Toxoptera (*Aphidius* sp.) whenever they came in contact with it, tearing the larvæ out of the old dead bodies of Toxoptera and destroying them.

REMEDIAL AND PREVENTIVE MEASURES.

With an outbreak of this pest fully established, and the winged adults being carried by the winds and scattered over the fields, there to settle down and reproduce, the difficulties in the way of control are quite insurmountable.

FIELD EXPERIMENTS.

The brush-drag experiments that were carried out under the direction of the junior author at Hobart, Okla. (see Plate IX, fig. 1), have not, with the trials we have given the brush drag, proved satisfactory, although Mr. Thos. J. Anderson, Government entomologist of British



FIG. 1.—BRUSH DRAG USED BY THE JUNIOR AUTHOR IN EXPERIMENTS AND ALSO BY FARMERS IN DESTROYING THE SPRING GRAIN-APHIS IN THE FIELDS AT HOBART, OKLA. (ORIGINAL.)



FIG. 2.—ROLLER USED IN EXPERIMENTS BY JUNIOR AUTHOR AND BY FARMERS IN DESTROYING THE SPRING GRAIN-APHIS IN OKLAHOMA. (ORIGINAL.)



East Africa, states that it is with them the most effective measure at their command for destroying the "green fly" in wheat fields. With us it was used after the aphidid had fully established itself and was literally swarming over the growing grain. Earlier, at the commencement of an outbreak, the effect of its use might prove more satisfactory.

Similar experiments were carried out with a heavy roller, such as is generally used among farmers for crushing clods in fields and compacting the ground. (See Pl. IX, fig. 2). In this case the results were even less satisfactory than with the brush drag, because the roller acted only on the clods and other inequalities in the surface of the ground. Where the wheat had been drilled the effect on the *Toxoptera* was less decisive than where the grain had been sown broadcast. The wheat plants grow in the narrow furrows or grooves and the insects that were displaced dropped down about the plants and the passing roller struck only the ridges, leaving the insects practically untouched.

Where the invasion is not chiefly from outside the field itself, and the pest makes its first appearance in spots, management is less difficult. By plowing under these infested spots and immediately harrowing and rolling them further damage may be effectually prevented. The junior author had an opportunity to test this measure in western Oklahoma. Covering these spots with straw, where easily obtainable, and burning, is equally effective, but where this last measure was applied by farmers in Oklahoma in 1907 the fields were so completely overrun from the outside that the good effects were entirely obliterated.

As between these two methods of suppression, it must be borne in mind that while the seriously affected spots in a field are very small, a single load of straw will suffice to cover a number of them, preparatory to burning, but after these areas become enlarged it is much more practicable to plow them under.

Besides the above-mentioned methods of control, experiments were conducted with different kinds of spray materials. In all of our control methods we endeavored to place ourselves in the position of the farmer, and to use such apparatus as could be obtained locally. Accordingly the junior author, upon reaching Hobart, Okla., the first week in April, 1907, prepared to begin some spraying experiments. The only spray apparatus that could be found in the town was a knapsack pump. As stated above, since an outbreak of *Toxoptera* starts in small areas, where the infestation originates within the field, it was thought possible to accomplish something by spraying these areas. As the infestation at Hobart seemed to be quite general, apparently originating from migrations from farther south and east, the small pump was found to be utterly useless. From here the junior author proceeded to Kingfisher, Okla., where there were clearly defined areas of infestation, and, together with

Mr. C. N. Ainslie, began experiments with a barrel pump, loaned by a market gardener. One plat was sprayed with 5 per cent kerosene emulsion; another with 10 per cent kerosene emulsion; a third plat with ordinary hard soap, 1 pound to 4 gallons of water; a fourth plat with whale-oil soap, 1 pound to 6 gallons of water. The spraying was done carefully, so as to reach every aphid possible. Upon examination the next day it was found that the 10 per cent emulsion and the hard soap had injured the plants. Not more than 50 per cent of the plant-lice were killed in any of the experiments. On the 15th of April the sprayings were repeated with similar results. All of the aphidids could not be reached, no matter how thoroughly the spraying was done. It was quite evident that unless the ground was almost soaked there would be little or no relief. These sprayings cost at the rate of about \$4 per acre.

During the latter part of July it was found that *Toxoptera* was very abundant on the lawns of the Department of Agriculture at Washington, D. C. This outbreak became known to Mr. E. M. Byrnes, Superintendent of Experimental Gardens and Grounds, who at once had the entire infested block sprayed with a solution of one-half gill of blackleaf tobacco extract to each gallon of weak soapsuds. The application was, however, ineffective. Four days later a strip through this plat was thoroughly saturated with a strong solution of barnyard manure, made by soaking the manure in water. While there was no evidence that this killed any of the "green bugs," after nine days the pest was visibly less on this area than where the application of manure solution was not made.

A series of experiments was then undertaken under the senior author's direction by Mr. E. O. G. Kelly, as follows:

Tobacco dust was applied at rates of one-fourth, one-half, and 1 pound to each 100 square feet, but after over a week had elapsed from the date of application no effect was to be observed and no dead insects were found.

Kerosene emulsion was applied at 8 and 10 per cent strengths, and at the end of nine days no "green bugs" were to be found on the areas so treated. Also there was no perceivable injury to the grass.

Whale-oil soap solutions, varying in strength from one-fourth of a pound to 2 pounds of soap to each 5 gallons of water, were applied to similar areas. In this case the stronger solution injured the grass slightly, but not permanently; in the case of the lesser strengths there was no injury to the grass whatever. The effect on the "green bug" was the same in every case. They were not only literally exterminated over the areas treated, but the applications seemed to protect from a reinfestation, in case of even the weakest solution. An examination five days after the application was made revealed the "green bugs" in myriads and breeding freely on the untreated space, while only 8 inches away and on the treated area living bugs were

scarcely to be found, although the dead bugs were to be observed almost as abundantly as were the living on the space untreated. It must be remembered, however, that these experiments were carried out in grass kept closely cropped by frequent use of the lawn mower, and such areas can be sprayed much more effectively than a wheat field, where the ground would have to be literally soaked in order to reach all of the aphidids.

In the light of these experiments field spraying seems an impractical measure, even when small areas are involved. Burning or plowing would probably be more effective and the recommendations would probably be more readily complied with, as the average farmer does not usually have spray pumps of any description.

Lime and sulphur was dusted on the plants in badly infested areas with practically no benefits.

CULTURAL METHODS.

Examination of a large number of fields infested by Toxoptera, extending over a wide range of country, resulted in securing a considerable mass of information that may be included under the head of cultural methods.

The senior author visited Sumter, S. C., April 17, 1907, driving over much of the country in that vicinity. All fields of fall-sown oats, the only grain grown, were infested, there being no perceivable difference in severity of attack between fields following cotton, those following oats, and those on new ground, thus showing that the pest had swept over the country, diffusing itself generally.

At Winston-Salem, N. C., April 19-20, where both wheat and fall oats were grown, the ravages of the pest were much more serious, and fall-sown oats were completely ruined. A part of one field that had been in oats the previous year had, that fall, thrown up a heavy growth of volunteer grain, while the remaining portion was free of this growth. Wheat was drilled directly across both these areas on November 15, 1906, the whole field having first been prepared by disking, leaving much of this volunteer grain undisturbed. April 20, 1907, when examined by the senior author, the wheat on the part that had been overgrown with volunteer oats the previous fall was totally ruined, while on the clean part the damage was about 50 per cent. In wheat fields generally there was a marked difference in severity of attack as between those seeded before and those sown after about November 1, 1906, the later-sown suffering little while that sown earlier, on ground where there was much volunteer wheat or oats, was seriously damaged. This indicated that the trouble had been aggravated by the volunteer growth at the time of wheat seeding the previous autumn. It was very significant that in late-sown fields on clean ground the injury was comparatively small.

In Oklahoma it was observed by both the junior author and Mr. C. N. Ainslie that late-sown and pastured fields were destroyed much

more quickly and completely than earlier sown, unpastured fields. But it must be remembered that here the almost universal destruction was caused principally by *Toxoptera* drifting in from outside sources.

One feature of attack by *Toxoptera* has been especially noticeable throughout most portions of the country seriously ravaged by the pest, particularly where only wingless viviparous females have been found. In such fields the destruction was confined to circular areas which constantly increased in size as the season advanced, so long as meteorological conditions favorable to the increase of the pest prevailed; unless, in the meantime, the entire field had become overrun from the swarms drifting in from without. The occurrence of these spots (see Plate I, fig. 2) in the fields, while general, is not universal. For instance, the senior author did not observe them in the fields of fall-sown oats in South Carolina, in April, 1907, but he did find them about Winston-Salem, N. C., a day or two later. At Summers, Ark., Mr. C. N. Ainslie, observed a field of wheat, March 18, 1907, where a rectangular strip at one end had been totally killed out by *Toxoptera*, and learned from the owner that this area exactly corresponded with that of a small patch of oats which the previous year had failed to produce more than a very poor crop and had been plowed under without cutting. In preparing the ground for wheat in the fall of 1906, a volunteer growth of oats was reported to have sprung up on this area after plowing. Again the same observer, a little later in the season, found that the regularity of the occurrence of these spots in rows across a field, in northern Oklahoma, exactly corresponded to the location in this same field the previous summer of oat shocks, which had been allowed to stand out through a period of wet weather; the volunteer grain having sprung up there later in the season and remained growing amongst the young wheat in the fall. In Texas the relation of this volunteer growth in the fields, in autumn and early winter, to the abundance of *Toxoptera* does not appear to differ materially from what is known to occur elsewhere. When the secretary of the Texas Grain Dealers' Association first appealed to the Government for aid in investigating the pest, particular attention was directed to the possibility that methods might be devised for its control by spraying or otherwise treating the spots in grain fields, for the purpose of checking its ravages before these infested spots had increased in size and before the pest had spread from them over the entire field.

Thus it will be seen that primarily infestation is first invited by the volunteer growth starting up in cultivated fields in autumn. If such fields are sown to wheat or oats in the fall, the pest spreads from this earlier growth to the younger and more tender grain. This will of itself suggest several entirely practical cultural methods likely to restrict and prevent the development of the pest in the fields in autumn.

Crop rotation could scarcely fail of giving beneficial results. The destruction of all volunteer grain springing up in fields from which grain has been removed at thrashing gives promise of the greatest relief. Indeed, if careful attention were given to all fields in autumn, and all of this volunteer growth were destroyed before any grain whatever was sown, it is doubtful if such serious ravages as have occurred in the past could be repeated. This can all be accomplished by close pasturing and careful late plowing, followed as soon as possible by seeding.

At Hooker, Okla., the junior author found affected spots both on land that had been devoted to oats the previous year and on land that had previously grown cowpeas. This, as well as some other observations made by other parties, indicates that some of the grasses will have the same effect in inviting attack as volunteer grain growing up in the fields in the fall.

It is therefore most urgently recommended, and especially for the South, that all of this volunteer growth of whatever nature be completely killed out in the fields before seeding the following crop. Not only will this mode of procedure benefit especially the southern grain grower, but in the light of our present knowledge of the pest, it will serve as a protection to the spring oats crop over a large area of country where it is doubtful if serious ravages would occur at all were there not myriads of the pest continually developing to the South and drifting northward in spring with the advance of the season.

Following along the same line, attention should be directed to the probability that late seeding may prove a preventive of attack, for the reason that the pest will obviously gain less of a foothold in a late-sown field than it will where there has been an early growth of young grain plants. In other words, there is a likelihood that the pest may break out in spots, as has been several times previously noted, and to this extent late seeding is an advantage. However, this would be a serious disadvantage if the fields should afterward be overrun by hordes of migratory winged viviparous females in spring, for in this case the earlier sown and therefore the older and less succulent growth would suffer least from their attack. This is shown by the fact that late-sown and winter-pastured fields in Oklahoma suffered most in 1907. It must also be noted that at Winston-Salem, N. C., in April 1, 1907, wheat that had been sown about or a little prior to November 15, on ground free from young growth of volunteer grain, or the grasses, was practically uninfested even though located in the immediate vicinity of other badly infested fields sown earlier on ground more or less foul with young growth. All of this indicates pretty clearly that if all volunteer growth were eliminated in the fall, and the grain sown late, the pest would not become destructive. Of course the amount of benefit secured will depend upon the uniformity with which this method is carried into effect in any locality.

Over the northern part of the country where the insect passes the winter largely or wholly in the egg state, another measure can be applied to great advantage. The junior author has found that blue grass (*Poa*) is not only a summer food plant, but that it is very largely upon this grass that the eggs are deposited in the fall, and from which the offspring of the stem mothers make their way to the grain fields in spring. He has observed cases where the portion of a grain field bordered by bluegrass was the most seriously affected part of the entire field. If, then, roadsides, fence corners, and other waste lands were closely grazed in fall, winter, or early spring, these eggs would be largely destroyed and the food supply of the stem mother and her progeny cut off. This can always best be done during mild winters on account of a lack of snow. Where close pasturing is not practicable, burning over during the same season will have a similar if not an even more drastic effect.

ARTIFICIAL INTRODUCTION OF PARASITES.

As *Aphidius testaceipes* destroyed such hordes of *Toxoptera* in apparently very short periods of time, after they had once become established, we thought it possible materially to aid in this destruction by introducing the parasites artificially into localities where they were apparently absent. As Mr. C. N. Ainslie was unable to find any evidence of parasitization in the fields about Wellington, Kans., on April 1, 1907, it was decided to begin operations there. Accordingly, on April 9, over a bushel of wheat leaves that were almost covered with parasitized *Toxoptera* were collected at Kingfisher, Okla. Mr. Ainslie took charge of this material, and on April 10, made a careful survey of the fields about Wellington, Kans., to determine the situation relative to *Toxoptera* infestation, and on the morning of April 11 he scattered a portion of this material in one of the most badly infested fields that could be found in that vicinity, the remainder being left sheltered by the box lids. At this time he could find parasitized *Toxoptera* already in the fields, both the dead leathery bodies and those showing the characteristic yellow color. The parasites included in this introduction were roughly estimated at 2,500,000; this number, however, was probably not a "drop in the bucket" to those already in the field. If there were only one or two parasitized *Toxoptera* to a leaf, when a whole field is considered 2,500,000 would seem to be a very small number. So far as published records show this was the first artificial introduction of parasites into Kansas.

April 12 another lot of parasitized material, sent Mr. Ainslie by the junior author from Kingfisher, which was fully as large as the previous consignment, was introduced into another field 2 miles from the first. All of this material, originally intended for one field, was reported as one experiment by the junior author and appeared as one experiment in Circular 93, since Mr. Ainslie's notes were not on file in the office at the time. We find, however, that Mr. Ainslie,

on his own initiative, conducted two separate experiments, thus rendering the results twice as valuable.

April 18 a minor introduction of parasites was made at McPherson, Kans., and on April 21 there was another similar one at Sterling, Kans. Parasitized "green bugs" were observed present at each place on these dates.

Mr. Ainslie remained in the vicinity of Wellington, and more briefly at McPherson and Sterling, for the purpose of making accurate observations on the effect of these introductions.

Two weeks later, on visiting the two fields at Wellington, where the first introduction had been made, Mr. Ainslie found that on account of the cold weather the effect upon the parasites was almost the same as though they had been kept in cold storage. Some of those sheltered by the box lids had issued, but had apparently not ventured far from their shelter and were found in a semitorpid condition capable of little movement. The percentage of parasitism from *Aphidius* appeared to be the same in all other fields in this locality, irrespective of these introductions, except close about the box lids, where they seemed a little more numerous, the conditions of parasitization generally being about the same as had existed two weeks previous. The Toxoptera, however, had greatly increased in numbers, and the fields were now plainly showing the effects of their work.

Subsequent examinations of fields at Wellington showed that after the weather warmed up in May the parasites speedily overcame the Toxoptera and that the fields where these artificial introductions were made had suffered as much as any fields in the neighborhood from attack by the "green bug." All of this seems to indicate that no noticeable good resulted from these introductions, which, in the light of our present knowledge, is not at all surprising. The minor experiment at McPherson was also reported upon to us by Mr. W. Knaus, and his report was in accord with our own observations.

On May 17 an artificial introduction of parasites was begun at Manhattan, Kans.¹ While this experiment bore out our former observations, the results obtained here should not bear as much weight as the earlier introductions, since the Toxoptera was already nearly overcome when the introduction was begun.

When one stops to consider the numerous and varied hosts of *Aphidius testaceipes*, its manner of hibernation, its wide distribution, and the higher temperature required for its development over and above that needed by its host; also the fact that it may readily be transported along with its host as adults, or within the body of the latter, one can readily see the futility of attempting materially to increase its numbers or efficiency by artificial introduction into grain fields.

¹ Cir. 93, Bur. Ent. U. S. Dept. Agr., pp. 10-12, Aug. 22, 1907; Cir. 93, revised, Bur. Ent., U. S. Dept. Agr., pp. 12-13, June 23, 1909.

LITERATURE CONSULTED.

- ALDRICH, J. M.—Catalogue of North American Diptera.
 ALDRICH, J. M.—Cultivator and Country Gentleman, vol. 47. p. 498, June, 1882.
 ASHMEAD, WM. H.—Proc. U. S. Nat. Mus., vol. 11, 1888.
 BIRO, LAJOS.—Rovartani Lapok, vol. 2, p. 127, 1885.
 BUCKTON, G. B.—British Aphides, vol. 1, p. 80.
 BUCKTON, G. B.—British Aphides, vol. 3, pp. 135-136.
 DEL GUERCIO, GIAC.—Nuove relazioni ai lavori della R. Stazione di Entom. Agraria di Firenze, ser. 1, no. 2, pp. 144-145, 1900.
 HEGNER, R. W.—Biol. Bul., vol. 16, no. 1, pp. 19-26, 1908.
 HEGNER, R. W.—Journ. Morph., vol. 20, pp. 231-296, 1909.
 HORVATH, G.—Rovartani Lapok, vol. 1, p. 143, 1884.
 HORVATH, G.—Fauna Regina Hungarie, vol. 3 (Insecta Hemiptera), p. 60, 1897.
 HOWARD, L. O.—Ent. News, vol. 19, no. 8, pp. 365-367, 1908.
 HUNTER, S. J.—The green bug and its enemies, Bul. Univ. Kans., vol. 9, no. 2, 1909.
 HUXLEY, T. H.—Trans. Linn. Soc., vol. 22, pt. 3, p. 215, 1858.
 KELLY, E. O. G.—Proc. Ent. Soc. Wash., vol. 10, nos. 3-4, pp. 163-164, 1908.
 KELLY, E. O. G.—Proc. Ent. Soc. Wash., vol. 11, pp. 64-66, 1909.
 LECAILLON, A.—Contribution à l'étude des premiers phénomènes du développement embryonnaire chez les insectes, particulièrement chez les Coléoptères. Archives D'Anatomie Microscopique, tome 1, 1897.
 LECAILLON, A.—Recherches sur le développement embryonnaire de quelques Chrysomélides. Archives D'Anatomie Microscopique, tome 2, 1898.
 MACCHIATI, LUIGI.—Bol. Soc. Ent. Ital., vol. 14, p. 246, 1882.
 MANNS, THOS. F.—Bul. 210, Ohio Agr. Exp. Sta., 1909.
 MAXWELL-LEFROY, H.—Agricultural Journal of India, vol. 3, pt. 3, pp. 243-244, 1908.
 MAZZANTI, DR. DOM LUIGI.—Nuov. Ann. Sci. Nat. Bologna, ser. 3, vol. 6, pp. 342-352, 1852.
 PASSERINI, GIOVANNI.—Gli afidi (pamphlet), p. 25, 1860.
 PERGANDE, THEO.—Bul. 38, Div. Ent., U. S. Dept. Agr., pp. 7-19, 1902.
 PHILLIPS, W. J.—Proc. Ent. Soc. Wash., vol. 10, nos. 1-2, pp. 11-13, 1908.
 RILEY, C. V.—Rept. U. S. Dept. Agr. for 1889.
 RILEY, C. V., and HOWARD, L. O.—Insect Life, vol. 3, pp. 73-76, 1890.
 RONDANI, CAMILLO.—Nuov. Ann. Sci. Nat. Bologna, ser. 2, vols. 8, 9, 1847.
 RONDANI, CAMILLO.—Nuov. Ann. Sci. Nat. Bologna, ser. 3, vol. 6 (2), pp. 9-12, 1852.
 SAJO, KARL.—Zeitschr. f. Pflanzenkrankheiten, vol. 4, p. 4, 1894.
 SAJO, KARL.—Prometheus, vol. 1, 1889 (1890).
 SCHOUTEDEN, H.—Mem. Soc. Ent. Belg., vol. 12, p. 231, 1906.
 SETTERMAN, G. W.—Colman's Rural World, vol. 53, p. 193, 1890.
 STAHL, J. M.—Country Gentleman, vol. 55, p. 639, 1890.
 TANNREUTHER, G. W.—History of the germ cells and early embryology of certain aphids. Zoologische Jahrbucher, Band 24, Heft 4, 1907.
 WASHBURN, F. L.—Can. Ent., vol. 40, pp. 53-54, February, 1908.
 WASHBURN, F. L.—Special Report of the State Entomologist of Minnesota, March 1, 1908.
 WASHBURN, F. L.—Weather Crop Bul. Mo. State Bd. Agr., 1890.
 WEBSTER, F. M.—Insect Life, vol. 4, pp. 245-248, 1892.
 WEBSTER, F. M.—Cir. 93, Bur. Ent., U. S. Dept. Agr., 1907.
 WEBSTER, F. M.—Cir. 93, revised, Bur. Ent., U. S. Dept. Agr., 1909.
 WEBSTER, F. M.—Proc. Ent. Soc. Wash., vol. 9, pp. 110-114, 1907.
 WEBSTER, F. M.—Ann. Ent. Soc. Amer., vol. 2, no. 2, pp. 67-87, 1909.
 WEED, C. M.—Ohio Farmer, vol. 78, no. 3, p. 33, July 19, 1890.
 WHITE, GILBERT.—Natural history and antiquities of Selbourne, pp. 365-366, 1836.
 WILL, LUDWIG.—Entwicklungsgeschichte der viviparen Aphiden. Zool. Jahrb. Abth. f. Anat., Bd. 3, pp. 201-286, 1888.
 WITLACZIL, EM.—Entwicklungsgeschichte der Aphiden. Zeitschr. f. Wiss. Zool., Bd. 40, 1884.

INDEX.

	Page.
Abutilon, food plant of <i>Macrosiphum</i> sp.....	117, 125
<i>Adalia flavomaculata</i> , enemy of spring grain-aphis.....	18, 129
<i>Agropyron occidentale</i> , food plant of spring grain-aphis in America.....	32, 41, 42, 43
<i>repens</i> , food plant of spring grain-aphis in America.....	42, 43
Europe.....	41, 43
<i>tenerum</i> , food plant of spring grain-aphis in America.....	42, 43
Alfalfa. (See <i>Medicago sativa</i> .)	
<i>Allograpta obliqua</i> , enemy of <i>Macrosiphum granaria</i>	132
probable enemy of spring grain-aphis.....	132
<i>Allotria</i> sp., hosts.....	128
in bluegrass infested by spring grain-aphis at Washington, D. C..	37
secondary parasite of spring grain-aphis.....	128
<i>Alopecurus geniculatus</i> , food plant of spring grain-aphis in America.....	41, 43
<i>Ampelopsis</i> sp., food plant of aphidid.....	116, 125
<i>Andropogon hirtus</i> , food plant of <i>Toxoptera graminum</i> in Africa.....	43
<i>Andropogon</i> sp. (See Sorghum.)	
Ants, enemies of <i>Aphidius</i> sp.....	136
spring grain-aphis.....	136
<i>Aphelinus mali</i> , hosts.....	122, 125
parasite of spring grain-aphis.....	103, 122-123, 125
<i>nigritus</i> , life history and habits, notes.....	124
parasite of <i>Aphis setarix</i>	125
spring grain-aphis.....	103, 122, 123, 124, 125
<i>semiflavus</i> , hosts.....	125
parasite of spring grain-aphis.....	103
sp., probable host of <i>Aphidencyrthus aphidiphagus</i>	126
<i>Pachyneuron</i> sp.....	127
<i>Aphidencyrthus aphidiphagus</i> , hosts.....	126-127
secondary parasite of spring grain-aphis.....	126-127
Aphidid on <i>Ampelopsis</i> sp., host of <i>Aphidius testaceipes</i>	116, 125
<i>Baccharis viminalis</i> , host of <i>Aphidius testaceipes</i>	117, 125
bluegrass, host of <i>Aphelinus semiflavus</i>	123
<i>Capsella</i> sp., host of <i>Aphidius testaceipes</i>	116
<i>Chenopodium album</i> , host of <i>Aphidius testaceipes</i>	116
<i>Eragrostis</i> sp., host of <i>Aphidius testaceipes</i>	117, 125
<i>Kochia scoparia</i> , host of <i>Aphidius testaceipes</i>	116
sp., host of <i>Aphidius testaceipes</i>	125
locust, host of <i>Aphidius testaceipes</i>	116, 125
<i>Panicum</i> sp., host of <i>Aphelinus mali</i>	123
peach, host of <i>Aphidius testaceipes</i>	125
pigweed (?), host of <i>Aphidius testaceipes</i>	125
plum, host of <i>Aphidius testaceipes</i>	116, 125
<i>Aphidius avenaphis</i> , parasite of <i>Macrosiphum granaria</i>	125
spring grain-aphis.....	103, 122

	Page.
<i>Aphidius confusus</i> , parasite of <i>Macrosiphum erigeronensis</i>	125
spring grain-aphis	103, 122
sp., parasite of spring grain-aphis.....	18
prey of ants.....	136
probable host of <i>Allotria</i> sp.....	128
<i>Aphidencyrthus aphidiphagus</i>	126
<i>Megorismus</i> sp.....	126
<i>Pachyneuron</i> sp.....	127
<i>testaceipes</i> , artificial introduction against spring grain-aphis, futility. 142-143	
description.....	104-105
dispersion, effect of wet weather thereon.....	121
influence of winds thereon.....	118-119
effect of parasitism upon development of host.....	106-107
fecundity of host.....	107-109
fecundity.....	113-114
hibernation.....	117-118
hosts.....	115-117, 125
identity.....	104-105
larva, movement within host and manner of attaching it	
to plant.....	109-113
life history.....	105-118
oviposition.....	105-106
parasite of spring grain-aphis.....	40, 103, 104-121
parthenogenesis.....	114-115
period from egg to adult.....	106
synonyms.....	104
temperature influences.....	119-121
undescribed species, parasite of <i>Toxoptera graminum</i> in Africa.....	122
<i>Aphidoletes</i> sp., enemy of <i>Myzus persicae</i>	133
spring grain-aphis.....	133-134
<i>Aphis avenae</i> , <i>Allotria</i> sp. a secondary parasite.....	128
host of <i>Aphidius testaceipes</i>	116, 117, 125
prey of birds.....	135
<i>Eupeodes volucris</i>	130
<i>brassicæ</i> , <i>Allotria</i> sp. a secondary parasite.....	128
<i>Aphidencyrthus aphidiphagus</i> a secondary parasite.....	127
host of <i>Aphelinus mali</i>	123, 125
<i>Aphidius</i> other than <i>Aphidius testaceipes</i>	116
<i>Megorismus</i> sp. a secondary parasite.....	126
currant. (See <i>Myzus ribis</i> .)	
<i>gossypii</i> , <i>Allotria</i> sp. a secondary parasite.....	128
host of <i>Aphidius testaceipes</i>	116, 117, 125
<i>Pachyneuron</i> sp. a secondary parasite.....	127
(?), host of <i>Aphelinus semiflavus</i>	125
<i>graminum</i> = <i>Toxoptera graminum</i>	16
<i>maidi-radici</i> , host of <i>Aphidius testaceipes</i>	125
males, females, and eggs in North Carolina.....	47
<i>maidis</i> , host of <i>Aphelinus semiflavus</i>	125
<i>Aphidius testaceipes</i>	116, 125
<i>Pachyneuron</i> sp. a secondary parasite.....	127
prey of <i>Baccha clavata</i>	132
<i>medicaginis</i> , host of <i>Aphidius testaceipes</i>	116, 125
prey of <i>Baccha clavata</i>	132

	Page.
<i>Aphis middletoni</i> , host of <i>Aphidius testaceipes</i>	116
<i>monardæ</i> , host of <i>Aphelinus mali</i>	123, 125
<i>ænotheræ</i> , host of <i>Aphidius testaceipes</i>	116, 125
on peach, host of <i>Aphidius testaceipes</i>	117
<i>rumicis</i> , host of <i>Aphidius testaceipes</i>	116, 125
<i>sacchari</i> (?), host of <i>Aphelinus mali</i>	123, 125
<i>setariæ</i> , host of <i>Aphelinus mali</i>	122, 125
<i>nigritus</i>	123, 125
<i>Aphidius testaceipes</i>	116, 125
<i>Pachyneuron</i> sp., a secondary parasite	127
prey of <i>Baccha clavata</i>	132
sp., host of <i>Aphidius testaceipes</i>	125
<i>viticola</i> . (See <i>Macrosiphum viticola</i> .)	
<i>Arrhenatherum elatius</i> , food plant of spring grain-aphis in Europe	41, 43
<i>Astragalinus tristis</i> , enemy of spring grain-aphis	135
<i>Audibertia stochoides</i> , food plant of <i>Macrosiphum</i> sp.	117
<i>Avena barbata</i> , food plant of spring grain-aphis in Europe	41, 43
<i>elatior</i> = <i>Arrhenatherum elatius</i>	41, 43
<i>fatua</i> , food plant of spring grain-aphis in Europe	41, 43
<i>sativa</i> . (See Oats.)	
<i>Baccha clavata</i> , enemy of <i>Aphis maidis</i>	132
<i>medicaginis</i>	132
<i>setariæ</i>	132
<i>Baccharis viminalis</i> , food plant of aphidid	117, 125
Barley, food plant of spring grain-aphis in America	43
Europe	41, 43
"Bermuda grass," food plant of spring grain-aphis in Africa	43
Birds, enemies of <i>Aphis avenæ</i>	135
<i>Macrosiphum granaria</i>	135
spring grain-aphis	135
Black gum. (See <i>Nyssa sylvatica</i> .)	
Bluegrass (see also <i>Poa pratensis</i>).	
food plant of <i>Rhopalosiphum poæ</i>	123
African. (See <i>Andropogon hirtus</i> .)	
<i>Bromus commutatus</i> , food plant of spring grain-aphis in America	42, 43
<i>erectus</i> , food plant of spring grain-aphis in Europe	41, 43
<i>hordeaceus</i> , food plant of spring grain-aphis in Europe	41, 43
<i>inermis</i> , food plant of spring grain-aphis in America	42, 43
<i>maximus</i> = <i>Bromus villosus</i>	41, 43
<i>mollis</i> = <i>Bromus hordeaceus</i>	41, 43
<i>porteri</i> , food plant of spring grain-aphis in America	42, 43
<i>secalinus</i> , food plant of spring grain-aphis in America	41, 42, 43
<i>tectorum</i> (?), food plant of spring grain-aphis in America	42, 43
<i>unioloides</i> , food plant of spring grain-aphis in America	42, 43
<i>villosus</i> , food plant of spring grain-aphis in Europe	41, 43
Brush drag against spring grain-aphis	136-137
Buckwheat. (See <i>Fagopyrum esculentum</i> .)	
Burning-over infested spots against spring grain-aphis	137
pastures against spring grain-aphis	142
<i>Capriola dactylon</i> , food plant of spring grain-aphis in America	42, 43
Europe	43
<i>Capsella bursa-pastoris</i> , food plant of aphidid	116, 125
Cecidomyiidae, enemies of spring grain-aphis	133-134

	Page.
<i>Chxtochloa italica</i> , food plant of spring grain-aphis in America.....	42, 43
<i>viridis</i> , food plant of spring grain-aphis in America.....	42, 43
<i>Chaitophorus</i> sp., host of <i>Aphidius testaceipes</i>	116
<i>Megorismus</i> sp. a secondary parasite.....	126
<i>Pachyneuron</i> sp. a secondary parasite.....	128
<i>viminalis</i> , host of <i>Aphelinus semiflavus</i>	123, 125
Cheat. (See <i>Bromus secalinus</i> .)	
<i>Chenopodium album</i> , food plant of aphidid.....	116
Chess, soft. (See <i>Bromus hordeaceus</i> .)	
<i>Chrysopa plorabunda</i> , enemy of spring grain-aphis.....	132-133
<i>Coccinella abdominalis</i> , enemy of spring grain-aphis.....	129
<i>9-notata</i> , enemy of spring grain-aphis.....	129
<i>Colopha eragrostidis</i> , host of <i>Aphelinus mali</i>	123, 125
Corn, food plant of spring grain-aphis in America.....	41, 43
Europe.....	41, 43
Couch grass. (See <i>Agropyron repens</i> .)	
Cricket, snowy tree. (See <i>Cecanthus niveus</i> .)	
Crop rotation against spring grain-aphis.....	141
Cultural methods against spring grain-aphis.....	139-142
Currant, food plant of <i>Myzus ribis</i>	125
<i>Cynodon dactylon</i> . (See <i>Capriola dactylon</i> .)	
<i>Dactylis glomerata</i> , food plant of spring grain-aphis in America.....	41, 42, 43
Europe.....	41, 43
<i>Distichlis spicata</i> , food plant of spring grain-aphis in America.....	42, 43
Drag. (See Brush drag.)	
<i>Echinochloa crus-galli</i> , food plant of spring grain-aphis in America.....	42, 43
<i>Eleusine indica</i> , food plant of spring grain-aphis in America.....	42, 43
<i>Elymus canadensis</i> , food plant of spring grain-aphis in America.....	41, 42, 43
<i>striatus</i> , food plant of spring grain-aphis in America.....	42, 43
<i>virginicus</i> , food plant of spring grain-aphis in America.....	42, 43
<i>Eragrostis megastachya</i> , food plant of spring grain-aphis in America.....	42, 43
<i>pilosa</i> , food plant of spring grain-aphis in America.....	42, 43
sp., <i>Aphidius testaceipes</i> swept therefrom.....	117
food plant of aphidid.....	117, 125
<i>Eupeodes volucris</i> , enemy of <i>Aphis avenæ</i>	130
spring grain-aphis.....	130
<i>Fagopyrum esculentum</i> , food plant of spring grain-aphis in Europe.....	41, 43
Fescue, hard. (See <i>Festuca duriuscula</i> .)	
meadow. (See <i>Festuca elatior</i> .)	
sheep's. (See <i>Festuca ovina</i> .)	
various-leaved. (See <i>Festuca heterophylla</i> .)	
<i>Festuca duriuscula</i> , food plant of spring grain-aphis.....	42, 43
<i>elatior</i> , food plant of spring grain-aphis in America.....	42, 43
<i>heterophylla</i> , food plant of spring grain-aphis in America.....	43
<i>ovina</i> , food plant of spring grain-aphis in America.....	42, 43
<i>rubra</i> , food plant of spring grain-aphis in America.....	43
Fungous disease of spring grain-aphis.....	136
Grass, Bermuda. (See <i>Capriola dactylon</i> .)	
blue. (See <i>Poa pratensis</i> .)	
couch. (See <i>Agropyron repens</i> .)	
Italian rye. (See <i>Lolium multiflorum</i> .)	
Johnson. (See <i>Sorghum halepense</i> .)	
rye. (See <i>Elymus canadensis</i> .)	

Goldfinch. (See *Astragalinus tristis*.)

Grain-aphis, spring (see also *Toxoptera graminum*).

	Page.
aberrant individuals.....	81
age at which females begin reproducing.....	70-71
ant enemies.....	136
attack, character.....	44
bird enemies.....	135
birth of young.....	63
confusion with <i>Macrosiphum granaria</i>	13, 23
description of different instars.....	58-59
summer forms.....	59-61
diffusion, influence of temperature thereon.....	88-94
winds thereon.....	81
distribution in the eastern hemisphere.....	16-18
western hemisphere.....	18-19
earliest observations in America.....	13-16
early records in Europe.....	16
egg, description.....	95-97
embryology.....	94-103
observations.....	97-102
summary.....	102-103
enemies.....	103-136
miscellaneous.....	135-136
fecundity of oviparous forms.....	81
viviparous female.....	73-75
wingless versus winged females.....	75-76
first generation, fifth instar or adult stem mother, description.....	58-59
first instar, description.....	58
fourth instar, description.....	58
second instar, description.....	58
third instar, description.....	58
food plants.....	41-43
fungous enemy.....	136
generations, number.....	52-57
per year.....	63-70
literature consulted.....	144
longevity.....	72
of sexes.....	80
losses from depredations in 1907.....	39-40
methods and material for embryological studies.....	95
migratory female, description.....	60
molting.....	61-62, 78
number of generations per year.....	63-70
molts.....	61-62
oviparous development.....	78-81
female, description.....	77-78
forms, fecundity.....	81
oviposition, age begun by females.....	78-79
period.....	79-80
place.....	79
outbreak of 1890.....	19-24
1901.....	24

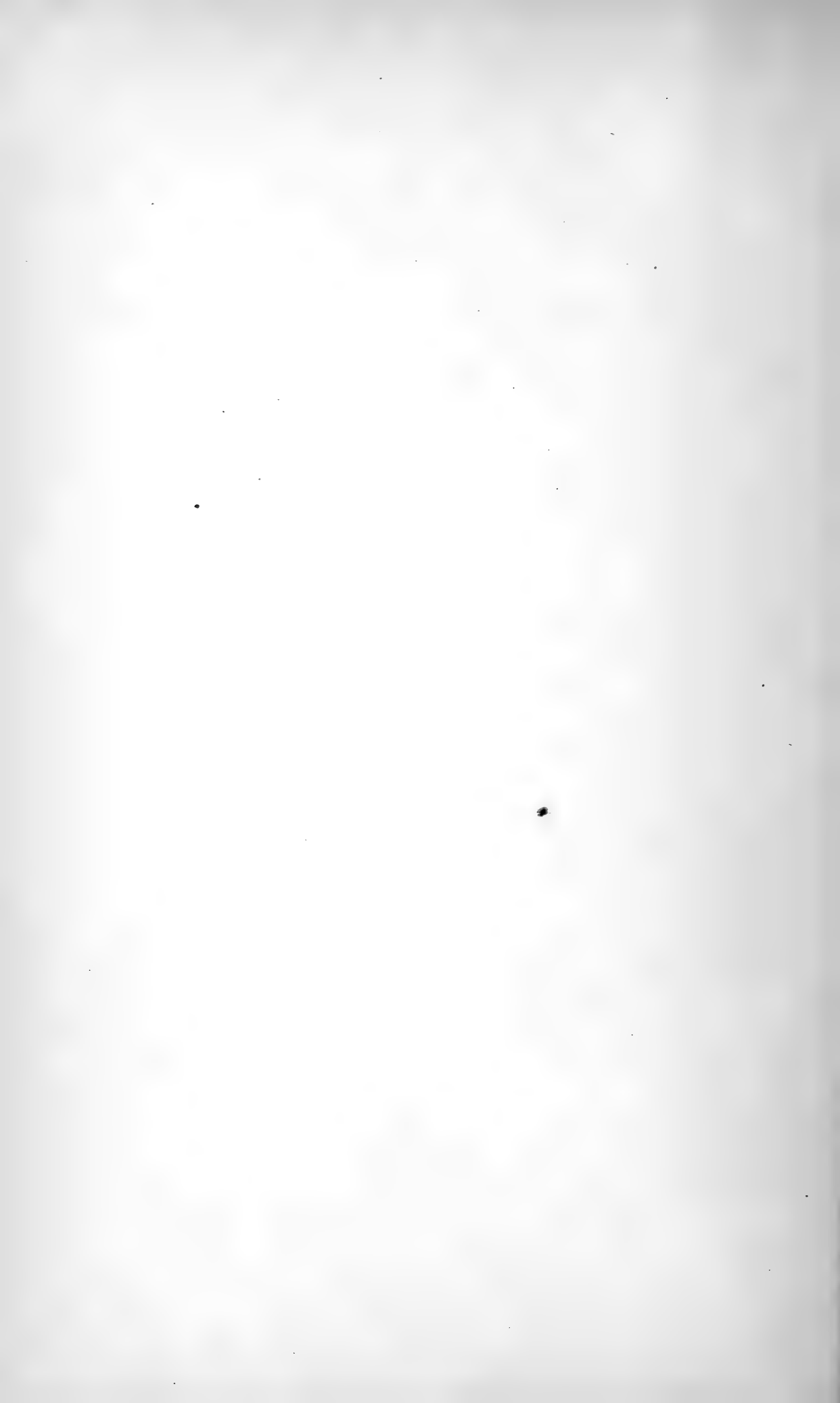
	Page.
Grain-aphis, spring, outbreak of 1903	24-26
1907	27-38
parasites, primary or true.....	104-125
secondary	125-128
predaceous enemies.....	128-136
preventive and remedial measures.....	136-143
pupæ, measurements of antennal joints.....	61
rearing methods.....	51-57
remedial and preventive measures.....	136-143
remedies, artificial introduction of parasites.....	142-143
cultural methods.....	139-142
field experiments.....	136-139
treatment of affected spots.....	140, 141
reproduction, age when begun by females.....	70-71
reproductive period.....	71-72
sexual forms.....	76-78
descriptions.....	77-78
situation in 1911.....	40
stem mothers.....	58
summer forms, first instar, description.....	59
fourth instar, description.....	59
second instar, description.....	59
third instar, description.....	59
viviparous development.....	44-78
in the North.....	49-50
South.....	44-49
female, fecundity.....	73-75
winged male, description.....	78
viviparous female, measurements of antennal joints.....	61
wingless female, description.....	60, 61
versus winged females, fecundity.....	75-76
young produced daily, average number.....	76
Grazing, close, against spring grain-aphis.....	142
"Green bug." (See Grain-aphis, spring.)	
Gum, black. (See <i>Nyssa sylvatica</i> .)	
Harrowing infested spots against spring grain-aphis.....	137
<i>Hippodamia convergens</i> , enemy of spring grain-aphis.....	129
<i>Holcus halpensis</i> , food plant of spring grain-aphis in America.....	43
<i>Hordeum cæspitosum</i> , food plant of spring grain-aphis in America.....	42, 43
<i>jubatum</i> , food plant of spring grain-aphis in America.....	42, 43
<i>murinum</i> , food plant of spring grain-aphis in America.....	42, 43
Europe.....	41, 43
<i>nodosum</i> , food plant of spring grain-aphis in America.....	42, 43
<i>pusillum</i> , food plant of spring grain-aphis in America.....	41, 42, 43
<i>vulgare</i> . (See Barley.)	
<i>Hosackia glabra</i> , food plant of <i>Myzus</i> sp.....	117, 125
<i>Hyalopterus dactylidis</i> , <i>Allotria</i> sp. a secondary parasite.....	128
<i>Megorismus</i> sp. a secondary parasite.....	126
<i>Juncus tenuis</i> , food plant of spring grain-aphis in America.....	42, 43
Kerosene emulsion against spring grain-aphis.....	138
<i>Kochia scoparia</i> , food plant of aphidid.....	116
sp., food plant of aphidid.....	125

	Page.
Lacewing flies, enemies of spring grain-aphis.	132-133
Ladybeetle, convergent. (See <i>Hippodamia convergens</i> .)	
nine-spotted. (See <i>Coccinella 9-notata</i> .)	
spotted. (See <i>Megilla maculata</i> .)	
Ladybeetles, enemies of spring grain-aphis.	128-129
Lime and sulphur against spring grain-aphis.	139
<i>Lipolexis piceus</i> , parasite of spring grain-aphis.	136
Locust, food plant of aphidid.	116, 125
<i>Lolium multiflorum</i> , food plant of spring grain-aphis in America.	43
<i>perenne</i> , food plant of spring grain-aphis in Europe.	41, 43
<i>Lysiphlebus abutilaphidis</i> = <i>Aphidius testaceipes</i>	104
<i>baccharaphidis</i> = <i>Aphidius testaceipes</i>	104
<i>basilaris</i> = <i>Aphidius testaceipes</i>	104
<i>citraphis</i> = <i>Aphidius testaceipes</i>	104
<i>coquilletti</i> (?)= <i>Aphidius testaceipes</i>	104
<i>crawfordi</i> = <i>Aphidius testaceipes</i>	104
<i>cucurbitaphidis</i> = <i>Aphidius testaceipes</i>	104
<i>eragrostaphidis</i> = <i>Aphidius testaceipes</i>	104
<i>gossypii</i> = <i>Aphidius testaceipes</i>	104
<i>minutus</i> = <i>Aphidius testaceipes</i>	104
<i>myzi</i> = <i>Aphidius testaceipes</i>	104
<i>persiaphidis</i> = <i>Aphidius testaceipes</i>	104
<i>persicaphidis</i> = <i>Aphidius testaceipes</i>	104
<i>piceiventris</i> = <i>Aphidius testaceipes</i>	104
<i>tritici</i> = <i>Aphidius testaceipes</i>	37, 104
<i>Macrosiphum cucurbitæ</i> , host of <i>Aphidius testaceipes</i>	117, 125
<i>erigeronensis</i> , <i>Pachyneuron</i> sp. a secondary parasite.	127
<i>granaria</i> , host of <i>Aphidius avenaphis</i>	125
<i>testaceipes</i>	116, 125
in North and South Carolina in 1907.	36
males and oviparous females in rearing cages in Texas.	47
<i>Pachyneuron</i> sp. a secondary parasite.	127
prey of <i>Allograpta obliqua</i>	132
birds	135
<i>Sphærophoria cylindrica</i>	131-132
<i>Syrphus americanus</i>	131
spring grain-aphis mistaken therefor.	13, 23
<i>pisi</i> , <i>Megorismus</i> sp. a secondary parasite.	126
<i>rosæ</i> , host of <i>Aphelinus mali</i>	123, 125
sp. on Abutilon, host of <i>Aphidius testaceipes</i>	125
black gum (<i>Nyssa sylvatica</i>), host of <i>Aphidius testaceipes</i>	116, 125
<i>viticola</i> , <i>Allotria</i> sp. a secondary parasite.	128
host of <i>Aphidius testaceipes</i>	116, 125
<i>Pachyneuron</i> sp. a secondary parasite.	127, 128
Manure against spring grain-aphis.	138
<i>Medicago sativa</i> , food plant of spring grain-aphis in America.	42, 43
<i>Megilla maculata</i> , enemy of spring grain-aphis.	129
<i>Megorismus</i> sp., hosts.	125-126
secondary parasite of spring grain-aphis.	125-126
<i>Melanoxantherium</i> sp., host of <i>Aphidius testaceipes</i>	116, 125
<i>Melospiza melodia</i> , enemy of spring grain-aphis.	135
Millet. (See <i>Chætochloa italica</i> .)	
Japanese. (See <i>Echinochloa crus-galli</i> .)	

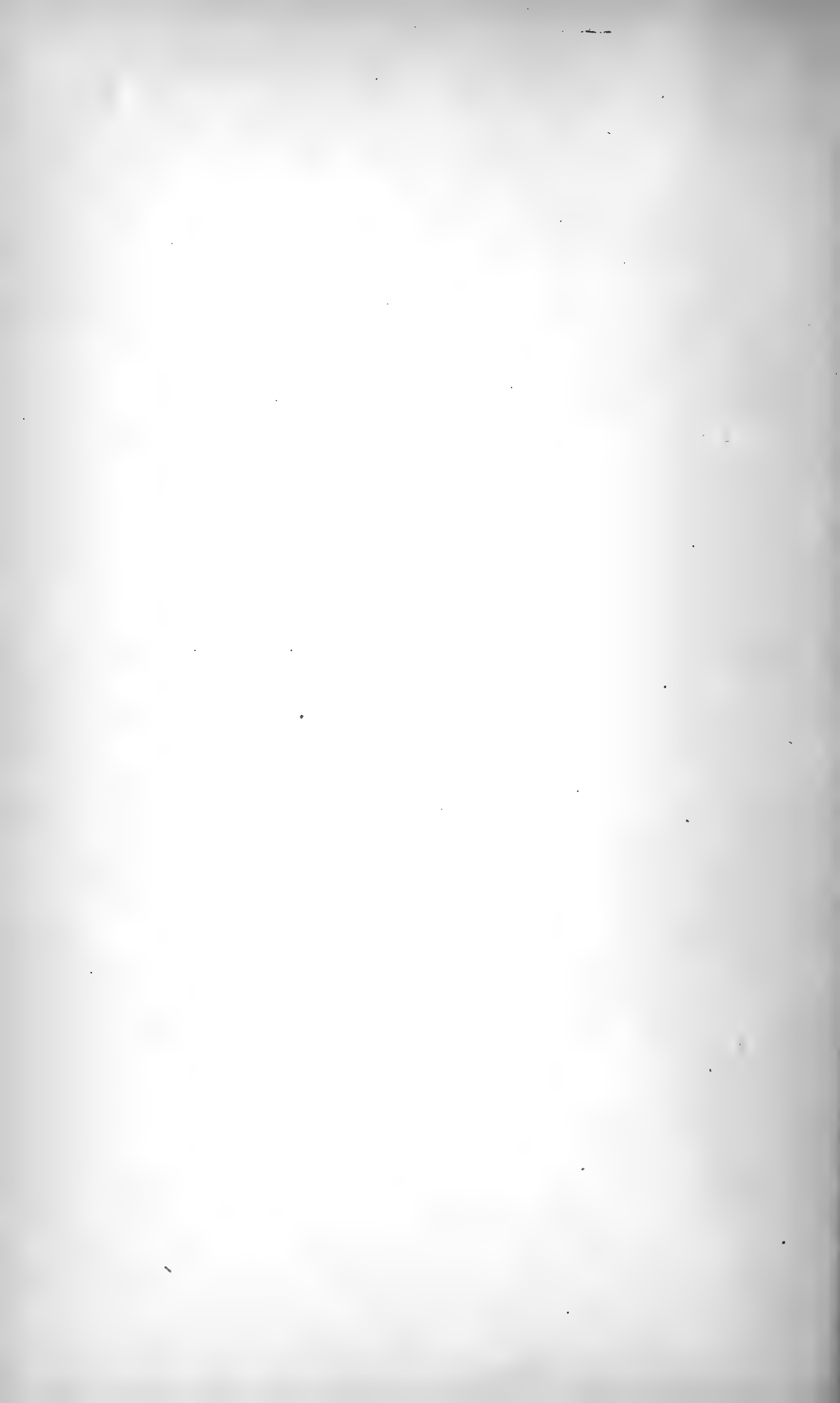
	Page.
<i>Myzus mahaleb</i> , host of <i>Aphelinus mali</i>	125
<i>persicæ</i> , <i>Allotria</i> sp. a secondary parasite.....	128
host of <i>Aphelinus semiflavus</i>	123, 125
<i>Megorismus</i> sp. a secondary parasite.....	126
prey of <i>Aphidoletes</i> sp.....	133-134
<i>ribis</i> , host of <i>Aphidius testaceipes</i>	117, 125
sp. on <i>Hosackia glabra</i> , host of <i>Aphidius testaceipes</i>	117, 125
<i>Nyssa sylvatica</i> , food plant of <i>Macrosiphum</i> sp.....	116
Oats, food plant of spring grain-aphis in America.....	41, 43
Europe.....	41, 43
<i>Æcanthus niveus</i> , enemy of spring grain-aphis.....	136
<i>Oryza sativa</i> . (See Rice.)	
<i>Pachyneuron</i> sp. hosts.....	127-128
probable parasite of <i>Aphelinus</i> sp.....	127
secondary parasite of spring grain-aphis.....	127-128
<i>Panicum</i> sp. food plant of aphidid.....	123
Parasites of spring grain-aphis, artificial introduction.....	142-143
<i>Passerculus sandwichensis savanna</i> , enemy of spring grain-aphis.....	135
Pasturing. (See Grazing.)	
Peach, food plant of aphidid.....	125
<i>Pemphigus fraxinifolii</i> , host of <i>Aphelinus mali</i>	123, 125
Pigweed. (See <i>Chenopodium album</i> .)	
(?), food plant of aphidid.....	125
Plowing-under infested spots against spring grain-aphis.....	137
Plum, food plant of aphidid.....	116, 125
<i>Poa annua</i> , food plant of spring grain-aphis in Europe.....	41, 43
<i>compressa</i> , food plant of spring grain-aphis in America.....	42, 43
<i>pratensis</i> (see also Bluegrass).	
food plant of spring grain-aphis in America.....	42, 43
<i>Polypogon montspeliensis</i> , food plant of spring grain-aphis in America.....	42, 43
<i>Poæcetes gramineus</i> , enemy of spring grain-aphis.....	135
Quail, enemy of spring grain-aphis.....	135
Rains, protracted, effects on diffusion of <i>Aphidius testaceipes</i>	121
<i>Reduviolus ferus</i> , enemy of spring grain-aphis.....	136
<i>Rhopalosiphum poæ</i> , probable host of <i>Aphelinus semiflavus</i>	123
Rice, food plant of spring grain-aphis in America.....	42, 43
Europe.....	41, 43
Rolling against spring-aphis.....	137
Rye, food plant of spring grain-aphis in America.....	41, 43
<i>Schizoneura americana</i> , host of <i>Aphelinus mali</i>	122, 125
<i>Pachyneuron</i> sp. a secondary parasite.....	128
<i>lanigera</i> , host of <i>Aphelinus mali</i>	122, 123, 125
<i>Scymnus</i> sp., enemy of spring grain-aphis.....	136
Seeding, late, against spring grain-aphis.....	141
<i>Siphocoryne avenæ</i> should probably be called <i>Aphis avenæ</i>	47
<i>Siphonophora avenæ</i> = <i>Macrosiphum granaria</i>	13, 23
sp. on Abutilon, host of <i>Aphidius testaceipes</i>	117
<i>Audibertia stochoides</i> , host of <i>Aphidius testaceipes</i>	117
Soap against spring grain-aphis.....	138
whale-oil, against spring grain-aphis.....	138-139
Sorghum, food plant of spring grain-aphis in America.....	43
Europe.....	41, 43
<i>halepense</i> , food plant of spring grain-aphis.....	42

	Page.
Sparrow, chipping. (See <i>Spizella socialis</i> .)	
savanna. (See <i>Passerculus sandwichensis savanna</i> .)	
song. (See <i>Melospiza melodia</i> .)	
vesper. (See <i>Poæcetes gramineus</i> .)	
Spelt, food plant of spring grain-aphis in America	43
Europe	41, 43
<i>Sphærophoria cylindrica</i> , enemy of <i>Macrosiphum granaria</i>	131-132
spring grain-aphis.....	131
<i>Spizella socialis</i> , enemy of spring grain-aphis	135
<i>Sporobolus neglectus</i> , food plant of spring grain-aphis in America.....	42, 43
Spraying experiments against spring grain-aphis	137-139
<i>Stipa leucotricha</i> , food plant of spring grain-aphis in America	42, 43
<i>viridula</i> , food plant of spring grain-aphis in America.....	42, 43
Sulphur and lime against spring grain-aphis	139
Syrphid flies, enemies of spring grain-aphis	129-133
<i>Syrphus americanus</i> , enemy of <i>Macrosiphum granaria</i>	131
spring grain-aphis	130
Temperature, influence on diffusion of spring grain-aphis	88-94
influences on <i>Aphidius testaceipes</i>	119-121
in relation to development of spring grain-aphis in North.....	49-50
South.....	44-49
outbreak of spring grain-aphis in 1907	28-29
<i>Tetraneura colophoidea</i> (?), host of <i>Aphelinus mali</i>	123, 125
"Texas louse," early name for spring grain-aphis	22
Tobacco dust against spring grain-aphis	138
extract against spring grain-aphis	138
<i>Toxoptera graminum</i> (see also Grain-aphis, spring).	
parasites and their hosts.....	125
<i>Triticum repens</i> . (See <i>Agropyron repens</i> .)	
<i>spelta</i> . (See Spelt.)	
<i>villosum</i> , food plant of spring grain-aphis in Europe.....	41-43
<i>vulgare</i> . (See Wheat.)	
Volunteer growth of grain in relation to outbreaks of spring grain-aphis	140, 141
Weather, wet, effect on diffusion of <i>Aphidius testaceipes</i>	121
Wheat, food plant of spring grain-aphis in America	41, 43
Europe	41, 43
Winds, influence on dispersion of <i>Aphidius testaceipes</i>	118-119
spring grain-aphis	81-88
<i>Zea mays</i> . (See Corn.)	

















U. S. DEPARTMENT OF AGRICULTURE,
BUREAU OF ENTOMOLOGY—BULLETIN No. 111.

L. O. HOWARD, Entomologist and Chief of Bureau.

THE HOP APHIS IN THE PACIFIC REGION.

BY

WILLIAM B. PARKER, M. S.,
Entomological Assistant.

ISSUED MAY 6, 1913.



WASHINGTON:
GOVERNMENT PRINTING OFFICE.

1913.

U. S. DEPARTMENT OF AGRICULTURE,
BUREAU OF ENTOMOLOGY—BULLETIN No. 111.

L. O. HOWARD, Entomologist and Chief of Bureau.

THE HOP APHIS IN THE
PACIFIC REGION.

BY

WILLIAM B. PARKER, M. S.,
Entomological Assistant.

ISSUED MAY 6, 1913.



WASHINGTON:
GOVERNMENT PRINTING OFFICE.
1913.

BUREAU OF ENTOMOLOGY.

L. O. HOWARD, *Entomologist and Chief of Bureau.*
C. L. MARLATT, *Entomologist and Acting Chief in Absence of Chief.*
R. S. CLIFTON, *Executive Assistant.*
W. F. TASTET, *Chief Clerk.*

F. H. CHITTENDEN, *in charge of truck crop and stored product insect investigations.*
A. D. HOPKINS, *in charge of forest insect investigations.*
W. D. HUNTER, *in charge of southern field crop insect investigations.*
F. M. WEBSTER, *in charge of cereal and forage insect investigations.*
A. L. QUAINANCE, *in charge of deciduous fruit insect investigations.*
E. F. PHILLIPS, *in charge of bee culture.*
D. M. ROGERS, *in charge of preventing spread of moths, field work.*
ROLLA P. CURRIE, *in charge of editorial work.*
MABEL COLCORD, *in charge of library.*

TRUCK CROP AND STORED PRODUCT INSECT INVESTIGATIONS.

F. H. CHITTENDEN, *in charge.*

C. H. POPENOE, WM. B. PARKER, H. O. MARSH, M. M. HIGH, JOHN E. GRAF, FRED
A. JOHNSTON, C. F. STAHL, D. E. FINK, A. B. DUCKETT, *entomological assistants.*
I. J. CONDIT, R. S. VAILE, *collaborators in California.*
W. N. ORD, *collaborator in Oregon.*
THOS. H. JONES, *collaborator in Porto Rico.*
MARION T. VAN HORN, PAULINE M. JOHNSON, ANITA M. BALLINGER, CECILIA SISCO,
preparators.

LETTER OF TRANSMITTAL.

U. S. DEPARTMENT OF AGRICULTURE,
BUREAU OF ENTOMOLOGY,
Washington, D. C., December 21, 1912.

SIR: I have the honor to transmit herewith the manuscript of a paper entitled "The hop aphid in the Pacific region," prepared with admirable thoroughness by Mr. William B. Parker, Entomological Assistant. The topic is one which has engaged Mr. Parker's attention for two seasons, 1911 and 1912. The work covers investigation in the States of Washington, Oregon, and California. The principal work was conducted in California, but the author has had considerable experience with hop insects, including the hop aphid, in British Columbia. The principal insect pests of the hop have not, until recent years, had adequate treatment in publications on economic entomology, and this paper should therefore prove of great value to hop growers.

I recommend its publication as Bulletin No. 111 of this bureau.

Respectfully,

L. O. HOWARD,
Entomologist and Chief of Bureau.

Hon. JAMES WILSON,
Secretary of Agriculture.



CONTENTS.

	Page.
Introduction.....	9
Economic importance.....	9
Life history.....	10
Hibernation.....	10
Aphides on hop roots.....	10
Emergence from hibernation.....	12
Method of reproduction.....	12
Number of generations on alternate host.....	13
Migrating forms.....	13
Migratory activities.....	13
Deposition of young.....	14
Rate of growth.....	15
Number of young deposited by viviparous females.....	16
The fall migrants.....	17
The winter egg.....	17
The life cycle.....	18
Theory regarding summer migrants.....	18
Habits.....	19
Habitation.....	19
Protection.....	19
Relation of ants to the hop aphid.....	19
First appearance of the hop aphid in the season.....	20
Favorable and unfavorable conditions for the aphid.....	20
Effect of heat.....	20
Food plants.....	21
Nature of damage.....	21
General effect of aphides upon hops.....	21
Honeydew and its effect on the hops.....	22
Blackening of hops.....	22
Natural enemies.....	22
Control of the hop aphid.....	23
Axioms of successful control.....	23
Insecticides used.....	23
Time to begin spraying.....	23
Number of applications.....	24
Necessity for early spraying.....	24
Necessity for thorough work.....	24
Procrastination.....	24
Spraying experiments.....	24
Mixing nicotine solutions and whale-oil soap.....	27
Preparation of the flour paste.....	27
Advantages of flour paste over whale-oil soap as a spreader for contact insecticides.....	28

Control of the hop aphis—Continued.

	Page.
Quassia.....	28
Effect of spray materials upon the quality of sprayed hops	30
Direction in which to work.....	30
Control on prune.....	31
Field observations.....	31
Spraying report.....	31
Spraying machinery.....	31
Boiling and mixing plant.....	32
Field operations.....	32
Supply wagon.....	33
Exchange tanks.....	33
Spray rods.....	33
Nozzles.....	33
The compressed-air spraying machine.....	33
Cost of spraying.....	35
Cultural methods.....	36
Clean culture.....	36
Stripping the vines.....	36
Picking off infested leaves.....	37
Fertilization and irrigation.....	37
General summary, with recommendations.....	37
The more important writings on the hop aphis.....	38
Index.....	41

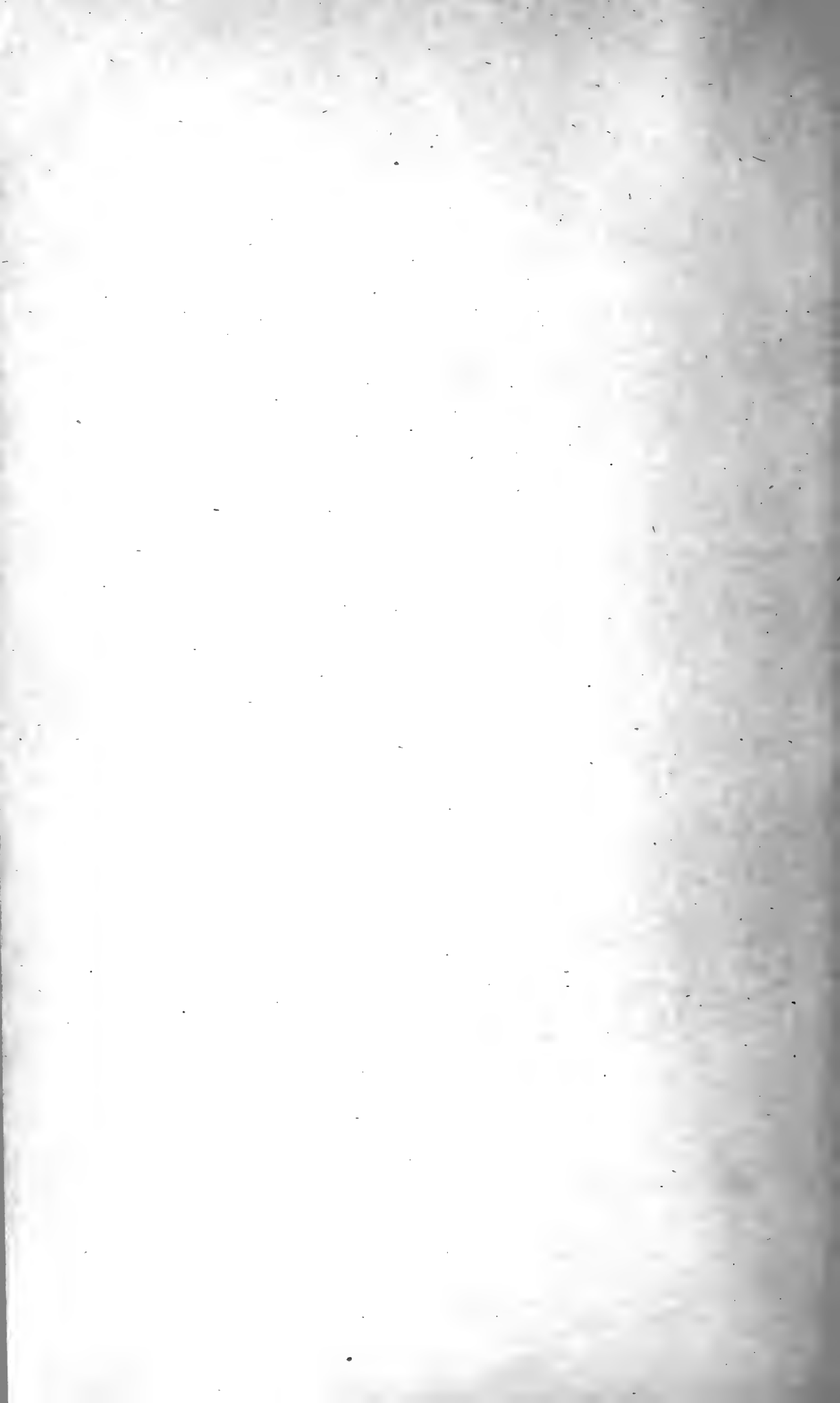
ILLUSTRATIONS.

PLATES.

	Page.
PLATE I. Fig. 1.—Nymphs and winged forms of the hop aphid (<i>Phorodon humuli</i>) on hop leaves. Fig. 2.—Winter eggs of the hop aphid	12
II. Fig. 1.—Wingless progeny of winged hop aphides from alternate host. Fig. 2.—Willows along edge of hopyard, which were erroneously supposed to harbor hop aphides	20
III. Fig. 1.—Normal hop cones and hop cones injured by the hop aphid. Fig. 2.—Vines severely injured by the hop aphid, showing lack of growth as compared with uninjured vines	20
IV. Fig. 1.—Hopvines severely injured by the hop aphid, and left in the field. Fig. 2.—Enlarged view of damaged and moldy hopvines . .	20
V. Fig. 1.—Eggs of <i>Hippodamia convergens</i> among hop aphides. Fig. 2.—Syrphus fly larvæ feeding upon the hop aphid	20
VI. Fig. 1.—Hindu laborer cooking flour paste. Fig. 2.—Boiling and mixing plant used at Independence, Oreg.	28
VII. Fig. 1.—Hand pump and barrel on sledge. Fig. 2.—Knapsack spraying machine in use in hopyard	32
VIII. Fig. 1.—Power outfit on narrow truck, in use in hopyard. Fig. 2.—Filling power outfit from improvised supply wagon	32
IX. Fig. 1.—Compressed-air spraying machine, showing air bottle, tank, reducing valve, and pressure gauge. Fig. 2.—Filling air bottles for compressed-air spraying machine	32
X. Fig. 1.—Hopvine stripped, and tied below the point of stripping, showing free condition of all foliage. Fig. 2.—Hopvine stripped, and tied above the point of stripping, showing matted condition of lower foliage	36

TEXT FIGURES.

Fig. 1. Field cages so placed as to catch any hop aphides that might emerge from eggs deposited upon the hop roots	11
2. The hop aphid (<i>Phorodon humuli</i>): Wingless viviparous female	13
3. The hop aphid: Winged female migrant	14
4. Head of the hop aphid, showing frontal tubercles	15
5. Head of the melon aphid (<i>Aphis gossypii</i>)	15
6. The hop aphid: Nymph, showing wing-pads	17
7. Diagram showing relative number of aphides in different parts of a single hopyard, indicating the increased infestation near Santa Rosa Creek	20
8. Short-pole hopyard, showing dense foliage around base of vines, which harbors the hop aphid	36



THE HOP APHIS IN THE PACIFIC REGION.

(*Phorodon humuli* Schrank.)

INTRODUCTION.

The hop aphis (*Phorodon humuli* Schrank) was known as a pest in the hop gardens of England and of Continental Europe long before hop growing became an industry in America. In the United States this aphis first appeared in New York in 1863, in Michigan in 1866, and in Wisconsin in 1867, and in these States it seriously injured that crop during the early eighties. It soon reached the Pacific Coast, where it first appeared in 1890, and it is now troublesome in most of the hop-growing sections of British Columbia, Washington, Oregon, and California.

The investigation upon which this paper is based began during the spring of 1911 and was continued through two seasons, being completed in the fall of 1912. Experiments were conducted and practical control work was carried on at Sacramento and Santa Rosa, Cal., and at Independence, Oreg. The recorded efficiency of the various insecticides tested is based upon actual counts of living aphides, made before and after spraying. The data upon the cost of control work and methods employed in field operations are based upon the work at Santa Rosa, Cal., and Independence, Oreg., where the prime object of this investigation was carried out, i. e., the economical control of the aphis of the hop.

Acknowledgments are due to Dr. F. H. Chittenden, in charge of Truck Crop and Stored Product Insect Investigations; to Mr. J. Williamson, of Santa Rosa, Cal., who generously assisted me in some of the experimental work; to Mr. Theo. Eder, superintendent of the E. Clemens Horst Co., who furnished me with a field laboratory and a temporary assistant during the summer; to Mr. R. S. Raven, who ably assisted me in the life-history and experimental work, and to Mr. H. N. Ord, who collected much of the data upon methods and cost of control and who carried out the field work in Oregon.

ECONOMIC IMPORTANCE.

The hop aphis has probably been present on the Pacific coast since the time hops have been grown there on a large scale. The greatest injuries from this pest occur in Oregon, Washington, and British Columbia, but serious losses are occasionally sustained in California.

In 1911 the hops at Santa Rosa, Cal., were severely attacked by this aphid. In fact, if the hop crop of the world had not been small and the demand for hops consequently very great, many of the growers in this section would have been unable to dispose of their crops. During the same season the financial loss due to injury by this aphid to the crops on two large yards in British Columbia was estimated at \$80,000.

In 1912 the loss due to this insect was particularly severe in Oregon. One company which handles about 20,000 bales estimated that 50 per cent of their hops were badly damaged and would sell for 15 cents per pound, while 30 per cent was slightly damaged and would sell between 15 and 18 cents per pound. The remaining 20 per cent was not injured and would sell for the prevailing price of 20 cents. At this rate the loss would aggregate \$124,000. The crop on a yard of 110 acres was so severely injured that 20 acres were not worth picking. The loss in this yard was \$12,000.

The damage in these cases was unusually severe, but this pest if not controlled is, under favorable conditions, capable of causing such injury to both the hopvines and the hop cones as to entail a total loss.

LIFE HISTORY.

HIBERNATION.

The winter egg is deposited by the oviparous female upon the plum, prune, and hop in the Pacific Coast States and upon the sloe, plum, bullace,¹ and probably the hop in England and Continental Europe.

The first generation and the winged migrants were observed upon French prune at Santa Rosa and Perkins, Cal., during May and June in 1911 and 1912. The migrants which were observed May 29, 1912, were upon the ordinary though tender foliage, but those observed later in the season were found only upon some very succulent, suckerlike growths. No hop aphides were found upon the surrounding older and tougher leaves. This observation was made both in Santa Rosa and Perkins, and it was found that by selecting such growths aphides could almost invariably be found.

APHIDES ON HOP ROOTS.

Prof. W. T. Clarke, of the California Experiment Station, stated that while studying this insect at Watsonville, Cal., during the last of January or first of February, 1904, some hop roots were brought to him on which were many living hop aphides. He stated that there is no doubt about the identification of this insect. The writer

¹ Journ. Board Agr. Great Britain, vol. 19, No. 4, p. 297, 1912.

was unable to find this condition, but the foregoing data show the possibility of another method of hibernation.

Many examinations of hop roots were made during this investigation, but no eggs of the hop aphid were discovered on or near them. The following data, however, lead the writer to believe that the aphides very frequently hibernate on or around the hop roots.

Wingless viviparous hop aphides were observed depositing young upon the lower leaves of a hopvine at Santa Rosa, Cal., March 16, 1912. This vine was half a mile from any prune tree. Many small wingless aphides were observed on the lower leaves of hopvines at



FIG. 1.—Field cages so placed as to catch any hop aphides that might emerge from eggs deposited upon the hop roots. (Original.)

Perkins, May 16, 1912. No winged migrants were observed at this time.

The first winged migrants were observed at Perkins on May 24, both on the prune and the hop, and in the latter case were only on the upper leaves, the lower leaves being entirely free.

Although field cages (fig. 1) which were placed over hopvines in February and removed after the surrounding vines were thoroughly infested did not contain any hop aphides, the fact that aphides were present on the hops before the winged migrants appeared and that they were found upon the lower leaves, while the winged forms

collect on the uppermost leaves, seems evidence enough to establish the hop as a winter host of the hop aphis, at least in these localities.

It has been thought possible that the hop aphis may hibernate upon some plants other than the plum, prune, sloe, and hop, and during this investigation many observations were made upon plants in the vicinity of the hops. for the winter eggs. While observing the winged migrants at Independence, Oreg., they were discovered upon cherry, alder, peach, and apple, and were found depositing young upon these plants.

In order to see if the young would mature on the cherry, some infested leaves were placed in covered jelly glasses and the leaves renewed each day. These insects matured on cherry as rapidly as on plum, but as there were no males present they died without depositing any eggs. Later observations upon the same trees at Independence, however, failed to reveal any eggs upon any but the plum, on which plant they were very numerous. Although no eggs were found on these trees, the fact that the aphides could grow to full size upon the cherry indicates that under some conditions this insect may hibernate on the various plants on which it was found at Independence.

EMERGENCE FROM HIBERNATION.

Whether the eggs are laid upon the plum, prune, sloe, or hop, the aphides emerge about the same time. The exact date was not obtained, but judging from the fact that full-grown aphides were observed April 23, and allowing 13 days for growth, they must have emerged from the egg about April 10. Again, allowing 26 days for the two generations on the prune and May 24 as the date of the appearance of the first winged insects, the eggs must have hatched by April 28. This assumption corresponds very closely with data obtained at Richfield Springs, N. Y., in 1888 by Mr. Theodore Pergande, who observed the emergence of the aphides from eggs on April 5, 16, and 18 and May 10.

The insects which emerge from the sexual eggs are wingless viviparous females—"stem-mothers," so-called. They are $1\frac{1}{2}$ to 2 millimeters ($\frac{1}{18}$ to $\frac{1}{12}$ inch) in length, whitish green in color, and have rather long antennæ set on frontal tubercles, which are provided on the inner side with a tooth (see fig. 2). These toothed frontal tubercles are very characteristic of this species and serve well to identify it.

METHOD OF REPRODUCTION.

These viviparous insects, instead of depositing eggs, as do the sexual generations which appear in the fall, give birth to living young by a process called "budding." These young may be readily seen protruding from the tip of the abdomen. This is also the method of



FIG. 1.—NYMPHS AND WINGED FORMS OF THE HOP APHIS (*PHORODON HUMULI*) ON HOP LEAVES. (ORIGINAL.)

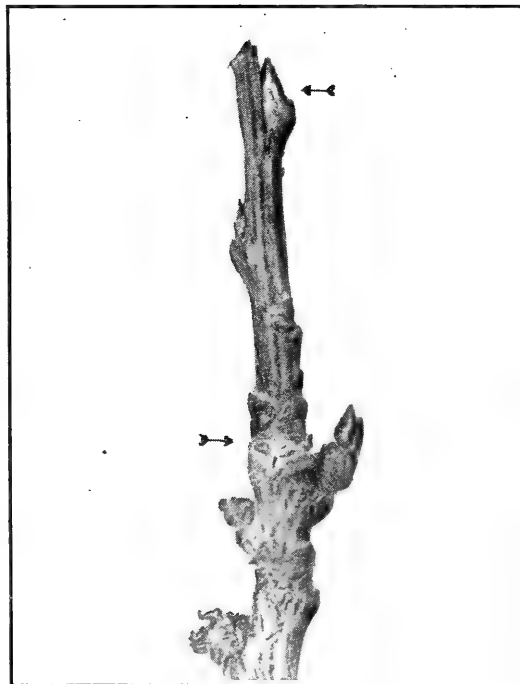


FIG. 2.—WINTER EGGS OF THE HOP APHIS. POSITION INDICATED BY ARROWS. (ORIGINAL.)

STAGES OF THE HOP APHIS.



reproduction of the winged migrants of both the spring and the fall generations. The stem-mothers are very prolific, as shown in Table III, one aphid being capable of populating several leaves in a very short time.

NUMBER OF GENERATIONS ON ALTERNATE HOST.

Mr. Franz Remisch, of Saaz, Bohemia, who observed the emergence from the winter eggs, obtained two generations on plum. The writer did not observe the emergence of the first generation, but during the spring only two generations were found on prune, the second one being winged. In Bulletin 160 of the California experiment station Prof. W. T. Clarke reports the appearance of winged aphides 14 days after the first wingless insects were observed. This would be sufficient time for but one generation to mature, and it is very probable that there are only two generations upon the prune in the Pacific region.

MIGRATING FORMS.

The winged or migrating aphides, except for the presence of two pairs of relatively large, delicate wings, some dark spots on the thorax, and a slightly more slender body (fig. 3 and Pl. I, fig. 1) differ little from the wingless form. They appeared at Perkins, Cal., May 15 and were present there and at Santa Rosa until June 15. Five belated individuals were observed at Perkins the latter part of July, but the migrations had taken place by the 20th of June.

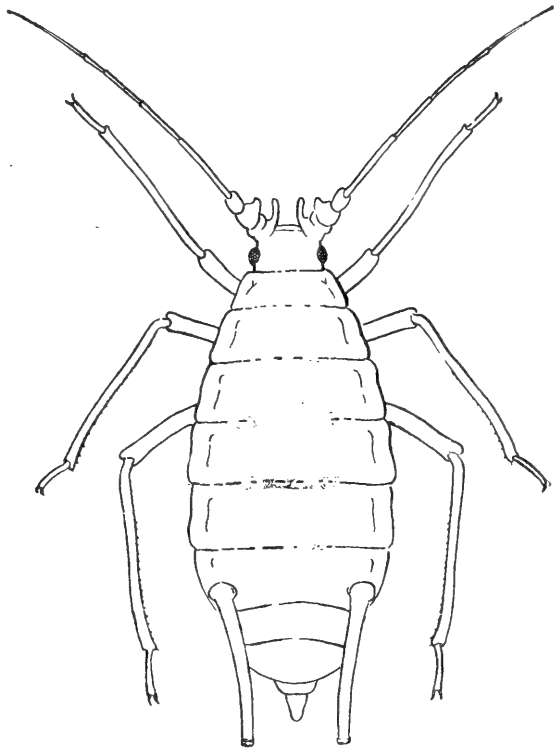


FIG. 2.—The hop aphid (*Phorodon humuli*): Wingless viviparous female. Greatly enlarged. (Original.)

MIGRATORY ACTIVITIES.

These winged aphides, which mature on the plum, are the first migrants. They are weak fliers, but when aided by a light wind may travel some distance. Their progeny, the wingless viviparous females, which are the most common forms found upon the hopvines throughout the season, are incapable of migration from one vine to another except where two vines come into contact so that the aphid

can crawl from one to the other. The winged forms, therefore, are the only ones that migrate during the spring and early summer.

In the fall the winged form (fig. 3) that produces the sexual female migrates from the hop to its winter host—the plum, prune, sloe, or hop—and later the winged male migrates to the plant on which the sexual female awaits fertilization.

In the rearing cages and in the field during 1912 winged forms did not appear except as noted above. Winged forms were observed, however, developing upon the hopvines during the summer, at Watsonville, Cal., by Prof. W. T. Clarke, of the California Experiment Station, in 1902; by Mr. Franz Remisch, at Saaz, Bohemia; by Mr. H. N. Ord, at Independence, Oreg.; and by the writer at Santa Rosa, Cal., in 1911.

As previously stated, the winged migrants are weak fliers, but when aided by the wind may travel some distance. Some individuals were

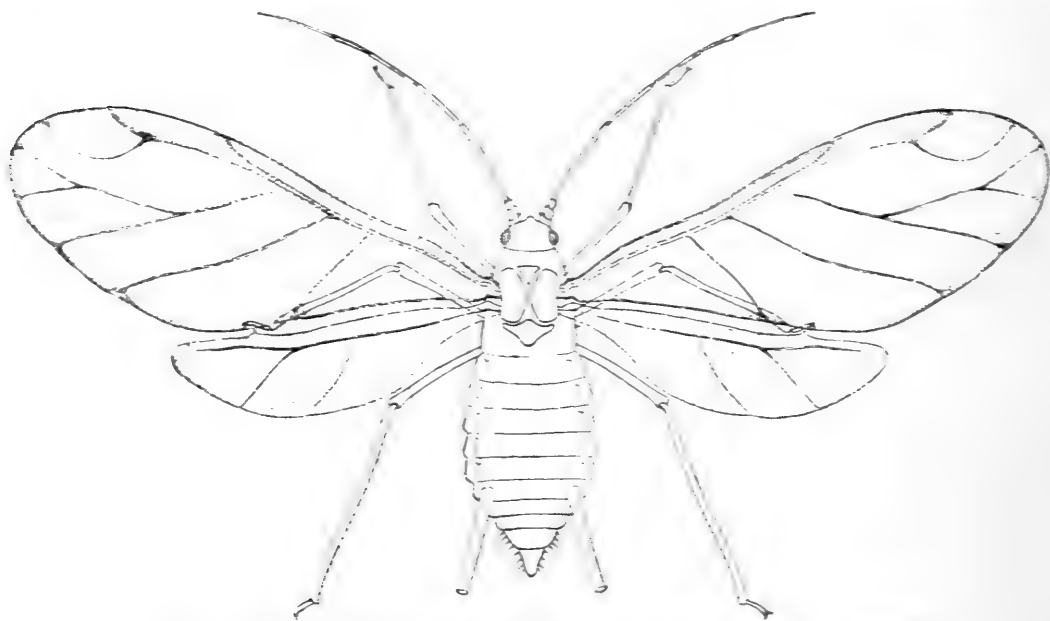


FIG. 3.—The hop aphis: Winged female migrant. Much enlarged. (Original.)

found half a mile from the infested prune trees. The infestation, however, decreases as the distance from the alternate host increases.

It was observed that more migrants collect upon the taller vines and the upper, newly expanded leaves of the other vines than upon the lower matured leaves. Very few winged aphides were observed on the fully expanded and hardened foliage, but were in every case some distance from the ground. The lower leaves were entirely free from the winged forms.

DEPOSITION OF YOUNG.

Upon reaching the hopvines these parthenogenetic migrants were observed giving birth to young, the number deposited by each individual varying between 1 and 8, as is shown in Table I.

TABLE I.—Rate of deposition of young by winged migrants of the hop aphid from prune trees.

Became winged..	Date and number deposited.						Total.
	May 28.	May 29.	May 30.	May 31.	June 1.	June 3.	
May 28.....	1	4	1	1			7
Do.....	2	2			1		5
Do.....	1	3			1		5
Do.....	2	4	1		1		8
May 30.....					1		1
Do.....				2		1	3
May 31.....					1		1
Average.....							4.3

The data in Table I were obtained by isolating nymphs, taken from the prune trees, upon clean prune leaves in covered jelly glasses. When the winged insect appeared it was immediately placed upon a hop leaf. The deposited young were removed daily.

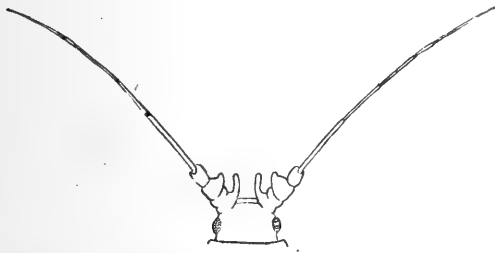
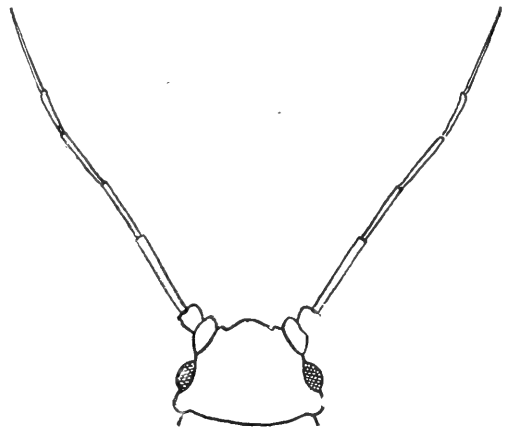


FIG. 4.—Head of hop aphid, showing frontal tubercles. Greatly enlarged. (Original.)

FIG. 5.—Head of melon aphid (*Aphis gossypii*). This aphid is frequently found on hops. Note differences in head from that of hop aphid. Greatly enlarged. (Original.)

These young deposited by the winged aphides are wingless parthenogenetic insects (Pl. II, fig. 1). They have the characteristic frontal tubercles (see fig. 4, in comparison with fig. 5) and vary in color from watery white to green. The very young insects and those that have just molted are very light, while the older ones may be quite green.

RATE OF GROWTH.

These young aphides grow very rapidly, molt four times, and immediately after the fourth molt commence depositing their young, as shown in Table II.

TABLE II.—Stages in the development of the wingless viviparous female hop aphid.

No.	De- posited.	First molt.	Second molt.	Third molt.	Fourth molt.	Com- menced depositing young.	Total days.
1.....	June 11	June 13	June 15	June 17	June 19	June 20	9
2.....	15	17	20	23	25	27	12
3.....	15	18	21	23	26	27	12
4.....	16	19	21	23	25	27	11
5.....	18	21	23	26	28	29	12
6.....	18	22	24	26	28	29	12

From these experiments, which were conducted with individual insects, it was found that a period of from 8 to 12 days is required for the aphides to pass through the four molts and begin depositing young.

NUMBER OF YOUNG DEPOSITED BY VIVIPAROUS FEMALES.

Some of the experiments that were carried on to determine the number of young that are deposited by individual aphides are recorded in Table III.

TABLE III.—*Number of young deposited by each of 12 individuals of the hop aphis.*

Date.	Number of young deposited by—											
	No. 1.	No. 2.	No. 3.	No. 4.	No. 5.	No. 6.	No. 7.	No. 8.	No. 9.	No. 10.	No. 11.	No. 12.
June 12.....	4											
13.....	5											
14.....	7	4	1									
15.....	4	3	3									
16.....	7	2	3									
17.....	2	3	4									
18.....	4	3	5									
19.....	2	4	3									
20.....	0	4	5	1								
21.....	3	2	4	1	1	2						
22.....	4	8	3	3	3	2	2	2	2			
23.....	0	3	3	4	3	3	2	3	4			
24.....	3	3	2	2	4	2	2	2	0			
25.....	5	3	2	5	3	8	4	3	4			
26.....	3	4	5	4	7	3	6	9	4			
27.....	3	4		3	5	3	5	4	4	1		
28.....	5	9		6	2	3	5	7	7		2	3
29.....	4	3		5	8	2	8	6	5	2	4	1
30.....	1	5		2	2	3	4	0	5	1	1	7
July 1.....	2	2		6	1	5	4	7	6	3	8	5
2.....	0	3		3	5	2	6	1	5	2	3	4
3.....	0	2		3	3	6	5	2	4	4	2	6
4.....	0	3		3	3	4	4	3	6	2	2	6
5.....				2	6	0	4	3	3	4	4	5
6.....					6	6	2	6	9	4	0	4
7.....					4	7	3	4	7	3	1	3
8.....					1	2	4	2	5	1	1	1
9.....					3	3		5	1	4	0	1
10.....					6	2		1	3	1	1	0
12.....					5	2		1	1	1		2
13.....					4	5		2	2	1		2
14.....					2	2						1
15.....					2	4						
16.....					3	3						
17.....						2						
18.....						1						
Total.....	68	77	43	53	92	87	70	73	87	38	29	51

In order to obtain the foregoing data nearly mature aphides were isolated on hop leaves in tin-covered jelly glasses. The leaves were changed daily and the aphides which had been deposited were removed. The number of young which are deposited by one stem-mother were thus found to be from 29 to 92, with an average of 64 for the 12 aphides under observation. The length of life of these aphides varied from 25 to 38 days, with an average of 30.75 days. Thus an aphis living an average life of 30.75 days, depositing an

average number of young (3.3 per day) over an average period of 19 days, would give birth to 63 aphides.

At this rate of reproduction, provided that none of the aphides were destroyed before they had lived an average life, one winged aphid which settles on the hop in the spring would at the end of the fifth generation be the parent of 4,068,989,826 living aphides. These aphides would weigh 2,152 pounds. From these figures the very sudden and extensive infestations by this insect are readily explained.

THE FALL MIGRANTS.

The nymphs of the fall migrants (fig. 6) became winged in the breeding cages at Perkins, Cal., on August 26 and in the field August 28. Migrants were observed upon plum at Independence, Oreg., September 22, 1912. Young were being deposited there and upon the next visit to the locality, October 16, large numbers of male aphides were observed copulating with the sexual females that had been deposited by the migrants. Many eggs were also present at this time.

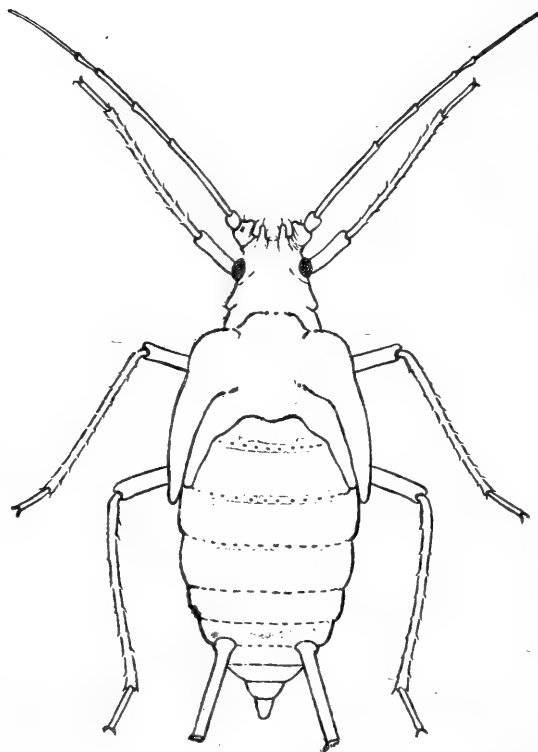


FIG. 6.—The hop aphid: Nymph, showing wing-pads. Greatly enlarged. (Original.)

THE WINTER EGG.

The winter egg, when first deposited, is a shiny-green object, ovate in shape, and a little smaller than the head of a pin ($\frac{3}{4}$ mm. in length). Soon, however, it turns dark green and then black and appears as a shiny-black point (Pl. I, fig. 2) on the branch of the alternate host plant.

The eggs are usually deposited close around the buds or on the rough leaf scars, but may sometimes be found upon the smooth parts of the twigs.

THE LIFE CYCLE.

The entire life cycle where the writer's observations were made is as follows: Two generations occur on the alternate host, the second one being winged. Five and six generations occur on the hop, a part of the fifth becoming winged and depositing young upon the

alternate host, and part being wingless and depositing young (sixth generation) upon the hop, producing the male aphides which fly to and copulate with the young deposited on the alternate host by the winged individuals of the fifth generation. These fertilized females deposit the winter eggs, which, hatching in the following spring, produce the viviparous insects for that season.

Table IV gives one series of dates for the life cycle. This series will vary according to the date of the emergence of the first generation from the egg in the spring. The variation in the date of hatching of the winter eggs causes an overlapping of generations, so that these are not in the least distinct.

TABLE IV.—*Life cycle of the hop aphis as observed at Perkins, Cal., in 1912.*

Emergence from eggs.....	June 3
Appearance of second generation, winged.....	June 17
Appearance of third generation (first on hops).....	June 30
Appearance of fourth generation (second on hops).....	July 11
Appearance of fifth generation (third on hops).....	July 22
Appearance of sixth generation (fourth on hops).....	Aug. 2
Appearance of seventh generation (fifth on hops), part winged.....	Aug. 15
Appearance of eighth generation (sixth on hops), males.....	Aug. 25
Appearance of eighth generation, sexual females, on plum.....	Aug. 25
Deposition of eggs.....	Sept. 14

In the report of the Department of Agriculture for 1888, Prof. C. V. Riley gives the following data upon the life history, which vary somewhat from the data given in this bulletin:

Three parthenogenic generations are produced upon *Prunus*, the third being winged.
 * * * A number of parthenogenic generations are produced upon the hop until in autumn, and particularly during the month of September winged females are again produced.

This account is also at variance with the writer's own observations in that no winged forms are noted during the summer.

THEORY REGARDING SUMMER MIGRANTS.

The presence of winged forms of the hop aphis throughout some seasons and the absence of such forms during 1912, both in the laboratory and in the field, except at the end of the fifth generation, are explained as follows: The eggs of the hop aphis have been observed to hatch individually during a period of one month and five days, April 5 to May 10. The winged forms were observed beginning to migrate from the prune May 24, and migration was not completed until June 20. Thus until the 20th of June migrants from the alternate host (the plum or hop) were present in the hopyards. Beginning the life cycle with the first insects that migrated, the seventh or winged generation on the hop would be mature July 19. These insects, finding some tender hop leaves upon which to settle,

would deposit young thereon. The deposited young, because of climatic and succulent food conditions, might become viviparous instead of oviparous, causing a continuous increased infestation of the hopvines.

At Perkins and Santa Rosa, Cal., in 1912, a hot, dry wind early in the season destroyed practically all of the aphides which came from the alternate host, and it was the progeny of the later migrants which became winged.

These data have not been proven, but remain as the only explanation of the presence of winged aphides between the spring and fall migrations.

Since the first insects that migrate to the hop are probably the progenitors of the winged forms that occur during midsummer, it is evident that the control of the aphids early in the season will tend to reduce the numbers of the winged insects and therefore lessen the chance that thoroughly sprayed yards will become reinfested.

HABITS.

HABITATION.

Hop aphides are usually found on the underside of the leaves (Pl. II, fig. 1), but in cases of severe infestation they may be found on the upper surface as well. They gradually work up the vines, and when the hops have formed many of them may be observed inside of the cones.

PROTECTION.

Many of the aphides, especially in cases of slight infestation, will be found close to the veins and in the hollow parts of the leaves. Here, besides being protected by the sheltering leaf, they are partially protected by the surrounding wall of leaf. Other than the natural formations of the leaves the hop aphid has no protection from wind, rain, or enemies.

RELATION OF ANTS TO THE HOP APHIS.

At Perkins, and especially at Santa Rosa, Cal., a large black ant, *Formica subsericea* Say, was continually observed among the aphides. The habit of the ants in caring for plant lice that they may feed upon the honeydew excreted by them is historical. These ants carry the aphides to the newly expanded leaves, thus spreading the infestation. They were so active at Santa Rosa that it was found necessary to put tree tanglefoot on the vines that were used for the experiments, to prevent the ants from reinfesting them.

FIRST APPEARANCE OF THE HOP APHIS IN THE SEASON.

The first wingless viviparous aphides of the season at Santa Rosa, Cal., at Independence, Oreg., and at Agassiz, British Columbia, were invariably observed upon hopvines near shrubby growth bordering a watercourse or fence, near a sheltering tree, or near buildings. At Santa Rosa and Agassiz, where the writer made observations during the early part of the season, the aphides were most numerous near shrubbery or buildings, the numbers decreasing as the center of the field was approached.

This condition is shown diagrammatically in figure 7. In fact, at Santa Rosa on May 30, 1911, and June 6, 1912, the aphides occurred in numbers only near the brush, trees, or buildings, the other parts of the field being almost entirely free.

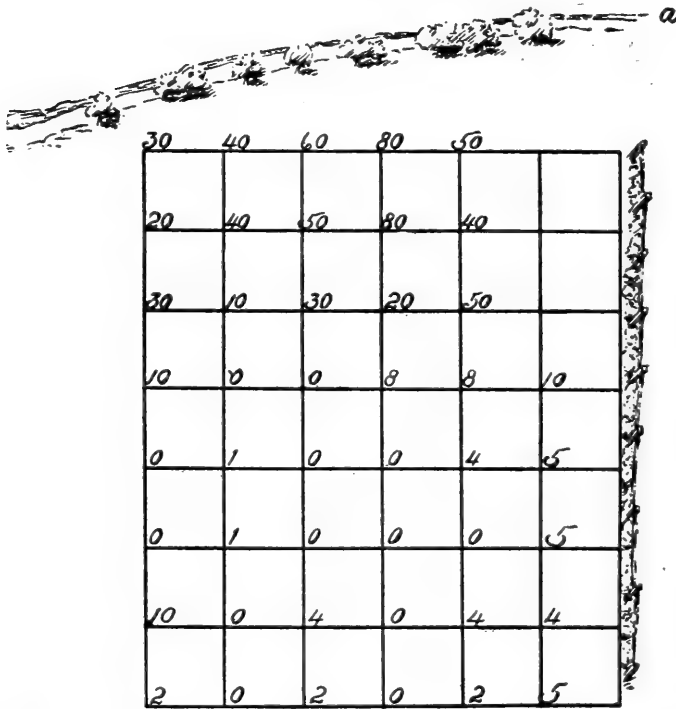


FIG. 7.—Diagram showing relative number of aphides in different parts of a single hopyard, indicating the increased infestation near Santa Rosa Creek (*a*). (Original.) (The numbers represent approximate counts of aphides which were present on the vines June 1, 1911. On September 1 these vines were grossly infested. The row nearest the creek (*a*) is row 1; the next is row 2; and after that the numbers were taken from every fifth row. Each number represents the number of aphides found on the hill in that location.)

and the most severe infestations occur during seasons of such weather.

A hot, dry wind is very unfavorable to the aphides and in some sections, when followed by dry, warm weather, will materially check infestation.

EFFECT OF HEAT.

Some careful observations on the condition of the hop aphis after continued hot weather, and especially when the hot weather was accompanied by a north wind, were made at Perkins, Cal.

FAVORABLE AND UNFAVORABLE CONDITIONS FOR THE APHIS.

Moderately warm, moist seasons with an occasional rain but with little strong wind are the most favorable for the development of the hop aphis,

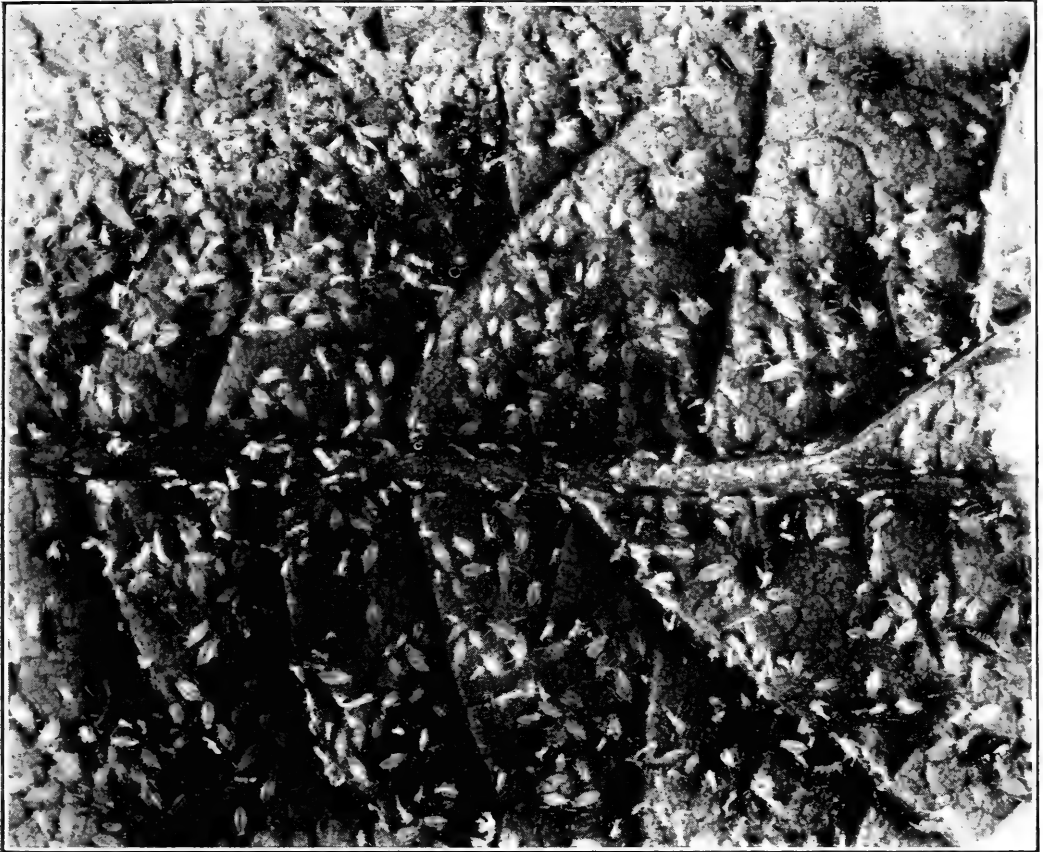


FIG. 1.—WINGLESS PROGENY OF WINGED HOP APHIDES FROM ALTERNATE HOST.
(ORIGINAL.)



FIG. 2.—WILLOWS ALONG EDGE OF HOPYARD, WHICH WERE ERRONEOUSLY SUPPOSED
TO HARBOR HOP APHIDES. (ORIGINAL.)

THE HOP APHIS.



FIG. 1.—UPPER ROW, NORMAL HOP CONES; LOWER ROW, HOP CONES INJURED BY THE HOP APHIS. (ORIGINAL.)



FIG. 2.—VINES IN FOREGROUND SEVERELY INJURED BY THE HOP APHIS SHOWING LACK OF GROWTH AS COMPARED WITH UNINJURED VINES IN THE DISTANCE. (ORIGINAL.)

INJURY TO HOPS AND HOPVINES BY THE HOP APHIS.



FIG. 1.—HOPVINES SEVERELY INJURED BY THE HOP APHIS, AND LEFT IN THE FIELD.
(ORIGINAL.)



FIG. 2.—ENLARGED VIEW OF DAMAGED AND MOLDY HOPVINES. (ORIGINAL.)
INJURY TO HOPVINES BY THE HOP APHIS.



FIG. 1.—EGGS OF HIPPODAMIA CONVERGENS AMONG HOP APHIDES ON LEAF. (ORIGINAL.)

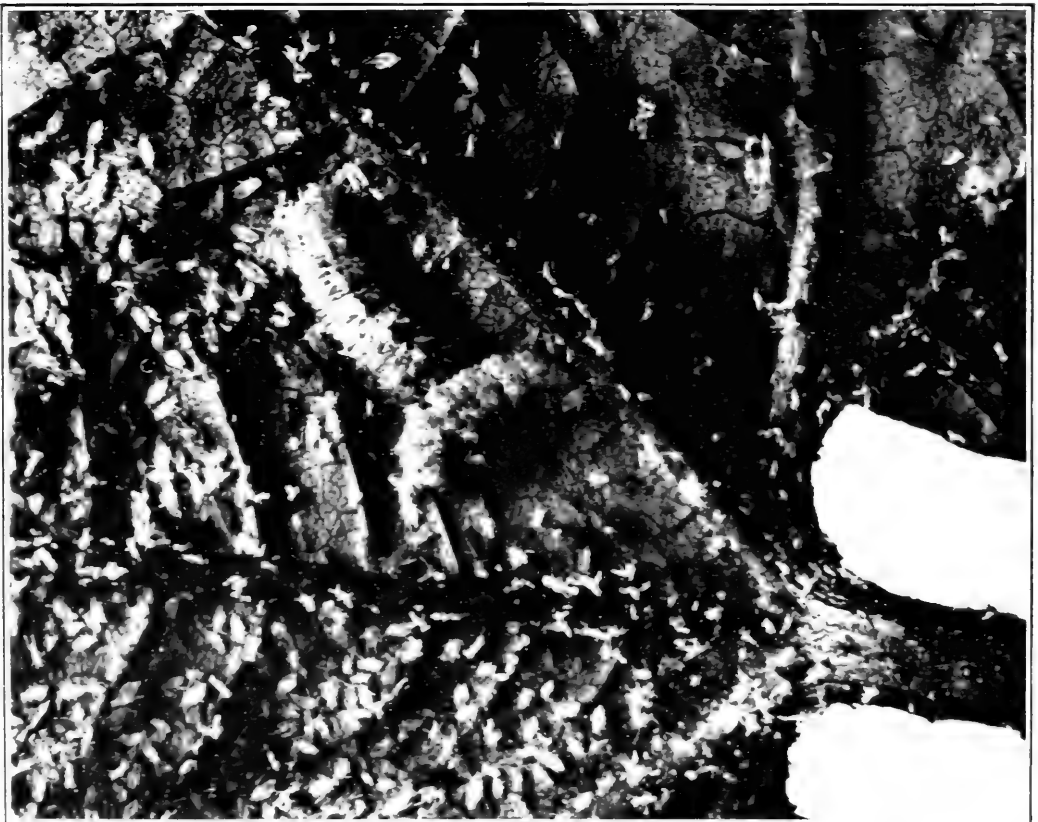


FIG. 2.—SYRPHUS FLY LARVAE FEEDING UPON THE HOP APHIS. (ORIGINAL.)
SOME NATURAL ENEMIES OF THE HOP APHIS.

It was noticed that in every case where the aphides were reduced by the effect of the heat, some small ones remained and upon maturing produced the following generation. In some cases not a single full-grown aphid was found after the hot weather had ceased, but many of the young aphides were present upon the vines. A similar observation was made at Santa Rosa, Cal.

FOOD PLANTS.

Phorodon humuli feeds principally upon the hop. It has, however, some alternate food plants on which the sexual forms develop. (See p. 14.)

It is a common belief that the aphides found upon the shrubs and trees growing near the hopyards (see Pl. II, fig. 2) are hop aphides and that they later migrate to the hops. Specimens of aphides were taken from various plants growing near the hopyards at Agassiz, British Columbia, Independence, Oreg., and Santa Rosa, Cal., and identified. In no case was *Phorodon humuli* found among the aphides collected. Even though aphides may be extremely numerous upon such near-by plants, they do not in the least menace the hop crops; hence their destruction, from the standpoint of hop-aphid control, is unnecessary.

NATURE OF DAMAGE.

GENERAL EFFECT OF APHIDES UPON HOPS.

The hop aphid injures the crops in two ways: By extracting the plant juices it prevents the normal growth of the plant, and by the excretion of honeydew, on which grows the black-smut fungus, *Cladosporium* sp., it injures the quality of the crop.

In one hopyard at Santa Rosa, Cal., May 31, 1911, several vines were found which were severely infested. Later in the season these vines were observed to have made little growth. The few hop cones which had formed were very small, some being only slightly larger than the burrs. Plate III, figure 1, shows some of these small cones compared with normal cones which were taken from near-by uninfested vines. The relatively small growth of the infested vines compared to that of the uninfested vines is well illustrated in Plate III, figure 2. The vines in the foreground were severely injured by the aphides, while those farther back were only slightly infested until late in the season and made a very fair growth.

Some vines that were only slightly infested were observed throughout the season. These vines grew well and bore a fine crop of hops, but just before the harvest the aphides entered the cones, extracted their vitality, and covered the scales with honeydew, in which the black-smut fungus soon established itself. These cones were so

severely injured that they were not worth picking, and they were left in the field. (See Pl. IV, figs. 1, 2.)

Where control work is attempted the infestation seldom becomes so severe as to retard the growth of the vines, and it is the late injury—the accumulation of honeydew upon the cones and the resulting growth of the black fungus—which is most to be feared.

HONEYDEW AND ITS EFFECT ON THE HOPS.

Honeydew is a substance which is excreted from the anal opening of the aphides. It is composed largely of gums and sugar and is sticky and sweet to the taste. On warm afternoons it may be seen falling as a mist from severely infested vines.

Hops covered with honeydew are sticky, do not have the normal amount of crispness, and when pressed between the fingers remain flattened out. Honeydew may under some circumstances increase the weight of the crop. One grower estimated that he made \$1,000 on honeydew in 1911. However, the quality of the crop was greatly injured, and had the demand for hops been less the grower would not have been able to sell, and his crop would have been a complete loss.

Even though under certain uncontrollable circumstances the presence of honeydew may increase the income from a crop of hops, their quality is injured, and the honeydew is the medium for the black-smut fungus, which will, in ninety-nine cases out of one hundred, so injure the quality of the crop that it will be unsalable.

BLACKENING OF HOPS.

Neither the honeydew nor the aphides are directly responsible for the blackening of the hops. The blackening is due to a smut fungus (*Cladosporium* sp.) commonly called "mold," which grows upon the honeydew. If the honeydew happens to be upon the hop cones, this fungus gives the hops a black, moldy appearance, which is extremely undesirable.

NATURAL ENEMIES.

Several predaceous insects have been observed attacking the hop aphis at Perkins and at Santa Rosa, Cal. The ladybirds *Hippodamia convergens* Guér., *Coccinella californica* Mannh., *Coccinella abdominalis* Say, and *Chilocorus orbis* Cas. were frequently found among the aphides. Some eggs of *Hippodamia convergens* deposited among the hop aphides are shown in Plate V, figure 1. *Chrysopa californica* Coq. was always abundant in the hop fields, and the larvæ were very active in feeding upon the aphides.

The larvæ of syrphus flies (Pl. V, fig. 2) were abundant in the hopyards. *Syrphus opinator* O. S. and *Syrphus americanus* Wied. were reared from the larvæ which were collected from hop leaves.

A small predaceous bug, *Triphleps insidiosus* Say, was occasionally observed among the aphides.

The following insects were observed by Mr. Theo. Pergande attacking the hop aphis at Richfield, N. Y., in 1887:

Triphleps insidiosus Say

Camptobrochis nebulosus Uhl.

Adalia bipunctata L.

Anthocoris sp.

Stethorus punctum Lec.

Parasites and predaceous insects destroy large numbers of hop aphides, but in no case have they been observed successfully to control an infestation.

CONTROL OF THE HOP APHIS.

AXIOMS OF SUCCESSFUL CONTROL.

In the economic control of the hop aphis, as of other insect pests, there are certain underlying principles which must be adhered to if the work is to be entirely successful.

(1) All of the machinery to be used must be capable of doing effective work and must be in good working condition prior to the time at which spraying should commence.

(2) Spraying must commence at the proper time; it must not be put off.

(3) The material used must be carefully prepared and thoroughly but not wastefully applied.

These are fundamental principles, and control work will be less effective and more costly if they are not closely adhered to.

INSECTICIDES USED.

Several contact insecticides have been used to control the hop aphis. The most extensively used sprays, however, are tobacco decoctions with whale-oil soap and quassia chips with whale-oil soap. In order to obtain exact data upon the effectiveness of these materials upon the hop aphis a series of experiments on a small scale was conducted at Santa Rosa, Cal., and notes were taken from experiments made on a large scale in Oregon. Tag counts were made; i. e., 20 tags were tied to as many leaves, and records of the number of aphides on the leaves before and three days after spraying were made on the tags; the percentage of aphides killed was thus accurately obtained.

TIME TO BEGIN SPRAYING.

It is very desirable to spray all plums or prunes that are infested by hop aphides as soon as the infestation is observed, both in the fall and in the spring. This will check the migration and lessen the infestation of the hops. The hops, however, should be sprayed as soon as the

aphides become numerous. This is usually from June 1 to 15, though in some cases it may be earlier. It is well to spray first the fields which are most seriously infested.

It is usually desirable to wait until the vines are stripped before spraying.

NUMBER OF APPLICATIONS.

The number of applications which are necessary to control the aphides will vary with the seasonal and local conditions. The object is to prevent injury to the vines and to have the vines practically free of aphides at the time hop picking commences. To obtain good results it is usually necessary to spray the vines from two to four times.

NECESSITY FOR EARLY SPRAYING.

Mr. H. N. Ord, who directed some very successful spraying operations in a large hopyard in Oregon, claims that the secret of his success was early spraying. He began before the aphides became very numerous and continued as long as there were any aphides in the field. Yards sprayed under Mr. Ord's direction were practically free from aphides, while the crops of a near-by grower were so severely damaged that 10 acres were left in the field unpicked.

NECESSITY FOR THOROUGH WORK.

The insecticides which are used for the hop aphis kill only by actual contact, and if satisfactory results are to be obtained it is absolutely necessary that the spray be thoroughly applied. Running the spray up and down the vine is not sufficient, because all of the leaves must be thoroughly wetted on both surfaces if good results are to be obtained.

PROCRASTINATION.

In sections where the aphides are frequently controlled by weather conditions some growers are likely to delay control work, hoping that a hot, dry wind will relieve them of the necessity of spraying. In one hop-growing section of California such a wind has appeared regularly for several years, but during the past two seasons (1911-12), which were favorable for the aphides, it did not arrive. Many growers, depending upon this wind, made no effort to control the aphides until late in the season, when much damage had been done. It was then difficult to make much progress against the insects, and severe injury resulted.

SPRAYING EXPERIMENTS.

The nicotine solutions appeared to be the most promising materials and were therefore the most extensively used in the experiments. The following tables, arranged according to relative costs,

show the results of these experiments and give the cost of the materials per 100 gallons of spray:

TABLE V.—Results of spraying experiments for the hop aphid, with costs of materials per 100 gallons of spray.

Experiment No.	Materials used.	Pressure.	Number of aphides.	Per cent killed.	Date sprayed.	Date counted.	Cost per 100 gallons.
		<i>Pounds.</i>					
1	Nicotine sulphate, 1 to 3,000.....	80-100	1,227	99.9	June 15	June 17	\$0.416
2	Nicotine sulphate, 1 to 2,000.....	80-100	1,005	97.8	June 13	...do....	.62
3	Nicotine sulphate, 1 to 3,000; whale-oil soap, 4 to 100.	80-100	3,089	99.2	June 14	...do....	.80
4	Nicotine sulphate, 1 to 3,000; cresol soap, 1 to 300.	80-100	1,990	95	June 15	...do....	.83
5	...do.....	80-100	3,474	84	...do....	...do....	.83
6	Blackleaf tobacco, 1 to 75.....	80-100	1,810	94	...do....	...do....	.86
7	Nicotine sulphate, 1 to 2,000; cresol soap, 1 to 300.	80-100	2,320	97	...do....	...do....	1.04
8	Blackleaf tobacco, 1 to 60.....	80-100	2,590	99.8	...do....	...do....	1.08
9	Nicotine sulphate, 1 to 1,000.....	80-100	654	98.2	June 13	...do....	1.25
10	Nicotine sulphate, 1 to 2,000; lye-resin soaps.	80-100	2,225	99.1	June 15	...do....	1.37
11	Nicotine sulphate, 1 to 1,000; whale-oil soap, 4 to 100.	80-100	2,512	99.4	June 14	...do....	1.42
12	Nicotine sulphate, 1 to 1,000; cresol soap, 1 to 300.	80-100	2,780	99	June 15	...do....	1.67

INEFFECTIVE MATERIALS.

13	Lime sulphate, 36° Baumé, 1 to 86.	80-100	1,950	14	June 16	June 19	\$0.24
14	Cresol soap, 1 to 300.....	80-100	129	0	June 13	June 16	.42

From the data in Table V it is evident that all the experiments except Nos. 5, 13, and 14 were quite satisfactory and that Nos. 1, 2, 3, and 4 were the cheapest materials to use. It was found that the nicotine sulphate without soap did not spread very readily and that the good results obtained were due to the very careful application. Either flour paste or soap should always be used with the nicotine solutions.

TABLE VI.—Spraying experiments conducted in Oregon against the hop aphid during 1911.

Experiment No.	Materials used.	Pressure.	Number of aphides.	Per cent killed.	Date sprayed.	Date counted.	Cost per 100 gallons.
		<i>Pounds.</i>					
1	Tobacco waste, 25 pounds to 100 gallons water.	100	213	100	Aug. 22	Aug. 25	\$0.18
2	Tobacco waste, 27½ pounds to 100 gallons water.	100	253	100	...do....	Aug. 24	.20
3	Nicotine sulphate, 1 to 2,000.....	100	695	89	Aug. 21	Aug. 23	.62
4	Nicotine sulphate, 1 to 2,000; whale-oil soap, 5 to 100.....	100	529	98	...do....	...do....	.845
5	Nicotine sulphate, 1 to 1,000.....	100	73	100	...do....	...do....	1.25
6	Nicotine sulphate, 1 to 2,000; whale-oil soap, 5 pounds to 100 gallons water.....	100	491	98	...do....	...do....	1.475
7	Nicotine sulphate, 1 to 750.....	100	130	97	Aug. 22	Aug. 25	1.66

Table VI represents the work done in Oregon by Mr. H. N. Ord and is in part a repetition of the results recorded in Table V. It also contains data upon tobacco waste, which appears very satisfactory and very cheap. If the decoction is allowed to boil or the tobacco happens to be low in nicotine, the spray will not be effective, and the vines will have to be resprayed.

If this material be used each tankful should be tested upon some aphides and a record of efficiency kept. It is for these reasons not so satisfactory as a material containing a known quantity of insecticide.

Nicotine-sulphate formulas for 100-gallon lots.

	Ounces.
Nicotine sulphate, 1 to 1,000.....	13
Nicotine sulphate, 1 to 2,000.....	6½
Nicotine sulphate, 1 to 2,500.....	5½
Nicotine sulphate, 1 to 3,000.....	4½

The formula "4-100," given for flour paste, means 4 gallons of flour paste (made according to directions) to each 100 gallons of spray. This paste contains 1 pound of flour in each gallon, so that there would be 4 pounds of flour (in the form of paste) in each 100 gallons of spray.

The formula "4-100," when referring to whale-oil soap, means 4 pounds of whale-oil soap to 100 gallons of spray.

Flour paste had proved to be a most efficient, cheap, and convenient spreader for the lime-sulphur solutions.¹ Some experiments were conducted during 1912 with this material in combination with nicotine sulphate against the hop aphis. Table VII gives some of the results obtained with this mixture.

TABLE VII.—*Experiments in the control of the hop aphis by sprays of nicotine sulphate and flour paste.*

Formula.	Number of aphides present.	Per cent killed.	Cost per 100 gallons.
Nicotine sulphate, 1-2,000; flour paste, 4-100.....	627	100	\$. 71
Nicotine sulphate, 1-2,500; flour paste, 4-100.....	611	100	. 60
Nicotine sulphate, 1-3,000; flour paste, 4-100.....	1,668	99	. 50
Do.....	148	99	. 50
Nicotine sulphate, 1-3,500; flour paste, 4-100.....	308	100	. 45
Nicotine sulphate, 1-4,000; flour paste, 4-100.....	271	96	. 40

From the results noted in the preceding tables it is evident that nicotine sulphate is effective in dilutions as high as 1-3,500, and that flour paste, 4-100, is an effective spreader for this material. The nicotine sulphate, 1-4,000, was not quite so effective, and it was also observed that its action was so slow that the sprayed aphides were able to deposit young on the leaves, thus reinfesting the hopvines.

¹ See Bulletin No. 117 and Circular No. 166 of this bureau.

Nicotine sulphate, 1-3,000 and 1-3,500, in combination with whale-oil soap or flour paste has been successfully used in experiments, but it would be safer in practice to use the lower dilutions. In case the greater dilutions are used, careful observations should be maintained to be sure that the spray is doing effective work. The nicotine preparations which come in cans have a slight tendency to settle. In case they do settle and are not thoroughly mixed before measuring, the percentage of active insecticide used in one lot of spray may be enough less than should be present in a uniform portion to render the spray ineffective. It is advisable, therefore, to be sure that these preparations are thoroughly mixed before measuring.

MIXING NICOTINE SOLUTIONS AND WHALE-OIL SOAP.

During certain spraying experiments with tobacco extracts and whale-oil soap some difficulty was experienced in mixing the concentrated solutions of blackleaf tobacco and whale-oil soap. When these were combined a greenish-gray precipitate of a flocculent nature was formed. A similar precipitate occurred when one of the materials was diluted and the other left concentrated. When each solution was diluted to half of the final amount, however, this objectionable nozzle-clogging precipitate did not appear.

Flour paste does not have this effect, but when whale-oil soap is used as a spreader for tobacco sprays, both solutions *must* be well diluted before mixing.

PREPARATION OF THE FLOUR PASTE.

In preparing the flour paste, mix a cheap grade of wheat flour with *cold* water, making a thin batter without lumps, or wash the flour through a wire screen with a stream of cold water. Dilute until there is 1 pound of flour in each gallon of mixture. Cook until a paste is formed, stirring constantly to prevent caking or burning. (See Pl. VI, fig. 1.) Add sufficient water to make up for evaporation.

If the paste is not sufficiently cooked, the resulting spray will not be effective. If overcooked, the paste will harden when thoroughly cool; it will then not mix with water very readily. Usually, however, the paste is used as it is prepared, and overcooking is not a disadvantage.

When mixed in a spray tank flour paste has a tendency to settle, and in order to do satisfactory work *agitation is necessary*. This is only a slight disadvantage, however, and is necessary with most spray materials. The large spray tanks are usually fitted with an agitator, and a hoe makes an effective agitator for the 50-gallon barrels, so that this problem is a simple one.

ADVANTAGES OF FLOUR PASTE OVER WHALE-OIL SOAP AS A SPREADER
FOR CONTACT INSECTICIDES.

Flour paste costs 8.8 cents per 100 gallons of spray. Cheap flour is always available, and the paste has no odor. Whale-oil soap costs 20 cents per 100 gallons of spray, is not always available, and has a disagreeable odor.

Both materials have to be heated before using.

The neutrality of flour paste was proven by the fact that when applied upon the foliage and blossoms of the hop, in proportions as high as 12 gallons of paste to 100 gallons of spray, no injurious effects resulted. When sprayed upon the hop burrs and delicate hop cones, it did not prevent pollination or injure the appearance of the scales.

QUASSIA.

Quassia is the extract from the wood of *Picræna excelsa*, a tree occurring in Jamaica and containing the alkaloid quassin ($C_{32}H_{42}O_{10}$) in the form of crystalline rectangular plates. Quassia chips contain no tannic acid.

EFFECT OF QUASSIA ON APHIDES.

A solution of quassia containing the extract from 5.33 ounces of quassia chips in 1 quart of water was diluted one-half and sprayed on *Hyalopterus pruni* on prune. It was found necessary to wash the waxy pulverulence from the insects before they could be wetted. The leaves were tagged with the numbers of aphides present and the twigs set into water in the laboratory. A check branch was sprayed with pure water. That the strong quassia solutions have a decided insecticidal value is shown by the following data:

Aphides present before spraying. 37. 40. 109. 92. 190. 75. 140. 40; total, 723.
Aphides present after spraying. 0. 30. 3. 1. 0. 25. 0. 0; total, 59.
Per cent killed, 92.

Quassia solution at the rate of 7 pounds of chips to 250 gallons of water was applied to the aphides with the following results:

Aphides present before spraying. 48. 60. 30. 40. 73. 30. 200. 100. 63. 128. 12; total, 784.
Aphides present after spraying. 0. 0. 5. 0. 0. 0. 1. 2. 7. 9. 10; total, 34.
Per cent killed, 96.

The aphides on sprayed leaves turned brown when dead. The check leaves contained living insects only.



FIG. 1.—HINDU LABORER COOKING FLOUR PASTE. (ORIGINAL.)

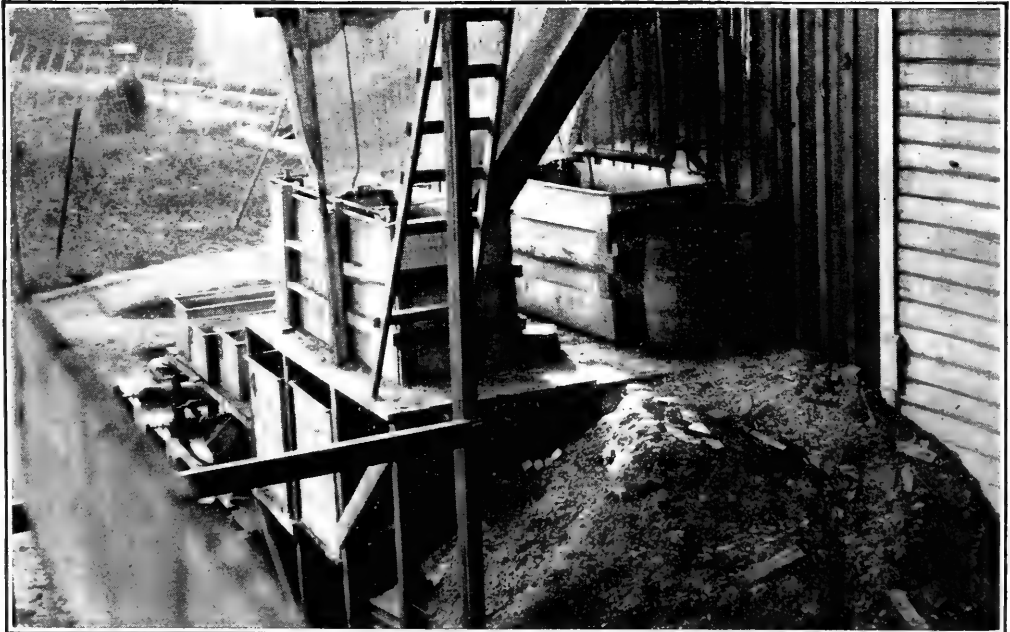


FIG. 2.—BOILING AND MIXING PLANT USED AT INDEPENDENCE, OREG. (ORIGINAL.)
FLOUR PASTE AGAINST THE HOP APHIS.



THE USE OF QUASSIA.

Various formulas for quassia spray are used in the field and were observed to be effective when properly prepared. Some of them are as follows:

Formula No. 1.

	Cents.
Quassia chips, 7 pounds, at 5½ cents per pound.....	37
Whale-oil soap, 9 pounds, at 4½ cents per pound.....	40.5
Water, 250 gallons. Total cost per 100 gallons.....	31

Formula No. 2.

	Cents.
Quassia chips, 8 pounds, at 5½ cents per pound.....	42
Whale-oil soap, 6 pounds, at 4½ cents per pound.....	27
Water, 100 gallons. Total cost per 100 gallons.....	69

Formula No. 3.

	Cents.
Quassia chips, 9 pounds, at 5½ cents per pound.....	47.2
Whale-oil soap, 6 pounds, at 4½ cents per pound.....	27
Water, 100 gallons. Total cost per 100 gallons.....	74.2

Formula No. 1 was used by Prof. W. T. Clarke in his work upon the hop aphid at Watsonville, Cal., in 1902. It was also successfully used by the writer in some field experiments at Santa Rosa, Cal., during 1911. The other formulas are stronger and have also been observed to be effective when properly prepared.

PREPARATION.

Many failures in control work, when quassia is used, are due to faulty preparation of the material. Some growers only soak the chips and use what soaks out. Others boil them without previous soaking. The proper way to prepare quassia spray, based on Formula No. 1, is as follows:

Soak the chips 24 hours, then boil for 2 hours in 3 gallons of water. Add this decoction to 247 gallons of water in which the soap has been dissolved. The whale-oil soap is readily dissolved by boiling in a small amount of water.

QUALITY OF QUASSIA.

The quality of quassia may vary and the percentage of quassin which can be extracted from the different grades of chips will not be the same. For this reason the use of quassia chips is not so certain in its results as a material containing a known amount of insecticide. When the quassia chips are used, it is well to look over sprayed areas three days after they are sprayed to be sure that the spray has been effective.

QUASSIA EFFECTIVE ONLY BY CONTACT.

There is an erroneous impression among some growers that the quassia spray after it has dried upon the leaves will kill the aphides which later appear upon them. The quassia, as well as the other sprays used for the hop aphis, is effective only when in actual contact with the insects.

EFFECT OF SPRAY MATERIALS UPON THE QUALITY OF SPRAYED HOPS.

It was suggested by some growers that nicotine sulphate, whale-oil soap, and quassia extract might injure the quality of the hops on which they were applied. In order to test this point some nearly ripe hops were sprayed with the following materials, and when the crop was being picked these sprayed hops were picked, dried in the kiln with the other hops, and later sent to Washington for analysis:

- Nicotine sulphate. 1-1,000; whale-oil soap. 4 pounds to 100 gallons.
- Nicotine sulphate. 1-2,000; whale-oil soap. 8 pounds to 150 gallons.
- Nicotine sulphate. 1-3,000; whale-oil soap. 4 pounds to 100 gallons.
- Blackleaf tobacco extract. 1-60 and 1-75, each with 2 pounds of whale-oil soap to 100 gallons.
- Quassia chips. 7½ pounds; whale-oil soap. 9 pounds to 250 gallons.

The following analyses were received from the Bureau of Chemistry:

TABLE VIII.—*Analyses of hops sprayed with various insecticides.*

No.	Whale-oil soap.	Nicotine.
1.....	None.	None.
2.....	None.	None.
3.....	None.	None.
4.....	None.	None.
5.....	None.	None.
6.....	None.	None.

The quassia was not tested for, as there is no test that is applicable.

From the above analyses it is evident that the nicotine or whale-oil soap that remained upon the hop cones was not present in sufficient quantities to be detected by a chemical analysis, and therefore would not injure the quality of the hops.

The flour paste is composed of starch and gluten, which has no distinct flavor or odor, and even through it were present in large amounts it can not be conceived how this material could influence the quality of the hops.

DIRECTION IN WHICH TO WORK.

Since the winged aphides travel largely with the wind, the best results will be obtained, especially where the winds are prevailing from one direction, by working with the wind. If this is done the

winged aphides will not be able to migrate to the sprayed hops so readily as if the wind were blowing from the unsprayed hopvines to those which have been sprayed.

CONTROL ON PRUNE.

The hop aphid apparently is capable of migrating some distance, provided the wind is right, and in prune-growing sections it is impossible to kill all of the migratory insects. Where there are only a few prune or plum trees in the neighborhood, however, the destruction of any nonproductive trees and any wild plums that may be present will reduce the number of trees that will have to be sprayed.

The spraying of the plums and prunes can not be relied upon for the control of the hop aphid, but where it is thoroughly and systematically done the severity of the season's infestation may be greatly lessened. Work along this line is strongly recommended.

FIELD OBSERVATIONS.

About the time that the aphides are expected to appear upon the plum or hop it is advisable to go through the prune orchards or hopyards and note the conditions. Careful observations, if maintained throughout the season, will keep the grower informed as to the severity of the infestation in all parts of his hopyards. He will then be able to check the infestation before any serious damage has been done.

SPRAYING REPORT.

The following form of a daily report was successfully used by Mr. H. N. Ord at Independence, Oreg., in 1912, to keep a record of the spraying operations in the field:

Date.	No. acres infested.	No. acres sprayed.	No. gallons used.	Formula and cost per 100 gallons.	Effectiveness of spray applied three days before.	No. machines used.	No. acres sprayed per machine.	Cost of operations per acre.
.....
.....
.....
.....
.....

If such a report is faithfully kept the grower will always know the condition of his hopyard and what his spraying operations are costing him.

SPRAYING MACHINERY.

Several forms of outfits may be successfully employed in the hopyards provided that they meet the following requirements: The machine should have a tank capacity of from 75 to 200 gallons,

should supply at least two lines of hose at 120 to 150 pounds pressure, and should be in such order that there will be few breakdowns or delays. Good work can be done with the hand pumps (see Pl. VII, fig. 1), the gasoline power outfits (Pl. VIII, figs. 1, 2), the compressed-air sprayers, etc., provided they meet these requirements and are supplemented by an efficient mixing and supply system.

The knapsack spraying machine (Pl. VII, fig. 2) may, under some circumstances, be of value for work on a very small scale, but is not at all practical in a commercial hopyard.

BOILING AND MIXING PLANT.

In designing a boiling and mixing plant for work on a large scale it is very desirable to arrange the tanks so that their filling and emptying is accomplished by gravity.

The uppermost tanks should be used for steeping the materials and should be supplied with water from a hydrant; the lower ones should be filled by drawing from the upper ones, or, when diluting is necessary, from a hydrant. The lower tanks, however, should be high enough to drain into a supply wagon.

DESCRIPTION OF TANKS.

The boiling and mixing tanks at Independence, Oreg., were made of No. 18 galvanized iron, riveted and soldered together, a $\frac{3}{4}$ -inch iron pipe forming a brace for the tops. Three braces of $\frac{1}{4}$ -inch angle iron, placed 3 feet 4 inches apart and riveted to the sides of the tanks, together with a framework of 2 by 4 planks, prevented the tanks from bulging.

ARRANGEMENT OF TANKS.

The arrangement of tanks shown in Plate VI, figure 2, was found very satisfactory. Two boiling tanks 10 by 3 by 3 feet 9 inches, heated by steam, were placed upon a 10 by 12 platform, elevated 10 feet from the ground. Passageways were left between and around the tanks. On a near-by but lower platform were three 375-gallon tanks for mixing and storage. A swinging outlet pipe drained the boiling tanks and directed the materials into any one of the three tanks. From the lower tanks the material was run through a long hose into the supply wagons. In order thoroughly to strain the materials the entrances of all the outlet pipes were screened with wire gauze and the ends of the hose were covered with cheesecloth.

FIELD OPERATIONS.

SUPPLY WAGONS.

When extensive spraying operations are being carried on it is essential to have an adequate supply system. In an emergency a farm wagon containing barrels of spray (Pl. VIII, fig. 2) can be used,



FIG. 1.—HAND PUMP AND BARREL ON SLEDGE. (ORIGINAL.)



FIG. 2.—KNAPSACK SPRAYING MACHINE IN USE IN HOPYARD. (ORIGINAL.)
SPRAYING AGAINST THE HOP APHIS.



FIG. 1—POWER OUTLET ON NARROW TRUCK IN USE IN HOWARD. ORIGINAL.



FIG. 2—FULL 3-POWER OUTLET FROM APPROVED SUPPLY WAGON. ORIGINAL.
SPRAYING AGAINST THE HOP APHIS.

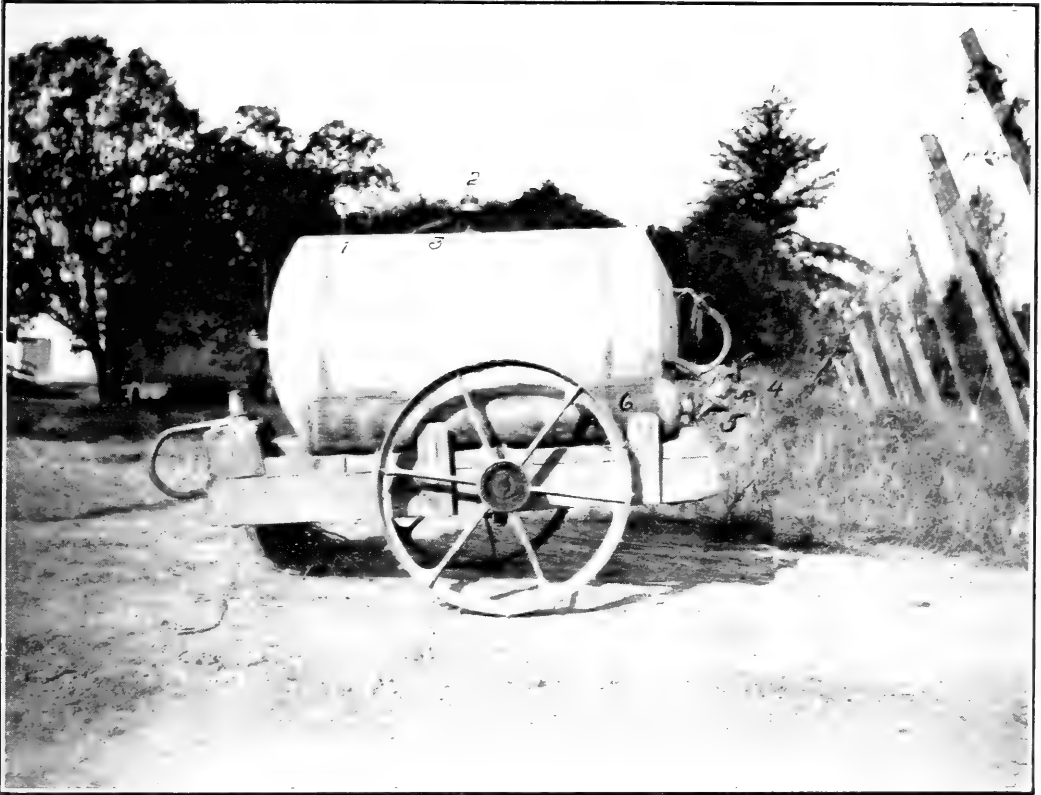


FIG. 1.—COMPRESSED-AIR SPRAYING MACHINE, SHOWING AIR BOTTLE, TANK, REDUCING VALVE, AND PRESSURE GAUGE. (ORIGINAL.)

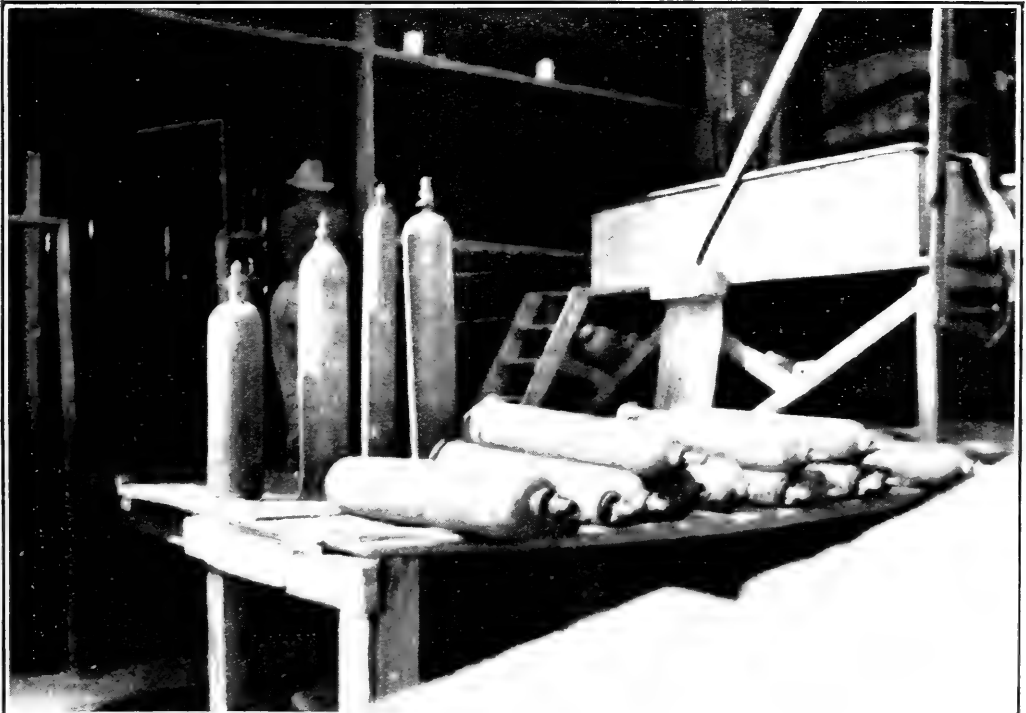


FIG. 2.—FILLING AIR BOTTLES FOR COMPRESSED-AIR SPRAYING MACHINE. (ORIGINAL.)
SPRAYING AGAINST THE HOP APHIS.



but it is very desirable to have a large tank wagon made expressly for this purpose. When low spray tanks are used the spray can be run from the supply tank by gravity, but in most cases it is necessary to employ a good pump.

EXCHANGE TANKS.

When conducting spraying operations it is desirable to keep the entire force constantly employed. The use of an exchange tank is one of the best methods for accomplishing this purpose. An extra machine is filled after the other machines have started and is exchanged for the first one emptied. The exchange tank is driven down the row in which the nearly empty tank is working. When empty the men move back and take the exchange tank, the empty tank being then refilled and exchanged for the next empty tank.

SPRAY RODS.

When the hops are growing upon short poles the spray is most readily applied with a short spray rod. In the trellised yards, however, the hops are much taller and a 10-foot rod is necessary. The aphides are mostly upon the underside of the leaves, and in order to wash them thoroughly the spray must be directed from below. When angle nozzles are not available the spray rod may be bent so that the spray is readily directed to the underside of the leaves. If one or the other of these methods is not employed the material will not be satisfactorily applied.

NOZZLES.

By exercising great care it was found possible to spray the hop-vines thoroughly with a nozzle that produced a very fine mist spray. It was found much easier, however, to do the same work with a nozzle that produced a slightly coarser washing or driving spray. This type of spray is more satisfactory because by its driving force it turns the foliage and dashes over it. When cheap labor is employed good work is more readily obtained with the coarse driving spray than with the very fine mist spray.

THE COMPRESSED-AIR SPRAYING MACHINE.

The compressed-air spraying machine (Pl. IX, fig. 1), which is described below, was invented by Mr. Theodor Eder, of Perkins, Cal., who by the following statement has generously dedicated it to the use of the public.¹

Whereas, I, THEODOR EDER, of the town of Perkins, county of Sacramento, and State of California, having invented certain improvements in spraying devices for

¹ A copy of this patent (No. 1046572) may be obtained for 5 cents by addressing the Commissioner of Patents, Washington, D. C.

which I filed on the 20th day of March, 1909, an application for patent of the United States, serial No. 484784; and

Whereas, it is my desire that the public generally shall have the right to use said invention,

Now, therefore, I, the said Theodor Eder, hereby dedicate, grant and convey to the public at large and to whomsoever may desire to use said invention, the full right, liberty and license to make, use and sell apparatus embodying the said invention for the full end of the term of any letters patent which may be granted on said application.

And I hereby authorize and request the Commissioner of Patents to issue any letters patent which may be granted on said application to the people of the United States and Territories thereof as the assignee of my entire right, title, and interests in and to the same.

In witness whereof I have hereunto set my hand and seal this 31st day of October, A. D. 1912

THEO. EDER.

This spraying machine (Pl. IX, fig. 1) is composed of a large iron tank, fitted with a pressure gauge (1), an inlet pipe with a strong screw cap (2) which is opened with a large wrench (3), an outlet pipe with cut-off (4) and connected through a pressure-reducing valve (5) with a large air bottle (6). (A large carbonic-acid gas bottle serves this purpose, the larger the better.) This machine is fastened onto a truck made from two old mower wheels and an iron shoe.

Provided that the spray material is thoroughly screened so that no dirt gets in to clog the nozzles, this machine is effective and is so small and light that it is readily hauled through a hopyard by one horse.

The air bottles are filled with air compressed by the air compress to 1,000 or 1,200 pounds (Pl. IX, fig. 2), loaded onto the supply wagon, and hauled with the spray to the field. The spray tank is filled, an air bottle connected with the reducing valve which has been set for 120 or more pounds pressure, the air is turned on, the pressure gauge indicates the pressure that is maintained, and the machine is ready for work.

The following information was received from Mr. Eder and gives data from which the cost of such a machine may be estimated:

Replying to your request in this regard, we beg to advise that the cost of these rigs depends upon the size of the spray tank, etc. A 100-gallon tank in black iron would cost about \$40. The reducing valves which we use between the air bottles and the tank cost \$10, including pressure gauges and fittings. Mowing machine wheels we buy old, costing from \$1 to \$1.50 per pair. The axles and other iron work on the truck cost in the neighborhood of \$8, and the woodwork, etc., would probably bring the entire truck construction up to \$15. The only things you would now have to add are spray hose, pipe, and nozzles, which expense would, of course, vary according to the number of leads and the length of same. We usually use four leads, two of 16 feet and two of 25 feet. We use seven-ply 3-inch hose, costing about 12 cents per foot, and use 20 feet of 3-inch pipe for spray rod to each lead, and a hop nozzle, which costs approximately 20 cents. The value of the pipe and valve would probably be \$1. The air bottles, if purchased in lots, cost \$12; singly, probably \$15.

For further information, we beg to advise that a crew of four spray hands will empty a 100-gallon spray tank on hops about five to six times a day, and this would require

one full air bottle to each tank of spray. However, the same bottles are charged several times in a day, and on some ranches we run 10 or 12 spray rigs with three dozen bottles, and could probably get along with a few bottles less, if necessary.

The air compressor we use is a 10 by 12 double-acting mine compressor with the valves removed from one end. The piston rod is continued on through and the initial compressor puts the air through pipes immersed in water that cool same, and the ram at the other end of the piston rod puts this air up to 1,000 pounds. We use XX $\frac{3}{4}$ -inch steel pipe for leads, and usually fill three or four bottles at a time, or new bottles can be put on and others taken off, without stopping the compressor. The compressor we have designed will charge about 25 bottles per hour, if necessary, all from 1,000 to 1,200 pounds. Lately we are charging quite a lot at 1,200 pounds, especially where we use 250-gallon tanks. Cost of compressor, as fitted, \$550.

For small growers it would seem to us that they could club together and buy a compressor and bring their empty air bottles in for recharging, as a bottle gets away with a lot of spray even at high pressure. The reducing valves are so constructed that any pressure desired is obtained. We have also tried the use of carbonic-acid gas for spraying, but we use the spray material up so fast that the gas freezes itself up in the valve while coming out of the bottle when the pressure is being reduced. This could be overcome by the use of an alcohol lamp in the lead line, but this is too cumbersome; besides, air costs less.

E. CLEMENS HORST Co.,
By THEO. EDER.

COST OF SPRAYING.

The following estimate of the cost of spraying for the hop aphid is made from data taken from actual field work on high-trellis yards. The amount of material needed for hops on short poles will be somewhat less.

It has been found that one machine will spray from 2 to 3 acres per day, and that in order to do thorough work it is necessary to apply from 300 to 500 gallons per acre according to the amount of foliage on the vines. The following data are based upon a machine which will spray 2 acres per day:

Materials: Nicotine sulphate, 1-2,000; flour paste, 4-100. Cost, 70.8 cents per 100 gallons.

	300 galls.	500 galls.
Applying per acre.....	\$2. 13	\$3. 54
Labor, 3 men, \$2 per day for $\frac{1}{2}$ day.....	3. 00	3. 00
1 horse, 50 cents per day for $\frac{1}{2}$ day.....	. 25	. 25
Total cost per acre of 1 application.....	5. 38	6. 79

QUASSIA AND WHALE-OIL SOAP.—FORMULA NO. 2.

Cost of materials per 100 gallons..... \$0. 69
Cost of cooking..... . 11

Total..... . 80

	300 galls.	500 galls.
Applying per acre.....	\$2. 40	\$4. 00
Labor, 3 men, \$2 per day for $\frac{1}{2}$ day.....	3. 00	3. 00
1 horse, 50 cents per day for $\frac{1}{2}$ day.....	. 25	. 25
Total cost of 1 application.....	5. 65	7. 25

The cost of stripping the vines preliminary to spraying will be from \$1.80 to \$2 per acre.

The cost of spraying for the hop aphis, although apparently great, is nothing compared to the losses which result from neglect to spray for this insect.

Thorough spraying is, then, a good business policy and should be carefully done by all commercial hop growers.

CULTURAL METHODS.

CLEAN CULTURE.

Suckers growing between the rows and vines growing over fences and near-by trees usually have much dense foliage, due to the growth



FIG. 8.—Short-pole hopyard, showing dense foliage around base of vines, which harbors the hop aphis. (Original.)

of several plants upon a limited area, and form an ideal breeding place for the aphides. Such plants may form a constant source of infestation and should be promptly removed.

STRIPPING THE VINES.

One of the most important cultural methods now in use is stripping the vines to a point about 4 feet above the ground (fig. 8). This removes the suckers and dense foliage, which protect and foster the aphides, from around the base of the vines. Experiments show that

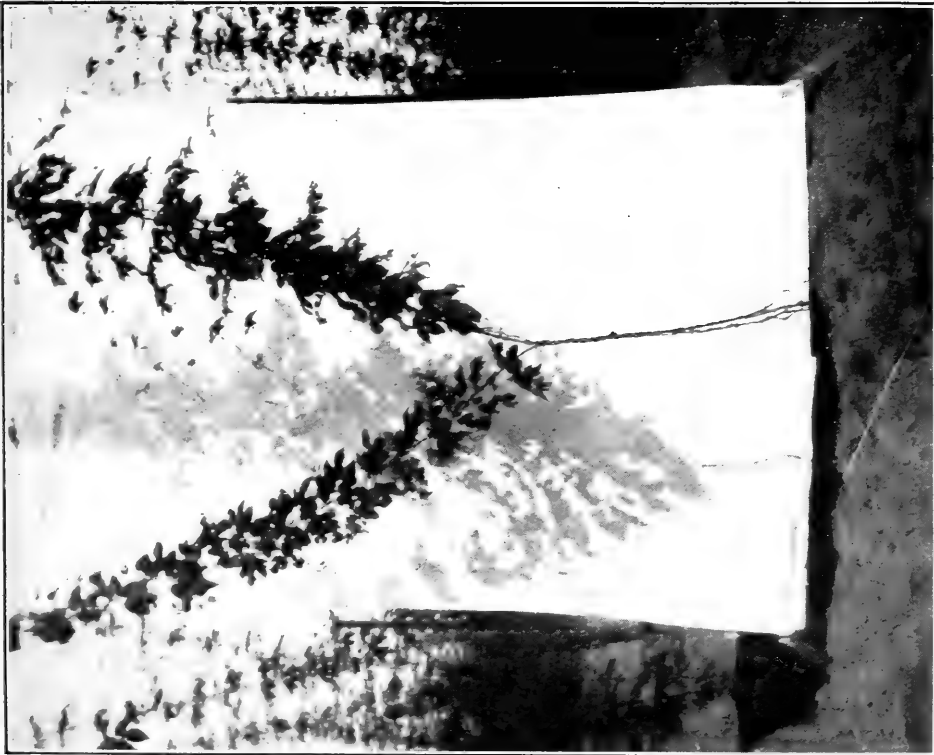


FIG. 1.—HOPVINE STRIPPED, AND TIED BELOW THE POINT OF STRIPPING, SHOWING FREE CONDITION OF ALL FOLIAGE.

[This vine may be successfully sprayed.] (Original.)

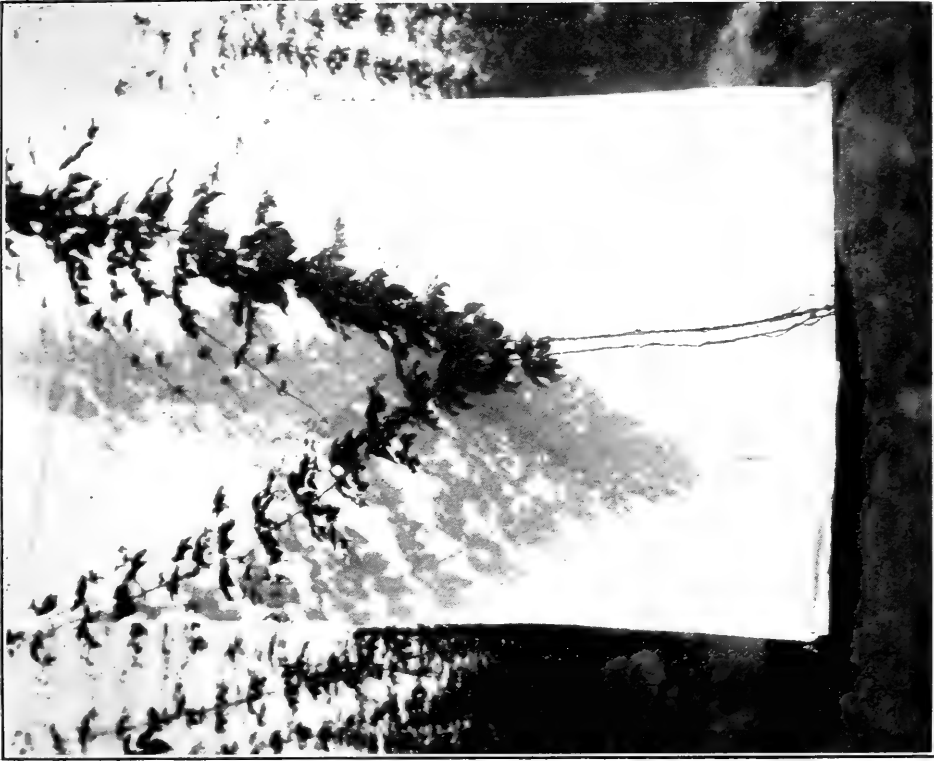


FIG. 2.—HOPVINE STRIPPED, AND TIED ABOVE POINT OF STRIPPING, SHOWING MATTED CONDITION OF LOWER FOLIAGE.

[These vines may not be successfully sprayed.] (Original.)

SPRAYING AGAINST THE HOP APHIS.

when the vines are stripped and tied together above the point of stripping (Pl. X, fig. 2) the foliage below this point is matted and difficult to spray thoroughly, but that when the vines are tied below the first foliage (Pl. X, fig. 1) the leaves are free and the undersides are readily treated. Stripping the vines is a necessary preliminary to the successful control of the hop aphid and should be done before commencing to spray.

PICKING OFF INFESTED LEAVES.

It is the custom of some growers to pick off the infested leaves and throw them on the ground. This practice reduces the infestation somewhat, but even though all of the removed aphides die, there are many scattered ones left upon the vines which will soon cause reinfestation. The writer has never observed any good results from this practice alone.

FERTILIZATION AND IRRIGATION.

Stimulation of the vines helps them to resist the draining effect of the aphides and encourages the production of the hops, but does not retard the insects in the least, the resulting dense foliage favoring their development. Proper irrigation and fertilization invigorate the hopvines and are very beneficial, but when an infestation occurs they should be supplemented by thorough spraying operations.

GENERAL SUMMARY, WITH RECOMMENDATIONS.

The investigation of the life history and control of the hop aphid has brought out the following points:

(1) The hop aphid, if not carefully controlled, always injures and may cause a total loss of a large portion of the crop.

(2) The insect may hibernate upon the plum or the hop. The destruction of the hibernating forms will aid in the control of this insect.

(3) The insect is readily killed by several contact insecticides.

(4) Several applications may be necessary to control an infestation successfully.

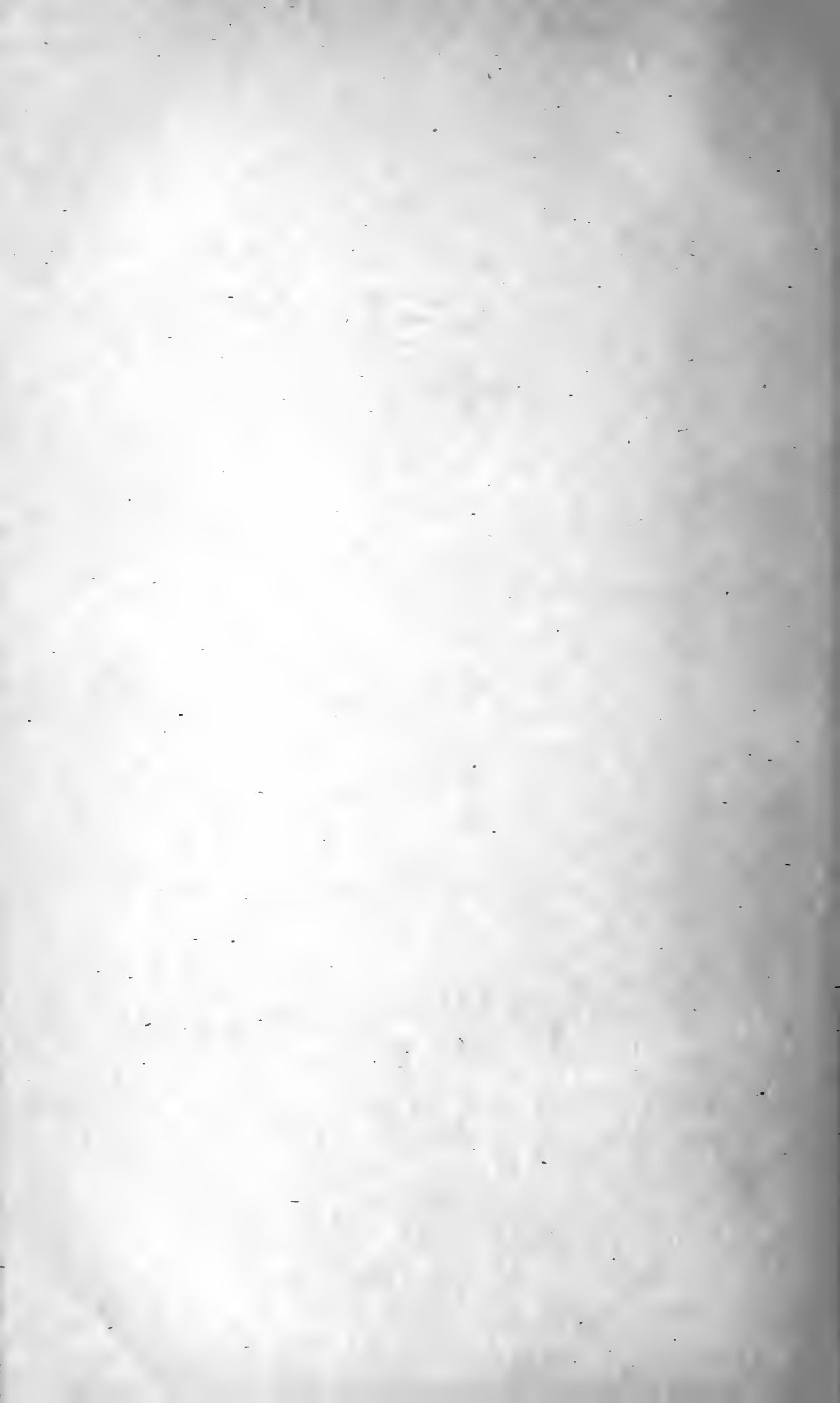
(5) If successful control is desired the spraying operations *must not be delayed* and the work must be very thorough; all of the leaves of the vines must be wetted on both sides. It is more economical to waste a little material than not to apply enough.

(6) Severe infestations have been successfully checked and clean hops obtained where the spraying operations were thorough.

THE MORE IMPORTANT WRITINGS ON THE HOP APHIS.

1904. CLARKE, W. T.—Bul. 160, Univ. Cal. Agr. Exp. Sta., 13 pp., 7 figs.
1897. CORDLEY, A. B.—Bul. 45, Oreg. Agr. Exp. Sta., pp. 99, 127, 13 figs., June.
Habits and remedies.
1906. FELT, E. P.—Proc. 24th Ann. Meet. Soc. Prom. Agr. Sci., pp. 39–48.
1865. FITCH, A.—The Country Gentleman, vol. 25, p. 274, April 27.
Destructiveness, enemies, and remedies.
1904. FLETCHER, J.—Bul. 46, Div. Ent., U. S. Dept. Agr., pp. 82–88, May.
1904. FLETCHER, J.—Rept. Exp. Farms Canada, pp. 163–215.
1887. HOWARD, L. O.—Country Gentleman, vol. 52, p. 875, November 17.
First published full life history.
1897. HOWARD, L. O.—Bul. 7, n. s., Div. Ent., U. S. Dept. Agr., pp. 84–87.
1899. HOWARD, L. O.—Hop Industry, Orange Judd Co., New York, pp. 113–141, 19 figs.
Accounts of the species known to affect hops.
1896. KOEBELE, A.—Insect Life, vol. 6, pp. 12–17, November.
Experiments with hop louse in Oregon and Washington.
1887. LINTNER, J. A.—Cultivator and Country Gentleman, vol. 52, p. 511, June 30.
Remedies.
1889. LINTNER, J. A.—New England Homestead, p. 253, July 27.
Remedies for hop-aphis.
1891. LINTNER, J. A.—New England Homestead, p. 193, May 2.
How to control the hop-aphis.
1900. LUGGER, O.—Bul. 69, Minn. Agr. Exp. Sta., pp. 250, 200 figs., 16 pls.
1904. PETTIT, R. H.—Spec. Bul. 24, Mich. Agr. Exp. Sta., pp. 79, 70 figs.
1908. REMISCH, FR.—Zeitschrift für wissenschaftliche Insektenbiologie, vol. 4, no. 10,
pp. 365–366.
Important enemy of hops.
1910. REMISCH, FR.—Zeitschrift für wissenschaftliche Insektenbiologie, vol. 6, no. 6,
p. 242.
Mentioned in article on *Adalia bipunctata* as the principal food of that species.
1911. REMISCH, FR.—Zeitschrift für wissenschaftliche Insektenbiologie, vol. 7, nos.
7–8, pp. 240–243; no. 9, pp. 282–285.
Article, "The hop leaf louse, *Aphis humuli*."
1891. RILEY, C. V.—Cir. 2, 2d ser., Div. Ent., U. S. Dept. Agr., pp. 7, 5 figs., 1 pl.,
June.
1891. RILEY, C. V.—Insect Life, vol. 3, pp. 181–210, January.
1893. RILEY, C. V.—Ann. Rept. U. S. Dept. Agr., pp. 199–226, 3 pls.
1891. RILEY, C. V., and HOWARD, L. O.—Insect Life, vol. 3, p. 350, April.
1891. RILEY, C. V., and HOWARD, L. O.—Insect Life, vol. 3, p. 486, August.
Hop lice on Pacific Coast.
1891. RILEY, C. V., and HOWARD, L. O.—Insect Life, vol. 4, p. 84, October.
Quassia for the hop-aphis.
1892. RILEY, C. V., and HOWARD, L. O.—Insect Life, vol. 4, pp. 342–343, June.
Hop louse in the extreme northwest.
1892. RILEY, C. V., and HOWARD, L. O.—Insect Life, vol. 4, p. 401, August.
Hop-aphis remedies.
1892. RILEY, C. V., and HOWARD, L. O.—Insect Life, vol. 4, p. 406, August.
The hop louse in Oregon.
1892. RILEY, C. V., and HOWARD, L. O.—Insect Life, vol. 5, p. 60, September.
The hop plant louse in Washington.
1893. RILEY, C. V., and HOWARD, L. O.—Insect Life, vol. 6, p. 53, November.
Hop lice in New York State.

1912. SANDERSON, E. D.—Insect Pests of Farm, Garden, and Orchard, pp. 275-278, figs. 202-204.
On hop.
1891. WASHBURN, F. L.—Bul. 10, Oreg. Agr. Exp. Sta., pp. 23-24, figs. 5.
Description and treatment.
1893. WASHBURN, F. L.—Bul. 25, Oreg. Agr. Exp. Sta., pp. 9-12.
Treatment.
1894. WASHBURN, F. L.—Bul. 31, Oreg. Agr. Exp. Sta., pp. 79-88, 3 figs., 2 pls., April.
1894. WASHBURN, F. L.—Bul. 31, Oreg. Agr. Exp. Sta., p. 82, April.
Brief notes, with suggestions as to remedies.

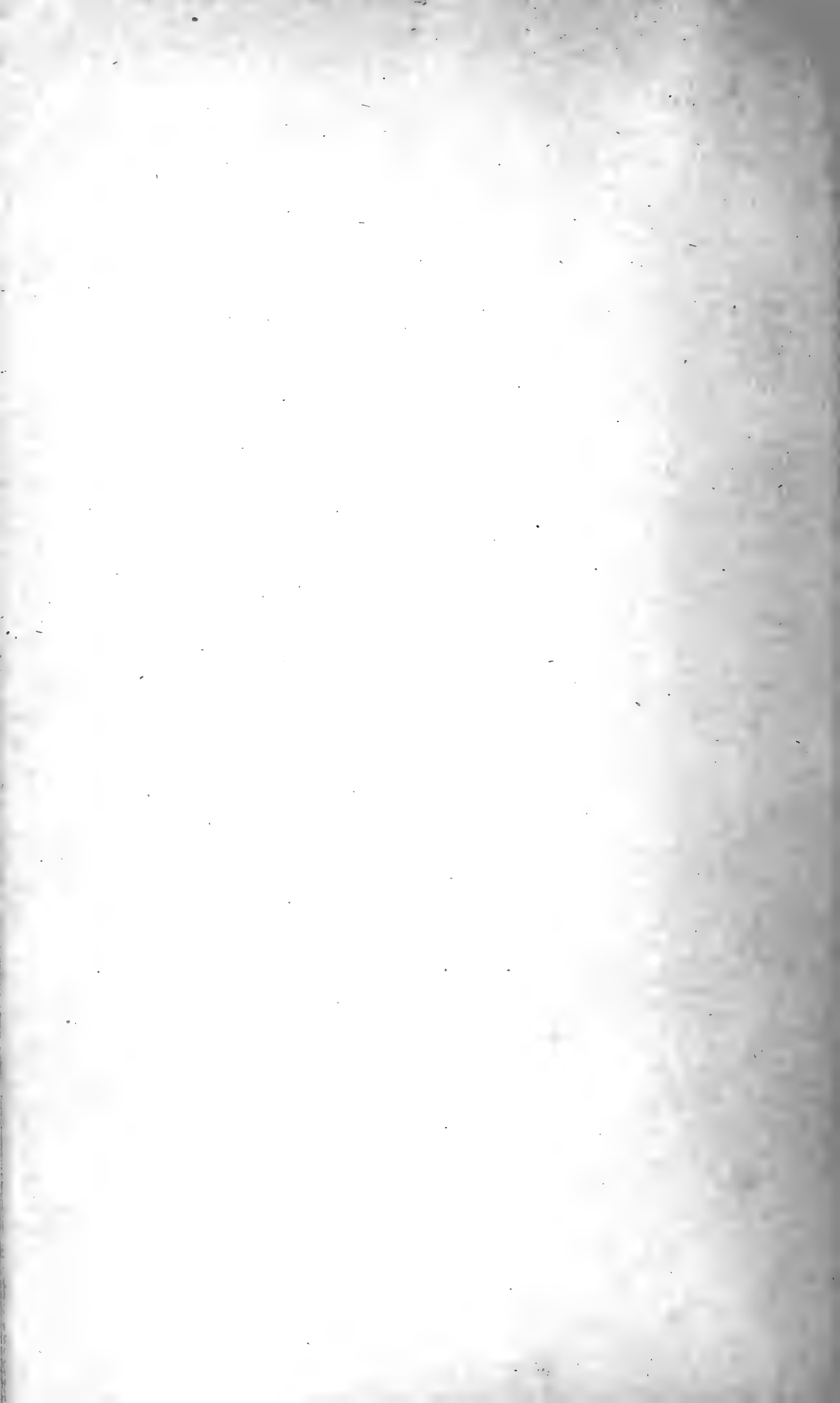


INDEX.

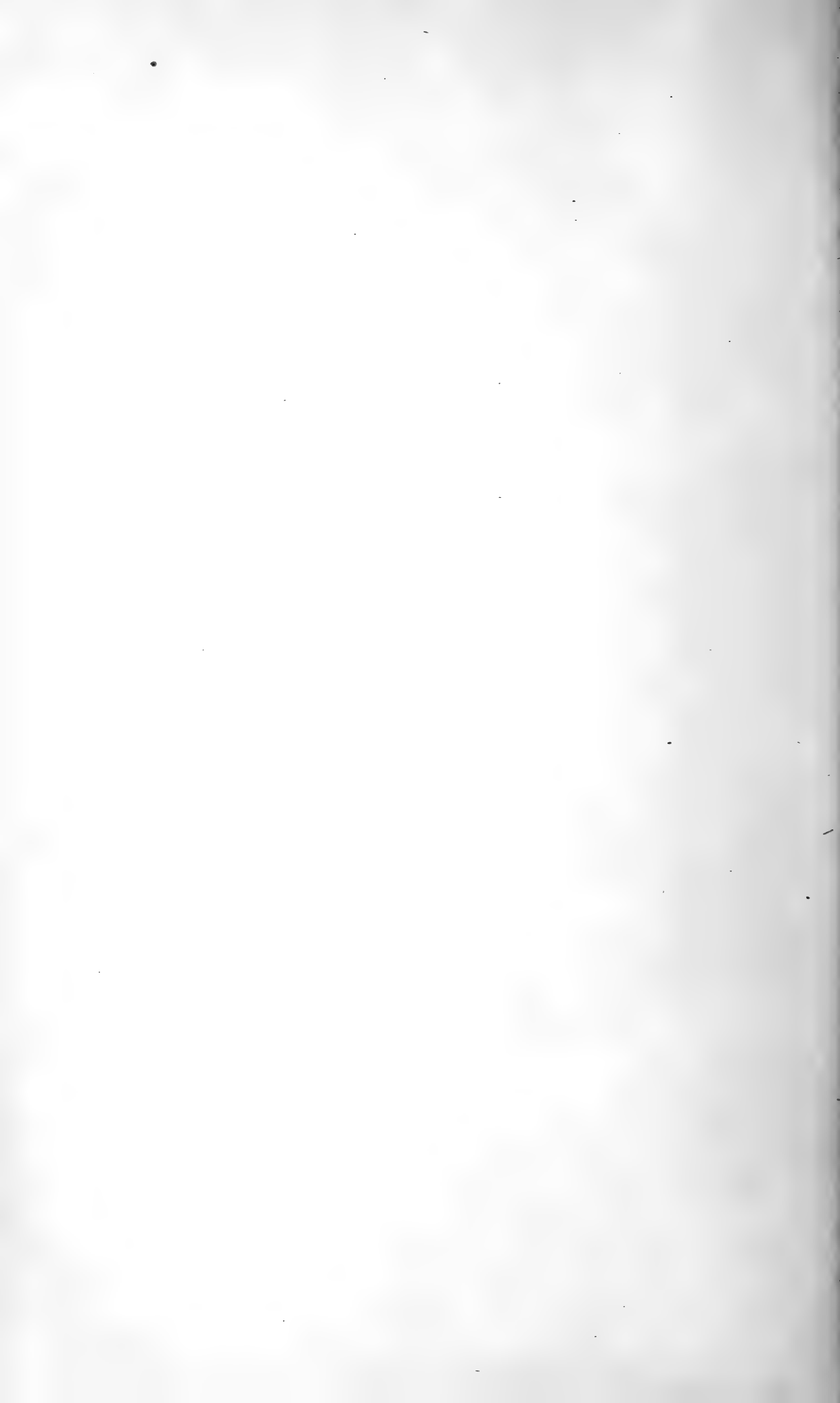
	Page.
<i>Adalia bipunctata</i> , enemy of hop aphis.....	23
<i>Anthocoris</i> sp., enemy of hop aphis.....	23
Ants, relation to hop aphis.....	19
Aphides on shrubs and trees near hopyards mistaken for hop aphis.....	21
Aphis, hop, bibliography of more important writings.....	38-39
control axioms.....	23
measures.....	23-37
on prune.....	31
recommendations, summary.....	37
damage, nature.....	21-22
deposition of young.....	14-15
early history.....	9
economic importance.....	9-10
effect, general, upon hops.....	21-22
of heat thereon.....	20-21
eggs, winter.....	17-18
emergence from hibernation.....	12
enemies, natural.....	22-23
favorable and unfavorable conditions therefor.....	20-21
field observations, importance in control work.....	31
operations in control.....	32-35
first appearance in season.....	20
food plants.....	21
generations, number on host.....	13
growth, rate.....	15-16
habitation.....	19
habits.....	19-20
head compared with that of melon aphid.....	15
hibernation.....	10
emergence therefrom.....	12
insecticides used in control.....	23
life history.....	10-19
losses due to its work.....	10
migrants, fall.....	17
summer, theory regarding them.....	18-19
migratory activities.....	13-14
migrating forms.....	13
necessity for thorough work in control.....	24
number of spray applications used in control.....	24
young deposited by viviparous females.....	16-17
on hop roots.....	10-12
procrastination in control work, results.....	24
protection.....	19
relation of ants thereto.....	19

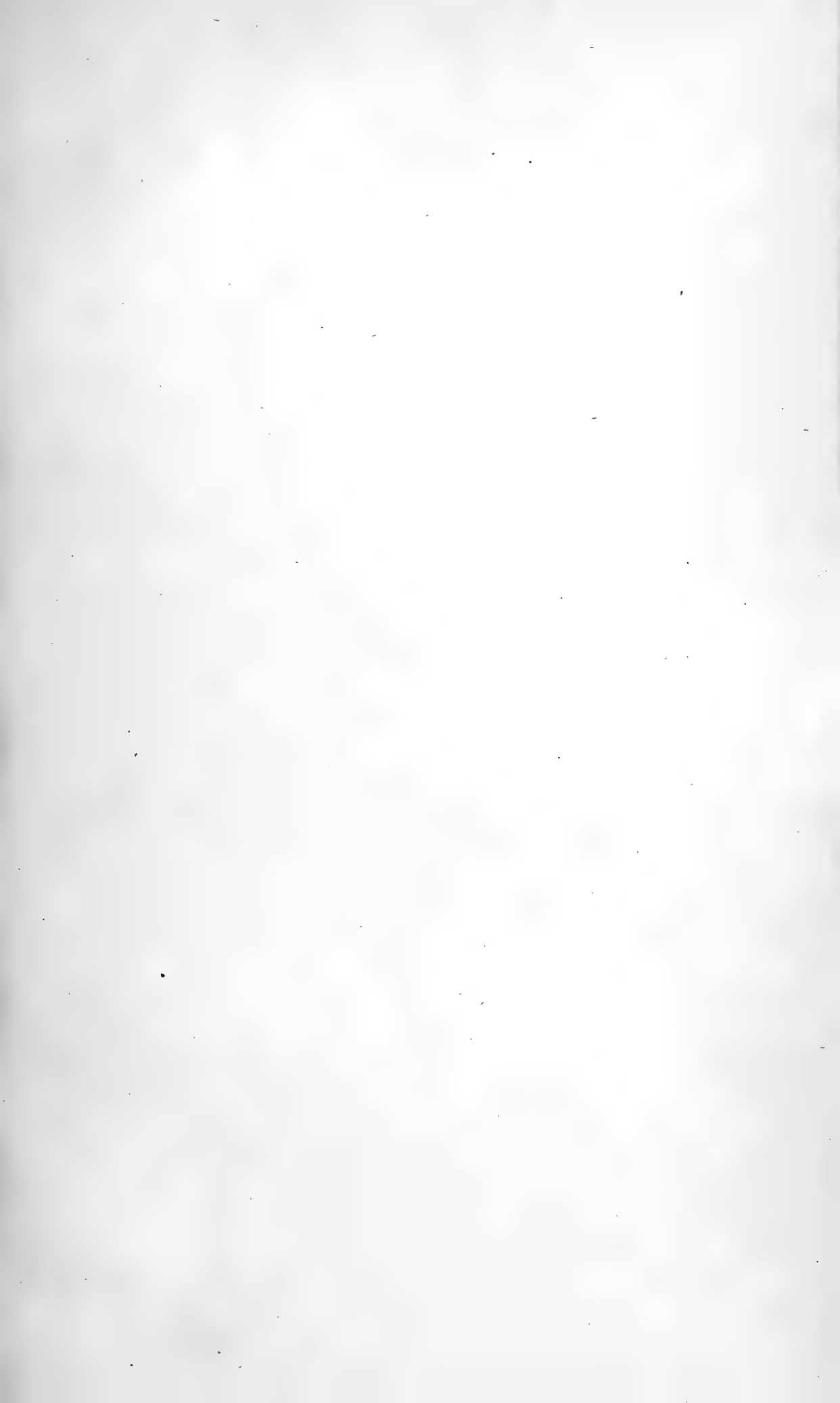
	Page.
Aphis. hop. reproduction, method.....	12-13
spraying experiments in control.....	24-27
time to begin.....	23-24
summary, general.....	37
young, number deposited by viviparous females.....	16-17
melon, comparison of head with that of hop aphis.....	15
<i>Aphis gossypii</i> . (See Aphis, melon.)	
Boiling and mixing plant for spraying against hop aphis.....	32
<i>Camptobrochis nebulosus</i> , enemy of hop aphis.....	23
<i>Chilocorus orbis</i> , enemy of hop aphis.....	22
<i>Chrysopa californica</i> , enemy of hop aphis.....	22
<i>Cladosporium</i> sp., blackening of hops caused thereby.....	22
growing on honeydew excreted by hop aphides.....	21-22
Clean culture against hop aphis.....	36
<i>Coccinella abdominalis</i> , enemy of hop aphis.....	22
<i>californica</i> , enemy of hop aphis.....	22
Compressed-air spraying machine, use against hop aphis, description.....	33-35
Cost of spraying against hop aphis.....	35-36
Cultural methods against hop aphis.....	36-37
Direction in which to work in spraying against hop aphis.....	30-31
Fertilization in control of hop aphis.....	37
Flour paste, advantages over whale-oil soap as a spreader for contact insecti- cides.....	28
and nicotine sulphate against hop aphis.....	26-27
cost per 100 gallons.....	35
effect on quality of hops.....	30
preparation.....	27
<i>Formica subsericea</i> , relation to hop aphis.....	19
Fungus, smut. (See <i>Cladosporium</i> sp.)	
Heat, effect on hop aphis.....	20-21
<i>Hippodamia convergens</i> , enemy of hop aphis.....	22
Honeydew excreted by hop aphis. black-smut fungus (<i>Cladosporium</i> sp.) grow- ing thereon.....	21
effect on hops.....	22
Hop aphis. (See Aphis, hop.)	
food plant of hop aphis.....	21
picking off infested leaves for control of hop aphis.....	37
sometimes winter host plant of hop aphis.....	14
vines, damage by black-smut fungus (<i>Cladosporium</i> sp.) growing on honey- dew excreted by hop aphis.....	21-22
stripping them in control of hop aphis.....	37
Hops, blackening caused by smut fungus, <i>Cladosporium</i> sp.....	22
quality as affected by spray materials used against hop aphis.....	30
Irrigation in control of hop aphis.....	37
Lime sulphate ineffective against hop aphis.....	25
Machinery for spraying against hop aphis.....	31-35
Nicotine solutions, mixing them with whale-oil soap.....	27
sulphate against hop aphis.....	25-27
and cresol soap against hop aphis.....	25
flour paste against hop aphis.....	26-27
cost per 100 gallons.....	35
lye-resin soap against hop aphis.....	25
whale-oil soap against hop aphis.....	25-27

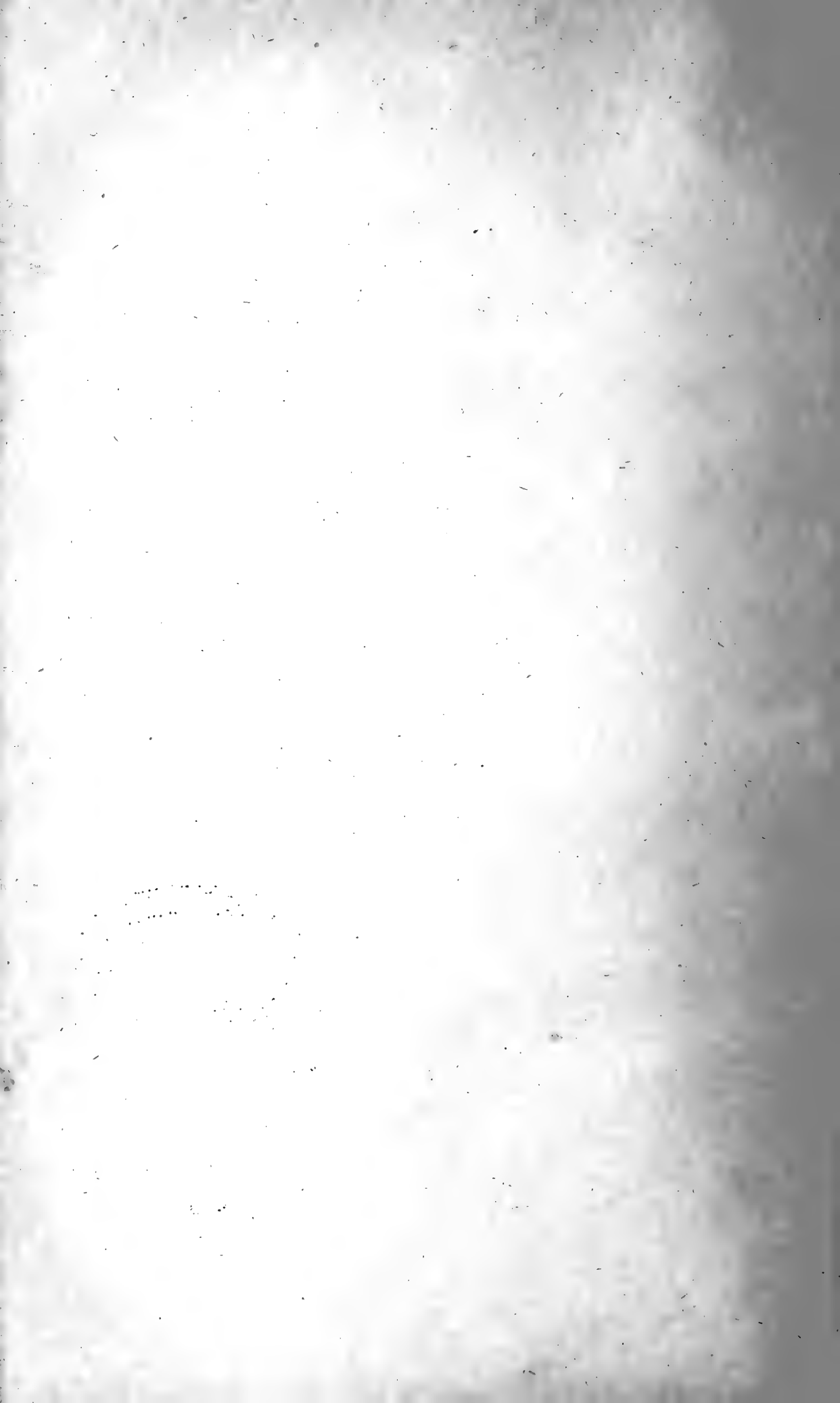
	Page.
Nozzles for spraying against hop aphis.....	33
<i>Phorodon humuli</i> . (See Aphis, hop.)	
Picking off infested leaves as remedy against hop aphis.....	37
<i>Picræna excelsa</i> . (See Quassia.)	
Plum, winter host plant of hop aphis.....	14
Prune, winter host plant of hop aphis.....	14
Quassia against hop aphis.....	28-30
and whale-oil soap, cost per 100 gallons.....	35
effective only by contact.....	30
effect on aphides.....	28
formulas.....	29
noninjurious to hops.....	30
preparation.....	29
quality.....	29
Report form for use in spraying against hop aphis.....	31
Rods for spraying against hop aphis.....	33
Sloe, winter host plant of hop aphis.....	14
Soap, cresol, and nicotine sulphate against hop aphis.....	25
ineffective against hop aphis.....	25
lye-resin, and nicotine sulphate against hop aphis.....	25
ineffective against hop aphis.....	25
whale-oil, and nicotine sulphate against hop aphis.....	25-27
quassia, cost per 100 gallons.....	35
mixing it with nicotine solutions.....	27
versus flour paste as a spreader for contact insecticides.....	28
Spraying against hop aphis, boiling and mixing plant.....	32
cost.....	35-36
direction in which to work.....	30-31
exchange tanks.....	33
nozzles.....	33
spraying machinery.....	31-35
report in daily use.....	31
spray rods.....	33
supply wagons.....	32-33
tanks, arrangement.....	32
description.....	32
exchange.....	33
Spraying machine, compressed-air, description and patent by Theo. Eder....	33-35
Spray materials against hop aphis, effect on quality of hops.....	30
<i>Stethorus punctum</i> , enemy of hop aphis.....	23
Supply wagons for spraying against hop aphis.....	32-33
<i>Syrphus americanus</i> , enemy of hop aphis.....	22
<i>opinator</i> , enemy of hop aphis.....	22
Tanks, exchange, for spraying against hop aphis.....	33
for spraying against hop aphis, arrangement, description.....	32
Tobacco solution, blackleaf, against hop aphis.....	25
waste solution against hop aphis.....	25-26
<i>Triphleps insidiosus</i> , enemy of hop aphis.....	23
Weather. (See Heat.)	











insects
U. S. DEPARTMENT OF AGRICULTURE,

BUREAU OF ENTOMOLOGY—BULLETIN No. 112.

L. O. HOWARD, Entomologist and Chief of Bureau.

PRELIMINARY REPORT ON THE ALFALFA WEEVIL.

BY

F. M. WEBSTER,

In Charge of Cereal and Forage Insect Investigations.

ISSUED MAY 14, 1912.



CANCELLED
221891

WASHINGTON:
GOVERNMENT PRINTING OFFICE.
1912.

THE UNIVERSITY OF CHICAGO
LIBRARY
540 EAST 57TH STREET
CHICAGO, ILL. 60637

U. S. DEPARTMENT OF AGRICULTURE,

BUREAU OF ENTOMOLOGY—BULLETIN No. 112.

L. O. HOWARD, Entomologist and Chief of Bureau.

PRELIMINARY REPORT ON THE ALFALFA WEEVIL.

BY

F. M. WEBSTER,

In Charge of Cereal and Forage Insect Investigations.

ISSUED MAY 14, 1912.



WASHINGTON:
GOVERNMENT PRINTING OFFICE,
1912,

BUREAU OF ENTOMOLOGY.

L. O. HOWARD, *Entomologist and Chief of Bureau.*
C. L. MARLATT, *Entomologist and Acting Chief in Absence of Chief.*
R. S. CLIFTON, *Executive Assistant.*
W. F. TASTET, *Chief Clerk.*

F. H. CHITTENDEN, *in charge of truck crop and stored product insect investigations.*
A. D. HOPKINS, *in charge of forest insect investigations.*
W. D. HUNTER, *in charge of southern field crop insect investigations.*
F. M. WEBSTER, *in charge of cereal and forage insect investigations.*
A. L. QUAINANCE, *in charge of deciduous fruit insect investigations.*
E. F. PHILLIPS, *in charge of bee culture.*
D. M. ROGERS, *in charge of preventing spread of moths, field work.*
ROLLA P. CURRIE, *in charge of editorial work.*
MABEL COLCORD, *in charge of library.*

CEREAL AND FORAGE INSECT INVESTIGATIONS.

F. M. WEBSTER, *in charge.*

GEO. I. REEVES, W. J. PHILLIPS, C. N. AINSLIE, E. O. G. KELLY, T. D. URBAHNS,
HARRY S. SMITH, GEO. G. AINSLIE, J. A. HYSLOP, W. R. WALTON, J. T. MONELL,
J. J. DAVIS, T. H. PARKS, R. A. VICKERY, V. L. WILDERMUTH, E. G. SMYTH,
HERBERT T. OSBORN, PHILIP LUGINBILL, C. W. CREEL, E. J. VOSLER, R. N. WIL-
SON, VERNON KING, *entomological assistants.*
NETTIE S. KLOPPER, ELLEN DASHIELL, *preparators.*
MIRIAM WELLES REEVES, *collaborator.*

LETTER OF TRANSMITTAL.

U. S. DEPARTMENT OF AGRICULTURE,
BUREAU OF ENTOMOLOGY,
Washington, D. C., January 2, 1912.

SIR: I have the honor to transmit herewith, for publication as Bulletin No. 112 of this bureau, the manuscript of a preliminary report on the investigation of the alfalfa weevil in Utah and adjacent States. The investigations of the Bureau of Entomology in cooperation with the Utah Agricultural Experiment Station began April 1, 1910, and still continue. The period covered by this report is from April 1, 1910, to November 15, 1911. From April 1, 1910, to April 1, 1911, the bureau was represented in the investigations with but one assistant. Since that time the force has been increased until eight or nine persons have been from time to time employed. The information given is exactly what the title of the bulletin implies, preliminary in nature and not to be taken as conclusive in all cases. It is simply a short account of what has been done within the period of time just indicated.

Respectfully,

L. O. HOWARD,
Entomologist and Chief of Bureau.

HON. JAMES WILSON,
Secretary of Agriculture.

CONTENTS.

	Page.
Introduction.....	9
First appearance of the alfalfa weevil in the United States.....	9
Spread of the pest.....	10
Investigations by the Utah Experiment Station.....	11
Cooperation of the Bureau of Entomology and the Utah Experiment Station..	12
Cooperation with other bureaus of the United States Department of Agriculture.	14
Variety experiment.....	14
Investigations of vertebrate enemies.....	15
The insect not correctly determined.....	15
Appearance of a second species in Utah.....	15
Description and seasonal history of the alfalfa weevil.....	15
Egg-laying period.....	19
Evidence of a partial second generation.....	20
The larva.....	21
Larval period.....	22
Cocooning and pupating.....	23
Food plants.....	24
Migration and diffusion.....	25
Field experiments in destroying the alfalfa weevil.....	26
Street-sweeper experiments.....	27
Wire-brush experiment.....	27
Cultivation in connection with irrigation.....	29
Burning machine.....	29
Reduction in quality of hay caused by the alfalfa weevil.....	30
Natural enemies.....	30
Invertebrates.....	31
Predaceous enemies.....	31
A native true parasite.....	34
Introduced parasites.....	34
Egg parasites.....	35
Mymarid egg parasite.....	35
Pteromalid egg parasite.....	35
Parasites of larvæ and pupæ.....	36
Pteromalid larval parasite.....	36
Other parasites.....	38
Vertebrates.....	40
Fungous enemies.....	41
Index.....	43



ILLUSTRATIONS.

PLATES.

	Page.
PLATE I. Conditions favoring the spread of the alfalfa weevil. Fig. 1.—Volunteer growth of alfalfa on vacant lots in Salt Lake City, Utah. Fig. 2.—Volunteer alfalfa growing along the right of way of the Oregon Short Line Railway, a short distance north of Salt Lake City, Utah	12
II. Hibernation of the alfalfa weevil. Figs. 1, 2.—Hibernating places of the alfalfa weevil along fences and borders of fields in the vicinity of Salt Lake City, Utah. Fig. 3.—One of the main irrigation ditches in the Salt Lake Valley, a favorable hibernating place for alfalfa weevils.....	16
III. Injury wrought by the alfalfa weevil. Fig. 1.—One of the worst infested fields in the Salt Lake Valley, showing injury to the first crop of alfalfa, which was left uncut. Fig. 2.—(a) Bunch of alfalfa uninjured by the alfalfa weevil; (b) bunch of alfalfa badly injured by the alfalfa weevil, showing growth made by first crop in the badly infested fields.....	20
IV. Injury wrought by the alfalfa weevil. Fig. 1.—Crop secured from first cutting of one of the worst infested fields. Fig. 2.—First cutting from another field damaged from attack by the alfalfa weevil. Fig. 3.—First cutting secured from one of the fields of alfalfa slightly injured by the attack of the weevil	20
V. Field experiments against the alfalfa weevil. Fig. 1.—Street sweeper in operation on alfalfa field after first crop was removed. Fig. 2.—Second crop ready to cut in field on which street sweeper was used June 14. Fig. 3.—Second crop of alfalfa growing on field where no treatment was given	28
VI. Field experiments against the alfalfa weevil. Fig. 1.—Wire-brush cultivator in operation on alfalfa field after first crop was removed. Fig. 2.—Second crop of alfalfa growing nicely as a result of treatment given. Fig. 3.—Condition of untreated fields about June... ..	28
VII. Field experiments against the alfalfa weevil. Fig. 1.—Second crop of alfalfa, estimated at 2 tons per acre, secured from field treated with wire-brush cultivator. Fig. 2.—Fourth crop of alfalfa secured from field where brush cultivator was used. Fig. 3.—Condition of field used as check (Pl. V, fig. 3)	28
VIII. Field experiments against the alfalfa weevil. Fig. 1.—Alfalfa field after first crop was removed, severely disked preparatory to application of "mudding" process against alfalfa weevil. Fig. 2.—Following the irrigation water with a drag, to puddle the weevils in the mud	28
IX. Field experiments against the alfalfa weevil. Fig. 1.—Second crop of alfalfa in field treated by the "mudding" process. Fig. 2.—Condition of untreated fields at time photograph shown in figure 1 was taken. Fig. 3.—Patch of first crop left in field shown in figure 1, showing how larvæ were disseminated from the first crop into the field where the weevil had been killed by the "mudding" process.....	28

	Page.
PLATE X. Fig. 1.—Burning machine experimented with as a method of destroying the alfalfa weevil. Fig. 2.—Boxes containing parasites of the larvæ and pupæ of the alfalfa weevil, showing how this material was imported from Italy. Fig. 3.—Boxes of parasite material imported from Italy which contain egg parasites of the alfalfa weevil.....	32
XI. Introduction of parasites of the alfalfa weevil. Figs. 1, 4.—Type of cages in which larval and pupal parasites of the alfalfa weevil were reared in the laboratory. Figs. 2, 3.—Boxes sealed and fitted with glass tubes into which imported parasites emerged and were separated in the laboratory.....	36
XII. Figs. 1, 2.—Field cages used in hibernation experiments on the alfalfa weevil. Fig. 3.—Planting a colony of imported parasites of the alfalfa weevil in Utah in an alfalfa field.....	36
XIII. Figs. 1, 2.—Laboratories of the Bureau of Entomology, United States Department of Agriculture, at Salt Lake City and Murray, Utah.....	40

TEXT FIGURES.

FIG. 1. The alfalfa weevil (<i>Phytonomus posticus</i>): Adult.....	10
2. The clover-leaf weevil (<i>Hypera punctata</i>): Stages and work.....	16
3. The alfalfa weevil: Eggs.....	17
4. The alfalfa weevil: Larvæ attacking foliage; eggs in stem.....	18
5. The alfalfa weevil: Larva.....	21
6. The alfalfa weevil: Cocoon.....	23
7. The alfalfa weevil: Pupa.....	24
8. The alfalfa weevil: Adults attacking sprig of alfalfa.....	24
9. Nine-spotted lady-beetle (<i>Coccinella 9-notata</i>): Adult, larva.....	31
10. Convergent lady-beetle (<i>Hippodamia convergens</i>): Adult, pupa, larva..	31
11. The two-spotted Collops (<i>Collops bipunctatus</i>): Adult.....	32
12. A predaceous mite, <i>Pediculoides ventricosus</i> : Adult female before the abdomen has become inflated with eggs and young.....	32
13. <i>Pediculoides ventricosus</i> : Adult female after the abdomen has become inflated with eggs and young.....	32
14. A predaceous mite, <i>Erythræus arvensis</i> : Adult.....	33
15. <i>Anaphes</i> sp., a mymarid egg parasite of the alfalfa weevil.....	34
16. Imported pteromalid egg parasite of the alfalfa weevil: Adult.....	35
17. Larva of pteromalid egg parasite of the alfalfa weevil.....	36
18. Pupa of pteromalid egg parasite of the alfalfa weevil.....	36
19. Pteromalid parasite of larva and pupa of the alfalfa weevil: Adult female.....	37
20. Pteromalid parasite of larva and pupa of the alfalfa weevil: Adult male.....	37
21. Pteromalid parasite of larva and pupa of the alfalfa weevil, showing eggs in place and enlarged figure of same.....	38
22. Pteromalid parasite of larva and pupa of the alfalfa weevil, showing parasite larva.....	38
23. Larva of pteromalid parasite attacking pupa of alfalfa weevil.....	38
24. Pupa of pteromalid parasite shown in figures 22 and 23.....	38
25. <i>Canidiella curculionis</i> , a parasite of the alfalfa weevil: Adult female....	39
26. <i>Itoplectis masculator</i> , a parasite of the alfalfa weevil: Adult female....	40
27. Cocoon of the alfalfa weevil, showing cocoon of the parasite <i>Canidiella curculionis</i> within.....	41

PRELIMINARY REPORT ON THE ALFALFA WEEVIL.

INTRODUCTION.

The alfalfa weevil belongs to a genus or group of beetles all of the members of which attack clover, alfalfa, and closely allied plants. Even before the appearance of this one, *Phytonomus posticus*¹ Gyll. (fig. 1), in our midst several other species had been introduced from Europe, had become established in our fields, and had spread to a greater or less extent over the country.² After becoming fully developed in early summer, all apparently have the same habit of scattering themselves over the country, a little later crawling into any secluded place that they can find, there to pass the winter. Years ago a lady residing in Michigan and spending the summer in New York, where one species of these beetles, *Hypera punctata* (fig. 2), was at the time very abundant, on her return home and on unpacking her trunk found some of them ensconced among the contents. They had in all probability secreted themselves, either in the trunk itself while it was being packed, or else among articles of clothing exposed out of doors prior to being packed in the trunk.

The alfalfa weevil is found in Europe, western Asia, and northern Africa, where, though it sometimes becomes abundant, it is not especially destructive. The foregoing will illustrate the numerous ways whereby it might have been introduced into this country in articles of commerce, in household goods, or among other belongings of immigrants coming from those countries.

FIRST APPEARANCE OF THE ALFALFA WEEVIL IN THE UNITED STATES.

The pest was first reported on the outskirts of Salt Lake City, Utah, in the spring of 1904. At that time it had seriously injured several acres of alfalfa, the first crop being damaged fully one-half and the second crop practically destroyed. The following spring, 1905, its work was observed several miles way. The particular locality where the pest was first observed is on the eastern border of the city. Although not far distant from nurseries, it is not in close

¹In a recent paper, "The Genera *Hypera* and *Phytonomus* in North America north of Mexico" (Annals of the Entomological Society of America, vol. 4, no. 4, pp. 383, 473, pls. 24-34, December, 1911), Prof. E. G. Titus has given this species as *P. posticus* Gyll. *Phytonomus punctatus* had already been placed in the genus *Hypera* by European authors.

²*Phytonomus punctatus* Fab.: See Report of the Commissioner of Agriculture for 1881-82, pp. 171-179; *Phytonomus nigrirostris* Fab.: See Bul. 85, Part I, Bur. Ent., U. S. Dept. Agr., 1909. For other species of the genus see paper by R. L. Webster, Ent. News, vol. 20, pp. 80-82, 1909.

proximity to any railway; it is, on the other hand, among the habitations of the more humble class of people, such as have come from foreign countries. The correct inference, therefore, would seem to be that it was introduced with nursery stock or in the household effects of immigrants. The pest had gained a foothold, doubtless, years earlier, but had increased from perhaps a single pair and was too few in numbers to attract attention up to the time when it had become destructive over several acres and when it had probably spread in limited numbers far beyond. In the immediate vicinity of this seriously infested field, and indeed throughout the country about Salt Lake, alfalfa long ago escaped from cultivation and now grows as a weed generally on vacant lots (Pl. I, fig. 1) and other uncultivated areas like roadsides and railroad rights of way (Pl. I, fig. 2), so that it would now be impossible to determine, even approximately, the

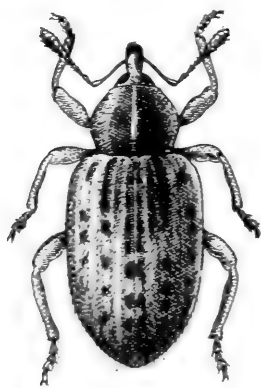


FIG. 1.—The alfalfa weevil (*Phytonomus posticus*): Adult. Much enlarged. (Author's illustration.)

exact time and location of the original landing of the first individuals in Utah. As a matter of fact the insect might easily have been brought into the country again and again and have perished because the locality in which it ended its voyage was destitute of growing alfalfa.

SPREAD OF THE PEST.

From the single infested alfalfa field near Salt Lake, the only one known up to the year 1904, the pest evidently became somewhat widely diffused and by the following year was found several miles distant to the southeast. It was not, however, until 1907 that it was brought to the attention of the Utah Experiment Station and not until 1908 that attention was called to the matter in print by Prof. E. G. Titus,¹ entomologist of the Agricultural College and Experiment Station, although by the fall of 1907 it had spread over all of the alfalfa-growing section lying immediately east of Salt Lake and Murray.² By July 1, 1910, the infested area covered the greater part of Salt Lake and contiguous portions of adjoining counties, aggregating an area approximately 60 by 70 miles in extent.³

Up to September, 1911, the insect had extended its area of diffusion directly northward as far as Tremonton, east to Evanston, Almy, and Lyman, Wyo., and northeast to Cokeville, Wyo., Randolph and Laketown, Utah, and Fish Haven, Idaho.

¹ Deseret Farmer, Salt Lake City, Utah, September 26 and October 3, 1908.

² Bul. 110, Utah Agr. Coll. Exp. Sta. The Alfalfa Leaf-Weevil, by E. G. Titus, Logan, Utah, September, 1910.

³ Loc. cit., map 1.

INVESTIGATIONS BY THE UTAH EXPERIMENT STATION.

From the time the attention of the Agricultural Experiment Station authorities at Logan, Utah, was called to the pest and its destructive proclivities they began to investigate and experiment with a view of overcoming its ravages. Following the breeding season of 1909, however, the situation became so alarming as to make it clear that the State of Utah could not hope to cope with the pest single-handed. Besides, there was no longer a doubt that it would soon spread to alfalfa fields in other States, thus becoming a matter of interstate concern.

On August 4, 1909, his excellency William Spry, governor of Utah, appealed to the honorable the Secretary of Agriculture for assistance in controlling the insect and, if possible, preventing its spread into other States.

It was exceedingly unfortunate that this outbreak of the pest was not made known long before in order that it might have been investigated, for at this time it had become too widespread and destructive to be dealt with by any ordinary force of men. Besides, at this time the funds available with which to carry on investigations were wholly inadequate.

The appropriations made for the Bureau of Entomology for the fiscal year 1910-11 gave a slight increase of funds, \$2,000 of which provided for cooperation with the State of Utah in investigation of the alfalfa weevil. None of this sum would, however, become available until July 1, 1910, after the season for the investigation of the insect had largely passed for the year. In view of the seriousness of the situation Mr. C. N. Ainslie was sent to Salt Lake, Utah, to take up cooperative work, April 1, 1910, lack of available funds prohibiting any further detail for the purpose.

At this time the entire cooperative force consisted of but two trained men, Mr. Ainslie, of the Bureau of Entomology, and Prof. E. G. Titus, of the Utah Agricultural College and Experiment Station, and Mr. Sadler, a student assistant, also from the experiment station.

From the fact that the experiment station people had carried out a number of field experiments against the weevil and had other experiments in view, and because of the bureau's limited funds for this work, it was deemed best that Mr. Ainslie devote his principal time to a close study of the insect itself and its habits, leaving the field experiments to be carried on by and under direction of the experiment station. The results and information thus obtained up to July 1, 1910, were embodied in Bulletin No. 110 of the Utah Experiment Station, by Mr. Titus, of which the author thereof has given the following synopsis:

The alfalfa leaf-weevil is a small, oval, brown snout-beetle, about $\frac{3}{16}$ of an inch long, that is attacking alfalfa in Utah. It is not a native species but has come to Utah from Europe.

It feeds on plants belonging to the alfalfa family, injuring all parts of the plant above ground.

The eggs are laid in the spring and early summer in the stems or on the buds and leaves, and hatch in about ten days. The young or larvæ are small alfalfa-green worms with a black head; they never become much more than one-quarter of an inch in length when full grown. They feed on and in the leaf-buds, in the stalks and on the leaves.

The larvæ have no true legs and have the habit of feeding or resting in a curled position.

When full grown, about 50 or 60 days after hatching, they go to the ground and spin around them a lace-cocoon, in which, in about fourteen days, they have turned into the full-grown, hard-shelled adult.

This adult feeds on the stems, leaves and buds for several weeks and in August goes into hibernation for the winter, seeking any well sheltered place.

The insect now occurs in Salt Lake, Davis, Weber, Morgan, Summit, Wasatch, Utah, and Tooele Counties, and threatens to eventually reach all our alfalfa growing regions. It spreads rapidly in the adult or beetle stage by flying in spring and summer and by being carried with articles shipped from an infested region, and on railroads, in wagons and automobiles, traveling through the places where it occurs.

It is recommended that alfalfa be disced in early spring to stimulate it to better growth. That the first growth be cut when the most of the eggs have been laid (middle of May), and then brush-drag the field thoroughly.

Sheep may be pastured on the fields at this time for two weeks, and alfalfa then watered and a good crop will usually be assured.

Gathering machines to capture the larvæ and beetles have given good results when used on the fields at the time the insects are most numerous.

Fields should be brush-dragged again after the first crop has been cut.

All weeds and rubbish should be cleaned from fields, yards, ditches and fence rows so that there will be less opportunity for the weevils to find winter shelter.

Alfalfa should not be allowed to grow more than seven or eight years in infested districts.

The amount of work that the Utah Experiment Station did with its limited means and lack of trained men is certainly most commendable, and it is difficult to see wherein the course adopted by the station director (Dr. E. D. Ball) and his subordinates could have been improved upon. It was from the beginning an unequal contest, and the only wonder is that so much good was accomplished with the limited means available.

COOPERATION OF THE BUREAU OF ENTOMOLOGY AND THE UTAH EXPERIMENT STATION.

There was the same basis of cooperation between the Bureau of Entomology and the Utah Experiment Station from April 1 until September 1, 1910, when Prof. Titus left the State, leaving Mr. Ainslie, and for a few weeks Mr. Sadler, to carry on the work. In the agricultural bill covering the fiscal year from 1911-12, under appropriations for cereal and forage insect investigations, \$10,000 of this appropriation was made immediately available on passage of the act, to enable the bureau to take up investigations of the alfalfa weevil promptly in the spring of 1911. With the aid of



FIG. 1.—Volunteer growth of alfalfa on vacant lots in Salt Lake City, Utah. The alfalfa plant beside the hat contained at the time approximately 1,200 to 1,300 eggs. This was in the midst of the egg-laying time. (Original.)

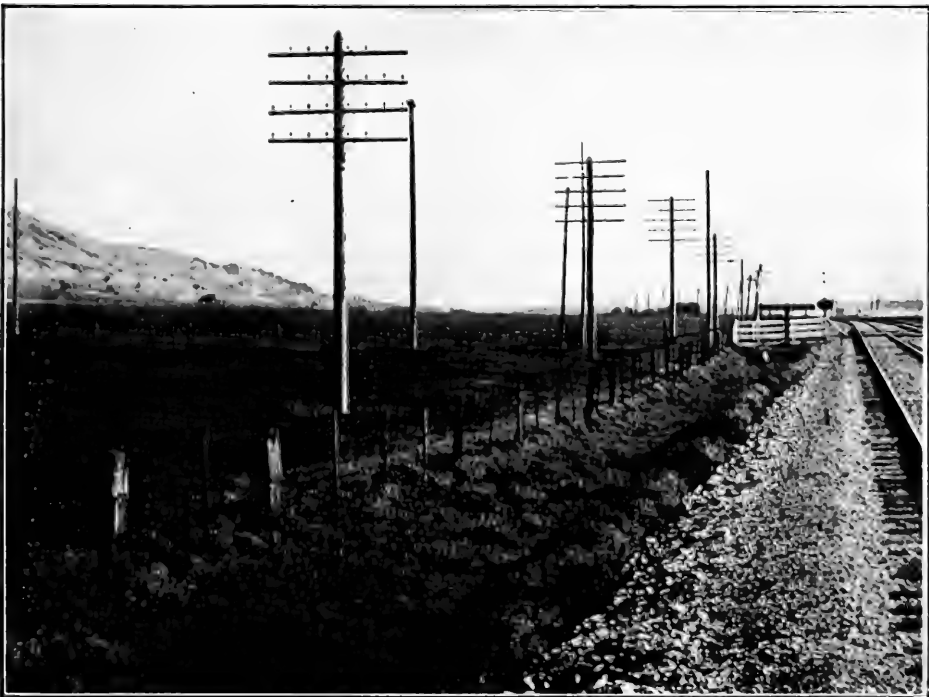


FIG. 2.—Volunteer alfalfa growing along the right of way of the Oregon Short Line Railway a short distance north of Salt Lake City, Utah. (Original.)

CONDITIONS FAVORING THE SPREAD OF THE ALFALFA WEEVIL.



this fund, on April 1 a corps of entomologists was sent to Salt Lake City, Utah, for the purpose of carrying out a thorough study of the insect and its ravages, with special reference to methods of control. Gradually other assistants were detailed, until the number employed in and about Salt Lake was increased to nine, exclusive of the student assistant detailed from the State Agricultural Experiment Station.

The primary object of this work was, so far as possible, to restrict the insect to the area it then occupied and to use every effort, by field experiments in measures of control, to devise means of lessening its destructiveness.

In the meantime it has been learned definitely that the alfalfa weevil was largely held in check in its native home by its natural enemies. Mr. W. F. Fiske, in charge of the Gipsy Moth Parasite Laboratory, having been detailed for work in Italy, kindly volunteered to look into the matter of natural enemies of the weevil and, so far as was possible without interfering with his other duties, to send over to this country any insect enemies that seemed to him susceptible of colonization in Utah. The object of this was to get these insect enemies established, in so far as it was practicable to establish them, at the earliest possible date, in order that they might have the opportunity to diffuse themselves during the spring of 1911. The value of Mr. Fiske's services at this time and in this direction can hardly be overestimated. A more detailed account of this matter will be found under a discussion of the introduction of the natural enemies of the alfalfa weevil.

Very naturally the alfalfa weevil work divided itself into two branches: (1) The field work, which included all mechanical measures for controlling the pest in the field; and (2) the work, necessarily carried out largely in the laboratories at first, involved in the care and management of the parasitic material dispatched by Mr. Fiske from Italy. After the beginning of the fiscal year 1911-12 the experiment station was able to add but slightly to the force of investigators. By this time, however, the annual generation of the weevil had developed to the adult stage and laboratory investigations had largely decreased.

While, as shown, the experiment station, owing to circumstances not under its control, was not able to put into the field men trained for this kind of work, the bureau was able by the aid of the immediately available fund to overcome this difficulty. In the meantime, however, the experiment station did its full share in other directions. Dr. Ball, director of the station, did not hesitate to use his personal and official influence whenever and wherever it could be of service in advancing this work. Besides this, in a great many cases he was able to relieve the bureau of expenses of field investigations as well as to carry a number of other items of expense for which it would

have been impracticable for the bureau to have provided. It may be stated, then, that from April 1 to September 1, 1910, the cooperative work was largely under the direction of Prof. E. G. Titus of the experiment station. From September, 1910, to April, 1911, it was mostly carried on personally by Mr. C. N. Ainslie. During the spring and summer of 1911 the investigation was carried on under the general direction of those connected with the Bureau of Entomology. Outside of the work on parasites, which has been carried on wholly by the bureau, it is not possible distinctly to indicate just what part of the cooperation was carried on by either the bureau or the experiment station. This combination has been for the purpose of accomplishing the greatest amount of good, and there has been no inflexible line separating the work of the two cooperative bodies. As a matter of fact, the results obtained could not have been secured under any other arrangement or with less unselfish feeling than has existed among those engaged in the investigation.

COOPERATION WITH OTHER BUREAUS OF THE UNITED STATES DEPARTMENT OF AGRICULTURE.

Observations made by Mr. W. F. Fiske in the vicinity of Naples, Italy, during the spring of 1910 appeared to indicate a possible preference on the part of the alfalfa weevil for certain varieties of alfalfa. Those varieties, notably, having a slender stem appeared to be less freely attacked as compared with those varieties having more robust stems. It was with the view of perhaps being able to find a variety of alfalfa more or less objectionable to the alfalfa weevil that a cooperative experiment was taken up with the Bureau of Plant Industry.

VARIETY EXPERIMENT.

The Chief of the Bureau of Plant Industry, therefore, detailed Mr. Roland McKee, of the Office of Forage Crop Investigations, to superintend the seeding of a number of varieties of alfalfa (*Medicago sativa*) and the following closely related species: *Medicago falcata* L., *M. ruthenica* (L.) Trautv., *M. lupulina* L., *M. ciliaris* (L.) All., *M. echinus* Lam., *M. hispida nigra* (Willd.) Burnet, *M. hispida confinis* (Koch) Burnet, *M. hispida terebellum* (Willd.) Urban, *M. muricata* (L.) All., *M. orbicularis* (L.) All., and *M. scutellata* (L.) Mill. The tests of these varieties are being conducted on a farm in the vicinity of Salt Lake City, Utah.

Such observations as it has been possible to make upon the young plants involved in this experiment will be found recorded under food plants. It will of course be understood that the most valuable and decisive information bearing upon the relative extent of attack in these different varieties of alfalfa can not be observed until the spring of 1912. Therefore the information now given must be regarded as only initiative.

INVESTIGATIONS OF VERTEBRATE ENEMIES.

In order to determine what assistance might be expected from birds and other animals besides insects, arrangements were made with the Biological Survey to send an assistant to Salt Lake in order to carry out extended investigations along this line. Mr. E. R. Kalmbach was detailed for this work by the Chief of the Biological Survey and proceeded to Salt Lake, Utah, making continuous observations there from May 7 to July 5, 1911.

It is not possible at the present time to give the results of this work in detail, but a list of the vertebrate enemies observed attacking the alfalfa weevil will be found under the heading Natural Enemies.

THE INSECT NOT CORRECTLY DETERMINED.

In the bulletin of the Utah Experiment Station, to which reference has already been made, the name of the insect is given as *Phytonomus murinus* Fab., and this name was also applied to the same insect by the writer in Circular No. 137 of the Bureau of Entomology, issued April 20, 1911. It had been so determined by one of the best American authorities on this order of insects. It has, however, proved to be a closely related insect (*Phytonomus posticus* Gyll.), much more common and injurious to alfalfa in Europe, western Asia, and northern Africa, and in these countries known generally as *P. variabilis* Hbst., meaning literally the variable *Phytonomus*. It is, however, less destructive in the Eastern Hemisphere than it bids fair to be in this country, because of its natural enemies at home, which, as it appears, were not brought over with it when it was first introduced.

APPEARANCE OF A SECOND SPECIES IN UTAH.

A much larger species, *Hypera punctata* Fab. (fig. 2), the clover-leaf weevil, has recently been found about Malad, Idaho, by Mr. H. T. Osborn, and about Ogden, Utah, by Mr. E. J. Vosler, both of this bureau. This is a larger insect than the alfalfa weevil, but may be confused with it by the ordinary farmer. It had not before been observed between the Rocky Mountains and the Cascades.

While known as a clover insect, this last beetle did some damage to alfalfa in Virginia during June, 1910.

DESCRIPTION AND SEASONAL HISTORY OF THE ALFALFA WEEVIL.

The fully-developed alfalfa weevil, *Phytonomus posticus* Gyll. (fig. 1), is a small, rather insignificant appearing beetle, slightly under one-fourth of an inch long, of a brown color, mixed with gray and black hairs arranged in indistinct spots and stripes on the back, as shown in figure 1. Rubbed individuals may be very dark, verging on black.

The beetles pass the winter hidden away among matted grass or other similar vegetation, including alfalfa, and, indeed, among most kinds of rubbish anywhere, wherever they will be protected from the weather. The beetles have also been found in early spring under clods and about the crowns of alfalfa plants where the ground had been roughly cultivated the previous autumn. The overgrown margins of fields and irrigation canals and ditches afford excellent places for hibernation, some of which are shown in Plate II, figures 1, 2, and 3.

With the first warm weather in spring the beetles become active and diffuse themselves over the alfalfa fields, feeding upon any living

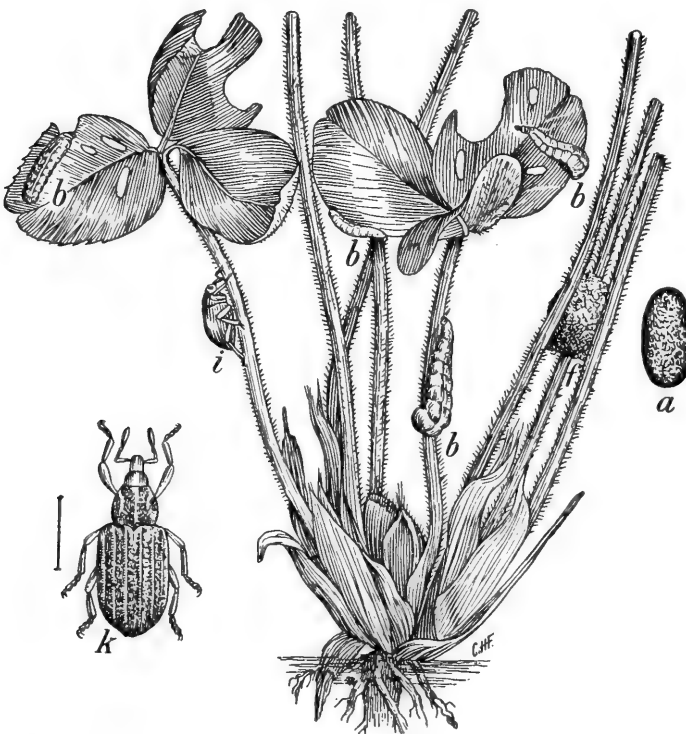
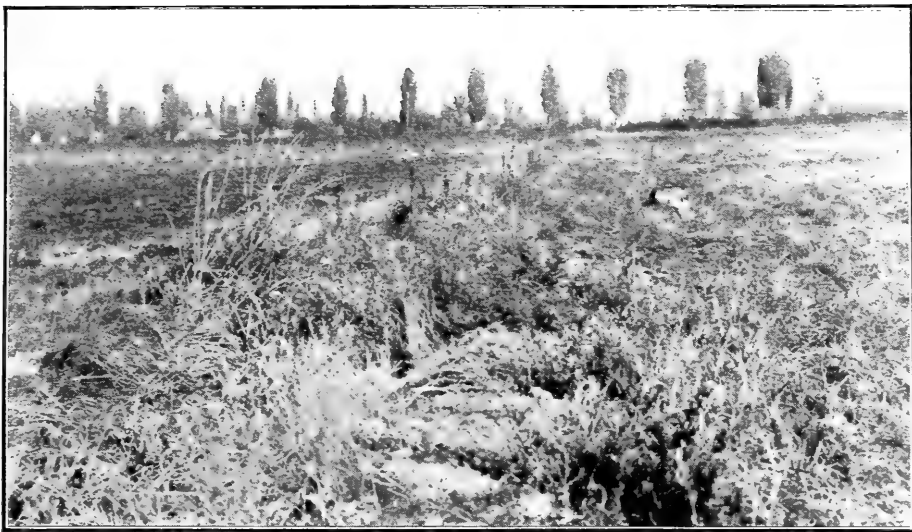


FIG. 2.—The clover-leaf weevil (*Hypera punctata*): a, Egg; b, b, b, b, larvae feeding; f, cocoon; i, beetle; k, same, dorsal view. (b, f, i, Natural size; k, enlarged; a, greatly enlarged.) (From Riley.)

part of the plants that have escaped the winter or, as soon as it commences to push forth, on the fresh growth, both leaf and stem. During some years the beetles are abroad in the fields in Utah early in March; in other and colder springs it may be April before they bestir themselves. Latitude and elevation, with the consequent modifications of temperature, will have much to do in deciding the time of emergence from winter quarters in spring. They also to some extent hibernate in the alfalfa fields.

As soon as the beetles have spread from their winter quarters out over the fields they pair, and the females are ready to deposit their eggs (figs. 3, 4). As a matter of fact, however, pairing has been observed in the fall, and females taken while hibernating are observed to lay 75 per cent of fertile eggs. According to the notes of Mr. Fiske, made in Italy, they may place their eggs in the old, dead, overwintered stems or even in the dead stems of plants other than those of alfalfa, but in Utah the beetles refused to oviposit in dead stems in the laboratory cages. According to Dr. Giovanni Martelli,¹ at Portici in 1909 the first adults which he obtained appeared toward

¹ First contribution to the biology of *Phytonomus variabilis* Herbet. Bollettino del Laboratorio di Zoologia Generale e Agraria della R. Scuola Superiore d'Agricoltura in Portici, vol. 5, March, 1911.

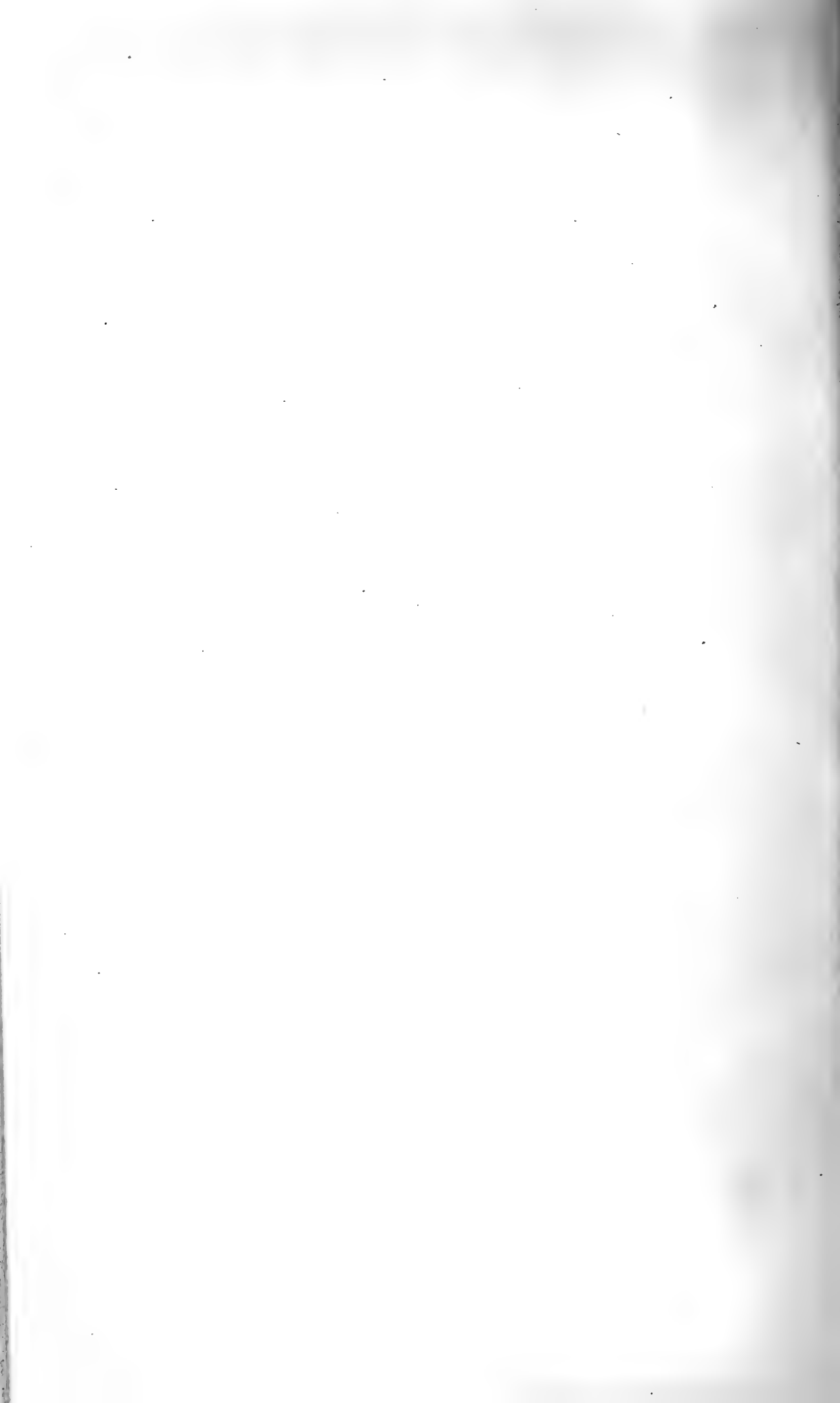


FIGS. 1 and 2.—Hibernating places of the alfalfa weevil along fences and borders of fields in the vicinity of Salt Lake City, Utah. (Original.)



FIG. 3.—One of the main irrigation ditches in the Salt Lake Valley, a favorable hibernating place for alfalfa weevils. Photographed July 7, 1911. (Original.)

HIBERNATION OF THE ALFALFA WEEVIL.



the end of April; at Acicastello in 1910 they appeared during the first part of the second half of April. The maximum birth at Portici in 1909 took place toward the end of the second decade of May and the last adults were hatched near the end of May. At Acicastello the maximum birth took place in the first decade of May and the last were hatched during the second decade of the same month.

The females do not, however, always confine themselves to alfalfa stems in ovipositing. On April 18, 1911, Mr. T. H. Parks found eggs of *Phytonomus* in punctures similar to those made in alfalfa in the stems of the ground plum, *Astragalus arietinus*. Later Mr. C. N. Ainslie found a number of these eggs in similar punctures, also in the stems of this plant, there being usually six or eight eggs in each puncture. Afterwards Mr. Ainslie found larvæ feeding on *Astragalus utahensis*.

A few days before, Mr. Parks had also found eggs deposited on the surface of leaves, on bits of trash, on the inside of a split stem of grass, and, in one case, upon the bare ground.

In a very early spring some of the eggs may be deposited outside of the plant, but evidently this is not usual and occurs mostly when the growing stems of alfalfa are too small or not sufficiently numerous to satisfy the requirements of the females in this direction. In preparing for egg deposition the female punctures the stem with her beak. The punctured stems and a group of these eggs in place are shown in figure 4.

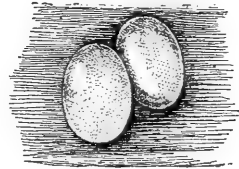


FIG. 3.—The alfalfa weevil: Eggs. Greatly enlarged. (Author's illustration.)

The method of oviposition has been described by Mr. Titus.¹

Observations were made by Mr. C. N. Ainslie in which he found that oviposition seemed to be accomplished by forcing the beak into the fleshy tissues of the stem, sometimes into a hollow stem, in which case the eggs are merely placed in the natural cavity. Where placed in a leaf petiole, as is sometimes the case, the cavity for the eggs must be necessarily eaten out. Generally in these eaten cavities only 4 or 5 eggs are placed, while in the hollow stems 15 or 20 seem not uncommon. Once or twice Mr. Ainslie found eggs placed below the enlarged base of the petiole. In this case the eggs were placed in position through a hole made through the base of the petiole and the mass of eggs was well protected by the hairy leaf buds and unfolded leaflets behind the base of the petiole. Once in a while the hole into the stem is eaten and the beak not merely forced in, in which case the gleam of the yellow eggs can be seen through the tunnel into the stem. When the opening is forced it is left more or less filled with fibers that have been disrupted or forced aside by the beak and the ovipositor. These fibers are often blackened from

¹ Bulletin 110, Utah Agr. Coll. Exp. Sta., pp. 38-39, September, 1910.

some cause, perhaps simple oxidation, and appear quite different from the "feeding holes" that are much more common. These latter are either saucer or cup shaped cavities eaten into the plant stem or punctures through the epidermis that are enlarged inside the stem.

In one alfalfa stem Mr. Ainslie found 4 egg "nests," the holes being in pairs. These pairs were one-half to three-fourths of an inch between the separate holes, and each pair was in a separate node, the



FIG. 4.—The alfalfa weevil: Larva attacking a sprig of alfalfa, and eggs in larva, enlarged, at right. (Author's illustration.)

pairs perhaps 3 inches distant from each other. There must have been 30 or 40 eggs at least in this one stalk. It was picked from a vigorous crown growing beside a manure pile, and nearly every other stem in this crown contained eggs. These shoots were tall and had evidently grown rapidly. Indeed this seems to be the kind of stem chosen by this insect in which to place the eggs; shorter, woodier stems seem seldom to be selected for this purpose

As observed by Messrs. Wilson and Parks, assistants of the bureau, the female beetle, after excavating the cavity for the eggs, inserted her ovipositor and laid a number of eggs before removing the ovipositor from the cavity. After this she began beating it up and down rapidly over the puncture as though pounding the orifice, sometimes but not always excreting a drop of watery

material over the puncture. This secretion when hardened appeared to seal the opening. In some cases the arrangement of the eggs in rows on each side of the puncture, as described by Mr. Ainslie, was verified.

Mr. Titus has described the egg¹ as being oval, rounded at the ends, and when first deposited lemon-yellow in color. As the eggs incubate they become darker at one end and a deeper yellow in the other

¹ Bulletin 110, Utah Agr. Coll. Exp. Sta., p. 34, September, 1910.

portions. Under the microscope the surface of the egg is very slightly roughened and sculptured.

Mr. Ainslie, who made a careful study of the egg (fig. 3) at oviposition and later, found that at time of laying the egg was a mere sac, the shell being little more than a transparent, homogeneous envelope or membrane. As segmentation proceeded this membrane became very faintly pitted, and under the microscope with proper illumination barely discernible reticulations, both pentagonal and hexagonal, were apparent. Both ends and sides seemed equally reticulated, the areolation being perhaps a little smaller at the ends. After the larva emerges the shell that remains is a transparent structureless membrane with no trace of reticulation.

The number of eggs placed in a cavity varies greatly, there sometimes being not more than 2 or 3, ranging up to over 30; probably 10 would be about the average number, although these figures are of course only approximate. Mr. Parks found that during the first half of April the number ranged from 3 to 18, averaging 7 or 8; during the last half and early May the number increased, 25 or 30 being the maximum, with an average of 8 or 9. With reference to the number of eggs that may be deposited in a single alfalfa plant, the one shown beside the hat in Plate I, figure 1, examined on April 23—at which date oviposition was still in progress and the beetles preparing for oviposition were still exceedingly numerous in the fields—indicated that this plant at this date contained nearly if not quite 1,300 eggs. Of course, in fields where the alfalfa grew up thickly there would be a relatively less number per plant, but these figures serve to illustrate the origin of the countless myriads of larvæ that swarm over the plants in an alfalfa field and render more easy of comprehension the destruction shown in Plate III, figure 1. The difference between uninjured and affected plants is shown in Plate III, figure 2, *a* and *b*. Other ravaged fields are shown in Plate IV, figures 1 and 2, in contrast with figure 3 of same plate.

In the Salt Lake Valley oviposition has been found to take place earlier on the bench lands than lower down in the valley itself.

EGG-LAYING PERIOD.

The period of egg laying is a matter of considerable significance, since in some degree it will decide the question of efficiency or practical measures of control. As is usual with insects, after a female has exhausted her supply of eggs she dies and there is no second depositing of eggs by her during that season. The actual time required for the individual female to deposit her supply of eggs is of course influenced by the weather. In 1909 egg laying began in the fields early in April, and eggs were found in greatest abundance during the last of May and the first of June. In 1910 egg laying began early

in March and was at its height by the middle of May, and Mr. C. N. Ainslie found eggs in a rearing cage where beetles were confined indoors as late as October 22, and others found them as late as November 10, and Mr. E. J. Vosler on December 6, while larvæ of all sizes were found rarely in the fields November 1. On this latter date the sexes were pairing in the fields and some of the females contained apparently mature eggs, but none could be found deposited in the fields. In 1911 Mr. Urbahns found eggs and very young larvæ March 31, and adults active in the field on a warm day (January 31, 1912); one feeding and one pair mating.

The time required for the eggs to hatch after being deposited is, according to Mr. Titus, from 7 to 16 days, as observed by Mr. Ainslie about 10 days, and according to Mr. Parks's observations about 13 days. The three series of observations were made during different years, 1909, 1910, and 1911, and, of course, under different temperature conditions. It would seem as though more or less pairing is done in very late fall and the eggs deposited the following spring. Of course, the scattering eggs and larvæ found throughout the late summer and fall have little economic importance except to indicate what might be expected in more southern localities, although even in Utah some eggs probably survive the winter.

EVIDENCE OF A PARTIAL SECOND GENERATION.

The occurrence of larvæ up to the approach of cold weather in late fall has already been noted. Some of these at least might be accounted for from the fact that overwintering females still containing eggs are found throughout July and early August; but that others of these larvæ are the offspring of parents developing during the preceding spring is strongly indicated by the fact that the females depositing eggs from which larvæ afterwards hatch are in perfect condition, unrubbed, and apparently fresh.

Under date of October 19, 1910, Mr. Ainslie found that eggs were being deposited in his rearing cages, dropped at random on stems and leaves and even on the sides of the cage, but in no case did he observe them placed within the stem. There were in this cage 150 adults, some of which were undeniably trim and fresh as though they had just emerged, while others were pretty well worn, and there were all intervening gradations. Adult females swept from alfalfa November 2 were found to have oviposited two days later. Adults taken from the fields November 7 and kept indoors were found to have deposited eggs within 2 or 3 days prior to November 30.

During the season of 1911 it was possible still further to substantiate the foregoing by an extensive series of observations carried on by several of those engaged in the investigation, and besides to add even more evidence that some of these late-appearing larvæ are the



FIG. 1.—One of the worst infested fields in the Salt Lake Valley, showing injury to the first crop of alfalfa, which was left uncut. Photographed June 26, 1911. (Original.)

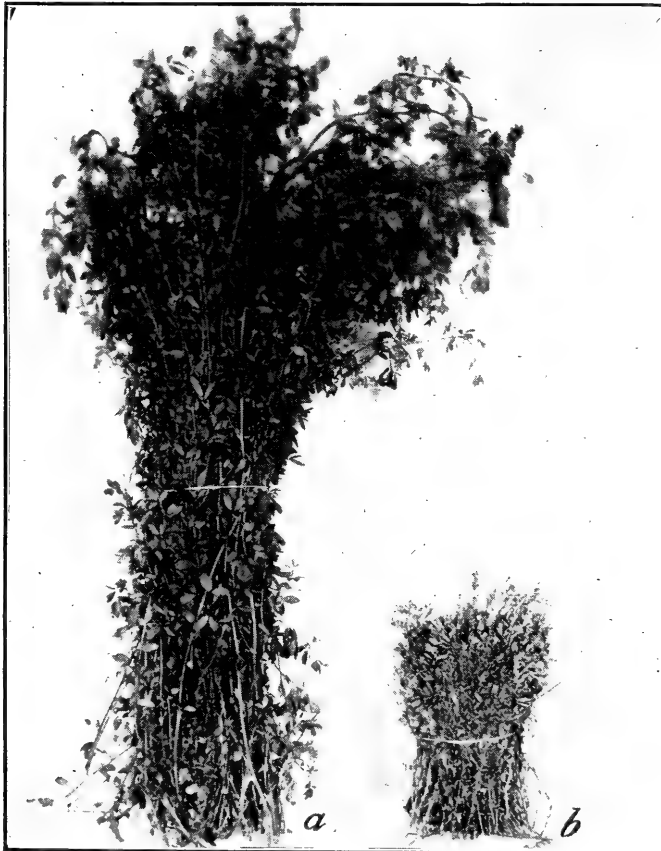


FIG. 2.—*a*, Bunch of alfalfa uninjured by the alfalfa weevil. *b*, Bunch of alfalfa badly injured by the alfalfa weevil, showing growth made by first crop in the badly infested fields. Photographed June 20, 1911. (Original.)

INJURY WROUGHT BY THE ALFALFA WEEVIL.



FIG. 1.—Crop secured from first cutting of one of the worst infested fields. Photographed June 9, 1911. Original.



FIG. 2.—First cutting from another field damaged from attack by the alfalfa weevil. Photographed June, 1911. Original.



FIG. 3.—First cutting secured from one of the fields of alfalfa slightly injured by the attack of the weevil. Photographed June 2, 1911. Original.

INJURY WROUGHT BY THE ALFALFA WEEVIL.

offspring of parents developing during the preceding spring. Eight apparently fresh adults taken from the field on August 18 by Mr. Urbahns were observed on the 21st to have oviposited to the number of about 20 eggs, in confinement. Nine additional eggs were found on the 23d. August 29, 10 adults, also seemingly fresh and un-rubbed, were confined in a glass vial, and the following day about 50 eggs were found in the vial. Under the same date 112 beetles, supposed from appearances to belong to the spring generation, were collected by another member of the force at an elevation of about 7,000 feet, and the following day 75 eggs were found in the box in which they were confined. Under the artificial conditions not all of these eggs hatched. This state of affairs continued and was observed by several of the men to occur up to the end of the season.

While the beetles go into hibernation in nearly perfect un-rubbed condition, they emerge in spring with scales and pubescence removed to such an extent that they are almost black in color, smooth, and shining. This appearance so contrasts with that of the newly-emerged adults of the new generation that the latter can be easily separated at sight, and it was these latter that were again and again observed to oviposit and their eggs to hatch out larvæ.

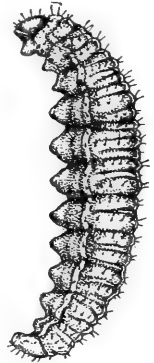


FIG. 5.—Thealfalfa weevil: Larva. Much enlarged. (Author's illustration.)

THE LARVA.

The larval stage is shown in dorsal view in figure 4 and in lateral view in figure 5. It is during this stage that the pest accomplishes the greatest destruction, although the beetles are of themselves capable of ruining the second hay crop of alfalfa.

Mr. Titus¹ states that soon after hatching from the eggs the larvæ, which at that time are quite active, begin feeding in the interior of the stalk, sometimes remaining there for 3 or 4 days, and isolated examples have been found that have passed into the second stage, still inside the stalk. Larvæ have been found inside hollow stems several inches away from the place where they hatched, working their way upward, and later issuing through a feeding puncture. Usually after 3 or 4 days they come out and work their way up the outside of the stems and conceal themselves in a leaf bud, usually at the tip of the plant.

That the very young larvæ are capable of traveling considerable distances to reach their food supply is not only indicated in Mr. Titus's published statement, but emphasized by the observations of Mr. C. N. Ainslie under date of April 28, 1910. The actions of newly hatched

¹ Bulletin 110, Utah Agr. Coll. Exp. Sta., pp. 39, 40, September, 1910.

larvæ, as observed by him, were remarkably vigorous, very young ones exhibiting great energy as travelers. Their mode of progression is to reach forward and then, with a slight hump, to bring up the rear part of the body. The head is at once thrust forward again. About one move is made per second, and three propulsions will carry the body forward 1 mm. When in doubt as to the direction to be taken, the larva elevates the head and swings it from side to side until some decision is reached, when the journey is resumed. The larvæ are positively phototropic.

After working their way upward on the alfalfa stems the larvæ begin to feed close down between the opening buds on the unfolding leaves. Their manner of feeding there, as observed by Mr. Ainslie, was by scraping off the epidermis with a sort of burrowing motion, leaving only the veins and fragments of uneaten tissue. This selection of the terminal buds may be in part due to the shelter offered as well as to the more tender and succulent nature of the plant growth. Large numbers of young larvæ may, however, be found feeding among the unfolding buds without being easily seen. This feeding is further described by Mr. Titus¹ as follows:

In feeding, the larvæ bore holes into the buds [see fig. 4], working their way in until they are often completely concealed inside the opening bud. The plant then sends out other buds below this point, and usually other young larvæ are present to destroy these, so that at times the growing tips of the plants become so injured as to give these tips the appearance of a gall. As many as 15 young larvæ have been found feeding in the terminal bud of one stalk. Sometimes, before they are fully developed, in the second stage, they pass out onto the leaves, at first eating the upper epidermis only.

The larvæ, after the usual habit of those of the genus to which it belongs, either cling around the edge of the leaf or feed in a curved position. This continual eating off of the fresh growth keeps the alfalfa so reduced that it does not produce a first crop. Seriously affected fields are shown in Plate III, figure 1, and Plate IV, figures 1 and 2, while a field that has not suffered from such attack is shown in Plate IV, figure 3. From these illustrations a good idea of the damage done by the larvæ to the first crop of alfalfa may be obtained.

LARVAL PERIOD.

From about 5 to 8 days after hatching from the egg the skin of the larva splits and the old skin is pushed off, leaving the larva in a new dress. This process is repeated after a period of from 12 to 20 days and again after about 12 to 30 days, as observed by Mr. Titus. Mr. Ainslie in some instances got pupæ in 18 to 20 days during May, 1910. These variations in time are probably largely due to temperature, which again may be due in part to elevation.

¹ Bulletin 110, Utah Agr. Coll. Exp. Sta., pp. 40-42, September, 1910.

When the larva is fully grown, it ceases to feed and seeks out some place in the crown of the plant among the litter and trash or on the ground among similar material, where it spins a cocoon (fig. 6).

COCOONING AND PUPATING.

The cocoon is composed of fine white threads and the construction by the apparently blind larva was in part observed by Mr. Ainslie, who describes its movements as follows: A larva was seen moving about in its snow-white, almost transparent, gauzy, unfinished cocoon. It proved to be spinning a closer mesh from within. Instead of spinning the silk from a gland that opened into its mouth, as was supposed, the fluid from which the silk is made is taken into the mouth apparently from a gland in the caudal segment. The larva applied its mouth to an opening or gland close to the anus, appeared to move its jaws slightly, and then, with a quick movement of the body, was straightened out as much as possible in its confined space, and instantly the head was applied to the inner network of the cocoon. A slender glistening thread was seen leaving the mouth, being attached glutinously to each thread that it crossed. The larva worked rapidly and nervously, nearly always carrying its new thread in a rather straight line. From 30 to 50 seconds were required to discharge a single mouthful supplying thread for one-third or one-half a revolution inside the cocoon.

When all the supply was exhausted, the head groped aimlessly about for a few seconds, then was applied to the caudal gland as before. The body would then straighten with a quick movement and almost instantly the thread would be again flowing as before. The new thread was guided skillfully across the meshes, rarely if ever following the line of a thread already laid. A very slight jar would cause a sudden halt for perhaps half a minute, then the operation would hesitatingly proceed. As the irregularly oval cocoon is too small in any diameter to allow the larva to straighten out, the larva moved about by thrusting its small head into a mesh, swinging the body into the desired position; the head would then be moved to another mesh and the operation repeated. The fluidity and amount of the silk must vary as spinning progresses, the silk becoming more viscous or less copious as the cocoon approaches completion.

The pupal period, according to Mr. Parks's notes, during the middle of May lasts about 9 days, the larvæ spinning their cocoons about 5 days before pupating. (A pupa is shown in fig. 7.) At the end

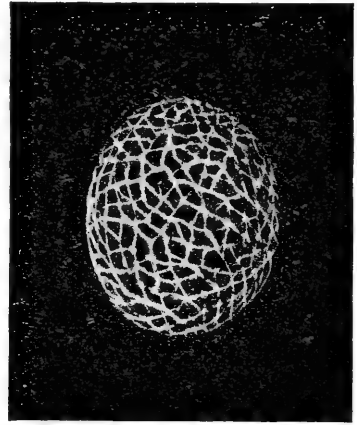


FIG. 6.—The alfalfa weevil: Cocoon. Much enlarged. (Author's illustration.)

of the season, however, during August, when the temperature is higher, the pupal period averages only 3 days, the cocoon being spun only about 36 hours before the larva pupated. The adult leaves the cocoon about a day after transformation, and unlike others of this genus does not devour the cocoon. Although the insect has passed

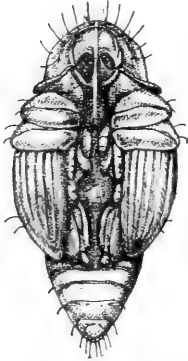


FIG. 7.—The alfalfa weevil: Pupa. Much enlarged. (Author's illustration.)

through its transformation from egg to adult the injury it causes is by no means ended. The beetles themselves not only feed upon the young growth (fig. 8), but gnaw off the bark of the stems, and, together with the larvæ still in the fields, in this way prevent the alfalfa from springing up for weeks after the first crop of hay has been removed. Two of such fields are shown in Plate V, figure 3, and Plate VI, figure 3, the ground being almost as bare of growing plants as in figure 1, Plate VIII, where the ground has been torn up with a spring-tooth harrow. The beetles sometimes cluster in great numbers upon a single plant, as illustrated in figure 8.

FOOD PLANTS.

In a series of experiments carried out by Mr. P. H. Hertzog, larvæ of *Phytonomus posticus* were placed in cages on various food plants, both alone and with alfalfa, and it was found that they fed freely upon the following plants, in combination with alfalfa:

Sweet pea, *Lathyrus odoratus*; Utah milk vetch, *Astragalus utahensis*; string bean, *Phaseolus vulgaris*; obtuse-leaved vetch, *Vicia* sp.; narrow-leaved vetch, *Vicia* sp.; white clover, *Trifolium repens*; red clover, *T. pratense*; alsike clover, *T. hybridum*; yellow sweet clover, *Melilotus indica*(?); whitesweetclover, *M. alba*; *Medicago lupulina*; *M. echinus*; *M. hispida nigra*; *M. hispida confinis*; *M. hispida terebellum*; *M. muricata*; *M. orbicularis*; *M. scutellata*; black locust, *Robinia pseudacacia*; fenugreek, *Trigonella fœnumgræcum*.

The following is a list of plants eaten by the larvæ when no other food was offered, but refused when offered together with alfalfa:

Hedysarum mackenzii; *Astragalus oreophilus*; downy lupine, *Lupinus*; sp. chick pea, *Lathyrus sativus*; *Vicia atropurpurea*; *Vicia dispema*; spring vetch, *Vicia sativa alba*; hairy or winter vetch, *Vicia villosa*; spider plant, *Cleome serrulata*.

The following plants were refused by the larvæ even when no other food was offered:

Everlasting pea, *Lathyrus latifolius*; round-leaved mallow, *Malva rotundifolia*; birds-knot grass, *Polygonum aviculare*; garden pea, *Pisum sativum*; lamb's-quarters, *Chenopodium album*; purslane, *Portulaca oleracea*; prickly lettuce, *Lactuca scariola*, perhaps var. *integrata*; ground cherry, *Physalis longifolia*(?); bitterweed, *Ambrosia psilostachya*; bitterweed, *Ambrosia trifida integrifolia*; rough pigweed, *Amaranthus retroflexus*.



FIG. 8.—The alfalfa weevil: Adults clustering on and attacking sprig of alfalfa. About natural size. (Author's illustration.)

MIGRATION AND DIFFUSION.

There are two periods during which the adult insects migrate, more or less aided by the winds and perhaps to a less extent by other agencies. Such as have not hibernated directly in the alfalfa fields become active in early spring and fly about freely, seeking such fields in which to deposit their eggs. This spring migration covers a considerable period of time—about six weeks, as estimated by Mr. Titus. As the females are more or less heavily laden with eggs, however, the flight of the individual is perceptibly shorter than in the second, or summer, migration, the season for which begins early in June and continues for three or four weeks. Another reason for the shorter flight in spring is that the beetles are searching about, not for places of hibernation, but for breeding places. Having found these, they naturally would not go farther unless carried by the winds. In case of a summer flight, however, the conditions are altogether different. This is the season during which most nomadic insects become more widely diffused. At this time the beetles fly high in the air and apparently over long distances. They are also to be observed crawling about in almost every situation, as with the larger species, *Hypera punctata*, which may be observed wandering aimlessly over the pavements in the midst of large cities. Then, too, they appear to float about freely on the surface of water, and are doubtless carried long distances down stream by the current. We know this is true in the case of irrigating ditches and canals, and it is also true of the larger species just mentioned in case of streams in the East. This habit of the beetles in hiding themselves away in any crevice or aperture that will accommodate them doubtless has considerable to do with their diffusion. As a matter of fact, however, it is absolutely impossible to lay down any law that appears to regulate the diffusion of the insect. There are instances where it would seem almost impossible to prevent the distribution of the pest, and yet most careful examination has failed to reveal anything of this sort. For a considerable time after the alfalfa weevil became abundant about Salt Lake and Murray hay was shipped from these points to Ely, Nev. This, too, in the midst of the season, when it would seem impossible to transport hay from these points to its destination without carrying greater or less numbers of the weevil. Notwithstanding this, years have gone by, and during the summer of 1911 two assistants examined the country about Ely most carefully without finding a single alfalfa weevil or any indications that it had ever existed there. While it is possible to account for the spread of the insect theoretically, we can not as yet account for its diffusion to the northeast into adjacent sections of Wyoming and Idaho. It does not appear to have entered Idaho by way of the Cache Valley, although Mr. Titus found beetles on a coal car at

Cache Junction in 1910. It does, however, occur in the Bear River Valley from Evanston, Almy, and Lyman, Wyo., northward into Bear Lake County in extreme southeastern Idaho. Previous observations would indicate that by a natural diffusion the insect has spread a distance of about 30 miles each year. As a matter of fact, the beetles are continually being found where least expected, and they have not been found where, judging from their habits, we would feel most confident of their occurrence.

The most rapid dispersion of the insect during the last two years has been toward the northeast from the original point of infestation in the Salt Lake Valley. Its injury is now noticeable wherever alfalfa is grown in the river valleys east of Ogden to the Wyoming State line and northward to the southern extremity of Bear Lake. It is known to occur, however, as previously stated, as far north as Cokeville, Wyo., and southward to Evanston and Lyman, where specimens were taken during the summer of 1911. This northeastward trend of diffusion in the weevil must be considered in connection with prevailing southwest winds at the time when the beetles are flying, and, in fact, careful search over the newly infested territory seems to render it highly probable that to this cause is due this northeastward diffusion. The finding of individual larvæ well scattered over Wyoming fields with little or no indications of introduction by human agencies, together with the finding of larvæ in an irrigated valley isolated from other cultivated crops by 35 miles of dry desert country, are conditions hard to explain in any other way than that the south winds of spring and summer have resulted in carrying flying beetles over low mountain ranges to fertile fields beyond. To just what extent the winds are able to carry the adults into new territory is not known, but at any rate migration in other directions has taken place much less rapidly.

FIELD EXPERIMENTS IN DESTROYING THE ALFALFA WEEVIL.

Several extended series of experiments in destroying the alfalfa weevil were carried out at various points in the infested territory in Utah, but only those that have shown the best results will here be mentioned.

Quite naturally, a measure that will destroy a greater or less number of the insects and at the same time encourage the growth of the plant, and is of practical application, will not only be the most attractive one to the farmer but will result in a double benefit. For this reason disking was looked upon as probably offering the best results. It was thought that by disking and spraying a more rapid growth of the alfalfa plants would be secured, and by following this with the use of a brush drag a great many of the larvæ would be crushed and destroyed. Mr. Ainslie's observations made in 1910

indicate, however, that the brush drag does not destroy as many of the larvæ as one would suppose, and for this reason some harsher measures have been put into application during the season of 1911.

STREET-SWEEPER EXPERIMENTS.

The ordinary street sweeper, such as is used in our cities, appears to be a most thorough measure of destroying the pupæ. This much was determined by the Utah Experiment Station. A street sweeper (Pl. V, fig. 1) was used in a field on June 22, 1911. While examination showed that the result of this treatment, at this time, was to kill most of the larvæ and pupæ, it did not kill a great percentage of the adult weevils, which had already developed in large numbers. It would have been much better had this work been carried out about two weeks earlier; not only the condition of this field but of others in the neighborhood treated between June 14 and July 1 indicated that considerable good had resulted from this treatment even at this late season. On another farm, owned by Mr. Breeze, southwest of Salt Lake City, a field was swept with the street sweeper about the 14th of June with a view of interfering with the work of the weevil.

By July 7 the alfalfa in the Breeze field was about 20 inches high with very few weevils present. (See Pl. V, fig. 2.) Twenty days later the alfalfa was 30 inches high and in full bloom, being ready for the taking of a second crop. Just across the road from this farm was a field where no treatment whatever had been applied against the weevil. In this field the alfalfa plants were only about a foot in height and very much delayed (Pl. V, fig. 3). This seems to indicate that as a protection for the second crop the measure has considerable value. The drawback here is in the expense of a street sweeper, although of course where the members of a community club together, or in case of very large alfalfa fields of several hundred acres, the first cost of this sweeping machine would not constitute such an important item.

WIRE-BRUSH EXPERIMENT.

A 13-acre field of alfalfa 7 years old had been disked in the spring of 1910. The first crop of alfalfa was reported to have been reduced to one-half by attack of the weevil. A weevil-collecting machine had also been used on this first crop, but there were still enough of the weevils left in the field to greatly retard the second crop. It was disked and dragged again and a fairly good yield of the second crop was secured. This was also true of the third crop in this same field.

On May 15, 1911, there was a good stand of alfalfa in this same field. One irrigation had at this date been applied. The plants were a little over a foot in height, and while at the time, May 15, they were in fairly good condition they were heavily infested with weevil larvæ. The gathering machine was used twice between the 17th and

25th of May, and observations made at the time indicate that while many of the full-grown larvæ were collected, most of the smaller ones were left among the buds. On May 29 the field received a second irrigation. The larvæ at this time were very abundant; the gathering machine, too, had retarded the growth of the plants by breaking off the growing tips and some of the plants themselves had been broken down by the collecting machine. As a result the alfalfa had apparently made little or no growth since about the 22d, and its value as forage was at that time rapidly decreasing.

A wire-brush machine (Pl. VI, fig. 1) was constructed by Mr. L. Hemenway by bolting about 30 pieces of No. 8 steel wire 7 inches long between iron clamps on each spring tooth of an old spring-tooth cultivator. The ground was gone over with one of these on June 1, as soon as the hay had been removed. The jumping action of the spring, together with the wire brushes, proved very effective in crushing larvæ and pupæ among the stubble. The field was then gone over with a plank leveler, shown in Plate VIII, figure 2, with square iron edges bolted to a plank. June 7, the field received another brushing with the wire-brush machine, which crushed cocoons and larvæ. By June 13 the second crop in this field had started nicely with very few weevils present. In another field near by no attempt had been made to treat it or to remove the weevil, and this field was taken as a check on the one under treatment. An examination at this time showed that when the former field was in good condition, with few larvæ, the field that had received no treatment was bare and brown from their attack.

On June 22 the second crop of alfalfa on the treated field was about 8 inches high, while the unworked field was still bare and its condition, on June 27, is shown in Plate VI, figure 3. By the 27th the alfalfa in the treated field was about 1 foot in height (see Pl. VI, fig. 2), the stand extra good, and the treatment had seemed to free the field from weeds and other foreign growth. By July 7 the plants were about 2 feet in height, while, of course, both the adults and larvæ could be found to some extent in this field. July 27 the second crop harvested 2 tons per acre, selling at \$9 per ton in the field. The field at time of harvest of second crop is illustrated in Plate VII, figure 1. The unworked field, however, was making an inferior second crop, coming just a little in advance of the third crop in the treated field.

From the treated field there was also a fourth crop of hay secured. The field was photographed on October 9, 1911, and the yield of hay is illustrated in Plate VII, figure 2. The condition of the check field a few days later, October 12, is shown in Plate VII, figure 3; here the second and third crops were both not only badly damaged, but so delayed in growth of alfalfa that, as shown by the illustration, no fourth crop was secured at all.



FIG. 1.—Street sweeper in operation on alfalfa field after first crop was removed. Larvæ and pupæ were crushed by the rotary brush. Photographed June 14, 1911. (Original.)



FIG. 2.—Second crop ready to cut in the field on which street sweeper was used June 14, 1911. Good stand and good crop. Photographed July 27, 1911. (Original.)



FIG. 3.—Second crop of alfalfa growing on field where no treatment was given. Crop short and about two weeks behind that of the field shown in figure 2. Photographed July 27, 1911. (Original.)



FIG. 1.—Wire-brush cultivator in operation on alfalfa field after first crop was removed. The brushes crush the larvæ and pupæ on the ground at this time. Photographed June 7, 1911. (Original.)

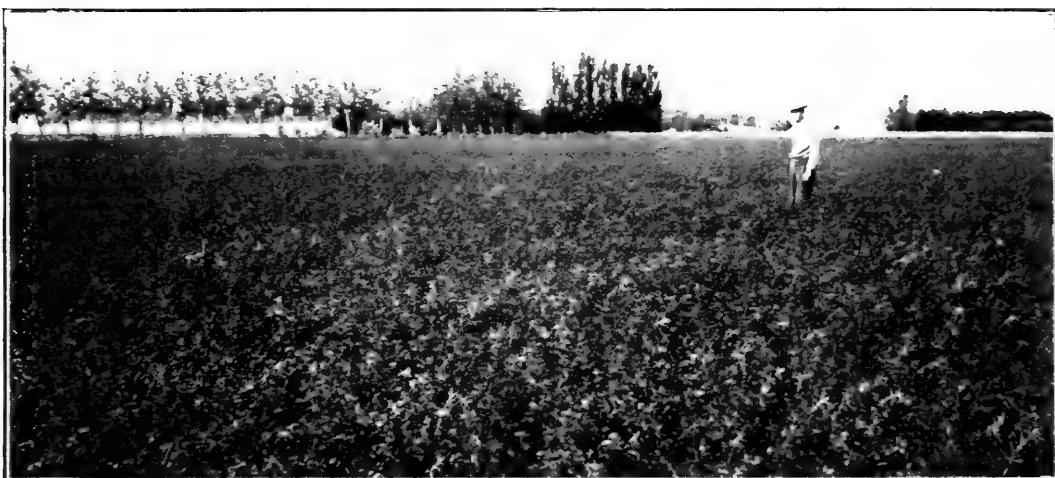


FIG. 2.—Second crop of alfalfa growing nicely as a result of treatment given. (See fig. 1, above.) Larvæ and pupæ were killed, so that second crop suffered only slight injury. (Original.)



FIG. 3.—Condition of untreated fields about June. Photographed June 27, 1911. (Original.)



FIG. 1.—Second crop of alfalfa, estimated at 2 tons per acre, secured from field treated with wire-brush cultivator. Photographed August 2, 1911. (Original.)

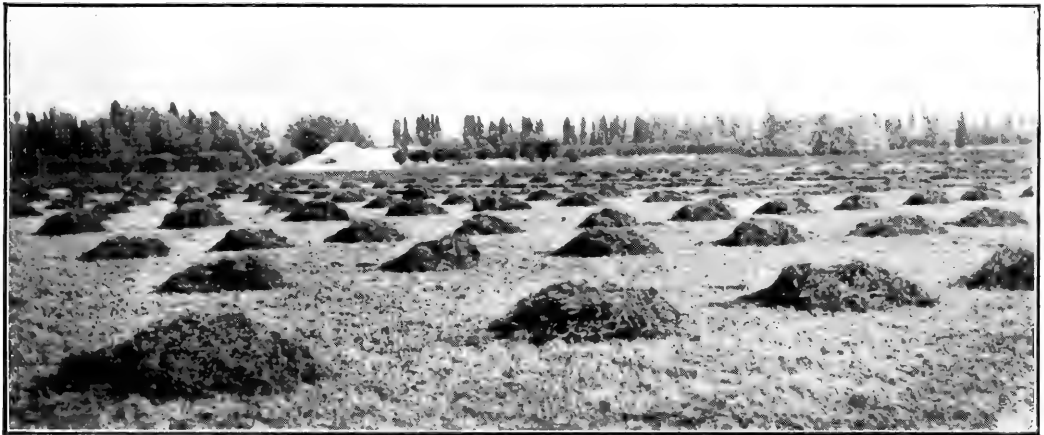


FIG. 2.—Fourth crop of alfalfa secured from field where brush cultivator was used. Photographed October 9, 1911. (Original.)



FIG. 3.—Condition of field used as check (Pl. V, fig. 3). The second and third crops on this field made little growth and were much delayed, so what would correspond to the fourth crop was caught by frost. Photographed October 12, 1911. (Original.)



FIG. 1.—Alfalfa field after first crop was removed, severely di-cked preparatory to application of “mudding” process against the alfalfa weevil. Photographed June 21, 1911. (Original.)



FIG. 2.—Following the irrigation water with a drag, to “puddle” the weevils in the mud. Photographed June 22, 1911.

FIELD EXPERIMENTS AGAINST THE ALFALFA WEEVIL.



FIG. 1.—Second crop of alfalfa in field treated by “mudding” process. Crop growing well and not seriously damaged by the alfalfa weevil. Photographed June 10, 1911. (Original.)



FIG. 2.—Condition of untreated fields at time photograph shown in figure 1 was taken. The alfalfa weevils have prevented the second crop from starting. Photograph taken July 10, 1911. (Original.)



FIG. 3.—Patch of first crop left in field shown in figure 1, illustrating how the larvæ were disseminated from the first crop into the field where the weevil had been killed by the “mudding” process. Photograph taken July 10, 1911. (Original.)



CULTIVATION IN CONNECTION WITH IRRIGATION.

For an experiment to determine the value of cultivation in connection with irrigation in controlling the alfalfa weevil a field was selected on a farm belonging to Mr. Hansen, 1 mile southeast of Sandy, Utah, containing 16 acres. The soil was a light sandy loam. Some of the weevils had been noticed in this field in 1908 and also in 1909, while the first crop of 1910 was severely damaged and the second also suffered considerable loss. May 11, 1911, the field was irrigated, the infestation being considered heavy. The first crop was cut during the week ending June 10. The plants were about 9 or 10 inches high and the hay yielded less than 1 ton per acre of very poor quality. This field was again irrigated and the more elevated portion of it worked with a spring-tooth harrow while the surface was still soft from the irrigation. This treatment was repeated and when finished the field had very much the appearance of any cultivated field, little resembling a meadow. (See Pl. VIII, fig. 1.)

On June 22, while the land was still soft and muddy, a light irrigation was given it, so that the water collecting in the lower portion of the field stood to a depth of 2 or 3 inches. Four horses were hitched to a plank leveler and dragged through this mud, as shown in Plate VIII, figure 2. This thoroughly "puddled" the weevil in all of its stages beneath the surface.

By the 30th of June a second crop was starting very nicely while neighboring untreated fields were being retarded by the continued attacks of the weevil. Ten days later the plants were about 12 inches high with very few of either larvæ or beetles present. However, a patch had been left uncut and unworked in one corner of this field and here the first crop of alfalfa was still standing. (See Pl. IX, fig. 3, at the right.)

There were a great many larvæ and beetles on this patch, which disseminated themselves into the growing alfalfa where the mudding process had been practiced, destroying a strip about 1 rod in width, clearly shown in Plate IX, figure 3. The second crop in this field, July 10, 18 days after the mudding experiment was carried out, was about 14 inches high. (See Pl. IX, fig. 1.)

In a near-by untreated field at the same time, four weeks after the first cutting was made, the condition is shown in Plate IX, figure 2.

BURNING MACHINE.

Several field experiments were carried out with a machine constructed with the idea of burning over alfalfa fields after the removal of the first crop for the purpose of destroying the weevils in any stage of development remaining in the field. The machine, as shown in Plate X, figure 1, consisted of an iron frame 9 feet square, 12 inches

high in front, and adjustable in the rear. The top was of light sheet iron bolted to the frame.

Oil was pumped from a barrel in the conveyance to which this machine was attached and forced through a rubber hose into a supply pipe which fed the nozzles and burners underneath. The oil under pressure came forth from the burners as a mist of fire blowing into the stubble and against the ground.

The sheet-iron cover served to hold the heat down while this oven passed slowly over the surface. In its unperfected state the machine did effective work and offered ideas of value, warranting the construction of more efficient burners.

In fields where there was a clean stand of alfalfa stubble this machine did very well in burning vegetation and destroying all insect life above the surface of the ground. Where many weeds, especially dandelions, were present, the insects found protection under the green leaves. Where parts of fields were burned over, the unburned area showed no growth for several weeks on account of the continued weevil attack. The burned area turned green within a very much shorter time.

REDUCTION IN QUALITY OF HAY CAUSED BY THE ALFALFA WEEVIL.

While studying the alfalfa weevil on various farms in the Salt Lake Valley during the month of April, 1911, it was found that many farmers, through a shortage of forage, were feeding the weevil-injured hay of the first crop to their horses. This hay contained so many old cocoons and was so dusty from larval excrement and dead bodies of weevil larvæ as to render it unfit as feed for horses. On several occasions horses were observed coughing from the effect of this dust. In fact, many farmers consider the first crop from severely infested fields almost valueless as horse feed.

On June 12, 1911, at Alpine, Utah, when the new hay from the first crop was fed to work horses these began coughing almost immediately after starting to feed upon this injured hay. The hay contained large numbers of dead weevil larvæ, some still on the skeletonized leaves and some in the freshly spun cocoons. On September 13 hay from the first crop, in stack, was examined at Layton, Utah, and found to be very dusty, containing many dead weevil larvæ and also pupæ.

NATURAL ENEMIES.

The natural enemies of the alfalfa weevil consist of vertebrates and invertebrates. The former have been studied by assistants of the Bureau of Biological Survey, and a list of species observed to attack the weevil is given herewith.

The invertebrate enemies are divided between native species and those imported from Italy, the native being largely predaceous and the foreign all parasitic.

Besides these, there are two fungous enemies, both of which affect the insect to a greater or less degree.

INVERTEBRATES.

When a foreign species, like the alfalfa weevil, is introduced into a new country, some time is required for the native insects to find out that it is suitable for food, precisely as man himself would under the same circumstances have to learn what products of a new country were edible. Besides, he would most likely cultivate a taste for some of these things which at first were distasteful to him. Thus it is that native insect foes of introduced species begin slowly at first to prey upon them.

The following native predaceous insects have been found attacking and devouring the alfalfa weevil:

PREDACEOUS ENEMIES.

A species of tiger-beetles, *Cicindela imperfecta* Lec., was in one instance observed to feed upon an alfalfa weevil larva in the field.

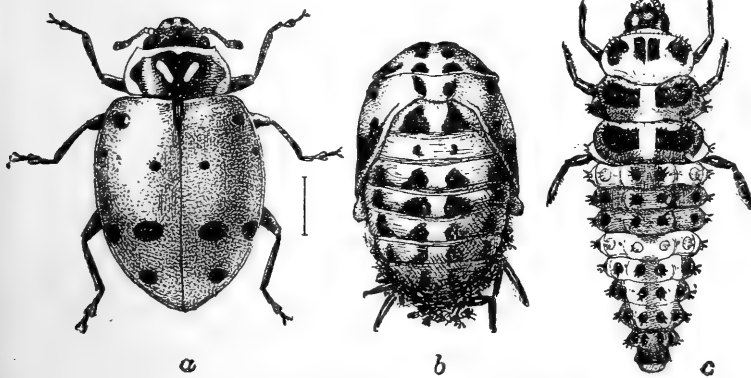


FIG. 10.—Convergent lady-beetle (*Hippodamia convergens*): a, Adult; b, pupa; c, larva. Enlarged. (From Chittenden.)

(fig. 10), in the larval stage attacked and devoured half-grown larvæ of the alfalfa weevil in the fields. Larvæ so taken were brought into the laboratory and adults reared, from which specific determinations were made. In case of *H. spuria* the adult was also observed devouring larvæ in the field.

The malachid beetle, *Collops bipunctatus* (fig. 11), was repeatedly observed feeding upon the weevil larvæ in the fields.

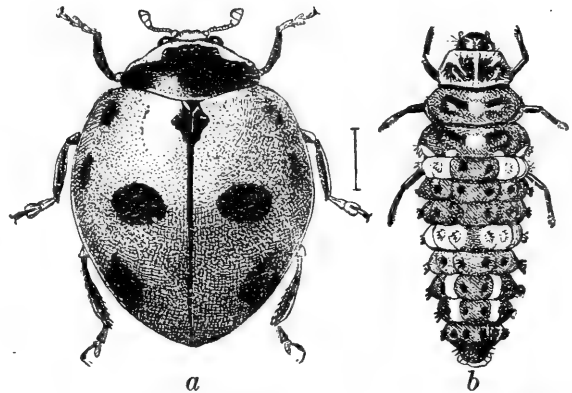


FIG. 9.—Nine-spotted lady-beetle (*Coccinella 9-notata*): a, Adult; b, larva. Much enlarged. (From Chittenden.)

Several other individuals belonging to the same species when taken to the laboratory readily devoured larvæ.

Three species of lady-beetles, *Coccinella 9-notata*, Hbst. (fig. 9), *Hippodamia spuria* Lec., and *H. convergens* Guér.

The tenebrionid beetle, *Eleodes sulcipennis* Mann., was accused by farmers of feeding upon the larvæ of the weevil and when taken to the laboratory it readily did this in confinement. An allied species, *E. suturalis* Say, was observed by Mr. E. O. G. Kelly to devour chinch bugs in the neighborhood of Wellington, Kans. In the latter instance the beetles seemed to prefer the partially decaying leaves of corn under which the chinch bugs were hiding. It is probable that while these insects may devour a few of the weevil larvæ they prefer other and vegetable food.

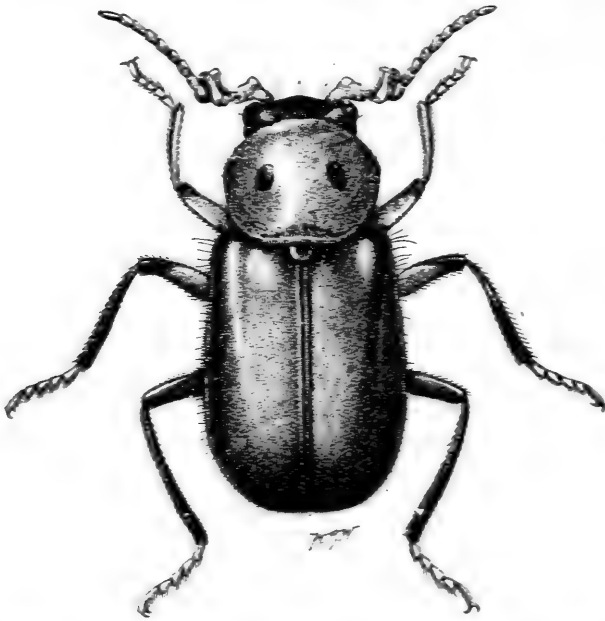


FIG. 11.—The two-spotted Collops (*Collops bipunctatus*): Adult. Enlarged. (Original.)

The predaceous mite, *Pediculoides ventricosus* Newp. (figs. 12, 13), was introduced from Indiana in March, 1911, but was afterwards

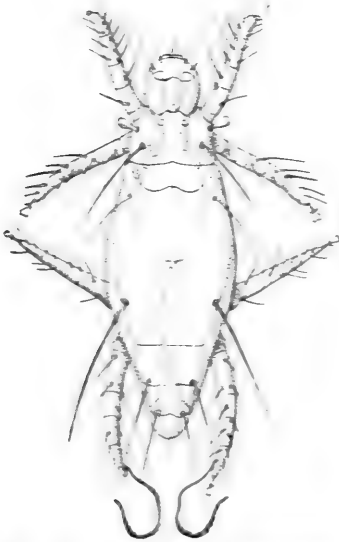


FIG. 12.—*Pediculoides ventricosus*, a mite predatory on the alfalfa weevil: Adult female before the abdomen has become inflated with eggs and young. In this condition the mite is nomadic and predatory. Greatly enlarged. (Redrawn from Brucker.)



FIG. 13.—*Pediculoides ventricosus*: Adult female after the abdomen has become inflated with eggs and young. Greatly enlarged. (Redrawn from Brucker.)

found a sufficient distance away from the points of introduction to show plainly that it was already an inhabitant of Utah. The results

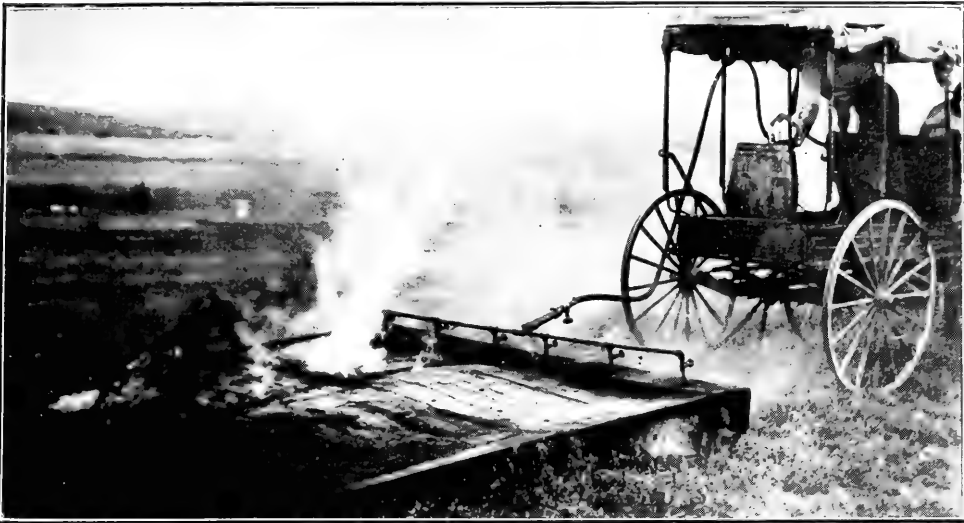


FIG. 1.—BURNING MACHINE EXPERIMENTED WITH AS A METHOD OF DESTROYING THE ALFALFA WEEVIL. (ORIGINAL.)

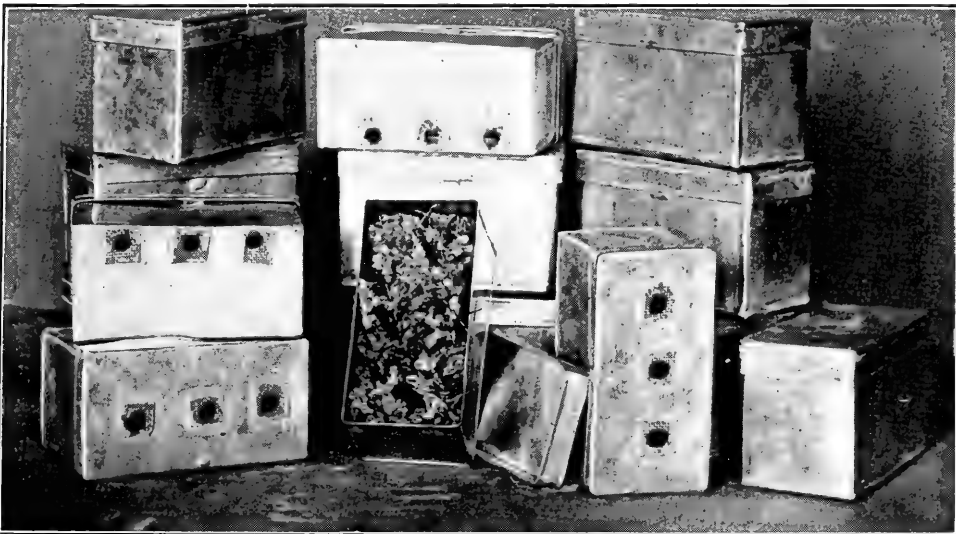


FIG. 2.—BOXES CONTAINING PARASITES OF THE LARVÆ AND PUPÆ OF THE ALFALFA WEEVIL, SHOWING HOW THIS MATERIAL WAS IMPORTED INTO THE UNITED STATES FROM ITALY. PHOTOGRAPH TAKEN JUNE, 1911. (ORIGINAL.)

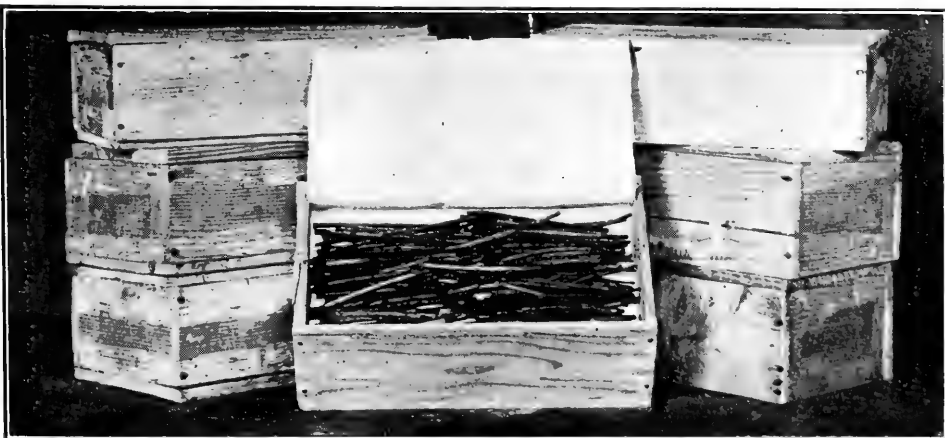


FIG. 3.—BOXES OF PARASITE MATERIAL IMPORTED FROM ITALY WHICH CONTAIN EGG PARASITES OF THE ALFALFA WEEVIL. PHOTOGRAPH TAKEN MAY, 1911. (ORIGINAL.)



of experiments with this mite, which is so effective in destroying the jointworm in the East, were unsuccessful, as it was found that the mites would not attack either the larvæ or the pupæ. They fed freely upon the eggs of the weevil, where these were easily accessible, but they seemed unable to gain access into many of the egg masses through the ordinary egg punctures. A single egg did not furnish sufficient food to bring one mite to maturity, and it would therefore necessarily perish; but where there were clusters of eggs in contact with each other, the female mite was able to shift her body about sufficiently to devour more than one egg and was thus enabled to reproduce. In the field, when placed in cages with an abundance of eggs of the alfalfa weevil, the mites appeared to make considerable headway in overcoming the weevil, but in no case could the effects of their attack be traced farther than 2 feet from the cage where they had been confined in the fields.

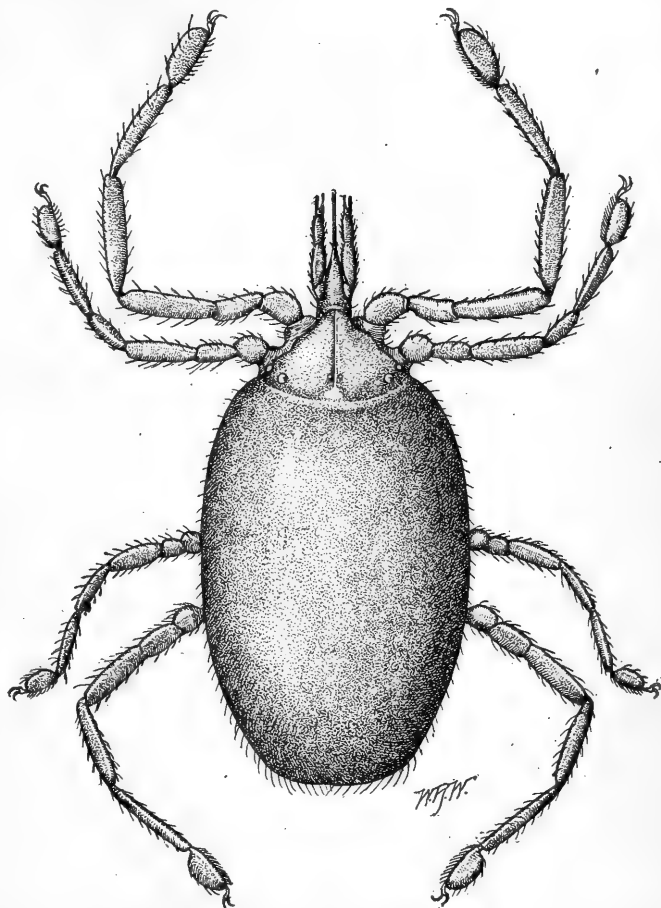


FIG. 14.—A predaceous mite, *Erythræus arvensis*: Adult. Greatly enlarged. (Original.)

A little mite (*Trombidium*) was found attached to the adult weevil beneath the wing covers, and while it was observed quite commonly in late summer and fall, so far as observations indicated it did not appear able to kill the host insect. A predaceous mite, *Erythræus arvensis* Banks (fig. 14), was found by Mr. Ainslie feeding on eggs of the weevil in the egg punctures. The economic value of this species is as yet very obscure. Spiders are occasionally found feeding upon the larvæ in the fields. Lace-wing flies (*Chrysopa*) fed upon the larvæ in confinement when forced to do so, but preferred aphides. They were not observed to attack the weevil in any form in the fields.

A NATIVE TRUE PARASITE.

Only one specimen of a single species of a true parasite of the alfalfa weevil has so far been found in America. This was described by Mr. Viereck as *Enoplegimorpha phytonomi*. It was found August 30, 1911, at Hoytsville, Utah, in the form of a cocooned pupa within the cocoon of the alfalfa weevil. The specimen was picked up from the surface of the ground in a badly infested alfalfa field and the adult parasite reared. The adult emerged September 3.

INTRODUCED PARASITES.

Several species of parasites were sent over from the vicinity of Portici, Italy, by Mr. W. F. Fiske during April, May, and June, 1911.



FIG. 15.—*Anaphes* sp., a mymarid egg parasite of the alfalfa weevil: Adult male; female antenna above at right. Greatly enlarged. (Original.)

The egg parasites were obtained by collecting stems of alfalfa containing eggs of the alfalfa weevil, placing these in boxes (Pl. X, fig. 3), and transporting them by cold storage on steamers bound for New York. On arrival from Europe they were promptly forwarded by refrigerator express to their destination, Salt Lake City, Utah, where they were at once taken either to the laboratory at Salt Lake City (Pl. XIII, fig. 1) or to the laboratory at Murray (Pl. XIII, fig. 2).

Parasites that attack the weevil after it has hatched and before it has developed to the adult were handled in much the same manner. The boxes in which they were consigned are shown in Plate X, figure 2. The time required to transport these boxes from Portici, Italy, to Salt Lake City, Utah, was from 16 to 21 days.

EGG PARASITES.

There were two egg parasites, one, a true egg parasite developing within the egg, and the second, a parasite the eggs of which are probably deposited in the alfalfa stems among, but not in, the eggs. The larva of the latter is predaceous on the masses of weevil eggs as placed by the female weevil, and among them it develops to the adult.

MYMARID EGG PARASITE.

A mymarid egg parasite, *Anaphes* sp. (fig. 15), was found in all of the seven shipments received from Italy. It was received in all stages of development, except perhaps the egg and adult, and was either left in the same boxes, these being perforated with holes and

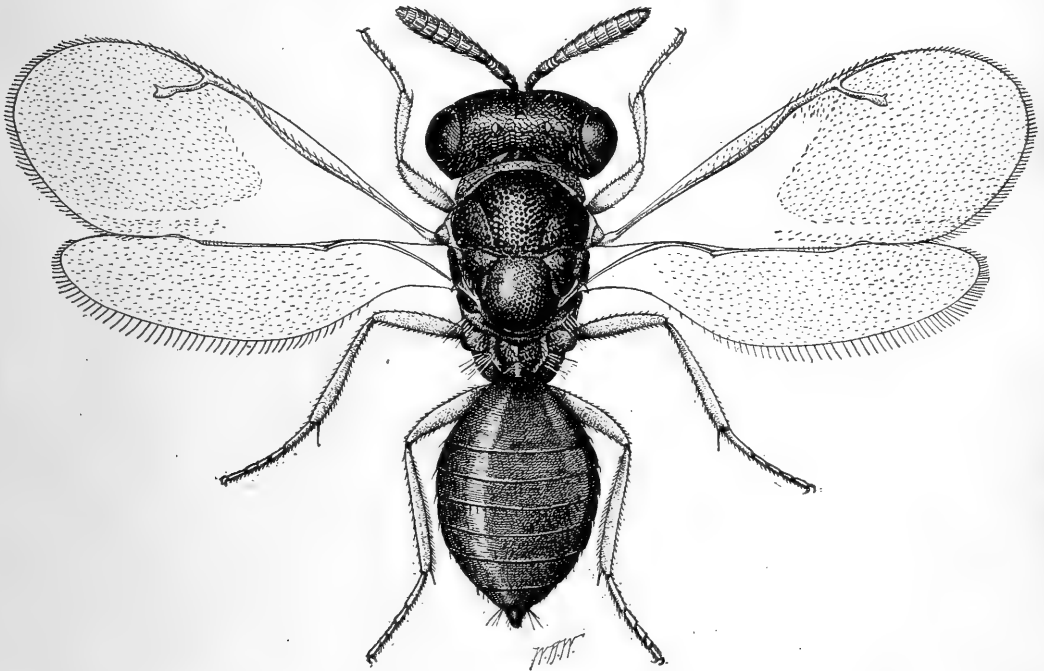


FIG. 16.—Imported pteromalid egg parasite of the alfalfa weevil: Adult. Greatly enlarged. (Original.)

glass tubes inserted (Pl. XI, fig. 2), or placed in specially prepared boxes (Pl. XI, fig. 3) which were also perforated and had glass tubes inserted. The parasites were reared from this imported material, and from the parent stock two generations were reared on American egg masses of the alfalfa weevil. The third generation, together with others of the first and second generations and natives from later shipments, was placed in field reproduction cages (Pl. XII, fig. 3) to the number of about 300. These cages were overstocked with eggs by confining numbers of weevils in them. After about 10 days the covers to these cages were removed, thus allowing the generation of parasites that developed within them to escape and scatter freely over the fields.

PTEROMALID EGG PARASITE.

A pteromalid egg parasite (fig. 16) was likewise found in all of the seven importations. The larva (fig. 17) feeds externally on the egg masses in the alfalfa stems, later transforming to the pupa (fig. 18).

The disposal and management of this species did not differ from that followed with the preceding, except that some of them were received too late in the season to use in the low valleys because the majority of the eggs of the weevil had already hatched. Owing to this the parasites were taken to places in higher elevations where eggs of *Phytonomus* were still abundant. Approximately 460 were placed in field cages like those previously mentioned and treated in the same way.

Mr. Fiske found this species to be very effective in controlling the alfalfa weevil in Italy.

PARASITES OF LARVÆ AND PUPÆ.

The parasites of the larvæ and pupæ of the alfalfa weevil, which were five in number, did not appear in the earlier consignments from Italy and were confined to the last three received at Salt Lake City May 16 to June 3. In these three shipments were metal boxes (Pl. X, fig. 2), which included only the cocoons of the alfalfa weevil. These boxes were especially

devised to guard against the accidental escape of adult insects of any species en route.

After being removed from the boxes in which the cocoons were received, they were placed in parasite boxes of the larger type (Pl. XI, fig. 3), where the parasites emerged and were separated from the weevils that had developed en route. Both weevils and parasites on emerging from the cocoons in the box would seek the light and appear in the glass tubes shown in the illustration, where they were readily separated and the weevils killed. The parasites were then transferred to glass cages (Pl. XI, figs. 1, 4) which had been previously well stocked with larvæ and cocoons.

PTEROMALID LARVAL PARASITE.

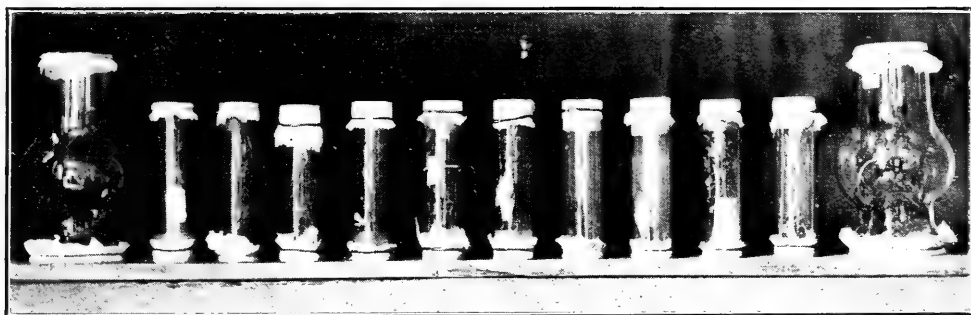
A pteromalid parasite of alfalfa weevil larvæ (fig. 19, female; fig. 20, male) was received in only the later consignments. Thus far it has not been possible to determine the species. In the laboratory rearings, preparatory to placing the parasites in the field cages, and later, the species was carried through five generations. (Fig. 21, *a* shows the pupa of the alfalfa weevil, with the egg (fig. 21, *b*) as it is placed on the pupa; fig. 22 shows the larva, and fig. 23 shows it destroying the pupa of the alfalfa weevil; fig. 24 shows the pupa of the parasite itself.) In order to accomplish this, however, it was necessary to secure weevil larvæ, as hosts for them, from high



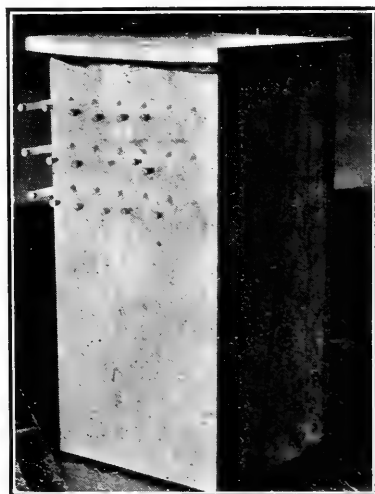
FIG. 17.—Larva of pteromalid egg parasite of the alfalfa weevil. Greatly enlarged. (Original.)



FIG. 18.—Pupa of pteromalid egg parasite of the alfalfa weevil. Greatly enlarged. (Original.)

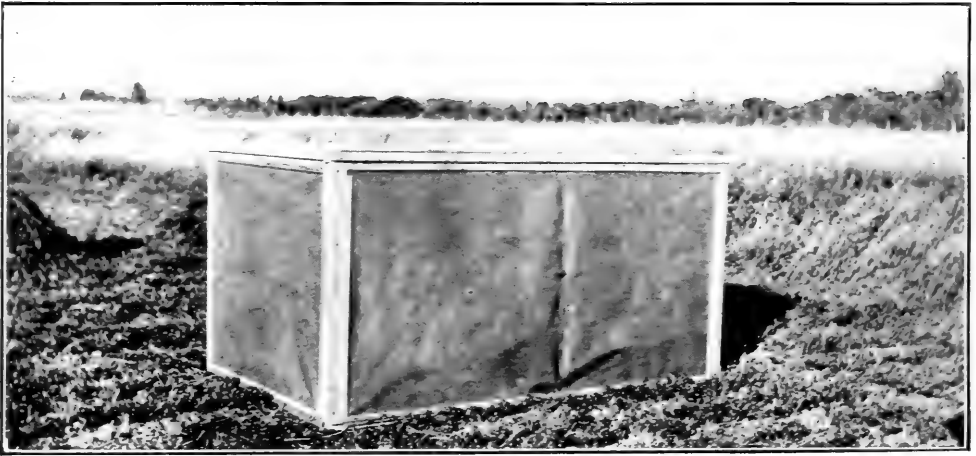
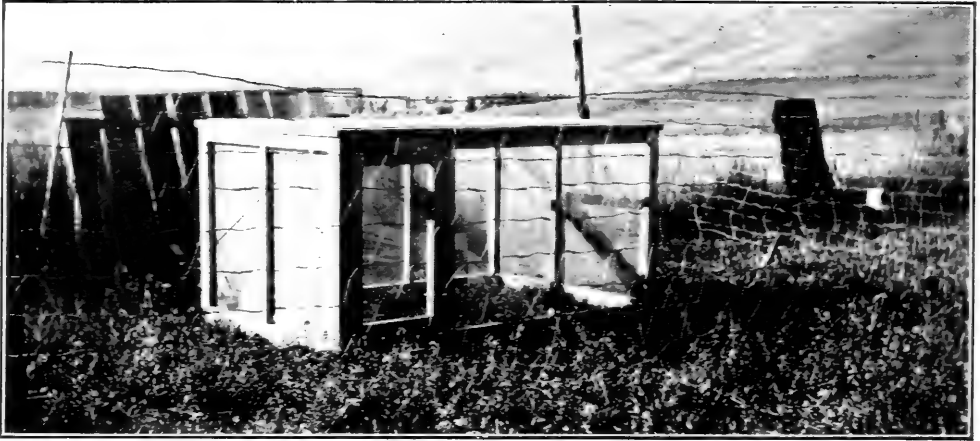


Figs. 1 and 4.—Types of cages in which larval and pupal parasites of the alfalfa weevil were reared in the laboratory. Photograph taken during June, 1911. (Original.)



Figs. 2 and 3.—Boxes sealed and fitted with glass tubes into which imported parasites emerged and were separated in the laboratory. Photograph taken during May and June, 1911. (Original.)

INTRODUCTION OF PARASITES OF THE ALFALFA WEEVIL.



FIGS. 1 AND 2.—FIELD CAGES USED IN HIBERNATION EXPERIMENTS ON THE ALFALFA WEEVIL. (ORIGINAL.)



FIG. 3.—PLANTING A COLONY OF IMPORTED PARASITES OF THE ALFALFA WEEVIL IN UTAH IN AN ALFALFA FIELD. PHOTOGRAPH TAKEN DURING JUNE, 1911. (ORIGINAL.)

elevations and bring these into the laboratory, thus supplying them artificially. There were 230 individuals liberated in field cages, the coverings of which were later removed, and 49 liberated directly

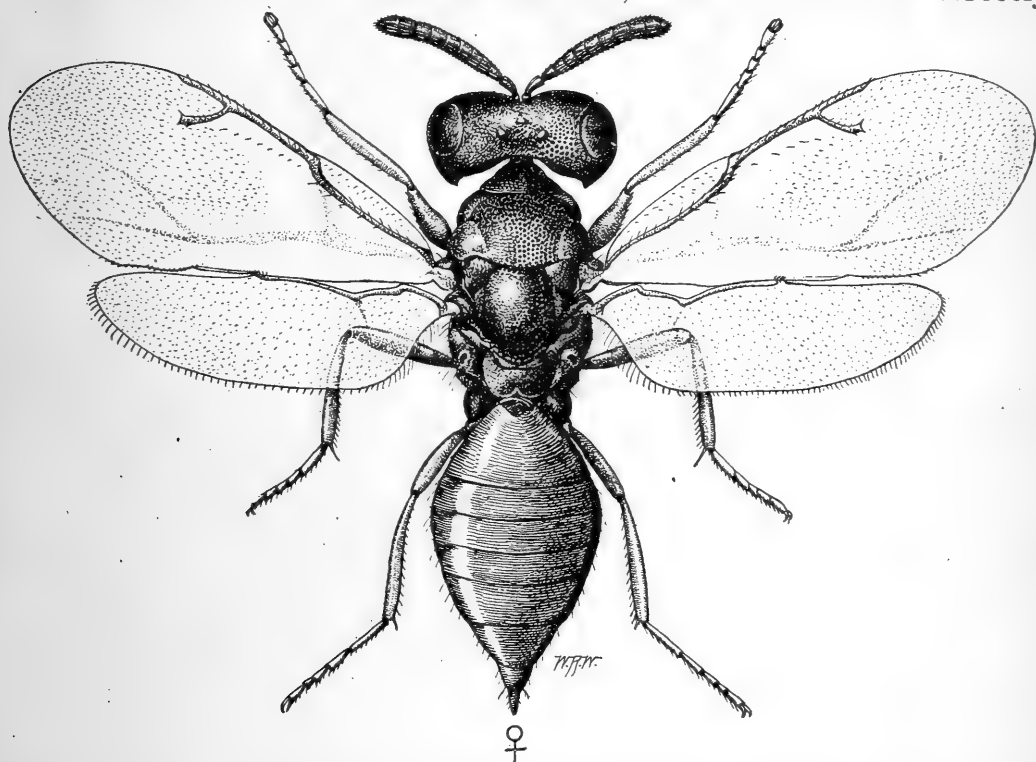


FIG. 19.—Pteromalid parasite of larva and pupa of the alfalfa weevil: Adult female. Greatly enlarged. (Original.)

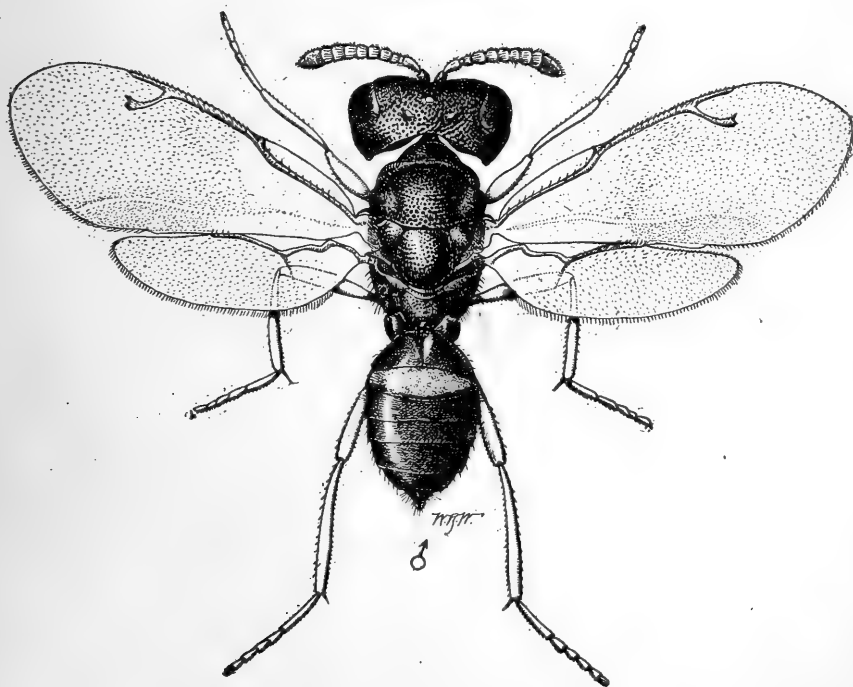


FIG. 20.—Pteromalid parasite of larva and pupa of the alfalfa weevil: Adult male. Greatly enlarged. (Original.)

into the open field. Observations have since shown that this species has actually colonized itself in the field; whether temporarily or permanently it remains to be seen.

OTHER PARASITES.

The following three parasites came mainly in the last two shipments from Italy. The adult of one species (*Canidiella curculionis* Thoms.) (fig. 25) oviposits in the larvæ of the alfalfa weevil in different stages of development, but the offspring therefrom

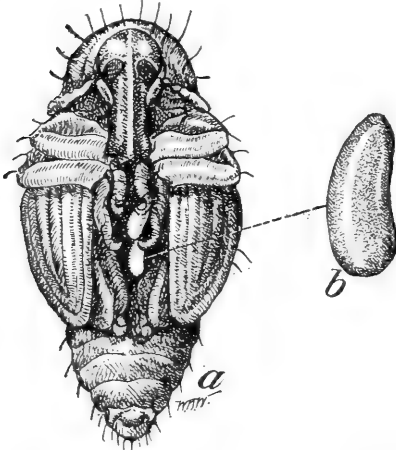


FIG. 21.—Pteromalid parasite of larva and pupa of the alfalfa weevil: *a*, Enlarged pupa of alfalfa weevil with eggs of parasite in place; *b*, egg, greatly enlarged. (Original.)

emerge from the cocoon spun by the weevil, the cocoons of the parasite always showing through the meshes of the cocoon of the weevil (see fig. 27). This species has two generations annually and hibernates as cocooned larvæ. The alfalfa stems from which the three species of parasites of this group were reared were also in-

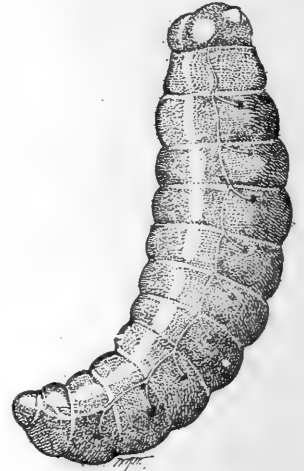


FIG. 22.—Pteromalid parasite of larva and pupa of the alfalfa weevil: Larva. Greatly enlarged. (Original.)

festated by *Apion pisi* Fab., and therefore some or all of the group may perhaps also parasitize this latter insect. Owing to its small size, however, as compared to the parasites, this seems rather unlikely. The two additional species reared with the preceding

are not definitely determinable, but one is *Phygadeuon* sp., and the other may prove to be *Mesochorus nigripes* Ratz. Of this latter species Mr. T. W. Wassiljew, a Russian entomologist, under date of February 6, 1911, wrote us:

I wish to say that I am able to give you only one instance of a parasite having been found, and that was in the vicinity of Taschkent (Turkestan), where I noticed in the past year [1910] that over 20 per cent of the larvæ of *P. variabilis* were attacked by an Ichneumon parasite. Judging from the elliptical, thick-shelled cocoon it might

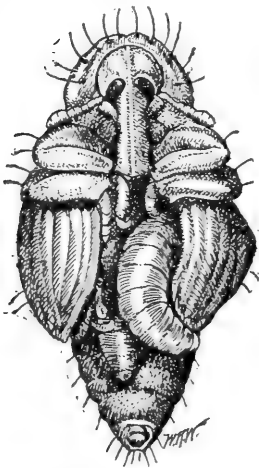


FIG. 23.—Larva of pteromalid parasite attacking pupa of alfalfa weevil. Enlarged. (Original.)

possibly have been *Mesochorus nigripes* Ratz., which Mr. Ratzeburg (The Ichneumonidæ, III, p. 120) gives as a parasite of *P. rumicus*.

All of these parasites resemble each other to a certain degree, and figure 25 will suffice to illustrate them, for the present at least. At the present stage of this experiment in introducing parasites of the



FIG. 24.—Pupa of pteromalid parasite shown in figures 22 and 23. Greatly enlarged. (Original.)

alfalfa weevil the possibility of permanent establishment and future efficiency in the case of these species seems rather more encouraging than in case of the others. During June, 1911, 40 individuals reared from imported cocoons were placed in field cages artificially overstocked with weevil larvæ, the cage covers being removed later. Besides this, there is at present on hand a considerable amount of hibernating material (Pl. XII, figs. 1, 2) artificially reared in the Murray laboratory (Pl. XIII, fig. 2), which will be allowed to escape, naturally, into the alfalfa fields.

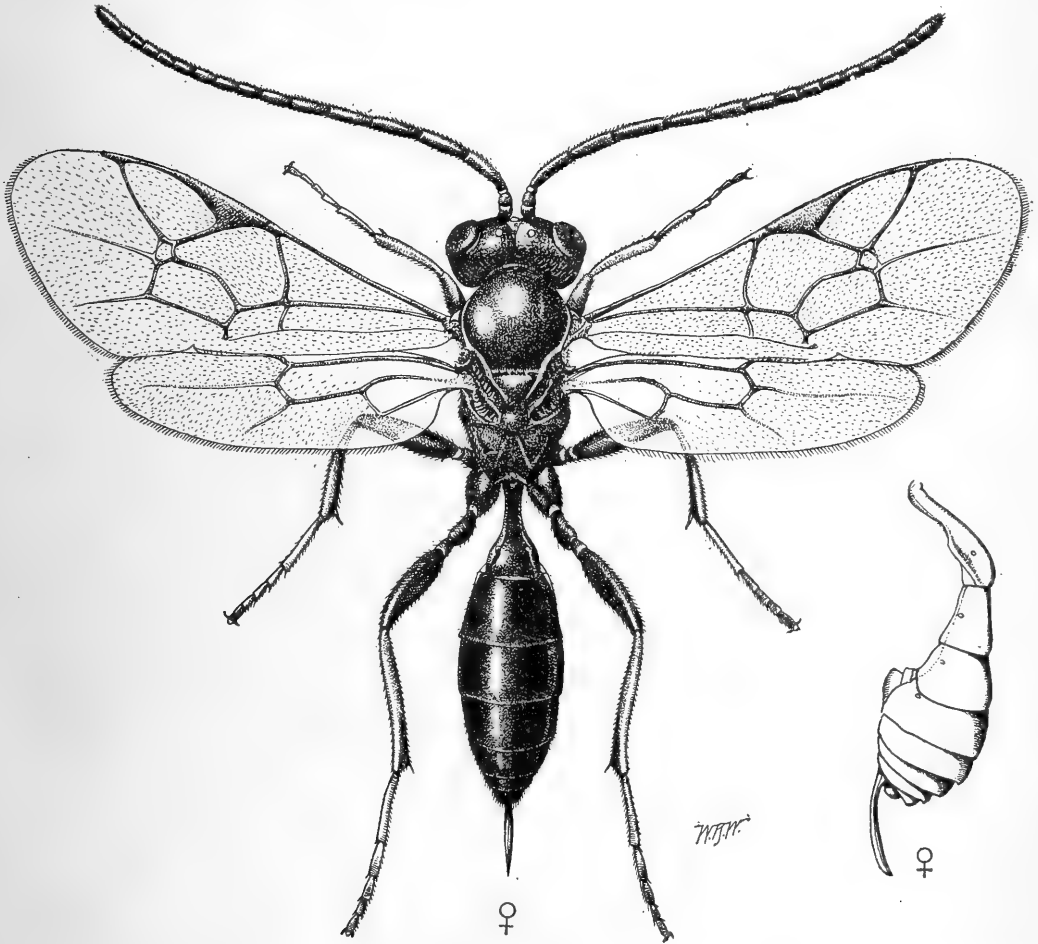


FIG. 25.—*Canidiella curculionis*, a parasite of the alfalfa weevil: Adult female; lateral view of abdomen of same below, at right. Enlarged. (Original.)

The parasite *Itopectis masculator* Fab. (fig. 26) differs from the preceding by reason of the fact that it pupates entirely within the pupa of its host. It is known to be a primary parasite, but the number so far secured is too limited to warrant any discussion regarding it, or any predictions as to its future in America.

Of the eighth and last of these parasites, *Hemiteles* sp., very little is known either in Europe or America, and with the obscurity surrounding its habits it may prove to be either a primary or secondary parasite, a friend or an enemy of the others. It is therefore being handled with the utmost caution, none having been liberated either in the fields or in field cages.

VERTEBRATES.

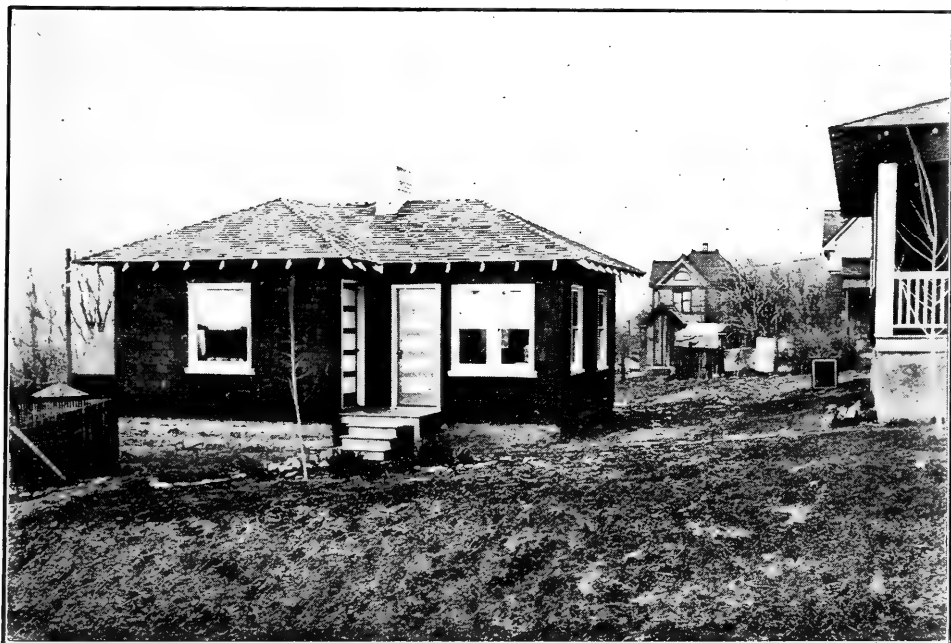
During the season of 1911 the Biological Survey, at the suggestion of the writer, kindly detailed an assistant, Mr. E. R. Kalmbach, to study the bird and other vertebrate enemies of the alfalfa weevil, and the following is a list of vertebrates found to feed on the alfalfa weevil in Utah, as determined by Mr. Kalmbach, May 7, 1911, to July 25, 1911.

Wilson's phalarope, *Steganopus tricolor*; killdeer, *Oxyechus vociferus*; valley quail, *Lophortyx californica vallicola*; mourning dove, *Zenaidura macroura carolinensis*; red-shafted flicker, *Colaptes cafer collaris*; Arkansas kingbird, *Tyrannus verticalis*; Say's

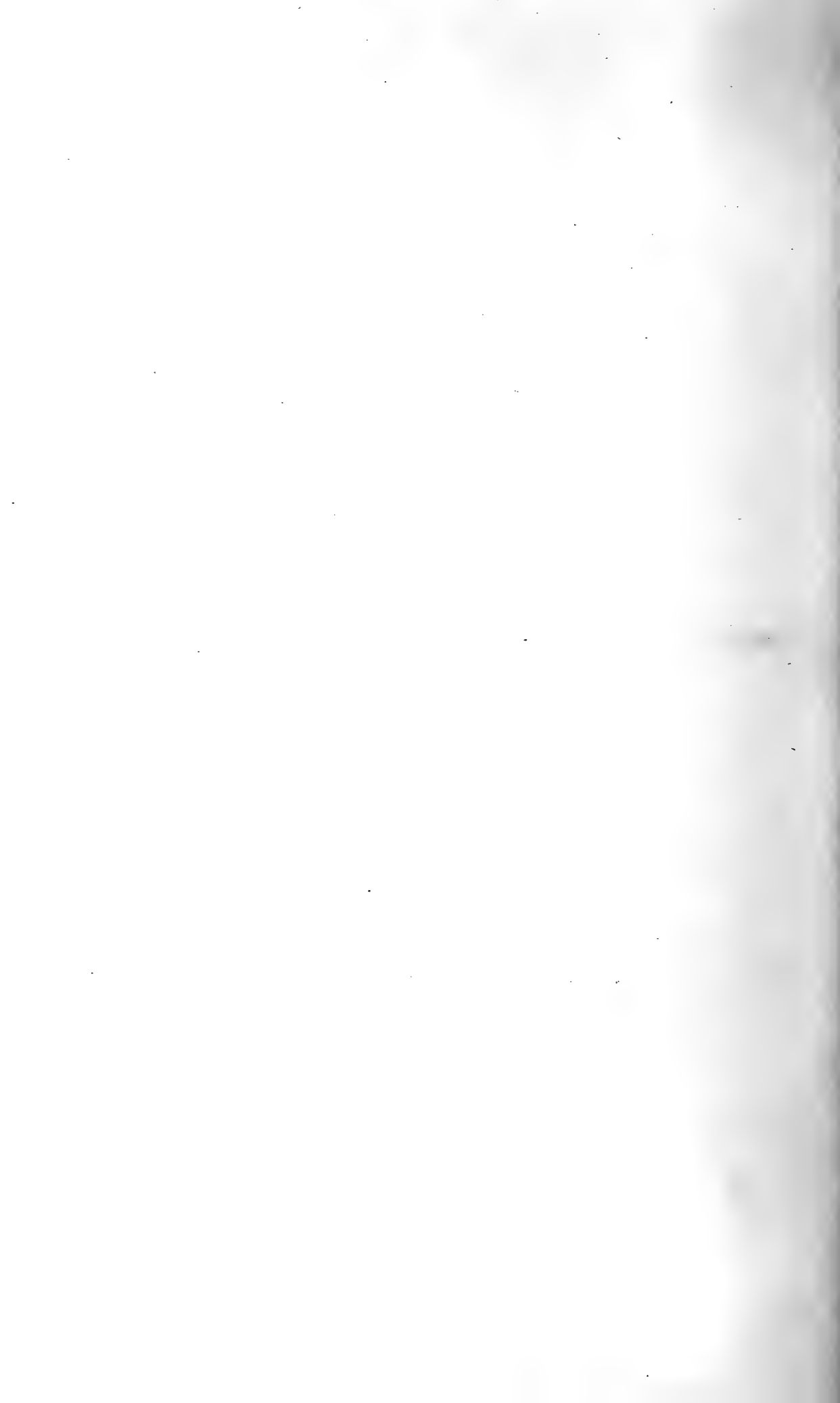


FIG. 26.—*Itoplectis masculator*, a parasite of the alfalfa weevil: Adult female; lateral view of first abdominal segment at right. Much enlarged. (Original.)

phoebe, *Sayornis sayus*; Traill's flycatcher, *Empidonax trailli*; desert horned lark, *Otocoris alpestris leucolæma*; magpie, *Pica pica hudsonia*; bobolink, *Dolichonyx oryzivorus*; cowbird, *Molothrus ater*; yellow-headed blackbird, *Xanthocephalus xanthocephalus*; thick-billed red-winged blackbird, *Agelaius phæniceus fortis*; Western meadowlark, *Sturnella neglecta*; Bullock's oriole, *Icterus bullocki*; Brewer's blackbird, *Euphagus cyanocephalus*; house finch, *Carpodacus mexicanus frontalis*; English sparrow, *Passer domesticus*; Western vesper sparrow, *Poæetes gramineus confinis*; Western savannah sparrow, *Passerculus savannarum alaudinus*; Western lark sparrow, *Chondestes grammacus strigatus*; white-throated sparrow, *Zonotrichia albicollis*; Brewer's sparrow, *Spizella breweri*; Western chipping sparrow, *Spizella socialis arizonæ*; desert song sparrow, *Melospiza melodia fallax*; green-tailed towhee, *Oreospiza chlorura*; black-



FIGS. 1 AND 2.—LABORATORIES OF THE BUREAU OF ENTOMOLOGY, U. S. DEPARTMENT OF AGRICULTURE, AT SALT LAKE CITY AND MURRAY, UTAH. (ORIGINAL.)



headed grosbeak, *Zamelodia melanocephala*; rough-winged swallow, *Stelgidopteryx serripennis*; sage thrasher, *Oreoscoptes montanus*; Western robin, *Planesticus migratorius propinquus*; Rocky Mountain toad, *Bufo lentiginosus woodhousi*; leopard frog, *Rana pipiens*; salamander, *Amblystoma* sp.

FUNGOUS ENEMIES.

Whenever the larger species *Hypera punctata* (fig. 2) becomes excessively abundant east of the Mississippi River, myriads of these larvæ may be observed coiled about the uppermost tip of blades of grass or similar vegetation, where they soon die and become black. These are apparently destroyed by a fungus, *Empusa sphærosperma*. When investigations of the alfalfa weevil were first undertaken there were great numbers of these dead and dying larvæ to be found in Washington, D. C., in Potomac Park. They were gathered up and sent out to Salt Lake City and placed in the hands of Mr. Ainslie with the hope of introducing this fungus among the larvæ of the alfalfa weevil. The experiment appeared to have been a failure, and it was thought that the climate of Utah was too dry to enable this fungus to exist there. Later this larger species was found in Utah, as has already been stated, and during the spring of 1911 the fungus was found in the vicinity of Salt Lake City. Apparently, however, the fungus does not affect the larvæ to the same extent that it does here in the East, except after these have reached their full size and constructed their cocoons. Larvæ of the alfalfa weevil (fig. 5) and pupæ (fig. 7) soon began to be observed in the cocoon (fig. 6) dead and thoroughly permeated with this fungus. No individuals in any case were found dead excepting within their cocoons. On June 13 in the vicinity of Salt Lake City it was estimated that one-fifth of the cocoons contained dead larvæ or pupæ. In the Weber Valley, about Hoytsville, Utah, on the last of August, it was found that of 580 cocoons examined 258, or 44.5 per cent, were dead, partly at least because of infestation by this fungus. Examination at another point showed that 38 per cent had apparently died from the same cause. To all appearances, then, this was more effective in killing the alfalfa weevil than all other natural enemies combined.

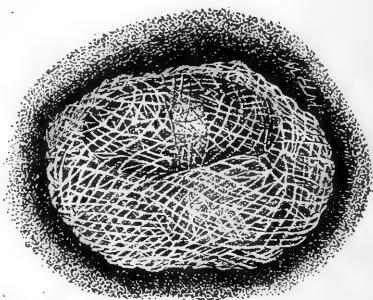


FIG. 27.—Cocoon of the alfalfa weevil showing cocoon of the parasite *Canidiella curculionis* within. Much enlarged. (Original.)



INDEX.

	Page.
<i>Anoplegimorpha phytonomi</i> , parasite of alfalfa weevil.....	34
<i>Agelaius phœniceus fortis</i> , enemy of alfalfa weevil.....	40
Alfalfa (see also <i>Medicago sativa</i>).	
duration of growing which should be allowed in weevil-infested districts.....	12
food plant of alfalfa weevil.....	1-41
clover-leaf weevil (<i>Hypera punctata</i>).....	15
hay, reduction in quality caused by alfalfa weevil.....	30
varieties experimented with in relation to alfalfa weevil.....	14
weevil, adult, description and habits.....	11-12, 15-17
allied species introduced from Europe.....	9
appearance of second species in Utah.....	15
cocoon, description.....	12
cocooning and pupating.....	23-24
cooperation of Bureau of Entomology and Utah Experiment Station.....	12-14
with other bureaus of U. S. Department of Agriculture.....	14-15
description and seasonal history.....	15-24
diffusion.....	25-26
distribution in the old world.....	9
egg.....	12, 17-19
laying period.....	19-20
evidence of partial second generation.....	20-21
field experiments in destruction.....	26-30
first appearance in United States.....	9-10
food plants.....	24
generally known in old world as <i>Phytonomus variabilis</i>	15
held in check in old world by natural enemies.....	15
hibernation.....	12
incorrectly called <i>Phytonomus murinus</i>	15
in Utah.....	1-41
investigations by Utah Experiment Station.....	11-12
of vertebrate enemies.....	15
larva.....	12, 21-22
larval period.....	22-23
less destructive in old world than in United States.....	15
means of dissemination (see also Alfalfa weevil, diffusion).....	12
migration.....	25-26
natural enemies.....	30-41
oviposition.....	17
possible confusion with clover-leaf weevil (<i>Hypera punctata</i>).....	15
pupating and cocooning.....	23-24
reduction in quality of alfalfa hay due to work.....	30
remedies, burning machine.....	29-30
cultivation in connection with irrigation.....	29

	Page.
Alfalfa, weevil, remedies, recommended by Utah Experiment Station.....	12
street-sweeper experiments.....	27
wire-brush experiment.....	27-28
seasonal history and description.....	15-24
spread in Utah and West.....	10
<i>Amaranthus retroflexus</i> refused as food by alfalfa weevil.....	24
<i>Amblystoma</i> sp., enemy of alfalfa weevil.....	40
<i>Ambrosia psilostachya</i> refused as food by alfalfa weevil.....	24
<i>trifida integrifolia</i> refused as food by alfalfa weevil.....	24
<i>Anaphes</i> sp., parasite of alfalfa weevil.....	35
<i>Astragalus arietinus</i> oviposited in by alfalfa weevil.....	17
<i>utahensis</i> , food plant of alfalfa weevil.....	17, 24
<i>oreophilus</i> eaten by alfalfa weevil.....	24
Bean, string. (See <i>Phaseolus vulgaris</i> .)	
Birds, enemies of alfalfa weevil.....	15, 30-31, 40
Bitterweed. (See <i>Ambrosia psilostachya</i> and <i>A. trifida integrifolia</i> .)	
Blackbird, Brewer's. (See <i>Euphagus cyanocephalus</i> .)	
thick-billed red-winged. (See <i>Agelaius phoeniceus fortis</i> .)	
yellow-headed. (See <i>Xanthocephalus xanthocephalus</i> .)	
Bobolink. (See <i>Dolichonyx oryzivorus</i> .)	
Brush drag against alfalfa weevil.....	12
<i>Bufo lentiginosus woodhousei</i> , enemy of alfalfa weevil.....	40
Burning machine against alfalfa weevil.....	29-30
<i>Canidiella curculionis</i> , parasite of alfalfa weevil.....	38
<i>Carpodacus mexicanus frontalis</i> , enemy of alfalfa weevil.....	40
<i>Chenopodium album</i> refused as food by alfalfa weevil.....	24
Chick pea. (See Pea, chick.)	
Chinch bug (<i>Blissus leucopterus</i>), prey of <i>Eleodes suturalis</i>	32
<i>Chondestes grammacus strigatus</i> , enemy of alfalfa weevil.....	40
Chrysopa. (See Lace-wing flies.)	
<i>Cicindela imperfecta</i> , enemy of alfalfa weevil.....	31
Clean culture to prevent alfalfa weevils from hibernating.....	12
<i>Cleome serrulata</i> eaten by alfalfa weevil.....	24
Clover, alsike. (See <i>Trifolium hybridum</i> .)	
food plant of clover-leaf weevil (<i>Hypera punctata</i>).....	15
leaf weevil (<i>Hypera punctata</i>) (see also <i>Phytonomus punctatus</i>).	
damage to clover.....	15
first appearance in Idaho and Utah.....	15
red. (See <i>Trifolium pratense</i> .)	
white. (See <i>Trifolium repens</i> .)	
sweet. (See <i>Melilotus alba</i> .)	
yellow sweet. (See <i>Melilotus indica</i> .)	
<i>Coccinella 9-notata</i> , enemy of alfalfa weevil.....	31
<i>Colaptes cafer collaris</i> , enemy of alfalfa weevil.....	40
<i>Collops bipunctatus</i> , enemy of alfalfa weevil.....	31
Cowbird. (See <i>Molothrus ater</i> .)	
Cultivation against alfalfa weevil.....	29
in connection with irrigation against alfalfa weevil.....	29
Discing against alfalfa weevil.....	12
<i>Dolichonyx oryzivorus</i> , enemy of alfalfa weevil.....	40
Dove, mourning. (See <i>Zenaidura macroura</i> .)	
Drag. (See Brush drag.)	
<i>Eleodes sulcipennis</i> , enemy of alfalfa weevil.....	32
<i>suturalis</i> , enemy of chinch bug (<i>Blissus leucopterus</i>).....	32

	Page.
<i>Empidonax trailli</i> , enemy of alfalfa weevil.....	40
<i>Empusa sphærosperma</i> , fungous enemy of alfalfa weevil.....	40-41
<i>Hypera punctata</i>	40-41
<i>Erythræus arvensis</i> , enemy of alfalfa weevil.....	33
<i>Euphagus cyanocephalus</i> , enemy of alfalfa weevil.....	40
Fenugreek. (See <i>Trigonella fenumgræcum</i> .)	
Finch, house. (See <i>Carpodacus mexicanus frontalis</i> .)	
Flicker, red-shafted. (See <i>Colaptes cafer collaris</i> .)	
Flycatcher, Traill's. (See <i>Empidonax trailli</i> .)	
Frog, leopard. (See <i>Rana pipiens</i> .)	
Fungous enemies infecting alfalfa weevil.....	40-41
Grass, birds-knot. (See <i>Polygonum aviculare</i> .)	
stem oviposited in by alfalfa weevil.....	17
Grosbeak, black-headed. (See <i>Zamelodia melanocephala</i> .)	
Ground cherry. (See <i>Physalis longifolia</i> (?)).	
plum. (See <i>Astragalus arietinus</i> .)	
<i>Hedysarum mackenzii</i> eaten by alfalfa weevil.....	24
<i>Hemiteles</i> sp., parasite of alfalfa weevil.....	39
<i>Hippodamia convergens</i> , enemy of alfalfa weevil.....	31
<i>spuria</i> , enemy of alfalfa weevil.....	31
<i>Hypera punctata</i> , accidental transportation from New York to Michigan.....	9
attacked by fungus.....	40
first appearance in Idaho and Utah.....	15
<i>Icterus bullocki</i> , enemy of alfalfa weevil.....	40
<i>Itopectis masculator</i> , parasite of alfalfa weevil.....	39
Killdeer. (See <i>Oxyechus vociferus</i> .)	
Kingbird, Arkansas. (See <i>Tyrannus verticalis</i> .)	
Lace-wing flies, enemies of alfalfa weevil.....	33
<i>Lactuca scariola</i> refused as food by alfalfa weevil.....	24
Lamb's-quarters. (See <i>Chenopodium album</i> .)	
Lark, desert horned. (See <i>Otocoris alpestris leucolæma</i> .)	
<i>Lathyrus latifolius</i> refused as food by alfalfa weevil.....	24
<i>odoratus</i> , food plant of alfalfa weevil.....	24
<i>sativus</i> eaten by alfalfa weevil.....	24
Leaves, eggs of alfalfa weevil deposited thereon.....	17
Lettuce, prickly. (See <i>Lactuca scariola</i> .)	
Locust, black. (See <i>Robinia pseudacacia</i> .)	
<i>Lophortyx californica vallicola</i> , enemy of alfalfa weevil.....	40
<i>Lupinus</i> sp. eaten by alfalfa weevil.....	24
Magpie. (See <i>Pica pica hudsonia</i> .)	
Mallow, round-leaved. (See <i>Malva rotundifolia</i> .)	
<i>Malva rotundifolia</i> refused as food by alfalfa weevil.....	24
Meadowlark, western. (See <i>Sturnella neglecta</i> .)	
<i>Medicago ciliaris</i> , experiment against alfalfa weevil.....	14
<i>echinus</i> , experiment against alfalfa weevil.....	14
food plant of alfalfa weevil.....	24
<i>falcata</i> , experiment against alfalfa weevil.....	14
<i>hispida confinis</i> , experiment against alfalfa weevil.....	14
food plant of alfalfa weevil.....	24
<i>nigra</i> , experiment against alfalfa weevil.....	14
food plant of alfalfa weevil.....	24
<i>terebellum</i> , experiment against alfalfa weevil.....	14
food plant of alfalfa weevil.....	24

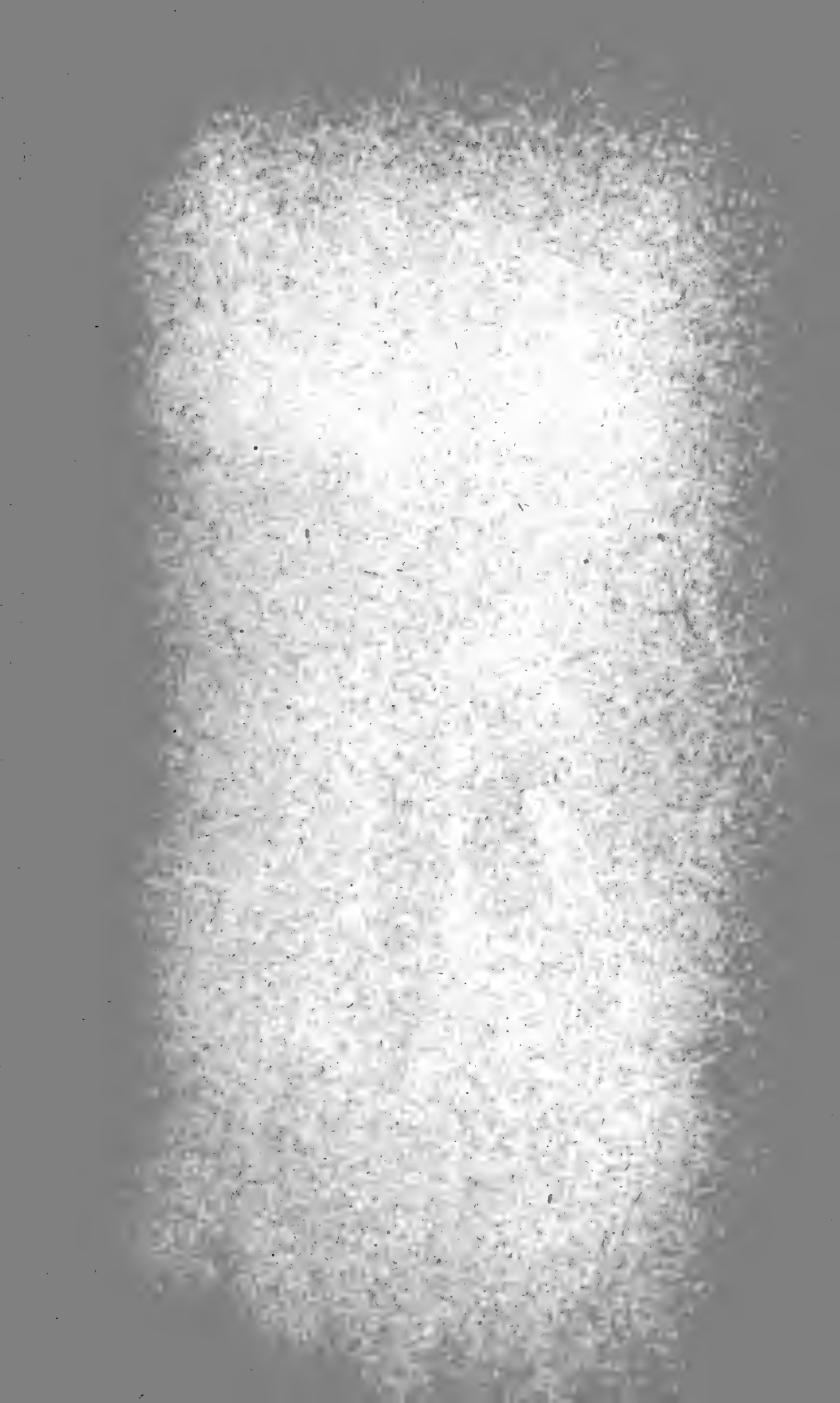
	Page.
<i>Medicago lupulina</i> , experiment against alfalfa weevil.....	14
food plant of alfalfa weevil.....	24
<i>muricata</i> , experiment against alfalfa weevil.....	14
food plant of alfalfa weevil.....	24
<i>orbicularis</i> , experiment against alfalfa weevil.....	14
food plant of alfalfa weevil.....	24
<i>ruthenica</i> , experiment against alfalfa weevil.....	14
<i>sativa</i> (see also Alfalfa).	
experiment against alfalfa weevil.....	14
<i>scutellata</i> , experiment against alfalfa weevil.....	14
food plant of alfalfa weevil.....	24
<i>Melilotus alba</i> , food plant of alfalfa weevil.....	24
<i>indica</i> , food plant of alfalfa weevil.....	24
<i>Melospiza melodia fallax</i> , enemy of alfalfa weevil.....	40
<i>Mesochorus nigripes</i> , parasite of alfalfa weevil.....	38
<i>Phytonomus rumicis</i>	38
<i>Molothrus ater</i> , enemy of alfalfa weevil.....	40
<i>Oreoscoptes montanus</i> , enemy of alfalfa weevil.....	40
<i>Oreospiza chlorura</i> , enemy of alfalfa weevil.....	40
Oriole, Bullock's. (See <i>Icterus bullocki</i> .)	
<i>Otocoris alpestris leucolæma</i> , enemy of alfalfa weevil.....	40
<i>Oxyechus vociferus</i> , enemy of alfalfa weevil.....	40
<i>Passerculus savannarum alaudinus</i> , enemy of alfalfa weevil.....	40
<i>Passer domesticus</i> , enemy of alfalfa weevil.....	40
Pea, chick, eaten by alfalfa weevil.....	24
everlasting. (See <i>Lathyrus latifolius</i> .)	
garden. (See <i>Pisum sativum</i> .)	
sweet. (See <i>Lathyrus odoratus</i> .)	
<i>Pediculoides ventricosus</i> , enemy of alfalfa weevil.....	32-33
<i>Phaseolus vulgaris</i> , food plant of alfalfa weevil.....	24
Phœbe, Say's. (See <i>Sayornis sayus</i> .)	
<i>Phygadeuon</i> sp., parasite of alfalfa weevil.....	38
<i>Physalis longifolia</i> refused as food by alfalfa weevil.....	24
<i>Phytonomus murinus</i> , name incorrectly applied to alfalfa weevil.....	15
<i>nigrirostris</i> , introduction into United States.....	9
<i>posticus</i> . (See Alfalfa weevil.)	
<i>punctatus</i> (see also <i>Hypera punctata</i>).	
<i>punctatus</i> = <i>Hypera punctata</i>	9
introduction into United States.....	9
<i>rumicis</i> , host of <i>Mesochorus nigripes</i>	38
<i>variabilis</i> , name given alfalfa weevil in old world.....	15
<i>Pica pica hudsonia</i> , enemy of alfalfa weevil.....	40
Pigweed, rough. (See <i>Amaranthus retroflexus</i> .)	
<i>Pisum sativum</i> refused as food by alfalfa weevil.....	24
<i>Planesticus migratorius propinquus</i> , enemy of alfalfa weevil.....	40
<i>Polygonum aviculare</i> refused as food by alfalfa weevil.....	24
<i>Poæcetes gramineus confinis</i> , enemy of alfalfa weevil.....	40
<i>Portulaca oleracea</i> refused as food plant by alfalfa weevil.....	24
Pteromalid egg parasite of alfalfa weevil.....	35-36
larval parasite of alfalfa weevil.....	36-37
Purslane. (See <i>Portulaca oleracea</i> .)	
Quail, valley. (See <i>Lophortyx californica vallicola</i> .)	
<i>Rana pipiens</i> , enemy of alfalfa weevil.....	40

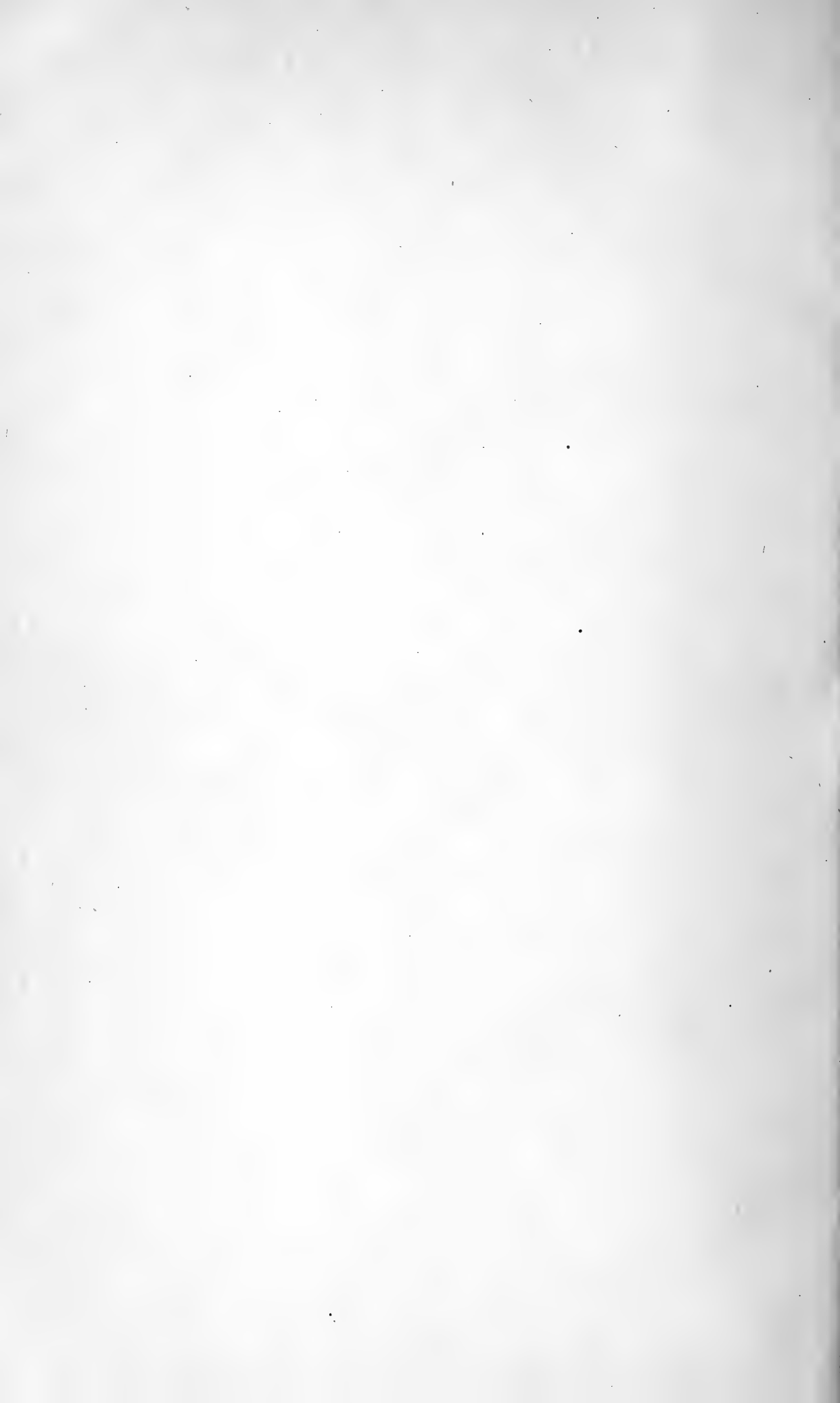
	Page.
<i>Robinia pseudacacia</i> , food plant of alfalfa weevil.....	24
Robin, western. (See <i>Planesticus migratorius propinquus</i> .)	
Salamander. (See <i>Amblystoma</i> sp.)	
<i>Sayornis sayus</i> , enemy of alfalfa weevil.....	40
Sheep, pasturing as remedy against alfalfa weevil.....	12
Sparrow, Brewer's. (See <i>Spizella breweri</i> .)	
desert song. (See <i>Melospiza melodia fallax</i> .)	
English. (See <i>Passer domesticus</i> .)	
western chipping. (See <i>Spizella socialis arizonæ</i> .)	
lark. (See <i>Chondestes grammacus strigatus</i> .)	
savannah. (See <i>Passerculus savannarum alaudinus</i> .)	
vesper. (See <i>Poæcetes gramineus confinis</i> .)	
white-throated. (See <i>Zonotrichia albicollis</i> .)	
Spider plant. (See <i>Cleome serrulata</i> .)	
Spiders, enemies of alfalfa weevil.....	33
<i>Spizella breweri</i> , enemy of alfalfa weevil.....	40
<i>socialis arizonæ</i> , enemy of alfalfa weevil.....	40
<i>Steganopus tricolor</i> , enemy of alfalfa weevil.....	40
<i>Stelgidopteryx serripennis</i> , enemy of alfalfa weevil.....	40
<i>Sturnella neglecta</i> , enemy of alfalfa weevil.....	40
Swallow, rough-winged. (See <i>Stelgidopteryx serripennis</i> .)	
Sweeper, street, against alfalfa weevil.....	27-28
Sweet pea. (See <i>Lathyrus odoratus</i> .)	
Thrasher, sage. (See <i>Oreoscoptes montanus</i> .)	
Toad, Rocky Mountain. (See <i>Bufo lentiginosus woodhousei</i> .)	
Towhee, green-tailed. (See <i>Oreospiza chlorura</i> .)	
<i>Trifolium hybridum</i> , food plant of alfalfa weevil.....	24
<i>pratense</i> , food plant of alfalfa weevil.....	24
<i>repens</i> , food plant of alfalfa weevil.....	24
<i>Trigonella fenumgræcum</i> , food plant of alfalfa weevil.....	24
<i>Tyrannus verticalis</i> , enemy of alfalfa weevil.....	40
Vetch, hairy or winter. (See <i>Vicia villosa</i> .)	
narrow-leaved. (See <i>Vicia</i> sp.)	
obtuse-leaved. (See <i>Vicia</i> sp.)	
spring. (See <i>Vicia sativa alba</i> .)	
Utah milk. (See <i>Astragalus utahensis</i> .)	
<i>Vicia atropurpurea</i> eaten by alfalfa weevil.....	24
<i>dispema</i> eaten by alfalfa weevil.....	24
<i>sativa alba</i> eaten by alfalfa weevil.....	24
sp., food plant of alfalfa weevil.....	24
<i>villosa</i> eaten by alfalfa weevil.....	24
Weevil, alfalfa. (See Alfalfa weevil.)	
Wilson's phalarope. (See <i>Steganopus tricolor</i> .)	
Wire brush against alfalfa weevil.....	27-28
<i>Xanthocephalus xanthocephalus</i> , enemy of alfalfa weevil.....	40
<i>Zamelodia melanocephala</i> , enemy of alfalfa weevil.....	40
<i>Zenaidura macroura carolinensis</i> , enemy of alfalfa weevil.....	40
<i>Zonotrichia albicollis</i> , enemy of alfalfa weevil.....	40

Howe

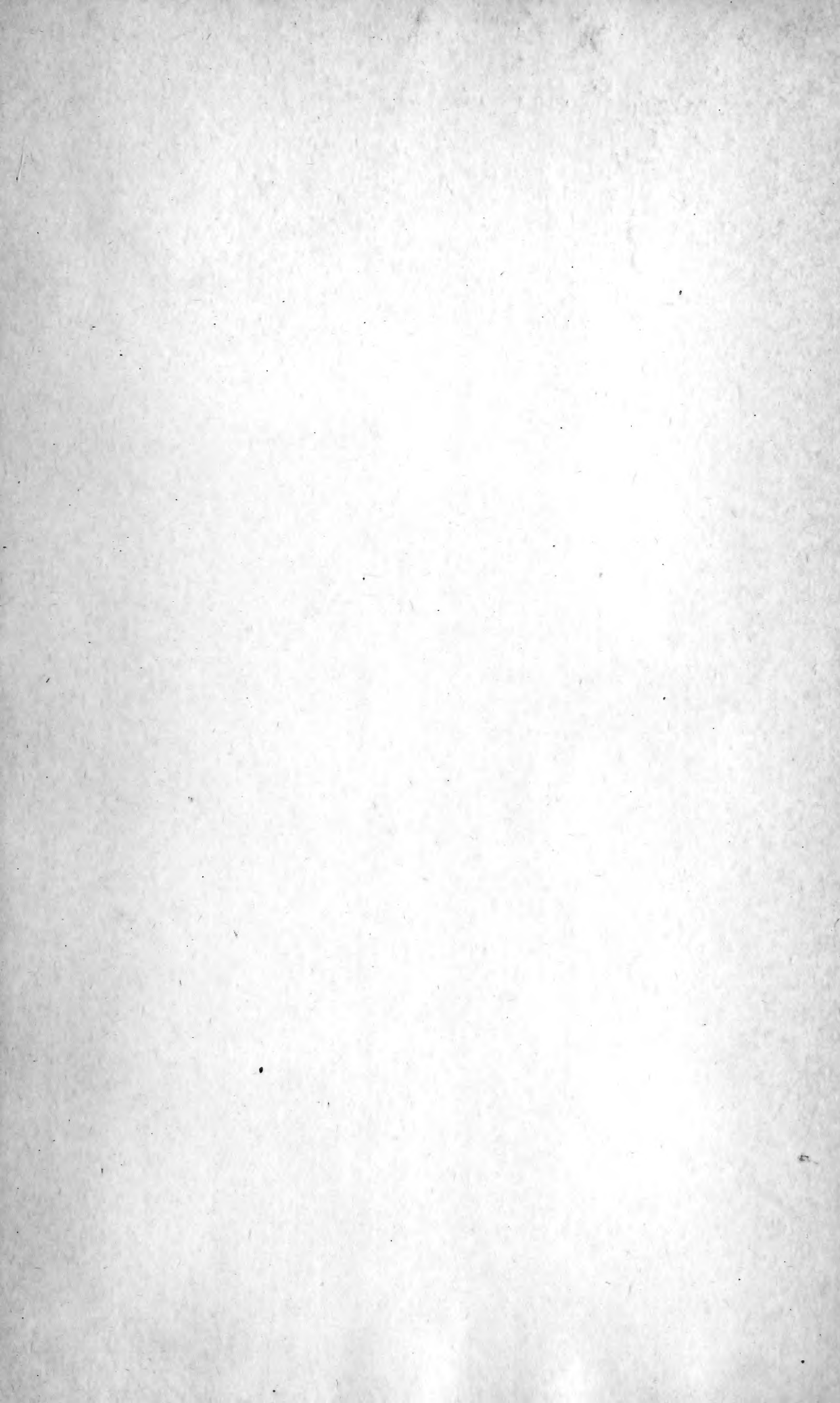
ADDITIONAL COPIES of this publication
may be procured from the SUPERINTEND-
ENT OF DOCUMENTS, Government Printing
Office, Washington, D. C., at 15 cents per copy

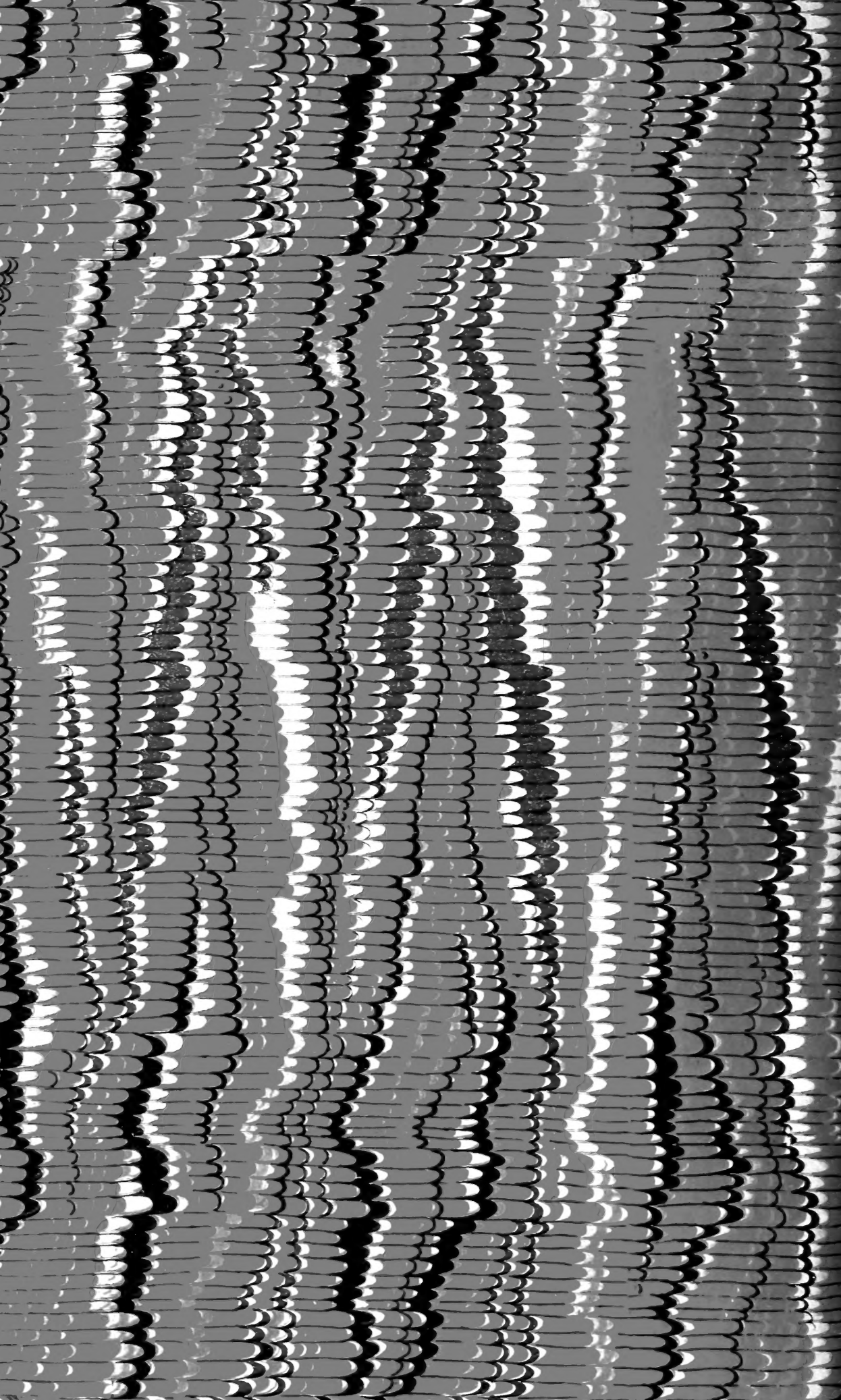












2
a.



SMITHSONIAN INSTITUTION LIBRARIES



3 9088 01267 7647