



Do not circulate

HARVARD UNIVERSITY.



LIBRARY

OF THE

MUSEUM OF COMPARATIVE ZOOLOGY

3189

GIFT OF

*Museum*

*February 20, 1915 - April 1, 1916*









APR 1 1916

# BULLETIN

OF THE

## MUSEUM OF COMPARATIVE ZOOLOGY

AT

HARVARD COLLEGE, IN CAMBRIDGE.

VOL. LIX.

---

CAMBRIDGE, MASS., U. S. A.

1915.

THE COSMOS PRESS:

E. W. WHEELER, CAMBRIDGE, U. S. A.



# CONTENTS.

---

	Page
No. 1.— Mammals obtained by the Phillips Palestine expedition. By GLOVER M. ALLEN. February, 1915 . . . . .	1
No. 2.— The cranial nerves of <i>Anolis carolinensis</i> . By WILLIAM A. WILLARD. (7 plates). July, 1915 . . . . .	15
No. 3.— Relics of Peale's Museum. By WALTER FAXON. July, 1915 . . . . .	117
No. 4.— Exploration of the coast water between Nova Scotia and Chesapeake Bay, July and August, 1913, by the U. S. Fisheries Schooner <i>Grampus</i> . Oceanography and plankton. By HENRY B. BIGELOW. (2 plates). September, 1915. . . . .	149
2 No. 5.— Notes on birds from East Siberia and Arctic Alaska. By W. SPRAGUE BROOKS. September, 1915 . . . . .	361
No. 6.— A revision of the lizards of the genus <i>Ameiva</i> . By THOMAS BARBOUR and G. KINGSLEY NOBLE. October, 1915. . . . .	415
No. 7.— Two new genera of myrmicine ants from Brazil. By WILLIAM MORTON WHEELER. November, 1915 . . . . .	481
No. 8.— New chilopods from Mexico and the West Indies. By RALPH V. CHAMBERLIN. (5 plates). November, 1915 . . . . .	493



3189

**Bulletin of the Museum of Comparative Zoölogy**

AT HARVARD COLLEGE.

VOL. LIX. No. 1.

---

MAMMALS OBTAINED BY THE PHILLIPS PALESTINE  
EXPEDITION.

BY GLOVER M. ALLEN.

---

CAMBRIDGE, MASS., U. S. A.:  
PRINTED FOR THE MUSEUM.  
FEBRUARY, 1915.

REPORTS ON THE SCIENTIFIC RESULTS OF THE EXPEDITION TO THE EASTERN TROPICAL PACIFIC. IN CHARGE OF ALEXANDER AGASSIZ, BY THE U. S. FISH COMMISSION STEAMER "ALBATROSS," FROM OCTOBER, 1904, TO MARCH, 1905. LIEUTENANT-COMMANDER L. M. GARRETT, U. S. N., COMMANDING, PUBLISHED OR IN PREPARATION:—

- A. AGASSIZ. V.<sup>5</sup> General Report on the Expedition.  
 A. AGASSIZ. I.<sup>1</sup> Three Letters to Geo. M. Sizewick, U. S. Fish Com.  
 A. AGASSIZ and H. L. CLARK. The Echini.  
 H. B. BIGELOW. XVI.<sup>16</sup> The Medusae.  
 H. B. BIGELOW. XXIII.<sup>23</sup> The Siphonophores.  
 H. B. BIGELOW. XXVI.<sup>26</sup> The Ctenophores.  
 R. P. BIGELOW. The Stomatopods.  
 O. CARLGREN. The Actinaria.  
 R. V. CHAMBERLIN. The Annelids.  
 H. L. CLARK. The Holothurians.  
 H. L. CLARK. The Starfishes.  
 H. L. CLARK. The Ophiurans.  
 S. F. CLARKE. VIII.<sup>8</sup> The Hydroids.  
 W. R. COE. The Nemerteans.  
 L. J. COLE. XIX.<sup>19</sup> The Pycnogonida.  
 W. H. DALL. XIV.<sup>14</sup> The Mollusks.  
 C. R. EASTMAN. VII.<sup>7</sup> The Sharks' Teeth.  
 S. GARMAN. XII.<sup>12</sup> The Reptiles.  
 H. J. HANSEN. The Cirripeds.  
 H. J. HANSEN. XXVII.<sup>27</sup> The Schizozopods.  
 S. HENSHAW. The Insects.  
 W. E. HOYLE. The Cephalopods.  
 W. C. KENDALL and L. RADCLIFFE. XXV.<sup>25</sup> The Fishes.  
 C. A. KOFOID. III.<sup>3</sup> IX.<sup>9</sup> XX.<sup>20</sup> The Protozoa.  
 C. A. KOFOID and J. R. MICHENER. XXII.<sup>22</sup> The Protozoa.  
 C. A. KOFOID and E. J. RIGDEN. XXIV.<sup>24</sup> The Protozoa.  
 P. KRUMBACH. The Sagittae.  
 R. VON LENDENFELD. XXI.<sup>21</sup> The Siliceous Sponges.  
 G. W. MÜLLER. The Ostracods.  
 JOHN MURRAY and G. V. LEE. XVII.<sup>17</sup> The Bottom Specimens.  
 MARY J. RATHBUN. X.<sup>10</sup> The Crustacea Decapoda.  
 HARRIET RICHARDSON. II.<sup>2</sup> The Isopods.  
 W. E. RITTER. IV.<sup>4</sup> The Tunicates.  
 B. L. ROBINSON. The Plants.  
 G. O. SARS. The Copepods.  
 F. E. SCHULZE. XI.<sup>11</sup> The Xenophyophoras.  
 HARRIET R. SEARLE. XXVIII.<sup>28</sup> Isopods.  
 H. R. SIMROTH. Pteropods, Heteropods.  
 E. C. STARKS. XIII.<sup>13</sup> Atelaxia.  
 TH. STUDER. The Alcyonaria.  
 JH. THIELE. XV.<sup>15</sup> Bathysciadium.  
 T. W. VAUGHAN. VI.<sup>6</sup> The Corals.  
 R. WOLTERECK. XVIII.<sup>18</sup> The Amphipods.

<sup>1</sup> Bull. M. C. Z., Vol. XLVI., No. 4, April, 1905, 22 pp.

<sup>2</sup> Bull. M. C. Z., Vol. XLVI., No. 6, July, 1905, 4 pp., 1 pl.

<sup>3</sup> Bull. M. C. Z., Vol. XLVI., No. 9, September, 1905, 5 pp., 1 pl.

<sup>4</sup> Bull. M. C. Z., Vol. XLVI., No. 13, January, 1906, 22 pp., 3 pls.

<sup>5</sup> Mem. M. C. Z., Vol. XXXIII., January, 1906, 90 pp., 96 pls.

<sup>6</sup> Bull. M. C. Z., Vol. L., No. 3, August, 1906, 14 pp., 10 pls.

<sup>7</sup> Bull. M. C. Z., Vol. L., No. 4, November, 1906, 26 pp., 4 pls.

<sup>8</sup> Mem. M. C. Z., Vol. XXXV., No. 1, February, 1907, 20 pp., 15 pls.

<sup>9</sup> Bull. M. C. Z., Vol. L., No. 6, February, 1907, 48 pp., 18 pls.

<sup>10</sup> Mem. M. C. Z., Vol. XXXV., No. 2, August, 1907, 56 pp., 9 pls.

<sup>11</sup> Bull. M. C. Z., Vol. LI., No. 6, November, 1907, 22 pp., 1 pl.

<sup>12</sup> Bull. M. C. Z., Vol. LII., No. 1, June, 1908, 14 pp., 1 pl.

<sup>13</sup> Bull. M. C. Z., Vol. LII., No. 2, July, 1908, 8 pp., 5 pls.

<sup>14</sup> Bull. M. C. Z., Vol. XLIII., No. 6, October, 1908, 285 pp., 22 pls.

<sup>15</sup> Bull. M. C. Z., Vol. LII., No. 5, October, 1908, 11 pp., 2 pls.

<sup>16</sup> Mem. M. C. Z., Vol. XXXVII., February, 1909, 243 pp., 48 pls.

<sup>17</sup> Mem. M. C. Z., Vol. XXXVIII., No. 1, June, 1909, 172 pp., 5 pls., 3 maps

<sup>18</sup> Bull. M. C. Z., Vol. LII., No. 9, June, 1909, 26 pp., 8 pls.

<sup>19</sup> Bull. M. C. Z., Vol. LII., No. 11, August, 1909, 10 pp., 3 pls.

<sup>20</sup> Bull. M. C. Z., Vol. LII., No. 13, September, 1909, 48 pp., 4 pls.

<sup>21</sup> Mem. M. C. Z., Vol. XLI., August, September, 1910, 323 pp., 56 pls.

<sup>22</sup> Bull. M. C. Z., Vol. LIV., No. 7, August, 1911, 38 pp.

<sup>23</sup> Mem. M. C. Z., Vol. XXXVIII., No. 2, December, 1911, 232 pp., 32 pls.

<sup>24</sup> Bull. M. C. Z., Vol. LIV., No. 10, February, 1912, 16 pp., 2 pls.

<sup>25</sup> Mem. M. C. Z., Vol. XXXV., No. 3, April, 1912, 98 pp., 8 pls.

<sup>26</sup> Bull. M. C. Z., Vol. LIV., No. 12, April, 1912, 38 pp., 2 pls.

<sup>27</sup> Mem. M. C. Z., Vol. XXXV., No. 4, July, 1912, 124 pp., 12 pls.

<sup>28</sup> Bull. M. C. Z., Vol. LVIII., No. 8, August, 1914, 14 pp.

**Bulletin of the Museum of Comparative Zoölogy**

AT HARVARD COLLEGE.

VOL. LIX. No. 1.

---

MAMMALS OBTAINED BY THE PHILLIPS PALESTINE  
EXPEDITION.

BY GLOVER M. ALLEN.

---

CAMBRIDGE, MASS., U. S. A.:  
PRINTED FOR THE MUSEUM.  
FEBRUARY, 1915.



No. 1.— *Mammals obtained by the Phillips Palestine Expedition.*

BY GLOVER M. ALLEN.

THE collection here reported on consists of about one hundred and fifty small mammals, mostly skins with skulls, presented to the Museum of Comparative Zoölogy by Dr. John C. Phillips, who obtained them during his expedition (March–June, 1914) to the Sinai Peninsula and Palestine. His route was from Cairo eastward along the west coast of the Gulf of Suez, to Mt. Sinai, thence northward to Akaba, at the head of the Gulf of Akaba, and on to the region of the Dead Sea. Mr. William M. Mann, who accompanied him, made further collections about the base of Mt. Hermon. Twenty-four species were obtained, some of which are yet very imperfectly known. The ranges of others are slightly extended by Dr. Phillips's collections. The country to the south of Syria is inhabited by a typical desert fauna of genera which for the most part are not found north of the Dead Sea region, where they give place to more strictly Palaearctic types, as *Apodemus*, *Microtus*, *Eliomys*. No new species were discovered, but the fine series of *Apodemus mystacinus* from the vicinity of Mt. Hermon makes it possible to determine the status of the form found in the Black Sea forest of Asia Minor, and it is here described as new.

CROCIDURA RUSSULA (Hermann).

White-toothed Shrew.

*Sorex russulus* Hermann, Zimmermann's Geogr. geschichte, 1780, 2, p. 382.

No specimens of this genus were met with except in the country about the western base of Mt. Hermon, at Rasheya, Bâniyâs, Ammik, and Aithenit. The series of seven skins is of very uniform appearance and seems to be indistinguishable from typical *russula*.

PIPISTRELLUS KUHLI (Kuhl).

Kuhl's Bat.

*Vespertilio kuhlii* Kuhl, Ann. Wetterau. ges. naturk., 1819, 4, p. 199.

A single specimen of this small species was taken at Shtora, Syria.

## EPTESICUS SEROTINUS (Schreber).

Serotine Bat.

*Vespertilio serotinus* Schreber, Säugethiere, 1774, **1**, pl. 53; 1775, **1**, p. 167 (description).

This common species of southern and central Europe was taken once at Shtora, Syria.

## TAPHOZOUS NUDIVENTRIS Cretzschmar.

Tomb-haunting Bat.

*Taphozous nudiventris* Cretzschmar, Rüppell's Atlas reise nördl. Afrika. Säugeth., 1826, p. 70, fig. 27*b*.

A small series was shot at evening from the walls of Jericho, which must be near its northward limit in Palestine.

## CANIS AUREUS Linné.

Jackal.

*Canis aureus* Linné, Syst. nat., ed. 10, 1758, **1**, p. 40.

Throughout much of the country traversed, jackals were common and frequently proved a great nuisance by following the lines of traps and carrying off both trap and mouse. One specimen brought back has a deformed lower jaw, which is so much shorter than the upper, that the lower canines close *behind* the upper ones. All the teeth seem normally formed, however, but on account of the shortness of the ramus the premolar series is greatly crowded.

## ELIOMYS MELANURUS Wagner.

Black-tailed Dormouse.

*Eliomys melanurus* Wagner, Abh. K. Bayer. akad. München, Math.-phys. cl., 1843, **3**, p. 176, pl. 3, fig. 1.

This beautiful dormouse was met with near the west base of Mt. Hermon, where at Ain Hersha and Rasheya, three specimens were taken. One from the former locality, May 31, is a young individual. It is known also from the Sinai region.



## PSAMMOMYS OBESUS Cretzschmar.

## Sand Mouse.

*Psammomys obesus* Cretzschmar, Ruppell's Atlas reise nördl. Afrika. Säugeth., 1826, p. 58, pl. 22, 23.

At Ain Abu Heran, to the north of Akaba, Dr. Phillips shot a sub-adult male which seems referable to this species. The type locality is Alexandria, so that this record extends its range well to the eastward. The Museum has also a skin from Palestine, without definite locality, but probably from near the southwest coast. The long-tailed *P. terraesanctae* of the Dead Sea region seems to be a species distinct from the shorter-tailed *obesus* and *algericus*.

## MERIONES TRISTRAMI Thomas.

## Tristram's Gerbil.

*Meriones tristrami* Thomas, Ann. mag. nat. hist., 1892, ser. 6, 9, p. 148.

This species was first described on the basis of specimens from the Dead Sea region and Mt. Carmel collected by Canon Tristram, who referred it to *M. tamaricinus*. Nehring (Sitzb. Ges. naturf. freunde Berlin, 1901, p. 171) records a specimen from the south of Jaffa on the coast, west of the Dead Sea.

On his way north from Akaba, Dr. Phillips first met with this gerbil at Shobek, and on successive days, trapped it at Ain Gleidah and Tafleeh. The locality first-named, probably represents nearly its southern limit, as it was not found on the high plateau country to the south. Three individuals, not quite fully grown, lack the bright sandy color of the adults, and are decidedly grayer. A young one from Beir el Doleh, Syria, is more fulvous.

## MERIONES CRASSUS Sundevall.

## Silky Gerbil.

*Meriones crassus* Sundevall, K. Vet. akad. Handl. för 1842, 1843, p. 233, pl. 2, fig. 4, a-d.

A single specimen sent by the Swedish traveller Hedenborg, served as Sundevall's type of this remarkable species. Hedenborg's note

accompanying it gives its habitat as the Sinai desert, "Ad vias circa fontes Mosis." The Wells of Moses (Ain Musa) near the west shore of the Gulf of Suez, may therefore be considered the type locality. Dr. Phillips obtained two adults near Mt. Sinai, at Wady Feiran and Um Shomer respectively, and a third on the eastern side of the Sinai peninsula, at Suweira, slightly to the north of Akaba. It therefore probably ranges over the greater part of the Sinai desert. Bonhote (Proc. Zool. soc. London, 1912, p. 226) has recorded a specimen from Tor in Sinai, collected by Capt. S. S. Flower.

The peculiar inflation of the auditory meatus causing it to touch the angle of the squamosal process, and the posterior enlargement of the bullae, so that they extend behind the supraoccipital and notably constrict the exoccipitals, may prove to be characters of generic value, when the time comes for a revision of the group. The pelage is extremely soft and silky; the pale, sand-colored hairs of the upper surface of the body are minutely black-tipped.

#### GERBILLUS CALURUS Thomas.

##### Bushy-tailed Gerbil.

*Gerbillus calurus* Thomas, Ann. mag. nat. hist., 1892, ser. 6, 9, p. 76.

One of the most interesting of Dr. Phillips's captures is a fine adult male of this rare gerbil. Hitherto but three specimens seem to have been recorded, all of which are in the British Museum. The original specimen is an alcoholic without locality; the second, also an alcoholic, is from Sinai, and unfortunately in poor condition; the third is a skin with imperfect skull, from Wady Sikait, south of Gebel Sebara, eastern Egypt. Dr. Phillips's specimen (the fourth to be recorded) is from the Sinai region at Wady Sa'al. The type was for many years in the British Museum before it was made known by Thomas, and it was not till the publication of the two other records by Anderson in his Zoology of Egypt, 2, Mammals, in 1902, that its probable range was indicated. The squirrel-like tail is a remarkable feature in the genus, but the skull seems sufficiently typical. The measurements of the present specimen are:—head and body 118 mm., tail 145, hind foot 33, ear 22; skull, greatest length 36.5, basal length 30, palatal length 19.3, diastema 8.5, zygomatic width 18.7, mastoid width 18.9, inter-orbital constriction 5.5, bullae  $14 \times 7.5$ , upper molar row (alveoli)

5.6. Posteriorly the inflated mastoids project slightly beyond the occipital region.

GERBILLUS GERBILLUS (Olivier).

Tawny Gerbil.

*Dipus gerbillus* Olivier, Voy. Egypt., 1801, 3, p. 157, pl. 28; Bull. Soc. philom. Paris, 1801, 2, p. 121.

This brightly colored gerbil was first trapped at Wady Shurandel in the Sinai region. Other specimens were taken at the head of the Gulf of Akaba to the northeast, namely at Akaba and Suweira, but none has been recorded to the northward of these places.

DIPODILLUS QUADRIMACULATUS Lataste.

Four-spotted Gerbil.

*Dipodillus quadrimaculatus* Lataste, Le naturaliste, 1882, 4, p. 27.

A series of six specimens from Akaba, at the head of the Gulf of the same name, appears to represent this species, and extends its known range somewhat to the eastward. Its apparent absence from the high rough country of the interior of the Sinai peninsula may indicate that it is confined to the low sandy areas along the coast.

DIPODILLUS DASYUROIDES Nehring.

Nehring's Smooth-footed Gerbil.

*Dipodillus dasyuroides* Nehring, Sitzb. Ges. naturf. freunde Berlin, 1901, p. 173.

A series of thirteen skins, old and young, seems referable to Nehring's species, the type of which is from Mount Moab, east of the southern end of the Dead Sea. The chief color character distinguishing it from Wagner's *dasyurus* of western Arabia is said to be the yellowish instead of pure white area above the eyes. In the series before me there is some variation in tint, chiefly due to the greater or less suffusion of the upper parts with buffy. This seems partly a matter of age, since the young and subadults are less buffy, the pale area above the eyes is dirty white, and the ventral side of the tail is

white. In the adults with worn teeth the entire pelage above is buffier, as well as the eye spots and ventral side of the tail. The adult males are brighter buff or fulvous as compared with the females, which even in the adult, seem grayer, like the young. One specimen has the extreme tip of the tail white. The type locality, Moab, must be near the northern limit of its range. Dr. Phillips obtained it at Suweira, Nuheibeh, and Um Shomer in the Sinai region, then farther north at Petra, and in Syria at Wady Hesa, Wady Ain Musa, and Beir el Doleh. Several young specimens from one third to one half the adult size were collected in late April and early May at Petra and Beir el Doleh.

DIPODILLUS MARIAE Bonhote.

Mrs. Bonhote's Pigmy Gerbil.

*Dipodillus mariae* Bonhote, Proc. Zool. soc. London, 1909, p. 792.

This minute grayish species was but recently described on the basis of two specimens from the Mokattam Hills, near Cairo, Egypt. A single male collected by Dr. Phillips at Wady Feiran, Sinai, corresponds completely with the published description, and seems thus to represent the third recorded specimen. The known range of the species is extended considerably to the eastward by this capture.

MICROTUS GUENTHERI (Danford and Alston).

Guenther's Vole.

*Arvicola guentheri* Danford and Alston, Proc. Zool. soc. London, 1880, p. 62, pl. 5.

Eight specimens of a short-tailed yellowish vole I have provisionally referred to *guentheri*, with the description of which they seem to agree. All are from localities in the valley west of Mt. Hermon. In the original diagnosis, the presence of five plantar tubercles is given as a chief distinguishing character, but in some specimens there seems to be a minute sixth one indicated. The ears project distinctly from the fur of the head, and instead of being well haired near their margins as stated by the describers of *guentheri*, they are clothed with very minute hairs and appear nearly naked unless narrowly examined. The relationship of this species to *M. socialis* is apparently close.

## APODEMUS SYLVATICUS TAURICUS (Barrett-Hamilton).

## Taurus Wood Mouse.

*Mus sylvaticus tauricus* Barrett-Hamilton, Proc. Zool. soc. London, 1900, p. 412.

Three specimens from Shiba, Rasheya, and Ain Hersha respectively, localities near the southwest base of Mt. Hermon, belong to the *sylvaticus* group, and here represent nearly the southern limit of its range in Palestine. Two of these, though nearly grown, are in the immature slaty gray pelage, and the third is an adult male. Barrett-Hamilton's name *tauricus* probably applies to these specimens, though he gives no description beyond the length and breadth of the type skull (23 × 12 mm.). His type is an alcoholic in the British Museum from Zebil in the Bulgar Dagh, southern Asia Minor, and thus not very far from Palestine. The adult skin brought back by Dr. Phillips's expedition is a very pale buffy animal uniformly 'lined' above with black hairs and quite without the russet tints of true *sylvaticus*. Judging from descriptions alone it is nearly indistinguishable from *A. s. dichrurus* of the European Mediterranean region and in its measurements it shows no appreciable differences. The skull of the adult male is 24.6 mm. in greatest length as against 23 mm. given for the type of *tauricus*, but the latter measurement may well be within the limits of variability for an immature individual.

## APODEMUS FLAVICOLLIS (Melchior).

## Yellow-collared Mouse.

*Mus flavicollis* Melchior, Den Danske Staats og Norges pattedyr, 1834, p. 99.

Two specimens, one adult, the other immature, from Ain Hersha near the base of Mt. Hermon extend the recorded range of this species well into Palestine and probably indicate nearly the southeastern limit of its distribution. Through the kindness of Mr. Gerrit S. Miller, Jr., I have been able to compare these with a series of European *flavicollis*, including topotypes from Denmark, in the U. S. N. M. The adult, in russet pelage, is a mere shade paler than any of the

European skins yet probably falls within the limits of individual variation. Skins from the Harz Mountains of Germany and others from Switzerland match it very closely. The feet are a little small and the skull, compared with those from Europe having equally worn teeth, is a trifle smaller, yet in both these respects it can be duplicated in the European series. The braincase seems smaller, however, and the angle formed by the sides of the frontoparietal suture is more acute. Additional specimens from Palestine may show that the local representatives of the species are entitled to rank as a separate race.

The immature specimen is in the slaty gray pelage, and though taken June 1st, is fairly well grown (total length 190 mm.), indicating as Barrett-Hamilton has suggested, that it breeds early in the year.

#### APODEMUS MYSTACINUS (Danford and Alston).

##### Gray Wood Mouse.

*Mus mystacinus* Danford and Alston, Proc. Zool. soc. London, 1877, p. 279.

A series of fourteen skins, young and adult, represents this species, which seems to be rare in collections. All are from the region about the base of Mt. Hermon, and correspond in all details with the original description. The young, unlike those of the *sylvaticus* group, are colored practically like the adults, though the fawn tints on the sides of the face and body brighten slightly with age. The original series in the British Museum comprised three specimens, two at least in alcohol, collected in the Bulgar Dagh region of southern Asia Minor. The pale coloration is typical of the dry country in which this mouse lives, and Mr. Oldfield Thomas (Ann. mag. nat. hist., 1903, ser. 7, 12, p. 188) has lately described an even paler race, *A. m. smyrnensis*, from extreme western Asia Minor at Smyrna. In this race the hairs of the lower surfaces are pure white to the roots instead of having slaty bases.

Through Mr. Thomas's kindness the M. C. Z. has received in exchange a specimen referred to *mystacinus* taken in the forest belt bordering the Black Sea, an area very different faunally from the arid country to the south. Dr. Phillips's fine series representing typical *mystacinus* shows that the Black Sea animal, as might be expected, is very different in color. It is much darker, and almost without the buffy tints of the former. It may be known as

**Apodemus mystacinus euxinus**, subsp. nov.

## Black Sea Wood Mouse.

*Type*.—Skin and skull 14,887 M. C. Z., from Scalita (near Trebizond), Asia Minor; male, collected November 25, 1905, by A. Robert, altitude 1,000 meters.

*General Characters*.—Similar to typical *mystacinus* but much darker, the back blacker, the buffy tints of face and sides replaced by grayish.

*Description*.—The type specimen is subadult, and in comparison with specimens of similar age from Palestine, is much darker throughout. The entire dorsal surfaces are grayish, heavily washed with black which predominates in the middle of the back. The sides of the head and body are paler gray very faintly washed with "pinkish-buff" but in much less degree than in the typical race so that the general appearance is dark gray. Along the sides of the body a faint band of 'pinkish buff' delimits the color of the dorsal surface from the white of the belly. The slaty bases of the hairs of the ventral surface show through sufficiently to darken the entire underparts except on the forearms, which are pure white below. Feet and hands white, ankles slaty, with a dusky prolongation reaching the calcaneum behind, though the tarsal joint is white on its upper surface. Tail sharply bicolor, blackish above, white below.

*Measurements*.—Head and body 94 mm., tail 109, hind foot 24, ear 18. The skull shows no appreciable differences from that of typical *mystacinus*; condylobasal length 26, palatal length 14, zygomatic width 14, upper cheek teeth (alveoli) 4.5.

*Remarks*.—Mr. Thomas has already described several new forms of mammals from the forest belt along the northern coast of Asia Minor on the Black Sea. Here, he says, "there is a strip of forest, some 50 miles wide, sloping northwards to the Black Sea from an altitude of 1500 to 2000 metres at its southern edge. The forest then abruptly disappears and an open steppe country commences, inhabited by Hamsters and Spermophiles, and continuous with the more desert countries further south. Compared with this more open and desert country the coast-forest has a very different fauna, of a distinctly northern character. \*\*\* Mr. Robert's work was done at two localities in the heart of the forest-strip — Sumela \*\*\* and Scalita \*\*\* a village in the same valley as Sumela but about 3000 m. [= 300 m.?] lower," and some 30 or more miles south of Trebizond (Ann. mag. nat. hist., 1906, ser. 7, 17, p. 415).

The dark color and lack of buffy patches on the sides of the head and behind the ears in the Black Sea form are no doubt correlated with life in this coastal forest. Apparently *A. mystacinus* is not closely related to *A. epimelas* of Europe which is sharply distinguished by the presence of a fourth minute tubercle at the posteroexternal margin of the first and second upper molars.

### MUS MUSCULUS Linné.

#### House Mouse.

*Mus musculus* Linné, Syst. nat., ed. 10, 1758, 1, p. 62.

Three skins from Akaba do not seem different from the form of House Mouse introduced into the eastern United States. Probably at Akaba the typical variety has been introduced by the shipping.

### MUS MUSCULUS ORIENTALIS Cretzschmar.

*Mus orientalis* Cretzschmar, Rüppell's Atlas reise nördl. Afrika. Säugeth., 1826, p. 76, pl. 30, fig. a.

Four skins are pale-bellied, yet with conspicuous dusky bases to the white-tipped hairs, and with a buffy line along the sides of the body. They are to be considered as representing *orientalis* though it seems questionable if they are not better referred to *gentilis*, of which they would be reckoned a dark extreme. The four specimens are from Akaba, Arabia, and from Rasheya, Hasbeiya, and Shiba, Syria (near Mt. Hermon).

### MUS MUSCULUS GENTILIS Brants.

#### White-bellied House Mouse.

*Mus gentilis* Brants, Muizen, 1827, p. 126.

This pale, white-bellied form was taken at Shobek in Arabia and at Wady Kerak and El Kerak in Syria. The hairs of the belly are clear white to the base, or with the very base only light plumbeous. Probably these are the native form of House Mouse.



## ACOMYS RUSSATUS Wagner.

## Short-tailed Spiny Mouse.

*Acomys russatus* Wagner, Abh. K. Bayer. akad. München, Math.-phys. cl., 1843, 3, p. 195, pl. 3, fig. 2.

Of this rare species, two specimens were procured at Wady Feiran, in the dry rocky country of Sinai, and so are practically topotypes. Nehring (Sitzb. Ges. naturf. freunde Berlin, 1901), records one each from Moab and Engeddi, Palestine, and Tristram had previously found it at Massada at the south end of the Dead Sea. In describing as a distinct race the specimens he found in the Mokattam Hills, near Cairo, Bonhote (Proc. Zool. soc. London, 1912, p. 229) also mentions a pair from Sinai that he kept alive. The known range of the typical form is thus from the region of the Dead Sea through the Sinai peninsula.

## ACOMYS DIMIDIATUS (Cretzschmar).

## Desert Spiny Mouse.

*Mus dimidiatus* Cretzschmar, Rüppell's Atlas reise nördl. Afrika. Säugeth., 1826, p. 37, pl. 13, fig. a.

This is the commonest small rodent in the collection. Many specimens were taken in the Sinai region, at Akaba (head of the Gulf of Akaba) and northward at Petra and Tafileh. The most northerly specimen is from Wady Kerak at the southern end of the Dead Sea.

## JACULUS MACROTARSUS (Wagner).

## Long-footed Jerboa.

*Dipus macrotarsus* Wagner, Abh. K. Bayer. akad. München, Math.-phys. cl., 1843, 3, p. 214, pl. 4, fig. 2.

A single specimen from Wady Feiran, Mt. Sinai, is practically a topotype of this species, which was originally described from specimens sent from Mt. Sinai. Nehring (Sitzb. Ges. naturf. freunde Berlin, 1901, p. 163), in naming *schlüteri* from southwestern Palestine, compared it with examples from western Arabia, which he took to represent *macrotarsus*. It seems likely that in this he was correct.

At all events the ventral hook-like process of the jugal is lacking in the Sinai specimen as in these, and they have two perforations of the angle of the jaw instead of one as in the other species. In color *J. macrotarsus* seems to be very much darker than *J. jaculus* by reason of the many dark-tipped hairs among the pale buffy fur of the back. These dark tips also extend to the sides of the belly, and give a soiled appearance to the white of this area. Among the vibrissae is a single one of great length on each side (some 104 mm.). The collector's measurements are:—total length 300 mm., tail 180, hind foot 55, ear 22.5. The skull measures: greatest median length 31.7 mm., basal length 28, palatal length 18.5, diastema 8.8, zygomatic breadth 21.5, width across malars 20.5, mastoid width 23, upper tooth row (alveoli) 5.1.

#### CAPRA NUBIANA SINAITICA Hemprich and Ehrenberg.

##### Sinai Ibex.

*Capra sinaitica* Hemprich and Ehrenberg, Symb. phys. zool., 1828, 1, pl. 18.

Dr. Phillips supplies the following interesting note as to the present status of this animal.

“The Sinai Ibex still persists over all the rugged parts of the Sinai peninsula, near Akaba and up at least as far as the northeast end of the Dead Sea. Although undoubtedly greatly reduced in numbers since Tristram's time (1884), it manages to persist in spite of the fact that every hand is against it during the entire year, and its freshly dropped kids are eagerly hunted by the natives with dogs. I hunted three days and saw only four smallish animals, but signs were fairly numerous. The Ibex appears to be independent of water, at least during winter and spring. The leopard hunts these Ibexes and presumably kills a good many, as various sportsmen have testified. We obtained a new born kid at Feiran, March 30th, and another at Akaba, April 16th.” Dr. Phillips found evidence that they frequent caves among the rocks as hiding places.

The following Publications of the Museum of Comparative Zoölogy are in preparation:—

LOUIS CABOT. Immature State of the Odonata, Part IV.

E. L. MARK. Studies on Lepidosteus, continued.

E. L. MARK. On Arachnactis.

A. AGASSIZ and C. O. WHITMAN. Pelagic Fishes. Part II., with 14 Plates.

H. L. CLARK. The "Albatross" Hawaiian Echini.

Reports on the Results of Dredging Operations in 1877, 1878, 1879, and 1880, in charge of ALEXANDER AGASSIZ, by the U. S. Coast Survey Steamer "Blake," as follows:—

A. MILNE EDWARDS and E. L. BOUVIER. The Crustacea of the "Blake."

A. E. VERRILL. The Alcyonaria of the "Blake."

Reports on the Results of the Expedition of 1891 of the U. S. Fish Commission Steamer "Albatross," Lieutenant Commander Z. L. TANNER, U. S. N., Commanding, in charge of ALEXANDER AGASSIZ, as follows:—

K. BRANDT. The Sagittae.

K. BRANDT. The Thalassicolae.

O. CARLGREN. The Actinarians.

R. V. CHAMBERLIN. The Annelids.

W. R. COE. The Nemerteans.

REINHARD DOHRN. The Eyes of Deep-Sea Crustacea.

H. J. HANSEN. The Cirripeds.

H. J. HANSEN. The Schizopods.

HAROLD HEATH. Solenogaster.

W. A. HERDMAN. The Ascidians.

S. J. HICKSON. The Antipathids.

E. L. MARK. Branchiocerianthus.

JOHN MURRAY. The Bottom Specimens.

P. SCHIEMENZ. The Pteropods and Heteropods.

THEO. STUDER. The Alcyonarians.

— The Salpidae and Doliolidae.

H. B. WARD. The Sipunculids.

Reports on the Scientific Results of the Expedition to the Tropical Pacific, in charge of ALEXANDER AGASSIZ, on the U. S. Fish Commission Steamer "Albatross," from August, 1899, to March, 1900, Commander Jefferson F. Moser, U. S. N., Commanding, as follows:—

R. V. CHAMBERLIN. The Annelids.

H. L. CLARK. The Holothurians.

H. L. CLARK. The Ophiurans.

— The Volcanic Rocks.

— The Coralliferous Limestones.

S. HENSHAW. The Insects.

R. VON LENDENFELD. The Siliceous Sponges.

G. W. MÜLLER. The Ostracods.

MARY J. RATHBUN. The Crustacea Decapoda.

G. O. SARS. The Copepods.

L. STEJNEGER. The Reptiles.

C. H. TOWNSEND. The Mammals, Birds, and Fishes.

T. W. VAUGHAN. The Corals, Recent and Fossil.

PUBLICATIONS  
OF THE  
MUSEUM OF COMPARATIVE ZOOLOGY  
AT HARVARD COLLEGE.

---

There have been published of the BULLETIN Vols. I. to LIV., and Vol. LVIII.; of the MEMOIRS, Vols. I. to XXIV., and also Vols. XXVI. to XXIX., XXXI. to XXXIV., XXXVI. to XXXVIII., XLI., and XLIV.

Vols. LV. to LVII. and LIX. of the BULLETIN, and Vols. XXV., XXX., XXXV., XXXIX., XL., XLII., XLIII., XLV. to XLVIII. of the MEMOIRS, are now in course of publication.

The BULLETIN and MEMOIRS are devoted to the publication of original work by the Officers of the Museum, of investigations carried on by students and others in the different Laboratories of Natural History, and of work by specialists based upon the Museum Collections and Explorations.

The following publications are in preparation:—

Reports on the Results of Dredging Operations from 1877 to 1880, in charge of Alexander Agassiz, by the U. S. Coast Survey Steamer "Blake," Lieut. Commander C. D. Sigsbee, U. S. N., and Commander J. R. Bartlett, U. S. N., Commanding.

Reports on the Results of the Expedition of 1891 of the U. S. Fish Commission Steamer "Albatross," Lieut. Commander Z. L. Tanner, U. S. N., Commanding, in charge of Alexander Agassiz.

Reports on the Scientific Results of the Expedition to the Tropical Pacific, in charge of Alexander Agassiz, on the U. S. Fish Commission Steamer "Albatross," from August, 1899, to March, 1900, Commander Jefferson F. Moser, U. S. N., Commanding.

Reports on the Scientific Results of the Expedition to the Eastern Tropical Pacific, in charge of Alexander Agassiz, on the U. S. Fish Commission Steamer "Albatross," from October, 1904, to April, 1905, Lieut. Commander L. M. Garrett, U. S. N., Commanding.

Contributions from the Zoölogical Laboratory, Professor E. L. Mark, Director  
Contributions from the Geological Laboratory, Professor R. A. Daly, in charge.

These publications are issued in numbers at irregular intervals. Each number of the Bulletin and of the Memoirs is sold separately. A price list of the publications of the Museum will be sent on application to the Director of the Museum of Comparative Zoölogy, Cambridge, Mass.

**Bulletin of the Museum of Comparative Zoölogy**  
**AT HARVARD COLLEGE.**  
**VOL. LIX. No. 2.**

---

**THE CRANIAL NERVES OF ANOLIS CAROLINENSIS.**

**BY WILLIAM A. WILLARD.**

**WITH SEVEN PLATES.**

**CAMBRIDGE, MASS., U. S. A.:**  
**PRINTED FOR THE MUSEUM.**  
**JULY, 1915.**

REPORTS ON THE SCIENTIFIC RESULTS OF THE EXPEDITION TO THE EASTERN TROPICAL PACIFIC, IN CHARGE OF ALEXANDER AGASSIZ, BY THE U. S. FISH COMMISSION STEAMER "ALBATROSS," FROM OCTOBER, 1904, TO MARCH, 1905, LIEUTENANT COMMANDER L. M. GARRETT, U. S. N., COMMANDING. PUBLISHED OR IN PREPARATION:—

- A. AGASSIZ. V.<sup>5</sup> General Report on the Expedition.
- A. AGASSIZ. I.<sup>2</sup> Three Letters to Geo. M. Bowers, U. S. Fish Com.
- A. AGASSIZ and H. L. CLARK. The Echini.
- H. B. BIGELOW. XVI.<sup>16</sup> The Medusae.
- H. B. BIGELOW. XXIII.<sup>23</sup> The Siphonophores.
- H. B. BIGELOW. XXVI.<sup>26</sup> The Ctenophores.
- R. P. BIGELOW. The Stomatopods.
- O. CARLGREN. The Actinaria.
- R. V. CHAMBERLIN. The Annelids.
- H. L. CLARK. The Holothurians.
- H. L. CLARK. The Starfishes.
- H. L. CLARK. The Ophiurans.
- S. F. CLARKE. VIII.<sup>8</sup> The Hydroids.
- W. R. COE. The Nemerteans.
- L. J. COLE. XIX.<sup>19</sup> The Pycnogonida.
- W. H. DALL. XIV.<sup>14</sup> The Mollusks.
- C. R. EASTMAN. VII.<sup>7</sup> The Sharks' Teeth.
- S. GARMAN. XII.<sup>12</sup> The Reptiles.
- H. J. HANSEN. The Cirripeds.
- H. J. HANSEN. XXVII.<sup>27</sup> The Schizopods.
- S. HENSHAW. The Insects.
- W. E. HOYLE. The Cephalopods.
- W. C. KENDALL and L. RADCLIFFE. XXV.<sup>25</sup> The Fishes.
- C. A. KOFOID. III.<sup>3</sup> IX.<sup>9</sup> XX.<sup>20</sup> The Protozoa.
- C. A. KOFOID and J. R. MICHENER. XXII.<sup>22</sup> The Protozoa.
- C. A. KOFOID and E. J. RIGDEN. XXIV.<sup>24</sup> The Protozoa.
- P. KRUMBACH. The Sagittae.
- R. VON LENDENFELD. XXI.<sup>21</sup> The Siliceous Sponges.
- R. VON LENDENFELD. XXIX.<sup>29</sup> Hexactinellida.
- G. W. MÜLLER. The Ostracods.
- JOHN MURRAY and G. V. LEE. XVII.<sup>17</sup> The Bottom Specimens.
- MARY J. RATHBUN. X.<sup>10</sup> The Crustacea Decapoda.
- HARRIET RICHARDSON. II.<sup>2</sup> The Isopods.
- W. E. RITTER. IV.<sup>4</sup> The Tunicates.
- B. L. ROBINSON. The Plants.
- G. O. SARS. The Copepods.
- F. E. SCHULZE. XI.<sup>11</sup> The Xenophyphoras.
- HARRIET R. SEARLE. XXVIII.<sup>28</sup> Isopods.
- H. R. SIMROTH. Pteropods, Heteropods.
- E. C. STARKS. XIII.<sup>13</sup> Atelaxia.
- TH. STUDER. The Alcyonaria.
- JH. THIELE. XV.<sup>15</sup> Bathysciadium.
- T. W. VAUGHAN. VI.<sup>6</sup> The Corals.
- R. WOLTERECK. XVIII.<sup>18</sup> The Amphipods.

<sup>1</sup> Bull. M. C. Z., Vol. XLVI., No. 4, April, 1905, 22 pp.

<sup>2</sup> Bull. M. C. Z., Vol. XLVI., No. 6, July, 1905, 4 pp., 1 pl.

<sup>3</sup> Bull. M. C. Z., Vol. XLVI., No. 9, September, 1905, 5 pp., 1 pl.

<sup>4</sup> Bull. M. C. Z., Vol. XLVI., No. 13, January, 1906, 22 pp., 3 pls.

<sup>5</sup> Mem. M. C. Z., Vol. XXXIII., January, 1906, 90 pp., 96 pls.

<sup>6</sup> Bull. M. C. Z., Vol. L., No. 3, August, 1906, 14 pp., 10 pls.

<sup>7</sup> Bull. M. C. Z., Vol. L., No. 4, November, 1906, 26 pp., 4 pls.

<sup>8</sup> Mem. M. C. Z., Vol. XXXV., No. 1, February, 1907, 20 pp., 15 pls.

<sup>9</sup> Bull. M. C. Z., Vol. L., No. 6, February, 1907, 48 pp., 18 pls.

<sup>10</sup> Mem. M. C. Z., Vol. XXXV., No. 2, August, 1907, 56 pp., 9 pls.

<sup>11</sup> Bull. M. C. Z., Vol. LI., No. 6, November, 1907, 22 pp., 1 pl.

<sup>12</sup> Bull. M. C. Z., Vol. LII., No. 1, June, 1908, 14 pp., 1 pl.

<sup>13</sup> Bull. M. C. Z., Vol. LII., No. 2, July, 1908, 8 pp., 5 pls.

<sup>14</sup> Bull. M. C. Z., Vol. XLIII., No. 6, October, 1908, 285 pp., 22 pls.

<sup>15</sup> Bull. M. C. Z., Vol. LII., No. 5, October, 1908, 11 pp., 2 pls.

<sup>16</sup> Mem. M. C. Z., Vol. XXXVII., February, 1909, 243 pp., 48 pls.

<sup>17</sup> Mem. M. C. Z., Vol. XXXVIII., No. 1, June, 1909, 172 pp., 5 pls., 3 maps.

<sup>18</sup> Bull. M. C. Z., Vol. LII., No. 9, June, 1909, 26 pp., 8 pls.

<sup>19</sup> Bull. M. C. Z., Vol. LII., No. 11, August, 1909, 10 pp., 3 pls.

<sup>20</sup> Bull. M. C. Z., Vol. LII., No. 13, September, 1909, 48 pp., 4 pls.

<sup>21</sup> Mem. M. C. Z., Vol. XLI., August, September, 1910, 323 pp., 56 pls.

<sup>22</sup> Bull. M. C. Z., Vol. LIV., No. 7, August, 1911, 38 pp.

<sup>23</sup> Mem. M. C. Z., Vol. XXXVIII., No. 2, December, 1911, 232 pp., 32 pls.

<sup>24</sup> Bull. M. C. Z., Vol. LIV., No. 10, February, 1912, 16 pp., 2 pls.

<sup>25</sup> Mem. M. C. Z., Vol. XXXV., No. 3, April, 1912, 98 pp., 8 pls.

<sup>26</sup> Bull. M. C. Z., Vol. LIV., No. 12, April, 1912, 38 pp., 2 pls.

<sup>27</sup> Mem. M. C. Z., Vol. XXXV., No. 4, July, 1912, 124 pp., 12 pls.

<sup>28</sup> Bull. M. C. Z., Vol. LVIII., No. 8, August, 1914, 14 pp.

<sup>29</sup> Mem. M. C. Z., Vol. XLII., June, 1915, 397 pp., 109 pls.

JUL 20 1915

**Bulletin of the Museum of Comparative Zoölogy**  
AT HARVARD COLLEGE.  
VOL. LIX. No. 2.

---

THE CRANIAL NERVES OF ANOLIS CAROLINENSIS.

BY WILLIAM A. WILLARD.

WITH SEVEN PLATES.

CAMBRIDGE, MASS., U. S. A.:  
PRINTED FOR THE MUSEUM.  
JULY, 1915.





No. 2.— *The Cranial Nerves of Anolis carolinensis.*

CONTRIBUTIONS FROM THE ZOOLOGICAL LABORATORY OF THE  
MUSEUM OF COMPARATIVE ZOOLOGY AT HARVARD  
COLLEGE. NO. 261.

By WILLIAM A. WILLARD.

TABLE OF CONTENTS.

	PAGE
A. Introduction . . . . .	18
B. Scope of the paper . . . . .	19
C. Material and methods . . . . .	20
D. Systematic position of <i>Anolis</i> . . . . .	22
E. Historical statement . . . . .	23
F. Skeletal structures . . . . .	24
1. Skull . . . . .	24
2. Hyoid apparatus . . . . .	25
G. Cutaneous sense organs . . . . .	25
H. Visceral end organs . . . . .	30
I. Muscles . . . . .	31
1. Muscles of the orbit . . . . .	31
2. Muscles of the tongue . . . . .	34
3. Muscles of the hyoid apparatus . . . . .	35
4. Muscles of the jaw and neck . . . . .	38
J. Oculomotor nerve . . . . .	44
K. Trochlear nerve . . . . .	45
L. Abducent nerve . . . . .	45
Ciliary ganglion and nerves . . . . .	45
M. Trigeminal nerve . . . . .	48
N. Facial nerve . . . . .	62
O. Glossopharyngeal nerve . . . . .	71
P. Vagus nerve . . . . .	73
1. Relation between nerves IX and X . . . . .	76
2. A vestigial dorsal ganglion on the roots of the vagus . . . . .	77
3. Terminal distribution of nerves IX and X . . . . .	80
Q. Spinal accessory nerve . . . . .	85
R. Hypoglossal nerve . . . . .	88
S. Summary on the distribution of nerves IX, X and XII . . . . .	92
T. Additional innervation to the ventral head region . . . . .	92

U. Spinal nerves . . . . .	93
1. Third spinal nerve . . . . .	93
2. Second spinal nerve . . . . .	95
3. First spinal nerve . . . . .	95
4. Connections of first three spinal nerves with sympathetic.	95
V. General considerations on nerve XII and the spinal nerves . . .	96
W. General summary . . . . .	98
Bibliography . . . . .	101
Explanation of plates . . . . .	109

## A. INTRODUCTION.

It is now generally recognized that the comparative anatomy of the nervous system can not be profitably studied without recourse to microscopic analysis in the peripheral region as well as in the central organs. It is further recognized that, for their final explanation, the highly complex nervous organs of mammals, including man, must await the revisions and additions which such a method of study, applied to the lower vertebrates, will suggest for their interpretation. Inasmuch as the nervous system is essentially a correlating structure, it follows naturally that changes in its mechanism should be studied in connection with a study of the correlated organs and functions. This gives to the study of the nervous system a broader biological significance than is possessed by other organs. But this relation adds much to the technical difficulties and makes it almost impossible to bring within the scope of a single research the complete analysis of even a single form. The shortcomings of the present study from that point of view are recognized by the author. However, in the methods pursued, he has had constantly in mind the larger problem, which does not recognize the arbitrary distinction between central and peripheral nervous systems. In fact, he has already collected much material and information on the central nervous system of *Anolis*; but it seems advisable to reserve that material for a more complete account of the *Anolis* brain. The present investigation is carried far enough toward the nerve centers to articulate easily with such a study.

A large part of this work was done a number of years ago in the Zoölogical Laboratory of Harvard University. Since then it has been continued in the Laboratory of Histology and Embryology of the University of Nebraska, College of Medicine. In this connection I wish to acknowledge my gratitude to Dr. E. L. Mark for placing every

facility at my disposal and for his continued interest and encouragement. Also the work has been aided not a little through the courtesy of Professor H. W. Norris of Grinnell College and Dr. C. J. Herrick of Chicago University, who on different occasions have given me working facilities in their laboratories.

## B. SCOPE OF THE PAPER.

This paper includes, to some extent, the general anatomy of the head of *Anolis*; much of this, however, is of quite secondary importance and there has been no attempt to treat critically anything but the nervous organs; even within this field certain features have been omitted, since they can better be considered in connection with the central nervous system. This is true of the larger sense organs and their nerves, *i. e.*, eye, ear, and olfactory organs. Also the distribution of the vagus nerve is not carried into the trunk region beyond the limits of the series of sections figured. Of the non-nervous structures, the skeleton is included for the purpose of more exact topography. The muscles and glands, and the integument and mucous membrane with their sense organs are included on account of their relation to the peripheral distribution of neurones.

The aim of this work is to give as complete an account as possible of a single reptilian form, which may serve as a basis for further comparative study. The entire absence of such an account within the whole sauropsidan group is believed to be sufficient justification for the publication of the present paper. But this plan is not compatible with the intensive treatment of many of the problems that arise in connection with various details of the work. Much of the literature that has been consulted in the course of the study has not been specifically cited as it would have been, had the field been more limited. This is particularly true of most of the reptilian studies whose results are based on dissections alone and are therefore open to more than one interpretation, because an attempt at detailed comparisons in such cases would serve only to impair the usefulness of the present study. In regard to the Ichthyopsida, where more exact work has been done, it seems premature to go far with comparisons until the study of the Sauropsida has covered several forms. Such comparisons as are made should, therefore, be considered tentative.

## C. MATERIAL AND METHODS.

The adults of *Anolis carolinensis* were obtained from Jacksonville, Florida, and later from Colmesneil, Texas. They were sent alive by express, being received in good condition. After arriving they could be kept alive for any length of time by feeding with living flies. With such material constantly on hand, the use of the various special nerve methods was practicable. The methods of staining found best adapted to the purpose of the present study were Weigert's and Vom Rath's. The projection drawings of the peripheral distribution of the cranial nerves were made from a head prepared by the Vom Rath method, which was found the best for this material.

The animals were killed with chloroform; the head, with the anterior part of the body as far back as the region of the fore legs, was removed and, after some of the tissue on the right side had been cut away so as to expose the brain and insure more rapid penetration, was put into a Vom Rath's solution (formula for vertebrates). The length of time necessary in this fluid depends upon the requirements of decalcification, for the fluid serves the double purpose of decalcifying the bone and impregnating the medullary sheaths of the nerve fibers. I found that a week to ten days served the purpose well. After the required length of time the specimen was brought through the grades of alcohol and left in 80% alcohol long enough to remove as much of the picric acid as would readily come out. The after treatment with pyroligneous acid was not used. From 100% alcohol it was cleared in cedar oil, then passed into xylol and, finally, embedded in paraffin. For better embedding it was found advantageous to use the air pump, either while the object was in the melted paraffin or before, while in the oil. It was always found necessary to re-embed several times during the cutting of a complete series, as there were cavities not filled at first. This resulted at several places in the series in partial sections which, however, were numbered in sequence with the others. The series from which the large plots were made was cut transversely 10 micra thick. In place of artificial orientation lines the median plane was used for projection on the frontal plane, but for projection on the sagittal plane there was no natural line available for the whole distance. The border of the upper lip served for this purpose as far back as the corner of the mouth. From this point caudad the orientation was determined from a comparison with a drawing of the lateral external view of the same head, and also with sagittal sections of heads of the same size.

The projection plots were made from camera drawings magnified 37 diameters and, except in regions of greatest complication, each nerve was projected accurately throughout its entire course. In a few cases some of the nerves are displaced a little from the position they really occupy in the middle of their course in order to avoid too great confusion of lines. Of course the essential points such as central and peripheral endings and relationship of branches given off in the intermediate course are strictly adhered to.

Even after the most careful study of serial sections and reconstructions, one is likely to fall into error unless the work is supplemented by free-hand dissections. This is particularly true in case of very small branching rami or fine plexuses. Animals that are small enough to be practicable for sectioning are generally too small for entire dissections, but by the following method it was possible to make accurate and fairly complete dissections of the head: — the integument of the part wanted for dissection was carefully removed to avoid cutting any of the underlying muscles. Then the animal was put into the Vom Rath fluid, as for sectioning, but treated a shorter time (24 to 36 hours). This decalcifies sufficiently well, hardens the muscles and leaves them well defined because of a slight shrinkage; it also hardens and blackens the nerves. Instead of further hardening in alcohol, the specimen was washed out in water and put into a mixture of alcohol and glycerine. It was afterwards dissected in water under a lens. For best results, however, it should be dissected soon. Although the whole muscle is much darkened, there is contrast enough between it and the nerves to allow the identification of the finest branches of the blackened nerves. The muscles are also more or less brittle, whereas the nerves retain their characteristic toughness. As the dissection progressed portions were removed and cleared for permanent mounts in balsam. I consider the making of balsam preparations a very valuable part of the technique of this work, for in no other way can the fiber course in the finer anastomoses be made out. For ascertaining the courses of nerves and for topographical relations this short Vom Rath method is a valuable adjunct and the two methods — sections and dissections — were constantly used together.

For the central relations I found that properly prepared Weigert preparations gave more satisfactory results than the Vom Rath, but the latter method allowed the roots to be followed well into the brain and in some instances served even there better than the Weigert. Portions of the courses brought out by one method overlap those by the other, so there could be no chance of error in combining these two methods of study.

For the best Weigert preparations, Herrick's method of fixation for fishes with Flemming's fluid was found the best for the lizard also, although I was unsuccessful in my attempts to get the best results in both the central and peripheral fibers by a single treatment. That is to say, when the sections were decolorized properly for the central nervous fibers, the peripheral nerves were decolorized too far. On the whole I found it much more satisfactory to base the study of the peripheral nerves on the Vom Rath series, and the present paper chiefly rests on the findings in such material.

#### D. SYSTEMATIC POSITION OF ANOLIS.

Following Cope (:00, p. 158, ff.), we have the following division of the living Reptilia:—

Class MONOCONDYLIA.

Subclass Reptilia

Orders Testudinata

Loricata

Rhynchocephalia

Squamata

Suborders Ophidia

Sauria

The group characters of the Sauria are as follows: "Quadrat bone articulating with the exoccipital; parietal bones not closing the brain case in front; generally an epipterygoid and sternum; teeth with dentinal roots; phalanges with condyles" (p. 178). The family Iguanidae is represented in North America by twelve genera; it is subdivided as follows:—

Subfamilies Anolinae

Basiliscinae

Iguaninae

The genus *Anolis* falls under the first of these three subfamilies, which includes six known genera, *Anolis* being the only one found in the United States. Cope (p. 233) describes *Anolis carolinensis* and states that it "is distributed from the Rio Grande to Florida, inclusive, and as far north as Kinston, North Carolina. It is, moreover, common in the Bahama Islands and Cuba, where it reaches a size rather superior to what is usual in the United States." Among other Iguanidae found in the United States are the well-known forms *Sceloporus*

and Phrynosoma. As to general external features and habits of life, the members of this family are most diverse, as will be seen by comparing two such forms as Phrynosoma and Anolis.

### E. HISTORICAL STATEMENT.

The Sauropsida have been quite generally neglected as regards the anatomy of the nervous system in the adult, most of the descriptive accounts having been written more than fifty years ago. This applies equally well to other reptiles and to birds, notwithstanding the fact that the latter have long since become of classic forms for embryological study. Aside from the embryological studies on birds and reptiles, such work as has been done has used exclusively the methods of gross anatomy and must necessarily be incomplete. It might be added that those who have more recently contributed to our knowledge of the sauropsidan nervous system and who use only the methods of the older anatomists increase our knowledge comparatively little. Much of the older work cannot be excelled within its limitations. The modern investigator should profit by modern methods and remove some of these limitations. The first important account of reptilian anatomy is by Bojanus ('19) in his monograph on the anatomy of the turtle. This is a classic, and is still the authority for much of the subject it covers. No other investigator has gone over the same field in so thorough a manner.

Vogt ('39) gives us, in his dissection of *Python tigris*, our first information on the cranial nerves of the Ophidia. This, however, is incomplete, nerves IV, VI, and IX not being found at all, and III only partially dissected out.

Müller ('40) about the same time discussed the nervous system of reptiles in his *Neurologie der Myxinoiden*. Bendz ('43) made a comparative study of the last four cranial nerves (or the vagus group) in reptiles, including among those studied two saurians, the alligator and the chameleon. Fischer's ('52) paper on the saurians is still the most important descriptive work on the cranial nerves of reptiles. He studied eleven species of lizards, two of crocodiles and the alligator. He treated the subject quite exhaustively and made use of comparative methods to establish certain homologies. Rabl-Rückhard ('78) gave in his description of the alligator's central nervous system, the first account of a reptilian brain. He incidentally mentioned the roots of the cranial nerves. Hoffmann ('79-90),

in the part of Bronn's Thier-Reich devoted to the Reptilia, based his description of the cranial nerves of lizards largely upon the work Fischer published forty years previously. More recently Osawa ('98) has given a quite full account of the anatomy of Hatteria, in which the cranial nerves are described. This work fails of much of its usefulness because of lack of plates; the text figures are too obscure to be of much use. Watkinson (:06) describes *Varanus bivittatus*, including the skull and musculature among her drawings. In matters of close comparison, however, her work has proved to be inadequately illustrated properly to supplement her description. In the same manner Cords (:04) attempts to meet a long felt need in the anatomy of the nervous system of birds; but here, again, the lack of a diagram of the complete system, for the purpose of comparison, is felt.

In addition to the works mentioned, the cranial nervous system of reptiles and birds has been touched upon by various authors in the comparative treatment of certain nerves or groups of nerves.

In the following work on *Anolis* there is presented for the first time a description of the cranial nerves of an adult amniote form based upon a complete series of sections.

## F. SKELETAL STRUCTURES.

### 1. SKULL.

The skeletal parts involved in this account are those which are related topographically to the cranial nerve roots or serve for the attachment of muscles whose description follows, or have some other important, though indirect, relation to the main subject. Many points of secondary importance in regard to length of rami, points of branching, and course of peripheral nerves are explained when reference is made to the skull and its foramina. The skeletal parts appearing in the transverse sections are not readily understood without reference to the entire structure, therefore the three drawings of the skull are made with accuracy with a view to their permanent value in any problem involving the comparative anatomy of the reptilian head. Cope (:00) is followed in naming the parts of the skull and hyoid apparatus. As he separates the Reptilia altogether on osteological characters, the basis for a large part of his definition of the Sauria may be recognized in this skull, *e. g.*, "Quadrato bone articulating with exoccipital; parietal bones not closing the brain case in



front, generally an epipterygoid present" . . . (p. 178). The labelled drawings of the skull (Plate 1, figs. 1-3), and the cross-section drawings (Plates 4-7) furnish all the description called for in this connection. Certain cartilaginous elements appearing in the sections were not preserved in the preparation of the skull.

## 2. HYOID APPARATUS.

The hyoid apparatus is entirely free from any cranial attachments. "The hyoid system in lizards consists of a glossohyal, which is continuous with a basihyal tract, a hypohyal, often continuous with the basihyal tract, a ceratohyal, a first ceratobranchial, and a second ceratobranchial, which is always continuous with the basihyal tract. There may be in addition an epibranchial, which belongs to the first ceratobranchial" (Cope, p. 489). Taking *Anolis carolinensis* as typical of the genus in this respect, Cope (p. 232) says, "the hyoid apparatus has the extreme development seen in all the lizards with a gular compressed pouch or fan. That is, the ceratobranchials of the second pair are closely appressed and produced to a great length. First pair of ceratobranchials and ceratohyals simple, the latter attached to the extremities of the moderately developed hypohyals."

## G. CUTANEOUS SENSE ORGANS.

The cutaneous innervation and the epidermal sense organs deserve exhaustive study in the reptiles in view of the fact that these sense organs are apparently absent as such in mammals, although abundant in the Amphibia and fishes. On the other hand, mammals possess dermal tactile organs of problematic origin. Inasmuch as some new facts are presented in this general account of *Anolis*, a brief statement of what has already been described within the group of reptiles is necessary. Maurer ('95, p. 228) refers to Reinhardt's ('61) article in which 191 species of snakes were examined for the epidermal sense organs. In 85 of these nothing of this nature was found; in 44 species there was one organ, and in 62 species two organs, to each scale. Maurer's ('95, p. 17, 196-239) own work covers the field sufficiently for our purpose. This can best be understood by reference to his text figures (9-14), which include most of his illustrations relating to the distribution of these sense organs. Besides Hatteria, only one

lizard (*Anguis fragilis*) is shown. Maurer studied *Lacerta*, but does not mention the occurrence of the "Tastflecken." He found them, however, in *Chamaeleo*, but does not figure them. He calls attention to their large number, as many as six on one scale, in the primitive reptile *Hatteria*, and to their reduction to one to a scale in some of the snakes and in the crocodiles. His study of the minute structure of these organs results in his putting forth a theory that the epidermal organs are evolving into dermal organs, the cells of which come in all cases from the epidermis. The condition found in *Coronella* (Maurer, '95, Taf. viii, fig. 2, *t.*) shows one stage in the process; the crocodile (Taf. vii, fig. 12, *t.*) a more advanced stage. Moreover the crocodile's single organ in the middle of the scale is really a multiple organ, as is indicated by the number of these tactile bodies, as many as six being found under one of the tactile spots. In *Hatteria*, which he regards as most primitive, the subepidermal tissue is involved in the organ (Taf. vii, fig 11, *s.*). In all cases he represents nerves going to these organs.

*The tactile organs of Anolis.* It is assumed that the organs in question are tactile in this animal for the reason that structurally there is more evidence for this view than has been put forth for any other related form. We find projecting from the center of each tactile spot a slender "tactile bristle" of considerable length. The distribution of these sense organs, provided with tactile bristles or "hairs," is very readily and accurately made out through the study of the moulted horny layer of the skin. From a lot of individuals procured in early spring a number showed a tendency to "shed" the skin. From an animal showing the beginning of this process it is possible to strip off artificially the whole corneous layer, and before it dries and curls it may be spread out on a slide and covered so as to remain in a perfectly flat condition. By mounting the whole cast, or at least half of it, piecemeal, on different slides, any part of the body surface can be readily referred to. While there is a variation in the number and size of these sensory organs there is no part of the body lacking them. Attention was first directed to a closer examination of the cast through the discovery of the central bristle in the sections. Under a low power ( $\times 37$ ), which was used for general drawings, these fine structures escaped notice, but a higher power never failed to bring them out. In the several camera drawings (Figures *A-D*) are shown some of the differences in arrangement and distribution that occur in several regions of the body. The sense organs are most abundant, although of inferior size, in the large pavement scales covering the

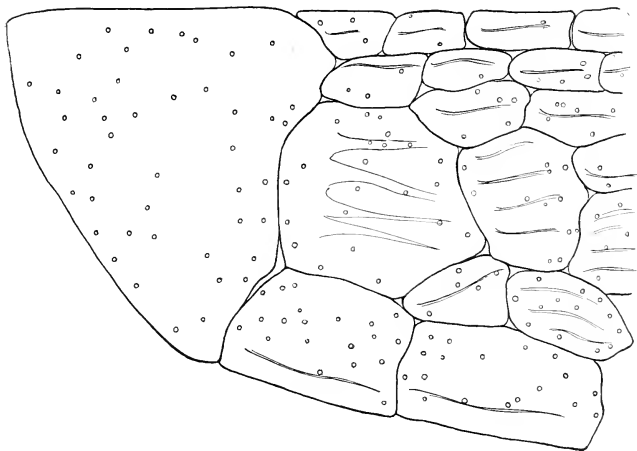

FIG. A.—Pavement scales covering the right half of the anterior end of lower jaw; the position of sense buds is shown by the circles; each bud possesses a tactile "hair," which is visible under higher magnification.

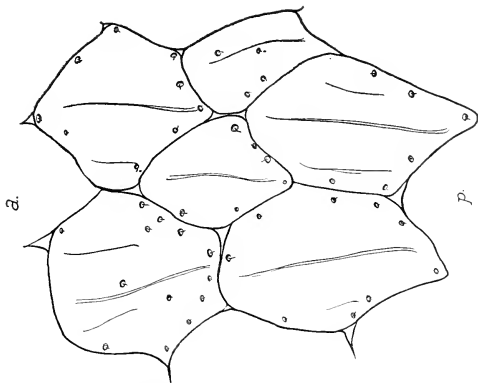

FIG. B.—Pavement scales from frontal region of the head, showing that the sense organs are arranged near the margin of the scales.

upper and lower jaws (Figure A). Where the scales show a tendency to be imbricated, as they are on most of the body region, the organs are situated on the thicker caudal border of each scale, the bristles projecting backward. From one to three were found on each scale



FIG. C.—Imbricated scales from the ventral tail region, showing sense organs at the posterior margin of the scales.

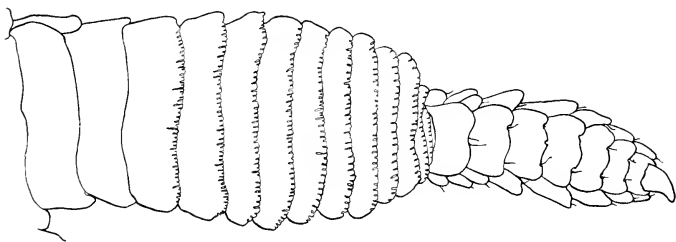

FIG. D.—Ventral surface of a portion of a fore-foot digit. The terminal part shows the "hairs" projecting from the distal edges of the scales; the subterminal part, where the tactile "hairs" are absent, shows the position of the adhesive organs.

in the dorsal cervical region, while they are more abundant in the dorsal tail region (Figure C). The scales from the frontal region of the head (Figure B) show a distribution of sense organs intermediated

between Figures *A* and *C*. An exception should possibly be made to the statement of their universal distribution, for they are apparently absent from that part of the digit which is provided with adhesive organs, "suckers," but they appear again on the small terminal part of the digit, where the bristle projects well beyond the imbricated margin of the scales (Figure *D*).

The structure of this tactile organ is described here only in so far as it was shown in the material prepared for general study. The fixation in Vom Rath's fluid is of course excellent, but it precludes varied staining methods, and certain differences that might thus have been brought out have not been observed. In section these organs are very inconspicuous, and if they did not interrupt slightly the free and basal margins of the epidermal layer, they would escape notice in the unstained osmic-fixed sections. In nearly all regions the corneous layer of the skin is slightly parted from the underlying epidermis and the abrupt thinning of this layer where it covers the tactile spot is more conspicuous than the organ itself. The modification in the horny layer, aside from the bristle, is effected more by the projection of the sense bud into this layer than by a depression of the circular area covering the bud. The cuticular bristle projects from the center of this circular area. It is slightly tapering, ending in a fine point. No structure could be recognized within this, nor any indication of how it is produced. The full length of these structures is not often preserved in sections. Those found in sections measure up to 20 micra in length. The surface view shows them somewhat longer; however, the text figures do not represent them with accuracy on this point. The structure of the organ itself agrees closely with that of *Coronella* (Maurer, '95), with this difference, however, that the column of cells forming the tactile end organ (*t*) could not be identified as a definite and separate structure. The continuity of the basal layer of the epidermal cells is interrupted by a ball of very small cells with rounded nuclei forming a bud which projects beyond the limits of the other cells and this approaches nearer to the free surface of the horny layer. Should the corneum be stripped off in *Coronella* (see Maurer), the tactile spots would appear in it as in *Anolis*. Despite the fact that all the other published figures show it, the innervation was not determined in *Anolis* beyond the fact that medullated fibers are often found directed through the corium toward the organ. Pieces of integument were stripped off in the fresh condition, stretched out, and stained with osmic acid, but with no more definite results. The skin is seen to be richly supplied with medullated nerve fibers, but their distribution

is not of such pattern as to point out these organs. It seems probable that the nerves innervating these organs lose their sheaths before reaching the epidermis. The exact innervation of these organs should not be difficult to determine by one of the finer histological methods, and offers an interesting problem.

## H. VISCERAL END ORGANS.

The organs in which visceral nerves terminate, both efferent and afferent, include glands and smooth muscle fibers for the former and specific visceral sense organs and mucous membrane epithelium for the latter. As no methods were employed to determine the actual nerve terminations, a detailed description of these structures at this time would have no significance for the general descriptive anatomy of the cranial nerves which follows. In *Anolis* the mucous membrane of the mouth cavity, the pharynx, and the nasopharynx presents a variety of conditions in different regions which are demonstrable without the use of special staining methods. It is throughout richly glandular, the glands having the simple vesicular or tubular type along the gums and the tongue, while in the postlingual region the epithelium is ciliated and has a rich supply of unicellular glands of the goblet-cell type.

The taste buds are confined almost entirely to the mouth cavity proper, although an occasional bud was found in the region of the larynx (Plate 4, Fig. 11, *gm. gus.*). They have the structure which is typical for these organs elsewhere, possessing a well-defined gustatory pit, in the base of which the sensory cells terminate. These taste buds are distributed along areas which stand out as sensory-glandular patches along the roof of the mouth and inner gums of both upper and lower jaws (Plates 4, 5, Figs. 9-12, *gm. gus. m.*, *gm. gus. l.*). Their position is shown by the course of the sensory rami of nerve VII (palatine and chorda tympani). No taste buds were found on the tongue itself. Whether there are other sensory buds besides taste buds, was a question that suggested itself through the presence of clumps of cells which lacked the gustatory pit and were less sharply defined but were not like glands in their structure. The fact of importance in connection with visceral end organs is that typical gustatory buds are readily demonstrated, and their distribution fully determined in the series of sections from which the study was made. Upon this are based certain conclusions as to the nature of some of the branches of nerve VII.

## I. MUSCLES.

## 1. MUSCLES OF THE ORBIT.

This group includes the muscles of the eyeball proper and those of the eyelid, or their derivatives. The former are the dorsal, ventral, anterior, and posterior recti, and the dorsal and ventral oblique, together with the m. retractor oculi and m. bursalis. Those of the eyelid consist of the m. depressor palpebrae inferioris and its specialized part, m. protrusor oculi (Bruner).

*Mm. rectus posterior (externus), bursalis, and retractor oculi.* Not only in their innervation but also in their skeletal connections, these muscles form one group, having a more posterior origin than any of the other muscles of the eyeball. The bursalis (*brs.*) and the retractor oculi (*rt. oc.*) arise close together within the basisphenoid bone (Plate 6, fig. 16), that of the bursalis being on the inner lateral surface of the bony cap containing the distal end of the pituitary body. The area of origin of the fibers of the retractor forms a median forward continuation of that of the bursalis; the two muscles then run rostrad together into the orbit, where they separate (Plate 5, figs. 14, 15). The bursalis fibers bend rather sharply dorsolaterad within the orbit to be inserted on the posterior median side of the eyeball, thus offering a sort of loop through which passes the tendon from the nictitating membrane (Plate 5, fig. 14, *tud. mb. nic.*).

The retractor oculi passes directly forward across the floor of the orbit as a relatively slender muscle to be inserted on the median side of the eyeball anterior and ventral to the optic nerve (Plate 5, figs. 13, 14).

Somewhat anterior to the origin of these the posterior rectus arises from the presphenoid bone (*presph.*) along the median line and passes directly out around the posterior side of the orbit to its insertion on the eyeball (Plate 3, fig. 7 and Plate 5, fig. 15, *rt. p.*).

*Mm. recti dorsalis and ventralis.* These muscles arise at the same cross-section level as the rectus posterior, but dorsal to it, from a median fascia between the presphenoid and a cartilaginous rod which continues forward from the inner lamellae of the basisphenoid bone (Plate 5, fig. 15, *rt. d., rt. v.*). The one passes dorsal to the optic nerve, the other ventral, and each spreads out into a broad fan-like insertion on the dorsal and ventral sides of eyeball respectively (Plate 5, figs. 12, 13).

*M. rectus anterior (internus)* has its origin around the cartilaginous rod mentioned in the preceding paragraph, a little anterior to the others and dorsal to the optic chiasma. This muscle is flattened out against the median connective-tissue septum which forms the common floor of the orbits, so that the muscles of the two sides are close together and parallel, inclosing between them the cartilaginous bar. It has a wide insertion on the anterior side of the eyeball (Plate 5, figs. 12, 13; Plate 4, fig. 11, *rt. a.*).

*Mm. obliquus dorsalis and obliquus ventralis.* Both oblique muscles (*ob. d., ob. v.*) arise at about the same level along the cartilaginous bar which is a continuation of the interorbital septum, their fibers diverging to their respective insertions on the eye ball (Plate 4, figs. 10, 11; Plate 5, figs. 12-14). The dorsal oblique takes origin from two distinct bundles (Plate 4, fig. 11), the ventral thickened edge of the muscle beginning as a separate bundle, which has a tendinous origin anterior to that of the inferior oblique (Fig. 10 and Fig. 7). As nerve IV reaches the dorsal oblique, crossing the orbit mesad to the dorsal rectus, it divides to innervate by one part this ventral portion, while the rest of the nerve passes across the muscle a little distance to innervate the more dorsal and anterior part. There is in the muscle, however, no apparent separation into two bundles at the level where this distinction in innervation occurs (Plate 5, fig. 12, *II*).

Somewhat in contrast with the uniformity of the six principal eye muscles of vertebrates, is the variability in occurrence and structure of the accessory muscles which arise from them. Osawa ('98, p. 536) describes for *Hatteria* a retractor oculi muscle only, but from his description it is evident that he has found practically the same conditions as exist in *Anolis*, for he states that it is inserted "mit zwei Portionen an der Umgebung der Eintrittsstelle des N. opticus und an der laterale Fläche des Bulbus etwa in der Gegend des Aequators." This would indicate the presence of a bursalis muscle included in his retractor oculi. He ('98, p. 537) describes the innervation of *m. retractor oculi* in *Hatteria* as follows: "Der *M. retractor oculi* weist in der Innervation eine Eigenthümlichkeit auf insofern, als er am Ursprung einen Zweig aus dem N. abducens und in seinem weiteren Verlauf mehrere kleine Zweige vom Ganglion ciliare bekommt." The probability of such innervation in *Anolis* is discussed in connection with the ciliary nerves (p. 46).

*M. depressor palpebrae inferioris.* This is the muscle first described by Bojanus ('19) for the turtle as the *m. palpebralis*, and later by Fischer ('52) as the *m. adductor maxillae*, and finally by Weber ('77)



as the *m. depressor palpebrae inferioris*. Bradley (:03), in analyzing the musculature with a view to explaining its relation to the masticatory movements, recognizes in several of the lizards a double function for this muscle, as suggested by the fact that some of its fibers are inserted on the lower eyelid, while others appear to have their insertion in the "fibrous membrane circumscribed by the pterygoid, palatine and the transverse bones" (p. 481). This is also brought out more fully by Bruner (:07),<sup>1</sup> who, in looking in the head musculature for an apparatus to control the flooding and distension of the orbital blood sinuses, discovered that a part of this muscle was completely differentiated into a *m. protrusor oculi*, and records its occurrence in eleven lizards, including *Anolis*. It is apparent, however, from a study of several series of sections that the two are not completely distinct morphologically in *Anolis*, as the following description will indicate. It seems probable, however, that the two functions as described by Bruner are here subserved. The following is the condition in *Anolis*:—the thin layer of striated muscle (Plate 3, fig. 7; Plates 4, 5, figs. 11–15, *protru. oc.*, *dep. palp. if.*) which lines the floor of the orbit ventromesad to all other orbital structures has two distinct origins; one (*protru. oc.*) is from a slender tendon attached to the membranous wall of the cranium just anterior to the bony part on a level with the Gasserian ganglion (Plate 3, fig. 7; Plate 6, fig. 16). This tendon passes down mesad to the columella (epipterygoid) and is continuous with a muscle band which lies closely applied to the membranous region (Plate 5, figs. 14–15) referred to by Bradley. While some of its fibers may be inserted here, most of them continue and spread out to form the anterior part of the broad palpebral muscle with insertion on the lower lid. This is best shown in the dissection (Plate 3, fig. 7). The second origin, ventral to that of the first, is from the fascia on the ventral face of the bursalis muscle; this band crosses ventral to the posterior rectus muscle (Plate 3, fig. 7; Plate 5, fig. 15, *dep. palp. if.*) and turns sharply to form the posterior half, or more, of the palpebral muscle. The two bundles of origin include between them the jugular vein and suborbital sinus of the same side. The innervation of these muscles favors the view of a double function, and suggests for a part of it at least a more visceral function, such as that assigned to it by Bruner. This will be described in detail in connection with the account of the nerves (p. 50).

<sup>1</sup> Bruner does not mention the earlier recognition of this muscle by Bradley.

## 2. MUSCLES OF THE TONGUE.

The tongue musculature consists of a set of longitudinal muscles and an interlacing system of intrinsic fibers inserted on its mucous membrane perpendicularly to the surface. The longitudinal muscles consist of *m. genioglossus* (*gen-gls.*) and some others, to which specific names will not be given. The genioglossus muscle is a paired structure having its origin along a considerable extent of the cerato-branchial I. (Plates 5-7, figs. 13-22; Fig. E). These bands passing forward form rounded bundles extending the full length of the tongue and are more or less surrounded by the other tongue muscles. Ventrally, however,

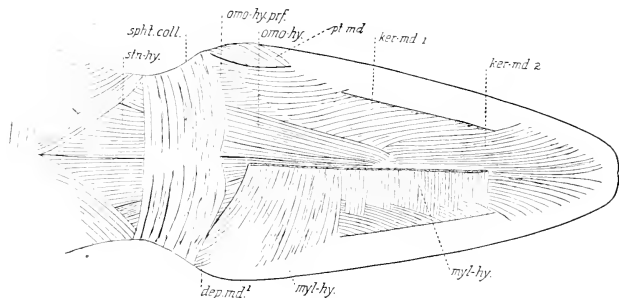

FIG. E.—Ventral aspect of head and neck after complete removal of the mm. mylo-hyoideus, sphincter colli, cerato-mandibularis 1 and 2, and omo-hyoideus (superficialis). The *m. omo-hyoideus profundus* and the *m. cerato-mandibularis 1* of the left side remain to show more clearly their position and extent. The origin of *m. cerato-mandibularis 2*, indicated by dotted lines, covers that of a part of the longitudinal tongue muscle.

they are bounded by large lymph sinuses, which leave the tongue attached by only its lateral muscular walls and thus permit its free movement and change of form (Plate 4, figs. 9-11).

Two other longitudinal muscles may be recognized. These are not separable in their origin, but differ in their anterior attachment. They arise on the ventral face of the genioglossus (Fig. E) at about the level of the larynx, and the bundles are increased by fibers springing apparently from the connective tissue underlying the mucous membrane lateral to this muscle (Plate 5, fig. 12, *lng. lg.*) Passing forward this divides into two bundles with different relations to the tongue.

One (Plate 4, fig. 9, *lng. lg. 1*) forms the lateral wall of the tongue at its base and continues forward in the same relative position finally to dwindle out in the mucous membrane anterior to the sublingual gland (Plate 4, fig. 8). For practically its whole distance it is closely adherent to the mucous membrane lateral to the tongue proper. The second part of this muscle (*lng. lg. 2*) separates from the ventro-median side of the common bundle and has nothing to do directly with the tongue or mucous membrane. It passes forward as a free bundle to be attached to the anterior end of the mandibular ramus (Fig. E). Its action is to pull the base of the tongue forward. In addition to these longitudinal muscles there is an intrinsic musculature. A detailed analysis of this is not attempted, but it is somewhat as follows:— At about the level of the larynx there appears in cross sections a mass of transverse fibers (*lng. t.*) applied to the dorsal face of the m. genioglossus and a mass of vertical fibers (*lng. vrt.*) on the median side of the same muscle (Plate 4, figs. 10, 11). Farther cephalad this intrinsic tongue musculature becomes what might be called a vertical decussating system; these fibres, originating along the median side of m. genioglossus and around the glossohyal, cross the median plane just dorsal to the latter and radiate up into the long lingual papillae, which are well developed in the subterminal region of the tongue (Plate 4, fig. 9).

The innervation of the tongue musculature is from the main bundle of nerve XII, although a part of this innervation occurs distal to the anastomosis of XII with lingual V, making an analysis by means of sections impossible. However, other facts, to be referred to later, support the assumption that lingual V provides a general cutaneous sensory component to the papillae and mucous surface in the anterior part of the mouth cavity, that the chorda tympani comes in with it to innervate the taste buds, and that XII innervates the tongue musculature.

### 3. MUSCLES OF THE HYOID APPARATUS.

*M. cerato-mandibularis 1* (*ker-md.<sup>1</sup>* = mylohyoides, Sanders). This is a broad, rather thin muscle (Figs. E, F, G) having its origin along the inner margin of the dentary bone and inserted along the whole extent of the cerato-branchials I.

*M. cerato-mandibularis 2* (*ker-md.<sup>2</sup>*). This is a compact bundle (Fig. F) having its origin on the ventral face of the anterior end of the

mandibular ramus near the median line and its insertion on the basi-hyal.<sup>1,2</sup> In section it appears as a median part of *m. cerato-mandibularis*<sup>1</sup>, except anteriorly, where it extends forward beyond the origin<sup>2</sup> of the latter.

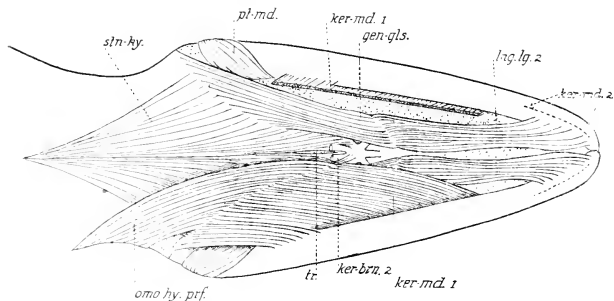

FIG. 6.—Ventral aspect of the head and neck with integument removed to show the superficial muscles. The right half of the mylo-hyoideus muscle is also removed exposing the underlying muscles.

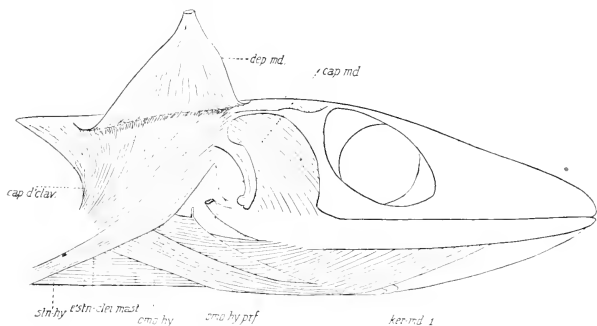

FIG. 7.—Right lateral aspect of the head with the mm. mylo-hyoideus and sphincter colli removed; digastric muscle (*dep. md.*) is cut at its insertion and turned up.

*M. cerato-mandibularis* 3 (*ker-md.*<sup>3</sup>). This is a very small muscle band, to which the above name is applied because, like the other two, it extends from the mandible to the hyoid apparatus. This, however,

is a perfectly distinct muscle, having its origin under cover of m. cerato-mandibularis I about half way along the jaw, and being inserted near the distal end of the cerato-hyal instead of the cerato-branchial (Plates 5, 6, figs. 13-19). No corresponding muscle has been found in any of the descriptions of saurians.

The innervation of the above three muscles is from nerve XII, which passes across the deeper surface of the first described portion (*ker-md.*<sup>1</sup>); two branches are given off here, the anterior of which runs cephalad to supply also the anterior muscle (*ker-md.*<sup>2</sup>). The small bundle (*ker-md.*<sup>3</sup>) is innervated by an independent ramus, directly from XII.

*M. ceratohyoideus = hyoglossus (hy-gls.)*. This is a muscle (Plates 5, 6, figs. 13-19) extending between the first and second horns of the hyoid apparatus (i. e., between cerato-hyal and cerato-branchial I). The attachment on the latter is more extended than that on the cerato-hyal, so that the muscle sheet is much thinned posteriorly, consisting of fine bands somewhat separated from one another. The pharyngolaryngeal branch of IX + X (*phr-lar.*<sup>1</sup>) passes along the superficial face of this muscle between it and m. genioglossus. It is innervated by motor fibers carried in this branch (Plate 2, fig. 5), which might indicate either a visceral origin for the muscle or the presence of fibers from XII in the nerve.

*M. omohyoideus (omo-hy.)*. This (Figs. F-G; Plates 6, 7, figs. 16-24) has its origin on the shoulder girdle along the clavicle, extending to near the median line, and passes forward as a broad sheet slightly converging with its mate to be inserted on the cerato-branchial I along almost its entire length and also on the basihyal. The fibers with the latter insertion form a bundle which, through a difference in direction, differentiates the superficial part (*omo-hy.*) from the deeper part (*omo-hy. prf.*), a distinction of slight importance in this form.

*M. sternohyoideus (stn-hy.)*. The removal of m. omohyoideus uncovers a muscle (Plate 5, figs. 13-15) which takes its origin from the sternum, the muscles of the two sides having a common median origin. The insertion is along the cerato-branchial I, co-extensive with that for the omohyoideus, but at a deeper level. At the angle of cerato-branchials I and II (Plate 5, fig. 13) the fibers of the median edge of sternohyoideus turn mesad to be inserted on the base of cerato-branchial II, on both the ventral and dorsal sides. The median edges of these muscles are the thickest and they spread out fan-shaped from median origin to insertion on the cerato-branchial I. A little of the trachea (*tr.*) is exposed just caudad to the basihyal, as is shown in Figure E.

The innervation of the two preceding muscles is from the ventral ramus of the first spinal nerve, which passes between *m. sternohyoideus* and *m. omohyoideus* to supply both (Plate 7, fig. 22; Plates 2, 3).

#### 4. MUSCLES OF THE JAW AND NECK.

*M. pterygo-mandibularis* (Bradley). This is the muscle (Plates 5, 6, figs. 14–19, *pt-md.*) generally described as the external pterygoid. It is best seen from the ventral side with the roof of the pharynx removed (Fig. I). Its origin is along the entire posterior edge of the main portion of the pterygoid bone, and chiefly by means of a strong tendinous fascia that is continuous with the muscle sheath on the

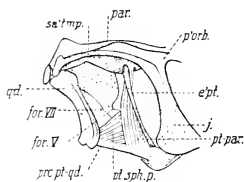

Fig. H.

FIG. H.—Right lateral aspect of a portion of the skull to show attachments of the deeper muscles, *m. pterygo-parietalis* and *m. pterygo-sphenoidalis posterior*.

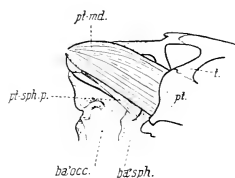

Fig. I.

FIG. I.—Ventral aspect of a portion of the right half of the skull with mandible removed to show *m. pterygo-mandibularis*. This really covers the *m. pterygo-sphenoidalis posterior*, but is slightly displaced to show the position of the latter.

ventral side. The most posterior fibers have a fleshy origin along the posterior wing of the pterygoid. The insertion of this muscle is on the angular and articular over the entire ventral plate as well as on the dorsal face of the median extension of these bones (Plate 6, fig. 19). Those muscle fibers that pass around the ventral side of the jaw to an extreme lateral insertion have their origin along the surface of the tendinous sheath instead of extending to the pterygoid bone.

The innervation (Plate 3, fig. 6, *pt-md.*) is from a ventral twig of the same ramus of mandibular V which innervates the deeper portion of the *m. pterygoideus*.

*M. pterygo-sphenoidalis posterior* (*pt-sph. p.*, Figs. H, I, Plate 6, figs. 16, 17) of Bradley. The following is Bradley's (:03, p. 478)

description for this muscle in *Varanus*: — "This is a triangular muscle arising by its apex from that part of the basisphenoid which forms the lower boundary of the notch whose upper limit is established by the proötic bone and into which the Gasserian ganglion projects, . . . Insertion to the full extent of the upper and lower surfaces of the pterygoid bone from its posterior extremity to as far forward as a level with the articulation between the basiptyergoid process of the sphenoid and the pterygoid." With this *Anolis* agrees quite closely; in the latter the origin is also from the basiptyergoid process of the sphenoid, and its insertion is along the whole length of the pterygoquadrate.

The innervation is from a motor ramus separating itself from the other motor components at the Gasserian ganglion (Plate 3, fig. 6; Plate 6, figs. 16, 17).

*M. pterygo-parietalis* of Bradley. (Fig. II; Plate 6, fig. 16, *pt-par.*) This muscle lies just posterior to the epiptyergoid bone and its tendinous origin passes mesad of the latter to attach to the edge of the parietal, while its fibers take a direction that diverges somewhat from the epiptyergoid and find insertion on the pterygoid just mesad to that of the deeper part of the pterygoideus, that is, on the upper surface of the pterygoid bone immediately caudad to the articulation of the epiptyergoid.

Bradley homologized these two muscles, pterygo-parietalis and pterygo-sphenoidalis posterior, with muscles described by Katheriner (:00) in the snakes under the same name, and calls attention to the fact that there are but two references to them found by him in the literature of the Saurians, viz., Stanius ('56) and Sanders ('70). Hoffmann ('79-90) does not refer to them in his description of Reptilia given in Bronn's Thier-reich. Bradley, therefore, concludes that these muscles are peculiar to snakes and to those lizards (*Kiokrania*) which have a columella (epiptyergoid).

In *Anolis m. pterygo-parietalis* also has a special motor-nerve ramus (Plate 3, fig. 6, *pt-par.*) leaving the main motor bundle through the ganglion.

*M. capiti mandibularis* (temporalis). (Plates 5, 6, figs. 14-19, *cap. md.*) The origin of this large muscle is from the postfrontal, jugal, postorbital, supratemporal, parietal, proötic, and quadrate bones. The superficial part of the muscle shows a parallel sheet of fibers running diagonally down to the lower jaw. The deeper portions, however, show toward their insertions a tendency to differentiate into several bundles. When the quadrato-jugal arch is removed, it is shown that the fibers having origin on the median face of the jugal

and postfrontal converge to a tendinous insertion on the coronoid bone of the lower jaw. There is also a tendinous fascia at the dorsal end of the quadrate, which extends forward on to the parietal. In large part the fibers have a fleshy insertion along the complementare. The innervation (Plate 3, fig. 6, *cap. md.<sup>1</sup>* and *cap. md.<sup>2</sup>*) is from several motor rami which leave ramus mandibularis V just distal to the Gasserian ganglion.

*M. pterygoideus* (internal pterygoid). It is difficult clearly to delimit this muscle from the foregoing, as that part of its origin on the parietal is simply a continuation of the area of origin of *m. capiti mandibularis*; the part of it originating along the epipterygoid (Plate 6, fig. 16, *pt.<sup>1</sup>*), known as the "deeper portion," forms a mass of fibers more vertical in direction and innervated by a branch of the ramus which also innervates the *m. pterygo-mandibularis*. The portion described by Bradley as the "superficial" part (Plates 5, 6, figs. 14-16, *pt.*) originates from the parietal and upper end of the columella, its fibers converging to a tendinous insertion on the coronoideum mesad to that of *m. capiti mandibularis*. With the pterygo-mandibularis removed, the deeper part of the pterygoideus is well demonstrated from the ventral aspect, where it appears as a flat band extending from nearly the whole length of the epipterygoid to be inserted mesad to the superficial part.

*M. sphincter colli* (*spht. coll.*, Fig. *F*). This is not a well developed muscle in *Anolis* and is very easily torn off with the skin. Its fibers are so little massed that the innervation is very difficult to determine, except by means of the dissection of preparations blackened in osmic acid. The fibers have their origin superficial to the digastric, they cover this muscle to some extent and, forming an extremely thin band, pass as a continuous bundle to the opposite side. The distinctness of this muscle is emphasized in the figure. In the median ventral region its fibers pass dorsal to cerato-branchials II, where they are interrupted by fascia, and some of them dip under the fibers of the ventral longitudinal muscles so that it becomes impossible to dissect the sphincter colli free along the ventral median line. Its innervation (Fig. *J*) is from a very fine bundle of the ventral division of motor VII.

In *Anolis* this muscle does not take any part in bounding the external auditory meatus, nor does it form a "Schliessmuskel," as described by Versluys ('98) for some of the Geckoniden.

*M. mylo-hyoideus* (intermandibularis). This muscle (Fig. *F*, *myl-hy.*) is also very thin and similar to the sphincter colli, although not so attenuated as the latter. It forms a sheet of muscle extending from



one ramus of the mandible to the other, and reaching from the articulare to the anterior fourth of the mandible, thus covering all of the intermandibular space except a small anterior area. From the figure it is seen that the posterior half of the sheet has its origin on the ventral side of the mandible, while the anterior half is inserted on the median face of that bone. Many of the fibers from the latter pass underneath those of the cerato-mandibularis, so that there is an interlacing of these two muscles along the inner border of the mandible. The innervation is from the anterior fibers of ramus hyoideus VII and from two or three rami of the mandibular V (*myl-hy.*, Fig. J.), which leave the main trunk as mixed nerves (Plate 2, fig. 5; Plate 3, fig. 6, *myl-hy.*).

Versluys ('98, fig. 60-62) figures the m. mylo-hyoideus of *Mabuia multifasciata* as dovetailing with the cerato-mandibularis, as in *Anolis*.

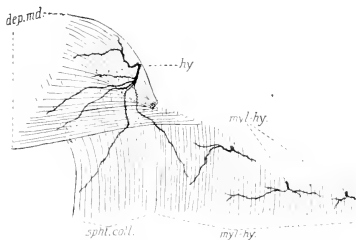

FIG. J.— Camera drawing of the distribution of the motor rami of the facial nerve and the motor rami of the trigeminal nerve that are carried in the ramus mandibularis. From a preparation made by removing sphincter digastric, and mylo-hyoideus muscles from a specimen fixed in vom Rath's solution: the muscles are retained in their relative positions to one another and mounted for microscopic examination. The nerve fibers are all well blackened as far as the myelin extends. The preparation is viewed from its deeper surface. Three rami from the fifth nerve are shown in this figure, whereas only two appear in the plotting (figures 5 and 6 of Plates 2 and 3). Although not demonstrated, it is probable that the two more anterior rami arise from a common branch of the mandibular ramus, which corresponds to the second ramus of the mylo-hyoideus shown in figs. 5 and 6, Plates 2 and 3.

The muscle described as the posterior part of the mylo-hyoideus is designated by Versluys as the m. intermandibularis. This is the part innervated by a branch of VII.

*M. depressor mandibular* (digastric). This (*drp. md.*) is a well-developed, but not a powerful muscle in *Anolis*. It is broad and fan

shaped, having its origin from the parietal ridge and neck fascia along an irregular line which anteriorly lies near the median plane, but posteriorly assumes a more lateral position (Fig. *G*). All the fibers converge to the articulare of the lower jaw, where most of them are inserted at the extreme posterior point by means of a ligamentous attachment. A thin band (*dep. md.*<sup>1</sup>), however, passes around to the ventral side and a little farther cephalad finds attachment in the fascia which also serves for the posterior fibers of *m. mylohyoides* (Figs. *F* and *J*). The anterior border of this muscle (Plate 3, fig. 7, *dep. md.*) forms the posterior border of the external auditory meatus and is the thickest and strongest part of the muscle. This portion is roughly separable from the sheet-like part behind it and has a firmer origin in the skull, the thinner portions behind arising from the neck. The tympanic chamber extends backward underneath this muscle (Plates 6, 7, figs. 19-24).

The innervation of this muscle is wholly from motor VII, which supplies it by two main branches (Fig. *J*).

Versluys ('98, p. 285) refers to the thinner posterior portion as occurring in many Lacertilia. It corresponds to the "superficial" portion and *C<sub>2</sub> md* of Ruge ('97, p. 326-331) for *Varanus*. The thicker part is the "Hauptportion" of Versluys.

*M. episterno-cleido-mastoides* (Versluys) *capiti-cleido-episternalis*, (Watkinson). This muscle (*c'stu-clei-mast.*), which extends from the skull, having its origin underneath the main part of the *m. depressor mandibulae*, passes caudo-ventrad to be inserted on the sternum (Fig. *G*). It forms a thickened ventral border to the *cucullaris* muscle, next to be described, and has the same innervation (Plate 7, fig. 24).

*M. capiti-dorso-clavicularis* (trapezius, or *cucullaris*). The fibers of this muscle (Fig. *G*, *cap. d'clar.*), have the same direction as the preceding, but both origin and insertion are different. It is an extremely thin sheet of fibers having origin underneath the thin posterior part of the *m. depressor mandibulae* and being inserted on the pectoral girdle. The line of origin extends well back past the level of insertion, so that the most posterior fibers are directed forward. It does not form a continuous sheet, but between the successive bundles are spaces which leave exposed the underlying lymph sac (Plate 7, fig. 24, *sac. cn'lym.*). These spaces are not indicated in figure *G*.

The innervation of the two foregoing muscles is from two or more spinal nerves, (Plates 2 and 3, figs. 4, 6, *spi. v. 3*) the first muscle being supplied wholly from the motor part of the third spinal nerve, which comes out to the muscle as a mixed lateral ramus. The sensory part

passes through this muscle and is distributed to the ventral skin region. Three branches of spinal nerves are shown to innervate the cucullaris muscle; their precise relation to particular spinal nerves was not determined owing to apparent anastomoses of rami. No relation that would suggest an innervation from a spinal accessory nerve was established with any nerves anterior to spinal II.

*M. laxator tympani* of Versluys (*lax. tym.*). A very small muscle, less than one half mm. in length, extends caudad from the insertion of the tympanic ligament on the extra-columella (Plate 7, figs. 21, 22). Its fibers end on the connective-tissue covering of the parotic process. The motor component of nerve VII passes ventral to the posterior end of this small bundle and in contact with it. The series of sections did not show with certainty the innervation of this muscle from motor VII, but a few fibers are given off from the main nerve bundle which in all probability accomplish such innervation. This is the more probable because there is no other nerve in the vicinity. Owing to its minute size this muscle was not isolated in dissection, but is a constant feature of the sections.

This muscle was first described by Versluys ('98) and given the name descriptive of its function. He found it in a number of lizards, all members of the family Geckonidae, while he failed to discover it in as many others, which belonged to different families. No more positive statement of its innervation than is here given for *Anolis* is contained in Versluys's account.

*M. constrictor venae jugularis internae* of Bruner (*co'st. vn. j. i.*). In *Anolis* this muscle is found in relations similar to those described by Bruner (:07, p. 42) for *Phrynosoma*. These striate muscle fibers surround the internal jugular vein for a distance of .84 mm. The most anterior fibers, for a distance of .14 mm., have their origin from the most posterior portion of the parotic process (Plate 7, fig. 23, *prc. pa'ot.*) and from the ligamentous extension of it. These anterior

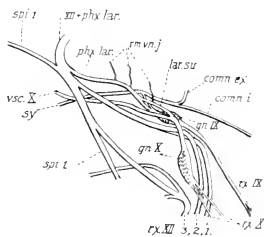

FIG. K.—Frontal projection, dorsal aspect, of nerves IX and X of the left side, showing the region of the roots and ganglia only, together with their connections. Plotted from *Anolis*, transverse series 48a. Two tumefactor nerves (*rm. vn. j.*) are given off from the ramus pharyngo-laryngeus and one from the ramus superior laryngeus.

fibers surround the vessel in a circular manner. For the remainder of the distance the fibers are diagonal or longitudinal to the wall of the vessel. Here the latter lies in immediate contact with the thymus gland.

The muscle is innervated by some very fine rami (not included in plotting) from X and IX + X (Fig. K, *rm. rn. j.*), as was determined by study of the sections. Some undetermined rami appearing in the dissection (Plate 3, fig. 7) are probably of like function.

### J. OCULOMOTOR NERVE.

The oculomotor nerve (*III*) arises from its nucleus of origin in the floor of the aqueduct of Sylvius and emerges as one large root from the ventral side of the mesencephalon (Plate 2, fig. 4). It swings laterad and cephalad to pass out of the cranium through the membranous wall, being covered laterally at this point by the bursalis muscle. (Plate 6, fig. 16). Posterior to the origin of the recti muscles the nerve divides into three large rami; the dorsal one goes to the dorsal rectus; a large ventral one, which later divides (Plate 5, fig. 14, *III*), supplies the ventral rectus, the anterior rectus and the ventral oblique; between these two large rami is the short root of the ciliary nerve. The latter is composed chiefly of fine neuraxons, which may be recognized as a distinct bundle in the center of the main trunk from the point where it emerges from the brain to its separation from the somatic motor components as the ciliary root. Within the brain itself it could not be independently traced in this series.

The branch of nerve III to the dorsal rectus muscle (Plate 2, fig. 4, *rt. d.*) is a large one. It follows the lateral face of this muscle near its anterior ventral edge (Plate 5, fig. 14), several successive bundles of fibers being given off to accomplish the innervation of the muscle.

The large ventral ramus (Plate 5, fig. 15, *III*) passes mesad of the retractor oculi to attain a position on the ventral face of the ventral rectus muscle. It is in this part of its course that a group of long rami separate from it, and penetrate the ventral rectus from both the dorsal and ventral surfaces (Plate 2, fig. 4). The remainder of the nerve (Plate 5, fig. 14, *III*) passes cephalad close to the median line, dividing to send more than half of its fibers dorsally into the anterior rectus (Plate 5, fig. 13, *rt. a.*), the remainder passing on to the ventral oblique (Fig. 13, *ob. v.*).

### K. TROCHLEAR NERVE.

Nerve IV (Plate 2, fig. 4, *IV*), from its nucleus of origin on the side of the aqueduct floor opposite to that of its emergence, passes dorsal of the mesocoel directly to the surface, the whole central course showing in a single transverse section. Peripherally it turns cephalad for a short intracranial course, lying between the brain and the Gasserian ganglion. It then passes through the membranous cranium, but keeps a median position throughout its course, to the dorsal oblique muscle, which receives all of its fibers (Plates 5, 6, figs. 12-17).

### L. ABDUCENT NERVE.

The central origin of nerve VI (Plate 2, fig. 4, *VI*) in the metencephalon was readily found. The neuraxons leave this part of the brain in small groups as large heavily medullated fibers. These emerge from the ventral side of the brain in small rootlets, which immediately combine into one main trunk. After a short intracranial course nerve VI enters the sphenoid bone and takes a course cephalad through a special foramen between the outer and inner lamellae of this bone, and dorsal to the beginnings of the basipterygoid process of the sphenoid (Plate 6, fig. 17). This foramen opens mesally into the bony pocket protecting the ventral end of the pituitary body and at the point of origin of the bursalis and retractor oculi muscles. Nerve VI passes through these muscles to reach the posterior rectus, which it innervates (Plate 5, 6, figs. 15, 16). The bursalis and retractor oculi muscles are innervated by a small ramus of not more than 25 fibers which is given off from VI as it passes between them. This is shown in Plate 6, fig. 16 (*brs.*), but in the plotting (Plate 2, fig. 4) it is covered by the main trunk. It is difficult to explain the very pronounced disproportion between this small ramus and the remainder of the abducent nerve. No connection was found which would relate the abducent nerve to any structures other than the three muscles named.

### CILIARY GANGLION AND NERVES.

In their macroscopic features the ciliary nerves and ganglion and their relation to the trigeminal and oculo motor nerves are compara-

tively simple. The ganglion (Plate 5, fig. 15, *gn. cil.*) lies between the membranous cranium on one side and the bursalis and retractor oculi muscles on the other, and is separated from both III and V by roots of considerable size. It is connected with nerve III, as is generally the case in other forms, by a shorter, thicker root, radix brevis (Plate 2, fig. 4, *rx. cil. III*), while the root from V (*rx. cil. V*) is longer and more slender. Only the proximal end of this root is shown in the figure. Both roots communicate with the ganglion directly and in like manner the two ciliary nerves arise directly from its distal end. In the plotting (Plate 2, fig. 4) this point is hidden by nerve III. These ciliary nerves (Plate 5, figs. 13, 14, *cil.*) cross dorsad of the optic nerve to enter the sclerotic coat of the eyeball. They keep close together in their course as they pass laterad and cephalad around the eyeball to their terminations in the striated muscles of the ciliary body and epithelial surfaces. From the smaller of these ciliary nerves is given off a very fine branch, which follows the others for a distance but is lost before its entrance into the eyeball. In sections individual medullated fibers are seen to be given off from this small ramus. These are lost along the walls of the small blood vessels. The presence of these fine rami in immediate contact with the retractor oculi muscle at its end of insertion could readily give rise to a misinterpretation in regard to their distribution (see p. 32). It is possible that Osawa ('98, p. 537), basing his conclusions on dissections alone, made such an error in his account of *Hatteria*. In *Anolis* every recognized fiber leaving the ciliary nerves could be traced cephalad beyond the most anterior extent of this muscle (*otr. oc.*), and in no case were these fibers distributed to the muscle.

In many points the microscopic evidence was far from conclusive for determining the relations of the ciliary roots and nerves to the ganglion, but they offer certain facts worth recording. The short root is a large one and is principally composed of fibers of very light medullation, but not of the smallest caliber, *i. e.*, they are larger than those of the visceral sensory system as shown in palatine VII. Among these are a very few coarser fibers of a medullation sufficiently heavier to make them conspicuous. These are as large as many that remain in the somatic motor rami, but do not equal in size those which predominate in these motor nerves, nor are they segregated into a single group to be readily followed through the ganglion. However, the fact that every section through the ganglion shows about the same number of these coarser fibers points to the possibility of their uninterrupted passage. The ganglion is a uniformly oval structure, the cells of which entirely surround the short root.

The long root (*rx. cil. V.*), from the nasalis division of the ophthalmic, is composed of both medullated and non-medullated fibers and joins the ganglion on its dorsal side (Plate 5, fig. 15) about midway of its length, many of its fibers immediately mingling with the ganglion cells. The independence of the bundle is, however, preserved throughout by the continuity of the non-medullated components of this root, which passes across the dorsal side of the anterior half of the ganglion and on into the large ciliary nerve, in which it appears for a considerable distance as a lighter area in the cross section. These facts do not preclude the possibility that many of the non-medullated fibers end in the ganglion, nor that a part of the postganglionic bundle of fine fibers takes origin in the ganglion. Further analysis of the ciliary nerves discloses some of the coarse fibers of the short root in each. The rest are of the smaller medullated variety and appear to take their rise as peripheral neuraxons of the cells of the ciliary ganglion, since they do not occur in the ciliary roots.

In comparing *Anolis* with other Sauropsida we find that the arrangement of roots, ganglion and ciliary nerves is that which Fischer ('52, p. 117) describes as typical for reptiles. As an exception he mentions *Salvator merianae*, where the trigeminal and oculomotor roots join proximal to the ganglion. Other accounts agree with *Anolis*. Osawa ('98, p. 602), in describing *Hatteria*, establishes another exception, wherein the ganglion itself is not connected with the trigeminal nerve by an independent root, but, if at all, through recurrent fibers, as in the fowl, the ciliary rami from V joining the ciliary nerve distal to the ganglion.

Carpenter's (:06, p. 158) careful analysis of the ciliary ganglion and its connections in the adult fowl is the only basis we have for a comparison of histological features with conditions in birds. In the fowl, the short root from the oculomotor being much the same as for *Anolis*, one main ciliary nerve leaves this ganglion. This contains all the well medullated fibers. Another small bundle, of feebly medullated fibers, leaves the ganglion dorsal to the large one. A third (small) ramus accompanies the other two; microscopic study, however, showed Carpenter that it contains no fibers from the ganglion, but is merely a communicating ramus from the trigeminal, which meets the ciliary nerve distal to the ganglion. The same ramus sends some recurrent fibers back to the ganglion. Other fine rami may be given off from the communicating ramus. All the trigeminal elements are non-medullated. The ciliary ganglion itself is divisible into a sympathetic and a cerebro-spinal part.

As compared with this, we find in *Anolis* the following differences:— (a) nerve V connects directly with the ciliary ganglion by a branch which contains a large proportion of medullated fibers; (b) the non-medullated components from the trigeminal are carried in the large ciliary nerve and form no small non-medullated rami; (c) the ganglion is not divisible into two parts and has more the appearance of a cerebro-spinal ganglion. It should be noted, however, in regard to this last point (c), that the complete Vom Rath method was not used in the preparation of the *Anolis* material, the treatment with pyroligneous acid being omitted. This omission may have resulted in less differentiation within the ganglion and a consequent failure to discover the differences recorded by Carpenter.

### M. TRIGEMINAL NERVE.

The afferent and efferent neurons that go to make up the mixed root of nerve V form one large bundle, in the cross section of which there is shown no segregation of components at the point of emergence from the brain. More centrally, however, the main sources of these components may readily be found. More complete study of the brain will no doubt result in some addition to this account of peripheral structure and possibly to some revision. The central relations of the neurons are here referred to briefly and only in so far as they were brought out in the series of sections from which the plottings were made.

*The efferent neurons.* The motor components were seen, in sections posterior to the superficial origin of the root, to arise from two sources: (a) a group of cells lying a short distance mesad and slightly dorsad to the connection of the root with the brain, and (b) from a region just laterad to the median longitudinal fasciculus. From both these sources the bundles of heavily medullated fibers pass directly out to the ventro-median part of the root. Here they form with the afferent components a common root-bundle, in which it is difficult to distinguish the two. At the point of superficial origin the mixed root-bundle is covered dorsally by the ganglion of nerve VIII (Plate 6, fig. 18, *rx. V*; *gn. VIII*). The root passes cephalad between the proötic bone and the skull to the Gasserian ganglion (Plate 6, fig. 17, *gn. V*), which lies in the foramen proöticum (Gaupp). The foramen is represented in the skull of *Anolis* by a notch in the anterior border



of the proötic bone, being bounded anteriorly by the membranous part of the cranial wall (Plate 1, fig. 2; *for. V*).

Before the ganglion is reached, the root shows a distinct separation into three parts, which in cross section appear as three unequal segments of a circle. The largest is the dorsal segment, which passes into the main part (*gn. V*) of the ganglion (semilunar of Fischer); the ventral comprises the motor neurons, while the median division from this point on is free from all other connections and passes into the ophthalmic ganglion (Plate 2, fig. 4; Plate 3, figs. 6, 7, *gn. V*; *gn. oph.*).

The motor components, thus segregated just proximal to the ganglion, are almost exclusively distributed in small pure rami directly from the ganglion (Plate 3, fig. 6). A few motor fibers are, however, included in mandibular V and reappear in several small mixed rami innervating a part of *m. mylo-hyoideus* (Plates 2 and 3, figs. 5 and 6).

Those rami which supply the dorsal and lateral jaw musculature arise from the dorsal division of the main motor bundle. This passes across the ventral side of the ganglion and the base of mandibular V to be split into two rami, one of which (*cap. md. 1 and 2*) supplies chiefly the *m. capiti mandibularis*, and the other (*pt.*) the greater part of the *m. pterygoideus*. Of the former a part passes directly dorsad, while the rest follows the course of maxillaris V as several slender rami to supply the anterior part of these muscles (Plates 2 and 3, figs. 4 and 6).

The motor components which do not enter into this dorsal and lateral distribution pass directly cephalad on the ventral face of the ganglion. A part follows for a short distance mandibular V on its ventral side and then divides, one branch (*pt-md.*) going to innervate the *m. pterygo-mandibularis*, the other (*pt.*) to innervate the deeper part of the *m. pterygoideus*. The rest separates into three rami, two of which are very small. Of these one (*pt-par.*) innervates *m. pterygo-parietalis*, the other (*pt-sph. p.*) *m. pterygo-sphenoidalis posterior*. The third ramus (*protru. oc.*) is larger than either of these two. It passes cephalad to the orbit to innervate *m. protrusor oculi* and *m. depressor palpebrae inferioris*. Because of its special functional and structural relations, this nerve demands a more detailed account.

*Ramus ad m. depressor palpebrae inferioris (dep. palb. inf.)*. This ramus is recognizable on the ventral side of the main motor bundle opposite the proximal end of the ganglion (Plate 6, fig. 17). The bundle as a whole has a characteristic appearance, the fibers being well medullated but somewhat finer than those of the other motor

nerves. Upon closer examination it is found to contain fibers of still finer caliber and of lighter medullation and also possibly some non-medullated fibers. The latter point is difficult to establish where such fibers are relatively few and not grouped into a bundle. The course of this nerve is directly cephalad to the orbit keeping to the ventro-lateral side of all the eye muscles (Plates 3, 5, 6). Soon after this nerve has begun its peripheral course its lightly medullated fibers become grouped into a bundle on its ventral side. These leave the main ramus about midway between the Gasserian ganglion and the orbit, and form a communicating ramus (*conn.*), which joins palatine VII a short distance cephalad of this point (Plate 3, figs. 6, 7; Plate 5, figs. 14, 15). In the palatine nerve its identity is wholly lost, although the nature of its union strongly indicates that it does not form a recurrent bundle, but continues its course cephalad.

Two very small but noteworthy twigs (Plate 3, figs. 6, 7, *protru. oc.*) are given off from this communicating ramus to innervate the muscle which has been described as the protrusor oculi. In the dissection (Plate 3, fig. 7), where this was clearly worked out, it will be noticed that one twig is given off from the *rm. palpebralis inferior* itself and only one from the communicating ramus. The fibers innervating this muscle are of the same character as those of the communicating ramus and in distinct contrast to those remaining in the main motor ramus, which, farther cephalad, innervate the depressor muscle of the lower eyelid. A comparison with the opposite side of the head and with other series of sections shows practically the same relation, although on the opposite side in the same series a twig is given off proximal to the communicating rami, as in Plate 3, fig. 7. It comes, however, from the ventral lightly medullated bundle, which is as clearly marked off as though it were a separate ramus.

Although Fischer ('52) describes the innervation of the *m. depressor palpebrae inferioris* by a ramus coming directly from the motor root, as in *Anolis*, he makes no mention of a communicating ramus between this nerve and palatine VII. The one mention of it met with is by Watkinson (:06, p. 457, 463) in *Varanus*, where it is described as a communicating ramus between palatine VII and the Gasserian ganglion by way of this motor nerve. From dissections alone it would appear to be mere assumption that it takes this course. From the sections of *Anolis* it seems quite clear that the components of this connecting ramus have a distal existence in the palatine. Such an anastomosis between a pure motor ramus and the viscerosensory is not met with in *Anolis* in any other connection. No reference is made

by any writer to a muscle innervation similar to the one above described. This peculiarity, coupled with the described function (p. 33) of this muscle, offers a problem for comparative study. It is to be noted that no ganglion cells were found at the point of union either on V or VII.

*Afferent neurons.* The central course of these fibers is so involved in other brain tracts that the present description will begin at the superficial origin of the root. The descending root of the trigeminal nerve traced cephalad approaches the surface of the medulla and produces a swelling of the surface beneath the roots of nerves VII and VIII (Plate 6, fig. 18, *rx. I*). The motor neurons, as before described, join this bundle rather abruptly from a more median position, and the two together leave the brain as a single root. The fibers making up the sensory components of the trigeminal lack uniformity of size and medullation. They are, however, of a size approximately that of the motor components of the trigeminal and facial, but also have among them both larger and smaller fibers. A characteristic feature of the cross sections is the presence of a few very large, strongly medullated fibers. These are recognizable in the brain, and a central connection may possibly be established for them. Peripherally they seem to offer no special relation to end organs. They occur in limited numbers and are always scattered as isolated fibers. It is possible they are motor in their character and are transferred to the motor rami.

The ophthalmic, maxillary, and mandibular divisions of the trigeminal are recognizable even proximal to the ganglion (*gn. V*; *gn. ophth.*), the two ganglia being entirely distinct and scarcely in contact in series 30. The relative sizes and positions of the ganglia are best seen from the figures on Plates 2, 3. The cross section (Plate 6, fig. 17) shows the segregation of the two cell groups. In addition to these two ganglia, one of the figures (Fig. 6) shows a third; a very small ventral group of cells entirely similar in the sections to those of the larger ganglia. Careful study was made of this small ganglion to discover any structural features that would indicate a sympathetic character, but comparison showed no such group on the opposite side of the same individual; in this case therefore it is probably a separation (inconstant) of a few cells of the main ganglion. From what we know of other forms, it seems probable that the sympathetic rami of the lachrymal plexus send fibers to the Gasserian ganglion, but that could not be demonstrated in *Anolis*, and there is no deep sympathetic trunk connecting the Gasserian with more posterior ganglia.

A detailed account of the peripheral distribution of the sensory

components of the trigeminal nerve will be preceded by a more general statement. The main branches of this nerve correspond quite closely with the typical condition found in lower vertebrates. The ophthalmicus profundus, proceeding from its own independent ganglion, is distributed to the skin of the dorsal surface of the head over an area extending from a post orbital region forward to the tip of the snout, the frontal region receiving its fibers over a special ramus, which leaves the ophthalmic at the ganglion; the rest of the nerve, as the *nasalis* branch, takes the course through the orbit typical of the profundus, receiving the long root of the ciliary nerve on its way, and supplies the skin of the dorsal surface of the snout and the epithelium of anterior nasal chamber.

The second and third (maxillary and mandibular) branches of the trigeminus join the main trigeminal ganglion as large branches from the upper and lower jaw regions. The maxillary supplies the skin around the eye and the upper and lower lids; it crosses the floor of the orbit to the upper jaw, in which it runs forward to the tip of the snout, supplying the skin lateral to the jaw and the epithelium of the gums and the teeth.

The mandibular branch passes down to the lower jaw, which it enters, supplying the skin, gums and teeth in a manner similar to that described for the upper jaw. It also supplies the anterior regions of mouth and tongue. In this latter distribution it is closely associated with the somatic motor components of XII and the viscerosensory components of the chorda tympani. Certain plexuses and anastomoses omitted from this general account will be included in the detailed description which follows.

I. *Nerveus ophthalmicus profundus*. This term, as including all the fibers entering the ophthalmic ganglion, has no application in *Anolis*, as the two main branches (*r. nasalis* and *r. frontalis*) do not unite distal to the ganglion. These two branches will be described as the frontal and nasal rami.

Ia. *Ramus frontalis (f.)*.—The point where in different reptiles the frontal ramus joins the *nasalis* is determined somewhat by the relation of the ganglion to the orbit. In *Anolis* (Plates 2, 3) the orbit is large and the frontal ramus takes rather an abrupt dorsal course to reach the skin posterior to it; the ramus therefore joins the ganglion directly. The *frontalis* is about half the size of the *nasalis*. Both are composed of the same kind of fibers, except that the *nasalis* carries the non-medullated fibers of the *radix longa* of the ciliary nerve, which collectively can be recognized from the beginning of the

ramus. The frontal ramus lies dorsal to the other and both run cephalad for some distance, passing between the membranous cranium and the ligamentous origin of the protrusor oculi muscle (Plate 6, fig. 16, *f.* and *na.*). A little farther forward the frontalis turns abruptly dorsad to the posterior angle of the orbit (Plate 5, fig. 15). In this course it keeps next the membranous cranium and attains a position just caudad to the lachrymal gland. As it turns dorsally it gives off a branch that becomes involved in the sympathetic plexus (Plate 3, figs. 6, 7), but, like the other branches, this contains cutaneous sensory elements that can be traced to the skin. The main branch continues between the brain and the large blood sinus which lies just posterior to the lachrymal gland (Plate 5, fig. 15). A little farther forward, and at a level where the gland is beginning to be cut, there are given off a number of branches, which anastomose with the sympathetic, but for the most part supply the upper lid. These lie just mesad of the lachrymal gland (Plate 5, fig. 14, *gl. lch.*). The main part continues forward and supplies, from time to time, small rami to the skin between the eyes (Plate 5, figs. 12, 13).<sup>^</sup>

*Ib. Ramus nasalis (na.).* This is the main ophthalmic branch and takes the characteristic course through the orbit (Plates 4, 5, 6, figs. 10-17). It passes into the orbit with nerve III and passes dorsally to the optic nerve and over the ocular face of the dorsal rectus muscle (Plate 5, fig. 14). Just before its entrance into the orbit (Plates 2, 3, figs. 4, 6, *rx. cil. V.*) it gives off the long root of the ciliary nerve (see p. 46). With this exception there are no branches or connections within the orbit. It passes out of the orbit on the median side of the Harderian gland (Plate 3, fig. 7; Plate 4, fig. 11) into the space bounded by the anterior median wing of the palatine, the frontal, the prefrontal and the origin of the ventral oblique muscle (Plate 4, fig. 10). Here the nerve passes through the "ethmoidal" sympathetic ganglion (*gn. eth.*), which will receive especial description. This ganglion lies on a level with the anterior boundary of the bony orbit, and through it a cutaneous branch of coarse fibers is given off to the skin of the anterior angle of the eyelids (Plate 4, fig. 10, *na.*<sup>1</sup>). Soon after this the main nerve divides into a *lateral* branch (Plate 4, fig. 9, *na. l.*) and a *median* branch (*na. m.*). These richly supply the skin of the snout. The median one gives off in addition a branch to the mucous membrane of the nose; its cutaneous branch passes forward along the median line to be distributed to the end of the snout (Plate 2, fig. 4).

According to Watkinson (:06, p. 458), who mentions both the fron-

talis and the nasalis, *Varanus* agrees with *Anolis* in so far as no branches are given off from the nasalis between the ciliaris and the posterior extremity of the internal nares, where, as she states, the "r. comm. cum ramo platinus VII" is "composed of at least two distinct fiber bundles," which communicate with palatine VII; then follow the same divisions as noted for *Anolis* anterior to this, i. e., "r. lateralis" and "r. medialis," these having much the same distribution as in *Anolis*. To the medialis are assigned the following branches, r. premaxillaris superior (dorsal) and r. premaxillaris inferior, these innervating the skin of the nose and the lips.

*Ethmoidal ganglion (gn. eth.)*. This is a ganglion of oval form and one fourth mm. in length, which lies closely applied to the ventral and lateral sides of the nasalis nerve (Plates 2, 3; Plate 4, fig. 10). The ganglionic cells do not entirely surround this nerve, and there is no passage of medullated fibers from nerve to ganglion. The ganglion is in connection with the median branch of the palatine nerve through communicating bundles of fibers; these fibers are also accompanied by sympathetic ganglion cells, which form a sort of column of cells extending from the side of the ganglion opposite the nasalis nerve to the palatine ramus (Plate 4, fig. 10). A dissection of this ganglion and its connections, mounted in balsam, shows some fine, lightly medullated fibers from the stalk passing both caudad and cephalad in the palatine. The almost complete lack of medullated fibers among the cells indicates that the ganglion has to do largely with non-medullated fibers. A very small bundle of such fibers joins the ganglion on its posterior side close to the nasalis nerve. To what extent this ganglion may be in connection with non-medullated fibers of the nasalis, could not be determined, but such a relation would appear to be the only explanation of the anatomical relations observed. The cells of the ganglion are smaller and less clearly defined than those of the cerebral ganglia, showing in this their sympathetic character (Carpenter, :06).

The ethmoidal ganglion occurs regularly in birds, as far as they have been studied, as a group of ganglion cells on the ophthalmic branch of V. Bonsdorff ('52) gave it the name of "ganglion ethmoidale," and Rochas ('85) "g. orbitonasale." In the goose Cords (:04, p. 59) describes this ganglion as being 1 mm. long and  $\frac{1}{2}$  to  $\frac{2}{3}$  mm. broad, and as having the same connections as we find in *Anolis*, i. e., with the ophthalmic branch of V and the palatine branch of VII. There can be no doubt of the homology of this ganglion as described for birds with the structure to which the name has been given in *Anolis*.

An anastomosis of palatine VII with the ophthalmic branch of V in the anterior orbital region seems to be of wide occurrence in the Sauropsida and Amphibia. It is described in *Amblystoma* (Herrick, '94), tadpole of the frog (Strong, '95 [farther forward here]), *Spelerpes* (Bowers, :00), *Amblystoma* (Coghill, :02) and *Amphiuma* (Norris, :08).

Of the above mentioned investigators, Coghill finds a ganglion at the point of union, and Norris (p. 540) says "there seems to be a ganglion on the palatine nerve shortly before the anastomosis"; beyond the anastomosis he finds mixed cutaneous and viscerosensory rami. With this observation by Norris agrees the statement I have made regarding *Anolis*; that this ganglion, while surrounding ophthalmic V, is really more closely related to palatine VII.

Among the reptiles an anastomosis is mentioned by Gaupp ('88), Osawa ('98), and Watkinson (:06). On the other hand Fischer ('52) does not mention it at all. The presence also of a ganglion, at least one discernible by dissection, seems to be less general in the described reptiles than the condition in *Anolis* would suggest. The only mention of it which I have found was in Gaupp's ('88, p. 469) description of the snake *Tropidonotus*, in which he refers to it as "eine leichte Anschwellung," and further "Vielleicht entspricht dieselbe dem ganglion ethmoidale der Vögel." Watkinson (:06, p. 463) speaks of palatine VII and nasalis V as lying quite close together at a point corresponding to the ethmoidal ganglion and having one or two connecting branches. It is probable that sections would have disclosed a ganglion here. She found no cutaneous branch of the nasalis at this point.

*Peripheral distribution of the ramus nasalis.* The distribution of the cutaneous sensory fibers carried in this nerve begins with the bundle of coarse fibers entering the posterior end of the ethmoidal ganglion. Distal to the ganglion the main nerve divides into the lateral and median branches before mentioned (Plates 2, 3, figs. 4, 6, *na. l.*, and *na. m.*), which are of about equal size. One of these retains a median position while the other crosses the roof of the nasal capsule to a more lateral one.

(a) *Ramus lateralis nasi.* This ramus in passing cephalad and laterad across the roof of the olfactory chamber occupies a position between the cartilaginous capsule of the chamber and the cranial bones. It is distributed to the skin over the subterminal region of the snout, that is, just posterior to the external nares. Before reaching the integument the lateral ramus passes through the nasal gland,

where it bifurcates. Each branch gives off a small twig (Plate 2, fig. 4, *na. l.<sup>1</sup>* and *na. l.<sup>2</sup>*), which passes out through this gland to the skin. The more lateral of the two bundles again divides, and these three terminal divisions of the ramus (Plate 4, fig. 9) then emerge from the anterior side of the gland to innervate the skin overlying that region. The two small twigs proximal to the three terminal divisions (Fig. 4) supply a somatic sensory innervation to the olfactory epithelium.

(b) *Ramus medialis nasi*. After giving off a few fibers to the olfactory epithelium, the median ramus supplies a larger branch (*na. m.<sup>1</sup>*) to the skin over the nasal bone; the foramen (*for. na. m.*) through which this nerve emerges is clearly indicated in fig. 1, Plate 1. The main ramus then passes cephalad without branching to the extreme tip of the snout to innervate richly the skin anterior to the external nares. Its terminal branches are shown in Plate 2, fig. 4, but not in Plate 3, fig. 6. In its course it keeps close to the internasal septum and the median dorsal part of the premaxillary bone (Plate 4, figs. 8, 9).

II. *Ramus maxillaris* (Plates 2, 3, figs. 4, 6, 7, *mx.*). The second main branch of the trigeminus is given off from the lateral side of the portio major of the Gasserian ganglion. It passes between mm. pterygoideus and capiti-mandibularis to reach the posterior ventral rim of the bony orbit. It makes a circuit of this ventral rim to the anterior side of the orbit where it passes into the marrow cavity of the maxillary bone and continues its course in the upper jaw. Besides numerous rami distributing somatic sensory components, this nerve becomes involved with the superficial sympathetic rami of the head in what may be called the "lachrymal plexus," and with the viscerosensory-sympathetic in the orbital plexus. It will simplify the account to describe first the somatic sensory rami, as far as possible, as though the plexus did not exist and give an account of the latter separately.

The following branches are given off from the ramus maxillaris: (a) the first branch (*mx.<sup>1</sup>*) is given off from the dorsal side. It passes around the anterior side of the m. capitis mandibularis and turning back supplies the skin (Plate 2, fig. 4; Plate 3, fig. 6). In its course it crosses the sympathetic rami in the lachrymal region, but its cutaneous fibers do not mingle. In some dissections it appears to be independent, although in figure 7 it joins the lachrymal plexus in such a way that its terminal ramus could not be identified. (b) The second branch (*mx.<sup>2</sup>*) also passes across the plexus, where it is difficult to follow it in sections, but a dissection, upon being cleared and mounted,



showed the continuity of the cutaneous fibers, which is indicated in Plate 3, fig. 6, by dotted lines. This ramus divides into several branches to supply the skin at the posterior angle of the eyelids, and also the posterior half of the lower eyelid. (c) Another branch ( $mx.^3$ ), similar to ( $mx.^2$ ), runs forward to supply the anterior half of the lower eyelid. This shows an anastomosis with  $mx.^2$  (Plate 3, figs. 6, 7). (d) A branch ( $mx.^4$ ) which passes into the cavity of the ventral bony arch of the orbit supplies the skin over it as far forward as the anterior limits of the orbit. The rest of the nerve ( $if^o orb.$ ) now passes cephalad across the orbit to enter the infraorbital foramen, an opening bounded by the maxillary, lachrymal and jugal bones (Plate 1, fig. 1, *for. if<sup>o</sup> orb.*). Before entering this foramen it gives off cutaneous fibers at two points, which, however, are not free from connection with the palatine rami and are indicated only by the somatic sensory component (yellow) included in these palatine rami. One of these combines with the visceral components of VII to form a good sized branch (*pal. l.*), which passes cephalad under the fold of epithelium on the median side of the maxillary bone. This fold is rich in tubular glands and taste buds (Plate 4, figs. 9-11). The other passes mesad to meet the intermediate ramus of the palatine (*pal. i<sup>m</sup>.*), and the combined nerve comes out to the mucous membrane farther cephalad, where it continues the innervation of the lateral field (Plates 2, 3).

*Ramus alveolaris superior (alv. su.)*. This is the term applied to the intra-maxillary portion of the maxillary nerve. In *Anolis* its distribution is wholly to the integument at the side of the jaw, which it reaches through numerous foramina that are indicated in the skull (Plate 1, fig. 2), and to the teeth, as described more fully for the lower jaw.

*Connection of the sympathetic with the ramus maxillaris trigemini*. There is one well defined and constant sympathetic ganglion on the main trunk of the maxillary nerve. This, because of its position at the beginning of the infraorbital course of this nerve, is known as the *infraorbital ganglion* (Plate 2, 3, figs. 4, 7, *gn. if<sup>o</sup> orb.*). It is much flattened laterally (Plate 5, fig. 14), the flattening being due, no doubt, to its location. It is connected with the main superficial sympathetic ramus of the head by a strand of non-medullated, or very slightly medullated, fibers. The medullation is so slight that the connection is very difficult to establish in the sections, the dissection preparations, however, leave no doubt on this point. It is impossible to tell to what extent recurrent fibers may connect with the trigeminal ganglion. It is certain, however, that the main

extension of the sympathetic ramus is cephalad in the infraorbital nerve. This is shown by the character of the cross section of the nerve and by the direction of the fibers in the ganglion. The further anastomoses of nerves V and VII to form the infraorbital plexus offers opportunity for the wide distribution of this system throughout the head region. Practically every point of juncture in this complex is the seat of a larger or smaller group of sympathetic ganglion cells (Plate 2, fig. 4, *cl. gn. sy.*). Except in the case of the infraorbital ganglion, none of those on the maxillary nerve is large enough to have been discovered by gross dissection without the aid of mounted preparations of dissected parts, a method which apparently has not been used by my predecessors. It is noticeable that, after the nerve is free from visceral connection, as in the ramus alveolaris superior, no more ganglia are found.

III. *Ramus mandibularis (md.)*. This is the largest of the trigeminal branches, but, unlike the other two, it is not wholly afferent in its composition. It includes a certain number of motor components, which are given off to the mylo-hyoideus muscle. The mandibular ramus leaves the portio major of the Gasserian ganglion from its ventro-lateral side (Plate 3, figs. 6, 7), being covered dorsally by the ramus maxillaris. Its course to the lower jaw lies between the mm. pterygoideus and pterygo-sphenoidalis posterior. It crosses dorsal (lateral) to the pterygoquadrate process just behind the insertion of the m. pterygo-parietalis, passing through the deeper part of the pterygoideus to reach the median side of the mandible (Plates 5, 6, figs. 15-17). As it approaches the mandible two rami are given off together to be distributed to skin and muscle of this region. The continuation of the main nerve is known as the *ramus alveolaris inferior (alv. inf.)*. It still contains a few motor fibers for the innervation of the anterior part of the m. mylo-hyoideus.

III, 1. The two branches above mentioned are given off from the main ramus at the point where the latter makes a turn cephalad to enter the mandible. They might be considered one branch which immediately divides into a posterior and an anterior ramus. The posterior ramus (*md.*<sup>1</sup>) turns back (Plates 2, 3, figs. 5, 6) and crosses Meckel's cartilage dorsally, reaching the lateral side of the mandible (Plate 6, fig. 16) through a foramen between the dentary and angulare bones. It passes through the superficial throat muscles to the mylo-hyoideus muscle, a very small sensory twig passing on to the skin. Most of the fibers are motor, innervating a part of the mylo-hyoideus muscle (Fig. J).

The anterior ramus (*lab. if. md.*) is much the larger of the two and appears in the sections to be purely cutaneous sensory. It passes into the cavity of the complementare bone (Plate 5, fig. 15) to run cephalad a little distance and then out through a foramen on the dorsal side of this bone. It passes forward along the side of the mandible to innervate the integumentary portion of the lower lip for about two thirds of its length (Plates 4, 5, figs. 10-15), the anterior part of the labial region being cared for by branches from the alveolar ramus (Plates 2, 3, 4, figs. 5, 6, 8, 9, *lab. if. md.*).

III, 2. *Ramus alveolaris inferior.* This (*alv. if.*) is the continuation of the mandibular ramus into the lower jaw. It takes a position on the dorsal side of Meekel's cartilage (*crt. Mkl.*) where this is still exposed (Plate 5, fig. 15), and when the membrane bones of the mandible close around the cartilage they include both this nerve and the chorda tympani. The latter is at first ventral to the alveolaris, but gradually assumes a more median position and finally takes up the medio-dorsal part of the cross section of the combined nerves (Plate 5, figs. 13-15, *alv. if.* and *cd. tym.*). The two bundles are easily distinguishable up to the place where the first branches are given off. The alveolaris gives off several branches at a level with the angle of the mouth.

(a) A small branch, not shown in the figures, is given off from the dorsal side of the main ramus at the line of separation between the fine fibers of chorda tympani and the coarser ones of the alveolaris. It contains the coarser, well-medullated fibers, not more than ten or twelve in number. This appears to be a constant structure, but its distribution and its function remain undetermined. There is nothing in the nature of its fibers to indicate that it is viscerosensory or sympathetic, yet it cannot be followed to any peripheral structure; the fibers separate in the interosseous tissues of the jaw and cannot be traced outside. It is recurrent in its course, passing caudad and dorsad between the outer dentale and the enclosed complementare and is lost on the epitheliod osteoblastic layer between the dentale and coronoideum. Its course continued a little farther caudad would bring it to the lateral side of the coronoideum, to the place of insertion of a part of the m. pterygoideus, but such a distribution was not established. Some of the fibers passing out in this nerve appear to be the coarser ones originally carried by the corda tympani.

(b) Opposite the point where (a) is given off a ventral mixed branch (*md.*<sup>2</sup>) leaves the ramus alveolaris. In passing cephalad it circles Meekel's cartilage swinging down the lateral side and up the median

side to emerge through the same foramen with another large branch (*lng. V. + cd. tym.*), which includes the chorda tympani (Plates 2, 3, and 5, figs. 5, 6, 12). Upon its exit from the jaw it turns ventrally, dividing to send to the skin a branch which also includes a small motor twig (*myl-hy.*) supplied to the mylo-hyoideus muscle. The main part goes farther cephalad among the interlocking ends of the mylo-hyoideus and cerato-mandibularis muscles to an overlying cutaneous area between mandibles (Plate 4, fig. 9, *md.*<sup>2</sup>).

(c) A short distance cephalad of the place where (a) and (b) are given off, the main ramus bears on its dorsal side a sympathetic ganglion (Plates 2, 3, figs. 5, 6, *gn. md.*), which is composed of small cells forming a group flattened against the sides of the chorda tympani and alveolar portions of the nerve. As the combined lingualis and chorda tympani separate from the intramandibular portion of the nerve, the cells of this ganglion crowd down into the angle thus formed in the shape of a wedge. As in other sympathetic ganglia, there appears to be no admixture of medullated fibers among the cells. The ganglion seems to be more closely associated with nerve V than with nerve VII, and after the division its cells continue forward, appearing in a number of sections within the perineurium of the alveolar part.

Gaupp ('88, p. 460) states that in *Lacerta* there is an "Anschwellung" at the point of union of the chorda tympani with the alveolaris. He also refers to the lingualis, which includes the chorda tympani, as given off immediately after this union. This swelling undoubtedly corresponds to the mandibular ganglion (*gn. md.*) of *Anolis*.

The lingual ramus of V passes out of the jaw in a common sheath with the chorda tympani (Plates 2, 3, 5, figs. 5, 6 and 12, *lng. V + cd. tym.*). The combined bundle goes cephalad for some distance without branching, then divides into two rami of about equal size. The dorsal one is composed almost entirely of the fine fibers of the chorda tympani and will be considered as the continuation of that nerve, to be described with the facialis. It includes, however, about a dozen large cutaneous fibers. The other (ventral) division is almost entirely cutaneous, as is shown by comparison with ramus (*md.*<sup>2</sup>), which lies next to it. It contains, however, some of the fine fibers characteristic of the chorda tympani. It appears, therefore, that in the final separation of the lingualis and chorda tympani there is a slight interchange of fibers.

The lingualis (*lng. V.*) now runs cephalad and divides for distribution to the papillae of the tongue. In this peripheral region, however,

its fibers are inextricably mingled with those of XII, which they closely resemble. The difficulties of plotting the mixed rami are here further increased by the retraction of the tongue muscles, which throws the terminal rami into numerous coils. The plotting (Plate 3, fig. 5) attempts to trace the lingualis and XII only so far as to show the union of the entire lingualis by two branches with branches of XII. This takes place after the lingualis has been traced cephalad for some distance parallel with the chorda tympani and then back again parallel with XII close to the mucous membrane at the base of the groove which bounds the tongue laterally (Plate 4, figs. 10, 11). Numerous dissections were made in this region, which added little information as to the exact form of the anastomoses. The fact was established, however, that, after joining XII, some of the fibers of V continue caudad presumably to reach the periphery through more proximal branches.

*Terminal distribution of the ramus alveolaris inferior.* The final distribution of the sensory components, left in the alveolar branch after the separation of the chorda tympani, the lingualis, and a large cutaneous branch, is accomplished through a series of terminal rami, which make their exit from the alveolar canal through a number of foramina on the lateral side of the dentary bone (Plates 2, 3, figs. 5, 6, *lab. inf. alv.*). These are termed by Watkinson (:06, p. 462) the "rami ad glandulae labiales inferiores," the emphasis thus being placed upon their distribution to glands. They probably carry sympathetic fibers to the glands, but if so, these are non-medullated and are not distinguishable in sections. A conspicuous feature in *Anolis* is the highly sensitive nature of the lips, as is indicated by the rich supply of typical cutaneous sensory fibers to the skin in this region. The epidermal sense organs are also more numerous here than elsewhere. The strongly medullated sensory fibers are strictly limited to the epidermis at the sides of the lips lateral to the external labial gland (Plate 4, figs. 8-10). The external glands are not very largely developed here, although they occur along the entire length of the lips both upper and lower.

The n. alveolaris does not emerge as a whole from the alveolar canal until the end of the mandible is reached. Here it comes out as four or five terminal branches, giving to this region an even richer nerve supply than was accorded the lips along the lateral part.

*Innervation of the teeth.* The teeth are of the typical pleurodont type, being fused directly with the median side of the dentary bone. The pulp cavity of each tooth is in communication with the cavity

of the dentary bone, which carries the nerve. Through this opening into its cavity the tooth receives its nerve and blood supply. The innervation was not determined for the posterior teeth, the first fibers given off from the alveolar nerve being farther forward, where a small number (3 or 4) of fibers with distinct sheaths come off from the main ramus and run forward within the alveolar cavity for some distance, but eventually pass into the cavities of the teeth (Plate 4, fig. 9, *rm. dc.*). Where these fibers are given off they show a character similar to the cutaneous sensory components, although they either become less heavily myelinated or, what is more likely, their position makes fixation defective, for they can with difficulty be traced through the communication into the pulp cavity of the tooth. It is not improbable that here they do lose their myelin sheaths. It is noticeable in the mature teeth that the dentinal tubules are particularly large at the apex of the teeth. No nerve fibers could be followed, however, as far as the odontoblasts underlying this region.

This alveolar ramus is described by Watkinson (:06, p. 462) as innervating the teeth through the "rami dentales." Such rami in *Anolis* would consist of a few fibers given off at wide intervals, which would be difficult to discover except by microscopic methods, even though they were not entirely within the bony part of the jaw. Norris (:08, p. 522) referred the innervation of the teeth in *Amphiuma* to a combined V and VII nerve which runs along the median side of the mandible. This nerve corresponds to the main part of the chorda tympani in *Anolis*, which after temporary union with the mandibular nerve has separated from it, reappearing with a mixture of cutaneous components, which are distributed with it. Although many fine fibers pass from this nerve along the base of the teeth to the epithelium of the lingual gums, no connection was established with the teeth themselves.

## N. FACIAL NERVE.

*The roots of the facial nerve.* Two roots can be demonstrated for nerve VII, a lateral (motor) one and a dorsal (sensory) one. The sensory passes out directly from the fasciculus solitarius (Plate 6, fig. 18, *rx. VII*) as a strong bundle to emerge from the brain dorsal to, but in contact with, the root of VIII. It passes around the anterior side of this root, being entirely covered laterally by the large acoustic ganglion. On the ventral side of the root of VIII the sensory root of

VII joins the motor root and the combined roots pass out through the foramen as one (Plate 6, fig. 18).

The motor root leaves the brain just ventral to the fibers of nerve VIII where it is joined by the sensory root. It was traced centrally as a distinct bundle near to the ventro-lateral floor of the fourth ventricle. Here the root bundle becomes diffuse and its nucleus of origin was not identified among the several groups of cells occurring in this locality.

The motor components of the facial are all included in the hyomandibular nerve (*hy-md.*), with a distribution posterior to the ear. The viscerosensory components are distributed anterior to the ganglion, the roof of the mouth being supplied through the palatine ramus (*pal. VII*), while the tongue and adjacent regions are supplied by the chorda tympani (*cd. tym.*), which leaves the ganglion in company with the motor elements and includes the sensory components of the hyomandibular nerve.

The geniculate ganglion (Plate 3, fig. 7, Plate 6, fig. 18, *gn. VII*.) lies closely applied to the cranial wall just outside the foramen (Plate 1, fig. 2, *for. VII*), through which the roots make their exit. It is a small ganglion, but one readily demonstrated by dissection. Fischer ('52) found it in all cases, but Watkinson (:06) states that in *Varanus VII* shows no swelling at the point where the ganglion should appear.

(1) *Ramus palatinus VII* (Plates 2-6, *pal.*). This is composed wholly of fine lightly medullated fibers of quite uniform character. This at least is the condition presented by the sections. The presence of *some* non-medullated fibers cannot be denied, however, in regard to any nerve described. The source of these medullated fibers of the palatine nerve is twofold: (1) from the cells of geniculate ganglion, and (2) from fibers carried in the communicating branch between the IX + X complex and nerve VII. The latter is known in lower groups of vertebrates as Jacobson's anastomosis, where it is homologized with the pretrematic ramus of IX and considered viscerosensory in character. It was pointed out by Cole ('98, p. 145) that many fishes show this communicating ramus as combined sympathetic and viscerosensory components derived from IX. This appears to be the condition in *Anolis*. The connection is by one or two fine strands (*conn. i.*), which lie close to the artery just outside the ear capsule (Plate 3, fig. 7). They come into the proximal part of the palatine ramus where some, if not all, of the medullated fibers of the communicating ramus join those of the palatine to be distributed with the latter. Other fibers, for the most part non-medullated,

apparently stop here, and a small group of sympathetic ganglion cells is found at the point of juncture of the two nerves. These facts support the conclusion that we have here a combined sympathetic and viscerosensory ramus.

The palatine ramus passes cephalad from the ganglion swinging in toward the median line (Plate 3, fig. 7). Its course is along the groove which marks the division between the proötic and the basioccipital (Plate 1, fig. 3). It passes into the sphenoid and crosses the base of its process dorsally, being carried in an imperfectly closed foramen (Plate 6, fig. 17, *pal*). The palatine passes into a narrow space of the sphenoid and out again on the median side to assume a position just underneath the mucous membrane median to the basiptergoid process of the sphenoid (Plate 5, fig. 15). In its course cephalad it keeps along the dorsal side of the pterygoid near its median border, gradually taking a more lateral position, to the point where it bears the ganglion palatinum (Plate 3, fig. 7, *gn. pal.*). Throughout this portion of its extent it gives off no fibers for distribution. It receives (or gives off) the anastomosing branch connecting with V by way of the ramus to the palpebral muscle (Plate 3, fig. 6, *dcp. palp. if.*, see p. 50). This does not change the character of the palatine in any recognizable way, and there are no ganglion cells in connection with this anastomosis.

*The ganglion palatinum* is a sympathetic ganglion, which appears on the main palatine ramus proximal to any terminal branches. It lies on the floor of the orbit ventral to the palpebralis muscle and marks the beginning of the infraorbital plexus between nerves V and VII. A small number of medullated fibers are given off laterally, the main bundle dividing again just distal to the ganglion. The ganglion cells are strongly grouped at the first division point and also extend along the lateral branch for a considerable distance (Plates 2, 3, figs. 4-6). From this point forward to the level of the ethmoidal ganglion the palatine components are carried in rami which anastomose more or less with each other and with the infraorbital ramus of nerve V.

*The infraorbital plexus* consists of a number of anastomosing branches spread out in the orbit on the dorsal side of the pterygoid and palatine bones, these branches connecting *rm. palatinus VII* with *maxillaris V* (infra orbital portion). The posterior (proximal) limits of this plexus are marked by the sympathetic ganglia of palatine VII and infraorbital V (Plates 2, 3, figs. 4, 6, 7, *gn. pal.* and *gn. if' orb.*). This plexus was studied both from series of sections and from dissections with a view to determining its constant features. The complete plexus was much better demonstrated by the latter method



(Plate 3, fig. 7), the plotting from sections (Plates 2, 3, figs. 4, 6) being incomplete. Notwithstanding great variation in detail, the scheme of the plexus seemed to be in the main the following:— (1) Taking the main palatine as a point of departure, all the rami have their origin from VII at one point, or nearly so. This is where the palatine ganglion lies, as described by several authors. The palatine here is a ramus of considerable size and immediately gives off two main branches. These come off separately, but close together, in the plotted series (Plate 2, 3, figs. 4, 6). In fig. 7, Plate 3, they both arise from the ganglion. One of these (*pal.*<sup>1</sup>) swings abruptly outward crossing ventral to the infraorbital ramus of V (Fig. 7). It innervates the mucous membrane and taste buds (*gm. gus.*) on the way. The other (*pal.*<sup>2</sup>) keeps a more median position until it crosses V to anastomose with the first (*pal.*<sup>1</sup>) to form the lateral branch of the palatine (*pal. l.*). (2) There is an anastomosis (*an'stm. pal. l.*) with V, from near this juncture, and sections always show ganglion cells at this point (Fig. 4, *cl. gn. sy.*). (3) There are always two or three branches (Fig. 7,  $\alpha$ ,  $\beta$ ,  $\gamma$ ) which turn back to join V just distal to the infraorbital ganglion, and their appearance indicates a large proportion of non-medullated fibers. (4) Anterior to the orbit there are anastomoses (a) that connect the intermediate branch of the palatine with the maxillary nerve just before the latter passes into the maxillary bone (Plate 2, 3, figs. 4, 6 and 7, *an'stm. pal. i'm*), and (b) that connect the median palatine ramus with ramus nasalis V through the ethmoidal ganglion. These anastomoses account for the mixed character of the lateral and intermediate rami of palatine VII.

*Terminal twigs given off from the infraorbital plexus.* Of more importance than the exact form of the anastomoses are the twigs for terminal distribution given off from the branches making up this plexus. In all cases the main course of the principal branches is explained by an examination of the mucous membrane of the roof of the mouth. All the rami carry viscerosensory fibers for the innervation of the taste buds. These sense organs are distributed within two restricted fields of the mucous membrane underlying the orbit, a small median area and a lateral one. The median group of taste buds (Plate 5, fig. 12, *gm. gus. m.*) is much more limited than the lateral group. Here the buds are within a sensory-glandular patch little more than a millimeter in length (between sections 732 and 874), which lies on the pterygoid. The position is approximately indicated in the figure of the skull by the foramen in the pterygoid bone (Plate 1, fig. 3, *for. pt.*). The innervation is from a twig (*gm. gus.*) of the median

palatine ramus (Plate 3, figs. 6, 7, *pal.*<sup>3</sup>), which passes through the foramen along with an artery and vein. The medullated fibers in this twig can not be followed farther in their distribution than the limits of this gustatory patch.

Anterior to the orbit the viscerosensory fibers are found in three rami, a median (*pal. m.*), an intermediate (*pal. i'm.*), and a lateral (*pal. l.*) ramus. All these rami carry a few coarser fibers not characteristic of the palatine proximal to its anastomoses. These are interpreted as cutaneous sensory from V.

(a) *Ramus medialis.* This is a continuation of the principal branch of the palatine (*pal.*<sup>3</sup>). At about the level of the ethmoidal ganglion (*gn. eth.*), or proximal to it, there is a division of the principal ramus (*pal.*<sup>3</sup>), which results in a branch passing laterad to help make up the intermediate ramus (Plates 2, 3, figs. 4, 6, 7), but the main branch is continued forward as the ramus medialis (*pal. m.*). In the dissection (Plate 3, fig. 7) this connection seems to be opposite the ganglion instead of proximal to it. A very small group of sympathetic ganglion cells is found at this junction. Another, shorter, branch connects the median ramus with the ethmoidal ganglion, thus forming an anastomosis with the nasalis. It would appear that this anastomosis serves the purpose of bringing the ethmoidal ganglion into connection with all the other rami. This connection of the median ramus with the ethmoidal ganglion has already been described (p. 54). Distal to this point the median ramus continues an uninterrupted course to the tip of the snout to innervate the mucous membrane of the premaxillary region. This is a glandular region richly supplied with taste buds. It is produced by the median union of the lateral glandular gustatory folds of the two sides. The course of the ramus medialis is just dorsal to the median edges of the palatine and vomer bones on either side of the interscapular nasal cartilage (Plate 4, figs. 8, 9). A short distance proximal to its distribution this ramus is joined beneath the cartilage with its fellow of the opposite side by a median group of sympathetic ganglion cells (Plate 2, fig. 4, *cl. gn. sy.*). Distal to this the united mediales continue forward for some distance as a common median bundle; this bundle, however, splits again near the region of its distribution.

(b) *Ramus intermedius (pal. i'm.).* This one of the terminal rami of the palatine is formed by the union of two branches lying dorsad of the palatine bone, one from maxillary V, just before its entrance into the infraorbital foramen, the other from the ramus medialis at, or proximal to, the ethmoidal ganglion. At all three of these junction

points sympathetic ganglion cells are to be found. When formed, the ramus is a mixed nerve containing some fine medullated viscerosensory fibers from the palatine VII, some coarser medullated fibers of the cutaneous type from the maxillary V, and likewise non-medullated sympathetic fibers. The distribution of the medullated fibers of this ramus (Plate 4, figs. 9-11) is along the median side of the glandular gustatory strip (Plate 4, fig. 9, *gm. gus. l.*), which begins at the angle of the mouth and extends to the anterior end of the upper jaw. Posterior to the distribution of this ramus the glandular band is narrower and is innervated wholly from the ramus lateralis (Figs. 10, 11); here however, it broadens. By the narrowing of the jaw the two rami (*r. lateralis* and *r. intermedius*) are brought closer together, until finally their terminal branches mingle (Plates 2, 3, figs. 4, 6; Plate 4, fig. 9).

(c) *Ramus lateralis (pal. l.)*. This, like the preceding, is a mixed ramus; but contains a larger proportion of cutaneous fibers. These are drawn off from the maxillary ramus at the anastomoses indicated in the plotting and dissection (*an'stm. pal. l.*). In the dissection (Plate 3, fig. 7) these anastomoses of the intermediate and lateral palatine branches with maxillary V are effected at the same point. The ramus lateralis passes cephalad along the median side of the maxillary bone and innervates taste buds and general epithelial surfaces (Plate 4, fig. 10). As described above, it has a terminal area of distribution which is common to it and to the intermediate ramus.

The relation between nerves V and VII, described here as the infra-orbital plexus, may be taken as representative of the group. About the only constant feature in the complex, however, is the palatine ganglion or the point corresponding to it. It is believed that this junction of V and VII would always disclose a ganglion if examined microscopically, and the apparent importance of this ganglion as a structural feature in Hatteria (Osawa, '98, p. 603, fig. 45) may be due to the fact that the cells are clustered instead of being scattered along the nerve. The latter condition is probably due to the position of the nerve, compressed as it is against the floor of the orbit. There is seen to be some evidence, from the character of the fibers in these anastomosing branches, to justify the acceptance, in a general way, of Fischer's ('52, p. 138, 139) distinction between a posterior and an anterior anastomosis, the posterior being a "sling" of the sympathetic system, while the anterior is a mixture of fibers from V and VII for distribution. Fischer did not recognize the sympathetic ganglia present in this region, but based his view on the proximity of the

connection between the superficial sympathetic trunk of the head and the infraorbital nerve.

(2) *Ramus hyomandibularis* (*hy-md.*). This nerve leaves the geniculate ganglion (Plates 2, 3, figs. 4, 6, 7, *gn. VII*) at its posterior end. It embraces visceromotor and viscerosensory components. In cross sections it is to be seen that these two components are entirely separate throughout their course, the motor fibers having the more dorsal position. The latter include all the motor elements of nerve VII; these pass from the root across the dorsal side of the geniculate ganglion, not penetrating it, and then turn sharply into the ramus hyomandibularis. The motor and sensory elements each take up about half the area of a cross section of the nerve, the sensory components being of course much finer in caliber than the others. The course of this ramus is dorsal and caudad, following the same projecting ledge of the proötic bone (Plate 1) as does the palatine, but in an opposite direction (Plate 3, fig. 7). This course leads it to a point just ventral to the articulation of the quadrate with the proötic process of the ear capsule (Plate 6, 7, figs. 19-20). Here occur the crossing and anastomoses of the head sympathetic trunk (*conn. ex.*) with the hyomandibular ramus of VII (Plate 3, fig. 7). The superficial sympathetic trunk (*conn. ex.*) from this point to the lachrymal plexus and infraorbital ganglion is called by Watkinson (:06, p. 464) "ramus recurrens nervi trigemini ad facialem"; its continuation to nerve IX, the "ramus communicans externus cum glossopharyngeo."

In a series of sections of *Anolis*, in which fixation in this region was excellent, it is shown with certainty that practically all the medullated fibers in this sympathetic ramus, which in every way resemble viscerosensory fibers, pass the facial nerve in continuous course. The facial, however, makes its way between the sympathetic fibers, most of which cross the facial nerve mesally; a few only split away from the others to cross it laterally, and then immediately rejoin the main bundle. This is not a sympathetic center of any importance, although from four to six very small ganglion cells are inclosed between the two nerves at the point of crossing. While there was no evidence that any of the fibers in the part of the sympathetic ramus between VII and V turned into any of the parts of VII at this point of union, there does seem to be a strong indication that some of the fine medullated fibers contained in the hyomandibular ramus of VII are continuous with a part of those in the posterior section of this sympathetic trunk, i. e., that between VII and IX.

Attention is here called to the fact that cutaneous fibers are not

demonstrable in VII and are not generally considered present in reptiles. They are, however, found in the Amphibia (Norris and others), and their distribution there would agree quite closely with the reptiles if it were discovered that a trace of the cutaneous component were carried to the skin in this sympathetic ramus, for the course of this ramus is superficial, and anteriorly it anastomoses freely with the cutaneous fibers of V. The conditions for study here were not such that a failure to observe this would preclude the possibility of a *very few* cutaneous fibers taking this course, should the central relations indicate a connection with the somatic sensory tract. The hyomandibular just distal to the crossing of the sympathetic divides into the motor ramus hyoideus and the sensory chorda tympani (Plate 7, figs. 20, 21, *hy.* and *cd. tym.*).

(a) *Ramus hyoideus (hy.)*. After parting with its sensory components, the motor part of the hyomandibularis continues its course to the muscles supplied by it. As this nerve reaches the depressor mandibular (digastric) muscle it divides into two branches for dorsal and ventral distribution (Plate 3, figs. 6, 7, *hy.*, and Plate 7, fig. 23). The final distribution of this nerve is well shown in figure J, which is a drawing from a mounted dissection that had previously been treated with vom Rath's mixtures. This shows that the digastric, sphincter colli, and the most posterior part of the mylo-hyoideus are innervated by ramus hyoideus (motor VII). This agrees with what Ruge ('97, p. 331) found in *Varanus*, although Watkinson (:06) was not able to discover it in her dissection.

Ruge ('97), in his extensive monograph on the facial nerve in the vertebrates, considers the mylo-hyoideus muscle in reptiles as belonging to the innervation field of motor VII, and he finds this demonstrable in *Hatteria* (p. 325), where the ventral ramus of VII is figured as extending almost to the end of the jaws. In the same form the ramus mylo-hyoideus of V leaves the jaw in the manner typical of that nerve, but Ruge considers it wholly cutaneous sensory. In the alligator the same muscle is innervated by the motor fibers carried in the ramus mylo-hyoideus of V, and Ruge (p. 381) concludes that V has received these "intracranially" from VII. Comparing with the amphibian *Amphiuma*, as described by Norris (:08), the motor components in ramus hyoideus VII of *Anolis* are directly homologous with the ramus jugularis of *Amphiuma*, which innervates the digastric, sphincter colli and posterior part of the mylo-hyoideus muscles, leaving the anterior part of the mylo-hyoideus to be innervated by the ventral division of the main mandibular, which is evidently the ramus mylo-hyoideus of V as described in *Anolis* (p. 61).

(b) *Chorda tympani* (*cd. tym.*). This nerve, which draws off all the sensory elements from the hyomandibular ramus (except possibly some which turn back into the sympathetic trunk), passes laterad on the roof of the middle ear chamber to reach the median face of the quadrate bone (Plate 3, fig. 7, *qd.*). In its course it passes dorsad of the ligament of the columella auris (Plate 3, fig. 7, *clml. aur.* and Plate 7, fig. 20, *lig. tym.*) and then follows the quadrate ventrally on the anterior side of the middle ear chamber (*aur. m.*). It at once enters the cavity of the articulare (Plate 6, fig. 18) through a special foramen. Its course is now cephalad within the jaw; but at some distance forward it passes out through the dorsal side of the articulare (or angulare) to take a position on the dorsal side of Meckel's cartilage, which is here exposed (Plate 5, figs. 14, 15). It keeps this position in its forward course until joined by mandibularis V, which comes down on to it from the dorsal side. It becomes included within the same perineurium with this mandibular ramus, gradually shifting around to the dorso-median side of it (Plate 5, fig. 13). At about the middle of the length of the jaw it is split off with a large somatic-sensory contingent and passes out of the foramen as previously (p. 59) described (Plates 2, 3; Plate 5, fig. 12).

The question of the homology of the chorda tympani in the different vertebrate groups has been recently discussed by Sheldon (:09) in a very thorough manner and it need only be added here that *Anolis* offers no obstacle to the conclusions there reached. My studies of *Anolis* embryos in connection with the present work show the chorda tympani to have a history similar to what it has in mammals (Emmel :04), in that it belongs to a posttrematic ramus which is drawn across the developing tympanum after it has established connections distally with the lower jaw.

Vershuys (:03) has recorded for *Lacerta* a development similar to that of *Anolis* and shows in an embryo with one open cleft that the chorda tympani passes posterior to the cleft to reach the lower jaw. He interprets the adult condition as due to the fact that the closing membrane of this cleft does not give rise to the adult tympanum, this structure being developed posterior to the chorda tympani nerve. Thus the latter is a true posttrematic ramus notwithstanding the evidence to the contrary which is presented in the adult.

In the adult *Anolis* the chorda tympani can be followed in the main to its terminal branches, and the close correspondence between these and the distribution of taste buds in the lower mouth region adds a new kind of evidence to support the conclusion that the chorda tympani is the nerve of taste for the tongue region.

Gaupp ('88) made a comparative study of the innervation of the mouth and nasal glands in vertebrates. Of the saurians he studied *Chamaeleo*, *Platydactylus*, and *Lacerta*. He also described the conditions in the other reptilian orders. His results for the lizards, briefly summarized, are as follows.

Superior labial glands innervated by maxillary V in the maxillary part, by the ophthalmic V (*nasalis*) in the premaxillary part, possibly by VII also. Median palatine glands by palatine VII exclusively. Lateral palatine glands by V and VII. Inferior labial glands by the terminal twigs from *ramus alveolaris inferior* V. Sublingual gland by lingual V and *chorda tympani* VII. Lingual glands same as sublingual. On the basis of innervation he homologizes the palatine glands of the lizard with the "Rachendrüse" (Born '76) of Amphibia, and the reptilian sublingual with the mammalian sublingual and submaxillary. In the nerve distribution described, Gaupp recognized the essential relations between V and VII in both upper and lower mouth wall that have been pointed out in *Anolis*. He does not take into account other structures associated with the glands, which might account for the presence of certain nerves in proximity to them; for example, the taste buds, which are universally present wherever glands occur within the mouth region (not including the labial glands). Nor does he recognize important visceral elements in the form of sympathetic fibers which are carried by all these nerves and whose relation to the glands is not well understood.

#### O. GLOSSOPHARYNGEAL NERVE.

Nerve IX is connected with the brain by two roots (Plates 2, 3, figs. 6, 7), a dorsal fine-fibered and a more ventral coarse-fibered root. Both roots appear at about the same point in the series of cross sections, which, because of the flexure of the medulla, would indicate a more posterior position for the ventral one. The dorsal root is composed wholly of fine fibers of the viscerosensory type. The ventral is presumably a motor root because the fibers are similar to the motor components of VII and may be traced directly through the ganglion and to its union with XII along with some of the fine fibers. The motor and sensory roots pass down separately to the closing membrane of the foramen, through which they emerge as a common trunk (Plate 6, fig. 19, *rx. IX*).

The central courses of these two components were partly made out from the series of cross sections. The *fasciculus solitarius* is a clearly

marked tract posterior to the sensory root of nerve VII and, as in the case of nerve X described below, the fine-fibered sensory root of IX passes directly to this tract. What is stated regarding the motor components of IX would apply equally well to nerve X.

The combined roots pass out of the cranium by way of the recessus scalae tympani between the ear capsule and the basoccipital bone. Versluis's ('98, p. 180) general statement applies to *Anolis* on this point: "Bei allen Lacertilia vera tritt demnach der Nervus glosso-pharyngeus nicht durch ein eigenes Loch in der Paukenhöhle, sondern durch eine grosse Oeffnung, welche die ältern Autoren meist Fenestra rotunda, die neuern Foramen jugulare externum genannt haben." The root passes caudad underneath the mucous membrane to its ganglion (Plate 7, figs. 20-23). This, the ganglion petrosum (*gn.* IX), as compared to the root ganglion of the vagus, has a much more distal position on its root (Plates 2, 3), and probably represents the trunk ganglion of X, inasmuch as there has been described in other forms a root ganglion in addition to the petrosum. This ganglion occupies the free space between the other organs on a level with the posterior edge of the ear capsule (Plate 7, fig. 23). Its form is that of a uniform oval, and it lies on the dorsomedian side of its fiber bundle, which it incompletely surrounds.

The coarse motor fibers may be traced directly through this bundle and out into the nerve trunk beyond. They have the most ventral position — that farthest removed from the ganglion cells — in their course through the ganglion. The other fibers seem to be non-medullated within the ganglion, but this appearance may be due to absence of impregnation by the osmic acid.

Between the ganglion of IX and the union of its main trunk with XII there are connections with X and with the sympathetic system. These vary in their position, as study of several series of sections has shown, although certain relations are quite constant. In the series plotted (Plates 2, 3) the anastomoses are relatively simple. The frontal projection (Plate 2, fig. 4) is the only one that shows them. These will be described first and the variations referred to later. A very small bundle of fibers from the vagus (Plate 3, fig. 7, *conn.* IX-X) enters the petrosal ganglion on its proximal side; these become entirely mingled with fibers of IX so that the two are not separable beyond the limits of the ganglion. When the bundle emerges from the ganglion as the main trunk of IX, it shows in cross section six or eight coarse motor fibers, which have been followed from the motor root above described; the rest are very fine fibers, but with sharply



staining medullary sheaths. These fibers are not placed compactly together and there is an appearance as though non-medullated fibers lay between them. The second connection of IX with other nerves occurs at the level of the distal end of the ganglion. Here the sympathetic, formed by the union of the "rami communicantes internus et externus IX et VII" (*conn. i.* and *conn. ex.*), joins the bundle of IX on its ventral side and, after contact and some mingling of fibers for the distance of 1/10 mm. becomes free again (Plates 2 and 3, figs. 4, 7). (In dissections, no distinction can be made between the actual mingling of fibers and inclosure within a common sheath). This connection apparently has no relation to the ganglion, for it occurs on the ventral side of the ganglion at a point where the most distal ganglion cells occupy only the dorsal side. After this contact the nerve shows no more connections up to its union with the superior laryngeal X.

The variability in these connections is further emphasized when figure *K* is compared with figs. 4-7, Plates 2, 3. In the former the first named connection is absent and the second is accomplished by means of a small ramus joining the sympathetic trunk.

## P. VAGUS NERVE.

The central connections of the vagus nerve were less fully determined than those of the other nerves, owing to the fact that the roots are extremely small and the few fibers which each contains do not keep together within the brain but separate into even smaller bundles or single fibers. There is also some variation as to the number of roots that could be identified peripherally. There is considerable shifting of central nuclei in the sharp flexure of the hind brain, making it impossible to determine conclusively the origin of efferent fibers from particular cell groups without the aid of the Golgi, or some similar method.

*Roots of the vagus.* In series 30 (Plates 2, 3, figs. 4-6) the vagus enters the jugular foramen as three roots (*cf.* Fig. *K*). Two of these appear in Plate 7, fig. 20 (*rx. X*); to avoid confusion of lines, the plottings show only one root for each component. Of the three, the posterior one contains the deeply staining motor roots; the fibers in the other two do not appear to be of uniform character. The middle root is the smallest. The posterior root has its superficial origin along

the lateral surface of the medulla a few sections anterior to the foramen. Its fibers enter the brain at a sharp upward angle. The coarser fibers of the posterior root remain together and may be traced as they pass mesad in a broad upward curve to become spread out in the midst of a group of cells lying a little dorsal and lateral to the fasciculus solitarius. The more lightly medullated components of this root could be found making continuous connection with the fasciculus solitarius, into which they abruptly turn. The other two roots enter the brain along the same line as the posterior one. The smaller one could not be followed, but the larger could be traced to the fasciculus solitarius. It also contained several coarse fibers, which take the same direction as those of like character in the posterior root. The three roots remain separate until they enter the jugular ganglion.

The *ganglion jugulare*, or root ganglion of the vagus (Plates 2, 3, figs. 4, 5, 6, *gn. rx. X*), Plates 3, 7, figs. 7, 22, *gn. X*), lies closely crowded into the angle formed between the otic capsule and the basioccipital where the jugular foramen opens. This foramen appears in the same transverse section as the first occipital foramen of XII (Plate 7, fig. 20). The ganglion which is larger than that of IX or VII, is triangular in transverse sections of the head (Fig. 22, *gn. X*). This form is the result of the pressure of surrounding structures, the ganglion being crowded against the otic capsule by the spinalis colli muscle (Plate 7, fig. 22, *spi. coll.*). The form of the ganglion as a whole is notable, owing to the fact that the ganglion cells are so grouped on the mesial side of the fiber bundle that in dissections (Plate 3, fig. 7) the ganglion appears to lie free along the root bundles for a short distance.

The fibers entering the ganglion as separate roots emerge on its distal side as one bundle, the coarse motor fibers, about sixteen in number, being grouped in its dorsal portion. This bundle (*X*) passes caudad parallel with IX and XII (Plates 2 and 3). On its way it shows the small ramus connecting it with IX (Plates 2 and 3, figs. 4, 7, *conn. IX-X*). Posterior to the ganglion of IX, the trunk of the vagus divides into a *superior laryngeal* ramus and a *visceral* ramus (*esc. X.*). The superior laryngeal ramus soon joins the pharyngeal ramus of IX to form the pharyngo-laryngeal ramus of IX + X (Plate 2, fig. 4, *phx-lar.*). This then combines with the trunk of XII (fig. 7) to reach the ventral side of the pharynx. (*cf.* fig. *K*).

(a) *Ramus laryngeus superior (lar. su.)*. This division of the vagus includes all the coarse fibers of the main trunk and about one half

the fine fibers. It forms a bundle about two thirds the diameter of the main trunk of IX, which it joins to form the pharyngo-laryngeal nerve (fig. *K*, Plate 2, fig. 4, *pha-lar.*). From this ramus are given off several small twigs to the constrictor muscle of the jugular vein (p. 44). These are fibers somewhat larger than the viscerosensory fibers, but with extremely delicate myelin sheaths, and for this reason they were not discovered in the series of sections plotted; but in another series through this region (Fig. *K*), especially fixed, the innervation of these muscle fibers was determined. Of the three twigs shown in the drawing only one is given off from the superior laryngeus before its union with the ramus pharyngeus IX.

It is important to note that these visceral muscle fibers (Plate 7, fig. 23, *co'st. vn. j.i.*), although striated, do not draw off any of the coarse fibers from the vagus, but are supplied by nerve fibers which are indistinguishable from the other fine fibers when mingled with them, but which nevertheless possess slight differences, as is shown when they are grouped together. We probably have in the innervation of this muscle a case analogous to that of the ciliary muscle, which primarily is non-striated, but in the sauropsida is striated. If the striated muscle fibers surrounding the jugular vein have been differentiated from the smooth muscle cells of the vessel wall, which are believed to be innervated by non-medullated postganglionic neurons, the question suggests itself as to what modification of the innervation has accompanied that of the musculature. As before stated the nerve fibers show a slight medullation indicating to that extent a change from the sympathetic type, but their continued course through the ganglion, suggesting direct central origin, was not shown in the sections although this was clearly demonstrated for the more heavily medullated fibers passing into the pharyngo-laryngeal branch. Onuf and Collins (:00, p. 174) describe two nuclei for efferent neurons of nerves IX and X in the mammals (cat). The dorsal glossopharyngeal and vagus nucleus, is, according to them, the nucleus of origin for the efferent sympathetic fibers carried in the roots of these nerves; the ventral, nucleus ambiguus, gives rise to the nerve fibers innervating muscles of visceral origin but of somatic function, derivatives of the striated gill-arch musculature of the fishes. The spinal accessory nerve, when present, is exclusively of the latter type. The innervation of the special jugular vein muscle of *Anolis* suggests a condition intermediate between the sympathetic and the visceromotor of the cerebro-spinal type. The slight development of this latter component in nerves IX and X made it impossible to establish this suggestion as a fact through the analysis of the central terminations.

Bruner (:07, p. 47) gives quite a detailed description of the innervation of the striated muscle of the jugular vein in reptiles. He finds this muscle in *Lacerta agilis* to be innervated by a number of nerve twigs which are given off from the rami communicantes internus et externus. The latter join the proximal end of the petrosal ganglion, of nerve IX, which, in addition to its root is also joined by a communicating ramus from ganglion X. Bruner applied stimulation methods at various points in this nerve complex and thus determined the path of the motor fibers to the "m. constrictor venae jugularis internae" to be from the brain through the roots and root ganglion of nerve X, across to the petrosal ganglion through the communicating ramus between IX and X, and then cephalad along the rami communicantes internus and externus to points where the "nervi tumefactores capitis" are given off to the adjacent muscle surrounding the jugular vein. According to Bruner the function of this musculo-nervous mechanism is to contribute to the swelling of the cephalic veins and sinuses of the head by blocking the return of blood through the internal jugular vein. In *Anolis* (Fig. K) these "tumefactor" nerves show closest anatomical relations to nerve X, the indirect course described by Bruner being unnecessary because here the constrictor muscle lies relatively more caudad than in *Lacerta*. Notwithstanding the fact that these nerves are given off elsewhere, the ramus communicans X et IX occurs quite constantly (see Plates 2, 3, absent Fig. K). It is possible, then, that this communicating ramus is an efferent sympathetic path not exclusively related to the constrictor muscles of the jugular vein.

After the union of the superior laryngeal ramus of X with that of pharyngeal IX the combined nerve (*phx-lar.*) joins XII in its course to the ventral side of the pharynx. Beyond this point not all the components of IX and X can be followed and accounted for positively in their distribution. It seems certain, however, that the laryngeal branch (*phx-lar.*), the first given off from XII after it reaches the ventral side (figs. 5, 6), represents a large portion of this nerve, although its smaller size establishes the fact that the trunk of XII still carries some of the fine fibers. By using fine needles in dissection this laryngeal ramus can be split away from the main trunk of XII and thus it may be demonstrated to represent the larger part of ramus pharyngolaryngeus, whose union with XII is mentioned above.

## 1. RELATIONS BETWEEN NERVES IX AND X.

Preceding an account of the terminal rami of IX and X, a generalized summary of the relations of roots and main trunks of these two

nerves will be given. It is based on the details of this nerve complex as worked out in six cases, and gives the features common to all.

There is much variation in the details of the connection between nerves IX and X. Without reference, for the time being, to the anastomoses of uncertain significance, the essential features of the two nerves may be stated as follows:

(a) Nerves IX and X arise each by several separate roots, at least one root of each nerve being motor. The component character of each nerve appears to be the same, although X exceeds IX in the number of both its sensory and motor components. The ganglion of IX (Plates 2, 7, figs. 4, 23) lies some distance from the brain, as already stated, and probably is not strictly homologous with the ganglion of X, the jugular, which is just outside the foramen.

(b) The coarser motor fibers in each case are readily seen to pass through their respective ganglia.

(c) There is a postganglionic division of each nerve which results in each case in two bundles; a bundle of mixed coarse and fine fibers and a bundle composed exclusively of fine fibers.

(d) The *mixed* bundles come together (as pharyngo-laryngeal branch) and then join XII for distribution on the floor of the pharynx.

(e) The *fine fibered* bundle of IX is very small and joins the sympathetic trunk, from which it *may* later separate, along with sympathetic elements, to reach palatine VII.

(f) The purely sensory bundle of X is a large one, and passes caudad to its trunk ganglion, ganglion nodosum (*gn. nd.*); it then divides (Fig. L) to form the ramus recurrens X and the ramus visceralis distributed to the lungs, heart and alimentary canal.

(g) In all cases studied except one IX and X show an anastomosing ramus (Fig. 4, *conn. IX-X*) which connects a preganglionic point of IX with a postganglionic point of X. The one exception is shown in Figure K, already referred to, where there is no connection whatever between IX and X proximal to the union of the pharyngeal and laryngeal rami.

## 2. A VESTIGIAL DORSAL GANGLION ON THE ROOTS OF THE VAGUS.

There was found in several cases in *Anolis* a very small group of ganglion cells situated on the dorsal side of one of the roots of nerve X. Such ganglia were studied in three cases. In two cases they were situated upon the largest, most posterior root, which carries the motor fibers. In the third case the ganglion, being smaller than in the others, consisted of only three or four cells located on the small middle root.

In no case observed did there occur more than one group of such ganglion cells upon the several roots of the same vagus nerve. No such ganglia were found upon IX. The size of these cells shows them to be of the cerebro-spinal rather than the sympathetic kind. This fact is brought out by comparing them with cells of the geniculate ganglion, and also with those of the spinal ganglion, and contrasting these with the sympathetic cells found at the base of the palatine.

Embryological studies by various investigators have demonstrated for both reptiles and mammals transitory root ganglia in this region. These are generally interpreted as the remnants of the lost dorsal roots between the first spinal ganglion and the vagus. Van Wijhe ('86) and Chiarugi ('89) considered these ganglia as contributing permanently to the accessorius part of the vagus. Fürbringer ('97, p. 502) recognizes the existence of these ganglia in Sauropsida, but states that they later disappear entirely and have nothing to do with the vago-accessorius. In mammals such rudimentary ganglia have been noted in the embryo of the pig (Lewis, :03) and in man (Streeter, :04). In the Amphibia IX, X, and sometimes VII, possess cutaneous components. In mammals these are reduced to a small bundle, which proceeds from the jugular ganglion as the ramus auricularis, and small clumps of cells may remain among the vagus roots even in the adult, an indication of the more extensive existence of this cutaneous component.

In *Anolis* no cutaneous fibers were discovered in any of the nerves between V and the third spinal; unless these rudimentary vagus ganglia be ascribed to the cutaneous components, all traces of these components have been lost in these segments. In the whole group of reptiles this absence of cutaneous rami appears to prevail, as no mention of such nerves is made by any author. If this is the case, the reptiles stand alone in the extent to which this component has been lost. The birds, however, need investigation on this as well as on other points. Cords (:04) has described in birds a cutaneous sensory branch of VII going to the lining of the external auditory meatus, to which she gave the name "ramus auricularis," the same term that is applied to a nerve of similar component character in mammals, but derived from X. If microscopic study should verify Cords's observation, we should have in birds the persistence in VII of a component which is absent from this nerve in practically all other forms above fishes; but the same component would in birds be absent from a nerve (X) which possesses it in all vertebrates except the Sauropsida. It is important in this connection to note

that Cords describes a root ganglion, "ganglion jugulare," for IX in addition to the petrosal ganglion. When this appears in a rudimentary form it is called a somatic sensory structure. If it is large enough to be discovered by dissection methods, one might look for a cutaneous ramus associated with it. Is it possible that Cords's ramus auricularis VII has any relation to her "ganglion jugulare" IX?

The value of Fischer's ('52) work lies in the range of his material, which justifies certain deductions, the validity of which might be arrived at directly by microscopic study. For comparison with *Anolis* some of the more important statements made by Fischer may be considered. This author does not find a root ganglion on IX, although the petrosal ganglion is to be recognized in practically all cases. This ganglion is united with nerve X and joined by rami of larger or smaller size, the union with the latter is generally on the proximal end of the ganglion through the combined rami *communicantes internus et externus IX ad VII*. In *Platydactylus*, however, the external sympathetic ramus does not join the internal; this leaves, then, only the connection to palatine VII known as Jacobson's anastomosis and consequently no apparent connection with the sympathetic system. In another form (*Varanus bengalensis*) the reverse is true, the internal communicating ramus passes IX to join the main sympathetic trunk farther distad. A Jacobson's anastomosis in this case would have to go by way of the external ramus. In this form also no ganglion petrosum was discoverable, although it is very large in another species (*Varanus niloticus*) of the same genus. Neither Watkinson (:06) nor Osawa ('98) discovered with certainty the petrosal ganglion. This would indicate either a scattered condition of the ganglionic cells along the trunk, or a less developed viscerosensory component in *Varanus* and *Hatteria* than exists in the case of *Anolis*, in which, though a smaller animal, it was demonstrable by dissection methods. The failure to find the ganglion by this method would not indicate its entire absence.

The union of IX and X also shows considerable variation, as does likewise the union of these two, combined or separately, with the main trunk of the hypoglossal. In comparing with all the forms hitherto described, *Anolis* may be put down as typical in the combination of the main pharyngeal branches of IX, X, and XII into a common trunk, which later separates; but as this union has no significance other than as a common path around the pharynx, it is modified wherever there is much variation in shape of head and relative position of parts innervated. In a few cases XII is wholly free, and in

others IX is independent of both X and XII; these conditions have significance in determining the probable source of the terminal branches in such a form as *Anolis*, where these branches cannot be followed back through the combined trunk; they will be referred to again in the account of the terminal distribution of IX and X. Since nerve X is larger than IX in all the forms described, its ganglia have been more regularly found than those of IX. The trunk ganglion of X (*gn. nd.*) is a more constant feature than its root ganglion (*gn. rx. X*, *gn. X*), having been described for all species hitherto studied. On the other hand, the root ganglion, such as is found in *Anolis*, has been definitely identified as an independent ganglion in only three forms.

### 3. TERMINAL DISTRIBUTION OF NERVES IX AND X.

From the foregoing account it is seen that all the components of IX and X (excepting the rami to the jugular vein) are distributed peripherally from three rami. (1) Jacobson's anastomosis, carrying viscerosensory fibers to VII; (2) Pharyngo-laryngeal, carrying the superior laryngeal branch of X and the pharyngeal branch of IX, both of which include viscerosensory and visceromotor fibers; (3) ramus visceralis, carrying viscerosensory fibers of X. To what extent efferent sympathetic fibers may be carried in any of these rami could not be determined.

(1) *Jacobson's anastomosis*. This term is here used for the communicating ramus (*comm. i.*) between IX and VII, which joins the base of the ramus palatinus. As the term is generally employed it is restricted to a connection between these points, which carries a viscerosensory palatine branch from IX to be distributed with palatine VII, and also innervates the mucous surfaces caudad to VII. Because of the development of the sympathetic system of the head, the main trunk of which takes this course, it is difficult to determine to what extent this is a true viscerosensory branch. In *Anolis* two points on VII are connected with IX, usually at the distal end of the petrosal ganglion. This connection is often so slight that it is lost sight of in the more evident fact of the direct passage of this sympathetic bundle caudad to its ganglion. It is always large enough, however, to give rise to all the medullated fibers contained in the internal communicating branch, which is the one having the position of Jacobson's anastomosis. Whether it *does* give rise to them cannot be stated. It can be stated that if Jacobson's anastomosis (as restricted) exists in *Anolis*, it contains very few viscerosensory elements.



A comparison with other reptiles would seem to warrant the broadening of this statement to a general one applicable to reptiles as a group. There are found in practically all forms of reptiles these two sympathetic rami named by Fischer ('52, p. 30) "ramus communicans internus rami palatini cum glossopharyngeo" and "ramus communicans externus nervi facialis cum glossopharyngeo." The first of these, which would have the position of Jacobson's anastomosis, Fischer (p. 30) refers to as one of the finest nerves in saurian anatomy, which could be identified only with great difficulty; at the same time he adds that it belongs to "den beständigsten Nerven," and for this reason must be considered essential to the plan of the saurian nervous system. Fischer, however, showed one case, before referred to (p. 79), where this internal ramus makes no connection with IX, which supports the view that it is principally a sympathetic ramus from the deeper part of the head to the common cervical trunk.

Bender (:06, p. 388) gives to this connection both a sympathetic and viscerosensory function in *Chelonia*, and states that the petrosal ganglion is closely bound up with a ganglion of the sympathetic. In *Anolis* no sympathetic cells were recognized, nor did the petrosal ganglion show any division. Cords (:04, p. 79) also specifically states that, in the goose, this anastomosing branch from IX to VII is composed of fibers from IX and from the sympathetic ganglion.

(2) *Ramus pharyngo-laryngeus* (*phx-lar'*). This nerve is given off from the main trunk of XII, in which it is temporarily carried, at about the posterior end of the genioglossus muscle. Its course is cephalad and mesad between the genioglossus and the cerato-hyoideus to the trachea posterior to the larynx. As it leaves XII its composition is almost identical with that of the combined IX and X pharyngeal rami before they join XII, although it is somewhat smaller. There are about 20 coarse fibers mingled with the fine ones. In its course across the m. cerato-hyoideus it loses about half of the larger fibers, so that it is found to contain about eight or ten of these fibers distal to its course across that muscle. The remaining coarse fibers supply the muscles of the larynx, the fine fibres being sensory. When the nerve has reached a position just beneath the mucous membrane (Plate 5, fig. 13), some very fine fibered branches are given off from the main trunk (not shown in the figure). They are so twisted about the blood vessels that their final distribution, whether to the epithelium or elsewhere, was not demonstrable. A small ganglion at the base of the fine fibered ramus indicates that a part of the fibers are of sympathetic character.

The main trunk passes forward, giving off two more branches to the mucous membrane (Plate 2, fig. 5) before turning abruptly across the ventral floor of the larynx to form an H-shaped anastomosis with the same nerve of the opposite side (Plate 2, fig. 5, *an'stm. lar.*). The chiasma is not a complete one; hence each muscle of the larynx is stimulated through motor fibers from both sides of the brain.

The muscles of the larynx consist of an outer longitudinal (dilator) and an inner transverse (constrictor) pair, (Plate 4, fig. 11, *lar. lg.* and *co'st. lar.*). They are innervated exclusively from the coarse fibered elements carried in the pharyngo-laryngeus IX and X. Attention is called to the fact that this motor innervation may be from IX, from X, or from both. There is no possibility of determining in *Anolis*, except experimentally, which nerve has given up its fibers to the cerato-hyoideus muscle. If dissections may be trusted on this point, the condition as described by Watkinson (:06) in *Varanus* would support the view that the fibers innervating the cerato-hyoideus (hyoglossus) muscle are from IX. In *Varanus* IX does not anastomose with XII and does not appear to combine with X in a manner corresponding to the condition in *Anolis*. In the former the nerve described as IX innervates the cerato-hyoideus muscle as it crosses the ventral face of that muscle. There are more proximal anastomoses, however, making possible some combination of the fibers of IX and X as in *Anolis*; so, in the absence of microscopic observation, any conclusion must be tentative.

The laryngeal anastomosis is quite generally mentioned where the innervation of this region is described in higher vertebrates. The ramus recurrens X is usually described as entering into this "sling" and joining in the motor innervation. In *Anolis*, however, the ramus recurrens takes no part in the sling, although the terminal ramus of this nerve passes through the longitudinal laryngeal muscle (Plate 2, Fig. 5, *lar. lg.*) to reach the dorsal free edge of the laryngeal cartilage, where its fibers may be seen turning in to innervate the epithelium of the larynx (Plate 2, fig. 5, *rer. X*).

(3) *Ramus visceralis (vsc. X)*. This is the name given the main trunk of the vagus after the superior laryngeal nerve is given off. It is a fine-fibered bundle, which closely resembles the main sympathetic, with which it has a parallel course across the dorsal side of the thymus gland. It bears the large trunk ganglion (*gn. nd.*) in its course and then gives off to the mucous membrane sensory branches, which correspond to the posterior laryngeal, and also the ramus recurrens X. In the series plotted the sections are not carried

back far enough to reach the trunk ganglion. This was done in another series. The best demonstration however, of the course of the vagus to show the trunk ganglion and the postganglionic branches was furnished by a dissection of this region mounted in balsam. As these structures lie underneath all muscles, it was possible to remove the floor of the pharynx in this region and pin it out on cork and then fix it in Vom Rath's fluid. The preparation, which consisted of the mucous membrane, the blood vessels and the nerve trunk with all the branches to the mucous membrane, was cleared and mounted on a glass slide giving a diagrammatic picture of the distribution of the nerves. A drawing (Fig. L) of a portion of such a preparation is given

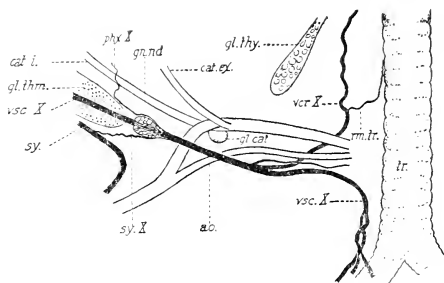

FIG. L.—Camera drawing of a portion of a dissection to show trunk ganglion of the vagus and the relation of ramus recurrens to the arterial arches. This is part of a preparation made in the same manner as that showing distribution of motor VII (figure J). For *ver. X*, read *rer. X*.

to supplement the plotting. It will be seen that no branches are given off proximal to the ganglion, which lies just clear of the thymus gland at its posterior end. The ganglion itself is a pear-shaped structure through the center of which there is a distinct fiber path. At its distal end two very fine rami are given off, one (*phx. X*) mesally, to the pharynx wall, the other (*sy. X*) to the main sympathetic trunk. The vagus nerve crosses the arterial arches on their ventral side and reaches a position alongside the trachea just cephalad of the bronchial division. As it nears the median line the ramus recurrens laryngis (*rer. X*) is given off. It crosses the arterial arches on their dorsal side thus forming the loop. The posterior ramus visceralis proper was not followed farther than is shown in this preparation. Its branches

almost immediately and the lungs are very richly supplied. The branches to the heart did not appear.

*Ramus recurrens laryngis X* (Plate 2, fig. 5; *rer. X*). The course of this ramus is directly cephalad to the larynx, following along the lateral side of trachea to reach it. Numerous very fine branches are given off in its course (not shown in Plate 2, fig. 5). Reaching the larynx this nerve breaks up, first dividing into the two main terminal divisions shown in the figure. One of these lies on the dorso-lateral side of the larynx and passes through a portion of the longitudinal muscle to reach a more anterior position, where it innervates the *mucous membrane* just posterior to the glottis. The other branch, the more median one in the figure, innervates the mucous membrane of the ventro-lateral part of the larynx. The first branch in its passage through the muscle becomes closely involved in the motor complex, and is separable from it only through the study of sections. If it contributes motor fibers to this, it is only very slightly, and my belief is that in *Anolis* the ramus recurrens is wholly sensory. Section 659 (Plate 4, fig. 11) is anterior to the main branches so that no part of the recurrent ramus appears. Some motor twigs are shown in the muscle.

More data are needed to homologize the branches of nerves IX and X with those of Amphibia. In the latter the ramus recurrens X innervates the *muscles* of the larynx (Coghill, :02, p. 245; Norris, :08, p. 552).

Through comparative anatomy Fischer arrived at conclusions which conform with the facts as stated for *Anolis*. He found the intimate mingling of the terminal twigs of the ramus recurrens X and the pharyngo-laryngeus, so generally described in other forms, to be absent in two cases, so that the distribution of the two nerves was distinct, and in these cases the recurrent ramus is held to be sensory, not motor. "In den Fällen, wo der R. recurrens sich nicht mit jenem [pharyngo-laryngeus] verbindet (*Varanus Bengalensis*, *Platydictylus guttatus*) geht dieser [r. recurrens] nicht in die Muskeln, sondern an die Schleimhäute des Kehlkopfes" (Fischer '52, p. 48). But Watkinson (:06, p. 467) for another species of *Varanus* states that the united fibers of the ramus recurrens X and the terminal branches of IX are distributed to the *muscles* of the larynx. Her observation was not properly supported, however, in regard to either point, as in her species (1) nerve IX previously received fibers from X, as in *Anolis*, and (2) a mere union of rami as demonstrated in dissection does not in itself prove similarity of distribution.

By the same comparative method Fischer ('52, p. 49) established the innervation of the cerato-hyoideus from IX and the laryngeal muscles from X. For in two cases (*Euprepes sebae* and *Lacerta ocellata*) IX was found to be free from X, and in these cases its distribution was to the cerato-hyoideus muscle and to the pharynx wall anterior to the larynx. Nerve X in these cases is a pure superior laryngeal and goes to muscles and mucous surfaces of the larynx (i. e. is of mixed nature, carrying both motor and sensory fibers). This gives ground for the view that a like condition exists in those forms where it cannot be actually demonstrated.

Van Bemmelen ('89) considers Fischer's work open to criticism in this particular connection because he did not establish the homology of the rami by means of their relation to the aortic arches. Both Van Bemmelen and, more recently, Göppert ('99) contradict Fischer's conclusions regarding the sensory nature of ramus recurrens X. Göppert, in an article which deals comparatively with the larynx region in Amphibia and reptiles, concludes with this statement (p. 23): "Bei allen Reptilien haben wir also Berechtigung zu der Annahme, dass der Recurrens bis zum Kehlkopf gelangt, trotz des oft weiten, von ihm zurückzulegenden Weges. Dass er dann aber überall die Kehlkopfmuskulatur versorgt, wird keinem Zweifel unterliegen können, nachdem er sich für die Lactertier direkt erweisen liess." These differences of opinion cannot be attributed to the study of different reptiles, for Göppert makes use of the same genus (*Platydyactylus*) as that employed by Fischer.

The present results in *Anolis*, then, do not clear away the uncertainties of the general question of larynx innervation; they tend, however, to suggest the probability that both the superior laryngeal and the recurrent branch may carry motor fibers, these showing different proportions in the rami of different forms.

#### Q. SPINAL ACCESSORY NERVE.

A spinal accessory nerve was not discovered in *Anolis*. In all the described reptiles a portion of the vago-glossopharyngeal components are grouped as nerve XI, or spinal accessory. Peripherally there are generally two anatomical conditions which warrant this interpretation: (a) the caudad extension of the vagus series of roots beyond the limits of the cranium, and (b) the distribution of a motor ramus from the vagus (distal to the ganglion) to certain of the muscles of the shoulder girdle. Both these features are absent in *Anolis*.

By examination into the component character and central relations of this nerve, where it exists, it is found to be similar to those visceromotor components of X and IX which innervate striated muscles (Johnston, '06, p. 203), such as the laryngeal muscles. These all have their cells of origin (in the higher vertebrates at least) in a portion of the visceromotor column ventrally separated from the rest and known as the nucleus ambiguus. While the motor nuclei of this region of the hind brain have been incompletely identified in *Anolis*, microscopic study has fully demonstrated that IX and X contain a very limited number of components such as innervate the laryngeal muscles and that these *all* pass ventrally with XII, which gives off no branches that cannot be directly traced to muscles of the ventral head region.

It still remains to be demonstrated whether there is a caudally extended motor nucleus ambiguus which contributes fibers to the spinal nerves innervating the muscles originally supplied by the accessorius. In the absence of such a relation, it would then be a question whether the trapezius muscle in *Anolis* is homologous to the one so named elsewhere.

The apparent absence in *Anolis* of anything corresponding to the spinal accessory is an anomalous condition in reptiles, because, even making allowance for many misinterpretations depending on gross dissections, the universal mention of such a nerve in the literature bearing on reptilian anatomy would indicate a greater development of the vago-accessorius group than is shown in *Anolis*. Fischer ('52, p. 62) finds that the condition first described by Bischoff ('32) is realized in all the forms he studied, viz. that from 5 to 9 fine bundles, generally increasing in strength posteriorly, arise along an irregular line extending from the level of the second cervical nerve to the origin of the vagus. All these root bundles assemble into one trunk, which generally fuses with the vagus. In two species of the genus *Salvator*, however, this trunk remains separate, although it passes out through the same foramen with the vagus. This independent course of the accessorius was also described by Bendz ('43) for *Chelonia mydas*. What Fischer calls the accessorius includes, in addition to the ramus externus, fibers which have a distribution with the laryngeal branch of the vagus, or with the ramus recurrens vagi, or with both. The ramus externus, which by gross methods is the only portion of the accessorius that can be followed to its distribution, was not found by him in all forms. It was absent in *Chamaeleo vulgaris* and *Agama spinosa*. No mention was made as to whether there was a correlated

reduction of the posterior roots; if such a reduction occurred in these two species, they would be in correspondence with *Anolis*. Fischer demonstrated the ramus externus definitely in nine other species of lizards and in the crocodile. Bischoff ('32) and Vogt ('39) had described this ramus externus as supplying a small twig to the cervical muscle, but this could not be expected, and was not verified by Fischer.

Fürbringer ('76, p. 649) in his account of the innervation of the shoulder muscles of saurians refers to the part taken in their innervation by the vago-accessorius as though it were a regular feature to be met with in all forms. The ramus externus is distributed, he says, to the ventral half of the capiti-cleido-episternalis (capiti-dorso-clavicularis), where it as a rule anastomoses with the cervical plexus of the anterior spinal nerves.

More recently Osawa ('98, p. 616) has described in *Hatteria* a spinal accessory having the typical superficial origin, which extends caudally as far as the third spinal nerve. This accessory joins X, and distal to the ganglion there is given off a weak ramus internus and a strong ramus externus, the latter going to innervate the muscle capiti-dorso-clavicularis. Schauinsland's (:03, Taf. VIII, fig. 70) observation on the embryo of the same form practically coincides with Osawa's description.

There appears to be some confusion in Watkinson's (:06) account of this nerve in *Varanus*. She says (p. 467) "the ramus externus vagi innervates the muscle sterno-cleido-hyoideus near its origin from the skull. This muscle also receiving innervation from the third cervical nerve, the end fibers forming an intricate sling with those of the ramus externus." Reference to her Plate XII, figs. 10 and 11, shows that the author means "m. capiti-cleido-episternalis." Another ambiguity rests in the use of the term "m. cucullaris" (Plate XII, fig. VIII) for the most superficial neck muscle. This evidently corresponds to the sphincter colli of *Anolis* and, like the latter, is innervated by VII.

Notwithstanding the great number of papers that have appeared on the morphology of the nervus accessorius, the subject is far from settled, and, in view of the great range of variation in the anatomical relations of roots and peripheral nerves, the necessity of microscopical analysis is obvious. Lubosch's ('98 and '99) extensive review of the subject in vertebrates from the standpoint of comparative anatomy only tends to emphasize the fragmentary nature of our knowledge regarding this region in amniotes.

## R. HYPOGLOSSAL NERVE.

The twelfth cranial nerve is well developed in *Anolis*, in correlation with the condition of the tongue and especially with its muscular tongue papillae. It arises from three distinct roots and, with the exception of the brief union with the pharyngo-laryngeal ramus of IX and X, takes an independent course to the tongue, where the greater part of its fibers are distributed to the intrinsic musculature. A few small bundles are given off to the cerato-mandibularis group as it crosses these muscles. Not all the hypoglossal nerve is distributed to the ventral region, a part of the last (third) root retaining the dorsal and lateral rami of the spinal nerve from which it phylogenetically has arisen. These go to the cervical muscles.

*Roots of the hypoglossal.* Although nerve XII is a combination of roots which emerge from the cranium through three separate foramina, there is no separation of root bundles at their origin into three groups. They form a continuous series along the somatic motor line, and a comparison shows that they may be differently combined to emerge from the cranium. There is, however, one feature which is constant, viz., the presence of a *cervical* part on the last root of the series, which is marked off from the *hypoglossal* part by a difference in the size of its fibers, thus showing a correlation between its functions (as indicated by its distribution) and the structure of its fibers. Special series of sections prepared for the purpose of tracing these differences to central nuclei have thus far failed, owing to the difficulty of carrying them through the meninges of the brain. Where the root bundles pass through the foramina the fibers are well preserved and here the two kinds of fibers are distinctly segregated and were easily followed into their respective rami.

*Distribution of the cervical part* (Plates 2, 3, figs. 4-6). The cervical part is made up of larger fibers than those forming the hypoglossal nerve proper. They equal in caliber the motor components of the first and second spinal nerves, and their distribution is similar. The hypoglossal bundle in the posterior root of XII is in every way like the other roots of this nerve which join it to form the main hypoglossal trunk. The cervical portion, having a dorsal position in the common root as it emerges from the foramen, divides at once into a lateral (*err. l. XII*) and a dorsal (*err. d. XII*) ramus. The lateral ramus is the larger and is distributed to the spinalis colli muscle (Plate 7, fig. 23, *spi. coll.*). The dorsal ramus passes caudad on the



dorsal side of this muscle to join the dorsal ramus of the first spinal nerve, with which its terminal fibers become mingled (Plate 3, fig. 6, *spi. d. 1*). It is anticipated that, upon careful study of the brain with reference to the nucleus of XII, some difference in origin of these two bundles (*crv. l. XII* and *crv. d. XII*) as compared with XII proper, will be demonstrable.

In its course around the pharynx to reach the ventral side of the neck XII crosses dorsad of the thymus gland (Plate 7, fig. 24, *gl. thy.*), and also of the visceral ramus of X and the sympathetic trunk, which lie close together on the dorsal side of this gland (Plates 2, 3, figs. 4, 6, and 7, *esc. X* and *sy.*). XII, turning ventrally, passes between the thymus gland and the jugular vein mesad of all muscles. Section 1595 (Plate 7, fig. 24) falls in a plane just caudad of XII so that no part of it appears; the other structures referred to show well in this section. Section 1480 (Plate 7, fig. 23) shows XII after it has attained its ventral position. This is reached by crossing the end of the first cerato-branchial on its lateral side. Nerve XII then takes a direction cephalad (Plate 7, figs. 22, 23) between the cerato-hyal (*ker-hy.*) and the first cerato-branchial (*ker-brn. I*), on the ventral side of the cerato-hyoideus (*hyo-glossus*) muscle. Its direction from this point onward is cephalad and mesad along the lateral edge of the genio-glossus muscle and the median side of the cerato-hyal. As it passes forward it comes to lie on the ventral side of the genio-glossus (*gen-gls.*), where it parallels the mandible to a point as far forward as the basi-hyal (Plate 6, figs. 16-18). Here we find a division of the main trunk into two rami of about equal size. The median one immediately divides, so we then have a three-fold division (Plate 5, fig. 12, *lng. l. XII*, *lng. v'm. XII*, and *lng. m. XII*) of the main trunk, the lateral one containing about half the fibers. From this point forward these three main rami diverge and pass up into the tongue musculature for distribution (Plate 2, fig. 5). This course of the main trunk and terminal divisions of XII has been described without reference as yet to certain small rami which it gives off. The branches of XII will now be described in more detail:

*Distribution of the hypoglossal nerve.* (a) *Ramus pharyngo-laryngeus* (*phar-lar'*). Although r. pharyngo-laryngeus is given off as a branch of XII, the principal, if not the sole, source of its fibers is from nerves IX and X, as described in connection with the account of those nerves.

(b). Between (a) and the main divisions of XII there are given off several very small rami, which innervate the muscles between which the hypoglossal nerve passes. The first of these (Plate 2, fig. 5, *XII*<sup>1</sup>) supplies the cerato-mandibularis 1 (Fig. 18) in its posterior

region. The second (*XII*<sup>2</sup>) goes to the small slip of muscle described as the cerato-mandibularis 3 (Plate 6, figs. 16-19, *ker-md.*<sup>3</sup>) sending also a few fibers to the same muscle that receives the first twig. Some distance cephalad a third ramus (*XII*<sup>3</sup>) is given off, which innervates this first muscle, the most of the bundle, however, passing far forward to reach the portion described as cerato-mandibularis 2 (Plate 2, fig. 5; Plates 4, 5, figs. 9-12, *ker-md.*<sup>2</sup>). Just anterior to this several small branches (Plate 2, fig. 5, *XII*<sup>4</sup>) supply the posterior portion of the genioglossus.

It is noticeable that all these small rami to the more superficial tongue muscles draw off from XII the largest and most strongly medullated of its fibers, although not exclusively fibers of this kind. There is no further distribution of fibers of XII from the main trunk, which now may be said to supply the tongue proper through the three main divisions referred to above. For convenience in description these will be described as median, intermediate and lateral rami.

*Ramus lingualis medialis XII (lng. m. XII).* This ramus crosses the ventral side of the main longitudinal tongue muscle, genioglossus, to reach the median edge of this muscle. Here, on either side of the glossohyal (*gls-hy.*) and underlying the larynx, begins a mass of muscle composed of short vertical fibers (Plate 4, fig. 11, *lng. vrt.*). This forms a continuous vertical muscle surrounding the glossohyal as far forward as its anterior end, which is well toward the tip of the tongue. The median ramus of XII runs the length of this muscle supplying it on the way (Plate 2, fig. 5). As the vertical fibers gradually run out, this nerve also dwindles. The fibers innervating this muscle are less heavily medullated than those of the small rami previously described.

*Ramus lingualis intermedius XII (Plate 2, fig. 5, lng. i'm. XII).* This ramus is a little larger than the median one and the fibers are larger and more heavily myelinated. It runs cephalad first on the surface of the muscle genioglossus then within that muscle. This ramus appears to supply the genioglossus exclusively. Its course may be followed in the drawings of cross sections (Plate 4, 5, figs. 9-12).

*Ramus lingualis lateralis XII (lng. l. XII).* This is the largest division of XII and the one which forms the anastomoses with the lingual branch of V (Plate 2, fig. 5, *lng. l.*<sup>1</sup>); before this union, however, it divides into two rami of about equal size (*lng. l. XII*<sup>1</sup> and *lng. l. XII*<sup>2</sup>) giving off just proximal to the division a small ramus (*XII*<sup>5</sup>) supplying the longitudinal tongue muscles. Of the two main divisions one is distributed at once in a series of branches to the transverse musculature (Plate 4, figs. 10, 11, *lng. t.*) on the upper surface of the tongue, the nerve fibers reaching this muscle at its extreme lateral

margin by passing around the genioglossus muscle (Plate 4, fig. 10, *lng. l. XII*<sup>1</sup>). The other division (*lng. l. XII*<sup>2</sup>) of the lateralis XII combines with lingual V and the two mingled components are distributed together (Plate 2, fig. 5). The dorsal musculature of the tongue begins here to take on the crossed arrangement of its fibres (p. 35), and this seems to be related to the presence of papillae on the surface characteristic of the anterior end of the tongue (Plate 4, fig. 9).

In the distribution of the three main divisions of XII, it is important to note how each is quite definitely limited to a particular part of the musculature, and that the part of XII which is mingled with V innervates only the strictly intrinsic musculature, for the most part those short muscle fibers which are inserted into the mucous membrane of the papillae-bearing dorsal surface.

These papillae deserve special study because of certain peculiarities in their finer structure. These conditions were in part brought out in the unstained material. The muscle fibers, which show a high degree of differentiation between the light and dark transverse bands, extend all the way to the tip of the papillae, and medullated nerve fibers could also be followed the same distance. Inasmuch as these somatic motor and general cutaneous fibers are approximately of the same size, it is not possible to distinguish between them by this criterion. It is fair to assume, however, that the fibers at the ends of the papillae are sensory, for, from what we know of the innervation of striated muscle, it is not to be expected that the muscle fibers are innervated at their scattered distal ends rather than at a more proximal point, where they are closer together and nearer the source of nerve supply. We know also that nerve fibers of the general cutaneous type have come into this region in the lingual branch of ramus maxillaris V, and presumably they must reach the surface. No taste buds were found among these papillae, although at the sides of the tongue such buds were found among the tubular glands.<sup>1</sup> In a region where these papillae are best developed they are flattened at the end, where the epithelium is of the stratified columnar type. The sides are covered with simple glandular epithelium. The flattened ends show many cells extending out as though protruding individually. The free ends, being knob-like, contain the nuclei, while the base is attenuated into a slender column. The result is a sort of tuft of knobbed projections forming the end of each papilla. It is to this flattened terminal portion that the muscle and nerve fibers pass.

<sup>1</sup>Later study on the histology of the tongue has disclosed a few papillae-bearing single taste buds in their flattened ends.

## S. SUMMARY ON THE DISTRIBUTION OF NERVES IX, X AND XII.

These nerves contain viscerosensory (red), visceromotor (dark blue), and somatic motor (pale blue) elements. The viscerosensory (red) are contained in IX and X, and reach their end organs by two nerves, (a) the pharyngo-laryngeal branch, coming off from XII, and (b) the visceral and recurrent rami of X. The sensory elements of the former appear to be distributed to the mucous membrane of the pharynx lateral and anterior to the glottis; those of the latter (not including those in the posterior visceral ramus) to the pharynx wall posterior to (a) and, through the ramus recurrens X, to the tracheal and laryngeal epithelium itself.

The visceromotor elements (dark blue) are carried in the pharyngo-laryngeal ramus of XII (excepting the fine motor fibers to the m. constrictor jugulae) and may reasonably be assumed to be the same as those found in the coarse fibered roots of IX and X. They first give off fibers to the cerato-hyoideus muscle, then, after losing the sensory elements to the pharyngeal wall, they form a partial crossing and each has a bilateral distribution to the laryngeal muscles.

The somatic motor components (pale blue) comprise the three roots of XII. These differ from the somatic motor of the spinal nerves in presenting collectively a much smaller-fibered nerve. A marked exception exists however, in the third root, which possesses a cervical part and a hypoglossal part, the two standing in contrast to each other in size of fibers. The cervical part is distributed to the dorso-lateral longitudinal neck muscle. The hypoglossal part, combining with all the components of the other two roots to form the main trunk of XII, innervates all the muscles of the ventral longitudinal series except those extending from the girdle to the hyoid apparatus and the cerato-hyoideus.

## T. ADDITIONAL INNERVATION TO THE VENTRAL HEAD REGION.

The other muscles of the ventral head region are supplied by V and VII, thus indicating their visceral origin. Nerve VII innervates the digastric and superficial constrictors, *i. e.*, sphincter colli and mylo-hyoideus in part; V innervates the mandibular series and all but the

posterior part of mylo-hyoideus. The mucous membrane covering the tongue and along the inner side of the lower jaw is innervated by somatic sensory and viscerosensory components, these being mingled in the same rami, the former by way of the lingual branch of mandibular V, the latter through the chorda tympani from VII. The somatic sensory elements appear to be especially well distributed to the long papillae in the glandular subterminal region of the tongue, while the viscerosensory are associated with regions bearing taste buds and glands along the sides of the tongue and the jaw.

#### U. SPINAL NERVES.

Inasmuch as the anterior spinal nerves have undergone modification of their typical character due to the same process of cephalization which has affected the cranial nerves, an account of the first three is included in this paper. The third cervical is the first one that possesses both somatic-motor, and somatic-sensory components typical of a complete spinal nerve.

1. *The third spinal nerve*, as might be inferred from the last sentence, is the most anterior spinal nerve to have both ventral and dorsal roots. The two roots and the spinal ganglion lie in nearly the same transverse plane (Plate 7, fig. 24). The dorsal root enters the spinal cord on its dorso-lateral side as one compact strand, coming, within the vertebral canal, from the spinal ganglion, which lies in the large intervertebral foramen at the level of the ventral side of the spinal cord. This foramen is between the second and third cervical vertebrae. It is impossible to analyze these roots further than to indicate the position of their somatic components. The sections do not show visceral components in the distribution of peripheral branches, but since the muscles tend to obstruct the fixation and blackening of the nerve fibers, it is possible that some have escaped observation. The sensory bundles emerge from the ganglion as parts of dorsal and ventral rami, the ventral ramus being about double the diameter of the dorsal. The ventral root, composed of somatic-motor fibers, arises as a number of rootlets passing out from the ventral horn of the cord. This root, while on the median side of the ganglion, splits into dorsal and ventral divisions (Plates 2, 3, figs. 4, 6). The ventral immediately joins the ventral sensory ramus, while the dorsal again divides, dorsal to the ganglion, into a part which joins the dorsal sensory ramus and a

lateral part (*spi. l. 3*), which divides at once into several small rami, innervating the muscles immediately adjacent and caudad to it.

The *dorsal ramus* (*spi. d. 3*) divides into two branches; the one, wholly motor (Plate 2, fig. 6), passes dorso-mesad to supply the muscle lying against the neural arch; the other, a mixed sensory-motor, receives a communicating branch from the dorsal ramus of the second spinal nerve and innervates the most dorsal portion of the longissimus muscle anterior to the general position of the nerve as a whole (Plates 2, 3, figs. 4, 6). The cutaneous part passes through this muscle to the skin, where it divides to be distributed both dorsally and laterally; but like the motor part its field of distribution is chiefly anterior to the nerve.

The *ventral ramus* is a combination of the ventral divisions of the motor and sensory components. The mixed branch thus formed passes ventro-laterad between the m. longissimus colli and spinalis colli (Plate 7, fig. 24, *spi. v.3*). It crosses on the dorsal side of ramus visceralis X and the sympathetic trunk (Plate 2, fig. 4). Between the muscles above mentioned it receives a reinforcement of motor fibers from the ventral ramus of the second spinal nerve (Plate 7, fig. 24, *spi. v. 2*), about half of whose fibers join the third spinal for distribution, the rest continuing caudad. This combined ventral ramus now passes laterad into m. capiti-cleido-episternalis. Here the motor elements leave the main ramus to supply this muscle in both caudal and rostral directions. (The motor fibers appearing in m. depressor mandibulae adjacent to this region are found by dissection to come from ramus hyoideus VII). The cutaneous components also divide into two branches (Plate 2, fig. 4). One passes ventrad between mm. cucullaris and depressor mandibulae, the other passes directly through the latter muscle to a position just lateral to the main trunk of nerve XII, where it turns cephalad to be distributed to the integument along the ventro-lateral region of the neck and throat (Plates 3, 7, figs. 6, 23, *spi. v. 3*).

A variation in the ganglion of the third spinal nerve deserves mention in this connection. This is indicated in the plotting and consists of a small group of ganglion cells on the dorsal sensory ramus not far from the main ganglion. In the labelling a dotted line runs to this as well as to the main ganglion from the letters (*gn. spi. 3*). In other series of sections of *Anolis* this small ganglion did not appear. The size of its cells and its nerve connections do not suggest for it a sympathetic function, the cells being in every way similar to spinal ganglion cells, their position probably being due to a migration of some of these cells from the main ganglion.

2. *Second spinal nerve.* The ventral root of the second spinal, which constitutes the entire nerve, is similar to that of the 3rd spinal, being composed of coarse somatic-motor fibers arising from several bundles that have their origin in the ventral-horn cells. The 2nd spinal is somewhat smaller than the 1st. The rootlets in each case combine to form a compact bundle, which passes out through the intervertebral foramen and immediately divides into a large dorsal ramus (Plates 2, 3, *spi. d.2*) and a smaller ventral ramus (*spi. v.2*). A lateral ramus (*spi. l.2*) is given off as a branch of the dorsal ramus.

The ventral ramus passes ventrad between the neck muscles, where it turns abruptly caudad to cross the ventral ramus of the 3rd spinal on its median side, giving up a portion of its fibers to that nerve, as already mentioned. The rest continues caudad to be distributed to the ventral neck muscles in the region of the 4th spinal nerve.

The dorsal ramus of the 2nd spinal is a large branch, which supplies the dorsal and lateral neck musculature.

3. *First spinal nerve.* This nerve (Plate 7, fig. 23) has the largest number of somatic motor fibers of any yet described. It supplies the dorsal muscles with a large dorsal ramus, as does the 2nd spinal, and, in addition, sends a good sized branch to the ventral side to innervate the omo-hyoideus and sterno-hyoideus muscles. The large root trunk passes out between the cranium and the first vertebra. Just outside the foramen it divides into ventral and dorsal rami.

The ventral ramus (Plates 2, 3, figs. 4, 6, *spi. v.1*) passes ventrally along the body of the vertebra and gives off one branch supplying the ventral cervical musculature, and another that passes between the longus colli and more superficial muscles. The latter then turns slightly dorsad to pass on the dorsal side of X and the sympathetic nerve, attaining a position alongside the third root of XII, with which it is sometimes loosely bound. From here it passes ventrally (Plates 2, 3, figs. 5, 6, *omo-hy.* and *stn-hy.*) between the omo-hyoideus and sterno-hyoideus muscles, both of which it richly supplies.

The dorsal ramus (*spi. d.1*). This splits into three branches (Plate 3, fig. 6), the lateral (Plate 7, fig. 23, *spi. l.1*) is distributed immediately to the adjacent muscle, another to the ventral part of the longissimus muscle, and the largest to the dorsal neck muscle, a portion being distributed at once to the muscle lying alongside the vertebra (Plate 7, fig. 23), while the rest passes into the most dorsal division of the longissimus, where it divides into four small terminal branches, two passing cephalad and two caudad.

4. *Connections of first three spinal nerves with sympathetic.* While

dissections indicated a connection with the median sympathetic trunk, the study of sections shows this to be only a connective-tissue union, the sympathetic bundle passing directly across without any break in its sheath that would indicate the passage of nerve fibers.

## V. GENERAL CONSIDERATIONS ON NERVE XII AND THE SPINAL NERVES.

From a comparative standpoint the hypoglossal nerve in *Anolis* presents two questions for consideration: First, as to the number of spinal nerves that enter into its formation and their position in the series of spino-occipital nerves, and, secondly, as to the differentiation of its component neurons from the typical somatic-motor type from which they come. The first question appears to be answered in part by the obvious facts presented by *Anolis* itself, through the persistence of three distinct occipital foramina, indicating three separate segmental nerves. Only rarely have three cranial roots for XII been described in the adult saurian. Among all those described by Fischer ('52, p. 66), three roots are mentioned for only *Platydictylus*; but in *Anolis* not only are there three roots, but they emerge through separate foramina. In two species he finds only one root, and in seven he finds two. In all cases XII either unites with the first spinal or receives branches from it. Fischer states that, as a rule, the first two spinal nerves are without dorsal roots and ganglia, although sometimes there occurs a weak dorsal root on the second spinal nerve. As in *Anolis*, the third is a nerve well developed in both its motor and sensory components. The relation of XII to the spinal nerves varies according to the strength and number of its roots. This fact points to the correctness of Fischer's view that the cranial part of XII does not represent the same number of spinal nerves in all lizards. Fürbringer ('97, p. 501) arrives at the constant number of three roots for all sauropsida, although the first and second emerge through a common foramen in most reptiles. Reference to Fürbringer's table (p. 546) shows his conclusion regarding the homologies of these nerves. He designates them, the first three, as *occipito-spinal* nerves, their position being fixed through discovery in the embryo of the older *occipital* nerves (anterior to these), which have a transitory existence. There are two features in the twelfth nerve of *Anolis* which seem to show that it is less completely incorporated into the head than in other rep-



tiles: (1) the persistence of three occipital foramina, and (2) the mixed spinal and hypoglossal character of its third root. The latter condition is not described for any other lizard. There is practically no union of the hypoglossal part of the last root of XII with the first spinal nerve, a condition which is described by Fischer as general. If we imagine the cephalization process to progress further in *Anolis*, we should expect roots one and two of XII to merge with each other, the spinal or cervical part of root three to disappear and the first spinal nerve to be drawn more into the field occupied by it. This is practically what is represented (Fischer) in those forms where but two roots have been described. Evidence from the embryological side (Van Wijhe, '86, Van Bemmelen, '89, Hoffmann, '79-90) supports Fürbringer's ('97) generalization that the hypoglossal of reptiles represents three ventral spinal roots.

The *cervical plexus* is represented in *Anolis* by the combination of XII with the first spinal and the commissure between the second and third spinal nerves. The ventral ramus of the first spinal is but loosely associated, sometimes not at all, with XII. The only constant connection, then, is that of the dorsal ramus of XII (*cervicalis dorsalis* XII) with the same ramus of the first spinal (Fig. 6, *crv. d. XII*). This anastomosis may be considered a remnant of the closer relation of these nerves which existed before the rise of the tongue musculature.

*Anolis* agrees with the typical condition of reptiles in the absence of a sensory component in the first and second spinal nerves. Fischer's reference to the exceptional occurrence of a dorsal root for the second spinal is not carried farther in his descriptions. Rabl-Rückhard ('78, p. 342) states that in the alligator the third is the first of the spinal nerves to possess a sensory part, but in contrast to the lizards (*Anolis*) the third and fourth spinal nerves also have (Fischer) greatly reduced dorsal roots, indicating a less sensitive integument in the alligator. It will be seen that in *Anolis* the field innervated by the sensory components of the third spinal nerve extends far cephalad both on the dorsal and ventral sides, thus demanding a strong dorsal root.

In regard to the second point in the comparison, i. e., the differentiation of the nerve itself, we have to deal with a histological problem which cannot be profitably discussed without a complete knowledge of the histological elements involved. The fixation of my material is not uniform enough in all parts to admit of a detailed comparison of the caliber of the medullated fibers as found in different nerves. However, in *Anolis* the difference in the fibers of XII, as compared with

those of the ventral roots of the spinal nerves, is further emphasized in the third hypoglossal root and points to a very direct correlation between the size of the fiber and its function. In this case there is no doubt that the larger fibers run the shorter distance, thus contradicting Schwalbe's ('82) law and confirming Dunn's (:02, p. 323) results in the spinal nerves of the frog. There may be, and probably are, other factors entering into this particular case. Koch ('88) and Brandis ('93) speak of a differentiation in the central nucleus of XII in the medulla of birds, where a "dorsal" portion is separated from the rest; and the suggestion is made by them that this may be correlated with the syringeal musculature. In *Anolis* any relation of XII to central nuclei bearing on peripheral differences must await a detailed study of the brain.

#### W. GENERAL SUMMARY.

1. *Anolis* possesses the cranial nerves typical of the amniote vertebrate with one exception; there was not discoverable any representative of the spinal accessory nerve described in other reptiles, and the muscles innervated by this nerve in other forms seemed to be supplied in *Anolis* wholly from spinal nerves posterior to the second cervical.

2. The ganglia of cranial nerves V, VII, IX, and X are distinct from one another and the roots of all issue from the cranium through independent foramina. The ophthalmic ganglion also shows no fusion with the other portion of the Gasserian ganglion.

3. There is a wide distribution of sympathetic ganglion cells along the afferent rami of the cranial nerves. These form definite ganglia on palatine VII (palatine ganglion) on palatine VII and nasalis V (ethmoidal ganglion), on maxillaris V (infraorbital ganglion), and on mandibular V (mandibular ganglion). The topographical facts would lead one to associate the development of these ganglia with specialization of the glands of the head. No medullated nerve fibers were found passing through the connective tissue surrounding these glands. The presence of smooth muscle fibers in the head region might also affect the development of the sympathetic. The sympathetic system of the head in the matter of the arrangement of rami and ganglia (as worked out incidentally to the study of the cranial nerves), when compared with other described forms of reptiles, points to the existence of a typical sauropsidan type of quite constant character.

4. The nerve components (excepting the sympathetic) reach their

end organs, or peripheral terminations, through the following nerve trunks; *Somatic sensory* (yellow), via nerve V, over ophthalmic (rmm. frontalis and nasalis), maxillary and mandibular rami. *Somatic motor* (light blue), via nerves III, IV, VI, and XII. *Viscero-sensory* (red), via nerve VII over the palatine ramus and the chorda tympani; via nerve IX over the pharyngeal ramus and probably Jacobson's anastomosis; via nerve X over the superior laryngeal and recurrent rami. *Viscero-motor* (dark blue), via nerve V by a number of independent rami and over the mandibular ramus; via nerve VII over hyomandibular division and ramus hyoideus; via nerve IX over the pharyngeal ramus; and via nerve X over the superior laryngeal ramus.

(a) This shows a greater reduction of the somatic sensory (as indicated by peripheral paths) in *Anolis* than is found in the described forms of other groups, such components not being found in nerves IX or X of *Anolis* although their presence in the same nerves has been reported in each of the other classes of vertebrates.

(b) Vestigial ganglia exist in a variable manner on the intracranial roots of X, which may be somatic sensory in their origin.

5. The morphological character of the fibers of different components is sufficiently differentiated to form types peculiar to each component. But the distinction in character appeared to be less than that described for the lower groups of vertebrates. However, there was considerable individual variation in the size of fibers. Nerve XII shows a marked difference in the size of the fibers going to neck muscles and those going to tongue muscles. In this case the smaller fibers have much the longer course. In at least three instances striated muscle fibers of visceral origin are innervated by nerve fibers of smaller caliber and lighter myelin sheaths than is characteristic of the other viscero-motor components of V, VII, IX, and X. These are the ciliary muscle, the protractor oculi, and the constrictor of the jugular vein, all of which are more closely associated with visceral functions than the other striated visceral muscles.

6. The skin is well-supplied with special tactile organs, which are more abundant along the jaws than elsewhere. These organs are quite generally, if not always, covered by a thinned plate of the horny layer of the epidermis, which bears in its center a tapering "hair." The innervation of these hairs was not determined beyond the fact of the proximity of the strongly myelinated cutaneous fibers in the dermis beneath.

7. The distribution of taste buds is such as to preclude their innervation (save a very limited number in the laryngeal region) by

anything except the chorda tympani and palatine VII. A large proportion of the fibers carried by these rami are for such sense organs, their innervation fields being covered for general sensory purposes by the somatic sensory of V.

8. *Anolis* presents a well-balanced form for the study of the reptilian nervous system. It is an active, responsive animal with well-differentiated muscles and sense organs, yet presenting no excessively specialized features. It is small enough readily to be sectioned and large enough for experimental operations, and it is suggested that degeneration and stimulation experiments on this form would advance our knowledge of the reptilian nervous organs even more than similar anatomical work on other forms. The anatomical work already done, however, should be supplemented by the proper technique to determine the final nerve terminations.

## BIBLIOGRAPHY.

**Allis, Jun., E. P.**

- '98. The Homologies of the occipital and first spinal Nerves of Ania and Teleosts. *Zoöl. Bull.*, **2**, p. 83-97.

**Andersson, O. A.**

- '92. Zur Kenntniss des sympathischen Nervensystems der urodelen Amphibien. *Zool. Jahrb., Abt. f. Anat.*, **5**, p. 184-210, taf. 15-18.

**Bayliss, W. M.**

- :00. The Presence of efferent Vaso-dilator Fibres in posterior Roots. *Journ. Physiol.*, **25** (Proc. Physiol. Soc.), p. xiii-xiv.

**Bender, O.**

- :06. Die Schleimhautnerven des Facialis, Glossopharyngeus und Vagus. *Semon's Reiseberichte*, **4**, p. 341-454, taf. 1-9, 22 text fig.

*Also* *Jena. Denkschr.*, **7**.

**Bendz, H.**

- '43. Bidrag til den Sammenlignende Anatomie af Nervus glossopharyngeus, vagus accessorius Willisii og hyoglossus hos Reptilierne. *K. Danske Vidensk. Selsk. Naturv. og Math., Afl. Deel 10*, p. 113-152, tab. 1-10.

**Béraneck, E.**

- '84. Recherches sur le développement des nerfs crâniens chez les Lézards. *Recueil Zool. Suisse, sér. 1*, **1**, p. 519-603, pl. 27-30.

*Also* *Diss., Geneve*, 1884.

**Bischoff, T. L. W.**

- '32. *Nervi accessorii Willisii anatomia et physiologia*. 4 maj., 6 pp., *Darmstadii, Commentatio. Acced. tabb. VI.* 1832.

**Bojanus, L. H.**

- '19. *Anatome testudinis europeae*. *Vilnae*, 1819-21, vi + [viii] + 179 pp., 31 tav.

**Bonsdorff, E. J.**

- '52. *Symbolae ad anatomiam comparatum nervorum animalium vertebratorum*. I. *Nervi cerebrales Corvi cornicis (Linn.)*. *Acta. Soc. Scient. Fennicae*, **3**, fasc. 2, p. 505-569, pl. 6, 6a, 7, 7a.

**Born, G.**

- '76. Ueber die Nasenhöhlen und den Thränenangang der Amphibien. *Morph. Jahrb.*, **2**, heft 4, p. 577-646, taf. 39-41.

**Bowers, Mary A.**

- :00. Peripheral Distribution of the cranial Nerves of *Spelerpes bilineatus*. *Proc. Amer. Acad. Arts Sci.*, **36**, p. 179-193, 2 pls.

**Bradley, O. C.**

:03. The Muscles of Mastication and the Movements of the Skull in Lacertilia. Zool. Jahrb., Abt. f. Anat., **18**, p. 475-488, taf. 44.

**Brandis, F.**

'93. Untersuchungen über das Gehirn der Vögel. II. Ursprung der Nerven der Medulla oblongata. Arch. f. mikr. Anat., **41**, p. 623-649, taf. 35.

**Bruner, H. L.**

:07. On the cephalic Veins and Sinuses of Reptiles, with Description of a Mechanism for raising the venous Blood-Pressure in the Head. Amer. Journ. Anat., **7**, p. 1-118, 3 pls.

**Busch, C. H.**

'98. Beitrag zur Kenntniss der Gaumenbildung bei den Reptilien. Zool. Jahrb., Abt. f. Anat., **11**, p. 441-500, taf. 34-40.

**Carpenter, F. W.**

:06. The Development of the Oculomotor Nerve, the ciliary Ganglion, and the abducent Nerve in the Chick. Bull. M. C. Z., **48**, p. 139-230, 7 pls.

**Cartier, O.**

'72. Studien über den feineren Bau der Haut bei den Reptilien. I. Abth. Die Epidermis der Geckoiden. Verhandl. d. phys.-med. Gesellsch. Würzburg, n. f., **3**, p. 281-295, 2 taf.

**Cartier, O.**

'74. Same. II Abth. Ueber die Wachstumserscheinungen der Oberhaut von Schlangen und Eidechsen bei der Häutung. Ibid., **5**, p. 192-211, 1 taf.

Also in Arb. a. d. Zool.-Zoot. Inst., Würzburg, **1**, p. 83-96; p. 239-258, taf. 3, 4, 12, 1874.

**Chiarugi, G.**

'89. Lo sviluppo dei nervi vago, accessorio, ipoglosso e primi cervicali nei Sauropsidi e nei Mammiferi. Atti Soc. Toscana d. Sc. Nat., Mem. **10**, p. 149-245, tav. 11, 12.

**Coghill, G. E.**

:02. The cranial Nerves of the *Amblystoma tigrinum*. Journ. Comp. Neur., **12**, p. 205-289, pls. 15-16.

**Cole, F. J.**

'98. Observations on the Structure and Morphology of the cranial Nerves and lateral Sense Organs of Fishes; with special Reference to the Genus *Gadus*. Trans. Linn. Soc. London, ser. 2, Zool., **7**, p. 115-221, pls. 21-23.

**Cope, E. D.**

:00. The Crocodilians, Lizards, and Snakes of North America. Rept. U. S. Nat. Mus., 1898, p. 153-1270, 36 pl., 347 text fig.

**Cords, Elisabeth.**

:04. Beiträge zur Lehre vom Kopfnervensystem der Vögel. Anat. Hefte, **26**, p. 49-100, taf. 1-4.

**Corning, H. K.**

- '95. Über die Entwicklung der Zungenmusculatur bei Reptilien. Verhandl. d. Anat. Gesellsch., Versamml. 9, in Basel, p. 165-175.

**Dunn, Elizabeth H.**

- :02. On the Number and on the Relation between Diameter and Distribution of the Nerve Fibers innervating the Leg of the Frog, *Rana virescens brachycephala*, Cope. Journ. Comp. Neur., **12**, p. 297-328.

**Emmel, V. E.**

- :04. The Relation of the Chorda Tympani to the visceral Arches in *Microtus*. Journ. Comp. Neurol. and Psychol., **14**, p. 411-417.

**Fischer, J. G.**

- '52. Die Gehirnnerven der Saurier anatomisch untersucht. Abhandl. Naturw. Verein in Hamburg, Abt. 2, p. 109-212, 3 taf.

**Froriep, A., und Beck, W.**

- '95. Ueber das Vorkommen dorsaler Hypoglossuswurzeln mit Ganglion, in der Reihe der Säugetiere. Anat. Anz., **10**, p. 688-696.

**Fürbringer, M.**

- '76. Zur vergleichenden Anatomie der Schultermuskeln. III. Morph. Jahrb., **1**, p. 636-816, taf. 23-27.

**Fürbringer, M.**

- '97. Ueber die spino-occipitalen Nerven der Selachier und Holocephalen und ihre vergleichende Morphologie. Festschr. Gegenbaur, **3**, p. 349-788, 8 taf.

**Gaskell, W. H.**

- '86. On the Structure, Distribution and Function of the Nerves which innervate the visceral and vascular Systems. Journ. Physiol., **7**, p. 1-80, pls. 1-4.

**Gaskell, W. H.**

- '89. On the Relation between the Structure, Function, Distribution and Origin of the cranial Nerves; together with a Theory of the Origin of the nervous System of Vertebrata. Journ. Physiol., **10**, p. 153-211, pls. 16-20, 3 text fig.

**Gaupp, E.**

- '88. Anatomische Untersuchungen über die Nervenversorgung der Mund- und Nasenhöhlendrüsen der Wirbelthiere. Morph. Jahrb., **14**, p. 436-489, taf. 19.

**Göppert, E.**

- '99. Der Kehlkopf der Amphibien und Reptilien. Theil. II. Reptilien. Morph. Jahrb., **28**, p. 1-27, taf. 1, 2.

**Günther, A.**

- '67. Contributions to the Anatomy of Hatteria (*Rhynchocephalus Owen*). Phil. Trans. Roy. Soc. Lond., **157**, p. 595-629, pls. 26-28.

**Herrick, C. J.**

- '94. The cranial Nerves of *Amblystoma punctatum*. Journ. Comp. Neurol., **4**, p. 193-207, pls. 19, 20.

**Herrick, C. J.**

- '99. The cranial and first spinal Nerves of Menidia; A Contribution upon the Nerve Components of bony Fishes. Journ. Comp. Neurol., **9**, p. 153-155, pls. 14-20.

**Hoffmann, C. K.**

- '79-90. In Bronn's Klassen und Ordnungen des Thier-Reichs, **6**, Abt. 3, Reptilien. 2089 pp., 170 taf.

**Hoffmann, C. K.**

- '89. Über die Metamerie des Nachhirns und Hinterhirns, und ihre Beziehung zu den segmentalen Kopfnerven bei Reptilienembryonen. Zool. Anz., **12**, p. 337-339.

**Holl, M.**

- '76. Beobachtungen über die Anastomosen des Nervus hypoglossus. Zeitschr. f. Anat. u. Entw., **2**, p. 82-97, taf. 6.

**Holl, M.**

- '78. Über den Nervus accessorius Willisii. Arch. f. Anat. u. Physiol., Anat. Abth., p. 491-518, 4 fig. auf taf. 18.

**Huber, G. C.**

- '99. A Contribution on the Minute Anatomy of the sympathetic Ganglia of the different Classes of Vertebrates. Journ. Morph., **16**, p. 27-90, 3 figs., pls. 3-5.

**Johnston, J. B.**

- '98. Hind Brain and cranial Nerves of Acipenser. Anat. Anz., **14**, p. 580-602.

**Johnston, J. B.**

- :06. The nervous System of Vertebrates. Philadelphia, 1906, xx + 370 pp.

**Kathariner, L.**

- :00. Die Mechanik des Bisses der solenoglyphen Giftschlangen. Biol. Centralbl., **20**, p. 45-53.

**Klein, E.**

- '71. On the peripheral Distribution of non-medullated Nerve-fibres. Quart. Journ. Micr. Sci., **11**, p. 405-416, pls. 19, 20.

**Koch, P. D.**

- '88. Untersuchungen über den Ursprung und die Verbindungen des Nervus hypoglossus in der Medulla oblongata. Arch. f. mikr. Anat., **31**, p. 54-71, taf. 6.

**Langley, J. N.**

- '98. On the Union of cranial autonomic (visceral) Fibres with the Nerve Cells of the superior cervical Ganglion. Journ. Physiol., **23**, p. 240-270, figs. 1-6.

**Lewis, F. T.**

- :03. The gross Anatomy of a 12-MM Pig. Amer. Journ. Anat., **2**, p. 211-226, 4 pls.



**Leydig, F.**

'72. Zur Kenntniss der Sinnesorgane der Schlangen. Arch. f. mikr. Anat., 8, p. 317-357, taf. 15, 16.

**Leydig, F.**

'73. Über die äusseren Bedeckungen der Reptilien und Amphibien. Arch. f. mikr. Anat., 9, p. 753-794, taf. 32.

**Lubosch, W.**

'98. Die vergleichende Anatomie des Accessoriusursprunges. Diss. Berlin, 1898, 31 pp.

**Lubosch, W.**

'99. Vergleichend-anatomische Untersuchungen über den Ursprung und die Phylogenese des N. accessorius Willisii. Arch. f. mikr. Anat., 54, p. 514-602, taf. 17.

**Maurer, F.**

'95. Die Epidermis und ihre Abkömmlinge. Leipzig, 1895, ix + 352 p., 9 taf., 28 text fig.

**Merkel, F.**

'80. Über die Endigungen der sensiblen Nerven in der Haut der Wirbelthiere. Rostock, vii + 214 p., 15 taf.

**McMurrich, J. P.**

'85. The cranial Muscles of *Amia calva* (L), with a Consideration of the Relations of the postoccipital and hypoglossal Nerves in the various Vertebrate Groups. Studies Biol. Lab. Johns Hopkins Univ., 3, p. 121-153, pl. 10.

**Minot, C. S.**

:03. A Laboratory Text Book of Embryology. Philadelphia, 1903, xvii + 380 pp.

**Mivart, St. G.**

'67. Notes on the Myology of *Iguana tuberculata*. Proc. Zool. Soc. Lond., p. 766-797, 18 text fig.

**Mivart, St. G.**

'70. On the Myology of *Chamaeleon parsonii*. Proc. Zool. Soc. Lond., p. 850-890, 29 text fig.

**Müller, J.**

'40. Vergleichende Neurologie der Myxinoiden. Abh. Akad. Wiss. Berlin, 1838, pp. 171-252, 4 taf.

*Also sep.* 1840, 83 pp., 4 taf.

**Noack, [T.]?**

:07. Über die Entwicklung des Mittelohres von *Emys europaea* nebst Bemerkungen zur Neurologie dieser Schildkröte. Arch. f. mikr. Anat., 69, p. 457-490, taf. 18, 6 text fig.

**Noon, L.**

:00. Some Observations on the Nerve Cell Connection of the efferent Vagus Fibres in the Tortoise. Journ. Physiol., 26, pp. v-vii.

**Norris, H. W.**

'08. The cranial Nerves of *Amphiuma means*. Journ. Comp. Neur. and Psych., **18**, p. 527-568, pls. 4-8.

**Onuf, B., and Collins, J.**

'00. Experimental Researches on the central Localization of the Sympathetic with a critical Review of its Anatomy and Physiology. Arch. Neurol. and Psychopathol., **3**, p. 3-252, 9 pls.

**Osawa, G.**

'98. Beiträge zur Anatomie der *Hatteria punctata*. Arch. f. mikr. Anat., **51**, p. 481-691, 53 text fig.

**Parker, W. K.**

'79. On the Development of the Skull and its Nerves in the Green Turtle (*Chelone midas*), with Remarks on the Segmentation seen in the Skull of various Types. Proc. Roy. Soc. London, **28**, p. 329-346.

**Penzo, R.**

'93. Über das Ganglion geniculi und die mit demselben zusammenhängenden Nerven. Anat. Anz., **8**, p. 738-744, 1 fig.

**Ploschko, A.**

'97. Die Nervenendigungen und Ganglien der Respirationsorgane. Anat. Anz., **13**, p. 12-22, 10 fig.

**Rabl, K.**

'87. Über das Gebiet des Nervus facialis. Anat. Anz., **2**, p. 219-227.

**Rabl-Rückhard, [H.]**

'78. Das Centralnervensystem des Alligators. Zeitschr. f. wiss. Zool., **30**, p. 336-373, taf. 19, 20.

**Reinhardt, J.**

'60. Herpetologische Meddelelser. I. Om nogle smaa Gruber, hvormed Skjæell'ene hos mange Slanger ere forsynede. Videnskabelige Meddelelser fra den naturhistoriske Forening i Kjøbenhavn, no. 10-14, pp. 209-228.

**Reinhardt, J.**

'61. Über einige kleine Gruben an den Schuppen mancher Schlangen. Arch. Naturg., Jahrg. 27, **1**, p. 127-147. [Cf. Reinhardt, J., '60.]

**Retzius, G.**

'84. Das Gehörorgan du Wirbelthiere. II. Das Gehörorgan der Reptilien, der Vögel und der Säugethiere, Stockholm, 1884, viii + 368 pp., 39 taf.

**Rochas, F.**

'85. Des nerfs qui ont été appellés vidiens chez les Oiseaux. Compt. Rend. Acad. Paris, **101**, p. 573-575.

**Ruge, G.**

'97. Über das peripherische Gebeit des Nervus Facialis bei Wirbelthieren. Festschr. Gegenbaur, **3**, p. 193-348, 76 text fig.

**Sanders, A.**

'70. Notes on the Myology of *Platydictylus japonicus*. Proc. Zool. Soc. Lond., p. 413-426.

**Sanders, A.**

'72. Notes on the Myology of *Liolepis belli*. Proc. Zool. Soc. Lond., p. 154-183, 16 text fig.

**Sanders, A.**

'74. Notes on the Myology of the *Phrynosoma cornutum*. Proc. Zool. Soc. Lond., p. 71-89, 6 text fig.

**Schauinsland, H.**

:03. Beiträge zur Entwicklungsgeschichte und Anatomie der Wirbeltiere. I, II, III. Zoologica, Heft 39, 16. (Stuttgart), p. 1-168, 56 taf.

**Schwalbe, G.**

'68. Über den Bau der Spinalganglien nebst Bemerkungen über die sympathischen Ganglienzellen. Arch. f. mikr. Anat., 4, p. 45-72, taf. 4.

**Schwalbe, C.**

'82. Ueber die Kaliberverhältnisse der Nervenfasern, Leipzig, iv + 51 pp.

**Shore, T. W.**

'88. The Morphology of the Vagus Nerve. Journ. Anat. and Physiol., 22, p. 372-390.

**Sheldon, R. E.**

:09. The Phylogeny of the facial Nerve and Chorda Tympani. Anat. Rec., 3, p. 593-617, 6 figs.

**Staderini, R.**

'89. Sopra la distribuzione dei nervi glosso-faringeo, vago e ipoglosso in alcuni lettili ed uccelli. Atti. Accad. Fisiocritici Siena, ser. 4, 1, p. 585-599.

**Stannius, H.**

'56. Zootomie der Amphibien. In Handbuch der Zootomie von v. Siebold und Stannius. Theil 2, Die Wirbelthiere, (Aufl. 2), Buch 2, Berlin, 1856, 270 pp.

**Sternberg, M.**

'98. Über den ausseren Ast des Nervus accessorius Willisii. Arch. f. d. ges. Physiol., 71, p. 158-175, 1 text fig.

**Stirling, W.**

'76. Note on the Effects of Division of the sympathetic Nerve of the Neck in young Animals. Journ. Anat. and Physiol., 10, p. 511-512.

**Streeter, G. L.**

:04. The Development of the cranial and spinal Nerves in the Occipital Region of the Human Embryo. Amer. Journ. Anat., 4, p. 83-116, 14 figs., 4 pls.

**Strong, O. S.**

'95. The cranial Nerves of Amphibia. A Contribution to the Morphology of the Vertebrate nervous System. Journ. Morph., 10, p. 101-230, pls. 7-12.

**Van Bemmelen, J. F.**

'88. Beiträge zur Kenntniss der Halsgegend bei Reptilien. I. Anatomischer Theil. Bijdragen tot de Dierkunde. Aflivering 16, Leiden, p. 99-146, 2 pl.

**Van Bemmelen, J. F.**

'89. Ueber der Herkunft der Extremitäten- und Zungenmuskulatur bei Eidechsen. *Anat. Anz.*, **4**, p. 240-255.

**Van Wijhe, J. W.**

'86. Über Somiten und Nerven im Kopfe von Vögel- und Reptilienembryonen. *Zool. Anz.*, **9**, p. 657-660.

**Versluys, J.**

'98. Die mittlere und äussere Ohrsphäre der Lacertilia und Rhynecephalia. *Zool. Jahrb., Abt. f. Anat.*, **12**, p. 161-406, taf. 10-17.

**Versluys, Jr., J.**

:03. Entwicklung der Columella auris bei den Lacertiliern. Ein Beitrag zur Kenntniss der Schalleitenden Apparate und des Zungenbeinbogens bei den Sauropsiden. *Zool. Jahrb., Abt. f. Anat.*, **19**, p. 107-186, taf. 8-11, text figs. A-K.

**Vogt, C.**

'39. Zur Neurologie von *Python tigris*. *Arch. f. Anat. Physiol. und wiss. Medicin*, Jahrg. 1839, p. 39-58, fig. 1-4 auf taf. 3.

**Vogt, C.**

'40. Beiträge zur Neurologie der Reptilien. *Denkschr. allg. schweiz. Gesellsch. Naturw.*, **4**, p. ii + 60, 4 taf.

**Watkinson, Grace B.**

:06. The cranial Nerves of *Varanus bivittatus*. *Morph. Jahrb.*, **35**, p. 450-472, taf. 11-13.

**Weber, M.**

'77. Ueber die Nebenorgane des Auges der Reptilien. *Arch. f. Naturgesch.*, **43**, Bd. 1, p. 261-342, taf. 17-19.

## EXPLANATION OF PLATES.

All figures are from *Anolis carolinensis*. The projection drawings, figures 4, 5, and 6, and the drawings of transverse sections are from the same series of sections (designated "Anolis trans. 30"). In figures 4, 5, and 6 the outlines of the head, the brain and the eye are indicated. The places of passage of the nerves through bony foramina are indicated by circles. The drawing from a dissection, figure 7, is made to conform as nearly as possible to the size of the projection drawings, although it was taken from a somewhat larger specimen.

Note.—Since the nerves and muscles are readily distinguishable in the figures, the abbreviations *mu.* (for muscles), *n.* (for nerve) and *rm.* (for ramus) are omitted in text and plates. The colors used have the following meanings:—

On Plate 2 and 3	On Plates 4-7
yellow.....general cutaneous	bones (cartilages).
red.....viscero-sensory	muscles.
light blue....somato-motor	brain and retina.
dark blue....viscero-motor	
pale gray....brain	integument and mucous membrane.
black.....contours of nerves, ciliary roots and nerves, and sym- pathetic rami	nerves in section.

## LIST OF ABBREVIATIONS.

<i>a, β, γ</i> .....	See end of list of abbreviations.
<i>a</i> .....	anterior.
<i>alv. inf.</i> .....	ramus alveolaris inferior V.
<i>alv. sup.</i> .....	ramus alveolaris superior V.
<i>ang.</i> .....	os angulare.
<i>an'stm. lar.</i> .....	anastomosis between motor laryngeal nerves of right and left sides.
<i>an'stm. pal. l.</i> .....	anastomosis through which the lateral divi- sion of ramus palatinus VII receives its general cutaneous fibers.
<i>an'stm. pal. i'm.</i> .....	anastomosis through which the intermediate division of ramus palatinus VII receives its general cutaneous fibers.
<i>ao</i> .....	aorta.
<i>atc</i> .....	os articulare.
<i>aur. ex</i> .....	external ear.
<i>aur. m.</i> .....	middle ear.
<i>ba'hy.</i> .....	basihyal.

<i>ba'occ</i> .....	basioecipital.
<i>ba'sph</i> .....	basisphenoid.
<i>brs</i> .....	bursalis muscle.
<i>can. p</i> .....	posterior vertical semicircular canal.
<i>cap. crv</i> .....	capiti cervicalis muscle.
<i>cap. d'clav</i> .....	capiti-dorso-clavicularis muscle. (m. trapezius, m. cucullaris); nerve ramus of same.
<i>cap. md</i> .....	capiti-mandibularis muscle.
<i>cap. md</i> <sup>1</sup> .....	nerve ramus to dorsal part of m. capiti-mandibularis.
<i>cap. md</i> <sup>2</sup> .....	nerve ramus to anterior part of m. capiti-mandibularis.
<i>cat</i> .....	common carotid artery.
<i>cat. ex</i> .....	external carotid artery.
<i>cat. i</i> .....	internal carotid artery.
<i>cd. tym</i> .....	chorda tympani.
<i>cil</i> .....	ciliary nerve.
<i>clav</i> .....	clavicle.
<i>cl. gn. sy</i> .....	cells of small sympathetic ganglia at different places along viscerosensory rami.
<i>clml. aur</i> .....	columella auris.
<i>cmpl</i> .....	os complementare.
<i>cnch. na</i> .....	concha nasalis.
<i>comu</i> .....	ramus connecting the ramus to m. depressor palpebrae inferioris with rm. palatinus VII.
<i>comm. ex</i> .....	communicating ramus between lachrymal plexus and nerve IX uniting with rm. hyomandibularis.
<i>comm. i</i> .....	communicating ramus between nerve IX and rm. palatinus VII.
<i>comm. IX-X</i> .....	communicating ramus between radices IX et X.
<i>cor</i> .....	os coronoideum.
<i>co'st. lar</i> .....	constrictor muscle of the larynx.
<i>co'st. vn. j. i</i> .....	constrictor muscle of the internal jugular vein.
<i>ert. Mkl</i> .....	Meckel's cartilage.
<i>crv. d. XII</i> .....	ramus cervicalis dorsalis XII.
<i>crv. l. XII</i> .....	ramus cervicalis lateralis XII.
<i>de</i> .....	os dentale; ramuli to teeth from ramus alveolaris inferior.
<i>dep. md</i> .....	depressor mandibularis (digastric) muscle.
<i>dep. md</i> <sup>1</sup> .....	depressor mandibularis muscle, most ventrally inserted fibers.
<i>dep. palb. if</i> .....	depressor palpebrae inferioris muscle; nerve ramus innervating it.

<i>dt. lch.</i> .....	ductus lachrymalis.
<i>e'crac</i> .....	epicoracoid.
<i>e'pt.</i> .....	epipterygoid (columella).
<i>e'stn-clci-mast.</i> .....	episterno-cleido-mastoideus muscle (of Versluis); nerve ramus supplying it.
<i>ex'cml.</i> .....	extracolumella.
<i>f.</i> .....	os frontale; ramus frontalis V.
<i>fen. orl.</i> .....	fenestra ovalis.
<i>for. if'orb.</i> .....	infraorbital foramen.
<i>for. lch.</i> .....	foramen for the lachrymal duct.
<i>for. na. l.</i> .....	“ in the maxilla for passage of <i>na. l.</i>
<i>for. na. m.</i> .....	“ os nasale “ “ “ <i>na. m.</i>
<i>for. pal.</i> .....	foramen in the pterygoid bone for the first branch of the palatine nerve to the taste buds and mucous membrane.
<i>for. par.</i> .....	parietal foramen.
<i>for. pt.</i> .....	foramen in the pterygoid bone for passage of nerve to taste buds.
<i>for. V.</i> .....	notch in proötic bone in which rests the Gasserian ganglion.
<i>for VII.</i> .....	foramen for radix VII.
<i>for. XII.</i> .....	foramina for radices XII.
<i>gen-gls.</i> .....	genioglossus muscle.
<i>gl. cat.</i> .....	carotid gland.
<i>gl. Hard.</i> .....	Harderian gland.
<i>gl. lab. ex.</i> .....	external labial glands.
<i>gl. lab. i.</i> .....	internal “ “
<i>gl. lch.</i> .....	lachrymal gland.
<i>gl. na.</i> .....	nasal gland.
<i>gl. sb'lng. l.</i> .....	sublingual gland (lateral).
<i>gl. sb'lng. m.</i> .....	sublingual gland (median).
<i>gls-hy</i> .....	glossohyal.
<i>glt.</i> .....	glottis.
<i>gl. thm.</i> .....	thymus gland
<i>gl. thy.</i> .....	thyroid gland.
<i>gm. gus.</i> .....	gustatory bud in region of larynx; nerve twigs to taste buds given off from infraorbital plexus.
<i>gm. gus. l.</i> .....	lateral field of gustatory buds (both dorsal and ventral).
<i>gm. gus. m.</i> .....	median field of gustatory buds (dorsal).
<i>gn. cil.</i> .....	ciliary ganglion.
<i>gn. crv.</i> .....	first cervical ganglion of the sympathetic.
<i>gn. eth.</i> .....	ethmoidal ganglion.
<i>gn. if'orb.</i> .....	infraorbital ganglion.

<i>gn. md.</i> .....	mandibular ganglion.
<i>gn. nd.</i> .....	ganglion nodosum (trunk ganglion of X).
<i>gn. oph.</i> .....	ophthalmic ganglion.
<i>gn. pal.</i> .....	palatine ganglion.
<i>gn. rx. X.</i> .....	root, or jugular, ganglion of X.
<i>gn. spi. 3.</i> .....	spinal ganglion of third spinal nerve.
<i>gn. sy. VII.</i> .....	sympathetic ganglion cells of the geniculate ganglion.
<i>gn. V.</i> .....	Gasserian ganglion of V.
<i>gn. VII.</i> .....	geniculate ganglion of VII.
<i>gn. VIII.</i> .....	ganglion of VIII.
<i>gn. IX.</i> .....	petrosal ganglion of IX.
<i>gn. X.</i> .....	ganglion of X. (This is the same as <i>gn. rx. X.</i> )
<i>h'hy.</i> .....	hypohyal.
<i>hy.</i> .....	hyoideus muscle; ramus hyoideus VII.
<i>hy-gls.</i> .....	hyoglossus muscle (m. cerato-hyoideus).
<i>hy-md.</i> .....	ramus hyo-mandibularis VII.
<i>if'orb.</i> .....	ramus infraorbitalis V.
<i>j.</i> .....	os jugale.
<i>ker-brn. I.</i> .....	cerato-branchial I.
<i>ker-brn. II.</i> .....	cerato-branchial II.
<i>ker-hy.</i> .....	cerato-hyal cartilage; ramus to cerato-hyoid (= hyoglossus) muscle, a branch of the pharyngolaryngeal.
<i>ker-md. 1, 2, 3.</i> .....	cerato-mandibularis muscle and its subdivisions; rami to cerato-mandibularis muscle.
<i>lab. if. alv.</i> .....	rami labiales inferiores given off from ramus alveolaris inferior V.
<i>lab. if. md.</i> .....	ramus labialis inferior from main ramus mandibularis V.
<i>lar. lg.</i> .....	longitudinal (dilator) muscle of the larynx.
<i>lar. su.</i> .....	ramus laryngeus superior X.
<i>lax. tym.</i> .....	laxator tympani muscle.
<i>lch.</i> .....	os lachrymale.
<i>lgs. coll.</i> .....	longissimus colli muscle.
<i>lig. stp.</i> .....	stapedial ligament.
<i>lig. tym.</i> .....	tympanic ligament.
<i>lng. i'm. XII.</i> .....	ramus lingualis intermedius XII.
<i>lng. l. XII.</i> .....	ramus lingualis lateralis XII.
<i>lng. l. XII.<sup>1</sup></i> .....	lateral division of rm. lateralis lingualis XII.
<i>lng. l. XII.<sup>2</sup></i> .....	median division of rm. lateralis lingualis XII.
<i>lng. lg.</i> .....	longitudinal tongue muscle superficial to <i>gen-gls.</i>
<i>lng. lg.<sup>1</sup></i> .....	longitudinal tongue muscle with deep insertion.



- lng. lg.*<sup>2</sup>.....longitudinal tongue muscle with superficial insertion on the mandible.
- lng. m. XII*.....ramus lingualis medialis XII.
- lng. t.*.....transverse tongue muscle.
- lng. vrt.*.....vertical tongue muscle.
- lng. V*.....ramus lingualis of V.
- lng. XII + V*.....combined lingual rami of XII and V.
- md.*.....ramus mandibularis V.
- md.*<sup>1</sup>.....first motor-sensory branch of *rm. mandibularis V*, supplying skin and *m. mylo-hyoideus*.
- md.*<sup>2</sup>.....second motor-sensory branch of *rm. mandibularis V*, supplying skin and anterior part of *m. mylo-hyoideus*.
- mx.*.....maxillary bone; ramus maxillaris V.
- mx.*<sup>1</sup>.....temporal cutaneous branch of *rm. maxillaris V*.
- mx.*<sup>2</sup>.....branch of *rm. maxillaris* to part of lower lid and its posterior angle.
- mx.*<sup>3</sup>.....branch to anterior part of lower lid.
- mx.*<sup>4</sup>.....branch to suborbital region.
- myl-hy.*.....mylo-hyoideus muscle; branches of nerve V supplying it.
- na.*.....os nasale; ramus of *nasalis V* through ethmoidal ganglion to skin.
- na.*<sup>1</sup>.....cutaneous branch of *rm. nasalis* through the ethmoidal ganglion.
- na. l.*.....ramus *nasalis lateralis V*.
- na. l.*<sup>1</sup>.....
- na. l.*<sup>2</sup>.....} branches to the skin given off through external nasal gland.
- na. m.*.....ramus *nasalis medialis V*.
- na. m.*<sup>1</sup>.....cutaneous branch of *rm. nasalis medialis V* passing through nasal bone.
- ob. d.*.....dorsal oblique muscle; branch of nerve VI supplying same.
- ob. v.*.....ventral oblique muscle; ramus of III supplying it.
- occ. crv.*.....occipito-cervicalis muscle.
- occ. crv. m.*.....occipito-cervicalis medialis.
- omo-hy.*.....omohyoideus muscle; nerve ramus supplying it.
- omo-hy. prf.*.....deeper part of omohyoideus muscle.
- omo + stn-hy.*.....branches of ventral ramus of first spinal nerve to omohyoid and sternohyoid muscles.
- opt.*.....optic nerve.
- or. lch.*.....opening of the duct of the lachrymal gland.

<i>ot</i> .....	otic capsule.
<i>p</i> .....	posterior.
<i>pal</i> .....	os palatinum; ramus palatinus VII.
<i>pal</i> <sup>1</sup> , <i>pal</i> <sup>2</sup> , <i>pal</i> <sup>3</sup> .....	three divisions of <i>rm. palatinus</i> VII at beginning of infraorbital plexus.
<i>pal. i</i> <sup>2</sup> <i>m</i> .....	ramus palatinus intermedius VII.
<i>pal. l</i> .....	ramus palatinus lateralis VII.
<i>pal. m</i> .....	ramus palatinus medialis VII.
<i>pa</i> <sup>1</sup> <i>occ</i> .....	paroccipital.
<i>par</i> .....	os parietale.
<i>pa</i> <sup>1</sup> <i>sph</i> .....	parasphenoid.
<i>p</i> <sup>1</sup> <i>f</i> .....	postfrontal.
<i>phx-lar</i> .....	ramus pharygo-laryngeus IX + X.
<i>phx-lar</i> <sup>1</sup> .....	first branch given off by the combined XII and IX + X, containing most of the nerve fibres of <i>rm. phx-lar</i> .
<i>phx. X</i> .....	small pharyngeal branch given off on distal side of trunk ganglion X.
<i>plx. lch</i> .....	lachrymal plexus.
<i>p</i> <sup>1</sup> <i>orb</i> .....	postorbital bone.
<i>prc. pa</i> <sup>1</sup> <i>ot</i> .....	parotic process.
<i>prc. pt-qd</i> .....	pterygo-quadrate process.
<i>pref</i> .....	prefrontal.
<i>premx</i> .....	premaxillary.
<i>presph</i> .....	presphenoid.
<i>pro</i> <sup>1</sup> <i>ot</i> .....	prootic.
<i>protru. oc</i> .....	protrusor oculi muscle; nerve twigs supplying it.
<i>prt. pt-qd</i> .....	error (fig. 18) for <i>prc. pt-qd</i> .
<i>pt</i> .....	pterygoid bone, pterygoid muscle, or nerve ramus to latter.
<i>pt</i> <sup>1</sup> .....	deeper part of <i>m. pterygoideus</i> ; nerve ramus to same.
<i>pt-md</i> .....	pterygo-mandibularis muscle; nerve ramus to <i>m. pterygo-mandibularis</i> .
<i>pt-par</i> .....	pterygo-parietalis muscle; nerve ramus to <i>m. pterygo-parietalis</i> .
<i>pt-sph. p</i> .....	pterygo-sphenoidalis posterior muscle; nerve ramus to <i>m. pterygo-sphenoidalis posterior</i> .
<i>qd</i> .....	quadrate.
<i>rer. X</i> .....	ramus recurrens laryngis X.
<i>rm. de</i> .....	nerve fibers entering pulp cavity of tooth.
<i>rm. tr</i> .....	ramus trachealis.
<i>rm. vn. j</i> .....	rami of IX and X to jugular vein.

- rt. a.*.....rectus anterior muscle; ramus of III supplying it.  
*rt. d.*.....rectus dorsalis muscle; ramus of III supplying it.  
*rt. p.*.....rectus posterior muscle.  
*rtr. oc.*.....retractor oculi muscle.  
*rt. v.*.....rectus ventralis muscle; ramus of III supplying it.  
*rx. III, V, VII, IX, X, XII*<sup>1 2 3</sup>.....roots of nerves III, V, VII, IX, X and XII.  
*rx. cil. III*.....radix brevis of ciliary nerve.  
*rx. cil. V*.....radix longa of ciliary nerve.  
*rx. d. spi. 3*.....dorsal root of third spinal nerve.  
*rx. v. spi. 1, 2, 3*.....ventral roots of first, second and third spinal nerves.  
*rx. XII*<sup>1 2 3</sup>.....first, second and third roots of nerve XII.  
*sa'ang.*.....supra angulare.  
*sac. en'lym.*.....saccus endolymphaticus.  
*sa'tmp.*.....supratemporal.  
*sph.*.....os sphenoidale.  
*sph. coll.*.....sphincter colli muscle.  
*spi. coll.*.....spinalis colli muscle.  
*spi. d. 1, 2, 3*.....main dorsal ramus of first, second and third spinal nerves.  
*spi. l. 1, 2, 3*.....main lateral ramus of first, second and third spinal nerves.  
*spi. v. 1, 2, 3*.....main ventral ramus of first, second and third spinal nerves.  
*sq.*.....squamosal.  
*stn-hy.*.....sterno-hyoideus muscle; nerve ramus supplying it.  
*sy.*.....sympathetic trunk posterior to union of communicating rami (internus and externus).  
*sy. X*.....communicating ramus between cervical sympathetic trunk and ramus visceralis X.  
*t.*.....os transversum.  
*tis. tnd.*.....tendinous tissue.  
*tnd.*.....tendon.  
*tnd. mb. nic.*.....tendon of nictitating membrane.  
*tr.*.....trachea.  
*tym.*.....tympanum.  
*vcr. X*.....error in fig. *L* for *rcr. X*.  
*vn. j. i.*.....internal jugular vein.  
*vom.*.....vomer.  
*vsc. X*.....ramus visceralis X.  
*v. spi. 1, 2, 3*.....ramus ventralis of spinal nerves 1, 2 and 3.

- I-XII*.....cranial nerves I-XII.....
- XII. 1*.....nerve branch to posterior part of m. cerato-  
mandibularis 1.
- XII. 2*.....nerve branch to m. cerato-mandibularis 3 and  
to anterior part of m. cerato-mandibularis  
1.
- XII. 3*.....nerve branch to m. cerato-mandibularis 2  
(a few fibers to cerato-mandibularis 1).
- XII. 4*.....nerve branch to posterior part of genioglos-  
sus muscle.
- XII. 5*.....nerve branch of *lng. l. XII* to longitudinal  
tongue muscles.
- $\alpha, \beta, \gamma$ .....posterior communicating rami of the infra-  
orbital plexus (interpreted as sympathetic).

PLATE 1.

PLATE 1.

Fig. 1-3. Skull.

Fig. 1. Dorsal aspect.

Fig. 2. Left lateral aspect.

Fig. 3. Ventral aspect.

All were drawn from a specimen that had been macerated in water and then dried. The cartilaginous parts are not preserved in such a preparation.

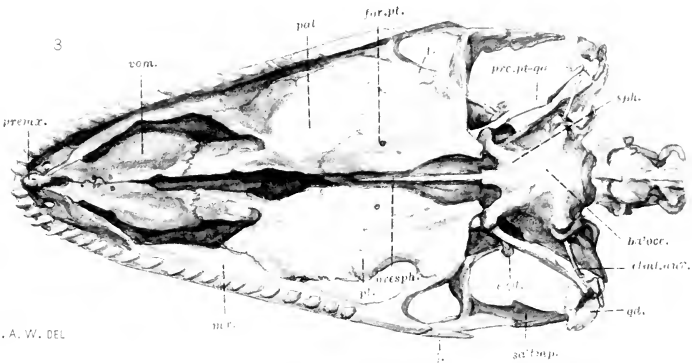
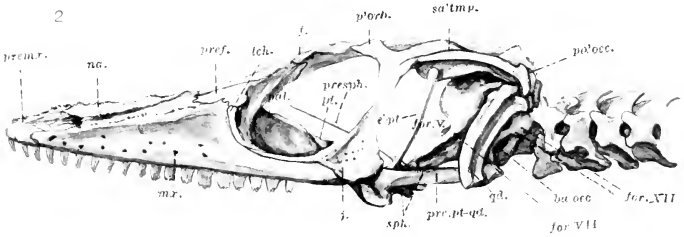
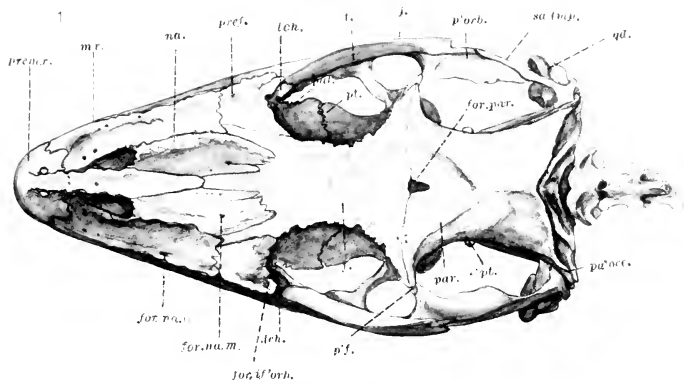





PLATE 2.

PLATE 2.

Fig. 4. Cranial and first three spinal nerves of the *left* side as projected upon a horizontal plane, *dorsal* aspect. For clearness, the nerves distributed to the ventral side of the head are shown in a separate figure (fig. 5). The connections of the viscerosensory components with the fasciculus solitarius are shown by dotted lines. The terminal branches of some of the rami are not carried out in both the figures (4 and 6), being included only in the figure which shows them with least confusion.  $\times 21$ .

Fig. 5. Continuation of the nerves shown in figure 4, showing their course and distribution in the jaw, tongue, pharynx and larynx. The terminal distribution of the combined nerves V and XII is not included in this figure. Same view and magnification as figure 4.





PLATE 3.

## PLATE 3.

Fig. 6. Cranial and first three spinal nerves of the *left* side as projected upon a sagittal plane and *seen* from the *median* side. Nerves III, IV and VI with ciliary ganglion and its nerves are omitted; also the terminal rami of V and XII are omitted, because they fall so nearly in the same frontal plane.

Fig. 7. *Ventral* aspect of a dissection of the right side of the head showing about the same group of nerves as figure 4. The figure represents the dorsal portion of the head, the ventral portion, including the bony roof of the mouth, having been cut away to expose the nerves. The plane of division is carried through the tympanum, the quadrate bone and the posterior bony arch of the orbit. The whole mandibular group and ventral cervical muscles are removed, while all those related to the orbit are retained. The shaded background against which the maxillary bone is seen, represents the skin of the dorso-lateral side of the head, the cut edge of which forms the margin of the figure. The two superficial sympathetic rami connecting nerve VII with the lachrymal plexus pass in part through the *m. capiti mandibularis*, which has been dissected away. The structures of the orbit are those immediately exposed upon the removal of the pterygoid and palatine bones. The portion of the maxillary bone forming the ventral rim of the bony orbit is cut away exposing the deeper surface of the lower eyelid. The hind brain is exposed, in the region where the last three cranial nerves show their superficial origin, by the removal of parts of the basisphenoid and basioccipital bones. The finer rootlets of nerves IX and X were nearly transparent and practically invisible under the dissecting microscope; the drawing, therefore, does not show their exact number nor connection with the lateral side of the medulla. The part of the medulla exposed is bent sharply away from the observer, making it difficult to represent the linear arrangement of the roots of nerve XII and the occipital foramina through which they emerge. The representation of the details of the muscles of the cervical region is not attempted. The *m. spinalis colli* and part of the *m. longissimus colli* are removed, but the roots of the spinal nerves are hidden by the remaining part of the *m. longissimus colli*. The distribution of the small nerve branch given off from X at the point where the communicating ramus (*comm. IX-X.*) joins IX, was not determined. It is represented too large in the figure.

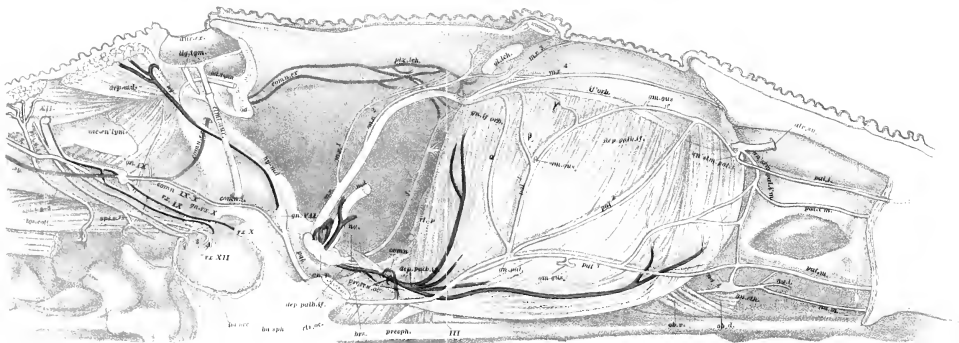





PLATE 4.

## PLATE 4.

The sections represented in Plates 4-7 were selected at intervals through the series from which the projection drawings (Plates 1 and 2, figs. 4-6) were made. The scale included in these drawings (Figs. 4, 6) shows the position of every hundredth section in the series. The planes of the sections shown in figures 8-24 may be determined by referring their numbers to this scale. Branches of minor importance which are not included in the plottings may appear in the sections. No importance can be placed on a close comparison of the relative diameters of the nerves. These have suffered shrinkage to a different degree in different parts of the head and are represented approximately as they appear in the sections, while they are for the most part enlarged and made uniform in the plottings in order to demonstrate their components. The sections were drawn as projected by the camera and are accurate in respect to those structures which are considered.

Fig. 8. Transverse section (No. 130) anterior to external nares. The space between the nasal cartilage and the premaxillary bone is filled with pericapsular vascular tissue. The median palatine rami are here united. The sublingual gland opens by three ducts (one median, two lateral) anterior to this section. Labial glands open by numerous ducts. The mucous membrane in the floor of the mouth has numerous taste buds located between the gland openings and in the epithelium just median to the upper and lower jaws.

Fig. 9. Transverse section (No. 319) through nasal organ, showing external and internal nasal chamber and external nasal gland. The tongue is cut through the region of the greatest development of the lingual papillae, the out lines of which are represented somewhat diagrammatically. The muscle fibers extend to the ends of these, which are provided with long protruding epithelial cells. The taste buds are seen along both upper and lower lingual gum at points indicated (*gm. gus. l.*). No taste buds were observed on the papillae. A single taste bud was found near the median line in the roof of the mouth, while on the floor of the mouth they appear to be limited to the lingual gum.

Fig. 10. Transverse section (No. 579), through ethmoidal ganglion and internal nares, just anterior to the orbit and the larynx. In addition to the series of taste buds found in section No. 319, they appear along the lateral border of the tongue in the stratified epithelium between the openings of the tubular glands.

Fig. 11. Transverse section (No. 659) cutting into the anterior wall of the eyeball and through the Harderian gland. The muscles at the root of the tongue are diverging to each side of the larynx, which is here cut through the glottis. The two laryngeal muscles appear.

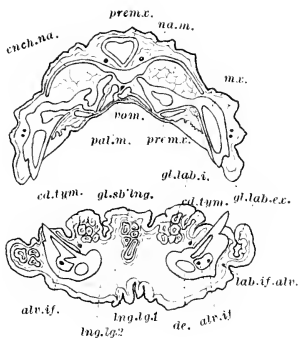

8  
130

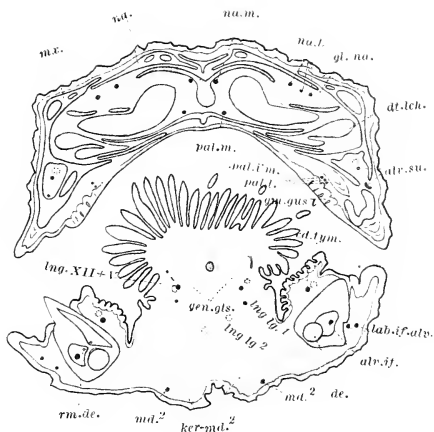

9  
319

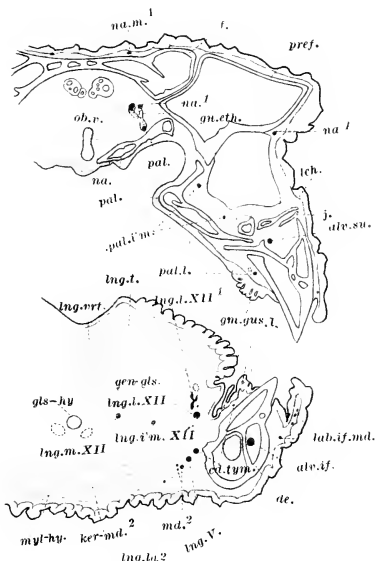

10

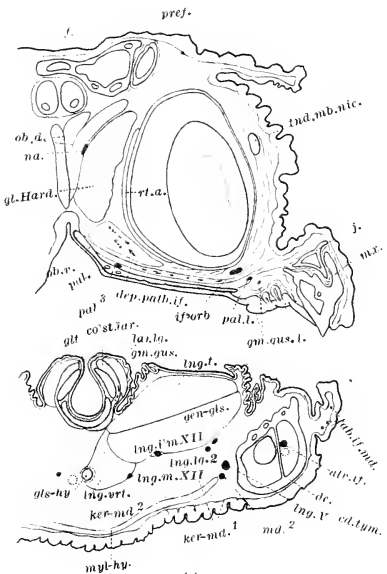

11



PLATE 5.

PLATE 5.

Fig. 12. Transverse section (No. 767) through the mid-orbit region. The lingual and chorda tympani nerves are leaving the alveolar canal. No taste buds are found on the floor of the mouth, but they appear in the roof of the mouth among the median palatine glands, and to a less extent along the lateral glandular area. Different parts of the infraorbital plexus appear in the floor of the orbit.

Fig. 13. Transverse section (No. 909) through orbit, showing the connection of the optic nerve with the retina. The chorda tympani is closely applied to the median side of the ramus alveolaris inferior. The muscle of the lower lid (*dep. palb. inf.*) shows some of its fibers originating from the connective tissue near the median part of the roof of the mouth.

Fig. 14. Transverse section (No. 988) through the anterior part of the optic chiasma (blue tint omitted), showing entrance of ciliary nerves into the eyeball. The retina is cut tangentially; the infraorbital ganglion, the anterior part of the lachrymal gland, and the mechanism of the bursalis muscle in its relation to the ligament of the nictitating membrane, also fall in the plane of the section.

Fig. 15. Transverse section (No. 1064), posterior to the orbit, through the posterior part of the optic chiasma (not lettered). The ciliary ganglion and the lachrymal plexus around a large post-lachrymal blood sinus are shown. The columella (epipterygoid) is cut where it articulates with the pterygoid bone.

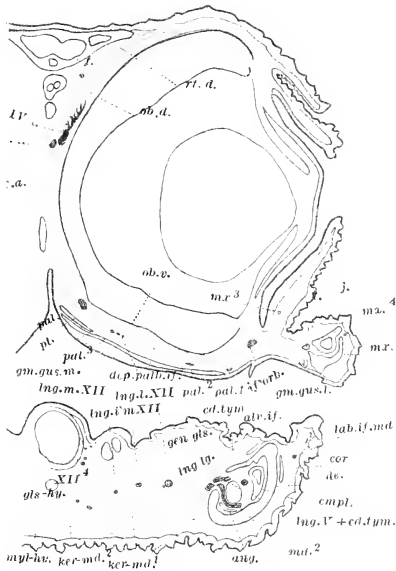

12  
767

par.

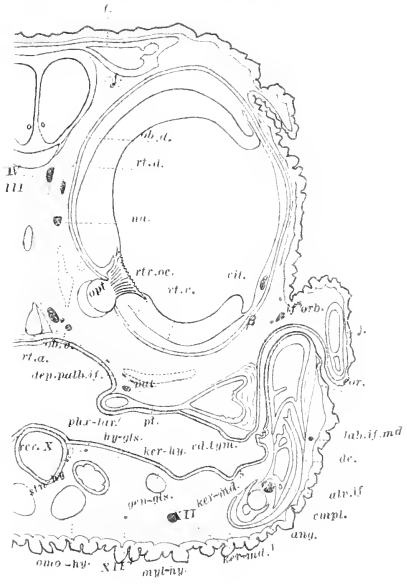

13  
305

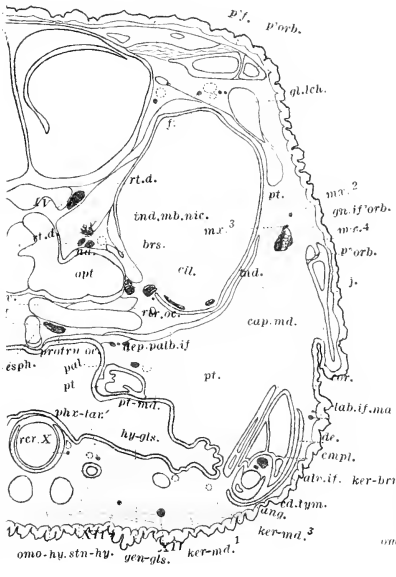

14

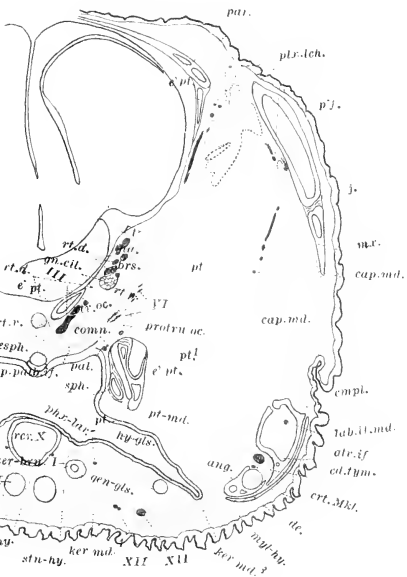

15





PLATE 6.

PLATE 6.

Fig. 16. Transverse section (No. 1175) through the pituitary body (not lettered) and origin of the retractor oculi and bursalis muscles. The roots of nerves III and IV here have an intracranial course. Ramus frontalis V is shown (*f.*) mesad to the origin of the protractor oculi muscle. The insertion of the m. pterygoparietalis on the pterygoid bone is shown.

Fig. 17. Transverse section (No. 1226). This falls in a plane where few main nerve rami are cut, as reference to the plotting will show. The ophthalmic ganglion is shown as completely separate from the mandibular-maxillary part of the Gasserian ganglion. Nerve IV is labelled V by mistake.

Fig. 18. Transverse section (No. 1320) through the geniculate ganglion and also showing a portion of the ganglion of nerve VIII. The otic capsule and the tympanic chamber are just appearing. The insertion of m. pterygo-sphenoidalis posterior on the pterygo-quadrate process (*prt. pt-ql.*) is shown.

Fig. 19. Transverse section (No. 1399) through the inner, middle and outer ear, showing the root of nerve IX about to emerge from the cranium. The chorda tympani, which is shown in this and preceding sections occupying a position in the lower jaw, is here cut at a second place, where it is still in combination with the motor part (*hy-md.*) of nerve VII, although its components are distinctly segregated on the lateral side of the hyomandibular ramus.

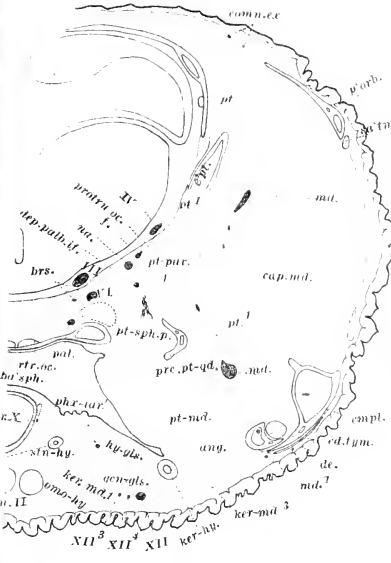

16  
117E

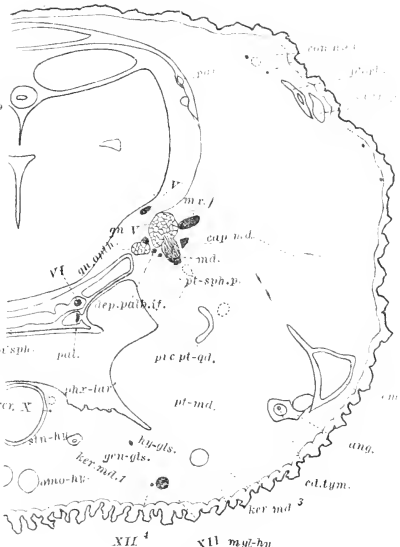

17  
112

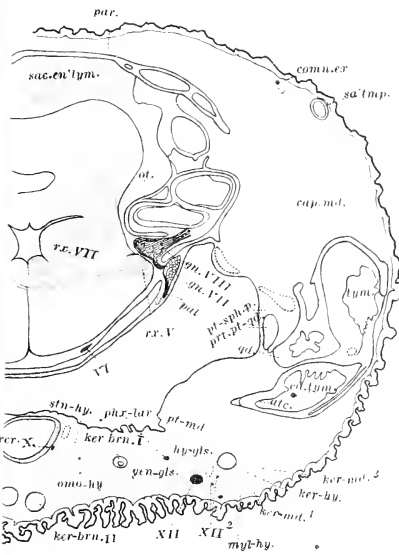

18  
1320

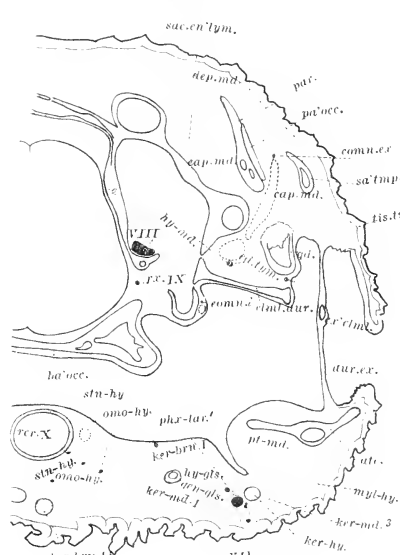

19  
1334



PLATE 7.

PLATE 7.

Figs. 20 and 21. Transverse sections (Nos. 1435 and 1441) through the posterior part of the middle ear cavity, showing the relation of the chorda tympani to the ligament of the extra-columella (*lig. tym.*). Fig. 20 shows also foramina for nerve X and the second root of nerve XII. Fig. 21 shows the laxator tympani muscle continuing caudad from the place of insertion of the ligament.

Fig. 22. Transverse section (No. 1453) through the ganglion of nerve X and the three roots of nerve XII before their union, and immediately anterior to the juncture of Jacobson's anastomosis with the main sympathetic trunk.

Fig. 23. Transverse section (No. 1480) through the anterior end of the petrosal ganglion. The skeletal attachment of the constrictor of the internal jugular vein is shown, also the root and distribution, in part, of the first spinal nerve.

Fig. 24. Transverse section (No. 1595) showing ganglion of the third spinal nerve and the position of the sympathetic trunk and ramus visceralis X on the dorsal side of the thymus gland.

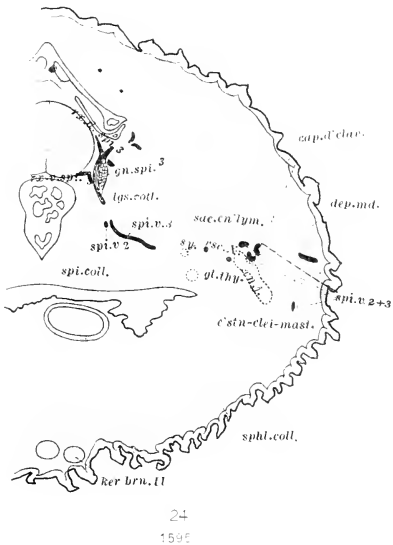
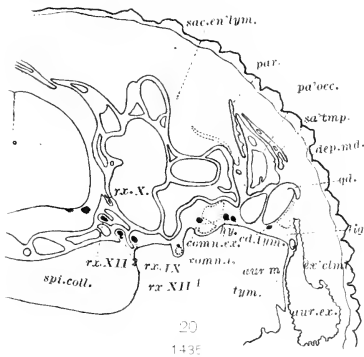





The following Publications of the Museum of Comparative Zoölogy are in preparation:—

- LOUIS CABOT. Immature State of the Odonata, Part IV.  
E. L. MARK. Studies on Lepidosteus, continued.  
E. L. MARK. On Arachnactis.  
H. L. CLARK. The "Albatross" Hawaiian Echini.

Reports on the Results of Dredging Operations in 1877, 1878, 1879, and 1880, in charge of ALEXANDER AGASSIZ, by the U. S. Coast Survey Steamer "Blake," as follows:—

- A. MILNE EDWARDS and E. L. BOUVIER. The Crustacea of the "Blake."  
A. E. VERRILL. The Alcyonaria of the "Blake."

Reports on the Results of the Expedition of 1891 of the U. S. Fish Commission Steamer "Albatross," Lieutenant Commander Z. L. TANNER, U. S. N., Commanding, in charge of ALEXANDER AGASSIZ, as follows:—

- |   |   |
|---|---|
| K. BRANDT. The Sagittae.                        | W. A. HERDMAN. The Ascidians.               |
| K. BRANDT. The Thalassicolae.                   | S. J. HICKSON. The Antipathids.             |
| O. CARLGREN. The Actinarians.                   | E. L. MARK. Branchiocerianthus.             |
| R. V. CHAMBERLIN. The Annelids.                 | JOHN MURRAY. The Bottom Specimens.          |
| W. R. COE. The Nemerteans.                      | P. SCHIEMENZ. The Pteropods and Heteropods. |
| REINHARD DOHRN. The Eyes of Deep-Sea Crustacea. | THEO. STUDER. The Alcyonarians.             |
| H. J. HANSEN. The Cirripeds.                    | — The Salpidae and Doliolidae.              |
| H. J. HANSEN. The Schizopods.                   | H. B. WARD. The Sipunculids.                |
| HAROLD HEATH. Solenogaster.                     |   |

Reports on the Scientific Results of the Expedition to the Tropical Pacific, in charge of ALEXANDER AGASSIZ, on the U. S. Fish Commission Steamer "Albatross," from August, 1899, to March, 1900, Commander Jefferson F. Moser, U. S. N., Commanding, as follows:—

- |                                 |   |
|---------------------------------|---|
| R. V. CHAMBERLIN. The Annelids. | MARY J. RATHBUN. The Crustacea Decapoda.        |
| H. L. CLARK. The Holothurians.  | G. O. SARS. The Copepods.                       |
| H. L. CLARK. The Ophiurans.     | L. STEJNEGER. The Reptiles.                     |
| — The Volcanic Rocks.           | C. H. TOWNSEND. The Mammals, Birds, and Fishes. |
| — The Coralliferous Limestones. | T. W. VAUGHAN. The Corals, Recent and Fossil.   |
| S. HENSHAW. The Insects.        |   |
| G. W. MÜLLER. The Ostracods.    |   |

PUBLICATIONS  
OF THE  
MUSEUM OF COMPARATIVE ZOÖLOGY  
AT HARVARD COLLEGE.

---

There have been published of the BULLETIN Vols. I. to LIV. and Vol. LVIII.; of the MEMOIRS, Vols. I. to XXIV., and also Vols. XXVI. to XXIX., XXXI. to XXXIV., XXXVI. to XXXVIII., XL. to XLII., and XLIV.

Vols. LV. to LVII., and LIX. of the BULLETIN, and Vols. XXV., XXX., XXXV., XXXIX., XLIII., XLV. to XLIX. of the MEMOIRS, are now in course of publication.

The BULLETIN and MEMOIRS are devoted to the publication of original work by the Officers of the Museum, of investigations carried on by students and others in the different Laboratories of Natural History, and of work by specialists based upon the Museum Collections and Explorations.

The following publications are in preparation:—

Reports on the Results of Dredging Operations from 1877 to 1880, in charge of Alexander Agassiz, by the U. S. Coast Survey Steamer "Blake," Lieut. Commander C. D. Sigsbee, U. S. N., and Commander J. R. Bartlett, U. S. N., Commanding.

Reports on the Results of the Expedition of 1891 of the U. S. Fish Commission Steamer "Albatross," Lieut. Commander Z. L. Tanner, U. S. N., Commanding, in charge of Alexander Agassiz.

Reports on the Scientific Results of the Expedition to the Tropical Pacific, in charge of Alexander Agassiz, on the U. S. Fish Commission Steamer "Albatross," from August, 1899, to March, 1900, Commander Jefferson F. Moser, U. S. N.; Commanding.

Reports on the Scientific Results of the Expedition to the Eastern Tropical Pacific, in charge of Alexander Agassiz, on the U. S. Fish Commission Steamer "Albatross," from October, 1904, to April, 1905, Lieut. Commander L. M. Garrett, U. S. N., Commanding.

Contributions from the Zoölogical Laboratory, Professor E. L. Mark, Director.  
Contributions from the Geological Laboratory, Professor R. A. Daly, in charge.

These publications are issued in numbers at irregular intervals. Each number of the Bulletin and of the Memoirs is sold separately. A price list of the publications of the Museum will be sent on application to the Director of the Museum of Comparative Zoölogy, Cambridge, Mass.

3189

Bulletin of the Museum of Comparative Zoölogy  
AT HARVARD COLLEGE.  
VOL. LIX. No. 3.

---

RELICS OF PEALE'S MUSEUM.

BY WALTER FAXON.

CAMBRIDGE, MASS., U. S. A.:  
PRINTED FOR THE MUSEUM.  
JULY, 1915.

REPORTS ON THE SCIENTIFIC RESULTS OF THE EXPEDITION TO THE EASTERN TROPICAL PACIFIC, IN CHARGE OF ALEXANDER AGASSIZ, BY THE U. S. FISH COMMISSION STEAMER "ALBATROSS," FROM OCTOBER, 1904, TO MARCH, 1905, LIEUTENANT COMMANDER L. M. GARRETT, U. S. N., COMMANDING, PUBLISHED OR IN PREPARATION:—

- A. AGASSIZ. V.<sup>6</sup> General Report on the Expedition.
- A. AGASSIZ. I.<sup>1</sup> Three Letters to Geo. M. Bowers, U. S. Fish Com.
- A. AGASSIZ and H. L. CLARK. The Echini.
- H. B. BIGELOW. XVI.<sup>16</sup> The Medusae.
- H. B. BIGELOW. XXIII.<sup>23</sup> The Siphonophores.
- H. B. BIGELOW. XXVI.<sup>26</sup> The Ctenophores.
- R. P. BIGELOW. The Stomatopods.
- O. CARLGREN. The Actinaria.
- R. V. CHAMBERLIN. The Annelids.
- H. L. CLARK. The Holothurians.
- H. L. CLARK. The Starfishes.
- H. L. CLARK. The Ophlurans.
- S. F. CLARKE. VIII.<sup>8</sup> The Hydrozoa.
- W. R. COE. The Nemertean.
- L. J. COLE. XIX.<sup>19</sup> The Pycnogonida.
- W. H. DALL. XIV.<sup>14</sup> The Mollusks.
- C. R. EASTMAN. VII.<sup>7</sup> The Sharks' Teeth.
- S. GARMAN. XII.<sup>12</sup> The Reptiles.
- H. J. HANSEN. The Cirripeds.
- H. J. HANSEN. XXVII.<sup>27</sup> The Schizopods.
- S. HENSHAW. The Insects.
- W. E. HOYLE. The Cephalopods.
- W. C. KENDALL and L. RADCLIFFE. XXV.<sup>25</sup> The Fishes.
- C. A. KOFOID. III.<sup>3</sup> IX.<sup>9</sup> XX.<sup>20</sup> The Protozoa.
- C. A. KOFOID and J. R. MICHENER. XXII.<sup>22</sup> The Protozoa.
- C. A. KOFOID and E. J. RIGDEN. XXIV.<sup>24</sup> The Protozoa.
- P. KRUMBACH. The Sagittae.
- R. VON LENDENFELD. XXI.<sup>21</sup> The Siliceous Sponges.
- R. VON LENDENFELD. XXIX.<sup>29</sup> Hexactinellida.
- G. W. MÜLLER. The Ostracods.
- JOHN MURRAY and G. V. LEE. XVII.<sup>17</sup> The Bottom Specimens.
- MARY J. RATHBUN. X.<sup>10</sup> The Crustacea Decapoda.
- HARRIET RICHARDSON. II.<sup>2</sup> The Isopods.
- W. E. RITTER. IV.<sup>4</sup> The Tunicates.
- B. L. ROBINSON. The Plants.
- G. O. SARS. The Copepods.
- F. E. SCHULZE. XI.<sup>11</sup> The Xenophyphoras.
- HARRIET R. SEARLE. XXVIII.<sup>28</sup> Isopods.
- H. R. SIMROTH. Pteropods, Heteropods.
- E. C. STARKS. XIII.<sup>13</sup> Atelaxia.
- TH. STUDER. The Alcyonaria.
- JH. THIELE. XV.<sup>15</sup> Bathyscladium.
- T. W. VAUGHAN. VI.<sup>6</sup> The Corals.
- R. WOLTERECK. XVIII.<sup>18</sup> The Amphipods.

<sup>1</sup> Bull. M. C. Z., Vol. XLVI., No. 4, April, 1905, 22 pp.

<sup>2</sup> Bull. M. C. Z., Vol. XLVI., No. 6, July, 1905, 4 pp., 1 pl.

<sup>3</sup> Bull. M. C. Z., Vol. XLVI., No. 9, September, 1905, 5 pp., 1 pl.

<sup>4</sup> Bull. M. C. Z., Vol. XLVI., No. 13, January, 1906, 22 pp., 3 pls.

<sup>5</sup> Mem. M. C. Z., Vol. XXXIII., January, 1906, 90 pp., 96 pls.

<sup>6</sup> Bull. M. C. Z., Vol. L., No. 3, August, 1906, 14 pp., 10 pls.

<sup>7</sup> Bull. M. C. Z., Vol. L., No. 4, November, 1906, 26 pp., 4 pls.

<sup>8</sup> Mem. M. C. Z., Vol. XXXV., No. 1, February, 1907, 20 pp., 15 pls.

<sup>9</sup> Bull. M. C. Z., Vol. L., No. 6, February, 1907, 48 pp., 18 pls.

<sup>10</sup> Mem. M. C. Z., Vol. XXXV., No. 2, August, 1907, 56 pp., 9 pls.

<sup>11</sup> Bull. M. C. Z., Vol. LI., No. 6, November, 1907, 22 pp., 1 pl.

<sup>12</sup> Bull. M. C. Z., Vol. LII., No. 1, June, 1908, 14 pp., 1 pl.

<sup>13</sup> Bull. M. C. Z., Vol. LII., No. 2, July, 1908, 8 pp., 5 pls.

<sup>14</sup> Bull. M. C. Z., Vol. XLIII., No. 6, October, 1908, 285 pp., 22 pls.

<sup>15</sup> Bull. M. C. Z., Vol. LII., No. 5, October, 1908, 11 pp., 2 pls.

<sup>16</sup> Mem. M. C. Z., Vol. XXXVII., February, 1909, 243 pp., 48 pls.

<sup>17</sup> Mem. M. C. Z., Vol. XXXVIII., No. 1, June, 1909, 172 pp., 5 pls., 3 maps.

<sup>18</sup> Bull. M. C. Z., Vol. LII., No. 9, June, 1909, 26 pp., 8 pls.

<sup>19</sup> Bull. M. C. Z., Vol. LII., No. 11, August, 1909, 10 pp., 3 pls.

<sup>20</sup> Bull. M. C. Z., Vol. LII., No. 13, September, 1909, 48 pp., 4 pls.

<sup>21</sup> Mem. M. C. Z., Vol. XLI., August, September, 1910, 323 pp., 56 pls.

<sup>22</sup> Bull. M. C. Z., Vol. LIV., No. 7, August, 1911, 38 pp.

<sup>23</sup> Mem. M. C. Z., Vol. XXXVIII., No. 2, December, 1911, 232 pp., 32 pls.

<sup>24</sup> Bull. M. C. Z., Vol. LIV., No. 10, February, 1912, 16 pp., 2 pls.

<sup>25</sup> Mem. M. C. Z., Vol. XXXV., No. 3, April, 1912, 98 pp., 8 pls.

<sup>26</sup> Bull. M. C. Z., Vol. LIV., No. 12, April, 1912, 38 pp., 2 pls.

<sup>27</sup> Mem. M. C. Z., Vol. XXXV., No. 4, July, 1912, 124 pp., 12 pls.

<sup>28</sup> Bull. M. C. Z., Vol. LVIII., No. 8, August, 1914, 14 pp.

<sup>29</sup> Mem. M. C. Z., Vol. XLII., June, 1915, 397 pp., 109 pls.

Bulletin of the Museum of Comparative Zoölogy  
AT HARVARD COLLEGE.  
VOL. LIX. No. 3.

---

RELICS OF PEALE'S MUSEUM.

BY WALTER FAXON.

See corrections and annotations  
in separate copy. MCZ-F

CAMBRIDGE, MASS., U. S. A.:  
PRINTED FOR THE MUSEUM  
JULY, 1915.

REPORTS ON THE SCIENTIFIC RESULTS OF THE EXPEDITION TO THE EASTERN TROPICAL PACIFIC, IN CHARGE OF ALEXANDER AGASSIZ, BY THE U. S. FISH COMMISSION STEAMER "ALBATROSS," FROM OCTOBER, 1904, TO MARCH, 1905, LIEUTENANT COMMANDER L. M. GARRETT, U. S. N., COMMANDING, PUBLISHED OR IN PREPARATION:—

- A. AGASSIZ. V.<sup>6</sup> General Report on the Expedition.  
 A. AGASSIZ. I.<sup>1</sup> Three Letters to Geo. M. Bowers, U. S. Fish Com.  
 A. AGASSIZ and H. L. CLARK. The Echini.  
 H. B. BIGELOW. XVI.<sup>16</sup> The Medusae.  
 H. B. BIGELOW. XXIII.<sup>23</sup> The Siphonophores.  
 H. B. BIGELOW. XXVI.<sup>26</sup> The Ctenophores.  
 R. P. BIGELOW. The Stomatopods.  
 O. CARLGRÉN. The Actinaria.  
 R. V. CHAMBERLIN. The Annelids.  
 H. L. CLARK. The Holothurians.  
 H. L. CLARK. The Starfishes.  
 H. L. CLARK. The Ophiurans.  
 S. F. CLARKE. VIII.<sup>8</sup> The Hydrolds.  
 W. R. COE. The Nemerteans.  
 L. J. COLE. XIX.<sup>19</sup> The Pycnogonida.  
 W. H. DALL. XIV.<sup>14</sup> The Mollusks.  
 C. R. EASTMAN. VII.<sup>7</sup> The Sharks' Teeth.  
 S. GARMAN. XII.<sup>12</sup> The Reptiles.  
 H. J. HANSEN. The Cirripeds.  
 H. J. HANSEN. XXVII.<sup>27</sup> The Schizopods.  
 S. HENSTRAW. III.<sup>3</sup> The Crustacea.  
 W. E. H.  
 W. C. KJ  
 XX  
 C. A. KC  
 Prot

- C. A. KOFOID and J. R. MICHENER. XXII.<sup>22</sup> The Protozoa.  
 C. A. KOFOID and E. J. RIGDEN. XXIV.<sup>24</sup> The Protozoa.  
 P. KRUMBACH. The Sagittae.  
 R. VON LENDENFELD. XXI.<sup>21</sup> The Siliceous Sponges.  
 R. VON LENDENFELD. XXIX.<sup>29</sup> Hexactinellida.  
 G. W. MÜLLER. The Ostracods.  
 JOHN MURRAY and G. V. LEE. XVII.<sup>17</sup> The Bottom Specimens.  
 MARY J. RATHBUN. X.<sup>10</sup> The Crustacea Decapoda.  
 HARRIET RICHARDSON. II.<sup>2</sup> The Isopods.  
 W. E. RITTER. IV.<sup>4</sup> The Tunicates.  
 B. L. ROBINSON. The Plants.  
 G. O. SARS. The Copepods.  
 F. E. SCHULZE. XI.<sup>11</sup> The Xenophyphoras.  
 HARRIET R. SEARLE. XXVIII.<sup>28</sup> Isopods.  
 H. R. SIMROTH. Pteropods, Heteropods.  
 E. C. STARKS. XXX.<sup>30</sup> The

- <sup>1</sup> B1  
<sup>2</sup> B1  
<sup>3</sup> B1  
<sup>4</sup> B1  
<sup>5</sup> M  
<sup>6</sup> B1  
<sup>7</sup> B1  
<sup>8</sup> M  
<sup>9</sup> B1  
<sup>10</sup> M  
<sup>11</sup> B1

- <sup>12</sup> Bull. M. C. Z., Vol. LII., No. 1, June, 1908, 14 pp., 1 pl.  
<sup>13</sup> Bull. M. C. Z., Vol. LII., No. 2, July, 1908, 8 pp., 5 pls.  
<sup>14</sup> Bull. M. C. Z., Vol. XLIII., No. 6, October, 1908, 285 pp., 22 pls.  
<sup>15</sup> Bull. M. C. Z., Vol. LII., No. 5, October, 1908, 11 pp., 2 pls.  
<sup>16</sup> Mem. M. C. Z., Vol. XXXVII., February, 1909, 243 pp., 48 pls.  
<sup>17</sup> Mem. M. C. Z., Vol. XXXVIII., No. 1, June, 1909, 172 pp., 5 pls., 3 maps.  
<sup>18</sup> Bull. M. C. Z., Vol. LII., No. 9, June, 1909, 26 pp., 8 pls.  
<sup>19</sup> Bull. M. C. Z., Vol. LII., No. 11, August, 1909, 10 pp., 3 pls.  
<sup>20</sup> Bull. M. C. Z., Vol. LII., No. 13, September, 1909, 48 pp., 4 pls.  
<sup>21</sup> Mem. M. C. Z., Vol. XLI., August, September, 1910, 323 pp., 56 pls.  
<sup>22</sup> Bull. M. C. Z., Vol. LIV., No. 7, August, 1911, 38 pp.  
<sup>23</sup> Mem. M. C. Z., Vol. XXXVIII., No. 2, December, 1911, 232 pp., 32 pls.  
<sup>24</sup> Bull. M. C. Z., Vol. LIV., No. 10, February, 1912, 16 pp., 2 pls.  
<sup>25</sup> Mem. M. C. Z., Vol. XXXV., No. 3, April, 1912, 98 pp., 8 pls.  
<sup>26</sup> Bull. M. C. Z., Vol. LIV., No. 12, April, 1912, 38 pp., 2 pls.

Bulletin of the Museum of Comparative Zoölogy

AT HARVARD COLLEGE.

VOL. LIX. No. 3.

---

RELICS OF PEALE'S MUSEUM.

BY WALTER FAXON.

CAMBRIDGE, MASS., U. S. A.:  
PRINTED FOR THE MUSEUM

JULY, 1915.





No. 3.—*Relics of Peale's Museum.*

By WALTER FAXON.

THE zoölogical collection of the Boston Museum, which had been given to the Boston Society of Natural History in 1893 and 1899, was transferred in 1914 to the Museum of Comparative Zoölogy at Cambridge. It is generally understood that this collection consisted chiefly of the moiety of the old Philadelphia or Peale Museum property purchased by Moses Kimball in 1850, after the dissolution of that institution in 1846. Since the Peale Museum was the repository of a large number of the types of species described by C. L. Bonaparte, Richard Harlan, George Ord, Thomas Say, and Alexander Wilson, it would seem that a careful study of this material might reveal some of these much-desired types. I have lately examined the North American birds in the collection, with a view to the recovery of specimens described and figured by Wilson in his "American Ornithology," 1808-1814. On account of the total loss of the original Peale Museum labels, the task has been a difficult one, and the results achieved are meagre and often vitiated by uncertainty; but such as they are, they are placed on record in this paper.

Since Wilson had no training as an artist, he found it expedient to draw a bird after it had assumed a definite form and attitude by being stuffed and mounted, often by his own hands. We know this not only by tradition but also by the written testimony of the artist Charles R. Leslie. In his "Autobiographical Recollections,"<sup>1</sup> 1, p. 245 (Amer. ed., p. 163), Leslie says:—

"Wilson was engaged by Mr. Bradford as tutor to his sons, and as editor of the American edition of 'Ree's Cyclopædia'; while at the same time he was advancing his Ornithology for publication. I assisted him to colour some of its first plates. We worked from birds which he had shot and stuffed, and I well remember the extreme accuracy of his drawings, and how carefully he had counted the number of scales on the tiny legs and feet of his subject."

Wilson usually refers to a Peale Museum specimen by its catalogue number at the beginning of his description of each species. Seventy-one out of about eighty-five of the birds described by him under new

<sup>1</sup> Autobiographical Recollections. By the late Charles Robert Leslie, R. A. Edited by Tom Taylor. In two volumes. London: John Murray, 1860. American Edition in one vol., Boston: Ticknor and Fields, 1860.

names<sup>1</sup> are thus definitely associated with specimens in the Peale Museum. That the specimens thus referred to by number were in all cases the subjects that he drew and described cannot be affirmed, but is highly probable because even in the case of an extremely abundant bird, like the Robin, of which there must have been several specimens in the Peale Museum, he cites but one specimen or rarely two.

Wilson's custom of drawing from a mounted specimen affords a clue in some instances for tracing the subject of his pencil. In the absence of original data, we are forced, like Polonius, to find directions out by indirections. When Wilson drew his bird in a simple, conventional attitude, agreement between his drawing and a mounted specimen in the old collection will obviously be of slight significance,—an accidental co-incidence, perhaps, since the same correspondence will in all likelihood hold true of birds in divers museums, the work of divers taxidermists. When, on the other hand, he depicts a bird in an unusual or singular posture, conformity of specimen and figure may fairly be taken as evidence that they bear to each other the relation of subject and copy; the weight of the evidence being in strict proportion to the preciseness of the similitude. In a few cases, individual peculiarities of plumage may assist in identifying the originals of Wilson's figures.

It does not follow conversely that specimens which do not conform to Wilson's figures are not the subjects that he drew: the exigencies arising from the arrangement of the figures might often compel him to adapt the posture of the bird to the requirements of the plate. With the disappearance of the original Peale labels the chance of recovering most of Wilson's types vanished for ever.

Can types ascertained by intrinsic evidence, in the absence of lawful credentials in the form of original labels, be of any practical use? I think they can. Let us suppose, in the way of argument, that it is found convenient to separate a species, *Mniotilta varia* for example, into two races or subspecies, differing from each other in size or plumage. In the synonymy of this species stands *Certhia maculata* Wilson. Will the name *maculata* be usable for the supposed new subspecies? In order to decide this, it seems to me that it would be incumbent upon the reviser of the species to examine, in the absence of a more authentic type, a specimen in the Boston Museum collection which exactly agrees with Wilson's drawing of *Certhia maculata*; for we know it was a habit of Wilson's to draw from a mounted specimen; that his

<sup>1</sup> Names borrowed by Wilson from William Bartram (Travels through North and South Carolina, etc., 1791) are allotted to Wilson, since their validity depends on his adoption of them.

type was in the Peale Museum; and that one half of the Peale Museum came to the Boston Museum.

It is generally believed that little was added to the Boston Museum collection of birds after the accession of the Peale collection in 1850. It is equally probable that the nucleus of the Boston Museum collection antedating 1850 was very slight and unimportant. At least four primitive shows of the early nineteenth or late eighteenth centuries were the springs which fed the first exhibition of the Boston Museum in 1841. Oldest of these was the Columbian Museum, a collection first exhibited in the American Coffee-House in State Street, Boston, in 1791, by Daniel Bowen.<sup>1</sup> Removed afterward to the corner of Bromfield and Tremont Streets, where in 1795 it assumed the name of the Columbian Museum, it was destroyed by fire in 1803, but was afterward revived at the corner of Milk and Oliver Street, and in 1806 the exhibition, under the management of Bowen and W. M. S. Doyle, was moved to a new five-storey building on Tremont Street, near King's Chapel; this building again was burned in 1807 and rebuilt as the "Columbian Hall" during the same year. The Columbian Museum collections were sold Jan. 1, 1825, to the proprietors of the New England Museum for about \$5000.

Woods's Boston Museum, also known as the Market Museum, was opened by Philip Woods in 1804 in Market (Faneuil Hall) Square, Boston. This museum, like the Columbian, was sold at auction in 1822 to the proprietors of the New England Museum.

The New England Museum, E. A. Greenwood, manager, was chartered by the Massachusetts Legislature and opened July 4, 1818, in the block of buildings on Court Street, Boston, occupying the space between Brattle Street and Cornhill. It commenced with the collection of Edward Savage called the New York Museum, which was opened in 1812 in Boylston Hall, over the Boylston Market. J. Mix's New Haven Museum was added in 1821, and, as we have seen above, Woods's or the Market in 1822, and the Columbian in 1825. In 1839 Moses Kimball became the proprietor of the New England Museum, and in 1841 it passed into the Boston Museum, located at first on the corner of Tremont and Bromfield Streets, afterward, in 1846, further down Tremont toward Court Street. In 1850 Mr. Kimball bought one half of the collections of the Peale or Philadelphia Museum, the

<sup>1</sup> For facts relating to the old museums of Boston, the reader is referred to *Old Landmarks and Historic Personages of Boston*, p. 41, 42, 132. By Samuel Adams Drake. Boston: James R. Osgood and Company, 1873. Woods' Boston Museum. By Arthur W. Brayley. < *The Bostonian*, 2, No. 2, May, 1895, p. 125-130. Boston Museum: The Passing of an Historic Playhouse. By John Bouvé Clapp. < *Boston Evening Transcript*, April 25, June 13, 1903.

other half going to P. T. Barnum's American Museum, New York, where it was consumed by fire on the thirteenth of July, 1865.

That little of value in the shape of natural history specimens accrued to the Boston Museum up to the time of the Peale Museum purchase scarcely admits of a doubt. The stuff received before that time was contributed by museums that partook partly of a dime museum, partly of a vaudeville show.<sup>1</sup> Among the announcements made by the proprietor of the Columbian Museum in the *Boston Centinel* newspaper in 1797 I find the two following, which will serve to show the character of those primitive places of amusement whose property went to form the nucleus of the Boston Museum collection:—

[Nov. 29, 1797.]

LATE ADDITIONS TO THE

Columbian Museum,

*Head of the Mall, Boston.*

MR. BOWEN informs the Public, That, he has purchased Mr. *Paff's* much admired Exhibition of CONCERT CLOCKS, which are placed at the head of the *Museum Hall*, as a valuable and pleasing addition to that very extensive Repository of CURIOSITIES.

1. CANARY BIRD, which sings a variety of beautiful Songs, Minuets, Marches, &c. as natural as life. 2. A company of Automaton Figures, which dance to the music of a Harpsichord. 3. Three figures which play the Organ and Clarinet, in Concert. 4. Three figures which play the Harpsichord and Hautboys in concert. 5. King Herod beheading John the Baptist, and his daughter holding a charger to receive the head. 6. A Chimney Sweep, and his boy, on the top of a chimney. 7. Three figures which strike the hours and quarters. 8. A butcher killing an Ox.

The above CONCERT CLOCKS have been exhibited in New-York, with universal applause, and are well worthy the attention of the Citizens of Boston, and the public in general.

The Museum also contains the most extensive Collection of ELEGANT PAINTINGS, that ever was exhibited in the United States, some of which are 10 by 12 feet, elegantly framed, and valued from 500 to 1000 Dollars each.

*Also, a collection of upwards of*

50 elegant Figures of W A X - W O R K, large as life, among which are the following (the most interesting) viz.

<sup>1</sup> The lack of appreciation of natural history by the American public during the early part of the last century appears in Scudder's avowal to Wilson that the "Witch of Endor" and "Potiphar's Wife" brought ten dollars to his museum where the natural history brought one. Scudder was the founder of the old American Museum of New York (Dunlap's History of the Rise and Progress of the Arts of Design in the United States, 1834, 2, p. 199).

The late King of France, taking an affectionate leave of his family, just before he suffered under the guillotine: The Queen appears in a rage of distraction: The King's sister deeply affected. The young Princess is fainting: And the Dauphin is embracing his unhappy father: The Queen's Maid of honor also appears in great distress: A guard of soldiers are waiting to conduct him to the place of execution. This is an affecting scene, which appears natural as life, and is the most interesting group of WAX FIGURES that ever was exhibited in the United States.

GEORGE WASHINGTON, late President of the United States, is elegantly situated in the centre of the Museum Hall, surrounded by four beautiful Wax Figures, representing LIBERTY, with the staff and cap; — JUSTICE, with the sword and balance; — PEACE, with the olive branch extended; — And PLENTY, with a cornucopia, or horn of Plenty, loaded with fruit. The President is dressed in an elegant suit of black, and his figure is 6 feet and one inch in height, with exact proportion, and the likeness is universally allowed to be the most perfect of any ever offered to the public view. With a great variety of

Natural and Artificial Curiosities,—

Among which are, a variety of Birds, Beasts, Reptiles, Serpents, one of which is a Rattle Snake, 9 years of age, and 4 feet in length, Insects, Diamond Beetle, Glass Frigates, two feet in length, completely rigged and mounted with Glass Guns, Live Owls, &c.

The Museum has lately received the principal Additions for this season.— It is opened every Day (except Sundays) and illuminated every Tuesday, Thursday, and Friday Evenings.

Tickets, Half a Dollar; 25 Cents for Children.

Nov. 29.

[July 8, 1797.]

*On Tuesday next, 11th inst.*

At BOWEN'S COLUMBIAN MUSEUM,

Messrs. Chalmers and Williamson, respectfully inform the Ladies and Gentlemen of Boston and its vicinity, that they intend giving their entertainment of

*JUST IN TIME,*

With Mr. BARRETT'S EVENING LOUNGE,

being an antidote for the Spleen; such things have been; Such things are; such things may be.

*Mirth, Song and Sentiment,*

Consisting of Readings, Lectures, Recitations and Songs, as performed at Dibden's, Vauxhall, and the Theatres in Europe: — Being a Comic, Satirical, Whimsical, Humorous, Moral, Illustrative Dissertation and display of Heads, Hearts, Passions, Humours, Whims, Oddities and Characters.— To "*Catch*

*the living manners as they rise*" Has ever been held, not only allowable, but meritorious; so it is to be hoped the same wish to please and entertain, will in the present case, be viewed at least with candor.

Mr. Philip Woods of the older Boston or Market Museum advertised, March 24, 1805: <sup>1</sup>—

A Monstrous Crocodile, which measured when alive 12 feet in length and 4 feet around the body — was killed in Egypt, when devouring a black boy; which is naturally represented with Mungo in his mouth.

On June 29, 1805, he designates among the attractions added to his show: <sup>1</sup>—

The Philadelphia, New York, and Salem beauties and a number of other figures, also a number of natural curiosities, among which is the skin of the sea-elephant in natural preservation, which measured eighty feet in length and six feet around the body.

The Boston Museum thus derived by direct inheritance the unique position which it afterward held among American theatres. Even after its dramatic company came to be one of the best in the United States, it still offered to its patrons its side-shows of picture-galleries, stuffed animals, and chambers of horror in wax-work. Many an old Bostonian remembers his Saturday afternoons as a child at the "Museum," — afternoons ending with ice-creams at Copeland's or oysters at Higgins's, and followed by a restless night perturbed by strange dreams of wax images, boa constrictors, and "Aladdin," or "The Forty Thieves," fused into one composite horror such as never was on sea or land. Perhaps some may recall the taxidermic "artist" who stood ready to set up a pet canary-bird or kitten "as natural as life," while its owner was assuaging his grief for his lost pet by "seeing Warren." And all this, except the supper and the kitten, for fifteen cents! I doubt if children of the present time can get so much for their mothers' money.

Peale's Museum was an institution of a very different kind from its Boston contemporaries,— at least during its earlier period under the management of its founder. Charles Willson Peale <sup>2</sup> — artist, soldier,

<sup>1</sup> Brayley, *l. c.*

<sup>2</sup> See Biographical Sketch of Charles Willson Peale. [By Rembrandt Peale]. < Doughty's Cabinet of Natural History, 1. p. i-vii, portr., Philadelphia: 1830. Lieber's Encyclopædia Americana, 9. p. 571-572, Philadelphia: 1832. Dunlap's History of the Rise and Progress of the Arts of Design in the United States, 1. p. 136-142, New York: 1834. Peale's Museum. By Harold Sellers Colton. < *Popular Science Monthly*, 5, Sept., 1909, p. 221-238.

and founder of the Philadelphia Museum—was born of English parents in Chestertown, Md., in 1741. His museum had its modest origin in 1784, in a Paddle Fish from the Allegheny River, some bones of a Mastodon from Ohio, and his pictures, at first stored in a frame building annexed to his dwelling at the southwest corner of Lombard and Third Street. In 1794 his collection was moved to the Hall of the Philosophical Society and in 1802 the State of Pennsylvania granted a part of the old State House (Independence Hall) for the exhibition of Peale's accumulations. The active management of the Museum devolved upon Peale's sons in 1808, and in 1820 the property was divided into shares and a stock company incorporated by act of the Pennsylvania Legislature, the official title of the corporation being the Philadelphia Museum Company. The collection was transferred in 1828 to the Arcade on Chestnut Street above Sixth Street and again in 1838 to a building in Ninth and Sansom Street. Eight years after, the Museum Company came to grief, the collections were sold off by auction, but the natural history collection was still kept together and exhibited in Masonic Hall till 1850, when it was bought for \$5000 or \$6000 by Moses Kimball and P. T. Barnum.

The scientific importance of Peale's Museum arose from several causes. The records show that the institution was in touch not only with the contemporary museums in the United States, such as the Columbian of Boston, the New York Museum, and Mix's New Haven Museum, but also with the great scientific establishments of Europe, in Paris, London, Stockholm, etc. Peale and his sons were in correspondence, moreover, with many of the most prominent naturalists of Europe; as, Geoffroy Saint-Hilaire, Cuvier, Lamarck, Maximilian, Prince of Wied, and John Latham. I believe that a part of the Leverian Museum<sup>1</sup> found its way into Peale's Museum; certainly the booty of the Lewis and Clark Expedition (1804–1806) was deposited there in December, 1809, and the collections made by the Expedition of Major Long to the Rocky Mountains in 1819–1820 were added on March 23, 1821. Peale's son Titian R. was Assistant Naturalist of the latter expedition, Thomas Say being the head naturalist. But the chief cause of the importance ascribed to Peale's collection lay in the use made of it by that remarkable coterie of naturalists who made Philadelphia the metropolis of natural history in America during the early part of the nineteenth century; as ob-

<sup>1</sup> Sir Ashton Lever's famous collections were disposed of by lottery in 1788 to James Parkinson, and were finally dispersed at public auction sale in London in 1806, the sale numbering 7,879 lots and lasting sixty-five days.

served at the beginning of this paper, the Peale Museum became the depository of a very large number of the types of animals described by the Philadelphia naturalists.

At length the venerable collection was given by the Boston Museum to the Boston Society of Natural History. The bulk of it was transferred to the Society's rooms in Berkeley Street in 1893, the residue in 1899, after the fire that damaged the upper part of the Boston Museum building in May. After the collection came into the possession of the Boston Society of Natural History some of the specimens were destroyed, but most of them were sold in 1900 to Mr. C. J. Maynard. The following notice appeared in the *Boston Evening Transcript* newspaper of April 13, 1900:—

“At the rooms of the Appalachian Mountain Club this afternoon and evening, Walter R. Davis exhibits his collection of . . . birds. . . . Two of the most valuable birds in the collection are an English Skylark, from the old Charles Willson Peale collection made in 1784 in Philadelphia, and a Golden Pheasant presented to Mr. Peale by George Washington. These specimens have recently been discovered by C. J. Maynard of Newtonville, after having been lost for over fifty years. When the Peale Museum was sold, a portion was bought by P. T. Barnum, much of the remainder was purchased by Moses Kimball of the Boston Museum, and its identity became lost. When this museum was broken up a few years since, the collection was given to the Boston Natural History Society, who sold the birds to Mr. Maynard, not knowing their origin. Many of Alexander Wilson's types are in the collection.”

What is said in the above-quoted passage about the Boston Society's ignorance of the origin of the Boston Museum collection is not true: in his report at the annual meeting of the Boston Society of Natural History, May 2, 1894,<sup>1</sup> the Curator, Alpheus Hyatt, narrated at some length the history of this collection and its connection with the historic Peale Museum.

After Mr. Maynard bought the collection it was sent to his residence in Newtonville, Mass., and stored for a while in his barn. It was subsequently redeemed by the Boston Society, all of the specimens, or nearly all of them, being recovered. Then the birds, with exception of a few of the larger kinds, were wrenched from their stands and packed into tin cases, to the great detriment of their legs and plumage. This should have been done, if at all, only after the collection had been submitted to a careful study.

Mr. J. D. Sornborger was then employed by the Society to examine

<sup>1</sup> Proc. Boston Soc. Nat. Hist., 26, p. 275-276.



the collection and report upon it; but nothing resulted from this endeavour except the deplorable loss of such of the original Peale Museum labels as still remained, pinned to or tucked under the wings of some of the birds. These labels were removed from the specimens and put into a paper envelope which was afterward lost. The tickets which now accompany the specimens were probably printed after the collection passed into the custody of the Boston Museum; they consist merely of the name and habitat of the animals, without any data. I believe the only surviving labels which probably go back to the Peale Museum are two wooden ones belonging to a pair of Golden Pheasants presented to Charles Willson Peale by George Washington.<sup>1</sup>

I now proceed to my notes made during an examination of the North American birds in this collection, premising that heretofore the originals of only three of Wilson's birds have been located; *viz.*:—

*SYLVIA MARITIMA* Wils., *Type*. 6, 1812, p. 99, pl. 54, fig. 3.

[ = *Dendroica tigrina* (Gmel.), 1788].

In coll. Vassar College, Poughkeepsie, N. Y. See ORTON, *Amer. Nat.*, 4, 1871, p. 714.

*FALCO MISSISSIPPIENSIS* Wils., *Type*. 3, 1811, p. 80, pl. 25, fig. 1.

In coll. Academy of Natural Sciences of Philadelphia. See STONE, *Proc. Acad. Nat. Sci. Phila.*, 1899, p. 11; *Auk*, 16, 1899, p. 169.

*FALCO PENNSYLVANICUS* Wils., *Type*. 6, 1812, p. 92, pl. 54, fig. 1.

[*Nom. pracoc.* = *Sparvius platypterus* Vieill., 1823; *Falco wilsonii* Bonap., 1824; *Falco latissimus* Ord., 1824].<sup>2</sup>

In coll. Acad. Nat. Sci. Phila. See STONE, *ut supra*.

<sup>1</sup> Mr. Maynard tells me that there were also two groups of mounted birds arranged in two glass cases, presented by Washington to the Peale Museum; these were transferred with the rest from the Boston Museum to the rooms of the Natural History Society, but they had been disposed of before Mr. Maynard purchased the collection.

<sup>2</sup> See Faxon, *Auk*, 18, April, 1891, p. 217.

NOTES ON SOME OF THE NORTH AMERICAN BIRDS IN THE BOSTON  
MUSEUM COLLECTION, NOW IN THE MUSEUM OF  
COMPARATIVE ZOÖLOGY.

ALLE ALLE (Linn.).

In a foot-note on page 94 of the ninth volume of Wilson's "American Ornithology," Philadelphia, 1814, Ord refers to one specimen of *Alca alle* in the Peale Museum that differs from the rest in having a white spot *below* as well as above each eye. One of the three specimens in the Boston Museum collection (M. C. Z., No. 67811) has this spot and is very likely the specimen Ord alluded to. Wilson's figure (pl. 74, fig. 5) shows a white mark both above and below the eye and may have been drawn and coloured from the same specimen.

GELOCHELIDON NILOTICA (Linn.).

*Sterna aranea* Wils., 8, 14, p. 159.

According to Ord (2d. ed. of Wilson, 8, 1824, p. 159), Wilson's type of *Sterna aranea* in the Peale Museum was lost. Titian R. Peale succeeded in procuring another specimen which became the subject of Bonaparte's remarks on this species in his "Observations on the Nomenclature of Wilson's Ornithology," Philadelphia, 1826. The single specimen in the Boston Museum collection (M. C. Z. No. 67812) is very probably the bird examined by Bonaparte.

RHYNCHOPS NIGRA Linn.

M. C. Z. No. 67813. One specimen, which I think is without doubt the original of Wilson's figure, 7, 1813, pl. 60, fig. 4.

OCEANODROMA LEUCORRHOA (Vieill.).

M. C. Z. No. 67814. Probably the specimen drawn by Titian R. Peale to illustrate *Procellaria leachii* Temm. for Bonaparte's paper "An Account of four Species of Stormy Petrels," Journ. Acad. Nat. Sci. Phila., 3, 1824, p. 229, pl. 9.

## OCEANITES OCEANICUS (Kuhl).

*Procellaria pelagica* Wils., 7, 1813, p. 90, pl. 60, fig. 6. *Nec* Linn.

*Procellaria wilsonii* Bonap., Journ. Acad. Nat. Sci. Phila., 3, 1824, p. 231, pl. 9.

M. C. Z. No. 67815. A specimen of Wilson's Petrel agrees so well with the figure drawn by T. R. Peale for Bonaparte that I have no doubt of its being the figured type of *Procellaria wilsonii* Bonap.

## ANHINGA ANHINGA (Linn).

*Plotus melanogaster* Ord, Wils. Amer. Orn., 9, 1814, p. 82, pl. 74, fig. 2. *Nec* Gmel.

M. C. Z. Nos. 67816, 67817. A pair, the female (No. 67817) without doubt the one figured by Wilson (pl. 74, fig. 2). In a MS. in the possession of the Pennsylvania Historical Society entitled "A Walk through the Philadelphia Museum, by C. W. Peale," a pair of Anhingas are referred to on page 94,—one as collected at Elk Ridge, on the Pelapsewa River, the other in Georgia. Mr. J. D. Sornborger made extracts from this manuscript when he was in Philadelphia a few years ago.

## MERGELLUS ALBELLUS (Linn.).

M. C. Z. No. 67818. One specimen, without question the original of Wilson's figure of *Mergus albellus*, 8, 1814, pl. 71, fig. 4. Audubon was convinced that Wilson copied this bird from a European specimen in Peale's Museum (Ornithological Biography, 4, 1838, p. 350, Birds of America, 6, 1843, p. 408).

## AIX SPONSA (Linn.).

M. C. Z. No. 67819. Probably the original of Wilson's figure of *Anas sponsa*, 8, 1814, pl. 70, fig. 3.

## SOMATERIA DRESSERI Sharpe.

*Anas mollissima* Wils., 8, 1814, p. 122, pl. 71, fig. 2. *Nec* Linn.

M. C. Z. No. 67820. Perhaps the original of Wilson's figure.

## ERISMATURA JAMAICENSIS (Gmel.).

*Anas rubidus* Wils., 8, 1814, p. 128, pl. 71, fig. 5.

M. C. Z. No. 67821. Very probably Wilson's type, although the head is turned to one side, which is not the case in the figure.

## CHEN HYPERBOREUS NIVALIS (Forst.).

*Anas hyperborea* Wils., 8, 1814, p. 76, pl. 68, fig. 5. *Nec Anser hyperboreus* Pall.

M. C. Z. No. 67822. Original of Wilson's drawing, without much doubt.

## CHEN CAERULESCENS (Linn.).

*Anas hyperborea* (Young) Wils., 8, 1814, p. 89, pl. 69, fig. 5. *Nec Anser hyperboreus* Pall.

M. C. Z. No. 67823. Original of Wilson's figure. Supposed by him to be the young of the Snow Goose.

## BRANTA BERNICLA GLAUCOGASTRA (Brehm).

*Anas bernicla* Wils., 8, 1814, p. 131, pl. 72, fig. 1. *Nec* Linn.

M. C. Z. No. 67824. Probably the specimen figured by Wilson.

## PHOENICOPTERUS RUBER Linn.

M. C. Z. No. 67825. Wilson's Plate 66, fig. 4 (8, 1814)? Neck differently disposed, and foot uplifted in the figure.

## AJAIA AJAIA (Linn.).

M. C. Z. No. 67826. Wilson's pl. 63, fig. 1, 7, 1813. Even the artificial colours on the bill and bare parts of the head are copied in the figure. This specimen (Peale Mus. No. 3553) was killed in the neighbourhood of Natchez, Tenn. (Wilson, 7, p. 123).

## PLEGADIS AUTUMNALIS (Linn.).

*Tantalus mexicanus?* Ord, Journ. Acad. Nat. Sci. Phila., **1**, 1817, p. 53. *Nec* Gmel.

*Ibis falcinellus* (Linn.) Bonap., Amer. Orn., **4**, 1833, p. 23, pl. 23, fig. 1.

*Ibis ordi* Bonap., Geogr. & Compar. List, 1838, p. 49.

Coll. W. Brewster No. 48861. This is without question the specimen described and figured in Bonaparte's "American Ornithology" as *Ibis falcinellus*, and afterward considered by Bonaparte to be a new species, *Ibis ordi*. Whether it is the same specimen as the one described at an earlier date by Ord, as *Tantalus mexicanus?*, is not clear from Bonaparte's narrative. The latter author says that Ord's specimen (which was shot at Great Egg Harbour, N. J., in May, 1817) was well preserved in Peale's Museum. Our specimen is more probably the one presented to the Peale Museum by Bonaparte on Oct. 10, 1827, as entered in the MS. Records of the Museum, now in the possession of the Pennsylvania Historical Society. There are two more examples of the Glossy Ibis in the Boston Museum collection.

Mr. Brewster bought the Bonaparte specimen of Mr. Maynard when the Boston Museum collection was in his possession in Newtonville, Mass. (see page 126).

## ARDEA HERODIAS HERODIAS Linn.

M. C. Z. No. 67827. This specimen appears to be the bird represented on Wilson's plate, **8**, 1814, pl. 65, fig. 2.

## GRUS AMERICANA (Linn.).

M. C. Z. No. 67828. Making allowance for bad drawing, I think this is the bird figured by Wilson as *Ardea americana*, **8**, 1814, pl. 64, fig. 3. In the figure the wings are more closely applied to the sides than they are in the specimen. Wilson's drawing in this instance is very poor; the conspicuous tertials look as if they sprang from the middle line of the body, like a Cock's tail.

Wilson's bird was no. 3704 of the Peale Museum. According to Dr. Mease<sup>1</sup> the Peale Museum specimen came from the Capes of the Delaware.

<sup>1</sup> The Picture of Philadelphia. By James Mease, M. D. Philadelphia: 1811. p. 312.

## RALLUS ELEGANS Aud.

M. C. Z. No. 67829. Wilson's account of the Clapper Rail, *Rallus crepitans* Gmel., relates to that species, but his figure, 7, 1813, pl. 62, fig. 2, is a King Rail, *R. elegans* Aud., as Audubon pointed out. There are two large Rails in the Boston Museum collection, both of them *R. elegans*, although one is labelled *Rallus crepitans*, a name probably copied from the original Peale Museum label. This is very probably the individual that served as a model for Wilson, although its attitude is vitalized in the drawing.

## STEGANOPUS TRICOLOR Vieill.

M. C. Z. No. 67830. Wilson saw but one specimen of this Phalarope, in Trowbridge's Museum, Albany, N. Y. He left after his death an imperfect sketch and description of this specimen which were published by Ord in the ninth volume of Wilson's Ornithology, p. 72-74, pl. 73, fig. 3, 1814, as "*Phalaropus lobata*." In the second edition of the ninth volume, p. 234-235, 1825, Ord added a fuller description of a new specimen in Peale's Museum, shot by T. R. Peale near Philadelphia, May 7, 1818. In 1833 Bonaparte described the same specimen again and gave a coloured figure of it, in the fourth volume of his continuation of Wilson's Ornithology, p. 66, pl. 24, fig. 1, under the name *Phalaropus wilsoni* Sabine. I am convinced that the specimen in the Boston Museum collection is the one described by Ord and Bonaparte. Its bill unluckily has been badly shattered.

## RECURVIROSTRA AMERICANA Gmel.

M. C. Z. Nos. 67831, 67832. Two specimens, probably collected by Wilson on their former breeding-ground in Cape May Co., N. J. (Amer. Ornithology, 7, 1813, p. 126). One of these (No. 67831) seems to be the specimen figured by Wilson, pl. 63, fig. 2.

## HIMANTOPUS MEXICANUS (Müll.).

*Recurvirostra himantopus* Wils., 7, 1813, p. 48, pl. 58, fig. 2. *Nec Charadrius himantopus* Linn.

M. C. Z. Nos. 67833, 67834. There are likewise two specimens of this bird which probably have the same origin as those of the preceding species (see Amer. Orn., 7, p. 48). One of them (No. 67833) is probably the specimen drawn by Wilson.

PELIDNA ALPINA SAKHALINA (Vieill.).

*Tringa alpina* Wils., 7, 1813, p. 73, pl. 59, fig. 6. *Nec* Linn.

M. C. Z. No. 67835. A headless specimen, probably the remnant of the bird figured by Wilson.

OXYECHUS VOCIFERUS (Linn.).

M. C. Z. No. 67836. Perhaps the original of Wilson's figure, 7, 1813, pl. 59, fig. 6.

ÆGIALITIS SEMIPALMATA (Bonap.).

*Tringa hiaticula* Wils., 7, 1813, p. 65, pl. 69, fig. 3. *Nec Charadrius hiaticula* Linn.

*Charadrius semipalmatus* Bonap., Journ. Acad. Nat. Sci. Phila., 5, 1825, p. 98.

M. C. Z. Nos. 67837, 67838. An adult and a young. The former I believe to be Bonaparte's type, and the individual figured by Wilson as *Tringa hiaticula* on his 69th plate. The young is probably the specimen afterward described and figured by Bonaparte in his "American Ornithology," 4, 1833, p. 92, pl. 25, fig. 4.

OCHTHODROMUS WILSONIUS (Ord).

*Charadrius wilsonia* Ord, Wils. Amer. Orn., 9, 1814, p. 77, pl. 73, fig. 5.

M. C. Z. Nos. 67839, 67840. Male and female. Probably the types of the species, the male being the one figured by Wilson, and both described by Ord in the accompanying text. If I am right as to their identity, they were both shot by Wilson at Cape Island, N. J., May 13, 1813.

## HAEMATOPUS OSTRALEGUS Linn.

M. C. Z. No. 67841. There is scant room for doubt that this is the individual figured by Wilson, 8, 1814, pl. 64, fig. 2, whatever the original of his *description* may have been. It is a European Oyster-Catcher, not *palliatu*s. There is also a specimen of *H. palliatu*s in the collection. In C. W. Peale's MS. "A Walk through the Philadelphia Museum," page 113, a pair of Oyster-Catchers in the Museum are referred to:—"the darkest of this pair is from England, and the other from Cape May."

## MELEAGRIS GALLOPAVO SILVESTRIS (Vieill.).

M. C. Z. No. 67842. This is without much doubt the original of T. R. Peale's beautiful figure of the Wild Turkey Cock in Bonaparte's "American Ornithology," 1, 1825, pl. 9.

## ECTOPISTES MIGRATORIUS (Linn.).

M. C. Z. No. 67843. A fine specimen of this extinct species conforms so well to Wilson's figure, 5, 1812, pl. 44, fig. 1, that I incline to think it is the subject he drew.

## CATHARISTA URUBU (Vieill.).

*Vultur atratus* Ord, Wils. Amer. Orn., 9, 1814, p. 104, pl. 75, fig. 2.

M. C. Z., No. 67844. Wilson's figure was very likely drawn from this specimen, with some adaptation to the life attitude of feeding on the carcass of a sheep.

## BUTEO LINEATUS LINEATUS (Gmel.).

M. C. Z. No. 67845. Probably the model for Wilson's figure, 9, 1812, pl. 53, fig. 3.

## HALIAEETUS LEUCOCEPHALUS LEUCOCEPHALUS (Linn.).

M. C. Z. Nos. 67846, 67847. One of these birds, a fine adult in full plumage, is the one shown on Wilson's plate 36 (6, 1812). Its atti-



tude is the same as in the plate, but it grasps in its talons an Hudsonian Curlew instead of a fish. I well remember the old Peale Museum label (since lost) which accompanied this bird after it came into the custody of the Boston Society of Natural History, with the inscription "Presented by A. Wilson." This Eagle was shot near Great Egg Harbour, N. J., in January, 1812, or earlier.

The other specimen, in immature plumage, is the original of Wilson's plate 55, figure 2 (7, 1813, p. 16). Although Wilson suspected that it was the young of *H. leucocephalus*, it stands in his work as the Sea Eagle, *Falco ossifragus*, which is in reality the young of the Old World *Haliaeetus albicilla*.

#### FALCO PEREGRINUS ANATUM (Bonap.).

*Falco peregrinus* Ord, Wils. Orn., 9, 1814, p. 120, pl. 76. *Nec* Tunstall.

*Falco anatum* Bonap., Geogr. & Compar. List., 1838, p. 4.

M. C. Z. No. 67848. Although this specimen is mounted with its wings differently placed from those of Wilson's beautiful drawing, I am persuaded by a careful perusal of Ord's description and scrutiny of Wilson's plate that it is the original of both. Wilson's bird was shot near Great Egg Harbour, N. J., Dec., 1812.

#### TYTO PERLATA PRATINCOLA (Bonap.).

*Strix flammea* Wils., 6, 1812, p. 57, pl. 50, fig. 2. *Nec* Pontoppidan *nec* Linn.

*Strix pratincola* Bonap., Geogr. & Compar. List., 1838, p. 7.

M. C. Z. No. 67849. Appears to be the original of Wilson's figure.

#### ASIO WILSONIANUS (Less.).

*Strix otus* Wils., 6, 1812, p. 73, pl. 51, fig. 3. *Nec* Linn.

M. C. Z. No. 67850. Very probably the specimen drawn by Wilson.

#### OTUS ASIO NAEVIUS (Gmel.).

M. C. Z. No. 67851. Perhaps the original of Wilson's figure, 3, 1811, pl. 19, fig. 1.

## BUBO VIRGINIANUS VIRGINIANUS (Gmel.).

M. C. Z. No. 67852. Very probably the bird drawn by Wilson, 6, 1812, pl. 50, fig. 1.

## CONUOPSIS CAROLINENSIS (Linn.).

M. C. Z. No. 67853. Original of Wilson's figure, 3, 1811, pl. 26, fig. 1.

## ASYNDESMUS LEWISI Riley.

*Picus torquatus* Wils., 3, 1811, p. 31, pl. 20, fig. 3. *Nomen praeoccupatum.*

M. C. Z. No. 67854. A single venerable looking specimen, probably either the type, which was No. 2020 of the Peale Museum (Lewis and Clark Expedition), or else one of the two individuals shot by T. R. Peale near the Rocky Mountains, on the Long Expedition, I presume (see Bonaparte, Journ. Acad. Nat. Sci. Phila., 3, 1824, p. 370).

## CHORDEILES VIRGINIANUS VIRGINIANUS (Gmel.).

*Caprimulgus americanus* Wils., 5, 1812, p. 65, pl. 40, fig. 1. *Nomen praeoccupatum.*

M. C. Z. No. 67855. Without doubt Wilson's figured type, male, mounted in the attitude of "booming," like the figure. When I first saw this specimen, after it had reached the Boston Society of Natural History rooms, the open mouth was lined with pinkish sealing-wax, just the colour of this part in Wilson's plate. Wilson probably copied the colour of the wax instead of the inside of a living bird's mouth.

## OTOCORYS ALPESTRIS ALPESTRIS (Linn.).

*Alauda alpestris* Linn., Wils., 1, 1808, p. 85, pl. 5, fig. 4.

*Alauda cornuta* Wils., 1, 1808, p. 87.

M. C. Z. No. 67856. Perhaps the original of Wilson's figure.

## COTURNICULUS SAVANNARUM AUSTRALIS (Mayn.).

*Fringilla passerina* Wils., **3**, 1811, p. 76, pl. 24, fig. 5. *Nomen praecoccupatum.*

M. C. Z. No. 67857. Very probably Wilson's type.

## SPIZELLA PASSERINA PASSERINA (Bechst.).

*Fringilla socialis* Wils., **2**, 1810, p. 127, pl. 16, fig. 5.

M. C. Z. No. 67858. The chestnut crown has the dusky spots of the winter plumage, similar to Wilson's figure. A possible type.

## SPIZELLA PUSILLA PUSILLA (Wils.).

*Fringilla pusilla* Wils., **2**, 1810, p. 127, pl. 16, fig. 5.

M. C. Z. No. 67859. Very likely the type.

## MELOSPIZA MELODIA MELODIA (Wils.).

*Fringilla melodia* Wils., **2**, 1810, p. 125, pl. 16, fig. 4.

M. C. Z. No. 67860. This specimen is one of those large, heavily marked Song Sparrows, of a pronounced rufous tint, such as pass through eastern Massachusetts in small numbers in the spring, along with the Fox Sparrows. It agrees well with Wilson's figure, if some allowance is made for adapting the bird to its place on the plate. Mr. Outram Bangs (Proc. N. E. Zoöl. Club, **4**, 1912, p. 86) is quite confident that it is the individual figured by Wilson.

## MELOSPIZA GEORGIANA (Lath.).

*Fringilla palustris* Wils., **3**, 1811, p. 49, pl. 22, fig. 1.

M. C. Z. No. 67861. In the same plumage as the one described and figured by Wilson, with a great deal of blackish colour on the nape. Probably the type.

## ZAMELODIA LUDOVICIANA (Linn.).

*Loxia rosea* Wils., 2, 1810, p. 135.

M. C. Z. No. 67862, 67863. Wilson describes the adult male and female and a young male in the first spring plumage, citing three corresponding specimens in the Peale Museum, 5806, male; 5806 A, male one year old; 5807, female. This is the sole instance of his referring to more than two specimens of a kind in the Museum. The species is represented in the Boston Museum collection by two specimens, a female and a young male of the first spring in the plumage described by Wilson. The presence of the young male in this peculiar plumage makes it extremely probable that we have here two of the three Peale specimens. Both of the males described by Wilson were shot late in April a few miles from Philadelphia.

As I am reading the proof of these pages, Mrs. L. C. Kimball sends to the Museum a few specimens from the Boston Museum collection which had been retained by the Kimball family. Among them is the missing Rose-breasted Grosbeak, — the adult male, mounted with the wings half spread, as in Wilson's plate 17, figure 2, substantiating the surmise ventured in the preceding paragraph. This specimen, now M. C. Z. No. 67864, may, I think, be accepted without doubt as the figured type of *Loxia rosea* Wils.

## PETROCHELIDON LUNIFRONS LUNIFRONS (Say).

M. C. Z. No. 67865. Mounted to simulate a flying bird, like Bonaparte's figure of "*Hirundo fulva* Vieill." (Amer. Orn., 1, 1825, pl. 7, fig. 1, Peale Mus. No. 7624), and probably the specimen drawn. According to Bonaparte the Cliff Swallow had not at that time advanced further east than western New York, and it is possible that his drawing was made from one of Say's types from the Long Expedition, which were in the Peale Museum.

## VIREOSYLVA GILVA GILVA (Vieill.).

*Muscicapa melodia* Wils., 5, 1812, p. 36, pl. 42, fig. 2.

M. C. Z. No. 67866. Posed as in the act of singing, with open bill and swelling throat, like Wilson's figure, but with the tail more depressed. A probable type.

## VIREO GRISEUS GRISEUS (Bodd.).

*Muscicapa cantatrix* Wils., **2**, 1810, p. 166, pl. 18, fig. 6.

M. C. Z. No. 67867. Although badly battered, this specimen appears to me to be the original of the portrait of *Muscicapa cantatrix* Wils. Even the ghastly stare of the white glass eye is caught in Wilson's copy. The gape of the beak, too, is exactly the same.

## MNIOTILTA VARIA (Linn.).

*Certhia maculata* Wils., **3**, 1811, p. 23, pl. 19, fig. 3.

M. C. Z. No. 67868. Wilson's figured type, I doubt not.

## WILSONIA PUSILLA PUSILLA (Wils.).

*Muscicapa pusilla* Wils., **3**, 1811, p. 103, pl. 26, fig. 4.

*Sylvia wilsonii* Bonap., Journ. Acad. Nat. Sci. Phila., **4**, 1824, p. 179.

M. C. Z. No. 67868. Probable type.

## SIALIA SIALIS SIALIS (Linn.).

M. C. Z. No. 67870. This specimen looks as if it had served as the pattern for Wilson's beautiful and oft-copied portrait of the Bluebird, **1**, 1808, pl. 3, fig. 3.

## LIST OF THE NORTH AMERICAN BIRDS (NORTH OF MEXICO) IN THE BOSTON MUSEUM COLLECTION.

NOTE.—Synonyms imposed by Wilson, Bonaparte, or Ord, are added, because so many of the types of these authors were deposited in the Peale Museum. The numbers in parentheses indicate the number of specimens called for by the Boston Museum labels and show the loss of specimens since the birds were removed from their stands.

	No. of Specimens.
1. <i>Colymbus auritus</i> Linn.	2
2. <i>Podilymbus podiceps</i> (Linn.)	4
3. <i>Gavia immer</i> (Brünn.)	2
4. " <i>stellata</i> (Pont.)	2
5. <i>Fratercula arctica arctica</i> (Linn.)	2
6. <i>Cephus grylle</i> (Linn.)	2
7. <i>Uria troille troille</i> (Linn.)	2
8. <i>Alca torda</i> Linn.	3
9. <i>Alle alle</i> (Linn.)	3
10. <i>Stercorarius parasiticus</i> (Linn.) Coast of New Jersey	1
11. <i>Rissa tridactyla tridactyla</i> (Linn.)	1
12. <i>Larus argentatus</i> Pont.	7
13. " <i>delawarensis</i> Ord	2 (3)
14. " <i>atricilla</i> Linn.	3
15. " <i>philadelphia</i> (Ord)	2 (3)
16. <i>Gelochelidon nilotica</i> (Linn.) ( <i>Sterna aranea</i> Wils.)	1
17. <i>Sterna caspia</i> Pall.	1
18. " <i>sandvicensis acufflava</i> (Cabot)	1
19. " <i>forsteri</i> Nutt. Young	1
20. " <i>hirundo</i> Linn. ( <i>Sterna wilsoni</i> Bonap.)	2
21. <i>Sterna antillarum</i> (Less.)	3 (4)
22. <i>Hydrochelidon nigra surinamensis</i> (Gmel.) ( <i>Sterna plumbea</i> Wils.)	2
23. <i>Anous stolidus</i> (Linn.)	2
24. <i>Rhynchops nigra</i> Linn.	3
25. <i>Oceanodroma leucorhoa</i> (Vieill.)	1
26. <i>Oceanites oceanicus</i> (Kuhl) ( <i>Procellaria wilsonii</i> Bonap.)	1

	No. of Specimens.
27. <i>Sula leucogastra</i> (Bodd.)	1 (2)
28. " <i>bassana</i> (Linn.)	1 (2)
29. <i>Anhinga anhinga</i> (Linn.)	2
30. <i>Phalacrocorax carbo</i> (Linn.)	1
31. " <i>auritus auritus</i> (Linn.)	1
32. <i>Pelecanus erythrorhynchos</i> Gmel.	2
33. " <i>occidentalis</i> Linn.	2
34. <i>Mergus americanus</i> Cass. ♂ & ♀	4
35. " <i>serrator</i> Linn. ♂	4
36. <i>Lophodytes cucullatus</i> (Linn.) ♂ & ♀	2 (3)
37. <i>Mergellus albellus</i> (Linn.) ♂	1
38. <i>Anas boschas</i> Linn. ♂	1
39. " <i>rubripes</i> Brewst. ♀	1
40. <i>Mareca americana</i> (Gmel.) ♂ & ♀	2
41. <i>Nettion carolinense</i> (Gmel.) ♂ & ♀	3
42. <i>Querquedula discors</i> (Linn.) ♂ & ♀ (1 albino)	3 (4)
43. <i>Spatula clypeata</i> (Linn.) ♂	1
44. <i>Dafila acuta</i> (Linn.) ♂ & ♀	2
45. <i>Aix sponsa</i> (Linn.) ♂ & ♀	3
46. <i>Marila americana</i> (Eyt.) ♂ & ♀	2
47. " <i>vallisneria</i> (Wils.) ♂ & ♀	3
48. " <i>marila</i> (Linn.) ♂	1
49. " <i>affinis</i> (Eyt.)	1
50. " <i>collaris</i> (Don.) ♂	1
( <i>Anas rufitorques</i> Bonap.)	
51. <i>Clangula clangula americana</i> (Bonap.) ♂ & ♀	2 (3)
52. <i>Charitonetta albeola</i> (Linn.) ♂ & ♀	2
53. <i>Harelda hiemalis</i> (Linn.) ♂ & ♀	2
54. <i>Histrionicus histrionicus</i> (Linn.) ♂ & ♀	3
55. <i>Somateria dresseri</i> Sharpe ♂ & ♀	2
56. <i>Oidemia americana</i> Swains. ♂	1
57. " <i>deglandi</i> Bonap. ♂ & ♀	2 (3)
58. <i>Erismatura jamaicensis</i> (Gmel.)	3
( <i>Anas rubidus</i> Wils.)	
59. <i>Chen hyperboreus nivalis</i> (Forst.)	1
60. " <i>caerulescens</i> (Linn.)	1
61. <i>Branta canadensis canadensis</i> (Linn.)	2
62. " <i>bernicla glaucogastra</i> (Brehm)	2
63. <i>Olor columbianus</i> (Ord)	1
64. <i>Phoenicopterus ruber</i> Linn.	2

	No. of Specimens.
65. <i>Ajaia ajaia</i> (Linn.)	2
66. <i>Guara alba</i> (Linn.)	1
67. <i>Plegadis autumnalis</i> (Linn.) ( <i>Ibis ordi</i> Bonap.)	3 (1 in coll. W. Brewster)
68. <i>Botaurus lentiginosus</i> (Mont.) ( <i>Ardea minor</i> Wils.)	1
69. <i>Ixobrychus exilis</i> (Gmel.) ♂ & ♀	2
70. <i>Ardea herodias herodias</i> Linn.	1
71. <i>Herodias egretta</i> (Gmel.)	3
72. <i>Egretta candidissima candidissima</i> (Gmel.) ( <i>Ardea carolinensis</i> Ord)	3
73. <i>Hydranassa tricolor ruficollis</i> (Gosse) ( <i>Ardea ludoviciana</i> Wils. <i>Nom. praeoc.</i> )	2
74. <i>Florida caerulea</i> (Linn.)	4
75. <i>Butorides virescens virescens</i> (Linn.)	3 (4)
76. <i>Nycticorax nycticorax naevius</i> (Bodd.) ( <i>Nycticorax americanus</i> Bonap.)	3
77. <i>Nyctanassa violacea</i> (Linn.)	2
78. <i>Grus americana</i> (Linn.)	1
79. <i>Rallus elegans</i> Aud.	2
80. <i>Porzana carolina</i> (Linn.) Young & albino	3
81. <i>Ionornis martinicus</i> (Linn.)	1
82. <i>Gallinula galeata</i> (Licht.)	1
83. <i>Fulica americana</i> Gmel.	2
84. <i>Steganopus tricolor</i> Vieill.	1
85. <i>Recurvirostra americana</i> Gmel.	2
86. <i>Himantopus mexicanus</i> (Müll.)	2
87. <i>Philohela minor</i> (Gmel.)	1 (2)
88. <i>Gallinago delicata</i> (Ord.)	1
89. <i>Tringa canutus</i> Linn. ( <i>Tringa rufa</i> Wils.)	2
90. <i>Pelidna alpina sakhalina</i> (Vieill.)	1 (2)
91. <i>Calidris leucophaea</i> (Pall.)	1
92. <i>Limosa fedoa</i> (Linn.)	1
93. <i>Totanus melanoleucus</i> (Gmel.) ( <i>Scolopax vociferus</i> Wils.)	2
94. <i>Bartramia longicauda</i> (Bechst.) ( <i>Tringa bartramia</i> Wils.)	1
95. <i>Tringites subruficollis</i> (Vieill.)	1
96. <i>Numenius americanus</i> Bechst. ( <i>Numenius longirostris</i> Wils.)	1



	No. of Specimens.
97. <i>Squatarola squatarola</i> (Linn.) Summer & winter plumage	2
98. <i>Charadrius dominicus dominicus</i> (Müll.)	1 (2)
99. <i>Oxyechus vociferus</i> (Linn.)	3
100. <i>Aegialitis semipalmata</i> (Bonap.)	2
101. " <i>meloda</i> (Orl)	2
102. <i>Ochthodromus wilsonius</i> (Ord) ♂ & ♀	2
103. <i>Haematopus ostralegus</i> Linn.	1
104. " <i>palliatu</i> s Temm.	1
105. <i>Canachites canadensis canace</i> (Linn.) ♀	1
106. <i>Bonasa umbellus umbellus</i> (Linn.)	2
107. <i>Lagopus rupestris rupestris</i> (Gmel.)	1
108. <i>Tympanuchus americanus americanus</i> (Reich.) ♂	2
109. <i>Meleagris gallopavo silvestris</i> (Vieill.) ♂ & ♀	2
110. <i>Ectopistes migratorius</i> (Linn.)	1
111. <i>Zenaidura macrura carolinensis</i> (Linn.)	3 (4)
112. <i>Geotrygon chrysia</i> Salv.	2
113. <i>Cathartes aura septentrionalis</i> (Wied)	2
114. <i>Catharista urubu</i> (Vieill.) ( <i>Vultur atratus</i> Ord)	2
115. <i>Ictinia mississippiensis</i> (Wils.)	2
116. <i>Circus hudsonius</i> (Linn.)	2
117. <i>Accipiter velox</i> (Wils.) Young ( <i>Falco velox</i> Wils., vol. 5, young; <i>Falco pennsylvanicus</i> Wils., vol. 6, adult)	3 (4)
118. <i>Accipiter cooperii</i> (Bonap.)	5
119. <i>Astur atricapillus atricapillus</i> (Wils.)	2
120. <i>Buteo borealis borealis</i> (Gmel.) (1 albino)	3
121. " <i>lineatus lineatus</i> (Gmel.)	4
122. <i>Archibuteo lagopus sancti-johannis</i> (Gmel.) ( <i>Falco niger</i> Wils., dark phase)	6
123. <i>Haliaeetus leucocephalus leucocephalus</i> (Linn.) Mature & immature	6
124. <i>Falco peregrinus anatum</i> (Bonap.)	4
125. " <i>columbarius columbarius</i> Linn.	3
126. " <i>sparverius sparverius</i> Linn. ♂ & ♀	4
127. <i>Pandion haliaëtus carolinensis</i> (Gmel.)	1
128. <i>Tyto perlata pratincola</i> (Bonap.)	1
129. <i>Asio wilsonianus</i> (Less.)	2
130. " <i>flammeus</i> (Pont.)	3
131. <i>Scotiaptex nebulosa nebulosa</i> (Forst.)	1
132. <i>Otus asio naevius</i> (Gmel.) Gray phase & rufous phase	2

	No. of Specimens.
133. <i>Bubo virginianus virginianus</i> (Gmel.)	4
134. <i>Nyctea nyctea</i> (Linn.)	4
135. <i>Speotyto cunicularia hypogaea</i> (Bonap.)	2
136. <i>Conuropsis carolinensis</i> (Linn.)	2
137. <i>Coccyzus americanus americanus</i> (Linn.) ( <i>Cuculus carolinensis</i> Wils.)	2
138. <i>Coccyzus erythrophthalmus</i> (Wils.)	1
139. <i>Streptoceryle alcyon alcyon</i> (Linn.)	3
140. <i>Campephilus principalis</i> (Linn.) ♂ & ♀	2
141. <i>Dryobates pubescens medianus</i> (Swains.) ♂	1 (2)
142. <i>Sphyrupicus varius varius</i> (Linn.) ♂	1
143. <i>Phloeotomus pileatus abieticola</i> (Bangs) ♂ & ♀	3
144. <i>Asyndesmus lewisi</i> Riley ( <i>Picus torquatus</i> Wils. <i>Nom. pracoc.</i> )	1
145. <i>Centurus aurifrons</i> (Wagl.) ♂	2
146. <i>Colaptes auratus luteus</i> Bangs ♂ & ♀	3
147. <i>Antrostomus carolinensis</i> (Gmel.) ♀	1
148. <i>Chordeiles virginianus virginianus</i> (Gmel.) ♂ ( <i>Caprimulgus americanus</i> Wils. <i>Nom. pracoc.</i> )	1
149. <i>Chaetura pelagica</i> (Linn.)	2
150. <i>Tyrannus tyrannus</i> (Linn.)	2
151. " <i>dominicensis</i> (Gmel.)	2
152. <i>Myiarchus crinitus</i> (Linn.)	2
153. <i>Sayornis phoebe</i> (Lath.) ( <i>Muscicapa nunciola</i> Wils.)	1 (2)
154. <i>Myiochanes virens</i> (Linn.) ( <i>Muscicapa rapax</i> Wils.)	2
155. <i>Empidonax flaviventris</i> (W. M. & S. F. Baird)	1
156. " <i>minimus</i> (W. M. & S. F. Baird)	1
157. <i>Otocoris alpestris alpestris</i> (Linn.) ( <i>Alauda cornuta</i> Wils.)	2
158. <i>Pica nuttallii</i> Aud.	1 (2)
159. <i>Cyanocitta cristata cristata</i> (Linn.)	1 (2)
160. <i>Perisoreus canadensis canadensis</i> (Linn.)	1
161. <i>Corvus corax</i> , subsp. indet.	2
162. " <i>brachyrrhynchos brachyrrhynchos</i> Brehm	2
163. " <i>ossifragus</i> Wils.	1
164. <i>Dolichonyx oryzivorus</i> (Linn.) ♂ & ♀	5
165. <i>Molothrus ater ater</i> (Bodd.) ♂ & young	3 (5)
166. <i>Xanthocephalus xanthocephalus</i> (Bonap.) ♂	1

	No. of Specimens.
167. <i>Agelaius phoeniceus phoeniceus</i> (Linn.) Albino ( <i>Sturnus predatorius</i> Wils.)	1
168. <i>Sturnella magna magna</i> (Linn.)	4
169. <i>Icterus spurius</i> (Linn.) ♂ & ♀ ( <i>Oriolus mutatus</i> Wils.)	4 (5)
170. <i>Icterus galbula</i> (Linn.) ♂	2 (4)
171. <i>Euphagus carolinus</i> (Müll.)	4
172. <i>Megaquiscalus major major</i> (Vieill.) ♂ & ♀	6
172a. " " <i>macrurus</i> (Swains.) ♂	1
173. <i>Carpodacus purpureus purpureus</i> (Gmel.) ♂	2
174. <i>Loxia curvirostra minor</i> (Brehm) ( <i>Curvirostra americana</i> Wils. <i>Nom. praeoc.</i> )	2
175. <i>Acanthis linaria linaria</i> (Linn.)	1 (2)
176. <i>Astragalinus tristis tristis</i> (Linn.) ♂	3
177. <i>Plectrophenax nivalis nivalis</i> (Linn.)	2
178. <i>Coturniculus savannarum australis</i> (Mayn.) ( <i>Fringilla passerina</i> Wils. <i>Nom. praeoc.</i> )	1
179. <i>Ammodramus caudacutus</i> (Gmel.)	1
180. <i>Zonotrichia albicollis</i> (Gmel.) (1 albinistic)	2 (3)
181. <i>Spizella passerina passerina</i> (Bechst.) ( <i>Fringilla socialis</i> Wils.)	2
182. <i>Spizella pusilla pusilla</i> (Wils.)	2
183. <i>Junco hiemalis hiemalis</i> (Linn.) ( <i>Fringilla nivalis</i> Wils. <i>Nom. praeoc.</i> )	2
184. <i>Melospiza melodia melodia</i> (Wils.)	3
185. " <i>georgiana</i> (Lath.) ( <i>Fringilla palustris</i> Wils.)	2
186. <i>Passerella iliaca iliaca</i> (Merrem) ( <i>Fringilla rufa</i> Wils.)	1
187. <i>Pipilo erythrophthalmus erythrophthalmus</i> (Linn.) ♂ & ♀	3
188. <i>Cardinalis cardinalis cardinalis</i> (Linn.) ♂	2
189. <i>Zamelodia ludoviciana</i> (Linn.) ♂ & ♀ ( <i>Loxia rosea</i> Wils.)	3
190. <i>Passerina ciris</i> (Linn.) ♂ & ♀	4
191. <i>Spiza americana</i> (Gmel.)	1
192. <i>Piranga erythromelas</i> Vieill. ♂	1
193. " <i>rubra rubra</i> (Linn.) ♀	1
194. <i>Progne subis subis</i> (Linn.) ♂	2 (3)
195. <i>Petrochelidon lunifrons lunifrons</i> (Say)	2
196. <i>Hirundo erythrogastra</i> Bodd. (1 albino) ( <i>Hirundo americana</i> Wils. <i>Nom. praeoc.</i> )	3

	No. of Specimens.
197. Iridoprocne bicolor (Vieill.) (Hirundo viridis Wils.)	3
198. Riparia riparia (Linn.)	1
199. Bombycilla cedrorum Vieill. (Ampelis americana Wils.)	1
200. Vireosylva olivacea (Linn.)	1
201. " gilva gilva (Vieill.) (Muscicapa melodia Wils.)	2
202. Lanivireo flavifrons (Vieill.) (Muscicapa sylvicola Wils.)	1
203. Lanivireo solitarius solitarius (Wils.)	1
204. Vireo griseus griseus (Bodd.) (Muscicapa cantatrix Wils.)	1
205. Mniotilta varia (Linn.) ♂ (Certhia maculata Wils.)	2
206. Helminthophila pinus (Linn.) (Sylvia solitaria Wils.)	2
207. Compsothlypis americana usneae Brewst. (Sylvia pusilla Wils. <i>Nom. pracoc.</i> )	1
208. Dendroica aestiva aestiva (Gmel.) ♂ & ♀ (Sylvia citrinella Wils.)	2
209. Dendroica caerulescens (Gmel.) ♂ & ♀ (Sylvia pusilla Wils. <i>nom. pracoc.</i> , Sylvia leucoptera Wils., Sylvia sphagnosa Bonap.; female)	2
210. Dendroica coronata (Linn.) ♂	2
211. " magnolia (Wils.) ♂	1
212. " pennsylvanica (Linn.)	2
213. " castanea (Wils.) ♂	1
214. " striata (Forst.) ♀	1
215. " fusca (Müll.)	2 (3)
(Sylvia parus Wils. Young)	
216. Dendroica virens (Gmel.) ♂	3
217. " vigorsii (Aud.) (Sylvia pinus Wils. <i>Nom. pracoc.</i> )	1
218. Dendroica palmarum hypochrysea Ridgw.	1
219. " discolor (Vieill.) (Sylvia minuta Wils.)	1
220. Seiurus aurocapillus (Linn.)	2
221. " noveboracensis noveboracensis (Gmel.) (Turdus aquaticus Wils.)	1 (2)

	No. of Specimens.
222. <i>Oporornis philadelphia</i> (Wils.) ♂	1
223. <i>Geothlypis trichas trichas</i> (Linn.) ♂ & ♀ ( <i>Sylvia marilandica</i> Wils.)	2
224. <i>Icteria virens virens</i> (Linn.) ( <i>Pipra polyglotta</i> Wils.)	2
225. <i>Wilsonia citrina</i> (Bodd.)	1
226. " <i>pusilla pusilla</i> (Wils.) ( <i>Sylvia wilsonii</i> Bonap.)	1 (2)
227. <i>Wilsonia canadensis</i> (Linn.) ♀ ( <i>Sylvia pardalina</i> Bonap.)	1
228. <i>Setophaga ruticilla</i> (Linn.) ♂	1 (2)
229. <i>Mimus polyglottos polyglottos</i> (Linn.)	1
230. <i>Dumetella carolinensis</i> (Linn.) ( <i>Turdus lividus</i> Wils.)	2
231. <i>Toxostoma rufum</i> (Linn.)	3
232. <i>Troglodytes ædon</i> Vieill. ( <i>Sylvia domestica</i> Wils.)	1
233. <i>Cistothorus stellaris</i> (Naum.)	1
234. <i>Telmatodytes palustris palustris</i> (Wils.)	1
235. <i>Certhia familiaris americana</i> (Bonap.)	1
236. <i>Sitta canadensis</i> Linn. ( <i>Sitta varia</i> Wils.)	1
237. <i>Baeolophus bicolor</i> (Linn.)	1
238. <i>Regulus satrapa satrapa</i> Licht. ♂	1
239. <i>Polioptila caerulea caerulea</i> (Linn.)	2
240. <i>Hylocichla mustelina</i> (Gmel.) ( <i>Turdus melodus</i> Wils.)	1
241. <i>Hylocichla guttata pallasii</i> (Cab.) ( <i>Turdus solitarius</i> Wils. <i>Nom. pracoc.</i> )	1
242. <i>Planesticus migratorius migratorius</i> (Linn.) (4 albinistic)	7
243. <i>Sialia sialis sialis</i> (Linn.) (1 albino)	5

In order to complete the record of the North American birds in the Boston Museum collection, I append a list of twenty species called for by the *labels*, but not found. The names of these lost birds are of course given just as they appear on the labels.

1. Glaucous Gull, variety. Young. <i>Larus glaucus</i> Brünn.	1
2. Fulmar Petrel. <i>Procellaria glacialis</i> Linn.	1
3. Virginia Rail. <i>Rallus virginianus</i> Linn.	1

	No. of Specimens.
4. Ground Dove. <i>Chaemepelia passerina</i> Linn.	3
5. Blue-headed Ground Pigeon. <i>Starnaenas cyanocephala</i> Linn.	1
6. Ring-tailed Eagle. Young. <i>Aquila chrysaetos</i> Linn.?	1
7. Canada Woodpecker. <i>Picus leucomelas</i> Bodd.	1
8. Black-chinned Woodpecker. <i>Melanerpes formicivorus</i> Swains.	1
9. Red-shafted Woodpecker. <i>Colaptes rubricatus</i> Licht.	2
10. Whip-poor-will. <i>Caprimulgus vociferus</i> Wils.	1
11. Florida Jay. <i>Cyanocorax caerulescens</i> Vieill.	1
12. Crimson-winged Troopial. <i>Agelaius gubernator</i> Wagl. Female.	1
13. Purple Grakle. <i>Quiscalus purpureus</i> Licht. Young & albino.	2
14. Pine Grosbeak. <i>Strobilophaga enucleator</i> Linn.	1
15. Tree Sparrow. <i>Zonotrichia monticola</i> Gmel.	1
16. Blue Grosbeak. <i>Guiraca caerulea</i> Linn.	1
17. Townsend's Mocking Bird. <i>Mimus montanus</i> Towns.	2
18. Black-capped Titmouse. <i>Parus atricapillus</i> Linn.	1
19. Wilson's Thrush. <i>Turdus fuscescens</i> Shaw	2
20. Arctic Bluebird. <i>Sialia arctica</i> Swains.	1

Four relics of the Peale Museum were contained in the oölogical collection of Dr. T. M. Brewer which came to the Museum of Comparative Zoölogy in 1880. They consist of eggs collected by Alexander Wilson and obtained by Dr. Brewer from Moses Kimball in 1850, the year in which Mr. Kimball bought one half of the collections of the Peale Museum. These eggs, according to the Brewer MS. catalogue, are as follows:

	No. of Specimens.
1. <i>Recurvirostra americana</i> Gmel. Coll. T. M. Brewer No. 57	1
2. <i>Cathartes aura septentrionalis</i> (Wied) " " " 4	1
3. <i>Haliaeetus leucocephalus leucocephalus</i> (Linn.) Coll. T. M. Brewer No. 38	1
4. <i>Bubo virginianus virginianus</i> (Gmel.) New Jersey Coll. T. M. Brewer No. 40	1

Of these eggs I find two, the Turkey Vulture's and the Eagle's; the other two are perhaps temporarily misplaced, since the collection is now undergoing a re-arrangement. The Avoset's egg is probably one of those taken by Wilson from a nest on this bird's old breeding-ground on the coast of New Jersey. See "American Ornithology," 7, 1813, p. 126.

The following Publications of the Museum of Comparative Zoölogy are in preparation:—

- LOUIS CABOT. Immature State of the Odonata, Part IV.  
E. L. MARK. Studies on Lepidosteus, continued.  
E. L. MARK. On Arachnactis.  
H. L. CLARK. The "Albatross" Hawaiian Echini.

Reports on the Results of Dredging Operations in 1877, 1878, 1879, and 1880, in charge of ALEXANDER AGASSIZ, by the U. S. Coast Survey Steamer "Blake," as follows:—

- A. MILNE EDWARDS and E. L. BOUVIER. The Crustacea of the "Blake."  
A. E. VERRILL. The Alcyonaria of the "Blake."

Reports on the Results of the Expedition of 1891 of the U. S. Fish Commission Steamer "Albatross," Lieutenant Commander Z. L. TANNER, U. S. N., Commanding, in charge of ALEXANDER AGASSIZ, as follows:—

- |   |   |
|---|---|
| K. BRANDT. The Sagittae.                        | W. A. HERDMAN. The Ascidians.               |
| K. BRANDT. The Thalassicolae.                   | S. J. HICKSON. The Antipathids.             |
| O. CARLGRÉN. The Actinarians.                   | E. L. MARK. Branchiocerianthus.             |
| R. V. CHAMBERLIN. The Annelids.                 | JOHN MURRAY. The Bottom Specimens.          |
| W. R. COE. The Nemertean.                       | P. SCHIEMENZ. The Pteropods and Heteropods. |
| REINHARD DOHRN. The Eyes of Deep-Sea Crustacea. | THEO. STUDER. The Alcyonarians.             |
| H. J. HANSEN. The Cirripeds.                    | — The Salpidae and Dolloidae.               |
| H. J. HANSEN. The Schizopods.                   | H. B. WARD. The Sipunculids.                |
| HAROLD HEATH. Solenogaster.                     |   |

Reports on the Scientific Results of the Expedition to the Tropical Pacific, in charge of ALEXANDER AGASSIZ, on the U. S. Fish Commission Steamer "Albatross," from August, 1899, to March, 1900, Commander Jefferson F. Moser, U. S. N., Commanding, as follows:—

- |                                 |   |
|---------------------------------|---|
| R. V. CHAMBERLIN. The Annelids. | MARY J. RATHBUN. The Crustacea Decapoda.        |
| H. L. CLARK. The Holothurians.  | G. O. SARS. The Copepods.                       |
| H. L. CLARK. The Ophurans.      | L. STEJNEGER. The Reptiles.                     |
| — The Volcanic Rocks.           | C. H. TOWNSEND. The Mammals, Birds, and Fishes. |
| — The Coralliferous Limestones. | T. W. VAUGHAN. The Corals, Recent and Fossil.   |
| S. HENSHAW. The Insects.        |   |
| G. W. MÜLLER. The Ostracods.    |   |

PUBLICATIONS  
OF THE  
MUSEUM OF COMPARATIVE ZOOLOGY  
AT HARVARD COLLEGE.

---

There have been published of the BULLETIN Vols. I. to LIV. and Vol. LVIII.; of the MEMOIRS, Vols. I. to XXIV., and also Vols. XXVI. to XXIX., XXXI. to XXXIV., XXXVI. to XXXVIII., XL. to XLII., and XLIV.

Vols. LV. to LVII., and LIX. of the BULLETIN, and Vols. XXV., XXX., XXXV., XXXIX., XLIII., XLV. to XLIX. of the MEMOIRS, are now in course of publication.

The BULLETIN and MEMOIRS are devoted to the publication of original work by the Officers of the Museum, of investigations carried on by students and others in the different Laboratories of Natural History, and of work by specialists based upon the Museum Collections and Explorations.

The following publications are in preparation:—

Reports on the Results of Dredging Operations from 1877 to 1880, in charge of Alexander Agassiz, by the U. S. Coast Survey Steamer "Blake," Lieut. Commander C. D. Sigsbee, U. S. N., and Commander J. R. Bartlett, U. S. N., Commanding.

Reports on the Results of the Expedition of 1891 of the U. S. Fish Commission Steamer "Albatross," Lieut. Commander Z. L. Tanner, U. S. N., Commanding, in charge of Alexander Agassiz.

Reports on the Scientific Results of the Expedition to the Tropical Pacific, in charge of Alexander Agassiz, on the U. S. Fish Commission Steamer "Albatross," from August, 1899, to March, 1900, Commander Jefferson F. Moser, U. S. N., Commanding.

Reports on the Scientific Results of the Expedition to the Eastern Tropical Pacific, in charge of Alexander Agassiz, on the U. S. Fish Commission Steamer "Albatross," from October, 1904, to April, 1905, Lieut. Commander L. M. Garrett, U. S. N., Commanding.

Contributions from the Zoological Laboratory, Professor E. L. Mark, Director.  
Contributions from the Geological Laboratory, Professor R. A. Daly, in charge.

These publications are issued in numbers at irregular intervals. Each number of the Bulletin and of the Memoirs is sold separately. A price list of the publications of the Museum will be sent on application to the Director of the Museum of Comparative Zoology, Cambridge, Mass.



3189  
Bulletin of the Museum of Comparative Zoölogy  
AT HARVARD COLLEGE.  
VOL. LIX. No. 4.

---

EXPLORATION OF THE COAST WATER BETWEEN NOVA  
SCOTIA AND CHESAPEAKE BAY, JULY AND  
AUGUST, 1913, BY THE U. S. FISHERIES  
SCHOONER GRAMPUS. OCEANOGRAPHY AND PLANKTON.

BY HENRY B. BIGELOW.

WITH TWO PLATES.

CAMBRIDGE, MASS., U. S. A.:  
PRINTED FOR THE MUSEUM.  
SEPTEMBER, 1915.

REPORTS ON THE SCIENTIFIC RESULTS OF THE EXPEDITION TO THE EASTERN TROPICAL PACIFIC, IN CHARGE OF ALEXANDER AGASSIZ, BY THE U. S. FISH COMMISSION STEAMER "ALBATROSS," FROM OCTOBER, 1904, TO MARCH, 1905, LIEUTENANT COMMANDER L. M. GARRETT, U. S. N., COMMANDING, PUBLISHED OR IN PREPARATION:—

- A. AGASSIZ. V.<sup>5</sup> General Report on the Expedition.  
 A. AGASSIZ. I.<sup>3</sup> Three Letters to Geo. M. Bowers, U. S. Fish Com.  
 A. AGASSIZ and H. L. CLARK. The Echini.  
 H. B. BIGELOW. XVI.<sup>16</sup> The Medusae.  
 H. B. BIGELOW. XXIII.<sup>23</sup> The Siphonophores.  
 H. B. BIGELOW. XXVI.<sup>26</sup> The Ctenophores.  
 R. P. BIGELOW. The Stomatopods.  
 O. CARLGREN. The Actinaria.  
 R. V. CHAMBERLIN. The Annelids.  
 H. L. CLARK. The Holothurians.  
 H. L. CLARK. The Starfishes.  
 H. L. CLARK. The Ophiurans.  
 S. F. CLARKE. VIII.<sup>8</sup> The Hydroids.  
 W. R. COE. The Nemertean.  
 L. J. COLE. XIX.<sup>19</sup> The Pycnogonida.  
 W. H. DALL. XIV.<sup>14</sup> The Mollusks.  
 C. R. EASTMAN. VII.<sup>7</sup> The Sharks' Teeth.  
 S. GARMAN. XII.<sup>12</sup> The Reptiles.  
 H. J. HANSEN. The Cirripeds.  
 H. J. HANSEN. XXVII.<sup>27</sup> The Schizopods.  
 S. HENSHAW. The Insects.  
 W. E. HOYLE. The Cephalopods.  
 W. C. KENDALL and L. RADCLIFFE. XXV.<sup>25</sup> The Fishes.  
 C. A. KOFOID. III.<sup>3</sup> IX.<sup>9</sup> XX.<sup>20</sup> The Protozoa.
- C. A. KOFOID and J. R. MICHENER. XXII.<sup>22</sup> The Protozoa.  
 C. A. KOFOID and E. J. RIGDEN. XXIV.<sup>24</sup> The Protozoa.  
 P. KRUMBACH. The Sagittae.  
 R. VON LENDENFELD. XXI.<sup>21</sup> The Siliceous Sponges.  
 R. VON LENDENFELD. XXIX.<sup>29</sup> Hexactinellida.  
 G. W. MÜLLER. The Ostracods.  
 JOHN MURRAY and G. V. LEE. XVII.<sup>17</sup> The Bottom Specimens.  
 MARY J. RATHBUN. X.<sup>10</sup> The Crustacea Decapoda.  
 HARRIET RICHARDSON. II.<sup>2</sup> The Isopods.  
 W. E. RITTER. IV.<sup>4</sup> The Tunicates.  
 B. L. ROBINSON. The Plants.  
 G. O. SARS. The Copepods.  
 F. E. SCHULZE. XI.<sup>11</sup> The Xenophyophoras.  
 HARRIET R. SEARLE. XXVIII.<sup>28</sup> Isopods.  
 H. R. SIMROTH. Pteropods, Heteropods.  
 E. C. STARKS. XIII.<sup>13</sup> Atelaxia  
 TH. STUDER. The Alcyonaria.  
 JH. THIELE. XV.<sup>15</sup> Bathysciadium.  
 T. W. VAUGHAN. VI.<sup>6</sup> The Corals.  
 R. WOLTERECK. XVIII.<sup>18</sup> The Amphipods.

<sup>4</sup> Bull. M. C. Z., Vol. XLVI., No. 4, April, 1905, 22 pp.

<sup>5</sup> Bull. M. C. Z., Vol. XLVI., No. 6, July, 1905, 4 pp., 1 pl.

<sup>6</sup> Bull. M. C. Z., Vol. XLVI., No. 9, September, 1905, 5 pp., 1 pl.

<sup>7</sup> Bull. M. C. Z., Vol. XLVI., No. 13, January, 1906, 22 pp., 3 pls.

<sup>8</sup> Mem. M. C. Z., Vol. XXXIII., January, 1906, 90 pp., 96 pls.

<sup>9</sup> Bull. M. C. Z., Vol. L., No. 3, August, 1906, 14 pp., 10 pls.

<sup>10</sup> Bull. M. C. Z., Vol. L., No. 4, November, 1906, 26 pp., 4 pls.

<sup>11</sup> Mem. M. C. Z., Vol. XXXV., No. 1, February, 1907, 20 pp., 15 pls.

<sup>12</sup> Bull. M. C. Z., Vol. L., No. 6, February, 1907, 48 pp., 18 pls.

<sup>13</sup> Mem. M. C. Z., Vol. XXXV., No. 2, August, 1907, 56 pp., 9 pls.

<sup>14</sup> Bull. M. C. Z., Vol. LI., No. 6, November, 1907, 22 pp., 1 pl.

<sup>15</sup> Bull. M. C. Z., Vol. LII., No. 1, June, 1908, 14 pp., 1 pl.

<sup>16</sup> Bull. M. C. Z., Vol. LII., No. 2, July, 1908, 8 pp., 5 pls.

<sup>17</sup> Bull. M. C. Z., Vol. XLIII., No. 6, October, 1908, 285 pp., 22 pls.

<sup>18</sup> Bull. M. C. Z., Vol. LII., No. 5, October, 1908, 11 pp., 2 pls.

<sup>19</sup> Mem. M. C. Z., Vol. XXXVII., February, 1909, 243 pp., 48 pls.

<sup>20</sup> Mem. M. C. Z., Vol. XXXVIII., No. 1, June, 1909, 172 pp., 5 pls., 3 maps.

<sup>21</sup> Bull. M. C. Z., Vol. LII., No. 9, June, 1909, 26 pp., 8 pls.

<sup>22</sup> Bull. M. C. Z., Vol. LII., No. 11, August, 1909, 10 pp., 3 pls.

<sup>23</sup> Bull. M. C. Z., Vol. LII., No. 13, September, 1909, 48 pp., 4 pls.

<sup>24</sup> Mem. M. C. Z., Vol. XLI., August, September, 1910, 323 pp., 56 pls.

<sup>25</sup> Bull. M. C. Z., Vol. LIV., No. 7, August, 1911, 38 pp.

<sup>26</sup> Mem. M. C. Z., Vol. XXXVIII., No. 2, December, 1911, 232 pp., 32 pls

<sup>27</sup> Bull. M. C. Z., Vol. LIV., No. 10, February, 1912, 16 pp., 2 pls.

<sup>28</sup> Mem. M. C. Z., Vol. XXXV., No. 3, April, 1912, 98 pp., 8 pls.

<sup>29</sup> Bull. M. C. Z., Vol. LIV., No. 12, April, 1912, 38 pp., 2 pls.

<sup>30</sup> Mem. M. C. Z., Vol. XXXV., No. 4, July, 1912, 124 pp., 12 pls.

<sup>31</sup> Bull. M. C. Z., Vol. LVIII., No. 8, August, 1914, 14 pp.

<sup>32</sup> Mem. M. C. Z., Vol. XLII., June, 1915, 397 pp., 109 pls.

**Bulletin of the Museum of Comparative Zoölogy**

AT HARVARD COLLEGE.

VOL. LIX. No. 4.

---

EXPLORATION OF THE COAST WATER BETWEEN NOVA  
SCOTIA AND CHESAPEAKE BAY, JULY AND  
AUGUST, 1913, BY THE U. S. FISHERIES  
SCHOONER GRAMPUS. OCEANOGRAPHY AND PLANKTON.

BY HENRY B. BIGELOW.

WITH TWO PLATES.

CAMBRIDGE, MASS., U. S. A.:  
PRINTED FOR THE MUSEUM.  
SEPTEMBER, 1915.



No. 4.— *Exploration of the Coast Water between Nova Scotia and Chesapeake Bay, July and August, 1913, by the U. S. Fisheries Schooner Grampus. Oceanography and Plankton.*

BY HENRY B. BIGELOW

CONTENTS.

	PAGE.
Itinerary . . . . .	152
Equipment and methods . . . . .	154
Oceanography . . . . .	155
Temperature, Cape Cod to Chesapeake Bay . . . . .	155
Temperature in the Gulf of Maine . . . . .	170
Salinity, Cape Cod to Chesapeake Bay . . . . .	186
Salinity in the Gulf of Maine . . . . .	200
Density, at the temperature in situ, Cape Cod to Chesapeake Bay .	214
Density in the Gulf of Maine . . . . .	221
Color of the sea . . . . .	224
Current measurements . . . . .	225
Circulation over the continental shelf, July, 1913 . . . . .	230
Previous records of temperature and salinity, Cape Cod to Chesapeake Bay . . . . .	234
Oceanography of the Gulf of Maine in the summers of 1912 and 1913 . . . . .	246
Origin of the coast water . . . . .	250
Oceanography of the Gulf of Maine and of the North Sea . . . . .	263
The coast water as a biological environment . . . . .	264
The plankton . . . . .	267
General account of the macroplankton . . . . .	267
Gulf of Maine plankton . . . . .	273
Distribution of <i>Salpa</i> and <i>Doliolum</i> . . . . .	275
The hyperiid amphipods . . . . .	278
Table of hyperiids . . . . .	279
Copepods . . . . .	285
Table of copepods in the horizontal hauls . . . . .	287
The <i>Sagittae</i> . . . . .	297
Tomopteris . . . . .	301
Pteropods and heteropods . . . . .	301
Pelagic hydroids . . . . .	306
Medusae, siphonophores and ctenophores . . . . .	314
Distribution of pelagic coelenterates . . . . .	318

	PAGE.
Quantitative hauls in the Gulf of Maine . . . . .	326
Microplankton . . . . .	330
Gulf of Maine plankton, 1912 and 1913 . . . . .	335
Macroplankton of the Gulf of Maine, and of the northeastern Atlantic . . . . .	338
Table of stations, nets used, and depths of hauls in fathoms . . . . .	342
Table of temperatures, salinities, and densities . . . . .	344
Table of surface temperatures, taken by W. W. Welsh, between Cape Cod and Cape May . . . . .	350
Salinities of water-samples collected by Capt. McFarland . . . . .	351
Bibliography . . . . .	352
Plates	

### ITINERARY.

OCEANOGRAPHIC and plankton studies were carried on by the *GRAMMUS* during the summer of 1913 from Nova Scotia to Chesapeake Bay. The success of the cruise was largely due to the skill with which Mr. W. W. Welsh, of the Bureau of Fisheries, handled the oceanographic apparatus. It is a pleasure to acknowledge the assistance of Dr. C. O. Esterly for identifying the copepods; Dr. H. J. Hansen the schizopods; Dr. C. McLean Fraser the hydroids; Mr. W. F. Clapp the heteropods, pteropods, and Salpae, and to Capt. John McFarland of the schooner *VICTOR* for taking tows and water-samples.

We sailed southward from Gloucester on July 7; occupied the first station off Cape Cod, and then ran across the northwest part of Georges Bank to Nantucket light-ship, to commence the first line to the Gulf Stream. Some thirty miles southward from the light-ship, floating patches of Gulf weed, and the brilliant blue color of the water showed that we were approaching the Stream; but the sea and wind were rising so rapidly meanwhile, that we made the station at the outer edge of the shelf. And even as it was, the nets were badly torn, though water-bottles and thermometers were handled successfully. The wind continued to rise during the afternoon and evening, and by the time we had sailed northward again as far as the 40 fathom curve, there was a very heavy sea running. Nevertheless by using a hemp rope, instead of the wire, for the large plankton net, the work (Station 10062) was carried out without mishap.

From Station 10062 we turned off shore again, occupying the second Gulf Stream station 80 miles south of Montauk Point, at the 500 fathom curve.

The next run was to New York; and it was at one of the Stations on this line (10065) that the extensive beds of sea scallops (*Pecten magellanicus*) which promise great commercial value, were discovered; and I may forestall the narrative by stating that scallops were found in considerable numbers, between the 25 and 50 fathom curves, as far south as the latitude of Cape Charles (Stations 10070, 10072, 10073, 10074, 10077).

Remaining in New York long enough to restock the larder and replenish the supply of gasoline, on the 17th we ran down the coast as far as Barnegat (Station 10069), thence eastward across the shelf to the Gulf Stream (Station 10071). From this point we worked southerly, in a zigzag course, past the mouth of Delaware Bay, to Cape Charles, then off shore once more, for the last complete section of the shelf and so to Norfolk, arriving there on July 24th. The courses and stations are shown on the chart (Plate 1).

Current measurements were made at three stations between Cape Cod and Norfolk; off Long Island, off Cape May (Station 10072), and off Chincoteague (Station 10074); observations being taken hourly for six hours at each station, both at the surface and on the bottom; the data is given below (p. 225). At Stations 10065 and 10074, the work was done from the dory, but at Station 10072 the *Grampus* herself was anchored for the purpose.

Refitting in Norfolk until July 29th, the voyage was resumed northward, following the coast, and locating stations to fill the gaps left on the way south: On August 3 the *GRAMPUS* reached Woods Hole, on the 4th, sailed through Vineyard Sound; and arrived in Gloucester on the 5th after a most successful voyage.

On August 9th we put to sea again for the Gulf of Maine, sailing eastward from Cape Ann to the sink at the mouth of Massachusetts Bay (Station 10087), thence to the centre of the Gulf (Station 10090), crossing the western basin where the deepest Gulf Station (10088, 150 fathoms) was located. Jeffrey's Bank was the next objective (Station 10091), where a strong northwest wind was encountered, though work under shortened sail was possible. We then ran toward Cape Sable, making the same stations as the year before, two in the basin, one on the coast slope, and one on German Bank. And, as in 1912, the sudden cooling of the surface as we approached the Bank was a striking phenomenon. In 1912 the *GRAMPUS* was wrapped in a blanket of fog day after day in this part of the Gulf, feeling her way about by soundings. But in 1913 the most delightfully clear, calm, weather imaginable, with light northwest breezes, was enjoyed; and so trans-

parent was the air that the whole coast, from Cape Sable to Yarmouth, was plainly visible, though we were nowhere within 20 miles of the land.

We took surface temperature and water-samples close to Lurcher Shoal light-ship on the 12th, and then stood across the mouth of the Bay of Fundy to the Maine coast (Station 10098), making a Station (10097) in the north end of the basin *en route*; and thence followed the outer islands southward to Mt. Desert Rock (Station 10100). The weather now grew foggy, and the GRAMPUS crossed the mouth of Penobscot Bay in the fog, passing close to Matinicus Island (Station 10101). Three stations were made between Monhegan and Cape Ann, two in the trough west of Jeffrey's Ledge, and on August 15th the GRAMPUS returned to Gloucester.

During the cruise oceanographical observations were taken at 50 stations; and, thanks to an ample supply of water-bottles, samples were taken at three to five levels at every station. One hundred and sixty-five tows were made with the various plankton nets; the quantitative net was used at fifteen stations in the Gulf of Maine; the otter trawl employed at ten stations. The distance sailed was about 2100 miles.

The GRAMPUS lay in Gloucester until the 20th, to refit; and on the 20th, sailed southward once more, in charge of Mr. Welsh, for a detailed survey of the scallop beds, a report of which has already been published by the U. S. Bureau of Fisheries (1914).

## EQUIPMENT AND METHODS.

The general equipment of the GRAMPUS has been described (1914a, p. 35). In 1913 a second Ekman current-meter, several more Negretti and Zambra reversing deep-sea thermometers, and two more stop-cock water-bottles, were added; the latter so arranged that any number could be used simultaneously, in series, on the wire rope, and tripped by a messenger. The outfit was further enlarged by the addition of a Helgoland "shear board" tow-net (Steuer, 1910, p. 131), which proved to be most effective, a 1-meter tow-net of the MICHAEL SARS pattern (Murray and Hjort, 1912), and a Lucas sounding machine. On the other hand the Sigsbee water-bottle, which was unreliable, was discarded and an otter trawl was substituted for the beam-trawl.

The salinities listed below were all obtained by titration by the ordinary method, and are probably correct to  $\pm .02$  of salinity. The subsurface temperatures are reliable to  $\pm .3^{\circ}\text{F}$ ; the surface temperatures to  $\pm .5^{\circ}\text{F}$  (1914a, p. 40). All temperatures are Fahrenheit.



## OCEANOGRAPHY.

## 1. TEMPERATURE, CAPE COD TO CHESAPEAKE BAY.

*Surface temperature.* Surface temperature was taken hourly, day and night, during the cruise (Fig. 1, 2).

Off Cape Cod (Station 10057) the surface temperature, early in July, was  $62^{\circ}$  to  $63^{\circ}$ ; and similar readings prevailed on the southerly run until the southwest part of George's Bank (Station 10059) was reached where a sudden chilling to  $55^{\circ}$  and  $56^{\circ}$  was noted;

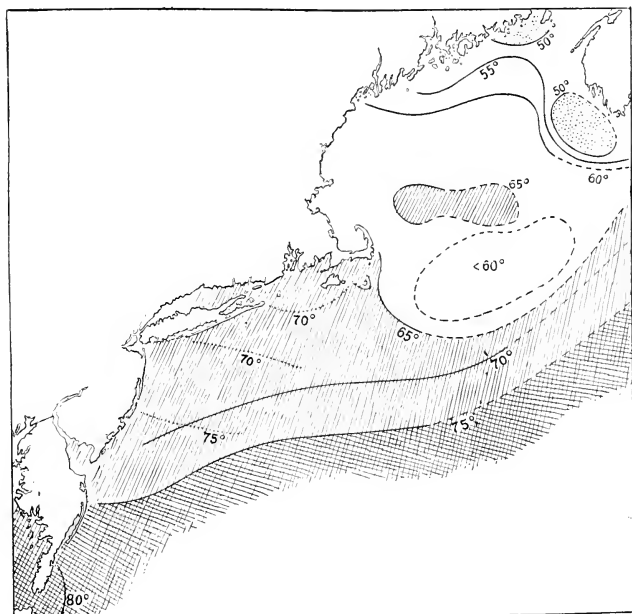

FIG. 1.— Surface temperature for the waters south of Cape Cod in July, and for the Gulf of Maine in August, constructed from the hourly readings. Temperatures below  $50^{\circ}$ , dotted;  $65^{\circ}$  to  $75^{\circ}$ , single hatched; over  $75^{\circ}$ , cross hatched; dotted curves, July 30–Aug. 1,  $75^{\circ}$ ,  $70^{\circ}$ .

Low temperature ( $55^{\circ}$  to  $56^{\circ}$ ), characterized the surface waters very generally as Nantucket Shoals were crossed, though with occasional readings of  $60^{\circ}$  or  $61^{\circ}$ , irregularities associated with the violent tidal currents of that region. But when the deeper water to the south was reached the temperature rose to  $65^{\circ}$  and higher. The coldest surface water west or southwest of Nantucket was just off New York ( $62^{\circ}$ – $63^{\circ}$ ) the warmest off the mouth of Chesapeake Bay ( $79^{\circ}$ – $80^{\circ}$ ). And in a general way we found a rise of temperature over the continental shelf from north to south (Fig. 1). Thus it was  $64^{\circ}$ – $67^{\circ}$  between Nantucket Shoals and the edge of the continental shelf, rising to  $69^{\circ}$  and  $70^{\circ}$  abreast of Long Island, 70 miles off shore. Near New York, however, it was much colder, as pointed out above; though it rose again to  $66^{\circ}$  and  $67^{\circ}$  off Barnegat. Off shore on the line from Barnegat to the Gulf Stream, the surface temperature rose to  $74^{\circ}$  at Station 10071. Off Delaware Bay it was  $75^{\circ}$ ;  $76^{\circ}$  close in shore off Cape Charles, and  $78^{\circ}$  off the mouth of the Chesapeake. In general, on the several lines across the continental shelf, the surface water was slightly warmest at the off shore station, *i. e.*, nearest the Gulf Stream, as shown in the following table:—

Line A.	Station 10063	$67^{\circ}$	Line C.	Station 10069	$69^{\circ}$
	10062	$67^{\circ}$		10070	$74^{\circ}$
	10061	$68^{\circ}$		10071	$76^{\circ}$
Line B.	10067	$63^{\circ}$	Line D.	10078	$78^{\circ}$
	10066	$69^{\circ}$		10077	$77^{\circ}$
	10065	$69^{\circ}$		10076	$76^{\circ}$
	10064	$70^{\circ}$			

but this was reversed off Chesapeake Bay (Line D), where the off shore station was  $76^{\circ}$ , the in shore one  $78^{\circ}$ . Short though the stay in the Chesapeake was, it was long enough for a decided warming of the surface water to take place. On July 29, the surface temperature of the Bay had risen  $2^{\circ}$  to  $80^{\circ}$ , and as we sailed northward, a considerably greater discrepancy between our two sets of readings was noted. Thus when the northerly line approached our previous course, south of Cape Henlopen, the temperature had risen from  $75^{\circ}$  to  $78^{\circ}$ : off Barnegat from  $66^{\circ}$  to  $75^{\circ}$ ; and off Fire Island light-ship, where the lines cross, the surface had warmed  $4^{\circ}$ , ( $69^{\circ}$  to  $73^{\circ}$ ) during the two weeks interval. Since the salinity showed that no shoreward movement of the surface waters of the Gulf Stream had taken place, this rise of surface temperature was no doubt the result of solar warming.

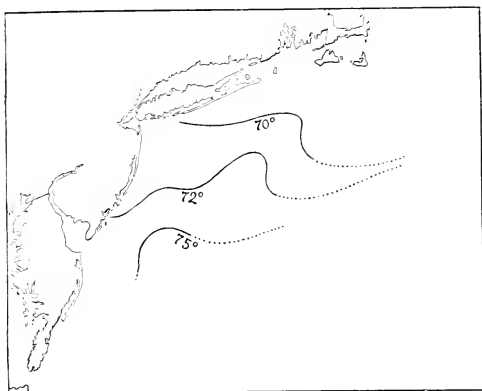

FIG. 2.— Surface temperature south of Cape Cod, Aug. 20–Sept. 1.

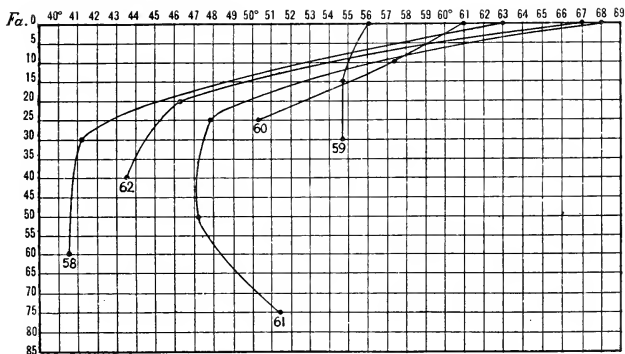

FIG. 3.— Temperature sections in the southern part of the Gulf of Maine (Station 10058); on George's Bank (Station 10059), and on the continental shelf south of Nantucket (Station 10060, 10061, 10062).

And it is probable that the surface was at or near its warmest by the end of July.

The surface temperature off Long Island on August 1st (Station 100S3) was  $68^{\circ}$ ;  $69^{\circ}$  off Block Island; and  $72^{\circ}$  thence to the entrance of Vineyard Sound, though at the westerly end of the Sound it fell to

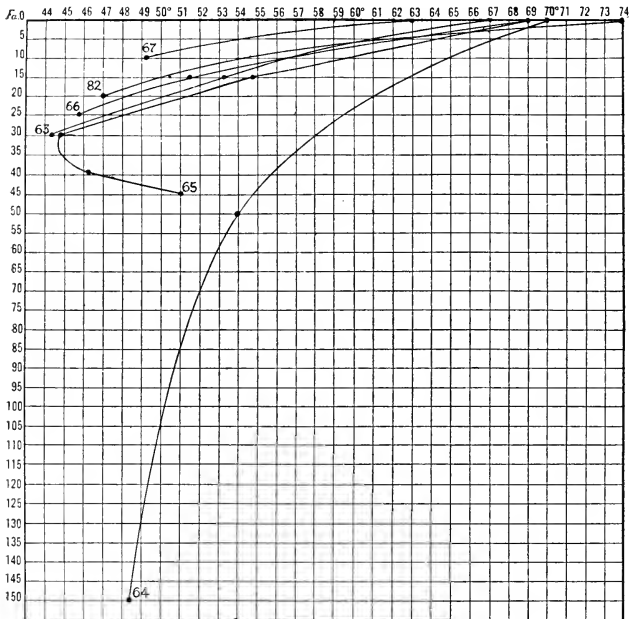

FIG. 4.—Temperature sections on the continental shelf off New York and Long Island (Stations 10063, 10065, 10066, 10067, 100S2) and at the edge of the Gulf Stream, Lat.  $39^{\circ} 55'$  (Station 10064).

$68^{\circ}$ , no doubt influenced by the violent tide. Two days later the surface water was  $72^{\circ}$  from Woods Hole to the east end of the Sound. But it was much colder ( $61^{\circ}$ ) off Monomoy; and only  $50^{\circ}$  on Pollock Rip, this last being evidence, of course, of thorough vertical mixing

by the tidal currents. When this dangerous channel was left, the surface temperature rose to  $63^{\circ}$ , the normal figure for the southern half of the Gulf of Maine at this time of year. Late in August, when the GRAMPUS came southward again (p. 154) the temperature was practically unchanged off Block Island and over the shelf south of

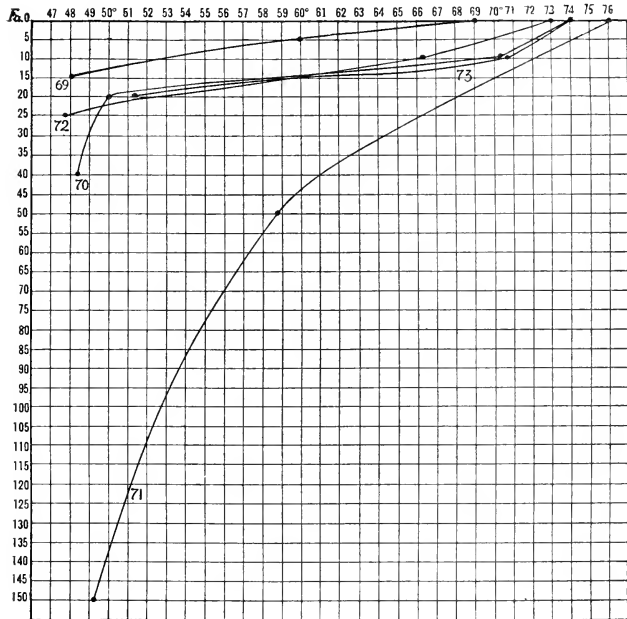

FIG. 5.— Temperature sections on the continental shelf south of New York (Stations 10069, 10070, 10072, 10073) and at the edge of the Gulf Stream in Lat.  $38^{\circ} 56'$  (Station 10071).

Marthas Vineyard; but near shore south of New York, the water had cooled to  $71^{\circ}$ – $72^{\circ}$ ; immediately off Cape May to  $74^{\circ}$  (Fig. 2). On the other hand, the surface south of Nantucket Shoals was several degrees warmer than it was in July, the temperature having risen from

61° to about 67.5° at Nantucket light-ship; and the curves for 70° and 72° reveal a tongue of warm water extending from the outer edge of the shelf south of Long Island northeastward toward Nantucket. Probably it was Gulf Stream water driven northward over

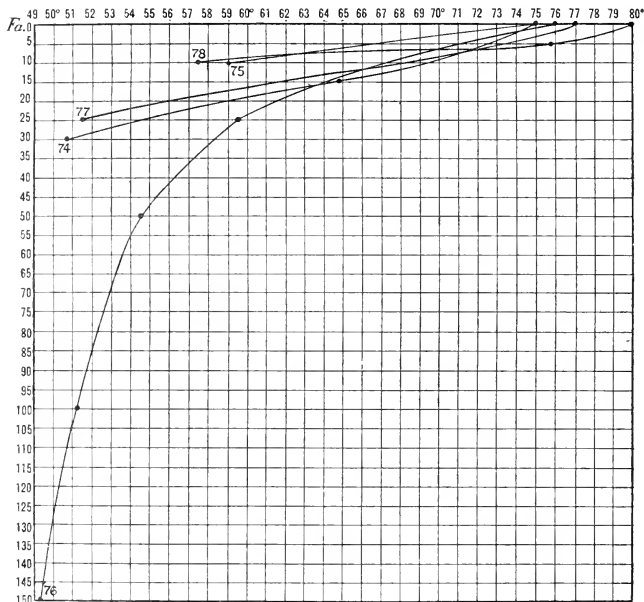

FIG. 6.— Temperature sections on the continental shelf south of Delaware Bay (Stations 10074, 10075, 10077), at the mouth of Chesapeake Bay (Station 10078) and at the edge of the Gulf Stream opposite Chesapeake Bay (Station 10076).

the shelf by the southerly gale of August 23; but no salinities were taken. For a list of the surface temperatures taken by Mr. Welsh, see p. 350.

*Temperature sections* (Table, p. 344). In general there was a rapid fall in temperature from the surface downward, all over the continental shelf, from Cape Cod to Chesapeake Bay; and the sections

show that depth for depth the temperature was lowest in the north-west corner of the broad bight formed by the coast line, off New York; warmest, as might be expected, along the edge of the continental slope, next the Gulf Stream. Over Nantucket Shoals as a whole, there was probably very little difference between bottom and surface water, the surface, in July, often being as cold as  $55^{\circ}$ ; and this rather cold water apparently showed its effect as far westerly as Station 10062 (Fig. 3), which was  $1-3^{\circ}$  colder at all depths down to 25 fathoms than the next station to the westward (Station 10063). Over the outer part of the continental shelf south of Long Island, the temperature was comparatively uniform, station for station, down to 30 fathoms (Fig. 4) cooling rapidly from the surface downward. But the curves for Stations 10061 and 10065 reveal a warm layer of water on the bottom. The water was very much colder close to the shore near New York than it was further off shore (p. 156), and the same was true along the New Jersey coast, for though by the time we came north, the surface had warmed to about  $75^{\circ}$ , a rise of about  $7^{\circ}$ , the bottom water in ten fathoms was still only about  $52.6^{\circ}$ . Off Barnegat the temperatures increase regularly at all depths from the coast eastward (Fig. 5). The ten fathom temperatures for these stations are successively  $52^{\circ}$ ,  $58.5^{\circ}$ ,  $70^{\circ}$ ,  $71^{\circ}$ ; while the fact that at twenty fathoms there was a difference of  $17^{\circ}$  between Stations 70 and 71 ( $50^{\circ}$  and  $67^{\circ}$ ) only fifteen miles apart, and that the latter, lying

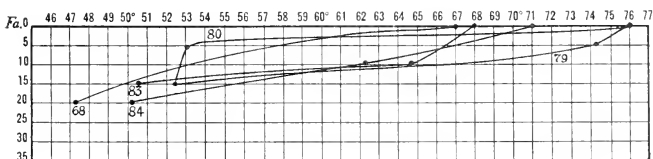

FIG. 7.— Temperature sections close to the land, south of New York (Stations 10068, 10079, 10080) and off Long Island (Stations 10083, 10084).

over the 500 fathom curve, is much warmer than any of the stations on the continental shelf, shows how sudden the temperature transition between coast and ocean water was. Our only station abreast of the mouth of Delaware Bay (Station 10073, Fig. 5) was considerably warmer above twenty fathoms than the station next north of it (10072); and several degrees warmer, at all depths, except for the surface layer of five fathoms or so, than the water south of it (Station

10079). And as the high surface temperature of the latter was almost certainly due to the seasonal warming which had taken place during the interval between our two visits, it is safe to say that at Station 10073 a mass of water warmer than the water either north or south of it was crossed. South of Delaware Bay the water was also found coldest next the coast (the warm surface at Station 10078 was the result of the unusually hot weather of the preceding three or four days). And the curves show, further, that the two stations abreast of Chesapeake Bay (10078 and 10077) were from  $1.5^{\circ}$  to  $3.5^{\circ}$  colder, depth for depth, at the lower levels than the two stations immediately north of them, a fact of interest in connection with the salinity of the region.

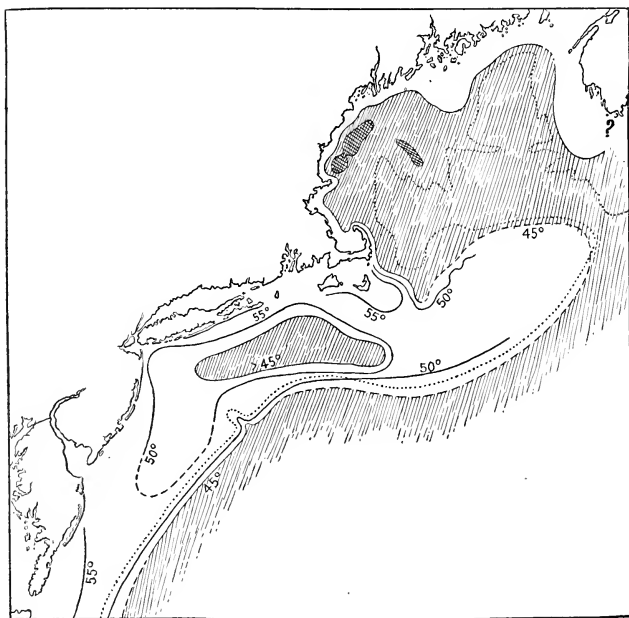

FIG. 8.— Chart of bottom temperature on the continental shelf for July; and in the Gulf of Maine for August. Temperature below  $41^{\circ}$ , cross hatched;  $41^{\circ}$ – $45^{\circ}$ , single hatched. The dotted line, . . . ., is the 100 fathom curve.



Station 10071 was considerably the warmest at all depths above 150 fathoms of the three stations outside the continental shelf (Figs. 4, 5, 6) and presented a fairly typical Atlantic curve; the temperature falling rapidly at first from  $76^{\circ}$  at the surface to  $58.8^{\circ}$  at fifty fathoms; then more and more slowly until at the lowest level, 250 fathoms, a reading of  $43.6$  was obtained. Station 10064 was some  $6^{\circ}$  colder at the surface, the difference gradually decreasing downward; but even at

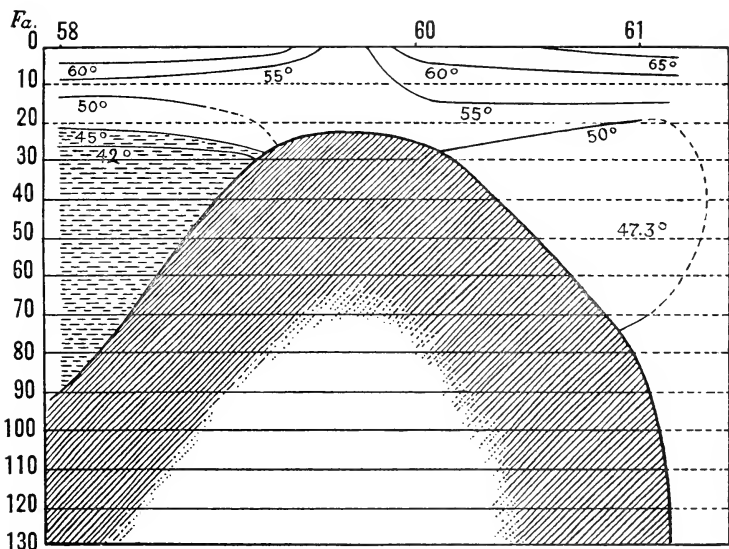

FIG. 9.— Temperature profile from the southern end of the basin of the Gulf of Maine (Station 10058) across Nantucket Shoals to the continental slope south of Nantucket (Station 10061).

250 fathoms it was  $2^{\circ}$  colder ( $41.6^{\circ}$ ). Station 10076 was the most southerly of the three, and might, therefore, have been expected to be the warmest, as it lay at about the same relative position on the slope. But as a matter of fact the temperature ( $49.3^{\circ}$ ) at 150 fathoms (the deepest reading) was about the same as that of Station 10071: and above this level, Station 10076 was considerably the colder of the two.

*Bottom temperature.* The chart of bottom temperature (Fig. 8) illustrates the localization of cold bottom water on the mid-zone of the continental shelf south of Long Island and Marthas Vineyard in July, the southern boundary of which must have been somewhere between the latitude of New York and the line off Barnegat. Shoreward as well as seaward, the bottom water was warmer than  $45^{\circ}$ . That this should have been the case nearer land was to be expected, because of the steady shoaling of the water. But the fact that the bottom water was warmer ( $50^{\circ}$ - $51^{\circ}$ ) between 50 and 125 fathoms

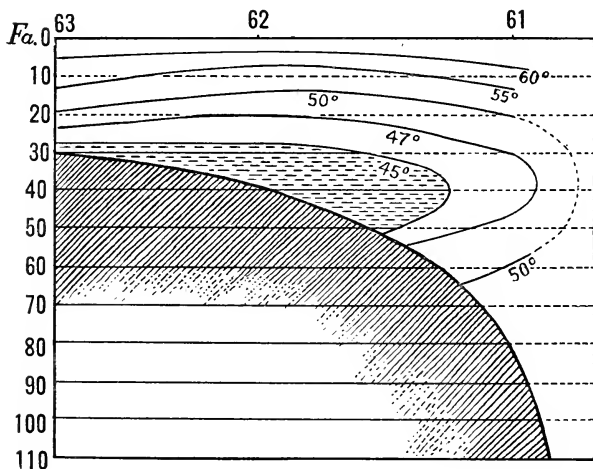

FIG. 10.— Temperature profile across the outer part of the continental slope southwest of Nantucket (Stations 10063, 10062, 10061).

than at 35-50 fathoms, would have been a surprise had not a similar phenomenon been encountered by Libbey (1891) south of Marthas Vineyard in 1889 (p. 241). As pointed out (p. 165) this cold bottom water was not continuous with the cold water in the Gulf of Maine, being interrupted on Nantucket shoals, where the bottom temperature is raised, and the surface correspondingly chilled, by vertical tidal mixing. But no doubt, in winter, the cold water is continuous across the shoals. On the continental slope the temperature was  $45^{\circ}$  at about 200 fathoms.

The bottom temperature was higher south than north of Delaware Bay, and instead of being coldest over the mid-zone of the continental shelf, decreased from the shore seaward, with increasing depth.

*Temperature profiles.* The lines were planned to afford three complete profiles across the continental shelf, one abreast of Montauk, one off Barnegat, and one opposite the mouth of Chesapeake Bay respectively, besides several incomplete ones in intermediate positions, and a complete profile from the deep basin of the Gulf of Maine to the Gulf Stream via Georges and Nantucket Shoals. The latter (Fig. 9) shows that there was a marked temperature contrast between the waters on either side of the Shoals which form the southern boundary of the basin of the Gulf. On the north, the deep basin, below twenty-five fathoms, was filled with water of  $42^{\circ}$  or colder, with a rapid rise in the upper twenty fathoms to the surface temperature of  $62^{\circ}$ - $63^{\circ}$ . On the southern side, the coldest water was about  $47^{\circ}$ , at sixty fathoms, while the surface temperature was some  $6^{\circ}$  warmer at the off shore end of the profile (Station 10061) than in the Gulf ( $68^{\circ}$ ). Over the Shoals in the centre of the profile there are local regions of complete vertical mixing by the tidal currents, as for instance on the southwest side of George's Bank (Station 10059) where the temperature was practically uniform from surface to bottom ( $54.7^{\circ}$ ). On outer edge of the continental shelf the coldest water ( $47.3^{\circ}$ ) was not on the bottom, but at fifty fathoms, with warmer water ( $51.5^{\circ}$ ) below it. And as Gulf Stream water was to be expected only a few miles further off shore, it is fair to assume that this water colder than  $50^{\circ}$  indented the warmer ocean water like a tongue, as represented by the curve for  $50^{\circ}$ . The fact that there was no water on this line colder than  $47^{\circ}$  shows that the cold bottom water ( $45^{\circ}$ ) west of Nantucket Shoals (Fig. 10) was not continuous with the still colder water of the Gulf of Maine.

The next profile (Fig. 11), running from the neighborhood of New York to the 500 fathom curve in Lat.  $39^{\circ} 55'$ , shows the cold water on the shelf at 20-40 fathoms, indenting into the warmer water over the slope. The temperature was much higher, depth for depth, outside the edge of the shelf, than over the latter, as is shown by the sharp seaward dip of all the curves. And at the shore end of the profile the same was the case, the curves rising as the land is approached, with equal temperatures about five fathoms nearer the surface at Station 10067 than at Station 10066. In the central part of the profile (Station 10065 to 10066) there was little horizontal change in temperature from east to west.

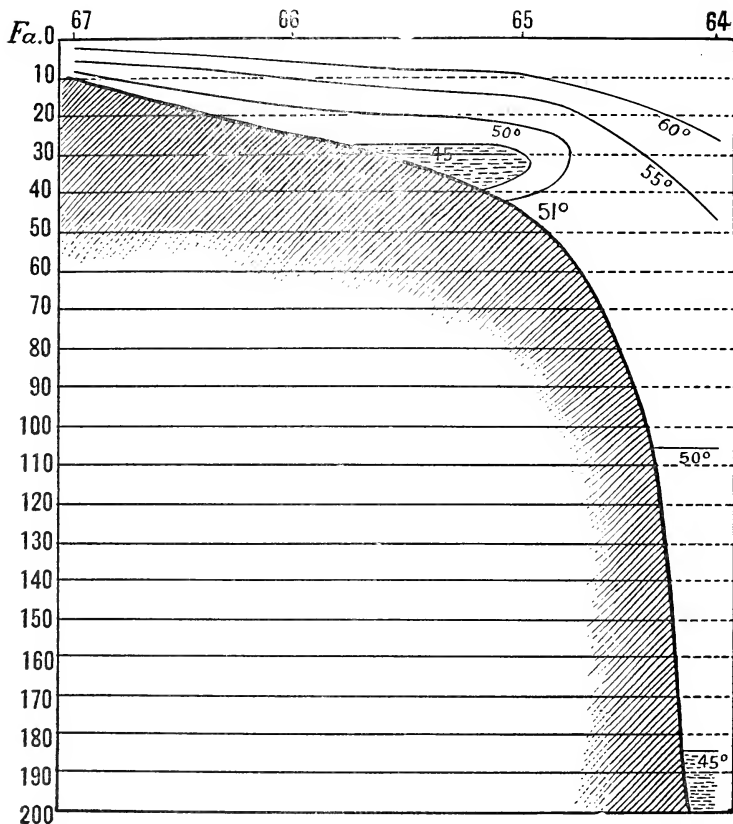

FIG. 11.— Temperature profile across the continental shelf from New York to the edge of the Gulf Stream in Lat.  $39^{\circ} 55'$  (Stations 10067, 10066, 10065, 10064).

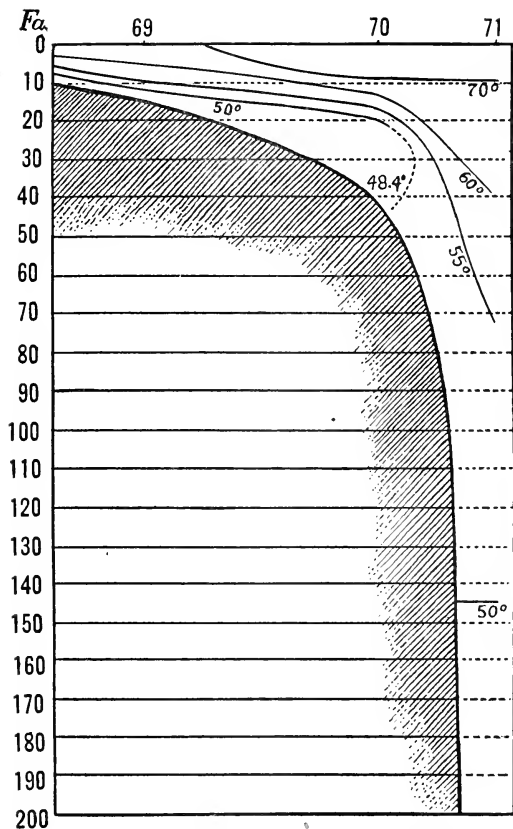

FIG. 12.— Temperature profile across the continental shelf abreast of Barnegat (Station 10069), to the Gulf Stream in Lat.  $38^{\circ} 56'$ . The immediate shore end of the profile is reconstructed from the temperature section a few miles further north (Station 10068).

In the fourth profile, off Barnegat (Fig. 12), the water on the shelf was warmer, its minimum being  $48^{\circ}$  on the bottom at 40-50 fathoms. But on the slope it was only below 150 fathoms that the water was as

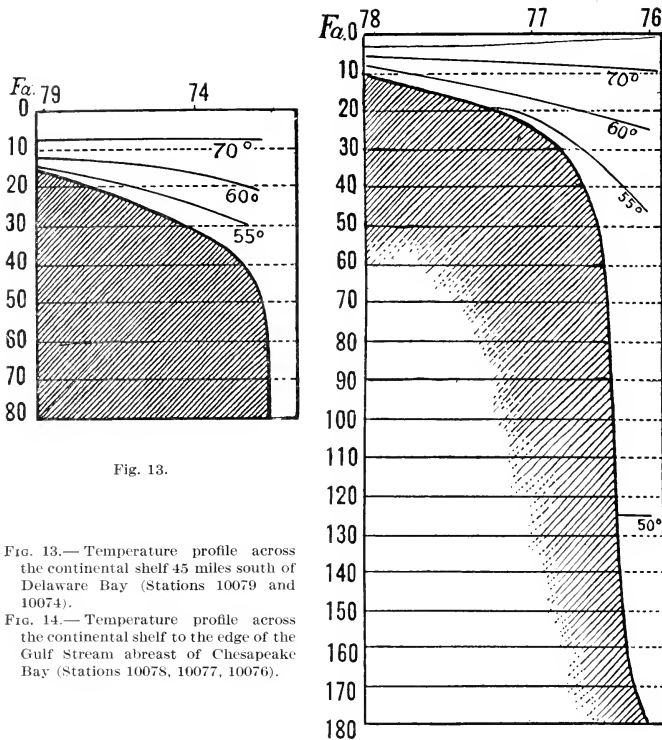

Fig. 13.

FIG. 13.—Temperature profile across the continental shelf 45 miles south of Delaware Bay (Stations 10079 and 10074).

FIG. 14.—Temperature profile across the continental shelf to the edge of the Gulf Stream abreast of Chesapeake Bay (Stations 10078, 10077, 10076).

Fig. 14.

cold as this. And probably there was a belt of bottom water of  $50^{\circ}$ - $55^{\circ}$  at about 100 fathoms, to judge from the other profiles. But there is no bottom reading at this level. In the upper part of the profile

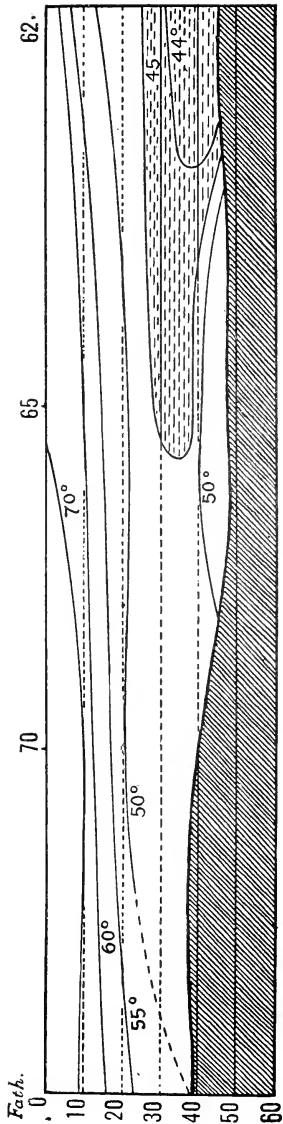

FIG. 15.—Temperature profile along the 40-50 fathom contour from abreast of Delaware Bay to a point south of Nantucket (Stations 10070, 10065, 10062).

the temperature rises, depth for depth, from the land seaward, as in the preceding one. Two partial profiles, one just north, the other just south of Delaware Bay, connect the Chesapeake Bay profile with the one just described. The stations composing the first of these (Stations 10080 and 10072) were, unfortunately, occupied at an interval of two weeks; but other observations have shown that it is only the intermediate surface layer which had warmed up appreciably in the interval. At the outer of the two stations the bottom temperature was  $47.8^{\circ}$  at twenty-five fathoms; and corresponding to the steepness of the shelf, this cool water was found nearer shore, though at about the same depth, than further north.

Just south of Delaware Bay (Fig. 13) there was no water colder than  $50^{\circ}$  on the shelf; the lowest temperature being  $50.8^{\circ}$  at thirty fathoms (Station 10074). But the curves show the progressive warming, depth for depth, from land to sea, which characterize the preceding profiles; the reading ( $52.5^{\circ}$ ) being the same at fifteen fathoms at the shore end as at twenty-seven fathoms at the offshore end of the profile.

Off Chesapeake Bay (Fig. 14) the slope was bathed with water of  $50^{\circ}$ - $52^{\circ}$  from twenty-five fathoms down to 130 fathoms. There the surface water cooled from the shore seaward instead of warming as it does further north (p. 165). But though the temperature above five fathoms was highest at the shoreward end of the profile, the ten fathom (bottom) temperature was lower ( $57.6^{\circ}$ ) there than further off shore.

The general rise in temperature on the shelf from north to south is illustrated by a profile parallel with the coast at about the forty fathom curve (Fig. 15). Below twenty-five fathoms the curves are distorted by the intrusion of warm water ( $51^{\circ}$ ) on the bottom near Station 10065, resulting in the extension of cold water southward over warm. The lowest temperature is at the northerly end at forty-five fathoms.

#### TEMPERATURE IN THE GULF OF MAINE.

*Surface temperature.* The distribution of surface temperature in the Gulf of Maine was the same in general as in 1912, the north-eastern part being coldest, the southwestern warmest. The surface water (Fig. 1) abreast of Massachusetts Bay, along shore from Cape Cod to Cape Elizabeth, and eastward nearly to German Bank was  $60^{\circ}$  or warmer, usually  $60^{\circ}$ - $62^{\circ}$ ; and although the surface was considerably warmer ( $64^{\circ}$ - $66^{\circ}$ ) northeast of Cape Cod and in the neighborhood



of Cashes Bank, this was the result of solar warming, not of Gulf Stream water, as proved by the low salinity (p. 200). The northern, western, and eastern limits of this warm region can be defined with some accuracy from the hourly temperatures; but how far it extended to the south is doubtful. It is not likely, however, that it was directly continuous with the warm surface water south of Georges Bank, for the surface temperature on the latter is lowered by the violent tidal currents (p. 155).

At the eastern side of the Gulf a sudden transition from the high temperature of the basin to cold surface water on German Bank was noted, the temperature dropping from  $60^{\circ}$  to  $48^{\circ}$ , the coldest surface reading of the cruise. Off the Nova Scotia coast the surface temperature was  $52^{\circ}$ - $53^{\circ}$ , rising to  $54^{\circ}$ - $56^{\circ}$  abreast of the mouth of the Bay of Fundy. Off Mt. Desert Rock Station 10100 showed that the zone

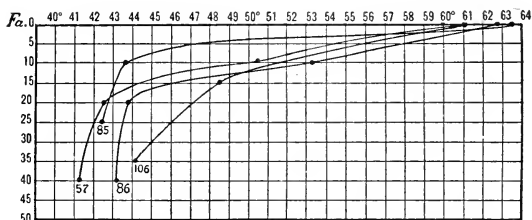

FIG. 16.— Temperature sections off Cape Cod in July (Station 10057) and in August (Stations 10085, 10086) and in Massachusetts Bay in August (Station 10106).

of  $54^{\circ}$ - $56^{\circ}$  water was of considerable breadth. Near the northeast coast of Maine the surface temperature was  $50^{\circ}$ - $52^{\circ}$ ; rising to  $54^{\circ}$ - $56^{\circ}$  off Mt. Desert Island.

*Temperature sections.* The temperature curves off Cape Cod (Station 10057, Fig. 16; Station 10058, Fig. 3) and off Cape Ann (Station 10087, Fig. 17); near Platt's Bank (Station 10089, Fig. 18) and near Cashes Ledge (Station 10090, Fig. 18) show a very rapid cooling from the surface down to about thirty fathoms, followed by a layer, reaching down to the bottom, in which the temperature was almost uniform. In 1912, the temperature of the uniform bottom water was  $40.3^{\circ}$  at all the stations off Cape Ann and Massachusetts Bay; in 1913 it was  $43.9^{\circ}$  near Cashes Ledge,  $41.3^{\circ}$  near Platt's Bank;  $40.3^{\circ}$  in the southern part of the trough between Jeffrey's Ledge and

the mainland. In the northern part of the trough (Station 10104), it was  $39.8^{\circ}$  at eighty fathoms.

In the summer of 1912, the water of the Gulf was invariably coldest at the bottom; but in 1913 the western basin and two stations in the eastern basin (Stations 10092, 10093, Fig. 17) were coldest in

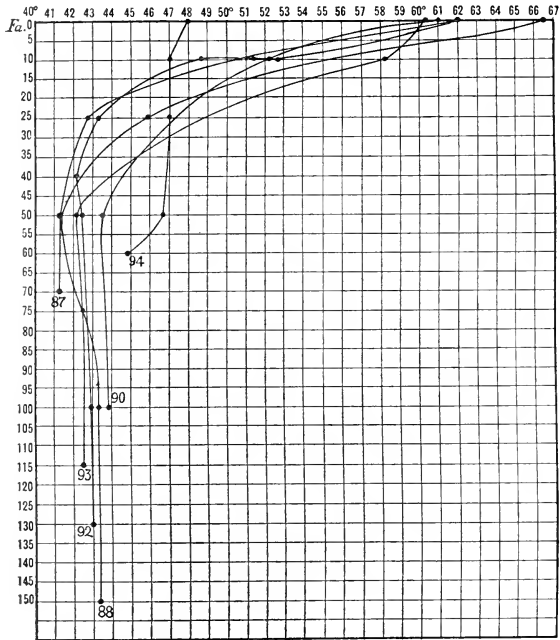

FIG. 17.— Temperature sections in the Gulf of Maine from Massachusetts Bay to German Bank (Stations 10087, 10088, 10090, 10092, 10093, 10094).

the intermediate depths; the minimum in the former being  $41.3^{\circ}$  at fifty fathoms, *i. e.*, precisely the same as the uniform bottom water nearer shore, rising to  $43.3^{\circ}$  at 100 fathoms, below which level it was uniform down to the bottom (150 fathoms). On the western

side of the eastern basin (Station 10092) the upper layers were colder, but the minimum was warmer ( $42.2^{\circ}$  at forty fathoms), with about  $43^{\circ}$  at 100 fathoms, below which it was practically uniform to the bottom (130 fathoms). At the eastern side of the eastern basin (Station 10093) the minimum ( $41.1^{\circ}$  at fifty fathoms) was about the same as in the western basin, though the upper layers, and the bottom water ( $41.6^{\circ}$  at 115 fathoms) were both colder than the latter.

All these temperature curves are characterized by a sudden change

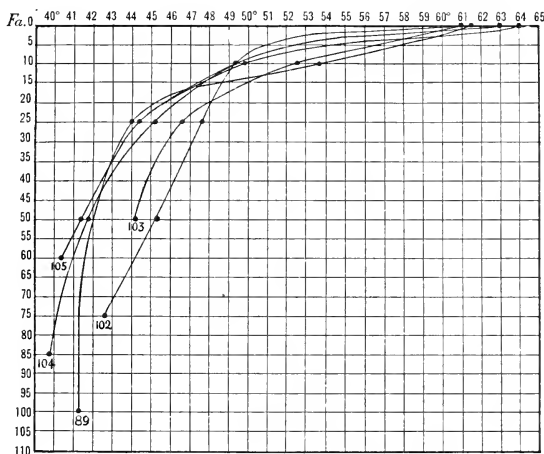

FIG. 18.— Temperature sections in the Gulf of Maine near Platt's Bank (Station 10089) and north of Cape Ann (Stations 10102, 10103, 10104, 10105).

in direction at about the 30–40 fathom level, corresponding to the point at which the fall of temperature ceases to be rapid. And in 1912 this was true of the trough west of Jeffrey's Ledge. But in 1913 the temperature sections at the two Stations in the latter (Stations 10104 and 10105, Fig. 18) show a steadily decreasing rate of cooling from the surface downward. And this is true in general of the Stations off the coast of Maine (Stations 10098, 10099, 10101, 10102, Fig. 19, and 10103) and of the northern end of the eastern basin (Stations 10097, 10100, Fig. 20). The water next the coast was, progressively,

colder on the surface, warmer on the bottom, from Cape Ann toward the Bay of Fundy, for example the surface and fifty fathom temperatures were  $64^{\circ}$  and  $41.05^{\circ}$  at Station 10105;  $61^{\circ}$  and  $44^{\circ}$  at Station 10103;  $54^{\circ}$  and  $47.5^{\circ}$  at Station 10101. And though this change was interrupted off Mt. Desert (Station 10099), the difference between surface ( $50.5^{\circ}$ ) and bottom ( $48.3^{\circ}$ ) off the Grand Manan Channel (Station 10098) was only  $2^{\circ}$ .

At Stations 10097 and 10100 the temperature agreed at the surface ( $55^{\circ}$ ) and at 100 fathoms ( $43.2^{\circ}$ ); but from about ten fathoms down to about fifty fathoms, Station 10100 was the colder of the two, with a difference of  $3^{\circ}$  at twenty fathoms, a fact probably due to an upwelling of cold water from below.

On the Nova Scotia slope, off Lurcher Shoal (Station 10096), the temperature curve (Fig. 19) agrees very closely with that for Station

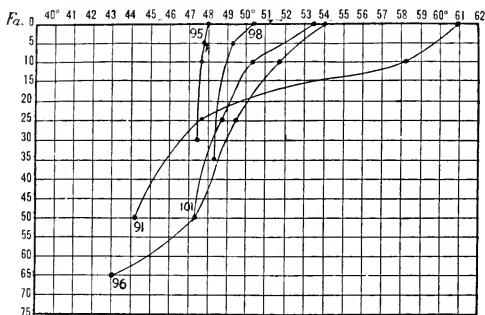

FIG. 19.— Temperature sections in the Gulf of Maine, on Jeffrey's Bank (Station 10091); off Matinicus Island (Station 10101); off the coast of Maine near the Grand Manan Channel (Station 10098); near Lurcher Shoal (Station 10096); and on German Bank (Station 10095).

10097 from the surface down to fifty fathoms, cooling from  $54^{\circ}$  to about  $47^{\circ}$ , and although the seventy fathom reading ( $43^{\circ}$ ) was colder than the water at the corresponding level in the northern part of the basin, it was almost precisely the same as the bottom water there (Stations 10097 and 10100). The temperature was practically uniform from the surface downward, on German Bank; and even over the seventy fathom curve on its western slope (Station 10094, Fig. 17) the difference between surface and bottom was only about  $3^{\circ}$  ( $48^{\circ}$ – $44.9^{\circ}$ ).

At the one Station in Massachusetts Bay (Station 10106, Fig. 16) the upper part of the temperature curve agreed almost exactly with the water off Cape Ann, (Station 10087) and near Platt's Bank (Station 10089), cooling from  $61^{\circ}$  at the surface to  $48.5^{\circ}$  at fifteen fathoms. But at thirty-five fathoms (bottom) it was  $2^{\circ}$  warmer ( $44.1^{\circ}$ ) than either of these.

All the temperatures described so far for the Gulf were taken in August, during a week's period: and hence directly comparable

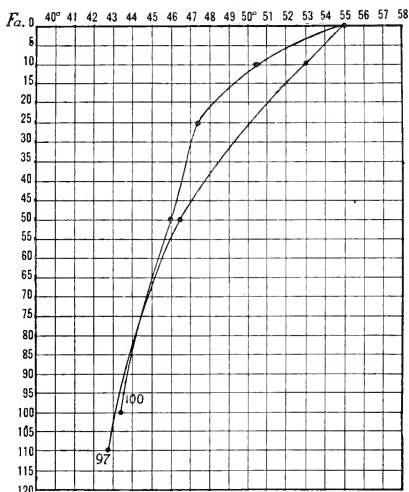

FIG. 20.—Temperature sections in the northeastern part of the basin of the Gulf of Maine (Stations 10097, 10100).

with one another. But three Stations, one off Cape Cod (Station 10057, Fig. 16) at the same location as Station 10086, one over the southern part of the basin (Station 10058, Fig. 3), the third on George's Bank (Station 10059, Fig. 3), were made a month earlier. The surface temperature of the first ( $61^{\circ}$ ) is exactly the same as it was at the same locality in August (Station 10086); but below the surface the July section is colder at all depths, the greatest difference being on the

bottom (forty fathoms), where the water was  $41.2^{\circ}$  as against  $43.2^{\circ}$  a month later. Station 10058 was about  $2.5^{\circ}$  warmer than the Cape Cod stations down to twenty fathoms; but at thirty fathoms it was about  $.5^{\circ}$  colder ( $41.1^{\circ}$ ); with a minimum of  $40.6^{\circ}$  at sixty fathoms, below which it warmed slightly; and its curve is almost exactly parallel with that of the nearest August Station (10085), though about  $3^{\circ}$  warmer at all depths.

The water on the southwestern part of George's Bank (Station 10059) was nearly uniform from the surface downward, in temperature as well as in salinity (p. 188).

*Mean temperature.* If all the temperature curves in the Gulf were parallel, a direct comparison between them would show which regions were potentially warmest, which coldest. But they are so distorted by greater or less active vertical circulation, that it is only by calculating the mean temperatures for each station that light can be obtained on this subject. The mean temperatures for the zone between the surface and the fifty fathom level are given in the following table:—

Station	Mean tem.	Station	Mean tem.
10087	$46.3^{\circ}$	10096	$50.2^{\circ}$
10088	$49.4^{\circ}$	10097	$50.3^{\circ}$
10089	$47^{\circ}$	10100	$48.4^{\circ}$
10090	$47.5^{\circ}$	10101	$49^{\circ}$
10091	$50^{\circ}$	10102	$48.5^{\circ}$
10092	$46.5^{\circ}$	10103	$48.4^{\circ}$
10093	$50^{\circ}$	10104	$47.2^{\circ}$
10094	$47.1^{\circ}$	10105	$47^{\circ}$

The mean between the surface and forty fathoms, was  $46^{\circ}$  at Station 10057;  $48.5^{\circ}$  at Station 10086;  $48.8^{\circ}$  at Station 10106; the thirty fathom mean was  $47.6^{\circ}$  at Station 10095;  $55^{\circ}$  at Station 10059. Thus the upper fifty fathoms was coldest, as a whole, on the western side of the Gulf. Passing northeastward along the coast, the mean temperature rose from  $46.3^{\circ}$  near Cape Ann to  $48.4^{\circ}$  off Cape Elizabeth,  $49^{\circ}$  off Penobscot Bay,  $48.4^{\circ}$  off Mt. Desert Rock and  $50.3^{\circ}$  over the northern end of the basin. In the centre of the Gulf it was generally  $49^{\circ}$ – $50^{\circ}$ , except for one cold Station (10092). Off the mouth of the Bay of Fundy the mean ( $50.3^{\circ}$  at Station 10096) was as high as anywhere in the Gulf. But the upper fifty fathoms over the slope of German Bank (Station 10094), and the whole column of water on the Bank itself

Station 10095), was distinctly colder ( $47.1^{\circ}$ – $47.5^{\circ}$ ) than the corresponding layer of water either west, north or northwest of it (Stations 10093, 10096, 10097, 10100). Consequently vertical mixing of the upper fifty fathoms of water immediately surrounding the Bank could not reproduce the temperature observed on the latter; there must have been either an influx of cold water from elsewhere, or some upwelling.

The mean temperature of the layer of water between 50 and 100 fathoms was:—

Station	Mean tem.	Station	Mean tem.
10088	$42.4^{\circ}$	10093	$42.4^{\circ}$
10089	$41.3^{\circ}$	10097	$44.5^{\circ}$
10090	$43.7^{\circ}$	10100	$44.5^{\circ}$
10092	$42.6^{\circ}$		

At Station 10087, 50–70 fathoms, the mean was  $41.2^{\circ}$ ; at Station 10104, 50–85 fathoms,  $40.5^{\circ}$ .

Thus the bottom water of the deeper parts of the Gulf, like the upper layers was warmest in the northern part of the eastern basin (Stations 10097, 10100); coldest, next the western shore (Stations 10087, 10104).

In the preceding sentences the differences in mean temperature have been emphasized; but in reality the striking result of the calculation is the uniformity of the Gulf, the extreme divergence of the mean of the upper fifty fathoms being only about  $4^{\circ}$ , that of the mean between fifty and 100 fathoms about the same, over an area of about fourteen thousand square miles.

The mean temperature of the upper 15 fathoms, *i. e.*, of the zone most subject to solar warming, shows a much greater range (about  $11.2^{\circ}$ ), as illustrated in the following table:—

Station	Mean tem.	Station	Mean tem.
10087	$54.5^{\circ}$	10096	$52.3^{\circ}$
10088	$58.5^{\circ}$	10097	$53.5^{\circ}$
10089	$55.1^{\circ}$	10098	$49.3^{\circ}$
10090	$55.5^{\circ}$	10100	$52^{\circ}$
10091	$55.1^{\circ}$	10101	$51.5^{\circ}$
10092	$53.7^{\circ}$	10103	$55.2^{\circ}$
10093	$58^{\circ}$	10104	$53.2^{\circ}$
10094	$47.3^{\circ}$	10106	$55^{\circ}$
10095	$47.7^{\circ}$		

The distribution of the fifteen fathom mean, highest in the central part of the Gulf (Stations 10088 and 10093), falling to about  $54^{\circ}$ - $55^{\circ}$  over the western half of the Gulf generally, and lowest in its northeast corner and on German Bank, corresponds with the distribution of surface temperature, and with the proportional strength of the tidal currents, just as might be expected, solar warming being most effective where vertical circulation is least active.

*Temperature profiles.* The general distribution of temperature across the Gulf, from east to west, is illustrated by a profile from Massachusetts Bay to German Bank (Fig. 21, Stations 10106, 10087, 10088, 10090, 10092, 10093, 10094, 10095), its most interesting feature being its illustration of the fact (p. 172) that in the central part of the Gulf the water was coldest at about fifty fathoms, not on the bottom. Water of  $41^{\circ}$ - $43^{\circ}$  filled the sink at the mouth of Massachusetts Bay, rising there to within twenty-five fathoms of the surface; and projected eastward, like a shelf, over the western basin, without any rise in temperature at fifty fathoms as far east as Station 10088; warming to  $43.5^{\circ}$  in the middle of the Gulf (Station 10090). In the eastern half of the profile, the coldest water extended from shore, westward into the centre of the Gulf. But on this side there was no water colder than  $42^{\circ}$ , the lowest reading being  $42^{\circ}$ , and the cold mass of water was not horizontal but oblique, rising from a depth of 80-100 fathoms on the shore slope, to 40-60 fathoms at its western end, with the coldest water ( $42^{\circ}$ ) limited to a very thin layer 40-50 fathoms. The cold layer was interrupted in the middle of the Gulf (Station 10090) by water  $1^{\circ}$ - $2^{\circ}$  warmer at the fifty fathom level. The temperature of the water underlying the cold zone ranged from  $43^{\circ}$  to  $43.9^{\circ}$ , coldest at the eastern side of the Gulf, depth for depth, warmest in the centre (Station 10090), *i. e.*, just the reverse of the temperature at fifty fathoms.

Above thirty fathoms the water was warmest at Station 10088, coldest on German Bank and off the mouth of Massachusetts Bay (Station 10087), where the temperature was below  $43^{\circ}$  at a depth of only twenty-five fathoms. The profile shows the spreading of the curves over German Bank (Station 10095) which characterized that region in 1912 (1914a, p. 56); caused by vertical mixing by the tides. And there is a similar phenomenon in Massachusetts Bay (Station 10106); limited in this case to depths below ten fathoms.

A profile running northeast from the mouth of Massachusetts Bay to Station 10089 (Fig. 22) shows that water colder than  $42^{\circ}$  extended unbroken across the northern end of the western basin, to the south-



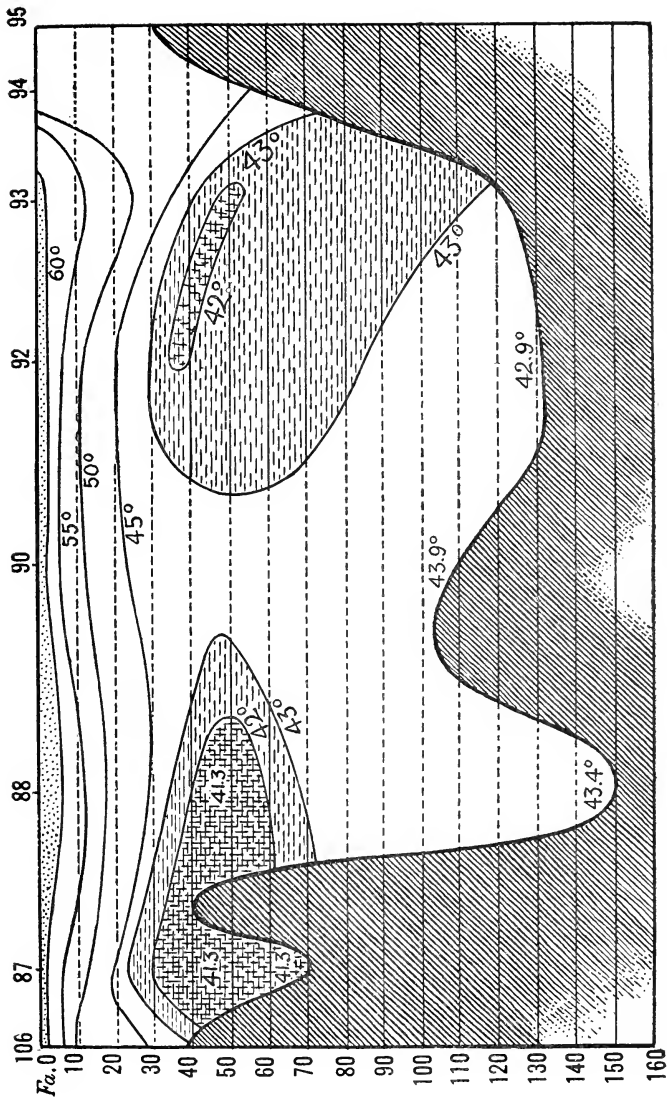

FIG. 21.—Temperature profile across the Gulf of Maine from Massachusetts Bay to German Bank (Stations 10106, 10087, 10088, 10090, 10092, 10093, 10094, 10095).

western slope of Jeffrey's Bank. But it gradually receded from the surface, passing toward the northeast, the curve of  $42^{\circ}$  dipping from thirty fathoms at Station 10087 to forty fathoms at Station 10089, and to the bottom, in about sixty fathoms, on the slope of the Bank. And there was no water as cold as  $42^{\circ}$  on the northeast side of the bank. Whether the  $42^{\circ}$  water was underlaid by warmer water in the

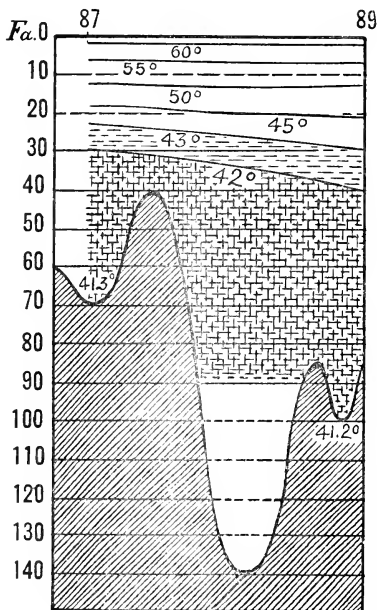

FIG. 22.—Temperature profile running northeastward from off Cape Ann (Station 10087) toward Platt's Bank to Station 10089.

northern end of the western basin, as it was further south (Station 10088), is uncertain; but this was probably the case.

Profiles running off shore from the western side of the Gulf further delimit the  $42^{\circ}$  water. The first of these, from the trough between Jeffrey's Ledge and the mainland (Station 10104) to the centre of the

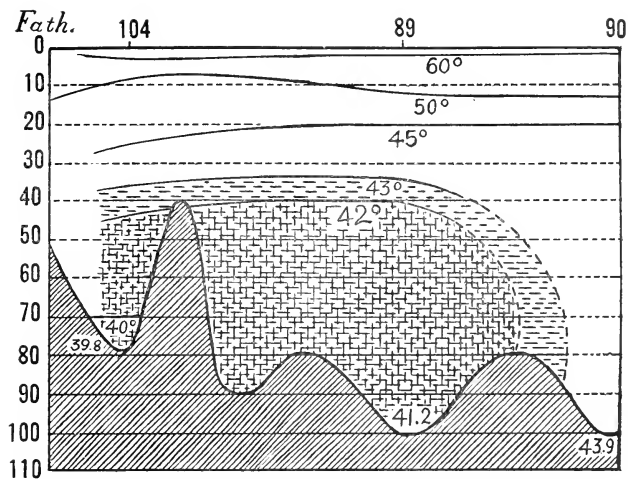

FIG. 23.—Temperature profile from the trough between Jeffrey's Ledge and the coast (Station 10104) toward the centre of the Gulf (Station 10090) via Station 10089.

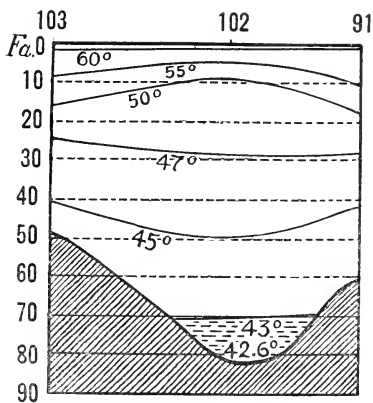

FIG. 24.—Temperature profile from the neighborhood of Cape Elizabeth (Station 10103) to Jeffrey's Bank (Station 10091) via Station 10102.

Gulf (Station 10090, Fig. 23), shows that below forty fathoms the trough was filled with water colder than  $42^{\circ}$ : and this was also true as far off shore as the ridge which is crowned by Cashes Ledge. But, as already pointed out,  $42^{\circ}$  water did not extend to Station 10090. And the fact that at the latter the lowest temperature ( $43.5^{\circ}$ ) was at fifty fathoms, not on the bottom, suggests a slight shelf-like projection of the  $42^{\circ}$  water. It is safe to say that Jeffrey's Ledge rises above the coldest water locally, for in places it is covered by less than thirty fathoms. And tidal currents may be expected to cause temperature

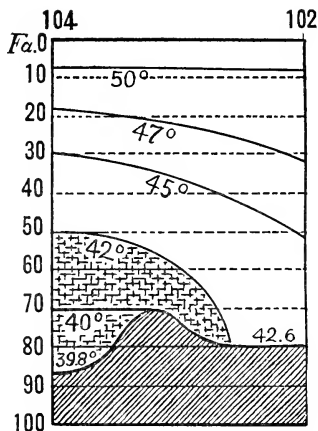

FIG. 25.— Temperature profile lengthwise of the trough between Jeffrey's Ledge and the mainland (Stations 10104, 10102).

disturbances over it. Between the thirty fathom level and the surface the temperature was nearly uniform, depth for depth, from one end of the profile to the other.

A profile (Fig. 24) parallel to the last, but some twenty-five miles further north, from Cape Elizabeth (Station 10103) to Jeffrey's Bank (Station 10091) is warmer at all depths, except the immediate surface, than the preceding one, with water colder than  $43^{\circ}$  limited to depths greater than seventy fathoms, and a minimum of  $42.6^{\circ}$  at eighty fathoms. Between five and fifteen fathoms the difference between the

two profiles is slight; but below that level it grows progressively greater and greater, as shown by the following table:—

Depths <i>A</i>	Temperature	Depths <i>B</i>
5 fathoms	55°	5 fathoms
10	50°	12-15
18	47°	about 30
22	45°	40-50
35	43°	70

(*A* is the profile across the Ledge, and *B* the profile off Cape Elizabeth).

The temperature was almost precisely the same, depth for depth, off Cape Elizabeth (Station 10103) as on Jeffrey's Bank (Station 10091).

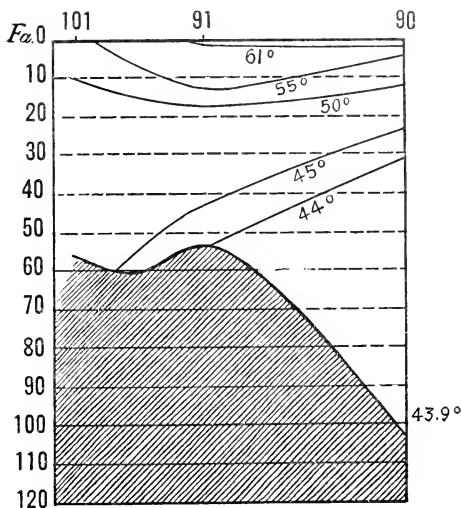

FIG. 26.— Temperature profile from the neighborhood of Matinicus Island (Station 10101) across Jeffrey's Bank (Station 10091) toward the centre of the Gulf (Station 10090).

But in the middle of the profile (Station 10102) there is a pronounced spreading of the curves between ten and fifty fathoms, which, however, is limited to the mid-depths; it is probably an evidence of local disturbances. A profile (Fig. 25) running parallel to the coast (Stations 10104-10102) connecting the preceding two, shows that the  $42^{\circ}$  water can hardly have extended beyond the northern end of Jeffrey's Ledge,

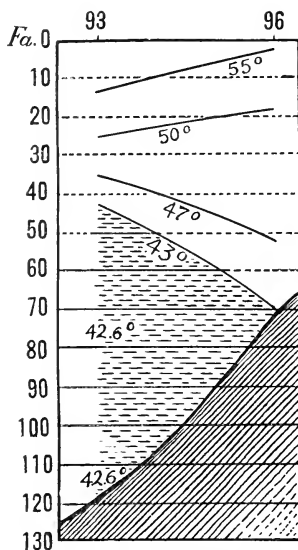

FIG. 27.— Temperature profile from the eastern basin of the Gulf (Station 10093) toward the mouth of the Bay of Fundy (Station 10096).

while water colder than  $40^{\circ}$  (p. 178) was confined to the deeper parts of the trough. A profile (Fig. 26) running off shore from the neighborhood of Matinicus Island to the centre of the Gulf shows that the bottom water was distinctly warmer on Jeffrey's Bank (Station 10091) than in the centre of the Gulf (Station 10090). And a profile from Station 10102, off Monhegan, to Station 10089, would show an even greater temperature-difference between the two ends.

Evidently then, the immediate coast water from Cape Elizabeth to and across the mouth of Penobscot Bay was distinctly warmer than the coast water further south, or than the water off shore, water colder than  $42^{\circ}$  being limited, on the northeast by the slope of Jeffrey's Bank. We have no means of knowing how far south water colder than  $42^{\circ}$  may have extended in August. But the fact that in early

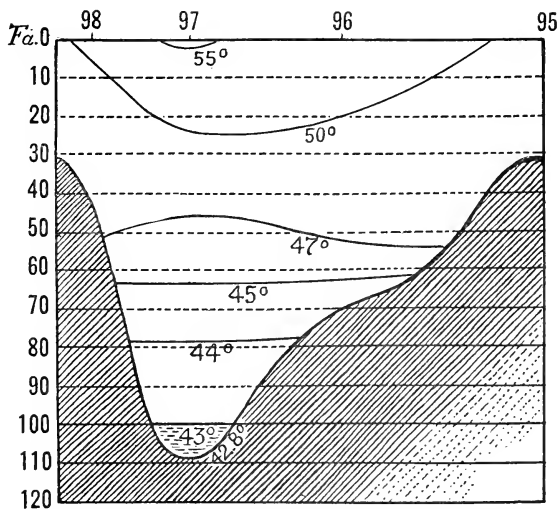

FIG. 28.— Temperature profile across the mouth of the Bay of Fundy, from the coast of Maine (Station 10098) to German Bank (Station 10095) crossing the northern end of the basin (Station 10097).

July it filled the basin off Cape Cod, from thirty fathoms to bottom, suggests that it reached the northwestern side of Georges Bank, though probably underlaid by warmer water in the southern part of the basin, just as at Station 10088.

A profile from the basin toward the Bay of Fundy (Fig. 27) shows that vertical tidal mixing was effective from German Bank to Lurcher Shoal, diminishing toward the north, to reappear again off the coast of Maine (Fig. 28).

## SALINITY, CAPE COD TO CHESAPEAKE BAY.

1. *Surface salinity.* The surface salinity (Plate 2) from Cape Cod to the southern edge of Nantucket Shoals was  $32.2\text{‰}$ – $32.6\text{‰}$ . And the record of  $32.3\text{‰}$  at the eastern end of Vineyard Sound agrees so well with Sumner, Osburn, and Cole's (1913) records for the surface waters of that region in August, 1906 ( $32.2\text{‰}$  to  $32.3\text{‰}$ ) that we can

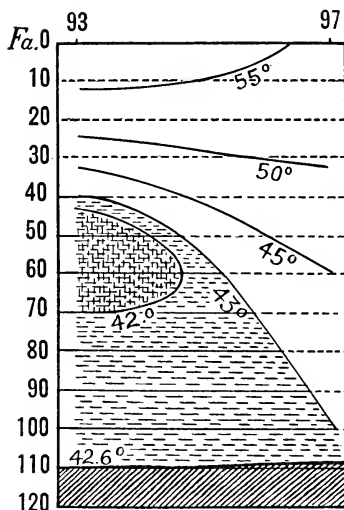

FIG. 29.— Temperature profile lengthwise of the northeastern part of the basin from south to north (Stations 10093, 10097). For  $42^\circ$  read  $42.5^\circ$ .

assume that value as normal for summer. The few stations in this region suggest that the curve of  $32.3\text{‰}$  swings westward toward the mouth of Vineyard Sound, which agrees with their statement (1913, p. 36) that there is a dominant westerly movement of the water through the Sound of about two knots per day.

From Nantucket light-ship out to the edge of the continental shelf there was a steady, and fairly uniform rise in salinity to about  $33.4\text{‰}$



over the seventy-five fathom curve; and there is every reason to assume that by a run of a very few miles further to the south Gulf Stream water of 35‰ would have been found. Close to the shore of Long Island the salinity was only about 31.2‰, with an expansion of water fresher than 32.2‰ off its eastern end. And there was a second tongue of comparatively low salinity abreast of Barnegat. On the other hand Gulf Stream water (35‰) was encountered on the surface at the outer edge of the continental slope off New Jersey, with a rise of salinity from 32.4‰ to 35.25‰ in a distance of only twenty miles (Station 10070 to Station 10071).

Close to the New Jersey coast the salinity rose, north to south, from 31.2‰ near New York to 32.2‰ off Cape May. And the importance of Delaware Bay, like that of the Connecticut and Hudson Rivers, as a source of land water, was shown by the pronounced off shore swing of the curve of 32.2‰ abreast of its mouth. At the time of our visit its influence was evident for at least fifty miles from Cape May (Station 10072). The curves show a tongue of comparatively salt water approaching the shore north of Delaware Bay; and a much more pronounced one just south of it, where the curve of 33.5‰ lies only thirty miles from land, good evidence that the Delaware water had but little effect either south or north of the Bay in July. The approach of water of high salinity toward the coast south of New York is further illustrated by the fact that off Cape Henlopen the curve of 33‰ was within thirty-five miles of land instead of at a distance of eighty miles, as was the case abreast of Long Island. And while this phenomenon is in part a concomitant of the steadily decreasing breadth of the continental shelf, the water was saltier over the twenty-five fathom curve off Cape Henlopen than over the 100 fathom curve off Long Island.

The freshening effect of Chesapeake Bay on the surface is unmistakable; the water fifteen miles off its mouth being the freshest (29.25‰) water encountered during the cruise. And the surface salinity was only 32.2‰ over the 100 fathom curve, though 33.5‰ water occupied this relative position on the shelf only thirty miles further north. But the water from the Bay had little effect further seaward, for in the next fifteen miles the salinity rose to 33.5‰, *i. e.*, to practically the same saltness as at the same relative position off Barnegat.

The work south of Cape Cod occupied only about three weeks time; hence it is hardly to be expected that any considerable change in salinity would have taken place. And as a matter of fact the stations on the way north show no clear evidence of any. But water samples

collected by Mr. Welsh on August 22, near the sixty fathom curve off Block Island (Station 10112) proved to be very much saltier (surface salinity 34‰) than the water in this region during the first of July; saltier, in fact, than any water on the shelf at that time, showing that an indraught of ocean water took place in August.

During the spring of 1913, Captain McFarland, of the schooner VICTOR, collected water samples at nine localities between Nantucket and Delaware Bay, seven at the surface, four from 15–25 fathoms, which show that early in June the surface salinity was 32.9‰ thirty miles south of Marthas Vineyard, 32.6‰ over the southwest slope of Nantucket shoals twenty miles west of Nantucket light-ship; and that it was practically unchanged at the latter locality on June 21 (p. 351). Thus the water was saltier in June than in July; but while the difference was considerable off Marthas Vineyard (32.9‰ as against 32.2‰) it was very slight over Nantucket Shoals (June 6, 32.65‰; June 21, 32.68‰, July 9, 32.5‰).

Off Cape May, a few miles south of the location of our Station 10072, Capt. McFarland encountered water of 34.18‰ on the surface, and near the bottom at twenty-five fathoms, on May 3 and May 9, which is much saltier than it was there in July (about 32.4‰ on the surface). But as the curves show (Plate 2), 34‰ water would have been reached only fifteen miles further off shore at that season. Apparently, then, the coast water, from Cape Cod to Chesapeake Bay, is freshest in July; and hence, since the outrush of river water is at its maximum in May, seaward expansion must be a slow process. After July, ocean water once more has the upper hand.

*Salinity sections.* The water is usually freshest on the surface, saltiest on the bottom, over the continental shelf south and west of Cape Cod, as, indeed, is the general rule in coastal waters in summer. But at three Stations, 10073, 10074, and 10077, all south of Delaware Bay between the 20 and 30 fathom curves, the intermediate layers, were saltiest (Fig. 31, 34). The remaining, more normal, sections fall into several distinct classes. There is, to begin with, one Station (10059) with only a very slight rise in salinity from the surface downward (surface 33.06‰; 30 fathoms, 33.1‰), a type familiar in the northeast part of the Gulf of Maine in regions of strong tidal currents; its location on George's Bank, where the currents are proverbially violent, and where temperature like salinity was practically uniform at all depths, shows that it is a similar example of vertical circulation. Judging from the tidal currents, it is probable that more or less similar conditions obtain locally on Nantucket Shoals; but on their

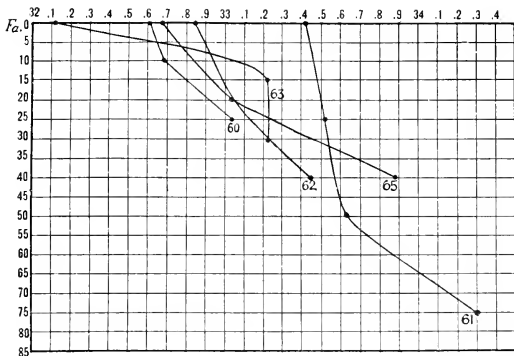

FIG. 30.— Salinity sections on the continental shelf south of Nantucket and Long Island (Stations 10060, 10061, 10062, 10063, 10065).

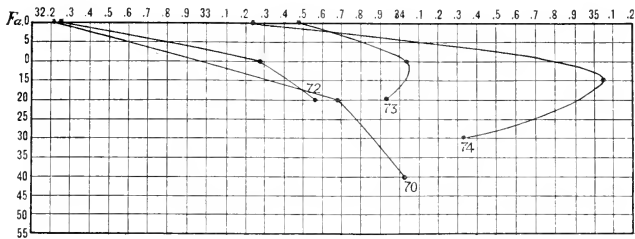

FIG. 31.— Salinity sections on the continental shelf south of New York (Stations 10070, 10072, 10073, 10074).

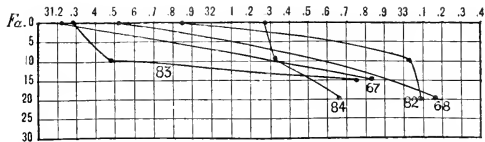

FIG. 32.— Salinity sections close to land off New York (Stations 10067, 10068, 10082) and Long Island (Stations 10083, 10084).

southern slope the vertical range of salinity was greater (Station 10060, Fig. 30). A considerable vertical range in salinity, with more or less regular increase from the surface downward, characterized Stations 10062, 10065, (Fig. 30), 10066, 10070, 10072, (Fig. 31), 10075 (Fig. 33), and probably 10067, and 10068 (Fig. 32). And though

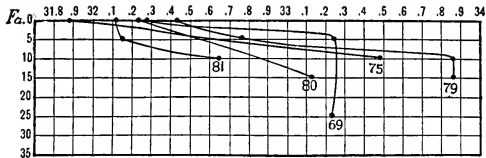

FIG. 33.—Salinity sections close to land, New York to Chesapeake Bay (Stations 10069, 10075, 10079, 10080, 10081).

there was a good deal of variation from station to station in the precise rapidity of increase, as a whole the difference between surface and bottom increased from northeast to southwest. At Stations 10063 (Fig. 30), 10066, 10069 (Fig. 33) and 10082 (Fig. 32), there was a rapid rise immediately below the surface, followed by a bottom zone of uniform salinity, 10–20 fathoms thick. The curves for Stations 10081, 10083, 10084, 10060, 10061, are the reverse, the surface layer being nearly uniform with a rapid rise below. As a whole the water was freshest near shore, saltiest over the outer part of the continental

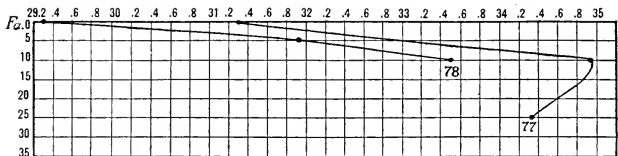

FIG. 34.—Salinity sections on the continental shelf abreast of Chesapeake Bay (Stations 10077, 10078).

shelf, with a progressive rise in salinity from northeast to southwest at stations occupying the same relative positions on the shelf.

The salinity sections at the three Stations outside the 100 fathom curve (10064, 10071, 10076, Fig. 35) are all of one type, fresh at the surface, saltiest in the intermediate layers, and growing slowly

fresher once more below 100 fathoms or so. Station 10064 is the freshest of the three, with 10071 the saltest, 10076 is intermediate between these two. And they approach one another so closely below 150 fathoms as to suggest that they would have been all alike below that depth, had the stations been located a few miles further off shore.

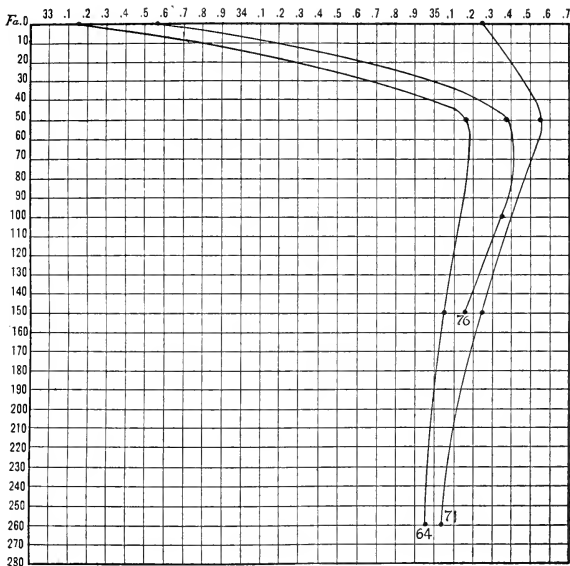

FIG. 35.— Salinity sections at the edge of the Gulf Stream at Lat.  $39^{\circ} 55'$  (Station 10064); Lat.  $38^{\circ} 56'$  (Station 10071) and abreast of Chesapeake Bay (Station 10076).

Of the three, Station 10071 most nearly approaches a typical oceanic section; but even here the effect of coast water is evidenced by the fact that the surface salinity is lower than that of the intermediate layers, while Stations 10064 and 10076 both give a similar result though to a greater degree.

*Salinity on the bottom.* The salinity on the bottom of the shelf

(Fig. 36) is of comparatively little importance in oceanography, because so largely dependent on depth; but it can not be neglected because of the part it plays in the biology of the bottom fauna. South and west of Cape Cod the bottom salinity (leaving out of consideration the zone between the shore line and the fifteen fathom contour), ranged from about 32.6‰ to 35‰, lowest along the south shore of

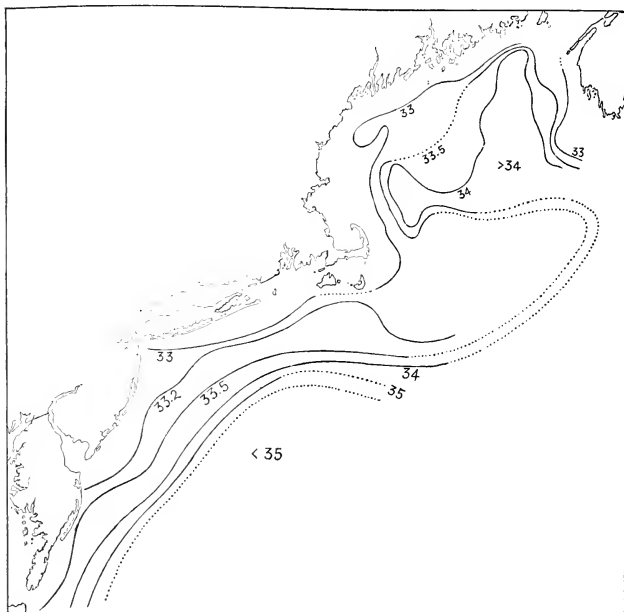

FIG. 36.— Chart of bottom salinity on the continental shelf between Cape Cod and Chesapeake Bay in July, and in the Gulf of Maine for August.

Long Island, and off Block Island, highest, as might be expected, along the outer edge of the shelf. In a general way, it corresponded to depth; but there was also an unmistakable increase, independent of depth, from northeast to southwest. Thus a bottom salinity of 34‰ was found at about the seventy fathom curve south of Nantucket,

at about the forty-five fathom curve off Cape May, and at about the eighteen fathom curve off Chesapeake Bay; and 33.5‰ water at the forty, thirty, and ten fathom contours at the same localities. Bottom water fresher than 33‰ was restricted to a narrow coastal zone north of Delaware Bay; and the curves for this value and for 33.5‰ show evidence of water from the Bay, by swinging seaward off its mouth. But the outflow from Chesapeake Bay has no apparent effect on the curves, although it probably does reduce the bottom below what would otherwise obtain. The chart (Fig. 36) represents July conditions only; earlier as well as later in the season, the bottom water was much saltier at the few localities where water-samples were taken (34.18‰ off Cape May, May 9; 35.17‰ in 60 fathoms, southwest of Nantucket August 22).

*Salinity profiles.* A profile (Fig. 37) running from the southern edge of the basin of the Gulf of Maine (Station 10058) across Nantucket

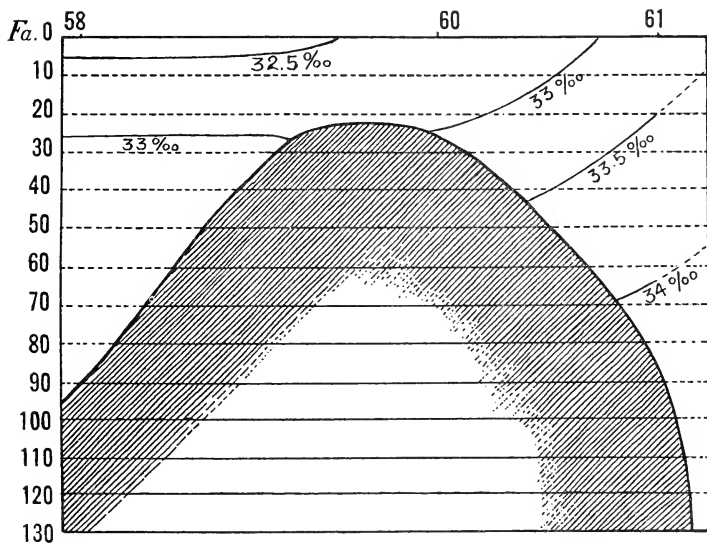

FIG. 37.— Salinity profile from the southern part of the basin of the Gulf of Maine (Station 10058) across Nantucket Shoals to the outer edge of the continental shelf south of Nantucket (Station 10061).

tucket Shoals (Station 10060) to the edge of the continental slope (Station 10061), shows that the water was much saltier south than north of the Shoals, early in July. In the southern part of the Gulf there was comparatively little increase in salinity with depth below thirty fathoms, and the bottom salinity was about the same on the Shoals as at the same depth further north; but the surface shows the influence of the saltier southern water by a steady, though slight, rise in salinity from Station 10058 to Station 10060, as well as in the fact that the

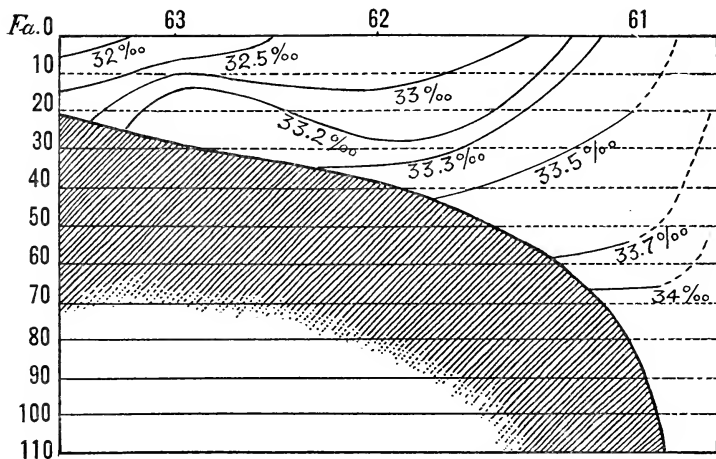

FIG. 38.—Salinity profile from the neighborhood of Montauk Point across the continental shelf (Stations 10063, 10062, 10061) to the edge of the shelf south of Nantucket.

average salinity for the upper ten fathoms was higher at Station 10060 ( $32.65\text{‰}$ ) than at Station 10058 ( $32.5\text{‰}$ ).

South of the Shoals there was a rapid rise in salinity, depth for depth, from north to south across the continental shelf. But the Shoals are an effective barrier to any active mixing of water on the two sides below about thirty fathoms.

The next profile (Fig. 38) runs across the continental shelf from Montauk Point (between Station 10083 and Station 10087) to the continental slope south of Nantucket Shoals (Station 10061). Its



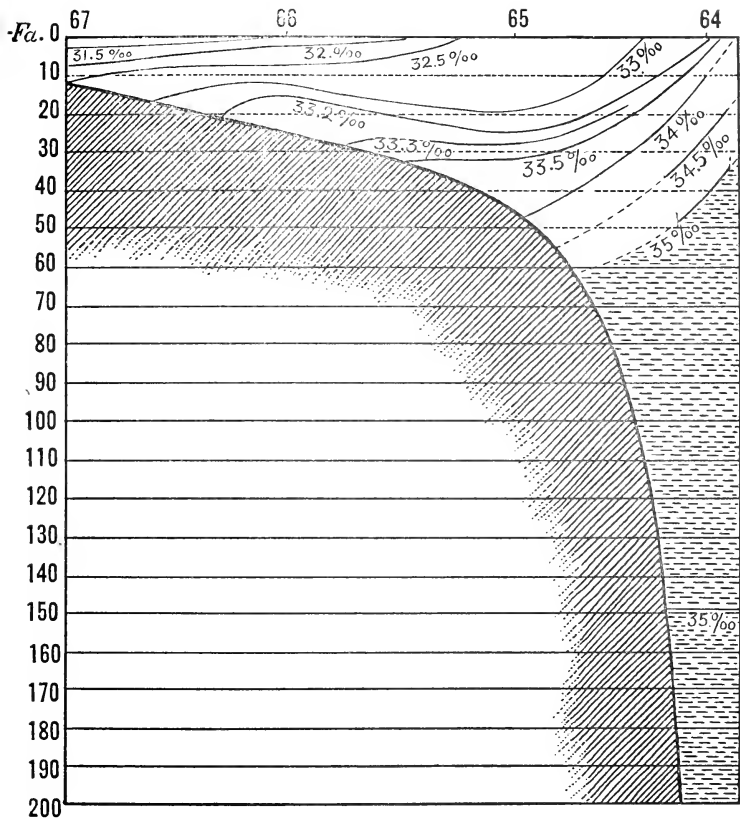

FIG. 39.— Salinity profile across the continental shelf from New York to the edge of the Gulf Stream in Lat.  $39^{\circ} 55'$  (Stations 10067, 10066, 10065, 10064).

most striking feature, apart from the separation into comparatively fresh water on the continental shelf, and much saltier oceanic water on the slope, is a succession of zones of comparatively uniform salinity alternating with zones in which there is a rapid change in salinity both vertical and horizontal. Next the shore there is first a mass of bottom water of  $33.2\text{‰}$ , fifteen fathoms thick (Station 10063), separated by a zone of rapid transition from a much fresher though hardly less uniform surface zone of about  $33\text{‰}$  (Station 10062), some twenty-five fathoms thick. This, in turn, gives place to much saltier water, over the edge of the shelf (Station 10061), where salinity increases only by  $.2\text{‰}$  ( $33.41\text{‰}$ – $33.62\text{‰}$ ) from the surface down to fifty fathoms; below which there is a sudden rise. Since some of these masses of uniform water reappear in other profiles, it is convenient to designate them from the shore seaward, as A, B, and C.

On the profile from the neighborhood of New York to the slope, in about latitude  $40^\circ$  (Fig. 39), the salt ocean water is much more in evidence than it is further east, water of  $35\text{‰}$  bathing the slope nearly to the fifty fathom curve, although the surface water at the shore end is about the same salinity as in the last profile (Station 10067,  $31.2\text{‰}$ ). Two of the bands, which were noted in the preceding profile, reappear here, *i. e.*, A and B, with about the same salinities which characterized them further east. Band A is as well defined as in the preceding profile, occupies the same relative position on the shelf; and has the same salinity ( $33.2\text{‰}$ ). But in the present profile the transition to the fresher water near shore is less sudden than it was further east. Band B is less clearly defined than in the preceding profile, and its salinity is less uniform, both vertically and transverse to the continental shelf, though of the same general value (about  $33\text{‰}$ ); nor does it so nearly reach to bottom, but overlies a layer of much saltier water. Nevertheless the band is distinctly more uniform than the water immediately below, or on either side of it; hence its individuality still deserves recognition. But the third band, C, which characterized the outer part of the preceding profile, can not be distinguished in this one. As a whole the surface is fresher along this profile than the preceding; and this is true even of its off shore end, although the bottom water near the edge of the shelf is much saltier than further east. And not only is water saltier than  $33.2\text{‰}$  nearer the surface over the middle of the shelf, but water with salinity of  $33\text{‰}$  and higher washes the bottom to the fifteen fathom, instead of only to the twenty-five fathom curve. All this shows that off New York shore water was more in evidence on the surface, Atlantic water on

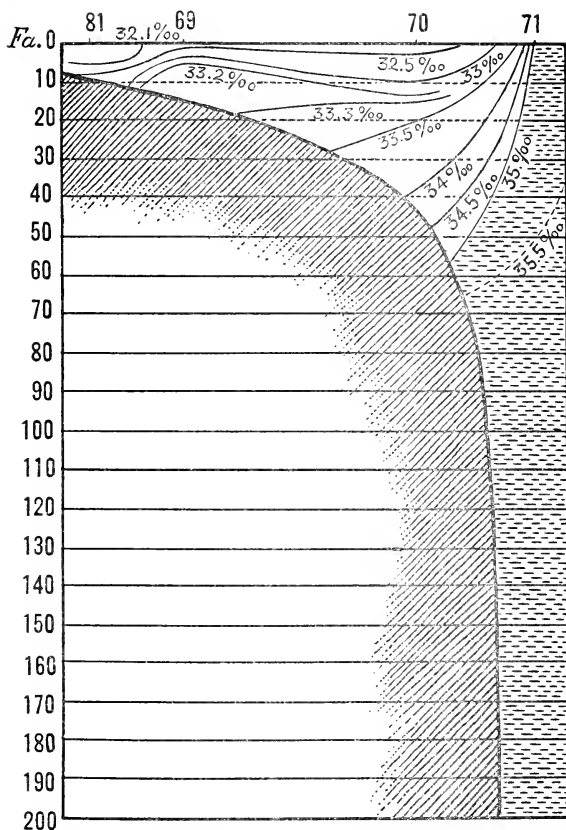

FIG. 40.— Salinity profile across the continental shelf abrest of Barnegat to the edge of the Gulf Stream in Lat.  $38^{\circ} 56'$  (Stations 10081, 10069, 10070, 10071).

the bottom, than off Montauk or south of Nantucket Shoals; and that the transition between the two waters was very sudden. In the profile from off Barnegat to the continental slope in about latitude  $39^{\circ}$  (Fig. 40), water of  $35\text{‰}$  washes the slope below about sixty fathoms, and the curve of  $35\text{‰}$ , which may be taken as an arbitrary division between coast and Gulf Stream water, is almost vertical. Generally speaking, too, the surface water was saltier along this whole profile than in the preceding one, except at Station 10070; an exception explained by the fact that this part of the profile cut the southerly tongue of surface water fresher than  $32.4\text{‰}$ , noted above (p. 187, Plate 2). Neither band B nor C can be traced as far south as this profile. But Band A is still evident, with precisely the same salinity ( $33.2\text{‰}$ ) as in the two preceding profiles, washing the bottom rather nearer shore than was the case further north, and gradually merging into the Gulf Stream water of  $35\text{‰}$  on its off shore side, instead of being limited seaward by a sudden transition

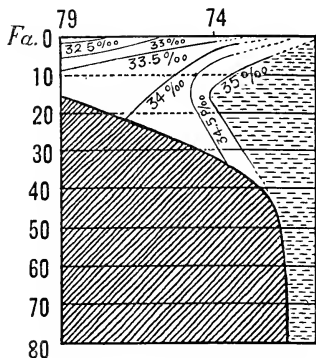

FIG. 41.—Salinity profile across the continental shelf south of Delaware Bay (Stations 10079, 10074).

ward by a sudden transition zone. On the other hand there is a great difference in salinity between it and the surface water over it, and also between it and the zone of water closer to shore.

The partial profile off Cape May is instructive chiefly because it shows no sign of band A; hence it is safe to conclude that the latter comes to an end north of Delaware Bay. The profile is otherwise so much like the preceding one, that I have not thought it necessary to reproduce it here. But the next one (Fig. 41), which is south of Delaware Bay, reveals an entirely new phenomenon, namely, a tongue of salt off shore water with salinity of  $35\text{‰}$  or more, intruding into the intermediate depths over the continental shelf, with fresher water both above and below it. Its landward end lies about over the thirty fathom curve, where the bottom water has a salinity of about  $34.3\text{‰}$ , with  $33.24\text{‰}$  on the surface. Apart from the salt tongue, the salinity as a whole is higher

than in the preceding profile, the bottom salinity in fifteen fathoms being  $33.86\text{‰}$  as against  $33.14\text{‰}$ , with  $34\text{‰}$  as against  $33.5\text{‰}$  on the bottom at the twenty-five fathom curve. The shallower layers, too, are saltier, depth for depth, than north of Delaware Bay.

A similar shoreward intrusion of  $35\text{‰}$  water into the intermediate

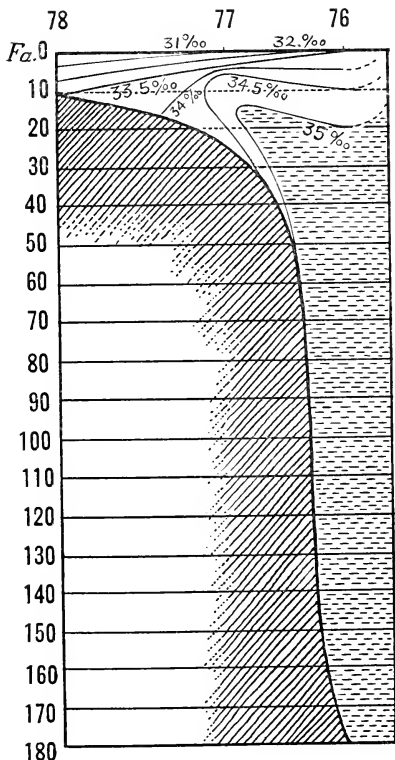

FIG. 42.— Salinity profile across the continental shelf to the edge of the Gulf Stream, abreast of Chesapeake Bay (Stations 10078, 10077, 10076).

depths over the shelf is also to be seen in the profile abreast of Chesapeake Bay (Fig. 42); and it has about the same extent and conformation there as further north, the curve of 35‰ rising from the sea floor at about the fifty fathom curve, with fresher water underneath it. But here the water near shore was much fresher down to five fathoms than in the preceding profile; the immediate surface layer fresher than any water we encountered further north, as might be expected from the volume of river water which debouches from the Bay in spring. And though this layer was very thin, the salinity rising from 29.25‰ on the surface to 33.5‰ on the bottom in ten fathoms at the shore end of the profile, its influence is unmistakable out to the edge of the continental shelf. At the outer end of the profile (Station 10076) the water was saltest at 50–100 fathoms (about 35.4‰), just as at the other deep water stations; below that level salinity decreased very slowly, as it does over the north Atlantic as a whole.

The change in salinity from north to south over the shelf north of Delaware Bay is illustrated by a profile following the forty fathom contour from Nantucket Shoals (Station 10060) to Station 10070 (Fig. 43). Below about ten fathoms there is a general increase in salinity, depth for depth, from northeast to southwest. But the surface water is freshest at the southern end of the profile (32.2‰), saltest at Station 10062 (32.86‰), and fresher once more (32.63‰) over the slope of Nantucket Shoals.

#### SALINITY IN THE GULF OF MAINE.

*Surface Salinity.* Early in July the surface salinity (Plate 2) of Massachusetts Bay, immediately off Gloucester, was about 31.56‰, a rise of about .5 since the middle of May (1914b, p. 393), and it was 31.9‰ off Cape Cod (Station 10057, p. 205) with 32.4‰ over the southern part of the basin (Station 10058), and 33‰ on the southwest side of George's Bank (Station 10059). When we returned to the Gulf of Maine a month later, the water was slightly saltier along the eastern shore of Cape Cod (32.05‰, Station 10085; 32.09‰, Station 10086), while a greater increase of salinity had taken place off Gloucester (to 32.03‰). And by the 25th of August it had risen to 32.16‰ in the mouth of Massachusetts Bay (Station 10106). The water immediately abreast of the Bay and along Cape Cod (Plate 2) was 32–32.2‰, the curve for the latter value swinging eastward from the mouth of Vineyard Sound, and then northerly, toward Penobscot Bay.

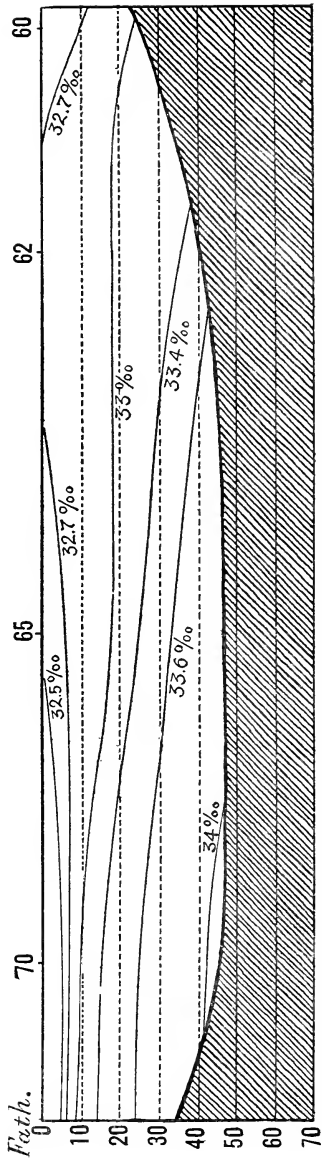

FIG. 43.—Salinity profile parallel to the shore, along the 30–45 fathom contour from Delaware Bay to Nantucket Shoals (Stations 10070, 10065, 10062, 10060).

Water fresher than 32‰ was restricted to a narrow zone close to shore, extending from just north of Cape Ann to Monhegan Island, broadest (twenty-five miles) off Cape Elizabeth.

In general there was a rise of surface salinity from west to east across the Gulf, the water being 32.5‰ some sixty miles off Cape Cod;

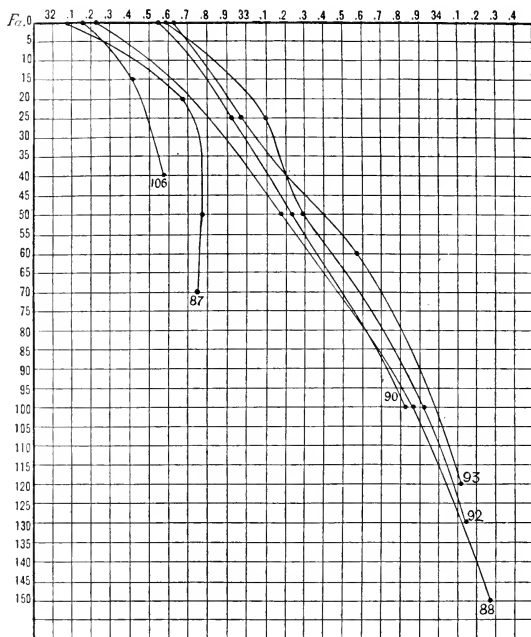

FIG. 44.— Salinity sections in the Gulf of Maine, from Massachusetts Bay to the eastern basin (Stations 10087, 10088, 10090, 10092, 10093, 10106).

32.6‰ in the centre of the Gulf, and 32.7‰ near the Nova Scotia coast bank. But the increase was far from uniform, the course of the curves being distorted by an outrush of comparatively fresh water (32.2‰ to 32.5‰) off the west mouth of Penobscot Bay, and by a



band of water of the same low salinity extending thence along the coast of Maine to the Grand Manan Channel. The salinity was 32.5‰ or less over the coast bank west of Nova Scotia; and it is probable that the surface of the Bay of Fundy was even fresher than this. The curve for 34.4‰ shows that the direct effect of Penobscot water did not extend further south than Jeffrey's Bank (Station 10091), south of which it runs in an S, roughly parallel with the coast, crossing the southern end of the basin, and thence westward across Nantucket

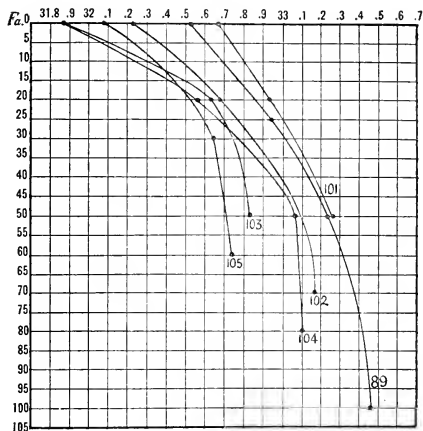

FIG. 45.— Salinity sections in the Gulf of Maine near Platt's Bank (Station 10089); along shore between Cape Ann and Penobscot Bay (Stations 10102, 10103, 10104, 10105) and near Matinicus Island (Station 10101).

Shoals. The surface of the eastern half of the Gulf as a whole was saltier than 32.6‰; the curve for that value outlining a tongue some sixty miles broad, with an eddy-like curve from southeast to northwest. Water as salt as this lay close to the land east of Mt. Desert Island, and indented westward, as far as Matinicus Island, into the fresher Penobscot water. The curve of 32.6‰ probably crossed the mouth of the Bay of Fundy. At any rate it paralleled the western shore of Nova Scotia, where it was separated from the land by fresher water (32.45‰ on Lurher Shoal).

The only record from George's Bank was considerably saltier (about 33‰). And judging from the strong tidal currents of the Bank, from the few previous records (1914b) and from the proximity of the Gulf Stream, the general surface salinity over the bank is probably above 32.5‰.

The saltiest surface water which we found in the Gulf was 32.79‰ on German Bank (Station 10045); but this is an abnormal value, caused by vertical circulation (p. 178). And though even saltier water

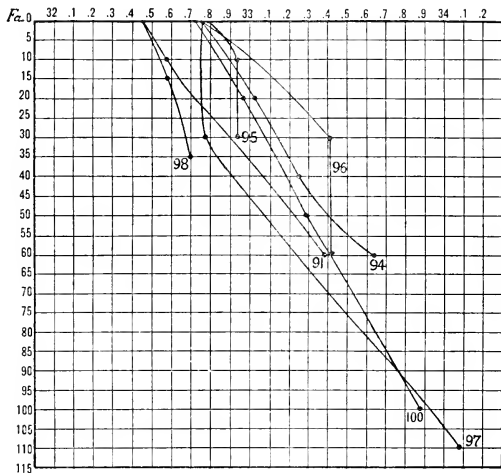

FIG. 46.— Salinity sections in the northeastern end of the basin of the Gulf of Maine (Stations 10097, 10100); on Jeffrey's Bank (Station 10091); German Bank (Stations 10094, 10095), near Lurcher Shoal (Station 10096) and off the coast of Maine near Grand Manan Channel (Station 10098).

may have spread from the south across George's Bank into the southeastern part of the Gulf in August, there is no actual evidence that such was the case.

*Salinity sections.* The waters of the Gulf of Maine were freshest at the surface, saltiest at the bottom, just as in 1912 (1914a). In its central part (Stations 10088, 10090, 10092, 10093, Fig. 44), the rate of increase with depth was comparatively constant over the whole column

of water; with a maximum difference of about  $2.1\text{‰}$  between surface and bottom salinity at the deepest Station (10088, surface  $32.1\text{‰}$ ; bottom  $34.2\text{‰}$ ); and this same type of curve likewise characterized the deep water off Mt. Desert (Station 10100, Fig. 46). The salinity curves at the Stations near shore, north and east of Cape Ann, (10101, 10102, 10103, 10104, 10105 Fig. 45), are of rather different type, the vertical increase in salinity being most rapid near the surface. In the northeast corner of the Gulf (Fig. 46), on the Nova Scotian Banks, and again off Cape Cod and on George's Bank, the salinity curves show unmistakable evidence of vertical tidal disturbance. Thus at Station 10098 the total vertical range of salinity, in thirty-five fathoms, was only about  $.2\text{‰}$  (Fig. 46); off Lurcher Shoal (Station 10096, Fig. 46) there was a rise of  $.6\text{‰}$  from the surface down to thirty fathoms ( $32.75\text{‰}$ – $33.4\text{‰}$ ); but below that depth the salinity was uniform down to the bottom in sixty fathoms. On German Bank the total range was only  $.1\text{‰}$  ( $32.79\text{‰}$ – $32.92\text{‰}$ ), and on George's Bank (Station 10059) the water was practically uniform from surface to bottom. The upper layers in the northern end of the eastern basin (Station 10097) must likewise be disturbed by vertical currents, because the salinity was uniform from the surface down to thirty fathoms, with a sudden increase below that depth (Fig. 46). But there was no evidence of vertical mixing on Jeffrey's Bank.

In general the upper fifty fathoms of water was freshest off Cape Cod (Stations 10086, 10087), in Massachusetts Bay (Station 10106),

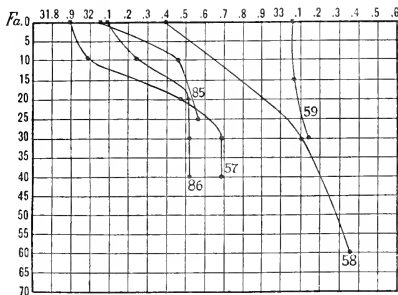

FIG. 47.—Salinity off Cape Cod in July (Station 10057) and in August (Stations 10085, 10086); in the southern part of the basin of the Gulf (Station 10058) and George's Banks (Station 10059) in July.

just north of Cape Ann (Station 10103), and close to the coast of Maine east of Mt. Desert (Station 10098); saltiest in the centre of the Gulf and over the eastern basin (Stations 10092, 10093, and 10100), and over the edge of the Nova Scotian slope (Stations 10094, and 10096). And this is further illustrated by the following table of the mean salinity of the upper 50 fathoms:—

Station	Mean sal.	Station	Mean sal.
10058	32.9	10095 <sup>2</sup>	32.9
10086 <sup>1</sup>	32.4	10096	33.2
10087	32.6	10097	32.8
10088	32.7	10098 <sup>1</sup>	32.5
10089	32.9	10100	33.
10090	32.9	10101	33.
10091	32.8	10102	32.7
10092	33.	10103	32.5
10093	33.	10104	32.6
10094	33.1	10105	32.5
		10106 <sup>1</sup>	32.4

The mean salinity between 50 and 100 fathoms was lowest at Station 10089, highest in the eastern basin (Station 10093), as follows:—

Station	Mean sal.	Station	Mean sal.
10088	33.5	10093	33.7
10089	33.35	10097	33.5
10090	33.55	10100	33.6
10092	33.6		

*Salinity on the bottom.* The bottom salinity of the Gulf (Fig. 36) depended chiefly on depth, the bottom water of the basins being from 34‰ to 34.27‰. The bottom salinity of the coastal zone surrounding the whole Gulf was below 33‰ (32.5‰–32.9‰), the curve of 33‰ agreeing, roughly, with the fifty fathom contour of the bottom. But there were various local anomalies, already pointed out, especially the abnormally low bottom salinities of the several circumscribed sinks on the western side of the Gulf.

*Salinity profiles.* The profile from Massachusetts Bay to German Bank (Fig. 48, Stations 10106, 10087, 10088, 10090, 10092, 10093, 10094, 10095), shows that the water was saltier in general, depth for

<sup>1</sup> Mean for 40 fathoms.

<sup>2</sup> Mean for 30 fathoms.

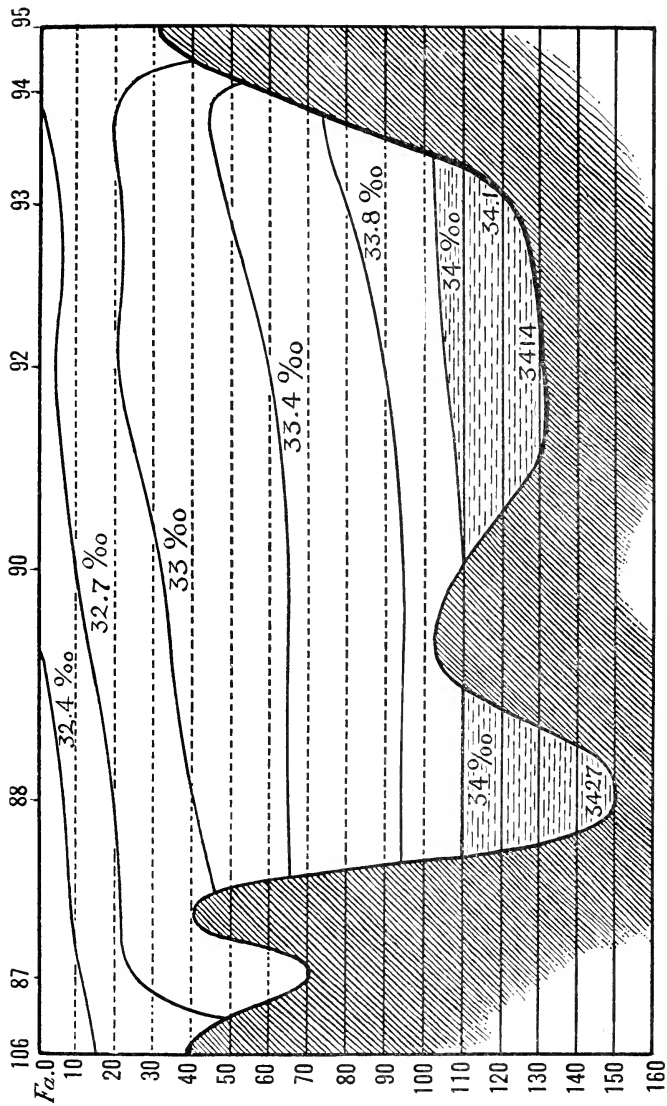

FIG. 48.—Salinity profile across the Gulf of Maine from Massachusetts Bay to German Bank in August (Stations 10106, 10087, 10088, 10090, 10092, 10093, 10094, 10095).

depth, at the eastern than at the western side of the Gulf, down to about 100 fathoms, equal salinities being found about 15–20 fathoms deeper on the Massachusetts Bay than on the Nova Scotia side. Below 100 fathoms there was much less variation in salinity from west to east, depth for depth, the curve of 34‰ following the 110 fathom level right across the western basin. At 130 fathoms the salinity was almost precisely the same (34.1‰) in the two basins.

The water was much fresher at the mouth of Massachusetts Bay

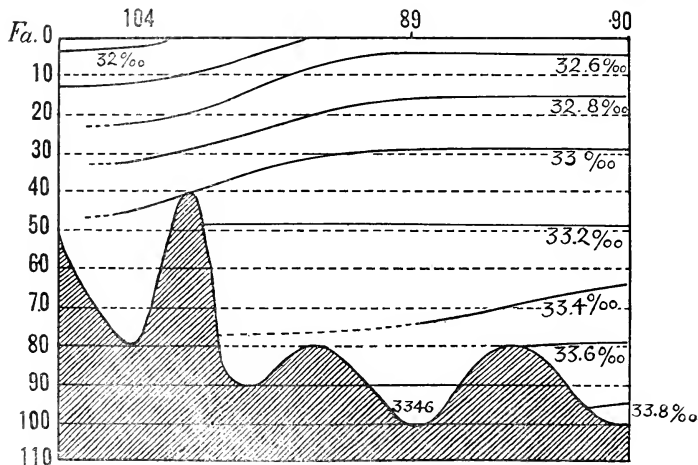

FIG. 49.— Salinity profile from the trough between Jeffrey's Ledge and the mainland (Station 10104) to the centre of the Gulf of Maine (Station 10099).

than further east, especially at the bottom, while the very sudden dip of the curve of 32.7‰ suggests that vertical circulation was active in the Bay. And this may well have been the case, as the tidal currents are of some strength in the neighborhood of Station 10106. The eastern end of the profile shows a sudden spreading of the curves over the coast bank, such as we found in 1912 (1914a), the range of salinity for the entire column of water on German Bank being only from 32.79‰–32.94‰. The only exception to the rule that salinity increased from west to east is afforded by Station 10093, where the

salinity of the water between five and twenty fathoms was slightly lower than at Stations 10092 and 10094, on either side of it.

Successive profiles from near shore toward the centre of the Gulf, at right angles to the last, show that the water was fresher along the western coast than off shore. In the profile (Fig. 49), from Cape Porpoise, across the northern end of Jeffrey's Ledge, to Station 10090, the salinity curves all dip toward the land; but in the eastern half of the profile (Stations 10089 to Station 10090), they are practically

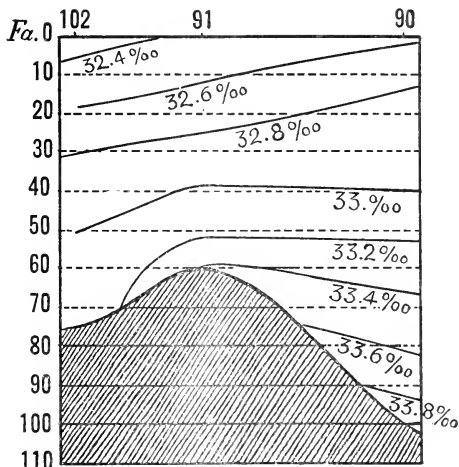

FIG. 50.—Salinity profile from Station 10102, off the mouth of Penobscot Bay, across Jeffrey's Bank (Station 10091) to the centre of the Gulf of Maine (Station 10090).

horizontal, *i. e.*, the salinity in the upper fifty fathoms was uniform horizontally; though below that depth the off shore water (Station 10090) was slightly saltest. The fact that the salinity was precisely the same (33.4–33.5‰) on the bottom in the sink where Station 10089 was located, as at seventy fathoms in the basin to the east of it, shows that its rim, which rises to a general level of about seventy-five fathoms, and is crowned by the much shallower Cashes Ledge, is an effective

barrier to the entrance of the salt bottom water from the centre of the Gulf. And Jeffrey's Ledge evidently acts in the same way, for though it leaves an open entrance on the north to the trough west of it, the fact that the salinity was the same at eighty fathoms in the trough as at forty fathoms east of the Ledge, shows that little if any salt water flows in across the latter.

In the profile (Fig. 50) from the mouth of Penobscot Bay (Station 10102) to the centre of the Gulf (Station 10090) via Jeffrey's Bank

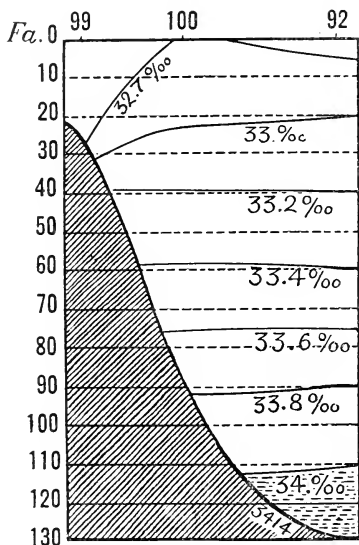

FIG. 51.— Salinity profile from the neighborhood of Mt. Desert Island (Station 10099) to the eastern basin of the Gulf of Maine (Stations 10100, 10092).

(Station 10091), the salinity curves all dip shoreward between the surface and forty fathoms. This is true for the whole column of water between Jeffrey's Bank (Station 10091) and the mouth of the Bay Station 10102). But between Station 10090 and the Bank, the reverse is the case below forty fathoms. The curve of 33.2‰ is espe-



cially interesting because while it runs almost horizontal at about fifty fathoms from Station 10090 to and across Jeffrey's Bank, it must then dip to bottom in about seventy fathoms, the bottom salinity at Station 10102 being only 33.17‰, suggesting a shoreward movement of salt bottom water across the Bank.

The next profile (Fig. 51) is parallel to the last, some 30 miles further east (Station 10099, 10100, 10092). Here the slope of the bottom is

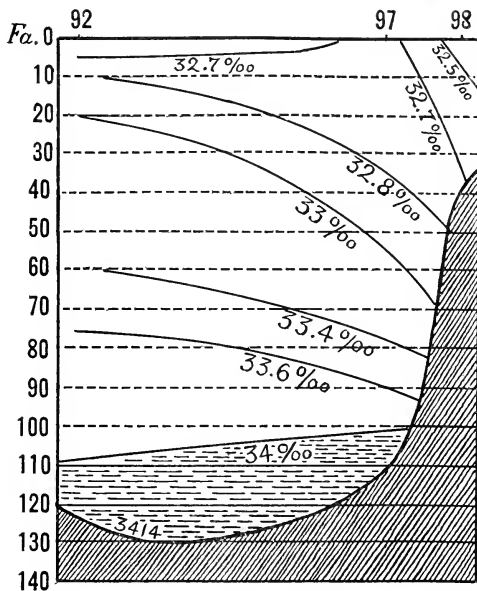

Fig. 52.— Salinity profile lengthwise of the northeastern part of the Gulf of Maine from south to north (Stations 10092, 10097, 10098).

an even one, consequently the salinity curves do not show the anomalies noted for the profiles further west; but they agree with the latter in dipping shoreward between the surface and thirty fathoms.

The water close to the surface was slightly saltier at Station 10100 than at Station 10092, though the former is the nearer shore; but this

does not invalidate the thesis of a general freshening near land, because the profile crosses the long-shore tongue of 32.7‰ surface water (Plate 2). Below forty fathoms there was practically no change in salinity, depth for depth, along the profile. Comparison between this profile and the one off Penobscot Bay (Fig. 50) shows that the off shore water was slightly saltier off Mt. Desert, than off Penobscot Bay,

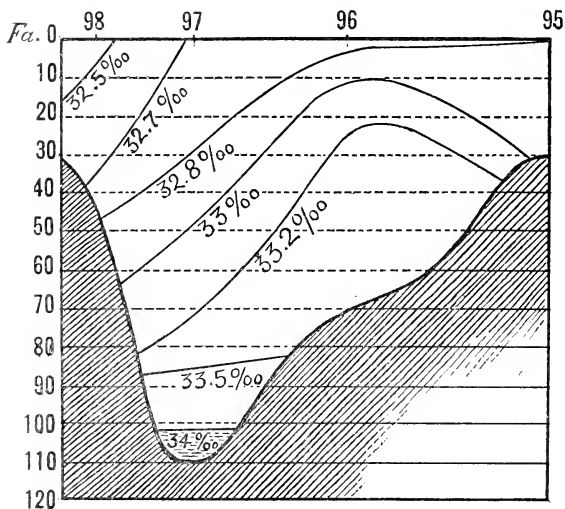

FIG. 53.—Salinity profile across the mouth of the Bay of Fundy, from the coast of Maine (Station 10098) to German Bank (Station 10095), crossing the basin (Station 10097).

the difference being greatest at 10–40 fathoms, where equal salinities are found 10–20 fathoms deeper at the former than at the latter.

A profile (Fig. 52) from the eastern basin (Station 10092) to the coast of Maine near the entrance to the Grand Manan Channel (Station 10098) shows an even more pronounced freshening toward the land, down to about ninety fathoms, the curve of 33‰ dipping from the twenty fathom level at Station 10092, to seventy fathoms on the shore slope. But below one hundred fathoms the dip of the curves

is reversed, *i. e.*, the water was saltest, depth for depth, next the land, suggesting a movement of bottom water up the slope. The general rule that the salinity of the upper layers rose steadily passing off shore was broken at Station 10097; but this was probably due to local vertical circulation, as evidenced by the vertical uniformity of salinity for the upper thirty fathoms.

The profile crossing the mouth of the Bay of Fundy from the coast of Maine to German Bank (Stations 10098, 10097, 10096, and 10095, Fig. 53) shows the same comparatively fresh shore water off the coast of Maine, and the water was only slightly saltier on German Bank, at the southern end of the profile. But the salinity was much higher in the centre of the profile, where 33‰ water came up to within ten fathoms of the surface, though the immediate surface was slightly fresher there than on German Bank. The course of the curves over the outer part of the Nova Scotia slope (Station 10096) is especially instructive because they reveal the existence of a zone of uniform water, between thirty fathoms and the bottom (sixty fathoms) the salinity of which agrees with the eighty fathom level over the basin (Station 10097). And this, of course, suggests an up-draught of bottom water over the slope. Vertical circulation was active in the shallow water at each end of the profile; slightly more so on German Bank than next the Maine coast, as shown by the fact that the difference between surface and bottom salinity in thirty fathoms on the latter was only .13‰, as against .23‰ in forty fathoms at Station 10098.

A profile from the basin (Station 10093) toward the mouth of the

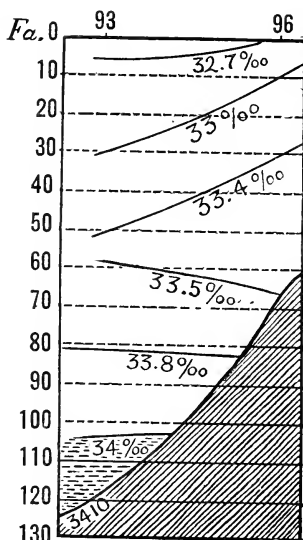

FIG. 54.—Salinity profile from the eastern basin of the Gulf of Maine (Station 10093 toward the mouth of the Bay of Fundy (Station 10096).

Bay of Fundy (Fig. 54), shows that the upper layers at Station 10096 are saltier than the water at corresponding depths further off shore. And this is true whether Station 10092 or Station 10093 be taken as the outer end of the profile, though the difference is slightly greater in the case of the latter. The uniform water between thirty and sixty fathoms at Station 10096 is slightly saltier (33.4‰) than the mean (33.27‰) of the corresponding column of water at Station 10093. Station 10096 was likewise considerably saltier as a whole than the water over the slope of German Bank (Station 10094), especially in the mid-depths; and though the latter was the saltier of the two on the surface this does not invalidate the general statement, because its high surface salinity was due to local vertical mixing by tidal currents (p. 204). In short, the upper thirty fathoms of water was saltier off the mouth of the Bay of Fundy (Station 10096) than on the coast bank to the south, the eastern basin, or for that matter, anywhere else in the Gulf; probably due to an updraught from the mid-depths off shore. And the profile is further interesting because the spreading of the curves for 33.4‰ and 33.5‰ over the coast slope at 50–80 fathoms suggests that vertical mixing, which in the Gulf is synonymous with tidal currents, was active on the bottom at Station 10096, though not on the surface.

#### DENSITY, AT THE TEMPERATURE IN SITU, CAPE COD TO CHESAPEAKE BAY.

The chart of density on the surface south of Cape Cod (Fig. 55), for the first half of July, is less significant in detail than the chart of surface salinity, because surface density was constantly falling, with the seasonal rise in surface temperature (p. 156). The off shore water was as a whole heaviest, the coast water lightest. But on our voyage south we encountered a secondary area of low density over the central part of the continental slope off New Jersey (Station 10070), as outlined by the curve for 1.0220, with heavier water (1.0227) between it and the coast, a phenomenon caused by the rapid warming of comparatively fresh surface water (p. 187) by warm southerly winds from the Gulf Stream, which prevailed at that time. And by the end of July the rise of surface temperature (p. 156) caused even lower densities next the coast (Station 10080, density 1.0215; Station 10081, density 1.02145). The density was lowest (1.0184) at the mouth of Chesapeake Bay, highest outside the continental shelf (Station 10071);

but as noted (p. 221) the water was even denser on George's Bank and in the Gulf of Maine. In general, the density rose from southwest to northeast, corresponding to the general decline of surface temperature (Fig. 1).

At all our stations south of Cape Cod the water was heaviest at the bottom, *i. e.*, it was in stable equilibrium, as is the rule everywhere,

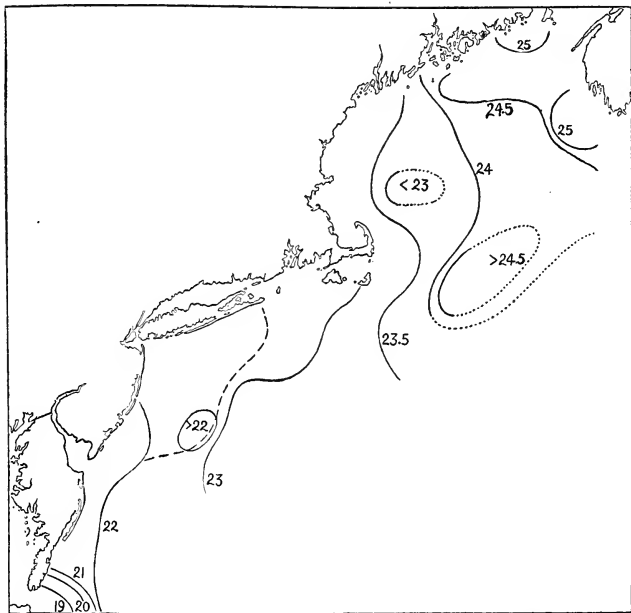

FIG. 55.— Chart showing surface density of the water south and west of Cape Cod in July, and of the Gulf of Maine in August. Curve - - - - , July 29-Aug. 1.

in temperate regions in summer. But it varied so much, level for level, at different stations, as to suggest a potent cause for circulation. To facilitate comparison with salinity and temperature, density is reproduced here by corresponding profiles.

The first (Fig. 56), from the southern part of the basin of the Gulf of Maine (Station 10058), to the outer edge of the continental shelf (Station 10061) shows that there was very little difference in density, depth for depth, on the two sides of Nantucket Shoals, above the level of the latter (about thirty fathoms). Below that level the water was distinctly lighter on the south than on the north side of the Shoals; and the vertical stability of the water was very slight over the outer part of the shelf between the thirty-five and fifty fathom levels.

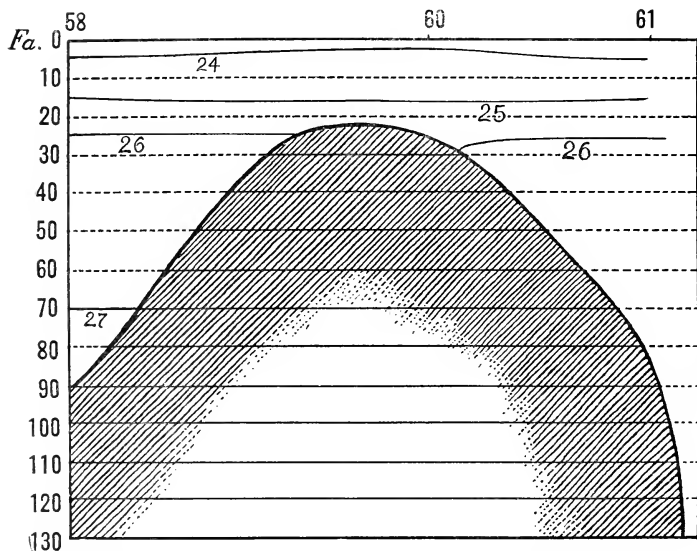

FIG. 56.— Density profile from the southern part of the basin of the Gulf of Maine (Station 10058) across Nantucket Shoals, to the continental slope south of Nantucket (Station 10061) July 8-10.

The next profile (Fig. 57) from Station 10063, off Nantucket, to the edge of the continental shelf (Station 10061), shows that down to about twenty fathoms the water was considerably lightest at the shore end. Below thirty fathoms the density curves dip seaward, especially at the outer edge of the shelf, coincident with the cold

tongue (p. 165). But this condition must have been limited to a narrow east and west zone, for in the profile off New York (Fig. 58) the dip of the curves in the same relative position, is just the reverse, being steepest at the level (fifty fathom contour) where the slope of the bottom becomes rapid, *i. e.*, just below the cold tongue. At about thirty fathoms the density curves are generally horizontal, and they are probably horizontal below 100 fathoms. The next, off Barnegat

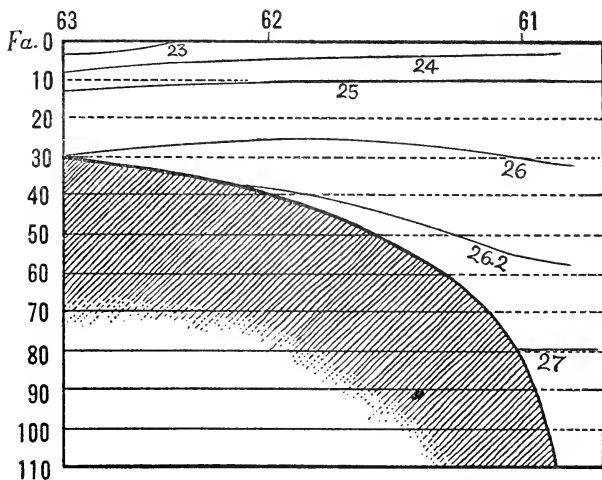

FIG. 57.— Density profile across the continental shelf southwest and south of Nantucket (Stations 10063, 10062, 10061) July 10-11.

(Fig. 59), shows a similar distribution of density, except that the surface, as well as the deeper water was densest at the seaward end, the dip of the curves being especially pronounced in the upper fifteen fathoms or so, and again at 40-50 fathoms over the continental slope.

A profile running from Station 10079 to Station 10074 (Fig. 60) shows that just south of Delaware Bay where the surface water was lightest next the coast, the reverse was true below about twelve fathoms, the bottom water being heaviest, depth for depth, next the land, while the seaward dip of the curve of 1.026, suggests a seaward

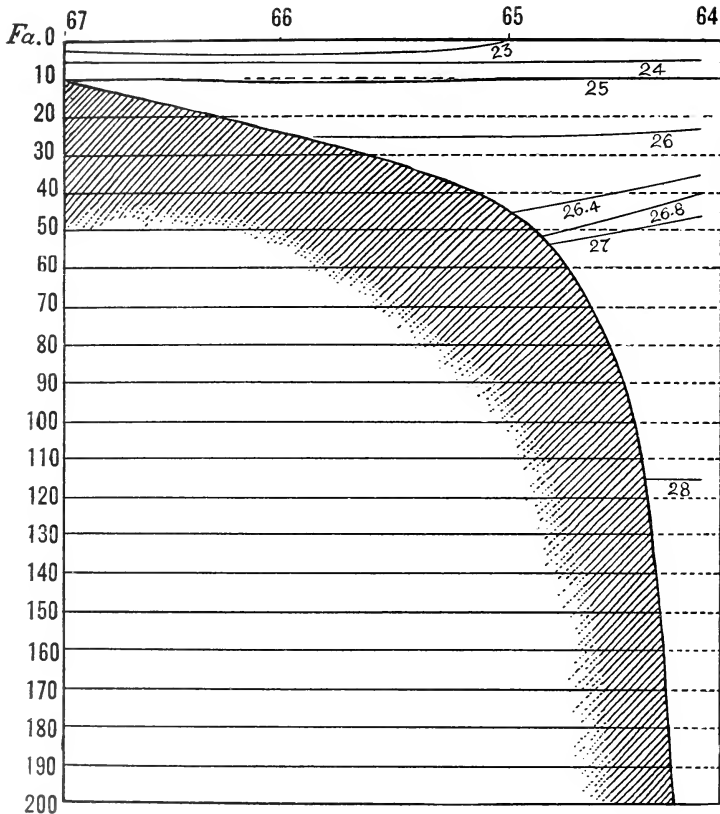

FIG. 58.— Density profile from New York to the edge of the Gulf Stream in Lat.  $39^{\circ} 55'$  (Stations 10067, 10066, 10065, 10064) July 11-13.



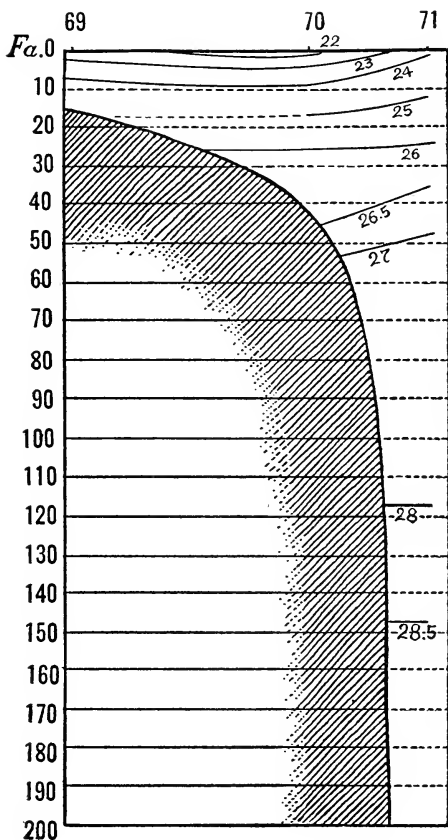

FIG. 59.— Density profile across the continental shelf abreast of Barnegat to the edge of the Gulf Stream in Lat.  $38^{\circ} 56'$  (Stations 10069, 10070, 10071) July 19-20.

flow over the bottom. And the level at which density is uniform, horizontally (twelve fathoms) exactly coincides with the salt tongue (p. 198). The profile abreast of Chesapeake Bay (Fig. 61) shows a similar distribution of density over the inner part of the continental

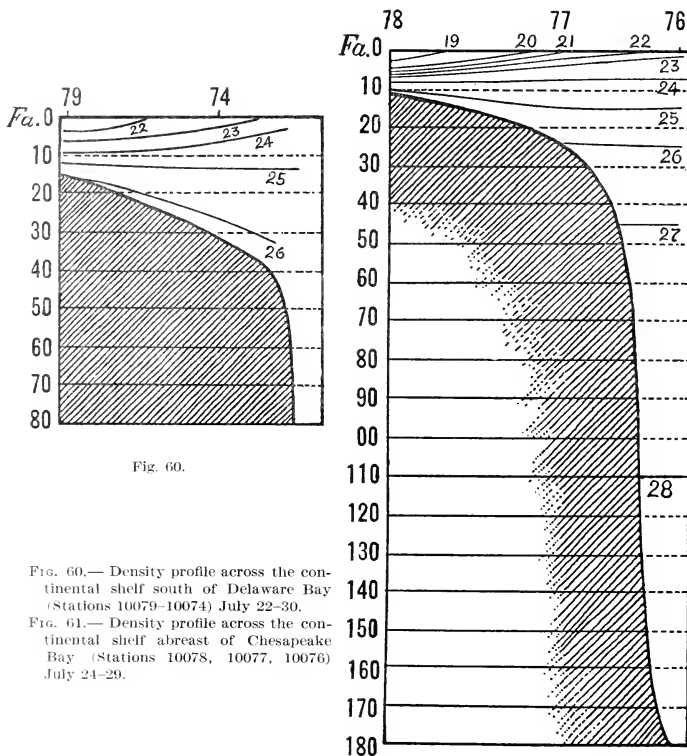

Fig. 60.

FIG. 60.— Density profile across the continental shelf south of Delaware Bay (Stations 10079-10074) July 22-30.

FIG. 61.— Density profile across the continental shelf abreast of Chesapeake Bay (Stations 10078, 10077, 10076) July 24-29.

Fig. 61.

shelf. But the seaward rise of density on the bottom is less rapid than it is further north; and density is uniform, horizontally, below twenty-five fathoms.

## DENSITY IN THE GULF OF MAINE.

In the Gulf, in August (Fig. 55) the surface water was lightest close to shore north of Cape Ann (1.0231), off Cape Cod (Station 10085, 1.0231), and, in an isolated region, over the western basin (Station 10088, 1.0229); the latter was a local phenomenon, due to high surface temperature. Surface density was highest on German Bank (1.0254) and along the northern part of the coast of Maine (1.025), *i. e.*, in those regions where tidal currents cause the most effective vertical mixing of the water. And the surface was only slightly less dense off Lurcher Shoal, owing to its low surface temperature. We likewise encountered surface water of high density off Matinicus (Station 10101, 1.0248); And no doubt many other anomalies of this kind might be found in the Gulf, caused by local surface cooling by tide rips and vertical currents.

The surface density of most of the Gulf was 1.0236–1.0248, increasing from southwest to northeast; *i. e.*, considerably higher than over the continental shelf south of Cape Cod a month earlier; had the observations been taken simultaneously the discrepancy would have no doubt been greater, it being only reasonable to assume that the surface of the Gulf would have been cooler early in July than early in August, but with nearly the same salinity (1914a).

The table of density (p. 344) shows that the water was lightest at the surface, heaviest on the bottom, *i. e.*, was in stable equilibrium, everywhere in the Gulf. Where vertical and tidal circulation is active, as on German Bank, the stability was so slight as to offer little resistance to vertical overturning of the water. But where tides are weak, as for example off Massachusetts Bay, over the western basin, and in the trough west of Jeffrey's Ledge, the difference between surface and bottom density, and hence the vertical stability, is great. In the western parts of the Gulf in general there was a very rapid rise of density from the surface down to about 20–30 fathoms, corresponding to the rapid rise of salinity and fall in temperature in this zone; followed by a very much slower, though continuous increase, down to the bottom. But the density curves, like those for temperature are progressively straighter and straighter, passing across the Gulf from southwest to northeast. And in the northern end of the eastern basin, as well as on the Nova Scotian and Maine banks, the rise in density, whether great or little, was nearly uniform in rate, from surface to bottom; most nearly so where the stability of the water was slightest (*i. e.*, German Bank).

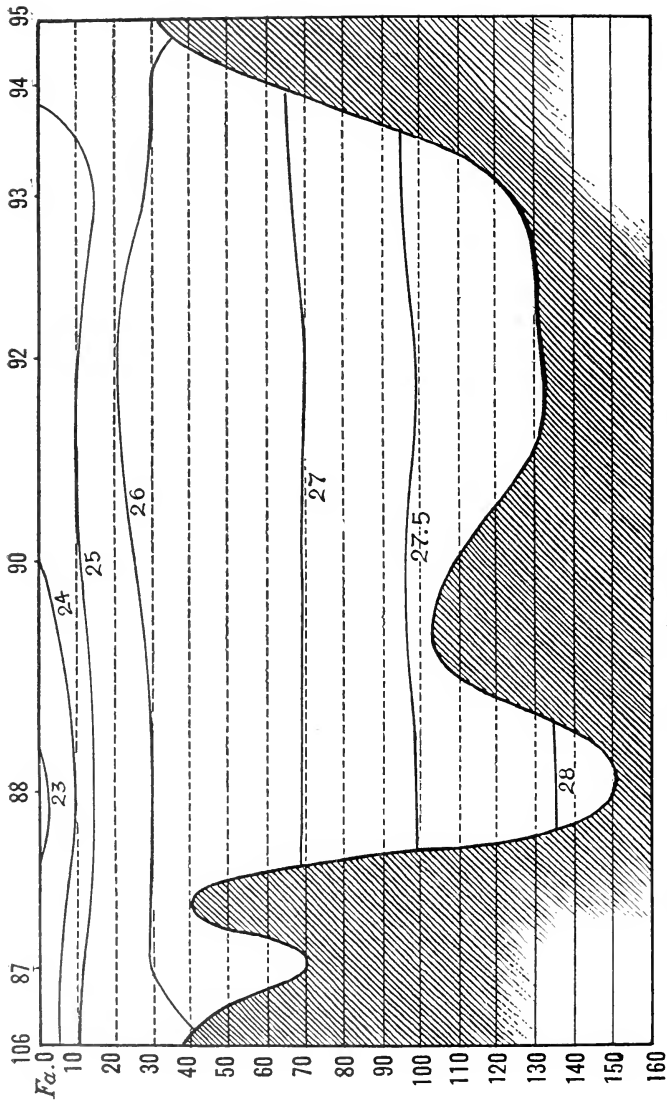

FIG. 62.—Density profile across the Gulf of Maine from Massachusetts Bay to German Bank (Stations 10106, 10087, 10088, 10090, 10092, 10093, 10094, 10095) August 9-20.

The density profile (Fig. 62) crossing the Gulf from Massachusetts Bay (Station 10106) to German Bank (Station 10095) shows that the water was nearly uniform horizontally, depth for depth, below seventy fathoms. In the mid-depths the water was densest at Station 10092. Over German Bank there is a distinct spreading of the curves reminiscent of, and due to the same cause, as the spreading of the temperature and the salinity curves in that region. And the same condition

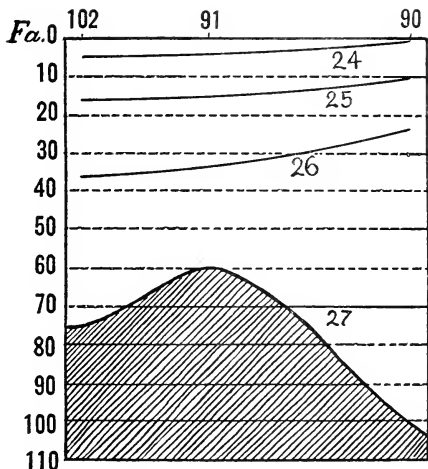

FIG. 63.— Density profile from the mouth of Penobscot Bay (Station 10102) to the centre of the Gulf of Maine (Station 10090) crossing Jeffrey's Bank (Station 10091) August 10-14.

prevails below twenty fathoms in Massachusetts Bay, just as described for salinity (p. 208).

A profile from Station 10102, near Penobscot Bay, across Jeffrey's Bank to the centre of the Gulf (Fig. 63) shows a slight rise in density passing off shore, the difference being greatest in the mid-depths. But a parallel profile further east would be exactly the reverse, the surface density being higher at Stations 10101, 10100, and 10098 than at either Station 10092 or 10093.

## COLOR OF THE SEA.

The observations on color, tabulated below, are interesting chiefly because there is very little precise information as to the color of the water over the continental shelf south of Cape Cod.

*Color, in % of yellow, according to the Forel scale (Steuer, 1910).*

Station	Color	Station	Color	Station	Color	Station	Color
10057	27	10070	5	10083	20	10096	20
10058	9	10071	2	10084	27	10097	—
10059	20	10072	9	10085	27	10098	20
10060	5	10073	2	10086	27	10099	27
10061	2	10074	5	10087	14	10100	27
10062	9	10075	20	10088	—	10101	35
10063	20	10076	2	10089	—	10102	20
10064	2	10077	9	10090	9	10103	—
10065	5	10078	14	10091	20	10104	20
10066	—	10079	14	10092	9	10105	20
10067	54	10080	14-20	10093	—	10106	—
10068	54	10081	9	10094	27		
10069	27	10082	—	10095	27		

The water was very green (27% yellow) along Cape Cod both in July and in August, and this was also the case on the western side of George's Bank (20%). But it was distinctly bluer (9% yellow) over the southern end of the basin of the Gulf and after crossing Nantucket Shoals the water grew visibly blue to the eye, being almost pure blue (2% yellow) at the 80 fathom curve south of Nantucket (Station 10061).

In general the water was greenest near land, bluest off shore, as might be expected, the water being greenest of all near New York (Stations 10067, 10068). The color was 20-27% yellow along the coast of New Jersey; that of the coast water south of Delaware Bay 14-20% yellow. The water was nearly pure blue (2% yellow) at all the stations outside the edge of the continental shelf.

The water of the Gulf of Maine was considerably greener, most so along Cape Cod (27% yellow), over German Bank (27% yellow), and along the coast of Maine between Mt. Desert and Penobscot Bay (27-35% yellow). The water was considerably bluer (9%) over the

deep basins; but nowhere in the Gulf did we find the beautiful ultra-marine water which washes the continental slope.

South of Cape Cod the general rule is that the water is bluest where saltiest, greenest where freshest; though this does not exactly cover the case, because the water was bluer close off Chesapeake Bay than off New York, although the salinity was lower. But in the Gulf of Maine this rule did not hold either in 1912 (1914a) or in 1913, the greenest water being intermediate in salinity, while the saltiest water was not the bluest.

#### CURRENT MEASUREMENTS.

Measurements of surface and bottom currents with the Ekman Current meter (Ekman, 1905b) were taken at three stations between Cape Cod and Chesapeake Bay, with hourly readings for six hours at each station. The directions are the compass bearings (magnetic) toward which the current flows. Velocity in knots per hour is to the nearest tenth of a knot.

##### I. STATION 10065, JULY 12.

High water at Fire Island Inlet at 2.05 P.M.

Hour	Depth	Duration	C. C. per sec.	Direction	Knots per hour
9 A.M.	0	4' 58"	19.1	WNW.	.4
9 "	40	5' 10"	10.2	NW. by N.	.2
10 "	0	5'	9.3	WNW.	.2
10 "	40	2' 20"	22.1	W. by N.	.4
11 "	0	5' 18"	10.7	W. by N.	.2
11 "	40	5' 10"	3.2	NW.	Trace
12.30 P.M.	0	5' 5"	26.9	NNW.	.5
12.30 "	40	5' 45"	27.9	S. by E.	.5
2 "	0	4'	24.	NE.	.4
2 "	40	4' 45"	24.9	S. by E.	.5
2.45 "	0	5'	33.3	NE.	.6
2.45 "	40	5' 5"	15.1	S.	.3

## II. STATION 10072, JULY 21.

Low water Barnegat Inlet at 4 A.M.

1.46 A.M.	24	5'	10.	S. by E.	.2
2.15 "	4	5'	12.4	S. by W.	.2
2.30 "	0	5'	7.3	SSW.	.14
3 "	24	5'	7.2	WSW.	.14
3.15 "	4	5'	7.3	S. by W.	.14
3.20 "	0	5'	7.2	SSW.	.14
4 "	24	5'	7.3	NNW.	.14
4.15 "	4	5'	7.7	W.	.15
4.20 "	0	5'	27.3	SSW.	.5
5 "	24	5'	25.3	S. by W.	.5
5.15 "	4	5'	34.3	W. by S.	.7
5.25 "	0	5'	38.2	S. by W.	.74
6 "	24	5'	17.3	N. by W.	.3
6.15 "	4	5'	36.8	W.	.7
7 "	24	5'	14.1	N. by E.	.3
7.15 "	4	5'	36.3	W. by N.	.7
7.30 "	0	5'	36.3	W. by S.	.7
8 "	24	5'	13.2	NE. by N.	.3
8.15 "	4	5'	28.	WNW.	.54

## III. STATION 10074, JULY 22.

High water Cape May 11 A.M.

High water Barnegat 10.35 A.M.

7.45 A.M.	30	5'	5.9	S. by E.	.1
8 "	0	5'	30.	W.	.6
8.45 "	30	5'	2.8	?	Trace
9 "	0	5'	28.8	W.	.55
9.45 "	30	5'	9.7	SSE.	.2
10 "	0	5'	20.	NW. by W.	.4
10.45 "	30	5'	9.7	S. by E.	.2
11 "	0	5'	9.7	NNW.	.2
11.45 "	30	5'	16.3	SSE.	.3
12 "	0	5'	10.5	N. by W.	.2
1.10 P.M.	30	5'	7.7	S $\frac{1}{2}$ W.	.15
1.20 "	0	5'	4.	NNE.	.1
2 "	30	5'	9.9	S.	.2
2.10 "	0	5'	18.3	ENE	.35
3 "	30	5'	5.6	SSE.	.1
3.10 "	0	5'	14.3	E $\frac{1}{2}$ N.	.3



At Station 10065, over the 45 fathom curve, fifty miles south of Long Island, the first reading was taken about five hours before high water at Fire Island Inlet, the nearest shore station for which tidal data is available. The surface current ran northwesterly for the first three hours; and then veered to the north and northeast, in which direction it flowed, till the end of the set. Of course the observation does not show conclusively whether or not there was a dominant drift in any direction, because it did not cover the last half of the ebb; but it goes far enough to show that the flood current ran about northwest; the first half of the ebb to the northeast, the strength of the flood being .2-.6 knots, of the ebb .4-.7 knots per hour (Fig. 64).

The total drift for the part of the tide covered by the set is about 1.8 knots north. And it seems hardly probable that the last few hours of the ebb would wholly nullify this, the general trend of the coast in this region being such that it is safe to assume that the last part of the ebb flows about east, the first part of the flood westerly. And even if the late ebb ran southeast with a velocity of .5 knots, there would still remain a net northerly drift of nearly .5 knots. It is therefore fair to conclude that there was a slight dominant northerly movement of the surface water over this part of the continental shelf.

The bottom current turned an hour earlier than the surface current. During the last three hours of the flood the flow on the bottom was toward the northwest, with a velocity diminishing from .4 knot to zero. It then veered to the south by east, and south, running in that direction for three hours with the considerable velocity of .35-.5 knot per hour. The total set showed a net movement of water of about 1.4 knot toward the south-southwest; but it is a question whether there was any dominant flow on the bottom, for if the current veered to the southeast and east during the last of the ebb, with a northwest current throughout the flood, as is not unlikely, the net drift would be neutralized.

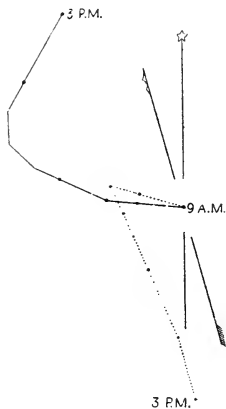

FIG. 64.—Surface current———, and bottom current.....at Station 10065; hourly from 9 A.M. to 3 P.M., July 12. The distance between dots (.) shows the drift for each hour; 2.25 cm. = 1 sea mile. The compass arrows are true and magnetic.

Fifty miles off Cape May (Station 10072) readings were taken at zero, four, and twenty-four fathoms, from 1-46 A.M. to 8-15 A.M., the time of low water being 4 A.M. at Barnegat Inlet (Fig. 65). The surface current ran southwest during the entire set, veering toward the west (S. S. W. to W. by S.) with velocities ranging from .15 knot at the beginning to .7 knot at the end, showing that the tide started to flood shortly before we began work. The total drift was about

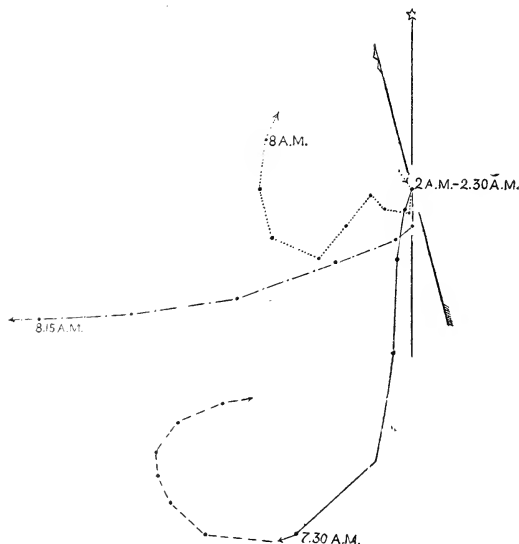

FIG. 65.— Surface current ———, 4 fathom current — · · · — ·, and bottom current . . . ., at Station 10072; hourly from 2 A.M. to 8 A.M., July 21. The surface current of Station 10074, . . . ., is combined with Station 10072 to show total drift for an entire tide. 2.25 cm. = 1 sea mile.

3 knots southwest. At four fathoms the current veered from S. by W. through west, to W. W., N. the velocity ranging from .14 knot to .7 knot, the net drift 3 knots west, *i. e.*, toward shore. The bottom current at twenty-four fathoms veered irregularly from S. by E., through S. W. west, and northwest to northeast, with velocities

ranging from .14 knot to .5 knot, greatest when the flow was southwesterly and northwesterly. The total drift was about 1 knot toward the northwest. These three sets were planned to cover the last half of the ebb, and the first half of the flood. But the observations show that the flood current had begun to run one to two hours earlier than the time of low tide at Barnegat. Hence, the set must have been confined to the flood, and therefore can not show whether there was any dominant drift. To remedy this defect it would have been necessary to continue the set for six hours more, but this was impracticable, owing to a sudden squall. Consequently a third set of current measurements was made the next day at Station 10074, so timed as to

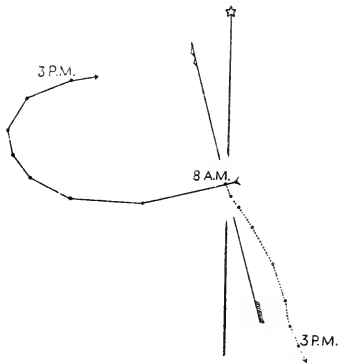

FIG. 66.—Surface current ———, and bottom current . . . , at Station 10074, for each hour from 8 A.M. to 3 P.M., July 22. 2.25 cm. = 1 sea mile.

cover the last of the flood and most of the ebb (Fig. 66). The surface current at Station 10074 set westerly for the first two hours, *i. e.*, during the last of the flood. It then veered gradually through northwest, north, and northeast to east, in which direction it was running with a velocity of .3 knot at the end of the set. The velocities were .6 knot for the first two hours; .1 knot to .4 knot after that. The total net drift was about 1.5 knot to the northwest.

The bottom readings were less satisfactory than those on the surface, because of the weakness of the current. In general the flow was toward the south and south-southeast, varying irregularly between

these two bearings, the total drift being about 1.2 knot toward the south by east. On combining the stations, omitting the first hour of 10074 to compensate for the advance of the tide during twenty-four hours, a southwesterly surface drift of 2.2 knots and a southwesterly bottom drift of about 1 knot results.

The last two hours of the ebb are still to be accounted for; the regular veering of the surface current suggests that it continues to swing toward the east and southeast, and general knowledge of similar tidal currents suggests a diminishing velocity. These two stations, then, taken together, indicate a dominant southwesterly current with a velocity on the surface, of two to three knots for an entire tide, *i. e.*, four to six knots in twenty-four hours. Of course the validity of this conclusion depends on whether a combination of these two sets of observations, as though they had been made at one station, is justified, and there is no apparent objection to so doing, either in the contour of the bottom, the course of the shore line, or in the amplitude of the tide at the two stations. Nor was there anything in the weather conditions to suggest that the surface current was a wind drift at either, because Station 10074 was occupied during a calm, and after a calm night; Station 10072 likewise after a calm night, and in a moderate breeze. And so far as the observations go, the velocity of the tidal currents was apparently about the same at the two stations, being about .7 knots per hour for the fifth hour of the flood at Station 10072, .6 knot at Station 10074. The bottom currents likewise suggest a slight southwesterly drift.

#### CIRCULATION OVER THE CONTINENTAL SHELF, JULY, 1913.

Our current measurements, salinities, and densities allow a tentative reconstruction of the movements of the water over the continental shelf at the time of our visit. During the spring there must have been off shore surface currents opposite four main sources of fresh land water, *i. e.*, Long Island Sound, the Hudson River, Delaware Bay, and Chesapeake Bay, to produce the tongues of low salinity which we encountered there (Plate 2). These currents must have been at their height at least a month earlier, *i. e.*, at the time of the greatest river freshets; the Delaware current reaching its maximum after the middle of May, because the salinity was higher off the Bay on May 9 (p. 188) than we found it (p. 198). The drift, as indicated by salinity, was easterly off the mouth of Long Island Sound, and there must have

been a similar, but more pronounced off shore current opposite Chesapeake Bay, much as it is represented on the current chart of the North Atlantic (Soley, 1911), and surface density suggests that the fresh water from the Bay spreads out, fan-like, to the north, as well as over the heavier ocean water. The salter water which alternates with these comparatively fresh tongues is in part a contrast phenomenon; but the salinity curves immediately south of Delaware Bay can only be explained as due to an actual shoreward drift of water of high salinity (p. 187). And the current data at Station 10074 suggest, though they do not prove, that this salt tongue was swinging, eddy-like, toward the southwest. Just north of Delaware Bay, there seems to have been a similar eddy-like movement which, added to the southerly flow of coast water, produced the strong southwest current which was found at Station 10072. Surface salinities, like the current measurements at Station 10064 suggest traces of a northerly movement, or "banking up" of the ocean water south of Long Island, a process which had progressed so far by the end of August as to raise the surface salinity from about 32.8‰ (Station 10062) to about 34‰ (Station 10112).

Surface density, being practically the same off Cape Cod as over the outer part of the continental shelf south of Nantucket, does not indicate any general flow across Nantucket Shoals into the Gulf of Maine in July, or *vice versa*; nor does surface salinity afford any unmistakable evidence of a dominant current in that region, though the curve of 33‰ suggests a possible southeasterly drift. Salinities show that there must have been an indraught of ocean water into the eastern side of the Gulf, which is consistent with the fact that the surface density of the northern and eastern parts of the Gulf was very much higher than that of the ocean water outside George's Bank. To compensate for this tongue of ocean water, there was an outflow of land water off Penobscot Bay; and the salinity curves suggest a general southward drift of surface water along the western coast of the Gulf (Plate 2).

The salinity curves, and our actual current measurements, agree very well with the earlier data, as summarized in the U. S. Coast Pilot (1912). According to the latter the prevailing drift over Nantucket Shoals is easterly, which agrees so well with our salinity curves as to make it a fair assumption that there is actually a dominant easterly current in this region in summer. The few current measurements which have yet been made on George's Bank (U. S. Coast Pilot, 1912, Mitchell, 1881) indicate a similar easterly drift, veering northward

near the eastern edge of the Bank. And although the observations are insufficient for any definite mapping of currents in a region where the tides are so strong, it is certainly suggestive that this northerly trend near the eastern end of the Bank corresponds with the salt tongues which were found in the eastern side of the Gulf in both 1912 and 1913. But an easterly and northeasterly movement of water on the Shoals and over George's Bank, does not mean that there is a general easterly long-shore current, both because there is no dominant drift at Nantucket light-ship (U. S. Coast Pilot, 1912, p. 10), and because the various records agree in crediting the coast waters south of Marthas Vineyard as a whole with a westerly, southwesterly, or northwesterly drift. In short, present indications point to the conclusion that the movements of surface water are tidal there, in the form of an irregular, perhaps intermittent eddy, which receives greater or less accessions of Gulf water on its northern side, and of ocean water along its southern and southeastern edge. The latter is an important factor in summer when it must influence hydrographic conditions on the banks profoundly, just as it does over the continental shelf further west (p. 198). And it exerts an unmistakable influence on the oceanography and plankton of the Gulf of Maine as well.

The outrush of comparatively fresh water from Long Island Sound, shown by the salinity curves, is substantiated by current records; and the northwesterly current over the forty fathom curve south of Block Island, represented on the current chart in the Coast Pilot, corresponds with our current records over the same part of the shelf a few miles further west. But the changes which take place in the surface salinity of this region at different seasons show that it is by no means a permanent phenomenon, probably being reversed in spring by the outrush of shore water.

The combined evidence of the various records of ocean currents, our own included, points to the conclusion that the dominant drift over the continental shelf, south of New York, is to the southwest; and this is certainly the prevalent opinion of practical navigators and hydrographers. But it does not necessarily follow that this drift is a simple, long-shore current, as has so often been suggested. On the contrary, surface salinity shows that it is interrupted by outpourings of comparatively fresh water off the rivers and bays, at least in spring and summer, and, conversely, by shoreward movements of salt ocean water. Furthermore little evidence was found of any appreciable southerly flow on the bottom, even in water as shallow as twenty-four fathoms, though there was an unmistakable southwesterly current on

the surface. The correct explanation is that the movement of the surface waters over the shelf is chiefly a series of great eddies, receiving water, on the one hand from the Gulf Stream off shore, on the other, from the land. The accompanying chart (Plate 2) shows an attempt to reconstruct the surface currents, for the summer months; but so intricate is the problem, and so scanty the reliable information yet at hand, that it is only tentative.

It is even more difficult to reconstruct the movements of the subsurface water, because we must rely almost wholly on the GRAMPUS observations. These current measurements do not prove any dominant flow on the bottom north or south of Delaware Bay (p. 230), and it is questionable whether any general flow can be deduced from them south of Long Island. But salinity, density, and temperature show that the bottom and intermediate waters over the shelf are far from being stagnant, though their movements, other than tidal currents, are probably slow as compared with the surface currents.

The density profile across Nantucket Shoals does not suggest any flow into, or out of the Gulf of Maine in this region at any depth; nor does the density of the bottom water of the Gulf suggest any influx of ocean water from the zone between fifty and 130 fathoms, via the Eastern Channel.

The seaward dip of the density curves south of Nantucket together with the cold tongue (p. 165) shows that the bottom water was flowing seaward down the shelf from the fifty fathom curve, indenting into and mixing with the ocean water over the slope (Fig. 10); and this agrees with the salinity curves. But south of Long Island, the fact that the density curves are just the reverse, together with the sudden rise of salinity immediately below the cold tongue, suggests that here the ocean water was sinking, obliquely, toward the land below the cold, fresh coast water. And to judge from the densities, a similar movement of water must have been taking place over the outer part of the shelf off Barnegat also.

The salt tongue which indents the fresher coast water in the mid-depths over the continental shelf between Delaware Bay and Chesapeake Bay (p. 198) is as interesting as the cold tongue off Long Island. Just south of Delaware Bay, there seems to have been an actual movement of surface water toward the coast (Fig. 60), gradually mixing with and sinking below the much fresher, hence lighter coast water. At twelve fathoms, *i. e.*, the axis of the salt tongue, the density was uniform, east and west; below twelve fathoms, the density gradient dipped from land to sea. Thus ocean water must have been coasting,

as it were, down the density gradient, from near the surface over the 100 fathom contour to about twelve fathoms over the thirty-five fathom contour, with the heavier, though fresher, bottom water of the shelf moving seaward below it. Density points to a similar type of circulation off Chesapeake Bay. But this phenomenon must be transitory, because as the coast water grows warmer with the advance of the season its density on the bottom must fall as low as that of the saltier water off shore.

The band of uniform salinity which we traced from Station 10063 to Station 10069 (p. 194) was not the result of vertical mixing; had it been temperature like salinity would have been equalized. Its origin is obscure.

Neither density, salinity, nor temperature indicates any general longshore movement of the bottom waters on the shelf.

#### PREVIOUS RECORDS OF TEMPERATURE AND SALINITY CAPE COD TO CHESAPEAKE BAY.

The existence of a band of cold water between the Gulf Stream and the coast has been recognized since the days of the early voyages to these shores. By 1850 its general geographic limits were well understood (Maury, 1855), since which time a vast body of surface temperature readings has been taken over the continental shelf by vessels entering the ports of New York, Philadelphia, and Chesapeake Bay, as well as by various expeditions and government services. But most of these have never been published; and since, in any event, the general range of summer temperature is now well known, I need refer here to only a few of the more important sets of observations. The data obtained by the U. S. Fish Commission south of Marthas Vineyard between 1880 and 1882, (Tanner, 1884a, 1884b; Verrill, 1880-1884b), show the general rise of temperature passing off shore from the southern coast of New England. And records have constantly been kept at Woods Hole since that time, so that there are very satisfactory data of the temperature close to shore in that region. The more recent of these are summarized by Sumner, Osburn, and Cole (1913), who find that the monthly surface mean for a five year period, at the Woods Hole Station, is  $31^{\circ}$  in February,  $43.9^{\circ}$  in April,  $68.8^{\circ}$  in July,  $69.7^{\circ}$  in August,  $48.2^{\circ}$  in November. In Vineyard Sound the mean surface temperature, August, 1907, was  $64.7^{\circ}$ , November, 1907,  $50.9^{\circ}$ ; March, 1908,  $36.6^{\circ}$ ; June, 1908,  $56.5^{\circ}$ . The surface



temperatures of the water close to the coast south of New York are likewise well known for all months in the year (Rathbun, 1887) owing to the extensive series of temperatures taken at various light-houses and light-ships, notably "Winter quarter Shoal," and "Five fathom bank" off Cape May from 1881-1885. At the former, on July 25, *i. e.*, about the time the GRAMPUS passed there, the temperature was 74° in 1881, 72° in 1882 and 1883, 69° in 1884, and 74° in 1885. Our records, a few miles away, July 21, were 74°-75°. But by July 30, a surface temperature of 76° close to the light-ship was noted. At "Five fathom bank" the temperature, on July 25, 1881, was 71°; 73° in 1882; 71° in 1883; 74° in 1885: on July 21, 1913, it was 73°-74°, a few miles to the east, rising to 77° close to the light-ship on July 31. Off Sandy Hook, July 19, the surface temperature was 71° in 1881 and 1882; 74° in 1883; 65.5° in 1884; 69° in 1885. On July 17, 1913, it was 68°-69°. On Nantucket Shoals, 40° 54' N., 69° 49' W., *i. e.*, some seventeen miles north of the present location of the light-ship, the surface temperature, July 10, ranged from 55° to 60° for the five-year period. On July 9, 1913, it was probably about 56°, *i. e.*, about the same; but the GRAMPUS did not visit this exact spot; and the surface temperature varies with the greater or less violent tides over the shoals.

The general summer temperature of the water over the outer part of the continental shelf is now well known for the region south of Martha's Vineyard, thanks to Verrill (1880-1884b) and Libbey (1891, 1895).

In July and August, 1881, the surface temperature south of Marthas Vineyard was slightly cooler than in 1913, from 63° over the forty fathom curve, to 66° over the fifty fathom curve, and 72° over the 100 fathom curve (Verrill, 1881, 1884b), whereas on July 11, 1913, a few miles further east, it ranged from 65°-67° between the forty and the seventy-five fathom curves. Over the 100 fathom curve, on the other hand, the 1913 temperatures are a little the lower (69°-70°, as against 72°). Unfortunately Verrill's data for 1882 are not directly comparable, because taken in August. But during that month the surface water outside the sixty fathom curve south of Marthas Vineyard was constantly warmer than 70°, *i. e.*, about as much warmer than the year before for that month, as 1913 was warmer than 1881 in July. In 1889 Libbey (1891) took an extensive series of surface temperatures south of Block Island and Marthas Vineyard, affording the most complete temperature survey of a limited locality yet attempted off the American coast. Any analysis of these records would require a

study of diurnal warming and nocturnal cooling, to make them comparable with one another. But this is not necessary here, because, after all, they are not strictly comparable with our observations, having been taken from three to six weeks later in the season, and hence may be expected to be higher. They suggest that the surface water in that year may have been rather cooler than we found it, for Libbey (1891) found much the same temperature at the end of July that was observed in the first half of the month; *i. e.*, July 24, 1881, 62.8° at the 25 fathom curve south of Nantucket; 66°-67° over the outer half of the shelf; 68° at the 100 fathom curve.

A large number of surface temperatures have been collected by Dickson (1901) for the years 1896, 1897. In July 1896, according to his charts, the surface temperature from Marthas Vineyard to New York was between 60° and 68°, above 68° off New Jersey. By August it had risen to 68°, the greater number of the records having been taken, no doubt, along the direct steamship line from Nantucket light-ship to Fire Island light-ship. In 1897 the water was warmer, being upwards of 68° from Nantucket to New York. According to the British Meteorological office (Sumner, Osburn, Cole, 1913, p. 438) the mean surface temperature, some thirty miles south of Marthas Vineyard, is 67° in July, 69° in August: 66° and 70° respectively in Long Island Sound; 71° and 73° in the mouth of Delaware Bay; 75° for both months over the 100 fathom curve off Chesapeake Bay. Hautreux (1911) gives the average surface temperature, for a five-year period, off Fire Island light-ship, as 66.2° for both July and August. How closely the temperatures obtained in July, 1913, agree with Sumner's averages is illustrated by the fact that we had precisely the same reading off Fire Island light-ship; off Marthas Vineyard (Station 10063, 67°); off the edge of the continental slope abreast of Cape May (73°); and the difference off Chesapeake Bay was only 1°-2°. And they lie within the range for 1896, as given by Dickson, but are colder than his records for 1897. On the other hand the water was warmer off New York in 1913 than the five-year average given by Hautreux, 69° instead of 66.2°.

The summer temperatures outlined above are enough to show that 1913 may be considered a perfectly normal year; 1881, 1884, and 1889 were cooler, and 1897 warmer. And in view of the fact that in summer the surface temperature over the continental shelf depends largely on the wind, it is doubtful whether the very slight differences between these years have any general significance.

The general range of surface temperature over the continental shelf

between Cape Cod and Chesapeake Bay, so far as known, may be summarized as follows:—in February, the coldest season of the year, the temperature of the water is very low indeed close to the coast and in the bays and sounds,  $31^{\circ}$ – $36^{\circ}$  near Woods Hole, rising, toward the southwest, to about  $35^{\circ}$  near New York (Rathbun, 1887); about  $36^{\circ}$  off Cape May,  $37^{\circ}$ – $38^{\circ}$  at Winter Quarter Shoal; and even south of New York, freezing temperatures may occur near shore during very cold weather. But such low temperatures are limited to a very narrow belt, the winter temperature over the continental shelf as a whole being  $40^{\circ}$ – $45^{\circ}$ , rising suddenly to about  $50^{\circ}$  over the continental slope. And, of course, the surface water is still warmer further to the east and southeast, *i. e.*, in the Gulf Stream. With the advance of spring the temperature of the shore water rises steadily, until by the first part of July, the water over the continental shelf ranges, in temperature, from  $75^{\circ}$  off Chesapeake Bay to  $68^{\circ}$ – $70^{\circ}$  south of Marthas Vineyard. During mid-summer the temperature is locally higher next the coast than it is over the shelf, often even higher than the surface water of the Gulf Stream in these latitudes. For instance, the temperature immediately off Chesapeake Bay, in July, 1913, rose to  $80^{\circ}$ ; off New York to  $75^{\circ}$ ; off Long Island to  $70^{\circ}$ – $71^{\circ}$ . And the summer warming of such enclosed waters as Woods Hole and Nantucket Sound outstrips the rise of temperature over the shelf, until, as the summer advances, the shoreward movement of Gulf Stream water may obliterate this difference by raising the surface temperature over the shelf as a whole to  $70^{\circ}$  or over. And Gulf Stream water, with its characteristic plankton, often floods Narragansett Bay and Vineyard Sound in late summer, though the extent to which this happens differs from year to year, depending on the direction of the wind. The surface temperature of the coast water reaches its maximum in August.

To the student of ocean circulation one phenomenon in this annual cycle is of great importance, namely, the fact that where the water cools most rapidly, and to the greatest degree, in autumn and winter, *i. e.*, close to the shore, there it warms up most rapidly in spring and summer.

A large number of subsurface temperatures have been taken in the waters south of Marthas Vineyard, beginning with a series of bottom readings, by the vessels of the U. S. Bureau of Fisheries, in 1880, 1881, and 1882; and continued by Libbey (1891, 1895), who took several thousand readings at intermediate depths in 1889, 1890, and 1891. But these were all made in summer and early autumn; and our

knowledge of subsurface temperatures on the continental shelf at other seasons, and at any season elsewhere than in the region studied by Libbey and Verrill, is limited to a few bottom readings taken by the FISH HAWK (Tanner, 1884a, 1884b), BLAKE (Smith, 1889) and ALBATROSS (Townsend, 1901). Verrill's observations were located at successive points across the zone between the fifty and 150 fathom contours, and they are especially valuable, because they were taken before and after the extraordinary mortality of the tile fish, *Lopholatilus chamaeleonticeps*, of 1882 (p. 266). On July 21, 1880, the BLAKE ran a line across the continental shelf from Montauk Point, getting the following bottom temperatures: 24 fathoms, 60°; 43 fathoms, 49°; 71 fathoms, 51°; 129 fathoms, 51°; and 732 fathoms, 39.5°. Although these readings were taken with the Miller-Casella (maximum-minimum) thermometer, and hence register merely the coldest water at each station, which may not have been on the bottom, they show that the cold water on the shelf was separated from the even lower temperature of the abyss by a warmer belt at 75-130 fathoms, just as it was in July, 1913; and that this condition obtained as far east as the north-east end of George's Bank, where the bottom temperature, following down the continental slope, rose from 42° at seventy fathoms to 44° at 139 fathoms, and then fell to 40.5° at 300 fathoms. This "warm belt" was certainly distinguishable as late as August 17, 1880, when the FISH HAWK found bottom temperatures of 40°-48° in about thirty fathoms off Block Island. In September and October of the same year, the FISH HAWK took a considerable number of bottom temperatures on the shelf south of Block Island with deep-sea thermometers of the reversing type, finding about the same temperature (51°-53°) at 100-142 fathoms as in July, with colder water deeper down the slope (Verrill, 1880, Tanner, 1884a). But no readings were taken on the inner part of the shelf except in the very shallow water close to shore. The BLAKE records suggest that the water on the shelf south of Block Island was several degrees warmer, depth for depth, in 1880 than in 1913; but the discrepancy may be due to the fact that the observations were taken two weeks later in the former year.

The FISH HAWK temperatures for 1881 (reversing thermometers), again demonstrate the existence of the "warm belt" bathing the bottom at 70-100 fathoms, with lower bottom temperatures in the shallower water near shore (Verrill, 1881, 1884a, Tanner, 1884b), much the same distribution of temperature as in 1913. Thus on a line S 1/2 W from Marthas Vineyard, the bottom temperature rose from 42° at forty-four fathoms to 52° on the bottom between the sixty-

seven and ninety-eight fathom curves, below which it fell slowly to  $42^{\circ}$  at 229 fathoms, as illustrated by the following table, constructed from Verrill's data.

*Line S 1/2 W from Marthas Vineyard, July 16, 1881.*

Fathoms	Bottom temperature
44	$42^{\circ}$
46	$45^{\circ}$
53	$42.5^{\circ}$
63	$49^{\circ}$
67	$52^{\circ}$
98	$52^{\circ}$
164	$44.5^{\circ}$
199	$44^{\circ}$
229	$42^{\circ}$

The absolute temperatures of 1881 closely parallel those of 1913, *i. e.*, Verrill found a bottom temperature of  $52^{\circ}$  at seventy-seven fathoms, August 14, close to the location of Station 10061, where the bottom reading was  $51.5^{\circ}$  in seventy-five fathoms. Near Station 10062 Verrill's bottom reading was  $42^{\circ}$  in forty-four fathoms,  $43.6^{\circ}$  that of the GRAMPUS in forty fathoms, five days earlier in the season.

The records for 1881 and 1913 are not directly comparable outside the 100 fathom curve because the former were made six weeks later in the season than the latter, at the one location visited in both years. And the seasonal difference shows its effect in higher temperatures for 1881. Thus, near Station 10064 Verrill's readings, September 8, were  $47.5^{\circ}$  and  $45^{\circ}$  at 182 and 216 fathoms, depths at which the temperatures, on July 11, 1913, were  $45.7^{\circ}$  and  $43^{\circ}$ . In October, 1881, the FISH HAWK took a series of temperatures off Delaware Bay, finding  $51^{\circ}$  on the bottom at about 100 fathoms (Verrill, 1882a; Tanner, 1884b). And on November 16, of the same year, she found the bottom temperature  $56^{\circ}$  in 31 fathoms,  $55^{\circ}$  in 56 fathoms and  $48^{\circ}$  in 157 fathoms, off Cape Charles (Tanner, 1884b).

In 1882 the bottom water on the continental shelf was decidedly colder than it was the year before (Tanner, 1884c; Verrill, 1882, 1884a). And even more important is the fact that Verrill found no trace of the warm belt at 75-100 fathoms. On the contrary the bottom readings grew colder and colder seaward from the seventy fathom curve, as follows:—

*Bottom temperatures south of Marthas Vineyard, August 22, 1882.*

Fathoms	Temperatures	Fathoms	Temperatures
65-70	49°	145-155	46°
89	48°-49°	171	43°
100	47°-48°	245	43°
116	48°	300	40°
124	47°		

And the fact that the temperatures of 1882 were taken when the water was at its warmest (a month later than those of 1881) suggests that the discrepancy for the two years would have been even greater had both sets of readings been taken at the same season. The only one of our stations directly comparable with the above is Station 10112, over the sixty fathom curve south of Marthas Vineyard, August 22, where the temperature was 58.9° at sixty fathoms, *i. e.*, nearly 10° warmer than in 1882. The deep waters of the Gulf of Maine were likewise unusually cold in 1882 (p. 244), and the remarkable mortality of fish which took place in the spring of that year has usually been accounted for by the abnormally low temperature (p. 266).

The only records available for the next year (1883) are a few scattered observations by the ALBATROSS (Townsend, 1901), unfortunately all outside the 100 fathom curve. They show that the temperature south of Marthas Vineyard was 48° at 131 fathoms in May, and 49° at 117 fathoms in September. In September, 1884, the ALBATROSS took a series of bottom temperatures south of Nantucket, extending from the eighteen fathom curve out to the continental slope, with the following results:

*Bottom temperatures, south of Nantucket, September 26-28, 1884.*

Fathoms	Temperature	Fathoms	Temperature
18	55.9°	58	52.9°
25	54.4°	78	51.9°
38	50.3°	98	50.9°
43	50.2°	122	48.8°
46	51.4°		

This series was taken a month later in the season than our 1913 stations, which perhaps explains the high temperatures on the inner part of the shelf in 1884. And the fact that our one Station (10112) at the end of August was considerably warmer than the 1884 records shows how difficult it is to compare scattered records, owing to fluctuating

influences on the part of the Gulf Stream. Nevertheless the ALBATROSS temperatures are instructive because they show that in 1884 the cool water which bathes the shelf was once more separated from the cold water of the depths by a warm belt; *i. e.*, that the normal distribution of temperature was reestablished.

We know nothing about the subsurface temperatures of the next four years. But in 1889 Libbey took no less than 1600 temperatures on the surface and at depths, over the region south of Marthas Vineyard and Block Island. These records are so arranged as to show the distribution of temperature in great detail for the region studied; and they are so extensive that I can only summarize them here. Full tables, with charts and profiles, have been published by the U. S. Bureau of Fisheries (Libbey, 1891). Libbey's profiles show a cold tongue projecting southward into the warm off shore layers, in the mid-layers, such as we found south of Marthas Vineyard (p. 165, figs. 9, 10). The course of the curve of  $50^{\circ}$  in most of his profiles suggests that the cold bottom water of the shelf was directly continuous with the cold water of the depths under the Gulf Stream, instead of being separated from it by a zone of warm bottom water. But his own tables show that the few bottom readings which he took in the zone bounded by the seventy and ninety fathom contours were warmer than the bottom water either in shallower or in greater depths. And although his profiles off Nantucket, (Longitude  $70^{\circ}$ - $71^{\circ}$ ) even more strongly suggest a continuity between the cold bottom water of the shelf and of the deeper part of the slope, this is chiefly because a  $10^{\circ}$  interval between the curves is too great to illustrate the actual conditions, the temperatures on which his profile D (Longitude  $70^{\circ}$  to  $70^{\circ} 20'$ ) was constructed showing that the coldest water on the shelf ( $42^{\circ}$ , 50 fathoms) was underlaid by warmer water ( $45.3^{\circ}$  to  $47.4^{\circ}$ ). And the bottom temperature was even higher at ninety fathoms. In short, the cold coast water was separated from the cold water of the abyss by a warmer zone, in 1889, with a temperature of about  $47^{\circ}$ - $51^{\circ}$  at 70-100 fathoms. And the same was also true in 1890 (Libbey, 1895).

In 1889 the absolute temperature of the cold tongue was  $46^{\circ}$ - $47^{\circ}$  off Block Island, falling to about  $42^{\circ}$ - $43^{\circ}$  south of Nantucket, which agrees fairly closely with our observations at Stations 10065 and 10061, in July, 1913. But the facts that Libbey's temperatures were taken late in August, by which time the water was much warmer in 1913 (Station 10112), and that the cold tongue projected much further seaward in 1889 than in 1913, are good evidence that the water as a whole over the continental shelf was colder in that year. Judging

from his profiles, 1890 seems to have been intermediate between 1889 and 1913.

Libbey continued his survey of subsurface temperatures in subsequent years; but the results have never been published, nor, except in a few instances, have the various bottom temperatures taken by the vessels of the U. S. Bureau of Fisheries on collecting trips south of Marthas Vineyard. Hence it is not possible to draw any comparison between 1913 and any year since 1890.

There are no records of subsurface temperatures for winter, or spring, except in the water close to the coast, *e. g.* at Woods Hole.

The temperatures taken in the Gulf of Maine by Verrill are summarized elsewhere (1914a); but the records obtained by the *SPEEDWELL* (Smith, 1887), the *FISH HAWK* (Verrill, 1882, 1884a, Tanner, 1886) and by Dawson, (1905), were omitted there. The *SPEEDWELL* took bottom and serial temperatures in various parts of the Gulf in the summers of 1877, 1878, and 1879; but those of 1877 are of little value, because taken with Miller-Casella thermometers, two instruments often differing by as much as  $6^{\circ}$  when used simultaneously at the same depth. In 1878 and 1879, however, the Negretti and Zambra reversing thermometers were employed. Sixteen serial temperatures, in July, August, and September, 1878, in depths greater than twenty-five fathoms, show that the water was slightly colder below about forty-five fathoms at the mouth of Massachusetts Bay, and off Cape Ann, than in 1913, and less uniform vertically; with bottom temperatures of  $38.5^{\circ}$  to  $41.2^{\circ}$ , instead of about  $40.3^{\circ}$  as in 1912;  $41^{\circ}$  or more as in 1913. And the bottom water of the western basin was  $38.5^{\circ}$ - $39^{\circ}$ , as late as August 31 in 1878. But in August the surface layers were decidedly warmer in 1878 than in either 1912 or 1913, as illustrated by the following serial temperatures in Massachusetts Bay.

Depth	1878	1912	1913
	Aug. 29	Station 10045 Aug. 31	Station 10106 Aug. 20
	T $^{\circ}$	T $^{\circ}$	T $^{\circ}$
0	64.2 $^{\circ}$	61 $^{\circ}$	61 $^{\circ}$
5	60	57	56
10	57	53	51.5
15	52.5	50	48.5
25	50.5	45	46
30	45	44.9	45
35	44	43.6	44
40	42.5	43.1	
45	41.5		



In 1879 the water was colder in the southern part of Massachusetts Bay than we found it in 1912, except on the immediate surface, as illustrated by the following pair of stations some eight miles north-west of Race Point:—

	1879	1912
Depth	Aug. 25	Aug. 31
0	61.2°	58.0°
5	49	55
10	44.5	52.7
15	43.5	47
20	43.5	45.9
25	43.5	44.6
30	43.5	44.3

and the difference can not be explained by differences in vertical circulation, the mean temperature being 46.7° in 1879, 49.9° in 1912. But by the end of September, 1878, the SPEEDWELL found the temperatures in this region very close to the GRAMPUS records of a month earlier, *e. g.*, 58°–59° at the surface, 44°–45° at thirty fathoms. There was even a greater difference between the two years in the deep water east of Cape Cod, especially in the mid-depths, as illustrated by a pair of stations within five miles of each other.

	1879	1912
Depth	Sept. 1	Aug. 29
0	60°	60°
10	52	55
20	47	50.9
30	43	48.5
40	41	44.3
50	40.8	44
60	40.7	42
70	40.6	41.7
80	40.6	41.3

The 1879 temperatures are not directly comparable with those of 1913, there being no pairs of stations at the same locality and date; but this side of the Gulf was even warmer in 1913 than in 1912 (p. 250).

The FISH HAWK records for August, 1882, are especially important, because in that year the subsurface temperatures were very low south of Cape Cod. They yielded the following results. Off Race Point,

near Provincetown, the thirty-four fathom temperature was  $39^{\circ}$ – $39.5^{\circ}$ . A few miles further south, *i. e.*, along the shore off Cape Cod and Nauset light-houses, the bottom readings were:—

Fathoms	Temperature	Fathoms	Temperature
28	$40^{\circ}$	61	$37^{\circ}$
33	$39^{\circ}$	83	$38^{\circ}$
44	$39^{\circ}$	90	$38^{\circ}$
55	$37^{\circ}$	110	$38.5^{\circ}$

These records, taken with reversing thermometers (Tanner, 1884c), show that the deeper waters of the Gulf were considerably colder in the summer of 1882 than in any other year of which there is record; and, that in that year, as in 1913, the coldest water was not the deepest but in an intermediate zone at 50–70 fathoms. But the surface temperature of the Gulf in 1882 was apparently normal, just as it was south of Cape Cod, so far as the readings taken at various light-houses along the coast show (Rathbun, 1887).

In 1904 Dawson took a few subsurface temperatures at the mouth of the Bay of Fundy, finding water of  $44.6^{\circ}$ – $48.4^{\circ}$  in July, at fifteen fathoms;  $48^{\circ}$  to  $52.1^{\circ}$  in the middle of August, which agrees very well with our results. And Dawson seems the first to notice how the shoals and banks lower the surface temperature of the Gulf by causing vertical circulation (Dawson, 1905, p. 15).

Observations on salinity previous to 1913 are very scanty and many of them unreliable. Libbey (1891) took a large number of specific gravities in 1889, in the waters south of Marthas Vineyard, with the ordinary floating hydrometer. And although this instrument, as now universally recognized, is not sufficiently accurate to satisfy the demands of modern oceanography, his surface records agree fairly well with those of 1913, when reduced to salinity by Knudsen's (1901) tables. Thus on August 19, 1889, the surface salinity south of Block Island rose from  $33.5\%$  at the thirty fathom curve to  $34\%$  at the 100 fathom curve; in 1913 it was  $34\%$  near by, over the sixty fathom curve. Apparently, then, his instruments do not require the correction which Clark (1912) found necessary to apply to those used on the ALBATROSS. But his subsurface readings yield salinities as high as  $38.5\%$  at 100 fathoms,  $39\%$  or more at 500 fathoms. Such values as these are, of course, out of the question in the North Atlantic, where the 500 fathom salinity is known to be about  $34.9\%$  (Murray and Hjort, 1912) being equalled only in the eastern half of the Medi-

terranean and in the Red Sea, and a similar error runs through Libbey's whole series of subsurface densities. As just pointed out it can not be charged to the instruments, and in absence of information as to how soon the observations were made after the samples were collected, there is no means of judging whether it can be laid to evaporation of the samples. But whatever its origin, it is useless to attempt any reconstruction of the density curves along his profiles. Had this been possible, it would have thrown light on the origin of the cold tongue which Libbey suspected was a "mechanical intrusion of cold water from the surface of the continental platform, reinforced by the specific gravity of the water" (1891, p. 407), as was certainly the case in 1913.

In the neighborhood of Woods Hole, Sumner, Osburn, and Cole (1913) took a considerable series of hydrometer readings, checking them from time to time by titration. And though from their very nature they can not claim the accuracy of the latter method, yet their averages must be very close to the truth. They found the mean salinity of Vineyard Sound in July and August about  $32.2^{\circ}\text{C}_{60}$  which agrees very well with our record of  $32.29^{\circ}\text{C}_{60}$  off the entrance to Vineyard Sound (Station 10084). Dickson's (1901) charts show the water immediately south of Marthas Vineyard as  $32^{\circ}\text{C}_{60}$  in July, 1897, with the salinity  $33^{\circ}\text{C}_{60}$  and higher over the 100 fathom contour. In August of the same year, the coast water between Delaware Bay and Nantucket Shoals was below  $32^{\circ}\text{C}_{60}$  bounded seaward by a zone of water with salinity between  $32^{\circ}\text{C}_{60}$  and  $33^{\circ}\text{C}_{60}$  over the outer part of the continental shelf. These charts, taken at their face value, suggest that the salinity was considerably lower in 1897 than in 1913, for in July of the latter year water fresher than  $32^{\circ}\text{C}_{60}$  was confined to a small area off the mouth of the Hudson River, and along the south shore of Long Island. But the records on which they are based are so few that it is a question whether there actually was any such difference between the two years. And Schott represents the salinity of the water over the continental shelf between Cape Cod and Chesapeake Bay as  $32\text{--}33^{\circ}\text{C}_{60}$  (1902, taf. 33). Further information as to the salinity of our coastal zone is contained in the Bulletins of the International Conseil for the exploration of the sea. In August, 1907, and February, 1908 (1909), the water along the coast of Nova Scotia was  $32^{\circ}\text{C}_{60}$  or less; the curve for  $32^{\circ}\text{C}_{60}$  touching Cape Cod in the latter month. And the curves for May of that year afford the interesting information that  $32^{\circ}\text{C}_{60}$  water spread seaward in an obtuse wedge, abreast of the Gulf of Maine, and that water of that same salinity bathed the coast as far as New York. Unfortunately there were no

data from the continental shelf south of New York in that year, but in May, 1909 (1910), when there were no records for the northern part of the shelf,  $34^{\circ}\text{C}_{60}$  water was found over the shelf opposite Cape May, just as was the case in May, 1913 (p. 188). And in August, 1909 (1911),  $34^{\circ}\text{C}_{60}$  water lay close to land south of Cape Cod, agreeing with the GRAMPUS station in this region in August, 1913. In November, 1909, the curve of  $34^{\circ}\text{C}_{60}$  salinity followed the southern edge of George's Bank: but the Bulletins contain no more recent records for the continental shelf.

So far as the rather meagre data show, salinity, like temperature, was normal in 1913.

#### OCEANOGRAPHY OF THE GULF OF MAINE IN THE SUMMERS OF 1912 AND 1913.

The surface water next the coast between Cape Ann and Penobscot Bay was  $1^{\circ}$ – $4^{\circ}$  warmer in 1913 than the year before. But from Penobscot Bay to Mt. Desert and again off the Grand Manan Channel the readings were about  $2^{\circ}$ – $3^{\circ}$  below those of the preceding year. And this was also the case on German Bank ( $48^{\circ}$  in 1913,  $50^{\circ}$  in 1912).

The readings at corresponding stations, tabulated below, show how closely the surface temperature agreed in the two summers, in the central and southwestern parts of the Gulf:—

10024	$61^{\circ}$	10027	$59^{\circ}$
10089	$61.5^{\circ}$	10092	$60^{\circ}$
10002	$63^{\circ}$	10045	$61^{\circ}$
10087	$62^{\circ}$	10106	$61.2^{\circ}$
10028	$59^{\circ}$	10012b	$65^{\circ}$
10093	$60^{\circ}$	10105	$64^{\circ}$

The area which was warmest in 1913 (Fig. 1) was not visited in 1912. Conversely less attention was devoted to Massachusetts Bay and to the coastal zone in general in 1913 than in 1912. But so far as the observations in the Bay go, the surface temperature, month for month, was about the same there in the two years.

The subsurface temperatures of 1913 did not differ anywhere in the Gulf from those of 1912 by more than  $5^{\circ}$ . August stations in Massachusetts Bay in the two years, at nearly the same locality

(Stations 10044, 10045, 10106) agree very closely with each other, the curves being practically parallel, and it is probable that the same was also true of the waters immediately off the mouth of the Bay, for while the temperature as a whole was higher there in 1913 (Station 10087) than at the same locality in 1912, the greatest difference was only about  $1^{\circ}$  in the intermediate depths, while the two were alike below forty fathoms.

The water immediately north of Cape Ann (Stations 10104, 10105) was  $2^{\circ}$ - $5^{\circ}$  warmer in 1913 than in 1912 (Stations 10011, 10012b) down to 50-60 fathoms; below fifty fathoms the two sets of observations hardly differ at all. Here again we are confronted with the difficulty that the 1913 stations were occupied a month later than those of 1912, hence the higher temperature of the former might be explained as due to seasonal warming during the last part of July and August. However, the waters off Cape Elizabeth were also slightly warmer ( $.5^{\circ}$ - $3^{\circ}$ ) in 1913 than in 1912, though studied only fourteen days later in the season, which suggests that the upper layer of the coast water from Cape Ann to Cape Elizabeth was actually warmer in 1913 than in 1912.

Near Monhegan Island the temperature was about the same below fifteen fathoms in 1913 (Station 10102) as it was a week earlier in 1912 (Station 10021), though over  $5^{\circ}$  warmer on the surface.

The mean temperature on Jeffrey's Bank was about  $1^{\circ}$  higher in 1913 than in 1912 ( $50^{\circ}$  as against  $48.7^{\circ}$ ); and the fact that the vertical range of temperature was much greater there in 1913 than in 1912 shows that vertical circulation was less active. A few miles further east, however, the 1913 temperatures (Station 10101) are  $1.5^{\circ}$ - $3^{\circ}$  lower than those of 1912 (Station 10038) at all depths.

The 1913 temperatures are likewise consistently lower than those of 1912 off the northeast coast of Maine (Station 10098) and over the coastal bank off Nova Scotia, the observations having been taken at about the same date. For example, the Station of 1913, off Lurcher Shoal (10096) was  $2^{\circ}$  colder on the surface;  $2.5^{\circ}$  colder in the mid-depths;  $3^{\circ}$  colder at sixty-five fathoms than the water a few miles further south in 1912 (Station 10031). And German Bank was  $1.5^{\circ}$ - $2.5^{\circ}$  colder in 1913 than in 1912.

Our discovery that in 1913 the basins were coldest in the mid-depths, with warmer water below, was totally unexpected, because in 1912 they were coldest on the bottom; or the temperature was at least vertically uniform below about fifty fathoms. In the western basin the water was  $2^{\circ}$  warmer at the surface,  $1^{\circ}$  warmer at fifty fathoms,

3° warmer at 100 fathoms in 1913 than in 1912 (Stations 10088, 10007). The higher temperature in the upper layers in 1913 was probably due to the fact that the observations were made a month later than in 1912. But this will not account for the difference at fifty fathoms and below.

Off Cape Cod the 1912 temperatures were 3.5° lower on the surface, 3°-7° higher in the mid-depths, than those of 1913. But this is the type of difference which might be expected from the advance of the season (the 1912 Station, 10043, was three weeks later than that of 1913), being the first step in the equalization of temperature which is complete, down to forty fathoms, by November (1914b). And I doubt whether there was any more temperature difference between the Cape Cod waters of 1912 and 1913 than can be explained on this ground.

Off Platt's Bank the stations for the two years were made at so nearly the same season (August 7, 1912 and August 10, 1913) that no seasonal difference need be allowed for. The upper thirty-five fathoms proved to be almost exactly the same in 1913 as in 1912, except for the immediate surface, which was 2° colder, a difference which may be due to the fact that in 1912 (Station 10023) the temperature was taken in the afternoon of a very warm and calm day; in 1913, at daybreak. But below thirty-five fathoms, the water was about 1° warmer in 1913.

Our stations of 1913 in the eastern basin were made at almost the same localities, and within a few days of the dates of those of the year before. On its western side the water was warmer down to ten fathoms in 1913 than in 1912; but the difference was so slight that it is a question whether it is anything more than evidence of diurnal warming, one station having been occupied in the daytime, the other at night. And the two were almost precisely alike below eighty fathoms. But the temperatures of 1913 are 2-3° colder in the mid-layers. The east side of the basin was warmer in 1913 than in 1912, down to thirty-five fathoms, the greatest difference being almost 4° at twenty fathoms. But below that level it was 3° colder all the way down to the bottom. And this is also true of its northern end (Stations 10097, 10026), the extreme variation being 2°, at 100 fathoms.

The range of salinity on the surface was smaller in 1913 (31.8‰-32.8‰) than in 1912 (31.06‰-32.84‰); but this is probably chiefly due to the fact that in 1913 most of our work was carried on in August, by which time the salinity of the coast water may be expected to be higher than a month earlier. But seasonal difference does not explain

the higher salinity of 1913 off Penobscot Bay, for there our observations were made at practically the same season in the two years. Comparison of the charts for the two years (Plate 2, and 1914a, Plate 2) shows how much further northwestward toward Penobscot Bay the salt tongue of off shore water extended, and, conversely, how much less evident was the outrush of comparatively fresh water from the bay, in 1913. But east of Mt. Desert the surface water next the coast was fresher in 1913 than in 1912.

Over the Nova Scotia coast bank, near Lurcher Shoal, likewise, the surface salinity was higher in 1912 ( $32.84\text{‰}$  at Station 10031) than in 1913 ( $32.75\text{‰}$  at Station 10096); but on German Bank the reverse was the case ( $32.70\text{‰}$  at Station 10029,  $32.79\text{‰}$  at Station 10095). Over the eastern basin the surface salinity was slightly higher in 1912 than in 1913, the readings at three pairs of stations being:—

Station	10027	1912	$32.66\text{‰}$
	10092	1913	32.59
	10028	1912	32.75
	10093	1913	32.61
	10036	1912	32.75
	10097	1913	32.75

And in 1913 the surface salinity was nowhere so high in the Gulf as it was off Lurcher Shoal in 1912 ( $32.84\text{‰}$ ).

The subsurface salinity for the two years was about the same in Massachusetts Bay, in August, for, though there was much less difference between surface and bottom in 1913 (Station 10106) than at the same locality in 1912 (Station 10045), the mean for the entire column is almost precisely the same ( $32.4\text{‰}$ ).

The observations off the mouth of the Bay were taken a month later in 1913 than in 1912. And while the salinity was considerably higher above forty fathoms, lower below that depth, in 1913 than in 1912, the mean salinities for the two years differs by only about  $.1\text{‰}$  (Station 10002, July, 1912,  $32.54\text{‰}$ ; Station 10087, August, 1913,  $32.63\text{‰}$ ), no more than can be charged to the general rise of salinity which takes place after the spring freshets from the rivers have passed (1914b). In the western basin the observations for 1913 (Station 10088) were intermediate in date, as well as in geographic location, between the two stations of 1912 (10007, 10043); and they were likewise intermediate in salinity all the way from surface to bottom, *i. e.*, it was about the same in this general region in the two years. The same is also true of the

deep water off Platt's Bank, where the stations were occupied within six days of the same date.

In the eastern basin, the water was considerably less salt in 1913 than in 1912, although the two sets of observations were taken within a few days of the same dates. On its western side (Station 10027, 1912; Station 10092, 1913) the difference was greatest in the mid-depths (.35‰ at fifty fathoms), very slight at surface and bottom; but further east (Station 10028, 1912; 10093, 1913), it was uniform (.3‰-4‰) all the way from twenty fathoms down to the bottom. And the 120 fathom salinity at Station 10028 in 1912 (34.54‰) is almost .3‰ higher than any salinity in 1913. In the northern end of the basin, on the coastal bank near Lurcher Shoal, and off the northeastern coast of Maine the water was also slightly saltier at all depths in 1912 (Station 10036) than in 1913 (Station 10097), though the two sets of observations were taken at nearly the same season, and the geographic locations were almost identical. But on German Bank the reverse is true, the water being about .05‰-.1‰ saltier at all depths in 1913 than in 1912. The salinity of the coast water between Cape Ann and Cape Elizabeth was about the same in August, 1913, as it was two to three weeks later in 1912, correspondingly saltier than the July salinities of that year (1914a). Off Monhegan, where the observations for the two years were taken at practically the same date, the water was slightly fresher on the surface, slightly saltier at sixty fathoms, in 1913 (Station 10102) than in 1912 (Station 10021).

Thus, in brief, the Gulf was colder and fresher in its eastern, warmer, but of about the same salinity, in its western half, in 1913 than in 1912.

In the preceding lines the differences between the two years have been emphasized. But the most important general conclusion is that these differences are really very slight; and that the general distribution of salinity, highest in the east, lowest in the west, was the same in 1913 as in 1912.

#### ORIGIN OF THE COAST WATER.

In few parts of the world is the coast water so sharply defined by salinity, temperature, and color, from oceanic water, as it is over the coastal shelf between Nova Scotia and Cape Hatteras. And not only are the physical differences great, but the transition from one type to the other is often surprisingly sudden.

The general characteristics of the coast water, as they impress the



voyager, have been so well described by Schott (1912), and are a matter of such common knowledge, that it suffices to state here that water with a mean annual surface temperature below  $59^{\circ}$ , and mean salinity below 34‰ may be so classed, as distinguished from the warm and saline ocean waters of the Gulf Stream. This cold, comparatively fresh water, which bathes the whole breadth of the continental shelf between Nova Scotia and Chesapeake Bay, out to about the 100 fathom curve, except when temporarily obscured or dispossessed by Gulf Stream water, and which fills the Gulf of Maine, has usually been explained as coming from the north, or from the abyss of the Atlantic. According to the first of these theories, the coast water is a branch of a current flowing from the north and northeast. Almost all the ocean atlases show something of this sort; and it has been accepted in one form or another in almost all the textbooks on physical geography and oceanography (for example, Maury, 1855; Reclus, 1873; Attmayer, 1883; Thoulet, 1904, Krummel, 1911; Schott, 1912; the German marine observatory, *Deutsche Seewarte*, 1882; the current chart of the U. S. Navy by Soley, 1911; and the British Admiralty current chart). The mere coldness of the coast water suggests a northern origin, as does its comparatively low salinity; while the fact, long ago emphasized by Verrill and others, that it supports a boreal littoral fauna, contrasting sharply with the warm water fauna carried northward in the sweep of the Gulf Stream is evidence in the same direction. The continuity, too, of the cold zone all along the coast as far north as Newfoundland, with gradually decreasing mean temperature from south to north; and its sharp limitation seaward by the Gulf Stream, argue for a northern origin. And when we add to this the southwesterly drift which has been noted at many points along the coast between Nova Scotia and Cape Hatteras, it would require very strong evidence to prove that northern currents do not enter, in greater or less degree, into the composition of our coast water.

Up to 1897 the Labrador Current, a polar stream which has borne an unsavory reputation among mariners ever since its discovery in 1497 by John Cabot, was generally accepted as the source of this northern water, being so represented in practically all of the early atlases and textbooks; while Libbey (1891, 1895) expressly describes the cold water on the continental shelf south of Nantucket as one of its branches. And this view is still widely held, for example, the U. S. Navy Department states that the Labrador Current flows from the Grand Banks past Nova Scotia, southward in a narrowing belt as far even as the coast of Florida (Sumner, Osburn, and Cole, 1913,

p. 35); and Engelhardt (1913, p. 9, chart B), thinks it certain that the Labrador Current bathes our coast at least as far as New England.

But in 1897 a new light was thrown on the subject by Schott, whose analysis of the currents on the Grand Banks led him to conclude that the chief source of our cold coast water was not the Labrador Current, but water flowing out of the Gulf of St. Lawrence via Cabot Straits. And his work was founded on so large a body of temperatures, and current records taken by vessels at anchor on the Banks, that it may well serve as the starting point of our modern knowledge of the relationship of the Labrador Current to the Gulf Stream in that region. The most important feature of Schott's work, from the present standpoint, is his failure to find any evidence that the Labrador Current, as such, flows southwest across the Grand Banks, although it follows their eastern edge southward to the southern extremity. It is true, he says, that a small amount of polar water turns westward, and flows along the southern coast of Newfoundland; but it enters the Gulf of St. Lawrence. And though movements of polar water toward the southwest across the banks have been observed, he maintains that they are too small in amount, and too irregular in occurrence, to be anything more than local surface currents caused by the frequent strong northeast winds.

This is perhaps an extreme view, for as Krümmel (1911) points out part of the polar water which flows around the south coast of Newfoundland, joins the outflow from the Gulf of St. Lawrence. And Krümmel furthermore maintains that there must be a general tendency for the polar water to flow southwestward across the Grand Banks, and thus to reach the coast of Nova Scotia directly, instancing the fact that icebergs, coming south with the Labrador Current, have occasionally been known to drift southwest from the Grand Banks. But Capt. C. E. Johnston (1913), whose experience as commander of the U. S. Revenue Cutter on ice patrol duty on the Banks in 1913 and 1914 has given him unusual opportunities to study the currents in that region, states that the "currents on the Grand Bank... are almost wholly tidal. In a general way they flood to the northward and ebb to the southward. Winds drive them to the eastward or westward, sometimes overcoming the strength of the tidal current"; and we can hardly suppose that there is any constant movement of polar water southwestward around the southern edge of the Grand Banks, for although bergs have occasionally been known to drift for long distances in that direction (Krümmel, 1911), the general movement of the ice, after reaching the southern point of the Bank, is just

the reverse, *i. e.*, toward the east and northeast, as graphically described by Captain Johnston (1913).

At present it seems safe to say that although there may be sporadic movements of Labrador Current water from the Grand Banks toward Nova Scotia, there is no constant current in that direction; and that the increment of polar water which reaches our coasts in that way, plus the polar water which joins the Cabot Current at Cabot Strait is too small in amount to have much effect on temperatures and salinities off New England. And it certainly has very little influence on the plankton west of Nova Scotia, where true polar organisms, such as characterize the plankton of the Labrador Current, are seldom recorded.

The existence of an outflow from the Gulf of St. Lawrence via Cabot Straits has been recognized by oceanographers for many years (Maury, 1855); but Schott (1897) seems to have been the first to emphasize its importance. Fortunately we now have considerable data as to its volume and physical characters, thanks to the tidal and current observations, temperatures and densities, taken by the Tidal Survey of Canada under the direction of Dr. W. B. Dawson (1896-1913). These establish a constant outflow along the south side of Cabot Straits, with velocities as high as 1-2 knots per hour between Cape North and St. Paul Id., termed the "Cape Breton current" by Dawson, but for which the earlier name, "Cabot Current" is appropriate; and an inflow along the north side of the Strait. The Cabot Current has sometimes been explained as polar water, entering the Gulf via the Straits of Belle Isle, and flowing southerly along the west coast of Newfoundland. But Dawson's (1907) survey of the Straits of Belle Isle proved that no great volume of water enters the Gulf from that quarter, there being very little balance of inflow over outflow, if any, in summer, though with a possibility of rather greater influx in early spring. The distribution of temperature in the Gulf likewise shows little or no effect of polar water, for in summer polar temperatures are not found within the Straits of Belle Isle (Krümmel, 1907, Dawson, 1907). And there is no evidence that such water as does enter via the latter flows southerly along the Newfoundland coast, but just the reverse, because the current along this coast is from south to north caused by the water which enters the Gulf along the north side of Cabot Straits. To enter further into Dawson's very interesting results is not necessary since the Gulf of St. Lawrence concerns us here only in its relation to the coastal water further south. What is important is that his work demonstrates beyond a doubt that the water which flows out through Cabot Straits is not polar, but true

coast water. True, the Cabot Current contains small amounts of polar water, both from the Straits of Belle Isle, and from the Labrador Current via the south coast of Newfoundland, but this is modified past recognition in the general circulation of the Gulf. (For an excellent summary of Dawson's results, and of the general circulation of the Gulf of St. Lawrence, see *Nature*, April 18, 1901, p. 601).

The amount of outflow through Cabot Straits must be considerable for the Cabot Current is at least thirty miles broad abreast of Cape North, with a velocity of from .5 knot to 2 knots per hour on the surface (Dawson, 1913, p. 12). Its temperature is particularly characteristic in summer when the water is coldest ( $31^{\circ}$ - $33^{\circ}$ ) at about fifty fathoms, with warmer water ( $37^{\circ}$ - $40^{\circ}$ ) below at 100 fathoms,  $39^{\circ}$ - $40^{\circ}$  at 150 fathoms, while the surface warms to  $58^{\circ}$ - $60^{\circ}$  (Dawson, 1913, p. 37). And the discovery, by the ALBATROSS in July, 1885 (Townsend, 1901) of a corresponding layer of minimum temperature, at about the same depth, off the east coast of Nova Scotia, ranging from about  $32^{\circ}$  opposite Cape Breton to  $35^{\circ}$  off Halifax, and  $39^{\circ}$  off Cape Sable, with warmer water at greater depths, shows its influence along that part of the Coast. Surface temperature likewise indicates that the Cabot Current flows toward the southwest over the continental shelf (Schott, 1897); and so does salinity, for as Dickson (1901) has shown, water with a salinity of  $32\frac{0}{100}$  or less, is continuous along the coast from the Gulf of St. Lawrence to the Gulf of Maine in spring and summer, though often separated from the equally fresh water over the Newfoundland banks by a salter wedge. And this salt wedge is normal for the whole year, according to Schott (1902, plate 33), though it may be temporarily obscured, as, for example in August 1897 (Dickson, 1901); and, finally, a southwesterly current has often been observed by mariners off the Nova Scotian coast. But although a southwesterly long-shore movement of St. Lawrence water is incontestable, it is by no means clear how far it can be traced as a recognizable current. According to Schott (1897) it makes its effect felt in the form of low temperatures to the neighborhood of New York. But according to the statement in the Nova Scotia and Bay of Fundy Pilot (British Admiralty, 1903), based on many years data of greater or less value, obtained by mariners, no true southwesterly current can be distinguished beyond Cape Sable, the movements of the surface water over George's Bank being wholly governed by tide and wind. And the work of our own coast survey, mentioned above (p. 231) has failed to reveal any dominant movement of water from northeast to southwest over George's Bank. According to the British

Admiralty (1903) there is a northerly drift into the east side of the Gulf of Maine; and our own records of salinity show that an indraught of comparatively saline water does take place more or less constantly into the eastern side of the Gulf. But it must be slow, or intermittent, for Dawson's (1905) measurements of currents failed to show any dominant drift along the west coast of Nova Scotia. And the organisms which it carries with it are good evidence that Gulf Stream as well as St. Lawrence water enters into its makeup. In short, it is extremely doubtful whether the Cabot Current can be traced, as an observable or measurable drift beyond Nova Scotia. Consequently the southwesterly currents noted south of New York (p. 230) require some other explanation.

In 1907, Pettersson offered a totally different explanation for our cold coast water, namely, that it was not northern water flowing southward, but water welling up from the Atlantic abyss. And although few, if any oceanographers have adopted this view in its entirety, both Schott (1912) and Krümmel (1911) believe that there is more or less upwelling along our coast, particularly in winter. And Clark (1914) maintains that the cold water off Nova Scotia must be abyssal in part, to account for the distribution of crinoids.

Upwelling, whether on a large or a small scale, must obviously largely depend on the prevailing direction of the wind; consequently along our coast, where off shore winds prevail in winter, winds parallel to the coast in summer, it might be expected to be seasonal. And for this reason our data for 1913 can only be expected to show its presence or absence in summer. But they are worth analyzing, because the occurrence of upwelling in this region has so far been deduced from theoretical grounds, rather than from actual observation, previous knowledge of subsurface salinity on the continental shelf being practically *nil*. If abyssal water had been flowing up the continental slope in any considerable amount at the time of our voyage, salinity and temperature would necessarily reveal its presence, just as they do in parts of the oceans where there is a well-marked updraught of bottom water, next the coast. Perhaps as useful an index as any in the warm months, in temperate zones, is surface temperature, for in regions of active upwelling, the constant access of cold water from below retards seasonal warming, and consequently causes the surface to be abnormally cold. And unless the updraught should extend along the whole coast line, a most improbable supposition, the cold region would be surrounded by warmer surface water, north and south as well as off shore, just as it is off the coast of California (McEwen, 1912), and off the

southwest coast of Africa (Schott, 1902, taf. 8). Subsurface temperatures would reveal upwelling by continuity between the cold water near the surface and in the abyss; and surface salinity in regions of active upwelling, is about the same as the salinity of the layer from which the updraught comes, as is very clearly illustrated by the salinity curves off the coast of Morocco (Schott, 1912, pl. 33).

I have already pointed out (1914a) that the salinities and temperatures of the Gulf of Maine in 1912 do not suggest upwelling, except locally on a small scale; and the records for the winter of 1912-1913 and for the summer of 1913 all support this view. If abyssal water enters at all into the complex of the Gulf of Maine it must be in such insignificant amount that it has no appreciable effect on its temperature or salinity. However, this semi-enclosed basin may well differ hydrographically from the waters over the shelf south and west of Cape Cod.

In weighing the evidence of temperature, we must first consider whether the surface over the continental shelf is abnormally cold, as it has usually been characterized, most recently by Clark (1914). So firmly grounded is this idea, that the waters of the Gulf of Maine have often been called "Arctic." But, as I have already pointed out (1914a, 1914b) the observations in the Gulf of Maine during the summers of 1912 and 1913 and the winter of 1912 and 1913, corroborate Verrill's early contention that its temperature is nearly normal for its geographic location. It is, of course, much colder than the Gulf Stream; its surface temperature  $7^{\circ}$ - $9^{\circ}$  lower than the average for its latitude (Krümmel, 1907). But the waters of its deeps are no colder than the mean annual air temperature over the part of its watershed from which blow the chilling winds of winter, with their accompanying snowfall (1914a, p. 97). And the bottom temperature of its eastern basin in 1913, was almost precisely the same as the mean annual temperature of the air at Yarmouth, on the neighboring Nova Scotian coast ( $43.3^{\circ}$  as given by the Nova Scotian Coast Pilot, British Admiralty 1903, p. 11), and about a degree warmer than the mean for the year at St. John, New Brunswick, on the Bay of Fundy. And as Tizard (1907) has pointed out, the coast water is warmer off New York in summer than off England, and even in November its surface temperature is no lower than west of Ireland, though the latter is commonly described as warmed by the Atlantic Current. In short, as Schott (1897) and others have insisted, it is more because of its contrast with the Gulf Stream than because of its absolute temperature that the coolness of our coast water has so impressed itself on

students and laity alike. It is true that the surface temperature falls very low in winter near the coast, cooling to about  $39^{\circ}$  over the zone between Marthas Vineyard and New York (Sumner, Osburn, and Cole, 1913), with even lower winter temperatures in enclosed sounds and bays, for instance,  $31.2^{\circ}$  in February at the Woods Hole Station of the Bureau of Fisheries (Sumner, Osburn, and Cole, 1913, p. 48, average of three years). But this only happens where surrounding islands give the waters more or less the hydrographic character of lakes. And the zone over which the surface temperature falls below  $40^{\circ}$  in the coldest month (February) is nowhere more than thirty-five miles broad, south and west of Cape Cod, with a steady rise of surface temperature from the land seaward. The cold water is also correspondingly shallow, bottom water colder than  $40^{\circ}$  being probably limited seaward by the fifty fathom contour in this region. In short, the water is coldest just where it might be expected to be influenced most by the icy north-west winds of winter. And so far as the scanty winter data show, this is true all along the coast as far as Chesapeake Bay.

Air temperatures  $10^{\circ}$ – $15^{\circ}$  F. below freezing, such as are common in winter in southern New England, are surely enough to account for considerable cooling of the adjacent water. How closely the winter temperature of our coast water depends on the influence of the land is illustrated by the fact that Gloucester Harbor, which opens freely to the deeps off Massachusetts Bay, is  $1^{\circ}$ – $2^{\circ}$  warmer than the more enclosed waters of Woods Hole in winter, although a degree of latitude further north, and bordering a colder ocean area. Gloucester Harbor in turn, is colder than Massachusetts Bay; for example, its surface temperature fell to about  $34^{\circ}$  during the winter of 1912–1913, the lowest reading a few miles outside being  $37^{\circ}$ . And Boothbay Harbor, seventy-five miles north of Gloucester, which bears something the same relation to the land as Woods Hole, being shut in by numerous islands, is colder than either Gloucester or Woods Hole (about  $30^{\circ}$  F. in February), reflecting the very cold winter climate of northern New England; and likewise colder than the water off shore. (The mean temperature for December and March, at Mt. Desert Rock, is about  $38^{\circ}$  and  $36^{\circ}$ ; at Boothbay,  $37^{\circ}$  and  $32.2^{\circ}$ ). These comparisons of surface readings apply just as well to the whole of the upper 30–40 fathoms, for our winter work (1914b) has shown that the temperature of the Gulf of Maine is practically uniform, vertically, to at least that depth from December to March. The fact that in summer the water is coldest at the bottom of such partially enclosed sinks as the trough between Jeffrey's Ledge and the mainland, *i. e.*, just where

outside influences of any kind must be least active, is further evidence that it is winter cooling by the air that is responsible in the main for the cold water. And this same process equally well explains the general persistence of low temperature in summer near shore below twenty fathoms or so, solar warming progressing but slowly below that depth, consequent on the progressive increase in the vertical stability of the water.

And how closely mean air and water temperatures agree, for bays and sounds, is illustrated by Long Island Sound, where the mean surface temperature for the year ( $52^{\circ}$ - $53^{\circ}$ ) is practically the same as the mean air temperature for the year at New York. The mean surface temperature in Massachusetts Bay is about  $50^{\circ}$ - $52^{\circ}$ ; the mean air temperature at Boston about  $4.9^{\circ}$ . In short, the temperature of the coast water between Cape Sable and Chesapeake Bay is not abnormally low, considering its relation to the land mass to the west, and the winter climate of the latter. Hence it gives no direct support to the upwelling theory.

Neither is there anything in the surface temperature curves to suggest such upwellings as those off California, off Morocco, and off South Africa, for though the surface temperature is much lower over some of the coast banks, and in the northeast corner of the Gulf of Maine as a whole, than elsewhere, subsurface temperatures, salinities, and tidal currents prove that their cold surface is the result of violent vertical circulation, accompanied by correspondingly high bottom temperatures. Furthermore, the mean temperature is lowest where there seems to be the least possibility of abyssal upwelling, *i. e.*, in partially enclosed basins next the coast.

The rapid rise of surface temperature during July and August is in itself a strong argument against the view that upwelling can have been active at that time; and so is the great annual range of surface temperature ( $30^{\circ}$  for the Gulf of Maine, nearly  $40^{\circ}$  off New York, with an even greater extreme range, Murray, 1898); for any considerable upwelling of cold abyssal water would necessarily check the former, and consequently lessen the latter. It would be hard to reconcile our subsurface temperatures with an upwelling over the upper part of the continental slope at the time of our visit, whatever may have been the case earlier in the season, because if such a process had been taking place, the cold water over the shelf would have been continuous with the cold water at greater depths further off shore, instead of separated from the latter by the warm bottom zone, which was found south of Cape Cod and Long Island; and which probably extended to Ches-



peake Bay. And the considerable difference in temperature between the surface and the water a few fathoms down is almost as conclusive evidence in the same direction, because any constant accession of cold water from below would have made the temperature more uniform, vertically.

The evidence of salinity supports that of temperature, for although Schott (1912) believes that the low salinity of the coast water suggests upwelling, a more rational explanation of this phenomenon is that it results from the large amount of river water which enters the sea between Chesapeake Bay and Newfoundland, as maintained by Tizard (1897). I have already pointed out (1914a), that the river water which enters the Gulf of Maine would be sufficient to raise the level of the latter half a fathom per year, were it an enclosed basin, evaporation being more than offset by rainfall. And even larger amounts of fresh water come from the rivers west and south of Cape Cod; *e. g.*, the Connecticut, Hudson, Delaware, and the watershed draining into Chesapeake Bay. There is therefore no more need to call upon upwelling to account for the low salinity of our coast water, than for that of the Baltic, of the Gulf of St. Lawrence, or of the waters off the mouths of the Niger and Amazon rivers. Furthermore, while upwelling would lower the salinity of the surface water below that of the Gulf Stream, it could not possibly reduce it to the comparatively fresh state of the coast water ( $32^{\circ}\text{C}_{\text{O}}$  to  $33^{\circ}\text{C}_{\text{O}}$ ), because the deeper layers of the Atlantic, from which any updraught must come, are far saltier than this ( $34.9^{\circ}\text{C}_{\text{O}}$ , Murray and Hjort, 1912). In short, low surface salinity does not indicate upwelling in this case, though it does not necessarily preclude the possibility that such a process might be taking place to a small extent. Unfortunately our salinity profiles across the continental shelf do not establish the upper limits of the water of the abyss as well as the temperature profiles, for they leave a bare possibility that the fresh coast water may have been connected with the abyssal water of  $34.9^{\circ}\text{C}_{\text{O}}$  by a continuous zone of bottom water fresher than  $35^{\circ}\text{C}_{\text{O}}$  (p. 344). But although the data are not absolutely conclusive, for want of bottom salinities at the crucial depth (75-100 fathoms), it is very much more probable that the bottom water at this depth was saltier (above  $35^{\circ}\text{C}_{\text{O}}$ ), just as it was warmer (p. 164), than the water below it. And this was certainly the case south of Nantucket in August, when the salinity of the bottom water, in sixty fathoms, was  $35.17^{\circ}\text{C}_{\text{O}}$  (p. 193). If our salinity profiles are correct in this respect, it is impossible to reconcile them with active upwelling. Density, likewise, argues against the existence of an updraught of abyssal water

over the continental shelf, in summer, because, as the profiles show (p. 233), the tendency must have been just the reverse. And the very considerable difference in density between surface and deep water off the coast must be a bar to upwelling, even though it may not absolutely prevent it, as it does in stratified waters where the layers of different densities are sharply defined (Sandstrom, 1908; Wedderburn, 1908).

It is not to be expected that our work could conclusively settle such a complex problem. But considering that the evidence of temperature, salinity, and density agree, and that it is hardly conceivable that one or other of them would not have revealed upwelling, it is safe to say that no widespread vertical movement of this sort was taking place over the continental shelf in July, 1913. And the fact that the cold water over the shelf south of Marthas Vineyard is usually separated from the cold water of the abyss by a zone of warmer bottom water in summer, suggests that this conclusion holds good for that season normally. It is true that during one summer, 1882, the whole shelf is known to have been bathed by cold water; but it is as likely that this resulted from an unusual accession of northern water or from abnormal winter cooling, as from upwelling.

Upwelling may be more important in winter, for, as Krümmel (1911) and Schott (1912) point out, the prevailing north and north-west winds, which often rise to storm strength, would have more tendency to produce this type of circulation, than the southwest, long-shore winds of summer. Furthermore, density is not so effective a barrier to upwelling in winter as in summer, because its vertical range is much smaller then. Nevertheless, it is probable that upwelling caused by off shore winds would be from a comparatively shallow depth, say 100 to 200 fathoms, both because the direction of the wind is not constant but often reversed, and because the abyss water must be considerably heavier than coast water even in winter. And gravity would similarly resist any upwelling which the effect of the rotation of the earth might tend to produce along the inner edge of a current moving parallel to the coast. Upwelling of this latter type may play a very important part in the movements of ocean waters, as pointed out by Ekman (1905a) and recently by McEwen (1912); but until the movements of the bottom water of the North Atlantic are better understood, discussion of this theoretic aspect of the case may well be postponed.

The real explanation of the low temperature of the coast waters is to be found neither in upwelling, nor in a northern current, but

in the land climate of eastern North America. On this side of the North Atlantic the relation between land climate and ocean temperatures is exactly the reverse from what it is off the west coast of Europe, because the winds as a whole, and the great majority of cyclonic disturbances, drift from the land out over the sea, instead of from sea to land. Hence the coast water must necessarily borrow its temperature, in large degree, from the land climate, instead of tempering the extremes of the latter, as is the case in the favored continent of Europe. Granting this, and the principle is so important, and so obvious, that it is remarkable that it has not been emphasized more strongly in the past, the fact that the water is coldest next the coast, and in enclosed troughs, with a steady rise of temperature, depth for depth, passing off shore, is at once explained, for the cold winds of winter would necessarily be most effective as cooling agents near shore. And they would become progressively less so, further and further from land, being warmed by the absorption of heat from the sea water over which they blow. The change from our torrid summer to frigid winter, with its prevalent off shore winds, sufficiently explains the rapid cooling of the coast water in autumn and winter. Conversely, solar warming and the warm land winds of spring and summer are the only agencies which could produce the very rapid warming of the surface, which characterizes our coastal zone at that season; for if the change were due to flooding by Gulf Stream water, salinity would rise correspondingly, something which does not happen until the surface water has warmed by some  $25^{\circ}$ - $30^{\circ}$  F, if at all (p. 188). The change in land climate, with latitude, is an obvious explanation for the rise in surface and subsurface temperatures over the continental shelf from north to south. Still another continental influence, which must play a part in chilling the coast water is the low temperature of the river water, and the river ice which enters the sea in spring; but this can hardly have as much effect south of Cape Cod as supposed by Tizard (1907).

The Gulf of St. Lawrence affords an excellent example of the degree to which winter cooling takes place, and of the rapidity with which the temperature falls in autumn, in an enclosed basin under the influence of the rigorous climate of eastern North America, for its low temperature is certainly due to local causes (Krümmel, 1907). Were the Gulf of Maine as nearly enclosed as the Gulf of St. Lawrence, it would reproduce the temperature of the latter even more closely than is now the case, the northern part of the former being separated from the southern part of the latter by only forty miles of latitude.

In short, the Gulf of Maine is warmed, not cooled, by the combination of northern and Gulf Stream water which enters it; and this is even more true of the coastal waters south and west of Cape Cod. This does not mean that more or less northern water does not enter into the composition of the coast water; on the contrary, such water enters into the Gulf of Maine in amounts varying from year to year. But by the time it has flowed so far south as this, it has been so warmed by mixing with warm off shore water, that it is no longer cold enough to chill the coast water below the temperature which would be given it by the land climate alone. And the northern water has even less effect on salinity than on temperature south of Nova Scotia, because the volume of fresh water which empties into the Gulf of Maine, and over the shelf beyond Cape Cod, is sufficient to lower the salinity of the coast water nearly to that of the water which flows out of Cabot Strait (p. 259).

The upper layers of the Gulf Stream can not be neglected in studying coast waters. It has long been known that Gulf Stream water drifts northward almost every summer, flooding the surface even to the southern shores of New England. And salinity profiles suggest that it was a shoreward movement of the surface waters of the Stream, dipping below the fresher coast water, which raised the salinity of the bottom water of the shelf southwest of Nantucket so considerably during July and August (p. 193). In the Gulf of Maine, too, Gulf Stream water is probably of more importance than is usually realized, its entrance being an annual phenomenon, signaled by the tropical organisms it bears with it (p. 336).

The evidence marshalled in the preceding pages shows that our coast water is not of any one origin; it does not even have any one predominant source, as has been so often assumed, but is really very complex and variable in its composition. The constituents which enter into it are northern water, chiefly from the Gulf of St. Lawrence, and hence itself coastal, not polar, plus a possible small component of polar Labrador water; river water from the land; water of high salinity from the upper layers of the Gulf Stream; water from the mid-layers off shore, and possibly Atlantic abyssal water, besides rain water. In just what proportions these components mix, is for more detailed studies to show. But temperature and salinity suggest that it is St. Lawrence water which is the most important off Nova Scotia. In the Gulf of Maine, St. Lawrence water, land water, and water from the upper 100 fathoms off shore play more equal rôles, now one, now another having the upper hand with the succession of the seasons;

and there is no actual hydrographic evidence that abyssal water enters at all into the Gulf. Between Cape Cod and New York, the chief components of the coast water are the surface and upper layers of the Gulf Stream, which is far more important here than in the Gulf of Maine, and river water, northern water being hardly appreciable, except perhaps in exceptional years (p. 266). Salinities and temperatures do not afford any actual indication of upwelling here in summer (p. 260). South of New York the problem of upwelling assumes more importance, because of the prevailing direction of the winter winds; though no evidence of it was found in summer. But the questions to what degree it is effective in winter and whether it floods the shelf, or is limited to the waters outside the slope can not yet be answered.

#### OCEANOGRAPHY OF THE GULF OF MAINE AND OF THE NORTH SEA.

A brief comparison between the Gulf of Maine and the North Sea is pertinent because the latter is now the best known water-area, both physically and for its plankton, on the globe. (For an excellent summary of the hydrography of the North Sea, see Knudsen, 1909). Both also support fisheries, which differ more in extent than in kind.

The salinity of the North Sea as a whole, 34‰ to 35‰, is considerably higher than that of our Gulf. At the west end of the English Channel, and off the north coast of Scotland, the two sources from which ocean water enter, it is above 35‰. On the other hand, there is a coast-belt fresher than 34‰, near Denmark; and of course the surface grows much fresher passing through the Skagerrak into the Baltic. The salinity of the North Sea further differs everywhere from that of our Gulf in being practically uniform from surface to bottom, the result of strong currents; and in changing very little from season to season.

The Gulf of Maine agrees very closely in mean surface temperature (about 48°) with the central parts of the North Sea (48.2°); and Massachusetts Bay (50°-52°) corresponds with its southern part (50°). This generalization can be extended also to the upper ten fathoms of the whole of the North Sea, and to the whole column of water (about twenty fathoms) in its southern half. The coldest winter temperature of the North Sea ranges from 37.4° near Denmark to 42° near Scotland—in the central part it is 39°-40°; which is slightly warmer than the Gulf of Maine, where the winter temperature as a whole is about 36°-37°. On the other hand the North

Sea is rather cooler as a whole than our Gulf in summer, its warmest water, off the coast of Belgium, being about  $62.5^{\circ}$ ; with the greater part of its surface area  $55^{\circ}$ – $60^{\circ}$ . But nowhere in the North Sea are the surface temperatures of summer as low as they are in the north-east corner of the Gulf of Maine. At fifty fathoms the temperatures of the North Sea and of the Gulf are about the same, though the range is somewhat greater in the latter, the extreme limits being from  $38^{\circ}$ – $48^{\circ}$ . And they also agree closely in greater depths, which, in the North Sea, are limited to a small area at its northern entrance. Thus the 100 fathom temperature of the North Sea is between  $41.9^{\circ}$  and  $44.6^{\circ}$ ; the temperature of the Gulf between  $38^{\circ}$  and  $46^{\circ}$  at that depth.

The surface density, at the temperature *in situ*, like the salinity, is considerably higher, as a whole, in the North Sea than in the Gulf of Maine. In summer the densities of the two overlap, that of the Gulf ranging, from about 1.0227 to about 1.0254; the North Sea from about 1.0247 to 1.0266. But during the rest of the year the density probably does not rise as high anywhere in the Gulf as in the North Sea. And in May the difference is great, for at that season, owing to the inrush of fresh river water, the surface density of the western side of the Gulf of Maine falls below 1.023, whereas in the North Sea it ranges from 1.0263–1.0273. Subsurface densities, likewise, are lower in the Gulf, for, while the temperature is not very different from that of the North Sea, the salinity is much lower.

In short, there is nothing in the temperatures to cause any faunal difference between the two bodies of water, but the difference in salinity is so great that it might well have some influence. And it would not be surprising to find that the density was an important factor in determining the fish fauna of our Gulf by governing the flotation of pelagic eggs.

#### THE COAST WATER AS A BIOLOGICAL ENVIRONMENT.

The hydrographic facts outlined in the preceding pages have a twofold interest: first for their bearings on the general problems of oceanography; secondly for their relation to the animal population which the coast waters support. As a biological environment, the different parts of the continental shelf differ greatly, though all are characterized by relatively low temperature and salinity. The Gulf of Maine, except for its uppermost layers, is a region of great physical

uniformity from season to season. Below say sixty fathoms the extreme range of temperature over the entire Gulf, throughout the year is probably not over  $10^{\circ}$  ( $38^{\circ}$ – $48^{\circ}$ ); at 100 fathoms the extreme range is about  $8^{\circ}$  ( $38^{\circ}$ – $46^{\circ}$ ). And the deep parts of the western half of the Gulf are still more uniform; the extreme temperature variation at all depths below sixty fathoms, being not more than  $4^{\circ}$  in the basins and troughs next the western shore. Salinity, too, is surprisingly uniform in the deeper parts of the Gulf. In short, the fauna which occupies these depths enjoys an environment whose physical factors are practically unchanging from year's end to year's end.

But quite the opposite is true of the surface layers of the Gulf, where there are violent seasonal fluctuations of both temperature and salinity. Along the western shore, and in Massachusetts Bay, the surface temperature rises from about  $36^{\circ}$  in winter to  $63^{\circ}$  or  $64^{\circ}$  in summer, *i. e.*, a range of almost  $30^{\circ}$ . And though the annual range is smaller along the eastern side, it is still considerable. The salinity, too, oscillates between wide limits, and the changes are very sudden in spring. For example, north of Cape Ann, the range is from about  $32.8\%$  in February to about  $29\%$  early in May.

In addition to these regular seasonal changes, the Gulf is subject to sporadic invasions, on the one hand by water from the Gulf Stream, with its characteristic fauna, on the other by St. Lawrence water. But these are not extensive enough to cause much change in the Gulf as an environment, though they do alter the *facies* of the plankton by the addition of either southern, or northern organisms, as the case may be.

South and west of Cape Cod there are no parts of the continental shelf where the water is as uniform, from season to season, as it is in the deeps of the Gulf of Maine. On the contrary, the entire water mass over the shelf is subject to violent fluctuations, both seasonal and sporadic. These are most violent, of course, near the surface and next the coast. For example, the surface temperature off New York ranges from about  $38^{\circ}$  to over  $70^{\circ}$  during the year; the salinity from about  $31\%$  to possibly  $34\%$ . And even as deep as sixty fathoms the temperature may rise from below  $45^{\circ}$  to nearly  $60^{\circ}$  in a month (p. 349), the salinity from  $33.5\%$  to  $35.1\%$  in the same short period. And this general statement is true all along the coast, at least as far as Chesapeake Bay. Thus any bottom animal may be subjected to great and sudden changes. At the edge of the shelf, where the water is deeper (75–125 fathoms), conditions are more uniform. And this is a particularly interesting zone zoologically, as Verrill (1880, 1884a)

long ago pointed out, because it is the only place where the bottom is normally bathed by water varying only a few degrees, either way, from 50°. Deeper down the slope the bottom water is constantly colder; nearer the shore it is so for at least part of the year. Along this zone, too, salinity is much more constant than it is nearer the shore, as well as higher, and probably with but little seasonal change. Added to these hydrographic advantages, is the abundant food supply which usually characterizes the contact-zone between warm and cold waters, the importance of which was long ago realized by Verrill (1881). The result is that the bottom fauna of this zone is remarkably rich, both in species and in individuals, and largely of southern origin (Verrill, 1880, 1881, 1884b). But its biological advantages are partly compensated for by its dangers, for at least once within the memory of man its inhabitants have suffered widespread destruction, the surface, for some hundred of miles, being strewn with the dead bodies of the tile-fish (*Lopholatilus*), as so graphically described by Collins (1884) and Verrill (1882, 1884b) and often commented upon by subsequent writers (Murray, '98, Murray and Hjort, 1912, Sumner, Osburn, and Cole, 1913). And at the same time the invertebrate bottom fauna was practically obliterated (Verrill, 1884a, p. 656; 1884b). Verrill believed that this was due to an off shore movement of the cold bottom water on the shelf, under the influence of violent northerly storms which swept the coast during the late winter and early spring of 1882. And whether this was the true cause, or whether an unusual accession of northern, or of abyssal, water was to blame for the lowered temperature observed by Verrill in that year (p. 239), the occurrence serves to illustrate the fluctuations to be expected along the meeting zone of cold and warm waters. And it was evidently not a unique, though no doubt an unusual occurrence, for in July, 1884, the ALBATROSS encountered great numbers of dead cephalopods floating on the surface, over the 100 fathom curve, further south (Lat. 37° 47', Tanner, 1886). Conversely the failure of various northern littoral animals to extend their ranges beyond Cape Cod, is probably due to the excessive summer warming, partly due to solar heat, but also to sporadic flooding by Gulf Stream water.



## THE PLANKTON.

## GENERAL ACCOUNT OF THE MACROPLANKTON.

The plankton work of the cruise had two main objects:—first, a qualitative survey of the various species, which must precede any quantitative study to make the latter valuable; and, secondly a faunistic examination of the plankton as a whole, at each station, to illustrate the geographic occurrence of associations of species.

When the work in Massachusetts Bay in May, 1913, was finished the vernal diatom swarm had largely disappeared, and copepods, which had been very scarce during the preceding month, had reappeared in the shape of swarms of nauplii and older larvae; while by June, hauls off Gloucester yielded an almost pure *Calanus* plankton. Much this same condition obtained early in July, surface hauls off Gloucester, on July 7th, yielding a rich harvest of *Calanus finmarchicus*, with great numbers of the large blue copepod *Anomalocera pattersoni*, together with young schizopods, and a few other boreal organisms; while the importance of this region as a spawning ground for food fish was attested by the presence of numerous gadoid fry in the nets.

The hauls off Cape Cod (Station 10057) revealed the same type of macroplankton that occupied the greater part of the Gulf during the summer of 1912, namely, swarms of *Calanus finmarchicus*, a few *Euchaeta norvegica*, many small schizopods (*Thysanoessa*), *Euthemisto* and *Hyperoche* among amphipods, the pteropod *Limacina balea* (p. 303); *Sagitta elegans* (p. 299); the Medusae *Staurophora mertensii* and *Melicertum campanula*; the siphonophore *Stephanomia cara* (p. 315); and the ctenophores *Beroe cucumis* and *Pleurobrachia pileus*. Although open nets alone were used, their contents clearly showed that the plankton was bathymetrically stratified. Thus it was the surface hauls alone that yielded any considerable number of copepod nauplii and eggs; and while the haul at 15-0 fathoms caught swarms of *Calanus*, and many schizopods, and hyperiids, but only a few *Sagittae*, the haul from thirty fathoms contained almost no schizopods, hyperiids, or pteropods, but on the other hand brought back great numbers of *Sagittae*; and *Euchaeta* was taken in the deep haul only; *i. e.*, *Calanus*, schizopods, hyperiids, and pteropods were mostly above fifteen fathoms, *Euchaeta*, and *Sagittae* below that depth, *Beroe*, *Pleurobrachia*, and *Stephanomia* more evenly distributed horizontally.

Over the southern part of the basin of the Gulf (Station 10058) the plankton was qualitatively much the same — but quantitatively very different, for *Calanus* was not nearly so abundant in the haul from forty fathoms; the net, however, yielded many *Euchaeta norregica*, with few *Calanus hyperboreus*; and fully one half the catch consisted of *Stephanomia* bells and denuded stalks (p. 316); there were also more fish fry than were found nearer shore.

At the Station on the northwest side of George's Bank, a rather surprising discovery was made, namely that the surface water was full of campanularian hydroids (*Obelia*) broken from their attachments, and many of them entirely regenerated. A similar phenomenon was noted on George's Bank during the winter of 1912–1913 (1914b, p. 414). It is interesting faunistically as showing how the strong tides of the region, by keeping the detached hydroids afloat, mechanically introduce an exotic element into the plankton. So far as I can learn, nothing of the sort has been observed elsewhere, at least on so large a scale. The place of *Calanus* was taken by another copepod, *Temora longicornis*, while the bulk of the deep haul consisted of Sagittae (*S. elegans*). The net also yielded many young *Cyanea*, and several caprellids, no doubt shaken loose from the hydroids.

In the waters over Nantucket Shoals (Station 10059) *Calanus* was again the prevalent organism, with but few Sagittae; near the light-ship, however, (Station 10060), Sagittae about equalled *Calanus* in bulk; and this Station was also notable for swarms of young *Euthemisto* (p. 281), of pteropods (*Limacina balca*, p. 304), and of the free medusae of *Obelia*.

We saw fragments of Gulf weed on the surface south of Nantucket light-ship, and at Station 10061, over the eighty fathom curve, the influence of the Gulf Stream was made evident by the presence of *Salpae*, *Phronima*, and the amphipod *Vibilia*, though the bulk of the plankton still consisted of *Calanus finmarchicus*, with such other boreal forms as *Euchaeta norregica*, *Euthemisto*, *Sagitta elegans*, and *Limacina balca*. The plankton over the shelf south of Marthas Vineyard and Block Island (Stations 10062 and 10063) consisted chiefly of swarms of young and old *Euthemisto* (p. 281), with smaller numbers of copepods (*Calanus* and *Centropages*, p. 287), Sagittae and an occasional *Pleurobrachia pilsus*. And here for the first time large numbers of fish fry, a striking feature of the tows further south, were encountered. When the deep water outside the shelf south of Long Island (Station 10064) was reached the boreal plankton was replaced by a warm water assemblage, for while the 175 fathom haul still

yielded many Euthemisto, the rest of the catch consisted of such typical Gulf Stream species as small "black fishes" (Myctophidae), swarms of Salpae of several species (p. 275), Doliolum, Phronima, Vibilia, Saphirrina and other species of copepods not taken in the cold waters nearer shore (p. 296); and such typical warm water coelenterates as *Rhopalonema relatum*, *Physophora hydrostatica*, and *Agalma elegans* (p. 316). But the haul from twenty-five fathoms yielded little except hundreds of colonies of *Agalma elegans*, with only a few Salpae; and the surface water was practically barren. Along this part of the coast Gulf Stream fauna was confined to the waters outside the continental shelf, for as we ran shoreward once more a typical Calanus plankton in great abundance was encountered, together with other boreal organisms, over the forty fathom curve (Station 10065).

Cape Cod is often spoken of as the dividing line between warm and cold water faunae on our coast; but at the time of the cruise it was not until we neared New York that any decided change in the character of the plankton of the coast water was noted. East of this, and in the Gulf of Maine (p. 285), copepods, chiefly Calanus, everywhere played an important rôle, though occasionally overshadowed by the extraordinary abundance of some other organism, for example, the hydroids on George's Bank, and the swarms of Euthemisto south of Block Island. But they were a very insignificant part of the plankton south of New York and were occasionally entirely lacking in the hauls. Near New York (Stations 10067 and 10068) the water was filled with swarms of *Pleurobrachia pileus* to the exclusion of almost everything else, except on the immediate surface, where the no. 20 net brought back a considerable number of small copepods (*Centropages typicus*). A few miles further south (Station 10069) large numbers of Salpae (p. 277) were seen on the surface close to land. At this Station, too, swarms of the large warm water ctenophore, *Mnemiopsis leidyi*, which has never been known to enter the Gulf of Maine, but which is common along shore as far as Cape Cod later in the summer, were noted for the first time. Other interesting coelenterates, common near the surface at this Station and further south, are the well-marked southern variety of the large hydromedusa, *Aequorea groenlandica*, and the pale southern *Cyanea* (p. 315). But all these warm water forms seem to have been limited to a shallow surface zone, because the haul from fifteen fathoms yielded great numbers of *Pleurobrachia pileus*, but no Salpae or *Mnemiopsis*, and only a few *Aequorea* which were probably caught near the surface. Besides the *Pleurobrachia* there were about twenty *Aglantha digitale*

(p. 316) besides a few Sagittae (p. 298), Euthemisto, one large *Tomopteris helgolandica*, and many fish fry of several species. We fully expected to find Salpae more abundant on our line seaward opposite Barnegat; but this was not the case, for, though great numbers of Mnemiopsis and Salpae were noted on the surface for some thirty miles from the land, both then disappeared, and at Station 10070, over the forty fathom curve, the hauls yielded no Mnemiopsis, and only seventeen specimens of Salpa, though the latter represented no less than six species. And Salpae were nearly as scarce at about the same relative position on the shelf off Cape May (Station 10072), none being seen on the surface, and the total catch only about thirty (p. 275). But the water there was full of Mnemiopsis, which clogged the nets; and the haul from fifteen fathoms yielded swarms of Pleurobrachia, many fish fry and one unmistakable warm water species, the small hydromedusa Niobia (p. 317).

The Gulf Stream station off Cape May (Station 10071) yielded much the same plankton that was found in the edge of the Stream off New York (Station 10064), as might have been expected from the high temperature and salinity of the water (p. 163). Little was to be seen on the surface except a few bits of Sargassum; and the surface nets yielded practically nothing. But the hauls from 175 and 190 fathoms brought in masses of Salpae of four species, notably *S. cylindrica* (p. 277); and such other warm water organisms as Phronima, *Agalma elegans*, *Diphyes serrata*, young myctophids, Leptocephali, *Sagitta inflata*, Rhizophysa, several southern pteropods (p. 302), and the oceanic schizopod *Nematoscelis megalops*. The only members of the list from this Station which are regular inhabitants of the coast water north of New York are a few copepods (*Calanus* and *Metridia*), which shows how little the coast water influences the plankton outside the continental shelf.

The plankton of the coast water was composed of much the same constituents south of Delaware Bay as off Barnegat. At Station 10073 the surface water was very barren, the total yield of the surface nets being only a few small Doliolum, one Pleurobrachia, two Sagittae, seven or eight copepods, a few small appendicularians, and fish eggs. But at fifteen fathoms the net was clogged by Mnemiopsis, while Geryonia, Diphyes, Cuboides, Sapphirina, several species of warm water pteropods (p. 302), and two specimens of the Leptocephalus of the conger eel gave it a more southern aspect than that of the shallow water further north. The hauls over the forty fathom contour, some fifty miles further south (Station 10074) contained an even larger pro-

portion of warm water animals, and loggerhead turtles, sharks, and pilot fish were seen on the surface. And the deep haul contained many oceanic species, *e. g.*, Criseis, Corolla, Firoloides, Liriope, Aglaura, Rhopalonema, *Agalma elegans*, and the tropical hydromedusa Niobia, which, owing to its asexual budding, comes into the oceanic category so far as its dispersal is concerned. But there were also many neritic forms, *e. g.* fish eggs and fry, stomatopod larvae, gammarids, young crabs, and the ctenophore Pleurobrachia. Five miles nearer land the water was crowded with copepod larvae and the ctenophore Mnemiopsis, though still with an occasional Agalma, Doliolum, and Liriope. The swarm of Mnemiopsis, which revealed its presence by its phosphorescence (for we ran through it at night) as well as by an occasional use of the dip net, was some twenty miles broad. But as land was approached it gave place to hosts of Salpae, which filled the surface waters at Station 10075. At this Station we noted an occasional Cyanea, and Aequorea, and many large specimens of *Beroe forskalii*, besides schools of menhaden (*Brevoortia*) and porpoises (*Tursiops*).

The final Gulf Stream Station (10076) lay abreast of Chesapeake Bay. And though the plankton consisted chiefly of the same oceanic forms which were encountered further north, the presence of stomatopod larvae, Aequorea, considerable numbers of small copepods, and eel grass (*Zostera*) instead of Sargassum floating on the surface, showed as clearly as did the salinity (p. 200) that the influence of the fresh water from the Bay was felt over the whole breadth of the continental shelf. And perhaps this also explains the fact that all the hauls at this Station were scanty, and contained a large proportion of debris.

As the mouth of the Bay (Station 10077) was approached the macroplankton grew even more scanty, though there was a decided increase of microplankton (p. 334); and *Beroe* was once more found in considerable numbers, together with the neritic hydromedusa *Laodicea*, while a new element of shore origin was added by swarms of larvae of the blue crab (*Callinectes*) on the surface. The few oceanic elements were now much in the minority; but even near the mouth of the Bay (Station 10078), the nets yielded a few Liriope and an occasional siphonophore (*Diphyes*).

The stations on the run northward to Cape Cod all lay close to land, hence yielded chiefly neritic plankton. The swarm of *Callinectes* larvae extended for about thirty-five miles along the coast, being no doubt recruited from the various bays and inland sounds, as well as from the Chesapeake itself; but it had disappeared by the time Station 10079 was reached, and it is interesting to note that its disappearance

coincided with a decided rise in the salinity of the surface water (Plate 2). On the other hand *Mnemiopsis*, together with a few *Aequorea*, *Cyanea*, and *Pleurobrachia*, was again numerous at this Station, and there was a great increase in the number of Salpae (p. 275), which were but sparsely represented at the stations off the mouth of Chesapeake Bay. The hauls at Station 10079 likewise yielded such oceanic genera as *Doliolum*, *Criseis*, and *Firoloides*. Immediately north of Delaware Bay (Station 10080) we once more found swarms of small Salpae (p. 275) and *Mnemiopsis*, the nets coming in full to the brim. But both of these genera must have been limited to a very shallow surface zone, because a net working about a fathom down caught very few of either. Deeper down, about ten fathoms, the water was occupied by a swarm of *Pleurobrachia*. Stations 10080 and 10081 illustrate how much more varied the plankton was near shore along this part of the coast than in the Gulf of Maine, for no *Pleurobrachia*, and very few *Mnemiopsis* were taken at the latter only about forty miles north of the former and about the same distance from land, with about the same temperature and salinity. But the deeper water layers must have swarmed with small Salpae, for the haul at ten fathoms yielded a perfect Salpa soup; and the surface hauls caught great numbers of *Callinectes* larvae, which were not represented at all at Station 10080.

By August 1, Salpae, which were first met in numbers off Barnegat, on the voyage south, had spread northward as far as the Hudson trough (Station 10082) where they formed the bulk of the surface tow. But the haul at twenty fathoms yielded very little except *Pleurobrachia*. When the shore of Long Island (Station 10083) was approached, the Salpae, and the *Pleurobrachia* swarm, were replaced by a rather scanty copepod plankton.

The remainder of the work was carried on in the Gulf of Maine. And no sooner had the *GRAMPUS* rounded the southern angle of Cape Cod (Station 10085) than the boreal plankton, with which we are familiar from previous work in the Gulf, was encountered. Stations 10057 and 10086 were located at the same geographic position off Highland light, and the only apparent change which had taken place during the interval of four weeks which separated them was that the *Staurophora*, *Stephanomia*, and *Beroe*, which had been prominent in the tow early in July were no longer found. Off Massachusetts Bay we found a typical *Calanus* plankton, with *Euchaeta norvegica*, northern schizopods, *Sagitta elegans*, *Euthemisto*, *Limacina balca*, *Pleurobrachia*, *Melicertum*, *Tomopteris helgolandica*, *Euchaeta*, and hosts of

## GULF OF MAINE PLANKTON.

SPECIES	STATIONS													% of sta- tions for each species						
	10087	10081	10088	10089	10090	10091	10092	10093	10095	10096	10097	10098	10099		10100	10101	10102	10103	10104	10105
<i>Calanus finmarchicus</i>																				100
<i>Pseudocalanus elongatus</i>																				80
<i>Metridia lucens</i>																				80
<i>Anomalocera pattersoni</i>																				80
<i>Euchaeta norvegica</i>																				70
<i>Meganyctiphanes norvegica</i>																				40
<i>Thyanassa inermis</i>																				90
<i>Euthemisto compressa</i> 4																				50
<i>Hyperoche kroyeri</i>																				40
<i>Limacina balaia</i>																				80
<i>Tomopteris belgolandica</i>																				60
<i>Sagitta elegans</i>																				100
<i>Phialidium languidum</i>																				80
<i>Stauriphora mertensii</i>																				40
<i>Pleurobrachia pileus</i>																				50
Total species per stations	8	11	12	12	11	10	10	11	10	10	14	8	8	14	11	10	12	9	7	

larvae of the red fish (*Sebastes marinus*). And the assemblage over the western basin was the same, with the addition of the schizopod, *Meganyctiphanes norvegica*. Off Penobscot Bay (Stations 10091 and 10100) there were swarms of *Limacina balea*, a pteropod represented at most of the other Gulf Stations by small numbers only; at several stations the nets brought back numerous specimens of *Staurophora* (p. 273), and at Stations 10091 and 10092 the surface waters were swarming with young amphipods (*Euthemisto*), as well as with young stages of *Calanus finmarchicus*, in the proportion of about one of the former to four of the latter. The accompanying table showing the occurrence of fifteen of the more characteristic and faunistically important species, illustrates the extreme uniformity of the plankton of the Gulf. At fourteen of the nineteen stations in the Gulf ten or more of these fifteen species are represented; and at only three stations were less than eight found; the poorest even (Stations 10098, 10099, 10105) had half of the species. Two forms, *Calanus finmarchicus*, and *Sagitta elegans* were taken at every station; and a third, *Pseudocalanus elongatus* was probably also universal (p. 291). *Euthemisto compressa*, *Anomalocera pattersoni*, *Limacina balea* and *Phialidium languidum* occurred at 80-90% of the stations and *Euchaeta norvegica* at every station where the haul was deeper than forty fathoms. And no subdivision of the Gulf into faunal regions is possible for any of the species, except that in a general way neritic forms, *e. g.*, *Tomopteris helgolandica*, *Staurophora*, and *Phialidium*, and the various metazoan larvae which are always more or less in evidence in the tows near shore, occurred less regularly at the stations in the centre of the Gulf.

The only region which showed a decided variation from the general plankton type just described was German Bank (Station 10095) where the copepods were largely replaced by a swarm of *Pleurobrachia pileus*. But this was an impoverishment, rather than a different plankton type, for *Pleurobrachia* is widely though irregularly distributed over the Gulf in summer; and when it swarms, seems to obliterate or devour almost everything else in the water.

In 1913, as in 1912, we found a few pelagic organisms of unmistakably oceanic and warm water origin in the Gulf, *e. g.*, *Salpa*, two copepods, *Euchirella rostrata*, and *Pleuromamma robusta*, and a chaetognath, *Sagitta serratodentata*; but the Gulf Stream component was smaller than in the previous year; while on the other hand, three cold water species, which, though not truly polar, are at least at home in low temperatures, *i. e.*, *Calanus hyperboreus*, *Euchaeta norvegica* and *Eukrohnia hamata*, were more abundant than in 1912, and a fourth,



the copepod *Metridia longa*, which is more typically arctic than any of the preceding, is recorded from the Gulf for the first time. Northern species, however, were not uniformly more abundant than in 1912, the reverse being true of *Clione limacina* (p. 305).

## DISTRIBUTION OF SALPA AND DOLIOLUM.

Identified by W. F. Clapp.

Table of occurrence.

Station	Depth	Date	fusiformis v. cchinata		filosii	democratica	zonaria	cylindrica	confederata	Doliolum
			♂	♀						
			agg. sol.	agg. sol.	agg. sol.	agg. sol.	agg. sol.	agg. sol.	agg. sol.	00z. blast
10061	30-0	7/10/13			Chain 9					
10064	175-0	7/11/13	m.	56			2 33 13 23 1			2
10065	20-0	7/12/13								
10069	Surface	7/19/13				Swarm m. m.				
10070	0	"							1	
10070	20-0	"	2	2	2	1	1		1	1
10071	0	"	1	1					1	
10071	190-0	7/20/13	1	m.		1	f.	m. m.		
10072	15-0	7/21/13				×	23			
10073	Surface	"							f. chains	
10073	15-0	"				f.			chains	m.
10074	Surface	7/22/13			f.	3			m.	
10074	20-0	"				3	29		11	1 f.
10075	8-0	7/23/13				swarms m. m.				
10 miles E. off Hog Id.	Surface	7/29/13				m.				
10076	20-0	7/24/13			1		14		23	
10076	120-0	"	f.	2	2	f. f.	1 2			1
10077	20-0	"			1	m. m.				
10078	8-0	7/29/13				f. f.				
10079	0	"				swarms m. m.				
10079	10-0	7/30/13				swarms m. m.				
10080	Surface	7/31/13				swarms m. m.				12
10080	12-0	"				m. m.				
10081	10-0	"				m. m.				
10082	0	"				m. m.				
10082	15-0	8/1/13				m. m.				
10096	30-0	8/12/13			6					
10064	25-0	"					f.			
10076	0	"							chains m.	

f. = few = 25 +      m. = many = 100 +

Judging from the general distribution of the various species of Salpa in northern waters (Apstein, 1909) their occurrence in numbers was

expected only where the surface temperature was high. And this proved to be the case. Salpae were more or less abundant at all the stations south of New York and over the outer edge of the continental shelf (Fig. 67). By the first of August they had extended their range to the waters off New York (Station 10082). And although they had

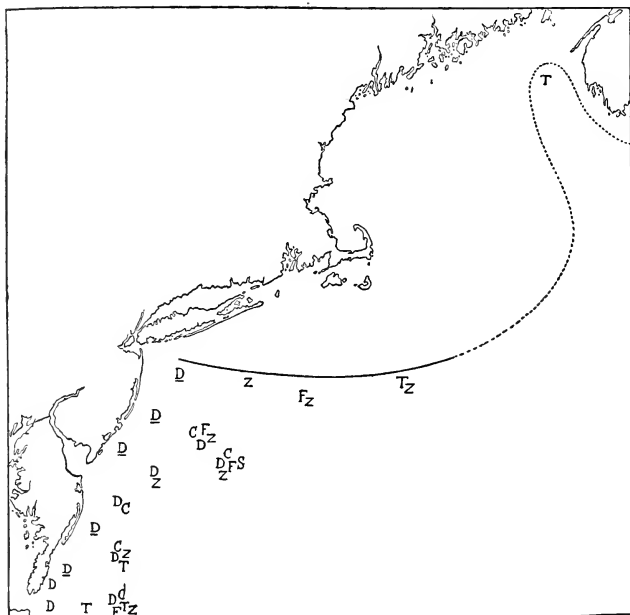

FIG. 67.— Distribution of Salpa. *D*, *S. democratica*; *D*, *S. democratica* swarms; *T*, *S. tilesii*; *F*, *S. fusiformis*; *C*, *S. confoederata*; *S*, *S. cylindrica*; *Z*, *S. zonaria*. The curve is the probable northern limit of Salpae at the time of our cruise.

not then reached the south shore of Long Island (Station 10083), they do so more or less regularly later in the season. The only Salpae encountered in the Gulf of Maine were a few specimens of *S. tilesii* which were taken on the eastern side (Station 10096). And I

may note that great numbers of this species were taken by fishermen in Massachusetts Bay in the ensuing November and December. The commonest species was *S. democratica*. It was not taken over the edge of the shelf south of Nantucket and Long Island. But it swarmed on the surface off Barnegat (Station 10069); and was taken at all the stations further south, though it was far less abundant in the Gulf Stream than at certain localities near land, *e. g.*, Stations 10069, 10075, 10079, 10080, 10081, and 10082. But it was not universally common over this part of the shelf, there being regions of scarcity off Delaware Bay and off Chesapeake Bay (Stations 10070, 10072, 10074, 10078). All the captures were from temperatures higher than 65°. Salinity was about the same (32.1‰–32.4‰) at several of the poor Stations (10070, 10072) as at several rich ones (10069, 10079, 10080, 10081); and the total range of salinity occupied by the species was very great (32.27‰ to 35.25‰). The unequal quantitative distribution of *Salpa democratica* is, I believe, an index of the abundance of the food supply, not of the amount of Gulf Stream water. During the early summer the surface temperature rises sufficiently to make the coast water a favorable habitat for the Salpae which are dispersed over this part of the continental shelf by the constant mixture between land and Gulf Stream water, and wherever they find a plentiful food supply, they reproduce with marvelous rapidity. Examination of the intestinal contents of *S. democratica* supports this view, for the specimens taken at Stations 10069, 10077, 10081 contain large amounts of diatom and peridinian debris. *Salpa democratica* occasionally swarms in the Gulf of Maine, for example, off Chatham in September, 1912 (1914a), though not encountered there in 1913.

The five other species of *Salpa* do not agree in distribution with *S. democratica*, for they were all absent in the coastal belt south of New York, (Stations 10069, 10075, 10078 off Hog Island, 10079, 10080, 10081 and 10082), *i. e.*, just where *democratica* was most abundant (p. 275). *Salpa zouaria* was second to *democratica* in the number of stations at which it was observed, but unlike the latter, it was most abundant at the edge of the Gulf Stream and over the outer part of the shelf (Stations 10064, 10071, 10072, 10074); absent close to land.

*Salpa fusiformis* was even more restricted to the edge of the Gulf Stream, being most abundant in the deep hauls at the Stations where Gulf Stream water was purest (10064, 10071), much less so off Chesapeake Bay Station (10076). It was not found anywhere over the continental shelf, except a few specimens at Station 10070.

Our only capture of *S. cylindrica* was at the most typical Gulf Stream Station (10071), where it was numerous, far outnumbering

all other Salpae put together. And the few chains of *S. confederata* which were seen, or collected, it was nowhere abundant, were restricted to Gulf Stream Stations (10071, 10076) and to the outer part of the shelf (10070, 10073, 10074). *Salpa tilesii*, on the contrary, was not taken at all at Stations 10064 and 10071, but was found in adulterated Gulf Stream water at Station 10076, and was more or less common along the edge of the continental shelf (Stations 10061, 10070, 10077); and in the eastern part of the Gulf of Maine (Station 10096).

Salpae as a whole were far less numerous along the inner edge of the Gulf Stream in July, 1913, than they were in July, 1908 (1909, p. 198), when they were more abundant on the surface south of Nantucket than I have ever seen them.

#### THE HYPERIID AMPHIPODS.

Hyperiid amphipods often form a large part of the macroplankton in boreal waters and are of considerable importance as food for pelagic fishes. The species so far captured in the GRAMPUS hauls, all of which are easily recognizable, are *Hyperia medusarum*, *Hyperia galba*, *Hyperoche kröyeri*, *Parathemisto obliqua*, *Euthemisto compressa*, *Euthemisto bispinosa*, *Phronima atlantica*, *Phronima sedentaria*, *Tyro atlantica*, and *Vibilia jeangerardi*. Their occurrence, in the summer of 1913, is shown in the following table (p. 279).

(The identifications follow Bovallius, 1887-1889, and Sars, 1895. For previous records off the New England coast, see Holmes, 1905, and Rathbun, 1905).

The most widely distributed hyperiids in the coast water, as well as the most abundant numerically, were the two species of *Euthemisto*, *compressa* and *bispinosa* (Fig. 68). This genus as a whole (the relationship of the two species to each other will be considered later) was generally distributed over the Gulf of Maine (Stations 10058, 10087 to 10105); it was present on George's Bank (Station 10059), in the waters over Nantucket Shoals (Station 10060), over the outer part of the continental shelf, south of Block Island and Long Island (Stations 10062, 10063, 10065, 10066); and in the mixed water at the inner edge of the Gulf Stream (Stations 10061, 10064, and 10076). But we did not find it in Gulf Stream water proper (Station 10071, 10073), in any of the tows in the comparatively fresh water off Chesapeake Bay (Stations 10077 and 10078), or at any of the stations near shore between New York and the Chesapeake (Stations 10067, 10068, 10079-10083), except in one instance (Station 10075).

TABLE OF HYPERIIDS.

STATIONS	<i>Hyperia galba</i>	<i>Hyperia medusarum</i>	<i>Hyperoche krøyeri</i>	<i>Euthemisto compressa</i>	<i>Euthemisto bispinosa</i>	<i>Vibilia</i>	Tyro	<i>Phronima sedentaria</i>	<i>Phronima atlantica</i>
10057	.....	.....	16	2					
10058	14	4	17	f.					
10059	5	2	.....	f.					
10060	.....	.....	.....	m.	m.				
10061	.....	.....	.....	m.	m.	1		1	
10062	.....	.....	.....	.....	m.				
10063	.....	.....	.....	f.	m.				
10064	.....	.....	.....	m.	m.	10	.....	5	7
10065	.....	.....	.....	2	m.	3			
10066	.....	.....	.....	1	13				
10069	.....	.....	.....	3	1				
10071	1	.....	.....	.....	.....	14	1	7	4
10074	.....	.....	.....	2	2				
10075	.....	.....	.....	4					
10076	.....	.....	.....	f.	f.	21			
10080	.....	.....	.....	.....	.....	.....	.....	1	
10085	.....	.....	3	1					
10086	.....	.....	4	m.					
10087	1	.....	1	f.					
10088	5	1	1	f.					
10089	.....	.....	.....	f.	f.				
10090	.....	.....	.....	m.	m.				
10091	.....	.....	.....	f. <sup>1</sup>	f.				
10092	1	.....	.....	m.	m.				
10093	.....	.....	.....	f.	f.				
10095	.....	.....	.....	m.	f.				
10096	.....	1	.....	m.	f.				
10097	.....	.....	1	6	2				
10098	.....	.....	6						
10100	.....	.....	6	m.					
10101	.....	.....	.....	f.					
10102	.....	.....	.....	m.	2				
10103	.....	.....	.....	f.					
10104	3	.....	5	m.					
10105	.....	.....	4	f.					
10112	.....	.....	.....	m.	m.				

m. = 50+.

f. = 20+

<sup>1</sup> and a swarm of larvae, probably this species.

The distribution of the two species is not exactly the same, though roughly parallel, for while *compressa* was taken at practically every station where *bispinosa* occurred, it alone occurred off Cape Cod and on George's Bank, near the coast south of New York (Station 10075)

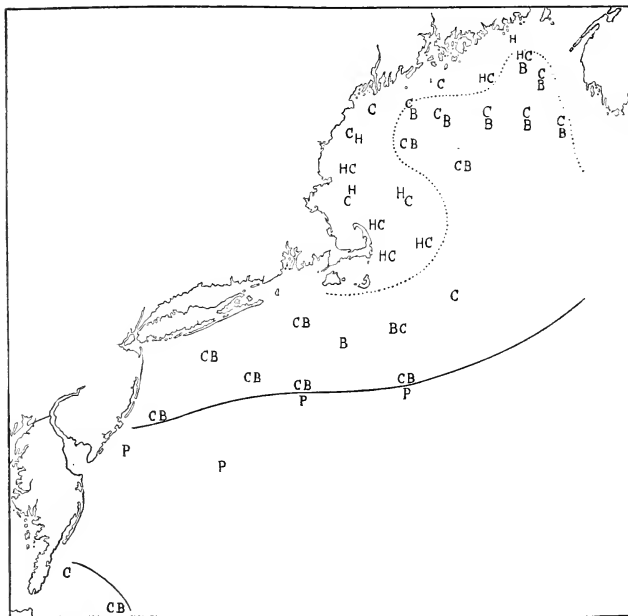

FIG. 68.— Distribution of hyperiid amphipods.

B = *Euthemisto bispinosa*; C, *E. compressa*; H, *Hyperoche*; P, *Phronima*.  
The curve —, is the probable southeastern limit to *Euthemisto*, the dotted curve, . . . , the northern limit of *E. bispinosa* in the Gulf of Maine, at the time of the cruise.

off Massachusetts Bay (Stations 10087, 10088), and, in general, in the coast water north of Cape Ann (Stations 10100, 10101, 10103, 10104, 10105). Of course horizontal hauls can not afford an accurate idea of its abundance, but they do show that it swarmed on the surface

over the eastern basin of the Gulf of Maine (Station 10092); and the swarms of larval *Euthemisto* which were taken on the surface off Penobscot Bay (Station 10091) probably belong to this species. Secondary centres of abundance for *compressa* in the Gulf were at Station 10102, and German Bank (Station 10095). The only place south of Cape Cod where it was taken in large numbers was on the south side of Nantucket Shoals (Station 10060). *Euthemisto bispinosa* was most abundant, in July, over the outer part of the continental shelf south of Nantucket and Long Island (Stations 10060, 10061, 10062, 10063, 10065); with a second centre of abundance in the eastern part of the Gulf of Maine (Stations 10092, 10093). Late in August young *bispinosa* swarmed in the water southwest of Nantucket (Station 10112) where the large specimens were about evenly divided between that species and *compressa*.

The hauls throw some light on the bathymetric occurrence of the two species. To begin with, it was seldom that the surface hauls contained more than a few representatives of either, though made by night as well as by day. But, as just pointed out, there were swarms on the surface at Stations 10062, 10091, 10092, and 10093. Judging from the stations where two or more intermediate hauls were made at different depths *E. compressa*, like *Calanus finmarchicus*, was most abundant above say forty fathoms in coastal waters, as illustrated by the counts of specimens at three representative stations in the Gulf of Maine and on Nantucket Shoals.

Stations	Fathoms	<i>P. compressa</i> specimens
10061	40-0	29
	70-0	3
10092	35-0	19
	85-0	6
10097	30-0	3
	80-0	0
10104	15-0	35
	50-0	8

And this difference is an actual one, not the accidental result of different nets, etc., because, as pointed out (p. 327) sometimes one net, sometimes another, was used for the deepest haul; and other things being equal, it is the net which worked the deepest, not the shallowest, which would be expected to yield the largest catch, because of the longer column of water through which it fished on its way down and up.





Thus the two species were about equally abundant over Nantucket Shoals (Station 10060), in the centre of the Gulf of Maine (Stations 10090 and 10091), and in the upper layers near the edge of the Gulf Stream south of Long Island (Station 10064). But *compressa* preponderated off Barnegat (Station 10069) and at all the stations near shore in the Gulf of Maine where both were taken, (Stations 10089, 10095, 10096, 10097, 10102), as well as on the surface over the eastern basin (10092); *E. bispinosa* over the outer part of the continental shelf south of Nantucket and Long Island, in the deep haul off Chesapeake Bay, and in the deep hauls in the eastern basin of the Gulf of Maine. When *bispinosa* outnumbered *compressa*, its preponderance was usually greatest in the deep hauls.

Both species were living at a wide range of temperature, with a maximum of about  $69^{\circ}$  (Station 10066, surface). And swarms of *bispinosa* were taken in water as warm as  $67^{\circ}$  (Station 10062, surface); but *compressa* was not common in water warmer than  $62^{\circ}$  (Station 10092), and most of its captures must have been from considerably colder water. The lowest temperatures for both was about  $42^{\circ}$  (deep hauls in the Gulf of Maine); and *bispinosa* must have been living in numbers in this cold water, because plentifully represented in one of the deepest hauls in the Gulf as well as in the shallower ones (p. 282).

The range of salinity was likewise very wide for both species, with an upper limit of  $35.2\%$  (the deep haul at Station 10064) and a lower limit of about  $31.5\%$  (surface, Station 10066). But it was only once that either was taken in water fresher than  $32\%$ , and the freshest water in which they were abundant was  $32.8\%$  for *bispinosa* (surface, Station 10062),  $32.6\%$  for *compressa* (surface, Station 10092).

The data outlined above suggest that both *compressa* and *bispinosa* belong to the coastal, not oceanic waters, of which *compressa*, at least, is almost as regular an inhabitant as *Limacina balea*, *Calanus*, or indeed any of the typical boreal plankton animals. Both species, it is true, were found in large numbers, and of unusually large size, in the deep water under the edge of the Gulf Stream; but the fact that this was only where the surface of the stream was considerably diluted with fresh water, and that both were absent in the Gulf Stream water proper (Station 10071, 10073) shows that neither of them is a regular inhabitant of the stream. They thrive below the inner edge of the stream, not because of temperature or salinity, but because of the abundant food supply.

*Hyperoche kroyeri* was taken only in the Gulf of Maine where it occurred at twelve stations, all near shore, as follows:—

Station	Fathoms	Specimens	Stations	Fathoms	Specimens
10057	15-0	10	10088	80-0	1
	30-0	6	10097	80-0	1
10058	40-0	17	10098	18-0	6
10085	20-0	3	10100	40-0	7
10086	20-0	4	10104	50-0	5
10087	15-0	5	10105	50-0	3
	30-0	1			

The numbers of specimens concerned are so small that they do not show anything about bathymetric distribution.

The few captures of *Hyperia medusarum* are likewise from the Gulf of Maine, and so are most of the *Hyperia galba*, which is consistent with the distribution of their medusan host *Cyanea*. But one specimen of *H. galba* was taken in the Gulf Stream (Station 10071, 190-0 fathoms).

The remaining hyperiids were all taken either in the Gulf Stream, or where Gulf Stream water was in evidence: they are all visitors from the south, or at least from the warmer parts of the Atlantic, and do not belong to the permanent plankton of the coast water.

*Vibilia* was taken at all the stations outside the continental shelf, and twice over the outer part of the shelf; curiously enough, however, it was not encountered in the Gulf Stream tongue south of Delaware Bay. The depths of the captures are:—

Station	Fathoms	Specimens	Station	Fathoms	Specimens
10061	70-0	1	10071	20-0	2
10064	175-0	10		190-0	12
10065	20-0	3	10076	20-0	2

Thus most of the specimens came from deep hauls, none from the surface.

Tyro was taken only once, in the Gulf Stream, one specimen, twenty fathoms, Station 10071.

The two species of *Phronima* were likewise restricted to the Gulf Stream, and to the outer edge of the shelf, except for a single specimen of *sedentaria* near Cape May (Station 10080). Though the two agree geographically *sedentaria* was living deeper than *atlantica* as shown in the following table of captures.

Station	Depth	Sedentaria	Atlantica
10061	40-0	1	
10064	20-0		7
	175-0	5	
10071	20-0		4
	190-0	7	
10080	12-0	1	

The only *sedentaria* taken in shallow water was dead and very fragmentary; those from the deep hauls were all alive, and most of them inside their "houses" (*Doliolum* shells). The *atlantica* were all free, and alive. Neither was taken on the surface, which agrees with the rarity of *Salpae* and *Doliolum* on the surface, in the Gulf Stream (p. 278) at the time of our visit. When *Salpae* swarm at the surface of the stream, as they occasionally do (1909b), *Phronima* appears there too.

#### COPEPODS.<sup>1</sup>

Copepods were by far the most important constituent of the plankton in the Gulf of Maine (p. 274), where they were extremely abundant; and the hauls revealed a rich copepod plankton over the shelf south of Cape Cod. But on the run west and south, these little crustaceans gave way to other organisms (p. 269), the copepods in the hauls south of New York being counted by individuals, instead of by hundreds of cubic centimeters. And in some of the southern hauls, *e. g.*, at Stations 10068, 10069, 10078, no copepods at all were detected, something never experienced in the Gulf of Maine. The geographic occurrence of the various copepods is listed in the following table.

<sup>1</sup> Identified by Dr. C. O. Esterly.

Table of the numbers of individuals of several species of copepods in the quantitative hauls (column of water .1 square meter) in the Gulf of Maine, from samples counted by Dr. Esterly.

STATIONS →	10087	10089	10090	10092	10095	10096	10097
<i>Calanus finmarchicus</i>	3750	1650	3750	8800	375	3000	2800
<i>Calanus hyperboreus</i>				80			
<i>Pseudocalanus elongatus</i>	360	1050	375	2600	2400	3000	5600
<i>Euchaeta norvegica</i>			15			20	30
<i>Centropages typicus</i>	90		75				
<i>Temora longicornis</i>				40	150	60	
<i>Metridia lucens</i>	900	225	60	160	105	240	280

STATIONS →	10098	10099	10100	10101	10102	10103	10105
<i>Calanus finmarchicus</i>	500	1200	5400	3000	2250	2000	1350
<i>Calanus hyperboreus</i>			270				
<i>Pseudocalanus elongatus</i>	3200	600	4500	3200	600	1200	975
<i>Euchaeta norvegica</i>							
<i>Centropages typicus</i>							150
<i>Temora longicornis</i>	80	300	1800	1200		160	
<i>Metridia lucens</i>	60	60	450	300	180	80	225

TABLE OF COPEPODS IN THE HORIZONTAL HAULS.<sup>1</sup>

STATIONS →												
	10057	10058	10059	10060	10061	10062	10063	10064	10065	10066	10067	10068
<i>Calanus finmarchicus</i>	s.	m.	1	m.	s.	.....	m.	.....	s.	3	.....	.....
<i>Calanus hyperboreus</i>	.....	2	.....	.....	.....	.....	.....	.....	.....	.....	.....	.....
<i>Pseudocalanus elongatus</i>	.....	.....	×	.....	.....	.....	.....	.....	.....	.....	.....	.....
<i>Rhincalanus nasutus</i>	.....	.....	.....	.....	.....	.....	.....	30	.....	.....	.....	.....
<i>Euchirella rostrata</i>	.....	.....	.....	.....	.....	.....	.....	70	.....	.....	.....	.....
<i>Euchaeta norvegica</i>	f.	f.	.....	.....	m.	.....	.....	.....	.....	.....	.....	.....
<i>Euchaeta media</i>	.....	.....	.....	.....	.....	.....	.....	.....	.....	.....	.....	.....
<i>Undeuchaeta minor</i>	.....	.....	.....	.....	.....	.....	.....	6	.....	.....	.....	.....
<i>Undeuchaeta major</i>	.....	.....	.....	.....	.....	.....	.....	.....	.....	.....	.....	.....
<i>Centropages hamatus</i>	.....	.....	.....	1	.....	.....	.....	.....	.....	.....	.....	.....
<i>Centropages typicus</i>	.....	.....	.....	.....	.....	s.	1	.....	m.	s.	m.	.....
<i>Temora longicornis</i>	.....	.....	m.	s.	.....	.....	.....	.....	.....	f.	.....	.....
<i>Metridia lucens</i>	f.	f.	.....	.....	.....	.....	.....	35	.....	.....	.....	.....
<i>Metridia longa</i>	f.	.....	.....	.....	.....	.....	.....	.....	.....	.....	.....	.....
<i>Pleuromamma robusta</i>	.....	.....	.....	.....	.....	.....	.....	400	.....	.....	.....	.....
<i>Pleuromamma xiphias</i>	.....	.....	.....	.....	.....	.....	.....	.....	.....	.....	.....	.....
<i>Pleuromamma rotundum</i>	.....	.....	.....	.....	.....	.....	.....	.....	.....	.....	.....	.....
<i>Pleuromamma sp.?</i>	.....	.....	.....	.....	.....	.....	.....	.....	.....	.....	.....	.....
<i>Anomalocera pattersoni</i>	.....	.....	.....	.....	.....	.....	.....	.....	.....	.....	.....	.....
<i>Scolecithrix persecans</i>	.....	.....	.....	.....	.....	.....	.....	2	.....	.....	.....	.....
<i>Candacia armata</i>	.....	.....	.....	.....	.....	.....	.....	.....	.....	.....	.....	.....

STATIONS →												
	10069	10070	10071	10072	10073	10074	10075	10076	10077	10078	10079	10080
<i>Calanus finmarchicus</i>	.....	.....	6	.....	.....	4	.....	6	4	.....	1	6
<i>Calanus hyperboreus</i>	.....	.....	.....	.....	.....	.....	.....	.....	.....	.....	.....	.....
<i>Pseudocalanus elongatus</i>	.....	.....	.....	.....	.....	.....	.....	.....	.....	.....	.....	.....
<i>Rhincalanus nasutus</i>	.....	.....	12	.....	.....	.....	.....	7	.....	.....	.....	.....
<i>Euchirella rostrata</i>	.....	.....	.....	.....	.....	.....	.....	1	.....	.....	.....	.....
<i>Euchaeta norvegica</i>	.....	.....	.....	.....	.....	.....	.....	.....	.....	.....	.....	.....
<i>Euchaeta media</i>	.....	.....	.....	1	.....	.....	.....	.....	.....	.....	.....	.....
<i>Undeuchaeta minor</i>	.....	.....	.....	.....	.....	.....	.....	.....	.....	.....	.....	.....
<i>Undeuchaeta major</i>	.....	.....	1	.....	.....	.....	.....	.....	.....	.....	.....	.....
<i>Centropages hamatus</i>	.....	.....	.....	.....	.....	.....	.....	.....	.....	.....	.....	.....
<i>Centropages typicus</i>	.....	m.	.....	.....	.....	11	3	60	.....	.....	m.	7
<i>Temora longicornis</i>	.....	.....	.....	.....	.....	.....	.....	.....	.....	.....	.....	.....
<i>Metridia lucens</i>	.....	.....	10	.....	.....	.....	.....	10	.....	.....	.....	.....
<i>Metridia longa</i>	.....	.....	.....	.....	.....	.....	.....	.....	.....	.....	.....	.....
<i>Pleuromamma robusta</i>	.....	.....	2	.....	.....	.....	.....	.....	.....	.....	.....	.....
<i>Pleuromamma xiphias</i>	.....	.....	1	.....	.....	.....	.....	.....	.....	.....	.....	.....
<i>Pleuromamma rotundum</i>	.....	.....	.....	.....	.....	.....	.....	15	.....	.....	.....	.....
<i>Pleuromamma sp.?</i>	.....	.....	40	.....	.....	.....	.....	.....	.....	.....	.....	.....
<i>Anomalocera pattersoni</i>	.....	7	3	.....	.....	.....	.....	.....	2	.....	.....	10
<i>Scolecithrix persecans</i>	.....	.....	.....	.....	.....	.....	.....	.....	.....	.....	.....	.....
<i>Candacia armata</i>	.....	.....	.....	.....	.....	40	.....	m.	6	.....	.....	.....

<sup>1</sup>The occurrences of *Pseudocalanus* are chiefly from the quantitative hauls, p. 291.

STATIONS →	10081	10082	10083	10085	10086	10087	10088	10089	10090	10091	10092	10093
	Calanus finmarchicus	1	....	s.	s.	s.	s.	m.	s.	s.	s.	s.
Calanus hyperboreus	.....	.....	.....	.....	.....	.....	.....	.....	.....	.....	.....	.....
Pseudocalanus elongatus	.....	.....	f.	.....	.....	m.	f.	s.	m.	.....	×	.....
Rhincalanus nasutus	.....	.....	.....	.....	.....	.....	.....	.....	.....	.....	.....	.....
Euchirella rostrata	.....	.....	.....	.....	.....	.....	.....	.....	.....	.....	.....	.....
Euchaeta norvegica	.....	.....	.....	.....	.....	f.	f.	f.	m	f.	m.	f.
Euchaeta media	.....	.....	.....	.....	.....	.....	.....	.....	.....	.....	.....	.....
Undeuchaeta minor	.....	.....	.....	.....	.....	.....	.....	.....	.....	.....	.....	.....
Undeuchaeta major	.....	.....	.....	.....	.....	.....	.....	.....	.....	.....	.....	.....
Centropages hamatus	.....	.....	1	.....	.....	.....	.....	.....	.....	.....	.....	.....
Centropages typicus	.....	15	m.	.....	.....	f.	m.	.....	f.	1	6	.....
Temora longicornis	.....	.....	4	.....	.....	.....	.....	.....	.....	.....	f.	.....
Metridia lucens	.....	.....	20	.....	m.	×	5	×	1	.....	m.	.....
Metridia longa	.....	.....	.....	.....	.....	.....	5	.....	2	.....	2	.....
Pleuromamma robusta	.....	.....	.....	.....	.....	.....	.....	.....	.....	.....	.....	.....
Pleuromamma xiphius	.....	.....	.....	.....	.....	.....	.....	.....	.....	.....	.....	.....
Pleuromamma rotundum	.....	.....	.....	.....	.....	.....	.....	.....	.....	.....	.....	.....
Pleuromamma sp.?	.....	.....	.....	.....	.....	.....	.....	.....	.....	.....	.....	.....
Anomalocera pattersoni	40	.....	.....	.....	.....	.....	55	×	f.	×	m	f.
Scolecithrix persecaus	.....	.....	.....	.....	.....	.....	.....	.....	.....	.....	.....	.....
Candacia armata	.....	.....	.....	.....	.....	.....	.....	.....	.....	.....	.....	.....

STATIONS →	10095	10096	10097	10098	10099	10100	10101	10102	10103	10104	10105
	Calanus finmarchicus	m	s.	s.	s	s.	s.	s.	s.	s.	s.
Calanus hyperboreus	.....	.....	.....	.....	.....	m.	f.	.....	f.	.....	.....
Pseudocalanus elongatus	s.	s.	s.	s.	m.	s.	s.	m	s.	.....	m.
Rhincalanus nasutus	.....	.....	.....	.....	.....	.....	.....	.....	.....	.....	.....
Euchirella rostrata	.....	6	.....	.....	.....	.....	.....	.....	.....	1	.....
Euchaeta norvegica	.....	m.	m.	.....	.....	m.	×	×	.....	f.	f.
Euchaeta media	.....	.....	.....	.....	.....	.....	.....	.....	.....	.....	.....
Undeuchaeta minor	.....	.....	.....	.....	.....	.....	.....	.....	.....	.....	.....
Undeuchaeta major	.....	.....	.....	.....	.....	.....	.....	.....	.....	.....	.....
Centropages hamatus	.....	.....	.....	.....	.....	.....	.....	.....	.....	.....	.....
Centropages typicus	.....	f.	.....	.....	.....	.....	.....	.....	.....	f.	m.
Temora longicornis	f.	f.	f.	f.	f.	f.	m.	f.	f.	.....	.....
Metridia lucens	f.	m.	m.	f.	f.	f.	m	m.	f.	f.	×
Metridia longa	.....	.....	.....	.....	.....	.....	.....	.....	.....	.....	.....
Pleuromamma robusta	.....	.....	.....	.....	.....	1	.....	.....	.....	.....	.....
Pleuromamma xiphius	.....	.....	.....	.....	.....	.....	.....	.....	.....	.....	.....
Pleuromamma rotundum	.....	.....	.....	.....	.....	.....	.....	.....	.....	.....	.....
Pleuromamma sp.?	.....	.....	.....	.....	.....	.....	.....	.....	.....	.....	.....
Anomalocera pattersoni	f.	f.	f.	×	.....	1	1	f.	60	f.	f.
Scolecithrix persecaus	.....	.....	.....	.....	.....	.....	.....	.....	.....	.....	.....
Candacia armata	.....	.....	.....	.....	.....	.....	.....	.....	.....	.....	.....

f. = few, 20 +  
s. = swarm, 1000 +

m. = many, 100 +  
× = the species occurred.

*Calanus finmarchicus* was, by far the most widespread and abundant species in 1913, as in 1912, very numerous in the Gulf of Maine in every haul from ten or more fathoms (Fig. 69). This was generally the case in the waters south of Nantucket also, as far as the edge of the continental shelf (Station 10061), except for Station 10062, where

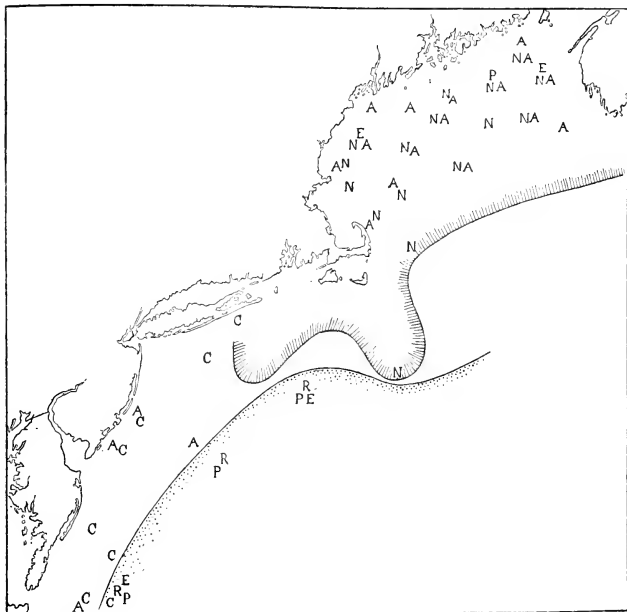

FIG. 69.— Distribution of copepods, July–August, 1913.

N, *Euchaeta norvegica*; A, *Anomolocera pattersoni*; R, *Rhincalanus nasutus*; P, *Pleuromamma*; E, *Euchirella*. — Southern limit to abundant *Calanus finmarchicus*; ··· Northern limit to *Rhincalanus*, *Pleuromamma*, and *Euchirella*.

it was wholly lacking, its place being taken by swarms of *Centropages typicus*, and of the amphipod *Euthemisto*. But it was represented by occasional specimens only, in the hauls off New York (Stations 10066, 10067) and further south; and only one specimen was detected

in the hauls on George's Bank (Station 10059). It was also notably lacking in the Gulf Stream water (Stations 10064, 10071), except for a few specimens at Station 10076 abreast of Chesapeake Bay. *Calanus* appears to be uniformly rare, or absent, in the bays and sounds of the southern coast of New England in summer: but it swarms in Narragansett Bay in winter (Williams, 1906). *Calanus* was rare on the surface, even in the Gulf of Maine, except at Stations 10085, 10093, 10096, 10097, 10100, 10101, and immediately off Gloucester, July 8, where it swarmed at that level. Four of these stations were occupied in daylight, three after dark; which shows that its absence on the surface, in the regions where it swarms in deeper water, does not depend altogether on sunlight, though the latter may be one of the factors which confine it to deeper levels. And *Calanus* certainly did not come to the surface off Cape Cod during the night of August 5, for surface hauls, taken at 2 A.M., and at practically the same locality at 8 A.M. (Station 10086), yielded very few *Calanus*, although the deep haul caught thousands. Stations 10057, 10061, 10087, 10090, 10092, 10102, 10104 where hauls were taken at three levels, surface, intermediate, and deep, show that *Calanus* was not usually equally abundant at all depths, the yields of hauls at 15-20 fathoms being very much larger than those at 50-85 fathoms. The numbers of specimens per haul were far too large for counting; but the shallower catches were usually two to four times as large in bulk as the deep ones, a difference too great to be charged to the difference in mouth area between the four foot and the Helgoland nets. And this source of possible error was further checked by occasionally alternating the two nets. The only exceptions to this rule were Stations 10093, 10097, and 10100, all in the eastern half of the Gulf, where *Calanus* was about equally abundant in deep and shallow hauls, *i. e.*, just the stations where it was abundant on the surface.

*Calanus finmarchicus* was taken through a very wide range of temperature, from about 42° (the deep hauls in the Gulf of Maine) to 76° (surface, Stations 10079 and 10080). But it was not abundant in water warmer than 62° (surface hauls, eastern part of the Gulf of Maine), and the great majority of the species was living in much cooler water (42°-50°). The lowest salinity for *Calanus* was 31.8‰ (surface, Station 10103), the highest may have been as high as 35‰ (Station 10074, 20-0 fathoms haul). But it is by no means certain that the specimens taken at that Station came from such salt water, the net having passed through water as fresh as 33.2‰. The vast majority were living in water of 32.7‰ to 33.4‰, in the intermediate



depths of the Gulf of Maine. *Calanus* was wholly absent in pure Gulf Stream water, as exemplified by Station 10071, and the deeper layers at Stations 10064 and 10076; and it was likewise lacking in the very fresh water at the mouth of Chesapeake Bay. The possibility that the density of the water may determine the bathymetric distribution of copepods, by its effect on flotation, just as is the case with fish eggs, must be taken into account in geographic studies. The *Calanus* swarms in the Gulf of Maine were living in water of about 1.024 to 1.027. The lowest density in which adults were found abundant was 1.0239 (Station 10093, surface) though larval stages swarmed in water of 1.0231 (Station 10085, surface); the highest, for swarms, was about 1.027 in the deeper parts of the Gulf. None of the physical factors just outlined offer an obvious explanation for the scarcity of *Calanus* in the waters south of New York in July, for the subsurface salinities, temperatures, and densities of many of those stations were well within the range occupied by the species in the Gulf of Maine. What the limiting factor is, is one of the numerous questions raised, but not answered, by our cruise. Most of the specimens were large adults, as was the case in the summer and autumn of 1912. But the catch off Cape Cod on July 9 (Station 10057) was larval stages; and young stages swarmed in Massachusetts Bay during the early spring of 1913. (For an account of the biology of *Calanus finmarchicus* in Norwegian waters, see Damas, 1905).

The results of the quantitative hauls give a rough idea of the absolute abundance of *Calanus* in our Gulf (p. 286). Taken at their face value, they show that the numbers of *Calanus* in a column of water of one square meter cross section varied from 3750 to 88000, being greatest, as the plankton as a whole was richest (p. 237), off Massachusetts Bay and over the eastern basin, least in the northeast corner of the Gulf (Station 10098) and German Bank. The average of the hauls for the Gulf as a whole is 28000 per square meter of surface area. But *Calanus* must have actually been more numerous than this, because the calculations take no account of the failure of the net to filter the water completely.

The only species which vied with *Calanus finmarchicus* in abundance in the Gulf of Maine was *Pseudocalanus elongatus*; though it was far less important in the economy of the Gulf because of its small size. *Pseudocalanus* outnumbered *Calanus* on German Bank (Station 10095) and in the northeast corner of the Gulf (Stations 10097, 10098); and it was taken in large numbers in every haul of the quantitative net; though *Calanus* was usually the more abundant of the two. But the

four foot and Helgoland nets failed to capture it at seven out of these thirteen stations. Probably their larger mesh allowed this minute species to pass through. The coarse nets alone being used for the subsurface work in the water south and west of Cape Cod, the apparent absence of this species there may have been partly due to the apparatus. But it can hardly have been abundant there, or it would have appeared occasionally in the catches of the four foot net, just as it did in the Gulf of Maine. And this agrees with Williams's observation (1906) that it is only in winter that *Pseudocalanus* appears in Narragansett Bay. In July and August it is abundant off Nova Scotia (Wright, 1907).

*Eucheata norvegica* was taken at practically every deep haul in the Gulf; as well as in three hauls from twenty fathoms (Stations 10090, 10091, 10101), one from fifteen fathoms (Station 10104) and one surface haul (Station 10097). It was found only once south of Cape Cod (Station 10061, 70-0 fathoms). The largest numbers were yielded by the deeper hauls, *e. g.*, 90-0 fathoms at Station 10100; 80-0 fathoms at Stations 10088 and 10097; 75-0 fathoms at Station 10090; 70-0 fathoms at Station 10061. At Stations 10092 and 10097 it was as abundant in the hauls at thirty fathoms, as in the deep hauls, and this was an interesting phenomenon for it was at these same stations that *Calanus* was uniformly distributed from the surface downward instead of being localized in the mid layers (p. 290). *Euchaeta* is never abundant in the Gulf of Maine, in the sense that *Calanus*, or any of the other small copepods can be so described, the richest hauls yielding a couple of hundred specimens at most. It occurred in only three of the quantitative hauls, and then only in small numbers (p. 286); but since the other nets yielded considerable numbers where the quantitative nets missed it, it is probably sufficiently active to avoid the latter, just as the *Sagittae* are (p. 329). *Euchaeta* was living in water colder than 50°; and at a comparatively high salinity (33‰-34‰); and its quantitative occurrence indicates the lower temperature and higher salinity for its optimum. The exceptions afforded by the one surface capture, and by its abundance at thirty fathoms at Stations 10092 and 10097, where the salinity was about 32.9-33‰ are probably due to local causes.

*Metridia longa* was likewise restricted to the Gulf of Maine in marked contrast to its relative *M. lucens*. Its captures are too few to allow any general statement of its range in our waters; but the fact that it occurred at all is of interest because it is the "most typically Arctic copepod of whose distribution there is any accurate knowledge"

(Farran, 1910, p. 70). It was not found in the Gulf in 1912, nor has it been recorded before from American waters.

The only other species limited to the waters north of Cape Cod was *Calanus hypoboreus*, which was taken at four stations in the Gulf, both on the surface (Station 10103) and in deep hauls. The only haul which yielded any considerable number was at 90-0 fathoms (Station 10100); where the quantitative net contained 270 *C. hypoboreus* to 5400 *C. finmarchicus*; at Station 10092 the relative numbers were 80 to 88008.

All the other copepods found regularly in the Gulf of Maine likewise occurred over the continental shelf south and west of Cape Cod. *Centropages typicus* was taken irregularly in the Gulf (eight stations) (Fig. 70), but never in large numbers. It did not appear at all in the hauls on George's Bank or on Nantucket Shoals; but it was represented at the shallow Stations south of Long Island (10062, 10063); and at most of the stations on the shelf further south and west. It was not taken at Stations 10064 or 10071; but was well represented in the deep haul at Station 10076: and it swarmed south of Nantucket (Station 10062), off Long Island (Station 10066); and on the surface off Fire Island July 13. South of New York it was much less numerous, as was the case with copepods as a whole. And it never rivalled the *Calanus* swarm in abundance (p. 286), for which reason and because of its small size, it must be of comparatively little economic importance in our waters in summer. *Centropages* was most abundant near the surface, for example, the surface haul at Station 10088 yielded ten times as many specimens as the haul from eighty fathoms, though made with a net of only  $\frac{1}{8}$  the mouth area. And the discrepancy was even greater at Station 10083, where the surface haul yielded several hundred *Centropages*, the haul from twenty fathoms only one specimen. The swarms at Stations 10062 and 10066 were on the surface, and between fifteen fathoms and the surface. The species was living at a rather high temperature (about 54° to 76°), and rather low salinity (31.5‰, surface, Station 10066 to 33.2‰, surface, Station 10074), with an optimum, as suggested by its greatest abundance, of about 65°-69° and 31.5-33‰.

*Temora longicornis* was abundant only on Nantucket Shoals (Station 10060), *i. e.*, just where *Centropages typicus* was wanting, and was occasional in the surface tows on George's Bank, south of Long Island (Station 10066) and in the Gulf of Maine. But it was not taken at all outside the continental shelf or over the shelf south of New York. It was most numerous on the surface; for example, the surface haul

at Station 10060 yielded thousands, while the haul from twenty fathoms only caught twenty-five specimens. And it was not taken at all in hauls from depths greater than thirty-five fathoms. Its range of temperature was from about  $54^{\circ}$  (surface, Station 10096) to about  $69^{\circ}$  (surface, Station 10066); salinity  $31.5\text{‰}$  (surface, Station 10066) to  $33\text{‰}$  (Station 10059); *i. e.*, it was living in rather

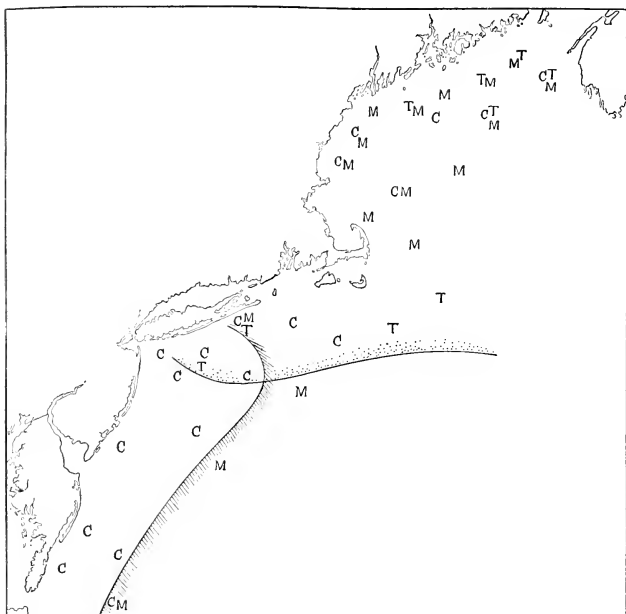

Fig. 70.— Distribution of copepods, July–August, 1913.

c, *Centropages typicus*; m, *Metridia lucens*; t, *Temora longicornis*;  
 ..... Probable southern limit to *Temora longicornis* in July.    Western  
 limit to *Metridia lucens* in July.

colder water than *Centropages typicus*, which corresponds with its abundance as far north as the Labrador Current (Herdman, Thompson, and Scott, 1898) and with its abundance in summer off Nova Scotia

(Wright, 1907). Its absence in the Gulf Stream water and in southern waters in general, agrees with its distribution in European waters (Farran, 1910) where it seems to be of northern origin, and with Wheeler's (1901) and Williams's (1906) statements that it is most abundant in winter at Woods Hole and in Narragansett Bay.

*Metridia lucens*, unlike *M. longa*, was taken regularly in the Gulf of Maine (eighteen out of twenty-one stations), and it likewise occurred at all three of the Stations outside the continental shelf (10064, 10071, 10076). But it was found at only one Station on the continental shelf, south or west of Cape Cod, (10083) where the haul yielded twenty specimens. And we did not find it on George's Bank or Nantucket Shoals. *Metridia lucens* was not abundant anywhere; in fact so far as known it never swarms in the Gulf of Maine as it does in European waters. It was not taken in any surface haul, the shallowest captures being 15-0 fathoms off Cape Ann (Station 10104), and 8-0 fathoms off Long Island (Station 10083). And its invariable absence from the surface in our waters is evidence that it was not at home in the high temperatures and low salinities of the surface, because it has a well-marked habit of coming to the surface at night in other regions (Farran, 1910). The lowest salinity in which its presence can be established was about 32.4‰ (Station 10104), with a maximum of at least 35.00‰ (Station 10071). In the Gulf of Maine most of the specimens were living in water of 32.6‰ to 33.7‰. The limits to the temperature range of our captures were about 42° to about 50°. *Metridia lucens* has usually been called a northern species (Cleve, 1900). But Farran's (1910) tabulations of the data of the International Committee seem to show that it really belongs to the oceanic waters of the North Atlantic; and that it is carried to the coasts of Iceland and to the northern part of the North Sea by the Atlantic Current; an explanation which agrees fairly well with its occurrence in our waters.

*Anomalocera pattersoni* was taken at most of the stations in the Gulf of Maine, which supports my suggestion (1914a) that it is more universal in the Gulf than the records of 1912 would indicate; at five localities on the shelf south of New York (Stations 10070, 10077, 10080, 10081 and off Hog Island) and at one of the off shore Stations (10071); while Wheeler (1900) records it as abundant in the Gulf Stream south of Woods Hole. Most of the records are from the surface; only one from a haul as deep as forty fathoms; and of course that one specimen may have been caught at or near the surface; and this may also be true of the few specimens yielded by hauls from twenty, twenty-five, and thirty fathoms in the Gulf of Maine. Its

surface habitat makes it easy to establish the hydrographic conditions in which it was living, the temperature range being 54°-76°; the salinity 32.1‰ to 35.25‰.

In European waters, likewise, *Anomalocera pattersoni* is chiefly found on the surface (Scott, 1911) though it inhabits rather saltier water there, and our catches support Scott's statement that it is a creature of the open seas, to the extent that it was not found in enclosed bays or harbors. But its regular occurrence in the Gulf of Maine shows that it is not typically oceanic in the sense in which *Pleuromamma* or *Rhincalanus* may be so described.

The copepods discussed so far are more or less regular inhabitants of the Gulf of Maine; but several species were found outside the continental shelf which enter the Gulf only sporadically if at all. Such are *Rhincalanus nasutus*, *Euchirella rostrata*, the several species of *Pleuromamma*, *Euchaeta major*, *E. minor*, and *Candacia armata*. The first of these was taken at all three off shore stations (Fig. 69), and nowhere else, the total number of specimens detected being only forty-nine. The salinity was about 35‰-35.25‰ which agrees very well with the high salinities of 34.9‰ to over 35.6‰ from which it is recorded by Cleve (1900) and Farran (1910). The temperatures can not be established exactly, the catches all being in open nets from considerable depths: but the absence of the species on the surface and in the hauls from twenty fathoms, and its occurrence in hauls from 175 fathoms (Station 10064), 190 fathoms (Station 10071) and 120 fathoms (Station 10076) leads to the conclusion that it was living at a temperature of about 48°-55°. According to Cleve (1900, p. 139) the mean temperature for the species is 59°. But, as Farran (1911) points out, its range of temperature is very great. Its occurrence in the deeper layers at the edge of the Gulf Stream, and its absence from our coastal waters, whence it has never been recorded, agree with its oceanic habitat, for it is only in the sweep of the Atlantic current that it is recorded by the International Committee.

*Pleuromamma robusta* was taken in some numbers (about 400 specimens) in the deep haul (175-0 fathoms) at Station 10064; two specimens were detected in the haul from twenty fathoms at Station 10071, and a single specimen in the Gulf of Maine (Station 10100, 90-0 fathoms). Thus it, like *Rhincalanus*, was living in water of high salinity, from about 33.8‰ in the deeps of the Gulf to upwards of 35.2‰ (Station 10071). And it, too, is rarely taken near the surface anywhere (Scott, 1911), though widely distributed in the North Atlantic. *Pleuromamma rhipias* and *P. rotundum*, likewise oceanic, were

each taken at one station, outside the continental shelf, in hauls from 190 and 120 fathoms respectively (p. 287).

*Euchirella rostrata*, a member, according to Cleve (1900), of the oceanic plankton of the temperate North Atlantic, was taken at four Stations, two at the edge of the Gulf Stream outside the continental shelf (10064 and 10076) and two in the Gulf of Maine (10096 and 10104). And it was found twice in the Gulf in 1912 (1914a, p. 116); though Wheeler (1900) does not record it from the Woods Hole region.

*Candacia armata* was taken at three Stations, 10074, 10076, and 10077, all south of Delaware Bay, in hauls from twenty fathoms.

The remaining copepods were taken so seldom (one or two stations and only one or two specimens each) that the captures throw little light on their distribution in our waters.

#### THE SAGITTAE.

The identifications and notes on the Sagittae are due to the kindness of Dr. A. Pringle Jameson, of the University of Sheffield, England.

Eight species of Sagittae were collected by the *Grampus*, the numbers of individuals in the various hauls being given in the following table:—

Stations, and depths, fathoms.	10057, 15-0	30-0	10058, 40-0	10059, 20-0	10060, 0	20-0	10061, 40-0	70-0	10062, 15-0	10063, 25-0	10064, 175-0	0
<i>Sagitta elegans</i>	1050	223	28	997	379	1158	633	144	112	129	.....	5
<i>Sagitta serratodentata</i>	.....	.....	.....	.....	.....	.....	16	6	17	7	3	1
<i>Sagitta enflata</i>	.....	.....	.....	.....	.....	.....	.....	.....	.....	.....	.....	.....
<i>Sagitta bipunctata</i>	.....	.....	.....	.....	.....	.....	.....	.....	.....	.....	.....	.....
<i>Sagitta hexaptera</i>	.....	.....	.....	.....	.....	.....	.....	.....	.....	.....	.....	.....
<i>Sagitta lyra</i>	.....	.....	.....	.....	.....	.....	1	.....	.....	.....	29	.....
<i>Pterosagitta draco</i>	.....	.....	.....	.....	.....	.....	.....	.....	.....	.....	.....	.....
<i>Eukrohnia hamata</i>	.....	.....	.....	.....	.....	.....	8	29	.....	.....	9	.....

Stations, and depths, fathoms.	10068, 10-0	10069, 10-0	10070, 0	20-0	10071, 0	20-0	190-0	10072, 15-0	10073, 0	15-0	10074, 0	20-0
<i>Sagitta elegans</i>	2	.....	.....	.....	.....	.....	.....	.....	.....	.....	.....	.....
<i>Sagitta serratodentata</i>	.....	10	453	621	3	4	1	175	2	4	3	221
<i>Sagitta enflata</i>	.....	.....	4	11	12	59	5	.....	.....	.....	12	55
<i>Sagitta bipunctata</i>	.....	.....	.....	.....	.....	5	.....	.....	.....	.....	3	.....
<i>Sagitta hexaptera</i>	.....	.....	.....	.....	.....	.....	2	.....	.....	.....	.....	.....
<i>Sagitta lyra</i>	.....	.....	.....	.....	.....	.....	2	.....	.....	.....	.....	.....
<i>Pterosagitta draco</i>	.....	.....	.....	.....	.....	1	.....	.....	.....	.....	.....	.....
<i>Eukrohnia hamata</i>	.....	.....	.....	.....	.....	.....	.....	.....	.....	.....	.....	.....

Stations, and depths, fathoms.	10076, 20-0	120-0	10077, 20-0	10079, 5-0	10080, 12-0	10081, 10-0	10082, 15-0	10085, 20-0	10086, 20-0	10087, 30-0	10088, 80-0	10089, 15-0
<i>Sagitta elegans</i>	.....	.....	.....	.....	.....	.....	45	24	53	142	14	8
<i>Sagitta serratodentata</i>	162	.....	.....	8	15	5	4	.....	.....	.....	.....	.....
<i>Sagitta enflata</i>	10	3	33	10	.....	.....	.....	.....	.....	.....	.....	.....
<i>Sagitta bipunctata</i>	.....	.....	.....	.....	.....	.....	.....	.....	.....	.....	.....	.....
<i>Sagitta hexaptera</i>	.....	1	.....	.....	.....	.....	.....	.....	.....	.....	.....	.....
<i>Sagitta lyra</i>	.....	1	.....	.....	.....	.....	.....	.....	.....	.....	.....	.....
<i>Pterosagitta draco</i>	1	.....	.....	.....	.....	.....	.....	.....	.....	.....	.....	.....
<i>Eukrohnia hamata</i>	.....	5	2	.....	.....	.....	.....	.....	.....	.....	.....	.....

Stations, and depths, fathoms.	10090, 20-0	75-0	10091, 20-0	10092, 35-0	85-0	10093, 35-0	85-0	10095, 20-0	10096, 30-0	10097, 0	30-0	80-0
<i>Sagitta elegans</i>	10	22	9	37	13	24	15	14	11	14	73	16
<i>Sagitta serratodentata</i>	1	5	.....	3	.....	.....	.....	1	23	.....	1	.....
<i>Sagitta enflata</i>	.....	.....	.....	.....	.....	.....	.....	.....	.....	.....	.....	.....
<i>Sagitta bipunctata</i>	.....	.....	.....	.....	.....	.....	.....	.....	.....	.....	.....	.....
<i>Sagitta hexaptera</i>	.....	.....	.....	.....	.....	.....	.....	.....	.....	.....	.....	.....
<i>Sagitta lyra</i>	.....	.....	.....	.....	.....	.....	2	.....	.....	.....	.....	.....
<i>Pterosagitta draco</i>	.....	.....	.....	.....	.....	.....	.....	.....	.....	.....	.....	.....
<i>Eukrohnia hamata</i>	.....	4	.....	2	35	25	63	2	2	.....	10	18



Stations, and depths, fathoms.	10098, 18-0	10099, 20-0	10100, 40-0	90-0	10101, 25-0	10102, 20-0	10103, 30-0	10104, 15-0	50-0	10105, 40-0
<i>Sagitta elegans</i>	16	4	27	11	4	13	349	15	7	503
<i>Sagitta serratodentata</i>	.....	.....	16	.....	.....	2	.....	.....	.....	.....
<i>Sagitta enflata</i>	.....	.....	.....	.....	.....	.....	.....	.....	.....	.....
<i>Sagitta bipunctata</i>	.....	.....	.....	.....	.....	.....	.....	.....	.....	.....
<i>Sagitta hexaptera</i>	.....	.....	.....	.....	.....	.....	.....	.....	.....	.....
<i>Sagitta lyra</i>	.....	.....	.....	.....	.....	.....	.....	.....	.....	.....
<i>Pterosagitta draco</i>	.....	.....	.....	.....	.....	.....	.....	.....	.....	.....
<i>Eukrohnia hamata</i>	.....	1	2	9	.....	2	.....	.....	.....	.....

The most important feature of the collection, from the geographic standpoint, is the presence of a very characteristic tropical fauna, *i. e.*, *Sagitta enflata*, *S. hexaptera*, *S. bipunctata*, small *S. serratodentata*, and *Pterosagitta draco* in the coast water south of Delaware Bay and in the inner edge of the Gulf Stream. This is just what was to be expected from hydrography, and agrees with the tropical aspect of the plankton as a whole in those regions.

Elsewhere in the GRAMPUS collecting ground the chaetognath fauna is typically boreal, characterized by the presence of *Sagitta elegans* in abundance, and of large specimens of *S. serratodentata*. Though Sagittae were taken at nearly all our Stations, it was only at eight (10057, 10059, 10060, 10061, 10070, 10103, 10105) that they were an important constituent of the plankton, quantitatively speaking.

*Sagitta elegans* was the prevalent Sagitta in the Gulf of Maine, where it was found at all Stations, three times in swarms (10057, 10103, 10105). It likewise swarmed on George's Bank early in July (Station 10059); and was the most abundant species over the continental shelf east of Long Island. But it was rare in the coast water further west and south, and lacking outside the continental slope, as well as over the shelf south of Delaware Bay. And this agrees with its boreal habitat on the other side of the Atlantic. It was usually most abundant at about twenty fathoms depth; being numerous on the surface on one occasion only.

*Sagitta serratodentata* was likewise taken in the Gulf of Maine; but at eight stations only, and always in small numbers. And it was less numerous than *elegans* over the shelf south of Marthas Vineyard. But it was the prevalent Sagitta in the shallow waters south of New



clearly enough distinguished from allied species for its truly warm water habitat to become apparent (Ritter-Zahony, 1911). Finally, *Eukrohnia hamata* deserves brief mention. The GRAMPUS has never found it on the surface; and only rarely, and in small numbers in hauls as shallow as 20 fathoms. But it was fairly numerous in the deeps of the Gulf of Maine, (much more so than in 1912), and in the deep hauls under the inner edge of the Gulf Stream (Stations 10064, 10076). As previously noted (1914a) it was to be expected in the deeper layers, its range being from the surface in the arctic, to the mid depths in low latitudes.

#### TOMOPTERIS.

The specimens of Tomopteris all belong to *T. helgolandica* Graeffe. The records are from Stations 10057, 10058, 10068, 10069, 10082, 10088, 10089, 10091, 10093, 10095, 10096, 10097, 10099, 10100, 10101, 10103; off Chatham, at Lat.  $41^{\circ} 48'$ , Long.  $70^{\circ} 5'$  and at Lat.  $41^{\circ} 39'$ , Long.  $69^{\circ} 15'$ . Thus *T. helgolandica* was very generally distributed in the waters of the Gulf of Maine and off New York; but it was not found over the shelf south of New York, or in the Gulf Stream waters.

#### PTEROPODS AND HETEROPODS.

Identified by Mr. W. F. Clapp.

Besides the occurrences listed (p. 301) *Limacina balca* was taken by Capt. McFarland as follows:—

$38^{\circ} 45' N$ ; $73^{\circ} 32' W$ ; May 3, 1913	— 8-0 fath.	6 specimens
$40^{\circ} 45' N$ ; $70^{\circ}$ W. June 21, 1913	— 10-0 "	swarm
$40^{\circ} 42' N$ ; $69^{\circ} 38' W$ . Aug. 8, 1913	— 10-0 "	13 specimens
15 miles S. E. of Chatham, Mass., Aug. 16, 1913	— 10-0 fath.	16 specimens
10-18 miles S. E. of Chatham, Mass., Aug. 21, 1913	— 20-0 fath.	5 specimens

Station	Depth	<i>Clione limacina</i>	<i>Corolla calceola</i>	<i>Diacria trispinosa</i>	<i>Crescis acicula</i>	<i>Crescis conica</i>	<i>Crescis virgula</i>	<i>Limacina balca</i>	<i>Limacina inflata</i>	<i>Pterotrachea keraudrenii</i>	<i>Pterolida desmarestia</i>	<i>Atlanta peronii</i>	<i>Atlanta</i> sp.?	<i>Crescis</i> sp.?
Off Gloucester	0	.....	.....	2	.....	.....	.....	.....	.....	.....	.....	.....	1	.....
10057	15-0	.....	.....	.....	.....	.....	.....	9	.....	.....	.....	.....	.....	.....
10058	40-0	.....	.....	.....	.....	.....	.....	m.	.....	.....	.....	.....	.....	.....
10059	20-0	.....	.....	.....	.....	.....	.....	5	.....	.....	.....	.....	.....	.....
10060	20-0	.....	.....	.....	.....	.....	.....	m.	.....	.....	.....	.....	.....	.....
10061	40-0	.....	.....	.....	.....	.....	.....	m.	.....	.....	.....	.....	.....	.....
	70-0	.....	.....	.....	.....	.....	.....	f.	.....	.....	.....	.....	.....	.....
10063	25-0	.....	.....	.....	.....	.....	.....	m.	.....	.....	.....	.....	.....	.....
10064	175-0	.....	.....	.....	.....	.....	.....	4	.....	.....	.....	.....	.....	.....
10065	20-0	.....	.....	.....	.....	.....	.....	m.	.....	.....	.....	.....	.....	.....
10070	20-0	.....	m.	.....	.....	.....	.....	.....	.....	.....	.....	.....	.....	.....
		.....	juv.	.....	.....	.....	.....	.....	.....	.....	.....	.....	.....	.....
10071	190-0	.....	.....	.....	.....	.....	.....	.....	27	1	1	1	.....	.....
10073	30-0	.....	13	.....	3	1	.....	.....	.....	.....	1	.....	.....	.....
10074	30-0	.....	9	.....	12	5	11	.....	.....	.....	3	.....	.....	.....
10075	8-0	.....	.....	.....	2	.....	.....	.....	.....	.....	.....	.....	.....	.....
10076	150-0	.....	.....	.....	.....	.....	.....	.....	.....	.....	.....	.....	.....	2
off Hog I.	0	.....	.....	.....	1	.....	.....	.....	.....	.....	.....	.....	.....	.....
10078	8-0	.....	.....	.....	.....	1	.....	.....	.....	.....	.....	.....	.....	.....
10079	10-0	.....	23	.....	.....	40	4	.....	.....	.....	6	.....	.....	.....
10081	10-0	.....	.....	.....	.....	2	.....	.....	.....	.....	.....	.....	.....	.....
10085	20-0	.....	.....	.....	.....	.....	.....	2	.....	.....	.....	.....	.....	.....
10086	20-0	.....	.....	.....	.....	.....	.....	f.	.....	.....	.....	.....	.....	.....
10088	80-0	.....	.....	.....	.....	.....	.....	7	.....	.....	.....	.....	.....	.....
10090	20-0	.....	.....	.....	.....	.....	.....	m.	.....	.....	.....	.....	.....	.....
	75-0	.....	.....	.....	.....	.....	.....	f.	.....	.....	.....	.....	.....	.....
10091	20-0	.....	.....	.....	.....	.....	.....	s.	.....	.....	.....	.....	.....	.....
10092	35-0	.....	.....	.....	.....	.....	.....	m.	.....	.....	.....	.....	.....	.....
	85-0	.....	.....	.....	.....	.....	.....	f.	.....	.....	.....	.....	.....	.....

f. = few — 25+

m. = many — 100+

s. = a swarm

Stations	Depth	<i>Clione limacina</i>	<i>Corolla calceola</i>	<i>Diacria trispinosa</i>	<i>Crescis acicula</i>	<i>Crescis conica</i>	<i>Crescis virgula</i>	<i>Limacina balca</i>	<i>Limacina inflata</i>	<i>Pterotrachea keraudremii</i>	<i>Firoloida desmarestia</i>	<i>Atlanta peronii</i>	<i>Atlanta</i> sp.?	<i>Crescis</i> sp.?
10093	25-0	.....	.....	.....	.....	.....	.....	m.						
	85-0	.....	.....	.....	.....	.....	.....	f.						
10095	20-0	.....	.....	.....	.....	.....	.....	m.						
10096	30-0	2	.....	.....	.....	.....	.....	m.						
10097	-0	.....	.....	.....	.....	.....	.....	1						
	30-0	.....	.....	.....	.....	.....	.....	m.						
	85-0	.....	.....	.....	.....	.....	.....	f.						
10098	15-0	.....	.....	.....	.....	.....	f.							
10099	15-0	.....	.....	.....	.....	.....	f.							
10100	30-0	.....	.....	.....	.....	.....	.....	m.						
	70-0	1	.....	.....	.....	.....	.....	f.						
10101	25-0	.....	.....	.....	.....	.....	35							
10102	20-0	.....	.....	.....	.....	.....	.....	54						
	50-0	.....	.....	.....	.....	.....	.....	f.						
10103	0	.....	.....	.....	.....	.....	.....	31						
	30-0	.....	.....	.....	.....	.....	.....	f.						
10104	15-0	.....	.....	.....	.....	.....	.....	s.						
	50-0	.....	.....	.....	.....	.....	.....	4						

The pteropods and heteropods of the cruise fall into two distinct groups, *Limacina balca* and *Clione limacina* in one; *Corolla*, *Crescis acicula*, *C. conica*, *C. virgula*, *Limacina inflata*, *Pterotrachea*, *Firoloida*, and *Atlanta peronii* in the other. *Limacina balca*, by far the commonest species, was universal from the neighborhood of Gloucester as far as Station 10065; and was taken again at nearly all our Gulf of Maine Stations. But it was wholly lacking in all the southern stations, and even in the cool water off New York (Stations 10066 to 10083, fig. 72). Its bathymetric range, likewise, must have been somewhat circumscribed, for, as the table shows, it was only once taken on the surface (Station 10103), although a surface haul was made at every station, usually with a net of the same mesh as the one in which Lima-

cina was taken in the depths. On the other hand, most of the *Limacina*s did not come from any very great depth, because whenever two hauls were made, a deeper and a shallower, it was usually the latter which made the largest catch. This was the case both south of Cape Cod (Station 10061) and in the Gulf of Maine (Stations 10092, 10093, 10097, 10100, 10102) and the only exception (10064) yielded so few

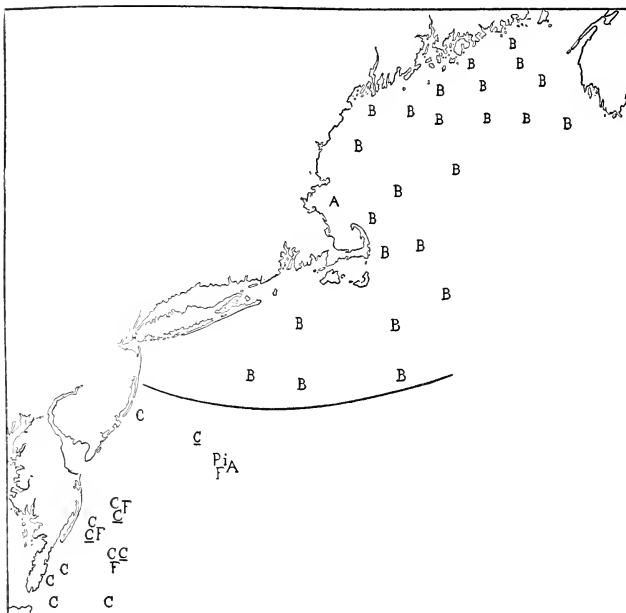

FIG. 72.— Distribution of pteropods and heteropods, July–August, 1913.

A, Atlanta; B, *Limacina balea*; c, *Criseis*; C, *Corolla*; F, *Fioloida*; I, *Limacina inflata*; P, *Pterotrachea*.

The curve shows the probable southern limit to *Limacina balea*.

specimens (4) that no deductions can be drawn from it. The precise depths where *Limacina* was most abundant can hardly be determined by the open nets which were used, but the fact that the nets which

were sent to the greater depths did not capture many specimens in their passage upward through the water, is good evidence that the large catches were made at about the depth at which the nets were working horizontally. This was fifteen fathoms at Station 10104; twenty-five fathoms at Station 10093 and 30-35 fathoms at Stations 10092, 10097 and 10100. The largest catch of all was made at twenty fathoms (Station 10091); and the depths of the rich hauls south of Cape Cod (Stations 10060, 10061, 10065) were twenty to forty fathoms. *Limacina bala* covers a considerable range both of salinity and of temperature: but was never found in the warm salt Gulf Stream water, nor is it at home anywhere in tropical seas. According to Meisenheimer (1906), it is the only pteropod endemic in the northern boreal region; and is a good index of boreal waters. All the captures were from salinities of 31.8‰ or more, and the absolute maximum may have been higher than 35‰ (Station 10064). But the few specimens from that Station were probably only stragglers from the coast waters. The maximum salinity for the rich hauls was 32.5‰-33.2‰. At the two Stations (10091 and 10104) in the Gulf where swarms were encountered, the salinities were respectively 32.5-32.6‰ and 31.9-32.5‰. Thus in summer the optimum for *Limacina bala* is neither the freshest coast water, with salinities of 32‰ or less, nor the ocean water outside the continental slope with salinity above 33‰, but the transition water.

The temperature can be precisely stated for only four captures, *i. e.*, 55° (Station 10059), 55° (Station 10097, surface), about 48° (Station 10095); and 61° at Station 10103 (surface). But the fact that no specimens were taken at the surface at any of the stations south or west of Cape Cod indicates that none of the captures were from temperatures above 60° except possibly in one or two instances; and even then (Stations 10064, 10065) the specimens may have been living in much colder water. The rarity of *Limacina* on the surface in the Gulf of Maine further simplifies the problem, because, to assume that the specimens came from even as small a depth as five fathoms, lowers the upper limit of temperature for most of the captures to about 58°. On the other hand, most of the Gulf specimens were certainly from water warmer than 46° (Stations 10091, 10095-10104); and we have no proof that any of them were living in water colder than this, for though the deep water temperature was 43° at several stations, there is no reason to suppose that the specimens of *Limacina* came from the deepest layers (p. 304). The other northern pteropod, *Clione limacina*, was restricted to the Gulf of Maine, where it was decidedly rare. And we have never found it common in the Gulf, although specimens

occasionally appear there both in summer (1914a) and in winter (1914b).

The demarcation between the ranges of *Limacina balea* and of the warm water pteropods and heteropods, *i. e.*, the various species of *Creseis*, *Corolla*, *Limacina inflata*, *Pterotrachea*, *Firoloida*, and *Atlanta*, was remarkably sharp, for the latter were only taken at the southern and Gulf Stream stations where *Limacina balea* was lacking (Fig. 72); and not a specimen of any of them was found at any of the northern stations where *Limacina balea* occurred, except for a single *Atlanta* off Gloucester. They are all oceanic, as pointed out by Meisenheimer (1905). None of them occurred regularly, only one (*Creseis conica*) at as many as five of the eighteen stations south of the limits of *Limacina balea*; and the total number of specimens of this species was only forty-nine. The other warm water forms were even more sporadic in their distribution:—*Corolla calceola*, *Firoloida*, and *Creseis acicula* occurring at four stations each; the others at only one or two. Under these circumstances it is impossible to say much about the influence of hydrographic conditions on their distribution further than to point out that all have a southern, or oceanic origin, and that it is doubtful whether any of them would have been found in the coast water in winter. Direct evidence to the effect that they are summer visitors only is afforded by the fact that none of them were taken by Capt. McFarland off Cape May in May, 1913, although several were encountered there in July.

The occurrence of two living specimens of *Diatria trispinosa*, and of an *Atlanta*, in a haul off Gloucester early in July is surprising, because it is certain that neither of these genera is a regular inhabitant of the Gulf of Maine; both belong to the warmer parts of the north Atlantic, not to boreal waters (Meisenheimer, 1905). It is difficult to account for their presence, because they were taken with an otherwise typical boreal assemblage of plankton organisms, *e. g.*, *Calanus*, *Euthe-misto*.

#### PELAGIC HYDROIDS.

BY C. MCLEAN FRASER.

During the month of July, 1913, the GRAMPUS made a collection of floating hydroids off George's Bank, which, through the kindness of Dr. H. B. Bigelow, was sent to me for examination. Under ordinary circumstances the material would scarcely be worth a comment as



none of the various species found are new to the Atlantic Coast or even rare, but when the location is taken into consideration and the effect of the conditions of such a location on at least two of the species, the collection proves to be of more than passing interest.

It is not unusual to find fragments of hydroid colonies torn from their support or from the rest of the colonies, living for a considerable time as they float on the surface. The majority of the species in this collection are represented by just such fragments, but the fact that there are so many of these species must indicate that in this region a vortex must be formed by currents whose influence reach to the shallow water some distance away. Furthermore, it would seem that some time not so very long previous to the time of collection, there must have been a rather violent storm, sufficient to make the effect of the waves felt at a greater depth than usual, as some of the species represented are not usually found at low tide or even in very shallow water. It is doubtful if any data have been obtained as to the length of time that fragments or even whole colonies of hydroids would live under such conditions. It is quite true that Sargassum torn away by storms, will carry hydroids in a perfectly fresh condition for weeks, during which time they may be carried hundreds of miles by the current, but the case is scarcely parallel as the Sargassum itself remains in good condition during this period unless it drifts ashore and dries out in the sun. In the present instance, no support was present in any case except portions of blades of eelgrass. Even here if the roots were attached, the eelgrass would remain fresh for some time, but there were no roots. There were only small fragments of leaves that may have been dead before they were carried away. In the majority of cases even this support was lacking, while one species, *Clytia cylindrica*, to which special attention is paid later, ordinarily making much use of a support, apparently regenerated and continued to grow without any support.

Doubtless if the spot where these were found is a vortex, there would be abundance of food material and the hydranths would not suffer in that regard. They might be better off even than in their own habitat. If light and specific gravity have any special directive influence on the growth of the colony, some power must have been exerted to overcome it, since the different position of the support or the lack of it places the colonies in entirely new positions. Many cases of adaptability to unusual circumstances have been cited among hydroids and this must be added to the list.

The thirteen species found make quite a varied collection, as only

in two cases is a genus represented by more than one species, although but four families are included. *Clytia cylindrica* forms the great bulk of the material, although there is a good supply of *Obelia geniculata*; and *Diphasia rosacea*, *Sertularia cornicina*, and *Campanularia calceolifera* are represented by good specimens. The remainder of the list consists of larger or smaller fragments. In many cases gonangia are present.

*List of Species.*

EUDENDRIDAE

*Eudendrium ramosum* (Linné)

CAMPANULARIDAE

*Campanularia calceolifera* Hincks

*Clytia cylindrica* Agassiz

*Obelia geniculata* (Linné)

HALECIDAE

*Halccium articulatum* Clark

*halccinum* (Linné)

SERTULARIDAE

*Diphasia rosacea* (Linné)

*Hydrallmania falcata* (Linné)

*Sertularella gayi* (Lamoroux)

*Sertularia cornicina* (McCrary)

*Thuiaria argentea* (Linné)

*cupressina* (Linné)

*thuja* (Linné)

*Clytia cylindrica* Agassiz (Fig. 73, 74)

This species was first described from Massachusetts Bay by L. Agassiz,<sup>1</sup> and has since been collected at various points near Woods Hole. It has not been reported to the northward but the range extends far southward as I have found it in abundance at Beaufort, N. C.<sup>2</sup>

<sup>1</sup> Cont. nat. hist. U. S., 1862, 4, p. 306.

<sup>2</sup> Hydroids of Beaufort, N. C. Bull. U. S. bureau fisheries, 1912, 30 p. 358.

The stolon commonly runs along its support nearly in a straight line and it never forms a very complicated network. From the stolon the individual zooids arise, the pedicel being usually rather rigidly erect. In the GRAMPUS material there are hundreds of colonies all of them entirely removed from their support. I say "removed" because one can scarcely conceive of a planula settling down to form a hydroid colony unless it had something on which to settle. As the stolons adhere quite closely to their means of support, they must have been

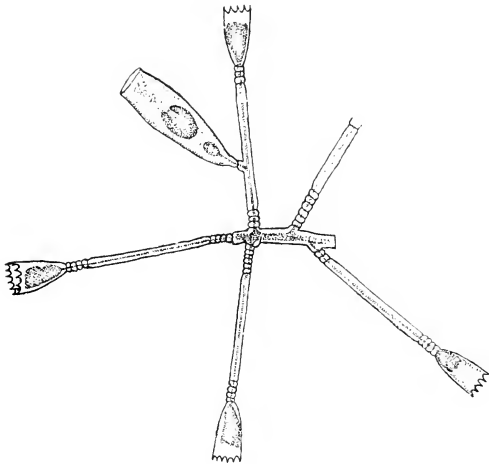

FIG. 73.— *Clytia cylindrica*.

torn away with some violence so that the stolons were broken in pieces as well. This separation and setting adrift produced complications, to the results of which reference must now be made.

With the first glance at a mass of this material one is immediately impressed with the fact that there are very few free stolon ends. In colonies collected under ordinary conditions, we can usually see the growing ends of the stolons. Here there seems to be nothing of the kind except in very rare instances. What has happened to them? Again one would suppose that when the colonies were torn away there

would be one or two free broken ends for each piece, but one does not find it so. Occasionally a single free end may be found but scarcely ever two free ends on the one piece.

In the case of the growing end of the stolon it appears that since there is no longer any inducement to continue in the same general direction in which growth has previously taken place, on account of the lack of support, the growth is completed by producing a zooid which thus terminates the stolon and leaves no free growing end. The lack of free broken ends seems bewildering at first and it seems permissible to conclude that here is something new in hydroids, viz:—colonies developing from planulae at the surface of the high seas, for how could so many colonies, perfect ones at that, appear if they had been broken away from their regular support. Further examination

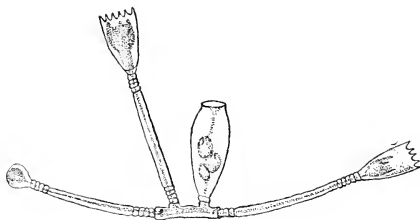

FIG. 74.—*Clytia cylindrica*.

brings out the fact that regeneration is responsible for the deception, but conditions must be very favorable for such regeneration since in almost every instance a zooid is growing out from the broken end and all are in good condition. In many cases the regenerated portion is so nearly equal in size to the original part, both in the perisarc and in the coenosarc, that it is difficult to detect the junction and hence the deception is complete. In other cases the regenerated part is sufficiently smaller to be readily noticed.

Besides the zooids that grow out from the broken ends, others appear to have developed in the regular way after the separation from the support, as, instead of coming off regularly in the one direction, they may come off on any side of the stolon to make the colony decidedly irregular (Fig. 73). Commonly when a straight piece of stolon regenerates, a zooid grows out from each end in line with the stolon itself, while the zooids previously attached were at right angles

to this (Fig. 74). The directive influence which causes the regular erect growth must be overcome in such a case since two of them grow in a diametrically opposite direction. There seems to be no hindrance to the growth of the hydranths, as they are found in various stages of development as well as in the adult condition, and when they were preserved several of them had undigested food in the enteric cavity. The development of the gonophore is not interfered with either, as medusae of different ages are found in the gonangia and some free medusae were found just liberated in the plankton. All the gonophores were found either on the stolon or on original pedicels, none on the regenerated portions.

Regeneration is no new thing in hydroids as it has been noticed by many observers, but I know of no case where anything on such a large scale as this and in such a location has been recorded. It is quite possible that some of the experimental work that has been done on such forms as *Tubularia crocea* and *Hydractinia echinata* would have given more satisfactory results if it had been done on *Clytia cylindrica*. It may be that the election of gymnoblastic forms for such experiments might have been improved upon by taking some of the simple calyptoblastic species. I am very doubtful if under artificial conditions in any case regeneration could be successfully brought about in over 99% of the cases as it must have been here if one is to judge from the generous sample that was collected.

*Obelia geniculata* (Linné). (Fig. 75-78).

As this is a cosmopolitan form and as it has been described and figured in so many instances, a description of a typical specimen from a typical locality is quite unnecessary, but as many of the specimens in this material are not typical and as the location is unique, mention is especially made of the species here.

Two lots of specimens were present, both attached to eelgrass. In one case the stolon ran irregularly along throughout the whole length of the fragment of eelgrass, on both sides, making rather a dense mass. In the other case a few colonies were distributed among several colonies of *Sertularia cornicina*. I do not know that *O. geniculata* is commonly found on eelgrass, as I do not remember having found it there, or of having seen it recorded as so growing, but it does grow on certain Algae and hence the difference in the nature of the support is not sufficient to make this case remarkable. Other species, *c. g.*,

*O. longissima*, are very often found on floating eelgrass, hence as long as the eelgrass fragments are of sufficient size to form a good basis of support for the stolon, it is not especially remarkable that *O. geniculata* should remain in good condition when floating. However, in hundreds of cases where *O. longissima* has been seen floating, there has been no great difference observed from the regular type (that may be because it very generally is found attached to floats, etc., where it is near the surface at all times), but in these specimens

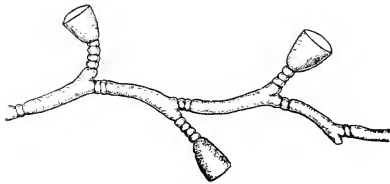

FIG. 75.—*Obelia geniculata*.

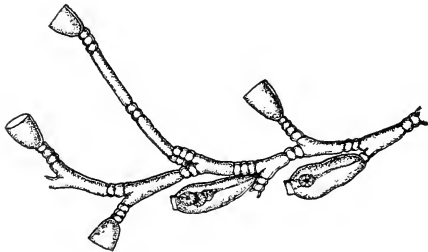

FIG. 76.—*Obelia geniculata*.

there are some unusual features, that may have been caused by a certain tendency towards orientation disturbed on account of a change in the position of the support. This change does not show itself in the hydranths themselves as they seem perfectly normal, possibly because the hydrotheca pedicels have sufficient adaptability to allow for sufficient change. In the stems, however, there is variation. Some of them are quite typical (Fig. 75) but a large number of them

are more branched than usual, so much so, that if they were examined by themselves they would scarcely be recognized as belonging to the species. The branching sometimes is far from being regular, the position and the length of the branches vary so much. From a stem that is otherwise normal, there may be one or two hydrothecae borne on much elongated pedicels, arising either as ordinary hydrotheca pedicels, or in the axils of these. They are annulated slightly at both ends as well as towards the centre, with smooth places between (Fig. 76). The stem internodes, which typically are quite uniform in length, vary much in this respect in some specimens and the nature of the geniculation at each node also varies. The terminal internode may be much prolonged into a tendril-like process such as occurs late in the season in *Campanularia angulata*, *Obelia commissuralis*, and other similar species. These tendrils are noticeable chiefly on account of their breadth and the bluntness at the end (Fig. 77). Within the



FIG. 77.—*Obelia geniculata*.

perisarc, at the end, the coenosarc has the appearance of a developing hydranth but no case was observed where such a hydranth had really developed.

In a previous paper<sup>1</sup> I referred to a specimen of this species in which the gonophores were in an unusual position. In this material a still greater variation occurs. Some gonophores are placed typically, *i. e.*, in the axils of the hydrotheca pedicels. Others appear as those in the above reference, *i. e.*, in place of hydrothecae (Fig. 76). Besides these there were several in a row growing directly from the stolon (Fig. 78). They have similar short, annulated pedicels to those in the normal position and agree very well with them in other respects, although they are slightly larger than the others usually are. The development has not been stopped at any rate, as the young medusae were in as good condition as they were in any of the others. If the

<sup>1</sup> Hydroids from Nova Scotia. Victoria Memorial Museum, Bull., 1913, no. 1, p. 167.

growth of the gonophores in this position is due to the change in position of the support of that particular part, the whole growth of these must have taken place after the colonies had been torn away.

Another instance is here exhibited of the ready interchange of the various parts of the colony and, here as well as in *Clytia cylindrica*, of considerable power of adaptability to varying conditions.

#### MEDUSAE, SIPHONOPHORES, CTENOPHORES.

The identifications in the table (p. 316-317) require explanation.

All with broad stomach, smooth subumbrella and considerable numbers of tentacles and canals are classed here as *Ae. aequorea*.

*Aequorea groenlandica* Péron et Lesueur. I follow Mayer (1910, p.

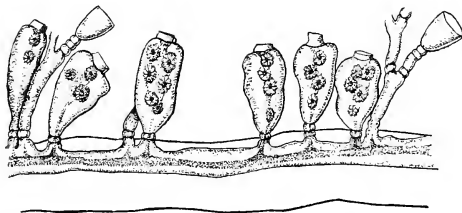

FIG. 78.—*Obelia geniculata*.

335) in identifying as a southern race of *Ae. groenlandica* the large aequorid, with stiff gelatinous substance, and numerous subumbrellal gelatinous papillae radially arranged, which is common off the coast of New Jersey in summer and autumn. The southern race has been recorded so seldom that a few counts of the radial organs are given:—

Station	Diam. mm.	Tentacles	Canals
10069	100	110	89, all with gonads
10075	75	71	96, 3 branched
"	75	68	88, 1 "
"	70	61	106, all simple
"	50	50	85, all simple

*Aglantha digitale* Fabricius. The status of the two forms of *Aglantha*, so often recorded from northern waters as "*rosea*" and "*digitale*,"



has been the subject of much discussion. The two have usually been separated according to the number of otocysts, specimens with eight being classed as *rosea*, those with four as *digitale*. But such a division is purely artificial, because specimens often have five, six, or seven otocysts. Mayer (1910) unites the two unequivocally. I have followed him in my discussion of *Aglantha* from Behring Sea (1913a) and Kramp (1914, p. 432) likewise concludes that the number of otocysts is not sufficiently constant to afford a specific character, though maintaining that *rosea* is recognizable as a variety of *digitale*. It is doubtful, however, whether even this last characterization of *rosea* will stand the test of time.

Every specimen of *Aglantha* in the present collection which was in good enough condition to show the otocysts at all had at least seven, and their spacing along the margin of the bell was such as to show that the number in life was eight. These specimens range from 7-11 mm. in height, with 39-94 tentacles; and are at various stages of maturity, from one with no gonads to one in which they are fully developed. The many specimens which I have studied from Labrador and Newfoundland likewise had eight otocysts (1909c, p. 312). These were recorded under the name *rosea*, following the custom usual at that time, for *Aglantha* with eight otocysts. And although Kramp (1913a, p. 527) has recently questioned whether these specimens were actually *rosea*, it was so simple a matter to count the otocysts that there can be no doubt that they belonged to the form with eight of these organs, no matter what may be its final nomenclatural resting place. And I may add that all the specimens of *Aglantha* from American waters, Atlantic or Pacific, on which I have been able to count the otocysts have more than four; usually eight.

*Cyanea*. The specimens from the Gulf of Maine and from George's Bank belong to the large, red northern race ("*arctica*"); but we found only the small yellowish form (*fulva* L. Agassiz) south of New York.

*Stephanomia cara*. The generic identity of the material is established by the fact that the few tentilla still intact have the involucre and single terminal filament. And the bracts and nectophores, which were taken in great numbers, agree perfectly with *S. cara* as described by A. Agassiz (1865) and by Fewkes (1888). But unfortunately the material was not in good enough condition to show whether or not the northern *cara* is actually separable from the southern *bijuga*.

*Pleurobrachia pileus*. Mayer (1912) has recently described a new *Pleurobrachia*, *P. brunnea*, from just the locality where *Pleurobrachia* was found in greatest numbers; which makes a review of the grounds on which I class our specimens as *pileus* desirable.

	10057	10058	10059	10060	10061	10063	10064, 20-0 F.	10064, 175-0 F.	10066	10067	10069	10070	10071, 20-0F.
HYDROMEDUSAE													
<i>Steenstrupia rubra</i>	.....	.....	.....	.....	.....	.....	.....	.....	.....	.....	.....	.....	.....
<i>Niobia dendrotentacula</i>	.....	.....	.....	.....	.....	.....	.....	.....	.....	.....	.....	.....	.....
<i>Calycopsis typa</i>	.....	.....	.....	.....	.....	.....	.....	1	.....	.....	.....	.....	.....
<i>Obelia</i> sp.?	.....	.....	.....	m.	.....	.....	.....	.....	.....	.....	.....	.....	.....
<i>Melicertum campanula</i>	×	.....	.....	.....	.....	.....	.....	.....	.....	.....	.....	.....	.....
<sup>1</sup> <i>Staurophora mertensii</i>	.....	.....	.....	.....	.....	.....	.....	.....	.....	.....	.....	.....	.....
<i>Laodicea cruciata</i>	.....	.....	.....	.....	.....	.....	.....	.....	.....	.....	.....	.....	.....
<i>Tiaropsis diademata</i>	2	.....	.....	.....	.....	.....	.....	.....	.....	.....	.....	.....	.....
<i>Mitrocoma cruciata</i>	×	.....	.....	.....	.....	.....	.....	.....	.....	.....	.....	.....	.....
<sup>1</sup> <i>Phialidium languidum</i>	.....	.....	.....	.....	.....	.....	.....	.....	.....	.....	.....	.....	.....
<i>Aequorea aequorea</i>	.....	.....	.....	.....	.....	.....	.....	.....	.....	.....	×	.....	.....
" <i>groenlandica</i>	.....	.....	.....	.....	.....	.....	.....	.....	.....	.....	×	.....	.....
<i>Aglaura hemistoma</i>	.....	.....	.....	.....	.....	.....	.....	.....	.....	.....	.....	.....	1
<i>Aglantha digitale</i>	2	.....	.....	12	2	.....	.....	1	.....	.....	22	.....	.....
<i>Rhopalonema velatum</i>	.....	.....	.....	.....	.....	.....	.....	.....	.....	.....	1	.....	.....
<i>Liriope scutigera</i>	.....	.....	.....	.....	.....	.....	.....	.....	.....	.....	.....	.....	.....
<i>Geryonia proboscidalis</i>	.....	.....	.....	.....	.....	.....	.....	.....	.....	.....	.....	.....	.....
<i>Cunoctantha octonaria</i>	.....	.....	.....	.....	.....	.....	.....	.....	.....	.....	.....	.....	1
SCYPHOMEDUSAE													
<i>Cyanea capillata</i>	×	.....	×	.....	.....	.....	.....	.....	.....	.....	×	.....	.....
<sup>2</sup> <i>Aurelia aurita</i>	.....	.....	.....	.....	.....	.....	.....	.....	.....	.....	.....	.....	.....
SIPHONOPHORAE													
<i>Abylopsis eschscholtzi</i>	.....	.....	.....	.....	.....	.....	.....	.....	.....	.....	.....	.....	1
<i>Galeolaria quadrivalvis</i>	.....	.....	.....	.....	.....	.....	.....	.....	.....	.....	.....	.....	×
<i>Diphyes appendiculata</i>	.....	.....	.....	.....	.....	.....	.....	.....	.....	.....	.....	×	×
<i>Agalma okeni</i>	.....	.....	.....	.....	.....	.....	.....	.....	.....	.....	.....	.....	3
<i>Agalma elegans</i>	.....	.....	.....	.....	.....	.....	m.	.....	.....	.....	.....	.....	.....
<i>Stephanomia cara</i>	×	×	×	.....	.....	.....	.....	.....	.....	.....	.....	.....	.....
<i>Physophora hydrostatica</i>	.....	.....	.....	.....	.....	.....	×	.....	.....	.....	.....	.....	.....
<i>Rhizophysa fliformis</i>	.....	.....	.....	.....	.....	.....	1*	.....	.....	.....	.....	.....	1
<i>Physalia physalis</i>	.....	.....	.....	.....	.....	.....	×	.....	.....	.....	.....	.....	.....
CTENOPHORAE													
<sup>1</sup> <i>Pleurobrachia pileus</i>	.....	.....	.....	×	.....	×	.....	.....	×	×	×	×	.....
<i>Bolinopsis infundibulum</i>	×	.....	.....	.....	.....	.....	.....	.....	.....	.....	.....	.....	.....
<sup>3</sup> <i>Mnemiopsis leidyi</i>	.....	.....	.....	.....	.....	.....	.....	.....	.....	.....	×	.....	.....
<i>Beroe cucumis</i>	×	×	.....	.....	.....	.....	.....	.....	.....	.....	.....	.....	.....
<sup>4</sup> <i>Beroe forskalii</i>	.....	.....	.....	.....	.....	.....	.....	.....	.....	.....	.....	.....	.....

<sup>1</sup> For the occurrences of *Phialidium languidum*; *Staurophora mertensii* and *Pleurobrachia pileus* in the Gulf of Maine, see table, p. 273.

<sup>2</sup> Noted occasionally near land in the Gulf of Maine.

\* On the surface.

<sup>3</sup> Also seen at other localities, p. 271.

<sup>4</sup> Also taken in Chesapeake Bay.

10071, 190-0 F.	10072	10073	10074	10075	10076	10077	10078	10079	10080	10081	10082	10085	10086	10087	10088	10090	10095	10096	10097	10099	10100
1	1 m.		m.																		
		×	×			×	×							×	×						
	×		1	×	×	×		×	×	×	×										
	1		1 9			m.	m.										×	9	1		6
				×		×		×				×		×							×
			1																		
	2		m.						8												
					1										×						
	×		×	×		×		×	×		×	×	×								
	×	×					×		×	×						×					
				×		×	×												×		

The characters by which he (1912, p. 14) separates his *brunnea* from *pileus* are that it is more oblong and egg-shaped, by the opaque yellow-brown color of the stomodaeum, and by the presence of terminal knobs on the tentacles. But the specimens from near New York and further south were quite as globular in life as any I have collected elsewhere, though now more or less contracted by preservation. The question whether or not the tentacles end in terminal knobs is easily settled in life; and in no case did I see anything which could be interpreted thus. And the tentacles are sufficiently extended in many of the preserved specimens to show that their calibre is uniform to the tip. In many, it is true, these organs are more or less thickened near the end; but this is obviously the result of contraction. Most of the specimens, as might be expected, are so violently contracted that it is impossible to determine anything about the tentacles. As to color, the stomodaeum in many of the southern specimens was of a pale reddish hue in life; but I have also found it so in northern specimens. Furthermore, the proportional lengths of apical canal and stomodaeum, and the relative level at which the adradial canals join the meridionals in the southern specimens are well within the range of variation of typical *P. pileus*.<sup>1</sup> In short there is nothing to separate southern from northern specimens except that the former were, as a whole, rather smaller.

*P. brunnea* may still be worthy of recognition; but it is not contained in the GRAMPUS collections, and until specimens agreeing with Mayer's account are reëxamined, its status will be dubious.

#### DISTRIBUTION OF PELAGIC COELENTERATES.

Pelagic coelenterates fall into two distinct categories according as they are, or are not bound to the coast line by a fixed stage, *i. e.*, they are either neritic or oceanic. And though some genera, for example *Niobia*, bridge the gap, they are not sufficiently abundant to invalidate the general classification. Among the neritic warm water species are *Stenstrupia rubra*, *Laodicea cruciata*, *Aequorea groenlandica* and the southern form of *Cyanea capillata*. Probably *Calycopsis typa* is also neritic if the term is used in its broad sense, for there is reason to believe that it passes through a hydroid stage on the continental slope (1909b). Omitting it for the moment, however, because

<sup>1</sup> I have been able to compare the collection with a large series from northern waters

of its deep-water habit, this southern neritic group was limited to a coastal zone south of New York, some forty-five miles broad (Fig. 79, Stations 10069, 10072, 10073, 10074, 10075, 10076, 10077, 10078, 10079, 10080, 10082). We found none of these species north of New York; but most of them appear along the southern shores of New England later in the season. The most important of the group, fau-

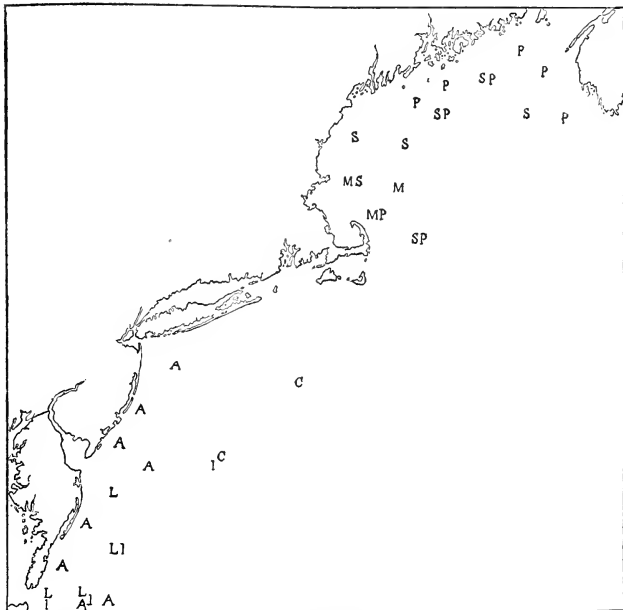

FIG. 79.— Occurrence of some neritic Medusae, July–August, 1913.

A, *Aequorea groenlandica*, southern form; I, *Liriope scutigera*; L, *Laodicea cruciata*; M, *Melicertum campanula*; P, *Phialidium languidum*; S, *Staurophora mertensii*.

nistically, *Aequorea groenlandica*, was confined to the waters over the inner half of the continental shelf south of New York; spreading seaward to the slope off Chesapeake Bay, but absent in the edge of the Gulf Stream (Station 10071) and in the tongue of ocean water off Dela-

ware Bay (Station 10073), its range being slightly more extensive than that of *Mnemiopsis leidyi* (p. 322). Probably it was the Chesapeake current which carried it to the outer edge of the shelf off Chesapeake Bay. *Acquorea groenlandica* like *Mnemiopsis* was living chiefly at the surface and for a fathom or so down, the deeper hauls yielding very few even where many were seen floating past the ship. The range of salinity was from about 31.3‰ (Station 10077) to about 34‰ (Station 10076), the temperature from about 65° to about 77°.

The boreal neritic species are *Melicertum campanula*, *Staurophora mertensii*, *Mitrocoma cruciata*, *Tiaropsis diademata*, *Phialidium languidum*, and the northern form of *Cyanea capillata*. In July and August these are all confined to the waters east and north of Cape Cod, (Fig. 79) though they appear in winter in the sounds and bays, as far west as Narragansett Bay. The occurrence of *Phialidium*, and *Staurophora* has been commented on (p. 274), and I need merely add that the rarity of the others in the central part of the Gulf agrees with our experience in 1912 (1914a).

Two important species, *Mnemiopsis leidyi* and *Pleurobrachia pileus* are intermediate between neritic and oceanic, for though neither has a fixed stage, and though *Pleurobrachia* occasionally occurs far from land, it is distinctly a creature of coast waters rather than of the open ocean (Kramp, 1913a, p. 532), while this is even more true of *Mnemiopsis*. The range of *Pleurobrachia* extends unbroken from Labrador (1909c) at least as far south as Pamlico Sound (1913a, p. 111) and perhaps farther. And we found it more generally distributed in the coast waters than any other coelenterate, swarming locally south as well as north of Cape Cod (Fig. 80).

From the distributional standpoint, localities where a species does not occur may be fully as significant as those where it does. And this is particularly true of *Pleurobrachia*, for it was absent in the inner edge of the Gulf Stream (Stations 10061, 10064, 10071, 10076, in the shoreward tongue of the Gulf Stream off Delaware Bay (Station 10073), on the one hand, and in the fresh water at the mouth of Chesapeake Bay (Station 10078) on the other. Otherwise there were only two Stations over the shelf where we failed to capture it (10081, 10083), at one of which (10083) the nets yielded very little of anything (p. 272). *Pleurobrachia* was taken at exactly half the stations in the Gulf of Maine, a rather larger proportion of occurrences than in 1912 (1914a, p. 126). But the species was rather more restricted in its range in the Gulf than in that year, occurring only once (Station 10103) in the coastal zone between Cape Ann and Penobscot Bay; and not at all in the central part of the Gulf (Stations 10090, 10092, 10093).

Although Pleurobrachia was widely distributed, it was by no means uniformly abundant. Its chief centre was from off New York (Stations 10067, 10068) nearly to Cape May (Stations 10069, 10080), where the deep water layers were filled with it, almost to the exclusion of other plankton (p. 269), extending for some twenty-five or thirty miles

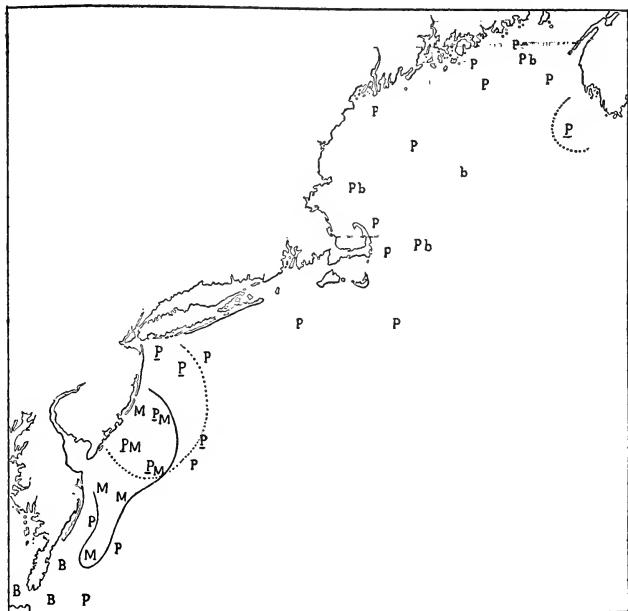

FIG. 80.— Distribution of ctenophores, July–August, 1913.

B, *Beroe forskalii*; b, *B. cucumis*; m, *Mnemiopsis leidyi*; P, *Pleurobrachia pileus*; P, *P. pileus* swarms. . . . , probable limit to *P. pileus* swarms.  
 ———, probable limit to *Mnemiopsis* in July.

seaward (Stations 10072, 10070) beyond which their numbers rapidly decreased. It was still numerous when this region was passed again on August 1, on our way north (Station 10082). South of Cape May it was much less common, and very few were taken over the shelf east

of New York (Stations 10060, 10063, 10066). The only place where *Pleurobrachia* was abundant in the Gulf of Maine in 1913 was German Bank (Station 10095), where small specimens swarmed. The southern swarm of *Pleurobrachia* only once reached the surface (off Scotland light-ship, July 12). Elsewhere it was limited to depths below about five fathoms; the water being from 15-30 fathoms deep over its area of abundance in this region. There were no *Pleurobrachia* in the immediate surface layers where *Salpae* and *Mnemiopsis* often swarmed (p. 269). And the absence of *Pleurobrachia* in the immediate surface layers and on the surface can not be credited to the effect of sunlight, because this was as true of night as of day time stations. Most of the Gulf of Maine captures were likewise in deep hauls; and there were none on the surface on German Bank, where a rich haul of *Pleurobrachia* was made at twenty fathoms.

The shallowness of the water in the region where *Pleurobrachia* was most abundant, and the general rarity of the genus on the surface, make it easy to establish the salinity and temperature in which it was living. The warmest water in which we can certainly establish its presence is  $69^{\circ}$  (Station 10066, surface), though some of the specimens from Stations 10074, 10077, and 10079, may have come from still warmer water. And south of New York in general the captures must have been in water warmer than  $59^{\circ}$ , that being the lowest temperature through which the nets fished. The swarm off New York was in temperatures of  $50^{\circ}$  (ten fathoms) to  $65^{\circ}$  (surface near Scotland light-ship). East of New York *Pleurobrachia* was usually living in water colder than  $60^{\circ}$ , with the minimum certainly as low as  $48^{\circ}$  (Station 10095), probably as cold as  $43^{\circ}$  (deep hauls in the Gulf). That is to say the genus covered practically the entire range of temperature encountered during the cruise, except the very warmest. It is not surprising to find *Pleurobrachia* at home in extremes as wide apart as this, because its range is known to be practically independent of temperature. Nevertheless, there is some evidence that specimens of *Pleurobrachia* grow much larger in cold than in warm water, as Esterly (1914) has pointed out for the *Pleurobrachias* of the west coast of the United States. And our captures strengthen this view, for although the genus swarmed in water warmer than  $58^{\circ}$  off New York and further south, the specimens taken there were all small (less than 10 mm. long). It was only in the cold water of the Gulf of Maine that we found large specimens; and work in previous years has shown that specimens upwards of 30 mm. long are common at the mouth of the Bay of Fundy, in summer, in temperatures of  $50^{\circ}$ - $55^{\circ}$ .



The extreme range of salinity for *Pleurobrachia* was from about 31.6‰ (surface, Station 10066) to about 35‰ (fifteen fathoms, Station 10074). But most of the captures were from water of about 32‰-33.4‰. And there is only one Station where it is safe to assert that *Pleurobrachia* was living in water salter than 34‰, *i. e.*, at Station 10074, where the number taken in the horizontal haul at fifteen fathoms was so large that most of them must have been captured at about that depth, not in the short column of water through which the net fished on its way down and up (there were none on the surface). The major part of the haul at Station 10077 was likewise in water of about 34.5‰; but so few specimens were taken that they may have come from anywhere between the surface and the greatest depth reached by the net; *i. e.*, from a salinity anywhere between 31.4‰ and 35‰. The southern swarm was living in water of about 32‰ to 33.2‰; the northern one (German Bank) in 32.8‰ to 32.9‰.

Rose (1913) has recently shown that the density of the water influences the vertical movements of *Pleurobrachia*; it is therefore worth while to correlate this physical constant with records for the genus. Near New York, where the captures can be located within a few fathoms because of the shallow water, they were from densities ranging from 1.022 (Station 10066, surface) to upwards of 1.0237. And the specimens taken at Stations 10082 and 10074 probably were living at a density of about 1.0252 to 1.0254. But the German Bank specimens were in much heavier water (nearly 1.026). Thus there does not seem to be any connection between the occurrence of *Pleurobrachia*, and density within a range of 1.022 to 1.026. But it is noteworthy that we found none in water lighter than 1.022, and seldom in densities less than 1.023, while it is doubtful whether any specimens were living in the densities of 1.027 and over, which characterize the bottom water of the deeper parts of the Gulf of Maine.

*Mnemiopsis leidyi* was generally distributed over the inner half of the continental shelf between Barnegat and Delaware Bay; and the mid-zone of the shelf south of the latter (Fig. 80). None were seen north of Barnegat though the species is abundant in the bays and sounds of the southern coast of New England later in the season, or off Chesapeake Bay. But the latter is not its southern limit, though it may interrupt the continuity of its range. It was most abundant near the coast, from Barnegat to Cape May, and again between Stations 10074 and 10075, swarming on the surface in myriads, and causing brilliant phosphorescence at night. And it seems to have been limited to a very shallow surface zone, the few taken in the deep

hauls having probably been caught in the passage of the net down and up. The salinity in which it was living ranges from 32.1‰ (Station 10081) to 33.48‰ (Station 10073), the optimum, as shown by greatest abundance, being 32.2‰ to 33‰. The upper limit of temperature was 76° (Station 10080), its lower limit was probably about 60° (the five fathom reading at Station 10069). Thus it was living in warm water; but not in salt Gulf Stream water on the one hand, nor where the salinity is lowered below 32‰ by the influence of the Chesapeake, on the other. And this agrees with its known occurrence, for, according to Mayer (1912, p. 34) it is a creature of the pure sea water along the outer shores, its place being taken by another species, *M. gardeni*, in the brackish bays.

The swarms of Mnemiopsis and of Pleurobrachia were mutually exclusive, for though both were often taken at the same station, Mnemiopsis was invariably limited to the surface waters which it shared with the various Salpae (p. 269), Pleurobrachia to the deeper layers. Pleurobrachia and Mnemiopsis were not found side by side on the surface.

The oceanic, like the neritic coelenterates of our waters, fall into two more or less overlapping groups, according as they are at home in high or in low temperatures (Fig. 81). The most typical member of the former found in our coastal waters is *Aglantha digitale*. The captures are so scattered, and from waters of such different salinities and temperatures that they throw very little light on the conditions which are the optimum for the genus. But it is significant that although *Aglantha* was as abundant off Barnegat as on German Bank, only one fragmentary specimen was taken anywhere within the immediate influence of the Gulf Stream. And I may further point out that though it is a constant inhabitant of the Gulf of Maine, it never seems to attain the faunal prominence there, or anywhere further south, that it does off the coasts of Newfoundland and Labrador, or in Greenland waters. It is a creature of cold water, limited in its southern extension by the Gulf Stream.

The southern oceanic members of the list are *Niobia dendrotentacula* (put in this group by its asexual multiplication), *Aglaura hemistoma*, *Rhopalonema relatum*, *Geryonia*, *Cunoclantha octonaria* and the siphonophores *Abylopsis*, *Diphyes*, *Galeolaria*, *Agalma okeni*, *Physophora*, *Rhizophysa*, and *Physalia*. The largest catch of these species was in the edge of the Gulf Stream (Station 10071) where no less than eight of them were taken; and four were taken at Station 10074. One or other of them was likewise taken at Stations 10064, 10070, 10076.

That is to say, it was only in the waters of the Gulf Stream or over the outermost part of the continental shelf that they formed an important constituent of the pelagic fauna. The genus *Liriope* is also usually classed as among the typically oceanic Medusae. And this is cer-

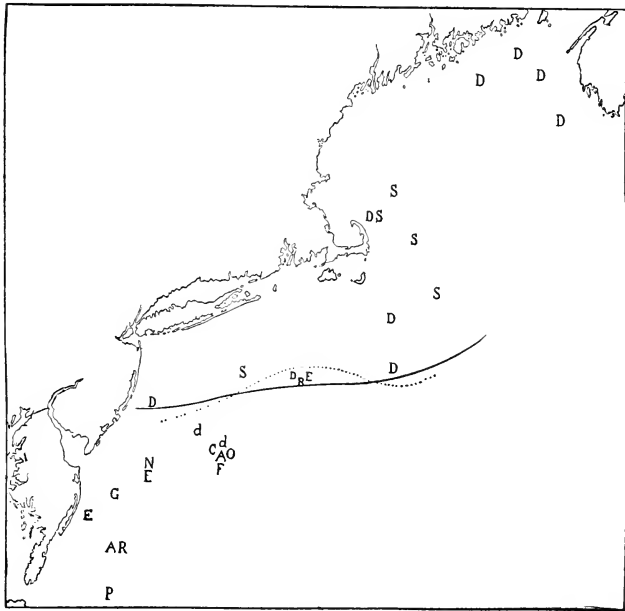

FIG. 81.— Distribution of oceanic Medusae and siphonophores, July–August, 1913.

A, *Aglaura hemistoma*; D, *Aglantha digitale*; d, *Diphyes*; e, *Agalma elegans*; f, *Rhizophysa filiformis*; g, *Geryonia*; n, *Niobia dendrotentacula*; o, *Agalma okeni*; p, *Physophora*; r, *Rhopalonema velatum*; s, *Stephanomia cara*.

....., probable limit to tropical species in July. ———, S, probable limit to *Aglantha digitale*.

tainly true of *L. tetraphylla*. But the species found off Chesapeake Bay, *L. scutigera* (p. 316), is so common in southern harbors and bays, that it can hardly be considered as oceanic. *Agalma elegans*, too,

though certainly not neritic, is not oceanic in the true sense, because most of its records are from the neighborhood of land, not from the high seas, in marked contrast to *A. okeni*.

#### QUANTITATIVE HAULS IN THE GULF OF MAINE.

Quantitative hauls were made at fourteen of the Gulf of Maine stations; and they are directly comparable with one another because the interval of time between the first and last haul was so short (six days) that they can be considered as practically simultaneous. The volumes of plankton under each square meter of sea area, calculated from them were:—

Station	cc. in a column 1 sq. meter in cross section	Station	cc. in a column 1 sq. meter in cross section
10087	180	10099	30
10089	80	10100	220
10090	120	10101	100
10092	160	10102	90
10095	60	10103	70
10096	120	10104	90
10098	70	10105	55

These volumes are not the absolute amounts actually present, because they take no account of the coefficient of filtration of the nets. This, however, would be the same for all the hauls, and with the comparatively coarse silk of which they were composed would be small. It is obvious that the volumes do not give a direct measure of the density of the plankton, because the length of the column of water through which the net fished varied from 20 to 120 fathoms, according to the depth of water at the various stations. The volume of plankton per cubic meter of water (coefficient of filtration neglected) was as follows:—

Station	cc. per. cu. m.	Station	cc. per. cu. m.
10087	1.4	10099	.8
10089	.44	10100	1.3
10090	.7	10101	1.4
10092	.7	10102	.7
10095	1.7	10103	.9
10096	1.3	10104	.6
10098	1.3	10105	.5

Were the macroplankton of the Gulf uniformly distributed at all depths from surface to bottom, this table would sufficiently establish the relative richness of different regions in plankton, and hence in food for the pelagic fishes. But unfortunately such is not the case (p. 290); hence to get a fair idea of the regional density of the plankton the less exact evidence of the ordinary tow nets must be used to check the results of the quantitative hauls.

VOLUMES OF HORIZONTAL HAULS.

Station	Fathoms	cc.	Station	Fathoms	cc.
10087	15	560	10097	25	750
	40	125		85	500
10088	80	375	10098	20	30
10089	25		10099	20	130
10090	20	1500	10100	25	500
	90	250		70	100
10091	20	875	10101	25	100
10092	35	300	10102	20	125
	85	100		50	100
10093	25	500	10103	30	175
	85	200	10104	15	675
10095	20	175	10105	50	200
10096	20	375		40	150

The depth is the level at which the major part of the haul was made.

This table shows that at every station where the hauls were made at two intermediate depths, the deeper invariably yielded the smaller volume of plankton. At first sight this difference might be laid to the use of different nets, the mouth area of the Helgoland net, which was usually used for the deeper haul, being only about 50% of that of the four foot net (the same grade of silk was used in both). But at Station 10092, where the nets were reversed, the catch of the Helgoland net was three times as great as that of the four foot net. And even allowing for the different sizes of the nets, the shallow haul is still considerably the richest at six of the eight stations. Apparently the plankton was usually densest in the upper layers, and decidedly impoverished below, say, forty fathoms. On the other hand the surface water was usually barren, except at Stations 10092, 10093, 10096, 10097, 10100, and 10103, but the surface hauls are not directly com-

parable with the deep ones, because they were made with small nets.

Thus the volumes of plankton per cubic meter, as calculated from the quantitative hauls, would be more representative of the true conditions, if the depths below about 40-50 fathoms were left out of account, because it appears that the vertical net can have caught but little below that level. In other words, to assume that the volume of plankton taken at, say, Stations 10092 or 10093, was evenly distributed down to 100 fathoms or more, results in far too small a density per cubic meter for the upper layers of water. I have attempted to offset this error by another table in which the volume of plankton per cubic meter is calculated on the assumption that the whole catch was made in the upper fifty fathoms. But this, though a closer reflection of actual conditions, is unsatisfactory, because the plankton is not vertically uniform even above fifty fathoms. Volume is itself so rough a measure, that it has largely been abandoned by students of plankton. But no other classification so far proposed gives so satisfactory an index of the comparative density of the plankton as a whole, as distinguished from its various individual components.

Station	cc. vol. per cu. m.	Station	cc. vol. per cu. m.
10087	2.	10099	.8
10089	.8	10100	2.4
10090	1.3	10101	1.4
10092	1.6	10102	1.
10095	1.7	10103	.9
10096	1.3	10104	1.
10098	1.3	10105	.6

According to this table, the plankton was densest off Massachusetts Bay (Station 10087) and off Mt. Desert Rock (Station 10100); distinctly less so over the central parts of the Gulf and the off shore waters in general. It was scantiest near the coast off Mt. Desert, and northeast of Cape Ann (Station 10105). And the plankton was rather less dense all along the coast, north of Cape Ann, than further off shore.

The table of qualitative hauls (p. 326) might suggest a rather different distribution, with the plankton densest in the centre of the Gulf (Station 10090) and off the mouth of Penobscot Bay (Station 10091); but this is not a valid objection to accepting the results of the quantitative hauls as approximately correct, because, with the plankton stratified as it undoubtedly was (p. 290), it was a matter of chance whether a horizontal net hit or missed the richest zone.

Copepods formed the bulk of the quantitative hauls, the more active of the larger organisms, *e. g.*, Sagittae and schizopods, being so poorly represented even at localities where the qualitative nets yielded large hauls of them, that they must have avoided the slow moving quantitative net; and our experience in 1912 (1914a) was the same.

The following counts of copepods were obtained by diluting the entire catch to 150 cc.; mixing well, then taking 3 cc. in a pipette while the plankton was in suspension, and counting. Each of the catches was sampled two or three times, and the results averaged.

Station	Relative no copepods in 3 cc.	Total number of copepods in a column 1 m. in cross section
10087	101	50500
10089	62	31000
10090	87	43500
10092	193	96500
10095	63	31500
10096	140	70000
10097	174	87000
10098	80	40000
10099	54	27000
10100	247	123500
10101	150	75000
10102	61	30500
10103	76	38000
10104	54	27000
10105	56	28000
Average,		53266

This table shows that the central part of the Gulf and the waters off Mt. Desert Rock were most prolific, numerically, in copepods (Stations 10092 and 10100); the Stations off Monhegan (10102) and northeast of Cape Ann (10104, 10105) the poorest. Thus there is a marked discrepancy between the numerical distribution of copepods, and the volumes of the quantitative hauls, as outlined above. This is due to the fact that besides the adult *Calanus*, the more prolific hauls contain hosts of a very much smaller copepod, *Pseudocalanus elongatus* (p. 291), which added very little to the volumes of the hauls. The *Calanus* component agrees more closely, numerically, with the plankton volumes (p. 286). The total counts of copepods are not a fair index to regional richness or poverty, as feeding grounds for pelagic fishes,

because one adult *Calanus* is worth many *Centropages* or *Pseudocalanus* in food value, though the latter are an important food for fish fry. It is the *Calanus* swarms which form the chief copepod constituent of the food of mackerel, pollack, and probably of the shad which summer in the Gulf; and for *Calanus* as for the volume of plankton, the richest parts of the Gulf were off Massachusetts Bay and off Mt. Desert Rock (Stations 10092, 10100), with a third prolific area off Chatham detected by Captain McFarland.

#### MICROPLANKTON.

The microplankton of the cruise will be treated later in special reports. But it is worth while to give a brief account of the distribution of general plankton types here, because of their bearing on general oceanographic problems (Fig. 82). They fall into four general types, which may be called "Ceratum," "diatom," "mixed" (a mixture of the two), and a tropical type characterized by the presence of considerable amounts of *Trichodesmium*. Of course these are not actually distinct, grading into one another; but they group sufficiently well to be treated in this way. To take the rarer types first, tropical plankton (the "Desmo Plankton" of Cleve) was encountered only once, in the inner edge of the Gulf Stream (Station 10071) where the rather scanty catch consisted chiefly of *Ceratum macroceros*, and of *Trichodesmium*, with an occasional diatom (*Rhizosolenia*). Diatom plankton was encountered in three distinct regions; on George's Bank (Station 10059); off the mouth of Chesapeake Bay (Stations 10075, 10077, 10078) and in the northern part of the Gulf of Maine near Mt. Desert (Stations 10099, 10101).

The species composing these diatom swarms were quite different in these three regions. On George's Bank the mass, which was rather rich, consisted chiefly of a species *Guinardia*, besides such forms as *Eucampia zoodiacus*, *Rhizosolenia stolforthi*, and *R. styliformis*, practically a pure diatom haul, except for an occasional *Peridinium* and *Ceratum*. The diatom swarm off Chesapeake Bay consisted chiefly of various species of *Chaetoceras* (among them *C. decipiens* and *C. contortum*) with smaller numbers of *Rhizosolenia*, *Leptocylindrus*, and *Thalassiothrix*. And at the mouth of the Bay the haul was chiefly *Rhizosolenia*.

The diatom plankton found in the Gulf of Maine is difficult to place because it was chiefly debris, and evidently moribund. But fragments of *Rhizosolenia* and *Chaetoceras decipiens*, with other species of *Chae-*



toceras can be distinguished. Mixed plankton (Fig. 82) partly diatom, partly peridinian, was found just north of George's Bank (no doubt the effect of the diatom swarm on the Bank); south of Nantucket Shoals (Station 10061), and at all the Stations close to land south of New York, except where the plankton was purely diatom (10069, 10072,

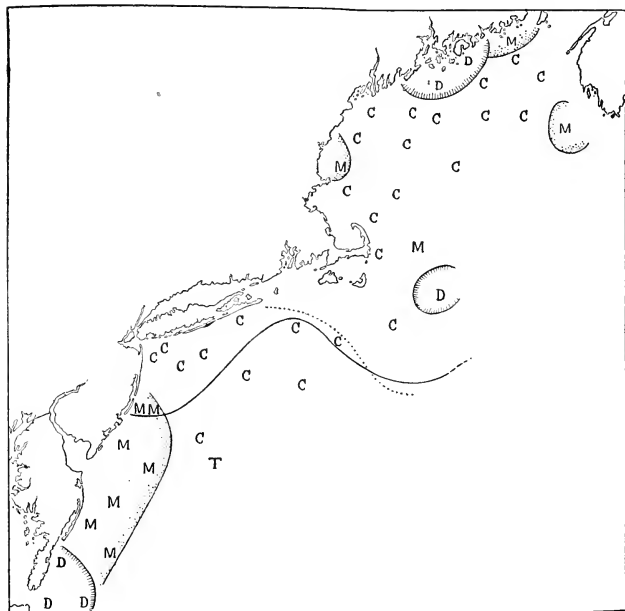

FIG. 82.— Distribution of different types of microplankton, July–August, 1913.

c, Ceratum plankton; M, mixed; d, Diatom; . . . . , northern limit to Ceratum macroceros ———; s. limit to c, longipes.

10079, 10080, 10081). The plankton along the outer part of the continental shelf, south of Delaware Bay (Stations 10073, 10074) was also of this type. In the Gulf of Maine mixed plankton was encountered on German Bank (Station 10095); near shore east of Mt. Desert Island; and again north of Cape Ann (Station 10105). There were

likewise more diatoms at our other stations near land than in the centre of the Gulf; but not enough to take the hauls out of the Ceratium class. The diatom constituents of the Gulf Stations were chiefly several small species of Chaetoceras, with occasional *C. decipiens*, *Rhizosolenia semispina* and *Nitzschia serriata*, etc.

Peridinian plankton, in greater or less abundance, and composed of different species at different localities, occupied the waters of the Gulf of Maine (Stations 10057, 10086-10093, 10096, 10097, 10102, 10104) except at the few limited regions just mentioned; Nantucket Shoals (Station 10060), the continental shelf from abreast of Nantucket to New York (Stations 10062, 10063, 10067, 10082, 10083, 10070) (Fig. 82). Unfortunately we have no data on the microplankton of the Gulf Stream water at Station 10076, the bottle being broken in transit. In the Gulf of Maine the prevalent organisms, of this plankton type, were two species of Ceratium, *tripos*, and the form classed by Paulsen (1904, 1908), as var. *oceanica* of *C. longipes*. (In my Report on the cruise of 1912, these two species were treated together). *Ceratium longipes* differs so noticeably from *tripos* in its curved apical horn and serrate shell, that it is easy to count the respective numbers of the two in plankton samples. And without delaying with the exact counts, the result of the comparison was as follows:—

<i>Longipes</i> outnumbered <i>tripos</i>	Roughly equal numbers <i>Tripos</i> and <i>longipes</i>	<i>Tripos</i> outnumbered <i>longipes</i>
Stations 10057	Stations 10058	Stations 10088
10059	10090	10089
10087	10092	
10091	10093	
10098	10095	
10102	10096	
10103	10099	
10104	10105	

On the whole, then, *longipes* was the more abundant of the two in the Gulf, where it was taken at practically every station, though notably absent at Station 10086, where it had been abundant a month earlier (Station 10057). The table likewise suggests that the preponderance of *longipes* was greater near shore than in the centre of the Gulf, the only stations where *tripos* predominated being far from land.

*C. longipes* occurred in the plankton on George's Bank, on Nantucket Shoals, and over the continental shelf as a whole as far as

Barnegat (Stations 10060 to 10068); but it was absent at the more southern stations, nor was it found over the outer part of the shelf south of Long Island (Stations 10063, 10065). And *tripos* invariably outnumbered it in the hauls south and west of Cape Cod. On our coasts, at least in summer, *longipes* evidently belongs to northern water. The salinity in which it was living (on the surface, where all the hauls with the  $\$$  20 silk net were made) ranged from 31.8‰ (Station 10104) to 33.4‰ (Station 10061); the temperature from 48° (Station 10095) to 69° (Station 10069). But it was far less abundant at temperatures above 62° or 63° than in the colder water of the Gulf:—for example at Station 10061, surface temperature 68°, only two specimens were detected; Station 10062, 67°, only an occasional specimen; Station 10069, 69°, only one specimen was found.

*Ceratium tripos* was taken at practically all our southern stations, as well as north and east of New York and in the Gulf of Maine, and at Stations 10063, 10065 over the outer part of the shelf where *longipes* was absent. At only three Stations have I failed to find it in the plankton, viz., 10075, 10076, 10078, all of them within the influence of Chesapeake Bay water (p. 200).

A third species of *Ceratium*, *C. macroceros*, easily distinguished by its very long, slender horns, occurred in the hauls at the southern stations. The most northerly records are Stations 10062, 10063, and 10083. East of Barnegat it was greatly outnumbered by *tripos* (Stations 10062, 10063, 10065, 10067, 10069, 10083). South of this, where *longipes* was not found, *macroceros* was always as numerous as *tripos*, the two species being, roughly, equal at Stations 10073, 10074, 10077, 10079, 10082. At Stations 10070, 10071, 10072, *macroceros* outnumbered *tripos*. *Ceratium macroceros* was living at a very wide range of salinity, as much so, even, as *tripos* (31.3‰ to 35.2‰); but its temperature range was considerably less, the records all being from water warmer than 63° (63° to 77°); it was only once found in water cooler than 67°, and then only an occasional specimen (Station 10067). And at only three Stations (10062, 10067, 10069) were both *longipes* and *macroceros* taken in the same haul. If the former belongs to boreal plankton, the latter is as certainly limited to warm water along our coasts.

A fourth species of *Ceratium*, *C. fusus*, plays a subordinate rôle. It has been found at twenty-seven stations, including the Gulf of Maine as a whole (Stations 10057, 10058, 10086–10090, 10092, 10093, 10096, 10097, 10099, 10102–10104), and the continental shelf south and west of Cape Cod (Stations 10061–10063; 10067–10070; 10073, 10074, 10077–10081). The only regions where it was notably absent were in the Gulf Stream water (Station 10071); and in localities

where diatoms swarmed (*i. e.*, George's Bank, the mouth of Chesapeake Bay, and near Mt. Desert Island). And even then its absence from the plankton samples examined may be accidental, because there are a few other stations also where I failed to find it in the tow. It was outnumbered by the other species of the genus everywhere, except at one station in the centre of the Gulf of Maine (10090) where there were about equal numbers of *tripos*, *longipes*, and *fusus* in a sample.

Two other genera of peridinians may be mentioned briefly. Peridinium occurs in practically every sample in which Ceratium has been noted, being absent only in the Gulf Stream hauls (Stations 10071, 10073), off Chesapeake Bay (Stations 10075, 10076, 10077, 10078, 10079), and in the diatom plankton found off Mt. Desert. One species, provisionally identified from Paulsen's account (1908) as *P. crassipes* Kofoid occurs over the whole range of stations, except as above; but always in small numbers. Two other species, *oceanicum* at Station 10062 and 10070; *pallidum* at Stations 10063, 10067 and 10090, have likewise been detected so far. And additional records for these, and other species, may be expected when the microscopic examination of the microplankton is completed.

The genus Dinophysis is represented by two species, *orum* (noted only twice) and *norvegica*; the latter being of considerable importance from the oceanographic standpoint, because it was found only in the Gulf of Maine (Stations 10090, 10096, 10097), and because of its northern distribution in general (Paulsen, 1908).

The hauls made in 1913 were not of a type calculated to reveal the exact quantitative amount of plankton in the water; for this purpose vertical hauls with a quantitative net must be resorted to. But as I have previously pointed out (1914a), the horizontal hauls do show in a rough way whether the water is barren, rich, or intermediate between these two extremes.

Off Cape Cod, in early July (Stations 10057 and 10058) the microplankton was rich: and this was likewise true south of Nantucket (Stations 10062, 10063); on George's Bank (Station 10059); off Chesapeake Bay (Stations 10075, 10078); and near Mt. Desert Island (Stations 10099, 10101). But nowhere, in 1913, was it found as dense as it was in several places in the Gulf in 1912 (1914a). And as a rule it was notably scanty, being so classed at Stations 10061, 10069-10073; 10079-10083; 10086-10090; 10092, 10093, 10096, 10098, 10102, 10104, 10105; perhaps most barren of all at Stations 10071, 10081, 10082 and 10083. It was intermediate, quantitatively, at Stations 10060, 10065, 10067, 10074, 10077, 10091, 10095, 10097, 10103.

## GULF OF MAINE PLANKTON, 1912 AND 1913.

The summer plankton of the Gulf of Maine was of the same general type in 1913 as in 1912 (1914a). The lists of copepods, far the most important constituent of the macroplankton, are practically the same for the two years, the most numerous and most regularly occurring species was *Calanus finmarchicus*. But *Calanus hyperboreus*, taken only once in 1912 occurred at four stations in 1913, once in large numbers (p. 286); *Eucheata norvegica* was, likewise, taken more regularly in 1913, where it was practically universal in the deep waters of the Gulf (fourteen stations) than in 1912 (nine stations); and *Metridia longa* is recorded for the first time from our waters. *Anomalocera* was taken more regularly in 1913 than in 1912, but in this case the difference is probably apparent rather than real, due to different types of nets used on the surface, where *Anomalocera* is most abundant. *Euchirella rostrata*, singularly enough, was taken twice in each year, once on each side of the Gulf.

In the case of the hyperiids the difference between the hauls of the two years was much greater, because *Euthemisto bispinosa*, a species common in the centre of the Gulf in 1913 was not found at all during the preceding summer. Its history during the year in Massachusetts Bay is as follows:—absent there during the summer of 1912, it must have appeared in the early autumn, for it was about half as numerous as *compressa* in November (1914b). But later in the season it was proportionately rare in the hauls (six *compressa* to one *bispinosa* in April) and by August, 1913, the *Euthemisto* component of the plankton of Massachusetts Bay was once more exclusively *compressa*. This local series of changes suggests the possibility that there may be a parallel series for the Gulf as a whole, *bispinosa* appearing seasonally, in winter and spring, to disappear again in summer. If this be the case, the species must have persisted longer in 1913 than it did in 1912. But the appearance of *bispinosa* may have been the result of an invasion of the Gulf by this species during the autumn of 1912. In both summers *Euthemisto compressa* was very generally distributed over the Gulf. *Parathemisto oblivia*, taken at two Stations (10032 and 10036) in 1912, was not detected at all in the hauls of 1913. The rarity of this species is interesting because of its wide distribution and frequent occurrence on the other side of the Atlantic (p. 341). The remaining hyperiids, *Hyperia galba*, *H. medusarum* and *Hyperoche* were occasionally represented in both years.

The only pteropod which we have found in any great numbers in the

Gulf is *Limacina balea*. In 1912 the range of this species was limited to two circumscribed areas, *i. e.*, the northwest corner of the Gulf off Casco Bay, and German Bank. But in 1913 it was much more generally distributed over the Gulf. In 1912 it was most abundant off Cape Elizabeth (1914a), in 1913, off the mouth of Penobscot Bay. *Clione limacina*, on the other hand, was more frequently represented in our hauls in 1912 (nine stations) than in 1913 (two stations). But as the total number of specimens taken in the former year was only sixteen, it is doubtful whether the apparent difference has any special faunal significance. And this is likewise true of the one record of *Diacria trispinosa* off Gloucester in 1913. In neither year did we find any of the typical warm water pteropods in the Gulf.

Salpae are especially important because they give certain evidence of the entrance of Gulf Stream water into the Gulf. In both years Salpae were found on the eastern side of the Gulf; but while in 1912 they occurred on the surface over a considerable area (Station 10030 to Station 10031), in 1913 Salpa was taken in only one haul (Station 10096). In 1912 the species concerned was *fusiformis*, while *democratica* swarmed on the surface off Chatham in September (1914a). But in 1913 the single catch was *tilcsii*.

The Sagitta fauna of the Gulf of 1913 was decidedly different from that of 1912, for while *S. elegans* was generally distributed over the whole area in both summers, *S. serratodentata* was far less numerous, and occurred at fewer localities in 1913. On the other hand *Eukrohenia hamata* was decidedly more abundant in 1913 (five stations) than 1912 (one station).

In 1912 at least one warm water siphonophore was taken in the Gulf, *Physophora hydrostatica* (one station), and probably a second, *Agalma elegans* (six stations) though the specimens of the latter were so fragmentary that identification was not so satisfactory as could be wished. In 1913 neither of these was found in the Gulf, though both were encountered south of Cape Cod, *Agalma* in abundance (p. 269). On the other hand *Stephanomia cara*, which appeared in numbers off Cape Ann during the winter (1914b) was occasionally represented in our tows in the Gulf in 1913 (three stations), though always in a very fragmentary condition (p. 315).

The neritic Medusa fauna of the Gulf was practically the same for the two years. But the only oceanic Medusa found there in either summer, *Aglantha digitale*, was much more generally distributed and locally more abundant in 1913 than in 1912.

These facts can be summed up as follows:—

The list is practically the same in 1913 as in 1912, hence it is evident

that no great change, *i. e.*, no great ingress of water of either northern or Gulf Stream origin had taken place. In both years the plankton of the Gulf was typically boreal. But species which we can safely say are contributed to the fauna of the Gulf by the surface water of the Gulf Stream, *i. e.*, Salpae, and the warm water siphonophores, were distinctly less abundant, and less widespread in the Gulf, in 1913 than in 1912. On the other hand, several boreal and Arctic-boreal species, *i. e.*, *Limacina balea*, *Calanus hyperboreus*, *Metricia longa*, *Eucheata norvegica*, *Eukrohnia hamata*, and *Aglantha digitale*, were more prominent faunally in 1913 than in the preceding summer. And there is good reason to include *Euthemisto bispinosa* in the Arctic-boreal category, judging from its occurrence on the other side of the Atlantic and in the Arctic Ocean (Tesch, 1911). This suggests, of course, that St. Lawrence water was proportionally greater, Gulf Stream water less in amount in the summer of 1913; the plankton thus corroborating the evidence of salinity and temperature (p. 250).

The general quantitative distribution of the macroplankton was much the same for the two years; but the local differences were far greater in 1912 than in 1913; and nowhere, in the latter year, was the water as barren as the coastal zone east of Penobscot Bay in 1912. Whether or not the very rich plankton which was noted in Ipswich Bay in 1912, was reproduced there in 1913, is not known, because that exact locality was not revisited.

A question of importance is whether the Gulf as a whole was richer or poorer in macroplankton, *i. e.* in food for pelagic fish, in 1913 than in 1912, and here copepods play the chief rôle. The actual volumes, and relative number of copepods (p. 329) at corresponding stations for the two years are given in the table:—

Station	Station	Volume cc.	Volume cc.	Copepods	Copepods
1912	1913	1912	1913	1912	1913
10002	10087	25	18	239	101
10025	10089	8	8	125	62
10028	10092	3	16	25	193
10031	10096	3	12	20	140
10036	10097	3	?	50	174
10035	10099	Trace	3	10	54
10038	10101	2	10	24	150
10022	10103	3	7	97	76
10011	10104	2	9	30	54
Averages		5.5	10.3	69	111

Thus the only part of the Gulf where volume, or number of copepods, or both, was greatest in 1912 was off Massachusetts Bay, and near Cape Elizabeth and Platt's Bank; a difference which may be seasonal. Everywhere else both the volume of plankton and the number of copepods was greater in 1913 than in 1912. It is possible that locations close to shore might have proved an exception; but judging from what was found east of Mt. Desert and on German Bank, there is no reason to suppose that shore stations would have altered the case materially. On the average, the hauls for the whole Gulf were nearly twice as large in bulk, and 60% larger in number of copepods, in 1913; a difference so great that it can hardly be accidental, especially as the same net was used in both years. In short, there seems no escape from the conclusion that both the plankton as a whole, and its copepod constituent, were richer in August, 1913, than in the summer of 1912.

Very little can be said about the microplankton of the two years until the microscopic examination of the hauls is completed. But enough has been done to show that diatoms were far less numerous in August, 1913, than in the corresponding month of 1912. And the species which formed the bulk of the catch in that year, *Asterionella japonica*, has not been detected at all in the 1913 hauls. Furthermore the Ceratium plankton was nowhere so dense in 1913 as off Cape Elizabeth in 1912.

#### MACROPLANKTON OF THE GULF OF MAINE AND OF THE NORTHEASTERN ATLANTIC.

Our survey of the plankton of the Gulf of Maine in 1912 led to the conclusion that it was characteristically boreal, in the sense in which the term is used by Hjort (Murray and Hjort, 1912, p. 637), not Arctic, though with Arctic and Gulf Stream components (1914a, p. 106). And subsequent catches support this general thesis. The most important member of the plankton of the Gulf, *Calanus finmarchicus*, it is true, is practically eurythermal, but it is only in boreal, and in Arctic-boreal waters that it swarms (Farran, 1911) and it is not distinctive of polar water, although it is very numerous and very large in the Labrador Current (Herdman, Thompson, and Scott, 1898). On our coasts *Calanus* plankton apparently occupies an unbroken belt from the Labrador Current to Cape Cod. The only copepod which vies with it in abundance in the Gulf, *Pseudocalanus elongatus*, is likewise chiefly boreal, not polar, and far more plentiful in coastal



than in oceanic water (Farran, 1910). And though *Temora longicornis* and *Euchaeta norvegica* are rather more northern, neither of them is distinctively polar. The only members of the copepod fauna which can be classed in that category, *Calanus hyperboreus*, and *Metridia longa*, are rare in the Gulf. The two oceanic copepods which are prominent in the Gulf belong, one, *Anomalocera pattersoni*, to the temperate Atlantic, the other, *Metridia lucens*, to rather more northern waters (Cleve, 1900); Pleuromamma and Euchirella alone are clearly of Gulf Stream origin, so far as the Gulf of Maine is concerned.

Only six species of euphausiid schizopods have yet been detected in the plankton of the Gulf (1914b, p. 410). One of these, *Meganyctiphanes norvegica*, is very widely distributed in the North Atlantic, but much more abundant in boreal water than in polar or warm waters; two, *Thysanoessa inermis*, and *raschii* are typical Arctic-boreal forms, one, *Thysanoessa longicaudata*, is rather more northern, but not polar, being found as far south as the southern part of the North Sea, and one, *Nematoscelis megalops* is oceanic, of very wide distribution in the North Atlantic. (For the general distribution of these species, see Kramp, 1913b). To one species only, *Thysanoessa gregaria* can a southern or Gulf Stream origin be assigned (Zimmer, 1909, p. 21), and this one has seldom been taken in the Gulf.

The only hyperiid amphipods which attain any faunal importance in the Gulf, *Euthemisto compressa* and *E. bispinosa*, are typical Arctic-boreal species, neither of them being found south of the English Channel in European waters. Of the two, *bispinosa* is decidedly the more northern (Tesch, 1911) which is suggestive in connection with the incursion of this species into the Gulf during the autumn of 1912 (p. 335).

The only pteropod which is common in the Gulf, *Limacina balea*, is one of the most typical of boreal organisms, at home neither in pure polar water, nor in the warmer parts of the Atlantic (Meisenheimer, 1906, Paulsen, 1910). *Clione limacina* is rather more northern, especially abundant on the Grand Banks of Newfoundland, though not an index of polar water (Murray and Hjort, 1912, p. 108).

The only chaetognath which is uniformly abundant over the Gulf as a whole, *Sagitta elegans*, has its centre of distribution in boreal coastal waters, though its extreme range includes the Mediterranean on the one hand, and the Arctic Ocean on the other (Apstein, 1911; Ritter-Zahony, 1911). The two other species which were taken in the Gulf in 1913 are of diametrically opposite origins: — *Sagitta serratodentata* is a southern species; *Eukrohnia hamata* is Arctic or from

the mid depths off shore (Apstein, 1911). *Sagitta hexaptera*, taken in the Gulf in 1912 but not in 1913, is oceanic, very widely distributed.

The Salpae are, of course, all visitors from the Gulf Stream, as are such coelenterates as *Physalia*, *Agalma elegans*, and *Physophora hydrostatica*.

The ctenophores of the Gulf are either cosmopolitan forms (*Pleurobrachia pilcus* and *Beroe eucumis*) or Arctic-boreal (*Bolinopsis infundibulum*); while a true Arctic species, *Mertensia orum*, has been recorded rarely (A. Agassiz, 1865, Fewkes, 1888) and the only oceanic Medusa, *Aglantha digitale*, is widely distributed over the North Atlantic.

In short, the more important members of the Gulf plankton are of three types, 1, Arctic-boreal; 2, Gulf Stream; 3, Arctic; of which the first greatly outnumbers the other two in number of species and in number of individuals.

I have already pointed out (1914a, p. 107) that the summer plankton of the Gulf of Maine resembles that of the Norwegian Sea and the North Sea; a parallel which can be drawn even more closely with the collections made during the winter of 1912-1913 (1914b), and the summer of 1913.

And it is not only in its individual components that the plankton corresponds to the other side of the North Atlantic, but in their method of association; for example Dr. D. Damas informs me that the plankton assemblages found in the Gulf in 1912 (1914a) correspond almost exactly to many of the hauls taken by the MICHAEL SARS off the coast of Norway. And Dr. Otto Pettersen writes calling attention to the similarity of the GRAMPUS plankton to that of the Skagerrak. The parallel does not extend to the Norwegian Sea and North Sea as a whole, but only to the southern part of the former and northern part of the latter, where Arctic-boreal plankton, temperate neritic species, and warm water species carried around the northern end of Scotland by the sweep of the Atlantic Current, meet. There, as in the Gulf, *Calanus finmarchicus* is perhaps the most important member of the plankton being found locally in vast shoals (Farran, 1911, p. 38), and *Pseudocalanus* in great numbers. *Sagitta elegans* is taken in almost every haul; *Limacina balea* is locally abundant; *Anomalocera pattersoni* is taken more or less regularly on the surface, though seldom in great numbers; *Aglantha digitale* is frequently, *Pleurobrachia* irregularly recorded (Kramp, 1913a), *Euchaeta norvegica* is more or less regular in the deep hauls; *Eukrohnia hamata*, *Calanus hypoboreus*, and *Metricidia longa* are both visitors from the north, as are the several northern species of *Thysanoessa*, and *Meganyctiphanes norvegica*. And all the

hyperiid amphipods known from the Gulf of Maine are more or less regularly recorded (Tesch, 1911). In fact, all the species without exception which are listed as particularly characteristic of our Gulf (p. 273) meet one another in this region, most of them being regularly recorded in the plankton lists of the International Committee for the exploration of the sea. And the various Salpae, southern siphonophores and other warm water species make their appearance in summer (Damas, 1909, p. 107), just as they do in smaller numbers in the Gulf of Maine. But the relative importance of the various species is not quite alike, for example, *Euthemisto compressa*, one of the most constant members of the plankton of the Gulf of Maine, especially in summer, is usually rare (Tesch, 1911) in European waters. Its place is taken there by *Parathemisto obliqua*, which occurs in at least 50%, usually 75% of the hauls in the Norwegian Sea and the northern part of the North Sea; but *P. obliqua* is so rare in the Gulf that I have detected only two specimens among the thousands of *Euthemisto* which have passed under my notice (p. 335). *Euthemisto bispinosa*, on the other hand, is far more abundant on the western than the eastern side of the North Atlantic.

It is not yet possible to state the quantitative relationship which the plankton of the Gulf of Maine bears to that of the North and Norwegian Seas, because the quantitative nets used, speed of hauling, etc., have not been alike; and because the coefficient of filtration has not been determined for our nets. But this phase of plankton study is so important in its practical bearing on the food supply for fishes that it is worth while to compare our results briefly with Apstein's list for the North Sea (Apstein, 1906; Johnstone, 1908). The bulk of plankton below each square meter of surface of the Gulf of Maine, in the summers of 1912 (1914a) and 1913, ranged from 10 cc. to 250 cc.; in 1913 the average for the whole Gulf was about 100 cc. Much greater amounts than this were found in the northeastern part of the North Sea by Apstein, who records volumes of 96-952 cc.; below each square meter of surface in August, 1903; with an average of about 340 cc. for thirteen hauls. And even admitting all the objections which can be urged to volume as a measure of plankton (Steuer, 1910), so great a difference as this can only mean that there was a greater bulk of plankton in the North Sea in 1903 than in the Gulf of Maine in 1912 and 1913. And the discrepancy between the two regions is even greater, if the comparison be extended to the amounts of plankton per cubic meter, for the largest amounts in the Gulf (p. 326) is only about one tenth of Apstein's largest record (27.2 cc.) for the North

Sea, August, 1903. Most of the volumes per cubic meter given by Apstein are not for the whole column of water, but for parts of it only, as given by closing nets; to make them directly comparable with the GRAMPUS hauls, the entire depth at each station must be taken into account. When this is done, the average per cubic meter, for the North Sea, is about 9.1 cc.; the average for the Gulf of Maine 1 cc.-1.3 cc.

Copepods were much more numerous in the North Sea than in the Gulf, the average of fourteen hauls in the Gulf of Maine in August, 1913, being about 66000 under each square meter of surface; the average in the North Sea August, 1903, about 1,000,000 (Apstein, 1906; Johnstone, 1908). And although *Calanus* is present in large numbers in the Gulf, it was never found in such swarms as occur in the southern part of the Norwegian Sea, where a surface haul of five minutes duration with a meter net may yield more than a litre of *Calanus* (Damas, 1905, p. 15).

TABLE OF STATIONS, NETS USED, DEPTHS OF HAULS IN FATHOMS.

NETS.

A = Albatross 4 ft. net. B = 24 cm. net # 20 silk. C = 36 cm. net # 3 silk  
 F = Young fish trawl. H = Helgoland net. S = Michael Sars 1 meter net.  
 Q = Quantitative net. T = Otter Trawl. Italics indicate "no bottom."

Station	Lat.	Long.	Date 1913	Depth	Nets	Depth of hauls
10057	42° 6'	69° 56'	July 8	47	B. C. A. H.	0, 0, 15-0, 30-0.
10058	41° 47'	69° 10'	" 8	90	B. H.	0, 40-0.
10059	41° 06'	68° 42'	" 9	30	B. C. H.	0, 0, 25-0.
10060	40° 41'	69° 33'	" 9	27	B. C. S. Q.	0, 0, 20-0, 20-0.
10061	40°	69° 29'	" 10	80	B. C. S. H.	0, 0, 30-0, 50-0.
10062	40° 29'	70° 29'	" 10	41	B. C. A.	0, 0, 15-0.
10063	40° 45'	71° 16'	" 11	33	B. C. H.	0, 0, 25-0.
10064	39° 55'	71° 13'	" 11	370	B. C. H. A.	0, 0, 25-0, 175-0.
10065	40°	72° 06'	" 12	45	B. C. H. T.	0, 0, 20-0, 45.
10066	40° 20'	72° 55'	" 12	25	A.	0
10067	40° 29'	73° 46'	" 13	12	B. H.	0, 10-0.
10068	40° 22'	73° 50'	" 17	20	H. T.	10-0, 20.
10069	39° 35'	73° 47'	" 19	15	B. H. F.	0, 10-0, 15-0.
10070	39° 09'	72° 58'	" 19	44	B. C. H. T.	0, 0, 20-0, 44.
10071	38° 56'	72° 39'	" 20	400	B. C. A. F.	0, 0, 190-0, 175-0.

Station.	Lat.	Long.	Date 1913	Depth	Nets	Depth of hauls
10072	38° 50'	73° 51'	" 21	24	B. C. H. T.	0, 0, 15-0, 24.
10073	38° 26'	74° 30'	" 21	22	B. C. H. T.	0, 0, 15-0, 22.
10074	37° 41'	74° 27'	" 22	30	B. C. H. T.	0, 0, 20-0, 30.
10075	37° 29'	75° 21'	" 23	9	B. C. H. T.	0, 0, 8-0, 9.
10076	37° 03'	74° 33'	" 24	150	B. C. H. A.	0, 0, 20-0, 120-0.
10077	37° 03'	74° 56'	" 24	25	B. C. H. T.	0, 0, 20-0, 25.
10078	37°	75° 38'	" 29	12	B. C. H. T.	0, 0, 8-0, 12.
10079	38° 02'	74° 53'	" 30	15	B. C. H. T.	0, 0, 8-0, 15.
10080	39° 07'	74° 24'	" 31	13	B. C. H.	0, 0, 10-0.
10081	39° 45'	73° 58'	" 31	11	B. C. H.	0, 0, 8-0.
10082	40° 09'	73° 21'	Aug. 1	22	B. C. H.	0, 0, 18-0.
10083	40° 48'	72° 17'	" 1	16	B. C. H.	0, 0, 8-0.
10084	41° 10'	71° 13'	" 2	20		
10085	41° 39'	69° 42'	" 4	26	B. C. H.	0, 0, 18-0.
10086	42° 6'	70°	" 5	40	B. C. H.	0, 0, 20-0.
10087	42° 31'	70° 21'	" 9	71	B. C. A. H. Q.	0, 0, 15-0, 40-0, 70-0.
10088	42° 33'	69° 33'	" 9	149	B. C. A. H.	0, 0, 80-0, 80-0.
10089	43° 02'	69° 19'	" 10	108	B. C. H. Q.	0, 0, 30-0, 100-0.
10090	42° 51'	68° 25'	" 10	101	B. C. A. H. Q.	0, 0, 20-0, 75-0, 90-0.
10091	43° 24'	68° 49'	" 11	60	B. C. H.	0, 0, 20-0.
10092	43° 27'	67° 55'	" 11	131	B. C. H. A. Q.	0, 0, 35-0, 85-0, 120-0.
10093	43° 24'	67° 12'	" 12	120	B. C. A. H.	0, 0, 25-0, 85-0.
10094	43° 25'	66° 43'	" 12	63		
10095	43° 20'	66° 27'	" 12	31	B. C. H. Q.	0, 0, 20-0, 20-0.
10096	43° 56'	66° 50'	" 12	61	B. C. H. Q.	0, 0, 25-0, 50-0.
10097	44° 13'	67° 21'	" 13	115	B. C. A. H. Q.	0, 0, 25-0, 85-0, 100-0.
10098	44° 24'	67° 29'	" 13	37	B. C. H. Q.	0, 0, 20-0, 30-0.
10099	44° 08'	68° 10'	" 13	21	B. C. H. Q.	0, 0, 15-0, 20-0.
10100	43° 52'	67° 58'	" 13	102	B. C. A. H. Q.	0, 0, 25-0, 70-0, 90-0.
10101	43° 44'	68° 44'	" 14	54	B. C. H. Q.	0, 0, 25-0, 40-0.
10102	43° 34'	69° 13'	" 14	75	B. C. A. H. Q.	0, 0, 20-0, 50-0, 70-0.
10103	43° 32'	69° 55'	" 14	50	B. C. H. Q.	0, 0, 30-0, 40-0.
10104	43° 08'	70° 06'	" 15	87	B. C. A. H. Q.	0, 0, 15-0, 50-0, 80-0.
10105	42° 48'	70° 27'	" 15	63	B. C. H. Q.	0, 0, 40-0, 60-0.
10106	42° 29'	70° 37'	" 20	38		
10112	40° 17'	70° 57'	" 22	60	T.	60.

## TABLE OF TEMPERATURES, SALINITIES, AND DENSITIES.

Temperatures are Fahrenheit; Salinity = grams of salts per kilogram of water. Density is at the temperature *in situ*, and = specific gravity at T°, compared to distilled water at 4°C.  $\times 1000$ .

The density readings for depths greater than fifty fathoms are corrected for pressure by Ekman's (1910) tables IV and V. Readings at 50 fathoms or less, are corrected for pressure by table IV (Ekman, 1910) alone.

Station	Depth Fathoms	Temp.	Salinity	Density
10057	0	61.°	31.9	23.43
	10	50.6°	31.97	24.69
	20	42.6°	32.48	25.75
	30		32.7	
	40	41.2°	32.68	26.19
10058	0	63.°	32.4	25.53
	30	41.1°	33.1	26.44
	60	40.6°	33.35	26.91
	90	41.3°	33.36	27.17
10059	0	56.°	33.06	24.93
	15	54.7°	33.07	25.20
	30	54.7°	33.13	26.38
10060	0	61.°	32.63	23.94
	10	57.4°	32.68	24.42
	25	50.3°	33.04	25.67
10061	0	68.°	33.41	23.55
	25	47.9°	33.51	26.18
	50	47.3°	33.62	26.55
		51.°		
	75	51.5°	34.30	26.86
10062	0	67.°	32.86	23.42
	20	46.2°	33.04	25.93
	40	43.6°	33.44	26.57
10063	0	67.°	32.11	22.71
	15	53.2°	33.22	25.54
	30	44.3°	33.22	26.30
10064	0	70.°	33.16	23.15
	50	54.°	35.18	27.54
	150	48.5°	35.05	28.38

Station	Depth Fathoms	Temp.	Salinity	Density
10064	250	41.6°	34.96	29.80
10065	0	69.°	32.68	23.03
	15	54.9°		
	20		33.04	25.62
	30	44.6°		
	40	46.2°	33.89	26.75
	45	51.°		
10066	0	69.°	31.55	22.17
	15	51.5°	33.26	25.56
	25	45.8°	33.22	26.10
10067	0	63.°	31.22	22.64
	12	49.2°	32.82	25.57
10068	0	67.°	31.53	22.41
	20	47.3°	33.16	25.99
10069	0	69.°	32.27	22.76
	7	60.°	33.2	23.58
	15	48.°?	33.25	24.97?
10070	0	74.°	32.23	21.85
	10	70.4°		
	20	50.°	33.68	26.16
	40	48.4°	34.02	26.96
10071	0	76.°	35.25	23.87
	50	58.8°	35.55	27.46
	150	49.1°	35.25	28.52
	250	43.6°	35.03	29.65
10072	0	73.°	32.22	22.12
	10	66.2°	33.29	23.81
	24	47.8°	33.56	26.40
10073	0	75.°	33.48	22.50
	10	70.5°	34.04	23.89
	22	51.4°	33.93	26.16
10074	0	75.°	33.24	22.31
	15	64.6°	35.06	25.48
	30	50.8°	34.32	26.72
10075	0	75.°	31.88	21.27
	9	59.°	33.48	24.9
10076	0	76.°	33.57	22.57
	25	59.5°		
	50	54.5°	35.37	27.64
	100	51.3°	35.36	27.92

Station	Depth Fathoms	Temp.	Salinity	Density
10076	150	49.3°	35.15	28.37
10077	0	77.°	31.32	20.59
	10	68.5°	34.96	24.74
	25	51.5°	34.33	26.36
10078	0	80.°	29.25	18.46
	5	75.7°	31.91	21.34
	12	57.6°	33.5	25.13
10079	0	76.°	32.41	21.70
	5	74.5°	32.76	22.22
	10		33.86	
	15	52.5°	33.86	26.05
10080	0	76.°	32.23	21.56
	5	53.6°		
		52.6°		
	13	52.6°	33.14	25.47
10081	0	75.°	32.11	21.45
	5	74.2°	32.14	21.51
	7	53.°		
	11	52.6°	32.65	25.02
10082	0	74.°	31.85	21.61
	10	54.7°	33.01	25.09
	22	47.°	33.09	25.92
10083	0	68.°	31.29	21.97
	8	64.8°	31.49	22.72
	16	50.6°	32.75	25.34
10084	0	71.°	32.29	22.32
	10	62.3°	32.33	23.58
	20	50.1°	32.65	25.30
10085	0	63.5°	32.05	23.15
	10	43.6°	32.47	25.68
	26	42.5°	32.56	25.87
10086	0	62.8°	32.09	23.30
	10	53.1°	32.23	24.56
	20	43.8°	32.52	25.71
	30	43.3°	32.52	25.89
	40	43.2°	32.52	25.93
10087	0	62.°	32.09	23.41
	10	51.4°		
	20		32.68	
	25	42.9°		



Station	Depth Fathoms	Temp.	Salinity	Density
10087	50	41.3°	32.77	26.37
	70	41.3°	32.75	26.40
10088	0	66.5°	32.21	22.91
	25	45.9°		
	50	41.3°	33.17	26.68
	100	43.3°	33.87	27.47
	150	43.4°	34.27	28.21
10089	0	61.5°	32.52	23.88
	10	53.7°		
	25	44.°	32.95	26.11
	50	44.°?	33.26	
	100	41.2°	33.46	27.29
10090	0	61.°	32.56	23.91
	10	52.1°		
	25	44.2°	32.92	26.08
	50	43.5°	33.21	26.59
10091	100	43.9°	33.84	27.41
	0	61.°	32.47	23.84
	10	58.1°	32.57	24.34
	25	47.5°		
	50	44.1°		
10092	60		33.40	26.69
	0	62.°	32.59	24.05
	10	52.6°		
		48.6°		
	25	43.2°	33.1	26.22
	40-45	42.°		
	50	42.5°	33.28	26.66
	100	43.°	33.91	27.53
130	42.9°	34.14	28.01	
10093	0	60.5°	32.61	23.95
	10	58.1°		
	20	51.2°		
	30		32.95	25.87
	50	42.°		26.81?
	60		33.58	
	75	42.6°		
120	42.6°	34.10	27.89	
10094	0	48.°	32.75	25.46
	10	47.°		

Station	Depth Fathoms	Temp.	Salinity	Density
10094	20		33.01	25.86
	25	47.°		
	40		33.24	26.22
	50	46.7°		
	60		33.62	26.84
	62	44.9°		
10095	0	48.°	32.79	25.43
	5	47.8°		
	10	47.6°	32.92	25.69
	30	47.4°	32.94	25.88
10096	0	54.°	32.75	24.89
	10	51.7°		
	25	49.4°		
	30		33.42	26.14
	50	47.2°		
	60		33.39	
10097	65	43.°		26.86
	0	55.°	32.75	24.80
	10	53.°		
	25			
	30		32.77	
	50	46.4°		
10098	60			
	110	42.8°	34.09	27.74
	0	50.5°	32.47	25.01
	10	49.2°		
	15		32.59	25.33
10099	37	48.3°	32.70	25.62
	0	55.°	32.38	24.39
	20	48.8°	32.61	25.39
10100	0	55.°	32.72	24.67
	10	50.2°		
	20		32.95	
	25	47.3°		25.86
	50	46.°	33.28	26.46
10101	100	43.2°	33.87	27.49
	0	53.5°	32.68	24.83
	10	50.2°		
	20		32.92	
	25	48.7°		25.79?

Station	Depth Fathoms	Temp.	Salinity	Density
10101	50	47.3°	33.26	26.27
10102	0	61.°	32.23	23.65
	10	49.2°		
	20		32.66	
	25	47.7°		25.63?
	50	45.4°		26.20?
	70		33.17	26.76
	75	42.6°		
10103	0	61.°	31.83	23.35
	10	52.5°?		
	20		32.63	
	25	46.5°		25.66
	50	44.1°	32.83	26.23
10104	0	63.°	31.85	23.14
	10	49.3°		
	20		32.57	
	25	45.2°		25.76?
	50	41.9°	33.06	26.54
	80		33.1	26.94
	85	39.8°		
10105	0	64.°	32.09	23.18
	10	49.7°		
	25	44.4°		25.78?
	30		32.66	
	50	41.6°		26.28
	60	40.3°	32.74	26.45
10106	0	61.°	32.16	23.59
	15	48.5°	32.41	25.26
	38	44.10	32.57	25.90
10112	0	69.5°	34.	
	20	63.°		
	35	60.2°	34.83	
	60	59.8°	35.17	

TABLE OF SURFACE TEMPERATURES, TAKEN BY W. W. WELSH,  
BETWEEN CAPE COD AND CAPE MAY.

August 21–September 1, 1913.

Stations	Latitude	Longitude	Date	Surface Temperature
10107	40° 36'	69° 38'	Aug. 21	67.5°
10108	40° 21'	69° 39'	"	69.5°
10109	40° 07'	69° 46'	"	69.°
10110	40° 16'	70° 07'	"	68.°
10111	40° 23'	70° 38'	Aug. 22	67.°
10112	40° 17'	70° 57'	"	69.5°
10113	40° 22'	71° 15'	"	69.°
10114	40° 26'	71° 30'	"	70.5°
10115	40° 31'	71° 45'	"	71.25°
10116	40° 37'	72°	"	70.°
10117	41° 01'	71° 43'	Aug. 25	66.°
10118	40° 51'	71° 58'	"	69.5°
10119	40° 22'	71° 55'	"	71.5°
10120	40° 10'	71° 50'	"	72.°
10121	40° 04'	71° 54'	Aug. 26	72.°
10122	39° 58'	71° 52'	"	70.5°
10123	40° 08'	72° 03'	"	72.°
10124	40° 03'	72° 03'	"	72.°
10125	40° 03'	72° 22'	"	72.°
10126	40° 09'	72° 37'	"	71.5°
10127	40° 16'	72° 56'	"	71.°
10128	40° 27'	73° 38'	Aug. 27	71.°
10129	40° 22'	73° 28'	"	71.°
10130	40° 17'	73° 34'	Aug. 28	72.25°
10131	40° 10'	73° 21'	"	72.°
10132	40° 05'	73° 11'	"	71.5°
10133	40°	73° 27'	"	71.5°
10134	39° 53'	73° 17'	Aug. 29	71.°
10135	39° 47'	73° 09'	"	72.°
10136	39° 39'	73°	"	73.°
10137	39° 39'	73° 16'	"	73.°
10138	39° 41'	73° 19'	"	72.°
10139	39° 46'	73° 30'	"	72.°
10140	39° 48'	73° 42'	"	72.°
10141	39° 50'	73° 53'	"	72.°

Stations	Latitude	Longitude	Date	Surface temperature
10142	39° 39'	73° 49'	Aug. 30	72.°
10143	39° 43'	74°	"	71.°
10144	39° 34'	73° 53'	"	72.°
10145	39° 29'	73° 44'	"	72.5°
10146	39° 23'	73° 34'	"	73.°
10147	39° 16'	73° 26'	Aug. 31	74.°
10148	39° 09'	73° 23'	"	74.°
10149	39° 02'	73° 19'	"	75.°
10150	39° 02'	73° 34'	"	76.°
10151	39° 02'	73° 46'	"	75.5°
10152	38° 54'	73° 53'	"	75.°
10153	38° 45'	74° 01'	"	74.5°
10154	38° 40'	74° 09'	Sept. 1	72.5°
10155	38° 42'	74° 15'	"	74.5°
10156	38° 46'	74° 25'	"	74.5°

SALINITIES OF WATER SAMPLES COLLECTED BY  
CAPTAIN McFARLAND.

May-Aug., 1913.

Lat.	Long.	Date	Depth Fath.	Sal. ‰
38° 45' N.	73° 52' W.	May 3	0	34.18
38° 49'	73° 38'	" 9	"	34.18
"	"	" "	25	34.18
40° 46'	70° 32'	June 5	0	32.94
40° 48'	70° 05'	" 6	"	32.65
"	"	" "	15	32.75
40° 45'	70°	" 21	0	32.68
40° 42'	69° 38'	Aug. 8	20	32.77

Locality	Date	Depth Fath.	Sal. ‰
off Chatham, Mass.	Aug. 1	0	32.07
15 miles SE. of Chatham	Aug. 16	0	32.38
SE. of Chatham	Aug. 21	20	32.34

## BIBLIOGRAPHY.

Anonymous.

1901. The currents in the Gulf of St. Lawrence. *Nature*, **63**, p. 601-602.

Agassiz, Alexander.

1865. North American Acalephae. *Mem. M. C. Z.*, **1**, 14, 234 pp. 360 figs.

Apstein, Carl.

1906. Plankton in Nord- und Ostsee. Part 1. *Wiss. meeresuntersuch. komm-Wiss. Deutsch. meere*, abt. Kiel, **9**, p. 1-26, I-LIX.

1910. Das vorkommen von Salpen in arktischen gebieten. *Fauna Arctica*, **5**, p. 1-12, 13 figs.

1911. Chaetognatha. *Bull. trimestr. Cons. int. expl. de la mer*, part 2, p. 170-175, pl. 24.

Attlmayr, F.

1883. *Handbuch der oceanographie*. Vienna, **1**, 598 pp., 3 taf.

Bigelow, H. B.

1909a. Reports on the scientific results of the expedition to the Eastern Tropical Pacific, 1904-1905. XVI. The Medusae. *Mem. M. C. Z.*, **37**, 243 pp., 48 pls.

1909b. Cruise of the U. S. fisheries schooner "Grampus" in the Gulf Stream during July, 1908, with description of a new Medusa (Bythotiaridae). *Bull. M. C. Z.*, **52**, p. 193-210, 1 pl.

1909c. Coelenterates from Labrador and Newfoundland. *Proc. U. S. nat. mus.*, **37**, p. 301-320, pl. 30-32.

1911. Reports on the scientific results of the expedition to the Eastern Tropical Pacific, 1904-1905. XXIII. The Siphonophorae. *Mem. M. C. Z.*, **38**, p. 171-401, 32 pls.

1912. Reports on the scientific results of the expedition to the Eastern Tropical Pacific, 1904-1905. XXVI. The Ctenophores. *Bull. M. C. Z.*, **54**, p. 367-404, 2 pls.

1913a. Medusae and Siphonophorae collected by the U. S. fisheries steamer "Albatross" in the Northwestern Pacific, 1906. *Proc. U. S. nat. mus.*, **44**, p. 1-120, pl. 1-6.

1913b. Oceanographic cruises of the U. S. fisheries schooner "Grampus" 1912-1913. *Science*, **38**, p. 599-601.

1914a. Explorations in the Gulf of Maine, July and August, 1912, by the U. S. fisheries schooner Grampus. *Oceanography and notes on the plankton*. *Bull. M. C. Z.*, **58**, p. 29-148, 9 pls.

1914b. Oceanography and plankton of Massachusetts Bay and adjacent waters, November, 1912-May, 1913. *Bull. M. C. Z.*, **58**, p. 383-420, 1 pl.

Bovallius, Carl.

1887. Contributions to a monograph of the Amphipoda Hyperiidea.

Part I: 1. Kongl. Svenska vet.-akad. Handl., **21**, no. 5, 72 pp., 10 pls.

1889. Contributions to a monograph of the Amphipoda Hyperiidea.

Part I: 2. Kongl. Svenska vet.-akad. Handl., **22**, no. 7, 434 pp., 18 pls.

British Admiralty.

1903. Sailing directions for the southeast coast of Nova Scotia and Bay of Fundy. London. 350 pp.

Brooks, W. K.

1886. The life-history of the Hydromedusae. Mem. Boston soc. nat. hist., **3**, p. 359-430, pl. 37-44.

Clark, A. H.

1912. A study of the salinity of the surface water in the North Pacific Ocean and in the adjacent enclosed seas. Smithsonian misc. coll., **60**, no. 13, 33 pp.

1914. The circulation of the abyssal waters of the oceans, as indicated by the geographical and bathymetrical distribution of the recent erinoids. Bull. Inst. océanogr., no. 285, 27 pp.

Cleve, P. T.

1900. Geographical distribution of Atlantic Copepoda and their physical conditions. Öfvers. Kongl. vet.-akad. förhandl. **57**, p. 139-144.

Collins, J. W.

1884. History of the tile-fish. Rept. U. S. fish comm. for 1882, p. 237-294a, 2 pls.

Conseil permanent international pour l'exploration de la mer.

1909. Bulletin trimestrial des résultats \* \* \* 1907-1908, part A, 45 pp. 12 pls.

1910. Bulletin hydrographique pour l'année Juillet 1908-Juin 1909, part A, 46 pp., 12 pls.

1911. Bulletin hydrographique pour l'année Juillet 1909-Juin 1910, part A, 33 pp., 10 pls.

Damas, D.

1905. Notes biologiques sur les copépodes de la mer Norvégienne. Publ. circ., Cons. int. expl. de la mer, **22**, 23 pp. 1 chart.

1909. Report on plankton, and spawning, eggs, and fry of fishes (the cod family). Norwegian fishery and marine investigations, **2**, part 1, p. 1-204.

Dawson, W. B.

1896. Survey of the tides and currents in Canadian waters. Report of progress, 32 pp., 8 pls.

1897. Survey of the tides and currents in Canadian waters. Report of progress, 49 pp., 1 pl.

1905. The currents at the entrance to the Bay of Fundy. Dept. marine fisheries, 17 pp., 1 chart.

1907. The currents in Belle Isle Strait. Dept. marine and fisheries, 43 pp., 4 pls.

Dawson, W. B.

1913. The currents in the Gulf of St. Lawrence. Dept. naval service, 46 pp., 1 chart.

Deutsche Seewarte.

1882. Atlantischer ozean. Atlas. Hamburg, 36 taf.

Dickson, H. N.

1901. The circulation of the surface waters of the North Atlantic Ocean. Philos. trans. Roy. soc., ser. A, **196**, p. 61-203, pl. 1-4.

Ekman, V. W.

- 1905a. On the influence of the earth's rotation on ocean currents. Arkiv. f. math. astron. och fysik, **2**, p. 1-53, 1 pl.

- 1905b. Kurze beschreibung eines propellstrommessers. Publ. circ. Cons. int. expl. de la mer, no. **24**, 4 pp., 1 taf.

1910. Tables for sea-water under pressure. Publ. circ. Cons. int. expl. de la mer, no. 49, 48 pp.

Engelhardt, Robert.

1913. Monographie der selachier. 1 teil. Tiergeographie der selachier. Abh. K. Bayer. akad. wiss. suppl., **4**, 110 pp., 2 charts.

Esterly, C. O.

1914. A study of the occurrence and manner of distribution of the Ctenophora of the San Diego region. Univ. California publ. Zool., **13**, p. 21-38.

Farran, G. P.

1910. Copepoda. Bull. trimestr. Cons. expl. de la mer, part 1, p. 60-79, pl. 8-10.

1911. Copepoda. Bull. trimestr. Cons. int. expl. de la mer, part 2, p. 81-105, pl. 11-16.

Fewkes, J. W.

- 1882a. Notes on acalephs from the Tortugas. Bull. M. C. Z., **9**, p. 251-290, 7 pls.

- 1882b. On the Acalephae of the east coast of New England. Bull. M. C. Z., **9**, p. 291-310, 1 pl.

1888. On certain Medusae from New England. Bull. M. C. Z., **13**, p. 209-240, 6 pls.

Hautreux, A.

1910. Atlantique nord. Bouteilles, glaces et carcasses flottantes de 1887 à 1909. Bull. Inst. océanogr., no. 173, 18 pp., 4 charts.

1911. Températures de l'Atlantique nord. Bull. Inst. océanogr., no. 201, 23 pp.

Herdman, W. A., Thompson, I. C., and Scott, Andrew.

1898. On the plankton collected continuously during two traverses of the North Atlantic in the summer of 1897. Trans. Liverpool biol. soc., **12**, p. 33-83, pl. 5-8.

Holmes, S. J.

1905. The Amphipoda of southern New England. Bull. U. S. bur. fisheries, **24**, p. 457-529, 13 pls.



Johnston, C. E.

1913. North Atlantic ice patrols. Patrol by U. S. R. C. "Seneca,"  
Pilot chart of the North Atlantic Ocean, for October 1913.

Johnstone, James.

1908. Conditions of life in the sea. Cambridge, 1 + 332 pp.

Knudsen, Martin.

1901. Hydrographical tables. Copenhagen, 63 pp.

1909. Résumé de l'hydrographie des mers explorées par le conseil. Bull.  
trimestr. Cons. int. expl. de la mer, 1906-1907, suppl., 78 pp., 23 pls.

Kramp, P. L.

- 1913a. Coelenterata. Bull. trimestr. Cons. int. expl. de la mer, part 3,  
p. 522-538, pl. 95-99.

- 1913b. Schizopoda. Bull. trimestr. Cons. int. expl. de la mer, part 3,  
p. 539-556, pl. 100-105.

1914. Meduser og siphonopherer. Conspectus Faunae Groenlandicae.  
Copenhagen, p. 383-456.

Krümmel, Otto.

1907. Handbuch der oceanographie. Leipzig, 1, 526 pp.

1911. Handbuch der oceanographie. Stuttgart, 2, 766 pp.

Libbey, William.

1891. Report upon a physical investigation of the waters off the southern  
coast of New England, made during the summer of 1889 by the U. S.  
fish commission schooner Grampus. Bull. U. S. fish comm. for 1889,  
9, p. 391-459, pl. 124-158.

1895. The relations of the Gulf Stream and the Labrador Current.  
Rept. Sixth int., geogr. congress, p. 461-474, 1 chart.

Maas, Otto.

1909. Japanische medusen. Abh. K. Bayer. akad. wiss., suppl., 1,  
52 pp., 3 pls.

McEwen, G. F.

1912. The distribution of ocean temperatures along the west coast of  
North American deduced from Ekman's theory of the upwelling  
of cold water from the adjacent ocean depths. Int. rev. hydrobiol.  
hydrogr., 5, p. 243-286.

Mauzy, M. F.

1855. The physical geography of the sea. 2nd ed., New York, 287 pp.,  
12 pls.

Mayer, A. G.

1910. Medusae of the world. Carnegie inst., Publ. no. 109, 3 vols.,  
734 pp., 76 pls.

1912. Ctenophores of the Atlantic coast of North America. Carnegie  
inst., Publ. no. 162. 58 pp., 17 pls.

Meisenheimer, Johannes.

1905. Pteropoda. Wiss. ergeb. Deutsch. tiefsee-exped., 9, lief. 1, p.  
1-314, atlas 27 taf., 9 charts.

Meisenheimer, Johannes.

1905. Die arktischen pteropoden. *Fauna Arctica*, **4**, p. 407-430, 1 chart.

Michael, E. L.

1911. Classification and vertical distribution of the Chaetognatha of the San Diego region. *Univ. California publ. Zool.*, **8**, p. 21-186, pl. 1-8.

Mitchell, Henry.

1881. Physical hydrography of the Gulf of Maine. *Rept. U. S. coast & geod. surv. for 1878-1879*, p. 175-190, 1 pl.

Mortensen, Th.

1912. Ctenophora. *Danish Ingolf-exped.*, **5**, part 2, 95 pp., 10 pl.

1913. Ctenophora. Report on the scientific results of the "Michael Sars" North Atlantic deep-sea exped., 1910, **3**, *Zool.*, 12 pp., 1 pl.

Murray, John.

1898. On the annual range of temperature in the surface waters of the ocean and its relation to other oceanographical phenomena. *Geogr. journ.*, **12**, p. 113-137, 1 chart.

Murray, John, and Hjort, Johan.

1912. The depths of the ocean. London, 20, 821 pp., ills.

Paulsen, Ove.

1904. Plankton-investigations in the waters round Iceland. *Medd. Komm. havundersøgelser, ser. Plankton*, **1**, no. 1, 40 pp., 2 charts.

1908. Peridinales. *Nordisches plankton*, *lif. 8*, XVIII, 124 pp.

1910. Pteropoda. *Bull. trimestr. Cons. int. expl. de la mer.*, part 1, p. 52-59, pl. 7.

Pettersson, Otto.

1907a. On the influence of ice-melting upon oceanic circulation. *Geogr. journ.*, **30**, p. 273-295.

1907b. On the influence of ice-melting upon oceanic circulation. *Geogr. journ.*, **30**, p. 671-675.

Rathbun, Mary J.

1905. *Fauna of New England*. 5. List of the Crustacea. *Occ. papers Boston soc. nat. hist.*, **7**, 117 pp.

Rathbun, R.

1887. Ocean temperatures of the eastern coast of the United States, from observations made at 24 light houses and light-ships. The fisheries and fishery industries of the U. S., sect. 3, appendix. *U. S. fish comm.*, p. 157-177, 32 charts.

Reclus, J. J. E.

1873. *The ocean*. . . [Transl. by B. B. Woodward]. London, **1**, 301 pp., 13 pls.

Ritter-Zahony, Rudolf von.

1911. Revision der chätognathen. *Deutsche Südpolar-exped.*, **13**. *Zoöl.*, **5**, heft 1, 71 pp.

Rómer, Fritz.

1901. Die siphonophoren. *Fauna Arctica*, **2**, p. 169-184.

Rose, Maurice.

1913. Recherches biologiques sur le plankton. Bull. Inst. océanogr., no. 276, 15 pp.

Sandström, J. W.

1908. Dynamische versuche mit meerwasser. Ann. hydrogr., 1908, p. 6-23.

Sars, G. O.

- 1890-1895. An account of the Crustacea of Norway. 1. Amphipoda. Bergen, 711 pp., atlas of 248 pls.

Schott, Gerhard.

1897. Die gewässer der Bank von Neufundland und ihrer weitem umgebung. Petermanns mitteil., 43, p. 201-212, pl. 15.

1902. Oceanographie und maritime meteorologie. Wiss. ergeb. Deutsch. tiefsee-exped., 1, 40 taf.

1912. Geographie des atlantischen ozeans. Hamburg, 12, 330 pp., 28 pls.

Scott, Thomas.

1911. Copepoda. Bull. trimestr. Cons. int. expl. de la mer, part 2, p. 106-149, pl. 17-22.

Smith Sanderson.

1889. Lists of the dredging stations \* \* \* in North American waters, from 1867-1887. Rept. U. S. fish comm. for 1886, p. 873-1017, 9 charts.

Soley, J. C.

1911. The circulation in the North Atlantic in the month of August. Supplement Pilot chart North Atlantic Ocean for 1911. Hydrographic office, U. S. navy dept. Washington.

Steuer, Adolf.

1910. Planktonkunde. Leipzig, 16, 723 pp., 1 taf.

Sumner, F. B., Osburn, R. C., and Cole, L. J.

1913. A biological survey of the waters of Woods Hole and vicinity. Bull. U. S. bur. fisheries, 31, part. 1, sect. 1, p. 11-442, 227 charts.

Tanner, Z. L.

- 1884a. Report on the construction and work in 1880 of the Fish commission steamer Fish Hawk. Rept. U. S. fish comm. for 1881, p. 3-54, pl. 1-18.

- 1884b. A report of the work of the United States fish commission steamer Fish Hawk, for the year ending December 31, 1881. Rept. U. S. fish comm. for 1881, p. 55-86.

- 1884c. Report on the work of the United States fish commission steamer Fish Hawk for the year ending December 31, 1882. Rept. U. S. fish comm. for 1882, p. 3-34, 3 pls.

1886. Report on the work of the United States fish commission steamer Albatross for the year ending December 31, 1884. Rept. U. S. fish comm. for 1884, p. 3-116, 3 pls.

Tesch, J. J.

1911. Amphipoda. Bull. trimestr. Cons. int. expl. de la mer, part 2, p. 176-193, pl. 25.

Thoulet, J.

1904. L'océan. Paris, 8, 397 pp., ill.

Tizard, T. H.

1907. Dr. Otto Pettersson on the influence of ice-melting on oceanic circulation. Geogr. Journ., **30**, p. 339-344.

Townsend, C. H.

1901. Dredging and other records of the United States fish commission steamer Albatross. Rept. U. S. fish comm. for 1900, p. 387-562, 7 pls.

United States bureau of fisheries.

1914. Opportunity for a new scallop fishery off the middle Atlantic Coast. Econ. circular, no. 7, 5 pp.

United States Coast pilot.

1912. Atlantic Coast, part 3.

Verrill, A. E.

1880. Notice of the remarkable marine fauna occupying the outer banks off the southern coast of New England. Amer. Journ. sci., ser. 3, **20**, p. 390-403.

1881. Notice of the remarkable marine fauna occupying the outer banks off the southern coast of New England, no. 2. Amer. Journ. sci., ser. 3, **22**, p. 292-303.

- 1882a. Notice of the remarkable marine fauna occupying the outer banks off the southern coast of New England, no. 3. Amer. Journ. sci., ser. 3, **23**, p. 135-142.

- 1882b. Notice of the remarkable marine fauna occupying the outer banks off the southern coast of New England, no. 7. Amer. Journ. sci., ser. 3, **24**, p. 360-371.

- 1884a. Notice of the remarkable marine fauna occupying the outer banks off the southern coast of New England, and of some additions to the fauna of Vineyard Sound. Rept. U. S. fish comm. for 1882, p. 641-670.

- 1884b. In Collins, 1884, p. 276-280.

Wedderburn, E. M.

1908. An experimental investigation on the temperature changes occurring in fresh water lochs. Proc. Roy. soc. Edinburgh, **28**, p. 13.

Wheeler, W. M.

1901. The free-swimming copepods of the Woods Hole region. Bull. U. S. fish comm. for 1899, **19**, p. 157-192.

Williams, L. W.

1906. Notes on marine Copepoda of Rhode Island. Amer. nat., **40** p. 639-660.

Wright, R. Ramsay.

1907. The plankton of eastern Nova Scotia waters. 39 ann. rept.  
Dept. marine and fisheries, Canada, 19 pp., 7 pls.

Zimmer, C.

1909. Die nordischen Schizopoden. Nordisches plankton, lief. 12, art.  
VI, 178 pp.





PLATE 1.

Chart of the route, showing the Stations, and the 20, 50, and 100 fathom curves.



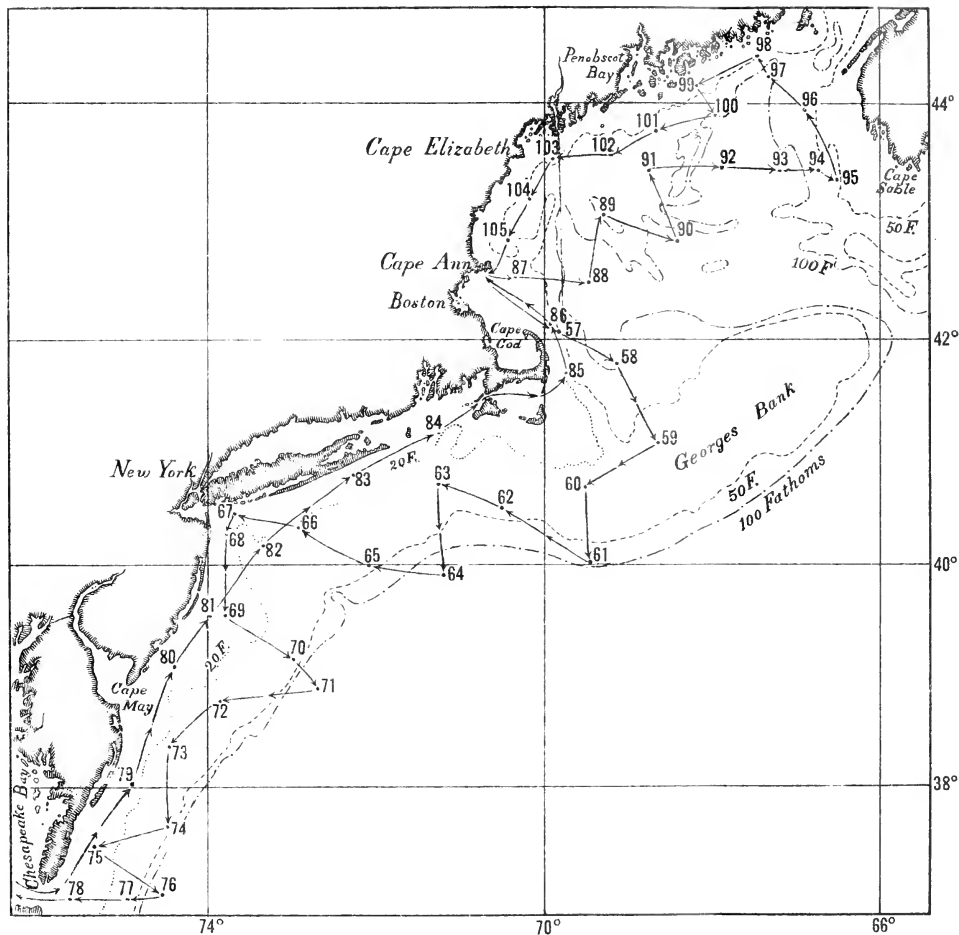
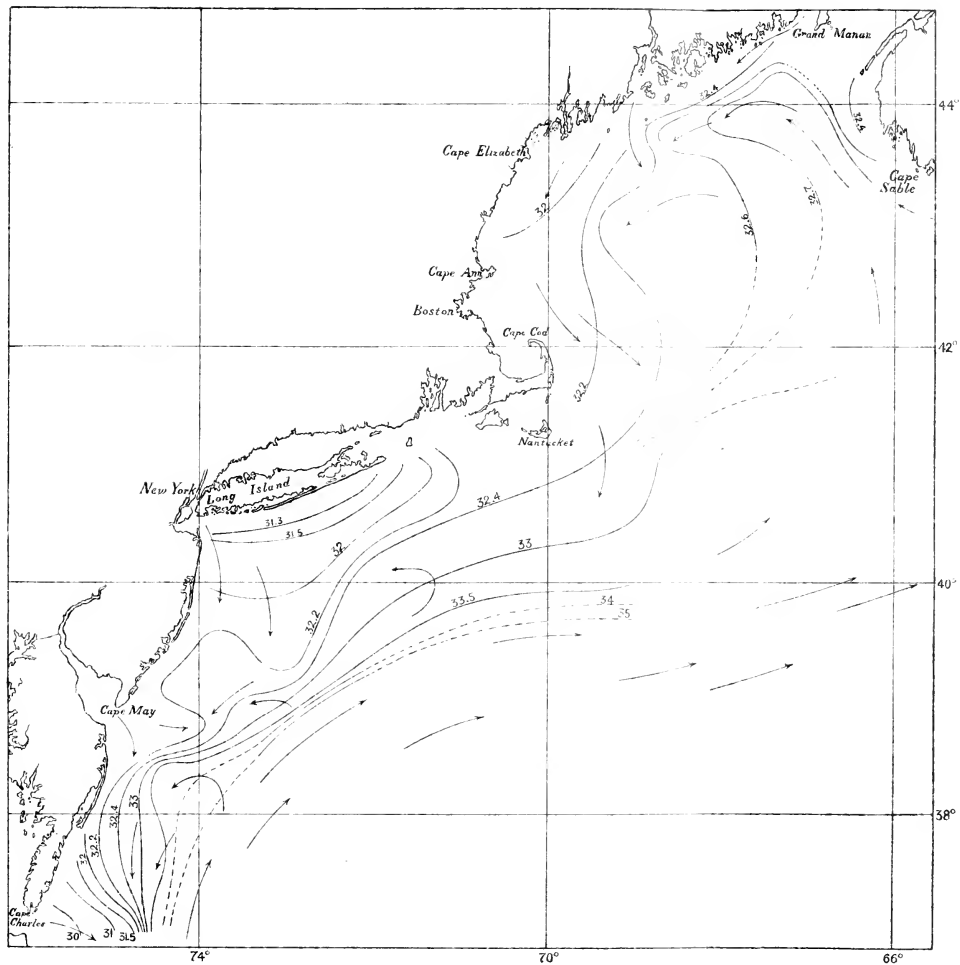





PLATE 2.

Chart of surface salinities and surface currents for the Gulf of Maine in August, and for the waters south and west of Cape Cod in July.





The following Publications of the Museum of Comparative Zoölogy are in preparation:—

LOUIS CABOT. Immature State of the Odonata. Part IV.

E. L. MARK. Studies on Lepidosteus, continued.

E. L. MARK. On Arachnaetis.

H. L. CLARK. The "Albatross" Hawaiian Echini.

Reports on the Results of Dredging Operations in 1877, 1878, 1879, and 1880, in charge of ALEXANDER AGASSIZ, by the U. S. Coast Survey Steamer "Blake," as follows:—

A. MILNE EDWARDS and E. L. BOUVIER. The Crustacea of the "Blake."

A. E. VERRILL. The Alcyonaria of the "Blake."

Reports on the Results of the Expedition of 1891 of the U. S. Fish Commission Steamer "Albatross," Lieutenant Commander Z. L. TANNER, U. S. N., Commanding, in charge of ALEXANDER AGASSIZ, as follows:—

K. BRANDT. The Sagittae.

K. BRANDT. The Thalassicolae.

O. CARLGREN. The Actinarians.

R. V. CHAMBERLIN. The Annelids.

W. R. COE. The Nemertean.

REINHARD DOHRN. The Eyes of Deep-Sea Crustacea.

H. J. HANSEN. The Cirripeds.

H. J. HANSEN. The Schizopods.

HAROLD HEATH. Solenogaster.

W. A. HERDMAN. The Ascidians.

S. J. HICKSON. The Antipathids.

E. L. MARK. Branchiocerianthus.

JOHN MURRAY. The Bottom Specimens.

P. SCHIEMENZ. The Pteropods and Heteropods.

THEO. STUDER. The Alcyonarians.

— The Salpidae and Doliolidae.

H. B. WARD. The Sipunculids.

Reports on the Scientific Results of the Expedition to the Tropical Pacific, in charge of ALEXANDER AGASSIZ, on the U. S. Fish Commission Steamer "Albatross," from August, 1899, to March, 1900, Commander Jefferson F. Moser, U. S. N., Commanding, as follows:—

R. V. CHAMBERLIN. The Annelids.

H. L. CLARK. The Holothurians.

H. L. CLARK. The Ophiurans.

— The Volcanic Rocks.

— The Coralliferous Limestones.

S. HENSHAW. The Insects.

G. W. MÜLLER. The Ostracods.

MARY J. RATHBUN. The Crustacea Decapoda.

G. O. SARS. The Copepods.

L. STEJNEGER. The Reptiles.

C. H. TOWNSEND. The Mammals, Birds, and Fishes.

T. W. VAUGHAN. The Corals, Recent and Fossil.

PUBLICATIONS  
OF THE  
MUSEUM OF COMPARATIVE ZOÖLOGY  
AT HARVARD COLLEGE.

---

There have been published of the BULLETIN Vols. I. to LIV. and Vol. LVIII.; of the MEMOIRS, Vols. I. to XXIV., and also Vols. XXVI. to XXIX., XXXI. to XXXIV., XXXVI. to XXXVIII., XL. to XLII., and XLIV.

Vols. LV. to LVII., and LIX. of the BULLETIN, and Vols. XXV., XXX., XXXV., XXXIX., XLIII., XLV. to XLIX. of the MEMOIRS, are now in course of publication.

The BULLETIN and MEMOIRS are devoted to the publication of original work by the Officers of the Museum, of investigations carried on by students and others in the different Laboratories of Natural History, and of work by specialists based upon the Museum Collections and Explorations.

The following publications are in preparation:—

Reports on the Results of Dredging Operations from 1877 to 1880, in charge of Alexander Agassiz, by the U. S. Coast Survey Steamer "Blake," Lieut. Commander C. D. Sigsbee, U. S. N., and Commander J. R. Bartlett, U. S. N., Commanding.

Reports on the Results of the Expedition of 1891 of the U. S. Fish Commission Steamer "Albatross," Lieut. Commander Z. L. Tanner, U. S. N., Commanding, in charge of Alexander Agassiz.

Reports on the Scientific Results of the Expedition to the Tropical Pacific, in charge of Alexander Agassiz, on the U. S. Fish Commission Steamer "Albatross," from August, 1899, to March, 1900, Commander Jefferson F. Moser, U. S. N., Commanding.

Reports on the Scientific Results of the Expedition to the Eastern Tropical Pacific, in charge of Alexander Agassiz, on the U. S. Fish Commission Steamer "Albatross," from October, 1904, to April, 1905, Lieut. Commander L. M. Garrett, U. S. N., Commanding.

Contributions from the Zoölogical Laboratory, Professor E. L. Mark, Director.  
Contributions from the Geological Laboratory, Professor R. A. Daly, in charge.

These publications are issued in numbers at irregular intervals. Each number of the Bulletin and of the Memoirs is sold separately. A price list of the publications of the Museum will be sent on application to the Director of the Museum of Comparative Zoölogy, Cambridge, Mass.



3189  
Bulletin of the Museum of Comparative Zoölogy

AT HARVARD COLLEGE.

VOL. LIX. No. 5.

---

<sup>2</sup>  
NOTES ON BIRDS FROM EAST SIBERIA AND ARCTIC  
ALASKA.

BY W. SPRAGUE BROOKS.

---

CAMBRIDGE, MASS., U. S. A.:  
PRINTED FOR THE MUSEUM.

SEPTEMBER, 1915.

REPORTS ON THE SCIENTIFIC RESULTS OF THE EXPEDITION TO THE EASTERN TROPICAL PACIFIC, IN CHARGE OF ALEXANDER AGASSIZ, BY THE U. S. FISH COMMISSION STEAMER "ALBATROSS," FROM OCTOBER, 1904, TO MARCH, 1905, LIEUTENANT COMMANDER L. M. GARRETT, U. S. N., COMMANDING. PUBLISHED OR IN PREPARATION:—

- A. AGASSIZ. V.<sup>5</sup> General Report on the Expedition.
- A. AGASSIZ. I.<sup>1</sup> Three Letters to Geo. M. Bowers, U. S. Fish Com.
- A. AGASSIZ and H. L. CLARK. The Echini.
- H. B. BIGELOW. XVI.<sup>16</sup> The Medusae.
- H. B. BIGELOW. XXIII.<sup>23</sup> The Siphonophores.
- H. B. BIGELOW. XXVI.<sup>26</sup> The Ctenophores.
- R. P. BIGELOW. The Stomatopods.
- O. CARLGREN. The Actinaria.
- R. V. CHAMBERLIN. The Annelids.
- H. L. CLARK. The Holothurians.
- H. L. CLARK. The Starfishes.
- H. L. CLARK. The Ophiurans.
- S. F. CLARKE. VIII.<sup>8</sup> The Hydroids.
- W. R. COE. The Nemereteans.
- L. J. COLE. XIX.<sup>19</sup> The Pycnogonida.
- W. H. DALL. XIV.<sup>14</sup> The Mollusks.
- C. R. EASTMAN. VII.<sup>7</sup> The Sharks' Teeth.
- S. GARMAN. XII.<sup>12</sup> The Reptiles.
- H. J. HANSEN. The Cirripeds.
- H. J. HANSEN. XXVII.<sup>27</sup> The Schizopods.
- S. HENSHAW. The Insects.
- W. E. HOYLE. The Cephalopods.
- W. C. KENDALL and L. RADCLIFFE. XXV.<sup>25</sup> The Fishes.
- C. A. KOFOID. III.<sup>3</sup> IX.<sup>9</sup> XX.<sup>20</sup> The Protozoa.
- C. A. KOFOID and J. R. MICHENER. XXII.<sup>22</sup> The Protozoa.
- C. A. KOFOID and E. J. RIGDEN. XXIV.<sup>24</sup> The Protozoa.
- P. KRUMBACH. The Sagittae.
- R. VON LENDENFELD. XXI.<sup>21</sup> The Siliceous Sponges.
- R. VON LENDENFELD. XXIX.<sup>29</sup> Hexactinellida.
- G. W. MÜLLER. The Ostracods.
- JOHN MURRAY and G. V. LEE. XVII.<sup>17</sup> The Bottom Specimens.
- MARY J. RATHBUN. X.<sup>10</sup> The Crustacea Decapoda.
- HARRIET RICHARDSON. II.<sup>2</sup> The Isopods.
- W. E. RITTER. IV.<sup>4</sup> The Tunicates.
- B. L. ROBINSON. The Plants.
- G. O. SARS. The Copepods.
- F. E. SCHULZE. XI.<sup>11</sup> The Xenophyphoras.
- HARRIET R. SEARLE. XXVIII.<sup>28</sup> Isopods.
- H. R. SIMROTH. Pteropods, Heteropods.
- E. C. STARKS. XIII.<sup>13</sup> Atelaxia
- TH. STUDER. The Alcyonaria.
- JH. THIELE. XV.<sup>15</sup> Bathyscladium.
- T. W. VAUGHAN. VI.<sup>6</sup> The Corals.
- R. WOLTERECK. XVIII.<sup>18</sup> The Amphipods.

<sup>1</sup> Bull. M. C. Z., Vol. XLVI., No. 4, April, 1905, 22 pp.

<sup>2</sup> Bull. M. C. Z., Vol. XLVI., No. 6, July, 1905, 4 pp., 1 pl.

<sup>3</sup> Bull. M. C. Z., Vol. XLVI., No. 9, September, 1905, 5 pp., 1 pl.

<sup>4</sup> Bull. M. C. Z., Vol. XLVI., No. 13, January, 1906, 22 pp., 3 pls.

<sup>5</sup> Mem. M. C. Z., Vol. XXXIII., January, 1906, 90 pp., 96 pls.

<sup>6</sup> Bull. M. C. Z., Vol. L., No. 3, August, 1906, 14 pp., 10 pls.

<sup>7</sup> Bull. M. C. Z., Vol. L., No. 4, November, 1906, 26 pp., 4 pls.

<sup>8</sup> Mem. M. C. Z., Vol. XXXV., No. 1, February, 1907, 20 pp., 15 pls.

<sup>9</sup> Bull. M. C. Z., Vol. L., No. 6, February, 1907, 48 pp., 18 pls.

<sup>10</sup> Mem. M. C. Z., Vol. XXXV., No. 2, August, 1907, 56 pp., 9 pls.

<sup>11</sup> Bull. M. C. Z., Vol. LI., No. 6, November, 1907, 22 pp., 1 pl.

<sup>12</sup> Bull. M. C. Z., Vol. LII., No. 1, June, 1908, 14 pp., 1 pl.

<sup>13</sup> Bull. M. C. Z., Vol. LII., No. 2, July, 1908, 8 pp., 5 pls.

<sup>14</sup> Bull. M. C. Z., Vol. XLIII., No. 6, October, 1908, 285 pp., 22 pls.

<sup>15</sup> Bull. M. C. Z., Vol. LII., No. 5, October, 1908, 11 pp., 2 pls.

<sup>16</sup> Mem. M. C. Z., Vol. XXXVII., February, 1909, 243 pp., 48 pls.

<sup>17</sup> Mem. M. C. Z., Vol. XXXVIII., No. 1, June, 1909, 172 pp., 5 pls., 3 maps.

<sup>18</sup> Bull. M. C. Z., Vol. LII., No. 9, June, 1909, 26 pp., 8 pls.

<sup>19</sup> Bull. M. C. Z., Vol. LII., No. 11, August, 1909, 10 pp., 3 pls.

<sup>20</sup> Bull. M. C. Z., Vol. LII., No. 13, September, 1909, 48 pp., 4 pls.

<sup>21</sup> Mem. M. C. Z., Vol. XLI., August, September, 1910, 323 pp., 56 pls.

<sup>22</sup> Bull. M. C. Z., Vol. LIV., No. 7, August, 1911, 38 pp.

<sup>23</sup> Mem. M. C. Z., Vol. XXXVIII., No. 2, December, 1911, 232 pp., 32 pls

<sup>24</sup> Bull. M. C. Z., Vol. LIV., No. 10, February, 1912, 16 pp., 2 pls.

<sup>25</sup> Mem. M. C. Z., Vol. XXXV., No. 3, April, 1912, 98 pp., 8 pls.

<sup>26</sup> Bull. M. C. Z., Vol. LIV., No. 12, April, 1912, 38 pp., 2 pls.

<sup>27</sup> Mem. M. C. Z., Vol. XXXV., No. 4, July, 1912, 124 pp., 12 pls.

<sup>28</sup> Bull. M. C. Z., Vol. LVIII., No. 8, August, 1914, 14 pp.

<sup>29</sup> Mem. M. C. Z., Vol. XLII., June, 1915, 397 pp., 109 pls.

SEP 2 1915

Bulletin of the Museum of Comparative Zoölogy  
AT HARVARD COLLEGE.  
VOL. LIX. No. 5.

---

31  
NOTES ON BIRDS FROM EAST SIBERIA AND ARCTIC  
ALASKA.

BY W. SPRAGUE BROOKS.

---

CAMBRIDGE, MASS., U. S. A.:  
PRINTED FOR THE MUSEUM.  
SEPTEMBER, 1915.



No. 5.— *Notes on Birds from East Siberia and Arctic Alaska.*

BY W. SPRAGUE BROOKS.

INTRODUCTION.

IN the spring of 1913, several graduates of Harvard University organized a hunting expedition in northern waters. Through the generous coöperation of Col. John E. Thayer and Prof. Theodore Lyman, Mr. Joseph Dixon and the writer had the pleasure of accompanying the expedition as zoölogical collectors. Our itinerary was as follows.

Leaving Seattle on the power schooner POLAR BEAR, Capt. L. L. Lane in command, we proceeded up the "inside" passage of south-eastern Alaska, stopping for a few hours at Woewodsky and Kupreanof Islands on April 9 and 10, and at two points on Icy Straits April 11 and 12. Thence to the Semidi Islands on April 18 and 19, and from there to several points along the Alaskan peninsula where little time for work was at our disposal.

Obtaining a few supplies at Unalaska we proceeded to Copper Island arriving on May 6. Here the snow was too deep for travelling and in two days we left for Bering Island where winter conditions also caused much trouble.

May 10 found us at Petropavlovsk and from this date to May 27 we worked on the Kamchatkan coast from Petropavlovsk to Cape Africa. At the latter point ice conditions prevented further travel in a northerly direction and we crossed Bering Sea to St. Lawrence Island. This Island and the Chukchi Peninsula of Siberia were the centre of our activities during June, including a brief stop at Big Diomedé Island in Bering Strait.

In July our work on the Siberian shore was extended to Cape Serdze from which point we crossed to Cape Lisburne, Alaska, and Point Barrow arriving at the latter Point on July 24. The favorable ice conditions east of Point Barrow soon ceased and we encountered every possible unfavorable condition of ice and weather during August, finally being forced to go into winter quarters at Humphrey Point, Alaska, after nearly losing the vessel. Humphrey Point lies about thirty-five miles west of the Alaskan-Canadian boundary. Though

frozen in on September 3, we were not settled in our camp on the sand spit until October 5.

On March 2, 1914, Mr. Dixon and I went to Demarcation Point five miles west of the boundary where I remained until July 20; Mr. Dixon returned to Humphrey Point on May 1, to collect until the ice broke up.

Both localities are low slightly rolling wastes of tundra, the five hundred foot contour at the foot hills of the Endicott Mountains being twelve miles from the coast at Demarcation Point, and some fifteen miles farther at Humphrey Point.

At the former point there were many pools and ponds but contrary to expectations it proved to be a poor resort for breeding birds. Our notes on the arrival of water fowl are unimportant, for these birds first arrive in the open leads off shore before the snow is melted from the tundra. To go on the ice in spring is a hazardous undertaking, for it is obviously less strong than in winter, and a sudden off shore gale, so prevalent in this region, is very liable to break the ice between one and the beach, rendering the situation very dangerous.

The spring and early summer of 1914 were very cold and foggy, the ice remaining intact about the Point until July 19, when the whaling ship *BELVEDERE* broke loose from the floe ice in which she wintered and passed about eight miles off shore.

On July 26, I left on the trading schooner *ANNA OLGA*, that wintered at Clarence Bay, as ice conditions forced me to believe that being picked up by the *POLAR BEAR* was a matter of considerable doubt. Mr. Dixon remained with the *POLAR BEAR* reaching Nome shortly after my arrival on the revenue cutter *BEAR* which brought me from Point Barrow.

The extreme kindness of Dr. Rudolph M. Anderson, leader of the southern division of the Canadian Arctic Expedition, and of Captain Cottle of the whaling ship *BELVEDERE* added greatly to the pleasure and success of our sojourn on the Arctic coast of Alaska.

I am greatly indebted to Mr. Outram Bangs of the Museum of Comparative Zoölogy, and Mr. H. C. Oberholser of the U. S. National Museum for generous assistance in working on the collection.

The unfortunate loss of Mr. Dixon's excellent field notes detracts greatly from the value of the paper.

## TETRAONIDAE.

## LAGOPUS LAGOPUS ALBUS (Gmelin).

## WILLOW PTARMIGAN.

During the first half of August, 1913, this species was abundant along the shores of Camden Bay, Alaska. At Humphrey Point during the same season they were often seen in small numbers late in September and early in October when they left for the mountains to spend the winter.

At Demarcation Point, a flock of about twenty, the first arrivals on the coast in the spring of 1914, were seen on April 6. These birds were in good condition and unusually wild. The day was hazy and for the first time that year there were evidences of thawing in sheltered spots with a southern exposure. During hazy weather when the whole landscape appears as a white mass with no shadows, ptarmigan in winter plumage are well protected for their feathers are not a pure white but seem to take on the same reflected colors as the snow. At a distance during flight the black tail feathers soon fail to attract the eye for there are many dark patches of exposed ground upon the wind swept tundra.

Willow Ptarmigan were found near the Point in considerable numbers until about the tenth of May when they began retiring to the foot hills. Very few were in pairs up to this time. During the day the flock about the Point could be found somewhere in the immediate vicinity scratching about in the snow for willow plants, on the twigs of which they seemed to feed exclusively. At night they would roost in the protected holes and angles of a pressure ridge close to the shore.

Only once did I note any signs of courting. On May 1, I saw a male running to and fro in front of a female, his breast puffed out and lowered close to the ground and tail elevated. The female appeared indifferent, but when her suitor finally flew out to the ice and with much cackling, had travelled about two hundred yards she followed.

After the middle of May I could find no Willow Ptarmigan near the Point, and saw none except a pair June 4, about three miles back on the tundra. The nest was not found.

Males taken early in April were acquiring summer plumage on the neck and head, but none in full plumage were found until late in June.

No summer plumage was noted in females until early in May, but

the change is more rapid than in the males, for a female in full summer plumage was taken on June 4.

During the last three days of September 1913, some males taken at Humphrey Point were entirely white except for a few brown feathers on the crown and sides of the head. Females taken at the same time were, with one exception, far less advanced towards full winter plumage.

*LAGOPUS LAGOPUS ALEXANDRAE* Grinnell.

ALEXANDER'S PTARMIGAN.

Quite common but exceedingly wild at Portage Bay, Alaska Peninsula, April 21, 1913. Seven were preserved.

*LAGOPUS RUPESTRIS RUPESTRIS* (Gmelin).

ROCK PTARMIGAN.

This is an abundant species on the coast from Camden Bay to the Mackenzie River delta during the spring and late summer after the breeding season which is spent in the foot hills of the Endicott Mountains.

At Demarcation Point the first of this species seen in the spring of 1914 was a pair on May 4. Their late arrival here was a matter of chance I believe, for at Humphrey Point, they were seen much earlier.

They seem to pair earlier than the Willow Ptarmigan, for while the latter were about in good-sized flocks the former were mostly paired or in groups of three to five. They were very tame in most cases, and this I do not understand for the Eskimo has as much opportunity to shoot this species as the other. Sometimes both species were seen together but very seldom.

The males are quite pugnacious, when in flocks, often pursuing each other and going through antics suggesting the young males of domestic fowls.

Rock Ptarmigan exhibit considerable curiosity at times, a trait I have not noticed in the Willow Ptarmigan. When one of its kind is dead or wounded the rest frequently show great concern and interest in the unfortunate one.

Many times while walking over the tundra I would be startled by the rattling call of a male Rock Ptarmigan, and turning about see him alight within a few yards of me with tail spread and eye-wattles erect.



After strutting about and "showing off" a moment he would busy himself searching for food as though no man were in the country. In the winter plumage the males are very beautiful.

The female begins to acquire summer plumage before the male, showing brown feathers on the crown and ear-coverts by May 6, though two observed with binoculars on May 20, revealed no summer plumage whatever. On May 8, I took two females, one in full winter plumage, the other in a state of transition not observed before. The head and neck were white but the right side of the rump and lower back had the summer plumage with its border down the middle of the back sharply defined. Females in full summer plumage were found early in June.

The earliest male showing any change was taken May 13, though one taken on the 20, showed no change. No opportunity was afforded for noting the plumage change in the males for the birds had gone back to the foot hills for nesting before acquiring full summer plumage.

During the latter part of May when most of the snow has gone the white males are very conspicuous. They do not roost on the snow patches that remain, and while on the tundra their form makes them very noticeable though the color might suggest a small bit of snow. For at least a month nature gives this bird little protection.

Beside a large series of birds from Camden Bay, Humphrey Point, Demarcation Point, and near Herschel Island, two males were taken at East Cape, Siberia, June 16, 1913, and a female at Portage Bay, Alaska Peninsula, April 21, 1913. The males from East Cape show summer plumage on the crown, nape, and sides of head.

#### LAGOPUS RUPESTRIS DIXONI Grinnell.

##### DIXON'S PTARMIGAN.

About three hundred were seen April 12, 1913, at Muir Inlet, Glacier Bay, Alaska. A series of five was preserved.

#### LAGOPUS RIDGWAYI Stejneger.

Several were seen on the mountain side at Copper Island, May 7, 1913. Dr. J. S. Kalinin who resides there and takes great interest in the local bird life stated that some years they were quite plentiful and during others absent. No doubt this is due to the blue foxes

which are plentiful on the Island. Lying at anchor near one of the cliffs we could see a number of these foxes threading their way along the face of the precipice.

LAGOPUS LEUCURUS LEUCURUS (Swainson).

WHITE-TAILED PTARMIGAN.

A few were seen in company with about three hundred *L. rupestris dixonii* at Muir Inlet, Glacier Bay, Alaska, April 12, 1913. Two males and a female were preserved.

DENDRAGAPUS OBSCURUS FULIGINOSUS (Ridgway).

SOOTY GROUSE.

Several were seen about Point Gustavus, Glacier Bay, April 11, 1913. A pair was taken.

GAVIIDAE.

GAVIA STELLATA (Pontoppidan).

RED-THROATED LOON.

This species was noted in small numbers about a large marsh on the west side of Providence Bay, East Siberia, June 19 and 20, 1913.

During the last week in June they were found breeding on the southern side of St. Lawrence Island where two sets of eggs were taken on June 27, 1913. A number of nests were found that appeared to have been robbed by Glaucous Gulls.

At Cape Serdze, East Siberia, several were seen July 17, 18, 1913.

None were seen at Demarcation Point in 1914 until June 12, when a female was secured. Though I could find no nests, two pair at least remained in the vicinity of the Point during my stay.

This species is the tamest of the loons and instead of stealing quietly away when one is at their nest they fly immediately and circling about above one's head utter continually their harsh cry "kark-kark-kark." This cry can be heard almost any time through the day or night where this bird is breeding.

## GAVIA PACIFICA (Lawrence).

## PACIFIC LOON.

This is the most abundant of the loons at Demarcation Point where it was first noted on June 3; a pair in a pond, and five flying east.

As other writers have remarked this bird delights in making the most hideous noises imaginable while on the water. On still calm nights one often hears a heart rending wailing on the distant waste of tundra, as of a child in agony. Another sound which, though I heard it many times, never failed to startle me; a bird would often be concealed in the aquatic vegetation along the margin of a pond, and when within a few feet of the bird it would utter a piercing shriek, just as it was diving under water. These weird sounds had a great effect on the expedition's cook who occasionally took short excursions after ducks for the table. One day he returned in a state of considerable agitation with the report that far back on the tundra he had heard the groans of a dying man but could find no one. Thereafter his peregrinations from the kitchen seldom extended beyond the wood pile.

Many of the birds are mated on arriving at Demarcation Point and they soon select a pond suitable for nesting about which one or both of the birds can generally be found at any hour. The size of the pond seems to be immaterial provided there is sufficient space for taking wing. A Red-throated Loon requires less space than a Pacific Loon to leave the water.

The nest of the Pacific Loon is composed of a pile of roots and stems of aquatic vegetation placed in a patch of water weeds that grow in abundance about the margins of many of the ponds. The whole affair is very wet and soggy.

Until the surrounding vegetation has grown to a considerable height the black and white back of the brooding bird is very conspicuous, though on one's approach she lies very flat and extends the head and neck straight out over the water. When disturbed, the bird slides from the nest and disappearing under the water does not come to the surface until the cover of some grass has been reached some fifty yards distant, from which she quietly watches the intruder.

Fresh eggs were taken July 4, and eggs slightly incubated on July 6 and 7.

Specimens of this species were taken in Camden Bay, August, 1913, and Providence Bay, E. Siberia, June 18, 1913.

We saw no evidence of *G. arctica*.

*GAVIA ADAMSI* (Gray).

## YELLOW-BILLED LOON.

This species was quite common at Humphrey Point during 1914, Mr. Dixon preserving nine males and five females. At Demarcation Point I took only two, for with the exception of three or four birds, those I saw were on large ponds far back on the tundra or high in air some distance from the coast. At Humphrey Point they were common by the shore.

We found no evidence of their breeding near the coast, and the Eskimo believe that they nest in large lakes on the other side of the mountains.

None were noted until early June, Mr. Dixon securing the first specimen, a female, on June 3.

## PROCELLARIIDAE.

*OCEANODROMA FURCATA* (Gmelin).

## FORKED-TAILED PETREL.

Fork-tailed Petrels were common in Bering Sea, May 27, 28, 29, 30, 31, 1913, from Cape Zhipanov, Kamchatka to St. Lawrence Island. A pair taken at Copper Island, May 24 was purchased.

*PUFFINUS TENUIROSTRIS* (Temminck).

## SLENDER-BILLED SHEARWATER.

We did not observe this species but a male taken at Copper Island, May 29, was purchased.

*FULMARIUS GLACIALIS GLUPISCHA* Stejneger.

## PACIFIC FULMAR.

Pacific Fulmars were first observed and taken about seventy miles southeast of Seward, Alaska, on April 16, 1913. On April 18, they were common in Shelikof Strait, Alaska, sailing gracefully about in a tremendous gale that forced us to seek shelter at the Semidi Islands.

About the cliffs of Copper Island, on May 6, 1913, they were abundant and specimens were secured.

During the last week in May we noted quite a number on Bering Sea as we were crossing from Cape Zhipanov, Kamchatka to St. Lawrence Island, at about latitude  $58^{\circ}$  N.

FULMAREUS RODGERSI Cassin.

RODGER'S FULMAR.

Rodger's Fulmar was quite common May 27, 28, 1913, in Bering Sea in the vicinity of  $174^{\circ}$  E.,  $58^{\circ}$  N. The species was abundant during June at the mouth of Providence Bay.

Three males taken at Copper Island, April 3, May 3, and July 27, were purchased.

DIOMEDEIDAE.

DIOMEDEA ALBATRUS Pallas.

SHORT-TAILED ALBATROSS.

One Short-tailed Albatross was seen a short distance northeast of Attu Island on May 2, 1913. On the following day four were seen when in sight of the same Island.

DIOMEDEA NIGRIPES Audubon.

BLACK-FOOTED ALBATROSS.

During the second week of September, 1914, while *en route* from Unalaska to Seattle a group of about a dozen Black-footed Albatrosses followed the vessel from Akitan Pass to the lower part of Vancouver Island.

ALCIDAE.

URIA LOMVIA ARRA (Pallas).

PALLAS'S MURRE.

Seen in great abundance about Bering Sea. On April 26, 1913, a great migration was arriving at Bogoslof Island, the birds flying high

until close to the Island, and descending in the disorderly zigzag manner of the Old Squaw.

Specimens were taken at Copper Island, Petropavlovsk, East Cape, Siberia, and St. Lawrence Island.

A few were seen on July 19, 1913, about eighty miles south of Wrangel Island.

*CEPPHUS MANDTI* (Mandt).

MANDT'S GUILLEMOT.

The only one of this species observed was a male shot by Mr. Dixon on July 19, 1913, about eighty miles south of Wrangel Island.

*CEPPHUS COLUMBA* Pallas.

PIGEON GUILLEMOT.

Abundant about Bering Sea wherever cliffs were to be found.

Our collection contains specimens from Copper Island, Cape Shipunski, and East Cape.

*CEPPHUS CARBO* Pallas.

SOOTY GUILLEMOT.

A male of this species was taken at Cape Shipunski, May 21, 1913. We saw no others.

*SYNTHLIBORIAMPHUS ANTIQUUS* (Gmelin).

ANCIENT MURRELET.

We saw no Ancient Murrelets. Our collection contains a purchased pair taken at Copper Island, May 29 and June 30, —, and a juvenile male from Bering Island without data.

*AETHIA CRISTATELLA* (Pallas).

CRESTED AUKLET.

This species was common about St. Lawrence Island (Cape Chibukak), June 3, 1913, and about Providence Bay, Siberia, and Bering Strait, in June, 1913.

Specimens were taken at St. Lawrence Island and East Cape.

## AETHIA PUSILLA (Pallas).

## LEAST AUKLET.

This is the most abundant bird of northern Bering Sea. We found them in enormous numbers at St. Lawrence Island, Providence Bay, East Cape, and Big Diomedé Island. At the latter place on June 15, 1913, there were literally swarms of Least Auklets; the air was full of them, the rocks covered with them, and judging from the noise every hole and crack in the rocks contained one or more. They go further inland from the cliffs here than either the Crested or Paroquet Auklets.

They make a considerable variety of noises, the least common of which is a note suggesting the call note of a Red-winged Blackbird. I have heard them utter it while on the wing on the breeding ground.

A large series of specimens was taken at St. Lawrence Island, East Cape, and Big Diomedé Island. Specimens from Copper Island and Bering Island were purchased including a female taken July 19, 1910, at Bering Island.

## PHALERIS PSITTACULA (Pallas).

## PAROQUET AUKLET.

Observed wherever the two preceding species were noted but by far the least common of the three.

Specimens were taken at East Cape, Siberia. A male taken at Copper Island, July 24 was purchased.

This species is much tamer than the Crested Auklet.

## LUNDA CIRRHATA (Pallas).

## TUFTED PUFFIN.

The collection contains specimens from Cape Shipunski, East Cape, Copper Island, and Bering Island.

## FRATERCULA CORNICULATA (Naumann).

## HORNED PUFFIN.

We found this an abundant species at all the suitable localities visited in northern Bering Sea. Specimens were secured at East Cape.

## LARIDAE.

## STERNA PARADISAEA Brünnich.

## ARCTIC TERN.

A colony of about twenty-five pairs was found breeding on a sand spit in the large lagoon on the south side of St. Lawrence Island in June 1913. Several sets of eggs taken June 25 showed that incubation had started.

One pair was seen at Cape Serdze, Siberia, July 17, 1913. A few were about the ice in Camden Bay, Alaska, during the last of July and early in August 1913.

The first noted at Demarcation Point in 1914 was a single bird seen May 31. With the exception of about twenty seen on June 8, during a heavy snow storm, there were never more than three or four about. They must have bred in the vicinity, but I could find no nests and came to the conclusion that they may have nested on Icy Reef across the mouth of Demarcation Bay.

No Common Terns were seen.

## STERNA LONGIPENNIS Nordmann.

A small flock was seen at the edge of the ice near the mouth of a small river at Cape Zhipanov, Kamchatka, May 25, 1913. Two males were taken.

## XEMA SABINI (J. Sabine).

## SABINE'S GULL.

We did not see many of Sabine's Gull during the expedition.

A few were in Avatcha Bay, Kamchatka during the second week of May 1913, and a single male was taken at Plover Bay, June 18, 1913.

Early in August 1913, several were noted about the ice in the vicinity of Camden Bay, Alaska.

The first appearance of this beautiful species during the spring of 1914 at Demarcation Point was on May 28 when a single bird was seen flying east. One pair was observed flying about a pond on June 8. Several were seen on June 5 and 7, three on June 8, and the last, a flock of seven, were travelling east on June 19; these, no doubt, bred somewhere east of Demarcation Point.



Mr. Dixon took several specimens at Humphrey Point during the early part of June.

One immature bird was taken at East Cape, August 29, 1914.

LARUS RIDIBUNDUS Linné.

A few were seen at the head of Avatcha Bay, during the second week of May. The collection contains a male taken at Copper Island, May 22, —, purchased.

LARUS SCHISTISAGUS Stejneger.

SLATY-BACKED GULL.

A few were seen in Avatcha Bay during second week in May and about Cape Shipunski where a male was taken May 21, 1913.

LARUS BRACHYRHYNCHUS Richardson.

SHORT-BILLED GULL.

Several gulls were seen on Demarcation Bay, Alaska, July 18, 1914, that I referred to this species. No specimens were taken.

LARUS GLAUDESCENS Naumann.

GLAUCOUS-WINGED GULL.

We found this species breeding at St. Lawrence Island, and Providence Bay, eggs taken June 20 at St. Lawrence Island being very advanced in incubation.

A female taken at Copper Island, May 22, is in the purchased collection.

LARUS THAYERI, sp. nov.

THAYER'S GULL.

I take great pleasure in dedicating this interesting species to Col. John E. Thayer whose enthusiasm and generosity have greatly enriched the collections of the Museum of Comparative Zoölogy.

*Type*.—Adult male, no. 40336, M. C. Z. Buchanan Bay, Ellesmere Land, collected June 10, 1901, by J. S. Warmbath.

*Characters*.—About the size of *L. kumliceni* Brewster, but differing in color of mantle, primaries, and having a larger and more heavy bill.

The color of the mantle is intermediate between *kumliceni* and *argentatus*, darker than the former, lighter than the latter.

The first primary is broadly tipped with white, the outer web blackish slate (Ridgway's Nomenclature of color), on the inner web this color extends rather less than one half across the web; second primary similar only with subterminal black band and blackish slate on inner web more narrow, on the outer web it does not extend as near the base of the feather as on the first; third primary with white tip, blackish slate on outer web less extensive, on inner web the black is limited to a subterminal patch about 35 mm. long extending across web; fourth primary with white tip, blackish slate on outer web extending about 45 mm., on inner web about 20 mm., fifth primary with white tip, then subterminal blackish slate band, then narrow poorly defined bar of white.

*Measurements*.—Type, adult male: wing, 406; tail 167; tarsus 65; bill 57.

Description of immature male taken by Joseph Dixon at Griffin Point, Arctic Alaska, June 25, 1914. Orig. no. 3752.

First primary fuscous hair-brown on outer web, lighter on inner web changing to a neutral gray, with narrow whitish tip; second primary similar but slightly darker on inner web, especially near tip where it is as dark as outer web, and extends to outer edge; third primary the same; fourth primary similar except that outer web has narrow lighter edge, and inner web for the most part neutral gray; fifth primary similar but no brown on inner web except a patch near the tip which extends across the web.

The tail feathers are white with subterminal patches of fuscous hair-brown varying in size, being smaller on the outer feathers.

The inner secondaries have light brown areas on outer webs about 30 mm. long, with pallid neutral gray edges.

Mr. Warmbath found this species breeding at Buchanan Bay, several sets of eggs being in Mr. Thayer's collection.

Besides the type there are three females in the M. C. Z. collection taken by Mr. Warmbath at the same locality, and Mr. Thayer's collection contains a small series.

Mr. Dixon took an adult female at Demarcation Point, Alaska, August 28, 1913.

Though there is no data to determine the range of this species it must be a very boreal form, and perhaps comparatively small in numbers. The Alaskan specimens may have wandered from Ellesmere Land, but it seems reasonable to believe that the bird may inhabit Prince Patriek, Melville or Bathurst Islands, nearly all this territory being north of  $75^{\circ}$ .

LARUS HYPERBOREUS Gunnerus.

GLAUCOUS GULL.

Glaucous Gulls were moderately common on the Arctic coast of Alaska, and young in the down were found at Camden Bay and on the mainland near Herschel Island.

None were seen at Demarcation Point in the spring of 1914 until May 14. After that two or three might be seen flying about over the tundra about every day, but no nest was found.

PAGOPHILA ALBA (Gunnerus).

IVORY GULL.

We did not see this bird alive and our collection contains only one specimen. It is an adult female found by an Eskimo in a trap he had set for white foxes about five miles out on the ice. It was taken November 25, 1913, five days after the sun had gone, but seemed fat and in good condition.

Murdoch rarely saw this species at Point Barrow.

RISSA TRIDACTYLA POLLICARIS Ridgway.

PACIFIC KITTIWAKE.

We found the Pacific Kittiwake common on the Commander Islands and east coast of Kamehatka during the first three weeks of May. It was very abundant about Bering Straits and extreme eastern Siberia.

We took specimens at Copper Island, Cape Shipunski, Indian Point, and East Cape.

## STERCORARIIDAE.

## STERCORARIUS POMARINUS (Temminck).

## POMARINE JAEGER.

This species was only identified at Griffin Point, where Mr. Dixon took two males and a female during the last week of May 1914. The female was in the dark phase of plumage.

## STERCORARIUS LONGICAUDUS Vieillot.

## LONG-TAILED JAEGER.

The first jaegers arrived at Demarcation Point on May 24, a flock of seven flying east. They seemed to be of this species but often it is impossible to determine them in the field, their best diagnostic character being a matter of bill measurements.

Neither the Long-tailed or Parasitic Jaegers were common at Demarcation Point and no nests of either were found.

## STERCORARIUS PARASITICUS (Linné).

## PARASITIC JAEGER.

Not common at Demarcation Point. All dark phase birds seen were paired with birds in dark plumage. It seems strange that in so many cases dark plumaged birds should be mated if this coloration is merely a matter of chance or as some have stated a character of immaturity. Mr. Johan Koren found a nest of this species on Kodiak Island, Alaska, June 19, 1911, and both birds were in the dark color phase (Birds of the Arctic coast of East Siberia. By John E. Thayer and Outram Bangs. Proc. N. E. Zool. Club, 1914, 5, p. 12).

## CHARADRIIDAE.

## MORINELLA INTERPRES MORINELLA (Linné).

## RUDDY TURNSTONE.

We found this bird very rare on the Arctic coast of Alaska. The only ones seen in 1913 were four specimens taken in Camden Bay, July 31.

Mr. Dixon took two males and two females at Griffin Point, June 28, 1914.

I saw one flying east at Demarcation Point, June 5, 1914.

*SQUATAROLA SQUATAROLA CYNOSURAE* Thayer and Bangs.

AMERICAN BLACK-BELLIED PLOVER.

We found the American Black-bellied Plover quite rare on the north coast of Alaska.

Several, including a pair with a downy young, were observed at Collinson Point, August 3, 1913. A few were about on the seventh, but by the ninth all but two or three had left. On August 11 several were noted on the Hula-hula River.

At Griffin Point, Mr. Dixon took two males on June 3 and 7, 1914.

At Demarcation Point the species was noted but once, a single bird flying east on June 7, 1914.

*PLUVIALIS DOMINICUS DOMINICUS* (Müller).

GOLDEN PLOVER.

Although we found quite a number of Golden Plover about Collinson Point during the first week in August 1913, we did not find the bird common between Collinson Point and Herschel Island.

It was the first wader to reach Demarcation Point; a single female was taken on May 21, 1914, most of the other early arrivals were males. This female was very thin. Very few were seen during this season, possibly only two pair, one of which nested about two miles from camp.

I found this nest on June 25 with three eggs about one quarter incubated. The male was on the nest. It took several days to find the nest, for the bird would leave when I was a long way off and begin running about and feeding as though it had nothing else to do. By placing a lump of tundra each day where I first saw the bird I eventually found the nest, a mere depression in some greenish moss which with scattered bits of brown dead vegetation harmonized extraordinarily with the eggs.

When the bird saw that its nest was finally discovered it showed great distress and ran towards me until about twenty paces distant where it stood tottering as if about to fall, with one wing raised over

its back. In a short time the bird with tail down and a wing dragging would walk slowly from me. As I never followed the bird would return and totter a while, repeating the same performance several times until secured for the proper identification of the eggs.

PLUVIALIS DOMINICUS FULVUS (Gmelin).

PACIFIC GOLDEN PLOVER.

A pair was taken at East Cape, Siberia, July 14, 1913, and a female at Cape Serdze July 17, 1913.

CHARADRIUS MONGOLUS (Pallas).

MONGOLIAN PLOVER.

We did not see this plover. Our collection contains five purchased specimens from Copper Island; a pair taken June 23, 1912, a pair taken June 20, —, and a female taken June 16, —.

CHARADRIUS HIATICULA HIATICULA (Linné).

RINGED PLOVER.

We saw very few of this species. Two were noted and a male taken at Providence Bay, June 4, 1913; two males shot on the north side of East Cape, July 15, 1913, and a male and female at Cape Serdze, July 17, 1913. The male was with a bird in down.

EUDROMIAS MORINELLUS (Linné).

DOTTEREL.

The only Dotterels seen were three specimens taken at the head of Providence Bay (Emma Harbor), June 14, 1913, by Mr. Dixon, and on June 17, 1913, farther up the Bay, a pair with two eggs. The eggs were fresh.

## LIMOSA LAPPONICA BAUERI Naumann.

## PACIFIC GODWIT.

A flock of about twenty was seen on a large marsh on the west side of Providence Bay, June 20 and 21, 1913. They were quite tame and we took eight, all being males.

## MACRORHAMPHUS GRISEUS SCOLOPACEUS (Say).

## LONG-BILLED DOWITCHER.

A pair taken by Mr. Dixon at Herschel Island, August 20, 1914. None were seen at Demarcation Point.

## MICROPALAMA HIMANTOPUS (Bonaparte).

## STILT SANDPIPER.

My observations at Demarcation Point lead me to believe that there is a possibility of the Stilt Sandpiper breeding west of the Mackenzie River delta.

It was first noted on May 23, a single very wild bird feeding about a small pool. On May 24 three were seen in a pool, and two more were associated with a flock of Pectoral Sandpipers. Ten were seen May 26; two pairs, five in one flock of Pectoral Sandpipers and a single bird in another flock. On the following day a pair was seen, the next day only one. From this date until June 8 when a pair was seen in the grass about a small pond, this species could not be found. I felt sure that this was a breeding pair it being so late in the season, but with the exception of one bird seen in the same place on June 10 I saw no more during my stay in the North.

Mr. Dixon secured two males and a female on August 2, 1914, at Herschel Island.

## HELODROMAS SOLITARIUS SOLITARIUS (Wilson).

## SOLITARY SANDPIPER.

A female was taken by Mr. Dixon at Griffin Point, June 1, 1914. Mr. Bangs and I after careful comparison refer this specimen to the eastern form of the Solitary Sandpiper.

*HETERACTITIS INCANUS* (Gmelin).

WANDERING TATLER.

We did not find this species and only brought back two purchased specimens, both females taken at Copper Island, on May 17 and 21, —.

*ACTITIS HYPOLEUCUS* (Linné).

COMMON SANDPIPER.

The collection contains the skin of a male taken at Copper Island, May 24, —. Purchased.

*TRINGA GLAREOLA* Linné.

WOOD SANDPIPER.

One pair was taken at Cape Zhipanov, Kamchatka, May 25, 1913. The purchased collection contains two males taken at Copper Island, May 19, —. These birds agree absolutely with western specimens.

*EREUNETES PUSILLUS* (Linné).

SEMIPALMATED SANDPIPER.

Between Collinson Point and Herschel Island this is a common bird. It was common at Collinson Point, on August 3 and 9, 1913. A few were seen at the delta of the Hula-hula River, August 11, 1913.

At Demarcation Point it is a common summer resident, the first arrivals coming May 22. On that date I saw three, and shot two which proved to be males. By May 27 they were common.

Most of these birds seemed to be paired on arrival, and could be found about pools or on the comparatively dry tundra.

Thirteen nests were found, the first, a set of three fresh eggs being taken on June 12. All the nests were essentially alike — mere cavities in damp tundra close to a pool, and lined with dry willow leaves. On seven nests the female was found, and the male on six. Although the male seems to take about an equal share in brooding on the eggs and taking care of the young I could not see that he did this at any particular time for I would find either sex on the nest at midnight or midday.



Neither sex showed any more concern than the other when an intruder was at the nest. In most cases the bird disturbed would flutter along a few yards and then remain walking quietly and watching. On one occasion, a female made a great disturbance, as does Baird's Sandpiper. Fresh eggs were found as late as June 27 and a very advanced set was taken on July 6.

Young in the down were found as early as June 25. Four broods were found, and in each case the male was caring for them.

Twice I carefully brought broods of downy young back to the cabin, only to have them die within half an hour, and yet on one occasion during a snowstorm I saw a parent bird trying to cover a brood of four with very poor success. No doubt they lived, for snow storms are a common occurrence during June and July.

Semipalmated Sandpipers on the breeding grounds are the most gentle and interesting birds in the North.

#### EREUNETES MAURI Cabanis.

##### WESTERN SANDPIPER.

The only Western Sandpipers seen on the expedition were three specimens taken in East Siberia — a male on the west side of East Cape, July 14, 1913, and two males at Cape Serdze, July 16, 1913.

I have not found a Siberian record for this species.

#### TRINGITES SUBRUFICOLLIS (Vieillot).

##### BUFF-BREADED SANDPIPER.

We found no evidence of this species breeding at Demarcation Point or Humphrey Point.

They were first seen on May 26, at Demarcation Point, a flock of twenty or more on a low hill near the shore. They were very active, pursuing each other about and forming a confused mass of birds. The bird pursuing invariably held one or both wings extended straight over the body. Two taken from this flock were females. On May 27, 28 and 29, several pairs were observed about this hill; three were taken at Collinson Point, August 3.

The protective coloration of the Buff-breasted Sandpiper is remarkable; it is difficult to see one at a short distance even when moving slowly.

## CALIDRIS LEUCOPHAEA (Pallas).

## SANDERLING.

The only Sanderling seen was an adult female taken at Demarcation Point, August 30, 1913.

## EURYNORHYNCHUS PYGMAEUS (Linné).

## SPOON-BILL SANDPIPER.

This interesting species was observed both at Providence Bay and Cape Serdze.

Its status at Providence Bay we failed to ascertain for its coloring and actions agree so with *Pisobia minuta ruficollis* that we did not discover its presence until June 20, after which we only had part of a night to continue our work on this Bay.

The males of both species during the nesting season have a habit of rising to a height of forty or fifty feet and flying a short distance by a series of dips, then hovering a moment with rapidly beating wings, and slowly descending to the ground uttering a pretty, twittering song. The only difference between the actions of these species was that the Spoon-bill Sandpiper seemed to ascend to a greater height before singing the flight song.

A glint of light on the flat surface of the bill finally betrayed the bird and on the night of June 22, 1913, Mr. Dixon discovered on a large marsh on the west side of Providence Bay a nest containing two eggs. The male was on the nest. It seems improbable that more than three or four pairs were about this marsh.

At Cape Serdze, we also observed Spoon-bill Sandpipers near the entrance of a large lagoon. Here there were only seven or eight pairs in two small marshy areas on either side of the entrance. A brood of three downy young was taken on July 17, the male being with them at the time.

## PISOBIA MINUTA RUFICOLLIS Seebohn.

## EASTERN LEAST STINT.

The Eastern Least Stint was seen at Providence Bay and Cape Serdze.

At the head of Providence Bay a few pairs were breeding. Two

sets of fresh eggs, numbering three and four respectively were taken on June 11, 1913; the male incubating one and the female the other. Both birds when disturbed fluttered off the nest like other sandpipers. The nests were cavities on small mounds of tundra lined with dry willow leaves.

A downy young with the male was taken at Cape Serdze, July 16, 1913. Its plumage agrees absolutely with that of *minuta* as described by Sharpe, in the Catalogue of birds of the British Museum, 24, p. 541. The shorter interscapulars which are just showing through the down in this specimen, are black with rufous margins, the longer have white edges with a slight mixture of rufous.

PISOBIA MINUTILLA (Vieillot).

LEAST SANDPIPER.

At Demarcation Point, on June 5, 1914, I saw three small sandpipers flying east that I am convinced were this species.

PISOBIA DAMACENSIS (Horsfield).

LONG-TOED STINT.

This uncommon bird was observed by us at Capes Shipunski and Zhipanov, Kamchatka. At the former locality three were seen and a pair taken on May 21, 1913. Several were seen at Cape Zhipanov, on May 25, 1913, and a female taken. Two females from Copper Island taken May 25, —, were purchased.

PISOBIA TEMMINCKII (Leisler).

TEMMINCK'S STINT.

A few were seen at Cape Serdze, July 17<sup>o</sup> and 18, 1913, where a series of adults and downy young was secured.

PISOBIA PECTORALIS (Say).

PECTORAL SANDPIPER.

Although this is a common bird throughout Arctic Alaska in general, it bred very sparingly in the vicinity of Humphrey and Demarcation Points.

At the latter place they were first seen May 23, about twenty-five, in pairs and small groups. In the early spring they are about the pools and seldom on the more dry tundra as they are in late summer. All were paired by May 29.

Though I had read the excellent descriptions of the breeding habits of this bird by Murdoch and Nelson I was very much astonished at the volume and ventriloquial quality of the hooting of the male, and on first hearing the sound I did not believe it came from so small a bird as a sandpiper.

Several scattered pairs bred in the vicinity of Demarcation Point, three sets of four eggs each being found. Eggs about one quarter incubated were found on June 21 and 25. A set about to hatch was taken June 26.

I had considerable difficulty in finding the first nest for the bird incubating (the female in each case) acted quite differently from other waders with which I am familiar.

On approaching the vicinity of the nest the bird would leave it quietly and walk slowly about feeding and showing no excitement whatever. This happened several times until I decided to watch the bird and see if by any chance she might have a nest. In a short time she walked to a bunch of grass a few feet from me and settled on the nest. Even while I was packing away the eggs she showed no concern. I had precisely the same experience with the other two nests.

All the nests were cavities lined with dry willow leaves, and well concealed in comparatively long grass near pools.

This species was common about Collinson Point early in August, 1913, and three specimens were taken at Cape Serdze July 17, 1913. At Herschel Island Mr. Dixon found them abundant during the early part of August 1914.

### PISOBIA BAIRDI (Coues).

#### BAIRD'S SANDPIPER.

Several pairs of Baird's Sandpipers bred in the vicinity of Demarcation Point, where they arrived in pairs on May 23. They were seen equally on dry and wet tundra.

Only once did I note any courtship activity. On this occasion (May 24), the male would fly a few feet above the female, while she rested on the ground, with quick erratic wing strokes suggesting a Nighthawk. Frequently he would alight and raise the wings high

over the back as a gull does before folding them. Then with the forearms perpendicular, the primaries would be slowly raised and lowered like a pump handle, generally lowered to right angles with the forearms, sometimes lower. Not a sound was uttered.

Two nests were found, each containing four eggs and about one quarter incubated on June 12 and 14, 1914. Murdoch found them nesting rather later than other waders at Point Barrow, but my experience at Demarcation Point was quite the opposite, for here they were the first to breed. A female taken June 2, had a fully formed and colored egg about ready to lay. Both of the above nests were on dry, well-drained tundra near the bases of knolls. The nests were like the other sandpipers, and lined with dry willow leaves, but the cavities were less deep than those of the Semipalmated Sandpiper.

The female was on one nest and the male on the other. The former left the nest when I was some distance away and flying directly towards me alighted within a few feet. While I was at the nest she walked hurriedly about close by constantly uttering a plaintive "weet-weet-weet" always repeated three times. Occasionally she would take a short flight about me and utter a note very similar to the rattling call of the Pectoral Sandpiper.

The male when disturbed acted quite differently. He sat closer and on leaving the nest showed the greatest concern, dragging a "broken" wing in the most distressing manner.

In neither case was the mate about as frequently occurs with the Semipalmated Sandpiper.

Baird's Sandpipers were found common by Mr. Dixon during the first part of August 1914, at Herschel Island. A few were taken at Collinson Point, and at the mouth of the Hula-Hula River August 9 and 11, 1913. One adult male was taken at the head of Providence Bay, Siberia on June 11, 1913.

### PISOBIA FUSCICOLLIS (Viellot).

#### WHITE-RUMPED SANDPIPER.

Only two White-rumped Sandpipers were noted during the expedition. A female associating with a small flock of Semipalmated Sandpipers was taken June 5, 1914, at Demarcation Point. On June 7, a male was shot. It also was with several Semipalmated Sandpipers.

## ARQUATELLA MARITIMA COUESI Ridgway.

## ALEUTIAN SANDPIPER.

A few were noted at Providence Bay, Siberia and at the south-east end of St. Lawrence Island during June 1913, and at East Cape during the middle of July of the same year. Specimens were taken at these localities.

## PELIDNA ALPINA PACIFICA Coues.

## AMERICAN RED-BACKED SANDPIPER.

As stated by Thayer and Bangs, (Birds of the Arctic coast of East Siberia. Proc. N. E. Zoöl. Club, 1914, 5, p. 17), there appears to be three distinct races of the Dunlin, the western European bird being the smallest; the North American form the largest; and the East Siberian bird intermediate.

Mr. Bangs and I carefully studied our series from Alaska and eastern Siberia comparing them with many Dunlin's taken from localities throughout its range. Our results confirmed the above statement. The size of the bill is a more constant character than coloration.

Red-backed Sandpipers though common at Point Barrow, where I saw them in abundance about the 20th of August, must be very rare east of Point Barrow, for we only noted one, a female taken at Collinson Point, August 3, 1913.

Several were taken on August 30, 1914, at Wainwright Inlet by Mr. Dixon.

## PELIDNA ALPINA SAKHALINA (Vieillot).

## EAST SIBERIAN DUNLIN.

We found this species rare at Providence Bay during June 1913, but quite common on low tundra near East Cape, and Cape Serdze during the middle of July 1913. Specimens were secured at these localities. Dunlins observed at St. Lawrence Island during the latter part of June 1913, were not taken.

## GALLINAGO GALLINAGO (Linné).

## EUROPEAN SNIPE.

The collection contains two purchased specimens, a female and male, taken at Copper Island, on April 30, —, and May 8, —, respectively.

## PHALAROPUS FULICARIUS (Linné).

## RED PHALAROPE.

We first noted this species in the loose ice off Cape Zhipanov, Kamchatka, May 26, 1913. At St. Lawrence Island it was common east of Cape Chibukak, June 24, on the south side June 25, and at the southeast end June 27, 1913. Several were seen at East Cape, July 14, 1913, at Cape Serdze, July 17, and about the ice eighty miles south of Wrangel Island, July 19, 1913.

At Demarcation Point Red Phalaropes were first seen June 4, 1914, two single birds and a pair. At Humphrey Point Mr. Dixon took one on June 3.

Although this species is quite common about Demarcation Point only one nest was found. This was on July 4, and the young were just picking through the shells. The nest was better built and in a more dry location than those of Northern Phalaropes I have found.

These birds seem to be very erratic in their movements, one day being common, another day quite rare. At all times they appear to be tamer than *Lobipes lobatus*.

Specimens were taken at St. Lawrence Island, Indian Point, Siberia, Humphrey Point, Flaxman Island, Alaska.

## LOBIPES LOBATUS (Linné).

## NORTHERN PHALAROPE.

During the summer of 1913 this species was observed once at Providence Bay, Mr. Dixon securing a female June 22. At the southeast end of St. Lawrence Island it was quite common on June 27.

At Collinson Point, Alaska, Northern Phalaropes were common on August 3 and 9, 1913.

These birds arrived paired at Demarcation Point, on May 23, 1914, quite a large migration arriving the night of May 28.

Murdoch found Northern Phalaropes very rare at Point Barrow only seeing two alive while the Red Phalarope was one of the commonest birds. McIlhenny took only six specimens in 1898 at Point Barrow; where a series of eighty-five Red Phalaropes was secured.

East of Point Barrow our experience would indicate that the Northern is nearly if not quite as common as the Red Phalarope. Like the latter its relative abundance varied greatly from day to day.

Fresh eggs (four to the set) were taken on June 17 and 21; eggs one fourth incubated on June 26, and a set about to hatch on July 9. In all cases the nests were very poor, mere hollows in tufts of grass lined with a few wisps of the same material, the eggs in two instances resting in a quarter of an inch of water.

#### GRUIDAE.

##### GRUS CANADENSIS (Linné).

##### LITTLE BROWN CRANE.

Two pairs of Little Brown Cranes were nesting on the west side of Providence Bay, in June 1913, and two pairs were seen on the south-east end of St. Lawrence Island where a pair and one juvenile about a week old were taken June 27, 1913.

Mr. Dixon saw a single bird at Humphrey Point, May 17, 1914.

#### ANATIDAE.

##### OLOR COLUMBIANUS (Ord).

##### WHISTLING SWAN.

Two pairs of swans were seen flying past the southeast point of St. Lawrence Island, June 28, 1913.

At Demarcation Point a single Whistling Swan flew west June 1, 1914. On the 28th of the same month an Eskimo killed one of these birds ten miles east of Demarcation Point, the unsexed skin of which he brought me. Mr. Dixon took a female at Humphrey Point, on June 15.



## CHEN HYPERBOREUS HYPERBOREUS (Pallas).

## LESSER SNOW GOOSE.

This does not seem to be a common species on the Arctic coast of Alaska though the spring of 1914 was so foggy that it was impossible to carry on observations of birds flying over the tundra back from the coast.

The only Snow Geese seen in 1913 consisted of a flock flying east on August 25, about twenty-five miles west of Demarcation Point.

At this locality the first birds were seen on June 11, 1914, a flock of about fifteen flying east. On June 20 about one hundred flew west in an evenly formed V. A single bird, a male, was taken June 30.

Mr. Dixon noted this species at Humphrey Point on June 1, and took two females on June 12 and 27, 1914.

A ship-wrecked sailor who was forced to spend the winter of 1913-14, at Point Barrow stated that in June he found the nest of a Snow Goose several miles inland from this Point. Mr. Charles Brower, an old trader at Point Barrow, and a man of integrity, vouched for this statement.

A pair of Snow Geese was shot at Herschel Island, on May 16, 1914.

## ANSER ALBIFRONS GAMBELI Hartlaub.

## WHITE-FRONTED GOOSE.

White-fronted Geese were seen by Mr. Dixon at Humphrey Point, June 1, 1914.

## PHILACTE CANAGICA (Sevastianoff).

## EMPEROR GOOSE.

We found this bird sparingly during June, 1913, at Providence Bay, and secured a male shot by an Eskimo at Indian Point on June 5.

On the south side of St. Lawrence Island during the latter part of June we found them abundant, where they were flying to and from a marsh by a large lagoon.

They were very tame, and possessed sufficient curiosity to be decoyed by the native method of lying on one's back and kicking the feet in the air.

We could find no nests.

## BRANTA CANADENSIS HUTCHINSI (Richardson).

## HUTCHIN'S GOOSE.

In the vicinity of Demarcation Point this species was not common.

On May 20, 1914, a flock of about thirty was seen far back on the tundra flying west. After this date small flocks were occasionally seen flying west until June 7, when a small flock flew east. The last Hutchin's Geese seen were a flock of seven flying east on June 29.

I think one pair bred about five miles southeast of the Point, but I was not able to find the nest.

A female taken by Mr. Dixon at Herschel Island, August 9, 1914, has the fresh primaries and middle tail feathers two thirds grown. The new feathers on the under surface, back and rump are nearly complete in development.

## BRANTA NIGRICANS (Lawrence).

## BLACK BRANT.

During 1913 we saw a few Black Brant near Seymour Narrows, southern Alaska, on April 5. On the west side of Providence Bay, Siberia, we saw a flock of about twenty June 19. Several were seen at Demarcation Point, September 1.

During the spring of 1914, the first Brant were seen at Demarcation Point, on May 20, a flock of about fifteen flying west. Nearly every day until the first of June one or more flocks would be seen about two miles back from the shore flying west. From June 1 to 11 all those seen flew east as though they had been waiting west of me until conditions somewhere east were more favorable. After June 11 none were seen.

Specimens were taken at Providence Bay, Humphrey, and Demarcation Points.

## ANAS PLATYRHYNCHOS Linné.

## MALLARD.

Mallards were common near Wrangel Narrows, southern Alaska, April 9, 1913. On the 10th and 11th of the same month several were seen at Kupreanof Island and Glacier Bay respectively.

MARECA PENELOPE (Linné).

EUROPEAN WIDGEON.

One purchased specimen is in the collection — a male taken at Bering Island, in April, 1910.

NETTION CRECCA (Linné).

EUROPEAN TEAL.

A male was shot on June 6, 1913, at Indian Point, Siberia, but unfortunately an Eskimo dog retrieved it.

NETTION CAROLINENSE (Gmelin).

GREEN-WINGED TEAL.

Two females and a male were seen at Demarcation Point, on May 23, 1914. I saw no others.

Mr. Dixon took a pair at Herschel Island, August 9, 1914.

DAFILA ACUTA (Linné).

PINTAIL.

We did not find the Pintail a common bird on the Arctic coast of Alaska.

During the summer of 1913 small flocks were occasionally seen flying east, the last seen being a flock of four flying east at Demarcation Point, September 2.

During the spring of 1914 the species was first noted on May 24, —, a single pair in a pond. From this date until June 1 several pairs were to be seen in the vicinity every day. Then pairs and small flocks were seen for several days, the sexes in the flocks about evenly divided, though sometimes males predominated. After June 12 I seldom saw any Pintails, except an occasional pair flying about. No nests were found.

## MARILA MARILA (Linné).

## SCAUP DUCK.

A single male was seen on a small pond at Demarcation Point, on May 31, 1914.

Several scaups of some kind were seen near Wrangel Narrows, southern Alaska, April 9, 1913.

## CHARITONETTA ALBEOLA (Linné).

## BUFFLE-HEAD.

A single specimen was seen in Cross Sound, Alaska, on April 13, 1913.

## HARELDA HYEMALIS (Linné).

## OLD-SQUAW.

During the spring and summer of 1913 this species was seen in abundance about Bering Sea and the Arctic coast of Alaska.

At St. Lawrence Island, on June 2, 1913, they were very common in pairs and small flocks. When paired the female very often flies ahead of the male as does the female eider. A set of six fresh eggs was taken at St. Lawrence Island, June 25, 1913.

At Humphrey Point, Mr. Dixon first saw Old-squaw on May 20; I did not note them at Demarcation Point until May 24.

Although they were quite common during June I found no nests, but I am convinced that some must have bred near by. Mr. Dixon found them breeding at Humphrey Point.

Throughout June the males could be found in every stage of plumage change. Two males taken on June 22, showed one in full summer plumage, and the other with the winter dress but little changed.

From July 5 until I left Demarcation Point males were constantly arriving in small flocks from the east and collecting in Demarcation Bay where they were no doubt about to moult, for at Cross Island on July 27, 1913, we found many male Old-squaw unable to fly owing to moulted primaries.



The female averages a more blunt bill, but this character is not so marked as in the male.

On examining a large series of White-winged Scoters from both sides of the continent there is no difficulty in separating the Atlantic and Pacific birds by means of this character of the bill.

This subspecies I dedicate to Mr. Joseph Dixon of Escondido, California, an untiring worker in the field, and a loyal companion in the wilderness where the best laid plans at times miscarry.

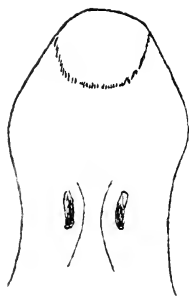

Fig. 1.

Fig. 1. — Bill of *Oedemia deglandi dixonii* Brooks. — Arctic Alaska.

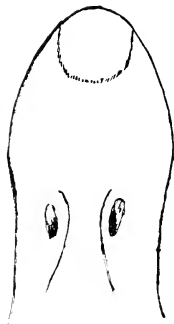

Fig. 2.

Fig. 2. — Bill of *Oedemia deglandi deglandi* Bonaparte. — Massachusetts.

This is an uncommon species on the north coast of Alaska. At Demarcation Point none were seen until June 25, 1914, a single bird on the Bay. An Eskimo brought me the unsexed skin of a specimen shot by him on June 28 about ten miles east of the Point. On July 12 about fifteen were in the Bay associated with approximately the same number of *perspicillata*. A male was taken from this flock.

### OEDEMIA PERSPICILLATA (Linné).

#### SURF SCOTER.

On July 12, 1914, two flocks each containing about thirty individuals were flying over Demarcation Bay, and in the Bay were some fifteen with about the same number of White-winged Scoter.

At Humphrey Point a male was taken by Mr. Dixon June 22, 1914.

## POLYSTICTA STELLERI (Pallas).

## STELLAR'S EIDER.

A few Stellar's Eiders were seen at Cape Shipunski, May 23, 1913, At Providence Bay they were quite common in flocks during the first three weeks of June 1913, and at East Cape, on June 7. On the south side of St. Lawrence Island a number of large flocks were about on June 25, 1913. These flocks consisted mostly of males, and the birds keeping in shallow water close to the beach were so massed that no space of water could be seen between them. We found no nests, but had little time at our disposal to devote to this branch of field work.

At Humphrey Point Mr. Dixon found a number of these birds, and secured a good series between June 12 and July 7. At Demarcation Point I saw on June 8, 1915, only one bird, a female sitting on the bank of a small pond in company with a pair of Old-squaw.

## ARCTONETTA FISCHERI (Brandt).

## SPECTACLED EIDER.

This species was only observed at St. Lawrence Island, and Humphrey Point. On the south side at the former locality three specimens were taken from a small flock on June 25, 1913.

At Humphrey Point, Mr. Dixon secured five on June 12 and 26, 1914.

## SOMATERIA SPECTABILIS (Linné).

## KING EIDER.

King Eiders were common about Cape Chibukak, St. Lawrence Island, in pairs and small flocks, on June 2, 1913. They were quite common at Providence Bay early in June, and a few were seen at East Cape, on June 7, 1913.

At Cape Serdze enormous flocks were flying east, on July 16, 1913.

Mr. Dixon found this species breeding sparingly at Humphrey Point where it arrived on May 15, 1914.

I found no nests at Demarcation Point nor did I see a bird until June 7. From this date I saw King Eiders about every other day but very sparingly and never paired; generally a male with three or four females or *vice versa*.

Once I found this species courting. On June 14 when approaching a small lagoon but still unable to see it owing to a slight elevation of the tundra before me, I heard a strange sound on the other side of the elevation. This peculiar noise came in series of three "Urrr-URRR-URRR," the last being the loudest, a sort of drumming call as when one expels air forcibly through the mouth with the tongue lightly pressed against the palate. I had heard this noise once before during the winter made by an Eskimo and used with indifferent results for encouraging his dog team. I thought this call was an invention of his own at the time, but when in sight of the lagoon I found that the disturbance came from a small flock of King Eiders, three females and five males. They were on the beach and three males were squatted in a triangle about a female, each about a yard from her. They did much neck-stretching as many male ducks do in the spring, and frequently bowed the head forward. The males constantly uttered the above drumming note. During this time the female was very indifferent to the attentions of her suitors doing nothing more than occasionally extending her head towards one of them. After a brief period of these tactics, one or more of the males would enter the water and bathe vigorously with much bowing of heads and stretching of necks, to return to the beach in a few moments and repeat the foregoing performance. Finally they all took wing uttering the croaking sound similar to the Pacific Eider.

By the middle of July a few small flocks of males were seen flying west.

#### SOMATERIA V-NIGRA Gray.

##### PACIFIC EIDER.

Pacific Eiders were first noted at the Semidi Islands, Alaska, on April 18, 1913. At St. Lawrence Island early in June they were common in pairs. At Providence Bay we found a number of nests of this species containing fresh eggs on June 19 and 20. The birds were very tame, always flying low and often passing close to one. The male always flies a few feet behind the female, and as a rule is uttering its characteristic guttural note, the only sound I have heard them make.

At Demarcation Point on September 1, 1913, a juvenile in the down was taken, and another with the scapulars and sides of back feathered.

At this Point in the spring of 1914 the first Pacific Eider, a single male, arrived May 26. They were rare and only occasionally seen



and then but two or three flying east. No doubt they all went along the off shore "leads" for they bred abundantly east of the Mackenzie River delta.

The first males began going west on July 2.

A male taken by Mr. Dixon on August 9, at Herschel Island has the eelipse plumage about one third developed on the head, neck, breast, and back.

### MERGUS SERRATOR Linné.

#### RED-BREASTED MERGANSER.

A rare bird on the Arctic coast of Alaska. At Humphrey Point Mr. Dixon took two males, on June 24 and July 1, 1914.

At Demarcation Point an Eskimo brought me a male killed on June 10, ten miles east of the Point. A male was seen at the Point on June 18, a pair June 21, and a male on June 28. Four males and two females were observed in Demarcation Bay, July 12.

Three juveniles in the down were taken by Mr. Dixon on August 3, 1914, on the mainland opposite Herschel Island.

### PHALACROCORACIDAE.

#### PHALACROCORAX PELAGICUS PELAGICUS Pallas.

##### PELAGIC CORMORANT.

Pelagic Cormorants were abundant at Copper Island, May 6, 1913, and quite common at the mouth of Providence Bay, in June.

At St. Lawrence Island they were beginning to lay by June 2, 1913, and eggs in an advanced state of incubation were taken at this Island, on June 28.

#### PHALACROCORAX URILE (Gmelin).

##### RED-FACED CORMORANT.

This species was positively identified only at Avatcha Bay, May 10, 1913, and at Cape Shipunski where a male was taken May 25, 1913. Only a few were seen.

## FALCONIDAE.

## ARCHIBUTEO LAGOPUS SANCTI-JOHANNIS (Gmelin).

## ROUGH-LEGGED HAWK.

I have a female shot at Herschel Island, May 21, 1914, by Mr. J. Heard, Jr. It contained an ovary measuring seven eighths of an inch. Mr. Heard found these birds very common at Herschel Island when he took this specimen.

Mr. Dixon noted this species at Humphrey Point, on May 13, and I saw a single specimen at Demarcation Point, on May 24.

## HALIAEETUS ALBICILLA BROOKSI (Hume).

## EASTERN GRAY SEA EAGLE.

At Cape Shipunski, on May 22, 1913, three eagles were seen, two with white tails, and one in brown plumage.

## HALIAEETUS LEUCOCEPHALUS ALASCANUS C. H. Townsend.

## ALASKAN BALD EAGLE.

Bald Eagles were common in southeastern Alaska in April, 1913. Nests were found on Woewodsky Island and on the North Semidi Island.

## THALASSAËTUS PELAGICUS (Pallas).

## KAMCHATKAN SEA EAGLE.

Two very large eagles were seen near the mouth of Avatcha Bay, May 10, 1913. No doubt they were this form.

The collection contains an adult male acquired by purchase.

## FALCO PEREGRINUS PEALEI Ridgway.

## PEALE'S FALCON.

We did not see this bird, but secured a pair taken at Copper Island by Dr. I. S. Kalinin, April 10 and 12, 1913, and a female from Bering Island.

A duck hawk seen flying across the tundra at Demarcation Point, June 10, 1914, was probably *F. peregrinus anatum* Bonaparte.

FALCO COLUMBARIUS COLUMBARIUS Linné.

PIGEON HAWK.

One was seen at Demarcation Point, May 31, 1914.

STRIGIDAE.

ASIO FLAMMEUS FLAMMEUS (Pontoppidan).

SHORT-EARED OWL.

Short-eared Owls were quite common in the vicinity of Demarcation and Humphrey Points arriving at the former Point, on May 12. We could find no nests.

NYCTEA NYCTEA (Linné).

SNOWY OWL.

Snowy Owls were seen at Cape Serdze, July 17, 1913, and Big Diomedé Island, June 25, 1913.

On the north coast of Alaska these birds are quite common in summer but scattered, each pair apparently having its own hunting ground.

A single bird was seen at Humphrey Point, December 5, 1913, flying low over the tundra in the noon twilight.

None were noted in the spring of 1914 at Demarcation Point until a single bird appeared on May 2. From that time until I left two or three birds would be seen every day but I could find no nest.

Snowy Owls are very shy and were best taken by means of traps set on poles. Their natural shyness is no doubt augmented by being constantly pursued by Eskimos who think their flesh a great delicacy. I attempted to eat a Snowy Owl that I captured but found it the most loathsome meat I have ever tasted, infinitely worse than fox.

Practically all the Short-eared Owls I trapped were eaten immediately by Snowy Owls so keen is their sight.

## HIRUNDINIDAE.

## IRIDOPROCNE BICOLOR (Vieillot).

## TREE SWALLOW.

An Eskimo brought me a male Tree Swallow that he killed on the roof of his igloo ten miles east of Demarcation Point, June 7, 1914.

## TROGLODYTIDAE.

## NANNUS HIEMALIS PALLESCENS (Ridgway).

## COMMANDER ISLAND WREN.

A specimen taken at Copper Island by Dr. I. S. Kalinin, August 25, 1912, is in the collection.

## NANNUS HIEMALIS PACIFICUS (Baird).

## WESTERN WINTER WREN.

A single specimen was seen and taken at Woewodsky Island, south-east Alaska, April 9, 1913.

## NANNUS HIEMALIS SEMIDIENSIS, subsp. nov.

## SEMIDI WINTER WREN.

*Type*.—Adult male, no. 66711 M. C. Z. Choyiet Island, Semidi Islands, Alaska, collected April 18, 1913, by W. S. Brooks.

*Characters*.—Similar to *N. alasensis*, but less rufescent, especially above; bill longer.

*Measurements*.—Type, adult male: wing, 52; tail, 34; tarsus, 18; bill, 16.

Adult male, North Semidi Island, April 19, 1913, J. Dixon: wing, 51.5; tail, 32.5; tarsus, 19; bill, 16.

## TURDIDAE.

## PLANESTICUS MIGRATORIUS CAURINUS Grinnell.

Several were seen about Glacier Bay, Alaska, April 11, 1913, and two on Inian Island, Cross Sound, Alaska, April 13.

*IXOREUS NAEVIUS NAEVIUS* (Gmelin).

VARIED THRUSH.

Two Varied Thrushes were seen at Point Gustavus, Glacier Bay, Alaska, on April 11, 1913, and one on Inian Island, Cross Sound, Alaska, April 13.

*TURDUS OBSCURUS* (Gmelin).

In the collection are two purchased specimens, a male taken at Copper Island, May 26, —, and a female from the same locality taken May 20, —.

*CALLIOPE CALLIOPE CAMTSCHATKENSIS* (Gmelin).

Two males taken at Copper Island, May 17 and 18, —. Purchased.

*OENANTHE OENANTHE OENANTHE* (Linné).

WHEATEAR.

Specimens were taken at the head of Providence Bay and East Cape during the first half of June, 1913. They were not common and exceedingly wild.

PARIDAE.

*PENTHESTES RUFESCENS RUFESCENS* (J. K. Townsend).

CHESTNUT-BACKED CHICKADEE.

A few Chestnut-backed Chickadees were seen at Woewodsky, and Kupreanof Islands, Alaska, April 9 and 10, 1913, and about Glacier Bay, April 11.

SYLVIIDAE.

*REGULUS SATRAPA OLIVACEUS* Baird.

WESTERN GOLDEN-CROWNED KINGLET.

This species was common about Kupreanof Island and Glacier Bay, Alaska, April 10 and 11, 1913.

## CERTHIIDAE.

## CERTHIA FAMILIARIS MONTANA Ridgway.

## ROCKY MOUNTAIN CREEPER.

A female was taken at Point Gustavus, Glacier Bay, Alaska, April 11, 1913.

## MNIOTILTIDAE.

## DENDROICA MAGNOLIA (Wilson).

## MAGNOLIA WARBLER.

A female? Magnolia Warbler was found dead on the sand spit at Humphrey Point, Alaska, October 1, 1913.

## SEIURUS NOVEBORACENSIS NOTABILIS Ridgway.

## GRINNELL'S WATER THRUSH.

A male taken at Demarcation Point, May 17, 1914.

## MOTACILLIDAE.

## MOTACILLA OCULARIS Swinhoe.

## SWINHOE'S WAGTAIL.

Several Swinhoe's Wagtails were seen at Providence Bay, on June 5, 1913, and two males secured.

## MOTACILLA LUGENS Kittlitz.

## BLACK-BACKED KAMCHATKAN WAGTAIL.

At Cape Shipunski, on April 21 and 22, 1913, we saw a number of this Wagtail about the cliffs and stony beaches and four males and a female were taken. Deep snow covered the land making these frail little birds appear singularly out of place.

## MOTACILLA BOARULA MELANOPE Pallas.

A male taken at Copper Island, May 20, —, was purchased.

## BUDYTES FLAVUS SIMILLIMUS Hartert.

## KAMCHATKAN YELLOW WAGTAIL.

A single Yellow Wagtail was seen at Cape Shipunski, May 21, 1913.

On June 14 and 19, 1913, three males and two females were taken at Providence Bay. Two of the males are typical *simillimus*, but the rest show intermediate characters with *B. f. alascensis*, but are still of a sufficiently bright yellow on the underparts to refer them to *simillimus*.

Clark in his paper on The birds collected and observed during the cruise of the United States fisheries steamer ALBATROSS in the North Pacific Ocean, and in the Bering, Okhotsk, Japan, and Eastern Seas, from April to December, 1906, (Proc. U. S. Nat. Mus., 1910, **38**, p. 71), states that two examples from Plover Bay, which is a small bay near the mouth of Providence Bay, appeared to be intermediate; one being nearer *alascensis*, the other nearer *simillimus*.

## ANTHUS CERVINUS (Pallas).

## RED-THROATED PIPIT.

A few Red-throated Pipits were observed and taken at Providence Bay, June 20 and 21, 1913, and at Indian Point, June 4 and 7, 1913.

## ANTHUS RUBESCENS (Tunstall).

## PIPIT.

Mr. Dixon took three males at Herschel Island, August 9 and 11, 1914.

## ANTHUS GUSTAVI Swinhoe.

## SCHLEGEL'S TITLARK.

A pair taken at Copper Island, on May 26, —, was purchased.

## ALAUDIDAE.

## OTOCORIS ALPESTRIS ARCTICOLA Oberholser.

## PALLID HORNED LARK.

The first arrival at Demarcation Point was a single male on May 6, 1914. Two females were taken on May 13 and 14. After this date none were seen until June 7, when a pair was noted. They could not be found again.

Mr. Dixon observed a Pallid Horned Lark, on May 7, at Humphrey Point, and took a male at Herschel Island, August 11, 1914.

## FRINGILLIDAE.

## FRINGILLA MONTIFRINGILLA Linné.

A male taken at Copper Island, May 4, —, was purchased.

## SPINUS PINUS PINUS (Wilson).

## PINE SISKIN.

Two males were taken April 10, 1913, at Kupreanof Island, Alaska.

## ACANTHIS HOLBOELLI (Brehm).

## HOLBÖLL'S REDPOLL.

Several Holböll's Redpoll's were seen near Petropavlovsk, May 19, 1913, and specimens taken. Specimens were also taken at East Cape and Big Diomedé Island, June 14 and 15, 1913, and at St. Lawrence Island, June 27, 1913. At the latter place a breeding female was secured.

## ACANTHIS HORNEMANNI EXILIPES (Coues).

## HOARY REDPOLL.

The first Hoary Redpoll seen at Demarcation Point was a male, on May 24, 1914. During the rest of the month a few pairs were noted. On June 1, a flock of about twenty was about some ruined igloos on



the sand spit. From this date to June 25, an occasional Hoary Redpoll was to be seen but no nest was found.

At Humphrey Point Mr. Dixon noted them May 13. He also took a male at Herschel Island, on August 16, 1914.

We also have a purchased male taken at Copper Island, April 23,—

LEUCOSTICTE GRISEONUCHA GRISEONUCHA (Brandt).

ALEUTIAN ROSY FINCH.

A few were seen on the Semidi Islands, April 18 and 19, 1913, and a series of specimens taken.

LEUCOSTICTE GRISEONUCHA MAXIMA, subsp. nov.

COMMANDER ROSY FINCH.

*Type*.—Adult male no. 66,725 M. C. Z. Copper Island, Commander Islands, collected May 7, 1913, by Joseph Dixon. Orig. no. 3057.

*Characters*.—Similar to *L. griseonucha griseonucha* but larger, and darker on breast, lower throat, and interscapulars, especially on the breast and lower throat.

*Measurements*.—Type, adult male:—wing, 123; tail, 79; tarsus, 24; bill, 14.5.

Another male taken May 3, affords the following measurements:—wing, 122; tail, 81; tarsus, 24; bill, 14.

Ridgway in the Birds of North and Middle America, 1, p. 73, gives measurements of rosy finches from the Commander, Aleutian, and Pribilof Islands. The Commander Islands specimens average larger. *Leucosticte griseonucha maxima* is an insular form constantly larger than *L. griseonucha griseonucha* from other localities justifying at least subspecific separation.

LEUCOSTICTE BRUNNEINUCHA (Brandt).

Several were seen about Petropavlovsk, on May 19, 1913, and a male taken.

CARPODACUS ERYTHRINA ROSEATA (Hodgson).

Five specimens of this species, three red males and two females, Copper Island, May 18 to June 5,—were purchased.

*Carpodacus erythrina grebnitskii* Stejn. was described from two very brightly colored males. The three males from Copper Island are not unusually bright red; indeed a majority of the specimens (Coll. M. C. Z.) from India and western Szechwan taken in the spring and early summer are more intense red than these Copper Island males. Hartert (Vogel der Palaarktischen fauna) doubted the validity of *grebnitskii* and from a study of our material I think his doubt well founded.

LOXIA CURVIROSTRA SITKENSIS Grinnell.

SITKA CROSSBILL.

Two males and three females were taken at Woewodsky Island, Alaska, on April 9, 1913, and a female at Kupreanof Island, April 10, 1913.

Examination of this series and other specimens in the M. C. Z. from the same general locality leads me to believe that *sitkensis* of Grinnell is a tenable subspecies, and I refer our series to this form.

Though I have no red specimens, those in "immature" plumage are rather more yellow than birds from the east, and all average noticeably smaller.

LOXIA LEUCOPTERA Gmelin.

WHITE-WINGED CROSSBILL.

A male, the only one seen, was taken at Point Gustavus, Glacier Bay, Alaska, April 11, 1913.

PYRRHULA PYRRHULA KAMTSCHATICA (Taczanowski).

KAMCHATKAN BULLFINCH.

Our collection contains a male and female of this species taken at Copper Island, May 21 and 25, —.

EMBERIZA PALLASI (Cabanis).

A single female taken at Copper Island, May 21, —, is in the collection.

## EMBERIZA RUSTICA Pallas.

A few were seen and two females taken at Cape Zhipanov, May 25, 1913. They were exceedingly shy and the deep snow rendered their capture most difficult.

## PLECTROPHENAX NIVALIS NIVALIS (Linné).

## SNOW BUNTING.

Snow Buntings though never so abundant as Longspurs were seen at nearly all the places visited by the expedition.

A few were noted on the Semidi Islands, April 19, 1913, and at King Cove on the Alaskan Peninsula, April 22. At East Cape and Providence Bay they were quite common and breeding in June of the same year. At the latter place a set of six eggs beginning to incubate was taken on June 19. The nest was under a pile of loose rocks averaging the size of one's head, and before securing the nest we were forced to remove perhaps two hundred pounds of stone. On June 15 two nests, one containing five eggs, the other six, were found on Big Diomedé Island. One nest was situated as far as one could reach under a shelving boulder, and the other in a deep crevice between two rocks. Both were well made of grass lined with feathers.

At St. Lawrence Island this was a common bird in June, and at Cape Serdze a few were noted July 17 and 18, 1913, where we found young birds able to fly.

They were common at Collinson Point on August 3, 1913, but returning on the ninth we found them greatly diminished in numbers.

Our latest record for the Arctic coast of Alaska is that of a female taken at Humphrey Point, on September 27, 1913.

At Humphrey Point Mr. Dixon found Snow Buntings breeding sparingly the first arrivals being noted May 1, 1914.

The first arrivals reached Demarcation Point, May 4, a flock of nine apparently all males, and two that were taken proved to be very fat. Two or three were seen nearly every day until the fifteenth when fourteen were noted. On May 16 about twenty were near the camp and on May 17 a flock of about one hundred and fifty containing both sexes; these were very shy.

After this date only a few remained in the vicinity, not more than seven or eight pairs breeding within a radius of four or five miles of the Point.

Up to May 20, quite a few still retained winter plumage, but none in this plumage were seen after May 25.

On the north coast of Alaska these birds nest equally in hollow driftwood logs on the beach or in ruined igloos, and in dark sheltered pockets under the overhanging sod of the cutbanks near the shore. Two conditions they seem to require, a dark sheltered nook for the nest and the site must be close to the shore of a bay or the ocean.

No eggs were found until June 28. This proved to be a set of seven, the largest I have seen and incubation was well started. This nest was in a hollow log on a sand spit and was composed largely of white fox hair with a lining of white ptarmigan feathers. On tearing the log to pieces to reach this nest I found a last year's one also composed of the same material. The female that I disturbed from the nest, was like other Snow Buntings very fearless and loath to leave her eggs uncovered, for she would return to them when I was beside the log.

On July 3 two sets of five eggs were found, one about to hatch and the other perhaps one third incubated. Both nests were in pockets under overhanging sod on the bank by the beach and were well made of fine grass lined with caribou hairs, presumably taken from a nearby abandoned Eskimo camp site.

Four eggs too advanced to save were found in a driftwood log on July 8, and on July 14 a nest was found containing young about ten days old.

Mr. Dixon took young birds at Humphrey Point, July 12, 1914, and at Herschel Island, July 30.

#### *PLECTROPHENAX NIVALIS TOWNSENDI* Ridgway.

##### PRIBILOF SNOW BUNTING.

We did not see any Pribilof Snow Buntings, and have only a purchased specimen, a male taken at Copper Island, on June 5, —.

#### *CALCARIUS LAPPONICUS ALASCENSIS* Ridgway.

##### ALASKA LONGSPUR.

Were it not for this gentle, sweet-singing little bird the tremendous wastes of Arctic tundra would be far more desolate than now. Tramping day after day over the soft mosses where everything looks alike and one never seems to get anywhere, the other sounds that are most

conspicuous are the wild cries of loons and the dreary wailing of white foxes, both of which add to the monotony and desolation of a country already dreary enough. The Alaska Longspur with its simple liquid melody heard on every side in June adds a cheer to one's existence and forms a link between the northern barrens and more favored climes where pleasing bird songs are the rule and not the exception.

The first Alaska Longspur seen was a single female taken at the Semidi Islands, April 19, 1913. They were quite common during June 1913, at Providence Bay, East Cape, and St. Lawrence Island, though we failed to find any nests. A few were noted at Cape Serdze, July 17 and 18, and on July 23, several young birds were flying about at Cape Lisburne, Alaska. They were common at Collinson Point, August 3 and 9, 1913. The last bird noted was a female shot at Demarcation Point, on September 2, 1913.

The first Alaska Longspur seen at Demarcation Point in the spring of 1914 was a single male on May 14. No more were seen until May 21, when about twenty males and two females were found sporadically. On May 23 Alaska Longspurs were abundant and a few pairs were noted, though males were greatly in the majority. They were also abundant on the following day and for the first time singing everywhere. By May 27 all the Alaska Longspurs seen were paired and immediately nest-building commenced, a task apparently falling exclusively to the female. The nests were made of dried grass and varied considerably in size and neatness of construction, but invariably were lined with the discarded winter plumage of ptarmigan. On the tundra about Demarcation Point there are many furrows, due I imagine to the action of frost. Along the sides of these furrows where the overhanging grass offers concealment one finds most of the nests though they are occasionally found in grass tufts on the more level ground.

Full complements of fresh eggs were found by June 7 and from this date until June 19. Young just hatched were found on June 27 and young able to fly July 3. This illustrates well the extraordinary rapidity with which birds breed in the far north, young able to fly being found forty-three days after the first females arrived.

Alaska Longspurs seem more prone to inactivity at night than other Arctic birds. Every night when the sun had dipped closer to the northern horizon and the temperature had fallen, a dozen or more of these birds were accustomed to squat behind various bits of wood, and the posts of a cache in front of my camp. Here they would remain from about eleven in the evening until two or three o'clock in the morning. If the

constant crying of loons were any criterion one would infer that these birds were constantly on the alert throughout the eight weeks of continual sunlight.

Mr. Dixon found Alaska Longspurs abundant at Herschel Island early in August.

*CALCARIUS LAPPONICUS COLORATUS* Ridgway.

COMMANDER ISLAND LONGSPUR.

One male was taken at Copper Island, May 7, 1913. We saw no others.

*PASSERCULUS SANDWICHENSIS ALAUDINUS* Bonaparte.

WESTERN SAVANNAH SPARROW.

A female, the only Savannah Sparrow seen, alighted on the roof of my camp on the night of June 5, 1914, and was secured.

*JUNCO HYEMALIS HYEMALIS* (Linné).

SLATE-COLORED JUNCO.

On October 1, 1913, a single female was secured at Humphrey Point.

*JUNCO HYEMALIS OREGONUS* (J. K. Townsend).

OREGON JUNCO.

We secured a female on April 10, 1913, at Kupreanof Island, Alaska.

*SPIZELLA MONTICOLA OCHRACEA* Brewster.

WESTERN TREE SPARROW.

Mr. Dixon took a juvenile Western Tree Sparrow at the mouth of the Firth River opposite Herschel Island, August 1, 1914.

*ZONOTRICHIA LEUCOPHRYS GAMBELII* (Nuttall).

GAMBEL'S SPARROW.

At 1.30 A.M. on the morning of May 17, 1914, two males, the only Gambel's Sparrows seen, were taken at the door of the camp. On this night the midnight sun was first seen.

*MELOSPIZA MELODIA RUFINA* (Bonaparte).

SOOTY SONG SPARROW.

A male was taken at Woewodsky Island, Alaska, April 9, 1913.

*MELOSPIZA MELODIA CAURINA* Ridgway.

YAKUTAT SONG SPARROW.

Three males were shot at Woewodsky Island, April 9, 1913. This locality is south of the breeding range of this subspecies.

*MELOSPIZA MELODIA SANAKA* McGregor.

ALEUTIAN SONG SPARROW.

Several Aleutian Song Sparrows were taken on the Semidi Islands, Alaska, April 18 and 19, 1913.

*PASSERELLA ILIACA TOWNSENDI* (Audubon).

TOWNSEND'S FOX SPARROW.

A single female was taken at Woewodsky Island, April 9, 1913.

ICTERIDAE.

*EUPHAGUS CAROLINUS* (Müller).

RUSTY BLACKBIRD.

Mr. Dixon took a female Rusty Blackbird at Indian Point, Siberia, on June 7, 1913. Indian Point is the most barren spot we saw on the Chukchi Peninsula. This is undoubtedly the first Asiatic record for the species.

## CORVIDAE.

## CORVUS CORAX BEHRINGIANUS Dybowski.

## COMMANDER ISLAND RAVEN.

After a careful study of Ravens from Copper Island and John Howland Bay, East Siberia, I am unable to detect the slightest difference between the birds and refer both to *behringianus*. The characters of *kamtschaticus* also appear unsatisfactory.

As Hartert suggests in Die Vogel der palaarktischen Fauna, that *Corvus corax sibiricus*, *ussurianus*, *kamtschaticus*, and *behringianus* may be the same, for the characters are variable and very unsatisfactory. If such is the case, the name *kamtschaticus* of Dybowski should be used. This form is intermediate in characters but not in range, between *corax* and *tibetanus* of Hodgson.

*Corvus corax principalis* from Alaska differs from our series of *behringianus* in having a slightly more slender and less deep bill, but the difference is slight; in fact it is often extremely difficult to separate American from European specimens.

The ravens seen but not taken by Koren on the Arctic coast of Siberia 1914, may have been *behringianus* instead of *sibiricus* as suggested by Thayer and Bangs (Proc. N. E. Zool. Club, 1914, 85, p. 478).

## CORVUS CORAX PRINCIPALIS Ridgway.

## NORTHERN RAVEN.

The Northern Raven was seen sparingly during the spring of 1914, at Demarcation Point, their first arrival on the Arctic shore being April 28. After this date two or three were noted during our daily excursions until May 21, when they disappeared, no doubt to breed back in the mountains. On the north coast of Alaska they are exceedingly wild, and we were unable to secure any.

## NUCIFRAGA CARYOCATACTES JAPONICUS Hartert.

Two specimens in worn plumage taken at Petropavlovsk, May 19, 1913. They are typical *japonicus*, and others noted about the town did not appear any darker in coloration.

Our observations lead me to infer that the dark form *kamchatkensis*



of Barrett-Hamilton may have been described from an abnormally dark or melanistic *japonicus*.

PERISOREUS CANADENSIS FUMIFRONS Ridgway.

ALASKA JAY.

A single Alaska Jay was seen at Demarcation Point, September 1, 1913.

CYANOCITTA STELLERI STELLERI (Gmelin).

STELLER'S JAY.

Two Stellar's Jays were seen on Inian Island, Cross Sound, Alaska, April 13, 1913.



The following Publications of the Museum of Comparative Zoölogy are in preparation:—

LOUIS CABOT. Immature State of the Odonata, Part IV.

E. L. MARK. Studies on Lepidosteus, continued.

E. L. MARK. On Arachnactis.

H. L. CLARK. The "Albatross" Hawaiian Echini.

Reports on the Results of Dredging Operations in 1877, 1878, 1879, and 1880, in charge of ALEXANDER AGASSIZ, by the U. S. Coast Survey Steamer "Blake," as follows:—

A. MILNE EDWARDS and E. L. BOUVIER. The Crustacea of the "Blake."

A. E. VERRILL. The Alcyonaria of the "Blake."

Reports on the Results of the Expedition of 1891 of the U. S. Fish Commission Steamer "Albatross," Lieutenant Commander Z. L. TANNER, U. S. N., Commanding, in charge of ALEXANDER AGASSIZ, as follows:—

K. BRANDT. The Sagittae.

K. BRANDT. The Thalassicolae.

O. CARLGREN. The Actinarians.

R. V. CHAMBERLIN. The Annelids.

W. R. COE. The Nemertean.

REINHARD DOHRN. The Eyes of Deep-Sea Crustacea.

H. J. HANSEN. The Cirripeds.

H. J. HANSEN. The Schizopods.

HAROLD HEATH. Solenogaster.

W. A. HERDMAN. The Ascidians.

S. J. HICKSON. The Antipathids.

E. L. MARK. Branchiocerianthus.

JOHN MURRAY. The Bottom Specimens.

P. SCHIEMENZ. The Pteropods and Heteropods.

THEO. STUDER. The Alcyonarians.

— The Salpidae and Doliolidae.

H. B. WARD. The Sipunculids.

Reports on the Scientific Results of the Expedition to the Tropical Pacific, in charge of ALEXANDER AGASSIZ, on the U. S. Fish Commission Steamer "Albatross," from August, 1899, to March, 1900, Commander Jefferson F. Moser, U. S. N., Commanding, as follows:—

R. V. CHAMBERLIN. The Annelids.

H. L. CLARK. The Holothurians.

H. L. CLARK. The Ophiurans.

— The Volcanic Rocks.

— The Coralliferous Limestones.

S. HENSHAW. The Insects.

G. W. MÜLLER. The Ostracods.

MARY J. RATHBUN. The Crustacea Decapoda.

G. O. SARS. The Copepods.

L. STEJNEGER. The Reptiles.

C. H. TOWNSEND. The Mammals, Birds, and Fishes.

T. W. VAUGHAN. The Corals, Recent and Fossil.

PUBLICATIONS  
OF THE  
MUSEUM OF COMPARATIVE ZOOLOGY  
AT HARVARD COLLEGE.

---

There have been published of the BULLETIN Vols. I. to LIV. and Vol. LVIII.; of the MEMOIRS, Vols. I. to XXIV., and also Vols. XXVI. to XXIX., XXXI. to XXXIV., XXXVI. to XXXVIII., XL. to XLII., and XLIV.

Vols. LV. to LVII., and LIX. of the BULLETIN, and Vols. XXV., XXX., XXXV., XXXIX., XLIII., XLV. to XLIX. of the MEMOIRS, are now in course of publication.

The BULLETIN and MEMOIRS are devoted to the publication of original work by the Officers of the Museum, of investigations carried on by students and others in the different Laboratories of Natural History, and of work by specialists based upon the Museum Collections and Explorations.

The following publications are in preparation:—

- Reports on the Results of Dredging Operations from 1877 to 1880, in charge of Alexander Agassiz, by the U. S. Coast Survey Steamer "Blake," Lieut. Commander C. D. Sigsbee, U. S. N., and Commander J. R. Bartlett, U. S. N., Commanding.
- Reports on the Results of the Expedition of 1891 of the U. S. Fish Commission Steamer "Albatross," Lieut. Commander Z. L. Tanner, U. S. N., Commanding, in charge of Alexander Agassiz.
- Reports on the Scientific Results of the Expedition to the Tropical Pacific, in charge of Alexander Agassiz, on the U. S. Fish Commission Steamer "Albatross," from August, 1899, to March, 1900, Commander Jefferson F. Moser, U. S. N., Commanding.
- Reports on the Scientific Results of the Expedition to the Eastern Tropical Pacific, in charge of Alexander Agassiz, on the U. S. Fish Commission Steamer "Albatross," from October, 1904, to April, 1905, Lieut. Commander L. M. Garrett, U. S. N., Commanding.
- Contributions from the Zoölogical Laboratory, Professor E. L. Mark, Director.
- Contributions from the Geological Laboratory, Professor R. A. Daly, in charge.

These publications are issued in numbers at irregular intervals. Each number of the Bulletin and of the Memoirs is sold separately. A price list of the publications of the Museum will be sent on application to the Director of the Museum of Comparative Zoölogy, Cambridge, Mass.

3189

Bulletin of the Museum of Comparative Zoölogy

AT HARVARD COLLEGE

VOL. LIX. No. 6.

A REVISION OF THE LIZARDS OF THE GENUS AMEIVA

BY THOMAS BARBOUR AND G. KINGSLEY NOBLE.

CAMBRIDGE, MASS., U. S. A.:

PRINTED FOR THE MUSEUM.

OCTOBER, 1915.

REPORTS ON THE SCIENTIFIC RESULTS OF THE EXPEDITION TO THE EASTERN TROPICAL PACIFIC, IN CHARGE OF ALEXANDER AGASSIZ, BY THE U. S. FISH COMMISSION STEAMER "ALBATROSS," FROM OCTOBER, 1904, TO MARCH, 1905, LIEUTENANT COMMANDER L. M. GARRETT, U. S. N., COMMANDING. PUBLISHED OR IN PREPARATION:—

- A. AGASSIZ. V.<sup>5</sup> General Report on the Expedition.  
 A. AGASSIZ. I.<sup>1</sup> Three Letters to Geo. M. Bowers, U. S. Fish Com.  
 A. AGASSIZ and H. L. CLARK. The Echini.  
 H. B. BIGELOW. XVI.<sup>16</sup> The Medusae.  
 H. B. BIGELOW. XXIII.<sup>23</sup> The Siphonophores.  
 H. B. BIGELOW. XXVI.<sup>26</sup> The Ctenophores.  
 R. P. BIGELOW. The Stomatopods.  
 O. CARLGREN. The Actinaria.  
 R. V. CHAMBERLIN. The Annelids.  
 H. L. CLARK. The Holothurians.  
 H. L. CLARK. The Starfishes.  
 H. L. CLARK. The Ophiurans.  
 S. F. CLARKE. VIII.<sup>8</sup> The Hydroids.  
 W. R. COE. The Nemertean.  
 L. J. COLE. XIX.<sup>19</sup> The Pycnogonida.  
 W. H. DALL. XIV.<sup>14</sup> The Mollusks.  
 C. R. EASTMAN. VII.<sup>7</sup> The Sharks' Teeth.  
 S. GARMAN. XII.<sup>12</sup> The Reptiles.  
 H. J. HANSEN. The Cirripeds.  
 H. J. HANSEN. XXVII.<sup>27</sup> The Schizopods.  
 S. HENSHAW. The Insects.  
 W. E. HOYLE. The Cephalopods.  
 W. C. KENDALL and L. RADCLIFFE. XXV.<sup>25</sup> The Fishes.  
 C. A. KOFOID. III.<sup>3</sup> IX.<sup>9</sup> XX.<sup>20</sup> The Protozoa.  
 C. A. KOFOID and J. R. MICHENER. XXII.<sup>22</sup> The Protozoa.  
 C. A. KOFOID and E. J. RIGDEN. XXIV.<sup>24</sup> The Protozoa.  
 P. KRUMBACH. The Sagittae.  
 R. VON LENDENFELD. XXI.<sup>21</sup> The Siliceous Sponges.  
 R. VON LENDENFELD. XXIX.<sup>29</sup> Hexactinellida.  
 G. W. MÜLLER. The Ostracods.  
 JOHN MURRAY and G. V. LEE. XVII.<sup>17</sup> The Bottom Specimens.  
 MARY J. RATHBUN. X.<sup>10</sup> The Crustacea Decapoda.  
 HARRIET RICHARDSON. II.<sup>2</sup> The Isopods.  
 W. E. RITTER. IV.<sup>4</sup> The Tunicates.  
 B. L. ROBINSON. The Plants.  
 G. O. SARS. The Copepods.  
 F. E. SCHULZE. XI.<sup>11</sup> The Xenophyphoras.  
 HARRIET R. SEARLE. XXVIII.<sup>28</sup> Isopods.  
 H. R. SIMROTH. Pteropods, Heteropods.  
 E. C. STARKS. XIII.<sup>13</sup> Atelaxia.  
 TH. STUDER. The Alcyonaria.  
 JH. THIELE. XV.<sup>15</sup> Bathyscladium.  
 T. W. VAUGHAN. VI.<sup>6</sup> The Corals.  
 R. WOLTERECK. XVIII.<sup>18</sup> The Amphipods.

<sup>1</sup> Bull. M. C. Z., Vol. XLVI., No. 4, April, 1905, 22 pp.

<sup>2</sup> Bull. M. C. Z., Vol. XLVI., No. 6, July, 1905, 4 pp., 1 pl.

<sup>3</sup> Bull. M. C. Z., Vol. XLVI., No. 9, September, 1905, 5 pp., 1 pl.

<sup>4</sup> Bull. M. C. Z., Vol. XLVI., No. 13, January, 1906, 22 pp., 3 pls.

<sup>5</sup> Mem. M. C. Z., Vol. XXXIII., January, 1906, 90 pp., 96 pls.

<sup>6</sup> Bull. M. C. Z., Vol. L., No. 3, August, 1906, 14 pp., 10 pls.

<sup>7</sup> Bull. M. C. Z., Vol. L., No. 4, November, 1906, 26 pp., 4 pls.

<sup>8</sup> Mem. M. C. Z., Vol. XXXV., No. 1, February, 1907, 20 pp., 15 pls.

<sup>9</sup> Bull. M. C. Z., Vol. L., No. 6, February, 1907, 48 pp., 18 pls.

<sup>10</sup> Mem. M. C. Z., Vol. XXXV., No. 2, August, 1907, 56 pp., 9 pls.

<sup>11</sup> Bull. M. C. Z., Vol. LI., No. 6, November, 1907, 22 pp., 1 pl.

<sup>12</sup> Bull. M. C. Z., Vol. LII., No. 1, June, 1908, 14 pp., 1 pl.

<sup>13</sup> Bull. M. C. Z., Vol. LII., No. 2, July, 1908, 8 pp., 5 pls.

<sup>14</sup> Bull. M. C. Z., Vol. XLIII., No. 6, October, 1908, 285 pp., 22 pls.

<sup>15</sup> Bull. M. C. Z., Vol. LII., No. 5, October, 1908, 11 pp., 2 pls.

<sup>16</sup> Mem. M. C. Z., Vol. XXXVII., February, 1909, 243 pp., 48 pls.

<sup>17</sup> Mem. M. C. Z., Vol. XXXVIII., No. 1, June, 1909, 172 pp., 5 pls., 3 maps.

<sup>18</sup> Bull. M. C. Z., Vol. LII., No. 9, June, 1909, 26 pp., 8 pls.

<sup>19</sup> Bull. M. C. Z., Vol. LII., No. 11, August, 1909, 10 pp., 3 pls.

<sup>20</sup> Bull. M. C. Z., Vol. LII., No. 13, September, 1909, 48 pp., 4 pls.

<sup>21</sup> Mem. M. C. Z., Vol. XLI., August, September, 1910, 323 pp., 56 pls.

<sup>22</sup> Bull. M. C. Z., Vol. LIV., No. 7, August, 1911, 38 pp.

<sup>23</sup> Mem. M. C. Z., Vol. XXXVIII., No. 2, December, 1911, 232 pp., 32 pls.

<sup>24</sup> Bull. M. C. Z., Vol. LIV., No. 10, February, 1912, 16 pp., 2 pls.

<sup>25</sup> Mem. M. C. Z., Vol. XXXV., No. 3, April, 1912, 98 pp., 8 pls.

<sup>26</sup> Bull. M. C. Z., Vol. LIV., No. 12, April, 1912, 38 pp., 2 pls.

<sup>27</sup> Mem. M. C. Z., Vol. XXXV., No. 4, July, 1912, 124 pp., 12 pls.

<sup>28</sup> Bull. M. C. Z., Vol. LVIII., No. 8, August, 1914, 14 pp.

<sup>29</sup> Mem. M. C. Z., Vol. XLII., June, 1915, 397 pp., 109 pls.

Bulletin of the Museum of Comparative Zoölogy  
AT HARVARD COLLEGE.  
VOL. LIX. No. 6.

---

A REVISION OF THE LIZARDS OF THE GENUS AMEIVA.

BY THOMAS BARBOUR AND G. KINGSLEY NOBLE.

---

CAMBRIDGE, MASS., U. S. A.:  
PRINTED FOR THE MUSEUM.  
OCTOBER, 1915.





No. 6.— *A Revision of the Lizards of the genus Ameiva.*

By THOMAS BARBOUR AND G. KINGSLEY NOBLE.

INTRODUCTION.

THIS paper is based almost wholly upon the collection in the Museum of Comparative Zoölogy; we have, however, had loaned for study some important specimens from other institutions and wish to thank Dr. Leonhard Stejneger and the U. S. National Museum, Henry W. Fowler Esq., and the Academy of Natural Sciences of Philadelphia, as well as Dr. A. G. Ruthven and the Zoölogical Museum of the University of Michigan, for valuable aid. From the two latter institutions we have received important specimens in loan or exchange; from Dr. Stejneger permission to study in Washington the types of *Ameiva polops* and *Ameiva tobagana*, as well as complete sets of photographs and notes of these important specimens for study in Cambridge.

Citations of original descriptions have been omitted, also synonyms, except where these have been changed or added to. Both have already been adequately given in Boulenger's Catalogue of Lizards in the British Museum, 2, with later changes in Barbour's 'West Indian Herpetology,' Mem. M. C. Z., 44, no. 2.

Some characters, such as the entry of granules between the gulars and the extent to which they may do so, have been found to be variable and hence have been omitted in drawing up the descriptions. So far as possible all characters which have been found to be really diagnostic have been included. Special attention is called to the fact that, making allowance for the variation connected with age or sex, color-pattern has been found to be of excellent taxonomic value. This statement is made upon the basis of the study of the very extensive series of some races such as *A. ameiva praeignis* and *A. ameiva ameiva*.

GENERAL CONSIDERATIONS.

The genus *Ameiva*, because it ranges widely through the West Indies, Central and South America, is an excellent subject for careful zoögeographic study. Almost every one of the Antilles, which has been carefully collected, has been found to support a peculiar species,

while in Haiti, for example, three species occur in the very same localities. Since for a very long time there has been and is, especially just at present, considerable controversy regarding the origin of the Antillean fauna, we digress at some length regarding the light which a study of the species throws on the question.

Bland (*Ann. Lyc. nat. hist. N. Y.*, 1862, **7**, p. 335) was among the first workers in the field of Antillean zoögeography, studying the relationships of the Mollusca of the different islands. His division of the region into faunal areas is interesting because his groupings agree well with those of other writers who have based their conclusions on other data. Bland proposed the following areas:—

1. Cuba and the Isla de Pinos, Bahamas, and Bermudas.
2. Jamaica.
3. Haiti.
4. Puerto Rico and Vieques, the Virgin Islands, Sombrero, Anguilla, St. Martins, St. Bartholomew, and St. Croix.
5. The southern Lesser Antilles, embracing those south of St. Bartholomew to and including Trinidad.

This grouping of the islands is by no means inconvenient, but it is quite incorrect to conceive that these areas really represent zoögeographic entities, or to say that they are anything more than expressions of the close similarity of some species in certain chosen groups. Our thesis is that the West Indian region taken as a whole has a singularly compact, homogeneous fauna, the same elements appearing on island after island. This fact is perhaps the most conclusive single argument against the theory of the origin of the fauna by flotation. Several recent writers, among whom may be mentioned Allen (*Bull. M. C. Z.*, 1911, **54**, p. 175–263) and Barbour (*Bull. M. C. Z.*, 1910, **52**, p. 273–301; and *Mem. M. C. Z.*, 1914, **44**, p. 209–347) have been especially active in advocating the interpretation which required a presumed connection of the Antilles with the mainland and with each other to explain the present faunistic conditions. The most able of those who advocate the theory of haphazard population by flotsam and jetsam methods is W. D. Matthew, who has recently summarized his views in a scholarly review entitled *Climate and evolution* (*Ann. N. Y. acad. sci.*, 1915, **24**, p. 171–318; p. 205, p. 290). In general, the majority of recent naturalists, among them Stejneger, Gadow, and Schaff, are opposed to Matthew's thesis.

This revision, which is a detailed study of a single genus of strictly terrestrial teiid lizards, shows clearly the close relationship and origin from a common stock of many of the Antillean forms. The data derived from this study seem to argue strongly against the flotsam and jetsam theory. Stejneger (*Rept. U. S. N. M. for 1902, 1904,*

p. 562) and Barbour (Mem. M. C. Z., 1914, 54, p. 326) have suggested that the Antillean *Ameivas* were derived from a centre of dispersal in northeastern South America, and that they have spread thence northward over a continuous land area to the Greater Antilles. Proceeding northward along the islands we find species which show a gradual transition in morphological characters, and there is no obvious break in the series, except where the evidence is wanting, as for example where the species on Dominica seems very different from that of St. Vincent, we must remember that the form which formerly inhabited Martinique is undescribed zoologically and is probably now extirpated by the mongoose. This gradual transition, as we have said, points to a land migration and not to distribution by flotation. The latter means would not account for the presence of the genus upon so many islands, without presupposing an enormous amount of rafting. Such a constant flotation would have kept new immigrants coming to the islands already populated, as well as to those as yet without *Ameivas*, and would surely have tended to keep the whole Antillean group of individuals more homogeneous than they are. There is no real reason for supposing that there was more carriage in the past than at present. Then the derivation would probably have been from several stocks, whereas the Lesser Antillean *Ameivas* are all derived from the *Ameiva ameiva* stock, the Antillean and mainland races having probably had a common origin from an ancestral widespread stock which became differentiated as the stations occupied became separated. The comparatively fixed characters observed among the individuals of the island races stand at sharp contrast to the great variability of the same characters in the mainland races, and this points to a long complete isolation. Interchange of individuals between the islands is unthinkable on any basis, as their physical geographic characters make the setting free of rafts impossible. By the flotsam theory individuals must have reached all islands by rafts directly from mainland rivers.

Gadow (P. Z. S., 1906, p. 277-375) has shown that the closely related genus *Cnemidophorus* is composed of species having remarkably variable characters and that it is necessary to consider the sum of the distinguishing features when comparing two forms. Similarly in *Ameiva* too great stress cannot be laid upon a single character within a species, especially upon the mainland. This variability may make two species, probably but distantly related, appear closely similar. Some of these curiously close resemblances between widely separated forms may be mentioned, as they are interesting from an

evolutionary point of view. *Ameiva vittipunctata* in size, in certain color-pattern features, and in many details of scutation, is similar to *A. erythrocephala*; a species with which it doubtless has but a rather distant relationship. *Ameiva exul* has its nostril between the two nasal plates, a character typical of the mainland and southern Lesser Antillean species, but otherwise it is not anomalous. The characters which in general we have found to be most constant in species of this genus are to be seen among the supraoculars, gulars, antebrachials, brachials, postbrachials, ventrals, and tibials.

In view of this variability noticeable in the island, and greatly exaggerated in the mainland, forms, we must either recognize a number of subspecies or merge all of the mainland races into five or six species. To do this, especially since we find that some variations have a definite relationship to their distribution, would be to obscure the true state of affairs, especially since we find that in some of these races speciation has far advanced and the appearance of any barrier to an interchange of individuals would doubtless result in the fixation of a valid species in a short time. We therefore recognize several subspecies of *Ameiva ameiva*, two of *A. undulata*, and one of *A. bifrontata*.

The whole question of explaining the origin of this genus and its dispersal is difficult and unsatisfactory. We may say, fairly that *Ameiva* and its possible offshoot *Cnemidophorus* represent the most generalized, perhaps the most primitive existing representatives of the characteristic American family Teiidae. Of the geologic history of this family we know really nothing; we can only postulate its origin by saying that along with the much more archaic Xantusiidae the Teiidae probably arose in America from early immigrants of the same stock which in the old world has given rise to the Varanidae. That this migration took place from eastern Asia to America by way of the Bering Strait land bridge is not improbable. Change of climate then probably forced the ancestral teiids southward and they flourished and are now wholly confined to the tropics, except *Cnemidophorus sexlineatus*, which has invaded secondarily the Austroriparian zone of North America, and a few which have pushed into temperate South America. Our study leads to the conclusion that the existing *Ameivas* have not all arisen in one region as Gadow shows was most probable for the *Cnemidophori*, but rather that they have probably spread from two centres. We submit then that probably some widespread ancestral *Ameiva*-like stock left two relict types, one of which gave rise to *A. undulata* and its allies, and the other *A. ameiva* and its relatives. The difficulty with this explanation is the fact that part of Central

America was under water probably while this ancestral stock was migrating, but a short period of emergence or the presence of an ancient land mass joining north Central and northwest South America, but lying to the westward of the present Middle America, would have made possible the migration. This land mass, the existence of which we have suggested, has been postulated by various other writers on other grounds. The sinking of this area would then have left the *A. undulata* allies free to distribute themselves in Central America as it assumed its present form and also to reach the Greater Antilles while they were in connection with Central America. The temporarily isolated South American stock then spread widely through the continent and passed into Antillea extending to Haiti. Finally with the completion of the appearance of lower Central America in its present form, we find it invaded by the *Ameiva ameiva* types in the form of *A. praesignis*, while western South America received some immigrant representatives of *A. undulata*, which on reaching this region so peculiarly favorable for speciation in reptiles became transformed into the curious and hardly recognizable *A. edracantha* and *A. bridgesii*. The latter of these reached Gorgona Island off the Colombian coast.

An alternative would have been to conclude that possibly the genus arose in Antillea and spread to Central and South America, but this seems hardly likely in view of the definite grouping of the species about the two prominent mainland types.

Two other stocks remain to be mentioned, which show a somewhat anomalous condition. The *maynardi-wetmorei-polops* group does not seem to show any very close relationship with the other species, and we can only conclude that these three very distinct species all represent chance survivors from some stock which once had a wider distribution, but which has completely disappeared. The other anomaly is afforded by *Ameiva bifrontata* and its subspecies *divisa*. These are not very dissimilar to *Ameiva ameiva*, but yet occur side by side with other races which are probably more closely related to *Ameiva ameiva* than either of them are. Whether these represent the survivors of a primary unsuccessful elaboration of *Ameiva ameiva* itself or are the remnants of some other stock, which in the same environment has come to look much like *Ameiva ameiva*, it is impossible to say. One gropes in the dark in treating all of this problem. It is even far from easy to surmise which are the more primitive types, while, of course, we know but little of skeletal variation within the group and there is no particular object to seek it out when it cannot be applied to palaeontology. How sadly different are the opportunities for the mammalogist and the herpetologist in essaying studies of this sort.

## DIAGRAM OF THE PRESENT DISTRIBUTION OF THE GENUS AMEIVA.

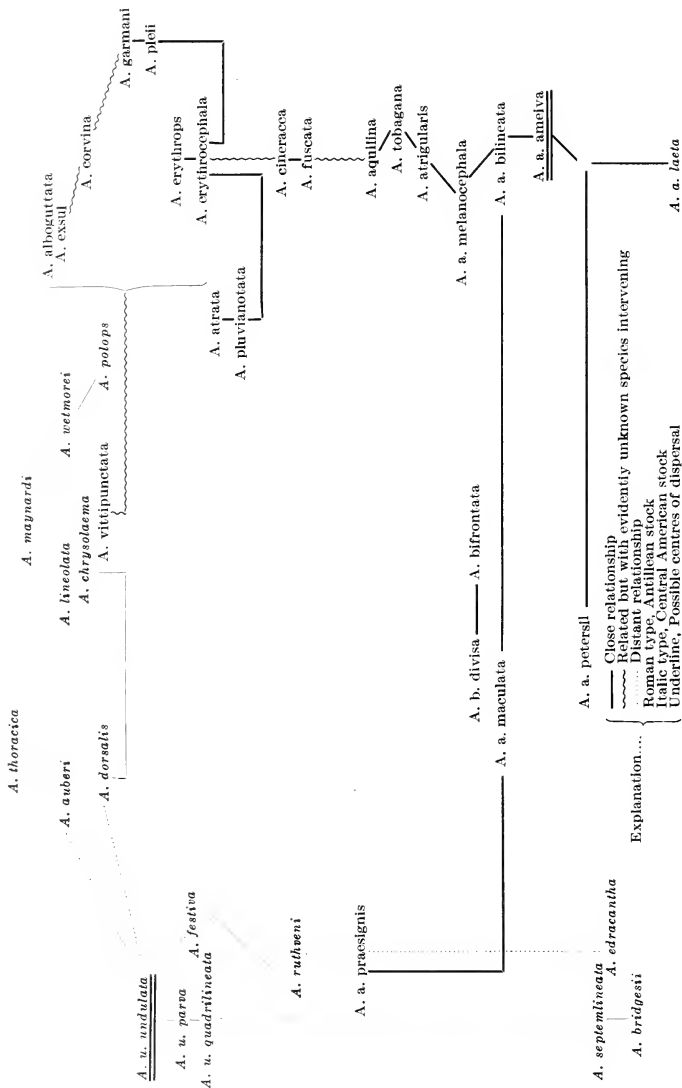

Although no very satisfactory conclusions, perhaps, can be reached regarding the main question of the origin of the species of this genus, nevertheless one feature stands out strongly and clearly, and this is that the distribution of the Antillean species show by their relationship to one another and to the mainland types that they arose from an orderly progressive migration, such as would only be possible over a continuous area of land, and in no wise display the haphazard character which would be the only possible character of a flotsam and jetsam fauna. When we remember that the Ameivas of twenty-six different islands are already known, this conclusion will in no wise surprise those naturalists who know these creatures in their native haunts. Quick and active, absolutely terrestrial, they are farthest removed in habits from the lizards which we now know are at times moved about fortuitously, probably most often by human agency. The gekkos which hide in or under the bark of trees, enter and abide in human habitations, were from the nature of their secretive ways probably a frequent companion of primitive man while upon his journeyings. The skinks seem also, probably largely on account of their very small size, to have been spread far and wide, especially in the Pacific Island area, by human agency, and with these resistant creatures dispersal by fortuitous flotation probably occurs, but we cannot believe that it ever takes place except under the rarest and most exceptional cases with even these skinks. With other types, so many of which could never be imagined, starting on, surviving, or landing from an ocean voyage taken upon a sodden, water-soaked natural raft, it is quite useless to argue that the enormous length of geologic time makes it possible to say that such flotation may *occasionally* occur even using occasionally in a geologic time sense. That so many, many types would die invariably were they started forth annually or monthly upon a rafting voyage, makes but the more

#### *Explanation of the Diagram.*

The diagram, page 422, shows the relationship of the different species in the genus, the name of each race standing with relation to the others in geographic position. Each name occupies a position as near as possible identical with the area its habitat would occupy if the whole diagram were superposed upon a map of the Antillean region, Central America, and South America, the latter somewhat contracted.

improbable the fact that they should arrive at, land upon, survive, and reproduce their kind, upon some distant land, were they permitted to essay this journey but once in a thousand years or even less often. The enormous sum-total of species which make up the fauna of the Antilles, and the many zoölogical groups which are represented upon so many of the islands alone refute the flotation theory. If they did not we could lie-to in the mid-Caribbean and watch the rafts go by, speculating as a pleasant game as to which bore Onychophora and earthworms and which cyprinodonts or Amphibia, wondering how the little ponds in the rafts in which the fresh water fishes, molluscs, and crustaceans would have to be carried, are kept from becoming a bit, only a bit to be fatally, brackish. So much for the message of Ameiva with regard to the problem of the origin of the Antillean fauna.

## KEY TO THE SPECIES.

- a<sup>1</sup> Caudal scales of adult oblique dorsally.
- b<sup>1</sup> Nostril anterior to nasal suture.
- c<sup>1</sup> Three supraoculars, the first not in contact with the loreal. . . . *lineolata*.
- c<sup>2</sup> Four supraoculars, the first in contact with the loreal. . . . *maynardi*.
- b<sup>2</sup> Nostril between the nasal plates.
- d<sup>1</sup> Caudal scales smooth or feebly keeled, whorls not raised posteriorly.
- e<sup>1</sup> Eight longitudinal rows of ventrals. . . . . *wetmorei*.
- e<sup>2</sup> Ten longitudinal rows of ventrals. . . . . *polops*.
- d<sup>2</sup> Caudal scales strongly keeled, the keels not parallel to the sides of the scale, whorls raised posteriorly.
- e<sup>1</sup> A single row of large postbrachials, two rows of tibial shields. *festiva*.
- e<sup>2</sup> Postbrachials small and irregular, three rows of tibial shields. *ruthveni*
- a<sup>2</sup> Caudal scales of adult straight dorsally.
- b<sup>1</sup> Nostril anterior to nasal suture.
- c<sup>1</sup> Fourteen longitudinal rows of ventrals. . . . . *pluvianotata*.
- c<sup>2</sup> Less than fourteen longitudinal rows of ventrals.
- d<sup>1</sup> Twelve longitudinal rows of ventrals.
- e<sup>1</sup> Gular scales minutely granular, a broad band of enlarged granules extending across the throat.
- f<sup>1</sup> Tibial shields with largest scale of outer row broader than high; pale spots on body not confluent. . . . . *pleii*.
- f<sup>2</sup> Tibial shields with largest scale of outer row about as broad as high; pale spots of body confluent. . . . . *garmani*



- e<sup>2</sup> Gular scales uniformly minute, or tending to form a central group of slightly larger ones.
- f<sup>1</sup> Uniform dark brown in coloration, gulars not differentiated from each other.
- g<sup>1</sup> Frontal and frontoparietals in contact with the third supra-ocular.....*atrata*.
- g<sup>2</sup> Frontal and frontoparietals separated from the third supra-oculars by granules.....*corvina*.
- f<sup>2</sup> Not uniformly colored, gulars differentiated into a median group or band.
- g<sup>1</sup> Brachial shields small, scarcely differentiated from the granules of the arm.....*vittipunctata*.
- g<sup>2</sup> Brachials in two or three rows of moderate sized plates.  
*chrysolaeama*.
- d<sup>2</sup> Ten longitudinal rows of ventrals.
- e<sup>1</sup> Antebrachials continuous with the brachials.....*dorsalis*.
- e<sup>2</sup> Antebrachials not continuous with the brachials.
- f<sup>1</sup> Tibial shields with the second scale of the outer row wider than long; adult with two broad lateral stripes of black...*thoracica*.
- f<sup>2</sup> Tibial shields with second scale of the outer row not wider than long, adult with dark spots on the sides.....*auberi*.
- b<sup>2</sup> Nostril between the nasal plates.
- c<sup>1</sup> More than twelve rows of ventral shields.
- d<sup>1</sup> Eighteen longitudinal rows of ventral plates.....*cineracea*.
- d<sup>2</sup> Fourteen longitudinal rows of ventral plates.
- e<sup>1</sup> Chin and throat bright flesh color in sharp contrast to the coloration of the neck region.
- f<sup>1</sup> Gulars forming a band of enlarged granules extending across the throat.....*erythropros*.
- f<sup>2</sup> Gulars not forming a band, but three groups of enlarged granules.  
*erythrocephala*.
- e<sup>2</sup> Chin and throat bluish or smoky.
- f<sup>1</sup> Nine irregular occipitals.....*fuscata*.
- f<sup>2</sup> Five regular occipitals.....*aquilina*.
- c<sup>2</sup> Less than or just twelve rows of ventral shields.
- d<sup>1</sup> More than eight rows of ventrals.
- e<sup>1</sup> Twelve rows of ventrals.
- f<sup>1</sup> Dorsal granules small.
- g<sup>1</sup> Preanal plates minute, and undifferentiated; brachial shields uniform in five or six rows of swollen scales...*ameiva maculata*.
- g<sup>2</sup> Preanal plates differentiated into a group of larger ones; brachial shields in two or three rows, outer row wider than others.
- h<sup>1</sup> Dorsal surface spotted with white or yellow.
- i<sup>1</sup> A black band on each side, the edges of which are undulating and have no white margin.....*tobagana*.



## DESCRIPTION OF THE SPECIES.

## AMEIVA AUBERI Cocteau.

*Description*.— Adult male; M. C. Z. 7277. Camaguëy, (Puerto Principe), Cuba; 1908; T. Barbour.

Rostral forming a little more than a right angle behind; nostril on the posterior edge of the anterior nasal; anterior pair of nasals broadly in contact behind the rostral; frontonasal as long as wide in contact with the loreal; prefrontals broadly in contact; frontal in contact with the first and second supraocular; a pair of frontoparietals in contact with the third supraocular for nearly their entire length; five occipitals in a transverse row, the two in contact with the median, largest; seven supraciliaries; three supraoculars, the first separated from the loreal; two posterior supraoculars separated from the supraciliaries by a double row of granules; last supraocular separated from the outer occipitals by three rows of small scales; seven large supralabials; five large infralabials; between the infralabials and chin-shields a wedge of one to three rows of granules extending anteriorly to the first chin-shield; chin and throat covered with granules, an indistinct band of very slightly larger ones extending across the middle, the median ones forming an ill-defined central group of scarcely enlarged scales; on the area between the two throat folds several rows of large hexagonal scales; under side of the body with ten longitudinal and thirty-five transverse rows of plates; preanal plates, two anterior median, and three posterior marginal ones; on the lower arm a double row of antebrachials, one much wider than the other, both decreasing in width towards the elbow joint; on the upper arm a similar but narrower single row of brachials continuous with the antebrachials; on the posterior side near the elbow a small group of enlarged postbrachials; under side of the thighs covered with six or seven series of hexagonal plates of which the outer series is considerably larger than the others; thirteen and fourteen femoral pores; on the under side of the tibia two rows of plates those of the outer row enormously enlarged; upper side of the wrist with a regular series of transverse plates corresponding to the inner and outer metatarsals; outer toe extending approximately as far as the inner; tail covered with straight scales with keels; about thirty-five scales in the fifteenth ring from the base.

*Coloration*.— Ground color of dorsal surface olivaceous brown, slightly reddish anteriorly, grayer on the tail; three poorly defined narrow stripes of a lighter color on the back; the two lateral stripes

bordered on their outer side by a series of broad, dark brown spots which tend to become confluent; the same two outer pale stripes are bordered on their inner side by a poorly defined and much lighter series of similar dark spots; flanks, sides of head, sides and upper surfaces of the tail and appendages covered with a network of irregular brown patches; ventral surface straw-color; traces of the same color on the head-shields.

*Variation:*— Females differ but little from the males. A specimen (M. C. Z. 7277) for example is slightly more bluish in tonality than the male described. On each side there is another pale stripe, more bluish in color, added to the three dorsal ones, and extending along the sides of the tail. The under surfaces of the body are light blue-green except for the appendages which are suffused with straw-color.

Young specimens often vary considerably from the adult. A specimen (M. C. Z. 6920) has on each flank two black bands edged with white while a narrow white line runs the length of the back in the median region. These lines are all very clear cut. The under side of the chin and throat varies from smoky to blackish, while traces of the same color extend down over the abdomen.

*Remarks:*— The description was made of a full grown male that measured seventy-seven millimeters from snout to vent.

*Habitat:*— Widely distributed throughout the whole of Cuba and the adjacent Isla de Pinos, but not very abundantly.

*List of specimens examined.*

M.C.Z. No.	No. of specimens	Ages	Sexes	Locality	Date	Collector	Remarks
6920	3	all	♂	Santiago, Cuba	1904	W. Robinson	Descrip. of im.
7277	2	ad.	both	Camaguëy, Puerto Principe, Cuba	1908	T. Barbour	Descrip. of ♂ & ♀
4388	1	"	♀	Bahia Honda, Cuba	1879	S. Garman	
7937	1	im.	♀	Cojimar, Havana, Cuba	1912	T. Barbour	
7938	1	"	♀	San Diego de los Baños, Cuba	1912	T. Barbour	
10823	1	ad.	♀	Guane, Cuba	1915	T. Barbour and W. S. Brooks	
10919-							
10923	5	all	both	Nueva Gerona, Isla de Pinos		T. Barbour and W. S. Brooks	
10868	1	ad.	♂	Cabo San Antonio, Cuba		C. de la Torre	

## AMEIVA DORSALIS Gray.

*Description*.— Adult male; M. C. Z. 7334. Kingston, Jamaica; 1908; T. Barbour.

Rostral forming an acute angle behind; nostril on the posterior border of the anterior nasal; anterior pair of nasals just in contact behind rostral; frontonasal as long as wide, in contact with the loreal; prefrontals just in contact; frontal in contact with the first and second supraoculars; a pair of frontoparietals in contact with the third supraocular anteriorly; five occipitals in a transverse row, the two in contact with the median largest; seven and eight supraciliaries; three supraoculars, the first separated from the loreal; last two supraoculars separated from the supraciliaries by one or two rows of granules; posterior supraocular separated from the outer occipitals by two rows of large granules and a group of smaller ones; six large supralabials; five or six large infralabials; between infralabials and chin-shields a wedge of one to three granules extending anteriorly to the postmental; chin and throat covered with minute granules, an indistinct band of a trifle larger ones extending across the middle, on the area between the two throat folds several rows of large hexagonal scales; under side of the body with ten longitudinal and thirty-five transverse rows of plates; preanal plates three, the median forming a triangle, two smaller ones at the basal angles; on the lower arm a double row of antibrachials, one very wide, both breaking up into granules near the elbow joint; on the upper arm a single row of narrower, more spherical brachials not continuous with the antibrachials, on the posterior side near the elbow a row of enlarged postbrachials; under side of the thigh covered with four or five series of hexagonal plates of which the outer series is considerably larger than the others; twenty-one and twenty-two femoral pores; on the under side of the tibia two rows of plates, the outer ones being twice as large as the inner; upper side of the wrist with a regular series of transverse plates corresponding to the inner and outer metatarsals; outer toe extending a trifle further than the inner; tail covered with straight keeled scales; about forty scales in the fifteenth ring from the base.

*Coloration*.— Ground color of dorsal surface olive varying to blue posteriorly; a pale light blue stripe in the middorsal region beginning just behind the occiput and gradually widening to the tail; on the sides a double row of light spots somewhat confluent into two longitudinal stripes; a series of black confluent blotches among the lateral stripes; ventral aspect light yellow-blue anteriorly, varying posteriorly into a checker pattern of dark ultramarine and light yellow-blue spots especially distinct laterally.

*Variation:*— The female and the young are very similar to the male in coloration; but, although the pattern is the same, the colors are much richer. In the female the dark blotches of the sides are more numerous and confluent than those of the male, while in the young these dark areas are so much increased that they often surround the light spots and make a dark background for them as for example in the specimen M. C. Z. 7334 (same data as above). Ventrally, the young have a wash of turquoise-blue varying to yellow instead of the checker pattern.

*Remarks:*— The description was taken from a full grown adult male that measures eighty-nine millimeters from snout to vent.

*Habitat:*— Confined to Jamaica where it has become rare, because of the introduced mongoose.

*List of specimens examined.*

M.C.Z. No.	No. of specimens	Ages	Sexes	Locality	Date	Collector	Remarks
7334	10	all	both	Kingston, Jamaica	1908	T. Barbour	Descrip. ♂
5440	8	all	both	Kingston, Jamaica	1879	S. Garman	

AMEIVA THORACICA Cope.

*Description:*— Adult male; M. C. Z. 6965. New Providence Island, Bahamas; 1904; T. Barbour.

Rostral forming approximately a right angle behind; nostril on posterior part of the anterior nasal; anterior pair of nasals broadly in contact; frontonasal as long as wide, in contact with the loreal; prefrontals in contact broadly; frontal in contact with the first and second supraoculars; a pair of frontoparietals in contact with the third supraocular for nearly its entire length; five occipitals in a transverse row, the two in contact with the median slightly larger; seven supraciliaries; three supraoculars, the first separated from the loreal; two posterior supraoculars separated from the supraciliaries by a single row of granules, last supraocular partly by a double row; last supraocular separated from the outer occipitals by a double row of small scales; five and six large supralabials; six and seven large infralabials; between the infralabials and chin-shields a wedge of one to three rows of granules extending anteriorly to the postmental; chin and throat covered with minute granules, an indistinct band of

very slightly larger ones extending across the middle; on the portion between the two throat folds several rows of large hexagonal scales; under side of the body with ten longitudinal and thirty-five transverse rows of plates; preanal plates in a subtriangular group of large scales irregularly arranged, but having four scales on the base and being three scales in height; on the lower arm a double row of small antebrachials and a single row of large ones, all gradually diminishing in size toward the elbow joint; on the upper arm a single row of brachials almost continuous with the antebrachials; on the posterior side near the elbow a single row of enlarged postbrachials; under side of thigh covered with six or seven series of hexagonal plates of which the outer series is considerably larger than the others; fourteen femoral pores; on the under side of the tibia two rows of plates, those of the outer being enormously enlarged; upper side of the wrist with a regular series of transverse plates corresponding to the inner and outer metatarsals; fifth toe extending approximately as far as the inner; tail covered with straight scales with keels; about thirty-five scales in the fifteenth ring from the base.

*Coloration:*—Ground color of dorsal surface olive-brown with traces of blue-gray posteriorly; on each side a rather wide black stripe becoming narrow anteriorly, extending posteriorly half the length of the tail; the black stripe on each side set off by two marginal stripes of pale blue; lower flanks and ventral surface turquoise-blue of low intensity; most of the throat, chest, and abdomen washed with black, darkest in the gular fold region; chin-shields, palms, lower surfaces of feet, lower side of tail washed with yellow.

*Variation:*—The female and young are very similar to the adult males except that the colors are brighter and the pattern more distinct. The pale margin of the lateral black bands become whitish anteriorly. There is often added a median stripe of pale blue-gray running the length of the back. Young specimens sometimes have no black throat, then the whole ventral surface is pale blue.

*Remarks:*—The description was made of an adult male that measured one hundred and eleven millimeters from snout to vent.

*Habitat:*—Common throughout its limited range which includes the Bahaman Islands of New Providence, Eleuthera, and Andros. It has been reported from Great Abaco but was not found there by the Harvard Bahama Expedition of 1904.

*List of specimens examined.*

M.C.Z. No.	No. of specimens	Ages	Sexes	Locality	Date	Collector	Remarks
6965	14	all	both	New Providence Island, Bahamas	1904	T. Barbour & G. M. Allen	Descrip.
7096	9	all	both	New Providence Island, Bahamas	1904	A. E. Wight	
6948	6	all	both	Mangrove Cay, Andros Island, Bahamas	1904	O. Bryant	
5823	3	ad.	♂	Bahamas	1886	C. J. Maynard	
6243	2	ad.	♂	New Providence Island, Bahamas	1888	C. S. Dolley	
6912	1	ad.	♂	New Providence Island, Bahamas	1900	T. Barbour	

## AMEIVA CHRYSOLAEMA Cope.

*Description*:— Adult male; M. C. Z. 8622. Manneville, Haiti; 1913; W. M. Mann.

Rostral forming an acute angle behind; nostril on the posterior part of the anterior nasal; anterior pair of nasals broadly in contact behind rostral; frontonasal as long as wide, in contact with the loreal; prefrontals broadly in contact; frontal in contact with the first and second supraocular; a pair of frontoparietals separated from the third supraocular by a row of granules; five occipitals in a transverse row the three median ones about the same size and very much larger than the outer ones; three large supraciliaries and four or five smaller ones; four supraoculars, the first separated from the loreal; three posterior supraoculars separated from the supraciliaries by a double row of granules; five and six large supralabials; six and seven large infralabials; between infralabials and chin-shields a wedge of one to three rows of granules extending anteriorly to the postmental; chin and throat covered with minute granules; a scarcely differentiated band of large scales extending across the mid-region of which the median granules are largest; on the area between the two throat folds there are a few rows of large hexagonal scales; under side of the body with ten longitudinal and thirty-six transverse rows of plates; preanal plates in a triangular group four scales wide at the base and three scales in height, the larger scales in the middle; on the lower arm a double row of antibrachials, one very much wider than the other, both breaking up in the mid-region into six or seven series of small scales; on the upper arm two rows, proximally three rows of



brachials; on the posterior side near the elbow a small group of enlarged postbrachials; under side of thighs covered with six or seven series of hexagonal plates of which the outer series is somewhat larger than the others; seventeen and eighteen femoral pores; on the under side of the tibia three rows of plates, distally four rows, the third and fourth plate of the outer row considerably enlarged; upper side of the wrist with a regular series of transverse plates covering only the outer region; outer toe extending a little further than the inner; tail covered with straight scales with keels; about forty-five scales in the fifteenth ring from the base.

*Coloration*:—Ground color of dorsal surface blue-gray; pattern of coloration like *A. vittipunctata* but the seven dorsal white lines running the length of the back broken up into a series of indistinct more or less confluent spots; on each side a rather indistinct black band sharply bordered by the broken white lines; ventral surface somewhat like *A. erythrocephala* in having a pale throat in distinct contrast to a dark chest and abdomen, but the throat is bluish instead of flesh-color, and the gular folds and chest are dark blue-gray suffused laterally by a brighter tone of blue; ventral surface washed posteriorly with straw-color.

*Variation*:—Another specimen, a female (M. C. Z. 8631) differs from the male in having the dark lateral bands more distinct and the longitudinal series of spots more nearly fused into lines as in *A. vittipunctata*. A young specimen (M. C. Z. 8629) is similar to the adult male except that the under parts are uniform blue-gray.

*Remarks*:—The description was made of an adult male that measured one hundred and one millimeters from snout to vent.

*Habitat*:—Confined to Haiti where it is still common.

*List of specimens examined.*

M.C.Z. No	No. of specimens	Ages	Sexes	Locality	Date	Collector	Remarks
8621-33	13	all	both	Manneville, Haiti	1913	W. M. Mann	Descrip.
6292	1	ad.	♀	Haiti			
8649-59	11	all	both	Diquini, Haiti	1913	W. M. Mann	

AMEIVA LINEOLATA Dumeril et Bibron.

*Ameiva taeniura* Cope, Proc. Acad. nat. sci. Phila., 1862, p. 63. Boulenger, Cat. lizards Brit. mus., 1885, 2, p. 350.

*Description*:—Adult male; M. C. Z. 8691. Diquini, Haiti; 1913; W. M. Mann.

Rostral forming a trifle more than a right angle behind; nostril on posterior part of anterior nasal; anterior pair of nasals broadly in contact behind rostral; frontonasal longer than wide in contact with the loreal; prefrontals broadly in contact; frontal in contact with the first and second supraoculars; a pair of frontoparietals in contact with the third supraocular for their entire length; five occipitals in a transverse row, the two in contact with the median largest, seven supraciliaries; three supraoculars, the first separated from the loreal; two posterior supraoculars separated from the supraciliaries by a single, part double row of granules, last supraocular separated from the outer occipitals by two rows of granules and a small scale; five large supralabials; five large infralabials; between infralabial and chin-shields a wedge of one to three rows of granules extending anteriorly to the postmental; chin and throat covered with minute granules, a band of somewhat larger ones extending across the middle; on the area between the two throat folds a few rows of large hexagonal scales; under side of body with eight longitudinal rows (ten including the small scales), and thirty-four transverse rows of scales; preanal plates in a triangular group of three large plates, anteriorly two smaller plates in a transverse line; on the lower arm a double row, one very wide, of antibrachials decreasing in width toward the elbow joint; on the upper arm a similar but narrower single row of plates continuous with the antibrachials; on the posterior side near the elbow a small group of slightly enlarged postbrachials; under side of the thighs covered with four or five rows of hexagonal plates of which the outer series is considerably larger than the others; fifteen femoral pores; on the under side of the tibia two rows of plates, those of the outer much the larger; upper side of the wrist with a regular series of transverse plates corresponding to the inner and outer metatarsals; outer toe extending about as far as the inner; tail covered with keeled, oblique scales dorsally, with smooth straight scales laterally and ventrally; about twenty-eight scales in the fifteenth ring from the base.

*Coloration:* — Ground color of dorsal surface very dark olive-gray, head slightly darker; flanks black; two rather widely separated, narrow white bands on each side, the superior starting from the supraciliaries and the inferior from the ear, both extending half way down the tail; a row of indistinct white spots between these white stripes; lower flanks profusely spotted with white or bluish, the spots arranged more or less in vertical rows; ventral surface pale straw-color suffused with dull blue-gray, edges of the shield lightest; chin-shields and under sides of legs more straw-color.

*Variation:* — A female (M. C. Z. 8693, same data as above) is similar to the male except that there are no white spots on the lower flanks. A young specimen (M. C. Z. 8742, Manneville, Haiti, 1913,

W. M. Mann) shows the extreme of variation in the juvenile stages. The whole dorsal and lateral surfaces are jet black. Eleven, narrow whitish or milky stripes run longitudinally on the back and sides, the median one starting just behind the shoulders, the two adjacent ones coming to an apex about mid-way between the shoulders. The remaining eight stripes are nearly parallel, four arising on each side from the supraoculars, the supraciliaries, the upper and lower corners of the eye, respectively. The ventral surface is pale straw-color, suffused with deep blue on the tail. A slight wash of smoky covers the abdomen. The dorsal surface of the legs are spotted with white.

*Remarks:*—The specimen from which the description was taken was an adult male that measured eighty-six millimeters from snout to vent.

A careful examination of a series of twelve specimens of this species makes it clear that *A. taeniura* is the adult of *A. lineolata*. The specimens have a wide range of variation both in color and scutation. According to Cope (Proc. Acad. nat. sci. Phila., 1862, p. 64) the distinguishing characters of *A. taeniura* are mainly of color and tail scutation. One, however, of the specimens before us has the typical nine white bands, and keelless caudal plates of *A. lineolata*. Another specimen shows the extreme variation in this direction by having eleven dorsal bands and keelless caudal scales. Representing the other extreme are six specimens having the characteristic lateral bands and keeled scales of the tail of *A. taeniura*. The remaining individuals have the coloration of *A. lineolata* but the keeled caudal scales of *A. taeniura*. These characters grade into one another and all the intermediate steps are present. Garman (Bull. Essex. inst., 1887, 19, p. 11) noticed the variation in the tail scutation, but pointed out the larger preanals, and the smaller mesotychium scales as characterizing *A. taeniura*. The larger series of specimens shows that these characters are not at all constant, and among the specimens there are many variations.

Dumeril et Bibron (Erpet gen., 1839, 5, p. 119) in describing *A. lineolata* possessed but a single young specimen as shown by their measurements and by Bocourt's figures of the type (Miss. sci. Mex. rept., pl. xxa, fig. 5). In our specimens, also, it is always the smaller individuals that have the typical *A. lineolata* characters.

*Habitat:*—Confined to Haiti where it is widely spread throughout both the republics.

*List of specimens examined.*

M. C. Z. No.	No. of specimens	Ages	Sexes	Locality	Date	Collector	Remarks
8691-95	5	all	both	Diquini, Haiti	1913	W. M. Mann	Descrip.
8742	1	yg.	♀	Manneville, Haiti	1913	W. M. Mann	Descrip. of young.
3614	3	ad.	both	Jeremie, Haiti	1859	D. F. Weiland	Type of <i>A. taeniura</i> .
5441	1	ad.	♂	Puerto Plata, San Domingo	1885	M. A. Frazar	
3608	5	all	both	Jeremie, Haiti		D. F. Weiland	
3609	1	ad.	♂	Jeremie, Haiti		D. F. Weiland	

## AMEIVA VITTIPUNCTATA Cope.

*Description*:—Adult male; M. C. Z. 8618. Manneville, Haiti; 1913; W. M. Mann.

Rostral forming an acute angle behind; nostril on posterior part of anterior nasal; anterior pair of nasals in contact for but a fraction of their length behind rostral; frontonasal as long as wide in contact with the loreal; prefrontals narrowly in contact; frontal in contact with the first and second supraoculars; a pair of frontoparietals in contact with the third supraocular anteriorly; five occipitals in a transverse row, the median slightly larger than the others; seven and eight supraciliaries; three large supraoculars and a small scale posterior to them, the first supraocular separated from the loreal, two posterior supraoculars separated from the supraciliaries by a double row of granules; last supraocular separated from the outer occipitals by two rows of small scales and several rows of granules; five and six supralabials; five large infralabials; between the infralabials and the chin-shields a wedge of one to three rows on granules extending anteriorly to the postmental; chin and throat covered with granules, a band of slightly enlarged scutes extending across the middle, the median ones forming a distinct group of slightly larger ones; on the area between the two throat folds several rows of large hexagonal scales; under side of the body with twelve longitudinal and thirty-eight transverse rows of plates; preanal plates in a marginal row of eight scales, median smallest, and in a double median series of about four pairs; on the lower arm two narrow, one very wide, rows of antebrachials separated from the brachials by several rows of small scales;

on the upper arm three rows of brachials somewhat larger but grading into the granules of the arm; on the outer side near the elbow a group of postbrachials poorly differentiated from the granules of the arm; under side of the thighs covered with seven or eight series of plates in the mid-region, the outer series considerably larger than the others; nineteen femoral pores; on the under side of the tibia three rows of plates, the second and third scale of the outer row considerably enlarged; upper side of the wrist granular; outer toe extending a little further than the inner; tail covered with straight scales with keels; about forty-two scales in the fifteenth ring from the base.

*Coloration*:—General tonality dark olive-gray; six narrow whitish stripes and part of a seventh, running the length of the back; the space between the two innermost stripes the lightest, and that between the two outermost on each side the darkest—almost black; beneath the lowest stripe on the flanks a series of pale bluish spots arranged somewhat in longitudinal rows; ventral surface straw-color washed laterally with light blue-gray.

*Variation*:—The female and young are similar to the adult male except that their colors are brighter and the pattern is more distinct.

*Remarks*:—The description was made of an adult male that measured one hundred and eighteen millimeters from snout to vent.

*Habitat*:—Widely distributed throughout San Domingo and Haiti, but peculiar to the island.

*List of specimens examined.*

M. C. Z. No.	No. of specimens	Ages	Sexes	Locality	Date	Collector	Remarks
S614-19	6	all	both	Manneville, Haiti	1913	W. M. Mann	Descrip.
S634-44	11	all	both	Momance, Haiti	1913	W. M. Mann	

AMEIVA MAYNARDI Garman.

*Description*:—Adult male; TYPE M. C. Z. 6225. Great Inagua, Bahamas; 1888; C. J. Maynard.

Rostral forming about a right angle behind; nostril on posterior part of anterior nasal; anterior pair of nasals broadly in contact; frontonasal wider than long in contact with the loreal; prefrontals broadly in contact; frontal in contact with the first three supraoculars; a pair of frontoparietals in contact with the third and fourth supraoculars; five large occipitals in a transverse row, the median slightly the largest; seven supraciliaries; four supraoculars the first in contact

with the loreal; three posterior supraoculars separated from the supraciliaries by a single row of granules; last supraocular separated from the outer occipitals by a double row of small scales; five large supralabials; five large infralabials; between infralabials and chinshields a wedge of three or four small scales extending only to the third infralabial; chin and throat covered with granules of slightly varying size, no distinct grouping of the larger granules; on the area between the two throat folds several rows of large hexagonal scales; under side of the body with eight longitudinal rows of scales (ten including the large granules terminal on each cross row) and thirty-five transverse rows; preanal plates, a pair of large marginal ones and a median pair of about the same size; on the lower arm a single, partly double row of antibrachials breaking up into granules just before reaching the elbow joint; on the upper arm a single row of much narrower brachials; on the posterior side near the elbow joint a double row of postbrachials scarcely differentiated from the granules of the arm; under side of the thigh covered with three rows (four proximally) of hexagonal plates of which the outer series is larger than the others; twelve femoral pores; on the under side of the tibia two rows of plates, the outer row greatly enlarged; upper side of the wrist with an irregular, part regular, series of transverse plates; outer toe extending a little further than the inner; tail covered with smooth, oblique scales; about thirty scales in the fifteenth ring from the base.

*Coloration:*—General tonality milky, slightly olive on the head, grayer on the tail; three dark brown or blackish bands running the length of the body but not extending on the tail; the median dark band arises in the occipital region and extends not so far as the thigh; the two lateral dark bands arise just before the eye and extend backward covering nearly all the flanks; ventral surface including the lower part of the flanks whitish tinged with blue; under surface of the tail, and the gulars tinged with greenish.

*Variation:*—The female and young differ from the adult males in being generally brighter, that is in being more black and white.

*Remarks:*—The description was made of an adult male that measured sixty-six millimeters from snout to vent.

*Habitat:*—Confined to Great Inagua in the southern Bahamas.

*List of specimens examined.*

M.C.Z. No.	No. of specimens	Ages	Sexes	Locality	Date	Collector	Remarks
6225	3	all	both	Great Inagua, Bahamas	1888	C. J. Maynard	Types Descrip.
10958	2	ad.	both	Great Inagua, Bahamas		W. W. Worthington	
10959							

## AMEIVA EXSUL Cope.

*Description*.—Adult male; M. C. Z. 2746. St. Thomas, D. W. I.; 1872; L. Agassiz.

Rostral forming an acute angle behind; nostril between the two nasals; anterior pair of nasals narrowly in contact behind rostral; frontonasal longer than wide in contact with the loreal; prefrontals broadly in contact; frontal in contact with the first and second supraoculars, just touching the third; a pair of frontoparietals in contact with the third supraocular anteriorly; five occipitals in a transverse row, the median largest; six or seven supraciliaries; four supraoculars, the first separated from the loreal; three posterior supraoculars separated from the supraciliaries by a double row of granules; last supraocular separated from the outer occipitals by three rows of granules; six large supralabials; five large infralabials; between the infralabials and chin-shields a wedge of from one to three granules extending anteriorly nearly to the postmental; chin and throat covered with minute granules, a faintly indicated band of slightly larger ones extending across the middle in which again the median ones form an ill-defined central group of somewhat enlarged scales; on the area between the two throat folds several rows of larger hexagonal scales; under side of the body covered with ten longitudinal and thirty-five transverse rows of plates; three large preanal shields forming a triangle; on the lower arm a series of very wide plates decreasing in width toward the elbow joint to form several rows of smaller hexagonal scales; on the upper arm a similar but narrower series of brachials not continuous with the antebrachials; on the posterior side near the elbow a small group of enlarged scales; under side of thighs covered with six or seven series of hexagonal plates of which three rows are considerably larger than the others; fourteen to fifteen femoral plates; on the under side of this tibia two rows of plates, two plates of the outer row enormously enlarged; upper side of the wrist with a regular series of transverse plates corresponding to the inner and outer metatarsals; outer toe extending about as far as the inner; tail covered with straight, keeled scales; about forty-three scales in the fifteenth ring from the base.

*Coloration*.—Ground tone of dorsal surface dull olive-green becoming more olive on the head and grayer on the tail; posterior part of the back with slight traces of black penciling; flanks, sides and upper surfaces of legs, and sides of tail spotted with pale blue-green, the spots arranged mostly in a series of transverse rows; on each flank a series of large irregular black spots; ventral surface straw-color, grayer on gulars, suffused along the sides with turquoise-blue.

*Variation:*—The females and young differ in general from the adult males by the presence of a pale line margined with blackish on each side of the body. In several specimens the pale line is indistinct and only the broad dark bands are present. Females are generally browner than the males and have a series of narrow blackish cross-bars on the back and flanks the interspaces of which are filled with roundish spots of isabella, more numerous posteriorly. The tail and the upper surfaces of the legs are similarly spotted. The young are generally more brightly colored than the females.

*Remarks:*—The description was made of a full grown adult male that measured one hundred and forty-five millimeters from snout to vent.

*Habitat:*—Common along the coast line of Porto Rico in the neighborhood of salt and fresh water preferably where the ground is sandy or gravelly; also found in the interior along the river courses but not reaching the high altitudes. Common in Saint Thomas, especially in the hills back of Charlotte Amalie, also in Vieques, St. John and Water Island, but probably extirpated in St. Croix where it was found before the introduction of the mongoose.

*List of specimens examined.*

M. C. Z. No.	No. of specimens	Ages	Sexes	Locality	Date	Collector	Remarks
2748	1	ad.	♂	St. Thomas, D. W. I.	1872	L. Agassiz	Descrip.
5432	1	ad.	♀	St. Thomas, D. W. I.	1879	S. Garman	
5433	4	all	both	St. Thomas, D. W. I.	1879	S. Garman	
6082-83	6	all	both	San Juan, Porto Rico	1879	S. Garman	

*AMEIVA ALBOGUTTATA* Boulenger.

*Description:*—Adult male; M. C. Z. 7898. Mona Island, W. I., 1908; B. S. Bowdish.

Similar to *A. exsul* in scutation except for the following:—five occipitals in a transverse row, the two adjacent to the median largest; last two supraoculars separated from the outer occipitals by four or five rows of small scales; four large infralabials and a fifth small one at the anterior extremity; preanal plates consisting of three large ones forming a triangle and two slightly smaller marginal ones on either side; on the upper arm a series of brachials more spherical than those of *A. exsul*; thirteen and fourteen femoral pores; about thirty-five scales in the fifteenth ring from the base.



*Coloration:*— Similar to *A. exsul* in ground color but tonality bluer and lighter; no black pencilings on the back; flanks blue-gray much lighter than those of *A. exsul*, and surmounted by a dark brown band which is somewhat broken into confluent spots; pale dapplings more numerous than in *A. exsul*, and covering the back, tail, and legs.

*Remarks:*— This form is so similar to *Ameiva exsul* that the distinguishing characters only are indicated in the description which was made of an adult male that measured ninety-six millimeters from snout to vent. As Stejneger (Rept. U. S. nat. mus. for 1902, 1904, p. 618) has pointed out this form as more readily distinguished from *A. exsul* by its numerous pale mottlings, than by any scutation characters. Only the specimen described was examined.

*Habitat:*— Confined to the small island of Mona.

#### AMEIVA WETMOREI Stejneger.

Stej., Proc. Biol. soc. Wash., 1913, 26, p. 69.

*Description:*— TYPE U. S. N. M. 49731. Guanica, Porto Rico; May 20, 1912; A. Wetmore.

“Nostril between the two nasals; anterior nasals broadly in contact behind rostral; frontonasal broader than long, in contact with the loreal; prefrontals broadly in contact; frontal pentagonal, in contact with the first and second supraoculars, not touching third; a single hexagonal frontoparietal broadly in contact with the third, very narrowly with the second supraocular; three occipitals; five supraciliaries; three supraoculars, the first in contact with the first supraciliary, the others separated from the supraciliaries by a single row of fine granules; last supraocular in contact with outer occipitals; seven supralabials; six large infralabials; between infralabials and chin-shields posteriorly a single line of flat scales, the anterior ones not reaching the first pair of chin-shields; chin and throat covered with small scales or granules diminishing in size posteriorly; mesopthygium with a median patch of enlarged scales, the larger ones about four times the size of the chin granules; under side of the body with eight longitudinal and thirty-five transverse rows of rectangular plates; one large preanal plate, preceded by one much smaller, and this one by two still smaller ones placed transversely; on the lower arms two rows of large antibrachials, separated from the much smaller single row of brachials by small scales; on the lower edge of the upper arm a single series of enlarged postbrachials; under side of the thighs

covered with two series of large scales or plates and three smaller ones; thirteen or fourteen femoral pores; under side of the tibia covered entirely across by three plates, of which the upper is larger than the other two together; upper side of the wrist with three series of enlarged plates; outer toe extending far beyond the inner (first) toe almost to the claw of the second; tail covered with smooth scales, the scales being oblique with parallel sides, except for the median row which is wedge shaped; about twenty-two scales in the fifteenth ring from the base.

*Coloration*:—Above dark brownish olive with seven distinct greenish white longitudinal lines, the median one somewhat wider than the others and starting from the tip of the tip of the snout, while the others originate in front of the eye, and continue some distance on the tail except for the outer row which terminate in the groin; upper side of limbs also dark olive-brown with very distinct round greenish white spots; under side greenish white darkening on tail. Mr. Wetmore describes the tail of the living animal as varying from brilliant emerald-green to grayish blue according to light, and the under side as dull clay-red."

*Remarks*:—The description was taken from the type and only known specimen; it measured forty-seven millimeters from snout to vent. It is probable that the specimen was about half grown.

*Habitat*:—An extremely rare and local form known only from Guanica, Porto Rico.

#### AMEIVA POLOPS Cope.

*Description*:—TYPE U. S. N. M. 30,695. St. Croix Island, D. W. I.; A. H. Riise. Type examined; photographs M. C. Z.

Rostral forming a right angle behind; nostril between the two nasals; anterior pair of nasals just in contact behind rostral; fronto-nasal slightly wider than long (in photograph), in contact with loreal; prefrontals broadly in contact; frontal in contact with the second, third, and fourth supraoculars; a pair of frontoparietals in contact with the fourth supraocular for almost its entire length (the two scales are separated posteriorly by a very few small granules); five occipitals, the two bordering the median the largest; eight supraciliaries; four supraoculars; last supraocular separated from the outer occipitals by a few small granules; seven supralabials five infralabials; between infralabials and chin-shields a wedge of a single row of granules extending anteriorly almost to the first chin-shield; chin and throat with small granular scales, median gulars very slightly enlarged; on the

area between the two throat folds several rows of scales considerably enlarged; under side of body with ten longitudinal and thirty-two transverse rows of plates; preanal plates irregular, in pairs, the posterior pair largest and with a small median scale wedged between; a row of large brachials hardly continuous with a row of large antebrachials; a few large postbrachials; four series of femoral plates; two series of tibials inner small; (details of plates on arms and legs *vide* Boulenger, as the photographs do not show these characters distinctly); eighteen femoral pores; upper scales of tail oblique, scales of sides smooth, others indistinctly keeled.

*Coloration*:—Dorsal region olive-gray; on each side three longitudinal white lines, the upper faint; the interspace between the two upper white lines brown-black; between the two lower lines dusky; limbs gray flecked and lined with darker; lower surfaces greenish white; according to Boulenger, a white black-edged line along the hinder side of the femur and tibia and the anterior side of the latter.

*Remarks*:—The type is in good preservation; it measures  $2\frac{3}{16}$ " from snout to vent and the tail is  $5\frac{1}{16}$ " long.

The species is confined to the Isle of St. Croix (Santa Cruz), where it is either extremely rare or perhaps quite extinct. Recent collectors have been unable to secure specimens.

#### AMEIVA CORVINA Cope.

*Description*:—Adult male; TYPE M. C. Z. 3616. Labeled Jeremie, Haiti, but undoubtedly one of the types from Sombrero.

Rostral forming an acute angle behind; nostril on posterior border of anterior nasal; anterior pair of nasals just in contact behind rostral; frontonasal longer than wide in contact with the loreal; prefrontals broadly in contact; frontal in contact posteriorly with the first supraocular, for nearly its entire length with the second; a pair of frontoparietals separated from the third supraocular by a single row of granules; eight occipitals in a transverse row of three pairs plus a single terminal scale on each side; seven supraciliaries; four supraoculars, the first separated from the loreal; three posterior supraoculars separated from the supraciliaries by a single, partly double row of granules; last supraocular separated from the outer occipitals by three rows of small scales; seven large supralabials; five or six infralabials; between infralabials and chin-shields a wedge of a single row of granules extending anteriorly to the first chin-shield; chin and throat covered with minute granules, an indistinct band of very slightly larger ones extending across the middle, the median ones forming an

ill-defined central group of scarcely larger ones; on the area between the two throat folds several rows of large hexagonal scales; under side of body with twelve longitudinal and thirty-six transverse rows of plates; preanal plates irregular and of varying size, the two median ones in a line with the axis of the body, and the two adjacent ones largest; on the lower arm one row of very wide, and two of very narrow antebrachials breaking up into small scales proximately; on the upper arm two or three rows of brachials, very slightly larger and grading into the granules of the arm; on the posterior side near the elbow a small group of slightly enlarged postbrachials; under side of the thighs covered distally with four rows of plates, outer row much the largest, breaking up proximally into ten or twelve smaller rows; thirty-four and thirty-six femoral pores; on the under side of the tibia four rows of plates those of the outer being about double the others; upper side of the wrist covered with granules; outer toe extending a little further than the inner; tail covered with straight, keeled scales; about thirty-three scales in the fifteenth ring from the base.

*Coloration*:—Upper and lateral surfaces dark brown tinged with olive or with blue, no pattern but nearly uniform dirt-color; head and tail more olive; ventral surface dark green, tinged with olive or with blue.

*Variation*:—There is apparently no variation in the female. We have been able to examine no young individuals, but it is probable that they also do not vary.

*Remarks*:—The description was made of an adult male that measured one hundred and eleven millimeters from snout to vent.

There is every reason to suppose that this specimen was one of the types. Cope when he described *Ameiva corvina* in 1861 stated that the types were in the Academy of natural sciences of Philadelphia (collected by Mr. Hanson) and in the Smithsonian institution (collected by Mr. Riise). Dr. Stejneger writes me that there are *no* specimens of this species in the U. S. N. M. and that there is no evidence that there ever were any. The types in the Philadelphia Academy collection are nos. 9115 to 9121. The additional specimens which Cope examined and which he credited to the Smithsonian collection are beyond doubt now in this Museum. One, M. C. Z. 5532, was received when the research collection of reptiles was sent to this Museum by the Peabody academy of science of Salem. It is marked as "a type of *A. corvina* Cope from Sombrero Island." It may have been given to the Museum in Salem by Cope, or received in exchange for the courtesy of permission to study and describe species in the Salem collection. The types of *Chamaeleo basiliscus* Cope and *Scpsina grammica* Cope were among those which Cope described from the

Salem collection and these are now in this Museum. The other specimens are four examples (M. C. Z. 3616) which are marked Jeremie, Haiti, collection of Dr. D. F. Weinland. Cope had the Weinland collection borrowed from the M. C. Z. for study at the time he described *Ameiva corvina* and when that Haitian material was returned these specimens were doubtless included. They are, we think, certainly the Riise specimens which were either destined for the Smithsonian or which had been borrowed from the collection by Cope before they had been entered in the Washington catalogue. These examples are those which Garman mentioned as types (Bull. Essex. inst., 1887, 19, p. 10) but apparently without suspecting the erroneous locality, Jeremie, Haiti.

There is also the possibility that Cope really received these specimens from Cambridge, that the mixing with Haitian material took place there, and that he wrote the Smithsonian Institution by mistake for the Museum of Comparative Zoölogy. Such a lapsus would have been easy to make when he was constantly receiving specimens from both institutions. In any case two of these examples have been transferred to the U. S. National Museum. One of the other series of cotypes, from the Philadelphia Academy, has been received recently in exchange.

*Habitat*:—Apparently confined to the islands of Sombrero and Anguilla of the Lesser Antilles. It is unusual that a small island like Anguilla should have two species of Ameivas upon it, for *A. garmani* is peculiar to that island. It is quite probable that this locality record is incorrect.

*List of specimens examined.*

M.C.Z. No.	No. of specimens	Ages	Sexes	Locality	Collector	Remarks
3616	2	ad.	both	(?) Jeremie, Haiti	D. F. Weinland	Descrip. See Remarks
5532	1	ad.	♀	Sombrero Id., W. I.		Type
10535	1	ad.	♀	Sombrero Id., W. I.	Hanson	Cotype from Acad. nat. sci. Phila.

AMEIVA PLEII Dumeril et Bibron.

*Ameiva scutata* Gray, Cat. lizards Brit. mus., 1854, p. 19.

*Ameiva analisera* Cope, Proc. Amer. philos. soc., 1869, 11, p. 158.

*Description*:—Adult male; M. C. Z. 6085. St. Bartholomew, F. W. I.; 1880; F. Lagois.

Rostral forming an acute angle behind; nostril on the posterior border of the anterior nasal; anterior pair of nasals narrowly in contact behind rostral; frontonasal longer than wide, in contact with the loreal; prefrontals broadly in contact; frontal in contact posteriorly with the first supraocular, for nearly its entire length with the second; a pair of frontoparietals separated for their entire length from the third supraocular by a double row of granules; eight occipitals in a transverse row consisting of a median pair and a group of three on either side; four supraoculars the first separated from the loreal; three posterior supraoculars separated from the supraciliaries by a single, partly double row of granules; last supraocular separated from the outer occipitals by three or four rows of small scales; seven large supralabials; five infralabials; between infralabials and chin-shields a wedge composed of a single row of granules and small scales extending anteriorly to the first chin-shield; chin and throat covered with minute granules, a distinct band of larger ones extending across the middle of which the median ones form an ill-defined central group of slightly larger ones; on the portion between the two throat folds several rows of large hexagonal scales; under side of the body with twelve longitudinal and thirty-four transverse rows of plates; pre-anal plates in a marginal row decreasing in size from the median pair, and in a median line one plate larger than the marginal ones, and another smaller one in advance of this; on the lower arm one row of very wide, and another narrow row of antebrachials breaking up into small scales proximally; on the upper arm three rows of brachials the median largest; on the posterior side near the elbow joint a group of slightly enlarged postbrachials; under side of thighs covered distally with four rows of plates, outer row considerably the largest; breaking up proximally into ten or twelve narrower rows; twenty-four and twenty-five femoral pores; on the under side of the tibia three rows of plates, those of the outer row greatly enlarged; upper side of the wrist covered with granules; outer toe not extending quite so far as the inner; tail covered with straight, keeled scales; about thirty-three scales in the fifteenth ring from the base.

*Coloration*.—Dorsal surface olivaceous gray, slightly yellowish especially on the head and tail; whole upper surface posterior to the shoulders spotted with pale whitish or yellowish blotches, those of the flanks being largest; ventral surface straw-color washed with blue on the belly.

*Variation*.—A female (same data as above) differs from the male in having fewer spots dorsally. A young specimen (same data) is very different from either of the adults. There are seven narrow white lines running the length of the upper surface of the body; the two outermost on each side border a wide brown band. In place of the pale spots of the adult male on the upper surface there are four series of black spots between the dorsal stripes. The ventral surface is paler and more green than that of the adult.

*Remarks:*—The description was made of an adult male that measured one hundred and twenty-two millimeters from snout to vent.

The confusion of the localities of Plee's specimens has already been discussed by Stejneger (Herpetology of Porto Rico. Rept. U. S. N. M. for 1902, 1904, p. 622-623) and by Barbour (Recent notes regarding West Indian reptiles and amphibians. Proc. Biol. soc. Wash., March 12, 1915, 23, p. 73). *A. pleii*, like so many other of Plee's species, was described as coming from Martinique. Since, however, *A. anallifera* and *A. pleii* are the same it is reasonable to assume that *A. pleii* originally came from St. Bartholomew where Plee probably touched on his way to Martinique. This leaves the Martinique Ameiva unknown, as indeed it will probably remain, because the introduced mongoose has for a long time been common there and every year does increasing harm to the fauna.

*Habitat:*—Confined to the closely associated islands of St. Martin and St. Bartholomew.

*List of specimens examined.*

M. C. Z. No.	No. of specimens	Ages	Sexes	Locality	Date	Collector	Remarks
6085	5	all	both	St. Bartholomew	1880	F. Lagois	Descrip.
4357	1	im.	♀	? ? Martinique <sup>1</sup>			
Phil. Acad.							
9143	1	ad.		? ? St. Eustatius			
9081	1	ad.		St. Bartholomew			
U.S.N.M.							
11176	1	ad.		St. Bartholomew			
11177	1	ad.		St. Martin			

AMEIVA GARMANI Barbour.

*Description:*—Adult male; TYPE M. C. Z. 6141; Anguilla Island; 1880; F. Lagois.

Similar to *A. pleii* in scutation from which it may be distinguished by the following characters:—median band of gular scales made up of larger and more irregularly arranged granules than those of *A. pleii*;

<sup>1</sup>An old specimen, and not improbably one of the types of the species, doubtless received from the Paris museum, whence came all the early material in the M. C. Z. labeled "Martinique."

brachials slightly larger, postbrachials distinctly larger than those of this species; the largest of the outer tibials is larger than that of *A. pleii*, and also much wider; in *A. pleii* the width of this scale is about twice that of the adjacent scale proximally, while in *A. garmani* the two plates are about equal; upper side of the wrist covered with scales rather irregularly arranged; about thirty scales in the fifteenth ring from the base.

*Coloration*:—Lighter in color than *A. pleii*, with numerous pale, blue-gray or straw-color spots posteriorly, giving the legs the appearance of being gray reticulated with brown instead of brown with gray spots as in *A. pleii*; the heavy blotching extending down the tail, the spots being often bordered anteriorly with a zigzag rim of dark brown.

*Remarks*:—The relationship of this form to *A. pleii* is so close that a detailed description is not necessary. The description was made of an adult male that measured one hundred and twenty-six millimeters from snout to vent. Only one example seen.

#### AMEIVA ERYTHROCEPHALA (Daudin).

*Ameiva punctata* Gray, Ann. nat. hist., 1838, p. 277; Boulenger, Cat. lizards Brit. mus., 1885, 2, p. 359. Zool. record. Reptiles, 1887, p. 11.

*Description*:—Adult male; M. C. Z. 10378. St. Christopher, W. I.; 1914; G. K. Noble.

Rostral forming an acute angle behind; nostril between the two nasals; anterior pair of nasals just in contact behind rostral; fronto-nasal longer than wide in contact with the loreal; prefrontals broadly in contact; frontal in contact with the first supraocular posteriorly, with the second supraocular anteriorly, the posterior half separated by a single row of granules; a pair of frontoparietals separated from the third supraocular by one to four rows of granules, five occipitals, the three median in a transverse row and slightly anterior to the outer two; nine supraciliaries, the posterior four small; four supraoculars, the posterior smallest and followed by a large granule, the first separated from the loreal; three posterior supraoculars separated from the suprailiaries by a double row of granules ending anteriorly in a large granule; last supraocular separated from the outer occipitals by four or five rows of granules; six and seven supralabials; six infralabials; between infralabials and chin-shields a wedge of one or two rows of granules extending anteriorly to the first chin-shield; chin and throat covered with minute granules, a band of slightly larger ones extending across the middle, the median ones and two groups slightly anterior



and on either side of them largest; on the area between the two throat folds a small group of enlarged scales formed of five transverse rows of about six or seven scales each; under side of the body with fourteen longitudinal and thirty-six transverse rows of plates; preanal plates irregularly arranged, the three largest forming a triangular group crowded slightly out of the median line by two or three smaller ones; on the lower arm a single row of four or five wide plates breaking up into granules before reaching the elbow; on the upper arm three or four rows of brachials, median largest, others grading into the granules of the arm; on the posterior side near the elbow a small group of slightly enlarged postbrachials; under side of the thighs covered distally with five, proximally with ten or twelve rows of scales, outer row widest; thirty-eight and thirty-nine femoral pores; on the under side of the tibia two rows of large and three of small scales, outermost considerably larger than the other two; upper side of the wrist with a regular longitudinal series of plates covering the outer part of wrist and hand only; outer toe extending a little further than the inner; tail covered with straight keeled scales; about thirty-seven scales in the fifteenth ring from the base.

*Coloration*.—Dorsal surface dark olive-green slightly tinged in life with russet, head lighter and more reddish olive, the sides of which are almost rosy in life; numerous black pencilings on the back and sides arranged in a very wide median band, and two narrower more distinct lateral bands running the length of the body but fading off on the tail; chin and throat pale flesh-color in sharp contrast to the rest of the under parts which are blue-gray; the pale throat almost brilliant in life serving to distinguish this form from all others except perhaps the closely related *A. erythrops*.

*Variation*.—The females are similar to the males except that the dark pencilings on the back are more numerous and distinct, forming almost a network of black lines having a generally transverse direction. There is a suggestion of a pale line anteriorly on each side of the body. This becomes more distinct in the young and borders a dark lateral band on the upper side while a similar white line forms a lower margin to the stripe. Generally speaking the young are like the adult females. One specimen, however, (M. C. Z. 10376) has a pale throat which is not in sharp contrast to the pale blue-gray under parts, and there are no ultramarine blue spots on the outer ventral plates as found in the adults.

*Remarks*.—The description was made of an adult male that measured one hundred and twelve millimeters from snout to vent. Old males often grow much larger than this specimen.

*Habitat*.—Apparently confined to the island of St. Christopher where it is common about the town of Basse Terre especially on the low-lying uncultivated fields to the west of the settlement.

*List of specimens examined.*

M. C. Z. No.	No. of specimens	Ages	Sexes	Locality	Date	Collector	Remarks
10375-8	4	all	both	Basse Terre, Saint Christopher	1914	G. K. Noble	Descrip.
6091	7	all	both		1881	F. Lagois	
6092	15	all	both		1879	S. Garman	

## AMEIVA ERYTHROPS Cope.

Careful search at the Philadelphia Academy has failed to reveal the types of this species and they are beyond doubt lost. A new description of this form so closely related to, yet seemingly distinct from *A. erythrocephala* would have been very desirable. The following is derived from the original description (Cope, Proc. Acad. nat. sci. Phila., 1871, p. 221).

*Description*.— Four supraorbitals; nine supraciliaries; five infra-labials separated by a few intermedials from posterior labials; seven rows of larger gular scales extending entirely across the throat; three larger series on gular fold which has several rows of granules near margin; abdominal plates 12-14 series; brachials small in four rows; postbrachials small; antibrachials large, two rows hexagonal, one transverse; preanal scales two large median with a single row of one or two in front; small scales occur in some specimens behind the posterior two; outer hind toe a little longer than inner.

*Coloration*.— Color brownish olive, with a broad greenish band extending on each side of the back beginning on the nape, above the ear. In young specimens these bands are bright. Another less distinct band extends along the side from above axilla to groin. Between these and the dorsals, and across the back are transverse black reticulations. Belly greenish, the color appearing as spots on the outer scales. Thorax and edge of sides of fold black; throat bright yellow; sides of head red; upper surface brown; limbs olive with black reticulations.

*Remarks*.— Cope's description was made in part from an adult that measured one hundred and twenty-six millimeters from snout to vent.

It has been pointed out by both Garman and Barbour that this form is closely related to *A. erythrocephala* but until fresh specimens are examined it will be impossible to state how close this relationship really is. There are apparently no specimens of this species in any museum. It was from St. Eustatius.

*AMEIVA PLUVIANOTATA* Garman.

*Description*.—Adult male; TYPE M. C. Z. 6086; Plymouth, Montserrat, B. W. I.; 1879; S. Garman.

Rostral forming about a right angle behind; nostril in the posterior border of anterior nasal; anterior pair of nasals just in contact behind rostral; frontonasal longer than wide in contact with the loreal; frontal in contact with the first, second, and third supraoculars; a pair of frontoparietals separated from the third and fourth supraoculars by one to four rows of granules; occipitals irregular, median largest, a group of five or six scales on each side of it, the outermost somewhat larger than the others; eight supraciliaries, last four small; four supraoculars, the first separated from the loreal; three posterior supraoculars separated from the supraciliaries by a single row of granules; last supraocular separated from the outer occipitals by four rows of granules; six and seven supralabials; six infralabials; between infralabials and chin-shields a wedge of one or two rows of granules extending anteriorly to the first chin-shields; chin and throat covered with minute granules, an indistinct band of larger ones extending across the middle, the median ones largest, two other groups on either side not quite as large as these; on the area between the two throat folds a transverse series of enlarged scales, the median row much larger than the others; under side of the body with fourteen longitudinal and thirty-six transverse rows of plates; preanal plates, consisting of three median scales, the posterior largest and followed by two granules, also a transverse series decreasing in size from the median pair; on the lower arm three rows of scales, the outer very broad and low; on the upper arm three or four rows of small brachials, medials largest, others grading into the granules of the arm; on the posterior side near the elbow joint a small group of slightly enlarged postbrachials; under side of thigh covered distally with five, proximally with ten or twelve rows of scales, outer row slightly larger than the others; thirty-one and thirty-three femoral pores; on the under side of the tibia five rows of scales, outermost much larger than the others; upper side of the wrist with a regular series of transverse plates covering the outer margin only; outer toe extending about as far as the inner; tail covered with straight keeled scales; about thirty-nine scales in the fifteenth ring from the base.

*Coloration*.—Ground tone of dorsal surface dirt-brown, grayer posteriorly; upper surface of thighs, sides of tail very slightly spotted with blue-gray; ventral surface straw-color, smoky on the throat, chest and upper abdomen; the straw-color carried up as a few odd spots on the sides of the head and thighs.

*Variation:*—The females and young males are very different from the adult males in being generally grayer and profusely dappled with light blue-gray. One specimen, an adult female (same data as above) is generally olivaceous gray above. Two indistinct brown bands run the length of the flanks. The sides and upper surface of the body, appendages and most of the tail is profusely spotted with light gray, while the under surface is bluish except for the gular folds which are suffused with black. A young specimen (same data as above) is identical with the female. Oddly enough the lateral bands are even less distinct than in the adult.

*Remarks:*—The description was made of an adult male that measured one hundred and thirty-five millimeters from snout to vent.

This species is a noteworthy exception to the general rule that the young tend more to be distinctly striped than the adults.

We have examined only the ten types of this species the data for which is given before the description. In this series of specimens there are young and adults of both sexes.

*Habitat:*—Apparently confined to the island of Montserrat. The Ameiva from the neighboring island of Antigua is unknown, if one still occurs there.

AMEIVA ATRATA Garman.

*Description:*—Adult female; TYPE M. C. Z. 6084. Redonda Island, B. W. I.; 1880; W. J. Branch.

Rostral forming about a right angle behind; nostril on posterior border of anterior nasal; anterior pair of nasals just in contact behind the rostral; frontonasal a trifle longer than wide, just touching the loreal; prefrontals broadly in contact and partly surrounding a small scale posteriorly, frontal in contact with the first three supraoculars; a pair of frontoparietals in contact, anteriorly, with the third supraocular; seven occipitals, rather small, irregular and in a transverse row, the two adjacent to the median smallest, the two outermost largest; eight supraciliaries; four supraoculars, the first separated from the loreal; three posterior supraoculars separated from the supraciliaries by a single, part double row of granules; six large supralabials; five infralabials; between infralabials and chin-shields a wedge of one or two rows of scales extending anteriorly to the first chin-shield; chin and throat covered with minute granules, an indistinct band of scarcely larger ones extending across the middle, the median ones slightly largest; on the area between the two throat folds several rows of large hexagonal scales; under side of the body with twelve longitudi-

nal and thirty-five transverse rows of plates; preanal plates in a marginal row, the two median largest and in a pair of large median plates just anterior to these; on the lower arm one row of wide and two of very narrow antibrachials, grading into four or five rows of smaller scales near the elbow joint; on the upper arm two or three rows of brachials scarcely larger and grading into the granules of the arm; on the posterior side near the elbow a small group of slightly enlarged postbrachials; under side of the thighs covered distally with four rows of plates, outer row much the wider, breaking up proximally into ten or twelve smaller rows; femoral pores twenty-nine and thirty; on the under side of tibia four rows of plates those of the outer being very much enlarged; upper side of the wrist covered with granules; outer toe extending a little further than the inner, tail covered with straight, keeled scales; about thirty-nine scales in the fifteenth ring from the base.

*Coloration*.—Upper and lateral surfaces uniform dark brown tinged with olive-green anteriorly with bluish gray posteriorly; ventral surface dark blue-gray spotted laterally with turquoise-blue of low intensity.

*Remarks*.—The description was made of an adult female that measured one hundred and four millimeters from snout to vent. The type is the only recorded specimen of this species. It is interesting to note the almost melanotic coloration of the Ameivas from the small islands of Sombrero and Redonda, which parallels that of the wall lizards (*Lacerta*) of Filfola and other rocky islets of the Mediterranean.

*Habitat*.—Confined to the small island of Redonda.

#### AMEIVA CINERACEA, sp. nov.

*Description*.—Adult male; TYPE M. C. Z. 10577. Grand Isle off Petit Bourg on the coast of Guadeloupe, F. W. I.; August 24, 1914; G. K. Noble.

Rostral forming slightly more than a right angle behind; nostril between the two nasals; anterior pair of nasals just in contact behind rostral; frontonasal longer than wide in contact with the loreal; frontal in contact with part of the first two supraoculars; a pair of frontoparietals in contact with the second supraocular posteriorly, the third anteriorly, separated from the posterior part of the third supraocular by one to four rows of granules; five occipitals, the median partly divided, arranged with outer two slightly posterior but in the

same transverse line as the other three; nine supraciliaries; four supraoculars, first separated from the loreal; three posterior supraoculars separated from the supraciliaries by two or three rows of granules becoming fused into a single row anteriorly; last supraocular separated from the outer occipitals by three or four rows of granules; six supralabials; six and seven infralabials; between the infralabials and chin-shields a wedge of one to three rows of granules and scales extending anteriorly to the first chin-shield; chin and throat covered with minute granules a scarcely differentiated band of larger ones extending across the throat of which the median group of scutes and two groups anterior to it and on either side of it are composed of the largest granules; on the area between the two throat folds a transverse series of scales, about a dozen of the median scales, in a group, somewhat enlarged; under side of the body with eighteen longitudinal and thirty-eight transverse rows of plates; preanal plates small, almost granular, in a transverse row of seven or eight scales and in a median row of two or three; on the lower arm three short rows of scales, the outer scales being much divided, all of the scales decrease rapidly in size from the mid-region to the elbow; on the upper arm a series of oblique rows each formed of four scales; on the posterior side near the elbow joint a small group of postbrachials scarcely differentiated in size from the granules of the arm; under side of thighs covered with seven or eight rows distally, with twenty-five or more proximally; thirty-one femoral pores; on the under side of the tibia five rows of scales, the two proximal ones of the outer row considerably larger than the others, the second the larger of the two; upper side of the wrist with a regular series of plates covering the outer edge only; outer toe extending about as far as the inner; tail covered with straight, keeled scales; about forty scales in the fifteenth ring from the base.

*Coloration:* — Dorsal surface ashy gray, more bluish on the flanks, slightly more olivaceous on the head and tail; a trace of three indistinct stripes of a slightly darker tone of gray running the length of the body along the back; a suggestion of another dark stripe on each side; in places all five of these bands are indistinguishable from the ground tone; ventral surface straw-color or milky encroached upon laterally by the blue of flanks and of the side of head.

*Variation:* — Neither of the two females before us show any variation of color from that of the adult male described. In this respect this species is rather peculiar.

*Remarks:* — The description was made of an adult that measured one hundred and fifty millimeters from snout to vent.

Three adult specimens, 1♂ and 2 ♀♀ of this species were examined. Their numbers are M. C. Z. 10575-10577.

*Habitat:* — Apparently confined to a small low island, known locally

as Grand Isle; lying about half a mile off shore from Petit Bourg, Guadeloupe. This island, only some fifty yards in extent, consists of a low tangled mass of vegetation upon a "coral" foundation. In character it is similar to the Isle of Grande Terre (a part of Guadeloupe politically) and from which it has doubtless been separated in comparatively recent geologic times. Since any considerable uplift would raise the bench bank on which the islands of Grande Terre and Guadeloupe both stand and bring both into connection with Grand Isle. The entire area between Grand Isle and both the main islands is simply an enormous *cul-de-sac* which is extremely shallow. There certainly cannot be more than a dozen or two of these *Ameiva* in this place. Observations made by the Junior author in Guadeloupe seem to show that this is the last place where the Guadeloupe *Ameiva* occurs.

#### AMEIVA FUSCATA Garman.

*Description*:— Adult male; TYPE M. C. Z. 6087. Dominica, B. W. I.; 1879; S. Garman.

Rostral forming slightly more than a right angle behind; nostril between the two nasals broadly in contact behind rostral; frontonasal longer than wide in contact with the loreal; prefrontals in broad contact; frontal in contact with the first two supraoculars, separated from the third supraocular by one to three rows of granules; occipitals irregular, a median group of three small ones, on each side of this a very large scale, further to the side and posterior to these two scales, a group of two or three small ones; nine supraciliaries; three supraoculars, the first separated from the loreal; two posterior supraoculars separated from the supraciliaries by one or two rows of granules; last supraocular separated from the outer occipitals by four or five rows of granules; six supralabials; six and seven infralabials; between infralabials and chin-shields a wedge of one or two rows of granules and scales extending anteriorly to only the second chin-shield; chin and throat covered with minute granules of somewhat varying size, a band of distinctly larger ones extending across the middle, the median scutes enlarged to form an ill-defined group; on the area between the two throat folds three or four transverse rows of scales, the middle row widest, the scales of all the rows grading off sharply in size from the mid-region; under side of body with fourteen longitudinal and thirty-four transverse rows of scales; preanal plates in a longitudinal, median row of four large plates with several scales on each side, the posterior ones largest; on the lower arm three rows of

antebrachials, outer row considerably larger than the others, all breaking up into small scales before the elbow joint; on the upper arm three rows of brachials, median largest; on the posterior side near the elbow joint a small group of small postbrachials; under side of the thighs covered with four rows distally, with fourteen proximally, outer row just above the knee formed of the widest scales; twenty-eight femoral pores; on the under side of the tibia five rows of scales, the two proximal ones of the outer row considerably larger than the others and both subequal; upper side of the wrist with a regular series of plates covering the outer edge only; outer toe extending a little further than the inner; tail covered with straight keeled scales; about forty-six scales in the fifteenth ring from the base.

*Coloration:* — Since the type specimen described is somewhat faded, another specimen (M. C. Z. 10571; adult male, collected 1914 on Dominica by A. G. Ruthven) is used for coloration. Dorsal surface very dark olive-blue; on each side, a row of irregular pale blue spots; upper surfaces of thighs spotted with the same color; ground tone of ventral surface straw-color; outer ventrals, lower part of flanks with two or three rows of pale bluish spots; whole throat, chest, and anterior part of the abdomen washed with very dark blue.

*Variation:* — The females are similar to the males but the colors are generally brighter. A young specimen (M. C. Z. 6087, same data as above) differs somewhat from the adults. Instead of the pale lateral spots, there is present a pale stripe on each side of the body. The flanks are blacker than the back and there are no series of light spots on its lower edge. The ventral surface is washed with blue-gray.

*Remarks:*— The description of the scutation was taken from an adult male that measured one hundred and fifty-four millimeters from snout to vent; the color notes from a slightly larger individual.

*Habitat:*— Confined to the island of Dominica where it is found commonly just outside of the town of Rouseau, "especially in the hills among the plantings of cocoa trees." (Ruthven, *in litt.*).

*List of specimens examined.*

M. C. Z. No.	No. of specimens	Ages	Sexes	Locality	Date	Collector	Remarks
6087	3	all	♂	Dominica, B. W. I.	1879	S. Garman	Types Descrip.
10571	1	ad.	♂	Dominica, B. W. I.	1914	A. G. Ruthven	Descrip.
U. of Mich. Mus.		ad.	♀	Dominica, B. W. I.	1914	A. G. Ruthven	



## AMEIVA AQUILINA Garman.

*Description*.—Adult male; TYPE M. C. Z. 6088. Grenada, B. W. I.; 1879; S. Garman.

Rostral forming a trifle less than a right angle behind; nostril between the two nasals; anterior pair of nasals broadly in contact behind rostral; frontonasal longer than wide in broad contact with the loreal; prefrontals broadly in contact; frontal in contact with the first two supraoculars, with the second for its entire length; a pair of frontoparietals separated from the third supraocular by one or two rows of granules; five subequal occipitals, the three median ones in a transverse line, the other two beyond these and slightly posterior; seven supraciliaries; four supraoculars, the first separated from the loreal; the three posterior supraoculars separated from the supraciliaries by a single row of granules ending anteriorly in a large granule, last supraocular separated from the outer occipitals by two or three rows of granules; five large supralabials; six infralabials; between infralabial and chin-shields a wedge of one or two rows of granules and scales extending anteriorly half the length of the second chin-shield; chin and throat covered with minute granules, a band of distinctly larger ones extending across the middle, the median scales largest and forming an ill-defined group; on the area between the two throat folds three or four transverse rows of scales all about the same size; under side of the body with fourteen longitudinal and thirty-three transverse rows of plates, the outer very small; preanal plates irregular, placed more or less in a series of transverse rows, a median group of four scales largest; on the lower arm three rows of antibrachials, outer row considerably larger than the two inner which are somewhat irregular, the series extending to the brachials; on the upper arm three rows of brachials the median row slightly the largest; on the posterior side near the elbow joint a small group of postbrachials; under side of thighs covered with four rows distally, with fifteen proximally, outer row just above the knee formed of wider scales; eighteen and nineteen femoral pores; on the under side of the tibia five regular rows of plates, the second and third scale proximally of the outer row largest; upper side of the wrist with a regular series of transverse plates corresponding to the inner and outer metatarsals; outer toe extending a little further than the inner; tail covered with straight, keeled scales; about forty-one scales in the fifteenth ring from the base.

*Coloration*.—Dorsal surface olive-brown more bluish on the sides of the head and appendages; on either side of the body a broad rufous brown band, the edges of which are somewhat undulating, extending part way down the tail; sides of the body with four or five longitudinal rows of pale blue or milky spots; ventral surface straw-

color, washed on the sides with bluish; outer ventrals, edges of the lateral spots often reticulated or marked with black.

*Variation*:—A female (same data as above) differs from the male in being more brightly colored. The dark lateral bands are almost black. On the back between these two bands there is a regular longitudinal series of two rows of dark spots. The dark bands on the sides are bordered by a series of pale spots. The flanks below the bands have each one or two more rows of similar spots. The outer ventrals are heavily marked with brown instead of black. A young male (same data as above) is similar to the adult female except that the region below the dark bands is considerably darker.

*Remarks*:—The description was taken from an adult male that measured one hundred and twenty-two millimeters from snout to vent.

*Habitat*:—Apparently confined to St. Vincent and Grenada, though it is probable that it also occurs in some of the Grenadines. In spite of the mongoose this species which was once almost exterminated seems now to be on the increase,—a peculiar fact due probably to the lizards' change of habits. Dr. Allen noticed this in Grenada and the same thing has been reported in Jamaica as happening with *Ameiva dorsalis*.

*List of specimens examined.*

M. C. Z. No.	No. of specimens	Ages	Sexes	Locality	Date	Collector	Remarks
6088	8	all	both	St. George, Grenada	1879	S. Garman	Descrip. Types
6089	25	all	both	Kingston, St. Vincent	1879	S. Garman	Types
8092-S	7	all	both	Sauteurs, Grenada	1910	G. M. Allen	
6090	2	ad.	both	St. George, Grenada	1886	W. B. Richardson	

AMEIVA TOBAGANA (Cope).

Dr. Stejneger has been kind enough to supplement photographs of the type of this species, with the following excellent description.

“Rostral forming an acute angle behind; nostril between two nasals; anterior pair of nasals broadly in contact behind rostral; frontonasal longer than wide, in contact with nasals, loreal, and prefrontals; prefrontals broadly in contact; frontal pentagonal, in contact with first and second supraoculars, well separated from third; a pair of frontoparietals in contact with second and third supraoculars anteriorly; five occipitals in a transverse row, much longer than wide,

median not larger than adjoining pair; seven superciliaries; four supraoculars, the first in contact with two anterior superciliaries, and separated from the loreal by the first of the latter; three posterior supraoculars separated from the superciliaries by a single row of granules; the last two supraoculars separated from outer occipitals by two rows of small scales or granules; loreal undivided; seven large supralabials, third, fourth, and fifth longest, first in contact with posterior nasal, scarcely with anterior, second in contact with posterior nasal, third with posterior nasal and loreal; center of temples granular, the size of the granules increasing gradually downward and forward; a series of four distinctly enlarged scales from the postocular backwards; mental followed by an unpaired postmental; six large infralabials, third and fourth largest; first pair of chin-shields broadly in contact except at the extreme posterior end; between infralabials and chin-shields an interrupted single series of granules, extending from the second chin-shield backwards, third infralabial in contact with first and second chin-shields, and fourth infralabial in contact with fourth chin-shield; chin and throat covered with granules of varying sizes, the larger ones in the middle in four ill-defined groups, one anteriorly in the angle between the jaws, the second forming a band across the throat at the level of the ears, rather sharply defined posteriorly against the granules behind, the third a median group in front of the first transverse fold, and the fourth a transverse group of about three rows on the mesopthygium, the enlarged scales on the second and third being considerably larger than the others; back, sides, and upper sides of limbs covered with very fine uniform granules, slightly smaller on the sides, and larger on the limbs; under side of body anteriorly with ten, posteriorly with twelve longitudinal and thirty-two transverse rows of square plates; on the preanal region an ill-defined group of about ten somewhat enlarged scales of varying size and shape; on the lower arm a series of wide plates (antebrachials) decreasing rapidly in size, and replaced by large granules or small hexagonal scales before reaching elbow joint; on the upper arm two distinct rows of similar but narrower scales, surrounded by somewhat slightly smaller scales, gradually decreasing in size, widely separated from the antebrachial series; on the under side near the elbow a group of slightly enlarged hexagonal postbrachials; seventeen femoral pores on the right side, eighteen on the left; under side of thighs covered with about five series of somewhat enlarged hexagonal plates, only the outer series being regular and somewhat larger than the others; on the under side of tibia four rows of enlarged hexagonal plates, those of the outer series very much larger than the others; upper side of wrist with four regular series of transverse plates corresponding to the metatarsals; first (inner) toe extending very slightly beyond the fifth (outer), fourth toe extending beyond the third for a distance much

longer than the third toe with claws; <sup>1</sup> tail covered with keeled scales in rings, scales being straight and the keels nearly parallel with the sides of the scales; about forty-three scales in the fifteenth ring from the base."

#### DIMENSIONS.

	mm.
Total length.....	288
Snout to vent.....	95
Tail.....	193
Snout to ear.....	23
Width of head.....	15
Fore leg from axilla.....	35
Hind leg from groin.....	76
Outer toe without claw.....	9
Inner toe without claw.....	5

*Description*:—TYPE U. S. N. M. 10113. Tobago, West Indies; F. A. Ober.

#### AMEIVA ATRIGULARIS Garman.

*Description*:—Adult male; TYPE M. C. Z. 6080. Trinidad, B. W. I.; 1879; C. S. Cazabon.

Rostral forming about a right angle behind; nostril between the two nasals; anterior pair of nasals in broad contact behind rostral; fronto-nasal longer than wide in broad contact with the loreal; prefrontals in broad contact; frontal in contact with the first two supraoculars, with the second for its entire length; a pair of frontoparietals separated posteriorly by one or two rows of granules from the third supraocular; five subequal occipitals, the two adjacent to the median slightly larger than the others; four supraoculars, the first separated from the loreal; three posterior supraoculars separated from the supraciliaries by a single row of granules ending anteriorly in a large granule; last supraocular separated from the outer occipitals by two or three rows of granules; five and six large supralabials; six infralabials; between infralabials and chin-shields a wedge of one or two rows of granules extending anteriorly half the length of the second chin-shield; chin and throat covered with small granules, a broad group in the median posterior region formed of large scales but varying gradually into the others; on the area between the two throat folds three or four rows

<sup>1</sup> In *exul* fourth toe extends beyond third not more than length of third toe without claw.

of scales, median largest; under side of the body with twelve longitudinal and thirty-three transverse rows of plates, the scales of the outer row much smaller than the others; preanal plate in a triangle of three large scales, with a smaller scale at each of the basal angles, and another at the base of the median suture; on the lower arm three rows of antibrachials, the outer row widest, the two inner somewhat irregularly arranged, the series extending to the brachials; on the upper arm three rows of brachials all about the same size; on the posterior side near the elbow joint a group of small postbrachials; under side of the thighs covered distally with four, proximally with twelve rows of scales; sixteen and seventeen femoral pores; on the under side of the tibia three, or partly four rows of plates, outer widest; upper side of the wrist with regular series of plates, longitudinally arranged; outer toe extending not so far as the inner; tail covered with straight, keeled scales; about fifty scales in the fifteenth ring from the base.

*Coloration*:—Dorsal surface pale olive-brown, slightly more reddish on head; upper and lateral surface of the body, legs, and tail finely speckled with black, the spots confluent posteriorly into reticulations; flanks with six or seven longitudinal rows of white spots encircled often with black, the lower three rows on the outer ventrals; sides of the tail spotted irregularly with black and white; chin and gular region, part of the sides of head and arms black; ventral surface straw-color encroached upon by the spotting of the sides and the dark wash of the throat.

*Variation*:—An adult female (same data as above) differs from the male in that the dark confluent spots are much less numerous. The general tonality is pale, and the lateral spots are not sharply defined. A young male (same data as above) differs considerably from the adult. Although having the same general ground tone there are no black specklings. On each side there is a broad black stripe, studded with a few white spots. The outer ventrals have two rows of black spots on either side. There is no black on the chin, throat, or sides of the head.

*Remarks*:—The description was made of an adult male that measured one hundred and fifty-five millimeters from snout to vent.

We have examined only the types of this species, M. C. Z. 6079 and 6080. There are fifteen specimens in this series, young and old of both sexes.

*Habitat*:—Apparently confined to the island of Trinidad.

## AMEIVA AMEIVA AMEIVA (Linné).

*Scps surinamensis* Laurenti, Syn. Rept., 1768, p. 59.

*Ameiva surinamensis* Boulenger, Cat. lizards, Brit. mus., 1885, 2, p. 352.

*Description*:—Adult male; M. C. Z. 6077. Paramaribo, Dutch Guiana, (Surinam); 1886; Wm. B. Richardson.

Rostral forming a trifle less than a right angle behind; nostril between the two nasals; anterior pair of nasals broadly in contact; frontonasal a trifle longer than wide, in contact with the loreal; prefrontals broadly in contact; frontal in contact with the first two supraoculars except for an abnormal granule lying on the suture; two pairs of frontoparietals, posterior smaller, both except for the anterior part of the first pair separated from the third and fourth supraocular by one to three rows of granules; five occipitals in a transverse row, the median one smaller and slightly anterior to the others; six supraciliaries; four supraoculars the first separated from the loreal; three posterior supraoculars separated from the supraciliaries by a single row of granules; last supraocular, part of the next to last separated from the outer occipitals by three or four rows of granules; seven large supralabials; five large infralabials; between infralabials and chin-shields a wedge of a single row of granules extending anteriorly to the middle of the second chin-shield; chin and throat covered with granules, an ill-defined band of larger ones extending across the throat of which a broad group in the median posterior region is composed of the largest granules; on the area between the two throat folds four or five irregular rows of scales, the median two rows widest; under side of the body with twelve longitudinal and thirty-three transverse rows of scales, the two outer scales on each side of the transverse rows much the smallest; preanal plates in a triangle of three large scales with another smaller scale at each of the basal angles; on the lower arm, two, or part three, rows of antebrachials, the outer widest; on the upper arm a single (partly double) row of very large brachials continuous with the antebrachials; on the posterior side near the elbow a group of small postbrachials; under side of thighs covered distally with four, proximally with twelve rows of scales; twenty-one femoral pores; on the under side of the tibia three, part four rows of plates, outer widest; upper side of the wrist covered with scales forming a regular series of longitudinal rows; inner and outer toe extending approximately the same; tail covered with straight, keeled scales; about forty-one scales in the fifteenth ring from the base.

*Coloration*:—Dorsal surface pale olive-brown tinged with green; head and neck, upper part of arms heavily spotted with black, the

spots confluent and forming irregular bars and triangles; sides of body with a series of whitish spots arranged in vertical rows, each spot surrounded with black; these black areas somewhat confluent into vertical rows; on each flank the trace of a white stripe running from the thighs only part way the length of the abdomen; two blackish stripes on each side of the tail; ground color of ventral surface straw-color tinged with bluish; gular and chin region sprinkled with black, outer ventrals heavily spotted with the same color.

*Variation:*—This species and its several races vary considerably in both scutation and coloration. As mentioned (p. 462) the rows are not sharply defined; the characters blend one into another. The sexual differences are not very constant. In general a female is browner and has not as many confluent black spots on its upper surface. None of the variations of scutation seem to be sexual. A young female (same data as above) falls within the scutation variations but its coloration is rather distinctive. On each side of the body there is a wide black stripe margined with white, running from the eye half way down the tail. No black spots are to be seen on the upper surface of the body or head, but a few dark mottlings are found below the black stripes. The under surface is pale blue varying to straw-color; there are no black spots on the gulars.

*Remarks:*—The description was made of an adult male measuring one hundred and eighteen millimeters from snout to vent. Old males often grow much larger than this specimen.

*Habitat:*—Widely distributed over the northeastern part of South America from the Demerara River in British Guiana as far south as Bahia, Brazil, inland along the Amazon to as far west as the Madeira River.

*List of specimens examined.*

M.C.Z. No.	No. of specimens	Ages	Sexes	Locality	Date	Collector	Remarks
6077	2	ad. & yg.	both	Paramaribo, Dutch Guiana	1886	W. B. Richardson	Topotype Descrip.
1169	2	ad. & h. g.	both	Para, Brazil	1862	J. C. Fletcher	
5533	1	ad.	♀	Para, Brazil			Bought 1886
5536	1	yg.	♂	Para, Brazil			Bought 1886
5531	2	ad.	♂	Para, Brazil			Bought 1886
1014	2	h. g. & yg.	♂	Para, Brazil	1859	C. Cooke	
2174	1	ad.	♂	Mana, F. Guiana			Bought
2 ?	1	ad.	♂	Para, Brazil		Wm. Knight	

M.C.Z. No.	No. of specimens	Ages	Sexes	Locality	Date	Collector
3361	1	h. g.	♀	Santarem, Brazil	1865, 6	L. Agassiz
2608	4	ad.	both	San Gonçalla, Brazil	1865, 6	L. Agassiz
2781	1	ad.	♂	Santarem, Brazil	1865, 6	L. Agassiz
3395	1	ad.	♂	Brazil	1865, 6	L. Agassiz
1158	1	ad.	♂	Villa Bella, Brazil	1865, 6	L. Agassiz
2624	1	ad.	♂	Silva Lake, Brazil	1865, 6	L. Agassiz
2632	1	ad.	♂	Maués, Rio Ma-deira, Brazil	1865, 6	L. Agassiz
2907	2	ad.	♂	Rio Puty, Brazil	1865, 6	L. Agassiz
2888	1	ad.	♂	Para, Brazil	1865, 6	L. Agassiz
3308	1	ad.	♀	?	1865, 6	L. Agassiz
2813	1	ad.	♂	Santarem, Brazil	1865, 6	L. Agassiz
3314	1	ad.	♀	Santarem, Brazil	1865, 6	L. Agassiz
3311	2	ad.	both	Tajapurú, Brazil	1865, 6	L. Agassiz
U. of M.						
43961	1	ad.	♂	Tumatumari, British Guiana	1912	E. B. Williamson

AMEIVA AMEIVA BILINEATA, subsp. nov.

*Description*.— Adult male; TYPE Mus. of Zoöl., Univ. Mich. 46142. Dunoon, Demerara River, British Guiana; August 24, 1914; A. G. Ruthven.

Similar to *Ameiva a. ameiva* in scutation but between *A. a. petersii* and *A. a. melanocephala* in coloration; ground color of dorsal surface dark olive-blue; a few indistinct black blotches on the head forming on the body two parallel rows from the shoulders to the thighs; on each side of the body a broad stripe of dark brown, the lower margin of which is indistinct because of the dark flanks; a series of white spots more or less regularly arranged in ventral rows covering the sides of the body and the outer ventrals; similar but bluish spots covering the sides of the thighs; under surface pale blue of a low intensity; throat sprinkled with a few black spots extending partly over the sides of the head.

*Variation*.— Females, for example U. of M. 46150 (same data as above), are readily distinguishable from the males by their browner tonality, by a distinct lateral band of dark brown and by the absence of white spots on the lower flanks. Instead of the spots there is a series of indistinct milky bars somewhat confluent especially just below the broad lateral band where they form a white margin for a part of its length. About the anal region and on the femoral pores there is a delicate salmon blush, a distinctive character in two of the three females examined.



*Remarks*:— The description was made of an adult male that measured one hundred and six millimeters from snout to vent.

We have examined five specimens, adults, of both sexes, from the University of Michigan No. 46137, 46140, 46141, 46141, 46142 and 46150. These were all taken August, 1904, at Dunoon, Demerara River, by Dr. A. G. Ruthven and his assistant Mr. Frederick Gaige. Thanks to Dr. Ruthven's generosity the Museum of Comparative Zoology has been able to retain one of the paratypes mentioned above.

*Habitat*:— Apparently confined to the region between the Demerara and Orinoco Rivers.

*AMEIVA AMEIVA MELANOCEPHALA*, subsp. nov.

*Description*:— Adult female; TYPE M. C. Z. 9993. Cumanacoa, Venezuela; 1896; W. H. Phelps.

Similar to *Ameiva a. ameiva* in scutellation except for the median gulars which are larger in this race and form a distinct group; unlike any of the other races of *Ameiva ameiva*, the throat, under side of neck and upper part of chest, of this form, are smoky; dorsal surface dark brown; numerous confluent black spots on the upper surface and extending down over the outer ventrals; an indistinct stripe on each flank margined by two light ones; ventral surface straw-color posteriorly, smoky anteriorly; legs and tail spotted with smoky blue.

*Variation*:— Three males from La Guayra, Venezuela, although having the characteristic smoky throat differ in other ways from this female in coloration. For example one specimen, U. S. N. M., 27788, is olive-gray above. There are no dark confluent spots nor any lateral stripes, but on each flank a series of pale blue spots, surrounded by dark circles. These spots are arranged somewhat irregularly in vertical rows. On the ventral side the smoky wash of the throat extends down over the abdomen. A young specimen M. C. Z. 9994 (same data as female described) has the broad lateral stripe of dark brown bordered with white. There is a faint smoky wash over the throat, and the lateral white spots are very faint. Only a few dark spots appear on the back.

*Remarks*:— The description was made of an adult female measuring one hundred and thirty-five millimeters from snout to vent.

We have examined three specimens from Cumanacoa, M. C. Z. 9993-5, adults and young. By the kindness of Dr. L. Stejneger we were able to compare with them three adult males, U. S. N. M., 22526, 27787 and 27788, from La Guayra, Venezuela, collected by

W. Robinson, and recorded by Dr. Stejneger in Proc. U. S. N. M., 1902, 24, p. 183.

*Habitat*:— Probably widely distributed throughout Venezuela.

AMEIVA AMEIVA PETERSII (Cope).

*Ameiva pleurotaenia* Peters, Monats. Berl. acad., 1871, p. 398, 652.

*Description*:— Adult male; M. C. Z., 3023. Teffé, Brazil; 1865; L. Agassiz.

Similar to *Ameiva a. ameiva* from which it may be distinguished by the following characters:— Gulars forming a distinct group of considerably enlarged scales in the middle of a band of others slightly enlarged; three rows of brachials instead of two, the scales of which are larger than those of *Ameiva ameiva*; dorsal surface pale-olive tinged with bluish; upper and lateral surfaces of the body sprinkled with black, the spots unlike *Ameiva ameiva*, not being confluent; under part of neck and chin similarly spotted; on each flank a series of whitish spots in vertical rows, the spots more or less surrounded with black; below the series of white spots and on the outer ventrals numerous irregular black blotches; on each side of the body a trace of two broad lateral bands of brown.

*Variation*:— A female (same data as above) differs from the male in that the dark spots on the back and head are nearly absent. The lateral dark stripes are more distinct than those of the male. On the lower border of these stripes there is on each side a narrow white line bordered with black extending the length of the body. A young male M. C. Z. 3432 (same data as above) is indistinguishable from the young of *Ameiva ameiva* in color except that the general tonality is darker.

*Remarks*:— The description was made of an adult male that measured one hundred and sixty-two millimeters from snout to vent.

*Habitat*:— Found along the upper Amazon, probably from the Madeira River westward.

*List of specimens examined.*

M.C.Z. No.	No. of specimens	Ages	Sexes	Locality	Date	Collector	Remarks
3023	4	ad.	both	Teffé, Brazil	1865	L. Agassiz	Descrip.
3432	1	yg.	♂	Teffé, Brazil	1865	L. Agassiz	
3430	2	ad.	both	Teffé, Brazil	1865	L. Agassiz	
3434	1	ad.	♂	Teffé, Brazil	1865	L. Agassiz	
3348	1	ad.	♂	Teffé, Brazil	1865	L. Agassiz	
3306	3	ad.	both	Manaos, Brazil	1865	L. Agassiz	

## AMEIVA AMEIVA MACULATA (Fischer).

*Description*:— Adult female; Mus. of Zoöl., Univ. Mich. 45299. La Tigrera, Santa Marta Mts., Colombia; August 4, 1913; A. G. Ruthven.

Closely related to *Ameiva a. ameiva* from which it may be readily distinguished by the following characters:— a single pair of fronto-parietals larger than the occipitals which are regular; median occipital as large as the others; preanals granular and numerous, not arranged in a group of some sort as found in *Ameiva a. ameiva*; four rows of brachials covering the entire upper surface of the arm and gradually varying into the granules of the same; shields of the under side of the thighs smaller, more uniform in size than those of *Ameiva a. ameiva*; five rows of these tibial shields distally, fifteen proximally; shields of the under side of thighs also smaller and more uniform in size than those of *Ameiva a. ameiva*; these shields in four rows.

*Coloration*:— Dorsal surface olive-gray washed with blue-gray on the sides of body and outer ventrals; a series of white spots regularly arranged in vertical rows covering the flanks; these white spots indistinctly surrounded by black which is somewhat confluent forming vertical bars; in the median region running the length of the back, two rows of faintly indicated black spots; ventral surface whitish, sprinkled with blue-gray on the gulars; outer ventral shields spotted with white and dark blue-gray.

*Variation*:— A young male (Mus. of Zool., U. of M. 45303, from Aguadulce, Santa Marta Mts., collected July 11, 1913, by A. G. Ruthven) is similar to the adult in scutation except that the brachials are not so uniformly small. In coloration it differs from the adult by being generally darker. The white lateral spots are less numerous, the median row of lateral white spots is confluent to form a stripe on each side. The ground tone of the flanks is dark gray instead of light blue-gray. The throat, outer ventrals, and some of the median ones spotted with blue-gray of low intensity.

*Remarks*:— The description was made of an adult female that measured one hundred and fifteen millimeters from snout to vent.

*Habitat*:— We have only seen specimens from the Santa Marta Mts., Colombia, but this species may occur elsewhere and probably does.

## AMEIVA AMEIVA LAETA Cope.

*Description*:— Adult female; TYPE M. C. Z. 10537. Rio Janeiro, Brazil; 1866; by L. Agassiz.

Related to *A. a. ameiva* but readily distinguished from it by its large dorsal granules, at least three or four times larger than those of *Ameiva a. ameiva*; the scales of the throat and neck also somewhat larger; instead of forming a median group of enlarged scales, the gulars are arranged in a distinct band across the throat, the scales of which, largest in the mid-region, rapidly diminish in size anteriorly.

*Coloration*:—Pattern more like *A. a. petersii* than *A. a. ameiva*. General tonality green; a sprinkling of a few dark spots dorsally; on each side a trace of a broad dark band, the upper and lower margins darkest; in the lower dark margin a very sharp and characteristic white line running the length of the body; in the upper margin of the dark band a faint white line; flanks and outer ventrals faintly spotted with dark brown, the latter edged with white.

*Variation*:—An adult male, M. C. Z. 4250 (Goyaz, Brazil, collected 1867 by Senor Honario) is similar to the female except that the upper white line is absent. On each flank there is a series of white spots somewhat irregularly arranged in vertical rows.

*Remarks*:—The description was made of an adult female that measured one hundred and twenty-five millimeters from snout to vent.

*Habitat*:—Southern Brazil as far north as Minas Geraes, and as far west at least as Goyaz.

*List of specimens examined.*

M. C. Z. No.	No. of specimens	Ages	Sexes	Locality	Date	Collector	Remarks
10536-7	2	ad.	♀	Rio Janeiro, Brazil	1866	L. Agassiz	Types. Descrip.
4250	3	ad.	both	Goyaz, Brazil	1867	S. Honario	Descrip.
1367	1	ad.	♀	Rio Janeiro, Brazil	1866	L. Agassiz	
3028	2	ad.	both	Minas Geraes, Brazil	1865	L. Agassiz	

AMEIVA AMEIVA PRAESIGNIS (Baird and Girard).

*Description*:—Adult male; M. C. Z. 9926. Panama (near city); 1904; W. W. Brown, Jr.

Related to *Ameiva a. ameiva* from which it differs considerably in coloration and slightly in scutation. Unlike any of the other races of *Ameiva a. ameiva*, the ground tone of the dorsal surface is pale yellow-brown of a low intensity becoming darker posteriorly. On each flank there is a series of pale straw-color spots arranged in vertical rows. The characteristic feature of this coloration is that each granule is entirely of one color, the effect being a "pepper and salt" mixture.

A narrow stripe of dark straw-color runs the length of the back in the median line. The upper surfaces, sides of tail and appendages are profusely spotted with straw-color varying to bluish. The ventral surface is pale straw-color varying to bluish on the outer ventral. Part of the thighs is spotted with whitish or bluish. In regard to scutation the only real difference from *Ameiva a. ameiva* is in that the brachials are considerably larger and break up proximally into three or four rows of scales. In other specimens these brachial shields are partly fused to form a single series of very wide and short scales.

*Variation*:—Females may be readily distinguished from the males by their color. For example, M. C. Z. 9924 (same data as above) has no series of lateral spots but instead on each side of the body are two narrow pale straw colored lines bordered narrowly above and below with black. Except for a series of dark blotches on the back, tail, and legs, the dark brown of the posterior part of the body in the male is absent. A young female (M. C. Z. 9938) has not the "pepper and salt" coloration of the adults but instead is olive-brown blotched and dappled with dark brown. On each side is a broad dark brown band edged with white. The blotching on the back and sides form two parallel rows above and below these lateral stripes.

*Remarks*:—The description was made of an adult male that measured one hundred and eighty-four millimeters from snout to vent.

*Habitat*:—If the locality Acapulco is correct it is distributed from southern Mexico as far south as Panama where it is very common on the savannah near the city of Panama itself.

*List of specimens examined.*

M.C.Z. No.	No of specimens	Ages	Sexes	Locality	Date	Collector	Remarks
9924-41	18	all	both	Panama (near city of Panama)	1904	W.W.Brown, Jr.	Descrip.
9942-47	6	all	both	San Miguel Island Panama Bay	1904	W.W.Brown, Jr.	
2727	2	ad.	both	Panama	1872	L. Agassiz	
2728 & 30	2	h.gr.	both	Acapulco, Mex.	1872	L. Agassiz	
7290	1	yg.	♂	Panama	1908	T. Barbour	
3977	3	ad.	both	San Pablo, Panama	1866	A. Lesley.	

*AMEIVA BIFRONTATA BIFRONTATA* Cope.

*Description*:—Adult male; TYPE M. C. Z. 10770. Labeled St. Thomas, D. W. I., but doubtless from Venezuela.

Rostral forming an acute angle behind; nostril between the two nasals; anterior pair of nasals just in contact behind rostral; fronto-nasal a trifle longer than wide, in contact with the loreal; prefrontals broadly in contact; frontal divided transversally in the mid-region, entirely separated from the supraoculars by a single row of granules; a pair of frontoparietals separated from the third supraocular, and part of the fourth by a double row of granules; five occipitals in a transverse row, the outer two slightly posterior to the others, the median scale slightly smaller than the rest; six supraciliaries; four supraoculars, the posterior one very much smaller than the others, the first separated from the loreal; the three posterior supraoculars separated from the supraciliaries by a double row of granules; last two supraoculars separated from the outer occipitals by four or five rows of granules; five and six supralabials; five and six large infralabials; between infralabials and chin-shields a wedge of a single row of granules extending anteriorly to the first chin-shield; chin and throat, except near the folds covered with small scales, the median posterior ones largest but varying gradually into the others; on the area between the two throat folds four or five irregular rows of scales; under side of the body with ten longitudinal and thirty-four transverse rows of plates, the two outer longitudinal rows formed of narrower and rounded plates; preanal plates in a triangle of three large ones cut into in the middle of its base by a small scale, and completed at the basal angles by two larger scales; on the lower arm a double row of antibrachials, the outer widest; on the upper arm a single row partly double, of very large brachials which are continuous with the antibrachials; on the posterior side near the elbow a single row of postbrachials; under side of the thighs covered distally with three and proximally with nine or ten rows of scales; sixteen femoral pores; on the under side of the tibia three rows of plates, outer widest; upper side of the wrist covered with scales forming a regular series of longitudinal rows; inner and outer toe extending approximately the same distance; tail covered with straight, keeled scales; about forty-nine scales in the fifteenth ring from the base.

*Coloration:*— In the badly faded specimen before us, the upper surface is uniform blue-gray, the under surface milky, the outer ventrals spotted with pure white. But according to the original description (Cope, Proc. Acad. nat. sci. Phila., 1862, p. 67) the color was "above brownish pea-green, tail paler; in young specimen traces of two lateral and one median pale line, sometimes visibly posterior in adults. Occasionally a few brown spots on the rump. External belly plates varied with blue and white. Inferior surfaces yellow."

*Remarks:*— The description was made of an adult male that measured one hundred and twelve millimeters from snout to vent.

The specimen described is one of the types received in exchange from the Philadelphia Academy. Ruthven (Occ. papers, Mus. zool. University Mich., December 27, 1913, no. 2), has discussed the locality data of the types and concludes, "It is highly probable that *Ameiva bifrontata* does not occur on St. Thomas but is a Venezuelan form that is represented in Colombia by *Ameiva divisa* (Fischer)." We may emphasize what Ruthven has said viz., that this lizard certainly does not occur upon St. Thomas, this is proved by the recent carefully made collections. There is no reason to believe that it ever did. It is found in Venezuela, and is probably confined to that state.

*Habitat*:—Venezuela.

#### *AMEIVA BIFRONTATA DIVISA* (Fischer).

*Description*:—Adult male; M. C. Z. 10573; near La Tigrera, Santa Marta Mts., Colombia; 1913; A. G. Ruthven.

This race differs from typical *bifrontata* only slightly in scutation but decidedly in coloration. As Ruthven (Occ. papers, Mus. zool. University Mich., December 27, 1913, no. 2), has pointed out the Colombian race differs from the Venezuelan form in having the series of granules on the inner margin of the supraoculars ending on the posterior corner of the second instead of having the "three posterior supraoculars surrounded with granular scales." This seems to be the only real difference in their scutation.

*Coloration*:—Dorsal surface olive-gray tinged with bluish; on each side a broad stripe of dark olive-gray bordered above and below by narrow, pale bluish lines; several dark olive-gray spots on the back; head, thighs, and tail tinged with brown dorsally; the head varying to a fleshy color on the sides; dorsal surface of thighs and tail faintly reticulated with black, and spotted with pale olive-gray; ventral surface milky varying to pale blue on the sides; the outer ventrals spotted with pale turquoise-blue.

*Remarks*:—The description was made of an adult male that measured one hundred and twenty-eight millimeters from snout to vent.

*Habitat*:—Three adult males from the Santa Marta Mts. were examined, but this race is probable widely spread over the north of Colombia.

#### *AMEIVA RUTHVENI*, sp. nov.

*Description*:—Adult male; TYPE M. C. Z. 9931. Panama (near city); 1904; W. W. Brown, Jr.

Rostral forming a trifle more than a right angle behind; nostril between the two nasals; anterior pair of nasals moderately in contact behind rostral; frontonasal longer than wide in contact with the loreal; prefrontals also moderately in contact; frontal in contact with only the first two supraoculars; a pair of frontoparietals separated, except anteriorly, from the third supraocular by one or two rows of granules; three large occipitals in a transverse row, with a pair of intercalated scales between the outer pair and the frontoparietals; five and six supraoculars, the third very long; three supraoculars the first in contact with the two anterior supraciliaries, separated from the loreal; two posterior supraoculars separated from the supraciliaries by a single, partly double row of granules; last supraoculars separated from the outer occipitals by two, partly three rows of granules; six and seven supralabials; five and six large infralabials; between infralabials and chin-shields a wedge of two rows of scales, extending anteriorly as far as the middle of the second chin-shield. Chin and throat covered with granules, a band of larger ones extending across the middle, a group of ten or a dozen very large ones in the mid-region of which no one scale is much larger than another; on the area between the two throat folds a single row of large scales; under side of the body with eight longitudinal and twenty-eight transverse rows of plates; preanal plates in a median longitudinally arranged pair and a marginal transverse pair, the former larger. On the lower arm one row of very large antibrachials becoming double proximally; on the upper arm one row of very large brachials continuous with the antibrachials; on the posterior side a group of small postbrachials; under side of the thighs covered distally with three rows of very large plates resolving proximally into six or eight rows; twenty-four and twenty-five femoral pores; on the under side of the tibia two, part three rows of very large shields; upper side of the wrist covered with three large scales and several smaller ones; inner and outer toe reaching approximately the same point; tail covered with keeled scales, the keels parallel with the longitudinal axis but the scales oblique; each whorl of caudal scales raised strongly on the sides, giving the tail a peculiar flattened appearance; about twenty-two scales in the fifteenth ring from the base.

*Coloration:* — Dorsal surface dark olive-brown, on each side, covering nearly the entire surface of the flanks a series of large vertical bars of black; these spots somewhat confluent, with the between spaces gray instead of brown like the back; indistinct mottlings of gray on the upper surfaces of the legs; ventral surface milky tinged with straw-color; outer ventrals, under surfaces of the legs reticulated with blue-gray.

*Variation:* — A half grown male M. C. Z. 9932 is not so distinctly marked as the adult, but the general pattern is the same.



*Remarks:*—The description was made of an adult male that measured one hundred and thirty-one millimeters from snout to vent.

*Habitat:*—Only known from near the city of Panama where it is found with *Ameiva a. praesignis* in the savannah of Panama.

#### *AMEIVA FESTIVA* (Lichtenstein).

*Description:*—Adult male; M. C. Z. 2723. Turbo, Isthmus of Darien; 1871; G. A. Maack.

Related to *Ameiva ruthveni* from which it may be distinguished by the following characters:—frononasal separated from the loreal by the posterior nasal; last supraocular separated from the outer occipitals by four or five rows of granules; no distinct band of enlarged gulars extending across the throat but all diminishing in size from the centre where there is a group of six or eight very large scales, one being four or five times larger than any of the other scales; preanal plates in a triangular group of three large rotund plates, anterior largest; postbrachials in a single row of very large scales; nineteen and twenty femoral pores; tibial shields in only two rows of very large plates, those of the outer largest; upper side of the wrist covered with six or eight subequal scales; the whorls of caudal scales not raised laterally so strongly as those of *Ameiva ruthveni*.

*Coloration:*—Although somewhat faded, the coloration seems to be distinctly different from that of *A. ruthveni*; dorsal surface olive-brown, two irregular black bands running the length of the flanks, the lower border of these bands strongly notched; a narrow somewhat broken band of olive-gray running down the middle of each of these bands; ventral surface blue-gray tinged with yellowish; two or three longitudinal series of dark brown spots on the ventrals; the outer spots very irregular and attenuated; shields of the under side of thighs bordered partly or wholly with dark blue-gray.

*Variation:*—The series of eight adult males from several localities show a considerable degree of variation in coloration. One specimen, M. C. Z. 9581 (from Honduras, collected in 1907 by E. C. Post) has a very wide stripe of olive down the middle of the back, making the lateral bands proportionally narrower than those of the specimen described. In another specimen M. C. Z. 9568 from Nicaragua the same general pattern as the typical one is present but the tonality is much darker, the ground color being a very dark olive-blue. The dark lateral stripes are not at all olivaceous. There are two, instead of one, bright bluish gray stripes on each side.

*Remarks:*—The description was made of an adult male that measured one hundred and eight millimeters from snout to vent.

*Habitat:*—Widely distributed throughout Central America from the Isthmus of Darien to southern Mexico.

*List of specimens examined.*

M.C.Z. No.	No. of specimens	Ages	Sexes	Locality	Date	Collector	Remarks
2723	2	ad.	♂	Turbo, Isth. Darien	1871	G. A. Maack	Descrip.
9585	1	ad.	♂	Matagalpa, Nicaragua	1910	W. B. Richardson	
9568	1	ad.	♂	Matagalpa, Nicaragua	1910	W. B. Richardson	
10773	1	ad.	♂	Matagalpa, Nicaragua	1910	W. B. Richardson	
10774	1	ad.	♂	Matagalpa, Nicaragua	1910	W. B. Richardson	
9580	1	ad.	♂	Honduras	1907	E. C. Post	
9581	1	ad.	♂	Honduras	1907	E. C. Post	

AMEIVA UNDULATA UNDULATA (Wiegmann).

*Description:*—Adult male; M. C. Z. 7473. Colima, Mexico; Barbour collection.

Rostral forming a trifle more than a right angle behind; nostril between the two nasals; anterior pair of nasals in broad contact behind rostral; frontonasal longer than wide, separated from the loreal by the posterior nasal; prefrontals fairly in contact with the first two supraoculars; a pair of frontoparietals in contact with the first two supraoculars; a pair of frontoparietals in contact with the third supraocular for nearly its entire length; three subequal occipitals in a transverse row; five and six supraciliaries, the second from the anterior end very much larger than the others; three supraoculars, the first in contact with the two anterior supraciliaries and loreal; two posterior supraoculars separated from the supraciliaries by a single row of granules; last supraocular separated from the outer occipitals by two or three small scales; six and seven supralabials; five and six large infralabials; between infralabials and chin-shields a wedge of one or two rows of small scales extending anteriorly to the first chin-shield; chin and throat covered with large granules becoming larger towards the centre, a longitudinal row of four larger ones in the mid-region; on the area between the two throat folds two or three rows of

scales, the median row largest, the scales differing in size from those in the middle; under side of the body with eight longitudinal and twenty-eight transverse rows of plates; preanal scales irregular, a marginal pair and two or three anterior scales the largest; on the lower arm a double row of wide antibrachials, outer row the widest; on the upper arm a single row of large brachials continuous with the antibrachials; on the posterior side a single row of large postbrachials; under side of the thighs covered distally with three, proximally with six or eight rows of scales; seventeen and nineteen femoral pores; on the under side of the tibia three rows of shields; upper side of the wrist covered with scales forming a series of longitudinal rows of two or three scales each; inner and outer toe extending to approximately the same distance; tail covered with keeled scales in rings, the scale and the keel being straight or slightly oblique on the sides; about twenty-two scales in the fifteenth ring from the base.

*Coloration*:—Dorsal surface dark olive-blue; on each side of the body a series of indistinct vertical stripes of black, somewhat confluent ventrally and spotted with indistinct blue blotches; ground tone of ventral surface steel-blue washed with straw-color about the anal region and on the under surfaces of legs.

*Remarks*:—The description was made of an adult male, the only specimen examined, that measured seventy-four millimeters from snout to vent.

*Habitat*:—Apparently confined to southern Mexico.

#### *AMEIVA UNdulata QUADRILINEATA* (Hallowell).

*Ameiva pulchra* Hallowell, Proc. Acad. nat. sci. Phila., 1860, p. 483.

*Ameiva gabbiana* Cope, Journ. Acad. nat. sci. Phila., 1876, ser. 2, 8, p. 117, pl. 28, fig. 3.

*Description*:—Adult female; M. C. Z. 9546. Chinandega, Nicaragua; 1910; W. B. Richardson.

Similar to *Ameiva u. undulata* from which it may be distinguished by the following characters:—a pair of frontoparietals nearly separated from the third supraocular by one or two rows of granules; three subequal occipitals, the median divided longitudinally; last supraocular separated from the outer occipitals by two or three rows of granules; chin and throat covered with small granules, an indistinct band of large ones extending across the middle, in the mid-region a group of eight or ten large scales varying into the others; preanal plates irregular, a longitudinal series of three pairs; on the posterior side of the upper

aria two irregular rows of postbranchials; on the under side of the tibia two rows of large plates and a few scales of a third row.

*Coloration*:—Dorsal surface olive-gray; two narrow white bands on each side, the uppermost very indistinct; the dorsal surface between the two upper lines marbled with black; a series of heavy black marblings on each side, the blotches very irregular in shape but evenly spaced; dorsal surface of tail and legs faintly mottled with black; ventral surface milkish or pale blue.

*Variation*:—A male M. C. Z. 9540 (same data as above) differs from the female slightly in coloration. The white lateral lines are absent and the dark mottlings of the flanks are very distinct because the spaces between them are bluish instead of olive-gray. The general tonality of the dorsal surface is brownish instead of blue-gray.

*Remarks*:—The description was made of an adult female that measured seventy-eight millimeters from snout to vent. Only two specimens were examined.

*Habitat*:—Our specimens come from Chinandega, Nicaragua, but this race probably has a wider distribution.

#### AMEIVA UNDULATA PARVA, nov. subsp.

This local race shows relationship to both *A. u. undulata* and *A. undulata quadrilineata* but may be distinguished from both in having a short stocky head, and in having the gular scales except for the median group very small.

*Description*:—Adult male; TYPE, M. C. Z. 5831. Guatemala.

Similar to *A. undulata quadrilineata* but differing in scutation as follows:—throat and neck covered with very fine uniform granules, a median group of a dozen or fifteen large scales varying into the others; postbranchials in three rows, median largest; tibial shields in three rows.

*Coloration*:—Much browner in tonality than *A. undulata quadrilineata*, having also more dark mottlings on the sides and on the back; the spaces between the black blotches brownish, not blue; ventral surface straw-color instead of blue.

*Variation*:—A female (same data as above) has the white lateral lines bordering a dark band on each side. A series of bluish spots arranged at regular intervals extends the length of this band. Several series of similar spots below these bands. A young specimen (same data as above) is similar to the female except that the entire flanks are blackish and that there are no spots present on the sides. The lower white line, however, is somewhat broken into spots.

*Remarks:*—The description was made of an adult male that measured seventy-four millimeters from snout to vent.

*Habitat:*—Apparently confined to Guatemala, and perhaps only found locally; the specimens before us are labeled simply Guatemala.

#### AMEIVA EDRACANTHA Bocourt.

Since it is impossible to examine a specimen of this species we are obliged to use this condensed form of the original description (Bocourt, *Ann. sci. nat.*, 1874, ser. 9, 19, art. 4).

*Description:*—Nostril between the two nasals; frontal proportionally large; frontoparietals united (perhaps abnormally); three occipitals; three supraoculars; six supraciliaries; supralabials and infralabials each five, the infralabials more attenuated and extending further behind; gular scales arranged like those of *A. ameiva*, but larger; on the portion between the two throat folds two or three rows of enlarged scales; under side of body with eight longitudinal rows of scales; a single oval preanal plate surrounded by small scales; on each side of this region six or seven spinose plates; on the upper arm a single row of brachials; under side of thighs covered with three rows of shields; twelve or thirteen femoral pores; on the under side of the tibia two rows of scales; caudal scales keeled.

*Coloration:*—Ground color olive-green, five yellowish longitudinal lines, the median beginning at the occiput and ending before the thighs, the second and third on each side running the length of the bodies, finally those of the flanks are a little less distinct and often broken; back and side with transverse dark brown lines; limbs and tail spotted with the same color; ventral surface yellowish.

#### AMEIVA SEPTEMLINEATA A. Dumeril.

*Description:*—Half grown male; M. C. Z. 8949. Rio Chan Chan, Ecuador; S. N. Rhoads.

Rostral forming about a right angle behind; nostril between the two nasals; anterior pair of nasals broadly in contact; frontonasal separated from the loreal; prefrontals separated by two intercalated scales; frontal formed by three or four scales continuous with the frontoparietals, which are formed of four or five scales in two longitudinal rows separated posteriorly from each other by a wedge of four scales, and separated from the supraoculars by one or two rows of granules; three large occipitals in a transverse row surrounded pos-

teriorly by many small ones; four supraoculars, the second divided longitudinally into three parts, the last two considerably larger than the anterior ones; two posterior supraoculars separated from the supraciliaries by a single row of granules; six large supralabials; five infralabials; between infralabials and chin-shields a wedge of a single row of scales extending anteriorly to the second pair of infralabials; chin and throat covered with minute granules, a band of slightly larger ones extending across the middle; on the area between the two throat folds a single row of very large scales; under side of the body with eight longitudinal rows, outer row much narrower than the others and twenty-six transverse rows of plates; a pair of large pre-anal plates arranged one ahead of the other in the mid-region and surrounded by a series of small scales; on the lower arm a single row of large antebrachials becoming double proximally; on the upper arm a single row of large brachials continuous with the antebrachials; on the posterior side near the elbow joint a single row of large post-brachials; under side of the thighs covered with three rows of large plates breaking up proximally into six or eight rows; fourteen femoral pores; on the under side of the tibia two rows of scales, outer about twice as large as the inner; upper side of the wrist with one or two transverse series of large scales; outer toe extending about as far as the inner; tail covered with straight, keeled scales, dorsally strongly keeled; about seventeen scales in the fifteenth ring from the base.

*Coloration*:— Dorsal surface dark olive-brown; on each side a dark brown or blackish band, bordered above and below by a light stripe, the three stripes running the length of the body from the eye to the middle of the tail; ventral surface pale blue-gray suffused with straw-color.

*Remarks*:— The description was made of a half grown male, the only specimen examined, that measured eighty-six millimeters from snout to vent.

#### AMEIVA BRIDGESII (Cope).

*Description*:— Adult male; M. C. Z. 6988. Gorgona Island, Colombia; 1905; W. W. Brown, Jr.

Rostral forming about a right angle behind; nostril between the two nasals; anterior pair of nasals broadly in contact behind rostral; frontonasal a trifle longer than wide separated from the loreal; pre-frontals keeled, separated by six or seven intercalated, keeled scales forming part of a series which divides the frontal and frontoparietals; frontal formed of about ten irregularly arranged keeled scales; frontoparietal and occipitals formed of numerous irregularly arranged, small keeled scales, the two scales in the median occipital region largest;

two keeled supraoculars preceded by a group of five or six small keeled scales in the place of an anterior supraocular; the two large supraoculars separated from the supraciliaries by a double row of granules; last supraocular separated from the outer occipitals by four or five rows of granules; six or seven large supralabials; five infralabials; between infralabials and chin-shields a wedge of a single row of small scales together with several large scales extending anteriorly to the first chin-shield; chin and throat covered with granules of varying size, a broad band of slightly larger ones extending across the middle; on the area between the two throat folds three or four rows of small scales, the median ones about three times as large as the gulars, all irregularly arranged; under side of the body with six longitudinal and twenty-six transverse rows of scales; three somewhat rounded preanal plates arranged in a triangle, the anterior one much larger than the others; on the lower arm a single row of large antibrachials extending its entire length on the lower arm two or three rows of very small, irregular keeled scales; on the posterior side near the elbow joint two or three rows of postbrachials, median row formed of very large ones; under side of thighs covered with three rows of large scales ending abruptly in granules; twenty-four femoral pores; on the under side of the tibia two rows of scales, the outer about twice as large as the inner; on the upper side of the wrist between phalanges and joint two transverse rows of large scales; outer toe extending a little further than the inner; tail covered with straight keeled scales, dorsally strongly keeled; about nineteen scales in the fifteenth ring from the base.

*Coloration*: — Dorsal surface dark olive-green; on each side a dark brown band, bordered above and below by a light blue-gray stripe, running the length of the body; a pale median line not very distinct running from the occipitals to the tail; ventral surface dark blue-gray suffused with yellow on the abdomen.

*Variation*: — A female (same data as above) is similar to the male except that the pale median stripe is brighter and wider than the other pale lines, a condition which is reversed in the adult male.

*Remarks*:— The description was made of an adult male that measured one hundred and eighteen millimeters from snout to vent.

Cope's type of *Holcosus bridgesii* (Acad. nat. sci. Phila. No. 9651) which we have examined is in fair preservation. It is rather less than half grown. The locality slip which accompanied it bore simply the word "?Ecuador." In the original description (Proc. Acad. nat. sci. Phila., 1868, p. 306-307) curiously enough no mention whatever was made of habitat or locality. An examination of a series of this species and a comparison with *A. septemlineata* and *A. undulata* makes clear the relationship of this form. It does not seem at all advisable to recognize Cope's monotypic genus.





The following Publications of the Museum of Comparative Zoölogy are in preparation:—

LOUIS CABOT. Immature State of the Odonata. Part IV

E. L. MARK. Studies on Lepidosteus. continued.

E. L. MARK. On Arachnactis.

H. L. CLARK. The "Albatross" Hawaiian Echini.

Reports on the Results of Dredging Operations in 1877, 1878, 1879, and 1880, in charge of ALEXANDER AGASSIZ, by the U. S. Coast Survey Steamer "Blake," as follows:—

A. MILNE EDWARDS and E. L. BOUVIER. The Crustacea of the "Blake."

A. E. VERRILL. The Alcyonaria of the "Blake."

Reports on the Results of the Expedition of 1891 of the U. S. Fish Commission Steamer "Albatross," Lieutenant Commander Z. L. TANNER, U. S. N., Commanding, in charge of ALEXANDER AGASSIZ, as follows:—

K. BRANDT. The Sagittae.

K. BRANDT. The Thalassicolae.

O. CARLGREN. The Actinarians.

R. V. CHAMBERLIN. The Annelids.

W. R. COE. The Nemerteans.

REINHARD DOHRN. The Eyes of Deep-Sea Crustacea.

H. J. HANSEN. The Cirripeds.

H. J. HANSEN. The Schizopods.

HAROLD HEATH. Solenogaster.

W. A. HERDMAN. The Ascidians.

S. J. HICKSON. The Antipathids.

E. L. MARK. Branchiocerianthus.

JOHN MURRAY. The Bottom Specimens.

P. SCHIEMENZ. The Pteropods and Heteropods.

THEO. STUDER. The Alcyonarians.

— The Salpidae and Doliolidae.

H. B. WARD. The Sipunculids.

Reports on the Scientific Results of the Expedition to the Tropical Pacific, in charge of ALEXANDER AGASSIZ, on the U. S. Fish Commission Steamer "Albatross," from August, 1899, to March, 1900, Commander Jefferson F. Moser, U. S. N., Commanding, as follows:—

R. V. CHAMBERLIN. The Annelids.

H. L. CLARK. The Holothurians.

H. L. CLARK. The Ophiurans.

— The Volcanic Rocks.

— The Coralliferous Limestones.

S. HENSHAW. The Insects.

G. W. MÜLLER. The Ostracods.

MARY J. RATHBUN. The Crustacea Decapoda.

G. O. SARS. The Copepods.

L. STEJNEGER. The Reptiles.

C. H. TOWNSEND. The Mammals, Birds, and Fishes.

T. W. VAUGHAN. The Corals, Recent and Fossil.

PUBLICATIONS  
OF THE  
MUSEUM OF COMPARATIVE ZOÖLOGY  
AT HARVARD COLLEGE.

---

There have been published of the BULLETIN Vols. I. to LIV. and Vol. LVIII.; of the MEMOIRS, Vols. I. to XXIV., and also Vols. XXVI. to XXIX., XXXI. to XXXIV., XXXVI. to XXXVIII., XL. to XLII., and XLIV.

Vols. LV. to LVII., and LIX. of the BULLETIN, and Vols. XXV., XXX., XXXV., XXXIX., XLIII., XLV. to XLIX. of the MEMOIRS, are now in course of publication.

The BULLETIN and MEMOIRS are devoted to the publication of original work by the Officers of the Museum, of investigations carried on by students and others in the different Laboratories of Natural History, and of work by specialists based upon the Museum Collections and Explorations.

The following publications are in preparation:—

- Reports on the Results of Dredging Operations from 1877 to 1880, in charge of Alexander Agassiz, by the U. S. Coast Survey Steamer "Blake," Lieut. Commander C. D. Sigsbee, U. S. N., and Commander J. R. Bartlett, U. S. N., Commanding.
- Reports on the Results of the Expedition of 1891 of the U. S. Fish Commission Steamer "Albatross," Lieut. Commander Z. L. Tanner, U. S. N., Commanding, in charge of Alexander Agassiz.
- Reports on the Scientific Results of the Expedition to the Tropical Pacific, in charge of Alexander Agassiz, on the U. S. Fish Commission Steamer "Albatross," from August, 1899, to March, 1900, Commander Jefferson F. Moser, U. S. N., Commanding.
- Reports on the Scientific Results of the Expedition to the Eastern Tropical Pacific, in charge of Alexander Agassiz, on the U. S. Fish Commission Steamer "Albatross," from October, 1904, to April, 1905, Lieut. Commander L. M. Garrett, U. S. N., Commanding.
- Contributions from the Zoölogical Laboratory, Professor E. L. Mark, Director.
- Contributions from the Geological Laboratory, Professor R. A. Daly, in charge.

These publications are issued in numbers at irregular intervals. Each number of the Bulletin and of the Memoirs is sold separately. A price list of the publications of the Museum will be sent on application to the Director of the Museum of Comparative Zoölogy, Cambridge, Mass.

Bulletin of the Museum of Comparative Zoölogy  
AT HARVARD COLLEGE  
VOL. LIX. No. 7.

---

TWO NEW GENERA OF MYRMICINE ANTS FROM  
BRAZIL.

BY WILLIAM MORTON WHEELER.

---

CAMBRIDGE, MASS., U. S. A.:  
PRINTED FOR THE MUSEUM.  
NOVEMBER, 1915.

REPORTS ON THE SCIENTIFIC RESULTS OF THE EXPEDITION TO THE EASTERN TROPICAL PACIFIC, IN CHARGE OF ALEXANDER AGASSIZ, BY THE U. S. FISH COMMISSION STEAMER "ALBATROSS," FROM OCTOBER, 1904, TO MARCH, 1905, LIEUTENANT COMMANDER L. M. GARRETT, U. S. N., COMMANDING, PUBLISHED OR IN PREPARATION:—

- A. AGASSIZ. V.<sup>5</sup> General Report on the Expedition.
- A. AGASSIZ. I.<sup>1</sup> Three Letters to Geo. M. Bowers, U. S. Fish Com.
- A. AGASSIZ and H. L. CLARK. The Echini.
- H. B. BIGELOW. XVI.<sup>16</sup> The Medusae.
- H. B. BIGELOW. XXIII.<sup>23</sup> The Siphonophores.
- H. B. BIGELOW. XXVI.<sup>26</sup> The Ctenophores.
- R. P. BIGELOW. The Stomatopods.
- O. CARLGREN. The Actinaria.
- R. V. CHAMBERLIN. The Annelids.
- H. L. CLARK. The Holothurians.
- H. L. CLARK. The Starfishes.
- H. L. CLARK. The Ophiurans.
- S. F. CLARKE. VIII.<sup>8</sup> The Hydroids.
- W. R. COE. The Nemerteans.
- L. J. COLE. XIX.<sup>19</sup> The Pycnogonida.
- W. H. DALL. XIV.<sup>14</sup> The Mollusks.
- C. R. EASTMAN. VII.<sup>7</sup> The Sharks' Teeth.
- S. GARMAN. XII.<sup>12</sup> The Reptiles.
- H. J. HANSEN. The Cirripeds.
- H. J. HANSEN. XXVII.<sup>27</sup> The Schizopods.
- S. HENSHAW. The Insects.
- W. E. HOYLE. The Cephalopods.
- W. C. KENDALL and L. RADCLIFFE. XXV.<sup>25</sup> The Fishes.
- C. A. KOFOID. III.<sup>3</sup> IX.<sup>9</sup> XX.<sup>20</sup> The Protozoa.
- C. A. KOFOID and J. R. MICHENER. XXII.<sup>22</sup> The Protozoa.
- C. A. KOFOID and E. J. RIGDEN. XXIV.<sup>24</sup> The Protozoa.
- P. KRUMBACH. The Sagittae.
- R. VON LENDENFELD. XXI.<sup>21</sup> The Siliceous Sponges.
- R. VON LENDENFELD. XXIX.<sup>29</sup> Hexactinellida.
- G. W. MÜLLER. The Ostracods.
- JOHN MURRAY and G. V. LEE. XVII.<sup>17</sup> The Bottom Specimens.
- MARY J. RATHBUN. X.<sup>10</sup> The Crustacea Decapoda.
- HARRIET RICHARDSON. II.<sup>2</sup> The Isopods.
- W. E. RITTER. IV.<sup>4</sup> The Tunicates.
- B. L. ROBINSON. The Plants.
- G. O. SARS. The Copepods.
- F. E. SCHULZE. XI.<sup>11</sup> The Xenophyphoras.
- HARRIET R. SEARLE. XXVIII.<sup>28</sup> Isopods.
- H. R. SIMROTH. Pteropods, Heteropods.
- E. C. STARKS. XIII.<sup>13</sup> Atelaxia.
- TH. STUDER. The Alcyonaria.
- JH. THIELE. XV.<sup>15</sup> Bathysciadium.
- T. W. VAUGHAN. VI.<sup>6</sup> The Corals.
- R. WOLTERECK. XVIII.<sup>18</sup> The Amphipods.

<sup>1</sup> Bull. M. C. Z., Vol. XLVI., No. 4, April, 1905, 22 pp.

<sup>2</sup> Bull. M. C. Z., Vol. XLVI., No. 6, July, 1905, 4 pp., 1 pl.

<sup>3</sup> Bull. M. C. Z., Vol. XLVI., No. 9, September, 1905, 5 pp., 1 pl

<sup>4</sup> Bull. M. C. Z., Vol. XLVI., No. 13, January, 1906, 22 pp., 3 pls.

<sup>5</sup> Mem. M. C. Z., Vol. XXXIII., January, 1906, 90 pp., 96 pls.

<sup>6</sup> Bull. M. C. Z., Vol. L., No. 3, August, 1906, 14 pp., 10 pls.

<sup>7</sup> Bull. M. C. Z., Vol. L., No. 4, November, 1906, 26 pp., 4 pls.

<sup>8</sup> Mem. M. C. Z., Vol. XXXV., No. 1, February, 1907, 20 pp., 15 pls.

<sup>9</sup> Bull. M. C. Z., Vol. L., No. 6, February, 1907, 48 pp., 18 pls.

<sup>10</sup> Mem. M. C. Z., Vol. XXXV., No. 2, August, 1907, 56 pp., 9 pls.

<sup>11</sup> Bull. M. C. Z., Vol. LI., No. 6, November, 1907, 22 pp., 1 pl.

<sup>12</sup> Bull. M. C. Z., Vol. LII., No. 1, June, 1908, 14 pp., 1 pl.

<sup>13</sup> Bull. M. C. Z., Vol. LII., No. 2, July, 1908, 8 pp., 5 pls.

<sup>14</sup> Bull. M. C. Z., Vol. XLIII., No. 6, October, 1908, 285 pp., 22 pls.

<sup>15</sup> Bull. M. C. Z., Vol. LII., No. 5, October, 1908, 11 pp., 2 pls.

<sup>16</sup> Mem. M. C. Z., Vol. XXXVII., February, 1909, 243 pp., 48 pls.

<sup>17</sup> Mem. M. C. Z., Vol. XXXVIII., No. 1, June, 1909, 172 pp., 5 pls., 3 maps

<sup>18</sup> Bull. M. C. Z., Vol. LII., No. 9, June, 1909, 26 pp., 8 pls.

<sup>19</sup> Bull. M. C. Z., Vol. LII., No. 11, August, 1909, 10 pp., 3 pls.

<sup>20</sup> Bull. M. C. Z., Vol. LII., No. 13, September, 1909, 48 pp., 4 pls.

<sup>21</sup> Mem. M. C. Z., Vol. XLI., August, September, 1910, 323 pp., 56 pls.

<sup>22</sup> Bull. M. C. Z., Vol. LIV., No. 7, August, 1911, 38 pp.

<sup>23</sup> Mem. M. C. Z., Vol. XXXVIII., No. 2, December, 1911, 232 pp., 32 pls.

<sup>24</sup> Bull. M. C. Z., Vol. LIV., No. 10, February, 1912, 16 pp., 2 pls.

<sup>25</sup> Mem. M. C. Z., Vol. XXXV., No. 3, April, 1912, 98 pp., 8 pls.

<sup>26</sup> Bull. M. C. Z., Vol. LIV., No. 12, April, 1912, 38 pp., 2 pls.

<sup>27</sup> Mem. M. C. Z., Vol. XXXV., No. 4, July, 1912, 124 pp., 12 pls.

<sup>28</sup> Bull. M. C. Z., Vol. LVIII., No. 8, August, 1914, 14 pp.

<sup>29</sup> Mem. M. C. Z., Vol. XLII., June, 1915, 397 pp., 109 pls.

30. 305  
Bulletin of the Museum of Comparative Zoölogy

AT HARVARD COLLEGE.

VOL. LIX. No. 7.

---

TWO NEW GENERA OF MYRMICINE ANTS FROM  
BRAZIL.

BY WILLIAM MORTON WHEELER.

---

CAMBRIDGE, MASS., U. S. A.:  
PRINTED FOR THE MUSEUM.

NOVEMBER, 1915.



No. 7.— *Two New Genera of Myrmicine Ants from Brazil.*

CONTRIBUTIONS FROM THE ENTOMOLOGICAL LABORATORY OF  
THE BUSSEY INSTITUTION, HARVARD UNIVERSITY. NO. 103.

BY WILLIAM MORTON WHEELER.

Mr. C. William Beebe, of the New York Zoölogical Park, recently sent me for identification nineteen vials of ants which he collected May 15, 1915, in a suburb of Pará, at the mouth of the Amazon. The specimens were all taken from four square feet of jungle mold at the foot of a single tree, whose bird fauna (76 species!) Mr. Beebe studied for a week. In addition to the ants he took from the same little patch of mold a number of beetles, termites, springtails, bugs, pseudoscorpions, ticks, mollusks, and worms. The collection of ants comprises seventeen species, two of which are of singular structure and evidently represent new genera. The fifteen other species are recorded in the following list:—

*Pachycondyla harpax* Fabr. One worker.

*Euponera* (*Trachymecopus*) *stigma* Fabr. Two workers.

*Ponera opaciceps* Mayr. Six workers.

*Anochetus mayri* Emery. One deälated female.

*Solenopsis subtilis* Emery. Fifteen workers, one male, and one deälated female.

*Crematogaster victima* F. Smith, var. One deälated female.

*Pheidole flavens* Roger subsp. *exigua* Emery. One soldier, three workers, three males, and one deälated female.

*Pheidole subarmata* Mayr. Two workers and one deälated female.

*Trachymyrmex* sp. One deälated female, without head.

*Cyphomyrmex rimosus* Spin. One deälated female.

*Rhopalothrix* (*Octostruma*) *balzani* Emery. Twelve workers and one deälated female.

*Strumigenys subedentata* Mayr. One deälated female.

*Prenolepis steinheili* Forel. Four workers and three males.

*Rhizomyrma goeldii* Forel. Nine workers.

*Camponotus* (*Myrmothrix*) *abdominalis* Fabr. var. One deälated female.

The solitary deälated females of the species of *Anochetus*, *Crematogaster*, *Trachymyrmex*, *Cyphomyrmex*, and *Camponotus* were evi-

dently establishing colonies. At least eight of the species, viz. those belonging to the genera *Euponera*, *Ponera*, *Solenopsis*, *Rhopalothrix*, *Strumigenys*, *Rhizomyrma* and the two new genera *Blepharidatta* and *Glamyromyrmex* are hypogaëic (subterranean) ants, with small-eyed workers. With the exception of *Pachycondyla harpax* and *Camponotus abdominalis* all of the species are small or very small. I subjoin descriptions of the two peculiar species representing new genera.

#### BLEPHARIDATTA, gen. nov.

*Worker.* Small, monomorphic. Mandibles triangular, their apical margins with a few subequal teeth. Clypeus vertical, bicarinate. Frontal area large, frontal groove absent. Eyes moderately large and very convex. Ocelli lacking. Antennae 11-jointed, funiculus with a well-defined 2-jointed clava. Head rather large, with a deep scrobe on each side, extending its full length and bordered above by the frontal carinae which are large, expanded and horizontal, lobulate in front and extending to the posterior corners of the head. The inferior or lateral border of each scrobe is formed by a ridge as long as the frontal carina and running just above the eye. Thorax moderately long and slender, without promesonotal and mesoëpinotal sutures; humeri and inferior angles of pronotum dentiform; epinotum armed with a pair of long spines; metasternal angles large, compressed and sharply angular above. Petiole long and slender, pedunculate, with a low, rounded node. Postpetiole small, subglobular. Gaster small, spherical, first segment very large, without ridges, grooves or tubercles; remaining segments very small. Sting vestigial. Legs rather slender; middle and hind tibiae without spurs; claws simple.

Head, thorax, pedicel, and appendages opaque, sculptured; gaster smooth. Upper surface of body beset with long, paired, very sparse, stiff, and blunt hairs.

#### BLEPHARIDATTA BRASILIENSIS, sp. nov. (Fig. 1).

*Worker.* Length nearly 2 mm.

Head nearly  $\frac{1}{3}$  longer than broad, narrower in front than behind, with strongly and broadly excised and marginate posterior border and nearly straight lateral borders, its dorsal and gular surfaces feebly



convex, its posterior corners produced as prominent angular tubercles. Scrobes of nearly uniform transverse diameter throughout their length and sufficiently deep to accommodate the antennae. Frontal carinae expanded and lobular anteriorly, with translucent and slightly reflected borders throughout their length. Mandibles rather large, with moderately convex external borders, the apical borders rather oblique, with four subequal teeth. Clypeus with evenly rounded, entire anterior border, flattened in the middle between the two prominent longitudinal carinae and transversely impressed at the anterior border. Frontal area semicircular. Antennae slender, scapes reaching nearly to the posterior corners of the head, their apical halves distinctly thickened; first funicular joint large, fully twice as long as broad; joints 2-7 narrower, a little broader than long, joint 8 as long as broad; joint 9, the basal joint of the clava, longer than broad and twice as broad as the preceding joints; terminal joint large, pointed, nearly three times as long as broad. Thorax narrower than the head, more than twice as long as broad, broadest through the humeri, in profile more than twice as long as high, feebly and evenly convex above. Pronotum with acute, dentate anterior corners, from which there run a pair of distinct longitudinal ridges, gradually converging posteriorly to the epinotal spines. Each of these ridges bears two minute teeth. Epinotum sloping, concave in the middle, marginate on the sides below the spines, which are long, straight, acute, close together at their insertions and directed backward, outward and upward. Metasternal angles thin, translucent, broad and sharply angular above. Petiole fully three times as long as broad or high, with a short distinct peduncle in front and constricted behind the node, which is evenly and feebly convex above; seen from above the segment is broadest at its posterior margin. Postpetiole a little broader than the petiole but scarcely higher, from above rectangular, a little broader than long, in profile feebly convex above. Gaster subcircular from above, with straight basal margin.

Gaster smooth and shining; remainder of the body, including the appendages opaque, very finely and densely punctate-rugulose. Head above between the frontal carinae with six coarse, longitudinal rugae connected by sparse, indistinct transverse rugules or reticulations. Pronotum above with four feeble longitudinal rugae. Pleurae very indistinctly and irregularly rugose. Petiole and antennal scapes indistinctly longitudinally rugulose. Postpetiole and legs very finely and densely punctate. Gaster very finely and indistinctly shagreened, at the base above densely punctate and opaque.

Hairs yellowish; those on the upper surface of the body very long, slightly curved, of uniform thickness and blunt, arranged very regularly in pairs. On the head nearly all of them arise from the edges of the frontal carinae where the insertion of each hair is a minute tubercle; on the thorax the hairs are inserted along the ridges connecting the humeral angles with the epinotal spines. The petiole bears three, the postpetiole two pairs of these peculiar pairs. On the gaster there are four regular equidistant rows, with about six hairs in each

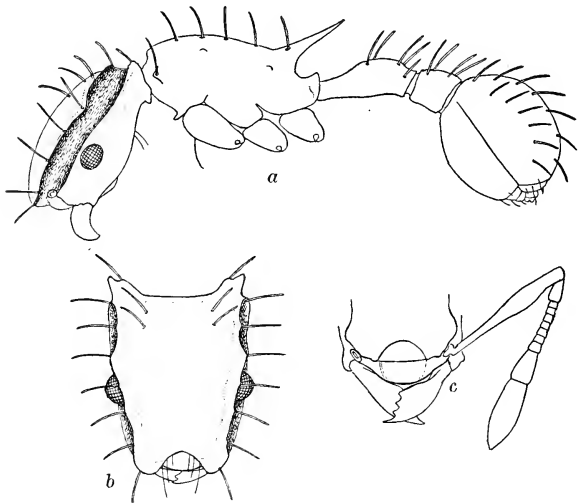

FIG. 1.—*Blepharidatta brasiliensis*, sp. nov. a. worker, lateral view; b, head of same from above; c, mandibles, clypeus and antenna of same from the front.

row. Each fore coxa bears a single long hair and there is a pair of hairs on the gula. Legs, antennae, and terminal gastric segments with numerous, short, appressed pointed hairs and the dorsal surface of the gaster also with a few scattered reclinate hairs.

Color ferruginous; antennae, legs, tip and sides of gaster somewhat paler and more yellowish.

Described from ten specimens; Cotype M. C. Z. 9040.

This extraordinary ant is evidently to be placed in the tribe Attiini,

but it differs so much from the other known genera in the structure of the head and especially in the 2-jointed club of the antennae, the 4-toothed mandibles and the regularly arranged, setiform hairs on the dorsal surface, that it seems necessary to establish a distinct genus for its accommodation. Apart from the head, the structure of the body is very simple and primitive for an Attiine ant, even simpler and more primitive than in the genus *Proatta*, recently established by Forel for a unique Sumatran species. It would be interesting to know whether *Blepharidatta brasiliensis* cultivates fungi like all the other known American Attiini.

#### GLAMYROMYRMEX, gen. nov.

*Worker.* Small, monomorphic; closely related to *Strumigenys* and *Epitritus*, but differing greatly from these genera in the structure of the head, which is suboblong, with deep scrobes on the sides above the eyes for the accommodation of the antennae. Lateral border of the head forming with the expanded frontal carina and external border of the clypeus a translucent plate overarching the scrobe on each side. Gular region rather narrow so that the eyes, which are small and in front of the middle of the head are approximated and seem to be on its lower surface. Upper surface of head rather flat, separated by a very indistinct suture from the transverse clypeus. Ocelli, frontal groove, and frontal area absent. Mandibles small, with distinct apical borders, armed with a regular row of rather slender acute teeth. Antennae 6-jointed, funiculus with a 2-jointed clava. Thorax, pedicel, and gaster much as in *Strumigenys*; petiole, postpetiole, and base of gaster bearing spongiform appendages. Epinotum armed with a pair of spines and with acute metasternal angles. Upper surface of head smooth and shining, sculpture of remainder of body much as in *Strumigenys*. Hairs slender and pointed, not clavate.

*Female.* Head decidedly shorter and broader than in the worker and narrowed in front, but otherwise of similar structure. Eyes larger, ocelli well-developed. Remainder of body much like that of *Strumigenys*, and the wings of similar but even more reduced venation, as the base of the cubital vein is largely obsolete, although the anal vein is present. Petiole, postpetiole, and base of gaster with fungiform appendages as in the worker.

*Male.* Closely resembling the male of *Strumigenys*. Mandibles very small, with only a single, apical tooth. Head of the usual struc-

ture, without dilated lateral margins or scrobes. Eyes very large and prominent, ocelli only moderately large and rather far apart. Antennae 13-jointed, with very short scapes. Thorax robust, broader than the head, mesonotum with deep Mayrian furrows, scutellum very convex. Petiole and gaster without fungiform appendages, those on the postpetiole minute and vestigial. Wings as in the female.

GLAMYROMYRMEX BEEBEL, sp. nov. (Fig. 2).

*Worker.* (Fig. 2a and b). Length 1.5–2 mm.

Head  $1\frac{1}{2}$  times as long as broad, slightly broader behind than in front, with deeply excised posterior and more feebly excised lateral borders and broadly rounded anterior and posterior corners; behind feebly convex, flattened in the middle and with sloping clypeus. Mandibles convex, with about 8 slender and crowded teeth, which are longest at the apex. Clypeus much broader than long, flattened, with arcuately and deeply excised anterior and convex posterior border. Antennal scapes tenuous at the base, somewhat thickened and fusiform in the middle. First funicular joint fully twice as long as broad and much broader than the two succeeding joints; second joint longer than broad, third as broad as long; fourth longer than broad and less than  $\frac{1}{3}$  as long as the rather tapering terminal joint. Thorax much narrower than the head, broadest through the pronotum, which is as broad as long and evenly convex above, with minute but distinct humeral angles. Pleurae rather flat. Mesonotum sloping to a feeble constriction in front of the epinotum, the latter a little longer than broad, its base marginate on the sides and passing into the subequal declivity through a blunt angle. Spines laterally compressed, straight and acute, as far apart at their bases as long, directed backward and upward. Petiole fully twice as long as broad, pedunculate in front, with a low rounded node behind and with three spongiform appendages, one forming a narrow longitudinal band on the median ventral surface, the others a triangular mass on each side of the node. Postpetiole transversely elliptical, distinctly broader than the petiole, with a large spongiform mass enveloping its sides and ventral surface. Gaster as large as the head, elliptical, with straight basal border and a small fungiform mass on the anteroventral surface. Legs rather slender.

Smooth and shining; mandibles and head covered with minute, sparse, piligerous punctures, the lateral borders of the head above

longitudinally striate. Gula, pleurae, meso- and epinotum, and petiole opaque, densely and coarsely punctate-rugulose; gaster with a series of strong longitudinal rugae on the dorsal surface at the anterior margin.

Hairs and spongiform appendages sordid yellowish. Head with delicate hairs, which are short, sparse, and appressed on the dorsal

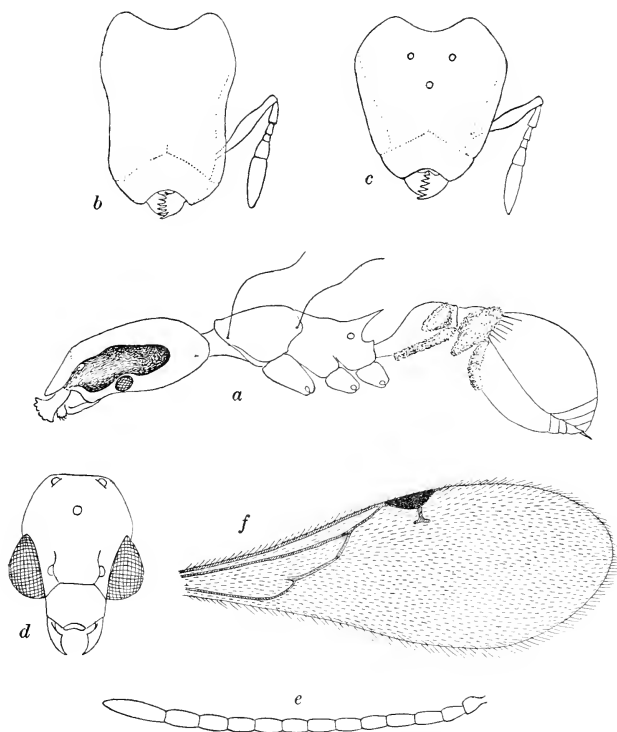

FIG. 2.—*Glamyromyrmex beebelii*, sp. nov. a. worker, lateral view; b. head of same from above; c. head of female from above; d. head of male from above; e. antenna of male; f. wing of same.

surface but longer, denser and more oblique on the gula. Thorax with two pairs of very long, slender, flagelliform hairs, one on the humeral angles and one on the posterior corners of the pronotum. Petiole, postpetiole, and gaster with a few long, slender, erect hairs. Antennae and legs with short, subappressed hairs.

Castaneous; upper surface of head and gaster blackish; mandibles, translucent lateral borders of head and clypeus, antennae and legs paler and more reddish or even slightly yellowish.

*Female.* (Fig. 2*e*). Length 2.6 mm.

Head only slightly longer than broad, decidedly broader behind than in front, with straight sides, deeply concave posterior border and obliquely truncated posterior corners; in other respects, except for the larger eyes and the presence of ocelli, like the head of the worker. Thorax through the wing-insertions nearly as broad as the head, somewhat longer than high, narrowed in the pronotal region, with bluntly angular humeri. Mesonotum flattened above; scutellum convex, with acute, projecting posterior border. Epinotum abrupt and concave in profile, its spines and metasternal angles larger than in the worker, more translucent and compressed. Petiole, postpetiole, and gaster as in the worker.

Sculpture, pilosity, and color as in the worker, but the upper surface of the mesonotum and scutellum is opaque and coarsely longitudinally rugose, with reticulate-rugulose interrugal spaces, the mesopleurae are smooth and shining and the postpetiole is subopaque and finely punctate above. The flagelliform hairs on the humeral angles are shorter and there are numerous erect, slender hairs on the mesonotum. Wings with uniformly brownish membranes, dark brown stigma and resin-colored veins.

*Male.* (Fig. 2*d*, *c*, and *f*). Length 2 mm.

Head longer than broad, with very short cheeks, feebly rounded postocular borders and rather straight, marginate occipital border. Mandibles very small, triangular, with feebly convex external borders and acute tips. Clypeus a little broader than long, subhexagonal, with the anterior border arcuately excised in the middle. Frontal carinae subparallel, reaching to the middle of the head, rather far apart. Antennae long, their scapes scarcely twice as long as broad and scarcely longer than the first funicular joint; all the funicular joints subcylindrical, longer than broad, the terminal joint longest. Thorax shaped much as in the female but broader than the head. Epinotal spines and metasternal angles shorter and blunter, not compressed and translucent. Petiole with a slightly more angular node in profile, postpetiole more transverse and less elliptical.

Opaque; with only the gaster, mesopleurae, and legs smooth and shining. Head densely and uniformly punctate; thorax, petiole and postpetiole coarsely punctate-rugulose; sides of mesonotum above irregularly and longitudinally rugose. Gaster with short longitudinal rugae at the base.

Hairs pale yellowish, very sparse, slender and rather short and inconspicuous on the body. Flagelliform hairs on the thorax feebly developed. Hairs on the legs delicate, appressed.

Black; thorax and pedicel dark brown; mandibles, antennal scapes, first funicular joint and legs piceous, tibiae and femora darker in the middle. Wing membranes, stigma, and veins distinctly paler than in the female.

Described from three workers, three females and two males belonging to the same colony: Cotype M. C. Z. 9039.

This singular ant belongs to the tribe Dacetoniini and is evidently closely related to the species of *Strumigenys*, *Epitritus*, and *Pentastroma* but differs greatly from these and all the other known members of the tribe in the structure of the head, which recalls that of the *Cryptoceriini*, though the eyes in this tribe are behind and not beneath the deep antennal scrobes.





The following Publications of the Museum of Comparative Zoölogy are in preparation:—

LOUIS CABOT. Immature State of the Odonata. Part IV.

E. L. MARK. Studies on Lepidosteus, continued.

E. L. MARK. On Arachnactis.

H. L. CLARK. The "Albatross" Hawaiian Echini.

Reports on the Results of Dredging Operations in 1877, 1878, 1879, and 1880, in charge of ALEXANDER AGASSIZ, by the U. S. Coast Survey Steamer "Blake," as follows:—

A. MILNE EDWARDS and E. L. BOUVIER. The Crustacea of the "Blake."

A. E. VERRILL. The Aleyonaria of the "Blake."

Reports on the Results of the Expedition of 1891 of the U. S. Fish Commission Steamer "Albatross," Lieutenant Commander Z. L. TANNER, U. S. N., Commanding, in charge of ALEXANDER AGASSIZ, as follows:—

K. BRANDT. The Sagittae.

K. BRANDT. The Thalassicolae.

O. CARLGREN. The Actinarians.

R. V. CHAMBERLIN. The Annelids.

W. R. COE. The Nemertean.

REINHARD DOHRN. The Eyes of Deep-Sea Crustacea.

H. J. HANSEN. The Cirripeds.

H. J. HANSEN. The Schizopods.

HAROLD HEATH. Solenogaster.

W. A. HERDMAN. The Ascidians.

S. J. HICKSON. The Antipathids.

E. L. MARK. Branchiocerianthus.

JOHN MURRAY. The Bottom Specimens.

P. SCHIEMENZ. The Pteropods and Heteropods.

THEO. STUDER. The Alcyonarians.

— The Salpidae and Doliolidae.

H. B. WARD. The Sipunculids.

Reports on the Scientific Results of the Expedition to the Tropical Pacific, in charge of ALEXANDER AGASSIZ, on the U. S. Fish Commission Steamer "Albatross," from August, 1899, to March, 1900, Commander Jefferson F. Moser, U. S. N., Commanding, as follows:—

R. V. CHAMBERLIN. The Annelids.

H. L. CLARK. The Holothurians.

H. L. CLARK. The Ophiurans.

— The Volcanic Rocks.

— The Coralliferous Limestones.

S. HENSHAW. The Insects.

G. W. MÜLLER. The Ostracods.

MARY J. RATHBUN. The Crustacea Decapoda.

G. O. SARS. The Copepods.

L. STEJNEGER. The Reptiles.

C. H. TOWNSEND. The Mammals, Birds, and Fishes.

T. W. VAUGHAN. The Corals, Recent and Fossil.

PUBLICATIONS  
OF THE  
MUSEUM OF COMPARATIVE ZOOLOGY  
AT HARVARD COLLEGE.

There have been published of the BULLETIN Vols. I. to LIV. and Vol. LVIII.; of the MEMOIRS, Vol. I. to XXIV., and also Vols. XXVI. to XXIX., XXXI. to XXXIV., XXXVI. to XXXVIII., XL. to XLII., and XLIV.

Vols. LV. to LVII., and LIX. of the BULLETIN, and Vols. XXV., XXX., XXXV., XXXIX., XLIII., XLV. to XLIX. of the MEMOIRS, are now in course of publication.

The BULLETIN and MEMOIRS are devoted to the publication of original work by the Officers of the Museum, of investigations carried on by students and others in the different Laboratories of Natural History, and of work by specialists based upon the Museum Collections and Explorations.

The following publications are in preparation:—

- Reports on the Results of Dredging Operations from 1877 to 1880, in charge of Alexander Agassiz, by the U. S. Coast Survey Steamer "Blake," Lieut. Commander C. D. Sigsbee, U. S. N., and Commander J. R. Bartlett, U. S. N., Commanding.
- Reports on the Results of the Expedition of 1891 of the U. S. Fish Commission Steamer "Albatross," Lieut. Commander Z. L. Tanner, U. S. N., Commanding, in charge of Alexander Agassiz.
- Reports on the Scientific Results of the Expedition to the Tropical Pacific, in charge of Alexander Agassiz, on the U. S. Fish Commission Steamer "Albatross," from August, 1899, to March, 1900, Commander Jefferson F. Moser, U. S. N., Commanding.
- Reports on the Scientific Results of the Expedition to the Eastern Tropical Pacific, in charge of Alexander Agassiz, on the U. S. Fish Commission Steamer "Albatross," from October, 1904, to April, 1905, Lieut. Commander L. M. Garrett, U. S. N., Commanding.
- Contributions from the Zoölogical Laboratory, Professor E. L. Mark, Director.
- Contributions from the Geological Laboratory, Professor R. A. Daly, in charge.

These publications are issued in numbers at irregular intervals. Each number of the Bulletin and of the Memoirs is sold separately. A price list of the publications of the Museum will be sent on application to the Director of the Museum of Comparative Zoölogy, Cambridge, Mass.

3189

Bulletin of the Museum of Comparative Zoology

AT HARVARD COLLEGE

VOL. LIX. No. 8.

---

NEW CHILOPODS FROM MEXICO AND THE WEST  
INDIES.

BY RALPH V. CHAMBERLIN.

WITH FIVE PLATES.

CAMBRIDGE, MASS., U. S. A.:  
PRINTED FOR THE MUSEUM.

NOVEMBER, 1915.

REPORTS ON THE SCIENTIFIC RESULTS OF THE EXPEDITION TO THE EASTERN TROPICAL PACIFIC, IN CHARGE OF ALEXANDER AGASSIZ, BY THE U. S. FISH COMMISSION STEAMER "ALBATROSS," FROM OCTOBER, 1904, TO MARCH, 1905, LIEUTENANT COMMANDER L. M. GARRETT, U. S. N., COMMANDING. PUBLISHED OR IN PREPARATION:—

- A. AGASSIZ V.<sup>5</sup> General Report on the Expedition.
- A. AGASSIZ. I.<sup>1</sup> Three Letters to Geo. M. Bowers, U. S. Fish Com.
- A. AGASSIZ and H. L. CLARK. The Echini.
- H. B. BIGELOW. XVI.<sup>16</sup> The Medusae.
- H. B. BIGELOW. XXIII.<sup>23</sup> The Siphonophores.
- H. B. BIGELOW. XXVI.<sup>26</sup> The Ctenophores.
- R. P. BIGELOW. The Stomatopods.
- O. CARLGREN. The Actinaria.
- R. V. CHAMBERLIN. The Annelids.
- H. L. CLARK. The Holothurians.
- H. L. CLARK. The Starfishes.
- H. L. CLARK. The Ophiurans.
- S. F. CLARKE. VIII.<sup>8</sup> The Hydroids.
- W. R. COE. The Nemerteans.
- L. J. COLE. XIX.<sup>19</sup> The Pycnogonida.
- W. H. DALL. XIV.<sup>14</sup> The Mollusks.
- C. R. EASTMAN. VII.<sup>7</sup> The Sharks' Teeth.
- S. GARMAN. XII.<sup>12</sup> The Reptiles.
- H. J. HANSEN. The Cirripeds.
- H. J. HANSEN. XXVII.<sup>27</sup> The Schizopods.
- S. HENSHAW. The Insects.
- W. E. HOYLE. The Cephalopods.
- W. C. KENDALL and L. RADCLIFFE. XXV.<sup>25</sup> The Fishes.
- C. A. KOFOID. III.<sup>3</sup> IX.<sup>9</sup> XX.<sup>20</sup> The Protozoa.
- C. A. KOFOID and J. R. MICHENER. XXII.<sup>22</sup> The Protozoa.
- C. A. KOFOID and E. J. RIGDEN. XXIV.<sup>24</sup> The Protozoa.
- P. KRUMBACH. The Sagittae.
- R. VON LENDENFELD. XXI.<sup>21</sup> The Siliceous Sponges.
- R. VON LENDENFELD. XXIX.<sup>29</sup> Hexactinellida.
- G. W. MÜLLER. The Ostracods.
- JOHN MURRAY and G. V. LEE. XVII.<sup>17</sup> The Bottom Specimens.
- MARY J. RATHBUN. X.<sup>10</sup> The Crustacea Decapoda.
- HARRIET RICHARDSON. II.<sup>2</sup> The Isopods.
- W. E. RITTER. IV.<sup>4</sup> The Tunicates.
- B. L. ROBINSON. The Plants.
- G. O. SARS. The Copepods.
- F. E. SCHULZE. XI.<sup>11</sup> The Xenophyphoras.
- HARRIET R. SEARLE. XXVIII.<sup>28</sup> Isopods.
- H. R. SIMROTH. Pieropods, Heteropods.
- E. C. STARKS. XIII.<sup>13</sup> Atelaxia.
- TH. STUDER. The Alcyonaria.
- JH. THIELE. XV.<sup>15</sup> Bathysciadium.
- T. W. VAUGHAN. VI.<sup>6</sup> The Corals.
- R. WOLTERECK. XVIII.<sup>18</sup> The Amphipods.

<sup>1</sup> Bull. M. C. Z., Vol. XLVI., No. 4, April, 1905, 22 pp.

<sup>2</sup> Bull. M. C. Z., Vol. XLVI., No. 6, July, 1905, 4 pp., 1 pl.

<sup>3</sup> Bull. M. C. Z., Vol. XLVI., No. 9, September, 1905, 5 pp., 1 pl

<sup>4</sup> Bull. M. C. Z., Vol. XLVI., No. 13, January, 1906, 22 pp., 3 pls.

<sup>5</sup> Mem. M. C. Z., Vol. XXXIII., January, 1906, 90 pp., 96 pls.

<sup>6</sup> Bull. M. C. Z., Vol. L., No. 3, August, 1906, 14 pp., 10 pls.

<sup>7</sup> Bull. M. C. Z., Vol. L., No. 4, November, 1906, 26 pp., 4 pls.

<sup>8</sup> Mem. M. C. Z., Vol. XXXV., No. 1, February, 1907, 20 pp., 15 pls.

<sup>9</sup> Bull. M. C. Z., Vol. L., No. 6, February, 1907, 48 pp., 18 pls.

<sup>10</sup> Mem. M. C. Z., Vol. XXXV., No. 2, August, 1907, 56 pp., 9 pls.

<sup>11</sup> Bull. M. C. Z., Vol. LI., No. 6, November, 1907, 22 pp., 1 pl.

<sup>12</sup> Bull. M. C. Z., Vol. LII., No. 1, June, 1908, 14 pp., 1 pl.

<sup>13</sup> Bull. M. C. Z., Vol. LII., No. 2, July, 1908, 8 pp., 5 pls.

<sup>14</sup> Bull. M. C. Z., Vol. XLIII., No. 6, October, 1908, 285 pp., 22 pls.

<sup>15</sup> Bull. M. C. Z., Vol. LII., No. 5, October, 1908, 11 pp., 2 pls.

<sup>16</sup> Mem. M. C. Z., Vol. XXXVII., February, 1909, 243 pp., 48 pls.

<sup>17</sup> Mem. M. C. Z., Vol. XXXVIII., No. 1, June, 1909, 172 pp., 5 pls., 3 maps.

<sup>18</sup> Bull. M. C. Z., Vol. LII., No. 9, June, 1909, 26 pp., 8 pls.

<sup>19</sup> Bull. M. C. Z., Vol. LII., No. 11, August, 1909, 10 pp., 3 pls.

<sup>20</sup> Bull. M. C. Z., Vol. LII., No. 13, September, 1909, 48 pp., 4 pls.

<sup>21</sup> Mem. M. C. Z., Vol. XLI., August, September, 1910, 323 pp., 56 pls.

<sup>22</sup> Bull. M. C. Z., Vol. LIV., No. 7, August, 1911, 38 pp.

<sup>23</sup> Mem. M. C. Z., Vol. XXXVIII., No. 2, December, 1911, 232 pp., 32 pls.

<sup>24</sup> Bull. M. C. Z., Vol. LIV., No. 10, February, 1912, 16 pp., 2 pls.

<sup>25</sup> Mem. M. C. Z., Vol. XXXV., No. 3, April, 1912, 98 pp., 8 pls.

<sup>26</sup> Bull. M. C. Z., Vol. LIV., No. 12, April, 1912, 38 pp., 2 pls.

<sup>27</sup> Mem. M. C. Z., Vol. XXXV., No. 4, July, 1912, 124 pp., 12 pls.

<sup>28</sup> Bull. M. C. Z., Vol. LVIII., No. 8, August, 1914, 14 pp.

<sup>29</sup> Mem. M. C. Z., Vol. XLII., June, 1915, 397 pp., 109 pls.

Bulletin of the Museum of Comparative Zoölogy

AT HARVARD COLLEGE.

VOL. LIX. No. 8.

---

NEW CHILOPODS FROM MEXICO AND THE WEST  
INDIES.

BY RALPH V. CHAMBERLIN.

WITH FIVE PLATES.

CAMBRIDGE, MASS., U. S. A.:  
PRINTED FOR THE MUSEUM.

NOVEMBER, 1915.



No. 8.— *New Chilopods from Mexico and the West Indies.*

BY RALPH V. CHAMBERLIN.

## SCOLOPENDROMORPHA.

### CRYPTOPIDAE.

TIDOPS, gen. nov.

BODY composed of twenty-three leg-bearing segments. Eleven pairs of elliptic spiracles, one pair being present on the seventh segment.

Head overlapping the first dorsal plate.

Antennae short, flattened; consisting of thirteen articles.

Claws of prehensors dwarfed. None of joints of prehensors armed. Prosternum bearing two long dentiform processes.

First dorsal plate with a transverse cervical sulcus. Other dorsal plates longitudinally bisulcate; most of them also with distinct lateral longitudinal sulci and, especially in the posterior region, with a median keel more or less set off by furrows. Last dorsal plate laterally margined.

Ventral plates with no distinct longitudinal furrows or sulci.

Coxopleura extended caudad in a long, acutely one-pointed process.

Tibiae unarmed or with only a subsppinescent bristle at distal end.

Tarsi, excepting of last two pairs of legs, undivided. Tarsus of fourteenth legs biarticulate.

Prefemur of anal legs armed ventrally; femur, also armed ventrally or mesally with spinules; tibia unarmed. Tarsus many jointed as in *Newportia*; clawless.

GENOTYPE.— *T. simus*, sp. nov.

This interesting genus is manifestly very close to *Newportia*, to which its relationship is suggestive of that of *Paracryptops* to *Cryptops*. The agreement of *Tidops* with *Newportia* will be particularly noted in the possession of a many jointed tarsus on the anal legs, this feature separating these two genera from all other *Cryptopidae*. *Tidops* is at once to be distinguished from *Newportia* by its dwarfed prehensorial claws, the strongly developed prosternal dental processes, the thirteen-jointed antennae; and the characters of the ventral plates. Only the type species is known.

## TIDOPS SIMUS, sp. nov.

General color ochraceous. Head and prosternum dark reddish brown or ferruginous. Legs yellow.

Head with median sulci showing as two short parallel lines across caudal border. Head differing slightly in width anteriorly and posteriorly; anterior margin widely semicircular; caudal margin subtruncate or but slightly excurved.

Antennae flattened, composed of thirteen articles of which the first two, three, or four are very sparsely hirsute, the others becoming gradually more and more densely and finely clothed with short straight hairs of the type usual in the family.

Claws of prehensors dwarfed. None of the articles of prehensors armed within.

Prosternum with two deep and continuous submedian longitudinal sulci. Anterior margin bearing two large, cylindrical, distally rounded teeth or dentiform processes.

Transverse sulcus of first dorsal plate strongly bent back in an angle at middle, the vertex lying in a rather deep depression or pit; sulcus wholly free from the cephalic plate. Longitudinal sulci subparallel or a little converging cephalad from the caudal margin to about two thirds the distance to the transverse sulcus where each bifurcates, sending its mesal branch to meet its mate at the angle of the transverse sulcus and its outer branch ectocephalad to meet the transverse sulcus farther laterad. Dorsal plates from the second one caudad longitudinally bisulcate. Lateral furrows distinct from the fifth plate caudad. Median keel low and flat, set off by furrows on the posterior plates, but becoming first indistinct and finally disappearing cephalad. Last dorsal plate with margin bowed out caudad as usual; the margin mesally truncate. With a median longitudinal sulcus.

Ventral plates long, longest cephalad, a little incurved near middle; more strongly narrowed caudad, the tongue-like, distally rounded caudal end lying well beneath the anterior portion of the succeeding plate. Widely but distinctly depressed transversely across middle of plate, but with no evident longitudinal furrows or sulci. Last ventral plate narrowed caudad. Caudal margin mesally indented or emarginate, the emargination very obtusely angular with the margin each side convex and the corners rounded. A pair of bristles on caudal portion.

Process of coxopleura rather short, acutely one-pointed. No spines proximad of tip of process or on caudal margin of coxopleura, but a stout bristle at base of each process. Pores of small size, numerous; the pore area not fully attaining the caudal margin, and removed from lateral margin caudally by a wide space but only by a narrow space anteriorly.



Spiracles obliquely and mostly narrowly elliptic.

Anterior tarsi undivided. Tibia with one distal spine, none being present on ventral side.

Antepenult legs with tarsus undivided; prefemur with two ventral spines and femur with one. The immediately preceding pairs of legs have one spine on femur and prefemur, these becoming bristle like cephalad.

Penult legs with prefemur bearing along ventral line two slender spines. Femur also bearing two ventral spines in a line, one of these being at distal end; in addition there are on mesal side toward distal end two additional similar spines. The biarticulate tarsus bearing a few long bristles ventrally, mesally, and dorsally, but ectally with numerous shorter and much finer hairs; the more proximal articles with but few bristles.

Tibia of anal legs unarmed; very much thicker than the tarsus, somewhat clavately widening distad and at ventroectal corner of distal end bearing a conspicuous cylindric process; sparsely clothed with bristles. First tarsal joint strongly clavately widening from base distad and compressed laterally; extended on ventromesal side at distal end into a conspicuous conical process; clothed with few long stiff bristles; clearly less than half as long as the tibia. Second division of tarsus abruptly much thinner than the first article is distally, its proximal article about half as long as the first division; articles of distal division, six to eight, clothed sparsely with long bristles like those of the preceding articles. Femur armed along ventromesal line with two small spines, one toward proximal end and one at or a little proximal of the middle; otherwise unarmed; clothed sparsely with bristles. Prefemur with a ventral row of three stout spines which are clearly shorter than the diameter of the article and are distally bent; along median line of mesal surface near middle of length with two spinules and along dorsomesal line with a series of five or six longer acute spinules; immediately ectad of ventral spines two short spinules and below middle of ectal surface about six longer spinules like those of the dorsomesal line; elsewhere bearing only hairs, which are sparse.

Length near 19 mm.

LOCALITY.—Grenada: Richmond Hill (C. T. Brues and G. M. Allen). TYPE, M. C. Z. 1746; one specimen.

#### NEWPORTIA CUBANA, sp. nov.

Dorsum olivaceous, excepting the first plate and the last two plates; a darker green to greenish black median longitudinal geminate band; lateral margins also darkened and caudal shorter mottled with dark green. Head with first and last two dorsal plates bright chestnut.

Antennae chestnut like the head, paler, yellowish, distad. Prosternum and prehensors and last ventral plate bright chestnut. Rest of venter light olivaceous, most plates showing a pair of circular dark spots on anterior border and an elongate one on anterior portion of episterna, each consisting of many fine dots. The pleural region also mottled with similar dark spots and streaks. Legs yellowish or ochraceous; the last pair darker, more or less chestnut; penult legs with prefemur, femur, and tibia ventrally whitish, the whitish area embracing an irregular mottling of fine dark dots.

Head densely finely punctate. Paired sulci represented merely by very short weak traces on the caudal border. Caudal margin widely convex.

Antennae short; consisting of the usual seventeen articles. Most articles densely clothed with the usual fine and very short hairs but these on proximal few articles becoming less and less dense and interspersed with longer, coarser hairs.

Prosternum with dental plates very wide but very short, their anterior margins forming a straight or nearly straight transverse line.

First dorsal plate with the cervical sulcus strictly semicircular and entirely free from the head. Paired sulci diverging cephalad and terminating at the cervical sulcus. Sulci of the second plate converging cephalad; those of the succeeding ones parallel. Most plates clearly longitudinally furrowed or depressed each side of the middle line and setting off a low keel-like elevation. Last dorsal plate mesally rather abruptly broadly produced caudad, the produced portion truncate; not sulcate.

Ventral plates, excepting the first and the last three, with a distinct median longitudinal sulcus which does not cross either the anterior or the posterior border. Last ventral plate with sides only very slightly convex, strongly converging caudad; caudal margin widely, sub-angularly incurved.

Coxopleural process long and slenderly conical, ending in a single spine; otherwise the process and coxopleura wholly unarmed.

Tarsi of all legs biarticulate. No tarsal spine present.

Tibia of anterior legs with a ventral spine at distal end but with no lateral one. No spinules on proximal joints of anterior legs.

Penult legs without spinules.

Anal legs with prefemur bearing ventrally a series of four long, distally curved spines which are shorter than the diameter of the joint; otherwise unarmed. Femur armed ventrally toward mesal side at proximal end with one shorter spine (and in one specimen on one leg with a second spine toward middle of length); otherwise unarmed. Tibia of uniform diameter throughout; more slender than, but equal in length to the femur; unarmed. First article of the tarsus more slender than the tibia though not greatly so; and a little more than

half its length. Distal division of tarsus long, composed of from fifteen short to but seven longer distinct articles.<sup>1</sup>

Length 35-42 mm.

LOCALITY.—Cuba: Juan Guerra Sagira de Panamo; Guantanamo, Arroyo Hondo. (C. T. Ramsden). TYPE, M. C. Z. 1753; two specimens, Type and M. C. Z. 1754.

#### NEWPORTIA OREINA, sp. nov.

General color clear yellow to light brown. Head and prosternum light brown or testaceous. Legs mostly clear yellow, the caudal pairs darker, more orange. Antennae brownish yellow.

Body very slender; narrowed from near the caudal end cephalad to the second dorsal plate.

Head smooth and shining, not distinctly punctate. A short, chitinized median sulcus extending from the anterior margin. A pair of parallel sulci, one a little each side of median line, extending from caudal border only a short distance cephalad; no transverse sulcus. Median portion of caudal margin straight, the margin bending forward at sides about the well-rounded caudal corners.

Antennae short; articles seventeen. Articles distad of the fifth, densely clothed with very short fine, straight hairs, the hairs on the more proximal articles longer and more sparse but none of the articles glabrous.

Anterior margin of the prosternum with a slight acute emargination at middle. A very short, narrow chitinous plate each side of the indentation, the edge of which is straight and slants a little caudad of ectad. Two well-separated longitudinal sulci which extend cephalad to a little distance caudad of the anterior margin where they are united by a weaker transverse impression.

First dorsal plate with the cervical sulcus angular at middle, the vertex lying in a moderate depression; lateral portions of sulcus covered by the cephalic plate. The longitudinal sulci distinct, converging cephalad and bifurcating to form a w-shaped mark the ends of which terminate on the transverse sulcus in the usual way; commonly a fainter transverse sulcus connecting the caudal angles of the w-mark and extending slightly ectad on each side. Longitudinal sulci of second dorsal plate gently converging cephalad and near

<sup>1</sup>The right leg of one specimen has the tarsus of the Scolopendrides type, the divisions being indistinct and irregular. The tibia of the same leg is of abnormal form, being somewhat bowed ventrad and distinctly constricted toward distal end. The leg is probably a regenerated one.

anterior border meeting a semicircular transverse sulcus the convexity of which is caudad. Sulci on the remaining plates parallel or very nearly so. On the third plate an oblique sulcus runs from the anterior end of each longitudinal sulcus obliquely ectocaudad. Some tergites of the posterior median region may show two longitudinal sulci close together and embracing between them a slight median ridge, but no true keel is present on any of the plates. The last dorsal plate with the caudal margin arcuate, the median portion protruding convexly with each lateral end becoming transverse or nearly so.

Ventral plates smooth and unfurrowed excepting for a transverse subsemicircular impression or furrow toward anterior end of each plate, this furrow usually more distinct in caudal region. Last ventral plate nearly equal in length and breadth. Sides convex, strongly converging caudad. Caudal margin mesally angularly emarginate.

Coxopleural processes moderately long, straight; the distal spine slender and acute. Process armed on ventral surface mostly with two spinules, but sometimes with only one. Caudal border of coxopleura also bearing usually two spinules.

Spiracles typically circular; the first very much larger than the succeeding ones, sometimes appearing more or less elongate.

Tarsi of all legs biarticulate. Second tarsal joint of anterior legs bearing a slender ventral spine near middle. Tibia with a small ventral but no lateral spine at distal end. Femora of all legs with ventral spinule at distal end. Prefemora with mostly two or three ventral spinules.

Penult legs with femur and prefemur bearing a considerable number of spinules chiefly on dorsal and mesal (caudal) surfaces.

Prefemur of anal legs bearing on ventral surface a longitudinal series of four long spines of which the most distal is farther ectad than the others and is at the very distal end of the article; these spines distinctly shorter than the diameter of the article. Femur with a similar ventral series of three spines nearly of same size as those of the prefemur; of these the most proximal is farther ectad than the others and the most distal one is about one fourth the length of the article from its distal end. Femur and prefemur in addition bearing numerous spinules on ectal and dorsal surfaces. Other joints unarmed. Tibia longer than the femur and longer than the first tarsal joint in about ratio 13:10. First tarsal joint much more slender than the tibia; somewhat angularly extended ventrad at distal end. Succeeding portion of tarsus abruptly very much more slender, proportionately short, commonly not much differing in length from the femur; composed of from five to eight distinct articles. Bristles sparse, moderate in length.

Length up to 22-23 mm.

LOCALITY.— Mexico: Hidalgo, Guerrero Mill (W. M. Mann).  
 TYPE, M. C. Z. 1758; ten specimens, several of which are immature,  
 Type and M. C. Z. 1719.

This species is closest to *N. spinipes* Pocock. It differs clearly in having all tarsi biarticulate; in having the anterior legs with but one tarsal spine additional to the ordinary dorsal one; in the number and disposition of spinules on the anterior legs; in the form and proportions of the first tarsal joint, and in the number of segments of the distal division of the anal legs (only 5-8 as against 13-14 in *spinipes*); in the very much smaller size.

#### CRYPTOPS MANNI, sp. nov.

Body yellow, with the head and caudal end a little darker.

Head subcordate; strongly narrowed cephalad from the middle; caudal margin between rounded corners straight. Clearly longer than wide (ratio about 39:35). Smooth. No sulci evident.

Prosternum with paired submedian longitudinal sulci which are not sharply defined. Not punctate. Anterior margin nearly straight except at ends where rounded caudad, also slightly indented at middle; on each side of middle bearing a pair of bristles directed cephalad and on each lateral curved portion another pair directed ectocephalad.

First dorsal plate with anterior border overlapped by the cephalic plate. A distinct transverse semicircular sulcus close to the margin of head, the sulcus not at all angulate at middle. Longitudinal sulci faint. Plates from the second caudad longitudinally bisulcate, the caudal ones especially showing in addition a curved sulcus on each side which is deepest on the cephalic part of plate. Plates not roughened or bearing cornicles. Hairs sparse. Last tergite with caudal margin mesally strongly convexly protruding; with a median longitudinal sulcus which is not distinct anteriorly; no pit-like depression caudad.

Last ventral plate with sides nearly straight, converging caudad. Caudal margin a little incurved or indented mesally.

Coxopleurae not at all produced caudally. Pores few.

First pairs of legs with tarsi entire but a division appearing and becoming more and more clearly detectable in proceeding caudad.

Prefemur of anal legs bearing numerous moderately stout spines ventro-laterally with longer bristles intermixed, a longitudinal ventral area free from spines but bearing bristles; dorsally at the distal end the joint is longitudinally furrowed and bears on the mesal side a stout short spine. Femur ventrally also with numerous long spines;

dorsally at distal end with two stouter short spines or teeth of which the ectal one is the larger. Tibia also somewhat flattened at distal end above and bearing two similar stout spines of which the ectal one is a little the larger; ventrally with a longitudinal series of five stout teeth. First tarsal joint bearing a ventral series of three, five stout teeth, followed by a small rounded process or lobe at distal end toward mesal side.

Length of type about 9.5 mm.

LOCALITY.— Haiti: Milot, January, 1913 (W. M. Mann). TYPE, M. C. Z. 1714; one specimen.

## SCOLOPENDRIDAE.

### SCOLOPENDRA POLYMORPHA PUEBLAE, var. nov.

Differs from typical *S. polymorpha* most clearly in having the distal process of the prefemur of the anal legs bearing uniformly only two stout spines (or in one specimen three on one side only). Spines of coxopleural processes three to five, of which one or two are stouter than the others, and one lateral one on the caudal edge of the coxopleura. Median sulcus of last dorsal plate fine, distinct. Dorsal plates sulcate from the tenth on. Tarsus of twentieth legs armed. Olive-brown with caudal borders of plates deeper green.

Length from 130 to 135 mm., much exceeding the average of the *forma typica* and the larger one exceeding the maximum length recorded for the species.

LOCALITY.— Mexico: Puebla (Mrs. L. C. Langton). TYPE, M. C. Z. 1705; two specimens, Type and M. C. Z. 1748.

## GEOPHILOMORPHA.

### ORYIDAE.

#### TITANOPHILUS, gen. nov.

Head relatively small. No frontal suture present. Antennae flattened, short, conspicuously pointed. Labrum entire; widely concave; densely fringed with spinescent teeth.

Mandible with several pectinate lamellae.

First maxillae with lappets present, these more or less dorsal in position. Palpus biarticulate, the second article long. Inner branch set off by a suture. Coxae fused at middle. Claw of palpus of second maxillae simple, concave. Coxae fused at middle, the median portion bulging ventrad and broadly triangularly extended caudad. Salivary pore opening toward proximal end of coxal plate, the pore breaking through the mesal border.

Prehensors not large but considerably exposed from above. Claws, when closed, not surpassing front margin of head.

Prosternum with chitinous lines absent or vague. Anteriorly widely emarginate; unarmed. Basal plate very wide; short.

Dorsal plates with distinct paired submedian sulci.

Prescutellum large, distinctly separated from the spiraculiferous plate. In the anterior segments these sclerites touch the tergite, there being no suprascutella. Farther caudad first one and then more indistinctly two series of suprascutella appear between the two sclerites mentioned and the tergites.

Ventral pores occurring over most of plate excepting a median transverse area.

Last ventral plate wide.

Coxopleurae without pores.

Anal legs each consisting of five articles distad of the coxopleura; clawless.

GENOTYPE.—*T. maximus*, sp. nov.

Closely related to *Notiphilides* with which it agrees in having the anal legs only five jointed. From this genus it is most readily distinguishable through the presence of the paired submedian sulci and the absence of all suprascutella from a considerable number of the most anterior segments.

#### TITANOPHILUS MAXIMUS, sp. nov.

Dorsum anteriorly yellow of dilute ochraceous cast; in median region darker, testaceous, of dull olivaceous tinge; again lighter, yellowish, at caudal end. Head light testaceous. Antennae and legs yellow. Prosternum and prehensors like head. Venter anteriorly and caudally clear yellow, the median region testaceous of dull weak olivaceous cast.

Head with anterior margin wide, subtruncate or mesally widely angulate; caudal margin widely convex or somewhat arcuate; head depressed along caudal border each side of middle. Plate of nearly same width anteriorly as posteriorly, sides convexly bulging between. A short median longitudinal sulcus evident on caudal portion and a

similar one on the anterior portion; 1.37+ times wider than long in type.

Basal plate very short, as wide as or slightly wider than the cephalic plate at its widest level; sides converging cephalad. Nine times as wide as median length.

Antennae moderate in length. First article broadest, the antenna being somewhat constricted at third article and then again widening to the fifth or sixth from where it narrows gradually to the distal end. Ultimate article shorter than the two preceding ones taken together (ratio 10:12 or 13).

Claws of prehensors when closed reaching anterior margin of head; slender. Other joints of prehensors very short.

Prosternum with a distinct median longitudinal sulcus over the caudal half of length; 2.4 times wider than the greatest length of the exposed portion. Margin between prehensors widely concave, smooth. Two, or a little more, times longer than the greatest length of femuroid.

First dorsal plate 1.5 times longer than the basal plate and considerably wider, its ends strongly depressed. Second plate longer but much narrower than the first. Dorsal plates of most of the body with two very sharply impressed longitudinal sulci close to middle of plate and a less sharply impressed median one between them, these sulci being faint or obscure on the most anterior plates and also faint on the last few. Plates otherwise unmarked; obscurely finely roughened.

Anal tergite broad, its caudal half strictly semicircular; 1.5 times wider than long.

Prescuta very short or quite concealed.

Most ventral plates a little concavely depressed from edges toward middle; some showing a vague longitudinal median sulcus. Under a lens the surface is seen to be very finely, somewhat obscurely, shagreened or tubercular. Last ventral plate short and very broad. Anterior and caudal margins straight; lateral margins straight, converging caudad; three times wider than long.

Anal legs in the male short, but longer than the penult and much stouter, being strongly crassate. Last four articles of about equal thickness and the ultimate and penult nearly of the same length. Hairs very short, rather sparse. Coxopleurae small, poreless.

Gonopods of male biarticulate, as a whole conical, the proximal article being very broad.

Pairs of legs 169 (♂).

Length between 190 and 200 mm. Greatest width of body 4 mm. Width of widest tergite, 3 mm.

LOCALITY.—Haiti: Grand Riviere (W. M. Mann). TYPE, M. C. Z. 1732, one male.



## TITANOPHILUS FRATRELLUS, sp. nov.

Dorsum anteriorly and at very caudal end of body ochraceous; in the middle of a distinctly olivaceous cast. The color of venter nearly the same as that of the dorsum. Head and prosternum with prehensors pale brown of a dilute olivaceous cast. Antennae and legs yellow.

Body robust; narrowed at very caudal end and less obviously in anterior region.

Head subcordate; widest caudally and conspicuously narrowed cephalad, as a whole somewhat convex, the caudal border apparently sharply depressed, the elevated edge arcuate. Only a little wider than long (37:34). A short, deep median longitudinal sulcus on middle portion of plate. Cephalic plate not wholly covering prehensors from above.

Basal plate very wide and very short; wider than the head; 6.5 times wider than its median length.

Antennae flattened as usual; very short; broad at base and uniformly narrowing distad. Ultimate article short, pointed, a very little shorter than the two preceding articles taken together.

Claws of prehensors slender; when closed not attaining front margin of head.

Exposed portion of prosternum a little more than twice wider than the greatest length; five times longer than the greatest length of femuroid. Margin between prehensors wide, weakly concave; a vague, dark nodular elevation each side of middle.

First dorsal plate wider than the basal plate and also than the second tergite. Not quite twice as long as the basal plate (ratio 11:6); shorter than the second in ratio 11:13; sides much converging caudad. Dorsal plates strongly bisulcate, with a much weaker or often obsolete median sulcus between the paired sulci; sulci becoming weaker or obscure on most anterior and most posterior plates. Anal tergite caudally semicircularly rounded or mesally somewhat obtusely angular; equal in length and breadth.

Prescuta in caudal region short but distinct, becoming very short cephalad. Prescutum of last pediferous segment longest at middle, running out to a point on each side, its caudal margin appearing convex and its anterior one straight.

Ventral plates not specially marked. Last ventral plate broad but relatively much longer than in *T. maximus*, being only twice as wide as long; sides straight, strongly converging; caudal margin weakly incurved from end to end.

Ventral pores small, not very dense, occurring over all of sternite excepting the usual median area.

Spiracles narrowly oblong, placed a little obliquely to the longi-

tudinal line. Anterior ones large and conspicuous, decreasing moderately caudad.

Anal legs in male very strongly crassate; flattened dorsoventrally; femur thickest. Trochanter not quite half as long as prefemur which is longer than the femur. Greatly exceeding the penult legs in length. Densely clothed with very fine short hairs.

Number of pairs of legs 149 (♂).

Length about 115 mm. Greatest width 2.6 mm. Width of widest dorsal plate 2 mm.

LOCALITY.—Haiti: Petionville, November, 1912 (W. M. Mann).  
TYPE, M. C. Z. 1718; one specimen.

## SOGONIDAE.

### *Key to Genera of Sogonidae.*

- A. Anal leg composed of but five articles distad of coxopleura.  
TIMPINA Chamberlin.
- AA. Anal leg composed of six articles distad of the coxopleura.  
B. Anal leg clawless; first maxillae with long lappets.  
SOGONA Chamberlin.
- BB. Anal leg ending in a well-developed claw; first maxillae without lappets.....GARRINA, gen. nov.

### GARRINA, gen. nov.

Head small; with no distinct frontal suture. (Prebasal plate exposed). Basal plate wide.

Antennae with proximal articles more or less flattened, attenuated and filiform distad.

Labrum mesally convex and laterally concave as usual.

First maxillae with palpus or outer process biarticulate; without lappets. Inner branch showing trace of a suture mesally but across most of branch to ectal side with no indication of separation. Coxae fused at middle. Coxae of second maxillae weakly narrowly united at middle. A deep narrow incision extending between them from anterior margin. Palpus of good size, triarticulate as usual, terminating in a well-developed, simple claw.

Prehensors small, wholly unarmed. Largely covered in dorsal view. Claws when closed not extending beyond front margin of head.

Prosternum with chitinous lines strongly developed.

Ventral pores small and few, arranged as usual in a narrow transverse band a little behind the middle of the sternite.

Last ventral plate wide.

Coxopleural glands opening into two large pits on each side.

Anal legs each consisting of six joints distad of the coxopleura; terminating in a well-developed claw.

GENOTYPE.—*G. ochrus*, sp. nov.

This genus is at once distinguishable from *Timpina* and *Sogona*, the other genera of the family, in having the anal leg armed with a distinct claw, and in lacking lappets on the first maxillae.

#### GARRINA OCHRUS, sp. nov.

Bright yellow, the color a little duller and somewhat dusky over middle. Head similar but color duller, darker caudad of suture antennae yellow of very faint brownish tinge. Prosternum yellow of dilute chestnut cast. Venter and legs clear yellow.

Body moderate, of nearly uniform width over much of length, but at very anterior portion strongly narrowed to the small head and over the caudal third of length gradually and considerably narrowing.

Head with no frontal suture; anterior border subtriangular; widest back of middle. Caudal margin wide; weakly excurved at middle and incurved toward each end. Equal in length and breadth. Basal plate with front margin concave, overlapped at sides by cephalic plate but mesally leaving prebasal plate exposed. Very wide, wider across base than the head (41:37).

Antennae approximate at base; first several articles broad and flattened, the antennae narrowing rapidly and becoming filiform distally. Short; slightly more than 2.5 times length of cephalic plate. Ultimate article nearly equalling the two preceding ones taken together.

Claws of prehensors moderately stout; when closed attaining front margin of head. Prehensors wholly unarmed.

Margin of prosternum between prehensors rather short; straight excepting for a weak median emargination. Sides straight and only slightly converging from anterior end back to the convex caudal portion. Wider than long in ratio 47:35; about 3.33 + times longer than greatest length of femuroid. Chitinous lines strongly developed, complete.

First dorsal plate anteriorly a little wider than the basal plate and much wider than the second tergite; sides convex, converging to the very strongly oblique caudal corners, the line of truncation of the corners being much more nearly horizontal than longitudinal. Dorsal

plates bisulcate; on anterior tergites also a clearly impressed median longitudinal sulcus.

Prescuta mostly very short over entire length, a longer one occurring occasionally at irregular intervals.

Ventral plates with a median longitudinal sulcus extending from anterior margin to caudad of middle where it commonly ends in a weaker transverse furrow.

Last ventral plate broad; sides straight and strongly converging; caudal margin moderately angularly bent in from ends to middle.

Ventral pores small and rather sparse; arranged in a very narrow transverse band between middle and caudal margin.

Coxopleurae each with two large pits of which the inner portion is covered by the last ventral plate.

First spiracle subvertically obovate, the second and third less elongate and the fourth and succeeding ones circular. First spiracle clearly the largest, the others very gradually decreasing in size caudad, the anterior ones being large and the most caudal ones small or minute.

Anal legs very much longer than the penult. In the male crassate; the femur thickest with the tibia and first tarsal joint a little thinner and the second tarsal joint abruptly much thinner (Plate 3, fig. 3). Armed with a distinct slender claw. Hairs mostly short, sparse.

Pairs of legs 59-63.

Length up to 26 mm.

LOCALITIES.—Mexico: Hidalgo, Guerrero Mill (W. M. Mann). TYPE, M. C. Z. 1723. Mexico: Pachuca (W. M. Mann); Distrito Federal, Esclava (O. W. Barrett); four specimens. Type and M. C. Z. 1721, 1722, 1724.

## LINOTAENIIDAE.

### PAGOTAENIA, gen. nov.

Head small; a true frontal suture not present. Basal plate wide. Prebasal plate not exposed. Dorsal plates not bisulcate.

Antennae filiform.

Labrum free; tripartite. Median piece very large, overlapping the small lateral pieces; conspicuously arcuate with the free caudal border fringed with close set spines across entire width much as in *Azathothus*.

First maxillae with coxae completely fused; coxal plate at each

ectal end extended cephalad into a conspicuous process which resembles a large proximal joint to the palpus which it bears, giving the latter the appearance of being triarticulate. Palpus distinctly biarticulate, the second article large, bending about distal end of inner process; no lappets present. Inner process set off by a distinct suture. Second maxillae with coxae completely coalesced. Palpus not long; ending in a large simple claw.

Prehensors small; largely concealed by head in dorsal view; wholly unarmed. Claw slender but not constricted or excavated proximally; when closed extending a little distance beyond front margin of head.

Prosternum with chitinous lines strongly developed but incomplete cephalad.

Ventral pores in a transverse band in front of caudal margin, the band commonly divided at middle.

Last ventral plate wide.

Coxopleurae each with pores opening as two pits of moderate size at edge of sternite.

Anal pores not manifest.

Anal legs composed of six articles distad of coxopleurae; clawless.

GENOTYPE.—*P. lestes*, sp. nov.

Apparently most closely related to *Agathothus*, from which it differs in having the inner branch of the first maxillae separated off by a suture, the outer branch elevated on a distinct process of coxa, the prosternum provided with chitinous lines, coxopleural pores in form of two pits on each side, and the anal legs clawless.

#### PAGOTAENIA LESTES, sp. nov.

Dorsum light greenish brown; darker, clearer brown cephalad; lightest caudad. Head, antennae, prosternum, and prehensors dilute chestnut. Venter of greenish brown cast. Legs pale brownish.

Body of typical *Linotaenia* form being strongly narrowed from middle region both caudad and cephalad; entire body clothed with numerous straight short hairs.

Head small with true frontal suture not present, but a pale line in its place more or less traceable. Wider than long in ratio 12:11. Anterior or frontal portion semicircularly rounded, or the anterior margin mesally somewhat angulate. Sides convex. Head widest between frontal region and caudal end. Caudal border a very little overlapped by the basal plate. A median longitudinal sulcus evident on posterior portion. Hairs short, numerous. Basal plate wide;

as wide as head; nearly as wide across anterior as across posterior border; 2.6 times wider than long.

Antennae very short, filiform; only about 2.25 times longer than the head. Articles short; the ultimate a little shorter than the two preceding ones taken together. Hairs very short and rather dense; increasing in length on proximal articles.

Claws of prehensors very slender, narrow at base; unarmed; when closed surpassing the anterior margin of head and attaining the distal end of the first antennal article. None of the articles armed.

Margin of prosternum between the prehensors wide; forming a gently reëntrant angle. Sides convex; strongly converging caudad. Wider than long in ratio 7:4; 1.7 times longer than greatest length of the femuroid. Chitinous lines distinct but incomplete at anterior end.

First dorsal plate a little wider than the basal plate; sides convex, converging caudad. Plates not sulcate.

Anterior ventral plates each with caudal border transversely conspicuously depressed or channelled and at middle with an angular process fitting into a corresponding process in the anterior border of the succeeding sternite.

Last ventral plate very broad; wider than the preceding one. Sides strongly converging caudad; caudal margin wide, weakly convex. Wider than long in about ratio 5:3.

Ventral pores numerous; arranged in a transverse band each side of the middle line and immediately in front of the caudal margin, the band on each side widest at ectal end.

Coxopleurae not large. Pores on each appearing as two pits near or partly beneath edge of sternite.

Spiracles all circular and small, scarcely differing in anterior and posterior regions; the first one not at all enlarged.

Anal legs distad of coxopleurae a little shorter than the penult pair. In the male strongly crassate; thickest at femur; ultimate article short, conically rounded distad. Clawless. Densely finely pubescent.

Legs of first pair a little shorter and more slender than those succeeding. Anterior pairs a little more robust than the posterior ones.

Pairs of legs 43 (♂).

Length 24 mm.

LOCALITY.—Mexico: Hidalgo; Guerrero Mill (W. M. Mann).  
TYPE, M. C. Z. 1715; one specimen.

## CHILENOPHILIDAE.

## NESIDIPHILUS, gen. nov.

Head with frontal plate usually not set off by distinct suture but this sometimes present or indicated by a pale line. Basal plate wide; trapeziform; overlapped by the cephalic plate. Dorsal plates bisulcate.

Antennae filiform, short.

Labrum free; tripartite. The median piece large; bearing along the caudal margin a series of long stout teeth of which the median ones are largest. Lateral pieces fringed with paler, distally more slender, spinescent processes.

Second maxillae with coxae completely united at middle, the isthmus moderately wide cephalocaudally and as well chitinized as the more lateral portions. Pleurosternal sutures strongly developed. The sclerite ordinarily appearing at caudal angles of inconspicuous size is in this genus large and extended cephalomesad parallel with suture, being separated caudally by a narrow slit but elsewhere united with portion of plate adjoining the suture. From between the anterior ends of these inner sclerites extends cephalad a median tongue-like chitinous process (Plate 5, fig. 3). Palpus triarticulate, terminating in a simple claw of moderate size. None of articles with a process. First maxillae with two long membranous lappets on each side. Inner division set off by a distinct suture. Coxae completely fused.

Prehensors large; conspicuously exposed from above and extending much beyond front margin of head. Claw commonly serrulate proximally within; always armed at base with a stout black conical tooth. Femuroid armed within near distal end with a larger distally rounded process which is paler and less strongly chitinized than the tooth of claw, of about same color as rest of article. Other articles unarmed.

No chitinous lines on prosternum.

Ventral pores numerous; arranged in four areas, one on each quarter of plate toward anterior or caudal margin as case may be.

Spiracles circular excepting the first one which is vertically more or less elongate and of large size.

Last ventral plate narrow; its sides strongly converging caudad.

Tergite of last pediferous segment broad, being anteriorly as wide as the preceding tergite; sides convex; largely concealing the coxopleurae from above (Plate 5, fig. 3).

Coxopleurae moderately inflated but not unusually elongate and not at all exposed at sides of last prescutum. Pores small and very numerous; most abundant dorsally and ventrally along and beneath edges of dorsal and ventral plate, fewer laterally and caudal end.

Anal leg with six joints distad of the coxopleurae. Unarmed or with obscure trace of claw. Not long.

GENOTYPE.—*M. latus*, sp. nov.

This genus corresponds in part to *Polyericus* as used by Cook but does not embrace the type of that genus (*P. toltecus*) as given by its authors, Humbert and Saussure. In addition to the genotype, *Nesidiphilus* includes *N. montis*, sp. nov., *N. nicaraguae*, sp. nov. and *N. marginalis* (Meinert), *Polyericus floridanus* Cook being a synonym of the last mentioned species.

#### NESSIDIPHILUS LATUS, sp. nov.

Dorsum rather dark brown with anteriorly a black median stripe which posteriorly becomes geminate and may be there indistinct; margins of plates and pleural sclerites may be mottled with purplish much as in *marginalis*. Head typically of a chestnut cast. Antennae brown, somewhat paler at tips. Prosternum and prehensors like head. Venter a lighter brown than the dorsum. Legs testaceous.

Body broad, robust; strongly narrowed from the middle caudad but only moderately narrowing cephalad to the head.

Head with place of suture taken by a pale line from the level of which cephalad the head is somewhat constricted. Anterior margin convex, the part between bases of antennae straight or a little concave. Head distinctly narrowing from near frontal region caudad to caudal region where the sides convexly round in and converge to the straight caudal margin. Nearly two thirds as wide as long (ratio in type 60:97). Basal plate 3.45 times wider than long; coarsely punctate.

Antennae short being only about 2.33 times longer than the head. Ultimate article scarcely narrowed distad, apically well rounded; three fourths as long as the two preceding ones taken together.

Claws of prehensors when closed reaching to between proximal and distal ends of second article of antennae. Claws stout, proximally serrulate or finely crenulate on mesal side; armed at base with a stout conical black tooth and distad of this showing a dark low eminence. Femuroid distally with a stout well-rounded nodular process which is pale. Other articles unarmed.

Sinus of prosternum semicircular, shallow; a low dark nodular eminence or tooth on each side of it. Sides a little converging caudad, at middle of length very slightly incurved. Free portion nearly 1.2 times longer than greatest length; 1.7 times longer than greatest length of femuroid. Subdensely punctate.

Dorsal plates deeply bisulcate; the anterior ones showing also a



deep median longitudinal sulcus extending caudad to a sharply impressed transverse sulcus extending across the plate caudad of the middle; farther caudad this median sulcus tends to be replaced by a pair of sulci.

Last ventral plate narrow but as wide across anterior end as its length. Sides straight, strongly converging caudad. Width across anterior end nearly twice as great as that across the caudal. Anterior margin convex, the caudal weakly incurved. A median longitudinal sulcus more or less evident.

Posterior prescuta short, the anterior ones very short.

Ventral plates with a median longitudinal furrow which is very deep at middle but on some anterior plates may not attain the margins; crossed near its middle by a weak transverse furrow.

Anal tergite broad. Wider than long in ratio 8:7. Sides only weakly convex, more abruptly bending in caudad. Caudal margin nearly straight.

Ventral pores in an area on each anterior quarter of sternite and in a transverse band across caudal border this band being more or less divided at median line by a poreless area.

Coxopleurae moderate. Pores small and numerous; most dense dorsally and ventrally along tergite and sternite, fewer laterally and absent from most caudal portion.

First spiracle much the largest, subcircular or vertically a little elongate; all others strictly circular; the second intermediate in size, the others decreasing caudad and in the caudal region becoming small or very small.

Anal legs exceeding the penult in length though not greatly so. In the female slender, the distal articles more slender than the proximal. Second tarsal article with a minute vague rudiment of claw. Anal legs in male more crassate than in female though not strongly so.

First legs shorter and much more slender than the second which are as large as those immediately succeeding. Posterior pairs longer than the anterior ones.

Pairs of legs 7 (♂)—49 (♀).

Length 24–40 mm. but mostly 30–40 mm.

LOCALITY.—Jamaica: Blue Mountain Peak. TYPE, M. C. Z. 1725; six specimens, Type and Paratypes, M. C. Z. 1749.

#### *NESIDIPHILUS MONTIS*, sp. nov.

Dusky brown. Head with prosternum and prehensors clearer brown of faint reddish cast. Antennae light brown. Legs brownish yellow. Body narrowing conspicuously caudad.

Head and anterior portion of body broad. Head anteriorly semicircularly rounded. Widest near caudal end of frontal region from where the sides are straight and converge very slightly caudad to the oblique caudal corners. Caudal margin straight. Frontal suture not present; 1.45 times longer than wide. Basal plate 3.4 times wider than long.

Antennae very short, pointed; only about 2.2 times longer than the head. The ultimate article moderately short, distally rounded, only three fourths as long as the two preceding articles taken together.

Claws of prehensors when closed reaching or nearly reaching the distal end of the second antennal article. Claw at base with a stout, conical, black tooth. Intermediate articles unarmed. Femuroid near distal end with a stout rounded pale process of the usual type.

Anterior margin of prosternum with a median sinus which is shallow and semicircular; on each side of sinus an obscure low nodule or tooth. Sides nearly straight back to the rounded caudal corners; a little converging caudad. Exposed part of prosternum 1.24 times wider than median length; 1.64 times as long as the greatest length of femuroid. Densely and rather coarsely punctate.

Dorsal plates deeply bisulcate, with a mostly equally well-impressed median longitudinal sulcus; a sharply impressed transverse sulcus across plate a little caudad of its middle.

Last dorsal plate broader, largely concealing the coxopleurae in dorsal view; shield shaped with the caudal end truncate and the anterior margin also straight. Wider than long in ratio 5:4.

All prescuta short, those of anterior region extremely so.

Ventral plates with a deep median longitudinal sulcus which is deepest at middle of its length; this crossed behind middle by a weaker transverse sulcus.

Last ventral plate narrow and long; its sides straight, strongly converging caudad; anterior margin convex; caudal margin also, but weakly, convex. Anteriorly the plate is twice as wide as across caudal end or nearly so; about three fourths as wide as long.

Ventral pores numerous; chiefly in a transverse caudal band more or less clearly divided at middle line; a smaller area toward each anterior corner.

Coxopleurae moderately inflated; not unusually elongate. Densely porose as usual.

First spiracle much the largest, vertically elongate, subelliptic; others circular, decreasing caudad.

Anal legs much longer than the penult; slender. Last tarsal article long and slender.

Pairs of legs 55.

Length near 26 mm.

LOCALITY.—Cuba: Monte Verde. TYPE, M. C. Z. 1726; one specimen.

## NESIDIPHILUS NICARAGUAE, sp. nov.

Dorsum light brown, becoming lighter, yellowish, caudad. Head and antennae dilute chestnut of weak ferruginous tinge. Prosternum and prehensors like the head. Venter yellow to testaceous. Legs testaceous to clear yellow.

Body moderately robust, conspicuously narrowing caudad from middle but only very gradually and moderately narrowed cephalad.

Cephalic plate about two thirds as wide as long. Sides back of suture nearly straight, slightly converging caudad and rounding in more strongly to a short strongly narrowed caudal portion of head. Frontal suture present. Punctae caudad of suture moderately coarse, not dense. Hairs sparse. Basal plate 3 times wider than long.

Antennae thick and moderately long. Ultimate article clearly shorter than the two preceding ones taken together.

Claws of prehensors when closed extending much beyond front margin of head and reaching to near distal end of second article. Claw armed at base with a stout, distally rounded black tooth. Femuroid with a more robust, distally rounded dark process or tooth projecting cephalomesad, this darker and more strongly chitinized than in the other known species of the genus.

Prosternum wider than long in the ratio 5:4. Anterior margin between prehensors widely concave; a slight pale tooth on each side. Sides of prosternum parallel between anterior end and the convex caudal corners; 1.76 times longer than greater length of femuroid.

Prescuta in anterior region short, becoming of moderate length in median region and then again decreasing in caudal region.

Ventral plates with a distinct transverse sulcus crossed by a median longitudinal one, the impressions deepest at the point of crossing, there being a pit-like depression on this part of anterior plates.

Last ventral plate narrow; its sides only slightly converging caudad, straight; caudal margin straight.

Ventral pores numerous; chiefly in two large areas in front of caudal margin and separated by a poreless area along the sulcus; a smaller porose area on each anterior quarter as usual.

First pair of legs shorter and much more slender than the second, the latter being intermediate in size between the first and the third. Anterior and posterior pairs in general scarcely differing in length or thickness.

Coxopleurae moderately enlarged; surface densely perforated with very numerous small pores.

Spiracles all circular; the first one much larger than the third with the second one intermediate in size; the others gradually decreasing caudad as usual.

Anal legs only slightly exceeding the penult ones in length. Slender. The distal article slender, distally rounded, with no trace of claw. Hairs sparse.

Pairs of legs, 79.

Length about 54 mm.

LOCALITY.—Nicaragua: Escondido River about 50 miles from Bluefields, September, 1892 (C. W. Richmond). TYPE, M. C. Z. 1731; one specimen.

#### TELOCRICUS, gen. nov.

Head without frontal suture. Basal plate trapeziform, wide, overlapped by the head. Dorsal plates bisulcate.

Antennae filiform, long.

Labrum and first and second maxillae essentially as described for *Nesophilus*.

Prehensors large, much exposed from above, projecting widely beyond front margin of head. Claw armed at base with a stout conical black tooth. Femuroid armed toward distal end with a similar stout black conical tooth equally as well chitinized as that of the claw.

Prosternum without chitinous lines.

Prescutum also long and narrow, the coxopleurae in dorsal view being much exposed each side of it.

Ventral pores arranged as in *Nesidiphilus* but usually fewer and less obvious.

Last ventral plate very narrow, typically much longer than wide; sides converging caudad.

Tergite of last pediferous segment unusually narrow, conspicuously narrower than the penult plate, clearly and considerably longer than wide; leaving coxopleurae much exposed from above.

Coxopleurae strongly inflated and unusually elongate in correspondence with the long tergite and prescutum, more or less encroaching cephalad. Pores very small and very numerous, densest dorsally and ventrally near plates.

Anal legs with six large joints distad of coxopleurae and in addition with a minute membranous but clearly defined terminal appendage replacing the claw.

GENOTYPE.—*T. cubae*, sp. nov.

Very close to *Nesidiphilus* from which it is most readily distinguished by the long and very narrow last tergite and the narrow prescutum which leave the elongate coxopleurae much exposed in dorsal view (Plate 4, fig. 5) as well as by the narrow elongate sternite. The

greater proportionate length of antennae and anal legs is readily noted in most cases.

TELOCRICUS CUBAE, sp. nov.

Anteriorly ochraceous, becoming clearer yellow caudad. Head darker, of very dilute chestnut cast. Antennae yellow. Prosternum and prehensors like head.

Body of nearly uniform width from middle forwards to head but conspicuously narrowing caudad.

Cephalic plate with anterior margin subtruncate; caudal margin straight. Head of nearly uniform width from frontal region to rounded caudal corners, the sides being straight. Frontal plate coalesced but line of union indicated by a faint pale line. Head 1.67 times longer than wide (ratio cir. 92:55). Basal plate three times wider than length at middle.

Antennae long, 3.25 times longer than the head. Rather thick. Articles long; the ultimate only about two thirds as long as the two preceding ones taken together.

Claws of prehensors when closed reaching to distal end of second antennal article. Claw armed at base with a stout black tooth. Intermediate articles unarmed. Femuroid with a stout, distally truncate black tooth toward distal end, the tooth larger than that of the claw; femuroid somewhat protruding midway between tooth and proximal end.

Prosternum with two short, bluntly rounded, well-chitinized teeth on anterior margin, one each side of the narrow, shallow, median sinus. Sides nearly straight, very slightly converging caudad. A little wider than long, the ratio being about 19:18; 1.63 times longer than the greatest length of femuroid. No trace of chitinous lines.

Dorsal plates deeply bisulcate. A conspicuously impressed median longitudinal sulcus also evident on the anterior plates especially. On most plates a strongly impressed transverse sulcus a little in front of the caudal margin. Hairs very short, sparse.

Anterior prescuta very short, gradually increasing caudad, but still short in caudal region.

Anterior spiracles very large, vertically subovate, gradually assuming the circular form caudad. First spiracle much the largest, the others gradually decreasing in size caudad, the most posterior ones being very small.

Ventral plates marked with a strong median longitudinal sulcus which is crossed between middle and caudal margin by a weaker transverse sulcus, impression deepest at point of crossing. On the anterior plates the median sulcus bifurcates widely cephalad, in a

somewhat Y form. Last ventral plate very narrow; its anterior border triangular; caudal margin straight or nearly so; sides moderately converging caudad, straight; plate 2.33+ times longer than greatest width.

Tergite of last pediferous segment with sides substraight and only slightly converging caudad; caudal margin weakly convex. Plate only two thirds as wide as long. Last prescutum long and rather narrow.

Coxopleurae inflated and much elongate, crowding cephalad toward bases of penult legs. Densely porose with numerous small pores as shown in the figures.

Anal legs very much longer and more robust than the penult; proportionately slender, the articles decreasing regularly in diameter from the femur distad. Articles from the prefemur to the first tarsal inclusive somewhat clavately enlarging distad; second tarsal article of nearly uniform diameter or a little decreasing in width distad. At end of second tarsal, joint a minute, membranous but clearly separated, appendage or article bearing short hairs.

Anterior legs more robust than those of the posterior region.

Pairs of legs 79.

Length 52-58 mm.

LOCALITY.—Cuba: Soledad, near Cienfuegos (Thomas Barbour).  
TYPE, M. C. Z. 1757; two specimens, Type and Paratypes, M. C. Z. 1756.

#### TELOCRICUS FRATER, sp. nov.

Dorsum ochraceous, the head nearly of same color. Antennae and legs yellow.

Head 1.55 times longer than wide. A little widest near caudal end of the frontal region, though only slightly narrowing caudad. Sides straight or nearly so back to the rounded caudal corners. Anterior margin substraight. Caudal margin straight. Basal plate much covered by the head and the first dorsal plate, the exposed portion being fully six times as wide as long.

Antennae rather thick, a little attenuated distad; three times longer than the head. Ultimate article much shorter than the two preceding articles taken together, being only about three fourths as long.

Claws of prehensors stout; when closed extending widely beyond front margin of the head as usual. Claw armed at base with the usual stout, conical black tooth. Femuroid bearing at its distal end a black tooth somewhat stouter than that of the claw, the tooth conical,

distally rounded and projecting cephalad of directly mesad; femuroid only vaguely bulging proximad of the tooth.

Anterior margin of prosternum armed with two pale nodular teeth, one each side of the narrow and shallow sinus, these much closer to each other than either is to the corresponding prehensor. Sides nearly straight, only very slightly converging caudad. Wider than long in ratio 21:19. Nearly 1.4 times longer than greatest length of femuroid.

Dorsal plates as usual showing in part a median sulcus in addition to the paired ones.

Prescuta short to very short.

Anterior spiracles large, vertically subelliptic, somewhat narrower ventrally than dorsally. Decreasing in size caudad and gradually becoming circular, those of the caudal region small as usual.

Ventral plates with the usual deep median longitudinal sulcus which is deepest when crossed by the weaker transverse sulcus behind middle.

Last tergite with sides straight, distinctly and considerably converging caudad. Caudal margin straight. Plate much longer than wide (ratio about 19:15).

Last ventral plate narrow. Sides conspicuously converging caudad, somewhat incurved toward anterior end and excurved toward the caudal.

Coxopleurae much enlarged and elongate, densely finely porose as usual.

Anal legs much longer than the penult; nearly as in *cubae*.

Pairs of legs 65.

Length near 26 mm.

LOCALITY.—Cuba: Monte Verde (Charles Wright). TYPE, M. C. Z. 1727; one specimen.

#### TELOCRICUS MAJOR, sp. nov.

Head and anterior portion of dorsum dark ochraceous, with a paler median longitudinal line; becoming yellow caudad. Antennae ochraceous. Prosternum chestnut, the prehensors paler, more ochraceous. Venter anteriorly dark ochraceous, caudally becoming yellow like the dorsum.

Body gradually and conspicuously narrowed caudad from the middle but scarcely at all narrowing cephalad. Body and legs in caudal region densely clothed with fine short hairs, these becoming more and more sparse cephalad.

Head anteriorly semicircularly rounded; caudal margin wide,

straight; very slightly wider just in front of caudal corners than anteriorly; sides straight between rounded anterior and posterior corners. Frontal suture not evident. Plate 1.6+ times longer than wide. Basal plate considerably overlapped the exposed portion in type being five times wider than long, but the shortness may have been caused in part by shrinkage of full dorsal plate over the basal in the alcohol; but measuring entire length of plate caudad of head gives a ratio of width to length of 4:1.

Antennae robust, short, only 2+ times longer than the head. Articles moderate; the ultimate only three fifths as long as the two preceding ones taken together.

Claws of prehensors when closed extending to distal end of the second antennal article. Claw armed at base with the usual stout, subconical, distally rounded black tooth. Tooth near distal end of femuroid of about same size and form as that of claw; femuroid broadly bulging between tooth and proximal end.

Anterior margin of the prosternum bearing the usual two teeth; these distally well rounded and somewhat nodular, not so close together as in the preceding species, the distance between them nearly equalling that between each one and base of corresponding femuroid. Sides straight, only very slightly converging from anterior end to caudal corners. Exposed portion nearly of same length as breadth, total length of median portion when all is measured being greater than the width.

Anterior prescuta very short, the prescuta becoming of moderate length in caudal region.

Anterior spiracles very large, vertically subovate, gradually decreasing in size caudad and becoming circular, those of the caudal region very small.

Anterior sternites with the median longitudinal sulcus deeply impressed, crossed at or a little behind middle by a wider transverse sulcus, the impression deepest at place of crossing, sulci weaker on caudal plates.

Last ventral plate very narrow and long, sides incurved, more strongly converging than in *cubac*; caudal corners obliquely truncate; caudal margin straight; anterior margin strongly convex. Anterior portion of plate densely clothed with fine very short hairs which are more sparse on other parts of plate.

Coxopleurae large, elongate as usual. Densely finely porose. Densely clothed between pores with fine and very short hairs.

Last dorsal plate proportionately narrow and long; twice as long as its greatest width; almost as wide caudad as cephalad; sides a little incurved between ends; caudal corners oblique; caudal margin weakly incurved.

Anal legs greatly exceeding the penult in length. Slender, the



tarsal articles especially so. Terminal membranous article minute, bearing very short hairs. Hairs short, dense, evenly distributed, like those of other parts of caudal portion of body.

Pairs of legs 89 (♀).

Length near 80 mm.

LOCALITY.—Cuba: San Diego de los Baños. TYPE, M. C. Z. 1728; one specimen.

*TELOCRICUS MULTIPES*, sp. nov.

Body light lemon-yellow anteriorly, paler yellow posteriorly. Head and prosternum darker. Antennae yellow. Legs yellow with the posterior pairs very pale.

Body very slender, gradually narrowing to the caudal end.

Frontal plate not discrete. Head widest anteriorly; sides nearly straight, considerably converging caudad. Anterior margin semi-circularly rounded, indented as usual between the antennae. Caudal margin straight; 1.45 times longer than wide. Basal plate largely overlapped by the head, the exposed portion being in the type eight times wider than long.

Antennae moderate, in type being 2.6 times longer than the head. Ultimate article pointed, a little shorter than the two preceding ones taken together. Other articles mostly short. The distal seven or eight articles subdensely clothed with fine short hairs, the others with sparse long bristles arranged chiefly about proximal ends.

Claws of prehensors when closed attaining or a little exceeding the distal end of the first antennal article. Claw at base with a black, acutely conical tooth and a small protuberance distad of this as usual. Femuroid with a stouter subconical black tooth at distal end, with no protuberance proximad of it.

Median sinus of prosternum narrow, semicircular at bottom, sides vertical. A relatively broad nodular elevation each side of sinus. Sides straight and parallel or nearly so. Exposed portion wider than long in ratio 11:10; 1.6 times longer than greatest height of femuroid.

Prescuta very short in anterior region, gradually increasing and becoming moderately long caudad.

First spiracle large, very much exceeding the second in size; sub-circular or vertically a little elongate. Others strictly circular, decreasing caudad and in posterior region becoming minute.

Median longitudinal sulcus of sternites very deep, crossing entire length of plate, transverse sulcus more or less vague.

Last ventral plate very narrow, longer than wide, strongly narrowed caudad, sides incurved.

Tergite of last pediferous segment with caudal margin strongly rounded; sides but slightly converging caudad; narrower than the penult tergite.

Coxopleuræ strongly enlarged but less elongate than usual. Densely, finely porose as usual.

Anal leg much exceeding the penult, moderately thickened in the male. Second tarsal article slender, with the usual minute membranous appendage at its end.

First legs considerably shorter and more slender than the second which are of full size. Anterior legs clearly shorter and stouter than the posterior ones.

Pairs of legs 113 (♂).

Length about 35 mm.

LOCALITY.—Haiti: Mannville, December, 1912 (W. M. Mann).  
TYPE. M. C. Z. 1717; one male.

This is the most aberrant species of the genus.

#### LESTOPHILUS, gen. nov.

Head without evident frontal suture. Basal plate wide, largely overlapped by the cephalic plate, the exposed portion being very short. Dorsal plates bisulcate.

Antennæ short, filiform.

Labrum free, tripartite. The median piece of good size, not at all overlapped by the lateral; its free margin with a series of stout conical teeth which are much less slender and spiniform than in *Taiyuna* (six in genotype). Lateral pieces fringed with many slender spinescent processes which are more numerous than in *Taiyuna*.

Outer process of first maxillæ distinctly biarticulate, bearing two very long membranous lappets. Inner process set off by a distinct suture. Coxæ completely coalesced. Second maxillæ with coxæ almost completely separated at middle, there being but a pale membranous connective or isthmus. The entire anteromesal border, or all excepting most mesal end, more strongly chitinous and at times appearing almost as a separate sclerite (Plate 5, fig. 4). Pleurosternal suture strongly marked; pore situated mesad of the suture a little in front of middle of its length and opening through the mesal margin. The sclerite at angle small, not at all enlarged or extended cephalad as in *Teloericus* and *Nesidiphilus* and no median chitinous process present (Plate 5, fig. 5). Palpus triarticulate; terminating in a large simple claw; none of the joints with processes.

Prehensors large, conspicuously exposed at the sides and projecting much beyond front margin of the head. Claw armed at base with a

stout conical black tooth. Femuroid armed toward distal end with a larger stout, distally rounded process or tooth which is less strongly chitinized than that of the claw and is pale like that of *Nesidiphilus*.

Prosternum without chitinous lines. Anterior margin with two teeth.

Ventral pores few; present on the anterior plates in a narrow transverse band in front of the caudal margin.

Spiracles all circular or the first one a little vertically elongate and much larger than the third one.

Last ventral plate intermediate in size, varying across the anterior end from slightly wider than long to a little longer than wide; sides strongly converging caudad.

Tergite of last pediferous segment mostly very broad and almost wholly, concealing the coxopleuræ in dorsal view. Not strongly narrowing caudad. As wide as penult tergite to a little narrower with sides more converging; equal in length and breadth to wider than long.

Coxopleuræ moderately inflated, not unusually elongate, not at all exposed at sides of last prescutum. Pores small and numerous; most dense on ventral surface; absent from caudal end and above excepting proximally where they open near and beneath the edge of the tergite and beneath border of prescutum.

Anal pores present but small.

Anal legs with six articles distad of coxopleuræ. Clawless.

GENOTYPE.—*L. paucipes*, sp. nov.

#### LESTOPHILUS PAUCIPES, sp. nov.

Ochraceous or in some clear yellow caudally. Head darker, of dilute chestnut tinge, darker along sides and in region of the frontal suture. Legs yellow. Prosternum and prehensors dilute chestnut like the head. Venter pale ochraceous to clear yellow.

Body moderately robust. From the middle region conspicuously narrowing to the caudal end but only very slightly narrowing cephalad.

Cephalic plate widest at junction of frontal and caudal divisions; semicircularly rounded cephalad and the sides converging caudad; the caudal corners rounded as usual; caudal margin straight or weakly widely incurved. Longer than wide in ratio 7:5. Place of frontal suture taken by a vague, incomplete pale line. Hairs short and very sparse. Basal plate largely overlapped by the cephalic plate; the exposed portion very short, in type being 6.44 times wider than its median length but in some specimens even as much as 13 times wider.

Antennae short and thick, near 2.5 times longer than the head. Ultimate article distally obliquely truncate; shorter than the two preceding articles taken together.

Claws of prehensors when closed extending much beyond anterior margin of head, attaining distal end of second antennal article. Claw at base with a stout conical black tooth just distad of which is a pale protuberance. Femuroid at distal end with a much thicker, paler, distally rounded process or tooth extending in a distomesal direction; near middle of length showing also a slight rounded protuberance.

Prosternum with anterior margin bearing two acute teeth close together, the sinus between them being narrow and not deep, its bottom straight. Sides subparallel from anterior end to rounded caudal corners. Wider than long in about ratio 7:6; 1.54 times longer than ectal height of femuroid.

Dorsal plates deeply bisulcate; a pair of weaker intermediate sulci more or less developed on some of the plates or in place of these a single median sulcus on most anterior plates. A transverse sulcus, angulate at middle, evident on some of anterior plates.

Anterior prescuta very short; the others increasing in length caudad and becoming long in the middle and posterior regions.

Spiracles all circular; the anterior one much larger than the third with the second intermediate; others of moderate size and not much varying from anterior to posterior regions.

Ventral plates with a distinctly impressed median longitudinal furrow which is deepest at middle of length, in some plates with a vague transverse furrow crossing this at middle.

Ventral pores free; present on anterior plates in a narrow transverse band across caudal border. Last ventral plate with sides conspicuously converging caudad; straight or a little incurved. Width across anterior end to width across caudal as 9:5; length to greatest width as 10:9, twice the width at caudal end.

For dorsal plate see Plate 5, fig. 6.

Coxopleurae of anal legs moderately enlarged. Pores small and numerous both below and above but not present on most caudal portion ventrally and on a still larger caudal area dorsally.

Anal legs much longer than the penult. Slender; the last article slender and moderately narrowing distad. Hairs moderately long, sparse. Clawless.

Pairs of legs in most cases 45; rarely 43 or 47.

Length 23 to 35 mm.

LOCALITY.—Mexico: Hidalgo, Guerrero Mills (W. M. Mann).  
TYPE, M. C. Z. 1730; many specimens, Type and Paratypes, M. C. Z. 1750.

## LESTOPHILUS DIDYMUS, sp. nov.

Dorsum yellowish, pale ochraceous anteriorly. Head darker, of a dilute chestnut cast. Legs yellow, the antennae a little darker. Prosternum and prehensors dilute chestnut. Venter yellow.

Body conspicuously narrowed caudad but as usual only slightly narrowed cephalad.

Head anteriorly subsemicircularly rounded but anterior corners somewhat angular. Narrowed from frontal region caudad, caudally abruptly rounding in mesocaudad with a very short caudal part having sides again subparallel. Caudal margin straight. 1.45+ times longer than wide. Basal plate 2.6— times wider than long; as long mesally as at sides; its width anteriorly equalling the width of the narrowed caudal division of the cephalic plate.

Antennae short and proportionately thick; 2.2 times longer than the head plate. Ultimate article distally conically rounded, about equal in length to the two preceding articles taken together.

Claws of prehensors when closed extending a little beyond distal end of the first antennal article. Claw armed at base with a conical subacute black tooth. Femuroid with a paler, distally rounded stout process or tooth of usual type and a small, rather vague protuberance proximad of this.

Prosternum with two small, well-chitinized conical teeth close together, one at each edge of the narrow, shallow median sinus. Prosternum a little widest across anterior end. Exposed portion wider than long in ratio 47:43; 1.65 times longer than greatest length of femuroid.

Anterior prescuta very short; the others gradually increasing in length toward the caudal end where they are of moderate size. Each prescutum with a single transverse row of short straight hairs, each scutum having a transverse row of fewer similar hairs across caudal border and another one across the anterior border.

Spiracles all circular. The anterior one much the largest with the second intermediate in size, the others decreasing caudad, mostly small.

Sternites with the usual median longitudinal sulcus which is deepest at or a little caudad of its middle where crossed by a weaker and often indistinct transverse impression.

Ventral pores few; as usual in a narrow transverse band in front of the caudal margin.

Coxopleurae of last pediferous segment moderate in size. Pores small, numerous, not dense; occurring above and below, but above confined to proximal end where in part covered as usual.

Anal legs much longer than the penult; slender; clawless as always. Bristles sparse, moderate, chiefly at distal ends of articles.

Pairs of legs 47.

Length 22 mm.

LOCALITY.—Mexico: Hidalgo, Pachuca (W. M. Mann). TYPE, M. C. Z. 1729; one specimen.

*LESTOPHILUS HAITIENSIS*, sp. nov.

Ochraceous, clearer yellow caudad. Head darker, of somewhat chestnut cast. Antennae ochraceous. Prosternum and prehensors like head. Venter like dorsum or but little paler. Legs yellow.

Body slender, a little narrowed cephalad; gradually and conspicuously narrowed caudad.

Anterior margin of head nearly straight or a little arcuate; anterior corners oblique. Caudal margin straight. Head widest just back of frontal region. Sides nearly straight, converging caudad to the widely rounded caudal corners. Head a little constricted at frontal region; 1.4 times longer than wide. Basal plate largely overlapped by the head, the exposed portion between 5 and 5.5 times wider than long.

Antennae nearly three times as long as the head plates; stout; moderately attenuated distad. Ultimate article not narrowed distad, apically rounded; about four fifths as long as the two preceding articles taken together.

Claws of prehensors stout, finely serrulate within proximally; when closed reaching to between proximal and distal end of the second article; armed at base with a stout subconical black tooth which is slightly bent caudad at tip; first distad of the tooth a small dark nodular eminence. Femuroid with a stout, subconical, distally blunt or truncate tooth as usual; also with a small dark protuberance immediately proximad of basal oblique suture.

Anterior border of prosternum with two distinct nodule-like teeth about as far from each other as each is from the femuroid of the same side. Sides straight, a little converging caudad. Wider than long in ratio 32:29.

Dorsal plates bisulcate as usual. The anterior ones, at least, also showing a distinct median longitudinal sulcus. A distinct transverse sulcus across plates a little in front of the caudal margin.

All prescuta short, those of the anterior region especially so.

First spiracle greatly exceeding the second one in size, subcircular or slightly vertically elongate. All others circular; gradually decreasing in size caudad and in the posterior region becoming very small.

Ventral plates with the usual median longitudinal sulcus and the weaker transverse one. Last ventral plate narrow, longer than the

greatest width in about ratio 8:7. Sides concave, diverging more strongly near anterior end.

Coxopleuræ strongly inflated. Pores small and numerous excepting for the usual pore-free areas above and less markedly below at caudal end.

Anal tergite broad; very slightly wider than long; sides convex, converging caudad; caudal margin rather wide, straight.

First legs a little shorter and considerably more slender than the second. Anterior legs more robust than the posterior ones.

Anal legs in the female considerably longer than the penult; slender. Distal article without membranous appendage. Short hairs uniformly distributed with much longer ones at or toward the distal ends of articles.

Pairs of legs 57.

Length about 29 mm.

LOCALITY.—Haiti: Furey (W. M. Mann). TYPE, M. C. Z. 1713; one female.

#### LESTOPHILUS NESIOTES, sp. nov.

General color of body yellow. Head with basal plate, prosternum, and prehensors very dilute chestnut, antennæ testaceous. Legs pale yellow.

Body conspicuously narrowed caudad as usual but of nearly uniform width over middle and anterior regions.

Head with sides between caudal corners and frontal region straight and only slightly converging caudad. Sides of frontal region convex, converging to ectal side of antennæ. Anterior and posterior margins truncate; 1.46 times longer than wide. Hairs few, moderate in length. Basal plate with exposed portion 3.66+ times wider than long.

Antennæ long, being in type about 3.77 times longer than the head plate. Articles long. Ultimate article much shorter than the two preceding ones taken together.

Claws of prehensors when closed extending a little beyond distal end of the first antennal article. Claw armed at base with a conical, distally rounded black tooth. Intermediate joints unarmed. Femur with a stout, subconical, distally truncate or bluntly rounded dark tooth.

Anterior margin of prosternum with a low dark nodular tooth each side of the narrow median sinus. Sides nearly straight, a little converging from the anterior ends. Caudad to the rounded posterior corners. Exposed portion equal in length and breadth.

Prescuta all short, those of the anterior region especially so.

Tergites with the paired sulci distinct as usual. A median sulcus also commonly clearly impressed.

Anterior spiracles large, vertically subelliptic. The first one largest. Others decreasing gradually caudad and beyond the first few becoming strictly circular.

Ventral plates with a median longitudinal sulcus which is deepest caudad.

Ventral pores more numerous than usual in the genus; arranged in a transverse band in front of the caudal margin, the band being widest at the middle when it is somewhat extended cephalad along the groove. Last ventral plate narrow. Sides a little concave cephalad but mesally straight, converging caudad, abruptly a little more strongly so toward caudal end. Caudal margin straight.

Coxopleuræ considerably inflated. Pierced by numerous small pores above and below as usual, fewer on lateral surface and caudal end poreless as usual, the pore-free area largest above.

Last tergite somewhat narrower than the preceding one, leaving the coxopleuræ more exposed above than usual in the genus. Sides straight, moderately converging caudad. Caudal margin straight. Nearly equal in length and breadth or but slightly longer.

Anal legs in the female longer than the penult, slender, the joints decreasing in diameter distad. Last tarsal joint especially slender, narrowing distad. Hairs mostly long, sparse.

Anal pores distinct.

Pairs of legs 77 (♀).

Length about 36 mm.

LOCALITY.—Haiti: Petionville, November, 1912 (W. M. Mann).  
TYPE, M. C. Z. 1712; one female.

## GEOPHILIDAE.

### PIESTOPHILINAE.

#### LEPTOPHILUS, gen. nov.

Head without frontal suture. Basal plate very wide. Dorsal plates bisulcate.

Labrum free; tripartite. Median piece large, armed with a series of stout conical teeth (six or seven in genotype). Lateral pieces with a fringe of spinescent processes as in *Geophilus*.

Coxae of second maxillae united at middle only by a weak membranous isthmus. Palpus triarticulate, ending in a simple claw.



Palpus of first maxillae large; consisting of two distinctly separated joints, of which the distal one is large and subconical and the proximal one bears ectodistally a very short membranous appendage or dwarfed lappet. Inner branch rather large, not separated from coxa by a suture; a deep incision separating it from its mate. Coxae fused proximally.

Prehensors small; wholly unarmed. Claws slender; when closed not extending beyond front margin of head.

Prosternum unarmed. Chitinous lines strongly developed.

Ventral pores present in a transverse area a little caudad of middle, the band leading to be divided at middle on the more caudal sternites.

Last ventral plate wide.

Coxopleural pores small; few.

Anal legs consisting of six joints distad of the coxopleura, the last of which bears a well-developed claw. First tarsal joint abruptly smaller than the preceding one and the second tarsal joint abruptly much smaller than the first, the latter being somewhat intermediate in size.

GENOTYPE.—*L. caribbeanus*, sp. nov.

Evidently closely related to *Eritrophilus* but differing especially in the structure of the first maxillae in which the palpus is large with both joints distinctly separated and not reduced and fused at base with coxa and laterally with the inner process. In *Eritrophilus* the two tarsal joints are equally slender whereas in the present genus the first joint is conspicuously thicker than the second (Plate 3, fig. 6).

#### LEPTOPHILUS CARRIBEANUS, sp. nov.

Entire body with legs, antennae, and frontal region of head yellow. Head darker over posterior portion.

Body slender; of nearly uniform width throughout, being only slightly narrowed caudad.

Caudal margin of head widely incurved; anterior margin truncate or slightly angulate at middle. Head widest caudad, the sides being convex and moderately converging cephalad. Equal in length and breadth. Exposing prehensors at sides. Prebasal plate slightly exposed. Basal plate large; very wide; sides convex, moderately converging cephalad. Slightly more than twice as wide as long.

Antennae long and slender; filiform, scarcely narrowing distad; 4.5 times longer than the head.

Prehensors small. Claws small and slender, when closed not attaining the front margin of the head. Prehensors wholly unarmed.

Margin of prosternum between prehensors forming an obtuse reentrant angle; wholly unarmed. Sides convex, strongly converging caudad. Chitinous lines strongly developed, complete: 1.36 times wider than long.

Anterior prescuta short, the median and posterior ones becoming long.

Spiracles all circular or the first one a little vertically elongate. First larger than the second, the others gradually decreasing caudad and in the posterior region minute.

Anterior ventral plates with the caudal margin angularly produced and extending into a corresponding shallow excavation in anterior border of succeeding plate. The excavation expanding on sternites from twelfth to twentieth into a clearly limited, large, transversely elliptic depressed area which is strongly chitinized.

Last ventral plate wide; wider than long; sides convex, converging caudad; caudal margin weakly concave over entire length (Plate 4, fig. 2).

Ventral pores present on anterior sternites in a transverse band a little caudad of middle. Pores also present on caudal plates but fewer the area showing a tendency to be divided at the middle. The pores detected on sternites of middle region of body.

Coxopleuræ small, not inflated. Pores small, few; opening beneath edge of sternite.

Dorsal plates distinctly bisulcate.

Last dorsal plate very broad. As wide anteriorly as the penult tergite. Sides convex, strongly converging caudad, the caudal end being rather narrow, rounded.

First pair of legs a little shorter and more slender than the second which are nearly as large as the third. Anterior pairs of legs shorter and stouter than the posterior.

Anal legs very much longer and thicker than the penult. In the male much inflated, a little thicker dorsoventrally than laterally. Second tarsal article abruptly and greatly more slender and the first article intermediate but still much more slender than the proximal ones. Claw well developed. Hairs sparse, moderately long.

Pairs of legs 60 ( $\sigma^7$ ).

Length near 30 mm.

LOCALITY.—Swan Island, April 13, 1913 (George Nelson). TYPE, M. C. Z. 1716; one male.

**LITHOBIOMORPHA.**

## LITHOBIOIDEA, superfam. nov.

Proposed to embrace the Lithobiidae *sens. str.*, Ethopolidae, fam. nov. (Ethopolys, Bothropolys and allies), Watobiidae, and Gosibiidae, fam. nov. (Gosibius, Arenobius and allies) in contrast with the Henicopioidea, superfam. nov. (the Henicopidae).

## GOSIBIIDAE, fam. nov.

All but one or two species of the known lithobioid fauna of Mexico belong to genera of this family, which ranges into the southern United States, extending in California as far northward as Oroville and north-eastward to Tennessee and North Carolina.

## ATETHOBIUS, gen. nov.

Head without distinct lateral marginal breaks much as in Bothropolys.

Antennae composed of numerous articles, numbering above forty.

Eyes composed of seriate ocelli.

Prosternal teeth 2 + 2. Spines ectal in position; stout and tooth like.

Posterior angles of the seventh, ninth, eleventh, and thirteenth dorsal plates, strongly produced, these plates appearing deeply mesally excavated posteriorly, processes broad and rounded. The fourteenth dorsal plate greatly enlarged, being distinctly wider than any of the more anterior plates and completely extending over and concealing the reduced fifteenth plate and the anal coxae.

Coxal pores uniseriate.

Claw of female gonopods large, strictly entire. Spines stout, conical.

Tarsi of all legs biarticulate. None of posterior coxae armed either laterally or dorsally.

Anal legs with two claws, dorsal spines 0, 0, 3, 2, 0. Dorsal spines

of penult legs 0, 0, 3, 2, 2. The anal leg in the male bears a lobe at distal end of tibia on mesal side.

GENOTYPE.—*A. mirabilis*, sp. nov.

This genus is remarkable because of the greatly enlarged tergite of the fourteenth segment, a feature at once separating it from all others.

ATETHOBIUS MIRABILIS, sp. nov.

Dorsum chestnut. Head back of the suture and the first dorsal plate a little darkest. Antennae typically darker distad than proximad.

Antennae reaching to middle of the fifth segment; articles above 40, in type being 43.

Eyes composed of about 13 ocelli in four series: *e. g.*, 1 + 3, 4, 4, 2. Single ocellus large, subcircular, pale. Most caudal ocellus of top series much larger than the others but smaller than the single one, often pale. Other ocelli black.

Prosternal teeth acute; well separated; the inner one on each side a little larger than the outer; line of apices distinctly recurved. Spines stout, more or less dentiform.

Posterior angles of seventh, ninth, eleventh, and thirteenth plates strongly produced; processes broad and long, distally more or less rounded. Fourteenth plate greatly enlarged, subcircular, covering the fifteenth.

Coxal pores large, circular, mostly 3, 4, 4, 3.

Claw of female gonopods entire as usual.

Spines of penult legs,  $\frac{0, 0, 3, 2, 2}{0, 1, 3, 3, 2}$ ; of the anal  $\frac{0, 0, 3, 2, 0}{0, 1, 3, 2, 0}$ , with two claws. None of coxae armed.

Anal legs in male slender and short. The tibial process small, subcylindric, the article at its level being about 3.66 times as wide as the process is thick.

Length up to 24 mm., that of the type being 22.5 mm.

LOCALITY.—Mexico: Distrito Federal; Esclava (O. W. Barrett).  
TYPE, M. C. Z. 1733.

DELOBIUS, gen. nov.

Head with lateral marginal breaks small but distinct.

Antennae short or intermediate; composed of thirty-six or more articles.

Eyes composed of seriate ocelli; the ocelli few.

Prosternal teeth 3 + 3 (or 3 + 4). A sinus present, wide, and semicircularly rounded at bottom. Spines ectal in position, small and bristle like.

Posterior angles of ninth, eleventh, and thirteenth dorsal plates produced. Fourteenth plate normal.

Coxal pores circular; uniseriate.

Claw of female gonopods long and entire. Spines 2 + 2, stout, subconical.

Anal legs in male not specially modified but penult with fifth joint bearing at distal end on mesal or caudal surface a longitudinally placed swelling or crest suggesting that of species of *Guanibius* but proportionately larger and different in position.

Posterior coxae either wholly unarmed, or the last two or three armed dorsally while the anal pair may also be armed laterally. Dorsal spines of anal legs 1 (0), 0, 3, 2, 0; ventral, in genotype, 0, 1, 2, 2, 2; claws 2. Dorsal spines of penult legs 1, 0, 3, 2, 0 or 0, 0, 3, 2, 0. Ventral spines of first legs 0, 0, 0, 0, 1; dorsal 0, 0, 2, 1, 1. First nine to thirteen pairs of legs with but a single dorsal tibial spine.

Length averaging near 20 mm.

GENOTYPE.—*D. simplex*, sp. nov.

In lacking a median ventral spine on the third and fourth segments of all legs, this genus is unlike any other lithobioid known to the writer.

#### DELOBIUS SIMPLEX, sp. nov.

Dorsum chestnut or with some of middle plates deep brown, with no distinct chestnut tinge; with irregular dusky streaks. Head like dorsum or color slightly clearer. Antennae dark brown proximally, paler and somewhat rufous distad. Prosternum and prehensors dilute chestnut, the latter of pale ferruginous cast distad. Venter light brown, the caudal plates darker. Legs brown; the posterior pairs darker, the tarsi, excepting proximal portion of first article, dilute ferruginous.

Body in male type 8.5+ times longer than width of tenth plate. Width of head and of first, third, eighth, tenth, and twelfth plates to each other as 53:47:49:56:55:52.

Head wider than long in about ratio 53:50. Head wider just back of eyes than at breaks. Caudal margin mesally weakly incurved. A longitudinal median sulcus which is deepest in front of frontal suture but which crosses the latter and is traceable to a transverse furrow some little distance in front of the caudal marginal thickening.

Antennae short, not very slender distad. Composed of 36-38

articles. First three articles moderate, the others short and very short. Ultimate article short, rounded, subequal to or a little shorter than the two preceding ones taken together.

Ocelli in type 8 to 11 arranged in 3 or 4 series: *e. g.*, 1 + 1, 3, 3; 1 + 1, 3, 3, 1; 1 + 3, 4, 3; 1 + 1, 3, 3, 2. Singles ocellus largest, separated. Others not very distinct. Organ of Tömösvary in outline smaller than the seriate ocelli.

Prosternum near 1.77 times wider than long. Distance between chitinous spots about 1.77+ times width at level of bottom of sinus; only 2.2 times the dental line. Teeth 3 + 3 or 3 + 4; not much differing in size; line of apices on each side a little convex with angle between lines at middle thus reentrant. Sinus shallow, broadly u-shaped or subsemicircular. Spine slender and short, on a tubercle just ectad of outer tooth. Margin evenly convexly rounding back from spine to prehensor on each side.

First dorsal plate in measured specimen 1.56 times wider than long. Sides between corners straight or toward middle of length a little incurved, only moderately converging. Posterior angles of ninth, eleventh, and thirteenth dorsal plates produced; the processes narrow and not long, those of ninth plate shortest.

Coxal pores moderately large, somewhat transversely elongate or subelliptic, decreasing on each coxa proximad: 5, 4, 4, 4; 5, 5, 5, 5.

Claw of female gonopods long, subacute, moderately curved. Spines 2 + 2, stout and rather short, of the usual subconical form. Mesal edge of first article sharp, strongly chitinized, conspicuously bending out ectad proximally.

Spines of first legs,  $\frac{0, 0, 2, 1, 1}{0, 0, 0, 0, 1}$ ; of the second,  $\frac{6, 0, 2, 2, 1}{0, 0, 0, 0, 1}$ ; of the third and fourth,  $\frac{0, 0, 2, 2, 1}{0, 0, 0, 1, 2}$ ; of the fifth,  $\frac{0, 0, 2, 2, 1}{0, 0, 0, 2, 2}$ ; of the sixth and seventh,  $\frac{0, 0, 3, 2, 1}{0, 0, 0, 2, 2}$ ; of the eighth to twelfth,  $\frac{0, 0, 3, 2, 1}{0, 0, 2, 2, 2}$ ; of the thirteenth,  $\frac{1, 0, 3, 2, 1}{0, 0, 2, 2, 2}$ ; of the penult,  $\frac{1, 0, 3, 2, 0}{0, 1, 2, 2, 2}$ ; of the anal,  $\frac{1, 0, 3, 2, 0}{0, 1, 2, 2, 2}$ , claws 2. Anal coxae laterally armed but the spine seemingly easily lost. The single dorsal tibial spine is in all cases on the anterior side.

Segments of legs longitudinally furrowed dorsally and ventrally, especially on the more posterior pairs.

Anal legs of male not specially modified. Penult legs with the fifth article at distal end on mesal surface presenting a longitudinally placed, pilose swelling or lobe somewhat similar to but proportionately larger than that borne on the corresponding article in males of *Guambius*.

Length 19–21 mm.; greatest width of tergites 2.25 to 2.6 mm.

LOCALITY.—Mexico: Hidalgo, Guerrero Mills (W. M. Mann). TYPE, M. C. Z., 1740; two specimens, Type and Paratype, M. C. Z. 1752.

## DELOBIUS SPINIFER, sp. nov.

Dorsum brown, somewhat dusky; some plates with a paler median longitudinal stripe. Head concolorous with dorsum. Antennae dusky brown, at very tips paler, yellowish. Prosternum and prehensors brown of a somewhat lighter cast; prehensors rufous distally. Legs brown, the tarsi, of the posterior pairs in particular, brighter, yellowish.

Body slender, only very gradually narrowed cephalad to the third plate which is of same width as the first. Head wider than any of the plates. Width of head and of first, third, eighth, tenth, and twelfth plates to each other as 56:47:47:54:54:47. Head wider than long in ratio 14:13; widest at marginal breaks. Lateral marginal breaks small but distinct, much closer to eyes than to caudal corners. Strongly narrowed in front of eyes, the margin between which and antennae is somewhat concave; margin near mesal side of antennae on each side more strongly chitinous. The anterior median sulcus sharply impressed, not attaining the suture caudad.

Antennae of medium length. Articles 45-46 in type. Articles distad of the third short and very short. Ultimate article much longer than the two preceding ones taken together.

Ocelli 1 + 3, 3, 2; 1 + 3, 4, 2. Ocelli in type pale and indistinct. Single ocellus well separated, largest, but the first one of the upper series is nearly as large and is much larger than the others of series of which those in bottom row are especially small, smaller than the organ of Tömösvary in outline.

Prosternum 1.84 times wider than long. Distance between chitinous spots 1.84 times width at level of bottom of sinus; 2.2 times the dental line. Teeth 3 + 3, small, the most ectal on each side more remote from the median one than the latter is from the most mesal; line of apices on each side slightly convex, omitting the median tooth on each side the line of apices would be straight. Sinus very wide and very shallow, the distance between the teeth at its ends being much greater than between adjoining teeth on each side. Spine small and bristle like, inserted just ectad of ectal tooth. Margin slanting back directly from spine.

First dorsal plate in type 1.51 times wider than long; sides only gently converging caudad, nearly straight cephalad of the rounded caudal corners. Posterior angles of the ninth, eleventh, and thirteenth dorsal plates produced, the processes moderate.

Porigerous areas of coxae moderately depressed. Pores circular: 3, 3, 3, 3 or with a small additional pore at proximal end on some of the coxae.

Spines of first and second legs,  $\frac{0, 0, 2, 1, 1}{0, 0, 0, 0, 1}$ ; of the third,  $\frac{0, 0, 2, 2, 1}{0, 0, 0, 2, 2}$ ; of the

fourth to seventh,  $\frac{0, 0, 2, 2, 1}{0, 0, 1, 2, 2}$ ; of the eighth and ninth,  $\frac{0, 0, 2, 2, 1}{0, 0, 2, 2, 2}$ ; of the tenth,  $\frac{0, 0, 3, 2, 2}{0, 0, 2, 2, 2}$ ; of the eleventh,  $\frac{0, 0, 3, 2, 1}{0, 0, 2, 2, 2}$ ; of the twelfth,  $\frac{0, 0, 3, 2, 2}{0, 0, 2, 2, 2}$ , the dorsal tibial spines equal; of the thirteenth,  $\frac{0, 0, 3, 2, 2}{0, 0, 2, 2, 2}$ , the caudal dorsal tibial spine small; of the penult,  $\frac{0, 0, 3, 2, 0}{0, 1, 2, 2, 2}$ , claws 3; (anal legs missing in type) none of the coxae at all armed.

Tibial process of penult legs of male dorsal in position; shorter and lower than in simplex, more crest like; not very conspicuous.

Length near 20 mm.

LOCALITY.—Mexico: Distrito Federal; Esclava (O. W. Barrett).  
TYPE, M. C. Z. 1742; one male.

Closely allied with the preceding species but readily separated by differences in spining of legs (*e. g.* in total lack of coxal spines); clearly by differences in the position and form of the tibial lobe on penult legs of the male; and by differences in proportions, etc.

#### LABROBIUS, gen. nov.

Lateral marginal breaks of head very weak or obsolete.

Antennae short or intermediate; articles from 29 to 57.

Eyes composed of seriate ocelli. Single ocellus clearly differentiated.

Prosternal teeth 2 + 2; line of apices from straight to a little recurved. Spines slender, bristle like. Sinus distinct, more or less u-shaped.

Posterior angles of ninth, eleventh, and thirteenth or of seventh, ninth, eleventh, and thirteenth dorsal plates produced.

Coxal pores circular; uniseriate.

Claw of female gonopods strictly entire as usual, spines stout, subconical, 2 + 2.

Anal legs in male with fifth joint bearing at distal end on dorsal or dorsomesal surface a conspicuous, laterally compressed crest.

Posterior coxae dorsally armed or else wholly unarmed dorsally but armed laterally instead. Dorsal spines of anal legs 1, 0, 3, 1, 0 to 0, 0, 3, 2, 1; ventral 0, 1, 3, 2, 1; claws 2. Dorsal spines of penult legs 1, 0, 3, 2, 2 or 0, 0, 3, 2, 2; ventral 0, 1, 3, 3, 1. Dorsal spines of first legs 0, 0, 1, 1, 1 or 0, 0, 2, 1, 1; ventral, 0, 0, 0, 0, 0 to 0, 0, 1, 1, 1.

Length 10–13 mm.

GENOTYPE.—*Labrobium minor*, sp. nov.

In addition to the genotype and *L. delus*, sp. nov., *L. sontus* (Chamberlin) and *L. vulcani* (Pocock) also belong in this genus.



## LABROBIUS MINOR, sp. nov.

Dorsum light brown to very deep brown or dull brownish black in individuals in full color. Head concolorous with dorsum or nearly so. Antennae deep colored like the head and either uniform, or, more commonly paler, rufous distad. Prosternum and prehensors dark brown but paler than the dorsum. Legs brown with tarsi, especially in posterior pairs, lighter.

Body unusually broad, varying from only four to six times longer than width of the tenth dorsal plate. Body very strongly narrowed cephalad to the first plate. Widths of head and of first, third, eighth, tenth, and twelfth dorsal plates to each other as 79 : 65 : 77 : 116 : 127 : 112.

Head broad, laterally convex; widest at breaks which are weak; anteriorly widely rounded; caudal margin straight. Clearly wider than long, the ratio being close to 15:14. A distinct median longitudinal sulcus in front of the suture; head elsewhere smooth. Hairs in part short and in part long, straight.

Antennae of intermediate length; becoming very thin distad. Articles mostly 49 to 57 in number; of these the first three are moderately large and the others very short and closely compacted. Ultimate article clearly longer than the two preceding ones taken together.

Ocelli 1 + 2, 4, 5, 2; 1 + 3, 3, 5, 2; 1 + 3, 3, 3, 3; 1 + 3, 4, 4, 1; etc. The single ocellus distinctly largest, subcircular. Other ocelli small, distinct and regular, with the second ocellus of top series nearly always the largest.

Prosternum with teeth 2 + 2, relatively close together; the inner tooth of each pair larger than the outer one and the line of apices in adults straight or nearly so. Spine slender, distally extremely fine, inserted a little ectad of outer tooth on dorsal surface proximad of edge. Anterior margin extending a considerable distance ectad from outer tooth almost horizontally and then bending abruptly back and but little ectad of directly caudad, then curving out to prehensor: 1.57 times wider than long. Distance between chitinous spots 1.88 times width at level of sinus; and nearly four times the dental line.

First dorsal plate short, strongly narrowed caudad; varying from 1.8 to 2.16 times wider than long. Posterior angles of the seventh, ninth, eleventh, and thirteenth dorsal plates produced, the processes broad with mesal side long and oblique.

Coxal pores mostly 3, 4, 4, 3 or 3, 4, 4, small. The porigerous area usually depressed with an elevated rim along each side.

Claw of female gonopods stout, relatively short, moderately curved, broadest a little distad of base. Spines 2 + 2; of the usual subconical form; the outer one of each pair a little longer than the inner. Inner edge of first article strongly chitinized, sharp, excavated proxi-

mally but excavation short and not deep and sometimes concealed; a narrow furrow across base of article. Excavation not always evident, especially in younger specimens.

Anal legs in male not especially crassate; fifth article at distal end on dorsal surface toward the mesal side with a conspicuous, laterally compressed and longitudinally placed crest which in side view is subtriangular, with dorsal surface convex and caudal end highest.

Spines of first legs,  $\frac{0, 0, 1, 1, 1}{0, 0, 0, 0, 0}$ ; of the second the same as first or  $\frac{0, 0, 1, 2, 1}{0, 0, 0, 0, 0}$ ; of the third,  $\frac{0, 0, 1, 2, 1}{0, 0, 0, 2, 1}$ ; of the fourth,  $\frac{0, 0, 1, 2, 2}{0, 0, 0, 2, 1}$ ; of the fifth,  $\frac{0, 0, 1, 2, 2}{0, 0, 0, 2, 2}$ ; of the sixth,  $\frac{0, 0, 2, 2, 2}{0, 0, 0, 2, 2}$ ; of the seventh,  $\frac{0, 0, 2, 2, 2}{0, 0, 0, 3, 2}$  or ventral spines, 0, 0, 0, 2, 2; of the eighth,  $\frac{0, 0, 2, 2, 2}{0, 0, 1, 2, 2}$  or ventral spines 0, 0, 1, 3, 2; of the ninth,  $\frac{0, 0, 2, 2, 2}{0, 0, 1, 3, 2}$  or ventral spines 0, 0, 2, 3, 2; of the tenth,  $\frac{0, 0, 3, 2, 2}{0, 0, 2, 3, 2}$ ; of the eleventh and twelfth,  $\frac{0, 0, 3, 2, 2}{0, 0, 3, 3, 2}$ ; of the thirteenth,  $\frac{0, 0, 3, 2, 2}{0, 0, 1, 3, 3, 2}$ ; of the fourteenth,  $\frac{0, 0, 3, 2, 2}{0, 1, 3, 3, 1}$ , claws 3; of the anal,  $\frac{0, 0, 3, 2, 1}{0, 1, 3, 2, 1}$  or  $\frac{0, 0, 3, 4, 0}{0, 1, 3, 2, 1}$ , claws 3, the inner accessory large, the outer one small but distinct. Last four pairs of coxae laterally armed, but none armed dorsally.

Length 10-13 mm.; width of tenth plate 1.9 to 2.5 mm.

LOCALITIES.—Mexico; Hidalgo; Guerrero Mills; San Miguel; Pachuca (W. M. Mann). TYPE, M. C. Z. 1737; eighteen specimens, Type, Paratypes, M. C. Z. 1751, and M. C. Z. 1738, 1739.

This species is notable for the relatively great width of the body in the posterior region.

#### LABROBIUS DELUS, sp. nov.

Dorsum from light to dark brown. Head of similar shade but color typically deeper. Antennae brown proximally, paler distad. Prothorax and prethorax clear brown. Venter paler brown, the caudal plates darker as usual. Legs light brown, the posterior pairs a little more brightly pigmented.

Body moderately narrowed cephalad to the first plate, which is clearly narrower than the plate and much narrower than the head. Widths of head and of first, third, eighth, tenth, and twelfth plates to each other as 74 : 63 : 67 : 80 : 80 : 74.

Head subcircular. Wider than long in ratio 37:35. Marginal breaks only obscurely indicated. Caudal margin nearly straight or very weakly incurved. The usual median sulcus in front of the suture and two longitudinal ones on caudal portion.

Antennae rather short. Composed of 29 to 33 articles. Articles

distad of the third short and very short, varying irregularly in length, closely united. Ultimate article rather slender, as long as the two preceding articles taken together.

Ocelli mostly 1 + 1, 3, 3. Single ocellus vertically subelliptic, of almost same size as first one of top series, these two being conspicuously larger than the remaining ocelli. Ocelli distinct and regular, often not contiguous with each other. Organ of Tömösoary in outline of about same size as an average seriate ocellus.

Prosternum 1.48— times wider than long. Distance between chitinous spots 2.3 times width at level of bottom of sinus; 3.9 times the dental line. Prosternal teeth 2 + 2; line of apices a little recurved. Sinus between V- and U-shaped. Spine bristle like, inserted a little ectad of outer tooth on same level. Margin extending abruptly ectocaudad from spine.

First dorsal plate in the type 1.53 times wider than long; sides only moderately converging caudad; caudal corners widely rounded. Posterior angles of ninth, eleventh, and thirteenth dorsal plates produced.

Coxal pores small; mostly 3, 3, 3, 3.

Anal legs of male with the tibial process small, low and inconspicuous.

Spines of first legs,  $\frac{0, 0, 2, 1, 1}{0, 0, 1, 1, 1}$ ; of the second,  $\frac{0, 0, 2, 2, 1}{0, 0, 1, 2, 1}$ ; of the third,  $\frac{0, 0, 2, 2, 1}{0, 0, 1, 2, 2}$ ; of the fourth,  $\frac{0, 0, 2, 2, 2}{0, 0, 1, 2, 2}$ ; of the fifth,  $\frac{0, 0, 2, 2, 2}{0, 0, 2, 2, 2}$ ; of the sixth to ninth,  $\frac{0, 0, 2, 2, 2}{0, 0, 2, 3, 2}$ ; of the tenth and eleventh,  $\frac{0, 0, 3, 2, 2}{0, 0, 2, 3, 2}$ ; of the twelfth and thirteenth,  $\frac{1, 0, 3, 2, 2}{0, 1, 3, 3, 2}$ ; of the penult,  $\frac{1, 0, 3, 2, 2}{0, 1, 3, 3, 1}$ , the ectal accessory claw obsolescent; of the anal  $\frac{1, 0, 3, 1, 0}{0, 1, 3, 2, 1}$ , claws 2 or also a minute ectal accessory claw sometimes evident. No lateral spines on any of the coxae.

Length 10–12 mm.

LOCALITY.—Mexico: Hidalgo, Guerrero Mills (W. M. Mann).  
TYPE, M. C. Z. 1741; six males, Type and Paratypes, M. C. Z. 1753.

#### MEXICOBIVS, gen. nov.

Head with marginal breaks present but small.

Antennae very short; articles thirty-five or above.

Eyes consisting of seriate ocelli. Single ocellus clearly differentiated.

Prosternal teeth 2 + 2, small and nodular. Anterior edge of prosternum well chitinized, wholly without true sinus. Spines large and stout, much exceeding the teeth in size.

Posterior angles of ninth, eleventh, and thirteenth dorsal plates

produced, those of ninth weakly so. Fourteenth tergite of normal form.

Coxal pores small, circular; uniseriate.

Claw of female gonopods strictly entire as always. Basal spines 2 + 2, conically acuminate. Inner edge of first article well chitinized; Article furrowed across base.

Posterior legs of male without special lobes or modifications.

Posterior coxae dorsally and laterally armed in type. Ventral spines of anal legs 0, 1, 3, 2, 0 or 0, 1, 3, 2, 1, rarely 0, 1, 3, 3, 1; dorsal, 1, 0, 3, 1, 0; claws 2, the accessory large and distinct. Ventral spines of penult legs 0, 1, 3, 3, 1; dorsal, 1, 0, 3, 2, 1, more rarely only 1, 0, 3, 1, 1. Dorsal and ventral spines of first legs 0, 0, 1, 2, 1. Legs from second to thirteenth with 2 dorsal tibial spines.

Length up to 18 mm.

GENOTYPE.—*M. hidalgocnsis*, sp. nov.

This genus is close to *Arenobius* in its restricted sense with which it agrees in the unusual character of the prosternum. It is most readily distinguished by the large number of antennal articles, the number in *Arenobius* being fixed at 20. It also differs in wholly lacking the special lobes characterizing the anal and penult legs of males in *Arenobius*.

#### MEXICOBIVS HIDALGOENSIS, sp. nov.

Dorsum clear shining brown to dusky brown, the first plate typically somewhat darker than the others. Head brown of a dilute ferruginous tinge, dusky caudad of the suture. Antennae dusky or blackish brown, rufous at tips and also paler proximally. Prosternum brown, the prehensors similar but rufous distally. Venter light brown, the legs similar to venter, brighter distad; the caudal pairs not clearly differing in color from the others.

Body moderately attenuated cephalad. The widths of head and of first, third, eighth, tenth, and twelfth plates to each other as 72:70:74:83:85:80.

Head widest at level of marginal breaks; widely rounded anteriorly; caudal margin straight. Marginal breaks small but distinct. Weakly punctate. The usual median sulcus in front of the suture. Equal in length and breadth or very nearly so.

Antennae very short; strongly narrowed distad. Articles 35-41; the first two of moderate length, the third shorter and the remaining ones very short and closely crowded; the ultimate article shorter than the two preceding ones together.

Ocelli 14 to 26 in four or, less commonly, (pseudomaturus) in three

series; *e. g.*, 1 + 3, 4, 4, 4; 1 + 4, 4, 4, 2; 1 + 4, 4, 3, 2; 1 + 4, 6, 6, 5, 4; 1 + 4, 4, 3. Single ocellus largest, contiguous with the others. First ocellus of uppermost series next in size to the single one; the others irregularly decreasing cephalad and ventrad. Ocelli deeply pigmented and commonly not clearly limited from each other, but those of the most ventral row sometimes pale.

Prosternal teeth small, nodular, inserted a little proximad of anterior edge, those of each side well separated. Anterior edge well chitinized, the two side portions meeting at middle in a very obtuse reentrant angle, the angle being but little less than  $180^\circ$ , with no true sinus. Spine on each side inserted at ectal end of anterior chitinous edge; large and stout, greatly exceeding the teeth in size. Edge outside each spine running at first but little caudad of directly ectad and then near middle of its length bending abruptly back more caudad to the prehensors; 1.7–1.77 times wider than long. Distance between chitinous spots 1.77–1.9 times greater than width at level of bottom of median reentrant angle; near 4.75 times the dental line.

First dorsal plate moderately narrowed caudad; 1.66 + times wider than long. Major dorsal plates with two submedian longitudinal furrows which are more deeply impressed on caudal plates. Posterior angles of eleventh and thirteenth dorsal plates strongly produced caudad, those of the ninth more weakly so.

Coxal pores small, circular, 3, 4, 4, 4; 3, 4, 4, 3; 4, 4, 4, 3; 4, 5, 4, 4.

Claw of female gonopods of moderate length; acute and well curved. Basal spines stout, conically acuminate, more strongly narrowing distally than proximally. Mesal edge of first article sharp, well chitinized, bending ectad proximally, constricted or furrowed across base.

Posterior legs of male without special lobes or modifications; slender, spines of first legs,  $\frac{0, 0, 1, 2, 1}{0, 0, 1, 2, 1}$ ; of the second to eleventh,  $\frac{0, 0, 2, 2, 2}{0, 0, 2, 3, 2}$ ; of the twelfth,  $\frac{0, 0, 3, 2, 2}{0, 0, 3, 3, 2}$ ; of the thirteenth,  $\frac{1, 0, 3, 2, 2}{0, 1, 3, 3, 2}$ ; of the penult,  $\frac{1, 0, 3, 2, 1}{0, 1, 3, 3, 1}$  or dorsal spines rarely 1, 0, 3, 1, 1, claws 3; of the anal,  $\frac{1, 0, 3, 1, 0}{0, 1, 3, 2, 0}$  or the ventral spines 0, 1, 3, 2, 1, and in one specimen observed as 0, 1, 3, 3, 1, claws 2, the accessory one large and distinct. Last two pairs of coxae laterally armed.

Length 13–18 mm.

LOCALITIES.—Mexico: Hidalgo; Guerrero Mills (type locality); El Chico (W, M. Mann). TYPE, M. C. Z. 1736; three specimens, Type and Paratypes. M. C. Z. 1735, and M. C. Z. 1734.



PLATE 1.

PLATE 1.

TIDOPS SIMUS Chamberlin.

- Fig. 1. Dorsal view of anterior portion.
- Fig. 2. Prosternum and prehensors.
- Fig. 3. Last dorsal plate.
- Fig. 4. Penult leg, mesal view.
- Fig. 5. Tarsus and portion of tibia of penult leg, ectoventral view.
- Fig. 6. Anal leg.



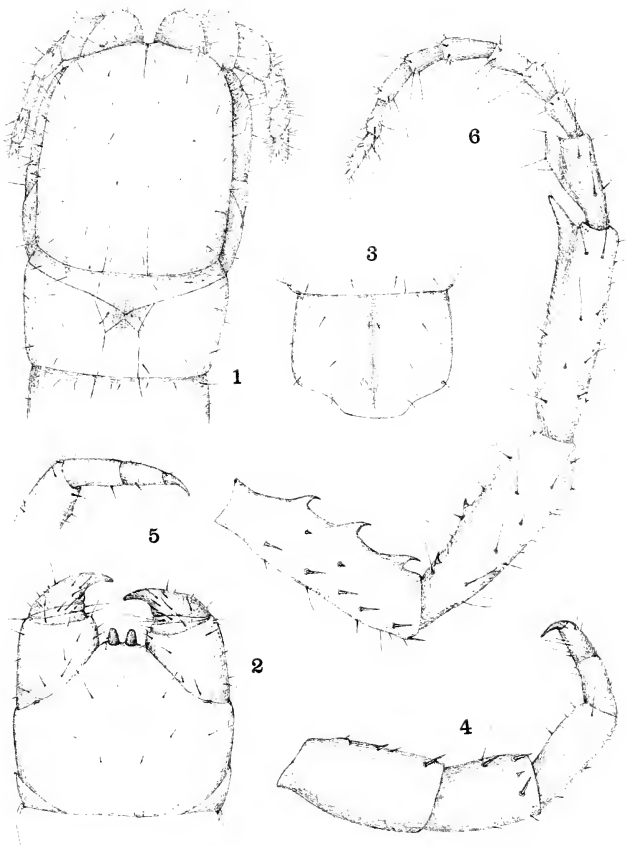



PLATE 2.

PLATE 2.

TITANOPHILUS MAXIMUS Chamberlin.

- Fig. 1. Dorsal view of anterior portion.  
Fig. 2. Ventral view of posterior portion of ♂.  
Fig. 3. Relations of spiraculiferous and prescutellar plates to tergites in eighth and ninth segments.  
Fig. 4. Relations of spiraculiferous and prescutellar plates to suprascutella and tergites in 118th and 119th segments.

TITANOPHILUS FRATRELLUS Chamberlin.

- Fig. 5. Dorsal view of anterior portion.  
Fig. 6. Ventral view of posterior portion.

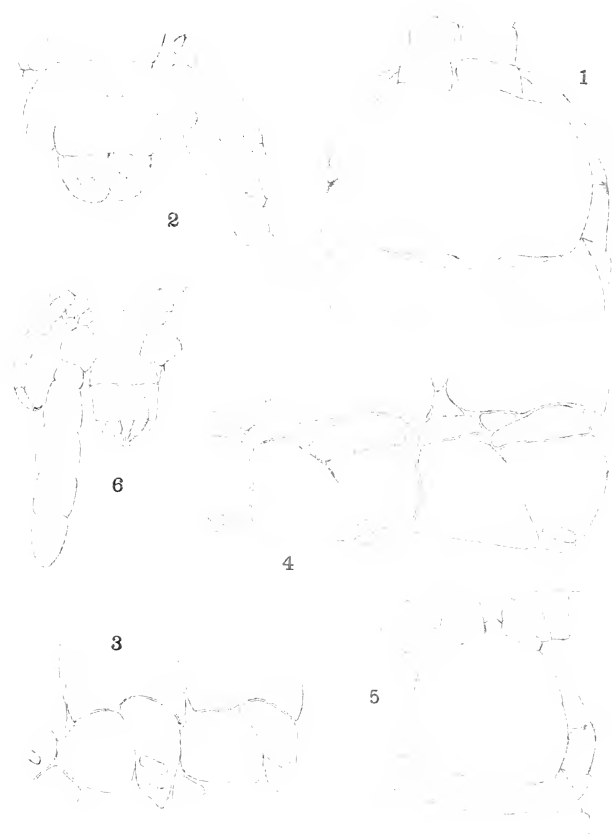



PLATE 3.

PLATE 3.

GARRINA OCHRUS Chamberlin.

- Fig. 1. Dorsal view of anterior portion.
- Fig. 2. Prosternum and prehensors.
- Fig. 3. Ventral view of posterior portion.

PAGOTAENIA LESTES Chamberlin.

- Fig. 4. Prosternum and prehensors.
- Fig. 5. Ventral view of posterior portion more enlarged ( $\sigma$ ).

LEPTOPHILUS CARRIBEANUS Chamberlin.

- Fig. 6. First maxillae.







PLATE 4.

PLATE 4.

LEPTOPHILUS CARRIBEANUS Chamberlin.

- Fig. 1. Prosternum and prehensors.
- Fig. 2. Caudal portion, ventral view, ♂.

TELOCRICUS CUBAE Chamberlin.

- Fig. 3. Second maxillae.
- Fig. 4. Prosternum and prehensors.
- Fig. 5. Caudal portion, dorsal view (♂).
- Fig. 6. Caudal portion, ventral view (♂).

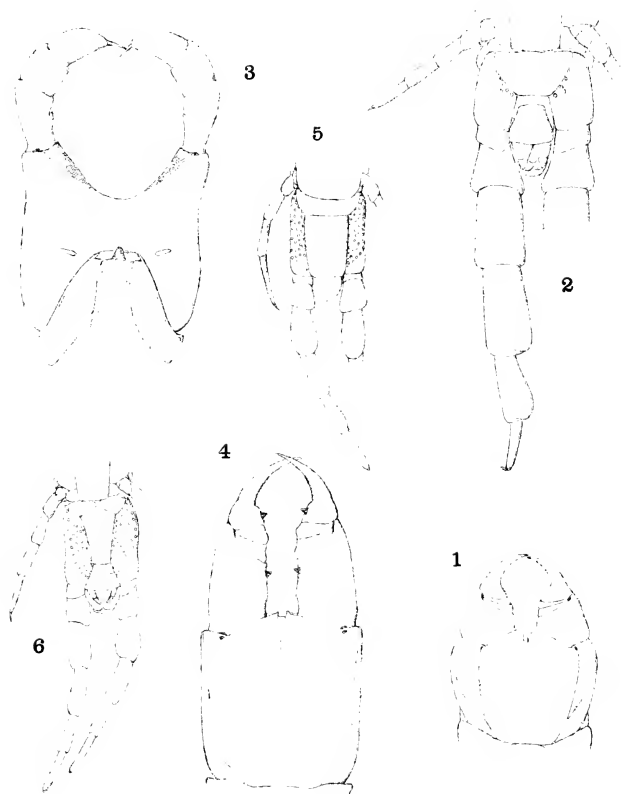



PLATE 5.

PLATE 5.

*NESIDIPHILUS LATUS* Chamberlin.

- Fig. 1. Prosternum and prehensors.
- Fig. 2. Caudal portion, dorsal view (♀).
- Fig. 3. Caudal portion, ventral view (♀).

*LESTOPHILUS PAUCIPES* Chamberlin.

- Fig. 4. Second maxillae.
- Fig. 5. Prosternum and prehensors.
- Fig. 6. Caudal portion, dorsal view.



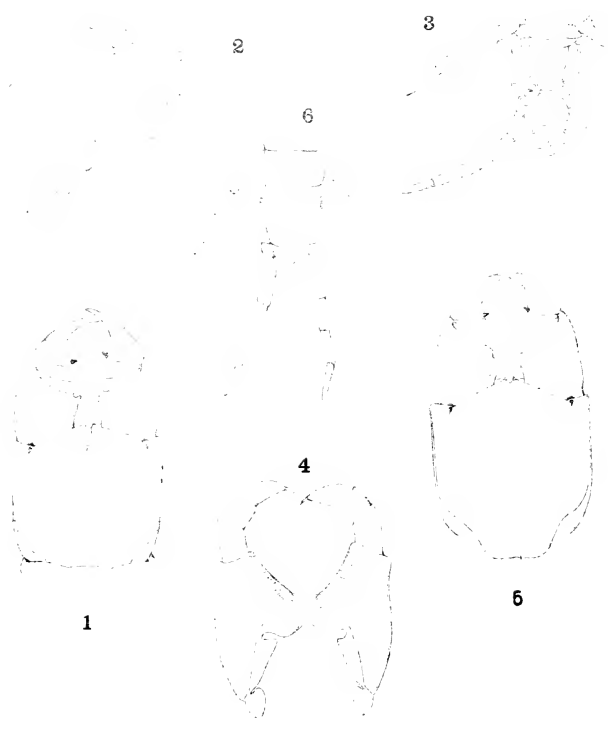



The following Publications of the Museum of Comparative Zoölogy are in preparation:—

LOUIS CABOT. Immature State of the Odonata, Part IV.

E. L. MARK. Studies on Lepidosteus, continued.

E. L. MARK. On Arachnactis.

H. L. CLARK. The "Albatross" Hawaiian Echini.

Reports on the Results of Dredging Operations in 1877, 1878, 1879, and 1880, in charge of ALEXANDER AGASSIZ, by the U. S. Coast Survey Steamer "Blake," as follows:—

A. MILNE EDWARDS and E. L. BOUVIER. The Crustacea of the "Blake."

A. E. VERRILL. The Alcyonaria of the "Blake."

Reports on the Results of the Expedition of 1891 of the U. S. Fish Commission Steamer "Albatross," Lieutenant Commander Z. L. TANNER, U. S. N., Commanding, in charge of ALEXANDER AGASSIZ, as follows:—

K. BRANDT. The Sagittae.

K. BRANDT. The Thalassicolae.

O. CARLGREN. The Actinarians.

R. V. CHAMBERLIN. The Annelids.

W. R. COE. The Nemertean.

REINHARD DOHRN. The Eyes of Deep-Sea Crustacea.

H. J. HANSEN. The Cirripeds.

H. J. HANSEN. The Schizopods.

HAROLD HEATH. Solenogaster.

W. A. HERDMAN. The Ascidians.

S. J. HICKSON. The Antipathids.

E. L. MARK. Branchiocerianthus.

JOHN MURRAY. The Bottom Specimens.

P. SCHIEMENZ. The Pteropods and Heteropods.

THEO. STUDER. The Alcyonarians.

— The Salpidae and Doliolidae.

H. B. WARD. The Sipunculids.

Reports on the Scientific Results of the Expedition to the Tropical Pacific, in charge of ALEXANDER AGASSIZ, on the U. S. Fish Commission Steamer "Albatross," from August, 1899, to March, 1900, Commander Jefferson F. Moser, U. S. N., Commanding, as follows:—

R. V. CHAMBERLIN. The Annelids.

H. L. CLARK. The Holothurians.

H. L. CLARK. The Ophiurans.

— The Volcanic Rocks.

— The Coralliferous Limestones.

S. HENSHAW. The Insects.

G. W. MÜLLER. The Ostracods.

MARY J. RATHBUN. The Crustacea Decapoda.

G. O. SARS. The Copepods.

L. STEJNEGER. The Reptiles.

C. H. TOWNSEND. The Mammals, Birds, and Fishes.

T. W. VAUGHAN. The Corals, Recent and Fossil.

PUBLICATIONS  
OF THE  
MUSEUM OF COMPARATIVE ZOÖLOGY  
AT HARVARD COLLEGE.

---

There have been published of the BULLETIN Vols. I. to LIV. and Vols. LVIII. and LIX.; of the MEMOIRS, Vols. I. to XXIV., and also Vols. XXVI. to XXIX., XXXI. to XXXIV., XXXVI. to XXXVIII., XL. to XLII., and XLIV.

Vols. LV. to LVII., LX. and XLI. of the BULLETIN, and Vols. XXV., XXX., XXXV., XXXIX., XLIII., XLV. to XLIX. of the MEMOIRS, are now in course of publication.

The BULLETIN and MEMOIRS are devoted to the publication of original work by the Officers of the Museum, of investigations carried on by students and others in the different Laboratories of Natural History, and of work by specialists based upon the Museum Collections and Explorations.

The following publications are in preparation:—

- Reports on the Results of Dredging Operations from 1877 to 1880, in charge of Alexander Agassiz, by the U. S. Coast Survey Steamer "Blake," Lieut. Commander C. D. Sigsbee, U. S. N., and Commander J. R. Bartlett, U. S. N., Commanding.
- Reports on the Results of the Expedition of 1891 of the U. S. Fish Commission Steamer "Albatross," Lieut. Commander Z. L. Tanner, U. S. N., Commanding, in charge of Alexander Agassiz.
- Reports on the Scientific Results of the Expedition to the Tropical Pacific, in charge of Alexander Agassiz, on the U. S. Fish Commission Steamer "Albatross," from August, 1899, to March, 1900, Commander Jefferson F. Moser, U. S. N., Commanding.
- Reports on the Scientific Results of the Expedition to the Eastern Tropical Pacific, in charge of Alexander Agassiz, on the U. S. Fish Commission Steamer "Albatross," from October, 1904, to April, 1905, Lieut. Commander L. M. Garrett, U. S. N., Commanding.
- Contributions from the Zoölogical Laboratory, Professor E. L. Mark, Director.
- Contributions from the Geological Laboratory, Professor R. A. Daly, in charge.

These publications are issued in numbers at irregular intervals. Each number of the Bulletin and of the Memoirs is sold separately. A price list of the publications of the Museum will be sent on application to the Director of the Museum of Comparative Zoölogy, Cambridge, Mass.











Harvard MCZ Library



3 2044 066 302 621

3 2044 066 302 621

