

SF 263

.M2

Copy 1

Buttermakers
Short
Course

McLaughlin

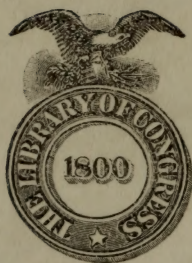

Class SF 263

Book M 2

Copyright N^o _____

COPYRIGHT DEPOSIT.

Buttermakers Short Course

By

MR. and MRS. W. J. McLAUGHLIN

Expert Buttermakers and Directors of the
Buttermaking Service Department
of the Minnetonka Company,
Owatonna, Minnesota

A reference book of practical and
scientific information on creamery
buttermaking and creamery
operation as based on
experience of the
authors

3
3
3 3 3
3 3
3 3 3
3 3

Published by
THE AUTHORS
Owatonna, Minn.

SF263
M 2

FIRST EDITION
—
COPYRIGHT, 1917.
By
W. J. McLAUGHLIN

\$ 2.00 

OCT 1 1917

©Cl.A 473762

No. 1.

To the creamery buttermaker, that
the operation of his plant may
reach its highest degree of effi-
ciency in operation, and that his
daily problems may be lessened by
the practical experience of others,
this book is respectfully dedicated

PREFACE

This volume is the result of practical experience in the scientific operation of creamery butter manufacturing plants. The daily problems of creameries and in buttermaking often hinders the operator and buttermaker in performing his duties successfully.

It is then reasonable that we should give the creamery industry the full benefit of our experiences, in plain, practical, easy to understand, information. The essential scientific buttermaking and creamery operating knowledge that we have acquired in our quarter century of experience as buttermakers and dairy experts is presented to the industry in this volume, so designed as to furnish both a text-book and a reference book for daily use.

Buttermaking and creamery operation have been thoroughly benefited by a combination of scientific principles and experience. You need only to compare the efficiency and rapidity of the buttermaking equipment in the modern creamery to know that there will come daily problems which can be most readily solved by reference to the experience of others.

In the first several chapters of this volume, we are indebted to Mr. Wm. Boss, of St. Paul, Minnesota, for the use of the illustrations. The figures used are from Mr. Boss' book entitled, "Instructions for Traction and Stationary Engines." This book is a useful volume and is broad in its scope of engineering information.

The chapter contained in this volume covering creamery refrigeration is a reprint from Bulletin No. 59 of the Minnesota Dairy and Food Department. In acknowledgment of the reprint of this bulletin we are presenting to the industry the most practical information on the subject.

The Minnetonna Company of Owatonna, Minnesota, has given valuable assistance by enabling the authors to take up every phase of buttermaking problems from first source of production to the larger points of distribution of the manufactured product.

Any problem in buttermaking or dairy work can be sent to the Minnetonna Company, who will immediately refer such problems to its service department, with which the authors are associated.

THE AUTHORS.

Table of Contents

CHAPTER	I.	Boilers	9
CHAPTER	II.	Engines and Engineering	21
CHAPTER	III.	Speed and Speeds of Pulleys	37
CHAPTER	IV.	Belt Lacing	40
CHAPTER	V.	Utilization of Exhaust Steam for Heat in Creameries	44
CHAPTER	VI.	Testing Dairy Products for Butterfat . . .	53
CHAPTER	VII.	Neutralizing Cream for Buttermaking . . .	56
CHAPTER	VIII.	Cream Blowing	60
CHAPTER	IX.	Pasteurization of Cream for Buttermaking	62
CHAPTER	X.	Commercial Starters	69
CHAPTER	XI.	Testing Milk and Cream for Acidity . . .	75
CHAPTER	XII.	Cream Ripening	77
CHAPTER	XIII.	Flavors in Cream and Butter	81
CHAPTER	XIV.	Churning of Cream	85
CHAPTER	XV.	Salting Butter and Salt Test	90
CHAPTER	XVI.	Moisture in Butter and Moisture Test . . .	92
CHAPTER	XVII.	Overrun	95
CHAPTER	XVIII.	Preparing Packages for Market	97
CHAPTER	XIX.	Scoring Butter	100
CHAPTER	XX.	Creamery Refrigeration	102
CHAPTER	XXI.	Ventilation of Creameries	122
CHAPTER	XXII.	Cream Separators' Speeds	131
CHAPTER	XXIII.	Milk for Market	133
CHAPTER	XXIV.	Chemistry and Chemical Analysis of Milk	136
CHAPTER	XXV.	Dairy Cow Judging	141
CHAPTER	XXVI.	Dairy Cows Feeds and Feeding	143
CHAPTER	XXVII.	General Creamery Information	147

CHAPTER I

BOILERS

A steam boiler is a vessel in which steam is generated by applying heat to water to be used for power or heating purposes. (Fig. 1.)

Size of Boiler and Horse Power

In speaking of the size of boiler, it is common practice to state size in horse power. The horse power means the size of a boiler, large enough to furnish steam to an engine doing equal to the given number of horse power contained in the engine.

Methods of Estimating Horse Power of Steam Boilers

One is to measure amount of heating surface upon the boiler, the other is to measure the amount of water the boiler will turn into steam in a given length of time, such as an hour.

Horse Power by Test

The commercial horse power of a boiler is an evaporation of 30 lbs. of water per hour from feed water at a temperature of 100° Fah. into steam at 70 lbs. gauge pressure with good fuel and ordinary firing. In this way a 20 H. P. boiler would use 20x30, or 600 lbs. of water in one hour, doing 20 H. P. work—water to enter the boiler at a temperature of 100° Fah. and steam used at 70 lbs. gauge pressure.

Horse Power by Heating Surface

For example, suppose we had a boiler 36 inches in diameter, 10 feet long, with thirty 3-inch tubes, and wished to know the

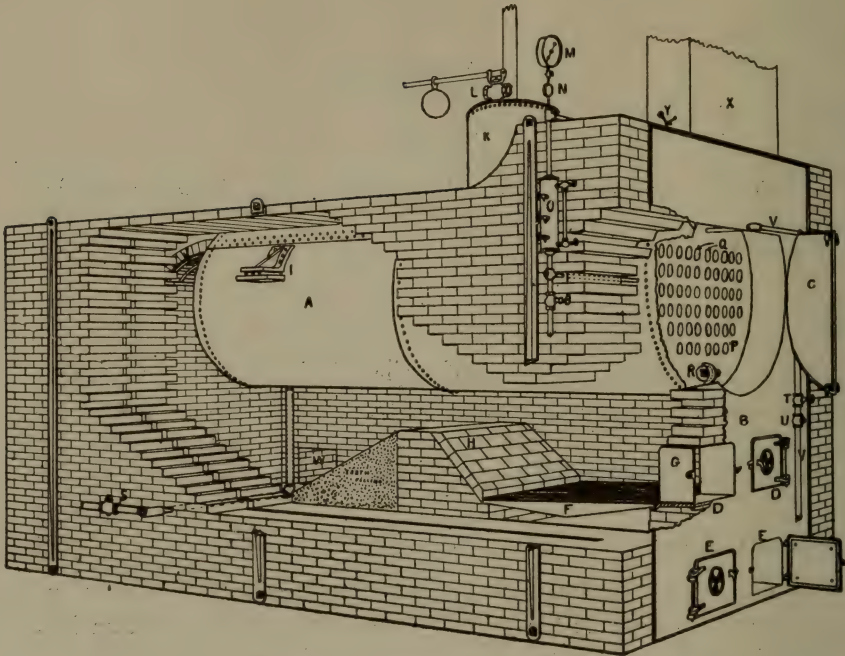

Fig. 1. Steam Boiler.

A—Boiler.
 B—Front.
 C—Flue Door.
 D—Fire Door.
 E—Ash Door.
 F—Grates.
 G—Door Liner.
 H—Bridge Wall.
 I—Bracket and Rollers.
 J—Back Arch.
 K—Dome.
 L—Safety Valve.
 M—Steam Gage.

N—Steam Gage Syphon.
 O—Water Column.
 P—Tube Sheet.
 Q—Tubes.
 R—Hand Hole.
 S—Blow Off Valve.
 T—Hand Stop Valve.
 U—Check Valve.
 V—Boiler Feed Pipe.
 W—Clean Out Door.
 X—Smoke Pipe or Britcher.
 Y—Damper.

amount of heating surface and horse power. One-half of the circumference equals 4.71 feet; 4.71 times 10 feet equals 47.1 square feet in the shell. The circumference of each tube is 9.42 inches; the length of each tube 120 inches; 9.42 times 120 equals 1,130.4 square inches; 1,130.4 square inches divided by 144 equals 7.85 square feet heating surface in one tube; 7.85 times 30 equals 235.5 square feet in thirty tubes. For the tube sheets we would measure the surface of both sheets and deduct the area of the tubes, also deduct the surface above the water. The heating surface of the sheets in this boiler would be about 7 feet. Adding the heating surface—47.1 feet in the shell, 235.5 feet in the tubes, 7 feet in the tube sheets—give us 289.6 square feet of heating surface: 289.6 divided by 14, the number of feet required for one horse power, equals 20.6 horse power.

Horse Power by Grate Surface

Sometimes the horse power of a boiler is roughly estimated by the number of square feet of grate surface. This is found by multiplying the length of the grates by their width. The amount of grate surface required under a horizontal tube boiler for one horse power would be from one-third to one-half square foot. If the grates of boiler were 36x42 inches, it would give $10\frac{1}{2}$ square feet. Allowing one-half square foot for one horse power, it would be sufficient grate surface for a 21 horse power boiler. Figuring the horse power of a boiler by grate surface is not nearly as accurate as figuring it by the heating surface.

Care of Steam Boilers

To give proper service and to be absolutely safe, a boiler must be kept clean especially. A boiler should be washed and examined at least every thirty days, the handhole plates taken out and the boiler washed clean. And the flues and crown sheets all looked over to see they are free from scale or mud.

Blowing Out Boiler

This should be done every day to remove mud and dirt in the boiler and also to prevent foaming.

Scale on Boiler

One-sixteenth of an inch will require 15% more fuel. Scale in a boiler is a non-conductor of heat, somewhat similar to brick or earth. The heat from the fuel is not conducted through the scale to the water, consequently it increases the fuel bills and is hard on the flues and other parts of the boiler, due to the terrible heat it requires to heat water through scale.

Cleaning Ashes from Pit

This is often neglected in creameries especially. It checks draughts and burns up the grates as the air cannot circulate under the grates when full of ashes also causes poor draught, requiring more fuel.

Boiler Compounds

When water forms a hard scale it is necessary to use a boiler compound to prevent scale from forming on flues or boiler shell. When a compound is necessary, the proper way is to have water analyzed by a chemist and get compound to fit the water, using just enough to act upon the scale forming substances in the water.

Blister in Boiler

A blister in a boiler is where the metal softens and stretches. This occurs when the metal is soft and often happens when exhaust steam heats water direct, getting cylinder oil into water, the oil adhering to the metal, over the fire box, keeping the water from coming in contact with the metal and the heat from the furnace softens the metal so the pressure from boiler stretches or blisters.

The only remedy is to cut out blister and put patch on boiler. A bag or sag is formed in the same way, and sometimes when not too bad it can be heated and driven back to place.

Banking Fire

Banking fire consists of covering fire with ashes or coal, closing dampers or draughts, and banking fire to hold over night. The fire should be pushed to one side of grates, and large pieces of coal put into the furnace, then covered with wet ashes. Fires can be banked to hold forty-eight hours.

Boiler Inspection

A boiler inspector should inspect a boiler by giving a thorough examination inside and outside and noting its general condition.

Hammer Test

A hammer test is made by striking boiler in places liable to be weak and noting the sound, whether the material is thick enough or whether there are cracks or defects in the boiler. A good boiler sheet will give a clear ringing sound when struck, while a thin or cracked sheet will sound dead or dull, and can be readily discovered by an experienced man. If there is any doubt about a boiler being safe it should have the hydrostatic test. This consists of filling the boiler with cold water and applying pressure with a force pump until the pressure is raised sufficiently high enough to warrant safe working pressure. Fifty per cent above the point where the steam pressure is carried, usually 100 lbs. of pressure to the square inch, is highest working pressure on creamery boilers.

Injectors

An injector is a device for supplying a steam boiler with water. Every boiler should have two sources of supply—a pump and an injector. The injector accomplishes its work by the energy of a

steam jet from the boiler. The energy which the steam jet has is derived by the heat given off by the condensation of the steam, the steam escaping through the jet at a high temperature and high velocity. As it comes in contact with the cold water the steam is condensed and its heat is given to the water, and sufficient velocity is imparted to the water to enable it to enter the boiler.

Injector Troubles

Dirt drawn into water, air leaks in suction pipe, water too hot, injector scaled up, overflow valve scaled up, check valve between boiler leaks making injector hot, pipe between injector and boiler may be closed.

To Clean Injector

Soak over night in a solution of one part of muriatic acid and ten parts of water; keep solution in jar, as it can be used several times.

Tensile Strength

Means pulling strength required to break a bar of material one inch square. Boiler iron contains from 50,000 to 60,000 pounds tensile strength. Single riveted boiler has 56% tensile strength. Double riveted boiler has 70% tensile strength. The lap or strap joint, three to four iron rivets, has 90% tensile strength.

Strength of Steam Boiler

A boiler 24 inches in diameter, $\frac{1}{4}$ -inch shell, will stand two times as much pressure as a boiler 48 inches in diameter, and $\frac{1}{4}$ inch thick; so a 48-inch boiler to compare in tensile strength should be $\frac{1}{2}$ inch thick.

Bursting Pressure of Steam Boiler

To find the bursting pressure of a steam boiler, multiply the

tensile strength of shell by thickness of shell in inches; multiply this by kind of riveted joint and divide this amount by radius, or one-half of diameter.

The safe working pressure is one-sixth of bursting pressure.

Example: Diameter of boiler, 36 inches; thickness of shell, $\frac{1}{4}$ inch; tensile strength, 60,000 lbs.; seams double riveted. What is the bursting pressure, and the safe working pressure?

60,000 multiplied by $\frac{1}{4}$ inch (thickness of shell) equals 15,000; 15,000 multiplied by 70% equals 10,500; 10,500 divided by 18 inches (radius of boiler) equals 583 lbs., bursting pressure.

583 lbs. divided by 6 (factor of safety) equals 97 lbs., safe working pressure.

Testing Chain

One foot of chain is put into machine and 14,000 lbs. pulled on chain and held for 3 minutes. Afterwards chain is examined to see if it has not stretched, nor pulled out in rivets. Stretching of chain causes the climbing of gears.

Rules for Figuring Ball and Lever Safety Valves

The following rules are given in order that a creamery engineer may be able to figure the proper blowing-off point of a safety valve. (Fig. 2.) In each of the three rules the same size valve, lever, etc., are used. The dimensions are as follows:

Weight of ball, $25\frac{1}{2}$ lbs.

Required pressure, 100 lbs. per sq. in.

Distance from fulcrum to valve stem, 2 inches.

Weight of lever, valve and valve stem (taken directly above the valve stem by means of a spring scale), 8 lbs.

Diameter of safety valve, 2 inches.

Area of safety valve ($2 \times 2 \times .7854$) equals 3.1416 sq. in.

Rule I. To find distance, ball should be placed on a lever, multiply the pressure required by the area of the valve. Subtract

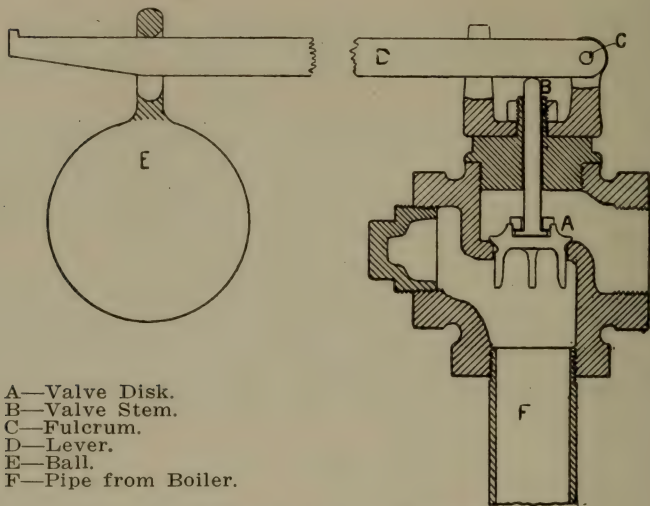

Fig. 2. Safety Valve.

the weight of the lever, valve and stem, and multiply the answer by the distance from fulcrum to center of valve stem. Divide by the weight of the ball, and the answer will give the distance to place the ball from the fulcrum.

Example: Pressure (100 lbs.) multiplied by area of valve (3.1416) equals 314.16; 314.16 less weight of lever, valve and stem (8 lbs.) equals 306.16; 306.16 multiplied by distance from fulcrum to center of valve stem (2 inches) equals 612.32; 612.32 divided by weight of ball (25½ lbs.) equals 24 inches, length of lever.

Rule II. To find weight required for a given pressure, multiply the pressure by the area of the valve. Subtract the weight of the lever, valve and valve stem, and multiply the answer by the distance from fulcrum to center of valve stem. Divide by the length of the lever from the fulcrum to the point of bearing of the ball upon the lever.

Example: Pressure (100 lbs.) multiplied by area of valve

(3.1416) equals 314.16 sq. in.; 314.16 less weight of lever, valve and stem (8 lbs.) equals 306.16; 306.16 multiplied by distance from fulcrum to center of valve stem (2 inches) equals 612.32; 612.32 divided by length of lever (24 inches) equals $25\frac{1}{2}$ lbs., weight of ball.

Rule III. To find the pressure, divide the length of lever by the distance from fulcrum to center of valve stem. Multiply answer by weight of ball. Add weight of lever, valve and stem, and divide by area of valve. The answer will be the steam pressure per square inch.

Example: Length of lever (24 inches) divided by the distance from fulcrum to center of valve stem (2 inches) equals 12; 12 multiplied by weight of ball ($25\frac{1}{2}$ lbs.) equals 306; 306 plus weight of lever, valve and stem (8 lbs.) equals 314; 314 divided by area of valve (3.1416) equals 99.95 lbs. Practically 100 lbs. steam pressure.

What is Steam?

Steam is a vapor given off from water when heated to a boiling point.

What is the Boiling Point of Water?

The boiling point of water depends upon the pressure. In an open kettle at the sea level water boils at 212° Fah. If confined in a closed boiler the boiling temperature will rise when the steam pressure rises. If a vacuum be produced, the water will boil at less than 212° Fah. The boiling point depends upon the vacuum secured.

The temperature of water at 100 lbs. gauge pressure is 337° Fah.

How much more space will water occupy when turned into steam than it occupied as water? The space occupied by water when turned into steam at a pressure of 100 lbs. will occupy 240

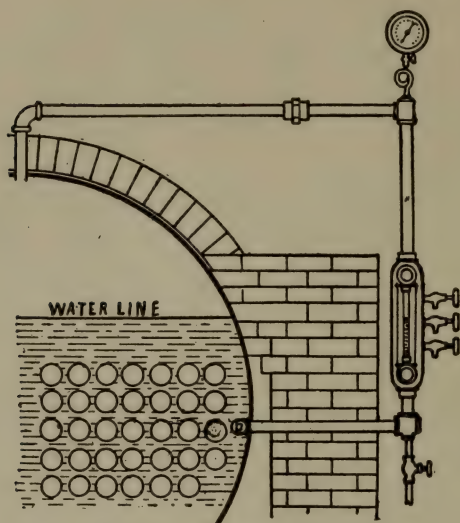

Fig. 3. Water Gauge.

times as much; and at an atmospheric pressure will occupy 1,700 times as much space.

How Should a Glass Gauge be Set on a Steam Boiler?

The glass gauge should be set so that the bottom of the glass is level or just a trifle higher than the top of the flues in the boiler. (Fig. 3.)

How Can We Tell a Gauge is Properly Set?

By removing handhole and measuring amount of water over flues and comparing with the level of bottom of glass.

How Should Gauge Cocks Be Set?

The lowest gauge cock should be set one inch above the crown sheet; the second one, four to six inches above; the third one, four to six inches higher.

Water Column

The water column on a boiler consists of a hollow cylindrical casting about 3 to 4 inches in diameter by 12 to 18 inches in length, into which are screwed the gauge cocks and glass gauge. Often the steam gauge is attached to the upper end, and a valve for blowing out, at the lower end. The lower end of the water column is connected to the boiler in the water space, and the upper end is connected to the top of the boiler or steam space, as shown in Fig. 3, which shows the manner in which they are generally placed on boilers set in brick work.

British Thermal Unit

The British thermal unit is amount of heat required to raise temperature of a pound of water one degree, or change the temperature from 62° Fah. to 63° Fah. British thermal is called Joule (J) = 778 lbs. work.

Sizes of Boilers for Creameries

A creamery making 300,000 lbs. of butter per year should have a 30 H. P. boiler and a 20 H. P. engine.

A creamery making 200,000 lbs. of butter yearly should have a 25 H. P. boiler and a 15 H. P. engine.

A creamery making 150,000 lbs. of butter yearly should have a 20 H. P. boiler and a 12 H. P. engine.

A creamery making 100,000 lbs. of butter yearly should have an 18 H. P. boiler and a 10 h. p. engine.

It is poor economy in purchasing a small power plant in either boiler or engine.

Steam Gauge

The steam gauge is an instrument for showing the steam pressure in the boiler, the pressure being shown in pounds per square inch. When the gauge shows 100 lbs., it means there is a pressure of 100 lbs. against every square inch of the boiler surface. (Fig. 4.)

How Gauge Works

The pressure of steam has a tendency to force the spring out of a coil shape to straight. This works the little V-shaped part with fine cogs on the hand, moving the hand to register number of pounds pressure to the square inch of space contained in the boiler. As the steam increases in pressure it straightens the spring and drives the hand around to register according to the figures the hand points to on steam gauge.

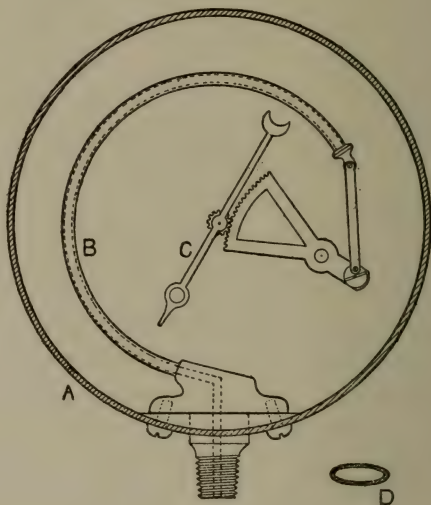

Fig. 4. Steam Gauge.

How to Test Steam Gauge

Use pump, screw up, forcing oil into gauge spring and have a tested gauge in connection so the pounds of pressure indicated on gauges can be compared.

To Set Spring

When spring becomes weak it can be set by bending down a little. The safest way is to get new gauge.

CHAPTER II

ENGINES AND ENGINEERING

Steam Engines

An apparatus for converting heat into work. A complex and powerful machine, a prime mover, anything used to effect a purpose. The modern steam engine is due to James Watt, an instrument maker in the University of Glasgow, Scotland. (Fig. 5.)

Kinds of Engines

Rotary; simple; compound; condensing; cross-compound; tandem compound and regenerating gas; gasoline.

History of Steam Engine

The beginning of the steam engine was in 1698, a water raising engine being invented by Thomas Savery. With this engine the steam worked directly on the water to be raised. In the same year Thomas Newcomb made a piston engine which approached nearer our modern steam engine of today.

Inventor of Cut-Off

A lazy but ingenious boy by the name of Humphrey Potter, who had been left to turn the valve, made the engine open and close its own valve by means of cords and thus invented the automatic cut-off or valve gear.

Dead Center

In setting the slide-valve on a steam engine, it is very necessary that the engine be placed on the dead center when the valve is

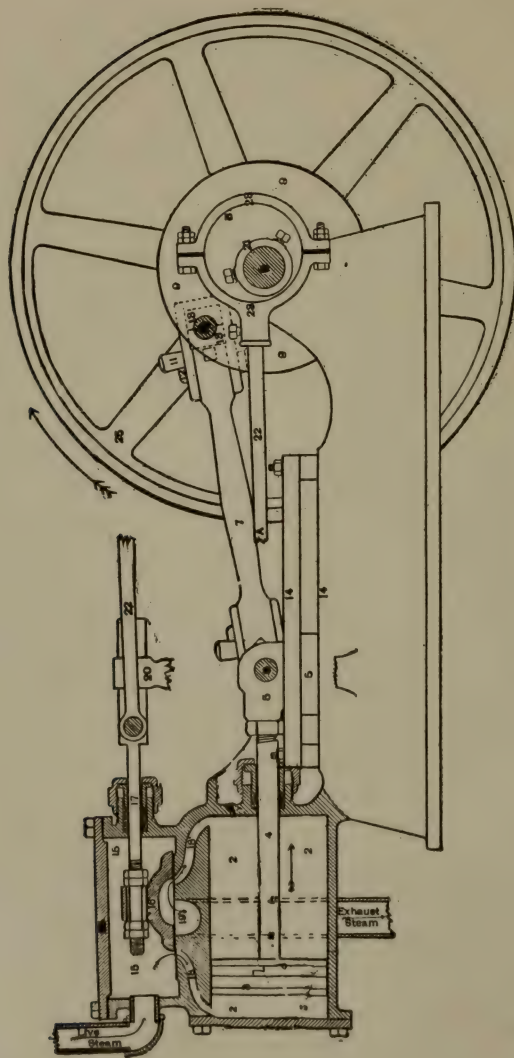

Fig. 5. Steam Engine.

- | | |
|------------------|--------------------------|
| 1—Engine Frame | 17—Slide Valve Rod |
| 2—Cylinder | 18—Steam Ports |
| 3—Piston | 19—Exhaust Cavity |
| 4—Piston Rod | 20—Slide Valve Rod Guide |
| 5—Cross Head | 21—Eccentric |
| 6—Wrist Pin | 22—Eccentric Rod |
| 7—Connecting Rod | 23—Eccentric Straps |
| 8—Main Shaft | 24—Cylinder Head |
| | 25—Fly Wheel |

adjusted. An engine is said to be on the dead center when the piston is at the end of its stroke, or when the center of the wrist pin, the center of the crank pin, and the center of the main shaft are all in a straight line. The crank passes two dead centers in each revolution.

If the engine has the proper amount of lead, steam is admitted to the cylinder when it is on the dead center, but the engine will not start when it is on the dead center, as the pressure on the piston will be pushing or pulling directly against the crank shaft. Locomotives, hoisting engines, and other engines, are often made with two cylinders and cranks connected to the same shaft, one crank a quarter of a revolution ahead of the other in order to always have one crank off the dead center, thus enabling them to start at whatever point the engine may have stopped.

It is very necessary when setting the slide valve to put the engine on the exact dead center. This should be done accurately, as a very little difference either way will make considerable difference in the valve. It will be noted that while the engine is on dead center, a little movement of the crank up or down has very little effect upon the piston, as the piston moves very slowly while the crank is passing the dead center. The motion of the slide-valve, however, when the engine is near the dead center is considerable, as it is controlled by the eccentric, and the eccentric is set a little more than a quarter of a turn ahead of the crank. It will be noted, then, that when the piston is traveling at its slowest speed near the end of the cylinder, the slide valve will be traveling at its fastest speed and any movement of the crank up or down which would have a slight effect upon the piston would have considerable effect upon the slide-valve.

There are several methods of putting an engine on the dead center. About the simplest and most accurate method is with the use of a tram; a tram being simply a rod with a point at each end turned at right angles.

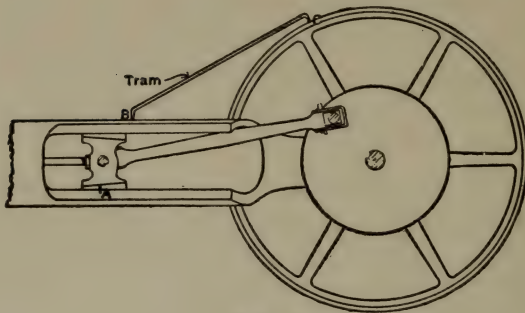

Fig. 6.

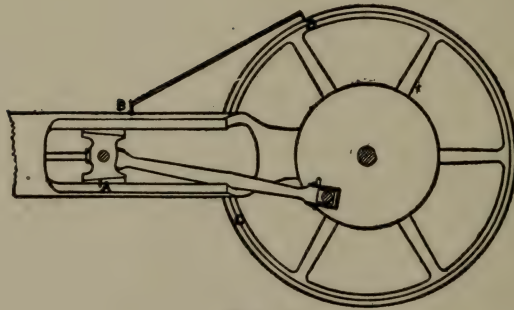

Fig. 7.

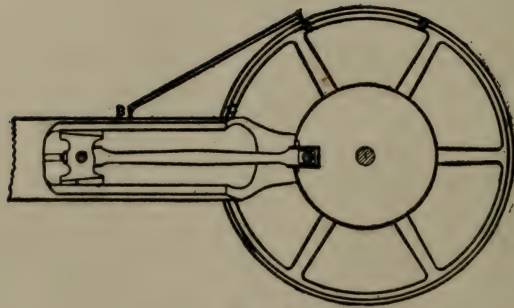

Fig. 8.

Illustrations for Finding Dead Center on Engine.

To put an engine on the dead center with a tram, turn the engine about one-eighth of a revolution off the center, and with a sharp knife make a mark on the cross-head and guide, as at A, Fig. 6.

At some convenient point on the engine frame make a mark (best with a sharp center punch), as at B. Then with a tram, which may be of any convenient length, place one end at the center punch mark B, and with the other end make the mark on the fly-wheel as at C. Now turn the fly-wheel over on the other side of the dead center until the marks on the cross-head and guide come together again, which will place the crank position as shown in Fig. 7, or as far below the center as it was above the center in Fig. 6. With the same tram make another mark on the fly-wheel, as at D. Now measure on the fly-wheel and find a point half way between C and D, as at E, Fig. 8, and turn the wheel until this mark is even with the tram. The engine will be on the dead center. Make a permanent mark on the fly-wheel at E. By keeping the tram it will be very easy at any time to put the engine on dead center, by simply turning it to fit the tram. After the permanent mark E is made on the fly-wheel, it is not necessary to preserve the marks on the cross-head.

The other dead center may be found in the same way by placing the engine near the other dead center and marking the cross-head at the other end, or it may be found by measuring half way around the wheel from E, and turning that point to fit the tram.

Occasionally a crank disk is used in place of the fly-wheel, it sometimes being more convenient to take measurements from.

In making the tram it is well to make it some definite length, such as twelve or eighteen inches from point to point. In case the tram gets lost at any time, another one may be made the same length and it will fit the marks upon the engine.

Setting Slide-Valve

To set the slide-valve of a simple engine, have the engine hot,

remove the cover from the steam chest in order to get at the slide-valve, put the engine on the dead center, and turn the high part of the eccentric 90° , or a quarter of a revolution, ahead of the crank, in the direction the engine is to run. Place the slide-valve in the center of its travel and fasten it to the slide-valve rod. Now turn the eccentric in the direction the engine is to run, until the desired amount of lead is obtained (about $1/16$ of an inch). Fasten the eccentric to the main shaft and turn the engine on the other dead center to see that it has the same amount of lead at the other end. If the lead is the same at both ends, the valve will be properly set. If there is more lead at one end of the slide-valve than at the other, it must be made even by moving the slide-valve on the rod one-half of the difference between the leads. If the engine then has too much lead, move the eccentric back towards the crank until the right amount is obtained. If the engine does not have enough lead, move the eccentric ahead, or away from the crank, to get more lead.

The lead of an engine must always be made even at both ends, by moving the slide-valve on the rod.

Moving the eccentric changes the lead at both ends of the slide-valve. Turning the eccentric ahead, or away from the crank, will give more lead at both ends. Turning the eccentric back towards the crank will give less lead at both ends. A vertical engine should have a little more lead on the lower end than it has at the upper end, as the weight of the rods, crosshead and piston requires more cushion on the lower end.

The above rule for setting the slide-valve applies to the simple slide-valve engine that has no rocker arm, and also to engines having a rocker arm pivoted at one end.

Horse Power

The common standard to which all work is reduced is horse power. Any combination that will, when multiplied together, give 33,000 foot pounds, raised one foot high, per minute is 1 H. P.

Horse power originated on a canal boat. It was found that a horse walking 2.5 miles per hour, pulling 150 lbs. on his traces, that the main effective energy which he developed was 33,000 pounds per hour; 150 lbs. x 5,280 ft. in one mile x 2.5 miles per hour x 60 seconds in one minute, equals 33,000 foot pounds.

Power and work is the overcoming of resistance.

Horse power of an engine is 33,000 pounds raised one foot, vertically, in one minute. The unit of power is work in foot pounds. One pound raised one foot in one minute is one foot pound.

The horse power of an engine may be known, where the size of the cylinder, the length of the stroke, the number of revolutions per minute, when the average steam pressure on the piston during its full stroke is known.

The average steam pressure on the piston can be determined by the use of an indicator. When this is not used it is customary to figure one-half the boiler pressure.

Main Effective Pressure

The average steam pressure on the piston during its full stroke is called main effective pressure and is marked M. E. P.

To Find the Horse Power of an Engine

Multiply the main effective pressure on the piston in pounds per square inch by the area of the piston in square inches, to obtain the total pressure on the piston. Multiply twice the number of revolutions per minute by the length of the stroke, and reduce it to feet to obtain the feet of the piston per minute. Multiply the total pressure on the piston by the piston speed to obtain the total work done per minute. Divide this last product by 33,000 (the number of foot pounds in one horse power); the quotient will be the theoretical horse power of the engine.

In determining the horse power of an engine in this manner,

some allowance should be made for the amount of power consumed by the engine itself while running.

In calculating the area of the piston, allowance should be made for the space on one side which is occupied by the piston rod. To obtain the average area upon which the steam acts, deduct one-half of the area of the piston-rod.

Figuring Horse Power of a Steam Engine

Q. What would be the horse power of a simple slide-valve engine having a cylinder 6x9 inches running 225 revolutions per minute, carrying 100 pounds steam pressure on the boiler? Diameter of the piston rod $1\frac{1}{4}$ inches.

A. Six times 6 equals 36; 36 times .7854 equals 28.2744 (area of piston); 28.2744 minus .6135 (half the area of the piston rod) equals 27.6639 inches (actual area of the piston); 27.6639 times 50 (half of boiler pressure) equals 1383.195 (total average pressure on piston); 9 inches (length of stroke) times 2 equals 18 inches of travel of piston with each revolution; 225 times 18 equals 4,050 inches; 4,050 inches divided by 12 equals 337.5 feet, travel of piston per minute; 1,383.195 times 337.5 equals 466,828 foot pounds; 466,828 divided by 33,000 equals 14.1 horse power.

Brake Horse Power

The brake horse power of an engine is the actual power which the engine will develop aside from the power required to drive the engine itself, and is the power it would be capable of supplying to a machine. The most common method of determining the power of the engine in actual operation is by means of the "Prony" brake. The Prony brake may be used for testing the power developed by a steam engine, gas engine, electric motor, or any machine from which power is obtained.

Fig. 9 illustrates a "Prony" brake as it is usually applied to the fly-wheel of an engine. It consists of two blocks of wood fitted to the pulley of the engine, and is so arranged that by tightening up

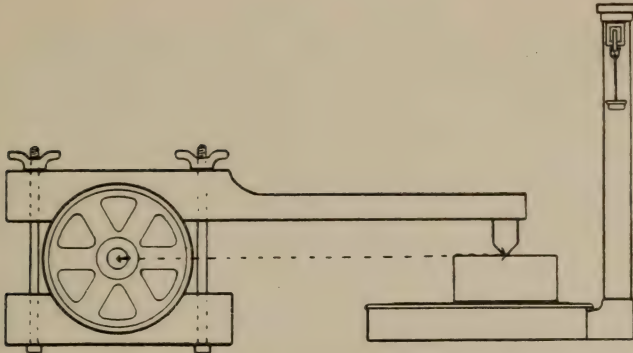

Fig. 9. Illustration for Determining Horse by Brake Test.

the bolts they may be made to grip the pulley more firmly. One of the blocks has an extension arm which rests upon a pair of scales, or, if the lever be turned on the opposite side from that shown, it may be weighted with weights, or, what is still better, held by means of a spring balance. When the engine is in motion and the screws are tightened on the blocks, the arm tends to be carried around with the pulley. With the end of the arm resting upon the scales this is presented, and the pressure with which the arm presses down upon the scales may be weighted upon the scales. The engine is started and the bolts drawn up until the friction of the brake causes the engine to work to its full capacity.

In applying the Prony brake to a large pulley, it is quite common to attach a number of blocks to a belt or iron band surrounding the pulley, having the ends attached to the arm resting upon the scales.

The blocks are kept cool by means of a stream of water running upon them, or in some cases they are greased or oiled. The running water is better, however.

It is evident that when the engine is in motion the pressure which is obtained at the end of the arm would be the same as would be obtained from a pulley having a radius equal to the distance from the center of the shaft to the point of the arm resting upon the scales.

Multiplying the circumference, then, of a pulley having a radius equal to the length of the arm in feet, by the number of pounds shown upon the scales, by the number of revolutions per minute, would give the foot pounds of work which the engine was doing. By dividing this product by 33,000 (the number of foot pounds in one horse power), the horse power of the engine is obtained.

It will be noted that the size of the pulley is immaterial, for the length of arm is taken from the center of the pulley to the point of bearing upon the scales.

Examples: Revolutions per minute, 200. Pressure given on the scales, 30 lbs. Distance from center of pulley to point of bearing of arm upon the scales, 3 feet. To find the horse power developed:

3 feet, length of arm

2

6 feet, diameter of pulley having radius equal to length of arm.
 × decimal, 3.1416 feet

= 18.8496 feet, circumference of pulley having radius equal to length of arm.

18.8496 × 200 revolutions per minute = 3769.9200 feet per minute
 × 30 lbs. pressure on scales = 113097.6000 foot pounds
 ÷ 33000 = 3.42.

33000) 113097.6 (3.42 horse power.

99000

140976

132000

89760

66000

Area

Area is the extent of any open surface, and is found by multiplying its length by its breadth, if square or rectangular. If the surface is circular the area is found by squaring the diameter, which is multiplying the diameter by itself, and multiplying this number by .7854. This rule will apply to any circular surface no matter what the diameter is. (Fig. 10.)

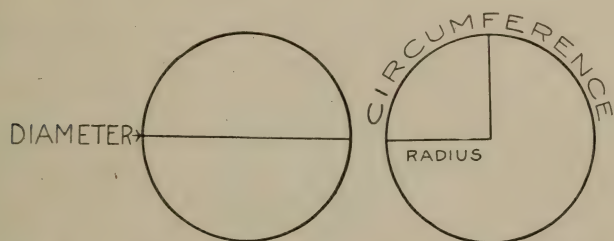

Fig. 10. Illustrating Diameter and Radius of Circle.

Circumference is the distance around a circle. The circumference is found by multiplying the diameter by 3.1416.

The diameter is the distance across a circle or through a sphere, passing through its center. Doubling the diameter of a circle will double its circumference, and will increase its area four times.

Governor

An automatic arrangement in which the osolation retardation of the motion of the governor is changed due to changes of speed of the engine is made to cut off the steam at an earlier or later period of the stroke of the piston so that when the steam raises in volume and pressure or with lighter work the steam shall be cut off earlier in the stroke. And when greater work is imposed on the engine the steam pressure flags the steam cylinder so as to admit more steam during the longer stroke of the piston.

In order to secure a steady motion from a steam engine,

it is necessary that some arrangement be made for regulating the amount of steam applied to the cylinder and piston. Engines that do not require a steady speed such as the locomotive and steam-boat engine, are not usually equipped with a governor, the speed of the engine being controlled by the engineer in charge opening or closing the throttle-valve. The throttle-valve is the valve between the boiler and the engine where the steam is turned on or off from the engine.

Engines are divided into three common types according to their governors. Throttling Engine, Automatic Cut-off Engine, and Corliss Engine, each of which has its distinct type of governor. The governor in common use upon traction and creamery engines, is the throttling governor. Engines equipped with governors of this type are said to be throttling engines.

Throttling Governors.

On an engine equipped with a throttling governor, the slide-valve has a fixed point of cut-off, the slide-valve traveling the same distance at all times. The speed of the engine is regulated by the amount of steam which the governor allows to pass through it. This regulates the pressure of the steam in the steam chest.

For instance, a large engine that has a throttling type of governor, when doing a small amount of work, might have steam in its boiler at, say, 100 pounds pressure. The governor would cut this steam pressure down as it enters the steam chest to perhaps 15 or 25 pounds, or whatever pressure is required to keep the engine at the desired speed. In case the speed of the engine fell below the required speed, the governor would open a trifle and admit more steam into the steam chest and cylinder. If the speed of the engine should increase, the governor would close a trifle and decrease the pressure of the steam in the steam chest. On an engine equipped with this type of governor, it is not possible to work steam on expansion to the same extent that it is in an automatic cut-off of Corliss engine.

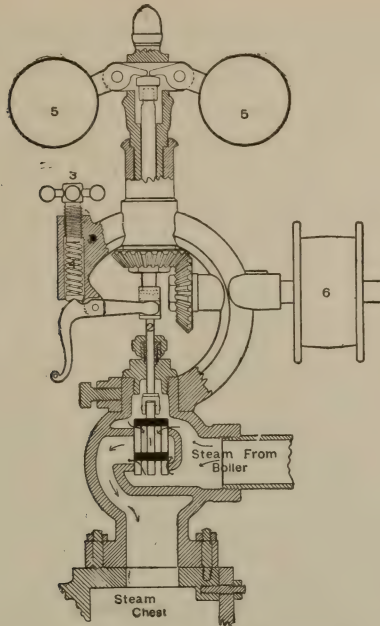

Fig. 11. Governor for Steam Engine.

Fig. 11 is a sectional illustration of a throttling Gardner governor, such as is in common use on stationary engines. The governor is usually placed upon the steam chest of the engine. Steam passes through the governor valve (1) in the direction indicated by the arrows. The valve in a governor is so constructed that steam pressure will have no effect upon its opening or closing. It will be noted that from the cut that the steam presses on the top of the valve as well as on the bottom, giving an equal pressure on both sides. The valve is raised or lowered in its seat, to allow more or less steam to pass through it, by the valve stem (2) which extends up near the top of the governor. The valve stem is held up and the valve opened by the spring (4) pressing down upon one end of the lever, the other end of the lever raising the valve and stem. The tension of the spring and the speed of the governor is regulated by the hand wheel (3). When the governor is at

rest the valve is wide open, and the governor balls (5) which are hung upon pivots, are dropped at the side of the governor.

The power which operates the governor and controls the speed of the engine, is carried from a pulley upon the main shaft of the engine to the governor pulley (6). The motion is then carried through the pulley shaft and by means of gear wheels up to the governor balls, and causes them to revolve upon their stem. When the governor is in motion, the balls revolving tend to swing outward and upward turning upon the pivots from which they are suspended. In doing this the end of the lever on which the balls are being pressed downward upon the top of the valve stem, partly closing the valve and decreasing the amount of steam which the governor lets through into the steam chest. In case the speed of the engine decreases, the speed of the governor will decrease and the balls will lower their position, allowing the valve stem to rise and admit more steam to the steam chest.

To increase the speed of the engine, screw down the hand-wheel (3), which will increase the tension on the spring and require more speed from the engine and governor before the balls will rise sufficiently to shut off steam from the steam chest.

To decrease the speed of the engine, screw up the handwheel (3), which will release the spring and allow the valve to be forced down with less speed of the engine.

Governor Belt Off

When the governor belt is taken off the pulley, the governor will open wide and remain in that position, giving the same effect that would be had were there no governor upon the engine. The engine is then controlled entirely by the steam pressure regulated by the throttle-valve. When the engineer has hold of the throttle and controls the steam admitted to the steam chest, and does not allow the engine to run too fast, it would have the same effect that the governor would have with the belt on. It is not a

good plan, however, to remove the governor belt, as the engineer is liable to give the engine too much steam and run it at too high a speed. Running it at a high speed causes a severe strain upon all of the bearings and parts of the engine. The governor belt should always be left on. If it is desired to increase the speed of the engine, adjust the regulating screw of the governor to the required speed. Any traction engine will travel as fast as the manufacturers have designed that it should travel when the governor belt is on.

Engine Racing

An engine is said to be racing when the speed of the engine increases and then decreases while the engine has the same load upon it. This is usually caused by some trouble with the governor. The most common trouble is from the governor valve stem being packed too tight. When it is packed too tight the packing binds upon the stem, and it will require considerable force from the balls before they will force it down. After they have forced it down, the speed will decrease, and will sometimes decrease considerably before the pressure from the spring will raise it to admit steam again. The valve stem should be packed quite loosely in order to give the governor perfectly free play up and down. It should be packed with a soft packing, and the packing renewed frequently before it hardens.

Occasionally an engine will race from the governor not being packed firmly enough. If an engine races, try loosening the packing until the governor is perfectly free. Then if it does not stop, tightening the packing a trifle will sometimes remedy it.

A governor will race in case it is not properly oiled. The pivots upon which the balls swing should be oiled, also the shaft upon which the balls revolve, and the shaft carrying the pulley wheel.

A governor will also race if the governor belt is too loose and slips.

In starting an engine, always turn the steam on slowly until the governor gets into operation and controls the speed of the engine. The throttle-valve should then be opened wide, the speed of the engine be controlled by the governor.

Indicators

Steam engine indicator is an instrument for recording the steam pressure at all points of the stroke of the piston on the steam engine.

Increasing speed of engine will increase power. Doubling speed of engine will almost double power if boiler pressure be maintained.

Speed indicator is an instrument to measure speed.

Engine Racing Causes

When the speed increases and decreases without difference of the load being pulled, we term it "Racing." This is caused by the governor.

Where to look for trouble:

Weak spring.

Governor valve rod packed too firm.

Not being packed enough.

Bearings sticking.

Not properly adjusted.

If bearings are out of line.

Engine not properly lubricated.

Valve stem bent.

Valve seat sprung by freezing.

Sometimes cannot be repaired outside of machine shop.

A governor admits 50 per cent of the boiler pressure.

To decrease speed of engine, speed up governor, and vice versa.

CHAPTER III

SPEED AND SPEEDS OF PULLEYS

Speeds

One hundred and fifty R. P. M. is maximum speed. Very much above or below is called high or low speed.

Speed of Pulleys and Gearing

In calculating the speed of pulleys for running shafting or machinery, it is not necessary to find their circumference. Pulleys are spoken of in reference to their diameter. The diameter of pulleys commonly run in even inches, and in calculating them, where the calculations come under or over a full inch, the fraction is either thrown off or added to, as the case may be, in order to allow for slipping. Belts will slip or creep a trifle on pulleys. The driven pulley should be a trifle smaller than it figures. The driving pulley should be a trifle larger than it figures, to allow for slipping. In calculating the speed of gear wheels or chain sprocket wheels, multiply or divide by the number of teeth in the wheels.

The pulley upon the engine, or the one which is doing the work, is called the driving pulley. The pulley upon the shafting, or the one that is being driven, is called the driven pulley.

Rule I. To find the number of revolutions of driven pulley, when the diameter of the driving pulley and its speed are given:

Multiply the diameter of the driving pulley by its number of revolutions per minute, and divide the product by the diameter of the driven pulley. The quotient will be the speed of the driven pulley.

Example: Diameter of driving pulley, 30 inches.

Revolutions per minute, 200.

Diameter of driven pulley, 15 inches.

What is the speed of the driven pulley?

30 multiplied by 200 equals 6,000.

6,000 divided by 15 equals 400, speed of driven pulley.

Rule II. To find the diameter required for driven pulley, when its number of revolutions and the diameter and number of revolutions of the driving pulley, are given:

Multiply the diameter of the driving pulley by its number of revolutions, and divide the product by the number of revolutions the driven pulley is to make:

Example: Diameter of driving pulley, 30 inches.

Revolutions of driving pulley per minute, 200.

Speed required of driven pulley, 400 revolutions.

What should be the diameter of the driven pulley?

30 multiplied by 200 equals 6,000.

6,000 divided by 400 equals 15 inches, diameter of driven pulley.

Rule III. To find the number of revolutions of driving pulley, when its diameter and the diameter and speed of driven pulley are given:

Multiply the diameter of driven pulley by its revolutions, and divide the product by the diameter of driving pulley. The quotient will be the speed required of driving pulley.

Example: Diameter of driving pulley, 30 inches.

Diameter of driven pulley, 15 inches.

Speed of driven pulley, 400 revolutions.

What is the speed of the driving pulley?

400 multiplied by 15 equals 6,000.

6,000 divided by 30 equals 200, required speed of driving pulley.

Rule IV. To find diameter of driving pulley, when its speed

and the speed of driven pulley and its number of revolutions per minute are given:

Multiply the diameter of the driven pulley by its number of revolutions per minute. Divide the product by the number of revolutions of the driving pulley. The quotient will be the diameter of the driving pulley required.

Example: Speed of driving pulley, 200 revolutions per minute.

Diameter of driven pulley, 15 inches.

Speed of driven pulley, 400 revolutions.

What should be the diameter of the driving pulley?

400 multiplied by 15 equals 6,000.

6,000 divided by 200 equals 30, size required driving pulley.

CHAPTER IV

BELT LACING

Lacing Belt

In order to get the best service from a belt, it should be cut the proper length and well laced. The belt should be tight enough to prevent slipping, but not tight enough to cause heating of the bearings. The proper tension of a belt can best be learned by experience.

In putting on a leather belt it should be placed with the "hair" side or hard side next the pulley. After a belt has been run for a short time and is in good condition, this side will carry the most power without slipping. The belt will also last longer when run with this side next the pulley. Upon examining a leather belt it will be noted that the hair side is much more firm than the flesh side. If a belt be put on with the flesh side next the pulley the hair side will be obliged to stand the pulling strain. As the belt becomes older or harder, this pulling strain will crack the belt on the hard side. The strain must then be carried by the flesh side alone, which will have a tendency to stretch and the belt become loose. If a belt be run with the hard side next the pulley, the flesh side will stretch a trifle and the strain will be distributed through the entire thickness of the belt. Leather belts should be placed so as to run off from the laps and not on to the laps. This will prevent the belt from turning up at the ends of the splices.

There are many patent belt fastenings upon the market, but probably the most satisfactory for all around work is the ordinary belt lace. If the lacing be well made, the belt should run for a considerable length of time without attention. One difficulty is that lacings are often put in hurriedly and are not properly done.

The ends of the belt should be cut perfectly square across. The holes should be punched exactly opposite each other in the two ends. In punching holes in a leather belt it is well to use an oval punch, the longer diameter of the punch being parallel with the belt, so as to cut off as little of the belt as possible. In a rubber or Gundy belt, the holes should be made with an awl, which will separate the canvas in the belt without cutting it.

For the best method of lacing there should be two rows of holes. It is usually better to put one more hole in the row next to the end, than in the second row. The size of lace to use will depend upon the size of the belt. If a light belt, the lace should be $\frac{1}{4}$ of an inch wide, or less. With medium belts, $\frac{3}{8}$ inch lace should be used. For heavy belt use $\frac{1}{2}$ inch lace.

Lace leather may be bought either in the hide or in bunches of 100 feet, 100 feet of lace would be pieces sufficient to reach 100 feet if they were laid end to end. Each piece is usually about four feet in length. Where much lace is used it is better to buy the hide, as in this way any desired width of lace may be cut.

In lacing belts always keep the lace straight on the side of the belt that runs next the pulley, crossing the lace on the outside of the belt. Always start lacing in the center of the belt and at the center of the lace. Lace out and back with each end of the lace. This will bring the end of the lace back to the center of the belt. By placing the ends of lace through small holes punched a short distance back from the other holes, so the lace will draw through firmly, there will be no need of tying it. Simply cut off the lace about one-half inch from the hole. In making the lacing, the belt should be held so the sides of the belt will be straight with each other.

After the lacing is made, it is a good plan to lay the belt on a block and with a hammer or mallet pound it down a little to flatten the lace where it passes through the holes and prevent jumping when the splice passes over the pulleys.

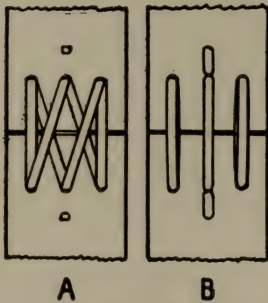

Fig. 12.

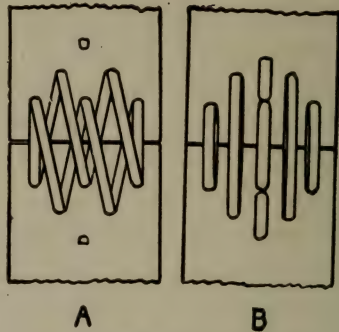

Fig. 13.

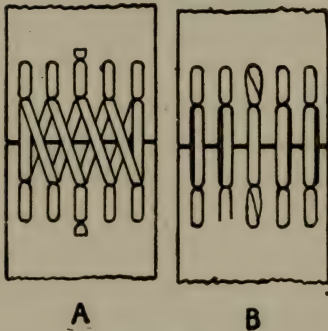

Fig. 14.

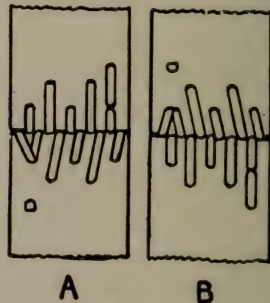

Fig. 15.

Figure 12 shows a lacing for a small belt pulling a medium load. This is a good lacing where too much strain is not put upon the belt. A shows the flesh side of the belt, or side away from the pulley. B shows the hair side, or the side running next the pulley.

Figure 13 shows a good lacing for a belt somewhat larger and heavier, and where much more work is required.

Figure 14 shows a lacing for a heavy belt, doing heavy work. While this lacing is a little more complicated to make, it will stand more strain and will probably run with less pounding than the other lacings. The central part of the splice has two thicknesses of the lace, while the part farthest away from the joint of the

belt has only one thickness. In this lacing the one thickness strikes the pulley first and then the double thickness, which allows the splice to mount the pulley without pounding to a great extent.

Figure 15 is the "hinge" lacing, and is frequently used on a belt running rapidly over a small pulley. This belt is laced the same as a baseball cover is sewed. In making this lacing the ends of the belt should be beveled off a trifle so as not to wear the lace. In making this lacing it is necessary that the ends of the lace come at the sides of the belt as the lace passes only once through each hole. This is in order to get as thin a lacing as possible and prevent pounding as it passes over the pulley.

Belts are sometimes made endless. It is accomplished by trimming the ends of the belt down so as to lap and cementing them together with a belt cement. A belt that is made endless will run much better and quieter than where lacing is used. The objection to an endless belt is that it requires some time to make the joint, and it is more difficult to take off when it becomes slack, as the joint would have to be opened and recemented.

A leather belt should be oiled with neats foot oil to keep it in good working condition. It should not be soaked full of the oil, as it would be liable to stretch, but just enough to keep it pliable and prevent cracking. It is not a good plan to apply rosin or anything of similar nature to a belt to prevent slipping. A belt should be wide enough and tight enough to do the work required of it without slipping. Rosin applied to a belt has a tendency to make it hard, and will shorten its life.

In putting on a rubber belt it should be placed with the lap where fastened together next to pulley. This will prevent belt from dividing where lap is made, as pulling next to pulley will hold in place and prolong life of belt.

CHAPTER V

UTILIZATION OF EXHAUST STEAM FOR HEAT IN CREAMERIES

The most economical heating system is made by laying 2-inch pipes in the floor. They should be laid in sand or gravel, under the cement floor and connected with the exhaust steam from the engine. These pipes should be laid about six or eight inches from foundation around the room to be heated, and then about two to two and one-half feet apart, sloping a little towards the center of the room so as to drain. (Fig. 16.)

Size of Pipe to Use

Size of pipe is two inches when common pipe is used. The elbows used should be common galvanized ells used for water spouts. Have elbows large enough to slip over pipes, then use the cement to make the joint. When the galvanized elbows have rusted out the cement joint elbow will remain. When the pipes are laid the floors can be laid right over them. This allows pipes to expand and contract without cracking floors.

Using Soil Pipe

Cast iron soil pipe can also be used in 3-inch size. Then the distance between the pipes can be 3 feet apart and 1 foot from the foundation. The joints should be corked with lead so as to give the pipes a chance to expand and contract.

Things to Remember if Using Exhaust Steam in the Floor

Never lay pipes in cement as they will expand and crack floor.

Be sure to use 2-inch pipes and 3-inch soil pipes when soil pipes are used.

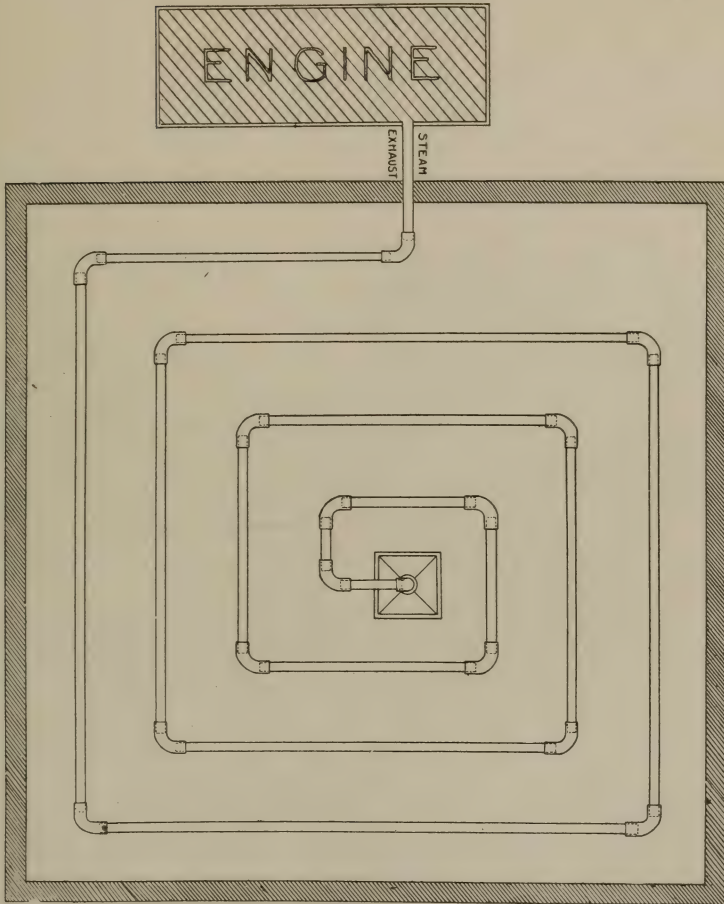

Illustrates how pipes are laid in the creamery floors for the purpose of heating the building, using exhaust steam from the engine.

Fig. 16.

Be sure pipes have proper slope.

Be sure to lay pipes in sand under cement, four to six inches of sand, under pipes are laid.

The Advantage of Heating With Exhaust Steam

It is economical as it costs practically nothing.

It is sanitary—no radiators to leak, no steam to corrode.

It does not take up any room.

It helps to ventilate a creamery.

It will last as long as a creamery will last.

The only expense is the first cost.

There is no up-keep.

First cost in installing the exhaust pipes: The cost of pipes should range from five to twenty cents per foot, as second-hand pipes can be used. The actual cost for pipe and labor will be from \$50.00 to \$150.00, depending upon the size of the creamery.

Heating of the Store Room.

One pipe should be laid in store room—just enough to remove dampness from floor—about four feet from the outside of the room, and around room and out to the work room again.

Capacities of Tanks

Multiply the height in feet by the width in feet, and this by length in feet. Divide result by 4. 4 x 10 equals 40 x 6 equals 240, divided by 4, equals 60 gallons.

To reduce to gallons, length in inches by the height in inches by width in inches dividing by .231.

UTILIZATION OF EXHAUST STEAM IN CREAMERIES

Of the many opportunities for more economical operation in creameries, none deserves attention any more than the proper utilization of the exhaust from the steam engine for heating feed water, wash water and skim-milk; also for heating the building in cold weather and for pasteurization of cream by the intermittent system.

In ordinary creamery practice less than 10 per cent of the heat value in live steam is used in driving the engine, and the other 90 per cent is piped outside and allowed to go to waste, yes, worse than waste, because the condensed water and oil is allowed to spatter all over at least one side of the building, which, to use a mild expression, does not add to the attractiveness of the creamery. The fact that some creameries have found it more economical to use the gas engine for power, is no doubt due to this waste of heat in the first place, and secondly, to a poor boiler work, poor draft, a careless fireman and a badly worn engine.

There is no one convenience that can be added in the creamery that will save the buttermaker so much time and labor and at the same time reduce the cost of operation as much as will the installation of an enclosed exhaust water heater, that has a capacity of 300 to 500 gallons of water, together with a belt driven boiler feed pump. It means a constant water level in the boiler by adjusting the pump to the proper speed, and plenty of hot water for washing the churns, utensils, floor, etc., at all times.

Cost

As compared with an injector for boiler feed, and live steam for heating all wash water, this outfit will pay for itself in about a year, as the total cost of tank, pump, pipes, valves, etc., will only be about \$150.00 to \$200.00, depending on the size of tank, kind of pump, and the amount of piping necessary.

Other Heaters

There are quite a number of creameries that have, or have had, so-called exhaust heaters, but they were not built along lines best suitable for creamery purposes, as they all held a small quantity of water and were dependent on a steady stream of exhaust, which is not always available. For this reason we have had a heater built and installed at the Albert Lea State Creamery as per plans on the following pages, which has proved practical and satisfactory, and which we recommend as an investment for all creameries using steam for power.

Size of Tank and Coils

A tank 8 feet long by 42 inches diameter, with a 2½-inch twelve-pipe coil will hold about 500 gallons of water, and is suitable for large creameries having two churns and everything else in proportion. A smaller tank, 8 feet long by 36 inches diameter, with a twelve-pipe coil made from 2-inch pipe, will hold a little over 300 gallons and will be found large enough for small and medium creameries where there is only one churn and the exhaust pipe on the engine is only two inches. The smaller coil can be used in the large tank if you have a small engine and a large creamery; or the large coil can be used in a small tank if you have a large engine and a small creamery. The idea is to use a coil that will correspond somewhat with the amount of exhaust it will have to handle, so as not to cause back pressure on the engine. It is also important that each pipe in the coil lay as nearly level as possible, so as not to form any water pockets.

Location

By studying the drawings anyone will easily understand the principle on which this heater will work. It can be placed anywhere, so long as the top of the heater is at least one foot below the bottom of the water tank, which is usually located in the upper story or suspended immediately below the ceiling. A suitable loca-

tion in most creameries will be on the rear part of the boiler work or tank suspended from ceiling, as shown in Figure No. 17, and as it only needs support near the two ends, it will not rest on the boiler or interfere with same in any way.

Water Connections

The water is piped from the water tank to the bottom of the heater, which, when full, will overflow to any part of the creamery as long as there is water left in the supply tank, but no longer. As the water warms up it will naturally rise to the top of the heater, and in this way the hottest water is always drawn first, while it may yet be quite cold at the bottom or center. It is most desirable to have the water inlet and outlet at opposite ends, and ordinarily 1¼-inch pipe is sufficiently large for this purpose, with 1 inch or three-fourths inch branch lines to the feed pump, churm, wash sink, etc. It is a disadvantage to have too large distributing pipes for the hot water, as it will quickly cool off, and considerable lukewarm water will be wasted. When connecting up the cold water be sure to screw a short pipe two or three inches up into the heater, then use a tee or cross on the outside, so that this inlet can be used for outlet as well, in case you were short of water after cleaning the boiler, or in case of emergency you could draw all the water that is contained in the heater.

Waste Water Tank

Every creamery should have a separate tank upstairs into which they could pump all the waste water from the cream vats, pasteurizing cooler, starter can and from the compressor where mechanical refrigeration is used. Then this waste water can be piped to the heater and will be found to be more than sufficient to feed the boiler, and for all possible washing purposes in a creamery, and will save the cost of a pump and tank many times over. This is especially true where water can only be had at great depth.

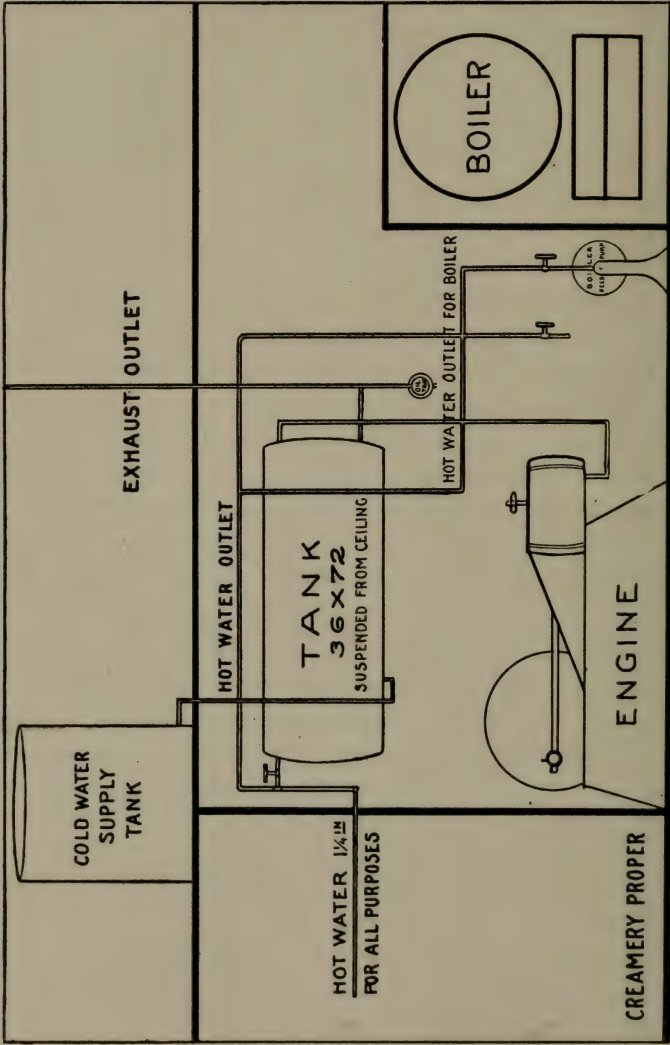

Fig. 17. Exhaust Heater for Hot Water Plant Used in Creameries.

Exhaust Connections

The exhaust should be piped directly up through the roof with as few turns as possible, and have an exhaust head above the roof and a back pressure valve just below the ceiling and it can then be branched off to the water heater, skim-milk heater or radiators with a separate valve on each of these branches, so as to properly regulate the amount of exhaust desired for each purpose. It is usually found most desirable to use the exhaust for two or more purposes at the same time. Where all the exhaust is not wanted the back pressure valve can be set to let all or any part of it out.

In some instances oil traps are used in connection with exhaust water heaters, the exhaust steam being run directly into the water, thereby saving the condensed water, but we do not deem this advisable, as no oil trap will take out all traces of oil, and they need some attention and are liable to be neglected, when they will soon fill up and not work at all.

Capacity of the Hot Water Tank Using the Exhaust Hot Water System for Creameries

A creamery making 100,000 lbs. of butter in a year, the hot water tank should be 30 inches in diameter, 72 inches long, holding 200 gallons of water. Should contain 305 square feet of coil surface; 48 lineal feet of 2-inch pipe.

Creamery making 150,000 lbs. of butter per year, the hot water tank should be 36 inches in diameter, 72 inches long, holding 315 gallons of water. Should contain 425 square feet of coils, 67 lineal feet of 2-inch pipe.

Creamery making 250,000 lbs. of butter in a year, the hot water tank should be 42 inches in diameter, 96 inches long, holding 525 gallons of water. Should contain 785 square feet of coils, 125 lineal feet of 2-inch pipe.

Creamery making 300,000 lbs. of butter in a year, the hot water tank should be 48 inches in diameter, 96 inches long, hold-

ing 750 gallons of water. Should contain 103 square feet of coil, 112 lineal feet of 3-inch pipe.

Cold Water Inlets on Tanks

The cold water inlet on those tanks should be larger than the hot water outlets. 1-inch outlet should have 1¼-inch inlet; 1½-inch outlet should have 2-inch inlet; 1½-inch outlet should have 2½-inch inlet; 2-inch outlet should have 3-inch inlet. This is for the purpose of keeping pressure on hot water tank.

Advantages of the Exhaust Water Heater

This exhaust water heater is a practical addition to the creamery equipment.

It furnishes abundant clean hot water for all purposes.

The water can be piped to every place in the creamery where hot water is wanted.

It is automatic and needs no attention and is ready at all times.

In an average creamery it will pay for itself in a year.

The time and labor saved is worth its entire cost of installation.

A large amount of impurities will be taken out of the water before it goes into the boiler.

It is cheap to construct and easy to take care of.

It is a handy reservoir to use when cleaning and refilling boiler.

It saves and relieves strain on the boiler to use warm water instead of cold water.

The feed pump in connection with the exhaust heater can be adjusted to give a steady water level in the boiler during the entire run with but little attention.

It will last a lifetime.

It is simple to clean.

The time for cleaning depends on the water used and once a year would ordinarily be sufficient.

The engine uses less than 10 per cent of the heat value in live steam. Why not utilize some of the remaining 90 per cent that is worse than wasted?

CHAPTER VI

TESTING DAIRY PRODUCTS FOR BUTTER FAT

Testing Cream, Milk or Cheese

To test cream: Carefully weigh up 18 grams of cream; then add enough sulphuric acid with a specific gravity of 1.82183 temperature of 60° Fah. until contents in bottles show a coffee brown; place in tester; run for 5 minutes at proper speed; then add water at temperature of 160° Fah. containing no lime or alkali, until fat flows up to zero mark. Place in the tester; run 5 minutes; then add water, temperature 145, until fat floats up in neck of bottle above zero mark; place in tester; run 2 minutes; then place in water at temperature of 145° Fah.; and after a few minutes, read.

To test milk: Carefully measure 17.6 c.c. milk in test bottles; add sulphuric acid; shake; add amount of acid until ingredients turn coffee brown; place in tester run at proper speed 5 minutes; add hot water at 150° Fah. which does not contain lime, alkali, or any foreign matters, until fat rises to zero mark; place in machine; run 4 minutes; fill with water, temperature 145, until fat rises above zero mark; run 3 minutes; then place in water at temperature 145° Fah. for 2 minutes; then read.

To test buttermilk: Carefully measure 17.6 c.c. buttermilk in skim-milk bottle; then add enough acid to dissolve solids; then add enough to get color of coffee brown; place in tester; run 10 minutes; fill up to neck with water at 170° Fah.; run 8 minutes then add hot water at 170° Fah.; run 5 minutes; place in hot water at temperature of 160° Fah. for 5 minutes; then read. (Figs. 18A and 18B.)

Skimmed milk is tested the same as buttermilk.

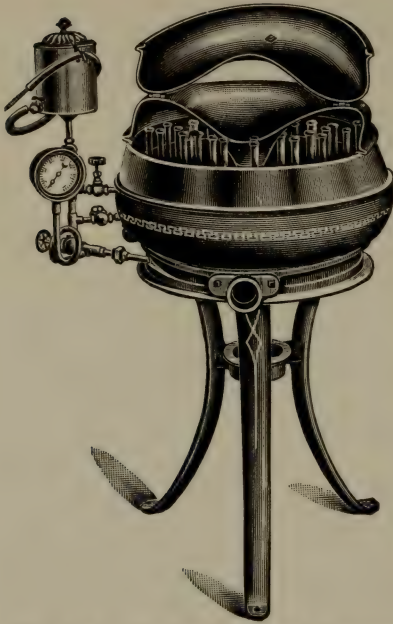

Fig. 18A. Facile Babcock Tester
Manufactured by D. H. Burrell Company, Little Falls, N. Y.

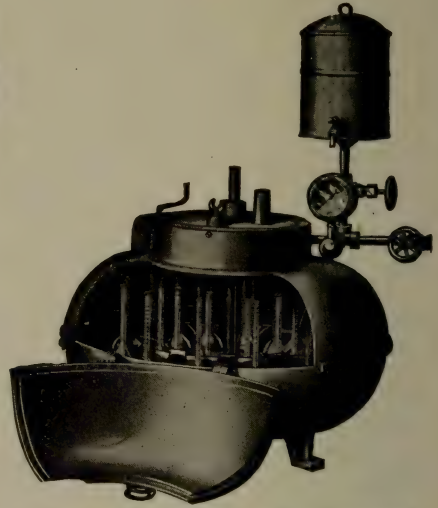

Fig. 18B. Wizard Babcock Tester
Manufactured by Creamery Package Mfg. Co., Chicago, Ill.

To test cheese: For testing cheese, weigh up 18 grams of cheese; add sulphuric acid until curd is dissolved and shows a brown color (dark brown); then proceed as in testing milk.

Causes of Defects in Tests

- Running tester too slow.
- Sour lumpy cream.
- Too much acid.
- Too strong acid.
- Too weak acid.
- Reading test too cold.
- Reading test too hot.
- Not thoroughly mixing sample before testing.
- Not taking a proportionate sample.

Speed of Babcock Testers

Diameter	R. P. M.
10 inches	1,074
12 inches	980
14 inches	909
16 inches	884
18 inches	800
20 inches	759
22 inches	724
24 inches	650

Temperatures of Cream

Temperatures of acid and temperatures of cream should be the same or nearly the same, about 70° to 80° Fah.

To Test Lumpy Cream

Add one-fourth stick of caustic soda. Put this in sample of sour cream and stir until lumps dissolve.

To find number of pounds butterfat in milk or cream, multiply the pounds of milk or cream by percentage as shown by test and divide by 100.

CHAPTER VII

NEUTRALIZING CREAM FOR BUTTERMAKING

This is done by adding lime water to the cream to be pasteurized when received with high acid (sour). Must be done before pasteurizing. It is necessary that cream should contain .25 of 1 per cent to .3 of 1 per cent so as to prevent the casein from becoming separated from the butter fat, causing it to whey off or turning into cheese while being heated.

To Neutralize

It is necessary to know the percentage of acid cream contains that the ratio of lime water can be figured in order to neutralize the acid. The danger point of coagulation, and when it will separate is at a temperature from 78 to 115° Fah. After it is above 120° Fah. there is no danger. The flash pasteurizer is preferable in using this kind of cream.

Heating to 110° Fah. and holding for several minutes also prevents coagulation of the casein. This is necessary especially when sour and sweet cream are mixed together before pasteurizing.

Making Neutralizer Solution.

Use 10 lbs. of lime, 10 lbs. of soda ash, and 30 gallons of distilled water; mix together 20 hours before using.

After mixing neutralizer place in refrigerator, mix in a clean wooden keg or barrel, and stir up well before using.

Percentage of Lime Water to Use

Neutralize in proportion to fat content and percentage of acid in cream.

Three hundred gallons of cream testing 20 per cent butterfat, containing .6 of 1 per cent of acid, will require 4 quarts of lime

water; the percentage of acid should show .28 of 1 per cent when ready to pasteurize.

Three hundred gallons of cream testing 25 per cent of butterfat, containing .6 of 1 per cent of acid, will require 3 quarts of lime water, and should show .27 of 1 per cent acid when ready to pasteurize.

Four hundred gallons of cream, containing .7 of 1 per cent of acid, will require 5 quarts of lime water, with butterfat test of 20 per cent; should show .28 of 1 per cent when ready to pasteurize.

Two hundred gallons of cream testing 20 per cent butterfat, containing .8 of 1 percent acid, will require $4\frac{1}{2}$ quarts of lime water, and should show .28 of 1 per cent of acid when ready to pasteurize.

Two hundred gallons of cream testing 20 per cent butterfat, containing .7 of 1 per cent of acid, will require 4 quarts of lime water, and should show .28 of 1 per cent of acid when ready to pasteurize.

Two hundred gallons of cream testing 30 per cent of butterfat, containing .8 of 1 per cent, will require 3 quarts of lime water, and should contain .31 of 1 per cent when ready to pasteurize.

Two hundred gallons of cream testing 30 per cent of butterfat, containing .7 of 1 per cent acid, will require $2\frac{1}{2}$ quarts of lime water, and should contain .31 of 1 per cent when ready to pasteurize.

Three hundred gallons of cream testing 25 per cent butterfat, containing .7 of 1 per cent, will require $4\frac{1}{2}$ quarts lime water, and should show .3 of 1 per cent when ready to pasteurize.

Three hundred gallons of cream testing 25 per cent butterfat, containing .8 of 1 per cent, will require 5 quarts of lime water, and should show .3 of 1 per cent acid when ready to pasteurize.

Four hundred gallons of cream testing 25 per cent butterfat, containing .7 of 1 per cent acid, will require 6 quarts of lime water, and should show .3 of 1 per cent acid when ready to pasteurize.

Four hundred gallons of creat testing 25 per cent of butterfat, containing .8 of 1 per cent, will require 6 quarts of lime water, and should show .3 of 1 per cent acid when ready to pasteurize.

Two hundred gallons of cream testing 40 per cent of butterfat, containing .8 of 1 per cent acid, will require 3 quarts of lime water, and should show .36 of 1 per cent acid when ready to pasteurize.

Two hundred gallons of cream testing 40 per cent butterfat, containing .7 of 1 per cent acid, will require 2½ quarts of lime water, and should show .36 of 1 per cent when ready to pasteurize.

Three hundred gallons of cream testing 40 per cent butterfat, containing .7 of 1 per cent acid, will require 3 quarts of lime water, and should show .36 of 1 per cent when ready to pasteurize.

In Neutralizing Cream the Main Features are:

- The percentage of fat in the cream.
- The age of the cream.
- The percentage of acidity in cream.
- Whether sweet cream is mixed with sour cream.
- Temperatures to be pasteurized.
- Kind of pasteurizer used.

The safe way is to add neutralizer to cream, watching very closely at temperatures from 80° Fah. to 120° Fah. Should there be any signs of casein coagulating, add more neutralizer.

The richer the cream is in butterfat, the less neutralizer to be used.

This table shows percentage of acid cream should contain when ready to pasteurize in proportion to butterfat content:

Cream testing	45%	butterfat	acidity	.36
"	"	40%	"	.32
"	"	35%	"	.30
"	"	30%	"	.28
"	"	25%	"	.28
"	"	20%	"	.26
"	"	18%	"	.20

TABLE NO. 1. NEUTRALIZING CREAM

Effects of Using Too Much Neutralizer

Precaution should be exercised in neutralizing cream for butter-making. Where too much neutralizer has been used in the cream, the buttermilk will whey off and become separated from the caseine or curd content. The butter will be dry in appearance, gummy and sticky and the salt will not dissolve. This is often the direct cause of blotchy, streaked or mottled butter. Salt should be wet and thoroughly worked into the butter uniformly. Such butter often contains too high a percentage of moisture and it is almost impossible to work the moisture out. This is true when a large percentage of soda ash is used for neutralizing and the cream is blowed.

Whenever pasteurizing can be done without the use of neutralizers it is much better, as neutralization does not improve butter and often does harm to the flavor, especially when too much is used.

CHAPTER VIII

CREAM BLOWING

This process is used for the purpose of eliminating bad odors and off flavors and also to reduce the high acidity and improve the keeping quality of the butter.

The Process

The process is to blow air through pipes connected to tanks or drums filled with water to treat the air by expanding it in fine jets through tanks of pure water, then direct into the cream while pasteurizing. Where high acid cream is used it is necessary to neutralize, but not to as low a degree of acidity as when the blower is not used.

It is necessary that the air is cooled to a temperature of 70° Fah. or lower during the blowing process, as when the air is of a higher temperature it has a tendency to produce spongy, savy and mealy butter. It is also very essential that the cream should not be blown at a temperature of over 130° Fah., as this also produces a mealy body. The process used with the most success is to neutralize the acid in the cream to a degree low enough so as to prevent coagulation of casein. (See Table No. 1.) When the temperature is raised to 70° Fah. turn blower on and blow until temperature reaches 130° Fah., then turn off and continue heating the cream until it reaches a temperature of 160° Fah. or 170° Fah. A good way is to add a portion of sweet milk after the cream has been pasteurized, blown, and cooled to a ripening temperature.

The Advantages of this System Are:

It cleans the cream, drives off the bad odors and flavors; added

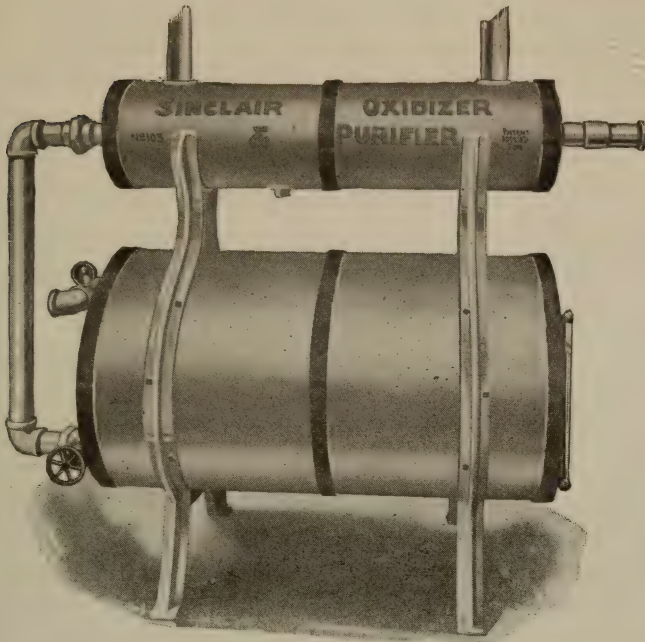

Sinclair Oxidizer and Purifier. Apparatus Used in Blowing Cream. Manufactured by Clifford L. Niles Co., Anamosa, Ia.

Fig. 19.

to the keeping quality of the butter, reduces the acidity of the cream when pasteurizing, improves the butter, especially when aged or high acid cream is used.

The mechanical equipment used in this process is manufactured by the Clifford L. Niles Company, Anamosa, Iowa, manufacturers of the Sinclair Cream Purifier and Oxidizer. (Fig. 19.)

CHAPTER IX

PASTEURIZATION OF CREAM FOR BUTTERMAKING

By pasteurization we aim to kill the lactic acid producing bacteria and as many other kinds of bacterial life as come within the thermal death point of the range of heat applied.

By destroying all abnormal fermentations and disease producing germs the milk or cream is rendered comparatively free from germ life, and when in this condition the cream is in a pure state and the best possible condition for home consumption or buttermaking.

Pasteurization for buttermaking is heating the cream. By this process it leaves it in a clean condition and leaves the germ life to be killed and the spores that still live are in a dormant condition, and when the cream is inoculated with a pure lactic acid starter it produces a pure desirable acid and fine flavor and keeping quality of butter. It gives the buttermaker control of the ripening process and improves every kind of cream in flavor for buttermaking.

Pasteurization is like the farmer getting his seed bed in condition to sow the seed. He cleans his ground so he can sow the seed, and reap a crop. This is true in pasteurizing the cream. We clean the cream, and by the addition of a pure culture added to the cream is like the farmer sowing the seed. It grows and produces the crop. It is absolutely necessary to pasteurize the cream when it is received from several different sources, in order to produce a uniform quality of butter.

Effect of Casein

Pasteurization softens the casein, and changes from a rubbery condition so it becomes brittle, and when the cream is ripened the butterfat globules will separate from the casein in the churning

process. Pasteurized cream will not swell as much as unpasteurized cream in the drum while being churned. It also produces a butter that is easy to incorporate moisture in and such butter containing the legal amount of moisture will be of a firm body and apparently dry.

Churnability of Cream

Pasteurized cream will churn at a much lower temperature than cream unpasteurized, as in pasteurizing we drive off all gases and fermentations and produce a velvet like smooth cream which churns ragged butter granules. This process also improves the texture of the butter and gives it a nice smooth body.

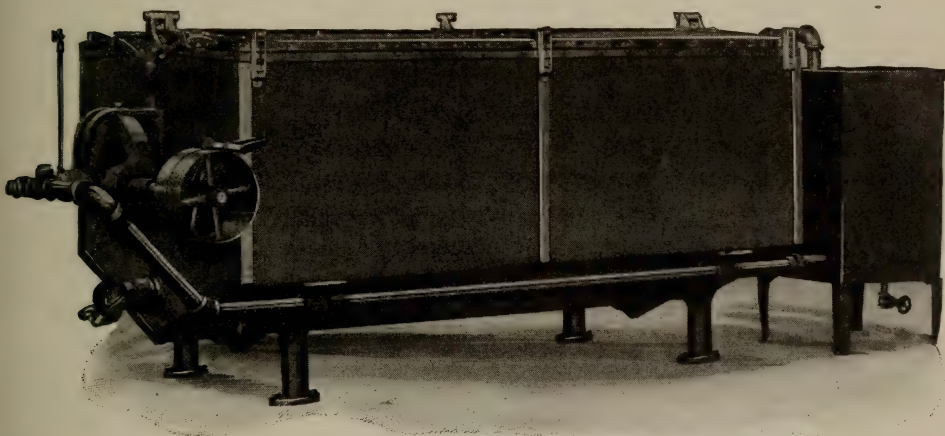

Fig. 20. Intermittent Pasteurizer, Cooler and Ripener **Manufactured by Minnetonna Co., Owatonna, Minn.**

Temperatures to be Used in Pasteurization

Intermittent pasteurization. (Fig. 20.) The temperatures should be from 145° Fah. to 150° Fah. Never over 150° Fah. In this process the temperature should be held from ten to twenty

minutes after being heated to 145 or 150° Fah. The temperature should be raised as fast as possible within a radius of 25 minutes. The cooling process in cooling the cream should be done as fast as possible, within 45 minutes, in order to get the best results.

Flash Pasteurization

In flash pasteurizing, is to heat to 170° Fah. or 180° Fah., then cool at once. This method is not considered as thorough as the intermittent process, especially for the city milk, also for butter-making. It leaves the cream in a thin condition and the casein does not coagulate while ripening, therefore it has not the churnability as the intermittent process. The advantage of flash pasteurization is that it can be best adapted to large plants where sour cream is received, as it takes up less floor space. When this method is used the cream should be heated twice. First to 160° Fah., the second time from 170° Fah. to 180° Fah. Then it should be cooled to a ripening temperature as soon as possible. Flash pasteurized cream not properly handled shows much more loss of butterfat in the buttermilk than unpasteurized cream, or pasteurized sweet cream. The losses are as high as .3 of 1% to .6 of 1% in the buttermilk.

In many instances pasteurization has been the salvation of the creamery business, as it has overcome the poor flavors and reduces the acidity of the cream that is termed "off" in flavor to a good desirable condition for buttermaking.

Pasteurization eliminates the gases and reduces the swelling of the cream that takes place in the churning process. It also reduces the volume of the cream by expelling the air, and does away with the foam, as cream properly pasteurized will not contain any foam.

Cost of Pasteurizing Cream

The cost of pasteurizing cream for buttermaking depends upon the supply of water, the medium of heat, how heat is applied and the time it requires.

The first cost is fuel. When cream is pasteurized in vats using exhaust steam the expense is the cost of running the engine. The second cost is labor, the time required to cool the cream, amount of water required, and the cost to pump the water. The third cost is the investment in the machinery, also the upkeep of the machines. The total cost for a creamery making 200,000 lbs. of butter a year is approximately about one-half cent per pound of butter manufactured.

Profit in Pasteurizing

The most profit of any branch of the creamery industry is in pasteurizing the cream for buttermaking, as it insures a very uniform piece of butter, improves the body and flavor, and butter made from properly pasteurized cream will score an average from one to five points higher than butter made from unpasteurized cream. This will raise the price from one to three cents per pound of butter.

The Regenerative Pasteurizer

One of the modern pasteurizing units is termed the "regenerative pasteurizer." The complete unit consists of three machines, i. e., continuous pasteurizing, sanitary regenerative and continuous and closed cooler. (Fig. 21.)

This pasteurizer and cooler consists of a revolving drum placed inside of a stationary cylinder, having a double jacket, and operating on a large hollow shaft of special construction. The cream or milk being pasteurized or cooled, as the case may be, is forced between the drum surface and outer jacket in a thin film, which film is heated or cooled uniformly as the case may be. The principal feature is that this equipment treats the liquid to the high temperature necessary and then brings it back to a safe temperature without exposing the product to the air during the high temperature, thus oxidation of the butterfat is minimized with this type of equipment.

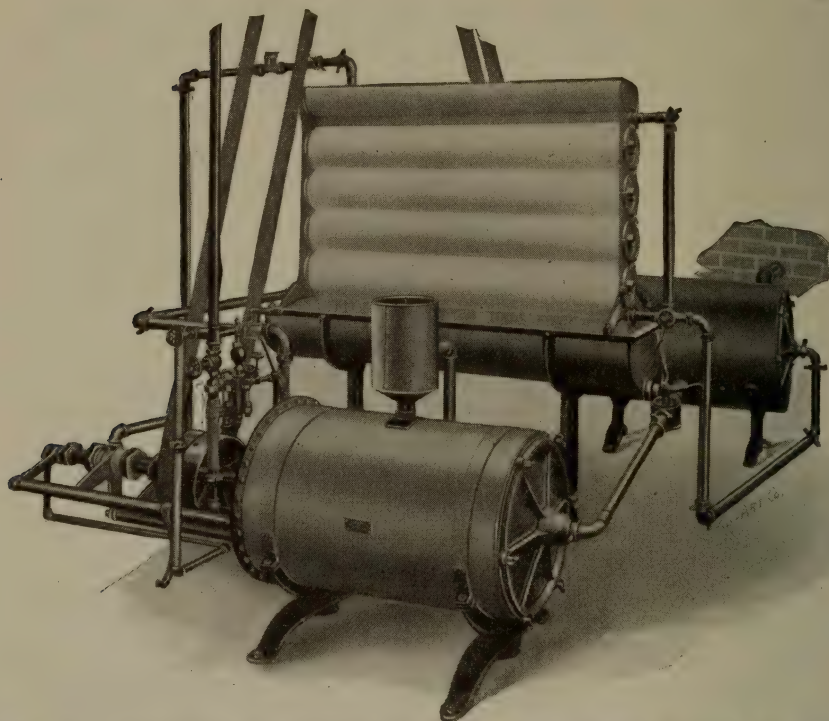

Fig. 21. Regenerative Pasteurizer and Cooler, Manufactured by Jensen Creamery Machinery Co., Long Island City, N. Y.

Facts That Apply to Pasteurization

Pasteurizing must be done right to be of any value.

The object of pasteurization is to make a more desirable and uniform product of better keeping quality.

Pasteurizing helps to make it possible to produce good butter from a poorer raw material.

Good results from pasteurization cannot be secured under unfavorable conditions.

Thin cream reduces the chances of successful pasteurization.

Pasteurization will not be successful without the necessary equipment and ample capacity.

Sufficient steam and power and a liberal supply of cold water are essential factors to be considered.

Pasteurization will do all that is claimed for it if it is properly applied.

A skilled buttermaker is necessary for successful pasteurization. Some regularity in the method of cream delivery is essential.

Uniform temperatures are important.

A forewarmer should always be used with the flash method of pasteurization.

The proper speed of the ripener coil is important in vat pasteurization. Speed of coil from 35 to 45 revolutions per minute.

Rapid heating and cooling increases the efficiency of pasteurization and lessens the danger of curdling or churning in vat.

Large steam and water connections increase heating and cooling capacity.

Use of exhaust steam reduces the cost of pasteurization. (Fig. 22.)

All sweet or all sour cream may be pasteurized without difficulty.

Curdling is due to pasteurizing sweet cream and sour cream without mixing or neutralizing the acidity.

Sweet and sour cream should be pasteurized separately when possible.

The cost of pasteurization is small when compared with the benefit derived.

Pasteurized cream should always be churned at a lower temperature than raw cream, from 6 to 10° Fah. lower.

Pasteurized cream should be held at a low temperature for some time before churning, usually from 4 to 12 hours.

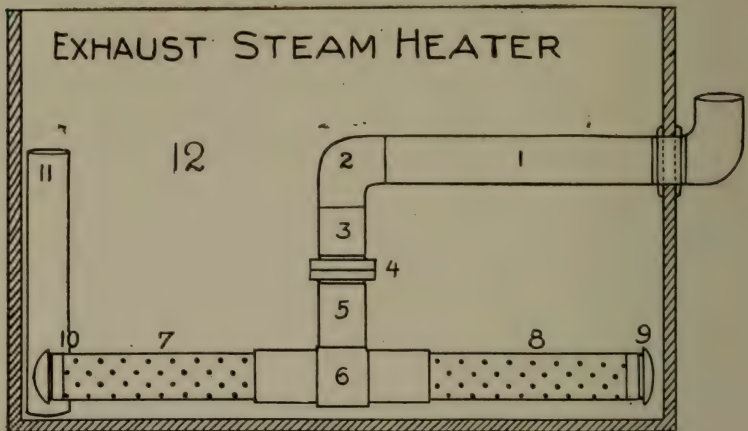

Fig. 22. Exhaust Steam Heater Adaptable to Any Creamery Vat Pasteurization.

It is used for heating the water to be circulated through the coils of the pasteurizer for heating the cream.

- | | |
|--------------------|--------------------------|
| 1—Pipe from engine | 7—2-inch perforated pipe |
| 2—2-inch ell | 8—2-inch perforated pipe |
| 3—2-inch nipple | 9—2-inch cap |
| 4—2-inch union | 10—2-inch cap |
| 5—2-inch nipple | 11—Overflow |
| 6—2-inch tee | 12—Tank |

Avoid high ripening whether pasteurized or raw cream is handled. Never have over .58 to .6 of 1% of acid.

A pasteurizer will not run itself; it requires constant attention.

Pasteurization increases the work in a creamery, and the necessary help should be furnished.

CHAPTER X

COMMERCIAL STARTERS

Starter Used for Ripening Cream

Commercial starter is made by taking a portion of the milk and pasteurizing to a temperature of 170° Fah. to 180° Fah. Then cooling down to a temperature of 85° Fah. and adding to this milk a pure culture; then set at this temperature to grow the lactic acid bacteria until the milk becomes coagulated within a reasonable length of time, usually 12 to 18 hours. This is called the first propagation, and is called the "mother starter." The second propagation is made by using one quart of sweet pasteurized milk with a glass stopper bottle and inoculating this milk with 50 c.c. of the starter from the first propagation, and set at a temperature of 78° Fah. until this coagulates. The third propagation is made by using one quart of sweet pasteurized milk and adding 50 c.c. of starter to milk from the second propagation, and set at a temperature of 70° Fah. until it coagulates.

Each propagation is carried out in this way.

Temperatures at which to ripen starter:

1st setting	85° Fah.
2nd "	80° Fah.
3rd "	75° Fah.
4th "	70° Fah.
5th "	68° Fah.
6th "	68° Fah.

Time it usually takes to ripen starter:

1st setting	14 to 16	hours
2nd "	12 to 14	"
3rd "	12 to 13	"
4th "	10 to 12	"
5th "	10 to 11	"

The large starter that is used to put into the cream is made by heating milk up to 170° to 180° Fah. and holding 8 to 10 minutes at this temperature, then cool down to 50° Fah. and hold until ready to set. When ready to set, heat up to 68° Fah. in the summer and from 70° to 80° Fah. in the winter, and add the "mother starter" and let it set until ripe, which will be when it contains from .5 to .7 of 1% of acid. (Figs. 23-A and 23-B.)

What to Do to Grow Commercial Starter

Be absolutely clean, careful and particular. Use only pure lactic acid culture. Use only clean, wholesome sweet morning's milk from fresh milk cows.

Pasteurize mother starter milk separate from large can. Use nothing but well tinned cans or glassware.

Always sterilize everything that comes in contact with starter milk. Maintain even temperature when ripening starter or startline. Maintain a temperature of 50° Fah. or below after ripening starter until it is to be used. Be sure to keep close watch on starter at all times. A buttermaker's success is how he attends to the little things in connection with startermaking and buttermaking.

What We Must Not Do in Growing Starter

Do not overripen starter—never over .6% of acid. Do not burn milk in heating. Use boiling water, and not dry steam.

Do not heat milk over 170° Fah. or 180° Fah.; 170° Fah. is high enough in pasteurizing.

Do not use milk that is not clean, sweet and from healthy cows.

Do not hold starter milk at a temperature higher than 46° Fah. to 50° Fah. until ready to ripen.

Do not expose mother starter to light, only at times when it cannot be helped.

Fig. 23A. Haughdahl Starter Can Manufactured by J. G. Cherry Co., Cedar Rapids, Ia.

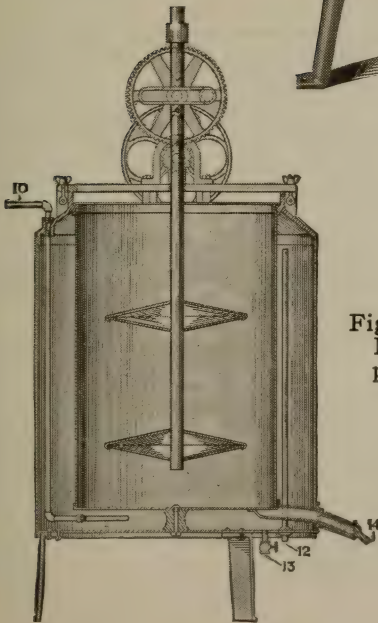

Fig. 23B. Minnetonna Starter Can, Manufactured by Minnetonna Company, Owatonna, Minn.

Do not allow any flies in milk used for starter.

Do not neglect the starter, as it takes constant study and attention.

A buttermaker's failure comes from neglecting little things in connection with startermaking and buttermaking.

Burnt Flavor in Starter

There is a peculiar flavor in milk from herds fed on corn stalks, especially in corn cutting season, or when frozen grass is being eaten by cows.

There appears on corn-cutting knives and feed cutters a sweetish substance from the juice in the corn. This has a sweetish peculiar smell, and taste is found in milk as it flows from the separator, or when heated in starter cans. Such flavor often shows up in the butter and is called burnt flavor.

Point of Coagulation Varies Somewhat

Percentage of acid at coagulation point:

Jersey cow's milk will have .3 of 1% at time of coagulation.

Guernsey cow's milk will have .32 of 1% at time of coagulation.

Holstein cow's milk will have .36 of 1% at time of coagulation.

Common breed cow's milk will have .22 to .28 of 1% at time of coagulation.

Amount of Starter to Use in Large Can

One-fourth pint mother starter to each 100 lbs. of milk to be ripened for starter. This should ripen in 10 to 14 hours. Acidity of mother starter should never be over .7 of 1% or under .5 of 1%.

Starter for ripening cream should contain from .5 of 1% to .6 of 1% to get the best results. This is from large can to be added to cream.

Body should be smooth and velvety, good and clean. Flavor should be pronounced in acid and have a sweet, sour, desirable taste.

Wheying off is caused by setting at too high temperature, and ripening too fast or where milk contains an abnormal amount of acid before pasteurizing. The milk should be the best obtainable for mother starter.

Bitter starter is caused by using old mother starter when the lactic acid germ is dead or using old, unclean milk, sometimes caused from ripening too slow.

Sweet starter is caused by not warming milk to proper temperature, using old culture and not using enough mother starter.

Vinegar flavor is caused by overripening, leaving at high temperature when ripened; also using mother starter containing too high percentage of acidity.

After starter coagulates and begins to ripen, very particular care should be taken to prevent overripening as the fermentation of the milk multiplies fast and the lactic acid germ will attack milk sugar, producing high acid and overripe starter. The danger occurs after coagulation takes place at about .4 of 1% of acid and .45 of 1% of acid, depending on ingredients milk is composed of.

Agitating Starter

Starter should be stirred as soon as ripened or contains the proper amount of acid, and cooled to 50° Fah. or lower.

Cooling starter cannot be injured by cooling after ripened. Mother starter can be packed in ice and frozen and no harm is done. When ripened mother starter should be kept at a temperature of below 45° Fah.

The proper utensils to make the mother starter in is a glass jar or bottle having glass stoppers; absolute cleanliness must be used in making starters.

To Carry Starters

A small portion of sweet milk can be added to the mother starter after .6 of 1% of acid has been developed so as to prolong the life of the starter until ready to set again. Use the very best pasteurized sweet milk that can be obtained, and milk from fresh milch cows.

Table of Temperatures to Use and Quantity of Milk

Quantity of Milk	Range of Temperature		Amount of Mother Starter or Startoline
	Winter	Summer	
20 gallons	68-70	62-67	1/2 to 2 qts.
30 "	68-73	63-67	1/2 to 2 1/2 "
40 "	68-73	63-68	1 to 5 "
60 "	68-71	64-68	1 1/2 to 7 1/2 "
80 "	68-70	66-66	4 to 10 "
100 "	68-70	66-68	4 to 12 1/2 "

Milk perfectly sweet, heated to temperature of 170° Fah. held 10 minutes, then cooled to ripening temperature.—From "Modern Buttermaking," by Martin H. Meyer.

Percentage

To find the percentage of starter used, divide the pounds of cream into the pounds of starter. For example:

1 quart of milk contains 950 c.c.

25 c.c. mother starter to 1 quart of milk.

25 c.c. divided by 950 c.c. equals .263% starter.

CHAPTER XI

TESTING MILK AND CREAM FOR ACIDITY

The Acid Test

To make the acid test pipette out 9 c.c. cream, then rinse, pipette into sample to be tested; add two drops of indicator, then draw from the burette neutralizer until the sample turns a faint pink, then read the figures on the burette, and this will give the per cent of acid in tenths. The figure 7 equals .7 of 1%; 68 equals .68 of 1%, and so on according to the figures that indicated shown by the neutralizer. (Fig. 24.) If all the neutralizer were used it would indicate there was 1% of acid in sample.

The Constituents of Neutralizer

Neutralizer contains sodium hydroxide; 40 grams of caustic soda dissolved in 1000 c.c. of distilled water makes a normal solution; .1 normal solution is 4 grams of caustic soda dissolved in 1 quart of water; 1 c.c. of .1 normal solution contains 1.004 grams of soda, and will neutralize 900 c.c. of lactic acid.

The Constituents of Indicator

Phenolphtholin is made by dissolving 1 gram of the powder in 100 c.c. of 50% alcohol.

To Reduce Readings

When more than 9 c.c. of the sample is used, multiply the reading on the burette by .009, and divide by sample used. For example:

Sample, 50 c.c.
Reading on burette, 40 c.c.
Multiply by .009.
Equals 360.
Divided by 50
Equals 4.32 of 1%.

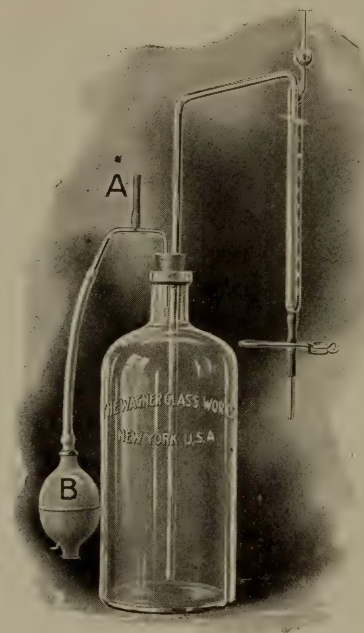

Fig. 24. Acid Tester.

Automatic Acidmeter for Reading Per Cent of Acidity Direct in Tenths, Using Tenth Normal Solution Manufactured by Wagner Glass Works.

This automatic acidmeter is operated by squeezing the rubber bulb. This forces the air into bottom of bottle, and forces liquid into burette. When burette contains too much solution by opening the pinch cock the liquid will syphon back into bottle. By doing this there is not any of the liquid wasted. Every creamery should have an acid tester.

CHAPTER XII

CREAM RIPENING

Ripening Cream and Its Effect on Buttermaking

In ripening cream we aim to develop the lactic acid and soften the curd content of the butter to a soluble condition in order that we can get an even separation between the butterfat globules and casein in the churning process. We also wish to develop lactic acid to produce a fine flavor, and add to the keeping qualities of the butter. Here lies the most scientific part of buttermaking.

Ripening temperatures depend on butterfat content contained in cream. Cream containing a light percentage of butterfat will ripen at a lower temperature than cream being rich in butterfat.

Cream obtained from cows during a late period of lactation requires much higher temperatures in ripening. Cream received from Jersey, Guernsey and Ayershire cows ripens slow and requires more careful attention. Any cream being high in stearin will ripen slower and require higher temperatures than cream high in olein, therefore great judgment must be used in this work. Olein and sterin are fats found in butterfat that influence the soluble condition of the cream. Where commercial starter is used, lower temperatures can be used and good results obtained. When no starter is used, usually the temperatures must be high. And this puts all the abnormal fermentations into action, and in ripening the cream causes a bitter flavor especially when low temperatures are used.

Ripening Pasteurized Cream

Pasteurized cream ripened without a starter makes a flat, greasy, undesirable quality of butter. Raw cream ripened without starter

produces a gasy fermentation, makes a coarse, undesirable flavor, and also has a tendency to deteriorate the flavor quickly, thus causing a poor keeping quality.

Ripening Sweet Pasteurized Cream

Ripening with a good commercial starter produces fine flavor, and keeping quality in a smooth body, fine texture, and a dry appearance, free from a leaky body and brine pockets contained in the butter. It also insures the consumer against disease and makes a safe, sanitary product.

Ripening Temperatures and Time Ripening

The following results were obtained in experiments at the Elgin Creamery, Elgin, Minnesota, when this plant was operated by the authors of this book.

Cream containing 40% fat, pasteurized, using 20% commercial starter, containing .7 of 1% of acid, set at a temperature of 70° Fah., ripened in 5 hours, and contained .4 of 1% of acid.

Cream containing 30% of butterfat, pasteurized, using 20% commercial starter, containing .7 of 1% acid, set at a temperature of 70° Fah., ripened in 4½ hours, and contained .5 of 1% of acid.

Cream containing 25% of butterfat pasteurized, using 20% of commercial starter, containing .7 of 1% acid, set at a temperature of 70° Fah., ripened in 3 hours, and contained .5 of 1% of acid.

Cream containing 18% of butterfat pasteurized, using 20% of commercial starter, containing .7 of 1% of acid, set at a temperature of 70° Fah., ripened in 3 hours, and contained .5 of 1% of acid.

Unpasteurized Cream

Cream containing 40% of butterfat, using 20% commercial

starter, containing .7 of 1% of acid, set at a temperature of 70° Fah., ripened in 6 hours, and contained .4 of 1% of acid.

Cream containing 30% of butterfat, using 20% of commercial starter, containing .7 of 1% of acid, set at a temperature of 70° Fah., ripened in 5 hours, and contained .5 of 1% of acid.

Cream containing 25% of butterfat, using 20% of commercial starter, containing .7 of 1% of acid, set at a temperature of 70° Fah., ripened in 4 hours, and contained .5 of 1% of acid.

This cream was all sweet cream.

Unpasteurized cream containing 28 to 30% of fat, using no starter, will ripen at a temperature of 70° Fah. in 7 to 10 hours.

Unpasteurized cream containing 22 to 25% of butterfat, using no starter, will ripen at a temperature of 70° Fah. in 6 to 8 hours.

Effects of Slow Ripening

Slow ripening is very detrimental in making good butter, as the abnormal fermentations produce a certain percentage of bacteria and high acid, causing rancid flavor in the butter. The proper temperature for ripening cream where no starter is used is at a temperature of 70° Fah.

The proper temperature to ripen cream where starter is used ranges from 65 to 72° Fah. The percentage of starter to use in ripening cream depends on the fat content contained in the cream. From 10% to 20%. Never over 20% and not under 10%.

How to Figure Percentage of Starter Used

For example: 400 gallons of cream containing 30 gallons of starter. What per cent of starter? 400 gallons of cream, 8 lbs. to 1 gallon, equals 3,200 lbs. of cream; 30 gallons of starter, 8 lbs. to 1 gallon, equals 240 lbs. of starter; 240 divided by 3,200 equals 7.5% of starter.

Fast Ripening of Cream

Fast ripening, especially where good commercial starter is used, develops the tiny plant life which helps it to grow and become vigorous before any undesirable fermentation takes place. This produces a good, clean lactic acid which is so greatly sought in good buttermaking.

Fast ripening indicates a good live and active starter, and produces the purest and most desirable and highest scoring butter of smooth texture and perfect grain.

Overcoming Undesirable Flavors

Undesirable flavors can be overcome by using a good commercial starter, and lowering temperatures during ripening process. All cream should be cooled down to churning temperature and held from 4 to 10 hours before churning, so as to insure a good body.

Percentage of Acid Cream Should Contain When Ready to Churn

18%	cream	should	contain	.6	of	1%	acid
20%	"	"	"	.6	of	1%	"
25%	"	"	"	.55	of	1%	"
35%	"	"	"	.5	of	1%	"
40%	"	"	"	.4	of	1%	"

TABLE NO. 2

The richness of the cream in butterfat, the less per cent of acid can be developed, as there is less milk serum in the high testing cream.

CHAPTER XIII

FLAVORS IN CREAM AND BUTTER

Aroma.

Aroma in butter is the quality that is detected by smell only. Flavor in butter is found by tasting only. This should be remembered, as in the quality of butter aroma is not always a true indication of quality of flavor.

Although in connection with the aroma the flavor can be very well judged in butter, as the quality of the aroma indicates very strongly the quality of the butter. In the aroma we find characteristics due to bacterial fermentations and chemical changes that come from overripe milk and cream held too long at ripening temperatures; not keeping utensils clean, allowing the milk or cream to be contaminated in any way, affects the aroma of the butter. In the flavor we find all defects in which the butter is made. Some are carelessness of the dairymen; some of the creamery operators; some of the main faults are old cream, unclean utensils, overripe high acid; the mixing of cold cream and warm cream together produces what is known as a fishy flavor.

High-grade wholesome butter must be made out of clean, sweet cream or milk, frequently delivered to the creamery. There is no process that will purify or improve poor milk and cream that will bring it back to the pure state as if properly cared for.

Unclean flavor in butter is due to unclean, unwholesome milk or cream, unsanitary conditions in the creamery, leaky vats, or starter cans, unsanitary milk pumps or conducting pipes, impure water, exposing butter after churning in an unsanitary refrigerator, packing in moldy tubs, using impure ice in the wash water or cream, poor ventilation or improper drainage of creamery.

Curdy Flavors

This is quite common in hot weather and is due to high acid, also pasteurizing very sour cream without neutralizing and overchurning high acid cream.

Mottled Butter

This defect comes by not having the salt evenly distributed in butter; salting too cold; not working enough; uneven temperature of butter in churn; overchurning; high temperatures.

To Overcome Unclean Flavors

Use clean milk or cream; keep creamery sanitary and well ventilated; prevent the use of leaky vats and starter cans; unsanitary pipes and conductor pipes; clean pumps every day; sterilize everything that comes in contact with milk and cream; keep the refrigerator clean and whitewashed; also sprinkle lime on floor to prevent mold.

To Overcome Curdy Flavor

Cool milk and cream to a low temperature, 46 to 48° Fah.; reduce acid before pasteurizing; do not overchurn. The smaller the butter granules are when butter is churned the better, just large enough to get a good separation from the buttermilk is all that is necessary. Washing the butter with cold water and hardening up the granule will prevent curdy flavor.

To Overcome Mottled Butter

Wet the salt; have the temperature of the salt near the temperature of the butter; work the rolls in the churn in wash water to maintain an even temperature in butter throughout the churn; running cold water in one end of churn chills the butter granules in one end and leaves them softer in the other end. The difference between the temperature in the butter after being worked **will** be the cause of

streaks and mottles, due to the fact that the salt dissolves slower in the cold butter than where it is warmer. Work thoroughly. The average buttermaker is afraid of overworking, and in many instances is not working the butter enough.

To Overcome Fishy Flavor

This flavor is very pronounced when butter is made from old, high acid overripe cream. It develops from keeping cream in unsanitary and rusty cans where the sun can shine on them, heating them up. The chemical action on the acid coming in contact with the heated metal often produces fishy flavor. It has been found that salt being kept in warehouses where fish has been stored will carry a fishy flavor. It is also due to unsanitary conditions and often disappears after improvement is made in sanitation.

Wood Flavor

This flavor may be imparted by not soaking tubs properly or from a new churn not properly soaked, or from a leaky vat where wood surrounds the inner lining. (See how to soak new churn page 150.)

Metallic Flavor

This is very objectionable in butter and has come into existence the past few years. It is developed from several sources—the high acid in cream, old rusty cans allowed to stand in the sun where cream becomes heated, or kept in the heat during transportation, or sour cream pasteurized at high temperatures and held at pasteurizing temperatures too long, or pasteurized in pasteurizers or vats poorly tinned.

Weak Bodied or Slushy Butter

This is caused by churning cream too warm, not holding it at a temperature long enough after being pasteurized or ripened, or

at a low enough temperature to harden butterfat globules. Also overchurning will show this defect in butter. Cream should be held from 5 to 7 hours at a temperature low enough to harden butterfat globules, 46 to 50° Fah. in the summer and 52 to 56° Fah. in the winter. The shorter time the cream is held before churning the lower should be the temperature held at. High temperatures used in washing butter is also instrumental in making weak bodied or slushy butter. The remedy is easily overcome and is in the power of every creamery operator. It is mostly due to neglect, or not knowing how to remedy it, generally by men who will not listen to anyone of experience.

CHAPTER XIV

CHURNING OF CREAM

Cream should be churned at a temperature so as to have the butter churned from 35 minutes to 1 hour. Any longer is too long and any less is too quickly. The granules should be ragged (not round) and gathered enough to give a good separation from the buttermilk.

The butterfat globules must be subjected to a certain amount of concussion. This solidifies the fat globules. These globules are in a liquid or semi-liquid state in the cream, and through the churning process they are separated from the casein that encloses them and formed into butter granules.

As soon as they are formed into granules they multiply fast in size and danger of overchurning occurs. This is one thing that is often neglected in buttermaking that plays an important part.

Washing the Butter

There seems to be quite a difference in opinion as to washing or rinsing butter. But through all experiments made the use of cold water ranging in temperature from 42 to 54° Fah. or even 56° Fah. has proven the most satisfactory. The amount of water to be used depends on the amount of butter in churn and the temperature and condition of the granules of the butter. Usually enough water in first washing to float butter up to rolls of churn and remove all the surplus buttermilk.

Number of Revolutions to Run Drum

Churn should be run from 8 to 12 revolutions on slow or working gear (with worker out of working gear). This water

should be drawn off and about $1\frac{1}{2}$ to 3 barrels at a temperature of 46° Fah. to 48° Fah. in summer and 50° Fah. to 58° Fah. in winter added; the rolls put into gear and worked from 6 to 12 revolutions of the drum. This water should be drained through the doors by loosening three buttons on door and leaving one closed to prevent butter from dropping out of churn.

Working the butter in water insures an even temperature throughout the butter, also controls the moisture by working into the butter (not mixing it). It also expels the loose, surplus moisture, thus saving the amount of salt used. It also gives the operator absolute control of the moisture content of the butter. This is important and very necessary.

Salting

Salt should be wet. Wet enough so it will float in a butter tub, the dirt and ingredients other than salt will float, and in this way salt is cleaned and the dirt and impurities washed out. Be sure to pour off top before using.

Trough Butter

The roll of butter should be split open with butter ladle, the salt inserted inside roll of butter, pulling together on top. By doing this we prevent the salt from adhering to the drum of the churn and therefore save the salt.

Working

Butter should be worked until the salt is dissolved and evenly distributed; also until butter contains right amount of moisture, with a perfect body and grain. When butter is properly worked it will pull apart like a piece of broken steel, long grained, and have a nice smooth appearance.

Temperature of Butter When Removed from Churn

Butter should not be over a temperature of 50° Fah. to 52° Fah. when finished during the summer months and a temperature of 56° Fah. to 60° Fah. in the winter months.

Cooling Salt

During summer when weather is hot, salt may be cooled with ice as low as 40° Fah. and good results obtained. Care must be taken to thoroughly work the butter.

Warming Salt

During winter months salt can be warmed up to 75° Fah. and good results obtained. Should butter be too cold and hard the salt can be warmed. More salt can be incorporated when the salt is warmed and there is less danger of having gritty butter.

Ripeness of Cream

Cream should contain between .4 and .6 of 1% of acid in order to churn out clean from the buttermilk and also develop a good flavor.

Time Churning

Cream should churn in one hour or probably less, depending on size of churning and temperatures used.

Size of Butter Granules

Butter granules should be the size of peas or even as large as corn; should be ragged, not hard or round. It is almost impossible to incorporate moisture when we have round granules.

Temperatures of Wash Water

The temperature of wash water should be from 6 to 10° Fah. colder than the buttermilk.

Amount of Wash Water to Use

About the same amount as there is buttermilk. Churn should be run on the slow gear 8 to 10 revolutions of the drum.

Second Wash Water

Usually from $1\frac{1}{2}$ to 2 barrels of water. Water should be of a temperature of 8 to 10° Fah. below the temperature of the butter. The machine should be put into working gear and work butter from 4 to 10 revolutions of drum in this water, then draw off all surplus water through the doors. This is very particular, as all surplus water left in the churn will have a tendency to wash out salt.

Butter

A fatty substance obtained from cream or milk; consists of butterfat oil, fat globules, water, salt, curd or casein, color and solids.

First discovered by the Egyptians carrying milk in skin sacks and the shaking of sacks on the camels' backs churned the milk, thus the human race discovered through this source the secret of churning butter from milk.

Where Buttermaking Begins

The kind of feed fed cow.

The cow's health.

The condition in which she is kept.

Kind of water she gets to drink.

The kind of barn she is kept in.

The kind of ventilation in barn.

Cleanliness of barn.

Cleanliness and condition of cow.

Time of lactation—cows milked too long is very bad.

Salting irregular.

Dairyman is responsible for all the cow does, how milk is handled, how milked, strained, separated and cooled, and kept from injurious odors, such as barn taint, silo and anything that contaminates milk or cream, proper and frequent delivery to creamery, washing separator every time used, washing cans, using clean cans not rusty or open in seams, not mixing warm milk with cold, etc.

Silage Flavor

This flavor is very pronounced in milk or cream when the silage is fed during milking time or when milk or cream is left in barns so it becomes contaminated with this odor. The feeding of silage will not effect the cream or milk unless same is exposed in barns where silage is fed, as it will not develop any odor through cows' systems. And in every instance the dairyman is wholly to blame when milk or cream contains this odor.

CHAPTER XV

SALTING BUTTER AND SALT TEST

Salting Butter

This should be gauged according to the market where the butter is sold and also the demand of the consumer; different markets vary in the amount of salt necessary to satisfy the trade. Markets along the sea coast demand a very light salted butter. This is due to the air containing a certain amount of salt, and people do not require the amount of salt in foodstuffs that is generally used in sections farther away from the salt water.

How to Incorporate Salt with the Least Possible Waste

First: Drain the water off butter before salting.

Second: Work through the rolls before adding salt to butter.

Third: Heat the salt to a few degrees higher temperature than butter.

Fourth: Add the salt inside of the butter to prevent from sticking to the drum of the churn.

Fifth: Salt at intervals in working butter. As high as 5% of salt can be incorporated into the butter without leaving it gritty with a loss ranging around 10% when properly done.

Salt Test

To make a salt test in butter, carefully weigh up 10 grams butter, transfer into flask, using water at a temperature of 150° Fah.; fill up to mark on flask and shake vigorously, then pipette it out with pipette into beaker, using 25 c.c.; use 2 drops of potassium chromate for an indicator, then draw solution out of the burette,



Fig. 25. Salt Test Apparatus.

adding to the sample until it becomes a permanent brown, then read figures on burette, and this will give percentage of salt content of butter. (Fig. 25.)

Formula of Ingredients Used in Salt Test

Neutralizer nitrate of silver neutralizer, 2.906 grams nitrate of silver added to 2000 c.c. distilled water, make a tenth normal solution.

Indicator

Three ounces of potassium chromate dissolved in 100 c.c. distilled water.

Caution: Do not expose the nitrate of silver to the light, as it deteriorates and loses its strength. Keep nitrate of silver in colored bottle.

CHAPTER XVI

MOISTURE IN BUTTER AND MOISTURE TEST

Incorporating Moisture

Incorporating moisture in butter is accomplished in different ways, such as raising temperatures, working butterworker rolls, and by adding water during time butter is worked. (Fig. 26.)

Controlling Moisture

The proper method is to first begin in the ripening of the cream, the condition of the casein will designate the size, structure and shape of the butter granules. Cream not properly ripened will churn a round granule, while cream properly ripened will churn a ragged granule, the latter being more susceptible to control of moisture.

Working moisture in butter is accomplished by lowering temperature and working churn rolls in second rinse water several revolutions of the drum. Wetting salt and working butter after salt is added is also a good moisture working method. Butter properly worked can obtain a proper amount of water and still retain perfect body and texture and not be leaky in body and constituting an apparent dry appearance.

How to Incorporate Moisture in Butter

First: Churning temperature depends upon conditions of the cream. Also per cent of butterfat contained in the cream.

Second: The amount of cream to be churned.

Third: Amount of fat designates condition of cream. Rich cream can be churned colder and much easier than cream containing light per cent of butterfat.



Fig. 26. Modern Moisture Testing Outfits.

Necessity of Controlling Moisture in Butter

It is absolutely necessary that butter should contain 16% of moisture in order to have the salt dissolved and evenly distributed throughout the butter. Salt and moisture becoming a brine enhances the keeping quality of the butter. It is absolutely impossible to make butter with an even color were it not for the moisture contained therein to dissolve the salt. Butter with 16% moisture properly controlled will have a perfect body and texture. Pull a full trier from the tub and not show excess moisture or be weak bodied or slushy in any way when moisture is properly controlled.

Moisture Test

To make moisture test, carefully weigh up 10 grams of butter, then evaporate moisture and re-weigh sample. The amount evaporated is per cent of moisture contained in butter. In evaporating moisture great care should be exercised not to burn sample. This is particular and should be done accurate.

CHAPTER XVII

OVERRUN

Overrun—Overchurn—Overyield

The above titles constitute the percentage in pounds of butter over pounds of butterfat.

To find the percentage of overrun subtract the pounds of butterfat from the number of pounds of butter made, and divide this sum by the pounds of butterfat.

Example 1,000 lbs. of butter — 800 lbs. of butterfat, equal 200 lbs. overrun; 200 lbs. of overrun divided by 800 lbs. of butterfat equals 25% of overrun.

Why Overrun Fluctuates

Conditions contributing to low overrun are such factors as the following:

- Carelessness of operator.
- Poor workmanship of operator.
- Incompetent assistance to operator.
- Inexperienced help to operator.
- Using poor machinery.
- Heavy shrinkage.
- Moisture not properly controlled.
- Too high butterfat content in butter.
- Loss in churning.
- Inefficient refrigeration.
- Making test without proper testing knowledge.
- Taking unproportionate sample.
- Insufficient amount of salt incorporated.

Pasteurizing very sour cream.

Leaky churns.

Churning cream at too high temperature.

Filling churn too full.

Not properly preparing packages.

Leaving top off sample jars, increasing evaporation of moisture from sample, which makes the test read too high.

Incompetent, incomplete, inaccurate tests for salt, moisture and fat.

Not keeping record of work to check leaks.

Heavy fat losses in buttermilk.

Careless weighing of cream.

Inaccurate work of operator.

CHAPTER XVIII

PREPARING PACKAGES FOR MARKET

Preparing Packages So As to Prevent Mold and Shrinkage

Where tubs are used for packing butter they should be soaked at least 10 to 12 hours in a brine solution strong enough to float an egg. This prevents mold and assures a nice clean package. The tub should be submerged under the brine water in a wooden tank. (Fig. 27.) The covers should also be soaked a couple of hours before being used.

The Liners

The liners for butter tubs or butter boxes should be soaked in a solution of brine from 4 to 6 hours before being used. This is very necessary, especially when butter is being stored. Dry salt should be rubbed inside of the tub before the liner is put in. When this system has been used there has never been a complaint about moldy butter.

Sizes of Tank to Use

For 12 butter tubs	2½ ft. wide	6 ft. long	2½ ft. deep
“ 20 “ “	2½ “ “	8 “ “	3 “ “
“ 28 “ “	2½ “ “	10 “ “	3 “ “
“ 35 “ “	3 “ “	12 “ “	3½ “ “
“ 50 “ “	3 “ “	16 “ “	3 “ “

Packing Butter in Boxes and Tubs

In packing butter in boxes for the market it is necessary to put small portions of butter into the box while packing, using a square

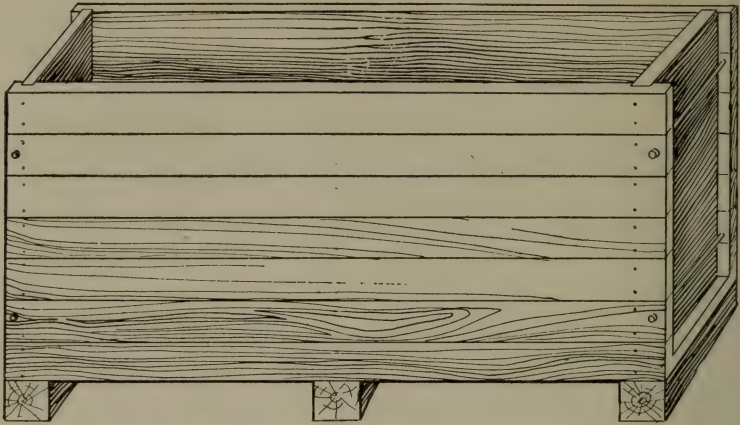

Fig. 27. Soaking Tank for Soaking Tubs.

packer and being careful to pack firm in the corners of the boxes. Putting large amounts of butter in the boxes and not thoroughly packing often causes mold, and a heavy shrinkage when being cut into prints. Never put more than 8 to 10 lbs. of butter in boxes at one time before tamping down with a butter packer. When butter is not properly packed the shrinkage is enormous when being cut into prints, and this makes it very unprofitable for both the commission merchant and the creamery. The loss in shrinkage falls on the manufacturer. (Figs. 28 and 29.)

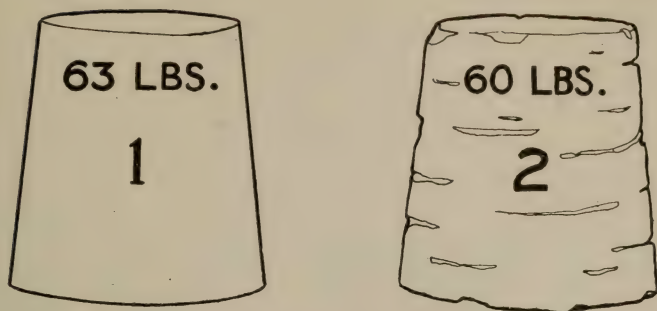

Fig. 28. No. 1 in the figure shows properly packed tub of butter. No. 2 is same size tub improperly packed. The loss in the moisture in cutting into prints in No. 1 was $1\frac{1}{4}$ lbs. The loss in No. 2 was $2\frac{1}{2}$ lbs. on a 63-lb. tub of butter. Experiments made in New York City, March 12, 1916, by the authors.

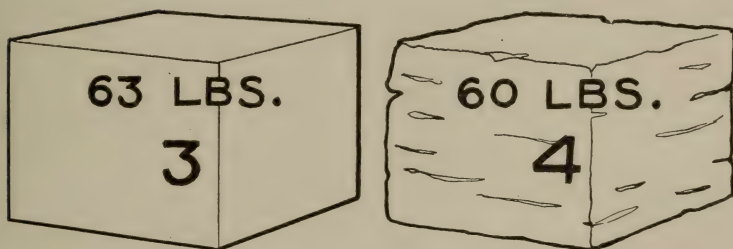

Fig. 29. No. 3 in the figure is a properly packed box of butter, containing 63 lbs. No. 4 is a box of butter improperly packed, box containing the same cubical contents. Contains 60 lbs. of butter. A loss of 3 lbs. on every package in weight.

CHAPTER XIX

SCORING BUTTER

Butter Grades and Scoring

With the butter trade—that is, butter buyers, wholesalers and retailers—butter is graded, as follows:

“Specials,” the very best; “Extras,” “Firsts” and “Seconds” in the order named. There is a wide variation in the prices between “Specials” and “Seconds.” There is always a good market for “Specials,” whereas the lower grades are a drug on the market most of the time.

In scoring butter for the markets the following division of points are made:

Flavor	45	Clean, distinctively sweet, nutty and full of character—fresh, pleasing aroma.
Body	25	Waxy, a grain that is firm, smooth, close and glossy and breaks like a piece of cold steel.
Salt	10	Medium, well dissolved, quite briny, sharp salt for western markets, light salt for eastern markets, very light for high score in contests; judges look for fine aroma and salt kills this when too much is added.
Color	15	Even, free from mottles or streaks, neither too high nor too low.
Package	5	Neat, clean, full, well put up. Free from holes or crevices when stripped from tub. Smooth surface on outside of butter after stripped.

Further Points Considered in Scoring

Flavor: Clean, sweet, fresh, high in aroma.

Body: Firm, uniform, pull full trier without showing feather edge or in any way indicating weak body. Should pull clean, not tallow like or sticky, but waxy. Butter should show a good even granule and look like a broken piece of steel.

Color: Uniform, light straw, free from mottles or being wavy or streaked.

Salt: To suit market, not too high, as too high salt spoils the fine flavor in the butter.

Package: Clean, neat and properly packed. A smooth finished body when stripped from package.

CHAPTER XX

CREAMERY REFRIGERATION

The following complete detail information is a reprint of Bulletin No. 59, Minnesota Dairy and Food Department, October, 1915:

During the past few years the interest in better creamery refrigeration has noticeably increased and so many inquiries from creameries all over the state have been received by the different state departments that it has been deemed wise to issue this small bulletin on refrigeration. We fully realize that this bulletin does not answer all questions relating to refrigeration, as the subject covers a wide scope and conditions in different sections are so varied, but we have attempted to furnish the reader with some general information on refrigeration with special reference to artificial refrigeration and insulated ice houses.

There can be no doubt that efficient and at the same time economical refrigeration is necessary for successful creamery operation. It surely is poor business for a creamery to spend a lot of good money for ripeners, pasteurizers and other equipment which is necessary to make the best butter, and then have no facilities for taking care of the butter after it is made.

A large percentage of the creameries in Minnesota and other states ship their butter to distant markets, which means that keeping quality in the butter is of the greatest importance, and when butter is kept in the creamery refrigerator for a number of days before it is shipped, it is not difficult to understand that the temperature and general condition of the refrigerator has considerable influence on the keeping quality of the butter. It is also reasonable to believe that when butter is kept in a dry and cold refrigerator it will arrive on the market in much better condition than it will if kept in a damp re-

frigerator at a comparatively high temperature before leaving the creamery. A dry and cold refrigerator will also prevent abnormal shrinkage in butter, often caused by holding the butter at a high temperature. The losses due to mouldy butter will also be materially reduced by the use of good refrigeration. Another advantage of good refrigeration is that it gives the buttermaker better control of the ripening process, as it enables him to cool his cream quickly and efficiently at any time desired.

There is no doubt that many creameries sustain heavy losses during hot weather, because of poor refrigerating facilities, and if for instance a creamery making 200,000 pounds of butter during the year could increase the value one-half cent on half of the output it would mean a gain of \$500 a year. If in addition to this the shrinkage could be reduced one-half pound per tub on this amount it would result in a gain of 800 pounds of butter which, at 30 cents per pound, would be worth \$240 or a total gain of \$740.

There is in Minnesota approximately one hundred creameries using mechanical refrigeration and insulated ice houses, and many of these creameries have furnished us with information relating to refrigeration, which has been of much assistance in preparing this bulletin. According to this information, there is not the least doubt that both mechanical refrigeration and insulated ice houses are very satisfactory if properly installed and intelligently handled.

System to Install

When a creamery gets to a point of deciding what to do to obtain better refrigeration, the question of what system to install necessarily arises, and while this bulletin does not definitely solve this problem, we trust that the information here set forth will materially assist those in charge of creameries to decide which system should prove the most satisfactory for them.

In deciding whether it would be wise for a creamery to install

mechanical refrigeration or build an insulated ice house, it would be necessary to consider such matters as cost of ice, and amount and quality of cream handled. The size of power plant should also be considered and it is advisable under certain conditions to improve or enlarge it, in order that the mechanical refrigeration plant can be operated economically. When a new creamery building is erected, it is not so difficult to decide which system of refrigeration is the most satisfactory, while if an old building must be used, it is often a more perplexing problem to solve.

When a new creamery building is erected the main factors to consider in deciding on what system of refrigeration to use, is cost of ice, and amount and quality of cream handled.

The cost of ice is, as a rule, the deciding factor, and when a creamery making 200,000 pounds of butter per year, for instance, can put up the yearly ice supply for less than \$150 the insulated ice house would appear to be the most practical, while, if ice costs more than this, it would be advisable to consider mechanical refrigeration. When a large creamery receives cream in a more or less sour condition, which makes quick cooling necessary, then it may be wise to install mechanical refrigeration regardless of cost of ice, as this system makes it possible to cool somewhat faster than can be done with ice.

If mechanical refrigeration is used, the power plant should always be large enough to run the compressor at the same time that other machinery is being operated, except where electric power is used, when it is desirable to have a separate motor for the compressor.

Another point to consider in deciding on what system of refrigeration is best suited for a creamery is whether or not it is an advantage to carry a temperature in the refrigerator of much below 40 degrees, and if it was found to be much value to have a lower temperature than this, it, of course, would be wise to install mechanical refrigeration, as 40 degrees is about as low a

temperature as can be had with any other system. We find, however, that the average temperature carried by creameries having mechanical refrigeration is about 39 degrees which would indicate that buttermakers consider this low enough for good results as a much lower temperature could be had with mechanical refrigeration, if desired.

There are some places where conditions do not justify the expenditure of much money for refrigeration, and for that reason we are describing in this bulletin what we call an insulated ice bunker refrigerator. This is practically the same as the old style refrigerator, except that it is insulated and built larger to accommodate more ice.

Mechanical Refrigeration

In explaining the different system of refrigeration, it is hardly necessary to say very much about mechanical refrigeration, as this system has been advertised considerably and it is generally well understood by most of those interested in this subject.

Mechanical refrigeration has been in general use for a number of years, but it is only during the past few years that some of the local creameries in Minnesota have adopted this system, and the methods used in applying this system to creamery use have been improved each year, and further improvement may be expected.

There is yet some difference of opinion among manufacturers of refrigerating systems, as well as among creamery men, in regard to the use of brine and sweet water for cooling cream, and it has not been generally demonstrated that one is much more satisfactory than the other. Brine has the advantage over water in that it can be pumped through the ripener several degrees below freezing, but it is more liable to corrode the metal it comes in contact with, and if a leak should occur in the ripener coil the brine would come in contact with the cream, causing more or less damage.

If cream is pasteurized in the ripener, or if well water is used

for cooling in connection with brine, there will be a loss of brine or the brine will be diluted by the water remaining in the coil.

Cooling cream with sweet water is necessarily a little slower than cooling with brine, but the advantages of using sweet water are worthy of consideration, and it is to be hoped that manufacturers of refrigerating plants will perfect some system of cooling sweet water quickly, which would be practical in all creameries having mechanical refrigeration.

Water Supply

It is not advisable to do all the cooling of cream with mechanical refrigeration or ice water, but cream should be cooled down to about 60 degrees with well water as this is cheaper than other methods of cooling, and water at 50 degrees or lower will cool cream reasonably fast down to 60 degrees.

It is also well to remember that mechanical refrigeration requires considerable water for cooling the compressor and ammonia condenser; from four to six gallons of water per minute is needed for a four-ton compressor, and this water should be as cold as possible, hence the necessity of having a good supply of well water.

What Size to Install

The size of refrigerating plant to install depends, of course, on amount of business done, but under ordinary creamery conditions we would recommend a four-ton compressor with condenser and other piping and coils in proportion for a creamery making 200,000 pounds of butter per year. If the run is much larger than this, it may be wise to install a larger refrigerating plant, but it would not be advisable to install a smaller plant unless the run is very small. It is well to remember that the capacity of a refrigerating plant does not depend altogether on the size of the ammonia compressor, and a plant can not be operated to its capacity, if the expansion coils and other piping is not of the

proper size. When buying a refrigerating plant it is well to keep in mind that the low side of the plant determines the capacity just as much as the compressor.

Installation

When installing a mechanical refrigerating plant some thought and attention should be given to the location of the compressor, as well as to placing the condenser and liquid receiver and other piping in a convenient place. It is advisable to have the compressor close to the source of power, in fact, a direct drive from the engine to the compressor is the most satisfactory.

If on account of lack of room, it is impossible to have the compressor driven direct from the engine, it is best to drive it from the main line shaft, and it is never wise to transmit the power to counter shafts, and from these to the compressor, unless it is absolutely necessary. It is desirable to have the compressor as close as possible to the refrigerator as this saves piping and insulation of the pipes, and also avoids some slight losses, due to carrying the liquid through long pipe lines. When the arrangement of the creamery building is such that the source of power is some distance from the refrigerator, we would advise to locate the compressor near the source of power and use a longer pipe line to reach the refrigerator, as the transmission of power would cause greater losses than would the carrying of liquid through a longer pipe line.

The condenser and liquid receiver should not be placed too far from the floor, as leaks will sometimes occur, and it is convenient to be able to make repairs without the use of a ladder.

If brine or sweet water has to be pumped from the refrigerator to the ripeners, it is best to have the pipes for carrying the brine or water laid under the floor. This can be readily done if a new building is erected, but such pipes should be well insulated and the insulation should be covered with asphalt to prevent absorption of moisture from the ground.

When a refrigerating plant is installed after a building is completed, it may be better to carry the pipes overhead, rather than to tear up the floor, in order to lay the pipes, but the pipes should be well insulated, the same as other pipes carrying cold liquid outside of the refrigerator.

The Refrigerator

It is economy to have a well insulated refrigerator when mechanical refrigeration is used, and we would recommend not less than six inches of board form insulation, with a cement finish. The size of refrigerator will, of course, depend on amount of business done, but it is always well to have the refrigerator of ample size to take care of an increase in the business.

The Floor

The floor should be insulated with not less than three inches of board form insulation. It should have from three-eighths-inch to one-half-inch slope to the foot, and should slope away from the door, so as to keep the bottom of the door as dry as possible. A good refrigerator door has felt pads at the bottom to make the door fit tight, and if these pads are kept wet, they will not last long.

The Door

It always pays to buy a good door for the refrigerator; in fact, the best door that can be bought will prove to be the cheapest in the end. This door should be three feet wide by six feet and six inches high, which will allow space for the starter can, and a thirty-inch truck to be taken through.

The Window

The refrigerator should have a small window with six or more sash; this window should be about twenty by twenty-four inches

in size, and it should be placed about five feet above the floor. Never build any kind of a creamery refrigerator without a window.

Winter Ventilation

The window should be so constructed that all but two of the sash can be removed during the winter time, and these two should be hinged at top or bottom, so they can be conveniently opened more or less according to outside temperature. The reason for this is, that it is necessary to have some cold fresh air in the refrigerator to avoid dampness and mould. The door to the churn room should be kept closed as much as possible, as warm and damp air is the principal cause of mouldy refrigerators.

Tanks and Coils

It is desirable to have the refrigerator constructed so that the brine tanks and coils can be removed without tearing down the refrigerator, as the tanks and coils are liable to give out after a number of years of service, and it is not so much of a job nor as expensive, to replace them if they can be changed without tearing any part of the refrigerator out.

The expansion coil in the brine tank should be so constructed that it can be kept submerged in brine all the time. Where the pipes enter and leave the brine tank, there should be two unions a few inches apart, one below the brine and the other one immediately above. This makes it possible to replace the short pieces of pipe which are exposed to both air and brine as at this point the corrosion is most rapid. The expansion coil in the brine tank should be one continuous coil without any fittings, except the unions as mentioned above. Such a coil should last a long time when completely submerged in brine, while if part of the coil is exposed to air at times, it will not last as long.

Air circulation

Circulation of air in the refrigerator is the greatest importance, as a refrigerator can not possibly be dry without circulation. Refrigerator is constructed with overhead tank and coils.

First Cost

A four-ton mechanical refrigerating plant will cost from twelve to fifteen hundred dollars installed. It is not always wise to buy a plant because it is cheap, and due consideration should be given to the quality of tanks, coils, pipes and fittings. Before buying any plant it is advisable to investigate the merits of same, and also obtain some information regarding the reliability of the manufacturer.

To the cost of the refrigerating plant must be added the cost of insulating the refrigerator, which will, of course, vary according to size. In a creamery making one hundred to one hundred twenty-five tubs of butter per week the cost of insulating a refrigerator would vary from \$300.00 to \$400.00.

Cost of Operation

The cost of operating and maintaining a mechanical refrigerating plant can not be definitely stated, and there is quite a difference in the cost of operating refrigerating plants in different creameries. The items which are considered in the cost of operation are fuel, oil, ammonia and calcium chloride, and according to information received from creameries using mechanical refrigeration, the cost of these will vary from \$50 to \$150 per year. In addition to the above there will be some expense for repairs, though this should not amount to much for some time, if a good plant is installed, and if no accidents occur. The cost of operating and maintaining a plant will depend much on the efficiency of the operator, as his watchfulness and careful operation of the plant will count for much in obtaining efficiency and operating the plant economically.

Care of Plant

If a good plant is properly installed it should only require the same good care that must be given all kinds of machinery to maintain its efficiency and durability, but it may be of value to some operators to mention a few of the points that are of special importance in operating a refrigerating plant. It is important that the whole system is kept tight so as to avoid losses due to ammonia leaks. When the compressor is run, there must be a steady stream of cold water passing around the cylinders and through the ammonia condenser, as this increases the capacity and efficiency of the plant. The water lines through the compressor and condenser should be taken down and cleaned about once a year, as iron rust and other sediment in the water will in time clog the pipes and obstruct the free circulation of the water. It is advisable to always have a small drum of ammonia on hand so that the plant can be charged if the supply of ammonia runs low, or if through some accident part or all of the ammonia should escape from the system.

The ammonia in the system should not be allowed to run too low as lack of ammonia decreases the capacity of the plant.

The calcium chloride brine should be kept up to the standard strength by adding a little calcium chloride from time to time. If any of the brine is lost, or if it is diluted with water from the ripener coil, it is necessary to add more calcium chloride to the brine than would be necessary if sweet water is used for cooling cream. It is advisable to have a salometer for testing the strength of the brine. A brine test of eighty to ninety is about right for a temperature of zero and above. If the brine is not circulated the calcium chloride will dissolve very slowly when placed in the brine tank, and it is, therefore, better to dissolve the calcium in warm water before adding it to the brine.

In a cold building it is necessary to take some precaution during the winter months to keep the condenser and other pipes from freezing and bursting. If a few drip-cocks are placed at the low

points the pipes may be drained without much trouble whenever it is necessary.

A Few Hints

Mechanical refrigeration will prove to be a poor investment without a competent buttermaker or operator.

Don't buy a refrigerating plant because it is cheap.

When buying a plant insist on good material and a guarantee from the manufacturer.

A refrigerating plant will not run itself. It will not produce refrigeration without ammonia.

Buy good ammonia, and buy from the same manufacturer all the time.

Mixing different kinds of ammonia may cause lots of trouble and should be avoided.

An efficient power plant is necessary for economical operation of a refrigerating plant.

The Insulated Ice House System

From drawing (Fig. 30) the reader will get some idea of the principles upon which the insulated ice house system works. It is simply a well-insulated refrigerator with the ice bunker large enough to hold the whole season's ice supply.

As the insulation is placed in the walls, floor and ceilings, there is no sawdust to shovel, or rot the building, and no ice to handle. Cream can be cooled with little or no labor, and to any desired temperature suitable for buttermaking.

The two main requirements for the successful operation of this system is; first, ample ice room; second, proper insulation. There are at present about fifty creameries in the state using this system, and among them there are several that are not getting satisfactory

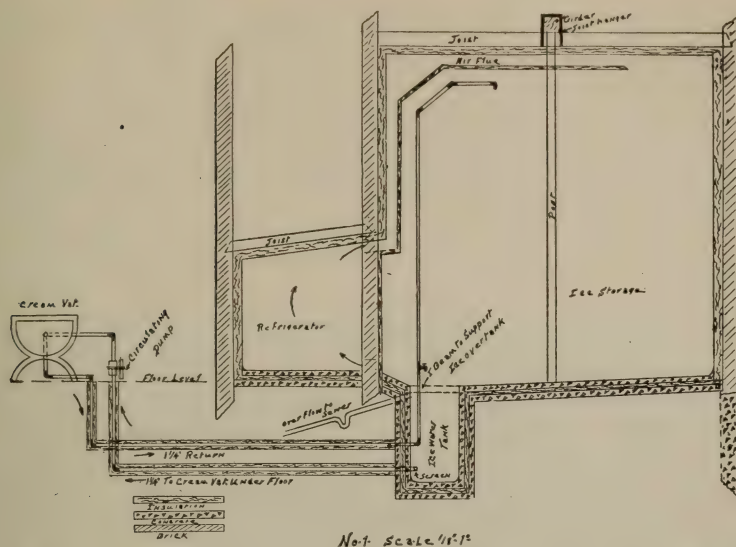

Fig. 30. Illustration showing the insulated ice house and ice water cistern for circulating ice water through the cream ripeners. This cut also shows the pipe connections and the refrigerator.

results, but we find in every case that their building is too small or poorly insulated, or both. The principle has proven practical, and satisfactory results depend on proper construction.

Cream Cooling

With this system an insulated cement tank is built in the ground in connection with the floor, in such a way that it will catch all the meltage from the ice, and this ice water can then be pumped through the cream ripener for cooling the cream, and back to the tank or up over the ice. For cooling a small amount of cream, the water in the tank is usually found to be sufficient, but for larger quantities it will be necessary to either pump the water over the ice, or else put some crushed ice in the tank.

Still another method would be to place a large cake of ice on

the grate over the ice tank and let the return water run directly over same, which will cool the water rapidly.

The size of water tank depends somewhat on the amount of cream to be cooled, but should contain at least as many gallons as the largest day's run of cream during the flush. A tank 3x5x6 feet deep is desirable size.

Construction

The walls can be constructed of lumber, brick, concrete or any other building material that will make an air-tight and moisture-proof wall. It is well to have the foundation under the frost line to prevent the walls from settling as that might damage the insulation.

The walls and ceiling in both rooms should have from four inches to six inches of board form insulation, or its equal in efficiency. The east, south or west outside walls should have six inches, a north outside wall five inches and inside walls and ceiling four inches of insulation. Board insulation can be set right against a concrete or brick wall in cement mortar, or nailed against a frame wall, and then finished off with cement plaster. Asphalt can be used in place of, or in connection with, Portland cement plaster. The manufacturers of the different insulating materials give full directions for applying same. The best method is to let the manufacturer put the insulation on and guarantee it.

The floors should be laid as follows: Grade the ground with a gradual slope the same as the finished floor is to have, and cover with about six inches of cinders or gravel, then lay a four to five-inch lean concrete floor, smooth but not troweled; over this lay three inches of corkboard flooded in hot asphalt and finish with four inches of concrete and one-half-inch facing. The floor in both rooms should have a slope of one-half inch to the foot as per direction of arrows on drawing No. 2, and have well rounded corners.

A cheaper floor can be used for the ice room temporarily, that will give fairly good results. Lay five or six rows of four-inch

drainage tile twelve inches to eighteen inches below the floor line, so that the weight of the ice will not crush them, connect them together at one end and then with a trap to sewer. Cover the tile with cinders or gravel even with the ground, and then cover the whole with twelve inches of clean cinders or gravel. The ice water will in this case soak through the gravel and tile, and then to the sewer. The ice water tank can still be there and ice put in same for cooling cream.

The pipes connecting ice water tank and ripener had best be brass, when laid underneath the floor, to insure durability. They should not be less than one and one-quarter inches and have two and one-half inches of the best obtainable insulating material. After the pipes and insulation are in place, the latter should be covered thoroughly with asphalt, or better still, completely submerged in asphalt, which will preserve them from moisture and decay.

In order to have light in the ice room, a window 30x30 inches should be placed near the ceiling, and have six sash well fitted, as this window never needs to be opened. The door connecting the refrigerator with the ice room can be made of two thicknesses of seven-eighths-inch of T. & G. lumber and need only fit moderately tight. It must be kept closed in order to insure proper circulation.

The outside door for filling ice house should be from three feet six inches to four feet wide and seven feet high, and can best be sealed up by nailing strips at the inner and outer edges of door frame in such a way as to form grooves into which can be fitted with boards of the same length as the width of the door. The space so formed should be at least twelve inches and can then be filled with granulated cork, flax fibre, mineral wool or dry mill shavings, well packed. If this is taken down each fall and dried carefully it can be used from year to year. A common door can be hung on the outside to keep rain and sun off. This door should be removed when filling ice house.

The refrigerator should have door, window and floor slope same as described for mechanical refrigeration.

Circulation

The ceiling in the ice storage should be as high as possible, or at least eighteen to twenty feet, as that will give better circulation than a lower ceiling and wider dimensions. In the butter storage part, or refrigerator, the ceiling should be seven to eight feet high. The wall between the two rooms does not necessarily have to be insulated, though an inch or two may benefit the circulation somewhat. This wall must, however, be airtight except at the floor and ceiling of the refrigerator, where a number of openings should be provided, so the cold air can come into the refrigerator at the floor, and then as it gradually warms up, it will rise to the ceiling, and finally pass back into the ice room through the air flues over head, and again come in contact with the ice.

It is desirable to extend these air flues over about two-thirds of the ceiling so as to make the air pass way over to the further wall, thereby creating a complete circulation in the whole room. The total area of these openings at the floor should be about five hundred square inches, those at the ceiling six hundred square inches, and, the flues in the ice room still a trifle larger, so as to not retard the circulation.

Size of Ice Storage

The size of ice room to build will depend mostly on the quantity of butter made and the amount and quality of insulation used, but under ordinary conditions a creamery making 200,000 pounds of butter per year needs about 8,000 cubic feet of ice storage space, which should be increased 20 per cent for each additional 100,000 pounds, and decreased 15 per cent if make is only 100,000 pounds. This will hold 150 tons of ice if well packed.

Filling Ice House

Ice should always be cut in oblong cakes, say 16x24 inches or 18x27 inches, and then piled lengthwise and crosswise every other layer. This way they will break joints and bind together and prevent falling out against the wall. There should be a space of one inch to six inches left between the ice and walls, so as to prevent the ice from crushing the plaster, and moisture reaching the insulation. When packing ice leave an opening the size of four cakes of ice by the door, and fill this space as far up as possible after the room has been filled. For hoisting ice, place a single pulley in the ceiling, directly in front of the door, and two feet from the wall, and another at the corner of the door sill; a three-quarter-inch rope through these, and a horse, will elevate a load of ice in a few minutes, and it does away with the long, heavy and cumbersome chute, and takes less room. Each layer of ice should be shaved off on top so as to form a level surface for the next layer.

First Cost of Insulated Ice House System

The first cost will depend chiefly on the size, amount and kind of insulation used. The cost of labor and material differ so much in different localities, that only some contractor in the vicinity can give somewhere near accurate figures on the cost of walls, roofing and foundation. From observation of a large number of cases, however, we venture to say that \$1,400 to \$1,800 will put in a first-class system complete.

We give below table showing the cost per square foot of insulation erected complete:

Four-inch insulation in two layers, 27 cents to 35 cents per square foot.

Five-inch insulation in two layers, 30½ cents to 40 cents per square foot.

Six-inch insulation in two layers, 34 cents to 45 cents per square foot.

Three inches of cork laid on floor, 20 cents to 22 cents per square foot.

These prices do not include walls, roof or concrete for floors, but does include all material and labor pertaining to insulation.

Cost of Operation

With this system there is no other cost than putting up the ice in the winter, which will vary from \$50 to \$175, depending, of course, on the amount of ice, distance it has to be hauled and cost of labor. In many communities ice could be put up much cheaper than it now is, if the job was auctioned off to the lowest bidder, or by sealed bids, well advertised beforehand. In some localities ice can be shipped by rail quite a distance and laid up in the ice house for around \$1 per ton.

The insulated ice house system needs no other attention than to see that ice is well packed and that the outside door is sealed up perfectly tight. We want especially to emphasize this door, as that is where so many have made mistakes. It is necessary to keep the refrigerator door closed as much as possible, also to use a truck for taking butter in and out of refrigerator, in order to avoid loss of refrigeration.

A Few Hints

The insulated ice house must be *insulated*, otherwise it is a failure.

Free circulation of air from the ice storage to the butter room is necessary.

Don't use a home-made door for the refrigerator, but buy the best ready made door; it will be cheaper in the end.

The refrigerator door should be kept shut as much as possible.

A truck should be used for taking butter in and out of refrigerator.

It is necessary to have the outside door of the ice storage perfectly tight and well insulated.

Have a small awning over refrigerator window if exposed to the sun.

Fill the ice house full.

Don't pack the ice against the walls.

Insulated Ice Bunker Refrigerator

In places where it is only a matter of a few years until a new building will have to be erected, and also where the volume of business does not warrant the expenditure of a large sum of money for refrigeration, a well insulated side ice bunker refrigerator can be made to answer the purpose quite efficiently.

It is practically the same as our old style refrigerators, only it is well insulated, and made large enough so it will hold nine or ten tons of ice when well filled, and this will give a low temperature in butter room. As it will only need refilling a few time during each year, a couple of extra men can be hired for that purpose.

Figure 31 shows the plan and principle of this system, and some of the most important details of its construction. Frame will undoubtedly be the cheapest and handiest construction and we would advise using three thicknesses of one-half-inch refrigerator Linofelt, Flaxinum, Keystone hair felt, or any other similar pliable form of insulation. Between the studdings, which should be sixteen-inch centers, can be placed two layers, which will form two air spaces, and the third layer can be nailed directly on the 2x4's with one-half-inch strips, to which should be nailed three-inch Georgia pine flooring. The walls of ice chamber should be lined with galvanized iron to protect from moisture.

The floor can best be insulated by laying two inches of cork board between two layers of concrete as shown in drawing No. 3. The ice rack can be made of 2x6's and should be well supported.

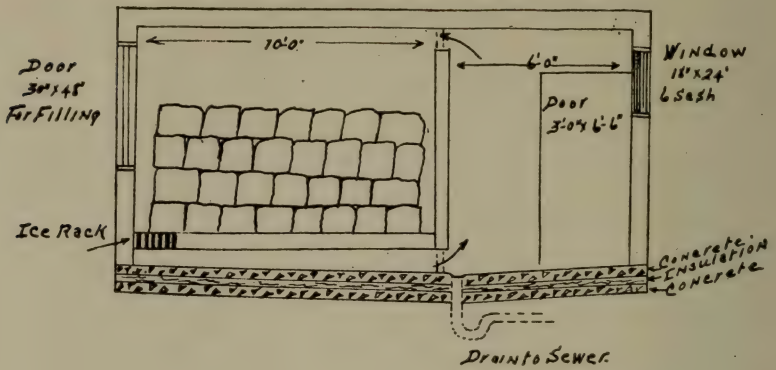

No. 3 Scale 1/8" = 1'

Fig. 31. This illustration shows a refrigerator with a large ice chest. The ice chest can be built large enough to hold a large amount of ice.

Doors for filling and taking out ice, and window, can be placed to suit local convenience. It is quite necessary to have a window at some point, otherwise the door will be left open too much.

Good quality refrigerator doors and frames ready made will prove the cheapest in the long run.

After having done your best to make a high-grade butter, is it not important that you provide good refrigeration until the product leaves the creamery?

Refrigerator Tables

Giving capacities and dimensions.

Number Tubs	Width, Length and Height	Number Tubs	Width, Length and Height
20	4x 6x7½	160	10x10x8
25	5x 6x7½	210	10x12x8
30	6x 6x7½	240	10x14x8

Number Tubs	Width, Length and Height	Number Tubs	Width, Length and Height
40	6x 6x8	280	10x16x8
50	6x 7x8	315	10x18x8
60	6x 8x8	385	10x20x8
75	6x 9x8	433	10x22x8
100	6x10x8	483	10x24x8
120	6x12x8	250	12x12x8
110	8x 8x8	300	12x14x8
125	8x10x8	320	12x16x8
150	8x12x8	360	12x18x8
200	8x14x8	400	12x20x8
225	8x18x8	440	12x22x8
280	8x20x8	460	12x24x8

TABLE No. 3

CHAPTER XXI

VENTILATION OF CREAMERIES

Importance of Ventilation

This is a very important factor in buttermaking as it is impossible to work in a damp, poorly ventilated building. Good ventilation conserves health and increases efficiency of employes. There are several things to be taken into consideration in ventilation. The heat required, location of the building, the height of the ceiling, the kind of building, and the size of the building, the arrangement of the machinery, the amount of steam produced and escaping while in operation; also the amount of air contained in the creamery, the number of machines in use.

Creameries using pasteurizing machinery, developing large quantities of waste steam, cannot be ventilated satisfactorily or near perfect without using a motor power or an exhaust fan.

The volume of steam exposed to the air and the amount of cold air coming in contact with the steam which causes evaporation has its influence on ventilation.

The first thing to consider when ventilating a creamery is the space to be ventilated in cubic feet, the corners, windows and doors, or any obstructions that tend to stop circulation; also the thickness of the walls and the materials the building is constructed of. A brick or cement creamery is harder to ventilate than a wooden structure. Creameries having high ceilings require larger inlets and outtakes than creameries with low ceilings.

The distance from the ceiling line to peak of roof is also an important factor, as the suction in a high flue will remove a greater volume of air than in a shorter flue, as air travels in a cylinder shape, therefore, round flues have more efficiency than square flues.

So, when square flues are used it is necessary to have the square flue contain air space in cubic feet equivalent to the air space of a cylindrical flue of same cubic feet capacity. As when a square flue is used it is necessary to have them large enough to remove the air from the building as small square flues for outtakes are worthless. Where a fan is used it is not necessary to have as large flues as when fans are not used. The use of flues of from 24 to 30 inches in diameter is usually large enough in creameries where a fan is used.

All joints where elbows are put together and where pipes are jointed together should be soldered tight in order to get the greatest efficiency. Leaky joints reduce efficiency to a great extent in ventilating systems.

Intakes

The intakes can be built in walls when possible; when not, should come up from outside of building and through walls. (Fig. 32.) There should be a damper outside and a door inside to close up in cold weather. The intake should enter the building from 10 to 16 inches below the ceiling line. And it should be large enough to admit the proper amount of fresh air necessary.

Sizes Usually Used

Sizes usually used are 6x8, 6x10, 8x12, 12x14 and 12x16. These are sizes commonly used in the average creamery. It is better to install a number of small intakes of medium size than a less number of large intakes, as the more evenly we distribute the cold air the better the ventilating system will work.

All ventilating systems must be regulated to suit the condition of the air, whether hot or cold. Good judgment must be used. There is no ventilating system, automatic or self-regulating, that can be used in a creamery with success. It is necessary to regulate

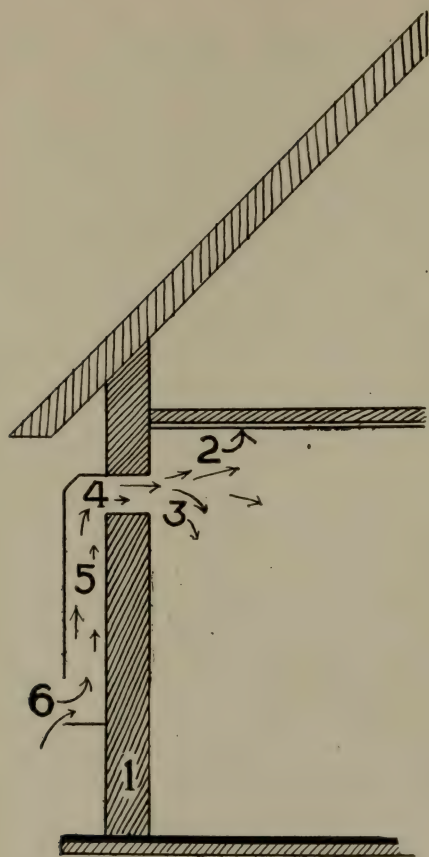

Fig. 32. Ventilating intake for air.

- 1—Creamery wall
 - 2—Ceiling
 - 3—Door
 - 4—Elbow
 - 5—Square flue on intake
 - 6—Door on outside of intake
- Material for this intake can be either of wood or galvanized iron.

the ventilating system in accordance with the humidity of air; also the temperature of the air. When it is hot weather most any ventilating system will work, but when it is muggy, damp and cold it takes a well-regulated, properly installed system to do the work satisfactorily.

The Use of Exhaust Fan

The fan should be used when the machinery is in operation when the separating, churning and pasteurizing is done. After

the work is done in the creamery, the dampers in the main flue should be closed, and the foul air be allowed to pass through the side flue, the aerator being the unit of power. (Fig. 33.)

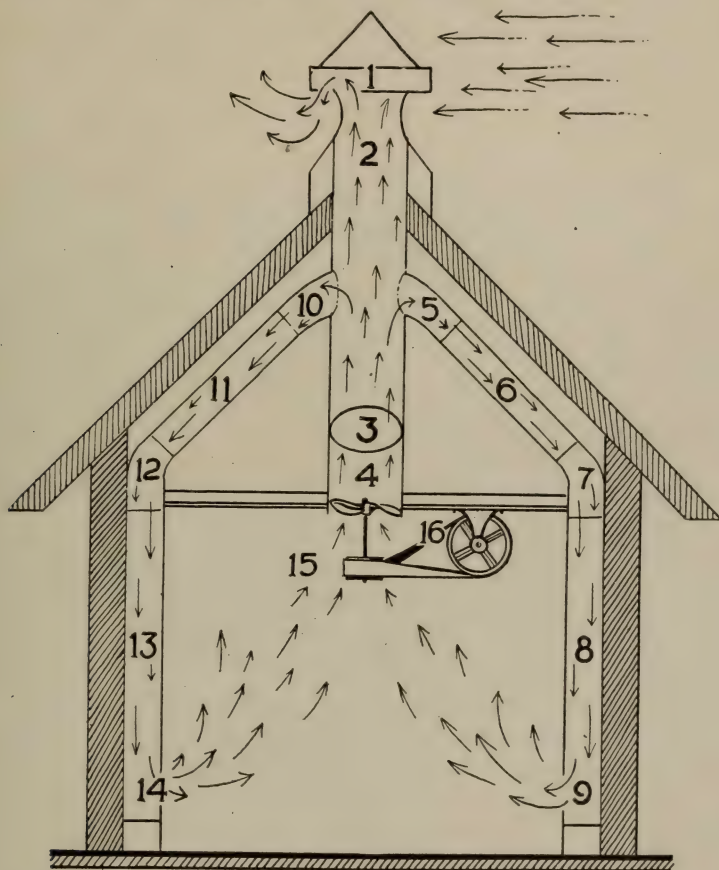

Fig. 33. Illustrating in detail creamery ventilating system, and the use of the exhaust fan for circulating the air.

- | | |
|------------------------------|----------------------------|
| 1—Aerator | 9—Register in square flue |
| 2—Main flue | 10—Elbow in main flue |
| 3—Damper | 11—Foul air flue |
| 4—Exhaust fan | 12—Elbow, square to round |
| 5—Elbow into main flue | 13—Square flue |
| 6—Foul air flue | 14—Register in square flue |
| 7—Elbow from square to round | 15—Pulley on exhaust fan |
| 8—Square flue | 16—Drivewheel for fan |

Measurement of Air

Number of cubic feet in a pound of air is 13,817.

Intake should be open just enough to admit quantities of air without cooling or chilling the building. They can be left open when the weather is not freezing.

Speed of Fan

An exhaust fan should run in proportion to its diameter. A fan 24 inches in diameter should not run over 800 revolutions per minute, and not below 500 revolutions per minute to do good work. The smaller the fan in diameter the higher the speed. It is much more satisfactory to install the larger fan, from 24 to 30 inches in diameter.

Where to Install Fan

The fan should be in the bottom of the flue below ceiling line from 8 to 10 inches. It should be built into a housing so as to form a suction from the creamery area. Fans installed in the top of the flues do not have range of capacity as when placed at bottom of flue. The housing for fan should come from 6 to 10 inches below the ceiling line so when the fan is in motion this prevents the removal of the warm air from the ceiling, and produces a good circulation and does not rob the building of the heat.

Elbows

Forty-five degree elbows should be used as much as possible so as to keep the circulating of air from back pressure and resistance. Doors on the intake should fit snug so when shut off will prevent cold air from entering the building. The material should be galvanized iron and no less than 20 gauge to wear and last.

Principles of Ventilation

To install a satisfactory working system of ventilation it requires, first a proper unit of air movement; second, the application governing the air movement; third, the proper construction with motive power to produce the required amount of air to be moved.

The Unit for Creamery

The unit for creamery will vary according to location; also the amount of steam generated; the temperature of the building; how the building is heated. It is advisable to install a system large enough so it can be shut off with dampers and regulated to fit the conditions as they exist. A small undersized system in a creamery is worthless, and is often installed at a great cost to the creamery which heretofore have discouraged the use of ventilating systems.

Motive Power

The proper motive power in a creamery where large volumes of steam are generated by pasteurizing in open vats or hot cream is run over coils exposed to the air, is the exhaust fan. This fan can be propelled by power used in the creamery, or by electricity or steam. The fan propelled from the line shaft is the most preferable as when the pasteurizing, separating or churning is being done the machinery is in motion and there is no extra expense for power. It is necessary to have two units of power, the fan and the aerator. The aerator working when machinery is not in operation.

Foul Air Flues

The foul air flues should be large enough to remove the damp air from the creamery when the fan is not running. They should be square from the ceiling down to the floor, ranging in size from 8x15 up to 15x20, and should have a register 10 inches from floor, and having an area as the flue. A flue 8x15 should have a register 8x15.

Location of Foul Air Flues

The foul air flues should always be next to the wall on inside of room, and should pass up through the ceiling and connect to round flues, those round flues connecting to the main flue using 45° Ells, shape of those ells should be from square to round where they pass through the ceiling. The square flue should figure out the same capacity as the round flues do from above the ceiling line to the main flue.

Main Flue

The main flue or flues should be in proportion to the space to be ventilated and when a large creamery is to be ventilated it is better to have two or more flues. Where two flues are used they should be set at equal distances from end of room to get the best results.

Location of Intakes

The intakes should be installed on the opposite side of the building and not too near the foul air flues. It is a good plan when possible to install intakes on south or east side of buildings. This part of the installation is very important.

Size of Fan to Use

The fan should be the size of the main flue in the center of the ceiling, or as near as possible and should run at a speed to produce a good circulation of air, and at the same time to draw the steam and dampness from the pasteurizers, preventing it from adhering to the walls or ceiling; that causes dampness and water dripping from walls and ceiling.

When pasteurizing is done it is impossible to ventilate without an exhaust fan.

Speed of Fans Used in Ventilating Systems

A fan 40 inches in diameter should run 350 to 400 r. p. m.

A fan 35 inches in diameter should run 400 to 450 r. p. m.

A fan 30 inches in diameter should run 500 to 550 r. p. m.

A fan 25 inches in diameter should run 600 to 700 r. p. m.

A fan 20 inches in diameter should run 700 to 800 r. p. m.

Advantages of Proper Ventilation

It insures the health of the operator, also prolongs the life of the building, as well as the life of the machinery and belting, and all equipment used. It prevents mold, improves the appearance of the creamery; it also saves fuel as it keeps the building dry and makes it easier to heat; it removes all the foul air and odors, giving the buttermaker a chance to make better butter. It is inexpensive when properly installed and it will do perfect work and last a lifetime.

Heat and Ventilation

It is impossible to ventilate a cold, poorly built building without having it warm, as circulating cold damp air does not ventilate. There must be enough of heat so as when the air is circulated to condense and dry the steam vapor. It is absolutely necessary to operate a ventilating system to fit the conditions as they exist.

Unnecessary Expense of Ventilation

Some of the mistakes to guard against are to use good material, and it should be heavy enough to withstand the strain and be as rust-proof as it is possible. A system should be large enough to do the work and then regulate it to fit the condition. Installing small systems that do not fit the conditions as they exist is money thrown away.

We recommend the King Ventilating System for Creameries, Cheese Factories and Milk Plants. Anyone not familiar with installing ventilating systems properly should consult the King Ventilating Co., of Owatonna, Minn., as they are specialists in this work.

CHAPTER XXII

CREAM SEPARATOR SPEEDS

Effect of Variations in Speed

When the hand separator is turned up to speed the specific gravity, or force of the bowl is at a high velocity, and this drives the heavy part of the milk (skimmed milk) to the outside or farthest point from the center of the bowl. This high speed forces the lighter part of the milk (cream) to the lowest specific gravity of the bowl, the center of the bowl.

Where the speed of the bowl is under its rated speed, the portion of the heaviest part of the milk will not become separated and passes off in the cream, and the cream will contain more milk and less butterfat.

Speed of the Machine

Cream separators should be run up to full speed all the time during the separation of the milk. Turning machines by hand is where the speed varies, as it is almost impossible to maintain an even accurate rate of speed, especially where more than one person turns the machine.

It is known that the mechanical separation of the fat and serum in the milk which differ in specific gravity is caused by centrifugal force. This force is produced by a rapid revolving motion of the separator bowl. Naturally the greater the speed of the bowl, the greater is the centrifugal force. And consequently the more efficient is the separation.

The speed of the average bowl about 4 inches in diameter is 9,000 r. p. m. If the crank is turned 60 times a minute the number

of revolutions of the bowl for each turn of the crank is 150. If the operator allows the crank to go only one-half of one turn, less than the required speed, the bowl travels 75 turns less than it should.

In terms of linear feet, is that one-half turn lost, a point on the wall of the bowl has fallen behind 80 feet. When it is considered that a point on the circumference of a cream separator bowl travels at the rate of nearly two miles per minute, the effect of a slight variation of speed on the centrifugal force and on the efficiency of skimming is great.

Rated Speed of Cream Separators

The rated speed of most cream separators are so rated that a drop of a few revolutions does not cause much loss of butterfat in skimmed milk, as might be supposed. But it affects the percentage of butterfat in the cream and is the most direct cause of variations in tests.

Temperatures of Milk for Separation

Centrifugal separators work most efficient where the temperature of the milk is about 85 to 95° Fah., which is a few degrees below the body temperature of the cow. Higher temperatures may be used with just as satisfactory results, but are not often used, especially on the farm. Lower temperatures make the milk flow more slowly, due to the viscosity of the milk and this produces a higher percentage of fat in the cream and also in the skimmed milk, causing great losses.

Conditions

Milk from fresh milch cows separates very easily. Milk from old milch cows and when cows are milked during a late period of lactation, the temperature of the milk should be higher, 90° Fah. to 95° Fah., and machine should be turned up to full speed to insure good separation.

CHAPTER XXIII

MILK FOR MARKET

Milk

Color: bluish white; opaque to light, due mostly to casein content. More viscous and heavier than water; .032 times heavier than water.

Market Milk

Inspected by inspector.

Clarified, running through clarifier and removing sediment.

Certified, from doctor's care and authority.

Standardized, mixed fat added or taken out.

Homogenized, fat globules broken by pressure.

Emulsified, run through emulsifier with fat globules broken.

Pasteurized, boiled to certain degrees of heat.

Sterilized, heat to a degree of 212° Fah.

Evaporated, moisture removed.

Condensed, part of moisture evaporated.

Composition of First and Last Milk Drawn From the Cow

First milk will contain 87.73 water, 11.37 solids, 1.97 butterfat.

The last milk of stripping will contain 80.37 water, 19.83 solids, 10.38 butterfat.

Defects in Milk and Cream

Sources to inspect:

First—Cow.

Second—Feed eaten.

Third—Health.

Fourth—Conditions, time of lactation.

Fifth—Condition of atmosphere and water used.

Cause of Off Flavors

First—Absorbed from poor ventilation.

Second—Stable unclean, poor floors.

Third—Milk house unclean.

Fourth—Kitchen—flavors from cooking.

Fifth—Ice chest—vegetable.

Sixth—Unsanitary milking machine.

Seventh—Keeping milk or cream where there is exhaust from air pump on milking machine very bad. Old rusty milk cans cause metallic flavor, over-ripe cream causes metallic flavor.

Bacterial Action

First—Sour.

Second—Bitter.

Third—Gasey.

Fourth—Ropey.

Fifth—Coagulated.

Sixth—Sticky.

Seventh—Viscosity. Slimey.

Bacteria

Shizomycetes—extremely small single-celled fungoid plant, single or grouped reproducing rapidly and regarded as active.

Bacterial Count

On different process of washing milk cans:

Cans washed on farm, 490,000 per c.c.

Cans washed in creamery using hot water and sterilized with steam, 185,000 c.c.

Cans washed and sterilized for 10 minutes, 9,500 c.c.

Bacterial Count in Market Milk

Common, loose, raw in cans, 5,000,000 per c.c.

Bottles, pasteurized with the flash system, 166,000 per c.c.

Pasteurized and held at 145° Fah. 15 minutes, 14,200 per c.c.

Pasteurized in bottles and held 30 minutes, temperature 160° Fah., 800 per c.c.

Certified milk, 10,000 c.c.

Pasteurized, clarified and held 30 minutes, temperature 145° Fah., 7,000 per c.c.

Sterilized at 212° Fah. and held 10 minutes, 500 per c.c.

This last milk showed the effects of being burned and showed a scorched flavor.

CHAPTER XXIV

CHEMISTRY AND CHEMICAL ANALYSIS OF MILK

Chemical Content of Milk

Normal milk solids	12.83	per cent
Water	87.17	per cent
	<hr/>	
Total	100.00	per cent

Chemical Analysis

Solids, ash71	per cent
Milk sugar	4.88	per cent
Albumen55	per cent
Casein	3.00	per cent
Fat	3.69	per cent
	<hr/>	
Total solids	12.83	per cent

Chemical Analysis of Milk From Different Dairy Breeds

	Fat	Casein	Sugar	Ash	
Jersey	5.61	3.91	5.15	8	14.75
Guernsey	5.12	3.61	5.11	8	13.92
Short Horn	4.48	3.50	5.00	8	12.86
Brown Swiss	5.00	3.00	4.90	8	12.98
Dutch Belted	4.80	3.20	4.98	8	13.06
Ayrshire	3.90	3.40	4.78	7	12.16
Scrub	4.00	3.00	4.50	8	11.58
Holstein	3.46	3.31	4.84	7	11.68

Fats Contained in Butterfat

	Percentage	Variations	Melting Temperature
Butryn	0.386		78° Fah.
Capuin	0.360		72° Fah.
Caperlyn	0.055		80° Fah.
Capron	1.000		116° Fah.
Laurin	7.400		112° Fah.
Myistin	20.100	3.25-25	98° Fah.
Palmetien	25.700	3.35-25	86° Fah.
Stearin	1.800	2.3 - 1	100° Fah.
Olein	35.000	20.25- 4	35° Fah.

Oil Contained in Cows' Milk From Different Breeds

Jersey	High Stearin	Low Olein
Guernsey	High Stearin	Low Olein
Brown Swiss	High Stearin	Low Olein
Short Horn	Low Stearin	High Olein
Dutch Belted	Low Stearin	High Olein
Ayrshire	Low Stearin	High Olein
Scrub	Normal	Varies quite a lot
Holstein	High Olein	Low Stearin

Cows when long in lactation high in stearin and new milk, low in stearin. Cows fed on dry feed high in stearin, low olein. Cows fed on soft feed low in stearin and high in olein. This is effective in churning and incorporating moisture, and the ripening process influences this very extensively.

Specific Gravity

Divide lactometer reading by 4 and multiply the fat by 1.2.
 Temperature 60° Fah. lactometer 32, fat 4.
 32 divided by 4 equals 8 times.
 4 divided by 1.2 equals 4.8.
 4.8 plus 8 equals 12.8.

Test can be made from temperature ranging from 50° Fah. to 70° Fah.

For every degree above 60° Fah. add 1/10 to lactometer reading.

For every degree below 60° Fah. subtract 1/10 from lactometer reading.

Temperature 62° Fah. reading 32.2.

Temperature 58° Fah. reading 32. 3.18

Normal milk contains 13 T. S.

Specific Gravity—Water	100	per cent
Butterfat	90	per cent
Skim milk	10.36	per cent
Whole milk	10.32	per cent

Lactometers

Board of Health. Quevenne Lactometer.

To find the percentage of solids in milk, divide the readings on the Quevenne Lactometer by four, and to this result add the number giving percentage of fat by 1.2. (Fig. 34.)

Example: Total solids equals 1.4 L. plus 1.2 F. Lactometer is graduated from 15 to 40. Read from top down. Standard of heat temperature is 60° Fah. Test can be made from 40° Fah. to 70° Fah. Milk must be from 1½ to 3 hours old after milking.

To Test Lactometers

Weigh up 3 grams of table salt—real fine salt—and dissolve in 100 c.c. water. If the lactometer is right the reading will show 22. When 4 grams of salt is used the reading will be 29, and with 5 grams of salt the reading will be 36.

Results Proved by Lactometer Test

Milk that is low in fat content is either skimmed or watered.

When low in lactometer reading it has water in it.

With a high lactometer reading and a low fat test it is skimmed.

The total solids in normal milk should range about 12.8.

High lactometer reading with a low percentage of butterfat contains water.

Low lactometer reading with a low percentage of butterfat is skimmed.



Temperatures of Lactometer Readings

Temperatures	Lactometer Reading	Fat
59° Fah.	34	4.6—normal
60° “	35	2.4—skimmed
62° “	22	2.3—watered
61° “	32	2.5—skimmed and watered
61° “	36	.03—skim milk

Casein

The casein is the curd part of milk or cheese. The manufacture of casein is very important and used in various ways. It is used in the manufacture of combs, knife handles, imitation of ivory. It is a smooth substance resembling hard rubber and can be polished very highly.

How Manufactured

It is made by adding a portion of sulphuric acid to skim milk. When the separation takes place from the water content of the milk then the casein is washed so as to eliminate all the acid, then it is put through a drying process and is ground up and ready for market.

Composition of Casein

Carbon	53	per cent
Oxygen	22.70	"
Nitrogen	15.70	"
Hydrogen	7.00	"
Phosphorus	.85	"
Sulphur	.75	"

CHAPTER XXV

DAIRY COW JUDGING

Head, 8 Per Cent

1. Muzzle, broad. 2. Jaw, strong, firmly joined. 3. Face, medium length, clean. 4. Forehead, broad between the eyes. 5. Eyes, large, full, mild, bright. 6. Ears, medium size, fine texture, secretions oily, yellow in color.

Fore-Quarters, 10 Per Cent

7. Throat, clean. 8. Neck, long, spare, smoothly joined to shoulders, free from Duclap. 9. Withers, narrow and sharp. 10. Shoulders, sloping, smooth, light. 11. Fore-legs, straight, clean, well set under body.

Body, 25 Per Cent

12. Cropps, free from fleshiness. 13. Chest, deep, roomy, broad. 14. Back, straight, strong, vertebræ open. 15. Ribs, long, deep, well sprung, wide apart. 16. Barrell, deep, long, capacious. 17. Loin, strong.

Hind-Quarters, 12 Per Cent

18. Hips, prominent, wide apart. 19. Rump, long, level, not sloping. 20. Bones, wide apart. 21. Tail, set high, tapering. 22. Thighs, spare, not fleshy. 23. Hind legs, well apart, room for udder.

Mammary Development, 30 Per Cent

24. Udder, large, very flexible, attached high behind, carrying

well forward, quarters even, not cut up. 25. Teats, wide apart, uniformly placed, convenient in size. 26. Milk veins, large, tortuous, extending well forward. 27. Milk wells, large.

General Appearance

28. Disposition, quiet, gentle. 29. Health, thrifty, vigorous.
30. Quality, free from coarseness throughout, skin soft and pliable.
31. Temperament, inherent tendency to dairy performance.

CHAPTER XXVI

DAIRY COW FEEDS AND FEEDING

A dairy cow is like a gasoline engine, over-feed her and she will stop producing. You flood the carburetor of a gasoline engine and you get no power. Properly feed and you will get good results.

Classes of Feed

Two classes: Bulk roughage, concentrates. Roughage contains all coarse portions of feed, hay, straw, corn fodder, stover, silage, roots, cowpeas, alfalfa, clover.

Concentrates include all grains, mill products, oats, wheat, corn, middlings, bran, barley, rye, flax seeds, meal.

Composition of Feeds

In feeds there are three kinds of substances known as protein, carbohydrates and fats.

Protein grows lean flesh, blood, tendons, nerves, hair, horns, wool, casein and albumen in milk.

Carbohydrates are starch, sugar, gum, crude fibre, coarse fodders, mill stuffs contain little fibre, but are rich in starch and sugar, and are stored up as fat or burned to produce heat and energy.

Fats are wax, green coloring matter of plants. One pound of fat is equal to 2.2 pounds of carbohydrates. Multiply 2.2 pounds of carbohydrates to obtain percentage of fat.

Balanced Rations for Milch Cows

The number of pounds stated in each ration is for one day's feed of 24 hours, and is applicable to an average cow weighing 900 to 1,200 lbs., giving from 3.6 to .4% milk.

	Pounds		Pounds
1. Corn silage	35	7. Corn silage	35
Hay	8	Hay	10
Wheat bran	4	Corn meal	3
Ground oats	3	Wheat bran	4
Oil meal	2	Ground oats	3
	—		—
	52		55
2. Corn silage	50	8. Corn silage	40
Corn stalks	10	Corn stover	8
Corn meal	2	Corn meal	2
Wheat bran	4	Wheat bran	4
Malt sprouts	3	Oil meal	2
Oil meal	1		—
	—		56
	70		
3. Corn silage	20	9. Corn silage	20
Corn stalks	10	Clover, timothy hay	15
Hay	4	Corn meal	3
Wheat bran	4	Ground oats	3
Gluten meal	3	Oil meal	2
Corn cob meal	3	Cotton seed meal	1
	—		—
	44		44
4. Corn silage	40	10. Clover silage	25
Clover, timothy hay	10	Corn stover	10
Wheat shorts	3	Hay	5
Gluten meal	3	Wheat shorts	2
Ground oats	3	Oats feed	4
	—	Corn meal	2
	59	Linseed meal	1
			—
			49

<table style="width: 100%; border-collapse: collapse;"> <tr><td>5. Silage</td><td style="text-align: right;">40</td></tr> <tr><td> Clover</td><td style="text-align: right;">10</td></tr> <tr><td> Oat feed</td><td style="text-align: right;">4</td></tr> <tr><td> Corn meal</td><td style="text-align: right;">3</td></tr> <tr><td> Gluten meal</td><td style="text-align: right;">3</td></tr> <tr><td> —</td><td></td></tr> <tr><td></td><td style="text-align: right;">60</td></tr> </table>	5. Silage	40	Clover	10	Oat feed	4	Corn meal	3	Gluten meal	3	—			60	<table style="width: 100%; border-collapse: collapse;"> <tr><td>11. Clover silage</td><td style="text-align: right;">30</td></tr> <tr><td> Dry fodder</td><td style="text-align: right;">10</td></tr> <tr><td> Oat straw</td><td style="text-align: right;">4</td></tr> <tr><td> Wheat bran</td><td style="text-align: right;">4</td></tr> <tr><td> Malt sprouts</td><td style="text-align: right;">2</td></tr> <tr><td> Oil meal</td><td style="text-align: right;">2</td></tr> <tr><td> —</td><td></td></tr> <tr><td></td><td style="text-align: right;">52</td></tr> </table>	11. Clover silage	30	Dry fodder	10	Oat straw	4	Wheat bran	4	Malt sprouts	2	Oil meal	2	—			52
5. Silage	40																														
Clover	10																														
Oat feed	4																														
Corn meal	3																														
Gluten meal	3																														
—																															
	60																														
11. Clover silage	30																														
Dry fodder	10																														
Oat straw	4																														
Wheat bran	4																														
Malt sprouts	2																														
Oil meal	2																														
—																															
	52																														
<table style="width: 100%; border-collapse: collapse;"> <tr><td>6. Silage</td><td style="text-align: right;">45</td></tr> <tr><td> Oat straw</td><td style="text-align: right;">5</td></tr> <tr><td> Brewers' grains</td><td style="text-align: right;">4</td></tr> <tr><td> Corn stalks</td><td style="text-align: right;">5</td></tr> <tr><td> Wheat shorts</td><td style="text-align: right;">4</td></tr> <tr><td> —</td><td></td></tr> <tr><td></td><td style="text-align: right;">63</td></tr> </table>	6. Silage	45	Oat straw	5	Brewers' grains	4	Corn stalks	5	Wheat shorts	4	—			63	<table style="width: 100%; border-collapse: collapse;"> <tr><td>12. Clover silage</td><td style="text-align: right;">40</td></tr> <tr><td> Hay</td><td style="text-align: right;">10</td></tr> <tr><td> Roots</td><td style="text-align: right;">20</td></tr> <tr><td> Corn meal</td><td style="text-align: right;">4</td></tr> <tr><td> Ground oats</td><td style="text-align: right;">4</td></tr> <tr><td> Linseed meal</td><td style="text-align: right;">1</td></tr> <tr><td> —</td><td></td></tr> <tr><td></td><td style="text-align: right;">79</td></tr> </table>	12. Clover silage	40	Hay	10	Roots	20	Corn meal	4	Ground oats	4	Linseed meal	1	—			79
6. Silage	45																														
Oat straw	5																														
Brewers' grains	4																														
Corn stalks	5																														
Wheat shorts	4																														
—																															
	63																														
12. Clover silage	40																														
Hay	10																														
Roots	20																														
Corn meal	4																														
Ground oats	4																														
Linseed meal	1																														
—																															
	79																														

Nutritive Value of Feeds

	Nutritive Ratio
Corn Fodder	1:14.9
Mixed Grass and Clover	1: 7.4
Wheat Bran	1: 3.7
Skimmed Milk	1: 2
Corn Silage	1:14.3
Gluten Meal	1: 2.5
Corn or Cornmeal	1: 9.7
Mangles	1: 5.1
Red Clover Hay	1: 3.1
Alfalfa (green)	1: 3.1
Alfalfa (hay)	1: 3.8

Feeding Calves

For feeding a young calf use 2 quarts of whole milk three times a day from its own mother for the first 100 pounds of live

weight. After the calf weighs 100 pounds, take 10 pounds of skimmilk and 2 pounds of whole milk, and for the third 100 pounds of weight feed 10 pounds of skimmilk three times a day.

Changing Feed

When we change the milk from whole to skimmed milk in feeding calves it should be done very gradually. First substitute $\frac{1}{2}$ pint of skimmilk to the whole milk for the first five days, then gradually decrease the whole milk and increase the skimmilk until the calf is getting all skimmilk.

Caution: Be sure that milk is sweet and clean. Using clean utensils and have the milk at blood heat (87° Fah.) and be very careful to prevent the calf from getting any foam from milk separated from a centrifugal separator, as this contains air and will cause bloat and has a direct effect on the calf's stomach.

Time to Feed.

Calves should be fed three times a day. Don't let the little calves wait all day, as they are babies and need care and attention. The correct percentage of fat in milk for feeding calves is 3 per cent. Milk containing more than 3 per cent fat is too rich.

CHAPTER XXVII

GENERAL CREAMERY INFORMATION

What to Do in Case of Accidents

Should flue spring leak during run, plug can be driven in with a sledge. Hardwood and iron plugs should be kept on hand.

Should governor break during run, run on throttle until repaired.

Should smoke stack blow off creamery, connect exhaust in smoke stack to produce a draught.

Should churn tip over when butter is in granular form, plug drain and flood creamery with cold water, and save all the butter.

Should boiler foam, shut down engine and keep pump or injector working.

Should steam pump refuse to work, run cold water on outside. Sometimes rings stick, lubricate well with heavy oil.

Should creamery catch on fire on roof, turn live steam on under roof. This will smother the fire.

Should friction clutch break on churn, tie clutch arm to main drive wheel and start and stop the engine.

In operating steam boiler and water glass brakes, cover up arms and head to prevent being scalded, closing lower valve first and then close upper valve.

In case throttle sticks and cannot be closed, engine can be stopped by using 2x6 foot lever on flywheel after throttling governor. Use lever between flywheel and floor.

Should you forget to put color in cream when churning, color the salt.

Should small belt slip, twist a few times until run is over.

Should box run hot, cool with cold water, turn stream on outside box.

Should injector refuse to work, look for trouble in upper check or lower spray connection. Pouring cold water on will sometimes help.

Should drain become clogged, connect with steam and put on pressure.

Should drain freeze, use salt brine and boil with steam hose. The hot brine will penetrate through the frost.

Cleaning Creamery Floors, Churns and Glassware

To clean a creamery churn use $\frac{1}{2}$ gallon of sulphuric acid and 20 gallons of boiling water. Put the acid into 2 gallons of cold water, then add to the hot water, being very careful that the acid does not explode when coming in contact with the hot water, then put into churn, run from five to six minutes, being careful not to get any of the solution on outside of churn. After running, draw out of the churn and rinse with a strong solution of alkali. Wyandotte washing powder is preferable, using a 5-lb. sack to 40 gallons of water. Rinse with boiling water several times, and then rinse with cold water. By using this method it will remove all stains and butter-fat from the wood; also will remove mold.

Floors

To clean a cement floor, rinse off with boiling hot water, then use coal oil (kerosene); rub in well; afterwards use sulphuric acid and bichromate of potash; rub well into the cement, then use boiling water and Lewis lye. Use boiling hot water to rinse the floor off. This method will remove grease and rust spots and whiten the floor.

Caution. Do not put sulphuric acid on floor until after the floor has been wet with boiling hot water as it will soften the cement and ruin the floors.

To Clean Glassware

To clean Babcock test bottles, pipettes, flasks or any glassware used in the creamery, use sulphuric acid and bichromate of potash or potassium chromate, using a mixture of five parts acid and one part bichromate of potash. After the bottles have been washed with this solution, rinse well with an alkali solution, Wyandotte washing powder, and then with clean hot water.

Proper Slant for Floors in Factories and Cheese Factories

The proper slant for floors in creameries and cheese factories is a drop of one inch per running foot. Any less does not give slant enough.

Red Reader Used for the Babcock Test

This solution is made from Emyl alcohol and a few drops of indelible ink for coloring it. This has no effect on the fat. Never use any kind of oils or foreign substance, as there is great danger of increasing the fat column and getting too high a reading.

Pressure

To find the pressure, multiply the height by .43. A tank 100 feet high will have 43 lbs. pressure to the square inch.

Temperature of Water as Indicated by Pressure

The boiling point of water is 212° Fah. At 5 lbs. of steam pressure, temperature will be 227° Fah. At 25 lbs. of steam pressure, temperature will be 267° Fah. At 50 lbs. of steam pressure, temperature will be 297° Fah. At 100 lbs. of steam pressure, temperature will be 337° Fah. At 200 lbs. of steam pressure, temperature will be 389° Fah.

Soaking a New Churn

When a new churn is being installed in a creamery it is necessary to clean and soak the drum. First use 40 to 60 gallons of boiling water and two quarts of Wyandotte washing powder, put in drum, close doors and run for 3 to 4 minutes; then remove doors and drain water out of churn through door openings. Then rinse out with 40 to 50 gallons hot water. After this is done, fill churn full of water at a temperature of 90° Fah., close doors, and turn down to soak, cork and let stand eight or twelve hours, then remove water from drum. Wash out drum with hot water, then cold water, and churn is ready for use and there will be no wood flavors in butter.

Caution

Be sure and fill drum full of water at a temperature of 90° Fah. Do not use cold water in soaking drum. It will color it black and ruin churn.

A churn properly soaked will retain a nice, clean, white appearance inside.

Churn should be scalded out with boiling water after being used every day. Use water 212°, running drum 4 to 5 minutes. Let churn cool off. Do not use cold water to cool with.

Rules and Information

To find the area of a triangle, multiply the base by the altitude and take half the product.

To find the area of a rectangle, multiply the length by the breadth.

To find the circumference of a circle multiply the diameter by 3.1416.

To find the diameter of a circle, divide the circumference by 3.1416.

To find the area of a circle, multiply the square of the diameter by .7854.

To find the cubic contents of a cylinder, multiply the area of the base by the height.

To find the surface of a sphere, multiply the square of the diameter by 3.1416.

To find the cubic contents of a sphere, multiply the cube of the diameter by .5236.

To find the cubic contents of any irregular solid, fill a vessel to the brim with water; sink the body in the water, catching the water which is displaced and measuring it.

A gallon of water weighs 8 1-3 pounds and contains 231 cubic inches.

A cubic foot of water contains 7½ gallons, 1,728 cubic inches, and weighs 62½ pounds.

To find the pressure in pounds per square inch of a column of water, multiply the height of the column in feet by .434.

The standard horse power is 33,000 pounds raised one foot in one minute.

The standard horse power for steam boiler is the evaporation of 30 pounds of water per hour from a feed water temperature of 100 degrees F. into steam at 70 pounds gage pressure.

Questions and Answers

The following is a list of questions and answers, some of which are usually asked by boiler inspectors when giving an engineer an

examination for a license. The questions asked by a boiler inspector depend to a considerable extent upon what kind and size of boiler the engineer desires to operate, also upon the engineer's experience and personal appearance. The boiler inspector will often ask questions which he does not expect the applicant will be able to answer. He asks the question simply to bring out an expression from the applicant, and learn whether he is honest and reliable. An applicant is usually questioned as to his age, the amount of experience which he has had, in firing and in operating an engine or machinery of any kind. Also as to what class and size of machinery he desires to operate. If the applicant has had experience with engines and boilers, he should be able to state the kind and size of boiler and engine, also state the general design of the engine and boiler. The applicant should not attempt to answer questions which he does not understand. He should be perfectly free in his explanations, and not attempt to explain anything which he does not understand.

Q. What is steam?

A. Steam is a vapor given off from water when heated to the boiling point.

Q. What is the boiling point of water?

A. The boiling point of water depends upon the pressure. In an open kettle, at the sea level, water boils at a temperature of 212 degrees Fahrenheit. If confined in a closed boiler, the boiling temperature will rise when the steam pressure rises. If a vacuum be produced the water will boil at less than 212 degrees, the boiling point depending on the vacuum secured.

Q. What is the temperature of steam at 100 pounds gage pressure?

A. 337 degrees Fahrenheit.

Q. How much more space will water occupy when turned into steam than it occupied as water?

A. The space occupied by the water when turned into steam will depend upon the pressure. At the pressure of the atmosphere it will occupy about 1,700 times as much space. At 100 pounds gage pressure it will occupy about 240 times as much space.

Q. How should the glass gage be set on a boiler?

A. The glass gage should be set so that the bottom of the glass is level with or just a trifle higher than the crown sheet or top row of tubes in the boiler.

Q. Are glass gages always properly set on boilers?

A. No. Often they are placed too high or too low.

Q. How could you tell if a gage was properly set?

A. By leveling it with a spirit level, or by removing the hand-hole and measuring the amount of water over the tubes or crown sheet, and comparing it with the amount shown in the glass gage.

Q. How should the gage-cocks be set?

A. The lowest gage-cock should be set about one inch above the crown sheet or top row of tubes. The middle gage-cock should be about four to six inches above the crown sheet or top row of tubes, the distance depending somewhat upon the size of the boiler. A large boiler should have the gage-cocks a little higher.

Q. How much water would you carry over the tubes or crown sheet?

A. From four to six inches, depending upon the size of the boiler. A large size boiler should have a little more water than one of a smaller size.

Q. What harm would it do to carry more water?

A. Carrying more water would not leave sufficient steam room in the boiler, and the boiler would be liable to foam or prime. Water would be carried over with the steam into the engine. This would be wasteful of fuel, as cold water must be pumped in to maintain the water level, and the engine would not run as well as it would with dry steam.

Q. What harm would it do to carry less water?

A. Carrying less water would be dangerous in case the pump or injector should stop working, the water level would become too low and there would be danger of burning the tubes or the crown sheet.

Q. How often would you clean the tubes on a boiler?

A. The tubes should be cleaned with a scraper as often as

necessary to keep them perfectly clean. The frequency of cleaning them will depend upon the amount of fuel used and to what extent the boiler is used. They should be cleaned in the morning before firing up, at least.

Q. How would you manage a boiler in regard to keeping it clean?

A. The frequency of cleaning a boiler will depend upon the amount of water that is used and to what extent the boiler is used. Under usual conditions the boiler should be blown out a little every day. It is a good plan before stopping after a day's run to pump in more water than is required while running. The next morning after the fire is started, and from 10 to 40 pounds pressure has been raised, open the blow-off valve and blow the water down to the proper level. If the water is very muddy, it is a good plan to blow it out a little after dinner, before starting up. After the boiler has been run for some length of time, usually from one to three weeks, the water should all be turned out, and the boiler opened and thoroughly washed inside. The boiler should not be blown out under steam pressure. The best time to blow it out is when the steam pressure has just gone down and the water is hot. Open the blow-off valve, let all the water run out, remove the handholes and manholes, and wash the boiler with a hose if pressure can be had. The boiler should also be scraped with a scraper consisting of an elliptical shaped piece of iron shaped to fit the side of the boiler and fastened to a rod for a handle.

Q. Is it always necessary to use a boiler compound?

A. No. In many cases boiler compounds would be of no benefit whatever, especially where the water is soft and contains only substances which form a mud, and do not turn into a hard scale.

Q. Under what conditions is a boiler compound necessary?

A. A boiler compound is necessary when the water is such as to form a hard scale on the shell and tubes of the boiler, and it is not possible to keep it from forming by washing the boiler frequently and scraping it with an iron scraper.

Q. Will boiler compound make the water perfectly pure?

A. No. All that a boiler compound can do is to change the scale-forming substance in the water so as to prevent it forming a hard scale, but it will remain in the boiler in the form of a soft mud which must be removed by blowing out and washing the boiler frequently.

Q. How low is it safe to allow the water to become in the boiler?

A. A boiler is safe, and more water may be admitted, as long as there is water over the tubes or crown sheet. It is always best, however, not to allow the water to become lower than one inch above the tubes and crown sheet.

Q. What should be done in case the water becomes as low as the tubes or crown sheet?

A. When the water becomes as low as the tubes or crown sheet, the fire should be pulled out and the boiler allowed to cool down before admitting more water.

Q. What precautions should be taken with the safety valve?

A. The safety valve should be opened every morning when about 40 pounds steam pressure has been raised, in order to see that it is in good working order and not stuck to its seat.

Q. Give several causes for a boiler feed pump refusing to work.

A. Leaks in the suction pipe; pump plunger worn; sticks, etc., getting under the pump valves or check valve; pump not properly packed; too high a lift; the water too hot; pump being air bound; suction pipe being clogged up; discharge pipe between the pump and the boiler may be filled with scale.

Q. Give several causes for an injector refusing to work.

A. Leaks in the suction pipe; sticks, etc., being drawn into the injector partly closing the openings; too high a lift; water too hot; not sufficient steam pressure; leaking check valve; the injector sealed up; discharge pipe between injector and boiler may be sealed up.

Q. What are the usual causes of leaking boiler tubes?

A. Boiler tubes are liable to leak when the flue doors are open and allow cold air to strike them. The tubes being of thinner material than the boiler shell will cool quicker, and in cooling contract more than the shell of the boiler, causing a strain at the tube ends. When the water is allowed to become below the tubes in the boiler; they will become overheated and are liable to leak.

Q. How would you stop boiler tubes from leaking?

A. Small leaks may usually be stopped by the use of a beading tool, turning the ends of the tube down against the tube sheet. If the tubes leak badly, they should be expanded with a tube expander and then beaded down with the beading tool.

Q. What causes "foaming" in a boiler?

A. "Foaming" is usually caused by the boiler being dirty or the water being impure. It is more liable to occur when the water is high in the boiler and the engine is working hard.

Q. How would you prevent "foaming"?

A. "Foaming" may be prevented by keeping the boiler clean and using as pure water as is possible to get. Carry the steam pressure high, and do not carry more water than is necessary to be safe.

Q. What parts would you examine closely on taking charge of a steam boiler and engine?

A. The boiler should be examined closely inside and out to determine whether it is clean, also if the boiler material is in good condition, the boiler not rusted, pitted, bagged or blistered. Also notice the ends of the tubes and see that the bead is not burned or rusted off. Trace out all pipes. See how the glass-gage and gage-cocks are set, comparing them with the top side of the top row of tubes, or with the crown sheet. Examine the pipe between the pump or injector and boiler to be sure it is not scaled up. See that all valves are packed and are in good working condition. If the boiler is set in brickwork, see that all cracks or openings which would admit air, except through the ashpit doors, are carefully closed.

Q. What is a simple engine?

A. A simple engine is an engine that uses steam once only.

Q. What is a compound engine?

A. A compound engine is an engine using the steam more than once, passing it first into a small or high pressure cylinder and exhausting from the high pressure cylinder into one or more other cylinders.

Q. What is a condensing engine?

A. A condensing engine is an engine that exhausts into a condenser, which is a contrivance for condensing the exhaust steam, thereby gaining part of the pressure of the atmosphere.

Q. What is "lead" on an engine?

A. "Lead" on an engine is the amount of opening which the slide valve allows into the steam port when the engine is on dead center.

Q. How would you give an engine more lead?

A. In a simple slide-valve engine give the engine more lead by turning the eccentric ahead on the shaft, or the direction in which the engine was running.

Q. If an engine had more lead on one end than on the other, how would you make it even?

A. The lead must be made even by moving the slide-valve on the rod, or by adjusting the eccentric rod, one-half of the difference between the lead on each end.

Q. If an engine is given more lead, what effect will it have on the point of cut-off, compression and exhaust of the engine?

A. If an engine is given more lead at the point of cut-off, the compression and opening of the exhaust port will all take place earlier in the stroke.

Q. What would you do if the water got out of sight in your glass-gage?

A. If the bottom of the glass-gage was set level with the top of the tubes or crown sheet, pull out the fire and allow the boiler to cool down before adding water. The engine should be allowed to run in order to relieve the pressure.

Q. What would you do in case the water was becoming low in the boiler?

A. When water got down to within one inch of the tubes or crown sheet, and it was not possible to get water in immediately, the fire should be banked with fresh coal or ashes. If a wood or straw fire, it should be allowed to die out. The engine should be stopped in order to hold what water there is in the boiler. As soon as water can be obtained and the pump or injector started, it will be safe to admit more water.

Q. How would you regulate the amount of water a cross-head pump puts into the boiler?

A. The amount of water which a cross-head pump will put into a boiler is regulated by a valve on the suction pipe.

Q. How would you reverse a simple slide-valve engine?

A. A simple slide-valve engine is reversed by placing the engine on dead center, turning the eccentric about one-third way around on the shaft in the direction the engine was running, or until it has the same amount of lead on the same end it had running in the other direction.

Q. Is the piston of an engine in the center of the cylinder when the crank pin stands at the top or bottom quarter?

A. No. When the crank is at top or bottom quarter the piston will be a little more than half way towards the crank end of the cylinder. The distance it would be past the center would depend upon the length of the crank and connecting rod.

Q. Is the area of the piston the same on each side?

A. No. The side of the piston towards the crank has less area on account of the space occupied by the piston rod. In estimating horse power one-half the area of the piston rod is deducted from the area of the piston. This is done for the reason that one-half the work on the piston is done on the end where the rod does not take up part of the piston area and one-half is done on the end where the piston rod occupies part of the area.

Q. What would be the horse power of a simple slide-valve engine having a cylinder 6x9 inches running 225 revolutions per minute, carrying 100 pounds steam pressure on the boiler. Diameter of the piston rod $1\frac{1}{4}$ inches.

A. 6 times 6 equals 36, 36 times .7854 equals 28.2744 inches (area of piston).

28.2744 minus .6135 (half the area of the piston rod) equals 27,6639 inches (actual area of the piston).

27.6639 times 50 (half of boiler pressure) equals 1383.195 (total average pressure on piston).

9 inches (length of stroke) times 2 equals 18 inches of travel of piston with each revolution.

225 times 18 equals 4050 inches.

4050 inches divided by 12 equals 337.5 feet, travel of piston per minute.

1383.195 times 337.5 equals 466,828 foot pounds.

466,828 divided by 33,000 equals 14.1 horse power.

Q. State by steps how you would put an engine on dead center.

A. First, turn the engine about $\frac{1}{8}$ of a turn above dead center.

Second. Make a mark across the cross-head and guide.

Third. With one end of a tram placed upon a permanent mark on the engine frame, make a mark on the fly wheel or disk with the other end of the tram.

Fourth. Turn the engine below dead center until the mark on the cross-head is brought in line with the mark on the guide.

Fifth. With one end of the tram placed in the same permanent mark on the engine frame, make another mark on the engine fly wheel or disk.

Sixth. Measure on the fly wheel or disk and find a point half way between the two marks made with the tram.

Seventh. Turn the engine so as to bring this center point on the engine fly wheel or disk even with the point of the tram. The engine will then be on dead center.

Eighth. Find the opposite dead center by repeating the operation on the other end, or by measuring around one-half way on the fly wheel or disk.

Q. State by steps how you would proceed to set a slide valve in a simple slide-valve engine.

A. First. Put the engine on dead center.

Second. Turn the eccentric one-fourth of a turn ahead of the crank.

Third. Place the slide-valve in the center of its travel so as to cover both steam ports equally, and fasten it to the valve rod.

Fourth. Turn the eccentric ahead the direction the engine is to run until $1/32$ of an inch lead is obtained on the same end of the cylinder that the piston is on. Fasten the eccentric to the shaft.

Fifth. Turn the engine on the other dead center to see if you have the same amount of lead on the other end. If the lead is equal on both ends the valve will be set.

Sixth. If there is more lead on one end than on the other, make the lead even by moving the slide-valve on the rod, or adjusting the length of the eccentric rod, until it has the same lead at both ends.

Seventh. If the valve has too much lead on both ends, but the lead is equal, give less lead by turning the eccentric back. If there is not enough lead turn the eccentric ahead.

Melting Point of Substances

Substance	Deg. Fah.
Butter	82.95
Lard	88.96
Tallow	92.111
Butter containing large amount of sterin.....	96
Butter containing large amount of olein.....	80
Sterin melts at	110
Olein melts at	35

Substance	Deg. Fah.	Substance	Deg. Fah.
Mercury	39	Antimony	815
Ice	32	Bronze	1692
Tallow	92	Silver	1740
Sulphur	239	Gold	1975
Tin 1, Lead 1.....	408	Copper	2000
Tin	446	Cast Iron	2075
Bismuth	505	Steel	2480
Lead	613	Wrought Iron	2822
Zinc	780	Brass	1850

Weight of a Cubic Foot of Substances

Substance	Wt. Lbs.	Substance	Wt. Lbs.
Aluminum	162	Hickory, dry	53
Brass	504	Ice	58.7
Brick	125	Iron, cast	450
Cement (Portland)...	90	Lead	711
Coal, hard, heaped		Mercury at 32° Fah...	849
bushel, loose	80	Oak, dry	50
Coal, soft, heaped		Salt	45
bushel, loose	76	Sand, dry	100
Earth, common loam,		Snow	15 to 50
dry	76	Steel	490
Gold	1204	Water	62.5

Standard Bolt Threads

Diameter	No. Threads per Inch	Diameter	No. Threads per Inch
1/4 inch	20	9/16 inch	12
5/16 inch	18	5/8 inch	11
3/8 inch	16	3/4 inch	10
7/16 inch	14	7/8 inch	9
1/2 inch	13	1 inch	8

Temperature of Fire Corresponding to its Appearance

Appearance	Temp. Fah.	Appearance	Temp. Fah.
Red, just visible	997°	Orange, deep	2010°
Red, dull	1290°	Orange, clear	2190°
Red, cherry dull	1470°	White heat	2370°
Red, cherry dull	1650°	White, bright	2550°
Red, cherry clear	1830°	White, dazzling	2730°

Composition of Metals and Alloys

	Copper	Tin	Zinc	Lead	Anti- mony	Melting Point
Babbitt	4	88	8
Brass, common	85	..	15	1850°
Bronze	80	18	2
Fusible plug	..	100	446°
Plumbers' solder	..	33	..	67	..	450°
Tinners' solder	..	50	..	50	..	408°

Proper Size of Pop Safety Valves, Crosby's

Diameter of Valve, inches	1	1 1/4	1 1/2	2	2 1/2	3
Capacity in Horse Power	10	20	30	50	80	100

Water

Colorless, liquid, toned by transparent liquid, chemically neutral, devoid of taste or smell. Maximum density is at a tem-

perature of 39° Fah. At a temperature above 39° Fah. expands. At a temperature below 39° Fah. expands.

One cubic inch of water will make one cubic foot of steam and occupies 1,700 times as much space. One cubic foot of water weighs $62\frac{1}{2}$ lbs. and contains 7.5 gallons, or 1,728 cubic inches. One gallon of water weighs $8\frac{1}{3}$ lbs., and contains 231 cubic inches. Freezes at 32° Fah. and boils at 212° Fah.

Zero

Zero means nothing. A starting point. In arithmetic called "naught." Means no number in algebra, zero. Point of commencement on a thermometer or scale. On a Fahrenheit thermometer the freezing point is marked at 32. The boiling point is 212. Zero is 32. Above 32 is warmer. Below is colder. Freezes at 32. In the centigrade thermometer zero is freezing point. Zero indicates the commencement of any scale or reckoning.

INDEX

A

Accidents, What to Do in Case of.....	147
Area	31

B

Babcock Testers, Speed	55
Bacterial Count in Market Milk.....	135
Ball and Lever Safety Valves, Rules for Figuring.....	15
Belt Lacing	40
Boilers	9
Boiler Blisters	12
Boiler Blowing Out	12
Boilers, Care for Steam	11
Boilers, Cleaning Ashes from Pit.....	12
Boilers, Compounds	12
Boilers, Horse Power by Grate Surface.....	11
Boilers, Horse Power by Heating.....	9
Boilers, Horse Power by Test.....	9
Boiler Injectors	17
Boiler Injectors to Clean.....	14
Boiler Injector Trouble	14
Boiler Inspection	13
Boiler Inspection, Hammer Test	13
Boilers, Method of Estimating Horse Power.....	9
Boilers, Scale Inside	12
Boilers, Size of and Horse Power	9
Boilers, Strength of Steam	14
Boilers, Tensile Strength	14
Boiling Point of Water, What Is.....	17
Bolt Threads, Standard	162
Brake Horse Power of Steam Engine.....	25
Butter	88
Butter, Amount of Wash Water to Use.....	88
Butter, Controlling Moisture	92
Butter, How to Incorporate Moisture	92
Butter, Moisture and Moisture Test.....	92
Butter, Moisture Test	94
Butter, Mottled	82
Butter, Mottled, To Overcome	82
Butter, Necessity of Controlling Moisture.....	93
Butter, Over Run	94
Butter, Over Run, Why Fluctuates	95
Butter, Packing in Boxes and Tubes.....	97
Butter, Salt Test	90
Butter, Salting	86
Butter, Scoring	100
Butter, Second Wash Water	88
Butter, Size of Granules	87
Butter, Temperature of Washed	87
Butter, Temperature When Removed from Churn.....	87

Butter, Time for Churning.....	87
Butter, Trough	86
Butter, Washing	85
Butter, Weak Bodied or Slushy.....	83
Butter, Working	86

C

Calves, Feeding	145
Casein	140
Casein, Composition of.....	140
Cheese, Proper Slant for Floor in Factory.....	149
Churn, Soaking a New.....	150
Cleaning, Creamery Floors, Churns and Glassware.....	148
Commercial Starters	69
Commercial Starters, Agitating	73
Commercial Starters, Amount to Use in Large Can.....	72
Commercial Starters, Burnt Flavor	72
Commercial Starters, How to Figure Percentage Used.....	79
Commercial Starters, Quantity of Milk.....	79
Commercial Starters, What to Do to Grow.....	70
Commercial Starters, What Not to Do to Grow.....	70
Cream, Blowing	60
Cream, Effects of Slow Ripening	79
Cream, Cooling	113
Cream, Churning	85
Cream, Cost of Pasteurizing.....	64
Cream, Fast Ripening	80
Cream, Pasteurization, Facts That Apply to.....	66
Cream, Pasteurization of for Butter-Making	62
Cream, Pasteurization Ripening	77
Cream, Regenerative Pasteurizer	65
Cream, Ripening	77
Cream, Temperature to Be Used in Pasteurization	147
Creamery, General Information	147

D

Dairy Cows, Feed and Feeding	143
Dairy Cows, Judging	141
Dairy Products, Causes of Defects in Tests	55
Dairy Products, Testing for Butter Fat.....	53

E

Engines, Steam	21
Engines, Figuring Horse Power	28
Engines, Governors	31
Engines, Governors, Throttle	32
Engines, History of	21
Engines, Indicators	36
Engines, Inventor of Cut-Off	21
Engines, Racing	35

Engines, Racing Causes	36
Engines, Side Valves Setting.....	25
Engines, Steam Gauge	20
Engines, Steam, How to Test	20
Engines, To Find Horse Power	27
Exhaust Steam, Advantages of Heating with.....	46
Exhaust Steam, Capacity of Tanks	46
Exhaust Steam, Location of Tanks and Coils	48
Exhaust Steam, Size of Pipe to Use.....	44
Exhaust Steam, Size of Tanks and Coils.....	48
Exhaust Steam, Things to Remember if Using in the Floor...	44
Exhaust Steam, Utilization of Exhaust Steam in Creameries...	47
Exhaust Water Heater, Advantages of	52
Exhaust Water Connections	49
Exhaust Water Heater System	51

F

Fans, Size to Use	128
Fats, Contained in Butterfat	137
Flavors in Butter and Cream	81
Flavors, Curdy	82
Flavors, Metallic	83
Flavors, To Overcome Curdy	82
Flavors, To Overcome Fishy	83
Flavors, To Overcome Unclean	82
Flavors, Wood	83
Flues, Foil Air	128
Flues, Foil Air, Location of	128
Flues, Location of Intake	128
Flues, Main	128

G

Glassware, to Clean	149
---------------------------	-----

H

Ice Bunker, Insulated Refrigerators	119
Ice House, Filling	117
Ice House, The Insulated System	112
Ice House, The Insulated System, First Cost.....	117
Ice House, Refrigerator Table	112

L

Lactometers	139
Lactometers, Temperature Reading	139
Lactometers, To Test	139
Lumpy Cream, To Test	55

M

Melting Point, in Substances.....	161
Metals and Alloys, Composition of.....	162
Milch Cows, Balanced Rations.....	143
Milk, Analysis from Different Dairy Breeds.....	136
Milk, Chemistry and Chemical Analysis.....	136
Milk, Composition of First and Last Drawn from Cow.....	133
Milk, For Market	133
Milk, Oil Contained in Milk from Different Breeds.....	137
Milk, Specific Gravity	138
Milk, Temperature for Separation	132

N

Neutralizer Solution, Making of	56
Neutralizer, Effects of Too Much.....	59

O

Oils Contained in Cow Milk from Different Breeds.....	137
---	-----

P

Packages, Liners	97
Packages, Preparing for Market	97
Pop Safety Valves, Proper Size.....	162
Pulleys, Speed of	37

R

Refrigeration, Creamery	102
Refrigeration, Mechanical	105

S

Salt Test, Formula	91
Salt Test, Indicator	91
Separators, Cream, Speed	131
Separators, Effect of Variation in Speed.....	131
Separators, Speeds	131
Steam, What Is	17

T

Tank, Size to Use.....	97
------------------------	----

V

Ventilation, Advantages of Proper	129
Ventilation, Elbow	127
Ventilation, Exhaust Fan	124
Ventilation and Heat	129
Ventilation, Importance of	122
Ventilation, Measurement of Air.....	126
Ventilation, Motive Power	127
Ventilation, Principles of	127
Ventilation, Speed of Fan	126
Ventilation, Unnecessary Expense of	129
Ventilation, Where to Install Fan	126

W

Water, Temperature as Indicated by Pressure.....	149
--	-----

Z

Zero	163
------------	-----

LIBRARY OF CONGRESS

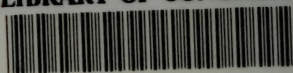

00008859504

