

CALIFORNIA FISH AND GAME

"CONSERVATION OF WILDLIFE THROUGH EDUCATION"

VOLUME 58

OCTOBER 1972

NUMBER 4



California Fish and Game is a journal devoted to the conservation of wildlife. If its contents are reproduced elsewhere, the authors and the California Department of Fish and Game would appreciate being acknowledged.

The free mailing list is limited by budgetary considerations to persons who can make professional use of the material and to libraries, scientific institutions, and conservation agencies. Individuals must state their affiliation and position when submitting their applications. Subscriptions must be renewed annually by returning the postcard enclosed with each October issue. Subscribers are asked to report changes in address without delay.

Please direct correspondence, except regarding paid subscriptions, to:

CAROL M. FERREL, Editor
California Fish and Game
987 Jedsmith Drive
Sacramento, California 95819

Individuals and organizations who do not qualify for the free mailing list may subscribe at a rate of \$2 per year or obtain individual issues for \$0.75 per copy by placing their orders with the Office of Procurement, Documents Section, P.O. Box 20191, Sacramento, California 95820. Money orders or checks should be made out to Office of Procurement, Documents Section. Inquiries regarding paid subscriptions should be directed to the Office of Procurement.

CALIFORNIA FISH AND GAME

VOLUME 58

OCTOBER 1972

NUMBER 4



Published Quarterly by
STATE OF CALIFORNIA
THE RESOURCES AGENCY
DEPARTMENT OF FISH AND GAME

STATE OF CALIFORNIA

RONALD REAGAN, *Governor*

THE RESOURCES AGENCY

NORMAN B. LIVERMORE, JR., *Secretary for Resources*

FISH AND GAME COMMISSION

JOSEPH RUSS III, *President, Ferndale*

SHERMAN CHICKERING, *Vice President*
San Francisco

C. RANS PEARMAN, *Member*
San Gabriel

PETER T. FLETCHER, *Member*
Roncho Santa Fe

TIMOTHY M. DOHENY, *Member*
Los Angeles

DEPARTMENT OF FISH AND GAME

G. RAY ARNETT, *Director*

1416 9th Street

Sacramento 95814

CALIFORNIA FISH AND GAME

Editorial Staff

CAROL M. FERREL, Editor-in-Chief	Sacramento
KENNETH A. HASHAGEN, Editor for Inland Fisheries.....	Sacramento
MERTON N. ROSEN, Editor for Wildlife	Sacramento
ROBSON COLLINS, Editor for Marine Resources.....	Long Beach
DONALD H. FRY, JR., Editor for Salmon and Steelhead	Sacramento
HAROLD K. CHADWICK, Editor for Striped Bass, Sturgeon, and Shad	Stockton

CONTENTS

Page

Primary Productivity in a New and an Older California Reservoir	<i>Lawrence L. Chamberlain</i> 254
A Midwater Trawl for Threadfin Shad, <i>Dorosoma pentacense</i>	<i>C. E. von Geldern, Jr.</i> 268
Morphology and Variation of the Modoc Sucker, <i>Catostomus microps</i> Rutter, with Notes on Feeding Adaptions	<i>Michael Martin</i> 277
Contributions to the Life History of the Pinte Sculpin in Sagehen Creek, California	<i>Albert C. Jones</i> 285
The Effects of Diesel Fuel on a Stream Fauna.....	<i>R. Bruce Bury</i> 291
A Subpopulation Study of the Pacific Sardine.....	<i>Kenneth F. Mais</i> 296
Check List of Intertidal Fishes of Trinidad Bay, California, and Adjacent Areas	<i>John R. Moring</i> 315
<i>Notes</i>	
Two New Sea Urchin—Acorn Barnacle Associations	<i>James L. Houk and John M. Duffy</i> 321
New Hosts and Bathymetric Range Extension for <i>Colobomatius cambiolocae</i> (Crustacea, Copepoda)	<i>Ernest W. Iverson</i> 323
Southern Range Extension for the Yellowfin Goby, <i>Acantho- gobius flavimanus</i> (Temminck and Schlegel)	<i>Gary E. Kukowski</i> 326
California Condor Survey, 1971.....	<i>W. Dean Carrier, Robert D. Mallett, Sanford Wilbur, and John C. Borneman</i> 327
<i>Book Reviews</i>	329
<i>Index to Volume 58</i>	333

PRIMARY PRODUCTIVITY IN A NEW AND AN OLDER CALIFORNIA RESERVOIR¹

LAWRENCE L. CHAMBERLAIN

Inland Fisheries Branch

California Department of Fish and Game

The sport fishery in new reservoirs often reaches a peak and then undergoes a marked decline a few years following impoundment. One theory attributes such declines to diminishing basic fertility. To test this theory, primary productivity in a new reservoir was measured by the C¹⁴ method for 4 years. An older reservoir served as a control. High initial rates of carbon fixation in the new reservoir, attributed to flooding of organic material, were transitory. Subsequent patterns of primary productivity were similar in the two waters. Increases in primary productivity in both reservoirs were associated with establishment of planktivorous fish populations and demonstrated that declining primary productivity is not an inevitable result of initial reservoir aging.

INTRODUCTION

Since the 1930's, fisheries workers have become increasingly aware that after an initial period of good fishing in new impoundments, yield to the angler and the overall production of game fish tend to decline, often dramatically. Although there is considerable variation among such waters, it appears that the long term yield of many reservoirs is half or less of that enjoyed during the first few years following impoundment (Abell and Fisher 1953; Kimsey 1958; Jenkins 1961). Among hypotheses advanced to explain this phenomenon, major emphasis has been accorded those which maintain either (i) that changes in fish population structures are responsible for such declines (Bennett 1947) or (ii) that these declines reflect diminishing basic fertility in the reservoir (Ellis 1937). As yet there is insufficient evidence to determine whether either theory might fully explain these fishery declines, but clearly a better knowledge of those factors most important in determining ultimate fish yields of our freshwater reservoirs is essential to the development of sound management programs.

The completion in late 1964 of Merle Collins Reservoir in the foothills of the Sierra Nevada northeast of Marysville, California, provided an opportunity to study various aspects of initial aging in a reservoir. To gather information on changes in primary productivity which might influence fish yields, C¹⁴ measurements were begun in June 1964 on the partial pool forming at the reservoir and continued through December 1968. In order to provide a comparative baseline to aid in the interpretation of test results from Merle Collins, limnological studies were also conducted from August 1964 through June 1967 on Folsom Lake, a large foothill reservoir formed in 1955 by the impoundment of the American River near Sacramento. Concurrent studies were un-

¹ Accepted for publication June 1972. This work was performed as part of Dingell-Johnson Project California F-18-R, "Experimental Reservoir Management", supported by Federal Aid to Fish Restoration Funds.

dertaken at Merle Collins to define changes in the fish populations (K. A. Hashagen, Calif. Dep. Fish and Game, MS), and to describe various aspects of the fishery (Rawstron and Hashagen 1972).

STUDY RESERVOIRS

Inherent in the experimental design of this study was the assumption that the similarity of the two reservoirs in respects other than age and size (Table 1) would allow a meaningful comparison of primary productivity in each water. However, there are also differences in the operating schedules of these two reservoirs.

TABLE 1—Comparison of Some Characteristics of Folsom Lake and Merle Collins Reservoir, California *

	Folsom	Merle Collins
Location	lat 38° 42' N long 121° 9' W	lat 39° 20' N long 121° 19' W
Surface elevation; m above m.s.l.	142.0	360.6
Surface area; ha	4,633	401
Capacity; m ³	1,246.3 × 10 ⁶	70.3 × 10 ⁶
Maximum depth; m	79.3	47.2
Observed annual fluctuation in surface elevation; m		
Maximum	16.2 (1964)	14.3 (1966)
Minimum	11.6 (1966)	9.5 (1968)
Observed surface temperature range; C	7.8–28.3	6.1–28.6
Observed pH range	6.2–8.1	6.2–8.5
Observed total alkalinity range; mg × 1 ⁻¹ CaCO ₃	11–32	15–52
Observed range, Secchi transparency; m	0.27–7.92	0.19–6.25
Flushing rate †	2.59	1.18

* Data at reservoir gross stage, where applicable.

† Flushing rate = mean annual discharge ÷ capacity.

Folsom Lake is a large multipurpose reservoir, operated principally for flood control but also to provide water for irrigation, domestic, municipal, industrial, and power production purposes, as well as to contribute to water quality control in the Sacramento-San Joaquin Delta. Releases are made through adjustable lower outlets which draw water from the upper hypolimnion or metalimnion (Rawstron 1964). Merle Collins Reservoir is a single-purpose impoundment designed to provide storage for irrigation water for the Browns Valley Irrigation District. A single-level outlet structure draws water from near the deepest part of the hypolimnion.

Both reservoirs are drawn down through the summer and minimum surface elevations occur in fall or early winter. Over half of the precipitation in central California occurs from December through February and produces substantially increased inflow during this period. High flows into Folsom generally persist into late spring, due to snowmelt. Relatively little snowfall occurs in the Merle Collins drainage.

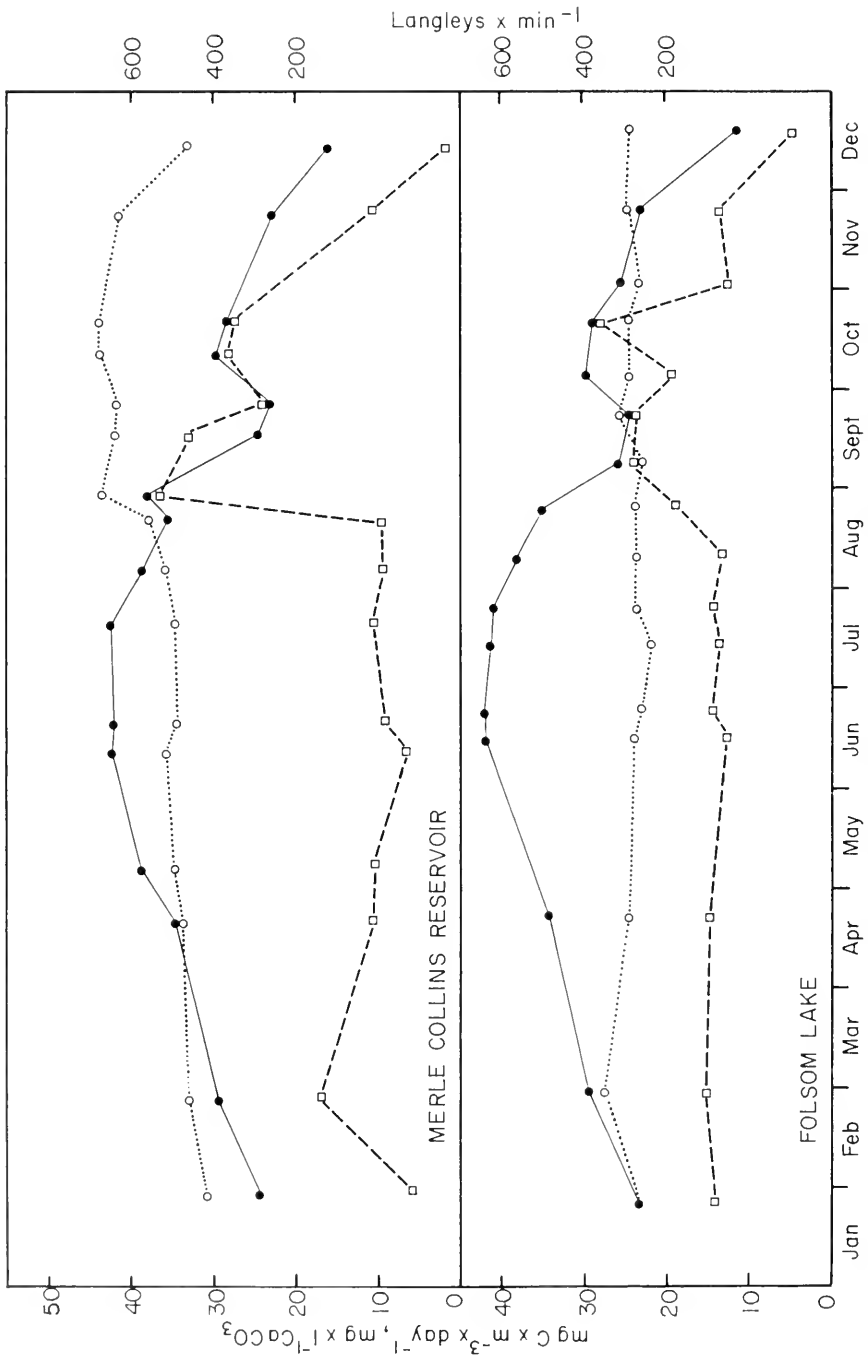

FIGURE 1. Seasonal variation in mean carbon uptake (broken lines), total alkalinity (dotted lines), and solar radiation, measured in langleys (solid lines) at Merle Collins Reservoir and Folsom Lake from 1966 observed data.

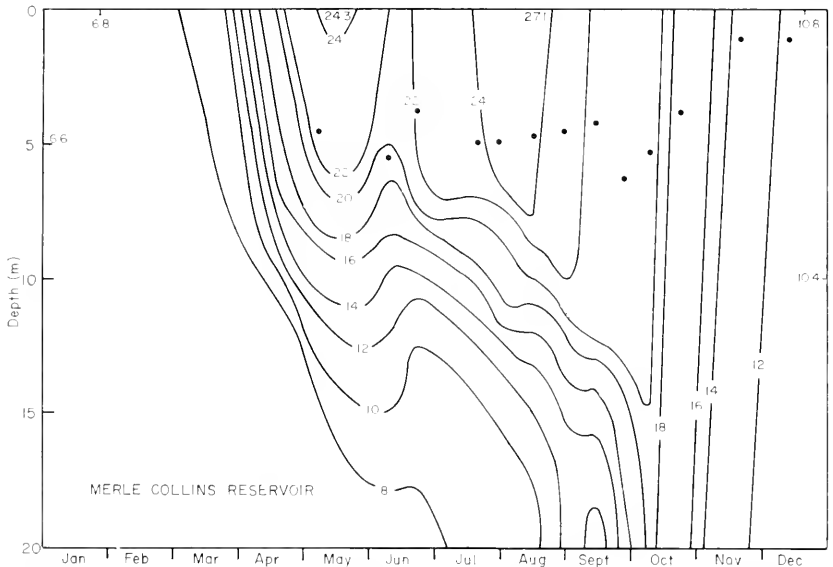

FIGURE 2. Typical Merle Collins Reservoir annual isotherms and Secchi depths (·) from 1966 observations.

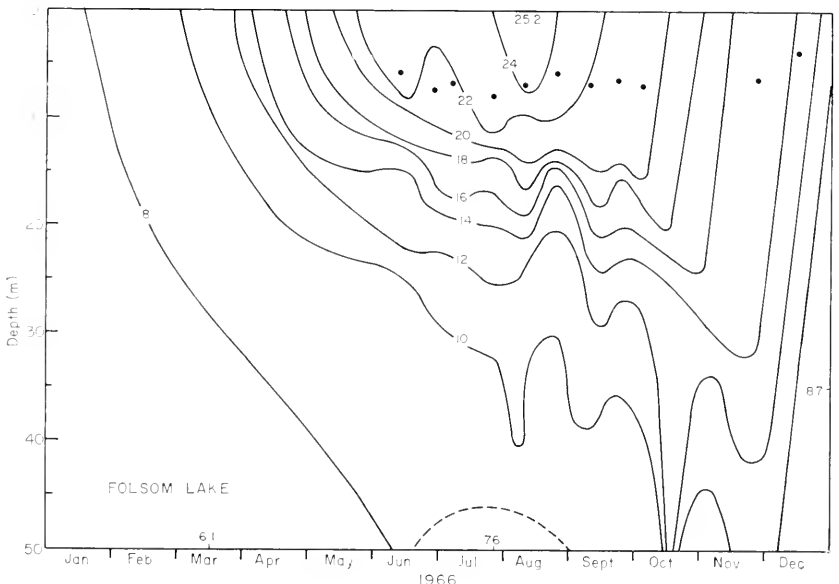

FIGURE 3. Typical Folsom Lake annual isotherms and Secchi depths (·) from 1966 observations.

Merle Collins is allowed to fill during the winter and uncontrolled surface spill generally occurs by early February and may persist through May. Depending on predicted runoff from snow accumulations at high elevations, up to $493.4 \times 10^6 \text{ m}^3$, or nearly half of the total

capacity of Folsom, may be reserved for control of flood flows through late fall and winter. Maximum surface levels generally occur in June. Despite these differences, the total alkalinity, pH, DO, and temperature regimes of the reservoirs are quite similar (Table 1, Figures 1, 2, and 3).

METHODS AND MATERIALS

Primary productivity was measured by the C^{14} method of Steemann-Nielsen (1952) as modified by Goldman (1960, 1963). To allow for isotope discrimination, a correction factor of 6% was applied in the calculations.

Primary productivity was usually sampled two to five times each month while the reservoirs were thermally stratified and once monthly during the winter. A permanent sampling station near the deepest point in each reservoir was marked by an anchored buoy from which samples were suspended. Based on Secchi transparencies observed at the start of the study, eight sampling strata were chosen at fixed depths to 15 m in Merle Collins and to 30 m in Folsom. Dark bottles were included at the upper, lower, and two intermediate depths to provide a correction for nonphotosynthetic carbon uptake. This sampling regime proved adequate to include the maximum compensation depth in each reservoir. Water samples were collected from the appropriate depths with a 3-liter, non-metallic Van Dorn bottle and transferred to 125-ml glass-stoppered Pyrex bottles. Each sample was injected with 0.5 ml of radioactive sodium carbonate tracer solution by means of an automatic hypodermic syringe, and then suspended at the depth from which that sample had been drawn. Incubation was for the 4-hr period spanning local mid-day and except during actual handling for injection or filtration, samples were kept and transported in a lightproof box. Samples were filtered in simultaneous series of four on a plexiglass multiple filtration manifold produced by Min Plastics & Supply Center, Honolulu, Hawaii. A filtration vacuum of 10–15 inches Hg allowed an entire set of 12 samples to be filtered in approximately 15–20 min. The filtration funnels were treated with Desicote (Beckman Instruments, Inc.), which effectively prevented adherence of sample material to the funnel sides (C. R. Goldman, Univ. Calif., Davis, pers. comm.). Early in the study 50-ml sub-samples were filtered on 25-mm HA Millipore filters (porosity 0.45 ± 0.02 microns), but in later experiments the entire 125-ml sample was filtered to increase total activity of the filtered samples and reduce counting errors.

During the first year of the study a tracer solution with an absolute activity of 2.30 microcuries per milliliter ($\mu\text{c/ml}$), obtained from Hazelton-Nuclear Science Corp., Palo Alto, California, in 100-ml rubber-stoppered serum bottles, was used at both reservoirs. Beginning in July 1965, a more active tracer solution was used. This solution, with an absolute activity of 3.58 $\mu\text{c/ml}$, was prepared in a single large lot by C. R. Goldman and sealed in individual, 10-ml sterile glass ampules. The higher activity decreased sample counting time; the packaging in individual sealed sterile containers insured against possible contamination and loss of radioactivity.

Water samples for both total alkalinity and primary productivity measurements were drawn from the same 3-liter sample and available

carbon was determined from total alkalinity using the conversion table of Saunders, Trama, and Bachmann (1962). Ancillary limnological data, such as Secchi transparency and vertical profiles of temperature and dissolved oxygen, were collected during the primary productivity sample incubation period. Solar radiation was measured at each reservoir on sampling days with a recording pyrreheliograph (Belfort 53850), and the ratio of daily insolation to the 4-hr sample period insolation was used to expand partial photoperiod results to full-day photosynthesis.

Sample activity was measured by the staff of C. R. Goldman using an automatic gas-flow Geiger-Muller counter with a Micromil window. A standard sample of known activity was routinely counted with each set of experimental samples and the counting efficiency of this equipment was periodically calibrated by gas-phase assay of representative filters following a Van Slyke wet combustion of the labeled algae to CO₂. The resultant values were compared with gas-phase assays of National Bureau of Standards samples (Goldman 1968a).

RESULTS AND DISCUSSION

The carbon assimilation rates observed from sampling the partial pool at Merle Collins in 1964 were not only quite variable but reached levels over three and a half times the rates observed during the remainder of the study. Although experimental error may sometimes be related to the familiarity of field personnel with C¹⁴ sampling procedures (Goldman and Carter 1965), the relatively uniform results obtained at Folsom by the same field crews during this period indicate that experience was not an important consideration in this instance (Table 2).

TABLE 2—Primary Productivity in the Partial Pool at Merle Collins Reservoir and in Folsom Lake During 1964

Merle Collins		Folsom	
Date	mgC · m ⁻³ · day ⁻¹	Date	mgC · m ⁻³ · day ⁻¹
June 16.....	56.44	Aug. 21.....	3.88
July 20.....	148.71	Sept. 8.....	5.14
Aug. 4.....	51.30	Oct. 24.....	2.77
Aug. 17.....	29.34	Dec. 12.....	5.84
Sept. 1.....	9.67		
Oct. 14.....	41.57		
Nov. 23.....	25.97		

Before inundation, the basin of Merle Collins Reservoir consisted largely of grazing land interspersed with brush. Even though most of the brush was removed before basin flooding, the substantial amount of organic debris remaining undoubtedly contributed a fertilizing effect. It is also possible that, in the early stages of reservoir formation, the

succession from lotic to lentic plankters was reflected by these marked changes in primary productivity. During this period, the partial pool contained about $185 \times 10^4 \text{ m}^3$ and covered about 182 ha. Runoff from heavy precipitation in late November 1964 resulted in the rapid filling of Merle Collins Reservoir. Thereafter, such extreme and erratic fluctuations in primary productivity were not observed and photosynthetic rates in the two reservoirs were similar (Table 3).

TABLE 3—Mean Annual Carbon Assimilation in $\text{mgC} \cdot \text{m}^{-3} \cdot \text{day}^{-1}$
(Range of Monthly Means in Parentheses)

Year	Merle Collins	Folsom
1964*	53.78 (9.67-148.71)	4.28 (2.77-5.81)
1965	10.98 (5.68-16.92)	9.41 (3.63-16.01)
1966	13.43 (1.51-28.08)	15.32 (1.88-23.81)
1967†	19.66 (3.56-32.29)	16.35 (8.25-33.04)
1968	25.52 (6.33-38.90)	

* Partial year results.

† Folsom experiments terminated in June.

Expansion of the 4-hr mid-day results by the ratio of daily insolation to 4-hr mid-day insolation gave an underestimate of about 8% when compared to the total observed carbon uptake during a diurnal experiment (Figure 4), which consisted of a series of 4-hr experiments

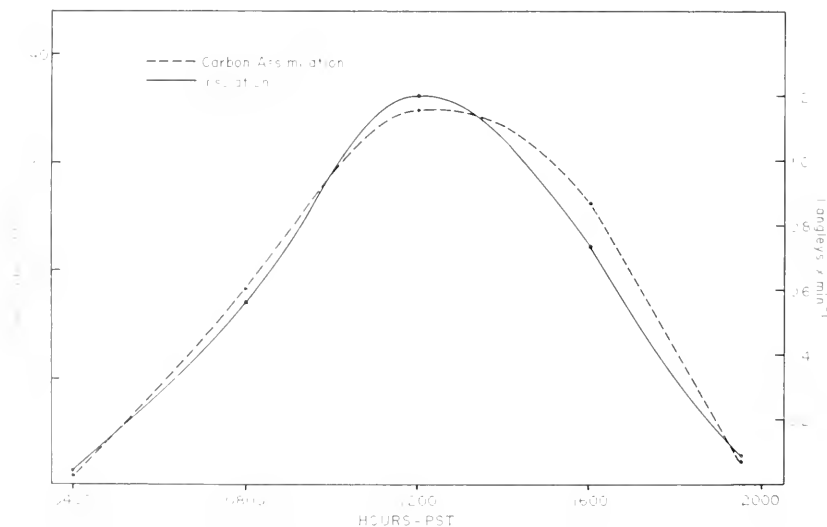

FIGURE 4. Net primary productivity and incident solar radiation during a diurnal experiment at Merle Collins Reservoir, June 21, 1967.

spanning the period from dawn to dusk. The use of this expansion to obtain day-rate estimates throughout the study appeared to be a reasonable expedient since the introduced error probably remained small (Vollenweider 1965; Wetzel 1965). Seasonal variation in primary productivity could not, however, be predicted from insolation, total alkalinity, or a combination of the two (Figure 1).

Although volumetric rates of carbon fixation were generally similar in Merle Collins and Folsom, except in 1964 (Table 3), the mean compensation depth in Folsom was 15.3 m, with a range of 8.0 to 30.0, while the mean compensation depth in Merle Collins was 6.1 m, with a range of 2.0 to 13.7, reflecting the greater transparency of Folsom Lake (Figures 2 and 3). Because of this consistently thicker euphotic zone, Folsom was actually the more productive water.

To properly account for such variations in euphotic depth, comparisons of primary productivity are more meaningful when results are expressed in terms of unit area. For the reasons outlined below, my comparisons between primary productivity in Merle Collins Reservoir and Folsom Lake (Figure 5) represent integral photosynthesis at the sampling sites rather than mean primary productivity per unit area.

It is well established that photosynthesis may vary considerably in different parts of large lakes and that such variation can be largely influenced by the contributions of tributary inflow (Sorokin 1959; Goldman 1960; Goldman and Wetzel 1963; Goldman and Carter 1965). Rawstron (1964) found that limnological conditions in Folsom Lake were well represented by conditions measured at the same sampling location as that used in this study. Observations of transparency and of vertical profiles of temperature and dissolved oxygen at various locations in Merle Collins indicated that the sampling location used there during this study was also representative of conditions in the reservoir as a whole. However, both sampling sites are near that end of each reservoir farthest from major tributary inflow and therefore at a location least representative of overall limnological conditions during periods of high inflow. Since patterns of high inflow do not coincide exactly in the two reservoirs, results obtained at these sampling stations are not always comparably representative of average limnological conditions.

In a fluctuating reservoir, not only does the volume of the euphotic zone vary with changes in compensation depth, but also the relationship between euphotic zone volume and compensation depth varies with changes in surface elevation. Surface area also changes at a variable rate with respect to elevation. The method outlined by Rupp and DeRoche (1965) in describing the primary productivity of three small Maine lakes is therefore particularly appropriate for use with fluctuating reservoirs. This method divides the euphotic zone into strata and the mean volumetric rate of carbon assimilation in each stratum is multiplied by the volume of that stratum. The products are summed and division by total surface area yields the desired estimate of mean productivity per unit area. In large reservoirs particularly, synoptic sampling of both off- and onshore areas should be included.

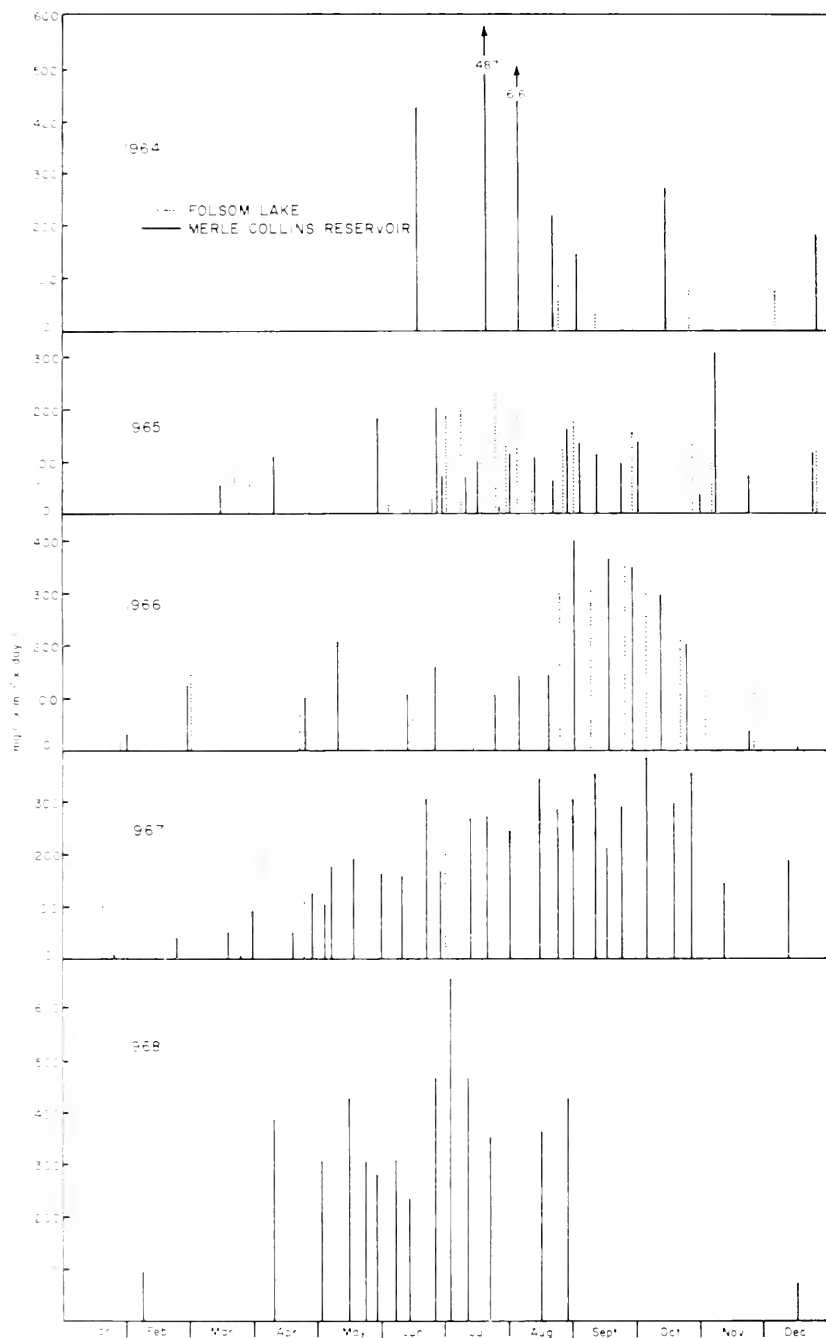

FIGURE 5. Net primary productivity and distribution of sampling effort for all years in Merle Collins Reservoir and Folsom Lake.

There are no records of elevations for Merle Collins Reservoir before mid-April 1966; therefore, the volumes of the sampling strata cannot be determined before that time. In August, September and October 1964, compensation depth exceeded mean depth in Folsom by as much as 5 m, or nearly 20% of the compensation depth at that time. In August and September 1966, compensation depth exceeded mean depth in Merle Collins by as much as 1.2 m, or about 9% of the compensation depth. Again, the lack of surface elevation records for Merle Collins prevents the correction suggested by Goldman (1960), of substituting mean depth for compensation depth when the average surface area productivity is limited by mean depth.

While estimates of mean areal productivity are desirable because they allow calculation of net annual production, integral photosynthesis is suitable for the descriptive comparisons of this study. From these comparisons it is evident that not only did the primary productivity in Merle Collins Reservoir not decline, but both reservoirs exhibited an increase in primary productivity over the course of the investigation. The patterns of increase, however, were dissimilar.

It appears that Folsom Lake experienced a substantial increase in primary productivity each year at least through 1966, and partial year results indicated no major departure from that trend in 1967. Merle Collins Reservoir, in contrast, after demonstrating a high degree of variability during the initial stages of impoundment, exhibited the first persistent increase in net carbon fixation during the late summer and fall of 1966. Primary productivity in Merle Collins increased noticeably during 1967 relative to the two previous years and, although data are lacking for the fall of 1968, it is apparent that a dramatic increase in primary productivity occurred in that year, particularly during mid-summer. No relationships were apparent between these patterns of primary productivity and any combination of climatological and/or water withdrawal variables.

The increase in primary productivity in Merle Collins in 1966 seems to have been initiated by a single, unusual event. The structural failure of part of the dam forming Lake Mildred, a small (ca. 32 ha), privately owned recreational reservoir located about 3 km upstream from Merle Collins, allowed the entire contents of the smaller impoundment to be discharged down the stream channel into Merle Collins in the late summer of 1966. A noticeable increase in turbidity, which persisted for several days in Merle Collins Reservoir, gave evidence of the considerable amount of bottom sediment which accompanied this discharge. Since the C^{14} technique is sufficiently sensitive to detect photosynthetic response to nutrient additions even below the level of ordinary chemical detectability, it is probable that the increase in primary productivity noted in 1966 was in response to nutrients contained in these sediments. The increases in Merle Collins in 1967 and 1968, and the trend of increasing primary productivity in Folsom, seem to be associated only with the establishment in each reservoir of planktivorous fish species.

Novotná and Kořinek (1966) noted quantitative differences in the phytoplankton of two backwaters of the River Elbe. In a backwater with fish, the phytoplankton was more abundant than in one without fish. More recently, Hurlbert, Zedler, and Fairbanks (1972) demon-

strated that phytoplankton became extremely abundant after reduction of the zooplankton by mosquitofish (*Gambusia affinis*). Using data on phytoplankton, zooplankton, and juvenile sockeye salmon (*Oncorhynchus nerka*) in three lake systems, Broeksen, Davis, and Warren (1970) developed the conceptual framework which might explain such relationships.

In a given ecosystem, as the phytoplankton biomass increases from a low level, primary productivity also increases to some maximum. Further increases in biomass result in decreasing primary productivity as the effects of competition for nutrients, shading, and the accumulation of inhibitory metabolites combine to lower the growth rates of the individual components of the phytoplankton. If grazing by zooplankton in the natural environment suppresses phytoplankton abundance below that level at which maximal productivity would occur, a reduction in zooplankton should be followed by an increase in primary productivity.

The apparent year-to-year increase in primary productivity in Folsom Lake paralleled the establishment and development of a population of kokanee, a freshwater form of the sockeye salmon. Approximately 1,000,000 kokanee swimup fry (200-240/oz) were stocked in Folsom each spring from 1964 to 1966, and a moderately successful fishery resulted from these introductions (R. D. Beland, Calif. Dep. Fish and Game, pers. comm.). Since kokanee feed primarily on zooplankton, the increasing biomass of this species may have resulted in a corresponding decrease in zooplankton abundance, hence the increases in primary productivity.

Similarly, in Merle Collins Reservoir the first successful introduction of threadfin shad (*Dorosoma petenense*) was made in early 1967, when approximately 15,000 juveniles and 400 sexually mature adults were stocked. By September scattered spawning activity was observed and several schools of age 0 shad were encountered during electrofishing activities in December. During 1968, shad became a significant item in the diet of several species of game fishes and gill net catches of adult shad increased dramatically (K. A. Hashagen, Calif. Dep. Fish and Game, MS). Although threadfin shad are omnivorous, they do feed heavily on zooplankton (Kimsey, Hagy, and McCammon 1957; Gerdes and McConnell 1963; Miller 1967). Thus, the biological impact of threadfin shad on primary productivity in Merle Collins could have been the same as that postulated for kokanee in Folsom.

It is also possible that grazing by these planktivorous fishes hastened biological cycling of nutrient material in the reservoir. This explanation would not seem as appropriate for Folsom, however, since the kokanee are largely excluded from the epilimnion by high temperatures and thus the nutrients present in their metabolic by-products would not be readily available to the bulk of the phytoplankton during that part of the year when increased primary productivity was noted. Even though information concerning changes in the zooplankton in Merle Collins and Folsom is lacking, it is apparent from the known changes in primary productivity and planktivore populations that a cause-and-effect relationship, involving the zooplankters as intermediate consumers, did exist.

The fishery in Merle Collins Reservoir developed in a manner more easily ascribable to changes in the fish population structure (Hashagen MS) than to changes in primary productivity. Initial stocking in 1964 of largemouth bass (*Micropterus salmoides*) as both fry and adults gave rise to an extremely strong 1964 year class which apparently inhibited reproduction of all centrarchids for several years. Over 90% of the largemouth catch each year through 1967 was from this initial year class and these fish attained a mean length of only about 10 inches by 1967. The catch rate for this species reached a peak of about 0.36 fish per angler hour in 1967 and declined to about 0.13 by 1970 (Hashagen MS).

Green sunfish (*Lepomis cyanellus*) comprised a minor component of the fishery from 1965 through 1967 but have since been supplanted by bluegill (*L. macrochirus*) and redear sunfish (*L. microlophus*). Angler success for these species was less than 0.01 fish/hr in 1965 but reached almost 0.33 in 1970. The increased catch rate for these sunfishes was clearly associated with the declining abundance of bass (Hashagen MS).

Although fishery data are incomplete for a like period at Folsom Lake (von Geldern 1972), there is no indication that the observed changes in primary productivity have caused changes in the fishery there.

Various studies have attempted to relate primary productivity to fish yields or standing crop (McConnell 1963; Rupp and DeRoche 1965; Nicola and Borgeson 1970) with but limited success. This is not surprising since, although the C^{14} method of measuring primary productivity allows us to estimate the rate at which photosynthetic activity introduces organic energy into an aquatic ecosystem, we are not yet able to describe, in any but the most general terms, how this photosynthate is transferred through, and contributes to, the trophic structure of that system (Goldman 1968b). This study indicates that in addition to the common practice of attempting to improve the efficiency of energy transfer by introducing suitable forage and predator species into a reservoir, it may also be possible to alter the rate at which energy enters the system at the primary level by manipulating fish populations. And, even though it is not possible to say how trends in primary productivity would have compared in these two reservoirs without the planktivore introductions, it is obvious that declining primary productivity need not be an inevitable consequence of initial reservoir aging.

ACKNOWLEDGMENTS

Robert R. Rawstron planned and initiated this study. C. R. Goldman was retained as a technical consultant by the Department and his advice, encouragement, and technical assistance were invaluable. A succession of project personnel, too numerous to mention individually, accomplished the bulk of the field work. I particularly thank Linda Fry, Thomas J. Reece, and E. Ross Thompson for their unselfish contributions in data reduction and summary. Nanci Dong drafted the figures. Charles Goldman, Leo Shapovalov, and Charles von Geldern, Jr. provided helpful criticisms of the manuscript.

REFERENCES

- Abell, Dana L., and Charles K. Fisher. 1953. Creel census at Millerton Lake, California, 1945-1952. Calif. Fish Game 39(4):463-484.
- Bennett, George W. 1947. Fish management—a substitute for natural predation. No. Amer. Wildl. Conf., Trans. 12:276-285.
- Brocksen, R. W., G. E. Davis, and C. E. Warren. 1970. Analysis of trophic processes on the basis of density-dependent functions. Marine Food Chains, Oliver and Boyd, Edinburgh, p. 468-498.
- Ellis, M. M. 1937. Some fishery problems in impounded waters. Amer. Fish. Soc., Trans. 66:63-75.
- Gerdes, J. H., and Wm. J. McConnell. 1963. Food habits and spawning of the threadfin shad *Dorosoma petenense* (Günther) in a small, desert impoundment. Ariz. Acad. Sci., Jour., vol. 2, p. 113-116.
- Goldman, C. R. 1960. Primary productivity and limiting factors in three lakes of the Alaska Peninsula. Ecol. Mono. 30:207-230.
- . 1963. The measurement of primary productivity and limiting factors in freshwater with Carbon-14. In: M. S. Doty (ed.) Proceedings of the conference on primary productivity measurement, marine and freshwater. U.S.A.E.C. TID-7633, Wash., D.C.
- . 1968a. The use of absolute activity for eliminating serious errors in the measurement of primary productivity with C¹⁴. J. du Conseil Internatl. Explor. Mer. 32(2):172-179.
- . 1968b. Aquatic primary production. Am. Zool. 8:31-42.
- Goldman, C. R., and R. C. Carter. 1965. An investigation by rapid carbon-14 bioassay of factors affecting the cultural eutrophication of Lake Tahoe, California-Nevada. Wat. Poll. Contr. Fed., J. 37:1044-1059.
- Goldman, Charles R., and Robert G. Wetzel. 1963. A study of the primary productivity of Clear Lake, Lake County, California. Ecology 44(2):283-294.
- Hurlbert, Stuart H., Joy Zedler and Deborah Fairbanks. 1972. Ecosystem alteration by mosquitofish (*Gambusia affinis*) predation. Science 175 (4022):639-641.
- Jenkins, Robert M. 1961. Reservoir fish management—progress and challenge. Sport Fishing Institute, Washington, D. C. 22 p.
- Kimsey, J. B. 1958. Fisheries problems in impounded waters of California and the lower Colorado River. Amer. Fish. Soc., Trans. 87:319-332.
- Kimsey, J. B., R. H. Hagy, and G. W. McCammon. 1957. Progress report on the Mississippi threadfin shad, *Dorosoma petenense atchafaylae* [sic], in the Colorado River for 1956. Calif. Dep. Fish and Game, Inland Fish. Admin. Rep. 57-23, 48 p. (mimeo.)
- McConnell, William J. 1963. Primary productivity and fish harvest in a small desert impoundment. Amer. Fish. Soc., Trans. 92(1):1-12.
- Miller, Robert V. 1967. Food of the threadfin shad, *Dorosoma petenense*, in Lake Chicot, Arkansas. Amer. Fish. Soc., Trans. 96(3):243-246.
- Nicola, Stephen J., and David P. Borgeson. 1970. The limnology and productivity of three California coldwater reservoirs. Calif. Fish Game 56(1):4-20.
- Novotná, Marie, and Vladimír Kořínek. 1966. Effect of the fish stock on the quantity and species composition of the plankton of two backwaters. p. 297-322. In: Jaroslav Hrbáček (ed.) Hydrobiological studies, Czech. Acad. Sci., Academia, Prague.
- Rawstron, Robert R. 1964. Limnology of Folsom Lake, 1961-63. Calif. Dep. Fish and Game, Inland Fish. Admin. Rep. 64-13, 9 p. (mimeo.)
- Rawstron, Robert R. and Kenneth A. Hashagen, Jr. 1972. Mortality and survival rates of tagged largemouth bass (*Micropterus salmoides*) at Merle Collins Reservoir. Calif. Fish Game 58(3):224-230.
- Rupp, Robert S., and Stuart E. DeRoche. 1965. Standing crops of fishes in three small lakes compared with C¹⁴ estimates of net primary productivity. Amer. Fish. Soc., Trans. 94(1):9-25.
- Saunders, George W., F. B. Trama, and R. W. Backman. 1962. Evaluation of a modified C¹⁴ technique for shipboard estimation of photosynthesis in large lakes. Great Lakes Research Division Publication No. 8, Univ. Michigan, Ann Arbor.
- Sorokin, Y. I. 1959. Determination of the photosynthetic productivity of phytoplankton in water using C¹⁴. Fiziol. Rast. 6:125-133.

- Steemann-Nielsen, E. 1952. The use of radioactive carbon (C^{14}) for measuring organic production in the sea. *J. du Conseil Internatl. Explor. Mer.* 18:117-140.
- Vollenweider, R. A. 1965. Calculation models of photosynthesis-depth curves and some implications regarding day rate estimates in primary production measurements, p. 425-427. *In*: C. R. Goldman (ed.) Primary productivity in aquatic environments. Mem. Ist. Ital. Idrobiol., 18 Suppl., Univ. California Press, Berkeley.
- von Geldern, C. E., Jr. 1972. Angling quality at Folsom Lake, California, as determined by a roving creel census. *Calif. Fish Game* 58(2):75-93.
- Wetzel, Robert G. 1965. Techniques and problems of primary productivity measurements in higher aquatic plants and periphyton, p. 249-267. *In*: C. R. Goldman (ed.) Primary productivity in aquatic environments. Mem. Ist. Ital. Idrobiol., 18 Suppl., Univ. California Press, Berkeley.

A MIDWATER TRAWL FOR THREADFIN SHAD, *DOROSOMA PETENENSE*¹

C. E. VON GELDERN, JR.
Inland Fisheries Branch
California Department of Fish and Game

A midwater trawl designed to monitor threadfin shad abundance in restricted environments was developed at Lake Nacimiento, California, in 1966 and 1967. The trawl features hydrofoils and depressors which plane at 45° angles. It dives rapidly without supplementary weights or diving doors along the bridles or towing warps.

INTRODUCTION

Midwater trawls are of comparatively recent origin and have undergone almost continual modification and refinement since World War II. Their initial use was restricted largely to the commercial exploitation of a few species of marine fishes, most notably herrings and cods (Parrish 1959). With the introduction of echosounding devices, the successful use of midwater trawls in the ocean became much more widespread (Barraclough and Johnson 1956, McNeely 1963, Sharfe 1964, and others), and they have also been adapted for use in large inland reservoirs (Houser and Dunn 1967).

In 1965, a study was undertaken at Lake Nacimiento, San Luis Obispo County, California, to evaluate the effects of an experimental introduction of threadfin shad on the existing warmwater fishery. Of primary concern was the need to develop an efficient method of sampling shad populations in the pelagic areas of the lake. Lake Nacimiento has been described previously by von Geldern (1971), and it need be stated here only that this impoundment covers 5,300 acres and has an unusually irregular shoreline with an abundance of long arms, sunken islands, and peninsulas which create hazards to normal midwater trawling operations. This report describes the development of a midwater trawl for sampling shad in this type of environment.

PRELIMINARY INVESTIGATIONS

A 24-ft commercial type fishing vessel powered with a 185-hp gasoline engine and fitted with midwater trawling gear and an echosounder became available to the project in late 1965. The trawling rig was of double warp design and featured a single flat wooden quarter door at each of four corners of the mouth of a 10 x 10 x 50-ft trawl. Accessory weighted diving doors were added at the junctions of 100-ft bridles and towing warps at times when it was necessary to fish deep. A double drum winch powered by a 6-hp gasoline engine was used to retrieve the net.

¹ Accepted for publication February 1972. This work was performed as part of Dingell-Johnson Project California F-18-R, "Experimental Reservoir Management", supported by Federal Aid to Fish Restoration funds.

Preliminary nighttime sampling with this equipment was conducted to obtain information on shad abundance and distribution. The results of this initial study revealed that (i) shad were extremely abundant and (ii) the horizontal and vertical distribution of shad was distinctly nonrandom. Further efforts were then centered on finding an efficient method of sampling extremely heterogeneous populations.

Taylor (1953) demonstrated that the efficiency of sampling heterogeneous populations is improved by reducing the size of sample units and increasing the number of samples. This finding seemed appropriate to the situation at Lake Nacimiento and I attempted to develop a simple trawl which would dive rapidly below fish concentrations and could be immediately retrieved. The sampling program, therefore, would be one in which the sample unit consists of two diagonal hauls (one down and one up) and which would equally sample all water depths containing shad.

The trawling apparatus initially made available to the project was not designed for rapid diving. In setting out or retrieving the net, it was necessary to stop the winch at the junctions of the towing warps and bridles to add or remove diving doors. This procedure inevitably resulted in a greater share of the sample collected near the surface. In addition, the flat quarter doors created considerable drag and were expensive and difficult to duplicate.

In June 1966, I visited the South Central Reservoir Investigations of the U. S. Bureau of Sport Fisheries and Wildlife in Fayetteville, Arkansas, and observed midwater trawling operations at Bull Shoals Reservoir by Alfred Houser and his staff. Houser was using an 8 x 8 x 45-ft trawl, of single towing warp design, equipped with hydrofoils, depressors, and aluminum otterboards (Houser and Dunn 1967). The hydrofoils and depressors opened the net vertically while the otterboards, suspended from 30-ft pennant lines, kept the net spread in a horizontal direction. This equipment functioned quite well on 45,400-acre Bull Shoals Reservoir, but was not well suited for trawling on small waters because of the diving characteristics of the net and the presence of otterboards on pennant lines. Nonetheless, I consider Houser's trawl as the "model" from which I was able to develop equipment better suited for trawling on small waters.

My principal need was a trawl with the following basic features: (i) it must be of double warp design; (ii) it must dive rapidly; and (iii) it must not require the addition of supplementary otterboards or diving doors at any point along the bridles or towing warps. The following sections describe a midwater trawl having these general characteristics.

DESCRIPTION OF THE NET

The body of the net is composed of four tapered sections of equal dimensions. Each section contains seven panels with graduated mesh sizes ranging from 8 inches (stretch measure) in the forward panel to 1 inch in the rear or seventh panel. Sections are joined to four rib lines of $\frac{3}{8}$ -inch polypropylene rope. The rib lines extend from the rear of the seventh panel to about $2\frac{1}{2}$ ft forward of the mouth of the net. Wire rope thimbles are spliced into the forward ends of the rib lines

for attachment to hydrofoils and depressors. Top, bottom, and side lines of polypropylene rope encompass the mouth of the net. These also extend $2\frac{1}{2}$ ft forward of the webbing and are spliced to wire rope thimbles. A gang of three thimbles is therefore present at each corner of the net mouth. Overall net dimensions are approximately 10 x 10 x 50 ft. A 7-ft cod end of $\frac{1}{2}$ - and $\frac{1}{8}$ -inch nylon mesh with a single seam for each mesh size is attached to the rear of the seventh panel (Figure 1).

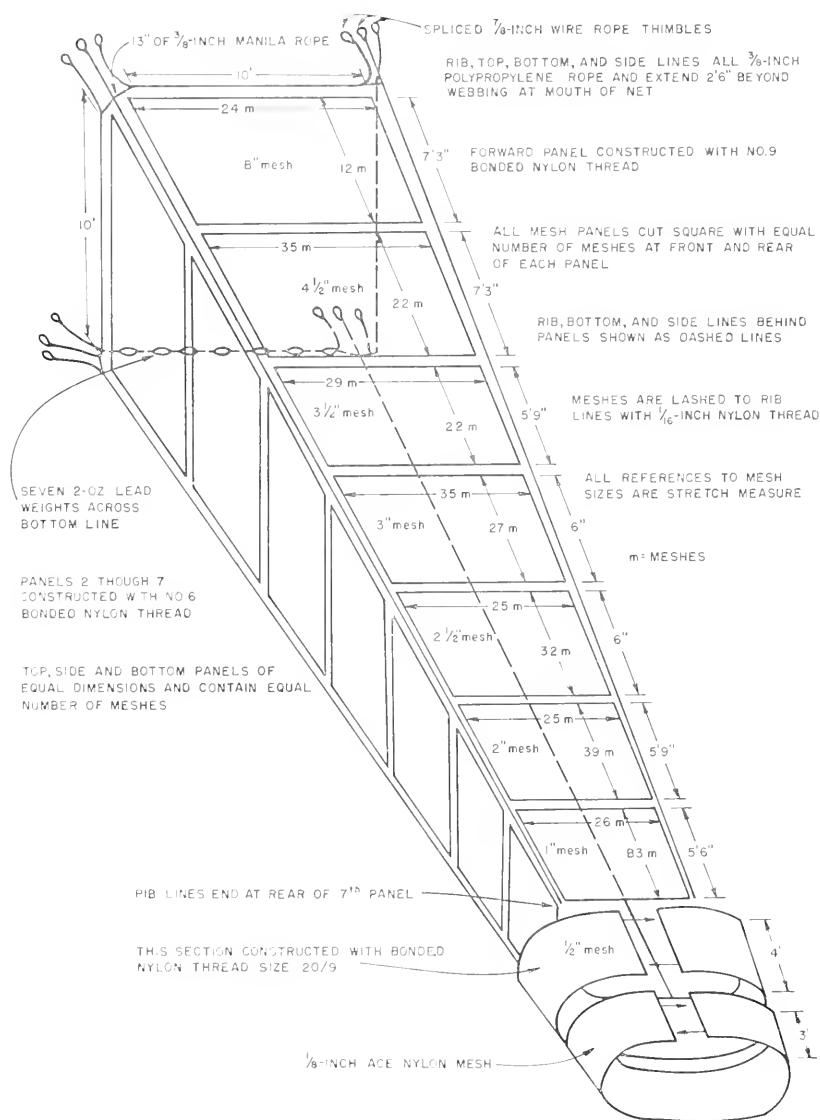
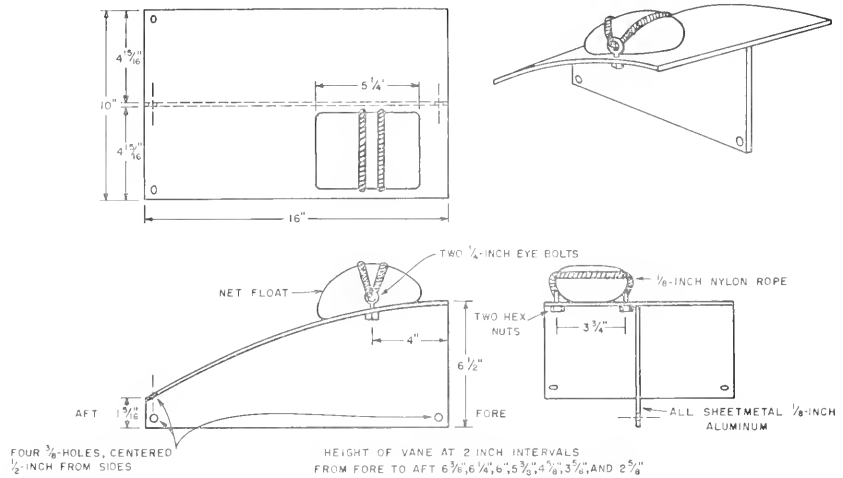

FIGURE 1. Sectional view of midwater trawl.

DESCRIPTIONS OF HYDROFOILS AND DEPRESSORS

The hydrofoils are constructed of $\frac{1}{8}$ -inch aluminum alloy plate. A single curved sheet of 10 x 18-inch plate representing the planing surface is welded to the top of a 16-inch curved tapered vane. The vane



is situated along the mid-axis of the planing surface at a 90° angle. Three-eighths-inch holes are punched near the trailing edge of the vane and the trailing corners of the shearing surface for attachment to the thimble gangs. An additional hole is punched in the lower fore corner of the vane for attachment to the bridles. A split $5\frac{1}{4} \times 3\frac{1}{2}$ -inch urethane seine float is lashed to the top of the inner edge of the planing surface so that the hydrofoils will ride at a 45° angle (Figures 2, 3, and 4). The hydrofoils, which weigh about 5 lb. each, are shackled to the upper thimble gangs as follows: (i) the inner edge of the planing surface to the top line, (ii) the trailing edge of the vane to the rib line, and (iii) the outer edge of the planing surface to the side line (Figures 3 and 4).

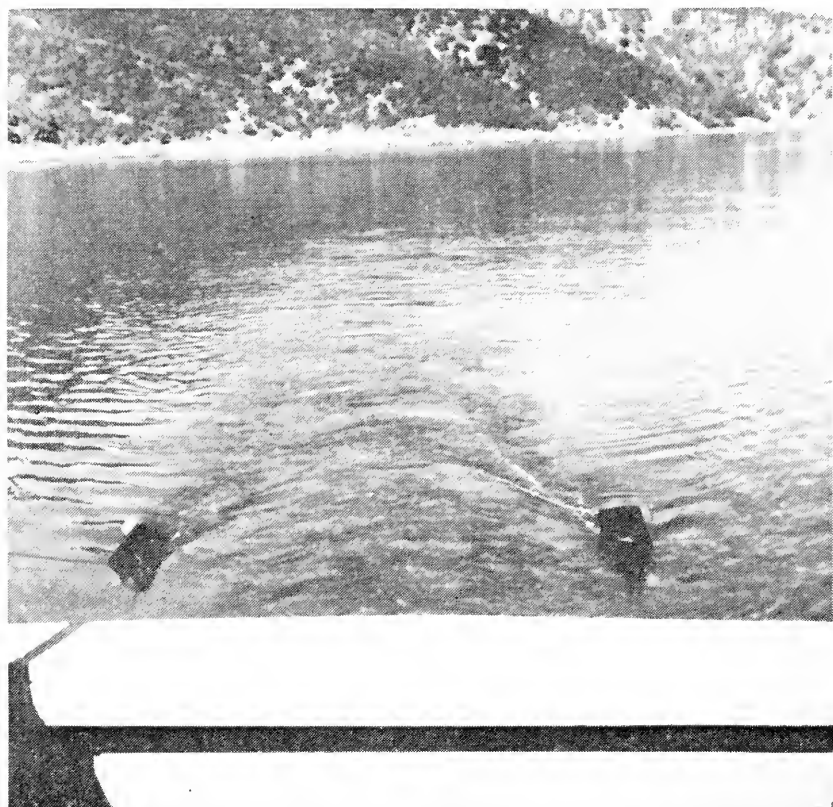

FIGURE 4. View of hydrofoils from afterdeck of research vessel. Photograph by George Bruley.

One-eighth-inch steel plate is used to construct the depressors. The planing surface consists of a single flat 16×15 -inch sheet of plate welded at 90° angles to three 16-inch vanes tapered at each end. The middle vane is located on the mid-axis of the planing surface and the others are situated 2 inches from the inner and outer edges. Three-

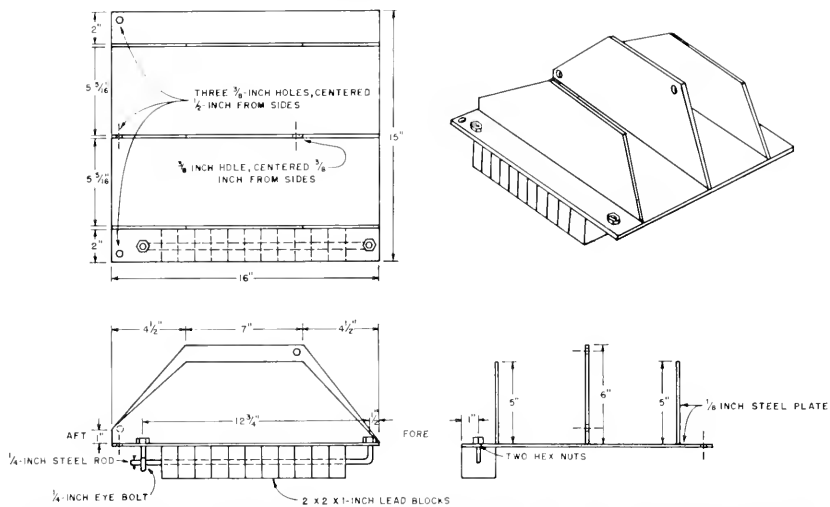

FIGURE 5. Top, side, front, and diagonal view of left depressor.

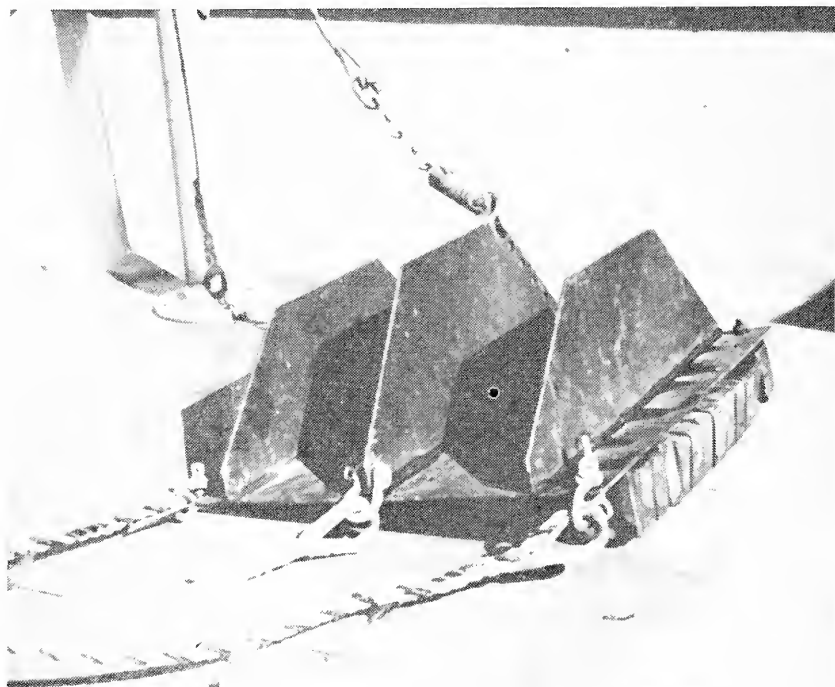

FIGURE 6. Left depressor showing hookup to thimble gong and bridle. Photograph by George Bruley.

eighths-inch holes are punched in the trailing corners of the planing surface and the trailing edge of the center vane for attachment to the thimble gangs. A hole is also punched in the upper leading corner of the center vane for attachment to the bridles. The underside of the inner edge of the planing surface is fitted with a 14-inch steel rod of $\frac{1}{4}$ -inch diameter which is used to contain 2 x 2 x 1-inch lead blocks bored with $\frac{1}{4}$ -inch diameter holes. These weights cause the depressors to plane at 45° angles (Figures 5 and 6). The depressors, which weigh about 31 lb. each, are shackled to the bottom thimble gangs as follows: (i) the inner edge of the planing surface to the bottom line, (ii) the trailing edge of the center vane to the rib line, and (iii) the outer edge of the planing surface to the side line (Figure 6).

The hydrofoils and depressors are attached to $\frac{3}{8}$ -inch thimbles spliced into the ends of 100-ft. $\frac{1}{8}$ -inch diameter wire rope bridles by a chain and Miller swivel assembly (Figures 3 and 6). Type 2, $3\frac{1}{8}$ -inch, Miller swivels are used for the hydrofoils and depressors. The bridles and $\frac{1}{8}$ -inch diameter galvanized wire rope towing warps are joined with Type 2, $4\frac{7}{16}$ -inch Miller swivels.

OPERATION OF THE TRAWL

The trawl is normally operated with a three-man crew. One man operates the boat, a second is responsible for the operation of the winch, and the third attends the net. Before setting out the net, the depressors and hydrofoils are arranged on the afterdeck for easy access (Figure

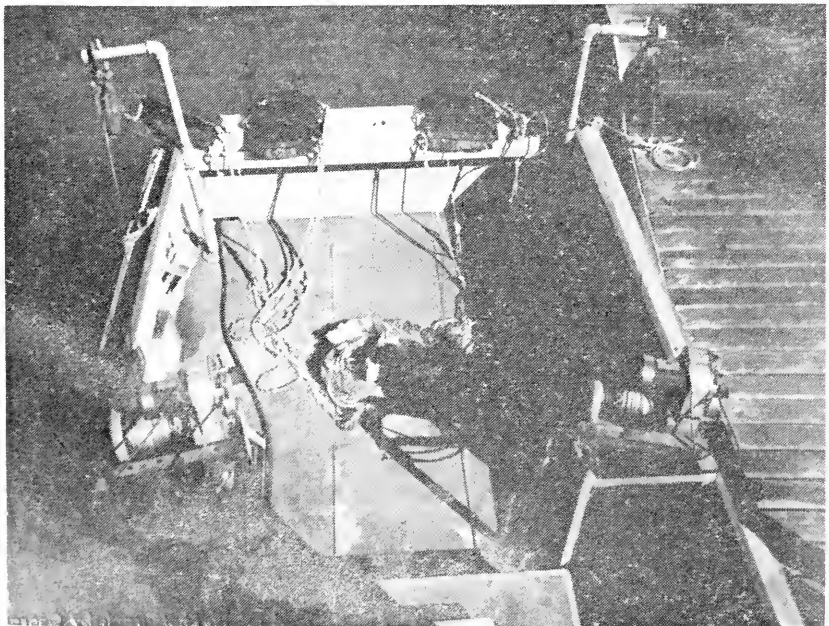

FIGURE 7. Afterdeck of research vessel showing arrangement of trawl and accessory equipment prior to setting out the net. Photograph by George Bruley.

7). The net is then cast out between the depressors while the boat is traveling about 1 mph. When the net has cleared the afterdeck, the depressors and hydrofoils are placed in the water. The boat is then accelerated to 3 mph and cable is let out to a point where the hydrofoils "bite". A very brief inspection of the assembly is then made to make certain that the net is fishing properly. The desired amount of towing warp is then let out.

Trawl retrieval procedures are conducted in reverse order. The towing warps and bridles are retrieved and the hydrofoils and depressors taken on board. The net is then pulled in directly over the stern. A speed of 3 mph is maintained until the depressors and hydrofoils approach the stern of the boat. The vessel is then decelerated to about 1 mph and maintained at that speed until the net is retrieved.

FISHING CHARACTERISTICS OF THE TRAWL

This trawl solved the sampling problems encountered at Lake Nacimiento and ultimately proved useful for detecting changes in threadfin shad abundance (von Geldern 1971). The addition of floats and weights to the hydrofoils and depressors which caused them to plane at 45° angles eliminated any need for supplementary doors to spread the net. Tangling or fouling of the gear were never serious problems. This was attributed largely to the high degree of stability provided by the thimble gangs at each corner of the net mouth (Figure 8). The trawl also dived rapidly, reaching a depth of 55 ft when towed at 3 mph with 200 ft of towing warp out.

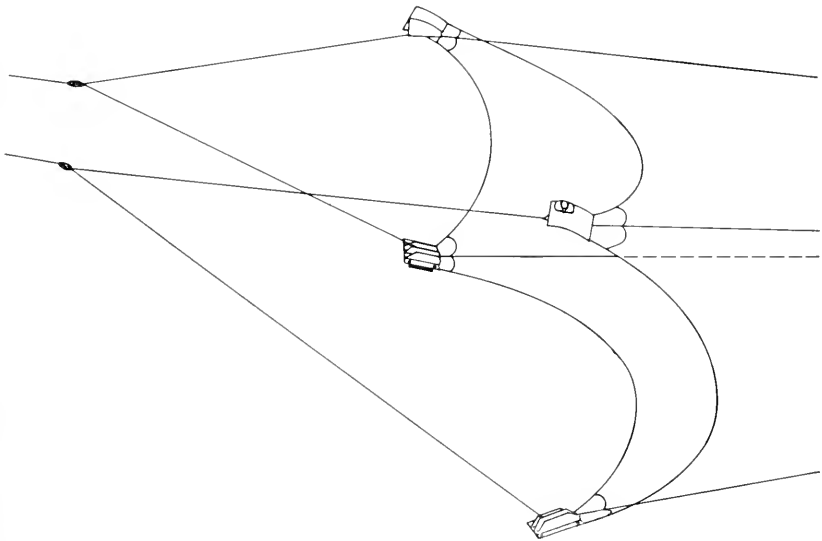

FIGURE 8. Schematic view of mouth of midwater trawl.

In order to test the potential diving speed range of this trawl design, depressors of $\frac{1}{8}$ -inch aluminum alloy plate with similar dimensions to those described previously were constructed and fitted with urethane

seine floats to achieve the proper 45° planing angle. When these doors were used, the trawl dived much less rapidly, reaching a depth of only 20 ft when towed at 3 mph with 200 ft of towing warp out (Table 1). It appears, therefore, that this trawl design can be modified to operate successfully in situations where rapid diving is not required.

TABLE 1—Depth of Trawl When Fitted With Steel and Aluminum Depressors and Fished at 3 MPH

Type of depressor	Cable out (ft)	Fishing depth (ft)
Steel.....	100	21
	150	38
	200	55
Aluminum.....	100	8
	150	14
	200	20

ACKNOWLEDGMENTS

Edward E. Miller worked closely with me through all phases of the development of this trawl and the final product is a result of our joint efforts. As previously noted, I consider the trawl used by Alfred Houser of the Bureau of Sport Fisheries and Wildlife as the "model" from which this equipment was developed. The hydrofoils described in this report are identical to the ones used by Houser in 1966 in all respects other than size, the placement of the seine floats, and the assembly for attachment to the net. Vincent Catania (deceased) supervised the construction of the nets and assisted the project in various other ways.

REFERENCES

- Barraclough, W. E., and W. W. Johnson. 1956. A new mid-water trawl for herring. Fish. Res. Bd. Canada, Bull. no. 104, 25 p.
- Houser, Alfred, and James E. Dunn. 1967. Estimating the size of threadfin shad populations in Bull Shoals Reservoir from midwater trawl catches. Amer. Fish. Soc. Trans. 96(2):176-184.
- McNeely, R. L. 1963. Development of the John M. Cobb pelagic trawl—a progress report. Comm. Fish. Rev. 25(7):17-26.
- Parrish, B. B. 1959. Midwater trawls and their operation, p. 333-343. In: Modern fishing gear of the world, ed. by Hilmar Kristjonnsson. London, Fishing News (Books) Ltd.
- Scharfe, J. 1964. One-boat midwater trawling from Germany. p. 221-228. In: Modern fishing gear of the world 2. London, Fishing News (Books) Ltd.
- Taylor, Clyde C. 1953. Nature of variability in trawl catches. U. S. Fish Wildl. Serv., Fish. Bull. 54:145-166.
- von Geldern, C. E., Jr. 1971. Abundance and distribution of fingerling large-mouth bass, *Micropterus salmoides*, as determined by electrofishing at Lake Nacimiento, California, Calif. Fish Game 57(4):228-245.

MORPHOLOGY AND VARIATION OF THE MODOC SUCKER, *CATOSTOMUS MICROPS* RUTTER, WITH NOTES ON FEEDING ADAPTATIONS¹

MICHAEL MARTIN²

Department of Biological Sciences, Sacramento State College,
Sacramento, California

Occurrence of the Modoc sucker, *Catostomus microps* Rutter, one of the most localized species in the freshwater fish fauna of California, is reported from the type locality at Rush Creek, Modoc County. A diagnosis of the species with data from ten recently collected topotypes and a summary of the morphometric and meristic variation of this species is reported. *Catostomus microps* shows distinct adaptation to swift-stream conditions in the osteological features of the oromandibular region and in the closure of the fontanelle of the neurocranium. It differs from all other members of the *Pantosteus* subgenus by the absence of lateral notches in the lips and by the possession of a silvery peritoneum. Ecological information is included in the discussion of this rare species.

INTRODUCTION

The native freshwater fish fauna of California contains several species of the genus *Catostomus*. These belong to the subfamily Catostominae, tribe Catostomini; there are also two other genera of catostomids: *Xyrauchen* and *Chasmistes* (Bailey 1970). These three genera occupy diverse ecological habitats in western North America. This study was initiated to examine more intensively one species, *Catostomus microps* Rutter, which is particularly adapted to a mountain-stream habitat.

The geological history of northern California has been recently reviewed by MacDonald (1966). The northeastern corner of California, included in the physiographic provinces of the Cascade Mountains and the Modoc Plateau, is characterized by wide-spread volcanism of recent origin and fault-block mountain ranges. This extreme disruption of the Modoc Plateau and subsequent isolation has had a significant effect on the fishes of the region, principally the catostomids as well as the cyprinids and cottids (Bailey and Bond 1963).

There have been few ecological studies of the catostomid species of California, but systematic studies have been presented by Hubbs et al. (1943), Miller (1959), Weisel (1960), and Smith (1966). Koehn (1969) reported that species of the subgenus *Catostomus* are generally in warmer lowland habitats, but they are occasionally found at higher elevations in lakes. Smith (1966) characterized the subgenus *Pantosteus* as primarily associated with rapidly flowing mountain streams.

The generalized ecological and morphological adaptations of catostomids (Smith 1966) and cyprinids (Brittan 1961) apparently are

¹ Accepted for publication May 1972.

² Present address: North American School of Conservation and Ecology, 1100 Claudina Place, Anaheim, California 92805.

responsible for the widespread distribution of these two groups in western North America, including California. Smith (1966) and Koehn (1969) have reported that in western montane areas members of the subgenus *Catostomus* occur sympatrically with species of the subgenus *Pantosteus*, and there are several records of breakdown of the reproductive barriers (Hubbs et al. 1943).

Catostomus microps and the Sacramento sucker, *Catostomus occidentalis*, occur allopatrically in the upper Pit River system of Modoc County, California. Rutter (1908) recognized *C. microps* as a small-scaled relative of the more ubiquitous largescaled *C. occidentalis*.

MATERIALS AND METHODS

Specimens were collected from Rush Creek, Modoc County, California, 6 miles east of Adin on U.S. Highway 299, T. 40 N., R. 9 E. This creek is the type locality for *C. microps*. Five extensive collections were made on Rush Creek on 4 April 1966, 8 October 1966, 26 December 1966, 12 March 1967, and 9 April 1967.

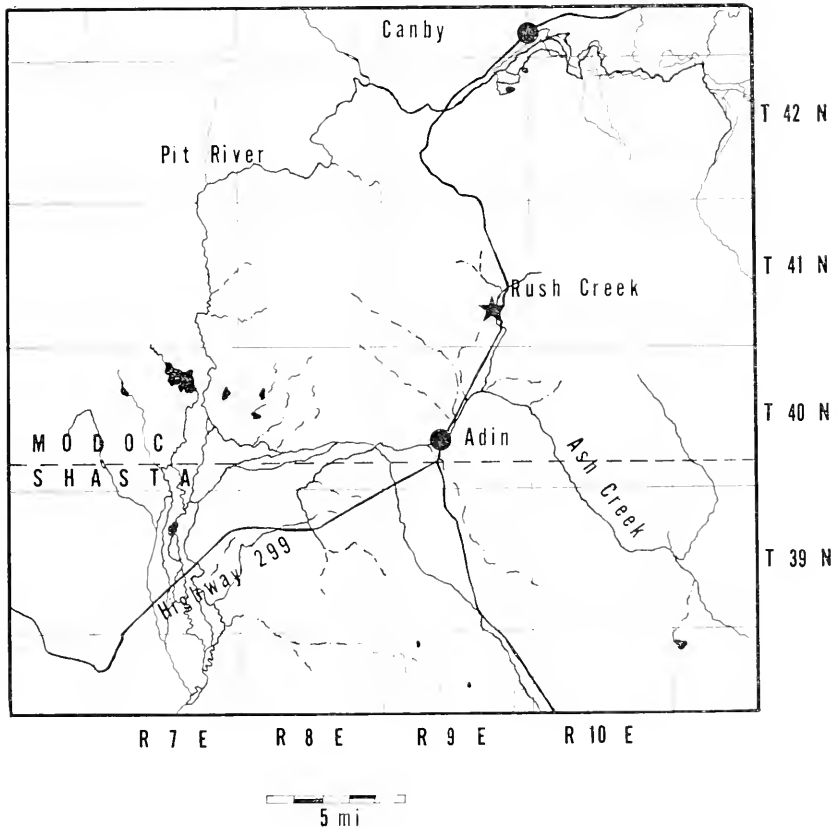

FIGURE 1. Map of study area, showing area of collections on Rush Creek, Modoc County, California.

Rush Creek is a mountain stream, 5 miles in length, averaging 5 to 20 ft in width and attaining a maximum depth of 6 ft. Its headwaters are located on Horsehead Mountain and Hunters Ridge, Modoc County (Figure 1). From the upper Rush Creek Campground to the upper crossing of the Adin-Canby Highway (U.S. 299), the stream is exceedingly swift, and has a very steep gradient. Below the upper highway crossing, the stream passes through the rather long, gently sloping Rush Creek Valley, where the greatest numbers of *C. microps* were captured. The flora surrounding the headwaters of Rush Creek is a yellow pine forest, which changes abruptly to a northern juniper woodland in Rush Creek Valley. A riparian flora (Axelrod 1944) is located on the margins of the creek throughout its lower course. The entire habitat which is suitable for *C. microps* on Rush Creek does not exceed 3 miles. There is little or no aquatic vegetation, but some leaf litter is present during the fall and winter months. The stream bottom is rock rubble, with limited sand and gravel areas.

From this habitat, 10 *C. microps* were collected utilizing a 6 ft \times 20 ft minnow seine in the first four collections and electrofishing apparatus in the final collection. All fish were preserved in the field in 10% formalin, transferred to 40% isopropyl alcohol, and were placed in the Natural History collections of Sacramento State College.

Twenty characters were utilized and tabulated for each specimen. Morphological characters and meristic data compilation follow the methodology of Smith (1966). Counts and measurements were taken from the left side of adult and juvenile specimens, utilizing dividers and ruler to the nearest 0.1 mm. On specimens less than 50 mm SL, scale counts were not analyzed due to excessive variation (after Smith 1966). Age class determinations were made by counting the number of scale annuli.

MODOC SUCKER

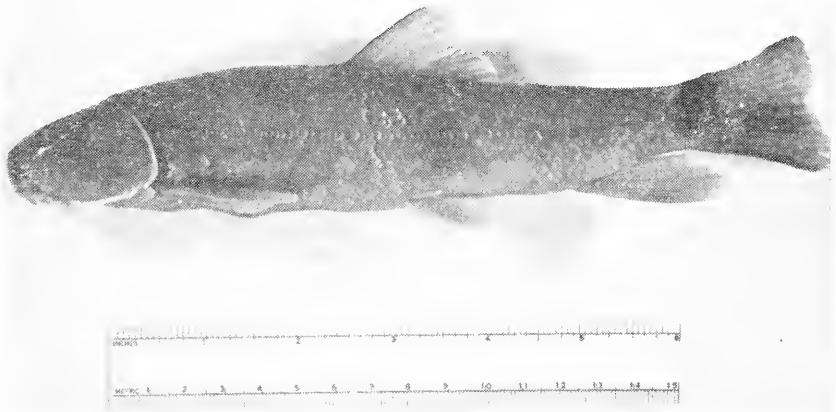

FIGURE 2. The Modoc sucker, *Catostomus microps* (female; 187 mm SL).

Catostomus microps. Rutter, 1908:120-121 (original description) (Rush Creek, Modoc County). Jordan, Evermann, and Clark 1930:106 (streams of lava beds of California). Schultz 1936:144 (upper Sacramento River and Goose Lake drainage). Shapovalov and Dill 1950:386 (check-

list). Eddy 1957:78 (key). Shapovalov, Dill, and Cordone 1959 (check-list). Kimsey and Fisk 1960:467 (key). Bailey 1960:17 (common name). Miller 1961:384 (description of habitat). Bailey 1970:24 (common name).

DIAGNOSIS

A species of *Catostomus* characterized by the small eyes located in the middle of the head (Rutter 1908), whence the specific name. Standard length ranging to 190 mm. Lips moderate, with two rows of papillae evident on the oral surface of the upper lip, but absent from the anterior face of the upper lip; lateral notches at the juncture of the upper and lower lips faintly evident or absent on either side; anterior medial papillae are enlarged; medial notch in lower lip deep, separated from the cartilaginous sheath of the lower jaw by one row of papillae on the symphysis. Frontoparietal fontanelle reduced in young specimens and almost obsolete in specimens over 150 mm SL. Scales small and regular; lateral line scales, 80 to 89, modally 81; scales above lateral line, 15 to 17, modally 16; scales below lateral line 9 to 12, modally 10. Dorsal rays 10 or 11. Pelvic axillary process absent. Caudal peduncle depth ranges from 9.0 to 10.0% SL (Table 1).

TABLE 1—Measurements of *Catostomus microps*, Collected in Rush Creek, Modoc County, California. Proportions Are Expressed as Hundredths of Standard Length. Specimen 1 = SU 9277;* 2, 3 = SSC 149-2;† 4 to 6 = SSC 162-1; 7 to 11 = SSC 168-3.

Measurements	Specimen number										
	1	2	3	4	5	6	7	8	9	10	11
Standard length (mm).....	103	44	97	187	89	97	48	99	76	76	87
Head length.....	23	28	25	23	24	24	28	24	26	28	27
Orbit diameter.....	4	6	4	4	2	5	6	4	5	5	4
Snout length.....	10	12	12	10	11	11	14	13	13	13	15
Caudal peduncle depth.....	9	10	10	9	10	9	10	9	10	11	10
Caudal peduncle length.....	16	12	15	15	16	15	13	10	12	16	15
Snout to dorsal.....	51	56	50	48	50	49	53	51	52	52	52
Dorsal fin base.....	15	16	15	15	16	15	16	15	15	15	16

* SU = Stanford University.

† SSC = Sacramento State College.

VARIATION IN *C. MICROPS*

The following fin ray counts, scale counts, and gill raker counts are presented for the materials included in this report, expressed as the count, followed by the number of specimens with that count. In the case of pectoral and pelvic fins, the two numbers represent the counts of the left and right fins, respectively. Dorsal fin rays 10 (7), 11 (3); anal fin rays 7 (10), typical for American *Catostomus*; pectoral fin rays 15-15 (3), 16-16 (5), 17-17 (2); pelvic fin rays 9-9 (7), 10-10 (3); caudal fin rays 18 (7), 19 (3). Scales in lateral line 80 (1), 81 (3), 82 (2), 84 (1), 85 (1), 87 (1), 89 (1); scales above lateral line 15 (3), 16 (6), 17 (1); scales below lateral line 9 (1), 10 (6), 11 (2), 12 (1); scales around caudal peduncle 20 (1), 22 (2), 23 (2), 25 (3), 26 (2); predorsal scales 45 (1), 46 (2), 49 (1), 50 (3), 51 (2), 53 (1). Gill rakers 18 (1), 19 (1), 22 (3), 23 (2), 24 (1), 25 (1), 26 (1).

The life colors of *C. microps* have not been recorded. The back varies from greenish-brown through bluish to deep grey and olive; the sides are lighter with light yellowish below; caudal, pelvic, and pectoral fins

are light yellowish orange. There are three characteristic dark spots along the sides in the region of the lateral line. The belly region is cream-colored to white.

Breeding coloration of *C. microps* is similar to that of the mountain sucker, *C. platyrhynchus* (Smith 1966). The male (76 mm SL) pattern consists of a red lateral stripe, which intensifies in 10% formalin and fades in isopropyl alcohol. This stripe originates behind the fleshy lobe of the opercular flap and extends to the origin of the last anal ray. The fins also become brightly colored, especially the mesial and distal parts of the pectoral fins, about the bases of the pelvic fins, and in the center part of the caudal fin. Breeding tubercles on the anal fin include: four small, three medium on the first element; two medium, one large on the second element; four large on the third element; two medium, one large on the fourth element; four large on the fifth element; three medium on the sixth element; and two small on the seventh element. Small tubercles are scattered over the dorsal region of the body, about half the way down the back. Tubercles are also scattered on the caudal and pectoral fins.

Age class determination and size indicated that *C. microps* matures in the second year. Nuptial males as small as 75 mm SL were collected, as well as second-year mature males up to 90 mm SL. Females are generally larger than males; one third-year female measured 184 mm SL.

Osteological differences are well developed above the species level in the subgenera *Pantosteus* and *Catostomus* (Smith 1966) and provide a useful taxonomic tool for differentiation of these groups. One of the most significant adaptations in the evolution of the genus has been trophically oriented and, consequently, reflected in the osteological features of the jaw bones (Smith 1966). The mandible consists of four pairs of bones. The dentary is the largest of the bones; it has a dorsal anterior gnathic ramus which has been modified for scraping the substrate. The dentary is not as ventrally deflected as that of species of the subgenus *Pantosteus* and has become decidedly reduced in *C. microps* (Figure 3). The dentary of *C. occidentalis* is more robust than the dentary of *C. microps*. The dentary of *C. microps* shows more ridging than *C. occidentalis* (Figure 3D), indicating an increased musculature in the oromandibular region of *C. microps*. This feature seems to be correlated with adaptation of the jaws as scrapers of the substrate as Smith (1966) found in species of the subgenus *Pantosteus*.

The ventral part of each mandibular bone is composed of a coronomeckelian, a retroarticular, and an angular (Figure 3A); all except the angular are thought to be derived from Meckel's cartilage (Harrington 1955). The configuration of the ventral mandible is similar in large and smallscale species of the Pit River drainage with three exceptions. First, as viewed mesially, the coronomeckelian is reduced and slightly serrate on the dorsal margin in *C. occidentalis* (Figure 3B), while *C. microps* lacks these slight serrations. Secondly, the anterior dorsal facet of the dentary is reduced in *C. occidentalis*, and this area is enlarged in *C. microps*. Thirdly, the mental foramen is pronounced in *C. occidentalis* and slightly reduced in *C. microps*.

The mandible of the Tahoe sucker, *C. tahoensis*, (Figure 3A) is specialized toward the small stream type as shown by *C. microps*. The

coronomeckelian is slightly reduced, and the anterior dorsal facet of the dentary is enlarged as in *C. microps*.

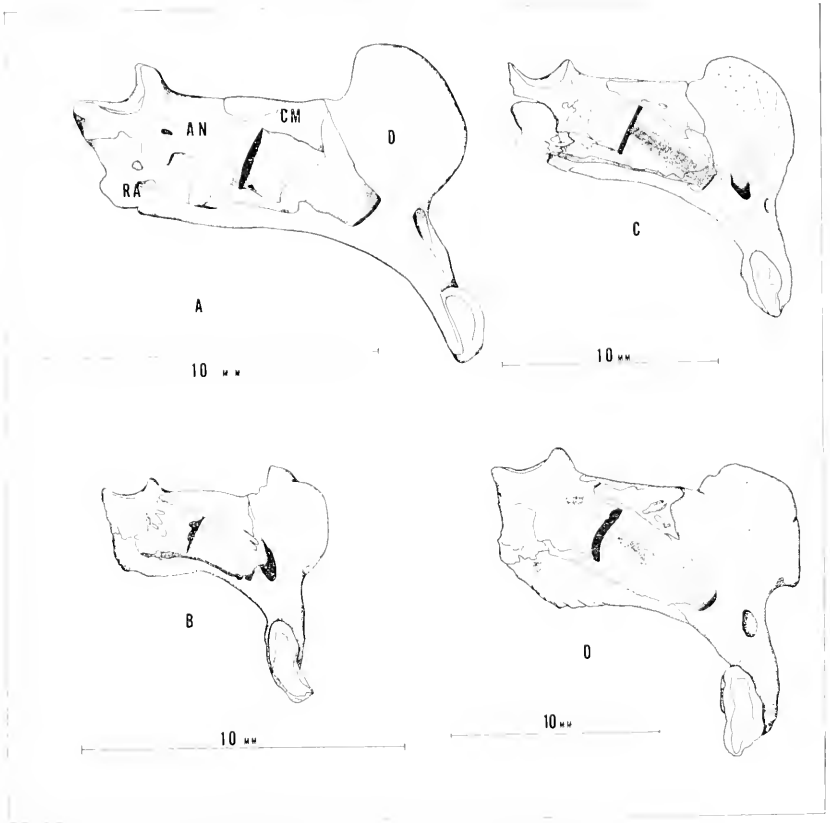

FIGURE 3. Mesial view of the left mandibles of (A) *Catostomus tohoensis* (Lahontan Basin) from Smith, 1966; (B) *Catostomus occidentalis* (Goose Lake Basin), 84 mm SL; (C) *Catostomus occidentalis* (upper Pit River Basin), 101 mm SL; (D) *Catostomus microps* (Rush Creek), 97 mm SL. The bones of the lower jaw are the angular (AN), the coronomeckelian (CM), the dentary (D), and the retroarticular (RA).

Smith (1966) suggested that although the function of the fontanelle of the neurocranium is not known, its closure may be involved with an increase in opercular musculature and the reduction in the size of the pterotic. *C. microps* is definitely a small riffle type of sucker, although, heretofore, it has been considered as a member of the subgenus *Catostomus*. *C. microps* is separable from all *Pantosteus* species by the absence of lateral notches at the junction of the upper and lower lips and the lack of a black peritoneum. The lip and jaw modifications, other than the lateral notches, of *C. microps* show parallel adaptation with *Pantosteus* species.

FEEDING ADAPTATIONS

In addition to the extreme specialization and orientation of the oromandibular region, there is a behavioral modification for suctorial

feeding and other general morphological adaptations for bottom dwelling.

Juvenile and adult behavior was qualitatively observed: juveniles (15 to 50 mm SL) tend to remain in the shallows of large pools, free swimming above the substrate. Adult suckers remain mostly on the bottom or close to it. Adults in aquaria remained at the bottom, resting either on the pelvic fins and folded anal fin or with their ventral surface contacting the substrate. While resting on their ventral surface, the dorsal fin was generally elevated, with the paired fins extended to support the body. Suckers do not actively forage during daylight hours unless disturbed. Feeding and foraging as well as migration usually occur nocturnally (La Rivers 1962 on *Catostomus tahocensis*). The ventral surface of slow-stream inhabiting *Catostomus* is widened and flattened from the tip of the snout to the anal fin base. In contrast to these forms, *C. microps* and several members of the subgenus *Pantosteus* have a more rounded ventral surface, reflecting the necessity for more active swimming. The anal fin has a short base which can be folded so as not to interfere with substrate contact.

The sensory apparatus of *C. microps* is specialized toward the bottom feeding habit. The presence of large numbers of papillae and taste buds in *Catostomus* (Stewart 1926), the extremely limited eyesight, and the position of the eyes in the head are all indicators of the bottom feeding habits of this species.

MATERIAL EXAMINED

Catostomus microps. SU 9277 (1, 103) paratype; Rush Creek, near Ash Creek, Pit River Drainage, T. 40 N., R. 9 E.; September 1, 1898, Rutter and Chamberlain. SSC 149-2 (2, 44-97); Rush Creek, 6 miles E Adin, T. 40 N., R. 9 E., sec. 35; October 8, 1966, M. Martin, R. B. Bury, J. Brode. SSC 162-1 (3, 89-187); Rush Creek, 6 miles E Adin, T. 40 N., R. 9 E., sec. 35; December 26, 1966, M. and G. A. Martin, Jr. SSC 168-3 (5, 48-99); Rush Creek near mouth of Johnson Creek, 7 miles E Adin, T. 40 N., R. 9 E., sec. 24; April 9, 1967, M. Martin, R. B. Bury, D. Kritsky, and R. Armstrong.

ACKNOWLEDGMENTS

I wish to express my sincere appreciation to Martin R. Brittan for his constant encouragement, guidance, and friendship during my studies at Sacramento State College. I also sincerely appreciate the courtesy of those persons responsible for museum collections in making animals available for study: CAS, California Academy of Sciences (W. I. Follett, L. J. Dempster, and J. Hoopkirk); Stanford University—Division of Systematic Biology (now at CAS) (W. C. Frehofer and E. H. Neil); and Sacramento State College—Museum of Natural History (M. R. Brittan). I thank those fellow graduate students of Sacramento State College, R. Armstrong, J. M. Brode, R. B. Bury, D. Kritsky, and my brother, George A. Martin, Jr., who spent many uncomfortable days collecting. Facilities and equipment were provided by Sacramento State College. Without the constant aid and encouragement of my wife, Demi, this study would not have been completed.

SUMMARY

The Modoc sucker, *Catostomus microps*, occurs as an isolated population in Rush Creek, Modoc County, California which survives despite

disruption or destruction of most of its available habitat, primarily through stream channel change. The species apparently survives in marginal undisturbed areas. The synonymy, nomenclature, and diagnosis of the species is given. Variation in meristic and morphometric characters are given for 10 individuals captured during 1966 and 1967. The breeding coloration of *C. microps* is described, and observations of its feeding habits discussed.

REFERENCES

- Axelrod, D. I. 1944. The Alturas flora (California). In R. W. Chaney (ed.) *Pliocene floras of California and Oregon*. Carnegie Inst. Washington Publ. (553).
- Bailey, R. M. (editor) 1960. A list of common and scientific names of fishes from the United States and Canada. Spec. Publ. No. 2, Amer. Fish. Soc., Washington, D.C. 102 p.
- . 1970. A list of common and scientific names of fishes from the United States and Canada. Spec. Publ. No. 6, Amer. Fish. Soc., Washington, D.C. 150 p.
- Bailey, R. M. and C. E. Bond. 1963. Four new species of freshwater sculpins, genus *Cottus*, from western North America. *Occ. Pap. Mus. Zool., Univ. Mich.* 634:1-27.
- Brittan, M. R. 1961. Adaptive radiation in Asiatic cyprinid fishes, and their comparison with forms from other areas. *Proc. 9th Pac. Sci. Congress* 10:18-31.
- Eddy, S. 1957. How to know the freshwater fishes. William C. Brown Company, Dubuque. 253 p.
- Harrington, R. W. 1955. The osteocranium of the American cyprinid fish, *Notropis bifrenatus*, with an annotated synonymy of teleost skull bones. *Copeia* 1955 (4):267-290.
- Hubbs, C. L., L. C. Hubbs, and R. E. Johnson. 1943. Hybridization in nature between species of catostomid fishes. *Cont. Lab. Vert. Biol., Univ. Mich.* 22:1-76.
- Kimsey, J. B. and L. O. Fisk. 1960. Keys to the freshwater and anadromous fishes of California. *Calif. Fish Game* 46 (4):453-479.
- Koehn, R. K. 1969. Hemoglobins of fishes of the genus *Catostomus* in western North America. *Copeia* 1969 (1):21-30.
- Jordan, D. S., B. W. Evermann, and H. W. Clark. 1930. Checklist of the fishes and fish-like vertebrates of North and Middle America north of the northern boundary of Venezuela and Colombia. *Rep. U.S. Comm. Fish* 1928:1-670.
- La Rivers, I. 1962. Fishes and fisheries of Nevada. *Nevada State Fish Game Comm.* 782 p.
- MacDonald, G. A. 1966. Geology of the Cascade Range and Modoc Plateau, p. 65-96. In *Geology of northern California*. Calif. Div. Mines Geology Bull., (190).
- Miller, R. R. 1959. Origin and affinities of the freshwater fish fauna of western North America, p. 187-222. In *Zoogeography*. Amer. Assoc. Adv. Sci. Publ., (51).
- . 1961. Man and the changing fish fauna of the American Southwest. *Pap. Mich. Acad. Sci., Arts, and Letters* 46 (1960):365-404.
- Rutter, C. 1908. The fishes of the Sacramento-San Joaquin basin, with a study of their distribution and variation. *Bull. U.S. Bur. Fish.* 27 (1907):103-152.
- Schultz, L. P. 1936. Keys to the fishes of Washington, Oregon, and closely adjoining regions. *Univ. Wash., Publ. Biol.* 2 (4):103-288.
- Shapovalov, L. and W. A. Dill. 1950. A checklist of the freshwater and anadromous fishes of California. *Calif. Fish Game* 36 (4):382-391.
- Shapovalov, L., W. A. Dill, and A. J. Cordone. 1959. A revised checklist of the freshwater and anadromous fishes of California. *Calif. Fish Game* 45 (3):159-180.
- Smith, G. R. 1966. Distribution and evolution of the North American catostomid fishes of the subgenus *Pantosteus*, genus *Catostomus*. *Misc. Publ. Mus. Zool., Univ. Mich.* 129:1-132.
- Stewart, N. H. 1926. Development, growth, and food habits of the white sucker, *Catostomus commersonii* Lesueur. *Bull. U.S. Bur. Fish.* 42:147-184.
- Weisel, G. R. 1960. The osteocranium of the catostomid fish, *Catostomus macrocheilus*. A study in adaptation and natural relationship. *J. Morph.* 106 (1):109-129.

CONTRIBUTIONS TO THE LIFE HISTORY OF THE PIUTE SCULPIN IN SAGEHEN CREEK, CALIFORNIA¹

ALBERT C. JONES
Southeast Fisheries Center
National Marine Fisheries Service
Miami, Florida

The Piute sculpin, *Cottus beldingi* Eigenmann and Eigenmann, is the dominant fish by number and weight in Sagehen Creek, a mountain stream on the east slope of the Sierra Nevada. Sculpins are at their greatest density in the middle part of the creek where they, along with brook trout (*Salvelinus fontinalis*) and rainbow trout (*Salmo gairdneri*), find good foraging for bottom dwelling aquatic insect larvae. The numbers of sculpins are low in the precipitous headwaters of Sagehen Creek and also low in the lower reaches of the stream, which are frequented by their chief predator, the brown trout (*Salmo trutta*), and by other fishes. Sculpins in Sagehen Creek and Lake Tahoe exhibit minor differences in growth and reproduction but appear to occupy a similar ecological niche in the two areas.

INTRODUCTION

The Piute sculpin lives in lakes and streams of the Lahontan and Columbia River Basins of the western United States. Baker and Cordone (1969) and Ebert and Summerfelt (1969) described the biology of *C. beldingi* living in Lake Tahoe, an oligotrophic mountain lake. This report concerns the Piute sculpin in Sagehen Creek, a nearby mountain stream, and compares the biology of stream and lacustrine dwellers of this species.

Sagehen Creek is a spring-fed stream that is tributary to the Little Truckee River, itself tributary to the Truckee River draining Lake Tahoe. The creek rises in the Sierra Nevada at an altitude of 7,400 ft, flows through a watershed approximately 19.2 square miles in area, and after about 13 miles enters the Little Truckee River at 5,800 ft elevation. Climatic conditions are boreal. Between 1954 and 1961, minimum daily flows in Sagehen Creek in fall ranged from 1.0 to 2.6 cfs and momentary maximum daily flows in spring ranged from 27 to 212 cfs (Gard and Flittner MS).

ABUNDANCE

The Piute sculpin is the most common fish in Sagehen Creek and, by number and weight, is a significant part of the stream ecosystem. The population density (number of fish per acre) of sculpins in Sagehen Creek was estimated from the number of fish collected from 10 short sections of stream (Table 1). The sections, numbered from I (upstream) to X (downstream), totaled approximately 2,000 ft in length and were located at approximately 1-mile intervals along the course of the stream. The water flow was diverted from each section, the pools in the section drained with a pump, and the fish captured. Later the fish were returned to the stream, except for samples retained for study. Details of the collecting methods are given by Flittner (1953).

¹ Accepted for publication March 1972.

TABLE 1—Population Density and Total Weights of the Piute Sculpin in Sagehen Creek in August and September of 1952 and 1953. (Data exclude age-group 0 sculpins which were not sampled representatively. The gradient and bottom type of each stream section and the dominant fish present in each section are from Flittner (1953) and Gard and Flittner (MS).)

Stream section	Ft., 100 ft	Bottom type	1952		1953		Pounds per acre	Number per acre	Pounds per acre	Dominant fish species by weight
			Number per acre	Pounds per acre	Number per acre	Pounds per acre				
I	6.8	Boulders	0	0	0	0	0	0	Brook trout	
II	2.7	Rubble-gravel	67	1.0	33	1.0	33	33	Brook trout	
III	3.6	Boulders	1,119	15.2	355	4.5	355	355	Brook trout	
IV	1.6	Rubble-gravel	5,801	83.7	24,609	115.5	24,609	24,609	Sculpin	
V	3.9	Boulders-rubble	2,859	38.6	4,817	32.4	4,817	4,817	Sculpin	
VI	3.1	Gravel-rubble	6,098	59.5	8,163	85.4	8,163	8,163	Sculpin	
VII	1.6	Rubble-gravel	9,443	92.1	22,970	76.8	22,970	22,970	Sculpin	
VIII	0.8	Silt-gravel	3,758	41.5	8,976	48.8	8,976	8,976	Sculpin	
IX	0.8	Marl-gravel-clay	376	5.0	782	6.2	782	782	Brown trout	
X	1.0	Gravel-mud-clay	112	2.9	528	7.2	528	528	Suckers	

TABLE 2—Calculated Age Composition of Piute Sculpins in Sagehen Creek in August and September of 1952 and 1953. (Data exclude age group 0 sculpins which were not sampled representatively. Dash indicates no age sample collected.)

Stream section	1952					1953					Total	
	I	II	III	IV	V	Total	I	II	III	IV		V
I	---	---	---	---	---	0	---	---	---	---	---	0
II	33*	0	---	34	0	67	---	---	---	---	---	33
III	615	129	518	97	0	1,419	32	129	129	65	0	355
IV	106	2,427	2,110	1,055	106	5,801	21,777	0	531	1,770	531	24,609
V	---	---	---	---	---	2,859	4,091	0	282	471	0	4,817
VI	---	---	---	---	---	6,098	3,172	1,085	2,170	1,519	217	8,163
VII	---	---	---	---	---	9,413	21,531	0	574	862	0	22,970
VIII	516	2,119	641	129	0	3,758	7,911	0	516	516	0	8,976
IX	17	308	51	9	0	376	101	313	203	155	0	8,976
X	0	47	55	9	0	112	17	297	82	115	17	528

Sculpins were most abundant in middle Sagehen Creek, which included sections IV-VIII, where the stream gradient was intermediate, the bottom consisted of gravel-rubble and brook trout, rainbow trout, and brown trout were the only other fish present. (A few individuals of other species were present in section VIII as noted below.) Sculpins were absent or scarce in upper Sagehen Creek (sections I-III), which was the precipitous, boulder-strewn headwaters of the stream inhabited primarily by brook trout. Sculpins also were scarce in lower Sagehen Creek, which included sections IX and X, where the stream had a slight gradient, a bottom of gravel, mud and clay, and a fish population that included in addition to the 3 trouts, Tahoe suckers (*Catostomus tahoensis*), mountain suckers (*C. platyrhynchus*), Lahontan redsides (*Richardsonius egregius*), speckled dace (*Rhinichthys osculus*), and mountain whitefish (*Prosopium williamsoni*). The non-salmonid fishes in sections IX and X also occurred in reduced numbers in section VIII (Gard and Flittner, MS).

The apparent success of sculpins in middle Sagehen Creek may be due to a combination of favorable conditions; gravel riffle areas which provide cover for the sculpins and a substrate for their forage (bottom dwelling aquatic insect larvae) and the general absence or scarcity of predaceous brown trout. In Lake Tahoe sculpins ranged from the littoral zone to 700 ft in depth, but similarly were most common in the rubble-boulder areas of intermediate depth which offered protection from lake trout (*Salvelinus namaycush*), the sculpin's chief predator in the lake (Baker and Cordone 1969).

AGE COMPOSITION

Sculpins in Sagehen Creek reach 5 years of age, determined by counting annuli in otoliths. Calculated age distributions of the sculpin populations in sections I-X are shown in Table 2. In 1953, 1-year-old fish (the 1952 year class) made up 82% of the total number of sculpins sampled, but in 1952, 1-year-old fish made up only 11% of the total number of sculpins. Seegrist and Gard (in press) reported that the severe spring floods in 1952 decimated the eggs of spring-spawning rainbow trout. Our observations indicate that the high-water conditions present in the summer of 1952 may have benefited the survival of young-of-the-year sculpins. In sections IX and X, 1-year-old sculpins were less numerous than 2-year-olds in both 1952 and 1953; this suggests that reproduction in lower Sagehen Creek is relatively unsuccessful and that the sculpin population there is maintained partly by migration into the area.

REPRODUCTION

Piute sculpins spawn a small number of eggs which are relatively large in size. The fecundity of 70 fish from 65 to 86 mm TL ranged from 77 to 235 (average 132). The linear regression of fecundity on total length of fish was $Y = -151.59 + 3.81X$, $r = 0.69$, $P < 0.01$. Eggs taken from the ovaries of several unspawned females collected during the spawning season averaged 2.54 mm in diameter and water-hardened eggs collected from the two nests averaged 2.90 and 2.97 mm.

Measurements of the eggs were made after the fish had been preserved initially in 10% formalin and then transferred to 60% ethyl alcohol.

The spawning season of sculpins in Sagehen Creek in 1953 was short. At section VI the first spawned-out female was collected on June 2 and by June 8 all females collected in this section had spawned. Males also appeared to be in spawning condition for only a short time. Males from which milt could be extruded by applying pressure to the abdomen were collected in section VI only from June 1 to 8. The average daily maximum and minimum water temperatures at this location were 52.2 F and 38.3 F (May 25-31) and 57.0 F and 40.1 F (June 1-7). Water temperatures are lower upstream from section VI and higher downstream (Gard and Flittner MS), so that if spawning time is dependent on water temperature, spawning probably occurs at different times in different sections of the creek.

Sculpins in Lake Tahoe spawned primarily in May and June (Ebert and Summerfelt 1969). The report by Miller (1951) of ripe female sculpins in lake trout stomachs (which are inhabitants of the deeper, cooler water) as late as August 28 suggests that the spawning season in Lake Tahoe also varies in different parts of the lake in relation to temperature. The average fecundity of Lake Tahoe sculpins (123) (Ebert and Summerfelt 1969) was close to that of sculpins in Sagehen Creek.

The two sculpin nests observed in the spawning season of 1953 were located in riffle areas of the stream, under rocks 8 to 12 inches in diameter and in water 6 to 10 inches deep. Egg clusters were attached to the undersurface of the rocks. Each female sculpin apparently spawns only once per year and presumably deposits a single egg cluster, since the number of eggs in the two nests (122 and 160) was close to the average fecundity.

In the month previous to spawning, female sculpins contained two distinct size groups of ovarian eggs. The smaller, immature eggs were less than 0.60 mm in diameter and the mature eggs were 1.55 to 3.55 mm in diameter. (The preserved eggs were usually misshapen; and, as a result, their diameters had a greater than normal range.) After spawning, only immature eggs were present; enlargement of the ova preparatory to the next season's spawning was not noticeable until October.

GROWTH

Sculpins in Sagehen Creek grew primarily from May to October. Age group 0 sculpins sampled in section VI increased from 12.0 mm in August to 25.4 mm in October. Growth slowed after October; in January the average length was only 24.5 mm. Growth from January to May is probably also slow, since age group I fish collected in January 1954 (24.5 mm) were about the same size as age group I fish collected in May 1953 (24.8 mm). The length of age group I fish increased from 24.8 mm in May to 54.4 mm in October. By January the I age group had increased to only 58.0 mm. Older sculpins also increased most in length from May to October but little from October to May.

The increased growth rate of Sagehen Creek sculpins observed in spring and summer corresponds with the higher water temperatures in

these months; the mean daily maximum water temperature was higher than 50 F only in the months of May through October (Needham and Jones 1959). Ebert and Summerfelt (1969) concluded that the Piute sculpin in Lake Tahoe grows primarily in the spring and early summer and found a larger volume of food in their stomachs in spring and summer compared to fall and winter. Sculpins in Lake Tahoe were generally larger at a given age than those in Sagehen Creek, especially for younger age groups. No records of water temperature were available to interpret the seasonal growth patterns in Lake Tahoe as compared to Sagehen Creek.

The sculpins collected in August 1953 in the downstream sections of Sagehen Creek were larger than those in the upstream sections. This difference was probably because during most of the year water temperatures are higher in the downstream portion of the stream and as a result the growth rate is more rapid. Gard and Seegrist (in press) also found increased growth of brook, rainbow, and brown trout at lower elevations of Sagehen Creek.

Male sculpins grow faster than females. The difference in growth rate between the sexes was apparent in age group I individuals collected in August, when sexual differentiation of the gonads was first apparent from gross examination. The growth curve for males was $L = 44.4 t^{0.5415}$, where L = total length (mm) and t = age (years). The growth curve for females was $L = 43.4 t^{0.4793}$. Males apparently live longer than females; out of 12, 5-year-old fish collected, 11 were males.

The relationship between length (mm) and weight (g) of Sagehen Creek sculpins was $W = 8.8356 \times 10^{-6} L^{3.10617}$.

DISCUSSION

The Piute sculpin is the most abundant fish in Sagehen Creek and is the dominant species in the gravel-rubble parts of the stream where the gradient is intermediate. Brook trout and rainbow trout coexist with sculpins throughout the stream; brown trout, which inhabit primarily the lower sections of the creek, are their most important predator. Predation, food supply, and stream flow may be factors which limit population size. Growth and spawning time of sculpins in Sagehen Creek are related to the seasonal cycle of water temperature and are different in Sagehen Creek than in Lake Tahoe. Except for minor differences in biology, the Piute sculpin appears to occupy a similar ecological niche in the two areas.

ACKNOWLEDGMENTS

The University of California Sagehen Creek Wildlife and Fisheries Research Station was initiated by Dr. Paul R. Needham who directed its activities until his death in 1964. This paper is dedicated to Dr. Needham.

REFERENCES

- Baker, Phillip M., and Almo J. Cordone. 1969. Distribution, size composition, and relative abundance of the Piute sculpin, *Cottus beldingii* Eigenmann and Eigenmann, in Lake Tahoe. Calif. Fish Game 55 (4): 285-297.

- Ebert, Verlyn W., and Robert C. Summerfelt. 1969. Contributions to the life history of the Piute sculpin, *Cottus beldingii* Eigenmann and Eigenmann, in Lake Tahoe, Calif. Fish Game 55 (2): 100-120.
- Flittner, Glenn Arden. 1953. The composition and distribution of the fish populations in Sagehen Creek, Nevada-Sierra counties. MA Thesis (Zoology), University of California, Berkeley, 150 p.
- Gard, R., and D. W. Seegrist. (In press). Abundance and harvest of trout in Sagehen Creek, California. Amer. Fish. Soc., Trans.
- Gard, R., and Glenn A. Flittner. (MS). A ten-year study of distribution and abundance of fishes in Sagehen Creek, California. MS, Univ. of California, School of Forestry and Conservation.
- Miller, Richard Gordon. 1951. The natural history of Lake Tahoe fishes. Ph. D. Thesis, Stanford University, 169 p.
- Needham, Paul R., and Albert C. Jones. 1959. Flow, temperature, solar radiation, and ice in relation to activities of fishes in Sagehen Creek, California. Ecology 40 (3): 465-474.
- Seegrist, D. W., and R. Gard. (In press). Effects of floods on trout in Sagehen Creek, California. Amer. Fish. Soc. Trans.

THE EFFECTS OF DIESEL FUEL ON A STREAM FAUNA¹

R. BRUCE BURY
Museum of Vertebrate Zoology
University of California, Berkeley 94720

The spillage of approximately 2,000 gallons of diesel fuel into Hayfork Creek, California, resulted in a large kill of invertebrates, fishes, and other life. Subsequent effects on the stream fauna are discussed. This study examines the increasing threat of pollution in remote areas due to the transportation of petrochemicals.

INTRODUCTION

Water pollution by petroleum products is a serious environmental problem, since oily substances contain toxic components and, in general, are stable compounds that can remain in an ecosystem for a relatively long time. Oil spills have caused widespread detrimental effects in California waters and elsewhere (McCaull 1969; Mitchell, et al. 1970; Blumer, et al. 1971; and Straughan 1971).

McKee (1956) reported that petroleum products can be detrimental to aquatic organisms in the following ways: (i) free oil and emulsions may act on the epithelial surfaces of fish, thereby interfering with respiration, or may coat and destroy algae and plankton, which remove sources of food; (ii) oily substances that settle to the bottom may coat and destroy benthic organisms, and interfere with spawning areas; (iii) soluble and emulsified material may be ingested by fish and thereby taint the flavor of the flesh, or water-soluble parts may have a direct toxic action on aquatic life; (iv) organic materials may deoxygenate the water sufficiently to kill fish; and (v) heavy coatings of free oil on the surface may interfere with reaeration and photosynthesis.

Distilled petroleum substances are immediately toxic to animal life. Gutsell (1921) found gasoline had a toxic effect on rainbow trout (*Salmo gairdneri*) at about 100 mg/liter. McKee and Wolf (1963) reported that agitated solutions of automobile gasoline at a concentration of 100 mg/liter and jet aviation fuel at 509 mg/liter is lethal to fingerling salmon (*Oncorhynchus* sp.). Diesel fuel is acutely toxic to rainbow trout within the range of 350 to 1,000 mg/liter (Richard Hansen, pers. comm.).

There are relatively few documented cases of oil pollution in freshwaters. In fact, Wilbur (1969) stated that there is such limited information on the effects of oily wastes in water on livestock and wildlife that any extended discussion would be futile. Swift et al. (1969) surveyed the literature on the biological and ecological effects following an oil spillage, noting that while some information is available on the damage that can occur, few quantitative and coherent data are available to assess past incidents or to predict potential effects in the future.

¹ Accepted for publication March 1972.

The present study reports the detrimental effects of diesel fuel, a moderately toxic substance, on an unspoiled freshwater stream.

On July 28, 1970, the rear tank section fell off a truck on a sharp curve along U. S. Forest Service Road 2N01. The accident occurred about 0.5 miles upstream from the 'fish ladders,' Hayfork Creek, a tributary of the Trinity River, Trinity County, California (about 7 air miles SSE of the town of Hayfork). The 4,000-gallon tank, reported to be about half full of diesel fuel, burst when it rolled down a steep canyon. Some of the fuel evaporated or soaked into the ground, but about 2,000 gallons entered the creek.

MATERIALS AND METHODS

A survey of the biological effects of the diesel fuel spill in the creek was conducted from 1 to 2.5 miles downstream from the site of the accident because the pre-spill conditions in this area were well known. Field studies had been carried out along this part of the creek during the summers 1968 to 1969 and in June and July, 1970 (Bury 1972). The study area consisted of 36 pools varying in size from 5 to 50 yards long, mostly 10 to 20 yards, and 5 to 10 yards wide. The pools are 3 to 12 ft deep in the summer and are connected by long, shallow riffles 0.5 to 1 ft deep. For comparison of the effects of the diesel fuel on the stream fauna, the surveyed area was divided into 10 equal parts with each section 800 ft in length. Dead animals were counted in the study area from August 1 through 5 and then periodically until mid-September.

EFFECTS ON THE FAUNA

The diesel fuel entered the study area about 36 hr after the accident. Initially a thin film of fuel extended entirely across the surface of the creek. The first effects were observed on the morning of July 31, 1970, when the normally clear waters turned a murky, brown color with visibility less than 1 ft and small droplets of fuel floated on the surface.

Most animals were adversely affected 1 to 4 days after the fuel entered the study area. Thousands of aquatic insects perished, especially water boatmen (Corixidae), belostomatid water bugs, water striders (Gerridae), adult and larval diving beetles (Dytiscidae), mayfly nymphs (Ephemeroptera), and dragonfly and damselfly nymphs (Odonata). Many crayfish (*Astacus* sp.) were actively moving in the creek during daylight hours, a condition which had not been noticed in previous years. Ten crayfish were found dead. Hundreds of aquatic leeches (Class Hirudinae) and freshwater planarians (Planariidae) were killed.

Over 2,500 fishes were killed, including about 1,000 lamprey ammocoetes (*Entosphenus tridentatus*), 688 small-scaled suckers (*Catostomus rimiculus*), 75 speckled dace (*Rhinichthys osculus*), and 849 rainbow trout (Table 1). Further, several fishes were seen near the surface, mouths gaping and then slowly sinking into the murky water. In one pool I observed a 7-inch trout moving slowly along the bottom upside down, and a 12-inch fish swimming on its side near the surface. Other trout in the pool remained almost motionless near the bottom, frequently gaping widely.

TABLE 1—Vertebrate Losses Caused by Diesel Fuel Contamination of Hayfork Creek, 1970.

Section	Salmonid fishes					Suckers	Pace	Ammono-coetes	Tadpoles	Snakes	Turtles	Birds	Total number
	1 to 3 inches	4 to 6 inches	7 to 9 inches	10 to 12 inches	13 to 15 inches								
1	150	12	1	--	--	256	15	321	389	6	--	--	1,141
2	109	5	1	--	--	113	20	137	263	3	1	--	652
3	34	12	2	--	1	23	1	53	319	8	--	--	453
4	18	12	1	--	--	13	1	53	140	6	--	--	244
5	112	10	7	1	1	106	12	35	158	10	--	1	462
6	57	7	3	1	--	116	10	93	122	1	--	--	331
7	146	23	3	--	--	117	13	162	300	1	--	--	764
8	20	9	2	--	--	8	2	17	68	--	--	--	126
9	74	9	2	--	--	15	1	60	55	--	--	--	196
10	5	--	--	--	--	1	--	35	58	1	--	--	100
Total	725	99	22	1	2	688	75	976	1,843	36	1	1	4,169

Tadpoles and partly metamorphosized individuals of the foothill yellow-legged frog (*Rana boylei*) were killed in large numbers. No adult frogs were found dead. Thirty-six western aquatic garter snakes (*Thamnophis couchi*) were killed. Several snakes were seen that appeared to be noticeably sluggish in their movements.

Subsequent to the initial toxic impact on the stream other effects were observed. Large quantities of dead animals and algae (*Spirogyra* sp., *Cladophora* sp., *Zygnema* sp.) sank to the bottom or formed floating mats. Some of the surface masses were 2 to 4 inches thick and covered several square yards. A log across the surface of one pool caused accumulation of floating material that covered an area 20 ft wide and 40 ft long. Loose aggregations of organic matter accumulated on the bottom where there was little current, and in places formed a slurry 6 to 12 inches deep. The organic matter putrefied rapidly and formed a layer of scum on the bottom of the creek. Most of the diesel fuel was flushed out of the study area 3 weeks after the spill, but some fuel remained trapped in the accumulations of dead organic matter and small slicks of fuel were observed until mid-September when observations ended.

On August 8, a dead common merganser (*Mergus merganser*) was found along the creek and its feathers were in disarray and smelled of diesel. On September 10, a pond turtle (*Chrysemys marmorata*) measuring 5 inches in shell length was found dead on the bottom of a pool. Two young ones, alive, but in poor condition, were found on the shores of other pools. The eyes and necks of all these turtles were swollen. Movements of both young turtles were uncoordinated and they were unable to either swim or sink. Also, 30 pond turtles captured in early September had sloughed off pieces of epidermis on their appendages, and their necks and eyes were swollen.

DISCUSSION AND CONCLUSIONS

The large die-off of animals was a direct result of the diesel fuel pollution. Only rarely was a dead animal found in the creek during prior studies, and usually these were due to predation. The toxicity of the fuel killed most animals on contact and, later, caused other detrimental effects to the stream fauna due to large quantities of putrefying organic matter.

Many fishes displayed unusual behavior due to irritating or immobilizing effects of the diesel fuel. Adult frogs were not killed, and their survival is related to their mode of life. Frogs usually rest along banks out of water and feed principally on live insects. Hundreds of tadpoles perished since they were directly exposed to the fuel in the water and, perhaps, ingested tainted algae. Garter snakes probably died because they regularly swim in the water and prey on tadpoles and fish. Exposure to the fuel and ingestion of food contaminated with fuel may have killed the pond turtle and common merganser.

There was a heavy concentration and prolonged exposure to the fuel in the upstream parts of the study area, and the mortalities were greater than in sections farther downstream where the fuel was diluted, evaporated, or dispersed sufficiently to have a reduced impact on the stream fauna. There were 2,952 dead vertebrates found in sections 1

through 5, and 1,517 in the downstream sections 6 through 10 (Table 1). Although no dead organisms were found farther than 5 miles downstream from the site of the spillage, chronic toxicity and other sublethal effects may have extended many miles along the creek.

Blumer et al. (1971) reported that hydrocarbons taken up into the fat and flesh of fish and shellfish are not removed by excretion or by internal metabolic processes, and that these substances remain in the animals for long periods of time, possibly for their entire lives. They state that crude oil and oil products are persistent poisons, resembling in their longevity DDT and other synthetic materials. It is expected that the diesel fuel pollution of Hayfork Creek resulted in long term effects on the stream fauna.

Caution in the transport of oily substances is obviously required to prevent accidental spills, especially in the vicinity of flowing waters because pollutants can be dispersed great distances in a relatively short time. Bönig (1965) reported that a great deal of oil pollution occurs in spite of safety measures. Persons who dispense or transport petroleum products need to be acutely aware of the great damage that these substances have on fisheries and wildlife resources.

The risk of accidental spills of petroleum products is an ever present danger of pollution to aquatic ecosystems and will undoubtedly increase with rising consumption and transportation of fossil fuels. This study indicates that oil pollution is a serious threat to life even in remote, unspoiled streams and rivers.

ACKNOWLEDGMENTS

I thank Dr. Robert C. Stebbins for his careful review and comments on the manuscript, and Mr. Richard Hansen for providing helpful information on the pollution at Hayfork Creek.

REFERENCES

- Blumer, M., H. L. Sanders, J. F. Grassle, and G. R. Hampson. 1971. A small oil spill. *Environment* 13(2) :2-12.
- Bönig, 1965. Danger to waters from the use and storage of oily substances in industry and their prevention. *Industrieabwasser*, 1965:51-57.
- Bury, R. B. 1972. Habits and home range of the Pacific pond turtle, *Clemmys marmorata*, in a stream community. Ph.D. Thesis, Univ. California, Berkeley.
- Gutsell, J. S. 1921. Danger to fisheries from oil and tar pollution of waters. Bur. of Fisheries, Doc. 910, Appendix to Rep., U.S. Comm. of Fisheries, 10 p.
- McCaul, J. 1969. The black tide. *Environment* 11(9) :2-16.
- McKee, J. E. 1956. Report on oily substances and their effects on the beneficial uses of water. Calif. Water Poll. Control Board, Publ. No. 16, 71 p.
- and H. W. Wolf, eds. 1963. Water quality criteria, 2nd ed. Calif. Water Quality Board, Publ. No. 3-A, 548 p.
- Mitchell, C. T., E. K. Anderson, L. G. Jones, and W. J. North. 1970. What oil does to ecology. *J. Water Pollut. Control Fed.* 42(5) :S12-S18.
- Straughan, D. 1971. Biological and oceanographical survey of the Santa Barbara Channel oil spill. Vol. I. Biology and bacteriology. Allen Hancock Foundation, Univ. So. Calif. Sea Grant Publ. No. 2, 426 p.
- Swift, W. H., C. J. Touhill, W. L. Templeton, and D. P. Roseman. 1969. Oil spillage prevention, control, and restoration—state of the art and research needs. *J. Wat. Pollut. Control Fed.* 41(3) :392-412.
- Wilber, C. G. 1969. The biological aspects of water pollution. Charles C. Thomas, Springfield, Illinois, 296 p.

A SUBPOPULATION STUDY OF THE PACIFIC SARDINE¹

KENNETH F. MAIS

Marine Resources Region
California Department of Fish and Game

A subpopulation study was made of Pacific sardines inhabiting the west coast of North America and Mexico. A method of statistical treatment was utilized to determine the amount of overlap of single and combined meristic and morphometric characters. Results indicate the existence of three stocks centered in California, Baja California (Mexico), and the Gulf of California (Mexico). California and Baja California fish were very similar, but Gulf of California sardines appear to be a more distinctive and separate stock.

INTRODUCTION

The Pacific sardine, *Sardinops caeruleus*, inhabits coastal waters from British Columbia, Canada, southward to the tip of Baja California, Mexico, including the Gulf of California. In former years, sardines were common throughout their range and were abundant in central and southern California where they supported a very large and valuable commercial fishery. The population is at an extremely low level at present (1971). In the past 18 years, sardines have disappeared from the northern limits of the range and are generally very scarce in areas of former abundance. They are common only in the southern half of Baja California, Mexico, including the Gulf of California. The fishery was maintained at a high level in the 1930's and early 40's with yearly catches exceeding 400,000 tons. A drastic decline followed which eventually resulted in a moratorium limiting the catch to 250 tons in California.

There have been three brief upsurges since the decline began in 1946. At least two of these, 1954-55 and 1958-59 seasons, were attributed to sardines migrating from Mexico since no large incoming year classes or adults were present previously (Ahlstrom 1959; Calif. Mar. Res. Comm. 1960).

These apparent migrations indicated the necessity of identifying and delineating sardine subpopulations. Does the fishery draw on one homogeneous population or several? If more than one subpopulation exists, what proportion does each contribute to the fishery? Does a sudden upsurge in landings represent entry of a good year class or a migration of a stock from outside the normal fishery range?

Previous studies relating to sardine subpopulations have been conducted by a number of investigators. Clark (1947) compared vertebral counts of a large number of specimens over the species' range. Results indicated a heterogeneous group from British Columbia to Point Eugenia central Baja California, Mexico. A second group that appeared to be separate and not mixing to any extent with the first group inhab-

¹ Accepted for publication April 1972.

ited the Gulf of California and southern Baja California, Mexico. McHugh (1950) using larval and post larval material demonstrated different rates of development and growth of various body parts by morphometrical comparisons of fish from southern California and Baja California, Mexico. Radovich and Phillips (1952) found sardines of the same year class were larger in southern California than those in central Baja California, Mexico. Felin (1954) made a similar study of fish from California and the Pacific Northwest and found different growth characteristics between the two areas.

Age and size composition of the commercial catch of central Baja California indicate sardines have a slower growth rate, a larger number of age groups, and a smaller maximum size than California fish (Wolf and Daugherty 1964). Egg and larvae surveys by the National Marine Fisheries Service (formerly the U.S. Bureau of Commercial Fisheries) discovered a summer spawning group in central Baja California in addition to the regular spring spawners. These spawning groups may be evidence of subpopulations. A California Department of Fish and Game tagging program (Clark and Janssen 1945) indicated extensive migration between California and the Pacific Northwest, and to a lesser degree between California and central Baja California, Mexico. Blood genetic studies by Vrooman (1964) indicate three subpopulations: northern, which ranges from California to northern Baja California; southern, which ranges from Baja California to southern California; and gulf, which is confined to the Gulf of California.

MATERIAL

Most specimens for this study were collected from 1958 to 1962 on routine fish surveys by the California Department of Fish and Game. These surveys were conducted primarily to assess sardine year class strength and covered the species' present range which is from San Francisco southward to and including the Gulf of California. Sampling was accomplished by attracting fish with a night light and capturing them with a blanket net. A few samples of adults were obtained from central and southern California commercial catches. Several samples of juveniles were obtained from southern California live bait haulers. One exotic sample originated in the Galapagos Islands off South America.

Originally only spawning adults were to be used for the study, but difficulty in capturing sufficient numbers necessitated taking all sizes and stages of sexual maturity. Although collections were made over a period of years, most samples were taken in 1958-1959. Southern California samples were taken over the greatest time span and during more seasons of the year. This area also was the most intensively sampled. Many Mexican samples were taken during fall and summer months. Gulf of California fish were taken on three survey cruises at various times of the year. During the later stages of collecting, several samples also were subjected to blood serology tests and classified into one of the three genetic groups reported by Vrooman (1964).

Fish sizes ranging from 110 to 209 mm SL were used for the study. The central and southern California samples contained the largest fish both in proportion and actual sizes. Central California samples consisted exclusively of large fish and southern California samples con-

tained mostly large and medium fish. Samples from Mexican waters including the Gulf of California adequately represented small and medium fish but contained a low proportion of large sizes. Seventy-five samples comprised of 3,706 fish were used in this study (Figure 1). The 1956-58 year classes predominated most areas sampled.

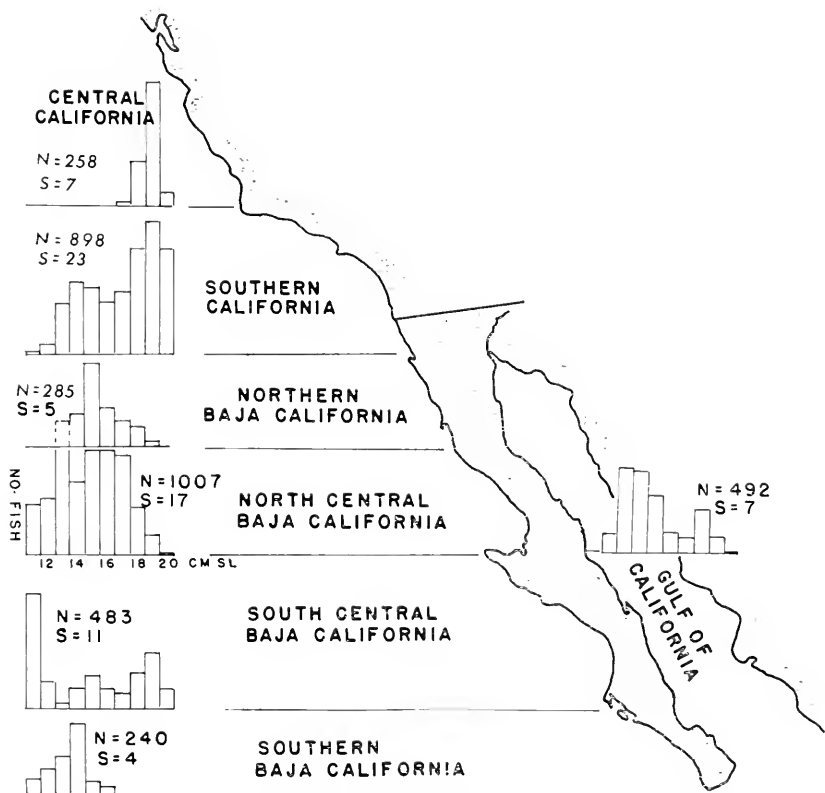

FIGURE 1. Pacific sardine subpopulation study region with size composition in each sampling area. N = number sampled. S = number of samples.

METHODS

Specimens were laid out straight and frozen immediately after capture at sea. After thawing in the laboratory, identification tags were attached and scales taken for age determination. The fish again were laid out straight and preserved in a 10% solution of formalin for a minimum period of 3 weeks.

Morphometric characters were selected on the basis of least likelihood of correlation with each other. Meristic characters were limited due to the difficulty of making accurate counts on some. All morphometric measurements were made by the author and all meristic counts were double checked. The following morphometric measurements were made: standard length, head length, pectoral fin length, and postpelvic length. Standard length consisted of the distance from the tip of the snout to

the end of the hypural plates. The latter point was determined by bending the tail forward and inserting a pin where a crease appeared in the caudal peduncle. Head length was measured from the tip of the snout to posterior edge of the opercular flap. Pectoral fin length was measured from the base of the fin to the tip of the longest ray. Post-pelvic length consisted of the distance from the end of the hypural plate to the origin of the pelvic fins.

Meristic counts were made of vertebrae and gill rakers. Vertebral counts were made from X-ray photos and included the hypural. Gill raker counts were made on the lower half of the first gill arch. Age determination was made by a routine scale reading process conducted by California Cooperative Oceanic Fisheries Investigations (CalCOFI).

STATISTICAL TREATMENT

Most samples used in this study were fairly representative of areas from which they originated. The large number of samples from the major areas and the span of time over which they were collected contributed to their representativeness (Figure 1). One exception was the southern California area where an apparent influx of migrants from Mexico at time of sampling may have affected representativeness. The size composition of sardine samples in all areas is typical of fish taken in the past 15 years by California Department of Fish and Game sea surveys. Night light blanket net gear is equally effective in taking all sizes of fish.

Before morphometric data could be statistically treated, it was necessary to determine if their relation to fish size was linear. Tests were made for linearity on morphometric characters and gill rakers counts. All were linear except pectoral fin length which was only slightly curvilinear and gill raker counts which were quite curvilinear. This problem and the effects of allometric growth were minimized by stratifying samples into different size groups. These groups designated as small, medium, and large were composed of fish 110-139, 140-169, and 170-209 mm SL respectively. Regression of gill rakers was calculated using head length instead of standard length.

Variance and Covariance

Samples were grouped by area. The areas consisted of central California, southern California, northern Baja California, north-central Baja California, south-central Baja California, southern Baja California, Gulf of California, and Galapagos Islands (Figure 1). Analysis of variance and covariance tests were made of samples from the same area (within area) for each character. Significant differences at the 5% level resulted for each area and character when all samples were considered. This is quite normal when large numbers and samples are involved. Royce (1957) concluded significant differences can always be found between very closely related stocks if large and numerous samples are taken. This phenomenon has been widely experienced by taxonomists in other investigations (Mayr, Linsley, and Usinger, 1953). Samples stratified by year class, age, and spawning condition were subjected to the same tests. Similar results were obtained except for 3-year

old central California samples. No significant differences were found between samples of this age group in all characters except pectoral fin length. Age 0 fish in north-central Baja California and the Gulf of California did not differ significantly within each area in some characteristics. Females in spawning condition also were homogeneous in several characteristics in southern California, south-central Baja California, and southern Baja California. Thus it is apparent there is heterogeneity in all areas, but some strata are nearly homogeneous.

Comparisons were made between adjacent areas using all fish stratified by size group. Results similar to those of within areas were obtained. F values (F statistic used in analysis of variance) were generally larger giving some indication of greater differences between areas than within areas.

Regression formulas were computed for each morphometric character in all size groups and areas. Using these formulas, mean values of each character adjusted for standard fish sizes were determined and plotted with 1 SD and 2 SE's on each side of the mean (Figure 2, Appendix 1-5). Standard lengths of 126 mm, 154 mm, and 188 mm were used as standard fish sizes to represent small, medium, and large size groups. Gill rakers were adjusted to the mean head length of a standard size fish of each size category. Vertebral plots were made for only the total number of fish in each area (Figure 3). Clines are present in head length, postpelvic length, and vertebrae. Irregularities occur notably in Gulf of California large fish. Pectoral fin length and gill raker counts gave only vague indication of elines with numerous irregularities present.

The relative head length of sardines was greater in fish captured to the south with a maximum mean difference of 3 mm which occurred between medium size fish from southern California and the Galapagos Islands. The greatest difference in Pacific Coast samples was 1.94 mm between large fish from southern California and south-central Baja California (Figure 2).

Postpelvic length exhibited a well defined cline which was present in all size groups. This character decreased from north to south. A maximum difference of 3.32 mm was observed between large fish from central California and north-central Baja California (Figure 2).

A definite cline was evident in vertebral counts with a decrease to the south. Although this cline was very consistent, actual differences were quite small amounting to .63 vertebra between extremes (Figure 3).

Pectoral fin lengths gave no definite indication of a cline. This character appears useful only in distinguishing Gulf of California fish which had longer pectoral fins in all 3 size groups. Their means differed between .68 to 1.65 mm from fish of other areas (Figure 2).

The mean number of gill rakers varied irregularly with respect to a cline. A very slight discontinuous north-south cline was discernible in the medium and large size groups which indicated a small decrease to the southward. The Gulf of California large fish mean was considerably less than the other areas. It differed by .91 gill rakers from southern California mean which was the next lowest (Figure 2).

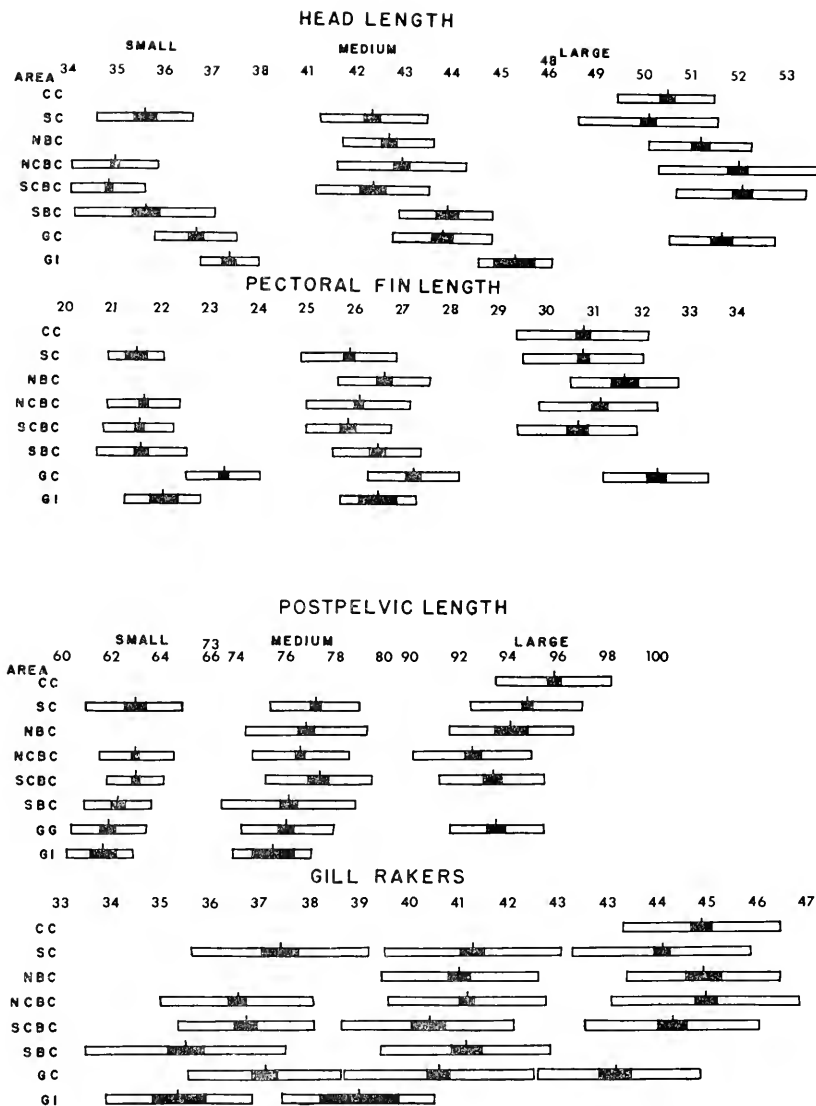

FIGURE 2. Morphometric and meristic statistics for a standard fish in each size category. Head length, pectoral fin length and post-pelvic length reduced to fish of a standard body length. Gill raker counts reduced to fish of a standard head length. Centerline, solid bar, and hollow bar respectively represent mean, two standard errors on each side of mean, and one standard deviation on each side of mean. CC = central California, SC = southern California, NBC = northern Baja California, NCBC = north central Baja California, SCBC = south central Baja California, SBC = southern Baja California, GC = Gulf of California, GI = Galapagos Islands.

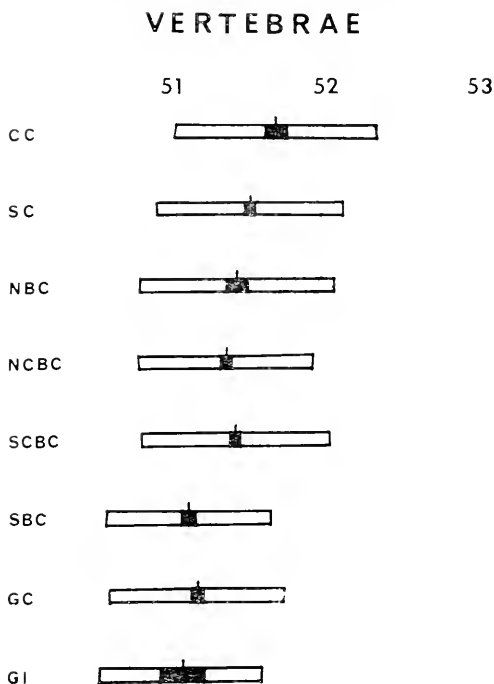

FIGURE 3. Vertebral statistic plots for all fish in each sampling area. Centerline, solid bar, and hollow bar respectively represent mean, two standard errors on each side of mean, and one standard deviation on each side of mean. CC = central California, SC = southern California, NBC = northern Baja California, NCBC = north central Baja California, SCBC = south central Baja California, SBC = southern Baja California, GC = Gulf of California, GI = Galapagos Islands.

Discriminant Function and Overlap

Analysis of variance and covariance showed differences existing within and between areas. Such information is useful in preliminary analysis but does not afford a good measure of the magnitude of differences. Employing the concept of overlap described by Royce (1957), an estimate can be made of the proportion of one group having identical characteristics of another. Using Royce's basic formula, D is the distance between means in units of standard deviation:

$$D = \frac{\bar{X}_1 - \bar{X}_2}{s} \text{ and } \bar{X}_1 \text{ and } \bar{X}_2 \text{ are the means}$$

of the characteristic in question and s is the pooled average standard deviation. From a table of normal probability integral using the value $D/2$ as an entering argument, the area of half the normal curve plus the mean to the argument is obtained. This area Royce calls the relative probability, $1-P$, which is the probability of correctly classifying an individual as belonging to one group or another. It varies from .5 with complete overlap to 1.0 with no overlap. The percentage of overlap is

obtained by multiplying P by 200. This value is the combined area of the overlapping tails of each distribution and measures the area or percentage of one curve which is included in the other. For example, in computing overlap of head length of large fish between southern and central California, $\bar{X}_1 = 15.70 + .1850X$, $\bar{X}_2 = 7.38 + .2273X$ (regression equations from Appendix II), $X =$ the grand means of body lengths of the two areas = 191.72. Solving the regression equations $\bar{X}_1 = 51.17$, $\bar{X}_2 = 50.96$. The pooled standard deviation from regression = 1.342.

$$D = \frac{51.17 - 50.96}{1.342} = 0.156$$

$$D/2 = 0.078, P = 0.469, \text{overlap} = 93.8\%$$

The concept of overlap thus gives an estimate of the proportion of one group having identical characteristics of another. The amount of similarity is therefore measurable and inferences concerning intermingling can be made. A high degree of overlap between two areas doesn't prove intermingling has occurred, but does represent a maximum that could have occurred. Very low overlap values on the other hand provide good evidence of little or no intermingling.

To use this method for morphometric characters, means were computed from the regression equation of each group under consideration as was the grand mean of their body lengths. The pooled standard deviation was replaced by the pooled standard deviation from regression.

Overlap percentages were calculated between adjacent areas for all meristic and morphometric characters using samples stratified by the size categories mentioned previously (Table 1). No single character consistently excelled in distinguishing groups. The value of each character in separating stocks varied greatly between each set of adjacent areas as well as between size categories. Overlap between the adjacent areas of north-central and south-central Baja California was large, averaging 90.17% for all characters. Comparisons of all large California fish with all large Mexican fish, except those from the Gulf of California, produced overlap values of 57.1% and 67.2% in head length and postpelvic measurements. The remaining characters overlapped from 88.0% to 94.0%. These examples give some indication as to how characteristics may differ even through these differences are not large enough to support inferences.

Discriminant function and overlap of multiple characters.

This form of multivariate analysis employs the generalized distance function developed by Mahalanobis (1936) which gives a measure of distance between two groups using a combination of characters. Each character is considered only after correlation with a previous one has been excluded. The general formula is:

$$D^2 = W^{ij} d_i d_j$$

in which W^{ij} is the inverse of the variance-covariance matrix W_{ij} and $d_i d_j$ are differences between means. D^2 is similar to D used for single

TABLE 1—Overlap Percentages of Morphometric and Meristic Characters

Areas compared	Size group	Head length	Pectoral fin length	Postorbital distance	Gill rakers	Number vertebrae	Sample size of first area	Sample size of second area
Southern California-North central Baja California	Small	74.9	96.8	92.8	78.8	88.2	87	325
North central Baja California-South central Baja California	Small	92.8	95.2	97.6	93.6	96.4	325	202
South central Baja California-Southern Baja California	Small	76.4	99.9	81.0	63.8	80.8	202	112
Southern Baja California-Gulf of California	Small	68.9	31.2	93.6	81.8	96.4	112	151
Gulf of California-Galapagos Islands	Small	61.5	53.5	90.4	54.9	90.0	151	28
Southern California-Northern Baja California	Medium	88.0	71.9	93.6	92.0	93.6	258	211
Northern Baja California-North central Baja California	Medium	88.8	81.0	95.2	96.0	91.6	211	438
North central Baja California-South central Baja California	Medium	77.9	91.2	87.0	81.0	96.4	438	101
South central Baja California-Southern Baja California	Medium	41.7	68.9	68.9	80.3	80.8	101	128
Southern Baja California-Gulf of California	Medium	89.6	77.2	92.8	87.2	96.4	128	228
Gulf of California-Galapagos Islands	Medium	39.5	68.9	79.1	67.1	88.1	228	15
Central California-Southern California	Large	43.6	98.3	80.2	81.8	90.0	258	553
Southern California-North central Baja California	Large	54.9	88.0	62.1	80.3	88.2	553	241
Northern Baja California-North central Baja California	Large	76.4	76.4	82.6	91.2	91.6	241	211
North central Baja California-South central Baja California	Large	96.0	81.2	83.1	85.8	96.4	211	177
South central Baja California-Gulf of California	Large	88.0	39.7	96.8	72.6	81.0	177	110
(Central California + Southern California)-Northern Baja California + North central Baja California + South central Baja California	Large	57.1	94.0	67.2	92.6	88.0	811	495

character overlap and can be used in the same way. At the same time D^2 is computed, a linear function of the combined characters is obtained which may serve as an index for discrimination. A complete explanation is given by Rao (1952). This method was used by Royce (1964) in a racial study of yellowfin tuna and by Hill (1959) to distinguish races of American shad.

For this study a computer program developed at the University of California at Los Angeles was utilized to perform the computations. Output included D^2 , discriminant function coefficients, and discriminant function frequencies of both compared groups. A small bias in D^2 , due to unequal sample sizes, is removed by subtracting the value

$$P \frac{n_1 + n_2}{n_1 n_2};$$

P is the number of characters and n_1 and n_2 are sample sizes.

Morphometric data were adjusted for use in this analysis by computing a character value for each individual fish based on a standard fish size. Deviations of individuals from their computed regression means were added or subtracted from the regression mean of a standard fish size. For example, if a 175 mm SL fish had a head length of 48 mm and the computed regression mean head length for this size was 50 mm, the difference of 2 mm would be subtracted from the mean computed head length of the standard size fish. Standard fish sizes, 126 mm SL (small), 154 mm SL (medium), and 188 mm SL (large) were determined by computing the grand mean of each size category.

RESULTS, SMALL AND MEDIUM SIZES

Overlap percentages derived from D^2 values were calculated (Table 2). Small and medium size fish from southern California were compared with each area to the south (Figure 4). Small fish differed relatively little from southern California to southern Baja California with overlap ranging from 56.6% to 64.3%. This overlap range also was found between samples from the same school group so it cannot be considered low enough to infer separate stocks. Small fish from the Gulf of California and Galapagos Islands overlapped the southern California group by 25.0% and 24.6% respectively. This low degree of overlap is a clear indication of different stocks.

Medium size fish were compared in the same manner (Figure 4). A great similarity was apparent between fish from southern California southward to and including south-central Baja California. A great degree of multiple character overlap ranging from 70.4% to 79.3%, was found between these areas. This may have been due to the migration of medium size fish into California during the period of data collection. From 1957 to 1960 there was an appearance of large quantities of medium size fish in areas where none had occurred for many years.

Fish from southern Baja California, the Gulf of California, and the Galapagos Islands overlapped southern California fish by 46.0%, 34.7%, and 10.8% respectively. These differences are large enough to suspect separate stocks in these areas.

TABLE 2—D Square and Overlap Values of Multivariate Analysis
Size I Small

Area	Morphometric and meristic means*							D:	Percent overlap
	Sample size	Mean standard length	Gill rakers	Head length	Pectoral fin length	Postpelvic distance	Number vertebrae		
Southern California	87	132.6	38.1	35.5	21.6	62.7	51.54	0.806	61.3
North central Baja California	325	127.4	37.2	35.0	21.5	63.0	51.22	1.351	57.5
South central Baja California	202	116.0	37.0	34.8	21.5	62.7	51.31	1.353	56.6
Southern Baja California	112	128.0	36.4	35.7	21.6	62.4	51.16	5.360	25.0
Gulf of California	154	133.1	37.8	36.8	23.3	61.8	51.25	5.659	21.6
Galapagos Islands	28	124.7	35.9	37.4	24.9	61.4	51.07		
Size II Medium									
Southern California	258	153.5	41.0	42.3	25.9	77.2	51.54	0.632	70.1
Northern Baja California	211	155.4	40.6	42.6	26.6	76.8	51.35	0.309	79.3
North central Baja California	438	156.2	40.8	43.0	26.1	76.6	51.40	0.523	73.4
South central Baja California	104	151.4	39.9	42.3	25.9	77.3	51.32	3.510	34.7
Gulf of California	228	150.8	40.1	43.8	27.2	76.0	51.16	10.356	10.8
Galapagos Islands	15	148.6	38.7	45.4	26.3	75.1	51.00		
Size III Large									
Central California	258	192.4	44.6	50.5	30.7	95.7	51.84	0.435	63.6
Southern California	553	191.4	43.8	50.1	30.7	94.8	51.50	1.123	61.0
Northern Baja California	74	181.2	44.5	51.3	31.6	94.1	51.41	2.472	43.5
North central Baja California	244	179.2	44.7	51.9	31.2	92.6	51.42	2.696	41.8
South central Baja California	177	190.5	44.0	52.0	30.7	93.3	51.44	1.534	29.4
Gulf of California	110	185.0	42.9	51.7	32.3	93.5	51.08		
Southern California Blood Serology Groups									
Santa Catalina Island northern type	85	194.2	43.6	49.0	30.4	95.6	51.54	1.163	58.9
Santa Cruz Island northern type	83	192.8	43.9	48.8	29.2	95.7	51.37	0.800	65.4
Santa Catalina Island northern type	93	187.5	43.1	49.8	31.0	94.8	51.46	1.989	48.2
San Pedro southern type	96	187.2	41.3	50.8	30.9	94.1	51.52	0.125	36.4
Ensenada northern type	72	181.3	44.6	50.9	30.8	93.8	51.61		

* Morphometric means adjusted to standard size fish for each size category.

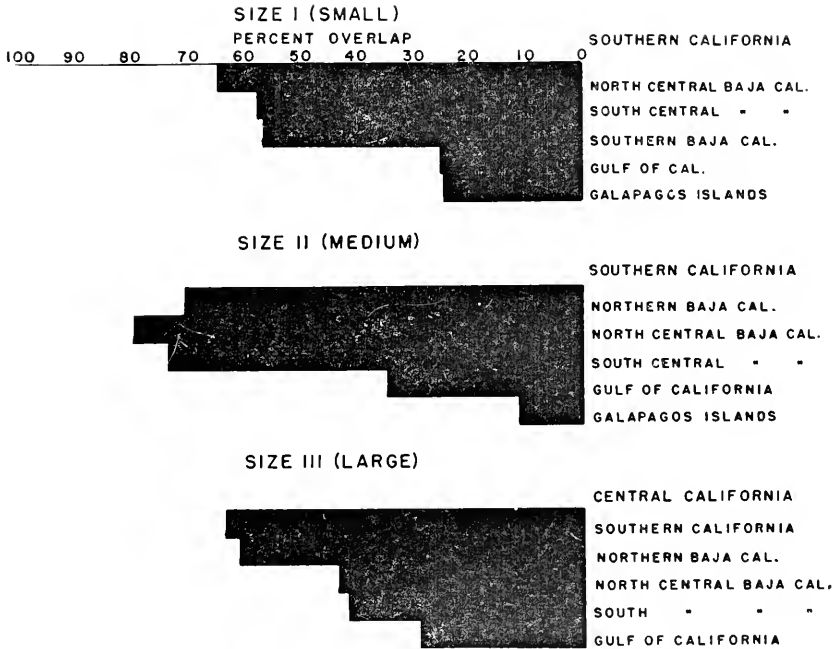

FIGURE 4. Overlap percentages derived from multivariate analysis of Pacific sardine morphometric and meristic characters. Small, medium, and large size fish from central and southern California compared with successively southward sampling areas.

RESULTS, LARGE FISH

Central California large fish, which analysis of covariance indicated was the least heterogeneous group, were compared with large fish from each of the remaining areas for which samples were collected (Figure 4). Fish from central California, southern California, and northern Baja California differed only moderately. Fish from the latter two areas overlapped those from the first by 63.6% and 61.0%. North-central and south-central Baja California fish were very similar to each other and substantially different from the areas to the north. Stock differences are indicated by the relatively low overlap values (43.5% and 41.8%) of these fish with those from central California. Gulf of California fish differed greatly from all other areas and most certainly comprise a separate stock. Overlap between fish from this area and those from central California was 29.4%.

Von Bertalanffy growth parameters, L infinity and K , were added to the morphometric and meristic characters for each fish 3 or more years old. Very little was gained by using these extra characters as D^2 values increased only slightly even when large growth rate differences were apparent. This was due to the extremely large variance in the growth parameter values.

Overlap comparisons were made using five samples of large fish upon which blood serology tests were performed by the National Marine Fisheries Service, La Jolla. These samples were classified into the north-

ern or southern groups as postulated by Vrooman (1964). All but one were classified northern. The southern sample originated in San Pedro Bay and the northern ones at Santa Catalina Island, Santa Cruz Island, and Todos Santos Bay. These locations are in southern California except the last which is in northern Baja California, Mexico.

Two samples were taken from the same school group at Santa Catalina Island. One Santa Catalina Island northern sample was compared with each of the other samples. Overlap with the three other northern samples was 65.4%, 58.9%, and 36.4%. The highest was between samples from the same school group and the lowest with the Todos Santos Bay sample. The southern sample overlapped 48.2%. The overlap of the same school samples indicates how variable very closely related stocks can be and affords some idea of the amount of overlap necessary to differentiate stocks.

Differentiation using the overlap method agreed favorably with the blood serology method except the Todos Santos Bay northern sample differed more from other northern samples than did the southern sample. A possible explanation is a sampling error could have occurred either in the blood serology test or the morphometric-meristic multivariate analysis due to a small sample size of 72 fish.

DISCUSSION

Results of this study indicate three stocks of sardines occur in the eastern temperate Pacific. These stocks are located in California, central Baja California (Mexico), and the Gulf of California (Mexico). California and central Baja California stocks are quite closely related and undoubtedly intermingle to a considerable degree. Small and medium size fish from these areas overlapped so greatly that no inference of separate stocks can be made. This large overlap (56.6% to 79.3%) was probably due to a heavy influence of migrants from Mexico and a paucity of native born fish in the California samples. Large fish from these regions overlapped considerably less (41.8% to 43.5%), but would have probably differed even more if the California samples had not been influenced by migrants from Mexico.

At first glance the overlap between large fish from California and Mexico indicated a considerable difference, but when fish of the same school and blood group overlapped by 65.4%, an overlap of 41.8% to 43.5% between these areas indicates a relatively small difference. The actual physical differences between stocks are extremely small thereby precluding any differentiation of individual fish or assessing the degree of intermingling.

Gulf of California fish appear to be a more distinct stock. Analysis of all size groups in this area indicated the least similarity to fish of other California areas with overlap values ranging from 25.0% to 34.7%. Small and medium sized southern Baja California fish were quite similar to those of central Baja California. No large fish from southern Baja California were available but they probably resemble central Baja California fish.

Galapagos Island fish differed greatly from those of all other areas as indicated by the low overlap of 10.8% to 24.6%.

These fish are separated from the others by extensive geographic and oceanographic barriers which exclude intermingling.

SUMMARY

A subpopulation study was made of the Pacific sardine population inhabiting the eastern Pacific Ocean. Seventy-three samples comprised of 3,706 fish were collected from California, Baja California, Gulf of California, and the Galapagos Islands off South America. Morphometric measurements and meristic counts consisting of: standard length, head length, pectoral fin length, postpelvic length, gill rakers, and vertebrae were made. Samples were stratified by fish size and area of catch.

Analysis of variance and covariance indicated a high degree of heterogeneity of fish from both within and between geographic areas. A method of statistical treatment which computes the proportion of one group having identical characteristics of another (overlap) was used for single characters to compare samples from adjacent areas. A more sophisticated method employing the same concept was used with all characters combined in aggregate. Single character comparisons gave rather large overlap values with over three-fourths of all comparisons exceeding 70%. Head length was the most useful distinguishing character and number of vertebrae the least.

Overlap comparisons using all characters in aggregate were made between California samples and those from each successive area to the south. This analysis produced much lower overlap values ranging from 10.8% to 79.3%. Small and medium size fish from California to southern Baja California, Mexico, overlapped so greatly that no inference of separate stocks can be made. Fish of these size groups from the Gulf of California and the Galapagos Islands overlapped California fish 10.8% to 34.7% and must certainly be separate stocks, both from each other and all other areas.

Similar comparisons of large fish produced overlap values ranging from 29.4% to 63.6%. California samples overlapped each other and northern Baja California 63.6% and 61.0% respectively. They overlapped Baja California samples from 41.8% to 43.5%, and those from the Gulf of California 29.4%. These results indicate California and northern Baja California sardines are probably a separate stock but are vary similar to a second stock off southern and central Baja California. Gulf of California fish are a third more distinctive stock.

REFERENCES

- Ahlstrom, E. A. 1959. Distribution and abundance of eggs of the Pacific sardine, 1952-1956. U.S. Dep. of Interior, Fish Wildl. Serv., Fish. Bull. 60(165): 185-213.
- California Marine Research Committee. 1960. Review of the partial resurgence of the sardine fishery during 1958-59. Calif. Coop. Oceanic. Fish. Invest. Reports, 7:8-10.
- Clark, Frances N. 1947. Analysis of populations of the Pacific sardine on the basis of vertebral counts. Calif. Dep. Fish and Game, Fish Bull. (65):1-26.
- Clark, Frances N., and John F. Janssen. 1945. Movements and abundance of the sardine as measured by tag returns. Calif. Dep. Fish and Game, Fish. Bull. (61): 7-42.
- Felin, Frances E. 1954. Population heterogeneity in the Pacific pilchard. U.S. Dep. of Interior, Fish Wildl. Serv., Fish Bull. 54(86): 201-225.

- Hill, Donald R. 1959. Some uses of statistical analysis in classifying races of American shad (*Alosa sapidissima*). U.S. Dep. of Interior, Fish Wildl. Serv., Fish. Bull. 59(147):269-284.
- Mahalanobis, P. C. 1936. On the generalized distance in statistics. Proceedings of the National Institute of Sciences (India) 2(1):49-55.
- Mayr, Ernst, E. G. Lindsley, and R. L. Usinger. 1953. Methods and principles of systematic zoology. McGraw-Hill, New York:1-328.
- McHugh, J. L. 1950. Variations and population in the clupeoid fishes of the North Pacific. Doctoral thesis, University of California, Los Angeles:1-116.
- Radovich, John R., and J. B. Phillips. 1952. Distribution and abundance of young sardines. Calif. Dep. Fish and Game, Fish. Bull. (87):1-63.
- Rao, C. R. 1952. Advanced statistical methods in biometric research. Wiley, New York:1-390.
- Royce, William F. 1957. Contributions to the study of subpopulations of fishes. U.S. Dep. of Interior, Fish Wildl. Serv., Spec. Sci. Rep.-Fish. (208):7-28.
- . 1964. A morphometric study of yellowfin tuna, *Thunnus albacares* (Bonaterre). U.S. Dep. of Interior, Fish Wildl. Serv., Bur. of Com. Fish., Fish. Bull. 63(2):395-413.
- Vrooman, A. M. 1964. Serologically differentiated subpopulations of the Pacific sardine, *Sardinops caerulea*. Res. Bd. of Can., J. Fish. 21(4):691-701.
- Wolf, Robert, and Anita E. Daugherty. 1964. Age and length composition of the sardine catch off the Pacific Coast of the United States and Mexico in 1961 and 1962. Calif. Fish Game 50(4):241-252.

APPENDIX I—Vertebrae All Fish

Area	N	\bar{X}	SD	SE
Central California.....	258	51.85	0.60	0.04
Southern California.....	898	51.51	0.61	0.02
Northern Baja California.....	285	51.36	0.64	0.04
North-Central Baja California.....	1,007	51.33	0.58	0.02
South-Central Baja California.....	483	51.36	0.59	0.03
Southern Baja California.....	210	51.17	0.54	0.04
Gulf of California.....	492	51.17	0.56	0.03
Galapagos Islands.....	43	51.05	0.49	0.07

N = Sample size

 \bar{X} = Mean

SD = Standard Deviation

SE = Standard Error

APPENDIX II—Head Length

Small (126 mm SL)

Area	N	Regression Equation	\bar{Y}	S_y	SE
Central California.....	0				
Southern California.....	87	$3.68 + .2533 X$	35.60	1.01	0.11
Northern Baja California.....	0				
North-Central Baja California.....	325	$4.55 + .2416 X$	31.99	0.91	0.05
South-Central Baja California.....	202	$4.60 + .2412 X$	34.85	0.77	0.06
Southern Baja California.....	112	$2.11 + .2661 X$	35.64	1.43	0.14
Gulf of California.....	154	$5.63 + .2466 X$	36.70	0.88	0.07
Galapagos Islands.....	28	$3.94 + .2654 X$	37.38	0.62	0.01

Medium (154 mm SL)

Central California.....	0				
Southern California.....	258	$8.59 + .2190 X$	42.32	1.10	0.07
Northern Baja California.....	211	$0.41 + .2741 X$	42.62	0.97	0.07
North-Central Baja California.....	438	$-1.32 + .2877 X$	42.98	1.37	0.07
South-Central Baja California.....	104	$4.96 + .2427 X$	42.34	1.20	0.12
Southern Baja California.....	128	$11.67 + .2089 X$	43.81	0.95	0.09
Gulf of California.....	228	$4.24 + .2569 X$	43.80	1.02	0.07
Galapagos Islands.....	15	$10.01 + .2292 X$	45.31	0.77	0.20

Large (188 mm SL)

Central California.....	258	$15.70 + .1850 X$	50.48	1.01	0.06
Southern California.....	553	$7.38 + .2273 X$	50.11	1.46	0.06
Northern Baja California.....	74	$9.51 + .2216 X$	51.17	1.06	0.12
North-Central Baja California.....	244	$13.52 + .2045 X$	51.97	1.64	0.10
South-Central Baja California.....	177	$2.70 + .2625 X$	52.05	1.39	0.10
Southern Baja California.....	0				
Gulf of California.....	110	$0.75 + .2708 X$	51.66	1.11	0.11
Galapagos Islands.....	0				

N = Sample Size
 X = Standard Length
 \bar{Y} = Mean Character Length
 S_y = Standard Deviation from Regression
 SE = Standard Error

APPENDIX III—Post Pelvic Length

Small (126 mm SL)

Area	N	Regression Equation	\bar{Y}	Sy	SE
Central California.....	0				
Southern California.....	87	$-0.21 + .5011 X$	62.89	1.87	0.20
Northern Baja California.....	0				
North-Central Baja California.....	325	$-8.38 + .5667 X$	63.02	1.50	0.09
South-Central Baja California.....	202	$-0.06 + .4998 X$	62.91	1.17	0.08
Southern Baja California.....	112	$0.18 + .4928 X$	62.27	1.37	0.13
Gulf of California.....	154	$-4.47 + .5265 X$	61.87	1.59	0.13
Galapagos Islands.....	28	$-7.01 + .5430 X$	61.41	1.23	0.23

Medium (154 mm SL)

Central California.....	0				
Southern California.....	258	$-2.37 + .5167 X$	77.20	1.84	0.11
Northern Baja California.....	211	$4.52 + .4698 X$	76.86	2.46	0.17
North-Central Baja California.....	438	$4.05 + .4713 X$	76.63	1.94	0.09
South-Central Baja California.....	104	$4.18 + .4752 X$	77.36	2.10	0.21
Southern Baja California.....	128	$-8.41 + .5489 X$	76.12	1.67	0.15
Gulf of California.....	228	$5.31 + .4593 X$	76.04	1.85	0.12
Galapagos Islands.....	15	$-14.36 + .5834 X$	75.48	1.58	0.41

Large (188 mm SL)

Central California.....	258	$-11.85 + .5727 X$	95.82	2.32	0.14
Southern California.....	553	$-4.69 + .5289 X$	94.74	2.22	0.10
Northern Baja California.....	74	$-12.23 + .5654 X$	94.07	2.56	0.30
North-Central Baja California.....	244	$-3.29 + .5095 X$	92.50	2.39	0.15
South-Central Baja California.....	177	$5.22 + .4686 X$	93.32	2.13	0.16
Southern Baja California.....	0				
Gulf of California.....	110	$-4.29 + .5200 X$	93.47	1.91	0.18
Galapagos Islands.....	0				

APPENDIX IV—Pectoral Fin Length

Small (126 mm SL)

Area	N	Regression Equation	\bar{Y}	S_y	SE
Central California	0				
Southern California	87	$-1.31 + .1809 X$	21.48	1.07	0.11
Northern Baja California	0				
North-Central Baja California	325	$3.15 + .1466 X$	21.62	0.75	0.04
South-Central Baja California	202	$1.99 + .1554 X$	21.57	0.71	0.05
Southern Baja California	112	$1.24 + .1615 X$	21.59	0.93	0.08
Gulf of California	154	$6.32 + .1347 X$	23.29	0.75	0.06
Galapagos Islands	28	$-1.93 + .1902 X$	22.03	0.80	0.15

Medium (154 mm SL)

Central California	0				
Southern California	258	$4.54 + .1386 X$	25.88	0.99	0.06
Northern Baja California	211	$3.98 + .1469 X$	26.60	0.95	0.07
North-Central Baja California	438	$2.33 + .1543 X$	26.09	1.09	0.05
South-Central Baja California	104	$2.43 + .1522 X$	25.87	0.89	0.09
Southern Baja California	128	$9.34 + .1112 X$	26.46	0.93	0.08
Gulf of California	228	$3.50 + .1540 X$	27.22	0.96	0.07
Galapagos Islands	15	$0.79 + .1669 X$	26.49	0.79	0.20

Large (188 mm SL)

Central California	258	$6.65 + .1281 X$	30.73	1.39	0.09
Southern California	553	$3.45 + .1451 X$	30.73	1.28	0.06
Northern Baja California	74	$9.79 + .1161 X$	31.62	1.11	0.13
North-Central Baja California	244	$10.23 + .1110 X$	31.10	1.22	0.08
South-Central Baja California	177	$7.88 + .1211 X$	30.65	1.27	0.10
Southern Baja California	0				
Gulf of California	110	$-3.46 + .1902 X$	32.30	1.08	0.10
Galapagos Islands	0				

APPENDIX V—Gill Rakers

Small (36 mm HL)

Area	N	Regression equation	\bar{Y}	S_y	SE
Central California	0				
Southern California	87	15.92 + .6157 X	37.38	1.73	0.19
Northern Baja California	0				
North-Central Baja California	325	15.15 + .6132 X	36.52	1.52	0.09
South-Central Baja California	202	19.67 + .4881 X	36.69	1.39	0.10
Southern Baja California	112	8.06 + .7608 X	35.45	2.00	0.19
Gulf of California	151	20.19 + .4838 X	37.05	1.51	0.12
Galapagos Islands	28	19.16 + .4634 X	35.31	1.41	0.27

Medium (43 mm HL)

Central California	0				
Southern California	258	28.43 + .2984 X	41.26	1.74	0.11
Northern Baja California	211	22.37 + .4332 X	40.99	1.59	0.11
North-Central Baja California	438	19.78 + .4970 X	41.14	1.60	0.08
South-Central Baja California	104	20.07 + .4718 X	40.35	1.73	0.17
Southern Baja California	128	26.96 + .3294 X	41.12	1.69	0.15
Gulf of California	228	23.60 + .3942 X	40.55	1.96	0.08
Galapagos Islands	15	31.12 + .1819 X	38.94	1.50	0.39

Large (51 mm HL)

Central California	258	19.34 + .4949 X	44.90	1.58	0.10
Southern California	553	23.14 + .4049 X	44.66	1.79	0.08
Northern Baja California	74	12.76 + .6222 X	41.99	1.56	0.18
North-Central Baja California	244	23.39 + .4176 X	44.96	1.87	0.11
South-Central Baja California	177	22.29 + .4259 X	44.04	1.73	0.13
Southern Baja California	0				
Gulf of California	110	23.41 + .3822 X	43.15	1.66	0.16
Galapagos Islands	0				

HL = head length.

CHECK LIST OF INTERTIDAL FISHES OF TRINIDAD BAY, CALIFORNIA, AND ADJACENT AREAS¹

JOHN R. MORING²

Department of Fisheries, Humboldt State College,
Arcata, California 95521

Intertidal fishes of Trinidad Bay, California, were sampled from May 1965 to May 1970. The 1,517 fishes collected represented 20 species. Three additional species were collected intertidally near Point St. George, Del Norte County. As no check lists of tidepool fishes of Humboldt and Del Norte counties are currently available, a check list is provided for Trinidad Bay species, with supplemental notes for adjacent regions.

INTRODUCTION

There have been few reviews and descriptions of intertidal fishes of the northern California coast. Most descriptions have been included in regional monographs and studies. Jordan and Evermann (1896, 1898) and other workers included intertidal fishes in early monographs. Rutter (1899) studied intertidal fishes of Kodiak Island, Alaska. Hubbs (1926) reviewed the intertidal cottid genera of the Pacific coast, and later discussed several intertidal blennioid fishes (Hubbs, 1927). Schultz (1936) included many intertidal fishes in his key to fishes of Washington, Oregon, and adjacent regions. Bolin (1944, 1947) discussed intertidal cottids, and Clemens and Wilby (1961) reviewed intertidal fishes of northern California in discussing fishes of the Pacific coast of Canada.

Several workers included brief descriptions of dominant northern California intertidal fishes in their reviews of fishes of other regions. Starks and Morris (1907) and Barnhart (1936) included intertidal fishes in their descriptions of fishes of southern California, and Evermann and Goldsborough (1907) included intertidal fishes in their review of fishes of Alaska. Intertidal residency of juvenile northern California fishes has been noted for *Scorpaenichthys marmoratus* (O'Connell, 1953) and *Sebastes mystinus* (Wales, 1952).

Gersbacher and Denison (1930), Williams (1957), and Green (1971) studied fish movement in the intertidal zone. Morris (1960) and Graham (1970) analyzed temperature sensitivity of several species, and Mitchell (1953), Johnston (1954), and Nakamura (1971) reviewed food habits of many dominant northern California tidepool fishes. Other studies, including those by Hubbs and Barnhart (1944), Schultz (1944), and Briggs (1955), are helpful in considering distributional patterns.

Two workers have concentrated solely upon enumerating and describing California tidepool fishes (Greeley, 1899; Bolin, 1964). However, both based their discussions upon central California intertidal fishes. There have been no reviews of tidepool fishes of Trinidad Bay, California, or adjacent regions along the coasts of Humboldt and Del Norte

¹ Taken in part from a Master of Science thesis submitted to the faculty, Humboldt State College. Accepted for publication January 1972.

² Present address: Fisheries Research Institute, University of Washington, Seattle, Washington.

counties. It is the purpose of this paper to provide a check list of the intertidal fishes of Trinidad Bay, and furnish notes on other intertidal species from adjacent regions.

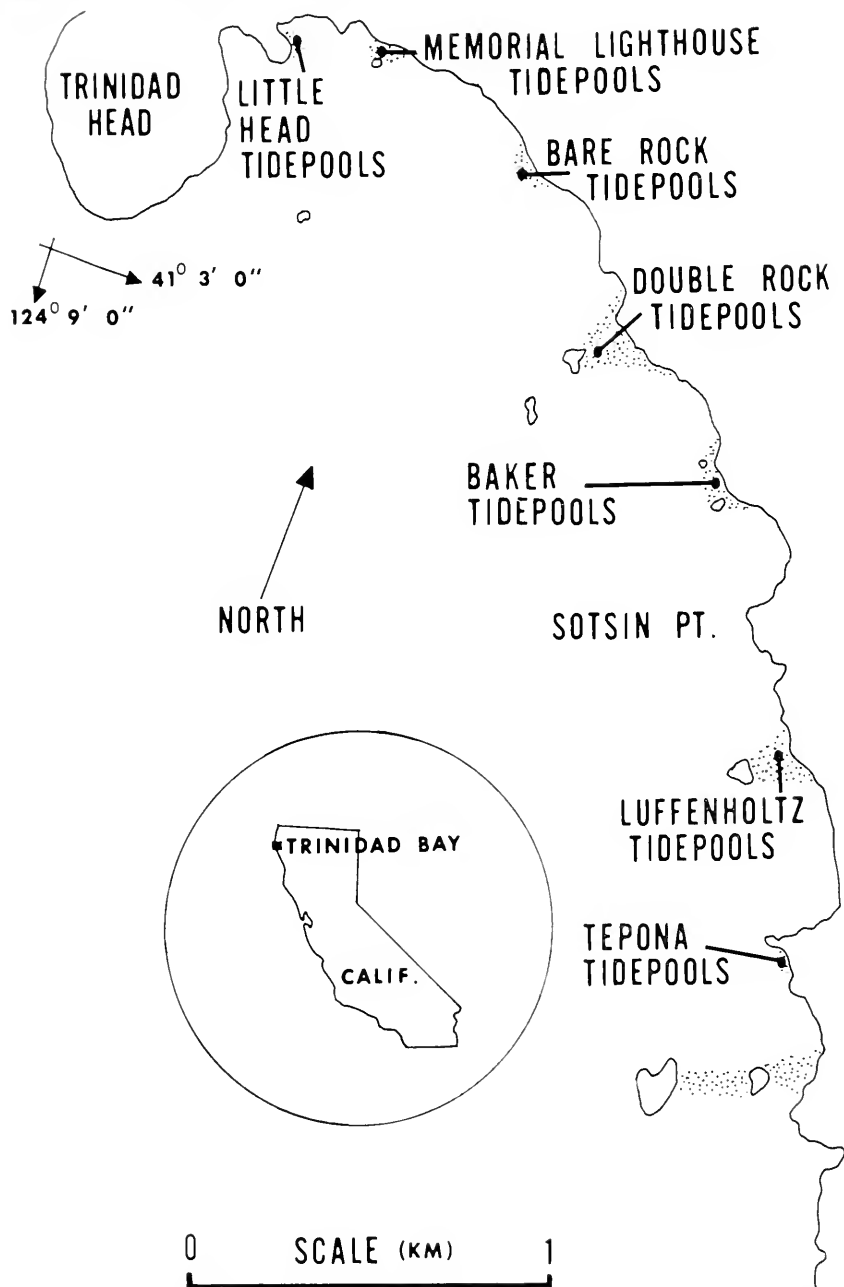

FIGURE 1. Trinidad Bay, California: site of intertidal fish sampling, May 1965 to May 1970.

COLLECTION

Trinidad Bay, California, is located approximately 14 miles north of Humboldt Bay, at lat 41° 31' N; long 124° 8' W (Figure 1). It is semi-protected, and characterized by rocky shores with scattered tidepools. Tidepools were sampled at several areas within the bay for intertidal fishes: Tepona, Luffenholtz, Baker, Double Rock Tidepools, Bare Rock Tidepools, Memorial Lighthouse and Little Head. Tidepool areas, in most cases, have been identified herein by their proximity to certain geographical landmarks in Trinidad Bay.

Between May 1965 and May 1970, 1,517 intertidal fishes were collected and measured during 53 collecting trips. Twenty species were identified in Trinidad Bay. Fishes ranged from 10 to 180 mm TL, averaging 49.4 mm. Of the 20 species collected, six occurred intertidally only as juveniles (*Citharichthys stigmaeus*, *Hemilepidotus spinosus*, *Hexagrammos decagrammus*, *Scorpaenichthys marmoratus*, *Sebastes melanops*, and *S. mystinus*), and these were generally seasonal in appearance.

Specimens were collected with a variety of hand nets and small seines. Fishes were anesthetized with quinaldine for ease in handling during measurement (Moring, 1970).

Intertidal fishes were also collected and measured from April 1967 to March 1970 from tidepools near Cape Mendocino, Pewetole Island (north of Trinidad State Beach), Patricks Point State Park, and Point St. George. Such sampling provided opportunities for examining fishes from varying intertidal environments.

SPECIES COLLECTED

The twenty intertidal species noted for Trinidad Bay, and the additional species collected in Humboldt and Del Norte counties, by no means complete the check list for intertidal species in northern California. Undescribed fish species may exhibit restrictions of habitat, low density in tidepools, or seasonal availability. The check list included in Table I attempts to provide a basis for further collection and enumeration of Humboldt and Del Norte county species. Reference to keys and descriptions by Schultz (1936), Bolin (1944, 1964), and Clemens and Wilby (1961) will supplement the check list.

Other Species

Additional intertidal species were collected from tidepools along the coasts of Humboldt and Del Norte counties. Some or all of these species may occur in Trinidad Bay, but are either uncommon, restricted in habitat, or seasonal in appearance.

Embiotocidae: Three juvenile *Embiotoca lateralis* (77, 78, and 79 mm TL) were collected in July 1969 in tidepools near Point St. George, Del Norte County.

Scorpaenidae: A single *Sebastes paucispinis* (88 mm TL) was collected in July 1969 near Point St. George. It was schooling in a deep tidepool with juvenile *S. melanops* and *S. mystinus*.

Cottidae: Several additional species of cottids may be found in Trinidad Bay. Bolin (1944) reported *Aselelichthys rhodorus* and *Oligocottus rimensis* from Crescent City. He noted the latter species was

TABLE 1—Check List of Intertidal Fish Species Collected, and Their Size Ranges in Trinidad Bay, California, During May 1965 to May 1970.

Species	Tidepool areas							Total collected	Size range (mm TL)
	Tepona	Langenholtz	Baker	Double-Rock	Rare-Rock	Memorial Light-house	Little Head		
Gobiesocidae:									
<i>Gobiosox macandricus</i>	x	x	x	x		x	x	77	25-91
Stichaeidae:									
<i>Anoplarchus purpureocens</i>		x	x			x		21	35-110
<i>Cebidichthys vulnaceus</i>		x						*	*
<i>Xiphister atropurpureus</i>		x	x	x		x		38	26-189
Pholidae:									
<i>Apodichthys flavidus</i>		x	x	x				11	48-170
<i>Pholis ornata</i>			x					1	61
<i>Xerocpes fuorum</i>		x	x					15	46-155
Scorpaenidae:									
† <i>Sebastes melanops</i>		x	x					71	42-65
† <i>Sebastes mystinus</i>			x					1	58-80
Hexagrammidae:									
† <i>Hexagrammos decagrammos</i>		x	x					7	65-75
Cottidae:									
<i>Artedius fenestralis</i>	x							1	47
<i>Artedius lateralis</i>		x	x					2	119-126
<i>Clinocottus acuticeps</i>			x		x			5	22-41
<i>Clinocottus globiceps</i>		x	x					5	42-136
† <i>Hemilepidotus sp.</i>		x						2	34-36
<i>Oligocottus maculosus</i>	x	x	x	x	x	x	x	1,031	10-95
<i>Oligocottus snyderi</i>		x	x	x		x		191	13-101
† <i>Scorpaenichthys macleodii</i>		x	x		x	x		24	33-134
Cyclopteridae:									
<i>Liparis florae</i>						x		2	26-98
Bothidae:									
† <i>Chthareichthys stansburii</i>			x					6	47-62

* One specimen, approximately 1 m TL, not measured.

† Juveniles.

uncommon, *Leptocottus armatus*, a common subtidal species in Trinidad Bay, has been reported intertidally in central California (Bolin, 1964), Tomales Bay (Jones, 1962), and British Columbia (Clemens and Wilby, 1961).

Pleuronectidae: A juvenile *Parophrys vetulus* (26 mm TL) was collected in May 1969 from a sand-mud bottomed tidepool near Point St. George. A larger juvenile (43 mm TL) was collected in the same area in July 1969. The only apparent previous literature record of young *P. vetulus* found in tidepools was by Villalobid (1927) concerning early collections by Hubbs. Hubbs (pers. comm.) collected one juvenile *P. vetulus* (20 mm SL) in June 1923 from tidepools near Point St. George. Hubbs reported other intertidal collecting of *P. vetulus* juveniles along the San Luis Obispo County coast.

ACKNOWLEDGMENTS

Special thanks are due David Misitano and my wife, Kathleen, for assisting me on many collecting trips over the past years.

Carl L. Hubbs of Scripps Institution of Oceanography kindly supplied field notes and other information concerning his intertidal collections. George H. Allen, of Humboldt State College reviewed the manuscript, and offered helpful suggestions throughout the course of the study.

REFERENCES

- Barnhart, P. S. 1936. Marine fishes of southern California. Univ. California Press, Berkeley, 209p.
- Bolin, R. L. 1944. A review of the marine cottid fishes of California. Stanford Ichthyol. Bull. 3(1) : 1-135.
- . 1947. The evolution of the marine Cottidae of California with a discussion of the genus as a systemic category. Stanford Ichthyol. Bull. 3(3) : 153-168.
- . 1964. Key to intertidal fishes. In S. F. Light, R. I. Smith, F. A. Pitelka, D. P. Abbott, and F. M. Weesner, Intertidal invertebrates of the central California coast. Univ. California Press, Berkeley : 313-322.
- Briggs, J. C. 1955. A monograph of the clingfishes (Order Xenopterygii). Stanford Ichthyol. Bull. 6, 224p.
- Clemens, W. A., and G. V. Wilby. 1961. Fishes of the Pacific coast of Canada. Fish. Res. Bd. Canada Bull. (68) 2nd ed. : 1-443.
- Evermann, B. W., and E. L. Goldsborough. 1907. The fishes of Alaska. U.S. Bur. Fish. Bull. 26 (1906) : 219-360.
- Gersbacher, W. M. and M. Denison. 1930. Experiments with animals in tide-pools. Publ. Puget Sound Mar. Biol. Sta. 7:209-215.
- Graham, J. B. 1970. Temperature sensitivity of two species of intertidal fishes. Copeia 1970(1) : 49-56.
- Greeley, A. W. 1899. Notes on the tide-pool fishes of California, with a description of four new species. Bull. U.S. Fish. Comm. 19 : 7-20.
- Green, J. M. 1971. High tide movements and homing behaviour of the tidepool sculpin *Oligocottus maculosus*. J. Fish. Res. Bd. Canada 28(3) : 383-389.
- Hubbs, C. L. 1926. A revision of the fishes of the Subfamily Oligocottinae. Occ. Papers Mus. Zool., Univ. Michigan 7(171). 18p.
- . 1927. Notes on the blennioid fishes of western North America. Papers Michigan Acad. Sci., Arts, and Letters 7 : 351-394.
- , and P. S. Barnhart. 1944. Extensions of range for blennioid fishes in southern California. Calif. Fish and Game 30(1) : 49-51.
- Johnston, R. F. 1954. The summer food of some intertidal fishes of Monterey County, California. Calif. Fish and Game 40(1) : 65-68.
- Jones, A. C. 1962. The biology of the euryhaline fish *Leptocottus armatus armatus* Girard (Cottidae). Univ. California Publ. Zool. 67(4) : 321-368.
- Jordan, D. S. and B. W. Evermann. 1896. A checklist of the fishes and fish-like vertebrates of North and Middle America. Rep. U.S. Comm. Fish. (1895), Appendix 5 : 207-584.
- . 1898. The fishes of North and Middle America. Bull. U.S. Nat. Mus. 47 (Part II) : 1241-2183.
- Mitchell, D. F. 1953. An analysis of stomach contents of California tide pool fishes. Amer. Midl. Nat. 49 : 862-871.
- Moring, J. R. 1970. Use of the anesthetic quinaldine for handling Pacific coast intertidal fishes. Trans. Amer. Fish. Soc. 99(4) : 802-805.
- Morris, R. W. 1960. Temperature, salinity, and southern limits of three species of Pacific cottid fishes. Limnol. and Oceanogr. 5(1) : 175-179.
- Nakamura, R. 1971. Food of two cohabiting tide-pool Cottidae. J. Fish. Res. Bd. Canada 18(6) : 928-932.
- O'Connell, C. P. 1953. The life history of the cabezon, *Scorpaenichthys marmoratus* (Ayres). Calif. Dep. Fish and Game, Fish Bull. (93) : 1-76.
- Rutter, C. 1899. Notes on a collection of tide-pool fishes from Kadiak (sic) Island in Alaska. Bull. U.S. Fish. Comm. 18(1898) : 189-192.
- Schultz, L. P. 1936. Keys to the fishes of Washington, Oregon, and closely adjoining regions. Univ. Washington Publ. Biol. 2(4) : 163-228.
- . 1944. A revision of the American clingfishes. Family Gobiesocidae, with descriptions of new genera and forms. Proc. U.S. Nat. Mus. 96(3187) : 47-77.

- Starks, E. C. and E. L. Morris. 1907. The marine fishes of southern California. Univ. California Publ. Zool. 3(1) : 159-251.
- Villadolid, D. V. 1927. The flatfishes (Heterosomata) of the Pacific coast of the United States. Ph.D. dissertation, Stanford University, Stanford. 332p.
- Wales, J. H. 1952. Life history of the blue rockfish, *Sebastes mystinus*. Calif. Fish and Game 38(4) : 485-498.
- Williams, G. C. 1957. Homing behavior of California rocky shore fishes. Univ. California Publ. Zool. 59(7) : 249-284.

NOTES

TWO NEW SEA URCHIN-ACORN BARNACLE ASSOCIATIONS

On August 25, 1970, John Duffy, Bob Hardy, and Jack Ames collected a purple sea urchin, *Strongylocentrotus purpuratus* (Stimpson), off Mussel Shoal, Ventura County, California. This 66 mm urchin, (Figure 1) living on a rocky substrate at a depth of 15 ft, had an acorn barnacle, *Balanus concavus pacificus* Pilsbry, attached to the surface of its test.

On October 12, 1970, Reinholt Banek, Fish and Wildlife seasonal aid, collected a red sea urchin, *Strongylocentrotus franciscanus* (Agassiz), 1 mile south of Davenport Landing, Santa Cruz County,

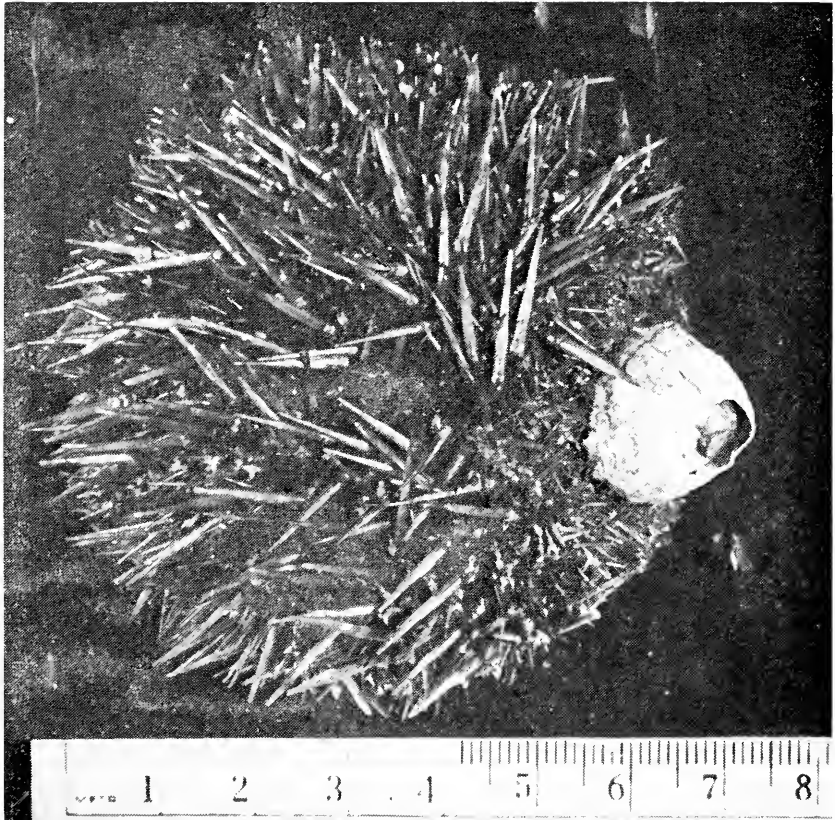

FIGURE 1. The acorn barnacle *Balanus concavus pacificus* attached to the purple sea urchin, *Strongylocentrotus purpuratus*. Photograph by John Duffy and Jack Ames.

California. The urchin test measured 124 mm (204 mm including spines), and was collected in a rocky, sandy area at a depth of 40 ft. Attached to the urchin was a large barnacle *Balanus nubilis* Darwin measuring 41 mm basal width (Figure 2).

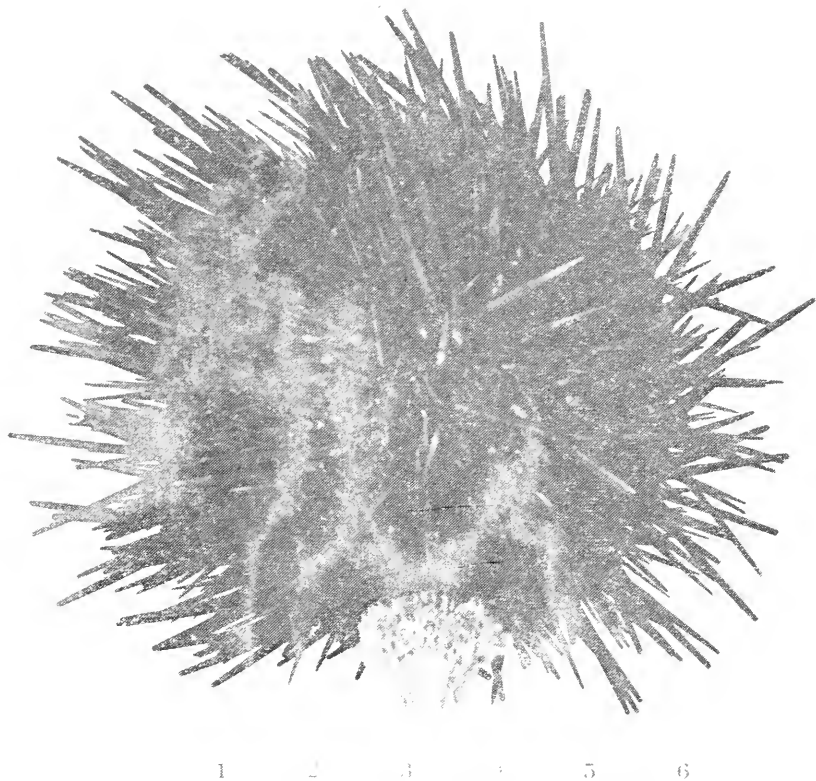

FIGURE 2. The large barnacle, *Balanus nubilis* attached to the red sea urchin, *Strongylocentrotus franciscanus*. Photograph by John Geibel.

To our knowledge only two reports of growths on urchins have been published. Strachan (1969) reported *Balanus tintinnabulum californicus* Pilsbry living on *Lytichinus anamesus* H. L. Clark. Boolootian (1958) reported the same species of barnacle living on the red sea urchin, *Strongylocentrotus franciscanus* (Agassiz).

The attachment of *B. concavus pacificus* to *S. purpuratus* represents the first report of any barnacle attaching to *S. purpuratus*. It also represents the first report of *B. concavus pacificus* attaching to any urchin. *Strongylocentrotus franciscanus* has been reported in the literature as harboring the barnacle *B. tintinnabulum californicus*. However, the attachment of *B. nubilis* to *S. franciscanus* represents the first report of *B. nubilis* attaching to any urchin.

Since this note was submitted, two Department of Fish and Game biologists have called other urchin-barnacle associations to our attention. R. A. Hardy noted three, *S. purpuratus* encrusted with unidentified barnacles at Point Fermin San Pedro, and M. W. Odemar reported a large number of both *S. purpuratus* and *S. franciscanus* harboring barnacles at Point Dume, Los Angeles County.

REFERENCES

- Booolootian, R. A. 1958. Notes on an unexpected association between a common barnacle and echinoid. So. Calif. Acad. Sci., Bull. 57(2):91-92.
- Light, S. F., R. I. Smith, F. A. Pitelka, D. P. Abbott and F. M. Weesner. 1964. Intertidal invertebrates of the central California coast. U. C. Press, Berkeley. 446 p.
- Strachan, A. R. 1970. A white sea urchin-acorn barnacle enigma. Calif. Fish and Game 56(2):134-135.
- James L. Houk and John M. Duffy. *Marine Resources Region, California Department of Fish and Game. Accepted for publication February 1972.*

NEW HOSTS AND BATHYMETRIC RANGE EXTENSION FOR COLOBOMATUS EMBIOTOCAE (CRUSTACEA, COPEPODA)

In July and August, 1971, the *R/V Searcher*, while otter trawling in Monterey and Bodega bays, for the California Academy of Sciences recovered 131 pink seaperch, *Zalambius rosaceus*, and five spotfin surfperch, *Hyperprosopon anale*. Eleven, or 13.4%, of the 82 adult pink seaperch were parasitized by the philichthyid copepod, *Colobomatus embiotocae* Nobel, Collard and Wilkes, 1969. Two of the five spotfin surfperch were parasitized by the copepod. The occurrence of *C. embiotocae* on the pink seaperch and spotfin surfperch represents two new host records for this parasite, which was previously known from nine other species of embiotocids (Nobel et al. 1969).

C. embiotocae is found under the thick cartilaginous skin covering the bony ridges of the head, and in the cephalic sensory canal system (Nobel et al. 1969). In this study, female copepods were recovered only from the preopercular section of the preopercular-mandibular canal (terminology follows Freilhofer, pers. comm.); see Figure 1.

The pink seaperch occupies a habitat distinct from the characteristic intertidal and shallow subtidal inshore habitat of other embiotocids. It occurs commonly between 15 to 50 or more fathoms, and rarely enters shallow water (Roedel, 1953). De Martini (1969) reported that the pink seaperch is a benthonic feeder, with the principal foods being gastropods and gammarid amphipods; pelecypods and small fish make up a minor portion of the diet. Examination of the stomach contents from six of the pink seaperch revealed a similar dependence on the benthos. Identifiable molluscan fragments included in the gastropods *Nassarius medicus*, *Olivella* sp. and *Turbonilla* sp., the scaphopods *Cadulus fusiiformis*, and *Dentalium pretiosum*, and the pelecypods *Nuculana taphria*

and *Lasaca cystula*. Based on the feeding of the pink seaperch on benthic molluscs, it seems reasonable to conclude that these fish were trawled on or near the bottom, thus extending the bathymetric range of *C. embiotocae* from near-shore shallow water (Nobel et al. 1969) to a depth of 40 fathoms.

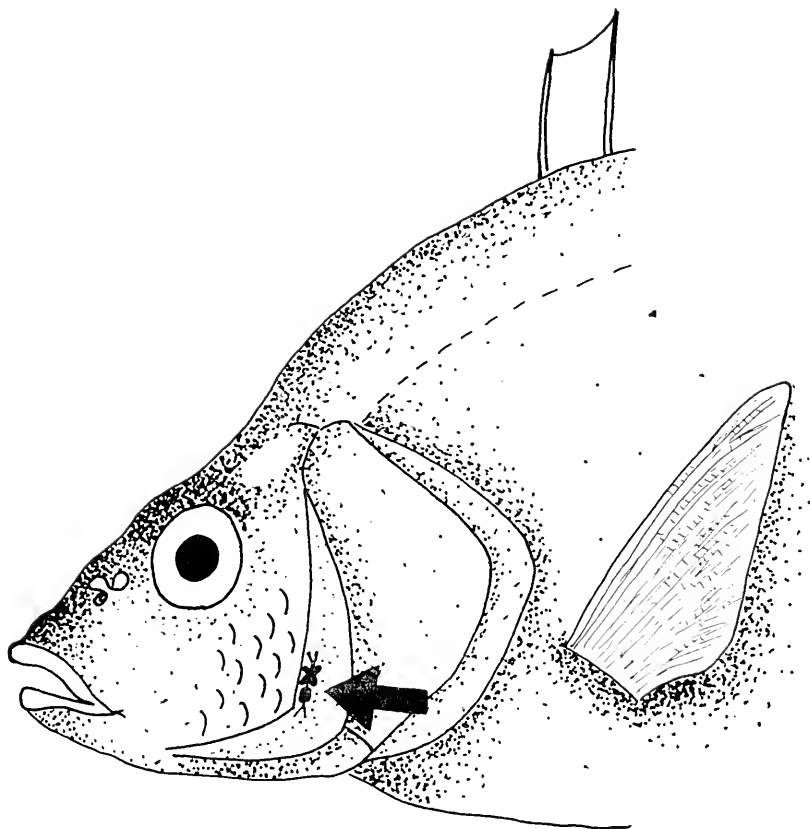

FIGURE 1. *Colobomatus embiotocae* in the preopercular section of the preopercular-mandibular canal. Copepod is a little longer than normal.

Young of the year pink seaperch, perhaps 2 or 3 months old, were found at every station producing pink seaperch, except Station 3 (Table 1). At Station 2 (20 fathoms), young of the year pink seaperch composed over two-thirds of the pink seaperch taken at that station. Pink seaperch in this age group were not parasitized, and therefore have not been included in the calculation of the rate of infection. All of the copepods recovered were ovigerous females, except one from the pink seaperch and two from the spotfin surfperch. Male copepods were not observed. Equal infection rates were found at Monterey Bay (Station 1) and a month later at Bodega Bay (Station 3 and 4).

Spotfin surfperch are found typically along sandy beaches of the outer coast. Isaacson and Pool (1965) reported spotfin surfperch be-

tween 25 and 37 fathoms in the Bodega Bay region. The *R/V Scarcher* trawled five specimens in one tow off the mouth of Tomales Bay in 10 fathoms of water. Pink seaperch were not taken at this station.

Twelve eopepods have been deposited in the Department of Invertebrate Zoology, California Academy of Sciences, Golden Gate Park, San Francisco, California and three specimens in the Smithsonian Institution.

TABLE 1—Collection Data and Infection Rates of the Parasitic Copepod *Colobomatus embiotocae* on the Pink Seaperch.

Station number	Number of pink seaperch trawled	Number of young of the year	Number of adults	Number of adults parasitized	Rate of infection %
Station 1 Monterey Bay, 4-6 miles WNW of Elkhorn Slough, 30-40 fathoms.....	35	5	30	4*	13.3
Station 2 Bodega Bay, 2.5 miles W of Dillon Beach 20 fathoms.....	54	39	15	2	13.3
Station 3 Off Bodega Bay, 3-4 miles W of Tomales Bay, 30 fathoms.....	17	0	17	2	11.8
Station 4 Off Bodega Bay, 3 miles SW of Bodega Head, 40 fathoms.....	25	5	20	3*	15.0
Total.....	131	49	82	11	13.4

* A bilateral infection was found on one fish from these stations.

ACKNOWLEDGMENTS

I am indebted to the Janss Foundation, Thousand Oaks, California, and to Dr. Earl Herald, Steinhart Aquarium, California Academy of Sciences, for the ship time aboard the *R/V Scarcher*. Mr. Dustin Chivers and Mr. James Carlton offered many helpful suggestions throughout the preparation of this paper, and Mr. Allyn G. Smith kindly identified the molluscan material. Dr. Warren C. Freihofer provided the name of the ephalie sensory canal.

REFERENCES

- De Martini, Edward E. 1969. A correlative study of the ecology and comparative feeding mechanism morphology of the Embiotocidae (surf-fishes) as evidence of the family's adaptive radiation into available ecological niches. *Wasman J. Biol.* 27(2) : 177-247.
- Isaacson, Peter A. and Richard L. Pool. 1965. New northern records for the spotfin surfperch, *Hyperprosopon anale*. *California Fish Game* 51(1) : 47.
- Nobel, Elmer R., Sneed B. Collard, and Stanley N. Wilkes. 1969. A new phyllichthyid copepod parasitic in the mucous canals of surfperches (Embiotocidae). *J. Parasitol.* 55(2) : 435-442.
- Roedel, Phil M. 1953. Common ocean fishes of the California coast. *Calif. Dep. of Fish and Game, Fish Bull.* (91) : 1-184.
- Ernest W. Iverson, *Skaggs Island, Sonoma, California 95476. Accepted for publication April 1972.*

SOUTHERN RANGE EXTENSION FOR THE YELLOWFIN GOBY, *ACANTHOGOBIUS FLAVIMANUS* (TEMMINCK AND SCHLEGEL)

Four specimens of the yellowfin goby, *Acanthogobius flavimanus* have been collected from Elkhorn Slough, Monterey County, California. Brittan, et al. (1963) first reported its occurrence in California waters from the San Joaquin River. Since this report, the yellowfin goby has spread throughout the San Francisco Bay-Delta area and has recently been reported from Bolinas Lagoon. (Brittan, et al. 1970).

The first specimen from Elkhorn Slough was collected by L. J. Hendricks of San Jose State College, 17 July 1970. It was collected with a beach seine in the northern arm of Elkhorn Slough near the Elkhorn Yacht Club. It has a standard length of 155 mm (196 mm TL) and is deposited in the fishes collection at San Jose State College (SJSJC no. ES-39).

The second specimen was collected by Larry Wade of Moss Landing Marine Laboratories on 13 July 1971, by hand from Bennett Slough (a northern extension of the northern arm of Elkhorn Slough) near the locality of capture of the first specimen. The standard length is 177 mm (231 mm TL). It has been deposited in the fishes collection at Moss Landing Marine Laboratories (MLML no. ES-27).

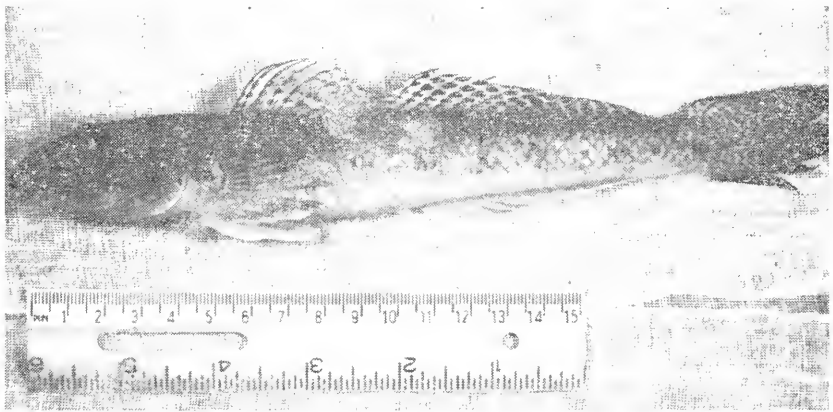

FIGURE 1. Yellowfin goby, *Acanthogobius flavimanus*, 186 mm SL, collected from Elkhorn Slough near Kirby Park, Monterey County, by G. Victor Morejohn. Photograph by the author, March 1972.

The other two specimens were collected by G. Victor Morejohn of Moss Landing Marine Laboratories on 8 October 1971, by seine in the upper reaches of Elkhorn Slough near Kirby Park. Their standard lengths are 186 mm and 132 mm (235 mm and 162 mm TL) and also have been deposited at Moss Landing Marine Laboratories (MLML nos. ES-29 and T-75). Figure 1 is a photograph of the larger specimen (MLML no. ES-29).

Brittan, et al. (1970) discussed three possible methods of introduction of the yellowfin goby into Bolinas Lagoon from San Francisco Bay: migration, discard of baitfish and transport in a ship's sea water system. One or a combination of these methods is probably responsible for the introduction of the yellowfin goby into Elkhorn Slough. Since no vessels visiting the Orient anchor near the mouth of Elkhorn Slough, the source of the introduction may be a natural dispersion of the species population of San Francisco Bay.

ACKNOWLEDGMENT

Support for this note was provided by NOAA Office of Sea Grant, Department of Commerce at the Moss Landing Marine Laboratories of the California State Universities.

REFERENCES

- Brittan, Martin R., Arnold B. Albrecht, and John B. Hopkirk. 1963. An oriental goby collected in the San Joaquin River Delta near Stockton, California. *Calif. Fish Game* 49(4) : 302-304.
- Brittan, Martin R., John D. Hopkirk, Jerrold D. Connors, and Michael Martin. 1970. Explosive spread of the oriental goby *Acanthogobius flavimanus* in the San Francisco Bay-Delta region of California. *Proc. Calif. Acad. Sci.*, ser. 4, 38(11) : 207-214.
- Gary E. Kukowski, *Moss Landing Marine Laboratories, Moss Landing, California 95039. Accepted for publication April 1972.*

CALIFORNIA CONDOR SURVEY, 1971

The seventh annual California condor (*Gymnogyps californianus*) survey was conducted on October 13 and 14, 1971. Survey methods and evaluation procedures were essentially the same as has been reported in past surveys (Malette, et al., 1966, 1967, 1970, 1972, Sibley, et al., 1968, 1969). Eighteen observation stations were manned during the survey, an increase of two over 1970; however, the number of observers remained the same at 45. Observation stations were manned from noon until condor activity ceased, normally around 5:00 PM. No baiting was attempted. Weather on October 13, was low overcast and fog in the Tehachapi Mountain area and clear skies in the Sespe Condor Sanctuary and vicinity. Winds were calm. Temperatures ranged from 68 F on Frazier Mountain to 98 F in the Sespe Condor Sanctuary. Weather on October 14, was clear with gusty winds to 20 mph in the Tehachapi Mountain area with visibility of zero in the Sespe Condor Sanctuary due to fog. Temperatures ranged from 60 F on Frazier Mountain to 77 F on Grapevine Peak.

An analysis of the sightings was made to eliminate duplication and indicated a minimum of 29 individual condors were seen on October 13, and 34 on October 14. The age structure for October 14, was 28 adults, 4 immatures and 2 unclassified. Only the Tehachapi portion of the population was counted as no sightings were reported from the Sespe Condor Sanctuary on October 14. It is believed no exchange of

birds occurred between these two areas on this day. Other raptors observed were:

Species	Numbers	
	10/13/71	10/14/71
Turkey vulture (<i>Cathartes aura</i>).....	605	153
Golden eagle (<i>Aquila chrysaetos</i>).....	46	48
Sharp-shinned hawk (<i>Accipiter striatus</i>).....	3	4
Cooper's hawk (<i>A. cooperi</i>).....	11	5
Red-tailed hawk (<i>Buteo jamaicensis</i>).....	55	48
Swainson's hawk (<i>B. swainsoni</i>).....	0	2
Ferruginous hawk (<i>B. regalis</i>).....	2	1
Sparrow hawk (<i>Falco sparverius</i>).....	11	26
Prairie falcon (<i>F. mexicanus</i>).....	1	0
Peregrine falcon (<i>F. peregrinus</i>).....	0	3
Marsh hawk (<i>Circus cyaneus</i>).....	3	9
	737	299

A comparison of the data collected over the past seven surveys indicates that the condor population has remained fairly constant during this time. Fluctuations of the total number seen during the 1965 through 1971 surveys is more an indication of weather conditions during the survey days than it is of any major changes in the actual population structure.

REFERENCES

- Mallette, Robert D. and John C. Borneman, 1966. First cooperative study of the California condor. California Fish Game 52(3) : 185-203.
- Mallette, Robert D., John C. Borneman, Fred Sibley and Raymon S. Dalen, 1967. Second cooperative survey of the California condor. California Fish Game 53(3) : 132-145.
- Mallette, Robert D., Fred C. Sibley, W. Dean Carrier and John C. Borneman, 1970. California condor surveys, 1969. California Fish and Game 56(3) : 199-202.
- Mallette, Robert D., Sanford Wilbur, W. Dean Carrier and John C. Borneman, 1972. California condor survey, 1970. California Fish Game 58(1) : 67-68.
- Sibley, Fred C., Robert D. Mallette, John C. Borneman and Raymond S. Dalen, 1968. Third cooperative survey of the California condor. California Fish Game 54(4) : 297-303.
- Sibley, Fred C., Robert D. Mallette, John C. Borneman, and Raymond S. Dalen, 1969. California condor surveys, 1968. California Fish Game 55(4) : 298-306.

—W. Dean Carrier, U.S. Forest Service; Robert D. Mallette, California Department of Fish and Game; Sanford Wilbur, Bureau of Sport Fisheries and Wildlife; John C. Borneman, National Audubon Society. Accepted for Publication July 1972. Supported by Federal Aid to Wildlife Restoration Project W-54-R "Special Wildlife Investigations." Prepared for and with approval of the Condor Technical Committee.

BOOK REVIEWS

Mountain Sheep: A Study in Behavior and Evolution.

by Valerius Geist; University of Chicago Press, 1971;
383 p. \$14.50

Valerius Geist used the behavior of mountain sheep as a tool to study the animal; thus this is not just another case of using the animal to study behavior. It is a book that deals with the evolutionary forces that have shaped the sheep's behavior patterns and developed the animal to what it is today.

There is something about mountain sheep that is extremely fascinating and challenging to study. Once exposed to this animal in the wild you are "hooked," something akin to gold fever. Whether you are a "hooked" student, photographer, or hunter of mountain sheep or not, I recommend this book. You will find his approach unique. He has deliberately slighted some ecological factors and management or conservation considerations, instead concentrating on developing a comprehensive theory of mountain sheep evolution. Yet the information developed will be very useful in giving administrators the understanding of the animal necessary in developing and implementing necessary management programs.

If you are not a professional wildlifer and you think the graphs, charts, and formula are beyond your comprehension, do as the author suggests: first read Chapter 1 and the conclusions in Chapter 12, then Chapters 5 and 11, and then the introductions to the remaining chapters.

I waited anxiously the availability of this book for I had the good fortune of discussing sheep with Dr. Geist in Bishop, California, where he was the invited speaker of the Desert Bighorn Council in April 1970. I also got to view some of the 16 mm film taken during his studies. He mentions these films in the preface where information is given on how to purchase or borrow them. I believe these films should be viewed to augment the knowledge you can gain from the book. The 89 black and white plates in the book give you an indication of the quality of the pictures taken during his 3½ years in the field with the Stone, the Dall, and Rocky Mountain bighorn. The pictures, all taken at close range, will also let you appreciate the incredible feat of conducting a study of wild free-ranging mountain sheep at all seasons of the year.

This book will be the sheep biologists' bible for many years to come. His methods for recording quantitative behavioral data with a minimum of subjective evaluation will be copied by many. For those of you who will buy the book and use it as reference there is a very good index.

Dr. Geist has answered for me in Chapter 5, Tradition and Evolution of Social System, a paradox that I have been at a loss to explain. Wild sheep as a group have been very successful, spreading during the Pleistocene through most of the mountain ranges of the northern hemisphere. However, today sheep maintain their distribution as a living tradition and rarely will they fill empty suitable habitat. Today sheep in the western United States survive in a situation far different from that of the ideal bighorn habitat of post glacial period during which they evolved and developed behavior patterns. Sheep habitat is not as continuous today as it once was. Young sheep follow adults and adopt their habitat. Natural selection would be against dispersing animals wandering into unsuitable habitat.

—R. A. Weaver

Fishes of Montana

By C. D. J. Brawn; Big Sky Books, Montana State University, Bozeman, Montana; 1972.
207 p. Illustrated. \$4.50 paper.

There is a wealth of information in this book, of use to the professional fisheries worker as well as the interested angler or student. The information is logically presented. Short introductory sections describe the history of fish collections in Montana and the rivers, lakes and reservoirs and present a map of Montana showing major waters, and notes on the preservation of fish and the use of keys. There is a brief but complete glossary which identifies the few scientific terms used in language easily understood by the layman. Diagrams of a cutthroat trout and a largemouth bass are used to identify the major characters used in the keys.

There are keys to both family and genus, including all known Montana fishes. The keys are easy to use, with sketches showing outstanding features.

Eighteen families and 50 genera are included in the book. Information for each species includes: (i) both common and scientific names, (ii) a drawing or black-and-white photograph, (iii) a map of Montana showing collection locations, (iv) a brief description, (v) native range and, if not native to Montana, details of introductions, (vi) life history information (age and growth, spawning information, and food habits) and, (vii) a brief paragraph on the species abundance and importance for sport or forage. The book concludes with a reference section, an index of common and scientific names, a map of the major drainages of Montana, and a listing of all species discussed.—*K. A. Hashagen, Jr.*

Remembrances of Rivers Past

By Ernest Schweibert; The McMillan Company, N.Y., 1972. 287 p., illustrated. \$6.95.

This is the book for those long winter evenings next to the fire, when trout season is several months away. "Remembrances of Rivers Past" is a collection of 25 short stories about fly fishing for trout and salmon on rivers and streams throughout the world. The stories are Schweibert's reminiscences of past fishing experiences, some from his childhood, some quite recent. The waters he has fished are among the most famous waters of the world: the Little Manistee, Schoharie, Beaverkill, Neversink, Esopus, the Firehole, and the Letort. Salmon were taken in Norway, Labrador, and Iceland and huge trout in Tierra del Fuego and Argentina. The stories are well written, describing not only the fish caught or lost, but also his companions, native customs, and the history of the area. The reader can feel he is right with Schweibert, and considering some of the fish taken, certainly must wish he was. Many of the stories have been published previously in sporting magazines under different titles. In almost every story the author expresses concern for the environment, citing examples of prime waters destroyed by pollution, dams, or poor management. His obvious knowledge of trout, stream entomology, and tackle add to the authenticity of his recollections.—*K. A. Hashagen, Jr.*

A Trout and Salmon Fisherman for Seventy-Five Years

By Edward R. Hewitt; Van Cortlandt Press, Croton-On-Hudson, N.Y., 1972; XXIV + 338 p. illustrated. \$8.50.

Seventy-five years of a life devoted to fishing and, as quickly becomes apparent, little time spent on matters not related to fish or fishing. Obviously wealthy and opinionated, Mr. Hewitt records his observations on fish and fishing. He conducted detailed experiments on fish vision, color perception, and physiology. Tackle and techniques were developed, tested and modified. Anecdotes from his fishing diary point out the success of his methods and, usually, the deficiencies of other methods.

A Trout and Salmon Fisherman for Seventy-Five Years was originally published as two volumes, *Telling on the Trout* and *Secrets of the Salmon*, but they were combined in 1948 and revised and updated with knowledge and anecdotes from the 20 years between publication dates. It was reprinted in 1966 and now again in 1972. Much of the information, particularly on tackle, is now outdated but still interesting from a historical standpoint. Some of Mr. Hewitt's observation on behavior and life history have been modified by the research of professional biologists; however, there is much information in this book, much to think about, many new techniques to try next time the fish aren't rising. Most of the book pertains to fly fishing and much to dry fly fishing for Atlantic salmon. I think that any fisherman reader will find the book informative and interesting.—*K. A. Hashagen, Jr.*

The Dry Fly and Fast Water and The Salmon and the Dry Fly

By George M. L. LaBranche; Van Cortlandt Press, Croton-On-Hudson, N.Y., 1972. 252 p. \$6.95.

The Dry Fly and Fast Water was first published in 1914; *The Salmon and the Dry Fly* in 1921. In 1951 they were combined into one volume and reprinted. Now, over 20 years later, another unrevised edition has been printed.

It is necessary to know the past history of these two short books in order to appreciate them. In *The Dry Fly and Fast Water*, LaBranche tells of his experiences

in learning to fish the dry fly. He fished with large rods, silk lines, and gut leaders and began using the dry fly when it was considered a novelty in the U.S. His observations on fish behavior, stream conditions, and fly presentation are valid today—and are often touted as “new” information by more recent authors.

The Salmon and the Dry Fly is less than a hundred pages long and tells how he and his associates pioneered techniques and tackle to successfully take Atlantic salmon on dry flies. He relates pertinent experiences to illustrate his points and concludes with a comprehensive chapter on “Casting the Curve”, which includes detailed instructions for this rather difficult maneuver.

Both books are written in a rather stilted, wordy fashion but the information is there. Both are considered classics in the history of fly fishing, and I feel they are a welcome addition to any fisherman's library.—*K. A. Hashagen, Jr.*

Hardy's Book of Fishing

By Patrick Annesley (Editor); E. P. Dutton and Co., Inc., N.Y., 1972; 304 p., illustrated. \$16.50.

As any serious fisherman knows, Hardy Bros. of England is one of the most famous tackle manufacturers in the world and has been for over 100 years. During this period they have issued catalogs describing their fine rods, reels, and other fishing tackle. In addition to the product information, there have been helpful articles for the angler and testimonials from satisfied customers.

Hardy's Book of Fishing is the best of the catalogs. Loosely arranged in three sections—“The Equipment”, “Fish and Fishing”, and “The Angler at Large”—with each section further arranged chronologically, the book provides a history of English angling and the development of fishing tackle and delightful fishing stories and advice. The book is attractively illustrated with reproductions of illustrations of fish and tackle and “how to” diagrams. Much of the advice given is still valid today.

The language for the most part, is delightfully wordy. The readers of early Hardy Bros. catalog were told “How to Fish” and “How to Tell a Salmon Pool”. A detailed article describes “Spinning and Prawnning for Salmon”. In 1888 there was the question “Wet Fly or Dry?” A question which is still debated today. The rods ranged from “light” trout rods of 9 ft to double-handed, 20-ft salmon rods. Gillies “grassed” fish and the catch was recorded in hundreds of pounds.

The “Angler at Large” section describes fishing in the late 1800's and early 1900's in Norway, Finland, Tasmania, Kashmir, New Zealand, North America and other countries.

I found the book very entertaining and spent many enjoyable evenings reading *Hardy's Book of Fishing*.—*K. A. Hashagen, Jr.*

The Art and Science of Fly Fishing (revised edition)

By Lenox H. Dick; Winchester Press, New York; 1972. 169 p., illustrated. \$6.95.

Both novice and advanced fly fishermen will benefit from reading “The Art and Science of Fly Fishing”. As in the first edition, the book begins with a section on “Fundamentals”, with chapters on basic tackle, casting, fly presentation, reading water, entomology, and flies. The second part has four comprehensive chapters on “Stream Tactics”, well illustrated with figures and black and white photos. In the second part the author utilizes the information presented in the first chapters to take the reader on four fishing trips where all basic stream situations, water conditions, and casting techniques are encountered. This method is effective and for the most part the information is clearly and interestingly presented. The final section, new in this edition, consists of eight chapters on “Salmon, Steelhead, and Others”.

Most of the information is accurate; however, experienced anglers will take exception to some of the author's opinions and statements. Occasionally, I felt basic terms, such as “drag”, were not explained sufficiently for the novice. The author also describes 4X tippet as “quite fine”, which doesn't help the beginning fly fisherman. Chapters on “Cutthroat Trout”, “Silver Salmon”, and “Jacks or Grilse Fishing” are so brief they make the reader wonder why they were included. In addition to these negative comments, I must mention the numerous typographical errors, deletions, incorrect references to figures, plates and page numbers, and occasional misspellings. They definitely detract from what otherwise is an interesting and informative book.—*K. A. Hashagen, Jr.*

World Dynamics

By Jay W. Forrester; Wright-Allen Press, Inc., 238 Main Street, Cambridge, Massachusetts 02142, 1971; 142 p.

This book is likely the most advanced treatment of the Malthusian argument. Professor Forrester, unlike Malthus, has cybernetics, computer technology and a greater array of information with which to predict the future. This book's greatest value will be in stimulating further development of predictive models of the world social system. Such models will hopefully assist the world in making the transition from growth and "progress" to economic and social stability.

Forrester and his colleagues at MIT constructed a world model of 5 system level variables which are Population, Pollution, Capital Investment, Agriculture Capital Investment Fraction, and Natural Resources. Each system level is controlled by other system levels and assumed rate functions which have negative or positive feedbacks. Secular trends under various assumptions and inputs are lucidly presented by graphs and the accompanying text.

The results are generally depressing. Current trends of population growth will most likely only be altered by a dramatic rise in the death rate as the limits of the earth are exceeded in terms of carrying capacity. A pollution crisis, dwindling natural resources, crowding or food shortages may bring the population explosion to a catastrophic halt. Birth control programs are not likely to have enough leverage to effectively forestall disaster only delay it.

This book should be mandatory reading for those concerned about the future and man's fate on this planet. This should include all resource biologists and especially the resource administrators who set policies, priorities and budgets. The material is intellectually stimulating and helps to quantify what many of us observe to be happening to the planet. Although Forrester's model is simplistic it will undoubtedly serve as a framework for constructing more sophisticated models as we increase our knowledge of social systems.—Lee W. Miller.

The New York Aquarium Book of the Water World

By William Bridges; American Heritage Publ. Co., N.Y., 1970; 287 p., illustrated. \$6.95.

Bridges gives a brief look at some of the numerous animals that live in or are closely associated with the aquatic environment. The book includes extensive, professional photographs with non-technical descriptions of one-celled animals, amphibians, reptiles, birds, mammals and invertebrates (excluding insects).

The main theme concerns animals (mainly fish) that can be kept in aquaria. Starting with the Chinese, credited as the first to keep fish for observation, a condensed history of fish keeping is covered. During the Sung dynasty, 960-1278, fancy goldfish and carp were held in porcelain vessels. The ancient Romans confined marine fish in ponds connected to the ocean.

Among the oddities covered is the walking catfish, *C. batrachus* and its establishment into Florida's waters. Bridges presents this as a rather casual observation without pointing out the real dangers involved to native species with the introduction of exotics.

In a book of this nature it was disappointing not to find real concern with the continued premature extinction of many species. Unless the problem is recognized and meaningful accomplishments are made, there won't be many species left to view, even in public aquaria.—James A. St. Laurent.

INDEX TO VOLUME 58

AUTHOR

- Alton, Miles S. and Christine J. Blackburn: Diel changes in the vertical distribution of the euphausiids, *Thysanoessa spinifera* Holmes and *Euphausia pacifica* Hansen, in coastal waters of Washington, 179-190
- Azevedo, John A., Jr., Eldredge G. Hunt and Leon A. Woods, Jr.: Melanistic mutant in ringneck pheasants, 175-178
- Barlow, George W., and Victor L. De Vlaming: Ovarian cycling in long-jaw gobies, *Gillichthys mirabilis*, from the Salton Sea, 50-57
- Barnhart, Roger A.: *see* Kesner and Barnhart, 204-220
- Benville, Pete E., Jr.: *see* Earnest and Benville, 127-132
- Blackburn, Christine J.: *see* Alton and Blackburn, 179-190
- Borneman, John C.: *see* Carrier, Mallette, Wilbur and Borneman, 327-328; *see* Mallette, Wilbur, Carrier and Borneman, 67-68
- Briggs, Kenneth T., and C. William Davis: A study of predation by sea lions on salmon in Monterey Bay, 37-43
- Bury, C. Bruce: The effects of diesel fuel on a stream fauna, 291-295
- Cappucci, D. T., Jr., and W. M. Longhurst: Rabies in deer, 141-144
- Carrier, W. Dean: *see* Mallette, Wilbur, Carrier and Borneman, 67-68
- Carrier, W. Dean, Robert D. Mallette, Sanford Wilbur and John C. Borneman: California condor survey, 327-328
- Castle, William T. and Leon A. Woods, Jr.: DDT residues in white croakers, 198-203
- Chamberlain, Lawrence L.: Primary productivity in a new and older California reservoir, 254-267; *see* Lasker, Tenaza and Chamberlain, 58-66
- Chen, Lo-Chai: *see* Rosenblatt and Chen, 32-36
- Clark, William E.: *see* Espinosa and Clark, 149-152
- Davis, C. William: *see* Briggs and Davis, 37-43
- Day, John S.: *see* St. Amant and Day, 154-155
- Demory, Robert L.: Tailless Dover sole from off the Oregon coast, 147-148
- De Vlaming, Victor L.: *see* Barlow and De Vlaming, 50-57
- Dexter, Deborah M.: Molting and growth in laboratory reared phyllosomes of the California spiny lobster, *Panulirus interruptus*, 107-115
- Duffy, John M.: *see* Houk and Duffy, 321-323
- Earnest, Russell D. and Pete E. Benville, Jr.: Acute toxicity of four organochlorine insecticides to two species of surf perch, 127-132
- Elliott, George V. and T. M. Jenkins, Jr.: Winter food of trout in three high elevation Sierra Nevada lakes, 231-237
- Espinosa, Lawrence R. and William E. Clark: A polypropylene light trap for aquatic invertebrates, 149-152
- Farley, David G.: A range extension for the logperch, 248
- Fitch, John E.: A case for striped mullet, *Mugil cephalus*, spawning at sea, 246-248; The cottonmouth jack, *Uraspis scenedra*, added to the marine fauna of California, 245-246
- Franklin, George W.: *see* Schneegas and Franklin, 133-140
- Grover, Charles A.: Population differences in the swell shark *Cephaloscyllium ventriosum*, 191-197
- Haaker, Peter L.: First record of a reversed butter sole, *Isopsetta isolepis*, 244-245
- Hanson, Jack A.: Tolerance of high salinity by the pileworm, *Neanthes succinea*, from the Salton Sea, California, 152-154
- Hashagen, Kenneth A., Jr.: *see* Rawstron and Hashagen, 221-230
- Hawthorne, Vernon M.: Coyote food habits in Sagehen Creek basin, north-eastern California, 5-12
- Hobson, Edmund S.: The survival of Guadalupe cardinalfish *Apojyon guadalupeensis* at San Clemente Island, 68-69
- Houk, James L. and John M. Duffy: Two new sea urchin—acorn barnacle associations, 321-323
- Hunt, Eldredge G.: *see* Azevedo, Hunt and Woods, 175-178

- Iverson, Ernest W.: New hosts and bathymetric range extension for *Colobumatus cubitogae* (Crustacea, Copepoda), 323-325
- Jenkins, T. M., Jr.: *see* Elliott and Jenkins, 231-237
- Jones, Albert C.: Contributions to the life history of the Piute sculpin in Sagehen Creek, California, 285-290
- Kesner, William D. and Roger A. Barnhart: Characteristics of the fall-run steelhead trout (*Salmo gairdneri gairdneri*) of the Klamath River system with emphasis on the half-pounder, 204-220
- Knaggs, Eric H.: *see* Parrish and Knaggs, 13-21; Southern California Pacific mackerel fishery and age composition of commercial landings during the 1968-69 and 1969-70 seasons, 116-120
- Kukowski, Gary E.: Southern range extension for the yellowfin goby, *Acanthogobius flavimanus* (Temminck and Schlegel), 326-327
- Lasker, Reuben, Richard H. Tenaza, and Lawrence L. Chamberlain: The response of Salton Sea fish eggs and larvae to salinity stress, 58-66
- Lea, Robert N.: Southern geographical records for four surfperches, family Embiotocidae, with notes on a population resurgence of the sharpnose seaperch, 27-31
- Longhurst, W. M.: *see* Cappucci and Longhurst, 141-144
- Mais, Kenneth F.: A subpopulation study of the Pacific sardine, 296-314
- Mallette, Robert D.: *see* Carrier, Mallette, Wilbur and Borneman, 327-328
- Mallette, Robert D., Sanford Wilbur, W. Dean Carrier and John C. Borneman: California condor survey, 1970, 67-68
- Martin, Michael: Morphology and variation of the Modoc sucker, *Catostomus microps* Rutter, with notes on feeding adaptations, 277-284
- Miller, Lee W.: Migrations of sturgeon tagged in the Sacramento-San Joaquin estuary, 102-106; White sturgeon population characteristics in the Sacramento-San Joaquin estuary as measured by tagging, 94-101
- Moring, John R.: Check list of intertidal fishes of Trinidad Bay, California, and adjacent areas, 315-320
- Morrell, Stephen: Life history of the San Joaquin kit fox, 162-174
- Odenweller, Dan Bowman: A new range record for the umbrella crab, *Cryptolithodes sitchensis* Brandt, 240-243
- Parrish, Richard H.: Symbiosis in the blacktail snailfish, *Careproctus melanurus*, and the box crab, *Lopholithodes foraminatus*, 239-240
- Parrish, Richard H., and Eric H. Knaggs: The southern California Pacific mackerel fishery and age composition of the catch for the 1964-65 through 1967-68 seasons, 13-21
- Penhale, Leonard B.: Reproductive failure of pelagic cormorant, San Luis Obispo County, California, 1970, 238
- Rawstron, Robert R.: Harvest, survival, and cost of two domestic strains of tagged rainbow trout stocked in Lake Berryessa, California, 44-49; Nonreporting of tagged largemouth bass, 1966-1969, 145-147
- Rawstron, Robert R. and Kenneth A. Hashagen, Jr.: Mortality and survival rates of tagged largemouth bass (*Micropterus salmoides*) at Merle Collins Reservoir, 221-230
- Rosenblatt, Richard H., and Lo-Chai Chen: The identity of *Sebastes babcocki* and *Sebastes rubrivinctus*, 32-36
- Schneegas, Edward R. and George W. Franklin: The Mineral King deer herd, 133-140
- Shaw, Stanton B.: DDT residues in eight California marine fishes, 22-26
- Spratt, Jerome D.: Age and length composition of northern anchovies, *Engraulis mordax*, in the California anchovy reduction fishery for the 1969-70 season, 121-126
- St. Amant, James A. and John S. Day: Range extension of *Palaeomonetes paludosus* (Gibbes) in California, 154-155
- Tenaza, Richard H.: *see* Lasker, Tenaza and Chamberlain, 58-66
- Varoujean, Daniel H.: The recurrence of the California scorpionfish, *Scorpaena guttata* Girard, in Monterey Bay, 238-239
- von Geldern, C. E., Jr.: A midwater trawl for threadfin shad, *Dorosoma petenense*, 268-276; Angling quality at Folsom Lake, California, as determined by a roving creel census, 75-93
- Wilbur, Sanford: *see* Carrier, Mallette, Wilbur and Borneman, 327-328; *see* Mallette, Wilbur, Carrier and Borneman, 67-68
- Woods, Leon A., Jr.: *see* Azevedo, Hunt and Woods, 175-178; *see* Castle and Woods, 198-203

SCIENTIFIC NAMES

- Acanthogobius flavimanus*: 326-327
Accipiter cooperii: 67
 sriatus: 67
Acipenser medirostris: 102-106
 transmontanus: 94-101, 102-106
Alces alces: 141
Amphistichus argenteus: 27
Anisotremus davidsoni: 58-66
Anoplopoma fimbria: 22-26
Apogon guadalupensis: 68-69
 retroscella: 68
Aquila chrysaetos: 67
Arctostaphylos sp.: 137
Artemia sp.: 107-115
Astacus sp.: 292
Bairdiella chrysura: 65
 icistia: 58-66
Balanus concavus pacificus: 321-322
 nubilis: 321-322
Buteo jamaicensis: 67
Cadulus fusiformis: 323
Canis latrans: 5-12
Capreolus capreolus: 141
Carpocetus melanurus: 239-240
Cathartes aura: 67
Catostomus microps: 277-284
 platyrhynchus: 287
 rimiculus: 292
 tahocensis: 287
Cephaloscyllium ventriosum: 191-197
Cerrus canadensis: 141
 claphus: 141
Chaenogobius urolucnia: 54
Chara, sp.: 154
Chasmichthys dolichognathus: 54
Chromis punctipinnis: 30
Circus cyaneus: 67
Citellus beecheyi: 5-12
 beldingi: 5-12
 lateralis: 5-12
Citharichthys sordidus: 22-26
Cladophora sp.: 294
Clemmys marmorata: 294
Clostridium botulinum: 149
Colobomatus embiotocae: 323-325
Coryphaenoides aequalis: 22-26
Coltus beldingi: 285-290
Crago sp.: 94
Cryptolithodes sitchensis: 240-243
Cymatogaster aggregata: 28, 127-132
Cynoscion xanthalus: 58-66, 152
Dama dama: 141
Dentalium pretiosum: 323
Dorosoma petenense: 44, 92, 268-276
Echidnophaga gallinacea: 170
Engraulis mordax: 121-126
Eutrophenus tridentatus: 292
Eopsetta jordani: 22-26
Erethizon dorsatum: 5-12
Euaetios americanus: 137
Eumetopius jubata: 38
Euphausia pacifica: 179-190
Eutamias sp.: 5-12
Falco mexicanus: 67
 sparverius: 67
Fasciola hepatica: 142
Fundulus confluentus: 55
Genyonemus lineatus: 22-26, 198-203
Gillichthys mirabilis: 50-57
Glaucomys sabrinus: 5-12
Gobius paguacellus: 51
Gymnogyps californianus: 67-68, 327-328
Hippocampus zosterae: 55
Hyperprosopon anale: 323
 ellipticum: 27
Ictalurus catus: 78-93
 melas: 78-93
 nebulosus: 78-93
Isopsetta isolepis: 244-245
Lasaca cystula: 324
Lepomis cyanellus: 78-93
 macrochirus: 75-93
 microlophus: 78-93
Lepus americanus: 5-12
 sp.: 5-12
Lipoptena depressa: 142
Lopholithodes foraminatus: 239-240
Lytechinus sp.: 109
Macrocypris sp.: 68
Marmota flaviventris: 5-12, 136
Medialuna californiensis: 30
Mephitis mephitis: 143
Mergus mercanser: 294
Micrometrus minimus: 127-132
Micropterus dolomieu: 75-93
 salmoides: 75-93, 145-147, 221-230
Microstomus pacificus: 147-148
Microtus sp.: 5-12
Mugil cephalus: 246-248
Mytilus sp.: 107-115
Nassarius mendicis: 323
Neanthes succinea: 152-154
Neolipoptena ferrisi: 142
Nuculana luphras: 323
Odocoileus hemionus: 141
 californicus: 133-140
 columbianus: 141-143
 virginianus: 141
Olivella sp.: 323
Oncorhynchus nerka: 87
 sp.: 37-43
Ophiodon elongatus: 22-26
Palaeomonetes paludosus: 154-155
Panulirus interruptus: 107-115
Parophrys retulus: 22-26
Percina caprodes: 248
Peromyscus sp.: 5-12
Phalarocorax pelagicus: 238
Phanerodon atripes: 28-31
 fuscatus: 30
Phasianus colchicus torquatus: 175-178

- Phoradendron villosum*: 136
Poecilia latipinna: 151
Pomoxis annularis: 86
 nigromaculatus: 86
Prosopium williamsouii: 287
Pterogobius chapoides: 51
Pulex simulans: 112
Rana boylei: 291
Rangifer tarandus: 141
Rhacochilus toxotes: 28
 racca: 30
Rhinichthys osculus: 287, 292
Richardsonius cyregicus: 287
Salmo clarki henshawi: 11
 gairdneri: 44-49, 78-93, 231-237, 285, 292
 g. gairdneri: 201-220
 trutta: 285
Salvelinus fontinalis: 231-237, 285
Sardinops caeruleus: 296-314
Scomber japonicus: 13-21, 116-120
Scorpaena guttata: 238-239
Scyllarus americanus: 107
Schastis babeoeki: 32-36
 rubrivinctus: 32-36
Spirogyra sp.: 294
Strongylocentrotus franciscanus: 321-322
 purpuratus: 321-322
Sylvilagus sp.: 5-12
Tamiasciurus douglasi: 5-12
Thamnophis couchi: 294
Thelazia californiensis: 142
Thysanoxssa spinifera: 179-190
Tilapia mossambica: 154
Trachurus symmetricus: 13, 22-26, 116
Tubificor sp.: 109
Turbonilla sp.: 323
Uraspis secunda: 245-246
Urocyon cinereoargenteus: 143
Vulpes macrotis nutica: 162-171
Zalembius rosaceus: 323
Zalophus californianus: 37-43
Zygocma sp.: 294

SUBJECT

- Age: of anchovies taken the 1969-70 season, 121-126; of Klamath River fall-run steelhead, 204-220; of Pacific mackerel during 1964-65 through 1967-68 seasons, 13-21; of Pacific mackerel in southern California fishery, 1968-69, 1969-70, 116-120
Aldrin: toxicity to surfperch, 127-132
Anchovy, northern: fishery during 1969-70 season, 121-126
Angling: quality at Folsom Lake, 75-93
Bairdiella: effect of salinity on eggs and larvae, 58-66
Barnacle, acorn: association with sea urchins, 321-323
Bass: fishery at Folsom Lake, 83
Bass, largemouth: mortality and survival at Merle Collins Reservoir, 221-230; nonreporting of tagged fish, 145-147
Birds: as food for coyotes, 9
Cardinalfish, Guadalupe: survival at San Clemente Island, 68-69
Cattfish: fishery at Folsom Lake, 84-85
Cattle: as food for coyotes, 7
Census, roving creek: of fishery at Folsom Lake, 75-93
Check list: intertidal fishes of Trinidad Bay and vicinity, 315-320
Chlorinated hydrocarbons: residues in California marine fishes, 22-26
Coleman Kamloops trout strain: performance at Lake Berryessa, 44-49
Condon, California: 1970 population survey, 67-68; population survey of 1971, 327-328
Copepod, parasitic: on embiotocid fish, 323-325
Cormorant, pelagic: reproductive failure in San Luis Obispo County coastal area, 238
Costs: of planting two domestic trout strains at Lake Berryessa, 44-49
Coyote: food habits in Sagehen Creek basin, 4-12
Coyote, juvenile: food habits at Sagehen Creek basin, 9-11
Crab, box: case of symbiosis with blacktail snailfish, 239-240
Crab, umbrella: range extension, 240-243
Croaker, white: DDT residues, 22-26, 198-203
Cycling, ovarian: of gobies at the Salton Sea, 50-57
DDT: in the diet of pheasants producing melanistic mutants, 175-178; residues in California marine fishes, 22-26; residues in white croakers, 198-203; toxicity to surfperch, 127-132
Deer: as food for coyotes, 6-7; occurrence of rabies, 141-144; study of Mineral King herd, 133-140
Dieldrin: toxicity to surfperch, 127-132
Disease: occurrence of rabies in deer, 141-144
Distribution, geographic: appearance of California scorpionfish in Monterey Bay, 238-239; extension of range of yellowfin goby, 326-327; of flag and redbanded rockfishes, 32-36; of the cottonmouth jack, 245-246; of the logperch, 248; of the umbrella crab, 240-243; of white and green sturgeons, 102-106; range extension for four surfperches, 27-31; range ex-

- tension of *Palaeomonetes pulex*, 154-155
- Distribution, vertical: of euphausiids off the coast of Washington, 179-190
- Eggs, fish: effect of salinity on Salton Sea fish, 58-66
- Elkhorn Slough: yellowfin goby occurrence, 326-327
- Embiotocidae: geographical records for four species, 27-31
- Endrin: toxicity to surfperch, 127-132
- Estuary, Sacramento-San Joaquin: white sturgeon population study, 94-101; migration study of white and green sturgeons, 102-106
- Euphausiids: diel changes in the vertical distribution, 179-190
- Fauna, stream: effects of diesel fuel, 291-295
- Feeding: of spiny lobster phyllosomes in the laboratory, 107-115
- Fishery: characteristics at Folsom Lake, 75-93; for northern anchovy during 1969-70 season, 121-126; for trout at Lake Berryessa, 44-49; for white sturgeon, 99-100; of Pacific mackerel in southern California 1964-65 through 1967-68 seasons, 13-21; of Pacific mackerel 1968-69 and 1969-1970 seasons, 116-120
- Fishes, intertidal: of Trinidad Bay and vicinity, 315-320
- Folsom Lake: angling quality study, 75-93; site of primary productivity studies, 254-267
- Food habits: of coyotes in Sagehen Creek basin, 4-12; of Klamath River fall-run steelhead, 217-218; of San Joaquin kit fox, 167-169; of trout in high elevation Sierra lakes in winter, 231-237
- Fox, San Joaquin kit: life history, 162-174
- Fuel, diesel: effects of spilling into stream, 291-295
- Goby, longjaw: ovarian cycling at the Salton Sea, 50-57
- Goby, yellowfin: southern range extension, 326-327
- Growth: characteristics of Klamath River steelhead, 207-211; of spiny lobster phyllosomes in laboratory, 107-115; of Pinte sculpin, 287
- Half-pounder: steelhead of the Klamath River, 204-220
- Harvest: of two domestic trout strains at Lake Berryessa, 44-49
- Insecticides, organochlorine: toxicity to surfperch, 127-132
- Insects: as food for coyotes, 9
- Invertebrates, aquatic: capture by use of polypropylene light trap, 149-152
- Jack, cottonmouth: added to marine fauna of California, 245-246
- Klamath River: characteristics of fall-run steelhead, 204-220
- Lake Berryessa: study of planting two domestic strains of rainbow trout, 44-49
- Larvae, fish: effect of salinity on Salton Sea fish, 58-66
- Length: composition of anchovies taken 1969-70 season, 121-126
- Life history: of Pinte sculpin, 285-290; of San Joaquin kit fox, 162-174
- Lingcod: DDT residues, 22-26
- Lions, sea: predation on salmon, 37-43
- Lobster, California spiny: molting and growth of phyllosomes in laboratory, 107-115
- Logperch: range extension, 248
- Mackerel, jack: DDT residues, 22-26
- Mackerel, Pacific: age composition of the catch 1964-65 through 1967-68 seasons, 13-21; southern California fishery during 1968-69 and 1969-70 seasons, 116-120
- Merle Collins Reservoir: bass tagging study, 145-147; site of largemouth bass mortality and survival study, 221-230; site of primary productivity studies, 254-267
- Methods: aging Pacific mackerel 1964-65 through 1967-68 seasons, 13-21; constructing polypropylene light trap for aquatic invertebrates, 149-152; coyote food habits study, 4-12; determining DDT residues in marine fishes, 22-26; determining DDT residues in white croakers, 199; determining effects of salinity on eggs and larvae of Salton Sea fish, 58-66; determining organochlorine toxicity to surfperch, 127-132; ovarian cycling of longjaw goby, 50-57; rearing spiny lobster phyllosomes in laboratory, 107-115; separation of *Sebastes babcocki* and *S. rubrivinctus*, 32-36; studying life history of the kit fox, 162-174; studying mortality and survival of bass at Merle Collins Reservoir, 221-230; studying vertical distribution of euphausiids, 179-190; study of Mineral King deer herd, 133-140; study of fall-run steelhead of the Klamath River, 204-220; study of life history of Pinte sculpin, 285-290; study of Modoc sucker, 277-284; study of predation by sea lions on salmon, 37-43; study of subpopulations of Pacific sardines, 296-314; study of reservoir primary productivity, 254-267; study of trout fishery at Lake Berryessa, 44-49; study of variation in the swell shark, 191-197; tagging sturgeon to provide migration data, 102-106; tagging to determine white sturgeon population,

- 94-101; testing tolerance of pile worm to salinity, 152-154; use of roving creel census at Folsom Lake, 75-93
- Migration: of Klamath River steelhead, 211-214; of Mineral King deer, 133-140; of white and green sturgeons, 102-103
- Mineral King: deer study, 133-140
- Molting: of spiny lobster phyllosomes in laboratory, 107-115
- Monterey Bay: study of predation by sea lions on salmon, 37-43
- Morphology: of the Modoc sucker, 277-284
- Mortality rates: of largemouth bass at Merle Collins Reservoir, 221-230
- Mt. Whitney trout strain: performance at Lake Berryessa, 14-19
- Mullet, striped: apparent spawning at sea, 246-248
- Mutant: melanism in ringneck pheasants, 175-178
- Net: midwater trawl for taking threadfin shad, 268-276
- Perch, dwarf: pesticide toxicity studies, 127-132
- Perch, slimer: pesticide toxicity studies, 127-132; southern range record, 28
- Pesticides: chlorinated hydrocarbon residues in California marine fishes, 22-26; toxicity of organochlorines to surfperch, 127-132
- Pheasant, ringneck: appearance of melanistic mutant, 175-178
- Phyllosomes: growth of spiny lobsters under laboratory conditions, 107-115
- Pileworm: tolerance of high salinity, 152-154
- Pollution: effects of diesel fuel on a stream fauna, 291-295
- Population: of Mineral King deer herd, 133-140; resurgence in sharpnose seaperch, 28-31; study of variation within subpopulations of Pacific sardines, 296-314; survey of condors, 1971, 327-328; white sturgeon in Sacramento-San Joaquin estuary, 91-101
- Predation: by sea lions on salmon, 37-43
- Productivity, primary: in a new and old California reservoir, 251-267
- Rabbits: as food for coyotes, 8
- Rabbits: occurrence in deer, 141-144
- Raptors: numbers seen during 1970 condor survey, 67-68; seen during 1971 condor survey, 327-328
- Rainbow trout: roughscale: DDT residues, 22-26
- Ringneck pheasant: failure of pelagic cormorant to breed, 238; of longjaw goby in Salton Sea, 50-57; of Piute sculpin, 285-290
- Reviews: A trout and salmon fisherman for seventy-five years, 330; Biology and water pollution control, 249; British Columbia game fish, 71; Come wade the river, 71; Fishes of Montana, 329-330; Fishless days, angling nights, 250; Hardy's book of fishing, 331; Hikers and back-packers handbook, 70; If deer are to survive, 157; Kamloops, 71; Life and death in a coral sea, 250; Mountain sheep: a study in behavior and evolution, 329; Remembrances of rivers past, 330; Round river, 250; Sea shells of tropical west America; marine molluscs from Baja California to Peru, 249; Systematics, variation, distribution, and biology of rockfishes of the subgenus *Sebastomus* (Pisces, Scorpaenidae, *Sebastes*), 156-157; The art and science of fly fishing, 321; The dry fly and fast water and the salmon and the dry fly, 330-331; The ecology of running waters, 156; The New York aquarium book of the water world, 332; The vanishing jungle—the story of the World Wildlife Fund expeditions to Pakistan, 70-71; Wildlife of Mexico: the game birds and mammals, 250; World dynamics, 332
- Rockfish, flag: identity and range, 32-36
- Rockfish, redbanded: identity and range, 32-36
- Rodents: as food for coyotes, 8
- Rusk Creek: site of study of Modoc suckers, 277-284
- Sablefish: DDT residues, 22-26
- Sagehen Creek: site of coyote food habits study, 4-12; study of life history of Piute sculpin, 285-290
- Salinity: tolerance by pileworm, 152-154
- Salmon: study of predation by sea lions, 37-43
- Salton Sea: ovarian cycling of longjaw goby, 50-57; study of salinity stress on fish eggs and larvae, 58-66; tests on pileworm tolerance of salinity, 152-154
- San Clemente Island: survival of Guadalupe cardinalfish, 68-69
- Sanddab, Pacific: DDT residues, 22-26
- Sardine, Pacific: subpopulation study, 296-314
- Sarge: effect of salinity on eggs and larvae, 58-66
- Scorpionfish, California: recurrence in Monterey Bay, 238-239
- Sculpin, Piute: life history, 285-290
- Seaperch, pink: host for parasitic copepod, 323-325
- Seaperch, rubberlip: southern range record, 28

- Seaperch, sharpnose: southern range records and notes on population resurgence, 28-31
- Sea urchin: in association with acorn barnacles, 321-323
- Shad, threadfin: trawl designed for catching, 268-276
- Shark, swell: population differences off California and Baja California, 191-197
- Sheep: as food for coyotes, 7
- Snailfish blacktail: case of symbiosis with box crab, 239-240
- Sole, butter: case of reversal, 244, 245
- Sole, Dover: tailless specimens taken off Oregon, 147-148
- Sole, English: DDT residues, 22-26
- Sole, petrale: DDT residues, 22-26
- Spawning: of striped mullet at sea, 246-248
- Stress, salinity: on Salton Sea fish eggs and larvae, 58-66
- Sunfish: fishery at Folsom Lake, 84
- Sturgeon, green: migration, 102-106
- Sturgeon, white: migration, 102-106; population in Sacramento-San Joaquin estuary, 94-101
- Sucker, Modoc: morphology, variation, feeding adaptations, 277-284
- Surfperch: pesticide toxicity studies, 127-132
- Surfperch, silver: southern range records, 27
- Surfperch, spotfin: host for parasitic copepod, 323-325
- Survey: 1970 California condor population, 67-68
- Survival: of Guadalupe cardinalfish at San Clemente Island, 68-69; of two domestic trout strains at Lake Berryessa, 44-49
- Survival rates: of largemouth bass at Merle Collins Reservoir, 221-230
- Symbiosis: between blacktail snailfish and box crab, 239-240
- Tagging: of largemouth bass at Merle Collins Reservoir, 145-147; to determine sturgeon migration, 102-106; to determine white sturgeon populations, 94-101
- Telemetry: use in studying kit foxes, 165; use in studying Mineral King deer, 138-140
- Toxicity: of organochlorines to surfperch, 127-132
- Trap: for aquatic invertebrates, 149-152
- Trawl, midwater: for threadfin shad, design and operation, 268-276
- Trinidad Bay: intertidal fishes, 315-320
- Trout, rainbow: fishery at Folsom Lake, 85; performance of two domestic strains at Lake Berryessa, 44-49
- Trout, steelhead: characteristics of fall-run in Klamath River, 204-220
- Trout: winter food habits in high elevation Sierra lakes, 231-237
- Vegetable matter: in coyote food habits, 9, 11

O

Notice is hereby given that the Fish and Game Commission shall meet on October 6, 1972, at 9:00 a.m., in the Auditorium of the Resources Building, 1416 Ninth Street, Sacramento, California, to receive recommendations from its own officers and employees, from the Department and other public agencies, from organizations of private citizens, and from any interested groups as to what, if any, regulations should be made relating to fish, amphibia, and reptiles, or any species or subspecies thereof.

Notice is hereby given that the Fish and Game Commission shall meet at 9:00 a.m., on November 3, 1972, in the Board of Supervisors' Chambers, County Courthouse, Redding, California, for public discussion of and presentation of objections to the proposals presented to the Commission on October 6, 1972, and after considering such discussion and objections, the Commission, at this meeting, shall announce the regulations which it proposes to make relating to fish, amphibia and reptiles.

Notice is hereby given that the Fish and Game Commission shall meet on December 8, 1972, at 9:00 a.m. in Room 1138 of the New State Building, 107 S. Broadway, Los Angeles, California, to hear and consider any objections to its determinations or proposed orders in relation to fish, amphibia and reptiles or any species or subspecies thereof for the 1973 sport fishing season, such determinations and orders resulting from the hearings held on October 6, 1972 and November 3, 1972.

FISH AND GAME COMMISSION

Leslie F. Edgerton
Executive Secretary

POSTMASTER: RETURN POSTAGE GUARANTEED
Editor, CALIFORNIA FISH AND GAME
CALIFORNIA DEPARTMENT OF FISH AND GAME
987 JEDSMITH DRIVE, SACRAMENTO, CALIF. 95819

BULK RATE
U.S. POSTAGE
PAID
Sacramento, Calif.
Permit No. 949