











# INVESTIGATIONS OF INFRA-RED SPECTRA

---

Part I—INFRA-RED ABSORPTION SPECTRA

Part II—INFRA-RED EMISSION SPECTRA

---

BY

WILLIAM W. COBLENTZ

---



WASHINGTON, D. C. :  
Published by the Carnegie Institution of Washington  
October, 1905.

CARNEGIE INSTITUTION OF WASHINGTON  
PUBLICATION NO. 35

FROM THE PRESS OF  
THE HENRY E. WILKENS PRINTING CO.  
WASHINGTON, D. C.

# CONTENTS

## PART I.—INFRA-RED ABSORPTION SPECTRA.

	Page
Chapter I.—Introduction.....	3-4
Chapter II.—Historical.....	5-8
Other investigations .....	8-11
Solvents .....	11-12
Ultra-violet .....	12-13
Total absorption temperature, etc.....	13-15
Chapter III.—Description of apparatus and methods.....	15-33
The spectrometers .....	16
The prisms used.....	16-17
Adjustment and calibration of apparatus.....	17
Adjustment of large spectrometer.....	18-21
The radiometer .....	21-23
The absorption cells.....	23-25
Source of radiation .....	25-26
Methods of observation.....	26-27
Sources of error.....	27-29
The chemicals used.....	29-30
Problems attacked.....	30-31
Chapter IV.—Investigation with a quartz prism.....	33-38
Chapter V.—Investigation with a rock-salt prism.....	39-101
Class I—Methane derivatives. Absorption spectra of gases.....	39-54
The absorption cell.....	41-43
Gases studied .....	43-54
Absorption spectra of liquids and solids.....	54-99
Halogen substitution products.....	54-56
Water and alcohol.....	56-59
Compounds containing the methyl group.....	59-65
Compounds containing sulphur.....	65-67
The mustard oils and sulphocyanates.....	67-69
The fatty acids.....	69-72
Petroleum distillates.....	72-77
Methylene series.....	73
Paraffin series.....	73
Acetylene series.....	73
Class II—Carbocyclic compounds.....	76-99
Benzene.....	76-77
Methyl derivatives of benzene.....	77-80
Various other benzene derivatives.....	80-83
Amido and nitro derivatives of benzene.....	84-86
Nitro derivatives.....	86-87
Phenols .....	87-89
Aromatic acids.....	89-90

PART I—Chapter V—Class II—Continued.	Page
Aldehydes .....	90-91
Terpenes .....	91-96
Pyridine group.....	96-97
Other cyclic compounds.....	98-99
Chapter VI.—General discussion of the spectra.....	101-119
Effect of structure.....	101-102
Effect of molecular weight.....	102-106
Effect of temperature.....	106-107
The effect of certain characteristic groups of atoms.....	107-110
Total absorption .....	110-111
Grouping of the spectra.....	111
Characteristics of the spectra of carbohydrates.....	111-112
Occurrence of harmonics.....	112-114
Summary .....	115-118
Appendix I.—Sources of radiation.....	119-121
Appendix II.—The emission spectrum of the Hefner lamp.....	122-123
Appendix III.—Electrification of radiometer vanes.....	124-125
Appendix IV.—Absorption of solids in solution.....	126-128
Appendix V.—Water of crystallization.....	129-131
Appendix VI.—Indices of refraction of rock salt.....	132-134
Appendix VII.—Correction of the work of Julius.....	135
Tables:	
Table I.—Line spectra of gases.....	136
Table II.—Line spectra of liquids and solids.....	136
Table III.—Observed transmission of benzaldehyde.....	137-139
Table IV.—Observed transmission, using a quartz prism at constant minimum deviation.....	140-141
Table V.—Maxima of infra-red absorption band—gases.....	142
Table VI.—Maxima of infra-red absorption bands—liquids and solids.....	143-146
Table VII.—Observed transmission through gases.....	147-148
Tables VIIIA to VIIIF.—Observed transmission through liquids and solids .....	149-165
Transmission curves .....	166-285
PART II.—INFRA-RED EMISSION SPECTRA.	
Chapter I.—Introduction .....	289-294
Historical .....	289-294
Infra-red spectrum.....	289-292
Visible spectrum.....	292-293
Temperature, dissociation, etc.....	293-294
Chapter II.—Scope of present investigation.....	295-301
The radiometer.....	295-298
Table I.—Sensitiveness of different instruments.....	298
Table II.—Sensitiveness of radiometer.....	299
Other experimental details.....	300-301
Object of the investigation.....	301
Chapter III.—Infra-red emission spectra of metals.....	303-322
Carbon arc.....	305-306
Sodium .....	306-307
Lithium .....	307
Potassium .....	307-308

PART II—Chapter III—Continued.		Page
Infra-red emission spectra of gases in vacuum-tubes.....		308-319
Clèveite gas.....		311
Water vapor.....		311-312
Hydrogen .....		312-313
Oxygen .....		313
Carbon dioxide .....		313-314
Carbon monoxide .....		314-315
Ethyl alcohol .....		315
Nitrogen .....		316-318
Ammonia .....		318-319
Radiation from a vacuum-tube when heated externally.....		319-321
Radiation from a black body when heated to 100° C.....		321-322
Temperature of gas in the vacuum-tube.....		322
Chapter IV.—Theoretical .....		323-329
Summary .....		330

## ERRATA

Page 8, first line.—For  $\text{CaSO}_3$ , read  $\text{CaSO}_4$ .

Page 17.—For equation  $i_1 = \arcsin(\sin \phi \sqrt{n^2 - \sin^2 i_2} - \cos \phi \sin i_2)$ ,  
read  $i_1 = \arcsin(\sin \phi \sqrt{n^2 - \sin^2 i_2} - \cos \phi \sin i_2)$

Line 25.—For “emerge from,” read “enter”.

Page 59, the ninth line from the bottom.—For  $\text{CH}_3-\text{O}-\text{N}$ , read  $\text{CH}_3-\text{O}-\text{N}=\text{O}$ .

Page 109, line 7.—For “caymol” read “cymol”.

Page 135, in the third column from the end of the table, the “corrected” values are shifted one line. Read  $14.1b = 9.44 \mu$ , instead of  $14.1b = 9.7 \mu$ , etc.



## PREFATORY NOTE

Originally it was intended to issue the report on "Absorption Spectra" and that on "Emission Spectra" separately. The publication of the former was unavoidably delayed, and, in the meantime, the latter being ready, the two are now combined into one volume, as Parts I and II. The arrangement of the separate parts has not been altered, however, and the appendices, which one would naturally find at the end of the volume, occur at the end of Part I, to which they belong.

PART I

---

INFRA-RED ABSORPTION SPECTRA





## CHAPTER I.

### INTRODUCTION.

The free vibration periods of molecular aggregations may be studied by means of their emission or absorption spectra. Emission generally implies a high temperature and uncertainty of the composition of the radiator, due to dissociation; hence it is more advantageous to study a substance at a low temperature by means of its absorption spectrum, since we then have a more definite knowledge of its composition. This is especially true of the highly complex compounds which are so abundant in organic chemistry.

Although generally assumed that in gases the molecules have the advantage of a greater freedom of vibration, it will be shown in the present paper that, starting with a simple liquid or solid compound, the free vibration of a given molecule or radical is not always seriously modified as the molecular complexity of the compound is increased. In fact, it has been found that there may be two sets of particles (or "ions"), which vibrate side by side, yet still retain the free period that they had when present, alone, in a simpler compound. Furthermore, their free vibration periods, manifested as absorption maxima, occasionally seem to repeat themselves harmonically throughout the spectrum investigated. This presence of groups of ions, each group having its own free period of vibration, is in accord with present ideas of absorption and anomalous dispersion.

Previous investigations of infra-red absorption spectra have never been extended farther than about  $7\mu$  for alcohols and to about  $10\mu$  for several other compounds. Now, it so happens that with the limited dispersion at our disposal (if that be the true reason), all carbohydrates investigated show a large absorption band between the wave-lengths  $3.0\mu$  and  $3.5\mu$ , and then there are, as a general rule, *no marked bands* until we arrive at  $6\mu$ . Beyond this point, to the limit of the working transparency of rock salt at  $15\mu$ , there are numerous large, well-defined bands. These facts were noticed in some preliminary work, when it became evident that, in order to gain a better knowledge of infra-red absorption spectra than obtained for the region up to  $7\mu$ , a very extended<sup>1</sup> and systematic investigation of the spectrum beyond this point would be necessary, in magnitude not unlike Kayser and Runge's work on the emission spectra of the metals, for the optical region.

---

<sup>1</sup>Subsequently it was found that this was the conclusion of all the preceding investigators in this field, who, however, never made further contributions to the work.

However, in infra-red work we are confronted with a difficulty not encountered in the optical region, viz., the permanent registration of the spectra under investigation. In the optical region we can photograph the spectra without much delay. In the infra-red, photography has not yet been possible beyond  $1.2 \mu$ , and, instead of being able to procure the entire spectrum simultaneously by projecting it upon a photographic plate, it is necessary to begin at one end of it, and with suitable apparatus explore point after point until we reach the other end.

As a consequence, the process of mapping infra-red spectra, whether due to emission or absorption, is, at best, a slow and tedious one. However, as a compensation for all this, with the limited dispersion at our disposal, the spectra, which are a series of curves, are quite simple, so that the process of "measuring up the plates" is of no importance. After this we are ready to study the curves individually and collectively.

The present investigation was begun while the author was a graduate student, at Cornell University, during the first three months of 1903. During that time the absorption spectra of 38 compounds were explored to  $14 \mu$ . It then became evident that, in order to gain a better knowledge of infra-red spectra than obtained at that time, a very extended and systematic investigation would be necessary. This was made possible under an appointment as Research Assistant by the Carnegie Institution of Washington during the year following June, 1903.

The successful completion of this investigation has placed me under deep obligations to numerous persons, to all of whom I am very grateful for services rendered. In particular would I mention Prof. E. L. Nichols, who placed every facility of the laboratory at my disposal and did for me many other deeds of kindness, and his colleague, Prof. E. Merritt, whose advice and suggestions were also asked. Professor Nichols has also read several chapters of this manuscript. In the Department of Chemistry I am indebted to Prof. L. M. Dennis for the facilities of the gas laboratories, to Prof. W. R. Orndorff for the use of chemicals, and, last but not least, to Dr. J. R. Teeple, whose advice and suggestions on the chemical side of this subject were constantly sought. To Profs. A. C. Gill and H. Ries, of the Department of Geology, I am also indebted for material placed at my disposal. It is a further pleasure to acknowledge the generosity of Prof. C. F. Mabery, of Case School of Applied Science, who presented me with 25 selected samples of pure distillates of petroleum, which could not have been procured elsewhere. When one considers that it has taken seven years to prepare them, and that his collection is the most complete in existence, the value of the accession of these samples to the list of compounds investigated becomes apparent.



## CHAPTER II.

### HISTORICAL.

In 1882 Abney and Festing,<sup>1</sup> by means of photography, investigated the absorption spectra of 52 compounds to  $1.2\mu$ , which was the limit of the sensibility of their photographic plates. They found many interesting relations among the absorption bands, which are of the greatest importance in the present investigation, since their work is in the region which is difficult to explore on account of the small dispersion and the numerous small bands which can not be detected without other measuring devices than photography. Certain radicals were found to have distinctive absorption bands at about  $0.7\mu$  and  $0.9\mu$ . The ethyl,  $\text{CH}_3$ , series gave a line at  $0.74\mu$  and a second band at about  $0.92\mu$ . Hence they decided that "when we find a body having a band at  $0.74\mu$  and another beginning at  $0.907\mu$  and ending at  $0.942\mu$  we may be pretty sure that we have an ethyl radical present. In the aromatic group (*c. g.*, benzene) the critical line is at wave-length  $\lambda = 0.867\mu$ . If that line be connected with a band we feel certain that some derivative of benzene is present." They found remarkable coincidences in ammonium hydroxide, benzene, aniline, diethyl aniline, etc. The presence of oxygen in a compound was observed to sharpen certain bands. They call attention to the "remarkable fact that the  $0.866\mu$  band of the sun should be the basic lines of the benzene series," and "it would not be at all surprising to find that  $\lambda = 0.76\mu$  was another nucleus of a hydrocarbon group." The recurrence of these lines is not to be overlooked in considering others far in the infra-red, which, like those of Abney and Festing, are broadened in some compounds and narrow in others. They found a marked linear spectrum for chloroform,  $\text{CHCl}_3$ , but could not detect these lines in carbon tetrachloride,  $\text{CCl}_4$ . Hence, they concluded that the C and Cl seem to have nothing to do with the linear spectrum observed in chloroform and, since two lines of water are coincident with those in the spectrum  $\text{HCl}$ ,  $\text{HNO}_3$ ,  $\text{H}_2\text{SO}_4$ ,  $\text{NH}_4\text{OH}$ , etc., that hydrogen must be the cause of the lines.

Again, in some of the compounds containing oxygen, certain lines coincided with the iodides, which were free from oxygen, and they "were forced to the conclusion that there must be some connection

<sup>1</sup>Abney & Festing: Phil. Trans., 172, p. 887, 1882.

between the one and the other, since such an agreement could not be fortuitous."

From 1889 to 1890 Ångström,<sup>1</sup> using a bolometer and rock-salt prism and lenses, found the absorption of CO and CO<sub>2</sub>. He also found the absorption spectra of methane, ethylene, ether, benzene, and carbon disulphide, several of the latter in the vapor and also the liquid state. His work extended to about 8  $\mu$ , and showed that the maxima of liquids and their vapors are coincident. He found the absorption band of CO at about 4.6  $\mu$ , and that of CO<sub>2</sub> at about 4.3  $\mu$ , which would indicate that the location of the maximum does not depend upon molecular weight.

About this time Julius<sup>2</sup> investigated the absorption spectra of some 20 organic compounds. He used a bolometer, and a prism and lenses of rock salt. His work extends to 10  $\mu$ , which by his straight-line extrapolation from 5  $\mu$  was supposed to be 16  $\mu$ . He used a cell hollowed out of rock salt, about 0.2 mm. in thickness, and found that about one-third of the substances, mostly alcohols, became opaque at 7  $\mu$ . He found that all compounds containing the methyl, CH<sub>3</sub>, group had an absorption band at 3.45  $\mu$ . The conclusion reached from this investigation, which had been the most extensive thus far, was that the absorption of heat waves is due to intramolecular movements; in other words, the internal structure, *i. e.*, the grouping of the atoms in the chemical molecule, determines the character of the absorption. He found that the chemical atom lost its identity in a compound; *i. e.*, the effect is not "additive," so that one can not foretell the absorption spectrum of the compound from a knowledge of the spectra of the constituent elements.

This conclusion that the constituent atom loses its absorbing power in a compound is further substantiated by the fact that of the six compounds containing chlorine investigated by Julius not one showed the Cl band found by Ångström<sup>3</sup> at 4.28  $\mu$ .

Donath,<sup>4</sup> in 1896, using a quartz prism and a bolometer, investigated half a dozen compounds (mostly the essential oils), and concluded that the absorption is intermolecular and not intramolecular, as found by Julius. His work extended to 2.7  $\mu$ , and covered the region of "practical significance," as he expressed it. For the aromatic compounds and the fatty oils he found maxima common at 1.69  $\mu$  and 2.2  $\mu$ . To my mind there is not sufficient evidence to draw conclusions like the above. However, after subsequent investigations by other observers on pure

<sup>1</sup>Ångström: Öfversigt Af Kongl. Vetenskaps-Akadem. Förhandl., Stockholm, S. 549, 1889; S. 549, 1889; S. 331, 1890.

<sup>2</sup>Julius: Verhandl. Koninkl. Akad. Amsterdam, Deel I, No. 1, 1892.

<sup>3</sup>Ångström & Palmer: Öfversigt Kongl. Vet. Akad., No. 6, p. 389, 1893.

<sup>4</sup>Donath: Ann. der Physik (3), 58, p. 669, 1896.

compounds, the work is valuable in showing that the spectra of the pure compounds were not seriously disturbed when they existed in the impure state in the essential oils.

Aschkinass,<sup>1</sup> using a flint-glass and a fluorite prism, and a mirror spectrometer, investigated the absorption spectrum of water to  $8\mu$ . He found characteristic maxima located at  $0.77\mu$ ,  $1.0\mu$ ,  $1.25\mu$ ,  $1.50\mu$ ,  $1.94\mu$ ,  $2.05\mu$ ,  $3.06\mu$ ,  $4.7\mu$ , and  $6.1\mu$ . Paschen<sup>2</sup> found the  $3\mu$  band at  $2.916\mu$ ,  $2.975\mu$ , and  $3.024\mu$ , depending upon the thickness of the film, while the second large maximum was found at  $6.06\mu$ . This was followed by the study of six alcohols, by Ransohoff,<sup>3</sup> his object being to learn the effect of the OH-group. He found marked bands at  $1.71\mu$ ,  $3.0\mu$ , and  $3.43\mu$ , and tacitly concludes that since this  $3.0\mu$  band agrees with the one found by Aschkinass, it is a characteristic of the hydroxyl-group. Although the alcohols were "chemically pure," that is a different question from the one of having them "water free," which he does not consider. This question will be considered later on. It is of interest to note that the  $1.71\mu$  band is harmonic with the one at  $3.43\mu$ , just as is true of the water bands at  $3\mu$  and  $6\mu$ .

The deepest exploration ever made into the infra-red is that of Rubens and Aschkinass,<sup>4</sup> who, using a sylvite prism, found the absorption of  $\text{CO}_2$  and water vapor to  $20\mu$ . They found  $\text{CO}_2$  transparent except at  $14.7\mu$ , while water vapor has a series of maxima throughout the whole region.

In 1899 and 1900 Puccianti<sup>5</sup> explored a number of benzene derivatives by means of a quartz prism, mirror spectrometer, and radiometer. He found that all compounds, in the molecules of which carbon is combined directly with hydrogen, presented a maximum at  $1.71\mu$ , while all the benzene derivatives have two other maxima in common at  $2.18\mu$  and  $2.49\mu$ . He found his results in agreement with the "hypothesis that the absorption depends upon the groups of atoms which exist in the molecule." The isomeric xylenes exhibit absorption spectra almost but not completely identical.

A series of double refracting crystals have been investigated by Königsberger.<sup>6</sup> He used a fluorite prism and bolometer. The observations of most interest here are that impurities changed the absorption curve, but not the maxima, and that *water of crystallization*, in com-

<sup>1</sup>Aschkinass: Ann. der Physik (3), 55, p. 406, 1895.

<sup>2</sup>Paschen: Ann. der Physik (3), 53, p. 336, 1894.

<sup>3</sup>Ransohoff: Inaug. Diss. Berlin, 1896.

<sup>4</sup>Rubens & Aschkinass: Astrophys. Jour., 8, p. 181, 1898.

<sup>5</sup>Puccianti: Nuovo Cimento, 11, p. 241, 1900.

<sup>6</sup>Königsberger: Ann. der Physik (3), 61, p. 687, 1897.

pounds like gypsum,  $\text{CaSO}_3 + 2\text{H}_2\text{O}$ , has the same maxima at  $1.5 \mu$  and  $2.0 \mu$  as those found in pure water. It is unfortunate that he did not compare the  $2.95 \mu$  band of muscovite (which has the H and O chemically combined) with pure water, since Paschen and Aschkinass disagree on the exact location of this band. This disagreement will be noticed in the present work.

The most recent work in this line is that of Iklé,<sup>1</sup> who used a fluorite prism and a linear thermopile  $10'.5$  wide. He investigated the relation of absorption and thickness of the liquid used. He found no relation between the refractive indices and dielectric constants, nor could he detect a shift in the maxima for increase in molecular weight. Unfortunately the thermopile used was wide, and for this reason the location of the maxima is not very exact.

#### OTHER INVESTIGATIONS.

Kundt<sup>2</sup> investigated a series of solutions showing anomalous dispersion. He observed that, in different colorless solvents, the absorption band of the solute is shifted toward the longer wave-lengths with increase in the *refractive* and *dispersive power* of the solvent. H. W. Vogel<sup>3</sup> found that this is not true, but that the shift occurs in *both* directions. A spectrophotometric study of indophenols by Camichel and Bayrac<sup>4</sup> also shows that Kundt's law of the influence of the solvent on the position of the maxima of absorption bands does not hold, for the shift was from red to violet in an ortho-phenol, while upon substituting a *meta*- in an indophenol the displacement was from red to violet or vice versa. Since then numerous investigations<sup>5</sup> have afforded verification of the statement that the absorption bands shift in *both* directions.

The most thorough and at the same time the most important investigation of solutions, for the optical region, is that of G. Krüss,<sup>5</sup> who examined 64 different compounds dissolved in  $\text{CS}_2$ ,  $\text{CHCl}_3$ , and  $\text{C}_2\text{H}_5\text{OH}$ . He observed that by the introduction of a methyl ( $\text{CH}_3$ ), ethyl ( $\text{C}_2\text{H}_5$ ), oxymethyl ( $\text{OCH}_3$ ), or carboxyl ( $\text{COOH}$ ) group, or bromine, etc., in the molecule of the solute, the maximum of the absorp-

<sup>1</sup>Iklé : Phys. Zeit., 5, p. 271, 1904.

<sup>2</sup>Kundt : Pogg. Ann., 1871-1872, and Weid. Ann., 4, p. 34, 1878.

<sup>3</sup>Vogel, H. W. : Berl. Monatsber., p. 409, 1878.

<sup>4</sup>Camichel & Bayrac : Jour. de Phys., III, 11, p. 148, 1902.

<sup>5</sup>G. Krüss : Zeitt. f. Phys. Chem., 2, p. 372, 1888 ; *ibid.*, 18, p. 559, 1895. Schültze : *Ibid.*, 9, p. 109, 1892. Grebe : *Ibid.*, 10, p. 673, 1892. G. Krüss : Ber. der Deutch. Chem. Gesell., 22, p. 2065, 1889. Krüss & Oecomonides : *Ibid.*, 16, p. 2051, 1883 ; 18, p. 1426, 1885. Bernthsen & Goske : *Ibid.*, 20, p. 924, 1887. Liebermann & Kostanski : *Ibid.*, 19, p. 2327, 1886.

tion band is shifted to the *red*, while by the introduction of a nitro ( $\text{NO}_2$ ) or an amide ( $\text{NH}_2$ ) group the band is shifted toward the *violet*.

Subsequent writers on this subject always mention the shift toward the *red with increase in molecular weight*, but rarely mention the fact that there is also a *shift in the opposite direction*; so that, unless one is familiar with the original work, the quotation is misleading. In quoting such a complete investigation which records two well-defined series of phenomena, apparently opposed to each other when considering the question of molecular weight, it seems highly desirable to have the complete observation rather than the part which fits the particular problem under investigation. This is especially desirable in work like that of Ransohoff, who thought that a small sharp band found at  $4.9 \mu$  in  $\text{CH}_3\text{OH}$  was shifted to  $5.2 \mu$  in  $\text{C}_2\text{H}_5\text{OH}$ , "which would be an example like that of Krüss." He found no shifting for larger bands.

The following is what Krüss (loc. cit.) observed for indigo:

Shift to red..	{	Indigo in $\text{CHCl}_3$ ..... $\lambda$ max. at $0.6048 \mu$
		Methyl indigo in $\text{CHCl}_3$ ..... $\lambda$ max. at $0.61917$
		Ethyl indigo in $\text{CHCl}_3$ ..... $\lambda$ max. at $0.6526$
Shift to violet	{	Indigo in $\text{CHCl}_3$ ..... $\lambda$ max. at $0.6048$
		Nitro-indigo in $\text{CHCl}_3$ ..... $\lambda$ max. at $0.5858$

	Water solution.	Alcohol solution.
Fluorescein.....	$\lambda$ max. $0.494 \mu$	$\lambda$ max. $0.4808 \mu$
Dibrom fluorescein.....	$0.5048$	$0.5094$
Tetrabrom fluorescein..	$0.5159$	$0.5251$

This is a shift of  $0.0055 \mu$  per atom of Br, which proportionality was found not to hold true.

E. Vogel<sup>1</sup> found that the occurrence of chlorine in the meta-position in the "Carboxylrest" in fluorescein shifts the absorption maximum more toward the red than when it is in the ortho-position. As with Krüss, he found that the more hydrogen atoms that have been substituted, the greater is the shift of the maximum of the absorption band, but that the shift is *not* proportional to the number of hydrogen atoms substituted.

The fluorescence and absorption of dyestuffs in solution and in solid gelatin was investigated by Stenger.<sup>2</sup> He concludes that the absorption of light depends primarily upon the size of the physical molecule, and it is only when a change in the aggregation conditions, or in solving

<sup>1</sup>E. Vogel : Ann. der Physik (3), 43, p. 449, 1891.

<sup>2</sup>Stenger : Ann. der Physik (3), 33, p. 578, 1888.

process, is accompanied by a change in the physical molecule that a change occurs in the absorption spectrum; and, vice versa, each change in the character of the absorption spectrum is connected with a change in the physical molecule. Hence, so long as the physical molecule has not changed, Kundt's law, of shifting toward the red, holds. In a solid state, *i. e.*, at a low temperature, the physical molecule is more complex. As a test of this last question we have the observations of Wiedemann<sup>1</sup> on iodine solutions. Iodine in CS<sub>2</sub> is violet, similar to the gaseous condition, while in alcohol it is brown, like melted iodine. The latter is the more complicated. Hence, if this assumption be true, we would expect the violet carbondisulphide solution to turn brown on cooling. This is the case. He also observed that cold brown solutions of iodine in stearic and oleic acid became violet on heating to 80°.

The absorption spectra of the alkaloids has been studied by Hartley<sup>2</sup> and others, and a remarkable similarity has been observed in their absorption spectra. After examining 30 alkaloids they think that, "as a general rule, those which agree closely in structure give similar absorption spectra, while those which differ in essential points of structure give dissimilar spectra. Most of these compounds have high molecular weight, and changes may be effected in their molecules without alteration of their spectra, which, in substances of lower molecular weight, would be attended by wide differences." Hence the alkaloids differ only in details of structure. This effect will be noticed, in the present work, for petroleum distillates.

The effects of dilution, of temperature, of acids, and of different solvents upon the absorption spectra of solutions of didymium and erbium salts have been investigated by Liveing.<sup>3</sup> He found that the spectra of the different salts of the same metal in a dilute condition are identical. Ostwald interprets this by saying that the spectrum, common to all the salts of the same metal, is due to the metallic ions. All the tests applied by Liveing contradict this assumption. He explains his observations by assuming that, in solution, the molecules are ruptured by collisions, but immediately recombine. Increased temperature and concentration mean more frequent encounters amongst the molecules and more frequent ruptures, which are counterbalanced by the more frequent encounters of the parts. These effects will compensate each other and leave the average number of absorbing parts of molecules constant, under changes of temperature or concentration as observed. In other

---

<sup>1</sup>Wiedemann : Ann. der Physik (3), 41, p. 299, 1890.

<sup>2</sup>Hartley : Phil. Trans., Part II, 47, p. 691, 1885; Hartley & Dobbie : Phil. Trans., 77, p. 846; Dobbie & Lawder : Chem. Soc. Jour., 83 and 84, pp. 605 and 626, 1903.

<sup>3</sup>Liveing : Trans. Cambridge Phil. Soc., XVIII, p. 298, 1900.



words, the absorption depends upon the form of the internal energy of the vibrating mass, *i. e.*, on its *structure*.

Laubenthal<sup>1</sup> found for the absorption spectra of solutions of the chlorides of the alkali metals that the absorption bands shift toward the red with increasing atomic weights, and that the shifts are proportional, so that the ratio between the wave-lengths of the two absorption bands of each spectrum is constant for each group of metals. The absorption spectra are thus brought in line with the emission spectra, and also the densities and melting points, as having their origin in the same fundamental cause.

In addition to these observations we have those of Stöckl<sup>2</sup> on solutions of fuchsine, cyanine, and iodine, in which the maximum of the absorption band depends upon the solvent. This corresponds to my own work on iodine in solution.<sup>3</sup>

To crown all this we have the "electromagnetic theory of selective absorption in isotropic nonconductors" of Planck,<sup>4</sup> in which Stöckl's observations are applied to the question of intra-molecular resonance. This is of great interest, since it is the first theoretical recognition of the possible unification of the selective absorption of a solution and the selective absorption of the solvent. Whether there is a distinction between the two is to be discussed later on. It will be sufficient to notice that in my work on iodine solutions (*loc. cit.*) the selective absorption of iodine (solute) is lost at  $7.3\mu$  in the infra-red, where solid iodine has a large absorption band, while the band continues in the visible spectrum, just as though there was a resonance of small particles in the optical region which is out of tune in the infra-red. (See, however, Appendix IV, on transparency of solutions in the infra-red.)

## SOLVENTS.

In the visible spectrum the absorption of but few solvents has been investigated. Schön<sup>5</sup> investigated methyl, ethyl, and amyl alcohol for columns of liquid 1.6 to 3.7 meters, and found a shifting of the maxima to the red, as follows:

Maxima.	I.	II.	III.
	$\mu$	$\mu$	$\mu$
CH <sub>3</sub> OH.....	0.6430	0.6428	.....
C <sub>2</sub> H <sub>5</sub> OH.....	.6515	.6328	0.5591
C <sub>5</sub> H <sub>11</sub> OH.....	.6591	.6362	.5627

<sup>1</sup>Laubenthal: *Ann. der Physik*, 7, p. 851, 1902.

<sup>2</sup>Stöckl: *Inaug. Diss.*, Tübingen, 1901.

<sup>3</sup>Coblentz: *Phys. Rev.*, xvi, 1, 1903.

<sup>4</sup>Planck: *Sitzungsber. d. Akad. d. Wiss.*, Berlin, Nos. 22 and 25, 1903.

<sup>5</sup>Schön: *Ann. der Physik* (2), 6, p. 267, 1879.

The amyl alcohol was yellow in color for the 1.6-meter cell, but colorless for a small thickness.

#### ULTRA-VIOLET.

Soret and Rillet,<sup>1</sup> using a fluorescent ocular, examined different thicknesses of ethyl, butyl, and amyl nitrates, and found that, to completely absorb certain cadmium lines used, it required the least thickness of amyl nitrate, while greater thicknesses were required for the butyl and ethyl, which is interpreted that with increasing molecular weight the absorption increases toward the longer wave-lengths. The benzene derivatives have been investigated by Pauer,<sup>2</sup> by photography. The benzene spectrum consists of four groups of bands. In the xylenes and aniline the original benzene spectrum seems crowded together and shifted toward the visible spectrum. For the liquid state the bands lie farther toward the visible spectrum than for the vapor phase, so that "if we consider each liquid body as a solution in itself, then Kundt's law holds for shift of the band with increase in molecular weight of the solvent." This seems to be giving the broadest possible interpretation of this law. In toluene the substitution of a  $\text{CH}_3$  group has not merely destroyed the arrangement of the lines found for benzene, but the new spectrum consists of a series of double lines, not regularly distributed. The isomeric xylenes are of the most interest. The *ortho* has scarcely any bands, while the *meta* has three and the *para* has five bands, which show no regularity. The results show that the *arrangement* of the atoms has a great influence on the absorption spectra, just as previously found by Hartley.<sup>3</sup>

In the benzene spectrum Pauer observed several groups of lines in which the "constant difference" of the vibration numbers is 98. He observed that the absorption spectra of vapors show lines or groups of lines which become bands in the liquid condition. Traces of benzene in the air were sufficient to show the four strong groups of lines. He also found that for nitro- or amido-benzene the bands shift toward the longer wave-lengths (to the red), while Krüss found exactly the opposite (to the violet). The question whether this is a real shift will be discussed in connection with the present investigation.

Martens<sup>4</sup> examined the spectrum of a number of transparent non-conducting elements (*e. g.*, C. P. S. Cl. Se. Br. I.) and found that the wave-length corresponding to the principal absorption band in the ultra-

<sup>1</sup>Soret & Rillet; Compt. Rend., 89, p. 147, 1879.

<sup>2</sup>Pauer: Ann. der Physik (3), 61, p. 363, 1897.

<sup>3</sup>Hartley: Phil. Trans., 170, p. 270, 1879.

<sup>4</sup>Martens: Ann. der Physik (4), 6, p. 603, 1901.

violet is approximately proportional to the square root of the atomic weight; and that this wave-length is independent of the state of aggregation of the element, and is unchanged in solution.

The most recent investigation in this region is that of Magini,<sup>1</sup> who examined some of the compounds already mentioned under the work of Pauer,<sup>2</sup> as well as 12 isomers, such as resorcin, hydroquinon, the oxybenzoic acids, and the pthalic acids. Like Pauer, he observed a shift toward the longer wave-lengths when an amido or carboxyl group is substituted for a hydroxyl group. For total absorption the arrangement of isomers is *meta*, *ortho*, *para*. Para-compounds have greater effect in forming entirely different absorption spectra. He concludes that the double bond causes the absorption in the ultra-violet, while it makes no difference, in the infra-red, whether the bands are double or single. The double bond can be thought of as changing the elasticity and cohesion in the molecule in such a manner that the molecule will be resonant with ultra-violet light. He finds that the effect of absorption is greatest when the replaceable groups are joined to opposite carbon atoms of the benzene ring, and also when the molecule is symmetrical. Isomers having a double bond have dissimilar absorption spectra. As a whole, he thinks the absorption is caused chiefly by the molecular configuration on the one hand, and by the nature of the compound on the other.

TOTAL ABSORPTION TEMPERATURE. ETC.

The change in diathermancy of liquids with temperature was investigated by Dechant,<sup>3</sup> who found that the transparency of mica did not change for a rise of 120°, while the diathermancy of water decreased. Königsberger<sup>4</sup> found that, in solid selective absorbing media, a rise of temperature shifts the absorption curve toward the long wave-lengths, while for the metals the absorption is constant. The work of Hagen and Rubens<sup>5</sup> on the metals, in which a film so thin that it transmits light but is uniformly opaque in the infra-red, can not be discussed here. Neither the work of Aschkinass and Schafer,<sup>6</sup> who determined the dielectric constants of several compounds for electrical waves, and found that, with increase in molecular weight, the maximum of resonance shifted toward the shorter resonators, which, if properly inter-

<sup>1</sup>Magini : Phys. Zeit., 5, p. 69, and p. 145, 1904.

<sup>2</sup>Pauer, loc. cit.

<sup>3</sup>Dechant : Wien Ber., III, p. 264, 1902 ; Beiblätter, 27, 1, 1903.

<sup>4</sup>Königsberger : Ann. der Physik (4), 4, p. 796, 1901.

<sup>5</sup>Hagen & Rubens : Ann. der Physik (4), 8, p. 432, 1902.

<sup>6</sup>Aschkinass & Schafer : Ann. der Physik (4), 5, p. 489, 1901.

preted, indicates a shift toward the long wave-lengths, as demanded by Kundt's law.

Finally, we have to consider the total absorption of an extended series of carbon compounds by Friedel<sup>1</sup> and by Zsigmondy,<sup>2</sup> using Tyndall's method, substituting a bolometer for a thermopile. They found that the transparency of a compound increases if, other conditions being equal, H, O, OH, or N are replaced by S, or halogens. Absorption does not depend upon the size of the molecule. The carbon atoms have little influence on absorption. As a whole the absorption of radiant heat depends upon the manner of the bonding of the atoms in the molecule, as well as upon the kind of compound in which the atoms of an element are united. If an amido group occurs in a carbohydrate it outweighs the hydroxyl, *e. g.*, an NH group substituted for an H atom in benzene reduces the intensity to one-fifth its original value. This opacity of nitrogen compounds will be noticed in the present work, where it will be shown that *not all* nitrogens are highly opaque.

---

<sup>1</sup>Friedel: Ann. der Physik (3), 55, p. 453, 1895.

<sup>2</sup>Zsigmondy: Ann der Physik (3), 49, p. 531, 1893; 57, p. 639, 1896.

## CHAPTER III.

### DESCRIPTION OF APPARATUS AND METHODS.

The work involves two distinct kinds of activity, viz, mapping the spectra, by means of a series of curves, and studying them. The spectrum is produced by means of a rock-salt prism mounted on a mirror spectrometer. For a source of radiation the "heater" of a Nernst lamp is mounted before the collimator slit. The distribution of the energy in this spectrum forms a smooth, continuous curve. If we interpose a hollow cell of rock salt, containing some compound, between the "heater" and the collimator slit, the distribution of the incident energy in the resulting spectrum will no longer form a smooth, continuous curve. The intensity will now be found to rise and fall, forming a series of maxima and minima. These maxima and minima are characteristic of each compound interposed; and it is with these curves that we are concerned in this work. To obtain these curves very narrow portions of the spectrum are successively projected upon a device (a Nichols radiometer), which is sensible to heat radiation. This is a slow process, but it is the most successful yet devised.

The number of organic compounds is so large, while many are so intimately related, that, after the preliminary work, it became evident that, in order to gain more definite information in regard to absorption spectra than had been obtained by previous investigations, a large number of compounds would have to be examined. This has been done. The absorption spectra of at least 130 compounds of hydrogen and carbon have been explored, the majority of them to  $14\ \mu$  and  $15\ \mu$ . About 30 compounds were examined twice, while 19 were explored to  $2.5\ \mu$ , using a quartz prism. They include solids, liquids, and gases, and belong to the principal groups of organic compounds.

The field is large, while many of the compounds ordered could not be obtained in commerce; hence it was necessary to proceed in this manner. It really amounts to a preliminary survey of the whole field. Subsequent work must be a detailed study of individual compounds belonging to a particular group, now that we know which groups are the most promising of results.

## THE SPECTROMETERS.

The general arrangement of the reflecting spectrometer is shown in fig. 1. The rays enter the instrument through the bilateral slit  $F$ , are brought to parallelism by the concave mirror  $M_1$ , traverse the prism  $P$ , and after being collected by the concave mirror  $M_2$ , are brought to focus on the slit  $F_2$ . The portion of the spectrum which passes through  $F_2$ , which is in the vertical focus, falls upon the exposed radiometer vane. The spectrometer stood in an inner basement room with cement floor, and the radiometer deflections were read through a hole in the wall. As a general rule, however, the temperature of the rooms was fairly constant, so that no difficulty was experienced in making the observations with the door open.

The spectrometer and radiometer were mounted upon a large slab of slate, which lay upon a large table. Although the latter stood upon the cement floor, there was rarely any trouble with earth tremors.

A 35 cm. focal length mirror spectrometer was used for the explorations to  $15 \mu$ . With this instrument the image of the collimator slit was slightly curved. For the region up to  $9.5 \mu$  the spectrometer slits were 0.4 mm. in width, while beyond this point the collimator slit was gradually widened to 1 mm. at  $15 \mu$ . A very considerable portion of the work was repeated to  $7 \mu$ , using a pair of 1-meter focal length, 20 cm. aperture mirrors mounted on a large spectrometer. The figuring of these mirrors was excellent and the slit image was perfectly straight. These mirrors gave about twice the dispersion of the smaller spectrometer, and, although the concentration of the energy in the spectrum was greatly reduced, which resulted in small radiometer deflections, the measurements obtained with them were so uniform in their agreement that for the region from  $3.43$  to  $6.86 \mu$  the results are more trustworthy than those obtained with the smaller apparatus.

With this larger apparatus the spectrometer slits were  $2'$  of arc, while with the smaller they were  $4'$  of arc on the spectrometer circle, so that for the large spectrometer the dispersion was comparable to that of fluorite. With it numerous bands were resolved from  $6$  to  $7 \mu$ , but only occasionally were small bands found in the transparent region from  $4$  to  $5 \mu$ , to be mentioned later, while the  $3$  to  $3.5 \mu$  region was sometimes found complex.

## THE PRISMS USED.

For the region from  $0.8$  to  $2.5 \mu$  a 60 mm. quartz prism, having a refracting angle of  $60^\circ 1' 32''$ , and the small spectrometer were used. For the region beyond  $2.5 \mu$  to  $15 \mu$  a 70 mm. rock-salt prism was

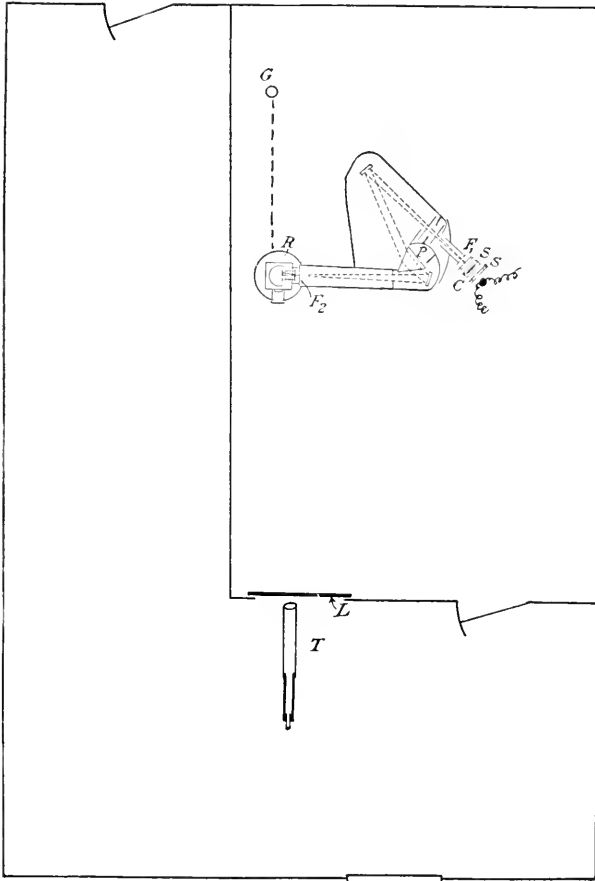

Fig. 1.—Inner room containing radiometer R, spectrometer and prism P, exhaust pump G, lamps and scale L, and telescope T. C is the holder for the absorption cell. S is the shutter, H the Nernst lamp-heater.

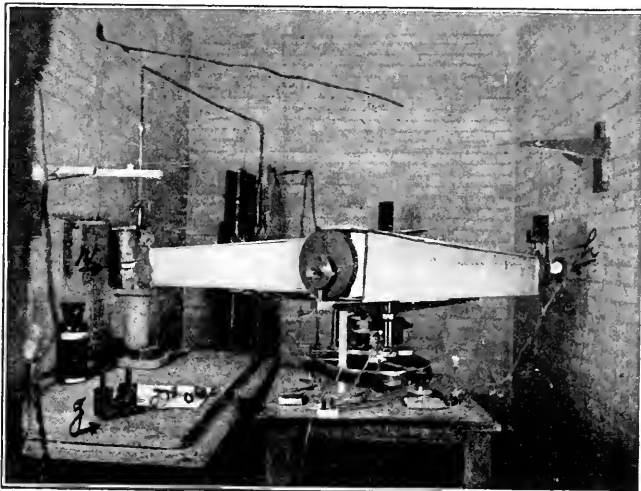

Fig. 1A.—Large spectrometer with Nernst heater, *h*, to the right, and radiometer, *r*, to the left. The gas-cell holder and glass cells are shown at *g*; Geissler pump in the rear. Photograph taken through doorway of inner room.





employed. Its refracting angle was  $59^{\circ} 57' 43''$  for the center of the faces. The prism was securely and accurately mounted upon the spectrometer table, and a dish containing phosphorus pentoxide was placed over it. When not in use it was covered with a glass bell-jar, as a further protection against moisture.

The whole apparatus was inclosed in a tin box to exclude air currents, moisture, and stray radiation from the radiometer and prism (fig. 1 A).

With the small spectrometer the prism was set at minimum deviation of the sodium lines by means of a Gauss eye-piece, which was placed in the focal plane of the second mirror.

#### ADJUSTMENT AND CALIBRATION OF APPARATUS.

Since the radiometer must remain stationary, the successive portions of the spectrum must be projected upon its vane by one of two methods, viz, by rotating the prism, or by rotating the collimating arm of the spectrometer. This involves the problem of keeping the prism at minimum deviation. With the small spectrometer it was not possible to have the different rays pass through the prism at minimum deviation by rotating the prism table as in the mirror-prism device described by Wadsworth.<sup>1</sup> An automatic attachment, like that used by Paschen and others, continued to give trouble, so it was discarded and the collimating arm was moved, while the prism remained stationary after setting it for minimum deviation of the sodium lines. As a consequence, when the collimating arm is revolved about the prism, the different wave-lengths emerge from the prism at a variable angle, which is, of course, no longer the minimum deviation angle, except for the sodium lines. This makes the computation of the dispersion curve more complex, since we can use the minimum deviation formula

$$n \sin \frac{\phi}{2} = \sin \left( \frac{\phi + \delta}{2} \right)$$

only for the sodium lines. The appropriate formula as used by Aschkinass<sup>2</sup> is

$$i_1 = \arcsin \left( \sin \phi \sqrt{n^2 - \sin^2 i_2} - \cos \phi \sin i_2 \right)$$

where  $i_1$  is the angle of *emergence*,  $\phi$  is the angle of the prism,  $n$  is the index of refraction, and  $i_2$  is the angle of *incidence* for the new wave-length. The deviation,  $\delta$ , from the sodium line is then,  $\delta = i_2 - i_1$ , where the sodium line is at minimum deviation. This formula is very unwieldy, and I preferred computing the calibration (dispersion) curve from the following simpler relations, from which the aforesaid equa-

<sup>1</sup>Wadsworth: Phil. Mag. (5), 38, p. 346, 1894.

<sup>2</sup>Aschkinass: Ann. der Physik (3), 55, p. 406, 1895.

tion can be derived. It has been noticed that as the collimator arm is rotated the different wave-lengths must emerge from the prism at a constant angle in order to be reflected into the radiometer slit. Hence we need to compute this quantity,  $\sin i$ , but *once*, viz, for the sodium lines. Reverse the rays. Then from the relations,  $\sin i_1 = n \sin r_1$ ,  $r_2 = \phi - r_1$ , and  $\sin i_2 = n \sin r_2$ , we obtain the value of  $i_2$  very readily, while the deviation is  $\delta = i_2 - c$ , where  $c = \phi - i_1$ .

The indices of refraction of rock salt used in these computations are due to Rubens and Trowbridge,<sup>1</sup> to Paschen,<sup>2</sup> and to Langley.<sup>3</sup> The indices of refraction of quartz are due to Rubens.<sup>4</sup>

#### ADJUSTMENT OF LARGE SPECTROMETER.

The question of harmonic relations among the absorption bands depends so much upon the accuracy of the adjustment of the apparatus that it will be necessary to go into details, even at the risk of being prolix. After struggling with the question of harmonics for a year and a half, in which the prism has been remounted and adjusted a great many times, it was found that the use of the prism by the non-minimum deviation ("constant emergence") method is precarious, since a slight error in the adjustment of the setting for minimum deviation of the sodium line may cause a great error in the infra-red. However, this is not so difficult as obtaining the "zero setting," in which it is necessary to project the image of the sodium lines within the radiometer slit.

Accordingly, the large spectrometer was set up. It was used in two ways, viz, the constant emergence method already described, and also the mirror-prism method of Wadsworth (*loc. cit.*), in which the prism table is rotated and the spectrometer arms remain fixed. In the latter all the different rays pass through at minimum deviation, after setting for minimum deviation of the sodium lines.

The long spectrometer arms, 1 meter, make the apparatus unwieldy, and since the prism and its accompanying mirror (fig. 2) were also large, all the adjustments were made after mounting the latter upon its table.

After adjusting the faces of the prism about a vertical axis by reflecting the beam from the collimating slit back on its own path and forming an image of the slit upon the slit, from the two faces, the prism and mirror faces were made parallel in the same manner by tilting the mirror in such a manner, by means of adjusting screws, that the beam reflected

<sup>1</sup>Rubens & Trowbridge; *Ann. der Physik* (3), 61, p. 224, 1897; also Rubens: *Ann. der Physik* (3), 53, p. 267, 1894.

<sup>2</sup>Paschen: *Ann. der Physik* (3), 53, p. 337, 1894.

<sup>3</sup>Langley: *Annals Astrophys. Obs.*, vol. 1, p. 258.

<sup>4</sup>Rubens: *Ann. der Physik* (3), 45, p. 260, 1892; 46, p. 529, 1892.

from the mirror also forms an image of the slit upon the slit. Since the slit lies in the axis of the collimating mirror, the prism and its mirror are truly vertical and parallel only when they reflect the image of the slit back upon the slit.

The angle  $m$  (fig. 2) between the mirror and the prism face was determined by reflecting the beam from the prism face back upon its path, thus forming an image upon the slit (or, better still, upon a fine line on a piece of paper just above it) and then noting the angular rotation of the prism table necessary to reflect the slit image upon the mirror back

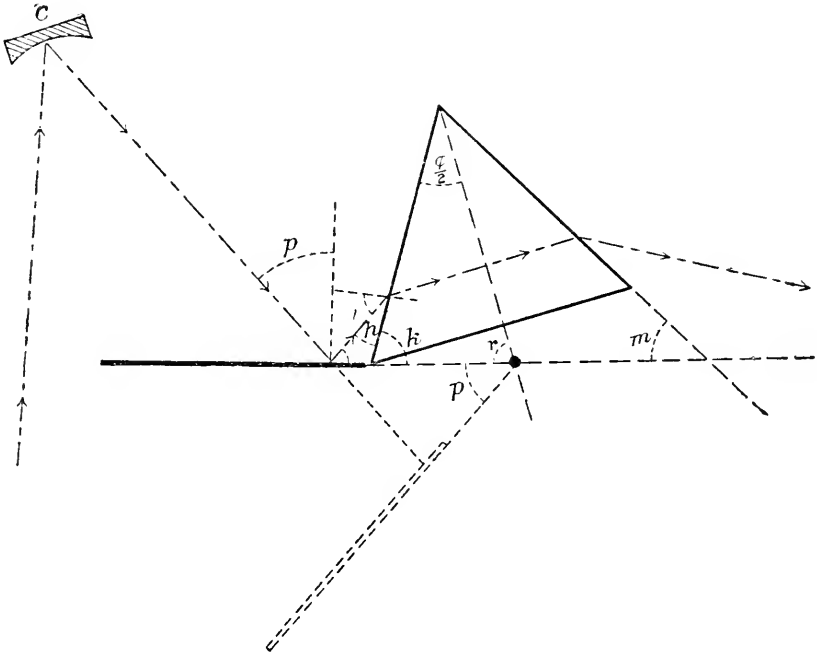

Fig. 2.

upon the slit. By this method the variation in the settings was only from  $5''$  to  $6''$  from the mean.

To determine the "zero setting" of the instrument it is necessary to determine the angle  $p$  (fig. 2), at which the incident rays from the collimating mirror must fall upon the prism mirror, in order that the rays reflected from it will enter the prism and emerge from it at minimum deviation. If we know this angle for the sodium lines, after fixing the spectrometer arms and rotating the prism table, then all the succeeding wave-lengths will pass through at minimum deviation.

From the equations,

$$k = (90^\circ - p) + (90^\circ - i) = 180^\circ - r - \frac{\phi}{2} \text{ and } r = m + \frac{\phi}{2}$$

we obtain the desired relation,  $p = \phi + m - i$ , where  $\phi$  is the angle of the prism,  $m$  is the angle between the mirror and opposite face of the prism,  $i$  is the computed angle of incidence of sodium light, for minimum deviation, and  $p$  is the *required rotation* of the prism table. All we have to do, then, is to turn the prism-mirror table so that the beam from the slit returns on its own path and forms an image of the slit upon the slit. Then rotate the prism table through the angle  $p$ , and the beam will be reflected from the mirror and enter the prism at the proper angle of incidence for minimum deviation.

A second method of minimum deviation adjustment used by Stewart<sup>1</sup> was also tried, and the results obtained agreed with the preceding.

Using these three methods, viz, the non-minimum deviation (constant emergence, as with the small spectrometer) method, and Wadsworth's mirror-prism device for constant minimum deviation, which was adjusted by the two methods just mentioned, the results obtained were in excellent agreement for the large spectrometer. But when these results were compared with the work done with the small spectrometer it was found that all the maxima, of a certain number of compounds, were shifted by a constant slight amount toward the longer wave-lengths, which would have been unimportant had it not been for the question of harmonics. Now, the work with the small spectrometer had also been found consistent. This was established by the repeated examination of certain sharp emission and absorption bands which were equivalent to the comparison spectrum in the optical region. After weeks of intercomparison only one explanation of this discrepancy could be found, viz, that on account of the slight curvature of the image of the slit found the small spectrometer, in projecting the sodium lines upon the radiometer slit, which served as a "zero reading" in testing the constancy of the adjustments and as a starting point in calibrating the apparatus, the whole spectrum was thrown forward about 30". Consequently every spectrometer circle reading represented a wave-length situated 30" farther toward the infra-red than that indicated on the calibration curve. Applying this correction to about a dozen compounds, the location of the maxima, as found with the small apparatus, coincided exactly with that found with the large spectrometer.

In the discussion of the curvature of the slit, in Kayser's Spectroscopy it is shown that such a shifting toward the long wave-lengths, as noticed above, is likely to occur.

<sup>1</sup>Stewart: Phys. Rev., xiii, p. 257, 1901. (The details of his method of adjustment were given the author in a private letter.)

This is the largest spectrometer yet set up for emission and absorption work. Greater sensitiveness of the radiometer would be necessary in order to be able to use a spectrometer of greater dimensions.

THE RADIOMETER.

The construction of the radiometer is shown in fig. 3, which is a section of the instrument at right angles to the one facing the spectrometer. It was built according to the design of Nichols.<sup>1</sup> The outer case is a block of bronze, 5 by 5 by 10 cm., with an axial boring 3 cm. in diameter. The top was made from the neck of a large round bottle, into which was fitted a glass tube, which led to the exhaust pump. In series with the radiometer and pump was placed a tube containing gold foil on cotton to absorb the mercury vapor, which was found to electrify the vanes and thus cause one of them to adhere to the window. As a further precaution against electrification, the inner rock-salt window was partly covered with tinfoil, which was in contact with the outer case. (See Appendix III.)

There were two lateral borings in the outer case; the one in front of the vanes was 2 cm. in diameter and admitted the energy to be measured upon the exposed vane; the one in front of the mirror, not shown in the figure, was long and narrow and was used to read the deflections of the suspension. This window was closed with plate glass. The windows were placed upon ground surfaces of the casing, which had been covered with a mixture of beeswax and tallow. Around the edges of the windows was a layer of beeswax covered with shellac. After the latter had dried there was no appreciable leaking.

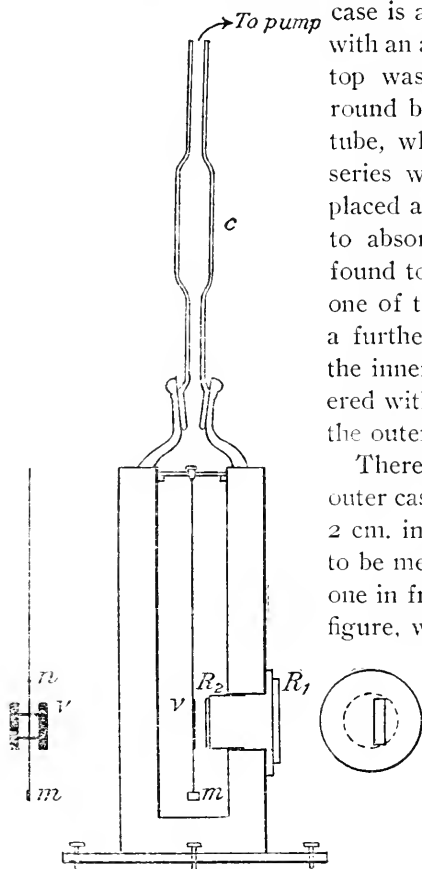

Fig. 3.

V=vanes; M=mirror; R<sub>1</sub>, R<sub>2</sub>=rock-salt windows.

Around the edges of the windows was a layer of beeswax covered with shellac. After the latter had dried there was no appreciable leaking.

<sup>1</sup>Nichols, E. F. : Phys. Rev., IV, p. 297, 1897.

The vanes were suspended from a cross-bar by means of a very fine quartz fiber, made by blowing it out in an oxyhydrogen flame. The vanes were of very thin mica, approximately 15 by 2.5 mm., and were held together by means of glass fibers, the distance between them being about 4 mm. On the line midway between the vanes was fastened a glass fiber, *nm*, which forms the axis of rotation, and carries near its lower end a bit of mirror, made by silvering a thin microscope-glass cover, which was then cut into areas of about 2 by 3 mm. The vanes were blackened by burning camphor gum. To cause the lampblack to adhere better to the mica a very thin coating of beeswax was first applied by means of a hot wire. When the vanes were held above the burning gum the wax softened and the soot was deposited in an even layer. The vanes, mirror, and fiber were fastened by shellac. The total weight of the suspension was about 10 mg. This was rather heavy, but since no other precautions were taken against earth tremors, it was more serviceable than a second one which was lighter. Generally there was no difficulty in reading to tenth millimeters on a scale situated 1.4 meters from the radiometer.

The sensitiveness of the instrument depends very much upon the nearness of the vanes to the inner rock-salt window. This distance was regulated by the tripod screw, which was on the rear side of the radiometer base. The pressure for maximum sensitiveness, measured with a McLeod gage, was from 0.05 to 0.08 mm., while the period was such that the maximum of the deflection was reached in from 30 to 45 seconds, so that it usually required about 1.5 minutes to make a reading. Such a slow period would militate against the use of a radiometer were it not for the fact that the readings are always trustworthy, so that nothing is gained by repeating them.

The deflections also depend upon the dispersion, and the kind of radiator used. For the small spectrometer, using acetylene, the maximum deflections were about 40 cm. on a scale 1.4 meters distant, while with the "heater" of a Nernst lamp they were from 10 to 15 cm. But the latter gives out a stronger radiation from 4 to 10  $\mu$ , and is therefore the more satisfactory. The radiation from this heater, as well as from other clays, will be discussed in Appendix I.

The advantages of the radiometer over the bolometer have been discussed by Nichols.<sup>1</sup> The chief difficulties to be experienced in using a radiometer is shifting of the zero, "drift," which was avoided by inclosing the radiometer case (see fig. 1) in a tin box, packed with wool. This avoided all sudden changes of the "drift," which was then only in

---

<sup>1</sup>Nichols, loc. cit., p. 302.

one direction as the temperature of the room increased, due to the presence of intense radiation from the Nernst "heater."

The drift lasted only a short time, in beginning a series of observations, and after that the shifting for a single reading was rarely greater than 0.1 mm., while generally for a period of 10 to 12 minutes no shifting at all could be detected.

As a consequence the deflections were always trustworthy, even at  $14\ \mu$ , where they were only from 2 to 3 mm., while in passing through absorption bands in this region they were often only from 0.1 to 0.2 mm. Since the rate of increase of a deflection with the time of exposure of the vane to heat follows a logarithmic curve, which increases very rapidly at first, then more and more slowly, and finally being asymptotic, one can make a reading, in the region where the deflections are small, in a shorter time than the actual period of the instrument, thus avoiding a possible drift.

The radiometer slit was mounted upon the spectrometer arm, so that if any shifting occurred in the relative positions of the radiometer and spectrometer<sup>1</sup> it would not affect the location of any point of the spectrum with respect to the slit. This is of importance in measuring the distribution of the energy in the spectrum of the radiator, but in this work we are dealing with the *ratio* of the intensity of the radiation which has *passed through* an absorbing medium to the intensity of the *direct radiation*, in any region of the spectrum, so that we are not concerned with the change in the sensitiveness of the radiometer, which varies from day to day, and it was sufficient to know that the sensitiveness did not change while determining this ratio. This is more likely to be affected by variation in the intensity of the source of radiation, which will be noticed in discussing that subject.

#### THE ABSORPTION CELLS.

One of the chief difficulties to contend against in this work is to obtain pure chemicals, and it is of the greatest importance to prevent contamination while investigating them. To this end a suitable absorption cell had to be devised for containing the liquids. The cell walls were made by splitting the rock-salt crystal parallel to a cleavage plane. This gave thin plates that were quite plane, smooth, and of a finer polish than could be obtained by hand polishing. Furthermore, the surfaces are not so easily attacked by moisture. One form of cell, used in examining the low boiling-point liquids, consisted of a fine wire, from 0.1 to 0.3 mm. in diameter, which was covered with Le Page's glue, pressed between

---

<sup>1</sup>Stewart, loc. cit., experienced this difficulty.

two plates of rock salt and permitted to dry. The substances investigated did not attack the glue. After filling the cell the top was covered with tinfoil, over which was melted a layer of beeswax.

A second form of cell, used for liquids boiling above  $110^{\circ}$ , is shown in fig. 4A. The plates were about 4 by 2.5 by 0.4 cm., split from the natural crystal. Between the common cleavage plane of the two plates

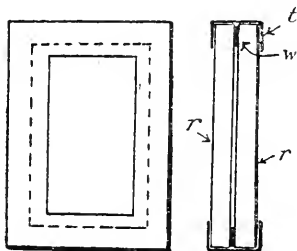

Fig. 4A.

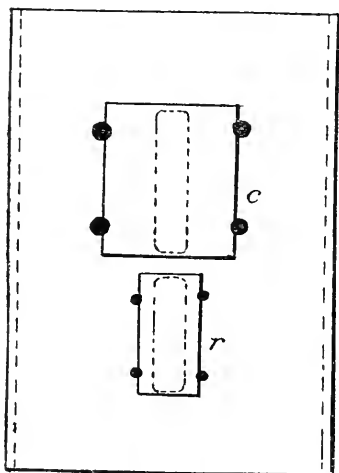
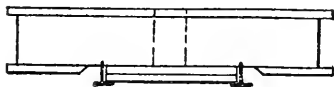

Fig. 4B.

was placed a washer,  $w$ , of tinfoil, 0.01 mm. in thickness, while around the edge was placed a strip of pure tin,  $t$ , 0.1 mm. in thickness, to prevent evaporation. This form of cell is much better than that used in previous investigations, in that it can be thoroughly cleaned, while the washer is discarded for each compound. Another advantage in using this form of cell is that the tinfoil assumes any small irregularities in the surface of the plates, so that one knows the actual thickness of the film more accurately than in previous forms of rock-salt cells. The cell was filled by placing the washer upon one plate, placing several drops of the liquid upon it, then covering it with the other plate. The tin edge was then put on the outside and pressed close to the plates. The cell,  $c$ , was then mounted in a constant position upon its holder (fig. 4B), which consisted of a heavy block of wood with a narrow opening cut through it. Below the cell was a clear piece of rock salt,  $r$ , which was used to eliminate the absorption of the cell, thus enabling one to obtain the transmission through the liquid directly. Furthermore, by using this

arrangement no radiation except that which passed through the cell, or through the rock-salt plate, could enter the spectrometer. In fig. 4A is shown the absorption cell, consisting of the rock-salt plates,  $r$ , the tinfoil washer,  $w$ , and the tin shield,  $t$ , while fig. 4B shows the cell,  $c$ , mounted upon its holder, with the clear piece of rock salt,  $r$ , below it.



In fig. 5 is shown the manner of mounting the cell-holder, *C*, in vertical guide *V*, upon the movable spectrometer arm, *A*. (See also fig. 1.) A double-walled sheet-iron and asbestos shutter moves in the vertical guide, *W*. The heater of a Nernst lamp is at *H*, while the spectrometer slit is at *F*.

The cell for the gases was of glass tubing, with rock-salt plates for windows. It is shown in fig. 10, while fig. 11 shows the manner in which it is mounted in its holder by means of the key, *k*. This holder could then be placed in the vertical guides shown in fig. 5.

The shutter and the cell holder were operated from the observing telescope by means of cords and pulleys, so that it was necessary to enter the room only in making the spectrometer settings.

#### SOURCE OF RADIATION.

The question of the source of radiation, with several curves showing the distribution of the energy in several kinds of electrically heated

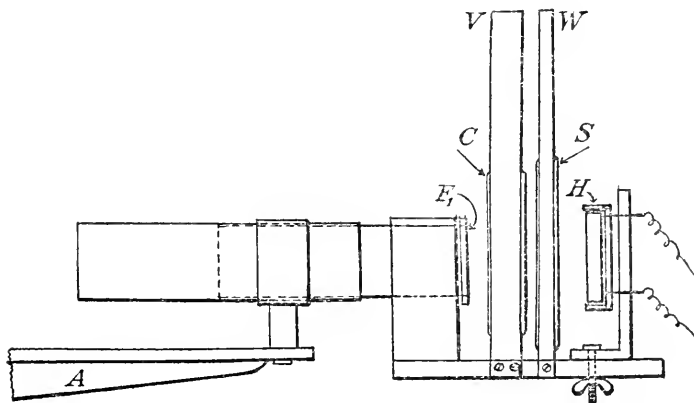

Fig. 5.

clay radiators is given in Appendix I, in which is shown the great adaptability of the "heater" of a Nernst lamp for this work, on account of its strong radiation beyond  $4\mu$ , and also on account of the ease with which the constancy of the radiation can be maintained. Although two 110-volt heaters were provided, only one was generally used. Current was obtained from a storage battery of 90 cells, which brought the "heaters" to a rich cherry red. The "heater" thus used would last for several months. But when used on a battery of 120 cells it lasted but a few weeks, when it was found that the platinum conducting wire, under the clay surface, had vaporized, and the surface of the heater was covered with beautiful microscopic crystals of platinum.

This heater is not adapted to the region from 0.8 to 2  $\mu$  on account of the weakness of the radiation. Here the "glower," or an acetylene flame, is preferable.

The constancy of the radiation and the cheapness of the "heater" make it a most useful source of infra-red radiation. Moreover, it has no products of combustion, such as water vapor, hence the room can be kept free from moisture, thus protecting the prism.

#### METHOD OF OBSERVATION.

The method of observation consisted in projecting successive portions of the spectrum upon the radiometer vane, noting its deflection when the absorption cell was before the slit  $F_1$  (fig. 5), and also the deflection when a clear piece of rock salt was substituted. The ratio of the *deflection* obtained for the radiation, from the "heater," which *passed through the cell* to the *deflection* for the radiation which *passed through the clear plate of rock salt* gave the percentage of transmission through the liquid directly and more accurately than by finding the absorption of the empty cell and deducting it. This also meant the reduction of the work by almost one-half. By plotting these ratios as ordinates, and the wave-lengths corresponding to the circle readings as abscissæ, the "transmission curves" of the different substances are obtained.

The general method of observation consisted in observing the zero reading through the telescope, then, with the cell before the slit, raising the iron shutter, by drawing a cord which extended to the observer in the outer room. The vane would then be deflected and come to rest in a new position in about 30 seconds. The carrier of the absorption cell was then raised, by drawing a second cord, until the clear piece of rock salt came before the slit. This height was regulated by a suitable stop on the ways, which permitted the cell to rise to a fixed height. The vane would then suffer a still greater deflection, and, when it came to rest, the shutter was dropped—when the deflection decreased to zero. If there was a shifting from the former zero reading, it was noted and the deflections were corrected. The spectrometer was then set for a new position in the spectrum and the operation repeated. If the zero shift was of any significance the reading was repeated, especially when going through an absorption band.

This method of observation meant a still further saving of time, so that the time to make a single measurement was reduced to about 1.5 minutes, while the exploration of the entire spectrum required from 3.5 to 4 hours. In the mean time the observations were plotted upon

cross-section paper. In this manner many slight variations in the transmission curve could be verified by repeating the observation before setting for a different wave-length, and, in going through an absorption band, the spectrometer settings were made more frequent, thus increasing the accuracy of its location.

That this method has not been prejudicial against the results obtained is shown in the transmission curves of the gases in which it was necessary to find the transmission of the cell and the included gas, and then deduct the absorption of the empty cell, in order to obtain the transmission through the gas itself.

The manner of recording the observations is shown in Table III,<sup>1</sup> which also shows the peculiar distribution of the energy in the spectrum of the "heater" used as a source of radiation. In the subsequent tables only the "transmission" of each substance examined is given.

At the beginning and at the conclusion of the exploration of each compound the sodium lines were thrown upon the radiometer slit to determine whether the apparatus was still in adjustment.

#### SOURCES OF ERROR.

It is a difficult matter to determine the accuracy attained in this work, as well as the sources of greatest error. With the smaller spectrometer and rock-salt prism it was not difficult to find one's work in agreement with that of previous investigations on absorption spectra. But the emission band of  $\text{CO}_2$ , which Paschen<sup>2</sup> and others found at  $4.40 \mu$ , by using a fluorite prism, which has about twice the dispersion of rock salt in this region, was sometimes found at  $4.42 \mu$ , or a difference of about  $10''$  in arc. This was found to be due to the curvature of the slit, as explained. With the large spectrometer, which gave about twice the dispersion of the small one, and accidentally equivalent to the fluorite dispersion of Paschen and of Ransohoff,<sup>3</sup> the emission maximum came *exactly* at  $4.40 \mu$  for both Bunsen-gas and Bunsen-acetylene flames. This is the best defined, the most accurately known, and the most easily obtained comparison line in the infra-red. The estimation of the degree of accuracy of this band is based upon the number of observers who have located it. The next in order of accuracy of location is the  $3.43 \mu$  absorption band found in compounds containing  $\text{CH}_3$ -groups, by Julius,<sup>4</sup> Ransohoff, and others. This band is not quite so sharp as the  $\text{CO}_2$  emission band. Using these as comparison bands the  $6.86 \mu$  band, found so frequently in the present work, has, in the writer's estimation, been

<sup>1</sup>Given at the end of the text.

<sup>2</sup>Paschen, loc. cit.

<sup>3</sup>Ransohoff, loc. cit.

<sup>4</sup>Julius, loc. cit.

located as accurately as the aforesaid lines, by using the large spectrometer. This estimation is based upon the fact that the prism has been remounted and reset for minimum deviation so often, upon two different spectrometers, with the adjustments made in three different ways, that the consistency in the location of this band can not be attributed to mere coincidence. If one were to set up similar apparatus, and repeat the work, the other absorption bands would be found accurate to about  $0.02 \mu$ . This is a liberal allowance for errors in computing, drawing, and reading wave-lengths from the calibration curve, in adjusting the apparatus, in drawing the curves, etc. As an example of the difficulty in keeping the apparatus in adjustment for a long period, the experiences of Donath<sup>1</sup> may be cited, who found his apparatus, which was of the finest construction, out of adjustment by the time he had examined half a dozen compounds. In the present work the adjustment was tested, by means of the sodium lines, at the beginning and conclusion of each series of measurements.

A source of error in determining the transmission is the possibility of the source of radiation varying in intensity while reading the deflection of the vane when the absorption cell is before the slit, and the deflection for the direct radiation. This is likely to occur with a gas flame, but did not occur with the "heater" used on a storage-battery circuit.

The rigidity of the mounting of the cell in its carrier, which moved to a fixed height in a plane parallel to that of the spectrometer slit, in accurately fitting wooden ways upon the spectrometer arm, eliminated errors due to variation in thickness of cell.

A great deal of time was spent on the question of the use of a prism kept at minimum and at non-minimum deviation. As is well known the minimum of deviation is not sharp, well defined; hence any variation from the real minimum in the setting for the sodium lines will be magnified far out in the infra-red when using the non-minimum deviation method. This appears to be the chief objection in this work. Since in the Wadsworth minimum deviation method the prism-mirror table is turned through only half the required angle, thus doubling any error in making a spectrometer setting, the writer preferred the constant emergence method, which requires the collimating telescope to be turned through the whole angle. In this manner a smaller power microscope could be used in making the spectrometer setting, the circle readings could be made more quickly, while there was less likelihood of losing one's place in the spectrum, which easily results in this work,

---

<sup>1</sup>Donath, loc. cit.

where one must shift back and forth in repeating any observations. Since the  $\text{CO}_2$  band at  $4.40 \mu$  has been determined so accurately by minimum deviation methods by Paschen<sup>1</sup> and by Stewart,<sup>2</sup> the operation of setting for minimum deviation with the small spectrometer was repeated until this band came exactly at  $4.40 \mu$ . With the large spectrometer this band was found exactly at  $4.40 \mu$  for the minimum and non-minimum deviation methods. The maximum is so sharp that it could be accurately located to two or three seconds of arc, with the large spectrometer, and, since no difference could be detected in the position and in sharpness of the large absorption bands, it appears that it makes no difference which method is used.<sup>3</sup>

Ransohoff,<sup>4</sup> assuming a lack of minimum deviation of  $3'$  at  $7.7 \mu$ , computed a change in deviation of  $11''$ , or  $0.0012 \mu$ , which agrees with the theoretical work of Wadsworth.<sup>5</sup>

As an illustration of the difficulty in establishing the absolute value of any absorption band, my experiences with the large spectrometer may be cited. Thinking that a marked band of carbon tetrachloride, found by Paschen at  $6.45 \mu$ , would be an excellent check on the present work, it was examined and found to consist of two bands, of which his is the mean value.

#### THE CHEMICALS USED.

In the beginning of this investigation it was never suspected that it would grow to the present magnitude; neither was the source of the chemicals considered of the greatest importance. But with the increase in my knowledge of the processes involved in manufacturing the chemicals, it became evident that the label "C. P." was of little significance, and it is considered thus by chemists. Obviously it would have been impracticable to purify all the chemicals used. The alternative was to duplicate the work by examining the same compound manufactured by different firms. In the "transmission curves," for many of the compounds thus examined, the duplicate curves are given, and it will be noticed that, disregarding their general appearance, due to the difference in the thickness of the films, which is of no consequence, rarely is there a difference in the spectra of the two samples. This means that the two samples of a compound were equally pure, or what amounts to the same thing, that they contained the same impurity if any was

<sup>1</sup>Paschen, loc. cit.

<sup>2</sup>Stewart, loc. cit.

<sup>3</sup>Helmholtz: *Physiol. Optik.*, p. 260, shows that for purity of color bands and sharpness of Fraunhofer lines it is not necessary that the rays are homocentric.

<sup>4</sup>Ransohoff, loc. cit.

<sup>5</sup>Wadsworth: *Astrophysical Jour.*, 2, p. 264, 1894.

present. As an illustration of the aforesaid, a series of "petroleum distillates" may be mentioned, of which 25 samples were obtained from crude petroleum, while one, "hexane," was made synthetically. The samples obtained by distillation have the same number of large absorption bands, while the synthetic product showed one new band, in addition to those common to the distillates.

For the earlier part of the work, the samples of the compounds were obtained from the museum of the department of chemistry. Many of these had been obtained from Merck, while some were prepared by students. Many of them were redistilled just before using. Out of a total number of 70 compounds, 43 were imported directly from Kahlbaum. Of this number, 23 were duplicates of the aforesaid compounds. They came in sealed glass-stoppered bottles, in quantities of 5 to 10 grams, and were insured to be the purest obtainable. He omitted to state the boiling points, however, as requested. With these small quantities it was difficult to determine the boiling points with precision, but of the samples tested every one had a boiling point so close to the theoretical value that its purity could not be questioned.

In addition to the above compounds, a series of 25 distillates was obtained from Prof. C. F. Mabery, of Case School of Applied Science (see p. 73). The gases were manufactured in the laboratory, as indicated elsewhere.

It will be noticed presently that water is the most opaque substance investigated; hence it is of the greatest importance to have the compounds free from water. The fact that ordinary alcohol blurred and glycerin etched the rock-salt plates of the cell, while all the other compounds did *not*, would indicate that the quantity of water in the latter must have been exceedingly small. Thus, for the petroleum distillates, of which a great number were examined in one cell, after completing the work the interior of the cell was found as clear and highly polished as when it was new.

#### PROBLEMS ATTACKED.

The problem before me was to determine the effect of molecular weight upon absorption spectra; also the effect of chemical structure, *i. e.*, the arrangement of the atoms in the molecule, and the effect produced by the substitution of a  $\text{CH}_3$  or  $\text{OH}$  group of atoms.

As a criterion for the effect of the substitution of a  $\text{CH}_3$ -group, the conspicuous band occurring between the wave-lengths  $3.0\ \mu$  and  $3.5\ \mu$  was critically examined. Julius<sup>1</sup> found this band at  $3.45\ \mu$  for com-

<sup>1</sup>Julius, *loc. cit.*

pounds containing  $\text{CH}_3$ -groups, and, hence, ascribed it to this group. As a standard for judging the effect of the OH radical in certain compounds, the water bands found by Aschkinass<sup>1</sup> at  $3\mu$  and  $6\mu$  were selected. Ransohoff,<sup>2</sup> in his study of several alcohols, had tacitly concluded that the band at  $3\mu$  was due to the OH radical. Such conclusions in regard to the  $\text{CH}_3$  and OH groups seemed contradictory to the work of Ångström and Palmer,<sup>3</sup> who found that the chlorine band at  $4.28\mu$  does not occur in the six chlorine compounds investigated by Julius. The latter had previously shown that the chemical atom lost its identity in a compound, so that one can not foretell the absorption spectrum of a compound from a knowledge of the spectra of the constituent elements.

In the detailed study of each compound the chemical properties will constantly be noticed. In some cases it will be found that certain chemically related compounds, especially groups like the fatty acids, or the mustard oils, give similarly related absorption spectra, while others which are unusually similar in their physical properties, *e. g.*, benzene and thiophene, show entirely different absorption spectra. In some compounds we shall find the evidence of the effect of absorption as being due to a *definite group of atoms*; in other compounds the evidence points just as strongly in favor of the *manner of bonding of the atoms*, while still other compounds show that both the groups of atoms and the manner of bonding with other atoms, as well as the kind of atom, are instrumental in causing absorption.

---

<sup>1</sup>Aschkinass, loc. cit.<sup>2</sup>Ransohoff, loc. cit.<sup>3</sup>Ångström & Palmer, loc. cit.





## CHAPTER IV.

### INVESTIGATION WITH A QUARTZ PRISM.

(Figs. 6, 7, and 8; Table IV<sup>1</sup>).

As is well known, a quartz prism is the most useful in exploring the spectrum from 0.8 to 2.8  $\mu$ , where it becomes opaque.

In the introduction, the work of Puccianti, who explored a number of benzene derivatives up to 2.75  $\mu$ , has been noticed. His curves show that all compounds, the molecules of which contain carbon directly combined with hydrogen, present a maximum absorption at 1.71  $\mu$ , while all the benzene derivatives have two other maxima in common at 2.18  $\mu$  and 2.49  $\mu$ . The three alcohols examined have a band in common at 2.05  $\mu$ . He examined 16 compounds, viz, carbon-tetrachloride, carbon disulphide, methyl, ethyl, and allyl alcohol, ethyl ether, methyl and ethyl iodide, ethyl benzene, ortho-, meta-, and para-xylene, toluene, benzene, pyridine, and water.

The results obtained by Puccianti seemed so unusual that a continuation of the work was deemed necessary. Accordingly, 18 new compounds were examined, also benzene to serve as a comparison with his work. The new compounds are l-pinene, benzaldehyde, chloroform, thiophene, phenyl mustard oil, methyl salicylate, eucalyptol, caproic and oleic acid, ethyl carbonate, methyl acetate, ethyl succinate, glycerin, methyl cyanide, allyl sulphide, nitro-methane, eugenol, and safrol. Their *transmission* curves are given in figs. 6, 7, and 8. Of the marked benzene maxima those at 2.18  $\mu$  and 2.49  $\mu$  agree with the values found by Puccianti. The band found by him at 1.71  $\mu$  was located at 1.68  $\mu$  to 1.69  $\mu$ , which agrees with Donath.<sup>2</sup> As a whole, the maxima of the curves are in agreement. His curves show an oscillation of the maximum about the value 1.71  $\mu$ , just as will be noticed in the present curves. The depression in the benzene curve at 1.02  $\mu$  is of interest, since the photographs obtained by Abney and Festing<sup>3</sup> show lines in this region.

It will be unnecessary to go into details in describing the absorption spectra given here, and it will simplify matters to discuss the conspicuous maxima.

*The band at 0.84  $\mu$ .*—In this region the dispersion of quartz is only slightly less than at 1.7  $\mu$ , while it is comparable with that of rock salt

<sup>1</sup>Table IV is given at the end of the text.

<sup>2</sup>Donath, loc. cit.

<sup>3</sup>Abney & Festing, loc. cit.

at  $12\ \mu$ , which would make it appear that the lack of large absorption bands in this region is due to the absence of ions whose free periods coincide with that of the heat waves transmitted. The photographs obtained by Abney and Festing usually show only fine lines, which can not be resolved with the radiometer. The characteristic band found by them at  $0.867\ \mu$  is represented in the present investigation by a small band whose maximum oscillates between the values  $0.83\ \mu$  and  $0.86\ \mu$ . This band occurs in nearly every compound studied, and is the most marked in eucalyptol, at  $0.83\ \mu$ , and in ethyl succinate, at  $0.85\ \mu$ . It has been found so frequently that one can hardly doubt its existence.

*The band at  $1.7\ \mu$ .*—Beyond  $0.85\ \mu$  the bands are more variable in their occurrence, and in their depth, until we approach  $1.7\ \mu$ . This band is found in *all* the carbohydrates studied, which agrees with Puccianti. Of course, it is slightly shifted at times, which does not always appear to be due to lack of precision in the apparatus. This is especially noticeable in thiophene, where the maximum occurs at  $1.66\ \mu$ , which is just double the  $0.83\ \mu$  band, and in ethyl succinate, where these two bands are shifted to  $0.85\ \mu$  and  $1.73\ \mu$ , respectively. In noticing the constant occurrence of bands in these two regions, one begins to inquire into their significance, and, after finding similar conditions at  $3.43\ \mu$ ,  $6.86\ \mu$ , and  $13.8\ \mu$ , this becomes still more urgent. The question of the importance to be attached to these facts must be reserved for a later discussion.

*The band at  $2.08\ \mu$ .*—This shallow band in Puccianti's curve of the alcohols was found at  $2.14\ \mu$  for a sample of de Haën's bidistilled glycerin. On adding a drop of water the band was broadened out, extending from  $2.08\ \mu$  to  $2.1\ \mu$ , as in ethyl alcohol. The gradual increase in the general absorption beyond  $2\ \mu$  is very marked in contrast to its almost complete transparency from  $0.8\ \mu$  to  $1.2\ \mu$ .

*The bands at  $2.18\ \mu$  and  $2.49\ \mu$ .*—In the present study of the simpler benzene derivatives, these two bands always occur, which substantiates the work of Puccianti. In the very complex derivatives, like pinene, eucalyptol, eugenol, and safrol, the bands are wanting or shifted to entirely new positions, which agrees with the observations farther in the infra-red.

As a whole, the curves form an interesting study by themselves. In comparing them with the curves obtained with the rock-salt prism, for this region of the spectrum, we can see how useless it would have been to explore it thoroughly with the rock-salt prism and the small spectrometer. Only in the chloroform curve do we find the marked bands resolved and in their proper places. With the larger spectrometer, however, the agreement in the location of the maxima with those obtained with the quartz prism is very close.

Fig. 6.

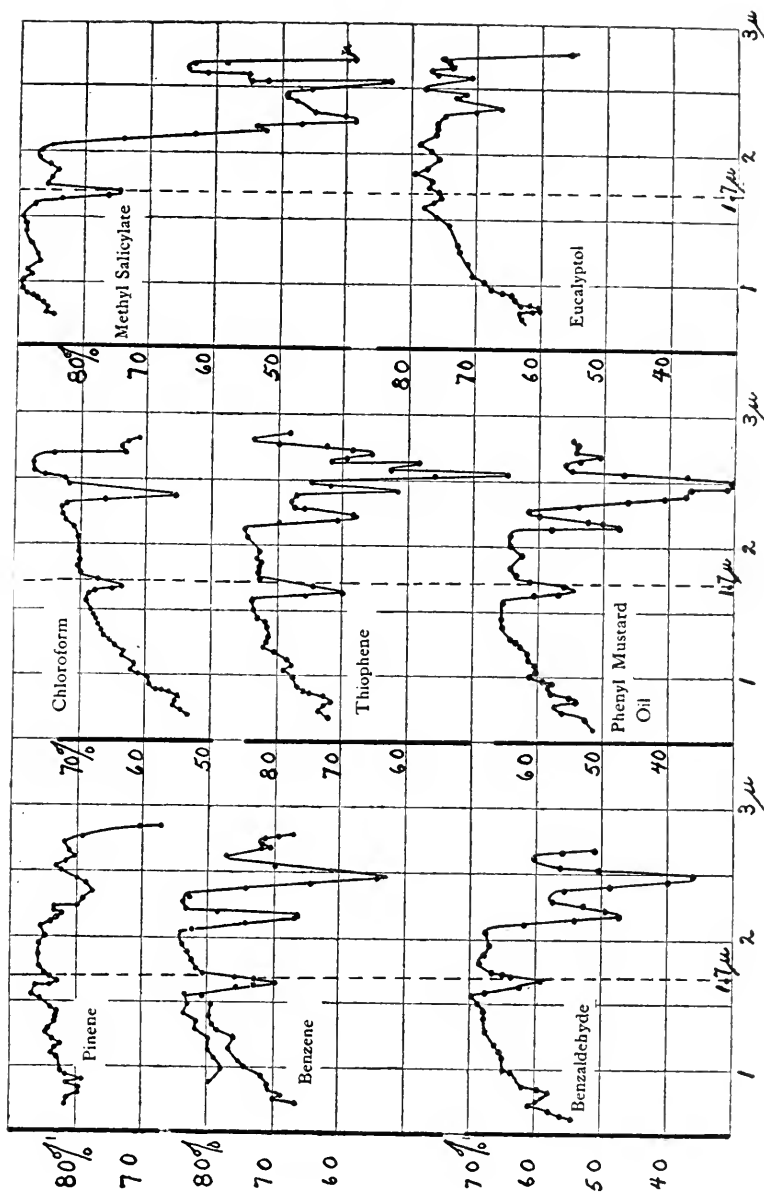

Fig. 7.

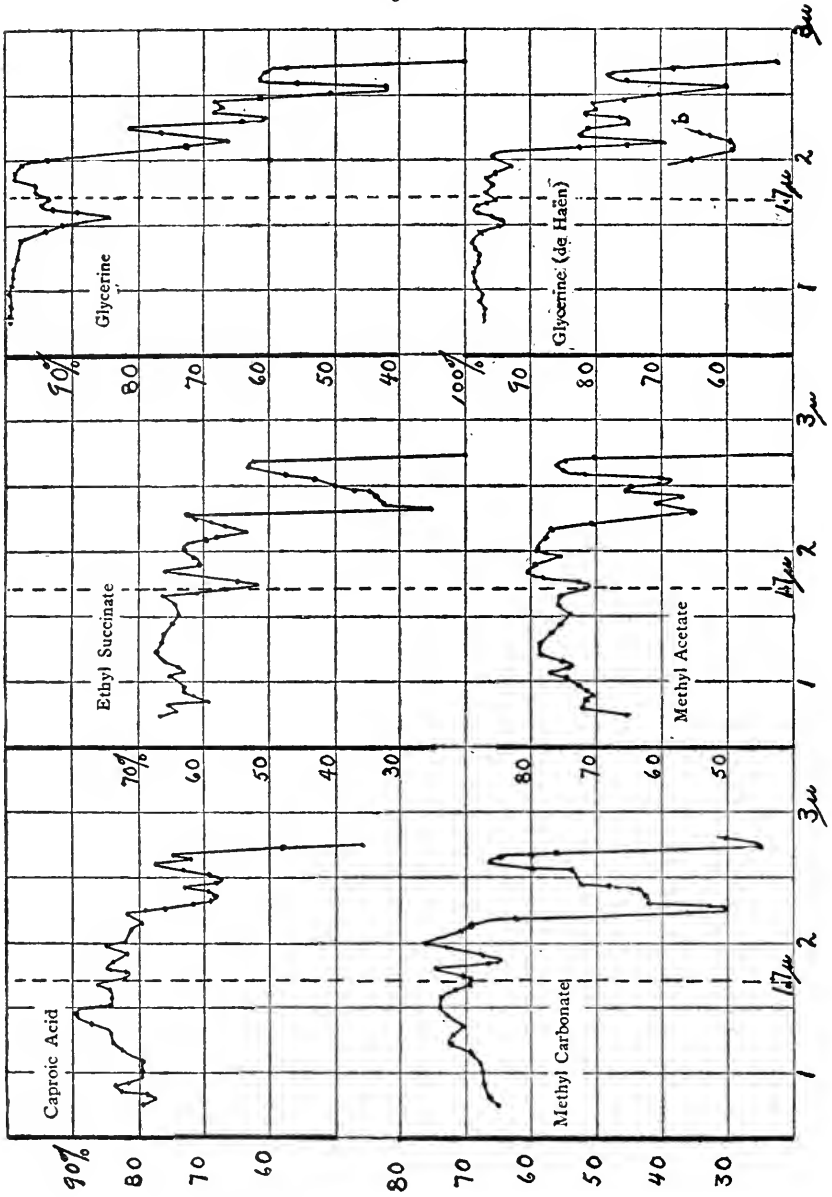
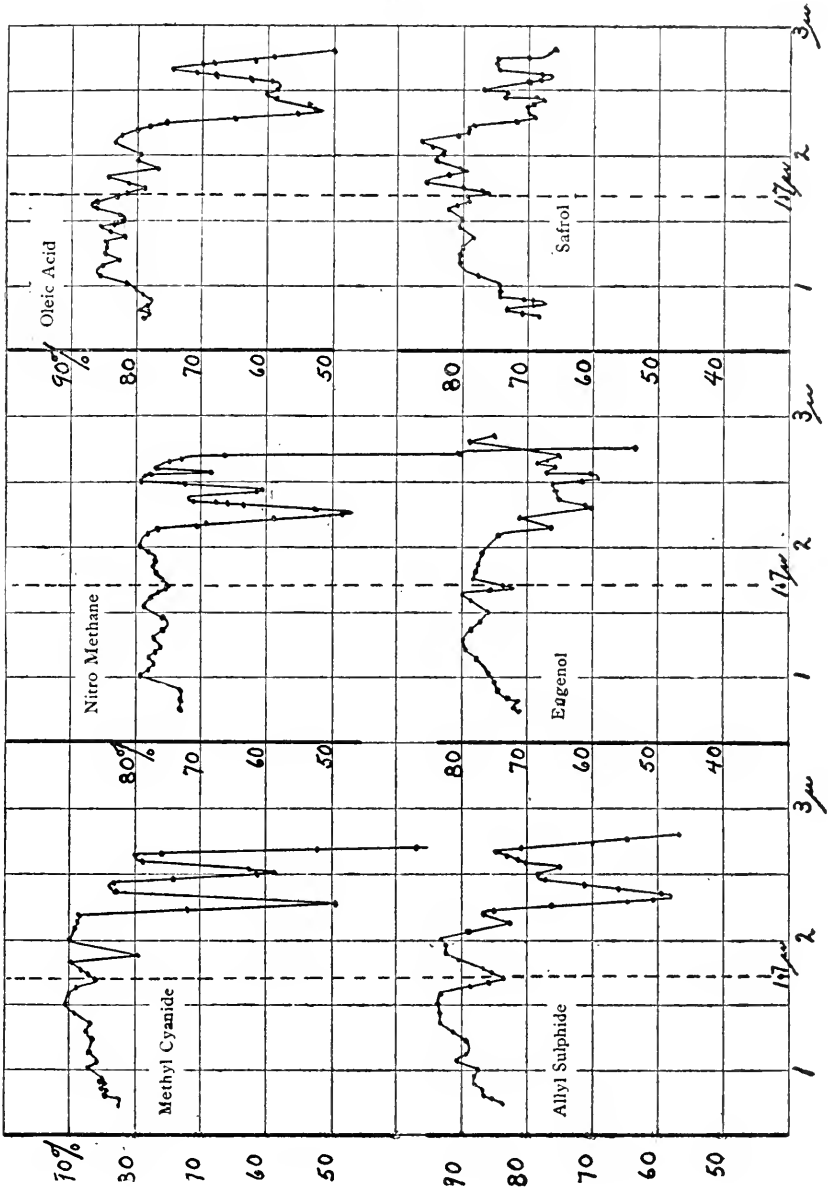

Fig. 8.





## CHAPTER V.

### INVESTIGATION WITH A ROCK-SALT PRISM.

#### CLASS I: METHANE DERIVATIVES.

This class comprises all carbohydrates having an open chain, the so-called "aliphatic compounds" as distinguished from the "cyclic" or ring compounds

#### ABSORPTION SPECTRA OF GASES.

(Figs. 9 to 25; Tables I, V, and VII.)<sup>1</sup>

Our knowledge of the absorption spectra of gases is confined to the work of Ångström,<sup>2</sup> who studied CO, CO<sub>2</sub>, CH<sub>4</sub>, C<sub>2</sub>H<sub>4</sub>, and (C<sub>2</sub>H<sub>5</sub>)<sub>2</sub>O. In fact, he is the pioneer in this subject.

In studying gases the chief difficulty lies in obtaining them in a pure state. The apparatus, including generator, purifiers, and gasometers, must be air-tight, so that after the air has once been removed, none can enter from outside. Fortunately, we have in liquid air a means for obtaining small quantities of other gases in a more tangible state. By combining fractional liquefaction and fractional distillation with the usual chemical methods of purification one can obtain gases in a very high state of purity, as will be noticed in the analyses of some of the gases studied. In the present work the gases were first purified by chemical methods. Several showed absorption bands in common, so the work was repeated, using the additional method of liquefaction. The way that the transmission curves have been changed and the impurity bands have disappeared as a consequence will be noticed in the several curves, especially ethane.

The arrangement of the apparatus for generating and liquefying the gases is shown in fig. 9, in which *a* is the generating flask, *b* is the washing tube, and *c* is the drying tube containing P<sub>2</sub>O<sub>5</sub> and cotton or glass wool—the latter to present a large surface. This tube was always thoroughly cleaned before making a new gas. At *d* and *e* are the liquefaction tubes, and *g* is the mercury gasometer, of 200 cc. capacity. The operation consisted of fractionally liquefying the gas in *d*, and what passed from *d* into *e* was liquefied there at a lower temperature. The

<sup>1</sup>Tables I to VIII and figs. 12 to 132 are given at the end of the text.

<sup>2</sup>Ångström: Öfversigt af Kon. Vetensk. Akad. Förhändligar, Stockholm, Nr. 7, 1890.

part that did not liquefy in *e* passed out at *f*. Petroleum thermometers were used to measure the temperature, which, of course, could be determined only approximately, but as close as one can make the fractional liquefactions.

The thermometer was placed in contact with the side of the bulb, and the whole suspended over the liquid air. By raising or lowering this combination, any desired temperature could be obtained.

From 5 to 10 cc. of the liquefied gas were collected in *e*, which was then closed at *h*, by means of a pinch-cock, and allowed to grow warmer. After the air had been thoroughly washed out at *f*, as shown by the lighted gas, the bulb was permitted to become still warmer, and the successive fractions were distilled into the mercury gasometers, *g*, where they were stored under mercury seals, awaiting analysis and examination. This method of procedure, for the present work, was certainly more desirable and efficient than the usual one of joining the generator, purifiers, and absorption cell with an exhaust pump. In that case one can not manipulate the gases after once generated. The desirability of handling the stored gases is shown in the purification of

ethylene, which is almost impossible to obtain

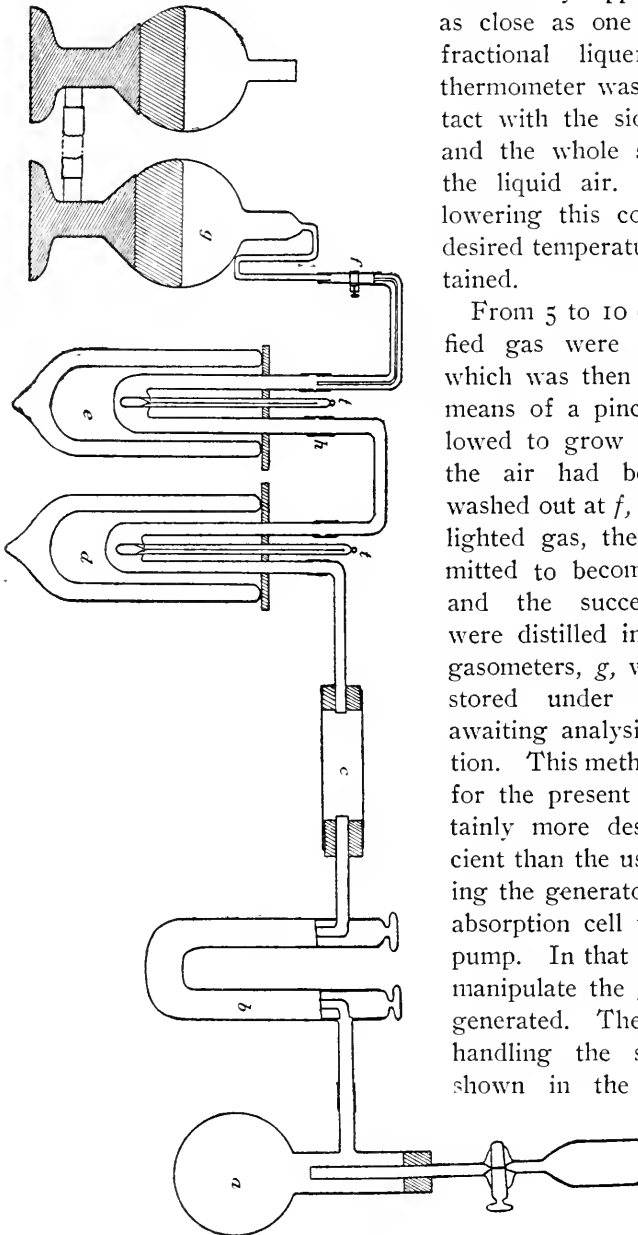

Fig. 9.



in a state sufficiently pure for this work. Not being satisfied with the usual washing in bromine water, and liquefaction method, the gasometer was placed in series with a wash-pipette of fuming sulphuric acid, and the gas washed back and forth half an hour, after which only a suspicious trace of ethylene remained, as will be noticed at  $10.5 \mu$  in the absorption curves.

THE ABSORPTION CELL.

The absorption cell for gases is shown in fig. 10. Two glass cells were used, in length 6.3 and 5.7 cm., diameters 2.4 and 2.2 cm., capacity 30.8 cc. and 21.5 cc., respectively.

The rock-salt windows were split from the natural crystal, which gave smooth, plane surfaces which were not attacked by moisture,

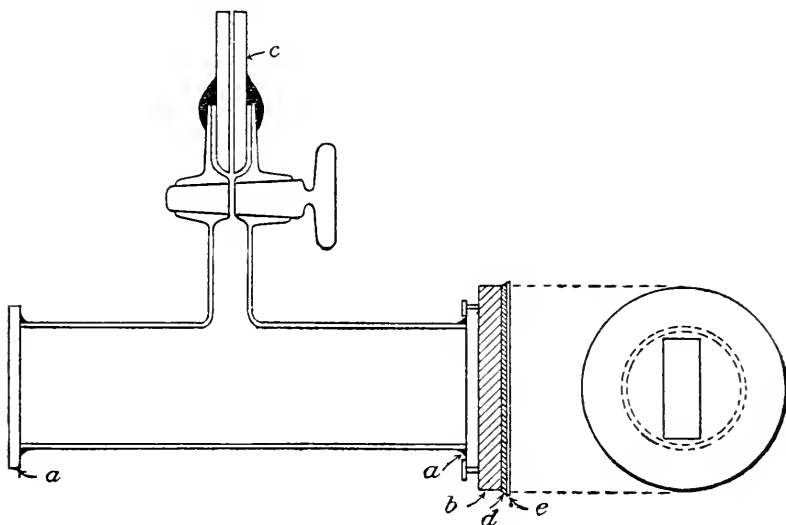

Fig. 10.

and lasted throughout the work of two months. The windows were attached with Le Page's glue, which became exceedingly hard on drying, and had such a low vapor pressure that no absorption bands could be detected, even after exhausting the cell to 0.02 mm. and permitting it to stand four days. One of the vapors to be expected from it would have been acetic acid. Before filling the cell with a new gas it was always washed out thoroughly with air. This was done by means of a water aspirator attached to the pump, the cell being exhausted from five to seven times, each time allowing it to fill with air. The final exhaustion was carried to 0.02 mm., and the absorption of the cell, thus exhausted, was found each time before filling it with a new gas. Only

once was absorption found for residual gas; this was ethyl ether at  $8.7 \mu$ , the cell having been washed but three times with air.

To fill the cell, previously exhausted to 0.02 mm., with gas from a gasometer, the capillary tube, *c*, was inserted in the rubber connection (*f*, fig. 9) of the latter, which contained a drop of mercury. On insertion, this drop of mercury would displace the air, except the trace contained in the bore of the capillary tube. The capillary bore was 0.024 cm. in diameter, 3 cm. in length, and had a volume of 0.013 cc., which, compared to the total volume of the cell, would introduce one part of air in 2,500 parts of pure gas. This trace of air could also have been prevented from entering the cell by filling the capillary with mercury.

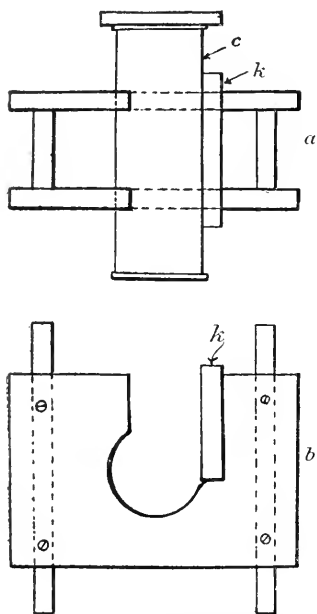

Fig. 11.—Top view of gas-cell holder with cell *c* in place. *a*, top view, *b*, side view.

Since the presence of this small quantity of air diminishes the total length of gas by only 0.003 cm., the effect on the total transmission can not be detected, as was found on trial, and in practice the capillary was not filled with mercury.

On opening the pinch-cock at *f* (fig. 9) and the stop-cock of the cell, the gas entered the latter and was brought to atmospheric pressure, which, with the temperature of the gas (room temperature), furnished data for computing the equivalent thickness for the liquid state.

A helix of iron wire inserted in the glass cell served as a diaphragm to prevent reflection from the walls, and seemed more serviceable than a black paint, since it also prevented occlusion of gases.

The cell was mounted in the usual manner, in a wooden carrier (fig. 11), which worked in vertical ways between the source of energy and the spectrometer slit.

The transmission through the exhausted cell was found each time before filling with a gas. As mentioned before, this also served as a test for residual gas, which could have been detected, if present, by setting on one of the absorption bands.

The ratio of the transmission of the cell filled with gas to that of the empty cell gave the transmission of the gas itself. The transmission of the empty cell changed but little in two months, and, as a typical example, transmitted 65 per cent at  $1.7 \mu$ , 75 per cent at  $4 \mu$ , decreasing to 70 per cent at  $6 \mu$ , then gradually increasing to 74 per cent at  $10 \mu$  and

to 78 per cent at  $12 \mu$ . Excepting regions of selective absorption, the gases, for this length of cell, were usually perfectly transparent, so that windows made from plates of rock salt split from the natural crystal were more serviceable and cheaper than highly polished ones, which would have transmitted about 80 per cent of the energy when new, but would have soon become tarnished with moisture.

Many of the gases show but few absorption bands for the length of cell used. Whether more exist, which are very weak and can be detected only in layers of great thickness, is an unanswered question. Rubens and Aschkinass,<sup>1</sup> using a column of  $\text{CO}_2$  gas 65 cm. long, found the same number of bands as for one 5 cm. long. On the other hand, Langley's curves of the atmospheric absorption show a great complexity, which can not be attributed to a mere variety of gases.

#### GASES STUDIED.

##### METHANE. $\text{CH}_4$ .

(Cell 6.3 cm.; barom., 75.0 cm.; temp.,  $22^\circ$ ; fig. 12. See end of text.)

The methane used in this work was made by heating a mixture of sodium acetate and soda lime, and washing it thoroughly in pipettes of potassium hydrate and of fuming sulphuric acid, which removes the unsaturated hydrocarbons, like ethylene. The latter is also formed when methane is made by this method. Since methane boils at  $-160^\circ$  and ethylene at  $-105^\circ$ , it is easy to apply the method of fractional liquefaction and fractional distillation. This was done as an additional precaution, but no change in the intensity or position of the transmission maxima could be detected. The slight shift of  $0.02 \mu$  at  $3.4 \mu$  is due to resetting of the prism, and will be noticed in ether, which was also one of the first gases studied. For curve *b* the gas was purified by liquefaction.

The spectrum of methane is distinguished by two large absorption bands at  $3.31 \mu$  and  $7.7 \mu$ , and a smaller one at  $2.35 \mu$ .

Methane was investigated by Ångström, who found the same number of bands, but since his calibration is wrong beyond  $5 \mu$  no comparison can be made.

The effect produced by substituting four Cl atoms for the four H atoms, and thus forming carbon tetrachloride, is very striking. Here we have an entirely different spectrum, with no bands in the region of  $3 \mu$  to  $3.5 \mu$ , characteristic to carbohydrates. In fact, we find no bands until we arrive at  $6.5 \mu$  and its prominent harmonic at  $13 \mu$ .

<sup>1</sup>Rubens & Aschkinass: Ann. der Physik, 64, p. 584, 1898.

ACETYLENE.  $C_2H_2$ .

(Cell, 6.3 cm.; barom., 74.5 cm.; temp., 22°.5; fig. 13.)

The acetylene used was generated from "selected calcium carbide, commercially pure, for bicycle lamps."

In the preliminary examination the gas was washed in c. p.  $H_2SO_4$  and dried in  $P_2O_5$ , curve *a*. For a subsequent examination the gas was washed by passing it through a solution of 20 grams of  $HCl + 10$  grams  $HgCl_2 + 80$  grams  $H_2O$  to remove the phosphene ( $PH_3$ ); then through a solution of  $KOH$  to remove  $H_2S$ ; then through concentrated  $H_2SO_4$  to dry it, and finally through a U-tube cooled in  $CO_2$  snow. In the latter there was a slight deposit of vapor on the side where the gas entered. This was found to be water vapor. After all this treatment, as well as an additional one, to be mentioned presently, not a single band was changed appreciably in transmission, nor in the position of its transmission minima, curve *b*. That ordinary acetylene is quite pure has been found by Rands,<sup>1</sup> who found a purity of 99 per cent.

Acetylene is distinguished for three deep, narrow regions of absorption at  $3.08 \mu$ ,  $7.73 \mu$ , and  $13.63 \mu$ , and two other bands, one at  $3.7 \mu$ , which is harmonic with the one at  $7.4 \mu$ . In order to be able to locate the band at  $13.63 \mu$  the cell had to be exhausted to a pressure of 7 cm., curve *c*. Elsewhere the gas is perfectly transparent. At first it seemed that the band at  $3.08 \mu$  might be due to water, but washing it thoroughly in new conc.  $H_2SO_4$  and leaving it stand in contact with it for three days, in a pipette, failed to alter the intensity or position of this transmission minimum, curve *d*, which would indicate that this band belongs to acetylene.

As a further check, a thin film of water, curve *h*, between fluorite plates, was examined. The first band occurs at  $3.02 \mu$ , while the second lies at  $6.02 \mu$ .

If this band at  $3.08 \mu$  in acetylene were due to water, one would expect a similar one at  $6.0 \mu$ , but in this region the gas is perfectly transparent.

It will be interesting to note the shifting of this band toward the infrared for an increase of two H atoms (keeping the number of C atoms constant) in each of the following series of compounds.

Acetylene brought to a red heat will polymerize, three molecules uniting to form one molecule of benzene ( $C_6H_6$ ), (Berthelot). This is one of the most striking transitions from the aliphatic to the aromatic series, and is at the same time a synthesis of the parent hydrocarbon of the aromatic substances. Acetylene is also chemically allied to ethyl alcohol, yet there is not the slightest trace of resemblance in the absorption curves in either case.

<sup>1</sup>Rands: Phys. Rev., xiv.

ETHYLENE.  $C_2H_4$ .

(Cell, 5.7 cm.; barom., 73.8 cm.; temp.,  $22.5^\circ$ ; fig. 14.)

This gas was prepared from ethylenebromide,  $C_2H_4Br_2$  (from Drs. Bender and Hobein, boiling at the theoretical temperature of  $131^\circ$ ), by using a zinc-copper couple,<sup>1</sup> and was dried by passing it through a glass tube containing  $P_2O_5$  and absorbent cotton, to present a large surface.

In the preliminary examination the gas showed ether bands. The ethylene bromide was then redistilled, and a second examination was made, the gas having been passed through a tube placed in  $CO_2$  snow. After the liquid-air apparatus was set up, this gas was dried in  $P_2O_5$ , then fractionally liquefied in bulb *d* (fig. 9), kept at  $-97^\circ$ , and the remainder liquefied in bulb *e*, kept at  $-120^\circ$ . These were the readings of the petroleum thermometers, which, although constant and in contact with the liquefaction bulbs, may not have been at the same temperature, since they presented a smaller surface to the evaporating air.

In the first bulb there was a liquid having a strong odor of  $C_2H_4Br_2$ . In the second tube were about 5 cc. of liquid ethylene, having a sweet odor much like that of  $C_2H_4Br_2$ , somewhat sharper, like pure acetylene. It burned with a beautiful yellowish-white flame. The second fractional distillate was used in this examination.

The transmission curves for these three samples of gas, differently prepared, showed but slight variation in the intensity and position of the transmission minima, excepting that the ether band found at  $7.8 \mu$  in the first sample was absent in the others.

That the gas was very pure is shown from the analysis by absorption, using bromine water. The quantity of unabsorbed gas was so small that it could not be measured accurately.

Amount of $C_2H_4$ taken.....	50.2 cc.
Unabsorbed gas.....	<u>0.6 cc.</u>
Total $C_2H_4$ .....	49.6 cc.
Purity.....	98.8 per cent.

A combustion analysis, made by Mr. R. C. Snowden, of the first fraction distilled, showed considerable impurity. From general experience it appears that this is due to the method of analysis rather than to any real impurity.

The transmission of ethylene is entirely different from acetylene, from which it differs in composition in having two more H atoms. It is also different from  $CH_4$ , in which there is one less C atom.

---

<sup>1</sup>A zinc-copper couple is made by placing pure granulated zinc in a dilute solution of  $CuSO_4$ , when the zinc becomes covered with copper. When this couple is placed in the liquid it immediately decomposes it.

The first large band is shifted to  $3.28 \mu$ . The large transmission minima at  $6.98 \mu$  and  $10.5 \mu$  are of interest in connection with the study of  $\text{CH}_2$  groups, and with piperidine.

For the region beyond  $9 \mu$  the pressure had to be reduced to 20 cm.

ETHANE.  $\text{C}_2\text{H}_6$ .

(Cell, 5.7 cm. ; barom., 74.5 cm.; temp.,  $23^\circ$ ; fig. 15.)

This was the most difficult gas to be prepared. Unlike ethylene, the chemicals used are more complex, and the reaction can not be controlled, so that—besides ethane—ethylene, methane, etc., are formed.

The ethane gas was generated according to the method first described by Frankland,<sup>1</sup> who found a "volume purity of 97.88 per cent, using liquefaction in addition. Equal parts of  $\text{C}_2\text{H}_5\text{I}$  (Kahlbaum) and absolute  $\text{C}_2\text{H}_5\text{OH}$  were poured over a zinc-copper couple, when the gases began to evolve immediately. No heat was applied, since that causes greater impurity. The gas passed through bromine water in a U-tube, with liquid bromine at the bottom, to remove the ethylene, then through KOH to remove the Br, and then through a tube of  $\text{P}_2\text{O}_5$  to remove the water. Since ethane boils at  $-93^\circ$  and ethylene at  $-105^\circ$ , fractional liquefaction and distillation is an uncertain method of purification. In this case the bromine water offers the most serviceable means of separation. Methane will not liquefy till cooled to  $-160^\circ$ , and hence will pass through the bulb without being condensed. The same is true of the free hydrogen.

After fractional liquefaction (about 6 cc.) and fractional distillation, the first and second fractions of the distillate were again washed in fuming sulphuric acid and KOH, and dried in  $\text{P}_2\text{O}_5$ , it being thought preferable to run the risk of letting in air in doing so, rather than be uncertain about the presence of ethylene, carbon dioxide, etc.

The analyses were not satisfactory. The second fraction was wasted in two attempts at combustion with oxygen, there being a violent explosion each time. The explosion-pipette method is less accurate on account of the small quantity (5.4 cc.) of gas that can be used. However, three separate analyses of the method gave a fairly concordant purity of 96 per cent. This is the first gas noticed in which the absorption bands decrease in intensity or disappear entirely, which is an excellent clue to the impurities present.

The change wrought in the transmission curves is most conspicuous at  $10.5 \mu$  (fig. 15). That transmission minimum has entirely disappeared, and the bands at  $12 \mu$ , which were obscured by it, now appear in their proper intensities.

<sup>1</sup>Frankland : Jour. Chem. Soc. London, 47, p. 236, 1885.

The position of the transmission minimum at  $3.39\ \mu$  does not vary, however. The very deep band at  $8.25\ \mu$ , which has almost disappeared in the second curve, is no doubt due to  $C_2H_5I$ , since that substance has a maximum at this point.

Ethane differs from ethylene in having the  $2.31\ \mu$  and the  $3.28\ \mu$  bands of the latter shifted to  $2.36\ \mu$  and  $3.39\ \mu$ , respectively, in the former. Some of the following gases show this same shifting for the region of  $3\ \mu$ . As noted before, for rock-salt dispersion, all carbohydrates studied show an enormous absorption band, varying in position from  $3.1\ \mu$  to  $3.7\ \mu$ . The same is true for the  $1.69\ \mu$  band, using quartz dispersion. Here it is difficult to establish a definite shifting, as is found for homologous compounds at from  $3.08\ \mu$  for acetylene ( $C_2H_2$ ) to  $3.39\ \mu$  for ethane ( $C_2H_6$ ).

This study of gases was undertaken to learn the behavior of the  $CH_3$  group in the molecule, as found in ethane. After studying many compounds of  $CH_3$ , simple and complex, having an absorption band at  $3.43\ \mu$ , which was first announced by Julius<sup>1</sup> to be due to  $CH_3$ , it was rather surprising to find that ethane ( $HC_3-CH_3$ ) has its maximum at  $3.39\ \mu$ . In the simple compounds, like  $CH_3I$ , this band occurs at  $3.4\ \mu$ .

When we compare ethane ( $C_2H_6$ ) with benzene ( $C_6H_6$ ) we find the latter has its transmission minimum at  $3.28\ \mu$ , which again shows that the structure as well as molecular weight influences the absorption.

The cell of ethane was partly exhausted, and one part of it was mixed with two parts of acetylene, and, as a result, the band due to acetylene was obliterated, except a slight break at  $3\ \mu$ , while the band due to both is at  $3.3\ \mu$ . Lack of time did not permit examination of other regions. The test was not quite a fair one, considering the one gas as an impurity in the other, yet it serves to show that, for the region of  $3\ \mu$ , where the dispersion of rock salt is still small, reliance upon the occurrence of an absorption band of an impurity, as a means for detecting the impurity, is not permissible. However, at  $4.4\ \mu$ , where the dispersion is greater, one can detect the presence of  $CO_2$  in  $CO$ . (See fig. 21.) In fig. 15 curve *a* is for the gas when purified by liquefaction, and curve *b* for the same gas after washing in fuming  $H_2SO_4$ .

#### BUTANE. $C_4H_{10}$ .

(Cell, 5.7 cm.; barom., 75.4 cm.; temp.,  $22^\circ$ ; fig. 15.)

This gas was made<sup>2</sup> from ethyl iodide ( $C_2H_5I$ ) by pouring it over an amalgam made of sodium and mercury. The presence of the mercury retards the action of the metallic sodium upon the ethyl iodide. After

<sup>1</sup>Julius, loc. cit.

<sup>2</sup>Loury: Jahrsber. in Forstschritte der Chemie, p. 397, 1860.

drying in  $P_2O_6$  the gas was passed into a U-tube placed in a freezing mixture of common salt and ice.

Butane liquefies at  $1^\circ$ , while its isomer liquefies at  $-17^\circ$ . The attempt to liquefy it was not very successful, and the gas collected may have contained the isomer as well as other impurities.

The transmission minima of ethane ( $C_2H_6$ ) at  $2.36 \mu$  and  $3.39 \mu$  and  $6.85 \mu$  are shifted to  $2.4 \mu$ ,  $3.42 \mu$ , and  $6.89 \mu$ , respectively. Beyond  $7 \mu$  there are a number of bands which occur as impurities, the most conspicuous of which are the two at  $7.8 \mu$  and  $14 \mu$ , due to ether, and the  $10.5 \mu$  band in ethylene. The bands at  $8.3 \mu$  and  $8.9 \mu$  (diff. =  $0.60 \mu$ ) find their counterpart in methyl ether, where they are shifted to  $8.58 \mu$  and  $9.16 \mu$  (diff. =  $0.58 \mu$ ), respectively, and in ethyl ether, where the bands are shifted to  $8.75 \mu$  and  $9.25 \mu$  (diff. =  $0.50 \mu$ ), respectively.

METHYL ETHER.  $(CH_3)_2O$ .

(Cell, 5.7 cm. ; barom., 76 cm.; temp.,  $22^\circ$  ; fig. 17.)

Prepared<sup>1</sup> by heating 1.3 parts of alcohol and 2 parts of sulphuric acid to  $140^\circ$  and washed in KOH to absorb the  $SO_2$ , and then dried in  $P_2O_6$ .

A study of this gas is of interest in connection with ethyl alcohol, with which it is isomeric. A more striking illustration of the effect upon absorption of the arrangement of the atom in the molecule has not been found, except perhaps for the sulphocyanates and mustard oils. From  $10 \mu$  to  $11 \mu$  alcohol (fig. 38) shows transparency, and beyond  $13 \mu$  there is complete opacity, while, for methyl ether, the very opposite effect was found. Beyond  $8 \mu$  the pressure of the ether had to be reduced to 10 cm. of mercury.

The only apparent impurity band to be noticed is that of butane at  $5.7 \mu$ . The bands at  $2.5 \mu$  and  $3.45 \mu$  and  $10.55 \mu$  are shifted to longer wave-lengths, as compared with those of butane. The  $6.9 \mu$  band is harmonic with the one at  $3.45 \mu$ . This compound, like all the gases, is conspicuous for the great depth of its absorption bands. Curve *b* is for a pressure of 10 cm.

ETHYL ETHER.  $(C_2H_5)_2O$ .

(Cell, 5.7 cm. ; barom., 74.9 cm.; temp.,  $24^\circ$  ; fig. 18.)

For studying this vapor some of the anhydrous liquid was placed in the absorption cell, which evaporated, thus giving a saturated vapor. Frequent opening of the stop-cock kept it at about atmospheric pressure.

Like the methyl ether, it has very deep bands, which are shifted as compared with the two preceding gases. The  $4.75 \mu$  band of methyl ether occurs at  $5.15 \mu$  in ethyl ether. The  $6.9 \mu$  band of the former

<sup>1</sup>Erlenmeyer & Kirchbaumer: Berichte d. Deutsch. Chem. Gesellschaft, 7, 699, 1874.



is double, and occurs at  $7.0\ \mu$  and  $7.3\ \mu$ . These two bands are to be noticed with this same region for ethyl alcohol (fig. 38), where there is but one flat band, which would, no doubt, be found complex, using a larger dispersion.

The  $14\ \mu$  band is also to be noticed, since it occurs in compounds having  $\text{CH}_3$  and  $\text{C}_2\text{H}_5$  groups, while the  $12\ \mu$  band is also found in many compounds.

Ethyl ether has been studied by Ångström,<sup>1</sup> both as a liquid and as a gas. He found that the maximum at  $3.45\ \mu$  did not coincide for the two states, the vapor being shifted by  $4'$  toward the long wave-lengths. He claims to have obtained this effect repeatedly, while no shifting was observed by him for other compounds examined in the liquid and the vapor state. In the present work the region of  $3.45\ \mu$  for liquid ether was explored at the *same time* that it was for the vapor. No such shifting was observed, as will be noticed in fig. 18, where the curves (indicated thus:  $\Delta\ \Delta\ \Delta$  and  $\times\ \times\ \times$ ) for liquid and vapor are seen to coincide. The slight difference in the position of the maximum for this day and that for the time of making the complete curve is due to the resetting of the prism in the meantime.

Ether belongs to the water type of compounds, *i. e.*, the  $\text{C}_2\text{H}_5$  takes the place of an H atom in  $\text{H}_2\text{O}$ , but it is not apparent in the curves.

The bands at  $7.3\ \mu$  and  $7.8\ \mu$  almost coincide with those of acetylene. Beyond  $7\ \mu$  three sets of bands, "triplets," have "constant differences" of their wave numbers, which agree so closely as to lead to the suspicion that they belong to a spectral series. The two most marked sets are:

$$\begin{array}{ll} 7.0\ \mu > \nu_1=60 & 10.14\ \mu > \nu_1=58 \\ 7.3 > \nu_2=90 & 10.77 > \nu_2=90 \\ 7.8 > \nu_2=90 & 11.95 > \nu_2=90 \end{array}$$

ILLUMINATING GAS. (Fig. 19.)

The sample used was taken directly from the pipes and examined. It contains bands due to  $\text{CH}_4$ ,  $\text{C}_2\text{H}_4$ ,  $\text{C}_4\text{H}_{10}$ ,  $\text{CO}$ ,  $\text{CO}_2$ ,  $\text{SO}_2$ , and  $\text{H}_2\text{S}$ . Ordinary analysis shows about 60 per cent of  $\text{CH}_4$ , 6 per cent of  $\text{CO}$ , 2 per cent of  $\text{CO}_2$ , and the remainder principally unsaturated hydrocarbons. The curve is of interest in showing the presence of  $\text{CO}$  and  $\text{H}_2\text{S}$ .

#### OXYGEN.

(Cell, 5.7 cm.; barom., 74.6 cm.; temp.  $23^\circ$ ; fig. 20.)

Made by heating  $\text{KClO}_3 + \text{MnO}_2$ , purified in  $\text{KOH}$ , and dried by passing through a glass tube containing absorbent cotton covered with  $\text{P}_2\text{O}_5$ .

<sup>1</sup>Ångström, loc. cit.

This gas is of considerable interest, because it enters into so many compounds. It shows two large shallow bands at  $3.2\ \mu$  and  $4.7\ \mu$ , respectively. They are only 4 per cent in depth. It appeared that this might be due to impurities, but repeated attempts to remove them failed to change the intensity. After passing the gas back and forth through a tube of  $P_2O_5$ , from one gas pipette to another, the bands still existed. The oxygen was then placed for three days in an absorption pipette containing concentrated  $H_2SO_4$ , but, as will be noticed in curve *b*, the bands still remain, showing that their presence is not due to water vapor.

One sample was not washed in KOH, and then showed the Cl band at  $4.3\ \mu$ . Ångström<sup>1</sup> found this band at  $4.28\ \mu$  for pure chlorine. It is interesting to note that Dewar, and also Olzewski, found several absorption bands of liquid oxygen in the visible spectrum.

#### HYDROGEN AND BROMINE.

(Cell, 6.3 cm.)

Generated from c. p. Zn + HCl, washed in  $H_2SO_4$ , and dried in  $P_2O_5$ .

The hydrogen gas showed no absorption bands. Paschen<sup>2</sup> examined hydrogen and nitrogen, but, after repeated measurements, failed to find any absorption bands.

The vapor of bromine showed no bands. The cell was lined with paraffin to prevent the bromine from attacking the glue.

#### CARBON MONOXIDE (CO).

(Cell, 5.7 cm.; barom., 73.2 cm.; temp.,  $23^\circ$ ; fig. 21.)

Made by heating oxalic acid ( $C_2H_4O_2$ ) and concentrated  $H_2SO_4$ . This forms  $CO + CO_2 + H_2O$ . The  $CO_2$  was absorbed by passing the gas through KOH solution, after which the CO was dried in  $P_2O_5$ .

As will be noticed in curve *a* (fig. 21), there was still some  $CO_2$  present, as shown by the maxima at  $2.75\ \mu$  and  $4.3\ \mu$ . After washing the gas back and forth for half an hour, in a burette of KOH, and drying in  $P_2O_5$  the  $CO_2$  was entirely removed, as shown by curve *b*.

The maxima of CO occur at  $2.4\ \mu$  and  $4.59\ \mu$ . Ångström<sup>3</sup> found these maxima at  $2.48\ \mu$  and  $4.52\ \mu$ .

The absorption spectrum of CO was examined to  $14\ \mu$ , but *no* maxima were found.

As shown by Ångström, the fact that the CO band occurs at  $4.59\ \mu$  and the  $CO_2$  at  $4.29\ \mu$  invalidates the assumption that molecular weight has a great influence on absorption.

<sup>1</sup>Ångström & Palmer: Öfversigt Kongl. Vet. Akad., No. 6, p. 389, 1893.

<sup>2</sup>Paschen: Ann. der Physik, 53, p. 334, 1894.

<sup>3</sup>Ångström, loc. cit.

CARBON DIOXIDE.  $\text{CO}_2$ .

(Cell, 5.7 cm. ; barom., 74.0 cm. ; temp.,  $23^\circ$  ; fig. 22.)

Made from  $\text{K}_2\text{CO}_3 + \text{H}_2\text{SO}_4$  and dried in  $\text{P}_2\text{O}_5$ .

This gas has been examined by nearly every person who has investigated absorption spectra. It is noted for its variation in the location of its maxima, in emission and absorption spectra. This is most evident at  $4.4 \mu$  and  $14 \mu$ .

The emission<sup>1</sup> band of a Bunsen burner occurs at  $4.4 \mu$ , while the *atmospheric absorption* band occurs at  $4.26 \mu$ . Rubens and Aschkinass,<sup>2</sup> using a sylvite prism, studied  $\text{CO}_2$  to  $20 \mu$ , and found a large band at  $14.7 \mu$  for absorption and at  $14.1 \mu$  for emission. The column of  $\text{CO}_2$  in the absorption work was 65 cm. in length. It will thus be noticed that at  $4.4 \mu$  the emission band shifts to the longer wave-lengths with rise of temperature, while at  $14 \mu$  the shift is toward the shorter wave-lengths.

Ångström found the  $\text{CO}_2$  bands at  $2.6 \mu$  and  $4.32 \mu$ , while in the present examination they occur at  $2.75 \mu$  and  $4.29 \mu$ . The fact that the *atmospheric* band of  $\text{CO}_2$  occurs at  $4.26 \mu$  leads me to think that the present value is more nearly correct. A slight trace of CO would tend to shift it toward that band, at  $4.59 \mu$ . The actual position of the atmospheric band of  $\text{CO}_2$ , as located in a radiation curve, depends upon the temperature of the radiator. This is well illustrated in the curves of the heaters (fig. 126), where for the more intense radiation the absorption band is shifted from  $4.25 \mu$  to  $4.28 \mu$ . The  $14.66 \mu$  band is in excellent agreement with the value,  $14.7 \mu$ , found by Rubens and Aschkinass, when we consider that rock salt is already quite opaque in this region. As a whole, the work agrees well with that of other observers, considering how precarious a problem it is to map out infra-red absorption spectra.

Carbon dioxide is the only gas studied which has *no* absorption bands at  $4.5 \mu$  and  $14 \mu$ .

From the fact that gases dissociate at high temperatures are we to conclude that as the temperature rises the  $\text{CO}_2$  dissociates into CO, thus shifting the *emission* maximum of  $\text{CO}_2$  from  $4.26 \mu$  toward the absorption band of CO at  $4.59 \mu$ , and forming the well-known band at  $4.4 \mu$ ?

But how are we to account for the great Y band in Langley's bolographs, which show a broad band extending from  $4.3 \mu$  to  $4.65 \mu$ ? We can not say that it is due to the combined action of CO and  $\text{CO}_2$ , since the CO is not found in the atmosphere. Oxygen has slight bands at

<sup>1</sup>Paschen, loc. cit., vol. 53.

<sup>2</sup>Rubens & Aschkinass: *Astrophys. Journal*, 8, p. 191, 1898.

3.1  $\mu$  and 4.65  $\mu$ , but the absence of bands in the bolographs at 3.1  $\mu$  would seem to indicate that the broad Y band is not the composite of the CO<sub>2</sub> and O bands.

As mentioned by Rubens and Aschkinass (*loc. cit.*), the absence of CO<sub>2</sub> bands in the curves shows that this gas can not have a great influence upon the general transparency of the earth's atmosphere.

#### SULPHUR DIOXIDE. SO<sub>2</sub>.

(Cell 6.3 cm. ; barom., 74.4 cm. ; temp., 23° ; fig. 23.)

Generated by adding concentrated H<sub>2</sub>SO<sub>4</sub> to sodium bisulphide (NaHSO<sub>3</sub>) and drying in P<sub>2</sub>O<sub>5</sub>.

This same gas was fractionally liquefied, and then fractionally distilled, but, as will be noticed, the curves coincide for the two samples, showing that nothing has been eliminated. This is a striking contrast to ethane, in which for successive purifications certain bands continued decreasing in intensity, showing that they were due to impurities.

Compared with CO<sub>2</sub> we have few examples which are more conspicuous in showing marked changes by substituting an S for a C atom.

In the region where CO<sub>2</sub> is transparent the SO<sub>2</sub> has its greatest absorption bands. The one at 10.4  $\mu$  coincides with that of ammonia.

Certain lines seem to belong to a spectral series, as determined by the law of "constant difference" of the wave-numbers. For example, take the following absorption maxima :

$$\begin{array}{l} 3.18 \\ 3.97 \end{array} > \nu_0 = 605 \qquad \begin{array}{l} 5.68 \\ 8.70 \end{array} > \nu_0 = 610$$

Considering that the 8.7  $\mu$  band is broad, and hence not well defined, the agreement is very close, but, unless we find more lines toward the visible spectrum, we can not determine the constants in the spectral series equations.

The two curves given in fig. 23 are for ordinary SO<sub>2</sub> and for the same gas when purified by fractional liquefaction and distillation.

#### HYDROGEN SULPHIDE. H<sub>2</sub>S.

(Cell, 5.7 cm. ; barom., 74.0 cm. ; temp., 21° ; fig. 24.)

Generated by adding HCl to ZnS, dried in P<sub>2</sub>O<sub>5</sub>.

Liquefied in two fractions, one at -15°, the other at -60°. The sample liquefied at -60° was distilled fractionally, and several fractions were examined. A sample which had been made from ZnS + H<sub>2</sub>SO<sub>4</sub>, but not liquefied, showed SO<sub>2</sub> bands, which would naturally be expected.

The changes wrought in the absorption spectrum by substituting hydrogen for oxygen are not so marked as that from CO<sub>2</sub> to SO<sub>2</sub>. For H<sub>2</sub>S we have a greater number of lines, especially beyond 9  $\mu$ , but there are no deep bands like in SO<sub>2</sub>. It was noticed that the bands were not

so intense after the gas had stood a while in the mercury gasometer. Whether this is due to decomposition into  $\text{HgS}$  and  $\text{H}$  has not been determined, on account of lack of time. Certain samples tarnished the mercury, while others did not, after standing in the gasometer for some time.

Sulphur has a band at  $7.9 \mu$ , while  $\text{H}_2\text{S}$  has a band at  $7.8 \mu$ . Julius found the emission band of a sulphur flame at  $7.85 \mu$  ( $\text{H}_2\text{S}$ ?) instead of at  $7.4 \mu$ , which is the first large maximum in  $\text{SO}_2$ . The second maximum of  $\text{SO}_2$  occurs at  $8.65 \mu$ . It does not seem possible that in the sulphur flame he observed the mean of these two bands of  $\text{SO}_2$ .

AMMONIA.  $\text{NH}_3$ .

(Cell, 6.3 cm., barom., 74.8 cm.; temp.,  $22^\circ.5$ ; fig. 25.)

Made by heating  $\text{NH}_4\text{Cl}$  and solid  $\text{KOH}$  and drying over freshly heated  $\text{CaO}$ . Upon finding several bands in common with those of certain carbohydrates, and that  $\text{NH}_2\text{CH}_3$  or  $\text{NH}_2\text{C}_2\text{H}_5$  might be present in the  $\text{NH}_4\text{Cl}$ , the latter was purified according to the method of Stas,<sup>1</sup> by boiling with  $\text{HNO}_3$  for half a day. The gas was liquefied in order to remove the supposed water band at  $2.95 \mu$ . A sample was placed in a combustion pipette containing freshly heated  $\text{CaO}$  over mercury, for five days, when the band at  $2.95 \mu$  was found to be as intense as on previous determinations. Moreover, the absorption band of water was found at the same time at  $3.0 \mu$ , which shows that the  $2.95 \mu$  band is characteristic of ammonia. It will be noticed elsewhere that this band is to be found in compounds containing amido ( $\text{NH}_2$ ) groups, as well as in certain ones containing nitrogen.

Ammonia is one of the most interesting compounds studied, because of the numerous deep, narrow bands from  $9 \mu$  to  $13 \mu$ . At  $5.7 \mu$  and  $7.3 \mu$  there is evidence of existing bands, but the narrow dispersion of rock salt prevents their being resolved. This is the only compound studied having such a series of maxima, which are, in addition, so regularly distributed that it reminds one of the ammonia and the hydrogen spectrum in the optical region. Whether the "law of constant difference" of the wave-numbers is true, or whether the coincidence in the values of certain wave-numbers is simply accidental, is difficult to decide with the few examples at hand. We have the following examples:

I	II	III
$6.1 > I_0 = 100$	$10.4 > I_0 = 31$	$11.18 > I_0 = 20$
$6.5 > I_0 = 100$	$10.75 > I_0 = 31$	$11.43 > I_0 = 20$
$9 > I_0 = 112$	$12.30 > I_0 = 31$	$11.69 > I_0 = 22$
	$12.78 > I_0 = 31$	$11.98 > I_0 = 22$

<sup>1</sup>Stas: Fresenius Zeit. f. Anal. Chemie, 6, p. 423.

It thus appears that there are three subordinate series, but how are we to establish the validity of these observations? More pairs of bands are necessary, but, as we approach the visible spectrum, the pairs of maxima must lie closer together, and, hence, can only be resolved with a larger dispersion. In addition to this, the regions at  $2\ \mu$  and  $4\ \mu$  are transparent. This, however, can probably be remedied by using longer columns of the gas. In fig. 25 curve *b* is for a pressure of 24 cm. of mercury, while the curve thus,  $\times\times\times\times$ , is for the purified  $\text{NH}_4\text{Cl}$ .

#### ABSORPTION SPECTRA OF LIQUIDS AND SOLIDS.

(Tables II, VI, and VIII A to F.)

##### HALOGEN SUBSTITUTION PRODUCTS.

###### CHLOROFORM. $\text{CHCl}_3$ . (Fig. 26.)

This is one of the first compounds investigated, and is of interest because it is one of the simplest combinations of carbon and hydrogen.

Numerous small absorption bands are to be noticed throughout the whole curve, and one is reminded of the line spectrum found by Abney and Festing at  $1.2\ \mu$ . The wide band from  $6.8\ \mu$  to  $7.2\ \mu$  is complex. The  $5.9\ \mu$  band is very small here, but is to be noticed, since it occurs in so many other compounds having CH-groups. Since chloroform is one of the simplest compounds having a CH-group, one would expect to find absorption bands due to this group, provided it has the power to act alone. Turning to benzene ( $\text{C}_6\text{H}_6$ ), which has a ring of CH-groups, we find that none of the conspicuous absorption bands are in common. The largest band of  $\text{CHCl}_3$  at  $8.3\ \mu$  is shifted to  $8.7\ \mu$  in benzene, while the  $10.82\ \mu$  band has disappeared entirely in the latter. If this disappearance of the  $10.82\ \mu$  band is to be attributed to the lack of Cl in benzene, one would look for it in monochlorbenzene ( $\text{C}_6\text{H}_5\text{Cl}$ ). It occurs there (fig. 85) as a slight depression in the transmission curve. It also occurs in S and in benzaldehyde ( $\text{C}_6\text{H}_5\text{CHO}$ ), which brings us back to the previous conclusion of the nonentity of the atom in the molecule.

###### IODOFORM. $\text{CHI}_3$ . (Fig. 27.)

This is a crystalline solid, and hence difficult to obtain in a thin film. The film used was 0.05 mm. thickness, but, not being homogeneous, it increased the opacity by scattering the incident energy. As a result, the general transmission is reduced to about 40 per cent, and only two strong bands are resolved, at  $8.6\ \mu$  and  $9.3\ \mu$ , respectively. In chloroform these bands are quite obliterated by others of greater depth. The  $9.4\ \mu$  band is to be found in numerous other compounds. On melting, iodine was set free, thus coloring the film red, but this evaporated in a

few hours. The iodine band at  $7.3 \mu$  could not be detected, although special care was taken in the examination. This is due to the thinness of the film and the weakness of the band.

The  $3.3 \mu$  band is very weak, due to the opacity of the crystalline film. Julius<sup>1</sup> found this same band very weak in bromoform ( $\text{CHBr}_3$ ). It is a little stronger and shifted in the simpler CH compounds.

CARBON TETRACHLORIDE.  $\text{CCl}_4$ . (Fig. 28.)

This compound is noted for the absence of large absorption bands up to  $6 \mu$ , as seems to be true of carbochlorates as distinguished from carbohydrates. Two small bands, at  $2.9 \mu$  and  $4.45 \mu$ , do not appear in Julius's curves. The first deep maximum is at  $6.5 \mu$ . This band shows a break in the curve for the small spectrometer, and was found to be double, by using the large spectrometer, the maxima being at  $6.45 \mu$  and  $6.57 \mu$ , respectively. The mean of these two is at  $6.51 \mu$ . Paschen<sup>2</sup> found this band at  $6.45 \mu$ . Thinking that it would be a good check upon my work, the observations were repeated with the large spectrometer (curve  $\times\times\times\times$ ), with the result that two bands were found. This is an excellent example of what may be expected if a large dispersion can ever be applied to the region at  $3 \mu$  for some of the other compounds.

There are no further large absorption bands until we arrive at  $13 \mu$ . Here a broad, deep band exists which is harmonic with the double band at  $6.5 \mu$ .

Since the photographs of Abney and Festing<sup>3</sup> show *no* lines for the region up to  $1.2 \mu$ , and since Puccianti<sup>4</sup> found no bands up to  $2.5 \mu$ , it appears that the absence of bands up to  $6 \mu$  is *not* due to the lack of resolution of the fine lines, but is more likely due to their entire absence. For this reason this compound ought to be an excellent solvent for studying selective absorbing solids in solution. (See Appendix IV.)

The great change introduced by substituting four Cl atoms for four H atoms is very evident by comparing this spectrum with that of methane ( $\text{CH}_4$ ), which has only two large bands, at  $3.3 \mu$  and  $7.7 \mu$ , respectively.

TETRACHLOROETHYLENE.  $\text{C}_2\text{Cl}_4$ . (Fig. 29.)

As in carbon tetrachloride, this compound has no absorption bands until we arrive at  $5.5 \mu$ . The large band of  $\text{CCl}_4$  at  $6.5 \mu$  is entirely wanting, while the  $12.9 \mu$  band is present, but is narrower. At  $8 \mu$  are two bands common to  $\text{CCl}_4$ . This compound has some of the properties

<sup>1</sup>Julius, loc. cit.

<sup>2</sup>Paschen, loc. cit.

<sup>3</sup>Abney & Festing, loc. cit.

<sup>4</sup>Puccianti, loc. cit.

of ethylene ( $C_2H_4$ ), but not a single band is in common, just as was found for  $CH_4$  and  $CCl_4$ .

The maximum at  $6.4 \mu$  is closely harmonic with the one at  $12.9 \mu$ . The sample of  $C_2Cl_4$  used was presented me by Dr. W. C. Geer, who had prepared it with great care. Nevertheless the small bands at  $8 \mu$  seem to indicate the presence of  $CCl_4$ , which may have been formed in the process of making of  $C_2Cl_4$ . The latter is an intermediate product. However, the absence of the  $6.5 \mu$  band and the presence of the  $12.9 \mu$  band leaves the question of the presence of  $CCl_4$  somewhat in doubt. This, however, does not interfere with the comparison of  $C_2Cl_4$  with ethylene ( $C_2H_4$ ).

ETHYLENE BROMIDE.  $C_2H_4Br_2$ . (Fig. 30.)

(From Bender and Hobein; boiling point,  $131^\circ$ .)

The absorption spectrum of this compound is of special importance because the ethylene gas ( $C_2H_4$ ) was made from it. The difference between the two absorption curves of these two compounds is found mostly in the general absorption. The  $C_2H_4$  has a large triple band at  $10.5 \mu$ , where  $C_2H_4Br_2$  is quite transparent. The bands at  $3.35 \mu$ ,  $6.98 \mu$ ,  $9.8 \mu$ ,  $11.2 \mu$ , and  $13 \mu$  are found common to both compounds, although they vary in intensity. The  $C_2H_4Br_2$  boiled at the theoretical temperature,  $131^\circ$ , and must have been pure. The fact that so many bands are in common with ethylene indicates that the addition of two Br atoms has not had any great influence upon the original absorption bands, just as the substitution of a Br atom in benzene has not changed the benzene spectrum. Two pairs of bands at  $8.0 \mu$  and  $8.44 \mu$ , and at  $11.14 \mu$  and  $12.0 \mu$  have a "common difference" of  $V=66$ , which would indicate that they belong to a spectral series.

WATER AND ALCOHOL.

WATER. H-O-H. (Fig. 31.)

This substance has been extensively studied by Julius,<sup>1</sup> Paschen,<sup>2</sup> Aschkinass,<sup>3</sup> and others, both as a vapor and as a liquid film—emission and absorption spectra. The investigators do not quite agree in the location of the maxima, although the work of each one, taken by itself, appears consistent. All have found an extreme opacity to infra-red radiation, so that the films of water had to be reduced to a few thousandths of a millimeter in order to be able to study it at all. Were it not for this property, water could be used as a solvent for studying sub-

<sup>1</sup>Julius: Verhandl. Kon. Akad., Amsterdam, 1892.

<sup>2</sup>Paschen: Ann. der Physik, 53, p. 334, 1894.

<sup>3</sup>Aschkinass: Ann. der Physik, 55, p. 431, 1895.



stances in solution. The idea that water becomes more opaque when alum is dissolved in it is still to be found in some quarters, although Aschkinass has made a special study of it, which gave negative results. The work of E. F. Nichols<sup>1</sup> also disproves this belief. The work of Aschkinass is of special interest, since he examined pure water, instead of a salt solution, as did Julius, and found no difference in the maxima for the two methods. The maxima differ somewhat for different kinds of water, depending, no doubt, upon its purity.

A series of absorption bands at  $3.06 \mu$ ,  $4.7 \mu$ , and  $6.1 \mu$  are of importance in connection with the present work. First, the  $6.1 \mu$  band is just double the  $3.06 \mu$ . Paschen found the first maximum at  $2.916 \mu$ ,  $2.97 \mu$ , and  $3.024 \mu$ , depending upon the thickness of the film, and the second maximum at  $6.061 \mu$ , which is a fair agreement, considering the difficulties in calibrating the apparatus.

The  $6.1 \mu$  band is as closely harmonic with the  $3.06 \mu$  band as one can expect. A glance at the curves shows this. The bands are broad, and the exact location of the maximum can not be determined beyond the second decimal place. Curve *c* in fig. 31 shows the transmission through a gypsum crystal ( $\text{CaSO}_4 + 2\text{H}_2\text{O}$ ) 2.58 mm. thick. The bands at  $1.5 \mu$  and  $2.0 \mu$  coincide with those of pure water. This shows that the molecule of the water of crystallization is in a condition like that of pure water. This curve is due to Königsberger,<sup>2</sup> who made a study of the absorption of doubly refracting crystals. He found that muscovite mica ( $\text{H}_4\text{K}_2\text{Al}_6\text{Si}_6\text{O}_{38}$ ), which contains water, or, rather, hydrogen and oxygen chemically combined, shows a band at  $2.95 \mu$ , but no band at  $1.5 \mu$ .

Julius and Aschkinass found a layer of water 0.17 mm. in thickness to be almost opaque beyond  $7 \mu$ . The region from  $7 \mu$  to  $14 \mu$  has been re-explored by the writer, using a salt solution of water, about 0.03 mm. in thickness, between rock-salt plates. This film decreased gradually in transmission of 6 per cent at  $7 \mu$  to opacity at  $12 \mu$ . It thus becomes evident that no water solutions nor compounds containing water could be used in this work.

Curve *e* is due to Rubens and Aschkinass,<sup>3</sup> who examined  $\text{CO}_2$  and water vapor to  $20 \mu$ . No explanation is offered for its great transparency at  $11 \mu$  as compared with liquid water. Water is the most opaque substance examined; in fact, beyond  $2 \mu$  it is the most opaque substance known. Further work on the question of water of crystallization is given in Appendix V.

<sup>1</sup>Nichols, E. F. : Phys. Rev., vol. 1, p. 1.

<sup>2</sup>Königsberger : Ann. der Physik, 61, p. 687, 1897.

<sup>3</sup>Rubens & Aschkinass, loc. cit.

Since, in all infra-red work, the calibration consists essentially in setting for minimum deviation of some known line, like the D lines, in the visible region, and using that for a base, or "zero setting," and since a slight error in setting for minimum deviation or in the "zero setting" may introduce great errors in the infra-red, it is unfortunate that Königsberger did not compare the  $2.95 \mu$  water of crystallization band with that of pure water, found by Paschen at from  $2.916 \mu$  to  $3.024 \mu$  and by Aschkinass at  $3.06 \mu$ . The same is true of Ransohoff,<sup>1</sup> who considers the alcohol band at  $3.0 \mu$  in coincidence with the  $3 \mu$  band of water, as found by Aschkinass, though he made no direct comparison. In the present work, using the *large* spectrometer, the best value for the water band is  $2.95 \mu$ , which agrees with the value found for water of crystallization. (See Appendices V and VI.)

ALCOHOLS. (Figs. 32 and 38.)

In the present work alcohols were but briefly studied, because of their great opacity beyond  $7 \mu$ , as well as on account of the difficulty of freeing them from water. The higher alcohols, like glycerin, even if they could be freed from water, are so hygroscopic that they are difficult to investigate.

MYRICYL ALCOHOL.  $C_{30}H_{60}OH$ . (Fig. 32.)

Ethyl alcohol was studied with the small spectrometer, and has been discussed with the other simple  $CH_3$  compounds. Amyl alcohol was examined at  $3 \mu$  with the large spectrometer to compare with the work of Ransohoff.<sup>1</sup> The maxima were found at  $2.95 \mu$  and  $3.43 \mu$ . Ransohoff found these bands at  $3.0 \mu$  and  $3.43 \mu$ .

The only other alcohol which has been studied thoroughly is myricyl, which is a solid from beeswax. A very thin solid film was obtained by melting between two plates of rock salt. The spectrum is very marked for several strong absorption bands which correspond to those in the petroleum distillates. The dispersion with the large spectrometer at  $3 \mu$ , curve *b*, is comparable with that of fluorite, and hence comparison can be made with the work of Ransohoff. In the present work the maxima occur at  $1.71 \mu$ ,  $2.95 \mu$ ,  $3.43 \mu$ , and  $5.8 \mu$ . The water bands were found at  $2.95 \mu$  and  $6.0 \mu$ , so that the  $2.95 \mu$  band of myricyl alcohol coincides with the one for water, while the one at  $5.8 \mu$  does not. The discrepancy at  $2.95 \mu$  and  $3 \mu$  may be due to inaccuracies in the dispersion of rock salt as compared with that of fluorite. The rock-salt dispersion curve passes through a double curvature at this point,

<sup>1</sup>Ransohoff, loc. cit.

hence difficult to determine, especially since data are almost entirely lacking at  $2.9 \mu$ , just where they are most needed. (See Appendix VI.)

Two examinations were made, the first with the myricyl alcohol just taken from the containing bottle. For the second examination several grams of the myricyl were heated to  $110^\circ$  for seven hours in a drying oven, which was sufficient to expel any water present. Immediately after this heating a thin solid film was examined, and the bands at  $2.95 \mu$  and  $3.43 \mu$  coincided exactly with those found previously, which would indicate that the  $2.95 \mu$  band is not due to water. Whether it is due to the OH-group is a different question. If it is due to OH, then the  $5.8 \mu$  band should coincide with the water band found by Aschkinass<sup>1</sup> at  $6.0 \mu$ . The spectrum of myricyl alcohol consists essentially of five large bands. The bands at  $1.71 \mu$ ,  $3.43 \mu$ ,  $6.86 \mu$ ,  $10.2 \mu$  and  $13.9 \mu$  are closely harmonic. These large bands occur in ethyl alcohol, where they are very much broadened and obliterated in details, due to the greater opacity of the film investigated.

Like water, the alcohols are very transparent up to  $1 \mu$ , beyond which point they suddenly become more opaque.

In connection with these alcohols, phenol (fig. 99) and menthol (fig. 117) are also to be noticed, since they show the  $2.95 \mu$  band, which is characteristic of the alcohols.

#### COMPOUNDS CONTAINING THE METHYL ( $\text{CH}_3$ ) GROUP.

Under this heading have been collected a number of compounds that contain  $\text{CH}_3$ -groups. This method of discussing these compounds is of great help in considering certain absorption bands which are probably due to the methane radical. Thus the  $3.45 \mu$  band found in 8 compounds (mostly alcohols) containing  $\text{CH}_3$  led Julius<sup>2</sup> to believe that it was due to that group of atoms. In this present investigation, which covers nearly the whole field of organic chemistry, it remains to be seen how constantly this band occurs.

#### NITROMETHANE (METHYL NITRITE). $\text{CH}_3\text{NO}_2$ ; $\text{CH}_3\text{-O-N}$ . (Fig. 33.)

In this compound the introduction of the  $\text{NO}_2$ -group has not disturbed the  $3.41 \mu$  band. Several new ones are to be observed from  $4$  to  $6 \mu$ , and are more prominent when examined with the large spectrometer. The region from  $6$  to  $7 \mu$  is noticeable because of its great opacity, due to a number of large absorption bands. Beyond this there is the same general transparency of 80 per cent, as in the first part of the spectrum, interspersed with sharp absorption bands, especially at  $9.1 \mu$ .

<sup>1</sup>Aschkinass, loc. cit.

<sup>2</sup>Julius: Verhandl. Koninkl. Akad., Amsterdam, Deel I, No. 1, 1892.

NITROËTHANE.  $C_2H_5NO_2$ . (Fig. 33.)

The  $3.4 \mu$  band is still undisturbed. In the region from  $6 \mu$  to  $7.5 \mu$  the addition of a  $CH_2$ -group seems to have brought about a greater freedom of vibration, and, instead of a continuous band, we find several small sharp lines. The same is true of the  $7.9 \mu$  and  $10 \mu$  bands, which are also more prominent. There are two new bands located at  $11.45 \mu$  and  $12.45 \mu$ , as well as the  $14 \mu$  band, which is of frequent occurrence in methyl and ethyl compounds. On viewing these curves with their profusion of absorption bands, one can see why nitrogen compounds are so opaque as compared with the sulphides. The thickness of the cell used was only  $0.01 \text{ mm.}$ , while in ethyl sulphide the thickness was ten times as great. In these two compounds the N atom is thought to be trivalent. The spectra are entirely different from nitrobenzene.

METHYL CYANIDE.  $CH_3CN$ . (Fig. 34.)

In the pyridine group mention was made of the great opacity of nitrogen compounds. In those cases the N or NH replaced a CH-group in the ring compounds. In the present compound the N atom is joined to the C atom. The result is a more transparent compound like  $C_2H_5CN$ .

The  $3.4 \mu$  band appears complex, while a small depression appears at  $3.0 \mu$ . The  $4.37 \mu$  band occurs prominently here, as it does in a few of the succeeding compounds. No band occurs at  $5.7 \mu$ , but a small one is found at  $6.2 \mu$ , ending in a large band at  $7.0 \mu$ . The  $8.2 \mu$  band of  $CH_3I$  is wanting, while the  $10.5 \mu$  and  $14 \mu$  bands, to be noticed frequently in other compounds, are very weak. As a whole, an entirely new series of lines has been produced, most of which are very sharp. The  $7.08 \mu$  band is to be noticed in connection with the ethyl cyanide. The band at  $3.0 \mu$  is to be found in many compounds containing N atoms. The curves are practically identical for the museum and Kahlbaum's samples.

ETHYL CYANIDE.  $H_2C_5CN$ . (Fig. 35.)

The difference between methyl and ethyl cyanide is as marked as that of the respective iodides. This is especially true at  $11 \mu$ , where the large band of  $CH_3CN$  is entirely wanting. The  $9.6 \mu$  band of  $CH_3CN$  is found at  $9.35 \mu$ . The transparent region extending from  $11.5 \mu$  to  $13.5 \mu$  in  $CH_3CN$  is shifted so as to extend from  $10.5 \mu$  to  $12.5 \mu$  in  $C_2H_5CN$ . The  $3.4 \mu$  band occurs in its proper place, while the  $7.7 \mu$  band is probably a new one. The unusually sharp bands at  $6.98 \mu$ ,  $9.3 \mu$ , and  $12.75 \mu$  are very marked, and they make it appear that oxygen is not the only element that sharpens the bands. The  $6.98 \mu$  band of  $C_2H_5CN$  is *not* the same as the  $7.04 \mu$  of the  $CH_3CN$ . To make sure

of this these two substances were examined on the same day, and the apparent shift is simply due to the fact that the  $\text{CH}_3\text{CN}$  band is complex, with its second component at  $7.25 \mu$ . This is an excellent example of what might have been considered a *shifting* of the absorption band, with change in molecular weight, if a smaller dispersion had been used.

In  $\text{C}_2\text{H}_5\text{SCN}$  the CN part is joined to the S atom. The result is a shifting or stretching apart of all the strong bands, beginning at  $4.4 \mu$  and extending to  $10.4 \mu$ , where a transparent region occurs which extends to  $12.8 \mu$ , just as in the  $\text{C}_2\text{H}_5\text{CN}$ .

#### METHYL IODIDE. $\text{CH}_3\text{I}$ . (Fig. 36.)

This compound gives a curve conspicuous for three regions of great absorption, viz,  $3.4 \mu$ ,  $7.2 \mu$ , and  $11.4 \mu$ , while there are two transparent regions, at  $9.5 \mu$  and  $13 \mu$ , where ethyl alcohol is opaque. At  $10.5 \mu$  there is gentle decline in transmission, with a possible band at  $10.8 \mu$ , and terminating in a large minimum at  $11.3 \mu$ . Methyl iodide is quite transparent, 60 per cent, if considered in height of the transmission minima and thickness of absorbing cell, also if one were to consider the total transmission. It will be noticed that these great absorption bands lie in the region where the radiation from a black body is very weak, while the  $3.4 \mu$  band is shallow, so that the great transparency of  $\text{CH}_3\text{I}$  observed by Friedel<sup>1</sup> (using Tyndall's method of total absorption), as compared with nitrogen compounds, is due apparently to the lack of strong absorption bands in the region of strong radiation. That the transparency of a medium depends upon the radiation employed is shown in a striking manner in Drew's<sup>2</sup> work on vacuum-tube radiation. He used  $\text{CS}_2$  as an absorbing medium, and found it as opaque as water, due to the fact that the emission is concentrated in a strong band at  $4.75 \mu$ , which coincides with a strong absorption band of  $\text{CS}_2$  at  $4.7 \mu$ . No absorption band is to be found at  $7.3 \mu$ , where solid iodine has a large band. The  $5.95 \mu$  band is only slight. The  $4.6 \mu$  band is to be noticed in connection with the several of the simpler  $\text{CH}_3$  compounds mentioned in the following pages. It is found in only a few compounds.

#### ETHYL IODIDE. $\text{C}_2\text{H}_5\text{I}$ . (Fig. 37.)

Like the preceding, this substance is quite transparent, so that a  $0.16$  mm. cell could be used except beyond  $13 \mu$ , where it is more opaque.

The region from  $6$  to  $12 \mu$  is conspicuous for its regions of great transparency and of opacity. The  $11.4 \mu$  band of  $\text{CH}_3\text{I}$  is absent, and

<sup>1</sup>Friedel; Ann. der Physik (3), 55, p. 453, 1895.

<sup>2</sup>Drew: Phys. Rev., vol. XVII, p. 321, 1903.

in its stead is a large band at  $10.5 \mu$ . It will thus be seen that the three large bands of  $\text{CH}_3\text{I}$  occur in slightly shifted positions in  $\text{C}_2\text{H}_5\text{I}$ , and, in addition to this, they are also more prominent in the latter. The bands from  $3.4 \mu$  to  $6 \mu$  are more prominent in this compound, while beyond  $12 \mu$  several new ones occur. As a whole there are a greater number of transmission minima in  $\text{C}_2\text{H}_5\text{I}$  than in  $\text{CH}_3\text{I}$ , which is to be expected, if absorption depends upon the groups of atoms in the molecule. The  $14 \mu$  band is overshadowed by the one at  $13.6 \mu$ . With the  $0.05 \text{ mm.}$  film, the band at  $7.15 \mu$  occurs at  $7.06 \mu$ , the sides appearing unsymmetrical. In photographic spectra such examples of the blurring of the band is of frequent occurrence. As with other compounds, no shifting of absorption bands could be detected.

ETHYL ALCOHOL (ABSOLUTE).  $\text{C}_2\text{H}_5\text{OH}$ . (Fig. 38.)

As already mentioned, a number of alcohols have been examined by Julius and found to become suddenly opaque at  $7 \mu$ , due to thickness of the cell of  $0.2 \text{ mm.}$  The curves (fig. 38) explain this, as will be noticed in the great opacity which extends from  $7$  to  $10 \mu$ , beyond which there is a transparent region at  $10.5 \mu$ , and again opacity beyond  $13 \mu$ .

Puccianti<sup>1</sup> has also examined this compound and several of the iodides up to  $2.5 \mu$ . He found that all compounds in which carbon is directly united with hydrogen showed absorption maxima at  $1.71 \mu$ . In the above curve there is a slight depression at  $1.6 \mu$ , which represents the band found by him, but, on account of the narrowness of the dispersion in this region, no attempt has been made to adjust this disagreement. This obliteration of the band is due entirely to the overlapping of the slit, on account of narrow dispersion. The  $3.45 \mu$  band is broad for the  $0.18 \text{ mm.}$  cell, but appears complex for the  $0.04 \text{ mm.}$  cell. No doubt the  $7.3 \mu$  band is likewise a composite of two or more bands, which would be resolved with greater dispersion. The  $5.95 \mu$  band is only a slight depression. The curve is of importance in showing the freedom from water, which the alcohols so easily absorb. Ordinary ethyl alcohol and glycol were found to be opaque beyond  $7 \mu$ , using a thin film, like the one above. At its best, however, alcohol is very opaque to infra-red radiation, as seen in curve *a*,  $0.18 \text{ mm.}$ , which is opaque at  $6 \mu$ , and continues thus. Curve *b*,  $0.02 \text{ mm.}$  thickness, was repeated, using a new film to be certain that the transparency at  $8.5 \mu$  and  $10.5 \mu$  is real. This sample had been treated with sodium and contained perhaps about  $0.4$  per cent of water. There is quite a contrast between this compound and the others considered in this group, all of which are much

<sup>1</sup>Puccianti, loc. cit.

more transparent. Ransohoff,<sup>1</sup> using a larger dispersion, found the region a complex of two bands, at  $3.0\ \mu$  and  $3.43\ \mu$ , while the band at  $5.2\ \mu$  is deeper and better defined.

ETHYLHYDROSULPHIDE.  $C_2H_5SH$ . (Fig. 39.)

The low boiling-point,  $36^\circ$ , of this ill-smelling compound makes it a difficult subject for investigation, as will be noticed from the curves in fig. 39, which were obtained after giving the cell an additional coating of paraffin to prevent leaking. In depth and number of transmission minima the curve agrees exactly with that of Julius, and was used to reduce his values (given for his straight-line extrapolation from  $5\ \mu$ ) back to the true dispersion curve. The last band found by Julius was the one at  $10.4\ \mu$ . No attempt was made to locate accurately the band found by him at  $3.88\ \mu$ .

The curve is quite simple. The deep double band at  $7.0\ \mu$  and  $8.0\ \mu$  is strikingly repeated in ethyl sulphide. The  $5.9\ \mu$  band is not prominent, while the ones found in sulphur at  $7.9\ \mu$  and  $12\ \mu$  are replaced by a strong minimum at  $8\ \mu$  and another at  $11.6\ \mu$ . As a whole this compound is quite transparent.

ETHYL SULPHIDE.  $(C_2H_5)_2S$ . (Fig. 40.)

As compared with ethylhydrosulphide this compound is very similar in general absorption, as well as in the location of absorption bands. The band at  $6.86\ \mu$  is worth noticing, since it occurs in so many other compounds. The addition of a  $C_2H_5$ -group for an H atom has not seriously disturbed the spectrum of the hydrosulphide. The latter represents some of the earliest work, using a wider slit, and the evidently complex band at  $7.3\ \mu$  is resolved in the present compound. In comparison with these sulphides it will be noticed that the allyl is far more opaque.

TRIETHYLAMINE.  $(C_2H_5)_3N$ . (Fig. 41.)

In this compound we have an additional ethyl group, while the S has been replaced by an N atom. The result is an increase in the complexity of the region from  $7$  to  $10\ \mu$ , thus making the compound more opaque as a whole. The greater transparency at  $11$  to  $13\ \mu$  is quite a contrast to ethyl alcohol. There is not so marked an effect of the N atom at  $3\ \mu$  as in the case of aniline and several other benzene derivatives. This compound has a strong ammonia odor, and is similar to it, yet with the large spectrometer *no* marked band of ammonia could be detected at  $3\ \mu$ ; in fact the curve has no resemblance to that of ammonia.

<sup>1</sup>Ransohoff, loc. cit.

The  $3.43 \mu$ ,  $6.86 \mu$ ,  $9.3 \mu$ , and  $13.6 \mu$  bands are found in the petroleum distillates. The great difference between this curve and that of the iodides is significant of the effect produced by introducing such elements as I, S, and N into the methyl and ethyl compounds.

ALLYL SULPHIDE.  $(C_3H_6)_2S$ . (Fig. 42.)

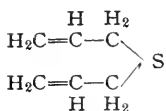

The structural formula of this compound shows that the  $\text{CH}_2$ -groups of atoms predominate. There are also two  $\text{CH}$ -groups. But when we compare the absorption curve with that of piperidine, which compound has a ring of  $\text{CH}_2$ -groups, we find so similarity between them. The same is true when compared with benzene ( $\text{C}_6\text{H}_6$ ), which has a ring of  $\text{CH}$ -groups, so that the compound seems to have a spectrum peculiar to itself, and the question of groups of atoms is of less significance than the manner of bonding of the groups with others in the molecule. In general, the sulphides have been found quite transparent. Allyl sulphide is an exception, which, according to Friedel,<sup>1</sup> is to be accounted for by the preponderance of H atoms.

ETHYL SULPHATE.  $(C_2H_5)_2SO_4$ . (Fig. 43.)

This compound decomposes when exposed to light. The sample used was distilled just before using. The distilling had to be done fractionally under reduced pressure. Since the best sample obtained had a slight odor of  $\text{SO}_2$ , the exploration of its absorption spectrum was not continued beyond  $7 \mu$ , where there was complete opacity for the cell used. The  $3.45 \mu$  and  $5.95 \mu$  transmission minima are of interest in considering the action of the ethyl radical.

METHYL ACETATE.  $\text{CH}_3\text{OOCH}_3$ . (Fig. 45.)

Methyl acetate belongs to the fatty acids and shows some similarity to that group. The region at  $3.3 \mu$  reminds one of phenyl acetate, while at  $11 \mu$  the transparent region is similar to that of alcohol.

This compound is very opaque, and its study has not aided materially in determining the effect of  $\text{CH}_3$ -groups. The region of great opacity, from  $6$  to  $9 \mu$ , is to be found in methyl carbonate, ethyl succinate, and several other compounds containing oxygen.

ACETONE.  $\text{CH}_3\text{COCH}_3$ . (Fig. 46.)

Acetone differs from methyl acetate in having a C atom substituted for an O atom in the latter.

<sup>1</sup>Friedel, loc. cit.



This compound was studied in the vapor state, and also as a liquid at  $3.4 \mu$ . No difference could be detected in the location of the  $3.4 \mu$  band for the liquid and vapor phase. The acetone curve has a great similarity to that of methyl acetate and methyl carbonate, especially at  $4.75 \mu$ ,  $5.75 \mu$ , and  $8 \mu$ , but the great opacity and breadth of the absorption bands prevents a minute study of them. The large spectrometer failed to resolve the region at  $3.3 \mu$ , just as was found for the fatty acids at  $7 \mu$ , and as Ransohoff found for the alcohols at  $6 \mu$ .

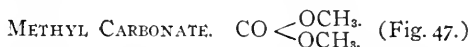

Like the preceding compound, methyl carbonate has an opaque region, extending from  $6$  to  $9 \mu$ , but as a whole it is distinguished for several sharp transmission minima. But few compounds have been found that show such extraordinary variations in transparency and opacity. The minimum at  $12.65 \mu$  has a depth of 70 per cent. If this sharpness and depth is due to the presence of oxygen, as mentioned in discussing benzaldehyde, then the same is to be noticed here. The  $3.5 \mu$  band is evidently complex. The  $5.8 \mu$  band occurs strong and well defined. The  $8 \mu$  band is to be noticed for the first time in considering this group of compounds. This band is no doubt complex.

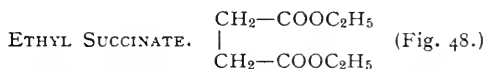

As the structural formula shows, this compound is derived from succinic acid,  $\text{C}_2\text{H}_4(\text{CO}_2\text{H})_2$  (from amber), by replacing the H atom by the  $\text{C}_2\text{H}_5$  radical. The curve is conspicuous for its sharp transmission minima and a region of great opacity extending from  $7$  to  $10 \mu$ . Other compounds, having great opacity in this region, have been noticed. Eucalyptol is an excellent example for showing great opacity followed by great transparency. But this compound is almost the only one having a narrow opaque region, beginning abruptly at  $7 \mu$  and ending just as abruptly at  $10 \mu$ , which is followed by a region of great transparency, interspersed by deep, narrow transmission minima. The  $5.85 \mu$  band is large, which is unusual except in the fatty acids.

These last four compounds were selected in order to learn the effect of the different combinations of O and  $\text{CH}_3$  upon absorption spectra. It will be noticed that the whole spectrum undergoes a change, except the region at  $3.4 \mu$ , which is not seriously disturbed.

#### COMPOUNDS CONTAINING SULPHUR.

The sulphur compounds represent the earliest work on absorption spectra, when the approximate coincidence of the absorption bands of sulphur and carbon disulphide, at  $11.7 \mu$ , presented the question whether

or not the effect of the atom in the molecule gave rise to selective absorption, and especially whether this particular band in  $\text{CS}_2$  was due to sulphur. As the work progressed it was found that this band was frequently wanting in sulphur compounds, and finally it was found in chloroform, which does not contain sulphur. The sulphur compounds are distinguished by their great transparency, except allyl sulphide  $(\text{C}_3\text{H}_5)_2\text{S}$ , which has a predominance of hydrogen. This agrees with the work of Friedel,<sup>1</sup> who found that the transparency increases in a compound if H, O, OH, or N are replaced by S or the halogens.

#### SULPHUR. S. (Fig. 49.)

Sulphur is quite transparent throughout the spectrum. Nothing was known about the direction of the optic axes. Since this is a problem by itself, in pleochroism, it will be sufficient to add that a natural crystal, 1.06 cm. in thickness, transmitted on an average about 50 per cent, where this plate of 3.6 mm., but not so highly polished, transmitted only about 38 per cent. The absorption bands are few, the most important one being at  $11.8 \mu$ .

The emission curve, *b*, for a sulphur flame is due to Julius,<sup>2</sup> while curve *c* is for a film of S melted between rock-salt plates. Its opacity is due to its crystalline surface. The emission band at  $7.9 \mu$  coincides with the absorption band of  $\text{H}_2\text{S}$  instead of the  $\text{SO}_2$  band, as one would expect.

#### CARBON DISULPHIDE. $\text{CS}_2$ . (Fig. 50.)

This compound is distinguished for its general transparency and its large absorption bands. But few of the compounds studied have such a great transparency at 9 to  $11 \mu$ , the general experience being a great transparency from 4 to  $6 \mu$ , then a sudden opacity to  $12 \mu$ . The transmission minimum at  $12 \mu$  has already been mentioned. The rest of the curve shows no similarity to the sulphur curve, except a possible slight depression at  $7.9 \mu$ . The emission curve, *c*, of  $\text{CS}_2$  is due to Julius. It shows well the behavior of emission and absorption. It should also be noted that here the  $4.6 \mu$  band has a greater maximum than the  $6.8 \mu$  band, which is just the reverse in the absorption spectrum. This, however, is what one would expect from our knowledge of the distribution of the energy of a black body at the same temperature.

The curve of the iodine solution coincides with that of the pure  $\text{CS}_2$ . In connection with the  $\text{CS}_2$  curve the benzene bands at  $6.75 \mu$  and  $11.8 \mu$  are to be noticed. The curve as a whole is in excellent agreement with

<sup>1</sup>Friedel: Ann. der Physik, 55, p. 453, 1895.

<sup>2</sup>Julius, loc. cit.

that of Julius, which extends to about  $10 \mu$ . Carbon disulphide is similar to carbon dioxide (fig. 22), but we find no such similarities in their absorption spectra.

#### THE MUSTARD OILS AND SULPHOCYANATES.

Of all compounds studied, this group is the most conspicuous for demonstrating the fact that absorption depends upon the arrangement of the atoms in the molecule. The mustard oils are unique in having an enormous absorption band in the region of short wave-lengths, this side of  $5 \mu$ . In carbon disulphide the first strong band occurs at  $6.7 \mu$ . Just as the fatty acids and terpenes were noticed to have similar absorption spectra, so the mustard oils have a characteristic group of absorption bands; and if we knew nothing of their chemical relations to the sulphocyanates, their absorption spectra would lead to a classification by themselves. The characteristic band of the mustard oils is at about  $4.8 \mu$ , which happens to be close to a somewhat less prominent one in  $CS_2$  at  $4.6 \mu$ .

#### METHYL SULPHOCYANATE. $CH_3-S-C=N$ . (Fig. 51.)

In the discussion of the simple methyl ( $CH_3$ ) and ethyl ( $C_2H_5$ ) compounds it was noticed that a marked change was brought about in the absorption spectra by adding a CN or  $NO_2$  group to the methyl or ethyl radical. In the present compound the substitution of the SCN for the CN group is just as marked. The bands at  $3.4 \mu$  and  $7 \mu$  show some similarity, but beyond this point we have an entirely new spectrum. Usually the region from 4 to  $5 \mu$  shows no maxima, but in some of the simpler compounds like this one, and in  $CH_3I$ , there is quite a marked absorption band.

#### METHYL MUSTARD OIL (METHYL ISOSULPHOCYANATE). $CH_3-N=C=S$ . (Fig 51.)

This compound is isomeric with methyl sulphocyanate, and the effect upon the absorption spectrum is very marked. Unless we can show that every compound has its own characteristic absorption spectrum, just as is true of the elements, we have here an excellent demonstration of the effect of *structure* of the molecule upon the transmission of heat-waves. There is plenty of evidence against the belief of an individual spectrum for each compound, as will be noticed in phenyl mustard oil and other benzene derivatives, in which traces of the original benzene spectrum are still present, and we must conclude that the effect observed is due to structure. Whether it is due to a specific group of atoms like CS or the manner of the bonding of these atoms, or whether it is due to both, will be discussed elsewhere. It will be sufficient to notice that

the enormous band at  $4.78 \mu$  is an insignificant line at  $4.68 \mu$  in the sulphocyanate, while just the reverse is true of the  $10.2 \mu$  band.

ETHYL SULPHOCYANATE.  $C_2H_5-S-C=N$ . (Fig. 52.)

The substitution of an ethyl for a methyl group has left the regions at  $3.4 \mu$  and  $4.68 \mu$  of methylsulphocyanate undisturbed. Elsewhere the spectrum is entirely rearranged, just as was noticed in changing from  $CH_3I$  to  $C_2H_5I$ . The band at  $7.93 \mu$  is new, and is not found in the following isomeric compound.

ETHYL MUSTARD OIL (ETHYL ISOSULPHOCYANATE).  $C_2H_5-N=C=S$ . (Fig. 52.)

The effect of structure is just as marked as in methyl mustard oil. In changing to the ethyl the  $3.4 \mu$  and  $4.78 \mu$  bands have not shifted. New bands occur at  $7.53 \mu$  and  $8.98 \mu$ . The  $4.78 \mu$  band is as strong as ever. No new bands were found at  $3 \mu$  when examined with the large spectrometer.

ALLYL MUSTARD OIL.  $C_3H_5-N=C=S$ . (Fig. 53.)

The large spectrometer was used to examine this compound, and consequently the exploration could not be extended beyond  $8 \mu$ . The results were as anticipated. A large band occurs at  $4.8 \mu$ , just as in the other mustard oils. The region at  $7 \mu$  and  $7.53 \mu$  is the same as in ethyl mustard oil. The  $1.70 \mu$  and  $3.4 \mu$  bands are harmonic and are to be found in all compounds containing  $CH_3$ -groups. The curve at  $6.8 \mu$  is very asymmetrical, and no doubt that band is obliterated by the one at  $7 \mu$ . The  $4.8 \mu$  band is double, with maxima at  $4.5 \mu$  and  $4.85 \mu$ . For the other mustard oils examined with the large spectrometer, this band was too opaque to determine the number of separate lines in it. The absence of a band at  $3 \mu$  is to be noticed, since it occurs in several compounds in which the N atom is differently bonded.

PHENYL MUSTARD OIL.  $C_6H_5-N=C=S$ . (Fig. 54.)

This benzene derivative has the chemical characteristics of the mustard oils. It remains to be seen what relations it has in transmitting infra-red radiation.

The first thing to be noticed is its greater opacity than benzene, so that for the first cell used ( $0.18 \text{ mm.}$ ) it became practically opaque at  $4.9 \mu$ . This is one of the few substances investigated which does not have a deep band in the region of from  $3.3 \mu$  to  $3.6 \mu$  and then become more transparent at  $4 \mu$ . Instead of this the curve continues to drop from  $2.5 \mu$  to  $5 \mu$ , with only one break at  $4.8 \mu$ , which band is to be found in the mustard oils.

When a thinner film was examined the band at  $6.5 \mu$  was found double, while with the large spectrometer the region at 3 to  $4 \mu$  was found a complex of three bands.

This is the most important compound investigated, since it shows the *superposition of the spectra of benzene and the mustard oils*. We have not only the maxima of benzene at 3.25, 6.25, 6.75, 8.7, and  $10 \mu$ , but also the marked band at  $4.8 \mu$ , which is common to *all* the mustard oils. This band at  $4.8 \mu$  in phenyl mustard is probably the strongest argument we have in favor of the effect of a group of atoms, like CS, in causing absorption. Here the NCS is bonded to a C atom, just as in the preceding compounds, and we would expect it to produce the same effect. In addition to this, however, we have the vibration of the benzene nucleus, or ion, and it seems the simplest to think of the result as being due to the resonance of the two kinds of ions.

#### THE FATTY ACIDS.

This group of compounds forms a distinct class by itself. They can be obtained by oxidation of the primary alcohols. In fact, the constitution of the alcohols, ethylene, the aldehydes, etc., has been derived from that of the fatty acids. Hence we would expect to find physical relations between them. The first thing to be noticed in the curves is the prominence of the  $5.8 \mu$  band, which is weak in the alcohols, and the transparent region at  $9.5 \mu$ , where the alcohols have a large absorption band. The regions of  $3.5 \mu$ , from 7 to  $8 \mu$ , and of  $14 \mu$  are similar for the alcohols and the acids.

The fatty acids were studied in connection with the question of the effect of an OH-group in the molecule. In the primary alcohols,  $R-CH_2OH$ , the OH is joined to a carbon atom, while in the fatty acids,  $R-CO-OH$ , the OH is joined to an oxygen atom. Another distinction is that in electrolysis, or the formation of an ester, the OH of the alcohol is separated as a hydroxyl, while in the acids it is simply the H atom that is replaced.

The question of the effect of the OH-group will be discussed separately, and it will be sufficient to add here that the  $2.95 \mu$  band, which is characteristic of the alcohols and is suspected to be due to OH, is *not* found in the fatty acids.

#### ACETIC ACID (GLACIAL). $C_2H_4O_2$ . (Fig. 55.)

This compound is of interest on account of the difficulty to free it from water. From its curve and that of pure water one would infer that the acetic acid was free from water. It has three regions of great opacity, viz,  $3.5 \mu$ , 6 to  $8 \mu$ , and 10 to  $12 \mu$ , while at  $15 \mu$  it is fairly trans-

parent. The enormous drop of 97 per cent in transparency in going from 2 to  $3.5 \mu$  has been observed in no other substance except resin. The transparent region at  $5 \mu$  is to be found in many compounds. The  $5.88 \mu$  band is very sharp and occurs in nearly all of this group of compounds. The bands at  $7.2 \mu$  and  $14 \mu$  are to be noticed frequently. The increased transparency beyond  $12 \mu$  reminds one of eucalyptol. As a whole, this compound is extremely opaque, and the film of 0.01 mm. made it barely possible to explore the regions from  $7 \mu$  to  $8 \mu$  and  $10 \mu$  to  $12 \mu$ .

LE PAGE'S GLUE. (Fig. 55.)

Having used this glue (fish glue) in making some of the thicker cells, an examination of a dry film, on rock salt, was imperative. The curve is given with that of acetic acid, since that substance is used as a solvent of the glue. Two dried films, 0.17 mm and 0.06 mm. in thickness, were explored. Although six times thicker than acetic acid, they have the same transparency up to  $3.5 \mu$ , beyond which the glue becomes more opaque and is entirely so at  $6 \mu$ . The 0.06 mm. film was likewise found to be entirely opaque beyond  $6 \mu$ . It will thus be seen that in the cases where glue was used, if any of it had dissolved, it would have manifested itself. This occurred but once, for a solution of iodine in acetic acid, and the result was opacity beyond  $3 \mu$ . None of the other substances was found to dissolve glue.

VALERIC ACID (NORMAL).  $C_5H_{10}O_2=CH_2(CH_2)_3CO-OH$ . (Fig. 57.)

Both Kahlbaum's and the museum specimens were examined, but no difference was found in the spectra. The curve is marked for the depth and size of its absorption bands, especially the ones at  $3.45 \mu$  and  $13.5 \mu$ , which are to be found in all the fatty acids. If the presence of oxygen sharpens absorption bands, as noticed by Abney and Festing, the effect is to be found in these compounds. The height of the general transmission is about 50 per cent beyond  $3 \mu$ . The  $9.15 \mu$  band is deepest in this compound and is smaller in the following compounds. An examination with the large spectrometer showed no new bands except at  $3 \mu$ , which appears complex.

CAPROIC ACID.  $C_6H_{12}O_2$ .  $CH_3(CH_2)_4COOH$ . (Fig. 57.)

This compound is a little more opaque than valeric acid. The transmission seems to be in two steps, just as in acetic acid, with an opaque region at  $8 \mu$  and  $10 \mu$ , due to large absorption bands. The band at  $8 \mu$  is double in valeric acid, the maxima being at  $7.9 \mu$  and  $8.3 \mu$ . The  $10.8 \mu$  band is also more opaque than in valeric acid.

ISOCAPROIC ACID.  $(\text{CH}_3)_2\text{CH}(\text{CH}_2)_2\text{COOH}$ . (Fig. 58.)

The curve of this isomer is identical with that of caproic acid up to  $8 \mu$ . The first new bands are found at  $9.08 \mu$  and  $12.15 \mu$ , while the  $13.8 \mu$  band of caproic is absent. The isomer seems a little more transparent, and the large band of caproic at  $8 \mu$  is resolved into two bands.

OLEIC ACID.  $\text{C}_{18}\text{H}_{34}\text{O}_2$ . (Fig. 59.)

The sample used was colorless, showing that it had not decomposed. This is an unsaturated acid,  $\text{C}_n\text{H}_{2n-2}\text{O}_2$ , but whether the increased transparency is due to this cause or to the increase in the number of  $\text{CH}_2$  groups is an unanswered question. Except for a few minor details, the curve is similar to those of the saturated acids,  $\text{C}_n\text{H}_{2n}\text{O}_2$ . An examination with the large spectrometer failed to locate new bands except in the region at  $3.45 \mu$ , where there are three. The band at  $7 \mu$  shows complete opacity from  $6.9 \mu$  to  $7 \mu$ . No band could be detected at  $3 \mu$ . A drop of water was added to several grams of liquid. The emulsion was examined, but no water band could be detected at  $3 \mu$ . This is of interest in the question of the effect of an OH-group.

STEARIC ACID.  $\text{C}_{17}\text{H}_{30}\text{O}_2$ . (Fig. 60.)

The solid films for this compound were  $0.07$  and  $0.02$  mm. in thickness. The curves are marked for their great transparency interspersed with four deep, narrow absorption bands. This high transmission in certain regions is to be noticed in other compounds. It is no doubt a characteristic of this acid, although the transparency might have been enhanced by its crystalline condition, since the film was very thin and not continuous. The absence of absorption bands is very significant, and shows that *molecular weight* and the *number of groups of atoms* are not of great importance in causing selective absorption.

CEROTIC ACID.  $\text{C}_{26}\text{H}_{50}\text{O}_2$ . (Fig. 61.)

This solid is obtained from beeswax, and, although we do not know its exact molecular weight, it is high enough to show that absorption does not depend upon that question, as will be seen in comparing it with valeric acid, in which the film was the same thickness. The discussion of stearic acid applies to this compound, since the spectra are the same, except that in cerotic acid there are new bands at  $11$ ,  $11.65$ , and  $12.85 \mu$ . All the fatty acids are chains of  $\text{CH}_2$  and  $\text{CH}_3$  groups, like the petroleum distillates. They differ in composition only in having two additional O atoms. The result is that we have only the  $3.45$  and  $13.8 \mu$  regions in common. The absorption bands are broad and deep in the acids, while they are *shallow* and narrow in the oils. The  $7 \mu$  band of

the other fatty acids is resolved into two bands, viz,  $6.85 \mu$  and  $7.06 \mu$ . It would be of interest to learn whether the others are likewise double. From experience gained at  $3 \mu$ , using the larger spectrometer, it appears that a very much larger dispersion is necessary to decide this question.

#### PETROLEUM DISTILLATES.

Through the generosity of Prof. C. F. Mabery,<sup>1</sup> of Case School of Applied Science, who presented me with 25 samples of distillates from Ohio, Pennsylvania, and California petroleum, I was able to examine these most interesting oils. They belong to the paraffin ( $C_nH_{2n+2}$ ), the methylene ( $C_nH_{2n}$ ), and the acetylene ( $C_nH_{2n-2}$ ) series of hydrocarbons. During the past seven years they had been fractionally distilled many times, some at least thirty times, and were in a high state of purity. They differ considerably in specific heats, being lower in the methylene hydrocarbons. "Whether<sup>2</sup> this is due to greater compactness in the methylene molecule or some quality of its ring structure, it would be interesting to ascertain."

These oils were examined with the hope of discovering a shift of the absorption bands with increase in molecular weight. As will be noticed, no such shift could be detected. Besides, all the compounds showed the same absorption bands, differing, of course, in intensity in different compounds. This is the same result that was obtained by Hartley and Dobbie<sup>3</sup> for the alkaloid solutions in the ultra-violet.

The methylene series consists of a *ring* of  $CH_2$ -groups, while the paraffin and acetylene series consist of a *chain* of  $CH_2$  and  $CH_2$  groups. Hence, if we had investigated these compounds with only a small spectrometer, it would appear that *structure does not seriously affect* absorption spectra. However, with the large spectrometer some of the compounds showed small absorption bands in the transparent region from  $4$  to  $6 \mu$ , while others showed no bands whatever. One absorption cell was used for quite a number of these compounds, and at the end of that time the inside of the cell was as smooth as at the beginning, showing that no water was present.

Although the compounds, as a whole, have a great bearing on this work, their discussion can be confined to a small space, since the curves are so similar. By similarity here is meant in the location of the marked absorption bands.

<sup>1</sup>Mabery : Composition of Petroleum, Proc. Amer. Acad., 37, p. 565, 1902.

<sup>2</sup>Mabery & Goldstein : Proc. Amer. Acad., 37, p. 540.

<sup>3</sup>Hartley & Dobbie, loc. cit.



METHYLENE SERIES (C<sub>n</sub>H<sub>2n</sub>).

	Boiling point.	
California :		
Dimethylpentamethylene { C <sub>7</sub> H <sub>14</sub> . . .	89°-90°	Methylene ring : $\begin{array}{c} \text{C}_{10}\text{H}_{20} = \\ \text{CH}_2-\text{CH}_2-\text{CH}_2-\text{CH}_2 \\ \diagup \quad \diagdown \\ \text{H}_2\text{C} \quad \text{CH}_2-\text{CH}_2-\text{CH}_2-\text{CH}_2 \\ \diagdown \quad \diagup \end{array}$
Methylhexamethylene . . . { C <sub>7</sub> H <sub>14</sub> . . .	98°-99°	
Octylene or dimethylhexamethylene (C <sub>8</sub> H <sub>16</sub> ) . . . . .	121°-122°	
Decylene (C <sub>10</sub> H <sub>20</sub> ) . . . . .	162°-164°	
Pentadecylene (C <sub>15</sub> H <sub>30</sub> ) . . . . .	158°-160° (50 mm.).	
Ohio oils :		
Dodecylene (C <sub>12</sub> H <sub>24</sub> ) . . . . .	111°-113° (30 mm.).	
Hexadecylene (C <sub>16</sub> H <sub>32</sub> ) . . . . .	164°-168° (30 mm.).	
Pennsylvania oils :		
Octadecylene (C <sub>18</sub> H <sub>36</sub> ) . . . . .	166°-170° (50 mm.).	
Tricosylene (C <sub>23</sub> H <sub>46</sub> ) . . . . .	260°-262° (50 mm.).	
Tetracosylene (C <sub>24</sub> H <sub>48</sub> ) . . . . .	270°-272° (50 mm.).	

PARAFFIN SERIES (C<sub>n</sub>H<sub>2n+2</sub>).

Pennsylvania oils :		
Hexane (Kahlbaum) (C <sub>6</sub> H <sub>14</sub> ) . . . . .	69°	Chain compounds : $\begin{array}{l} \text{C}_6\text{H}_{14} = \text{CH}_3(\text{CH}_2)_4\text{CH}_3 \\ \text{C}_9\text{H}_{20} = \text{CH}_3(\text{CH}_2)_2\text{C}_2\text{CH}_3 \end{array}$
Octane (C <sub>8</sub> H <sub>18</sub> ) . . . . .	148°-120°	
Decane { C <sub>10</sub> H <sub>22</sub> . . . . .	150°-160°	
{ C <sub>10</sub> H <sub>22</sub> . . . . .	170°-172°	
Dodecane (C <sub>12</sub> H <sub>26</sub> ) . . . . .	209°-210°	
Tetradecane (C <sub>14</sub> H <sub>30</sub> ) . . . . .	134°-136° (50 mm.).	
Hexadecane (C <sub>16</sub> H <sub>34</sub> ) . . . . .	169°-171° (50 mm.).	
Octadecane (C <sub>18</sub> H <sub>38</sub> ) . . . . .	200°-202° (50 mm.).	
Tricosane (C <sub>23</sub> H <sub>48</sub> ) . . . . .	256°-258° (50 mm.).	
Tetracosane (C <sub>24</sub> H <sub>50</sub> ) . . . . .	274°-276° (50 mm.).	
Pennsylvania oils (chlorine compounds of C <sub>n</sub> H <sub>2n+2</sub> ):		
Monochlortridecane (C <sub>13</sub> H <sub>27</sub> Cl) . . . . .	130°-135° (12 mm.).	
Monochlortetradecane (C <sub>14</sub> H <sub>29</sub> Cl) . . . . .	145°-150° (20 mm.).	
Monochlortetradecane (C <sub>17</sub> H <sub>35</sub> Cl) . . . . .	170°-173° (15 mm.).	
Ohio petroleum :		
Hydrocarbon (C <sub>16</sub> H <sub>34</sub> ) . . . . .	.....	

ACETYLENE SERIES (C<sub>n</sub>H<sub>2n-2</sub>).

Ohio oils : Hydrocarbon { C <sub>19</sub> H <sub>36</sub> . . . . .	198°-202°	
{ C <sub>22</sub> H <sub>42</sub> . . . . .	224°-227°	

It will be noticed that some compounds appear a little more transparent than others in certain regions of the spectrum. This no doubt is due to absorption bands which are obliterated in some and do not exist at all in others. For example, dodecane (C<sub>12</sub>H<sub>26</sub>) has four small absorption bands between 4 and 6 μ, while there are none in octadecylene (C<sub>18</sub>H<sub>36</sub>), but they are so small, *i. e.*, narrow, that the large spectrometer was necessary to detect them. The solids were more trans-



parent because of the thinner films thus used. On account of evaporation they could not contain any quantity of the liquids boiling at  $100^{\circ}$ , so that the absence of shifting can not be attributed to the presence of hydrocarbons of lower boiling point.

The different hydrocarbons studied, with their boiling points, are given on page 73. The petroleum distillates are conspicuous for three regions of absorption, at  $3.43 \mu$ ,  $6.86 \mu$ , and  $13.8 \mu$ . The spectra are entirely different from those of the fatty acids, which have an addition of two oxygen atoms. In the methylene series it is not known whether the Ohio oils ( $C_{12}H_{24}$  and  $C_{16}H_{32}$ ) have the same structure as that of the California oils.

The Pennsylvania oils ( $C_{18}H_{36}$  to  $C_{24}H_{48}$ ) are probably the same as the Ohio oils. They occur with the solids of the paraffin series, and were separated from them at  $-10^{\circ}$  by filtering under pressure. The impure paraffin series of distillates are a mixture of solid and liquid. The solid was separated in a crude state by cooling and filtering; it was then purified by dissolving in ether and precipitating it from solution by means of alcohol.

The chlorine compounds,  $C_{13}H_{27}Cl$  [b. p.  $130^{\circ}$ - $135^{\circ}$  (12 mm.)]  $C_{14}H_{26}Cl$  [b. p.  $145^{\circ}$ - $150^{\circ}$  (20 mm.)] and  $C_{17}H_{35}Cl$  [b. p.  $170^{\circ}$ - $173^{\circ}$  (15 mm.)], were obtained from chlorinated oils boiling at  $223^{\circ}$ - $224^{\circ}$ , at  $240^{\circ}$ , and at  $189^{\circ}$  (50 mm.), respectively.

The band at  $5.8 \mu$  seemed to vary in depth when examined at different dates. This was thought to be due to the absorption of moisture, but a subsequent examination, with the large spectrometer, of a specimen which had stood over  $P_2O_5$  for several weeks, and the same specimen after it had been exposed to the moist air of the room, showed no difference in the absorption band, which was small. Since the samples obtained were small, varying from a few drops to 2 cc., it was impossible to distill them, so they were placed in wide-mouthed bottles containing  $P_2O_5$ , and left there from several days to several weeks, depending upon their tendency to evaporate. This drying made no difference on the absorption spectra, and it was concluded that the oils were free from moisture.

HEXANE.  $C_6H_{14}$ . (Fig. 62.)

This sample came from Kahlbaum, and is of importance here, since it belongs to the same group of compounds as the petroleum distillates. On account of its low boiling point,  $69^{\circ}$ , it had to be inclosed in a thicker cell than the oils, hence it appears more opaque. Except for a new band at  $8.82 \mu$  and a slight shift at  $9.42 \mu$ , the absorption spectrum is the same as for the oils. This is a synthetic product, which fact adds interest to the agreement of its absorption spectrum with the other com-

pounds. The general absorption is somewhat different than the oils, which indicates more bands not resolved with the small spectrometer.

DODECANE.  $C_{12}H_{26}$ . (Fig. 64.)

In addition to the small spectrometer examination, the large one was used, with the result that four small bands were found between 4 and 6  $\mu$ . The other bands are much deeper because a film 0.01 mm. was used instead of a cell of 0.15 mm. thickness, as for the small spectrometer. This shows that the bands are sharp and narrow, and for this reason are blotted out when using the thicker cell and the smaller dispersion.

The bands at 3.43  $\mu$  and 6.86  $\mu$  are harmonic.

OCTADECYLENE,  $C_{18}H_{38}$ ; TETRACOSYLENE,  $C_{24}H_{48}$ . (Figs. 73 and 74.)

These two compounds were also re-examined with the large spectrometer, but no new bands could be found between 4 and 5.5  $\mu$ . The bands at 3.44 and 6.87  $\mu$  are harmonic, and have no indications of being complex. A small band exists at 6.6  $\mu$ , where the curve is very asymmetrical for the small spectrometer.

It has just been noticed that dodecane ( $C_{12}H_{26}$ ) has several bands in the region where these two compounds are transparent. It would have been interesting to determine whether this is due to the difference in structure of the two series of compounds. It seems quite probable that this is due to structure, but time did not permit an examination of more compounds, using the large spectrometer, in order to thoroughly establish this fact.

MONOCHLORTRIDECANE,  $C_{13}H_{27}Cl$ ; MONOCHLORHEPTADECANE,  $C_{17}H_{35}Cl$ . (Fig. 75.)

The two chlorine compounds studied do not happen to be substitutions in the distillates examined. However, since they have the same maxima as all the distillates, it shows that the introduction of a chlorine atom has little effect on those maxima.

HYDROCARBON.  $C_{10}H_{20}S$ . (Fig. 76.)

This product was obtained from the sludge of Ohio petroleum. Its properties are unknown. The transmission curve is essentially the same as that of the oils. It seems more transparent than the oils beyond 11  $\mu$ .

ASPHALTUM. (Fig. 44.)

Asphaltum is a mixture of different hydrocarbons, part of which are oxygenated. It is of variable composition. Two specimens were examined. The film of varnish was first examined, after it had been drying for several months. Thinking that some of the solvent might

still be present, a film was made by melting solid asphaltum on rock salt. The whole seemed of interest in connection with the absorption and anomalous dispersion of asphaltum investigated by Nichols<sup>1</sup> in the optical region. The curves show several marked bands. As is to be expected, the bands are found in the petroleum distillates.

#### CLASS II: CARBOCYCLIC COMPOUNDS.

In this class the carbon atoms are joined in a closed chain or ring. To it belong the methylene hydrocarbons of the petroleum distillates, already discussed, the pyridine group, thiophene and pyrrol, and, most important of all, benzene and its derivatives. As will be pointed out elsewhere, the benzene spectrum is so wholly unlike that of the petroleum distillates that, if we had no knowledge of the latter, gained from organic chemistry, the evidence presented in their absorption spectra would be sufficient to show that we are dealing with two distinct classes of compounds. In a more restricted sense, pyridine, thiophene, and pyrrol belong to the so-called heterocyclic compounds of carbon.

#### BENZENE. C<sub>6</sub>H<sub>6</sub>. (Fig. 77.)

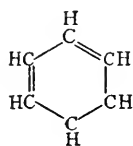

Benzene is the parent hydrocarbon of a large number of compounds. The idea that the constitution of benzene is a closed chain or ring of carbon atoms was first propounded by Kekulé,<sup>2</sup> in his "Benzoltheorie," in 1865. It is based on numerous facts, such as the power to form three isomeric biderivatives, which is not possible in an open chain like stearic acid, but which is possible if each C atom is joined to an H atom and the six CH-groups are joined together in a ring. This forms a fairly complicated molecule, not easily reduced to simpler compounds, like CO<sub>2</sub>. These facts should be remembered in considering the following curves, in which certain benzene bands persist even in very complicated derivatives. The relations of the benzene derivatives to benzene are very limited,<sup>3</sup> although the derivatives are intimately connected by many reactions. This fact is not out of place in considering the following curves. The great dissimilarity between them and the curve of benzene also shows that the relations are limited. Nothing has been found more marked than the change in the maxima by substituting a Cl or Br atom for an H atom in benzene. On the other hand, the curves of the Cl and Br derivatives show many bands in common,

<sup>1</sup>Nichols, E. L.: Phys. Rev., xiv, p. 204, 1902.

<sup>2</sup>Kekulé: Liebig's Annalen der Chemie, 137, p. 129 (1865.)

<sup>3</sup>Berthsen: Organ. Chemie, p. 330; also, p. 327.

which makes it appear that the facts gained by chemical and physical analysis are intimately related.

Benzene shows a great transparency throughout the whole spectrum to  $14 \mu$ , where it suddenly becomes opaque. The well-defined transmission minima are seven in number. The  $7.3 \mu$  band found by Julius<sup>1</sup> occurs only as a slight depression, and the possibility of its being due to thiophene, which has a strong band in this region, is mentioned in the discussion of that substance. This sample was known to be free from thiophene. Certain regions of the spectrum were re-examined thoroughly, but no new transmission minima could be found. The shorter curves show slight depressions sometimes, but no deep bands occur in them. The cell containing the benzene was dismantled and stood aside for two weeks, but on examination no change was detected in the maxima. The curve found was so similar to the first that it was quite evident that the benzene had not attacked the glue of the cell in the meantime. The complex band at  $9.8 \mu$  to  $10.3 \mu$  is to be noted, also the  $11.8 \mu$  band, which is in common with other compounds; also the  $3.25 \mu$  and  $6.75 \mu$  bands, which occur even in very complex derivatives, showing that the vibration of the benzene ion is not destroyed.

In benzene and its derivatives the  $5.8 \mu$  band is not to be found except in those containing  $\text{CH}_3$ -groups and in benzaldehyde. Whether this band is due to  $\text{CH}_3$  or some group of atoms vibrating like a  $\text{CH}_3$ -group is a pertinent question.

The slight band at  $6.25 \mu$  is to be noticed, since in certain derivatives it is very strong, just as though the vibrations were less damped. This is *the only example* found in the whole research.

#### METHYL DERIVATIVES OF BENZENE.

##### TOLUENE. $\text{C}_6\text{H}_5\text{—CH}_3$ . (Fig. 79.)

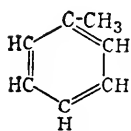

By studying a group of benzene derivatives, increasing in the number of  $\text{CH}_3$ -groups, it was hoped that the effect of those groups could be determined, as well as the shifting of an absorption band, with increase in molecular weight.

The introduction of a  $\text{CH}_3$ -group has shifted the  $3.25 \mu$  band of benzene to  $3.34 \mu$ . The one at  $6.25 \mu$  has been strengthened, while the  $6.75 \mu$  is quite obliterated by the  $6.86 \mu$  maximum found in the petroleum distillates and other chain compounds. This is shown to better advantage in the curves obtained with the large spectrometer, which also show fine bands at  $5 \mu$ , not detected with the smaller apparatus. Whether

<sup>1</sup>Julius, loc. cit.

the shift at  $3.3 \mu$  is real will be discussed elsewhere. It will be sufficient to notice that in mesitylene the  $6.2 \mu$  band is double ( $6.18 \mu$  and  $6.3 \mu$ ), so that with a smaller dispersion it would appear as one band, with the maximum shifted. At  $6.1 \mu$  and  $9.3 \mu$  the bands are in common with thiophene. The sample was labeled "free from thiophene," so that this may be mere coincidence, rather than impurity.

ANISOL.  $C_6H_5-O-CH_3$ . (Fig. 78.)

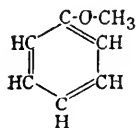

Here the benzene maximum is shifted from  $3.25 \mu$  to  $3.32 \mu$ . With the large spectrometer numerous small bands were detected in the transparent region from  $4$  to  $5 \mu$ , while the  $6.8 \mu$  band was found double with maxima at  $6.65 \mu$  and  $6.86 \mu$ . The whole spectrum is composed of deep, narrow bands, which reminds us of the observation of Abney and Festing that oxygen sharpens absorption bands. The strong band at  $6.22 \mu$ , which is only a slight depression in the benzene curve, is analogous to the work of Liveing and Dewar,<sup>1</sup> who found that mixtures of metals (Mg and K) often showed lines not seen at all when these elements are taken separately. It also strengthens the belief, mentioned elsewhere in this work, that many apparently new bands are not really *new*, but that they are due to a condition in the molecule such that the original vibrating ion is less damped by its neighbor. The spectrum is entirely rearranged as compared with the original benzene spectrum.

ORTHO, META, AND PARA XYLENES.  $C_6H_4(CH_3)_2$ . (Figs. 81 to 83.)

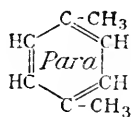
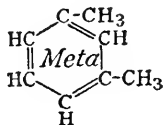
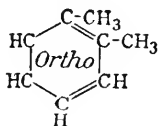

The three isomeric xylenes afford an example for investigating the structure, as well as the question of bonding, in the molecule. As found by Pauer<sup>2</sup> for the ultra-violet, the spectrum is channeled, *i. e.*, the bands occur in groups, in the origins of  $3.4$ ,  $6.7$ ,  $9.6$ , and  $1.3 \mu$ . The first maximum for the three compounds occurs at  $3.38 \mu$ . They have great similarity to  $6 \mu$ , where they begin to show the effect of structure. At  $6.8 \mu$  they show great differences in the appearance of their curves. Apparently the *ortho* is shifted the most, while the *para* appears double. This is best shown in the curves obtained with the large spectrometer.

<sup>1</sup>Liveing & Dewar: Kayser's Spectroscopy, II, p. 251.

<sup>2</sup>Pauer, loc cit.

The maxima occur in the following order of increasing wave-length:

[Para, meta, ortho.]

At 6.8 $\mu$ .....	p	m	o	(p)
At 9 $\mu$ .....	(m), p	m	o	
At 9.7 $\mu$ .....	p	m	o	
At 13 $\mu$ .....	p	m	o	

Apparently the *ortho*, in which the CH<sub>3</sub>-groups are the closest together in the benzene ring, has the greatest shifting of the maxima. If we take the center of gravity of the groups of maxima found by Pauer<sup>1</sup> in the ultra-violet, the shift of the long waves is just the reverse, viz, *o*, *m*, *p*. However, we can not place great reliance upon the location of the center of gravity determined in this manner. In cumene, in which the CH<sub>3</sub>-group is joined to the benzene ring by means of a CH-group, the band lies at 13.4  $\mu$ , while in orthoxylene it is at 13.6  $\mu$ . The probable significance of this must be reserved for later discussion. With the large spectrometer a trace of the 3.25  $\mu$  band is noticeable in the orthoxylene curve, while the 6.2  $\mu$  to 6.3  $\mu$  band is double, as is also the 6.81  $\mu$  band, which is the mean of 6.75  $\mu$  and 6.86  $\mu$ . This would indicate that the vibration of the benzene nucleus has not been destroyed. The *para* is still more complex at 6  $\mu$ , having an additional maximum at 6.55  $\mu$ . These three compounds furnish the best evidence in favor of a resonance effect of small, electrically charged particles. In the *ortho*, which has the two CH<sub>3</sub>-groups *nearest together*, the large absorption bands lie farthest toward the long wave-lengths, while in the *para*, where the CH<sub>3</sub>-groups are separated the most, the large bands lie farthest toward the short wave-lengths; the *meta* has its bands in intermediate positions. This is right in line with the idea that absorption is due to a resonance of small, charged particles, whose capacity, and hence whose period, depends upon their proximity to similarly charged particles; the closer the particles, the greater the capacity; hence the slower the period, and hence the farther is the absorption band shifted toward the longer wave-lengths. (See Appendix IV.)

MESITYLENE. C<sub>6</sub>H<sub>3</sub>(CH<sub>3</sub>)<sub>3</sub>. (Fig. 80.)

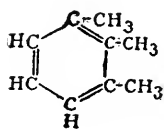

By substituting three CH<sub>3</sub>-groups, the 3.25  $\mu$  band is entirely obliterated by the one at 3.4  $\mu$ . The region at 6.18 to 6.3  $\mu$  is similar to that of the other methyl derivatives. The curve as a whole is very similar to toluene, except at 5.5  $\mu$  and the new band at 11.95  $\mu$ . From the asymmetry of the curve there are indications of the 3.25  $\mu$  band of benzene. All these methyl derivatives are very transparent. The benzene

<sup>1</sup>Pauer, loc. cit.

cell was 16 times as thick, so that no comparison can be made for total absorption. According to Magini,<sup>1</sup> the absorption of isomeric compounds in the ultra-violet increases in the order *meta*, *ortho*, *para*. The present curves do not show this, except a possible indication at 4  $\mu$ . Mesitylene is isomeric with cumene. Their absorption spectra are entirely different.

VARIOUS OTHER BENZENE DERIVATIVES.

MONOCHLORBENZENE.  $C_6H_5Cl$ . (Fig. 85.)

This compound is of about the same transparency as benzene. However, the substitution of a Cl atom for an H atom has wrought a marked change in the general outline of the benzene curve. The lower curve was made with a wide slit and a 0.19 mm. cell, hence serves only for a general comparison with benzene. The upper curves were made with a narrow slit, while the parts of curves were made with the large spectrometer. They show that the original bands of benzene at 3.25  $\mu$  and 6.75  $\mu$  still exist. There are new bands at 6.27  $\mu$  and at 6.94  $\mu$ . The 6.27  $\mu$  band is a characteristic of benzene derivatives, and strengthens the belief that it exists in benzene, since that curve has a slight depression in this region. It adds weight to the belief expressed frequently in this paper, that the substitution of a new element is not so much the cause of new bands as it is the cause, in some manner, of a greater freedom among the original benzene ions, whereby those bands are intensified.

Comparing same thicknesses of cells, the benzene curve has been radically changed, which seems to show that the limited chemical relation of benzene to its derivatives is also to be found in the absorption curves.

MONOBROMBENZENE.  $C_6H_5Br$ . (Fig. 86.)

In this substance we have a striking similarity to the preceding compound. In fact, the curves for the same thickness of cell seem almost superposable, excepting at 8  $\mu$ . The region of 5.7  $\mu$  shows great similarity, as does the 6.9  $\mu$ , 11.1  $\mu$ , and 12.2  $\mu$  band. The general transmission seems to progress in two steps; the first, of 75 per cent, extends to 5  $\mu$ ; the second, of 40 per cent, extends to 13  $\mu$ , where the substance becomes opaque. The same facts are to be noted in  $C_6H_5Cl$ , and the discussion of that substance applies to this one. It is unfortunate that time did not permit a further examination of this compound, using a larger dispersion. As in  $C_6H_5Cl$ , the 3.25  $\mu$  band of benzene still exists.

<sup>1</sup>Magini, loc. cit.



SAFROL.  $C_{10}H_{10}O_2$ . (Fig. 87.)

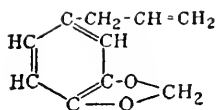

In safrol quite a number of points are to be noticed. It is far more opaque than benzene out to  $12\ \mu$ , where it becomes more transparent. As in several other benzene derivatives, the absence of common transmission minima is conspicuous, except the one at  $12.9\ \mu$ . The  $9.1\ \mu$  band is also to be found in other compounds not related to benzene, *e. g.*, piperidine, which has a ring of  $CH_2$ -groups. The curve, *b*, of safrol, at  $3.42\ \mu$  was obtained by using the large spectrometer. It shows the absence of the  $3.25\ \mu$  band of benzene, while the  $2.9\ \mu$  band of eugenol, to which it is related, is very small.

In safrol the bands are sharp and deep, and are of importance in connection with the idea propounded by Abney and Festing<sup>1</sup> that the O atom sharpens the absorption bands. The large spectrometer failed to detect new bands at  $3\ \mu$ , but several were found at  $6\ \mu$ . This is an example where the benzene ring vibration is almost entirely overshadowed by that due to the preponderance of  $CH_2$ -groups.

CUMENE (ISOPROPYL BENZENE).  $C_6H_5-CH(CH_3)_2$ . (Fig. 84.)

In this compound we have the original benzene ring complete, except for one H atom, which has been replaced by a  $CH$ -group, to which is attached two  $CH_3$ -groups. The result is a struggle between the benzene ion and the  $CH_3$ -groups, and there is a compromise for different parts of the spectrum. Thus the maximum at  $3.43\ \mu$  is a little greater than that for mesitylene, in which three  $CH_3$ -groups are joined directly to the benzene ring. At  $6.2\ \mu$  we have the band common to the xylenes. At  $6.65\ \mu$  there is a new band. At  $6.86\ \mu$  we find the mesitylene band, while at  $9.75\ \mu$  we have the band found in benzene, in orthoxylene, and in numerous other compounds not related to the benzenes. At  $13.4\ \mu$  we have a deep maximum like the one in orthoxylene at  $13.6\ \mu$ . As a whole this compound behaves like the xylenes, anisol, and mesitylene, which strengthens the argument for  $CH_3$ -groups, especially for their bonding with the benzene nucleus.

CYMENE.  $C_{10}H_{14}$ .

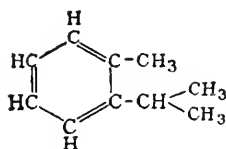

Cymene is obtained from caraway, and can also be prepared from turpentine oil and thymol. On comparing cymene with the terpene group of curves, we see that the general transmission is in two steps remarkably like the terpenes, while there are quite a number of transmission minima in common. Cymene is the more transparent of the two, but, like pinene, has three  $CH_3$ -groups.

<sup>1</sup>Abney & Festing, *loc. cit.*

The first maximum at  $3.43 \mu$  is to be noticed in considering the possibility of its being due to  $\text{CH}_3$ ; also the  $6.86 \mu$ , which appears to be harmonic with it. The  $5.8 \mu$  band found prominent in so many compounds is shifted to  $6.0 \mu$ , as in the terpenes. As a whole the benzene is changed so that there is only a slight indication of the benzene band at  $3.25 \mu$  and at  $6.25 \mu$ . In this connection it is well to notice toluene and mesitylene, which have fewer  $\text{CH}_3$ -groups. The upper curve was obtained with a narrow slit,  $0.4 \text{ mm.}$ , and a film,  $0.01 \text{ mm.}$  in thickness. It shows that the general transmission is on a line of about 80 per cent. It also brings out the fact that the greater opacity beyond  $6 \mu$  is due to the numerous absorption bands, which, by overlapping, lower the whole curve when a thicker film is used. Of still greater interest is the fact that the  $6.86 \mu$  and  $7.3 \mu$  bands occur in the petroleum distillates, which are chain compounds. The latter predominate in  $\text{CH}_2$ -groups and generally have two  $\text{CH}_3$ -groups, but whether we are to attribute them to the former is difficult to decide. The similarity in the curves of cymene, pinene, and limonene is a strong argument in showing that the cyclic structure is not the only cause of the characteristic spectra of the terpenes.

CYANINE.  $\text{C}_{20}\text{H}_{19}\text{N}_3\text{I}$ . (Fig. 89.)

The chemical constitution of cyanines is unknown. Nietzki<sup>1</sup> says of it that "possibly the cyanines possess a structure analogous to that of the phenylmethane dyestuffs," *e. g.*, fuchsine,  $\text{C}_{20}\text{H}_{19}\text{N}_3\text{HCl} + 4\text{H}_2\text{O}$ . The absorption spectra of these two compounds had previously been investigated by me<sup>2</sup> to  $10 \mu$  and found unusually similar. Hartley and Dobbie<sup>3</sup> found that alkaloids having similar structure give similar absorption spectra, showing that it is only in the details that the structure is different. The same is true in the present work on the petroleum distillates. The band at  $3.43 \mu$  occurs in the usual place for compounds having  $\text{CH}_3$ -groups. Whether the benzene nuclei have any effect is difficult to decide, although the  $6.7 \mu$  and  $8.7 \mu$  bands are close to those of benzene. The broad regions of opacity at  $7 \mu$  and  $13 \mu$  are very marked.

BENZONITRILE.  $\text{C}_6\text{H}_5\text{CN}$ . (Fig. 90.)

The result of the substitution of a CN-group for an H atom in benzene has produced an absorption spectrum of an unusual character. Its general transmission is about 80 per cent throughout the spectrum.

There are *no* deep absorption bands, except one of 80 per cent at

<sup>1</sup>Nietzki: *Chemie der Organischen Farbstoffe*, p. 262, 1901.

<sup>2</sup>*Phys. Rev.*, vol. xvi, p. 119, 1902.

<sup>3</sup>Hartley & Dobbie, *loc. cit.*

13.25  $\mu$ . This is the *only* compound studied that has such a spectrum composed chiefly of fine lines. The vibration of the benzene nucleus at 3.25, 6.25, and 6.75  $\mu$  has not been obliterated. The 4.45  $\mu$  band is to be found at 4.38  $\mu$  in  $\text{CH}_2\text{CN}$  and  $\text{C}_2\text{H}_5\text{CN}$ , while it is shifted to 4.8  $\mu$  in phenyl mustard oil,  $\text{C}_6\text{H}_5\text{NCS}$ , which should be noticed in connection with this compound. But few compounds have been found which have so many absorption bands at from 3 to 6  $\mu$ . The large spectrometer was very useful in determining them with certainty. The contrast between the curve for this compound and the one for  $\text{C}_6\text{H}_5\text{Cl}$  is very marked. In the latter the substitution of a Cl atom has not affected the 3.25  $\mu$  (6.25  $\mu$ ) and 6.75  $\mu$  bands of benzene, but beyond this point the absorption bands at 9.3  $\mu$  are much deeper, while at 13.25  $\mu$  the band is broad and shallow. On the other hand the substitution of the CN-group has caused a narrowing of all bands except the one at 13.25  $\mu$ , which is unusually strong. The spectrum of this compound shows that the numerous shallow bands in other compounds are not always due to the small dispersion used, but that the actual width of the lines must also be considered.

#### DIPHENYL. ( $\text{C}_6\text{H}_5$ )<sub>2</sub>.

Diphenyl, as the structural formula shows, consists of two benzene rings. It is made by passing benzene vapor through red-hot tubes, the heat causing it to polymerize into this larger molecule. The substance itself is a solid, of large lamellar crystals, which melt at 71°. It was of great interest to study this compound in connection with benzene. The results were somewhat disappointing on account of the difficulty, always experienced with crystalline solids, in obtaining a film that was smooth and continuous and at the same time thin enough to be transparent. This one shows great opacity, but this is probably due to scattering of the transmitted energy. The film was continuous and 0.12 mm. in thickness. No marked bands are to be found in this curve except at 7.3  $\mu$  and 9.3  $\mu$ . Only a few—the least conspicuous—bands of benzene are common with diphenyl, *e. g.*, 10.2  $\mu$ .

This compound was studied in solution in  $\text{CCl}_4$  (Appendix IV), where it was found that the 3.25  $\mu$  benzene band occurs in its usual place and its usual intensity. It is quite transparent, showing that in the solid film the opacity is due to the scattering of the energy.

Naphthalene and azobenzene were also studied. They have the 3.25  $\mu$  benzene band, showing that the vibration of the benzene nucleus *still exists*.

## AMIDO AND NITRO DERIVATIVES OF BENZENE.

ANILINE.  $C_6H_5NH_2$ . (Fig. 91.)

This compound differs from toluene,  $C_6H_5CH_3$ , in that it has an  $NH_2$ -group instead of a  $CH_3$ -group attached to the benzene nucleus. The selection was made purposely to compare the effect of an  $NH_2$  to a  $CH_3$  group when substituted for an H atom in the benzene ring. The result is a marked change in the region of  $3 \mu$ . The  $NH_2$ -group has the greatest effect; at least it is able to manifest the  $2.98 \mu$  band found in  $NH_3$ , as distinguished from the benzene band at  $3.25 \mu$ , while the  $CH_3$ -group has only caused a shifting in the benzene maximum to  $3.32 \mu$ , which is the mean of the  $3.25 \mu$  band of benzene and the  $3.43 \mu$  band found in  $CH_3$  compounds. However, this may depend upon the actual width of the lines. In the latter case the  $CH_3$ -group would appear to have the greater influence. At  $6.1 \mu$  the large spectrometer failed to resolve the line, so that it is difficult to say whether the  $6.25 \mu$  band of benzene is actually shifted or whether it is double, like the one at  $3.2 \mu$ . This *apparent* shift is toward the shorter wave-lengths, just as observed by Krüss<sup>1</sup> for nitrogen compounds. However, in the present case the band of the original benzene nucleus *still remains*, with a *new band* toward the shorter wave-lengths. It will be interesting to learn whether Krüss actually found a shifting toward the shorter wave-lengths or whether, in his nitro-indigo solutions, the original indigo band disappears in the process of diluting the solution. As a whole, the introduction of the  $NH_2$ -group has seriously disturbed the spectrum of the benzene nucleus, except at  $3.25 \mu$ . When compared with its isomer, picoline, we find but few bands in common, except at  $2.92 \mu$ . The observations were made of freshly distilled aniline.

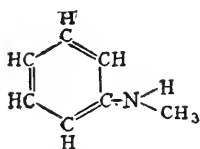
METHYL ANILINE.  $C_6H_5NH(CH_3)$ . (Figs. 32 and 93.)

The introduction of the methyl group in aniline has decreased the intensity of the  $2.97 \mu$  band, while the  $3.25 \mu$  band of benzene is almost obliterated by the one at  $3.4 \mu$ . The compound is far more transparent, so that two strong bands at  $13.3 \mu$  and  $14.5 \mu$  could be located. The aniline film of same thickness becomes opaque at  $12 \mu$ . Certain bands of aniline are in common with this compound. The large spectrometer shows the  $6.1 \mu$  band of aniline shifted to  $6.2 \mu$ , while a new band occurs at  $6.95 \mu$ .

<sup>1</sup>Krüss, loc. cit.

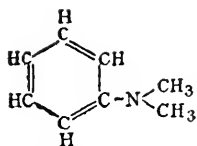
DIMETHYL ANILINE.  $C_6H_5N(CH_3)_2$ . (Figs. 92 and 93.)

As in the preceding compound, the  $2.98 \mu$  and  $3.25 \mu$  bands are almost obliterated by the  $CH_3$  band at  $3.43 \mu$ . A new band is found at  $10.58 \mu$ , while the strong  $13.35 \mu$  and  $14.5 \mu$  bands are in common with methylaniline. As a whole the introduction of  $CH_3$ -groups has made the derivatives more transparent than aniline. No real shifting of the maxima can be observed in the maxima.

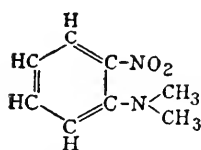
 P-NITROSODIMETHYLANILINE.  $C_6H_4(NO)N(CH_3)_2$ . (Fig. 94.)

This is a solid which is light-green by transmitted light and blue by reflected light. The film was continuous, but somewhat striated, due to crystallization, which made it unusually opaque. The bands at  $3.43 \mu$ ,  $6.86 \mu$ ,  $7.3 \mu$ ,  $9.3 \mu$ , and at  $13.74 \mu$  remind us of the petroleum distillates, which have maxima in common with this compound. The  $3.43 \mu$ ,  $6.86 \mu$ , and  $13.74 \mu$  bands are harmonic.

 XYLIDINE.  $C_6H_3(CH_3)_2NH_2$ . (Fig. 95.)

Xylidine is an excellent compound to study the effect of the presence of  $NH_2$  and  $CH_3$  at the same time. A similar example was noticed in phenyl mustard oil, where the characteristic vibration of the mustard oils at  $4.78 \mu$  is superposed upon that of the benzene nucleus at  $3.25 \mu$  ( $6.25 \mu$ ) and  $6.75 \mu$ . The  $6.1 \mu$  band is to be found in compounds containing  $NH_2$ .

The large spectrometer resolves the  $3 \mu$  band into two maxima, which are at  $2.96 \mu$  and  $3.42 \mu$ . It will be noticed that for the smaller dispersion the  $2.95 \mu$  band is not fully resolved. Here the  $NH_2$  and  $CH_3$  groups are sufficiently strong to obliterate the benzene band at  $3.25 \mu$ , and we have the  $2.96 \mu$  and the  $3.43 \mu$  bands brought out in their full strength, just as in ammonia and in the petroleum distillates. Several maxima, like those at  $8.6 \mu$  and  $11.5 \mu$ , are in common with the simpler methyl anilines. As in most of the compounds studied, the region from  $4 \mu$  to  $6 \mu$  is lacking in strong absorption bands.

This compound had decomposed and was distilled at  $214^\circ$  to  $217^\circ$  just before using. Ordinary xylidine contains five of the six isomeric modifications in which this compound can exist. Their boiling points lie between  $212^\circ$  and  $226^\circ$ .

Considering this compound with several others containing  $NH_2$  or  $NCS$ , it appears as though certain groups of elements had definite absorption bands which are obliterated by stronger bands, as, for example, in thiophene and pyrrol, at  $2.95 \mu$  and  $3.2 \mu$ . This point must be

reserved for later discussion, but it is well to keep it in mind in considering the various curves.

*o*-TOLUIDINE.  $C_6H_4(CH_3)(NH_2)$ . (Fig. 96.)

Considered chemically, this compound is a homologue of the aniline compounds. The absorption curves also show this fact. The substitution of the  $CH_3$  and the  $NH_2$  groups has almost obliterated the benzene bands, except at  $6.75 \mu$  and  $11.8 \mu$ .

The curve of this compound is very similar to that of xylidine,  $C_6H_3(CH_3)_2(NH_2)$ , which is to be expected. The large band at  $3 \mu$  is to be noticed, since, like xylidine, it is not resolved. However, the  $2.96 \mu$  and the  $3.43 \mu$  bands are apparent, as is also the  $6.85 \mu$  band. The  $6.1 \mu$  band, to be found in compounds having  $NH_2$ , is shifted to  $6.15 \mu$  in this compound. The  $8.8 \mu$  band occurs in pyrrol. As a whole, the curve shows bands belonging to  $CH_3$ ,  $NH_2$ , and  $C_6H_6$ . This sample was distilled just before using. The para modification is solid, and was not examined.

NITRO DERIVATIVES.

NITROBENZENE.  $C_6H_5NO_2$ .  $C_6H_5N \begin{matrix} \text{O} \\ \diagup \\ \diagdown \\ \text{O} \end{matrix}$ . (Fig. 97.)

This compound was studied because comparative refractometric investigations by Loewenherz<sup>1</sup> show that the nitro group in nitroethane ( $C_2H_5NO_2$ , fig. 33) and in nitrobenzene do not have the same structure. In the latter the N atom is pentavalent, while in the former it is trivalent.

The curve shows the benzene bands at  $3.25 \mu$ ,  $6.25 \mu$ ,  $8.62 \mu$ , and  $9.8 \mu$ . In the  $6.75 \mu$  region the benzene bands are quite obliterated. In this region the  $CH_3NO_2$  and  $C_2H_5NO_2$  have what appears to be the characteristic band of nitrites. The  $9.05 \mu$  band is in common with a similar band in these two compounds. As a whole the spectrum is marked for its numerous deep, well-defined absorption bands, especially the one at  $14.4 \mu$ . The introduction of the  $NO_2$ -group has not seriously affected the benzene spectrum, but, in addition to this, there does not seem to be a characteristic vibration, due to the  $NO_2$ -group, unless it be the band at  $9.05 \mu$ , which band is in common with all the spectra of compounds having  $NO_2$ -groups.

ORTHO AND PARA NITROTOLUENE.  $C_6H_4(CH_3)(NO_2)$ . (Fig. 98.)

In the xylidines mention was made of the fact that the principal absorption bands shift toward the long wave-lengths, with increase in the nearness of the  $CH_3$ -groups in the benzene ring. In the present

<sup>1</sup>Loewenherz: Zeit. fur Phys. Chem., 6, p. 552, 1890.

compound the  $\text{CH}_3$  and the  $\text{NO}_2$  groups occur in the *ortho*, *meta*, and *para* positions. The latter is a crystalline solid, hence very opaque, due to scattering of the light.

In this compound no shifting occurs, except at  $13.6\mu$  and  $13.8\mu$ , which appears to be accidental. If this shifting is due to a resonance of *similar groups* of particles, as already mentioned under the xylenes, then one would *not* expect a shifting of the bands in these two compounds.

To test this theory of resonance, dinitrobenzene,  $\text{C}_6\text{H}_4(\text{NO}_2)_2$ , or some other benzene derivative having two similar groups of atoms, will have to be examined. Unfortunately these compounds are solids, hence difficult to examine in thin films.

These compounds are so complex that little can be accomplished in studying them. Thus, in the region at  $6\mu$  to  $7\mu$  the bands of the benzene, the  $\text{CH}_3$ , and the  $\text{NO}_2$  ions are superposed, and the result is great opacity. In the *para* compound the groups seem to have greater freedom, and the  $6.86\mu$  of  $\text{CH}_3$  compounds and the  $9.08\mu$  of  $\text{NO}_2$  compounds are more apparent; also the  $3.25\mu$ ,  $8.7\mu$ , and  $11.9\mu$  bands of benzene are more conspicuous. The  $3.43\mu$ ,  $6.86\mu$ , and  $13.8\mu$  bands are to be noticed, since they appear by the addition of a *single*  $\text{CH}_3$  group, just as in toluene. The  $6.25\mu$  band occurs only as a slight asymmetry. The  $9.08\mu$  band is the *only one* in common with the five  $\text{NO}_2$  compounds studied.

#### PHENOLS.

##### PHENOL. $\text{C}_6\text{H}_5\text{OH}$ . (Fig. 99.)

The phenols are oxygen derivatives of benzene, which in their chemical character stand between the alcohols and the acids.

Phenol, or phenyl alcohol, melts at  $44^\circ$ , and hence could be kept liquid before the spectrometer slit. Unfortunately, time did not permit an examination beyond  $8\mu$ , using the small spectrometer. With the large spectrometer the regions at  $3\mu$  and  $6\mu$  to  $7\mu$  were examined. The  $3.25\mu$  band of benzene is almost obliterated by the much stronger band at  $2.97\mu$ . The bands at  $6.23\mu$  and  $6.75\mu$  of benzene are not disturbed. The  $6.23\mu$  band is much more prominent than in benzene. This strengthening of the  $6.23\mu$  band and the weakening of the  $3.25\mu$  confirm the belief, frequently mentioned in this paper, that when an H atom is replaced by a different atom, or group of atoms, the result does not seem to show so much the introduction of new lines as it does a condition of the molecule whereby the original bands are strengthened or weakened.

Whether the  $2.95\mu$  band is due to the OH-group will be discussed elsewhere. The absence of the  $6\mu$  band would indicate that the one at  $2.95\mu$  is *characteristic of the alcohols and the phenols*.

Commercial ether contains from 3 to 4 per cent of water. An examination with the large spectrometer showed only a slight depression at  $2.9\ \mu$ , so that the presence of water is not the cause of the band at  $2.95\ \mu$ .

THYMOL.  $C_{10}H_{14}O$ . (Fig. 100.)

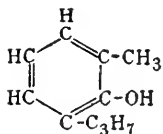

This compound comes from the oil of thyme, frequently investigated. It melts at  $44^\circ$ , and hence could be examined in its liquid condition. It was investigated with its isomer, carvacrol, on account of the OH-group it contains, as well as the question of effect of structure.

The spectrum as a whole is marked for great transparency at  $4.5\ \mu$  and a large opaque region from  $6\ \mu$  to  $9\ \mu$ , followed by greater transparency. The bands are unusually sharp. Those belonging with benzene have entirely disappeared. The  $2.92\ \mu$  band lies close to that of water at  $2.95\ \mu$ , while the  $3.43\ \mu$  band is found in compounds containing  $CH_3$ -groups. The region from  $6\ \mu$  to  $7\ \mu$  was found to contain four bands when examined with the large apparatus. For a solid film the small spectrometer failed to resolve the band at  $3.0\ \mu$ , because of the greater opacity of the film.

CARVACROL.  $C_{10}H_{14}$ . (Fig. 101.)

Carvacrol is isomeric with thymol, and is a liquid. It begins to show the effect of structure at  $7.44\ \mu$ , beyond which point the bands are entirely rearranged. The  $2.92\ \mu$  and  $3.43\ \mu$  bands are in common with thymol, as are also the bands at  $12.3\ \mu$  and  $13.55\ \mu$ . This compound was dried with fused sodium hydrate, also by exposing it to  $P_2O_5$  for several days, but no change could be detected in intensity nor in the position of the absorbing bands.

As a whole the spectrum of carvacrol is marked for several regions of great transparency and of great opacity, like thymol, while the *group itself behaves more like the alcohols than the acids*. This is to be noticed especially at  $2.93\ \mu$ , where the fatty acids show no band, while the very marked band of the acids, at  $5.85\ \mu$ , is absent in this group of compounds.

EUGENOL.  $C_{10}H_{12}O_2$ . (Fig. 102.)

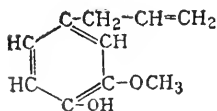

Eugenol is derived from the oil of cloves, sometimes investigated.<sup>1</sup> No bands of eugenol are in common with benzene. It is also more opaque. There are no bands in common with safrol, to which it is related, but there are several which differ but slightly in the position of their maxima. The sharpening of

<sup>1</sup>Donath, loc. cit.



the bands here, due to the presence of the O atom, has been noticed in benzaldehyde. The region of  $3\ \mu$  is complex, and when examined with the large spectrometer shows bands at  $2.9\ \mu$  and  $3.4\ \mu$ . Whether the  $3.25\ \mu$  band of benzene is still present could not be determined. The indications at  $6.26\ \mu$  and  $6.75\ \mu$  are that the benzene ion still manifests itself. The great opacity from  $7\ \mu$  to  $8\ \mu$  is found in thymol and numerous other compounds having oxygen or a hydroxyl group.

ACETYL-EUGENOL.  $C_{12}H_{14}O_3$ . (Fig. 103.)

This compound differs from the preceding in the substitution of  $COOCH_3$  for the OH radical. The effect on the eugenol curve is not very marked either in the general absorption or in the transmission minima. The greatest change is from  $5\ \mu$  to  $6\ \mu$ , where the absorption is increased, producing a new band at  $5.8\ \mu$ . The region from  $11$  to  $12\ \mu$  is also changed, a band appearing at  $12.3\ \mu$ , while the one at  $12.5\ \mu$  is barely visible. The whole seems to indicate that the OH-group can not have seriously affected the transmission of infra-red radiation. In fact, the great opacity beyond  $8\ \mu$ , thought by some investigators to be due to the OH radical, is in the present work, to be found only in water. Three atoms of oxygen are present in this compound, but the maxima are not so sharp as in benzaldehyde, in which the O atom is quite free, being bonded with only one C atom. An unusual arrangement of the bands in pairs is to be noticed in this compound.

AROMATIC ACIDS.

PHENYL ACETATE.  $C_6H_5-CH_2-COOH$ . (Fig. 104.)

The aromatic acids are in many points analogous chemically to the fatty acids. But generally no such similarity is to be observed in their transmission curves. An exception is methyl acetate. There are great similarities in the present and the following compound. For example, they have an opaque region from  $6\ \mu$  to  $9\ \mu$ , followed by a more transparent region. However, there are no important absorption bands in common. The  $5.8\ \mu$  band is present in this compound, but is absent in the following one. The  $7.0\ \mu$  to  $7.4\ \mu$  band appears complex. The great opacity from  $8\ \mu$  to  $9\ \mu$  seems to be due to a large transmission minimum, the maximum of which lies at about  $8.5\ \mu$ .

METHYL SALICYLATE.  $CH_3-O_2C-C_6H_4-OH(o)$ . (Fig. 105.)

This ester of the aromatic acids, familiar as oil of wintergreen, has a region of great absorption extending from  $6\ \mu$  to  $9\ \mu$ , which is followed by a transparent region that ends in opacity at  $13\ \mu$ . The probability of this opacity being due to the OH radical will be noticed elsewhere. Other examples, like acetic acid and ethyl alcohol, show that

the opacity in this region is variable, and, since similar cases are found where there is no OH present, it appears that water is the only substance that remains opaque beyond  $8\ \mu$ .

The  $5.8\ \mu$  band is absent, or shifted to  $6.2\ \mu$ , while the  $7\ \mu$  band is indeterminate, as is also the one at  $14\ \mu$ . It would have been interesting to learn whether there are bands at  $7.0\ \mu$  and  $14\ \mu$ , but the great opacity of this substance makes its investigation difficult. The region at  $3\ \mu$  was examined with the large spectrometer, and appears to be complex, with the largest maximum lying between the benzene and supposed water bands. The chief value in examining these two compounds lies mostly in showing the general transmission of the acetate. The most significant point is their great opacity from  $6\ \mu$  to  $10\ \mu$ .

#### ALDEHYDES.

BENZALDEHYDE.  $C_6H_5CHO$ . (Figs. 106 and 108.)

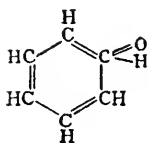

Here one H atom (figs. 106 and 108) in the benzene ring has been replaced by the group CHO. The result is a remarkable change in the transmission curve, the like of which, for depth and sharpness of absorption bands, is to be found in but few of the other substances studied. It represents a mode of vibration as free as that of the gas-molecule. In this connection the photographic work of Abney and Festing<sup>1</sup> is to be noticed. They found that when O, with H, is combined in a radical it causes the spectrum to be linear, rather than banded, the lines being better defined than when O is more loosely banded. In eucalyptol ( $C_{10}H_{18}O$ ) the atom is banded to two C atoms, while the transmission curve is quite smooth with shallow minima. This, however, is due in part to the thick film of eucalyptol used. In benzaldehyde the general transmission is about 70 per cent, with a sudden decrease to almost zero at many points, *e. g.*,  $12.1\ \mu$ . The exploration, in which 110 settings were made, extends to  $16\ \mu$ , beyond which it was impossible to go, on account of the absorption of rock salt. The  $5.84\ \mu$  band, so often to be noticed, is very prominent.

The fact that the O atom is bonded with the C atom, instead of being an OH-group, is to be noticed in connection with the question of the transparency of a compound containing this radical; also whether the OH-group has a definite effect in causing certain absorption bands.

With the large spectrometer the regions examined at  $3\ \mu$  and  $6\ \mu$  were found complex. The benzene bands at  $3.25\ \mu$  and  $6.25\ \mu$  come out strong, while the  $6.75\ \mu$  band is obliterated by the new one at  $6.9\ \mu$ ,

<sup>1</sup>Abney & Festing: *Phil. Trans.*, 172, p. 887 (1882).

showing that the original benzene vibration has not been seriously disturbed. A new band occurs at  $3.55 \mu$ .

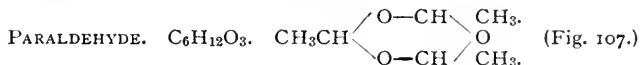

This is an interesting compound, being a polymer of  $CH_3$  groups.

The conspicuous  $5.83 \mu$  band of numerous other  $CH_3$  compounds is scarcely noticeable. The first large maximum occurs in the usual place at  $3.46 \mu$ , while the  $6.86 \mu$  and  $7.32 \mu$  bands of many compounds occur at  $6.9 \mu$  and  $7.2 \mu$ . The complex band at  $7 \mu$  is also found in benzaldehyde and cuminol, and as a whole this band at  $7.2 \mu$  seems characteristic of the aldehydes. It will be noticed that the  $11.7 \mu$  band of paraldehyde is found shifted to  $12.1 \mu$  in benzaldehyde and in cuminol, while the  $13.4 \mu$  band is in common with that of benzaldehyde, which is much broader. The bands are even more marked than in benzaldehyde.

CUMINOL (CUMINIC ALDEHYDE).  $C_9H_{10}CHO$ . (Figs. 109 and 110.)

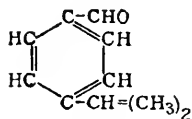

This benzene derivative is interesting because of its combination of the benzene ring, of the  $CH_3$ -groups and of the aldehyde radical,  $CHO$ . As a result the benzene band at  $3.25 \mu$  is obliterated, and a complex band occurs at  $3.4 \mu$ , the weaker component lying at about  $3.7 \mu$ . The  $5.9 \mu$  band is strong, as in benzaldehyde. A complex band occurs at  $6.25 \mu$  (benzene?) and at  $6.35 \mu$ . The  $6.86 \mu$  of the petroleum oils is also present. As a whole, the vibration of the benzene nucleus has disappeared. In comparison with cumene,  $C_6H_5CH(CH_3)_2$ , a marked change has been brought about in the absorption spectrum by the addition of the  $CHO$ -group.

The  $12 \mu$  band is to be noticed, since it occurs equally strong in mesitylene, where the three  $CH_3$ -groups are joined directly to the benzene nucleus. The  $13 \mu$  band is also found in benzene.

#### TERPENES.

This distinctive group of compounds is interesting on account of its manner of occurrence and its unusual characteristics. All compounds have a pleasant odor. Many are optically active, and as a whole this group is an interesting one for study. Considered chemically,<sup>1</sup> the constitution of only a few of the terpenes and camphenes has been thoroughly established. They have a closed ring of six members in the simpler "monocyclic terpenes" (*e. g.*, limonene), while in the "complex terpenes" (pinene) the structure is a combination of two rings.

<sup>1</sup>Berthsen : *Org. Chem.*, p. 542.

As a whole, the terpenes are more opaque to infra-red radiation than benzene and the sulphides. The absorption spectra are characteristic of the group, just as was found in the fatty acids. The curves show numerous well-defined absorption bands in all of the compounds investigated. The contrast between them and those of the simple compounds, like  $C_2H_5OH$  and  $CH_3I$ , is worthy of notice. All curves show a sudden increased general absorption from  $7 \mu$  to  $12 \mu$ . This is especially noticeable in eucalyptol ( $C_{10}H_{18}O$ ).

The number and especially the position of the absorption bands are very striking when compared with similar groups of other compounds in Table VI.<sup>1</sup>

The ever-recurring  $5.85 \mu$  band in other compounds is formed at its usual place in Venice turpentine and resin, while it is shifted beyond  $6.05 \mu$  in limonene and pinene. In eucalyptol that region appears complex.

The large absorption band at  $3.43 \mu$  is no doubt complex in the terpenes, while the benzene bands have disappeared. In pinene and limonene the maximum occurs at  $3.43 \mu$ , with a slight depression at  $3.78 \mu$ , being most marked in limonene. On the other hand, in Venice turpentine the maximum occurs at  $3.78 \mu$ , with a slight depression at  $3.45 \mu$ . The terpene compounds were separated with great care in the chemical laboratory of the university, and were considered very pure. The slight depression of the curves at  $1.6 \mu$  to  $1.7 \mu$  is probably due to an absorption band found by Puccianti and Donath at  $1.7 \mu$ .

LIMONENE.  $C_{10}H_{16}$ . (Fig. III.)

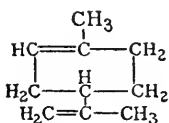

Limonene ( $C_{10}H_{16}$ ) belongs to the simpler "monocyclic terpenes," and, with pinene ( $C_{10}H_{16}$ ), is an excellent example for studying the constitution of the molecule, especially since they have the same number of atoms. In this work d-limonene ( $C_{10}H_{16}$ ; boil. pt.,  $176^\circ$  to  $177^\circ$ ; rot.  $+100^\circ.7$ ) was used, and 102 points were found on the curve. A number of points are of special interest in examining these curves. First, it will be noticed that the thickness of the l-pinene is about double that of the limonene. Yet the general absorption is about the same up to  $3 \mu$ , beyond which the difference is very marked. Again, if the curve did not extend beyond  $9 \mu$ , the limit of previous investigations, one would feel that here is an example in which the arrangement of the atoms in the molecule exerts little influence. The transmission minima coincide out to  $8.9 \mu$ , where the first new one occurs in limonene. The deep bands of limonene at  $11.3 \mu$  and  $12.6 \mu$  find their counterpart in d-pinene at  $11.4 \mu$  and  $12.7 \mu$ , both of which are complex, while the slight depression at  $11.8 \mu$  in the latter does not occur in the former.

<sup>1</sup>The tables will be found at pages 136 et seq.

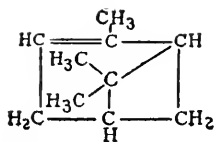
PINENE.  $C_{10}H_{16}$ . (Figs. III and II2.)

Pinene belongs to the complex "terpenes," consisting of two rings. Nevertheless, when compared with limonene ( $C_{10}H_{16}$ ), which is considered a simpler compound, the difference is not very marked, except in the transparency. The number of transmission minima is about the same, while the position of several of them is changed.

For the present work *dextro*- and *laevo*- pinene ( $C_{10}H_{16}$ ; boil.pt.,  $156^{\circ}$ - $157^{\circ}$ ; rot.  $+8^{\circ}.10$  and  $-33^{\circ}.62$ ; thickness of cells, 0.07 mm. and 0.08 mm.) were used. Whether or not the optical activity manifests itself in the transmission is not apparent from the curves. The difference in the transparency of the two substances can be accounted for by the difference in thickness of the two films. One would next consider the absorption bands. From the curves it will be seen that the transmission minima coincide so closely that, as a whole, this single comparison shows that the effect of the *shape* of the molecule, *i. e.*, the geometrical relation of the atoms in it, is not apparent. It is probably what one would expect for unpolarized light. The two compounds were examined because a more thorough exploration for absorption bands was desired than that made on the *dextro*-pinene, so it seemed interesting to try the *laevo*-pinene, with the aforesaid results. Unfortunately, time did not permit an examination of the terpenes with the large spectrometer. Only *l*-pinene was examined. No new bands were found at  $3.43 \mu$ , showing that the absorption band integrated through by the radiometer is fairly well resolved. This is quite a contrast to the xylenes. The  $6.1 \mu$  band is resolved into three, while the one at  $7.1 \mu$  consists of two bands.

Pinene is viewed as a derivative of a combined hexa and tetra methylene ring. But we find no relations between its bands and those of methylene and the methylene hydrocarbons from petroleum.

## VENICE TURPENTINE. (Fig. II3.)

Venice turpentine is a mixture of pinene, resin, etc. It is far more transparent than pinene, and differs from it in that the  $3.45 \mu$  band is barely visible, while its greatest absorption occurs at  $3.75 \mu$ . The  $5.95 \mu$  band is very sharp, as well as the one at  $6.95 \mu$ . From  $7 \mu$  to  $9 \mu$  it appears less complex than pinene, while beyond this point the transmission minima agree well with those of pinene.

RESIN.  $C_{44}H_{60}O_4$ . (Fig. II4.)

Violin resin (colophonium),  $C_{44}H_{60}O_4$  (?), is residue from distilling oil of turpentine. On account of its amorphous condition, it is easily

formed into a thin, uniform film. Being polymeric, it has a high molecular structure, the constitution of which is not known. The enormous drop in the transmission of 94 to 10 per cent in going from  $2.5 \mu$  to  $3.5 \mu$  has been found in but few other substances, *e. g.*, the mustard oils, at  $4.8 \mu$ . The  $3.5 \mu$  band is strong and appears complex. The  $5.94 \mu$  band and the  $14 \mu$  band are well defined. The transparency, in general, is strikingly similar to pinene, except that it becomes more transparent beyond  $12 \mu$ . The region from  $7 \mu$  to  $12 \mu$  is marked by a very sharp band of general absorption. This will be noticed in the following compound. If the selective absorption were dependent upon the number of atoms in the molecule, *i. e.*, its *size* rather than upon *groups of atoms*, one would expect to notice their effect in this many-atomed compound. In this connection it is well to notice stearic acid ( $C_{18}H_{36}O_2$ , fig. 60), which has but few bands. Unless it can be shown that the absorption bands are complex, then these curves indicate that the cause of absorption is simpler than one would suppose. The sharpness of these bands is worthy of notice in connection with other compounds containing oxygen.

The effect of the size of the molecule is not so easily illustrated, since as the number of atoms increases in a molecule there is a tendency for the substance to be solid. Since most of the solids are crystalline, there is great difficulty in obtaining uniform films, free from rills. Friedel<sup>1</sup> has studied the total absorption of a great many organic compounds, and has found that the absorption does not depend much upon the size of the molecule, but seems to depend upon some property of the compound.

EUCALYPTOL.  $C_{10}H_{18}O$ . (Fig. 115.)

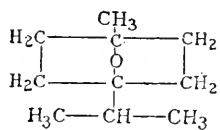

Eucalyptol belongs to the simpler, monocyclic terpenes. The first thing one notices in glancing at the curves of this substance is the enormous band of general absorption from  $6.5 \mu$  to  $14.5 \mu$ . This seems to blot out the bands of selective absorption, so that they are not very deep in this region.

The structural formula shows the O atom joined to two C atoms, while the ring is composed of  $\text{CH}_2$  and  $\text{CH}_3$  groups. In connection with this, notice the curves of piperidine, which has a ring of  $\text{CH}_2$  groups, and stearic acid, which has a chain of them. Here there is no similarity in the curves. The  $3.43 \mu$  band is sharp, while the one at  $5.9 \mu$  to  $6.1 \mu$  is complex. The depression at  $14 \mu$  is peculiar, considering the fact that beyond  $11 \mu$  this substance becomes more transparent

<sup>1</sup>Friedel: Ann. der Physik (3), 55, 453, 1895.

the farther one penetrates the infra-red. But few substances show this property. Examined with the large spectrometer, the complex  $3\ \mu$  region shows a band at  $2.9\ \mu$  and  $3.43\ \mu$ , with a possible small one at  $3.7\ \mu$ . The region at  $5.9\ \mu$  is complex, showing three bands—at  $5.8\ \mu$ ,  $6.0\ \mu$  and  $6.2\ \mu$ , respectively. A small band is found at  $6.45\ \mu$ . The  $6.87\ \mu$  band is found in many aliphatic compounds (at  $6.86\ \mu$ ), especially the petroleum distillates and other compounds having  $\text{CH}_2$  groups. It is harmonic with the one at  $3.43\ \mu$ .

The lower curves represent work done before the arrangement was devised whereby thin films could be used. Time did not permit a re-examination of the region from  $7$  to  $12\ \mu$  with the small spectrometer. From the unusual depth and narrowness of the bands found with the large spectrometer it is quite evident that the presence of oxygen has a great effect in sharpening the absorption bands, just as shown by Abney and Festing.<sup>1</sup> This would have been more evident from  $11\ \mu$  to  $14\ \mu$ , using a thinner film. The sample of eucalyptol was quite pure, having been prepared with the pinenes already mentioned.

TERPINEOL.  $\text{C}_{10}\text{H}_{18}\text{O}$ . (Fig. 116.)

This compound is isomeric with eucalyptol. Just how pure it was is difficult to say. It is supposed to be a solid, melting at  $35^\circ$ , and having a mayflower odor. This compound was a viscous liquid, boiling at  $208^\circ$ , obtained from Merck. The whole curve reminds one of eucalyptol, except that it is less transparent, when we compare the films, which were  $0.01$  mm. thick. The opaque region from  $7$  to  $8\ \mu$ , followed by a greater transparency, is noticeable, as in the rest of the terpenes. The absorption bands are not quite so sharp as for eucalyptol. The large spectrometer resolves the double band at  $3.2\ \mu$  into two bands. Here the  $3.43\ \mu$  band is not harmonic with the one at  $6.95\ \mu$ , the latter being shifted from its usual place at  $6.86\ \mu$ .

MENTHOL.  $\text{C}_{10}\text{H}_{18}\text{OH}$ . (Fig. 117.)

This saturated secondary alcohol of the monocyclic camphors is the chief constituent of peppermint oil. It melts at  $42^\circ$ , hence, after once melted, could be kept in that condition before the spectrometer slit by permitting the intense heat of the radiator to fall upon it.

Only part of the spectrum of this compound was examined with the large spectrometer, to learn the effect of the OH-group. Lack of time did not permit an examination beyond  $8\ \mu$ , using the small spectrometer.

The spectrum examined is characteristic of the terpenes. The bands at  $3.45\ \mu$  and  $6.9\ \mu$  (harmonic) occur as usual, as does also the one at

<sup>1</sup>Abney & Festing, loc. cit.

6.2  $\mu$ . The region at 3  $\mu$  is complex. In addition to the 3.45  $\mu$  band, we have another at 3.7  $\mu$ , as in the other terpenes, and a strong band at 3  $\mu$ , which is also found in eucalyptol. Since eucalyptol is an oxide, and since limonene, pinene, and Venice turpentine show small bands in this region, for small dispersion, it would appear that the 3  $\mu$  band is also characteristic of the terpenes, and *not* due to the OH-group. The band for pure water occurs at 2.95  $\mu$ .

#### PYRIDINE GROUP.

PYRIDINE.  $C_5H_5N$ . (Figs. 118 and 120.)

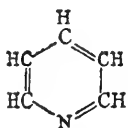

The pyridine group of compounds is marked for its great opacity. A cell 0.19 mm. becomes quite opaque at 6  $\mu$ . The transmission is in two steps, the first ending at 6  $\mu$ , while the second extends to 13  $\mu$ , where the thick films are entirely opaque. It is well known that nitrogen exerts<sup>1</sup> a great influence in the diathermancy of certain compounds. This work shows where its effect is greatest. The thin films appear quite transparent. This is due to the fact that the unusually numerous sharp bands begin to overlap in the thicker films, and the general absorption increases more rapidly than required by the law of variation of absorption with thickness. Ångström<sup>2</sup> concluded that this is due to the fact that the bands are complex groups of lines, not dispersed by the prism. Here we have a practical demonstration of the validity of his conclusions.

Pyridine has the 3.25  $\mu$ , 6.25  $\mu$ , 6.75  $\mu$ , as well as several other bands in common with benzene. In addition it has the 2.95  $\mu$  band found in ammonia and nitrogen compounds. The large spectrometer resolved several lines at 6.75  $\mu$ , as shown in the curve.

ALPHA-PICOLINE.  $C_5H_5N(CH_3)$ . (Figs. 119 and 120.)

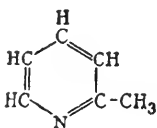

This compound differs from pyridine in having a  $CH_3$ -group. It is isomeric with aniline, and is an excellent demonstration of the effect of structure as well as the effect of the  $CH_3$ -group on absorption. Its spectrum is quite different from pyridine. The band at 2.92  $\mu$  is much deeper. The next band, at 3.35  $\mu$ , is the mean of the 3.25  $\mu$  band of benzene and the 3.43  $\mu$  band of compounds predominating in  $CH_3$ -groups. Taken in consideration with the facts gained from the spectra of mesitylene, toluene, and the xylenes, and also from the fact that the band is asymmetrical, it appears that the benzene, 3.25  $\mu$ , band still exists, but that it is not apparent because of the lack of dispersion.

<sup>1</sup>Friedel, loc. cit.

<sup>2</sup>Ångström, loc. cit.



Several other bands are in common with benzene and pyridine. There are an unusual number of bands in common with toluene, from which it differs in having an additional N atom.

When examined with the large spectrometer the small bands, *e. g.*,  $2.92 \mu$ , are brought out very prominently. The  $6.86 \mu$  band is to be noticed, since it is found in many  $\text{CH}_3$  compounds.

PIPERIDINE.  $\text{C}_5\text{H}_{11}\text{N}$ . (Fig. 121.)

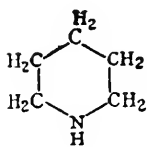

Piperidine is of special interest on account of its ring of  $\text{CH}_2$ -groups and the  $\text{NH}$ -group of atoms. The petroleum distillates are rings or chains of  $\text{CH}_2$ -groups, hence we would expect to find some relations among the absorption bands. But no such relations exist, except at  $13.7 \mu$ , showing again the effect of *bonding*, as well as of the presence of certain groups of atoms like  $\text{NH}$ . The piperidine spectrum is unlike the pyridine, except at  $6.95 \mu$  and  $9.55 \mu$  and the band at  $3.0 \mu$ , which is shifted a little toward the long wave-lengths. The  $3.5 \mu$  band is unusual, being found in paraldehyde. Since the  $\text{NH}$ -group occurs in pyrrol one would expect to find similarities if a specific group of atoms cause absorption. The only band which seems in common is the one at  $2.95 \mu$ , and this one does not coincide with that of piperidine at  $3.0 \mu$ .

These three compounds were fresh and colorless, showing that they had not decomposed, so they were not redistilled before using. Since there was no difference in the absorption bands for the museum and Kahlbaum's preparations, it seems evident that there could not have been a great difference in their purity.

This compound is of the greatest importance in this work, for it is a ring of  $\text{CH}_2$ -groups, while benzene is a ring of  $\text{CH}$ -groups.

Moreover, the C atoms in the piperidine ring are united by a single bond, while in the benzene ring the bonding is alternately double and single. We might, then, conclude from this fact that the difference in their spectra is due solely to the manner of bonding of the atoms. But this is not admissible, because in pyrrol, which is a ring of four  $\text{CH}$ -groups and an  $\text{NH}$ -group, one would then expect to find bands in common with benzene. No such bands exist. It has already been mentioned that in the piperidine ring of  $\text{CH}_2$ -groups and in the methylene ring of  $\text{CH}_2$ -groups of the petroleum distillates no bands are in common. This method of reasoning excludes the idea that simply the *bonding of the atoms* causes these characteristic bands. Since we have not yet established the fact that a definite group of chemical atoms causes certain absorption bands, and since certain groups of compounds have

characteristic bands, *e. g.*, the alcohols at  $2.95 \mu$ , the mustard oils at  $4.78 \mu$ , etc., the whole points to a joint effect of bonding and the "nature of the compound," as mentioned by Zsigmondy<sup>1</sup> and by Magini.<sup>2</sup> This does not elucidate matters very much, for the chemist has already classified the compounds in this manner.

QUINOLINE.  $C_9H_7$ . (Fig. 122.)

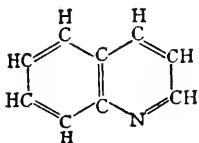

The quinoline group of benzene derivatives have the same properties as the pyridine group. Quinoline is formed by the condensation of a pyridine and a benzene nucleus. But no close relations are to be found with them, just as is true of the terpene derivatives, showing again that the bonding of the groups of atoms in a molecule has great influence on absorption spectra. Quinoline is very opaque, like the pyridines. The only band in common with benzene is at  $3.25 \mu$ .

OTHER CYCLIC COMPOUNDS.

THIOPHENE.  $C_4H_4S$ . (Fig. 123.)

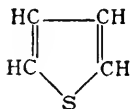

In benzene and its extraordinarily large number of derivatives it is quite probable that the six carbon atoms are joined together in a closed chain or ring. The question as to what sort of chains can exist has been investigated extensively. It has been found that closed chains of carbon, having three, four, five, or seven carbon atoms, can be formed, those having five or six atoms being especially easy to produce.

Thiophene<sup>3</sup> is one of these rings of five carbon atoms, having one C atom replaced by an S atom. Its derivatives have the *same properties* as the benzene derivatives. The behavior of thiophene and benzene is strikingly different, excepting the  $3.22 \mu$  band, which lies close to that of benzene at  $3.2 \mu$ . Since in each one the ring is of CH-groups, we may assume for the present that the  $3.22 \mu$  band is due to this group. Then we look in vain for more bands in common, and, if there are more bands due to CH, they are not to be found by this method of analysis. The thiophene bands at  $5.6 \mu$  and  $7.3 \mu$  were found in benzene by Julius,<sup>4</sup> but were not found by the writer, excepting as a slight asymmetry at  $7.3 \mu$ , while the  $5.5 \mu$  band was found complex  $5.4 \mu$  and  $5.7 \mu$ . Since thiophene occurs as an impurity in benzene, it is quite probable that the benzene used by Julius contained a slight trace of it.

<sup>1</sup>Zsigmondy, loc. cit.

<sup>2</sup>Magini, loc. cit.

<sup>3</sup>See Bernthsen, Organ. Chemie, p. 323.

<sup>4</sup>Julius, loc. cit.

Like most of the other sulphides, thiophene is quite transparent. Like allylsulphide, it very abruptly changes in opacity at  $6\ \mu$ , but as a whole is more transparent than that substance. The small band at  $4.65\ \mu$  is of interest, since it coincides with the  $\text{CS}_2$  band found at this place. With the large spectrometer the band at  $6.4\ \mu$  was found double, the maxima being at  $6.28\ \mu$  and  $6.5\ \mu$ .

As a whole the thiophene spectrum is entirely different from the one of benzene. This is rather unexpected, since the two compounds are so similar in their physical properties that they are easily confounded. In previous discussions of groups of compounds having similar chemical properties we have always observed like similarities in their absorption spectra. This is an interesting exception, and is as strong evidence in favor of the argument that the *bonding* of the atom in the molecule determines the absorption spectrum as is the evidence, deduced from the mustard oils, that a *particular group of atoms* causes certain absorption bands.

PYRROL.  $\text{C}_4\text{H}_4(\text{NH})$ . (Fig. 124.)

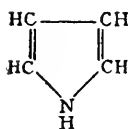

In pyrrol we have the four-membered carbon chain of thiophene united by the bivalent imide group. It is, therefore, a secondary amine. It also shows great similarity to the phenols. We are not surprised, then, to find a strong band at  $2.95\ \mu$ , as in ammonia and in certain compounds containing nitrogen or  $\text{NH}$ . The  $3.22\ \mu$  band of thiophene is almost obliterated, while the  $4.3$ ,  $4.6$ , and  $6.4\ \mu$  bands are shifted to the longer wave-lengths. Beyond  $7\ \mu$  the spectrum is entirely different. The whole reminds us of the bands of the benzene nucleus, which persist, even in some of its very complex derivatives. It also shows that the S atom has little influence at  $3.22\ \mu$ , and that the greater opacity of pyrrol is due to the  $\text{NH}$  group. For pyrrol the film was only  $0.01$  mm. in thickness, while in thiophene it was  $0.08$  mm. Pyrrol decomposes very readily, and for that reason was distilled just before using. The unusually sharp, narrow band at  $2.95\ \mu$ , and its weaker component at  $3.2\ \mu$ , which occurs as a deep, narrow band in thiophene, were not quite resolved with the small spectrometer, showing that a similarly asymmetrical band at  $7.05\ \mu$  is no doubt likewise double.



## CHAPTER VI.

### GENERAL DISCUSSION OF THE SPECTRA.

#### EFFECT OF STRUCTURE.

In order to learn what effect a group of atoms in a molecule has upon infra-red absorption spectra, the most logical procedure is to study isomeric compounds, in order to determine fully that the phenomenon is intramolecular, and after that to attempt to locate the particular group of atoms suspected of causing the disturbance. As already mentioned, in many cases the spectra of isomers is very similar until we extend our observations far into the infra-red. The total number studied is so large and varied, while the change in the spectra of a pair of isomers is so marked, that there can be no question that this is due to structure rather than impurities. In aniline,  $C_6H_5NH_2$ , and its isomer, picoline,  $C_6H_4N(CH_3)$ , the effect of structure is very marked. The benzene band at  $3.25 \mu$ , found in aniline, is entirely obliterated by the one at  $3.35 \mu$  in picoline, while in the spectrum of picoline, only one band, at  $10 \mu$ , is in common with that of aniline. In the sulphocyanates  $R-SCN$ , and the mustard oils,  $R-NCS$ , the effect of structure is still more pronounced. As previously mentioned, the small band of the sulphocyanates at  $4.68 \mu$  is completely outclassed by the  $4.78 \mu$  band in the mustard oils. As the band occurring from  $3 \mu$  to  $3.4 \mu$  is a characteristic of carbohydrates, so is this band a characteristic of the mustard oils. Of all compounds studied, the mustard oils are unique in having an enormous absorption band in the region of shorter wavelengths, this side of  $5 \mu$ . In  $CS_2$  the first strong band occurs at about  $6.7 \mu$ , in methyl iodide at  $11.35 \mu$ , and in carbon tetrachloride at  $13 \mu$ .

In allyl mustard oil,  $C_3H_5NCS$ , using the large spectrometer, this band was found to be complex, being opaque from  $4.5 \mu$  to  $4.9 \mu$  with the maximum located at about  $4.8 \mu$ . Phenyl mustard oil,  $C_6H_5NCS$ , is still more interesting, since it contains the  $3.25 \mu$  band, as well as several others belonging to benzene, and has, in addition, this strong band of the mustard oils, located at  $4.8 \mu$ , just as though the CH and the CS ion were vibrating side by side but independent of each other.

Other isomers, like pinene and limonene,  $C_{10}H_{14}$ , have a great similarity until we arrive at  $10 \mu$ , while the caproic acids are identical to  $6 \mu$  and begin to show dissimilarity at  $8 \mu$ . Probably the most evident

example of the influence of structure is in the aliphatic or chain-linked groups of atoms, like octane, and the carbocyclic or ring compounds, like benzene. If we consider simply the number of atoms in the molecule, then the benzene series  $C_nH_{2n-6}$ , can be classed with the chain series,  $C_nH_{2n-2}$ ,  $C_nH_{2n}$ ,  $C_nH_{2n+2}$ . Hence, reasoning from the fact that in the three groups of chain compounds studied all the conspicuous bands occur in common, one would expect at least a few of these bands to occur in the benzene ( $C_nH_{2n-6}$ ) series. But no such coincidence occurs, and only after the substitution of  $CH_3$ -groups for H atoms in benzene do we find bands, *e. g.*,  $3.43 \mu$ , in common with those of the chain compounds. If, then, we had no knowledge of organic chemistry, the evidence presented here would be sufficient to conclude that we are dealing with two distinct classes of compounds.

Thymol and carvacrol, methyl ether and ethyl alcohol, eucalyptol and terpineol, and the three isomeric xylenes are additional examples showing very clearly the marked influence of the arrangement of the chemical atom in the molecule upon the resulting absorption spectrum. In the xylenes the bands occur in groups, as noticed in discussing their curves (Chapter V), while the location of the maximum of each group seems to occur in the order *para*, *meta*, *ortho*, with *increase* in wave-length. In thymol and carvacrol the change in the spectra begins to manifest itself at  $5 \mu$  and  $6 \mu$ , while from  $9 \mu$  to  $14 \mu$  the spectrum is entirely rearranged. In methyl ether and ethyl alcohol we have the most marked change in the location of the absorption bands, which is noticeable throughout the whole spectrum.

As a whole, the present investigation substantiates the conclusions of Julius (*loc. cit.*) of the influence of structure upon absorption spectra.

#### EFFECT OF MOLECULAR WEIGHT.

In the present work the results agree with that of Krüss (*loc. cit.*) in so far as it seems permissible to assume that the occurrence of a certain conspicuous absorption band in a different place is a real shift. The benzene derivatives are the most noticeable example. In benzene,  $C_6H_6$ , the maximum occurs at  $3.25 \mu$ , and is shifted to  $3.3 \mu$  in toluene,  $C_6H_5CH_3$ , to  $3.38 \mu$  in the xylenes,  $C_6H_4(CH_3)_2$ , and to  $3.4 \mu$  in mesitylene,  $C_6H_3(CH_3)_3$ . In other words, by substituting three  $CH_3$ -groups for an H atom we have shifted the maximum from  $3.25 \mu$  to  $3.4 \mu$ . Of all the compounds studied, excepting the gases, this is the only example where such a supposed shifting occurs. For a shift toward the *shorter* wave-lengths certain derivatives of benzene containing nitrogen are the most conspicuous, just as found by Krüss. In aniline,  $C_6H_5NH_2$ , we find the benzene band almost obliterated and the minimum shifted to

2.97  $\mu$ , just as in ammonia, while in picoline we have the ammonia band at 2.92  $\mu$  and a second band at 3.35  $\mu$ . It is to be noticed that in the xylenes and in pyridine the benzene band at 3.25  $\mu$  has *not been entirely obliterated*, just as though there were two resonating ions, benzene and  $\text{CH}_3$ , vibrating side by side. This is more evident in xylidine and the mustard oils.

In xylidine,  $\text{C}_6\text{H}_5(\text{CH}_3)_2\text{NH}_2$ , which has an  $\text{NH}_2$ -group and two  $\text{CH}_3$ -groups, we have the respective bands *found in ammonia*, at 2.95  $\mu$ , and in compounds predominating in  $\text{CH}_3$ -groups, at 3.43  $\mu$ . The structural formula of aniline indicates that in the original benzene ring an H atom has been replaced by an  $\text{NH}_2$ -group, while in picoline we have the double benzene ring containing an N atom and a  $\text{CH}_3$ -group. The absorption spectra support this theory, for in the aniline spectrum we have the original benzene band at 3.25  $\mu$  and the  $\text{NH}_2$  band found in ammonia, xylidine, etc., while in picoline we have the benzene band obliterated and the  $\text{CH}_3$  band substituted. The latter band occurs at 3.35  $\mu$ , the mean of 3.25 and 3.43  $\mu$ , instead of 3.43  $\mu$ . Can we say, then, that there is a *real shifting* of the 3.25  $\mu$  band in the xylenes? It must be remembered that we are integrating through a complex band, which, with ordinary dispersion, can not be resolved with a bolometer or a radiometer. Hence, when we find the maximum shifted to 3.3  $\mu$  in anisol, and to 3.4  $\mu$  in mesitylene, and find the separate bands in aniline, etc., it is a difficult matter to decide whether we have a true shifting, or whether we have simply determined the center of gravity of the several bands. An excellent example of this type is thymol, which melts at 44°. The solid film gave a deep band at 3.2  $\mu$ . In the melted condition the film was more homogeneous, and two bands were found, at 2.92  $\mu$  and 3.42  $\mu$ , respectively, instead of the mean at 3.2  $\mu$ . Other examples have been observed when the layer of liquid under examination was too thick.

In view of the fact that we have such a striking similarity between the phenomena recorded here and those observed by Krüss, it appears highly desirable to make a spectrophotometric study of dilute solutions, say of indigo and of methyl and nitro-indigo, in chloroform, to see whether there is but one band, or whether there are two, viz. the original one due to the indigo ion, which disappears on dilution,<sup>1</sup> and a second, due to the methyl or the nitro group of ions, just as in the

<sup>1</sup>Since writing this, through the kindness of the Badische Anilin- & Soda-Fabrik, Ludwigshafen, Germany, who sent me samples of methyl, brom, and dibrom indigo, I have made a cursory examination of Krüss's work, and have found but *one* band in the visible spectrum, which shifts as was found by him. A saturated solution showed but one band, with the possibility of a second in the extreme violet.

present work on aniline we have the original benzene band, at  $3.25 \mu$ , and a second at  $2.97 \mu$ . As already mentioned, it has not yet been shown that the selective absorption of a solid in solution and the intra-molecular absorption of the solvent are closely related, but the question can be better settled by a photometric study as just indicated. (See, further, Appendix IV.)

There are other bands farther out in the infra-red, which shift back and forth, just as noted above, but here the original benzene bands are more numerous. The most noticeable ones are those of the methyl sulphocyanate at  $7.06 \mu$  and  $7.61 \mu$ , which occur at  $6.91 \mu$  and  $7.27 \mu$  in ethyl sulphocyanate. However, in all the benzene derivatives studied the occurrence of an apparently new band in the derivative does not always seem to be a *new* band, but simply that the derivative has brought about a condition within the molecule such that the original resonating ion has a greater freedom.

In the gases there is a more definite shifting of the absorption band lying between 3 and  $3.5 \mu$ , as shown in the following table.

Gases.	Maxima.	Maxima.
	$\mu$	$\mu$
Acetylene, $C_2H_2$ .....	3.08	7.38
Ethylene, $C_2H_4$ .....	3.28	6.98
Ethane, $C_2H_6$ .....	3.39	6.85
Butane, $C_4H_{10}$ .....	3.42	6.85
Methyl ether, $(CH_3)_2O$ .....	3.45	6.88
Ethyl ether, $(C_2H_5)_2O$ .....	3.45	7.00
Methane, $CH_4$ .....	3.31	7.70

In the region at  $6.8 \mu$  to  $7.0 \mu$  there is a similar shifting, but there is less regularity in the positions of the bands. Ångström (loc. cit.) has shown that the location of the  $CO_2$  band at  $4.28 \mu$  and the CO band at  $4.59 \mu$  invalidates the assumption that the position of an absorption band depends upon molecular weight. Ransohoff's (loc. cit.) work on the alcohols shows that for the alcohols there is no shifting with increase in molecular weight.

Within the experimental errors of observation Puccianti's (loc. cit.) work for the region of  $1.71 \mu$  shows no shifting of the maximum of an absorption band.

In all my work on the different compounds like methyl and ethyl iodide, nitrate, cyanide, aniline, etc., no shifting can be detected. To make this test conclusive for the marked band at  $3.43 \mu$  this region was repeated for both compounds (methyl and ethyl) before setting the spectrometer for another part of the spectrum. In this manner a slight



shift noticed in methyl and ethyl iodide, which had been examined on different dates, several months intervening, was found not to exist, showing an instrumental error. This method of testing a series of compounds at one region of the spectrum on the same day is the only way to be certain of slight differences in wave-length. With the 25 pure distillates of petroleum, already mentioned, belonging to the series  $C_nH_{2n-2}$ ,  $C_nH_{2n}$ , and  $C_nH_{2n+2}$ , a final test was applied to this perplexing question. The absorption spectra of two of these, octane ( $C_8H_{18}$ ) and tetracosane ( $C_{24}H_{50}$ ), are to be noticed in figs. 63 and 69.

In these, as well as in the intermediate ones, no shifting could be detected, although the greatest efforts were made to do so. This was not a little surprising, for, according to the measurements on the alcohols shown by Schön (loc. cit.) in the visible spectrum, a shift for this greater number of  $CH_2$  groups should have occurred. For, even if we assume that the shifting is *least* for the infra-red and *increases as we approach the ultra-violet*, unless the total shift for this increase of 16  $CH_2$ -groups [octane,  $C_8H_{18}=CH_3(CH_2)_6CH_3$ ; tetracosane,  $C_{24}H_{50}=CH_3(CH_2)_{22}CH_3$ ] is less than  $0.01 \mu$ , it is safe to assume that no shifting occurred. At least, if there is a shifting, it is less than  $0.01 \mu$ , which is much smaller than one would anticipate from observations in other regions of the spectrum.

A shift of  $0.01 \mu$  at  $3.43 \mu$  is  $8''$  of arc on the spectrometer circle, and at  $6.86 \mu$  it is  $12''$  of arc for the small spectrometer, while on the larger apparatus the values are *twice as great*, viz,  $16''$  and  $24''$  of arc, so that it would have been impossible to escape detection, especially in the case of such deep, well-defined bands as these. It is to be remembered that a separate examination was made of the  $3.43 \mu$  and the  $6.86 \mu$  bands for  $C_{18}H_{36}$  and  $C_{24}H_{48}$ , using the large spectrometer. This was done to avoid the possibility of a shifting while examining the whole spectrum, and, instead, only 7 spectrometer settings, at intervals of  $1'$ , were made for each of these two bands. First, the zero of the instrument was determined by means of the sodium flame; then the  $3.43 \mu$  region was examined for  $C_{18}H_{36}$ , the examination being from *right to left*, say; the  $C_{24}H_{48}$  was then examined going backward, from *left to right*, and then from *right to left*, after which the zero was again tested by means of the sodium flame. The  $6.86 \mu$  band was examined in the same manner, but in neither case could a shifting of the band be detected, as will be noticed in the curves (fig. 74) and tabulated data. These two bands are so sharp that if a shifting of  $0.01 \mu$  had occurred it could have been detected. It is true that these bands vary by  $0.01 \mu$  for some of the other oils, but that is to be ascribed to errors in reading the curves, as well as to the fact

that the small spectrometer was used, and that in general it was not practicable to make the examinations in the manner just described. A shift of  $0.02 \mu$  was easily observed in the bands of xylene and mesitylene at  $3.4 \mu$ .

An interesting fact to be noticed in this connection is that *all* the prominent lines found in the two oils just mentioned are present in all the petroleum oils studied, as well as in many other compounds, like myricyl alcohol, piperidine, etc. For a larger dispersion the transparent region at  $4$  to  $6 \mu$  remains so for some oils, while in others numerous small bands were found.

The difference between the spectra of the oils (aliphatic series) and the benzene spectrum (carbocyclic series) has been noticed under the question of structure. The benzene spectrum, as well as that of its methyl derivatives, is banded, "channeled," *i. e.*, the lines occur in groups, just as Pauer<sup>1</sup> found for the ultra-violet. He found the bands of the benzene spectrum, which extend from  $0.267 \mu$  to  $0.235 \mu$ , condensed and shifted toward the visible spectrum for toluene, the xylenes, aniline, etc., and considered it due to increase in molecular weight. If we consider the center of gravity of the benzene bands at about  $0.245 \mu$ , and that of the methyl derivatives at about  $0.267 \mu$ , this shift amounts to  $0.02 \mu$ , while for aniline it is about  $0.05 \mu$ .

As a whole, there is no evidence of a real shifting of the maximum, with increase in molecular weight, if we except the xylenes and the gases mentioned, for the region at  $3.1$  to  $3.5 \mu$ , which is not resolved for most compounds. The condition is similar to that in Kayser and Runge's work for the emission spectrum of the elements, in which they observed that, for the alkali metals, the violet lines shifted toward the longer wave-lengths, with increase in atomic weight, but they could not establish<sup>2</sup> this relation for all the elements.

#### EFFECT OF TEMPERATURE.

There is little to be said on this subject, for no effect due to rise of temperature of about  $20^\circ$  has been observed. As already mentioned the absorption cell was between the spectrometer slit and the Nernst heater, with the double sheet-iron-asbestos shutter intervening. It was necessary to have the heater close to avoid loss of radiation. Consequently, in the course of a series of observations, lasting four hours, the cell would unavoidably become warmer, due principally to the raising of the shutter in making observations. This was first noticed in thymol,

<sup>1</sup>Pauer: *Ann. der Physik*, 61, p. 363, 1897.

<sup>2</sup>Kayser's *Spectroscopy*, II, p. 591.

melting point  $43^{\circ}$ , which in the course of examination as a solid film became a liquid. It is quite crystalline in a solid film, hence more opaque, due to scattering of energy, so that it became more transparent on melting. This is the only compound found to behave thus.

It was an easy matter to repeat the observations on several sharp absorption bands, after finishing the exploration of the whole spectrum, to see whether the transparency remained the same as in the beginning, and *in no case* was there a change observable, excepting for the solid thymol just mentioned.

This heating of the cell was applied in examining several compounds with low melting points, *e. g.*, phenol and menthol in their liquid state. It was only necessary to melt them before placing them upon the spectrometer arm, then to keep the shutter raised longer than usual. This made possible the examination of several compounds which as solids would have been too opaque because of their scattering effect.

#### THE EFFECT OF CERTAIN CHARACTERISTIC GROUPS OF ATOMS.

Having shown that the infra-red absorption spectra depend upon the internal structure of the molecule, and that their maxima are not influenced by molecular weight (of the molecule as a whole, *e. g.*, the petroleum distillates), the next step is to determine, if possible, what groups of atoms, or ions, have the power of absorbing heat waves. This is of considerable importance, since many recorded phenomena have been credited to "the resonance<sup>1</sup> of the OH ion in the molecule."

Aschkinass (*loc. cit.*) found the absorption bands of water at the wave-lengths  $1.51 \mu$ ,  $3.06 \mu$ , and  $6.1 \mu$ . Although he says little about the sequence of the maxima, subsequent writers have laid considerable stress upon it, as showing harmonics, *i. e.*, electromagnetic resonance. Marx,<sup>1</sup> in finding the dielectric constants of water for electrical waves, finds a double harmonic relation for the electrical region. Ransohoff (*loc. cit.*) studied six alcohols, and found the bands harmonic at  $1.71$  ( $3.0$ ) and  $3.43 \mu$ . Although the alcohols were "chemically pure," that is a different question from the one of having them "water free," which he does not consider, and the  $3.0 \mu$  and  $6.06 \mu$  bands may be due to water. The higher alcohols, like glycerin, even if they could be freed from water, are so hygroscopic that they are difficult to investigate. As already mentioned, in the present work alcohols were avoided because

---

<sup>1</sup>Marx: "Potential Fall und Dissociation in Flammgasen," *Drude's Ann.*, 2, p. 795, 1900; also on Electromagnetic Resonance, *Wied. Ann.*, 66, p. 600, 1898. After a lengthy discussion he concluded that although it is a plausible assumption it has not been proven that electrolytic dissociation in a flame depends upon the effect of the electromagnetic resonance of the OH ion upon the infra-red radiation.

of their great opacity beyond  $7 \mu$ , as well as on account of the difficulty in freeing them from water. Only one alcohol was studied, viz, myricyl,  $C_{30}H_{61}OH$ , which is a solid obtained from beeswax. Its maxima occur at  $1.71$ ,  $2.95$ ,  $3.43$ , and  $5.8 \mu$ . The water bands were found at  $2.95 \mu$  and  $6.0 \mu$ , so that, if the alcohol bands are due to the OH-group, then one would expect the  $5.8 \mu$  band likewise to coincide with that of water, at  $6.0 \mu$ .

The various compounds having an absorption band in the region of  $2.95 \mu$  have been collected in the following table:

Compound.	Maxima.	Remarks.
Water, HOH.....	$2.95$	Depth is 70 per cent as found with larger spectrometer.
Thymol.. } Carvacrol } $C_{10}H_{18}OH$ .....	$2.92$	
Eugenol, $C_{10}H_{11}O-OH$ .....	$2.89$	Depth 70 per cent., probably the mean of the $3.25$ and $2.95 \mu$ bands.
Methyl salicylate, $CH_3OOC-C_6H_4OH$ .	$3.1$	
Menthol, $C_{10}H_{19}OH$ .....	$3.0$	50 per cent, comparison spectrum of $H_2O$ at $2.95$ .
Phenol, $C_6H_5OH$ .....	$2.97$	60 per cent.
Ammonia, $NH_3$ .....	$2.92$	30 per cent.
Pyridine, $C_5H_5N$ .....	$2.95$	30 per cent.
Picoline, $C_5H_4N(CH_3)$ .....	$2.92$	Band shallow, 3 per cent.
Piperidine, $C_5H_{11}N$ .....	$3.00$	30 per cent.
Aniline, $C_6H_5NH_2$ .....	$2.97$	70 per cent, very sharp.
Xylidine, $C_6H_3(CH_3)_2NH_2$ ....	$2.95$	50 per cent.
Pyrrrol, $C_4H_7(NH)$ .....	$2.95$	70 per cent.
Eucalyptol } Terpineol. } $C_{10}H_{18}O$ { .....	$2.90$	30 per cent, an oxide, does not contain an OH-group.
	$2.93$	

It will be noticed that ammonia also has a band near that of water, and at a slightly less wave-length. Considerable time was spent in showing that it is not due to water vapor. The gas was fractionally liquefied and distilled, and then placed in a glass pipette containing freshly heated calcium oxide over mercury, for eight days. At the end of this time the absorption band coincided exactly with the one previously found, showing that the band is characteristic of ammonia. Furthermore, it will be noticed that the compounds containing the amido ( $NH_2$ ) group and certain ones containing nitrogen have a characteristic band in this region. These compounds were dried with potassium carbonate, which would have removed traces of water. Other compounds, like the aldehydes and fatty acids, do not show this band. Commercial ethyl ether contains about 3 per cent of water, but there is

only a slight depression in the absorption curve at  $2.95 \mu$ . The fatty acids, *e. g.*, caproic, stearic, etc., are of interest because they have no band at  $2.95 \mu$ . In electrolysis the alcohols are separated into ethyl and OH ions, while in the fatty acids, instead of the OH ion, we have simply an H ion. Hence, reasoning from this analogy, one would not expect a band at  $2.95 \mu$  for the fatty acids. In the other compounds having an OH-group, *e. g.*, eugenol, caymol, menthol, and phenol, strong bands are to be found shifting from  $2.87 \mu$  to  $3.0 \mu$ . They show no bands at  $6.0 \mu$ . Can we assume, then, that the bands at  $2.9 \mu$  to  $3 \mu$  are due to OH? The evidence is not very favorable. Considering the bands of ammonia and of the compounds containing  $\text{NH}_2$ , or certain ones containing nitrogen, the coincidence appears to be somewhat accidental. Farther in the infra-red we have numerous cases of the coincidence of absorption bands.

As a whole, the most definite conclusion we can draw at present is *that the alcohols have a characteristic band at about  $2.95 \mu$ , just as the band at  $4.78 \mu$  is characteristic of the mustard oils.*

The  $\text{CH}_3$ -group of atoms is probably the most important to be considered, but only a few cases can be noticed here. The most noticeable effect is in benzene derivatives. It was shown under the discussion of the effect of structure that the benzene group ( $\text{C}_6\text{H}_6$ ), although it appears as a series ( $\text{C}_n\text{H}_{2n-6}$ ), is entirely different from the chain compounds, like  $\text{C}_n\text{H}_{2n-2}$ . But a substitution of several  $\text{CH}_3$ -groups completely absorbs the  $3.25 \mu$  benzene band, and the  $3.43 \mu$  band, characteristic of all compounds containing  $\text{CH}_3$ , takes its place. Whether the  $3.25 \mu$  band has actually disappeared is an open question. In mesitylene there is still a trace of the  $6.75 \mu$  band of benzene, showing that the benzene "ion" has not been destroyed by the substitution of three  $\text{CH}_3$ -groups. In the xylenes the  $6.75 \mu$  band is least affected, while the  $3.25 \mu$  suffers the most, and the whole strengthens the belief mentioned in the beginning, that certain vibrating ions always seem to be present, but that their effect in absorbing heat waves seems to depend upon their surroundings. Thus the effect of substituting an  $\text{NH}_2$ -group for an H atom, forming aniline, has the least effect on the benzene,  $3.25 \mu$ , band, while those from  $6$  to  $7 \mu$  have disappeared entirely. In benzaldehyde ( $\text{C}_6\text{H}_5\text{CHO}$ ) the  $3.25 \mu$  band is not seriously influenced by a more intense absorption band at  $3.55 \mu$ , while in benzonitrile ( $\text{C}_6\text{H}_5\text{CN}$ ) and in monobrombenzene ( $\text{C}_6\text{H}_5\text{Br}$ ) the  $6.25 \mu$  band suffers no change.

As a whole, the substitution of a  $\text{CH}_3$  or  $\text{NH}_2$  group has a great effect on the resulting absorption spectrum. In the benzene derivatives these groups form new bands, which occur beside the benzene bands,

showing that the vibration of the original benzene ion has not been destroyed. Such examples as these would indicate that the new bands are due to the groups of atoms substituted. But how are we to establish this with certainty, especially when in the myricyl alcohol the evidence is contradictory for the direct effect on the OH-group?

#### TOTAL ABSORPTION.

This is not so well illustrated here as in the work of Friedel and of Zsigmondy (*loc. cit.*), who used the undispersed radiation. The present work agrees with theirs in showing that compounds having sulphur and the halogens are more transparent than H, O, OH, or N, which they have replaced. But *not all* the nitrogen compounds are highly opaque, *e. g.*, nitromethane. The present investigation illustrates best the question of the location of the regions of greatest absorption. Thus in pyridine and picoline a 0.16 mm. layer is almost opaque beyond  $6\ \mu$ , while methyl cyanide is quite transparent. Methyl iodide is quite transparent, since its large absorption bands lie in the region where the radiation from a black body is very weak, while the  $3.4\ \mu$  band is shallow, so that the great transparency of this substance, observed by Friedel, as compared with nitrogen compounds, is apparently due to the lack of absorption bands in the region of intense radiation. As a whole, the work agrees with that of Friedel and of Zsigmondy in showing that the absorption of radiant heat depends upon the manner of the bonding of the atoms in the molecule, as well as upon the kind of compound in which the atoms of an element are united.

The curves of pyridine and picoline illustrate the meaninglessness here of the application of the law of variation of absorption with thickness, which law Ångström<sup>1</sup> found not to hold true in certain cases, and concluded that it is due to the presence of unresolved absorption bands. The pyridine curves show this, especially the one for the thicker film, where the overlapping of the bands has lowered and blotted out the deep depressions in the curves.

Friedel and Zsigmondy (*loc. cit.*) found that total absorption does not depend upon the size of the molecule. In the present instance we have noticed that the number and intensity of the absorption bands does not depend upon molecular weight, *e. g.*, in the petroleum distillates.

---

<sup>1</sup>Ångström : Öfversigt af Kongl. Vetenskaps, Akad. Förhandl., S. 331-352, 1890 ; S. 549, 1889. He computed the absorption of a liquid or vapor as a function of the thickness, from the equation  $(A=I_0(1-e^{-kx}))$  and obtained smaller values than those observed. He concludes that the observed bands are complex groups of lines which are unresolved on account of the small dispersion.

In the present work on dextro-pinene and laevo-pinene the maxima of the bands coincide, showing that the *shape* of the molecule has no influence on absorption spectra.

#### GROUPING OF THE SPECTRA.

Abney and Festing (*loc. cit.*) say their results indicate "without much doubt that the substances we have examined can be grouped according to their absorption spectra, and that such a grouping, as far as we have examined it, agrees, on the whole, with that adopted by chemists." In other words, certain great groups of compounds have characteristic absorption spectra. This is just what Hartley and Dobbie (*loc. cit.*) observed for the alkaloids, in which the ultra-violet absorption spectra vary only in minor details. Aschkinass<sup>1</sup> found that the minerals containing Ca, *e. g.*, fluorite, calcspar, marble, and gypsum, have a band of metallic reflection (absorption) in the region of  $30\ \mu$ .

These observations apply to the present work. For example, the terpene group of compounds has a series of bands which is common to *all* of the compounds belonging to this group. In the same manner the general trend of their absorption curves is similar. The petroleum distillates have all the principal bands in common. The spectra of the fatty acids are conspicuous for the lack, but great depth, of their absorption bands. A glance at their line spectra in Table III gives ample proof of the foregoing statements.<sup>2</sup> Having observed that certain groups of spectra are similar, one would naturally search for certain characteristic absorption bands in them; and, reasoning from this standpoint, we may possibly be able to locate the group of atoms which causes the band. Thus the  $2.95\ \mu$  band and the OH-group of atoms are characteristic of alcohols, while the  $4.78\ \mu$  band and the NCS radical are characteristic of the mustard oils. But this avails us little, for a great many other facts, besides the group of atoms, serve as characteristics of these groups of compounds.

#### CHARACTERISTICS OF THE SPECTRA OF CARBOHYDRATES.

The absorption spectra of carbohydrates are conspicuous for the recurrence of absorption bands in certain regions of the spectrum. The first of these regions was found by Abney and Festing (*loc. cit.*) at  $0.74\ \mu$  and  $0.867\ \mu$ . Puccianti (*loc. cit.*) found that in all cases where the carbon atom is joined directly to the hydrogen atom in the molecule the absorption spectrum shows a band at  $1.71\ \mu$ . This has been verified

<sup>1</sup>Aschkinass: *Ann. der Physik* (4), 1, p. 42, 1900.

<sup>2</sup>The tables will be found at the end of this volume.

in the present work, in which the band was found to oscillate between the values of  $1.68 \mu$  for benzene to  $1.74 \mu$  for caproic acid, for ethyl succinate, and for methyl acetate. From this point to  $3 \mu$  there are numerous small bands of minor importance. Somewhere between  $3.1$  to  $3.43 \mu$  a band is found for every carbohydrate studied, oscillating from  $3.25 \mu$  in benzene to  $3.43 \mu$  in the alcohols and compounds rich in  $\text{CH}_3$ -groups. In the region extending from  $4$  to  $5 \mu$  there is great transparency and often no strong bands (except in the case of the mustard oils), and for the more complex compounds, *e. g.*, the petroleum distillates, there are generally no lines that could be detected even with the large dispersion used. Beyond  $5.5 \mu$  the transmission curve decreases, often very abruptly, terminating in strong absorption bands varying from  $6.75 \mu$  in benzene,  $6.86 \mu$  in aliphatic compounds, and  $7 \mu$  in terpenes. Beyond this region the bands become stronger, better defined, while the transmission curve varies from great transparency to complete opacity. The region at  $12 \mu$  is often lacking in absorption bands, and finally we come to a region of frequently great absorption, with bands occurring from  $13.6 \mu$  to  $14.2 \mu$ . Beyond this it is difficult to penetrate, but all observations made indicate conditions similar to those existing in the region investigated.

In addition to the general characteristics of the spectra of carbohydrates, it will be noticed that the characteristic bands of benzene derivatives are at  $3.25 \mu$ ,  $6.25 \mu$ , and  $6.75 \mu$ ; that of the aliphatic compounds, *e. g.*, the petroleum distillates, at  $3.43 \mu$ ,  $6.86 \mu$ , and  $13.6 \mu$  to  $13.8 \mu$ ; that of carbon tetrachloride at  $13 \mu$ ; that of compounds having  $\text{N}$  or  $\text{NH}_2$  at  $2.95 \mu$  and at  $6.1 \mu$  to  $6.2 \mu$ ; that of the fatty acids at  $3.45 \mu$  and  $5.86 \mu$ ; that of the alcohols at  $2.95 \mu$  and  $3.43 \mu$ ; and that of the mustard oils at  $4.78 \mu$ . The region of great transparency from  $4$  to  $5 \mu$  is also to be noticed, since the larger dispersion failed to show the presence of strong lines.

#### OCCURRENCE OF HARMONICS.

In discussing the question of the presence of simple relations among the spectral lines in the optical region Cornu<sup>1</sup> shows that it is useless to search for harmonic overtones, since the case is relatively rare. He adds that the law of vibration in whole numbers is applicable only to a particular form of sounding bodies, of which the type is a cylindrical column, whose length is great in comparison to the cross-section. In any other type except this special one the relations between the vibration numbers of the successive tones is very complex. In Kayser's

<sup>1</sup>Cornu: Compt. Rend., 100, p. 1181, 1885.



Spectroscopy it is remarked that such a search is delusive, and Grünwald's mathematical spectrum analysis<sup>1</sup> is cited as an example in which all wave-lengths of the so-called compound spectrum of hydrogen can be converted into corresponding wave-lengths of the water-vapor spectrum by multiplying by 0.5. Recent and more exact measurements on these lines show that no such relations exist.

Schuster<sup>2</sup> speaks of the iron spectrum, which has two lines which are in the ratio of 2 to 3, while hydrogen has lines in the ratios of 20:27:37. He demonstrates that in accordance with the Theory of Probability a certain number of coincidences between lines of two spectra might be expected to occur, even if the spectra be quite unrelated. Furthermore, there appears to be a tendency for functions formed by two lines to cluster around harmonic ratios, and, "most probably, some law hitherto undiscovered exists which in special cases resolves itself into the law of harmonic ratios." Of course, as is well known now, the nearest approximation to such a law is Balmer's Law and the numerous other convergent series formulæ used by Kayser and Runge and others. Nevertheless, in spite of these warnings, and fully realizing the danger from lack of dispersion, experimental errors, etc., I venture to call attention to certain marked absorption bands which occur so frequently in positions which so closely fulfill this relation that it is necessary to examine more fully into the probable significance.

Abney and Festing (*loc. cit.*) found that compounds having  $\text{CH}_3$ -groups have a band at  $0.74 \mu$  and another between  $0.907$  and  $0.942 \mu$ , while benzene and  $\text{CH}$  compounds have a band at  $0.867 \mu$ . Puccianti (*loc. cit.*) found a band at  $1.71 \mu$  for all compounds in which the C atom is joined directly to the H atom in the molecule. Aschkinass (*loc. cit.*) found the absorption bands of water at  $1.51 \mu$ ,  $3.06 \mu$ , and  $6.1 \mu$ , while Paschen (*loc. cit.*) found them at from  $2.916$  to  $3.024 \mu$  and at  $6.06 \mu$ , which values are closely harmonic. Ransohoff found closely harmonic bands for alcohols at  $1.71$  and  $3.43 \mu$ .

In the present work, using a quartz prism, the first band occurs at from  $0.83$  to  $0.86 \mu$ , while the second one oscillates between the values  $1.66 \mu$  for the thiophene and  $1.73 \mu$  for ethyl succinate. The next disturbance is in the region of  $3.4 \mu$ , the maximum being at  $3.25 \mu$  for benzene and  $3.43 \mu$  for compounds rich in  $\text{CH}_2$  or  $\text{CH}_3$  groups.

The next region where there is a constant recurrence of bands is at  $6.75 \mu$  for benzene and  $6.86 \mu$  for other compounds rich in  $\text{CH}_2$  or  $\text{CH}_3$

---

<sup>1</sup>Grünwald: *Wien. Ber.*, 96 to 101, 1887 to 1892.

<sup>2</sup>Schuster: *Proc. Roy. Soc.*, 31, p. 337, 1881.

groups. In discussing the sources of errors it was shown that the  $6.86 \mu$  band is quite accurately known.

Beyond  $13.6 \mu$  there is a band of frequent recurrence. In this region, however, it is difficult to locate the bands with great accuracy, because of the weakness of the radiation. As a whole, however, the bands at  $1.71$ ,  $3.43$ ,  $6.86$ , and  $13.6$  to  $13.8 \mu$  are closely harmonic, *e. g.*, in the petroleum distillates, and, taken with the  $0.867 \mu$  band of Abney and Festing ( $0.83$  to  $0.86 \mu$  in present work), would seem to indicate a vibration about a fixed point. Even if in the future this relation should ultimately be found false, the constant recurrence of these bands in so many compounds can not be without meaning. These bands are so sharp and symmetrical that it is difficult to conceive how, with greater dispersion, they can be resolved into lines which are very unsymmetrically placed about the present centers of gravity.

In carbon tetrachloride and tetrachlor-ethylene it was shown that this group of compounds is conspicuous for its absence of absorption bands except at  $6.5$  and  $13 \mu$  (harmonics), where there are large bands, each of which is evidently complex. The complete table of wave-lengths of absorption bands contains still further illustrations. An explanation of the significance of these relations is not attempted, and it will be sufficient to add that any such harmonic relation would seem to indicate the resonance of a definite group of atoms, or "ions," to which these lines are solely due. But to attribute a given line to a certain group of chemical atoms is dangerous, for it has already been shown in the case of the mustard oils that the manner of grouping of the atoms is not the only characteristic of this group of compounds. Thus the physical properties of benzene and thiophene are so similar that these two compounds are readily confounded,<sup>1</sup> yet their absorption spectra are entirely different. It might be added that in the gases, where one would naturally expect such harmonic relations, only acetylene at  $3.7$  and  $7.4 \mu$ , and methyl ether at  $3.45$  and  $6.9 \mu$  have bands satisfying this condition. Whether this relation will ultimately be proved absolutely true remains to be seen. To determine this question a very much larger dispersion will have to be employed than has yet been available. This means a far more sensitive recording apparatus than has yet been devised.

In dismissing this question it will be sufficient to add that after a year's struggle with it, to prove or disprove it, the result has been a closer agreement in the values first obtained, especially for the bands at  $3.43 \mu$  and  $6.86 \mu$ .

---

<sup>1</sup>Smith's (Richter) Organic Chem., vol. 2, p. 47.

## SUMMARY.

The infra-red absorption spectra of organic compounds have been studied, the majority to  $15\ \mu$ , using a radiometer, two mirror spectrometers, and a rock-salt prism. Out of a total number of at least 135 compounds examined with the rock-salt prism, 131 have been recorded in this paper. They include solids, liquids, and gases. In addition to this, 19 compounds were examined to  $2.7\ \mu$ , using a quartz prism.

The following are some of the results obtained:

(1) A study of isomeric compounds shows that the arrangement, or bonding, of the atoms in the molecule, *i. e.*, its structure, has a great influence upon the resulting absorption spectrum, which agrees with Julius (*loc. cit.*).

This is of considerable significance, and is in marked contrast with stereomeric compounds, like dextro- and laevo-pinene, which were found to have identical spectra, showing that the spacial arrangement of the atoms, *i. e.*, the configuration of the molecule, had no effect upon the resulting absorption spectrum.

(2) No shifting of the maxima of absorption, with increase in molecular weight, "Kundt's Law," could be detected, except in the case of the band lying between  $3.1$  and  $3.5\ \mu$ , for gases. Instead of a shifting of the maximum in certain compounds, there occurs a new band beside the original one when a methyl or amido group is substituted for a hydrogen atom, the new band lying toward the longer wave-lengths when a methyl group is substituted, and toward the shorter wave-lengths when the hydrogen atom is replaced by an amido group. This disagrees with investigations of Krüss in the optical region, where *only the new band* was observed.

(3) A rise in temperature of  $20^\circ$  had no effect upon the transparency of the compound, nor upon the position of its maxima.

(4) The effect of replacing an H atom by certain groups of atoms, like  $\text{NH}_2$  and  $\text{CH}_3$ , is very marked, and usually shows new bands, *e. g.*,  $2.96$  and  $3.43\ \mu$ , in the resulting absorption spectrum. In the spectra of certain benzene derivatives, however, the bands of the benzene spectrum are usually present, showing that the vibration of the benzene nucleus has not been destroyed. However, the writer does not consider this sufficient evidence to consider the new bands to be due to the groups of chemical atoms substituted.

(5) Total absorption is not influenced by the size of the molecule, while compounds having sulphur or halogens are more transparent than those having H, O, OH, or N, which they have replaced, just as found by Friedel and by Zsigmondy.

(6) The spectra of groups of compounds are similar, and are characteristic of the grouping adopted by chemists, as found by Abney and Festing.

(7) Carbohydrates have a characteristic spectrum, with absorption bands at  $0.83$  to  $0.86 \mu$ ,  $1.67$  to  $1.72 \mu$ ,  $3.25$  to  $3.43 \mu$ ,  $6.75$  to  $6.86 \mu$ , and  $13.6$  to  $14 \mu$ . The first large absorption band in carbohydrates occurs in the region of  $3.2 \mu$ , which is in general followed by a transparent region from  $4$  to  $5 \mu$ . The work of Puccianti, in which he found that all carbohydrates have an absorption band at  $1.71 \mu$ , while benzene derivatives have two additional bands, at  $2.18$  and  $2.49 \mu$ , respectively, has been confirmed on 18 new compounds. The  $1.7 \mu$  band deserves especial notice.

(8) In addition to the characteristic carbohydrate spectrum, certain bands in it occur in positions which are close harmonics, the maximum wave-length of each succeeding band being twice the preceding. The question whether this is merely a coincidence or whether it is an exact relation is not fully determined. To decide this question a larger dispersion will be necessary, while the spectrum will have to be explored to  $27.6 \mu$  for the next harmonic. In the same manner more pairs of bands will have to be located in the ammonia spectrum, etc., in order to show that the constant difference of the wave numbers found is not merely a coincidence, hence, that there is a true spectral series present.

(9) The three isomeric xylenes have banded, "channeled," spectra, in which the most important line in each group lies farthest toward the long wave-lengths, in the order *ortho*, *meta*, *para*. In other words, the *ortho*, in which the  $\text{CH}_3$ -groups are the closest together in the benzene ring, has the "head" of each group of bands lying farther toward the infra-red than are the heads of the corresponding bands of the meta and para compounds. This seems to indicate a resonance of electrically charged particles ( $\text{CH}_3$ ), whose capacity is increased, whose period becomes slower, and, hence, whose maxima are shifted toward the longer wave-lengths, with a decrease in the distance between the particles.

(10) In many compounds numerous bands are in coincidence, which would no doubt be found in different positions when using a larger dispersion. Other bands, like the one at  $3.25 \mu$  in benzene, in benzaldehyde, and in pyridine, or the  $3.43 \mu$  and  $6.86 \mu$  found in aliphatic compounds, seems to point to a specific group of atoms as their source, or to some "ion" or "nucleus" common to them.

The most marked example of this type is phenyl mustard oil, in which the vibration characteristic of the mustard oils at  $4.78 \mu$  is superposed upon the vibration of the benzene "nucleus" or "ion," which has its maxima at  $3.25 \mu$ ,  $6.75 \mu$ , etc. In some compounds there is evidence

that certain bands, *e. g.*, the  $3.43 \mu$  band, are due to a definite group of atoms, *e. g.*, the  $\text{CH}_3$ -groups in the chain compounds and terpenes; in other compounds the evidence is just as strongly in favor of the manner of bonding of the atoms, *e. g.*, the methylene hydrocarbons of the petroleum distillates; still other compounds, *e. g.*, benzene and its derivatives, especially *phenyl mustard oil*, in which we have the *characteristic vibration of the mustard oils superposed upon the vibration of the benzene nucleus*, show that both the groups of atoms and their manner of bonding with other atoms, as well as the kind of atom, have a great influence upon the absorption curve.

In the present work the spectra have been discussed from the standpoint that since compounds of the same chemical composition (isomers) have different spectra the source of the disturbance is intramolecular. If we had assumed ignorance of the composition of the compounds, we would have expected, from our knowledge of the spectra of the elements, that each compound ought to have a different spectrum. This has been found to hold true, except for certain lines in them, as shown in the following table:

Group.	Characteristic maxima.					
$\text{CH}_2$ or $\text{CH}_3$ .....	$3.43\mu$	$6.86\mu$	$13.6$ to $13.8$ and $14\mu$			
$\text{NH}_2$ .....	$2.96$	$6.1$ to $6.15$				
$\text{C}_6\text{H}_6$ .....	$3.25$	$6.75$	$8.68$	$9.8$	$11.8$	$12.95$
$\text{NO}_2$ .....			$7.47?$	$9.03$		
$\text{OH}$ .....	$2.95$					
$\text{NCS}$ .....		$4.78$				

There would be no reason for deciding whether the cause is inter or intra molecular. The compounds might then be grouped according to the marked absorption bands which they have in common, *e. g.*, those having a band in common at  $3.25 \mu$ , at  $3.43 \mu$ , or at  $4.78 \mu$ . One compound (*phenyl mustard oil*) would then be placed in the  $3.25 \mu$  and in the  $4.78 \mu$  group. Another (*xylidine*) would belong to the  $2.95 \mu$  group and to the  $3.43 \mu$  group. This would then suggest a disturbance common to both groups, and we are brought to the point arrived at by the other line of argument, *viz.*, there is a something, call it "particle," "group of atoms," "ion," or "nucleus," in common with many of the compounds studied, which causes absorption bands that are characteristic of the great groups of organic compounds, but we do not know what that "something" is.

The presence of these groups of ions, each group having its own free period of vibration, is in accord with present conceptions of absorption



and anomalous dispersion. The most conspicuous regions where these ions manifest themselves is at 3.43 and 6.86  $\mu$  for  $\text{CH}_3$  compounds, at 3.25, 6.25 and 6.75  $\mu$  for benzenes, and at 4.78  $\mu$  for mustard oils. The latter is superposed upon the  $\text{CH}_3$  or the benzene vibration depending upon the compound. Alcohols and compounds having  $\text{NH}_2$  have a band at 2.95  $\mu$ .

To assign the cause of these bands to a particular group of chemical atoms rather than to a less definite, ultra-atomic source does not elucidate matters very much, although it is true that these bands do *not* appear until these groups of atoms are introduced into the compound.

## APPENDIX I.

### SOURCES OF RADIATION.

In previous investigations the radiator used was a zircon lamp, or a platinum strip covered with iron oxide and heated to redness by means of an electric current. In the foregoing work a light portable radiator was desired which could be mounted upon the spectrometer arm and be moved with it. For this purpose the Nernst lamp was found to be the most serviceable because it is light, compact, and has no products of combustion, such as  $\text{CO}_2$  and water vapor, which would contaminate the room (which was small), thus endangering the prism. The "glower" causes some trouble, and since the distribution of the energy in the spectrum of the "heater" is more uniform, the latter was used. This is a very satisfactory radiator, since it is not affected by air currents, while it can be maintained at a uniform temperature by using current from a battery of storage cells. As is well known, the "heater" consists of a hollow cylinder of clay wound with a fine platinum wire, over which is a thin coating of a more refractory clay. When the platinum wire is heated to incandescence the clay gives out the desired radiation. By using such a heater requiring 110 volts on a 90-volt circuit it lasted for at least three months, when the platinum wire had volatilized sufficiently to cause it to break. This was easily repaired and covered with clay. The volatilized platinum condenses upon the surface of the heater in small, flat, triangular and hexagonal crystals. Joly<sup>1</sup> found that on covering a strip of platinum with topaz dust and heating it to redness microscopic crystals of platinum were formed on the partially decomposed topaz, the prevailing form being the octahedron.

The extraordinary distribution of energy from these heaters is shown in fig. 125. The minima lie close to the well-known absorption bands of  $\text{CO}_2$  and water vapor. The maxima are not so easily explained. The first one, at  $2.5 \mu$ , is no doubt due to the hot platinum wire. The third maximum lies close to the absorption band of quartz found<sup>2</sup> at  $5.3 \mu$ . The suppression of this apparently selective radiation at  $5.2 \mu$  is well illustrated in curve *b*, which was obtained from a "heater" cov-

---

<sup>1</sup>Joly : Nature, 43, p. 541, 1891.

<sup>2</sup>E. F. Nichols : Physical Review, 4, 1897.

ered with a film of  $F_2O_3$ . The film was obtained by dipping the heater in a  $FeSO_4$  solution, which was then oxidized by heating.<sup>1</sup> For the curves *a* and *b* the spectrometer slit was the same width. Curve *c* represents the distribution of curve *a* for a wider slit. It was obtained while finding the absorption of a certain compound, and is of interest since, by its regularity, it shows the constancy of the radiation.

The radiation from this heater was found when covered with borax, also when a strip of mica 0.3 mm in thickness was wound on it, but in neither case was the energy curve different from the original. The mica did not show emission minima at  $8.4 \mu$  and  $9.4 \mu$  as computed by Rosenthal<sup>2</sup> (fig. 126, curve *b*).

That an emission band should exist at  $5.2 \mu$  seemed doubtful. To test this some finely ground quartz (French flint), pure feldspar, and a number of kaolin clays were obtained from Prof. H. Ries, of the department of geology. The original clay was removed from the platinum wire, and then the heater was covered with a thin paste of one of these clays. After drying, the heater was used as before. In the course of the investigation of absorption spectra as many curves (the "direct deflections") could be obtained as was desired. The quartz powder would not adhere well to the heater, even when mixed with starch and applied as a paste. The result was that the surface never became so hot as it did when the finer-grained clays were employed. This, of course, decreased the intensity of the radiation, as will be noticed in curve *d* of fig. 125, where it will also be noticed that the sharp maximum has disappeared, showing that it is *not* a selective emission band of quartz, but that it is simply due to the adjacent absorption bands in the atmosphere.

There are really two emission maxima, viz, the partially suppressed one at  $2.5 \mu$ , due to the white-hot platinum wire, and a second maximum in the region of  $3.8 \mu$ , which may be due to the cherry-red (color) clay covering. The latter maximum is partly reversed by the strong atmospheric absorption band of  $CO_2$  at  $4.25 \mu$ . The platinum conductor under the clay is very much hotter than it would be if exposed to the air. It does not seem possible, however, that it is sufficiently volatilized to give emission bands. It would seem as though the clay would be a sufficient covering to suppress them. In fig. 126 is shown the radiation curve *c* of a different heater, which shows the variation in the distribution of the emission of different heaters, this one being made of a finer-grained clay than the preceding. This heater contained

<sup>1</sup>Paschen : Ann. der Physik, 56, p. 762, 1895.

<sup>2</sup>Rosenthal : Ann. der Physik, 68, p. 792, 1899.



less than 3 per cent of  $\text{SiO}_2$ . The examination of the pure feldspar radiator was not successful, the platinum breaking soon after beginning the observations, and the examination was never repeated. Whether the platinum was acted upon by the feldspar is not known. The heater, when covered with ordinary blue clay, gave a curve quite similar to curve *a*, the only difference being slight depressions at  $6\ \mu$ . Since some of these curves were obtained at different periods, several months intervening, the relative intensity of the radiation from the different heaters can not be compared, except curves *a* and *b* in the two figures. They are given for the purpose of showing the relative distribution of the energy in the different spectra.

Curve *d* in fig. 126 shows the radiation from a new heater, using the large spectrometer, which had mirrors of 1 meter focal strength; consequently the radiation from the heater had to traverse almost 3 meters of air before entering the radiometer. The result is a marked transformation of the whole curve. The water-vapor bands at 2.9, 4.8, 5.1, 5.8 to 6.0, and at  $6.6\ \mu$  and the  $\text{CO}_2$  bands at  $2.7\ \mu$  and  $4.28\ \mu$  have been determined by Paschen (*loc. cit.*). The source of the  $3.45\ \mu$  band is not known, unless it be due to the presence of hydrocarbon vapors, which manifest themselves, just as Pauer (*loc. cit.*) found for the ultra-violet. As far as known to the writer this is the next to the largest spectrometer ever constructed for such work (Langley's being the largest), and it illustrates well the difficulties to be encountered in increasing the dispersion by lengthening the spectrometer arms. For example, the intensity of the radiation drops from 21 to 8 in the  $\text{CO}_2$  band at  $4.25\ \mu$ , which shows that a very much more intense source of radiation will be necessary if a larger spectrometer is to be used. What is needed, then, is a device giving larger dispersion, with short spectrometer arms. For example, a fluorite prism on the small spectrometer would have given about the same dispersion as this large spectrometer and rock-salt prism.

## APPENDIX II.

### THE EMISSION SPECTRUM OF THE HEFNER LAMP.

Having had occasion to compare the radiation from a Hefner lamp (amyl-acetate flame) with an acetylene flame of the Bunsen and the cylindrical types, the results obtained seem of sufficient interest to record in this paper. The large spectrometer was used, hence the atmospheric absorption bands at 1.4, 1.8, and 2.6  $\mu$  are prominent.

The products of combustion are solid carbon, water vapor, and  $\text{CO}_2$ . In fig. 127 curve *c* shows the radiation from the Bunsen acetylene flame, while curve *a* shows the radiation from the cylindrical acetylene flame. Curve *b* gives the radiation from the Hefner lamp.

The Hefner lamp is weak in light-giving power as compared with the acetylene flame. The curves at 2  $\mu$  show that this is due to the difference in temperature of the incandescent carbon particles. It would be interesting to learn whether this is due to the greater quantity of water vapor present in the amyl-acetate flame or to the greater completeness of the combustion; it has twice as much water vapor as has the acetylene flame for the same amount of carbon dioxide.

The emission bands at 4.4  $\mu$  are of about equal intensity. The curves when corrected for slit width are shown in fig. 128. The maximum for the acetylene flame comes at 1.05  $\mu$ , as found by Stewart,<sup>1</sup> while the amyl-acetate maximum occurs at 1.50  $\mu$ .

Now, the question of the precise relation between the temperature of an ideal "black" body, computed by means of the constant  $A$  ( $\lambda_m T = A$ ), and the actual temperature of a flame is not settled. Stewart (loc. cit.) adopted the value  $A = 2282$ , which gave values for the temperature of the acetylene flame, the ordinary gas flame, and a candle flame, computed from the maxima of their respective energy curves, which agree with the temperatures obtained by Nichols<sup>2</sup> by direct measurement, viz, 1900° C., 1780° C., and 1670° C., respectively. Using this value of the constant  $A$ , the computed temperature for the amyl-acetate flame is 1250° C. Using Paschen's constant, 2940, gives a value of 1690° C. Ångström<sup>3</sup> finds this temperature to be 1557° C., while Wannier found it to be 1162°. Paschen<sup>4</sup> found the shifting of the emission band of  $\text{CO}_2$  with rise of temperature, using a stream of

<sup>1</sup>Stewart, G. W.: Phys. Rev., xv, p. 311, 1902.

<sup>2</sup>E. L. Nichols: Phys. Rev., x, p. 248, 1900.

<sup>3</sup>Ångström: Phys. Rev., xvii, p. 302, 1903.

<sup>4</sup>Paschen: Ann. der Physik, 50, p. 409, 1893.

CO<sub>2</sub> heated to different stages from 300° to 1460°, which is the temperature (?) of the Bunsen flame. The latter has its maximum at 4.40 μ. It will be noticed in the curves that, for the amyl-acetate flame, the CO<sub>2</sub> maximum is situated at 4.36 μ, while for the Bunsen acetylene and the Bunsen gas flame the maximum is sharp at 4.40 μ. This would appear to indicate a *lower* temperature than 1460°. Plotting the values of temperatures and wave-lengths, found by Paschen, it was found that for the amyl-acetate lamp the maximum at 4.36 μ indicates a temperature of 1370° C.

This discrepancy is no doubt due to the use of the large spectrometer, which magnifies the atmospheric absorption band at 1.37 μ (Langley's  $\psi=1.4 \mu$ ), and consequently lowers the emission curve of the amyl-acetate lamp, which happens to come just at this point. However, this still leaves a difference of 200° unaccounted for, which emphasizes the lack of our knowledge of the term "temperature" as applied to such a radiator.

### APPENDIX III.

#### ELECTRIFICATION OF RADIOMETER VANES.

One of the few defects of a radiometer is the electrification of its vanes, which is caused by air currents in exhausting the apparatus or by standing with the stop-cocks open to the exhaust pump. Since this effect has not been recorded except by Stewart (*loc. cit.*) and myself, and since no efficient remedies to prevent it have been given heretofore, it seems desirable to indicate the progress made in this direction.

The electrification of the vanes by air currents occurs in exhausting the radiometer, especially when it is first assembled and *the vanes are new*. This does not occur until a critical pressure of about 0.1 mm. is attained, when the deflection is generally thrown entirely off the scale, and the vanes may not return for many hours. In the present work, for quite a while the joints of the apparatus leaked a slight amount, so that the stop-cocks were left open to the exhaust pump, in order that the change of pressure would not affect the sensibility of the radiometer for a day's work. It was then found that the vanes became electrified, without any apparent provocation, while making readings, and that it was more aggravated in the hotter summer months. As far as could be ascertained, the vane that was nearest to the rock-salt window would be attracted to it. The mercury vapor was at once suspected as the source of electrification. The remedy consisted in inserting a glass tube containing gold foil spread on absorbent cotton, to present a large surface. After that there was no further electrification either from air currents or the mercury vapor, until the gold had become amalgamated. As an example, the apparatus stood from October 20, 1902, to February 20, 1903 (four months), without becoming electrified. The pump was then cleaned and a little more gold foil added, when the apparatus stood from March 10 to June 12, 1903, before it became electrified. The gold was then found to be entirely amalgamated. Of course, part of this could have been obviated by closing the stop-cocks, but this in time starts them to leaking, hence the present method was the more preferable. This was especially desirable after the joints had become so tight that there was practically no leaking when the radiometer stood from June to September, 1903 (stop-cock closed) and maintained a sufficient sensitiveness that a candle several meters from the slit threw the deflection clear off the scale.

It is a peculiar fact that with gold foil in series old vanes do not become electrified in exhausting the apparatus. Just the opposite is true for newly blackened values, which on exhausting adhere to the

window with great tenacity. After standing several days the vanes no longer become electrified so easily.

Since the completion of this research the radiometer has been remodeled, in order to gain a greater sensitiveness, and at the same time to shorten the period. It became evident that on account of the viscosity of the residual gas in the radiometer the period is more affected by the *size of the vanes* than by the moment of inertia of the system or the diameter of the fiber suspension. In order to decrease the area of the vanes they must be situated near the slit of the spectrometer. To this end the outer window,  $R_1$ , was discarded, and only the inner one,  $R_2$ , was used (fig. 3). It rested on a wide flange, and was made airtight by means of beeswax covered with shellac varnish. The slit  $F_2$ , of the spectrometer (fig. 1) was mounted directly upon the outside of this window, while the vanes were about 2 mm. from the inside surface. To prevent the spectrometer from slipping, with respect to the radiometer (and the slit  $F$ ), it was held in place by means of heavy weights.

The vanes were of very thin strips of mica, 12 mm. long and 1 mm. wide, secured to fine glass rods. The mirror was about the size of the preceding. Unfortunately, the weight the suspension was not determined, but since the area of the vanes, instead of their mass, concerns us most, that is of minor importance.

The half period, *i. e.*, time for maximum of deflection, of this system was only 6 seconds, and at 0.05 mm. pressure its damping was so small that it was used ballistically. The sensitiveness was about 4, *i. e.*, a paraffin candle at a distance of 1 meter gave a deflection of 4 cm. per square millimeter of exposed surface (slit 0.1 mm.) upon a scale situated at a distance of 1 meter. This was a somewhat greater sensitiveness than the preceding, and was equal to that used by Stewart (*loc. cit.*), which had a period of 40 seconds. A still greater sensitiveness was attained by selecting a much finer fiber which was aperiodic in air. In comparison with the bolometer this does not seem a fair test of sensitiveness, for the large vanes of the Stewart radiometer, with a new fiber (period 20 seconds), had a sensitiveness of only 1 instead of 4. Nevertheless, the dispersed radiation from the hand was sufficient to give a deflection of from 1 to 2 mm. at  $9\mu$ .

For work where a very narrow linear absorbing surface is required it seems quite probable that the sensitiveness of the radiometer can not attain that of the bolometer. Nevertheless for ordinary laboratory work it seems superior to it on account of its simplicity and its freedom from magnetic and thermal disturbances. The radiometer, as ordinarily used, is from 4 to 8 times as sensitive as the Boys radiomicrometer, which was thought capable of detecting a rise in temperature of  $0.000001^\circ$  C.

## APPENDIX IV.

### ABSORPTION OF SOLIDS IN SOLUTION.

In the ultra-violet Hartley and Dobbie (*loc. cit.*) have studied the absorption spectra of solids dissolved in water. They found that groups of chemically related compounds have similar absorption spectra. In the visible spectrum we also find absorption bands, especially when the solute is a colored substance. Iodine is an example of this type. But in the infra-red the writer found iodine transparent beyond  $1.1 \mu$ . As far as is known to the writer, only one other substance, sulphur in  $CS_2$ , has been examined far out in the infra-red. This was done by Julius, who found that S had no appreciable effect upon the transparency of the  $CS_2$ .

That a solid in solution should be transparent to infra-red radiation seemed doubtful. It would indicate a resonance of small particles in the optical region, as distinguished from the intramolecular resonance of the solvent.

After studying so many compounds it seemed imperative to consider this question more thoroughly. It was suspected that this transparency is simply due to the thin cell used and to the slight solubility of the solids. For example, assuming that 0.05 gram of iodine per cubic centimeter is dissolved in  $CS_2$ , using a cell 0.3 mm. thick, this would be sufficient to form a solid film only 0.03 mm. It seemed that the proper method of answering this question would be to select a solid having a *strong* absorption band in a region of the spectrum where the solvent has *no absorption bands*.

#### DIPHENYL. $C_{12}H_{10}$ .

The curves of carbon tetrachloride,  $CCl_4$  showed no marked bands up to  $6.5 \mu$ . Accordingly this liquid was selected for a solvent. The sample used with diphenyl showed the water band at  $2.97 \mu$  and a second band at  $4.5 \mu$ . The saturated diphenyl solution showed an additional large band at  $3.25 \mu$ , which is the characteristic band of the benzene nucleus. This is of considerable interest, since diphenyl,  $C_6H_5-C_6H_5$ , is a double benzene ring. The curve, fig. 129, shows that solids in solution *do* absorb heat waves, and that the selective absorption of a solid in solution and that of the solvent are identical.<sup>1</sup> It also shows that the

---

<sup>1</sup>In my preliminary communication on Infra-red Absorption Spectra, *Astrophys. Jour.*, xx, p. 215, 1904, it appeared to me that there might be a difference.

*benzene vibration still exists*, and that solids in solution can be studied in the infra-red, just as in the ultra-violet.

NAPHTHALENE.  $C_{10}H_8$ .

Naphthalene was also examined at  $3.25 \mu$ . Its solubility in  $CCl_4$  is unusually great, *e. g.*, the present solution contained 0.25 gram per cubic centimeter of  $CCl_4$ . This is sufficient to make a homogeneous solid film 0.28 mm. thick (sp. gr. = 1.15; cell = 0.6 mm.).

This compound is of considerable importance, for its molecule is formed by the condensation of two benzene nuclei. As a result, its chemical properties are quite different from that of benzene; but its absorption spectrum shows the  $3.25 \mu$  band of benzene, with which it is also comparable in general transmission. As a whole, for the region investigated, this compound shows that the vibration of the benzene nucleus has not been disturbed.

AZOBENZENE.  $C_6H_5-N=N-C_6H_5$ .

This compound is also quite soluble in  $CCl_4$ , so that a saturated solution contained about 0.2 gram per cubic centimeter of the liquid. As with the preceding compounds, the rock-salt cell was 0.6 mm. thick.

The curve shows the  $3.25 \mu$  benzene band, indicating that the presence of the N atoms does not disturb the vibration of the benzene nucleus. This solution is far more opaque than the preceding, showing the effect of the introduction of the N atoms, just as in other compounds containing nitrogen.

Moreover, this solution is of a reddish-brown color, showing an absorption band in the visible spectrum, as well as in the infra-red. This shows that both are due to an intramolecular disturbance, and disapproves the idea of a resonance of small particles (of molecular dimensions, as for, example, Kosonogoff's butterfly scales and Wood's metal films) in the optical region, as distinguished from the intramolecular resonance in the infra-red. Of course, one might say that the infra-red band, *e. g.*, the  $3.25 \mu$  band, is also a resonance effect. Possibly it is, but the evidence of a resonance of small, electrically charged particles whose capacity, and hence whose periods (like a condenser), depend upon their proximity to similarly charged particles (the closer the particles the greater the capacity, hence the slower the period, and hence the farther is the absorption band shifted toward the longer wavelengths), is somewhat contradictory in the infra-red.

The best evidence in favor of this idea of a resonance effect is in the xylenes, in which for the *ortho*, which has the two  $CH_3$ -groups nearest together, the large absorption bands lie farthest toward the *long* wavelengths, while in the *para*, in which the two  $CH_3$ -groups are farthest

apart, the large absorption bands lie farthest toward the *short* wavelengths; the *meta* has its bands in intermediate positions.

The dielectric constants of a number of solvents and solutions have been determined by Schlundt<sup>1</sup> and by Eggers.<sup>2</sup> They found that the dielectric constants of  $C_2N_2$ ,  $CH_2(CN)_2$ , and  $C_2H_4(CN)_2$  to be 2.52, 46.3, and 61.2, respectively, which would indicate that the dielectric constant is dependent upon the comparative freedom of the cyanogen radicals from each other. In general, however, they find that the dielectric of a substance is affected not only by the elements entering into its decomposition, but also by the grouping of those elements in the molecule. The dielectric constant decreases with increase in molecular weight. Methyl, ethyl, amyl, and phenyl mustard oil have the respective dielectric constants, 17.9, 22, 17.3, and 8.5, so that evidently we gain nothing in considering them in connection with the large band at  $4.78 \mu$ . The value of the phenyl mustard oil is just about one-half that of the others.

These compounds were not examined for the  $6.25$  and  $6.75 \mu$  benzene bands, because  $CCl_4$  has a large band at  $6.5 \mu$ , and the cell was opaque.

It is to be noticed that these solids in solution are practically transparent, except in the region of their absorption bands, which corresponds to the results found for iodine in solution, as already mentioned. In the present state of our knowledge of the subject it appears that a solid in solution is far more transparent than in its undissolved state in the infra-red, which seems a rather unusual condition that deserves further inquiry.

---

<sup>1</sup>Schlundt: Bull. Univ. of Wisconsin, 2, 353, 1901.

<sup>2</sup>Eggers: Jour. Phys. Chem., VIII, p. 14, 1904.



## APPENDIX V.

### WATER OF CRYSTALLIZATION.

BRUCITE (MAGNESIUM HYDRATE).  $\text{Mg}(\text{OH})_2$  or  $\text{MgO} \cdot \text{H}_2\text{O}$ . (Fig. 130.)

This mineral was studied with reference to the question of the effect of the OH-group. It is also of interest because it *does not* contain carbon. The common massive foliated variety was used, from which a thin, clear lamina was removed.

The transmission curve is conspicuous for a very large minimum at  $2.5 \mu$ , beyond which there are no bands until we arrive at  $9 \mu$ , beyond which point there is complete opacity. The characteristic band of carbohydrates, at  $3.1$  to  $3.43 \mu$ , is absent; in fact, there are no bands in the whole spectrum which are to be found in the hydrocarbons.

This is the *first* compound studied which has a large absorption band situated near the visible spectrum.<sup>1</sup> In fact, it is but the second compound discovered which has a large band in this region, the first mineral being beryl,  $\text{H}_2\text{Be}_6\text{Al}_4\text{S}_{12}\text{O}_{37}$ , which Königsberger<sup>2</sup> found to have a large band at about  $0.86 \mu$ .

The question of the condition of the water in these different compounds is of interest. By "water of constitution" is meant that the  $\text{H}_2\text{O}$  is chemically combined with the other constituents of the molecule. On heating, water will be given off, but the residue will not take up water when placed in it. This is not unlike the combustion of a carbohydrate, which contains O atoms. Brucite, beryl, tourmaline, and mica are examples of this class of compounds. On the other hand, in crystals having "water of crystallization" the molecules of water and of the mineral are thought to exist in their entirety. Here water is also given off on applying heat, *e. g.*, ordinary copper sulphate, but in these compounds water *will again be taken up*. Gypsum ( $\text{CaSO}_4 + 2\text{H}_2\text{O}$ ), which has been discussed with water, belongs to the latter class of compounds.

The curves of gypsum, which has "water of crystallization," and of brucite and of mica, which have "water of constitution," are radically different. The former has the bands found in water, the latter

---

<sup>1</sup>Königsberger: Ann. der Physik (4), 4, p. 796, 1901, calls attention to the fact that no substances are known which have large absorption bands near the visible spectrum.

<sup>2</sup>Königsberger: Ann. der Physik, 61, 687, 1897.

does not show the water bands. This would indicate that water of crystallization is not different<sup>1</sup> from ordinary water, as mentioned by Königsberger.

The entire absence of the water band at  $3.0 \mu$ , which in this compound *could not be obscured* by the carbohydrate band at  $3.1$  to  $3.43 \mu$ , since it is absent, would make it appear that the  $3.0 \mu$  band in the alcohols is not due solely to the *OH-group*.

Curves *b* and *c* of fig. 130 are from Königsberger (loc. cit.). The former (muscovite,  $\text{H}_2\text{O}-\text{K}_2\text{O}-3\text{Al}_2\text{O}_3-6\text{SiO}_2$ ), has a band at  $2.9 \mu$ , but since it has no band at  $1.5 \mu$ , and since its whole aspect is unlike the water curve, we can not consider the  $2.9 \mu$  band due to water. Curve *c* is for biotite mica (reddish-brown color due to iron oxide), and has even less similarity to the water curve. As a whole the curves show that the H and O which exist in these compounds, and which *unite to form* water, on applying heat, are in a different condition from the *combined* O and H, which exists as "water of crystallization." The mica curves are for polarized light. Aschkinass<sup>1</sup> found that mica has bands of metallic reflection (absorption) at  $8.32$ ,  $9.38$ ,  $18.40$ , and  $21.25 \mu$ .

SELENITE (CRYSTALLINE GYPSUM).  $\text{CaSO}_4+2\text{H}_2\text{O}$ . (Fig. 131.)

This is one of the most easily obtained minerals for studying water of crystallization. Moreover, it can be split into thin, highly polished folia, the thinness being necessary in order to obtain transparency at  $3.0 \mu$ .

In fig. 131 the curve *a* is due to Königsberger (loc. cit.), who used a fluorite prism. It shows the  $1.5 \mu$  water band. Curve *b* shows the water bands at  $2.95$ ,  $4.55$ , and  $6.0 \mu$ , the latter being obliterated by the increasing opacity of the mineral, which has a large metallic absorption (reflection) band at  $8.69 \mu$ . The comparison spectrum of water is given in curve *c*, which is for an exceedingly thin film of water pressed between fluorite plates, hence the  $4.7 \mu$  band is almost absent. The full curve for water is given in fig. 31, which shows curves for films  $0.01$  and  $0.05$  mm. in thickness, from which it will be seen that the  $4.7 \mu$  band is considerably deeper. By computation it is found that the film of selenite, of  $0.126$  mm. thickness, contains a layer of water  $0.059$  mm. in thickness. This is indicated by the greater opacity of this curve as compared with the  $0.05$  mm. curve in fig. 31. Curve *a* contains a layer of water  $0.12$  mm. in thickness. The band of metallic

<sup>1</sup>In Graham (Otto's Lehrbuch der Chemie, 11 p. 173) the statement is made that water loses its properties, just as other bodies do when they enter into chemical compounds.

reflection (equivalent to metallic absorption) at  $8.69 \mu$ , curve *d*, is due to Aschkinass.<sup>1</sup>

The method of selective reflection seems better for studying minerals far in the infra-red. In fact it seems the proper method for making an extensive study of minerals containing water of crystallization, since, with few exceptions, they can not be obtained in thin films, especially for minerals containing several molecules of water of crystallization.

As already indicated, the unusual similarity of the curve of selenite and the great dissimilarity of the barite and the mica curves to that of water indicate that water of crystallization is not different from ordinary water, as mentioned by Königsberger. The present investigation at  $3.0$  to  $6 \mu$  is additional evidence to this effect.

The observations are of considerable significance, for,<sup>2</sup> "in the present state of our knowledge it is impossible to say that there is an absolute difference between the so-called water of constitution and water of crystallization, and not merely one of degree," although there is some evidence that there is a difference. The above curves are so marked that it is difficult to conceive how they can be one and the same thing.

I am indebted to Prof. A. C. Gill, of the department of mineralogy, for these two minerals.

---

<sup>1</sup>Aschkinass: *Ann. der Physik*, (4), 1, p. 42, 1900.

<sup>2</sup>*Encyc. Brit.*, 5, p. 505. See also *Rôle of Water of Crystallization in Salts of Organic Acids*, by T. Salzer, *Zeit. f. Phys. Chem.*, 19, p. 441, 1896.

## APPENDIX VI.

### INDICES OF REFRACTION OF ROCK SALT.

(Fig. 132.)

It will be noticed that in the present work, using a rock-salt prism, the maximum of the absorption band of water occurs at  $2.95 \mu$ , while Paschen (loc. cit.) found it at from  $2.95 \mu$  to  $3.0 \mu$ , and Aschkinass (loc. cit.) found it at  $3.0 \mu$ , both using a fluorite prism. Furthermore, it will be noticed that in the present work the conspicuous alcohol bands occur at  $2.95 \mu$  and  $3.43 \mu$ , while Ransohoff (loc. cit.) found them at  $3.0 \mu$  and  $3.43 \mu$ .

That this discrepancy can not be due entirely to errors in the observations has been shown in the discussion of the "sources of errors." From the nature of the dispersion curve, as well as the magnitude of the dispersion of fluorite, which is about twice as great as that of rock salt for the present work, and, furthermore, from the fact that the rock-salt dispersion curve passes through a double curvature near this point, it would appear that this discrepancy is due to errors in the indices of refraction of rock salt in the region of  $2.5 \mu$ .

Now, it so happens that we have no observational data for this region. The most recent and most reliable measurements of Rubens (loc. cit.) are for wave-lengths  $1.71 \mu$ ,  $2.35 \mu$ , and  $3.34 \mu$  (fig. 132). Langley's<sup>1</sup> values are *all much larger*, which can be interpreted, for the present, as a shifting of his zero of wave-lengths by about  $0.1 \mu$  toward the infra-red. The  $\text{CO}_2$  absorption band occurs at about  $4.28 \mu$ , while that of CO occurs at  $4.58 \mu$ . Unless it can be shown that the great atmospheric absorption band found by Langley at  $4.4 \mu$  is the composite of CO and  $\text{CO}_2$ , it would appear that his greater value,  $4.4 \mu$ , instead of  $4.28 \mu$ , is due to the shift noted above.

As indicated elsewhere, the great bench-mark in the infra-red is the emission band of  $\text{CO}_2$ , at  $4.40 \mu$ , using a Bunsen burner. The accuracy of the location of this band has also been noticed; and it was shown that all observers agree in the location of this band for fluorite, including myself, using rock salt. Langley (loc. cit., p. 215) finds this band at  $4.6 \mu$ , using a Welsbach mantle heated by the flame of a Kitson lamp,

---

<sup>1</sup>Langley : Annals of Astrophys. Obs., vol. I, p. 261.

which burns vaporized petroleum oil with a strong air draft. This is no doubt the  $\text{CO}_2$  emission band, as he himself thinks. Unfortunately, he does not give this band, using the lamp *without* the mantle, so we do not know whether the shift from  $4.4$  to  $4.6 \mu$  is due entirely to rise of temperature, as found by Paschen (loc. cit.), or whether it is due, in part, to the difference in the dispersion curves, as found by him and by Rubens.

Langley (loc. cit., p. 219) has also determined the dispersion of fluorite. "The method employed consisted simply in taking a number of bolographs with a fluorite prism, comparing these with bolographs taken with rock salt, picking out common absorption lines, measuring the position of these lines in the fluorite bolographs, and, after reduction of these measures, comparing their results with those obtained for the salt." The indices are *all smaller* than those recently found by Paschen,<sup>1</sup> who compared the fluorite prism directly with a grating.

Now, this is just what one would expect, viz, that Langley's indices of fluorite are too small, if the wave-lengths of his absorption lines are too large; and the wave-lengths of his absorption lines are too large beyond  $2 \mu$ , if his indices of refraction of rock salt are too large, as will be noticed in fig. 132. For, reasoning from the fact that the index of refraction *decreases* as the wave-length *increases*, if we find the dispersion of fluorite by simply "picking out common absorption bands" whose true wave-lengths are smaller than those found by Langley by means of the rock-salt prism, using his indices of refraction of rock salt, then it necessarily follows that, if the wave-lengths of the absorption lines are too large, the fluorite indices will be too small. The whole depends upon the question of the indices of refraction of rock salt.

From the general appearance of the dispersion curve of rock salt, using the indices found by Rubens, it appears that the value,  $n = 1.5255$  for  $\lambda = 2.35 \mu$  may possibly be too low. The dispersion curve may be a straighter line at  $2.35 \mu$  than is indicated in fig. 132. If it be a straight line, then the index is  $n = 1.5256$  for  $\lambda = 2.35 \mu$ , or the wave-length is  $\lambda = 2.39 \mu$  for  $n = 1.5255$ .

It is not for me to say which of these two investigators' indices are the more nearly correct. It will be sufficient to add that it is quite evident that the Langley values do not harmonize matters, while by *straightening the Rubens curve at  $2.35 \mu$*  (using  $n = 1.5256$ ) the discrepancy at  $2.95 \mu$  is *entirely obliterated* without affecting the wave-

<sup>1</sup>Paschen : Ann. der Physik, 4, p. 302, 1901.

lengths at  $3.43 \mu$ , and everything ever done with the infra-red absorption spectra that is worth considering is in agreement as far as the absolute value of wave-lengths is concerned.

In the same manner the absorption band at  $13.8$  to  $13.9 \mu$ , which is a close harmonic with the one at  $3.43 \mu$  and  $6.86 \mu$  (true value =  $13.72 \mu$ ), indicates the possibility of the observed indices<sup>1</sup> of rock salt at  $13 \mu$  being somewhat too low. The computed values are higher. Of course, it may ultimately be found that this apparent harmonic series is really a slowly converging "spectral series," in which case there ought to be this discrepancy between the computed value,  $13.72 \mu$ , and the observed values, viz,  $13.8$  to  $13.9 \mu$ —the latter values being more nearly correct.

The whole shows that the absolute value of the wave-lengths of the absorption bands are known as accurately as is possible with the present knowledge of the dispersion of rock salt.

---

<sup>1</sup>Rubens & Trowbridge: *Ann. der Physik*, 60, p. 733, 1897; corrections in *Ann. der Physik*, 61, p. 224, 1897.

## APPENDIX VII.

### CORRECTION TO THE WORK OF JULIUS.<sup>1</sup>

At the time when Julius found the absorption spectra of some 20 compounds the dispersion of rock salt beyond  $5\ \mu$  was unknown. Langley's (loc. cit.) dispersion curve extended to  $5\ \mu$ , at which point it became practically a straight line, and, since he had penetrated the infra-red beyond this point, he naturally desired to know how far he had explored the spectrum, expressed in wave-lengths. To do this he tentatively extrapolated the dispersion curve in a straight line beyond  $5\ \mu$ . Julius, with apparently less hesitation, has applied this extrapolation to his work, which appeared about the same time, and has given a table of wave-lengths of the absorption bands. As is well known now, the dispersion curve suddenly becomes curved beyond  $5\ \mu$ , and consequently all the succeeding wave-lengths thus found are too large.

All but seven of the compounds studied by him are recorded in this work. The remaining seven were not examined, and to make the comparison complete the corrected values of the absorption bands of five of the most important ones are given in the following table. The correction was made by drawing a straight line from  $5\ \mu$ . The position of this line was determined from the dispersion curve by comparing the values of the maxima of compounds studied by both of us. For example, for  $C_2H_5SH$  the band at  $7.1\ \mu$  on the dispersion curve was found at a point above it (at  $8.6\ \mu$ ), while the  $10.26\ \mu$  band on the curve lies still farther from the curve (at  $16.5\ \mu$ ). The maxima of numerous compounds thus located lay quite close to the straight line drawn through them, so that with few exceptions the difference in the values of the maxima, as found by both observers, usually amounts to only from  $0.02$  to  $0.05\ \mu$ , depending upon the sharpness of the band.

Compounds.	Old value.	Corrected value.	Old value.	Corrected value.	Old value.	Corrected value.	Old value.	Corrected value.	Old value.	Corrected value.	Old value.	Corrected value.
	$\mu$	$\mu$	$\mu$	$\mu$	$\mu$	$\mu$	$\mu$	$\mu$	$\mu$	$\mu$	$\mu$	$\mu$
$PCl_3$ .....	10.08	7.84 $a^*$	12.4	8.82	14.1	9.44	16.1	10.13 $a$	.....	9.44	.....	.....
$CHBr_3$ .....	6.42 $b$	5.82	8.6	7.1	10.05 $a$	7.82	12.7 $a$	8.95	14.1	9.7	.....	.....
$SiCl_4$ .....	6.1	5.64	6.8	6.1	11.1	8.27	13.0 $b$	9.04	14.85 $b$	.....	.....	.....
$SiHCl_3$ .....	6.0	5.57	11.15	8.27	13.0	9.04	14.9 $b$	9.74	.....	9.42	.....	.....
$S_2C_2l$ .....	6.45	5.85	9.65 $b$	7.63	11.8	8.58	12.9	9.0	14.05 $b$	.....	16.26	10.16

\*Depth of bands is indicated by the letters  $a$  and  $b$ , where  $a$  refers to the deepest band.

<sup>1</sup>Julius: Verhandl. d. Kon. Akad. v. Wetensch. Amsterdam., Deel. I, Nr. 1, 1892. Beiblätter, 17, p. 34.

TABLES.

TABLE I.—LINE SPECTRA OF GASES.

[Height of line indicates depth of absorption band.]

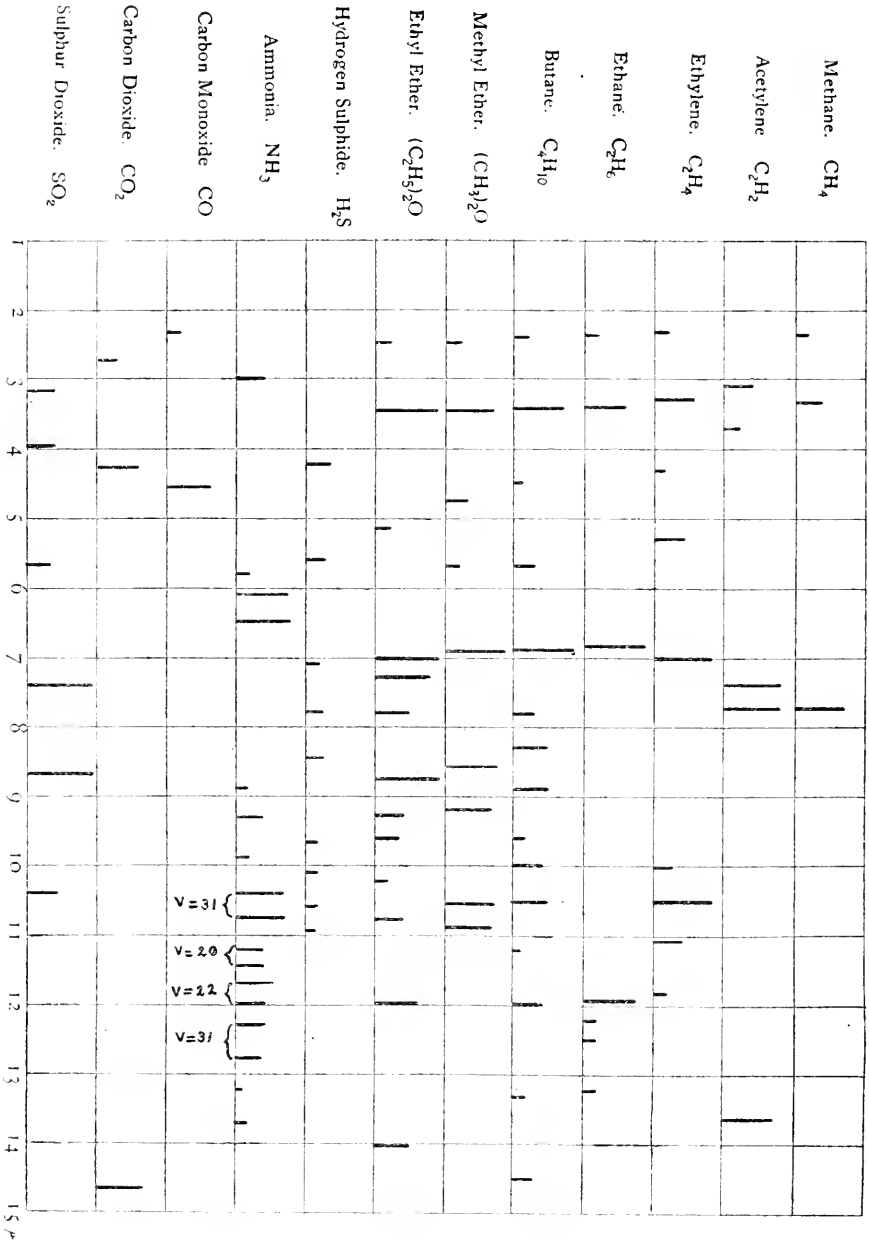



TABLE II



## LINE SPECTRA OF VARIOUS COMPOUNDS

The positions of the absorption bands are given in the same wavelength as the absorption curves. The symbols  $\square$  and  $\triangle$  indicate the positions of the absorption lines that are due to the presence of the compounds in the liquid phase.





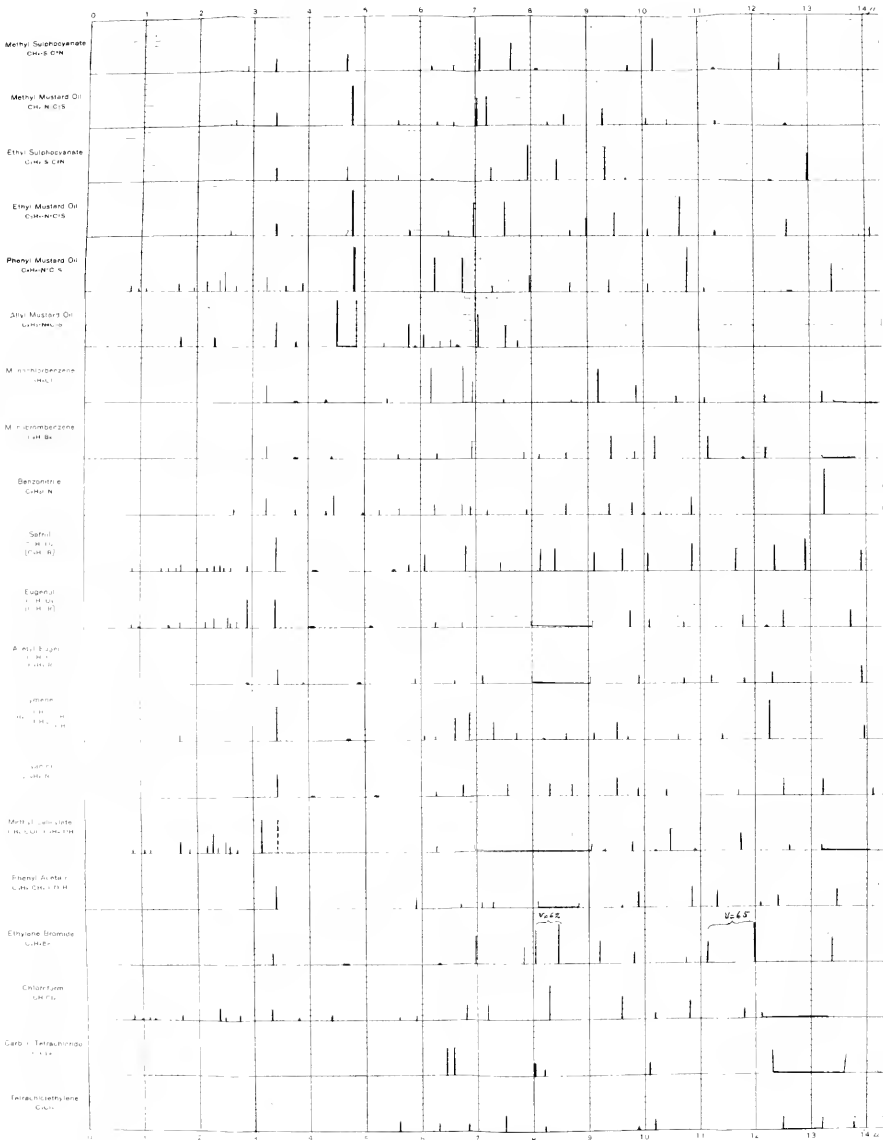

TABLE II. (continued)



## LINE SPECTRA OF VARIOUS COMPOUNDS

Height of line indicates the approximate depth of the band as found in the absorption curves

Lines thus  denote complete opacity between the points indicated. Lines thus    are broad and ill defined.

6  
7  
8  
9  
10  
11  
12  
13  
14  
15  
16  
17  
18  
19  
20  
21  
22  
23  
24  
25

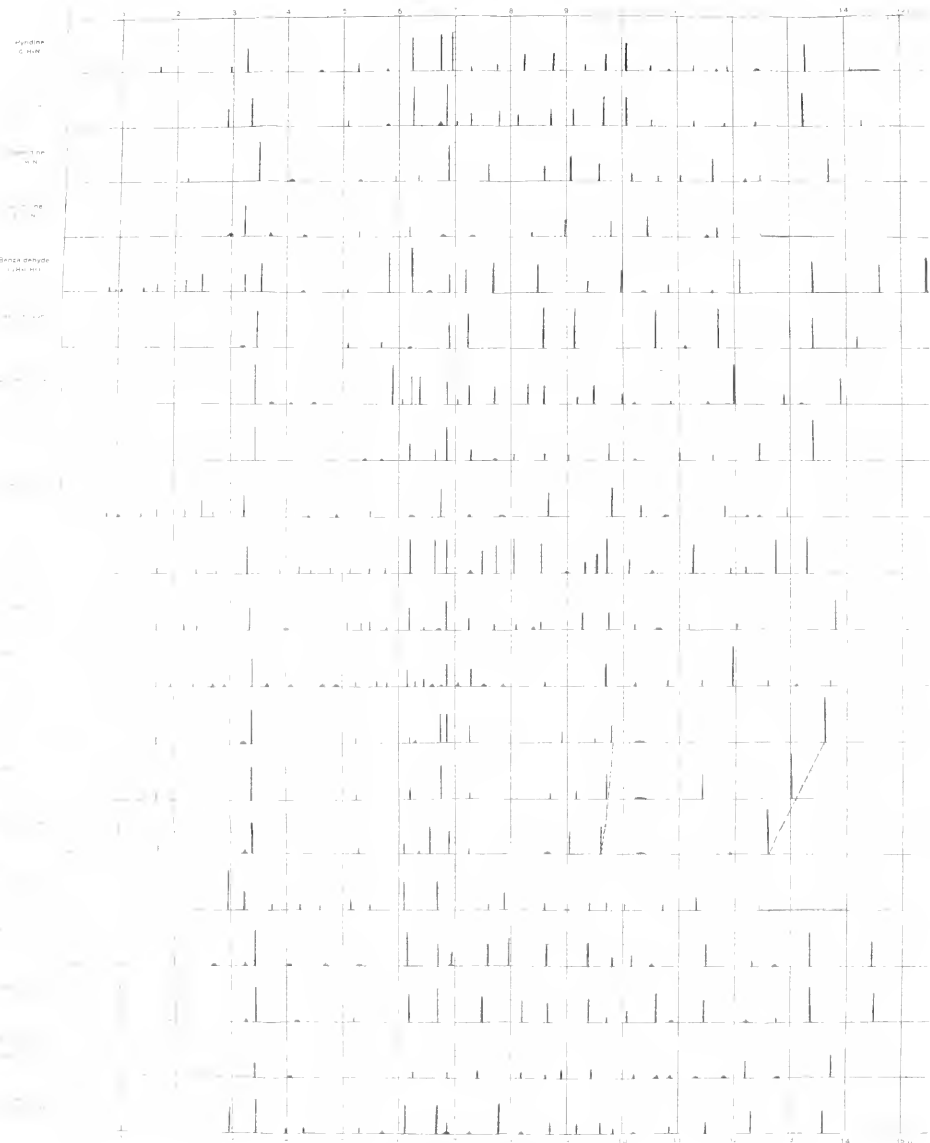

## LINE SPECTRA OF VARIOUS COMPOUNDS

Height of line indicates the approximate depth of the band as found in the absorption curves

———— band with a shoulder on the left side    ———— band with a shoulder on the right side    ———— band with a shoulder on both sides    ———— band with a shoulder on both sides and a tail

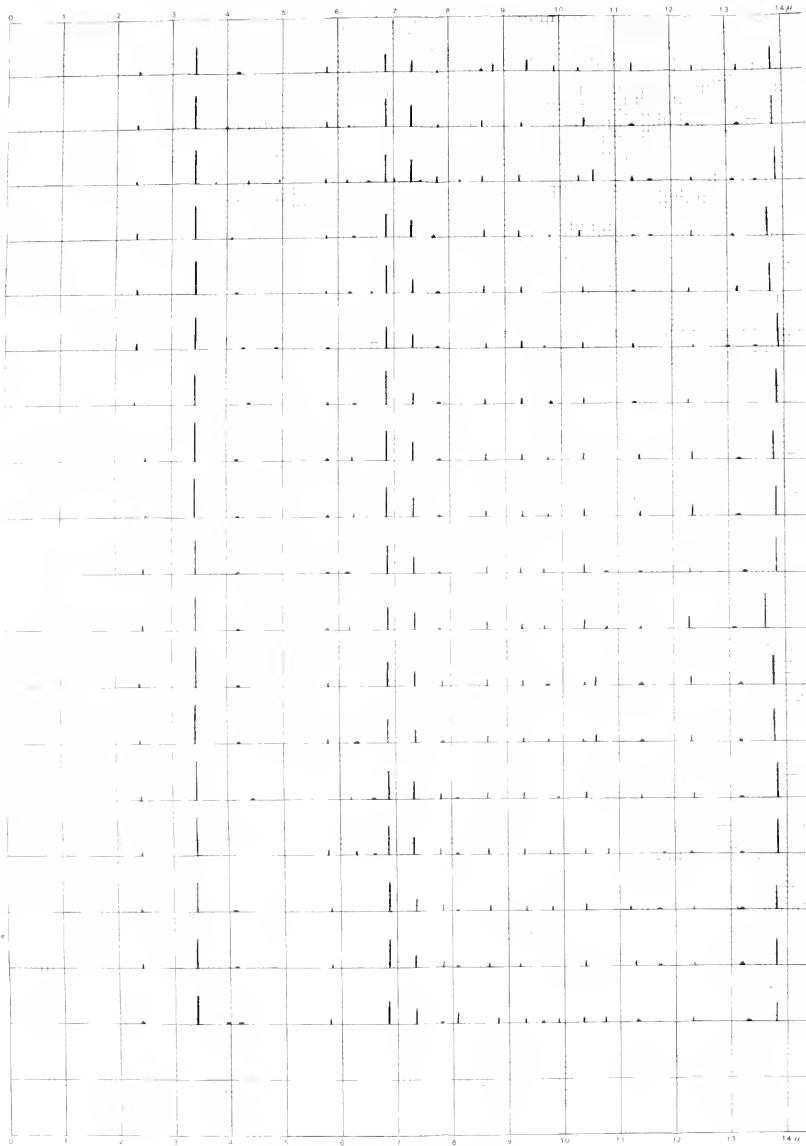







TABLE II. (continued)  
 (PETROLEUM DISTILLATES)



LINE SPECTRA OF VARIOUS COMPOUNDS

Height of line indicates the approximate origin of the band as found in the absorption curves.

Lines thus denote complete equality between the points indicated. Lines thus are broad and ill defined.



TABLE III.—OBSERVED TRANSMISSION OF BENZALDEHYDE (C<sub>6</sub>H<sub>5</sub>CHO).[Sat., Mar. 21, 1903. Slits: F<sub>1</sub> = 0.4 mm.; F<sub>2</sub> = 1 mm. Thickness of cell, 0.06 mm.]

[This compound has been selected at random, from the notes of the 125 + compounds studied, as a typical example of the method of recording the original observations taken in the laboratory. It is about the only compound whose transmission spectrum has been explored to 16  $\mu$ .

The direct deflections are of interest in showing the variation of the intensity of the radiation of the "heater" of a Nernst lamp for different parts of the spectrum.

For each compound such a set of deflections and spectrometer readings was obtained, but in the following tables only the "observed transmission" and the wavelengths corresponding to the circle readings have been tabulated. This represents some of the first work, when the spectrometer slits were much wider than for the compounds studied later.]

Spectrometer circle settings.		Deflection of radiometer, I <sub>1</sub> , when cell with liquid is before the spectrometer slit.	Deflection of radiometer, I <sub>0</sub> , when the clear plate of rock salt is before the spectrometer slit.	Transmission through the liquid. (I <sub>1</sub> ÷ I <sub>0</sub> .)
$^{\circ}$	$'$	$\mu$		
		Centimeters.	Centimeters.	Per cent.
*27	00	= 0.5896		
25	50	= 1.06	1.10	1.55
	40		4.1	5.5
	35		7.5	9.7
	32		10.2, 10.5	13.2, 13.7
	30		12.7	16.6
	28		15.2	19.6
	25		18.7	23.8
	23		20.0	25.1
	22		20.6	25.85
	20		21.0	26.9
	18		19.8	25.4
	16		17.8	23.6
	15		16.8, 16.8	22.8, 23.1
	14		15.7, 15.7	22.0
	12		13.5	21.1
25	10	= 3.3	12.5	22.2
	8		11.5	23.1
	7		11.2	24.3
	6		11.7	24.8
	4		13.1	26.4
	2		16.0	26.1
25	00	= 4.05	18.2	25.8
	57		18.5	23.7
	55		19.0	24.1
	53		20.1	24.9
	50		22.8	28.0
	47		22.9	29.1
	45		22.4	29.9
	43		21.6	29.6
	40		20.6, 20.6	28.6, 28.4
	37		18.6	26.3
	35		16.4	24.3
	32		13.05	22.1
24	30	= 5.8	5.6	17.8
	27		2.05	14.6
	25		2.3	14.0
	23		2.8	14.0

\*27° 00' 00" is the zero of the instrument; i. e., when the sodium lines fell within the radiometer slit the spectrometer circle reading was 27° 0' 00" = 0.5896  $\mu$ .

TABLE III.—OBSERVED TRANSMISSION OF BENZALDEHYDE—Continued.

Spectrometer circle settings.			Deflection of radiometer, I <sub>1</sub> , when cell with liquid is before the spectrometer slit.	Deflection of radiometer, I <sub>0</sub> , when the clear plate of rock salt is before the spectrometer slit.	Transmission through the liquid. (I <sub>1</sub> ÷ I <sub>0</sub> .)
o	r	μ	Centimeters.	Centimeters.	Per cent.
24	20		4.13	13.5	30.4
	18		5.2	12.1	39.7
	15		6.8	11.3	60.2
	13		7.3	10.7	68.1
	10		6.3	11.0	57.3
	8		5.82	11.2	51.8
	7		5.79	11.25	51.4
	5		5.5, 5.5	10.9, 11.1	50.0
	2		5.4, 5.4	10.6	50.9
24	00 =	7.3	5.43	10.6	51.3
	57		5.7	10.3	55.2
	55		5.9	10.0	59.0
	53		5.1	9.9	51.5
	50		3.4	9.8	34.7
	47		2.9	9.3	31.2
	45		3.4	8.82	38.6
	43		3.7	8.6	43.0
	40		3.35	7.95	42.3
	37		2.70	7.4	36.5
	35		1.95	7.2	27.1
	33		1.31	6.8	19.3
23	30 =	8.5	1.18	6.5	18.2
	27		1.20, 1.21.	6.1, 6.3	19.5
	25		1.20	5.83	20.6
	23		1.58	5.90	26.6
	20		2.3	5.3	43.4
	15		3.1	5.1	60.8
	10		2.75	4.5	61.2
	5		2.12	4.1	51.8
23	00 =	9.48	2.1	4.0	52.5
	55		2.4	3.78	63.5
	50		1.93	3.40	58.3
	45		1.4	3.1	45.2
	40		1.5	2.9	51.8
	35		1.89	2.76	68.6
22	30 =	10.37	1.80	2.5	72.0
	25		1.74	2.3	75.8
	20		1.67	2.3	72.7
	†15		1.30	2.14	60.8
	10		1.1, 1.1	1.92	57.3
	5		1.2	1.80	66.7
22	00 =	11.15	1.12	1.70	65.2
	55		1.09	1.6	68.4
	50		1.05	1.54	68.3
	45		.92	1.44	63.9
	40		.80	1.38	58.0
	35		.60	1.2	50.0
21	30 =	11.93	.28, .29	1.1	25.9
	25		.02, .02	1.0	2.0
	20		.10, .10	1.0	10.0
	10		.40, .38	.90	43.3
21	00 =	12.66	.50, .52	.82	62.2
	50		.41	.76	54.0
	40		.08, .09	.70	12.1
20	30 =	13.4	.01, .01	.60	1.6

TABLE III.—OBSERVED TRANSMISSION OF BENZALDEHYDE—Continued.

Spectrometer circle settings.		Deflection of radiometer, $I_1$ , when cell with liquid is before the spectrometer slit.	Deflection of radiometer, $I_0$ , when the clear plate of rock salt is before the spectrometer slit.	Transmission through the liquid. ( $I_1 \div I_0$ .)
°	'	<i>Centimeters.</i>	<i>Centimeters.</i>	<i>Per cent.</i>
20	20	.02, .03	.50	5.0
	10	.08, .10, .11	.40, .39	23.0
†20	00 = 14.06	.10, .20	.30, .60	33.3
	50	.18, .20	.50, .48	38.8
	40	.10, .09, .10	.30, .21, .26	37.4
19	30 = 14.63	.03, .02, .03, .03	.25, .27	11.5
	20	.09, .10, .11, .10, .08	.25, .23	41.5
	10	.09, .10	.18, .14	59.4
19	00 = 15.2	.10, .10, .08	.18, .15, .14	62.0
	50	.02, .01, .02, .02	.07, .04, .07, .06	32.5
	40	.01, .00, .02, .01	.05, .07, .04, .06	18.0
	30	.03, .02, .03, .04	.05, .05, .06, .05	60.0
18	20 = 15.92	.04, .03, .04, .03	.04, .05, .05	76.0

†Slit  $F_1$  widened.





TABLE V.—MAXIMA OF INFRA-RED ABSORPTION BANDS—GASES.

Methane. CH <sub>4</sub> .	Acetylene. C <sub>2</sub> H <sub>2</sub> .	Ethylene. C <sub>2</sub> H <sub>4</sub> .	Ethane. C <sub>2</sub> H <sub>6</sub> .	Butane. C <sub>4</sub> H <sub>10</sub> .	Methyl ether. (CH <sub>3</sub> ) <sub>2</sub> O.	Ethyl ether. (C <sub>2</sub> H <sub>5</sub> ) <sub>2</sub> O.	Hydrogen sulphide. H <sub>2</sub> S.	Ammonia. NH <sub>3</sub> .	Carbon monoxide. CO.	Carbon dioxide. CO <sub>2</sub> .	Sulphur dioxide. SO <sub>2</sub> .	Oxygen. O <sub>2</sub> .
$\mu$	$\mu$	$\mu$	$\mu$	$\mu$	$\mu$	$\mu$	$\mu$	$\mu$	$\mu$	$\mu$	$\mu$	$\mu$
2.35	3.08	2.31	2.36	2.4	2.5	2.5	4.24	2.98	2.35	2.75	3.18	3.1
3.31	3.69	3.28	3.39	3.42	3.45	3.45	5.6	5.8	4.59	4.29	3.97	4.7
7.7	7.38	4.32	6.85	4.5	4.75	5.15	7.12	6.1		14.65	5.68	
	7.73	5.3	11.94	5.7	5.7	7.0	7.78	6.51		*14.7	7.4	
	13.63	5.8	12.2	6.89	6.9	7.3	8.46	8.9			8.7	
		6.98	12.5	7.8	8.58	7.8	9.65	9.3			10.37	
		10.0	13.2	8.3	9.05	8.75	10.08	9.9				
		10.5		8.9	9.16	9.25	10.6	10.4				
		11.05		9.6	10.55	9.6	10.95	10.75				
		11.8		9.97	10.9	10.2		11.18				
				10.5		10.75		11.43				
				11.2		11.99		11.69				
				12.0		14.03		11.98				
				13.3				12.3				
				14.5				12.78				
								13.7				

\*Rubens and Aschkinass.



TABLE VI.—MAXIMA OF INFRA-RED ABSORPTION BANDS—LIQUIDS AND SOLIDS.  
(In  $\mu$ . = 0.001 mm. Values from Pucciati are marked with a star (\*).]

Carbon disulphide, CS <sub>2</sub> .	3.2 4.6 6.8 11.65 13.4	Carbon disulphide, CS <sub>2</sub> .	3.2 4.6 6.8 11.65 13.4
Thiophene, C <sub>4</sub> H <sub>4</sub> S.	0.12 1.12 1.4 1.66 2.0 2.3 2.64 2.92 3.2 3.6 4.0 4.3 4.6 4.9 5.2 5.5 5.8 6.1 6.4 6.7 7.0 7.3 7.6 7.9 8.2 8.5 8.8 9.1 9.4 9.7 10.0 10.3 10.6 10.9 11.1 11.4 11.7 12.0 12.3 12.6 12.9 13.2 13.5 13.8 14.1 14.4 14.7 15.0 15.3 15.6 15.9 16.2 16.5 16.8 17.1 17.4 17.7 18.0 18.3 18.6 18.9 19.2 19.5 19.8 20.1 20.4 20.7 21.0 21.3 21.6 21.9 22.2 22.5 22.8 23.1 23.4 23.7 24.0 24.3 24.6 24.9 25.2 25.5 25.8 26.1 26.4 26.7 27.0 27.3 27.6 27.9 28.2 28.5 28.8 29.1 29.4 29.7 30.0 30.3 30.6 30.9 31.2 31.5 31.8 32.1 32.4 32.7 33.0 33.3 33.6 33.9 34.2 34.5 34.8 35.1 35.4 35.7 36.0 36.3 36.6 36.9 37.2 37.5 37.8 38.1 38.4 38.7 39.0 39.3 39.6 39.9 40.2 40.5 40.8 41.1 41.4 41.7 42.0 42.3 42.6 42.9 43.2 43.5 43.8 44.1 44.4 44.7 45.0 45.3 45.6 45.9 46.2 46.5 46.8 47.1 47.4 47.7 48.0 48.3 48.6 48.9 49.2 49.5 49.8 50.1 50.4 50.7 51.0 51.3 51.6 51.9 52.2 52.5 52.8 53.1 53.4 53.7 54.0 54.3 54.6 54.9 55.2 55.5 55.8 56.1 56.4 56.7 57.0 57.3 57.6 57.9 58.2 58.5 58.8 59.1 59.4 59.7 60.0 60.3 60.6 60.9 61.2 61.5 61.8 62.1 62.4 62.7 63.0 63.3 63.6 63.9 64.2 64.5 64.8 65.1 65.4 65.7 66.0 66.3 66.6 66.9 67.2 67.5 67.8 68.1 68.4 68.7 69.0 69.3 69.6 69.9 70.2 70.5 70.8 71.1 71.4 71.7 72.0 72.3 72.6 72.9 73.2 73.5 73.8 74.1 74.4 74.7 75.0 75.3 75.6 75.9 76.2 76.5 76.8 77.1 77.4 77.7 78.0 78.3 78.6 78.9 79.2 79.5 79.8 80.1 80.4 80.7 81.0 81.3 81.6 81.9 82.2 82.5 82.8 83.1 83.4 83.7 84.0 84.3 84.6 84.9 85.2 85.5 85.8 86.1 86.4 86.7 87.0 87.3 87.6 87.9 88.2 88.5 88.8 89.1 89.4 89.7 90.0 90.3 90.6 90.9 91.2 91.5 91.8 92.1 92.4 92.7 93.0 93.3 93.6 93.9 94.2 94.5 94.8 95.1 95.4 95.7 96.0 96.3 96.6 96.9 97.2 97.5 97.8 98.1 98.4 98.7 99.0 99.3 99.6 99.9 100.2 100.5 100.8 101.1 101.4 101.7 102.0 102.3 102.6 102.9 103.2 103.5 103.8 104.1 104.4 104.7 105.0 105.3 105.6 105.9 106.2 106.5 106.8 107.1 107.4 107.7 108.0 108.3 108.6 108.9 109.2 109.5 109.8 110.1 110.4 110.7 111.0 111.3 111.6 111.9 112.2 112.5 112.8 113.1 113.4 113.7 114.0 114.3 114.6 114.9 115.2 115.5 115.8 116.1 116.4 116.7 117.0 117.3 117.6 117.9 118.2 118.5 118.8 119.1 119.4 119.7 120.0 120.3 120.6 120.9 121.2 121.5 121.8 122.1 122.4 122.7 123.0 123.3 123.6 123.9 124.2 124.5 124.8 125.1 125.4 125.7 126.0 126.3 126.6 126.9 127.2 127.5 127.8 128.1 128.4 128.7 129.0 129.3 129.6 129.9 130.2 130.5 130.8 131.1 131.4 131.7 132.0 132.3 132.6 132.9 133.2 133.5 133.8 134.1 134.4 134.7 135.0 135.3 135.6 135.9 136.2 136.5 136.8 137.1 137.4 137.7 138.0 138.3 138.6 138.9 139.2 139.5 139.8 140.1 140.4 140.7 141.0 141.3 141.6 141.9 142.2 142.5 142.8 143.1 143.4 143.7 144.0 144.3 144.6 144.9 145.2 145.5 145.8 146.1 146.4 146.7 147.0 147.3 147.6 147.9 148.2 148.5 148.8 149.1 149.4 149.7 150.0 150.3 150.6 150.9 151.2 151.5 151.8 152.1 152.4 152.7 153.0 153.3 153.6 153.9 154.2 154.5 154.8 155.1 155.4 155.7 156.0 156.3 156.6 156.9 157.2 157.5 157.8 158.1 158.4 158.7 159.0 159.3 159.6 159.9 160.2 160.5 160.8 161.1 161.4 161.7 162.0 162.3 162.6 162.9 163.2 163.5 163.8 164.1 164.4 164.7 165.0 165.3 165.6 165.9 166.2 166.5 166.8 167.1 167.4 167.7 168.0 168.3 168.6 168.9 169.2 169.5 169.8 170.1 170.4 170.7 171.0 171.3 171.6 171.9 172.2 172.5 172.8 173.1 173.4 173.7 174.0 174.3 174.6 174.9 175.2 175.5 175.8 176.1 176.4 176.7 177.0 177.3 177.6 177.9 178.2 178.5 178.8 179.1 179.4 179.7 180.0 180.3 180.6 180.9 181.2 181.5 181.8 182.1 182.4 182.7 183.0 183.3 183.6 183.9 184.2 184.5 184.8 185.1 185.4 185.7 186.0 186.3 186.6 186.9 187.2 187.5 187.8 188.1 188.4 188.7 189.0 189.3 189.6 189.9 190.2 190.5 190.8 191.1 191.4 191.7 192.0 192.3 192.6 192.9 193.2 193.5 193.8 194.1 194.4 194.7 195.0 195.3 195.6 195.9 196.2 196.5 196.8 197.1 197.4 197.7 198.0 198.3 198.6 198.9 199.2 199.5 199.8 200.1 200.4 200.7 201.0 201.3 201.6 201.9 202.2 202.5 202.8 203.1 203.4 203.7 204.0 204.3 204.6 204.9 205.2 205.5 205.8 206.1 206.4 206.7 207.0 207.3 207.6 207.9 208.2 208.5 208.8 209.1 209.4 209.7 210.0 210.3 210.6 210.9 211.2 211.5 211.8 212.1 212.4 212.7 213.0 213.3 213.6 213.9 214.2 214.5 214.8 215.1 215.4 215.7 216.0 216.3 216.6 216.9 217.2 217.5 217.8 218.1 218.4 218.7 219.0 219.3 219.6 219.9 220.2 220.5 220.8 221.1 221.4 221.7 222.0 222.3 222.6 222.9 223.2 223.5 223.8 224.1 224.4 224.7 225.0 225.3 225.6 225.9 226.2 226.5 226.8 227.1 227.4 227.7 228.0 228.3 228.6 228.9 229.2 229.5 229.8 230.1 230.4 230.7 231.0 231.3 231.6 231.9 232.2 232.5 232.8 233.1 233.4 233.7 234.0 234.3 234.6 234.9 235.2 235.5 235.8 236.1 236.4 236.7 237.0 237.3 237.6 237.9 238.2 238.5 238.8 239.1 239.4 239.7 240.0 240.3 240.6 240.9 241.2 241.5 241.8 242.1 242.4 242.7 243.0 243.3 243.6 243.9 244.2 244.5 244.8 245.1 245.4 245.7 246.0 246.3 246.6 246.9 247.2 247.5 247.8 248.1 248.4 248.7 249.0 249.3 249.6 249.9 250.2 250.5 250.8 251.1 251.4 251.7 252.0 252.3 252.6 252.9 253.2 253.5 253.8 254.1 254.4 254.7 255.0 255.3 255.6 255.9 256.2 256.5 256.8 257.1 257.4 257.7 258.0 258.3 258.6 258.9 259.2 259.5 259.8 260.1 260.4 260.7 261.0 261.3 261.6 261.9 262.2 262.5 262.8 263.1 263.4 263.7 264.0 264.3 264.6 264.9 265.2 265.5 265.8 266.1 266.4 266.7 267.0 267.3 267.6 267.9 268.2 268.5 268.8 269.1 269.4 269.7 270.0 270.3 270.6 270.9 271.2 271.5 271.8 272.1 272.4 272.7 273.0 273.3 273.6 273.9 274.2 274.5 274.8 275.1 275.4 275.7 276.0 276.3 276.6 276.9 277.2 277.5 277.8 278.1 278.4 278.7 279.0 279.3 279.6 279.9 280.2 280.5 280.8 281.1 281.4 281.7 282.0 282.3 282.6 282.9 283.2 283.5 283.8 284.1 284.4 284.7 285.0 285.3 285.6 285.9 286.2 286.5 286.8 287.1 287.4 287.7 288.0 288.3 288.6 288.9 289.2 289.5 289.8 290.1 290.4 290.7 291.0 291.3 291.6 291.9 292.2 292.5 292.8 293.1 293.4 293.7 294.0 294.3 294.6 294.9 295.2 295.5 295.8 296.1 296.4 296.7 297.0 297.3 297.6 297.9 298.2 298.5 298.8 299.1 299.4 299.7 300.0 300.3 300.6 300.9 301.2 301.5 301.8 302.1 302.4 302.7 303.0 303.3 303.6 303.9 304.2 304.5 304.8 305.1 305.4 305.7 306.0 306.3 306.6 306.9 307.2 307.5 307.8 308.1 308.4 308.7 309.0 309.3 309.6 309.9 310.2 310.5 310.8 311.1 311.4 311.7 312.0 312.3 312.6 312.9 313.2 313.5 313.8 314.1 314.4 314.7 315.0 315.3 315.6 315.9 316.2 316.5 316.8 317.1 317.4 317.7 318.0 318.3 318.6 318.9 319.2 319.5 319.8 320.1 320.4 320.7 321.0 321.3 321.6 321.9 322.2 322.5 322.8 323.1 323.4 323.7 324.0 324.3 324.6 324.9 325.2 325.5 325.8 326.1 326.4 326.7 327.0 327.3 327.6 327.9 328.2 328.5 328.8 329.1 329.4 329.7 330.0 330.3 330.6 330.9 331.2 331.5 331.8 332.1 332.4 332.7 333.0 333.3 333.6 333.9 334.2 334.5 334.8 335.1 335.4 335.7 336.0 336.3 336.6 336.9 337.2 337.5 337.8 338.1 338.4 338.7 339.0 339.3 339.6 339.9 340.2 340.5 340.8 341.1 341.4 341.7 342.0 342.3 342.6 342.9 343.2 343.5 343.8 344.1 344.4 344.7 345.0 345.3 345.6 345.9 346.2 346.5 346.8 347.1 347.4 347.7 348.0 348.3 348.6 348.9 349.2 349.5 349.8 350.1 350.4 350.7 351.0 351.3 351.6 351.9 352.2 352.5 352.8 353.1 353.4 353.7 354.0 354.3 354.6 354.9 355.2 355.5 355.8 356.1 356.4 356.7 357.0 357.3 357.6 357.9 358.2 358.5 358.8 359.1 359.4 359.7 360.0 360.3 360.6 360.9 361.2 361.5 361.8 362.1 362.4 362.7 363.0 363.3 363.6 363.9 364.2 364.5 364.8 365.1 365.4 365.7 366.0 366.3 366.6 366.9 367.2 367.5 367.8 368.1 368.4 368.7 369.0 369.3 369.6 369.9 370.2 370.5 370.8 371.1 371.4 371.7 372.0 372.3 372.6 372.9 373.2 373.5 373.8 374.1 374.4 374.7 375.0 375.3 375.6 375.9 376.2 376.5 376.8 377.1 377.4 377.7 378.0 378.3 378.6 378.9 379.2 379.5 379.8 380.1 380.4 380.7 381.0 381.3 381.6 381.9 382.2 382.5 382.8 383.1 383.4 383.7 384.0 384.3 384.6 384.9 385.2 385.5 385.8 386.1 386.4 386.7 387.0 387.3 387.6 387.9 388.2 388.5 388.8 389.1 389.4 389.7 390.0 390.3 390.6 390.9 391.2 391.5 391.8 392.1 392.4 392.7 393.0 393.3 393.6 393.9 394.2 394.5 394.8 395.1 395.4 395.7 396.0 396.3 396.6 396.9 397.2 397.5 397.8 398.1 398.4 398.7 399.0 399.3 399.6 399.9 400.2 400.5 400.8 401.1 401.4 401.7 402.0 402.3 402.6 402.9 403.2 403.5 403.8 404.1 404.4 404.7 405.0 405.3 405.6 405.9 406.2 406.5 406.8 407.1 407.4 407.7 408.0 408.3 408.6 408.9 409.2 409.5 409.8 410.1 410.4 410.7 411.0 411.3 411.6 411.9 412.2 412.5 412.8 413.1 413.4 413.7 414.0 414.3 414.6 414.9 415.2 415.5 415.8 416.1 416.4 416.7 417.0 417.3 417.6 417.9 418.2 418.5 418.8 419.1 419.4 419.7 420.0 420.3 420.6 420.9 421.2 421.5 421.8 422.1 422.4 422.7 423.0 423.3 423.6 423.9 424.2 424.5 424.8 425.1 425.4 425.7 426.0 426.3 426.6 426.9 427.2 427.5 427.8 428.1 428.4 428.7 429.0 429.3 429.6 429.9 430.2 430.5 430.8 431.1 431.4 431.7 432.0 432.3 432.6 432.9 433.2 433.5 433.8 434.1 434.4 434.7 435.0 435.3 435.6 435.9 436.2 436.5 436.8 437.1 437.4 437.7 438.0 438.3 438.6 438.9 439.2 439.5 439.8 440.1 440.4 440.7 441.0 441.3 441.6 441.9 442.2 442.5 442.8 443.1 443.4 443.7 444.0 444.3 444.6 444.9 445.2 445.5 445.8 446.1 446.4 446.7 447.0 447.3 447.6 447.9 448.2 448.5 448.8 449.1 449.4 449.7 450.0 450.3 450.6 450.9 451.2 451.5 451.8 452.1 452.4 452.7 453.0 453.3 453.6 453.9 454.2 454.5 454.8 455.1 455.4 455.7 456.0 456.3 456.6 456.9 457.2 457.5 457.8 458.1 458.4 458.7 459.0 459.3 459.6 459.9 460.2 460.5 460.8 461.1 461.4 461.7 462.0 462.3 462.6 462.9 463.2 463.5 463.8 464.1 464.4 464.7 465.0 465.3 465.6 465.9 466.2 466.5 466.8 467.1 467.4 467.7 468.0 468.3 468.6 468.9 469.2 469.5 469.8 470.1 470.4 470.7 471.0 471.3 471.6 471.9 472.2 472.5 472.8 473.1 473.4 473.7 474.0 474.3 474.6 474.9 475.2 475.5 475.8 476.1 476.4 476.7 477.0 477.3 477.6 477.9 478.2 478.5 478.8 479.1 479.4 479.7 480.0 480.3 480.6 480.9 481.2 481.5 481.8 482.1 482.4 482.7 483.0 483.3 483.6 483.9 484.2 484.5 484.8 485.1 485.4 485.7 486.0 486.3 486.6 486.9 487.2 487.5 487.8 488.1 488.4 488.7 489.0 489.3 489.6 489.9 490.2 490.5 490.8 491.1 491.4 491.7 492.0 492.3 492.6 492.9 493.2 493.5 493.8 494.1 494.4 494.7 495.0 495.3 495.6 495.9 496.2 496.5 496.8 497.1 497.4 497.7 498.0 498.3 498.6 498.9 499.2 499.5 499.8 500.1 500.4 500.7 501.0 501.3 501.6 501.9 502.2 502.5 502.8 503.1 503.4 503.7 504.0 504.3 504.6 504.9 505.2 505.5 505.8 506.1 506.4 506.7 507.0 507.3 507.6 507.9 508.2 508.5 508.8 509.1 509.4 509.7 510.0 510.3 510.6 510.9 511.2 511.5 511.8 512.1 512.4 512.7 513.0 513.3 513.6 513.9 514.2 514.5 514.8 515.1 515.4 515.7 516.0 516.3 516.6 516.9 517.2 517.5 517.8 518.1 518.4 518.7 519.0 519.3 519.6 519.9 520.2 520.5 520.8 521.1 521.4 521.7 522.0 522.3 522.6 522.9 523.2 523.5 523.8 524.1 524.4 524.7 525.0 525.3 525.6 525.9 526.2 526.5 526.8 527.1 527.4 527.7 528.0 528.3 528.6 528.9 529.2 529.5 529.8 530.1 530.4 530.7 531.0 531.3 531.6 531.9 532.2 532.5 5		

TABLE VI.—MAXIMA OF INFRA-RED ABSORPTION BANDS, ETC.—Continued.

Methyl salicylate, C <sub>8</sub> H <sub>7</sub> O <sub>2</sub> —OH.	0.84 1.034 1.155 1.682 1.781 1.815 2.029 2.099 2.173 2.252 2.331 2.410 2.489 2.568 2.647 2.726 2.805 2.884 2.963 3.042 3.121 3.200 3.279 3.358 3.437 3.516 3.595 3.674 3.753 3.832 3.911 3.990 4.069 4.148 4.227 4.306 4.385 4.464 4.543 4.622 4.701 4.780 4.859 4.938 5.017 5.096 5.175 5.254 5.333 5.412 5.491 5.570 5.649 5.728 5.807 5.886 5.965 6.044 6.123 6.202 6.281 6.360 6.439 6.518 6.597 6.676 6.755 6.834 6.913 6.992 7.071 7.150 7.229 7.308 7.387 7.466 7.545 7.624 7.703 7.782 7.861 7.940 8.019 8.098 8.177 8.256 8.335 8.414 8.493 8.572 8.651 8.730 8.809 8.888 8.967 9.046 9.125 9.204 9.283 9.362 9.441 9.520 9.599 9.678 9.757 9.836 9.915 9.994 10.073 10.152 10.231 10.310 10.389 10.468 10.547 10.626 10.705 10.784 10.863 10.942 11.021 11.100 11.179 11.258 11.337 11.416 11.495 11.574 11.653 11.732 11.811 11.890 11.969 12.048 12.127 12.206 12.285 12.364 12.443 12.522 12.601 12.680 12.759 12.838 12.917 12.996 13.075 13.154 13.233 13.312 13.391 13.470 13.549 13.628 13.707 13.786 13.865 13.944 14.023 14.102 14.181 14.260 14.339 14.418 14.497 14.576 14.655 14.734 14.813 14.892 14.971 15.050 15.129 15.208 15.287 15.366 15.445 15.524 15.603 15.682 15.761 15.840 15.919 16.000 16.079 16.158 16.237 16.316 16.395 16.474 16.553 16.632 16.711 16.790 16.869 16.948 17.027 17.106 17.185 17.264 17.343 17.422 17.501 17.580 17.659 17.738 17.817 17.896 17.975 18.054 18.133 18.212 18.291 18.370 18.449 18.528 18.607 18.686 18.765 18.844 18.923 19.002 19.081 19.160 19.239 19.318 19.397 19.476 19.555 19.634 19.713 19.792 19.871 19.950 20.029 20.108 20.187 20.266 20.345 20.424 20.503 20.582 20.661 20.740 20.819 20.898 20.977 21.056 21.135 21.214 21.293 21.372 21.451 21.530 21.609 21.688 21.767 21.846 21.925 22.004 22.083 22.162 22.241 22.320 22.399 22.478 22.557 22.636 22.715 22.794 22.873 22.952 23.031 23.110 23.189 23.268 23.347 23.426 23.505 23.584 23.663 23.742 23.821 23.900 23.979 24.058 24.137 24.216 24.295 24.374 24.453 24.532 24.611 24.690 24.769 24.848 24.927 25.006 25.085 25.164 25.243 25.322 25.401 25.480 25.559 25.638 25.717 25.796 25.875 25.954 26.033 26.112 26.191 26.270 26.349 26.428 26.507 26.586 26.665 26.744 26.823 26.902 26.981 27.060 27.139 27.218 27.297 27.376 27.455 27.534 27.613 27.692 27.771 27.850 27.929 28.008 28.087 28.166 28.245 28.324 28.403 28.482 28.561 28.640 28.719 28.798 28.877 28.956 29.035 29.114 29.193 29.272 29.351 29.430 29.509 29.588 29.667 29.746 29.825 29.904 29.983 30.062 30.141 30.220 30.299 30.378 30.457 30.536 30.615 30.694 30.773 30.852 30.931 31.010 31.089 31.168 31.247 31.326 31.405 31.484 31.563 31.642 31.721 31.800 31.879 31.958 32.037 32.116 32.195 32.274 32.353 32.432 32.511 32.590 32.669 32.748 32.827 32.906 32.985 33.064 33.143 33.222 33.301 33.380 33.459 33.538 33.617 33.696 33.775 33.854 33.933 34.012 34.091 34.170 34.249 34.328 34.407 34.486 34.565 34.644 34.723 34.802 34.881 34.960 35.039 35.118 35.197 35.276 35.355 35.434 35.513 35.592 35.671 35.750 35.829 35.908 35.987 36.066 36.145 36.224 36.303 36.382 36.461 36.540 36.619 36.698 36.777 36.856 36.935 37.014 37.093 37.172 37.251 37.330 37.409 37.488 37.567 37.646 37.725 37.804 37.883 37.962 38.041 38.120 38.199 38.278 38.357 38.436 38.515 38.594 38.673 38.752 38.831 38.910 38.989 39.068 39.147 39.226 39.305 39.384 39.463 39.542 39.621 39.700 39.779 39.858 39.937 40.016 40.095 40.174 40.253 40.332 40.411 40.490 40.569 40.648 40.727 40.806 40.885 40.964 41.043 41.122 41.201 41.280 41.359 41.438 41.517 41.596 41.675 41.754 41.833 41.912 41.991 42.070 42.149 42.228 42.307 42.386 42.465 42.544 42.623 42.702 42.781 42.860 42.939 43.018 43.097 43.176 43.255 43.334 43.413 43.492 43.571 43.650 43.729 43.808 43.887 43.966 44.045 44.124 44.203 44.282 44.361 44.440 44.519 44.598 44.677 44.756 44.835 44.914 44.993 45.072 45.151 45.230 45.309 45.388 45.467 45.546 45.625 45.704 45.783 45.862 45.941 46.020 46.099 46.178 46.257 46.336 46.415 46.494 46.573 46.652 46.731 46.810 46.889 46.968 47.047 47.126 47.205 47.284 47.363 47.442 47.521 47.600 47.679 47.758 47.837 47.916 47.995 48.074 48.153 48.232 48.311 48.390 48.469 48.548 48.627 48.706 48.785 48.864 48.943 49.022 49.101 49.180 49.259 49.338 49.417 49.496 49.575 49.654 49.733 49.812 49.891 49.970 50.049 50.128 50.207 50.286 50.365 50.444 50.523 50.602 50.681 50.760 50.839 50.918 50.997 51.076 51.155 51.234 51.313 51.392 51.471 51.550 51.629 51.708 51.787 51.866 51.945 52.024 52.103 52.182 52.261 52.340 52.419 52.498 52.577 52.656 52.735 52.814 52.893 52.972 53.051 53.130 53.209 53.288 53.367 53.446 53.525 53.604 53.683 53.762 53.841 53.920 54.000 54.079 54.158 54.237 54.316 54.395 54.474 54.553 54.632 54.711 54.790 54.869 54.948 55.027 55.106 55.185 55.264 55.343 55.422 55.501 55.580 55.659 55.738 55.817 55.896 55.975 56.054 56.133 56.212 56.291 56.370 56.449 56.528 56.607 56.686 56.765 56.844 56.923 57.002 57.081 57.160 57.239 57.318 57.397 57.476 57.555 57.634 57.713 57.792 57.871 57.950 58.029 58.108 58.187 58.266 58.345 58.424 58.503 58.582 58.661 58.740 58.819 58.898 58.977 59.056 59.135 59.214 59.293 59.372 59.451 59.530 59.609 59.688 59.767 59.846 59.925 59.999 60.078 60.157 60.236 60.315 60.394 60.473 60.552 60.631 60.710 60.789 60.868 60.947 61.026 61.105 61.184 61.263 61.342 61.421 61.500 61.579 61.658 61.737 61.816 61.895 61.974 62.053 62.132 62.211 62.290 62.369 62.448 62.527 62.606 62.685 62.764 62.843 62.922 63.001 63.080 63.159 63.238 63.317 63.396 63.475 63.554 63.633 63.712 63.791 63.870 63.949 64.028 64.107 64.186 64.265 64.344 64.423 64.502 64.581 64.660 64.739 64.818 64.897 64.976 65.055 65.134 65.213 65.292 65.371 65.450 65.529 65.608 65.687 65.766 65.845 65.924 66.003 66.082 66.161 66.240 66.319 66.398 66.477 66.556 66.635 66.714 66.793 66.872 66.951 67.030 67.109 67.188 67.267 67.346 67.425 67.504 67.583 67.662 67.741 67.820 67.899 67.978 68.057 68.136 68.215 68.294 68.373 68.452 68.531 68.610 68.689 68.768 68.847 68.926 69.005 69.084 69.163 69.242 69.321 69.400 69.479 69.558 69.637 69.716 69.795 69.874 69.953 70.032 70.111 70.190 70.269 70.348 70.427 70.506 70.585 70.664 70.743 70.822 70.901 70.980 71.059 71.138 71.217 71.296 71.375 71.454 71.533 71.612 71.691 71.770 71.849 71.928 72.007 72.086 72.165 72.244 72.323 72.402 72.481 72.560 72.639 72.718 72.797 72.876 72.955 73.034 73.113 73.192 73.271 73.350 73.429 73.508 73.587 73.666 73.745 73.824 73.903 73.982 74.061 74.140 74.219 74.298 74.377 74.456 74.535 74.614 74.693 74.772 74.851 74.930 75.009 75.088 75.167 75.246 75.325 75.404 75.483 75.562 75.641 75.720 75.799 75.878 75.957 76.036 76.115 76.194 76.273 76.352 76.431 76.510 76.589 76.668 76.747 76.826 76.905 76.984 77.063 77.142 77.221 77.300 77.379 77.458 77.537 77.616 77.695 77.774 77.853 77.932 78.011 78.090 78.169 78.248 78.327 78.406 78.485 78.564 78.643 78.722 78.801 78.880 78.959 79.038 79.117 79.196 79.275 79.354 79.433 79.512 79.591 79.670 79.749 79.828 79.907 79.986 80.065 80.144 80.223 80.302 80.381 80.460 80.539 80.618 80.697 80.776 80.855 80.934 81.013 81.092 81.171 81.250 81.329 81.408 81.487 81.566 81.645 81.724 81.803 81.882 81.961 82.040 82.119 82.198 82.277 82.356 82.435 82.514 82.593 82.672 82.751 82.830 82.909 82.988 83.067 83.146 83.225 83.304 83.383 83.462 83.541 83.620 83.699 83.778 83.857 83.936 84.015 84.094 84.173 84.252 84.331 84.410 84.489 84.568 84.647 84.726 84.805 84.884 84.963 85.042 85.121 85.200 85.279 85.358 85.437 85.516 85.595 85.674 85.753 85.832 85.911 85.990 86.069 86.148 86.227 86.306 86.385 86.464 86.543 86.622 86.701 86.780 86.859 86.938 87.017 87.096 87.175 87.254 87.333 87.412 87.491 87.570 87.649 87.728 87.807 87.886 87.965 88.044 88.123 88.202 88.281 88.360 88.439 88.518 88.597 88.676 88.755 88.834 88.913 88.992 89.071 89.150 89.229 89.308 89.387 89.466 89.545 89.624 89.703 89.782 89.861 89.940 90.019 90.098 90.177 90.256 90.335 90.414 90.493 90.572 90.651 90.730 90.809 90.888 90.967 91.046 91.125 91.204 91.283 91.362 91.441 91.520 91.599 91.678 91.757 91.836 91.915 91.994 92.073 92.152 92.231 92.310 92.389 92.468 92.547 92.626 92.705 92.784 92.863 92.942 93.021 93.100 93.179 93.258 93.337 93.416 93.495 93.574 93.653 93.732 93.811 93.890 93.969 94.048 94.127 94.206 94.285 94.364 94.443 94.522 94.601 94.680 94.759 94.838 94.917 94.996 95.075 95.154 95.233 95.312 95.391 95.470 95.549 95.628 95.707 95.786 95.865 95.944 96.023 96.102 96.181 96.260 96.339 96.418 96.497 96.576 96.655 96.734 96.813 96.892 96.971 97.050 97.129 97.208 97.287 97.366 97.445 97.524 97.603 97.682 97.761 97.840 97.919 98.000 98.079 98.158 98.237 98.316 98.395 98.474 98.553 98.632 98.711 98.790 98.869 98.948 99.027 99.106 99.185 99.264 99.343 99.422 99.501 99.580 99.659 99.738 99.817 99.896 99.975 100.054 100.133 100.212 100.291 100.370 100.449 100.528 100.607 100.686 100.765 100.844 100.923 101.002 101.081 101.160 101.239 101.318 101.397 101.476 101.555 101.634 101.713 101.792 101.871 101.950 102.029 102.108 102.187 102.266 102.345 102.424 102.503 102.582 102.661 102.740 102.819 102.898 102.977 103.056 103.135 103.214 103.293 103.372 103.451 103.530 103.609 103.688 103.767 103.846 103.925 104.004 104.083 104.162 104.241 104.320 104.399 104.478 104.557 104.636 104.715 104.794 104.873 104.952 105.031 105.110 105.189 105.268 105.347 105.426 105.505 105.584 105.663 105.742 105.821 105.900 105.979 106.058 106.137 106.216 106.295 106.374 106.453 106.532 106.611 106.690 106.769 106.848 106.927 107.006 107.085 107.164 107.243 107.322 107.401 107.480 107.559 107.638 107.717 107.796 107.875 107.954 108.033 108.112 108.191 108.270 108.349 108.428 108.507 108.586 108.665 108.744 108.823 108.902 108.981 109.060 109.139 109.218 109.297 109.376 109.455 109.534 109.613 109.692 109.771 109.850 109.929 110.008 110.087 110.166 110.245 110.324 110.403 110.482 110.561 110.640 110.719 110.798 110.877 110.956 111.035 111.114 111.193 111.272 111.351 111.430 111.509 111.588 111.667 111.746 111.825 111.904 111.983 112.062 112.141 112.220 112.299 112.378 112.457 112.536 112.615 112.694 112.773 112.852 112.931 113.010 113.089 113.168 113.247 113.326 113.405 113.484 113.563 113.642 113.721 113.800 113.879 113.958 114.037 114.116 114.195 114.274 114.353 114.432 114.511 114.590 114.669 114.748 114.827 114.906 114.985 115.064 115.143 115.222 115.301 115.380 115.459 115.538 115.617 115.696 115.775 115.854 115.933 116.012 116.091 116.170 116.249 116.328 116.407 116.486 116.565 116.644 116.723 116.802 116.881 116.960 117.039 117.118 117.197 117.276 117.355 117.434 117.513 117.592 117.671 117.750 117.829 117.908 117.987 118.066 118.145 118.224 118.303 118.382 118.461 118.540 118.619 118.698 118.777 118.856 118.935 119.014 119.093 119.172 119.251 119.330 119.409 119.488 119.567 119.646 119.725 119.804 119.883 119.962 120.041 120.1
---	--

TABLE VI.—MAXIMA OF INFRA-RED ABSORPTION BANDS, ETC.—Continued.

Laevo-pinane, C <sub>10</sub> H <sub>16</sub> .	Venice turpentine, C <sub>10</sub> H <sub>16</sub> .	Resin, C <sub>11</sub> H <sub>16</sub> O <sub>4</sub> .	Eucalyptol, C <sub>10</sub> H <sub>18</sub> O.	Terpineol, C <sub>10</sub> H <sub>18</sub> O.	Dextro-limonene, C <sub>10</sub> H <sub>16</sub> .	Hexane, C <sub>6</sub> H <sub>14</sub> .	Octane, C <sub>8</sub> H <sub>18</sub> .	Dodecane, C <sub>12</sub> H <sub>26</sub> .	Tetradecane, C <sub>14</sub> H <sub>30</sub> .	Hexadecane, C <sub>16</sub> H <sub>34</sub> .	Octadecane, C <sub>18</sub> H <sub>38</sub> .	Tetracosane, C <sub>24</sub> H <sub>50</sub> .	Hydrocarbon, C <sub>10</sub> H <sub>16</sub> .
0.84	3.45	3.45	0.83	2.93	2.7	3.19	3.19	2.37	2.38	2.39	2.38	2.35	2.55
0.93	3.75	3.75	0.92	3.43	3.45	3.43	3.43	3.43	3.43	3.43	3.43	3.43	3.44
1.04	5.95	5.94	1.70	3.53	3.75	4.19	4.19	3.50	4.1	4.0	4.8	5.83	4.82
1.2	6.95	6.9	1.80	4.0	4.3	5.81	5.81	4.0	5.8	5.80	5.8	6.3	5.8
1.44	7.19	7.12	1.93	4.6	4.6	6.86	6.86	4.3	6.3	6.3	6.87	6.86	6.86
1.68	7.6	7.0	2.18	5.1	6.9	7.8	7.8	4.95	6.86	6.87	7.35	7.33	6.87
2.18	9.1	8.6	3.37	6.05	7.15	7.8	7.8	5.78	7.33	7.35	7.8	7.8	7.34
2.37	9.1	9.0	3.47	6.35	7.5	7.6	7.6	6.15	7.33	7.3	8.66	8.64	7.8
2.37	10.05	9.8	3.58	6.95	8.4	8.4	8.4	6.55	8.63	8.63	9.30	9.28	8.65
3.42	10.5	10.2	3.67	7.35	8.6	9.42	9.42	6.86	9.25	9.3	9.7	9.8	9.3
4.4	11.4	10.6	3.92	8.15	9.9	9.9	9.9	7.02	9.8	10.0	10.39	10.4	9.75
5.5	12.2	11.2	3.43	8.12	9.2	10.35	11.3	7.33	10.34	10.4	11.3	11.3	10.4
5.5	12.6	12.2	3.71	9.0	9.1	11.3	11.3	7.78	11.3	11.3	12.36	12.28	11.4
5.9	13.2	14.0	4.1	9.8	10.5	12.4	13.2	8.12	12.3	12.3	13.0	13.2	12.35
6.3	14.0	15.2	5.78	10.16	11.3	13.4	13.4	8.62	13.1	13.16	13.9	13.87	13.25
6.9	14.3		6.0	10.5	12.6	13.8	13.8	9.26	13.7	13.75			13.8
7.128			6.2	10.9	13.92			10.34					
7.128			6.45	11.2	14.2			10.6					
7.128			7.128	11.95				11.3					
7.15			7.15	12.5				11.6					
7.15			7.15	12.7				12.36					
7.15			7.15	13.35				13.1					
7.15			7.15	14.0				13.5					
7.15			7.15					13.7					
10.1			9.4					13.5					
10.6			10.25										
11.4			10.25										
11.4			11.5										
12.7			12.0										
12.7			13.1										
14.0			14.0										

Hydrocarbon, C <sub>23</sub> H <sub>42</sub> .	Decylene, C <sub>10</sub> H <sub>20</sub> .	Dodecylene, C <sub>12</sub> H <sub>24</sub> .	Pentadecylene, C <sub>15</sub> H <sub>30</sub> .	Hexadecylene, C <sub>16</sub> H <sub>32</sub> .	Octadecylene, C <sub>18</sub> H <sub>36</sub> .	Tetracosylene, C <sub>24</sub> H <sub>48</sub> .	Monocholetridecane, C <sub>13</sub> H <sub>27</sub> Cl.	Monocholeheptadecane, C <sub>17</sub> H <sub>35</sub> Cl.	Hydrocarbon, C <sub>10</sub> H <sub>20</sub> S.	Thymol, C <sub>10</sub> H <sub>16</sub> O.	Carvacrol, C <sub>10</sub> H <sub>16</sub> O.	Pyridine, C <sub>5</sub> H <sub>5</sub> N.	Picoline, C <sub>5</sub> H <sub>7</sub> N (CH <sub>2</sub> ).
2.35	2.44	2.44	2.44	2.44	2.44	2.44	2.44	2.44	2.44	2.44	2.44	2.44	2.44
3.35	3.44	3.44	3.44	3.44	3.44	3.44	3.44	3.44	3.44	3.44	3.44	3.44	3.44
4.35	4.44	4.44	4.44	4.44	4.44	4.44	4.44	4.44	4.44	4.44	4.44	4.44	4.44
5.35	5.44	5.44	5.44	5.44	5.44	5.44	5.44	5.44	5.44	5.44	5.44	5.44	5.44
6.35	6.44	6.44	6.44	6.44	6.44	6.44	6.44	6.44	6.44	6.44	6.44	6.44	6.44
7.35	7.44	7.44	7.44	7.44	7.44	7.44	7.44	7.44	7.44	7.44	7.44	7.44	7.44
8.35	8.44	8.44	8.44	8.44	8.44	8.44	8.44	8.44	8.44	8.44	8.44	8.44	8.44
9.35	9.44	9.44	9.44	9.44	9.44	9.44	9.44	9.44	9.44	9.44	9.44	9.44	9.44
10.4	10.38	10.38	10.4	10.34	10.34	10.4	10.4	10.37	10.3	10.3	10.3	10.3	10.3
11.4	10.8	11.3	10.75	10.58	8.65	9.75	11.2	11.2	9.9	9.9	9.9	9.9	9.9
12.35	11.4	12.32	11.4	11.3	9.3	10.37	12.35	12.35	10.35	9.98	8.58	9.35	9.58
13.2	12.3	13.2	12.28	12.3	9.9	10.8	11.7	12.34	10.73	10.58	9.08	9.73	10.07
13.2	13.3	13.78	13.1	13.9	10.42	11.4	12.35	13.2	11.3	11.63	9.5	10.08	10.54
13.2	13.85		13.65	13.78		13.2	13.2	13.2	12.32	12.33	10.08	10.53	11.3
						13.2	13.2	13.2	13.3	13.6	10.65	10.85	11.85
						13.2	13.2	13.2	13.3	14.4	11.55	11.9	12.4
						13.2	13.2	13.2	13.3		13.1	12.4	14.3
						13.2	13.2	13.2	13.3		13.55		

TABLE VI.—MAXIMA OF INFRA-RED ABSORPTION BANDS, ETC.—Continued.

Piperidine, $C_5H_{11}N$ .	Quinoline, $C_9H_7N$ .	Acetic acid, $C_2H_4O_2$ .	n-Valeric acid, $C_5H_{10}O_2$ .	Caproic acid, $C_6H_{12}O_2$ .	Isocaproic acid, $C_6H_{12}O_2$ .	Oleic acid, $C_{18}H_{34}O_2$ .	Stearic acid, $C_{18}H_{36}O_2$ .	Cerotic acid, $C_{25}H_{50}O_2$ .	Nitrobenzene, $C_6H_5NO_2$ .	o-Nitrotoluene, $C_6H_4(CH_3)NO_2$ .	p-Nitrotoluene, $C_6H_4(CH_3)NO_2$ .	o-Toluidine, $C_6H_4(CH_3)NH_2$ .	Selenite, $CaSO_3 + 2H_2O$ .
1.70	2.95	3.45	3.45	0.80	3.45	0.78	3.45	3.45	3.25	3.22	3.25	2.96	1.5
3.0	3.23	3.75	3.23	0.95	3.84	0.86	5.85	3.75	5.1	3.43	3.25	2.96	1.5
3.5	3.7	5.86	5.85	1.05	7.05	1.0	6.9	4.0	6.25	6.33	6.33	3.3	1.05
5.3	4.1	7.2	7.06	1.3	7.9	1.2	7.05	5.4	6.6	6.6	6.6	6.15	1.54
5.95	5.5	8.15	7.9	1.6	8.3	1.36	8.2	8.4	7.42	6.86	6.86	6.75	1.95
6.35	6.3	9.6	8.3	1.74	8.6	1.50	8.3	7.07	8.0	6.86	6.86	6.86	2.5
6.90	6.5	9.9	9.15	1.9	9.08	1.75	9.15	7.76	7.62	7.5	7.5	7.94	3.5
7.61	7.3	10.7	10.75	2.5	9.78	1.9	10.0	8.3	9.07	8.75	8.75	7.75	5.5
8.00	8.4	11.5	11.4	2.35	10.0	2.0	10.6	9.15	9.38	9.33	9.33	7.3	6.8
8.62	8.98	13.9	12.23	2.48	10.7	2.2	11.2	9.8	9.8	9.63	9.63	8.82	8.5
9.1	9.7		13.5	2.64	11.6	2.35	12.2	10.6	10.0	10.0	11.6	9.05	10.5
9.58	10.45			3.45	12.15	3.2	13.1	11.0	10.7	10.5	11.93	9.65	11.7
10.18	11.15			3.75		3.45	13.95	11.65	11.7	11.6	12.73	10.17	12.2
10.65	11.7			5.84		3.75		12.85	12.6	12.74		10.78	12.47
11.05				7.05		4.3		13.88	14.4	13.8		11.3	13.7
11.63				8.1		5.83						11.78	
12.2				9.08		7.0						12.3	
12.47				10.7		7.83						13.1	
13.7				11.7		8.25							
				12.45		8.6							
				13.8		9.0							
						9.3							
						10.0							
						10.4							
						10.75							
						11.8							
						13.0							

TABLE VII.—OBSERVED TRANSMISSION THROUGH GASES.

Spectrometer circle.	Wave-lengths.	CH <sub>4</sub> .	C <sub>2</sub> H <sub>2</sub> .	C <sub>2</sub> H <sub>4</sub> .	C <sub>2</sub> H <sub>6</sub> .	C <sub>4</sub> H <sub>10</sub> .	Methyl ether.	Ethyl ether.	Hydrogen sulphide.	Ammonia.	Carbon monoxide.	Carbon dioxide.	Sulphur dioxide.	O.
		Methane.	Acetylene.	Ethylene.	Ethane.	Butane.	(C <sub>2</sub> H <sub>5</sub> ) <sub>2</sub> O.	(C <sub>2</sub> H <sub>5</sub> ) <sub>2</sub> O.	H <sub>2</sub> S.	NH <sub>3</sub> .	CO.	CO <sub>2</sub> .	SO <sub>2</sub> .	O.
25	30	1.7	93.0	100.0	94.2	100.0	98.0	100.0	.....	.....	.....	.....	.....	100.0
	25	2.00	93.0	99.0	91.8	99.0	96.8	98.0	.....	.....	99.0	.....	.....	99.0
	22	2.22	91.3	.....	74.4	74.4	87.2	89.1	8.10	.....	96.4	.....	.....	99.2
	21	2.37	.....	.....	74.7	74.7	87.2	.....	.....	.....	94.0	.....	.....	.....
	20	2.46	86.3	98.5	76.8	83.4	85.1	80.0	75.3	100.0	95.7	97.3	.....	99.0
	19	2.55	.....	.....	90.3	85.3	.....	.....	.....	.....	.....	91.4	.....	.....
	18	2.65	96.4	95.7	96.8	93.5	82.5	83.3	77.8	93.0	99.0	87.0	98.5	98.4
	17	2.73	.....	.....	.....	.....	.....	.....	.....	.....	.....	82.5	.....	.....
	16	2.82	97.5	95.4	92.8	93.3	88.6	92.2	88.7	94.1	93.7	93.0	82.5	97.2
	15	2.88	.....	.....	83.8	.....	.....	.....	.....	.....	93.5	80.6	86.3	91.7
14	2.97	92.4	88.7	73.0	86.0	78.2	88.0	85.2	91.2	93.7	74.0	92.4	92.8	94.8
13	3.03	.....	.....	.....	.....	.....	.....	.....	.....	.....	72.6	.....	.....	
12	3.13	75.0	77.3	70.0	62.8	55.0	59.2	70.4	79.8	94.6	77.2	99.0	78.2	95.8
11	3.20	63.0	70.2	77.3	43.5	.....	43.5	50.3	.....	.....	79.2	77.3	.....	
10	3.31	56.2	69.0	91.0	37.7	31.8	27.5	31.6	34.6	94.7	85.6	100.0	85.2	96.2
9	3.38	55.2	71.3	.....	43.7	31.0	22.4	18.6	22.8	.....	.....	.....	81.3	
8	3.46	58.3	74.4	96.3	59.8	38.6	25.1	16.2	11.9	96.8	90.8	.....	83.3	96.8
7	3.52	62.8	.....	95.2	.....	47.7	37.2	17.1	8.3	.....	.....	.....	.....	
6	3.60	.....	84.1	.....	86.4	61.8	50.8	23.8	11.2	93.3	.....	93.2	97.4	
5	3.67	83.4	.....	92.8	.....	.....	.....	.....	22.2	98.0	.....	92.2	100.0	
4	3.74	.....	94.4	93.2	93.6	81.3	80.8	48.3	.....	95.7	.....	.....	86.4	
3	3.81	93.0	94.6	94.0	.....	.....	.....	.....	59.6	.....	.....	.....	79.8	
2	3.88	.....	.....	.....	98.0	93.7	93.7	69.8	.....	.....	100.0	100.0	77.0	
25	00	4.04	95.0	98.0	96.0	91.0	95.1	81.7	86.3	87.1	100.0	94.0	89.3	99.4
	58	4.18	.....	.....	90.6	.....	.....	.....	.....	.....	91.8	59.2	59.2	81.8
	57	4.26	.....	.....	86.8	.....	.....	88.3	.....	79.4	.....	51.3	.....	.....
	56	4.32	.....	.....	.....	.....	.....	.....	.....	.....	85.1	49.8	88.7	97.8
	55	4.40	96.0	99.0	86.2	.....	93.1	90.0	87.0	87.3	100.0	58.7	74.2	94.3
	54	4.46	.....	.....	.....	.....	.....	.....	.....	.....	.....	70.2	.....	96.6
	53	4.51	.....	.....	88.7	.....	92.7	86.0	.....	.....	.....	61.3	.....	.....
	52	4.57	.....	.....	.....	.....	.....	.....	.....	.....	.....	59.8	91.5	95.8
	51	4.65	.....	.....	.....	.....	.....	.....	.....	.....	.....	60.3	.....	.....
	50	4.72	97.0	99.0	88.3	93.0	94.3	65.0	88.7	99.0	100.0	64.5	100.0	100.0
47	4.9	.....	.....	86.3	.....	95.3	62.5	.....	.....	.....	79.0	.....	97.4	
46	4.98	.....	.....	.....	.....	.....	.....	.....	.....	.....	89.2	.....	89.0	
45	5.04	96.0	.....	.....	85.8	95.0	79.8	80.7	100.0	.....	94.0	100.0	100.0	99.0
44	5.11	.....	.....	.....	.....	.....	.....	.....	.....	.....	.....	.....	.....	
43	5.15	.....	.....	.....	72.8	.....	92.8	.....	.....	.....	.....	.....	.....	
42	5.23	.....	.....	.....	.....	.....	.....	77.3	.....	.....	.....	.....	.....	
40	5.34	95.4	.....	.....	52.5	99.0	94.7	96.7	93.5	97.4	97.0	100.0	97.6	100.0
37	5.50	.....	.....	.....	73.8	.....	74.3	87.0	94.0	.....	.....	.....	91.0	
35	5.60	92.5	.....	100.0	91.0	.....	69.3	87.0	84.5	59.2	41.4	.....	85.6	
33	5.70	.....	.....	.....	.....	.....	78.3	85.6	86.8	46.0	.....	.....	86.0	
30	5.82	92.0	.....	.....	92.8	95.0	89.3	81.3	91.7	94.2	36.3	.....	93.2	
27	6.00	.....	.....	.....	.....	.....	88.2	78.8	91.7	99.0	19.3	.....	94.3	
25	6.10	93.0	.....	.....	95.0	88.5	88.2	74.7	.....	.....	21.7	.....	97.3	
23	6.20	.....	.....	.....	.....	.....	.....	.....	.....	.....	27.3	.....	.....	
21	6.30	.....	.....	.....	.....	.....	.....	.....	.....	.....	28.7	.....	97.3	
20	6.36	92.8	.....	.....	97.5	57.3	73.6	69.8	89.0	100.0	32.9	.....	.....	
18	6.47	.....	.....	.....	.....	.....	56.5	57.7	.....	.....	32.8	.....	.....	
17	6.51	.....	.....	.....	.....	.....	.....	.....	.....	.....	33.0	.....	.....	
16	6.56	.....	.....	.....	.....	.....	.....	.....	.....	.....	27.3	.....	97.3	
15	6.60	92.0	.....	.....	85.4	18.6	34.1	33.6	50.0	97.8	37.3	.....	.....	
14	6.66	.....	.....	.....	.....	.....	.....	.....	.....	.....	49.8	.....	.....	
12	6.77	.....	.....	.....	43.7	12.7	20.8	4.2	23.5	.....	64.7	.....	.....	
10	6.87	91.0	98.0	.....	21.8	11.9	18.8	2.8	9.6	95.0	64.7	.....	84.2	
8	6.96	.....	.....	.....	19.6	.....	19.4	6.4	7.8	.....	.....	.....	.....	
7	7.00	.....	.....	.....	18.9	22.4	.....	7.3	5.7	.....	74.7	.....	.....	
6	7.04	.....	.....	.....	.....	.....	26.3	.....	.....	.....	.....	.....	.....	
5	7.07	89.0	96.0	21.6	26.8	.....	.....	21.7	6.0	87.8	78.1	.....	44.4	
4	7.12	.....	.....	.....	.....	.....	28.4	30.5	7.4	.....	.....	.....	.....	
3	7.17	.....	.....	.....	.....	.....	.....	38.2	6.7	.....	.....	.....	.....	
2	7.22	.....	.....	44.5	44.0	.....	.....	55.2	3.3	87.9	83.0	.....	13.8	
0	7.32	50.0	.....	22.3	75.8	72.6	50.8	67.2	2.2	89.6	90.6	.....	3.1	
24	58	7.36	.....	10.6	.....	.....	.....	.....	.....	.....	.....	.....	.....	
	57	7.44	.....	14.6	89.5	81.6	68.4	74.9	7.6	.....	.....	.....	0.0	
	55	7.52	35.2	19.8	92.4	89.8	85.6	77.7	23.2	93.3	96.8	.....	10.7	

TABLE VII.—OBSERVED TRANSMISSION THROUGH GASES—Continued.

Spectrometer circle.	Wave-lengths.	CH <sub>4</sub> .	C <sub>2</sub> H <sub>2</sub> .	C <sub>2</sub> H <sub>4</sub> .	C <sub>2</sub> H <sub>6</sub> .	C <sub>4</sub> H <sub>10</sub> .	Methyl ether. (C <sub>2</sub> H <sub>5</sub> ) <sub>2</sub> O.	Ethyl ether. (C <sub>2</sub> H <sub>5</sub> ) <sub>2</sub> O.	Hydrogen sulphide, H <sub>2</sub> S.	Ammonia.	Carbon monoxide, CO.	Carbon dioxide, CO <sub>2</sub> .	Sulphur dioxide, SO <sub>2</sub> .	O.
53	7.59	.....	23.8	.....	.....	83.7	75.6	50.8	93.2	.....	.....	.....	17.2	.....
50	7.72	30.6	20.0	93.0	95.3	65.8	68.7	41.7	81.0	97.0	.....	.....	64.6	.....
47	7.84	.....	31.0	.....	.....	63.7	54.2	41.8	77.8	.....	.....	.....	85.6	.....
45	7.93	37.5	53.8	93.0	96.8	68.8	41.2	46.5	87.6	97.0	.....	.....	88.7	.....
43	8.00	.....	.....	.....	.....	71.8	.....	.....	.....	.....	.....	.....	.....	.....
40	8.12	56.5	96.0	93.0	95.8	63.4	75.0	61.7	99.2	89.0	.....	.....	76.8	.....
35	8.31	84.5	.....	Pres. 20cm.	.....	.....	.....	.....	.....	.....	.....	.....	.....	.....
30	8.49	97.6	.....	97.0	96.3	40.6	7.1	6.2	81.0	66.7	.....	.....	1.8	.....
25	8.67	99.0	.....	.....	97.2	47.8	9.1	0.0	90.8	.....	.....	.....	0.0	.....
23	.....	.....	.....	.....	.....	.....	.....	.....	Pres. 33 cm	.....	.....	.....	.....	.....
20	8.83	100.0	.....	89.0	97.4	32.2	39.3	0.0	92.0	62.4	.....	.....	4.2	.....
15	8.99	100.0	.....	96.5	96.5	41.0	18.4	.....	33.0	60.0	.....	.....	10.7	.....
10	9.16	.....	.....	80.8	97.0	62.3	12.9	5.3	95.5	55.2	.....	.....	69.0	.....
5	9.32	.....	.....	74.3	.....	73.2	39.9	8.6	95.0	40.0	.....	.....	30.8	.....
23	00	9.48	.....	60.7	95.0	55.3	86.0	30.7	91.4	44.3	.....	.....	82.2	.....
55	9.63	.....	.....	46.8	.....	53.0	95.0	35.5	86.8	50.0	.....	.....	88.6	.....
50	9.78	.....	.....	35.9	95.0	52.7	96.8	46.8	89.6	58.7	.....	.....	92.3	.....
45	9.95	.....	.....	26.5	95.0	48.7	99.0	72.7	94.6	62.7	.....	.....	94.8	.....
40	10.08	.....	.....	26.3	.....	51.5	89.7	87.3	90.6	64.8	.....	.....	94.7	.....
35	10.23	.....	.....	26.1	.....	60.3	75.2	87.3	95.3	68.7	.....	.....	77.0	.....
33	10.29	.....	.....	.....	.....	.....	.....	.....	.....	42.8	.....	.....	67.8	.....
30	10.37	.....	.....	25.3	94.0	57.0	54.3	95.0	99.0	17.1	.....	.....	56.8	.....
27	10.45	.....	.....	18.1	.....	.....	.....	.....	.....	31.4	.....	.....	61.6	.....
25	10.50	.....	.....	5.7	.....	50.4	38.4	87.3	95.4	44.3	.....	.....	70.3	.....
20	10.63	.....	.....	19.8	98.0	59.8	32.8	79.3	94.7	33.7	.....	.....	92.3	.....
18	10.70	.....	.....	.....	.....	.....	41.4	.....	.....	16.0	.....	.....	.....	.....
15	10.77	.....	.....	26.8	.....	64.6	43.4	62.8	97.3	17.1	.....	.....	100.0	.....
12	10.86	.....	.....	.....	.....	.....	34.0	.....	.....	40.8	.....	.....	.....	.....
10	10.92	.....	.....	25.1	96.8	57.6	35.0	82.3	95.8	82.3	.....	.....	.....	.....
5	11.03	.....	.....	24.0	.....	73.8	50.8	92.0	100.0	78.8	.....	.....	.....	.....
2	11.12	.....	.....	.....	.....	.....	.....	.....	.....	70.8	.....	.....	.....	.....
22	00	11.17	.....	28.0	88.8	67.2	67.0	97.0	100.0	55.8	.....	14.06=97.2	100.0	.....
55	11.30	.....	.....	43.2	61.4	62.7	76.5	.....	.....	81.0	.....	14.26=81.0	.....	.....
50	11.43	.....	.....	49.6	57.8	61.0	87.0	95.6	.....	62.9	.....	14.45=60.3	.....	.....
47	11.51	.....	.....	.....	.....	.....	.....	.....	.....	74.3	.....	14.63=55.2	.....	.....
45	11.55	.....	.....	57.7	51.7	57.3	92.7	.....	.....	80.0	.....	14.63=62.8	.....	.....
43	11.61	.....	.....	.....	.....	.....	.....	.....	.....	61.1	.....	15.00=73.6	.....	.....
40	11.68	.....	.....	69.8	44.3	53.0	98.0	77.1	.....	35.7	.....	15.20=91.3	.....	.....
37	11.77	.....	.....	.....	.....	.....	.....	.....	.....	65.0	.....	15.37=97.1	.....	.....
35	11.82	.....	.....	72.3	38.7	.....	.....	.....	.....	73.5	.....	.....	.....	.....
32	11.89	.....	95.0	.....	.....	.....	.....	.....	.....	68.4	.....	.....	.....	.....
21	30	11.94	.....	75.8	34.7	50.0	98.8	49.3	.....	12.3	.....	.....	.....	.....
27	12.02	.....	.....	.....	.....	.....	.....	.....	.....	41.4	.....	.....	.....	.....
25	12.06	.....	.....	95.0	40.0	.....	.....	.....	.....	58.1	.....	.....	.....	.....
20	12.20	.....	.....	89.0	99.0	42.0	51.4	99.0	66.8	67.2	.....	.....	.....	.....
15	12.32	.....	.....	79.0	.....	48.1	.....	.....	.....	45.8	.....	.....	.....	.....
12	12.40	.....	.....	.....	.....	.....	.....	.....	.....	67.2	.....	.....	.....	.....
10	12.45	.....	.....	100.0	50.2	62.8	100.0	87.3	.....	75.0	.....	.....	.....	.....
21	5	12.56	.....	Pres. 7 cm	.....	.....	.....	.....	.....	.....	.....	.....	.....	.....
00	12.66	.....	.....	96.0	.....	54.8	67.7	100.0	86.0	.....	.....	.....	.....	.....
55	12.93	.....	.....	78.4	.....	80.8	73.3	.....	.....	53.0	.....	.....	.....	.....
40	13.17	.....	.....	66.7	.....	87.3	73.3	.....	.....	55.0	.....	.....	.....	.....
30	13.40	.....	.....	55.7	.....	100.0	75.5	.....	.....	67.4	.....	.....	.....	.....
20	13.62	.....	.....	42.2	.....	.....	84.3	.....	.....	76.2	.....	.....	.....	.....
10	13.85	.....	.....	61.8	.....	.....	77.6	.....	.....	71.4	.....	.....	.....	.....
20	00	14.06	.....	70.3	.....	.....	71.8	.....	.....	83.0	.....	.....	.....	.....
50	14.26	.....	.....	75.0	.....	.....	77.4	.....	.....	.....	.....	.....	.....	.....
40	14.45	.....	.....	81.3	.....	.....	84.0	.....	.....	.....	.....	.....	.....	.....
19	30	14.63	.....	84.5	.....	.....	97.0	.....	.....	99.0	.....	.....	.....	.....

TABLE VIII A.—OBSERVED TRANSMISSION, USING SMALL SPECTROMETER, AND PRISM AT VARIABLE DEVIATION, AS EXPLAINED IN THE TEXT.

[For the petroleum distillates a single cell was used, made by cementing a copper wire, 0.15 mm. in thickness, between two plates of rock salt.]

Spectrometer settings; angular rotation from the sodium lines.		Wave-lengths.	C <sub>6</sub> H <sub>14</sub> .	C <sub>8</sub> H <sub>18</sub> .	C <sub>10</sub> H <sub>18</sub> .	C <sub>12</sub> H <sub>22</sub> .	Hexadecane, C <sub>16</sub> H <sub>34</sub> .	Tetraacosane, C <sub>24</sub> H <sub>50</sub> .	Hydrocarbon, C <sub>19</sub> H <sub>36</sub> .	Hydrocarbon, C <sub>22</sub> H <sub>42</sub> .	Decylene, C <sub>10</sub> H <sub>20</sub> .	Pentadecylene, C <sub>15</sub> H <sub>30</sub> .
Thickness in mm.		0.24	0.15	0.15	0.15	0.15	0.03	0.15	0.15	0.15	0.15	0.15
<i>Per cent transmission.</i>												
0	/	μ	82.0	83.0	78.5	64.5	85.6	87.0	85.5	82.0	.....	.....
1	30	1.70	79.0	84.4	82.5	63.8	83.0	87.8	83.7	83.1	84.0	84.0
	35	2.05	63.8	80.3	73.4	55.4	83.0	81.0	80.3	76.6	75.4	75.4
	37	2.18	52.8	72.7	65.5	45.0	80.6	70.0	70.5	66.2	67.4	67.4
	39	2.37	.....	73.0	65.5	42.0	80.4	69.3	.....	64.0	.....	.....
	40	2.46	.....	74.5	66.3	42.8	.....	68.6	66.0	64.8	65.1	65.1
	41	2.55	48.8	75.2	68.6	.....	81.7	68.8	66.5	65.6	.....	.....
	42	2.65	50.3	76.1	71.2	50.8	82.2	71.8	68.8	68.5	.....	.....
	43	2.73	.....	74.2	73.3	55.7	81.7	74.9	71.6	70.6	69.5	69.5
	44	2.81	.....	64.3	56.8	46.2	80.6	66.7	66.3	63.8	.....	.....
	45	2.88	48.3	.....	.....	41.8	.....	.....	.....	54.7	.....	.....
	47	3.04	37.1	.....	.....	33.8	.....	.....	.....	43.5	41.3	41.3
	48	3.13	.....	43.9	33.8	32.2	60.5	49.7	48.3	39.3	.....	.....
	49	3.21	22.7	35.8	23.1	23.8	49.8	39.1	.....	30.3	.....	.....
1	50	3.30	.....	.....	.....	.....	.....	.....	.....	.....	.....	.....
	51	3.38	6.3	35.6	14.7	13.9	40.3	27.0	28.5	22.4	.....	.....
	52	3.46	4.1	32.1	12.3	8.6	35.0	17.0	18.3	10.5	16.6	16.6
	53	3.53	3.7	22.4	13.3	6.5	35.7	15.2	15.4	14.8	14.9	14.9
	54	3.60	5.1	28.4	17.6	6.7	43.0	17.8	17.7	16.8	.....	.....
	55	3.67	8.9	37.8	22.6	10.2	32.4	25.4	.....	21.9	25.2	25.2
	56	3.71	.....	46.3	29.8	15.7	.....	30.3	28.4	28.4	.....	.....
	57	3.81	17.7	55.1	37.2	23.8	67.7	37.8	.....	38.7	40.0	40.0
	58	3.88	.....	61.2	43.0	28.5	.....	47.7	.....	.....	.....	.....
	59	3.96	30.5	67.8	50.8	36.2	77.4	56.3	51.4	51.8	.....	.....
2	1	4.18	45.5	.....	.....	.....	.....	68.6	.....	.....	.....	.....
	2	4.33	47.8	81.4	70.0	53.3	82.7	74.6	.....	70.8	.....	.....
	4	4.46	50.3	.....	.....	.....	.....	.....	.....	.....	.....	.....
	6	4.72	55.2	85.4	75.8	59.0	84.0	79.4	78.0	75.8	76.7	76.7
	10	5.04	58.6	86.3	78.0	61.0	86.2	82.7	.....	78.0	.....	.....
	15	5.16	.....	.....	.....	.....	.....	.....	.....	.....	.....	.....
	17	5.34	59.3	86.4	78.4	61.7	89.0	82.2	80.3	80.7	77.3	77.3
	20	.....	.....	.....	.....	.....	90.5	.....	.....	80.5	.....	.....
	23	5.55	54.0	81.2	71.3	58.8	91.4	81.0	78.7	80.3	75.2	75.2
	24	5.70	39.8	69.1	51.7	51.7	.....	75.1	73.7	73.8	69.7	69.7
	27	5.79	28.9	58.3	36.5	49.4	89.8	70.6	69.6	70.8	63.8	63.8
2	30	5.84	25.6	55.9	.....	.....	87.4	66.4	.....	66.3	59.8	59.8
	31	5.89	28.1	57.7	33.3	49.0	86.2	65.1	64.6	65.3	58.0	58.0
	32	5.95	30.5	61.2	39.8	49.8	87.9	64.7	61.8	62.8	56.8	56.8
	34	6.05	36.9	72.0	50.0	49.6	89.0	58.3	57.9	59.4	53.3	53.3
	36	6.15	37.9	74.4	53.3	46.3	89.4	52.4	50.2	59.5	45.8	45.8
	39	6.30	36.4	72.7	55.6	43.3	83.7	49.1	45.3	59.6	44.2	44.2
	41	6.41	29.1	71.8	52.4	40.0	81.8	50.7	45.6	54.3	40.1	40.1
	46	6.56	18.9	63.8	42.8	30.4	76.8	42.3	43.2	47.0	45.1	45.1
	47	6.70	7.0	41.3	23.1	11.9	55.3	24.6	.....	29.1	17.4	17.4
	49	6.80	2.8	18.6	8.9	3.9	37.8	1.15	10.5	13.9	7.8	7.8
2	51	6.91	0.5	8.0	3.0	1.3	31.7	3.5	4.1	4.3	2.7	2.7
	52	6.96	13.7	8.3	3.6	.....	37.7	4.1	.....	5.3	3.7	3.7
	53	7.00	.....	.....	6.0	2.2	.....	.....	.....	.....	.....	.....
	54	7.04	18.9	16.5	8.2	4.9	53.3	8.5	7.2	11.1	9.3	9.3
	55	7.08	2.2	20.6	10.0	7.3	.....	14.0	12.3	15.7	.....	.....
	57	7.17	2.4	22.6	11.6	5.9	71.2	20.7	17.1	16.9	14.1	14.1
	59	7.32	1.9	16.7	8.4	4.1	67.8	13.9	11.5	11.8	8.3	8.3
3	1	7.37	0.8	13.7	6.6	2.1	65.0	7.2	.....	5.9	.....	.....
	2	7.41	2.4	16.2	8.1	.....	66.2	8.0	7.6	6.5	5.1	5.1
	4	7.49	5.0	25.7	12.0	4.2	75.1	12.0	.....	11.9	.....	.....
	6	7.56	5.8	33.6	17.4	7.0	77.3	17.3	16.2	16.5	14.4	14.4
	9	7.68	7.1	35.7	16.0	9.3	78.4	22.5	.....	20.0	.....	.....
	12	7.80	7.8	38.0	13.3	9.7	79.5	23.7	21.8	21.8	21.6	21.6

TABLE VIII A.—OBSERVED TRANSMISSION, USING SMALL SPECTROMETER, AND PRISM AT VARIABLE DEVIATION, AS EXPLAINED IN THE TEXT—Continued.

Spectrometer settings; angular rotation (from the sodium lines).		Wave-lengths.	C <sub>6</sub> H <sub>14</sub> .	C <sub>8</sub> H <sub>18</sub> .	C <sub>10</sub> H <sub>22</sub> .	Hexadecane, C <sub>16</sub> H <sub>34</sub> .	Tetracosane, C <sub>24</sub> H <sub>50</sub> .	Hydrocarbon, C <sub>19</sub> H <sub>38</sub> .	Hydrocarbon, C <sub>22</sub> H <sub>42</sub> .	Decylene, C <sub>10</sub> H <sub>20</sub> .	Pentadecylene, C <sub>15</sub> H <sub>30</sub> .
Thickness in mm.			0.24	0.15	0.15	0.15	0.03	0.15	0.15	0.15	0.15
<i>Per cent transmission.</i>											
°	'	μ									
3	14	7.88	8.5	39.4	15.3	12.5	79.8	27.0	25.9	23.7	.....
	16	7.95	.....	40.8	19.8	15.3	.....	29.8	.....	.....	.....
	19	8.08	11.3	44.8	22.9	19.4	84.6	35.4	.....	30.8	34.0
	22	8.20	.....	.....	.....	.....	.....	.....	.....	.....	.....
	24	8.27	16.3	53.0	30.6	24.3	89.0	40.1	40.0	36.6	37.5
	26	8.35	17.5	.....	.....	.....	.....	.....	.....	.....	.....
3	29	8.46	20.0	54.0	38.5	25.0	89.2	42.2	41.8	37.5	38.5
	32	8.56	19.4	49.0	38.5	19.6	88.5	37.1	39.8	33.0	34.5
	34	8.63	18.8	45.4	36.0	18.1	88.8	37.4	37.6	30.0	29.5
	36	8.70	19.4	48.2	37.8	18.6	89.8	38.0	.....	29.6	30.0
	39	8.80	16.8	52.7	39.4	20.0	87.3	41.0	41.6	35.8	36.2
3	42	8.90	.....	.....	.....	.....	.....	.....	.....	.....	.....
	44	8.97	18.5	55.8	45.0	27.7	84.9	48.3	.....	44.8	43.4
	47	9.07	25.5	.....	.....	.....	.....	.....	.....	.....	.....
	49	9.13	27.5	59.4	44.0	28.6	84.2	56.0	52.3	44.5	44.8
	51	9.19	28.2	59.0	40.8	25.0	80.0	45.0	.....	43.7	.....
	54	9.29	22.8	50.0	40.2	23.8	77.3	41.8	43.0	42.8	42.5
	56	9.35	15.4	55.4	42.4	22.5	78.5	42.8	.....	43.8	.....
	59	9.45	12.5	60.3	46.7	25.4	80.0	43.8	43.7	49.0	47.0
4	4	9.60	15.0	61.0	46.8	30.5	80.4	42.7	42.8	43.3	32.8
	9	9.76	16.4	61.0	46.7	30.0	78.8	42.0	41.0	44.6	37.5
	14	9.92	16.0	60.8	.....	29.2	78.5	44.7	41.7	46.4	40.8
	19	10.06	20.2	59.4	46.4	29.7	79.0	45.4	.....	47.0	41.8
	22	10.15	.....	.....	.....	.....	.....	.....	.....	.....	.....
	24	10.21	26.8	55.2	41.3	31.0	79.5	46.3	44.0	42.6	39.2
	26	10.26	.....	53.0	.....	.....	79.6	42.0	.....	40.0	.....
	29	10.35	25.2	49.2	34.5	23.0	77.4	37.8	40.8	34.5	34.4
4	32	10.42	25.8	45.1	35.6	22.0	74.0	38.0	.....	34.6	34.0
	34	10.48	27.0	46.4	30.0	24.2	76.1	41.6	43.5	37.0	.....
	39	10.61	28.4	48.0	26.0	26.5	79.6	46.3	45.3	37.5	38.0
	44	10.75	21.2	56.3	28.5	25.5	80.8	46.8	.....	37.6	.....
	49	10.90	15.0	55.0	33.0	26.5	81.0	47.3	48.0	41.0	42.2
	54	11.00	10.0	55.0	34.0	25.8	.....	47.3	.....	44.1	.....
	59	11.14	10.4	55.0	35.0	25.7	80.0	47.2	46.0	46.5	42.7
5	4	11.25	11.0	55.2	36.4	26.6	.....	44.7	.....	47.6	.....
	9	11.41	13.8	57.6	41.5	29.5	79.9	42.0	.....	.....	38.0
	14	11.53	.....	.....	.....	.....	.....	44.7	.....	.....	.....
	19	11.65	36.3	66.0	54.0	33.4	82.0	48.2	48.8	52.8	42.7
	24	11.80	.....	.....	.....	.....	.....	.....	.....	.....	.....
	29	11.92	34.0	70.0	63.0	39.0	82.6	47.4	.....	59.8	45.3
	34	12.03	.....	.....	.....	39.7	.....	.....	.....	.....	.....
	39	12.18	25.0	71.2	60.0	39.0	78.8	36.0	35.5	61.3	23.3
	44	12.30	21.2	69.5	58.8	37.5	76.0	30.0	29.2	56.3	18.0
	49	12.42	20.2	65.0	53.0	35.5	80.0	32.1	.....	60.3	35.0
	54	12.54	.....	71.4	56.4	43.0	.....	44.5	.....	.....	.....
6	0	12.66	22.5	71.4	55.6	48.0	80.0	45.4	44.0	60.3	35.2
	10	12.93	23.8	66.8	50.0	30.1	81.0	35.0	40.0	57.0	28.5
	20	13.17	15.7	57.2	48.0	20.5	79.5	31.8	31.8	49.0	27.0
	30	13.40	15.0	52.0	30.1	23.2	77.0	30.0	27.0	45.3	12.0
	40	13.62	5.9	48.0	19.0	7.5	63.8	20.5	15.0	36.5	5.0
	45	13.72	.....	35.0	10.0	.....	50.0	.....	.....	24.0	.....
	50	13.85	.....	25.8	3.0	7.2	26.5	0.0	8.0	14.5	10.0
7	0	14.05	5.4	46.8	22.0	15.0	38.4	15.5	21.0	25.0	30.0
	10	14.26	25.0	64.0	42.0	30.0	57.5	27.0	41.5	47.0	51.2
	20	14.45	38.0	72.0	71.0	50.0	72.5	55.6	62.0	67.0	64.5
	30	14.63	50.0	76.0	80.0	56.0	74.0	71.0	72.0	77.0	70.0
	40	14.82	.....	71.0	.....	64.0	.....	.....	.....	.....	.....



TABLE VIII A.—OBSERVED TRANSMISSION, USING SMALL SPECTROMETER, AND PRISM AT VARIABLE DEVIATION, AS EXPLAINED IN THE TEXT—Continued.

Spectrometer settings. Angular rotation from the sodium lines.	Wave-lengths.	Dodecylene, $C_{12}H_{24}$ .	Hexadecylene, $C_{16}H_{32}$ .	Octadecylene, $C_{18}H_{36}$ .	Tetraacosylene, $C_{24}H_{48}$ .	Monochlordecane, $C_{10}H_{21}Cl$ .	Monochlorheptadecane, $C_{17}H_{35}Cl$ .	Hydrocarbon, $C_{10}H_{20}S$ .	Anisol, $C_6H_5OCH_3$ .	Thiophene, $C_4H_4S$ .
		Thickness of cell in mm. } 0.15	0.15	0.15	0.15	0.15	0.15	0.15	0.12	0.01
0 /	$\mu$									
1 30	1.70	52.8	83.4	29.0	79.6	73.0	81.0	72.3	80.1	87.5
35	2.05	51.5	81.0	77.6	77.3	73.6	77.4	74.3	79.5	80.1
37	2.18	78.5	.....	70.0	.....	65.0	71.3	68.0	78.0	.....
39	2.37	66.3	64.5	62.4	65.7	59.4	64.0	65.8	77.5	.....
40	2.46	.....	.....	61.7	.....	.....	.....	.....	.....	80.5
41	2.55	64.6	.....	61.7	61.0	57.0	63.3	65.5	.....	.....
42	2.65	67.0	.....	.....	.....	.....	.....	.....	.....	.....
43	2.73	69.7	68.4	62.4	61.8	60.0	53.6	66.0	76.5	77.4
44	2.81	.....	68.3	.....	.....	.....	.....	.....	.....	.....
45	2.88	67.0	.....	59.0	59.7	57.2	62.8	62.3	73.4	.....
47	3.04	55.4	.....	50.8	.....	47.4	53.8	54.7	69.7	75.0
48	3.13	.....	.....	.....	.....	.....	.....	.....	.....	66.8
49	3.21	32.6	38.0	38.1	37.1	32.5	38.0	41.0	53.9	57.7
1 50	3.30	25.9	.....	.....	.....	.....	.....	.....	.....	55.2
51	3.38	16.0	.....	19.0	18.9	19.1	20.6	27.2	43.0	56.3
52	3.46	12.2	15.4	14.3	14.6	15.0	15.4	25.0	44.6	.....
53	3.53	12.9	15.3	12.9	12.7	14.7	14.4	28.1	51.3	64.4
54	3.60	19.1	17.5	14.8	.....	19.0	.....	36.2	.....	.....
55	3.67	25.6	.....	21.9	20.2	25.0	23.5	.....	.....	77.5
56	3.71	.....	32.6	.....	.....	.....	.....	51.3	66.3	.....
57	3.81	39.6	.....	30.8	.....	38.1	.....	.....	74.3	.....
58	3.88	.....	.....	.....	.....	.....	.....	61.5	.....	.....
59	3.96	52.8	.....	43.7	.....	48.3	47.8	61.8	75.1	85.4
2 2	4.18	.....	.....	.....	.....	55.8	.....	65.8	75.7	81.5
4	4.33	68.2	.....	57.4	.....	57.9	59.6	67.0	75.3	80.8
6	4.46	.....	.....	.....	.....	.....	.....	.....	.....	79.0
10	4.72	74.0	.....	62.8	.....	62.3	.....	69.8	75.7	78.0
15	5.04	77.5	.....	64.1	.....	63.5	65.0	69.8	69.3	84.0
17	5.16	.....	.....	.....	.....	.....	.....	.....	69.1	.....
20	5.34	77.0	.....	63.2	65.0	63.5	.....	69.8	76.3	84.7
24	5.55	68.2	77.3	57.3	59.3	59.8	60.8	66.3	69.8	64.0
27	5.70	48.8	71.3	39.4	46.5	49.7	51.3	54.5	69.4	52.2
28	5.79	33.5	65.6	23.3	36.9	42.0	43.9	47.2	67.4	61.0
2 30	5.84	30.1	60.0	19.0	32.9	41.4	40.0	45.8	66.2	.....
31	5.89	32.0	62.2	20.4	32.0	40.0	41.2	47.2	.....	72.8
32	5.95	35.5	60.5	20.0	31.0	41.0	40.8	51.4	65.1	76.2
34	6.05	47.7	56.2	35.2	35.4	43.6	42.3	53.2	55.0	73.8
36	6.15	50.6	50.7	44.6	35.4	45.4	44.7	54.0	34.4	57.6
39	6.30	49.3	48.9	44.3	36.0	46.4	46.2	54.7	22.6	34.2
41	6.41	48.6	49.4	44.0	38.5	44.9	46.4	56.8	57.1	21.8
46	6.56	37.1	41.7	37.8	37.5	39.1	.....	50.7	40.0	25.7
47	6.70	17.0	.....	23.6	20.4	23.0	25.8	32.2	12.4	39.8
49	6.80	7.5	8.3	12.3	9.3	10.4	10.0	16.8	5.8	55.7
2 51	6.91	4.7	3.1	2.9	2.6	3.9	3.7	6.6	16.1	51.6
52	6.96	8.0	.....	3.3	.....	4.1	.....	6.8	21.6	.....
53	7.00	.....	.....	.....	4.5	.....	.....	.....	.....	.....
54	7.04	12.6	10.0	5.8	6.0	8.9	6.9	13.6	42.3	29.5
55	7.08	16.0	.....	7.1	9.6	11.2	11.3	17.4	.....	.....
57	7.17	15.5	15.6	8.9	.....	13.0	14.3	19.9	63.7	14.0
59	7.32	14.1	11.1	8.3	9.2	8.3	9.6	15.8	65.4	15.5
3 1	7.37	13.5	8.4	5.6	5.0	6.0	6.4	14.7	.....	.....
2 2	7.47	13.8	9.3	4.9	5.2	6.4	.....	15.6	59.8	44.0
4 4	7.49	19.3	.....	9.0	8.6	8.6	.....	25.5	49.3	55.8
6 6	7.56	22.9	20.4	10.8	.....	11.7	12.7	27.8	37.5	.....
9 9	7.68	21.2	21.8	12.1	13.9	10.0	11.7	23.8	23.7	60.3
12 12	8.80	19.3	21.7	9.2	14.9	7.2	10.9	18.5	12.9	47.7



TABLE VIII B.—OBSERVED TRANSMISSION THROUGH VARIOUS CARBOHYDRATES, USING THE SMALL SPECTROMETER, AND THE PRISM AT VARIABLE DEVIATION, I. E., "ANGLE OF CONSTANT EMERGENCE," AS EXPLAINED IN THE TEXT.

Spectrometer settings—Angular rotations from the D lines.	Wave-lengths.	Amiline.	Methyl aniline.	Dimethyl aniline.	Nyldine.	Methyl sulphocyanate.	Methyl isosulphocyanate.	Ethyl sulphocyanate.	Ethyl isosulphocyanate.	Phenyl mustard oil.	Myrryl alcohol.	Cumene.	Cuminol.	Toluene.	Mesitylene.
		$C_6H_5NH_2$ .	$C_6H_4NH_2(CH_3)$ .	$C_6H_3NH_2(CH_3)_2$ .	$C_6H_3(CH_3)NH_2$ .	etc. $CH_3-S-C \equiv N$ .	$CH_3-N-C \equiv S$ .	$C_2H_5-S-C \equiv N$ .	$C_2H_5-N-C \equiv S$ .	$C_6H_5NCS$ .	$C_{10}H_{16}O$ .	$C_6H_5-CH(CH_3)_2$ .	$C_9H_{10}CHO$ .	$C_6H_5CH_3$ .	$C_6H_3(CH_3)_3$ .
Thickness of cell in mm. )	0.01	0.01	0.01	0.01	0.01	0.01	0.01	0.01	0.01	0.01	0.01	0.01	0.01	0.01	0.01
<i>Per cent transmission.</i>															
0	μ	76.0	80.0	86.3	80.0	79.4	72.0	80.0	77.0	53.0	53.0	77.0	79.2	85.3	83.5
1	30	75.0	90.2	85.0	76.1	80.8	72.0	79.0	74.6	50.0	55.0	80.0	79.6	83.6	83.5
35	2.05	63.4	89.0	81.5	72.4	78.0	66.7	76.6	71.4	49.0	53.4	79.3	79.6	82.5	86.0
40	2.46	.....	83.5	.....	.....	.....	65.3	74.7	70.8	.....	.....	.....	.....	.....	87.5
42	2.65	51.0	73.7	79.5	61.0	74.5	65.0	74.4	72.3	49.4	42.7	76.1	79.2	82.6	.....
43	2.73	32.0	65.4	80.5	50.2	73.7	68.0	73.8	59.8	21.2	26.0	76.0	76.2	81.6	87.2
45	2.88	37.0	58.4	65.3	40.3	73.5	66.3	71.0	71.0	57.5	15.2	75.9	75.3	76.8	74.8
47	3.04	36.8	47.2	46.3	36.9	66.8	63.8	66.3	64.4	80.6	10.9	65.1	70.1	62.8	72.3
49	3.21	.....	.....	.....	.....	.....	.....	.....	.....	.....	.....	.....	.....	.....	.....
1	50	3.30	49.7	36.8	26.4	38.3	69.0	53.7	55.3	48.5	77.3	11.9	44.2	50.3	44.8
51	3.38	.....	40.0	25.8	45.3	38.3	50.6	50.0	45.0	.....	.....	41.7	42.4	45.3	42.5
52	3.46	58.2	.....	29.6	50.8	59.5	47.7	51.8	44.5	76.4	22.1	47.4	39.8	51.5	45.7
53	3.53	.....	58.2	.....	.....	.....	62.4	47.6	56.7	44.5	.....	.....	37.8	.....	51.4
54	3.60	.....	.....	50.4	62.7	71.1	50.8	65.0	51.0	.....	79.7	34.2	60.3	42.3	68.0
55	3.67	.....	.....	.....	.....	.....	.....	.....	.....	.....	.....	.....	.....	.....	.....
56	3.71	66.0	79.2	70.7	71.3	75.3	59.2	76.3	60.7	79.7	.....	78.3	62.3	81.0	80.5
58	3.88	65.2	80.6	74.8	70.0	75.0	64.2	79.4	66.8	78.3	56.3	82.2	76.1	84.4	86.4
59	3.96	66.7	84.8	.....	68.4	77.6	62.6	79.3	65.5	78.5	.....	.....	.....	84.3	.....
2	2	4.33	66.7	85.0	76.8	68.8	74.7	44.5	79.4	50.7	71.8	62.0	82.2	81.0	85.5
4	4	4.46	.....	83.0	.....	67.8	21.1	72.6	33.4	49.3	.....	.....	.....	.....	89.0
6	6	4.65	65.5	80.5	80.0	74.7	51.8	3.5	57.6	3.3	12.9	65.7	82.4	84.0	86.6
9	9	4.85	.....	81.6	.....	59.6	3.3	63.5	0.4	1.0	.....	.....	.....	.....	89.0
12	12	4.98	65.2	80.5	75.8	72.0	72.4	12.0	71.8	4.3	5.4	65.7	81.8	82.1	87.5
14	14	5.10	.....	.....	.....	77.0	27.4	78.9	32.0	21.4	.....	.....	.....	.....	.....
16	16	5.28	75.0	67.9	66.4	80.0	52.8	78.3	48.3	52.7	65.0	79.2	79.1	75.8	86.0
19	19	5.45	.....	.....	.....	.....	.....	.....	.....	.....	.....	78.6	.....	.....	.....
22	22	5.55	71.0	68.7	67.5	79.8	71.2	79.0	75.1	76.0	61.2	79.0	76.8	74.3	76.0
24	24	5.70	.....	67.4	64.2	.....	.....	78.0	.....	.....	62.2	77.4	65.2	76.0	79.7
27	27	5.79	47.7	69.2	63.9	59.3	78.4	66.2	79.0	70.4	78.6	69.8	77.4	46.2	79.3
29	29	5.89	.....	.....	.....	.....	.....	.....	.....	.....	.....	.....	.....	.....	84.0
31	31	5.95	25.3	60.9	53.0	39.8	76.4	67.0	76.8	69.5	.....	60.5	77.3	12.5	78.9
32	32	6.05	13.6	34.2	43.6	21.1	74.3	66.0	76.4	69.6	73.4	60.2	74.2	15.5	76.5
34	34	6.15	5.7	22.4	15.0	15.1	70.8	63.8	72.8	68.1	59.0	57.2	65.3	25.0	62.8
36	36	6.30	12.5	16.8	9.1	25.0	60.6	57.0	73.8	65.5	46.0	56.2	62.4	23.4	55.3
39	39	6.41	21.2	24.2	14.6	32.8	68.8	53.5	72.5	63.8	51.6	53.0	64.8	32.0	61.5
41	41	6.46	.....	.....	14.4	.....	.....	.....	.....	.....	.....	.....	.....	61.5	62.7
42	42	6.56	20.0	14.2	11.5	21.5	61.0	44.8	72.5	58.1	67.7	45.5	59.0	58.0	51.1
44	44	6.70	8.9	7.1	4.7	10.9	62.3	59.3	69.7	54.9	45.6	27.8	42.3	67.2	31.4
47	47	6.80	19.7	14.9	7.4	11.9	56.9	34.3	55.3	38.6	37.1	17.0	31.2	55.6	24.4
49	49	6.91	22.0	22.6	12.2	.....	39.9	24.6	35.0	19.3	51.3	18.2	27.6	.....	25.9
51	51	6.96	43.7	.....	.....	29.4	34.7	.....	27.4	.....	.....	30.0	36.9	31.1	31.6
52	52	7.04	.....	32.0	25.2	33.3	19.4	13.0	25.4	20.0	72.8	27.3	41.0	35.8	46.2
54	54	7.08	.....	.....	.....	17.6	13.0	.....	26.6	.....	.....	.....	.....	.....	.....
55	55	7.12	.....	.....	.....	.....	.....	26.0	.....	.....	82.4	.....	.....	.....	.....
56	56	7.17	50.3	39.4	46.0	25.5	11.0	42.6	31.6	.....	27.4	57.9	31.7	59.2	48.7
57	57	7.27	50.0	59.7	30.4	49.6	42.9	15.0	41.8	28.7	82.6	27.2	61.0	32.2	59.8
59	59	7.41	39.1	47.8	9.1	.....	59.2	.....	51.6	18.7	.....	62.0	41.2	66.8	54.6
3	3	7.49	22.0	26.0	6.1	56.1	59.3	42.3	60.8	13.4	84.3	36.4	65.3	50.8	73.0
4	4	7.56	.....	10.4	12.2	.....	47.8	.....	9.2	.....	.....	69.0	51.8	76.4	73.8
6	6	7.68	11.7	15.8	29.6	21.5	34.6	54.0	65.2	26.3	76.4	42.2	70.7	45.7	70.0
9	9	7.80	8.0	24.0	39.4	11.8	58.3	.....	46.2	44.3	.....	.....	41.7	80.0	
12	12	7.88	4.6	15.8	42.4	13.5	66.8	57.1	25.9	54.4	68.0	46.8	73.8	52.2	83.8
14	14	7.95	9.7	15.4	42.5	31.2	.....	15.8	.....	.....	.....	69.8	.....	81.3	
16	16	8.08	30.4	32.2	25.0	42.4	73.2	57.7	27.6	59.3	69.7	50.0	63.4	64.4	77.3
19	19	8.19	.....	55.0	9.6	.....	.....	.....	.....	.....	.....	69.6	51.0	81.5	
22	22	8.27	35.4	59.3	10.5	53.7	77.0	50.7	62.2	58.0	78.0	50.3	71.5	35.4	
24	24	8.35	.....	.....	.....	.....	.....	.....	.....	.....	.....	.....	.....	80.1	
26	26	8.46	26.0	37.1	11.8	58.1	76.8	47.5	78.1	51.5	81.6	51.3	74.0	30.4	
29	29	8.46	.....	.....	.....	.....	.....	.....	.....	.....	.....	.....	.....	75.4	
32	32	8.56	.....	.....	11.4	51.7	.....	.....	.....	.....	.....	.....	62.5	33.9	

TABLE VIII.B.—OBSERVED TRANSMISSION THROUGH VARIOUS CARBOHYDRATES, USING THE SMALL SPECTROMETER, AND THE PRISM AT VARIABLE DEVIATION, I. E., "ANGLE OF CONSTANT EMERGENCE," AS EXPLAINED IN THE TEXT.—Cont'd.

Spectrometer settings—Angular rotations from the D lines.	Wave-lengths.	Aminic.	Methyl aniline.	Dimethyl aniline.	Nylidine.	Methyl sulphonyl-ate.	Methyl isosulphonyl-ate.	Ethyl sulphonyl-ate.	Ethyl isosulphonyl-ate.	Phenyl mustard oil.	Myricyl alcohol.	Cumene.	Cuminol.	Toluene.	Mesitylene.	
		$C_6H_5NH_2$ .	$C_6H_4NH_2$ (CH <sub>3</sub> ).	$C_6H_3N$ (CH <sub>3</sub> ) <sub>2</sub> .	$C_6H_3$ (CH <sub>3</sub> ) NH <sub>2</sub> .	$CH_3-S-C-N$ .	$CH_3-N-C-S$ .	$C_2H_5-S-C-N$ .	$C_2H_5-N-C-S$ .	$C_6H_4NCS$ .	$C_{30}H_{46}OH$ .	$C_6H_5-CH$ (CH <sub>3</sub> ) <sub>2</sub> .	$C_9H_{11}HO$ .	$C_6H_5CH_3$ .	$C_6H_3(CH_3)_3$ .	
Thickness of cell in mm.		0.01	0.01	0.01	0.01	0.01	0.01	0.01	0.01	0.01	0.01	0.01	0.01	0.01	0.01	
<i>Per cent transmission.</i>																
3	24	19.3	24.6	9.3	41.4	76.4	44.7	78.2	48.3	71.4	52.6	62.8	26.0	70.0	78.2	
	26	19.3	24.6	10.0	38.0	77.0	44.7	78.2	48.3	71.4	52.6	62.8	26.0	70.0	78.2	
	33	34.2	29.6	13.9	47.2	77.0	52.5	78.2	48.0	70.7	48.7	71.6	49.7	74.4	81.6	
	41	33.7	47.2	31.6	63.0	77.0	55.0	78.4	30.0	79.4	45.5	63.7	60.6	75.0	81.4	
	47	33.0	61.2	52.8	50.8	76.5	46.7	77.0	33.6	80.8	43.0	61.0	54.6	71.8	81.1	
	49	31.2	36.6	40.0	45.4	76.3	31.0	74.6	39.0	68.7	33.0	69.0	54.8	44.5	81.0	
	51	21.0	31.8	30.0	29.3	75.0	42.0	46.2	33.0	64.6	7.5	66.4	49.6	51.6	77.0	
	54	9.60	24.6	69.5	34.2	42.2	64.6	51.1	58.7	33.2	80.7	20.5	52.3	41.3	54.0	
	56	9.45	23.3	60.5	39.0	44.5	60.0	35.0	72.8	56.3	84.0	24.0	34.4	50.6	51.0	
	59	9.66	35.9	66.5	39.8	45.0	55.2	54.6	73.7	59.8	75.0	30.8	52.5	47.8	68.5	
	6	9.76	24.4	55.5	31.7	53.7	47.0	65.0	61.8	71.0	37.2	64.7	58.4	74.2	76.3	
	9	9.86	33.8	61.6	62.6	57.8	32.5	67.3	35.0	65.6	44.0	70.0	66.6	78.0	82.0	
	12	9.92	35.0	52.5	36.0	48.7	28.3	53.6	70.0	59.8	69.2	34.2	59.8	52.7	75.5	
	14	9.97	32.5	51.5	44.5	53.7	37.0	65.0	61.8	71.0	37.2	64.7	58.4	74.2	76.3	
	16	10.06	33.8	61.6	62.6	57.8	32.5	67.3	35.0	65.6	44.0	70.0	66.6	78.0	82.0	
	19	10.15	35.0	52.5	36.0	48.7	28.3	53.6	70.0	59.8	69.2	34.2	59.8	52.7	75.5	
	22	10.21	32.5	51.5	44.5	53.7	37.0	65.0	61.8	71.0	37.2	64.7	58.4	74.2	76.3	
	23	10.35	33.8	61.6	62.6	57.8	32.5	67.3	35.0	65.6	44.0	70.0	66.6	78.0	82.0	
	24	10.42	35.0	52.5	36.0	48.7	28.3	53.6	70.0	59.8	69.2	34.2	59.8	52.7	75.5	
	32	10.48	35.0	65.6	34.3	64.5	55.0	68.0	48.0	52.3	66.4	51.8	73.3	69.0	85.8	
	36	10.52	33.8	71.2	32.2	62.5	67.8	72.0	68.6	10.6	24.7	56.3	75.7	71.0	86.0	
	39	10.61	26.7	71.2	55.8	56.2	68.7	75.8	21.9	4.7	58.6	75.0	68.8	81.5	80.0	
	42	10.70	28.7	72.0	70.0	53.8	69.0	74.3	89.0	55.0	14.8	58.8	68.8	66.7	83.3	
	44	10.83	25.8	72.5	75.8	56.0	60.0	74.3	89.0	55.0	14.8	58.8	68.8	66.7	83.3	
	49	10.90	14.2	71.8	77.5	52.4	70.0	70.0	83.5	65.8	32.9	65.0	65.0	74.2	82.0	
	54	11.00	3.5	57.3	74.0	40.7	73.8	70.0	83.5	65.8	32.9	65.0	65.0	74.2	81.3	
	5	11.25	4.0	33.4	47.0	36.5	73.8	70.0	83.5	76.8	81.8	62.0	75.8	68.6	78.0	
	9	11.41	20.0	39.5	57.1	34.5	81.0	72.8	83.0	78.2	81.2	64.0	69.6	67.6	83.0	
	14	11.53	21.8	55.0	80.2	38.4	81.0	72.8	83.0	78.2	81.2	64.0	66.7	58.8	88.5	
	19	11.65	18.3	65.8	73.8	37.5	82.7	73.0	81.0	79.3	.....	66.5	70.6	26.7	60.8	
	24	11.80	4.1	60.0	73.8	6.5	73.5	74.3	75.1	73.5	.....	62.1	64.7	2.0	79.8	
	29	12.03	0.0	58.0	0.0	0.0	.....	.....	.....	.....	.....	58.0	50.0	90.0	84.0	
	34	12.18	0.0	60.5	73.0	10.0	65.2	71.5	70.6	57.5	.....	54.3	43.0	66.5	90.0	
	39	12.30	0.0	50.5	66.0	35.1	66.7	71.0	50.2	64.5	.....	53.3	50.0	73.7	81.5	
	44	12.42	0.0	70.0	85.0	77.0	72.0	28.0	66.0	65.0	.....	53.4	56.7	56.0	73.0	
	49	12.54	0.0	25.0	20.0	80.0	71.0	36.0	78.0	31.0	.....	51.8	18.3	67.8	85.0	
	54	12.66	0.0	0.0	10.0	80.0	72.0	59.0	78.3	9.0	.....	50.0	0.0	75.8	88.0	
	60	12.80	13.0	16.0	0.0	81.5	71.5	70.1	75.0	36.0	.....	44.0	3.0	70.4	80.5	
	6	13.00	33.0	50.0	17.0	80.0	72.5	72.0	60.0	50.0	.....	2.0	42.0	35.0	82.0	
	10	13.17	0.0	6.0	25.0	20.0	80.0	71.0	36.0	78.0	.....	15.0	63.0	47.0	83.0	
	15	13.30	0.0	0.0	0.0	80.0	72.0	59.0	78.0	9.0	.....	43.0	75.0	67.0	84.0	
	20	13.40	0.0	0.0	0.0	80.0	72.0	59.0	78.3	9.0	.....	58.0	64.0	70.5	80.0	
	25	13.51	13.0	16.0	0.0	81.5	71.5	70.1	75.0	36.0	.....	44.0	3.0	70.4	80.5	
	30	13.62	0.0	33.0	17.0	80.0	72.5	72.0	60.0	50.0	.....	2.0	42.0	35.0	82.0	
	35	13.72	0.0	45.0	36.0	81.0	72.5	72.0	59.0	.....	.....	15.0	63.0	47.0	83.0	
	40	13.85	0.0	20.0	34.0	35.0	81.5	70.0	73.0	.....	.....	43.0	75.0	67.0	84.0	
	45	13.96	15.0	9.0	78.0	.....	.....	.....	.....	.....	.....	58.0	64.0	70.5	80.0	
	50	14.06	30.0	50.0	.....	.....	.....	.....	.....	.....	.....	58.0	64.0	70.5	80.0	
	55	14.17	15.0	9.0	78.0	.....	.....	.....	.....	.....	.....	58.0	64.0	70.5	80.0	
	60	14.28	30.0	50.0	.....	.....	.....	.....	.....	.....	.....	58.0	64.0	70.5	80.0	

TABLE VIII B.—OBSERVED TRANSMISSION THROUGH VARIOUS CARBOHYDRATES, USING THE SMALL SPECTROMETER, AND THE PRISM AT VARIABLE DEVIATION, I. E., "ANGLE OF CONSTANT EMERGENCE," AS EXPLAINED IN THE TEXT.—Cont'd.

Spectrometer settings. Angular rotation from the D line.	Wave-length.	Per cent transmission.															
		C <sub>5</sub> H <sub>5</sub> N. Pyridine.	C <sub>5</sub> H <sub>7</sub> N(CH <sub>3</sub> ). Picoline.	C <sub>10</sub> H <sub>11</sub> O. Thymol.	C <sub>10</sub> H <sub>11</sub> O. Carvacrol.	C <sub>11</sub> H <sub>12</sub> O. Paraldehyde.	C <sub>6</sub> H <sub>12</sub> Cl. MODOCHLOROBENZENE.	C <sub>3</sub> H <sub>10</sub> O <sub>2</sub> . Normal valeric acid.	C <sub>11</sub> H <sub>12</sub> O <sub>2</sub> . Caproic acid.	C <sub>11</sub> H <sub>12</sub> O <sub>2</sub> . Isocaproic acid.	C <sub>18</sub> H <sub>34</sub> O <sub>2</sub> . Oleic acid.	C <sub>23</sub> H <sub>40</sub> O <sub>2</sub> . Cerotic acid.	(C <sub>2</sub> H <sub>5</sub> ) <sub>2</sub> S. Ethyl sulphide.	(C <sub>2</sub> H <sub>5</sub> ) <sub>3</sub> N. Triethylamine.	(C <sub>6</sub> H <sub>5</sub> ) <sub>2</sub> N. p-Nitrosodimethylaniline.	(C <sub>6</sub> H <sub>5</sub> NO)(C <sub>6</sub> H <sub>5</sub> ) <sub>2</sub> .	
Thickness of cell in mm. )		0.01	0.01	0.01	0.01	0.01	0.01	0.01	0.01	0.01	0.01	0.01	0.01	0.01	0.15	0.035	
0																	
1	30	1.70	90.5	83.7	93.0	85.5	83.0	89.5	93.0	89.0	94.0	86.4	87.0	66.7	.....	.....	
	35	2.05	89.4	84.0	90.8	81.6	84.5	91.0	92.3	88.4	92.3	85.3	88.9	67.0	.....	.....	
	40	2.46	87.6	80.2	86.3	80.0	84.0	87.4	85.5	83.8	90.6	83.2	79.5	57.2	.....	.....	
	42	2.65	85.6	77.9	82.0	77.8	78.5	84.6	.....	.....	87.8	82.3	78.0	.....	.....	.....	
	43	2.73	79.6	58.0	67.5	.....	.....	83.9	82.3	69.8	.....	82.5	76.6	55.8	.....	.....	
	45	2.88	73.7	64.0	53.5	78.0	83.7	72.3	69.8	81.5	81.5	82.2	76.2	48.8	.....	.....	
	47	3.04	62.7	57.8	39.0	90.5	76.4	79.8	39.9	33.1	65.6	76.3	57.5	38.3	.....	.....	
	49	3.21	55.8	46.2	41.3	14.4	66.6	72.2	15.8	14.5	33.8	51.8	40.5	26.5	.....	.....	
	50	3.30	56.8	42.6	16.4	.....	.....	.....	.....	.....	.....	.....	.....	.....	.....	.....	
	51	3.38	61.9	43.0	42.5	20.6	46.6	70.7	3.8	2.8	2.9	17.7	37.3	33.9	9.6	15.0	
	52	3.46	.....	47.0	47.0	25.9	38.4	72.4	3.7	2.1	1.7	13.9	24.6	38.0	7.0	15.6	
	53	3.53	77.2	55.2	52.5	33.3	32.4	79.2	4.6	2.6	2.9	14.1	21.2	.....	7.3	17.1	
	54	3.60	.....	71.4	.....	.....	31.4	79.7	4.8	4.0	3.9	18.4	22.2	67.3	10.3	20.0	
	55	3.67	85.2	.....	70.0	51.0	37.8	81.6	7.3	5.2	5.9	24.2	28.1	.....	.....	23.8	
	56	3.71	.....	.....	.....	45.3	.....	.....	6.9	.....	.....	.....	.....	83.0	26.0	.....	
	58	3.88	88.2	78.9	79.6	65.7	53.3	83.8	12.9	9.3	8.7	34.1	43.3	.....	.....	27.0	
	59	3.96	88.2	78.8	85.6	72.2	70.0	84.0	19.9	17.8	19.7	45.7	53.7	83.9	46.0	28.8	
	2	4.18	.....	.....	.....	.....	.....	83.5	41.3	.....	40.2	65.6	.....	85.3	.....	.....	
	4	4.33	85.0	78.5	89.4	80.2	83.8	85.7	54.3	51.7	51.7	74.0	72.0	86.3	58.2	31.2	
	6	4.46	.....	.....	.....	.....	.....	.....	.....	.....	.....	.....	.....	.....	58.0	.....	
	9	4.65	87.8	78.0	90.3	86.8	81.4	86.7	65.7	62.0	61.8	80.0	80.0	86.0	57.2	33.4	
	12	4.85	.....	77.1	.....	.....	81.4	79.8	.....	.....	.....	.....	.....	85.5	.....	31.8	
	14	4.98	81.4	73.8	90.5	84.5	70.0	85.5	65.8	63.4	63.6	80.5	80.5	83.2	57.8	31.7	
	16	5.10	77.3	71.3	89.0	.....	77.0	.....	.....	.....	.....	.....	.....	83.6	.....	33.8	
	19	5.28	76.1	72.1	86.4	83.0	79.5	76.7	60.6	56.0	56.3	80.0	78.5	84.3	61.6	37.2	
	22	5.45	83.7	73.5	85.9	.....	.....	.....	.....	.....	.....	.....	.....	85.3	.....	.....	
	24	5.55	83.7	73.5	86.5	78.8	78.6	76.1	43.2	39.2	38.0	70.8	73.8	75.8	54.0	38.5	
	27	5.70	86.2	73.5	84.0	.....	.....	69.3	75.8	23.1	19.0	48.2	61.4	65.8	.....	33.4	
	29	5.79	81.5	72.0	82.6	71.3	69.0	75.2	9.4	7.1	6.5	25.2	38.1	67.0	51.2	26.0	
	31	5.89	.....	.....	.....	.....	.....	.....	5.5	4.5	5.9	17.3	19.3	.....	.....	.....	
	32	5.95	75.5	66.8	74.0	66.8	76.8	73.0	9.3	9.4	9.1	23.1	21.9	71.0	49.5	.....	
	34	6.05	63.5	56.3	61.2	52.8	80.2	69.4	20.7	21.6	22.9	42.2	41.6	70.6	48.6	20.6	
	36	6.15	42.4	36.4	42.4	34.3	81.0	63.5	38.3	.....	37.2	62.4	60.0	68.5	49.1	10.6	
	39	6.30	28.9	13.9	34.2	16.0	81.4	40.8	54.8	53.3	52.3	76.8	75.3	69.9	48.0	7.4	
	41	6.41	49.7	21.2	36.5	21.9	83.4	43.4	59.4	.....	58.1	77.8	78.1	61.0	43.4	7.9	
	42	6.46	.....	.....	33.4	.....	.....	.....	.....	.....	.....	.....	.....	.....	.....	.....	
	44	6.56	67.8	39.5	29.4	27.0	81.3	58.8	60.2	58.5	58.2	75.9	76.7	54.7	35.2	10.1	
	47	6.70	50.0	26.5	24.7	15.1	75.7	48.0	52.5	44.8	43.7	70.7	69.4	25.2	11.0	12.2	
	49	6.80	33.1	11.2	20.3	12.0	58.7	31.8	36.1	29.7	27.4	52.5	49.0	11.4	4.2	11.6	
	51	6.91	24.6	4.0	10.0	6.7	36.8	28.6	16.2	10.2	9.2	28.0	32.5	3.9	.....	11.0	
	52	7.96	25.4	4.8	5.3	3.1	30.0	34.1	11.1	7.3	4.9	20.9	51.5	.....	6.5	14.4	
	54	7.04	33.4	12.7	.....	2.0	27.1	49.9	5.5	4.2	3.9	15.7	33.6	8.9	10.2	.....	
	55	7.08	43.4	21.9	10.5	4.0	.....	.....	.....	.....	.....	.....	36.5	.....	.....	.....	
	56	7.12	.....	.....	.....	.....	22.8	.....	5.8	.....	4.2	19.5	.....	.....	.....	.....	
	57	7.17	59.4	35.7	21.7	8.6	18.0	69.8	7.9	6.7	4.7	26.3	41.6	15.9	3.7	.....	
	59	7.27	66.4	43.3	30.4	14.0	6.9	73.8	14.5	13.6	9.2	36.1	53.2	15.1	0.3	7.7	
	2	7.41	.....	.....	31.2	11.6	5.4	76.4	26.3	20.7	16.2	44.6	60.7	35.4	1.3	4.9	
	4	7.49	80.7	59.8	31.6	10.0	8.5	77.6	24.2	20.0	15.1	44.8	59.4	46.6	3.0	4.5	
	6	7.56	.....	.....	24.8	12.6	17.6	.....	18.9	.....	12.8	40.1	.....	45.6	.....	5.8	
	9	7.68	77.3	48.2	18.2	12.5	47.2	77.1	9.6	5.9	6.7	29.5	35.0	36.5	4.4	7.7	
	12	7.80	75.3	.....	11.3	7.1	.....	.....	4.2	.....	3.0	18.5	25.9	12.9	.....	.....	
	14	7.88	80.4	45.0	11.8	7.4	69.5	72.7	2.5	.....	0.0	18.1	38.8	4.9	16.4	10.5	
	16	7.95	82.4	46.4	13.8	5.2	.....	.....	3.0	0.0	0.0	20.0	42.8	0.6	.....	10.3	
	19	8.08	74.3	58.6	13.0	1.0	68.0	73.7	5.0	0.0	3.4	20.7	52.9	6.7	20.4	6.5	
	22	8.19	60.0	59.7	6.8	4.2	61.2	76.5	.....	.....	4.0	22.6	53.2	37.7	5.6	3.5	
	24	8.27	53.3	79.0	5.0	6.1	47.9	73.7	5.3	2.5	3.4	24.2	54.5	56.8	1.0	6.4	
	26	8.35	61.3	.....	12.5	.....	30.9	74.5	.....	.....	4.0	28.4	.....	.....	1.5	11.7	
	29	8.46	74.3	74.6	13.8	9.4	9.3	72.8	9.6	5.0	8.7	41.4	57.2	55.4	1.0	15.5	
	32	8.56	.....	.....	11.4	5.1	0.0	.....	.....	.....	.....	44.0	.....	.....	.....	13.0	
	34	8.63	64.7	56.3	8.8	6.6	0.0	69.0	20.2	18.9	17.1	47.5	69.8	60.0	13.9	8.4	



TABLE VIII C.—OBSERVED TRANSMISSION, USING SMALL SPECTROMETER, AND PRISM AT VARIABLE DEVIATION, AS EXPLAINED IN THE TEXT.

Spectrometer settings. Angular rotation from the D sodium lines.	Wave-lengths.	Nitromethane, CH <sub>3</sub> NO <sub>2</sub> .	Nitroethane, C <sub>2</sub> H <sub>5</sub> NO <sub>2</sub> .	Aceton, CH <sub>3</sub> ·CO·CH <sub>3</sub> .	Ethylene bromide, C <sub>2</sub> H <sub>4</sub> Br <sub>2</sub> .	Carbon tetrachloride, CCl <sub>4</sub> .	Tetrachlorethylene, C <sub>2</sub> Cl <sub>4</sub> .	Pyrrrol, C <sub>4</sub> H <sub>7</sub> (NH).	Benzonitrile, C <sub>6</sub> H <sub>5</sub> CN.	Cymene, C <sub>10</sub> H <sub>14</sub> .	Cyanine, C <sub>20</sub> H <sub>13</sub> Na <sub>3</sub> .	Terpineol, C <sub>10</sub> H <sub>18</sub> O.	ortho-xylene, C <sub>6</sub> H <sub>4</sub> (CH <sub>3</sub> ) <sub>2</sub> .	Meta-xylene, C <sub>6</sub> H <sub>4</sub> (CH <sub>3</sub> ) <sub>2</sub> .	Para-xylene, C <sub>6</sub> H <sub>4</sub> (CH <sub>3</sub> ) <sub>2</sub> .	Nitrobenzene, C <sub>6</sub> H <sub>5</sub> NO <sub>2</sub> .	Thickness of cell in mm.		
																	0.01	0.01	(α)
																		<i>Per cent transmission.</i>	
0	μ	90.0	78.75	71.0	79.0	79.0	89.0	94.0	81.0	67.3	76.4	89.8	88.0	89.3	87.0	88.0	87.0		
1	30	84.4	74.7	62.5	81.0	81.0	87.0	91.0	81.0	78.0	75.3	87.4	81.3	87.0	88.0	87.0	88.0		
	35	84.4	74.7	62.5	81.0	81.0	87.0	91.0	81.0	78.0	75.3	87.4	81.3	87.0	88.0	87.0	88.0		
	42	84.5	86.4	60.8	82.0	81.0	84.7	90.5	80.0	77.3	46.8	83.3	87.0	76.0	87.0	87.0	87.0		
	44	84.5	86.4	60.8	82.0	81.0	84.7	90.5	80.0	77.3	46.8	83.3	87.0	76.0	87.0	87.0	87.0		
	46	80.0	75.8	55.4	78.0	78.0	83.6	88.9	78.7	73.2	37.7	81.2	81.2	76.8	87.0	87.0	87.0		
	48	71.0	65.8	38.4	70.0	70.0	42.4	85.1	72.1	66.2	31.4	62.7	67.8	61.0	62.0	62.0	62.0		
1	50	60.4	62.7	26.7	63.4	80.0	56.3	81.2	60.0	47.6	32.2	44.4	50.3	42.7	54.7	54.7	54.7		
	51	3.38	3.38	3.38	3.38	3.38	3.38	3.38	3.38	3.38	3.38	3.38	3.38	3.38	3.38	3.38	3.38	3.38	
	52	59.3	59.5	24.2	66.4	66.4	68.7	85.7	48.0	41.3	29.8	42.2	43.5	37.2	37.2	37.2	37.2		
	53	64.7	63.8	35.6	77.4	77.4	74.3	88.9	49.1	43.7	31.2	50.0	49.1	73.5	73.5	73.5	73.5		
	54	3.60	3.60	3.60	3.60	3.60	3.60	3.60	3.60	3.60	3.60	3.60	3.60	3.60	3.60	3.60	3.60	3.60	
	55	76.8	77.6	57.3	79.5	79.5	76.8	88.9	58.8	63.4	53.5	67.7	80.8	75.8	77.6	77.6	77.6		
	56	3.74	3.74	3.74	3.74	3.74	3.74	3.74	3.74	3.74	3.74	3.74	3.74	3.74	3.74	3.74	3.74	3.74	
	57	3.81	3.81	3.81	3.81	3.81	3.81	3.81	3.81	3.81	3.81	3.81	3.81	3.81	3.81	3.81	3.81	3.81	
	58	78.5	83.3	64.3	80.8	80.8	81.0	81.0	81.0	81.0	81.0	81.0	81.0	81.0	81.0	81.0	81.0	81.0	
2	00	4.04	75.0	83.0	66.0	79.8	71.8	89.4	80.0	71.3	69.0	84.6	84.7	79.8	80.2	80.2	80.2		
	3	4.26	77.4	83.0	66.0	79.8	71.8	89.4	80.0	71.3	69.0	84.6	84.7	79.8	80.2	80.2	80.2		
	4	4.40	86.1	86.3	64.5	79.7	80.4	76.3	85.7	80.1	75.6	78.5	85.4	80.7	80.4	80.4	80.4		
	5	4.51	88.5	85.8	54.7	80.8	81.2	77.6	86.6	79.7	76.8	74.4	85.0	84.6	84.6	84.6	84.6		
	10	4.72	88.5	85.8	54.7	80.8	81.2	77.6	86.6	79.7	76.8	74.4	85.0	84.6	84.6	84.6	84.6		
	13	4.92	88.5	85.8	54.7	80.8	81.2	77.6	86.6	79.7	76.8	74.4	85.0	84.6	84.6	84.6	84.6		
	15	5.04	84.8	85.3	68.0	83.8	84.0	86.0	85.6	79.8	73.8	75.7	81.4	82.5	80.6	74.0	74.0		
	17	5.16	85.4	87.2	62.0	83.6	83.5	87.1	82.1	79.7	78.5	76.6	77.3	72.3	71.5	71.5	71.5		
2	20	5.34	87.4	87.2	62.0	83.6	83.5	87.1	82.1	79.7	78.5	76.6	77.3	72.3	71.5	71.5	71.5		
	23	5.50	87.0	85.3	32.0	81.7	74.3	65.6	83.8	80.5	72.3	74.2	79.1	79.0	74.3	69.4	69.4		
	25	5.60	87.0	85.3	32.0	81.7	74.3	65.6	83.8	80.5	72.3	74.2	79.1	79.0	74.3	69.4	69.4		
	28	5.75	81.8	5.1	80.2	70.4	69.0	62.1	86.7	79.7	73.0	79.3	79.3	79.3	79.3	79.3	79.3		
2	30	5.84	78.3	78.0	5.4	80.2	70.4	69.0	86.7	79.7	73.0	79.3	79.3	79.3	79.3	79.3	79.3		
	32	5.95	73.0	16.4	78.9	69.0	77.3	62.2	83.9	74.9	50.8	64.8	77.8	72.3	52.0	52.0	52.0		
	33	6.00	62.4	53.7	25.7	78.3	66.7	59.8	81.0	73.2	31.0	62.8	68.3	54.2	64.3	28.0	28.0		
	35	6.10	38.2	25.7	78.3	66.7	59.8	44.5	77.3	63.8	11.4	65.3	61.2	43.4	63.5	13.5	13.5		
	37	6.20	14.1	16.8	27.6	77.0	61.8	75.8	74.0	71.9	5.4	67.8	62.4	48.5	60.7	9.2	9.2		
	40	6.36	3.5	20.0	77.2	44.0	72.6	32.0	80.4	61.3	4.3	72.5	64.3	46.7	46.3	3.1	3.1		
	42	6.46	1.3	0.0	14.8	77.6	27.3	73.4	82.6	61.3	4.3	72.5	64.3	46.7	46.3	3.1	3.1		
	43	6.51	1.0	7.8	11.8	74.3	22.5	77.3	82.6	61.3	4.3	72.5	64.3	46.7	46.3	3.1	3.1		
	45	6.60	1.0	7.8	11.8	74.3	22.5	77.3	82.6	61.3	4.3	72.5	64.3	46.7	46.3	3.1	3.1		
	46	6.75	0.2	13.8	8.5	58.4	49.8	76.3	82.6	61.3	4.3	72.5	64.3	46.7	46.3	3.1	3.1		
2	50	6.86	0.0	11.4	7.3	42.3	61.2	74.9	83.5	26.6	3.8	23.7	8.2	16.2	23.3	25.4	25.4		
	52	6.96	0.0	6.3	6.3	20.8	75.5	19.7	86.3	26.8	7.2	20.0	26.9	22.0	22.0	22.0	22.0		
	53	7.00	0.0	3.6	5.2	19.8	70.0	76.8	84.1	26.8	17.8	20.0	26.9	22.0	22.0	22.0	22.0		
	55	7.08	0.0	5.9	34.0	70.0	76.8	17.1	71.7	41.4	13.8	24.4	42.3	40.8	36.5	36.4	36.4		
	56	7.12	0.0	6.1	39.8	74.0	74.0	17.9	47.3	42.2	6.4	22.1	49.7	47.2	45.3	15.7	15.7		
	58	7.22	0.0	4.0	5.7	58.7	67.8	23.4	80.8	46.3	3.4	22.1	49.7	47.2	45.3	15.7	15.7		
3	0	7.32	0.0	2.8	4.9	68.0	70.5	67.8	82.0	42.8	3.4	12.6	53.7	51.4	51.4	6.0	6.0		
	3	7.45	11.5	11.6	7.3	72.8	54.0	48.6	83.4	53.3	20.5	53.7	51.4	51.4	6.0	6.0	6.0		
	5	7.52	25.8	17.3	8.0	72.5	72.0	50.3	83.5	61.1	3.2	26.3	76.2	71.8	68.3	2.0	2.0		
	7	7.59	34.0	10.0	71.8	55.7	55.7	54.4	86.4	66.4	1.7	33.7	77.5	77.5	77.5	77.5	77.5		
	10	7.72	41.7	33.4	18.6	61.2	72.1	71.3	81.6	64.8	2.0	37.3	79.0	79.0	81.0	25.0	25.0		
	13	7.84	27.9	37.5	37.5	71.7	71.7	47.8	86.8	64.8	2.0	37.3	79.0	79.0	81.0	25.0	25.0		
	15	7.91	70.8	25.0	32.2	24.7	63.7	71.7	49.5	79.0	7.6	37.0	78.2	81.0	44.4	44.4	44.4		
	17	8.00	26.3	16.0	16.0	65.3	59.2	82.0	87.5	76.1	6.2	28.2	79.0	79.0	50.0	50.0	50.0		
3	20	8.12	75.0	42.3	14.4	22.5	59.0	66.8	87.5	76.1	6.2	28.2	79.0	79.0	50.0	50.0	50.0		
	23	8.23	40.8	8.5	40.8	58.8	67.0	44.3	82.0	71.2	1.4	25.5	79.5	77.0	57.8	57.8	57.8		
	25	8.31	66.2	69.8	9.7	36.3	59.0	69.3	82.0	71.2	1.4	25.5	79.5	77.0	57.8	57.8	57.8		
	27	8.35	24.6	65.0	41.8	43.3	43.3	43.3	73.4	75.0	5.8	30.0	79.5	77.8	73.0	43.3	43.3		
	30	8.50	64.3	71.6	13.5	11.4	68.0	69.3	71.4	75.0	5.8	30.0	79.5	77.8	73.0	43.3	43.3		

α Examined as a vapor in the gas-cell 5.7 cm. in length. To obtain the transmission through the vapor only, divide each number by 70 per cent.  
 β Solid film.

TABLE VIII C.—OBSERVED TRANSMISSION, USING SMALL SPECTROMETER, AND PRISM AT VARIABLE DEVIATION, AS EXPLAINED IN THE TEXT—Continued.

Spectrometer settings. Angular rotation from the D sodium lines.	Wave-lengths.	Nitromethane, CH <sub>3</sub> NO <sub>2</sub> .	Nitroethane, C <sub>2</sub> H <sub>5</sub> NO <sub>2</sub> .	Acetone, CH <sub>3</sub> -CO-CH <sub>3</sub> .	Ethylene bromide, C <sub>2</sub> H <sub>4</sub> Br <sub>2</sub> .	Carbon tetrachloride, CCl <sub>4</sub> .	Tetrachlorethylene, C <sub>2</sub> Cl <sub>4</sub> .	Pyrrol, C <sub>4</sub> H <sub>7</sub> (NH).	Benzonitrile, C <sub>6</sub> H <sub>5</sub> CN.	Cymene, C <sub>10</sub> H <sub>16</sub> .	Cyanine, C <sub>23</sub> H <sub>33</sub> N <sub>3</sub> .	Terpineol, C <sub>10</sub> H <sub>18</sub> O.	Ortho-xylene, C <sub>6</sub> H <sub>4</sub> (CH <sub>3</sub> ) <sub>2</sub> .	Meta-xylene, C <sub>6</sub> H <sub>4</sub> (CH <sub>3</sub> ) <sub>2</sub> .	Para-xylene, C <sub>6</sub> H <sub>4</sub> (CH <sub>3</sub> ) <sub>2</sub> .	Nitrobenzene, C <sub>6</sub> H <sub>5</sub> NO <sub>2</sub> .	Thickness of cell of mm. }	
																	0.01	0.01
<i>Per cent transmission.</i>																		
3 33	7.59	58.7	61.8	33.7	30.9	73.2	59.0	43.8	72.6	72.1	4.3	15.4	75.3	72.8	71.6	33.0	33.0	0.01
3 35	7.66	57.0	61.8	33.7	30.9	73.2	59.0	43.8	72.6	72.1	4.3	15.4	75.3	72.8	71.6	33.0	33.0	0.01
3 37	7.73	57.0	61.8	33.7	30.9	73.2	59.0	43.8	72.6	72.1	4.3	15.4	75.3	72.8	71.6	33.0	33.0	0.01
3 40	7.83	47.5	35.1	43.3	63.1	73.4	39.0	25.8	20.0	81.3	71.5	3.3	8.0	69.0	74.0	6.95	45.5	0.01
3 42	7.90	47.5	35.1	43.3	63.1	73.4	39.0	25.8	20.0	81.3	71.5	3.3	8.0	69.0	74.0	6.95	45.5	0.01
3 43	7.90	47.5	35.1	43.3	63.1	73.4	39.0	25.8	20.0	81.3	71.5	3.3	8.0	69.0	74.0	6.95	45.5	0.01
3 44	8.00	18.2	20.0	28.8	60.4	69.5	26.8	33.3	88.0	60.0	15.8	10.7	60.5	71.3	40.0	21.8	21.8	0.01
3 48	9.10	18.2	20.0	28.8	60.4	69.5	26.8	33.3	88.0	60.0	15.8	10.7	60.5	71.3	40.0	21.8	21.8	0.01
3 50	9.16	5.8	23.3	27.3	47.1	70.0	37.6	38.7	77.3	58.0	37.0	30.0	71.8	57.7	51.0	12.8	12.8	0.01
3 52	9.23	5.8	23.3	27.3	47.1	70.0	37.6	38.7	77.3	58.0	37.0	30.0	71.8	57.7	51.0	12.8	12.8	0.01
3 55	9.32	28.0	61.0	32.3	57.5	70.0	63.8	19.7	8.8	65.6	63.6	43.4	81.8	71.4	65.6	65.6	65.6	0.01
3 57	9.38	28.0	61.0	32.3	57.5	70.0	63.8	19.7	8.8	65.6	63.6	43.4	81.8	71.4	65.6	65.6	65.6	0.01
4 00	9.48	50.0	75.0	45.7	70.0	70.3	70.4	5.8	64.5	19.6	15.8	58.6	61.0	61.2	50.0	(d)	(d)	0.01
4 5	9.63	68.2	76.0	47.8	73.6	71.0	68.2	8.2	76.6	46.7	15.8	58.6	61.0	61.2	50.0	(d)	(d)	0.01
4 5	9.69	68.2	76.0	47.8	73.6	71.0	68.2	8.2	76.6	46.7	15.8	58.6	61.0	61.2	50.0	(d)	(d)	0.01
4 10	9.80	82.2	73.0	50.8	68.9	67.7	53.4	10.0	64.0	59.8	37.5	47.2	45.6	51.8	44.5	39.4	39.4	0.01
4 13	9.89	82.2	73.0	50.8	68.9	67.7	53.4	10.0	64.0	59.8	37.5	47.2	45.6	51.8	44.5	39.4	39.4	0.01
4 15	9.95	82.2	73.0	50.8	68.9	67.7	53.4	10.0	64.0	59.8	37.5	47.2	45.6	51.8	44.5	39.4	39.4	0.01
4 17	10.00	82.2	73.0	50.8	68.9	67.7	53.4	10.0	64.0	59.8	37.5	47.2	45.6	51.8	44.5	39.4	39.4	0.01
4 20	10.09	85.3	37.8	50.0	79.5	56.5	42.2	22.7	82.5	76.7	47.2	44.2	55.0	71.4	68.8	61.0	61.0	0.01
4 23	10.18	85.3	37.8	50.0	79.5	56.5	42.2	22.7	82.5	76.7	47.2	44.2	55.0	71.4	68.8	61.0	61.0	0.01
4 25	10.23	87.8	67.8	47.9	85.7	60.0	33.5	47.0	83.0	76.5	47.5	43.3	70.0	75.4	67.0	67.0	67.0	0.01
4 27	10.29	87.8	67.8	47.9	85.7	60.0	33.5	47.0	83.0	76.5	47.5	43.3	70.0	75.4	67.0	67.0	67.0	0.01
4 30	10.37	85.0	84.5	44.0	86.6	65.0	39.3	56.0	84.6	75.5	47.8	45.8	74.5	76.0	67.4	67.4	67.4	0.01
4 33	10.45	85.0	84.5	44.0	86.6	65.0	39.3	56.0	84.6	75.5	47.8	45.8	74.5	76.0	67.4	67.4	67.4	0.01
4 35	10.50	80.0	85.5	43.3	84.3	73.3	51.5	63.8	86.8	74.0	48.2	28.4	77.8	79.5	68.0	68.0	68.0	0.01
4 37	10.55	80.0	85.5	43.3	84.3	73.3	51.5	63.8	86.8	74.0	48.2	28.4	77.8	79.5	68.0	68.0	68.0	0.01
4 40	10.64	80.0	82.3	39.3	78.8	76.0	13.1	67.2	84.6	72.3	50.7	29.4	79.4	80.5	44.3	44.3	44.3	0.01
4 43	10.73	80.0	82.3	39.3	78.8	76.0	13.1	67.2	84.6	72.3	50.7	29.4	79.4	80.5	44.3	44.3	44.3	0.01
4 45	10.77	66.0	76.5	29.2	77.0	10.0	67.3	63.5	75.5	56.0	19.4	80.5	82.4	54.6	54.6	54.6	54.6	0.01
4 47	10.86	66.0	76.5	29.2	77.0	10.0	67.3	63.5	75.5	56.0	19.4	80.5	82.4	54.6	54.6	54.6	54.6	0.01
4 50	10.92	39.5	58.0	21.5	77.3	76.5	2.5	66.7	64.0	77.4	64.0	6.5	82.0	83.3	73.8	73.8	73.8	0.01
4 55	11.03	63.0	60.5	24.1	56.0	0.0	0.0	61.7	80.0	0.0	68.0	18.3	0.0	0.0	0.0	0.0	0.0	0.01
5 00	11.17	84.5	69.0	25.4	50.0	73.5	4.5	57.0	83.0	77.2	69.0	33.4	83.0	77.5	83.3	77.2	77.2	0.01
5 5	11.30	84.5	69.0	25.4	50.0	73.5	4.5	57.0	83.0	77.2	69.0	33.4	83.0	77.5	83.3	77.2	77.2	0.01
5 10	11.44	85.6	14.0	32.6	78.0	69.6	18.8	29.0	84.0	77.0	54.5	59.4	83.0	41.8	83.0	65.0	65.0	0.01
5 15	11.55	85.6	14.0	32.6	78.0	69.6	18.8	29.0	84.0	77.0	54.5	59.4	83.0	41.8	83.0	65.0	65.0	0.01
5 20	11.68	86.0	52.0	61.2	71.5	66.7	41.8	40.1	83.5	77.5	45.0	66.7	84.0	80.0	84.0	5.5	5.5	0.01
5 25	11.82	86.0	52.0	61.2	71.5	66.7	41.8	40.1	83.5	77.5	45.0	66.7	84.0	80.0	84.0	5.5	5.5	0.01
5 30	11.94	80.0	68.4	17.0	53.7	44.3	40.0	40.0	84.5	64.0	37.5	38.0	83.5	84.0	78.5	43.5	43.5	0.01
5 35	12.06	80.0	68.4	17.0	53.7	44.3	40.0	40.0	84.5	64.0	37.5	38.0	83.5	84.0	78.5	43.5	43.5	0.01
5 40	12.20	80.0	57.3	71.8	70.4	16.0	26.8	39.7	84.6	20.0	16.8	66.7	82.5	70.1	64.7	64.7	64.7	0.01
5 45	12.32	80.0	57.3	71.8	70.4	16.0	26.8	39.7	84.6	20.0	16.8	66.7	82.5	70.1	64.7	64.7	64.7	0.01
5 50	12.45	77.0	45.0	66.0	74.4	0.0	3.0	40.0	85.0	38.0	10.0	40.0	82.5	15.0	35.3	35.3	35.3	0.01
5 55	12.56	77.0	45.0	66.0	74.4	0.0	3.0	40.0	85.0	38.0	10.0	40.0	82.5	15.0	35.3	35.3	35.3	0.01
6 00	12.66	75.0	13.0	50.0	62.7	0.0	0.0	27.0	78.0	62.0	10.0	55.5	82.3	50.0	5.2	30.3	30.3	0.01
6 5	12.80	75.0	13.0	50.0	62.7	0.0	0.0	27.0	78.0	62.0	10.0	55.5	82.3	50.0	5.2	30.3	30.3	0.01
6 10	12.93	73.0	84.0	54.1	42.0	0.0	0.0	21.0	57.0	77.0	11.6	54.6	70.1	55.1	65.7	65.7	65.7	0.01
6 15	13.17	71.5	77.5	51.3	40.0	0.0	0.0	0.0	0.5	0.0	7.0	60.0	47.0	21.4	73.0	68.7	68.7	0.01
6 20	13.40	69.8	80.0	60.5	33.0	0.0	6.0	3.0	12.0	81.0	11.0	61.0	10.0	48.0	80.0	66.5	66.5	0.01
6 30	13.62	67.0	85.0	70.0	50.0	0.0	40.0	0.0	50.0	79.0	15.0	71.8	0.0	59.0	0.0	63.7	63.7	0.01
6 35	13.72	67.0	85.0	70.0	50.0	0.0	40.0	0.0	50.0	79.0	15.0	71.8	0.0	59.0	0.0	63.7	63.7	0.01
6 40	13.85	63.0	75.1	73.0	68.0	22.0	0.0	0.0	80.0	61.0	26.0	66.0	50.5	62.6	83.0	42.70	42.70	0.01
6 45	13.96	63.0	75.1	73.0	68.0	22.0	0.0	0.0	80.0	61.0	26.0	66.0	50.5	62.6	83.0	42.70	42.70	0.01
6 50	14.06	64.4	68.5	77.0	75.0	40.2	66.0	0.0	66.0	62.5	30.0	58.0	67.0	64.0	0.0	20.0	20.0	0.01
6 55	14.16	64.4	68.5	77.0	75.0	40.2	66.0	0.0	66.0	62.5	30.0	58.0	67.0	64.0	0.0	20.0	20.0	0.01
7 00	14.26	70.0	83.0	77.0	77.0	55.0	65.0	0.0	15.0	73.0	34.0	67.0	72.0	66.7	83.3	0.0	0.0	0.01
7 5	14.45	75.0	85.0	75.0	75.0	55.0	65.0	0.0	15.0	73.0	34.0	67.0	72.0	66.7	83.3	0.0	0.0	0.01
7 10	14.63	75.0	85.0	75.0														











TABLE VIII E.—OBSERVED TRANSMISSION, KEEPING THE PRISM AT CONSTANT MINIMUM DEVIATION.

[Films 0.01 mm. in thickness. Large spectrometer.]

Spectrometer set- tings. Angular ro- tation from the sodium D lines.		Wave-lengths.	Anisol. $C_6H_5OCH_3$ .	Toluene. $C_6H_5CH_3$ .	Mesitylene. $C_6H_3(CH_3)_3$ .	Dodecaene. $C_{12}H_{26}$ .	Octadecylene. $C_{18}H_{36}$ .	Spectrometer set- tings. Angular ro- tation from the sodium D lines.		Wave-lengths.	Anisol. $C_6H_5OCH_3$ .	Toluene. $C_6H_5CH_3$ .	Mesitylene. $C_6H_3(CH_3)_3$ .	Dodecaene. $C_{12}H_{26}$ .	Octadecylene. $C_{18}H_{36}$ .
°	'	"	$\mu$					°	'	"	$\mu$				
0	42	00	1.41	73.0	.....	.....	.....	12	30	54.3	.....	54.3	.....	.....	.....
	43	00	1.50	76.0	.....	.....	.....	13	00	55.52	.....	55.52	.....	.....	.....
	44	00	1.60	70.8	.....	.....	.....	14	00	56.62	.....	56.62	.....	.....	.....
	45	30	1.65	68.8	73.3	74.3	77.3	15	00	57.72	.....	57.72	.....	.....	.....
	45	00	1.71	69.3	71.5	73.3	77.3	14	00	57.07	.....	57.07	.....	.....	.....
	46	30	1.75	72.3	71.7	71.7	79.0	15	30	57.82	.....	57.82	.....	.....	.....
	46	00	1.83	71.7	73.7	73.7	78.0	16	00	58.83	.....	58.83	.....	.....	.....
	47	30	1.90	.....	74.4	74.9	79.3	16	30	58.84	66.7	69.4	75.8	86.0	86.0
	47	00	1.96	71.9	75.0	73.4	80.7	17	30	59.92	.....	59.92	.....	.....	.....
	48	30	2.05	.....	74.6	74.3	.....	17	00	59.97	65.0	66.0	77.0	86.0	86.0
	48	00	2.12	71.7	72.9	74.9	79.2	18	00	60.07	40.0	56.0	53.0	85.2	76.3
	49	30	2.18	.....	71.9	72.8	77.6	19	30	61.12	17.4	32.1	.....	.....	.....
	49	00	2.25	70.4	73.8	71.2	75.0	19	00	61.17	10.0	24.1	13.7	83.4	72.4
	50	30	2.33	.....	74.0	70.7	72.4	20	30	62.22	18.8	23.2	.....	.....	.....
	50	00	2.42	69.5	70.8	71.8	72.4	20	00	62.28	33.4	35.0	46.0	84.0	73.8
	51	30	2.50	71.0	72.3	72.8	73.7	21	30	63.33	.....	63.33	35.7	79.0	73.3
	51	00	2.58	75.0	73.6	73.2	76.6	21	00	63.38	56.0	49.0	35.0	79.0	73.3
	52	30	2.62	73.5	.....	74.3	.....	22	30	63.42	58.8	46.7	32.5	76.0	72.3
	52	00	2.77	70.8	73.8	76.6	77.3	22	00	63.46	60.0	40.8	35.0	76.0	72.3
	53	30	2.85	71.4	.....	75.0	.....	23	30	63.51	37.8	37.2	39.4	73.3	71.5
	53	00	2.92	71.3	72.7	73.0	75.7	23	00	63.57	15.1	35.0	.....	.....	.....
	54	30	3.00	70.2	.....	.....	.....	24	30	63.62	6.4	.....	.....	.....	.....
	54	00	3.06	65.0	68.3	71.2	77.2	24	00	63.67	0.0	6.0	33.3	72.3	57.7
	55	30	3.12	48.5	59.6	66.7	.....	25	30	63.72	0.0	.....	17.0	60.0	45.5
	55	00	3.23	38.3	40.3	44.3	61.3	25	00	63.77	6.8	2.0	11.0	39.2	47.4
	56	30	3.30	31.6	28.4	20.0	42.3	26	30	63.81	0.0	.....	7.5	23.6	.....
	56	00	3.38	35.0	32.7	13.1	23.8	26	00	63.86	0.0	0.0	5.0	17.2	20.2
	57	30	3.46	49.6	50.0	38.1	21.3	27	30	63.90	12.0	.....	12.5	27.6	30.0
	57	00	3.53	63.2	70.0	58.8	41.7	27	00	63.95	28.7	18.2	30.0	45.0	45.7
	58	30	3.60	75.0	73.8	68.0	58.9	28	30	64.00	.....	38.0	.....	62.3	.....
	58	00	3.67	76.8	74.3	68.4	69.0	28	00	64.04	51.7	41.7	35.0	63.7	62.2
	59	30	3.75	77.0	.....	71.3	72.2	29	30	64.08	.....	.....	.....	68.7	.....
	59	00	3.84	73.7	75.3	73.9	73.3	29	00	64.13	68.0	41.0	30.0	70.0	61.2
	60	30	3.90	73.6	.....	78.3	69.8	30	30	64.18	.....	36.2	.....	64.5	53.4
	60	00	3.98	73.7	75.8	74.4	70.8	30	00	64.23	68.0	28.3	32.5	50.0	47.4
1	00	30	4.05	.....	.....	78.0	73.2	31	30	64.27	.....	.....	.....	45.0	33.7
	1	00	4.12	76.3	78.5	74.7	81.3	31	00	64.31	68.4	37.5	32.5	38.7	42.3
	2	30	4.18	71.3	.....	83.0	71.5	32	30	64.35	.....	.....	.....	53.2	43.4
	2	00	4.25	67.8	80.0	78.0	82.5	32	00	64.39	60.0	46.8	50.0	62.0	.....
	3	30	4.32	76.6	.....	81.4	75.2	33	30	64.42	40.0	.....	57.5	.....	.....
	3	00	4.32	75.6	80.0	78.3	80.8	33	00	64.46	21.0	.....	65.0	69.0	.....
	4	30	4.45	76.0	.....	82.6	74.5	34	30	64.50	34.0	.....	.....	.....	.....
	4	00	4.52	77.0	80.0	79.8	82.8	34	00	64.54	40.0	.....	67.5	75.0	.....
	5	30	4.58	78.8	.....	83.8	75.3	35	30	64.59	36.0	.....	.....	.....	.....
	5	00	4.64	77.0	80.6	78.7	85.3	35	00	64.63	20.0	.....	.....	.....	.....
	6	30	4.70	74.4	.....	79.8	.....	36	30	64.68	14.0	.....	.....	.....	.....
	6	00	4.76	68.6	81.0	80.3	84.4	36	00	64.73	0.2	.....	.....	.....	.....
	7	30	4.82	65.0	.....	80.3	.....	37	30	64.76	0.6	.....	.....	.....	.....
	7	00	4.89	68.6	79.3	80.0	83.0	37	00	64.80	20.0	.....	.....	.....	.....
	8	30	4.95	73.3	.....	81.3	.....	38	30	64.83	21.0	.....	.....	.....	.....
	8	00	5.00	74.2	70.4	82.2	83.5	38	00	64.87	22.0	.....	.....	.....	.....
	9	30	5.06	.....	56.7	.....	.....	39	30	64.92	13.6	.....	.....	.....	.....
	9	00	5.13	65.6	60.5	79.9	85.7	39	00	64.96	2.0	.....	.....	.....	.....
	10	30	5.20	73.2	69.2	78.8	.....	40	30	64.03	0.0	.....	.....	.....	.....
	10	00	5.26	75.7	64.8	78.7	86.3	41	00	64.03	0.0	.....	.....	.....	.....
	11	30	5.31	76.0	57.7	80.0	.....	42	00	64.18	5.6	.....	.....	.....	.....
	11	00	5.37	75.0	54.2	82.1	86.0	43	00	64.25	29.4	.....	.....	.....	.....
	12	30	5.42	71.5	61.1	.....	.....	44	00	64.31	39.2	.....	.....	.....	.....
	12	00	5.47	68.3	57.3	82.6	86.0	45	00	.....	.....	.....	.....	.....	.....





FIG. 12.

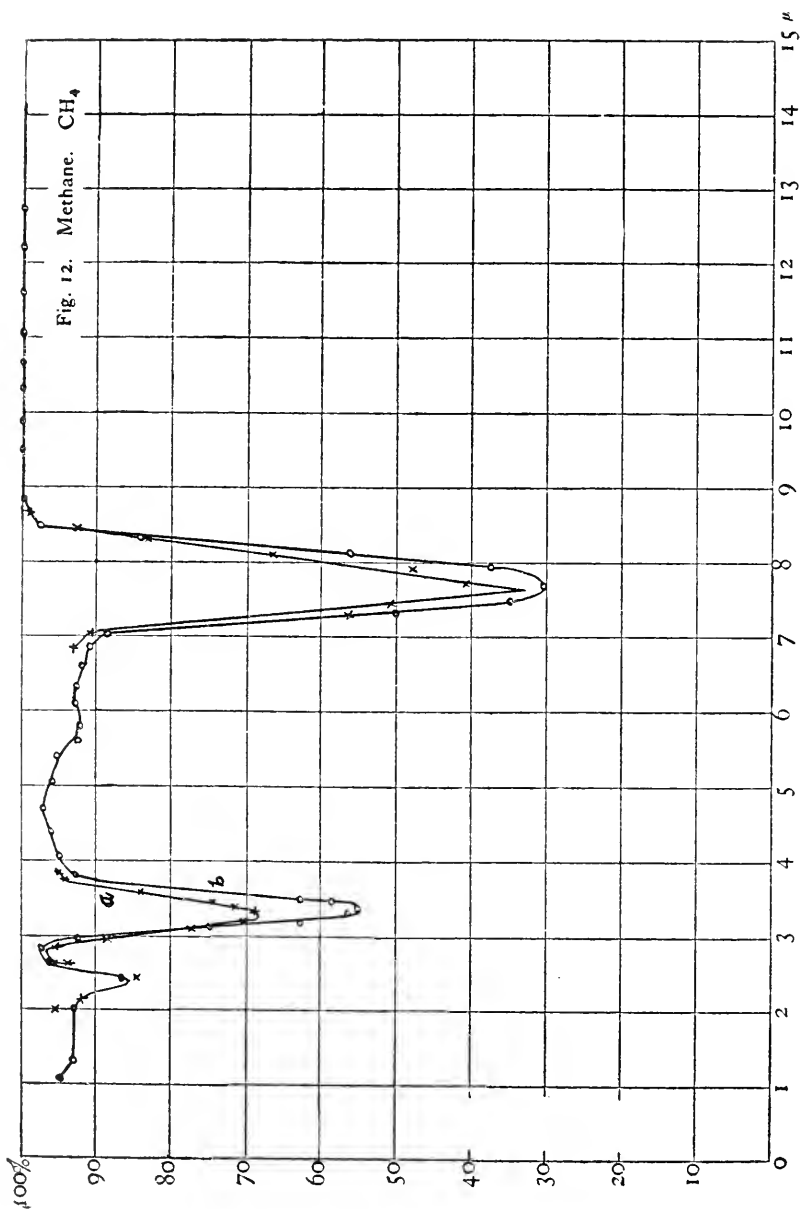



FIG. 13.

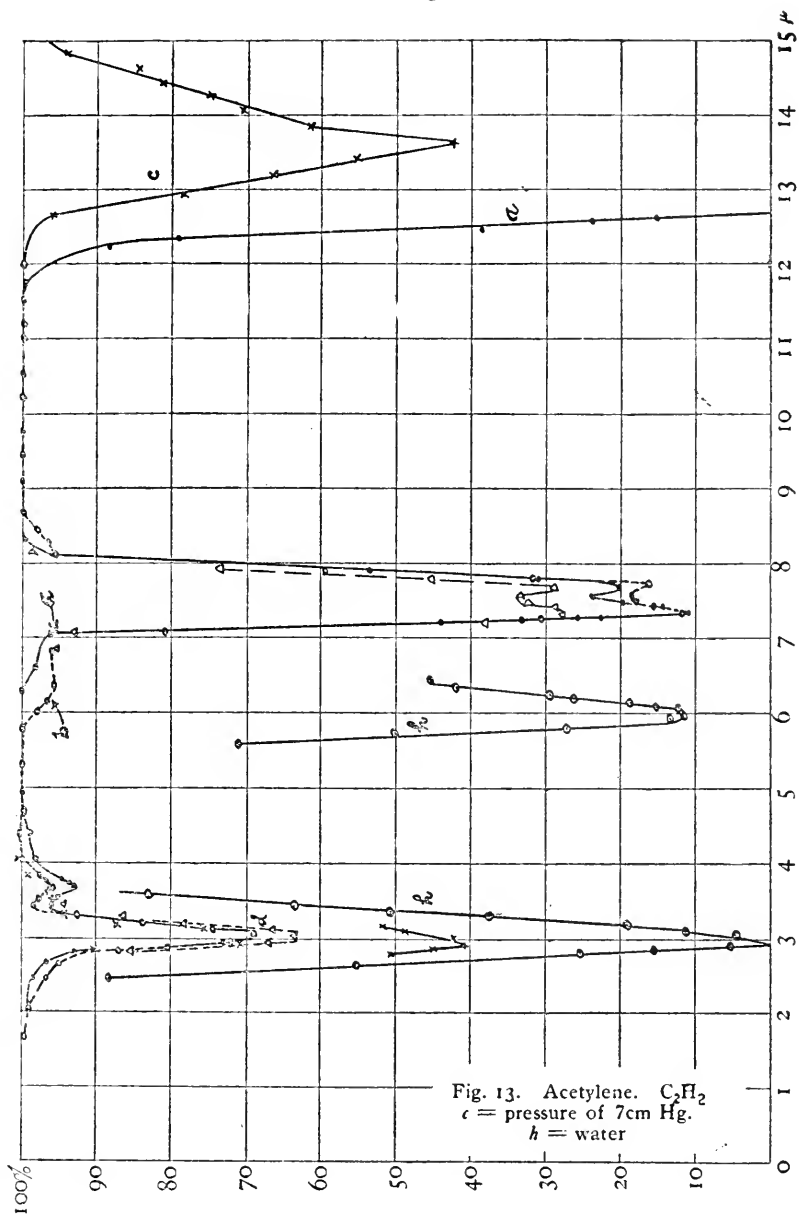

FIG. 14.

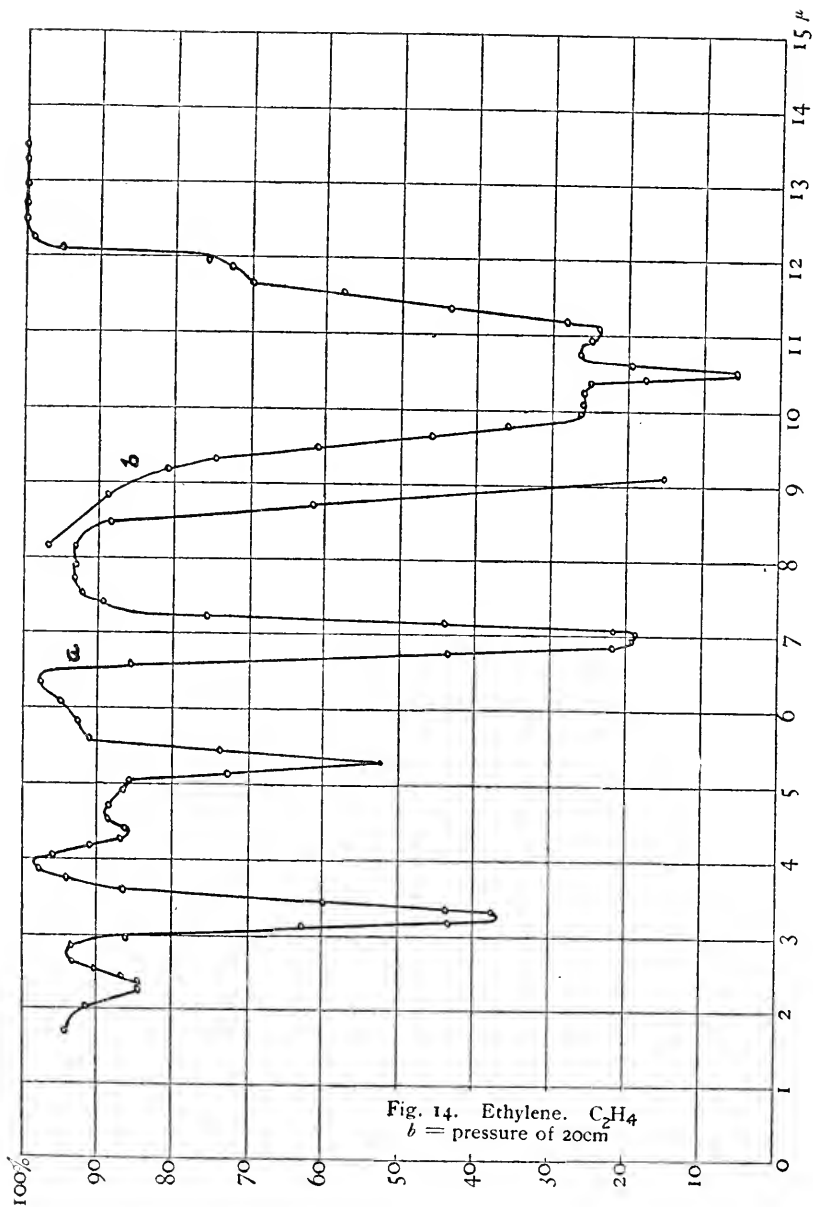

FIG. 15.

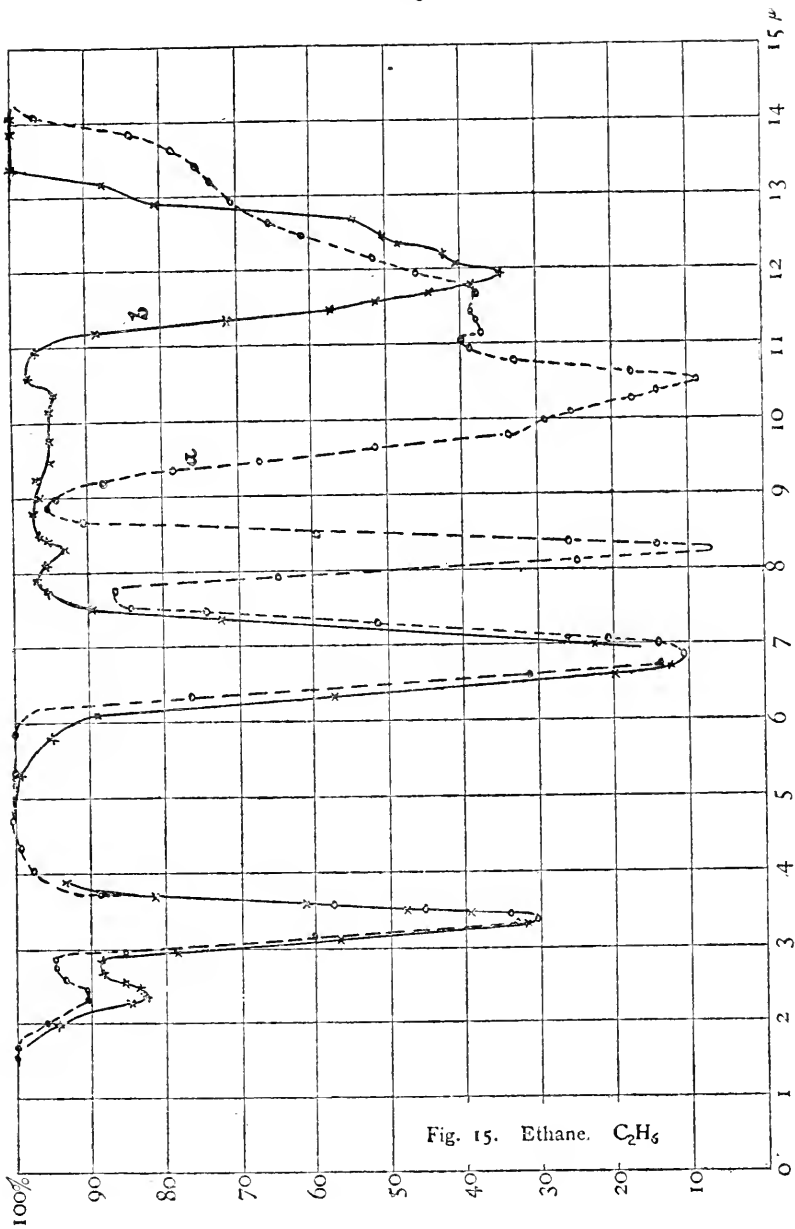

FIG. 16.

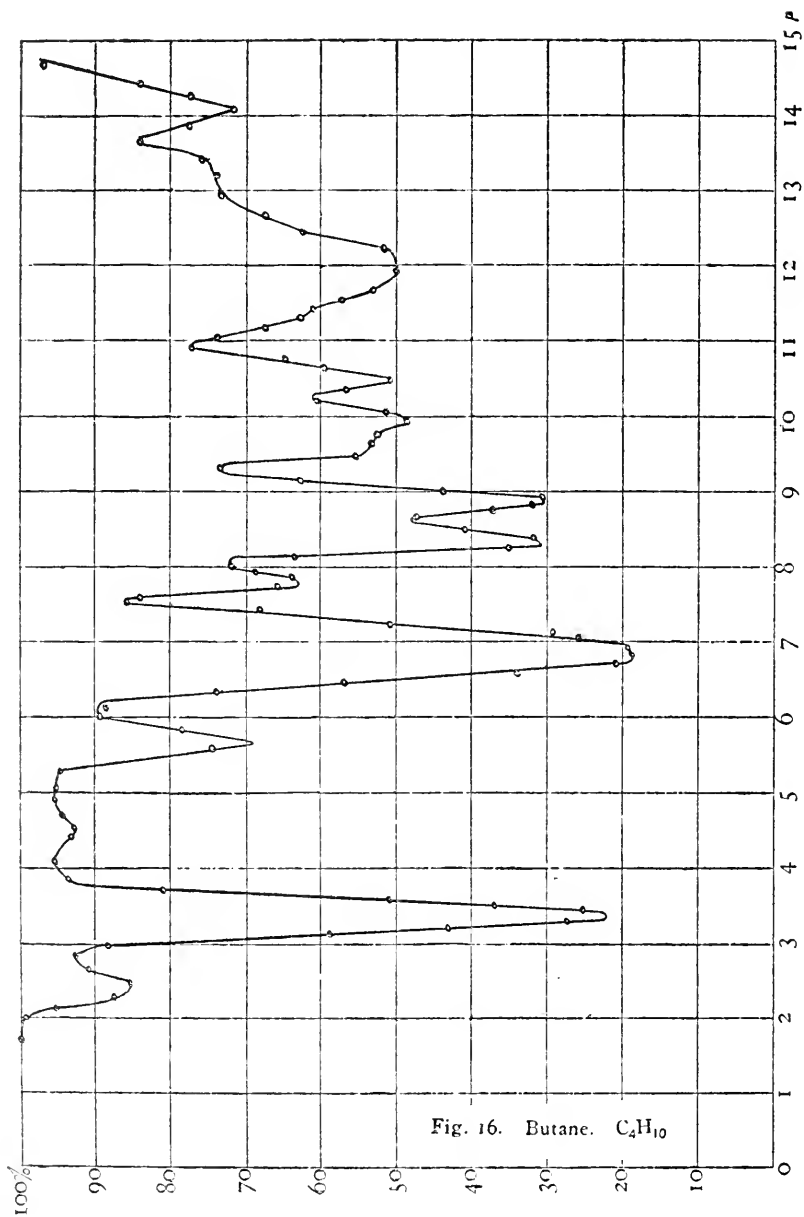

FIG. 17.

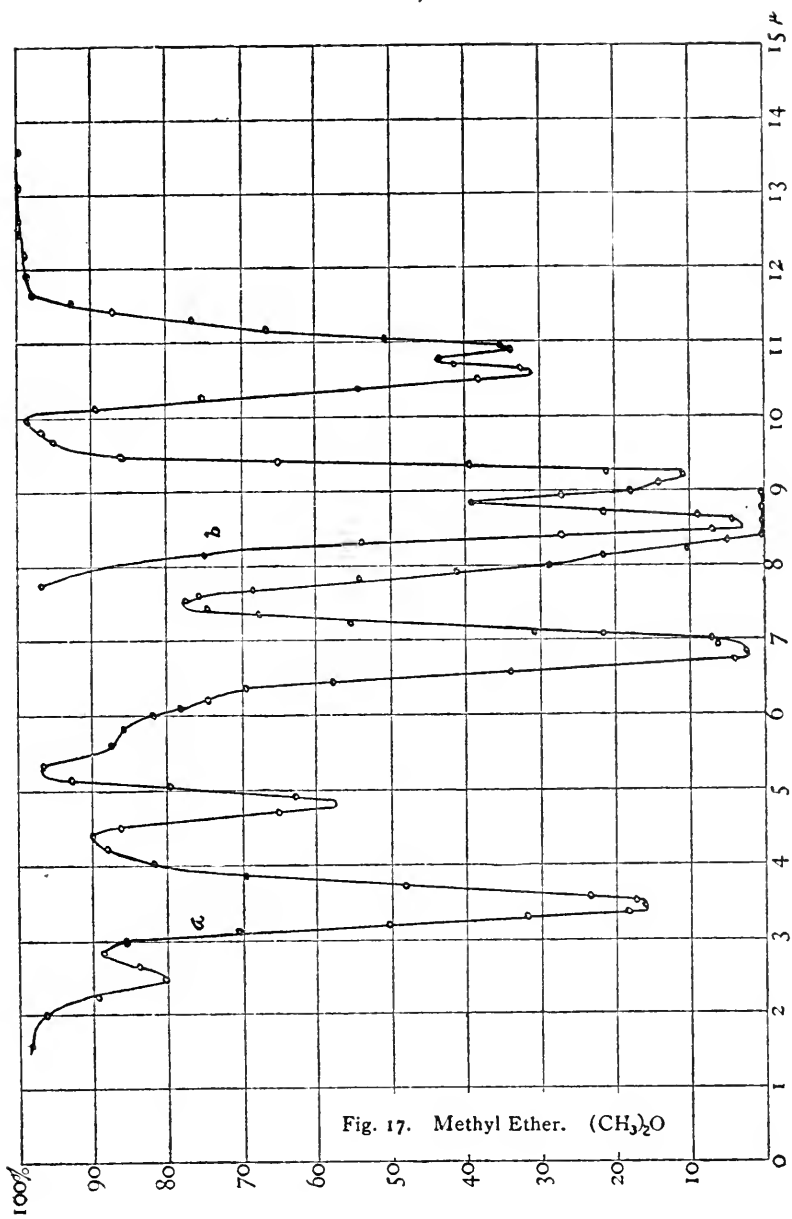

FIG. 18.

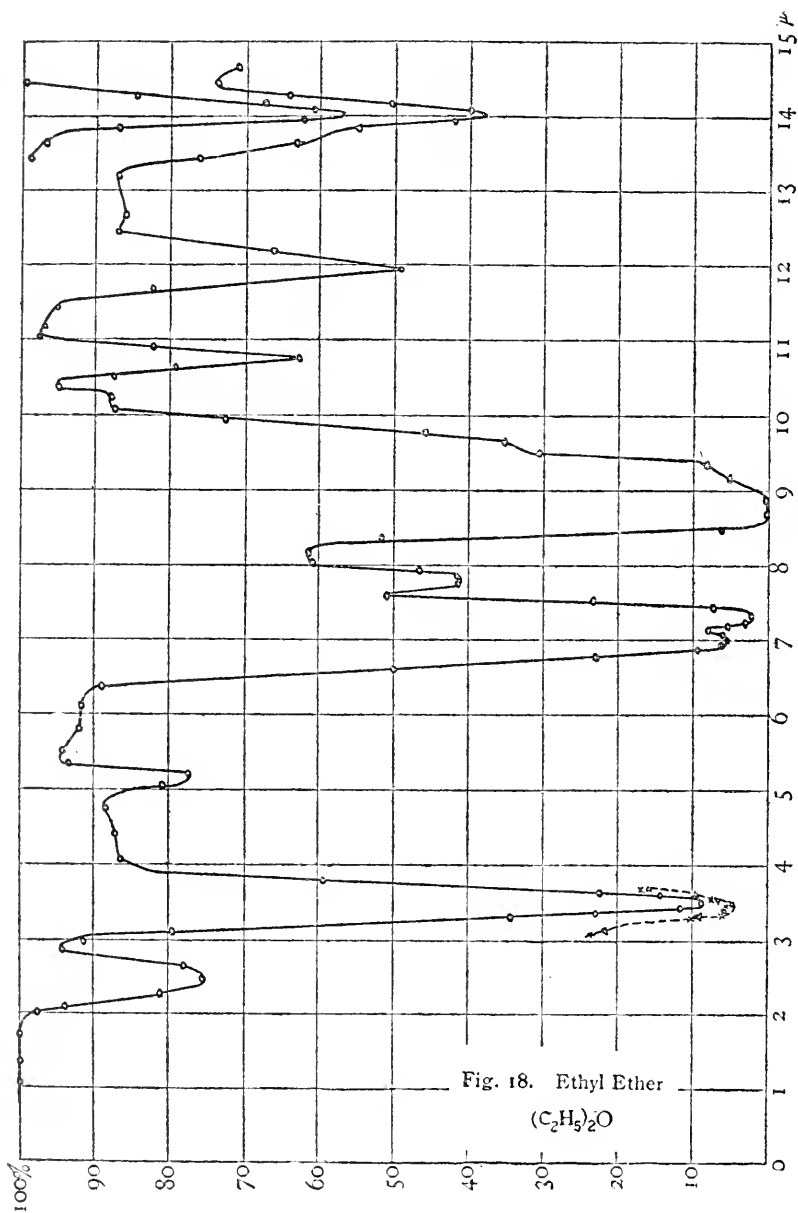

FIG. 19.

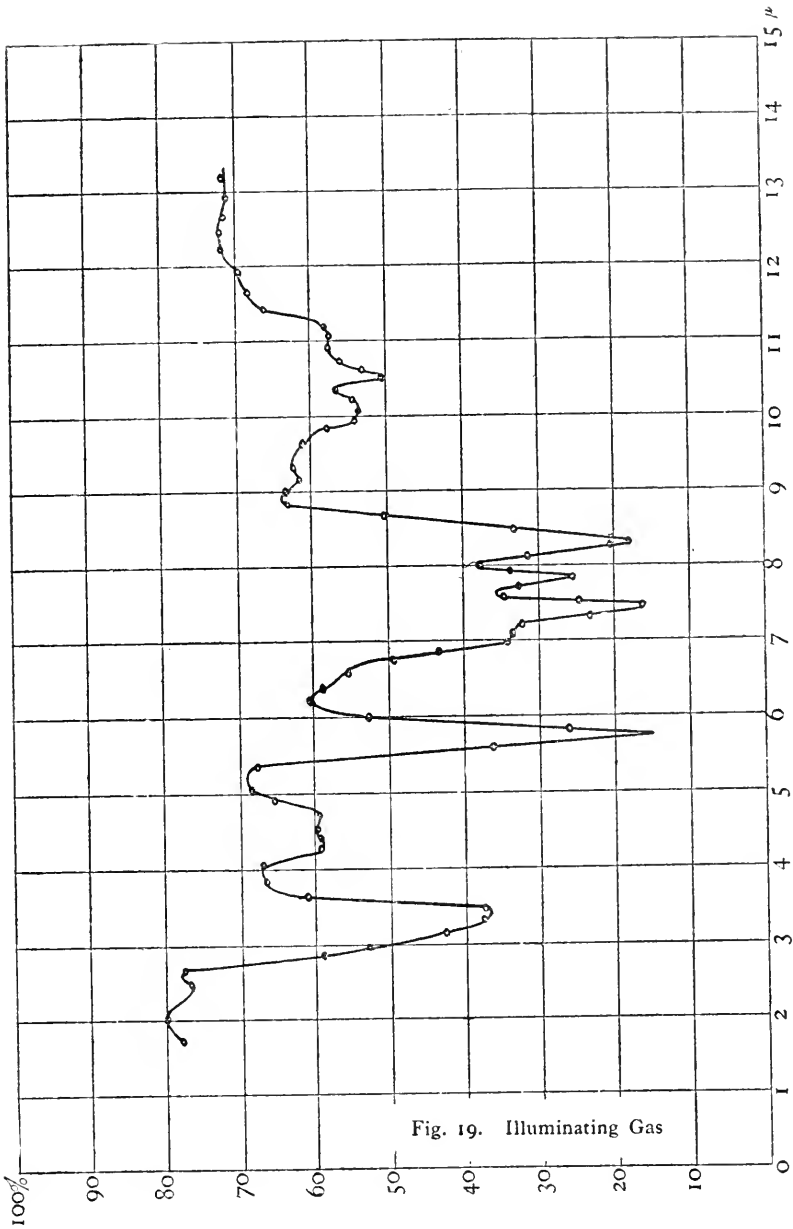

Fig. 19. Illuminating Gas

FIG. 20.

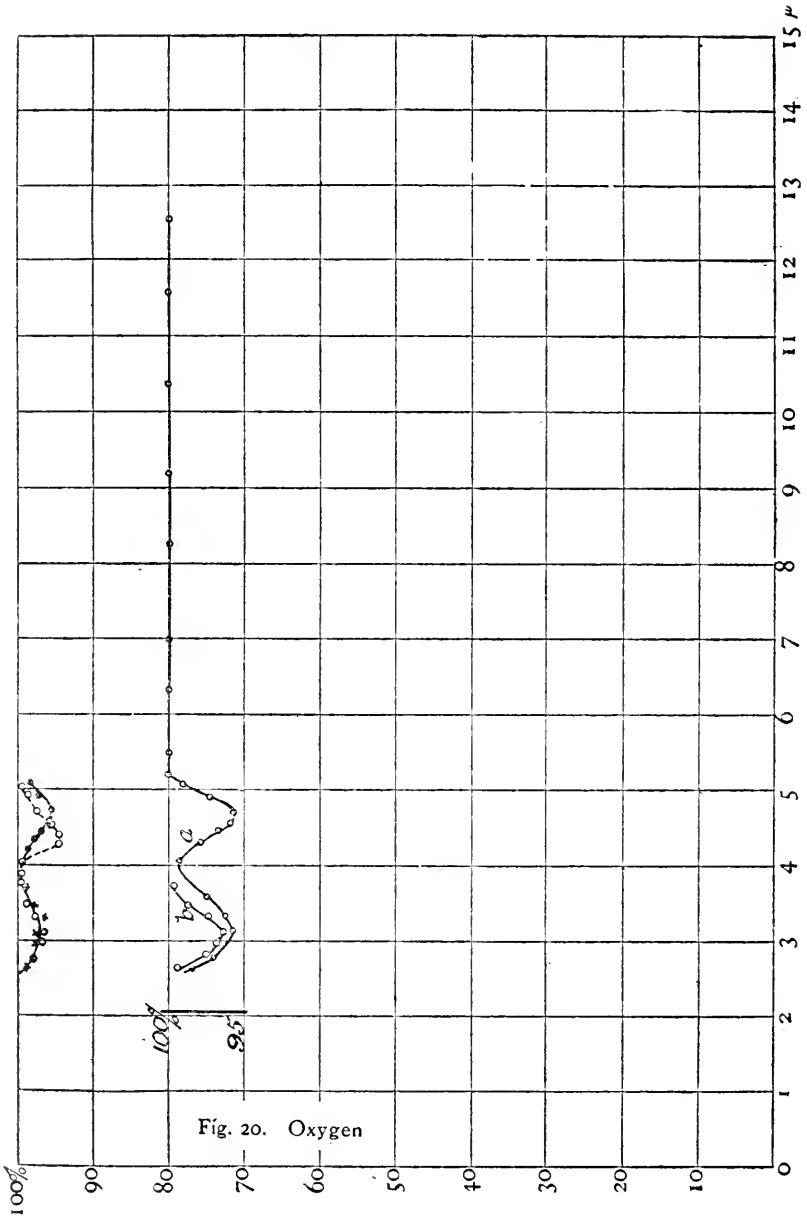



FIG. 21.

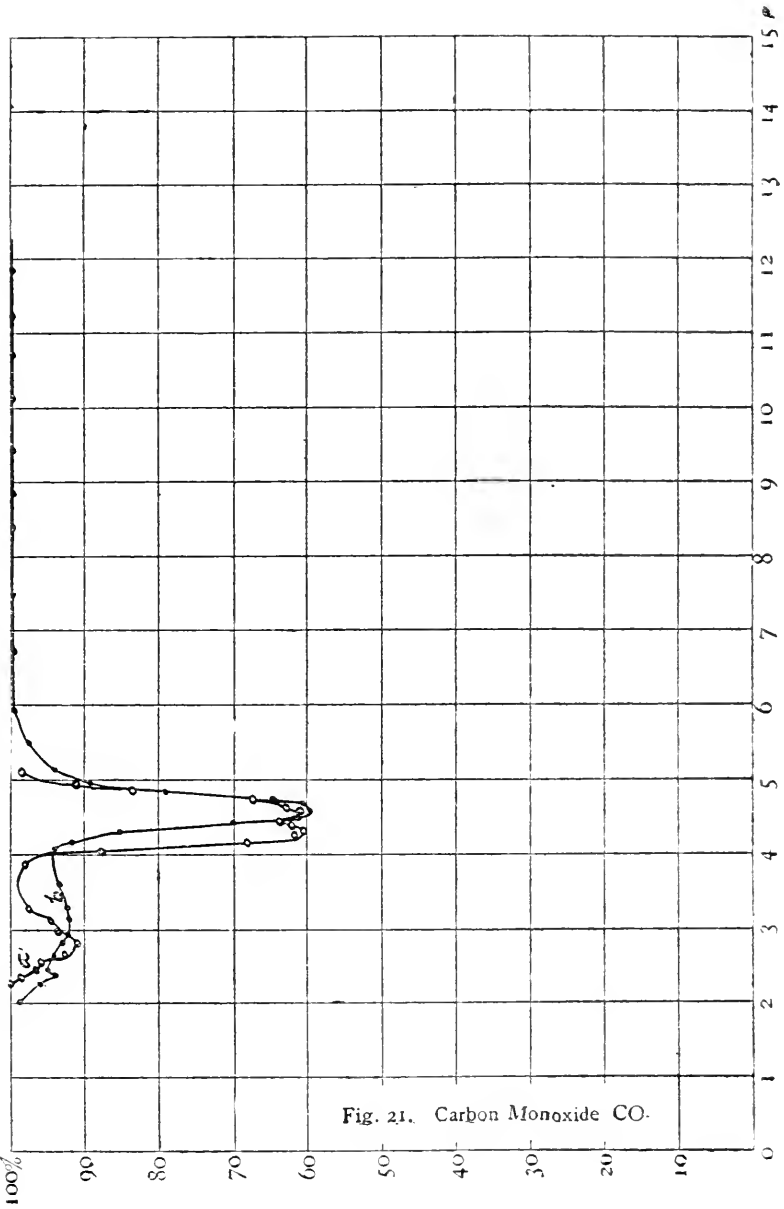

Fig. 21. Carbon Monoxide CO.

FIG. 22.

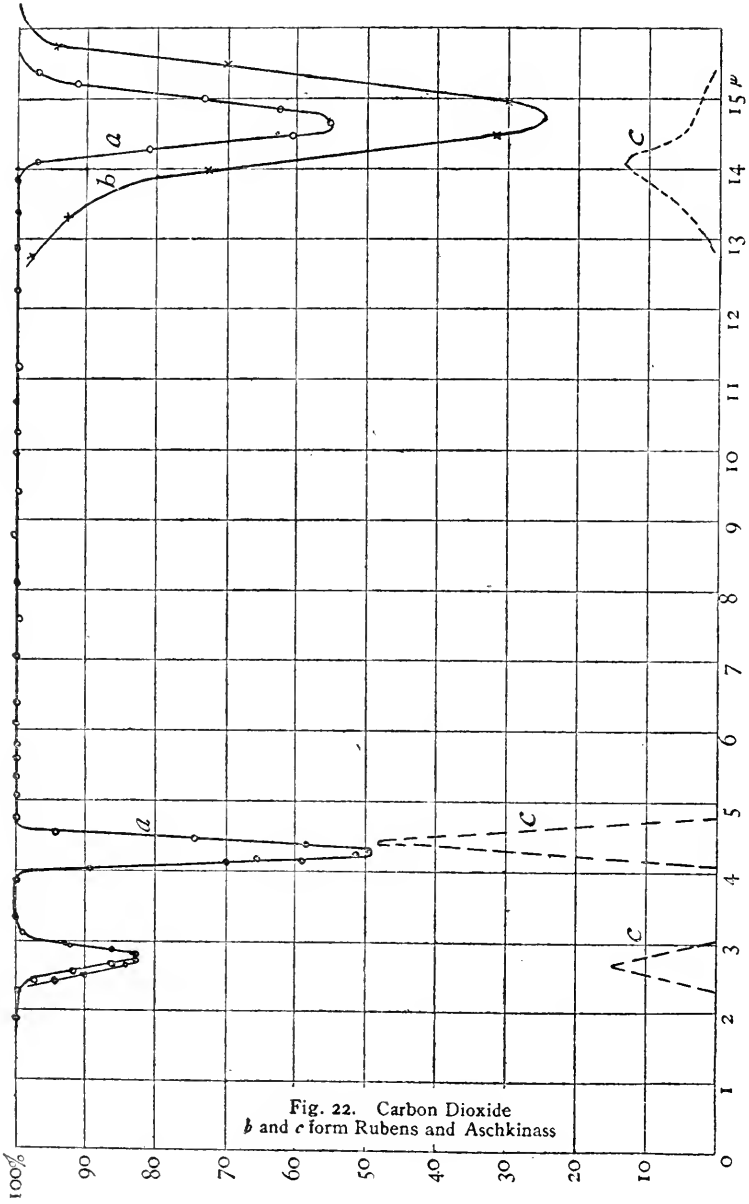

Fig. 22. Carbon Dioxide  
*b* and *c* form Rubens and Aschkinass

FIG. 23.

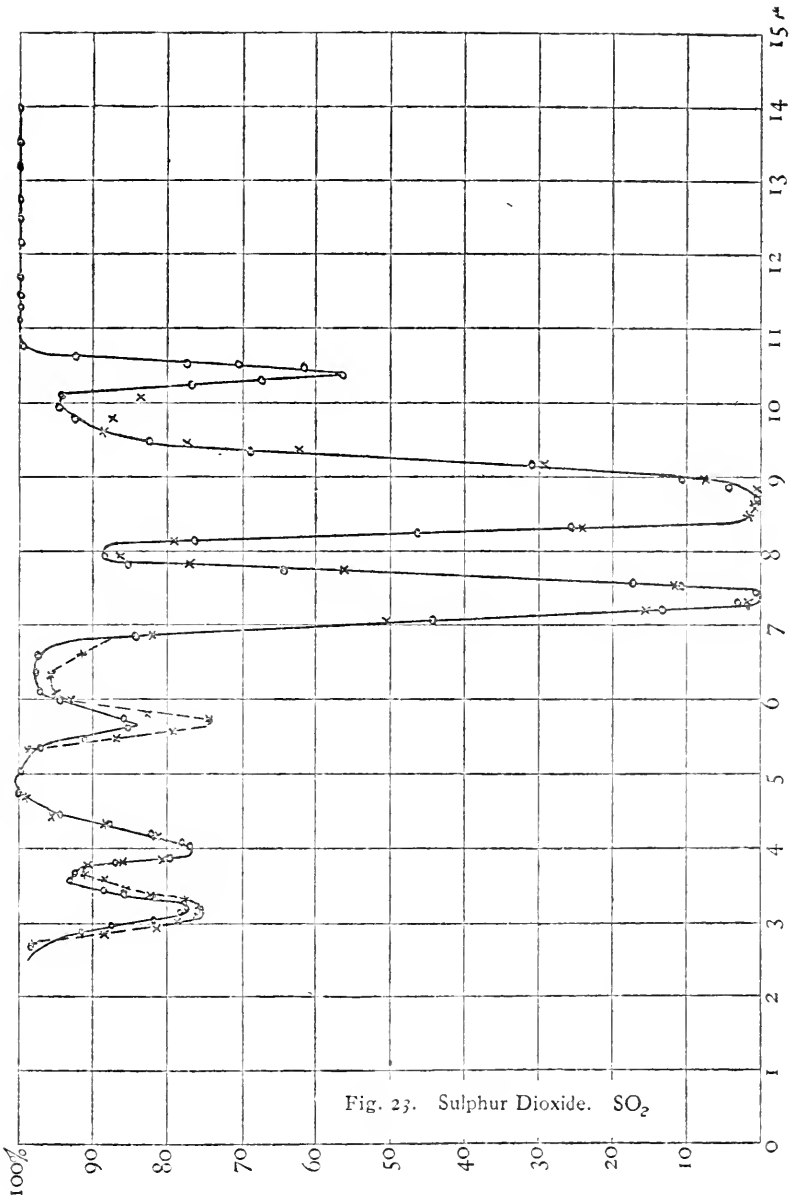

Fig. 23. Sulphur Dioxide. SO<sub>2</sub>

FIG. 24.

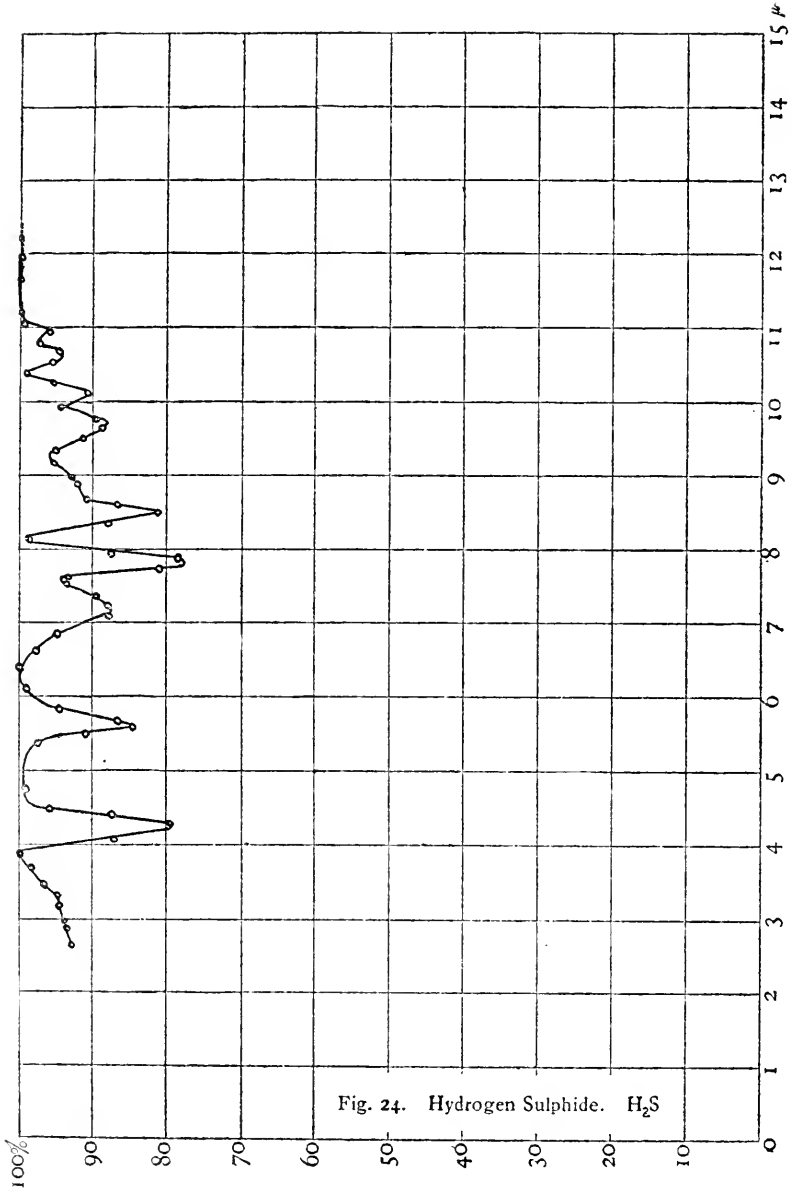

FIG. 25.

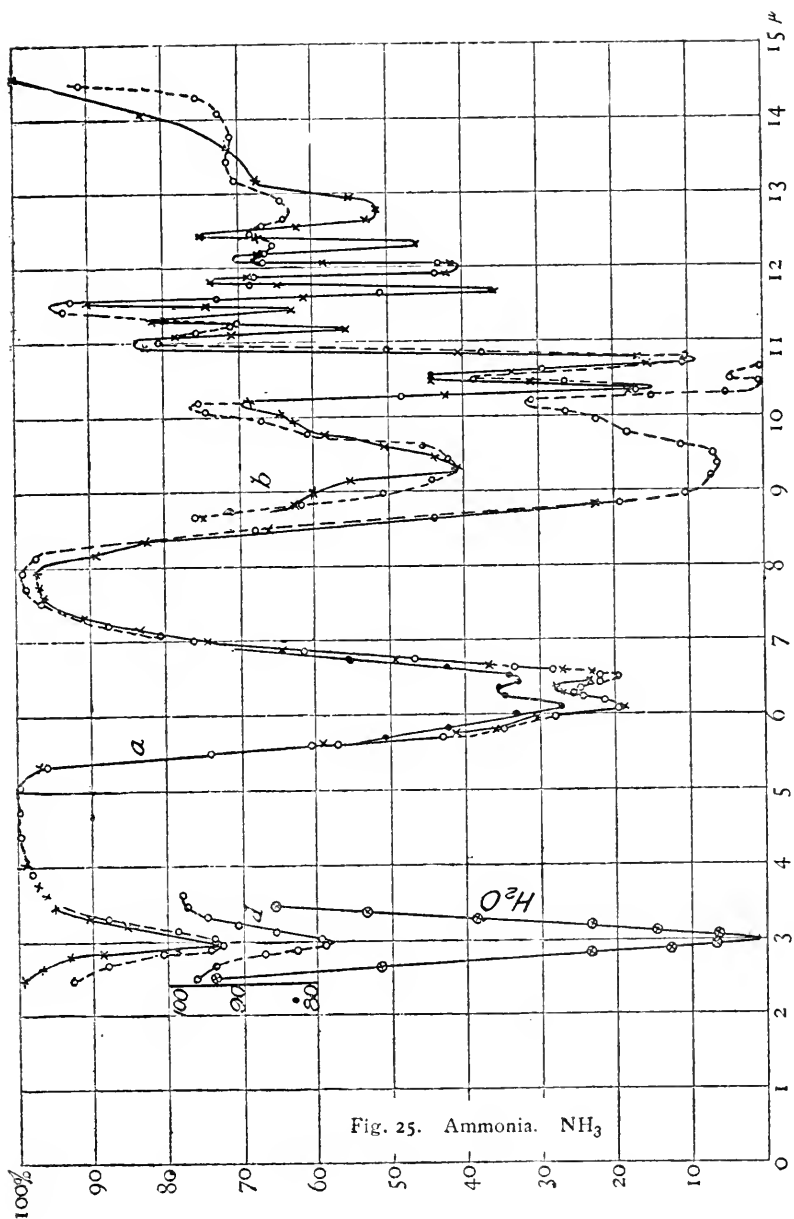

Fig. 25. Ammonia. NH<sub>3</sub>

FIG. 26.

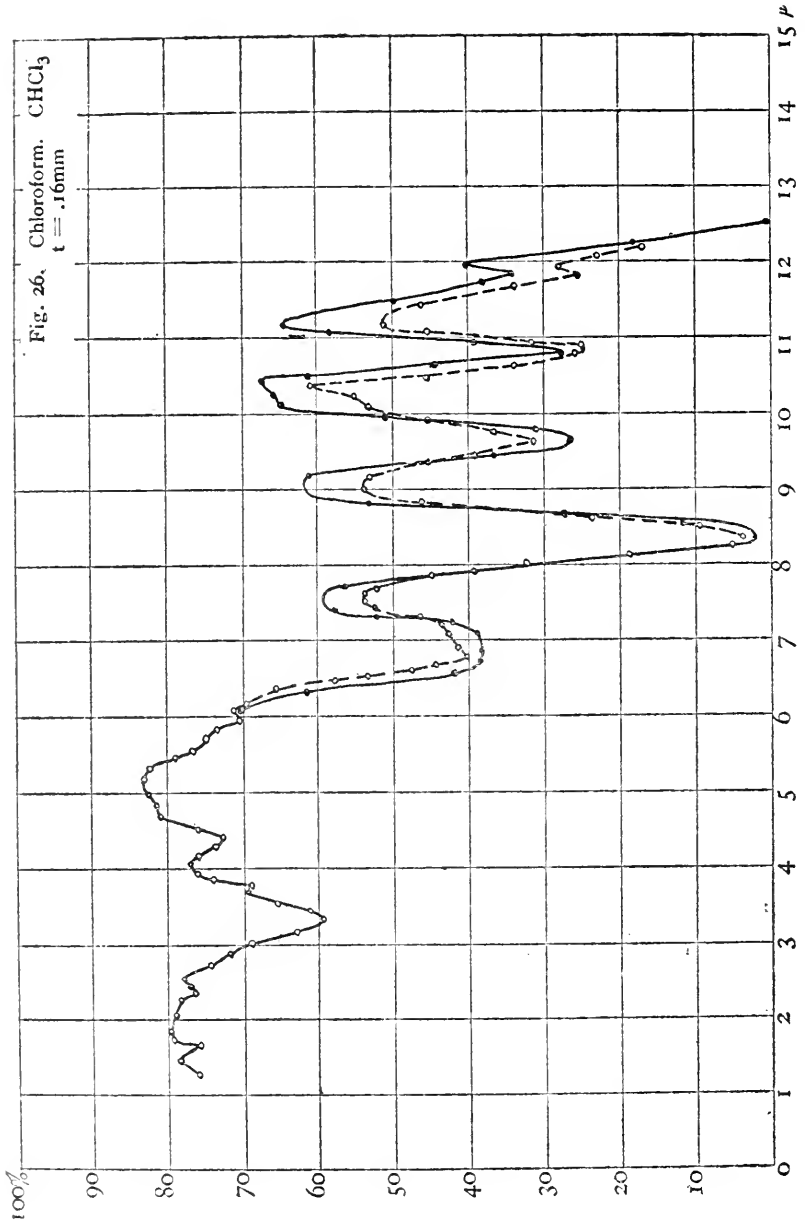

FIG. 27.

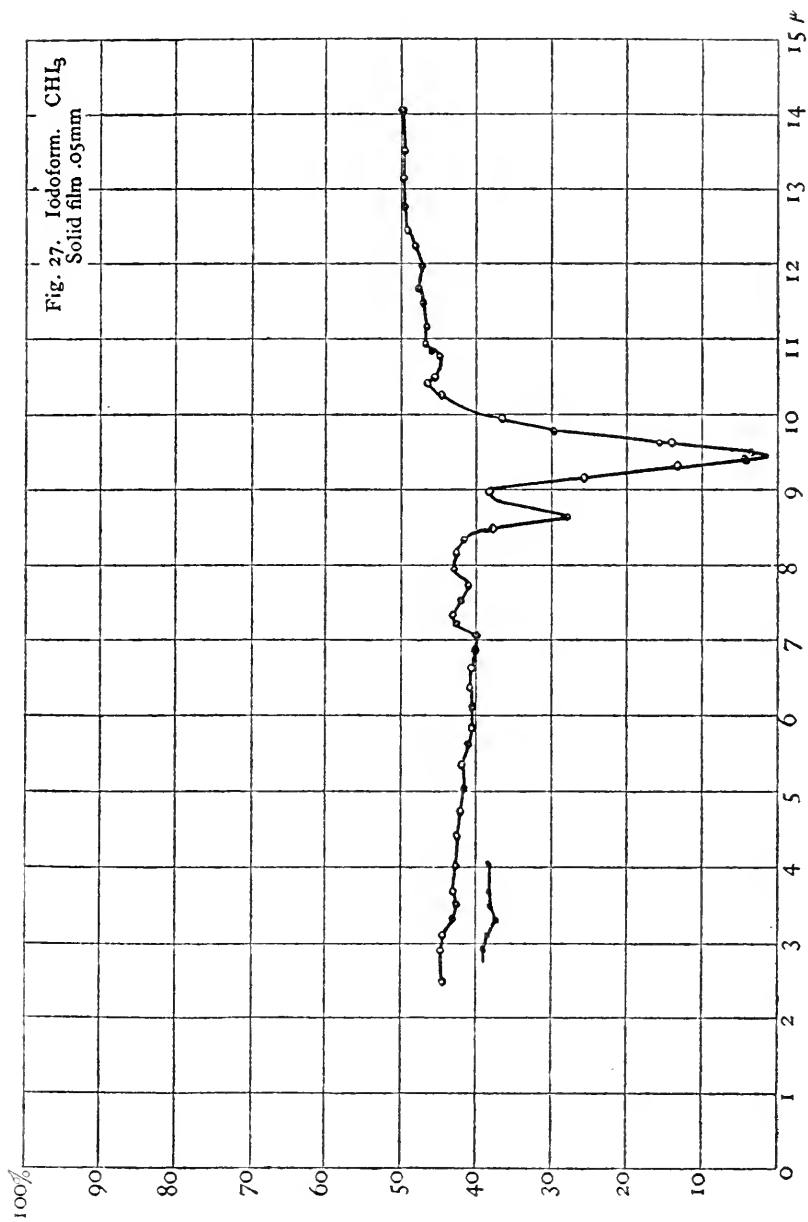

FIG. 28.

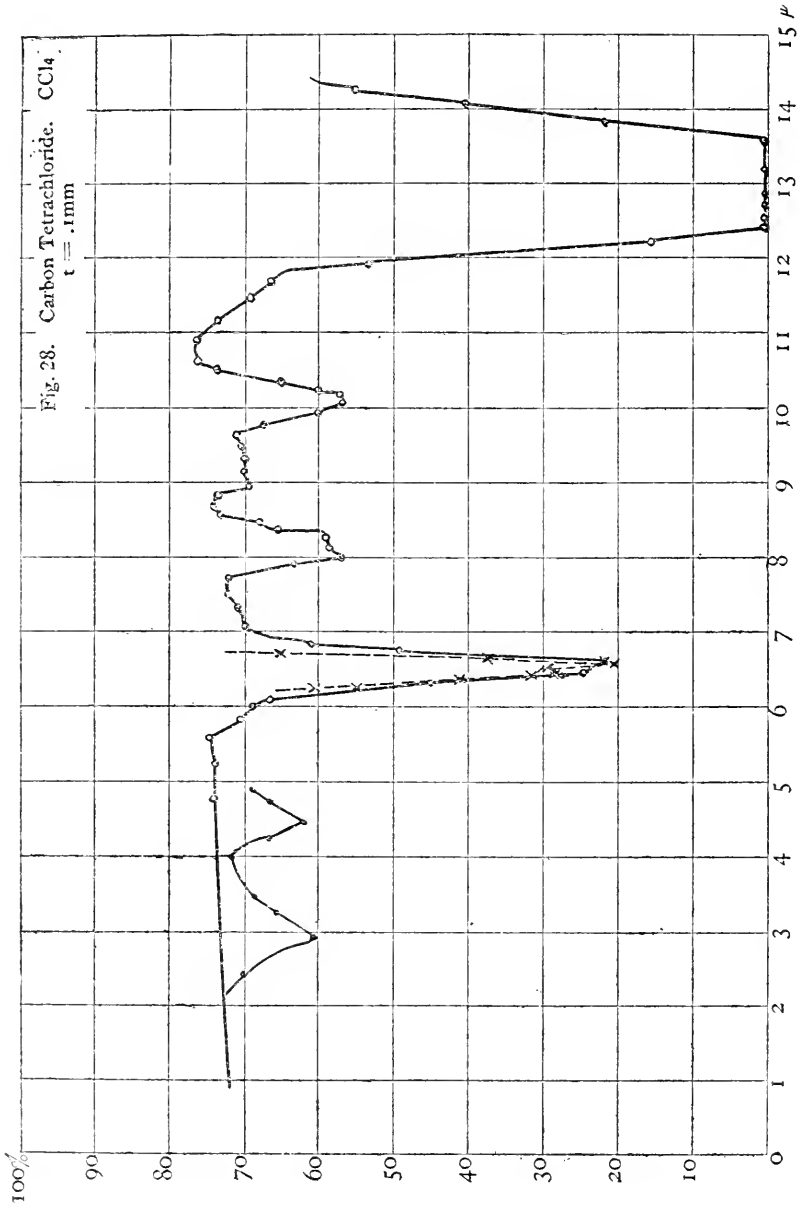



FIG. 29.

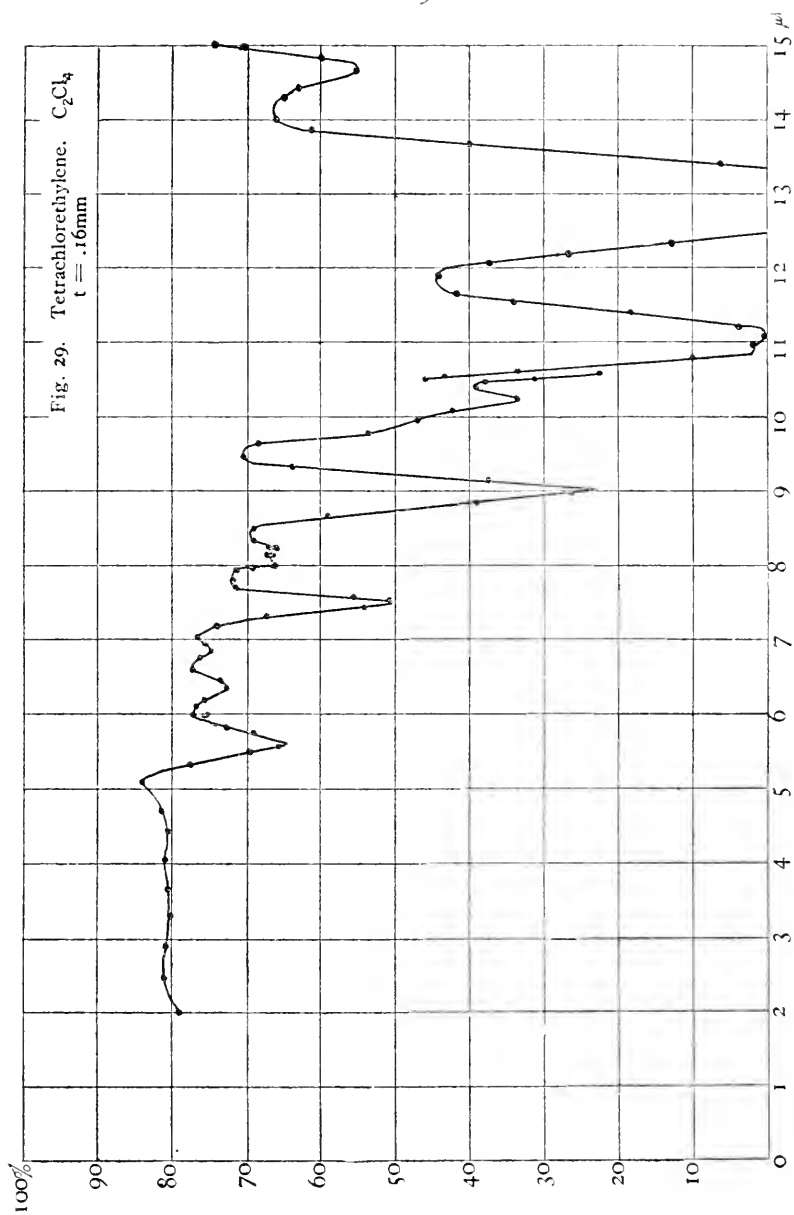

FIG. 30.

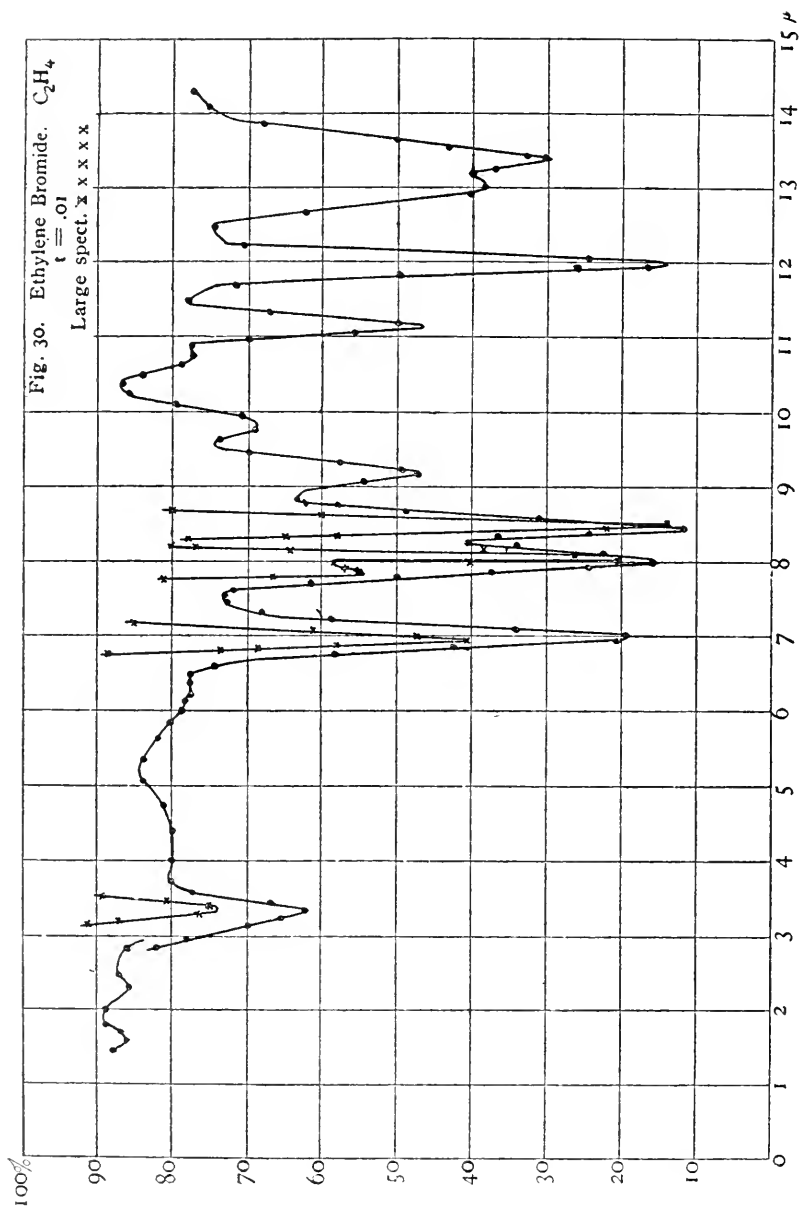

FIG. 31.

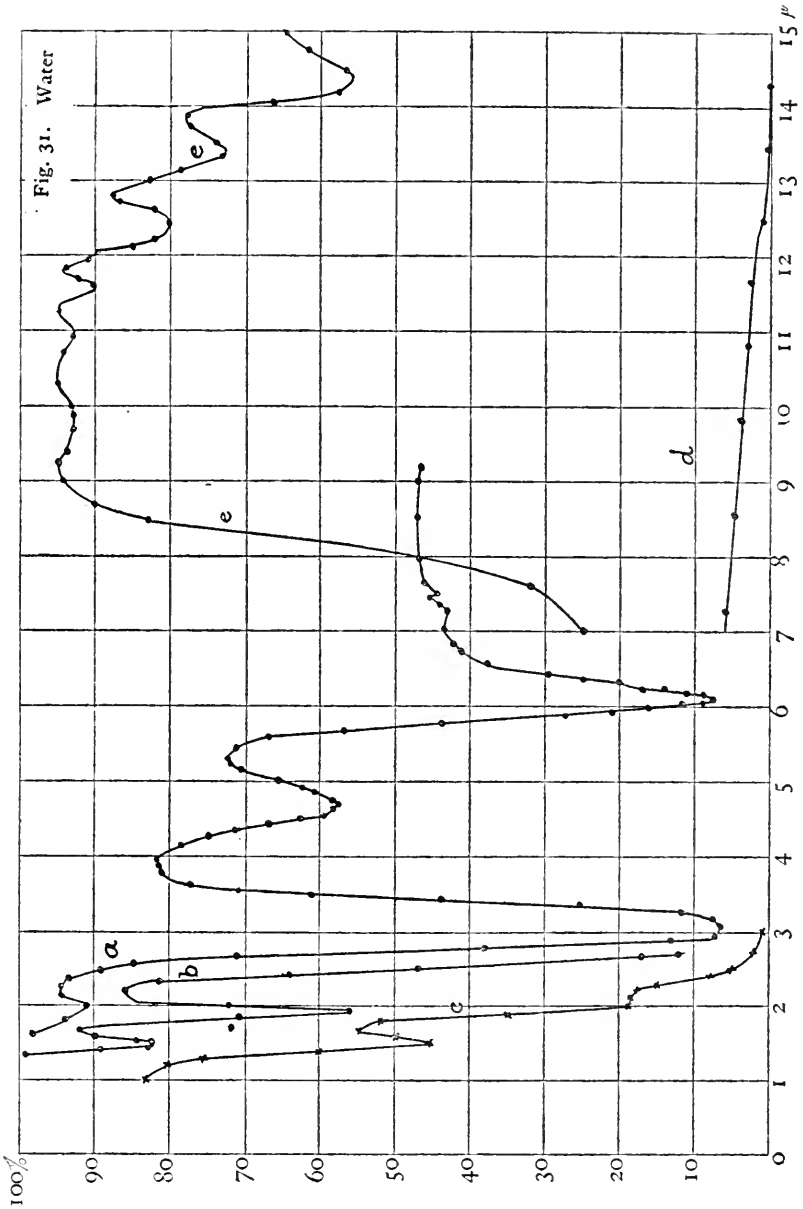

FIG. 32.

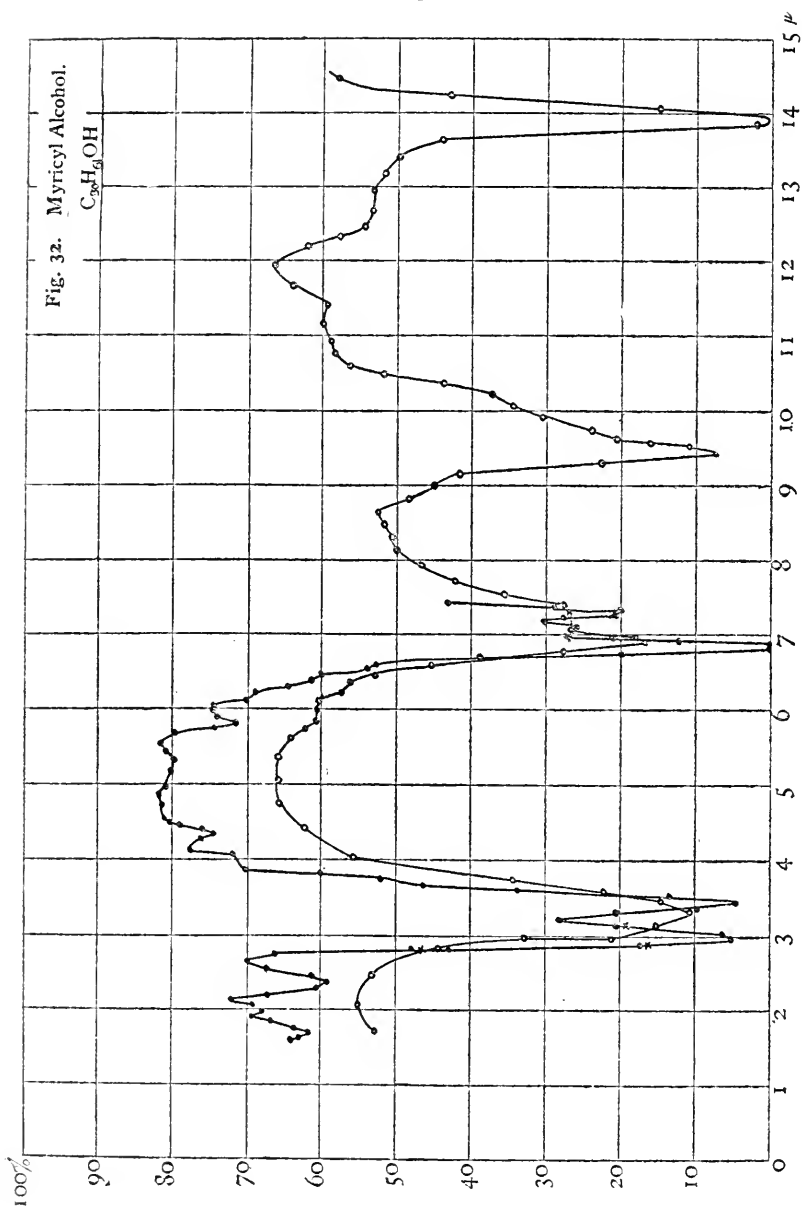

FIG. 33.

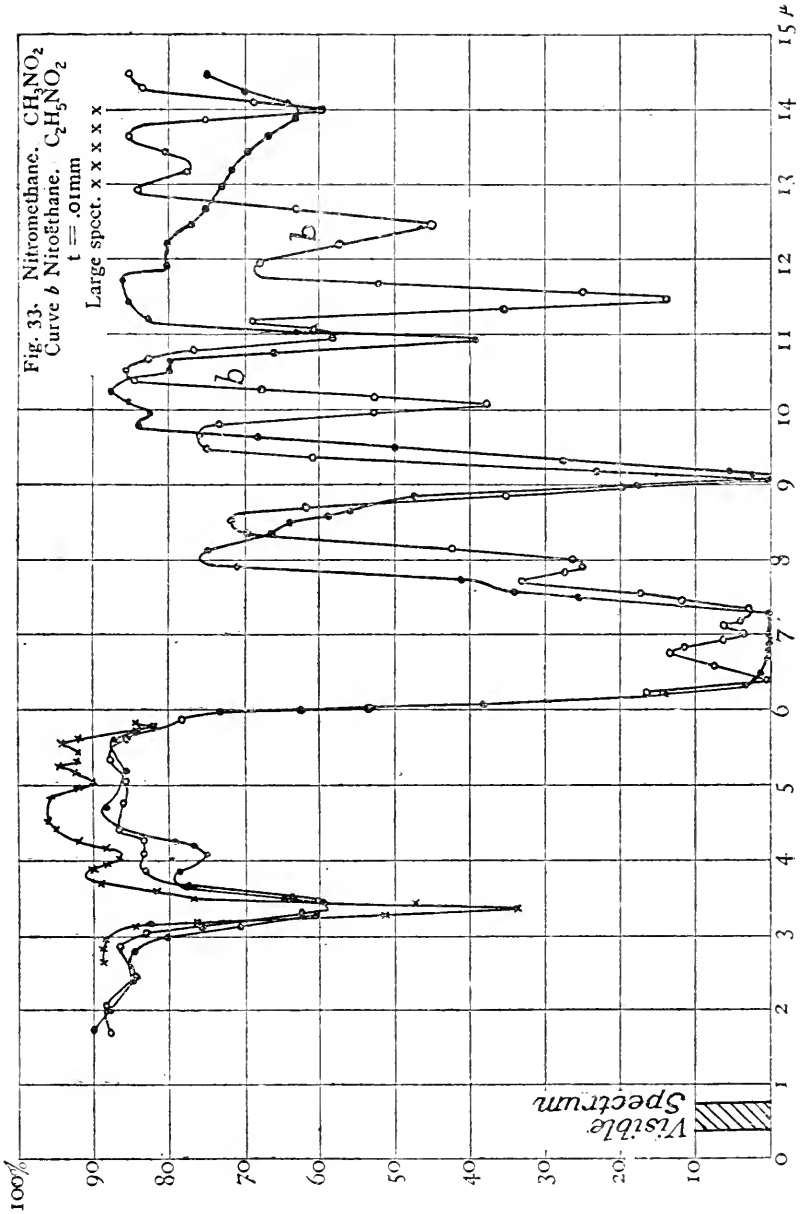

FIG. 34.

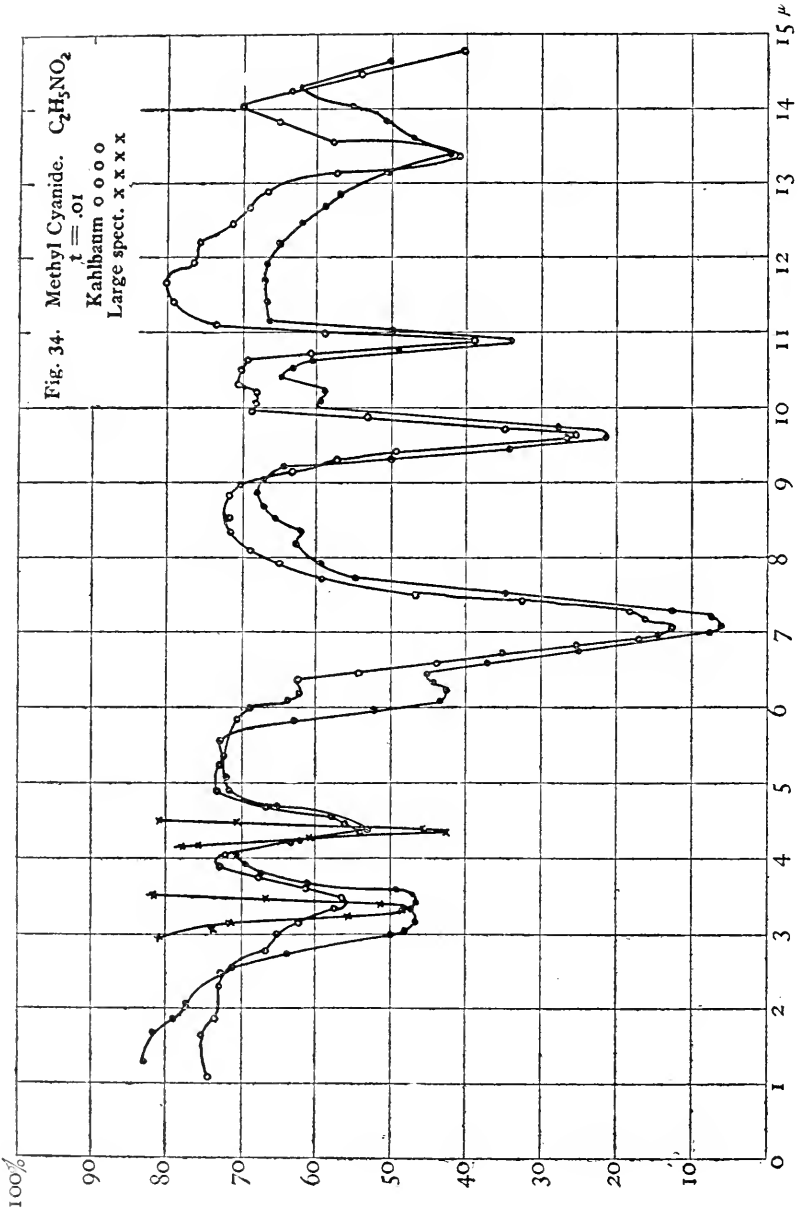

FIG. 35.

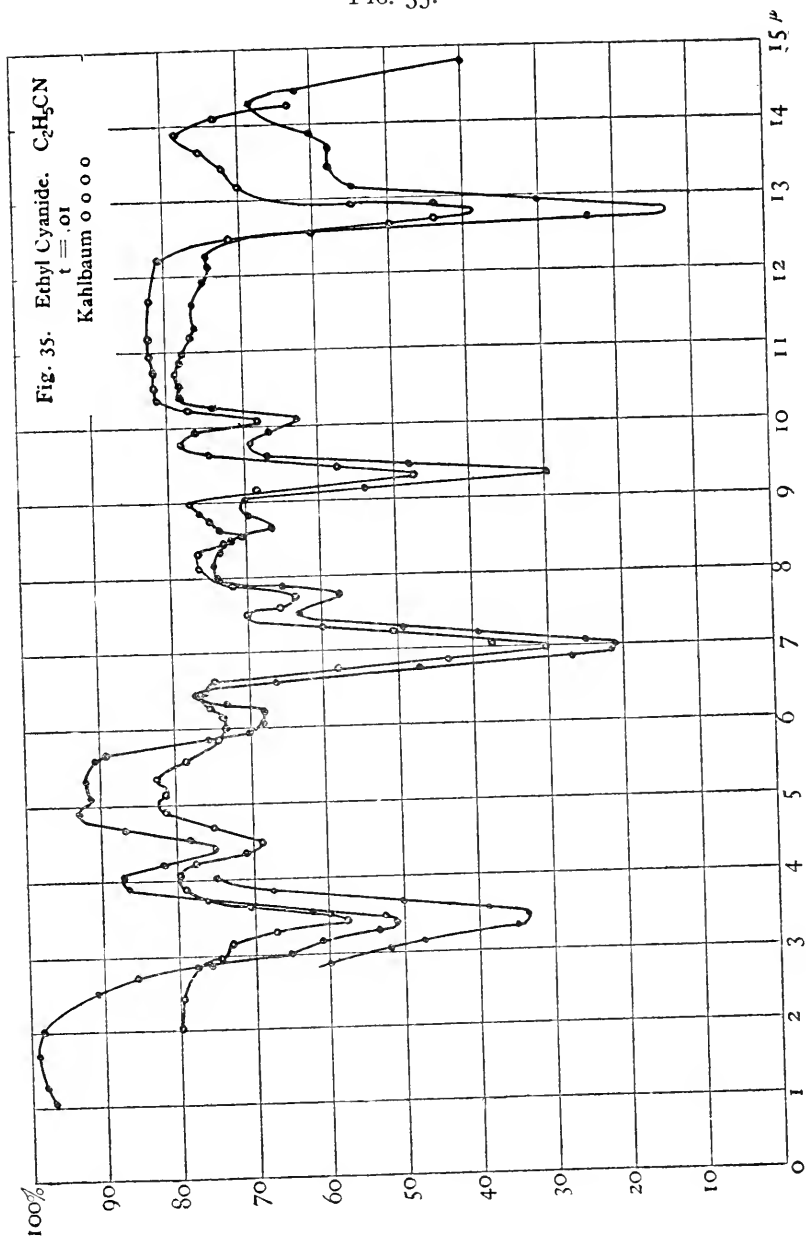

FIG. 36.

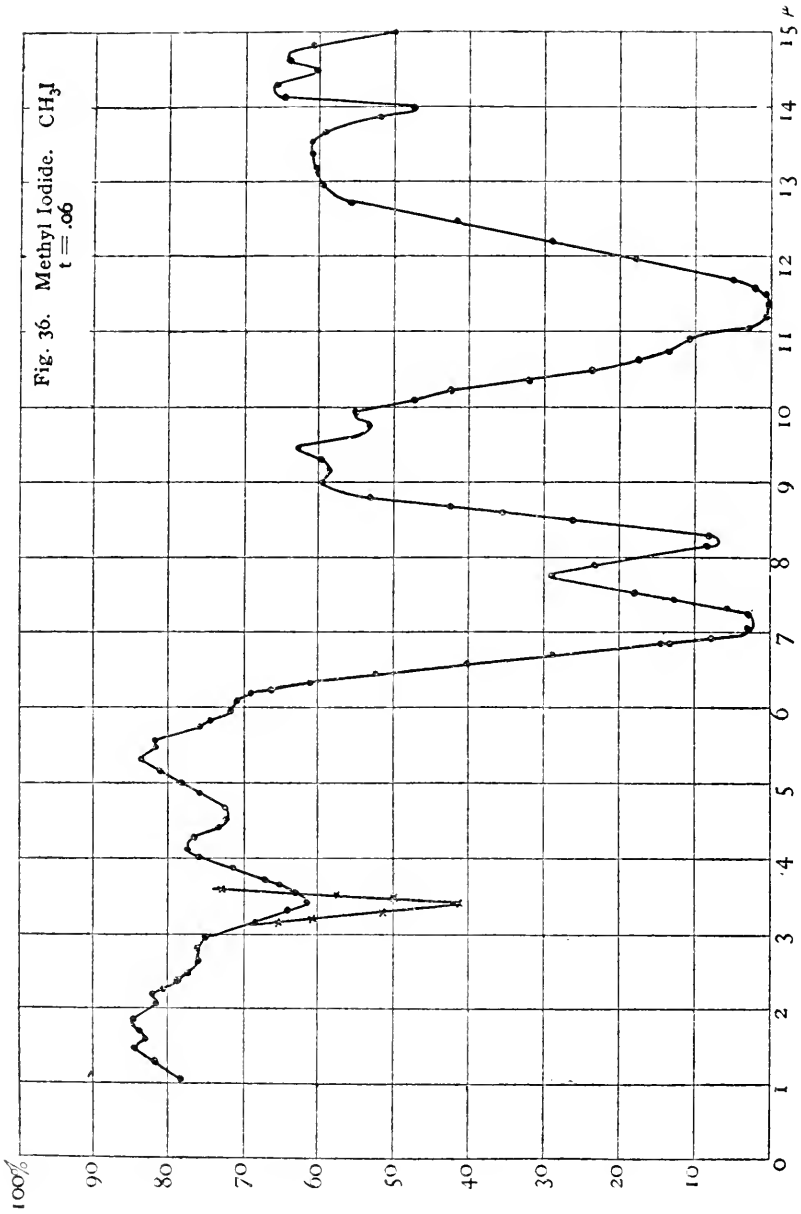



FIG. 37.

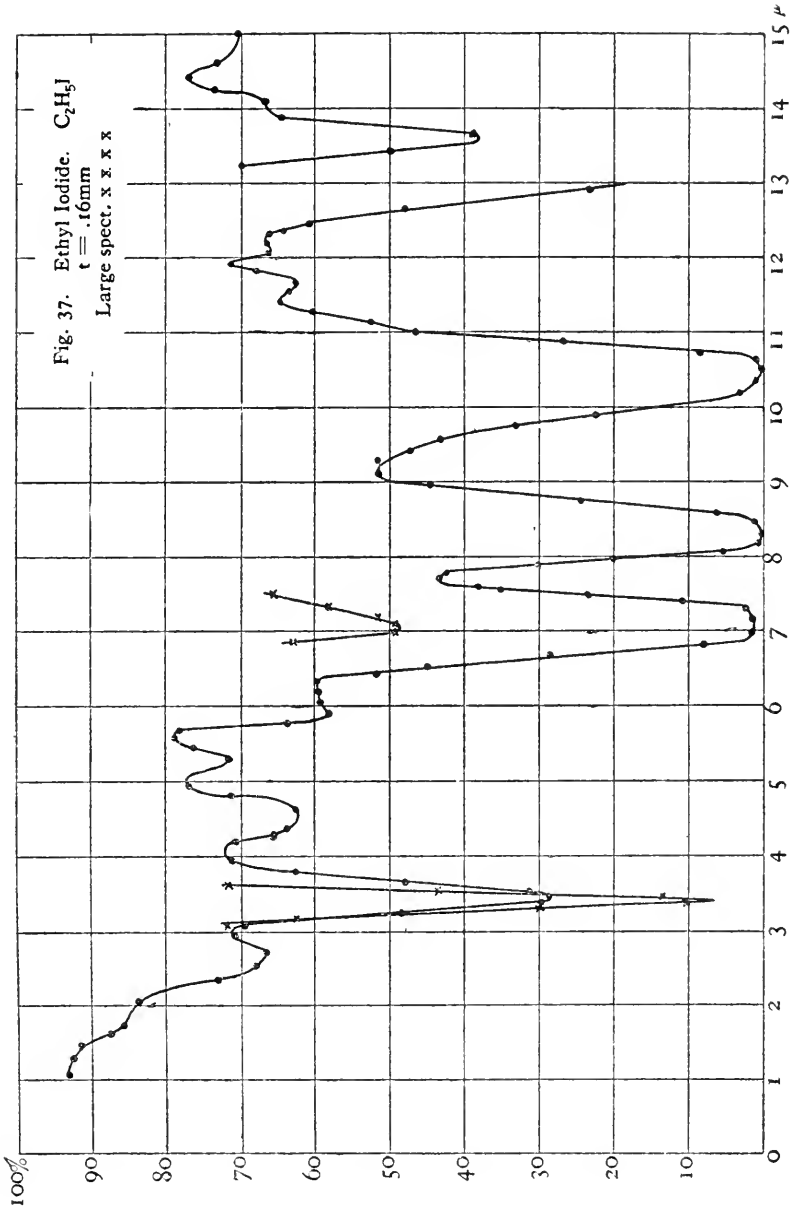

FIG. 38.

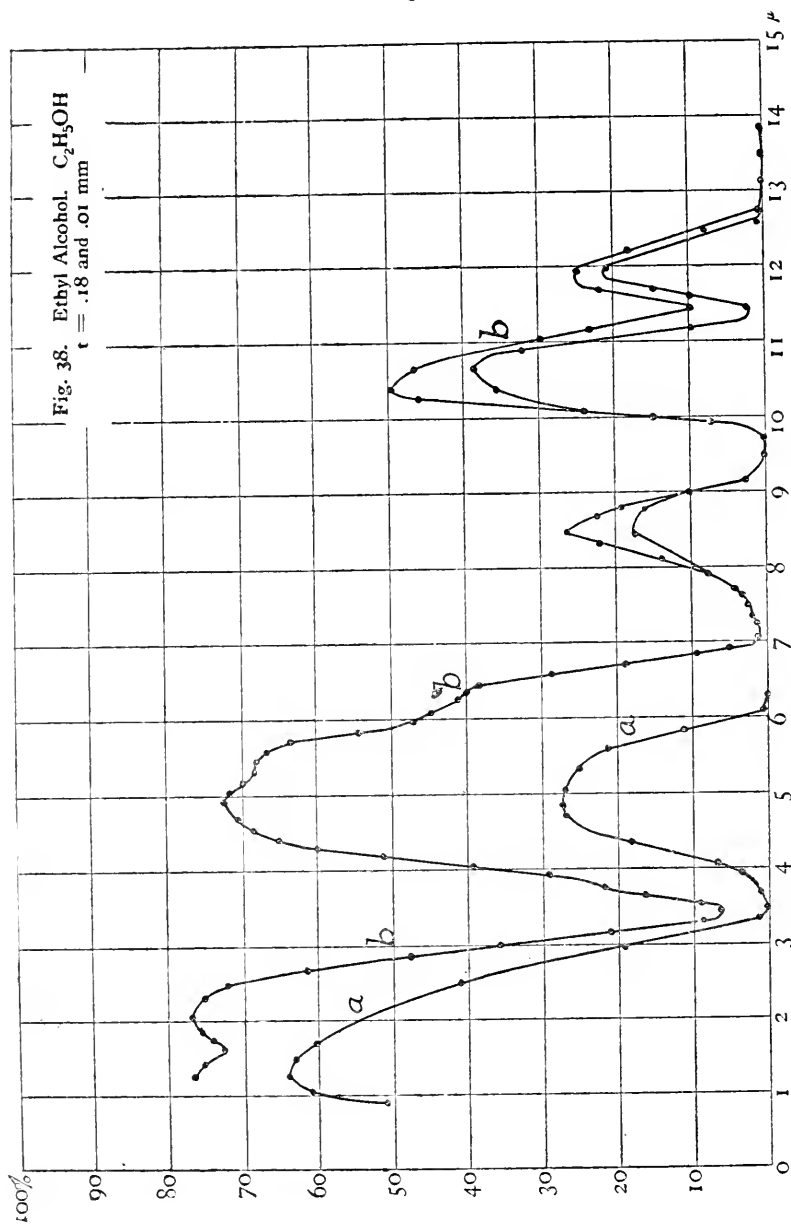

FIG. 39.

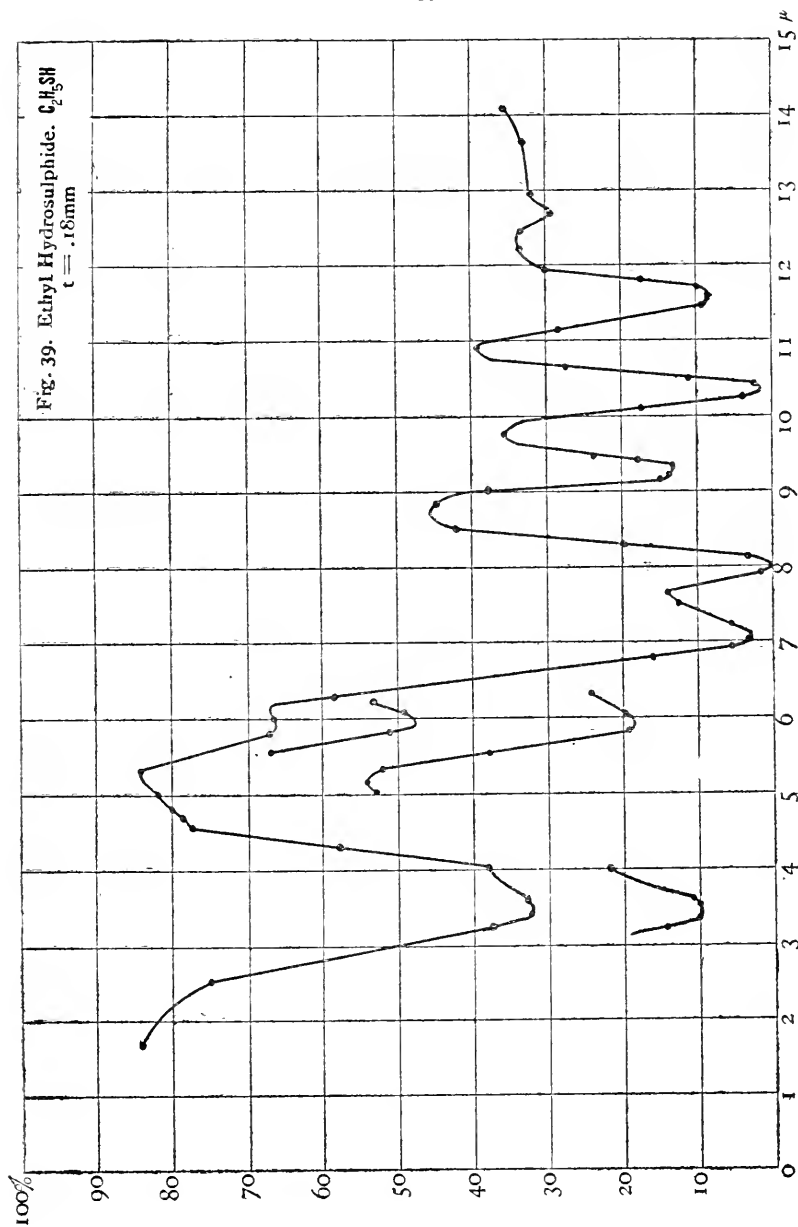

FIG. 40.

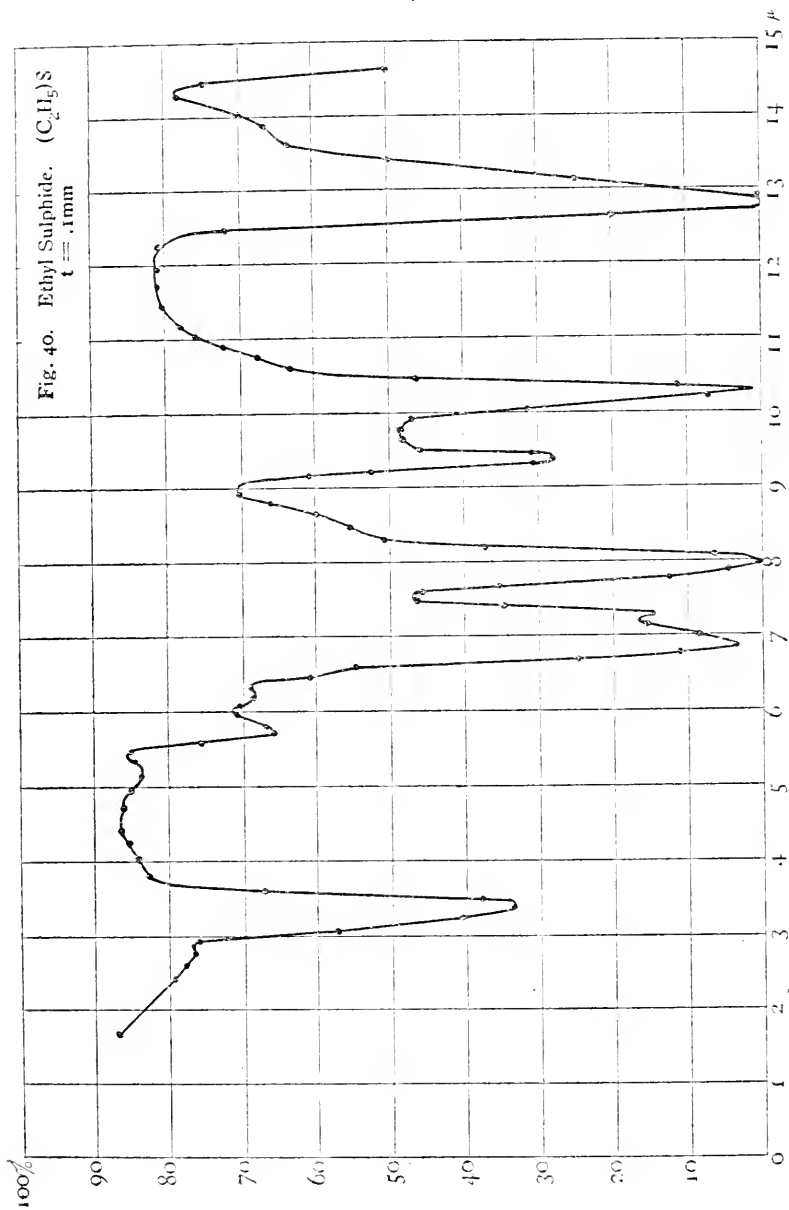

FIG. 41.

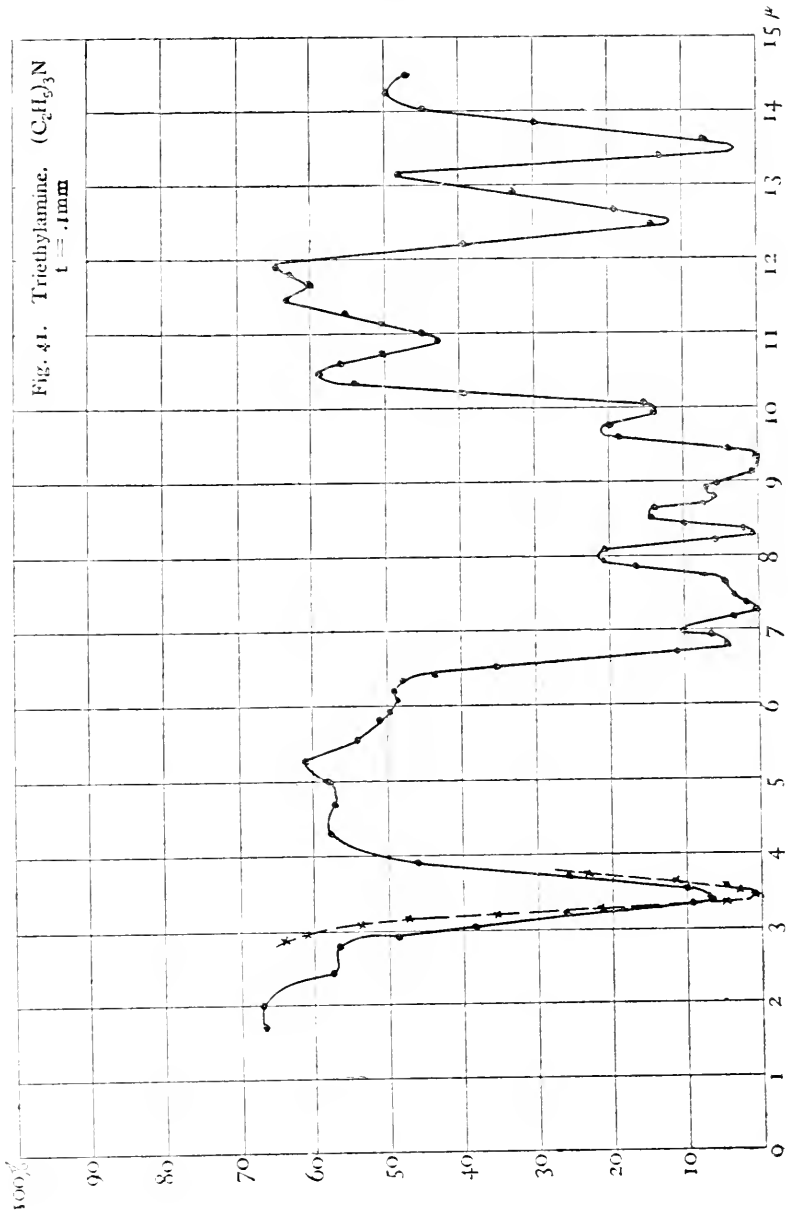

FIG. 42.

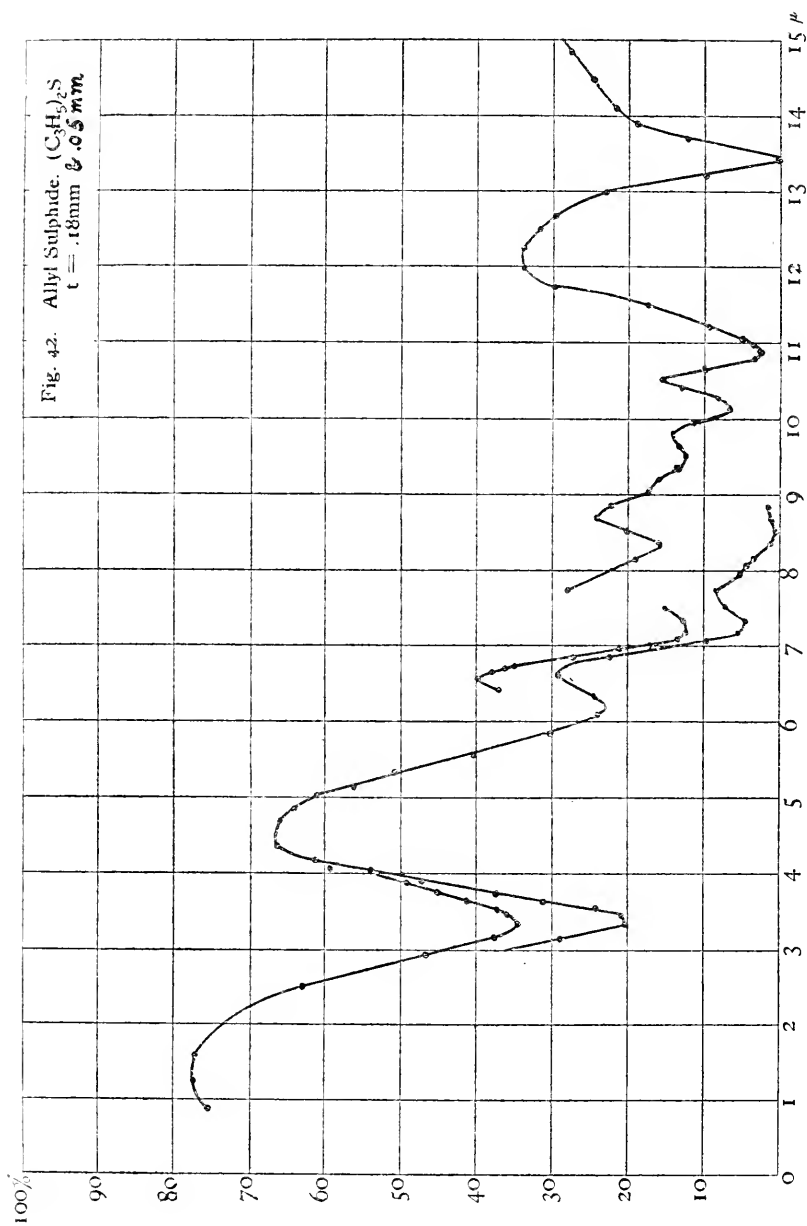

FIG. 43.

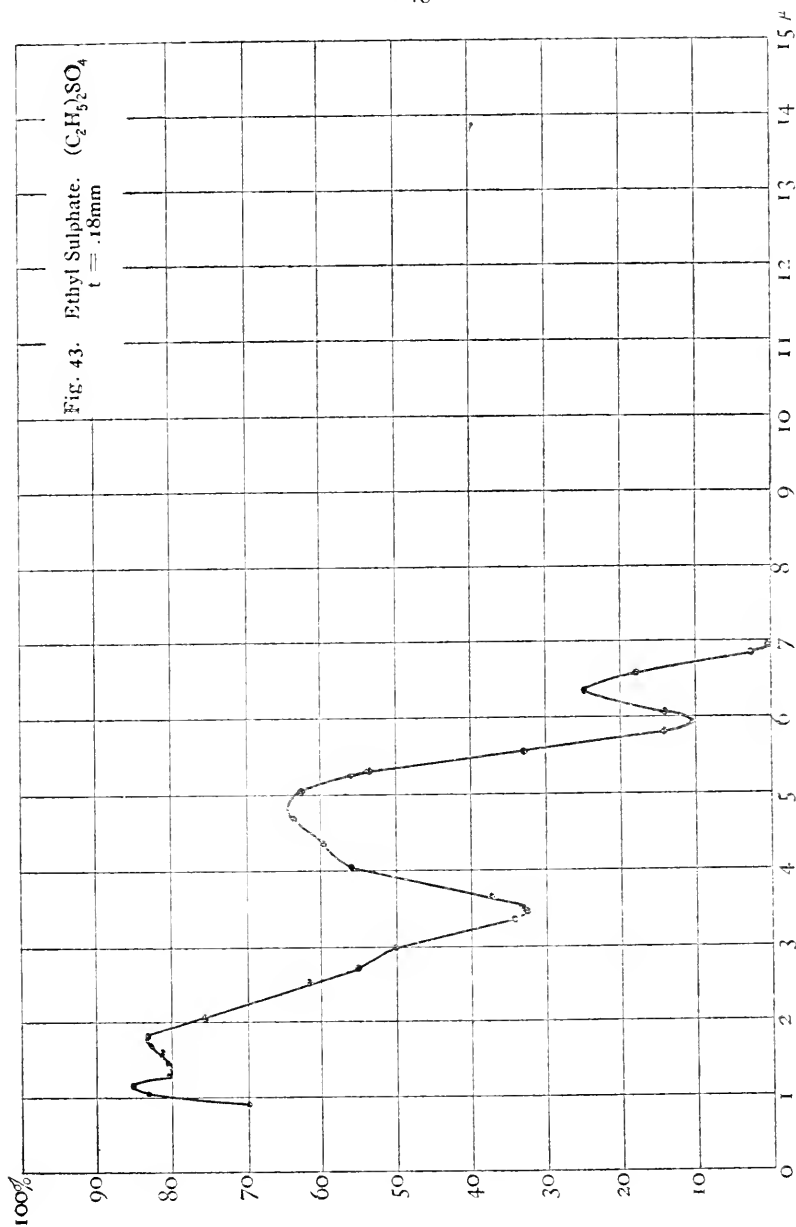

FIG. 44.

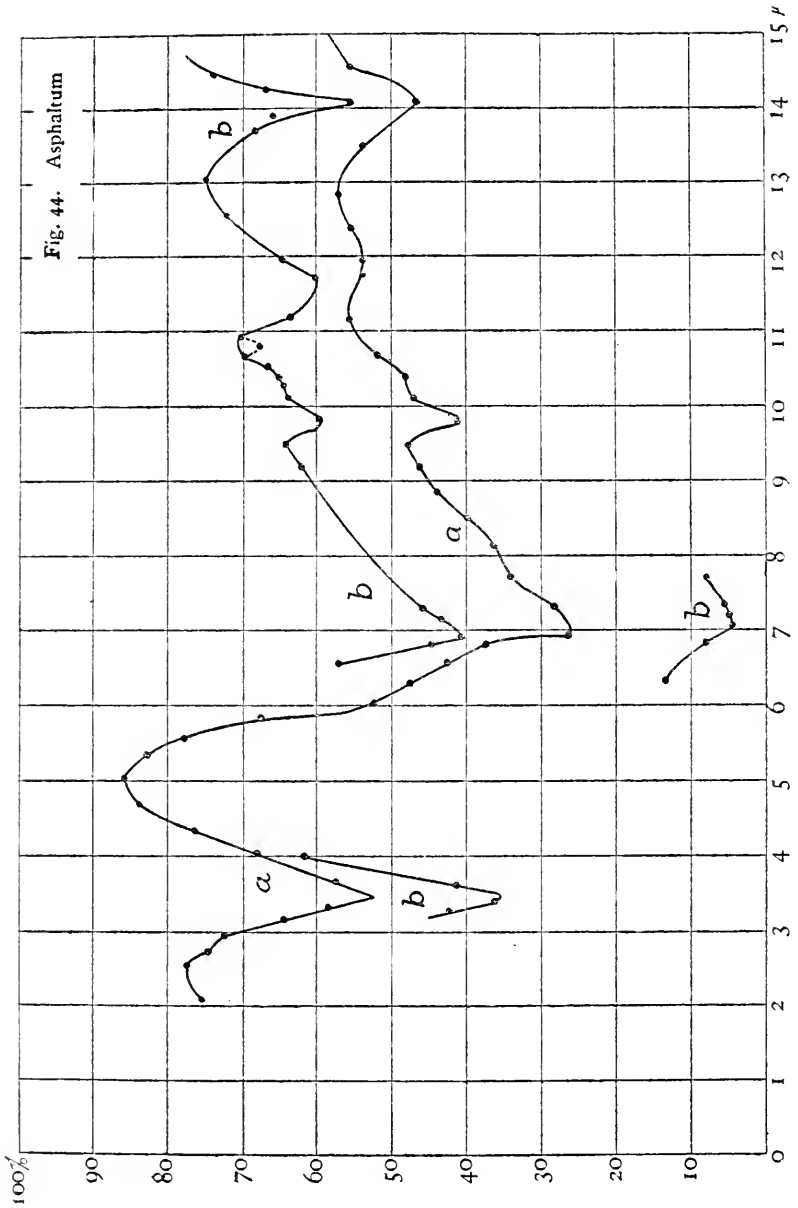



FIG. 45.

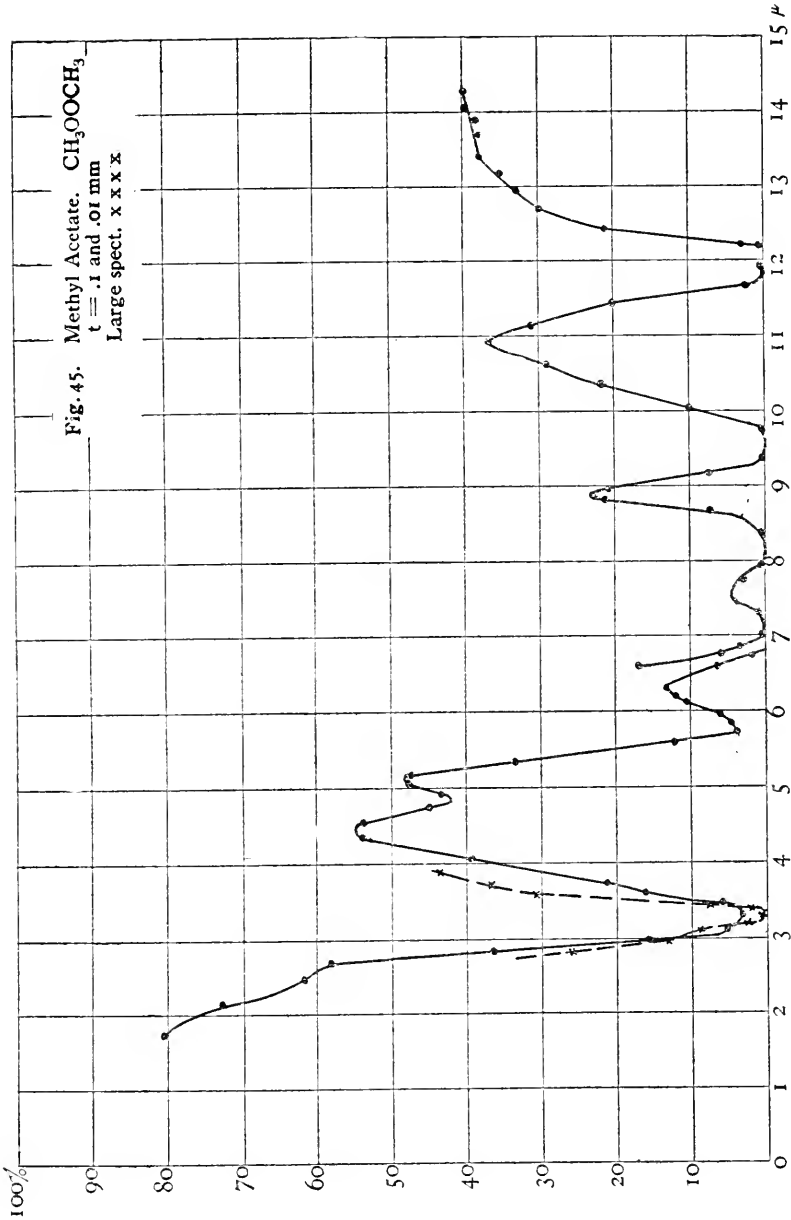

FIG. 46.

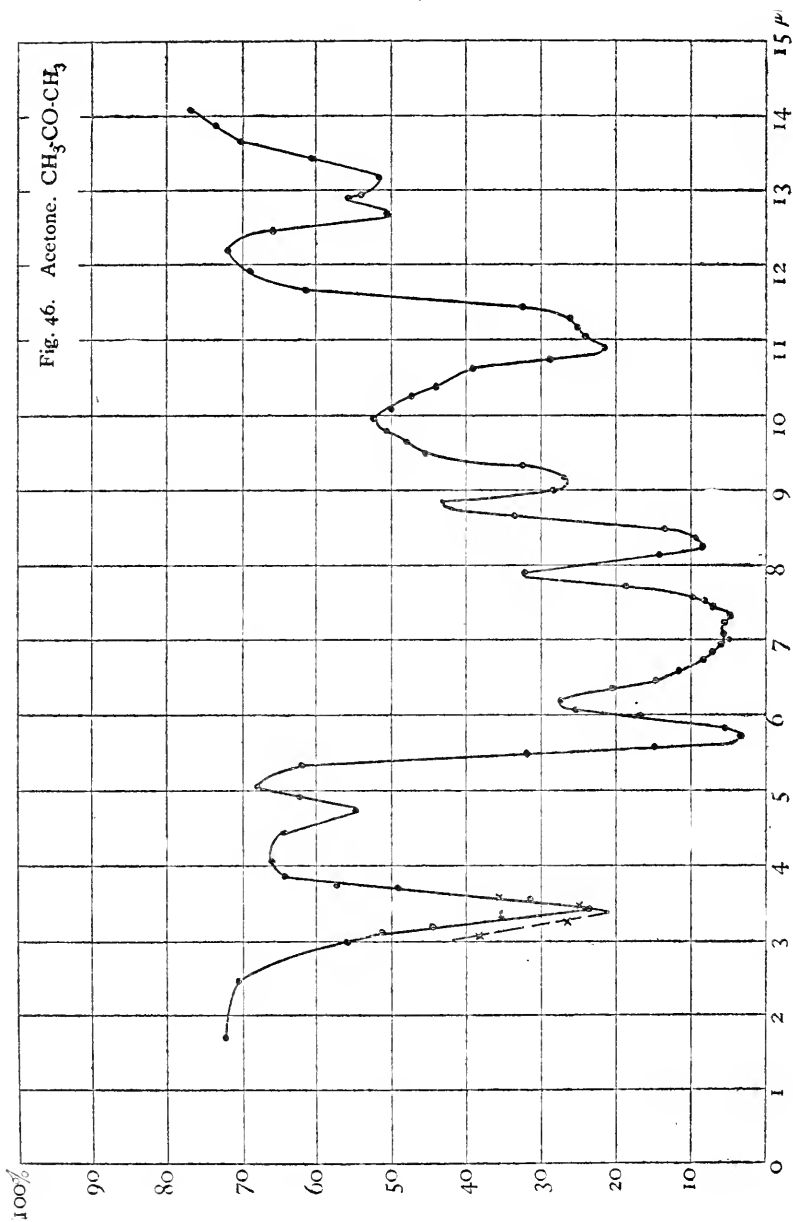



FIG. 48.

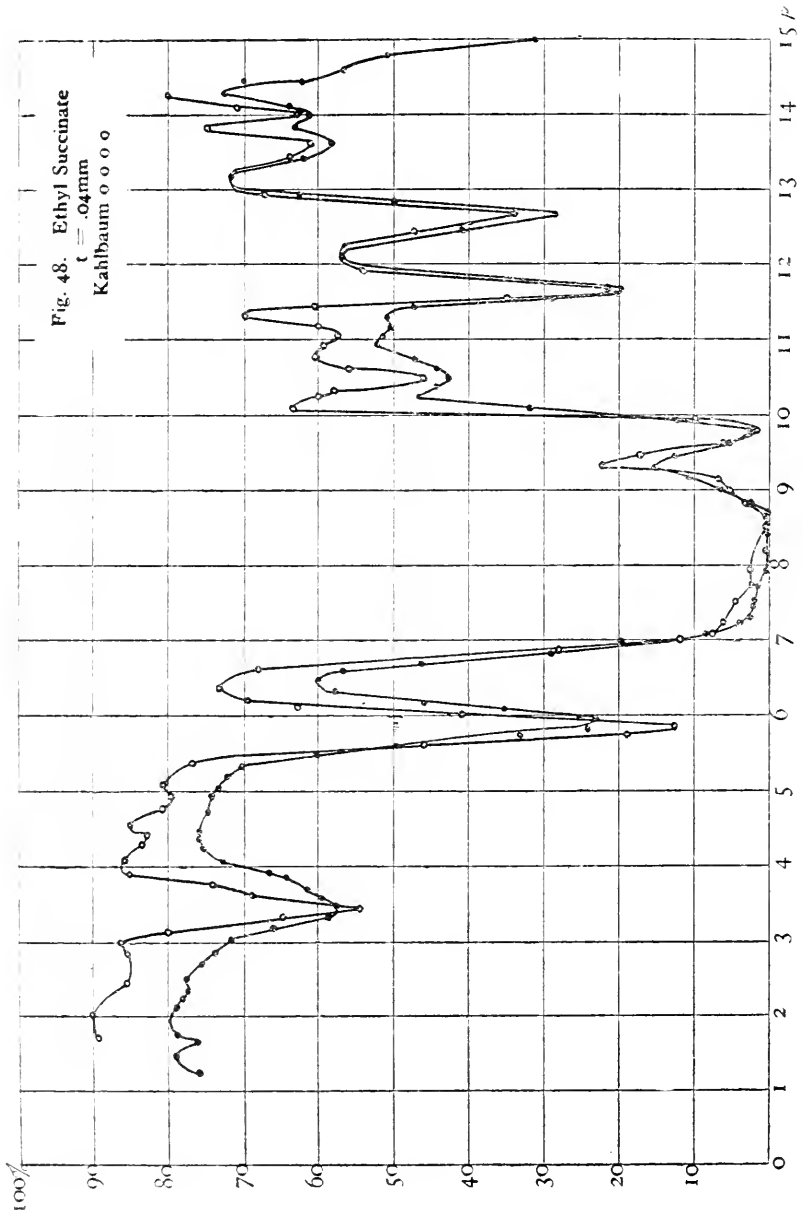

FIG. 49.

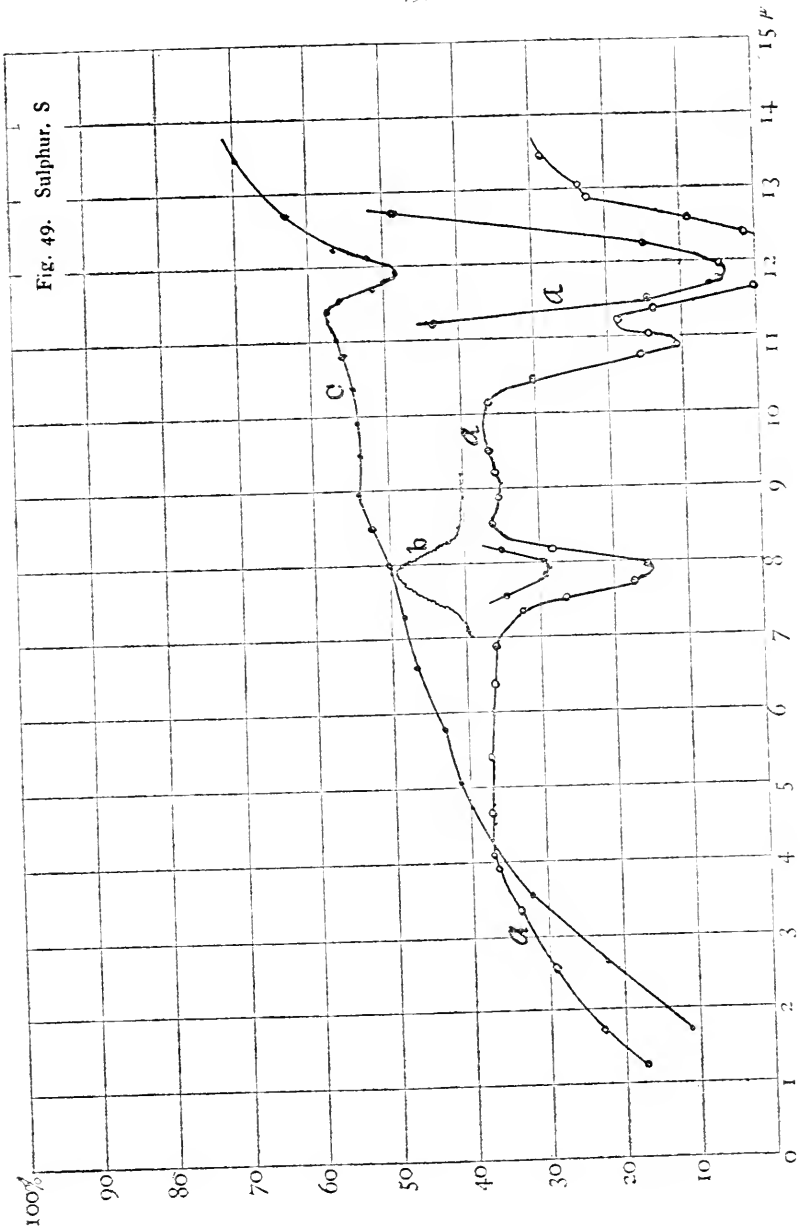

FIG. 50.

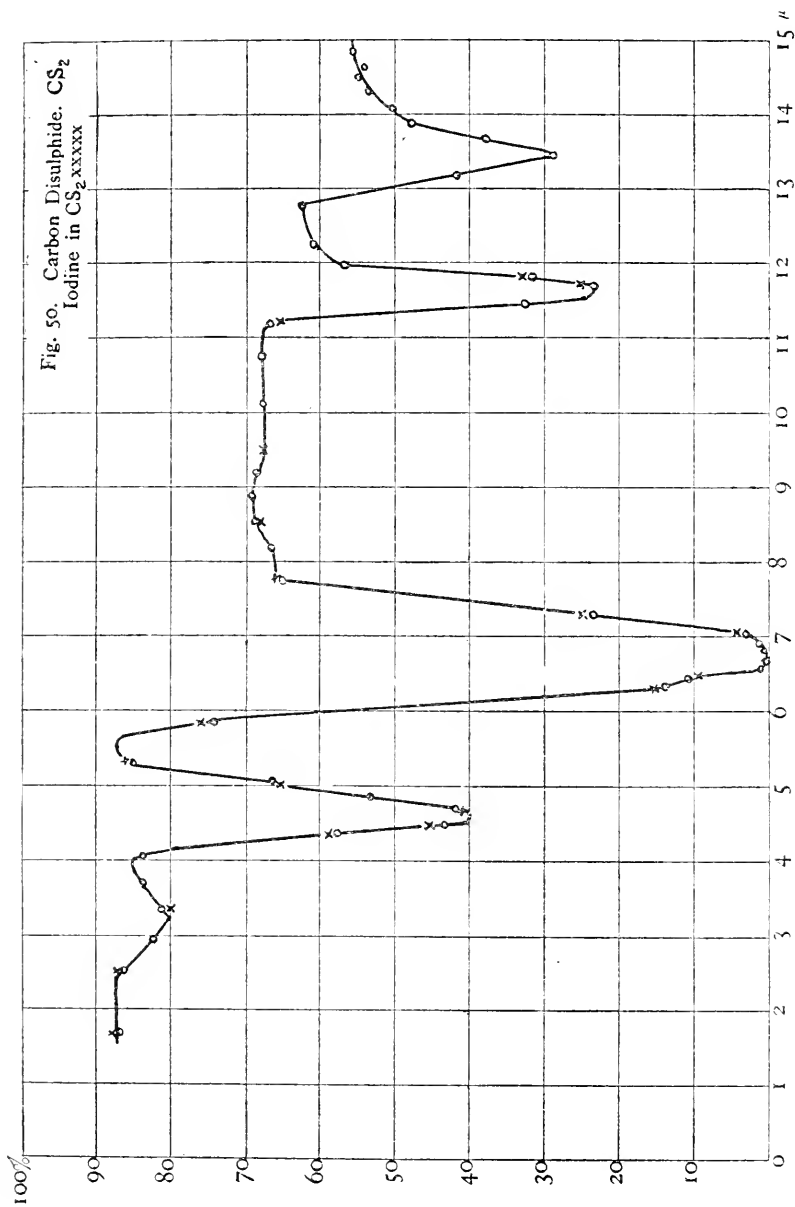

FIG. 51.

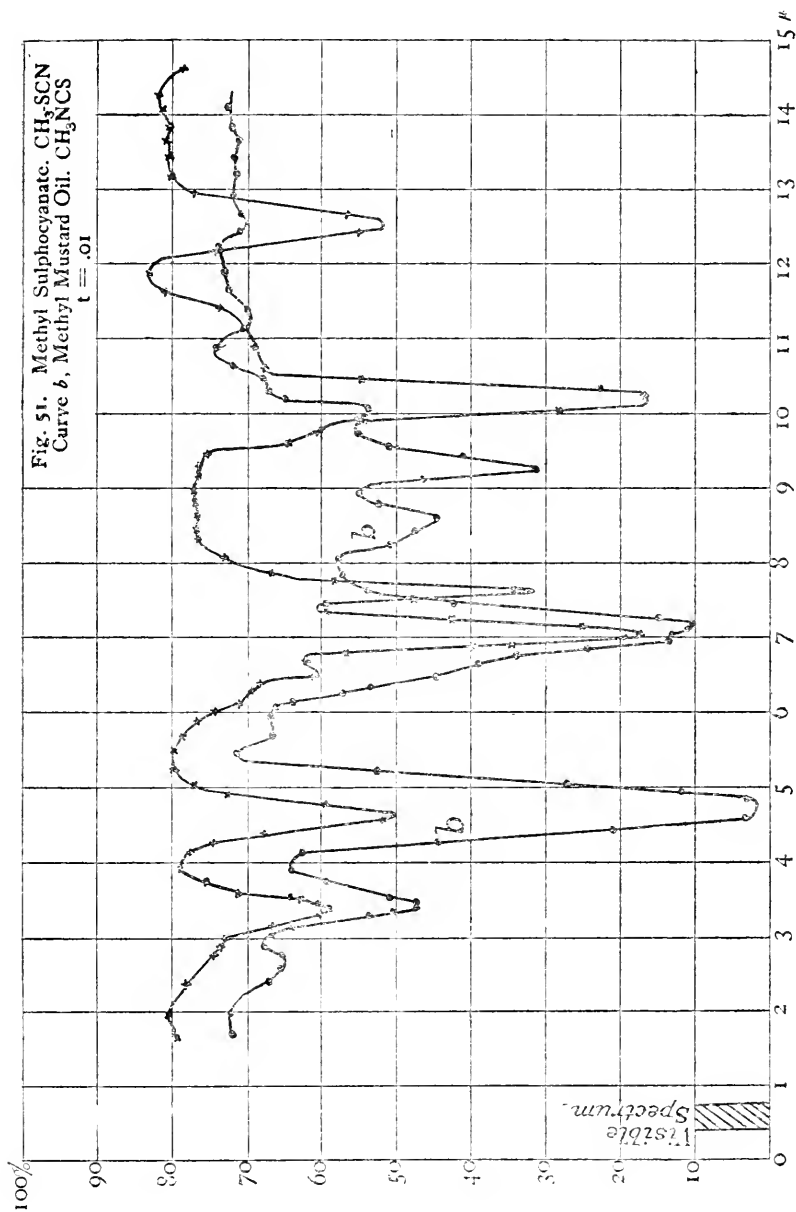

FIG. 52.

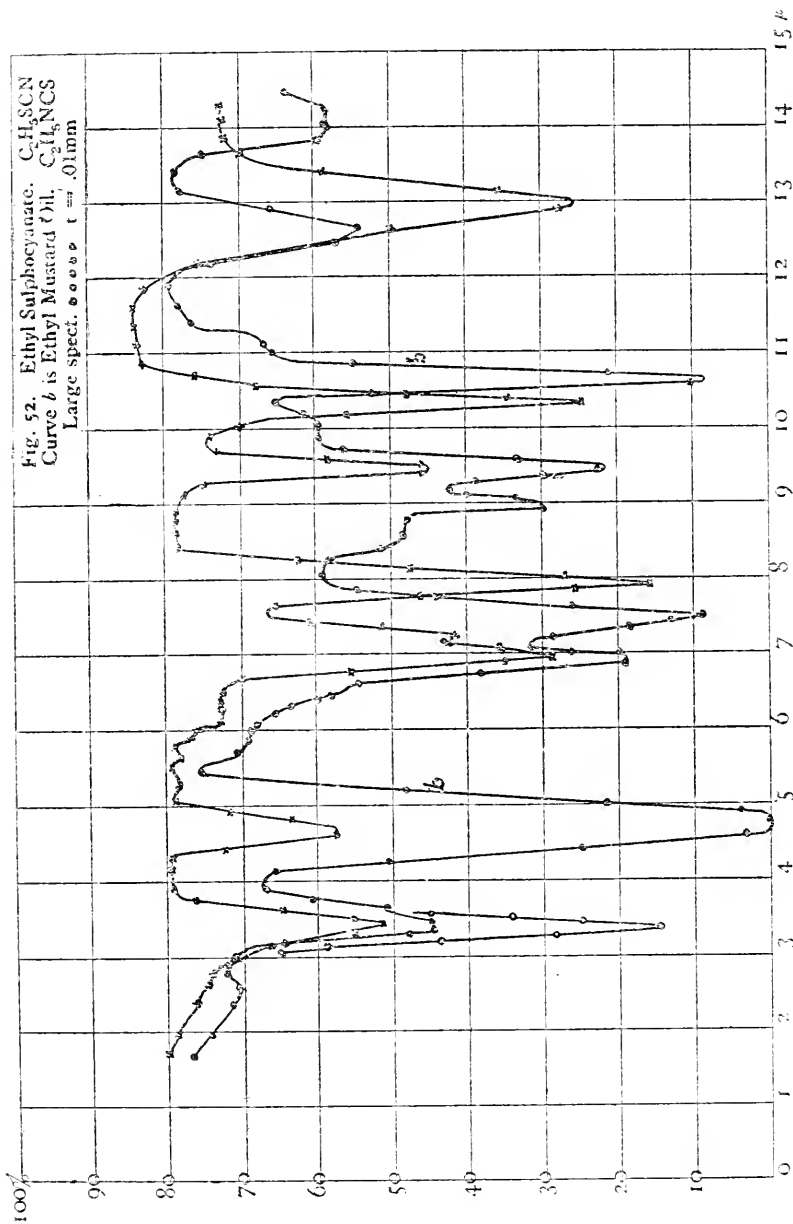



FIG. 53.

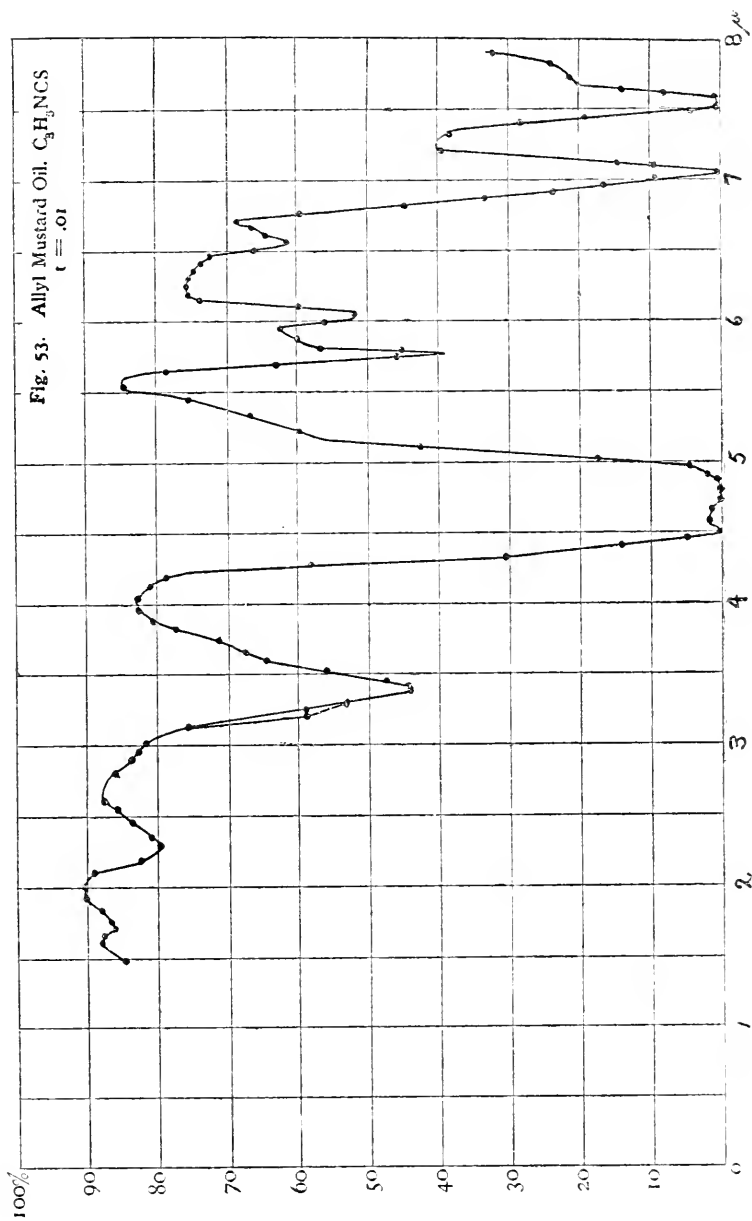

FIG. 54.

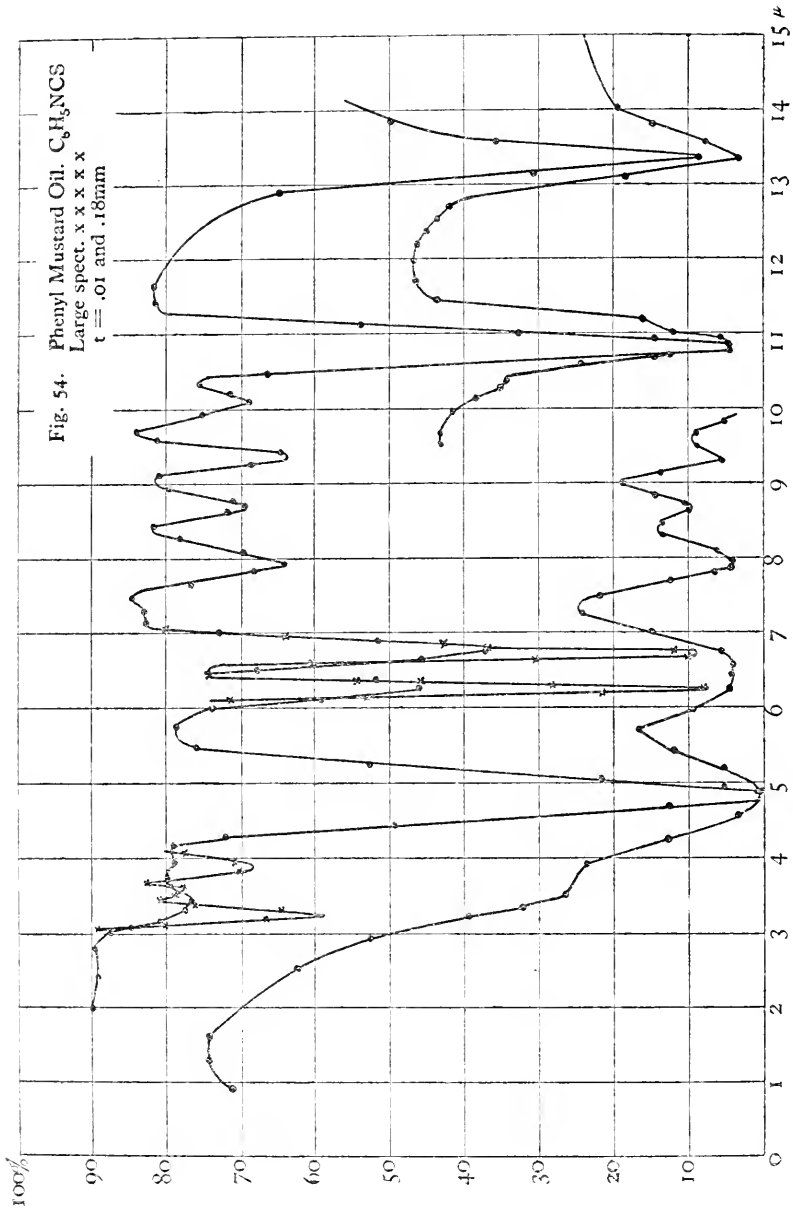

FIG. 55.

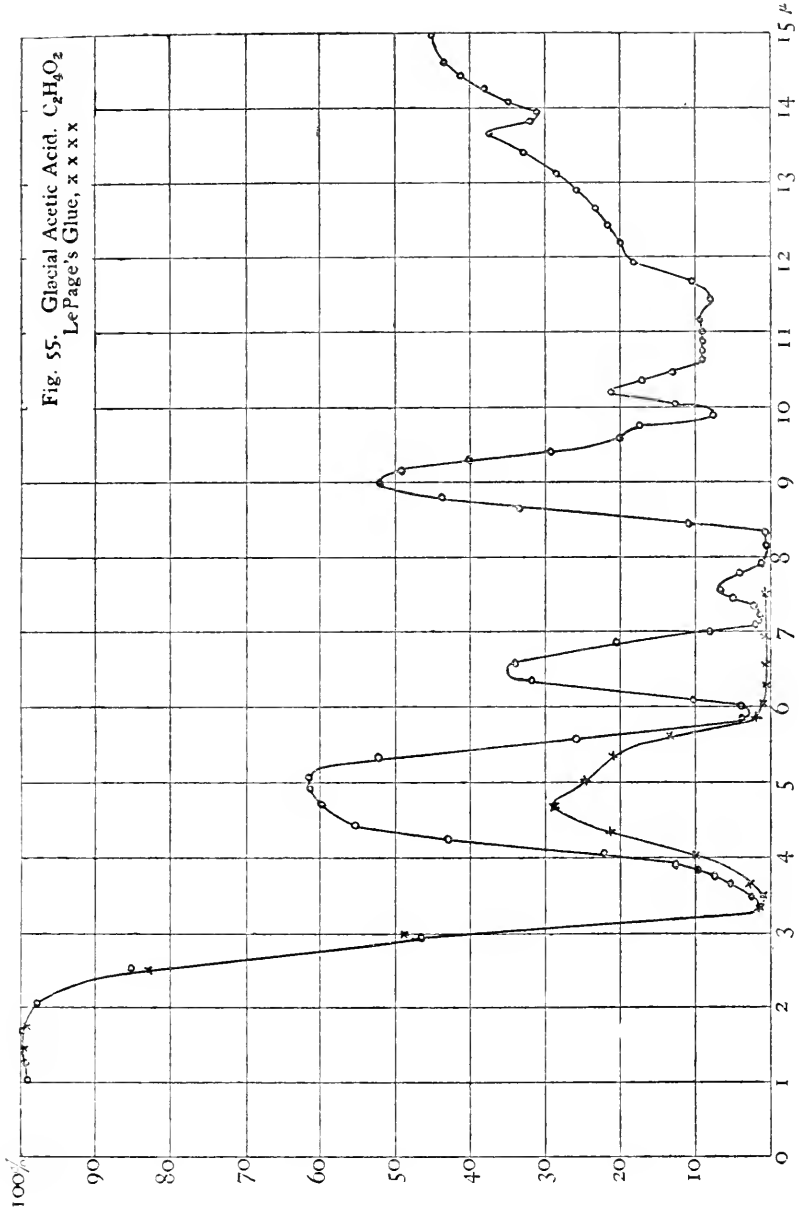

FIG. 56.

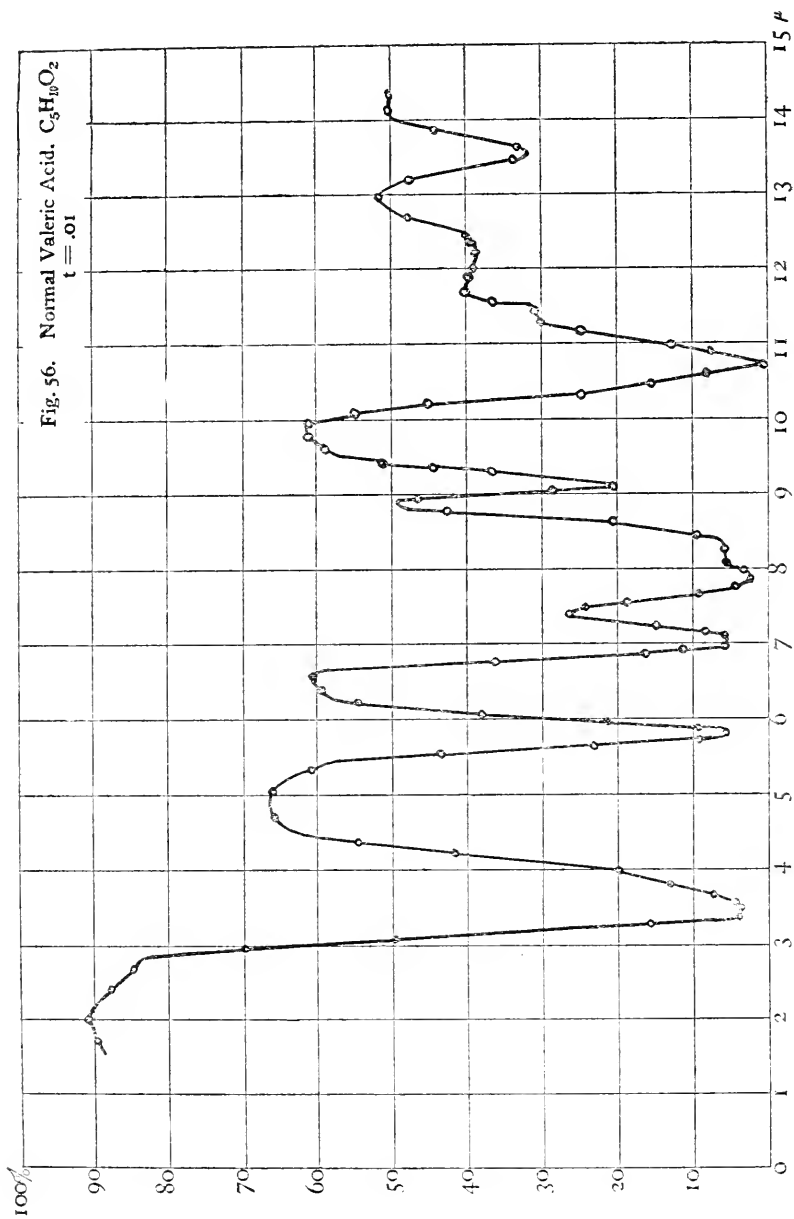

FIG. 57.

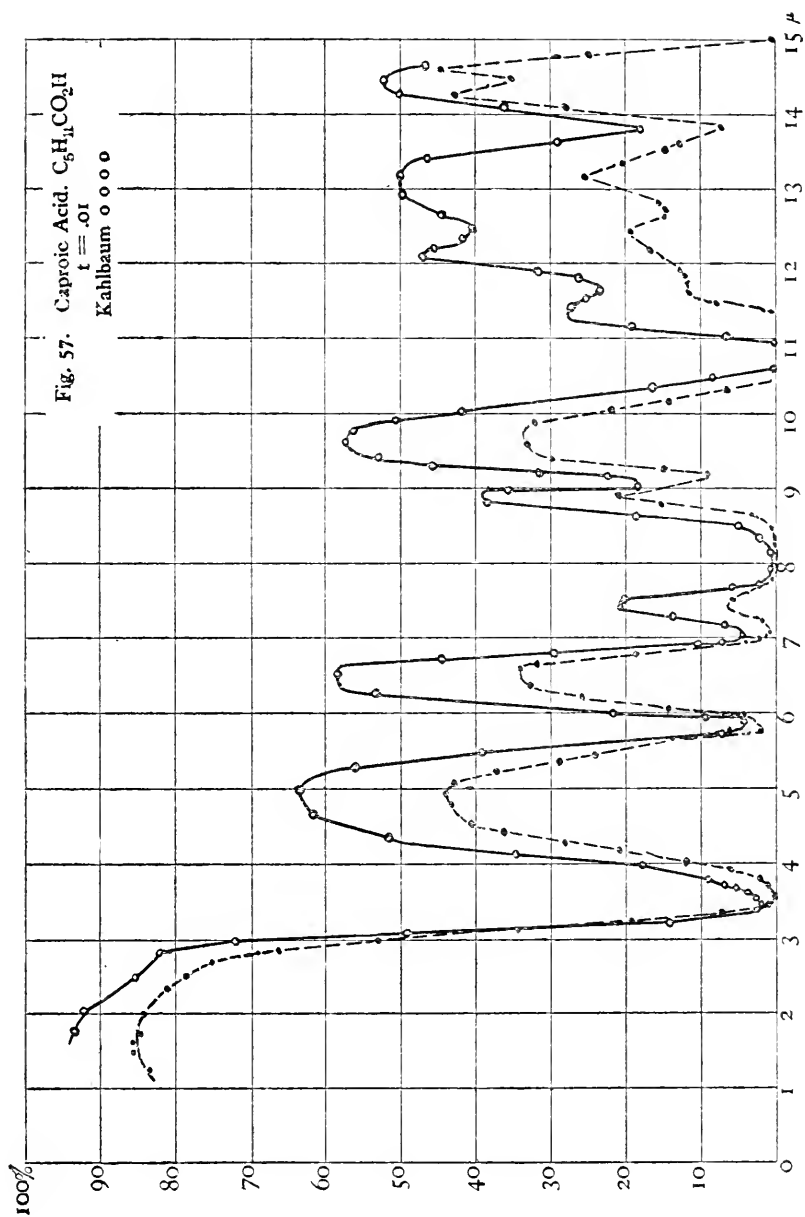

FIG. 58.

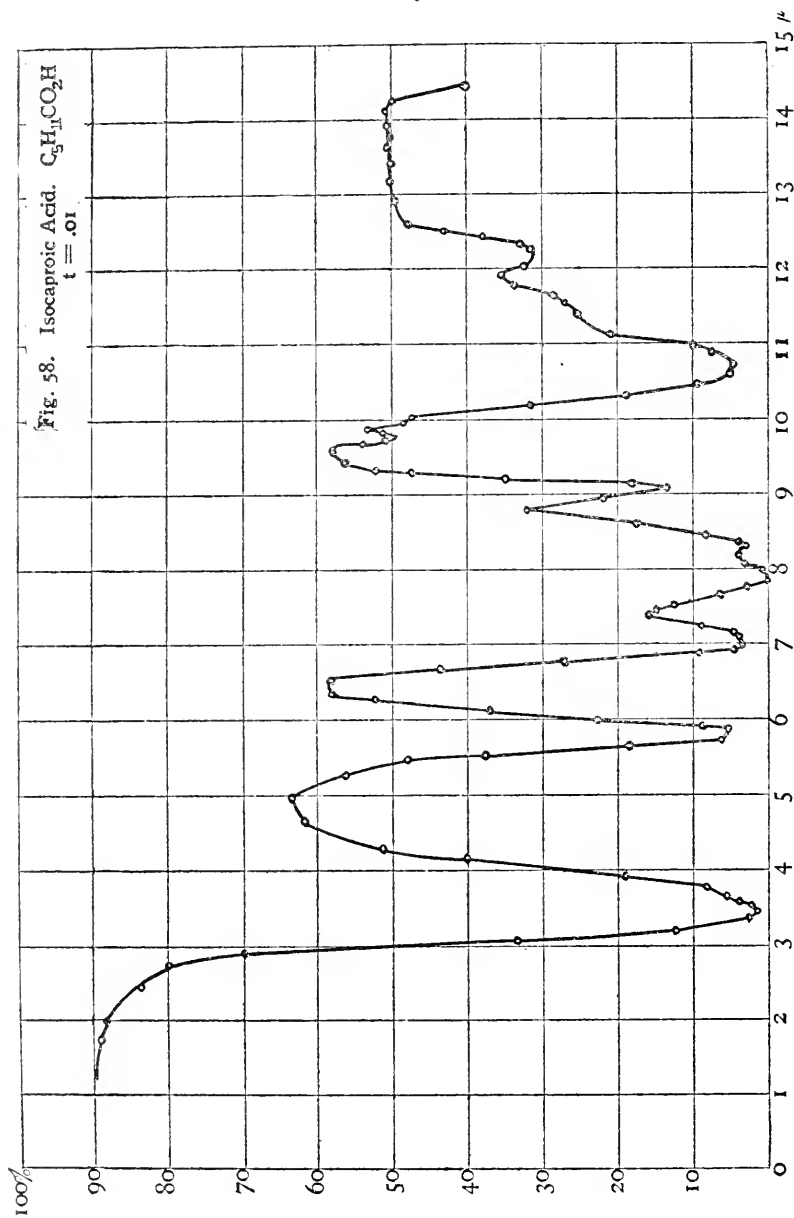

FIG. 59.

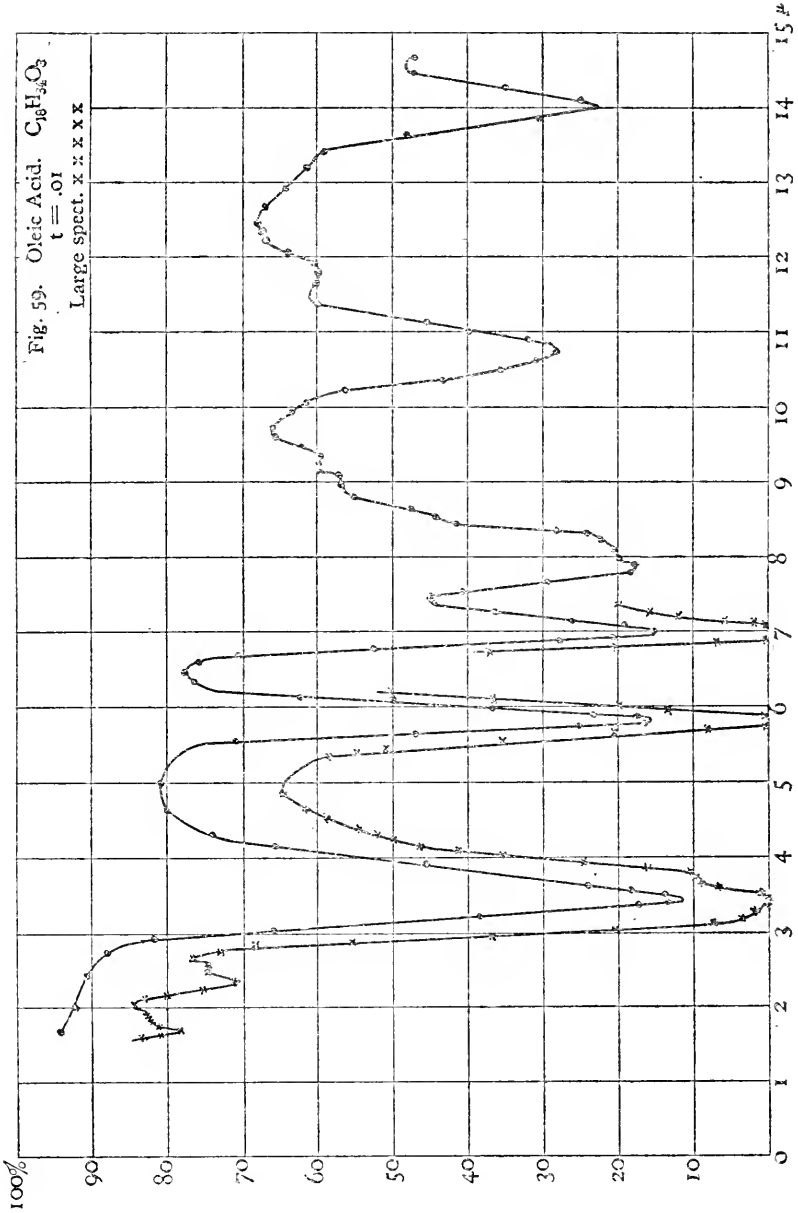

FIG. 60.

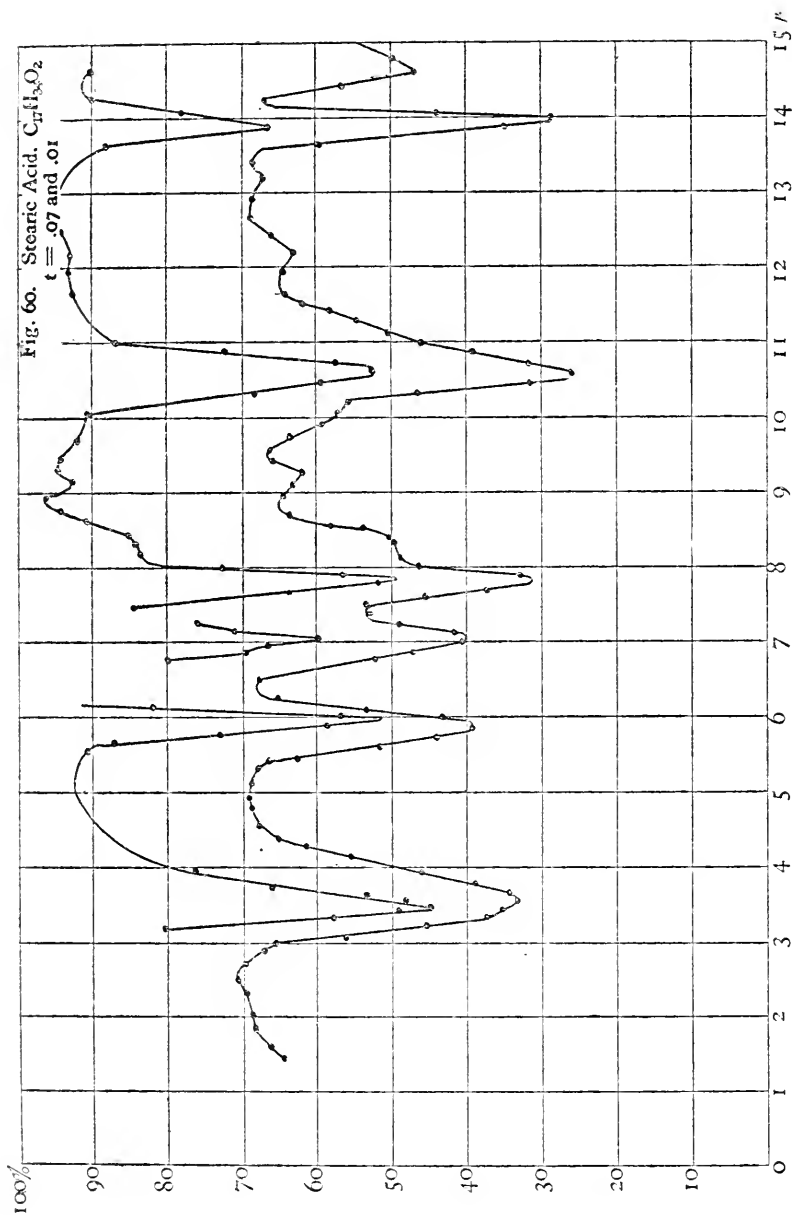



FIG. 61.

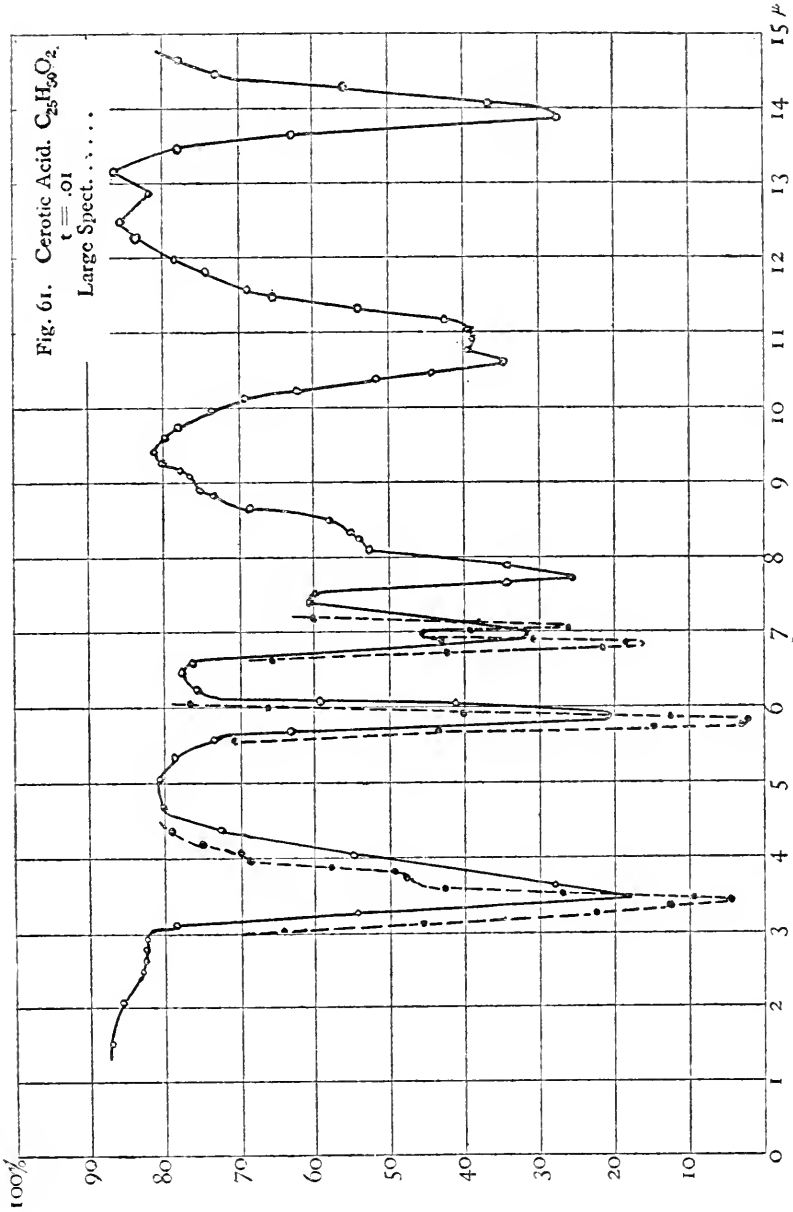

FIG. 62.

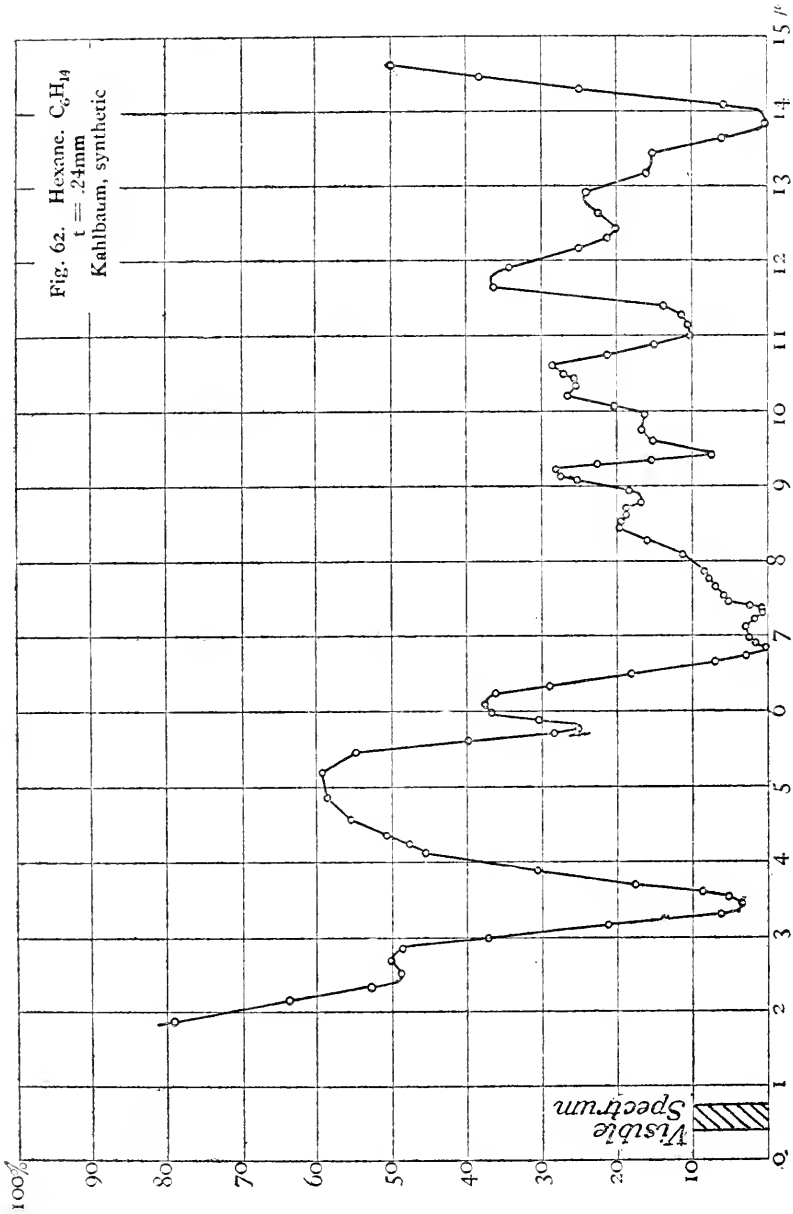

FIG. 63.

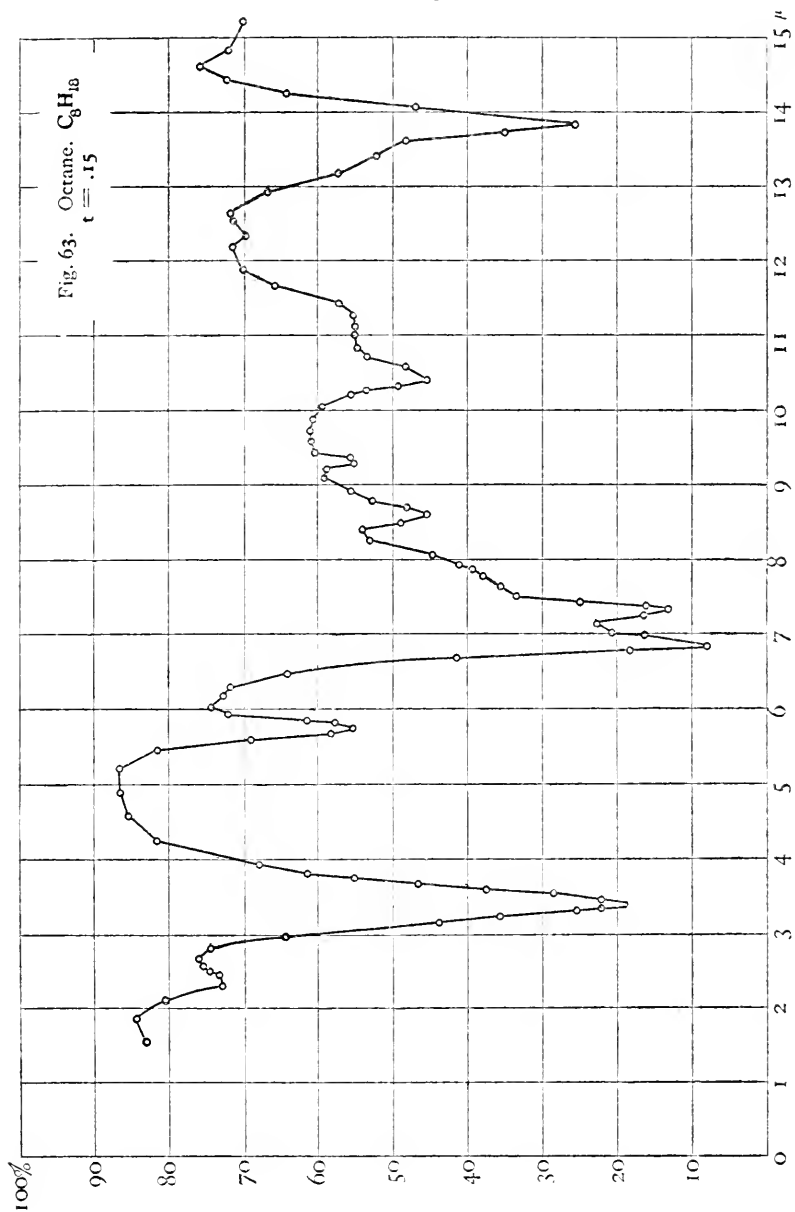

FIG. 64.

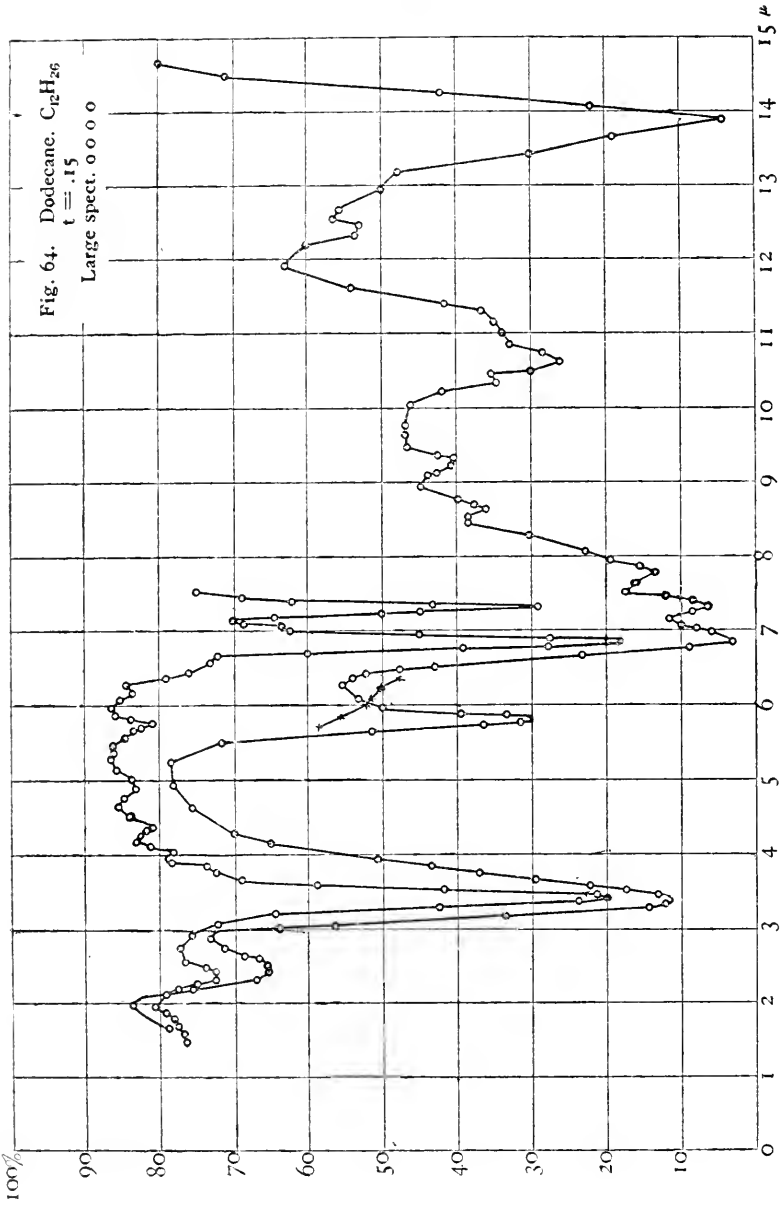

FIG. 65.

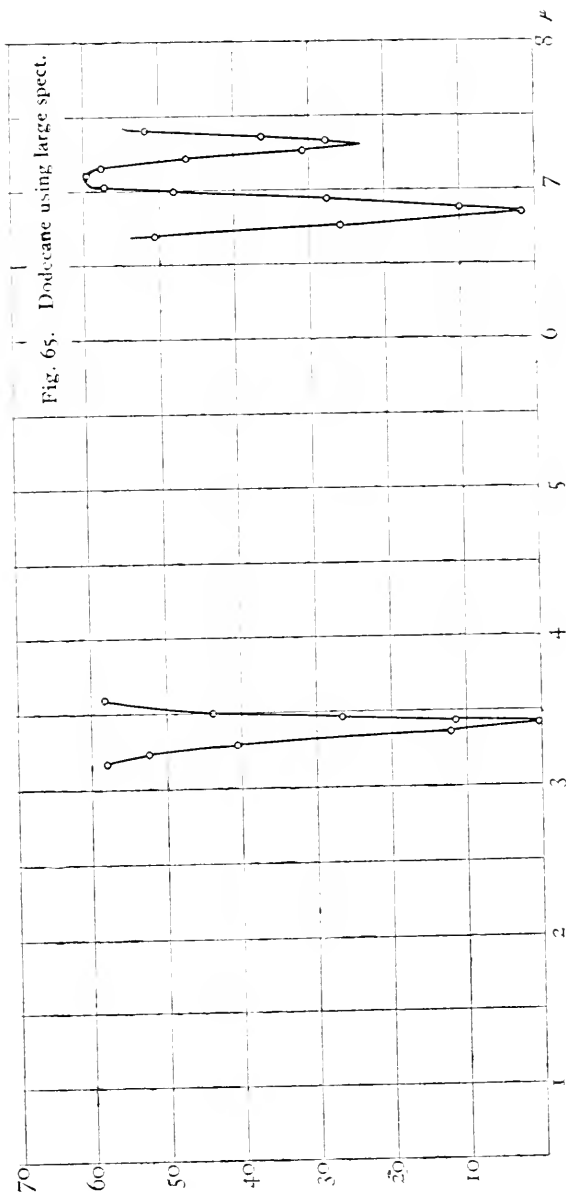

FIG. 66.

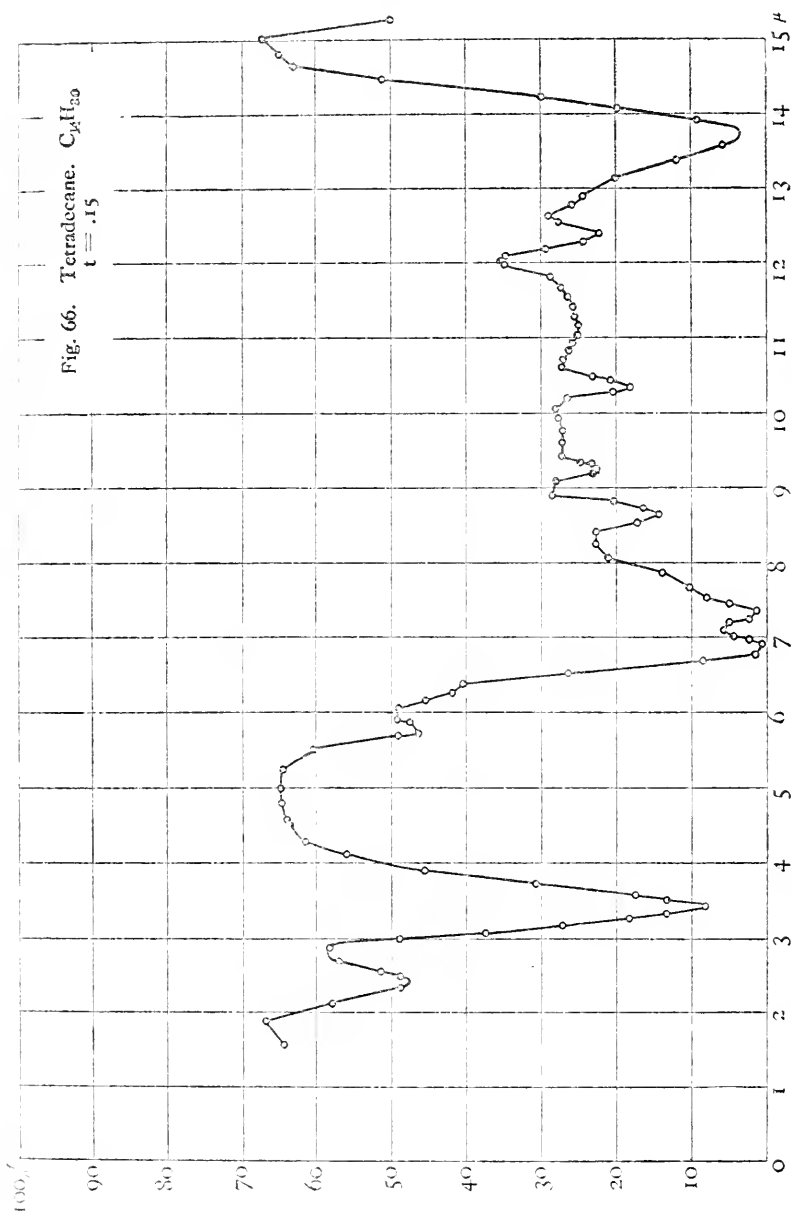

FIG. 67.

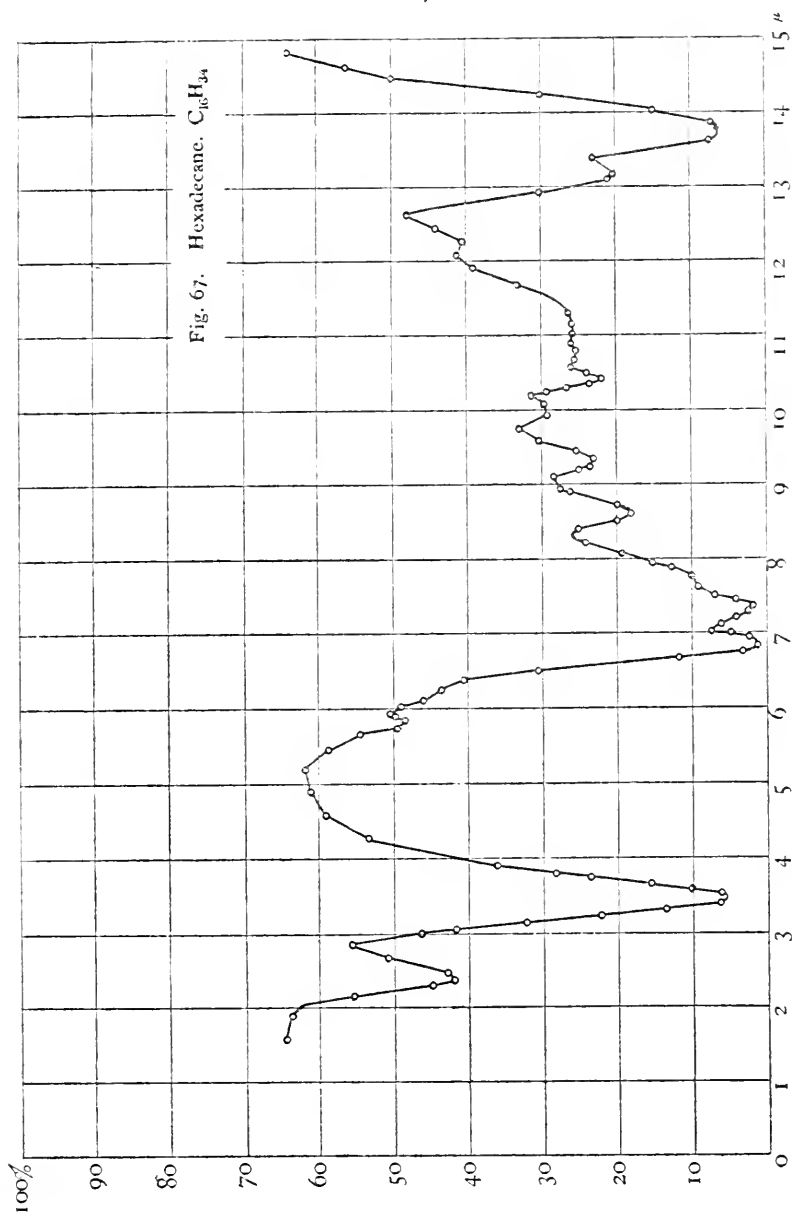

Fig. 68.

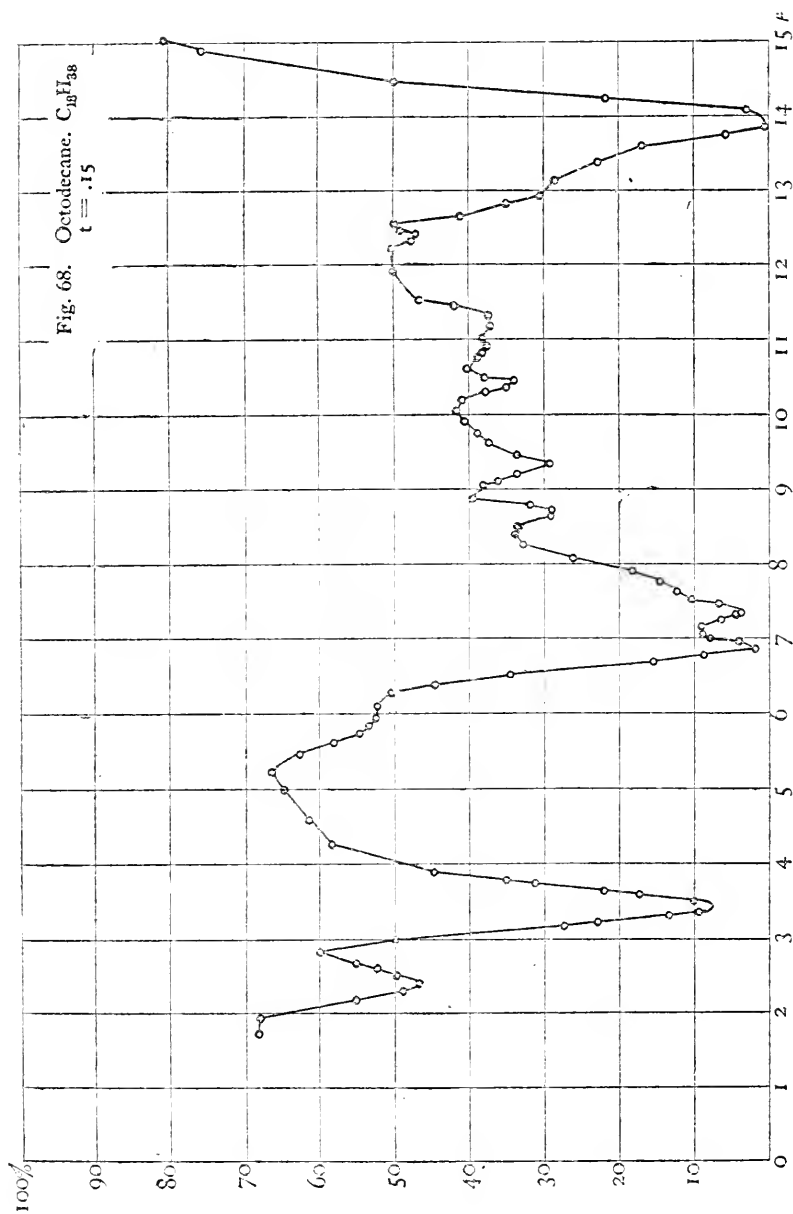



FIG. 69.

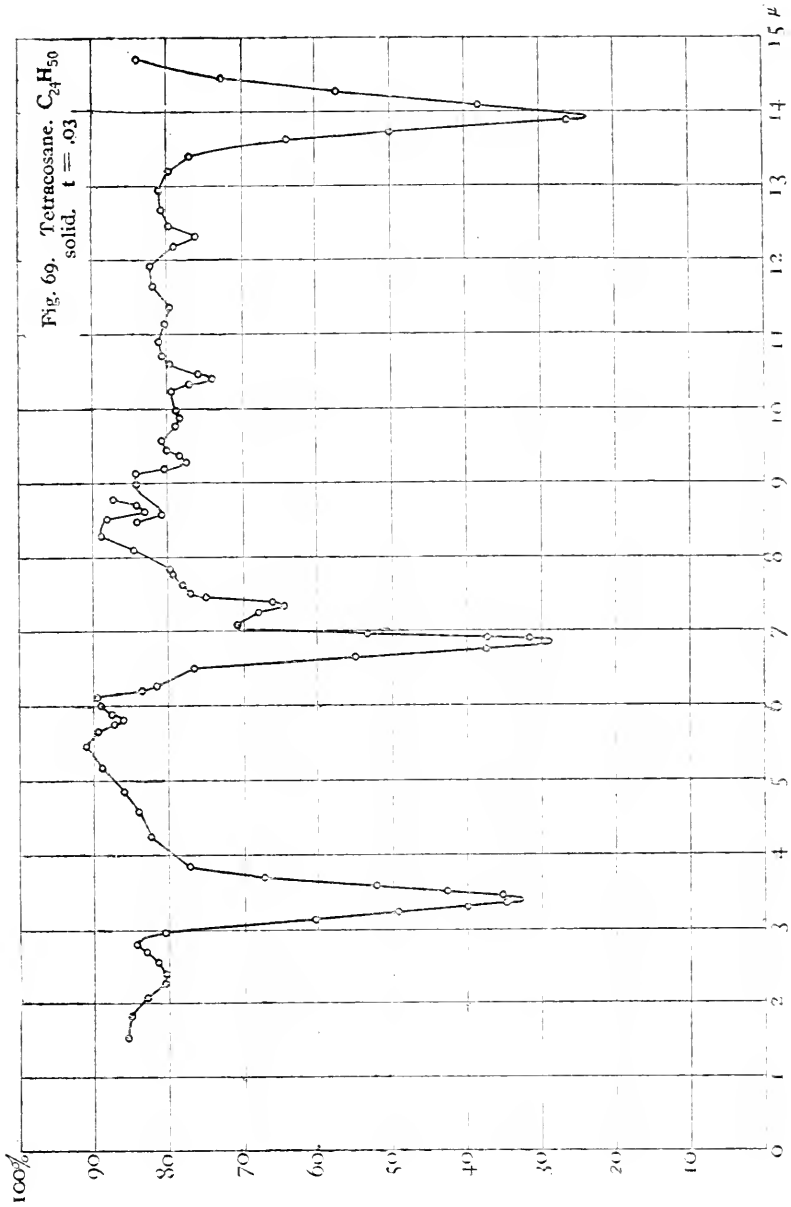

FIG. 70.

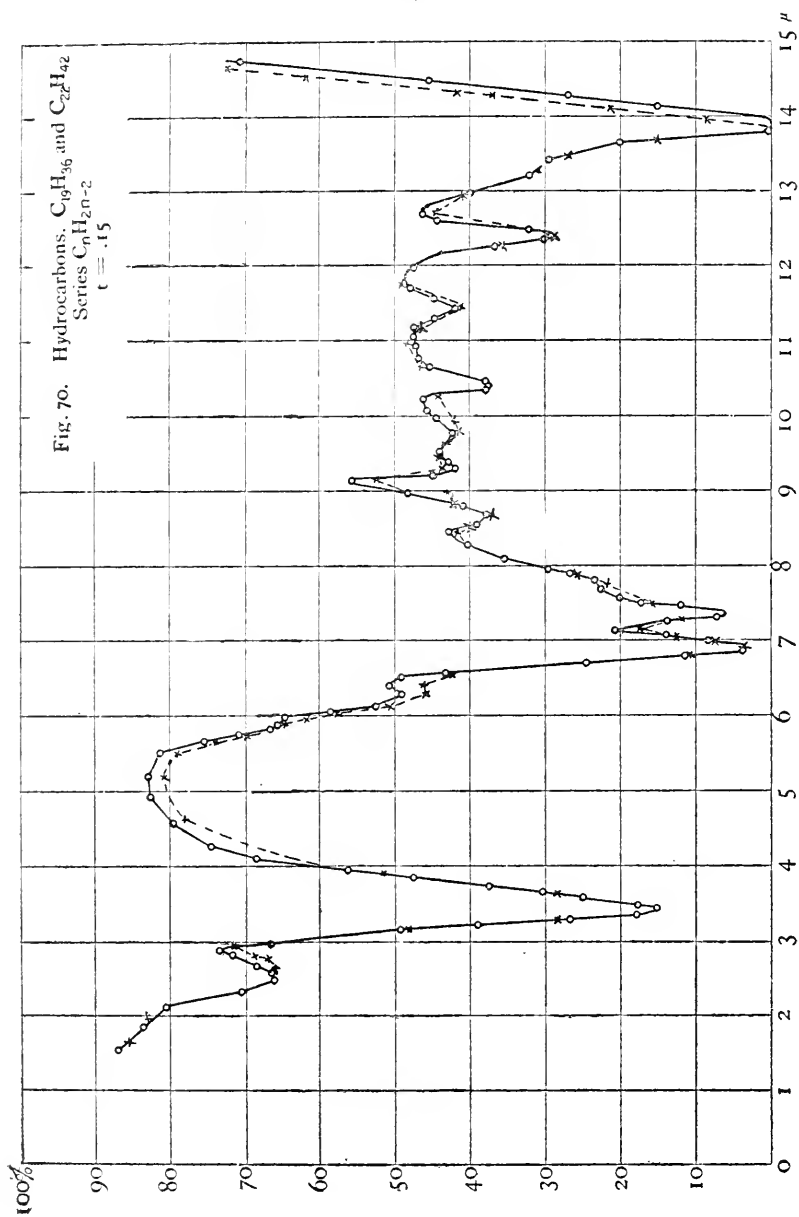

FIG. 71.

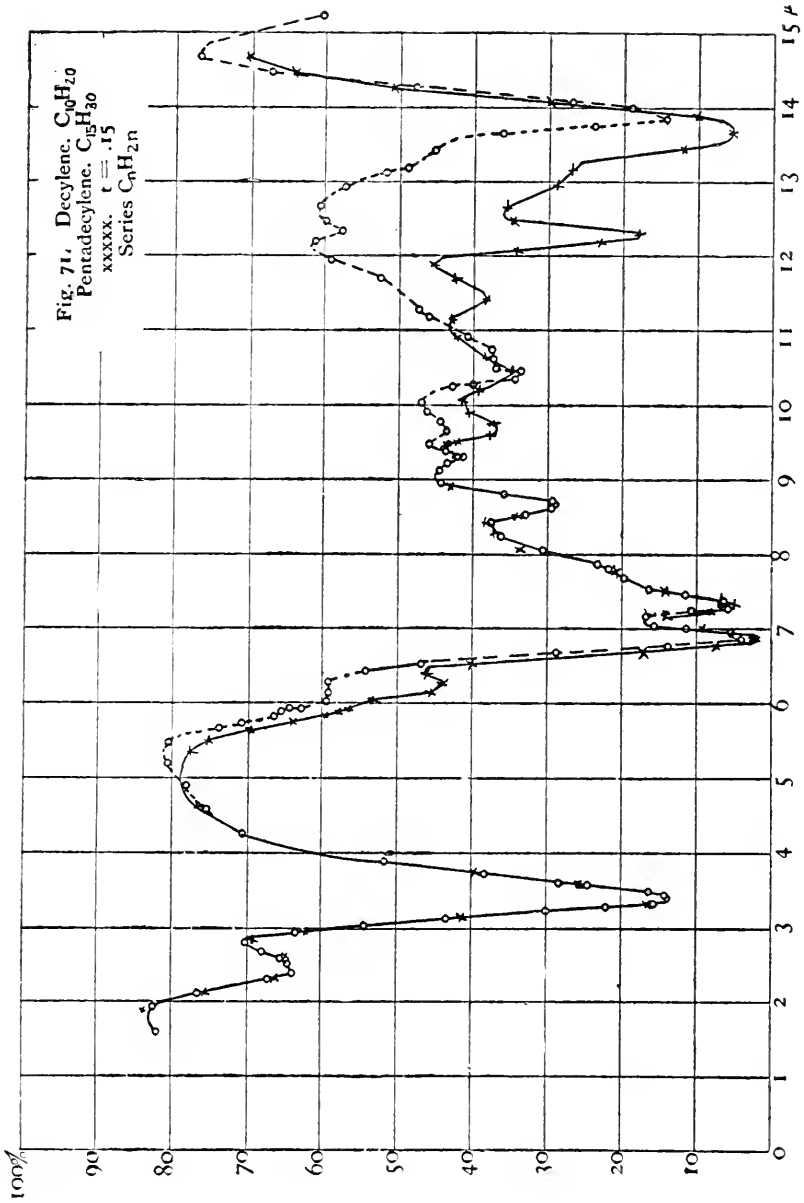

FIG. 72.

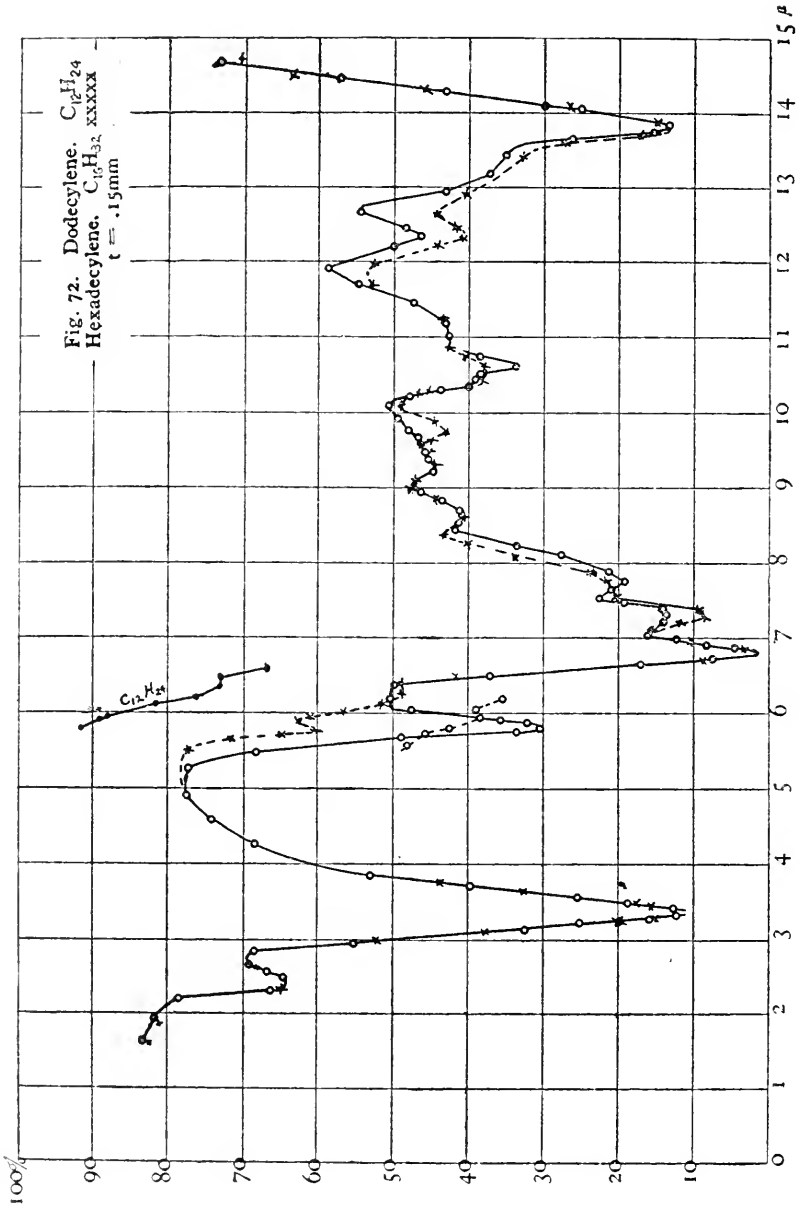

FIG. 73.

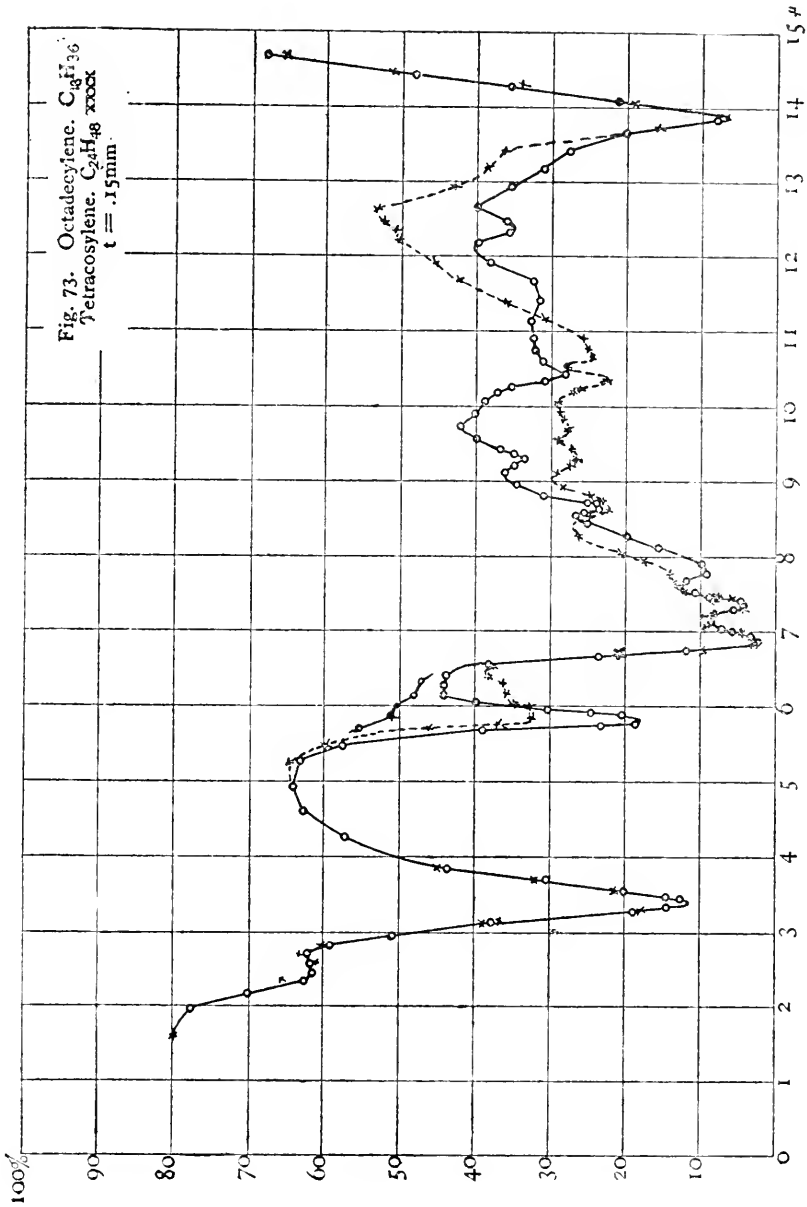

FIG. 74.

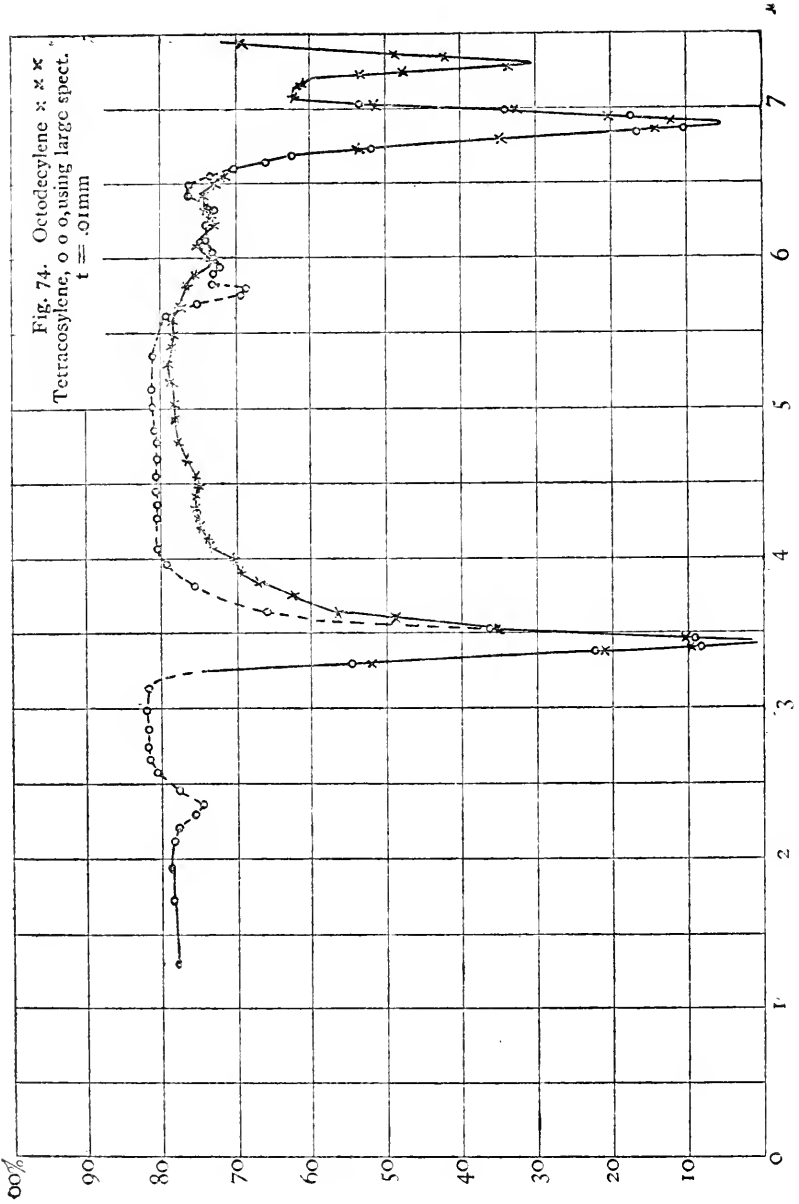

FIG. 75.

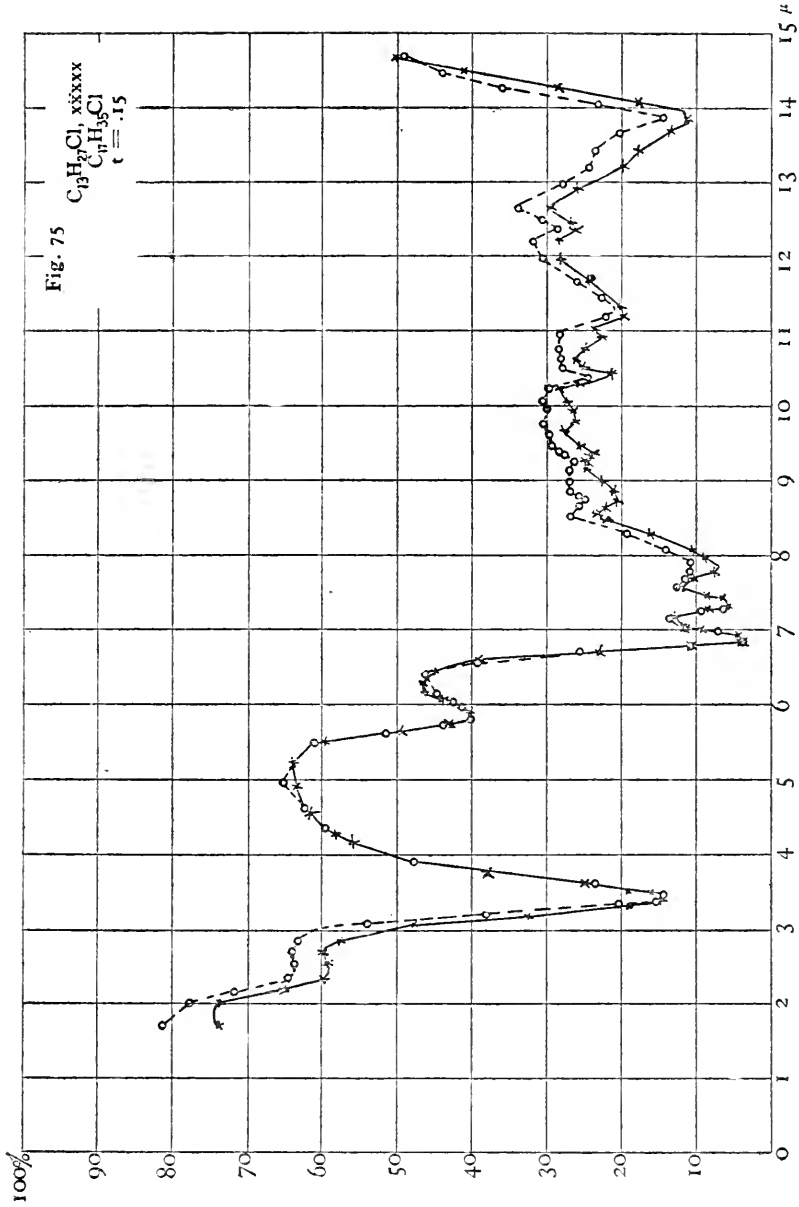

FIG. 76.

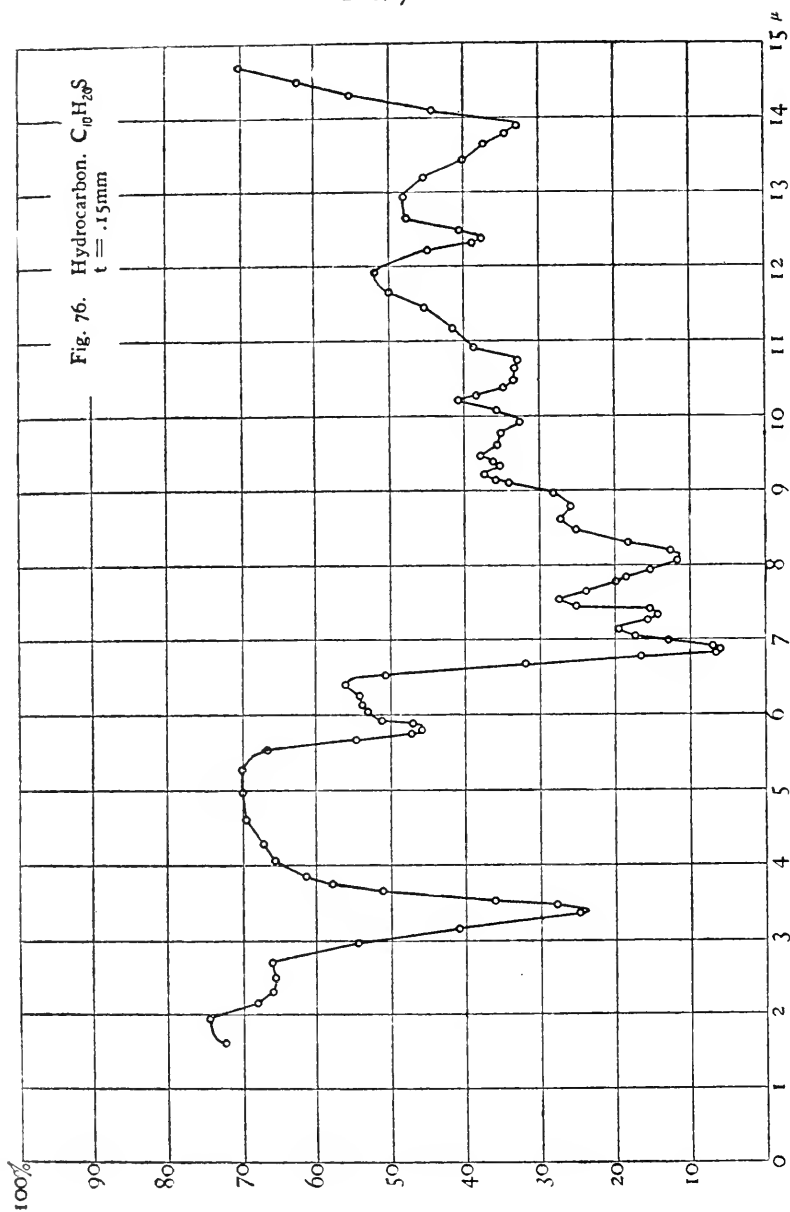



FIG. 77.

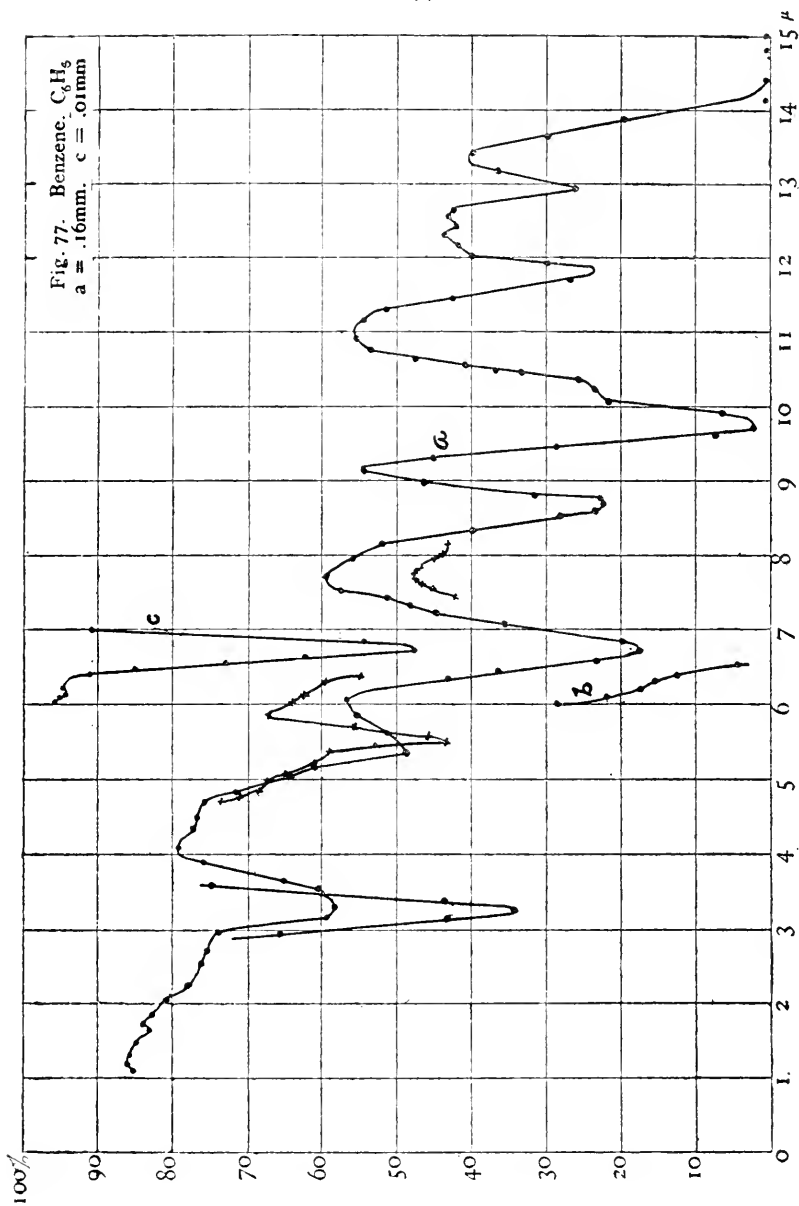

FIG. 78.

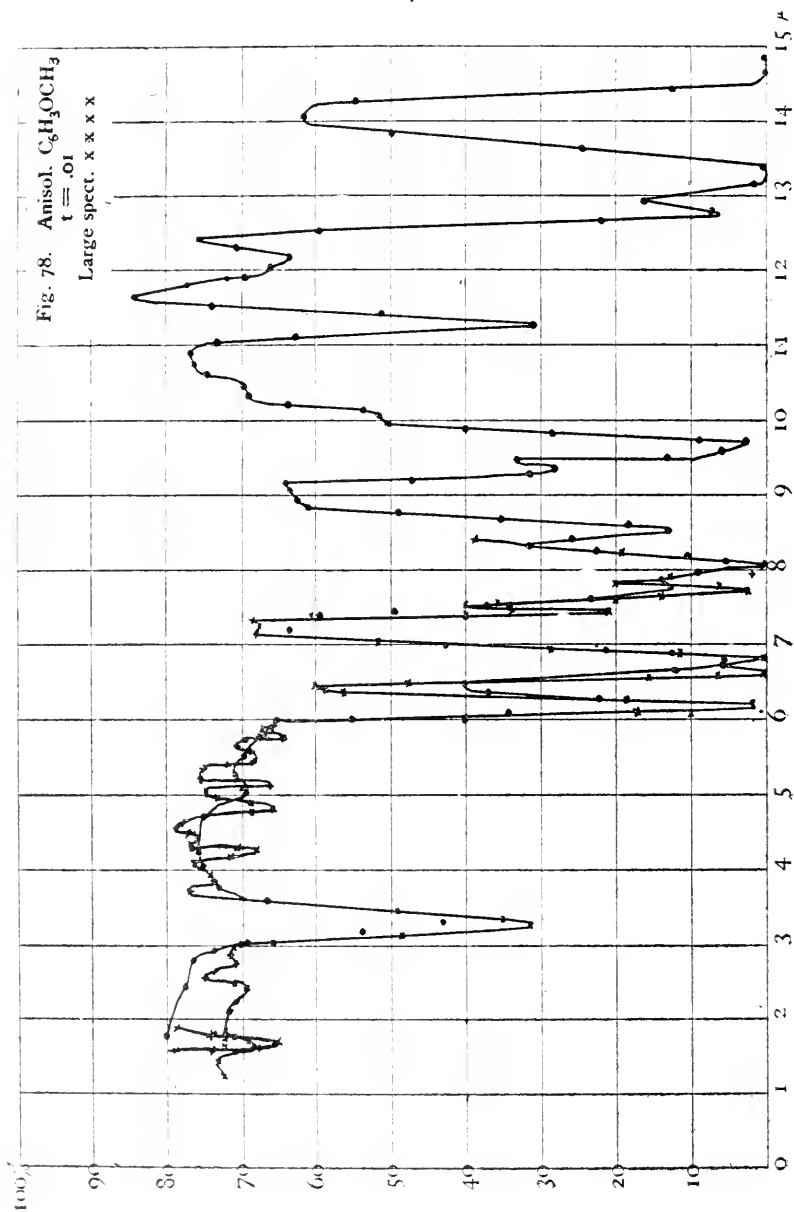

FIG. 79.

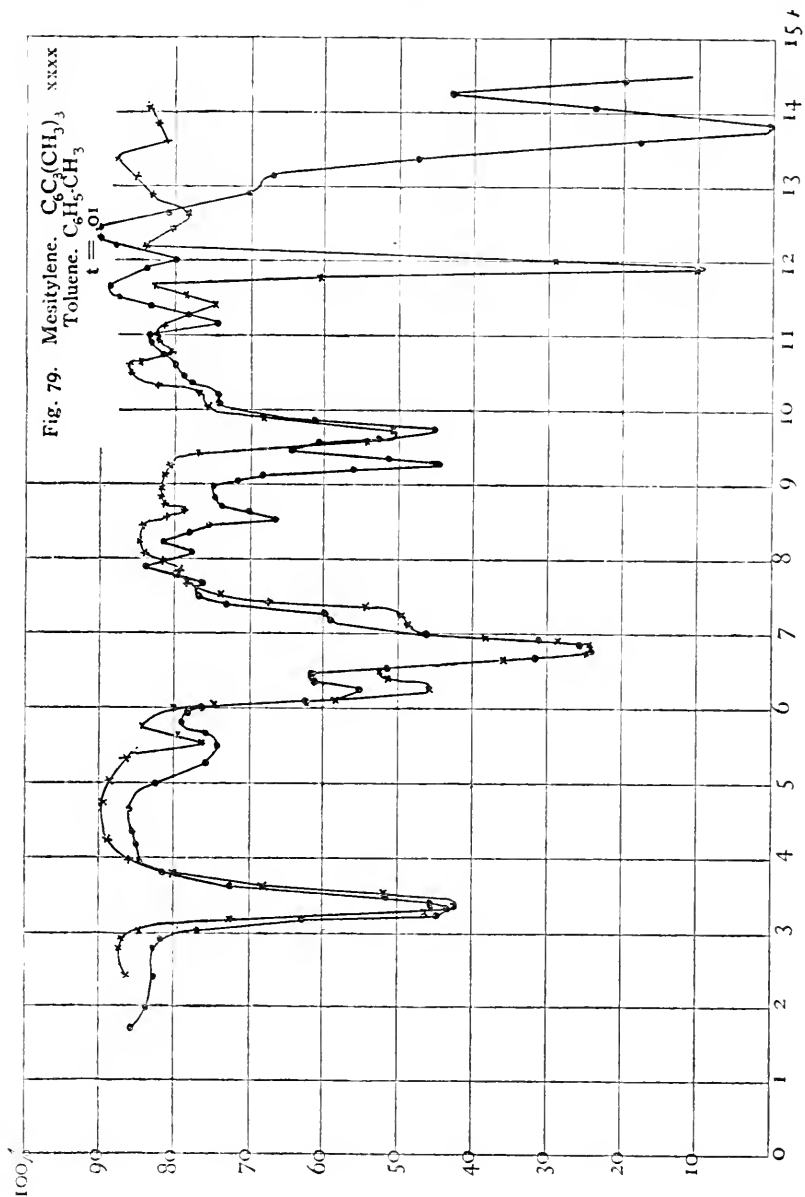

FIG. 80.

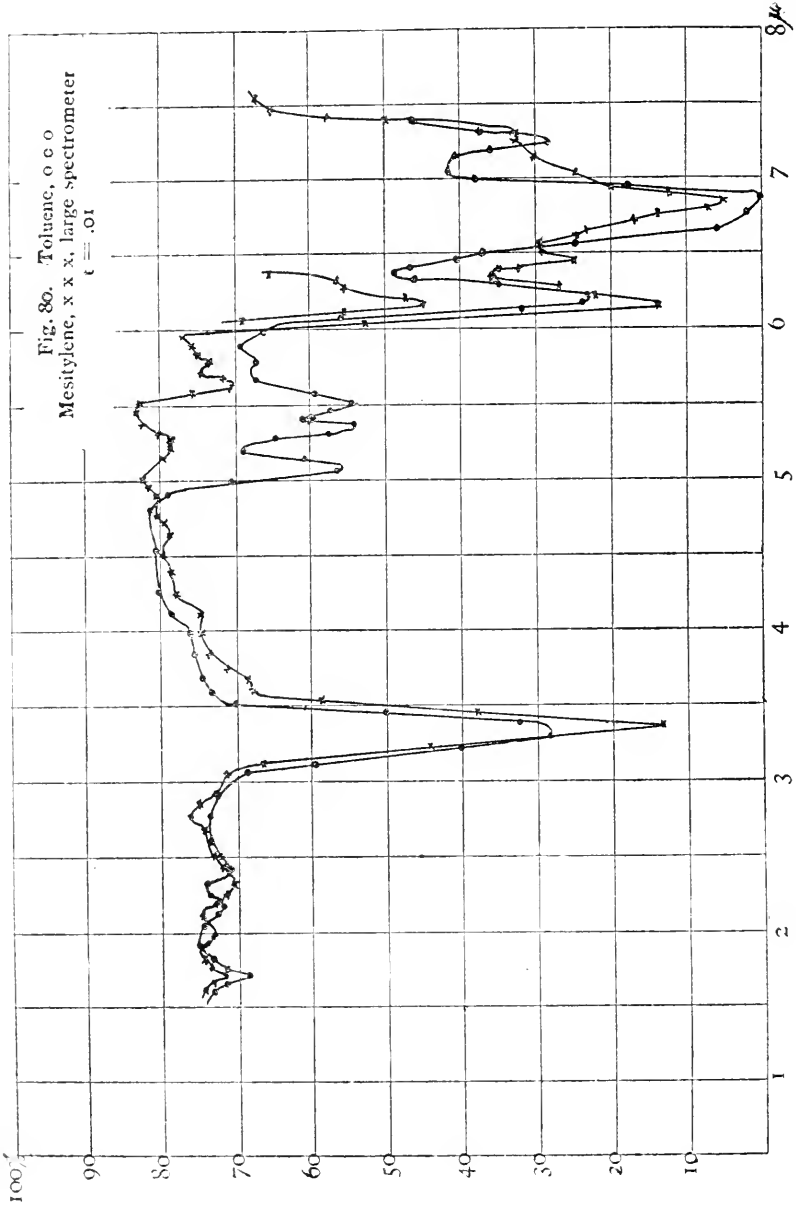

FIG. 81.

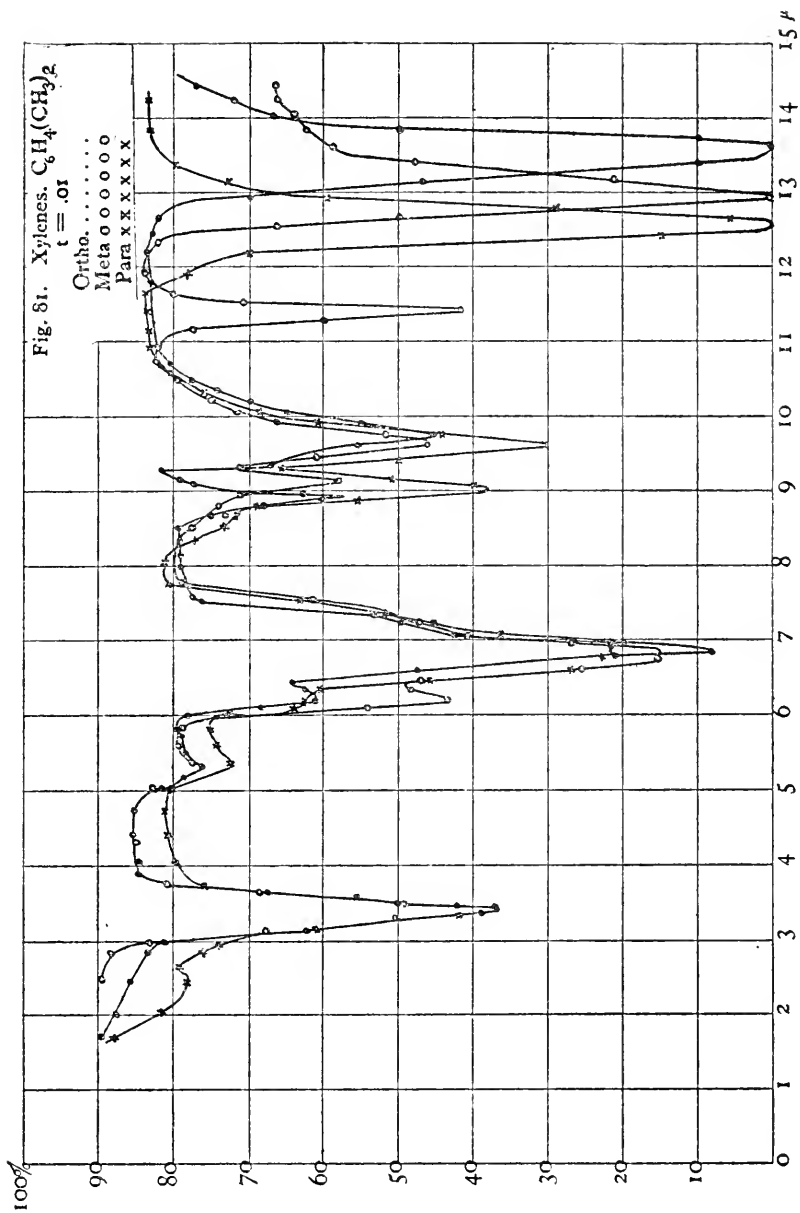

FIG. 82.

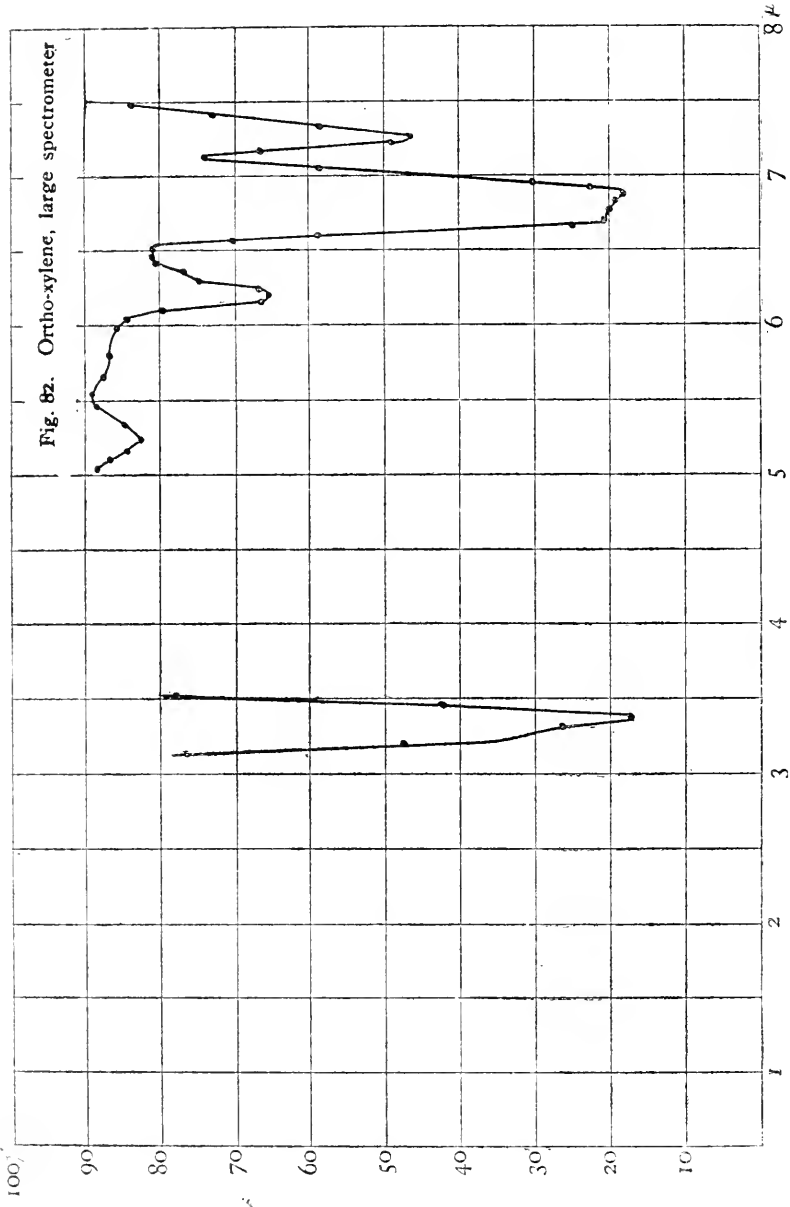

FIG. 83.

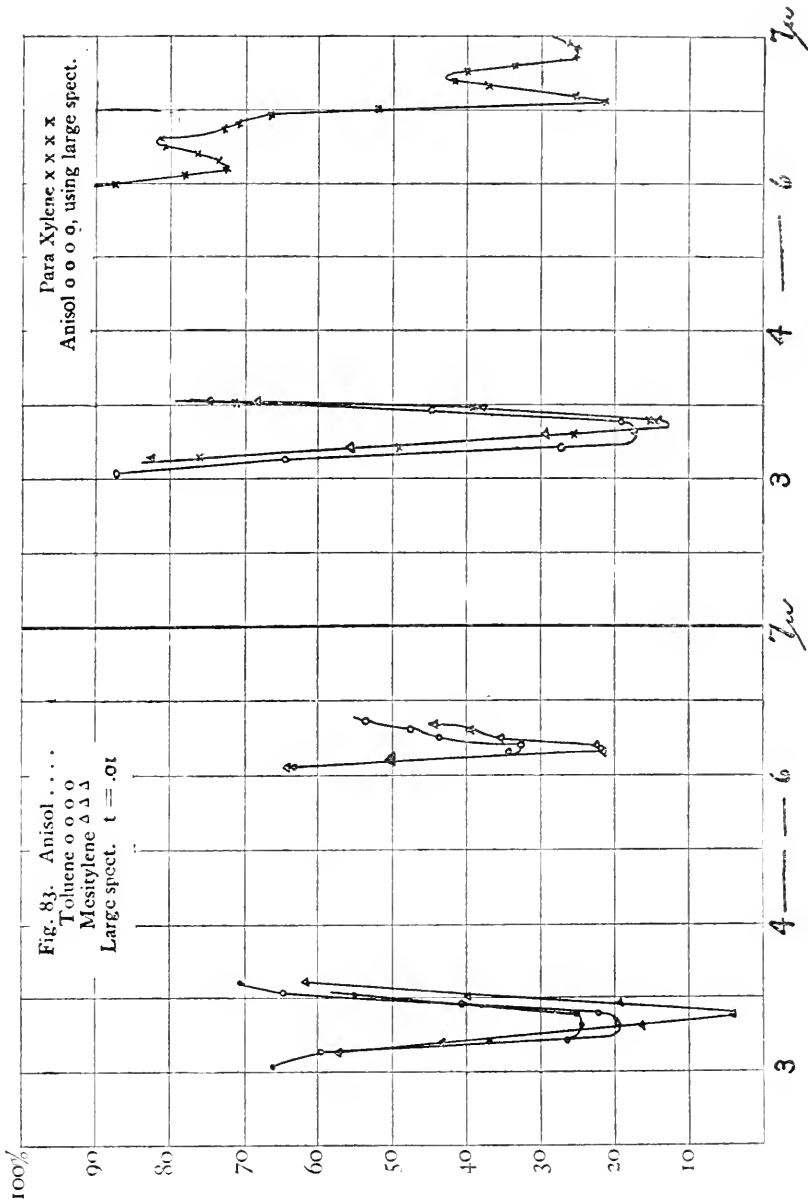

FIG. 84.

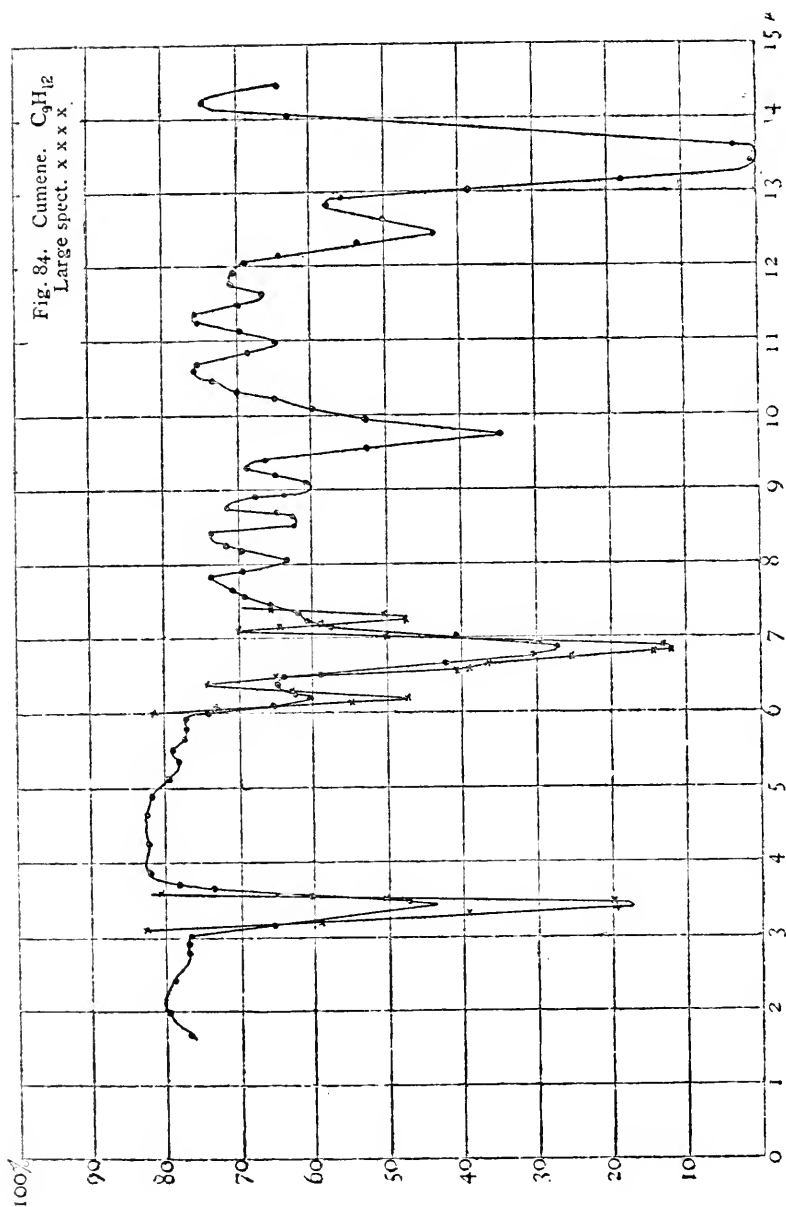



FIG. 85.

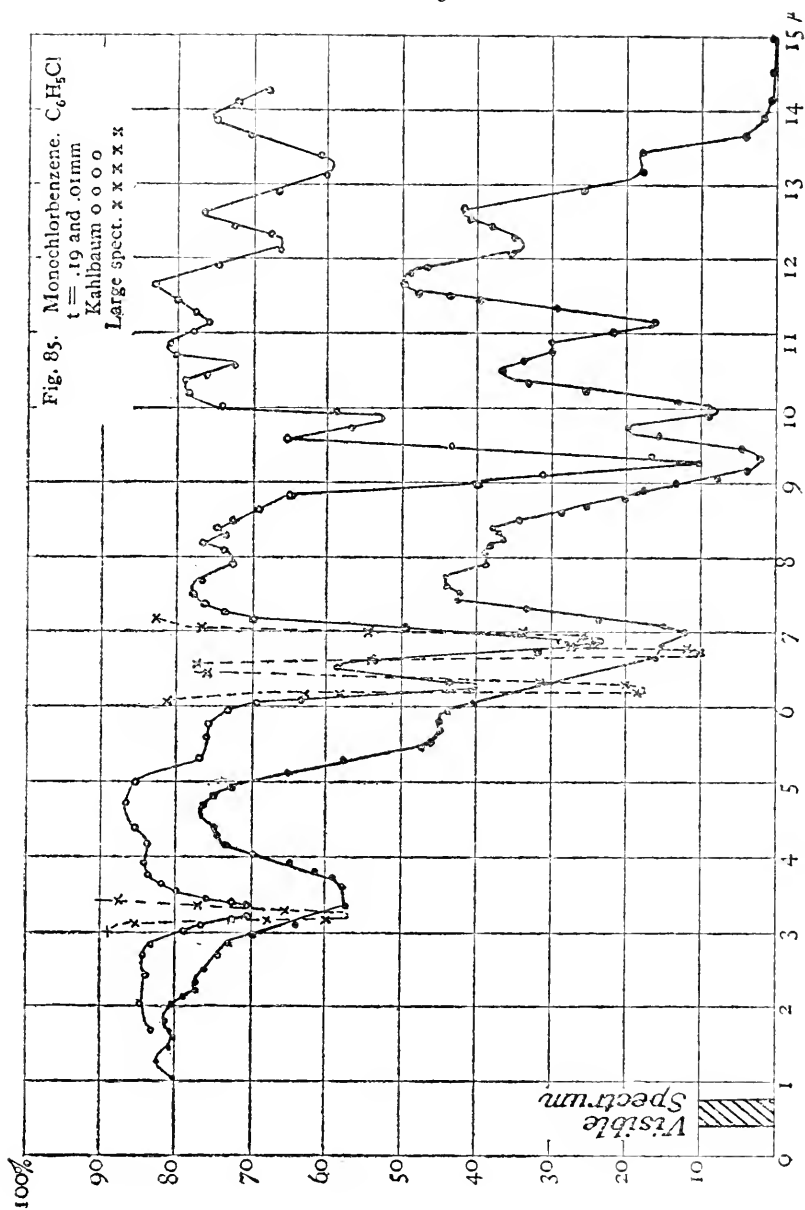

FIG. 86.

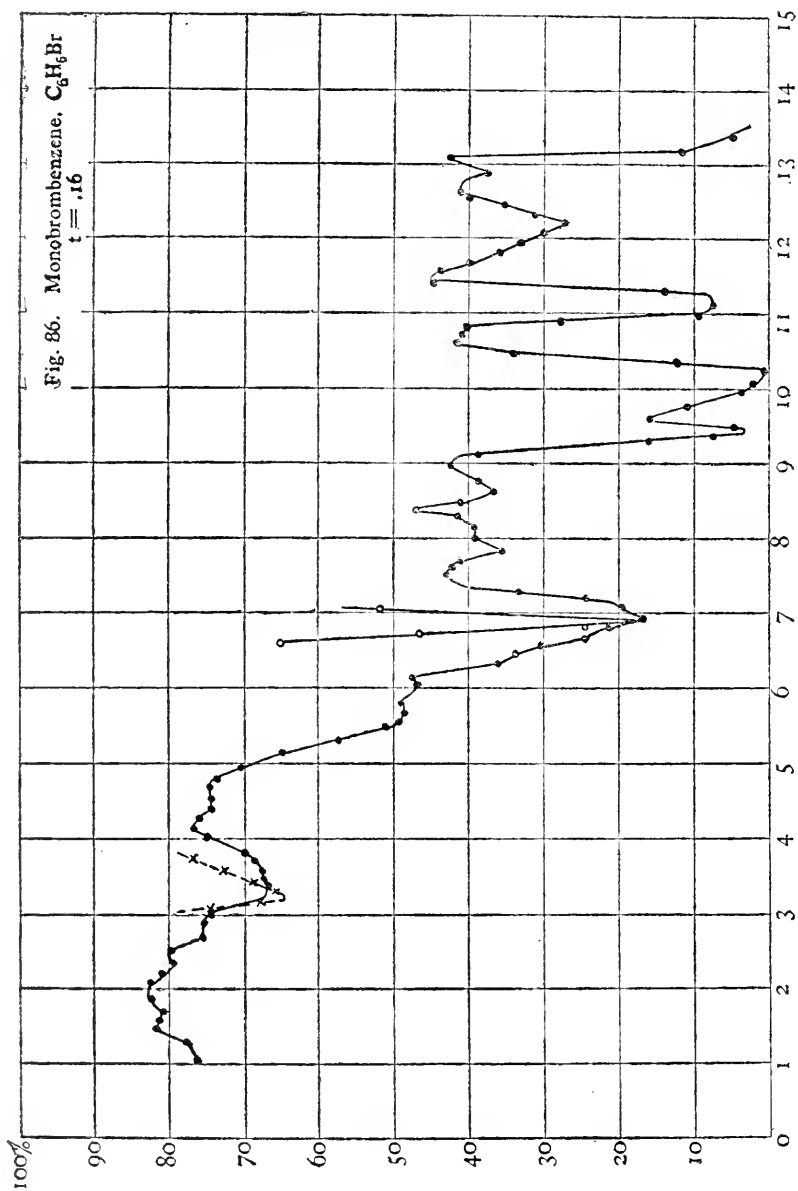

FIG. 87.

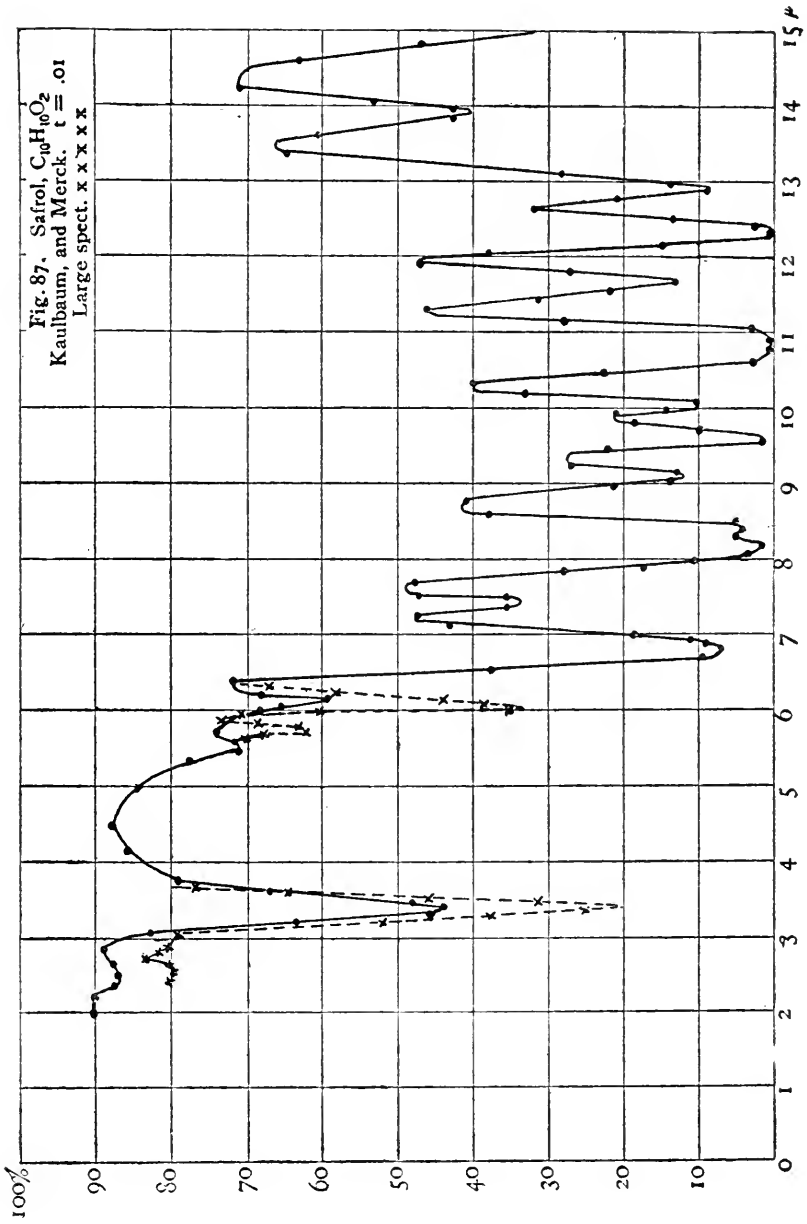

FIG. 88.

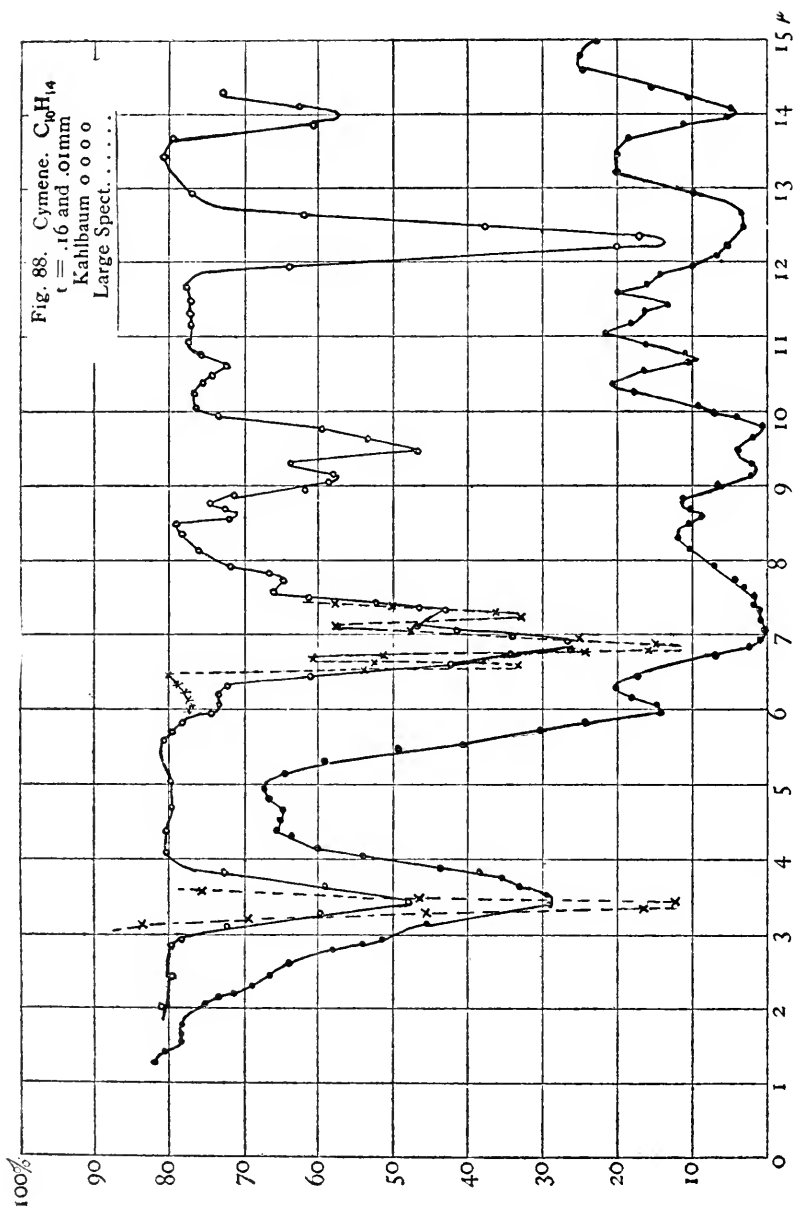

FIG. 89.

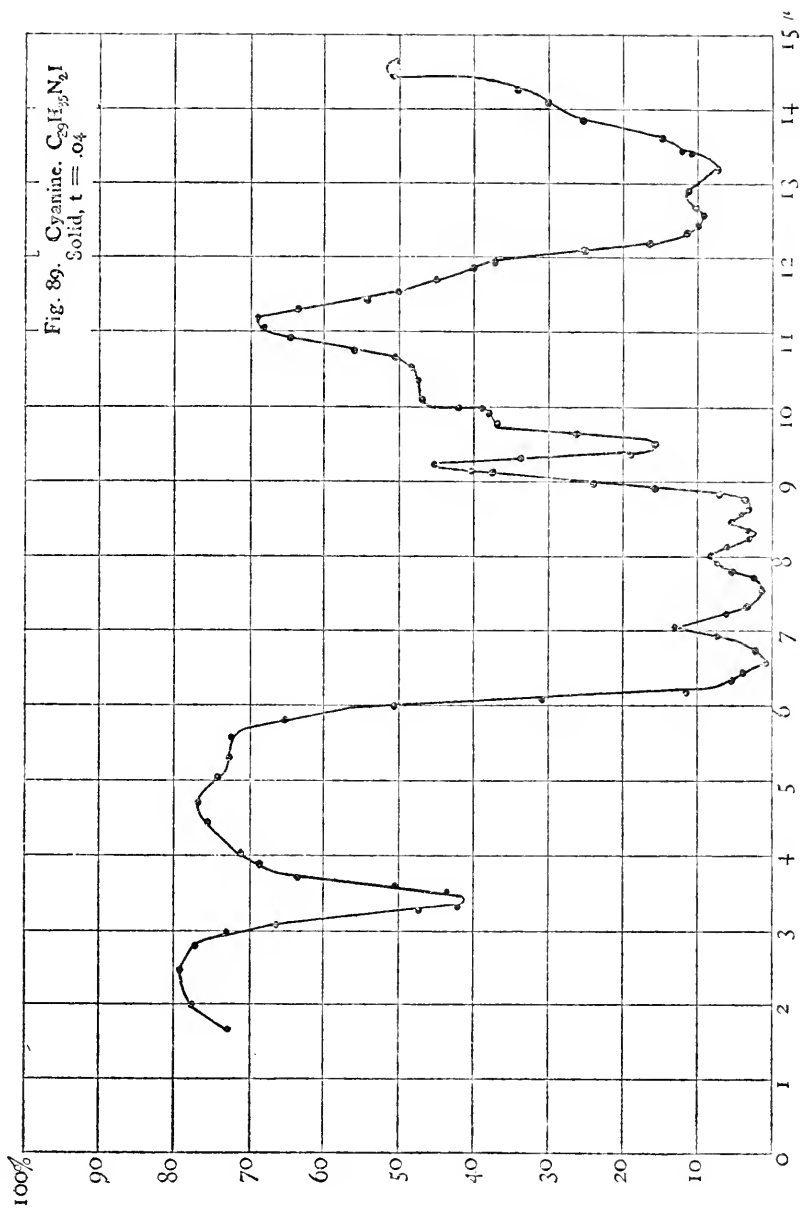

FIG. 90.

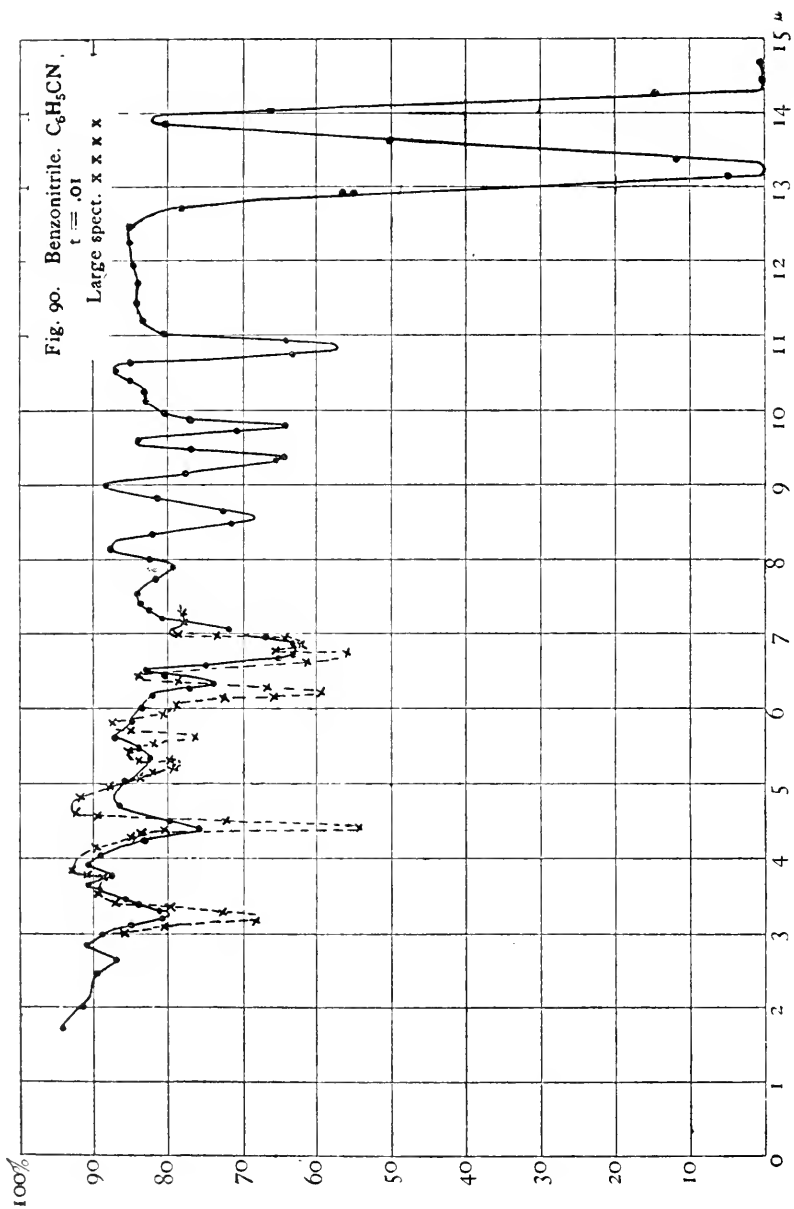

FIG. 91.

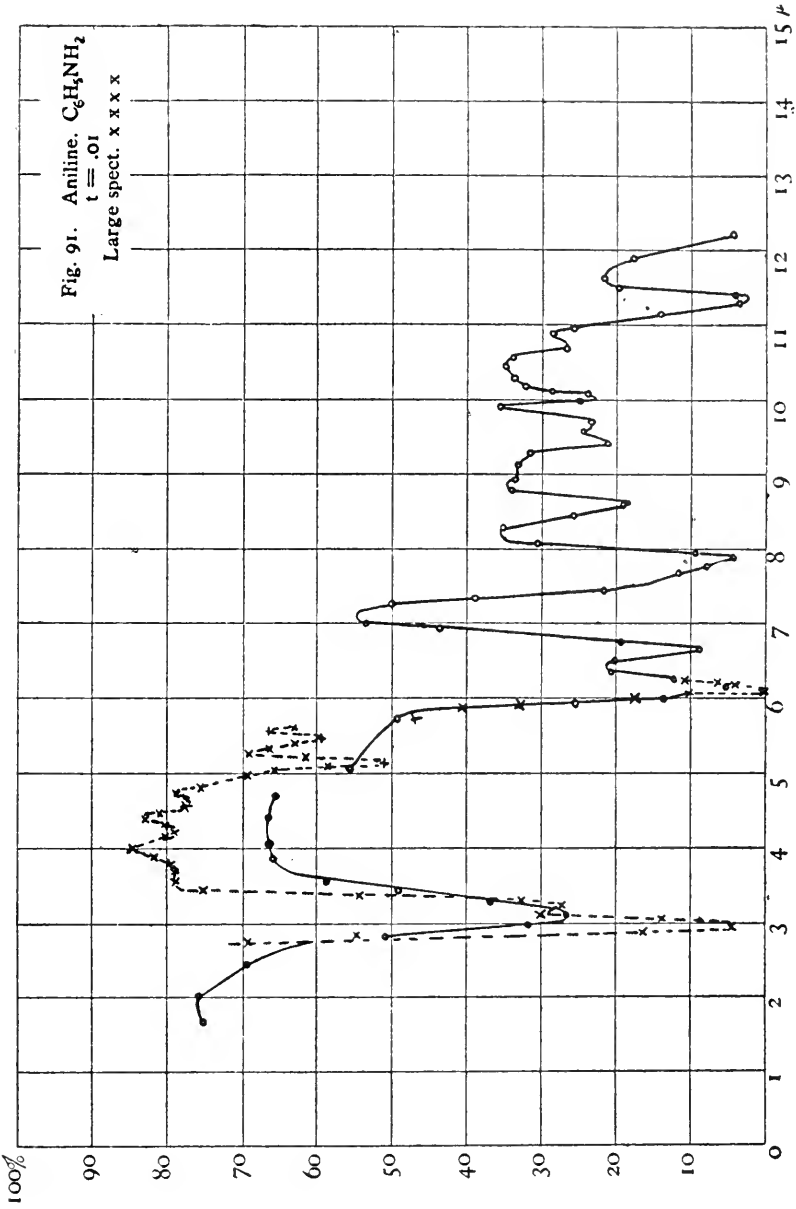

FIG. 92.

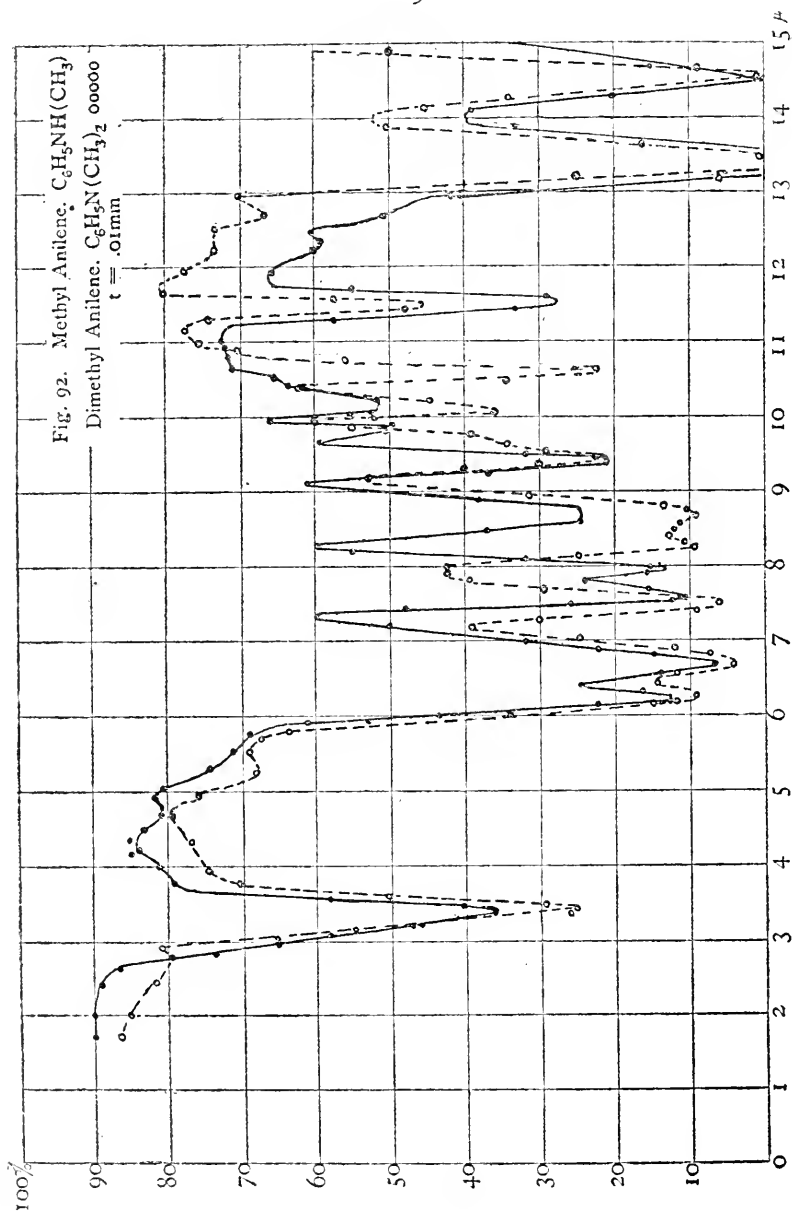



FIG. 93.

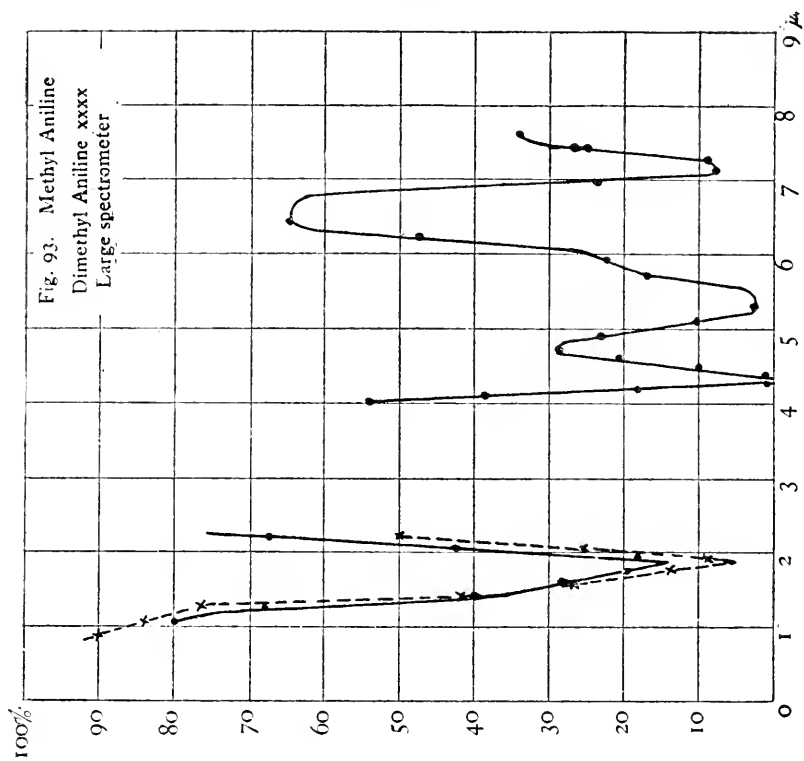

Fig. 94.

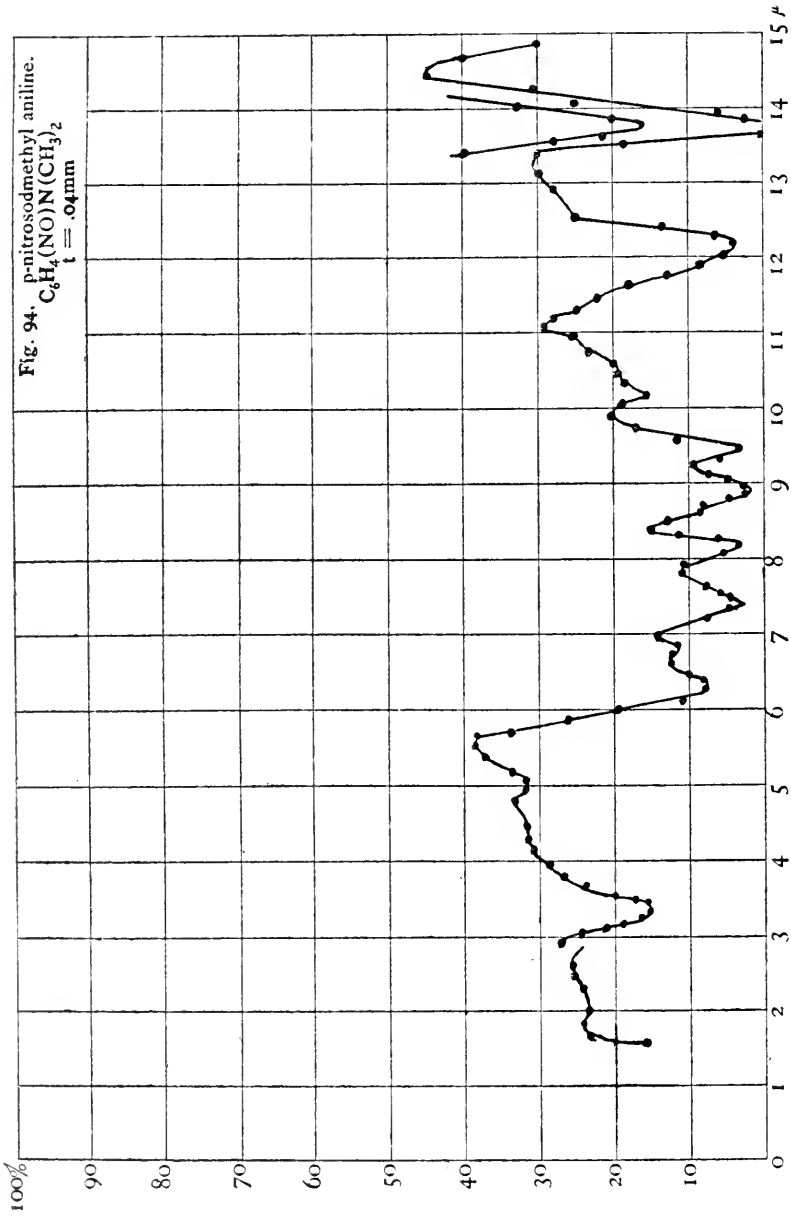

FIG. 95.

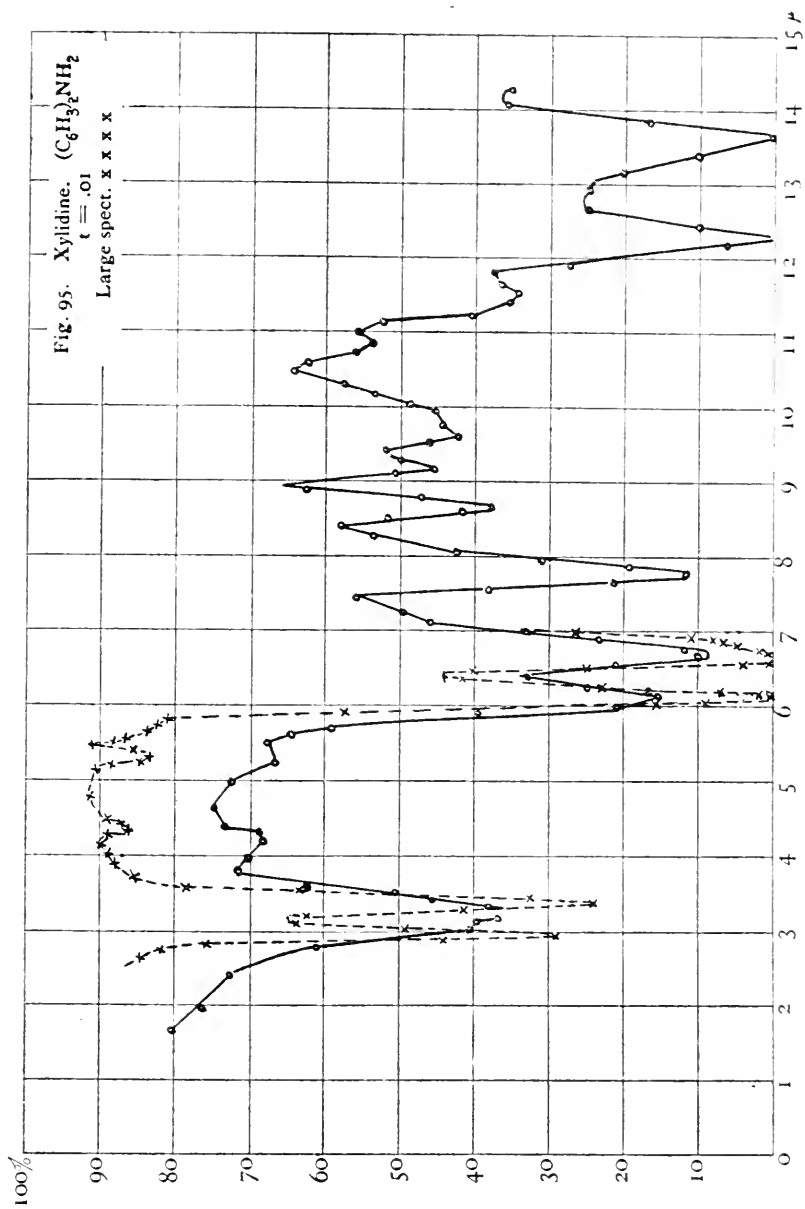

FIG. 96.

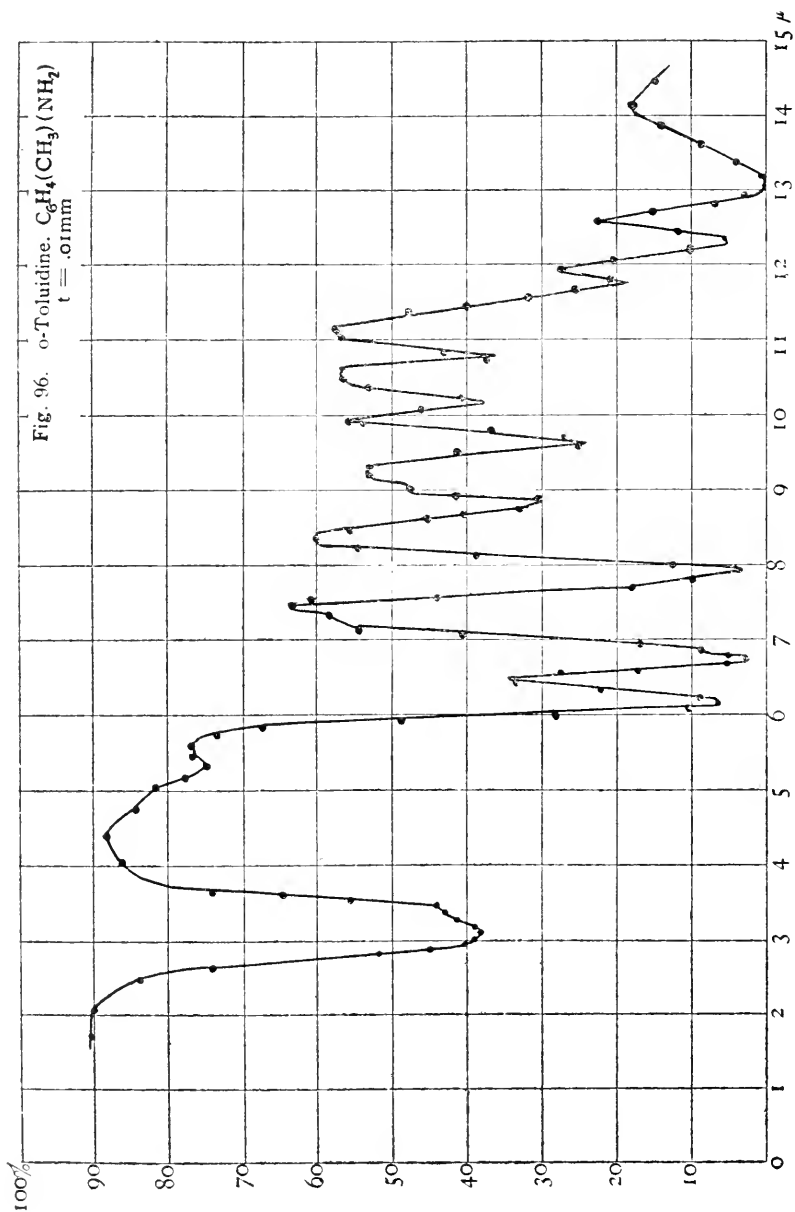

FIG. 97.

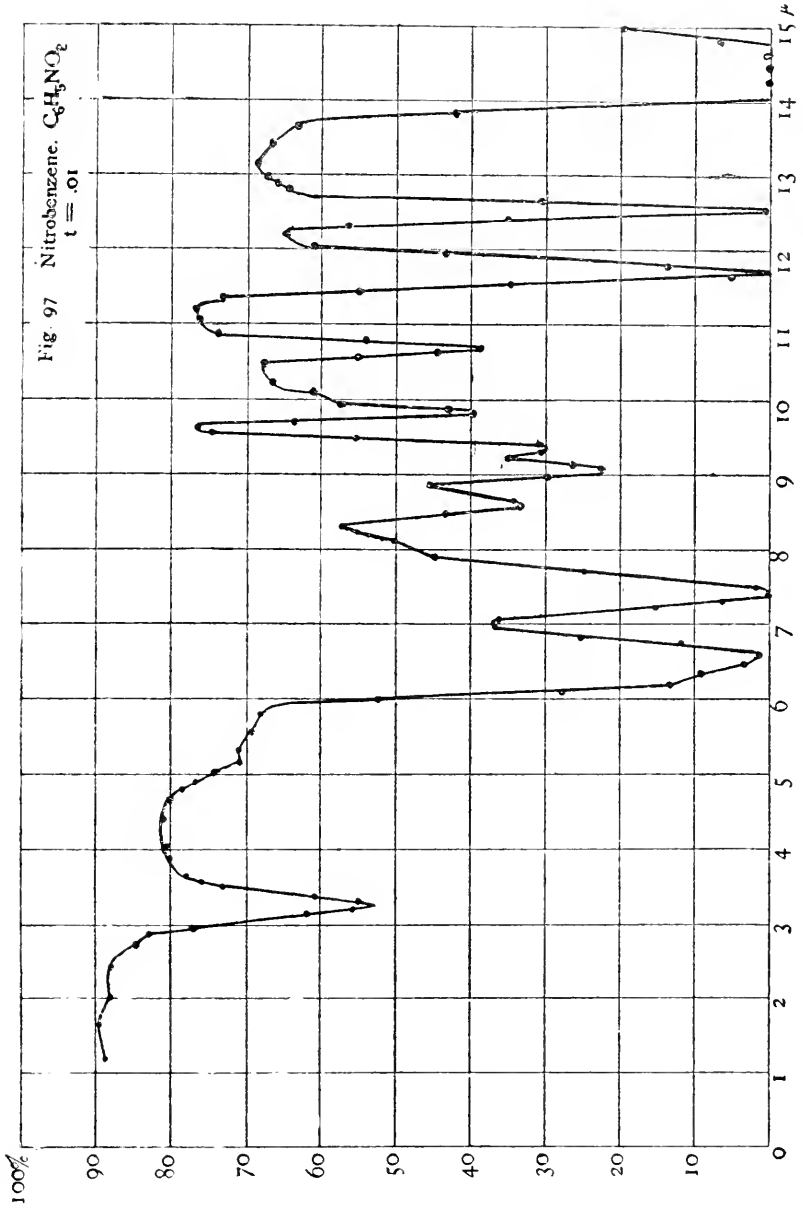

FIG. 98.

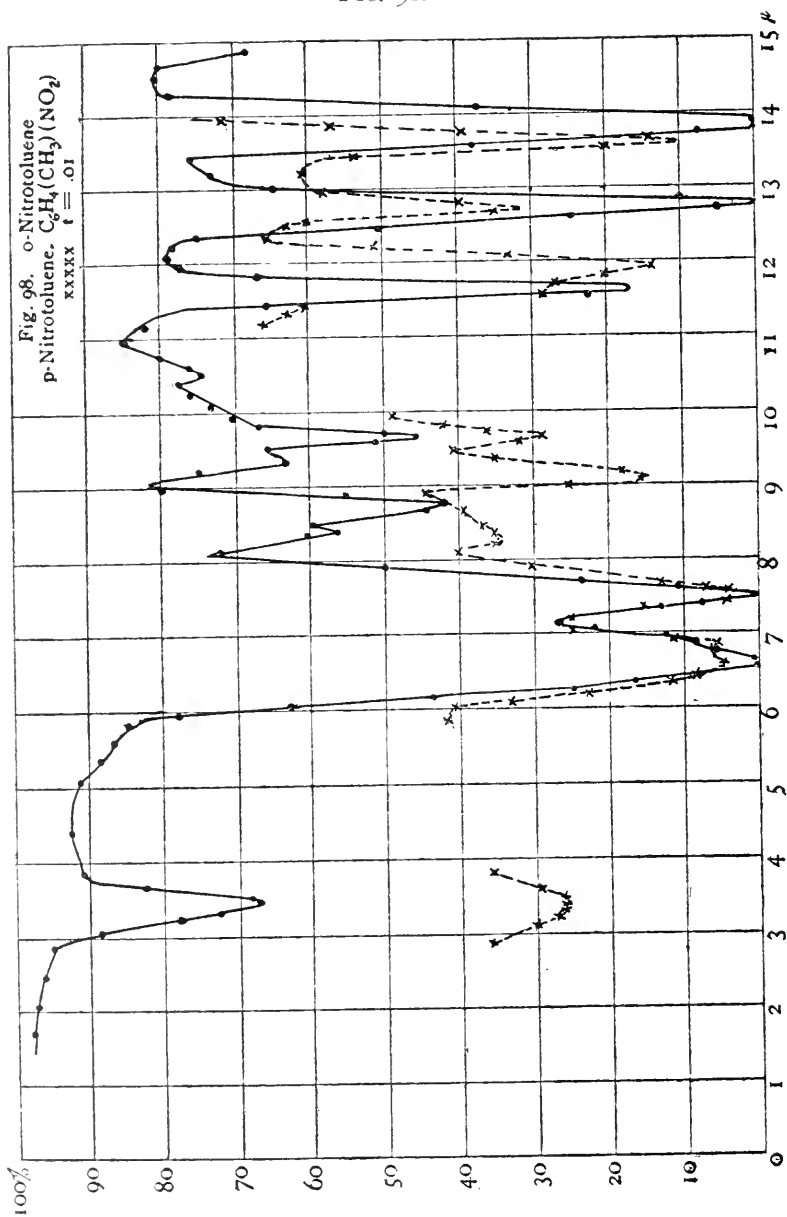

FIG. 99.

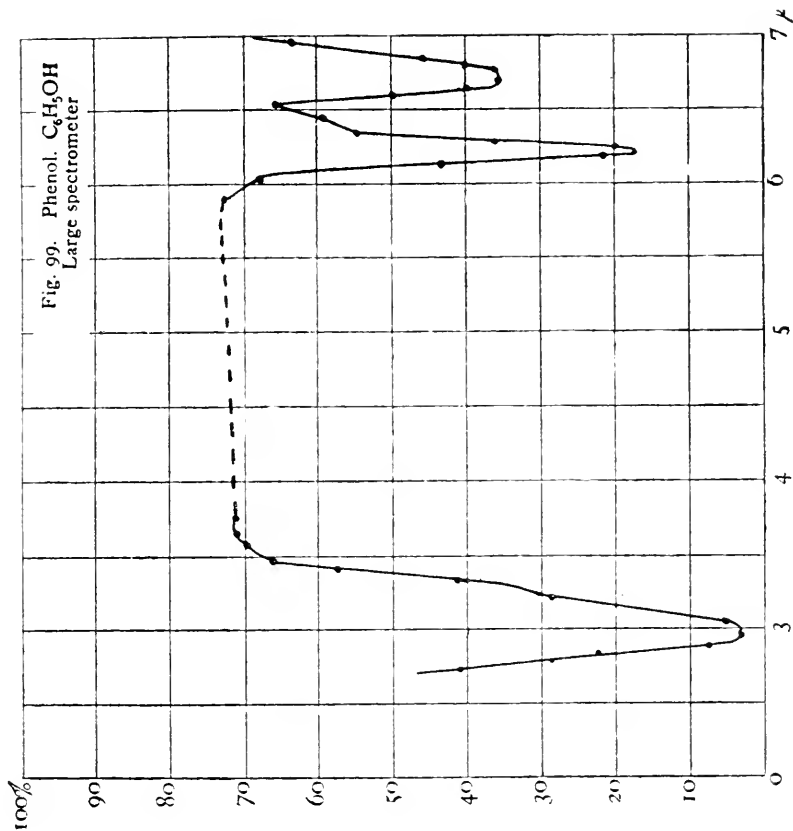

FIG. 100.

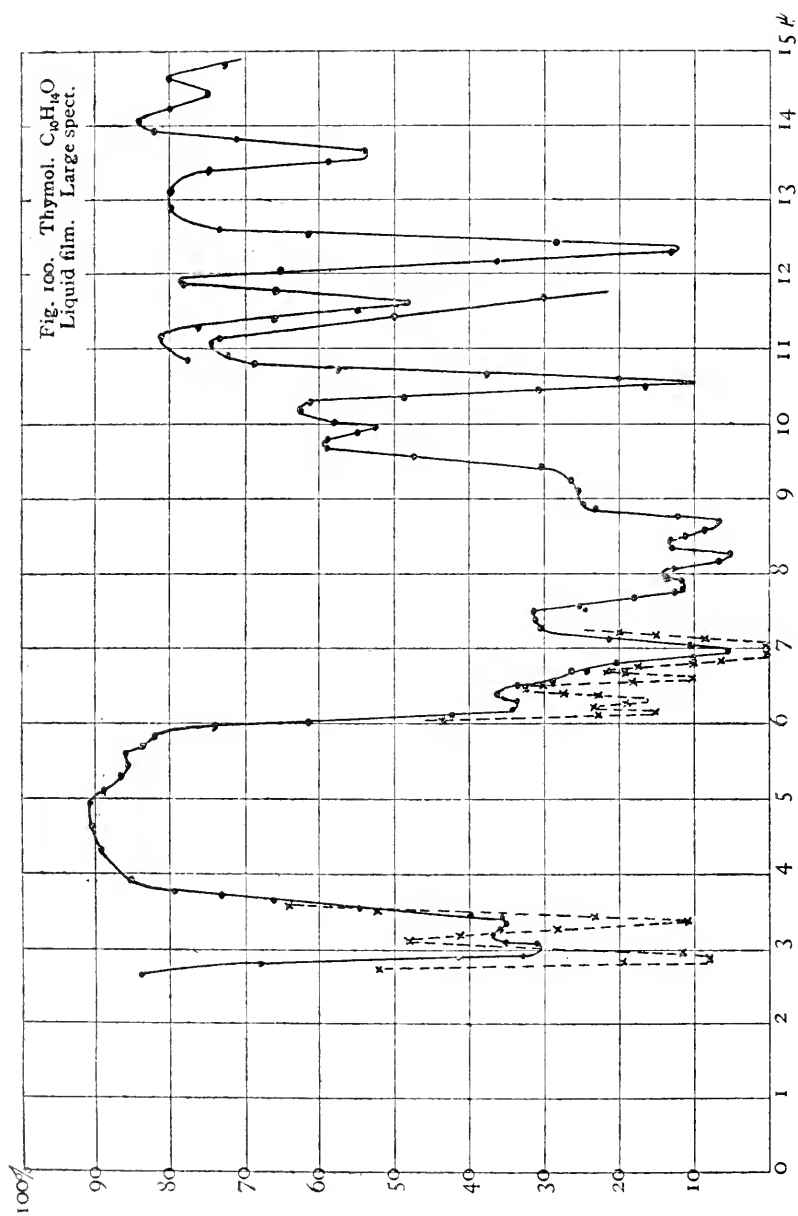



FIG. 101.

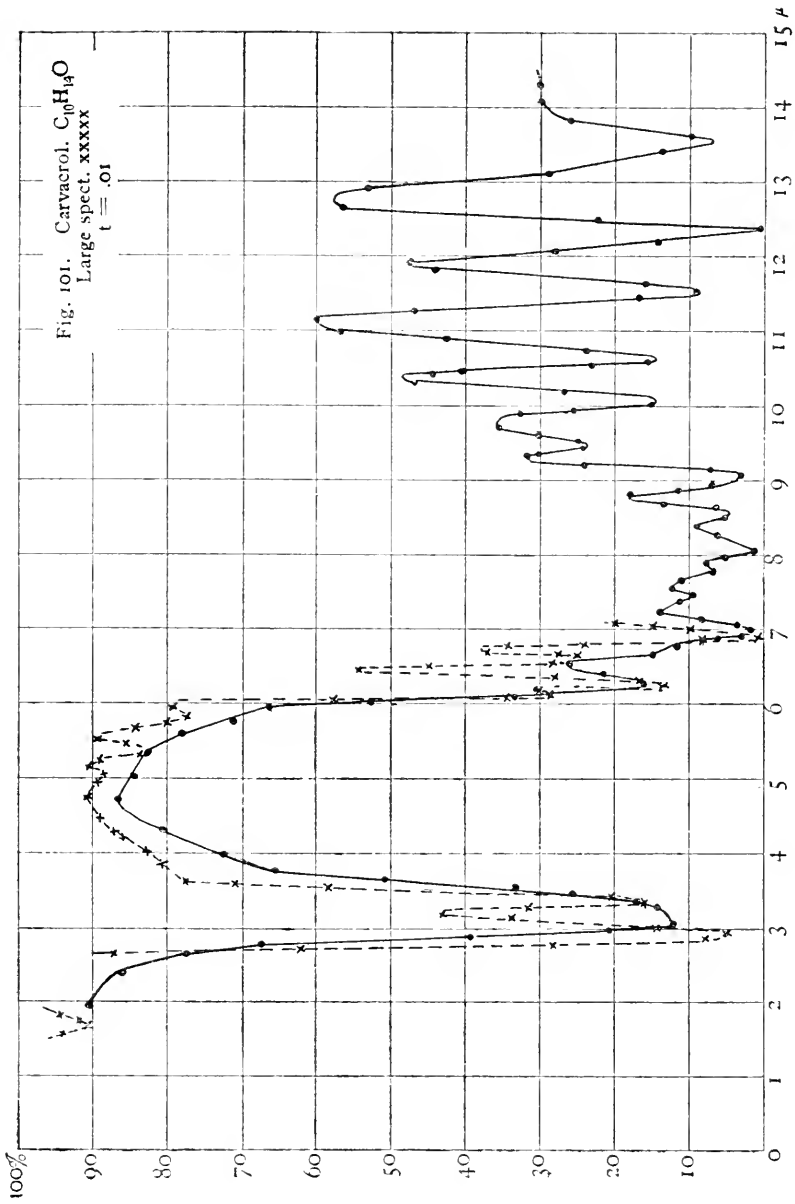

FIG. 102.

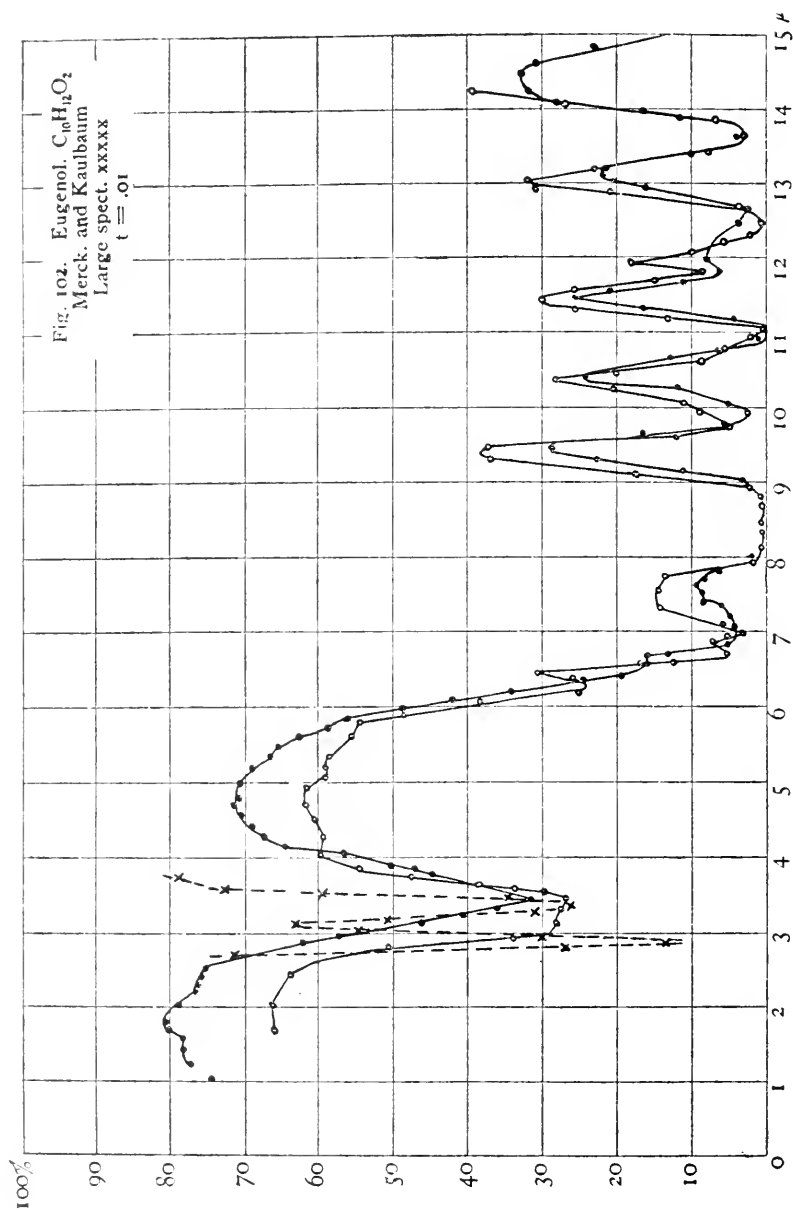

FIG. 103.

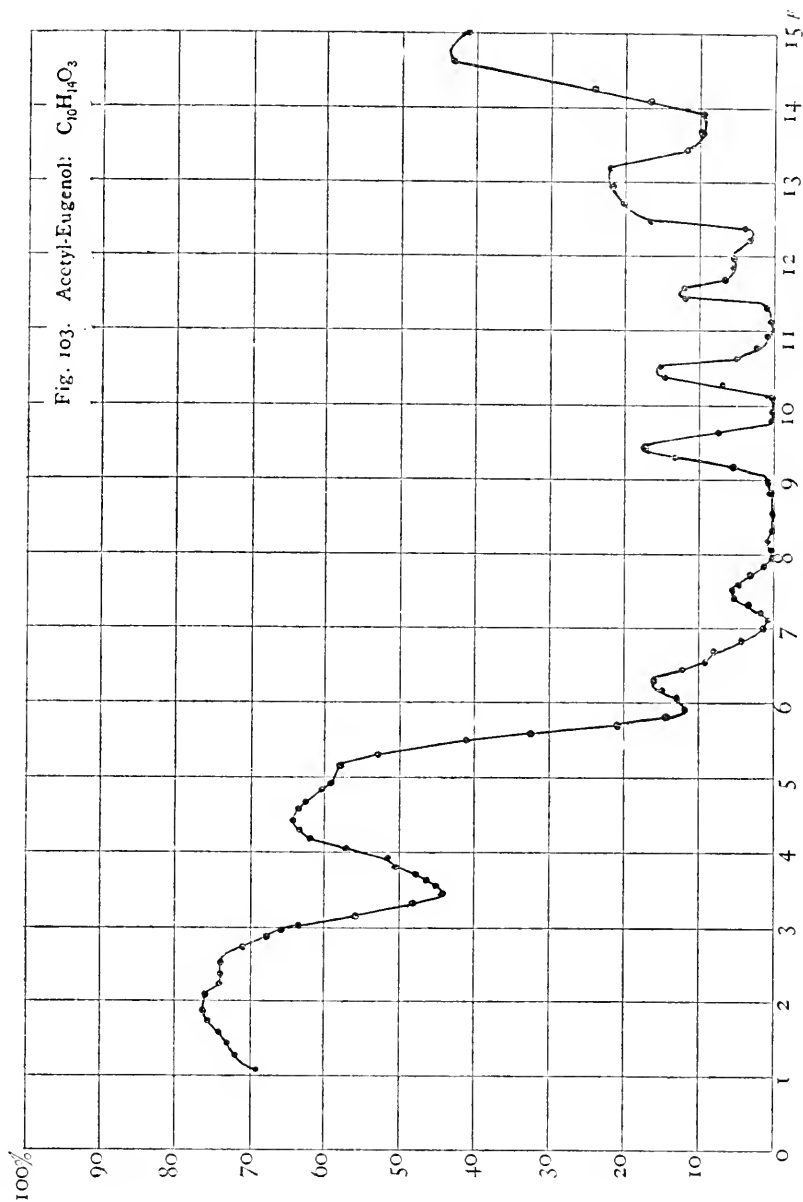

FIG. 104.

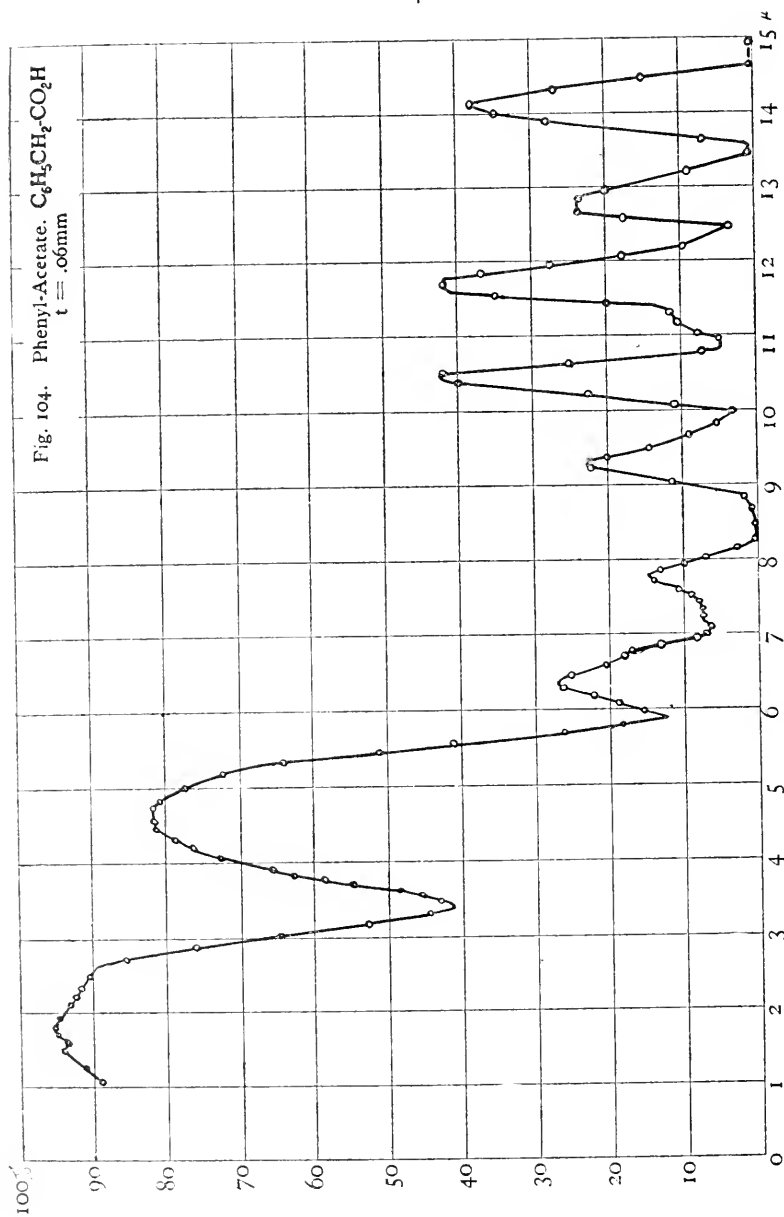

FIG. 105.

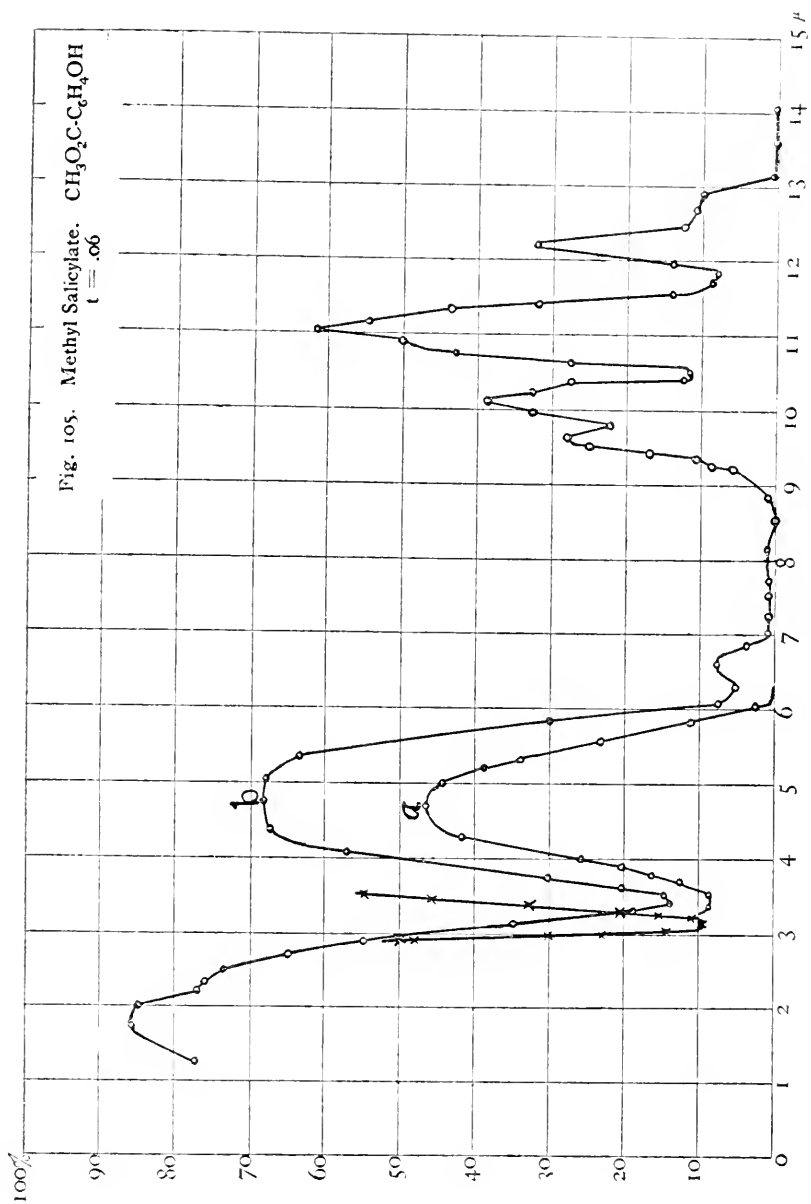

FIG. 106.

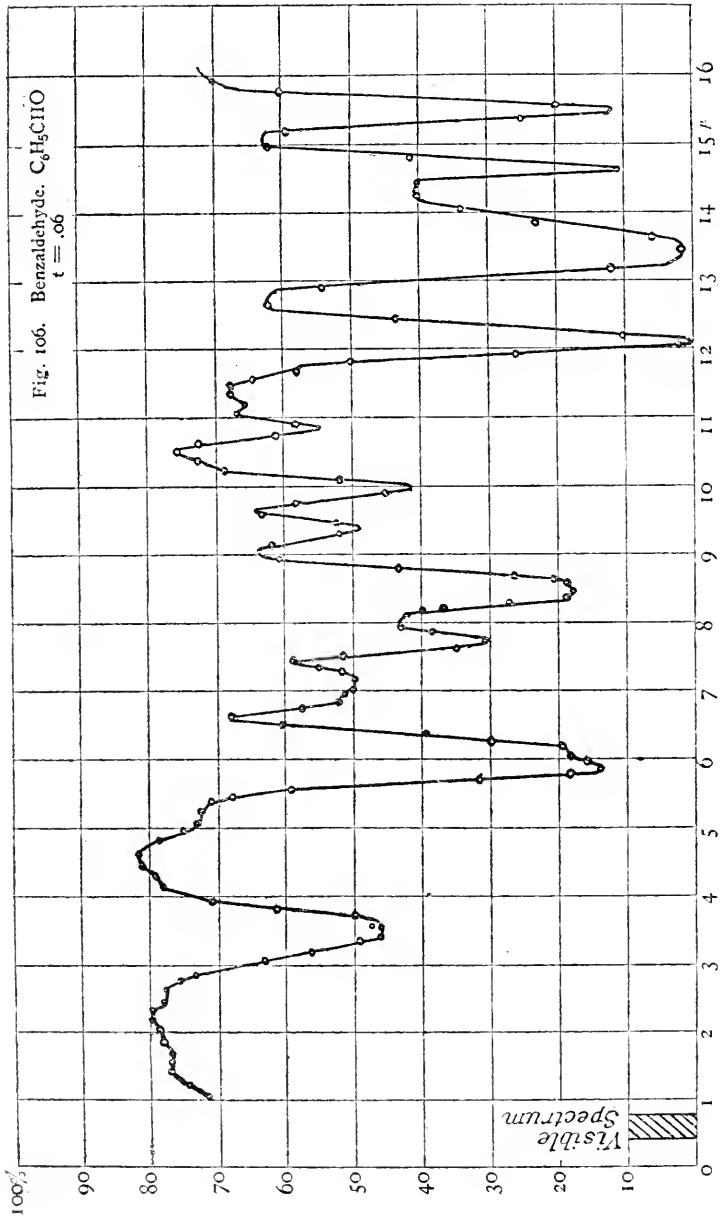

FIG. 107.

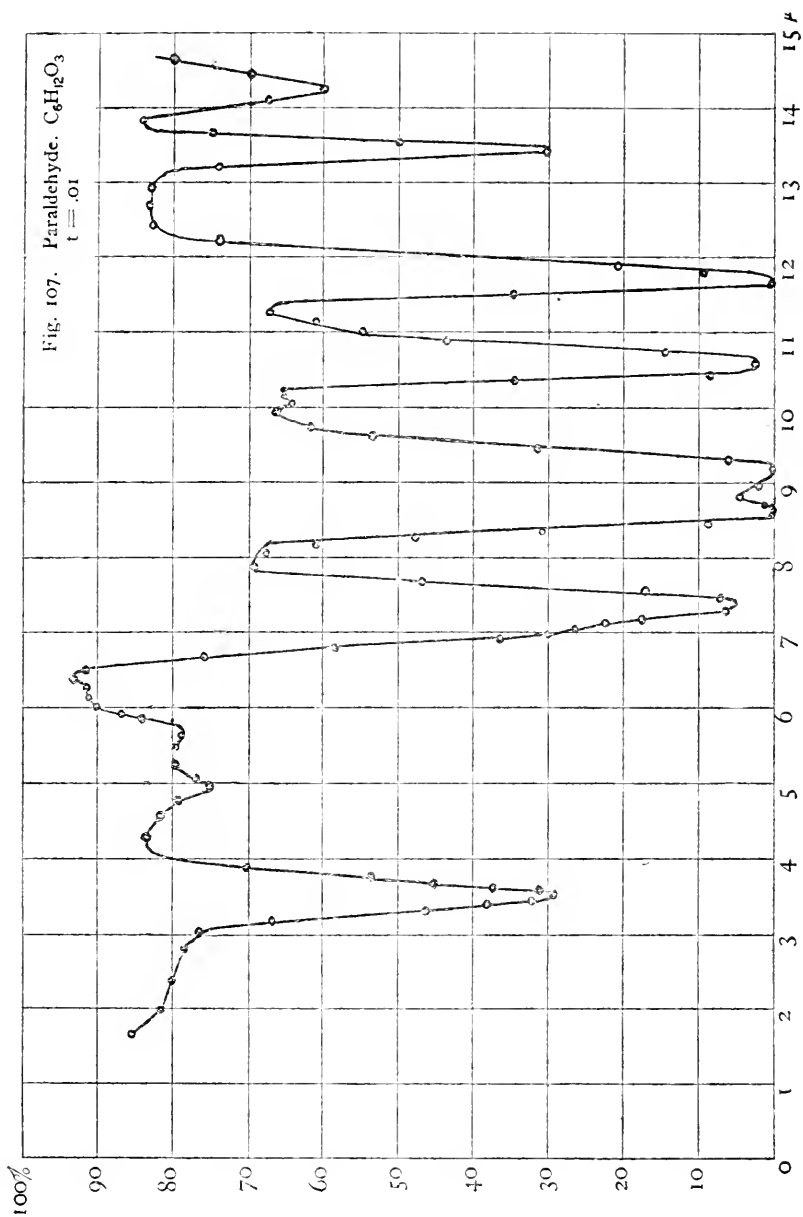

FIG. 108.

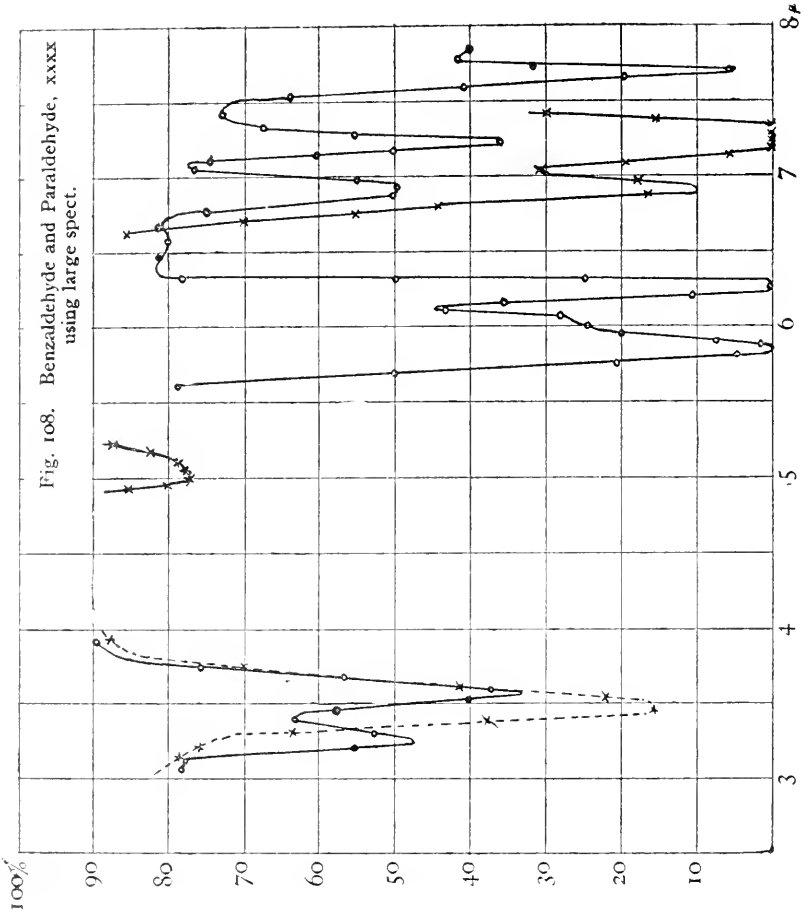



FIG. 109.

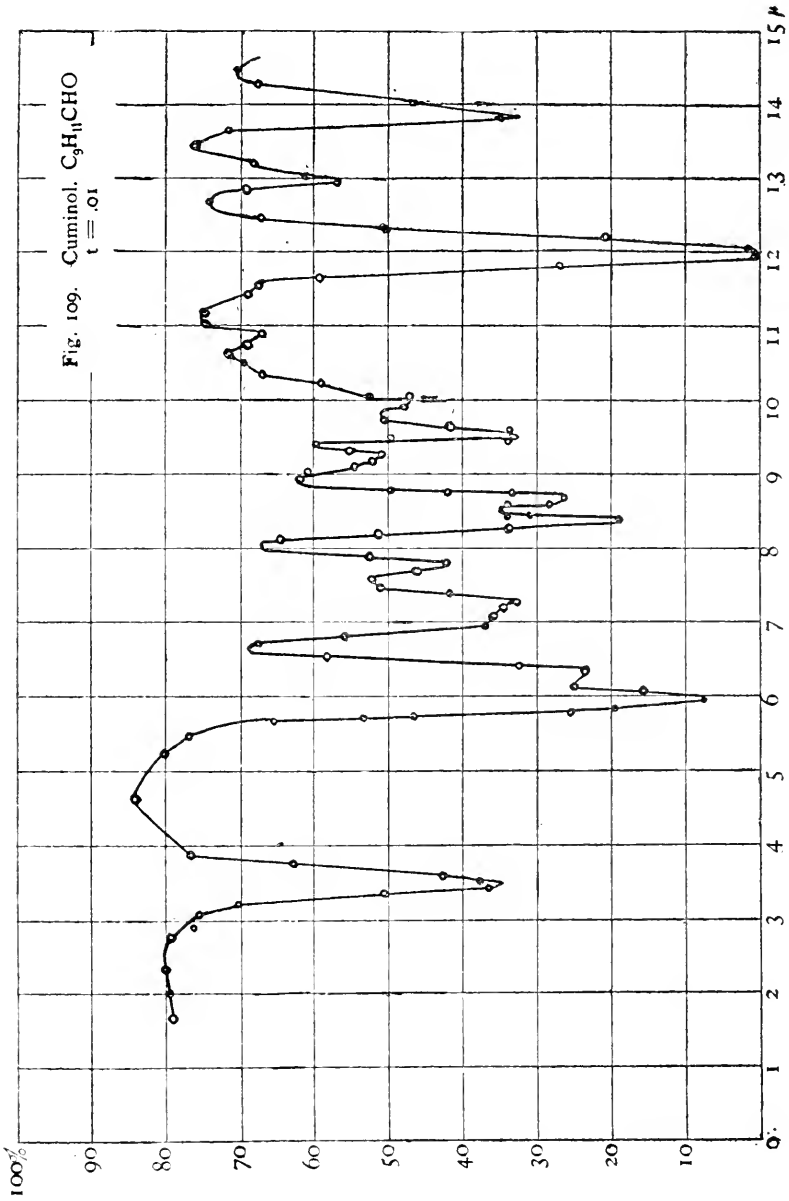

FIG. 110.

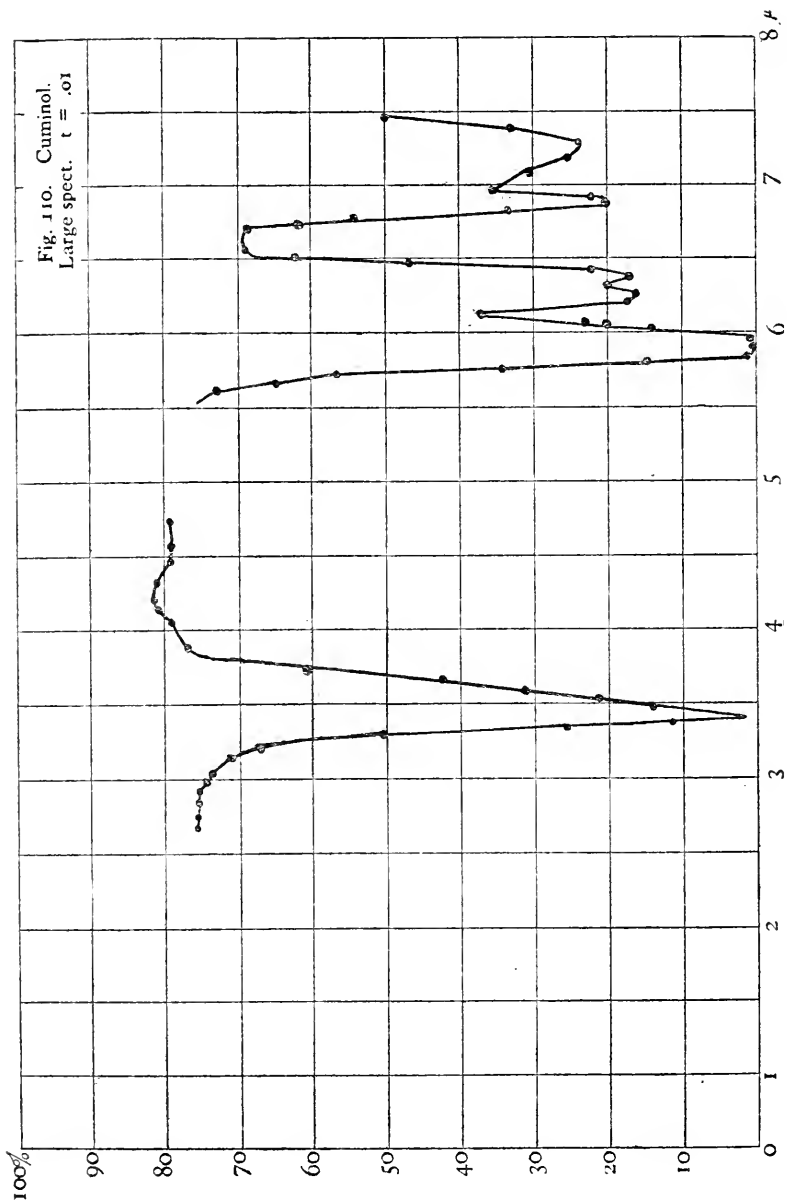

FIG. III.

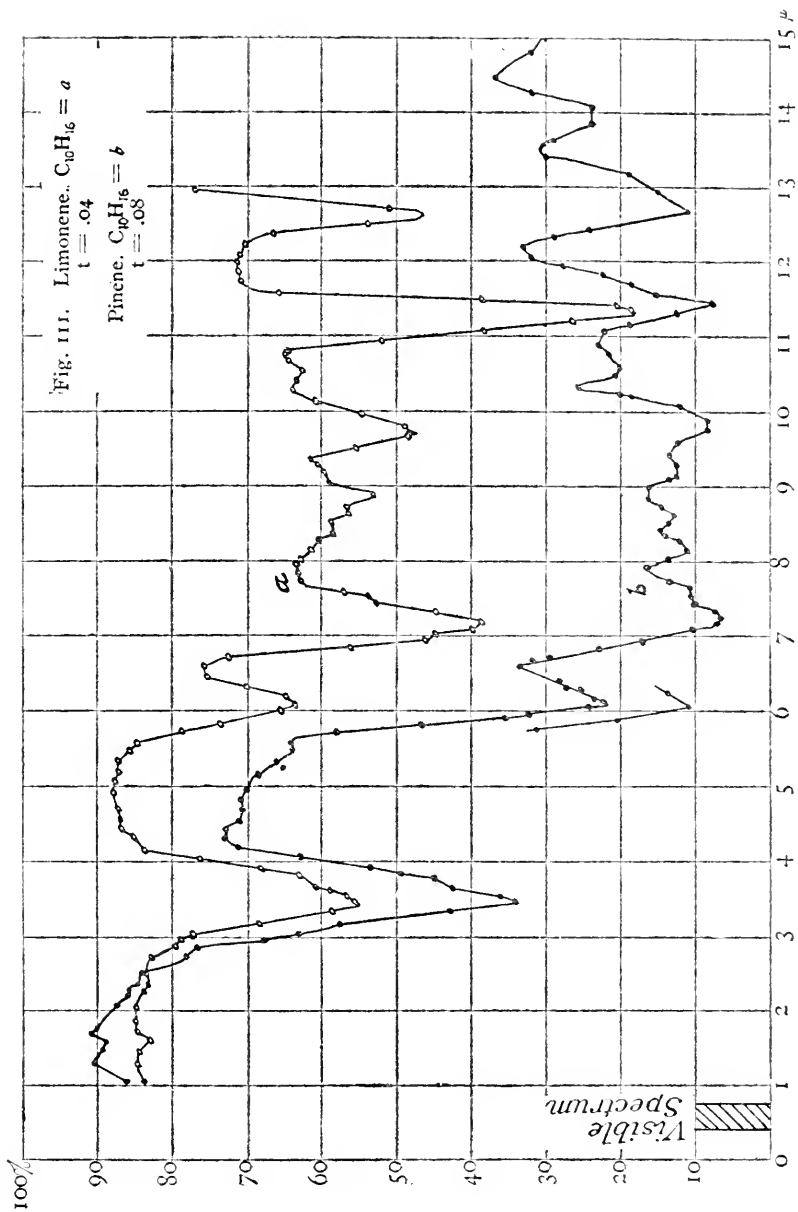

FIG. 112.

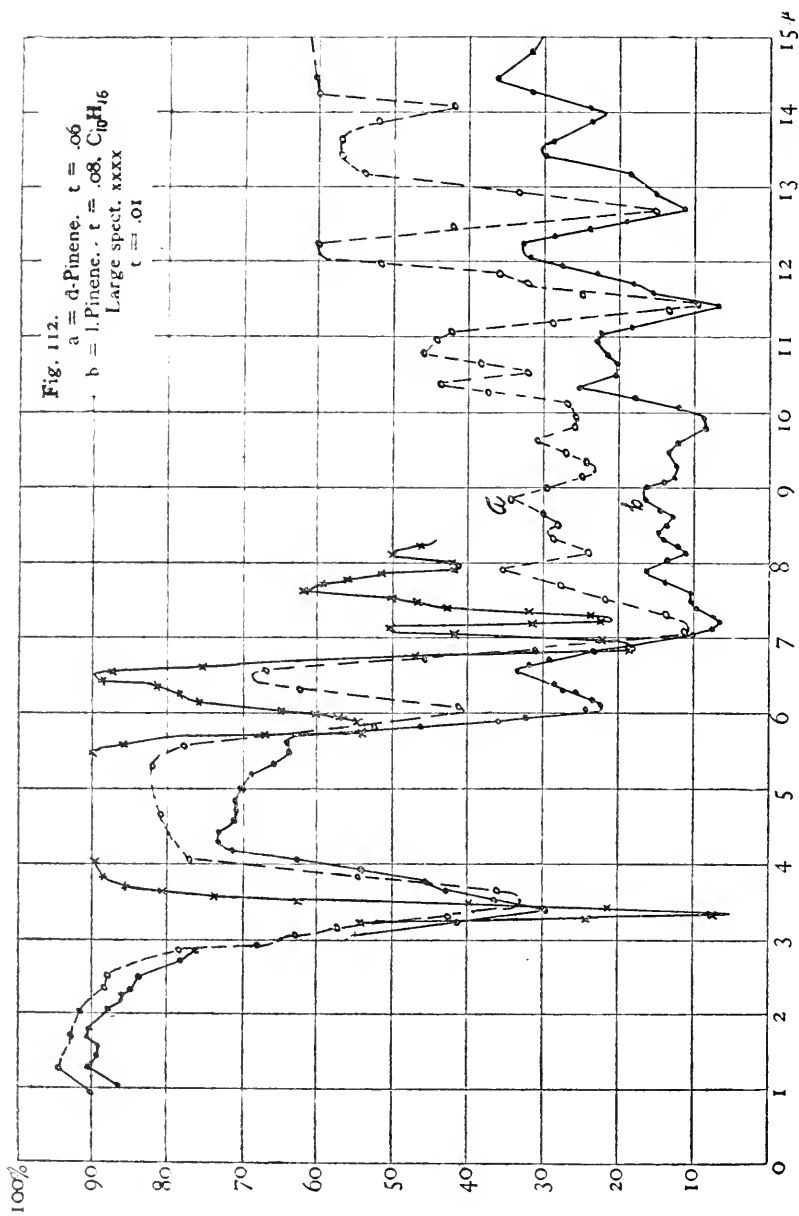

FIG. 113.

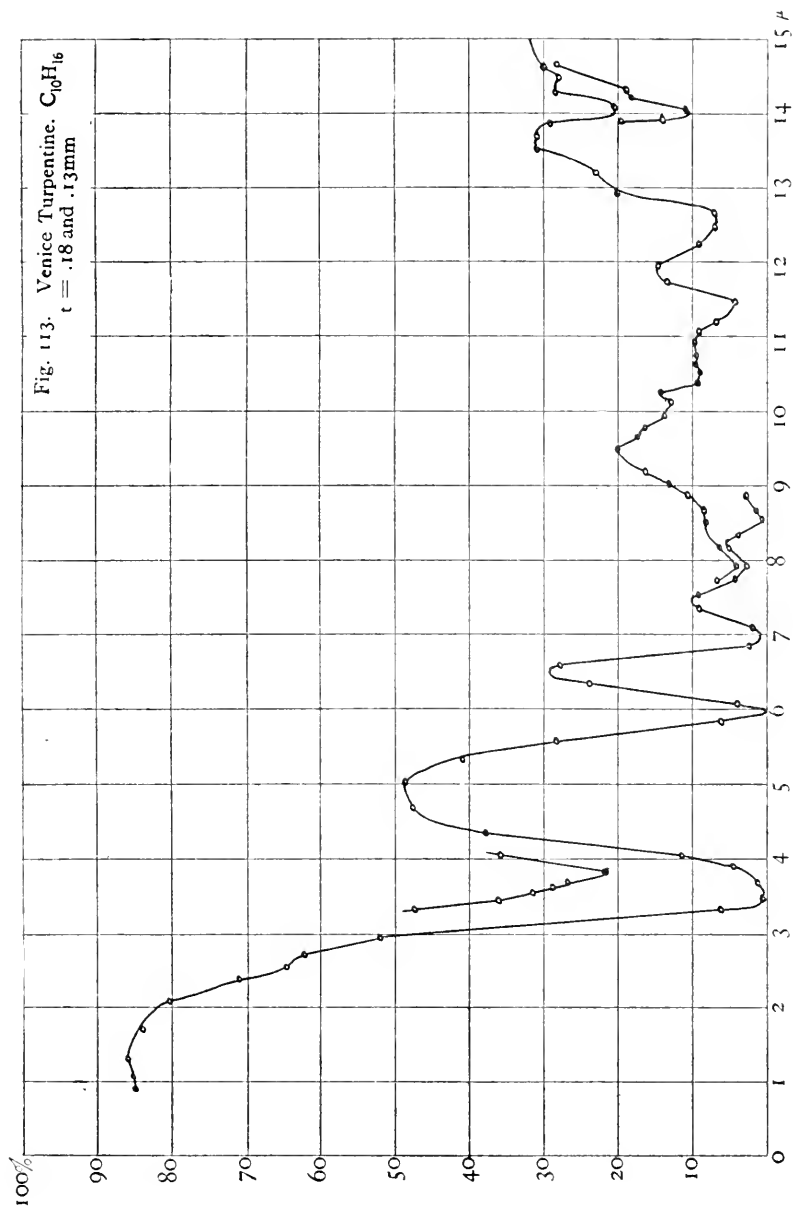

FIG. 114.

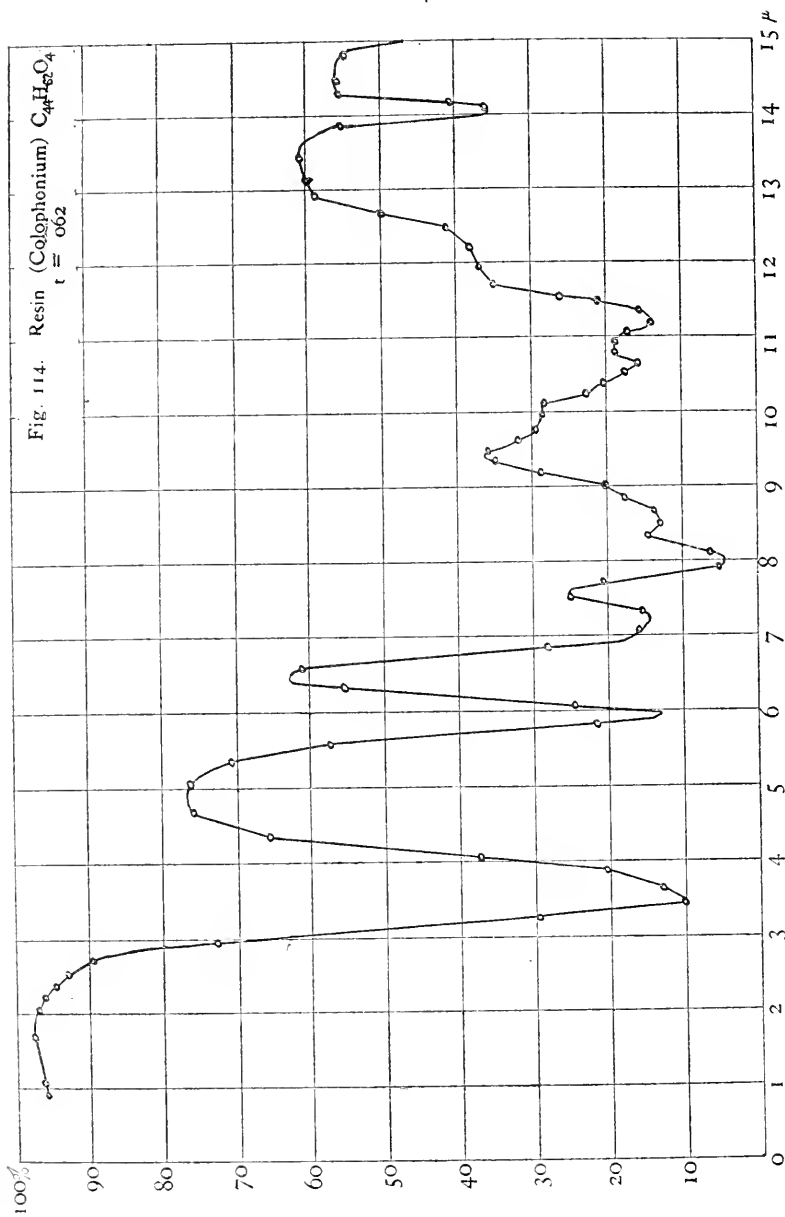

FIG. 115.

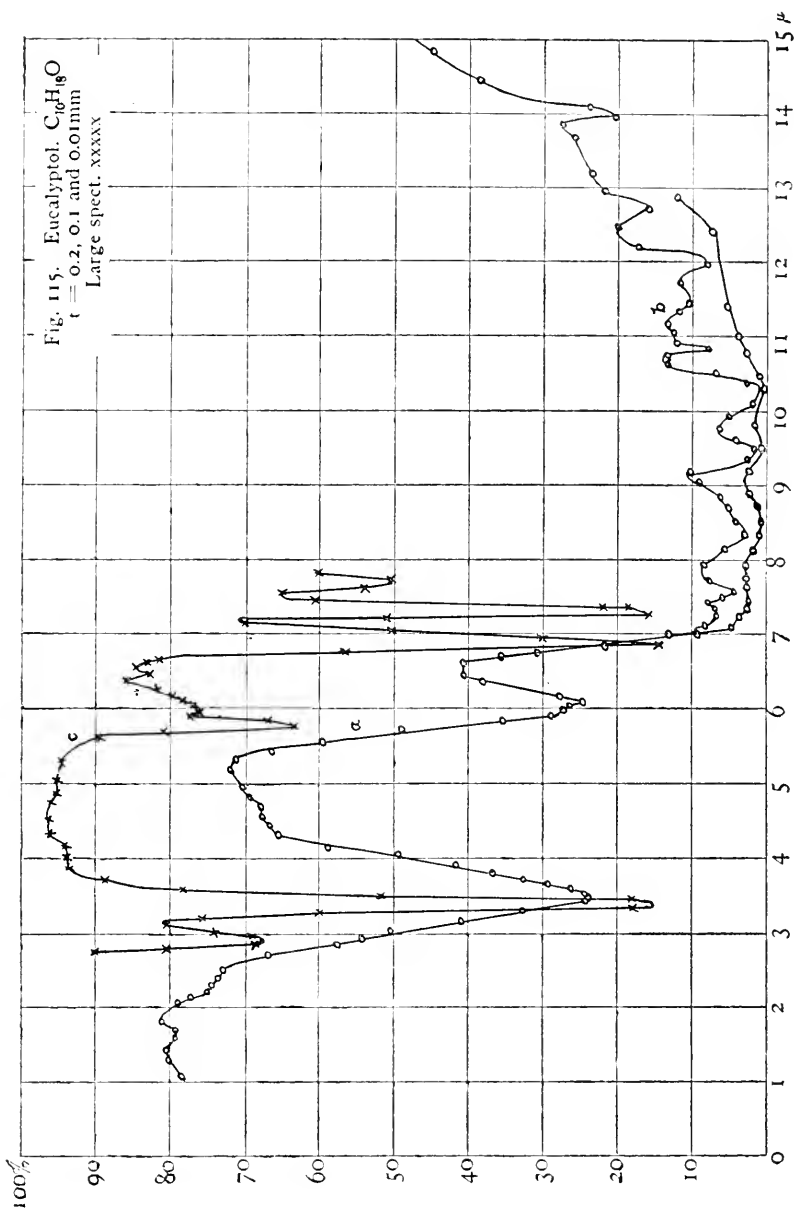

FIG. 116.

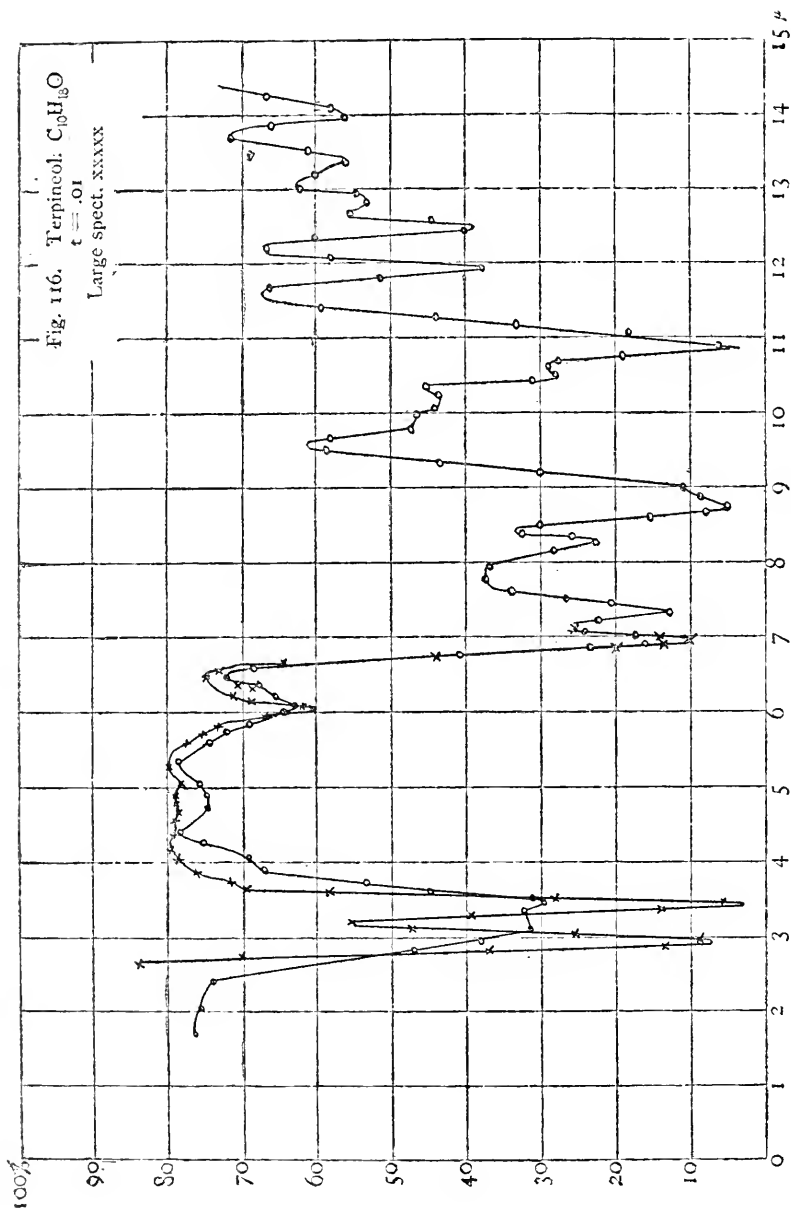



FIG. 117.

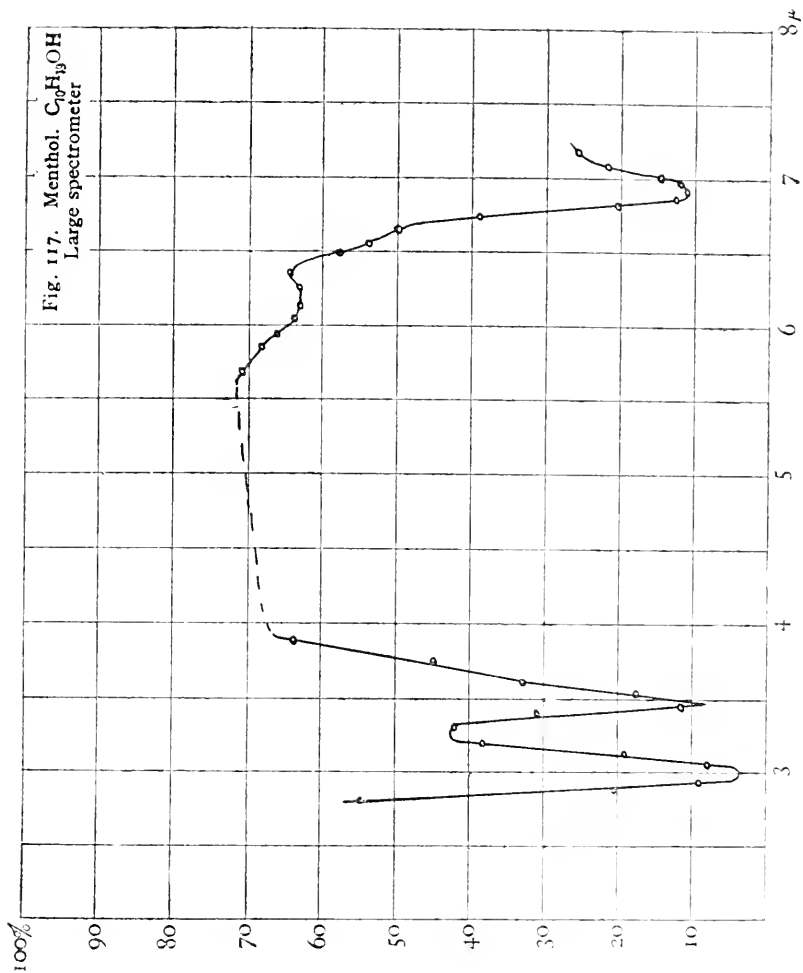

FIG. 118.

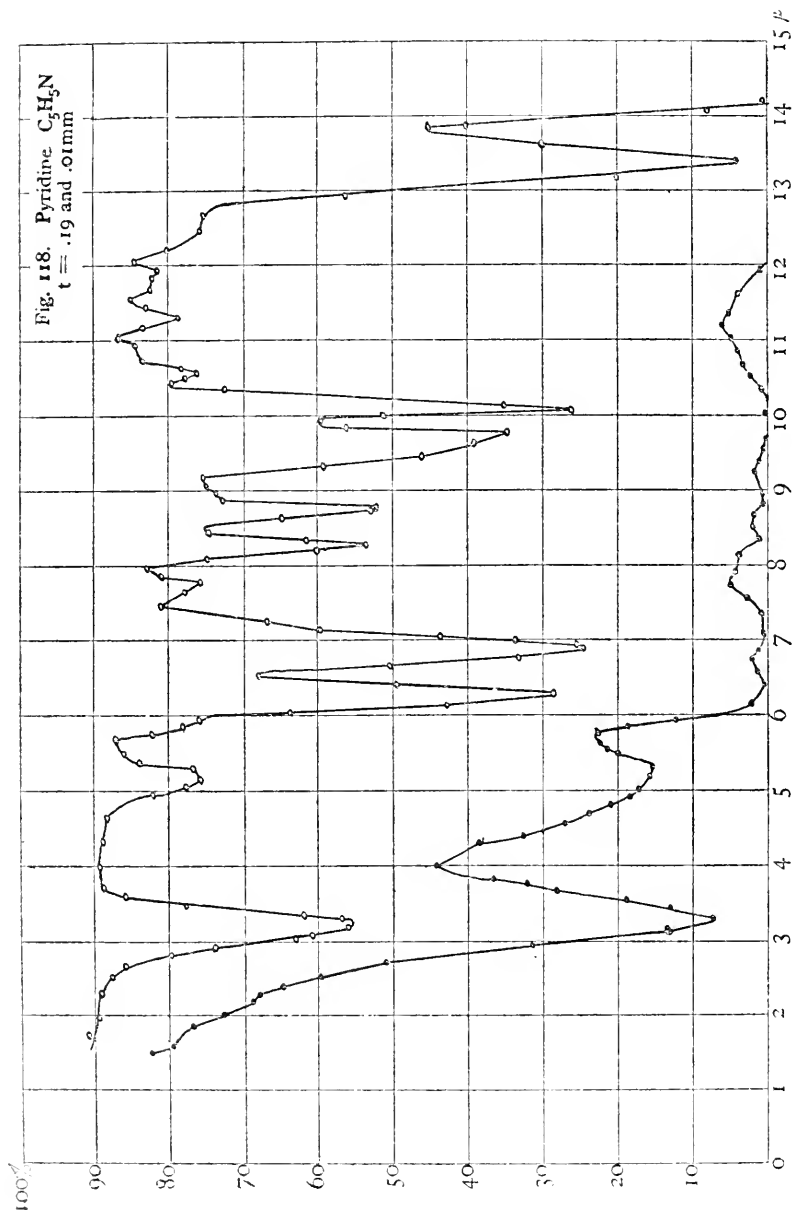

FIG. 119.

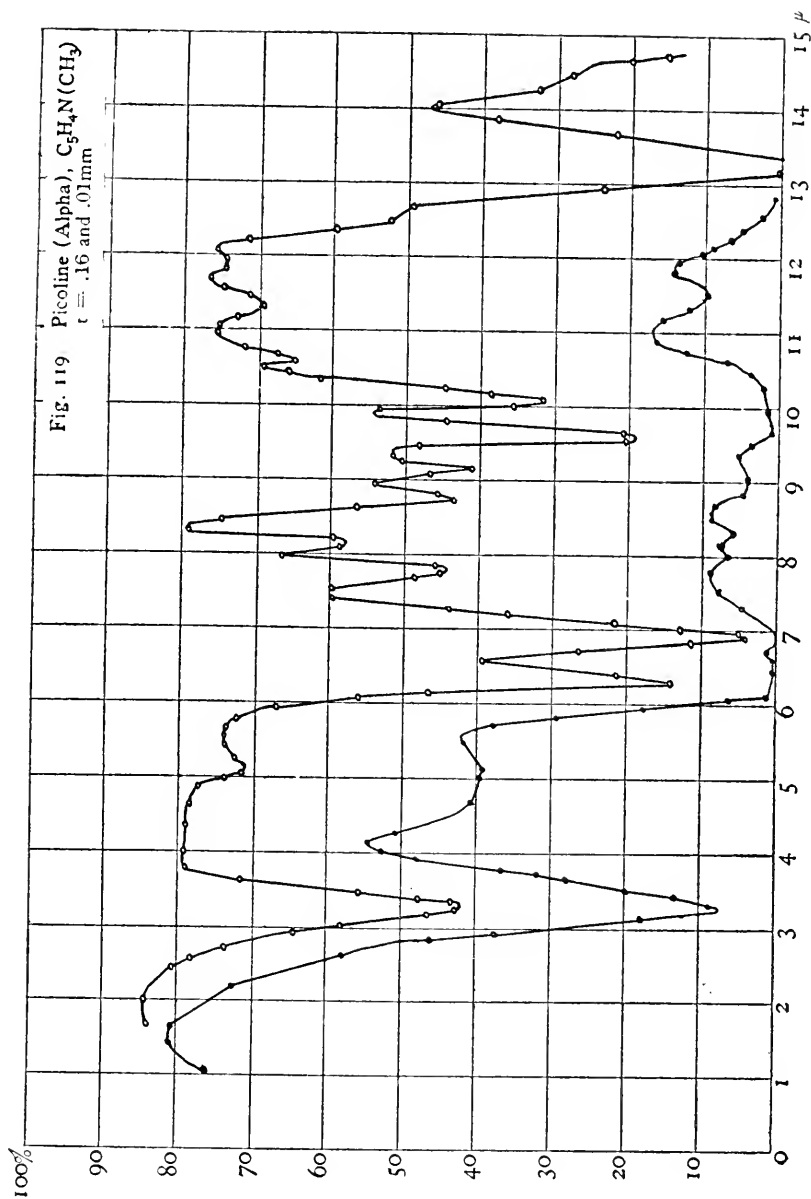

FIG. 120.

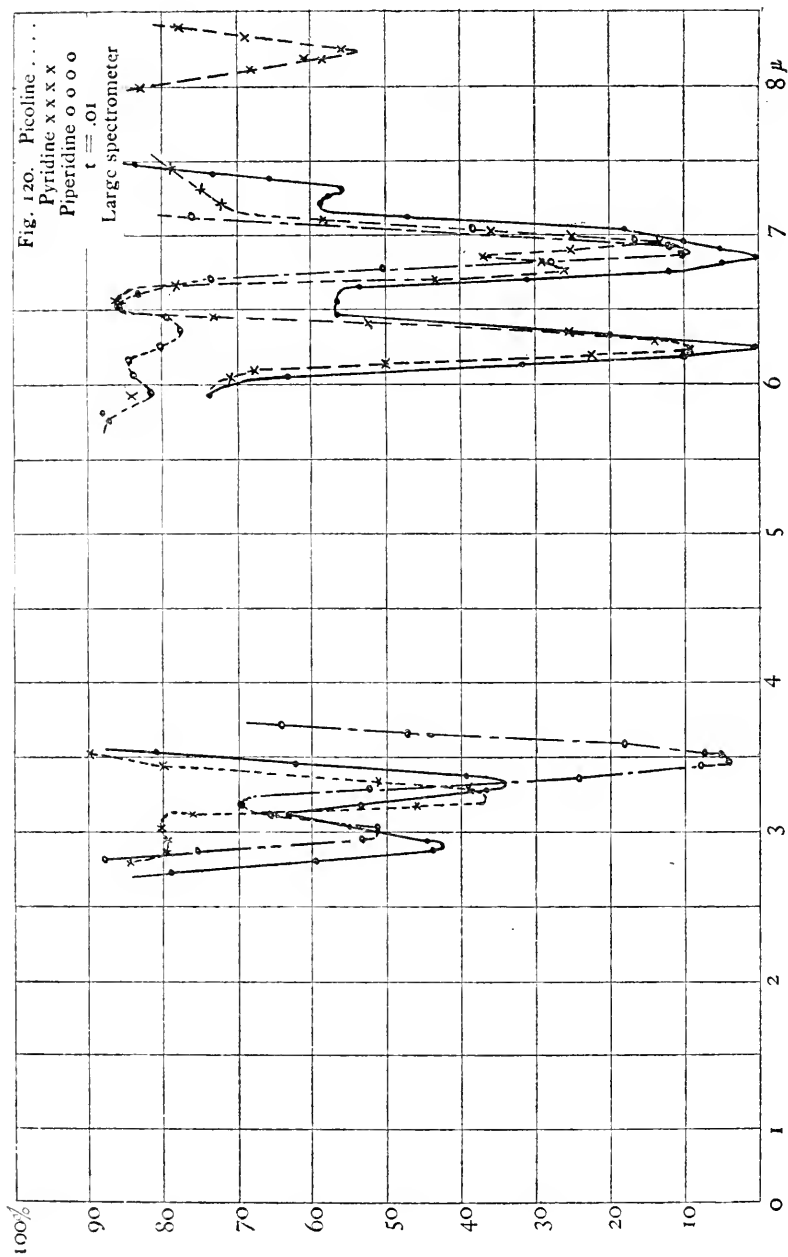

FIG. 121.

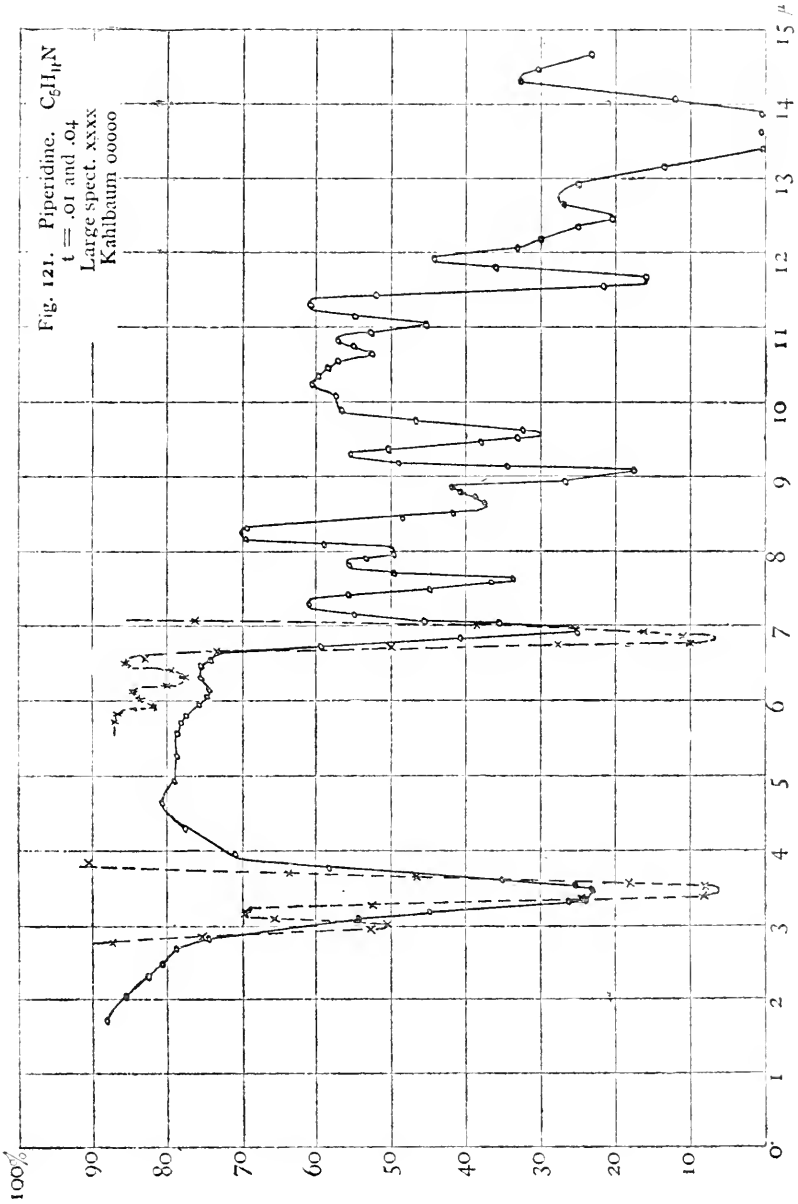

FIG. 122.

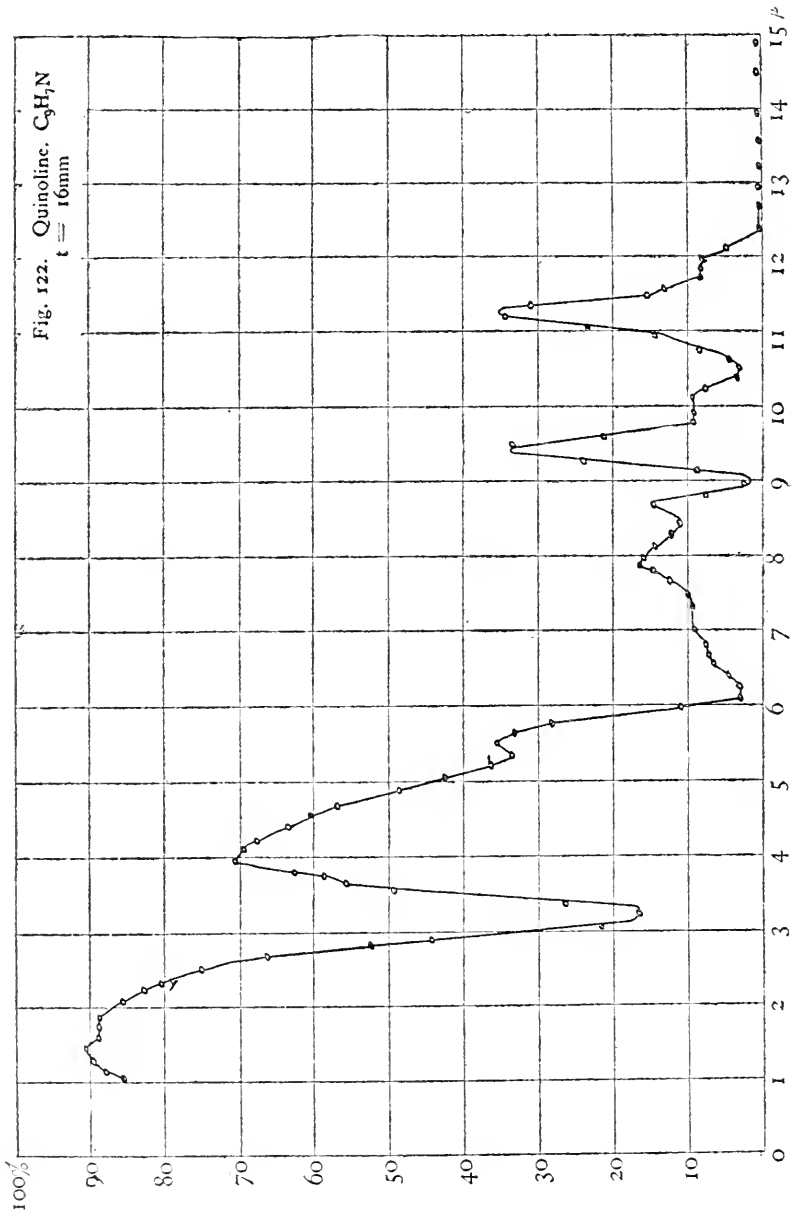

FIG. 123.

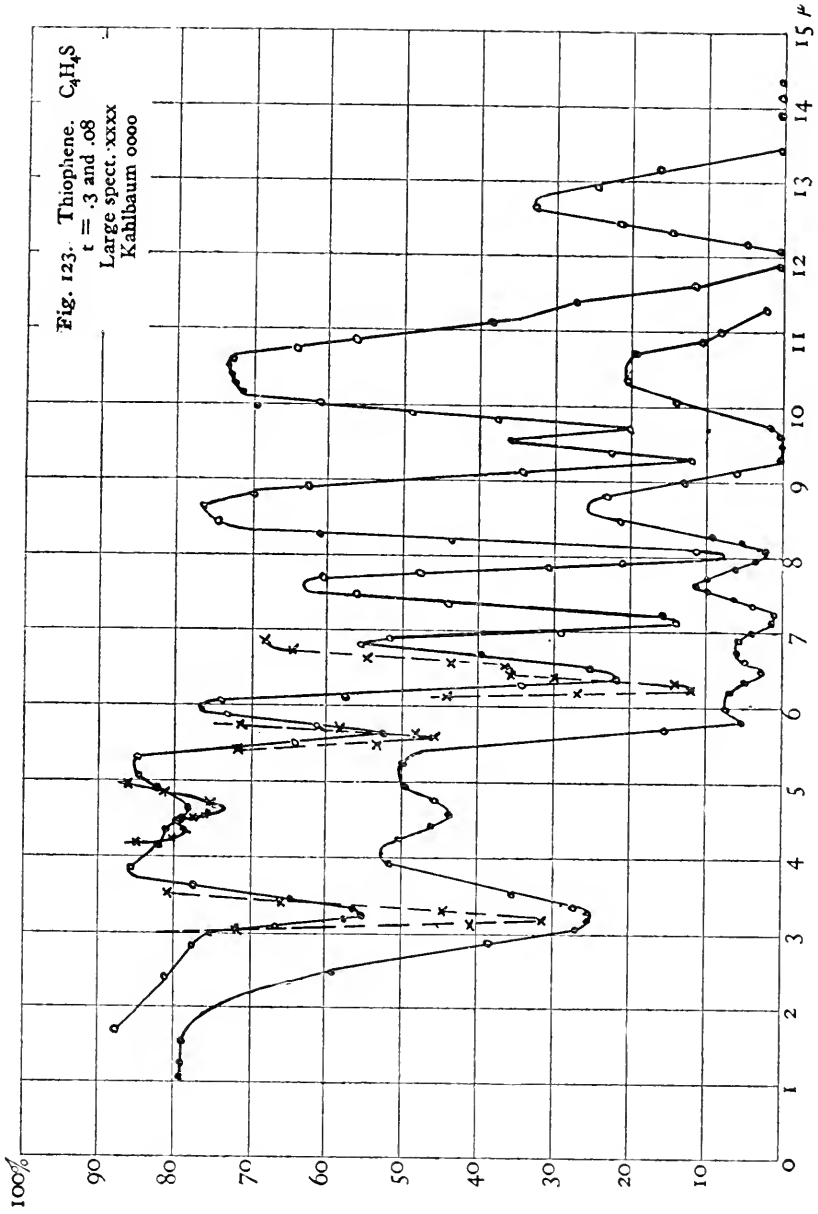

FIG. 124.

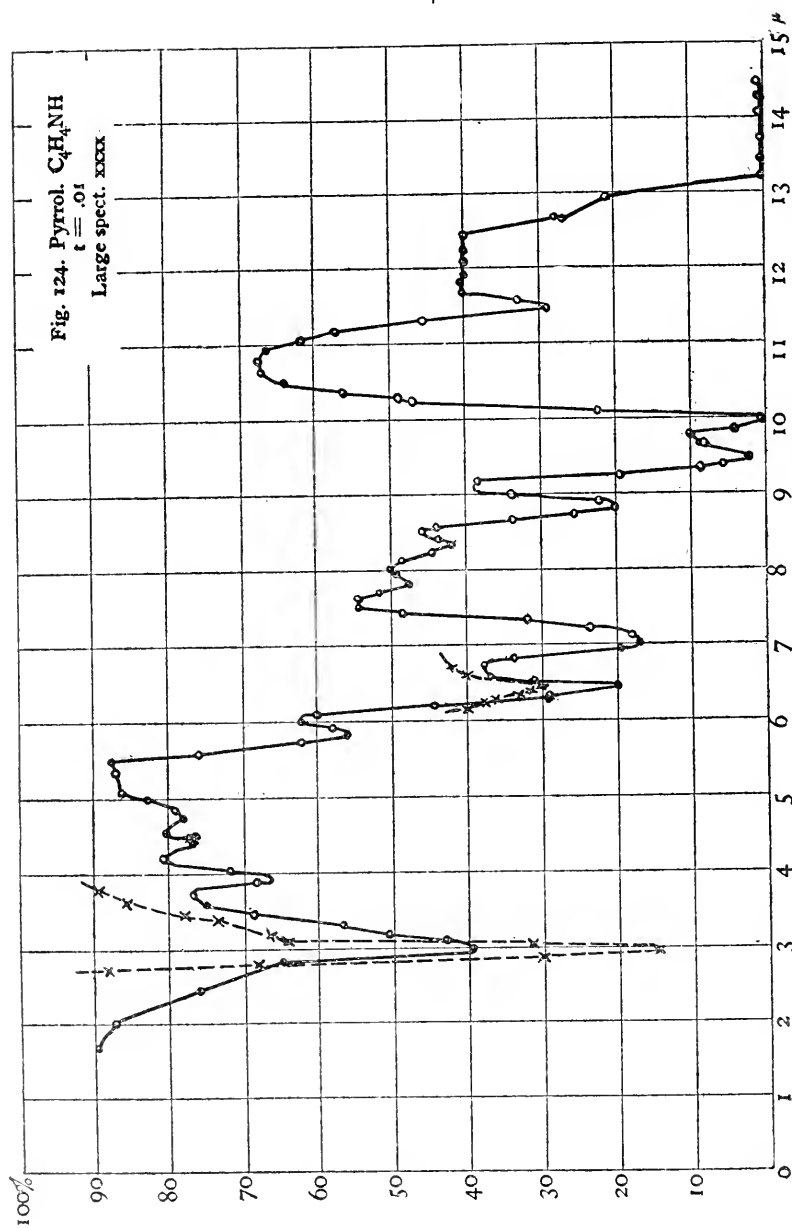



FIG. 125.

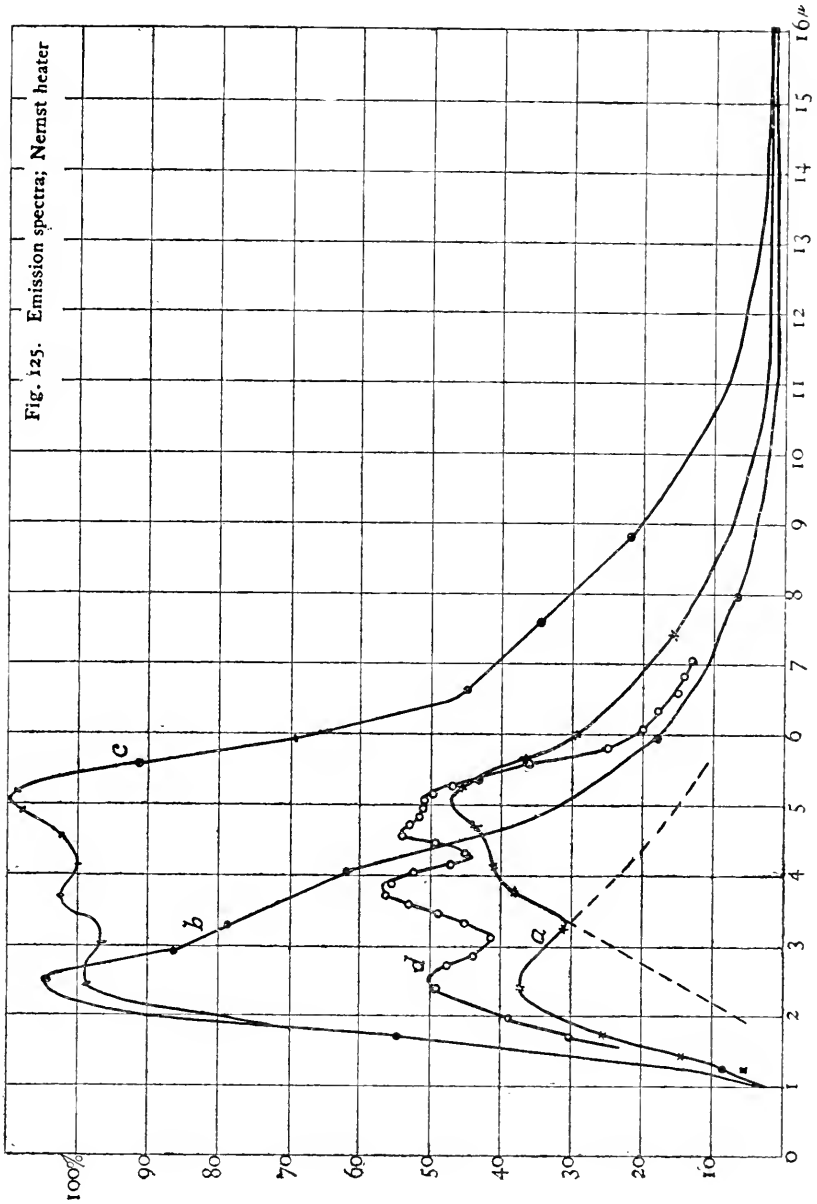

FIG. 126.

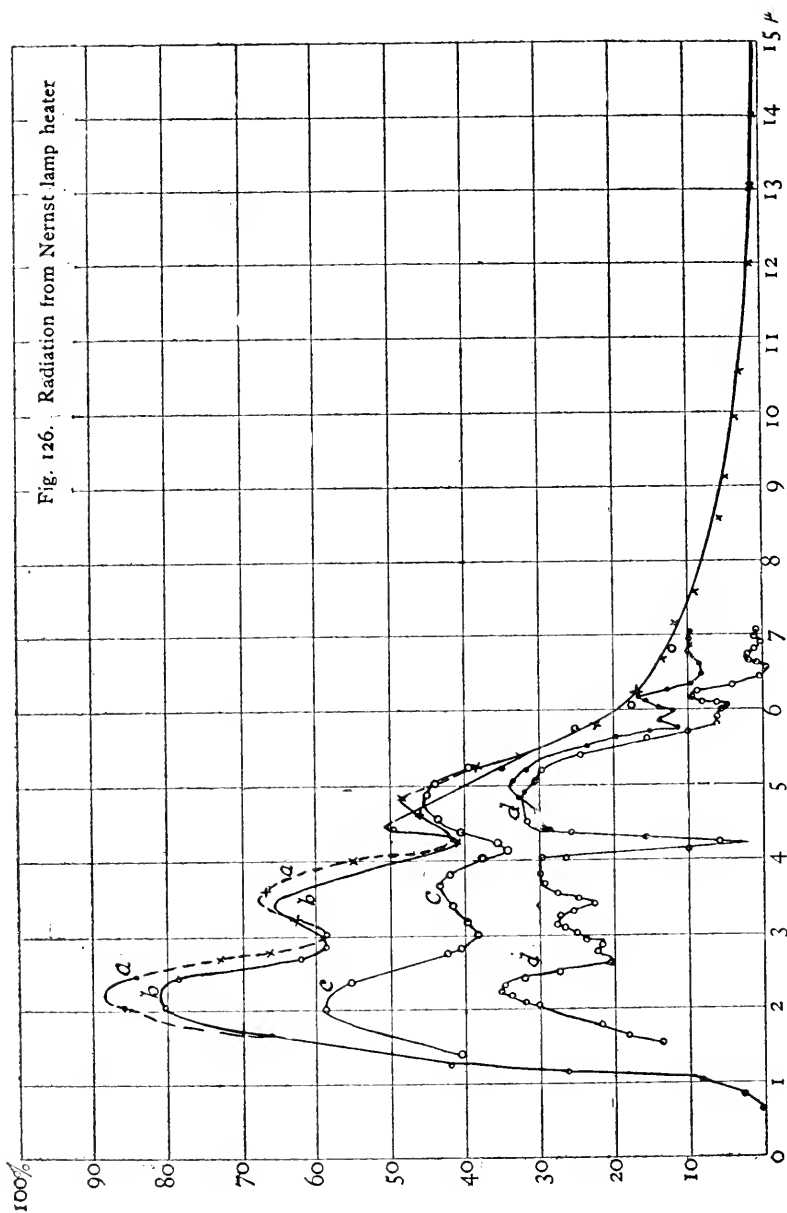

FIG. 127.

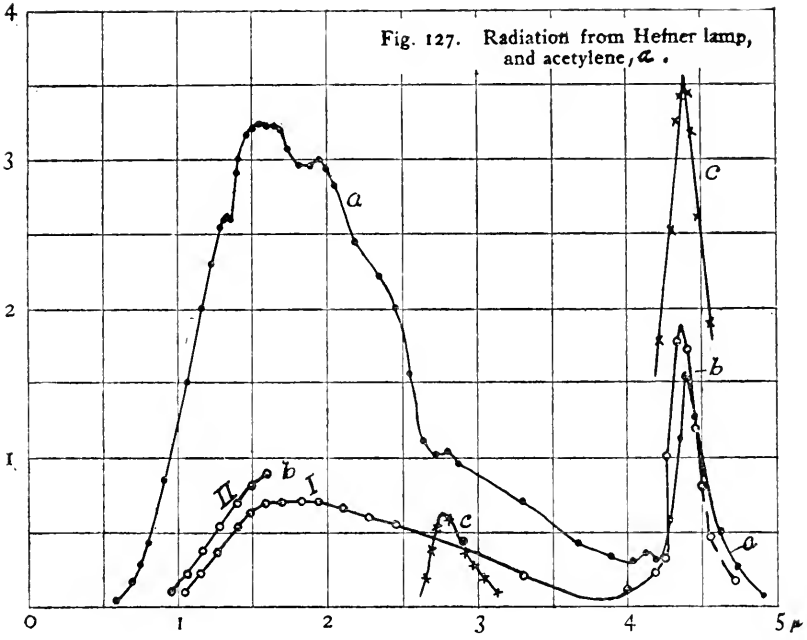

FIG. 128.

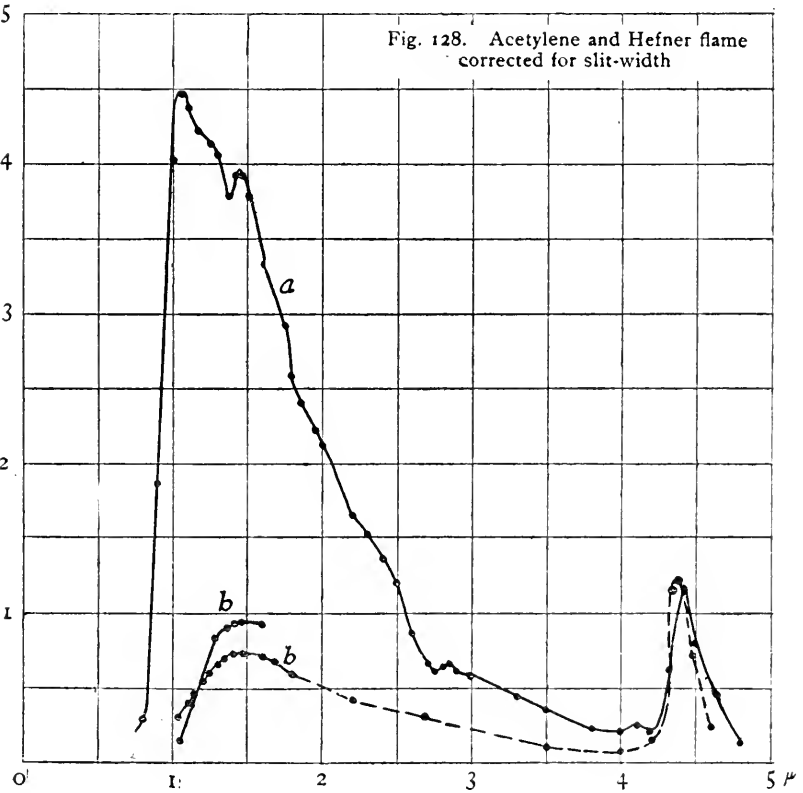

FIG. 129.

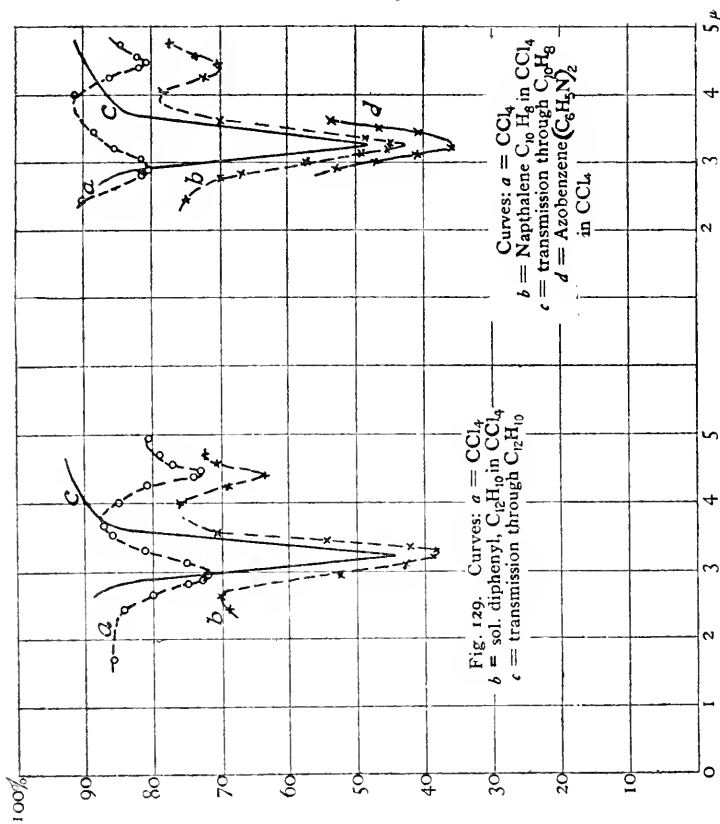

FIG. 130.

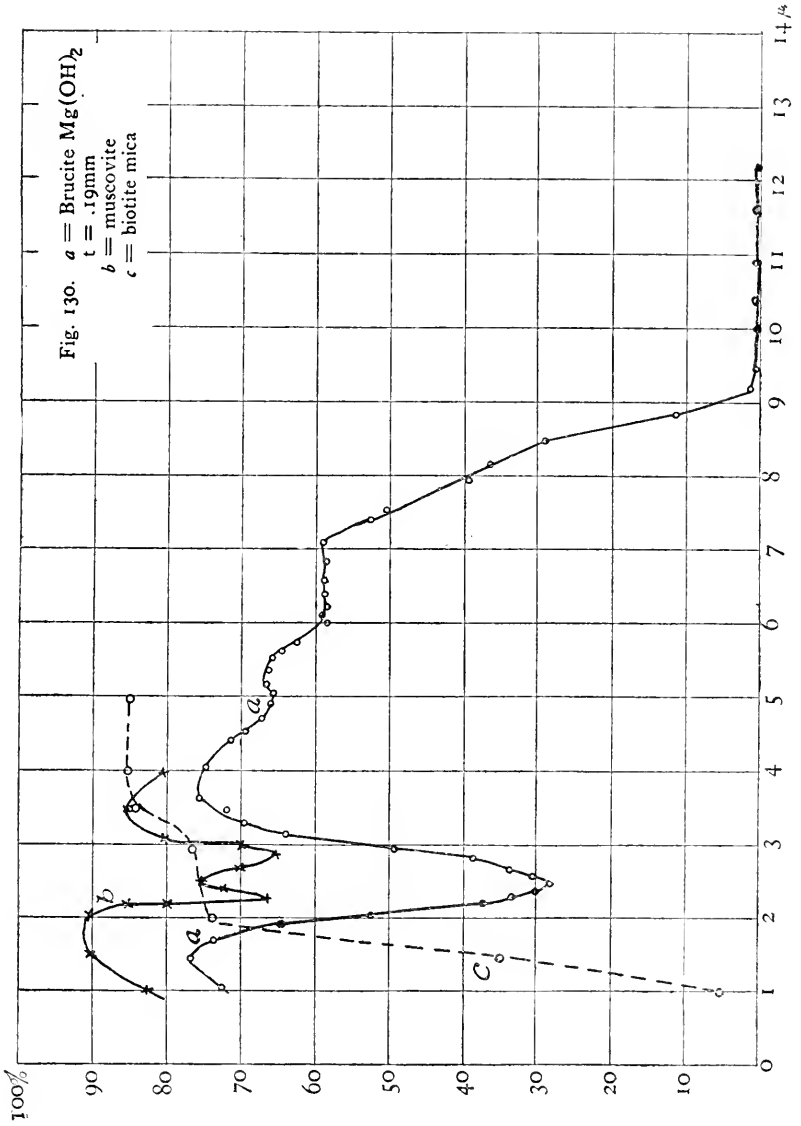

FIG. 131.

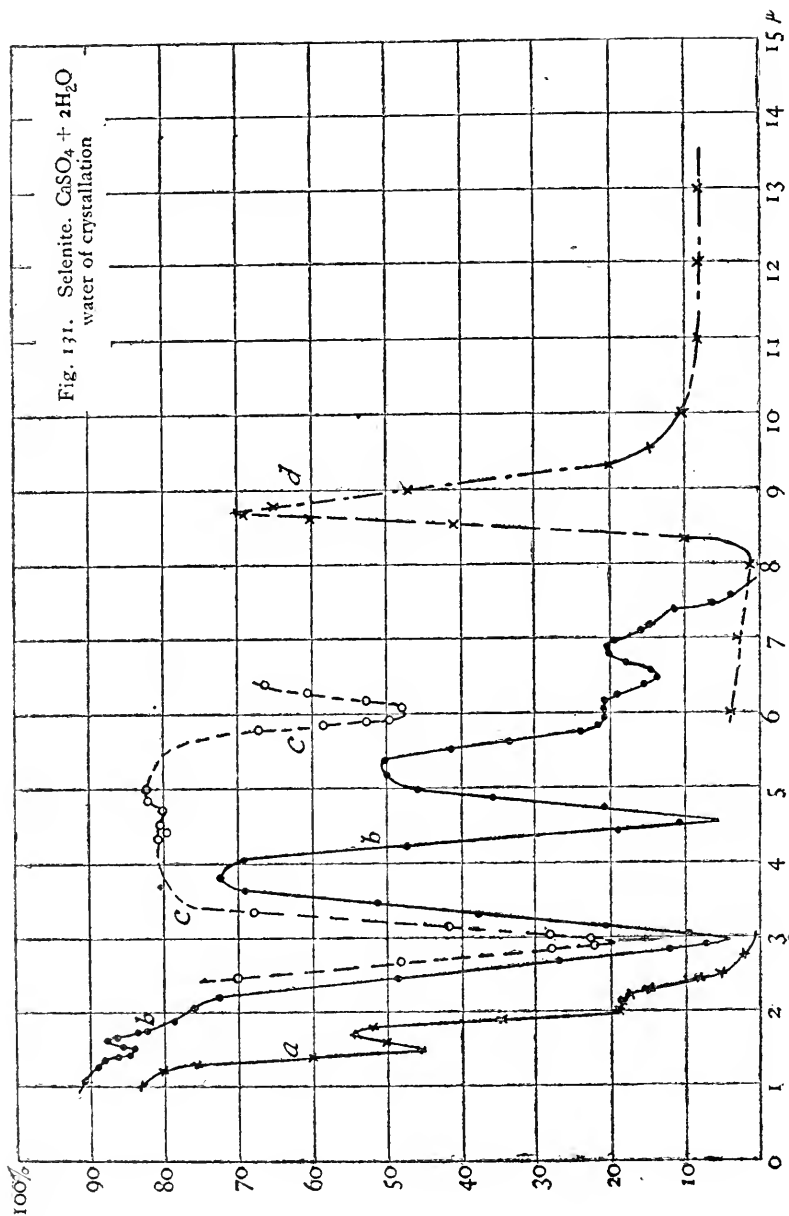
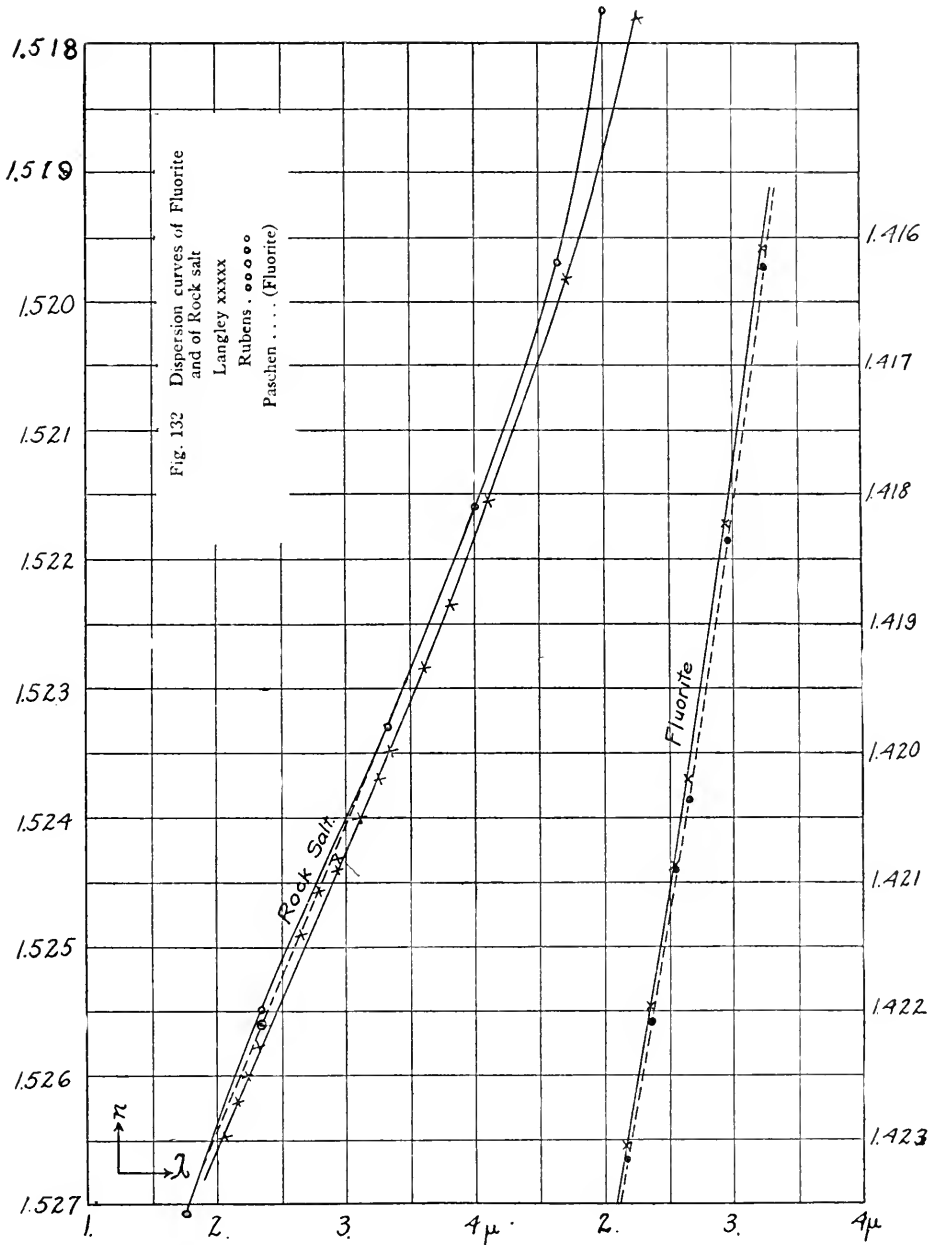

FIG. 132.







## PART II

---

### INFRA-RED EMISSION SPECTRA



## CHAPTER I.

### INTRODUCTION.

The following experimental investigation was performed in the Physical Laboratory of Cornell University during the academic year 1904-5. It forms the second part of an investigation of infra-red radiation, rendered possible by a grant from the Carnegie Institution of Washington. The first grant was for "Investigating infra-red emission and absorption spectra." Finding it impossible to complete the work in the time allotted, the Institution very generously renewed the grant, and the writer takes this opportunity to express his gratitude for the assistance rendered. In the Physical Laboratory he is under deep obligations to Profs. E. L. Nichols and E. Merritt for advice and criticisms as well as for the numerous facilities placed at his disposal. His dealings with the two institutions have been so agreeable that it is with regret that additional phases of the work could not be continued with them.

#### HISTORICAL.

##### INFRA-RED SPECTRUM.

In the visible and ultra-violet regions of the spectrum the most successful method of mapping the position of emission lines is by means of photography; and so long as we do not desire a measure of the energy in these lines this method is very satisfactory. On the other hand, in the infra-red, the photographic plate has never been made sensitive to rays of wave-length greater than about  $1.2 \mu$ . Other methods have been resorted to, one of the earliest being a phosphorescent plate. This method consists in placing the phosphorescent material (which is made into paint) upon an even surface and exposing it to the spectrum. The infra-red lines have the property of extinguishing the phosphorescence, thus leaving dark lines upon a bright background. The plate thus exposed is now placed in contact with a photographic plate which will be acted upon by the phosphorescing parts, but not by the darker lines. The photographic plate when developed is the equivalent of an ordinary positive plate. Becquerel<sup>1</sup> was one of the first to apply this method with success. He photographed quite a number of lines of the alkali metals in the carbon arc to  $1.2 \mu$ . Recently this method was taken up anew by Lehmann,<sup>2</sup> who was able to extend his investigations to  $1.7 \mu$ .

Phosphorescent substances sensitive to radiations beyond  $1.7 \mu$  are

<sup>1</sup>E. Becquerel: *Compt. Rend.*, 99, 374, 1884.

<sup>2</sup>Lehmann: *Phys. Zeit.*, 5, 823, 1904. See also *Sci. Abstracts*, 57, 425, and 898 (1903); 750 (1905); *Ann. der Physik* (4), 5, 633, 1901.

unknown. Since the effect upon the phosphorescent plate is cumulative, as is true of the photographic plate, this method is highly desirable for detecting weak lines, which could not be detected with a bolometer or thermopile. For measuring the energy of the different lines, the bolometer, radiometer, or the thermopile is the most useful. Julius,<sup>1</sup> using a bolometer, applied this method to explore the emission spectrum of a Bunsen flame, when different vapors, *e. g.*, CS<sub>2</sub> and Br, were burned in it. His results are of considerable interest, especially for CS<sub>2</sub>, for which he found emission bands whose maxima coincide with those of the absorption bands, and will be noticed in the present work on the radiation from gases in the vacuum-tubes.

The infra-red spectra of the alkali metals were investigated by Snow,<sup>2</sup> using a glass prism and a bolometer. He used the chlorides of the metals in an arc between hollow carbon electrodes. His observations extend to about 2  $\mu$ , and show *no* strong lines beyond 1.4  $\mu$ . The metals Rb and Cs show small lines up to 1.7  $\mu$  where Lehmann (*loc. cit.*) found small lines for these same metals. Whether this absence of lines beyond 1.5  $\mu$  was due to the opacity of the prism was not determined by Snow. Lewis,<sup>3</sup> using a radiomicrometer and a large grating, examined several alkali metals in the carbon arc. For Na he found a doublet at  $\lambda = 0.81837$  and  $\lambda = 0.8194$   $\mu$ .

The emission bands of CO<sub>2</sub> and H<sub>2</sub>O (vapor) have been investigated by Paschen.<sup>4</sup> He found a strong emission band for CO<sub>2</sub> which shifts toward the long wave-lengths with rise in temperature, the maximum being at 4.27  $\mu$  at 17° (absorption), at 4.3  $\mu$  for a temperature of 600°, at 4.388  $\mu$  for 1000° and 4.40  $\mu$  for the Bunsen flame, which has a temperature of at least 1800°. His method of observation consisted in heating the CO<sub>2</sub> by passing it through an electrically heated platinum spiral, and finding its emission just as it leaves the spiral.

Rubens and Aschkinass<sup>5</sup> have also investigated CO<sub>2</sub> and H<sub>2</sub>O (vapor) to 20  $\mu$ , using a sylvite prism and a linear thermopile. They found a small emission band of CO<sub>2</sub> at 14.1  $\mu$ . The gas was heated by passing it through a metal cylinder, open at the ends and heated by means of Bunsen flames.

Other emission bands of H<sub>2</sub>O and CO<sub>2</sub> will be referred to in the text, and it will be sufficient to add that where one shifts toward the long wave-lengths another shifts toward the short wave-lengths.

---

<sup>1</sup> Julius: Licht. u. Wärmestrahlung verbannter Gase. Berlin, 1890.

<sup>2</sup> Snow: Phys. Rev., 1, p. 35, 1893.

<sup>3</sup> Lewis: Astrophys. Jour., 2, p. 1, 1895.

<sup>4</sup> Paschen: Ann. der Physik (3), 53, p. 324, 1894.

<sup>5</sup> Rubens & Aschkinass: Ann. der Physik (3), 64, p. 584, 1898.

The dispersed radiation from gases in vacuum-tubes has been less extensively investigated. Runge and Paschen<sup>1</sup> investigated the infra-red emission spectrum of helium (clèveite gas) to  $7 \mu$ , using for the purpose a bolometer and a fluorite prism. They found strong emission bands at  $0.729 \mu$ ,  $1.134 \mu$ , and  $2.057 \mu$ . The bands shift slightly for the different vacuum-tubes used, and also vary in intensity in a manner that could not be explained. No lines were found beyond the region of  $2 \mu$ . The three strong lines belong to those of the visible spectrum as predicted by the spectral series formulæ.

Ångström<sup>2</sup> measured the total radiation of gases in vacuum-tubes and remarked that to do so is a difficult matter, so that after dispersing the radiation the task is well-nigh impossible. In fact, the bolometer used by him was not sensitive enough to measure the intensity of the individual lines, hence only the total radiation was measured. For the positive column, at constant pressure, Ångström found that the total radiation as well as the luminous radiation is proportional to the current. For hydrogen the total radiation is a maximum at a pressure of 1.02 mm., while the luminous radiation decreases with increase in pressure. For nitrogen the total radiation is a *minimum* at 3.6 mm. pressure. In the work of Drew (to be mentioned presently) the curves of total radiation of air also show a *minimum*, which, however, shifts with increase in size of the tube, the minimum being at a pressure of about 1.7 mm. for tube 0.9 cm. in diameter, and at a pressure of 0.5 mm. for a tube 1.8 cm. in diameter.

From the fact that the total radiation *increases*, while the luminous radiation *decreases*, with increase in pressure of the gas, Ångström concluded that there are two kinds of radiation present during the electrical discharge, viz, "regular" and "irregular" (*i. e.*, luminescence). With decrease in pressure the former decreases while the irregular radiation increases in proportion as the motions are less obstructed by the mass of the gas. At constant pressure a certain proportion of the energy in each molecule is converted into radiation; as the strength of the current increases the number of active molecules, and hence the radiation, increases in the same proportion.

The number of the active molecules being relatively small, the dampening effect of the rest may be taken as constant, and the composition of the radiation remains practically unaltered as the current increases. On increasing the pressure the dampening effect changes, and the radiation becomes richer in infra-red rays. A greater proportion of the

---

<sup>1</sup> Runge & Paschen : *Astrophys. Jour.*, 3, p. 4, 1896.

<sup>2</sup> Ångström ; *Ann. der Physik* (3), 48, p. 493, 1893.

energy supplied is spent in heating, and, for the same current work, the total radiation increases with increasing pressure.

After noticing the present results it will become quite apparent that Ångström's predictions are in remarkably close agreement with observed facts. On the other hand, in his review of the recent work on electrical gas spectra, the predictions of Berndt<sup>1</sup> are not so close in agreement with the present work. For example, in speaking of Ångström's observations, which show that total radiation increases while the visible radiation decreases with increased pressure of the gas, he remarks that this would show that the spectral distribution of the energy must shift with change in pressure, which has been observed. But, to say that the distribution of intensity changes in such a manner that, with decreasing pressure, the center of gravity of the distribution of the spectral energy shifts toward the shorter wave-lengths, does not seem admissible, since slight traces of CO<sub>2</sub> may have been present.

In his efficiency investigation of vacuum-tube radiation Drew<sup>2</sup> examined the emission spectrum of air, using for the purpose the writer's radiometer, which at that time was not very sensitive. He found several weak lines in the region of  $1 \mu$ , while the greater part of the energy is concentrated in a strong band at  $4.75 \mu$ . The other maxima worthy of notice are those at  $0.66$ ,  $0.74$ ,  $0.89$ , and  $1.03 \mu$ . For air the  $0.89 \mu$  band is more intense than the one at  $1.03 \mu$ , while in the present work on nitrogen the reverse has been found.

The infra-red emission spectrum of the mercury arc, in the form of the Arons lamp, has also been explored.<sup>3</sup> Three strong lines were found just beyond the red at  $0.97$ ,  $1.045$  and  $1.285 \mu$ , beyond which no lines were found, except in the region of  $4.2$  to  $5.8 \mu$  where the radiation from the hot cell interferes with the work. The fact that no line was observed at  $4.75 \mu$  is of interest in connection with the present work.

#### VISIBLE SPECTRUM.

Several investigations in the visible spectrum are of interest in the present work, and they will now be mentioned.

Certain prominent lines of hydrogen and nitrogen have been measured photometrically by Ferry.<sup>4</sup> The tube was excited by means of a battery of accumulators consisting of 1,200 cells, the same as Ångström used for his infra-red work. He found that at constant pressure the intensity is proportional to the current, and with constant current the intensity increases with decrease in pressure, in a regular manner,

<sup>1</sup> Berndt : *Jahrb. der Radioaktivität u. Elektronik*, 1, p. 247, 1904.

<sup>2</sup> Drew : *Phys. Rev.*, 17, p. 321, 1903.

<sup>3</sup> Coblenz & Geer : *Phys. Rev.*, 16, p. 279, 1903.

<sup>4</sup> Ferry : *Phys. Rev.*, 7, p. 1, 1898.

and differently for different lines. Langenbach<sup>1</sup> obtained similar results for the visible spectrum, except that with constant current the intensity passes through a maximum for decrease in pressure of the gas. He found the three prominent hydrogen lines most intense for a pressure of about 2.5 mm. to 3.5 mm., and that they are very similar in their behavior with change in current, which was obtained from an induction coil. With increase in pressure the intensity of the red line increases the most; the energy maximum shifts toward the long wave-lengths, *i. e.*, hydrogen behaves like a black body.

This work was repeated by Berndt,<sup>2</sup> who verified the work of Ferry, and added a new result, *viz.*, that a rise in temperature of 200° has no influence upon the individual lines. For hydrogen he found that the green line grows more rapidly in intensity than does the red one, while for nitrogen the reverse is true of the red and green bands, which disproves the displacement law for gases.

This work was continued by Waetzman,<sup>3</sup> who verified the work of Ferry and Berndt, and showed that for a slight impurity the gas behaves as the pure, but this impurity decreases the intensity of the long wave-lengths the most.

#### TEMPERATURE, DISSOCIATION, ETC.

The explanation of the luminous radiation from a vacuum-tube which is itself quite cool, has received considerable attention. Wiedemann,<sup>4</sup> using a calorimeter, shows that the average temperature of air in a vacuum-tube, at a pressure less than 3 mm., is less than 100° C., and that it depends upon the pressure. At a low pressure the temperature of the cathode is higher than that of the anode, while the reverse is true at a pressure greater than 2.6 mm. Although the average temperature is low, few molecules may possess an amount of kinetic energy much greater than that indicated by the bolometer. Naccari and Guglielmo<sup>5</sup> found that at a pressure of 5 mm. the cathode is the hotter, reaching a maximum at 0.3 mm., then decreasing until at very low pressure, where the anode is the hotter. They found this to be due to a secondary action coming from the cathode rays.

Wiedemann (*loc. cit.*) does not consider the radiation from the gas in a vacuum-tube to be due to a pure thermal effect, but of a phosphorescent nature. He applies the term luminescence to all those luminous

<sup>1</sup> Langenbach : *Ann. der Physik* (4), 10, p. 789, 1903.

<sup>2</sup> Berndt : *Ann. der Physik* (4), 12, p. 1101, 1903.

<sup>3</sup> Waetzman : *Ann. der Physik* (4), 14, p. 772, 1904.

<sup>4</sup> Wiedemann ; *Ann. der Physik* (3), 6, p. 298, 1879 ; 7, p. 500, 1879 ; 9, p. 150, 1880 ; 10, p. 202, 1880.

<sup>5</sup> Naccari & Guglielmo : *Nuovo Cimento* (3), 15, p. 272, 1884.





## CHAPTER II.

### SCOPE OF PRESENT INVESTIGATION.

The present work divides itself into two parts: (1) emission spectra of the arc between metallic electrodes and the emission spectra of the chloride of the metals in the carbon arc; (2) emission spectra of gases in vacuum-tubes. The contrast between these two forms of radiators is worthy of notice. The arc is noted for its enormous heat radiation in proportion to its light radiation. On the other hand, the vacuum-tube radiates but little heat. Consequently, in the study of these two kinds of radiators, the form of the device for exploring their spectra must differ. If a radiometer is used its period must be short for examining the arc in order to avoid heating of the window and the consequent shifting of the zero reading. This, however, is of less importance than the variation in intensity of the radiation from the arc, which requires a recording instrument having a short period. For the vacuum-tube a much greater sensitiveness must be used, which means a longer period for a linear radiometer vane. Fortunately the radiation from the vacuum-tube is uniform, which permits the use of a slow-period instrument.

### THE RADIOMETER.

In the present investigation a Nichols<sup>1</sup> radiometer, a 7 cm. rock-salt prism, and a 35 cm. focal length mirror spectrometer were used.<sup>2</sup>

As a device for exploring infra-red spectra the radiometer has some inherent advantages as well as disadvantages over the bolometer. The most prominent advantages are its freedom from magnetic disturbances and its ease of construction and use at a high degree of sensitiveness. Its lack of mobility is not objectionable in the present work. It is also of interest to notice that in all my infra-red work this radiometer has stood upon a table, which itself stood upon a cement floor of a basement room, without any protection against earth tremors. Nevertheless, only on rare occasions were the observations interrupted by earth

---

<sup>1</sup> E. F. Nichols: *Astrophys. Jour.*, 13, 101, 1901.

<sup>2</sup> Coblenz: *Phys. Rev.*, 16, p. 35, 77, 1903; also in "Absorption Spectra." (Washington, 1905).

tremors, even with the most sensitive arrangement used in the vacuum-tube radiation. Those who have used sensitive galvanometers with their bolometers have been obliged to provide elaborate suspensions to protect the instrument against earth tremors and confine their observations to the quiet hours of night. The chief disadvantages in a radiometer of great sensitiveness, having *linear* vanes, is its long period, due to the viscosity of the residual gas. In fact, viscosity is the chief problem to contend with in constructing a very sensitive radiometer having a short period. In a bolometer the spectrum is projected directly upon the bolometer strip, which can be made very narrow, while the period of the accompanying galvanometer is not to such a great extent determined by viscosity of the air. In the radiometer, since the vanes revolve about an axis, the spectrum must be projected upon a stationary slit, back of which one of the vanes is exposed. Now, the width of the vane that must be used depends entirely upon its distance from the slit. The slit is in the vertical focus of the spectral lines, which will diverge again after passing through it into the radiometer. In the original Nichols radiometer<sup>1</sup> the slit was at least 3 cm. from the vanes, which, as a consequence, had to be about 2.5 mm. wide and 1.5 cm. long. For his work on the radiation from stars<sup>2</sup> no slit was required and the size of the circular vane was made equal that of the star image, viz. 2 mm. diameter. This eliminated viscosity to a great extent, and he succeeded in obtaining a period of 11 seconds. For line spectra the omission of the slit would hardly answer the purpose where great accuracy in the position of the wave-length is concerned. In the latter case the problem is to place the vane as near the window as is possible. This can be done by using but one window,<sup>2</sup> as shown in figure 133.

The use of but one window introduces a new complication in that any slight change in its temperature will immediately affect the radiometer vane, *i. e.*, will cause a shift in the zero reading. This was particularly noticeable in the arc-spectra work, where the radiation is very intense. Consequently a suspension was used which gave a maximum deflection in 8 seconds. This was less sensitive than for the vacuum-tube work, but the arc lines are very intense and it answered the purpose, since exposing the vane for a longer time would warm the window and cause a large shift of the zero reading. On the other hand, for the vacuum-tube radiation, where the radiation is very weak, the radiometer must be of extraordinary sensitiveness, to obtain which a

---

<sup>1</sup> Nichols: Phys. Rev., 11, p. 891, 1897.

<sup>2</sup> Nichols: Astrophys. Jour., 13, p. 101, 1901.

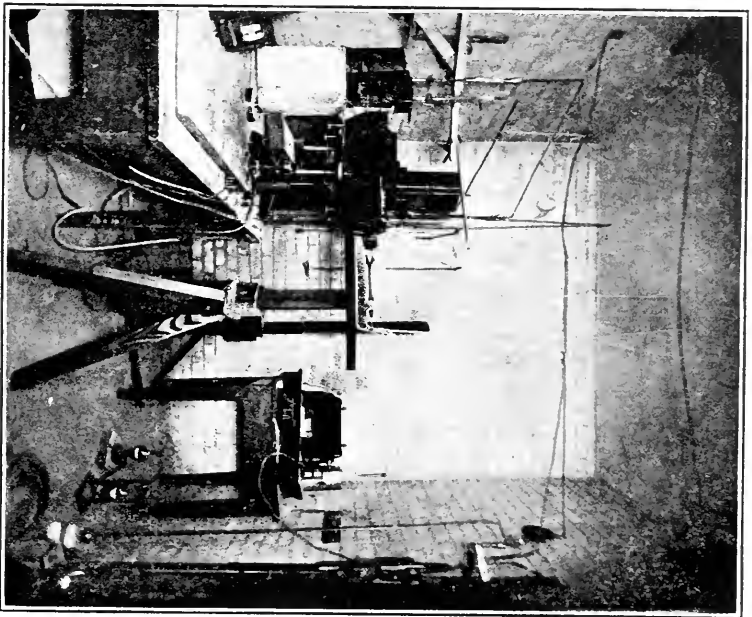
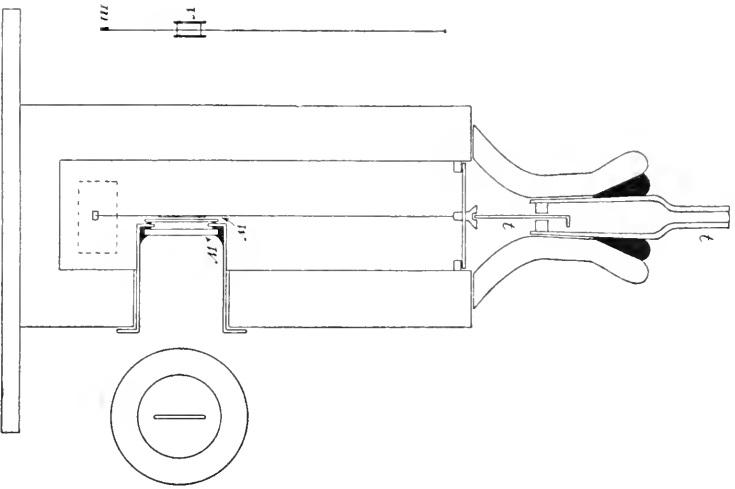



very fine quartz fiber must be selected—the present one was quite invisible except by diffraction in sunlight. Here one must sacrifice period for sensitiveness. In the present work the maximum of the deflection was reached in 45 to 50 seconds. Since the radiation is weak, the shifting of the zero was not very great while making observations. But as soon as the making of observations in the region of  $4.75 \mu$  ceased, the deflection moved off the scale, and had to be brought back by turning the torsion-head. By using a double window of rock salt ( $\tau \tau$ , fig. 133) some of the shifting of the zero due to changes in temperature of the outer window was avoided. In addition to this the pressure in the radiometer was kept at 0.01 mm., since at the point of maximum sensitiveness, 0.05 mm., heat conduction and convection currents were much greater.

For the emission spectra of the metals, the radiometer vanes had an area of about 2 by 15 mm. each, and the short period was due to the heavy fiber suspension. The vacuum-tube radiation being very weak required great sensitiveness, which was obtained in part by reducing the size of the vanes (of mica) to 1 by 10 mm. and selecting a fine fiber. The behavior of such a vane is entirely different from a heavier one. At low pressures the vane before the window was suddenly repelled from it, due apparently to the radiation through the window. This repulsion occurred when both vanes were black and when the unexposed one was not covered with lampblack. It was not due to electrification, and throughout the vacuum-tube work it was necessary to use a torsion-head ( $t$ , fig. 133) to keep the deflection on the scale.

All greased joints were covered with beeswax and painted several times with dilute shellac, which dries quickly and forms the most satisfactory protection against leaking yet found. The rock-salt window was secured in the same manner. The radiometer was packed in wool. The window and spectrometer were inclosed in one continuous box, and no radiation could enter except at the slit. As described elsewhere,<sup>1</sup> the apparatus stood in an inner room with an intervening door, which could be closed at will. In the region of  $4.75 \mu$ , where the deflections were large, the spectrum was explored in the daytime; but in the visible spectrum, and just beyond it, the observations were usually made at night, when the temperature could be more easily controlled. It was then necessary to enter the room and stay a while until the heat from the body established a new equilibrium. It was then possible, at times, to make readings for a quarter of an hour without detecting a shift of

---

<sup>1</sup> Phys. Rev., 16, p. 35, 1903.

the zero reading. Generally, however, the "drift" was from 1 to 2 mm. per 100 seconds, and since it was always in one direction it was easily eliminated from the total deflection.

From this prolix description it will be seen that a radiometer of such extraordinary sensitiveness as the present one is useful only for work where the radiation is weak. In all other work a less sensitive, quicker-period instrument is more serviceable.

From Table I the reader will obtain some idea of the sensitiveness of previous instruments used in radiation work. The paraffin candle is not a very satisfactory comparison source, but it is the only one for which data are available. The "sensitiveness" is expressed in deflections in centimeters per square millimeter of vane exposed, for a scale and a candle each placed at a meter's distance.

TABLE I.—SENSITIVENESS OF DIFFERENT INSTRUMENTS.

[Sensitiveness is defined as the deflection in centimeters per square millimeter of exposed surface, for a candle and a scale at a distance of 1 meter.]

Observer.	Deflection.	Distance of scale.	Distance from candle to instrument.	Area of surface.	Period.	Sensitiveness.
	<i>cm.</i>	<i>cm.</i>	<i>cm.</i>	<i>sq. mm.</i>	<i>secs.</i>	<i>cm.</i>
Boys, radiomicrometer...	6	(?)	152	4	10	0.9
Nichols, first radiometer...	6	1.3	600	$2 \times 1.5^2$	12	7 (?)
Lewis, radiomicrometer...	2	(?)	300	1.4	20	1.3 (?)
Snow, bolometer.....	15	300	100	.35	14	14.7
Stewart, radiometer.....	10.3	63	300	30	40	4.9
Another form, estimated.....						18
Nichols, radiometer for star work.....	1.1	183	811	3.14	11	12.5
Drew, radiometer.....	30	100	200	7	45	17.1
Coblentz:						52.3
Radiometer for vacuum-tube work.....	26	140	140	$1(=.095 \times 9.8)$	50	
Radiometer for absorption-spectra work.....					45	8 (?)

The test of sensitiveness of the radiometer used in the vacuum-tube radiation is given in Table II. Since it was impossible to place the candle at a sufficient distance to keep the radiometer deflection upon the scale for the slit width, 0.7 mm, used in the regular work, the slit was decreased to  $0.095 \times 9.8$  mm. (as found upon subsequent measurement under the microscope) and readings made for the candle at different distances. Several commercial paraffin candles having a diameter of 2 cm. were tried. The height of the flame was 5 cm. By keeping the wick well trimmed there was no appreciable change in the deflections.

Numerous shields were provided to prevent stray radiation from entering the radiometer. The data below the line in the center of the table show the constancy of the inverse square law which would indicate that within experimental errors the deflections are due to radiation from the candle only.

TABLE II.—SENSITIVENESS OF RADIOMETER.

[Deflections are in centimeters per square millimeter of exposed surface (viz. 1 sq. mm.) for a candle and a scale each at a distance of *one meter*.]

Deflections,	Remarks,
<i>cm.</i>	
56.3.....	Pressure 0.01 mm.; candle at 1.5 meters.
52.3 } .....	Trimmed candle; flame 5 cm. in height.
51.3 } .....	
52.3 } .....	
54.4 } .....	Exhausted to a pressure of 0.005 mm.
53.3 } .....	
68. } .....	Pressure 0.02 mm.
67.8 } .....	
52.3.....	Pressure kept constant at 0.01 mm.
51.3.....	Another candle, at a distance of 1.5 m. from vane.
50.8 } .....	Candle at 1.4 meters.
49.0 } .....	
50.3.....	Candle at 1.5 meters.
49.8 } .....	Candle at 1.3 meters.
47.6 } .....	
50.5 } .....	
49.8 } .....	
0.1 to 0.2.....	Shutter raised; radiation from a black wall when candle is extinguished.

In figure 134 is given the energy curve of acetylene for the visible spectrum, and that of a Nernst heater for the region of 14 μ, for the very sensitive radiometer used under similar conditions in the vacuum-tube work, curve *a*, and, for the old radiometer used in the absorption-spectra work, curve *b*—ordinates are deflections in centimeters, radiometer slit 0.7 mm., spectrometer slit 1 mm. The sudden drop from 30 cm. deflection at 13 μ to 2 cm. at 16 μ is due no doubt to the opacity of the rock-salt prism, which is very opaque in this region.

Radiometer construction is still in its infancy. Other improvements suggest themselves. For example, there is no special reason for having two vanes, for symmetry, when using a torsion-head. By using a metal counterpoise instead of one of the vanes, the viscosity effects would be reduced by almost one-half, hence the period shortened.

Another form, which is a combination of a radiomicrometer, which

also serves as the vane of a radiometer, suggests itself. Even the finest quartz fibers are quite strong, so that they would support the extra weight of the loop of conducting wire which passes between the poles of the magnet. The extra weight would increase the period, while a

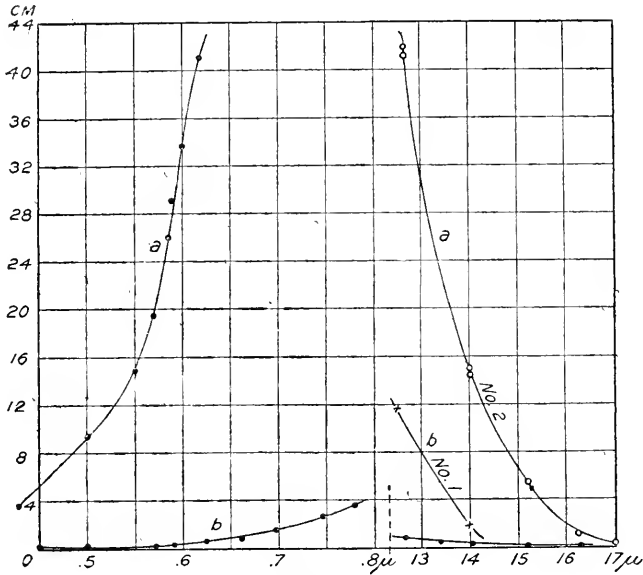

Fig. 134.

coarser fiber would decrease it; but whether the selection of the proper combination would compensate for the new difficulties involved remains to be determined.

#### OTHER EXPERIMENTAL DETAILS.

For the adjustment and calibration of the apparatus, the reader is referred to the memoir on "Absorption Spectra" (loc. cit.), and only certain details in the manipulation of the experiment will be mentioned.

Since the arc varies with such great rapidity it was necessary to have a radiometer of quick period, as already mentioned, while special provision had to be made to manipulate the arc and observe the deflections. The length of the arc was regulated by securing the electrodes in holders which could be separated or closed by means of a rack and pinion. This was mounted upon a holder which was in an asbestos-lined box, having a heavy sheet-iron shield through which the energy from the arc passed into the radiometer slit. The slit in the shield was 1 cm. high, while the length of the arc, which was directly back of



it, was about 2 cm. in length. In this manner no radiation from the electrodes could enter the spectrometer slit. An image of the arc could be seen in the prism, and any slight trace of the radiation from the electrodes, when visible in the prism, was sufficient to cause large deflections, or even to throw the deflection entirely off the scale. The spectrometer arm was rotated, and the arc was adjusted before the slit by hand. The image in the rock-salt prism showed whether the adjustment was correct in the horizontal direction and whether any part of the electrodes was visible. By raising or lowering the shield or arc only the radiation from the vapors could enter the spectrometer slit. By placing a mirror above the scale an image of the latter, in the radiometer mirror, was reflected back into the viewing telescope, which was situated near the spectrometer. In this manner the observer could adjust the arc, raise the shutter, and make a reading before the arc had changed in intensity, which was very annoying when using metallic electrodes. With the salts of the metals in the carbon arc there were no serious fluctuations in intensity after starting the arc.

#### OBJECT OF THE INVESTIGATION.

Ångström (loc. cit.) and others have found the absorption band of  $\text{CO}_2$  at  $4.28 \mu$  and  $\text{CO}$  at  $4.59 \mu$ ; Paschen (loc. cit.) found that the  $\text{CO}_2$  emission band shifts toward the  $\text{CO}$  band with rise in temperature, being at  $4.4 \mu$  in the Bunsen flame. The emission spectra work, particularly that of gases in a vacuum-tube, was undertaken with the hope of gaining information on the subject of the dissociation of  $\text{CO}_2$ .

As already mentioned, Snow (loc. cit.) mapped the infra-red emission lines of the alkali metals to about  $2 \mu$ , and found numerous lines just at the end of the red, but *no* strong lines were located beyond  $1.5 \mu$ . The present investigation deals with the question of the distribution of emission lines (bands) in the infra-red, especially with the question of presence of lines beyond  $1.5 \mu$ . All the infra-red lines predicted by our spectral series formulæ end in the short wave-length just beyond the red. Any information as to the presence of lines beyond this point will aid in establishing these formulæ upon a firmer, less empirical basis than they have at present. From our knowledge of the radiation from the "black body," which is most intense in the region of  $1.2$  to  $2.5 \mu$  at high temperatures, one would expect the emission bands at  $2 \mu$ , if there be any, to be just as intense as those found by Snow at  $1 \mu$ . Other points of interest which developed as the work progressed will be noted in their proper places.



## CHAPTER III.

### INFRA-RED EMISSION SPECTRA OF METALS.

This work was begun by examining the spark spectra of such metals as Zn, Al, and Cu. An induction coil and condenser were used. No emission lines could be detected; instead of lines a weak continuous radiation was detected in the region of  $2\ \mu$  to  $3\ \mu$ , which appeared to be due to the hot particles from the electrodes. The arc between metallic electrodes of Fe, Zn, and Cu was then tried; but no lines could be detected in the region of  $1\ \mu$ , beyond which point the incandescent oxides gave such an intense, continuous, "black body" spectrum that the emission lines would have been obliterated by the radiation from the oxides. The vapors from the copper arc had but little "black body" radiation. No emission lines were detected, however, although several have been predicted in the region of  $2.5\ \mu$ .

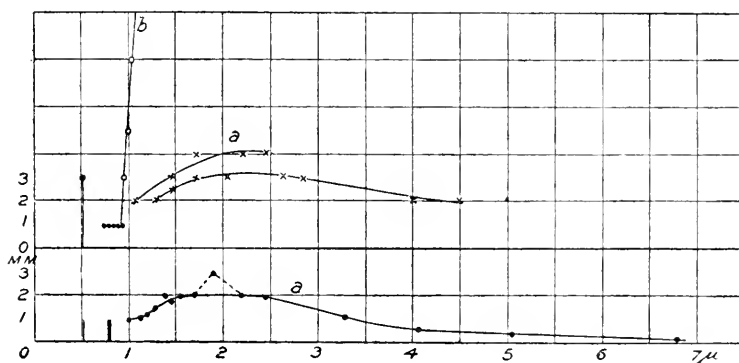

Fig. 135.

COPPER.

In figure 135 two sets of curve *a* are given for the vapors of the Cu arc, while curve *b* shows the radiation from the hot electrodes. In this figure it will be noticed that the terminals give a more intense radiation than the vapors, in which the density of the oxides is not so great as in the iron arc.

## IRON.

In figure 136 are given the curves of the arc between iron terminals. Curve *b* is for the electrodes, while curve *a* (scale is one-half of *b*) represents the distribution of the radiation from the vapors. Here the vapors have a more intense radiation than the solid terminals. This is no doubt due to the fact that we do not get the radiation from the hottest part of the electrodes, while in the arc, which is very rich in oxides, there is a better chance for the hottest region to emit radiation.

In the Zn arc the oxides are formed so rapidly that it is almost

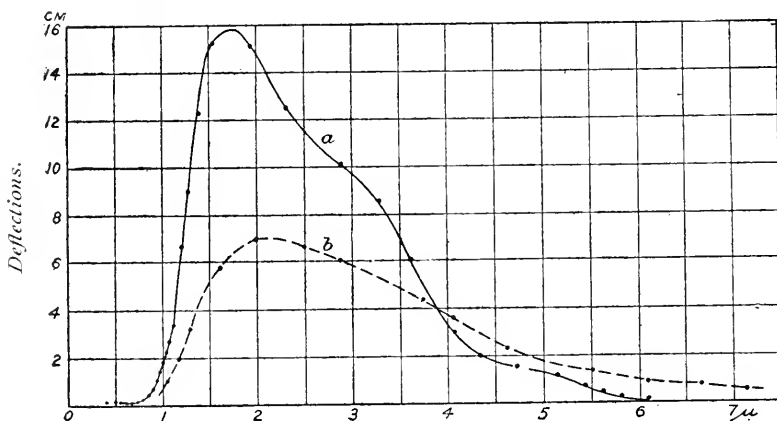

Fig. 136.

impossible to work with this metal. The problem then is to separate the black-body radiation of the oxides from that of the vapors, which is very different from the work in the visible spectrum.

## CHLORIDES OF METALS.

The chlorides of Na, Li, and K were then examined in the carbon arc, using for the purpose hollow carbon electrodes filled with the salt. The carbons used varied from 6 to 9 mm. in diameter, the holes being from 1.4 to 2.5 mm. A direct current of 15 ampères from a 104-volt circuit was used. The radiometer slit was reduced to 0.1 mm. in width, nevertheless the radiation at  $2\mu$ , which at most gave a deflection of only a few millimeters, was not resolved into individual lines. This is in marked contrast with the strong emission lines at  $1\mu$ , and as will be noticed later on, the continuous radiation at  $2\mu$  would blot out any weak emission lines, as far as a radiometer or a bolometer is concerned. Here a photographic process would be better, since the effect upon the

plate is cumulative, and one would have dark lines superposed upon a dark background, just as Abney and Festing<sup>1</sup> found for their absorption spectra at  $1 \mu$ .

## CARBON ARC.

In figure 137 is given the emission spectrum of the carbon electrodes, curve *a*, and that of the violet vapor of the arc, curve *b*. It will be noticed that there is but little radiation from the vapor except a slight amount from  $2$  to  $3 \mu$ . On the other hand the deflection was thrown off the scale for the radiation from the electrodes, just beyond the red. Snow (loc. cit.) found the radiation from the arc vapors con-

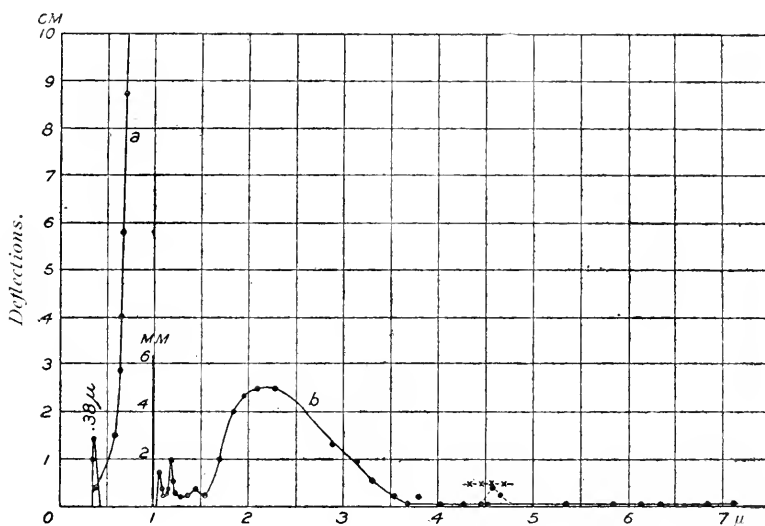

Fig. 137.

centrated in a single line, in the violet, at  $0.385 \mu$ . This line is four times as intense as the one at  $1.09 \mu$ . In the present work the lines are of about equal intensity, due in part to the loss of intensity of the violet line, caused by the radiometer window. A new line occurs at  $1.2 \mu$ , while on a thorough re-examination no line was found at  $4.52 \mu$ . This is of considerable interest, since it shows that no  $\text{CO}_2$  is formed, and that the electrodes are consumed in a different manner. They do not disappear in the ordinary form of combustion. There is but little residue from mechanical disintegration; they disappear chiefly in the form of vapor. The absence of radiation from the carbon vapors is in

<sup>1</sup>Abney & Festing, Phil. Trans., 177, p. 887, 1882.

marked contrast with the radiation from the electrodes, any trace of which, as already mentioned, was sufficient to cause large deflections. For the black body the radiation is not very intense at a low temperature and the maximum lies beyond  $3 \mu$ . The oxides in the arc have a high temperature; the maximum lies at  $2 \mu$  and the weak radiation in this region is to be found attributed to the low density of the vapors.

## SODIUM (Na).

Snow (*loc. cit.*) found that the salts of the metals gave the same emission lines as the metal itself, and that the chlorides were well adapted for emission-spectra work, using hollow carbon electrodes. For this reason only the chlorides of the metals were used. The present

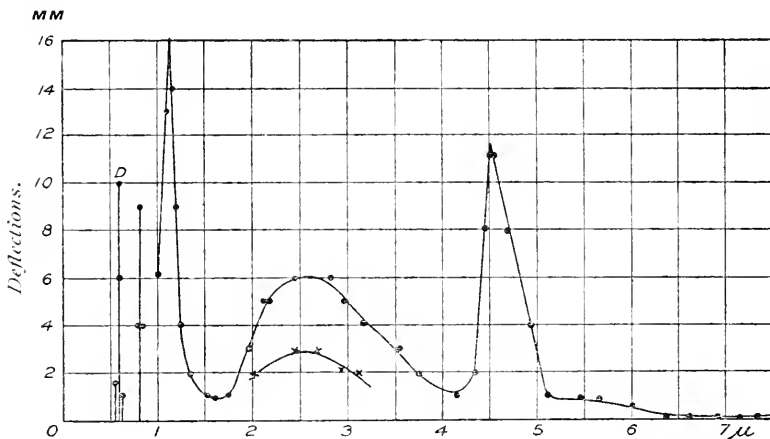

Fig. 138.

work was not concerned with the verification of Snow's results, which were used only in comparing the relative intensity of the lines investigated. He used a quartz prism, which on account of its larger dispersion permits a greater accuracy in determining wave-lengths. In the present work the question was whether there are lines beyond the region investigated by him. The distribution of the energy in the vapors of Na is shown in figure 138, where the ordinates are deflections in millimeters.

Snow found the intensities of the lines at  $0.589 \mu$ ,  $0.818 \mu$ , and  $1.13 \mu$  to have a ratio of 87:66:42. In other words, the energy in  $0.589 \mu$  is more than twice that of the line at  $1.132 \mu$ . In the present work the intensities of these two lines are exactly reversed, and in the same proportion. Since the dispersion is smaller this may be due to the impurity of the spectrum.

From 2 to 3  $\mu$  there is a weak continuous radiation, which appears to be due to the oxides of the metals in the arc. For Li this is not so intense, and, since the solid material (dust) coming from the arc is also less, the evidence is strengthened in favor of the emission at 2 to 3  $\mu$  being due to oxides. The emission band at 4.52  $\mu$  is also to be noticed. Since it occurs only when the salts of the metals are in the arc, and is *not* to be found in the carbon arc its source remains undetermined. If it be due to CO<sub>2</sub>, from the air, then from the shifting of the maximum to the longer wave-lengths (found by Paschen, loc. cit., being at 4.40  $\mu$  for the Bunsen flame) it would appear that the temperature of the arc is about 4,000° absolute.

## LITHIUM (Li).

The chloride of lithium vaporizes so easily that no true measure of the radiation from the dense vapor could be obtained. In like manner the radiation from the oxides at 2 to 3  $\mu$  is also weak. The bands at

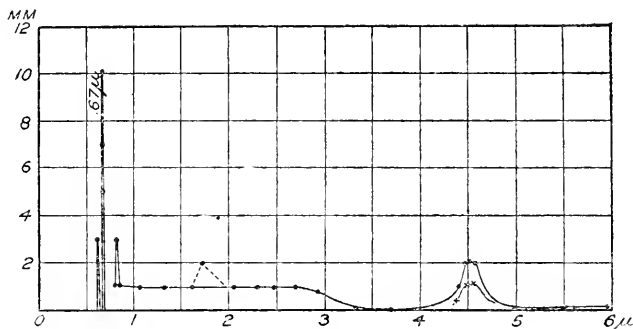

Fig. 139.

0.67  $\mu$  and 0.811  $\mu$  (fig. 139) have the same ratio of intensity as found by Snow. Beyond this point no lines could be detected, except a slight band at 4.52  $\mu$ .

## POTASSIUM (K).

In figure 140 is shown the emission curve of potassium. The KCl does not vaporize so easily and is readily adapted to the arc. Snow found strong lines at 0.768, 1.155 and 1.22  $\mu$ , the first one being four times the intensity of the band at 1.15  $\mu$ . In the present work the last two lines were not quite resolved and no comparisons can be made. The band at 1.47  $\mu$  was also found by Snow. The usual region of continuous radiation is found from 2 to 3  $\mu$ . The 4.52  $\mu$  emission band is strong. The emission band of CO<sub>2</sub> at 4.40  $\mu$ , using a Bunsen burner, is also given,

curve *b*; the latter is three times (deflection equals 3.2 cm.) as strong as the band at  $4.52 \mu$ .

As a whole from these curves it will be noticed that no emission lines occur beyond  $2 \mu$ , which is entirely unexpected. Beyond this point weak emission lines would be obliterated by the continuous spectrum. The band at  $4.52 \mu$  will be noticed shifted to  $4.75 \mu$  in the vacuum-tube radiation. The intensity of the emission lines found depends upon the density of the metallic vapor in the arc. From the fact that no lines were observed beyond those found by Snow it is not to be inferred that

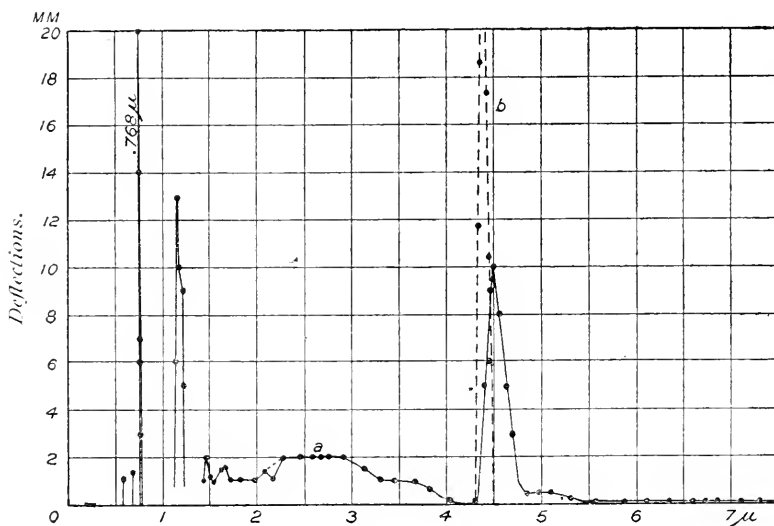

Fig. 140.

no lines lie beyond  $2 \mu$ . The work simply shows that, for the conditions which produce the lines at the end of the red, no lines of measurable intensity are to be found beyond this point. It is true that Lehmann (loc. cit.) has just shown that Rb and Cs have lines at  $1.7 \mu$ ; but the emission curves of these two elements, found by Snow, also show *weak* lines in this region, and it is only the cumulative effect upon the phosphor-photographic plate that has enabled Lehmann to map them.

#### INFRA-RED EMISSION SPECTRA OF GASES IN VACUUM-TUBES.

Since the incandescent oxides in the arc and spark emit a continuous spectrum of sufficient intensity to obliterate any weak emission lines, beyond  $2 \mu$ , it is impossible to detect them. The vacuum-tube lacks these defects and is adapted to this work, provided one has sensitive apparatus to detect the radiation emitted.



The dispersed infra-red radiation from gases in a vacuum-tube is of considerable interest in comparison with the radiation of gases in a flame. The work of Julius and of Paschen (*loc. cit.*) shows that by mere temperature elevation gases emit characteristic discontinuous spectra. From a theoretical standpoint such an investigation is also of importance, since all the infra-red lines predicted by our spectral series end in the short wave-lengths just beyond the red. This presents the interesting question whether emission lines are to be found beyond the region of  $2 \mu$ . Any information on this subject will aid in placing the numerous spectral series formulæ upon a firmer, less empirical basis. In this connection a recent theoretical paper by Garbasso<sup>1</sup> is to be noticed, in which he maintains that the series of Kayser and Runge have a real existence.

In the preliminary part of this work the vacuum-tube used by Drew (*loc. cit.*) was employed. In this tube the electrodes were at right angles to and at a short distance from the main part, which formed the



Fig. 141.

positive column. Several rubber joints were in series with the mercury pump, McLeod gauge, and the vacuum-tube. Several gases were examined, all of which, except hydrogen, showed an emission band in common at  $4.75 \mu$ . Hoping to gain intensity of the radiation, a tube was made similar to one used by Runge and Paschen (*loc. cit.*). (See fig. 141.) The aluminum electrodes were 2.5 cm. long, and 2.8 cm. in diameter, through which the radiation passed axially into the spectrometer slit of 8 mm. length and 1 mm. width. The radiometer slit was 0.7 mm. The internal diameter of the main portion of the vacuum-tube was 1 cm. and its length was from 15 to 18 cm. The window was of rock salt, secured on the outside by means of beeswax covered with shellac varnish. The window was also secured by means of shellac which had been boiled until it thickened. To avoid rubber joints the vacuum-tube was sealed to the pump and the gases introduced through a barometric column of mercury. The tube was airtight but, at a low pressure, it would become so hot that vapors would be given off and the cathode luminescence would disappear. This luminescence would reappear after the tube had cooled. According to Travers (*Study of Gases*) this

<sup>1</sup>Garbasso : *Nuovo Cimento*, 9, p. 113, 1905.

is due to gases absorbed by the electrodes. At any rate it did not interfere with the work, since the tube was used at such a pressure that it did not become heated. All evidences indicated that the impurity band at  $4.75 \mu$ , which was found in all the gases in the preliminary work, was due to something that entered with the gas; and it was finally shown to be due to contamination with  $\text{CO}_2$  while making the gas. The problem then was to make a gas which was free from even slight traces of  $\text{CO}_2$ . Previous experience showed that to bubble a gas through several purifying solutions in series with the pump was not sufficient. Hence, in preparing such a gas as  $\text{CO}$ , an ordinary mercury gas pipette was used. The gas was washed back and forth from the mercury pipette, through a tube containing  $\text{P}_2\text{O}_5$  into a pipette of  $\text{KOH}$  for about half an hour, to free it from  $\text{CO}_2$  and to dry it. After such a treatment nitrogen and oxygen *did not* show the impurity band at  $4.75 \mu$ .

The residual gas in the pump and glass connecting tubes was swept out by passing a discharge through it and heating it from the outside.

A large Charpintier (said to have 125 miles of wire for a secondary) and also a Max Kohl No. 4 induction coil were used to excite the vacuum-tube. For convenience, for most of this work, the primary was connected directly through a rheostat to a 104-volt, 60 or 120 cycle alternating current.

An ammeter was placed in the primary circuit, while an a. c. millivoltmeter having a resistance of 21,760 ohms was used to measure the current in the secondary.

The primary current varied from 3 to 6 ampères, and the secondary from 0.012 to 0.028 ampère.

Since the spectrometer arm was movable, the vacuum-tube had to be adjusted before the slit, by hand. The points on the curves are usually the mean of several readings.

Observations were made for constant current in secondary and variable pressure, and also for constant pressure and variable current.

The method of observation consisted in obtaining the radiometer deflection for the gas when the discharge was passing and then, after stopping the discharge, allowing the deflection to return toward its original zero reading. The hot cell would prevent the deflection from returning to the original zero in 50 seconds (radiometer period) and the difference in the two zero readings gave approximately the deflection due to the hot cell. Another method for finding the deflection due to the hot cell consisted in passing the discharge for 50 seconds, then on stopping the discharge and raising the shutter, reading the deflection. Of course the cell cools somewhat while obtaining the deflection, but

it is not a great amount in comparison with the total deflection. Since the cell became heated the least at 0.6 to 1 mm., it was used at this pressure. In the region up to  $1.5 \mu$  no radiation from the hot cell could be detected. Beyond  $3 \mu$ , for a pressure of 0.6 to 1 mm., the deflections often amounted to several centimeters. On the other hand, nitrogen shows strong lines at  $1 \mu$ , which would indicate that if nitrogen emits bands on account of its thermal condition, then it must be at a *higher temperature* than the cell.

## CLÈVEITE GAS.

In order to make the present work more complete, and from the fact that clèveite gas (helium) is one of the few gases known to have emission bands in the infra-red, the curves (fig. 142) found by Runge and Paschen,<sup>1</sup> are reproduced in this paper. They found the intensities of

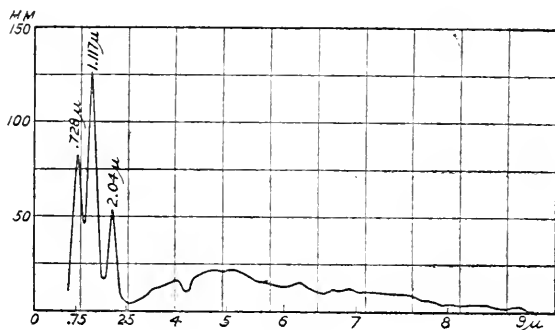

Fig. 142.

these lines to vary for different samples of the gas. The band at  $1.117 \mu$  gave a deflection of about 26 cm. The band at  $2.040 \mu$  is of interest, since it coincides with the value computed from the spectral series formula. Beyond  $2 \mu$ , as in the present work, no emission bands were found. The continuous spectrum from  $2.5 \mu$  to  $6 \mu$  is due to the radiation from the hot cell, the depressions in the curve being due to atmospheric absorption bands of  $\text{CO}_2$  and  $\text{H}_2\text{O}$ .

WATER VAPOR ( $\text{H}_2\text{O}$ ).

After finding the impurity band at  $4.75 \mu$  in all the gases except hydrogen, and knowing that water has an absorption band at this point, a special attachment was provided to introduce water into the previously exhausted pump and vacuum-tube.

The emission spectrum was found for various pressures, up to 3 mm.,

<sup>1</sup> Runge & Paschen: *Astrophys. Jour.*, 3, p. 4, 1896.

but no emission bands were found. On the contrary the hot cell, after stopping the discharge, gave deflections which were as large as those for the vapor. With water vapor the cell became much hotter than for the other gases.

A slight trace of water vapor has a great effect in depressing the intensity of the emission lines, as was found on allowing air to enter the tube; and only after filling the tube several times with air and exhausting it did the air lines at  $0.9 \mu$ ,  $1.05 \mu$ , and  $4.75 \mu$  appear in their usual intensity.

It will be noticed that the water vapor has *no* emission lines, which is true of the vapor in the Bunsen or oxy-hydrogen flame. On the other hand, alcohol vapor shows quite a strong emission spectrum from 2 to  $3 \mu$ .

#### HYDROGEN (H).

This sample of hydrogen was generated from  $\text{Zn} + \text{HCl}$  and dried in  $\text{H}_2\text{SO}_4$  and in  $\text{P}_2\text{O}_5$ . Its spectrum energy curve is given in figure 143, curve *a*, where the ordinates are deflections in centimeters.

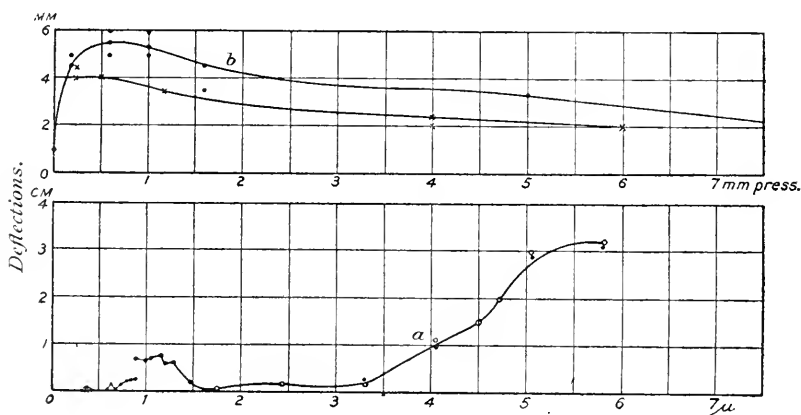

Fig. 143.

The curve is in two parts, representing different pressures. The red H line gave a deflection of only 2 mm.

In the region of  $1 \mu$  there is energy radiated which may be due to slight traces of nitrogen. *No* emission band is to be found at  $4.75 \mu$ . The radiation curve for the hot cell (observations plotted in circles) coincides with that of the gas.

In the upper part of figure 143, curve *b* gives the variation of intensity with change in pressure for the region of the spectrum at  $0.92 \mu$ . The



pressure, the current being 0.02 ampère. The results are shown in figure 146, which will be discussed in connection with CO, and it will be sufficient to add that the gas was first put into a pipette of phosphorus to remove the oxygen which was present. Starting with a sample of this gas at 1 mm. pressure, and adding oxygen until the pressure was 3.7 mm., no change could be detected in intensity of the  $4.75 \mu$  band which would indicate that if the band be due to CO then the  $\text{CO}_2$  is already dissociated when starting. Occasionally a dark ring or dark patches would appear on the inside of the constricted portion of the vacuum-tube. It would suddenly disappear and then reappear elsewhere. Whether it was due to carbon in tube, or to the dissociation of  $\text{CO}_2$ , remains undetermined.

Warburg's work (*loc. cit.*) shows that the temperature of the axis of the tube is much higher for nitrogen than for hydrogen, so that traces of  $\text{CO}_2$  in nitrogen ought to become the hotter. It was noticed that the  $4.75 \mu$  band occurring as an impurity was most intense in nitrogen, which, if the same amount of  $\text{CO}_2$  was present in each gas, would indicate that N was the hotter.

#### CARBON MONOXIDE (CO).

The CO was made by heating oxalic acid ( $\text{C}_2\text{H}_4\text{O}_2$ ) and concentrated  $\text{H}_2\text{SO}_4$  and passed through a KOH solution into a pipette of KOH. The generating flask was then replaced by a mercury gas

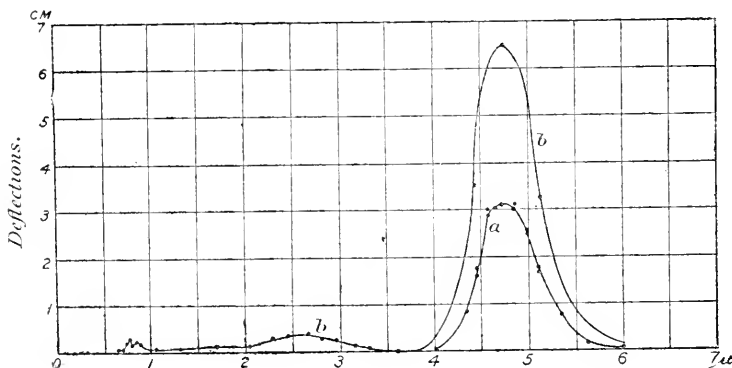

Fig. 145.

pipette and a tube of  $\text{P}_2\text{O}_5$  on glass wool, and the gas was washed back and forth through the  $\text{P}_2\text{O}_5$  for a long time. This sample showed no water vapor lines at low pressures. The emission curves of CO are given

in figure 145, where curve *a* is for a pressure of 0.3 mm. and *b* for a pressure of 0.8 mm. There seems to be a slight trace of radiation throughout the spectrum, but no strong lines are found except the one at  $4.75 \mu$ .

An examination of this band was made for a constant current of 0.2 ampère and variable pressure. The results are given in figure 146, in which the abscissæ are pressures in millimeters of mercury and the ordinates are deflections in centimeters. It is to be noticed that the intensity of the CO band is much greater than that of CO<sub>2</sub> for all pressures, the current of 0.02 ampère being the same for both gases. Moreover the intensity does not pass through a maximum, as is true of the H and N lines lying near the visible spectrum. The greater intensity of CO would make it appear as though the  $4.75 \mu$  band were due to this gas.

#### ETHYL ALCOHOL (C<sub>2</sub>H<sub>5</sub>OH).

Ordinary absolute ethyl alcohol was used. It was introduced into the previously exhausted pump through an especially provided bulb and stopcock. The emission curve (fig. 147) is very unusual. It shows no distinct lines except the strong band

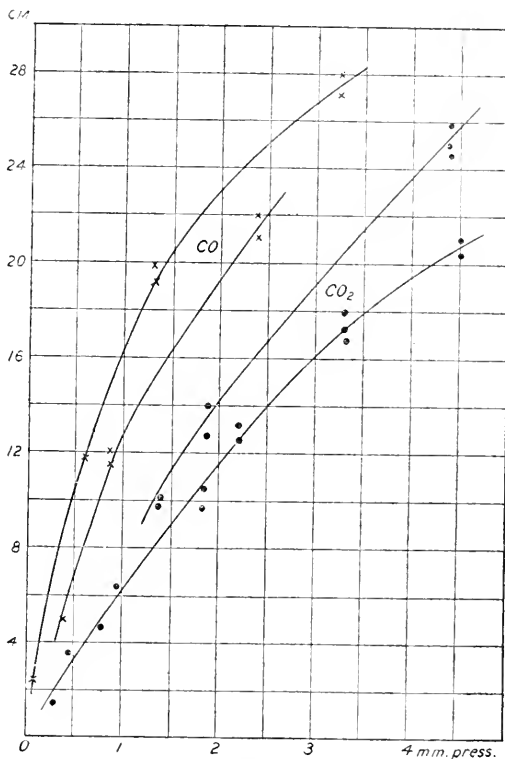

Fig. 146.

at  $4.75 \mu$ , which is to be found only in CO and CO<sub>2</sub>. The continuous spectrum from 2 to  $4 \mu$  is difficult of explanation. Possibly it is a composite of bands of alcohol vapor and the water-vapor bands found in the Bunsen flame. In the latter, however, the bands are in groups, with regions of zero radiation. The bands at  $4.75 \mu$  indicate a dissociation

of the alcohol vapor into H (red line) and  $\text{CO}_2$  or CO, just as ammonia shows nitrogen bands.

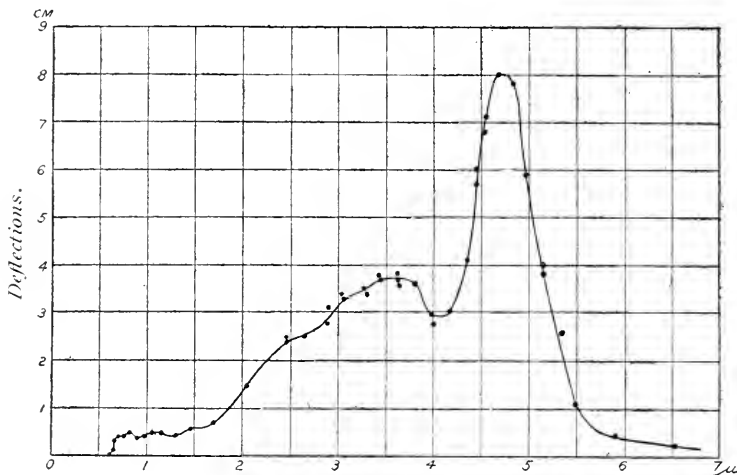

Fig. 147.

NITROGEN (N).

The first sample of nitrogen examined was made by heating a saturated solution of equal parts of sodium nitrate,  $\text{NaNO}_2$ , and ammonium chloride,  $\text{NH}_4\text{Cl}$ , washed in  $\text{KOH}$ , and dried in  $\text{H}_2\text{SO}_4$  and in  $\text{P}_2\text{O}_5$ .

The emission spectrum of this sample of N is given in figure 148, curve *b*. In addition to strong lines just at the end of the red we have the usual band at  $4.75 \mu$ , which is unusually intense. In fact, for a pressure of 5 mm. the deflections from this band were from 30 to 35 centimeters.

One difficulty in making nitrogen by this method is that the oxides are also formed. The pressure of the  $4.75 \mu$  band showed that it is due to  $\text{CO}_2$  or traces of N in CO or  $\text{CO}_2$ . The problem then was to prepare a small quantity of nitrogen which was free from oxides of nitrogen, and also free from O and  $\text{CO}_2$ . The presence of a trace of an inert gas like helium did not enter the question of the origin of the  $4.75 \mu$  band. Hence atmospheric nitrogen was most serviceable. To this end a glass tube containing  $\text{P}_2\text{O}_5$  on glass wool was connected in series with a gas pipette containing a strong  $\text{KOH}$  solution and a pipette containing sticks of red phosphorus under water. The phosphorus of course was used to remove the O, while the  $\text{KOH}$  removed the  $\text{CO}_2$ . The air was washed back and forth for some time. The  $\text{KOH}$  pipette was then replaced by a mercury gas pipette, and the gas was washed back and forth for about half an hour to dry it and remove the last traces of oxygen.



The result is shown in curve *a* of figure 148, which is of no small significance, especially in the region of  $4.75 \mu$ , where *no band* is to be found. The curve (dots and crosses at  $4.75 \mu$ ) shows that the radiation from the gas and from the hot cell is of equal intensity in this region. The decrease in the intensity, thus forming an apparent maximum at  $5.5 \mu$ , is due to the fact that in moving the spectrometer arm the vacuum-tube was not adjusted before the slit, hence the last two readings are for the radiation from the side of the tube instead of its axis.

In the final work the gases were not studied in the order given here, the  $\text{CO}_2$  and  $\text{CO}$  coming last. The absence of the  $4.75 \mu$  band in *N* and

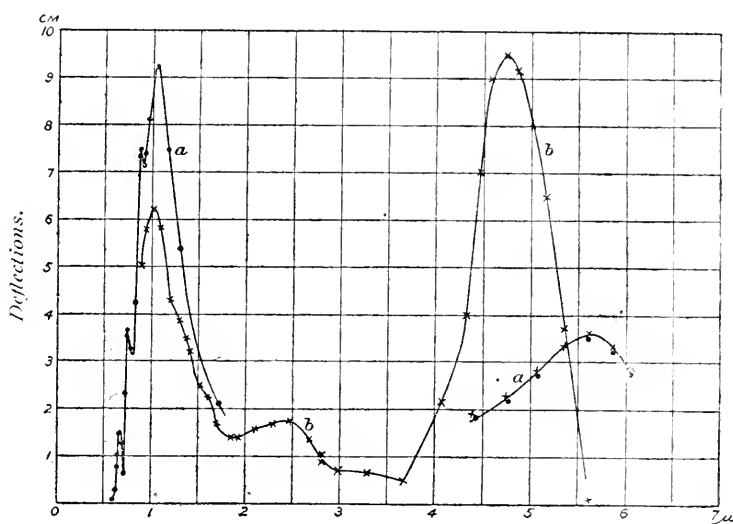

Fig. 148.

$\text{NH}_3$  excluded the possibility of its being due to nitrogen. Several drops of water were introduced into the nitrogen, but no change could be detected in the radiation at  $4.75 \mu$ , showing that this band is not due to water vapor. Hence it remained to be shown whether it is due to  $\text{CO}_2$  or  $\text{CO}$ . In discussing these two gases it was shown that the radiation from  $\text{CO}$  is much stronger than for  $\text{CO}_2$  at  $4.75 \mu$ .

The presence of strong emission bands just beyond the red having maxima at  $0.66 \mu$ ,  $0.75 \mu$ ,  $0.90 \mu$  and  $1.06 \mu$  was found only in nitrogen. Helium (*loc. cit.*) is the only other gas known which has strong lines (bands) in this region, and from the scanty data it appears as though this property were confined to the inert gases.

A study was then made of these emission bands under constant cur-

rent and variable pressure and vice versa. In figure 149, is given the curve of the  $1.06\ \mu$  band for variable pressure (current const. 0.02 ampère), which is the ordinary gas conduction curve of the visible

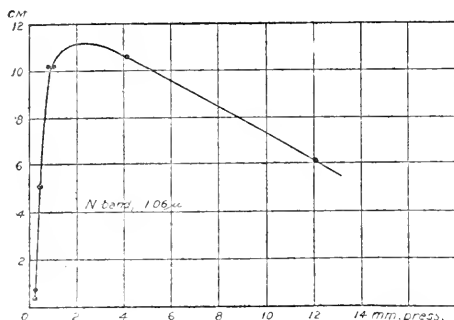

Fig. 149.

The curve *c* contains the green mercury line.

All the curves agree in showing that the intensity (plotted as ordinates) increases with increase in current in the secondary, which agrees with Langenbach and with Ferry (loc. cit.), for the visible spectrum.

Several large Leyden jars were used in parallel with the vacuum-tube when the intensity of the radiation increased, due to an increase in the current through the tube.

#### AMMONIA ( $\text{NH}_3$ ).

The ammonia used was made by heating  $\text{NH}_4\text{Cl} + \text{KOH}$  (solid) and passing the gas through tubes of  $\text{CaO}$  which had been heated for several hours.

These tubes were heated while starting, to expel the air. The first sample was examined just after the  $\text{C}_2\text{H}_5\text{OH}$  vapor, and from the appearance of the curve *a*

spectrum. Ordinates are deflections in centimeters, abscissæ are pressures in millimeters. The maximum lies at about 2 mm., which agrees well with observations in the visible spectrum.

In figure 150 are given the emission curves of the bands at  $0.546$ ,  $0.667$ ,  $0.75$ ,  $0.90$ ,  $1.06$ , and  $4.75\ \mu$ , keeping the pressure constant at 1.4 mm. and varying the current.

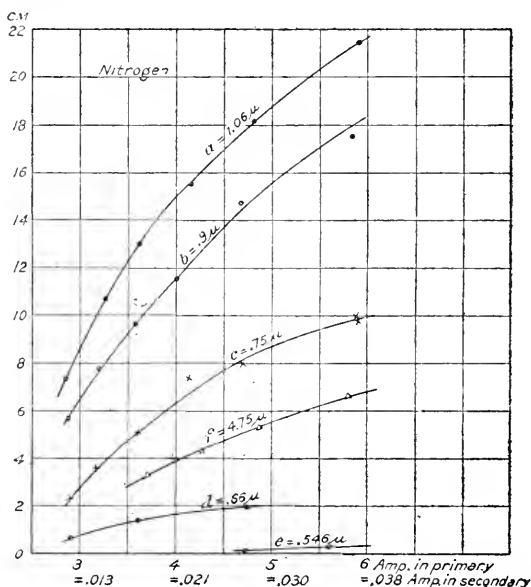

Fig. 150.

(fig. 151) some of the latter vapor must have been present. The second sample, made with greater precautions, did not show any radiation beyond  $2.5 \mu$ . In the region of  $4.75 \mu$ , curve *b*, the observations for

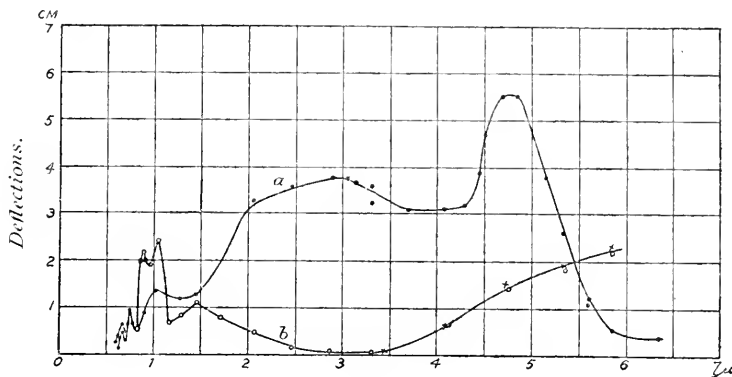

Fig. 151.

the radiation from the hot cell and the gas (indicated by circles and crosses) coincide. The nitrogen bands at  $0.75 \mu$ ,  $0.9 \mu$ , and  $1.06 \mu$  are due to the dissociated  $\text{NH}_3$ .

#### RADIATION FROM A VACUUM-TUBE WHEN HEATED EXTERNALLY.

The very different behavior of the  $4.75 \mu$  band from those at the end of the red made it highly desirable to learn whether it can be due to the mere rise in temperature of the gas. If it obeys Kirchoff's law, it can not be more intense than the black-body radiation at the same temperature. The radiation of the hot glass cell beyond  $3 \mu$ , when hot (at cathode rays pressure) gave deflections that were comparable with that of the  $4.75 \mu$  band. This would lead one to think that the  $4.75 \mu$  band is due simply to rise in temperature of the gas. On the other hand, in the region of  $1 \mu$  the hot cell gave no appreciable deflections, while the gas (nitrogen) gave *strong* emission bands, which would indicate that if these emission bands be due to a pure thermal excitation, following Kirchoff's law, then the temperature of the gas must be very high as compared with that of the cell walls. The problem then was to find the radiation from the vacuum-tube when heated externally to the temperature it had during the electrical discharge, which is really the black-body radiation; also to find the radiation from an approximate black body, *e. g.*, a Leslie cube, the temperature of which can be accurately determined.

In order to determine the radiation from the vacuum-tube when externally heated, the part between the electrodes was wound with an

iron wire through which an electric current was passed. The walls of the tube were heated to the temperature they generally had during the electrical discharge at very low pressure. The tube was filled with air and with  $\text{CO}_2$ , and the radiation was found for *all pressures* up to atmospheric. The deflections were thrown entirely off the scale for *all pressures*, for the region of  $4.75 \mu$ , hence this region of the spectra was not explored for emission bands. This indicates an intensity of radiation several times that from the vacuum-tube during the passage of the discharge. Although the ends of the tube were not hot, when heated externally, the tube is analogous to the black body. Whether or not it is entirely analogous is not of the chief importance. Its radiation was several times as intense as that from the electrically excited tube, which was the question to be answered. Whether or not the emission band at  $4.75 \mu$  is due to thermal excitation, due merely to a rise in temperature, or to electrical excitation, is undetermined.

The experiment shows that since its intensity is less than that of a black body, it is not untenable to consider it to be due a rise in temperature of the gas.

But this is not a sufficient criterion for judging the quality of the radiation. One objection is that the selective emission at  $4.75 \mu$  ceases immediately after the electrical discharge ceases, which is not true of the externally heated tube. Warburg (*loc. cit.*) has shown from theoretical considerations that after the discharge ceases it requires only a small fraction of a second for the gas to assume its original temperature.

In this connection it is well to notice Paschen's<sup>1</sup> work on the emission of  $\text{CO}_2$ , when heated in a metal tube, also when passed through a coil of sheet platinum 4 cm. long, 3 mm. internal diameter, heated electrically.

He found the radiation of the  $4.4 \mu$  band of  $\text{CO}_2$  for columns 7 cm. and 33 cm. long. The 7 cm. column behaved like a layer of infinite thickness, *i. e.*, the intensity of the emission of this wave-length is proportional to the intensity of radiation of a black body for the same wave-length and temperature. In figure 152, curve *b* represents the emission of the  $4.4 \mu$  band of  $\text{CO}_2$ , for a tube 7 cm. long when heated by means of a Bunsen burner from  $100^\circ$  to  $500^\circ$ . In this same figure curve *c*, also due to Paschen, shows the emission of the  $4.4 \mu$  band of  $\text{CO}_2$  when heated by passing the gas through a coil of platinum which was heated electrically.

The temperature of the gas was observed by means of two thermopiles, the first one being placed at the point where the gas issued from the orifice; the second one being placed about one centimeter above this

<sup>1</sup>Paschen : *Ann. der Physik* (3), 53, p. 26, 1894.

point. Both curves show very rapid increase in intensity of the emission lines with rise in temperature.

RADIATION FROM A BLACK BODY WHEN HEATED TO  $100^{\circ}$  C.

Since the temperature of the cell could not be determined accurately it was highly desirable to compare its radiation with that of a solid whose temperature could be varied and determined more accurately. To this end the radiation from a thin-walled, blackened copper vessel was found when filled with water which was heated electrically. The escaping vapors from the hot water caused such a variation in the temperature of the room that the radiometer became very unsteady, hence only the region of  $4.75 \mu$  was examined. In figure 152, curve *a* gives the emission curve of this vessel for different

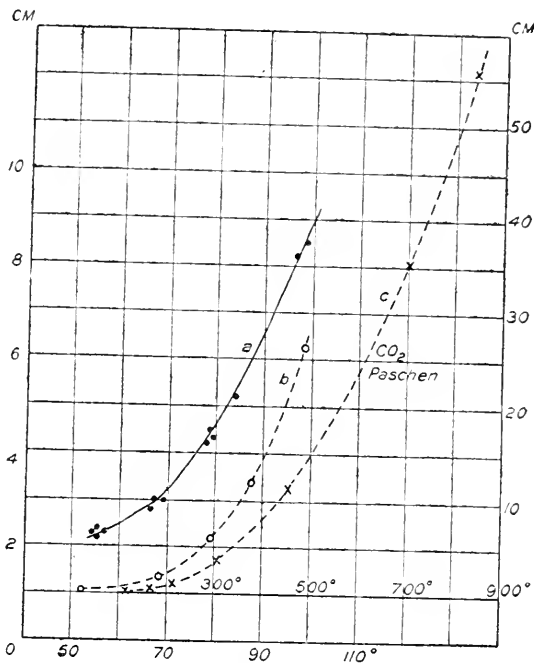

Fig. 152.

temperatures of the water. The curve is very similar to those found by Paschen. Of course, the temperature of the outside of the vessel is less than that of the water, but not sufficient to debar a comparison with the hot vacuum-tube. Mention has already been made of the fact that the constricted part of the vacuum-tube is the hotter at high pressures, while the regions surrounding the electrodes are the hotter at low cathode rays pressures. At the latter pressure the deflections for the hot cell were from 8 to 10 cm. The vessel of hot water, under similar conditions gave a deflection of 8.5 cm. for a temperature of about  $96^{\circ}$ . At a temperature of  $70^{\circ}$  the deflection is about 3 cm.

As a whole, the results show that the radiation from the cell walls is due to a rise in temperature which is not much, if any, greater than that of the vessel containing water. The temperature of the gas in the vacuum-tube is an entirely different question, which must be considered separately.

The fact must not be overlooked that the radiation from the vacuum-tube gave large deflections simply because of the great sensitiveness of the instrument and not on account of the actual intensity as compared with the deflections from gases in a Bunsen flame. In the latter the deflections for the  $4.4\ \mu$   $\text{CO}_2$  band were some 60 to 70 cm. for the old instrument, so that in the present work the deflections would be 50 times as great, viz, 3,000 cm. In other words, in the vacuum-tube curves the deflections are only from  $\frac{1}{250}$  to  $\frac{1}{3000}$  as great as from the Bunsen flame and the Nernst heater.

#### TEMPERATURE OF GAS IN THE VACUUM-TUBE.

Warburg's theoretical work on the temperature of the vacuum-tube has already been mentioned. He showed that the temperature of nitrogen is much higher than that of hydrogen.

The intensity of the  $4.75\ \mu$  impurity band in nitrogen, for all pressures, was so much greater than for all the other gases that one is led to think that it is due to the higher temperature of the gas.

Wood (*loc. cit.*) gives data for the observed mean temperature of gases in a vacuum-tube for different pressures, and currents of 0.001 to 0.003 ampère. In all cases the computed and observed temperatures are in fair agreement, the observed values being slightly less than the computed values, as one would expect, from the use of a thermopile which can not be made infinitely thin. The observed values fall upon a straight line, which shows the accuracy of the observations. Using these values and extrapolating to a current of 0.02 ampère, in the present work, for a pressure of 1.8 mm. of nitrogen this would indicate a temperature of about  $250^\circ\ \text{C}$ ., while for a pressure of 3 mm. the temperature of the axis would be about  $325^\circ\ \text{C}$ . For a current of 0.025 ampère the temperature would be  $300^\circ$  and  $400^\circ$  respectively.

The whole shows that for the large currents used (0.02 to 0.028 ampère) it is not unthinkable that the  $4.75\ \mu$  band is due to the heating of the residual gas. On the other hand, the black body at  $325^\circ$  does not emit a very perceptible radiation at  $1\ \mu$ , while the emission lines in this region are very intense. They indicate a very much higher temperature—some  $4,000^\circ$  abs., if we consider the maximum of the envelope of the curve, drawn through the highest points of these emission lines, which maximum lies just beyond the red. If the gas had this high temperature then one would expect the residual CO molecules to grow hotter. This reasoning leads to the result that the gas is at two distinct temperatures, which is hardly the case. Electrical excitation suggests itself, which brings us to a theoretical consideration of the phenomenon of vacuum-tube radiation.

## CHAPTER IV.

### THEORETICAL.

It remains for us to consider the theoretical side of this subject. Experimental observations always have some value. This is not always true of theories which are built, more or less, upon hypotheses and must stand or fall with them. For example, nowadays one no longer considers spectra to be due to molecular or atomic vibrations; the divisibility of the atom into smaller electrically charged particles, called "ions" or "corpuscles" must be assumed to account for observed facts.

The foremost and most conservative in propounding such a theory is J. J. Thompson.<sup>1</sup> J. Stark<sup>2</sup> is more daring in that he classifies these "ions," and gives the functions that each class has to perform.

Before considering these theories it will be well to distinguish between several forms of radiation, since every body gives out some form of radiation, in the form at least of heat waves of great wave-length. If a body can give out radiation continuously without changing its nature it is called a *pure thermal* radiation.<sup>3</sup> If it can not continue to give out this radiation indefinitely, without changing its nature, even when the temperature is kept constant (*e. g.*, fluorites which emit light on heating), then the radiation is termed *luminescence*. The vacuum-tube is thought to give out light by "*electro-luminescence*."

The vacuum-tube is always quite cool in comparison with the arc, this brings us to the question of "temperature." What do we mean by the temperature of a body, particularly with the two forms of radiation just mentioned? Both emit light; nevertheless, if we were to heat a piece of iron until it felt as hot to the touch, or until the mercury in a thermometer expanded to the same height, as it does for the vacuum-tube, we know from ordinary experience that the iron would not emit light. "Temperature" is something we are supposed to measure by ordinary means. The word itself is used carelessly and is an endless source of discussion. From a thermodynamic standpoint the mean value of the kinetic energy of a molecule is the mechanical measure of heat and temperature.<sup>4</sup> To anticipate a little what is to follow, Stark uses the terms "thermal" and "electrical" temperature. The purely "*thermal temperature*" for any one gas is proportional to the mean square of

---

<sup>1</sup> Thomson: Conduction of Electricity Through Gases.

<sup>2</sup> Stark: Elektrizität in Gasen.

<sup>3</sup> See Drude's Lehrbuch der Optik, p. 452.

<sup>4</sup> See Meyer's Kinetic Theory of Gases.

the *molecular* speeds. The "*electrical temperature*" is proportional to the mean square of the *ionic* speeds. In a strong electrical field, *e. g.*, spark between electrodes, the ionic velocities will be distributed in a very different manner from that prescribed by the Maxwell-Boltzmann Law, and the "*electrical temperature*" may differ very widely from the "*thermal.*" The arc is a region of high thermal and low electrical temperature; the spark has a low thermal and a high electrical temperature.

Of course, as the criticism can and has been made, the term "*electrical temperature*" has no meaning, if taken in the sense that the word is ordinarily used. I am not aware that the author meant it to be thus taken. If by "*electrical temperature*" is meant the temperature to which a body would have to be raised (by thermal means) in order to cause it to give out such light as is emitted in the spark and in the vacuum-tube during the electrical discharge, then the term is not meaningless. If by "*electrical temperature*" is meant the temperature of the ion (Stark equates the kinetic energy of the ion to its temperature), then one would hardly expect to measure at such a temperature by ordinary methods. Our experiences in using a platinum thermoelement in finding the temperature of a Bunsen flame suffice to warn us against such a fallacy; for, if the wires be fine enough, the platinum will melt, showing that certain parts at least of the flame are at a much higher temperature than indicated by the heavier wire which will not melt.

To return to the theory, there is considerable evidence for believing that the chemical atom or molecule is composed of positively and negatively charged particles called ions. These oppositely charged particles are equal in amount, since the molecule as a whole is electrically neutral. It is possible to separate from the molecule a minute particle which carries a negative charge, and thus leave an equal positive charge on the remainder of the molecule. The negatively charged particle, called "*corpuscle,*" "*electron,*" or "*electronion*" carries a charge equal to that of the hydrogen ion in electrolysis, as shown by Townsend,<sup>1</sup> while its mass is about 0.001 as great as the hydrogen atom.<sup>2</sup> This mass and charge of the electron is independent of the kind of matter from which it comes, and is invariable at low pressures. The mass of the positive ion is much larger, since it is always associated with the atoms of the gas in which it occurs. It is the residue after one or several negative ions (electrons) have been separated from a neutral atom by collision with a rapidly moving electron. This state of affairs is brought about whenever an electric field is produced, as, for example, the differ-

<sup>1</sup> Townsend: Phil. Trans., 193, 153, 1900.

<sup>2</sup> Thomson: Phil. Mag. (6), 5, 346, 1903; Wilson: Phil. Mag. (6), 5, 429, 1903.



ence of potential between the terminals in the carbon arc of the spark gap in the secondary on an induction coil, or of the electrodes of a vacuum-tube. Under the influence of an electric field these dissociated particles are set in motion. Beside their ordinary gas motion, there will be a component along the length of the tube (in a vacuum-tube) produced by the electrical forces. Although the charges are the same, the negative ions, the electrons, on account of their small mass will acquire a great speed, and by collision with neutral molecules will give rise to fresh ions. The energy acquired, however, will be the same for both, since they move through the same difference of potential. The mean free path of the electron will be the greater since it is smaller in size. The mean energy at collision, in any case, will be that acquired by the charged particle in moving through its path under the action of electrical forces. When the electron collides with a molecule several effects will be produced. The first is to increase the kinetic energy of the molecule as a whole, which in turn, by colliding with other molecules, will cause a rise in the thermal temperature of the gas. As a result the electrons in the molecules will be thrown out of their positions of equilibrium, and will execute a series of vibrations. In so doing they will emit radiation in the form of heat or light, depending upon the intensity of the excitation, which in turn depends upon the temperature. Since the mean temperature of the molecules is only about  $300^{\circ}$  abs. (Warburg, loc. cit.), it will be well to discuss presently the  $4.75 \mu$   $\text{CO}_2$  band in this connection.

When an electron collides with a molecule the second effect is an acceleration of the former, which, when properly interpreted, means a wave motion, hence periodicity (Stark, loc. cit.). This period will be determined by the time of impact, independently of the chemical nature of the body. Since all possible times of impact are possible, an infinite number of different electro-magnetic waves will be emitted, and we have a continuous spectrum. This is for the free electrons. The electrons that remain bound in the molecule will also be set into vibration by the impact of the collision. Since they are thus bound, there will be a relative motion among them, and the period of any one or group of these electrons will be characteristic of the kind of atom. The line and band spectra of the elements are, from this standpoint, due to these electrons within the atom.<sup>1</sup> In a more recent paper on this subject by Nutting<sup>2</sup> the recombination of these dissociated aggregates is emphasized as being the source of line spectra.

---

<sup>1</sup> Stark : *Ann. der Physik* (4), 14, p. 506, 1904.

<sup>2</sup> Nutting : *Astrophys. Jour.*, 21, p. 400, 1905.

For this second effect the energy increases with the potential gradient, since the radiation from the gas is caused by the collisions between molecules and electrons, which latter are moving with high speeds. As already mentioned in the high temperature radiation, where the collision is between molecules, the energy increases with the temperature. The electrical temperature distribution will be different from the thermal, and Kirchoff's law for the relation between emission and absorption will not hold for radiation from a gas in a vacuum-tube. The spectral distribution of intensity will be a function of the velocity distribution of the electrons. The greater the number of electrons with high speed in a volume element, the more will the intensity maximum be shifted towards the short wave-lengths.

For this reason the cathode glow is blue, since the cathode fall is about 300 volts. On the other hand, in the position column, where the fall is only about 30 volts, the light emitted is red (nitrogen). According to Stark's (*loc. cit.*) computations, in which the kinetic energy is equated to the temperature, this would indicate an electrical temperature of some  $6,000^\circ$  for the cathode glow.

The ionic energy<sup>1</sup> (the minimum kinetic energy) necessary to disrupt an atom is in the order, metals Hg (8 volts), H, N (27 volts), and O. From this it would follow that if we mix H with N the fall of potential and the electrical temperature of the positive column will be changed. The temperature will be increased if the gas to be added has a higher ionic energy, *e. g.*, N to Hg., or N to H. (Heuse,<sup>2</sup> Herz). This will be of interest in comparing the relative intensities of the  $4.75\ \mu$  band of  $\text{CO}_2$  when it occurs as an impurity in N (very intense) and in O or  $\text{NH}_3$ , where it is weak.

These views will now be briefly considered in connection with the results obtained in the present research.

Prior to this investigation on vacuum-tube radiation only one type of selective emission of gases in the infra-red had to be accounted for, *viz.*, emission bands of water vapor and  $\text{CO}_2$ . They were thought to be due to the thermal temperature of the gas. However, the data bearing upon this subject are so scarce that writers, in referring to them, generally expressed their opinions rather cautiously. Some have vaguely intimated that it might be something similar to luminescence in the visible spectrum—call it *thermalescence*.

From the present research on the intensity of the infra-red emission bands of N and  $\text{CO}_2$ , for constant current and varying pressures, and vice versa, it becomes evident that we have to deal with two distinct

<sup>1</sup>Herz: *Ann. der Physik* (3), 54, p. 244, 1893.

<sup>2</sup>Heuse: *Verh. d. d. phys. Ges.*, 1, 269, 1899.

types of radiation, the one being represented by the  $4.75 \mu$  band of CO and  $\text{CO}_2$ , the other being represented by the lines of N at  $0.90 \mu$  and  $1.06 \mu$ . The  $4.75 \mu$  band of CO and  $\text{CO}_2$  behave in an entirely different manner from all the rest. Its intensity increases with increasing pressure (for constant current) of the gas, but never reaches a maximum, becoming asymptotic at 5 to 6 mm. pressure.

On the other hand, the other bands increase in intensity with increase in pressure (for constant current), become a maximum at about 2 mm. pressure, and then decrease in intensity with a further increase in pressure, which agrees with observations in the visible spectrum.

All lines increase in intensity with increase in current, as found in the visible spectrum.

Condensers in parallel with the vacuum-tube caused a slight increase in the intensity of the lines, due to an increase in the current through the tube. This is due to the well-known fact that on account of the high self-induction of the coil, the discharge of the condenser takes the easier path through the vacuum-tube. The whole shows that the bands of N (He), and H, near the visible spectrum, are related to the visible bands, while the  $4.75 \mu$  band is of an entirely different type.

Returning to the theory, it is interesting to recall Ångström's (loc. cit.) predictions in regard to the mechanism which produces these radiations. As noticed elsewhere, he found that the total radiation *increases*, while the luminous radiation *decreases* with the increase in pressure of the gas, and concluded that there is a "regular" and an "irregular" radiation present during the electrical discharge. This would tend to change the efficiency of a vacuum-tube, as found by Ångström and by Drew.

In the present work, the *decrease* in infra-red radiation ( $4.75 \mu$  band) and the simultaneous *increase* in the visible radiation, with decrease in pressure, explains very clearly the rise in efficiency of vacuum-tubes. It also explains why the total radiation passes through a minimum as observed by Ångström, and by Drew (loc. cit.).

In connection with the theoretical work just mentioned the behavior of these two types of radiation may be explained in the following manner. Consider the lines in and near the visible spectrum. At high pressures the electrons will not attain a high speed on account of the numerous neutral molecules, and their freedom of motion will be limited. At a lower pressure their freedom of motion will be greater, the number of collisions will be more frequent, the ionization will increase, and the electrical temperature,<sup>1</sup> which is proportional to the mean square of the ionic speeds, will attain a maximum. At a still lower

pressure, on account of the scarcity of the molecules, there will be fewer collisions in a given time, the ionization will decrease, and the "electrical temperature" will decrease.

On the other hand, this explanation will not account for the behavior of the  $4.75 \mu$  band, which appears to be due to a thermal radiation, excited by the collision of electrons with the neutral gas molecules. The gas molecule as a whole will suffer an increase in its kinetic energy, and, in colliding with other molecules, will cause a rise in the thermal temperature of the gas. With increase in pressure, *i. e.*, in the number of gas molecules, the number of collisions will increase and the intensity of the thermal radiation will increase, but will not pass through a maximum, as is true of the other bands, because a stage will be arrived at where there will be a decrease in the ionization and in the collisions of the molecules. At still higher pressures the gas would cease to conduct the current.

Aside from these theoretical considerations, there is some experimental evidence for believing that the  $4.75 \mu$  band is of thermal origin. First, the gas must be hotter than the tube, for during the passage of the current the radiation tangential to the axis of the tube is probably different from the longitudinal, and the cell-walls assume the mean temperature of the gas only after the current has passed for some time. It has already been shown under the discussion of the temperature of the gas in the vacuum-tube (p. 322) that the mean thermal temperature is from  $300^{\circ}$  to  $400^{\circ}$  C., depending upon the current and the pressure. It was also shown there that the black body at these temperatures did not emit a perceptible radiation at  $1 \mu$ , while the emission lines in this region are very intense, indicating a temperature of perhaps  $4,000^{\circ}$  abs. On the other hand, the "black body" at  $4.75 \mu$  radiated almost as intensely as the vacuum-tube. This would indicate two distinct temperatures, which is hardly the case, and the term "electrical temperature" seems appropriate for the intense lines at  $1 \mu$ .

Second, the distribution of the heat in the vacuum-tube is very different for different pressures. At a high pressure the constricted portion of the vacuum-tube is the hotter, while at low pressure it is quite cool, and the region surrounding the electrodes is the hotter.

Third, the emission increases with the pressure (equivalent to an increase in the thickness of the emitting layer) and approaches a limiting value. Paschen (*loc. cit.*) has found for  $\text{CO}_2$  at atmospheric pressure, in a brass tube heated by a Bunsen burner, that a column 7 cm. long emitted and absorbed energy just as strong as a column 33 cm. long. In the present case the 15 cm. column of  $\text{CO}_2$  at 5 mm. pressure is equivalent to a column 1 mm. long at 760 mm. pressure.

---

<sup>1</sup> Stark, *Elektricität in Gasen*, from consideration of the kinetic energy of the electron computes an electrical temperature of some  $6,000^{\circ}$ .

This is not a very long column of the gas as compared with Paschen's, nevertheless, judging from the behavior of the small traces of  $\text{CO}_2$  in air, it does seem impossible for it to emit radiation as intense as that observed at  $4.75 \mu$ . This would require a very high temperature. If the shifting of the  $\text{CO}_2$  band toward the long wave-lengths continues with rise in temperature for the region beyond  $4.4 \mu$ , just as Paschen (loc. cit.) found for the region preceding  $4.4 \mu$ , then the  $4.75 \mu$  band would indicate a temperature of some  $6,500^\circ$  to  $7,000^\circ$  (found by extrapolating from Paschen's values). This is close to Stark's (loc. cit.) "electrical temperature" of  $6,000^\circ$  for the cathode glow. Returning to the strong emission lines just at the end of the red, if we consider the maximum of the envelope (the curve) drawn through the highest points on these emission lines, which maximum lies just beyond the red, then, from the "displacement law,"  $\lambda_{\text{max}} T = \text{const}$ , the thermal temperature appears to be about  $4,000^\circ$  abs.

From this line of reasoning it would appear that we can consider the  $4.75 \mu$  band and the bands at the end of the red to be due to a high thermal condition in the vacuum-tube, without having recourse to an "electrical temperature."

The continuous spectrum of alcohol vapor would indicate a higher temperature than that found by bolometric measurements. But even here the evidence is contradictory when compared with the emission of water vapor which showed no emission spectrum at  $2.8 \mu$ , where the Bunsen flame has emission lines.

Evidently further investigation is needed to elucidate this subject—and such an investigation is in progress.

Since submitting this paper for publication a similar investigation of  $\text{CO}_2$  and N, by Drew (Phys. Rev., 21, p. 122, 1905) has appeared. He studied the emission band at  $4.69 \mu$  (the  $4.75 \mu$  band in the present work) but did not succeed in eliminating it from N, which was made from sodium nitrate, as in the present work. Unfortunately he did not examine CO, and he reached a less definite conclusion as to the source of this line. He drew straight lines through the observed points, which gave an isosceles triangle, and from this he thinks that an observed shift of  $0.02 \mu$  for a change in pressure of the gas is real. His deflections were much smaller than in the present work, and the observed points do not always lie close enough upon the lines to convince one of the reality of the shift. Such a shift of the maximum from  $4.67 \mu$  for a pressure of 3 mm. to  $4.695 \mu$  for a pressure of 0.6 mm. is to be expected if  $\text{CO}_2$  dissociates into CO with decrease in pressure. In the present work the deflections were very much larger, but even here the variations in the readings are too great to be certain of a shift of the order of  $0.02 \mu$ .

## SUMMARY.

The present investigation of infra-red emission spectra had for its aim the study of the region of the spectrum lying beyond  $2\ \mu$ , which heretofore had never been examined. The question of the presence of emission lines beyond this point is chiefly of theoretical interest.

Two classes of radiation have been investigated, viz, the arc between metallic electrodes and the chlorides of the alkali metals in the carbon arc, and the discharge through a vacuum-tube using different vapors and gases.

It was found, for the arc between metal electrodes, that the oxides emitted a black-body spectrum of sufficient intensity to obliterate any emission lines, if any were present.

Using the chlorides of the alkali metals, the strong emission lines mapped by Snow were verified, but beyond  $2\ \mu$  no emission lines could be found.

The emission spectra of the following vapors and gases were examined in a vacuum-tube;  $\text{H}_2\text{O}$ ,  $\text{C}_2\text{H}_5\text{OH}$ ,  $\text{H}$ ,  $\text{N}$ ,  $\text{NH}_3$ ,  $\text{O}$ ,  $\text{CO}$ , and  $\text{CO}_2$ . Of this number the  $\text{C}_2\text{H}_5\text{OH}$ ,  $\text{CO}_2$ , and  $\text{CO}$  have a very strong emission band at  $4.75\ \mu$ .

Nitrogen is the only gas studied which has strong emission lines in the infra-red. The maxima are at  $0.75\ \mu$ ,  $0.90\ \mu$ , and  $1.06\ \mu$ . The behavior of these lines is entirely different from the  $4.75\ \mu$  band found in  $\text{CO}_2$  and  $\text{CO}$ . At a constant current the intensity of the  $4.75\ \mu$  band increases with the pressure, but never reaches a maximum, becoming asymptotic at 5 to 6 mm. pressure. On the other hand, the nitrogen bands increase in pressure, become a maximum at about 2 mm. pressure, then decrease in intensity with a further increase in pressure, which agrees with observations in the visible spectrum.

At a constant pressure all lines increase in intensity with increase in current, as found in the visible spectrum.

Condenser in parallel increased the intensity slightly, due to an increase in the current through the tube.

The aim in using a vacuum-tube was to avoid oxides. No lines, however, were found beyond  $2\ \mu$ , except the  $4.75\ \mu$  band, which seems to be due to the warming of the gas. Since the intensity of the vacuum-tube radiation is only from  $\frac{1}{2500}$  to  $\frac{1}{30000}$  as great as that of a black body, if there be weak emission lines beyond  $6\ \mu$  it would be almost impossible to detect them with our present measuring instruments.

The emission spectrum of  $\text{C}_2\text{H}_5\text{OH}$  shows that a vapor in a vacuum-tube can emit a continuous spectrum.

## INDEX OF COMPOUNDS.

Page.		Page.		Page.	
Acetone.....	64	Ethyl sulphide.....	63	Nitromethane.....	59
Acetic acid.....	69	sulphocyanate.	68	Nitrotoluene.....	86
Acetylene.....	44	mustard oil...	68	Octadecylene.....	75
Acetyl-eugenol.....	89	Ethylene.....	45	Octane.....	73
Allyl mustard oil.....	68	Ethylene bromide....	56	Octadecane.....	73
sulphide.....	64	Eucalyptol.....	94	Oleic acid.....	71
Ammonia.....	53, 318	Eugenol.....	88	Ortho-nitrotoluene...	86
Amyl alcohol.....	58	Glycerin.....	34	toluidine.....	86
Aniline.....	84	Hexadecane.....	73	xylene.....	78
Anisol.....	78	Hexadecylene.....	73	Oxygen.....	49, 313
Asphaltum.....	75	Hexane.....	74	Paraldehyde.....	91
Azobenzene.....	127	Hydrocarbons:		Para-nitrotoluene... 86	
Benzaldehyde.....	90	C <sub>19</sub> H <sub>36</sub> .....	73	nitrosodimethyl	
Benzene.....	76	C <sub>22</sub> H <sub>42</sub> .....	73	aniline.....	85
Benzonitrile.....	82	C <sub>10</sub> H <sub>20</sub> S.....	73, 75	xylene.....	78
Bromine.....	50	Hydrogen.....	50, 312	Pentadecylene.....	73
Brucite.....	129	Hydrogen sulphide...	52	Petroleum distillates.	72
Butane.....	47	Illuminating gas.....	49	Phenol.....	87
Caproic acid.....	70	Iodoform.....	54	Phenyl acetate.....	89
Carbon dioxide... 51, 313		Iron.....	304	mustard oil... 68	
disulphide... 66		Isocaproic acid.....	71	Picoline... ..	96
monoxide.. 50, 314		Le Page's glue.....	70	Pinene.....	93
tetrachloride.. 55		Limonene.....	92	Piperidine.....	97
Carvacrol.....	88	Lithium.....	307	Potassium.....	307
Cerotic acid.....	71	Laevo pinene.....	93	Pyridine.....	96
Chloroform.....	54	Menthol.....	95	Pyrrol.....	99
Clèveite gas.....	311	Mesitylene.....	79	Quinoline.....	98
Copper.....	303	Meta-xylene.....	78	Resin.....	93
Cumene.....	81	Methane.....	43	Safrol.....	81
Cuminol.....	91	Methyl acetate.....	64	Selenite.....	130
Cyanine.....	82	aniline.....	84	Sodium.....	306
Cymene.....	81	carbonate....	65	Stearic acid.....	71
Decane.....	73	cyanide... ..	60	Sulphur.....	66
Decylene.....	73	ether.....	48	Sulphur dioxide....	52
Dextro-limonene....	92	iodide.. ..	61	Terpineol.....	95
pinene.....	93	isosulphocyan-		Tetrachlorethylene...	55
Dimethyl aniline....	85	ate or must-		Tetracosane.....	73
Diphenyl.....	83, 126	ard oil... ..	67	Tetracosylene.....	75
Dodecane.....	75	salicylate....	89	Tetradecane.....	73
Dodecylene.....	73	sulphocyanate		Thiophene.....	98
Ethane.....	46	Monobrombenzene... 80		Thymol.....	88
Ethyl alcohol... 62, 315		Monochlorbenzene... 80		Toluene.....	77
cyanide.....	60	Monoheptadecane... 75		Triethylamine.....	63
ether.....	48	Monotridecane.....	75	Valeric acid.....	70
hydrosulphide. 63		Myrcyl alcohol.....	58	Venice turpentine... 93	
iodide.....	61	Napthalene.....	127	Water.....	56, 311
succinate.....	65	Nitrobenzene.....	86	Xylenes.....	78
sulphate.....	64	Nitroethane.....	60	Xylidine.....	85
		Nitrogen.....	316		





# INVESTIGATIONS OF INFRA-RED SPECTRA

---

Part I—INFRA-RED ABSORPTION SPECTRA

Part II—INFRA-RED EMISSION SPECTRA

---

BY  
WILLIAM W. COBLENTZ

---



WASHINGTON, D. C. :  
Published by the Carnegie Institution of Washington  
October, 1905.



