

*US Army Coast Eng Res Ctr. Tech. Rep. R&M-88
Abbey*



**US Army Corps
of Engineers**

**REPAIR, EVALUATION, MAINTENANCE AND
REHABILITATION RESEARCH PROGRAM**

TECHNICAL REPORT REMR-CO-3

**CASE HISTORIES OF CORPS BREAKWATER
AND JETTY STRUCTURES**

Report 2

SOUTH ATLANTIC DIVISION

by

Francis E. Sargent

Coastal Engineering Research Center

DEPARTMENT OF THE ARMY
Waterways Experiment Station, Corps of Engineers
PO Box 631, Vicksburg, Mississippi 39181-0631

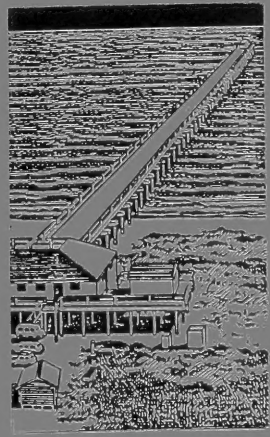

September 1988

Report 2 of a Series

Approved For Public Release: Distribution Unlimited

TC
203
.1155
no. REMR-
CO-3
rep. 2

Prepared for DEPARTMENT OF THE ARMY
US Army Corps of Engineers
Washington, DC 20314-1000

Under Work Unit 32278 and Work Unit 31269

U.S. Army Corps of Engineers, Civil Works Dept. REMR-CO
Abbey



US Army Corps
of Engineers

REPAIR, EVALUATION, MAINTENANCE AND REHABILITATION RESEARCH PROGRAM

TECHNICAL REPORT REMR-CO-3

CASE HISTORIES OF CORPS BREAKWATER AND JETTY STRUCTURES

Report 2

SOUTH ATLANTIC DIVISION

by

Francis E. Sargent

Coastal Engineering Research Center

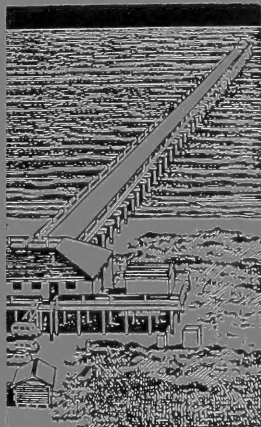

DEPARTMENT OF THE ARMY
Waterways Experiment Station, Corps of Engineers
PO Box 631, Vicksburg, Mississippi 39181-0631



September 1988

Report 2 of a Series

Approved For Public Release: Distribution Unlimited

TC
203
.U55
no. REMR-
CO-3
rep. 2

Prepared for DEPARTMENT OF THE ARMY
US Army Corps of Engineers
Washington, DC 20314-1000

Under Work Unit 32278 and Work Unit 31269

The following two letters used as part of the number designating technical reports of research published under the Repair, Evaluation, Maintenance, and Rehabilitation (REMER) Research Program identify the problem area under which the report was prepared.

	<u>Problem Area</u>		<u>Problem Area</u>
CS	Concrete and Steel Structures	EM	Electrical and Mechanical
GT	Geotechnical	EI	Environmental Impacts
HY	Hydraulics	OM	Operations Management
CG	Coastal		

Destroy this report when no longer needed. Do not return it to the originator.

The findings in this report are not to be construed as an official (Department) of the Army position unless so designated by other authorized documents.

The contents of this report are not to be used for advertising, publication, or promotional purposes. Citation of trade names does not constitute an official endorsement or approval of the use of such commercial products.

COVER PHOTOS

TOP = Field Research Facility, Dix, North Carolina

BOTTOM = View of Panama City jettes, February 1984



REPORT DOCUMENTATION PAGE

1a. REPORT SECURITY CLASSIFICATION Unclassified		1b. RESTRICTIVE MARKINGS	
2a. SECURITY CLASSIFICATION AUTHORITY		3. DISTRIBUTION / AVAILABILITY OF REPORT Approved for public release; distribution unlimited.	
2b. DECLASSIFICATION / DOWNGRADING SCHEDULE		5. MONITORING ORGANIZATION REPORT NUMBER(S)	
4. PERFORMING ORGANIZATION REPORT NUMBER(S) Technical Report REMR-CO-3		7a. NAME OF MONITORING ORGANIZATION	
6a. NAME OF PERFORMING ORGANIZATION USAEWES, Coastal Engineering Research Center	6b. OFFICE SYMBOL (if applicable) WESCV	7b. ADDRESS (City, State, and ZIP Code)	
6c. ADDRESS (City, State, and ZIP Code) PO Box 631 Vicksburg, MS 39180-0631		9. PROCUREMENT INSTRUMENT IDENTIFICATION NUMBER	
8a. NAME OF FUNDING / SPONSORING ORGANIZATION US Army Corps of Engineers	8b. OFFICE SYMBOL (if applicable)	10. SOURCE OF FUNDING NUMBERS <i>See reverse.</i>	
8c. ADDRESS (City, State, and ZIP Code) Washington, DC 20314-1000		PROGRAM ELEMENT NO.	PROJECT NO.
		TASK NO.	WORK UNIT ACCESSION NO. <i>See reverse</i>
11. TITLE (Include Security Classification) Case Histories of Corps Breakwater and Jetty Structures; Report 2: South Atlantic Division			
12. PERSONAL AUTHOR(S) Sargent, Francis E.			
13a. TYPE OF REPORT Report 2 of a series	13b. TIME COVERED FROM Jun 85 TO Mar 86	14. DATE OF REPORT (Year, Month, Day) September 1988	15. PAGE COUNT 109
16. SUPPLEMENTARY NOTATION See reverse.			
17. COSATI CODES		18. SUBJECT TERMS (Continue on reverse if necessary and identify by block number)	
FIELD	GROUP	SUB-GROUP	Breakwater
			Concrete armor units
			Jetty
			REMR (Repair, Evaluation, Maintenance, and Rehabilitation) Rubble-Mound structures
19. ABSTRACT (Continue on reverse if necessary and identify by block number)			
<p>This report is second in a series of case histories of US Army Corps of Engineers (Corps) breakwater and jetty structures at nine Corps divisions. Herein, chronological histories are presented for 32 breakwater and jetty structures located within the Corps of Engineers, South Atlantic Division (SAD), which encompasses the Atlantic and gulf coasts from North Carolina to Alabama and the Island of Puerto Rico. Presently, there are approximately 256,000 lin ft of breakwater and jetty structures managed by SAD. Structure cross sections of rubble mound or sand account for most of this total. Seventeen of the structures have undergone repairs or modification during their lifetimes. A variety of construction and repair methods have been used, including log and brush mattress (pre-1900's), steel sheet piles, asphaltic and concrete grouts, asphaltic mats, concrete sheet piles, toe aprons, sand tight cross sections, armor stone, and concrete caps.</p>			
20. DISTRIBUTION / AVAILABILITY OF ABSTRACT <input checked="" type="checkbox"/> UNCLASSIFIED/UNLIMITED <input type="checkbox"/> SAME AS RPT. <input type="checkbox"/> DTIC USERS		21. ABSTRACT SECURITY CLASSIFICATION Unclassified	
22a. NAME OF RESPONSIBLE INDIVIDUAL		22b. TELEPHONE (include Area Code)	22c. OFFICE SYMBOL

Unclassified

SECURITY CLASSIFICATION OF THIS PAGE

10. SOURCE OF FUNDING NUMBERS (Continued).
Work Unit 32278 and Work Unit 31269.

16. SUPPLEMENTARY NOTATION (Continued).

A report of the Coastal Problem Area of the Repair, Evaluation, Maintenance, and Rehabilitation (REMR) Research Program. Available from National Technical Information Service, 5285 Port Royal Road, Springfield, VA 22161.

Unclassified

SECURITY CLASSIFICATION OF THIS PAGE

PREFACE

This report was prepared as part of the Coastal Problem Area of the Repair, Evaluation, Maintenance, and Rehabilitation (REMR) Research Program. The work was carried out jointly under Work Unit 32278, "Rehabilitation of Rubble-Mound Structure Toes," of the REMR Program and Work Unit 31269, "Stability of Breakwaters," of the Civil Works Coastal Area Program. For the REMR program, Coastal Problem Area Monitor is Mr. John H. Lockhart, Jr., Office, Chief of Engineers (OCE), US Army Corps of Engineers (Corps). REMR Program Manager is Mr. William F. McCleese of the US Army Engineer Waterways Experiment Station's (WES's) Structures Laboratory, and Problem Area Leader is Mr. D. D. Davidson, Coastal Engineering Research Center (CERC). Messrs. John G. Housley and Lockhart, OCE, are Technical Monitors of the Civil Works Coastal Program.

This report is second in a series of case histories of Corps breakwater and jetty structures at nine Corps districts and divisions. The case histories herein were written from information obtained from several sources (where available) including inspection reports, conferences, telephone conversations, project plans and specifications, project files and correspondence, design memorandums, literature reviews, model studies, surveys (bathymetric and topographic), survey reports, annual reports to the Chief of Engineers, House and Senate documents, and general and aerial photography. Unless otherwise noted, any changes to the prototype structures subsequent to December 1984 are not included.

This work was conducted at WES during June 1985 to March 1986 under general direction of Dr. James R. Houston, Chief, CERC, and Mr. Charles C. Calhoun, Jr., Assistant Chief, CERC; and under direct supervision of Mr. C. Eugene Chatham, Jr., Chief, Wave Dynamics Division (CW), and Mr. D. D. Davidson, Chief, Wave Research Branch (CW-R). This report was prepared by Mr. Francis E. Sargent, Hydraulic Engineer, Wave Processes Branch, CERC, and edited by Ms. Shirley A. J. Hanshaw, Information Products Division, Information Technology Laboratory, WES.

Commander and Director of WES during publication of this report was COL Dwayne G. Lee, EN; Technical Director was Dr. Robert W. Whalin.

CONTENTS

	<u>Page</u>
PREFACE.....	1
CONVERSION FACTORS, NON-SI TO SI (METRIC) UNITS OF MEASUREMENT.....	3
PART I: INTRODUCTION.....	4
Background.....	4
Purpose.....	4
PART II: SUMMARY OF CORPS BREAKWATER AND JETTY STRUCTURES IN SAD.....	5
REFERENCES.....	105

CONVERSION FACTORS, NON-SI TO SI (METRIC)
UNITS OF MEASUREMENT

Non-SI units of measurement used in this report can be converted to SI (metric) units as follows:

<u>Multiply</u>	<u>By</u>	<u>To Obtain</u>
acres	4,046.873	square metres
cubic yards	0.7645549	cubic metres
feet	0.3048	metres
inches	2.54	centimetres
miles	1.609344	kilometres
pounds (force)	4.448222	newtons
pounds per cubic foot	16.01846	kilograms per cubic metre
square feet	0.09290304	square metres
square inches	6.4516	square centimetres
tons (2,000 lb, force)	8,896.443353	newtons

CASE HISTORIES OF CORPS BREAKWATER AND JETTY STRUCTURES

SOUTH ATLANTIC DIVISION

PART I: INTRODUCTION

Background

1. The US Army Corps of Engineers (Corps) is responsible for a wide variety of coastal structures located on the Atlantic, Pacific, and gulf coasts, the Great Lakes, the Hawaiian Islands, other islands, and inland waterways. Coastal improvements such as breakwaters or jetties are necessary where safe harboring or passage of shipping is required. These structures are continuously subjected to wave and current forces and are usually constructed on top of movable-bed materials. Under these conditions structural deterioration can occur and, at some point, maintenance is required if the structure fails to serve the existing needs of the project. Some of these projects have been maintained for 150 years or more. Methods of construction (and repair) have varied significantly during this time, principally because of a better understanding of coastal processes, availability of construction materials, existing wave climates, regional construction practices, and economic considerations.

Purpose

2. The purposes of the case histories of Corps breakwater and jetty structures are to lend insight into the scope, magnitude, and history of coastal breakwaters and jetties under Corps jurisdiction, to determine their maintenance and repair history, to determine their methods of construction, to make this information available to Corps personnel, and to address objectives of the Repair, Evaluation, Maintenance and Rehabilitation research program. To accomplish these objectives, case histories have been developed to quantify past and present problem areas (if any), to take steps to rectify these problems, and to subsequently evaluate the remedial measures. General design guidance can be obtained from those solutions that have been most successful. Information in this report should be of particular value to Corps personnel in the US Army Engineer Division; South Atlantic (SAD), and its coastal districts and possibly to non-Corps personnel. Where adequate solutions are lacking or where specific guidance is needed, further research will be conducted to address these problems (e.g. general armor stability, toe protection, localized damage, use of dissimilar armor, wave runup and overtopping).

PART II: SUMMARY OF CORPS BREAKWATER AND JETTY
STRUCTURES IN SAD

3. SAD has 32 projects which contain breakwater and/or jetty structures that are located in the following five coastal districts: US Army Engineer Districts, Wilmington (SAW) (7), Charleston (SAC) (4), Savannah (SAS) (1), Jacksonville (SAJ) (14), and Mobile (SAM) (6). Case histories for these structures are included in Tables 1-32 which are arranged according to the preceding districts and coastal locations. Twenty-five of the projects are situated in an ocean environment, and the remainder are located in sounds or bays. All of the structures have been constructed on top of existing sediments (usually fine to coarse sand), typical of barrier islands. Overall, there are approximately 256,000 lin ft* of breakwater (10.5 percent) and jetty (89.5 percent) structures in SAD. Although a variety of construction methods and materials have been used, the structures' cross sections are predominantly of rubble-mound (83.7 percent) or sand dike (14.8 percent) construction. Construction materials that have been used include steel sheet piles (Panama City, Casey's Pass), concrete cap (Jacksonville, Palm Beach), concrete grout (Bakers Haulover Inlet), asphaltic concrete (Panama City, Casey's Pass), asphalt mats (Panama City), precast concrete panels (weir jetties) and timber (Belhaven). Structures constructed prior to 1900 were built up from log and brush mattresses which were sunk by placing stone to a thickness of 12 to 18 in. The remainder of the section was built up with either additional stone or multiple layers of weighted log and brush mattresses (and then additional stone was placed).

4. Six of the projects have a sand weir in their design, and they are located at Masonboro Inlet, Little River Inlet, Murrells Inlet, Ponce De Leon Inlet, East Pass, and Perdido Pass. The weir segments of four of these (chronologically the first four constructed) were built with precast concrete sections. Shortly after construction, the concrete weir sections were supplemented with rubble-mound sections. The modified cross sections were required because of scour problems leading to potential or actual failure of the weir sections. The two most recently constructed sand weirs have a rubble-mound cross section.

* A table of factors for converting non-SI to SI (metric) units is presented on page 3.

5. Seventeen of the project structures have either been modified or repaired in the past 50 years (or since construction). The most frequent changes have come about because of the need to restrict the movement of bottom sediments through or along the toe of these structures. Other causes leading to repairs or modifications have been project improvements (new construction), general deterioration, or a consequence of structural features.

6. Typical armor stone used on the structures range from 4 to 16 tons, with extremes of 1 ton used on the inner trunk sections of several structures to 29 tons for the head section at Arecibo, Puerto Rico. Typical cross section geometries have crown elevations from +6 to +10 ft mean low water (mlw) (+5 to +15 ft mlw, extremes), crown widths from 6 to 20 ft wide (6 to 10 ft on older, 15 to 20 ft on newer projects), and 1V:1.5H or 1V:2H side slopes. Most of the more recent design analyses (last 30 years) employ an armor stone slope stability formula (typically Hudson's) and a depth-limiting breaking wave height. Design guidance is provided by the Shore Protection Manual (SPM) (1984) or appropriate Corps of Engineers manuals. Projects which were model tested at WES are identified in the tables.

7. Figures 1, 2, and 3 are maps of SAW, SAJ, and SAM, respectively, showing project locations. Location maps for SAC and SAS are incorporated into individual project maps. Pertinent summary information on each project is presented in the following tabulation.

Location	Table	Project Type & No**	Armor Type**	Length, ft	Date of Origin	Improvement†
Stumpy Point Bay, N.C.	1	B(2)	K	1,000	1967	N
Belhaven Harbor, N.C.	2	B(2)	T	3,900	1940	N
Hatteras SBH, N.C.	3	B(2)	S	600	1958	N
Smith Creek, N.C.	4	B	S	800	1956	N
Atlantic HR, N.C.	5	B	K	2,000	1972	N
Cape Lookout HR, N.C.	6	B	S	4,800	1917	N
Masonboro Inlet, N.C.	7	WJ,J	S	7,090	1966,1980	R,D
Little River Inlet, S.C.	8	WJ,J	S	14,475	1984	N
Murrells Inlet, S.C.	9	WJ,J	S	6,740	1981	N
Georgetown Harbor, S.C.	10	J	S	32,190	1890	N
Charleston Harbor, S.C.	11	J	S	34,500	1886	N
Savannah Harbor, Ga.	12	J	S	23,500	1890,1896	N
Fernandina Harbor, Fla.	13	J	S	30,350	1905	N
Jacksonville Harbor, Fla.	14	J	S,P	24,300	1892,1895	R
St. Augustine Harbor, Fla.	15	J	S	4,405	1941,1957	D
Ponce De Leon Inlet, Fla.	16	WJ	S	8,180	1972	R,D
Canaveral Harbor, Fla.	17	J	S	2,300	1954	D
Fort Pierce Harbor, Fla.	18	J	S	4,320	1929	R(1934)
St. Lucie Inlet, Fla.	19	J,B	S	5,975	1929,1980	N
Palm Beach Harbor, Fla.	20	J	S,P	2,840	1926	R,D
Port Everglades Harbor, Fla.	21	J	S	2,260	1928	R
Bakers Haulover Inlet, Fla.	22	J	S	1,410	1964	D
Miami Harbor, Fla.	23	J	S	6,450	1904	R(1934),D
Key West Bight, Fla.	24	B	S	800	1967	D
Casey's Pass, Fla.	25	J	S,A	1,320	1937	R
Arecibo Harbor, P.R.	26	B	S	1,220	1944	R
St. George Island, Fla.	27	J	S	1,930	1957	R
Two Mile Harbor, Fla.	28	B	K	6,000	1976	R
East Point Harbor, Fla.	29	B	S	5,300	1984	N
Panama City Harbor, Fla.	30	J	S	4,775	1934	R,D
East Pass, Fla.	31	WJ	S	7,120	1969	R,D
Perdido Pass, Ala.	32	WJ	S	3,600	1969	R,D

* Indicates type and number of structures: B-breakwater, (B(2) indicates 2 breakwaters), J-jetty, WJ-wier jetty.

** Indicates armor type: K-sand dike, T-timber pile, S-stone, P-concrete cap, A-asphalt cap.

† Indicates type of improvement: R-repair, D-modification, N-none.

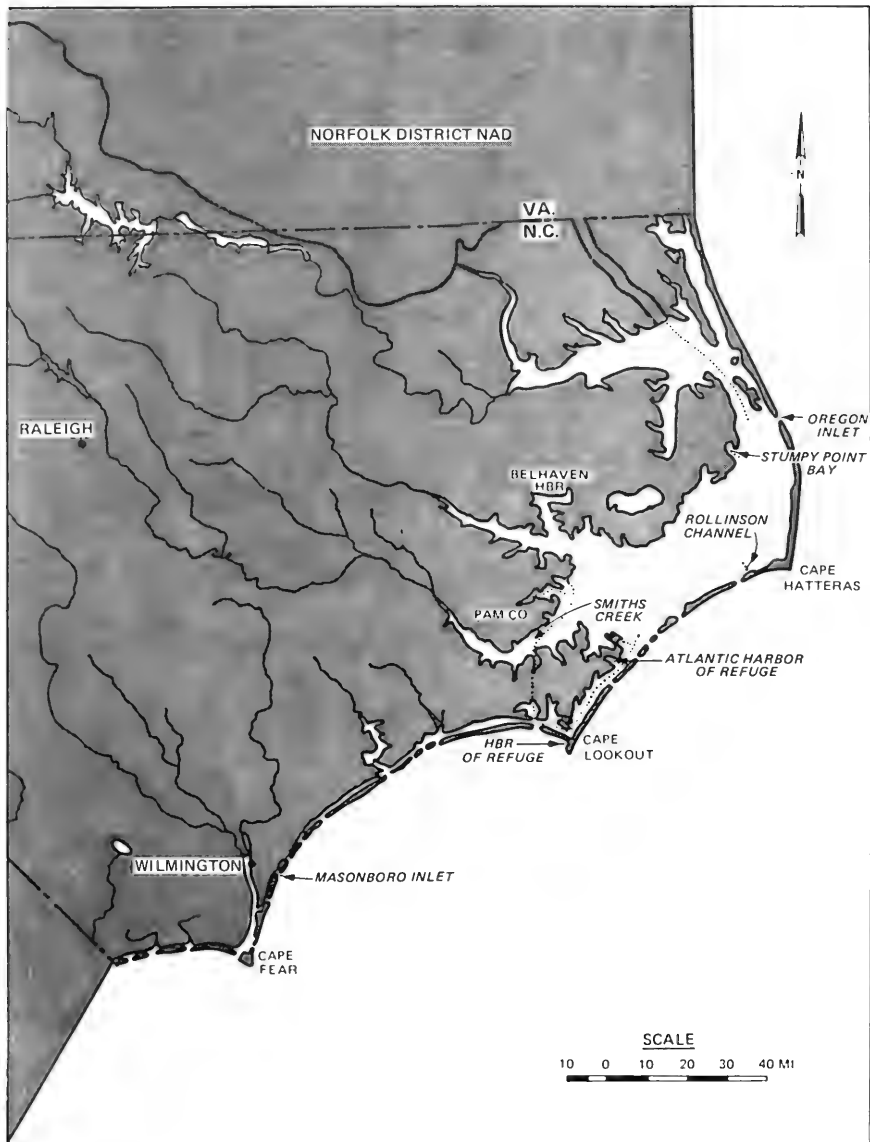

Figure 1. SAW breakwater and jetty project locations

Figure 2. SAJ breakwater and jetty project locations

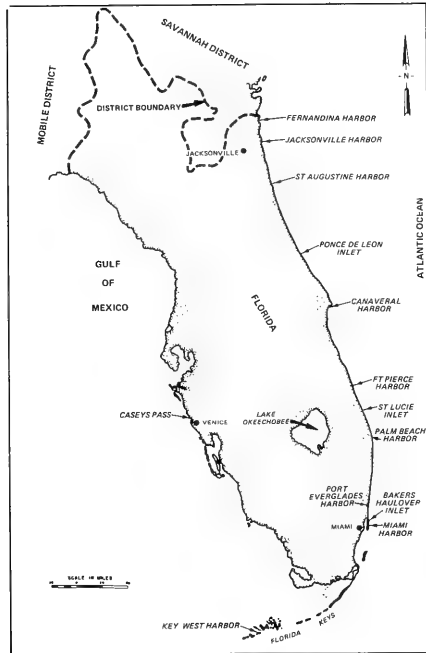

Figure 3. SAM breakwater and jetty project locations

Table 1
Stumpy Point Bay Breakwaters
Stumpy Point Bay, North Carolina, SAW

Date(s)	Construction and Rehabilitation History
1967	Two earthen breakwaters were constructed (Figure 4) in the harbor by the deposition of 74,200 cu yd of dredged fill reinforced at their seaward ends by 6,130 tons of riprap and stabilized by the planting of beach grass, all at a cost of \$218,300. The north and south breakwaters were 875 and 125 ft long, respectively. The breakwaters provide protection for the harbor area and 10-ft-deep channel entrance. The design section (Figure 4, insert) consisted of a 15-ft crest width at +8 ft mlw with side slopes of 1V:10H and 1V:20H, above and below +1 ft mlw, respectively. The 50- to 1,000-lb riprap stone on the seaward end of each breakwater was to be 3 ft thick and extend from -1 to +3 ft mlw. Bedding material was placed to act as a filter layer beneath the riprap.
1969	Visual examination of the breakwaters by the State of North Carolina Department of Water and Air Resources indicated that "both breakwaters seemed to be in good shape."
1974	A reconnaissance survey was made to determine the severity of erosion to the breakwaters. It was found that the riprap protected sections were functioning satisfactorily but that the fill material adjacent to the riprap sections had substantially eroded. Maximum vertical scarps of 7, 3, and 3 ft, respectively, were noted on the bay and harbor sides of the north breakwater and bay side of the south breakwater. The erosion on the north breakwater was on directly opposite sides of the breakwater with only 30 ft of original material separating the narrowest point. It was felt that "the southeasterly wind with its associated fetch is very erosive to the breakwaters on both sides of the dredged channel."
1985	Neither repairs nor maintenance has been carried out since the breakwaters were originally constructed.

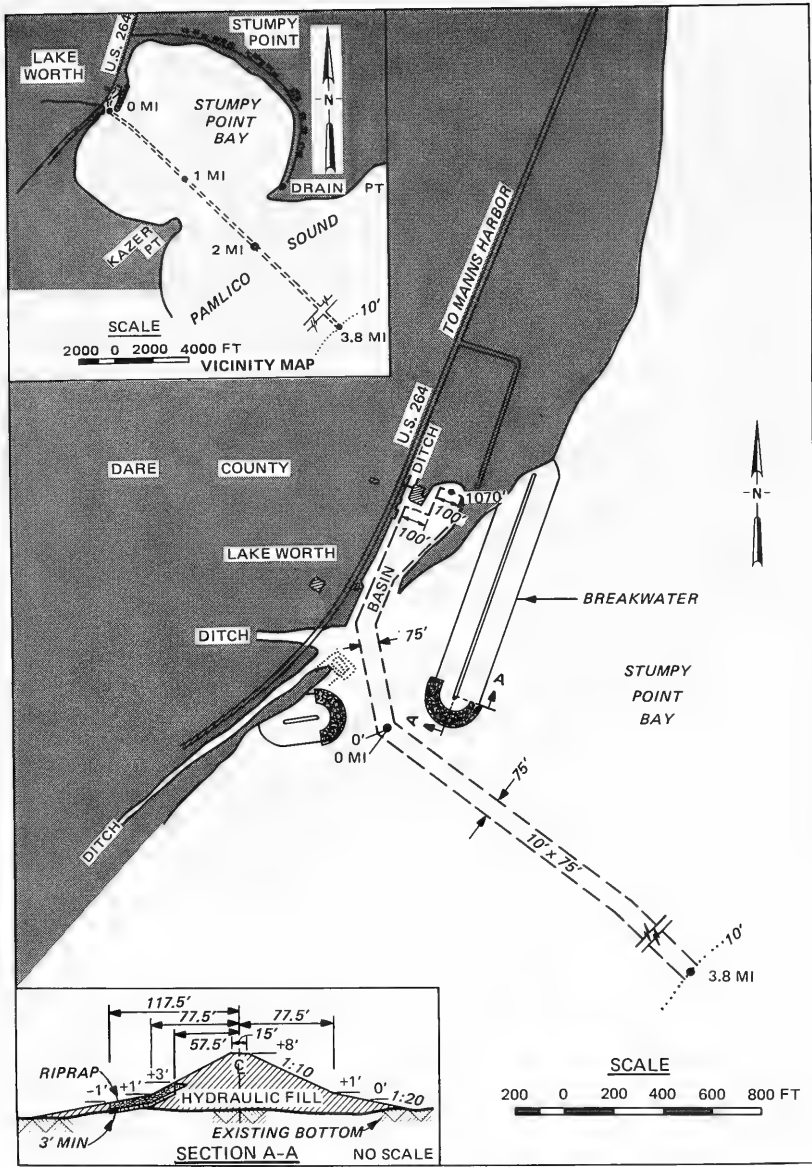

Figure 4. Stumpy Point Bay, North Carolina

Table 2

Belhaven Harbor Breakwaters
Belhaven Harbor, North Carolina, SAW

Date(s)	Construction and Rehabilitation History
1940	<p>Two creosoted timber breakwaters, each 1,950 ft long and located at the mouth of Pantego Creek (Figure 5), were constructed at a cost of \$73,187. As part of an existing project providing for a 12-ft mlw channel, the breakwaters were an experiment to provide some relief from beach erosion, high winds, and, generally, to make Belhaven a safe harbor for vessels. The face of the breakwaters consisted of 4- by 8-in. vertical timbers (pales) on 12-in. centers, extending from -1.2 to +3.5 ft mlw. The pales were held in place by timber wales, piles, and metal connectors.</p>
1972	<p>A survey of the structural condition of the breakwater indicated it was in poor condition and was not proving effective as a barrier to incoming wave energy. All the metal connectors were severely corroded, creating a navigation hazard when members broke away during storms. Numerous timber members were missing or decayed and broken. It was concluded that major repairs would be required to restore the breakwater to a safe and operational condition. Because of the shallowness of the structure (-1.2 ft mlw) and the openings between vertical pales (supplemented by visual examinations), it was concluded that the structures had little or no effect in attenuating wave energy.</p>
1982	<p>Visual examination showed that approximately three dozen timbers were missing over the length of the breakwaters. Also, a few pilings were missing. It was thought that the damage resulted from the impact of transient barges tied to the structure.</p>
1985	<p>The structure does not provide its intended wave protection, but at present there are no plans for improvement.</p>

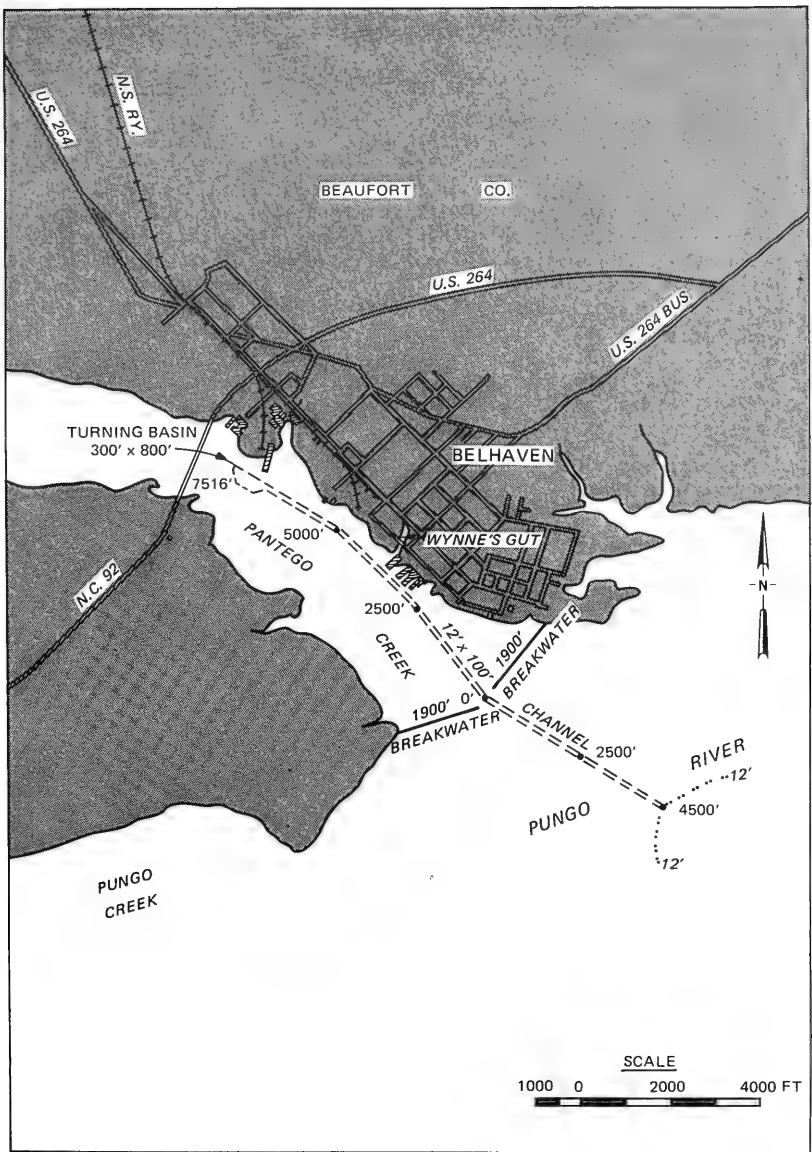

Figure 5. Belhaven Harbor, North Carolina

Table 3

Hatteras (Rollison Channel) Small-Boat Harbor Breakwaters

Hatteras, North Carolina, SAW

Date(s)	Construction and Rehabilitation History
1956- 1958	<p>In 1956, at a cost of \$115,600, two rubble-mound breakwaters were constructed at the entrance to Hatteras Small-Boat Harbor (Figure 6). The east and west breakwaters were 355 and 300 ft long, respectively. The design section consisted of a crown width of 8 ft at an elevation of +5 ft mhw and side slopes of 1V:1.5H and 1V:1.25H on the sound and harbor sides, respectively. The structures were made up of a 1-ft-thick mat of small stone (size unknown), core stone (size unknown), and 1- to 2-ton cover stone. The armor stone was sized using a 5-ft design wave height and Hudson's slope stability equation. Approximately 6,940 tons of stone were placed. After construction, local interests indicated difficulties with vessels passing through the narrow, 60-ft gap between the breakwater heads. In 1958 a timber dolphin fender system was placed on the heads to minimize potential damage to vessels.</p>
1985	<p>The breakwater has had no maintenance or repair since its completion.</p>

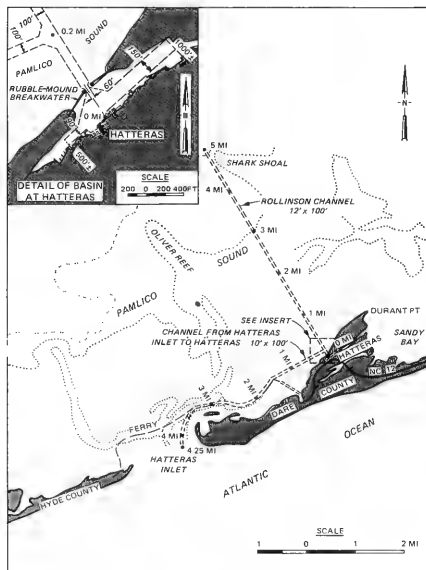

Figure 6. Hatteras (Rollison Channel) Small-Boat Harbor, North Carolina

Table 4

Smiths Creek Breakwater

Smiths Creek (Pamlico County), North Carolina, SAW

Date(s)	Construction and Rehabilitation History
1956	A 775-ft-long rubble-mound breakwater was constructed to provide channel and harbor protection (Figure 7). The cross-section geometry consisted of a +4-ft-mlw crown elevation, a 4-ft top width, and side slopes of 1V:1.5H and 1V:1.25H on the river and harbor sides, respectively. The structure was capped with 1-ton stone. The armor stone was sized using Hudson's slope stability formula and a 4-ft design wave height. The core and 1-ft-thick bedding layer consisted of somewhat smaller stone. The estimated construction cost and amount of stone needed were \$65,600 and 6,060 tons, respectively.
1973	An inspection of the breakwater showed that an 80-ft section, located approximately 100 ft from the outer end of the structure, was 2 ft below grade. This occurrence was attributed to structure settlement. Overall, the breakwater was considered to be in very good condition.
1985	The breakwater has required no maintenance or repair since its completion.

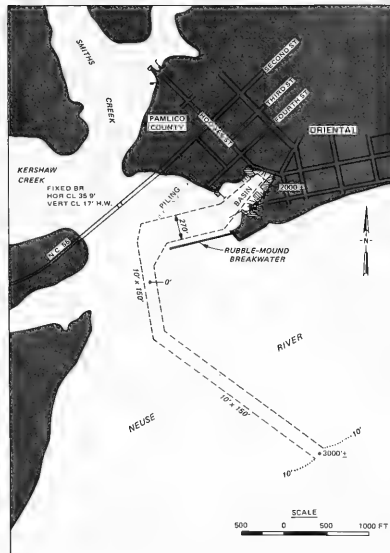

Figure 7. Smiths Creek (Pamlico County), North Carolina

Table 5
Atlantic Harbor of Refuge Breakwater
Atlantic, North Carolina, SAW

<u>Date(s)</u>	<u>Construction and Rehabilitation History</u>
1971- 1972	A 2,000-ft-long sand breakwater (Figure 8) with a riprap head was constructed in February 1972 as part of the Harbor of Refuge project. Material dredged from the access channel was used for the breakwater. A tentative design section called for a crest width of 15 ft at an elevation of +8 ft mlw, with side slopes of 1V:10H above mlw and 1V:20H below. The head of the breakwater would have a 3-ft-thick riprap section from -1 to +3 ft mlw. This design section was similar to the one used on the Stumpy Point Bay breakwaters. Estimated quantities were 46,500 cu yd of sand, 3,232 tons of stone, and 6.5 acres of grass (to hold the sand in place). The estimated total cost was \$51,400.
1973	Erosion had occurred along a 400-ft section of the southeastern face of the breakwater. The erosion extended from 35 to 60 ft into the embankment, creating an escarpment of about 3 ft, and the planted grass had been destroyed in this area. Also, the stone protection on the south end of the breakwater (previously covered with sand) had become uncovered, displaced, and scattered. The sand fill behind the stone apparently eroded away first, undermining the rock and subsequently displacing it.
1985	No maintenance work has been carried out since construction.

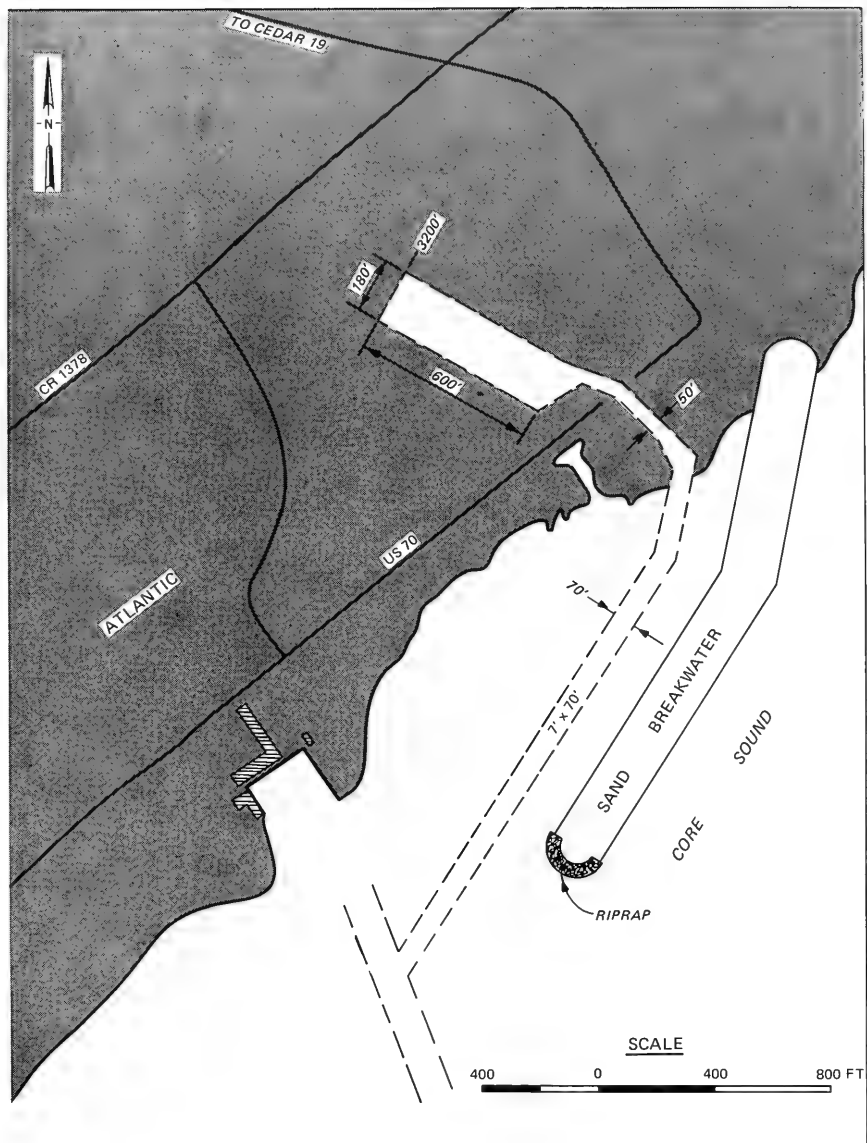

Figure 8. Atlantic Harbor of Refuge, North Carolina

Table 6

Cape Lookout Harbor of Refuge BreakwaterCape Lookout, North Carolina, SAW

Date(s)	Construction and Rehabilitation History
1914- 1917	The landward 4,800 ft of a 7,500-ft-long rubble-mound breakwater (Figure 9), authorized by Congress in 1912, was completed in 1917. Subsequently it was determined that the remaining 2,250 ft of the structure was not needed. The breakwater was constructed on a 2-ft-thick stone mattress. Specifications for the breakwater called for quarry-run stone graded so that at least 10 percent was greater than 10 tons, at least 40 percent greater than 7 tons, and at least 70 percent greater than 2 tons. The design section had a 20-ft crest width at +6.5 ft mlw with 1V:1H side slopes. About 651,400 tons of stone were placed at a total cost of \$1,363,800. (The cost included some other items such as constructing sand fences, a survey boat, and paying for rights-of-way.)
1921	In December cross sections were taken of the breakwater. They showed that the average top elevation of the breakwater was at mlw. The side slopes near the top were fairly flat (about 1V:2H to 1V:3H), and the lower part of the side slopes was fairly steep, generally 1V:1H. At that time the breakwater was visible only in places at extreme low water.
1985	Since its completion no maintenance or repairs have been made. Because of a sand spit in the lee of the structure, which results in a natural harbor, no plans exist to restore the breakwater to its original condition. (The breakwater was deauthorized on 1 November 1981.)

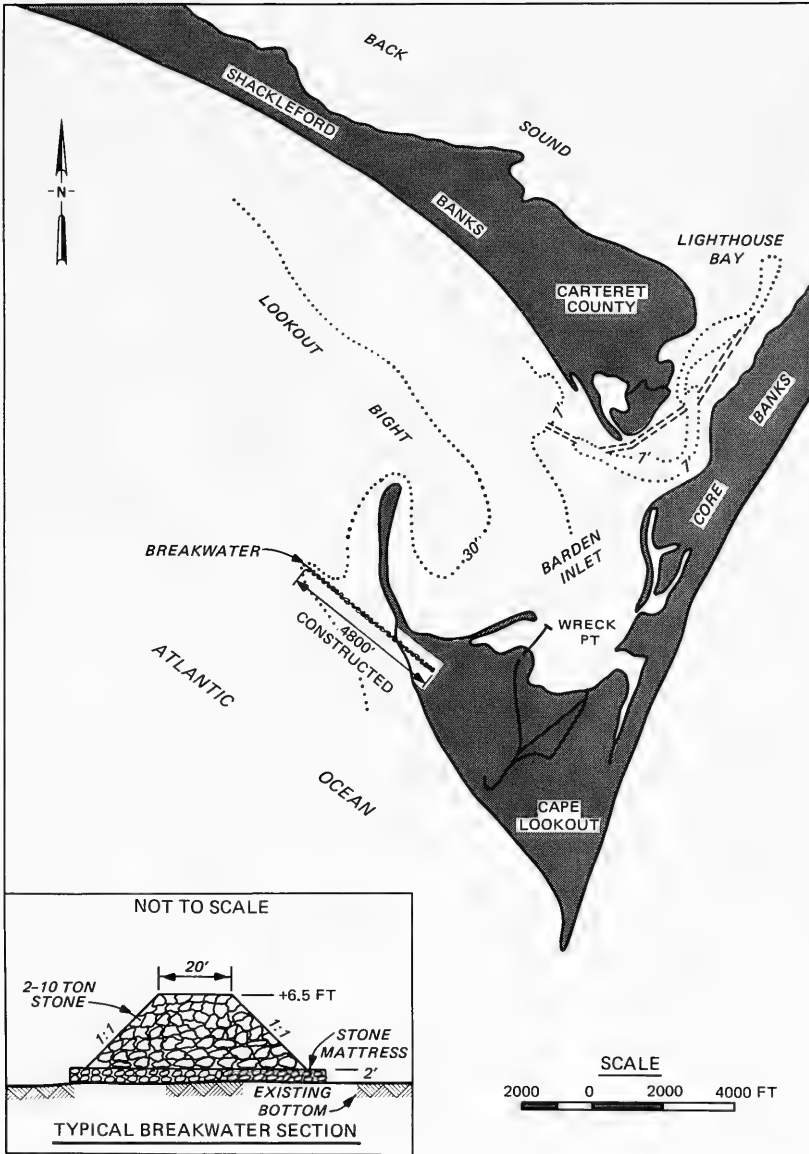

Figure 9. Cape Lookout Harbor of Refuge, North Carolina

Table 7

Masonboro Inlet JettiesMasonboro Inlet, North Carolina, SAW

Date(s)	Construction and Rehabilitation History
1947- 1959	In 1947 the district built two groins on the north shore. Shortly thereafter, three groins were constructed on the south shore, but all five proved to be ineffective in maintaining a channel through the inlet. In 1950 Congress authorized a channel 14 ft deep and 400 ft wide across the bar at Masonboro Inlet and dual jetties extending to the 14-ft depth contour (Figure 10). The jetties were to be constructed only if it were found impracticable to maintain the channel by dredging and if a study showed the jetties economically justified. The ocean entrance channel through the inlet was completed in 1959.
1965- 1966	Continued shoaling in the channel and attendant maintenance dredging problems led to a reactivation of the project's provisional jetties feature. Because of the predominant southerly littoral drift, only the north jetty was completed pending future evidence of the need for a south jetty. In addition, the north jetty was designed as a prototype sand-weir structure to add a sand-bypassing feature to the overall navigation improvements. This was the first time that the sand weir bypassing feature had been incorporated into a Corps of Engineers (Corps) jetty design. The overall length of the jetty was 3,639 ft, consisting of 1,739 ft of concrete sheet pile and 1,900 ft of rubble-mound on landward and seaward sections, respectively (Figure 11). The sections of sheet pile, 23.5 ft long by 3 ft wide by 16 in. thick, were precast and prestressed with cables, and, once placed, were interconnected with 12-in. ² treated timber wales. Subsequent to completion of the jetty, several sections of the timber wales came loose and required rebolting or removal from the sheet pile. 520 lin ft of wales were removed. It was recommended that any future designs were not to incorporate timber wales. The crest elevation of the shoreward 600 ft of the sheet pile varied from +12 to +2 ft mlw, with the 1,100-ft weir section at a crest elevation of +2 ft mlw. The rubble-mound portion of the north jetty had design crest elevations of +6 ft mlw for 850 ft, a transition from +6 to +8 ft mlw for over 100 ft, and +8 ft mlw for the seaward 950 ft. The design crown width was 10 ft, and the side slopes were 1V:1.5H and 1V:2.5H for the trunk and head sections, respectively. Capstone size ranged from 7 to 12 tons. Depth-limited design wave heights of 8 and 12 ft were used with Hudson's stability equation to select capstone for the trunk and head sections, respectively. The jetty design included a deposition basin on the leeward side of, and adjacent to, the weir section. The basin would periodically be dredged, with the material placed on the opposite shore as required.

(Continued)

(Sheet 1 of 4)

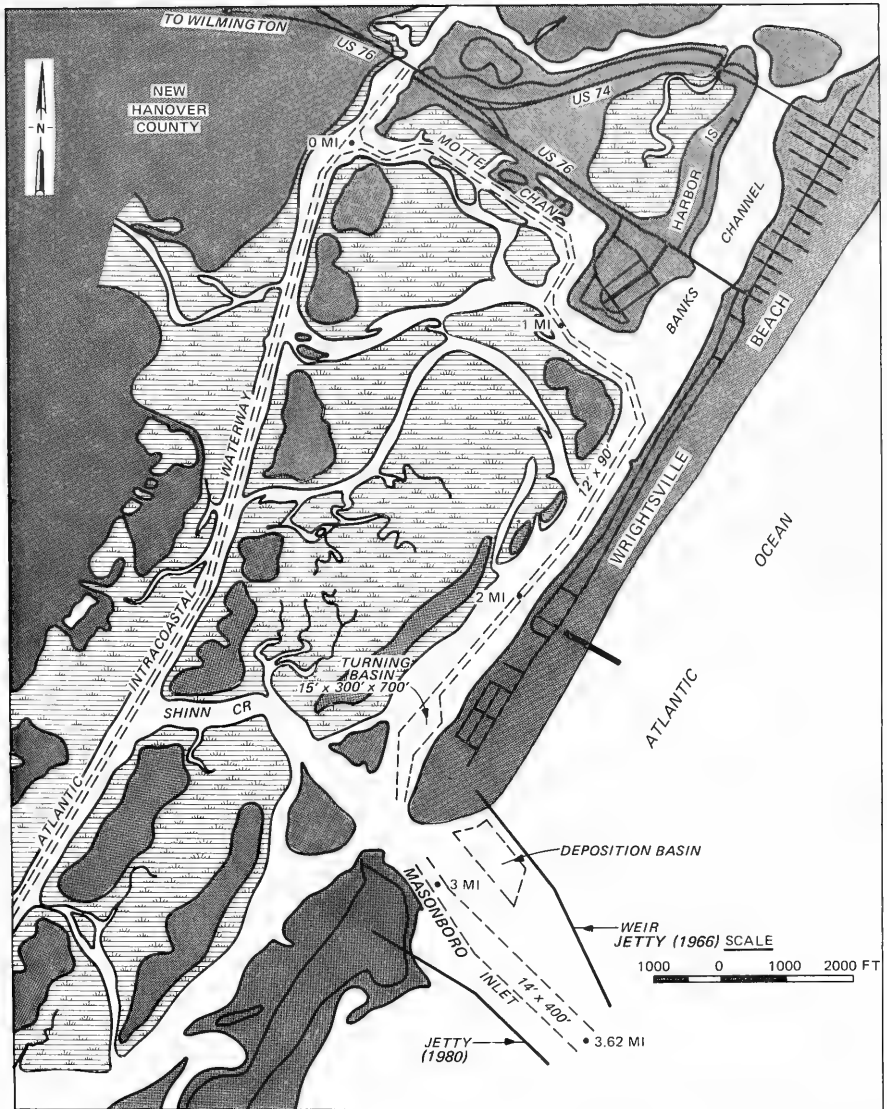

Figure 10. Masonboro Inlet, North Carolina

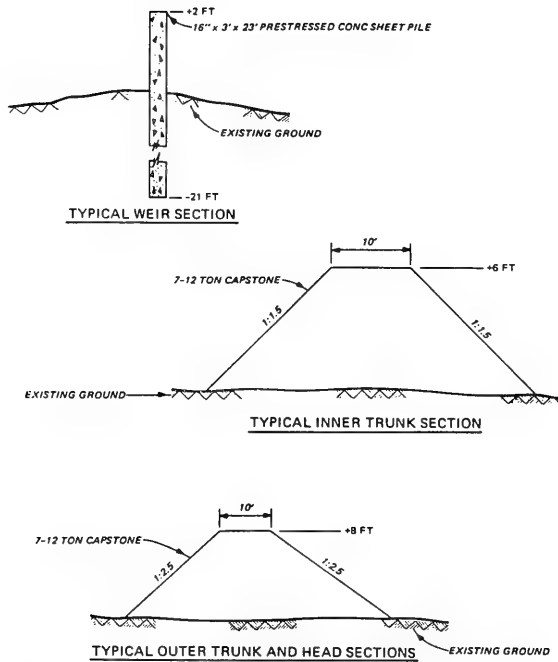

Figure 11. Typical north jetty cross sections
Masonboro Inlet

Table 7 (Continued)

Date(s)	Construction and Rehabilitation History
1965- 1966 (Cont)	Cost of the jetty construction was \$955,400, and dredging of the deposition basin was \$169,300.
1969- 1970	Because of the migration of the navigation channel toward the north jetty with its potential for scour and undermining, a stone apron was placed to provide toe protection along the rubble-mound section of the jetty (Figure 12). A survey of the structure taken during the first half of the year showed several sections, along the seaward 900 ft of the structure, with centerline elevations up to 5 ft below the design grade. The centerline elevations over the remainder of the rubble-mound section were within 1 ft of the design elevation. The sheet-pile weir section was usually within 0.2 ft of the design elevation of +2 ft mlw. The survey also showed that approximately 50 ft of rubble mound at the seaward end had either been displaced or had not been placed originally. The toe apron was placed along the entire channel side of the rubble mound and extended around the head section, covering an additional 50 ft on the ocean side. The width of the apron varied from 30 ft at the inner end to 50 ft at the seaward end of the repair. The apron consisted of a 1-ft-thick stone foundation blanket covered with a 2-ft-thick section of 25- to 250-lb riprap. In addition, the apron section encompassing the head had a third layer, 3 ft thick, of 500 to 2,000-lb riprap. Capstone totaling 510 tons was to be placed to bring the structure up to grade. On 1-2 November 1969, during the repairs, a moderate northeasterly storm, with estimated wave heights close to those of the design wave, displaced an additional 3,400 tons of stone from the structure. Costs of the original repair and subsequent repairs to bring the structure up to grade were \$479,400.
1973- 1974	Toe protection (Figure 12) was placed along the channel side of the 1,100-ft weir section because of continued movement of the navigation channel and the costs involved should a catastrophic failure occur (loss of sheet-pile sections resulting from scour and undermining). The toe apron was to be 50 ft wide with a 1-ft-thick foundation blanket of 2- to 6-in. stone overlain with a 2.5-ft layer of 25- to 250-lb riprap. Total cost of the repair was \$248,800.
1978- 1980	Construction of the south jetty, built of quarry stone and concrete sheet pile to a length of 3,450 ft, began in July 1978 and was completed in August 1980. A bathymetric survey taken in 1978 showed the channel to be extremely close to the north jetty with water depths up to -25 ft mlw along the rubble-mound section and -12 ft mlw along the weir jetty section. Model tests of the south jetty alignment and geometry, conducted at the US Army Engineer

(Continued)

(Sheet 2 of 4)

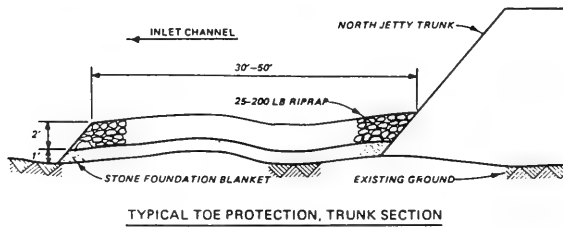
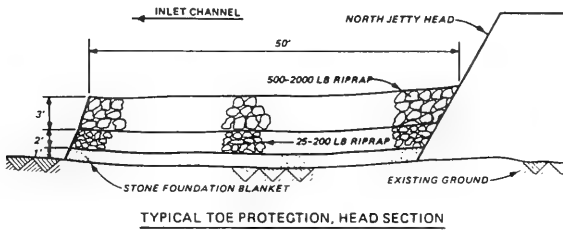
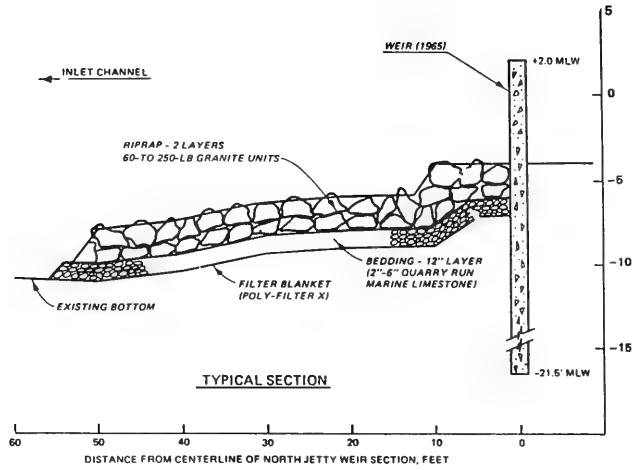

Figure 12. North jetty toe protection
Masonboro Inlet

Table 7 (Continued)

Date(s)	Construction and Rehabilitation History
1978- 1980 (Cont)	<p>Waterways Experiment Station (WES) (Seabergh 1976), indicated that the navigation channel would realign itself between the jetties in conjunction with inlet dredging. The outer portion of the jetty trunk was also model tested at WES (Carver and Markle 1978) to design a stable section for the breaking wave environment. From these tests it was determined that the design section was adequate for the +8.5-ft mlw storm surge condition but could accrue significant damage for storm surges greater than +8.5 ft mlw. Wave heights and periods used in the tests were 13.5 ft, 15 sec and 15.0 ft, 15 sec for +8.5 and +10.5 ft mlw surge levels, respectively.</p>

The jetty design (Figure 13) consisted of a 750-ft shore anchor section, two trunk sections, 550 and 2,050 ft long, respectively, and a 100-ft head section. The concrete sheet-pile sections were precast and prestressed with steel cable and were 3 ft wide, 12 or 16 in. thick, and 25.5, 31, or 33 ft long. The main purpose of the sheet pile was to provide an effective means of stopping the transport of sand through the jetty. The sheet-pile top elevation varied from +11 to +5 ft mlw, from the shoreward end to the seaward end (but not incorporated into the head section), respectively. The shore anchor section was built with sheet-pile top elevations of +11 to +9 ft mlw and channel side toe protection (20 ft wide) made up of 1.5-ft-thick foundation blanket of 2- to 12-in. stone and a single layer of 3,000 to 5,600-lb armor stone. The inner 550-ft trunk section consisted of the 1.5-ft-thick foundation blanket of 2- to 12-in. stone, 1,000- to 1,600-lb underlayer (core) stone, and 5- to 8-ton capstone. The capstone crown width and elevation were 16 ft and +9 ft mlw, respectively. The top elevation of the sheet pile was +7 ft mlw. Toe protection overlaying the foundation blanket was three stones wide (approximately 15 ft), using 5- to 8-ton stone on the channel side, and 25 ft wide using a double layer of 3,000- to 5,600-lb stone on the ocean side. The outer 2,050-ft trunk section consisted of a 1-ft-thick gabion foundation blanket of 4- to 8-in. stone, 300- to 5,600-lb underlayer (core) stone, and 14- to 22-ton capstone. The capstone crown width and elevation were 22 ft and +7 ft mlw, respectively. The top elevation of the sheet pile was +5 ft mlw. Toe protection, overlying the gabion mat, was 3 stones wide (approximately 21 ft) using 14- to 22-ton stone on the ocean side; 25 ft wide using a double layer of 3,000 to 5,600-lb stone for (inner) 1,200 ft of the channel side, and 4 stones wide (approximately 28 ft) using 14- to 22-ton stone for the remaining (outer) 850 ft of the channel side. The head section was similar to the outer trunk section except for an additional layer of 14- to 22-ton capstone. It excluded the concrete sheet pile, and the 4-stone-wide channel side toe protection extended around the head section to the

(Continued)

(Sheet 3 of 4)

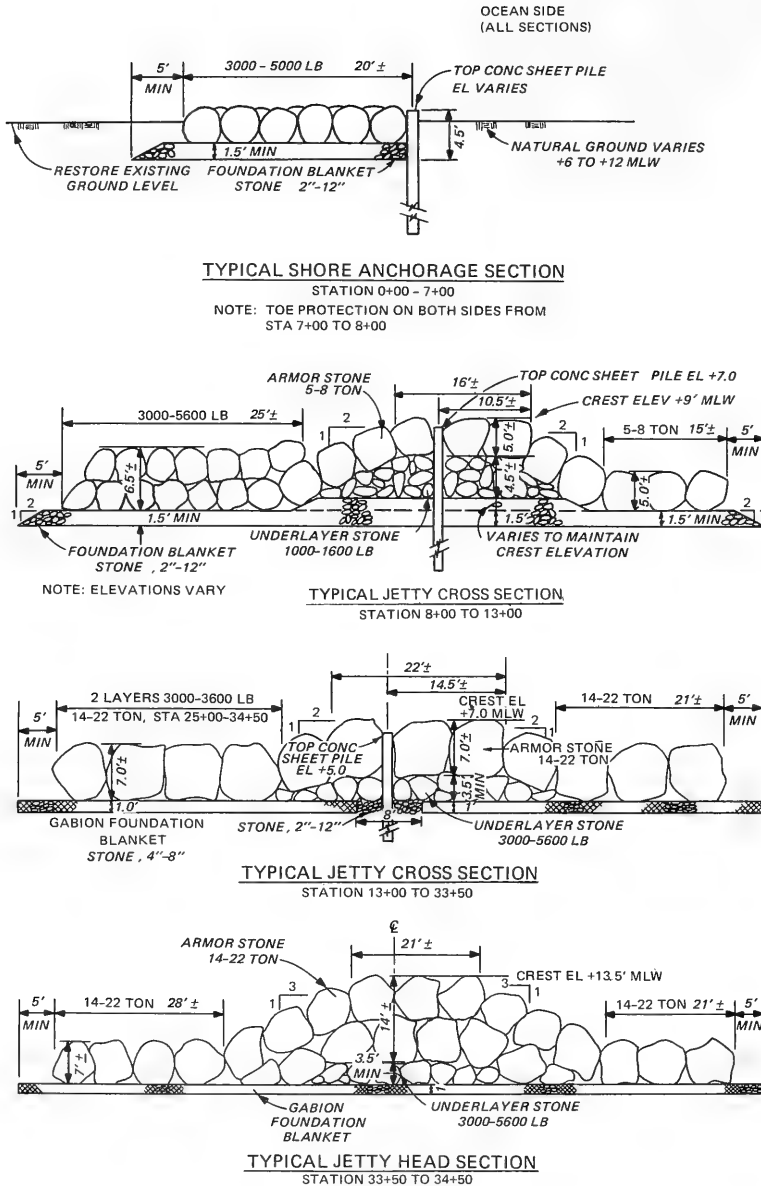

Figure 13. Typical south jetty cross sections, Masonboro Inlet

Table 7 (Concluded)

Date(s)	Construction and Rehabilitation History
1978- 1980 (Cont)	3-stone-wide ocean-side toe protection. The crown width and elevation were 21 and +13.5 ft mlw, respectively. Side slopes on the jetty were 1V:2H and 1V:3H for the trunk and head sections, respectively. Armor stone size for the inner trunk section was determined using Hudson's stability equation and design wave height of 10.1 ft. The cost for construction of the south jetty was \$5,614,000.
1981- 1984	Dredging to centralize the ocean entrance channel was accomplished in early 1981. Subsequent bathymetric surveys were taken in April 1981 and August 1984. The surveys showed that, in general, the basic pattern was one of scour occurring along the central zone between the jetty structures and deposition along the bottoms adjacent to the structures and inlet gorge. In effect, the basic functional purpose of the dual jetty system had been attained as a result of the south jetty construction.
1985	Presently, the south jetty is in good condition; whereas, the north jetty, which was constructed of smaller size armor stone, is in need of repair work in several areas showing localized armor stone damage.

Table 8

Little River Inlet JettiesLittle River Inlet, South Carolina, SAC

Date(s)	Construction and Rehabilitation History
1981- 1984	<p>The construction of two armor stone jetties at Little River Inlet (Figure 14) was started in 1981 and completed in 1984 at a cost of \$5.5 million. The jetties provide improvement and stabilization of the inlet, with the entrance channel maintained at -12 ft mlw. The total lengths of the upcoast and downcoast jetties were 5,660 and 8,815 ft, respectively. Each jetty (Figure 15) consisted of a sand dike, a sand-tight jetty section, a 650-ft weir section with "removable" cover stone, a trunk section, and a 150-ft head section. The cover stone along either weir section would be removed if, over a period of several years, excessive deposition of sand occurred. The jetty spacing at the parallel seaward ends was 1,000 ft. The minimum crest elevation of the structure was 8 ft mlw (exclusive of the weir section). The head sections consisted of a double layer of 5- to 8-ton stone on 1V:2H side slopes. The trunk sections had 1V:2H side slopes with one layer of 3.5- to 6-ton stone. Design procedures followed the SPM (1984), and the jetty configuration was model tested at WES (Seabergh and Lane 1977). The design wave height was 11 ft, determined from depth-limiting criteria.</p>
1986	<p>A visual examination of the structures indicated some displaced stone along the weir section of the north jetty. Surveys also revealed scour holes at the head of the north jetty and along the channel side of the south jetty. No apparent jetty damage was indicated above the water surface. Damage along the toe of the structures, if any, is unknown.</p>

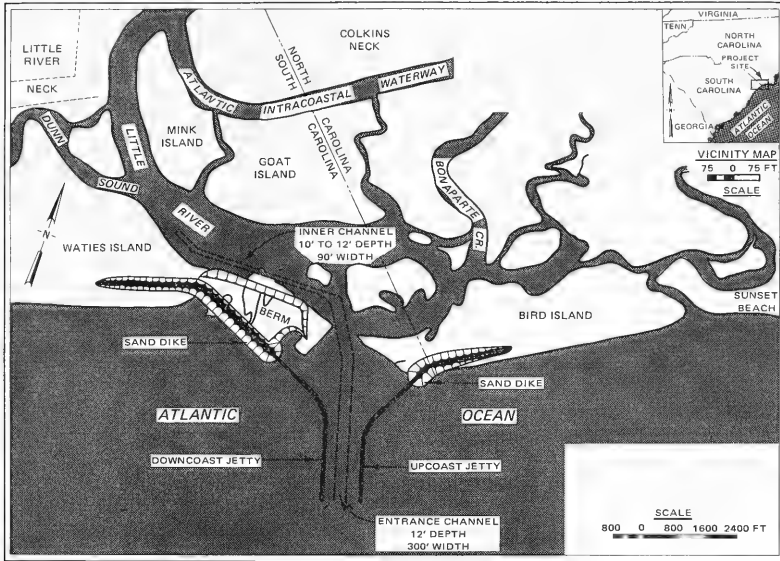

Figure 14. Little River, South Carolina

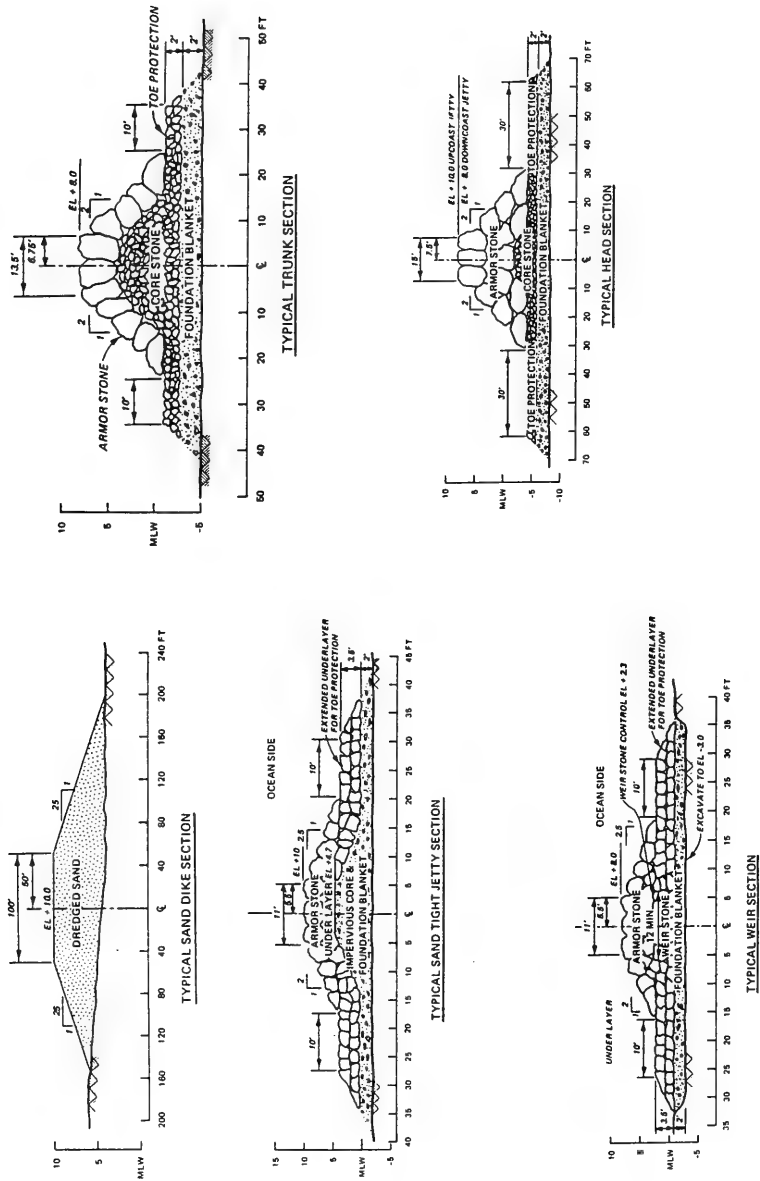

Figure 15. Typical jetty cross sections, Little River Inlet

Table 9

Murrells Inlet JettiesMurrells Inlet, South Carolina, SAC

<u>Date(s)</u>	<u>Construction and Rehabilitation History</u>
1977- 1981	<p>The two armor stone jetties (Figure 16) were constructed at a cost of \$7.4 million. The north jetty (total length, 3,420 ft) consists of the 560-ft-long shoreward jetty trunk; a 1,350-ft-long armor stone weir section (crest elevation +2.2 ft mlw); the 1,650-ft-long seaward jetty trunk; and the 150-ft-long head section. The south jetty (total length, 3,320 ft) consists of a 3,170-ft-long trunk and a 150-ft head section. The south jetty included an asphalt fishing walkway. Sand dikes composed of dredged material, 400 and 2,815 ft long on the north and south sides, respectively, tied the jetty roots into the existing dune lines. The seaward parallel sections of the jetties were 600 ft apart with a -12 ft mlw channel between them. The design head section called for a double layer of 6- to 10-ton stone, a crest width of 18 ft, and a crest height of +9 ft mlw. The trunk sections were composed of one or two layers of 4- to 7-ton stone, a 15-ft crown width, and a +9-ft-mlw crown elevation. Side slopes were 1V:2H for both head and trunk sections. The trunk and head sections were built upon a 2-ft-thick layer of 0.25- to 6-in. foundation stone followed by a 2-ft-thick layer of 200- to 2,000-lb stone. To provide toe protection, the double bedding layer was extended 10 and 30 ft beyond the toe of the cover stone on the trunk and head sections, respectively. The core stone varied in size from 200 to 2,000 lb. The weir section was made up of one layer of 1- to 9-ton cover stone (crest width of 12 ft) resting on a 2-ft-thick foundation blanket and buttressed on either side with 10-ft-wide by 2-ft-thick sections of 200- to 2,000-lb stone. The design followed the SPM (1984) procedures, and the jetty configuration was model tested at WES (Perry, Seabergh, and Lane 1978). The design wave height was 12 ft.</p>
1985	<p>The jetties have no history of damage or repair and appear to be functioning properly.</p>

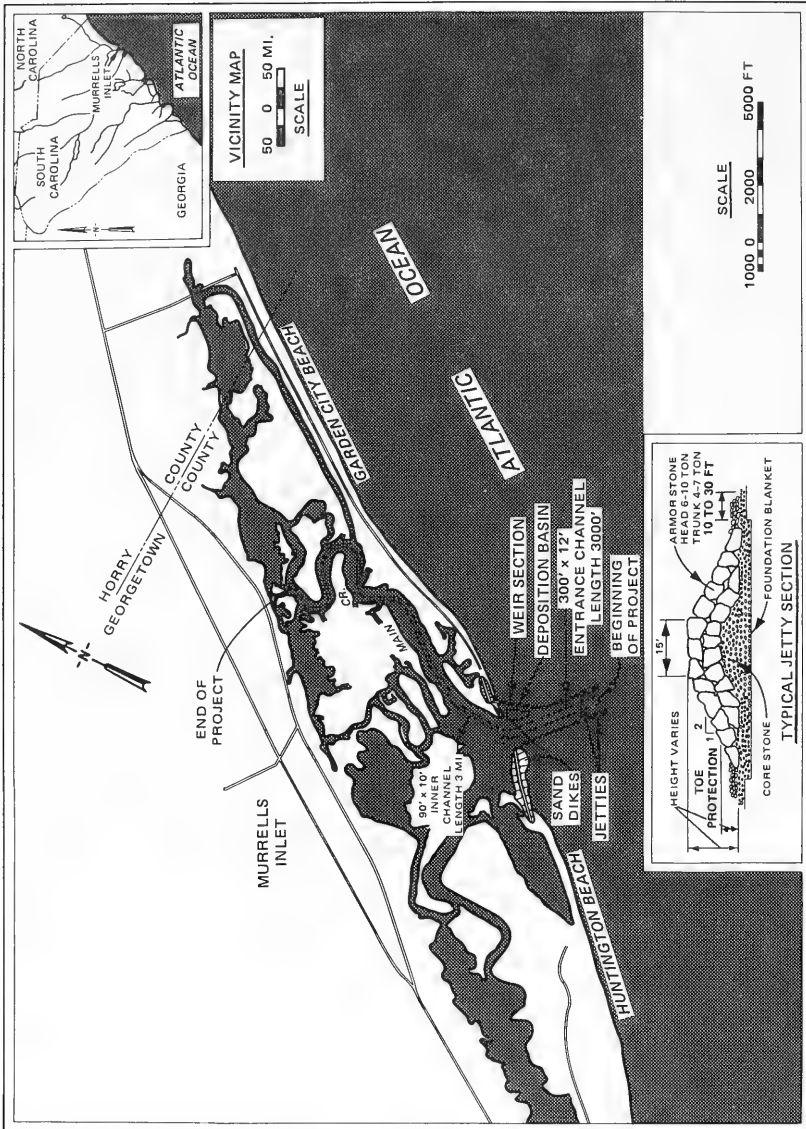

Figure 16. Murrells Inlet, South Carolina

Table 10
Georgetown Harbor Jetties
Georgetown, South Carolina, SAC

<u>Date(s)</u>	<u>Construction and Rehabilitation History</u>
1890- 1904	Two jetties (Figure 17) composed of stone on brush mattresses were constructed as part of a project to maintain a -15 ft mlw access channel. The north jetty was constructed to a length of 11,140 ft with a crest elevation of 4.5 to 6 ft mlw, except the outer 100 ft which was below mlw. The south jetty was constructed to a length of 21,050 ft with crest elevations ranging from +10 ft mlw at the root to mlw at the outer end. A 14,200-ft-long earthen dike was constructed to serve as a root for the south jetty and protection for South Island. The parallel ends of the jetties were approximately 4,800 ft apart.
1949- 1951	Crest elevations along the jetties were as much as 12 ft below original heights. Also at this time, the channel depth was increased to -27 ft mlw. Structural improvements, although considered, were not carried out since maintenance dredging was considered to be the most cost-effective means of providing the required channel depth.
1985	Periodic dredging maintains the channel depth through the jetties at -27 ft mlw. No repair or maintenance of the jetties has been undertaken since their construction.



Figure 17. Georgetown Harbor
jetties, South Carolina

Table 11
Charleston Harbor Jetties
Charleston, South Carolina, SAC

Date(s)	Construction and Rehabilitation History
1878- 1886	Rubble-mound jetties (Figure 18) with a shoreward submerged weir section and seaward raised section were constructed at Charleston Harbor to provide (in conjunction with dredging) for a navigation channel 21 ft mlw deep. The total lengths of the north and south jetties were 15,400 ft and 19,100 ft, respectively. The distance between the parallel seaward sections of the jetties was 2,900 ft. Shoreward portions of both jetties, each approximately 6,000 ft long, were built up to typical depths of -4 to -12 ft mlw (rising only a few feet above the bottom, with low sections as deep as 15 ft and 28 ft on the north and south jetties, respectively). The outer 7,200 ft of the north jetty was raised to an average of +7 to +8 ft mlw, the outer 9,200 ft of the south jetty was raised to an average of +10 ft mlw, and shoreward of this section an additional 2,400 ft was raised to +8 ft mlw. A typical section of the raised jetties consisted of a log and brush mattress foundation loaded with 30 to 60 tons of small stone weighing 10 to 250 lb. An additional narrow course of small stone was placed, and 1- to 7-ton granite blocks were placed as cover stone. Typical crest widths were 12 to 15 ft.
1935	Only minor dredging between the jetties has been required since the project depth was increased in 1917 to -30 ft mlw. Field survey showed very little deterioration to the submerged or raised portion of the jetties.
1966	Present channel depth of -35 ft mlw has been maintained since 1961. An inspection survey in August 1966 indicated a general subsidence of 1.5 to 3.5 ft along the raised portion of the jetties, with maximums of 5 and 6 ft over short sections of the north and south jetties, respectively.
1985	Present channel depth (-35 ft mlw) extends approximately 13,000 ft beyond the end of the jetties. There has been no history of maintenance or repair to the jetties since their completion.

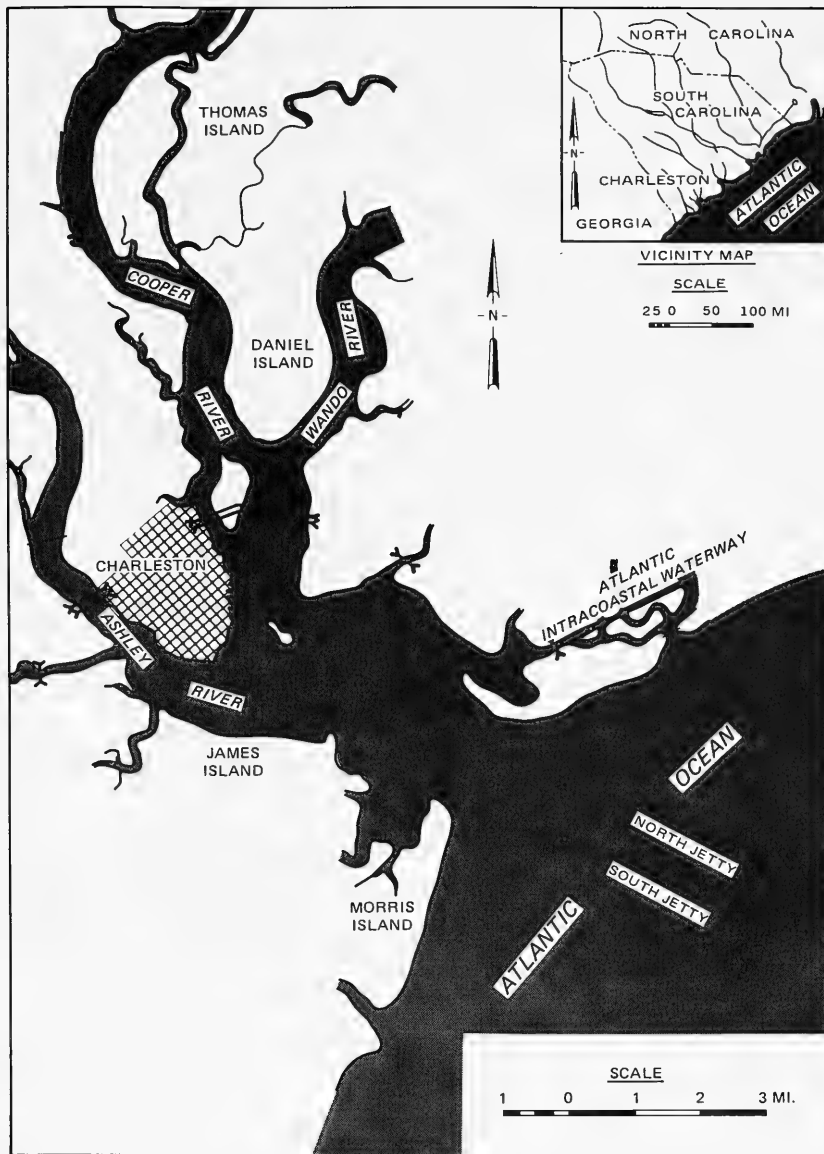

Figure 18. Charleston Harbor jetties, South Carolina

Table 12
Savannah Harbor Jetties
Savannah Harbor, Georgia, SAS

Date(s)	Construction and Rehabilitation History
1886	The River and Harbor Act of 5 August 1886 provided for two parallel training walls (hereafter referred to as jetties) at the mouth of the Savannah River (Figure 19).
1886- 1890	The Oyster Bed Jetty was constructed to a length of 12,000 ft with stone placed upon a timber and brush mat foundation.
1890- 1896	Cockspur Jetty was constructed to a length of 12,000 ft with stone placed upon a timber and brush mat foundation. By 1896 the channel had been dredged to the design depth of -19 ft mlw. The distance between the jetties was 2,500 ft.
1914	A survey of Oyster Bed Jetty showed crest elevations from +2 ft mlw nearshore to -2 ft mlw at 10,000 ft and from -4 to -8 ft mlw over the seaward 2,000 ft. Planned improvements called for raising the jetty to mean high water (mhw) by placing small stone over the existing stone with larger stone used as cover and design side slopes of 1V:1.25H.
1915- 1916	Part of Oyster Bed Jetty was raised to mhw.
1921	A survey of Cockspur Jetty showed the shoreward 2,000 ft at about +6 to +7 ft mlw, the next 9,000 ft from +3 to +5 ft mlw, and the seaward 1,000 ft from -4 to -8 ft mlw. A survey of Oyster Bed Jetty showed the first 6,000 ft of the jetty at +6 to +7 ft mlw. The outer unimproved portion of the jetty composed of small stone had subsided from 1 to 3 ft since the 1914 survey.
1923	The outer portion of Oyster Bed Jetty was raised to mhw. Design improvements consisted of a crest elevation of +6.8 ft mlw, crest width of 8 ft, and side slopes of 1V:1.25H. The cross section consisted of core stone with large cover stone (Figure 20). A post construction survey showed the seaward end of the jetty, with approximately 1V:1H side slopes, was the only section with side slopes exceeding the design value.
1926	During a survey of Oyster Bed Jetty, crest elevations varied from +5 to +7.5 ft mlw over the entire length.
1935	The Oyster Bed and Cockspur Jetties were surveyed. There were no major areas of damage and only negligible subsidence when compared to previous surveys of 1921 and 1926. Between the 1921 and 1935 surveys 500 ft of Cockspur Jetty, 500 ft from the original seaward

(Continued)

Table 12 (Concluded)

Date(s)	Construction and Rehabilitation History
1935 (Cont)	end, appeared to have been raised +3.5 to +4 ft mlw, from about -4 ft mlw. The jetty length at that time was considered to be 11,500 ft.
1962	A survey was taken of Oyster Bed and Cockspur Jetties. There were no major areas of damage. Except for the seaward end of the Cockspur Jetty, the outer 3,000 ft has subsided from 0.5 to 1 ft.
1985	Except for the improvements to the jetties mentioned previously, the jetties have no history of maintenance or repair. The jetties appear to be functioning properly by maintaining a navigable channel with minimal dredging. The present channel depth between the jetties is -38 ft mlw.

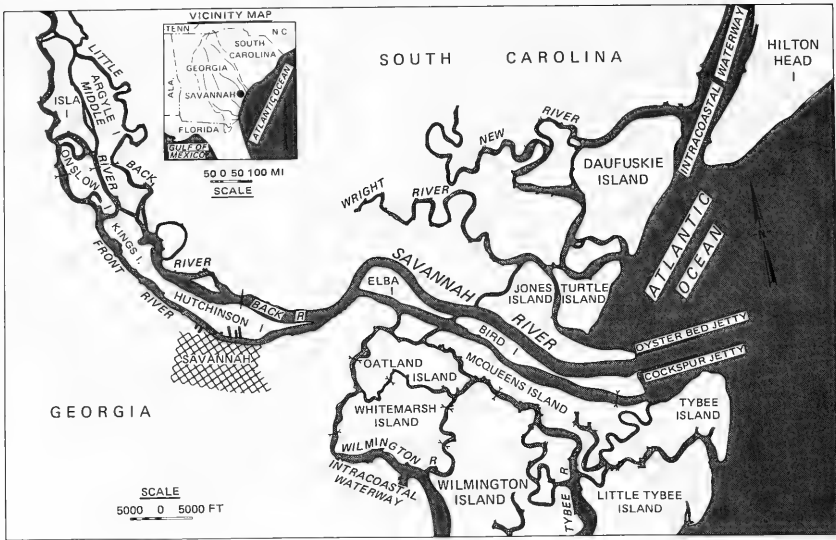

Figure 19. Savannah Harbor jetties, Georgia

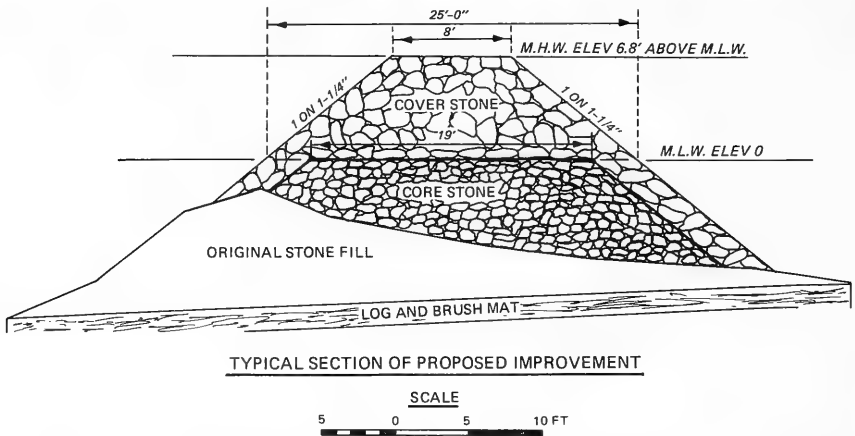

Figure 20. Design cross section, Oyster Bed (north) jetty, 1923

Table 13

Fernandina Harbor Jetties
Fernandina Harbor, Florida, SAJ

<u>Date(s)</u>	<u>Construction and Rehabilitation History</u>
1880- 1913	<p>As authorized in 1880, the north jetty was to be 18,000 ft long and the south jetty a little over 12,000 ft long. The crests were to be at the level of mean low tide, except the outer 3,300 ft of each, which was to be at midtide level. The River and Harbor Act of 1892 provided for a 19-ft-deep channel and fixed 3,900 ft as the width between the outer ends of the jetties. The north jetty was first to be raised to a height sufficient to retard effectively the sand movement southward. The south jetty was then to be raised and extended as necessary to secure the desired depth over the bar. The River and Harbor Act of 1896 provided for raising the jetties to mhw (+6 ft mlw).</p> <p>Jetty construction methods were in many respects similar to those used on other regional projects built during this time. The jetties were built using alternate layers of stone and log mattresses, as many as eight courses being used in some sections. Built initially at and below mean low water, the jetties were subsequently extended and raised (using rubble stone) over a period of several years. During construction, the south jetty had sections removed to allow the then existing channel (and shipping) to pass through it. The 1903 Annual Report to the Chief of Engineers stated that, except for a few low places where settlement had occurred or stones had been displaced by wave action, the north jetty was completed to the elevation of high water from the shore to 190+00 (approximately its present outer end). It stated that the inner slope between 20+00 and 106+77 had been reinforced with riprap, as the difference in head between the water inside and outside was so great that flow through the jetty caused dangerous scour at the base on each side. In 1903 the south jetty was completed to the elevation of high water for 7,500 ft of its length, to -5 ft mlw for the next 3,500 ft, and a 60-ft-wide apron was placed against the inner slope from sta 74+20 to 89+37. The jetties were completed to mhw in 1905, the north and south being 19,150 and 11,200 ft long, respectively (Figure 21). The seaward ends converged to a distance of 3,900 ft and were parallel over the final 1,500 ft of their lengths. After 1905 considerable repair work was done on the jetties to raise subsided sections and replace stone carried away by storms. These repairs were made from time to time up to 1913.</p>
1926- 1927	<p>Work under contract to repair both jetties began in February and was completed 1 year later. This repair resulted in raising the north jetty to +7 ft mlw and the south jetty to +6 ft mlw. In each case, the crest width was 8 ft.</p>

(Continued)

Table 13 (Concluded)

Date(s)	Construction and Rehabilitation History
1937	A survey in May showed crest heights of +2.5 to +8.5 ft mlw and +2.0 to +9.0 ft mlw for the north and south jetties, respectively.
1945	A survey of the south jetty in December showed crest heights from +1.5 to +9.0 ft mlw.
1985- 1987	At present, a 40-ft-deep by 400-ft-wide channel between the jetties is maintained by the Navy (the Federal project depth is 32 ft). A contract has been awarded to sand-tighten the landward 1,500 ft of the south jetty. (As of 17 Aug 87 the job had not been completed.) Plans call for removal of the existing jetty to -5 ft mlw, placing an impermeable core of precast concrete sections (inverted Y-shape), and rebuilding to a crown elevation of +9 ft mlw using 8-ton (maximum) armor stone.

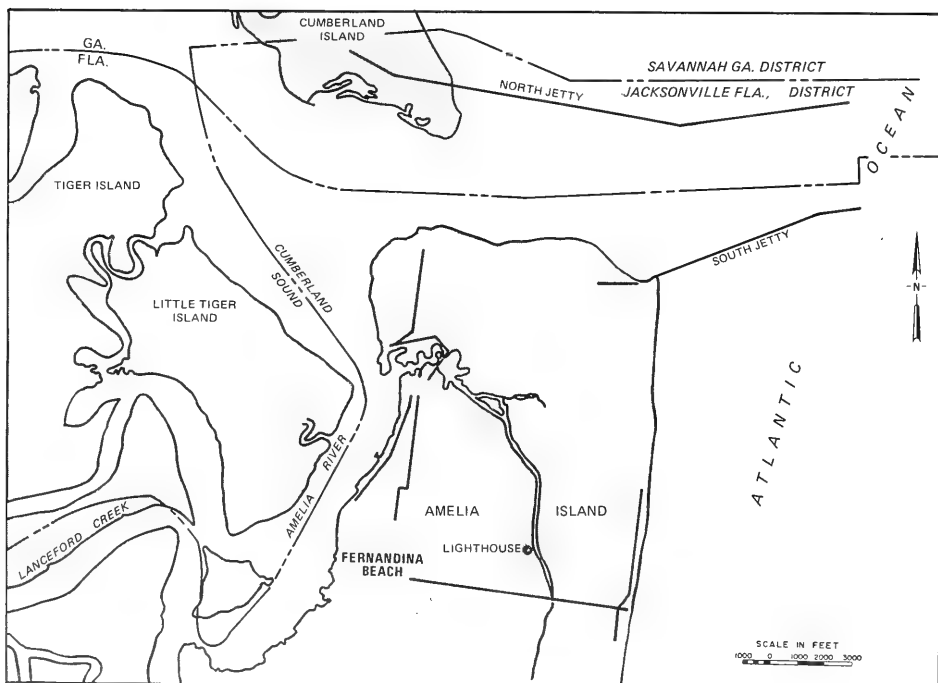

Figure 21. Fernandina Harbor jetties, Florida

Table 14

Jacksonville Harbor Jetties
Jacksonville, Florida, SAJ

<u>Date(s)</u>	<u>Construction and Rehabilitation History</u>
1879- 1895	<p>The original design consisted of two jetties, a 9,400-ft-long north jetty, and a 6,800-ft-long south jetty, which were to converge at their outer ends to a distance of about 1,600 to 1,800 ft (Figure 22, present location map). The outer 2,000 ft of the jetties would have a crest elevation at midtide level, and the inner portions would be at -3 ft mlw. The purpose of the jetties was to maintain a 15-ft-deep channel via the natural scour action that was expected to occur once the jetties were completed. The principal method of construction was placement of one to several courses (layers) of log and brush mattress (Figure 23a). Each layer was sunk and weighted down by placing a 12- to 15-in-thick layer of riprap stone. Once a firm foundation of mattresses was created, the remainder of the section geometry was built up with larger sized riprap stone. This method of construction was used at several other locations on the east coast during the late-1800's and early 1900's. The underlying concept of the method was that a supporting layer of material was required prior to stone placement since it was expected that direct placement of stone would sink into the "soft" bottom. Thus, without a supporting mattress, large amounts of stone would be required to provide a solid base. Many problems were encountered with this method, principally because of the methods of early construction, the dynamics of the natural bottom (scour and deposition), and destruction of the mattresses by the teredo (a wood-boring marine mollusk). The north jetty was completed in 1892 to a length of 10,930 ft at a total cost of \$411,000. In 1893 the south jetty was extended 2,900 ft, to a total length of 11,300 ft, using 15,900 tons of 1- to 6-ton stone and 123,000 tons of 15- to 400-lb stone. The south jetty was completed in 1895 at a total cost of \$993,000. Although there were no in situ section geometry details found for either jetty, it appears that both had been built up to approximately mlw.</p>
1897- 1928	<p>During this period both jetties were raised above mhw (+4.9 ft), numerous repairs were made to the jetties, the north jetty was extended seaward 2,070 ft, and the channel depth was increased to -30 ft mlw. The method of jetty construction by this time was to place the stone directly on the natural bottom with the smaller stone placed at the bottom and the larger stone placed above mlw. The size of the largest armor stone used increased during this time from a typical size of 4 to 7 tons. Figure 23b shows a cross section of the north jetty taken shortly after work was completed during 1923. This design section consisted of a 10-ft-wide crest at</p>

(Continued)

(Sheet 1 of 4)

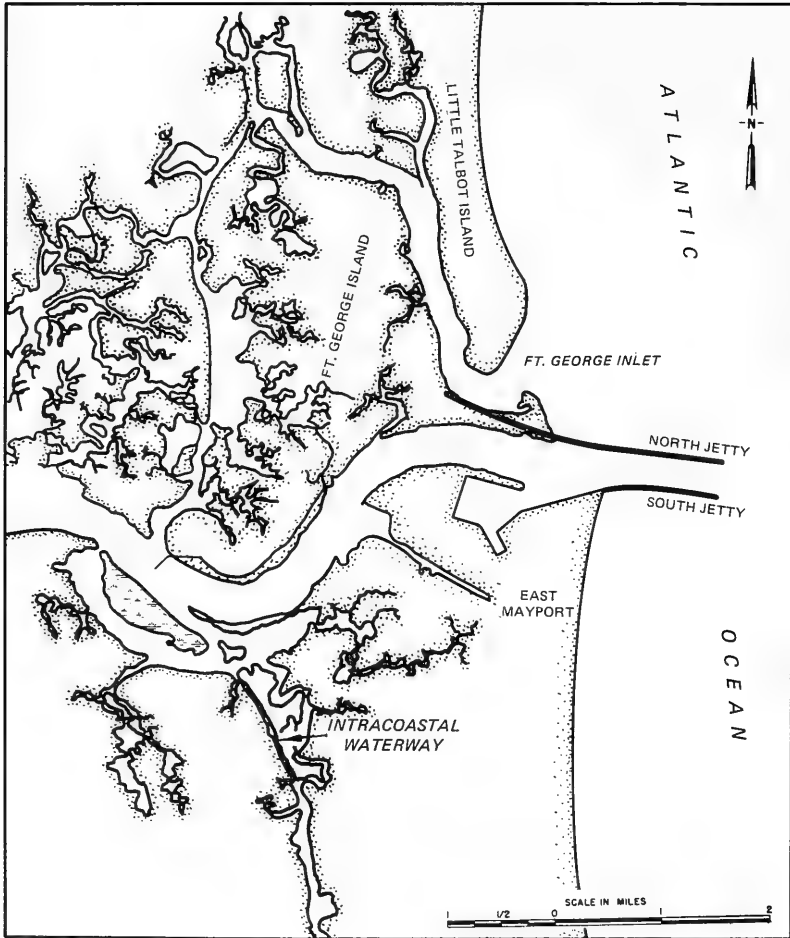
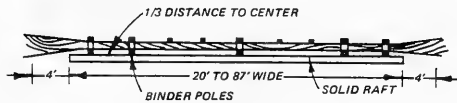
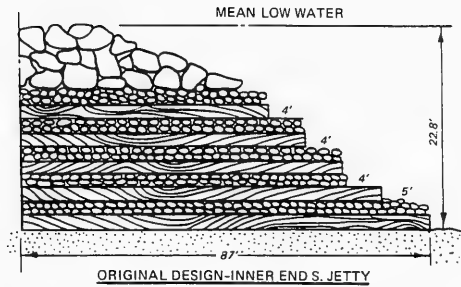

Figure 22. Jacksonville Harbor jetties, Florida



LOG AND BRUSH MATTRESS.
NOT TO SCALE

LOGS 11" TO 14" DIAM LARGE END.
BRUSH 6" TO 8" COMPRESSED.
BINDERS 6" TO 8" DIAM SPIKED.
BRUSH BINDERS 2" TO 3" DIAM TIED.
COVERED WITH 12" TO 15" STONE.

a. Pre-1900's log and brush mattress

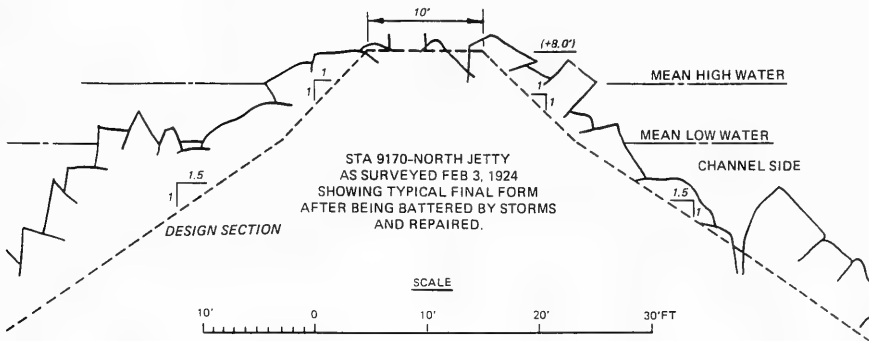

b. North jetty, 1923

Figure 23. Early jetty cross sections, Jacksonville

Table 14 (Continued)

Date(s)	Construction and Rehabilitation History
1897- 1928 (Cont)	+8 ft mlw and side slopes of 1V:1H and 1V:1.5H above and below mlw, respectively (50 percent of stone was to be greater than 7 tons). Cumulative stone quantities placed during this time were about 340,000 tons on the north jetty and 116,500 tons on the south jetty. Costs since 1895 for new work and maintenance were \$1,369,000 and \$1,501,000 for the north and south jetties, respectively.
1929	A centerline survey of the jetties showed that nearly the entire north jetty and the outer 7,000 ft of the south jetty had an approximate crest elevation of +8 ft mlw. The crest elevation of the inner 4,000 ft of the south jetty varied from 0 to +7 ft mlw. The outer ends of the jetties converged to a distance of 1,600 ft then ran parallel to each other for a distance of 4,000 ft. The water depth at the seaward toes was approximately -20 ft mlw.
1930	Repairs were made between sta 62+80 and 114+00 of the north jetty with 29,700 tons of granite stone (Figure 24). Nine gaps with an average height of +4 to +5 ft mlw were raised to +8 ft mlw. The crest elevations on the outer 500 ft of the jetty were from -5 to -15 ft mlw. The south jetty was repaired between sta 40+00 and 80+90 with 26,600 tons of granite (Figure 25). Twenty major gaps with average heights of +3 to +5 ft mlw were raised to +8 ft mlw. The crest elevations on the outer 700 ft of the jetty were from +3 to -10 ft mlw. The stone size was from 4 to 10 tons with an average size of 6 to 8 tons. The crown width was 10 ft, and the side slopes were 1V:1H. Cost of the repairs totaled \$228,000.
1931- 1932	Voids below +4 ft mlw on the ocean side of the south jetty were filled with 25- to 100-lb granite stone to stop the flow of sand through the structure, and 3,450 tons of stone were placed between sta 36+50 and 54+00 (Figure 25). A 110-ft-long groin (crest elevation +7 ft mlw) constructed of 550 tons of stone was placed at sta 44+56 on the ocean side of the south jetty to stop the flow of water along the jetty. Later, a head section on the groin was constructed using 245 tons of granite and 50 cu yd of oyster shell. Total cost of the groin was \$15,300. The seaward ends of the jetties were repaired (Figure 24), the north between sta 114+00 and 128+60 and the south between sta 88+00 and 106+30. Storm waves had, over time, lowered both jetties and created gaps, necessitating the repairs. Gaps (low points) on the jetties ranged from +3 to +4 ft mlw. The outer 500 ft of the north jetty ranged from -5 to -20 ft mlw, and the outer 700 ft of the south jetty ranged from +3 to -12 ft mlw. The armor stone ranged from 8 to 14 tons, and the design section consisted of a 10-ft crest width at +8 ft mlw and 1V:1H side slopes.

(Continued)

(Sheet 2 of 4)

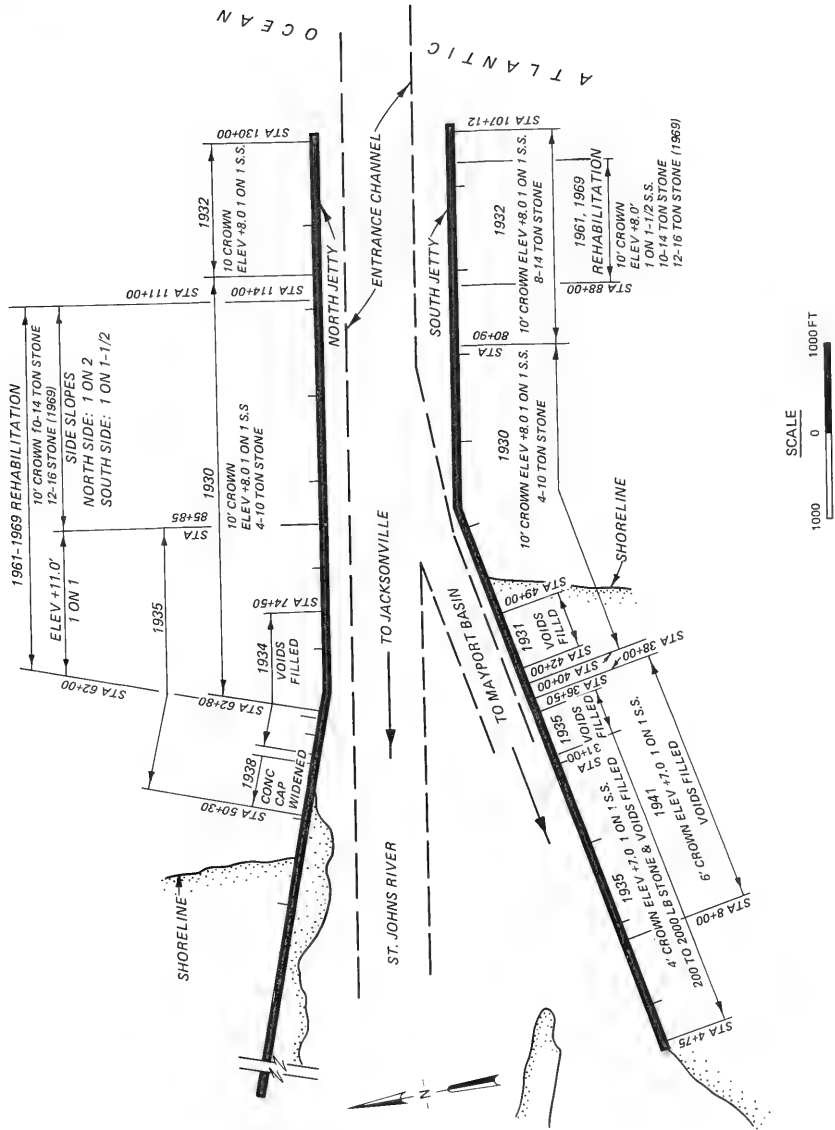

Figure 24. Plan view of cumulative repairs to Jacksonville jetties from 1930 to 1969

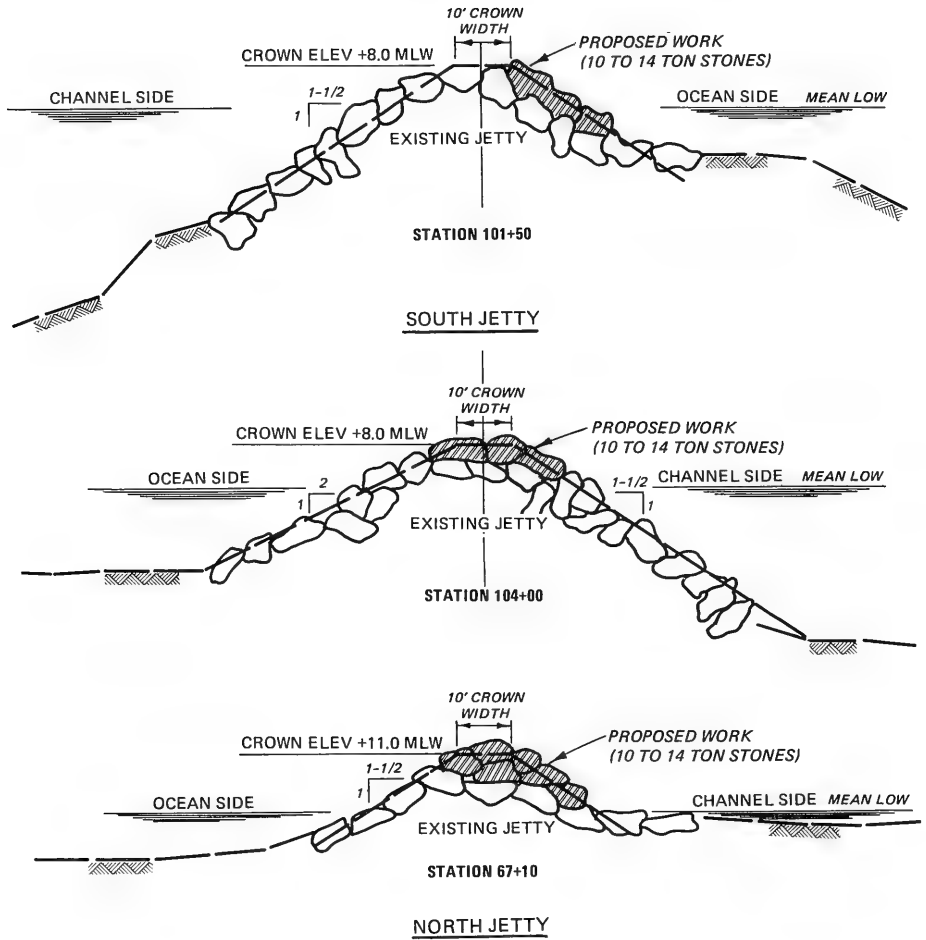

Figure 25. Typical 1961 repairs to Jacksonville jetties

Table 14 (Continued)

Date(s)	Construction and Rehabilitation History
1931- 1932 (Cont)	49,500 and 51,200 tons of stone were placed on the north and south jetties, respectively. The cost of the seaward repairs totaled \$376,000.
1934	Voids on the ocean side of the north jetty were filled with 25- to 100-lb of granite stone to arrest the flow of sand through the structure, and 4,800 tons of stone were placed between sta 57+50 and 74+50 at a cost of \$21,300 (Figure 24). A monolithic concrete cap ranging in width from 2 to 8 ft was constructed along the centerline of the north jetty between sta 50+30 and 85+85. The crown elevation ranged between +11 and +13 ft mlw. A total of 3,780 cu yd of concrete was placed on the structure at a cost of \$58,000 (Figure 24).
1935	Elevations on the north jetty varied from +6 to +14 ft mlw and on the south jetty varied from 0 to +14 ft mlw. Repairs were made to the inner portion of the south jetty, filling void spaces from sta -4+75 to 31+00 using 200 to 2,000-lb stone. From sta 31+00 to 36+50 the voids were filled between 0.0 and 4.0 ft mlw with smaller stone (less than 200 lb). This section was repaired using a 4-ft-crown width at an elevation of +7 ft mlw and 1V:1H side slopes (Figure 24).
1938	The north jetty concrete cap was widened from the existing 2-ft section to a width of 6 ft between sta 50+30 and 56+60 (Figure 24).
1940- 1941	Repairs were made to the south jetty between sta 8+00 and 38+00 (Figure 24). Granite stone of 1 to 3 tons and 3 to 6 tons was placed on the inner 1,200 ft and outer 1,800 ft, respectively. Void filling stone of 50 to 150 lb was placed throughout the repair section. The design called for a 6-ft crown width at +7 ft mlw with 1V:1H side slopes. Sand overlying the jetty was to be removed before stone placement. Small stone was removed between 33+00 and 38+00 as required to allow placing of the cover stone to the design section with the removed stone subsequently used to fill voids. 21,800 tons of 1- to 6-ton stone and 4,800 tons of 50- to 150-lb stone were placed at a cost \$105,000.
1961	Rehabilitation made to the seaward end of the south jetty between sta 88+00 and 102+70 and the north jetty between sta 62+00 and 11+100 (Figure 24). Areas of deterioration from settlement and dislodgement of stone had occurred at the ocean ends and along landward portions of both jetties. Also, several portions of the north jetty concrete cap had been broken and displaced from the crown along with some of the underlying support stone. The major causes of settlement seemed to be slope flattening and the possibility of wave

(Continued)

(Sheet 3 of 4)

Table 14 (Concluded)

Date(s)	Construction and Rehabilitation History
1961 (Cont)	<p>action causing increased consolidation. Repairs were made to bring the structure back up to previous designs but with larger stone. The design called for 10- to 14-ton granite stone and a crown width of 10 ft for all repair sections (Figure 25). On the concrete cap section of the north jetty, between 62+00 and 85+88, the crown elevation was to be +11 ft mlw, and the side slopes were 1V:1.5H. The remainder of the jetty repairs were to have a +8 ft mlw crown elevation and 1V:1.5H side slopes (with the exception of the north jetty ocean-side slope which was 1V:2H). The design was based on a 14- to 15-ft wave height and Hudson's stability equation. Cost of the rehabilitation with 5,500 tons of stone was \$54,600.</p>
1969	<p>Rehabilitation of jetties was carried out on approximately the same section as the 1961 repairs (Figure 25). Except for the use of 12- to 16-ton stone, the design sections were identical to those of 1961. The north jetty from sta 50+45 to 85+80 was built up to +11 ft mlw with 1V:1.5H side slopes and from sta 85+80 to 122+80 was built up to +8 ft mlw with 1V:2H and 1V:1.5H side slopes on the ocean and channel sides, respectively. The south jetty from sta 85+90 to 103+20 was built up to +8 ft mlw with 1V:1.5H side slopes. The crown width on all sections was 10 ft. Dislocation and consolidation of cover stone overlying smaller stone (below mlw) was thought to be the cause of jetty deterioration. The low areas to be repaired were wide which provided a good base to place new stone. Wave heights of 14 and 15 ft and Hudson's stability equation were used, similar to those in the 1961 design. A total of 21,500 tons of stone was placed at a cost of \$398,000. Inner areas of the jetties were not rehabilitated although in need of some repairs.</p>
1985	<p>The jetties are presently in need of another rehabilitation to bring them up to previous designs. The Navy maintains a 42-ft-deep channel between the jetties (Federal project depth is 38 ft) to provide deep-water access to its base at Mayport.</p>

Table 15

St. Augustine Harbor North Groin and South JettySt. Augustine Harbor, Florida, SAJ

<u>Date(s)</u>	<u>Construction and Rehabilitation History</u>
1941	During 1941 a sand-tight terminal groin of timber wall, native stone, and granite was constructed to a length of 1,580 ft, and 450 lin ft of cresote-treated timber was placed at its shoreward end (Figure 26). The groin (Figure 27) side slopes were 1V:1.5H. Crown widths varied from 6 to 12 ft, and the crown elevation varied from +10 to +6 ft mlw at the shoreward and seaward ends, respectively. A 2-ft-thick mat foundation was placed using 8,000 tons of native stone, and 13,300 tons of mostly 5- to 10-ton stone was used to complete the groin. (The largest stone was to be placed at the seaward end.) The cost of the structure was \$305,000.
1942	Granite stone, weighing 600 tons, was placed on the south side of the north groin at an exposed section of core wall. This placement was necessary since sand had been accreting on the north side and eroding on the south side to the point that the highwater line was 150 ft west of the structure. Cost of the repair was \$4,200.
1943	Repairs were made to 350 ft of the existing north groin, and a 300-ft shoreward extension was completed using 20- to 100-lb core stone and 300- to 1,000-lb cap stone to guard against flanking of the structure by the continued recession of the shoreline south of the groin. The repairs cost \$54,600.
1949	The seaward 100 ft of north groin had gradually subsided below mhw (+4.5 ft).
1956- 1957	A 2,825-ft-long sand-tight south jetty was constructed (Figure 28) approximately 2,400 ft south of the existing north groin, providing protection for a 16-ft-deep channel. The sand-tight section (landward 1,800 ft) was constructed to +10 ft mlw with a 10-ft crown width and 1V:1.5H side slopes. The cover stone was 2 to 8 tons with a core of 200-lb maximum stone placed on a 2.5-ft-thick foundation blanket (the entire length of the jetty) of 1- to 12-in. pieces. Seaward of this section the crown width was 12 ft, the crest elevation was +6 ft (via 300-ft transition), and the side slopes were 1V:1.5H. The core stone was 200 to 4,000 lb, and the cover stone consisted to 6- to 10-ton stone. The outermost 350 ft of the structure had side slopes of 1V:2H and used 10-ton minimum cover stone. The channel side of the jetty was protected by a 3-ft-thick apron, 40 ft wide consisting of a 1-ft-thick filter bed of 1- to 12-in. stone, overlaid with 75- to 1,500-lb riprap stone. The total cost of the jetty plus a shoreward revetment section was \$967,000.

(Continued)

Table 15 (Concluded)

Date(s)	Construction and Rehabilitation History
1985	No repair work has been done since construction of the south jetty (or since 1943 for the north groin). Although no detailed surveys of the jetties (considering the north "groin" as a jetty) have been made, they are functioning properly and appear to be in good condition.

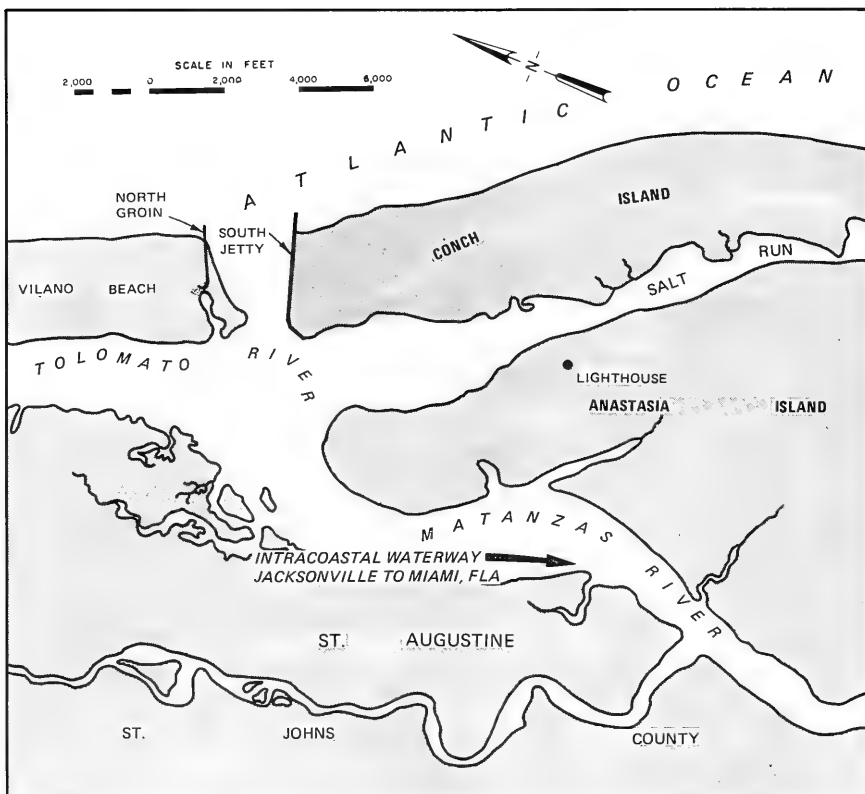
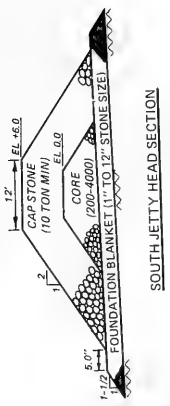
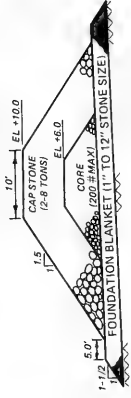

Figure 26. St. Augustine Harbor, Florida



SOUTH JETTY HEAD SECTION



SOUTH JETTY TYPICAL TRUNK SECTION

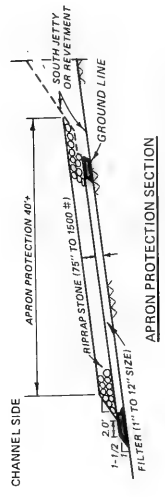

APRON PROTECTION SECTION

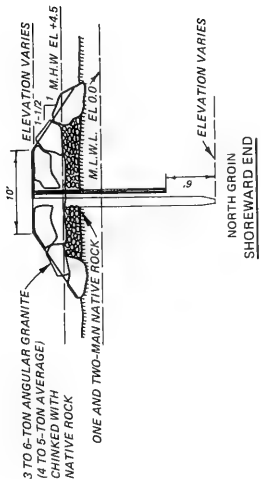

NORTH GROIN SHOREWARD END

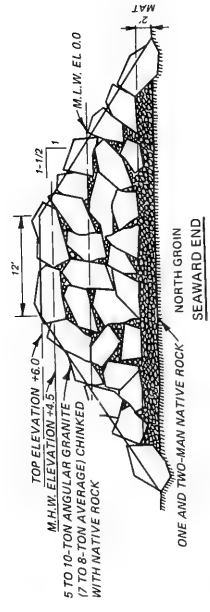

NORTH GROIN SEAWARD END

Figure 28. St. Augustine south jetty, typical sections

Figure 27. St. Augustine north groin, typical sections

Table 16

Ponce de Leon Inlet Jetties
Ponce de Leon Inlet, Florida, SAJ

Date(s)	Construction and Rehabilitation History
1968- 1972	<p>Rubble-mound jetties (Figure 29) were constructed to provide safe passage via a 15-ft-deep by 200-ft-wide dredged channel. The north jetty, as originally constructed, consisted of a landward concrete sheet-pile section 500 ft long, a 1,800-ft weir section consisting of horizontal precast concrete beams placed between king piles, and a 1,800-ft-long seaward rubble-mound section. The top elevation of the sheet-pile section consisted of 235 ft at +10 ft mlw, and 265 ft from +10 to +4 ft, mlw. The weir section consisted of 300 ft at +4 ft mlw and 1,500 ft at mlw. If needed, the elevation of the weir section could be changed by addition or removal of the horizontal beams. The rubble-mound section (Figure 29) was built to +7 ft mlw with a 10-ft crest width and 1V:1.5H side slopes for 650 ft and 1V:3H side slopes on the seaward 1,150 ft. The cross section consisted of a 2-ft foundation blanket (1- to 12-in. stone), 500- to 2,500-lb core stone, and one layer of 8- to 12-ton capstone (with 12-ton minimum on the outermost 50 ft of the structure). The south jetty was a curved rubble-mound structure 4,080 ft long. The crest elevation and width were +7 ft mlw and 10 ft, respectively, with 1V:1.5H side slopes on the inner 3,500 ft and 1V:3H on the outer 580 ft. A 2-ft-thick foundation blanket of 1- to 12-in. stone was placed along the length of the south jetty with similar size stone used as a core on the inner 2,215 ft (Figure 28) and covered with 1,000- to 2,000-lb capstone. An intermediate section, 235 ft long, consisted of 500 to 2,500 core stone and 1,000- to 2,000-lb capstone. The seaward section of the jetty consisted of 500- to 2,500-lb core stone and 8- to 12-ton capstone (with 12-ton minimum on the outermost 50 ft of the structure). The landward side of the south jetty (inner 3,200 ft) had a filter layer placed in the capstone voids prior to backfilling of dredged material. In selecting the capstone, design wave heights of 16 and 11 ft were used on seaward and landward sections, respectively, in conjunction with Hudson's equation. In 1972 the weir section was supplemented with a rubble-mound section which was added because of concern for the wave climate that the weir could receive over its design lifetime. The design section consisted of a 2-ft-thick foundation blanket (1- to 12-in. stone) with 500- to 2,500-lb core and capstone placed to +1 ft mlw, a 10-ft crest width, and 1V:2H side slopes. Total cost of the jetties was \$2,145,000.</p>
1978	<p>A blanket of armor stone was placed at the base of the north jetty along the seaward 2,550 ft. A total of 23,100 tons of up to 700-lb riprap stone and 9,100 tons of 500-lb to 3-ton stone (75 percent greater than 1 ton) was placed. The cost of the repair was \$1,453,000.</p>

(Continued)

Table 16 (Concluded)

Date(s)	Construction and Rehabilitation History
1981	Erosion at the root of the north jetty required placing stone over a 375-ft section of the existing jetty beginning 125 ft from landward end. The repair cross section consisted of a 1.5-ft layer of 1- to 50-lb bedding stone, a core of 30- to 1,000-lb stone, and 0.5- to 2-ton capstone. Side slopes were 1V:2H with a 5-ft crest width and crest elevations varying from +9 to +12 ft mlw. Additionally, 1,150 tons of bedding stone, 1,970 tons of capstone, and rearrangement of stockpiled core stone were used in the repair.
1982- 1983	The north jetty weir section was closed using core and armor stone (no details). Armor stone size and cross-section geometry were similar to those for the existing rubble-mound section at the seaward end of the weir section.
1985	The jetties are presently in good condition except for some damage on the north jetty head because of a recent storm and continued erosion at the root of the jetty.

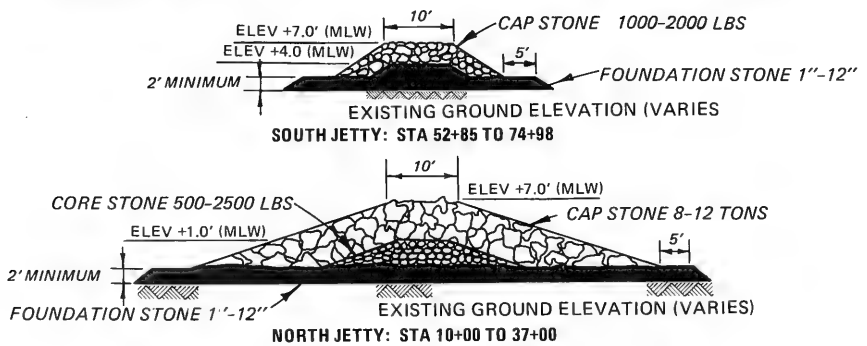
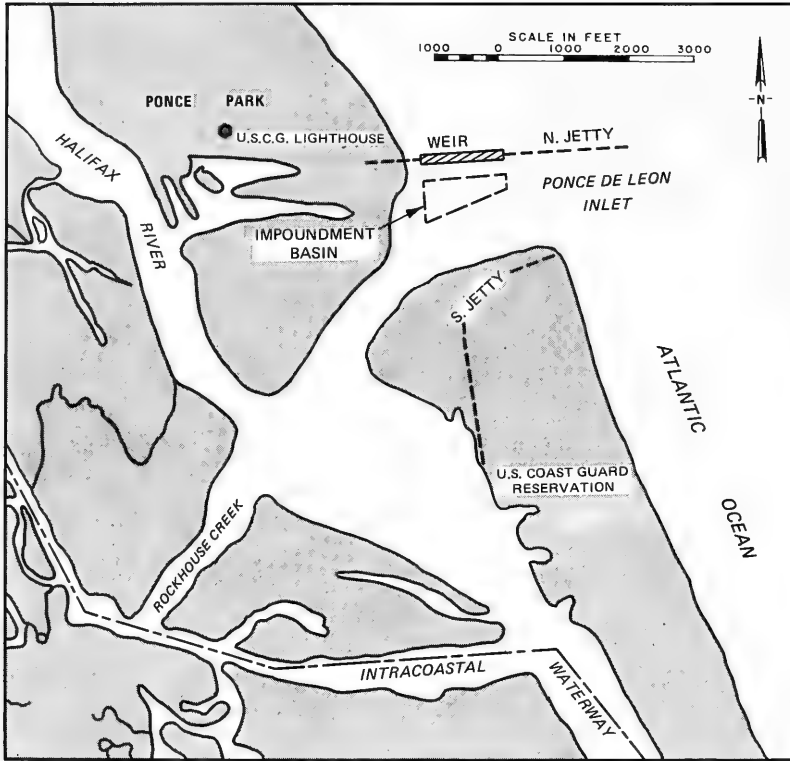

Figure 29. Ponce de Leon Inlet, Florida

Table 17

Canaveral Harbor Jetties
Canaveral Harbor, Florida, SAJ

<u>Date(s)</u>	<u>Construction and Rehabilitation History</u>
1953- 1954	Two rubble-mound jetties, each 1,150 ft long, were constructed to provide channel protection (Figure 30). The south jetty was originally built in 1953 to a length of 850 ft and extended 300 ft in 1954. A 2-1/2-ft foundation blanket of material ranging from sand to 125-lb stone was placed as a base for each jetty. Core stone ranged from 200 to 4,000 lb and was placed to an elevation of -1 ft mlw. Capstone ranged from 2 to 8 tons at the shoreward ends to 10+ tons at the seaward ends. Crest elevations ranged from 6 to 8 ft above mlw, and the crest width was 12 ft. Side slopes were 1V:1.5H over the inner 1,100 ft of the south jetty and the inner 800 ft of the north jetty and 1V:2H over the next 300 ft of the north jetty. The remaining 50-ft sections had transition side slopes to 1V:2.5H, this being the side slope of the semicircular head sections. The jetty design was based on Irribarren's equation using 9- and 12-ft wave heights. The estimated cost of the jetties was \$631,000.
1957- 1958	Revetment was placed at the shoreward ends of the jetties. Splash aprons were placed on the channel side of the jetties to prevent scour from wave overtopping (no details).
1985	The jetties have not been repaired since construction and are in good condition. The Federal project calls for a 37-ft-deep channel, but the Navy presently maintains a 44- by 400-ft channel between the jetties.

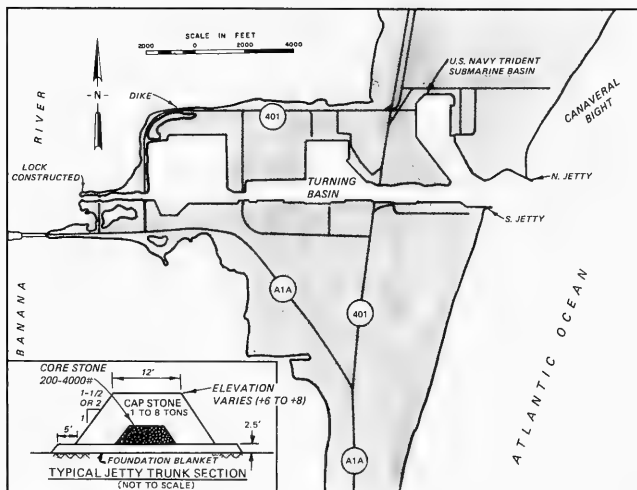

Figure 30. Canaveral Harbor, Florida

Table 18

Fort Pierce Harbor JettiesFort Pierce, Florida, SAJ

Date(s)	Construction and Rehabilitation History
1922- 1929	Local interests constructed parallel jetties, each 400 ft long and spaced 600 ft apart, to protect a dredged channel 5 ft deep by 90 ft wide. About 1925, seas eroded the north beach and flanked the north jetty, leaving it 200 to 300 ft offshore. In 1926 local interests started construction of another jetty 400 ft north of, and parallel to, the south jetty. At the completion of these improvements in 1929, the north and south jetties were 2,300 ft and 1,600 ft, respectively (Figure 31), and the channel between the jetties was 240 ft wide and had a controlling depth of 20 ft. The structures were constructed of native coquina stone with 1V:1H side slopes below, and 2V:1H slopes above -7 ft mlw.
1931	The district engineer report states that the jetties had settled and that wave action had created numerous gaps.
1933- 1934	The jetties, at that time under Corps jurisdiction, were repaired using 4- to 10-ton granite stone (Figure 31, inset). Prior to the repairs the existing side slopes were irregular but approximately 1V:2H, and the alignment of each jetty was irregular. These irregularities were corrected during the repairs. The existing crown elevation of the jetties ranged from mlw to +6 ft mlw. On the north jetty and outer 400 ft of the south jetty, old stone above -1 ft mlw was removed and placed below this elevation. New stone was placed along both jetties to a crown elevation of +6 ft mlw, a 10-ft crown width, and 1V:2H side slopes. In addition, the south jetty was extended 420 ft, the crown elevation on the inner 320 ft sloped from +6 ft mlw to -5 ft mlw, and the outer 100 ft consisted of a 3-ft-thick by 40-ft-wide stone apron. The estimated quantities of old rehandled stone and new stone were 7,500 cu yd and 38,000 tons, respectively. The water depth at the end of the jetties was approximately -10 ft mlw. The cost of the repair work was \$246,000.
1949	The annual report of the Chief of Engineers states, "both jetties are in good condition."
1985	Presently a 350-ft-wide by 27-ft-deep channel is maintained, running adjacent to the south jetty. The jetties have not been repaired since 1934 and are considered to be in good condition.

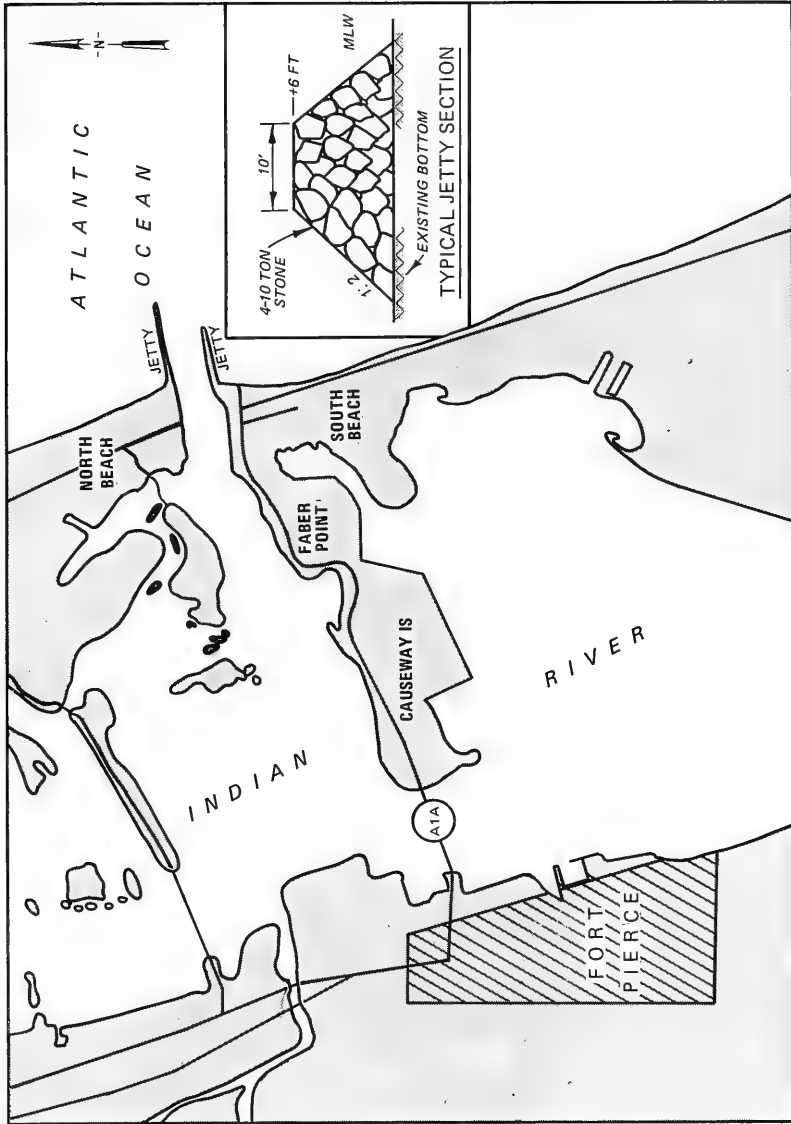

Figure 31. Fort Pierce Harbor, Florida

Table 19

St. Lucie Inlet Jetties and Detached Breakwater

St. Lucie Inlet, Florida, SAJ

Date(s)	Construction and Rehabilitation History
1926- 1929	Local interests constructed the north jetty out of coquina rock to a length of 3,325 ft. The maximum dimension of the rock was 6 to 7 ft with a density of about 120 pcf. The offshore 100- to 200-ft portion of the jetty was partly covered with granite blocks. At the same time, a channel 18 ft deep and 150 ft wide was dredged through the inlet. St. Lucie Inlet was created in 1892 by local residents desiring a connecting channel between the Indian River and the Atlantic Ocean.
1979- 1980	This Federal project (Figure 32) consisted of extension of the north jetty 650 ft (350 ft south-southeasterly and then 300 ft south-easterly), construction of a 1,600-ft south jetty with fishing walkway and a connecting rock bulkhead, and construction of a 400-ft detached breakwater directly south of the north jetty extension (700 ft apart at their outer ends). Capstone was to be 6 to 10 tons (at least 75 percent to be 8 tons or more), except on the outer ends of the jetties and the detached breakwater, where the capstone would weigh 10 to 12 tons. Estimated quantities for completion of the improvements were 64,800 tons of capstone, 8,000 tons of core stone, and 28,600 tons of foundation stone. The fishing walkway was built using asphaltic concrete cap and grouting mixes. During construction there was a severe problem with scour, and large apron blankets had to be added (no details on apron or jetty cross sections).
1985	Although structurally sound, it is functionally unsatisfactory (i.e. maintaining the required channel depth), and a major rehabilitation is in the planning states.

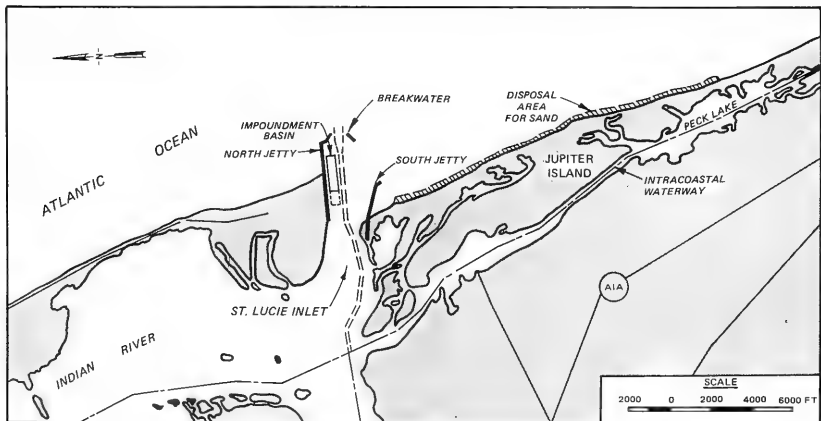

Figure 32. St. Lucie Inlet, Florida

Table 20

Palm Beach JettiesPalm Beach Harbor, Florida, SAJ

<u>Date(s)</u>	<u>Construction and Rehabilitation History</u>
1920	Local interests constructed two parallel jetties, 600 ft apart, providing for a 16-ft-deep channel entrance. The jetties were constructed of coquina rock and limestone.
1925- 1926	Local interests constructed two new granite stone jetties (Figure 33) 800 ft apart (north jetty constructed along its original alignment). The lengths were 1,700 and 2,150 ft for the north and south jetties, respectively. The design cross section consisted of a 10-ft crest width at +5 ft mlw and side slopes of 1.5V:1H.
1934- 1938	Lake Worth inlet became a Federal project in March 1934. A report of May 1935 stated that the jetties were in poor condition and that revetments were needed. Restoration of the jetties and construction of connecting revetments were accomplished from October 1936 to June 1938. The major features consisted of (a) the placing of new 8- to 10-ton granite stone and resetting of existing stone to elevations of +1 ft mlw (trunk crest width of 30 ft) and +7 ft mlw (head crest width of 10 to 20 ft) with 1V:2H side slopes, and (b) the placing of a solid concrete cap on the trunks above +1 ft mlw with side slopes of 1.5V:1H. The shoreward 850 ft of the 950-ft-long north jetty was capped to an elevation of +8 ft mlw with a top width of 6 ft, and the seaward 100 ft had void spaces filled with asphaltic concrete above -3 ft mlw. The shoreward 1,790 ft of the 1,890-ft-long south jetty was capped similarly, except that the seaward half had a crest elevation of +7 ft mlw and crest width of 9 ft. For comparison purposes, asphaltic concrete was not placed on the 100-ft head section. The jetties were placed on existing grade without a core of smaller stone. The total cost of the project was \$333,000. Shortly after completion of the north jetty/revetment areas, heavy seas caused loss of stone and deterioration of the revetment section immediately adjacent to shoreward end of the concrete cap. During this period the project depth was increased to 20 ft.
1945	A 40-ft section of the concrete cap on the south jetty approximately 420 ft from the shoreward end had settled about 4 in., had longitudinal cracks, and was acting as a beam. These occurrences were brought on by tidal scour through, and settlement of, the underlying armor stone. The cause of the problem was thought to result from the lack of additional armor stone placed in this and adjacent sections of the old jetty during the 1934-38 rehabilitation. The north jetty was in good condition, and its only problem was its ineffectiveness as a barrier to tidally-induced sand motion under the structure. This problem was evidenced in the original jetties and

(Continued)

(Sheet 1 of 3)

Table 20 (Continued)

Date(s)	Construction and Rehabilitation History
1945 (Cont)	was one reason for the 1934-38 rehabilitation. Examination of the jetty heads showed that the north jetty, with its asphaltic concrete, was in good condition but that the south jetty, without the asphaltic concrete, had deteriorated and needed 1,000 to 1,500 tons of 8- to 10-ton stone to restore the original design.
1948- 1949	The south jetty was inspected and surveyed. The outer 500 ft of the cap had settled 1 to 6 in. because of displacement of the underlying armor stone (occurred during the hurricane of 11-19 September 1947). On the landward half of the cap were a number of holes resulting from serious loss of armor stone from wave action. Near the shoreward end of the cap, a 40-ft section was cracked badly. By this time, the nonasphalted head of the jetty had largely disappeared. There was also some deterioration along a 170-ft section at the jetty cap revetment interface. Undermining of stone because of wave action and currents (scouring) was felt to be the major cause of deterioration. The channel was deepened to -27 ft mlw.
1950	In January 1950 repairs to the north jetty consisted of (a) placing a filter blanket of 1/4- to 6-in. stone along 200 ft of its shore-side landward junction (to impede sand motion) and (b) placing existing and additional 500- to 2,000-lb armor stone at the revetment/jetty cap interface (30-ft section). In March 1950 repair of the south jetty consisted of placing 2- to 10-ton armor stone as needed. Total cost of the repairs to the south jetty (26,000 tons of stone placed) and revetment was \$227,000. (The jetty portion was roughly 90 percent of the total.) In August 1950 an underwater survey of the asphalt-filled north jetty showed some deterioration on the channel side; otherwise, it continued to function properly.
1955	Repairs were made to the north jetty from the existing shoreline to the landward end of the concrete cap (500 ft). A total of 1,300 tons of 6-ton minimum capstone was placed on the channel side of the repair section. Filter layers were placed on the shoreward side of the cap as follows (Figure 34): (a) 2-ft-thick lower layer of 3- to 6-in. stone placed above, and shoreward of, new/existing armor stone, (b) overlaid with 9 in. of 0.1- to 0.4-in. material, and (c) covered by a layer of 500- to 4,000-lb riprap stone. Total cost of the repairs was \$51,000.
1958	The sand transfer plant began operation. The plant was built to maintain the net southerly littoral drift in addition to beach renourishment from dredging.

(Continued)

(Sheet 2 of 3)

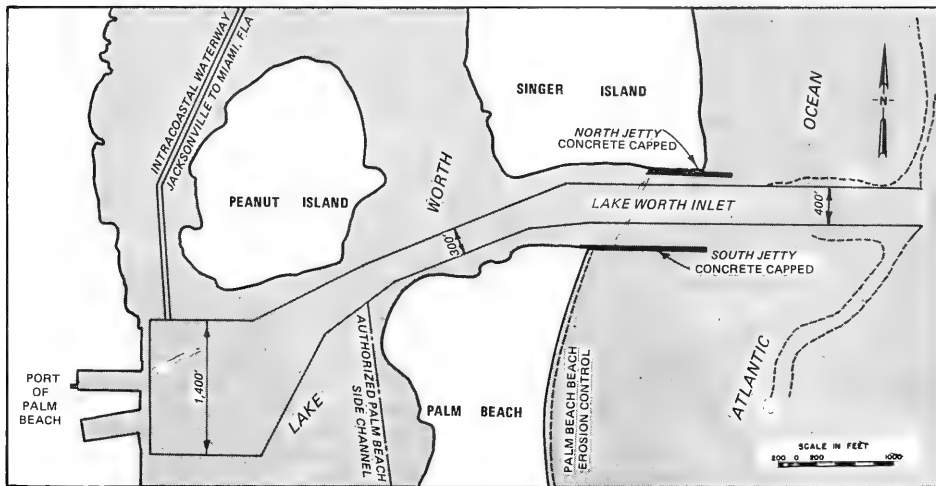

Figure 33. Palm Beach Harbor, Florida

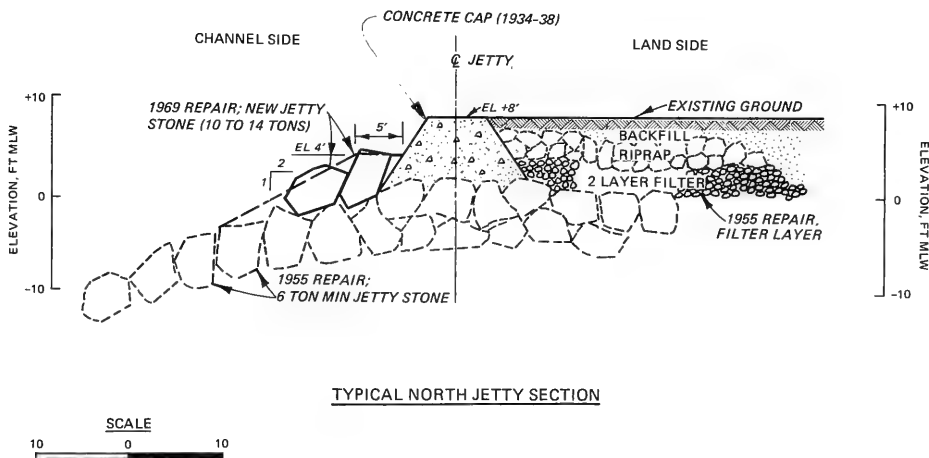

Figure 34. Palm Beach north jetty repairs of 1955 and 1969

Table 20 (Concluded)

Date(s)	Construction and Rehabilitation History
1967- 1968	The harbor was deepened to 35 ft. Federal support of the sand transfer plant ended.
1969	Rehabilitation of the 550-ft seaward section of the north jetty was made with 10- to 14-ton capstone on 1V:2H-side slopes (Figure 34). A total of 2,000 tons of armor stone was placed at a cost of \$83,000. A design wave height of 15 ft and a 14-sec wave period were used to select the capstone size.
1985	Present plans call for repairs to 1,300 ft of the south jetty. The jetty would be made impervious to sand motion via injection of silicate grout on the shoreward 800 ft and via a rubble filter on the seaward 500 ft. For slope protection, 5- to 10-ton stone were placed on 200 ft of the channel side (near shoreward end). The design wave height of 12.7 ft (obtained using the method outlined in Seelig and Ahrens (1980) used to compute size of cover stone to provide protection of the filter layer on the seaward end of repair). Cover stone will be 8 to 14 tons with an underlayer of 800- to 2,400-lb stone and 3- to 6-in. filter stone. The estimated first cost is \$2.2 million.

(Sheet 3 of 3)

Table 21

Port Everglades (Hollywood) Harbor JettiesHollywood, Florida, SAJ

Date(s)	Construction and Rehabilitation History
1928	Jetties were constructed (Figure 35) by local interests using native Florida limestone which ranged in weight from 300 lb to 8 tons (average of 2 tons). The design elevation, width, and side slopes were +6 ft mlw, 12 ft, and 1V:1.5H, respectively.
1931	The structure came under Corps jurisdiction in 1930. A survey of the existing structure showed elevations of from +10 to 0 ft mlw at the shoreward and seaward ends, respectively. Storm and wave action was believed to be major cause of subsidence at the seaward end. Seaward ends of jetties were in approximately 12 ft of water, and a 35-ft-deep channel passed between the jetties. The jetties were approximately 1,200 ft apart at their shoreward ends and converged at their seaward ends to a distance of 550 ft. The north and south jetties were approximately 1,250 and 1,025 ft long, respectively. Natural rock strata underlying the jetty and inlet areas exists at -10 to -15 ft mlw.
1932	Repairs made to the jetties consisted of placement of 2- to 10-ton granite stone to a height of +6 ft mlw, a crest width of 12 ft, and side slopes of 1V:2H. In addition, some old stone (about 400 pieces each weighing 1,000 lb or more) was rehandled in the construction phase. Total estimated quantities of stone were 4,900 and 5,230 tons for the north and south jetties, respectively. Total cost of the repair was \$49,400.
1935	A field survey showed approximate lengths of 1,250 and 1,000 ft for the north and south jetties, respectively. Centerline elevations on the north jetty range from +10 to +5 ft mlw over the shoreward (old) 500 ft and from +4 to +8 ft mlw over the seaward (repaired) 750 ft. Centerline elevations on the south jetty range from +9 to +7.5 ft mlw over the shoreward (old) 300 ft and from +9 to +4 over the seaward 700 ft. The outer 100 ft of each jetty appeared to have subsided 1 to 2 ft from the design elevation of +6 ft mlw.
1939	The jetty survey showed no major changes in centerline elevations. The north jetty elevations were +12 to +8 ft mlw from 0 (shoreward end) to 300 ft, +8 to +4 ft mlw from 300 to 1,200 ft, and +6 to +3 ft mlw from 1,200 to 1,250 ft (seaward end). On the south jetty the elevations were +9 to +6 ft mlw from 0 (shoreward end) to 220 ft, +10 to +7 ft mlw from 220 to 830 ft, and +7 to +3 ft mlw from 830 to 1,000 ft (seaward end).
1940	Repairs to jetties consisted of raising the seaward portions, straightening the seaward end of the south jetty, and placement of a special head section. The repaired lengths were 1,280 and 980 for

(Continued)

Table 21 (Concluded)

Date(s)	Construction and Rehabilitation History
1940 (Cont)	<p>the north and south jetties, respectively. The outer 990 ft and 450 ft of the north and south jetties were brought up to +8 ft mlw with a 12-ft crest and 1V:2H side slopes (Figure 35, inset). The head section of each jetty had a +15-ft mlw crest elevation, a 24-ft-diam crest, and 1V:2H side slopes radiating away from the crown. A total of 18,900 tons of 4- to 12-ton granite stone was placed. (Other work consisted of placing 750 tons of 25- to 150-lb chinking stone and handling of 1,200 pieces of old stone.) Total cost of the repairs was \$142,700.</p>
1978- 1979	<p>As part of harbor deepening improvements, the seaward 200 ft of the north jetty was realigned parallel to the entrance channel (Figure 35). The realignment allowed the channel width between the jetties to be increased from 300 to 450 ft. The estimated realignment cost was \$75,000.</p>
1984- 1985	<p>The inner ends of the jetties were repaired by rebuilding the armor stone layer with new and existing stone. To allow the jetties to be used as fishing piers, void spaces were chinked with smaller stone, and a layer of asphalt was piled on the crown. Prior to the repairs, the inner ends were in very poor condition with numerous void spaces while the remaining parts of the jetties were considered to be in satisfactory condition.</p>

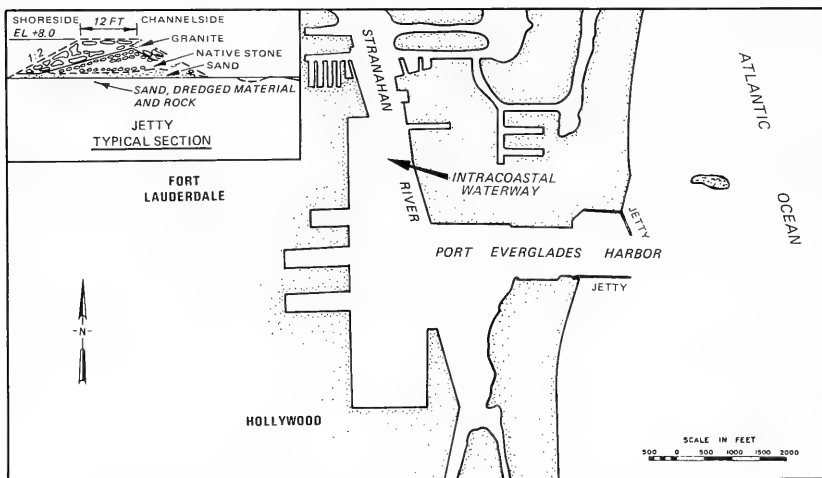

Figure 35. Port Everglades Harbor, Hollywood, Florida

Table 22

Bakers Haulover Inlet JettiesBakers Haulover Inlet, Florida, SAJ

<u>Date(s)</u>	<u>Construction and Rehabilitation History</u>
1925	A man-made inlet was constructed by local interests.
1963- 1964	Existing steel sheet-pile jetties (private construction, date unknown) had rusted through, and wave action had partially removed sand fill behind them. Loss of this fill caused the collapse of portions of an 8-in. concrete cap on both jetties. The sheet-pile jetties were removed and 150-ft-long rubble-mound jetties were constructed in their place (Figure 36). The jetty section consisted of 1,500- to 2,500-lb and 8- to 12-ton stone for the core and cap, respectively. 12-ton minimum cap stone was placed on the outer 50 ft of the jetties. The side slopes were 1V:2H with a crown width and elevation of 10 ft and +7 ft mlw, respectively. The design was based on a wave height of 14 ft and Hudson's slope stability formula. The centerline distance between the jetties was about 415 ft, the south jetty being placed about 100 ft south of the sheet-pile jetty. The channel was dredged to -11 ft mlw. Total cost of the jetties and connecting revetments was \$417,000.
1974	The south jetty was extended by non-Federal interests (Bal Harbour Village, no details) with subsequent reimbursement of applicable Federal share of costs. The 735-ft extension consisted of an armor stone jetty capped with concrete. The seaward end curves 90 deg (quarter circle) away from the inlet.
1985	The north jetty was essentially rebuilt to act as a sand-tight terminal groin since the existing jetty would not be effective in maintaining the planned beach renourishment north of, and adjacent to, the jetty. Prior to being rebuilt, an inspection indicated that the jetty had held up well since its construction but that it was ineffective in retaining sand which passed through it and around its seaward end. A general design memorandum describes the rebuilt jetty (though it appears some design change(s) have occurred) as follows: "a concrete block has been added to the jetty section, which has decreased the amount of rock required substantially." The 525-ft-long north jetty had a 425-ft section parallel to, and approximately 30 ft north of, the old jetty and a perpendicular section at the seaward end extending away from the channel (Figure 36, inset). The crest elevation of +9 ft mlw along the 425-ft section decreased to 7 ft between the "heel" and "toe" of the 100-ft section. A crest width of 21 ft extended over the innermost 250 ft, decreased to 16 ft at the heel, and then remained constant out to the toe. Side slopes were 1V:2H. The jetty section was made up of three layers; the innermost core and foundation layer of 1- to 12-in. stone, and two armor stone layers, an underlayer of 1,200- to 2,000-lb stone and a cover layer of 6- to 12-ton stone. Concrete grout was placed along the inner 300 ft of the jetty, over 15 ft of the crest width,

(Continued)

Table 22 (Concluded)

Date(s) Construction and Rehabilitation History

1985 and extended down to the core layer, thus creating a sand-tight jetty section. The estimated quantity of stone and cost were 34,000 tons and \$3,016,000, respectively. The design of the jetty was determined from several aspects, including (a) using the Wave Information Studies (WIS) 20-yr wave hindcast study to determine potential annual damage, a technique identical to that used in the design of the Arecibo breakwater and (b) using the N-line shoreline model of Perlin and Dean (1983) to determine the jetty length. The foundation material underlying the jetty consists of very shelly sand overlying limestone strata. The limestone varies in elevation from -15 to -20 ft mlw.

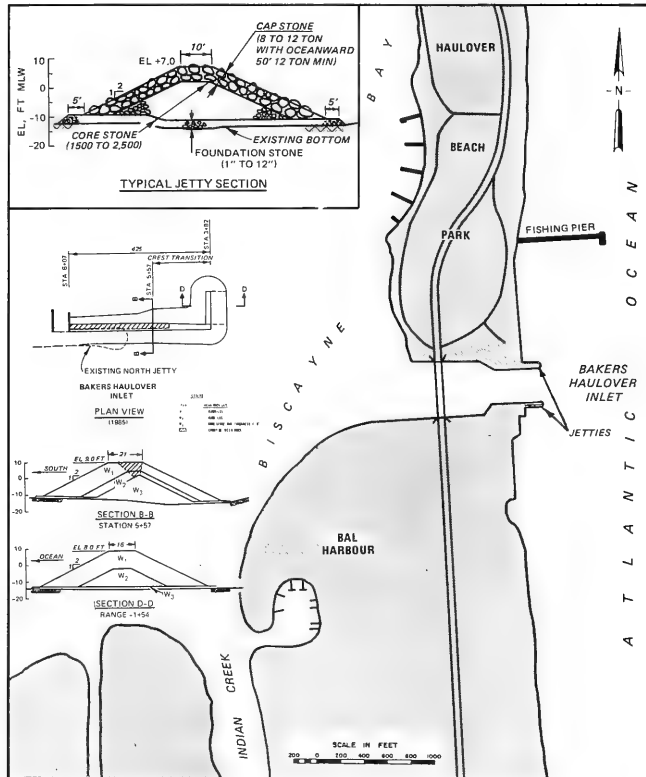

Figure 36. Bakers Haulover Inlet, Florida, 1964

Table 23

Miami Harbor Jetties
Miami Harbor, Florida, SAJ

<u>Date(s)</u>	<u>Construction and Rehabilitation History</u>
1904- 1926	North and south jetties (Figure 37) 2,300 and 2,200 ft long, respectively, and 1,000 ft apart, were constructed to provide channel protection.
1927	Repairs were made to the north jetty and revetment. The jetty section was rebuilt to original dimensions with an elevation of +6 ft mlw, a crest width of 10 ft, and the side slopes were 1V:1.5H below mlw and 1V:1H above mlw. A total of 3,450 tons of granite was placed on the inner 700 ft of the jetty, and approximately 100 tons was recovered and used over the same section. Total cost of the repair was \$30,600. These repairs were required because the hurricane of September 1926 (passed over Miami) which resulted in several jetty breaches extending below mlw.
1928	The north and south jetties were extended seaward 1,350 and 600 ft, respectively. The jetty section consisted of a 5-ft crest width at +5 ft mlw with 1V:2H side slopes above mlw and 1V:1.5H below mlw. A total of 9,500 tons of Florida limestone was used as core stone and 37,300 tons of granite as capstone. Total cost of the extensions was \$208,000. A December survey of the original jetties (excluding the extensions) showed crest elevations ranging from +4 to -2 ft mlw. Approximately 100 ft of the old seaward ends were below mlw.
1929	The jetties and north revetment were repaired. A total of 1,600 ft of the north jetty, 700 ft from its inner end, and 2,200 ft of the south jetty (exclusive of the 1928 extension) was repaired with granite stone to a crest width of 10 ft, an elevation of +5 ft mlw, and 1V:1H side slopes. Stone weighing 13,800 and 18,900 tons was used on the north and south jetties, respectively. The total cost of jetty repairs was \$181,000.
1931- 1932	Both jetties were surveyed in 1931 and 1932. Centerline elevations for the north jetty were from +9.5 to +4 ft mlw on the inner 2,300 ft and from -3 to +4.5 ft mlw on the outer 1,350 ft. (This section was damaged by storm waves during the survey period.) Centerline elevations for the south jetty varied from +4 to +8 ft mlw.
1933- 1934	Based on the previous survey of the jetties, repairs were made to bring the jetties up to the design section. The crest width was 10 ft, the crest elevation was +5 ft mlw, the side slopes were 1V:2H, and the granite stone varied from 2 to 10 tons. Several sections on the north jetty, totaling 2,100 ft, were repaired and a

(Continued)

Table 23 (Concluded)

Date(s)	Construction and Rehabilitation History
1933- 1934 (Cont)	700-ft section was repaired on the south jetty. A total of 45,000 tons of stone was placed, and additional stone was reset (200 pieces) at a total cost of \$232,000.
1950	A historical synopsis written at this time (which did not describe the condition of the jetties) stated that "the structure has served the purpose for which it was originally constructed." Repairs were made to the north revetment in 1948.
1983	At the shoreward end of the north jetty, a 1,200-ft-long section was made sand tight in conjunction with beach renourishment north of the jetty. The modification required raising the crest elevation, rebuilding damaged sections, and chinking voids with small stone (no details). This modification would inhibit the loss of sand placed adjacent to the jetty during, and subsequent to, beach nourishment. The cost of the modifications was \$608,000.
1985	Presently a 38-ft-deep by 400-ft-wide channel is maintained between the jetties. Except for the sand-tightened portion (1983), the jetties have not been repaired since 1934 and, although in poor condition, are still functioning properly.

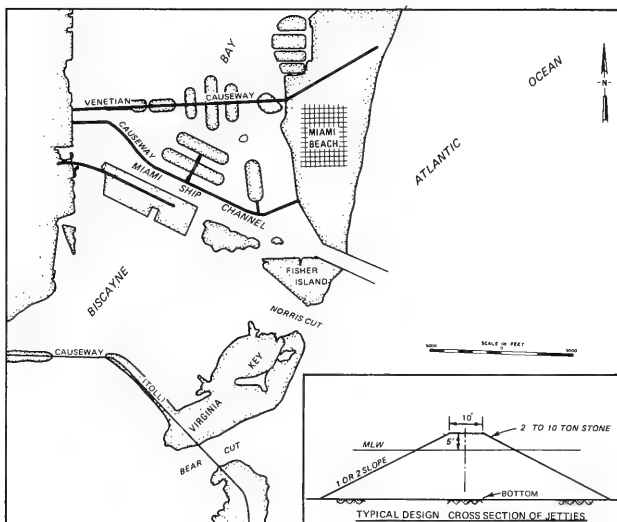

Figure 37. Miami Harbor, Florida

Table 24

Key West Bight Breakwater
Key West Harbor, Florida, SAJ

<u>Date(s)</u>	<u>Construction and Rehabilitation History</u>
1967	An 800-ft-long rubble-mound breakwater was constructed to provide harbor protection (Figure 38). The design section consisted of 1- to 12-in. core stone placed to an elevation of 0 ft mlw and overlaid with 2- to 6-ton capstone. The crest elevation was +6 ft mlw, the crest width was 10 ft, and the side slopes were 1V:1.5H. Estimated quantities were 15,100 and 18,800 tons for the foundation material and capstone, respectively. The breakwater design used Hudson's formula with an 8-ft wave height. To prevent potential overtopping, the crest elevation was selected based on a 3.2-ft, 4-sec wave (nonhurricane design wave). The cost of the breakwater plus necessary excavation was \$471,000.
1971	A portion of the breakwater was removed to aid in flushing of the harbor. The core stone removed was placed in a blanket 2 ft thick by 15 ft wide extending along one or each side of the breakwater as available stone would permit. The capstone removed was replaced to the existing design with the remainder placed in existing void spaces on the breakwater. The estimated cost of the modification was less than \$25,000.
1985	The breakwater has never been repaired and is presently in good condition.

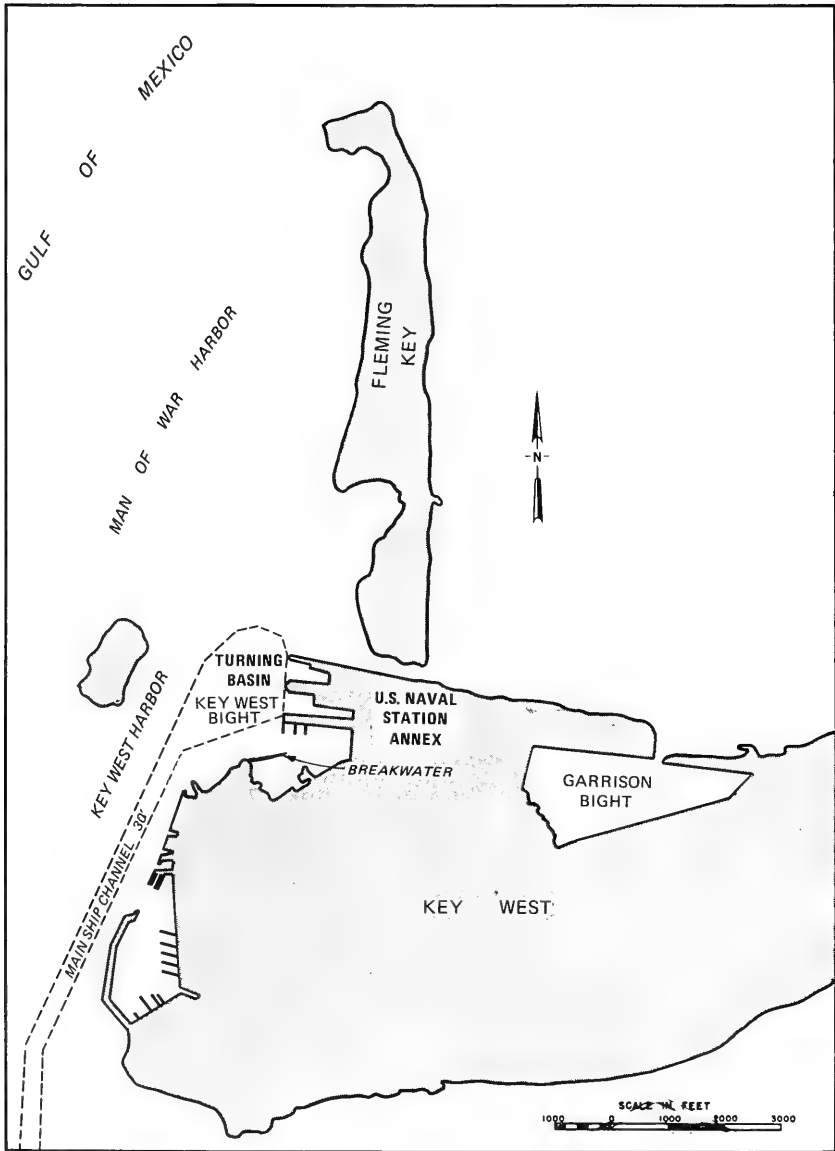

Figure 38. Key West Harbor, Florida

Table 25
Casey's Pass Jetties (Venice Inlet)
Venice, Florida, SAJ

<u>Date(s)</u>	<u>Construction and Rehabilitation History</u>
1937	Two parallel, 660-ft-long steel sheet-pile jetties, spaced 300 ft apart, were constructed at this man-made inlet. Each jetty was composed of 19 cylinders (caissons), 15 to 20 ft in diameter and interconnected by linear sections of sheet pile (Figure 39). Each cylinder was backfilled with sand, and a stone and grout cap was placed in the upper foot. The crest elevation of the jetties was +6 ft mlw. A channel 100 ft wide and 8 ft deep was dredged through the inlet. The jetties were connected to the shore via creosoted wooden sheet-pile bulkheads. The total cost for the jetties and bulkheads was \$137,000.
1938-1940	Limestone enrockments were placed along all exposed sections of the jetties (Figure 39). The section consisted of (total weights in parentheses) a crushed stone bedding layer (4,000 tons), followed by a layer of 50- to 200-lb (8,000-ton) stone, and covered with 500- to 6,000-lb (10,800-ton) stone placed on 1V:2H side slopes at an elevation of +2 ft mlw. The total cost of the improvements was \$122,000.
1950-1951	Jetty surveys showed that the heads and seaward sides of the jetties needed repairs. The channel side of the north jetty needed repair because of the proximity of the channel causing scouring at the toe.
1955	Repairs were made to the seaward end of the south jetty which was in a "severely damaged" condition. A total of 650 tons of 3- to 6-ton cover stone was placed on a 2-ft-thick foundation blanket of 2- to 6-in. stone at a total cost of \$6,500. Repairs were also made to the collapsed concrete caps on the 1st and 8th caisson from its seaward end. Nearly 3/4 of the first caisson was severely damaged, and 3- to 6-ton cover stone was placed to +6 ft mlw with a 10-ft crown width. The upper 4 ft of the 8th caisson was filled with stone, and the upper foot of this was capped with concrete grout.
1963	Repairs to the concrete cylinder caps and jetty stone/rock revetments were made at a cost of \$30,000. At this time, the channel was dredged to a depth of -9 ft mlw. Along the exposed seaward sections, 3- to 6-ton capstone totaling 615 and 770 tons was placed on the north and south jetties, respectively, and approximately 20 capstones were reset. Several of the seaward cylinders were repaired. Their caps and sand were removed to -1 ft mlw, replaced with the broken pieces of the cap and 20- to 200-lb stone, and grouted with concrete throughout the upper 18 in. of stone.

(Continued)

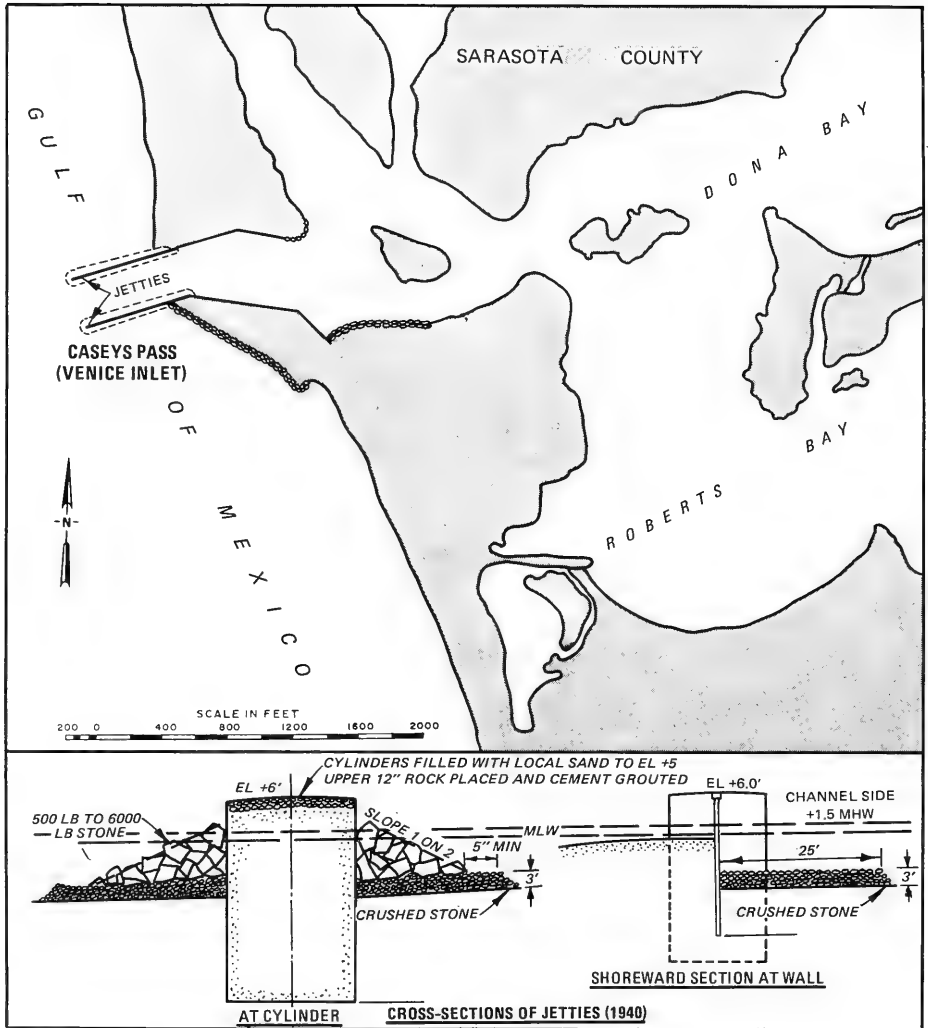
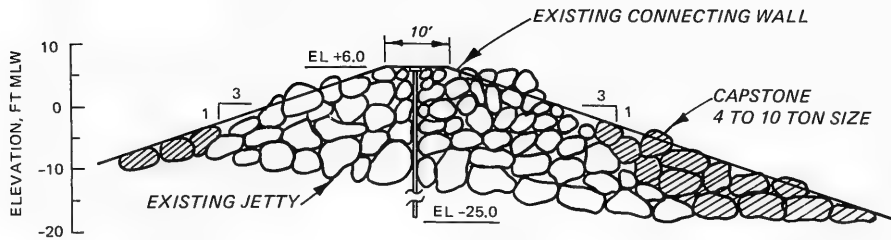

Figure 39. Casey's Pass, Florida

Table 25 (Concluded)

Date(s)	Construction and Rehabilitation History
1968- 1969	<p>Visual examinations and detailed surveys showed the sheet-pile cylinders and walls to be in need of immediate repairs. Voids between the original concrete caps and the underlying sand existed in virtually all cylinders not repaired in 1963. Corrosion was the main cause of deterioration, with subsequent removal of sand from the cylinders because of wave and current action. Rehabilitation of the jetties was carried out in 1969 (Figure 40). The sheet-pile walls and cylinders (except the outer two on the north and outer one on the south) were removed down to +2 ft mlw, and the sand within the cylinders were removed to mlw. The existing concrete cap (broken into pieces less than 12 in. long) and 1- to 12-in. bedding stone were placed in the cylinders to +2 ft mlw. This was overlaid with 4- to 10-ton capstone (70 percent > 8 tons), with similar capstone placed along the connecting walls, to bring the structure to the original design elevation of +6 ft mlw with a crown width of 10 ft. Additional 4- to 10-ton capstone was placed, as needed, to bring the side slopes up to 1V:2H. On the outer 50 ft of the jetties, the side slopes were 1V:3H. Finally, asphaltic concrete was placed (Figure 40) on the jetties. This material was placed over the entire crown width down to mlw, and had 1V:1H side slopes. The design of the jetties used Hudson's formula with wave heights of 12 to 16 ft and wave periods of 7 to 9 sec.</p>
1978	<p>Repair to jetties consisted of resetting stone and adding 6- to 12-ton stone (75 percent > 10 ton) on the outer 200 ft of the jetties and 2- to 6-ton stone on the next 450 ft of the jetties as needed to solidify the structure.</p>
1985	<p>The jetties are in good condition except for their head sections which are in need of some repair.</p>



TYPICAL JETTY HEAD SECTION AT WALL

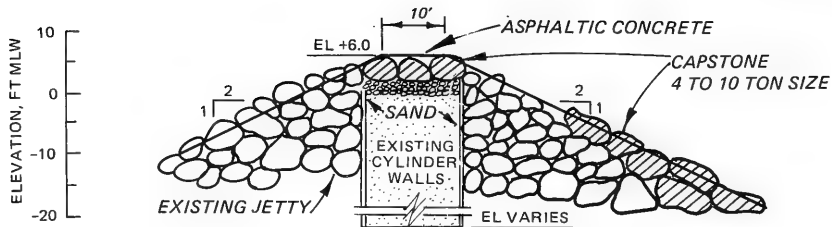

TYPICAL JETTY SECTION AT CYLINDER

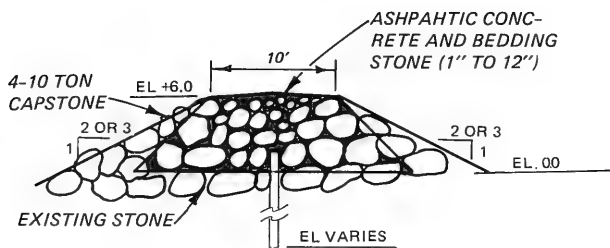

TYPICAL JETTY SECTION ALONG WALL

Figure 40. Typical 1969 jetty repair sections as Casey's Pass

Table 26

Arecibo Harbor Breakwater
Arecibo, Puerto Rico, SAJ

<u>Date(s)</u>	<u>Construction and Rehabilitation History</u>
1944	A 1,200-ft armor stone breakwater was completed, providing protection for the harbor and its 25-ft-deep access channel (Figure 41). The breakwater cross section (Figure 41, inset) was comprised of 25-lb to 10-ton core stone protected with one layer of armor stone, 10-ton minimum weight. A recent (1983) visual examination indicated that most of the armor units were 10 to 18 tons). The side slopes were 1V:1.5H on the ocean side and 1V:1H on the harbor side. The crest width and elevation were 20 ft and +15 ft mlw, respectively. The breakwater was constructed along a reef with a depth varying from -20 ft mlw at its seaward end to mlw at its landward end.
1951- 1952	Repair work consisted of resetting armor stone and placing about 8,300 tons of new granite stone at an estimated cost of \$66,400. The structure was rebuilt to its original design geometry and stone sizes, except for the outer 50 ft which was not repaired. Damage resulted from wave action which caused dislodgement of stone and settlement of portions of the breakwater. A subsequent Chief of Engineers report indicated that the armor stone along the slope of the structure showed signs of "sliding."
1983	A field inspection and a condition survey were made to identify damaged areas for rehabilitation purposes. The general damage (Figure 42) was above mlw, and the ocean-side slope of the submerged part of the structure had increased to 1V:2H or greater. In particular, about 160 ft of the seaward end had subsided to approximately mlw. Several areas on the trunk section had unprotected core stone on either side of the structure.
1984	Rehabilitation of the breakwater consisted of rebuilding the outer end of the breakwater and restoring damaged sections by placing about 42,000 tons of armor stone, ranging in size from 11 to 29 tons (Figure 42). A double layer of armor stones was provided on the seaward side of the structure along a reach beginning about 350 ft from the shore end of the breakwater and extended toward the outer end, a distance of 450 ft. A double layer of armor stone was placed on both sides of the structure for the next 265 ft. The remaining 155 ft, at the seaward end of the structure, was rebuilt to +15 ft mlw, as were the other sections. The crest of the damaged sections was restored to a width of about 26 ft for the first 800-ft reach. The crest of the outer 420-ft section was widened to about 36 ft, flaring out to about 50 ft at the extreme outer end. Armor stone slopes for the ocean and harbor sides were 1V:2.3H and 1V:1.5H, respectively. Based on utilizing local stone, the cost of the work was estimated to be \$3,900,000. The design analysis used was the

(Continued)

Table 26

Date(s)	Construction and Rehabilitation History
1984 (Cont)	WIS 20-year wave hindcast study (Corson, et al. 1982) together with a wave shoaling model (Seelig and Ahrens 1980) and a stability equation presented by the Danish Hydraulic Institute (Gravesen et al. 1979) in addition to SPM (1984) procedures.
1985	The structure is in excellent condition.

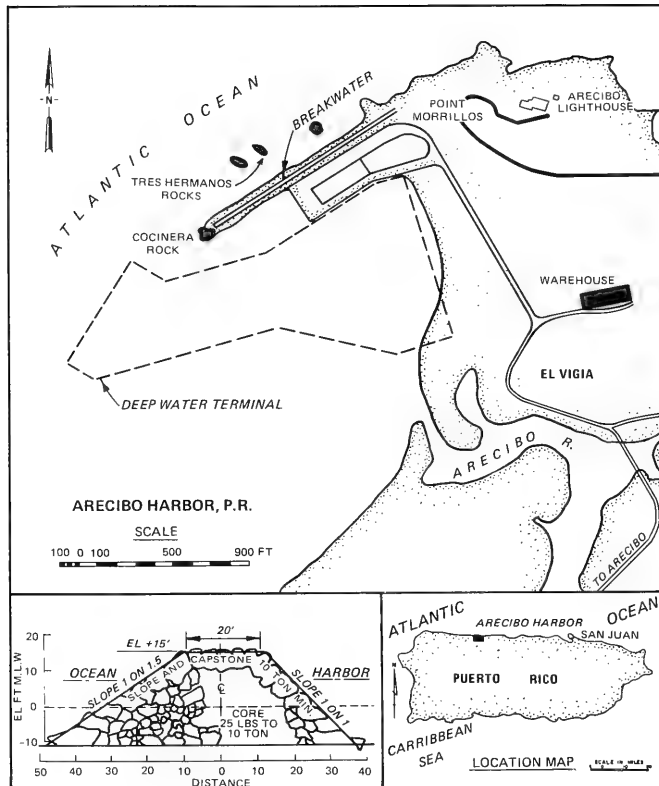

Figure 41. Arecibo Harbor, Puerto Rico

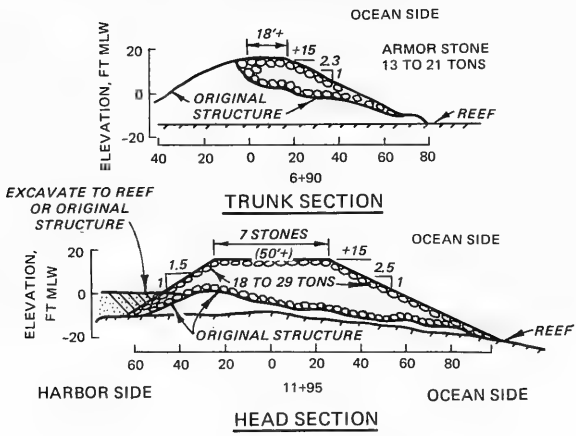
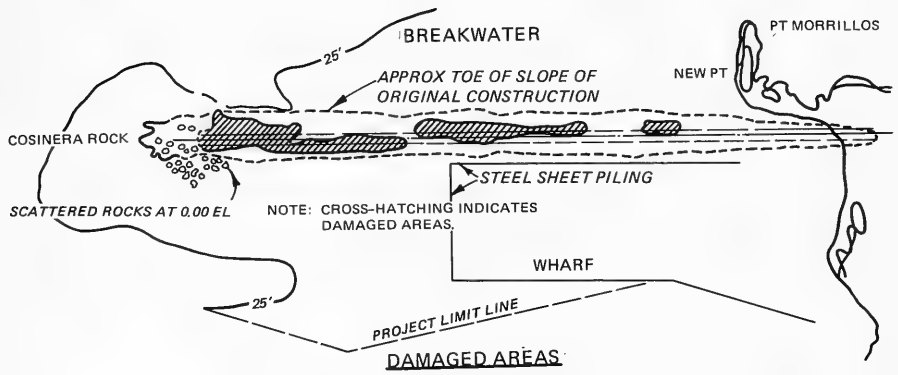
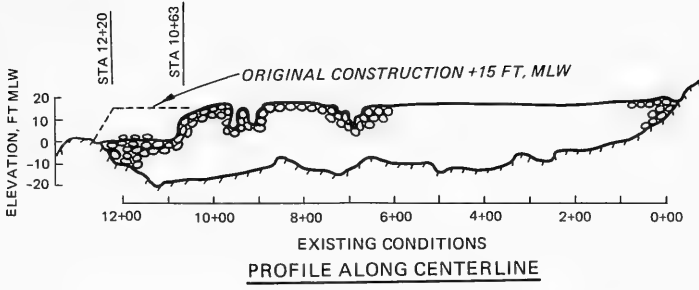

Figure 42. Arecibo Harbor existing damage prior to 1984 repairs and typical repair sections

Table 27

St. George Island Jetties
St. George Island, Florida, SAM

<u>Date(s)</u>	<u>Construction and Rehabilitation History</u>
1954- 1957	<p>In 1954, local interests cut a channel through St. George Island to provide a direct route to the Gulf from Apalachicola (Figure 43). In April 1957 the Corps completed the existing projects with the construction of two rubble-mound jetties on the Gulf and dredged the channel to a depth of 10 ft (Figure 43, inset). The east and west jetties, 900 and 1,030 ft long, respectively, and spaced 400 ft apart, were built out to the -10 ft mlw contour. Approximately 70 ft of the landward end of each jetty flared away from the channel. The design cross section (Figure 43, inset) had a crest width of 14 ft, a crest elevation of +6 ft mlw, and 1V:1.5H side slopes. On the seaward end of each jetty the side slopes changed to 1V:2H via a 100-ft-long transition section. Minimum cover stone sizes were 6 and 10 tons on the trunk and head/transition sections, respectively. The core stone weighed from 25 lb to 2 tons, and the 2- to 2.5-ft-thick foundation blanket used 15- to 200-lb stone. The stone size was selected using Hudson's slope stability formula, a maximum wave height of 13.7 ft, and a +6 ft mlw storm surge level. Figures 44a and 44b are photographs of the jetties taken before and shortly after the completion. "Keyhole" erosion on the landward side of the jetties (the jetties and the crescentic erosion yielding the silhouette of a giant keyhole) can be seen in the postconstruction photograph (44b).</p>
1977- 1978	<p>The jetties and channel were surveyed in early 1977. The east jetty showed substantial loss of material over 250-ft section at the seaward end, the outer 50 ft was at or below mlw, and the remainder varied from +3 to +5 ft mlw. The landward 350 ft of the east jetty was typically at +5 ft mlw except for the flared portion which was at +3 ft mlw. The west jetty was in good condition except for minor sections and the landward 150 ft which varied from +3.5 to +4.5 ft mlw. In 1978 the jetties were rehabilitated. A total of 4,700 tons of 3- to 6-ton cover stone were placed as required at low sections to bring the jetties up to the previous design elevations.</p>
1985	<p>The jetties are presently in good condition. The major problem, at present, is the keyhole erosion that has been removing material at an apparently constant rate since jetty construction (and is expected to continue). The proposed solution is to purchase title to additional land on both sides of the channel.</p>

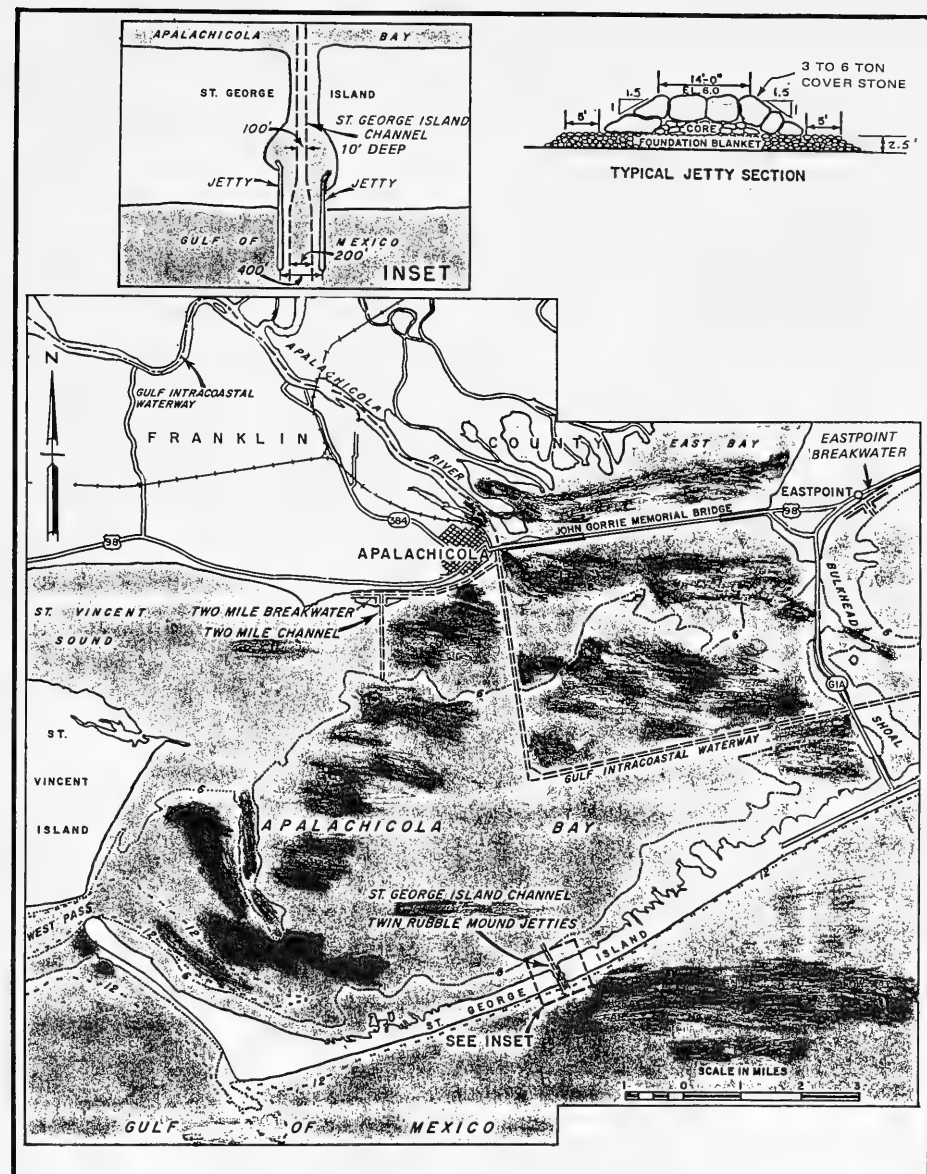
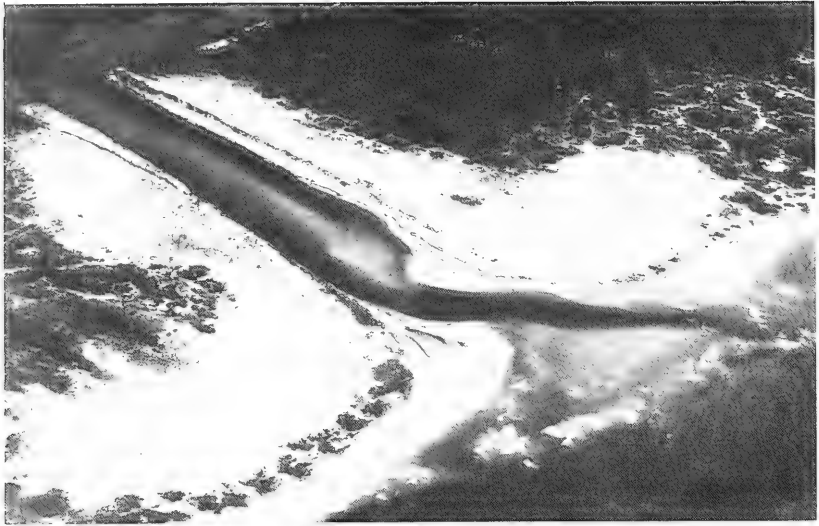

Figure 43. Projects at St. George Island, Two Mile, and Eastpoint Apalachicola Bay, Florida



a. Inlet channel prior to jetty construction



b. Jetties after construction, 1957

Figure 44. St. George Island

Table 28

Two Mile Breakwater
Two Mile, Florida, SAM

<u>Date(s)</u>	<u>Construction and Rehabilitation History</u>
1976	<p>Two breakwaters retaining dredged materials were constructed on either side of the entrance channel to Two Mile Channel (Figures 43 and 45). The breakwaters were constructed parallel to, and 465 ft seaward of, the Two Mile Channel centerline. Prior to construction, elevations from -2 to +10 ft and -2 to +2 ft existed on the east and west sides, respectively. These areas had been built up from the material obtained from dredging of the existing channels. Both L-shaped breakwaters had 810-ft-long sections facing the entrance channel and 1,685- and 2,685-ft-long sections on the east and west sides, respectively, parallel to Two Mile Channel. The design section was to be built to +7 ft mlw with a 30-ft crown width and 1-V:10-H side slopes. Because of the nature of the dredged material, construction dikes were built around the periphery to retain the dredged material, allowing excess water drainage and material consolidation. The construction dikes were built up from adjacent bottom material to a cross-section elevation of +6 ft mlw, a crown width of 5 ft, and side slopes of 1V:3H above +1.5 ft mlw and 1V:8H below. After completion of the breakwaters, the construction dikes were left in place, and the side slopes facing the entrance channel were revetted with filter fabric and rubble stone.</p>
1982	<p>The outer ends of the two breakwaters had been eroding and were revetted with stone left over from the original construction.</p>
1985	<p>The breakwaters are presently in good condition.</p>

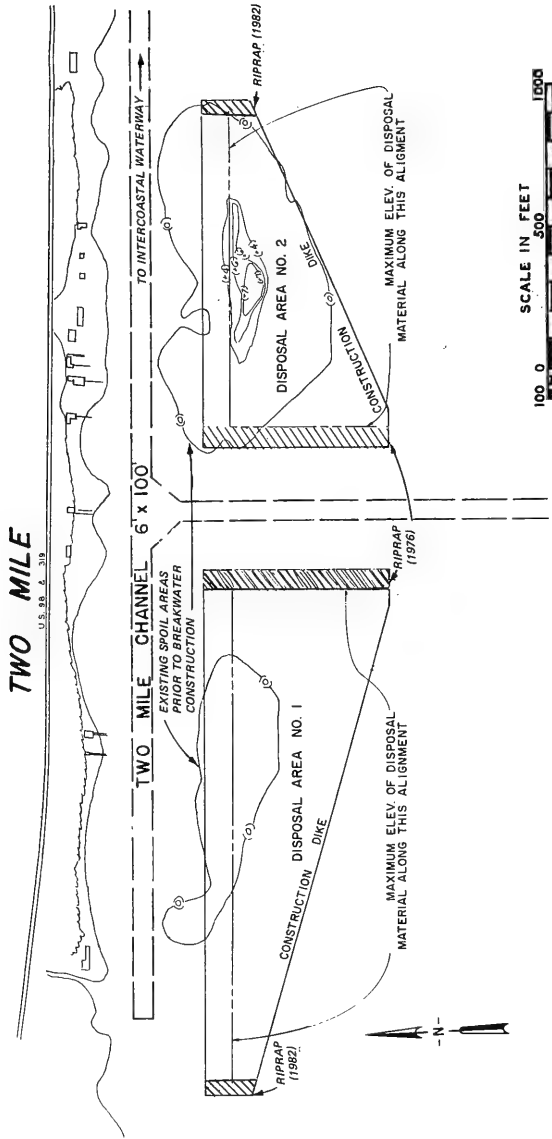

Figure 45. Two Mile breakwaters, Florida

Table 29
East Point Breakwater, Florida
East Point, Florida, SAM

<u>Date(s)</u>	<u>Construction and Rehabilitation History</u>
1984	Two rubble-mound breakwaters (Figures 43 and 46) were constructed to provide protection from wave damage for the fishing fleet operating from East Point, Florida. The east and west breakwaters, 2,550 and 2,750 ft long, respectively, were placed parallel to, and 350 ft seaward of, the existing channel. A 350-ft section of each breakwater, adjacent to the entrance channel, was placed at a 45-deg angle (in the offshore direction) with respect to the rest of the breakwater. The breakwater design section (Figure 46, inset) consisted of a 1-ft min thickness of 1/2- to 4-in. bedding material (approximately 3 ft thick by 15 ft wide on the channel side) and overlaid with 65- to 1,000-lb cover stone ($W_{50} = 300$ lb) cover stone to +5 ft mlw, a 6-ft crown width, and 1V:1.5H side slopes. The design of the breakwater followed SPM (1984) procedures with a maximum wave height (depth limiting) and period of 3.4 ft and 2.8 sec, respectively. The estimated first cost of the breakwaters was \$2,483,000.
1985	The structure was in excellent condition, and plans to extend its length were being considered.

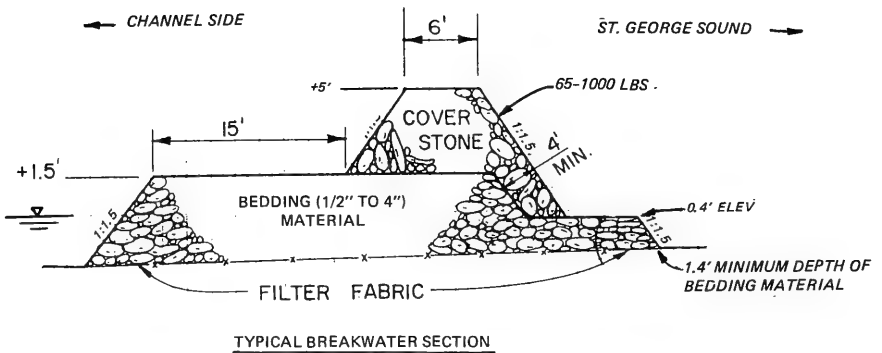
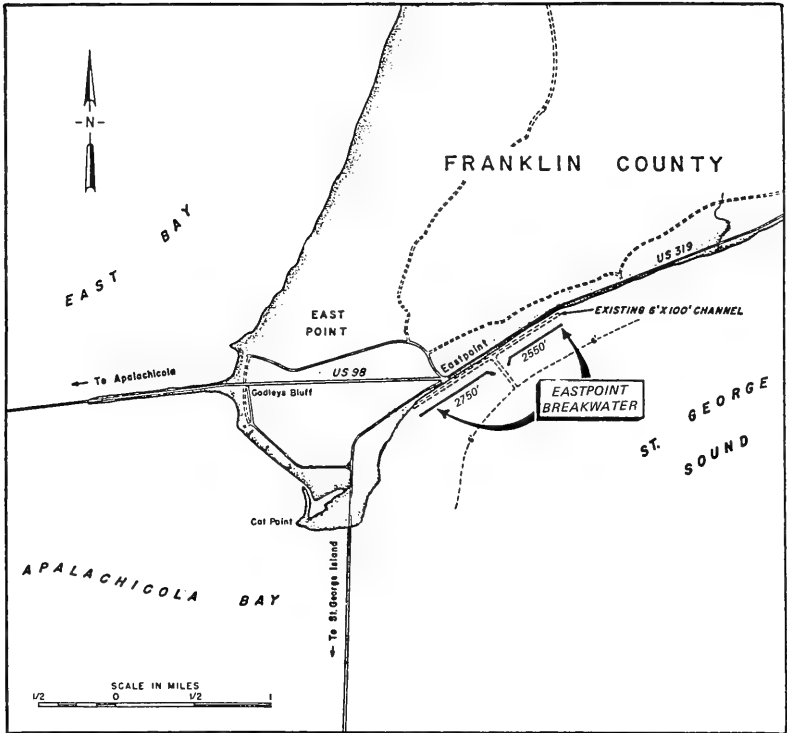

Figure 46. East Point breakwaters, Florida

Table 30

Panama City Harbor Jetties
Panama City Harbor, Florida, SAM

<u>Date(s)</u>	<u>Construction and Rehabilitation History</u>
1910- 1933	The River and Harbor Act of 1910 authorizes a 22-ft-deep by 200-ft-wide channel through East Pass connecting the Gulf of Mexico to St. Andrews Bay with maintenance dredging being done at the existing natural channel.
1933- 1934	Congress reauthorized the project providing for a 29-ft-deep by 450-ft-wide entrance channel. A man-made channel was cut through Lands End, and jetties were built (Figures 47 and 48) to provide channel protection. As constructed, the east and west jetties were 800 and 850 ft long, respectively, and spaced approximately 1,500 ft apart. The inner 300 ft of each jetty (hereafter called the jetty wings) flared out at a 30-deg angle from the channel centerline. The seaward end of each jetty was constructed out to about the -12 ft mlw depth contour. The jetties were of rubble-mound construction built to a crest width of 8 ft, a crest elevation of +6 ft mlw, and 1V:1.5H side slopes (Figure 48, inset). Mostly 6- to 10-ton cover stone was placed over core stone which was in turn placed on a 2-ft-thick stone foundation blanket. With the exception of the landward 175 ft of each jetty, steel sheet pile (varying in length from 15 to 40 ft) was placed along the jetty centerline to the crest elevation of +6 ft mlw. A total of 34,100 sq ft of sheet pile was driven and 1,340, 1,360, 10,350, and 12,240 tons of apron, foundation, core, and cover stone were placed, respectively. The total cost of the jetties was \$268,000.
1935- 1942	During this time extensions were made to the landward ends of the jetties to prevent channel erosion, undermining, and possible flanking of the jetties. The jetties also received minor repairs. Most of the stone repairs and wing extensions used 4- to 8-ton capstone and 25- to 2,000-lb corestone.
1935	Deterioration of the jetties began almost immediately, and extensive repairs, primarily to the jetty wings, were undertaken. Jetty wings were rebuilt and extended shoreward with steel sheet-pile bulkheads. The sheet-pile bulkheads were driven to a crest elevation of +2.5 ft mlw and were 800 and 1,050 ft long on the east and west wings, respectively. A total of 40,800 sq ft of sheet pile was placed. The total cost of the bulkheads and maintenance dredging was \$136,000.
1936	Within 6 months of completion, the west jetty bulkhead was almost entirely destroyed, and the east jetty bulkhead was badly damaged. A total of 1,173 lin ft of sheet pile were redriven, and 4,730 tons of rock riprap were placed along the base of the sheet pile. Also

(Continued)

(Sheet 1 of 6)



a. Inlet channel to Panama City Harbor prior to jetty construction

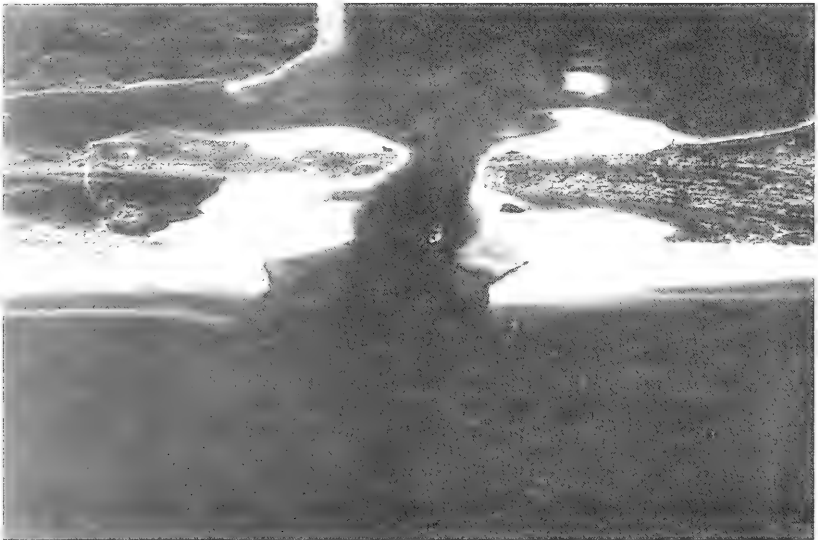

b. Panama City jetties after construction, 1938

Figure 47. Panama City Harbor

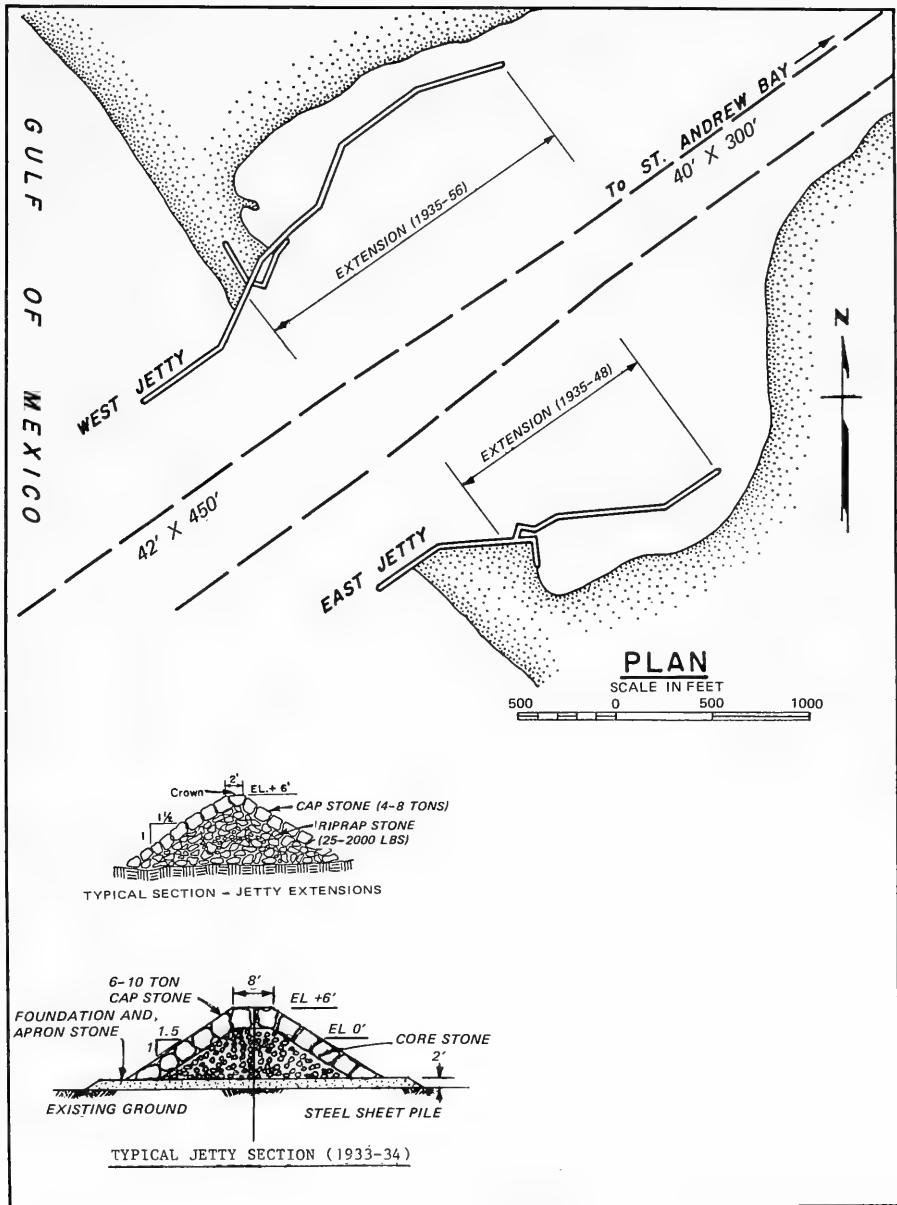

Figure 48. Panama City Harbor jetties

Table 30 (Continued)

Date(s)	Construction and Rehabilitation History
1936 (Cont)	827 tons of rock and 96 cu yd of concrete were placed to repair breaches in jetties. The efforts to reinforce the sheet pile with riprap failed, and erosion shoreward of the jetty wings continued, making further shoreward extensions of the jetties necessary. The cost of repairs, as of 1 July, was \$74,600 (FY 35). The 31 July hurricane severely damaged the jetties. The average crest elevation of the jetty wings was +1 ft mlw, and considerable erosion occurred, especially along the west jetty wing.
1937- 1938	Sheet pile (259 lin ft) was placed along the shore near the west jetty wing, and 7,600 sq ft of sheet pile was salvaged from damaged bulkheads. Including preparations for jetty repairs and maintenance dredging, the total cost, through 30 June 1937 (FY 36), was \$159,300. Repairs to jetties (including the wings) were made with hot asphaltic concrete and precast reinforced asphaltic concrete mats. The 2-in.-thick asphaltic mats extended 24 ft from the toe of the jetties and were anchored at the toe with precast asphaltic concrete blocks. The mats were consolidated with the existing jetty section by placing hot asphaltic concrete to form an impermeable section with a top width of 8 ft and elevation of +6 ft mlw. The east and west jetty wings were extended 210 and 270 ft, respectively. These extensions were made by grading sand slopes and covering with 2 layers of asphaltic mat. Steel sheet-pile retaining walls (10,300 sq ft) were placed along the inner ends of the jetties. Asphaltic mats (167,000 sq ft) and 25,870 tons of asphaltic hot mix and blocks were placed on various sections of the jetties. The cost of the jetty repairs plus maintenance dredging through 30 June 1938 (FY 37) was \$469,700.
1939- 1941	In 1939 the east and west jetty wings were extended 110 and 400 ft, respectively. These extensions and additional repairs were carried out by placing 1,465 and 1,540 tons of stone on the east and west wings, respectively. A 200-ft-long west jetty cross wall was constructed by placing 205 tons of stone. Although no details were available, the 100-ft-long east jetty cross wall was probably constructed about this time. An additional 820 and 2,370 tons of riprap and cover stone were placed on the west jetty during 1940-41 repair work. A total of 11,200 sq ft of steel sheet pile was salvaged as part of the jetty repair work. The cost of the 1939 jetty repairs and maintenance dredging was \$50,400 and of the 1940-1941 jetty repairs was \$35,900.
1942	The east jetty wing was extended 570 ft using 1,380 and 3,160 tons of riprap and cover stone, respectively. The west jetty wing was extended 400 ft using 640 and 2,030 tons of riprap and cover stone, respectively. The design cross section (Figure 48, inset) had a

(Continued)

(Sheet 2 of 6)

Table 30 (Continued)

Date(s)	Construction and Rehabilitation History
1942 (Cont)	+6-ft mlw crown elevation, a 2-ft crown width, and 1V:1.5H side slopes. (The cap stone was 4 to 8 tons, and the core stone was 25 to 2,000 lb.) The total cost of the extensions was \$51,100.
1945	An inspection of the jetties indicated that the seaward end of the west jetty had undergone some settlement. On the east jetty a low saddle allowed waves to overtop the structure, and subsequent erosion on the landward side threatened to create a continuous channel from Gulf to Bay. In addition, low sections on the jetty extensions allowed incoming waves to overtop them, with continued erosion of the shoreline behind the extensions. It was concluded that, as originally constructed (800 ft), the jetties were spaced too far apart (1,500 ft). For this reason, wave attack on the shore landward of the jetty wings was severe, and the shoreline receded rapidly which in turn required extensions of the jetties to halt the erosion and the potential for flanking of the jetties.
1948	Repair work and landward extensions of 300 and 360 ft on the east and west jetty wings, respectively, were made at a total cost of \$143,000. The design cross section was identical to that of the 1942 extension. Also, Congress authorized a 34-ft-deep (5 ft deeper) by 450-ft-wide channel between the jetties (this depth was being maintained as early as 1956).
1951	Repairs were made to the jetties with 1,980 tons of stone placed at a cost of \$22,000.
1956	The west jetty extended approximately 600 ft on its landward end with 410 and 7,330 tons of riprap and cover stone, respectively, at a total cost of \$76,300. At this time the cumulative lengths of the east and west jetties were approximately 2,000 and 2,750 ft, respectively.
1957- 1959	Minor repairs consisted of placing 631 tons of stone, and 960 tons of stone were stockpiled. Total cost was \$11,300.
1961- 1962	Repairs were made by placing 7,270 and 13,500 tons of stone along the landward sides of the east and west jetty wings, respectively. The repair section (Figure 49) was to have a crest elevation of +6 ft mlw, a crest width of 4 to 10 ft, and a 1-V:1.5-H side slope. Capstone of 8- to 10-ton size was placed on the inner 1,235 ft of the west jetty, and 6- to 8-ton capstone was placed along an adjacent 430-ft section and on the inner 1,025-ft of the east jetty. The design was based on Hudson's equation and 10- to 12-ft wave heights. A 2-ft foundation blanket of 15- to 200-lb stone was placed and overlaid on the capstone and 100- to 1,000-lb core stone.

(Continued)

(Sheet 3 of 6)

Table 30 (Continued)

Date(s)	Construction and Rehabilitation History
1961- 1962 (Cont)	<p>The total cost of the repairs was \$189,300. These repairs were required to prevent continued erosion (up to 60 ft/yr in places) of the channel banks and possible flanking of the jetties. In general, the top elevations for the jetties varied from +3 to +6 ft mlw and averaged about +5-ft mlw. (The seaward 80 to 100 ft of each had subsided to the extent that they were not considered active parts of the jetties.) Prior to the repairs, about 85 percent of the jetty wing extensions were below design grade, and there were several beaches below mhw (+1.4 ft). Thus, because of insufficient height and general permeability of the design cross section, waves passed over and through the jetty extensions causing continued bank erosion. The maximum width of the "keyhole" cut was 3,000 ft, and the width of land between the Gulf and jetty embayments was 500 and 250 ft on the east and west sides, respectively. Hydrographic surveys made from time to time showed that severe erosion was taking place along the toes of the jetties and their extensions. The loss of bottom material, as great as 30 ft in sections, was undermining the jetties and was felt to be the major cause of jetty subsidence. Also, a possible factor in the subsidence of the jetty extensions was that these sections were placed without any foundation blanket material. For these reasons the repairs incorporated a foundation blanket and a wider cross section with smaller core material and were placed on the landward sides since smaller quantities of stone were required and the potential for undermining would be less. At this time it was suggested that an experimental berm (toe apron) of stone be placed along a section of one of the jetties where undermining was occurring. This section would be periodically monitored, and its effectiveness in arresting the undermining could be evaluated.</p>
1963- 1965	<p>A 100-ft-long experimental rock berm was placed along the toe of the west jetty wing (beginning 30 ft landward of the jetty angle and extending landward). The berm was approximately 5 ft thick, 40 to 60 ft wide, had a design side slope of 1V:6H, and was composed of well-graded quarry stone varying in weight from 100 to 2,000 lb. A total of 1,710 tons of stone was placed at a cost of \$26,600. The berm was monitored by underwater inspections and surveys for 18 months following placement. During this time the berm maintained its integrity, even along sections where scour was evident.</p>
1966	<p>Rehabilitation of the west jetty consisted of placing 10- to 15-ton cover stone and toe berms on the seaward 700 ft (Figure 50) of the existing structure. The outer 80 ft of the original structure (considered destroyed) was not repaired. The toe berm was placed along the seaward 650 ft of the channel side (and included the existing 100-ft-long experimental berm) and along the seaward 200 ft of the</p>

(Continued)

(Sheet 4 of 6)

Table 30 (Continued)

Date(s)	Construction and Rehabilitation History
1966 (Cont)	land side. The berms were identical in design to the 1963 berm. The cover stone was placed to +6 ft mlw, a 15-ft minimum crown width, and 1V:1.5H side slopes. A total of 13,160 tons of stone was placed at a cost of \$145,700. The repairs were required to prevent further deterioration of the structure and eliminate the need for more costly repairs in the future. The erosion at the toe of the jetty had been most severe on the channel side, and the resulting settlement had caused a split in the jetty along the sheet-pile core wall. The combination of settlement and wave attack had lowered sections on the channel side to below mlw. The outer 100 ft of the jetty was seriously deteriorated with top elevations from +3 ft mlw to below mlw. The next 200 ft at the seaward end had considerable displacement of cover stone and exposed portions of core stone. The outer 100 ft of the jetty was not repaired because (a) it would be expensive to repair, and (b) it would act as a berm and prevent undermining of the repaired outer end. The design wave height of 21 ft was based on a +6 ft mlw surge level, a water depth of 21 ft, and depth-limiting conditions. Although several methods were used to compute cover stone size, these were used as a rough guide; and the size was determined from a number of practical considerations.
1968	The west jetty extension was rehabilitated during the summer at a cost of \$29,100 (no details available).
1973	The 2,025-ft-long east jetty, rehabilitated with cover stone and berm stone (toe apron), was placed along portions of the channel side. In many respects, this work was similar to the 1966 west jetty repairs. On the inner 1,525 ft 6- to 8-ton cover stone was placed, and on the seaward 500 ft 8- to 12-ton cover was placed. The design section called for a crest elevation of +6 ft mlw, crest widths of 9 and 15 ft on the landward and seaward sections, respectively, and 1-V:1.5-H side slopes. Berm stone was placed along the inner 950 ft and placed in a semicircle around the jetty head. Berm stone was also placed on two sections, one section extending 100 ft seaward from the jetty hook and the other section 50 ft long, starting 100 ft landward of the jetty hook. The berm design section was similar to the 1966 berm except for a specified thickness of 3 to 5 ft. The cost of repairs was \$172,200.
1983- 1984	The jetties were surveyed during the summer of 1983 to determine existing conditions prior to their rehabilitation in 1984. The trunk sections of both jetties were in good condition with average centerline elevations of +6 ft mlw. The outer 150 ft of the east jetty was in poor condition with an average elevation of +2 ft mlw, and the average water depth, seaward of the jetty, was -15 ft mlw.

(Continued)

(Sheet 5 of 6)

Table 30 (Concluded)

Date(s)	Construction and Rehabilitation History
1983- 1984 (Cont)	<p>The outer 200 ft of the existing west jetty was in fair condition with an average elevation of +4.5 ft mlw, and the average water depth, seaward of the jetty, was -20 ft mlw. A scour valley extended along the toe of the west jetty head and was approximately 50 ft wide and 10 to 12 ft deep seaward of the jetty axis. The east jetty wing extension was in fair condition with an average elevation of +4.5 ft. The west jetty wing extension was in poor condition with average elevations of +3.5, +0.5, and -7.5 ft mlw along successive landward sections of 700, 450, and 400 ft (landward end). Side slopes were typically 1V:2H or less (i.e. 1V:3H). Rehabilitation of 1,060- and 1,240-ft-long seaward sections of the east and west jetties, respectively, employed 3 design cross sections (Figure 51). The inner trunk section had a +6 ft mlw crown elevation and 5- to 9-ton cover stone. The outer trunk section had a +7.5-ft mlw crown elevation and 9- to 12-ton cover stone. Both sections had 15-ft minimum crown widths. The head section had a +9 ft mlw crown elevation, 20-ft minimum crown width, and 12- to 20-ton cover stone. All sections had 1-V:2-H side slopes except the head semicircles, which were warped from 1V:2H (normal to the jetty axis) to 1V:3H (along the jetty axis). Transition sections (both in geometry and stone size) between the design sections were 100 ft long, except for the east jetty inner to outer trunk transition, which was 79 ft long. The lengths of the head, inner trunk, and outer trunk sections on the east jetty were 100, 301, and 420 ft long, respectively, and on the west jetty were 100, 300, and 500 ft long, respectively. The estimated quantity of cover stone was 21,600 tons. The rehabilitation also required removing approximately 150 ft of collapsed steel sheet-pile wall on the west jetty (beginning 1,000 ft from the seaward end) and breaking up the asphalt layer which covered sections of both jetties (from the 1938 repairs), into segments no larger than 20 sq ft. The entrance channel is presently maintained at a depth of 42 ft and a width of 450 ft. Figure 52 is an aerial view of the jetties taken prior to their rehabilitation.</p>

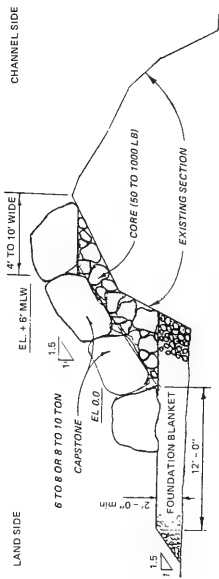

Figure 49. 1962 repairs to jetty wings at Panama City

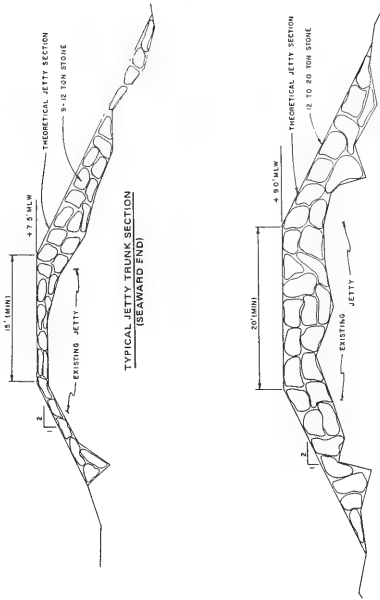

Figure 51. Typical 1984 repair sections of the east jetty at Panama City

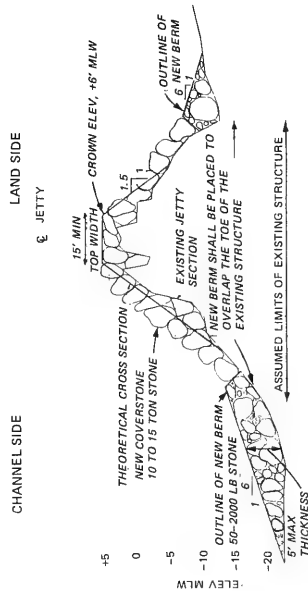

Figure 50. Typical 1966 west jetty repair section at Panama City



Figure 52. Panama City jetties, February 1984

Table 31

East Pass Channel Jetties
East Pass Channel, Florida, SAM

Date(s)	Construction and Rehabilitation History
1928- 1951	In April 1923 the present East Pass Channel, connecting Choctowhatchee Bay with the Gulf of Mexico, came into existence as a result of a severe storm and high tides. In 1930 Congress authorized a Federal project to provide a 6- by 100-ft channel through the inlet. In 1951, the project was authorized to provide a 12- by 180-ft channel (present project dimensions).
1968- 1969	Because of continued channel shoaling and hazardous navigation, twin converging jetties were constructed, extending from each shore of the inlet to about the -6 ft mlw contour and spaced 1,000 ft apart at their seaward ends (Figure 53). Similar in design to Corps jetties at Perdido Pass (built during this time) and Masonboro Inlet (completed in 1966) the west jetty incorporated a concrete sheet-pile weir to allow movement of littoral drift material into the deposition basin. This feature potentially minimizes the effect of the updrift jetty on the beach topography and provides a source of material for beach renourishment on the downdrift side, thus maintaining the net movement of littoral drift material. The 4,850-ft-long west jetty as constructed consisted of 1,200 ft of sand dike at the landward end, followed by 900 ft of rubble mound, followed by 1,000 ft of sheet pile, and ending with 1,750 ft of rubble mound (of which the seaward end consisted of 105- and 100-ft transition and head sections, respectively). The 2,270-ft-long east jetty consisted of 1,270 ft of sand dike and 1,000 ft of rubble mound. Design cross sections (Figure 54) were the same for both jetties. The sand dike sections had a 50-ft crest width at +10 ft mlw with 1V:20H side slopes and were built up with dredged material from the deposition basin. The jetty rubble-mound sections were placed on a 2.5-ft-thick bed of 5- to 100-lb blanket material. The jetty trunk sections had a 10-ft crest width at +6 ft mlw, 1V:1.5H side slopes, one layer of 3- to 6-ton cover stone, one layer of 500- to 1,000-lb underlayer stone, and 5- to 100-lb core stone. The 100-ft-long jetty head sections had a 14-ft crest width at +13 ft mlw, 1V:2H side slopes, two layers of 11- to 15-ton cover stone, one layer of 1 to 1.5 ton underlayer stone, and 100- to 350-lb core stone. The 105-ft-long transition section's geometry varied linearly between the trunk and head sections, with one layer of 4- to 11-ton cover stone, 500- to 3,000-lb underlayer stone, and 100- to 350-lb core stone. The concrete sheet-pile sections, placed to -0.5 ft mlw, were 10 in. thick, 2.5 ft wide, and 10, 14, or 18 ft long. They were reinforced with prestressed steel cable and had tongue-and-groove joints to provide interlocking between sections. In addition, 12- by 12-in. timber wales were bolted along the top of

(Continued)

(Sheet 1 of 4)

Table 31 (Continued)

Date(s)	Construction and Rehabilitation History
1968- 1969 (Cont)	the placed sheet pile. The deposition basin was dredged to provide a 300,000-cu yd volume to accommodate a 2-year supply of material and was roughly rectangular in shape and 300 ft from the weir section of the jetty. General design of the jetties was very similar to that of the Perdido Pass jetties. Armor stone sizes were determined for depth-limiting conditions for a +6 ft mlw storm surge superimposed on a 12-ft water depth, resulting in a wave height of 14 ft. Total quantities placed were 61,000 tons of cover stone and core stone and 24,200 tons of blanket material. The total cost of the project (including dredging) was \$990,000.
1969- 1970	<p>In March 1969 approximately 150 lin ft of timber wales were missing, and others had become loose in a number of spots. Similar problems with the timber wales had occurred at the Perdido Pass and Masonboro Inlet weir jetties. The loose wales were refastened by "lock" bolting.</p> <p>In April 1969 a field inspection (22 April) showed that all the refastened wales were in excellent condition. A scour though had formed on the channel side adjacent to the weir, while depths on the seaward side were similar to those encountered during construction of the weir.</p> <p>In June 1969 field inspection (June 5) showed that approximately 100 ft of the concrete sheet-pile weir had failed (apparently the sheet piles had been undermined by scour and had fallen inward toward the deposition basin) near the landward end of the weir section (where the piles were 10 ft long and originally driven into about 7 ft of sand). Water depths around the weir failure area were up to 15 ft, while on the seaward side of the still intact weir section they were 4 to 5 ft. By the end of June, 57,100 cu yd of dredged material was placed as a stop-gap measure to prevent further loss of sheet piles. The gap in the weir at that time was 135 ft.</p> <p>In March 1970 an annual survey revealed that the dredged sand placed on the damaged weir section was completely removed. Approximately 260 ft of sheet pile was missing and an additional 40 ft, on the landward side of the gap, was in poor condition. The existing depths were up to -25 ft mlw where the weir had existed originally.</p> <p>From June to September 1970 repairs were made to the sheet-pile weir when 71,500 cu yd of dredged material was placed in the weir gap to an elevation of -6.5 ft mlw. A 300-ft-long rubble-mound weir section was placed along the original weir line. The section (Figure 55) consisted of a 2.5-ft-thick layer of 5- to 100-lb blanket stone, 100- to 500-lb cover stone, and 3-ton minimum weir stone</p>

(Continued)

(Sheet 2 of 4)

Table 31 (Continued)

Date(s)	Construction and Rehabilitation History
1969- 1970 (Cont)	placed along the weir axis. The crown elevation was still at -0.5 ft mlw with a crown width of 10 ft and side slopes of 1V:1.5H. The remaining, intact section of the weir was modified with an identical rubble-mound section except that the 3-ton weir stone was not placed, and the crown width was 6 ft. The total cost of the repairs was \$203,000.
1972	A SAM report (prepared for the Coastal Engineering Research Center (CERC)) on the weir jetty indicated that the east jetty was too short since westward littoral drift was entering the channel during flood tide and being deposited within the inlet. Also, the eastward littoral drift appeared to be much smaller than expected (perhaps 50,000 cu yd/year).
1977	The jetties were rehabilitated. The west jetty, seaward of the weir section, was brought up to the previous design geometry (minor changes in cover stone), and the east jetty was modified with a rubble-mound groin at its landward end and toe protection at its seaward end. A survey of the west jetty, seaward of the weir section, shows typical elevations 1 to 3 ft below the design elevations. The seaward ends of the trunk and head sections were from 4 to 8 ft below the design elevations. Water depths around the east jetty head were up to 32 ft deep within 100 ft of the jetty centerline. Cover stone was placed on the west jetty as follows: (a) 3 to 6 tons on the trunk section, (b) 3 to 11 tons on the transition section and seaward 100 ft of the trunk section, and (c) 11 to 15 tons on the head section. A 300-ft-long groin was placed at the landward end of, and perpendicular to, the east jetty rubble-mound section. The groin design had (a) a crown elevation that varied uniformly from +3 to +6 ft mlw from its seaward end to the jetty function (1:100 slope), (b) a 10-ft crown width, (c) 1-V:2-H side slopes, (d) 3- to 6-ton cover stone, and (e) 1,000-lb maximum core stone. The east jetty toe protection consisted of a 3-ft-thick mat of quarry run stone (less than 1,000-lb pieces) placed at the seaward end, along 150 ft of the channel side and extending 150 deg around the head section. The width of the mat extended from the -6 ft mlw contour on the jetty side slope to a position 100 ft from the jetty axis (50 to 70 ft wide). Quarry run and cover stone, weighing 4,650 and 9,550 tons respectively, were placed at a total cost of \$278,000.
1982	A reconnaissance report on East Pass Channel indicated that shoaling of the channel at the entrance and adjacent to the deposition basin had been a problem for several years. The entrance channel shoaling was primarily attributed to natural bypassing of littoral material around the eastern jetty, and this indicated an inadequate design,

(Continued)

(Sheet 3 of 4)

Table 31 (Continued)

Date(s)	Construction and Rehabilitation History
1982 (Cont)	<p>providing for insufficient impounding capacity. Shoaling in the vicinity of the weir apparently resulted from inadequate maintenance of the deposition basin, which had only been dredged once (287,000 cu yd removed in 1972). The report recommended closing the weir section of the west jetty since the net littoral drift was, in fact, from east to west to reduce the shoaling in the inner channel areas caused by westward littoral drift passing through the weir section.</p>
1985	<p>The weir section of the west jetty was modified with the placement of a rubble-mound trunk section identical to the trunk section used in the original design (except that the blanket stone was to have a minimum thickness of 1 ft directly over the sheet piles and 2.5 ft thick elsewhere as called for in the original design). Estimated volumes of blanket, core, and cover stone were 5,300, 1,500, and 4,600 cu yd, respectively. At present, toe stability problems exist and have been documented with video footage of scour along the toe of the east jetty. Otherwise, the jetties are in good condition.</p>

(Sheet 4 of 4)

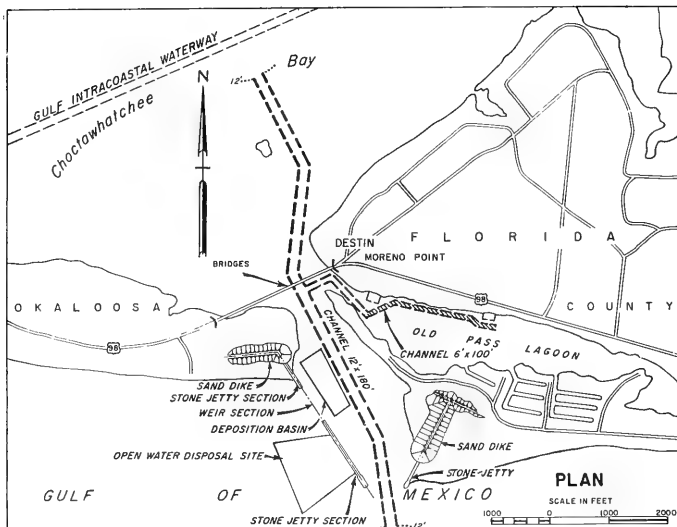

Figure 53. East Pass, Florida

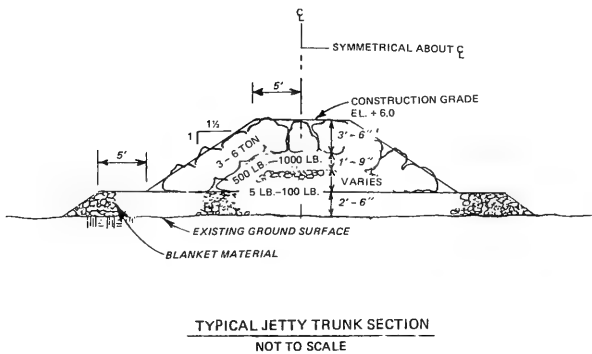
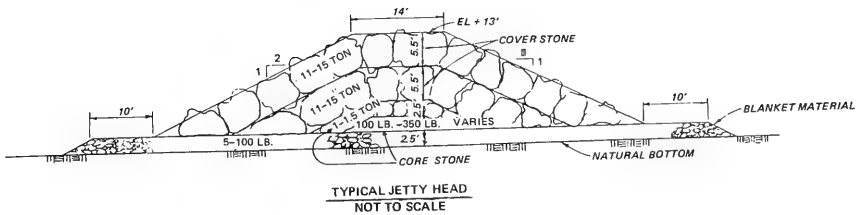

Figure 54. Typical cross sections of East Pass jetties

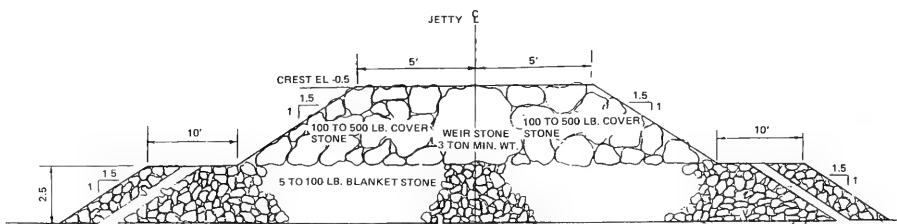

Figure 55. Design cross section of 1970 modification to the weir section of the west jetty at East Pass

Table 32

Perdido Pass Jetties
Perdido Pass, Alabama, SAM

<u>Date(s)</u>	<u>Construction and Rehabilitation History</u>
1968- 1969	<p>Twin converging jetties (Figure 56), spaced 600 ft apart at their seaward ends, were constructed as part of a weir-jetty system to help stabilize the natural inlet at Perdido Pass. The west jetty, 1,800 ft long, was of rubble-mound construction and extended from the south end of a vertical seawall constructed by the Alabama Highway Department. The east jetty, also 1,800 ft long, consisted of 1,290 ft of steel-reinforced concrete sheet pile and 560 ft of rubble mound (50 ft of overlap between the two sections). The west jetty trunk section (Figure 57) was built to a crown width of 10 ft at +6 ft mlw with 1V:1.5H side slopes. One layer of 2- to 3-ton cover stone and 400- to 1,000-lb core stone were placed on a 1.5-ft-thick bed of 5- to 100-lb blanket material. (A 2.5-ft-thick bed was used on all other rubble-mound sections.) The west jetty head section (Figure 57) was built to a crown width of 15 ft at +9 ft mlw with 1V:2H side slopes. Two layers of 12- to 16-ton cover stone, 1 layer of 1- to 1.5-ton underlayer stone, and 400- to 1,000-lb core stone were placed. The east jetty head section was similar except for a +6 ft mlw crown elevation and 1V:2.5H side slopes. The transition section on the west jetty consisted of 1 to 2 layers of 3- to 12-ton cover stone and 1,000- to 2,000-lb core stone. The east jetty trunk section was similar to the west jetty section except for the use of 3- to 5-ton cover stone placed in one or two layers. The east jetty transition section consisted of two layers of 5- to 12-ton cover stone and 1,000- to 2,000-lb core stone. The east jetty sheet-pile weir section was 1,000 ft long with a top elevation of -0.5 ft mlw. The shoreward 100 ft of the sheet pile was set to +6 ft mlw followed by a 140-ft transition section to the weir section. The concrete sheet-pile sections were 13 ft long (18 ft long at the landward end), 2.5 ft wide, and 8 in. thick and were reinforced with prestressed steel cable. The sheet pile was secured via tongue-and-groove joints and mechanically fastened through their support ends with 12- by 12-in. timber wales (on both sides of the sheet pile) and steel connectors. The sheet pile was secured to the existing dune line at its landward end with dredged material built up to a crest elevation of +10 ft mlw. The water depths at the seaward ends were 13 and 11 ft for the east and west jetties, respectively. The jetty design used Hudson's equation with design wave heights of 15 and 14 ft for the east and west jetties, respectively. The wave heights were determined assuming depth-limiting conditions and a 10-year frequency tide elevation of +6 ft mlw. Design of the jetties was based partly on the recently completed project at Masonboro Inlet, North Carolina, and discussion with personnel from CERC. Placement of the weir on the east jetty was based on the</p>

(Continued)

(Sheet 1 of 3)

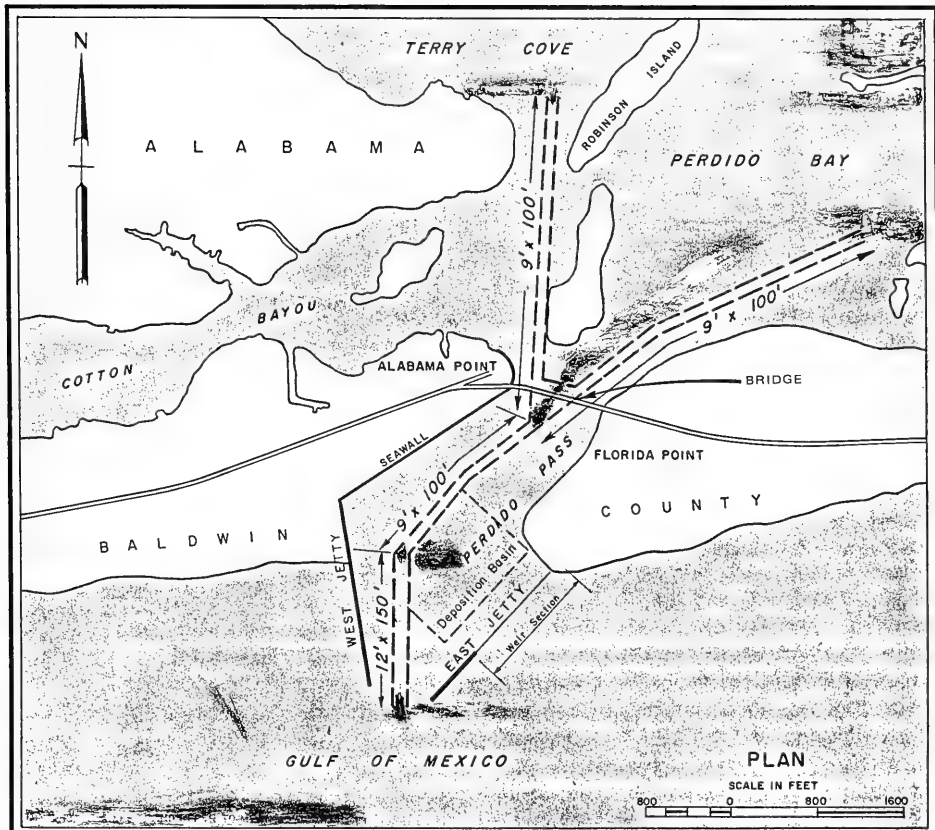

Figure 56. Perdido Pass, Alabama

Table 32 (Continued)

Date(s)	Construction and Rehabilitation History
1968- 1969 (Cont)	predominantly westward littoral drift. The deposition basin located on the channel side of the weir was to have a 400,000-cu yd capacity and provide for at least a 2-year volume of littoral drift. Estimated stone quantities, sheet pile, and costs (including dredging) were 49,400 tons, 7,190 lin ft, and \$1,180,000.
1969	Portions of the timber wale system on the weir section were lost shortly after project completion. Subsequent inspections revealed that the wales were slowly, but progressively, being lost. This problem was also encountered on the Masonboro Inlet weir jetty.
1970	An annual surveillance survey completed in March revealed a scour trough on the channel side immediately adjacent to, and extending almost the entire length of the weir. The scour appeared to be the result of the extreme turbulences created by waves breaking over the weir section. Immediate action was required to prevent possible failure of the concrete sheet-pile weir; therefore, the scour trough was filled with sand pumped by hydraulic dredge. During the summer the channel side of the 1,000-ft weir was rehabilitated with armor stone. The section (Figure 58) was to be placed at -6.5 ft mlw with a 2-ft layer of 5- to 100-lb blanket stone and a 3-ft layer of 100- to 500-lb cover stone. The crown width was 10 ft, the crown elevation was -1.5 ft mlw, and the side slopes were 1V:1.5H. The estimated amount of stone required was 4,850 tons. Cost of the repair work was \$84,000.
1972	A SAM report on the weir jetty (prepared for CERC) indicated that the deposition basin had filled to capacity during the first 2 years. The pattern of filling indicated that in addition to the westerly littoral drift material sand movement on the ebb tide was interrupted and collected in the basin. Subsequent encroachment of additional material into the navigation channel indicated the need for prompt dredging of the deposition basin on a regular basis.
1974	The rubble-mound sections of both jetties were rehabilitated to bring them up to design cross sections. A field survey taken prior to the rehabilitation showed substantial losses of material on both jetties. Crest elevations on the east jetty were (a) inner 75 ft at +0.5 ft mlw, (b) the next 200 ft from +3 to +5 ft mlw, and (c) the remainder (including the head section) within ± 1 ft of the design elevation of +6 ft mlw. The entire west jetty appeared to have undergone a substantial loss of bedding layer (it was 5 to 10 ft wide) and cover stone on the channel side when compared to the design cross sections (no previous survey data found). The crest elevations on the trunk section varied from 0 ft mlw to +5 ft mlw, and the head section crest elevations were at or above the design elevations.

(Continued)

(Sheet 2 of 3)

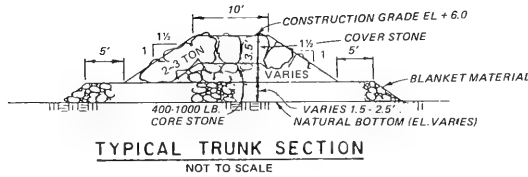
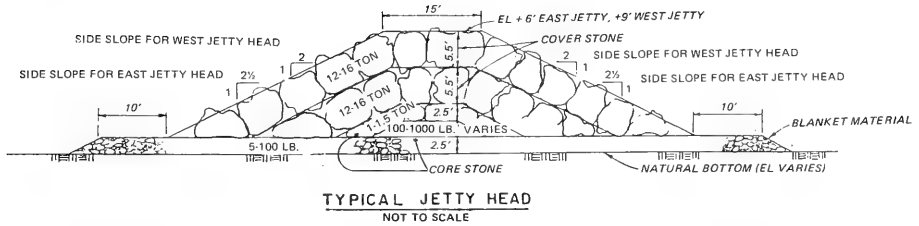

Figure 57. Typical cross sections at Perdido Pass jetties

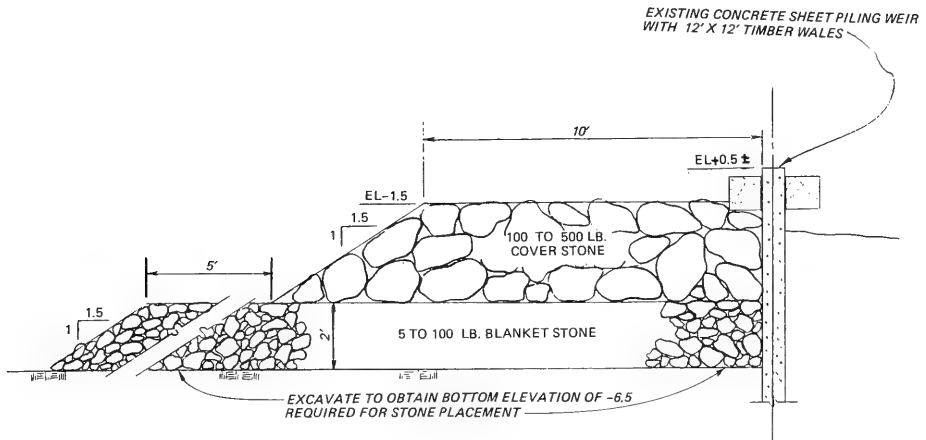

Figure 58. Design cross section of 1970 modification to the east jetty weir section at Perdido Pass

Table 32 (Concluded)

Date(s)	Construction and Rehabilitation History
1979	During Hurricane Frederick (September 12) approximately 50 ft of material flanking the weir was lost, forming a channel between the weir and the beach. Three sections of the concrete sheetpiling were dislodged. Dredged materials were used to close the breach and as beach fill to the east of the weir.
1980- 1981	A survey of the east jetty rubble-mound section (seaward of the weir) in February showed substantial loss of material (with respect to the design section) on two sections, the landward 175 ft and a 150-ft section centered 100 ft behind the seaward end. Crest elevations on the landward section ranged from +1 to +2 ft mlw. On the seaward section the crest elevations ranged from -1 to +5.5 ft mlw. (The majority of material in this section was missing from the seaward side slope.) The remaining sections were from +4' to +6 ft mlw. In 1981 the jetty was rehabilitated, and in addition a rubble-mound section 200 ft long was added to the then existing landward end of the sheet-pile weir (centered approximately 300 ft from the original landward end of the 1,000-ft weir section). The repairs brought the jetty up to the existing cross-section geometry using 5- to 10-ton cover stone on the transition and head sections. (Although the original design called for 5- to 12-ton and 12- to 16-ton cover stone on these sections, smaller stone was used to fill in void spaces and provide better interlocking.) Cover stone (3- to 5-tons) was used on the trunk section. The rubble-mound weir modification design section was identical to the east jetty trunk design section.
1985	The jetties are presently in good condition.

(Sheet 3 of 3)

REFERENCES

- Carver, R. D., and Markle, D. G. 1978 (Oct). "South Jetty Stability Study, Masonboro Inlet, North Carolina; Hydraulic Model Investigation," Miscellaneous Paper H-78-12, US Army Engineer Waterways Experiment Station, Vicksburg, Miss.
- Corson, W. D., Resio, D. T., Brooks, R. H. 1982 (Mar). "Atlantic Coast Hind-cast, Phase II: Wave Information," WIS Report 6, US Army Engineer Waterways Experiment Station, Vicksburg, Miss.
- Gravesen, H., Jensen, O. J., and Sorensen, T. 1979. "Stability of Rubble-Mound Breakwaters II," Danish Hydraulic Institute.
- Perlin, M., and Dean, R. G. 1983 (May). "A Numerical Model to Simulate Sediment Transport with Vicinity of Coastal Structures," Miscellaneous Report 83-10, US Army Engineer Waterways Experiment Station, Vicksburg, Miss.
- Perry, Maj. F. C., Jr., Seabergh, W. C., and Lane, E. F. 1978 (Apr). "Improvements for Murrells Inlet, South Carolina; Hydraulic Model Investigation," Technical Report H-78-4, US Army Engineer Waterways Experiment Station, Vicksburg, Miss.
- Seabergh, W. C. 1976 (Apr). "Improvements for Masonboro, North Carolina; Hydraulic Model Investigation," Technical Report H-76-4, US Army Engineer Waterways Experiment Station, Vicksburg, Miss.
- Seabergh, W. C., and Lane, E. F. 1977 (Nov). "Improvements for Little River Inlet, South Carolina; Hydraulic Model Investigation," Technical Report H-77-21, US Army Engineer Waterways Experiment Station, Vicksburg, Miss.
- Seelig, W. N., and Ahrens, J. P. 1980 (Jun). "Estimating Nearshore Conditions for Irregular Waves," CERC Technical Paper 80-3, US Army Engineer Waterways Experiment Station, Vicksburg, Miss.
- Shore Protection Manual. 1984. 4th ed., 2 vols, US Army Engineer Waterways Experiment Station, Coastal Engineering Research Center, US Government Printing Office, Washington, DC.

DEPARTMENT OF THE ARMY

WATERWAYS EXPERIMENT STATION, CORPS OF ENGINEERS

P.O. BOX 631

WICKSBURG, MISSISSIPPI 39180-0631

BULK RATE
POSTAGE & FEES PAID
Department of the Army
Permit No. G-5

Official Business

Penalty for Private Use, \$300

CEWES:JM:TS:1

37921/60/01

MR. DAVID AUBREY
DEPT OF GEOLOGY/GEOPHYSICS
WOODS HOLE OCEANOGRAPHIC INSTITUTE
WOODS HOLE MA 02545-1098