

2
91
py 1

CITRUS FRUITS.

PART I.

FIFTEEN YEARS WITH THE LEMON.

BY G. W. GARCELON, OF RIVERSIDE.

PART II.

NEW VARIETIES OF CITRUS FRUITS.

BY B. M. LELONG,

Secretary of the State Board of Horticulture, and ex officio Chief
Horticultural Officer.

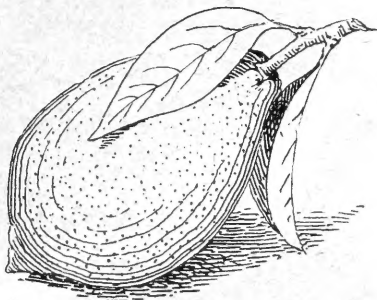

SACRAMENTO:

STATE OFFICE, : : : : : A. J. JOHNSTON, SUPT. STATE PRINTING.

1891.



California. State board of horticulture.

CITRUS FRUITS.

PART I.

FIFTEEN YEARS WITH THE LEMON.

BY G. W. GARCELON, OF RIVERSIDE.

PART II.

NEW VARIETIES OF CITRUS FRUITS.

BY B. M. LELONG,
Secretary of the State Board of Horticulture, and ex officio Chief
Horticultural Officer.

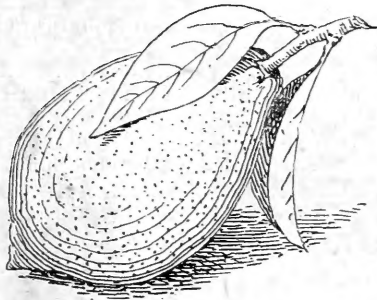

SACRAMENTO:

STATE OFFICE, : : : : A. J. JOHNSTON, SUPT. STATE PRINTING.

1891.

SB 369
C 2
1891

STATE BOARD OF HORTICULTURE.

OFFICERS AND MEMBERS.

- ELLWOOD COOPER, President..... Santa Barbara,
Commissioner for the Los Angeles District.
- L. W. BUCK, Vice-President..... Vacaville,
Commissioner for the Napa District.
- S. RUNYON, Treasurer..... Courtland,
Commissioner for the Sacramento District.
- J. L. MOSHER, Auditor..... San Francisco,
Commissioner for the State at Large.
- FRANK A. KIMBALL..... National City,
Commissioner for the State at Large.
- A. F. WHITE..... Santa Rosa,
Commissioner for the Sonoma District.
- FRED. C. MILES..... Penryn,
Commissioner for the El Dorado District.
- I. H. THOMAS..... Visalia,
Commissioner for the San Joaquin District.
- A. BLOCK..... Santa Clara,
Commissioner for the San Francisco District.
- B. M. LELONG, Secretary..... Ex officio Chief Horticultural Officer.
- ALEXANDER CRAW..... Clerk of the Publishing and Quarantine Bureau.
- ELLA F. HALLAHAN..... Clerk.

Office of the Board:

No. 220 SUTTER STREET, SAN FRANCISCO.

JAN 28 1911

Feb. 6, 1911,
1820 Oct. 18 11.
Repr. 17 Oct 16 895

PREFACE TO FIRST PART.

For a number of years extensive experiments have been conducted by lemon growers, with the aim to discover, if possible, a process that would keep lemons until such a time as there would be a market for them. Various methods have been tried, and while some of them have been more or less a success, yet they lacked the most essential point, *i. e.*, the keeping of the lemon without shriveling and becoming dry on exposure to the atmosphere. Dealers in San Francisco have greatly complained of California lemons not keeping long after exposure, and for that reason the foreign lemon has had the lead. But this is no longer so; the California lemon is fast supplanting the foreign. California lemons are now placed in the markets—not only of this State, but also in the East—in a fresh condition, and do not shrivel or dry on being exposed, even after several weeks.

That the growers have been able to place upon the markets a lemon having all the essential points, as well as quality, as late as ten months after being picked, only goes to show what constant experimenting and energy can accomplish. It is to G. W. Garcelon, of Riverside, that the success in this direction must be accorded. For a number of years he worked faithfully, experimenting at an outlay of considerable time and money, and now we give to the public the result of his "Fifteen Years with the Lemon," with the hope that others will be equally as successful. Certainly they can if they follow the directions and details closely, as in this lies the secret of success.

Respectfully,

B. M. LELONG,
Secretary.

SAN FRANCISCO, CAL., September 17, 1891.

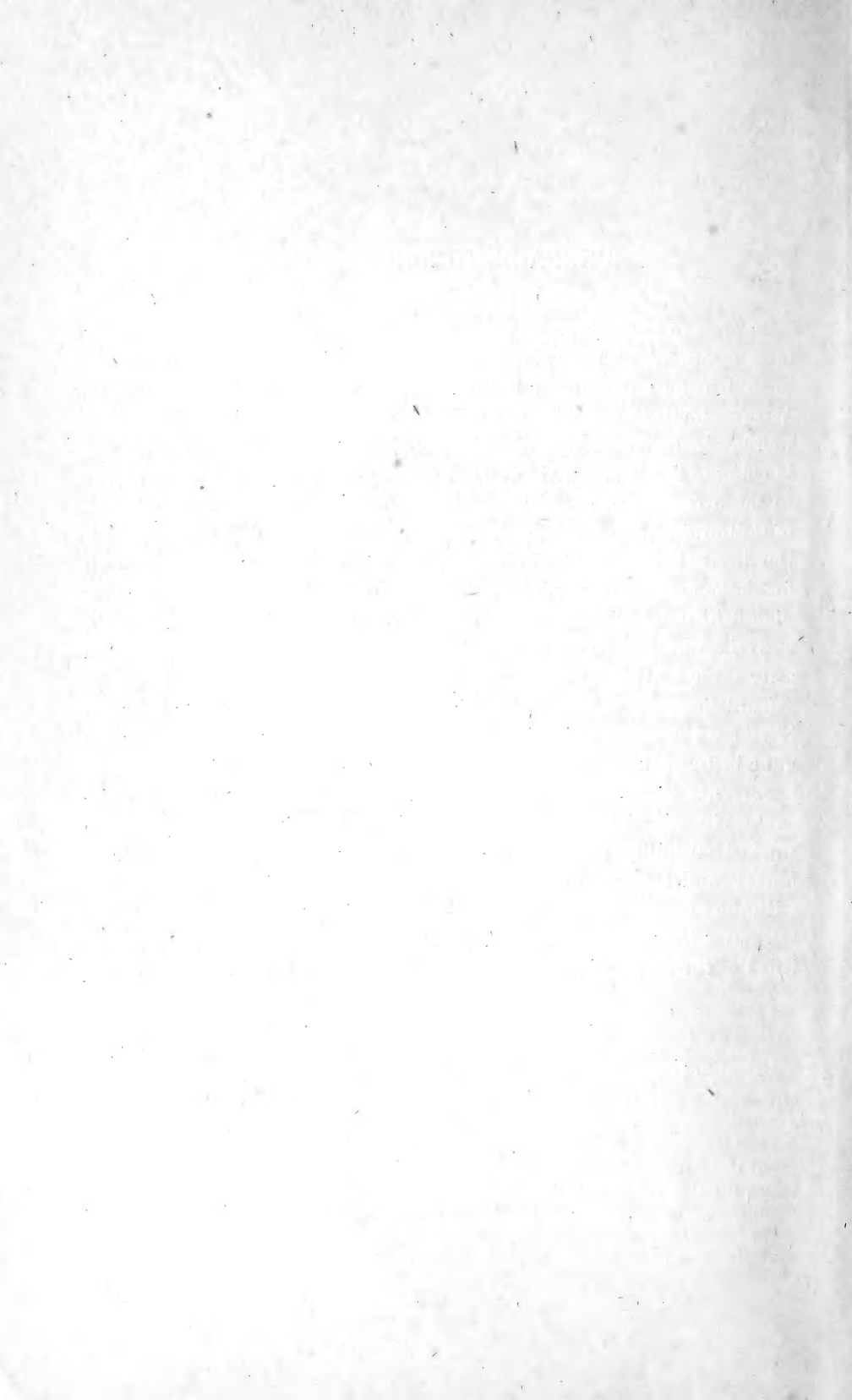

PART I.

FIFTEEN YEARS WITH THE LEMON.

By G. W. GARCELON, of Riverside.

In giving to the public the details of my experience with this most valuable of all citrus fruits, I will make no apology for a few introductory remarks.

As in every well built structure much depends upon the foundation, so much of the success of handling lemons depends upon observing *very carefully every detail*; care and gentle handling should *begin, continue, and end* every act. I am well assured that failure will be the result if one tried to succeed with lemons without particularly and always recollecting that he is dealing with perishable fruit, which, because of the extreme firmness of the rind, he thinks may sustain without injury rough handling. Oil cells upon the rind of a freshly picked lemon are as easily fractured as an egg shell; a slight pressure with the finger will often produce decay, and the surprise occasioned by spoiled lemons, when we were positive they were not bruised, will vanish if we could follow the lemon from the time it is clipped until decay overtakes it, especially when we recollect the frailty of the oil cells in the rind.

In foreign countries where lemons are produced, labor is much less valuable, and time can be devoted to working up necessary details without adding very much to the cost. Here, where labor costs, every hour of time should show to the employer corresponding progress; even the employed feel that there should appear advance with the work. But if the expression "make haste slowly" has a fitting application, it belongs to this lemon business.. And as foreigners have learned by years of experience, with probable losses, how to take graciously \$10 for a box of lemons which in nowise differed from our own at one time, and for which grumbling housekeepers begrudge us the paltry \$2, we ought to bend our energies to produce just as good, recollecting being on the ground and a little protection will go far to make up the difference between well paid and cheap labor.

Right here I wish to emphasize that not every man is going to make a success of lemon curing, not because it is not his intention to do his best, but because he cannot "steer the ship" and "take in the sail" at the same time. It has taken centuries for the natives of the Mediterranean shores to get into the rut of success. We are made of different material; and while we are working with our physical strength our mental visions are aloft after some new and shorter road to success, consequently mere animal strength and will often forget, because of the wandering brain, the details of which I believe are not the fort of the genus American, and "our basket of eggs," or lemons, are kicked over, and we tear down our poultry houses and take up our lemon trees. Now we are dependent more or less upon those who work for us—I

would not question the honesty of our laborers; I believe the most of them try to do their work well, yet this idea of making a *show* of having accomplished something does prevent thorough work. Men detest details, and hate worse to have their employers dwell upon and repeat the same thing over and over again; and while I have had some of the best of workmen, yet I often find myself much tried by small neglects, and I know I succeed very poorly in hiding away vexation under the bland smile of reproof. Now, this lemon industry, successfully done, demands the careful observance of small things. Right here I will add that the difficulty of trying to come up to the reputation of imported lemons with what few of the home production over which I had any control, I found insurmountable, consequently I discard in a measure the compliments for generosity that the press have awarded, as my object for the fifteen years has been to introduce in quantities lemons that our own people will prefer to the foreign.

In Riverside and surrounding places I have succeeded, but I fail to reach the quantities, even though I had control of them. I would not be able to extend the successful supervision they need, consequently I have concluded to give to the public my process of producing "Rip Van Winkle" lemons, hoping that the merits of the lemon and its popularity will induce many others to help me keep at home the many millions of dollars which annually go abroad to pay for lemons.

Years ago my attention was drawn toward the apparent truth that California could not produce a good lemon, for the San Francisco market quoted foreign lemons at \$5 and \$6; home, at \$1 and \$2, and even less. These last were always overgrown seedling lemons, which should have left the trees months before. But they grew larger, made fewer to the box, and made—*yes*, made those who used them profane over their efforts to extract any juice from them. Soon following the introduction of budded oranges, came budded lemons of different varieties. Even then, the fruit which should have been clipped as soon as it was ready was allowed to remain upon the trees months too long, because it was early winter, and no one wants lemons to any extent in winter.

The lemon is an everbearing tree. While the orange blossoms and matures its fruit at stated times, the lemon tree is in flower and different stages of fruit throughout the year. I think I am correct in writing that all fruits having seeds change at certain times the character and quality of juices. While in the first stages of growth, before seeds are developing, juices are fresh and characteristic, when seeds are being formed and matured the juices lose many properties and assist in maturing seeds. Now, how unreasonable to expect all the fruit of an everbearing tree, like the lemon, to be at the same time ready for clipping. We have learned already that lemons should be gathered from the tree many times through the year. At first, before we knew better, the whole crop was taken at one time, large and small, and to-day some growers persist in taking from the tree in early winter lemons no larger than walnuts, for fear of chill, having trees in exposed places. Now, if these trees had their growth checked earlier, so that in time of cold weather the trees were in a measure dormant, not so much harm would be done. Better still, do not put out lemon trees in badly exposed or low places. I have seen the fruit of orange trees hurt by frosty weather, while lemons on adjoining trees were not harmed. This was owing to the condition of the trees when the cold struck them. As a general

thing lemons are more tender than oranges. Put your lemon trees on the highest ground; it is always colder on the lowest soil.

Do not bud lemons into lemon stock—China lemon stock is worse. Seedling orange trees make the best stock for the lemon. Lemon root is sure sooner or later to be affected with the gum disease. I also think that the stock does affect the bud and fruit. When trees are well cared for in and about Riverside and all other places between the Coast Range of mountains and those on the east, from one half to two thirds of the fruit will be both sizable and mature enough to clip from the last of October to the middle of December; the balance of fruit will be in different stages of growth, and as often as once a month, for six or seven months, the fruit should be clipped. In lemon orchards between the Coast Range and the ocean, conditions are somewhat different. The saline atmosphere of the ocean modifies the cold, and the blossoms of the trees are not chilled; consequently the fruit crop is more evenly distributed throughout the year. But this same situation and condition produce, by excessive moisture, a fungus upon the trees and fruit which entails the expense of cleaning the lemons before marketing, and involves an extra handling, which, when fruit has to be kept for the market, is apt to impair its keeping qualities. On the other hand, lemon orchards east of the Coast Range produce the cleanest of fruit, and although the blossom in midwinter may drop from being chilled, yet the next blooming will have more fruit in consequence, and this makes the heavy crop which matures before the holidays.

The results of my experience have, from year to year, cost me time and money. Failure and loss had to be put on the income side of my returns, and if it had not been for the profit in growing oranges, which enabled me to use a little of the surplus to persevere, I would have been tempted, as others have been, to remove my lemon trees. Year after year a little more light on the subject encouraged me to continue, and to-day, although my system is not wholly perfect, yet I feel confident, when my plan becomes generally known, others more capable than I will further improve upon it. It is a fact that I have to-day (September first) lemons in excellent condition, after being clipped ten months. Experts pronounce them equal to any grown in any part of the world. I have been often amused by the comments of those of an inquiring mind, who, holding my fruit to their olfactory organs, pronounce sulphur, salt, lime, sawdust, sand, etc., to be the basis of the keeping and curing process, when the facts are that the main points of success are simple and inexpensive—no chemicals, only a little common sense. Too many of us are looking higher for the solution of our difficulties than the case warrants. Common sense, applied to a little persevering detail work, will often be the "open sesame" to success.

While many newspapers have encouraged me in my progress, and said kind words, knowing that my success meant much for California, others have called attention to my meanness in withholding from the public and my neighbors the information I had gained. Not until I was sure of success would I have been excusable for claiming any merit for my plan of curing lemons. While it is a sign of progress for our newspapers to vie with each other in being first to put news before the public, there is danger of being "too previous" in this respect. Not only does the adage "be sure you are right, then go ahead," apply generally to the press, but because our newspapers give first impressions,

and it is difficult to remove a false first impression, no newspaper is excusable for giving as facts what may work an injury, unless all the means for obtaining reliable news are used.

Although lemons handled as I care for them may be all right, yet the thing is to get them to market in good condition. Railroad companies charge the same price for landing a box of fruit spoiled by their careless handling as for a good box; thus, if I sent twenty boxes of lemons to Chicago it would cost me \$2 80 per box, even though half of them spoiled in transit. In almost all branches of business a responsibility is obligatory upon those who do the business, and if loss comes from want of proper facilities to do the business, common justice demands that the loss be made good. But in the matter of sending fruit the shipper not only loses his fruit, but has to pay freight to the party through whose neglect the fruit comes to grief. Now, not until the railroad either chooses or is made by law to make good what is lost by their poor facilities in transportation, or even to lose the freight on goods spoiled in transit, can we expect redress; and I favor a law which will encourage competition enough to give us better ventilated cars, and prevent railroad consolidation where the public suffers from a monopoly.

Having been in San Francisco lately, I observed that well cured California lemons are fast taking the place of the foreign. Some of the heaviest dealers assured me that the demand for home-grown lemons was for nine out of every ten boxes wanted. How different from a few years since, when the poor reputation of lemons of inferior quality prevented even the really good fruit finding a paying market.

Before proceeding to give the details of my process, I wish to publicly apologize for not replying to the many letters I have received about lemons. I had not the time to do so, and excused myself, knowing soon that all the many questions in said letters would be publicly answered. There may be a few more suggestions to make, but I will proceed to business, reserving, when each point is made plain, the right to make comments, which I think all interested in growing lemons will approve.

I think best to classify the different points involved, and treat them in the following order:

First—Where to grow lemons.

Second—How to plant.

Third—When to plant.

Fourth—What to plant.

Fifth—Pruning.

Sixth—Processing the lemon.

Seventh—Lemon house.

Eighth—Picking.

Ninth—How and when to clip fruit.

Tenth—How to keep fruit.

Eleventh—Marketing the lemon.

WHERE TO GROW LEMONS.

Select the highest and driest part of your citrus orchard for the lemon. If you have no situation which is comparatively free from frost, do not waste your time with lemons, for your crop will not be profitable to you, and will hurt your neighbor who may raise good lemons, as prices will be reduced by your poor fruit. There is wisdom in advising not only

each locality, but different orchards in each locality, to produce what it can do best—that will secure reputation and profit to all concerned.

HOW TO PLANT.

After having selected the proper location, see that the soil is properly leveled. After leveling break up as deeply as you can, so that the roots of your trees will have an opportunity to use the subsoil of your orchard. Look after the flume and irrigating apparatus. Stake not less than twenty-five feet apart each way; make the holes, according to age of tree, from two to two and one half feet each way. Be sure your tree is taken up with soil on roots sacked. Some how I think an evergreen tree ought never to have its roots exposed, so as to get dry; there are those who say that trees do just as well without the soil, but this opinion is given often to avoid trouble of sacking. Be careful and cut clean from ball of soil all roots mangled in digging. I think a lemon tree gets more injury from exposed and bare roots than an orange, because its growth is more luxuriant. Before the last two or three shovelfuls of soil are put around the tree run the water, and when the soil is settled around the roots put the reserved soil around the tree.

WHEN TO PLANT.

The best time to transplant citrus trees is just as the tree is starting out its new growth in March and April.

WHAT TO PLANT.

My favorite lemon is the Lisbon, and what I claim for it is rapid growth and good form of tree, profuse bearing, well proportioned and uniform fruit, with fine acid and good keeping qualities, as well as attractive appearance. The only thing that can be said against the tree is, it has thorns—yes, it has thorns; but I have for several years gathered lemons from the Eureka (thornless), and conclude that there is not much difference between the amount of culls—a cull is very seldom made from thorns; a very slight rubbing of branch, leaf, and limb upon a green lemon will make the cull. Then thorns diminish as trees grow older and mature their growth. The properties of the Eureka lemon are good, but its appearance and want of uniformity are against it; also, I believe, it is more tender than the Lisbon. The facts are that all varieties of lemons are improved by removing the fruit from the tree at the proper time, and not waiting until over mature, because as the pulp becomes fibrous the tendency to bitterness is increased.

It is claimed for the Villa Franca that it is hardier than other varieties. If that is true, it is desirable on some accounts; yet, while I claim that cold weather brings out the tone in fruit, still a little extra cold will tend to develop in fruit thus exposed a tough resisting condition, which rather thickens and roughens the rind at the expense of quality. The fact that Riverside, with her little frosts, now leads the world in citrus fruits really indorses my claim, or why have not wholly tropical climes made their mark on the mere insipid sweetness of their fruits before this? Now, this question, what to plant, has been put to me many times. I have advised those who are in doubt about the variety

of lemon to plant, to first set out two or three-year old seedling orange trees, and bud in the orchard after a year or two; then time, which solves many difficulties, will have revealed what is the best variety. One will lose nothing, as I am sure that too often buds are put in trees too soon after being transplanted, consequently less vigor of growth and poorer trees.

PRUNING.

This is a great question, and no doubt will call forth much contention. I give my opinion from observation and experience. After the tree is set let it grow. As soon as they appear remove all suckers, which some growers leave to protect the trunk of the tree from the sun; rather burlap the trunks and let the growth come from the top, which will constitute two thirds of the tree. Allow all top growth to remain, except shorten in any too luxuriant branches, and keep the trees well balanced, or winds will prune for you, and more than is desirable. Now, this is all that is necessary, except annually to clean out any wood in the tree which is too near or has got through being useful to the tree, always remembering that the best fruit of the lemon comes from the inside of the tree and nearest the ground.

PROCESSING THE LEMON.

For many years the question of lemon curing has puzzled me; so many plans for keeping lemons, each one partially successful, and the first warm days of May and June found the lemons on the market, because beginning to spoil or dry. My first experience was—well, it is time wasted, perhaps, to dwell upon those failures; suffice it to say that I have been through all, and not until I used a room plastered as for living, with attention turned to excluding light, draught, and heat, did I see the glimmerings of success; even then many lemons decayed, yet those that were good kept well and proved to be fine lemons. Having this clew, I began to think that the fruit was not taken from the tree with proper care, and gradually I used one plan and another until I reached my success of to-day.

LEMON HOUSE.

It is not necessary, unless one has a large lot of lemons, to build a very extensive or expensive house. Mine (see illustrations) cost me, with all appurtenances, about \$2,500, and will contain six to seven carloads of fruit, properly arranged, to keep from four to twelve months, and in addition I have in the basement two large rooms which I use for storing and packing, also for box material, etc. Feeling confident that the best success in handling lemons will come from each orchardist making arrangements to keep his own fruit, I recommend all growers of lemons to build a house somewhat after my plan, larger or smaller, according to their orchards. In a few words, a plastered room, or rooms, inside an unplastered but closely boarded and ventilated structure, and a hallway running around these rooms, which serves a double purpose, giving an inside passageway to rooms and allowing what is most essential, the boxes of lemons (newly picked) to be piled up in the outside passage until they gradually throw off excessive moisture and permit any lemon which has been bruised through careless handling, or otherwise, to

develop imperfections, etc., before the lemons are finally put to their "Rip Van Winkle" sleep. I would also advise that if the basement is not needed, to set the house nearer the ground and shade with trees and vines, which will keep the temperature down, as it is desirable to keep lemons as near the 60-degree limit as possible. The doors should be made to fit close in the inside rooms; no windows. A few windows, with close fitting shutters, ought to be placed in the outside structure; board tightly outside and inside rooms, and I now think lathing and plastering on the inside, with movable ventilator in ceiling, would be an improvement on mine. My rooms were plastered on ceiling, and sometimes moisture from spoiled lemons, which were not properly handled before putting in the rooms, caused the plastering to fall.

PICKING.

When to Clip Fruit.—When lemons, on well cared for trees, are from two and one half to three inches in diameter, they should be clipped. There should be a good proportion of the fruit, say one half to two thirds, ready to come from the tree from the middle of October to the middle of December, and it would be best to make two separate clippings in that time, for if you make only one some may be too large and others too small. Some growers clip smaller than I recommend, but the three hundred to the box size is the most popular. The longer you keep the lemon the more it will be reduced in size; you will have to make allowance for contraction—one third to one half—before it is marketed. Every three to four weeks the trees should be gone over for sizable fruit until all is gathered. Color cuts no figure, only if the tree is not in good condition, or suitable lemons are not all gathered, my rule will not hold. It has been claimed that the first clipped fruit keeps better than the last, and that there is some of the fruit that is not a true lemon. Now, I take no stock in such claims; the trouble comes either from excessive chill, or from lemons which have been overlooked in former clippings; both will spoil and affect those near them after being gathered. Of course, I do not say that there is not some fruit on lemon trees that, through some, as yet, unexplained reason, will be no good. This is true of all fruit, and is not confined to the lemon, or less to first clipping than the others; only wind and exposure will make more of this fruit in later clippings than first.

How to Clip Fruit.—The grower should provide himself with proper ladders, which may be extension or self-supporting. First, though, he should secure careful, trustworthy men, who will not think it too trivial to carry out the details which must be observed in order to secure success. Do not hurry them; recollect that, although their time costs you money, you will make more by giving them all the time necessary to do this work well, and should not be hired to pick by box or piece. I have never used rings for measurement, although some growers do. It may be an advantage in getting the exact size, yet there is a disadvantage in the fact that some lemons are ready to come from the tree a little smaller than others, and although purchasers desire mostly the three hundred size, yet three hundred and sixty, three hundred and twenty-four, as well as two hundred and fifty are good sizes. Also, the gloves and clip-pers which the workmen have to use with the rings delay the work. The eye of a good workman is all that is needed, and if he is at times

at a loss his forefinger and thumb around the lemon will, after he has the diameter, approximate the size wanted. I like oval baskets, holding about sixty to seventy-five lemons, lined with burlap, which may be carefully tacked in the bottom, being sure to cover the heads of tacks with the cloth. *Never clip lemons into sacks.* Fastened to the handle of the basket may be a stout, bent wire to attach the basket to the ladder or tree. Never pull the fruit; always clip. Put the fruit in the basket carefully, and when full empty into the picking box, first throwing a loose sack into the box so that it will break the fall of the fruit. The basket being oval, one end is put into the box, and then withdrawn, leaving the fruit in the box, and bruising avoided. Some take the fruit from the basket by hand and place into the box. This is very safe, but time can be saved by my way, but care must be used. After the first basketful is emptied the loose sack can be gently taken from under the lemons and used for the next. The size of picking boxes is immaterial. I use boxes that are twenty-four inches long, fifteen inches wide, and nine inches deep. Do not expose the fruit to the sun after clipping, and remove it in the boxes carefully the same day into the hallway of the lemon house. When clipping lemons do not leave a long stem, as in handling the stem will injure the fruit next to it.

HOW TO KEEP FRUIT.

We place our boxes of lemons in the hallway of the lemon house—if in early winter on the south side, if in late spring or summer on the north side, next to outside boarding of inside room. The main doors are kept closed, the ventilators open, and the excessive moisture will evaporate from the fruit in about four weeks in winter months, and from two to three in summer; then put the lemons away. Now provide yourself with trays just the size of raisin trays, only deeper; the ends should be one and one half inches deep, and nail a lath on each side, to keep the fruit from rolling out. I have utilized my raisin trays, and nailed one and one half inch pieces on the ends. Select one corner of a room which, to prevent loss of space, could be made a little larger than is necessary, for a number of tiers of trays. Under each tier put a closed empty tray—or two would be better—as I find the fruit next to the bottom as well as top cures faster and shrivels more. Upon this foundation put your tray for the first lot of lemons, which carefully empty from the picking box. It would be best to begin two tiers of trays at once, so that the lemons that are left over from filling the first tray, with *only one* layer, can be put on the second. Of course throw out as you come to them all imperfect fruit. In this way build up your tiers of trays as high as you conveniently can, using your empty picking boxes for staging. Lastly cover the top trays with one or two tight trays. In this way fill your room and keep your inside doors open for a few days, afterward close through the day and open through the night, according to the moisture in the room, which should be kept comparatively dry. After the lemons are once put away on trays, and if they have been properly cared for before, and the rooms looked after as I have advised, there will be no need of disturbing them until wanted for packing, even if it is four, six, eight, ten, or twelve months after. A few will spoil, say from 2 to 10 per cent. Although the lemons at first touch each other in the *one* layer on the tray, they will contract so that if any

spoil they will not often affect the next ones, and the few spoiling lemons give a little necessary moisture to the air of the room. This is all. You can look in from time to time to notice condition. If a ventilator is put in ceiling of inner rooms you will have to be careful of draughts, and perhaps use less door opening and closing.

MARKETING THE LEMON.

This brings me to my lastly, and I am going to plead a degree of ignorance, for I have been unable to follow the fruit in its travels so as to know the reason why some of the same fruit will reach its destination and give perfect satisfaction while other boxes of like fruit handled in the same way are reported as spoiled. However, as I have shipped lemons and oranges together, I find that just as large a percentage of oranges spoil as lemons, and I conclude, first, that the carrying facilities are faulty—different compartments for perishable fruits are necessary where less than carload lots are sent—and that our cars are very faulty in construction. Second, I advise that the strongest influence be brought to bear upon railroad authorities to prepare better cars for fruit. If some one could experiment on the different methods of conveying fruit over the continent something might come of it. It seems hard upon the shipper, after he has done his best and succeeded, that his work should be so marred because those who receive a high price for doing their part do not seem to care for anything but the money that is in it for them. There should be the most amicable feelings between the fruit grower and the railroad company, because each is necessary for the other, and both are necessary for the prosperity of the country. I dwell upon this because it is now the great barrier which rears itself up before our great lemon industry, and the sooner something is done to reduce this obstacle of 10 per cent loss in transportation and high price of freight for less than carload lots, the quicker will both railroad and grower reap larger profits. Could not the railroad appoint some competent man to go with each train of fruit and look after the condition of every car all along the journey, regulating the ventilation, etc.? Reports from fruit shipments read "fruit heated," "fruit chilled," "fruit rotted," etc., until the shipper gets weary and his pocketbook grows thin.

LEMON HOUSE.

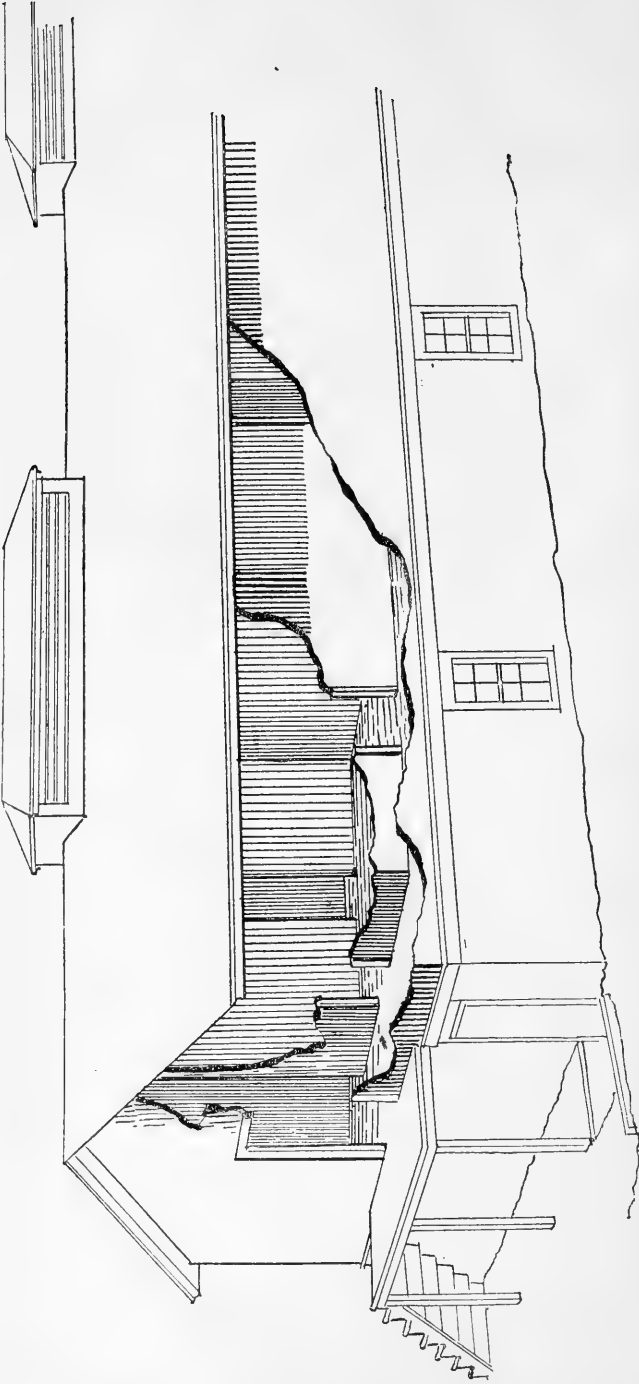

PERSPECTIVE VIEW SHOWING INTERIOR

LEMON HOUSE AND PROCESSING ROOMS OF G. W. GARCELON, RIVERSIDE.

LEMON HOUSE.

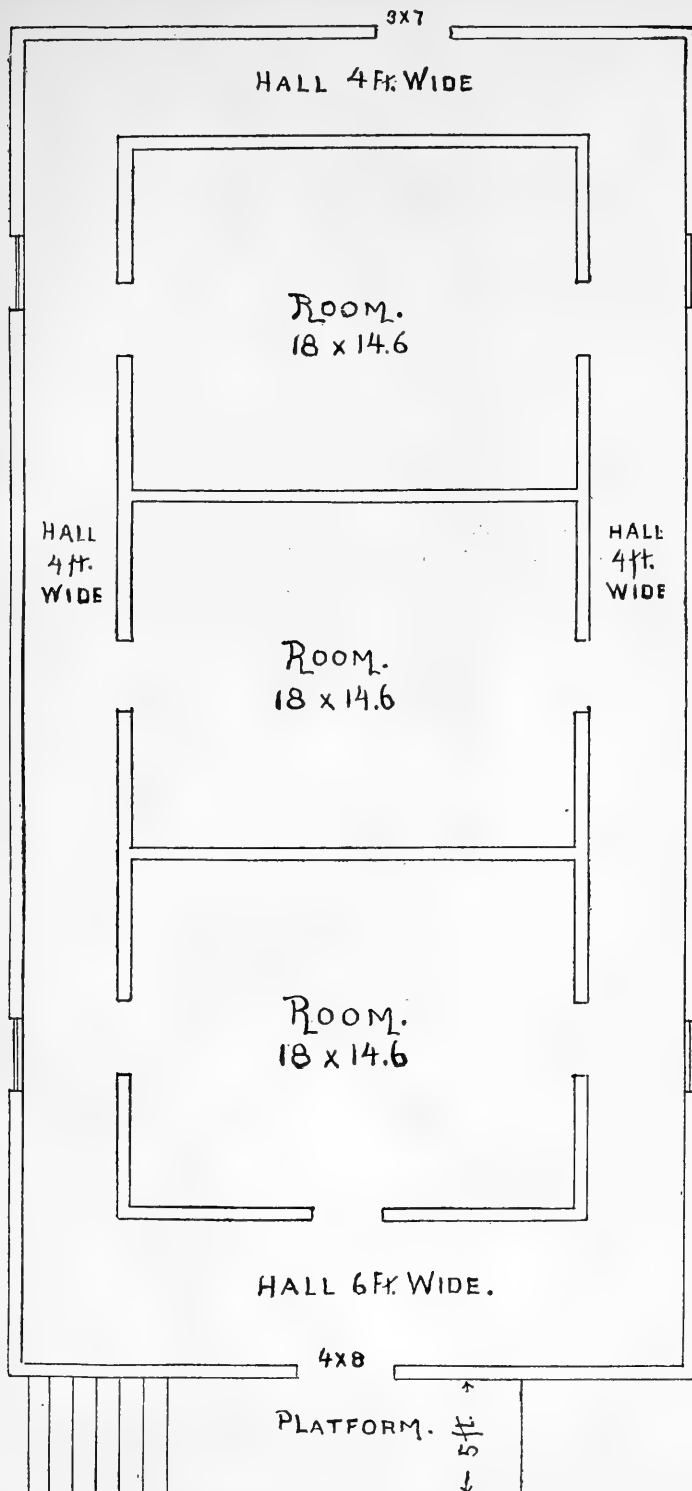

MAIN FLOOR

The outside of all the rooms is boarded with tongued and grooved boards. The ceilings of all rooms are plastered—two coats—with rough plaster.

LEMON HOUSE.

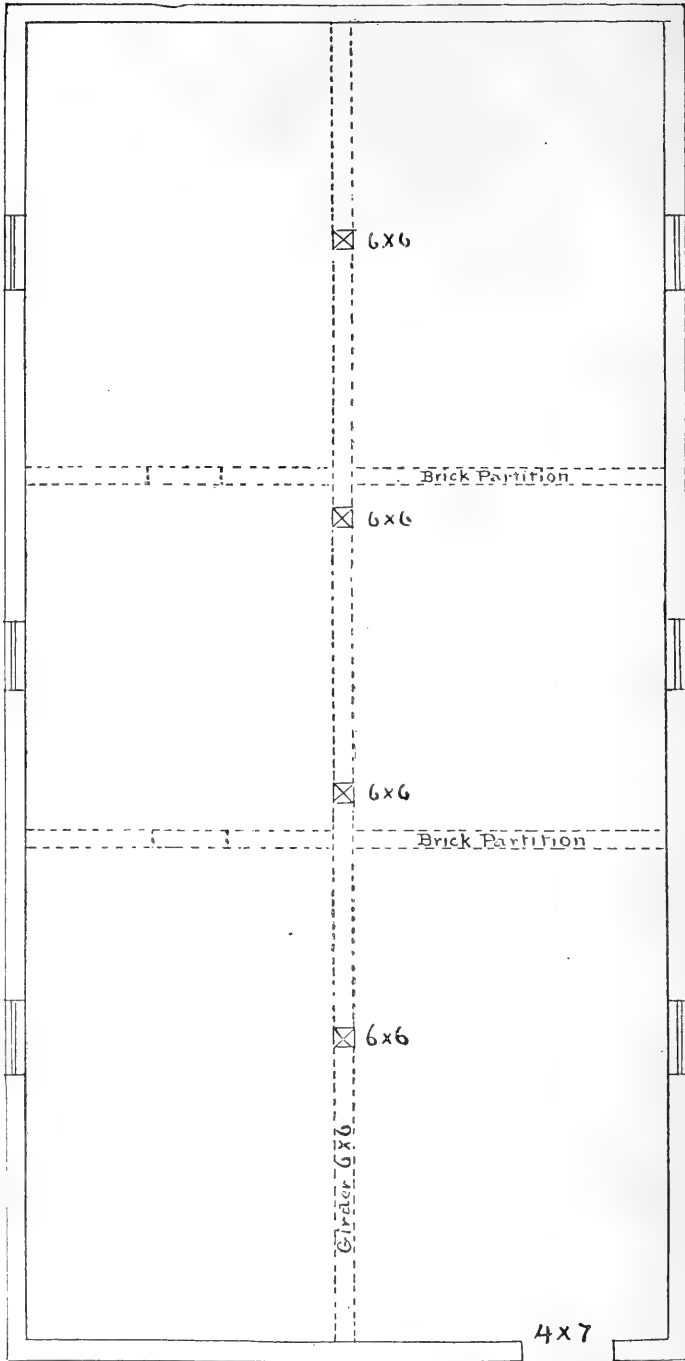

BASEMENT.

The basement is used for storing fresh fruit, box material, etc., and also for packing.

LEMON HOUSE.

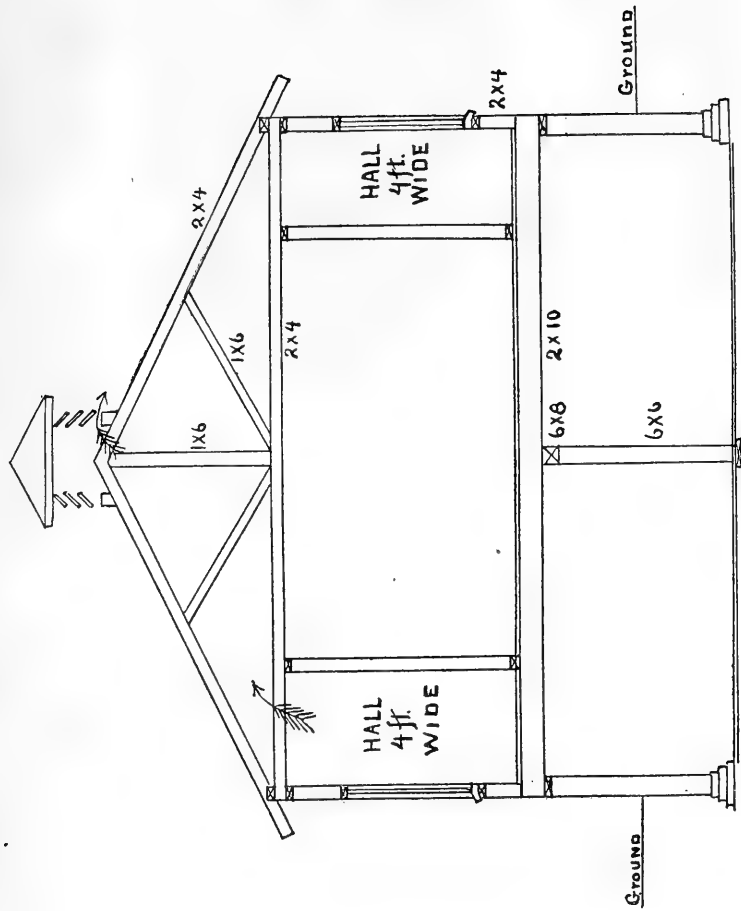

2-F

SECTION

Scale: One eighth of an inch to one foot.

PART II.

NEW VARIETIES OF CITRUS FRUITS.

By B. M. LELONG, Secretary of the State Board of Horticulture, and ex officio Chief Horticultural Officer.

For some time past there has been considerable inquiry as to new varieties of citrus fruits, and especially in regard to those lately introduced. In 1888 we published a very complete list of the varieties then in cultivation, and the merits of each. In that list appeared many varieties which did not come up to the expectations of those who imported them. Recently many thousands of trees have been introduced and planted throughout the State, and among these later importations many of those same varieties that proved of no merit have been reintroduced as "worthy of trial."

"It should always be borne in mind in considering the qualities of the oranges of the different sections of the country, that climate has a marked effect upon this as well as all other fruits. The skin of nearly all varieties is thicker and more free from defects in California than in Florida and Louisiana, and the flavor much more tart. The misunderstanding of this fact often leads to much confusion regarding the identity of varieties and their adaptability to certain localities. Those that are very mild flavored should not be grown in Florida, because they become insipidly sweet; and those of very tart flavor become really sour in California. If such kinds are planted reversely to the above, they will in both cases be much improved."*

In the past two years, and last year especially, I received several hundred specimens of these discarded kinds for identification. It is to be regretted that many of those planting extensively hardly ever question the merits of the variety, as long as the trees offered them are large and cheap. It is the extensive planter who mostly falls into this error. The small planter seldom ever buys a tree without examining it critically, and the honesty of the nurseryman growing it questioned. Were this rule followed by all who plant orchards, less inferior fruit would find its way into the market, which tends to injure the sale of the choice article.

It is the duty of this department to examine into the relative merits of such varieties, and new fruits, as come under its notice, and to report such facts of general interest to the public. No sooner is such a report made than we are flooded with inquiries asking, in the main, as to where and from whom they can be purchased, etc., information which we must decline to supply, and suggest that in future such communications be addressed to nurserymen.

* Professor H. E. Van Deman, Chief Pomologist, Report Department of Agriculture, 1887, p. 638.

A NEW ORANGE.

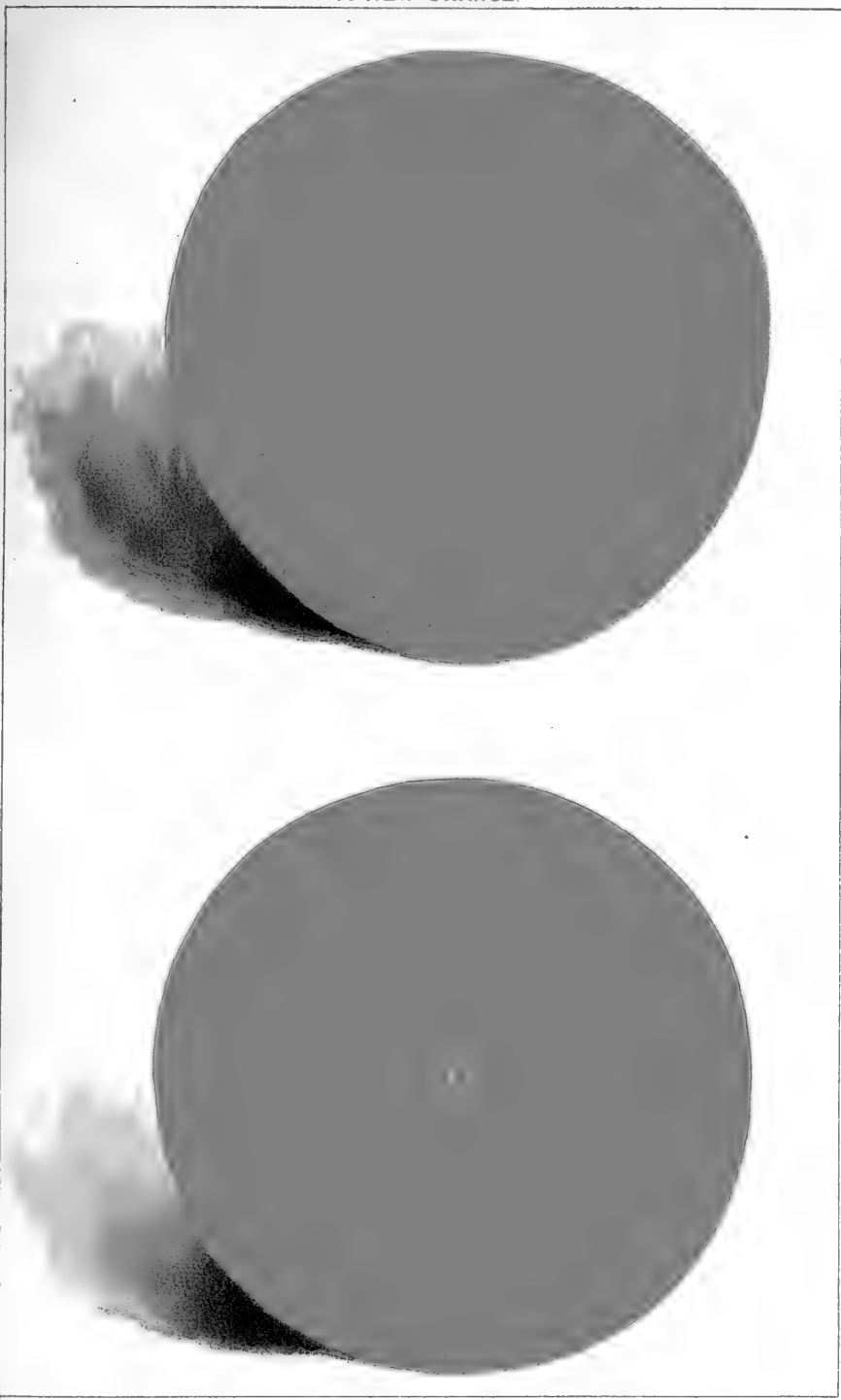

THE "JOPPA"

THE GILES COMPANY, UTAH, U.S.A.



1848



JOPPA.

[Colored Plate*.]

This is a remarkable orange, as it can be marketed early, being sweet and of a fairly high flavor from about the time it commences to color. In this respect it compares favorably with imported oranges often seen in our markets—picked quite green for transportation. It has the characteristics of an orange that comes nearer meeting the wants of all sections than any other, as it can be marketed early and yet remain on the tree till May and June without deterioration in quality.

At the December (1890) meeting of the State Horticultural Society, I exhibited specimens which were picked of a quite green color, but were highly flavored and sweet.

“The orange is large, seedless, exceedingly fine grained, and free from ‘rag,’ the significant term which is applied to the fluffy white layer which lies between the true skin and the pulp. The orange, though seedless, has no rudimentary seed vessel which forms the characteristic mark of the Navel orange, and occupies part of the space of the fruit with a non-edible material.”†

At the June (1891) meeting of the same society, I again exhibited specimens of the Joppa, and which were then in prime condition.

Fruit (see colored plate).—Very uniform, oblong, medium to large, firm, practically seedless, distinguished by a well defined corona at the blossom end; thin rind, solid and free from rag; pulp very fine, sweet, and juicy; resembles the pulp of the Washington Navel. The fruit does not drop from the tree, is very tenacious, and of a deep red color.

Tree.—Thornless, an upright and vigorous grower, attains the bearing surface of thrifty seedlings, and is a heavy bearer. A ten-year old tree from the bud, at Mr. Chapman’s, now measures eighteen feet in height and fourteen and one half feet in diameter; foliage large, dark green, symmetrical, and very abundant; leaves large, lanceolate; petiole prominently winged on either side.

Origin.—Mr. A. B. Chapman, of San Gabriel, was connected for a number of years with the law firm of Glassell, Chapman & Smith, of Los Angeles, who were the attorneys of the Southern Pacific Railroad. In 1877, in conversation with the late Charles Crocker and General D. D. Colton, on their return from the Mediterranean, and while on a tour of inspection, wherein the building of the Santa Ana branch was in contemplation, they praised an orange they had seen at Joppa, Palestine, above all others. Mr. Chapman sent to the American Consulate at that point for some seeds (instead of buds) of that orange, not thinking they would produce different fruit. He received from the Consul some seeds, which he planted that same year. Many plants were thus obtained, and when large enough were set out in orchard. All of them bore fruit of different quality, as is natural in growing trees from the seed. This one had then attained the size of large seedlings, and bore this superior and handsome orange, which was readily distinguished by its fine texture, deep red color, smooth skin, and other marked character-

* Lithographed by the H. S. Crocker Company, of San Francisco. The reason their name does not appear on the plate, is because the work was first undertaken by another firm.

† “Pacific Rural Press,” January 10, 1891, commenting upon specimens exhibited.

istics, which Mr. Chapman named "Joppa," in order to indicate the locality of its original home in the Holy Land.

RUBY.

[Figure 1.]

"A new orange of superior quality, recently imported. Tree strong, of vigorous growth, and nearly thornless. Fruit rather below medium size, nearly round, skin very thin and smooth, pulp in March and April ruby-red."*

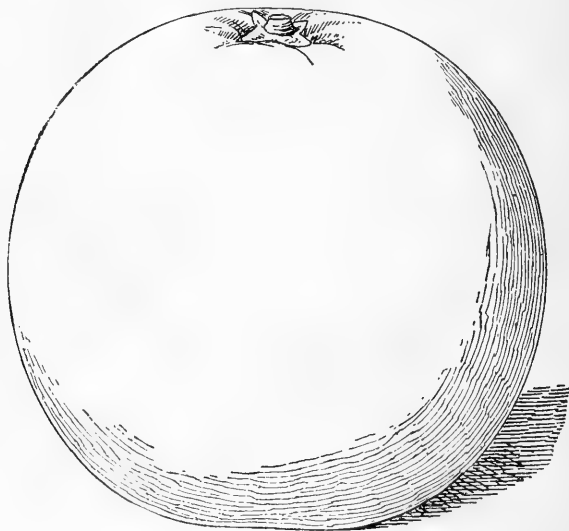

Fig. 1.

While at Riverside, July 21, 1891, Hon. E. W. Holmes showed me specimens of this orange grown by him. They showed no indications of deterioration, notwithstanding the lateness of the season. The specimens were in their prime, the flavor very good, and resembled the Maltese Blood to a considerable extent. The pulp was somewhat of a marked, vinous red, but not so prominent as in the Maltese Blood. There were no indications of "blood" coloration on the surface of the rind as is noticeable in the Maltese Blood. I was highly impressed with the orange, and think it will be worth propagation by those desiring to propagate an orange of vinous red, or "blood-stained" pulp. Mr. Holmes informed me that it was a very good grower and a late keeper.

PARSON BROWN.

[Figure 2.]

This is a favorite early orange in many parts of Florida, and will no doubt come into favor in this State after its merits become better known.

Trees imported in recent years from Florida have commenced to bear. Fine and highly colored specimens were shown at the Marysville Citrus

* Bulletin No. 1, Division of Pomology, Washington, D. C., 1887.

Fair last spring. These, however, having been grown on red soil highly impregnated with red oxide of iron, were of a deeper red color than this orange is known to possess.



Fig. 2.

Fruit.—Medium, oblong, and slightly flattened at the stem end, juicy and sweet—is sweet from the time it commences to turn, and has a very smooth skin.

Tree.—Medium thorny, a fair grower, and a good bearer. Originated in Florida.

DAUCY'S TANGIERINE.

[Figure 3.]

This variety has only been introduced within recent years, but many trees bore fruit this year that is quite promising. In another season we

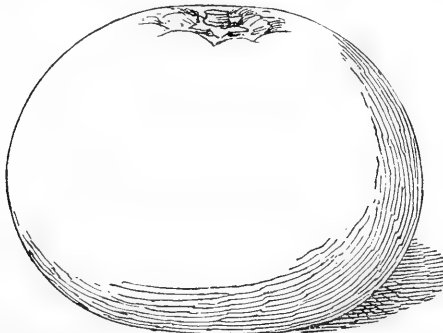

Fig. 3.

shall be better able to judge all its merits, and shall lose no time in making them known to the public. I received this last season samples

of fruit from Florida which I compared with those grown in this State, and judging from their appearance and quality it is a variety well worth propagating. It is a seedling from the China, a variety resembling our Mandarin, but of a better quality.

“Size small, much flattened, color deeper and more brilliant than parent variety (China). Longitudinal diameter one and three quarters inches; transverse diameter two and one fourth inches; the eye set in a deep cavity seven eighths of an inch in diameter; stalk straight and inserted in a ribbed depression; thickness of skin three sixteenths of an inch; general properties of pulp same as parent, only superior; fruit nearly seedless. In flavor and external appearance this variety is superior to the original. Seminal variety of the Tangierine raised by Col. F. L. Daucy, Buena Vista, St. Johns County, Florida.”*

“The foliage of Daucy’s Tangierine more nearly resembles that of the ordinary sweet orange than the other varieties of this class; tree thorny and an upright grower.”†

The illustration gives an idea as to size and shape of fruit. The leaf of the trees I have seen resembles the leaf of the Satsuma, but is more pointed. It does not have so much of a dwarfish tendency, but I do not think they will make large trees, as those I have seen seemed to be inclined to branch and spread out and become bushy.

VILLA FRANCA LEMON.

“At the head of the list we place this kind, imported from Europe. Strong, vigorous grower, few thorns, leaves long and pointed, very hardy; fruit oblong, thin skinned, and of superior flavor; ripens in July and August, and often has a second crop later—in November and December. The best shipping lemon we know.”†

After seeing trees of this variety fruiting for two seasons, I became so favorably impressed with it that in 1886 I secured a few buds from trees imported direct from Europe, and budded them into several orchard trees in the A. S. Chapman grove at San Gabriel. The growth the buds made was really astonishing. In one season they had formed a large and symmetrical top. The year following several lemons were seen on the trees, and from that time on they have continued to bear fruit. Mr. Chapman says that he, also, is very favorably impressed with this lemon, and thinks it will prove a valuable variety to propagate.

“We have this year fruited it, and can say from personal knowledge that it ranks among the first three varieties yet known in the United States. As the specimens tested were grown on young trees, they probably were not as smooth and fine-textured as they would have been if grown on mature trees; certainly not so nice in appearance as the Lisbon, which we deem the standard. But, upon sweating, the skin thinned down excellently, and showed a texture which inclines us to expect it to prove a fairly good keeper. The acid is strong, the aroma excellent, and in the specimens thus far we have discovered no seed. It has stood the test used to develop bitterness, and it is superior to the Eureka and equal to the Lisbon in this respect. If it shall prove a lemon which will keep as well as the Lisbon—which can only be thoroughly proven when it comes into extensive bearing—it will be the

* Report of Committee of Florida Fruit Growers Association.

† Bulletin No. 1, Division of Pomology, Washington, D. C., 1887.

equal of any lemon grown. The tree will stand frost better than the Eureka, and perhaps as well as the Lisbon; is more inclined than the latter to be an early bearer, and we can but pronounce it a thoroughly safe variety to plant. The only reservation we make is in regard to its keeping qualities, and of this we cannot know until it is handled in considerable quantities.”*

Fruit.—Medium size, oblong; slightly pointed at the blossom end; rind thin, without any trace of bitterness, even when green; acid strong; juicy; practically seedless.

Tree.—Practically thornless; branches spreading and somewhat drooping; foliage sufficiently abundant to prevent the fruit from scorching. This variety has the name of withstanding a lower temperature than other imported varieties.

PEAR-SHAPED LIME. (Castleman.)

[Figure 4.]

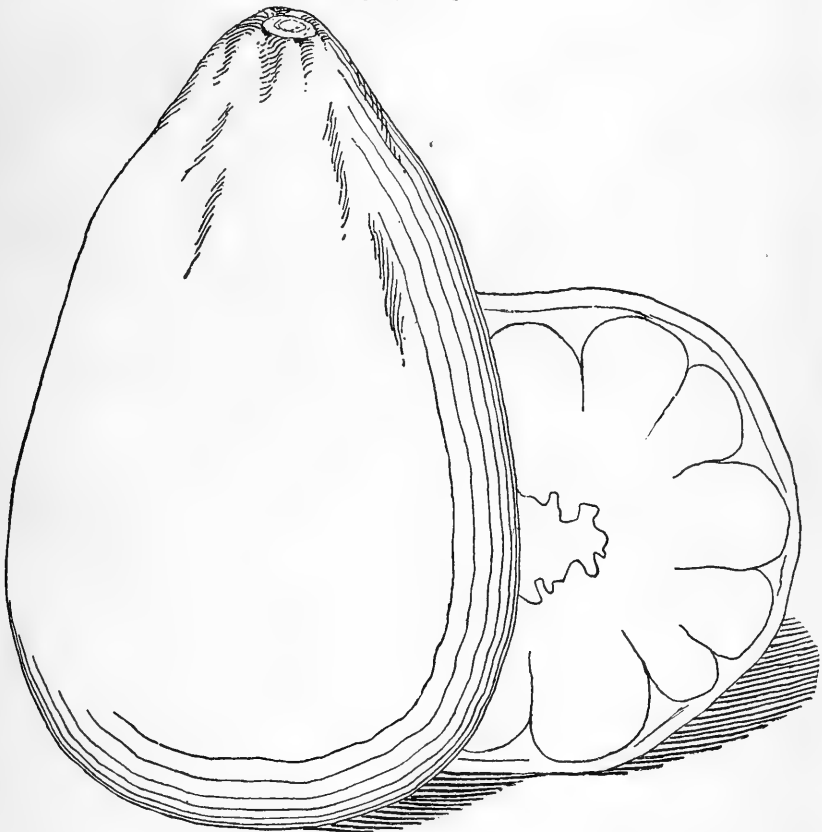

Fig. 4.

Fruit.—Large, pyriform, of a pale yellow color, with smooth, thin skin, and strong aroma of pomelo. Pulp juicy, with strong acid like the

* “Riverside Horticulturist,” April 29, 1891.

Mexican lime; seeds few and small. The fruits are treated the same as lemons, and are picked just as they begin to assume a yellowish cast.

If allowed to hang on the tree too long, becomes coarse and "puffy;" also a large cavity forms in center, which greatly tends to injure its shipping qualities. The outline illustration shows the size of the cavity and thickness of skin.

Tree.—Ornamental sort; very large, hardy, and prolific; leaf small, somewhat like the leaf of the Mexican lime.

Origin.—Mr. I. S. Castleman, of Riverside, several years ago purchased a number of citrus trees from the Garey Nursery at Los Angeles, and among the lot was this one, which is, no doubt, a sport, or perhaps crossed with the lime and pomelo. The tree serves both purposes—that of being ornamental as well as useful.

CITRON OF COMMERCE.

Newly introduced varieties sent to Hon. Frank A. Kimball, of National City, by the Department of Agriculture, for propagation and distribution.

On May 17, 1890, Mr. Kimball received one hundred plants of the following varieties: Forty Amalfi, thirty Serrento, and thirty Calabria. They arrived in excellent condition, having been shipped from Naples, Italy. Every plant had on it more or less scale insects; some of them were completely covered, so the bark could hardly be seen. The trees were denuded of every leaf, which, with the packing cases and coverings, were burned, and the trees disinfected, and were then planted (instead of being distributed to more than thirty individuals scattered through the five southern counties of the State, as he was directed to do by the department). Although Mr. Kimball worked faithfully to rid them of all scale, yet says he cannot even now say that a single scale could not be found on those which he retained for himself. He examined every tree before distributing, and not one has been sent out which was not perfectly clean. Mr. Kimball retained three trees of each variety for his own planting. When the trees were distributed he trimmed them to balance the loss of roots which were necessarily destroyed in digging. The small branches thus cut off he used for budding sticks, and thus saved some eight or nine hundred buds, which he had inserted in three-year old orange stocks, and finds that he has some exceedingly robust trees. Many of those which were budded June 1, 1890, were four feet high on December 1, 1890, and had branches which spread more than three feet. He has planted some six hundred of these trees and they are doing finely; many of them are loaded with fruit. On some of them he has counted about one hundred fruits, which of course he cut off, except one on each branch. The first buds he set were taken from trees which he feared might not survive, so he determined to save the varieties by cutting out buds, some of which were not larger than two kernels of wheat. From these he now has trees about five feet high, with branches spreading four feet.

June 18, 1890, he received ten trees, varieties as follows: Two Pomo de Adamo, two Macrocarpo, two Icompio, two Pireltono, and two "Citrus Medica" (?). These were shipped from Palermo, Sicily, and arrived in a very enfeebled condition, an attempt having been made to pack a box with ten trees, in which not less than fifty should have been packed,

loose earth having been thrown over the roots, with nothing to keep it in place; the result being that the earth was spread all over the bottom of the box, five feet long and fifteen inches wide, leaving the roots of the trees bare. He only saved four trees and a few buds, which are doing well—the buds especially.

On October 30, 1890, he received fifteen citron trees from Catania, Sicily. Varieties: Eight Cedro Vara, three Testa de Turco, two Pirel-tone, and two Limonzania, which had been budded on old stock, and from some cause had very poor roots; in fact, Mr. Kimball says he never before planted trees which had so poor a chance to live. Of these he saved seven.

None of these varieties have been described with any degree of accuracy, and their value can only be determined by growing the fruit and preparing the product for market, which Mr. Kimball hopes to do. Mr. Kimball says:

From a good deal of correspondence with Prof. H. E. Van Deman, Pomologist Department of Agriculture, as well as with American Consuls in the Mediterranean country, I am satisfied there is a mine of wealth in the growing of the citron. To Prof. H. E. Van Deman Southern California is indebted to an extent not at present conceived of. I have seen no other tree which has so quickly adapted itself to our conditions, nor one which exhibits such a robust character. The foliage is beautiful, the growing shoots being of a reddish-purple color, and very rich; the ripened leaves are not so dark as orange leaves, nor yet so light as the lemon; they are very fragrant. The flowers are very similar to the lemon, but have the fragrance of the orange. I hope to see every family in Southern California growing their own "citron."

Mr. Kimball, in a supplemental note, says:

I have no hesitation in saying that from all I can learn the citron will pay an enormous profit, as the fruit may be kept many months after it is picked, and may be processed by any one who can prepare preserves of any kind. Among the varieties there are some which bear fruit weighing six to eight pounds, and the price in Sicily seldom falls below 6 cents per pound when picked, and later on a much higher price. I have distributed nearly one hundred of the original importation, and thousands of buds.

SUPPLEMENTARY.

Imports and Exports of Citrus Fruits—Number of Trees in the State—
Temperatures of Italian, Floridan, and Californian Citrus Belts—
Acreage, etc.

ORANGE AND LEMON TREES IN CALIFORNIA.

*Schedule Showing the Number of Orange and Lemon Trees in the State up to September 17, 1891,
Collected from Reliable Sources.*

COUNTY.	Bearing.	Not Bearing.
Alameda—Orange trees	722	1,874
Lemon trees	525	622
Amador—Orange trees	72	44
Lemon trees	54	18
Butte—Orange trees	3,007	116,005
Lemon trees	362	1,400
Calaveras—Orange trees	145	85
Lemon trees	18	200
Colusa—Orange trees	195	6,728
Lemon trees	44	54
Contra Costa—Orange trees	155	243
Lemon trees	118	140
El Dorado—Orange trees	108	176
Lemon trees	30	265
Fresno—Orange trees	1,113	4,828
Lemon trees	400	980
Kern—Orange trees	425	852
Lemon trees	275	365
Lake—Orange trees	125	236
Los Angeles—Orange trees	475,726	511,376
Lemon trees	47,403	29,524
Marin—Orange trees	225	23
Lemon trees	16	-----
Mariposa—Orange trees	28	145
Lemon trees	18	115
Merced—Orange trees	325	625
Lemon trees	215	420
Monterey—Orange trees	75	146
Lemon trees	14	-----
Napa—Orange trees	455	920
Lemon trees	378	254
Nevada—Orange trees (estimated)	100	200
Orange—Orange trees	89,260	51,769
Lemon trees	5,097	19,969
Placer—Orange trees	6,055	5,480
Lemon trees	595	1,300
Sacramento—Orange trees	1,310	12,300
Lemon trees	166	976
San Bernardino—Orange trees	391,656	1,895,544
Lemon trees	24,066	155,934
San Diego—Orange trees	26,715	177,311
Lemon trees	7,006	58,916
San Joaquin—Orange trees	112	2,640
Lemon trees	22	65
San Luis Obispo—Orange trees	1,200	4,600
Lemon trees	600	1,950
San Mateo—Orange trees	126	244
Lemon trees	50	-----
Santa Barbara—Orange trees	6,700	37,500
Lemon trees	3,750	9,400
Santa Clara—Orange trees	920	415
Lemon trees	156	175

ORANGE AND LEMON TREES IN CALIFORNIA—Continued.

COUNTY.	Bearing.	Not Bearing.
Santa Cruz—Orange trees	120	96
Lemon trees	44	80
Shasta—Orange trees	74	125
Lemon trees	44	
Solano—Orange trees	1,303	2,114
Lemon trees	189	215
Sonoma—Orange trees	1,619	1,466
Lemon trees	255	840
Stanislaus—Orange trees	1,154	16,642
Lemon trees	254	314
Sutter—Orange trees	353	3,144
Lemon trees	27	125
Tehama—Orange trees	380	866
Lemon trees	104	114
Tulare—Orange trees	1,580	1,750
Lemon trees	455	1,430
Ventura—Orange trees	8,644	55,056
Lemon trees	4,215	32,512
Yolo—Orange trees	485	856
Lemon trees	214	309
Yuba—Orange trees	3,132	18,027
Lemon trees	327	

SUMMARY.

Orange trees—Bearing	1,025,899
Not bearing	2,932,451
Lemon trees—Bearing	97,486
Not bearing	318,981
Total orange and lemon trees in the State	4,374,817

NOTE.—The counties that are omitted do not grow citrus fruits, but in most of them orange and lemon trees are seen in gardens, planted for ornamentation.

Trees over five years old after planting are classed as bearing; under five years old as not bearing; and includes those of this year's planting.

NUMBER OF LEMON AND ORANGE TREES IN CALIFORNIA IN 1870.

(From Assessors' Statements.)

COUNTY.	Lemon.	Orange.
Alameda	88	64
Amador	130	120
Calaveras	10	28
Colusa	10	20
Contra Costa	35	80
Del Norte	6	4
El Dorado	8
Fresno	10
Kern	15	53
Lake	15
Los Angeles	3,700	34,000
Merced	10	5
Monterey	47
Napa	24	50
Nevada	15	120
Placer	40	62
Sacramento	275	542
San Bernardino	415	875
San Diego	290	233
San Joaquin	12	30
San Luis Obispo	50	50
San Mateo	10	15
Santa Barbara	1,200	1,508
Santa Clara	25	167
Santa Cruz	25	60
Sierra	2	1
Solano	27	81
Sonoma	40
Stanislaus	10
Sutter	21	60
Tehama	8	14
Tulare	374	129
Tuolumne	150	70
Yolo	12	217
Yuba	60	250
Totals	7,086	38,991

ORANGES AND LEMONS EXPORTED IN 1890.

	Pounds.
<i>By the Southern Pacific System—</i>	
San Francisco*	144,500
Marysville	20,850
Los Angeles	7,477,120
Colton	10,801,850
Total	18,444,320
Or 9,222 tons; or 922 carloads.	
<i>By the Santa Fe System—</i>	
From all points (South of Tehachapi)	49,975,000
Or 24,987 tons; or 2,498 carloads.	

ORANGE AND LEMON CROP OF 1890-91.

Cars	4,600
Boxes	1,380,000
Tons	48,300

* The shipments given from this point consist of fruit received from different parts of the State, but mostly from Southern California.

ORANGE CROP OF 1889-90.*

	Boxes.
Riverside	340,000
Los Angeles, outside of Pasadena and Pomona	450,000
San Diego	30,000
Anaheim	35,000
Pomona	22,000
Pasadena	30,000
San Bernardino, Colton, and Highland	20,000
Ontario and vicinity	2,000
Santa Ana, Orange, and Tustin	86,000
Redlands and Old San Bernardino	25,125
Ventura	15,000
Santa Barbara	2,000
Oroville	2,860
Yuba	5,000
Placer	2,500
Santa Clara	1,000
Fresno	500
Sutter	300
Solano	150
Total	1,069,435

ORANGES SHIPPED IN 1888-89.*

Los Angeles County:	Boxes.	
Los Angeles	23,412	
Winthrop	46,281	
Vernondale	40,940	
Dodsworth	13,008	
Tropico	20,988	
Alhambra	39,596	
San Gabriel	24,442	
Savannah	14,363	
Pomona	16,500	
Rivera	31,310	
Lamanda Park	15,500	
Pasadena	43,400	
Duarte	29,140	
Azusa	11,160	
Other places	30,807	
Total		400,847
San Bernardino County:		
San Bernardino	4,030	
Riverside	260,661	
Colton	5,656	
Redlands	15,169	
Ontario	600	
Highlands	3,650	
Other places	5,281	
Total		295,047
Other counties:		
Orange	92,896	
Santa Barbara	17,000	
San Diego	10,250	
Ventura	10,886	
Total		131,032
Grand total		826,926

* Report Internal Commerce of the United States, 1890, p. 318.

SAN GABRIEL AND RIVERSIDE SHIPMENTS.

(Compared with former years.)

SAN GABRIEL.

Oranges and Lemons Shipped from San Gabriel.

1876-7.....	14,305 boxes.
1878-9.....	43,856 boxes.

Acreage.

1877 (oranges and lemons).....	1,300 acres.
1880 (oranges and lemons).....	2,206 acres.

Trees Planted.

Orange—		
1877.....		71,793
1880.....		134,252
1877 (in bearing).....		5,752
1880 (in bearing).....		28,734
Lemon—		
1877.....		10,806
1880.....		11,885
Lime—		
1877.....		3,397
1880.....		5,544

Total Number of Citrus Trees.

Covering San Gabriel, Alhambra, Pasadena, and Duarte.

1877.....	86,285
1880.....	155,278

From 1877 to 1880 there was an increase of 12,671 trees in San Gabriel, or 181 acres a year.

Total Number of Oranges, Lemons, and Limes Shipped.

1876-77.....	2,383,166
1878-79.....	9,209,760

Entire Fruit Crop of 1878-79.

	Boxes.
Oranges.....	40,932
Lemons.....	2,619
Limes.....	305
Total.....	43,856

Total Value of Fruit Crop.

1876-77.....	\$47,683 32
1878-79.....	92,097 60

The citrus fruits shipped from San Gabriel from the crop of 1878-79 were raised by thirty-five persons, and out of the 43,856 boxes sold 36,440 were sold by ten persons, leaving only an average of 300 boxes each to the twenty-five other fruit growers. The oranges shipped from the crop of 1878-79 averaged 210 to the box; 40,932 boxes contained 8,595,720 oranges; value of crop, \$85,957 20. Total number of bearing trees, 28,734; number of trees to the acre, 70; total acres in bearing, 410; value of crop to the acre, \$209 68.

Shipments.

1871, Los Angeles County.....	1,730,000 oranges.
1872, Los Angeles County.....	4,000,000 oranges.
1879, From San Gabriel (about).....	{ 9,000,000 oranges.
	{ 500,000 lemons.

RIVERSIDE.

Oranges and Lemons Shipped from Riverside.

YEARS.	Carloads.	Boxes.
1880-81	15	4,500
1881-82	42	12,600
1882-83	45	13,500
1883-84	50	15,000
1884-85	456	136,800
1885-86	506	151,800
1886-87	375	112,500
1887-88	725	217,500
1888-89	982	294,600
1889-90	1,500	450,000
Totals	4,696	1,408,800

Crop of 1890-91—Shipments.

	Carloads.	Boxes.
December	33	9,652
January	111	31,691
February	99	28,125
March	374	106,806
April	338	97,108
May	163	46,884
June	243	69,239
July (up to July 23d)	51	12,823
By express	4	1,200
Totals	1,416	403,028

CHIEF PRODUCING COUNTIES.

ORANGE AND LEMON TREES GROWING IN SAN BERNARDINO COUNTY.

1889—Orange trees, four years old and over	391,656
Orange trees, three years old and under	472,826
Lemon trees, four years old and over	24,066
Lemon trees, three years old and under	7,009

Total planted

895,557

Trees in Nursery.

1890—Orange	426,356
Lemon	75,000
1891—Orange	591,973
Lemon	50,000

In Seed Beds.

1891—Orange	2,526,150
Lemon	50,000

Planted Prior to 1890.

Orange trees	10,175 acres.
Lemon trees	390 acres.
Total	10,565 acres.

Planted in 1890.

Orange trees	3,647 acres.
Lemon trees	1,144 acres.
Total	4,791 acres.

Planted in 1891.

Orange and lemon trees 9,316 acres.

Planted to Date.

Orange trees 22,872 acres.

Lemon trees 1,800 acres.

Total 24,672 acres.

ORANGE AND LEMON TREES GROWING IN LOS ANGELES COUNTY, 1891.

Orange trees, ten years old and over..... 327,659

Orange trees, under ten years old and over five..... 148,067

Orange trees, five years old and under..... 511,376

Total 987,102

Lemon trees, bearing..... 47,403

Lemon trees, not bearing..... 29,524

Total 76,927

Orange and lemon trees in nursery..... 2,430,724

Orange and lemon trees in seed bed..... 4,446,600

Total 6,877,324

ORANGE AND LEMON TREES GROWING IN ORANGE COUNTY, 1891.

Orange trees, bearing..... 89,260

Orange trees, not bearing..... 51,769

Lemon trees, bearing..... 5,097

Lemon trees, not bearing..... 19,969

Total 166,095

ORANGE AND LEMON TREES GROWING IN SAN DIEGO COUNTY, 1891.

Orange trees, five years old and over..... 26,715

Orange trees, under five years old..... 177,311

Total 204,026

Lemon trees, five years old and over..... 7,006

Lemon trees, under five years old..... 58,916

Total 65,922

ORANGE AND LEMON TREES GROWING IN SANTA BARBARA COUNTY, 1891.

Orange trees, over five years old..... 6,700

Orange trees, under five years old..... 37,500

Total 44,200

Lemon trees, over five years old..... 3,750

Lemon trees, under five years old..... 9,400

Total 13,150

ORANGE AND LEMON TREES GROWING IN VENTURA COUNTY, 1891.

Orange trees, over five years old..... 8,644

Orange trees, under five years old..... 55,056

Total 63,700

Lemon trees, over five years old..... 4,215

Lemon trees, under five years old..... 32,512

Total 36,727

IMPORTS.

VALUE OF IMPORTS OF ORANGES, LEMONS, AND LIMES INTO CALIFORNIA.

MONTHS.		Lemons.	Oranges.	Limes.
1882—	July			\$19,369
	August			16,870
	September			25,240
	October			25,206
	November			24,349
	December			25,781
1883—	January			20,569
	February			17,932
	March			8,308
	April			13,363
	May			8,348
	June			21,085
	July		\$1,725	12,400
	August	\$581	663	7,322
	September	1,735	844	8,803
	October	307	1,193	6,958
	November			3,884
	December		6,855	6,632
1884—	January		2,228	20,352
	February	135	271	5,312
	March			5,626
	April		4,304	6,828
	May		1,606	3,521
	June		2,500	7,154
	July		1,399	5,478
	August		540	3,238
	September			5,731
	October		6	6,505
	November			4,404
	December		9,063	4,972
1885—	January		110	3,339
	February			3,038
	March			2,445
	April		923	3,146
	May		2,976	2,519
	June		2,182	3,980
	July			3,674
	August		348	4,235
	September			4,362
	October			6,373
	November			3,595
	December		3,731	4,063
1886—	January			1,112
	February			1,441
	March			1,918
	April			2,979
	May		2,199	3,835
	June		1,310	6,307
	July		1,197	3,358
	August			4,718
	September		680	6,343
	October		122	5,557
	November		1,264	5,030
	December		2,471	6,497
1887—	January		79	2,718
	February		313	1,241
	March		1,578	2,046
	April		1,240	2,808
	May	154	1,168	5,631
	June		2,255	4,478
	July		571	5,404
	August			4,117
	September			5
	October		2,876	7,464
	November		1,157	3,918
	December		3,519	2,992

VALUE OF IMPORTS—Continued.

MONTHS.		Lemons.	Oranges.	Limes.
1888—	January		\$1,841	\$3,021
	February		1,478	1,738
	March		52	5,309
	April		770	3,844
	May		985	7,279
	June		985	6,095
	July			7,872
	August		614	4,760
	September		128	5,201
	October		4,041	7,738
	November		4,783	6,118
	December		1,906	8,131
1889—	January		1,399	4,589
	February		390	3,742
	March		16	5,347
	April			4,323
	May		1,149	4,341
	June			6,024
	July		2,145	5,902
	August			8,264
	September		1,152	6,319
	October	\$134	1,399	6,813
	November		4,377	8,855
	December		2,081	4,694
1890—	January		1,061	4,085
	February		1,024	6,396
	March		141	3,963
	April		53	3,599
	May	1,400		4,666
	June	1,250	3,242	10,011
	July		1,264	8,658
	August			5,529
	September		4,360	3,662
	October		5,130	7,597
	November		11,293	3,113
	December		12,496	7,402
1891—	January	695	3,724	2,401
	February	695	476	2,405
	March		276	2,687
	April		39	5,736
	May			7,484
	June	837	2,542	7,902
	July	97		5,210

CITRUS FRUITS IMPORTED INTO THE UNITED STATES.

	1882—Pounds.	1888—Value.	1890—Value.
Oranges	17,686,480	\$2,408,262	\$2,269,149
Lemons	*3,390,604	3,874,968	3,453,398
Limes		40,128	58,959

* Including limes.

IMPORTS OF MEXICAN ORANGES.

PERIOD DURING WHICH IMPORTED.	Boxes.	Value.
December 20, 1884, to June 8, 1885	5,740	\$10,993
December 13, 1885, to May 6, 1886	7,145	10,922
November 6, 1886, to March 30, 1887	7,955	14,654
November 5, 1887, to April 14, 1888	13,823	13,026
November 20, 1888, to April 6, 1889	9,859	15,241
November 4, 1889, to March 17, 1890	13,899	26,424
November 2, 1890, to February 19, 1891	18,346	34,667
Totals	76,767	\$125,867

CITRUS FRUITS IMPORTED INTO ENGLAND IN 1889.

	Bushels.	Value.
Oranges and lemons.....	573,516	\$4,553,380

ORANGE AND LEMON PRODUCT OF ITALY FOR 1880.

Adriatic region.....	85,000,000
Mediterranean region.....	725,000,000
Sicily region.....	1,622,000,000
Total fruits.....	2,432,000,000

TARIFF ON ORANGES, LEMONS, AND LIMES.

Oranges—In packages of 1½ cubic feet or less—Per package.....	\$0 13
In packages of 1½ to 2½ cubic feet—Per package.....	25
In packages of 2½ to 5 cubic feet—Per package.....	50
In packages of over 5 cubic feet—For additional cubic foot or fraction.....	10
In bulk—Per 1,000.....	1 50
Limes and lemons in bulk—Per 1,000.....	1 50

SCALE FOR JUDGING CITRUS FRUITS.

THE CALIFORNIA SCALE.

(Submitted for adoption by J. E. Cutter, of Riverside.)

Preliminary Classification:

Season: Early, December to April 1st; middle, February to July 1st; late, June to December 1st.

Size: Large, medium, small.

Divisions:

Size, form, color, peel, fiber, grain, seed, weight, taste. Possible, 100 counts.

Scale:

1. Size.....	0 to 10
Standards: Large (126s), 3½ inches diameter; medium (176s), 2¾ inches diameter; small (226s), 2¾ inches diameter; Tangierines, etc., 2½ inches diameter.	
2. Form.....	0 to 10
Standards: Round, oval, ovate, pyriform.	
3. Color.....	0 to 15
Of bloom, 0 to 2; of peel, 0 to 10; of flesh, 0 to 3.	
4. Peel.....	0 to 10
Sweetness, 0 to 3; protective quality, 0 to 7.	
5. Fiber.....	0 to 8
6. Grain.....	0 to 4
7. Seed.....	0 to 8
8. Weight.....	0 to 10
9. Taste.....	0 to 30
Sweetness, 0 to 10; citrus quality, 0 to 10; aroma, 0 to 10.	

THE FLORIDA SCALE.

1. Size.....	0 to 10
2. Appearance.....	0 to 10
3. Juiciness.....	0 to 10
4. Thickness of peel.....	0 to 10
5. Absence of seed.....	0 to 10
6. Absence of tissue.....	0 to 10
7. Acidity.....	0 to 15
8. Sweetness.....	0 to 15
9. Bouquet.....	0 to 10

Total points in a perfect orange..... 100

COMPARATIVE STATEMENT, SHOWING AVERAGE TEMPERATURE OF THE
ITALIAN, FLORIDAN, AND CALIFORNIAN CITRUS BELTS.

ITALIAN.

PLACE.	Average Yearly Temperature.....	Average Winter Temperature.....	Average Temperature, coldest month.....	Lowest Temperature.....
Naples	61.3	48.5	47.0	
Rome	60.7	48.9	45.0	
Florence	58.8	44.3	44.0	
Pisa	60.4	46.4	45.8	
Genoa	60.4	44.9	44.0	
San Remo	60.1	48.9	48.0	23.0
Mentone	60.9	49.0	48.7	23.0
Nice	59.5	47.8	40.9	
Cannes	59.5	49.6	48.8	20.0

FLORIDAN.

PLACE.	Average Yearly Temperature.....	Average Winter Temperature.....	Average Temperature, coldest month.....	Lowest Temperature.....
Jacksonville	69.5	58.7	57.4	19.0
Pensacola	68.4	55.7	54.1	16.0
Sanford	71.0	58.0	55.0	28.0

CALIFORNIAN.

PLACE.	Average Yearly Temperature.....	Average Winter Temperature.....	Average Temperature, coldest month.....	Lowest Temperature.....
Poway	50.3	50.2	48.4	21.0
Riverside	61.0	50.4	49.7	26.0
Los Angeles	60.5	50.0	52.0	23.0
Santa Barbara	61.1	54.0	52.9	30.0
Sacramento	60.2	48.3	47.0	18.0
Auburn	59.7	46.2	44.0	18.0
Marysville	64.2	50.0	48.7	18.0
Oroville	64.9	52.0	49.4	20.0

ANALYSIS OF THE ORANGE.

COMPOSITION OF THE ASHES OF THE FRUIT.

CONSTITUENTS.	Analysis No. 1.	Analysis No. 2.
Potash.....	20.15	15.28
Soda.....	10.22	12.14
Lime.....	30.12	30.24
Magnesia.....	9.02	8.10
Phosphoric acid.....	20.04	18.24
Sulphuric acid.....	1.08	4.14
Siliceous acid.....	4.50	5.82
Oxide of iron.....	4.25	4.75
Residue unaccounted for.....	.62	1.29
	100.00	100.00

Weight of the ashes of two hundred pounds of fruit—Analysis No. 1, 7.14 pounds; Analysis No. 2, 6.96 pounds.

COMPOSITION OF THE ASHES OF THE TRUNK, BRANCHES, AND LEAVES.

CONSTITUENTS.	Analysis No. 3— Trunk and Branches.	Analysis No. 4— Leaves.
Potash.....	14.15	10.18
Soda.....	16.67	10.82
Lime.....	31.57	41.22
Magnesia.....	10.64	6.54
Phosphoric acid.....	18.82	19.47
Sulphuric acid.....	4.89	4.53
Siliceous acid.....	2.82	5.48
Iron and unaccounted for residue.....	.44	1.76
	100.00	100.00

Weight of ashes of two hundred pounds—Analysis No. 3, 12.64 pounds; Analysis No. 4, 12.40 pounds. Nitrogen—Analysis No. 3, 1.57 per cent; Analysis No. 4, 1.60 per cent.

Leaving out of account the material required for the yearly production of leaves and buds—as to which precise data are wanting—and taking Analysis No. 1 as a basis, the cropping of thirty-two thousand pounds of fruit from two and one half acres will withdraw from the soil one thousand one hundred and forty-two pounds of mineral constituents, in the following proportions:

Potash.....	Pounds. 230.12
Soda.....	116.72
Lime.....	343.98
Magnesia.....	103.00
Phosphoric acid.....	228.86
Sulphuric acid.....	12.34
Siliceous acid.....	51.38
Oxide of iron and residue.....	55.60
Total.....	1,142.00

Nitrogen, .85 per cent of thirty-two thousand pounds.

The absolute and proportional percentage of the mineral constituents of stable manure is, of course, extremely variable. The following figures are given as the quantity of such constituents usually contained in

sixty thousand pounds of what may be called stable manure of normal type:

	Pounds.
Potash	242
Soda	16
Lime	288
Magnesia	120
Phosphoric acid	102
Sulphuric acid	60
Siliceous acid	300
Oxide of iron	204
Hydrochloric acid	18
Total	1,350

The general composition of these sixty thousand pounds of stable manure may be summed up thus:

	Pounds.
Mineral constituents	1,350
Nitrogen	240
Carbon, hydrogen, and oxygen	10,410
Moisture	48,000
Total	60,000

Suppose sixty thousand pounds of such manure to have been applied to two and one half acres of ground from which a crop of thirty-two thousand pounds of fruit has been raised, let us see what mineral constituents have been replaced and what proportion is still wanting:

CONSTITUENTS.	Contained in Crop.	Supplied by Manure.	Deficiency.
Potash	230.12	242	Excess.
Soda	116.72	16	100.72
Lime	343.98	288	55.98
Magnesia	103.00	120	Excess.
Phosphoric acid	228.86	102	126.86
Sulphuric acid	12.34	60	Excess.
Siliceous acid	51.38	300	Excess.
Oxide of iron	55.60	204	Excess.
Hydrochloric acid	18	Excess.





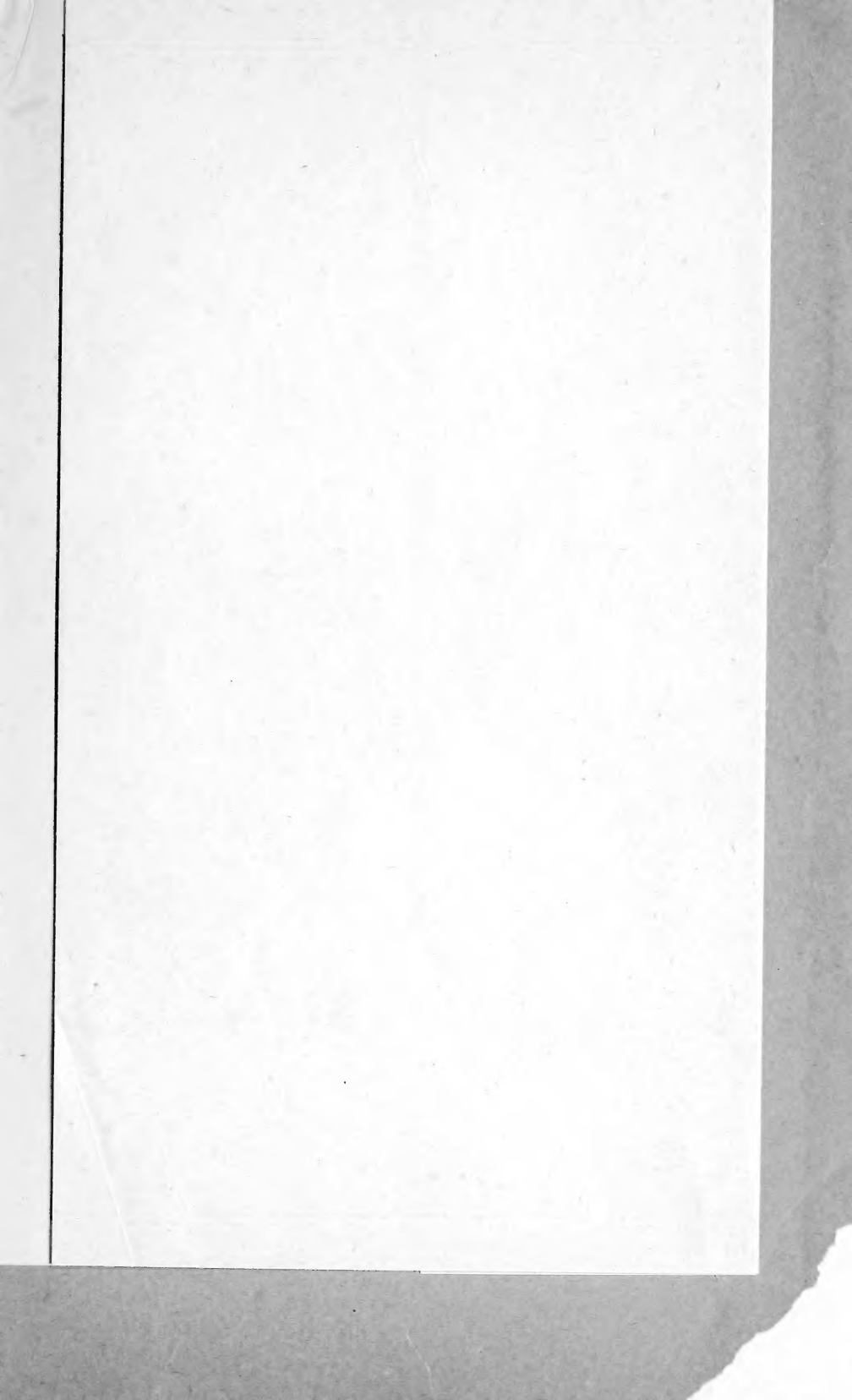

11

MAP
SHOWING THE
CITRUS GROWING REGIONS
OF
CALIFORNIA
PRINCIPAL DISTRICTS

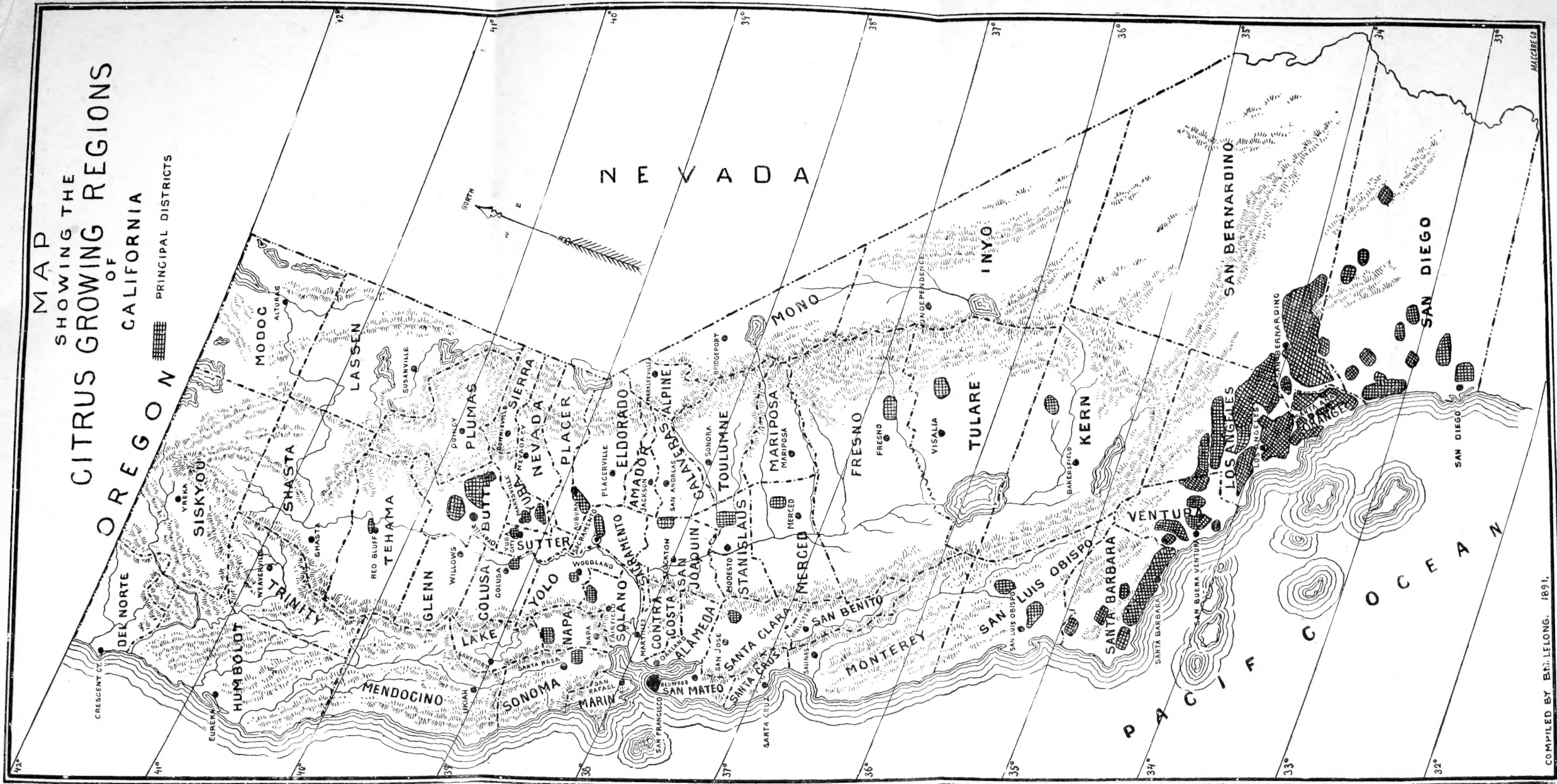

LIBRARY OF CONGRESS



0 000 917 743 7