

CALIFORNIA  
AGRICULTURAL EXTENSION SERVICE

CIRCULAR 79

NOVEMBER, 1933

Control of Injurious Rodents  
in California

TRACY I. STORER

Cooperative Extension work in Agriculture and Home Economics, College of Agriculture,  
University of California, and United States Department of Agriculture cooperating.  
Distributed in furtherance of the Acts of Congress of May 8, and June 30, 1914.  
B. H. Crocheron, Director, California Agricultural Extension Service.

THE COLLEGE OF AGRICULTURE  
UNIVERSITY OF CALIFORNIA  
BERKELEY, CALIFORNIA

# CONTENTS

	PAGE
Introduction . . . . .	3
Ground squirrels . . . . .	8
Burrows . . . . .	9
Feeding habits . . . . .	10
Estivation and hibernation . . . . .	11
Breeding . . . . .	11
Methods of control . . . . .	13
Costs of various control methods . . . . .	19
Tree squirrels . . . . .	19
Pocket gophers . . . . .	20
Burrows . . . . .	20
Breeding . . . . .	22
Damage due to pocket gophers . . . . .	23
Methods of control . . . . .	23
Moles . . . . .	32
Nature of damage . . . . .	32
Methods of control . . . . .	33
Introduced rats and mice . . . . .	34
Breeding . . . . .	35
Nature of damage . . . . .	35
Methods of control . . . . .	36
Meadow mice . . . . .	45
Wood rats . . . . .	46
Kangaroo rats . . . . .	47
Muskrats . . . . .	47
Rabbits . . . . .	48
Black-tailed jack rabbits . . . . .	48
Snowshoe rabbits . . . . .	49
Cotton-tail and brush rabbits . . . . .	49
Methods of control . . . . .	50
Formulas for preparing poisoned baits for rodents . . . . .	52
General precautions . . . . .	52

# CONTROL OF INJURIOUS RODENTS IN CALIFORNIA<sup>1</sup>

TRACY I. STORER<sup>2</sup>

---

## INTRODUCTION

California has a large and varied stock of native rodents, some 270 species and subspecies, to which have been added a few species introduced from other places. Among all these are a few widespread, aggressive, and adaptable rodents of serious economic concern to man because of their ability to thrive in cultivated areas, because of the damage which they do to crops, gardens, levees, or buildings, and because of the diseases which some of them carry and may transmit to man. Several others are of occasional or local concern, while many do no harm whatever, and some are beneficial. The principal injurious rodents are the ground squirrels, the pocket gophers, the introduced Norway, black, and roof rats, the house mouse, and the jack rabbits and cottontails.

The financial loss inflicted by rodents in California is difficult to determine. Gross estimates of more than 20 million dollars annually have been cited. Some specific estimates of earlier years are : ground squirrels, 5 to 12 million dollars; pocket gophers, 8 million dollars; introduced rats, 2 million dollars. Such estimates are necessarily crude and do not consider the probable effect of the additional crop (if saved) upon price depression. Nevertheless individual producers suffer material losses from rodents, and protection by moderate control is thoroughly justified. Losses to cereals by ground squirrels, where unchecked, may amount to 10 or 15 per cent of the crop. Pocket gophers damage field crops in ways not easily measured in crop units; they may injure or kill individual orchard trees. Ground squirrels, pocket gophers, or muskrats may do important damage to ditch banks or levees. Ground squirrels if unchecked may materially reduce the available forage in a pasture. Jack rabbits and—less often—cottontails, may gnaw bark on individual trees or vines necessitating replacements which will need several years to reach productive age. Jack rabbits may seriously reduce the pro-

---

<sup>1</sup> Particular indebtedness is acknowledged to previous publications by Mr. Joseph Dixon in this field (Bulletin 340, Circular 296, Extension Circular 29), material from which is used herein.

<sup>2</sup> Professor of Zoology and Zoologist in the Experiment Station.

duction in a truck patch by eating the young plants. On the other hand, certain rodents, in places, benefit the soil by "cultivation," and in other ways not well understood.

Efforts at suppressing injurious rodents date from the earliest days of farming in California; attempts at ground squirrel destruction were made by the mission fathers. Governmental aid early took the form of bounties paid by counties for squirrels and gophers. The introduction and spread of bubonic plague among ground squirrels in the coastal region of California during early years of the twentieth century stimulated federal and state organizations to reduce the numbers of these animals. In 1917, by legislative enactment, the control of rodents was made a duty of the county horticultural commissioners (now agricultural commissioners), and this led to establishment of cooperative relations between federal, state, and county agencies in the work.

Coordinated and persistent official efforts, together with stimulated activity among landowners, have reduced the ground-squirrel population in many places well below earlier levels.

Cooperative drives, especially during the '90's in the San Joaquin Valley and the coastal area of southern California, and less often in recent years, measurably reduced the jack-rabbit population.

Pocket-gopher control has always been mainly a problem for the individual farmer. Great variation exists in the numbers of these animals today; some large farms, especially orchards, are relatively free of them, while other cultivated areas have as many gophers as under primitive wild conditions, or more.

The introduced rats and mice are a perennial problem in stored products and about buildings where any kind of food is available; reduction of losses involves exclusion rather than destruction. While spasmodic "cooperative" campaigns of trapping or poisoning rats and mice kill limited numbers, there is no lasting effect unless these are followed up at frequent intervals.

The control of injurious rodents is now a function of several governmental agencies. In California, the Bureau of Biological Survey of the United States Department of Agriculture supervises rodent control on federally owned lands and, together with the State Department of Agriculture, advises and helps to direct operations in the counties. The agricultural commissioners in the several counties prepare and distribute poisoned grain for use against ground squirrels; each of the larger counties has one or more special rodent inspectors to study populations and to direct or actually apply control measures. The United States Public Health Service studies rodent-borne diseases and

conducts campaigns against rodents in and about the seaports, while the California State Board of Public Health through its Bureau of Sanitation does similar work elsewhere in the state.

Control on federal lands is financed by Congressional appropriations; supervisory work of state and county officials by appropriations from the state legislature and the county boards of supervisors. Some counties, in the past, have paid for materials and even labor in poisoning rodents by grain baits and gas, but in most counties the individual landowner or tenant pays for materials and either provides or pays for the labor needed to apply such materials to the land. During the decade 1921-1931 the annual expenditures for rodent control were approximately as follows: federal, \$10,000 to \$25,000 (average \$15,000); state, \$10,500 to \$24,000 (average about \$12,000); counties (including both supervision and materials, the latter often refunded by landholders), about \$290,000 to \$554,000; and the landowners have contributed labor estimated to be worth \$100,000 to \$130,000. The total therefore has been from half to three-quarters of a million dollars annually. In 1929-1931 the state expended a special fund of \$100,000 on rodent control work in the plague-infected central coast counties. Most of the funds indicated have been used against ground squirrels, especially the species known as the California ground squirrel. If private expenditures are considered, it is probable that all kinds of rodent control operations in California have involved as much as one million dollars annually in certain recent years. The area treated, in the decade indicated, has varied from 1.9 to 9.2 million acres.

From time to time governmental and private agencies have offered bounties for the destruction of rodents, requiring a scalp or tail as evidence. This system has everywhere proved costly, ineffectual, and open to corrupt practice—in short, unjustifiable. If tax-raised monies are to be used for rodent control, greater benefit will accrue from using trained personnel to direct or execute the operations.

Numerous commercial preparations are sold for rodent control. Besides the elementary poisons such as strychnine, carbon bisulfide, barium carbonate, red squill, and cyanide, various compounded poisons are sold under special proprietary or trade-marked names. Some are satisfactory, a few are dangerous, and others relatively useless. Several commercial houses make up the "government" ground-squirrel poison formula in proper manner; for small applications, such a preparation is economical. But certain proprietary poisons, especially for rat control, are too expensive. If the individual farmer or homeowner does not care to make up the preparations mentioned in this circular he will do well to

consult his local county agricultural commissioner as to the best materials.

It is recommended that methods other than poison be used wherever practicable, thereby reducing the danger to human beings, to domestic stock, and to harmless or beneficial wild animals. Such methods are, therefore, especially emphasized in this circular. Poisons other than strychnine alkaloid against ground squirrels, strychnine against pocket gophers, barium carbonate and red squill against rats, and strychnine against jack rabbits, are not recommended. Various other poisons, such as phosphorus and thallium sulfate, though exploited and used in rodent control operations, either give too uncertain results or endanger other animals or human beings too greatly to be used by individuals in routine rodent control.

Especially to be censured are the so-called "virus" or bacterial cultures intended to be placed upon food baits and disseminated among a rodent population. Not only do they often fail to reduce the rodents, but they sometimes spread the infection to man. The bacteria used belong to the paratyphoid group (*Salmonella*). If disseminated among a population of rats some die, but a certain percentage always survive and become "carriers" of the infection, and sometimes by their droppings contaminate supplies of food intended for human beings. The use of such "virus" in efforts to control rats about institutions has resulted in several outbreaks of food poisoning among the human inmates.

There are certain diseases among rodents living in the wild which at times decimate the populations of these animals; but too little is known about such diseases to employ them profitably, or else they are transmissible to man, which fact alone makes their employment for rodent control undesirable.

There has been much criticism recently of certain control work under official agencies. Scarcely any control operation (save selective shooting) is without some possible danger to some other forms of wild life, but proper application of the more conservative methods reduces this danger to a minimum.

There is no one easy means for controlling all kinds of rodents. Persistent application of tested methods will keep most species in check; knowledge of the habits and especially of the food preferences, seasonal or otherwise, of the animals is essential to successful control. Brief indications of such habits are included below, but the individual who desires to control rodents must study the animals continually and, especially, must check on the results and worth of each effort at control.

Wherever practicable, exclusion is the best method. Though more

expensive at the outset it produces lasting results. Unfortunately, it cannot be applied to all species under all conditions. Traps of specific kinds will control pocket gophers, house mice, woodrats, and sometimes other species; poisonous gases can be used against species inhabiting burrows in the ground where a deadly concentration of gas will reach the animal before being diffused. Shooting is applicable for small numbers of ground squirrels and jack rabbits. Poison baits may be used with effectiveness against most rodents but not with universal success and there is always danger of poisoning other animals, including domestic livestock, and even human beings.

All the native species of rodents had originally natural enemies which constituted one of the several checks on their increase. Many of these natural enemies have been reduced and some even eliminated, although, as detailed beyond, they constitute one of the assets of agriculture. As some of these also prey on domestic animals their economic status as checks becomes a matter of relative values. But certain natural predators such as the red-tailed hawk, the barn owl, and the gopher snake are so preponderantly beneficial that only a very short-sighted person would destroy them. Yet many farmers habitually kill every hawk and snake they see without regard to its economic status.

Bubonic plague has been found to be present in the California ground squirrel of the coastal region from Alameda, Contra Costa, and San Francisco counties south to Los Angeles County. This disease originally came in on ship rats and spread from them, probably through rats in the cities, to the squirrels; it may be retransferred from ground squirrels to rats. Although usually transmitted by fleas, in coming from ground squirrels to man it may take on the much more deadly pneumonic form in which it is transmitted directly from one human being to another by droplet (coughing) infection. No one, therefore, save a trained public health official, should handle ground squirrels in the area indicated, and under no circumstances should squirrels from this region be skinned or used for food.

A native disease, tularemia, first discovered in the California ground squirrel, is also present in rabbits and, less often, in other rodents; it varies in virulence according to time and place. Man may contract the disease by skinning infected animals; one case is recorded where the disease was contracted by eating rabbit flesh improperly cooked. Rocky Mountain spotted fever, a tick-borne disease, is present in the north-eastern plateau region of California embracing Lassen, Modoc, and eastern Siskiyou counties. At times it is transmitted to man by the bite of infected ticks inhabiting ground squirrels and rabbits. The mortality

in man is considerable. Another disease, relapsing fever, has recently come to attention in the Tahoe region and about Big Bear Lake in the San Bernardino Mountains. Carried by small chipmunks, it is transmissible to man, several cases having occurred in the past decade. *The handling of rodents or their capture as pets in any of the areas where these diseases occur is therefore not desirable.*

### GROUND SQUIRRELS<sup>3</sup>

Ground squirrels are among the most widely known and most destructive mammals in California. The large, long-tailed, grayish-brown California or "digger" squirrels (*Citellus beecheyi* and subspecies<sup>4</sup>) are the most important in relation to man: first, as destroyers of crops; second, as carriers of disease; and third, because of the damage they do to irrigation structures. Three varieties occur in California: the dark-colored Douglas ground squirrel, with much black between the shoulders, ranges from San Francisco Bay northward throughout the region west and north of the Sacramento and Feather rivers; the brownish Beechey ground squirrel occupies central California and the coast district from the Golden Gate, Carquinez Strait, and the Feather River, to the Mexican line; and the gray-toned Fisher ground squirrel lives in the southern San Joaquin and Owens valleys and south along the western border of the Mohave Desert. The differences between these three are not of significance in relation to the work of eradication (save that the Douglas ground squirrel seems to be somewhat easier to control) so they are here treated as one. Knowledge of their common habits of feeding, breeding, and hibernation is important in control work.

In the northeastern plateau region, embracing most of Lassen, Modoc, and northeastern Siskiyou counties, there is the smaller Oregon ground squirrel (*Citellus oregonus*), of stocky build, with a short tail and plain brownish-gray coloration; it is essentially an inhabitant of grasslands. Other species of ground squirrels inhabit the higher mountains of California and portions of the Mohave and Colorado deserts, but are of little or no economic importance.

Ground squirrels are essentially terrestrial animals finding most of their food on the surface of the ground and digging their burrows in the soil of open flat country, hillsides, or artificial embankments. The digger squirrels, however, climb readily and in places ascend nut and

<sup>3</sup> For a detailed account see: Grinnell, J., and J. Dixon. Natural history of the ground squirrels of California. California State Commission of Horticulture Monthly Bulletin 7(11-12):597-708. 1918 [1919].

<sup>4</sup> These have all recently been referred to as subspecies of *Otospermophilus grammurus*.



fruit trees such as almonds, apricots, and peaches. The Oregon ground squirrel practically never climbs.

Ground squirrels are "fair-weather animals," active by day in the warmer season of the year and on the occasional warm days in winter. The young are brought forth in the season of plentiful food. Part of the population in the lowlands spends a period from late summer to mid-

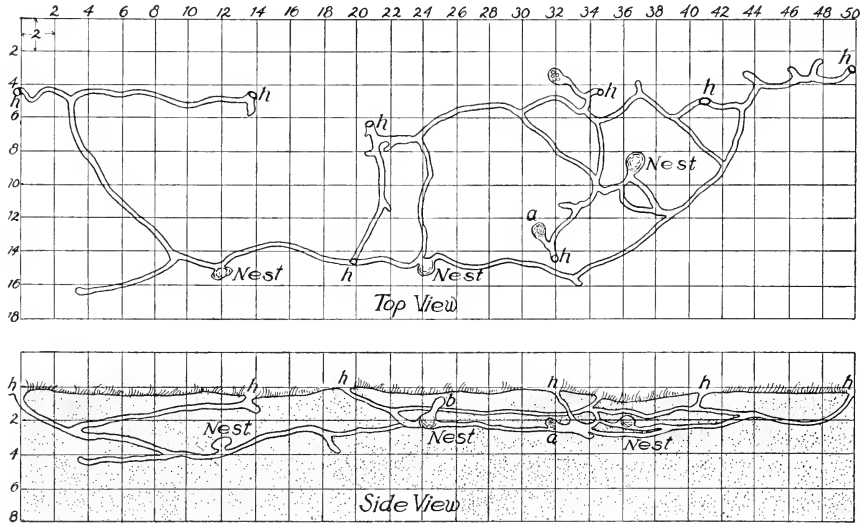

Fig. 1.—Plan and section of "colonial" burrow system of California ground squirrel: *h*, entrance; *a*, food store; nests as indicated. Each square is 2 feet. Excavated near Bakersfield, May 3, 1918, by Joseph Dixon and H. G. White. (From Grinnell and Dixon, 1919.)

winter in "summer hibernation" or estivation (as detailed beyond), in contrast to those digger squirrels living in the mountains and all the Oregon ground squirrel population which regularly hibernate in the colder season of the year.

*Burrows.*—All species of ground squirrels dig burrows, which are used for safety retreats, for shelter during inclement weather, and during estivation or hibernation, for the storage of food, and for the rearing of young. Burrows are made in flat land, in hillsides, and in ditch, road, and railroad embankments. These burrows vary in length, depth, and complexity. The diameter depends upon the species of squirrel. Dixon found that the burrows of the California ground squirrel averaged 4.3 inches in diameter, and that there were three kinds of burrows, "male," "female," and "colonial," the last being longest and most complex with numerous openings (fig. 1). The individual burrows were from 5 to 34 feet in length (including all side branches), while one

“colonial” system had a total of 138 feet with 8 entrance holes. Squirrel burrows vary in extreme depth; the deepest found by Dixon was 66 inches. Of six burrows of Douglas ground squirrel excavated at Davis, the deepest reached to 80 inches below the ground surface. In one instance reported from Fresno County California ground squirrel burrows were encountered in a chalk pit down to 28 feet below the surface. The estimated volume (which has a direct bearing on the amount of carbon bisulfide used in the gas method) varied from 1.03 to 17.8 cubic feet in the burrows excavated by Dixon; one Oregon ground squirrel burrow excavated by Grinnell and Jacobsen averaged 2.5 inches in diameter, was 66 feet in length, and had an estimated volume of 3.5 cubic feet.

*Feeding Habits.*—Although ground squirrels are often called “spermophiles” because the preferred food for many species consists of seeds, most of them will take other kinds of food, including grasses and herbs. Every ground squirrel has two thin, membranous internal cheek pouches, opening just inside the lips, one on each side of the mouth. The cheek pouches thus differ from the external, fur-lined pouches of pocket gophers and kangaroo rats, but are used for the same purpose in all these animals—namely, to carry food and (in some cases) nest material also.

The feeding habits of ground squirrels vary with the season and the locality. During the rainy months, from November to March or April, the digger squirrels eat some of the grain, seeds, or nuts stored below ground the previous summer; and they also glean scattered seeds on the surface of the ground, eating these wherever found. At this season, however, their principal food is grass and green herbage. As seeds begin to ripen the squirrels gather these in their cheek pouches to carry them below ground. Seeds of both wild plants and the cultivated grains are taken. The digger squirrels are fond of the soft, growing pits of peaches and apricots and in getting these they may destroy much fruit. They also eat almonds and walnuts.

The damage by ground squirrels, by reason of their feeding habits, is chiefly to grain and pasturage. In fields they dig up sprouting grain and later pull down the ripening heads. After harvest they concentrate about shocks and stacks, continuing to eat and carry off quantities of grain. On pasture lands they may take appreciable amounts of grasses and herbage that could otherwise be utilized by domestic stock. According to Dixon 200 California ground squirrels on open range might consume as much green forage as one steer or ten sheep. On isolated ranches

bordered by wild lands on one or more sides, squirrels may seriously deplete grain, fruit, and nut crops.

*Estivation and Hibernation.*—A period of torpidity obtains among some of the ground squirrels in the valleys of California. It may extend continuously from late summer (estivation) through midwinter (hibernation). A female ground squirrel regularly and continually observed under normal conditions in a dooryard in southern California did not estivate until its second year; thereafter, each succeeding year of its life, it estivated regularly, becoming very fat and retiring to its burrow during the last week in August. If removed from the burrow during this period, it proved to be torpid, without perceptible respiration. About February 22 of each year following, with marked regularity, it emerged in an emaciated condition. This habit of estivation affords an explanation for instances where all the squirrels active in a field during the autumn are killed, and yet old breeding squirrels suddenly appear the following spring, as sometimes happens when there is seemingly no chance for reinfestation from the surrounding fields. The extent of this habit of estivation among our ground squirrels is unknown because it is exceedingly difficult to follow an individual squirrel through its activities for any length of time. However, this suggests the advisability of control in the late spring and early summer rather than in the fall and early winter when some of the breeding stock may be underground out of the reach of poisoned grain. There is also some question as to whether dormant animals, in which respiration is extremely slow, are fatally injured by fumigation in their burrows.

The Oregon ground squirrel is reported to go into its quarters from the first week in August to mid-September, and may emerge as early as mid-March when there is still much snow on the ground.

*Breeding.*—The California ground squirrel, in the central part of the state, breeds during the first half of the year according to data secured on more than 20,000 females collected by the United States Public Health Service in 1910. Few females were pregnant in January, but the proportion rose steadily until at the end of February 42 per cent of the females contained embryos, in mid-April, 16 per cent, and in mid-May, 5 per cent; no females with embryos were found after June 4. However, examination of smaller numbers of squirrels in Los Angeles County during 1925 revealed a few pregnancies each week between July 4 and October 13. Regular breeding activity began there by December (71 pregnant females among 1,698 squirrels); and in March, 1926, no less than 70.3 per cent of 1,976 female squirrels contained embryos. Thus a longer season and a higher percentage of pregnancies is indicated for

the southern region.<sup>5</sup> Scattered data indicate that the breeding season is slightly earlier in the warmer interior valleys and somewhat later along the coast and in the mountains.

The exact period of gestation in the California ground squirrel is unknown; for the Douglas ground squirrel in western Oregon a period of 25 to 30 days is indicated, followed by about 7 or 8 weeks of growth in the nest and about the parent burrow. If the records for the year 1910 cited above represented, on the average, embryos half-way through the period of gestation, then embryos of any given date would be represented by young running about aboveground about 9 weeks later; this calculation indicates early May as the time when the greatest number of young squirrels should appear, and, indeed, coincides with field observations.

Ground squirrels in California usually produce but one litter annually. The number of embryos was found by the United States Public Health Service to average 7.2 per female. In southern California the averages were slightly higher; the actual number of embryos in individual females varied from 4 to 15 in the latter region.<sup>5</sup> In Tulare County, on an area where squirrel control had been carried on for two years or longer and where the available food supply for the squirrels remaining was therefore presumably greater, larger litters were found, an average of nearly 10 embryos per female being noted by W. C. Jacobsen.<sup>6</sup>

Less is known about the breeding of the other ground squirrels. The Oregon ground squirrel has about 8 in a brood; the season of appearance is from mid-May at the lower altitudes (3,000 feet), until early June at higher levels.

The important thing to remember regarding the breeding of squirrels is that one female killed before April 1 is equivalent to the destruction of about 8 squirrels later in the year—hence the great desirability of control in late winter and early spring.

The rate of reproduction in ground squirrels is such that any campaign which does not ordinarily succeed in eliminating 85 per cent in a given year will not effect any general reduction in numbers. Theoretically, if 90 per cent are removed each year it would require 8 to 9 years to eliminate completely the squirrels on a given parcel of land, provided no reinvasion occurred by migration of squirrels from adjacent areas. Squirrels have been known to migrate one or more miles into cleared

<sup>5</sup> Storer, T. I. Summer and autumnal breeding of the California ground squirrel. *Journal of Mammalogy* 11:235-237. 1930.

<sup>6</sup> Jacobsen, W. C. Rate of reproduction in *Citellus beecheyi*. *Journal of Mammalogy* 4:58. 1923.

areas. These facts indicate the importance and indeed the necessity for persistent and intensive work if a land owner wishes to keep down the squirrel population on his property. Furthermore, cooperative effort on the part of all ranchers in a region is necessary, else cleared areas will be invaded by squirrels from lands where control is not practiced or is ineffective.

*Methods of Control.*—The five most effective methods of destroying ground squirrels are: (1) poisoning with strychnine; (2) fumigation with carbon bisulfide; (3) trapping; (4) shooting; (5) encouragement of natural enemies.

1. Poisoning: Strychnine-coated barley (formula 1)<sup>7</sup> is to be used in that part of the dry season when squirrels are gathering seeds and grain in their cheek pouches for storage underground. The grain is coated with the less-soluble strychnine alkaloid, together with substances to disguise the taste. The kernels are picked up by the squirrels and quickly placed in the pouches, the strychnine coating is absorbed by the delicate membranous lining of the pouches, and causes the death of the squirrels. Before the storage season, squirrels eat scattered seeds as found and then will often reject strychnine-coated grain. After grain crops begin to mature the animals will be attracted to the more abundant supply and will be less interested in poisoned bait. The exact period, in any locality, when exposure of poisoned grain will produce results must be learned by the person doing control work; it will vary according to locality and may vary from year to year in any one locality.

The poisoned grain should be scattered from the hand, a tablespoonful at a time, on hard bare ground, as on squirrel runways radiating from burrows or along fences. If dropped into tall grass or in the soft earth about burrows, it is less likely to be found by the squirrels. One quart of poisoned whole barley will provide enough for 30 to 35 baits. Around farm yards or in pastures where livestock are present the poison, for the sake of safety, must be put well down the burrows. Placing of poisoned grain in the burrows has been used in some localities, especially where no control work with this material has been carried on in the immediate past. It is reported that the best results with grain placed in burrows are obtained during the summer and autumn months.

Failure to reduce or eliminate squirrels may follow use of poisoned barley when rain washes off the poison coating, when squirrels refuse, for one reason or another, to accept the poison, or when squirrels are feeding on filaree. F. E. Garlough reports that in areas where green

---

<sup>7</sup> Refers to section, "Formulas for Preparing Poisoned Baits for Rodents," appearing at the end of this circular.

filaree is being eaten abundantly, strychnine-coated barley is ineffective. His explanation, that the high tannin content of filaree counteracts the effect of the strychnine, has lately been questioned by Burnett.<sup>8</sup>

Animals other than ground squirrels, including domestic stock and various wild rodents and birds, are readily killed by strychnine. Quail and pheasants, and presumably also domestic poultry, can stand higher doses of strychnine, but this fact should not be taken as an excuse for careless placement of poison. Strychnine-coated barley is also poisonous to man; hence, supplies of the poisoned grain *must be locked up*, so as to be inaccessible to children and irresponsible adults.

Burnett in studies on the Wyoming ground squirrel, a species about half the weight of the California ground squirrel, has found considerable variation in the susceptibility of individual squirrels when fed strychnine-poisoned oats in captivity. He infers that difficulty in poisoning with strychnine under field conditions, where certain individuals survive, may result from this variation and also from a tolerance built up by repeated sub-lethal doses. Much individual variation was shown by the captive squirrels; some adults were killed by as few as 10 or 12 kernels; others survived relatively heavy doses; one squirrel ate over 1,000 kernels of poisoned hulled oats in 13 days before being killed. No corresponding studies have been published on the California ground squirrel. It has long been believed that 20 kernels are sufficient to kill an average squirrel of the latter species.

Oats (formula 2) and dandelion greens (formula 3) are recommended for the Oregon ground squirrel in place of barley. The oats are to be distributed in the same manner as barley; two or three of the dandelion greens are to be put in each burrow. Birds are not endangered by the poisoned greens.

2. Carbon bisulfide: This chemical, suggested for use against ground squirrels by E. W. Hilgard in 1876, has found extensive use ever since. From a half million to a million pounds (10.76 pounds per gallon) were used annually in California during the decade 1921-1931.

Carbon bisulfide is a liquid that volatilizes easily. The following facts should be kept in mind in using this material: (1) The fluid is highly inflammable and the gaseous form is highly explosive; it should be kept away from all fires and exposed lights; (2) being heavier than air, the gas settles in the lowest places in the underground burrow and hence will not go over an elevation higher than the entrance unless a pump is used to force it in; (3) when the ground is dry and full of cracks the gas

---

<sup>8</sup> Burnett, W. L. The action of strychnine on the Wyoming ground squirrel, *Citellus elegans elegans*. Colorado Agr. Exp. Sta. Bul. 384:1-19. 1932.

escapes and is less effective than when the ground is wet and the gas thus confined to the burrow; (4) it should be used only in holes known to be occupied by squirrels at the time of the treatment; (5) stocks of carbon bisulfide should be kept tightly corked for the fluid evaporates rapidly on exposure to the air.



Fig. 2.—Karbo-Killer, for pumping carbon bisulfide into rodent burrows.

Two methods of application are in use, either waste balls saturated with the liquid are thrown into the burrows, or the material is pumped into the burrow by means of a special machine. In earlier years waste, corn cobs or even horse droppings were used to carry the fluid.

In the waste-ball method, the balls are soaked in the fluid and one or two are thrown into each burrow. Since each waste ball requires about 2 fluid ounces, 50 to 60 waste balls may be dosed with a gallon of bisulfide, allowing for evaporation and spillage losses. As each burrow is treated, the entrance should be closed with a shovelful of earth and quickly tramped down.

When using the waste-ball method some operators ignite the gas by means of a flame. Matches are dangerous for this purpose. To explode the gas, a six-foot piece of  $\frac{1}{4}$ -inch pipe with one end closed and pointed

and the other end tightly wrapped with a rag soaked in kerosene adds safety to the operation. After the bisulfide has been confined in the burrow for a few seconds a hole is made with the pointed end of the pipe through the dirt plug at the burrow entrance. The gas is then "touched off" with the torch on the other end of the rod which has been previously lighted. The operator should stand well to one side of the burrow when igniting the gas. Exploding the gas may reveal open burrows in grassland which otherwise would not be noticed. The gas should be ignited only when the ground and surface vegetation are damp, never in dry grain fields, about buildings, or other places where there is risk of fire. The explosion and burning of the gas produces a mixture of carbon dioxide, carbon monoxide, and sulfur dioxide. The latter two are poisonous, especially the carbon monoxide. Stewart and Burd<sup>9</sup> concluded that there is probably a slight advantage in exploding the gas. The use of an adequate pump is much the better method.

The first practical "pump" was developed by Surgeon J. D. Long of the U. S. Public Health Service. In recent years the Karbo-Killer (fig. 2), a heavy metal cylinder with contained pump and reservoir for the liquid carbon bisulfide, has replaced practically all other machines. Application by pump tends to drive the gas into all portions of a burrow.

In using a pump, place the flexible hose in a burrow, throw a shovelful of earth over the hose to prevent loss of gas, and deliver 20 strokes with the pump. After the hose has been withdrawn tramp down the earth in the burrow entrance.

In Santa Barbara County, where as many as 50 Karbo-Killers have been used, workers go over an area and close all open squirrel burrows with mattocks, then apply the gas several days later. This practice obviates the need for treating uninhabited burrows. The gas should be pumped slowly. On retreatment of burrows found open after the first coverage, the number of pump strokes is doubled.

Surgeon Long found that his "destructor" would treat 200 to 250 holes with one gallon. A test of the Karbo-Killer in the laboratory (with no back pressure on the hose, as in a burrow) indicated that from  $\frac{1}{3}$  to  $\frac{2}{3}$  ounce of carbon bisulfide was delivered in 20 strokes of the pump, or 192 to 384 dosages per gallon. The slower rate of pumping delivered smaller dosages. Field tests of the Karbo-Killer by various rodent-control officials indicate that from 125 to 250 holes can be treated with one gallon of carbon bisulfide, using 10 to 20 strokes of the pump.

---

<sup>9</sup> Stewart, G. R., and J. S. Burd. Control of ground squirrels by the fumigation method. California Agr. Exp. Sta. Bul. 302:205-224. 1918.



In flat country the exhaust gas from an automobile may be employed to kill ground squirrels, as described beyond for pocket gophers.

Although many other materials have been tried for gassing squirrel burrows, both experimentally and otherwise, none has proved so satisfactory as carbon bisulfide. From 1925 to 1930, calcium cyanide flakes and dust were tried by official agencies but the material did not find favor.

3 and 4. Trapping and Shooting: Where ground squirrels are digging into ditch banks, and in other cases where they must be disposed of promptly at any cost, special means must be adopted. Trapping and shooting are valuable for such local application. These two methods can be used at any season, but the time required to keep traps properly set, which is essential to success, and the high initial cost of traps as well as of ammunition make them too expensive for general use on large acreages. Trapping and shooting are also useful in cleaning up the few "wise" squirrels that escape the poison and gas, and in reducing the breeding stock in the early spring before the annual increase.

The No. 91 Oneida jump trap is the best, being lighter, easier to set, and having larger catching surface (pan or treadle) than the ordinary steel trap with an outside spring. The jump trap lies flat on the ground; the jaws have wide contact surfaces that reduce the chance of breaking the animal's leg; and the inside spring causes the trap to jump up and take a high grip on the leg instead of on the foot only. Such a trap may be set without bait in the entrance to a burrow, or may be baited with rolled barley, and set in a squirrel path, or near a feeding place. In any case it is well to scrape out a slight depression so that the upper surface of the trap when set will be flush with the surrounding ground. The trap should be well secured. A long stake sharpened at one end, passed through the ring in the end of the trap chain, and then driven well into the ground will serve to hold the trap and also as a marker, enabling one readily to find the trap again.

Shooting with a long-range .22 caliber rifle may be used to clean up small numbers of squirrels.

5. Natural enemies: The natural enemies of the ground squirrel constitute one of Nature's checks on these rodents. Some of these are coyotes, badgers, weasels, wildcats, red-tailed hawks, golden eagles, rattlesnakes, and gopher snakes. Badgers, weasels, and snakes capture the ground squirrels in their burrows. Wildcats and coyotes lie in wait near the burrows until the squirrels venture forth in search of food. Dixon examined 186 stomachs of wildcats from forty different localities in California; 26 contained ground squirrels and these with other

rodents were found to constitute more than half of the food. Hawks and eagles swoop down on the squirrels from the air. The importance of preserving as many as possible of these native enemies of the ground squirrel is evident. The aid of coyotes and rattlesnakes may be dearly bought; but badgers, gopher snakes, hawks, and eagles cost little or nothing, and each catches ground squirrels almost throughout its lifetime. The accompanying table shows what certain hawks and eagles actually accomplish. The dead rodents counted in the nests listed represent merely the surplus which the old birds had carried to their young, in addition to food eaten on the days of observation. Hawks and eagles it thus appears capture, when prey is abundant, far more than they and their young can actually consume.

TABLE 1  
DESTRUCTIVE RODENTS FOUND IN NESTS OF HAWKS AND GOLDEN EAGLES  
IN SAN DIEGO COUNTY BY JAMES B. DIXON

Species of bird	Date	Young and eggs	Locality	Evidence
Red-bellied hawk.....	April 3 (1916)...	3 young, one week old.....	Pala.....	1 ground squirrel and 2 gophers
Western red-tailed hawk.....	March 28 (1906)	1 day-old young, 2 piped eggs.....	Vista.....	Remains of 2 ground squirrels
Golden eagle.....	March 26 (1909)	1 day-old young.....	Rincon...	9 jackrabbits
Golden eagle.....	April 4 (1907)...	2 young, one week old.....	Lilac.....	11 ground squirrels in and about nest

6. Other methods: Small orchards of deciduous fruits or nuts in isolated regions may be protected from ground squirrels by fastening smooth cylinders of tin about the tree trunks. This tinning, if started about 2 feet above the ground and continued upwards for 2 or 3 feet will usually keep the ground squirrels out of the trees unless there are drooping branches on which they can climb.

Flat collars or disk-like shields of sheet metal about 2 feet in diameter are often used to protect young roadside trees against defoliation by ground squirrels. A hole in the center of each shield admits the trunk of the tree, and a radial cut, from circumference to center, enables the shield to be placed in position, below the first branches.

Seed corn can be protected from ground squirrels during germination by being treated with coal tar.<sup>10</sup> For this purpose add one large spoonful of coal tar to a gallon of boiling water. When the mixture has cooled

<sup>10</sup> Lantz, D. E. Destroying rodent pests on the farm. U. S. Dept. Agr. Yearbook for 1916. p. 381-398. 1917.

somewhat the corn may be stirred in and allowed to remain several minutes; germinating qualities will not be impaired.

*Costs of Various Control Methods.*—The cost of ground-squirrel control varies with the degree of infestation, the method used, and the current cost of control materials and labor. Material costs have been as follows: Strychnine alkaloid per ounce, 1919, \$1.95; 1925, \$1.00; 1928, \$0.75 to \$0.60; 1932, \$0.45 to \$0.36; 1933, \$0.23. Carbon bisulfide, per gallon, 1912, \$0.90; later, \$1.25; 1932, carload lots, \$0.55, or 1 to 5-gallon lots, \$0.75 per gallon. Waste balls, per thousand, \$3.00. Prepared strychnine-coated barley was sold by county agricultural commissioners in 1931 to ranchers at 6 to 7 cents per pound. Labor costs in the decade 1921–1930 were about \$4.00 per man per day or \$5.00 for man and horse.

It is rather difficult to give exact current figures on costs per acre. In 1910, according to C. H. Merriam of the U. S. Biological Survey, single treatments with grain cost 3 cents per acre; with waste-ball gas, 1.5 cents per burrow. In 1912, on the basis of 10 holes per acre, Surgeon J. D. Long gave costs per acre as follows: poisoned grain (4 to 5 treatments), 35 cents; waste-ball gas (2 treatments), 68 cents; "destructor" (2 treatments), 20 cents. In 1922 F. E. Garlough of the Biological Survey cited costs as: poisoned grain, 6.5 cents per acre; waste-ball gas, 8.5 cents. The skill, speed, and accuracy of laborers, the degree of infestation, and the nature of the ground to be covered all tend to vary the costs.

### TREE SQUIRRELS

In the foothill and mountainous parts of California there are two kinds of tree-inhabiting squirrels, the gray squirrel (*Sciurus griseus*) and the red squirrel (*Sciurus douglasii*), also called chickaree or pine squirrel. The former of these often lives adjacent to nut and fruit trees and, at times, takes the products of these trees, to the dismay of the grower. One grower in Santa Cruz County reported that in years of short crops of acorns the gray squirrels took many English walnuts and also gnawed into boxes of apples stored in the open. By setting box traps he captured several squirrels, transported them less than a mile from his ranch, and released them; no further damage was noted. Tin guards, as detailed for ground squirrels, would exclude tree squirrels as well, provided there were no low-hanging branches on the trees and provided further that the trees were sufficiently isolated so that the gray squirrels could not travel overhead from tree to tree and so gain access to the nuts. Tree squirrels are protected under the California Game Code.

### POCKET GOPHERS

Pocket gophers are small, stout-bodied, short-legged rodents, with conspicuous front (incisor) teeth, a pair of external fur-lined cheek pouches or pockets—one on either side of the mouth—used for carrying food materials (and not earth), small eyes and ears, and a short, nearly naked tail. The term “gopher” is applied in the northern Middle West to one or more species of ground squirrels, and in Florida to a land tortoise; so the special designation “pocket gopher” is used for certainty of identification here.

The work of pocket gophers is sometimes confused with that of moles. The two animals are quite dissimilar, the pocket gopher being a rodent with blunt head, conspicuous incisor teeth, and a brownish-colored coat, a somewhat longer tail, and small front feet. The mole has a slender, conical snout; no eyes or ears evident externally; small, needle-like teeth; very large fore-feet and claws; and silvery black fur, velvety in texture and reversible. The mole has no cheek pouches of any sort. The accompanying illustrations (figs. 3, 9) show important differences between the workings made by moles and pocket gophers.

Pocket gophers are widely distributed over most of California, being absent only on certain portions of the southeastern deserts. They inhabit practically all kinds of soil, save very rocky areas, although they are more abundant on the better soils. Between 30 and 40 different species and varieties of these animals have been described from California, each inhabiting a special geographic area, but no two live in the same locality. For practical purposes they may all be treated as one, their habits and the methods for their control being essentially the same over the entire state.

*Burrows.*—The pocket gopher is strictly an inhabitant of the soil, living in burrows of its own construction, never climbing, and only seldom coming out on the surface of the ground. It digs clean-cut round tunnels, about 2 inches in diameter, more or less parallel with the surface of the ground, at depths of from 6 or 8 to 12 or 14 inches. The earth from these (fig. 3) is thrown out on the surface through short lateral tunnels made at frequent intervals. This results in a series of rounded surface mounds which, by their position, often give a clue to the location of the main tunnel. When putting earth out of a lateral tunnel the gopher pushes the successive loads of earth into a more or less crescentic pattern and when the lateral is closed a low central plug or depression in the mound often indicates the location of the mouth of the lateral.

The age of a mound may often be determined by the amount of moisture in the earth that has been pushed out and also by the degree of blanching (loss of chlorophyll) in any grasses or herbs in the mound. Trapping seems most productive in fresh workings.

Besides the laterals used to push out earth the gopher makes short, almost vertical laterals in coming to feed on surface vegetation. These often are closed with earth that does not rise above the adjacent ground surface.

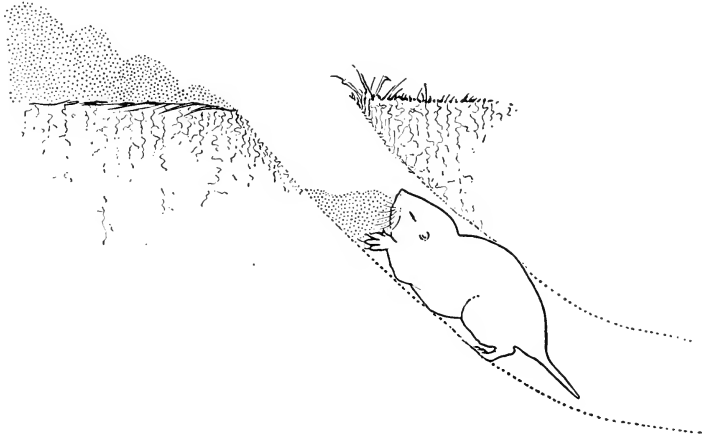

Fig. 3.—Method of pocket gopher in pushing earth out of main tunnel through a lateral tunnel and onto the surface of the ground. The mouth of the lateral remains open when excavation is in progress; successive loads of earth are pushed in different directions from the mouth of the tunnel, resulting often in a mound of crescentic outline.

Gophers construct deeper tunnels in connection with their nests, and there are also short, steeply pitched "sumps," presumably to drain adjacent tunnels. The nest is usually in a chamber about 8 inches in diameter; it is constructed of shredded fibers of grasses and other plants, giving a resemblance to fine excelsior. Food is often stored beside the nest or in other enlarged chambers off the tunnel system.

The burrow system of a pocket gopher may be extensive, involving up to 100 yards of tunnel length. Ordinarily each system is inhabited by a single gopher, although young may remain in the tunnel occupied by a female for a time after leaving the parental nest. The systems of adjacent gophers may be connected, but connecting tunnels, and even portions of the workings of a single animal, are often plugged firmly with earth. When a gopher is trapped out of a tunnel system another animal may later occupy that system, and moles have, at times, been trapped in gopher burrows. Pocket gophers are active throughout the year (even in mountain areas where they work beneath the snow and

put the surplus earth in tunnels in the snow), and fresh workings may be found in any month. Activity may be less on dry areas during the hot summer season. The animals are also less active during and immediately after a heavy rain.

*Breeding.*—On pasture lands and on uncultivated and unirrigated areas there is evidently a limited breeding season, after the beginning of the rains, when green forage becomes available in quantity; on such areas there is probably a single annual brood. But in irrigated regions, and especially in alfalfa fields, where green forage is available for much or all of the year, a longer if not year-round breeding season is evident. Dixon<sup>11</sup> has found that in southern California breeding begins early in November and is about two weeks later in central California. In an alfalfa field at Turlock he surmised that two or even three broods were raised in a single season.

At Davis, the writer examined gophers from November until May and found embryos during each month of this period. Information on gophers at high altitudes (5,000 feet and above) indicates breeding in June and July.

The average number of embryos is between 5 and 6 per female. Among gophers from all parts of California, Dixon<sup>12</sup> found limits of 3 to 12 embryos, with an average of 5.8 in 28 females; at Davis, in 1932, 53 of 224 females contained embryos, from 1 to 10 per female, the average being 5.7. In this latter group, all from the University Farm, the ratio of pregnant females varied in different weeks from 16.2 to 33.3 per cent, but many others among the females collected showed signs of recently having given birth or suckle to young so that a very high percentage of the females breed in any one year. Gophers (at Davis) begin to breed when about 3 ounces (90 grams) in weight, the head-and-body length then being about 5½ inches (135 millimeters).

The young remain in the nest for several weeks after birth but eventually leave the parent tunnel system for an independent existence, often wandering some distance overland and starting their small tunnels in new places. In cities, young gophers sometimes go out on the streets and are unable to mount the vertical surface of concrete curbs. Gardens and fields earlier free from gophers may become tenanted by young in the spring months. The following dates indicate approximately when the main crop of young becomes dispersed although young are scattered both earlier and later: southern California, March 20; San Joaquin and

<sup>11</sup> Dixon, Joseph. The breeding season of the pocket gopher in California. *Journal of Mammalogy* 10:327-328. 1929.

<sup>12</sup> Dixon, Joseph. Control of the pocket gopher in California. *California Agr. Exp. Sta. Bul.* 340:338. 1924.

Sacramento valleys, April 1; Owens Valley, April 15; foothills of the Sierra Nevada, April 30; northwest coast region, May 15.

*Damage Due to Pocket Gophers.*—On wild lands gophers are probably beneficial in the long run. Although pasture lands cleared of them often show an immediate increase in the amount of forage available for live-stock, it is unknown whether this increment would continue for a succession of years. On unplowed land gophers “cultivate” the soil, often turning over considerable percentages of the surface in a single year. Whether their burrowings contribute to or serve to check erosion on slopes is undetermined. The rich sediments of valley bottom lands have resulted from erosion at higher altitudes in past geologic time; to this process pocket gophers have contributed. The “long-time” values need to be studied carefully.

The immediate and specific damage to man’s interests by these animals results from their feeding habits and their tunneling. Production in alfalfa fields can be seriously reduced by their destruction of root crowns; truck plants suffer direct damage by consumption of roots; valuable plants in flower gardens, especially those with bulbous roots, are often destroyed. Gophers cut roots of trees and vines and gnaw the bark of trees, at times completely girdling the latter so that they die unless saved by bridge grafting.<sup>13</sup> Gopher burrows in home gardens often divert the relatively expensive metered water. Burrows in the banks of ditches and canals may lead to breaks in the earthwork whereby water is lost and adjacent lands are flooded, necessitating expensive repairs.

*Methods of Control.*—With persistence, pocket gophers may be effectively controlled and even eliminated over considerable areas. No other common rodent can be held down or exterminated so successfully, because of the slow rate at which gophers advance their tunnel systems and their general disinclination to travel long distances overland.

In general, gopher control may be practiced at any season. Prompt attention to the first evidence of gopher work in a garden will often save valuable plants. Obviously the best time to exercise control is before the young are abroad. Both trapping and poisoning are easiest soon after green vegetation starts in the early winter or spring, when the gophers are very active and the ground is soft. Wise old males, which usually cause the trapper most trouble, seem to lose their instinctive caution during the mating season, take poisoned bait readily, and often blunder into traps that they would never enter at other times. Every female caught

<sup>13</sup> Hodgson, R. W. Saving the gophered citrus tree. California Agr. Exp. Sta. Cir. 273:1-19. 1923. (Out of print.)

then, before the young are born, means from 4 to 12 fewer gophers for the next season.

The methods in use against pocket gophers are: (1) trapping; (2) poisoning; (3) gassing; (4) flooding; (5) fencing; (6) encouragement of natural enemies; (7) miscellaneous. Each has its particular advantages, and best results follow use of two or more methods.

1. Trapping: Many special kinds of traps have been designed to capture pocket gophers (fig. 4). The usual snap and steel traps used against

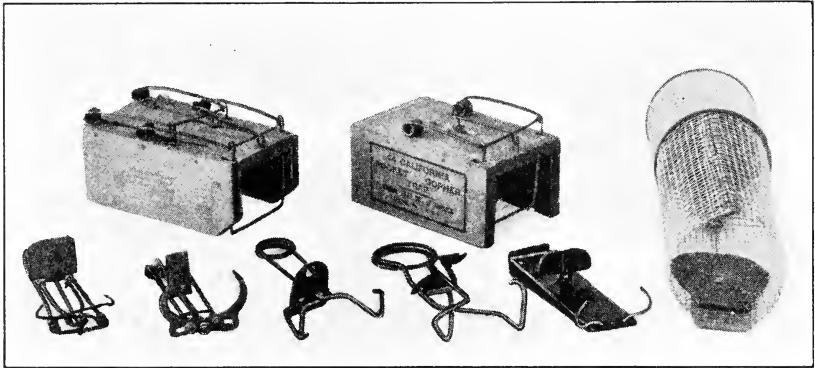

Fig. 4.—Different kinds of traps for pocket gophers; all are shown as set, ready for use.

rats and mice and for carnivorous mammals are ineffective against gophers, which must be trapped in their burrows where space for operation of a trap is limited. The special traps fall into two classes: those designed to spring when a gopher pushes a load of earth against the flat trigger pan of the trap, and those operated by a bait trigger, moved when the gopher seizes the special bait.

Trapping is especially adapted to gardens, orchards, small fields, and banks of irrigating canals. In California, more gopher control is probably accomplished by traps than by any other single method. Traps are useful in following up and capturing individual gophers. The special gopher traps are safe to handle and require only a limited amount of skill and a little digging to place them. On one ranch near Davis a workman handled about 75 traps, set usually in pairs. These required about 5 hours of time to examine and reset as needed daily, and on 3 successive days took 38, 40, and 37 gophers, respectively.

The most successful and most commonly used trap in California is the Macabee (fig. 5*a*), constructed entirely of wire except for the trigger. The next most popular is the box type with a choker effect (fig. 4, upper left). Numerous other types have been designed and marketed (fig. 4)



but none seems to have found any lasting demand. Certain explosive traps or "gopher guns" have been exploited but the danger attending their use makes them undesirable.

The most effective "set" for the Macabee trap is in the main runway (fig. 6), and not in the lateral run leading to the surface mound. This necessitates the use of two traps per setting, one in each direction; but the results are much more certain and quicker, so that the catch *per trap*

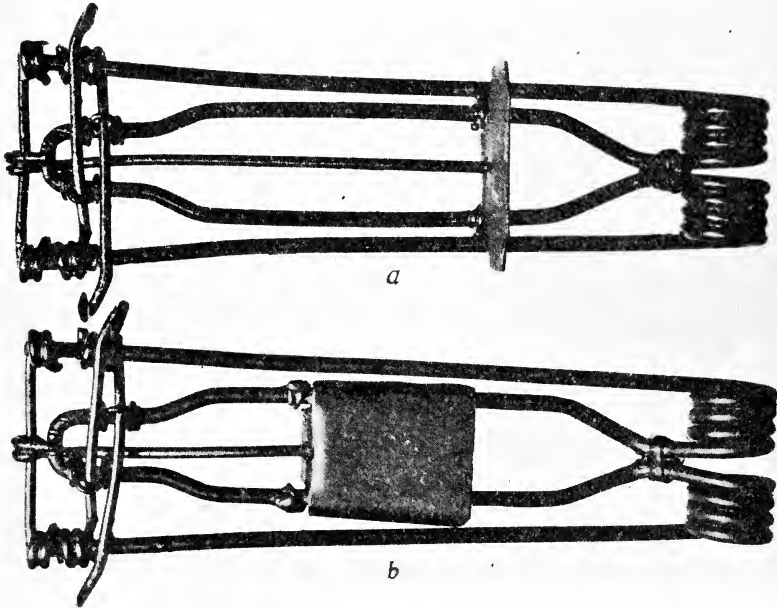

Fig. 5.—Regular Macabee gopher trap (a); modified (reconstructed) Macabee trap for "wise" gophers and for moles (b); both traps are set, ready for use.

*per day* is greater than if only one trap is set in a lateral run where it is often filled with dirt by the gopher. An ordinary stiff-handled 12-inch iron spoon helps greatly in finding the main run and in placing the trap properly. It should be supplemented with a light short-handled shovel, for digging down to the main run. The freshest mound should be selected, and the probable direction of the main run determined by noting the angle of the dirt-plugged hole. The mounds are usually situated 1 or 2 feet distant from, and the laterals nearly at right angles to, the main run.

The procedure is as follows: push the handle of the spoon into the ground where the lateral is believed to be. If the handle enters an open

lateral it will drop through the opening. If the lateral is filled loosely with dirt, the drop will be less noticeable but still plainly felt. If it is plugged tightly one must dig down a little distance with a shovel before probing again. Should this fail, try a new mound. When a lateral is located, follow it down to the main run, which is always kept open by the gopher. With the shovel clear a place so that a trap can be set in each direction. Clear out the main run with the spoon, disturbing it no more than necessary. Set the treadle, or pan, so that a slight touch will spring

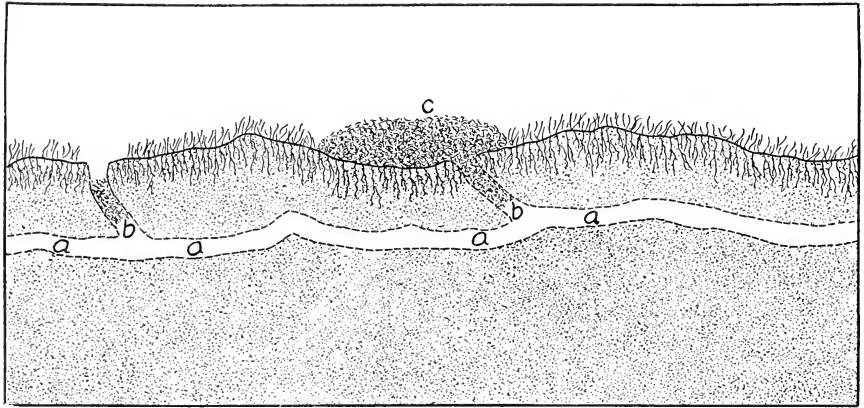

Fig. 6.—Section through portion of burrow system of pocket gopher, showing main tunnel (a, a) and closed laterals (b, b) together with surface mound (c). Traps are best placed at a, a. Poisoned baits should be inserted with a probe in the main tunnel.

the trap, and place the trap *well into* the hole. A little loose dirt should be left in the bottom of the hole to cover the prongs and front end of the trap when the latter is pushed into place. Press the trap down firmly so that it will not slide backward if a gopher pushes against it. Then cover the burrow with a clod or a handful of grass or alfalfa so that only a little light can reach the trap. A gopher instinctively closes all open burrows tightly to keep out natural enemies. A trap placed in an open hole may be sprung by the dirt which the gopher pushes ahead in plugging the hole.

Each trap should have a light wire or chain attached so that it can be fastened to a stake or some other object to mark its location; this plan also prevents the trap from being dragged far back into the tunnel by a wounded gopher or being removed by a carnivorous animal when it contains a gopher. If conspicuous stakes 2 feet or so in height are used, traps are less liable to be lost, should the field be cultivated while they are set. Stakes are essential to mark trap locations in alfalfa fields or truck patches, otherwise many will be lost. On a ranch where traps are used regularly it is well to have some distinctive kind of stake so that

all the farm laborers will recognize gopher sets. In case only one trap is available to set in a main run, a careful watch will often, but not always, reveal one or more little flies emerging from the run when it is first opened. These flies seem to have a direct relation to the gopher; experience has shown that they come from the side then occupied by the gopher—hence, from the tunnel in which to set the trap. Each setting should be visited morning and evening, or oftener.

Individual gophers will frequently be found that refuse to enter any sort of trap. These are generally old males, likely to be the ones that do

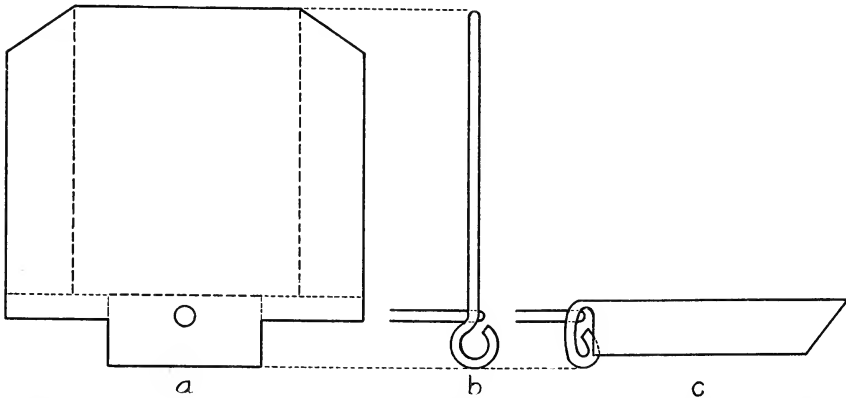

Fig. 7.—“Pan” of regular Macabee gopher trap (a, b); dotted lines show where this should be bent to form the horizontal “pan” for modified trap (c).

most of the gnawing on fruit trees. When such an old-timer repeatedly fills the trap with dirt, a special method becomes necessary (fig. 7). Take a Macabee trap and move the treadle forward about an inch and a half, placing the wire which carries the treadle below, instead of above, the two longitudinal wires. Cut off the wire trigger to meet this change. Then bend the treadle backwards at right angles to its former position so that it will lie parallel with the trap, instead of standing up at right angles to the runway (figs. 5b, 7). Set the trap so that it will spring easily. Put a pinch of loose cotton under the treadle to keep out dirt, place the trap in the run, and cover the whole trap lightly with a thin layer of loose earth. Another method is to take a recently caught female and rub the reproductive parts on the treadle of the regular Macabee trap. A few drops of urine, squeezed out during the process, will only add to the efficacy of the decoy. If all else fails, catch a gopher snake and turn him loose in the run.

After having put out traps, kick the tops off all mounds, so that on the next round any new mounds will show where gophers remain and where additional effort is needed.

2. Poisoning: Pocket gophers may be killed in numbers by use of poison bait. Since their external cheek pouches or pockets are lined with fur no poison can be absorbed there as with ground squirrels; dependence must be placed on stomach poisons. Strychnine alkaloid or sulfate is effective for this purpose. The bait must be something relished by gophers and must be placed in the main runs with as little disturbance as possible; if placed on the surface of the ground it would not often be found by gophers and might be a menace to other animals, wild or domestic, while if put into laterals or open holes it might easily be buried or

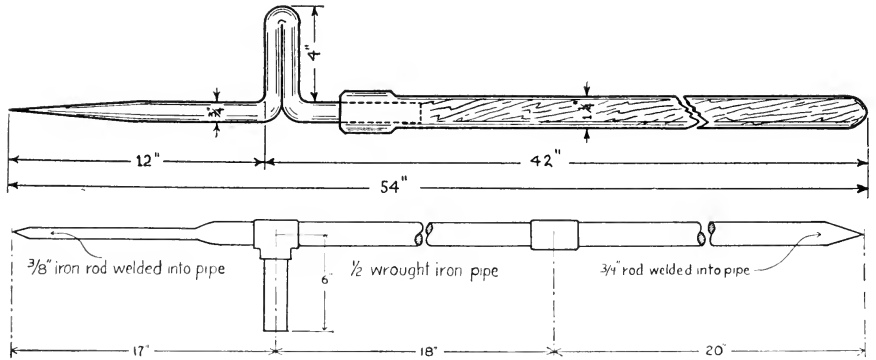

Fig. 8.—Probes for locating main tunnels of pocket gopher and for inserting poisoned baits: upper, probe of steel rod with wooden handle; lower, probe of  $\frac{1}{2}$ -inch iron pipe with points forged into place.

pushed out in the dirt. Cubed root vegetables dusted with strychnine and some sweetening material to disguise the taste are the commonest bait used (formula 4). Individual baits are placed in main runways by means of a special probe (fig. 8), with which burrows can easily be located and baits inserted with a minimum of disturbance.

The probe can readily be made by any blacksmith from a 2-foot length of  $\frac{3}{4}$ -inch round steel. The metal should be pointed at the lower end and bent near the upper end to form a foot-rest that may be stepped on by the operator to force the probe into the ground. For work in hard earth the steel point should be slender; in loose, sandy soil a blunter point is better. The upper portion of the probe can be made from an old shovel handle. It should be reinforced at the base by a heavy iron ferrule. An alternative method of construction is to use half-inch pipe, forging a pointed  $\frac{3}{8}$ -inch rod in one end and a larger point at the opposite end. Such a probe is slightly heavier but more rigid.

To use the probe, sink the smaller pointed end into the ground between the rows of gopher mounds or plugs, repeating the operation until the main burrow is recognized by a sudden drop as the probe goes through it.

The opening should then be enlarged, by rotating the probe or by using the opposite larger end, so that a poisoned bait may be dropped easily into the burrow. After putting in the poisoned bait, the hole made by the probe should be closed by the operator's heel. As the work proceeds, the tops of all mounds should be trampled down or kicked off; it is then easy to locate new mounds indicative of gophers that escaped the previous treatment and to place new baits only where needed.

Experiment has shown that 40 per cent more baits are taken when inserted by a probe than when burrows are dug open with a spoon or shovel, besides which the probe method is much faster. One man using this implement, can treat, in a single day, several hundred holes, covering as much as 40 acres. Use of the probe is easiest when the soil is damp and soft down to the level of the main tunnels, less easy when the ground is hard, and quite unsatisfactory in adobe or other soil that cracks when dry since the probe then drops as easily into a crack as into a burrow. In finely cultivated fields the dry surface soil should be scraped back before closing the hole, which may be done with a clod of earth.

The best time to use the probe is in the late autumn during the first cool weather or just after the first good winter rains. Burrows are easier to locate when the mounds are conspicuous, before green vegetation becomes abundant. The land should be gone over thoroughly at this season. Alfalfa fields, because of the abundant and continuous food supply, are sometimes more difficult to treat effectively than orchards or open fields.

Gophers are most apt to gnaw or girdle orchard trees during late summer, after the surface of the ground has become dry and green vegetation is scarce. Thus at the very season when the gopher is doing the most serious damage, and speedy destruction is most to be desired, the probing method is less easy and the operator may have to dig down to the main runways to place poisoned baits. In a garden, nursery, or lawn where it seems desirable to use poisoned baits rather than traps, formulas 4 or 5 may be employed.

In dry ground, where use of a probe is not practicable, the main runs of the gopher can be opened up in the same manner as for setting a trap. Then, using a slender pointed stick, place one of the poisoned baits a foot back in each runway, which should then be tightly closed. The hole may be opened two days later; if the bait is gone and the hole remains open, the gopher is probably dead.

3. Gassing: Poisonous gases are not often effective against pocket gophers. The great extent of the burrow system of gophers, the great chance for leakage of gas through the softer earth of laterals, the closeness of the main runs to the surface of the ground, and the fact that

gophers may at times quickly plug off their burrows when a poisonous gas is sensed and so evade destruction, are all factors which make the gas method less efficient. Some workers have reported success with gases, but in general other methods are believed to be more efficient.

Materials which have been used against pocket gophers include carbon bisulfide, calcium cyanide (flakes or dust), and the exhaust from an automobile. The waste-ball method (as applied to ground squirrels) of saturating a wad of cotton waste, corncob, or other material with the liquid, putting this into a gopher burrow, and then covering the opening with earth has been practiced. A pressure pump, such as the Karbo-Killer, tends to force the gas farther into the numerous branches of a tunnel system and is to be preferred. If gopher holes are accessible to an automobile, a hose may be attached to the exhaust pipe behind the muffler and the other end inserted in a burrow. A slight increase in engine speed, and enriching the exhaust gas by use of the choke on the carburetor, will force an abundance of carbon monoxide into the burrow. Calcium cyanide flakes placed in the dampish earth of a gopher burrow give off hydrocyanic acid gas, but are reported to be unsatisfactory. Whether use of cyanide dust forced in by a small hand duster is any more efficacious is unknown.

From time to time, various gopher "bombs" have appeared on the market. These, when lighted and placed in the burrows, are supposed to generate a poisonous gas that overcomes the gophers. On the whole, these preparations have not given much success, and their use is not widespread.

4. Flooding: In most sections of California where irrigation is practiced, crop lands and orchards are periodically flooded. On alfalfa, this is done regularly. At such times, the gophers are either drowned or forced out by the incoming water. If their tunnel systems include runs in the levees, they may avoid the water by entering the latter. Some, driven out into the open, seek the higher borders of the field. At this time they may be dispatched readily by a good dog or by a stroke of the irrigator's shovel.

5. Fencing: Small areas, such as flower or vegetable gardens, adjacent to wild lands over which the gardener has no control, sometimes merit especial protection against the entrance of gophers either by burrows or by overland migration. A fence of 1-inch mesh buried not less than 12 inches below the ground level and extending an equal distance above, will protect against gophers. If it is carried 24 to 36 inches above ground it will also be adequate protection against rabbits.

6. Encouragement of natural enemies: Two important aids in the control of pocket gophers are the barn owl and the gopher snake. The former, which commonly nests and roosts in barns, steeples, and holes in earth banks or cliffs, is one wild predatory bird whose activities are wholly beneficial to man. Its diet is always preponderantly of rodents—sometimes almost exclusively of pocket gophers. One pair of barn owls studied by Dixon caught 3 to 6 pocket gophers daily for their young. Among all the records of its food, instances of birds being eaten are exceptional. It has never been known to molest poultry. The gopher snake is likewise an efficient ally in gopher control; though it occasionally raids poultry houses and the nests of wild birds, it eats many gophers and in open fields and orchards merits full protection. Every gopher eaten by either of these animals means just one less for the farmer to catch.

7. Miscellaneous methods: Trees may be accorded some measure of protection against gnawing by gophers if a cylinder of 1-inch wire netting about 12 inches in diameter and 18 inches tall, is sunk in the hole around the tree when it is planted; the top of the wire should not quite reach to the surface of the ground, else difficulty will later be experienced in cultivating around the tree.

Trenching is successful for small-scale operations. A steep- or vertical-walled ditch 18 inches wide by 24 inches deep is dug around the plot that is to be protected against gophers. Open-topped 5-gallon cans, spaced at intervals of 25 feet, are sunk so their tops are level with the bottom of the ditch. Gophers getting into the ditch will be likely to fall into the cans whence they cannot escape.

Cementing ditches is effective where gophers are active in burrowing through the banks. A power company that had much trouble with pocket gophers in a large ditch dug a trench 4 inches wide and 6 feet deep straight down through the middle of the bank. The dirt was loosened with an iron bar and removed with a narrow shovel of the type used in digging telephone-pole holes. The trench was then filled with a "lean" mixture of cement and sand, carried by a barge that floated on the water in the ditch. The cement was conveyed to the trench by a galvanized iron chute built in sections. A small irrigation ditch having a 7-foot surface was protected from gophers, weeds, and leakage by applying, to the sides and bottom, first a  $\frac{7}{8}$ -inch coat of 1 to 7 cement and then a surface layer  $\frac{1}{4}$  inch thick of 1 to 3 cement. Such costly preventive measures are advisable only where the usual control methods are ineffective.

"Gopher repellent" plants are sometimes mentioned as helpful in gardens but there is no satisfactory evidence that any particular plant will repel gophers.

### MOLES

As already pointed out, the work of moles is often confused with that of pocket gophers. Moles are entirely different anatomically and in gross appearance, their workings differ considerably, and they subsist, in the main, on other kinds of food. Moles characteristically feed upon insects and worms in the soil (and are known, therefore, technically as Insectivora) although recently it has been found that they do, at times, take some plant materials.

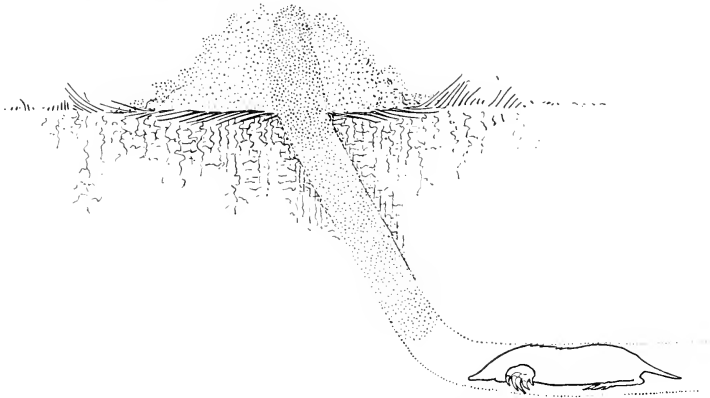

Fig. 9.—Deep tunnel and lateral of mole showing how successive loads of earth are forced up from below to form an irregular surface mound without exposing the mouth of the lateral.

Moles are common in the northwestern humid coast belt of California south to Monterey Bay; small numbers are found in the river bottoms of the lowlands and in other places affording damp soils. From much of the agricultural area of the state they are entirely absent. Two entirely different kinds of workings are made by moles: surface (or sub-surface) “runs” and deep burrows, the first being more extensive. In searching for food a mole goes along very close under the ground surface and pushes up a low rounded “ridge” of earth, leaving a tunnel or “run” below, through which the animal may travel repeatedly at irregular intervals. The deep burrows, like the main tunnels of pocket gophers, are farther below the ground surface; the earth from such excavations, instead of being pushed out of an open lateral, is forced up from below, there being always a central core of loose earth, so that the mound is “volcanic” in surface appearance (fig. 9).

*Nature of Damage.*—The runs and surface mounds disfigure lawns, golf greens, and flower beds, and the making of runs may loosen or up-root small plants. In addition, moles sometimes cut the roots of plants



and are now known to feed on sprouting seeds and on bulbs to a limited extent.

*Methods of Control.*—On the average, moles are more difficult to control than pocket gophers. Their extensive runs and tunnels generally preclude the use of gas, they do not always take poisoned baits placed for them, and trapping is slower.

1. Trapping: For individuals or small numbers of moles, the persistent use of traps is recommended. Even the ordinary Macabee trap will sometimes catch a mole if set in the lateral tunnel; the modified

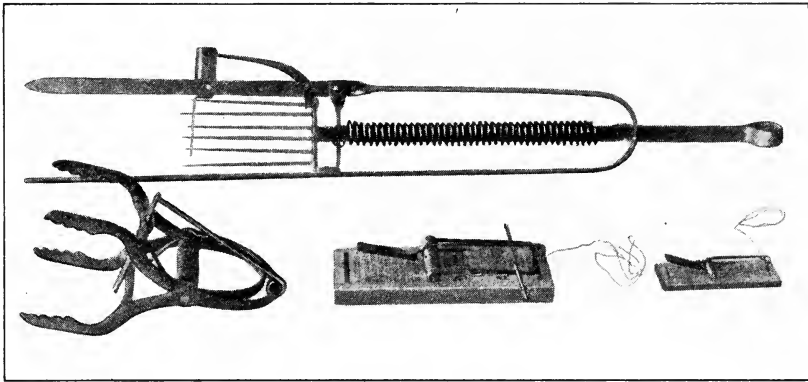

Fig. 10.—Mole traps and wooden traps for rats and mice.

Macabee (fig. 5*b*) is even more useful. Several special types are also available. "Choker loop" traps are used successfully against moles in the Pacific Northwest, in the Middle West, and in Europe, but these seem not to have gotten into the California trade to any extent. These traps have two loops of wire or metal which are pressed down to encircle a run and set off by a pan type of trigger over the top of the run. Two traps commonly offered by the hardware trade in California are the Out-o'-sight and Reddick traps (fig. 10). These are constructed so as to be set astride of a surface runway; each is equipped with a trigger "pan" that is to be pressed down on the top of the run. When the mole comes along, the upward pressure of its body releases the trap. The first-named trap is a "scissor-jaw" type, while the second has a series of downward directed spears. The spring of the first causes the two pairs of jaws to clamp the animal firmly and fatally; the spears of the second are driven downward through the earth and into the mole's body. The choker loop is generally reported to be the most effective; the spear type, least so. The latter has the disadvantage of puncturing the mole's skin, thus reducing its value if it is to be saved as fur.

To determine, before setting a trap, which runs are in use press down the soil here and there on several runs; if a run is in use the mole, in passing, will raise it again. Thereupon, press the soil down lightly once more and set a trap, pushing it down enough so that the trigger pan rests firmly against the earth over the run. Upon the next round the mole's body will force the trigger upward and release the trap.

2. Repellents and gassing: Scheffer<sup>14</sup> states that lye, paradichlorobenzene ("PDB"), or naphthalene, introduced into mole runways, a teaspoonful every 10 or 15 feet, is sometimes helpful in repelling moles. Dixon reports that 2 ounces of carbon bisulfide poured into a deep runway will sometimes kill the mole tenant. The latter chemical is, however, also likely to injure nearby plants. The Karbo-Killer may be used for deep tunnels. Exhaust gas from an automobile engine has also been tried in the Middle West, where moles are more abundant and cause greater economic concern.

3. Poison baits: In England, poison baits of red squill mixed with cereal and either meat or earthworms have been used experimentally on areas where moles were particularly numerous and troublesome. The results were satisfactory.

#### INTRODUCED RATS AND MICE

Three kinds of rats and one mouse introduced into California have considerable economic importance: the Norway rat, the black rat, the roof rat, and the house mouse. The Norway rat (*Rattus norvegicus*), is a large species, measures about 16 inches in total length, the tail being about 7½ inches; adult individuals weigh from one pound to as much as 1½ pounds. The nose is blunt, the ears are moderately small and slightly haired, and the tail is blunt and shorter than the head and body, so that when bent forward it does not reach to the nose. This rat lives chiefly at the ground level, seldom going above the first floor of buildings. It is generally distributed along the sea coast and in the interior lowland areas of the state, about residences, farm buildings, warehouses, and slaughter houses, on garbage dumps, and in sewers. The black rat (*Rattus rattus rattus*) and the roof rat (*Rattus rattus alexandrinus*) are smaller and more slender, about 15 inches in head and body length, the tail being 8½ to 10 inches long. The weight is seldom over ½ pound. The nose is sharply slender, the ears are relatively large and naked, and the slender tail when bent forward reaches to the tip of the nose or beyond. Both of these rats climb readily and may occupy the upper stories

<sup>14</sup> Scheffer, T. H. American moles as agricultural pests and as fur producers. U. S. Dept. Agr. Farmers' Bul. 1247:1-20. 1930.

of buildings, and they can travel overhead on heavy electric wires. The black rat occurs in sea ports and adjacent towns the entire length of California, while the roof rat lives in all these places and in the interior of the state, not only in the Sacramento and San Joaquin valleys but also up into the Sierra Nevada to as high as 5,000 feet altitude. The Norway and roof rats are grayish brown in color; the black rat is almost solidly black. The house mouse (*Mus musculus*) is small, 3 to 4 inches in head and body length with a tail 3 to 3½ inches long. On the upper surface it is nearly a uniform brown. The ears and eyes are small, the tail is scantily haired. The house mouse occurs about human habitations, barns, warehouses, and office buildings, and also lives entirely apart from man in some of the interior lowland districts. It is probably present in all counties of the state.

All these alien rodents have been in California at least since the 1850's. They have been distributed by commerce, the house mouse especially having often been carried in shipments of household goods, in bales of hay, and in packages of food materials. The aggregate population of these alien intruders is enormous. They cause serious financial losses to mankind, not only by the destruction of foodstuffs, but by damage to buildings, packages of food, furniture, paper records, and even electrical wiring. The alien rats were responsible for the introduction of bubonic plague and have been concerned in at least three epidemics of this disease in California cities. All are unpleasantly abundant, the mild climate of California favoring their survival both indoors and outside. In 1926-1927, house mice in the Buena Vista Lake region increased so in numbers as to constitute a "mouse plague."

*Breeding.*—The Norway rat has an average of between 8 and 9 young per litter and may rear 4 or more broods in a single year. The young are able to shift for themselves when only about three weeks of age and may breed when less than four months old. The black and roof rats average over 6 young per litter and are otherwise about as rapid in maturing as the Norway rat. House mice average 5 to 6 young per litter, the young can run about within three weeks after birth, and can breed when only 42 days old. Captive females have been known to produce 100 young in a year. Small numbers of any of these rodents may, therefore, increase to very large populations in a relatively short time. In an experiment with captive Norway rats, more than 1,500 were produced in one year from a single pair.

*Nature of Damage.*—Rats and mice feed upon practically anything used for food by human beings and domestic animals. They may, therefore, damage or destroy almost any kind of foodstuffs. Even more im-

portant than the actual amounts of food eaten is the damage to sacks, boxes, and other containers. In most warehouses constant campaigns against rats must be carried on, and despite these, much re-sacking of grain is necessary, involving expenditures for new sacks and for labor. Cardboard packages of cereals and numerous other food supplies in grocery stores are torn open, fouled, and otherwise rendered unsalable by the work of rats and mice. On poultry farms there is, in addition to the loss of foodstuffs and the cutting of sacks, some destruction of eggs and killing of young birds. Both rats and mice gnaw wood, plaster, and any material except strong metal in their efforts to get in or out of buildings and to gain access to food supplies, causing unsightly damage and facilitating the entrance of others of their kind. It is generally believed that rodents sometimes cause fires by gnawing at the insulation on electric wires and causing short circuits. Telephone service has been interrupted by the work of house mice. In addition to spreading bubonic plague, the alien rats carry other diseases, some transmissible to man, and these are becoming increasingly important in the United States.

*Methods of Control.*—Rats and mice have caused damage and distress throughout the recorded history of mankind. Every means that human ingenuity could devise has been used to combat these adaptable, hardy, and prolific pests, and from all of these a few methods have come to be recognized as of major importance: (1) exclusion, (2) trapping, (3) gassing, and (4) poisoning.

1. Exclusion: This is the only proper solution to the rat and mouse problem. All other methods give only temporary relief. Exclusion involves construction and maintenance of buildings so that none of these rodents can enter (figs. 11–13). It is practicable and not excessively expensive, but must be followed by proper maintenance and proper use of the structures. It involves not only the closing of all openings to a minimum aperture of  $\frac{3}{8}$  inch (since house mice can pass through an opening only  $\frac{1}{2}$  inch wide), but also protecting all food supplies against access by these rodents. In brief, exclusion calls for concrete floors, foundations carried well down into the ground, screening of all ventilators with hardware cloth or metal grilles with small apertures, cementing in or sheathing with metal around all pipes or electrical conduits which enter buildings, and provision for tight fitting of doors and windows. Once such rodent-proof construction is provided, continual care must be exercised that doors and windows are closed when not actually in use. Household supplies of food should be kept in covered containers of metal, crockery, or glass. Small stocks of animal feed should be put into clean galvanized-iron garbage cans; larger stocks

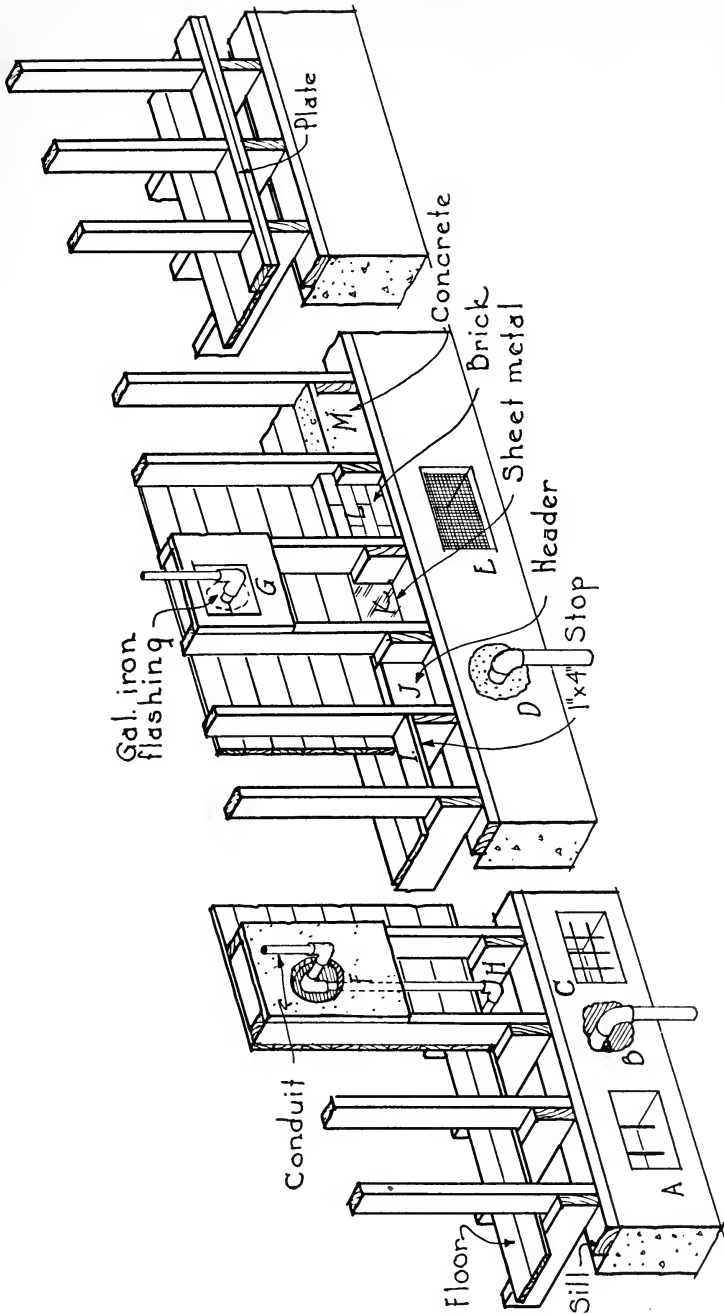

Fig. 11.—Structural details of buildings in relation to exclusion of rats and mice. Undesirable features: *A*, ventilator to basement with widely spaced bars; *B*, space about entrance of pipe; *C*, ventilator with wide-mesh grille; *F*, hole in wall around entrance of conduit; *H*, free passage for rats from below the floor into the walls.

Corrective measures: *D*, filling space around entrance of pipe with concrete; *E*, covering ventilator with hardware cloth of 1/4 or 1/2-inch mesh; *G*, covering entrance of conduit with close-fitting sheet-metal flashing; *I*, stop of wood at floor level; *J*, header block between joists, completely closing the space between sill and floor; *K*, sheet-metal "header"; filling space between studs with brick *L*, or concrete *M*.

At the right is shown the usual "western" type of framing which, when walls are in place, prevents rodents in a basement from gaining access to spaces between studs and walls.

should be housed in rooms with tightly sheathed walls, or, best of all, in bulk containers such as metal "elevators."

Concrete floors aid in preventing entry of rats and mice into buildings; unless a foundation wall extends down into the ground all around the margin of the floor, rats will often burrow underneath and establish nests there. Such a wall should reach about 18 inches below the ground surface but may be thin—3 or 4 inches in thickness—and of relatively low cement content; it can often be provided for by using a trenching spade. For aboveground construction solid concrete or masonry is the most permanent rat-proofing known; although initially expensive, it requires practically no upkeep. For all out-buildings and farm structures of frame construction on wooden studs, single walls are preferable. Double walls, especially those sheathed on both sides with wood, often provide ideal retreats for rats and mice and also passages by which these rodents may gain access to upper floors (fig. 11). Old buildings with double wooden walls may often be made rodent-proof by tacking pieces of galvanized sheet iron over the base of the outer wall, removing the lowermost boards on the inside, and putting in one or another of the stops illustrated in figure 11 (*I-M*). Windows and ventilators close to the ground should be screened with "hardware cloth" of  $\frac{1}{3}$  or  $\frac{1}{4}$ -inch mesh securely nailed on all sides (fig. 11, *E*). If such openings must be screened against insects, it is safer to use *both* hardware cloth and fly screen, placing the heavier mesh outside. Aboveground windows and doors are adequately protected by fly screen if the frames fit tightly in the openings and there are no breaks. Where pipes or conduits pass through walls of buildings, mechanics are prone to leave larger openings than necessary (fig. 11, *B, F*). Such spaces constitute the commonest paths of entry for rats and mice. Three methods of treatment may be used to close such openings: (1) in brick, tile, or concrete walls the space around each pipe is filled solidly with concrete (fig. 11, *D*); (2) on wooden walls a sheet-metal collar is fitted around each pipe, extending well beyond the edges of the opening and tacked or nailed to the wall (fig. 11, *G*); (3) entrances to steam tunnels, and other places where ventilation is necessary and workmen must enter from time to time, should be fitted with close-fitting but removable frames covered with hardware cloth of  $\frac{1}{3}$  or  $\frac{1}{4}$ -inch mesh and bolted or screwed into place.

If food materials are stored in such ways as to prevent mice and rats from getting at them, a major step in control will have been accomplished. Not all materials can be thus protected. Hay, either in bulk or in

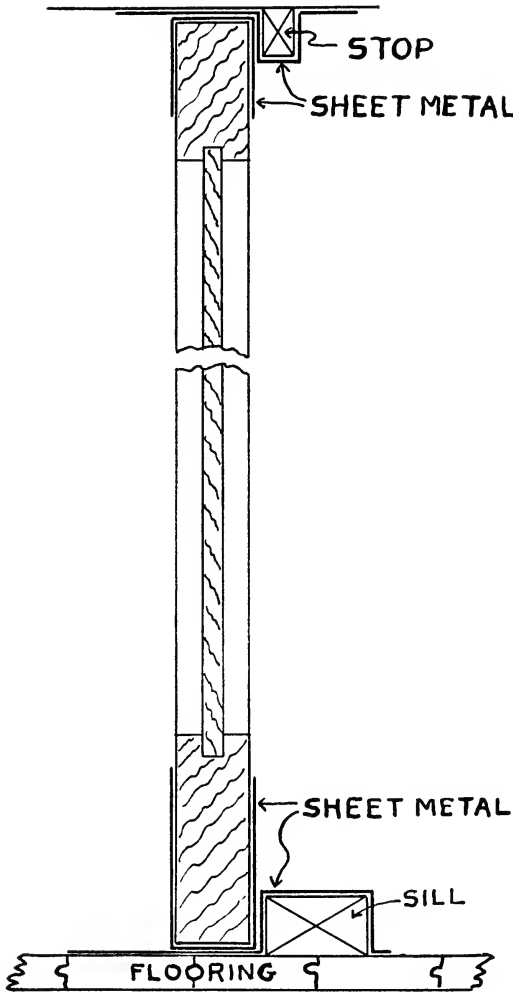

Fig. 12.—Sectional view through a door showing use of sheet-metal around edges of door (sides as well as top and bottom), and on the stop and sill to prevent entrance of rats and mice. Maximum clearance,  $\frac{3}{8}$  inch. A sill abutting *against* the door is preferable to a sill *beneath* the door.

bales, is almost impossible to protect against mice, but practically all other food materials *can* be protected if sufficient pains are taken.

About the home, large covered tin cans and glass bottles, crocks of 2 to 10-gallon capacity, and even small clean garbage cans for nuts, flour, cereals, dried fruit, etc., will protect against rodents besides affording clean containers from which the contents can be removed without incon-

venience or spilling. Incidentally, glass jars and cans with close-fitting tops will prevent moths and other insects from attacking foods so stored. Small stocks of poultry feed can be kept in large garbage cans, whence they may be easily removed; if the covers are kept in place at other times there will be little attraction for rodents. The larger commercially

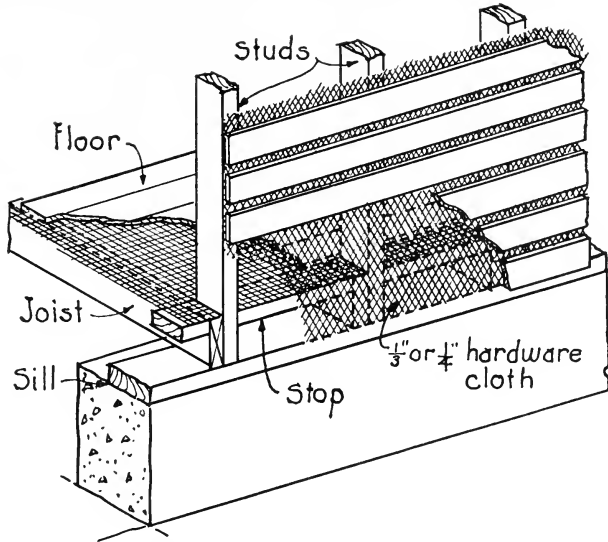

Fig. 13.—Construction for corn crib to exclude rats. The ends of studs and joists are nailed together to resist lateral pressure when the crib is filled. Spaces between studs are closed by wooden stops, at floor level. Hardware cloth is placed between joists and flooring and between studs and outside slats. The whole crib is elevated on concrete, field stone, or wooden sills so that the floor is at least 12 inches aboveground.

available cans will hold about two sacks of feed. If the amount of feed given to poultry at each feeding is limited so that the birds will clean it up rapidly, little or none will remain to attract rats and mice.

If the necessary supplies of animal feeds are large, economy of time as well as good practice demands that they be stored in bulk containers on the principle of the grain elevator. On the market are fairly cheap cylindrical tanks of galvanized sheet iron with metal covers and with metal spouts at the bottom; these are made in several sizes up to about two tons' capacity. Storage in such containers, besides excluding rodents, helps to reduce attacks by insects on the grain. Still another alternative is to construct bins of tongue-and-groove boards, with tight-fitting lids. As a further protection against rodents these may be sheathed on the inside with galvanized sheet iron or on the outside with hardware cloth. They should be framed on the outside so that the



interior is of smooth wood. The supporting legs should be sheathed with sheet-metal at some distance above the floor so that rodents will not be able to climb up the supports.

Doors to granaries, feed rooms, grocery stores, and feed stores should either be covered entirely with metal or provided with metal sheathing around the edges, and should fit against a metal-sheathed stop (fig. 12).

Corn cribs constitute a special attraction to rodents. The ordinary wooden crib being placed on the ground provides harbor for rats and mice beneath the floor while the open construction aboveground gives ample opportunity for them to obtain all the food they want. Metal corn cribs now available in manufactured form, find considerable use in eastern states. A rancher who cannot provide an all-metal structure may markedly reduce his losses by raising the crib 12 to 18 inches above the ground (using wooden sills, concrete blocks, or field stone for supports), and covering the aboveground part of the structure (including the door) with hardware cloth in addition to the usual wooden slats (fig. 13). New cribs should be constructed with the wire cloth.

Corrugated sheet iron as commonly applied to buildings does not provide complete protection, for mice and young roof rats can pass between the corrugations and the wooden frame. Save for failure to close such small apertures, however, this material is ideal for many kinds of structures. If the construction is altered slightly so that these small openings are stopped up, complete exclusion may be had.

Garbage and slaughter-house offal serve as food for rats in many places. All such refuse should, therefore, be put into metal containers until removed for final disposal. Although most communities now require their citizens to use metal cans for garbage, the carelessness of many housewives in not keeping the cans covered often nullifies the efforts of city officials to reduce rodent infestation. Even on the farm a garbage can will help keep down both rats and house flies. Throwing all kitchen scrap into a chicken or hog pen gets rid of much of the material, but too often such pens are never cleaned of accumulated refuse and so attract rats.

Irregular piles of empty boxes and of lumber afford rat harbor (provided there is a food supply adjacent), but the amount of such harbor can be markedly reduced if the material be piled in an orderly manner and the whole pile elevated a foot or more aboveground on trestles or other suitable supports.

Since piles of trash, accumulations of brush, old prunings from fruit trees, bundles of cornstalks, and all similar materials afford rat harbor, they should be promptly burned. Often they may be completely cleaned

up if some old crankcase oil or diesel oil is used to start the pile to burning well.

In brief, then, exclusion is the most important and practical method of dealing with the rat and mouse situation. It involves the actual structure of buildings, keeping them in repair, seeing that all doors, screens, and the like are properly closed, and storing all kinds of food in such a way that the animals cannot get at it. The most effective means to control rats and mice is to *build them out* and *starve them out*.

The farmer or houseowner who is bothered with rats and mice should look over his property in the light of these suggestions and determine wherein his buildings and food supplies favor the presence of rodents. Often by using materials already on hand he can do much to starve out and exclude these animals.

The remaining methods described here have to do with destruction of rats and mice already present on a property. As whole books have been written on detailed means for control of these rodents, only the most important methods can be mentioned here.

2. Trapping: Many different kinds of rat and mouse traps have been devised and manufactured, from the simple wooden spring traps (fig. 10) and guillotine traps, through cage traps, to elaborate maze-like devices of automatic character. Long experience has shown that the ordinary wooden, spring trap is as efficient as any. Almost any trap will catch some rodents, but even the most elaborate devices will fail to capture certain "wise" rats. The efficiency of cage traps is far below that of spring traps.

Few precautions are needed in setting traps for mice. They should be placed in locations where droppings, tracks, or gnawings on food indicate the presence of mice. Traps for either rats or mice should be placed with the trigger end against the wall of a room or building. They may also be placed on beams, on pipes, or in other places where the animals are accustomed to travel. Contrary to popular belief, cheese is not a universal bait. Rolled oats, corn meal, bread scraps, hamburger steak, bacon, fish, apples, raisins—in fact, almost any human food may be used successfully. The more solid materials should be pressed or even tied to the trigger; when using rolled oats or meal a few particles scattered under the trigger will make for results. If traps are placed where cats are likely to prowl they should be fastened to some nearby object with a fine wire.

Rats are often much more difficult to trap. Greater care should be exercised in setting and baiting. The trigger should be set so as to spring with as light a touch as possible. In difficult cases the operator should

wear clean cotton gloves when handling the trap. Success will sometimes follow when a trap is placed and baited several days but left unset. Then, after the rats have become accustomed to its presence, it should be baited anew and set. Sometimes covering the trap lightly with sawdust or similar material will aid in trapping a particularly wary rat.

Rats that ignore traps placed in the open will often be caught if a board or box is placed so as to shield the trap, leaving space for the rats to enter and for the trap spring to operate.

Daily renewal of baits, especially those which decompose, should be practiced and needless to say trapped rats should be removed as soon as possible. Traps should be examined at least once daily and preferably more often.

Trapping is preferable to use of gas or poison baits for destruction of mice and rats in dwellings or office buildings, since all rodents so killed may be removed at once from the premises. With gas or poison the animals are apt to die in inaccessible locations, behind walls or beneath floors, creating a long-persistent stench. This practically never happens when traps are used.

3. Gassing : Rats may often be measurably reduced by poisonous gases. Much of what is said regarding carbon bisulfide as used against ground squirrels will apply for rats. If there are fires or likely to be sparks from electric switches around dwellings or other buildings this explosive material should be used only with great caution. Much successful rat control is obtained with cyanide products. Ships are now regularly fumigated with compressed, liquid hydrocyanic acid gas. A small hand duster employing calcium cyanide dust gives excellent results about farm buildings but is dangerous in dwellings. Attaching a piece of rubber tubing to the end of the duster makes it easier to reach certain holes. As the burrows are dusted, the openings should be filled with earth. The moisture in the ground and in the air of the burrows combines with the calcium cyanide to form hydrocyanic acid gas. Corn cribs may be temporarily rid of rodents by use of such a dust pump. There is no danger in subsequently using corn from these cribs for stock feed, since the poisonous gas is generated rather quickly and the residue consists only of lime. Cyanide should never be used in an inhabited dwelling or in a farm building where animals are present. Finally, the exhaust of an automobile may be led down rat burrows through a hose. With a rich mixture, an abundance of poisonous carbon monoxide will be forced into the burrow by the pressure of the exhaust.

4. Poisoning : Many different materials have been used to poison rats. Some of these are successful, some are not readily taken by rats, and

some are also highly poisonous to other animals and to man. Of all these, red squill is the safest and most satisfactory, being either unattractive or less poisonous to other animals. Barium carbonate may also be used, but requires greater care.

Red squill<sup>15</sup> is obtained from a bulbous plant (*Urginea maritima*) native to the north shore of the Mediterranean Sea. As prepared for rat poison it is in the form either of powder or of fluid extract, the former being more commonly available. Since the strength of different squill preparations varies considerably, a dependable product must be obtained; white squill is not toxic to rats. Experimental tests have shown that poison baits as prepared for rats are not poisonous to cats, dogs, chickens, or pigeons; these animals either will not eat the baits or will vomit promptly any baits eaten.

For rat control the powdered red squill is mixed with any common foodstuff (formula 6) such as cereal, fish, or hamburger steak. In the interior drier portions of California some meal should be mixed with the meat or fish so that the baits will not "gloss over" by early drying, and become unattractive to the rats. Material so prepared is to be placed, a half teaspoonful at a spot, where rats occur. Even though such baits are reported not dangerous to domestic animals, they should not be carelessly placed where animals or children might find them.

Barium carbonate, a heavy white powder, has also been used against rats and until the introduction of red squill was extensively recommended. This material *is poisonous* to man and to domestic animals. For use (formula 7) it is mixed with cereal, meat, chopped vegetable, fruit, or scrap bread soaked in milk. The poisoned material should be placed as for red squill. Any baits not taken should be gathered up and buried, and if further poisoning is attempted a change to some other bait material should be made.

5. Miscellaneous methods: Several special "rat viruses" containing cultures of bacteria intended to disseminate disease through a population of rats have been exploited. Their use seems to be more common in continental Europe than in the United States. Extensive efforts have been made to encourage their use in this country and one or more commercial enterprises have used such cultures for rat control in California. However, unbiased studies by rodent control officials have shown that results are less than claimed by the manufacturers. Studies by bacteriologists in this country have failed to substantiate the claims set forth for these viruses as to their effect on rat populations. Finally,

---

<sup>15</sup> Munch, J. C., James Silver, and E. E. Horn. Red-squill powders as raticides. U. S. Dept. Agr. Tech. Bul. 134:1-36. 1929.

public health officials have felt that there was danger in the use of these bacterial cultures because of the possibility of transmitting the disease to human beings. Their use has therefore been discouraged by various official agencies and even prohibited by the State Board of Public Health in California for several years past.

The use of ferrets in rat control is frequently mentioned. In principle, a trained ferret is turned into a burrow and either destroys or drives out the rats; but practically, this method has not found general favor in the United States and is more spectacular than efficient.

Control of rodents and especially of rats is the regular business of various "rodent exterminating" and "vermin control" companies. Some of these are bona fide; others know little of rodent control.

Special rat poisons are extensively advertised in many magazines. Some contain only the materials described in the present circular—at relatively high prices; others contain poisons too dangerous for use by the average householder or farmer, and some are absolutely useless since they contain no poisonous material whatever. Persons who seek to control rats and mice about their dwellings or farms, therefore, will do well to inquire critically into the merits of any special preparation before purchasing.

#### MEADOW MICE

The term "field mice" is applied by many persons to several kinds of mice found in grain fields, about hay stacks, and in orchards where cover-crops are grown or where weeds and grass are not kept down. At least four different animals are involved: the introduced house mouse, the native harvest mouse, the white-footed or "deer" mouse, and the meadow mouse or vole. Control of the house mouse is discussed in preceding pages. Meadow mice (genus *Microtus*) are often abundant on farm lands and at times may increase enormously in numbers; the "mouse plague" at Buena Vista Lake in 1926–1927 included both house and meadow mice.

All meadow mice are blunt-nosed, with small ears, the body is covered with a dense soft fur, and the tail is relatively short and slender. The head and body measure about 4 to 6 inches, the tail from  $1\frac{3}{4}$  to  $2\frac{3}{4}$  inches. Meadow mice live on and in the ground; most species construct surface runways in the grass, by shearing off the vegetation to form little pathways about an inch in breadth running here and there in grassland; these connect with the numerous small burrows which the mice make in the ground.

Damage by meadow mice may involve destruction of standing grain, cutting of green vegetation including alfalfa, damage to hay in loose

cocks or stacks, and gnawing the bark and roots of trees surrounded by grass and weeds. The damage is irregular as to amount, season, and place of occurrence. These mice, more than most native rodents, fluctuate markedly in numbers. In the arctic regions there are periodic increases and decreases in the populations of the voles and their allies. In California, changes in the meadow mouse population have been noted, but it is not known whether these are periodic.

Preventive treatment consists of clean cultivation. Orchards where covercrops are grown should be watched for signs of damage by meadow mice and steps taken at once to check the mice if necessary. Otherwise clean cultivation in orchards, removal of grass and weed growths along fences and about farm buildings and piles of lumber will reduce the harbor available for these animals.

Meadow mice may be controlled either by traps or by poison. For small numbers the best plan is to use mouse traps, baited with oat meal, rolled oats, or bits of apple, carrot, or other root vegetables and set with the triggers of the traps *across* the runways. The traps will then be effective on mice running in either direction along the surface paths. Sometimes unbaited traps will suffice. Traps should be visited at frequent intervals, since these mice are active by day as well as at night and the efficiency of individual traps is increased by frequent attention.

If the meadow mice are very abundant poisoned bait must be used (formula 8). Great care must be exercised in placing any poison in surface runs to be certain that such baits are not taken by children, wild birds, or domestic animals.

### WOOD RATS

The native wood rats (genus *Neotoma*), known commonly as "trade rats" or "pack rats," are sometimes a nuisance in cabins in the foothills and mountains. The wood rats resemble the Norway rat in a general way; a conspicuous difference is that the body covering is much softer in the wood rat. The brown-footed wood rat which inhabits many foothill localities in California discloses its presence by building large conical nests of sticks and forest litter, on the ground or in trees. At times these animals gain access to cabins and build their nests indoors. They may also be attracted to food supplies left by the human tenants and may remove small bright objects such as spoons, forks, knives, or small mirrors, sometimes depositing sticks or other items "in trade." The directions given for making buildings and food supplies proof against the alien rats will apply here. All bedding, mattresses, or clothing stored in isolated cabins should be put into a closet or room sheathed

with sheet metal or "hardware cloth"; otherwise wood rats (and at times white-footed mice) may cut it while in search of nesting materials.

Wood rats being much less wary than the alien rats, are effectively controlled by the ordinary spring rat traps.

### KANGAROO RATS

In a few localities, especially where dry farming is practiced adjacent to wild land of desert or semi-desert character, trouble is sometimes experienced from kangaroo rats (genus *Dipodomys*). These distinctive rodents are easily recognized by their long hind legs and feet, short small fore feet, long tails, and the presence of a pair of external cheek pouches (like those in pocket gophers). They live in short shallow burrows, usually in sandy ground. Over much of interior California they are of negligible importance, having been exterminated from areas long under cultivation. When necessary, they may be easily controlled by use of strychnine-coated barley (formula 1).

### MUSKRATS

Muskrats (*Ondatra zibethica*) were earlier present in California only in a few scattered localities in Alpine and Lassen counties east of the Sierra Nevada, and along the Colorado River on the boundary between California and Arizona. Their numbers, and the area occupied by them, have been increased by man. The canal constructed to carry water from the Colorado River to the Imperial Valley formed a natural route for migration which they were quick to use. These large rodents are now fairly abundant and cause serious damage to the canals and ditches of the Imperial Valley. Their burrows in the banks sometimes contribute to causing breaks with consequent loss of water.

Elsewhere in California muskrats have been transplanted by man into the Kern River and adjacent canals about Bakersfield, into Guadalupe and Oso Flaco lakes west of Santa Maria, and into the Shasta River drainage in Siskiyou County. They are reported to have been transplanted into Little Lake, Inyo County. In Surprise Valley, Modoc County, they have escaped from "muskrat farms" in two places; early in 1933 a serious condition developed along Fall, Tule, and Pit rivers in northeastern Shasta County by escape of muskrats from a "fur farm" near McArthur.

In the eastern United States, where irrigation is not practiced, muskrats cause no particular damage to agriculture; but wherever irrigation or drainage canals are needed these animals are likely to cause trouble.

Muskrat farming is yet to be proved economically profitable, since millions of muskrats can be trapped cheaply on the natural marshes in other parts of North America.

Where muskrats must be prevented from damaging irrigation structures, No. 1 steel traps should be set in burrows or—better—on the characteristic “feeding mounds” in water 2 to 3 inches in depth, and should be partially sunk in the bottom material. The trap chain should be passed over a slender pole driven into the bank but leaning over the water; the outer end of the pole should have a crosspiece at the top to prevent the trap chain from being slipped off. A trapped muskrat will usually dive into deep water, so that the chain slides along the pole and the animal is quickly drowned. Some trappers use a bait of parsnip, sweet potato, carrot, or other root vegetable, suspended on a small stick so as to be about a foot over the trap site; but many trappers use no bait whatever. Other methods of capture have been described.<sup>16</sup>

Muskrats on canals have been reduced by fur trappers working under permits from the ditch owners. Such helpers though often eager to catch muskrats for their fur value, will never remain long enough to reduce these (or any other) animals to a low level, preferring to move to new localities when the catch declines. Control for economic purposes is more likely with paid and supervised trappers.

At Bakersfield recourse was had to use of carbon bisulfide pumped into burrows at a season when water had been withdrawn from the canals.

### RABBITS

Rabbits, while technically not rodents, operate in similar ways. This group has two main divisions: the “hares,” represented by the jack rabbits and the snowshoe rabbits, living entirely aboveground, making no nests, and bringing forth their young fully covered with fur, with their eyes open, and able to move about at once; and the true rabbits, including the cottontail and brush rabbits, dwelling in dense cover, under stone piles and brush, or in burrows, the young of which remain in the nest for a period of growth.

*Black-tailed Jack Rabbits.*—The common jack rabbits (*Lepus californicus*) occupy the lowland, foothill, and desert portions of California, are sparsely represented in the humid coast region, and are absent from the higher mountains above the yellow-pine belt. They depend upon speed and their ability in dodging to escape enemies. They live chiefly

---

<sup>16</sup> Lantz, D. E. The muskrat as a fur bearer with notes on its use as food. U. S. Dept. Agr. Farmers' Bul. 869:1–20. 1923.



in open places, seldom inhabiting thickets or wooded country to any extent. The average litter is about four, usually produced in the spring months; but young are in evidence over a considerable portion of the year. Although jack rabbits make no nests, individuals often have a more or less regular retreat or "form" beneath a bush where the animal is somewhat sheltered from the full heat of mid-day sun, and yet can watch for the approach of enemies. The food comprises a wide variety of plant materials, both wild and cultivated, including grain, alfalfa, and various truck and field crops, and at times the bark and tender shoots of small orchard trees. Formerly jack rabbits were enormously plentiful, especially in the San Joaquin Valley and on the flatter areas of southern California. Many spectacular "rabbit drives" were held; the whole human population of a district would turn out and surround a territory several miles in extent, driving the rabbits toward a central corral bordered by wing fences. After being concentrated in such an enclosure, the rabbits were clubbed to death by the hundreds and even thousands. Drives and other measures have reduced the population far below the earlier numbers, yet there are still enough jack rabbits in some places to do considerable damage to the more intensive agriculture of the present day.

*Snowshoe Rabbits.*—On the higher portions of the Sierra Nevada and in the northeastern plateau region of California there are two kinds of rabbits adapted to living on or in the snow during the winter months: the large Sierran white-tailed jack rabbit (*Lepus townsendi sierrae*) and the smaller snowshoe rabbit (*Lepus washingtonii*); both are "hares." These, like the black-tailed jack rabbits, are surface dwellers. Their feet being densely covered with long fur, they can travel on the snow. The tail in the snow-inhabiting rabbits is always white, and the animals themselves are white in winter. These rabbits live where there is little intensive agriculture; they occasionally nibble the twigs and bark of apple trees during the winter months.

*Cottontail and Brush Rabbits.*—These true rabbits (genus *Sylvilagus*) occur over the lower altitudes in California. Cottontails are more common in stream-side thickets and pastures; brush rabbits on brushy and chaparral-covered slopes in the hill country. Little is known about the rate of reproduction or manner of caring for the young. The litters are small, averaging about four, and are usually produced in the spring months. Both of these rabbits will feed upon cultivated crops of garden and field. They are classed as game, and, over most of California, may be hunted only between November 15 and December 15. In the southern part of the state (Districts 4, 4 $\frac{3}{4}$ , 19, and 21), because of their larger

numbers and the greater possibilities of damage to agriculture, there is no closed season. The California Game Code provides that owners, tenants of land, or their agents may kill rabbits on their properties at any time in any part of the state.

*Methods of Control.*—Rabbits are not difficult to control on small areas but present greater difficulty on large ranches. The methods used are: (1) exclusion, (2) shooting, (3) repellents, (4) trapping, (5) poisoning, and (6) encouragement of natural enemies.

1. **Exclusion:** A fence of mesh not greater than  $1\frac{1}{2}$  inches, buried to a depth of 6 inches in the soil and carried 24 to 36 inches aboveground, will exclude all rabbits, if it is patrolled at intervals to see that neither rabbits nor squirrels have dug passages under the buried portion. Such a fence, constructed of inexpensive poultry netting and combined with barbed wire, will often serve as a stock fence for horses and cattle. Sheep and hogs, however, are apt to damage a light wire fence, and hogs especially may root at the base of such a fence and so destroy its effectiveness. A barbed wire placed at the ground level will aid in the maintenance of a rabbit-proof fence. Neither jack rabbits nor cottontails will ordinarily jump over a 24-inch fence; but a jack rabbit when pursued by a dog may do so, particularly if the fence is not surmounted by closely spaced barbed wires. Such a protective fence must, of course, be provided with tight-fitting gates and with sills or other means for insuring that rabbits cannot dig below the bottom rails of gates. Its effectiveness is lost if the gates are not kept closed except when vehicles or persons are passing through. Small spring-closing gates may be used in many places. This method of exclusion is best for small flower or vegetable gardens, especially those adjoining large areas of pasturage, grain, alfalfa, or wild land. Any high-priced crop such as a small field of seed stock deserves the relatively inexpensive fencing here indicated. If such a small plot of ground needs to be enclosed for but a few months, light stakes may be used to support the wire, the bottom of which is buried in a furrow; then, after the crop has been harvested, the wire and stakes may be removed to permit the use of cultivating machinery. Around large acreages of farm land provision of rabbit-proof fencing is ordinarily impractical. The ordinary rectangular mesh used as the lower part of a stock fence, where sheep or hogs are being pastured, has openings of a size that permits the entry of rabbits. Fencing for large areas with wire of strength adequate to restrain livestock and of mesh sufficiently small to exclude rabbits will ordinarily cost one dollar or more per rod for the wire alone.

Over many years, farmers in California have used individual me-

chanical protectors to guard the trunks of young orchard trees against damage by rabbits. Earlier, thin slabs of yucca and other veneer materials were employed. Ordinary sacking has been tied around trees with effective results. Poultry netting of 1-inch mesh, No. 20 gauge galvanized wire, 18 to 24 inches in width, cut into strips 12 to 18 inches long and formed into cylinders around young trees, is a common means of protection. Such cylinders should be braced so that rabbits cannot press them against the trees and gnaw at the bark between the wire meshes. A fine mesh wire or "hardware cloth" would also be efficacious against meadow mice, especially if pressed down into the ground at the lower edge.

2. Shooting: Much effective control of rabbits can be had by shooting. Rabbits are prone to feed in the early morning, late afternoon, and dusk of evening, so that use of a gun is most effective at these times, but they may feed also at night making this method not entirely successful. Ranchers troubled by numbers of cottontails may obtain some relief by inviting sportsmen to hunt over their lands during the open season. On certain ranches spring hunting of jack rabbits is promoted, the hunter thereby obtaining a measure of sport at a season when other game cannot be shot, and the rancher some reduction of jack rabbits, although such hunting will seldom clear a ranch of the animals. Reduction of jack rabbits at this season is of especial benefit in limiting the number of young which might otherwise be produced. At times jack rabbits have been hunted for market use, and this aids in reducing their numbers.

3. Repellents: Various repellent substances have been used to prevent rabbits from gnawing the bark and twigs of trees and vines. An adhesive whitewash has some merit. Recently a foul-smelling sulfurized oil (formula 9) has been developed which is to be painted on the trunks of trees; it is reported to give excellent protection. A strychnine-poisoned wash (formula 10) has been used in Idaho to protect young orchards. Its use is contra-indicated where domestic animals are present. Fresh blood, daubed on young trees, has found some use as a repellent.

4. Trapping: The jack rabbit drives of earlier years may be considered to have constituted a type of trapping. In the Middle West cottontails<sup>17</sup> are sometimes captured in a special box trap known as the Wellhouse. A permanent rabbit trap, constructed with a horizontal run of sewer tile 6 inches in diameter and 4 feet long leading into a vertical 12 × 6 inch tile **T**, with a heavy cover, has been used in Kansas. The entrance, surrounded by stones and brush, gives a natural appearance. Such traps may help in capturing rabbits in orchards.

---

<sup>17</sup> Lantz, D. E. Cottontail rabbits in relation to trees and farm crops. U. S. Dept. Agr. Farmers' Bul. 702:1-14. 1924.

5. Poisoning: Use has been made of poison against jack rabbits in districts where ranches are scattered and the human population is sparse. Its use is not advised against cottontails and brush rabbits, since these animals have value as game. Other means should be tried wherever practicable since poisoning rabbits is hazardous. The poisoned bait may be any material relished by rabbits such as alfalfa leaves, grain heads, or oats. Since rabbits, like many other animals, both wild and domestic, are fond of salt, recourse has been had to poisoned salt. If any of these methods are deemed necessary the person responsible for the poisoning operations should make certain that all necessary precautions are taken to prevent domestic animals, harmless wild animals, and human beings from being endangered. On stock ranges where jack rabbits are so numerous as to reduce the pasturage, substantial pens excluding livestock but permitting jack rabbits to enter, have been used for the exposure of poisoned materials. In the event that the owner or tenant of land is having difficulty with rabbits which cannot be solved by methods indicated above, it is recommended that he consult the agricultural commissioner or farm advisor of his county as to the most appropriate methods to use.

6. Encouraging natural enemies: The red-tailed hawk and golden eagle both feed upon rabbits, while the gopher snake is known to capture small individuals. These and other natural enemies that subsist on rabbits and rodents are valuable aids to the farmer.

#### FORMULAS FOR PREPARING POISONED BAITS FOR RODENTS

*General Precautions.*—All of the substances used for poisoning rodents are dangerous to human beings and to domestic animals. They should, therefore, be handled with care. The minimum lethal dosages (of the elementary poisons) for a human being are approximately as follows:

Strychnine.....	0.5 grain or 35 milligrams
Red squill.....	150.0 grains or 10 grams
Barium carbonate.....	150.0 grains or 10 grams
Carbon bisulfide.....	1 part in 1,000 parts of air after 30 minutes' exposure

Thus, about 250 kernels of strychnine-coated barley, or 3 to 4 ounces of red squill bait, or 2 ounces of barium carbonate bait would constitute a lethal dose for a human being.

Antidotes for these poisons are uncertain; egg white and milk should be given and vomiting induced; these may help if administered immediately. In any instances of accidental poisoning of an adult or a child a physician should be summoned at once. In the preparation of poisoned

baits, as when dry strychnine is being dusted over bait material, care should be exercised not to breathe the dust. All utensils and the operator's hands should be washed carefully after mixing baits. Utensils used for this work should not be used for other purposes. Containers for poison and poisoned baits should be kept *locked up* except when in use and should always be out of the reach of children, irresponsible adults, and livestock. Cans or sacks of poisoned bait should be clearly labeled as **POISON**. Cans containing carbon bisulfide should be stored in a dry cool place away from all fire, matches and sparks, as this material is dangerously explosive.

**Formula 1.**—Strychnine-coated whole barley for California ground squirrels (Government formula).

Barley (clean whole grain).....	16 quarts
Strychnine (powdered alkaloid).....	1 ounce
Bicarbonate of soda (baking soda).....	1 ounce
Thin starch paste.....	$\frac{3}{4}$ pint
Heavy corn sirup.....	$\frac{1}{4}$ pint
Glycerin.....	1 tablespoonful
Saccharin.....	$\frac{1}{10}$ ounce

Mix the strychnine, baking soda, and saccharin together dry. Prepare the starch paste by dissolving 1 heaping tablespoonful of dry gloss starch in a little cold water, pour into  $\frac{3}{4}$  pint of hot water, boil and stir until clear. Add the dry strychnine, soda, and saccharin, then the corn sirup and glycerin; stir thoroughly. Pour the hot mixture over the grain, turning and stirring until each kernel is coated. Spread the coated grain out in a thin layer until the coating is thoroughly dried; then store in a can or sack, properly labeled as **POISON**, until used.

**Formula 2.**—Strychnine-coated whole oats for Oregon ground squirrels.

Use formula 1, but substitute 20 quarts of recleaned oats for the 16 quarts of barley.

**Formula 3.**—Strychnine-coated dandelion "greens" for Oregon ground squirrels.

Use formula 1, but substitute 5 gallons (bulk) of freshly cut green dandelion leaves for the barley. Water cress or alfalfa leaves are less satisfactory.

**Formula 4.**—Cut baits for pocket gophers.

Cut baits of sweet potatoes, parsnips, or carrots.....	4 quarts
Strychnine (powdered, either alkaloid or sulfate).....	$\frac{1}{8}$ ounce
Saccharin.....	$\frac{1}{80}$ ounce (5 grains)

Cut the vegetables into pieces about  $\frac{1}{2} \times \frac{1}{2} \times 1\frac{1}{2}$  inches, wash and drain. Mix the strychnine and saccharin thoroughly in a pepperbox or other sifting device. Sift this over the baits, meanwhile turning them over and over, until all are evenly coated. Put the baits in a covered container and use as soon as possible. Label, plainly, both the bucket and the sifter: **POISON**.

**Formula 5.**—Poisoned root vegetables, raisins, or prunes for pocket gophers.

Cut baits as directed in formula 4; with a slender knife-point insert a few crystals of strychnine sulfate into the center of each bait. Prunes that have previously been soaked for about two hours in water, or large raisins, may be poisoned in the same way. The cut baits should be used at once; the prunes if dried thoroughly after being poisoned, and the raisins, will keep; poisoned prunes or raisins should be stored in a bottle or can plainly marked **POISON**.

**Formula 6.**—Red squill baits for rats and mice.

Any cereal meal (oatmeal, corn meal, graham flour,  
bran or peanut meal), ground meat, or minced fish...10 parts  
Red squill, powdered, dry..... 1 part (by weight)

Equivalent is one level tablespoonful of dry squill to one measuring-cupful of meal; mix.

Fresh fruit or vegetables cut in thin slices may be dusted with red squill from a pepper sifter.

Liquid red squill may be used on dry meal or bread; cut  $\frac{1}{2}$  pound of stale bread into  $\frac{1}{2}$ -inch cubes; pour one pint of liquid red squill over it and mix thoroughly.

**Formula 7.**—Barium carbonate baits for rats and mice.

Cereal (corn meal, rolled oats), or bread; ground  
meat or fish; finely chopped vegetables or fruits..... 4 parts  
Barium carbonate, dry, powdered..... 1 part

For drier materials mix first with the barium carbonate, then moisten; "sloppy" baits may be more effective in warm weather; bread baits may be moistened with milk; fresh fruits and vegetables should have the dry barium carbonate sifted over them, and the poison well worked in. Baits may be wrapped in small pieces of newspaper with the corners twisted to make a closed container.

**Formula 8.**—Alfalfa leaves with strychnine for meadow mice.

Alfalfa leaves, dry..... 8 pounds  
Strychnine alkaloid, powdered.....  $\frac{1}{4}$  ounce  
Saccharin .....  $\frac{1}{32}$  ounce (13 grains)

Dissolve the strychnine and saccharin in 2 quarts of water; sprinkle over the leaves, turning the latter until all are moistened; distribute the poisoned leaves in burrows or in small piles in runways.

**Formula 9.**—Sulfurized oil to protect young trees against rabbits.

Raw linseed oil.....	1 gallon
Sulfur, powdered.....	12 ounces

Heat the oil, out-of-doors, in a 5-gallon can, to 470° F (243° C). Measure the temperature with a thermometer; the oil gives off bluish smoke at the temperature indicated. When the proper temperature is reached, remove the oil from the fire and begin adding the sulfur, a teaspoonful at a time, stirring constantly. The oil will become hotter and will foam a great deal. When all the sulfur has been added a black ill-smelling compound will result. Allow the oil to cool completely before it is used.

Clear grass and weeds from around the trees and paint the trunks with the oil, taking pains to cover knots and injured spots. One gallon will treat about 200 trees. The oil should be applied when the bark is dry. Such a protective coating will last through most of one winter. If applied in late winter a few early starting leaves may be stunted, but no other adverse results have been observed.

**Formula 10.**—Poison wash to protect young trees against rabbits.

Strychnine sulfate.....	1 ounce
Laundry starch.....	8 ounces
Glycerin.....	6 ounces
Water.....	3½ quarts

Prepare the laundry starch by mixing cold and then boiling in one pint of water; dissolve the strychnine in the remaining water by boiling; add the paste and glycerine. Cool and paint on trunks of trees. Do not admit domestic animals to orchards where this poison wash has been applied.

